



HAL
open science

African women's empowerment : a study in Amma Darko's selected novels

Koumagnon Alfred Djossou Agboadannon

► **To cite this version:**

Koumagnon Alfred Djossou Agboadannon. African women's empowerment : a study in Amma Darko's selected novels. Linguistics. Le Mans Université; Université d'Abomey-Calavi (Bénin), 2018. English. NNT : 2018LEMA3008 . tel-02049712

HAL Id: tel-02049712

<https://theses.hal.science/tel-02049712v1>

Submitted on 26 Feb 2019

HAL is a multi-disciplinary open access archive for the deposit and dissemination of scientific research documents, whether they are published or not. The documents may come from teaching and research institutions in France or abroad, or from public or private research centers.

L'archive ouverte pluridisciplinaire **HAL**, est destinée au dépôt et à la diffusion de documents scientifiques de niveau recherche, publiés ou non, émanant des établissements d'enseignement et de recherche français ou étrangers, des laboratoires publics ou privés.

THESE DE DOCTORAT DE

LE MANS UNIVERSITE ET DE L'UNIVERSITE D'ABOMEY-CALAVI
COMUE UNIVERSITE BRETAGNE LOIRE

ÉCOLE DOCTORALE N° 595
Arts, Lettres, Langues
Spécialité : *Littérature africaine anglophone*

ÉCOLE DOCTORALE PLURIDISCIPLINAIRE
«Espaces, Cultures et Développement»

Par

Koumagnon Alfred DJOSSOU AGBOADANNON

AFRICAN WOMEN'S EMPOWERMENT: A STUDY IN AMMA DARKO'S SELECTED NOVELS

Thèse présentée et soutenue à l'Université d'Abomey-Calavi, le 17 décembre 2018
Unités de recherche : 3 LAM Le Mans Université et GRAD Université d'Abomey-Calavi
Thèse N° : 2018LEMA3008

Rapporteurs avant soutenance :

Komla Messan **NUBUKPO**, Professeur Titulaire / Université de Lomé / TOGO
Philip **WHYTE**, Professeur Titulaire / Université François Rabelais de Tours / FRANCE
Laure Clémence **CAPO-CHICHI ZANOU**, Professeur Titulaire / Université d'Abomey-Calavi/BENIN

Composition du Jury :

Présidente : Laure Clémence **CAPO-CHICHI ZANOU**, Professeur Titulaire / Université d'Abomey-Calavi/BENIN
Examineurs : Augustin Y. **AINAMON**, Professeur Titulaire / Université d'Abomey-Calavi / BENIN
Benaouda **LEBDAL**, Professeur Titulaire / Le Mans Université / FRANCE
Komla Messan **NUBUKPO**, Professeur Titulaire/ Université de Lomé/ TOGO
Philip **WHYTE**, Professeur Titulaire / Université François Rabelais de Tours / FRANCE
Léonard **KOUSSOUHON**, Professeur Titulaire / Université d'Abomey-Calavi/ BENIN
Dir. de thèse : Augustin Y. **AINAMON**, Professeur Titulaire de Littérature africaine et d'Etudes américaines
Co-dir. de thèse: Benaouda **LEBDAL**, Professeur Titulaire de Littératures coloniales et postcoloniales

Invité(s)

Benaouda **LEBDAL**, Professeur Titulaire / Le Mans Université / FRANCE
Komla Messan **NUBUKPO**, Professeur Titulaire/ Université de Lomé/ TOGO
Philip **WHYTE**, Professeur Titulaire / Université François Rabelais de Tours / FRANCE

RESUMÉ et MOTS CLÉS

L'autonomisation des femmes africaines : Une étude à travers une sélection de romans d'Amma Darko

Résumé:

Cette thèse entreprend une analyse sur les romancières africaines qui ont un avis différent sur la question de la description des personnages féminins, un point de vue différent sur le rôle de leurs fictions qui peuvent être utilisées pour promouvoir les femmes. Cette recherche examine précisément l'influence de la culture, des coutumes traditionnelles africaines dans les romans de l'écrivaine ghanéenne, Amma Darko. Les romans publiés entre 1995 et 2007 inscrivent l'écrivaine ghanéenne dans la troisième génération de romancières africaines. Amma Darko est née un an avant l'indépendance du Ghana qui a eu lieu en 1957. Elle quitta le Ghana pour l'Allemagne où elle travailla pendant environ dix ans. Ses écrits partent de l'hypothèse générale de l'existence des groupes minoritaires au sein de la littérature africaine parmi lesquels celui des écrivaines dont les textes ont un écho plus en plus fort dans le champ littéraire. Son premier roman *Beyond the Horizon* (1995) donne la preuve palpable de cette capacité à revisiter l'histoire de son peuple en vue de raviver son identité dans un monde en mutation.

Ce travail de recherche montre comment la romancière souligne les pratiques culturelles comme étant le point de blocage dans l'émancipation des femmes africaines. Cette thèse montre que ses romans expriment davantage les opacités du malaise culturel et identitaire de la femme ghanéenne et africaine d'une manière générale. Ses romans s'inscrivent dans un contexte d'émergence littéraire et sociologique et montre comment leurs dispositions, leurs positions et leurs prises de positions retracent une trajectoire ancrée dans le roman œuvre didactique et d'éveil de conscience.

Cette thèse s'est construite sur une analyse approfondie du mode de transmission de l'émotion de la romancière, particulièrement à travers la mémoire, l'histoire et le traumatisme du peuple ghanéen et donc africain, et le mode par lequel elle représente et repositionne les personnages féminins pour répondre à la question de l'apport de la littérature dans la prise de pouvoir de la femme africaine. Amma Darko le justifie par le besoin constant de la solidarité entre femmes rurales, surtout pendant les moments difficiles. En ville, la chance est moindre pour que les femmes soient solidaires, mais cette solidarité engagée se retrouve au niveau des femmes de l'Organisation Non Gouvernementale, MUTE basée à Accra.

L'ensemble montre comment Amma Darko propose des solutions de règlement de cette crise relationnelle homme/femme à travers des personnages convaincants et bouleverse par ce mélange de genres l'esthétique en fragmentant l'histoire par le biais de flashbacks, en refondant une société dans laquelle l'action des personnages féminins exigent le respect. Amma Darko reflète ainsi sa maîtrise des différentes langues utilisées et de leur esthétique. La romancière utilise des mots et des histoires de son ethnie d'appartenance pour justifier son identité et celle de ses personnages. Cette thèse montre combien Amma Darko est aux avant-postes de la littérature engagée écrite par les femmes en Afrique.

MOTS-CLÉS:

- | | |
|-----------------------|-----------------------|
| 1 Littérature | 5 Autonomie |
| 2 Tradition africaine | 6 Féminisme |
| 3 Culture | 7 Société patriarcale |
| 4 Femmes | 8 Education |

African Women's Empowerment: A study in Amma Darko's Selected Novels.

Abstract:

This thesis addresses the question of whether African female writers have a different view in portraying their female characters and investigates whether their fiction can inspire women's empowerment in Africa. Therefore, this study examines the influence of culture and customs in the novels of the Ghanaian female writer, Amma Darko. In her writings, Amma Darko has consistently sought to portray cultural practices that bring embarrassment to her shared gender. She has used the same channel to teach her counterparts the formal ways to cope with those issues. Focusing on her novels, our study explores modes of memory, trauma and history writing and examines the way she represents, reaffirms and repositions women in their creative writings to answer the question of whether literature can help empower African women. Amma Darko proves it right by showing a constant need for female solidarity in order for women to remain or become empowered.

This thesis examines the histories of immigration and maps the transatlantic slave trade. It discloses the active implication of Ghanaian men in fictional narratives, modes by which memories of the past are formally and consciously structured and recorded. It also examines the way in which traditional customs control the conscience of women in African societies. Since women's roles are largely dictated by cultural expectations such as motherhood, docility, child bearing and rearing, the dissertation includes examination of the writers' attitudes towards those traditions relating to marriage, polygamy, unfaithfulness, and witchcraft.

Many womanist scholars have pointed out largely and unanimously that many aspects of African culture are hostile to women. Therefore, a need for a paradigm shift was deeply analysed. Their feminist points of view are indeed discussed in their creative works. This thesis draws attention to the fact that African female writers like Amma Darko are deeply concerned by female issues in villages as well as urban centres, but also by other pertinent issues like religious beliefs, modern evangelisation and street children phenomenon prevailing in their societies. It analyses the solutions regarding those issues through the writer's characters. Through realistic and imaginative works, solutions are suggested through strong characters. This research shows how much Amma Darko is at the forefront of a committed African literature written by African women.

KEY WORDS:

- | | |
|---------------------|----------------------|
| 1 Literature | 5 Empowerment |
| 2 African tradition | 6 Feminism |
| 3 Culture | 7 Patriarcal society |
| 4 Women | 8 Education |

EXCERPTS ON AFRICAN WOMEN'S IMPORTANCE _____

“Those women who struggle without giving up hope, herald the impending change [...] change in attitude for both men and women as they evaluate and re-evaluate their social roles [...]”.

-Rosemary Moyana

"No longer are we allowed to put the national question above gender issues; in fact, we are no longer allowed to think of the national question as something apart from the role and place of women in society" ~

Nelson Mandela speaking at a dinner celebrating Women's Month,
Johannesburg Country Club, Johannesburg, South Africa, 25 August 2003

ACKNOWLEDGEMENTS

The completion of this thesis is the result of the immense contributions of a number of individuals, who deserve every commendation and acknowledgement. High on the list is the Almighty God, whose grace and mercies have led to the successful achievement of this thesis. Praise and thanks be unto His Holy Name.

People who deserve every accolade, as far as the successful completion of this thesis is concerned are Professors Benaouda LEBDAI (France) and Augustin Y. AINAMON (Benin), my supervisors. Despite their busy schedules, they have painstakingly guided me. I am most indebted to them, and wish to express my profound gratitude for their constructive suggestions and inputs into this thesis. May the Lord bless and continue to protect them and their families.

My sincere thanks equally go to Professor Claude JULIEN (University of Tours/France), for facilitating the smooth achievement of this work and who directed me to books I could not have thought about and could not have read if I had stayed in Benin for my thesis. I am most grateful to Dr Rogers ASEMPASAH (University of Cape Coast /Ghana), Professor Laure Clémence CAPO-CHICHI ZANOU (University of Abomey-Calavi/Benin), Ms Sarah Monique REYNOLDS (University of Brandeis, USA), who have contributed in diverse ways to the success of this research work. I wish to extend my gratitude to all the faculty members who served on my different examining boards: Dr Patrice AKOGBETO, Dr Célestin GBAGUIDI.

I would also like to thank Mr John WEBB of the University of Angers in France. He was the first person to whom I wrote to disclose my wish to start PhD studies in African Literature in 2014. But before he could receive my academic records from Professor Antoine LOKOSSOU (University of Abomey-Calavi), the specialist in Colonial and Post-colonial Literatures in the University of Angers, Professor Benaouda LEBDAI, had already left to Le Mans University. Mr John WEBB then contacted the specialist, who accepted to be my supervisor. This is how I happened to be engaged for PhD studies in Le Mans University and not in Angers University.

Besides, I cannot fail to acknowledge the financial support I received right from the start from 3L.AM at Le Mans University to afford some of my international conferences and workshops and also the scholarship I received from the Ministry of Higher Education of my country, Benin. Although the latter came late, it beamed my travel and stay in France. I also sincerely thank the support from acquaintances, relatives and friends. The list is long to cite and an African proverb cautions me about trying to cite all those who helped. The proverb carries that a man who cites will never finish citing. I really appreciate their contributions to the successful completion of this thesis.

My heartfelt gratitude to Le Mans University's library and professionals for having bought the essential of the novels and critical books I have needed to complete the present thesis. I also acknowledge my indebtedness to scholars, authors and publishers whose works have been consulted, cited either verbatim or paraphrased.

I will not finish the series of acknowledgements without thanking Ms Benedicta Adjei from Kumasi who helped me get the true meaning of some Ghanaian words used in Amma Darko's selected novels.

I finally thank those who fought my idea of being enrolled for PhD study and those who worked to block insidiously the governmental scholarship related to it. Their scornful looks and remarks, instead of discouraging me, doped me to start and complete this work. The achievement of the thesis is to let them know that "the harder the battle, the sweeter the victory" (Bob Marley).

DEDICATION _____

First, this thesis is dedicated to the Almighty God for his spiritual help to successfully complete this work. For many times I have wished to stop writing, but have been filled up with courage and presence of HIM.

Secondly, the present work is dedicated to my dearest Wife and Children for having endured my frequent absences from home because of research. This has lasted four years. I love you.

Finally, it is dedicated to the ingenuity of all African women who have been at the forefront of all struggles to gain an inch of autonomy like my beloved Mother.

Table of contents

Résumé	iii
Abstract.....	iii
Excerpts on African women’s importance.....	iv
Acknowledgments.....	v
Dedication	vi
Introduction	4
PART ONE: THE FOUNDATION OF THE GHANAIAAN FEMALE LITERATURE.....	31
Chapter one: The Emergence of African female writers	39
1. Ghanaian women seeking for their place: Ama Ata Aidoo, the Cornerstone	40
1.1. Ama Ata Aidoo’s life experience	41
1.2. Exploring Ama Ata Aidoo’s African Feminism.....	44
2. Amma Darko: The awaited ‘successor’.....	50
3. Female literary history	59
4. Reasons for writing.....	65
4.1. Writing History.....	67
4.2. Writing Ghanaian Society.....	75
4.3. Writing Black Feminism	84
Chapter Two: Amma Darko’s Act of Writing Her Way	92
5. The act of writing: Telling Trauma	94
5.1. Trauma and History Writing.....	98
5.1.1. Trauma and Identity.....	101
5.1.2. Trauma control : Therapy	111
5.1.3. Trauma and Sexual Violence.....	123
6. Amma Darko’s Special Touch	133
6.1. Trauma, Globalization and Poverty	134
6.1.1. Trauma and Globalization.....	134
6.1.3. Trauma and Motherhood	142
PART TWO: SOCIO-CULTURAL FACTORS CONTRIBUTING TO THE GENDER GAP.....	149
Chapter three: Culture of silence: a factor for gender gap enlarging.....	150
7. Obedience and traditional marriage in <i>Beyond the Horizon</i> and <i>Faceless</i>	150
7.1. Obedience as mode of education	151
7.2. Patriarchy: The scope of the arranged marriage.....	159
8. Devaluation of the female child in <i>The Housemaid</i>.....	177

Chapter four: Exploring the Social conditions of Amma Darko’s Female characters	193
9. Barrenness and Widowhood practices in <i>Not Without Flowers</i>	193
9.1. The African concept of barrenness depicted in <i>Not Without Flowers</i>	194
9.2. African People’s cosmological foundation of Death, Suicide and Widowhood.....	211
10. Polygamy and Unfaithfulness in <i>Not Without Flowers</i>	224
10.1. African Polygamy depicted in <i>Not Without Flowers</i>	226
10.2. Unfaithfulness in <i>Not Without Flowers</i>	247
11. Premonition, Mood disorders and Witchcraft in <i>Not Without Flowers</i>.....	256
11.1. Premonition and Mood Disorders: NEMESIS Therapy	256
11.2. Witchcraft depicted in <i>Not Without Flowers</i>.....	272
PART THREE:	283
THE FACETS OF AFRICAN FEMINISM: AMMA DARKO’S TOUCH OF CHARACTERIZATION.....	283
Chapter five: Female characters’ roles in Amma Darko’s novels	288
12. Female Characters’ depiction	291
12.1. Main characters in <i>Beyond the Horizon</i>.....	291
12.1.1. The life of Mara in <i>Beyond the Horizon</i>	292
12.1.2. Mama Kiosk, a metaphor of African eternal spirit	317
12.1.3. Kaye, an angel of God	321
12.2. Female secondary characters	323
12.2.1. Gitte, the white female innocent.....	323
12.2.2. Comfort, the comfortable traitor	327
12.2.3. Mara’s mother, the co-conspirator	328
13. Female characterization in <i>The Housemaid</i>	330
13.1. Main characters’ depiction.....	331
13.1.1. Madam Sekyiwa, the doomed manipulator.....	331
13.1.2. Tika, a model of female revolutionary?	334
13.1.3. Teacher, the transformer	339
13.1.4. Efia, scapegoat of manipulation	340
13.1.5. Akua, the symbol of contemporary social failure	342
14.2. Female secondary characters	355
14.2.1. Mami Korkor, the symbol of female powerlessness.....	355
14.2.2. Bibio, a young revolutionary.....	358
14.2.3. Efia’s grandmother, the conspirator	361
14.2.4. Efia’s mother, the dumb witness	362

15.	Amma Darko's female characterization in <i>Faceless</i>	363
15.1.	Main female characters' portrayal.....	364
15.1.1.	Fofo, a model of youth revolt	364
15.1.2.	Baby T, the doomed.....	369
15.1.3.	Kabria, a sensitive female character	372
15.1.4.	Dina, the enlightened MUTE founder	376
15.1.5.	Maa Tsuru, the manipulated and selfish mother.....	378
15.2.	Secondary female characters.....	384
15.2.1.	Naa Yomo, Mother Africa's spirit	384
15.2.2.	Ms Kamame, a social model.....	388
15.2.3.	Mama Abidjan, the female conspirator	389
15.2.4.	Maami Broni, the co-conspirator	390
4.	Female characters' portrayal in <i>Not Without Flowers</i>	392
16.1.	Main characters' portrayal	393
16.1.1.	5 th Wife, a model of African modern woman.....	393
16.1.2.	Ma, the defender of her household.....	398
16.1.3.	Aggie, boomerang's victim.....	408
16.1.4.	Randa, the lost.....	410
16.1.5.	Cora, a 'bad teacher'	412
16.2.	Secondary female characters.....	415
16.2.1.	Mena Kabraba and Mena Penyin: The African sisterhood.....	415
16.2.2.	First wife, an enduring and hearty woman	418
16.2.3.	Second wife, the lost.....	421
16.2.4.	Akatasia's grandmother, the symbol of old age	424
16.2.5.	Pesewa's sisters, the reflection of patriarchy.....	426
	Chapter six: Masculinity under Amma Darko's Deconstruction	432
17.	Male characters' depiction in Amma Darko's novels	437
18.	Amma Darko's narrative technique	485
	CONCLUSION.....	525
	BIBLIOGRAPHY.....	541

INTRODUCTION

Societies that have been colonized are negatively affected by the erosion of their cultural values. A society whose cultural values have been eroded is like a one-eyed and one-legged person who has desperately lost his/her identity. For culture defines who we are, how other people see us and how we are able to be related to our natural and social environments in order to ensure our survival. The race for this survival often induces environmental debilitation geared by some uncontrolled contestation for political and economic supremacy. Given the fact that African societies are longing for the development which has been linked with the notions of culture and identity (Falola: 2003, 1) how do these societies map out plans for development in such a way that they are not seen as mere “appendages of their erstwhile colonial masters”?¹ The answer to this question can readily be found in the adoption of certain plans of action which political leaders believe could be grounded on particular value orientations of the people. Given the fact that culture is a beam of values which make some people, it follows that any plans of action implemented in the purpose of ensuring the development of those societies must have inherent connection with culture. However, the problem which arises in this connection is that culture is dynamic and as such an evolving element can certainly be regarded as an identity indicator. The search for cultural identity is one of the fundamental concerns in the majority of significant works of African writers and hence occupies a central place in the quest for authenticity. But in Africa, one cannot forget that the prevailing cultural norms are patriarchal, that is the system of male-power.

According to *Harrap's Chambers Compact Dictionary* (2000), patriarchy is defined as a “social system in which a male is head of the family and descent is traced through the male line.”² In patriarchal societies, women are faced with all sorts of dehumanisation ranging from deprivation, negligence, maltreatment, marginalisation, oppression, subjugation, exploitation, humiliation and even isolation, all of which emanate from aspects of the people's culture. In such a society, for instance, women are seen not heard. They live in the shadow of men from their maiden homes to their matrimonial homes; hence they are regarded as second class citizens though it is cautious not to generalize the African woman's conditions as bounding and that of

¹ Bamikole, L. O. (2012). *Nkrumah and the Triple Heritage Thesis and Development in Africana Societies in International Journal of Business, Humanities and Technology*, Vol. 2 No. 2; March 2012, p. 68

² Chambers Harrap's Publishers Ltd 2000.

western freedom. It is just a generic word to represent the patriarchal domination in which the African woman lives to be analysed intrinsically in an African scope.

Ifechelobi describes such societies as “characterized by current and historic unequal power relations between women and men where women are systematically disadvantaged, subdued and oppressed. Hegemony, subjugation and subservience are all factors of patriarchy” (Ifechelobi, 2014)³. Patriarchy as a way of doing things has been so deeply entrenched in most African settings, in norms, values and customs, that trying to separate it from our humanness and culture is not only unfathomable for most, but also a deeply unsettling and unwelcome ‘impossibility’: a very difficult process. The second reason why patriarchy has been particularly difficult to dismantle in some African societies is because it has managed to be as deeply entrenched as it is by using some women to pass the law from generation to generation. In order to find more illustrations to the understanding this predicament, the on-going study considers the case of Ghana where elderly people have traditionally been important figures in the society and their stance abounds in the national oral and written literature. However, critical studies of this implication have been slow in finding out the literary representation.

Gender is a social relation that enters into and partially constitutes all other social relations and activities. In this way, patriarchal practices shape and perpetuate gender inequalities and strip women of any form of control or decision in society. Traditional gender roles cast men as rational, strong, protective, and decisive whereas women are presented as emotional, weak, nurturing, and submissive. There was a sharp contrast between the African first novels set in the past and largely written by men, and contemporary ones, some of which have been authored by women. This allows Lazar Michelle to raise the point that “Based on the specific, asymmetric meanings of male and female, and the consequences assigned to one or the other within concrete social practices, such an allocation becomes a constraint on further practices”⁴. This contrast has to do with the delineation of women in the novels. A relatively short while ago the popular notion of Africa as an arid farmland with respect to literary production was sustained by some Eurocentric writers who believed that Africa had contributed

³ Ifechelobi, J. N. (2014). Feminism: Silence and Voicelessness as Tools of Patriarchy in Chimamanda Adichie’s *Purple Hibiscus* in *African Research Review, An International Multidisciplinary Journal*, Ethiopia Vol. 8(4), Serial No. 35, September, 2014:17-27 ISSN 1994-9057 (Print) ISSN 2070--0083 (Online).

⁴ Lazar, M. (2007). “Feminist Critical Discourse Analysis : Articulating a Feminist Discourse Praxis”, *Critical Discourse Studies*, 4 : 2, 141-164.

nothing of value to world literature. In their early writings, the Eurocentric scholars and writers have attempted to justify the imperialistic and colonial scramble for Africa by brainwashing the natives to accept the ‘new order’ of a pseudo civilization. We can cite examples such as Joseph Conrad, Daniel Defoe, Joyce Cary. More so, the writings of those Europeans have been targeted to be racist, which provoked rightly some African like Chinua Achebe, Elechi Amadi, Sol Plaatje, Ngugi wa Thiong’O, Ousmane Sembene, Kateb Yacine to write back to show the way it was. They began to give a more distinctively African voice to the erstwhile imitative literature sporadically written in various parts of the continent. What most of these writers share is an intense awareness of the political significance and didactic function of their task. They take on the right and necessity to guide the others. Chinua Achebe is straight away in the defence of his position in these learned terms: “The writer cannot expect to be excused from the task of re-education and regeneration that must be done”.⁵ While educating people on present social events, an African writer should not forget to bring the old to meet the new, without which Africans would be blind. By this way, Africans are sure to achieve their mind decolonization and cultural recovery. The reaction proves so much the social as well as political function of literature especially Africans. This is highly more than an ornament as intellectuals such as Jomo Kenyatta, Leopold Sedar Senghor, Julius Nyerere, Sekou Toure, Kwame Nkrumah, Agostinho Neto and recently Nelson Mandela soon understand. Then Achebe’s invitation is heard all over the corners of the continent.

By the 1960s works by African authors had begun to generate a great deal of interest because of the socio-political change occurring that time in African countries. By its sheer authenticity, African literature could no longer be ignored, and so, finally, its contribution to world literature received full recognition and acceptance two decades later. So the 1980s would go down in history as the decade during which African literature flourished. These women use these gender roles to justify their practices against their fellow women. It is erroneous to think that it does not exist today. However, what such a society seems to forget is that the history of women is largely the history of men and women (such as Eden’s garden in the Holy Bible) and know the first difference between a man and a woman is biological. Feminists all over the world do not deny that at all. In fact, they celebrate it. However, they do not accept that such differences should shape beliefs that men are superior to women.

⁵ Achebe, A. (1975). *Morning yet on Creation Day*. New York: Anchor: p. 45.

From girlhood to womanhood, the African woman has had to contend with many issues that restrain her 'being' as she journeys through life's winding cycles dictated by culture and cult. The woman's role has hitherto been canopied to the kitchen and to other chores that are akin to her femininity, while the men do the political talking and decision-making that unfortunately also affect the voiceless woman. Oseni Taiwo Afisi, in "Power and Womanhood in Africa: An Introductory Evaluation", quotes Bulkachuwa (1996, 15) saying that: "In many areas women are still regarded as chattels to be inherited, they are given no formal education...given out in marriage at an early age. They are forever under the control of either their husbands or male relatives...they cannot inherit or own property, nor can they participate fully in public life and the decision-making process within their immediate community"⁶.

In this sense, many cultures hold on to different beliefs and retain community-defined restrictions for menstruating women for example. In other cultures, people think it is the moment to shake away hidden diseases from the women's womb so as to allow new lives in. There may be grievous consequences if the women do not bleed at its right time. As it is thought to be strictly intimate, some women dig holes in remote places away from the main home over which they sit or squat continuously or intermittently during their menstrual periods in order to let out the blood directly into the ground. This natural biological female cycle of life seems to be full of myth, mystery and superstition. If women in their menses attend where the traditional ruler gives judgment on cases, the judgment may not be right because evil spirits might be hovering around. In some African cultures, menstruating women are firmly forbidden to enter places held as highly spiritual. They are barred from sleeping in the same room with their husbands especially in the polygamous setting because they think menstrual blood is 'toxic' to sperm and this will cause infertility not only to the woman but also to other wives of the man. Women are then assigned to stay in a special hut during their menstrual period. During that 'evil' period, they must neither cook nor permit marital sex to occur for several days until the period ends. Besides, in some Christian denominations, women are forbidden to receive the communion during their menses, the same in the traditional Islamic interpretation, the Qur'an forbids intercourses and physical intimacy during the women's menstrual period. Like in Christian church, they are also excused from performing prayers and fasting. The Judaism goes further to take the menstrual period as being totally impure. The purity system of the Bible

⁶ Afisi, O. T. (2010). "Power and Womanhood in Africa: An Introductory Evaluation" in *The Journal of Pan-African Studies*. Vol 3, No 6: pp. 229-238.

chiefly involved the Temple, sacrifices and priestly gifts, all of which had to be guarded from ritual impurity (Leviticus 15: 19, 24; 33).

In all cultures then, women are barred from all reviving and rejoicing events either for their young age or their old age. In fact, cultures allow no woman to be informed about things going around or occurring in their environment. In reaction to all this, champions among women repeatedly ask if God and nature had made women so clearly inferior to men, and why were such strong social inducements necessary to retain their subjugation. In reaction to claims that women are irrational, weak, vicious and sinful, early defenders of women again and again repeated the same beliefs. They claimed women were equal or superior to men, writing, for example, books about heroic, saintly, learned, and otherwise exemplary women. In another common strategy, they asserted equality less by raising the image of women than by lowering the image of men. Thereby they launched an inquiry into the meaning of equality that continues to the present. Idealistic depictions of men as the embodiments of reason and humanity flew in the face of the evils men. Then out of their social and economic conditions, female writings also depict men as characters embodying irrationality, the same way they accused women to be. These male characters' depiction in female writings, though not being real, seems to be retrieved from the day-to-day attitude in the society. It is evident that some of the fictional characteristics of male characters in female literature highlight the reality in homes and outdoors. The correlation between literature and reality, and the image of each character in African novels put on view the complicity between the two. Ndabayakhe upholds the idea this way "In Africa, the novel, a Western literary genre, has been adopted in a social-realist form. In writing their novels, many authors have attempted to reflect the cruelty and injustices that result from the misuse and imbalance of power in society"⁷ for example. Literature then helps tell stories partly some from the society and others as mere imagination. For sure, the relationship between imagination and literature is so tiny that one cannot distinguish the border. In this relationship, imagination is an important tool to writing and vice versus. Literature can create in us a sense of history and a desire to transform our society. Ben Okri, the Nigerian novelist, states that:

Our history hasn't hurt us enough or the betrayals would stop, the streets would erupt, till we are overcome with the inescapable necessity of total self-transformation – we burn for vision – clear, positive vision – for vision allied with action – for want of vision my people perish – for want of action they

⁷ Ndabayakhe, V. (2013). Attitudes Towards polygamy in select African Fiction, p.8.

perish – in dreams – in dreams begin responsibility – for we have become a people of dream-eaters, worshipping at the shrines of corruption – we can't escape our history – we will dwindle, become smaller, pulped, drained by predators, unless we transform – in vision begins [...] responsibility.⁸

Such profound thoughts and ideas are literature's heritage; they are the fruits of an excellent liberal education that can last one a lifetime. For example, in Chinua Achebe's *Things Fall Apart*, that was not the whole story about missionaries, impacts of European cultures and the tribulations of African traditional families of the time. In fact, A. Adogame points out here that "African novels principally communicate the African milieu's experiences in its historical setting but also critique it. There were even writers who heaped some blame on Africans too for the chaos experienced in the continent"⁹. Therefore, we see that the relationship between the two is a highly tensioned, crucial and necessary. The user of literature as art is a teacher according to Chinua Achebe and a speaker as for the French Philosopher Jean Paul Sartre. To illustrate this, Sartre puts that "A writer is a speaker, he designates, demonstrates, orders, refuses, interpolates, begs, insults, persuades, insinuates"¹⁰.

The above opinion corresponds to Ngugi wa Thiong'O's understanding of the social commitment and responsibilities of a writer which fully match up with a role of educator and making his people aware of political realities. Quoted by Sander, R. and B. Lindford, 2006: 23, Ngugi wa Thiong'O writes: "I think that any writer who is dealing with serious problems that confront an individual must write about the whole social and political society"¹¹. Literature is an art that imitates society. Literature is therefore about fictional people and retells their life experience which can be interpreted in different ways. The reason is that literature is a study of life itself, so it cannot be dissociated from its study ground. This position is corroborated by R. Taylor who argues that: "Literature is said to be a school of life in that authors tend to comment on the conduct of society and of individuals in society"¹². This evidence is apparent in the novel where it uncovers the relation between social cause and effect as it enables us to perceive reality beyond the words and characters' deeds. The more a society produces a flow of events, the more authors quench their thirsty and that of their potential readers. As society cannot stop providing

⁸ Okri, B. *Dangerous Love* (1996). London: Phoenix House, quoted in Akachi Ezeigbo's *Artistic Creativity: Literature in the service of Society* (Feb, 2008), University of Lagos Press, p.16.

⁹ Adogame, A. "Editorial: Religion in African Literary Writings" in *Studies in World Christianity*, p. 3.

¹⁰ Sartre, J. P. (1948) *Qu'est-ce que la littérature?* Paris: Gallimard. *What is Literature?* (Trans) Bernard Frechman, Philosophical Library, New York, p. 19.

¹¹ Sander, R. ; Lindfors, B. (2006). (eds) "Ngugi Wa Thiong'o Speaks". Nairobi: James Currey Oxford, p. 23.

¹² Taylor, R. (1981) *Understanding the Elements of Literature*. Macmillan Press Ltd: London, p. 13.

events, authors have regularly water in their mill. This position corroborates that of Michel Zérafra: « Le roman est destiné non seulement à montrer qu'il n'y a de condition humaine qu'historique et sociale, mais encore à expliciter cette condition, à l'illustrer par des exemples précis et cohérents »¹³.

Furthermore, literature in its oral and written forms has consistently remained the most evident tool to represent reality. It has become an important means of understanding and interpreting aspects of society such as politics, religion, social conflicts, class struggle and the human condition all over the world. The creation of the illusion of reality has been the preoccupation of every literary artist since ancient times. Africa has rich literary traditions as a part of its cultural heritage. Drama, epic and poetry and all the other literary forms had existed in an oral shape till the advent of literacy. "Written literature represents a radical departure for the community-centered African mind"¹⁴. As for Dathorne, the novel (fiction) is the only literary art form that has been totally imported and imposed over the indigenous tradition. African literature has its roots in performance, and is a part of community life. It is associated with ceremonial, festive and social occasions as so, the narrative art is not alien to Africa. Chinua Achebe represents that range of African writers who reacted to set African culture in its accurate stance. The Nigerian pioneer presents to the reader his people's history with both strengths and imperfections by describing for example, Igbo festivals, the worship of their gods and the practices in their ritual ceremonies, their rich culture and other social practices, the colonial era that was both stopping Igbo culture and also brought in some benefits to their culture. It is evident in Achebe's novel that the Europeans greatly influenced the lifestyle of Igbo society, yet they did not come with civilization and light in the darkness as they pretended to. For this reason, African literature, by virtue of its serious and crucial commitments with the people and human experience, has strong links with movements for the liberation and thereafter the modernization of Africa. An important feature of recent African literature is the emergence of women writers who focus on the plights and emancipation of women from the multiple dominations of patriarchy.

Our concern in this dissertation is to decipher Amma Darko's usage of her creative writing to explore African women's daily predicaments, to draw more attention to the socio-

¹³ Zérafra, M. (1971). *Roman et société*. Paris: P.U.F., p. 20.

¹⁴ Akachi-Ezeigbo. T. (2008). *Artistic Creativity: Literature in the Service of Society*, University of Lagos, p. 5.

cultural quandaries faced by women. Women in African societies are compelled to live and accept a permanent double yoke, patriarchal constraints in a colonized society with its boundaries. This work consists in interpreting the link between Amma Darko's literary writings and the socio-cultural reality of women in contemporary Ghana, the impacts of the social constraints on women's development and place in society. This will also lead us to analyse Amma Darko's female characters' refusal to conform to the '*modus vivendi*' accepted by their counterparts in patriarchal communities. Reading Amma Darko's fiction can infer that women have decided "to exploit multiple subjects as a textual strategy for challenging the marginal status allocated to them in male dominant discourses"¹⁵.

In the context of this dissertation, the contribution of literature is the core of our subject. This dissertation therefore focuses on the functions literature as a tool to empower African women. In this regard, the analysis is based on the relevance of the link between African literature and social reality because literature enlarges one's experience. In this vein and to make it real, African writers have had the task of writing about the experiences of Africans before white men settlement as well as post independent events. Their various responses to the white intruders are still considered as appraisal of the existing socio-cultural and political situation. Literature serves as a link between culture and language, to paraphrase Robert Frost.

For example, in *Things Fall Apart* (1958), a novel considered to be the first African writing¹⁶ in English language, Chinua Achebe attempts to present a realistic picture of Igbo culture, not shying away some problematic aspects which allow him to connect the issues of pre-colonial times to the advent of colonial rule. In the range of African metatext, we also have writings like those of Salman Rushdie's *Midnight's Children*, (Cape, 1981) Ben Okri's *The Famished Road* (Cape, 1991) or Keri Hulme's *The Bone People* (1998) which recuperate the pre-colonial culture, myths and fables of their native areas. For example, the *osu*, mothers of twins, and Okonkwo's rebelling son are the ones who deflect to Christianity. The loopholes in Igbo cultural fabric are what tear it apart when it is subjected to the colonial gaze and manipulation. Chinua Achebe achieves a complexity in describing Igbo culture with its positive

¹⁵ Bungaro, M. (2007). "Victims and / or Victimisers? Women's De(Con)structive power in *The Housemaid*". In *Broadening the Horizon: Critical Introductions to Amma Darko* (UK: Ayebia Clark Publishing Limited), p. 28.

¹⁶ Before the writing and the publication of *Things Fall Apart* by Chinua Achebe, there were several important writings like Sol T. Plaatje's *Native Life in South Africa* (1916), Peter Abrahams' *Dark Testament* (1942), *Tell Freedom* (1954) and Amos Tutuola's *The Palm-Wine Drunkard* (1952), *My Life in the Bush of Ghosts* (1954), *The Brave African Huntress* (1958).

and negatives that are present in all cultures as far as women conditions are concerned. By emphasizing the weakness of femininity and over-pouring masculine behaviour, the Igbo people emphasize the gender stratification of their culture, ensure the continuation of patriarchy. This conclusion can be traced if we follow the trials and tribulations of Okonkwo, the hero whose tragic flaw includes the fact that "his whole life was dominated by fear, the fear of failure and weakness"¹⁷. Men in patriarchal societies are supposed to be consistently strong and courageous, while anything weak and coward is portrayed as 'feminine'. As a matter of fact, African male writers often relegate female characters to the position of secondary importance. Early African writers are reluctant to recognize the paramount value of female characters in society. In this vein, Brown points out that this "male oriented" and exclusionary practice by male African writers has determined what constitutes African literature: "Those critics and anthologists have treated the African subject as an exclusively male product"¹⁸.

Knowledgeable observers rightfully believe that early African fiction relegates female characters to a position of secondary importance. Indeed, African male authors purposely do not write accurately from female perspective or do not (re) present feminist ideals because they have different view about female experience in the society. As Chinua Achebe justifies the writing of *Things Fall Apart* (1958), arguing that African pre-colonial history must be written by Africans themselves to avoid distortions (Booker: 1988, 65). Chinua Achebe does not either romanticize the way of living in that period. He depicts as simple as possible the customs and culture prevailing in the pre-colonial time. So, African writers think that the opportunity to write about themselves must also be allowed to them. Being members of the society, they should be granted the possibility and the right to size the 'plume' and write their experience as real as possible.

To set issues right, African female intellectuals took to their pens to say what the different components of the traditional or contemporary African society look like from a female perspective, pinpointing the real role of African women in their community. Women must write women and man, man. As H el ene Cixous¹⁹ urged "I wished that that woman would write and proclaim this unique empire so that other women, other unacknowledged sovereigns, might

¹⁷ Gikandi, S. (2003). *The Routledge Encyclopedia of african Literature*, (ed.) USA, New York, NY and Canada, Routledge 10016.

¹⁸ Brown, L. (1981). *Women Writers in Black Africa*. Westport: Greenwood Press, p. 5.

¹⁹ Born in Algeria to an Ashkenazy mother and a Sephardi father, H el ene Cixous taught in Bordeaux and Paris, where she was one of the founders of the experimental university at Vincennes (Paris 8). Her abundant work is comprised of novels, plays, and essays on literary criticism. In her manifesto "The Laugh of the Medusa" (1975), Cixous introduced the term of "feminine writing" so as to reject dogmatic Freudianism and dogmatic feminism.

exclaim: I, too, overflow; my desires have invented new desires, my body knows unheard-of songs”²⁰. Indeed, African women writers are “critical of the exploitation of women. African women explore what is useful and what is dangerous to them as women in traditional cultures”²¹. It will be very difficult to contend that women have achieved full equality with their male counterparts in society. However, female writers like Ama Ata Aidoo and Amma Darko know feminist writers like themselves pursue a clear ambition: to close on female pioneers’ heels by disclosing the right side of the masculine nature, giving women’s perspective and championing women’s potentials. The struggle for women liberation and the control of power require the control of the mind. Women believe in their brainpower, so they can overcome the present current challenges with their writing in their own way.

In the similar light of emergency, the African-American, Pauline Hopkins, writer, political activist, and literary editor of the *Colored American Magazine*, urged black women and men to use literature as an instrument of liberation. “No one will do this for us,”²² she wrote in the introduction to her first novel, *Contending Forces: A Romance Illustrative of Negro Life North and South* (1900). She urged her Negro counterparts to portray ‘Negro attitude’, which is the “inmost thoughts and feelings of the Negro with all the fire and romance which lie dormant²³” in African history. While African writing has established itself as one of the most important fields of contemporary literature, female or feminist literature has also been recognized as a significant facet of the literary output of the century. At that crucial time in the history of African people with the emergence of an ever more significant role for women on the continent, it might be useful to look at the roles of women in African societies as depicted by female writers themselves.

From this standpoint, it appears that African literature by women emphasizes the roles of women and the political and socio-economic problems of the African continent. They aim at playing a very important role in women’s struggle. It raises several issues related to the need to reconstruct the identity of African women and promote the social, cultural, economic and

²⁰ Cixous, H. (1976). *The Laugh of the Medusa*, (Trans) Petroleuse Press, p. 4.

²¹ Davies, C. B. ; Fido, E. S. (1993). African Women Writers: Towards a Literary History In: Owomoyela, O. (ed). A History of Twentieth Century African Literatures. Lincoln, Nebraska: University of Nebraska Press, pp 311-346.

²² Eagleton, M. (2011). *Feminist Literary Theory: A Reader*, Third Edition. India: Mary Eagleton: Wiley-Blackwell Publishing Ltd, Pondicherry, p. 23.

²³ Eagleton, M. (2011). *Feminist Literary Theory: A Reader*, Third Edition. India: Mary Eagleton: Wiley-Blackwell Publishing Ltd, Pondicherry, p. 23.

political the development of the continent. Consequently, African women writers, through their writings, expose the misfortune of their female counterparts with a view to criticising and transforming the status quo. That is why in an interview conducted by Vincent Odamtten and transcribed under, “*Beyond the Comfort Zone: Relation Between African Writers and Audience*”, Amma Darko says: “I want to delve deeper into the intimacies and emotions of womanhood under the various conditions that many African women find themselves in. Please note that I didn’t say “the intricacies and emotions of the African woman”. I said “of womanhood under the various conditions of that African women find themselves in”. Women are women everywhere. It is the conditions they find themselves in, in their various cultures, that determine their reactions and attitudes”²⁴.

Feminism, both as an activist movement and as a body of ideas that highlights the need for an optimistic change of society so that women are not marginalized but treated as full citizens in all the spheres of life, has received extensive theoretical treatment. Feminism throughout its long history has always been seen as “women’s conscious struggle to resist patriarchy”²⁵ (Widdowson & Brooker, 121). There are perhaps as many definitions as possible, for each continent claims to have its own diversity and range of particularities. Then, the way African-American women would want feminism to be defined could be different from African women. It could also be different from that of European women who first saw the birth of the movement. However, this definition of feminism does not mean that men cannot be part of the struggle. The question that sometimes arises is whether men can be feminist in the real sense because they benefit from a social and cultural organization that gives them all sort of privileges over women. However, some African female writers portray in their writing some of their male characters as feminist and also give chance to women surrounding to express freely themselves. The African writer of that kind is the Senegalese Ousmane Sembene²⁶. The question to ask then is: does feminism operate within the parameters of the hegemonic or does it hold a transformative potential? In this vein of idea, Chimamanda Ngozi Adichie accurately puts

²⁴ Odamtten, V. O. (2007). “Beyond the Comfort Zone: Relation Between African Writers and Audience”, in *Broadening the Horizon: Critical Introductions to Amma Darko* (UK: Ayebia Clark Publishing Limited), p. 5.

²⁵ Selden, R. ; Widdowson, P. & Brooker, P. (2004). *A Reader's Guide to Contemporary Literary Theory*, Fifth Edition, Routledge, p. 121.

²⁶ Ousmane Sembene was born the 1st January 1923 at Zinguenchor in Senegal and died the 9th June 2007. He remains the major figure in the rise of an independent post-colonial African cinema. He was the first film director from an African country to achieve international recognition, Sembene's roots were not, as might be expected, in the educated élite. After working as a mechanic and bricklayer, he joined the Free French forces in 1942, serving in Africa and France. In 1946, he returned to Dakar, where he participated in the great railway strike of 1947.

during TEDx Talk: “A feminist is a man or a woman who says ‘yes, there is a problem of gender as it is today and we must fix it to better it’²⁷. In saying so, Chimamanda Ngozi Adichie gives a new direction to gender struggle and strips it of its baggage and constraints. This position has already been taken by Ama Ata Aidoo in African feminism to precise men involvement into the struggle²⁸. It is crucial for men to be a part of feminist agency. If feminism is to attain its goal of liberating women, men must be a part of the struggle. Indeed, men probably bear more of the responsibility for ending oppression of women since patriarchal men have been the main perpetrators of that very oppression. But can men do this by becoming feminists? According to both prominent female writers, men being part of the struggle does not mean that women will fail to play fully their part or consider to be still enchained. Both will wave a network to trust each other for the on-going of the movement. Contrary to what common people think of female movement of equality seeking in society, the struggle will also be men’s concern. Issues and attitudes are changing and if African feminism is to continue to rise as a discourse and impacts Africans lives, it is important that the trend changes likewise.

In this sense, Davies outlines the issues of women writers in Africa including the relatively small number of women writers and the presentation of women in fiction written “by African men, as well as the development of an African feminist criticism”²⁹. In her treatment of the latter concern, she lists four major areas which African feminist critics tend to address: “the development of the canon of African women writers, the examination of stereotyped images of women in African literature, the study of African women writers and the development of an African female aesthetic, and the examination of women and the oral tradition”³⁰.

With the rise of feminism and doped by ideas about their liberation, emancipation and self-assertion, African women began reconsidering their beliefs about patriarchy. They realized that the inferior position they long occupied in patriarchal societies is not at all naturally but

²⁷ Ted Talks. The Danger of a Single Story. Chimamanda Ngozi Adichie. March 28, 2012. <http://www.ted.com/talks/chimamanda_adichie_the_danger_of_a_single_story.html>

²⁸ Goredema, R. (2009). African Feminism: The African woman’s struggle for identity, p. 2. http://reference.sabinet.co.za/webx/access/electronic_journals/ayor/ayor_v1_a5.pdf

²⁹ Davies, C. B. (1986). "Introduction: Feminist Consciousness and African Literary Criticism." *Ngambika: Studies of Women in African Literature*. (Ed.) Carole Boyce Davies and Anne Adams Graves. Trenton, NJ: Africa World Press, pp.1-23.

³⁰ Davies, C. B. (1986). "Introduction: Feminist Consciousness and African Literary Criticism." *Ngambika: Studies of Women in African Literature*. Ed. Carole Boyce Davies and Anne Adams Graves. Trenton, NJ: Africa World Press, pp. 1-23.

socially or culturally programmed. Then in this system, women are relegated to a marginal status. Women therefore began pushing forward the idea that their biological constitution does not make them inferior to men and that the inferiority attributed to them is a mere patriarchal assumption rather than a scientific justification. African women should no longer accept this misrepresentation. They must get out of the old subjugated body and assert themselves with no delay. As a result of this revolution, rise female artists, novelists, musicians to proof-show the emergence of female empowerment. One of the ways to prove this self-transformation is the writing of women by women at the crucial time. Writing by women is therefore the women's ultimate escape.

At last, literature is a portrait of mankind in its environment. It encapsulates the traditional knowledge, beliefs and values about the environment and the nature of the society itself. The artist holds it up for him to see by the artist, so that he can carry out profound reflections about his world view and general existence. Literary critics must understand its interdisciplinary nature for an intensive and extensive comprehension. Literature should contain ideology and psychology. That is the point between creativity³¹ and criticism. Consequently, African feminists, such as Molaria Ogundipe-Leslie³² establish female writers as primarily concerned with issues related to women. Molaria goes as far as possible appreciating female writers of Flora Nwapa and Buchi Emecheta for their attempt to educate the African world about a woman's realm of experience. Reversely, Molaria Ogundipe-Leslie criticizes this outcome as the result of a neo-colonial and fealty structure that society embraces and which elevates African male to the apex of societal stratification while women are depicted variables of indifference. Ogundipe-Leslie Molaria's approach to feminism explores issues like the brutality of polygamy; the unreasonable expectations of mothers who cannot bear to see their daughters choose different lifestyles; the inability of the modern African woman to make up her mind about feminist ideas and attitudes and, of course, 'female genital mutilation' (Nama 1986;

³¹ Akachi, Ezeigbo T. (2008). "Artistic Creativity: Literature in the Service of Society"? University of Lagos, p. 4. The word 'Creativity' in English comes from the Latin 'Creatus', which literally means 'to have grown'. To be creative means having the ability or the power to create. Human beings are creative animals. In the field of literature, creative writing is taught as a course, in which students are encouraged to be original and imaginative.

³² Molaria, Ogundipe-Leslie is a Nigerian feminist and Afro-Marxist writer who is considered one of the foremost writers on African feminism and Afro-marxism. She is a social critic who has come to be recognized as a viable authority on African women among black feminists and feminists in general. She rose to prominence early in her career in the midst of a male dominated artistic field concerned about "the problems afflicting the African man and with little written interest on a strong female perspective. Over the years, she has been a critic of what she termed "women oppression" and sometimes favour the view point of both the oppression of the wife by the husband, and the oppression by the husband's family".

Levin 1986). Feminism convinces by promising to “put African women at the centre [...]” (O’Barr, 59) and raise consciousness [...]” through the articulation of the inequalities they experience in fictional form (Idem, 69). Using consciousness creation approach, it evokes the need for a ‘crucial union of westernized, feminist and African culture [...]’ (Katherine Frank, 1987, 19)³³.

Many African women scholars oppose the silencing supported by a male-dominated African literary criticism. In theory, activist feminism maintains that only the African woman can convincingly explore her experience. This school seeks validation of the African woman through in-depth exploration of other exclusionary traditions. Subscribers also agree that: “African feminist criticism is definitely committed criticism in much the same way as progressive African literary criticism grapples with decolonization and feminist criticism with the politics of male literary dominance. This criticism therefore is both a textual and contextual criticism: textual in that close reading of texts using the literary establishment’s critical tools is indicated”³⁴. When talking about women’s creative works, we refer to the African and African-American female scholars, writers and critics like Alice Walker³⁵, who first dared to stand on their feet against pre-established male stereotypes and race. The American novelist furthered her study and coined ‘womanism’ as a literary theory like feminism but that which embodies both the frustration and promise of black feminist criticism. It is then the black feminism as it wants to detach from that of Europeans. As a group, they are distinct from white feminists because of their race, and that they have experienced the past and present subjugation. The term womanism shows black feminists (African Americans) readiness to reframe the racial and sexual debate around culturally specific differences between white women and black women. This form of feminism takes into account the American permanent issue of race. Then through the pen of Alice Walker, African-American women have voice to express their frustration, their desire and their future struggles. African-American women should have their own place in history while

³³ Frank, K. (1987). “Women Without Men: The Feminist Novel in Africa”. In Durosimi, E. et al (ed.) *Women in African Literature Today*. Trenton, NJ: African World Press, pp. 14-34.

³⁴ Davies, B. C. & Graves, A. A. (1986). *Ngambika: Studies of Women in African Literature*. Trenton, New Jersey: Africa World Press Inc, p. 12.

³⁵ Alice Walker (born in Feb 9, 1944) has been defined as one of the key international writers’ of the 20th century. Walker made history as the first African-American woman to win a Pulitzer Prize for Literature as well as the National Book Award in 1983 for her novel “*The Color Purple*,” one of the few literary books to capture the popular imagination and leave a permanent imprint. The award-winning novel served as the inspiration for Steven Spielberg’s 1985 film and was adapted for the stage, opening at New York City’s Broadway Theatre in 2005, and capturing a Tony Award for best leading actress in a musical in 2006.

struggling to free themselves from white men and women's jokes. In that particular quest for emancipation, no one would be shaken aside. African-American Men should also join the struggle for its total victory, although the core values of the theory help to fashion a framework of feminist resistance to patriarchy³⁶ from an African perspective. The right of African women in an African context with emphasis placed on two divides of culture as possible agents of female oppression and therefore, its relevance in promoting rights of women is the pattern governing all their fiction. The works of most of these female writers, with their focus on presenting or analysing women's experience, have gradually consciously or unconsciously carved out a distinct identity for themselves, thereby providing a unique tradition within the existing literary canon. They celebrate womanhood in general and motherhood in particular as the means to forge out their usefulness in African societies.

Amma Darko by writing of women's life is with no doubt a feminist and the practical aspects of works should be discussed as an attempt to recreate women's self and help turn the page of their hard days. The ideologies that have reinforced traditional social structures as male-dominance, patriarchy or institutionalized sexism in all societal strata are criticized. Understandably, patriarchy comes under severe attack and criticism by the feminists for the role it plays and continues to play in hindering women from achieving their creative possibilities. In *A Room of Her Own* (1929) and *The Second Sex* (1949), both Virginia Woolf and Simone de Beauvoir respectively made a thorough analysis of women's oppression within the patriarchal system. Both believe that women should establish and define for themselves their own identity by challenging the existing false cultural notions about their gender identity and develop a female discourse that will accurately portray their relationship to the world of reality and not to the world of men (Bressler, 2007). They tried to wake women's consciousness about their situation of social norms oppression and their contention in subordinate position because they have been made to feel complacent.

A major concern here is the re-entrenchment of women and/or female-related aspects of selected statements into contemporary discourse. For example, in his analysis Bressler postulates that in Flora Nwapa's *Efuru*³⁷ (1966) the eponymous character, Efuru (the lost) is also named Nwaononaku (the child/one-who-dwells-in-wealth). Her two names delineate the spaces

³⁶ Allan, J. T. (1995). "Womanist and Feminist Aesthetics". Athens & Ohio: Ohio University Press, p. 6.

³⁷ Nwapa, F. (1966). *Efuru*. London: Heinemann.

that have developed in prevailing analyses of the African woman. However, most examinations of Efurū's childlessness and her failed marriages mandate a literary criticism that mirrors Africa's economic dependence on the West. Analytically, this focus continues the disabling postures that sustained the trans-Atlantic slave trade and subsequent colonization. This viewpoint presumes that Efurū and her experiences are individual and personal losses in an Oguta that is focused on community harmony and growth.

In her essay "*Can the Subaltern Speak?*", Gayatri C. Spivak (2006: 28), reasons that the term "subaltern" denotes an inferior military rank. In India where the author is from, it is used to mean subordination or second-class. So as the subaltern is unable to escape from his hierarchy orders and expectations, it is also difficult for a woman to set herself free from a patriarchal community. The grip surely creates trauma that cannot be ripped off just by simple waves of hand. Feminists need to work to counterbalance the weight. For example, women may be represented by men in assemblies, rather than being fully accorded voices of their own. This somehow confirms Vincent Odamtten's view of Amma Darko's *Beyond the Horizon: Vending the Dream and other Traumas for the Obedient Daughter* who accuses Mara, the protagonist, for having been too obedient and trusted in her rapist and materialistic husband Akobi. As Vincent Odamtten puts it:

Amma Darko takes the familiar folk tale of the disobedient daughter, character we have seen in such works as Ama Ata Aidoo's *Anowa* and Amos Tutuola's *The Palm-Wine Drunkard*, and turns it on its head. We have instead tales of the obedient daughter. This is the young woman who, because of a sense of duty, wilfulness, naiveté or just plain ignorance, feels compelled to obey the rules, to play the game as her elders and betters have taught her; and yet, by the day's end, the young woman finds herself still trapped in that neo-colonial hall of mirrors, never sure if the image seen is the real reflected.³⁸

Unfortunately, it is her outer beauty and docility that have been long time greeted by literary writers who ignored the cultural experiences that shrouded the beauty of her everyday life. Amma Darko depicts the day-to-day realities of African women in patriarchal societies. A close analysis of her fiction provides credibility and proof to this assertion. For it presents literary qualities and is written with clear cut socio-cultural prevailing worries. Further, for Vincent Odamtten, Amma Darko's first novel *Beyond the Horizon*:

³⁸ Odamtten, V. O. (2007). "*Beyond the Horizon: Vending the Dreams and other Traumas for the Obedient Daughter*" in *Broadening the Horizon: Critical Introductions to Amma Darko*, p. 104.

Is successful due to the complexity and power of her major character/raconteur. The novel explores, in the reflective light of the confessional, the global trading in women's bodies, a fact that has often been denied, erased or discussed in terms of outside of the West-Thailand, the Philippines, the former Eastern European countries and Russia and less often Africa. Now, Darko dexterously relocates the site of the crimes in the white blankness of Europe and the West where 'snow' is to be sniffed into black bodies so that the pain of the real trauma may be ameliorated. And yet the story has been told: some things are indeed too dangerous to keep secret. (Darko, 109-10)

Yet, as Mary Eagleton observes, while literature by women provides essential insights into female experiences, the fact is it has not been easy for them to publish their works. As Ama Ata Aidoo says, "life for African woman writer is definitely 'not a crystal clear' to success (cited in Ogunyemi: 1985, 69), because they are women and also because of their skin colour. Yet in the face of these odds, African women writers strive to reverse aspects of female marginalization and seek to right the wrongs of the past. They investigate and explore ways in which women can overcome the obstacles hindering their personal empowerment. Basically, their message is that in the face of an oppressive system of deep-rooted norms and practices that foster female subjugation, women writers can attain self-realization and empowerment. In the texts, they redefine the role of African women and rectify the gender imbalance in their literary works.

For the degree to which works are penned by women, the manner with which those texts are critically received, and the roles women play within the general body of African literature, are all reflective of societal attitudes toward women. Unfortunately, the African literary canon is characterized by the inadequate representation of female-authored works. Moreover, literature often perpetuates the gender myths that are typically projected on African societies via the Western gaze. In many instances, African women writers are marginalized by their male counterparts, and their works either remain unacknowledged or tokenized by literary critics. This lack of inclusion is not without some socio-historical roots. For the marginalization of African women's literature may be clearly linked with the gender specific repercussions of European colonization. Although regional and cultural specificities affected the degree of demotion, the position of African women was significantly compromised by the imposition of colonial institutions. Ifi Amadiume, a social anthropologist, author of *Male Daughters, Female Husbands* (1987) argues that: "whereas indigenous concepts linked with flexible gender

constructions in terms of access to power and authority mediated dual-sex divisions, the new Western concepts. Carried strong sex and class inequalities supported by rigid gender ideology and constructions”³⁹.

Initially, colonial schooling was exclusively offered to males, and when education did become available to both sexes, the male to female ratios regarding student enrolment clearly demonstrated the perpetual restriction of formal education to female. These sex-based disproportions in student registration become further evident when considering progressive levels of study. Although theorists have attributed these discrepancies to a number of factors, C.K. Graham’s “The History of the Education of Ghana from the Earliest Times to the Declaration of Independence”, suggests that the apprehension of parents may have been a significant deterrent to the enrolment of female students. Because the type of employment formal education was solely offered to boys, parents were reluctant to send their daughters to school. Such a decision would intensify the familial workload without the guarantee of any future employment. Nevertheless, the correlation between decline in female registration and increasing levels of study suggests that social factors regarding gender resulted in the limited access and lowered prioritization of academia for women.

Consequently, feminist movements locate the oppression and subordination of women, which is seen to be historically extremely common and widespread, in the patriarchal domination of women by men. (Fortier: 2002, 108) In fact, they share the basic view that, western civilization is pervasively patriarchal and is organized and conducted in such a way as to subordinate women to men in all cultural domains: familial, religious, political, economic, social, legal and artistic (Abrams: 1999, 234-35). In this vein, the French atheism theorist Michel Onfray⁴⁰ rightly displays this pervasive trend in the three monotheist religions in the world. In *Atheism Manifesto: The Case Against Christianity, Judaism and Islam* (2005), Michel Onfray demonstrates that organised religion is motivated by worldly, historical and political power; that the three dominant monotheisms: Christianity, Islam and Judaism, exhibit the same

³⁹ Amadiume, I. (1987). *Male Daughters, Female Husbands: Gender and Sex in an African Society*. London: Zed Books, p. 119.

⁴⁰ Michel Onfray is a French philosopher. Born to a family of Norman farmers, he graduated with a Ph.D. in philosophy. He taught this subject to senior students at a technical high school in Caen between 1983 and 2002, before establishing what he and his supporters call the Université populaire de Caen, proclaiming its foundation on a free-of-charge basis, and the manifesto written by Onfray in 2004 (La communauté philosophique). He prefers to say though that his 'university' is committed to deliver high-level knowledge to the masses, as opposed to the more common approach of vulgarizing philosophic concepts through easy-to-read books such as "Philosophy for Well-being". <https://www.goodreads.com/book/show/81196.AtheistManifesto>.

hatred of women, reason, the body, the passions; that religion denies life and glorifies death. Michel Onfray exposes some uncomfortable truths: Judaism invented the extermination of a people; Christianity was enforced with extreme violence by Constantine; Islam is misogynist⁴¹. In these monotheist religions, according to Michel Onfray, the space given to women is rather second, the margin, at the bottom of the church, the synagogue or the mosque: silence in holy places, seated apart, or not permitted entrance at all.

In her novels, Amma Darko portrays situations whereby the relationship between men and women is one in which women are victims of various types of physical and psychological violence. Women are victims of rape, battery, betrayal, abandonment by irresponsible husbands, economic exploitation and obnoxious cultural practices. Thus, in Amma Darko's works, the text becomes the site to ventilate pent-up feelings about the experiences of women. The need 'to be angry' and 'to react' defines the way Amma Darko treats women and girls in relation to men and boys in her stories. In the end, the social issues she projects are subsumed in the pure power of male-bashing, although she gives sometimes important role to men in her writings. Amma Darko employs "a highly subjective female perspective which is expressed through verbal violence or language which is deflationary and condemnatory of men, including insults and curses; the caricaturing of male characters; the muting and banishment of male characters because the writer seems to show the readers that all the problems are supposedly caused by men."⁴²

Amma Darko follows in the footpaths of the two leading Ghanaian women writers, Efua T. Sutherland and Ama Ata Aidoo. However, as a writer, Amma Darko differs in her approach of social, political and cultural issues. Rather than viewing the marginal condition of African women as the "cause for reiterations of their victimhood, which then would cement them into this role, writers describe this marginalisation in ways that stress fluidity and movement."⁴³ This perpetrator-victim relationship leaves women consigned to fear, trauma, suffering and death. All

⁴¹ https://www.goodreads.com/book/show/81196.Atheist_Manifesto

⁴² Adjei, M. (2009). "Male-bashing and narrative subjectivity in Amma Darko's first three novels", in *SKATE Journal of Literary Studies*, vol. no. 1. pp. 47-61.

⁴³ Bungaro, M. (2007). "Victims and/or Victimisers? Women's De(Con)structive Power in *The Housemaid*" in *Broadening the Horizon: Critical Introductions to Amma Darko* (ed.) Odamtten V. O. UK/London: Ayebia Clarke Publishing Limited, p. 28.

such novels thus adopt “rhetorical violence and narrative subjectivity as a way of confronting and demolishing male dominance and exploitation”⁴⁴.

This research focuses on the literary representation of African women’s conditions in Amma Darko’s *Beyond the Horizon*, *The Housemaid*, *Faceless* and *Not Without Flowers*. Amma Darko’s novels suggest female self-definition and self-questioning on identity. Thus, our dissertation investigates how a number of female characters reflect the female African life in traditional and urban settings in contemporary Ghana. It explores how social tensions and norms such as polygamy, barrenness and stereotyping alongside economic hardship are presented through writing on Ghanaians. In the four novels under study, Amma Darko spares no details in describing the burning pain as well as the violation, humiliation and shame on women. She presents her female characters either exiled or prisoners of a historical and socio-cultural context. Amma Darko’s novels tell the story of women in African and the world in pain, in agony and in misery. Her novels float us on the world of inverted reality which becomes the norm. Each novel presents the thematic of sexual (marriage), social (problem of class) and economic dominations (poverty).

With her creative writing, Amma Darko confronts the social realities prevailing in contemporary Ghanaian society. As a matter of fact, one can notice the roughness between, on one hand, the strong desires to choose freely their own ways, to follow their own preference in their quest for happiness, and on the other hand, traditional and modern restrictions that require submission, abnegation, resignation, discouraging any slight wish of change, innovation and self-empowerment in the life of African women. African women suffer because of oppressive cultural traditions, many of which still persist in modern African societies. The question of African women’s well-being has been a subject of great debate both on a local level and global level. This is testified by several discussions in newspapers, journals and WebPages ranging from immigrant exit from Africa to foreign lands to their contribution to Africa from their new frontiers.

This dissertation has arisen from a recognition that while the development of African literature over the past four decades presents itself as an overt exercise in decolonization,

⁴⁴ Adjei, M. (2009). “Male-bashing and narrative subjectivity in Amma Darko’s first three novels”, in *SKATE Journal of Literary Studies*, vol. no. 1. pp. 47-61.

adopting as it does an anti-‘father’ stance, the development of African feminism turned out to be propelled towards being anti-Western feminism. This seeks “female agency and autonomy”⁴⁵. It is this fluid character of African feminism that this dissertation seeks to discover. The fear of patriarchal authority and the offensiveness about the female creation are phenomena that mark the sense of inferiority in women. Jones and Stevi write in *Contemporary Feminist Theories* that gendered hierarchy society questions the male-centred ways of knowledge. They argue that striving hard assert their identity in their creative writings no matter the means. “Women writers struggle for artistic self-definition and differentiate the efforts at self-creation from those of her male counterpart”⁴⁶. African female writers have portrayed patriarchy and opened ways for women to fight back or get away. Contemporary feminists like Amma Darko puts their special touch in this literary motivation, but its “victimisation of individuals in the form of rape, spousal abuse and spiritual and psychological oppression”⁴⁷.

Our choice for the novels is based on how Amma Darko gives an in-depth and intriguing presentation of Ghanaian women’s experience. By narrating the story in a parallel and special manner she addresses the challenges African women face as immigrants and helpless in a foreign country. At the same time, she portrays Ghanaian experience and implication in the transatlantic slave trade, women’s undermining in patriarchal households, prostitution and gender inequalities to name only a few. This research therefore interrogates the challenges faced by female African and examines the male-female relationship with the hope that we gain insight on Amma Darko’s vision of feminism. Today, critical views on the writer like Vincent O. Odamtten’s *Broadening the Horizon: Critical Introductions to Amma Darko* (2007), nonetheless, our study intends to contribute by analysing the novels under scrutiny to reveal the representation of the new challenges through fiction. We examine how the subject of Ghanaian women as a contemporary concern both locally and globally is defined.

The on-going evaluation of the selected novels (*Beyond the Horizon*, *The Housemaid*, *Faceless*, and *Not Without Flowers*) discusses the formation of an African literary canon, the representation of history, ideology, and the new role of women which empowers them to engage

⁴⁵ Adjei, M. (2009). “Male-bashing and narrative subjectivity in Amma Darko’s first three novels”, in *SKATE Journal of Literary Studies*, vol. no. 1. p. 56.

⁴⁶ Jones, J. ; Stevi, J. (1998). *Contemporary Feminist Theories*, Edinburgh University Press, UK, Paperback, p.50.

⁴⁷ Bungaro, M. (2007). “Victims and/or Victimisers? Women’s De(Con)structive Power in *The Housemaid*” in *Broadening the Horizon: Critical Introductions to Amma Darko* (ed.) Odamtten V. O. UK/London: Ayebia Clarke Publishing Limited, p. 30.

pressing social and political issues to show that they are no longer nonentities. Sex and gender-related issues are often critical and crucial to the conception and organization of societal roles in African patriarchal structures. The intersection of gender and power in African societies often manifests itself vividly in fictional works. The subsequent interpretation of feminism is within the framework of what Molaria Ogundipe-Leslie (1994) coins 'humanistic feminism' because Amma Darko criticizes severely motherhood and its constraints.

The second theoretical approach in this dissertation is psychoanalytical. With reference to the Dictionary of Concepts in Literary Criticism and Theory, psychoanalytical criticism is a brand of literary tool that uses psychological theory to interpret "the general processes of literary creativity; the origin of a literary work in individual authors' mind; the thoughts and actions of a character in a literary work, the structure of a literary work or readers' response"⁴⁸. For Wendell V. Harris, Sigmund Freud's psychoanalytic theory of personality argues that human behaviour is the result of interactions among three component parts of the mind: the id, ego and superego. This theory, known as Sigmund Freud's structural theory of personality,

places great emphasis on the role of unconscious psychological conflicts in shaping behavior and personality. Dynamic interactions among these fundamental parts of the mind are thought to progress through five distinct psychosexual stages of development. Over the last century, however, Freud's ideas have since been met with criticism, in part because of his singular focus on sexuality as the main driver of human personality development. (Wendell, 305)

Sigmund Freud illustrates in *Beyond the Pleasure Principle* that some pattern of suffering is inexplicably persistent in the lives of certain individuals. Sigmund Freud points out that the repetitions of the suffering are sometimes particularly striking because they seem not to be initiated by the individuals' own acts but rather appear as the possession of some people by a sort of fate, a series of painful events to which they are subjected (*Unclaimed Experience*: 2). Consequently, the analysis and interpretation are focused on the characters' psychological development and the response it generates in us, utilising evidence from Amma Darko's own writings. However, applied to African literature, one of the best known in psychoanalysis is

⁴⁸ Wendell, V. H. (1982). *The Dictionary of Concepts in Literary Criticism and Theory* (New York: Greenwood Publishing Group), p. 305.

Frantz Fanon⁴⁹. He based human behaviour interpretation on his *The Wretched of the Earth* (1961) and principally *Black Skin, White Masks* (Trans, 1968)⁵⁰ both are still now the best study of the psychology of racism and colonial domination. The author applies his therapy of decolonization to the malaise of his African fellows. In these inspired texts, Frantz Fanon brings to light and together the insights derived from his clinical study of the effects of colonial domination on the psyche of the colonized and his Marxist derived analysis of social and economic control. So far, many feminists draw to elements of psychoanalytic theory to help them examine issues relevant to women's experience. In that way, Frantz Fanon⁵¹ transparently shows how pervasively dangerous alienation can be among the colonized populace.

Further, Frantz Fanon discloses in his historical and relevant writings that the compartmentalization of the colonial world has been systemically divided into a dichotomous milieu, placing one group superior over another. As a socially constructed phenomenon within the colonial world, alienation creates an undying paradigmatic Apartheid-based realism. In a similar vein, "apartheid is simply one form of the division into compartments of the colonial world [...] the world of the dominator, guarded by the army and the police."⁵² Fanon embarked on a mission to depathologize the Third World peoples who were trapped in this world of colonialism, while simultaneously, attempting to politicize those who were oppressed. In this respect, Frantz Fanon's rationality of counter-memory enhanced his capacity to think critically and dialectically to facilitate dialogue, discourse, and spaces to build capacities to revolutionize the psyche of the *Wretched of the Earth*. To Judith Butler, as argued in *Violence, Nonviolence: Sartre on Fanon*, "Fanon's work gives the European man a chance to know himself, and so to engage in that pursuit of self-knowledge, based upon an examination of his shared practices, that is proper to the philosophical foundations of human life"⁵³.

⁴⁹ Fanon, F. (1961). *The Wretched of the Earth: A Negro Psychoanalyst's Study of the Problems of Racism & Colonialism in the World Today*. (Trans. 1968, New York, New York: Grove Press, Inc.), p. 31.

⁵⁰ Originally published by Editions de Seuil, France, 1952 as *Peau Noire, Masques Blancs* First published in the United Kingdom in 1986 by Pluto Press 345 Archway Road, London N6 5AA, English translation copyright © Grove Press Inc 1967.

⁵¹ Frantz Omar Fanon, born on 20 July 1925 in Fort-de-France, in the French colony of Martinique, was a complex figure, with multiple selves. He was, as he tells, from Antilles but he ended his life thinking of himself as an Algerian. As a young dissident, he agitated against the Vichy regime in the Antilles and travelled to Dominica to support the French resistance in the Caribbean. He was wounded; and was awarded the Croix de Guerre for bravery during his service in the Free French forces. In 1952 he married José Dublé, a French woman who shared his convictions against racism and colonialism.

⁵² Renate, Z. (1974). *Frantz Fanon: Colonialism and Alienation*. (New York: Monthly Review Press), p. 55.

⁵³ Butler, J. (2008). "Violence, Nonviolence: Sartre on Fanon" in Jonathan Judaken, *Race After Sartre: Antiracism, Africana Existentialism, Post-colonialism*. (New York: State University of New York Press) p. 216. ☒

We investigate in the present study the oppressive aspects of African tradition, as well as various interconnected forms class and gender oppression that hinder women from developing a full sense of selfhood. In order to carry this out, this study undertakes a comparative analysis of four primary texts by the same author, Amma Darko. However, it also explores the extent to which there are possibilities for self-realization and personal empowerment for women who are thus oppressed. The dissertation aims to show how Amma Darko by the means of literature, shows African women's struggle to blend their traditional culture in Ghana. As a result, the feminist voice like Amma Darko expects women in African society to behave like some strong willed and educated females depicted in the four novels. This way of portraying African society is to denounce the male-made phallogocentric system where men think the strongest are beings with male sex. Contemporary African women live in difficult social conditions and female writers have it right to explore them, and Amma Darko takes part in this. Each of the novels under study is about an acute postcolonial situation in Ghana and extended to other African countries. The feminism of Amma Darko proves that there is still hope and healing of wounds. As we will see, the primary texts draw attention to the importance of family bonds in various ways. This is indicative of feminist perspectives that Amma Darko uses in her writings in spite of feminism controversial definition.

In Africa, feminism has been received with mixed feelings because of the cultural difference leading to the proposal of alternative terms like womanism, black feminism, African feminism and clear cut definitions to unmistakably characterize the scope in which African women's struggle is focused on. There may be some difference in the method used by each woman or an association of women to win a battle against the global gender inequalities in patriarchal societies, but the absolute necessity for a particular feminism in Africa is to be reckoned. The search for diversity in feminism that is responsive to the different needs and concerns of different women, especially Ghanaian women, inspires this thesis.

In this light of thoughts, ranges the special touch of Amma Darko who backs up the fears, the expectations and hope of Ghanaian women in patriarchal society. Amma Darko's view of feminism tends to criticize some aspects of motherhood that seems to be a burden to women. The rush to motherhood with plenty children to rear is at stake in Amma Darko's second and third novels. There is no need thus for women to accept this burden. Women have the right to stop bearing or even to undergo surgical operation to remove their fallopian tubes to ensure their

being shallow and inoperative forever. In this sense, Amma Darko is one of the first female writers to promote birth control by modern technique. It seems to us that feminism has achieved relatively more progress in Ghana than other English speaking countries in West Africa. This is even why we opted to work on novels by Amma Darko.

The dissertation is organized in three parts, each subdivided into chapters with a specific purpose. The first chapter revisits the scope and reason of the Ghanaian female writers' emergence and the second focuses on the writing act of Amma Darko. The second part entitled "socio-cultural factors contributing to the gender gap" is divided into two chapters. While the first explores women's situations in rural and urban settings, the second centres on the socio-economic background of African women and the third the patriarchal embedding techniques. The details in the novels clearly show that the areas in question are as popular as Naka village to Sodom and Gomorrah⁵⁴ slum in Accra. They also shift to Germany, a European country. By means of illustration, the vivid images employed in *Beyond the Horizon*, *The Housemaid* and *Faceless* are enough to make anyone, who is familiar with Sodom and Gomorrah or any other slum in Accra, recognize the moral decay and the extreme economic despair of the population. But as to whether these descriptions fit present day Sodom and Gomorrah or not, is not important at this stage. It does not skip aside the sense that this township remains one the dreadful of Accra. So, its mentioning proves somewhat an attempt to sketch out a Ghanaian history based on slave trade's remembrance to contemporary concerns. Rather, what is important is the ordeal Mara, Tika, and Fofu go through.

Our reading of Amma Darko's fiction gives us the clue of her special technique of characterization. This is why the third part focuses on Amma Darko's techniques of characterization. This part is divided into two chapters. The first discloses Amma Darko's way of depicting her female characters under male physical, verbal and sexual assaults. This statement is made to reinforce the feminist ideology that regards masculinity as an oppressive and exploitative system. Though Amma Darko's female characters are each central and

⁵⁴ Amma Darko explains the genesis of the name given to that suburb of Accra. As she loves very much research and spends lot of her time in archives, Amma Darko comes to know that the area was used to be known as Fadama. So named by early settlers there who were mostly from the north. Fadama means swampy in Hausa, which the area was. Then in the early sixties, not too long after independence, the combination of a severe flooding, caused by days of a heavy downpour; and a government decision to dredge the lagoon to fill the lowlands of Fadama, necessitated the evacuation of the residents to Zongo, near Abossey-Okai and to New Fadama, near Abeka. See Amma Darko's *Faceless*, revised version (2010), p. 65.

important to the plot throughout the four novels, they do not operate in isolation. We then demonstrate how each female character's reaction depends on another's action and vice versa. The second chapter tries to find the link by the help Frantz Fanon's psychoanalysis and Sigmund Freud's neurosis. With that very chapter, we explore Amma Darko's method of masculinity deconstruction. Another point in this part discusses and draws a conclusion regarding Amma Darko's narrative technique, more importantly her use of metaphors to give way to her inner opinion. Our analysis focuses on a number of texts we think of as an ideological apparatus for the reproduction of gendered subjectivities in Africa. In fact, like her female counterparts such as Ama Ata Aidoo, Flora Nwapa and Buchi Emecheta, Amma Darko uses traditional tales to demonstrate the pervasiveness of some African customs. In that sense, according to Vincent O. Odamtten's article⁵⁵ on Amma Darko's *Beyond the Horizon*, Amma Darko is suspected to have turned head to the common tale of the obedient daughter. In the other novels of Amma Darko the use of folktales, stories and other African typical way fiction modes are present and visible.

To Isidore Okpewho, African folktales are ranged in African oral literature and as so he defines the term literature as a creative text that appeals to our imagination, such as stories, plays, and poems⁵⁶. In essence, Isidore Okpewho seems to disqualify factual texts such as newspapers as not being literature. Nowadays, many of these old tales are used in fiction as clues of fancy, but African writers live on because they capture our sense of wonder, interests, and aspirations. Moreover, we recognize their visions which are often more powerful than the explanations science provides. Rewriting these tales and stories or like Amma Darko turning their heads while telling is today the way of African writers to show the necessity of 'back to the roots' because in Africa, written form of literature borrows heavily from the immense resources of oral literature. Consequently, we cannot discuss written African literature without referring to the oral forms and the way writers have incorporated them in the exploration of their people's past and contemporary experiences. Critics of African literature have long realized that "writing is only a symbolic way of representing speech and as such is secondary to it"⁵⁷. However, there is a gap between both forms of literature. The gap is day by day being bridged by users, writers

⁵⁵ Odamtten, V. O. (2007). "Amma Darko's *Beyond the Horizon*: Vending the Dream and the Other Traumas for the Obedient Daughter" in *Broadening the Horizon: Critical Introductions to Amma Darko*, p. 100.

⁵⁶ Okpewho, I. (1992). *African Oral Literature: Backgrounds, Character, and Continuity*. Indiana University Press.

⁵⁷ Nwankwo, C. (1990). "The Oral Foundation of Nigerian Written Poetry." In E. Emenyonu (ed.). *Literature & Black Aesthetics*. Ibadan: Heinemann.

and scholars of oral and written who draw resources from both sides to enrich and embellish their creativity and render it dynamic and more attractive. One of the important sides of oral literature is when it is used to revive infants' knowledge. Children at their little age find themselves concern with the stories they are told. Through the tales, children begin to learn not only to adapt to the external environment, but also to learn the ways of life of their people. It creates mental development and a worldview, it makes them be aware of the knowledge of men's quest to achieve greatness despite the risk involved.

That is certainly the reason why Amma Darko uses traditional tales in her creative writings to teach the history of her people and keep in tune their memory for past glories and misdeeds. As so, the present work adopts some literary approaches as we have mentioned earlier which would help discern Amma Darko's style and special touch as a feminist writer. Our thesis, "African Women's Empowerment", will be explicitly illustrated and completed by the help of these literary tools. The present research work is set to give our contribution to the study of African women's reversing marginalisation and by making them more visible and efficient. We disclose then Amma Darko's strategies to increase African women's leadership and self-fulfilment. Finally, we will emphasize gender issues as a central part of Amma Darko's work a little longer, to stress that it is impossible to subsume it within the author's equally obvious allegiance to Ghanaian cultural identity. Indeed, this does not insinuate that it is the only issue in her work. However, the only question begging for quick answer is whether a man can be free while a woman is a slave.

PART ONE: THE FOUNDATION OF THE GHANAIAN FEMALE LITERATURE

Before attempting to write on Ghanaian literary engagement, it is important to explore briefly its history to better understand what the former Gold Coast was like. In accordance with the present perspective, we refer to historical records which disclosed that the present-day Ghana was a very important milieu of great migration of population for lands for settlement, trade, knowledge in medicine, astrology, war strategy, agriculture, culture, humanities. Archaeological evidence indicates that present-day Ghana was inhabited for many thousand years. The region shared its early history with all of West Africa⁵⁸. Some of the earliest finds shows trace of settlements along the coastline. In fact, the early Kingdom of Ghana (sometimes known as "Ghanata" or "Wagadugu") was one of the most powerful African empires for several hundred years. At the time it was far more developed than any European country. The Ghana Empire was in the Sahel and included most of present-day Senegal and some regions of Mali and Mauritania, but did not reach as far south as today's Ghana (see fig. below).

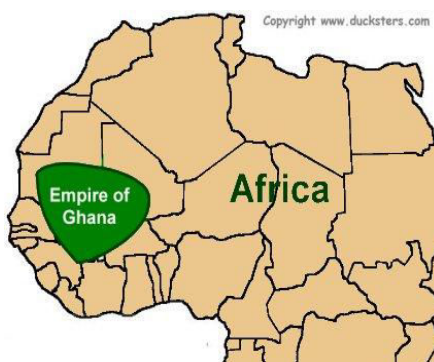

Fig. 1: The Place of the ancient Ghana Empire.

Uses of metals were known, and the Kingdom was well organized, with its laws and economy. While small and big Kingdoms emerged, are dissolved or followed by new ones, the population slowly migrated south. Tribes and clans combined and mixed as centuries went by. Prisoners of war were often kept or sold in North Africa or sometimes even to Europe. Those early signs of a slave trade are accounted for before the arrival of Europeans to West Africa, but

⁵⁸ Sir H. H. Johnston, *The opening up of Africa*, London, Williams and Norgate, p. 103. The name Africa could probably have been after 'Afarik' or 'Afriga', name of a remote Libyan tribe who had lived in the area of South Carthage. The tribe would have left for the neighbouring desert where they kept the name of 'Aurigha'. So when Greece has given this South Cartage part the name 'Libya', a woman's name, Africa had been given to the Roman former colony of the North-Eastern area of the present-day Tunisia in « *Individu et Société dans le Roman Négro-Africain d'expression anglaise de 1939 à 1986* », Noël Dossou-Yovo, p.30. Edition L'Harmattan, 1997, Paris, Collection Etudes Africaines. ISBN: 2-7384-5785-1.

can in no way be compared to what happened later. In fact, most African historians recognized that pre-colonial era was the time of glory for African empires for it was the time inside and outside wars and large conquests. The glorious time of those former kingdoms can be compared with the medieval period in Europe. Predominantly with Ghana's empire, the period was that of the flowing of gold implying all sorts of trades. According to historians and archaeological relics, "most ethnic groups constituting the modern Ghanaian population had settled in their present locations by the end of the 16th century and archaeological relics found in the coastal zone indicate that the area has been inhabited since the early Bronze Age (ca. 4000 B.C.), but these societies, based on fishing in the extensive lagoons and rivers, left few traces. Archaeological work also suggests that central Ghana north of the forest zone was inhabited as early as 3,000 to 4,000 years ago"⁵⁹. Most accurately, these historians further their early research with the help of oral history and other sources (written) that suggest that the "ancestors of some of Ghana's residents entered this area at least as early as the tenth century A.D. and that migration from the north and east continued thereafter"⁶⁰. Many European historians reported that the shift from oral to written means of communication and the echo of the ancient Ghana Empire's power reached up to the Greece of Homer in the Middle Ages.

A large number of people could move freely to any places. Those migrations resulted in part from the formation and disintegration of a series of large states in the western Sudan (the region north of modern Ghana drained by the Niger River). Prominent among these Sudanic states was the Soninke Kingdom of Ancient Ghana. Rightly speaking, Ghana was the title of the King, but the Arabs, who left records of the Kingdom, applied the term to the King, the capital, and the state. Margaret Blackburn White states in *Becoming White: My Family Experience as Slaves Holders and Why it still Matters* (2009):

the 9th Century Arab writer, Al Yaqubi, described ancient Ghana as one of the three most organised states in the region (the others being Gao and Kanem in the central Sudan). Its rulers were renowned for their wealth in gold, the opulence of their courts, and their warrior-hunting skills. They were also masters of the trade in gold, which drew North African merchants to the western Sudan.⁶¹

⁵⁹ Gerard, A. (1967). "Bibliographical Problems in Creative African literature", *Journal of General Education*, volume, 19, pp. 25-35.

⁶⁰ <http://vibeghana.com/ethnic-groups-of-ghana/>

⁶¹ White, B. M. (2009). *Becoming White: My Family Experience as Slaves Holders and Why it still Matters*, AuthorHouse Bloomington, IN47403, First published by AuthorHouse, ISBN: 978 1 438924168, p. 22.

The military achievements of those and later western Sudanic rulers and their control over the region's gold mines constituted the nexus of their historical relations with merchants and rulers of North Africa and the Mediterranean. This early organization forced historians to recognize that Africa did not get its civilization from its contact with the West. In spite of this authority, "Ancient Ghana succumbed to attacks by its neighbours in the eleventh century, but its name and reputation endured"⁶². Although none of the states of the western Sudan controlled territories in the area that is modern Ghana, several small Kingdoms that later developed in the north of the country were ruled by nobles believed to have emigrated from that region. The trans-Saharan trade that contributed to the expansion of Kingdoms in western Sudan also led to the development of contacts with regions in northern modern Ghana and in the forest to the south.

Additionally, F.M. Bourret pointed in *The Gold Coast: A Survey of Gold Coast and British Togoland, 1919-1951* "The roughly oblong block of territory know as Gold Coast lies midway of the Guinea littoral West Africa. The usually accepted limits of West Africa are the Senegal River on the west, the Niger Delta on the east, while the Saharan Desert forms the convenient boundary in the north."⁶³ In the 13th century, the Kingdom of Ghana was conquered by the Kingdom of Melle⁶⁴. William Edward Burghardt Du Bois reported in his *Black Folk Then and Now: An Essay in the History and Sociology of the Negro Race* that:

In the early part of the thirteenth century the prestige of Ghana began to fall before the rise of Mandigan Kingdom to the west. Melle, as it was called was founded in 1235 and formed an open door for Moslim and Moorish traders. The new kingdom, helped by its expanding trade, began to grow, and Islam slowly surrounded the older Negro culture west, north, and east. However, a compact mass of the older heathen culture pushing itself upward from the Guinea coast, stood firmly against Islam down to the nineteenth century.⁶⁵

⁶² <http://www.ghanaweb.com/GhanaHomePage/history/pre-colonial.php>

⁶³ Bourret F. M. (1952). "*The Gold Coast: A Survey of Gold Coast and British Togoland, 1919-1951*", Second Edition 1952, London University Press, p 1.

⁶⁴ William Edward Burghardt (WEB) du Bois (2007). "*black folk then and now: an essay in the history and sociology of the negro race*" melle kingdom eventually supplanted Ghana in prestige and power after Ghana had been overthrown by Soso in 1203. The territory of Melle (mali) lays southeast Ghana and some five hundred miles to the gulf of guinea. Its kings were known by the title of mansa, and from the middle of the thirteenth century to the middle of the fourteenth, the mellestine, as its dominion was called, was the leading power in the lands of the blacks.

⁶⁵ Du Bois, W. E. B. (2007). "*Black Folk Then and Now: An Essay in the History and Sociology of the Negro Race*", Oxford University Press, p. 33.

The growth of trade stimulated the development of early Akan states located on the trade route to the goldfields in the forest zone of the south. The forest itself was thinly populated, but Akan speaking peoples began to move into it toward the end of the 15th century with the arrival of crops from Southeast Asia and the New World that could be adapted to forest conditions. By the beginning of the 16th Century, European sources noted the existence of the gold rich states of Akan and Twifu in the Ofin River Valley. Despite all those military achievements and equipment, Ghana Empire fell in the hand the Western imperialistic forces and was colonized like any other kingdom of the time. Yet before the European settlement could be totally ensured on the behalf of a civilization mission, oriented literature was issued by the British Empire for the sole purpose of colonization. Again and as the Transatlantic Slave Trade that did not afford Africans any period of peace and rest, colonization era was so though and bloody. The African nature was transformed into one of bloodshed and fear owing to colonization and the native civilization degraded gradually, giving rise to ‘stupid’ black characters like Friday in Daniel⁶⁶ Defoe’s *Robinson Crusoe* or Joseph⁶⁷ Conrad’s *Heart of Darkness*⁶⁸.

In fact, Daniel Defoe's *Robinson Crusoe* (1719) and Joseph Conrad’s *Heart of Darkness* wrote when people were traveling abroad, exploring, discovering and conquering new lands and spreading Western ideology, Christianity and imposing their way of life. Their notion of imperialism was to brainwash all the people they came across with and therefore dominate them. They made people such as Africans feel inferior and useless in front of the rest of the world and particularly Europeans. Thus, as stated by Frantz Fanon, “The feeling of inferiority of the colonized is the correlative to the European’s feeling of superiority”⁶⁹ and from generation to generation the feeling is nurtured by both sides. The black man was supposed to be a good slave, looking downward before speaking to his master. He internalized that way of life in his

⁶⁶ Daniel Defoe was born about 1660 in London. His father, James Foe, was poor but hard working butcher. Defoe was not able to attend traditional institutions like Oxford and Cambridge because of his father's opposition. Defoe is often considered the father of English novel. He is a master of simple prose and powerful narrative with a love of realistic detail. He is a great imaginative writer who creates one of the most familiar resonant myths of modern literature. He is influenced by the writings of Addison, Steel and Swift. Defoe's important works are: *Robinson Crusoe* (1719), *Moll Flanders* (1722), *Capitan Singleton* (1720) and *The History of Peter the Great and Colonel Jack* (1722). Defoe died in London on April 24, 1731.

⁶⁷ Joseph Conrad was born in December 3, 1857. His childhood was affected by his homeland's struggle for independence. He is a Polish novelist and short story writer. Conrad is one of the English language's greatest stylists. He becomes one of the greatest writers in the world. His major works include *Heart of Darkness* (1902), *Lord Jim* (1900), *The Secret Agent* (1907), *Under the Western Eyes* (1911) and *Nostrome* (1904). He died of heart failure on August 3, 1924.

⁶⁸ Achebe, C. (1988). “An Image of Africa: Racism in Conrad's *Heart of Darkness*” *Massachusetts Review*. 18. 1977. Rpt. in *Heart of Darkness*, An Authoritative Text, background and Sources Criticism. 1961. 3rd ed. Ed. Robert Kimbrough, London: W. W Norton and Co., 1988, pp.251-261. *Heart of Darkness* projects the image of Africa as "the other world," the antithesis of Europe and therefore of civilization, a place where man's vaunted intelligence and refinement are finally mocked by triumphant bestiality. The book opens on the River Thames, tranquil, resting, peacefully "at the decline of day after ages of good service done to the race that peopled its banks." But the actual story will take place on the River Congo, the very antithesis of the Thames. The River Congo is quite decidedly not a River Emeritus. It has rendered no service and enjoys no old-age pension. We are told that "Going up that river was like travelling back to the earliest beginnings of the world."

⁶⁹ Fanon, F. (1967). *Black Skin, White Masks*. New York: Grove Press, Inc. Print, 93.

ordinary attitude towards the white man. His legendary self-esteem evaporated and gives way to fear and unstable personality. He ceases to be a self-motivated and self-confident.

The reading the novel portrays a powerful nation represented by Crusoe who controls the economy and the territory of a weak and savage country represented by Friday's island. By subjecting the character Friday (a non-White and servant) to Robinson Crusoe, Daniel Defoe proves allegorically the subjugation imposed by colonialism to "other". Crusoe denies to Friday a culture, a religion, a habit, a language just like the British Empire did to its African colonies. The novel of Daniel Defoe foresaw the awaiting ordeals of Africa because just as Crusoe claimed the island for England, the British Empire also claimed the colonies.

One after another, colonies saw the rise of frequent protests from its literate people (rooted in Marxist ideology) in the 1940s. The root point of African upheavals was the two World Wars. During those wars, the mask of European superiority came down and then, after the Japanese surrender in 1945, local nationalist movements in the former colonies campaigned for independence rather than a return to European colonial rule. In many cases, those nationalists, backed up by the educated elites, constituted guerrillas against former members of colonial military positions. These independence movements often called upon the United States Government or the Soviet Union for sustenance.

In 1950, Kwame Nkrumah called for a national strike and is jailed for his demands for independence. He was released from jail a year later after CPP wins the first election for the Legislative Assembly and in 1952: Kwame Nkrumah became the first African Prime Minister and government leader, but still shared the power with the British governor Sir Charles Arden-Clarke⁷⁰. He was re-elected in for the post in 1954 and 1956. He delivered his speech this militant speech on the day of independence:

Ghana our beloved country is free forever! ... The independence of Ghana is meaningless unless it is linked up with the total liberation of the African

⁷⁰ Sir Charles Noble Arden-Clarke (25 July 1898 – 16 December 1962) was a British colonial administrator. He was the Resident Commissioner of the Bechuanaland Protectorate between 1937 and 1942 (later Botswana), a time at which the ruling regent Tshekedi Khama was in violent conflict with the British authorities. In 1946, he was appointed as the first Governor of the newly created British Crown Colony of Sarawak, which was ceded in 1946 by the Kingdom of Sarawak. After Sarawak, he was the last governor of the Gold Coast from August 1949 until 1957 (later Ghana). On 12 February 1951 he authorized Kwame Nkrumah's release from imprisonment in James Fort. After independence, he was named the first Governor-General of Ghana in 1957.

continent. We are going to demonstrate to the world, to the other nations, that we are prepared to lay our foundation, our African personality"⁷¹.

As a result, on March 6, 1957 Ghana was the first of the colonies in sub-Saharan Africa to gain independence. Africa and the rest of the world watched the creation of the new state with high anticipations. The situation in Ghana inspired nationalist movements all over the continent. The economy seems to be good and promising as Ghana is rich with gemstones, forests and crops. Ghana is the leading cocoa exporter in the world and produces one tenth of the world's gold. 25% of the population is literate (a high proportion compared to other colonies at the time).

Toward the end of 1964, Kwame Nkrumah suspends democracy by suspending the constitution. Ghana officially became a one-party state and Kwame Nkrumah gained power; became a dictator. Criticised by the West, Kwame Nkrumah now turns to the Soviet Union and other communist countries. The economy is out of control and the population is getting poorer. Nkrumah is no longer a popular leader as he hits hard on demonstrations and arrests anyone in opposition. This is what Ali Mazrui terms 'negative Nkrumanism' quoted by Ama Biney in her article "The Legacy of Kwame Nkrumah in Retrospect" (Biney, 2008: p.131).⁷²

In doing so, he let loose of a broad literature on Ghana and Kwame Nkrumah that emerged in the 1960s. Early scholar writings included a social political history of the country and an important number of biographical works. Other scholars emphasize on the handover of power in Ghana. They portray what made Kwame Nkrumah's vision unpopular and combated as being a severe Hero worshipping overtly denounced in Ayi Kwei Armah's *Two Thousand Seasons*.⁷³ As Neil Lazarus argues, "Independence seems to have brought neither peace nor prosperity to Africa. Instead, it has paradoxically borne witness to stagnation, elitism, and class domination, and to the intensifying structural dependence, economic, political, cultural, and ideological of Africa upon the imperial Western powers."⁷⁴ Thus, independence failed to live up to its promises and marked the beginning of increasing disillusionment as it became clear that

⁷¹ From Kwame Nkrumah's Speech for Independence in March 6th, 1957 at Accra Memorial.

⁷² Ama, B. (2008). "The Legacy of Kwame Nkrumah in Retrospect" in *The Journal of Pan African Studies*, vol. 2. no.3.

⁷³ Atta, B. (1975). "Hero-Worshipping in the African Novel: The Case of Ayi Kwei Armah and Others" (Asemka N° 3, September 1975) in which he criticizes severely Hero Worshipping in African literary writings.

⁷⁴ Neil, L. (1990). *Resistance in Postcolonial African Fiction*. London: Yale University Press, p. ix.

for the majority of people nothing had changed and that domination and exploitation simply continued under a different name. Most of the African people could not think that their fellows African would be as wicked, interest greed and manipulators as the former colonizers. As a matter of fact, former friends during independence struggle become enemies and writers don't hesitate to portray their former adulated leaders as wolves in sheep's cloths. This period happens to be the debut of the waning of the hope that '*The suns of independence*' bring with itself.

The Beautiful Ones Are Not Yet Born (1968) depicts a society caught in a trance of whiteness, where everyone from the government minister to the lowliest clerk apes European manners and aspires to Western patterns of middle-class consumerism, privilege, and snobbery. In *Fragments* (1970), colonial dependency complexes produce a modern cargo mentality, and in *Why Are We So Blest?* (1972), Western luxury, class pyramids, and white mistresses have even infiltrated the fabric of African revolution. The west sees this as a new direction in Ghanaian politics and economics. He flew to asylum at his personal friend President Sékou Touré (1922-1984) in Guinea Republic. In the following days and weeks all Nkrumah statues in Accra are taken down by the crowds. Kwame Nkrumah died in 1972 in Conakry, Guinea. For the following years, though having been agitated by several coups, Ghana continues to have the highest growth rate in Africa. Rawlings speaks strongly against the economic globalisation allowing market prices on Cocoa to determine the future of a developing country like Ghana.

Chapter one: The Emergence of African female writers

Fiction represents the expression of human activities in written words; the expression and the impression of the people who have created it; it is the production of what purports to be an authentic account of the actual experience of individuals from his immediate or remote environment. Fiction portrays society, therefore facts. Facts can be defined as concrete reality or actual reality or actual presentation of events that have historical record. The reality could be social, economic or political. The rise of facts in the novel was necessitated when there came the need for the actual documentation of events that occurred in the life of the people in a society or the society itself. This mainstream is what Georg Lukasz called historical narrative in *The Historical Novel*. A novel then deals indirectly with a man in the social world. It does not, however, present a documentary picture of life. “Alongside the fact that a novel look at people in society, the other major characteristics of the genre is that a novel tell a story. It seems that novels tell the same few stories time and time again”⁷⁵. So novelists either historical or fictional tend to focus frequently on the tensions between individuals and the society in which they live, presenting characters who are at odds with that society to describe the prevailing events. In this scope, history teaches us how best to live in the present time and future and in so doing, it is bound up with our morality, in much the same way that story-telling is. Hayden White furthers the discussion and highlights the similarities between the methodology of the historians and that of the literary artists. The writer can then decide to talk essentially about social events such as marriage, child birth and related ceremonies, and death whereas the historian focuses on the relation between the past events and the present way of life.

One of the events that occur is the subjugation of women’s rights in African societies. The discourse on the rights of women in Africa has been a major focus of contemporary scholarship in Africa. Many scholars in feminist or womanist studies have pointed out largely unanimously, that many aspects of African culture are hostile to women. Thus, the need for a paradigm shift has been discussed by African women writers throughout their creative works. In this vein, scholars like Viviane Forrester asked remarkably questions such as: “we don’t know what women’s vision is. What do women’s eyes see? How do they carve, invent, decipher the

⁷⁵ Peck, J. & Coyle, M. (1984). *How to Study Literature: literary Terms and Criticism*. Hampshire & London: MacMillan Press Ltd, p. 103.

world?”⁷⁶ Forrester regrets in her paper that women did not seize, at the right moment, as men did their opportunity to react in literature or film making. She puts it that “Women will have to defend themselves against an accumulation of clichés, of sacred routines which men delight in or reject and which will frequently trap women as well. Why will they be more apt to rid themselves of whatever obstructs men’s vision? Because women are the secret to be discovered, they are the fissures. They are the source where no one has been”⁷⁷. This source seems to be hidden in female creative works. Women encode a secret in their writings that should be decoded with great care.

1. Ghanaian women seeking for their place: Ama Ata Aidoo, the Cornerstone

African female writers have, over years, made profound contributions to the development of society and the expansion of the literary canon through their writings. Not only have the works of these female writers dealt with very pertinent issues of society, they have equally contributed immensely to the widening of the literary canon, especially with their addition of a new strand of literature since the appearance of female authored works in mainstream literature. These African women seek, fight and find a place to express their view to their counterparts either in rural but also in urban areas. They defend their stance and then clear way to others to do so. Among these African pioneers to clear path in their own country for women’s right we have Ama Ata Aidoo. The present chapter has no pretention of paying tribute to Ama Ata Aidoo as being the first Ghanaian woman ever to venture in written literature, but to disclose Ghanaian women’s determination for “Positive Action”⁷⁸ to make use of Kwame Nkrumah’s word while standing against the British Empire. Amma Darko seems to follow the foot path of her senior sister because of her use of history in her writing. Thus, we see it right to seek the connecting point between the two. Hence, before Ama Ata Aidoo, Efua T. Sutherland prepared the ground for this struggle of self-story to put the image of Ghanaian women on its true side. This chapter discusses specifically two of Ama Ata Aidoo’s most intensive handling

⁷⁶ Forrester, V. (2011). ‘What Women’s Eyes See’. *New French Feminisms in Feminist Literary Theory: A Reader* (ed.). Eagleton, Mary (2011). *Feminist Literary Theory: A Reader*, Third Edition. Mary Eagleton: Wiley-Blackwell Publishing Ltd, Pondicherry, India, p. 51.

⁷⁷ Idem.

⁷⁸ According to K. Nkrumah, ‘Positive Action’ means the adoption of all legitimate and constitutional means by which Ghanaians can cripple the forces of imperialism in this country. The Weapons of Positive Action are: (1) Legitimate political agitation ; (2) Newspaper and educational campaigns and (3) as a last resort, the constitutional application of strikes, boycotts and non-co-operation based on the principle of absolute non-violence like that which the Indian M. Gandhi advocates.

<http://journals.democraticunderground.com/Kire/120>

of the “legacy of the transatlantic slave trade in relation to the ultimate struggle of the Diaspora dynamic and integration and the complicity of local forces in Gold Coast in her plays *The Dilemma of a Ghost* (1965) and *Anowa* (1970)”⁷⁹.

When talking about women’s creative works, we refer to the African and African-American female scholars, writers and critics like Alice Walker⁸⁰, who first dared to stand on their feet against pre-established male stereotypes. The American novelist furthered her study and coined ‘womanism’ as a literary theory like feminism which embodies both the frustration and promise of black feminist criticism. It is then black feminism as it wants to detach from that of Europeans. As a group, they are distinct from white feminists because of their race, and that they have experienced the past and present subjugation. The term womanism shows black feminists readiness to reframe the sexual debate around culturally specific differences between white women and black women. The cores values of the theory help to fashion a framework of feminist resistance to patriarchy⁸¹ from an African perspective. The right of African women in an African context with emphasis placed on two divides of culture as possible agents of female oppression and therefore, its relevance in promoting rights of women is the pattern governing all their fiction. The works of most of these female writers, with their focus on presenting or analysing women’s experience, have gradually consciously or unconsciously carved out a distinct identity for themselves, thereby providing a unique tradition within the existing literary canon. They celebrate womanhood in general and motherhood in particular as the means to forge out their usefulness in African societies. Among these people in Africa, we have the Ghanaian female writer Ama Ata Aidoo.

1.1. Ama Ata Aidoo’s life experience

Christina Ama Ata Aidoo, one of the most prolific and versatile African female dramatist, was born to Chief Yaw Fama (Father) with Maame Abba Abasema (Mother) in a small village called A beadzi Kyakor in Ghana's central Fanti⁸²-speaking region on March 23,

⁷⁹ Helen, G. (2001). “Colonial Plays Anthology”, (ed.) Helen Gilbert, London and New York: Routledge.

⁸⁰ Alice Walker (born in Feb 9, 1944) has been defined as one of the key international writers’ of the 20th century. Walker made history as the first African-American woman to win a Pulitzer Prize for Literature as well as the National Book Award in 1983 for her novel “*The Color Purple*,” one of the few literary books to capture the popular imagination and leave a permanent imprint. The award-winning novel served as the inspiration for Steven Spielberg’s 1985 film and was adapted for the stage, opening at New York City’s Broadway Theatre in 2005, and capturing a Tony Award for best leading actress in a musical in 2006.

⁸¹ Allan, J. T. (1995). “Womanist and Feminist Aesthetics”. Athens & Ohio: Ohio University Press, p. 6.

⁸² The Fante or Fanti or Fanteh people live around Cape Coast and Elmina. They are members of the Akan tribe. The Fanti language is part of the Kwa group that numbers about 1,170,000. Inheritance and succession to public office are determined mostly by matrilineal descent. According to oral tradition, the Fante arrived in their present habitat from the north by the 17th century. They served as middlemen in the

1942. She grew up then in the Fanti Royal household. Her father, an advocate of Western education, sent her to Wesley Girl's High School in Cape Coast. Her desire to learn and write set out after her "father had opened the first school in the village and was a strong power on her. At the age of 15 she decided that she wanted to be a writer and within just four years, she achieved that ambition. She was encouraged to enter a newspaper short story competition and only discovered that she'd won it when she saw her name in the newspaper."⁸³

Ama Ata Aidoo's direct inspirational source for her storyline is that she is from a family of storytellers as she puts it herself "I come from a people who told stories...and my mother 'talks' stories and sings songs. *Anowa*, for instance grew directly out of a story she told me although as the play has come out, she cannot even recognize the story she told. (Quoted in James, 1990: 19)"⁸⁴ Ama Ata Aidoo's skill with storytelling, oral and written, is not only due to the prevalence of her mother, but also of the village storyteller, some of her teachers, and the books she read. She explained that back, during an interview⁸⁵ with a Kenyan academic and writer Wangui wa Goro⁸⁶, it was not usual for mothers to tell stories to their children. Interestingly, the village had its own professional storyteller: "we would gather in his place of an evening and he would tell us stories."⁸⁷ To fully become storyteller, Ama Ata Aidoo studied literature at the University of Ghana, capped that with a degree in Creative Writing and worked with the playwright Efua Sutherland, the influential founder of the Ghana Drama Studio. Afterward, she became a University lecturer. In so doing, Ama Ata Aidoo respected word by word Chinua Achebe's recommendation as far as the role of a writer is concerned:

It is my business as a writer to teach that there is nothing disgraceful about the African weather, that the palm tree is a fit subject for poetry. Here then is an adequate revolution for me to espouse...to help my society regain belief in itself and put away the complexes of the years of denigration and self-

commerce between the interior and British and Dutch traders on the coast. In the early 18th century, the Fantes formed a confederation, primarily as a means of protection against Ashanti incursions from the interior. Several Fanti-Ashanti wars followed. The Fanti were aided by the British, who, however, destroyed the strong Fanti confederation established between 1868 and 1872, believing it a threat to their hegemony on the coast. In 1874 a joint Fanti-British army defeated the Ashanti, and in the same year the Fanti became part of the British Gold Coast colony. Retrieved from www.Mfantsemanco.com.

⁸³ http://www.bbc.co.uk/worldservice/arts/features/womenwriters/aidoo_life.shtml

⁸⁴ James, A. (1990). 'Ama Ata Aidoo', in A. James (ed.) *In Their Own Voices: African Women Writers Talk*, Portsmouth, NH, Heinemann: pp. 8-27.

⁸⁵ Royal African Society's annual *Africa Writes* Festival, August 2014.

⁸⁶ Wangui Wa Goro (born in 1961) is a Kenyan academic, social critic, researcher, translator and writer. She has translated the works of award-winning authors including Ngũgĩ wa Thiong'o's *Matigari*, from Gikuyu to English, and Véronique Tadjo's *A vol d'oiseau (As the Crow Flies)* from French. Wa Goro's own writing encompasses poetry, essays, short stories, fiction and non-fiction. She has also been an active campaigner for human rights in Africa and Europe, and co-edited with Kelly Coate and Suki Ali the book *Global Feminist Politics: Identities in a Changing World* (Routledge, 2001).

⁸⁷ Aidoo's interview with Wangui wa Goro, in Royal African Society's annual *Africa Writes* Festival, August 2014.

abasement. And it is essentially a question of education, in the best sense of that word. Here, I think, my aims and the aspirations of my society meet (...) I would be quite satisfied if my novels (especially the ones I set in the past) did no more than TEACH my READER that their past- with all its imperfections was not one long night of savagery from which the first Europeans, acting on God's behalf delivered them.⁸⁸(Italic added)

Further justifying his commitment, he posits that the artist, carver, composer, dancer or any artist else in contemporary African society has to perform the duties of educating his audience and helping them to reclaim their past patrimonial heritages. This happens to be the ultimate role of literature in empowering African woman as our dissertation topic is trying to prove. As a matter of fact, Ama Ata Aidoo produced her first play *The Dilemma of a Ghost* (1965). The play is about a Ghanaian man, Ato Yawson, who returns home from the United States with an African-American wife. He has not consulted his family about the marriage, and the conflict between the two cultures is played out through the characters' interactions. The man himself is torn between his Ghanaian past and his acquired American ideals. The tension between the communal and traditional Ghanaian value system and the individualistic American culture are further played out in the confrontations between Ato's mother and his American wife. She also does not offer her mother-in-law drinking water or an invitation to spend a night or two at her home, a basic behaviour very much appreciated in Ghanaian culture and by extension in African countries. There is born the clash and enmity between the two. There is also the possible misunderstanding between tradition and modernism and between Africans and African-Americans women in term of marriage, societal attitude, and feminism concept tackling.

At the end of the play, Ato's mother and his wife reconcile fortunately, and thus the dilemma of the title is solved. This fictional union is similar to that of the first political leader of Ghana, Kwame Nkrumah, whose wife was an Egyptian. Likewise, the marriage was welcome neither by Nkrumah's family nor by his wife's. Both families feared misunderstandings and clashes that can result from blood and cultural mixing. However, it was accepted afterward as being the "a political union between Mediterranean-oriented North Africa and the rest of the continent, often pejoratively termed sub-Saharan or Black Africa"⁸⁹. The early clash between

⁸⁸ Achebe, C. (1988). "The Novelist as Teacher", *Hopes and Impediments: Selected Essays, 1965-1987*. London: Heinemann, p. 30.

⁸⁹ Lucy Adoma Yeboah, Journalist with Daily Graphic in Accra (Ghana).

the two families is still a matter of literary writing in present Ghana. It inspires the Indian critic and prolific academic Ali A. Mazrui who wrote on Kwame Nkrumah's triple heritage. Ali A. Mazrui⁹⁰ even became one of the atypical writers to back up Nkrumah's ideology of African Conscience Rising.

1.2. Exploring Ama Ata Aidoo's African Feminism

Ama Ata Aidoo's writing such as *The Dilemma of a Ghost* (1965) is strongly influenced by historical and political issues such as the transatlantic slave trade and African Diaspora identity struggle resulting from a trade which drained millions of souls from 'Mother Africa' to America where, by now they are still not totally recognized as part of its economic development providers. African-Americans are torn apart by a daily violence, discrimination and inequalities. People used to think that racial discrimination in America was toppled, but alas it continues to cause havoc in present days. No need to recount the number of African-Americans who were shot dead on the streets by the police just because of their colour, the "wrong colour"⁹¹. The mainstream debates on gender and racial problems must grapple with how to address increased insecurity of male but surely female African-Americans. And by using creative writing as a weapon to make their voice heard, women like Alice Walker have already shown that literature can contribute in human rights solutions seeking.

In *Anowa* (1970), Ama Ata Aidoo focuses on "three levels of conflicts; namely society versus the female individual, husband versus wife and mother/father versus daughter. The three levels arise from the different perceptions of *Anowa*, the heroine, by the heroine herself, by her

⁹⁰ Ali A. Mazrui the great humanist joined the ancestors on Sunday October 12, 2014 in Binghamton, New York where he had lived since 1989. He had been living with his family and working as the Albert Schweitzer Professor in the Humanities and Director of the Institute of Global Cultural Studies at Binghamton University, State University of New York. Ali Mazrui was born in Mombasa, on February 24, 1933 and he will be buried next to his family. Ali was a prodigious writer who was the author or coauthor of more than 35 books, numerous book chapters, and hundreds of scholarly articles, magazine and newspaper commentaries and the host of the TV series the Triple Heritage. Mazrui toiled as an international scholar in every continent and he can be claimed as a great Pan Africanist, a great African, and a great East African, but for this tribute I want to hail Ali Mazrui as a great humanist.

⁹¹ Despite the election of the first African-American president, African Americans remain by far the most frequent victims of hate crimes. Of the 7,624 hate crime incidents reported nationwide in 2007 and 10,000 seven years later, the most recent year for which data is available, 34 percent (2,659) were perpetrated against African Americans, a number and percentage of incidents that has changed little over the past 10 years. According to the FBI's HCSA report, more than twice as many hate crimes were reported against African Americans as against any other group. From lynching, to burning crosses and churches, to murdering a man by chaining him to a truck and dragging him down a road for three miles, anti-black violence has been and still remains the prototypical hate crime, intended not only to injure and kill individuals but to terrorize an entire group of people. Hate crimes against African Americans have an especially negative impact upon society for the history they recall and perpetuate, potentially intimidating not only African Americans, but other minority, ethnic, and religious groups. <http://www.civilrights.org/publications/hatecrimes/african-americans.html>

mother, and by the larger (Yebi) society as *Anowa* interacts with other characters on stage”⁹². Our position is that the conflict in *Anowa* is central to the understanding of the play. This option leads us to find out the link between Anowa’s story and Ghanaian oral literature or any historical event. This projects and explores the experience of Ghanaian women and their struggles to have opportunity to choose their own direction in society and not that imposed onto them. This fits well with the womanist perspective. Bell hooks (1987) exposes the closeness in which African women or Black women have towards their oppression. The womanist is an accomodationist which Ama Ata Aidoo portrayed through her female characters like Opokuya, Anowa and Esi who and welcome the male presence and the centrality of motherhood⁹³. In fact, through womanist writings, female authors allow purposely their female characters to lead a normal life with their husbands, but one that they have chosen by themselves. These characters believe in love or seek their male characters’ sincere love regardless their sexual conditions.

Ama Ata Aidoo tells the story of a girl, Anowa, who defies tradition, preferring to choose a husband for herself and also attempts to live a life that she thinks suits her though knowing how important parental words are in a union. For Ama Ata Aidoo, part of this remembering lies in structure as well as narrative, hence her use of traditional forms to tell her story: “Everybody needs a backbone. If we do not refer to the old traditions, it is almost like operating with amnesia” (Aidoo: 1976, 124).⁹⁴ Ama Ata Aidoo uses here the folktale of the disobedient daughter known all over African countries. A marriage is not only the concern of the groom and the bride; it involves the extended family as well as the blessings of old age of both families, representing the ancestors. Anowa puts aside her family’s advice and chooses the man she loves. Her decision is taken as a rebellious attitude. Anowa’s life is ruined in the end of the play in punishment to her disobedience. She becomes crazy ultimately commits suicide by drowning herself (Aidoo: 1970)⁹⁵.

Ama Ata Aidoo makes her feminist position clear in her writings. In fact, many themes emerge from the action of the play. A dominant one is the effort to make her female characters on top of any action. The attentive reader will note that the deeper Ama Ata Aidoo moves into

⁹²Aliyu, I., A Socio-Semiotic Interpretation of Ama Ata Aidoo’s *Anowa*, p. 7.
www.unilorin.edu.ng/publications/aliyu-ibrahim/

⁹³ hooks, b. (1984). *Feminist Theory: From Margins to Centre*. Boston: South End.

⁹⁴ Adelugba, D. (1976). “Language and drama: Ama Ata Aidoo”, *African Literature Today* 8: 72-84.

⁹⁵ Aidoo, A. A. (1970). *Anowa*. London: Longman Group Ltd.

the synchronic narrative, the more Anowa's effort and attitude in the play single her out as a woman who is not ready to be relegated to the background despite her illiteracy. First of all, Anowa chooses her own husband without her parents' approval. She swears never to return no matter what happens. She says, "I will walk so well that I will not find my feet back here again." (Aidoo, 1). Culturally it is assumed that parents must accept a child's partner for marriage before the marriage can be a blessing. So we can approve Ama Ata Aidoo's decision to make her principal character 'disappear' to illustrate her word of feminine revolution to go no further.

In fact, Anowa committing suicide is then on the right way with the writer's feminist engagement to rescue her female characters from shame and failure no matter how, even if death by suicide is not accepted in African cosmology (which may be grounded in interdependence, collectivism and harmony with nature). A natural death is the way to enter ancestorship because old age is sacred and revered. In the spiritual epistemology (that is a system of truth and a method for revealing or understanding truth or generating knowledge (Grills: 2002), death is interpreted as the other way of life, the unseen one. As for King (King: 2013), death is a natural transition from the visible to the invisible or spiritual ontology where the spirit, the essence of the person, is not destroyed but moves to live in the spirit ancestors' realm. (King: 2013)⁹⁶. The above meaning attached to death is therefore consistent with the African's cultural, historical epistemological and methodological conceptions of being-in-world, and are premised on these dimensions. Perceptions and conceptions about death in any cultural system are based on certain philosophical presuppositions and worldviews.

To parallel what is above highlighted, for example in African society, when an old man dies, he is praised by his kinship for having lived so long to join his forefathers' cosmology. His people salute his fighting spirit and take him as a model. But in Ama Ata Aidoo's case, Anowa's tragic end paves way to a reverse advice. She demonstrates that certain traditional beliefs can be changed if there is no effort of adaptation to modern reality and female assertiveness. Hence, Africans are conscious that the elderly are to be respected because they are regarded as repositories of wisdom and knowledge. Their experiences constitute a treasure that the younger generation needs to listen to. Most of the time, people who refuse to listen to the admonishment of the elderly end up miserably. This is reflective of Anowa's situation. Her

⁹⁶ King, L. M. (2013). In discourse—towards a Pan-African psychology: Drum rolls for a psychology of emancipation. *Journal of Black Psychology*, 39, 223-231 in "The African Conception of Death: A Cultural Implication" Lesiba Bolayi & Molebogeng Makobe-Rabothata. South Africa: University of South Africa, p. 235.

parents try as much as possible to make her refrain from going with Ako without going through the proper marriage rites. The man is supposed to pay a bride price before Anowa is fully recognized as his wife but Anowa rejects this parental advice and even accuses her mother of being a witch. Her end becomes tragic because she drowns herself to death. Above all the deviant behaviour of Anowa, Ama Ata Aidoo shows that she is of strong personality who is responsible for her act and decision.

Further, male infertility is hardly condemned in patriarchal society, unthinkable, to the misfortune of women. The conception goes that the man is the seed planter on a ground which represents the woman. So how could it not grow if it is not the ground's incapacity to make it? The culprit is known, what remains is now the place of judgement as well as the final sentence. Then female characters with female writers in are depicted in 'nervous conditions', illness, madness, devastation and hysteria. Here with Ama Ata Aidoo, madness seems to be an honourable exit because "madness in some part of colonial Africa was seen as a largely male phenomenon, the women apparently lacking the self-consciousness necessary to turn mad"⁹⁷.

Taking experiences from society, an African writer depicts through her female characters the limit gamut of choice given to women and their bound to male rule making. The aim of a female writer is also to help correct the erroneous beliefs and stereotypes impede women to go forward and to be free to participation in her society's development. So much so that in 2014, the Royal African Society's annual Africa Writes Festival invited Ama Ata Aidoo to the United Kingdom for an interview with Wangui wa Goro, a Kenyan academic, social critic, translator and also writer. During the interview, Ama Ata Aidoo shared with the audience her experience of writing the ending of *Anowa* and the different possibilities she experimented with. She explains: "When they ask me why did you kill Anowa? I did not kill her; she committed suicide."⁹⁸ In an alternative ending Ama Ata Aidoo considered having Anowa on stage mad and dressed as a Victorian English woman, an ending which she soon discarded, explaining, "it would have been even more cruel to let Anowa survive as a mad woman"⁹⁹. Is this because the writer wants her heroin to have control over her body and soul? Is this a way of proving her

⁹⁷ Nair, S. (1995). Melancholic Women: The Intellectual Hysterical (s) in Nervous Conditions. *Research in African Literatures*, 26: 130-139, Summer.

⁹⁸ Royal African Society's annual Africa Writes Festival, 2014, UK <https://africanwords.com/2014/08/15/ama-ata-aidoo-in-conversation-review-africa-writes/>

⁹⁹ Royal African Society's annual Festival, 2014, UK <https://africanwords.com/2014/08/15/ama-ata-aidoo-in-conversation-review-africa-writes/>

feminist voice through her female character's portrayal? By this doing, though we know several other interpretations can be given to Ama Ata Aidoo's act of writing in this very scope. By this doing, Ama Ata Aidoo is persuaded that making her female character commit suicide (body and flesh are perishable) is more acceptable than to make her soul suffer (madness).

Another point made by Ama Ata Aidoo is that she puts forward the good and loving heart of her female character and portrays the male as a villain because of their double representation: colonialism and patriarchy. The identity that Ama Ata Aidoo puts forward in her play is that of a feminist perspective, defending the non-implication of Ghanaian women in the trade or in exploiting their fellows. The historical details are also part of the core of the message her plays or novels try to impart. As well, Ama Ata Aidoo emphasizes the importance of old age and extended family voices in a marriage to avoid incompatibility because elderly people are supposed to be more skilled and in contact with ancestors and the spiritual world than young men. Youth then needs to be trained and guided to good life management; thus rites of passage are necessary, which Anowa and her husband rejected before their marriage. The protagonist's barrenness is for Aidoo Africa's infertility due to years of transatlantic slave trade and then the determination not to bear children anymore to see them sold off into slavery. Yet, her dream to become "Mother Africa"¹⁰⁰ is unfulfilled as she commits suicide.

By taking part in the slave trade, Ghanaians accepted their self-destruction for centuries. The difficulties related to that implication are still obvious in present-day's Ghana. The mistrust within the different communities in the Fante, Akan and Asante people matters. It is still a nightmare for Ghanaian political leaders. Each community takes as responsible the other community for having sold off its members. Ama Ata Aidoo's creatively writing helps map the transatlantic slave trade. It is a call in her remembrance duty over the millions torn from 'Mother Africa' to become slaves in the West Indies and the Americas. The call for duty, the memories and history writing are what characterizes a talent writer and as for Chinua Achebe's assertion: "A Novelist is a TEACHER" because the writer is a pure part of his society. His writing should be a guide, an advice for young generation. A good book can change a whole course of an individual's life. African artists or writers have the responsibilities to contribute to

¹⁰⁰ Most of African female writers refer to Africa as a woman to be in conformity with the early writings of Sir H. Johnson's, *The opening up of Africa*, London, Williams and Norgate, p. 103. In Dossou-Yovo, Noel's « Individu et Société dans le Roman Négro-Africain d'expression anglaise de 1939-1986 », Tome 1, (ed.) Etudes africaines, L'Harmattan, Paris, 1997, p. 30.

restoring the self-confidence of his fellows. This is the educative role of the African writers. The Ghanaian controversial writer Ayi Kwei Armah does not disagree on that very position of his elder brother of Nigerian although many other points oppose them.

Further, we receive insights from the South African writer Nadine Gordimer. She believes that “a good writing makes great literature. If you are a writer, you can make the death of a canary stand for the whole mystery of death [...] it’s all a matter of the quality of the writing.”¹⁰¹ Nadine Gordimer urges her female counterparts to be of a dexterous quality while writing a story, because “this quality, when combined with a maturing political consciousness and a strong narrative strategy, keeps readers coming back to her work.”¹⁰² The dexterity that Nadine Gordimer refers to symbolizes Ama Ata Aidoo way of writing Ghanaian history without mentioning name and specifically places where the events happened. It is also the artistic way Ama Ata Aidoo writes fiction to empower Ghanaian women and show them the way of glory and victory.

In this process, we think that Ama Ata Aidoo is on the right footpath of Ayi Kwei Armah, one of the prominent Ghanaian fiction writers of his time. While reading Ayi Kwei Armah, we really see that “literature is the mirror of the society because the artists write or compose their works about the events and happenings in the society and that African writers have had the task of writing about the experiences of Africans before independence as well as post independent disillusionment”¹⁰³. Therefore, literary artists can offer through their works critical appraisal of existing political situation in order to mould or redirect the actions of society, its belief and values. In this scope, the metaphorical reference in Ayi Kwei Armah’s *The Beautiful Ones Are Not yet Born* (1968) is in this right way of political engagement. Ghanaian political leaders, before the power, behave as ‘The Messiah’ who promises sky and earth, or a gourd full of honey and mead to the mass, his mouth pouring lies. Then as soon as ‘The Messiah’ has the throne of power, he turns all the promises to unaffordable premises; the lies are then disclosed. The ‘national cake’ to refer to the national resources of the country being before

¹⁰¹ Bernth, L. (1999). Nadine Gordimer Revisited, Twayne’s World Authors Series, *African Literature*, Bernth Lindfords, Editor, University of Texas at Austin, p. 10.

¹⁰² *Ibid.*, p 11.

¹⁰³ Amase, E.; Kaan, N. & Aondover, C. (2013). “African Literature and English Language: A Political Literary Discourse” in *International Journal of Humanities and Social Science Invention* ISSN (Online): 2319 – 7722, ISSN (Print): 2319 – 7714 www.ijhssi.org Volume 2 Issue 3 || March. 2013|| PP.63-68

him, his friends and relatives, they have no place to think of the mass's poverty and everyday endurance.

To cap it all, the major concerns, of a writer, revolve around the idea of challenging and questioning the role of African women in modern society. Aidoo's poems, novels, and plays establish a feminine consciousness and strongly advocate women's emancipation. Ama Ata Aidoo develops female characters who are active, creative, successful, intelligent, and, most strikingly, defiant. The actions and words of the female characters reflect the kind of feminist rhetoric that seeks to present women as capable of doing whatever men are capable of. It rejects traditional gender stereotypes. Thus, it elides the necessity and validity of female gender roles. Ama Ata Aidoo's literary engagement inspires Amma Darko's *Faceless* which demonstrates female leadership and everyday life. Particularly, the novel *The Girl Who Can* (1997) is thematically similar to *Faceless*. In *The Girl Who Can*, Ama Ata Aidoo elevates the everyday life of women on an intellectual level, in an attempt to challenge the patriarchal structures of domination in African society. Written from the perspective of a child, Ama Ata Aidoo subverts traditional beliefs and assumptions about the child's voice. His inimitable sense of style and eloquence, explores love, marriage and relationships with all the issues thrown up for contemporary African women. Ama Ata Aidoo imagines a world of brotherhood among all women that can serve as a springboard for world peace. Thus, it manages to capture the essence of femininity.

2. Amma Darko: The awaited 'successor'

In this chapter, we venture to tread in a place where even 'angels' are reluctant to go, for in Africa nobody replaces no-one. It is forbidden by elderly people to be targeted as a 'successor' of a living adult. As a result, we do not dare to make out that Amma Darko, a writer of the third generation writer, is the successor of Ama Ata Aidoo, of the first generation writer in spite of the latter's old age. For example, unless a king dies, he will not be replaced and wisdom recommends to be cautious about the announcement of a king replacement in African societies. We replace or succeed to someone who is already dead or allow you to, not the contrary. So, Amma Darko is not the successor of the prolific and prominent Ama Ata Aidoo, but just a female writer following the footpath of her matriarch and living mentor in African fiction writing. Amma Darko is still relatively young for us to pretend that she could replace a matriarch in literature. Amma Darko's opinion about Ama Ata Aidoo is in line with ours which

states: “What I really appreciate about Ama Ata Aidoo, is that although she’s at a very different level from me, she doesn’t hold back support”¹⁰⁴. In fact, it is the need to see a female Ghanaian writer occupying a prominent position like that of Ama Ata Aidoo which motivates her not to hold back her advice to Amma Darko. The latter tries to carve out a unique identity for her female characters in terms of feminism and historical writing, the way her older sister did before. Amma Darko picks up some of the discussed issues where her predecessor, Ama Ata Aidoo, leaves them off in some of her novels. In actual fact, Ama Ata Aidoo engages her feminist writing to stir up social change and to better off the way to combat challenges. For instance, Ezekiel Mphahlele¹⁰⁵ writes in his introduction to Ama Ata Aidoo’s *No Sweetness Here and Other Stories* that “Ama Ata Aidoo celebrates womanhood in general and motherhood in particular. She stands for the woman¹⁰⁶. The male characters in Ama Ata Aidoo’s novels are depicted as simple shadows acting with a dark heart dictated by the desire to dominate and subjugate. That approach is similar to that of Amma Darko who discusses the same and pertinent issues of society in her novels presently under study.

It is significantly to note that “Amma Darko was one of the seven children in her family and was raised by her aunt and uncle, a hospital pharmacist. She succeeded in all her secondary school final exams and went to Kwame Nkrumah University of Science and Technology (KNUST) in Kumasi. Unlike Ama Ata Aidoo, she did not study Creative Writing, but Industrial Design. She was once involved in student drama theatricals. Amma Darko is married, lives with her husband and children. The typical family in which she lives is that of her female character Kabria in *Faceless*. When she graduated from the University in 1980, she tried like all Ghanaian modern educated students at the time to emigrate to Europe (Germany) in “search for job opportunities because of the political, economic and social woes”¹⁰⁷ amplified by repeated military coups. The economic situation in Ghana was so dismal that many of her compatriots left the country to seek a place ‘beyond the horizon’. The Ghanaian government of the time had

¹⁰⁴ Zak, A. L. (2007). “Amma Darko: Writing Her Way, Creating a Writing Life” Ed. Vincent O. Odamtten, in *Broadening the Horizon: Critical Introductions to Amma Darko*. London: Ayebia Clarke Publishing, Print., p. 17.

¹⁰⁵ Ezekiel Mphahlele (born Dec. 17, 1919, Marabastad, South Africa died Oct. 27, 2008, Lebowakgomo), novelist, essayist, short-story writer, and teacher whose autobiography, *Down Second Avenue* (1959), is a South African classic. It combines the story of a young man’s growth into adulthood with penetrating social criticism of the conditions forced upon black South Africans by apartheid.

¹⁰⁶ Akujobi, R. (2011). “Motherhood in African Literature and Culture”. In CLCWeb: Comparative Literature and Culture, Volume 13.1, Purdue University Press.

¹⁰⁷ *Source*: Commission of the European Communities: Eurostat, Netherlands Interdisciplinary Demographic Institute (NIDI). 2001. Push and Pull Factors Determining International Migration Flows, "Why and Where: Motives and Destinations."

also instituted strict measures to comply with the International Monetary Fund's requirements for economic restructuring. People were living wretchedly, so flee from that hell-like atmosphere was their sole wish and Amma Darko was among them. The author confesses later this "Home was suffocating me."¹⁰⁸ Thinking that Europe would be that imagined heaven described by the been-tos, she was confronted to the same joblessness and was confined to bleak jobs such as housemaid to survive and also send money to her parents. She discovered that her female compatriots who succeeded in sending money home were those involved in sex business, prostitution or fell in the hands of African transnational sexual traffickers' networks. All this inspires Amma Darko in writing her first novel *Beyond the Horizon*. However, more profoundly during her childhood, Amma Darko might have listened to a series of Ghanaian tales on the Slave Trade, stories of intrepid Queen Warriors in Fanti region. She might have read some historical books, novels, dramas. Her coming on the literary stage in 1991 was welcomed by many people as the poet and critic Kofi Anyidoho, noted in his introductory essay to Amma Darko's third published novel, *Faceless*:

Students and scholars of African Literature who, like me, have often wondered about the apparent absence of any major female Ghanaian writers following the remarkable pioneering work of Efua T. Sutherland and Ama Ata Aidoo, can now rest assured that a worthy successor has emerged in the person of Amma Darko.¹⁰⁹

In fact, Amma Darko might have loved and been personally inspired by the historical and brave words of Queen Mother Yaa Asantewaa, the Gatekeeper of the Golden Stool while the famous Ashanti Empire was about to fall in the hands of British colonizers in 1896, who declared the following:

Now I have seen that some of you fear to go forward to fight for our King. If it were in the brave days of Osei Tutu, Okomfo Anokye, and Opolu Ware, leaders would not sit down to see their King taken away without firing a shot. No white man could have dared to speak to a leader of the Ashanti in the way the Governor spoke to you this morning. Is it true that the bravery of the Ashanti is no more? I cannot believe it. It cannot be! I must say this, if you the men of Ashanti will not go forward, then we will. We the women will. I

¹⁰⁸ Zak, A. L. (2007). "Amma Darko: Writing Her Way, Creating a Writing Life" (Ed.) V. O. Odamtten, *Broadening the Horizon: Critical Introductions to Amma Darko*. UK/London: Ayebia Clarke Publishing, Print., p. 12.

¹⁰⁹ *Ibid.*, p. 4.

shall call upon my fellow women. We will fight the white men. We will fight till the last of us falls in the battlefields.¹¹⁰

The above passage is the word of a female ‘general of army’ talking to the troops before waging the last fight to defend her kingdom, her dignity which she felt duty-bound to defend to the last second of her life. Honourable Naa Yaa Asantewaa reminds her people how conquerors, brave and daring were women in the past. When Amma Darko writes her own way about the Ghanaian women, all the previous readings might have revolved around in her mind. But it was only when she travelled to Germany, after having obtained a degree from the College of Arts with a minor in English that she realized that she could write about the daily life of black Africans ‘beyond the horizon’. In this vein, Odamtten confirms:

What she and many others found was a life of menial jobs in order to survive and maintain some modicum of dignity. She was able to carve out the space and time from which she could write the kind of narrative about the sort of people she knew and met. Unlike her literary predecessors, who often wrote about individuals torn by the contradictions of negotiating the highways and byways of tradition and modernity [...], Darko rejected such self-absorbed characters.¹¹¹

In a conversation shared years ago, Amma Darko was sure of this “I harbour an unflinching conviction that I am filling a void with the stories I tell. I have faith and confidence in myself about my art. My love for my stories entrenches that.”¹¹² In Ghana, when talking about literary matriarchs, Ama Ata Aidoo is considered as the mother of Ghanaian literature, and as someone who paved the way for many female writers who came after her so important is the link between both. Amma Darko is one of the youngest members of the third generation like the Nigerian Chimamanda Ngozi Adichie. The academics and critics Pius Adesanmi and Chris Dunton discuss the third generation in their essay “Nigeria’s Third Generation Writing: Historiography and Preliminary Theoretical Considerations.” Some of the important differences between the first and second generation are, firstly, the shift from poetry to the fiction and, secondly, the recognition its output received from the international community.”¹¹³ Some of the important thematic features of the third generation’s fiction include an urban setting. The

¹¹⁰ <http://www.blackhistoryheroes.com/2010/05/queen-mother-nana-yaa-asantewaa.html>

¹¹¹ Odamtten, V. O. (2007) “Introduction: Beyond the Comfort Zone” (Ed.) Vincent O. Odamtten, *Broadening the Horizon: Critical Introductions to Amma Darko*. London: Ayebeia Clarke Publishing, Print., p. 5.

¹¹² Idem.,

¹¹³ Adesanmi, P. & Chris D. (2005). “Nigeria’s Third Generation Writing: Historiography and Preliminary Theoretical Considerations”, *English in Africa*, 1, 32.

thematic also emphasizes “deprivation, the denial of individual human rights and aspirations, the degradation of social relations under a series of increasingly despotic and corrupt regimes”¹¹⁴. Amma Darko is in that mainstream as depicted by Odamtten: “Darko wrote about the experiences of ordinary people, not the ones who won scholarship to go abroad, not the ones whose journey to Europe could be described as a Season of Migration to the North, the ones who were too poor or unfortunate to know anything other than what society made apparent” (Odamtten: 2007, 5).

In Kofi Anyidoho’s “Introductory Essay”, he describes Amma Darko as a major female Ghanaian writer whose works are akin to the likes of Efua T. Sutherland and Ama Ata Aidoo. Both her first and second novels, *Beyond the Horizon* and *The Housemaid*, focus on the plight of women and young girls in a merciless world dominated by greedy, irresponsible, sexual predators; dangerous and pitiless street masters like Akobi, Osey, Pompey, Poison and Macho. *Faceless* adds up to the other two novels to form what Kofi Anyidoho calls “an important trilogy.”¹¹⁵ The style strategy by which Amma Darko writes her novels is of quality and serves to temper her unflinching presentation of stark circumstances and human suffering. Her depiction of social situation makes non-existent the border between fiction and fact. For instance, the narrative about Sodom and Gomorrah in *Faceless* seems so authentic that one seems to meet imaginatively at every corner of the slum in Accra Fofo and her friends. Furthermore, Bible readers who know the story of Sodom and Gomorrah can image the hell-like life in there before its allegorical destruction and can doom the future of its inhabitants.

The story can be recounted here, but it has a just religious foundation. Yet the question is why Amma Darko uses that name to call the Agbogbloshie slum standing in the centre of Accra? Does it recall to her a particular life experience? Sodom and Gomorrah was destroyed finally by God. Does Amma Darko want Agbogbloshie to be destroyed for its growing sins? In fact, so many lives count and are concerned in that story. The writer seems to share affinity with her female characters as the story does not take a fictional method right away, rather it reveals her own life experience or that of her relatives and siblings. In doing this, Amma Darko takes the same option as Bessie Amelia Head. Both writers share the same literary engagement and

¹¹⁴ Adesanmi, P. & Chris D. (2005). “Nigeria’s Third Generation Writing: Historiography and Preliminary Theoretical Considerations”, *English in Africa*: 1-32, p. 8.

¹¹⁵ Anyidoho, K. (2010). Amma Darko’s *Faceless: A New Landmark in Ghanaian Fiction*, an Introductory Essay, (ed.) Sub-Saharan Publishers, p. ix.

are not systematically political writers. Bessie Head view the novel as “a subjective vehicle which plays a constructive and cathartic role in solving her own personal anxieties”¹¹⁶.

As for Lewis Nkosi (Nkosi: 1981, 102) feels that the “passion to make the feature of personal experience a governing emotion”¹¹⁷ may result in becoming “a compulsive disposition” in the works of any writer, especially in those of a so-called “protest” writer. In consequence, he justifies the inclusion of personal details in a novel only when it serves as an incentive to artistic creation. Just like Bessie Head¹¹⁸ used allegories in most of her writings, Amma Darko wants us to decode her urging message and the extent to which the use of the biblical allegories are necessary. For example, in the biblical narrative, like Lot and his daughters were saved from Sodom and Gomorrah sudden destruction, Fofu was also saved thanks to the intervention of Kabria, the angel of God. Additionally, Baby T dies because she looks back like Lot’s wife looked back and turned into a pillar of salt in remembrance of her material properties. In Sodom and Gomorrah Baby T remains nameless to her tragic end. The cruel fate befalls on Baby T not because she disregards the admonition and pays the price like Lot’s wife, but because she is betrayed by her own mother and the patriarchal system in force. She represents the dissent character. Amma Darko turns the head to biblical events to create her own story. She proves in her common writing procedure that a fiction is taken from reality and fact, and then it is possible that the story in a novel can somehow be ‘true’.

For example, her female character Mara in *Beyond the Horizon* is named after the biblical story of Naomi in the book of Ruth. The symbolic lesson to retrieve from those repeated biblical references by Amma Darko is to illustrate the social, sexual and moral decay of the modern Ghana and its possible blast. Amma Darko uses biblical references to depict the real life of Ghanaian men and women. She effaces the common limits of a fictional writing, but the only one difference is the names of the characters present in the novel. In fact, it is the feminine radical power that is at stake in the narrative as Kabria encounters by chance Fofu in the market

¹¹⁶ Cloete, N. (1998). Women and transformation: A recurrent theme in Head and Ngugi: *Literator*, 19 (2) ISSN 0258-2279. Sovenga: University of the North, pp. 31-45.

¹¹⁷ Nkosi, L. (1981). *Tasks and Masks: Themes and Styles of African Literature*. Essex: Longman.

¹¹⁸ Bessie Amelia Head was born on July 6, 1937 in Pietermaritzburg, Natal (South Africa). Bessie Amelia Head was the daughter of a white woman and black man. In 1961, Bessie met Harold Head. Bessie published *When Rain Cloud Gather* in 1968, *Maru* in 1971 and *A Question of Power* in 1973. She died from hepatitis on April 17, 1986, at the age of 48. Posthumously, the novel *The Cardinals* was published in 1993. In both her fiction and the autobiographical accounts within her letters, Head returns again and again to a narrative about the illicit union between a socially superior mother and a subordinate father, the mother’s trauma after being made to relinquish her child, and the daughter’s rejection by her mother’s family and stigmatization by society.

where the former comes just to purchase food items. Fofu on the one hand is desperate to steal money even from Kabria and to escape from the dangerous street lord who killed her sister and on the other hand, she is eager to investigate the murder. Amma Darko embodied by Kabria is like one of the Jewish ancient prophets warning Sodom and Gomorrah's citizens of the imminent blast. However, in Amma Darko's narrative the most important persons to save before the blast and the end of the sin city are young and innocent girls. No male character is in the list. Male characters represent the evil, the wrong-doers; the cause of women's suffering.

Amma Darko later confirms the good therapeutic utility of humour and orality in African narratives: "Humour is strength. The ability to laugh at one's self and crack jokes at one's own expense is a healthy balm for the soul. Our Ananse stories are full of humour even when the subject matter is suffering and death"¹¹⁹. The Kweku Ananse character Amma Darko is talking about is a spider with human characteristics. His eight limbs are often depicted as four arms and four legs. His special relationship with the Creator goes back to the time of creation. He is wise and cunning and a trickster. Kweku Ananse's tale bears some subtle advice and words of wisdom. Told and retold by the captives from the Ashanti tribe during the Transatlantic Slave Trade, the Kweku Ananse stories spread to other parts of the world. They have evolved in places like the southern parts of the USA; the West Indies and the Caribbean.

It is crucial for characters in African Literature to have humour and dreams because they elucidate hope: "The final paragraph seems to suggest that Tika, helped by Teacher, has learned this ultimate lesson of life, and is ready to reach out for her mother, Sekyiwa, now abandoned by wealth and society".¹²⁰ The illustration goes this way: "And she burst out laughing and crying at the same time. Teacher joined in. And, together, they laughed and cried; laughing and crying away their discomfort, their disappointment, their anger, their fear. And laughing with hope" (Darko, 107). Despite her return to Ghana in 1987, the influence of her stay in Germany is strong and visible on her writing that while reading her first novel, one can see that she writes for a German or a European readership. To illustrate, it is an evidence to see that Amma Darko writes her novels in German like *Beyond the Horizon* published under the German title *Der Verkaufte Traum* in 1991. The novel became Germany's best-selling novel by a black African

¹¹⁹ Odamtten, V. O. (2007) "Introduction: Beyond the Comfort Zone" (Ed.) Vincent O. Odamtten, *Broadening the Horizon: Critical Introductions to Amma Darko*. London: Ayebeia Clarke Publishing, Print., p. 7.

¹²⁰ Anyidoho, K. (2010). Amma Darko's *Faceless: A New Landmark in Ghanaian Fiction*, An Introductory essay, Sub-Saharan Publishers, p. xiii.

writer the same year. Amma Darko honestly recognizes that the novel came out at the time when migration, prostitution and female exploitation topic was at its highest peak. By having developed the topic at its right time helped establish herself internationally. Moreover, her latest novel *Between Two Worlds* (2015) has also a Germany setting to proof show what she said “Germany is my second home”. Then, “In 1998/99, she was granted a scholarship from "Akademie Schloss Solitude". She contributed to the Solitude publications, "Lexikon der sperrigen Wörter" (2010) and "Solitude Atlas" (2015). The first novels take place in Germany, the next in Ghana. A literary-documentary film based on the novel *Faceless* has been awarded by Camera Prize in 2007. In 2008, she received the most important literary prize in her country, the Ghana Book Award. She regularly takes part in authors' congresses and literature festivals all over the world.”¹²¹ Amma Darko acknowledges freely: “If I hadn’t left Ghana and come to Germany, I would never have written” ¹²²(28 May 1998). Amma Darko has been working as a tax inspector and has now retired.

Amma Darko’s female characters burst through the veil of tradition to establish their voice and identity. Amma Darko “sets aside the conventions of traditional African society, which often calls for decorum, to speak about issues that unsettle us. She wades into such controversial subjects as AIDS, child rape, prostitution, and polygamy.”¹²³ Amma Darko writes about the consequences of poverty on Ghanaian families, dislocation. All this has a pernicious consequence which is the growing risk of street children phenomenon. Consistent with the general trend in contemporary Ghanaian writing, Amma Darko focuses on the social malaise in Ghana after independence. However, while her male predecessors, Ayi Kwei Armah (*The Beautiful Ones Are Not Yet Born*, 1968) and Kofi Awoonor (*This Earth My Brother*, 1971), represent in broad terms the frustrations, emptiness, and the general disappointment in Ghana, Amma Darko like her ‘mentor’ Ama Ata Aidoo depicts gender issues, male capitalistic greed and patriarchy that hold at deeply felt individual levels. In another marked distinction, Amma Darko seeks a way out of this prolonged nightmare by rendering women visible and by creating a feminine voice and space either by using elderly characters or young voices. She urges women to revive their voice to sustain their lives. The women in Amma Darko’s novels are stigmatized,

¹²¹ <http://www.ammadarko.de/biography.htm>

¹²² Zak, A. L. (2007). “Amma Darko: Writing Her Way, Creating a Writing Life” (Ed.) Vincent O. Odamtten, *Broadening the Horizon: Critical Introductions to Amma Darko*. UK/London: Ayebia Clarke Publishing, Print., p. 13.

¹²³ Awuyah, C. K. (2013). *Faceless: Amma Darko's Face for the Faceless*. *Making Connections: Interdisciplinary Approaches to Cultural Diversity*: March 2013, Vol. 14, No. 1, pp. 28-39.

yet they engage in courageous acts to throw off the yoke of oppression as they decide to be no more all-enduring and all-giving. Amma Darko rather makes her female protagonists explore

new possibilities for identification and affiliation via experiments in friendship, pleasure and new kinds of collectivity, [...]. Freedom is uncoupled from individualism and constraint from group identity. Implicit in this narrative of heterosexual romantic love giving way to alternative models of intimacy is a critique of a masculine anti-colonial nationalism and of gender relations in the post-independence nation.¹²⁴

More distinctively, we look at how alternative uses of the female body, like physical violence, engaging in voluntary sexual acts may function as forms of resistance against sexual objectification and psychological colonization in Amma Darko's novels. In the novels under study, the writer's attempt is clearly stated: deconstruct male position through her roles attribution and her depiction. All Amma Darko's male characters are depicted as irresponsible, absentees at home, jobless, murderers, terrorists, rapists, authoritative, and all poisonous and chauvinist, pathologically predators. Conversely, she creates female characters resisting to evils, creative writers, assertive, and alternative society seekers. In this way, "Darko is not atypical"¹²⁵. While reading Amma Darko, two elements are fundamentally evident: the first, her narrative technique that brings women together to share their experiences, their torments, their weaknesses, their gains to be stronger and the second is that Amma Darko does not mention her female characters' beauty or material richness.

This point makes her atypical to Ama Ata Aidoo and among African female writers like Buchi Emecheta, Flora Nwapa, Grace Ogot to cite just a few. However, some her female characters are modern educated and their behaviour and choice making prove that they are different and empowered. In this vein, Amma Darko creates what has never been before by her female counterparts: female characters in *Not Without Flowers* in a polygamous household helping each other, though in sickness. Amma Darko also points accusingly the roles of some women to be 'gate washers' to patriarchy.

¹²⁴ Palmer, F. (2009). *Beyond Freedom and Constraint: Alternative Intimacies in the Novels of Yvonne Vera, Calixte Beyala and Amma Darko*: Columbia University Press, p. 191

¹²⁵ Adjei, M. (2009). "Male-bashing and narrative subjectivity in Amma Darko's first three novels", in *SKATE Journal of Literary Studies*, vol. no. 1. pp. 47-61.

3. Female literary history

Literature is not only a question of the primary texts of study, specific novels, poems, dramas and essays, but it is also the criticism that goes with it (Wiseman Magwa, 101)¹²⁶. Criticizing literature itself, its existence and its contents has existed almost as long as the word literature itself, but despite this seemingly long historical background, critics fail to reach a consensus on what is a good literature and the proper procedures to analyse it (Dutton, 1984)¹²⁷. This is because any attempt to analyse and criticize a piece of literary art carries with it value judgment. The sum of critical appreciation, interpretation, theories and commentaries often carries within itself an entire set of ideological assumptions about society and relations between human beings (Ngugi, 1997, 23)¹²⁸. Presently, we have many theories of analysing literature that have been brought to us by scholars from all over the world, Ngugi wa Thiong'o admits.

Among these are Marxism, Psychoanalysis, Feminism and Colonialism to name only a few literary theories developed by critics, theorists and scholars from the South like Frantz Fanon, Edward Said, Salman Rushdie, Ama Ata Aidoo, Gayatri Chakravorty Spivak, Homi K. Bhabha. Unfortunately, for a long time none of these theories is African oriented. African literature is seen as an emanation of the third world, the undeveloped one. Literature from this place is considered unworthy to attention. Therefore, African writers have seen their writings either rejected or criticized in the name of existing European literary tools which are not specifically applied to an African context. The denigration was as well due to the criteria to meet before being accepted. Then, African wrote texts for their people and Europeans evaluate them, meaning that are the judge bench of tests they do not know the context, the scope and even the authentic history. The long silence was due to the fact that people think that 'subjugated knowledge' like that of Africans cannot produce for themselves theories to judge their own works though experiences are not the same from a place to another. As Chinua Achebe argues,

Somewhat unfinished European and that somehow outsiders can know Africa better than the native writers. Achebe opposes, the European colonial prejudice, habit of ruling and discriminating other and comparing African people their literature, art and culture etc. He argues that African literature should not be judged with the canonical literature since it has its own

¹²⁶ Magwa, W. *The Dynamics of African Literature and its Criticism: Perspectives from Zimbabwe*, pp. 101-107.

¹²⁷ Dutton, R. (1984). *An Introduction to Literary Criticism*. Essex: Longman.

¹²⁸ Ngugi, W. T. (1997). "Writers in Politics". Nairobi: East African Educational Publishers.

particularity and peculiarity. The mask of European civilization does not know the history of African people.¹²⁹

As a result, Chinua Achebe's claim is that blacks (colonized) should write their own history neglecting what has been already universalized. He argues that "If the text is judged from European perspective a text doesn't get right evaluation and the essence of the text is killed. If this ultimate claim is perceived as Afro-centric, then Afro-centrism is simply defined as an effort by African people to be re-located historically, economically, socially, politically and philosophically (Molefi K. Asante, 1991)¹³⁰. Chinua Achebe's reaction when writing his historical novel *Things Fall Apart* (1958) may have been a way to respond and avoid distortion found in writings like that of Joseph Conrad's *Heart of Darkness* (1899), which painted African people as not "civilized, savage and deprived of humanity and sanity"¹³¹, silenced African women also react by responding to male depiction of women in their literary writings. In the same vein of reaction, Frantz Fanon, the psychoanalysis theorist from the Martinique, justifies the 'wretched's revolt' in his severe rhetoric against imperialism and its colonizer's denigration by asking for the same disobedience as Yambo Ouologuem's *Bound to Violence* (1968):

Face to face with the white man, the Negro has a past to legitimate, a vengeance to extract...In no way should I dedicate myself to the revival of an unjustly unrecognized Negro civilization. I will not make myself a man of the past [...] I am not a prisoner of history; it is only by going beyond the historical, instrumental hypothesis that I will initiate the cycle of my freedom.¹³²

In the passage, we can see that superiority complex of Whiteman is remarkable. Consequently, the earlier established centre (Africa) lost its power in the hands of colonizers. Colonizers then claimed to be creators of written forms of literature, drama and poetry and Africans just "savage" (Fanon)¹³³ with no knowledge. African writers have aptly discussed this

¹²⁹ <http://www.bachelorandmaster.com/criticaltheories/colonialist-criticism.html#.WOCZdM6cHIU>".

¹³⁰ Asante, M. A. (1991). The Afro-Centric Idea in Education Journal of Negro Education, Vol.60, Number 2, pp. 170-180.

¹³¹ Conrad, Joseph (1899). *The Heart of Darkness*, phrases from 10 to 22 like "'Black shapes crouched, lay, sat between the trees, leaning against the trunks, clinging to the earth, half coming out, half effaced within the dim light, in all the attitudes of pain, abandonment, and despair. Another mine on the cliff went off, followed by a slight shudder of the soil under my feet. The work was going on. The work! And this was the place where some of the helpers had withdrawn to die" [...] "You could see from afar the white of their eyeballs glistening. They shouted, sang; their bodies streamed with perspiration..." [...] "They were nothing earthly now,-nothing but black shadows of diseases and starvation lying confusedly in the greenish gloom." [...] "The man seemed young--almost a boy--but you know with them it's hard to tell." "Near the same tree two more bundles of acute angles sat with their legs drawn up".

¹³² Fanon, F. (1952). 'The Fact of Blackness' in *Black Skin, White Masks (Peau noire, masques blancs*, Paris: Seuil), trans. Charles Lam Markmann (1968), London: MacGibbon and Kee.

¹³³ Idem.,

theme of how bright looking white men contorted African life, history, culture, nature and social scenario. In the course, they imposed their own monotheist religion such as Christianity, their language (English and French) and implicitly their literature. There is no written literature from African writers without a line of proverbs, jokes, songs, sayings and tales. African writers usually take their materials from the past. This reminds us of one of the songs of the Jamaican singer Bob Marley who says “In this great future, you can’t forget your past”¹³⁴. This passage of the song means, to build a great future, it is important to know past events and Ngugi Wa Thiong’o is also one of the African writers to emphasize it repeatedly, except for his apprentice plays and earlier short stories. His works are “dense with allusions to historical personages and events”¹³⁵. References to historical events are as important as the historical settings in his writings. To point out his opinion, Ngugi wa Thiong’o argues that “History is very important in any people. How we look at our past is very important in determining how we look at and how we evaluate the present.”¹³⁶ In this respect, literature plays a crucial role in the recovery of national consciousness¹³⁷ the way it is defended by the Negritude’s pioneers. The pioneers tried to find and maintain on surface their identity within the realm of fictional stories in a world which was about to bury them alive with their history and culture.

Thus, oral literature makes Africans aware of themselves, their environment, history and even the culture of other people. It portrays how to live a moral life within a community bound with a tie of solidarity. Stories, songs, proverbs, riddles, metaphors and jokes in oral literature use colourful words and vivid images to describe human beings, their feelings and their behaviour towards one another. These performances also portray natural phenomena like landscapes, plants and creatures in the same lively language. In this sense, this “universal human realm, peopled by spiritual beings and their personalities, is revealed through stories, tales, songs, myths, legends, prayers, and ritual texts. Such literature recounts the work of the gods, explains how the world and human existence came about, and reveals the nature of human

¹³⁴ Words retrieved from the song “No woman, no cry” (1975), Bob Marley.

¹³⁵ Sicherman, C. M. (1989). Ngugi wa Thiong’o and the Writing of Kenyan History in *Research in African Literatures*, Vol. 20, No. 3 (Autumn, 1989), Indiana University Press, pp. 347-370.

¹³⁶ Klimkova, S. (2015). Ngugi Wa Thiong’o, 1978 quoted in History and fiction: Ngugi Wa Thiong’o’s vision in *Seria Filologicsna, Studia Anglica Resoviensia* 12, Constantine the Philosopher University in Nitra, p. 154.

¹³⁷ For e.g. in 1975, Thiong’o suggested in an interview that (...) literature must be able to freely and correctly mirror our society in all its strength and weakness (Thiong’o quoted in Sander, R and B. Lindfors, 2006: 95). Moreover, he says: “I believe that we in Africa or anywhere else for that matter have to use literature deliberately and consciously as a weapon of struggle in two ways: a) first, by trying as much as possible to correct reflect the world of struggle in its stark reality, and b) secondly, by weighting our sympathies on the side of side of those forces struggling against national and class oppression and exploitation, say, against the entire system of imperialism in the world today” (Thiong’o quoted in Sander, R and B. Lindfors, 2006: 246) .

frailty”¹³⁸. Oral literature serves to communicate ideas, emotions, beliefs and appreciation of life. This literature defines, interprets, and elaborates on the society’s vision of reality and the dangers in the world. It deals with the human adventure and achievements against odds. Consequently, failure to have a written form of literature does not mean that African people are savage and barbarian. It does prove just their particularity. What we are sure of is that with the arrival of literacy, the core of this oral literature and its art rapidly disappear.

To the question why women have so long remained silenced while male writings portrayed them as ‘negative beings’, ‘worth for nothing’, and ‘subaltern’, Gayatri C. Spivak¹³⁹ puts rightfully that:

The question is not of female participation in insurgency, or the ground rules of the sexual division of labor, for both of which there is ‘evidence’. It is, rather, that, both as object of colonialist historiography and as subject of insurgency, the ideological construction of gender keeps the male dominant. If, in the context of colonial production, the subaltern has no history and cannot speak, the subaltern as female is even more deeply in shadow.¹⁴⁰

In return, Benita Parry explains that the atmosphere of subjugation and subaltern prevented women from colonized areas to speak. It was overwhelmed by the double yoke system organized by the colonizers at the time. He justifies that “what Spivak uncovers are instances of doubly-oppressed native women who, caught between the dominations of a native patriarchy and a foreign masculine-imperialist ideology”¹⁴¹. It is clear that the ‘subjugated’ has to put aside his silence and talk one day. That’s why the link between literature and language, literature and socio-cultural and political reality is relevant and inseparable. Writers and gender theorists agree that the experiences of African women are different from those of their Western counterparts.

¹³⁸ Retrieved from “Fellowships for the Documentation of Oral Literature and Traditional Ecological Knowledge”, Culture, Language and Environment, 2016. Firebird Foundation for Anthropological Research. All rights reserved.

¹³⁹ Gayatri Chakravorty Spivak is the Avalon Foundation Professor in the Humanities at Columbia University. She received her B.A. at the University of Calcutta (1959); her M.A. (1962) and Ph.D (1967) from Cornell University. Professor Spivak has also taught at Brown, Texas at Austin, UC Santa Cruz, Université Paul Valéry, Jawaharlal Nehru University, Stanford, University of British Columbia, Goethe Universität in Frankfurt, Riyadh University, and Emory. Before coming to Columbia in 1991, she was the Andrew W. Mellon Professor of English at the University of Pittsburgh. She has been a Fellow of the National Humanities Institute, the Center for the Humanities at Wesleyan, the Humanities Research Center at the Australian National University, the Center for the Study of Social Sciences (Calcutta), the Davis Center for Historical Studies (Princeton), the Rockefeller Foundation (Bellagio). She has been a Kent fellow and a Guggenheim Fellow. Among her Distinguished Faculty Fellowships is the Tagore Fellowship at the Maharaja Sayajirao University of Baroda (India). She has been a member of the Subaltern Studies Collective. <http://www.cddc.vt.edu/feminism/Spivak.html>

¹⁴⁰ Spivak, G. C. (1988). Can the Subaltern Speak? in *The Post-Colonial Studies Reader* (ed.) Bill Ashcroft, Gareth Griffiths & Helen Tiffin, p. 28.

¹⁴¹ Parry, B. (1987). ‘Problems in Current Theories of Colonial Discourse’ *Oxford Literary Review* 9 (1&2) in *Post-Colonial Studies Reader* (ed.) Bill Ashcroft, Gareth Griffiths & Helen Tiffin, p. 36.

Moreover, the common definition we have is that feminism is the woman's freedom to decide her own destiny, freedom from sex determined role, freedom from society's oppression and restrictions, freedom to express her thoughts fully and to convert them freely into action. "Feminism is specifically directed at changing existing power relations between men and women so as to empower women and free them from all the manacles that hinder the release of their potentials"¹⁴². It is important to separate African women's struggle from that of their western counterparts. This feminism stands for the sub-Saharan African female ideology, also called "Negro-feminism" or "African feminism".¹⁴³ It stands for African women part of the struggle to dismantle the hegemony of patriarchy without effacing feminist identity in the society. In this scope, black or African feminism has precisely a pluralist discourse in the continent because there are powerful female hierarchies in certain African cultural communities, which would be neutralized in a universalist discourse. However, criticism of African literature is belated firstly because of the late arrival of African female writers on the literary scene in 1966. To respond to the European literary critics who raised their voice to castigate the inappropriateness of this authentic ideology to the African context, the Marxist and feminist critic 'Molara Ogundipe-Leslie opines that:

For those who say that feminism is not relevant to Africa, can they truthfully say that the African woman is all right in these areas of her being and therefore does not need an ideology that address her reality? When they argue that feminism is foreign, are these opponents able to support the idea that African women or cultures did not have ideologies which propounded or theorized woman's being and provided avenues and channels for women's oppositions and resistance to injustice within their societies?¹⁴⁴

In essence, Molara establishes female writers as primarily concerned with issues related to women. Molara goes as far as applauding female writers such as Flora Nwapa and Buchi Emecheta for their attempt to educate us about the woman's realm of experience. To back up Eisenmen's idea in "Difference Theory", we argue that there are social differences between men and women. According to her, even though men and women live in the same social group, they live in different or separate cultural worlds and, as a result, promote different ways of speaking,

¹⁴² Weedon, C. (1987). *Feminist practice and post-structuralist theory*. Oxford: Basil Blackwell Ltd, p. 1.

¹⁴³ hooks, b. (1997). "*Feminism: A Movement to End Sexist Oppression*". *Feminisms*. (Ed.) Sandra Kemp and Judith Squires New York: Oxford University Press: pp. 22-27.

¹⁴⁴ Ogundipe-Leslie, M. (1994). *Recreating Ourselves: African Women and Critical Transformations*, Trenton, New Jersey: Africa World.

“tackling and solving their problems”¹⁴⁵. In some feminist writings like that of Ama Ata Aidoo, patriarchy stands for colonialism and vice versa; both sharing the same structure of ideological domination of women in terms of political economy. In this regard and understandably, patriarchy comes under severe attack and criticism by the feminists for the role it plays and continues playing in hindering women from realizing their creative possibilities. These theorists suggest that African women should establish and define their own selves through a mechanism of self-empowerment and enlightenment by challenging patriarchy and then “developing a female discourse that will accurately portray their relationship to the world of reality and not to the world of men”¹⁴⁶. By achieving this, women will be able to move from the ‘margin to the centre as suggested by the Black American activist bell hooks in *Feminist Theory: From Margin to Center* (1984)¹⁴⁷. Bell hooks discusses freely in the book about black women’s marginalization. That movement of women is very important because all that is in the margin or at the peripheral is dangerous. She says: “being oppressed is absence of choices”¹⁴⁸. So African or African-American women should then avoid to be relegated to peripheral.

Furthermore, bell hooks also criticizes the European way of seeing black women’s struggle to quit the margin. Bell hooks writes,

Betty Friedan’s *The Feminine Mystique* is still heralded as having paved the way for contemporary feminist movement-it was written as if these women did not exist.... hooks, and many women of color theorists, found much fault with the work of Friedan whose pool of interviews, friends and neighbor’s she knew, were (for the most part) white, middle class women living in homes in nice neighborhoods. The assertion that these women wanted to step away from their homes and work was almost offensive to hooks because, as she contended, women of color have always worked. “She did not discuss who would be called in to take care of the children and maintain the home if more women like herself were freed from their house labor [...]”¹⁴⁹

What is remarkable is the problematic of boundary that has been constructed by

¹⁴⁵ Uchida, A. (1992). When difference is dominance: A critique of the anti-power-based cultural approach to gender differences. *Languages in Society*, 21, 547-568.

¹⁴⁶ Bressler, C. E. (2007). *Literary criticism: An introduction to theory and practice*. New Jersey: Pearson Education Inc.

¹⁴⁷ hooks, b. (2000). “*Feminist Theory: From Margin to Centre*”. Cambridge. MA South End Press. Print 1st Ed 1984.

¹⁴⁸ Idem.

¹⁴⁹ Trier-Bieniek, A. (2015). *Feminist Theory and Pop Culture*. (Ed.) Adrienne Trier-Bieniek Valencia College, Orlando, USA, Vol. 5. Sense Publisher, Rotherham.

patriarchal ideology to maintain women under subjugation. The womanist¹⁵⁰ writer Flora Nwapa highlights that it is rather strategic to give power to her female characters to break loose from male hegemony (marriage, household and motherhood) because patriarchal phallogocentric ideology enchains and enslaves women. They had better to settle as free women, for one experience of being enslaved is enough, a second is intolerable. The reasons that lead women to write are different and various, but the common point of all of that is the desire to share experience, memoirs and life traps in patriarchal settings.

4. Reasons for writing

Physiologically speaking, the history of man and woman is the same. Side by side with men, women have a long history of activism that can be traced to pre-colonial and colonial Africa. The national liberation struggle of African countries such as in Ghana, Nigeria, Kenya, Zimbabwe to name only these few, have been successful in the sense that, the colonial government in former colonies was overthrown thanks to the joint work of its male and female struggle, but in its place it simply installs sadly a new indigenous ruling class (male particularly) whose interests are in fact more closely tied with those of the ruling classes of the former colonial powers than with those of the majority of people in their own country. No historical paper document pays tribute to women although they were on the front line of decolonisation, political independence movement, African consciousness movement and anti-imperialism as well as men.

No historical, political and cultural account in these countries puts them in their right place. In this new established order, they are put aside. No tribute is paid to female participation in national, historical and political movement, because former colonial masters were more interested in manhood because than womanhood. Despite the fact that men and women were beaten mercilessly, sold and separated from love ones, subjected to physical and mental degradation, denied their most basic rights of life, treated as properties, the circumstances were different for black women and men. Men were considered more valuable workers than women,

¹⁵⁰ This desire to create a black-counter hegemony is realized through the establishment of Womanism which is a special kind of [black] feminist theory that aims at answering the needs of black women and their struggle to transform the patriarchal and racial system this minority has historically experienced. Coined by the American novelist, Alice Walker, in her seminal book, *In Search of our Mothers' Gardens: Womanist Prose Since 1983* (1983), Womanism is the black equivalent to mainstream feminism. However, Walker makes it clear that womanism can only be differentiated from feminism by the additional factor of color/race (See *Womanism*, 2007). Womanism is often used as a means for analyzing black women's literature, as it marks the place where race, class, gender, and sexuality intersected. It is unique because it does not necessarily imply any political position or value system other than the honouring of black women's strength and experiences.

because of their physical strength. Women were in essence there to provide company and sometimes fortuitously sexual pleasures for the masters in want. In slavery, womanhood is a mere economic advantage for the master, who multiplied his labour force by allowing numerous pregnancies. Women gave birth as early as possible to produce the maximum from their wombs before they became obsolete and weak. But in fact, the crucial and skipped point was that, women's responsibilities as nurturing mothers were added to the usual ones at the farm. Then the new mothers were obliged to leave their new-borns to other and resume their hard works. For the sake and the love for their children, attempts to escape among women were fewer than among men.

Since African male writers have decided to silence their female counterparts in their creative writings, African female writers have to write their own voice with reason. They started writing against the established order to make themselves heard. They exposed the 'real picture' of Africa women and their position in the struggle along with satirizing Western scholars and African male writers for their partial and inaccurate portrayal. Eminent writers (from the first to third generation) of this stream comprise Flora Nwapa, Nadine Gordimer, Doris Lessing, Bessi Head, Ama Ata Aidoo, Nawal Al Saadawi, Leila Aboulela, Chimamanda Ngozi Adichie, Tsitsi Dangaremba, Sefi Atta, Yvonne Vera, and NoViolet Bulawayo. They exhort Africans by creating national identity or history in present as well as the pre-colonial context. Those women have challenged the status quo in the cultural, political, and spiritual realms of their communities by using their craft to present women who challenge traditional roles and resist the structures of oppression. They write their own history in African society and claim for their inalienable right to be independent. Since men and women have different life experience, the writing of men and female author differ as gender plays an important role in human beings life. Then female writers also find important to write about history because they think many events have been distorted by men. The need to counter the distorted views drives their understanding of the writer's commitment though many of them were far from being historians. To write about history or 'her-story' as some feminist claim, needs specific skills that female writers are more and more aware of. In this respect, literature played a crucial role in the recovery of national identity in the struggle of gender equality. Literature is not a mere tool of entertainment but rather a medium of social and even political change, the real task of the writer that is to "raise consciousness of the people" (Sander, R. and B. Lindfors, 2006: 37). This understanding propels

literature as a serious and important power to have in hands, writing history is then a socio-political ‘armed-weapon’ to search for.

4.1. Writing History

According to Nadine Gordimer¹⁵¹, writing about history can have many various motivations, and these may be very different for a historian as opposed to a fiction writer. In this regard, Robert Green had once remarked: “Finally, when the history of the Nationalist Governments from 1948 to the end comes to be written, Nadine Gordimer’s shelf of novels will provide the future historian with all the evidence needed to assess the price that has been paid. (Green, 156)¹⁵²

Most of Nadine Gordimer’s works are believed to have a massive historical and political significance as a developing and shifting response to events in modern South Africa, spanning over forty years and reaching into six decades, from the 1940s to the 1990s. One of these revered works is *Burger’s Daughter* (1979) published three years after the Soweto students uprising brought apartheid’s brutality to the world attention. The female writer also paid tribute to Nelson Mandela while he was in prison. Her novel *A Sport for nature* (1987) prophesized the end of apartheid and the release of ANC leader, Nelson Mandela. This proves the link between literature and historical events as pointed earlier by Ngugi wa Thiong’O. Further, in *Grand Dictionnaire universel du XIX siècle* of Pierre Larousse: the historical novel is defined as “celui dont les personnages et les principaux événements sont empruntés à l’histoire et dont les détails sont inventés »¹⁵³. It means that the historical novel is partly true and partly from the imagination of the writer, more or less in the content. Another French scholar Madalénat precises that historical novel reveals a right image of the past by the means of fiction through behaviours, mentalities, and real historical characters¹⁵⁴.

¹⁵¹ Nadine Gordimer was born on November 20, 1923, in a small village, Springs, located just miles away from Johannesburg, South Africa. Gordimer was born into a family of white minorities in this gold-mining country. Her father was of Jewish decent; her mother was of English decent. Being a white minority in South Africa had little implications on her when she was young. However, she would soon realize that people spanning all portions of the globe would hear her point of view. After being educated throughout her adolescence, she moved on to Witwatersand University, located in Johannesburg, South Africa. Regardless of her education, she devoted her life to writing collections that dealt with the racial tension that plagued her home country. Her first set of short stories was completed in 1949, at the mature age of 26. Throughout her career, she has written a myriad of essays, short stories, and novels.

¹⁵² Green, R. (1987). “From *The Lying Days* to *July’s People*: The Novels of Nadine Gordimer,” *Journal of Modern Literature*, 14, 8)

¹⁵³ A historical novel is that whose characters and main facts are borrowed from the history and whose details are invented (my translation).

¹⁵⁴ Gengembre, G. (2006). *Le Roman historique: 50 Questions*. Paris: Klincksieck, p. 87. Above is my own translation of the words of Madalénat quoted by Gengembre : “le roman historique prétend donner une image fidèle d’un passé précis, par l’intermédiaire d’une fiction mettant en scène des comportements, des mentalités, éventuellement des personnages réellement historiques” Madalénat, 1987 : 2136)

Within a text, reality has been then decoded to the level of words. The reader must therefore see these words as signs and by stringing them together, he can amplify them to produce a picture of the reality under discussion. As for *The Stanford Encyclopedia* lists three broad reasons for historical representation:

The idea of learning some of the facts about human circumstance in the past; the idea of providing a narrative that provides human understanding of how a sequence of historical actions and events hangs together and “makes sense” to us; and the idea of providing a causal account of the occurrence of some historical event of interest. (Little, part1)¹⁵⁵

In order to come to an understanding of the relation between history and historical fiction, these two terms have to be clarified because Historical writing requires a combination of attention to structural considerations along with the finding and assessing of facts. Therefore, it is not sufficient to write well grammatically and stylistically. A writer of history must answer a variety of questions in his or her writing. These questions are not limited solely to what happened; they include why and how. The writer must also address the background of the event, the principals involved, significant dates, and the prevalence of the event upon future developments. This combination of structure and detailed factual analysis is what makes historical writing difficult, both for novices and even experienced writers (Lottinville, 3)¹⁵⁶. The question: “What is history?” takes this argument into the field of philosophy of history according to Joke De Mey in *The Intersection of History, Literature and Trauma* in Chimamanda Ngozi Adichie’s *Half of the Yellow Sun*. The *Stanford Encyclopedia of Philosophy* views “history” in the following way: “history is a temporally ordered sequence of events and processes involving human doings, within which there are interconnections of causality, structure, and action, within which there is the play of accident, contingency, and outside forces” (Little, Philosophy of History)¹⁵⁷. This relation between history and literature is also approved of in Ian Milligan’s “The Novel in English: An introduction”: “Novels are just stories; they must bear some relationship to the concepts of truth or of value which the author espouses”¹⁵⁸. Quite a number of novels published and still being published really seem to adopt

¹⁵⁵ Little, D. (2008). “Philosophy of History”, *The Stanford Encyclopedia of Philosophy* (Edition), Edward N. Zalta. <<http://plato.stanford.edu/archives/fall2008/entries/history>>.

¹⁵⁶ Lottinville, S. (1976). *The Rhetoric of History*. Norman: University of Oklahoma Press.

¹⁵⁷ Idem.,

¹⁵⁸ Milligan, I. (1983) “The Novel in English: An introduction”. Hong Kong: The Macmillan Press LTD, p. 21.

this stance deriving their essence from history. This reflects evidently Georg Lukàcs's¹⁵⁹ approach which defines historical novel is “a work of writing that reconstruct the past. The important element which enhances the believability of such writing is the true research made by the writer before and during his writing. An example is a novel about Ashante war with British Empire. Talking for sure the credibility of the story, what could the readers think if the author of the story makes one of the characters write an email to the Queen Elizabeth?

One of the characteristics of a historical novel is the use of real events with fictional people. The above different confrontations did happen in the past like Waterloo's battle in Europe. For instance, the past events Georg Lukacs refers to are that of Asante's implication in slave trade in Amma Darko's *Beyond the Horizon* and the German prolific critic makes a remarkable insight by arguing that “In history, nothing is true but names and dates. In fiction, everything is true but names and dates”¹⁶⁰.

However, the problem with Georg Lukacs is that he thinks people cannot know the past events except in historical novel because only names and dates are true in history. Yet, history does contain more evidence than just dates and names. In this way, Amma Darko does not mention any date in her novel, but an academic reader knows exactly that she is referring to slave trade by making Mara cross the ocean to Europe where she works in forced labour to fill some people's pockets. This is the very image of what happened in the past with slaves. They were ‘imported’ like mere goods to West Indies and Americas to work in plantations for free until exhausting. The slight difference here in Amma Darko's novel is that she makes ‘slave’ travel by plane and not on board ships like in the past. Mara is exactly the projection of that wealth maker. What makes essentially the difference between a historical novel and a historical narrative is that a historical narrative like that of Amma Darko is a character based writing which can give biased information. In both stream, the objective is to share the main events, the places and perhaps the periods. What we can also fear is what Frantz Fanon's *The Wretched of Earth* warns about. In the preface, Jean-Paul Sartre shares the impact of European culture upon the first generation of colonized intellectual this way:

¹⁵⁹ Georg Lukacs (1885-1971) is now recognized as one of the most innovative and best-informed literary critics of the twentieth century. Trained in the German philosophic tradition of Kant, Hegel, and Marx, he escaped Nazi persecution by fleeing to the Soviet Union in 1933. There he faced a new set of problems: Stalin dogmatism about literature and literary criticism. Manoeuvring between the obstacles of censorship, he wrote and published his longest work of literary criticism, “The Historical Novel”.

¹⁶⁰ Idem.,

The European elite undertook to manufacture a native elite. They picked out promising adolescents; they branded them, as with red-hot iron, with the principles of Western culture; they stuffed their mouths full with high-sounding phrases, grand glutinous words that stuck to the teeth. (...) These walking lies had nothing left to say to their brothers; they only echoed. From Paris, London, from Amsterdam, we would utter the words 'Parthenon!', 'Brotherhood!', and somewhere in Africa or Asia, lips would open '...thenon! ...therhood! It was the golden age.'¹⁶¹

When this ends up, another generation comes up to continue the assimilation. It was the time of political distortions through literature as many of these writers were intellectuals and political leaders highly associated and intimately engaged with the former colonizers. The root cause of this manipulation lies in the realization by the former colonizers to still hold up the African mind through his leaders and then the huge ground resources. When most of Africans burst in shouting 'thenon, therhood' and all the other propaganda sweet words, multinationals' long and large colon of trucks go ashore for overnight mine works. The Africans labour gold, cobalt, and diamond for Europe to get rich. In return, Africans go hungry because there is no food or not sufficient to cover all of them. This image of Africans working night and day for menial is portrayed in Peter Abraham's *Mine Boy* (1942) and Alex La Guma's *A Walk in the Night* (1962). Both novels trace up mostly one of the ailments of apartheid period that is poverty in native camps. During that dehumanizing period, racism was wide spread and caused major problems. For the slightest accusation, Africans miners were put in jail, harshly beaten or shot dead. All this came to existence as result of colonialism. Further, Africans go on the Europeans' battle-fields and discover that even those that the Frenchmen call wicked and enemies (Germans) are fighting to defend a cause, civilisation and liberty. As to the liberty of the colonized, no Frenchman gives it a right, not even a word. Africans have to walk alone. Others are too busy in urban centres like Lagos enjoying themselves to care about the doom of their compatriots who decide to battle side by side to get back their land and their pride. Amusa Sango in Cyprian Ekwensi's *People of the City* (1954) shares with one of his friends: "I like freedom. Not too much politics. [...] You know the sort of like I lead. Jazz ...girls...late hours"¹⁶². We do not rebuke these people's enthusiasm to celebrate in cities newly built in their postcolonial countries, but we are almost as deceive as Frantz Fanon about the native

¹⁶¹ Fanon, F. (1974). *The Wretched of the Earth*. Trans. Constance Farrington. Harmondsworth; Penguin, p. 1; originally published in French as *Les Damnés de la Terre*. Paris: François Maspero (1961).

¹⁶² Ekwensi, C. (1954). *People of the City*. London: Heinemann, p. 73

intellectual: “the native intellectual will very often fall back upon emotional attitudes and will develop a psychology which is dominated by exceptional sensitivity and susceptibility” (Fanon, 1977). It is with precision what the colonizers want of Africans, not being attentive regardless what goes around.

The claim of objectivity is of particular interest in this context, because it seems to be the decisive factor that separates history from historical fiction (Faizal, Risdianto, 2012: 2-3). Faizal’s claim of objectivity is relative to objective writing, which one can verify through evidence and facts. While laying bears of an objective writing one needs to be as neutral as possible to disclose unbiased information to an audience. This is opposed to subjective writing which one cannot evaluate, calculate or verify. Subjective writing does not suppress feelings, opinions and judgements. Therefore, the important steps one needs in objective writing are these: to be specific instead of vague and general, do not use opinionated language, avoid using first person pronoun.

This is the difference between informative literature and imaginative literature. Informative literature tells us about facts, explanations, history, real ‘great’ life figure. It tells us the world, for instance, the life of the Mali kingdom (1250-1400) defeated by the Songhai Empire (1450-1600), the story of Rosa Parks (1913-2005), Mariama Bâ (1929-1981), Miriam Makeba (1932-2008). Its main purpose is to offer knowledge. Hence, there is also imaginative literature that aims to arouse thoughts and feelings. Its author expresses his or her ideas, his or her feelings, his or her attitude, he or she may talk of things; people. The message conveyed by the writer has a meaning that lies beyond its being right or wrong (rewriting the colonial trauma for example), but it is the reader’s consciousness that is targeted. However, this will be further nuanced by Ankersmit’s insights on the historical novel (Ankersmit, F., 2010)¹⁶³. But what exactly makes African women write and draw their own path? In one of the earliest critical responses to the independence disillusion motif, Megan Behrent highlights the important factor that pushes African women to write by quoting Neil Lazarus (Behrent, Megan, 1997)¹⁶⁴: "In short, independence let loose the national bourgeoisie to behave as it would, like any bourgeoisie". Thus, hope leads to disillusionment as it becomes apparent that independence does not mean change for the majority of people as political leaders have chanted along but simply a

¹⁶³ Ankersmit, F. (2010). “Truth in History and Literature”, Narrative, p.18.

¹⁶⁴ Behrent, M. (1997). Ama Ata Aidoo: Independence and Disillusionment in Postcolonial Ghana in African Post-colonial Literature in English.

transfer of power and wealth into the hands of a new ruling class. That new ruling class setback and disillusionment have been depicted in almost all Ayi Kwei Armah's novels. From *The Beautiful Ones Are not Yet Born* to *Fragments, Why Are We So Blest?*, *Two Thousand Seasons*, *The Healers* and *Osiris Rising*, the Ghanaian writer prolific consistently uses the medium of prose fiction to cross-examine the complexity and enormity of Africa's problems. He presents a sober and pessimistic appraisal of Ghana's (Africa's) prospects for progress against the backdrop of instability, poverty, corruption, crude accumulation and annihilating consumption. In Bernth Lindfor's (ed) *Researches in African Literatures*, Neil Lazarus offers a poignant and engaging study of *The Beautiful Ones* entitled "Pessimism of the Intellect, Optimism of the Will: A Reading of Ayi Kwei Armah's *The Beautiful Ones Are Not Yet Born*". The study deals with thematic aspects of the novel and clarifies some hazy points about Armah's depiction of Ghanaian history. It becomes clear that the moral decay, the physical laxity and treachery now prevalent in neo-colonial Ghana had been seen and rejected in the decolonizing years by the masses, but these shameful behaviours of intellectuals are coming back like as boomerang. What the masses rejected to appeal for their own educated sons, brothers and friends was still living within them and more rampant, hungry foe-like.

Above all, Ama Ata Aidoo's work is representative of her own life and her struggle to find her identity as a free, and independent woman within Africa's rather patriarchal society" (Wilson-Tagoe, 2002: 48). In this way, Lazarus puts, "It was thus, in African literature, that the category of neo-colonialism came to be taken up. Independence was a fraud. It signified a refinement of the colonial system, not its abolition."¹⁶⁵ The work of writers Amma Darko, Ama Ata Aidoo, Mariama Bâ, Doris Lessing and others writing at this time is characterized by this sense of disillusionment and resounds with bitter critiques of the corruption and the betrayal of leaders of national liberation struggles and subsequent political leaders. Their novels clearly illuminate female suffering as a result of colonialism and patriarchal domination. Likewise, there are frequent indictments of the continued practice of imperialism in all its forms economic, cultural, political, and military.

Amma Darko has travelled for years and met several difficulties as an African woman in Europe, so that she began writing, she did not first turn to the trauma and pain resulting from the

¹⁶⁵ Neil Lazarus quoted in Behrent, Megan's (1997). *Ama Ata Aidoo: Independence and Disillusionment in Postcolonial Ghana in African Post-colonial Literature in English*.

African Diaspora. She materialized this knowledge of how conflictive was the encounter between African and Western cultures. Here she puts it: “It was a shock for me, my first shock, my first horror. And yet, my first lesson”.¹⁶⁶ This is mainly the reason why some of her female protagonists also undergo a physical and emotional journey that is stabbing and traumatic, though always instructive. We highlight here the impact of Amma Darko’s travelling to Europe as an important debut of her writing fiction. Zak Louis writes:

Darko was shocked when she arrived in Germany and found that the only jobs available to African women were in menial service and prostitution. She took a job as a domestic and made very little money. Unable to send money home, as was expected by many in her family, she felt a humiliating sense of failure, frustration, and anger...This experience of leaving home in order to come into writing is common to many writers, in Africa and elsewhere, and in fact seems almost an archetypal theme in the development of voice. Time abroad provides not only time and psychic distance but also the emotional impetus to begin to write. She acknowledges freely: ‘If I hadn’t left Ghana and come to Germany, I would never have written’ (28 May 1998).¹⁶⁷

As a matter of fact, Amma Darko recreates the history of her people through fiction, in *Beyond the Horizon* (1995), the events relating to the implication of the Ghanaian in the transatlantic slave trade, how innocent souls like Mara were ‘imported’ in Americas for forced labour. One of the central points that make the novel *Beyond the Horizon* so different from the others is that it is directly to a German readership, *Das Verkaufte Traum* (1991) before it could be later translated in English. The other side of the narrative is that Amma Darko’s way of re-telling the exile of her people in an exact period of time without mentioning the date. The concept of exile here is used historically not politically. The concept is also used in Christianity. In the narrative of the Book of Genesis God was obliged to chase Adam and Eve from Eden garden for having not respected His word. This kind of exile is the consequence of a historic-religious mistake. It has nothing to do with that which in the ancient city of Babylon narrated in Psalms one hundred and thirty-seven:

By the rivers of Babylon, we sat and wept when we remembered Zion. There on the poplars we hung our harps, for there our captors asked us for songs, our tormentors demanded songs of joy; they said, “Sing us one of the songs of Zion!” How can we sing the songs of the LORD while in a foreign land?¹⁶⁸

¹⁶⁶ Darko, A. (1995). *The Housemaid*. London: Heinemann, p. 61-2.

¹⁶⁷ Zak, L. A. (2007). Amma Darko: Writing Her Way, Creating a Writing Life in *Broadening the Horizon: Critical Introductions to Amma Darko* (ed.) Odamtten Vincent O., Oxfordshire UK, p. 13.

¹⁶⁸ Psalms 137: 1-4, the New King James Version.

So exile provokes severe heartbreak, then trauma which taints forever the victims' mind and determines their future attitude in a community. Amma Darko was obliged to leave her country in a period of time just like Mara and the captives to Babylon. Her writing justifies her traumatic position explained by Cathy Caruth¹⁶⁹. Cathy Caruth puts this:

If Freud turns to literature to describe traumatic experience, it is because literature, like psychoanalysis, is interested in the complex relation between knowing and not knowing. And it is at the specific point at which knowing and not knowing intersect that the language of literature and the psychoanalytic theory of traumatic experience precisely meet.¹⁷⁰

The excerpt means that it is possible to share a traumatic experience as a way to escape from it, just like to: 'I have seen it also'. Amma Darko's trauma does not seem to be pathology or illness, but just a wounded psyche which leads her to voice. The wounded psyche obliges Amma Darko to reveal the truth of her passage to Germany through a female character. She also makes an analogy of what happened to her as being a fragment of the past history of slaves imported beyond the horizon to execute forced work. For what seems striking in that experience of Amma Darko and her protagonist is the exaggerated innocence of Mara in the debut of the narrative, the moving and sorrowful voice that cries out physical alteration. The voice of Mara is in fact that of Amma Darko which releases the wound and the pain. We assume doubtless that Amma Darko wrote the novel as a feminist narrative because readers (academic and non-academic) surely get a deep understanding of the power men hold in society, as they manipulate, deceive and use aggression in oppression the right of women in this novel and sometimes in reality.

The second and third novels (*The Housemaid* and *Faceless*) are Amma Darko's attempt to write the impacts of change such as globalisation and urbanization on African cities and families psyche.

¹⁶⁹ Cathy Caruth is a leading figure in psychoanalytically informed literary theory and humanistic approaches to trauma. She is the Frank H. T. Rhodes Professor of Humane Letters at Cornell University, with appointments in the Departments of English and Comparative Literature. Her books include *Empirical Truths and Critical Fictions: Locke, Wordsworth, Kant, Freud; Unclaimed Experience: Trauma, Narrative, and History*; and *Trauma: Explorations in Memory*, all published by Johns Hopkins.

¹⁷⁰ Caruth, C. (1996). *Unclaimed Experience: Trauma, Narrative, and History*. Baltimore, Maryland: The John Hopkins University Press, p. 3.

4.2. Writing Ghanaian Society

In *The Housemaid*, Amma Darko once more relates her own life experience when she worked as a housemaid in Germany and turns it into a fictional event as Zak Louis reveals it: “She took a job as a domestic and made very little money.”¹⁷¹ Amma Darko gives voice to Mara to revenge and escape because of her ‘undocumented status’¹⁷² which leads her into physical (prostitution) and mental (sniff snow) slavery. Amma Darko enables the protagonist to become ‘a writer’ like she is.¹⁷³ Though some critics think that it is bad to judge a book by its title and its cover, we intend to reveal that those two elements are sometimes very important to pinpoint while analysing the novel. After all, a cover of a novel is just an ensemble of pictures and a title a mere phrase. A title of a book is the book’s name, so names are very important. When a name is good, it seduces the bearer. That is why people give to their children names of famous people. A simple name can bring down and make a whole life. For example, in the Roman Catholic believers’ families give their children names like Joseph, Sarah, Maria, Elizabeth, Joshua and never Jezebel, Judas, Pons Pilate. Others give names like Albert to signify Albert Einstein (the famous radioactivity physicist), Mike to mean Michael Jordan (the American famous basketball player) and Nelson to mean Nelson Mandela or Winnie to mean Mandela’s Penelope like wife.

In his *Art of Fiction*, David Lodge states that “The title of the novel is part of the text; the first part of it, in fact, that we encounter, and therefore has considerable power to attract and condition the reader’s attention.”¹⁷⁴ The title designates then the content of all or a part of the text. It is also considered as the essence of the book. The title of a book needs to be attractive to catch the attention of the reader. Here also its shortness and its capacity of encoding information related to the text are at stake. The title is very accurate to the story because it foreshadows a part of the story. One knows in advance that the novel is about the ‘adventures’ of a domestic. The cover also intends to inform the readers. So what one can see on the cover after reading the title is a pregnant female child of a rather young age with a rather sad face. It means she is not

¹⁷¹ Zak, L. A. (2007). “Amma Darko: Writing Her Way, Creating a Writing Life” in *Broadening the Horizon: Critical Introductions to Amma Darko* (ed.) Odamtten Vincent O., Oxfordshire UK, p. 13.

¹⁷² In the beginning of the novel Mara is jovially called ‘greenhorn (p.15)’ what unfortunately leads her to obey blindly and dumbly sheep like to a violent husband who uses her as slave. Darko proves that it could not be so if the protagonist was educated and informed about these possible actions.

¹⁷³ Sean P. O’Connell & Odamtten, V. O. (2007). “Licit Desires, Alien Bodies and the Economics of Invisibility in Amma Darko’s *Beyond the Horizon* and Stephen Frears’s *Dirty Pretty Things*” in *Broadening the Horizon: Critical Introductions to Amma Darko* (ed.) Odamtten Vincent O., Oxfordshire UK, p. 55.

¹⁷⁴ Lodge, D. (1992). *The Art of Fiction*, Vintage Books: London, p. 103.

happy with the pregnancy. It is then an unwanted pregnancy with an immature girl. The author of that pregnancy cannot be known just by reading a title and a cover. Frequently the suspected author of the pregnancy is usually in the immediate environment. That means either it is the husband of the woman who brings at home the young girl, or one of the male children of the home, the driver, the gardener, the gatekeeper. Here, when the housemaid gets pregnant, she blames it on one of the house owner's lovers according to a plan hatched by the grandmother and supported by the mother, aimed to extort a lot of money from Tika. The tricky plan is discovered and Efi flees. She is finally delivered but the baby is dead. She disposes of the corpse on a dump and disappears.

Likewise, the title and the cover of the novel *The Housemaid* are meaningful. When a non-academic takes the novel, he may be interested in the title as a clue which transports him beyond a horizon. That title can be interpreted in different ways because it is not like *The Housemaid* which is a clear cut title that designates its content at a one drop of eyes. Thus, the reason why a novel or a book is written is revealed through its title and its cover. But sometimes for some reasons, the latter is not really the concern of the writer as Ama Ata Aidoo confines: "As soon as I finish writing a novel, it is no more mine. It is for the reader and the critics"¹⁷⁵. In the world of book publishing, the cover is what will draw people's attention to a book. It is a representation of how seriously an author takes his work at a glance. Patrick Janson Smith, a literary agent and a former publishing director at Transworld puts it that: "A reader spends an average of about five to eight seconds looking at the front cover of a book [...] if it's good. That's second folks. If it's a bad cover, try one to three seconds and they don't even consider buying. But when the front cover catches his attention, he goes to the back cover and reads to decide"¹⁷⁶.

In the case of *Beyond the Horizon*, we can say doubtless that the title is many dimensional and ever-evoking, but not clear-cut. The reader can assume that the content is about for instance a failed and successful travel over sea. The title is more ambiguous than that of Douglas Kennedy's *Beyond the Pyramids*¹⁷⁷ (1989) which cover shows the content to the reader. On the cover are a camel (a Sahel animal, a man with a veil round his head and neck). Unlike

¹⁷⁵ Aidoo's interview with Wangui wa Goro, in Royal African Society's annual Africa Writes Festival, August 2014.

¹⁷⁶ <http://thewritingsickness.blogspot.fr/2011/03/importance-of-book-covers.html>

¹⁷⁷ Kennedy, D. (1988). *Beyond the Pyramids*. HarperCollins Publishers Ltd; New Ed edition (1989) Douglas Kennedy is the author of *The Job*, *The Big Picture*, *The Dead Heart* (now being filmed by the makers of Priscilla, Queen of The Desert) and three travel books, *Beyond The Pyramids*, in *God's Country* and *Chasing Mammon*. Born in New York City in 1955, he lives in London with his wife and two children.

Beyond the Horizon, the content can also treat of death and its spiritual implications in African societies. For death is not a simple phenomenon in Africa. When someone is dead, it is usually because of something wrong either within his family and him or his relatives and environment or generally himself and the spiritual world. It can also refer to expectations placed on some people over sea. They naturally embody the dream of a whole community and surely these expectations take the shape of their longing for a certain life of green pasture beyond the horizon. Yet, only the cover of the novel sheds light on the seeming content and the discussed events. *Beyond the Horizon*'s cover shows a man and a woman naked facing each other. First, the exact colour of the painting shows that both are Africans in an obscure place, maybe in a room with no light. In color psychology, black means power and control, and it holds on to information and objects instead of sharing them with others. In that very scope, black colour means intimidating, unfriendly and unapproachable, because of the power and the dread it radiates. Second, the woman, hair covered with a hat, seems to be lying down with her right breast visible. Her two legs totally scattered apart while the man is sitting on a white chair, his face not visible.

Besides, according to colour psychology, white is the colour of new beginnings. The right arm of the woman is covered by a red wrapper on which she seems to lie down. Red is a very strong colour. It is a noticeable colour that is often used on signs for signalling caution or warning. Red colour meaning is often associated with the word stop. But light red is a warm colour that “evokes a strong sense of passion, lust, sex, energy and blood”¹⁷⁸. The light red colour is good at stealing attention from other colours, which is useful in many contexts. The colour red is often used on flags as a symbol of pride and strength.

For more details, it is also noticeable that the woman's genital part is quite visible because of her position just under the man's left arm. On the right shoulder of the man seems to be a penis like painting under erection which end is not disclosed. The intimidating phallic object symbolizes male possession and dominance. In fact, in literature, the use of colour is plainly an art to discover. From a color psychology perspective:

¹⁷⁸ <http://www.empower-yourself-with-color-psychology.com/color-blue.html>

the blue color is reliable and responsible and radiates security and trust. You can be sure that the color blue can take control and do the right thing in difficult situations. The blue color needs order and planning in its life, including the way it lives and works. Blue is a giver, not a taker and is deeply hurt when the trust is betrayed¹⁷⁹.

Based on this, we can conclude that the woman shows then more love, trust and confidence to the man than the man does. However, the facial expression of the woman shows that she is not enjoying the moment. Her face is somehow frowned. In the fact the blue colour which is just around the man's body proves all that happens in the content of the novel between men and women's intimate relationship. The white colour used to paint the chair represents Europe, western ideology that haunted Amma Darko's male characters. A chair also represents authority.

Then, the cover shows an image of a scene of a sexual act being done or at hand to be done. The cover of the novel is full of symbols to be explained. In the same rank of decoding covers and titles, Leo H. Hoek defines the title of a book as being "a series of linguistic signs which can appear at the head of a text to designate it, to indicate its general content, and to appeal to the public."¹⁸⁰ According to Gérard Genette¹⁸¹, this definition is derived from Charles Grivel's formulation about book titles on three levels: (1) identify the work; (2), designate its contents; (3), and highlight it. In his textual theory, Genette classifies the title as an element of what he terms the 'paratext,' which he identifies as those things in a published work that accompany the text, such as the author's name, the title, preface or introduction, or illustrations:

¹⁷⁹ <http://www.empower-yourself-with-color-psychology.com/color-blue.html>

¹⁸⁰ Hoek, L. H. (1981). *La Marque du titre: Dispositifs sémiotiques d'une pratique textuelle* (Approaches to Semiotics; Paris: Mouton de Gruyter, 1981), quoted in Gérard Genette, "Structure and Functions of the Title in Literature," *Critical Inquiry* 14 (Summer 1988): 708.

¹⁸¹ Gérard Genette (b. 1930) is the most important French literary theorist after Roland Barthes. English speaking critics associate Genette primarily with Structuralism, and although it is true that Genette, like Tzvetan Todorov, produced much of his early work in the context of this movement for which Barthes served as intellectual leader and impresario, structuralism becomes one point of reference among many in Genette's later career. Genette is known best—and perhaps known only—for his work on narrative, in his treatise *Discours du récit* (1972, *Narrative Discourse: An Essay in Method*, 1980) and its sequel, "Nouveau discours du récit" (1983, *Narrative Discourse Revisited*, 1988), as well as in a number of essays.

More than a boundary or a sealed border, the paratext is, rather, a threshold. [It is] a zone between text and off-text, a zone not only of transition but also of transaction: a privileged place of pragmatics and a strategy, of an influence on the public, an influence that [...] is at the service of a better reception for the text and a more pertinent reading of it.¹⁸²

Gerard Genette explains that all those elements have a profound influence on the reader. He posits that the inside and outside meaning of a title for instance has an important role for the public. Genette discloses that there is a strong relationship between a title and the content of a text which a scholar cannot skip while analysing or interpreting. A simple reader cannot see that affiliation. In his book *Paratexts*, Gerard Genette develops the special pragmatic status of paratextual declarations requires a carefully calibrated analysis of their illocutionary force. With clarity, precision, and an extraordinary range of reference, *Paratexts* constitutes an encyclopaedic survey of the customs and institutions of the Republic of Letters as they are revealed in the borderlands of the text. Genette presents a global view of these liminal mediations and the logic of their relation to the reading public by studying each element as a literary function. Richard Macksey's foreword describes how the poetics of paratexts interacts with more general questions of literature as a cultural institution, and situates Genette's work in contemporary literary theory. Like Gérard Genette, Philippe Hamon (1982: 138) agrees that a title of a book or a novel is “strategic”¹⁸³.

A title is also part and parcel of the content of a novel. It is one of the clue which helps understand the book. Amma Darko's writing about the new problems of African big cities such as street children, juvenile prostitution due to globalization and urbanization, points an accusing finger on them as being post-colonial consequences to maintain African people in dependence and poverty, women being the first victims. She complains of urbanization under a weight of escalating population density as a vehicle of family dislocation and the disintegration of a traditional moral order, continuing high fertility and mortality and social dislocation that lead to women's abandonment, cultural breakdown and dire impoverishment. All this unfortunately creates street children phenomenon all over Ghanaian urban centres. As an illustration, when young souls like that of Fofu, Baby T and Odarley are dumped onto the streets, they are the possible victims of sexual predators such as Poison and Macho. Husbands and fathers often

¹⁸² Genette, G. (1987). *Paratext: Threshold of Interpretation*, trans. Jane E. Lewin (*Seuils*, 1987; Cambridge: Cambridge University Press): p. 1.

¹⁸³ Hamon, P. (1977). « Pour un statut sémiologique du personnage ». In : poétique du récit. Paris: Seuil, p. 115-180.

prove to be inadequate or incapable or simply absent and at worst their substitutes (step fathers and mothers' sex partners) may be selfish, hopeless, even abusive and furious and certainly uncaring to their partner's offspring.

In *Faceless*, the role of a father is shadowed by the writer in a constant absence that increases the risk of the children's liberty to move and go where they want. This children's freedom can affect their social education and thus leads them to juvenile delinquency. This is occurring in a context, Accra, which has been subjected to several centuries of cash market trading, a money economy, foreign exploitation and decades of colonialism and more recently partly neglectful and sometimes inadequate or corrupt national and local government. Amma Darko, surely but intentionally shows its importance because Maa Tsuru being alone, it allows her children (male and female) to make wrong decisions and she lets it happen as being also tired. As the narrator says through Ms Kamame:

In both cases however, the responsibility of the mother doubles. She becomes the only caretaker of the child's emotional or physical or financial needs. Or all three combined. That means performing the tasks of two. "hers and the absentee father." It is bad enough for a mother to have to perform the double role of any of the three. So if she has to take on all three...! "Which is what happens mostly in the former case. And if you are carrying a load and you begin to feel the first cracks of tension in the neck, what first thought comes to your mind? "Unload!" (Darko, 108-9)

On one hand, to unload the heavy baggage on her head, Maa Tsuru obliges insidiously her daughters to be sold for the sake of her relation with patriarchal instances; yet she does not sell her sons. She just allows them to go away with their possibilities to feed the family. On the other hand, the frequent absence of fathers in those families also implies a lack of paternal love in those children. It materializes itself like an invisible dark, firm and unbreakable line between the absentee fathers and the progenies and Amma Darko knows it well as her work as tax woman may have led her to venture in the sociology of Accra's families. The little Fofu has thus no respect to her stepfather because she does not know his importance. She sees him as the tribulation of the family. While referring to her substitute father, she never says 'father', but 'he' or 'him' or 'the man', as if he were a stranger or a common person. She also uses some adjectives like 'smallish' to refer to her stepfather's short-mind, height. In fact, her stepfather is a stranger to her and she feels no pity while talking about him with her mother. It seems a full repugnance when she says this:

Where is he, mother? she asked Maa Tsuru. Maa Tsuru winced. She attempted to say something but her voice failed her. She paused, swallowed saliva and tried again.

“He left.” She said simply.

“He left?” It was a wail of pain. [...]

“he left? And you stood by and just allowed this smallish man to leave? Just like that?”

What made him leave, mother? (Darko, 21)

The narrative illustrates the struggle of the oppressed versus their oppressor and here Fofu sees her stepfather as incarnating her mother’s predicament. She is angry to see her mother in the network of poverty and dumb submissiveness to a man, a smallish man who does not contribute in anything the house needs. Maa Tsuru’s silence depicts her helplessness and this fills her with sadness as the narrator puts “I have become a leper in my own home” (Darko, 19). The reference to Maa Tsuru’s being a leper provides evidence on her physical inability. Maa Tsuru believes intensely that she is living under a curse borne out of the declaration of her mother against her father. As if the curse was real and to continue to nurture gossips and suspicious eyes, Maa Tsuru’s choice of men in her life never works.

To parallel the situation, Amma Darko presents another family with the presence of the father to allow us to realize the importance of male presence in a family. Adade is somehow presented as a selfish and egocentric husband, nonetheless he is conscious of his duty to keep off sexual predators from his growing daughter, fortunately. The reality of male domination and oppression over women is acknowledged by Kabria because she does not reject her husband nor does she present him as a ‘problem’. She copes with his changing mood and then focuses on the positive qualities. Women like Kabria know that change is possible in men’s way of taking and viewing gender issues, but it depends on women’s manner of presenting them. Kabria knows that a change needs sacrifices and efforts from the women.

The novelist sets aside the conventions of traditional role of African men in society. The common role people entitle fathers in a family is that of settler, which often calls for decorum. But here Amma Darko speaks about issues that unsettle her audience radically. Some readers will think that she is building a society in which no male can leave because they set women unrest. They create a world of their own, so women create theirs through the ‘holy word’ of Amma Darko. In fact, Amma Darko creates women visible by bashing males and sustains space

and voice to her female characters. In the fashion of Jacques Derrida's *Of Grammatology*¹⁸⁴, Amma Darko creates a fictional narrative out of the peripheral subjects because most of her major characters are social rejects, homeless, housemaid.

Let aside the fictional face of Amma Darko's narrative, it is important to point out that she works for the Inland Revenue in Accra, and is totally aware of the reality of pauperisation, suffering and violence in those areas of Accra, with most actions fuelled by the will to survive at all costs; rank material ambitions and often untrammelled sexual drives. Amma Darko chooses rightly her characters to represent her overt opinion against Ghanaian governmental institutions which sole ambition is to collect taxes from those families and not preoccupied in their welfare. She portrays Ghanaian society through these characters' respectively families, just her own experience as tax woman in Accra's suburbs with its dry statistics of street children in a 'Heavily Indebted Poor Country'. Significantly, the physical absence of the father means the absence of affection from a father which creates an unbalanced relation between child/mother-father. The triangle relation of communication that creates affection, love and understanding does not exist and it leads Ma Tsuru family off track. Loneliness, poverty and social constraints block her vision to see far and then she welcomes the first opportunity granted by her little daughter labour with the pair Maami Broni and Mama Abidjan.

In these cities, some families become poorer and poorer, added to that, the extreme poverty and promiscuity create in them a weakness which impedes them to refuse to take part in the conspiracy against their own daughters' lives in *The Housemaid*. This moral weakness justifies what one of Wole Soyinka's character Bandele retorts when reacting against the cynic and malevolent proposal of the Doctor to abort a girl "As a Doctor of course...you prescribe death before dishonour [...] I hope you live to bury your daughters."¹⁸⁵ African society then fails to save its children in critical moments. As Wole Soyinka portrays the societal delinquency in his novel *The Interpreters* (1965), Amma Darko also shows the extent to which Ghanaian patriarchal society falls into mere materialism when, directed by a strong desire of getting wealth, a whole family accepts their little daughter take the risk to get pregnant and abort to survive in *The Housemaid* (1998). Amma Darko is a writer whose narratives confront patriarchal oppression and demonstrate quite evidently through her female characters a

¹⁸⁴ Derrida, J. (1974). *Of Grammatology*. Trans. Gayatri Chakravorty Spivak. Baltimore: The John Hopkins University Press, Print.

¹⁸⁵ Soyinka, W. (1965). *The Interpreters*. London: Heinemann, p 250-51.

resounding feminist position in how African women must rebuild their subjectivity from subaltern positions (Mara and Maa Tsuru); positions of disadvantage and subjection.

In her third novel (*Facesless*) Amma Darko begins with a dream of her protagonist which is achieved in the end. This gives right to Freud who proposed in *The Interpretation of Dreams* that “A dream is a disguised fulfilment of a suppressed or repressed wish” (Freud: 160). The fortunate fulfilment of the dream is realised thank to her determination to go forward. With the help of Amma Darko’s own agency (MUTE¹⁸⁶ NGO) she creates to rescue Fofo (a nameless street girl) by the force of ‘Alternative Library, meaning in fact education, the decision to help. This proves that two essential elements are possible as far as a policy of rescue is concerned. One needs a team work and education to save children from the streets in any African country. Our point of view is back up that of former President of South Africa who states that “education is the most powerful weapon we can use to change the world”. Therefore, as the young Fofo’s need is urgent and requires team work rather than individual, so does that of any Ghanaian youngster and woman. So the intervention needs the presence of Dina, Vickie and Aggie, the other workers of MUTE because Amma Darko supposes that together they are strong and can share experience. Amma Darko also presents the MUTE’s workers’ lifestyle as largely different from that of the street children’s. Both of them live in different world and belong to different social class. Whereas there is grinding and permanent poverty in the family of the street children, the MUTE workers live in middle class and are not exposed. They can cover the basic and essential needs of a human being. In this sense, it is urgent to find a way to allow the margin, the subaltern to speak. Thereby lies the idea of Amma Darko to create the NGO as an alternative library, where to hear and record defenceless women and children in her imaginative Accra.

Nevertheless, as it is argued earlier, this is obviously applied to all the low families in contemporary Ghana. People need to be heard and recorded because Accra becomes a kind of ‘sin city’ where faceless and voiceless livings at the margin are terrorised, left off or murdered. Just like the scenes from the movie *Sin City*, the female characters when they notice the importance of their teamwork to fight the crime directed to them by the male characters, their ex-pimps, they gathered in a network, armed themselves and stood against their marginality. They defended their territory and even conquered the neighbouring ones. In effect, to defend the

¹⁸⁶ MUTE: an acronym which mission is the contrary of its spelling because ‘mute’ is to silence.

thesis of margin rescue, bell hooks writes about the necessity to help people that kind by probing the psychological limits in the margin and then give all the means to cure them. It is after that therapy that a ‘subaltern can speak’ as to respond to the question of the prominent Indian critic Gayatri C. Spivak that is “Can a subaltern Speak?”

To interpret the experience, we know that Freud developed an important stream on dream. So far through the action of rescuing the little Fofu, Amma Darko shows the way to rescue the whole Ghanaian society. The attitude of Amma Darko in the text proves that dreams are not worthless fantasies, on the contrary one should not attempt to collapse the world of dreams with reality. The young girl represents here the generation to come, to grow and to lead, so it is important to give her chances to leave the streets and live her whole dream. Amma Darko creates an akin female Agency and radio station in her fourth novel *Not Without Flowers* to defend and save women from widowhood wicked and deviant practices. According to Ofose (2013:188) Amma Darko’s way of portraying real societal facts in her fiction is called “an objective feminist literary voice” which aim is to identify and expose societal ills against women. Amma Darko lets Fofu acts like a boy, the same way the matriarch Ama Ata Aidoo depicts Anowa as a strong woman who never permits failure and corruption.

4.3. Writing Black Feminism

Feminism has its origin in the struggle for women’s rights. The first movements began in Europe in the 1900, then it came in America few years after. African women discovered the movement in the late 1970. At the present, feminism has spread all over the globe and has been targeted a movement against men and their manhood because of its being painfully documented only. The movement’s opponents identify it as a lesbian one which is against the cultural values of Africa. Feminist ideas are now part of everyday thinking. Its definition varies from a continent to another. The idea that women writers and critics have been silenced by, and largely excluded from, literary history led them to create the movement. According to Barrow and Milburn (1990: 128) feminism is “a label for a commitment or movement to achieve equality for women”¹⁸⁷ and Maggie Humm (1992: 1) says “the word feminism can stand for a belief in sexual equality combined with a commitment to transform the society”¹⁸⁸.

¹⁸⁷ Barrow, R. & Milburn, G. (1990). *A Critical Dictionary of Education Concept*. (2nd Edition). New York: Harvester Wheatsheaf, p. 128.

¹⁸⁸ Humm, M. (1992). *Feminisms: A Reader*. New York: Harvester Wheatsheaf, p. 1.

Etymologically, feminism comes from the Latin word ‘femina’ which means women’s issues. Hence, feminism does not just attack biological, but also social, cultural, class issues that oppress women. But the aim was not simply to fit women into the male-dominated tradition. Rather, they wanted to produce the history of a tradition which has forgotten them for a long time. Women felt some strong affinity for each other according to Virginia Woolf. Yet, the special touch of African women is that it does not exclude men like what Chimamanda Ngozi Adichie and bell hooks defend in our introduction. Men can be also members of the movement to liberate women. bell hooks calls the inclusion of men in female revolution as a visionary feminism¹⁸⁹. Their advice is very important. That is why Pauline Hopkins wrote this urging collaboration in *Contending Forces: A Romance Illustrative of Negro Life North and South* (1900) “we must ourselves develop the men and women who will faithfully portray the inmost thoughts and feelings of the Negro with all the fire and romance which lie dormant in our history, and, as yet unrecognized by writers of the Anglo-Saxon race”.¹⁹⁰ It is important for African women writers to band together to promote themselves and to find male sponsors who are willing to help them with their cause. The categories of texts must put women forward and give them prominent roles in societies. Those writings can also depict women in real confronted with the erected constraints of patriarchal society to impede them from moving forward for their rights.

Although the text reflects the imagined reality of the post-independence period, Amma Darko participates in what MaryEllen Higgins, citing Odile Cazenave, has recognised as a discourse of the motif of the African woman who prostitutes her body in order to “provide materially for her family”¹⁹¹. Amma Darko rightfully “advocates strong perspectives”¹⁹² that critique the ways women are objectified for economic exchange through the various socio-

¹⁸⁹ “Visionary feminism is a wise and loving politics. It is rooted in the love of male and female being, refusing to privilege one over the other. The soul of feminist politics is the commitment to ending patriarchal domination of women and men, girls and boys. Love cannot exist in any relationship that is based on domination and coercion. Males cannot love themselves in patriarchal culture if their very self-definition relies on submission to patriarchal rules. When men embrace feminist thinking and practice, which emphasizes the value of mutual growth and self-actualization in all relationships, their emotional well-being will be enhanced. A genuine feminist politics always brings us from bondage to freedom, from lovelessness to loving.” bell hooks.

¹⁹⁰ Hopkins, P. (1900). *Contending Forces: A Romance Illustrative of Negro Life North and South* (Boston: Colored Co-operative Publishing House in *Feminist Literary Theory: A Reader*, (2009). (Third Edition). Pondicherry, India: Mary Eagleton: Wiley-Blackwell Publishing Ltd.

¹⁹¹ Higgins, M. E. (2007). “Ngambika and Grassroots Fiction: Amma Darko’s *The Housemaid* and *Faceless*.” Ed. Vincent O. Odamtten, *Broadening the Horizon: Critical Introductions to Amma Darko*. London: Ayeibia Clarke Publishing, pp.58-70. Print.

¹⁹² Alternative Library which will be discussed in the coming section.

cultural formations of this changing society of Ghana and by extension to all African societies. This too has been part of Buchi Emecheta's struggle as an African female writer. She has insistently described this permanent objectification of the female body in *The Bride Price* (1976). Her protagonist Aku-nna's bride price, a fee that is traditionally paid by the prospective husband's family for the prospective wife, has been claimed for by her stepfather to enhance his 'chi' (traditional chieftaincy) and become one of the notable of Ibuza. Emecheta's illustration means to show how an African woman is torn apart to fulfil her 'destiny' being part of patriarchal commodities.

It would seem from this position that the use of Chike side by side with Aku-nna in Emecheta's fiction stands for two ideas. The first confirms Aidoo's agreement about the heterogeneity of feminism. She once puts "men can also be part of the feminist struggle". The second reason is an appeal for the sacred union between social minorities to form a compact group for struggle. Emecheta also bears this point of view once during an interview with Marie Umeh quoted by Modupe Kolawole:

I am a feminist with a small 'f'. I love men and good men are the salt of the earth. But to tell me that we should abolish marriage like the capital 'F' (Feminist) women who say women should live together and all that. I say No. personally I'd like to see the ideal, happy marriage. But if it doesn't work, for goodness sake, call it off. (Marry Umeh, in Modupe Kolawole, 1997)¹⁹³

But this has been viewed as a mere provocative and defeatist voice by the feminist hard-front liner, Molaria Ogundipe-Leslie. She strongly frowns at these denials by some African feminist. She wonders why they should deny feminism 'as if it were a crime to be a feminist':

I would put this down to the successful intimidation of women by men over the issue of women's liberation and feminism. Male ridicule, aggression and backlash have resulted in making women apologetic, and the term "feminist" a bad name. Yet nothing could be more feminist than the writings of these women writers, in their concern and deep understanding of the experiences and fates of women in society. (The Guardian, 1983 quoted in Buchi Emecheta: Beyond the Task and the Mask-Olawale Taju Ajayi)

¹⁹³ Kolawole, M. E. Modupe (1987). "Womanism and African Consciousness". Trenton, New Jersey: African World Press.

On her side, Molara defends the impossibility for a man to be part of it, except being the villain, for the movement has been created because of patriarchal subjugation and women undermining years over years. Therefore, African feminists should be aware of these three key aspects of herself (1) she is a woman, (2) she is an African, and finally (3) she is a third world person (Molara Ogundipe-Leslie, 1987).¹⁹⁴ How could then a man be apart it? Molara's position is also shared by Amma Darko to some extent because of her special touch of "male-bashing"¹⁹⁵ or male-shadowing in her novels. To believe Amma Darko, man is the only responsible for women's hardship, so he cannot be included as part of the battle. Amma Darko demonstrates her faithfulness in this stream of consciousness of Molara in all her novels. She attempts so cheerfully to portray her male characters as dangerous, materialistic, hot-blooded, aggressive and selfish. She carves out a distinct identity for her female characters, thereby providing a unique tradition within the existing literary canon. Quickly on the literary stage, her works have earned the name, "feminist works", and have already attracted varied criticisms from critics and readers, depending on where such individuals stand as far as gender issues are concerned.

In *Broadening the Horizon: Critical Introductions to Amma Darko* (2007), the book of critics concentrates on women as 'victims of patriarchal violence'. Amma Darko portrays her male characters in such a 'disdainful manner' that it seems all the blame rests on male-oriented and materialistic society. During an interview with Raymond Ayinne (2004) Amma Darko confesses:

If we're writing, probably there is some pain that has to come out. And I think rather than take it as male-bashing, you must take it as a mean to better understand the women folk of Africa. You were always portraying us as all-enduring, all-giving mothers and that is the attitude we find in males, but I don't want to be all-giving all the time, I don't want to be all-enduring, I want to be angry, I want to react, I want to speak it out with no moderation (my italics).¹⁹⁶

The aforementioned passage is crystal clear. Women have the right to rebel against their 'master', for they do not want to be always all-enduring, all-giving and all forgiving.

¹⁹⁴Ogundipe-Leslie, M. (1987). "The Female Writer and her Commitment" in Jones, E.D., Palmer, E. and Jones, M., *Women in African Literature Today* 15, London & New York: James Currey.

¹⁹⁵ Adjei, M. (2009). "Male-bashing and narrative subjectivity in Amma Darko's first three novels", in *SKATE Journal of Literary Studies*, vol. no. 1. pp. 47-61.

¹⁹⁶ *Ibid.*, p. 49.

Correspondingly, in Toni Morrison's *Beloved*, slaves find no excuse their owners as will retaliate violently or escape when an opportunity arises. So much so that including a man in the movement is to inform the master about the strategy and the date set for running away, not a well-advised thing to do. W. Andrews points out that:

Slave narratives show that slaves suffered physically, emotionally, and spiritually under slavery; that slaves yearned for freedom and resisted slavery in every possible way; that slavery was a pernicious system ultimately destroying masters as well as slaves; that the narrators were telling the truth about their own experiences; and that each narrator was a "reliable transcriber of the experience and character of black folk"¹⁹⁷.

Likewise, according to Umezurike Uchechukwu Peter, Amma Darko's fiction essentially "tackles the (tragic) experiences and fate of African women caught in the stranglehold of patriarchal structures and how these women strive to achieve agency in such debilitating conditions"¹⁹⁸. In his "Introductions" to *Broadening the Horizon: Critical Introductions to Amma Darko*, Ghanaian poet and critic Vincent O. Odamtten observes that Amma Darko's writing has "elicited sophisticated readings that represent a variety of ideological perspectives and to some extent, divergent positions in feminist, deconstructive and post-colonial criticisms"¹⁹⁹. In *Beyond the Horizon*, Amma Darko portrays her male characters so plainly that it renders them visible and present in the text. Akobi is described as a 'boy' not a man, meaning he is immature. He is also of "big flat nose"²⁰⁰, meaning he is not good looking and Amma Darko portrays these parts of his physical appearance purposely. The representation of his face in the novel gives access, through the effect of presence it creates, to his privacy or the interiority of the subject. Amma Darko is implying that Akobi is an ugly boy, a portrait which induces the ugliness of all the male characters in the text. In Naka, only boys from rich family like that of Akobi Ajaman could go to school and Akobi is the first Naka's son ever to earn a Form Four General Certificate, and as a return, the only profession he can find with that degree is 'messenger clerk in ministries'.

¹⁹⁷ William, L. Andrews (1988). *To Tell a Free Story: The First Century of Afro-American Autobiography, 1760-1865* (Urbana), p. 1.

¹⁹⁸ Umezurike, Uchechukwu Peter (2015). Resistance in Amma Darko's *Beyond the Horizon* and Chika Unigwe's *On Black Sisters' Street*. *An International Journal of Language, Literature and Gender Studies (LALIGENS)*, Ethiopia Vol. 4 (2), Serial No 10, May, 2015: 152-163 ISSN: 2225-8604(Print) ISSN 2227-5460 (Online), pp. 152-163.

¹⁹⁹ Odamtten, V. O. (2007). "Introduction: Beyond the Comfort Zone." Ed. Vincent O. Odamtten, *Broadening the Horizon: Critical Introductions to Amma Darko*. UK/London: Ayebia Clarke Publishing, 1-11. Print.

²⁰⁰ Darko, A. (1995). *Beyond the Horizon*. Harlow, Essex: Heinemann, p. 10.

It is important to note that messenger clerk is the most inferior position in any administration in African and even in European countries. This implicitly means that Akobi is not intelligent enough to major to another higher degree though being the ‘*star*’ in his village. In getting married with Mara, Amma Darko makes him be her problem, the nightmare, and unfulfilled dream, ‘the door’ through which come all the trials faced by the female protagonist.

Throughout the novel, Akobi Ajaman, Mara’s husband and finally Mara’s pimp is given negative talks and is painted as brutish, very wicked, exploitative, eccentric, materialistic, lustful, greedy, deceitful, manipulator, reckless and heartless, all that fits a bad and dangerous man. He is an authoritative and shockingly brutal character:

Then suddenly there was this angry roar of, ‘Get up!’ like an over-irritated boar and the next second I was up at attention on my two feet. I didn’t know which I was most, scared, angry or perplexed. He studied me like he was studying filth [...], and before I knew what was happening...Wham! first slap...wham! wham! wham! three more in succession. And I scurried into what had now become my favourite corner, slumping to the floor. What had I done wrong? But I was to be given neither reasons nor explanations. (Darko, 17)

This scene of violence is preceded by Mara’s announcing her new condition, as a mother-to-be. In such a case, any expectant woman would normally expect her husband to be tender, solicitous of her wish, and rejoice over the prospect of becoming a father; oddly enough, the only return is a roar and a bullying. The autodiegetic narrator in Amma Darko’s *Beyond the Horizon*, Mara, is constantly battered by her husband at the least peccadillo. Mara’s pathetic perpetual ordeals from her brutish husband ring as follows, “When I forgot the chewing stick for his teeth, which he always demanded be placed neatly beside his bowl of served food, I got a slap in the face. And when the napkin was not at hand when he howled for it, I received a knuckle knock on my forehead (Darko, 19). The frequent beatings from her master are for a purpose: to render Mara totally obedient in the same way as slave drivers beat, raped, tortured, branded their names or their owners’ name on their backs and locked them in a-one-for-four room before ‘importing’ them to the Americas. Mara runs back home to her parents as she cannot bear the physical and emotional sufferings with her slave-owner-husband as some slaves escaped sometimes from Cape Coast castle²⁰¹ to safety, but the security around the castle and the

²⁰¹ When one takes a close look at the coast of Ghana, one finds myriad of ancient castles and forts where slaves were stocked, goods like, before their perilous journey during the slave trade. These fortresses were the last

surroundings villages was so though that they were returned back. In the same way, Mara is obliged to come back to Accra. The second reason she leaves her husband is because her egg business is no longer thriving due to her fight with Esiana (Darko, 27), unfortunately her husband does not back her up and share the rack with her. When back home, nobody sympathizes with her. This attitude of her own people disappoints her seriously, in spite of her sister's encouragement. She knows that she has lost hope to be saved. She is materially on the 'gate of no return' when her father uses her bride price to marry another wife. The society Amma Darko portrays in her novel stringently repeat to her at the end of her marriage rites the importance of her "obeying and worshipping her husband" (Darko, 13).

In this wake, Célestin Gbaguidi posits that "'Hatred' towards male characters in Amma Darko's [...] seems obvious since they are assigned wicked roles in the story. Male characters are taken as useless and irresponsible partners."²⁰² (Darko, 23). Old age people in African settings as Ama Ata Aidoo tries to demonstrate in *Anowa* are the eyes (to see very farther) and mouth (to speak the truth) of consciousness. They symbolize wisdom and knowledge. Likewise, Amma Darko uses an elderly character, Mama Kiosk, to warn the protagonist to open her eyes to the situation, not just like a green wife, a fully obedient girl. Mama Kiosk puts as follows, "this your Ministries man, he is not only a bad man and a bad husband, he has also got something inside his head. I only hope that he won't destroy you with it before you too start seeing red with your eyes like I do" (Darko, 17).

In the above chapter, one can see that we describe very briefly some characters in Amma Darko's fiction through having to tackle it in the third part of our work. It is crucial to make the task to let flicker characters' view for the reader to have a slim size of the characters. In fact, striking in Amma Darko's portrayal of male characters principally in her novels is her tactical move to reduce or deflate characters that perpetrate violence in the society while at the same time advertising or inflating female characters. Male characters' deflating in Amma Darko's novels is usual. In fact, Amma Darko deflates male characters to empower the female ones. It is her way to censure masculinity in African society. As pointed out by L. Clemence Cakpo-

memory slaves had of their homeland before being shipped off across the Atlantic, never to return again. These fortresses started being built in 1482 following the arrival of the Portuguese on the Gold Coast in 1471 and served to protect the Portuguese settlement area.

²⁰² Gbaguidi, C. (2013). "Misandry in Amma Darko's *The Housemaid*," in *Safara: Revue Internationale de Langues, Littératures et Cultures*. Saint Louis: Université Gaston Berger/Sénégal, N°12, ISSN 0851-4119.

Chichi-Zanou's and *al* article: "Amma Darko's Contribution in Beyond the Horizon to Contemporary Gender Portrayal", the technique "aims at rejecting the image depicted by African male writers and opens the floor to male characters portrayal as violent, selfish, and responsible for women's social and economic hardship"²⁰³. Amma Darko portrays gender issues at its best in Ghana. Every part of Ghana oozes out discrimination of various forms and dimensions. Amma Darko's method in the novels is that she uses these everyday practices to portray her disgust and hatred of the state of affairs in Ghana. Therefore, it is worth announcing the state of mind of some of the characters in our first chapters before dealing with them very seriously in the last one.

The aim of the following chapter is not to question the possibility of representing female characters' sufferings, but rather in African literary art to help transcend its own essence and limitations. By gathering critical studies that explore diverse bodily and psychological traumas expressed through a broad range of literary genres, the section will interrogate the way these expressive forms evoke a terrible reality and a whole life experience through imagination. If art is a medium for aesthetic, cultural, and ethical transmission of pain, writers are agents whose reflective witnessing and testimonial bring the addressee to comprehension, empathy, and understanding, or discomfort, rejection, and abnegation. Where the artist conveys the horrific event, the readers, the listeners or the viewers are necessary recipients, allowing trauma to finally be communicated and shared. However, when the message is spoken out, is the traumatized cured or made to fall in his trauma with no return?

²⁰³ Cakpo-Chichi-Zanou, Cl. ; Gbaguidi, C. & Djossou, A. (2017). "Amma Darko's Contribution in Beyond the Horizon to Contemporary Gender Portrayals" in *Africology: The Journal of Pan African Studies*, vol. 10, n°.1, pp. 111-139.

Chapter Two: Amma Darko's Act of Writing Her Way

When talking about women's creative works, we refer to the African and African-American female scholars, writers and critics like Alice Walker²⁰⁴, who first dared to stand on their feet against pre-established male stereotypes. The American novelist furthered her study and coined 'womanism' as a literary theory like feminism but that which embodies both the frustration and promise of black feminist criticism. It is then black feminism as it wants to detach from that of Europeans. As a group, they are distinct from white feminists because of their race, and that they have experienced the past and present subjugation. The term womanism shows black feminists readiness to reframe the sexual debate around culturally specific differences between white women and black women. The cores values of the theory help to fashion a framework of feminist resistance to patriarchy²⁰⁵ from an African perspective. The works of most of these female writers, with their focus on presenting or analysing women's experience, have gradually consciously or unconsciously carved out a distinct identity for themselves, thereby providing a unique tradition within the existing literary canon. They celebrate womanhood in general and motherhood in particular as the means to forge out their usefulness in African societies.

As a matter of fact, this chapter tackles the critical issue of an African type of feminism through female depiction of male characters using African cultural values and day-to-day realities. The chapter aims at revealing that Ghanaian feminist scholars like Efua T. Sutherland and Ama Ata Aidoo have tried to develop their own type of African feminist theory in their creative writing. Their approach is to correct the long-standing negative image depicted by African male writers. Above all, Ama Ata Aidoo's writings are representative of her own life and struggle to find an identity as a free, active and independent woman in a patriarchal society. She rejects the status quo of Ghanaian women: "In so many great literatures of the world, women are nearly always around to service the great male heroes. Since I am a woman it is natural that I not only write about women but with women in more central roles, the story which

²⁰⁴ Alice Walker (born in Feb 9, 1944) has been defined as one of the key international writers' of the 20th century. Walker made history as the first African-American woman to win a Pulitzer Prize for Literature as well as the National Book Award in 1983 for her novel "*The Color Purple*," one of the few literary books to capture the popular imagination and leave a permanent imprint. The award-winning novel served as the inspiration for Steven Spielberg's 1985 film and was adapted for the stage, opening at New York City's Broadway Theatre in 2005, and capturing a Tony Award for best leading actress in a musical in 2006.

²⁰⁵ Allan, J. T. (1995). "Womanist and Feminist Aesthetics". Athens & Ohio: Ohio University Press, p. 6.

is being told is normally about women [...]”Ama Ata Aidoo).²⁰⁶

This concerns the documentary account of male characters fictionally but with some facts taken from society. However, according to Philip Hamon, no discourse is realistic because a story is particularly written to entertain. A narrative is a story written to inform. It cannot be essentially real (P. Hamon, *Littérature et Réalité*: 150). Then, the portrayal of male characters in female writings that underlines men as rude, savage, liar, selfish, and responsible for the women’s social and economic hardships is to prove women’s presence to rehabilitate their image. As with other African women writers, to use Busia’s words (1989-90: 90), “Aidoo challenges, deconstructs, and subverts the traditional voicelessness of the black women trope”²⁰⁷. Ama Ata Aidoo challenges the existing order by giving her female characters’ power to talk, react and even retaliate against masculine violence and supremacy. Hence, Ama Ata Aidoo advocates that particularly Ghanaian feminism should not exclude men who want to take part in the struggle, the movement being not restricted to women only, since African development is not for women only:

I should go on to insist that every man and every woman should be a feminist especially if they believe that Africans should take charge of African land, African wealth, African lives and the burden of African development. It is not possible to advocate independence of African development without also believing that African women must have the best that the environment can offer. For some of us this is the crucial element of feminism.²⁰⁸



In the above passage, Ama Ata Aidoo wants her female counterparts to accept men being part and parcel of the movement. The politics of patriarchy have suppressed women’s voices in society, so it can be good if those men are part of the struggle to help find solution. This could induce their attitude’s change toward women’s rights in patriarchal societies. Ben Agger (1998) states that “the major achievement of feminist theory is to make the politics of sex and gender central to understanding oppression. However, feminist theory is not only about understanding but also about action”²⁰⁹. A goal of the feminist project is to end the oppression of women and attain social equity for them. Among other action in the same vein of struggle, we have the

²⁰⁶ Ama Ata Aidoo in: <https://www.w4.org/en/voices/african-poet-ama-ata-aidoo/>

²⁰⁷ Busia, A. (1989-90). “Silencing Sycorax: On African colonial discourse and Unvoiced Female”. *Cultural Critique* 14:pp. 81-103.

²⁰⁸ Aidoo, A. A. (1998). “African Women Today” in *Sisterhood Feminisms & Power: From Africa to the Diaspora*, O. Nnaemeka, (ed.) (Trenton, New Jersey: Africa Wide Press).

²⁰⁹ Agger, B. (1998). *Critical Social Theories: An Introduction*. Boulder: Westview Press.

‘women right to suffrage’ in the USA in 1920. In that period, while some women were used to cripple the fight, some men were actively engaged to support. It took activists and reformers nearly one hundred years to win the campaign. In the same vein, Amma Darko’s arrival on the literary stage to partake in the struggle for mind change of men is beyond description either in novels. As if Ghanaians have been waiting for a long time for an angel, Amma Darko arrives with her creative writing painted by a special touch.

5. The act of writing: Telling Trauma

Telling or writing trauma is the most important and recurring part of African writing. Fiction writers could not write about a topic if they have not been previously told about or read about since fiction is drawn from real life. Writers cultivate the seed that has been planted in them through oral literature. For example, Chimamanda Adichie Ngozi’s *Half of a Yellow Sun* (2006) and her novella “A Private Experience” (2004) foreshadow the female writer’s hearing about Biafra impassioned struggle to establish an independent republic. Being an Igbo native, she may have heard and read many times about that traumatic story and the devastating consequences her community has been bearing since then. Thus, it is necessary to diffuse that trauma. To Chimamanda Adichie Ngozi, the revealing of the trauma is so urging and necessary that she launched in 2013 the cinematographic adaptation of the novel *Half of a Yellow Sun*.

The influence of that traumatic past is exposed in Petar Ramadanovic’s *Forgetting Futures* (2001): “a discourse about the past is overwhelmed by certain present conditions”²¹⁰. The consequence is that African literature becomes right from the start “both performative and referential, the writing both enacts and describes the trauma”²¹¹. Then mostly, one of the strongest themes in African literatures is the urge to bear witness, to testify to the people the truth of their experience. This is the responsibility as survivor and to reconstruct hope in people and working to prevent the enactment of similar horrors in the future. But, the therapy does not work sometimes. Civil wars, bloodsheds and permanent violence are still African people’s lot in many countries. The recent genocide in Rwanda is still fresh in the collective memory of this traumatized society. Permanently, Rwandans are scarred by divisions, collective resentment and

²¹⁰ Ramadanovic, P. (2001). *Forgetting Futures: On Memory, Trauma, and Identity*. Lanham: Lexington Books.

²¹¹ Woods, T. (2007). *African Pasts: Memory and History in African literatures*. Manchester: Manchester University Press, p. 42

animosity. The commemoration of that genocide becomes a heavy and anxious moment each year. Then, telling trauma allows its writer to highlight each character's miseries, fear and hope.

In essence, the original meaning of trauma itself in both English and German derives from the Greek *trauma*, or 'wound' "referring to an injury inflicted on a body."²¹² Historically, it is Sigmund Freud who deepened the concept of trauma by turning to literature to describe the specific point in traumatic experience. But what seems to be suggested by Freud's *Beyond the Pleasure Principle* is that "the wound of the mind, the breach in the mind's experience of time, self, and the world, is not, like the wound of the body, a simple and healable event, but rather an event that repeatedly imposes itself in nightmares and repetitive actions of the survivors"²¹³. About the trauma writer, the scholar Subbar Mir posits that "He regards the novel not as an attempt to make the characters work out through action rather a flash back to the traumas that shaped their psychologies i.e. it depicts philosophical and psychological implications of history and memory by exposing private haunting without any deliverance²¹⁴". For example, Ama Ata Aidoo's writing about slavery in *Anowa* is the consequence of her hearing African oral literature power about it from her mother and also her seeing the El Mina Castle standing in Cape Coast (Micere Mugo, 2010)²¹⁵ and similar to Amma Darko's life experience of domestic helps her writing so cheerfully *The Housemaid* and Mara's hardship in Pompey's brothel stands for her frequent encounters and conversations with the Ghanaian prostitutes she met in Germany. In this regard and from Sindiwe Magona's point of view writing trauma serves as:

therapeutic because there is something soothing about talking an ache and bringing it out under the light, holding it to the light, and seeing it for what it is. In a way it's a form of letting go; it's part of the process. You may even cry doing it, you may even get angry doing it, you may re-experience all the motions that you walked through, but in putting it out, in sharing it with others, in getting reactions of other people who underwent similar experiences, you might find solace and even a better understanding. You might grow away from the pain.²¹⁶

²¹² Caruth, C. (1996). *Unclaimed Experience: Trauma, Narrative, and History*. Baltimore, Maryland: The Johns Hopkins University Press, p. 3.

²¹³ *Ibid.*, p. 5.

²¹⁴ Subbah, M. (2016). 'Shock in War-Gothic': Exploring War Shock and Trauma in Pat Barker's *Another World* in *Journal of Literature, Languages and Linguistics*, ISSN 2422-8435, An International Peer-reviewed Journal Vol.21.

²¹⁵ Micere, M. (2010). *A Conversation: Ama Ata Aidoo with Micere Mugo*. Interview, Brown University.

²¹⁶ Interview of Sindiwe Magona with Karin Orantes in *Trauma, Memory, and Narrative in South Africa : Interviews*, (ed.) Ewald M., Michela B. & Karin O. (Matatu 38; Amsterdam & New-York: Editions Rodopi, 2010), p. 36.

In the earlier stages of Sigmund Freud's psychoanalytical theory, trauma was basically seen as excessive influx of excitations which is related to the economic theory of Sigmund Freud, when excitation is at its top level, there is the traumatic effect. Trauma is a kind of breach, puncturing. Ego acts something like a layer, shield that protects the psyche from external stimuli, letting only right amounts. When the shield breaks, too much excitation comes in so general level of the circulation of the energy should be restored or reduced in order to restore the pleasure principle. This is the basics of the traumatic theory or neurosis in the early Freud. In trauma, a pathological defence is settled; in the normal state of things when the psyche is threatened by excitation, healthy ego redirects the attention to something else. When organism cannot deal with it, "the ego develops a pathological defence: Repression. The ego represses the excitation and this creates neurosis."²¹⁷ The details of the process by which repression changes a possibility of enjoyment into a source of pain are not yet fully understood, or are not yet capable of clear presentation, but it is certain that all depressive pain is of this kind, is excitation which cannot be experienced as described in Sigmund Freud's *Beyond the Pleasure Principle*.

For Sigmund Freud, in this early stage, 1895-1900, "this is basically the traumatic theory of neurosis. Freud considers trauma as a triggering factor in neurosis. Besides, he considers it as essentially sexual terms; overflow of the libidinal energy that the organism cannot bear"²¹⁸. Emphasis on the external effects isn't that strong in his theory; well, something happens for sure but the real trauma is inside the psyche. For example, "a sexual scene, seduction by adult become traumatic only later when something that reminds the subject occurs, and becomes invested with all fear, anxiety which the event elicited in the subject."²¹⁹ The ultimate feeling of 'not having been alone' to undergo this trauma, helps the storyteller to feel at ease. This is the first step to expel or to heal a trauma. To summarise Walter Ong's observations quoted in *Narrative across Media: The Languages of Storytelling*,

²¹⁷ Freud, S. (2012). *Beyond the Pleasure Principle*, London, Vienna: Paperback, p.22.

²¹⁸ Alparslan Nas in Jacques Lacan, Literature, Psychoanalysis, Sigmund Freud Trauma in Freud and in Jacques Lacan, p. 1.

²¹⁹ *Idem.*,

The contrast oral/written is felt in three areas: the pragmatic, or cultural, role of narrative, the shape of the plot; and the narrative themes, especially the presentation of characters. In oral cultures narrative used to be the sole vehicle of knowledge. Since stories deal with particulars, this affects the kind of knowledge being transmitted.²²⁰

Walter Ong's passage gives us insight on the relevance of the revival action that oral literature provokes in its listener as a key determinant of the 'burning' desire toward a written message. He illustrates further his point in the sense that: "Having heard perhaps scores of singers singing hundreds of songs of variable length about the Trojan War, Homer had a huge repertoire of episodes to string together, but, without writing, absolutely no way to organize them in strict chronological order."²²¹ Thus, it logically means that if the Greek poet Homer had not had the opportunity to live directly singers of Ancient Greece singing the mystic and mythic legacy of its great heroes, he could not have written down *The Iliad* and *The Odyssey* at that time. In spite of its being partly an invention, a fiction takes nonetheless and generally its source from past and present events and is nurtured by a good rhetoric. The modern African literatures have been in the same situation and so far, influenced to a remarkable degree by the continent's long tradition of oral artistry. Before the spread of literacy in the 20th century, texts were preserved in memory and performed or recited. A considerable number of epic, historical battles and wars were recited by thousands of guardians of tradition in African communities. Africa has this specific touch and manner which differ from the other continents. Examples are abound, but to cite only few we have Sundjata Keita, Samory Touré, Suny Ali Ber, Chaka Zulu, Gbè Hanzin, Ashanti Hene Prempeh. These traditional texts served many of the same purposes that written texts serve in literate society's entertainment, instruction, and commemoration, for example.

However, no distinctions were made between works composed for enjoyment and works that had a more utilitarian function. Quite clearly, this section is very large in scope and nearly indeed every African writer looks in the mirror of the past to go forward and to be relevant in their narrative. But what do we know about trauma? As far as Darko is concerned, how does she tell 'trauma' in her novels under study? While re-appropriating her people's history, Amma

²²⁰ Ong, W. J. (1982). *Orality and Literacy: The Technologizing of the World*. London: Methuen in *Narrative across Media: The Languages of Storytelling*. (2004). Edited by Marie-Laure Ryan, University of Nebraska Press, Lincoln and London, p. 29.

²²¹ Idem, p. 29.

Darko conveys the message about the importance of past events remembrance to build the present and better construct the future. The indication of the notion of trauma remembrance means that the present generation and that to come must be attentive about what happened, so that the hearing of cries of the victims should not happen in vain. African writers have a very crucial role to keep that inner flame burning and the dead revived.

5.1. Trauma and History Writing

Trauma, just like other psychosomatic concepts in medical history such as shock and stress, has been subjected to a variety of interpretations across disciplines since it emerged in the nineteenth-century as a notion to capture certain psychological experiences and conditions in modern societies and cultures. *The Concise Oxford Dictionary of Current English* defines trauma as “emotional shock following a stressful event, sometimes leading to long-term neurosis, an emotionally disturbing experience, any physical and emotional wound or injury.”²²² *The Chambers Dictionary* defines it as “a wound, an injury, an emotional shock” and traumatic as “causing a lasting emotional shock.”²²³ In our context of feminist approach, *The Chambers Dictionary* gives a more preferable definition of trauma as, ‘lasting emotional shock’ which is back up by an assertion from, this thematic becoming more popular in the past twenty years written themes in African literature. This analogical function here is more poignant. The analysis of trauma can then be extended to the feeling of the traumatized and the society that undergo this.

The traumatized decides to share the experience: the omnipresence of fear, the profound loss, of death and the possible strategies the person uses in order to survive. Claude Barrois posits that the point that matters in literary writings in a sense of metaphysical significance of death and violence.²²⁴ A traumatic experience may be unspeakable, but not necessarily unrepresentable. Even if a pain is a corporal expression of trauma, it can further isolate the victim with its crushing reminders of the event. J.-F. Lyotard argues that when a trendy occurs, it becomes an “event” precisely because it comes too soon in the development of that person or society’s knowledge for it to be understood as it happens. It instead takes place outside the scope of knowledge that exists within that situation. J-F. Lyotard carries on that “[w]hat is

²²² *The Concise Oxford Dictionary of Current English*, (1995). Ninth edition by Della Thompson, Clarendon Press. Oxford.

²²³ *The Chambers Dictionary*, (1993). Ed. Chambers Harrap Publishers Ltd, Edimburg, EH7 4AZ.

²²⁴ Barrois, C. (1994). "La psychologie du guerrier", *Sciences Humaines*, n° 041, juillet 1994, p. 17

already known cannot, in principle, be experienced as an event”²²⁵. In cases of hideous violence such as genocide, torture, imprisonment, and rape, conveying the experience through alternate modes of expression may, if not heal wounds left gaping for years and even decades, at least help the victim survive. Thus, the literary art is one viable mechanism for transmitting what was initially unspeakable. The unspeakable here is first about female destroyed identity depicted by male writers and the patriarchal and male-dominated setting into which gender issues are probed. That malevolent setting cannot allow women to speak out their way of performing things, but they have to in order to see their writings reckoned as creative art.

However, in a past colonized environment, there lies evidence that contemporary Africans write in order to lessen their trauma which is definitely part and parcel of their identity. Shoshana Felman (a literary critic and academic) and Laub Dori (psychiatrist) strongly believe that writing (literature) is one of the psychologically relaxing ways to diffuse trauma. Both researchers display their essay that “testimony has become a crucial mode of our relation to events of our times, our relation to the traumas of contemporary history: the Second World War, the Holocaust, the Nuclear bomb, and other war atrocities”²²⁶. Dori Laub pursues her point that “as a relation to events, testimony seems to be composed of bits and pieces of a memory that has been overwhelmed by occurrences that have not settled into understanding or remembrance, acts that cannot be constructed as knowledge or assimilated into full cognition, events in excess of our frames of reference”²²⁷. So, unless the victim of trauma accepts to share this part of his life, that he steps forward for convalescence to heal the past open sores, deep and stinking wounds. This simply means that leaving evidence is the first step to heal trauma.

Here Felman’s analysis is based on Sigmund Freud’s psychoanalysis theories. Thus, Shoshana Felman emphasizes the clinical dimension of bearing witness not only with the writer of the events, but also with the hearer who is “the blank screen on which the event comes to be inscribed for the first time”²²⁸. The opinion does not leave Van der Merwe and Gobodo-Madikizela indifferent. In *Narrating our Healing* (2007), they back up Felman’s idea that: “[r]econstructing the trauma into narrative form is one of the most crucial processes in the

²²⁵ Lyotard J-F. (1991). *The Inhuman*, Polity, Cambridge, p. 65.

²²⁶ Felman, S. (1992). “Education and Crisis, or the Vicissitudes of Teaching” Felman, Shoshana and Laub, Dori. *Testimony :Crisis of Witnessing in Literature, Psychoanalysis, and History*. New York: Routledge

²²⁷ *Ibid*

²²⁸ *Ibid*

journey towards the victim's healing"²²⁹. This is the reason why narratives have emerged from each corner of Africa to testify the trauma and to quench the thirst and the need to leave evidence to younger generation. And Chris Abani's narrative in *Song for Night* (2007) also corroborates this trauma lurking in the psyches of these little innocent beings in time of armed conflicts. A for-life-wound lies in the head of one of the children soldiers and he divulges:

Like a spider busy spinning a web, my mind weaves the night into terror. What does it mean to hide in a ceiling, in that narrow hot crawl space crouched like an animal smelling my own scent (...) while my mother stays below, in what seems like the brightest sunlight although it is only the light of a six-watt bulb, waiting to deflect the anger of people intent on murder, my murder, waiting so that I may live, and I watch what happens below and I am grateful that I can smell my smell, smell my smell and live while below it happens, it happens that night bright as day, but I cannot name it, those things that happened while I watched, and I cannot speak something that was never in words, speak of things I cannot imagine, could never have seen even as I saw it, and I hide and am grateful for my smell crouched like an animal in that dark hot space.²³⁰

The trauma is so harsh and vivid in the child's mind that he compares himself to a spider obliged to hide himself to feel secured and keep his vulnerability unnoticed. But this youngster is forced to witness the murder of another little girl, Faith. Here, Chris Abani's frequent reference to trauma leave the readers focused. It must inevitably draw their compassion to what can happen to children-soldiers. The narrative intentionally emphasizes surprised jet of blood drilling, extreme violence, AK47 shootings. Another example goes this way:

Barely a mile away, a man grabbed me. As I tried to grab my robe away from the man's clutches, my hand slipped on something hard and cold: the knife. I felt its sharp cut on my thumb goading me to action. I retrieved the knife. I struck. The first cut sliced off the man's finger, splashing surprised jets of blood onto his robes. A terrifying rage came over me and I slashed wildly, ripping gashes deep in the man's arms and face (...). It all seemed to happen in slow motion. (Abani, 95)

The second excerpt displays the horror that these soldiers live in the front line of the conflict and their struggle to forget it. What happens to these children also happened to slaves and then to African colonized in the past. For sure, it is this vital trauma sharing that helps

²²⁹ Van der Merwe ; Chris & Gobodo-Madikizela, Pumla. (). *Narrating our Healing: Perspectives on Working through Trauma*. Newcastle; Cambridge Scholars Publishing, p. 26.

²³⁰ Abani, C. (2007). *Song for Night: a Novella*. New York: Akashie Books, p. 43.

perpetuate African identity all the way. Here history, literature and trauma theory converge to make continuous what is discontinuous.

5.1.1. Trauma and Identity

The search for identity has always been a key issue facing mankind in its striving after significance and meaning. However, the African understanding of self is in crisis having been assailed from a number of directions. Rightly, the female Kenyan 2004 Nobel Peace Laureate Wangari Maathai, environmental activist and writer orates that if Africa is to build for the future it must first face its past. Books written to display African traumatic colonial history enumerate many of the problems faced by its people today stem from that past. These books tell of Africa's loss of identity under its transatlantic slavery, its colonial occupiers and the disintegration of societal hierarchies that had developed over centuries.

Apart from this, must not be forgotten is the thirteen centuries of the arabo-muslim slavery undertaken by the Arabic peninsula in Africa more violent and more dehumanizing than that of the Transatlantic. The Franco-Senegalese writer Tidiane N'Diaye reminds us of that in his book, *Le Génocide voilé* (2008): « Les déportés africains ont été soumis, dans le monde arabo-musulman, à des conditions d'exploitation et de survie comparables à un génocide méticuleusement préparé »²³¹. All this left the African continent physically and psychologically devastated and scarred. This unfortunately may prepare Africans to a tough present and future. At that point, their identity reinvention would be the most difficult element to gain back. This gives right to Frantz Fanon who forecasts the apocalyptic strategy of the colonizers against Africans identity in *The Wretched of the Earth*: “Violence in the colonies does not only have for its aim the keeping of these enslaved men at arm's length; it seeks to dehumanize them. Everything will be done to wipe out their traditions, to substitute our language for theirs and to destroy their culture without giving them ours”²³². This does not mean that Africans lose their struggle in advance and that it will receive no attention from others. Frantz Fanon warns the African continent to get ready for the struggle against any form subjugation, discrimination, racism, mental slavery.

²³¹ N'Diaye, T. (2008). *Le Génocide voilé : Enquête historique*. Paris: Gallimard, p. 227.

²³² Fanon, F. *The Wretched of the Earth*, p. 7.

The emerging thematic in African female writing is the representation or redefinition of female identity. The concept identity is of many folds' meanings. In fact, we distinguish a man from a woman by his or her head. An identity begins from that very point. Thereafter, come his personality, his ego and later what he has in mind. The character of a man is dependent upon which part of his mind dominates and triggers the outcome of his actions. To Sigmund Freud (1856-1939), the mind is in constant conflict within itself and also the cause of every anxiety, unhappiness as well as happiness of a man. According to Oxford English Dictionary, identity is "the quality or condition of being the same in substance, composition, nature, properties, or in particular qualities under consideration; absolute or essential sameness; ones"²³³. This is painted against the backdrop of various societal schisms that seek to keep status quo of the enslaved female in the continent's literature. In this light, early works of pioneers portrayed female characters as obedient, subjugated and submissive. However, with the coming of age of the group of female writers that T. Onwueme describes as literary foremothers, the resilience, inner beauty, radiating grace and energy, and faithfulness of the African woman started to be projected. Women then started their revolution started'. Sotunsa (2008) notes that:

The unfavourable portrayal of women by African male writers ignited a literary outburst which culminated in female writers attempt to counter the impaired picture of African womanhood by reversing the roles of women in African fiction written by men. African female writers began to present female protagonists who are pitted against all odds, yet emerge liberated and determined to exist with or without the man.²³⁴

Some female writers stood on their feet and drove the 'boat' of their identity back to reasonable pictures. Kauffmann argues that "identity is a permanent system of enclosure and integration of sense which basic model is wholeness"²³⁵. Then, a search for identity in this way can induce trauma and vice versa. The trauma's transmission depends on the person's capacity of memory and the female character of Amma Darko does not fail in the recollection of all that happened to her. This helps us introduce the female writing of trauma and identity. Hence, we

²³³ *Oxford English Dictionary* (1989). (2nd Edition) Murray James A. H.; Bradley, Henry; Craigie, W. A & Onionns C. T. Combined with A Supplement to the Oxford English Dictionary (ed.) Burchfield, R. W. Clarendon Press: Oxford.

²³⁴ Sotunsa, M. (2008). *Feminism and gender discourse: The African Experience*. Sagamu: Asaba Publishers, pp. 83-84.

²³⁵ Kaufmann, J. C. (2004). *L'Invention de soi. Une théorie de l'identité*, Armand Collin in *Identité (s) : L'individu, le groupe, la société* (2016). Editions Sciences humaines, p. 11. (l'identité au contraire ne cesse de recoller les morceaux. Elle est un système permanent de clôture et d'intégration du sens, dont le modèle est la totalité.

remark that Amma Darko special touch of telling trauma alongside with identity resides firstly in her using of the first-person pronoun narrative perspective in *Beyond the Horizon*. The second reason is the use of flashbacks as if biding the time to explain what happened in the past before the current event is now occurring. Amma Darko enlightens us about a story of a girl traumatized by her being abused, raped and stamped by her insecure husband obsessed by his acquiring quick wealth and living like Europeans. His capitalistic greed leads him to dump into prostitution own his wife. The attitude of Akobi and Osey denotes the ‘mal-être’ of Africans in Europe. Its source is far deep rooted in the dark period of colonization where the colonizer taught the colonized the way to accept to be subjugated and that his ceasing to be ‘other’ depends on his becoming completely European citizen. The black’s obsession grows greater and greater as his envy to escape the ‘nervous conditions’ boils inside him to borrow from Frantz Fanon’s *Black Skin, White Masks*.

The construction of race is for Fanon first and foremost designed toward the Black before being for any other in the world. So the negrophobia is visible in terms of racial discrimination. In that constructed cosmology, the Black takes as granted and normal that racial discrimination. The discrimination starts at the very moment when started racial categorisation and inferiority of a race from its skin colour. Mannoni emphases: “Le Noir a vraiment le mot *Nègre* écrit sur son visage²³⁶.” Therefore, the colonized sees himself as non-entity until he becomes a forced ‘black European’ like Akobi, Osey, Jean Veneuse the male character of René Mara and their alike. The Black turns his race to white in order to be sure he is accepted as a human being. His complex of inferiority is the “result of a series of aberrations of affect”²³⁷. Osey’s African wife also behaves the same way like her husband. She rejects her race not just because of her desire to have the German citizenship, but also she is psychologically attracted by white naked bodies and their long hair around her. In the second chapter of his book, Fanon emphasized the mental alienation a coloured woman named Mayotte Capécia which story was written in *Je suis Martiniquaise*: “I should have liked to be married, but to *a white man*²³⁸. But a woman of color is never altogether respectable in a white man’s eyes. Even when he loves her. I knew that”²³⁹. The passage above clarifies the motivation of the black woman which stand for

²³⁶ Mannoni, O. (1951). “La Plainte du Noir”, *Esprit*, n° 179, p. 743. “The Black has the word Negro written on his face”. (My translation).

²³⁷ Fanon, F. (1967). *Black Skin, White Masks*. (Trans.) Grove Press Inc, p. 41.

²³⁸ (the italics is mine)

²³⁹ Fanon, F. (1967). *Black Skin, White Masks*. (Trans.) Grove Press Inc, p. 28.

her desire to have as a husband white man in spite of the lack of love she may have. Frantz Fanon thought that it is pathologic for a colonized to whiten his blackness because of the fundamental desire to become ‘civilized’. Furthermore, the alienation of that coloured is so deep that Frantz Fanon illustrates her ignorance this ways:

Mayotte loves a white man to whom she submits in everything. He is her lord. She asks nothing, demands nothing, except a bit of whiteness in her life. When she tries to determine in her own mind whether the man is handsome or ugly, she writes, “All I know is that he had blue eyes, blond hair, and a light skin, and that I loved him.” It is not difficult to see that a rearrangement of these elements in their proper hierarchy would produce something of this order: “I loved him because he had blue eyes, blond hair, and a light skin.” We who come from the Antilles know one thing only too well: Blue eyes, the people say, frighten the Negro²⁴⁰.

This trauma of black people is an inheritance rooted in the colonization system. The burden of being considered as mere subjects in their own environment is a weight on their back until now. Many times, people try to take as dangerous and evil the black as colour. Here lies another illustration,

we can find, in Roget’s Thesaurus, over one hundred and thirty-four (134) synonyms for whiteness, most with positive connotations. In contrast, Roget’s Thesaurus tells us black means dirty, prohibited and funereal. It provides one hundred and twenty (120) synonyms for black and blackness, none with positive connotation. This is why a white lie is excusable; and black lie is all that is wicked and evil. Evolution itself moves from black to white. Indeed, even the Merciful God is white, with a bushy beard and bright pink cheeks. The conclusion: One is white as one is rich, as one is beautiful, as one is intelligent. And the corollary: he is Negro who is immoral. To become moral in this scheme of the universe, Fanon tells us, it is necessary to cease being a Negro, cease being true to history and himself²⁴¹.

The frantic and frenzied movement of Africans to become ‘White’ or to become European depends on their immigration and citizenship obtaining at all costs. Some of them are helped by their parents who think that the family future lies on their immigration to Europe. The idea of the ‘been-to’ is still vivid. A whole African village collects money to help a group of men to travel to Europe. When a ‘been-to’ returns home, his family and him are respected. In

²⁴⁰ *Ibid.*, p. 29.

²⁴¹ Sardar, Z & Bhabha, H. (2008). Introduction: “I think it would be good if certain things were said: Fanon and the epidemiology of oppression” in Foreword the 2008 Edition in Fanon, Frantz (1967). *Black Skin, White Masks*. (Trans.) 1986, Grove Press Inc.

the same vein of desolation, Frantz Fanon continues to illustrate rightly that black people identify a model of social class in a white colour, whiteness being the ideal to focus on, a model to desire. Likewise, the protagonist Jean Veneuse of René Maran²⁴² thinks that by loving a white woman, he could get to the ‘desired whiteness’ and then be accepted as white man, the highest colour hierarchy in his psychoanalytic neurotic mind. For instance, whenever a black man fails an “administrative transformation”²⁴³, he seeks his consolation in bleaching skin chemical products²⁴⁴ to remove his black skin. The black skin is the matter here because the black is not at ease with his skin colour, like Akobi and Osey are not. It is a curse to be black, so the two characters seek to be redeemed by getting married respectively to a German woman. They could become respected as the white skin confers to his bearer a title of ‘master’. African women are also obliged to do the same. In this physical acquired status is hidden a psychological motivation and Osey discloses it to Mara: “My wife came about nine months ago and is working to get plenty of money to marry a German man so that she too will have no problem living here. We do it because we have to” (*Beyond the Horizon*, 77). Thus, they get married to European men either to be granted the permission to live in Europe (the virtual model) or to be called ‘wives of white men’ in order to ‘shake aside’ their original colour. To illustrate this malaise, Homi Bhabha writes:

Whiteness, Fanon asserts, has become a symbol of purity, of Justice, Truth, Virginity. It defines what it means to be civilized, modern and human. That is why the Negro knows nothing of the cost of freedom; when he has fought for Liberty and Justice [...] these were always white liberty and white justice; that is, values secreted by his masters. Blackness represents the diametrical opposite: in the collective unconsciousness, it stands for ugliness, sin,

²⁴² René Maran was born on 5, November 1887 on the boat carrying his parents to Fort-de-France in Martinique where he lived till the age of seven. After that he went in Ubangui-Chari now Gabon where his father Héménéglide Maran worked as a representative of the colonial administration with his origin in slavery. René Maran was then a Guyanese poet and writer who died in 1960 in Paris. He may, in many respects, be considered a founding father of anticolonialism. He drew his inspiration for his novel *Batouala*, awarded the Goncourt prize in 1921, from that experience, unashamedly denouncing in its preface the abuses of the system in French Equatorial Africa. Considered after his death by Leopold Sédar Senghor as a precursor of Negritude, he remains without doubt an unavoidable point of reference in the colonial history of ‘Black’ literature.

²⁴³ To mean having a European citizenship materialized by a passport.

²⁴⁴ What is the best skin lightening soap for African Americans? There are different kinds of products for skin whitening. There are serums, creams, and soaps – all dedicated in helping make the skin a shade lighter – and even whiter. When it comes to soaps, it is important to do research and look for products that are worth buying. Furthermore, there are issues revolving soaps. One controversial ingredient, sodium lauryl, found in most shampoos can cause intense skin drying. Sodium lauryl forms suds that can sap away essential skin oil. Thus it is important to be meticulous about the soap that you are using. What is the best skin whitening soap? Look for best skin whitening soap reviews, ask experts about the most effective skin whitening soap, and look for best skin whitening ingredients. To add, here is the top 10 best skin lightening soap for African Americans. Retrieved from <http://beautylore.com/2013/04/29/most-effective-skin-bleaching-soap-black-women-america/>

darkness, immorality. Even the dictionary definition of white means clean and pure²⁴⁵.

So while projecting himself as a human being with needs, desires and wants, he lifts himself in a European context, not like a black man can do, but like white man norms dictate. We also find that because of these circumstances, Jean Veneuse feels lonely and has developed a hysteric complex rendering him inferior to his white woman Andrée Marielle, like Akobi does in front of Gitte. Many times, Akobi is ordered to cook evening meal by his white wife, something that can never happen with his African wife, Mara. Here we are with two scenes to illustrate, first:

Then somewhere along the line, Gitte must have issued an order to Akobi because I saw him nod obediently as she suddenly swerved round and thumped her way furiously towards the bedroom. He tottered behind her without a glance at me. [...] I saw it too clearly. Gitte had belittled him before my eyes and had brutally dented his ego (Darko, 96).

The second illustration is stated this way: “But Gitte responded reproachfully and gestured towards the kitchen. To this, Akobi got up lamely and went into the kitchen. My mouth fell open. I was shocked. Akobi to cook for me? Akobi [...] this own dear husband Akobi [...]. I needed time to let it sink” (Darko, 97). The protagonist’s repetition of the name of her husband proves how surprised she was to notice that the wicked and exigent man like husband she knew in Accra, grew into a docile man in Germany. In this context, Frantz Fanon is convinced that blacks and whites are operating on the basis of inferiority and superiority pre-requisite complexes, respectively. This attitude of Cobby cannot have occurred with his black wife. The complex of superiority of Akobi may have dictated him to order and stand still to see the result. The practice is evidently noticed in some African countries where black people want to cease to bear the colour of ‘evil’, the colour of failure and submission. Like Mayotte Capecia in Fanon’s *Black Skin, White Masks*, the attitude of Akobi and Osey is condemnable as their sole desire in Germany was to be converted into white no matter what happens and how it costs, for Mayotte Capecia confines that the simple fact that a man is white, he is desirable. Fanon condemns this male psychopathic behaviour and his condemnation and desolation upon black inferiority attitude are still relevant.

²⁴⁵ Bhabha, H. & Ziauddin, S. (2008). Forewords to Fanon, Frantz (1967). *Black Skin, White Masks*. (Trans.) Grove Press Inc, p.14

In the same light, the feminist activist Awa Thiam disapproves of that desire of physical transformation of Africans in *Paroles aux Nègresses* (1978). In that essay, she explains that when a black woman is in love with a white man, she devotes herself entirely to him because of his skin colour. She proves that this affiliation is the sum of the colonial brain wash which shows as model white skin colour and that a black man would love to be of white skin. This is in fact a final symbol of his alienation to whiteness and his disaffiliation to blackness. Awa Thiam declares that:

Some laboratories have in project to discover a bleaching skin product; some important laboratories have taken aside their test tubes, left their scales and begun research to help black women to bleach their skin and so help them bear the curse over their skin colour (My translation).²⁴⁶

Thus, the only action a black woman has to do to please her black man is to project herself physical and emotionally as a white woman, an image which is her other. In that case, the black is in deep alienation instead of liberation. In accordance with her disapproval of African women's psychological subjection, Awa Thiam wrote her insightful essay in 1978 and it is important to clarify that bleaching products from those laboratories are in all African countries. The chemical products help Africans to bleach their skin, though their blackness remains obvious. In fact, in *La Parole aux Nègresses*, Awa Thiam from an Islamic community represented the voice of voiceless and the face of faceless. She wanted things to change the same way her contemporary writer Amma Darko wants. The other similarity with both is that they all use the first person pronoun (I) which stands for (We). The pronoun (we) lies for the joint action that African women must have in common to confront their trauma and their struggle against the status quo. In the two female writings, women are talking to women and sharing intimate experience. Moreover, even if language sometimes cannot always adequately convey trauma, it has the capacity to contain heavy burden, what is not Mara's case. She speaks out her trauma. Here is one of her first battering scene with her supposed husband. Witness her confession:

²⁴⁶ Thiam, A. (1978). *La Parole aux Nègresses*, Paris, Denoel/Gonthier, I & II, p. 143. Here is Awa Thiam word « Depuis quelques années, des laboratoires ont projeté de découvrir un sérum de dénégification ; des laboratoires, le plus sérieusement du monde, ont rincé leurs éprouvettes, réglé leurs balances et entamé des recherches qui permettront aux malheureux Nègres de se blanchir, et ainsi de ne plus supporter le poids de cette malédiction corporelle».

I felt a painful kick in my ribs. Astounded to the point of foolishness, I jumped up in confusion. What had I done? He had never kicked nor slapped me before so what was wrong? He wasn't drunk. Before I could ask what I had done wrong, he bellowed angrily, 'You foolish lazy idiot! [...] You think here is a pension house?' [...] 'Shut up!' he roared, landing me a slap on one cheek. I scurried into a corner and slumped on the floor, my burning face buried in my hands. (Darko, 11)

It is obvious from the foregoing passage that Mara's husband is a rowdy, immoderate, tyrannical who wants to play it safe and craves recognition as a civilized person and a man of good manners with the other tenants of the eccentric Alhaji's "shabbily-constructed corrugated-iron sheet shelters, chicken houses like" (Darko, 8). The first experience of domestic violence opens the floor to a more brutal scene. Mara narrates that she is frequently slapped and kicked by her husband though being pregnant: "I got a slap in the face '[...] I received a knuckle knock on my forehead. He grabbed my left ear between his thumb and forefinger and, with my body slanted halfway towards him, my ears burning hot in pain, walked slowly and steadily with me back into our room. By the time he released me my left ear had gone numb" (Darko, 19). One might expect the feminist reaction of the authoress after having let the protagonist alone in her suffering. Mara meets then an old age person, Mama Kiosk, to share her suffering and to be counselled. Her association with the old ad experienced woman attenuates drastically her way of seeing things 'green'. She acknowledges the change:

Between Mama Kiosk and me now existed a mother daughter relationship. I had grown to trust her and to talk openly with her about everything. Then too she was the one person I spent most of my time with since I left in the morning with her to go to the station and returned in the evening with her. But probably what drew me even closer to her was that though I was well advanced in my pregnancy Akobi still wouldn't let me inform my people back in the village about it. (Darko, 23)

Amma Darko's feminist voice comes once more through the old age woman, Mama Kiosk, feeling the protagonist hurt, to show the place where brutish people like Akobi and his akin could live, "only bushmen beat their wives" (Darko, 22) and only animals live in bush. Here Akobi is perceived as an animal, someone to fear for. Things do not change till Mara is invited to come to Germany, where she thinks would be near heaven, where heaven is, and where peace reigns forever. Amma Darko highlights this innocent reflexion of Mara ironically to point out the hell like conditions awaiting her. Mara thinks naively that by accepting to turn her back to the past (Naka, Accra and her parents), she will face a bright and nice future; that's

why she foresees it as “a place so special and so very, and very far away, somewhere unimaginable, maybe even somewhere near Heaven, where not just anybody could go” (Darko, 34). The problem that literary critics face while analysing Amma Darko’s novel and its alike is its realism and the border between fiction and reality because no one has witnessed the events except the narrator and the writer. But here the narrator is an autodiegetic. Hence, the trauma is narrated by someone who visibly is expecting to be cured or rescued, afterwards, as she puts in the very beginning of the novel:

I am sitting here before my large oval mirror. I like oval things. There are not too round and not too square, is what I say when people ask my everything is oval, mirror, tables, all. Truth is, I just like ovals. I find them serene and they dispense more sympathy to me than other shapes. And God knows I need a bit of it (Darko, 1).

The preference is clearly emphasized, ‘ovals, oval everything’ and the repetition also is noteworthy. Mara seeing herself regularly in mirror is her struggle of her identity. As we know the foundation of an identity is the body full of sense and sentiments. In the construction of one’s identity lies on the first place one’s image of self. This image of self is sometimes forms in mirror. As the French scholar René Zazzo agrees rightly with his counterparts H. Wallon and Jacques Lacan that “a baby of one or two years learns to recognize his identity in a mirror”²⁴⁷ (translation is mine). It is the result of a double mechanism: objectivation and appropriation. By objectivation, an individual is conscious of his action as an object or a subject in a specific space. He becomes visible and active. By appropriation, he is aware of this physical possibility and internalizes it in his body. It is when all this forms an analogical self that the transposition such self becomes usual. The self here in Amma Darko’s novel is the self-reflection of Mara’s body in a mirror as oval, oval body, a transposition of her transformed body with no complex as the novel repeatedly highlights: “I am sitting [...] I like oval things [...] I need a bit of it [...] I am starring [...] I keep hearing [...] I feel so far away [...] I am just in brief silky underpants [...] I feel so cold [...] I am not sure. (Darko, 1). Remarkably, identification of self as a transformed body is present in Mara’s discourse. Thereby, her identity as sexual entity and psychologically present emerges.

²⁴⁷ Zazzo, R. (1973). “La Genèse de la conscience de soi”, *Psychologie de la connaissance de soi*, symposium, Puf, in *Identité (s): L’individu, le groupe, la société* (2016). Auxerre: Editions Sciences humaines, p. 30. « Dans la constitution de l’identité, l’image de soi, au sens propre tient une place très importante. C’est entre 1 et 2 ans que l’enfant apprend peu à peu à reconnaître son image dans un miroir comme l’ont montré, à la suite de H. Wallon et de Jacques Lacan, les recherches de René Zazzo. C’est le résultat d’un double mécanisme d’objectivation et d’appropriation », p. 30.

When analysing the foregoing passage, we remark that Amma Darko represents her feminist perspective of portraying women with their predestined capacity of conceiving life with their ‘eggs’ which are not totally round, nor square indeed. It symbolizes eggs. The oval shape’s analogy with an egg is striking. What can give egg? Eggs are not produced by male; whose shape are always static (*phallic*).

Furthermore, the central message in *Beyond the Horizon* is mainly the problems that beset young African women to whom dazzling promises are beckoned to travel to western countries for work and then forced into prostitution or forced labour, which is not too far from the method used by Europeans slave drivers and their alike materialistic Ghanaian families like that of Akobi. This drains thousand over thousands of Africans to feed gorgeously the transatlantic slave trade over centuries. This movement of people according to the Trinidadian historian, Walter Rodney, has truly been the basis to “Africa underdevelopment and present economic backwardness”²⁴⁸. Vincent Odamtten’s article takes the opposite direction arguing that the obsession with ovoid shape by the protagonist demonstrates geometrically her surrendering to the persistent pressure and difficulties she encounters not only in Accra as a battered woman, but also in Germany as a professional prostitute:

An oval, an avoid or ovum are all etymologically related, and speak to both Mara’s reproductive capacities, as a representative of the underclass of women and symbolically her existential state. As we consider the latter, we should envision the oval or ovoid as the transformation of a circle or sphere. We can imagine the sphere’s centre (the defining point of the shape-its being) as equidistant from the circumference. Thus, the object is able to keep all external and internal forces dynamic balance. However, when more pressure is exerted at the equator from external demands, the elasticity of the sphere or circle adjusts into an ovoid or oval. The ability of the shape to maintain its new form, or some semblance thereof without collapse, that is to say, its identity, depends on its elasticity, its resilience or integrity and the strength of those external forces. The ‘centre’ is always-and-already threatened with assault from without and even desire from within, i.e. under especially extreme circumstance such as *Der Verkaufte Traum*.²⁴⁹

²⁴⁸ Walter, R. (1973). *How Europe Underdeveloped Africa*. Bogle-L'Ouverture Publications, London and Tanzanian Publishing House: Dar-Es-Salaam, Transcript from 6th reprint.

²⁴⁹ O'Connell, Sean P. ; Odamtten, V. O. (2007). “Licit Desires, Alien Bodies and the Economics of Invisibility in Amma Darko's *Beyond the Horizon* and Stephen Frears' *Dirty Pretty Things*.” Ed. Vincent O. Odamtten, V. (2007). *Broadening the Horizon: Critical Introductions to Amma Darko*. London: Ayebia Clarke Publishing, Print., p. 108.

The physical change of Mara indicates then the shift of the relation between her former and the present shape. Amma Darko tries to show that her female character has changed from her permanent naiveté and ‘greenness’ to her state of consciousness. This is exactly what Amma Darko wants the reader to see in Mara: the analogy between the change of her physical appearance and her moral attitude. As soon as Mara recognizes that she changes, she tries to escape from her former condition with her husband and his pimp like friend. Evidently, we all know that an egg could not be broken unless it is throw away or squeeze laterally. And when the two extremities of an egg are pressed, the egg cannot break for sure. Amma Darko gives the opportunity to Mara to enter in an ‘invincibility’ shape. It is this new shape of hers that allows her to fight back and defend herself for her life. This is her therapy.

5.1.2. Trauma control : Therapy

The Chambers Dictionary (1993) defines therapy as “the treatment of physical or mental diseases and disorders by means other than surgery; treatment used to combat a disease or abnormal condition”. For sure, the ‘oval realm’ imagined by Amma Darko is a shape of resistance that helps repulse the persisting trauma knowing also that extreme neurosis can be treated by drugs like “snow” sniffed by the protagonist to feel at ease. The exert makes precision on the extent to which the protagonist depends on the ‘white powder’. She puts “Now I can’t go through a day without sniffing ‘snow’. I am hooked on it” (Darko, 39). ‘Snow’ here functions as a painkiller. It tempers the excruciating pain in the black body that has to be sharp-ready for others passes. Indeed, the tortured female body needs something extraordinary as help it feels over the permanent pain it has been subjected to.

In fact snow, according to *The Chambers Dictionary*, means “atmospheric vapour frozen in crystalline form, whether in single crystals or aggregated in flakes; a snowfall; a mass or expanse of snow, referred also to cocaine, morphine, heroin in old slang”²⁵⁰. The metaphorical reference to ‘snow’ is twofold to portray all that is painkiller and also the place where Mara leaves. Taking cue from Odamtten, we might very well understand that by using the term ‘snow’, Amma Darko wants to “relocate the site of the crimes in the white blankness of Europe and the West where ‘snow’ is to be sniffed into black bodies so that the pain of the real trauma

²⁵⁰ The Chambers Dictionary (1993).

may be ameliorated”²⁵¹. It also means that Mara is in Europe because when Amma Darko wants to talk about the same pain killer in *Faceless*, she refers to ‘devil leaf’ because of its African setting. For instance, when talking about the real snow, when people are hot and they take a snow in their hand, they feel its coldness. It calms them. It freezes them hand. It then kills them pain and anxiety while feeling hot. At the same, Amma Darko quenches her character’s neurosis by making her take ‘snow’. Snow stands here for drug because of its white colour as well as its psychotropic effect. By using ‘drug’ to kill her character’s throbbing and anxiety, Amma Darko acts like a specialist of pharmacology. Pharmacology is “a vibrant area of biomedical science that studies drug action (how medicines and other drugs work and are processed by the body). Drug action affects all of us in one way or another, through the medicines that we take, the effects alcohol or caffeine consumption or the inadvertent exposure to poisons and environmental pollutants, as well as many other aspects of modern life such as drug addiction and drug abuse including the abuse of drugs in sport”²⁵². After this insightful definition, we are now informed of the reason why Mara is ‘hooked’ to the ‘snow’. It is because her body develops a tolerance which is basically “the ability to adapt to the presence of a drug. Tolerance may be defined as a state of progressively decreased responsiveness to a drug as a result of which a larger dose of the drug is needed to achieve the effect originally obtained by a smaller dose”²⁵³.

In fact, Mara’s stage of ‘snow’ using is just a pre-stage of her being imaginarily liberated from her pimp like husband. In medical science, some illness demands that the sufferer uses a controlled quantity of ‘snow’, not to cure it, but to feel at ease. For example, patients suffering from cancer of all sorts are advised to use it to ease the pain. Other patients in neuro-deficiency are also prescribed the use of drug as painkiller. “Others who obtain less pleasure in natural routes such as from work, friendship and romantic relationship, are more thrill-seeking, or stimulus hungry”²⁵⁴. British Pharmacological Society puts that “Illnesses that were previously untreatable are now routinely and successfully treated. Transplant surgery only became possible following the discovery of a new class of immunosuppressant drugs”²⁵⁵. The user of drugs and Scientifics agree that it gives a ‘contemplative and mellow mood’ to artists and writers who use

²⁵¹ Odamtten, V. O. (2007). *Broadening the Horizon: Critical Introductions to Amma Darko*. London: Ayebia Clarke Publishing, Print., pp. 109-110.

²⁵² <https://www.bps.ac.uk/about/about-pharmacology/what-is-pharmacology>

²⁵³ <https://www.bps.ac.uk/about/about-pharmacology/what-is-pharmacology>

²⁵⁴ Davis, C. ; Loxton, N. J. (2013). Addictive behaviors and addiction-prone personality traits: Associations with a dopamine multilocus genetic profile. *Addictive Behaviors*, 38, 2306-2312.

²⁵⁵ British Pharmacological Society, *Today’s science, Tomorrow’s medicine*, p. 1.

it. Some drug addicts put cheerily this: “cannabis, marijuana, reveal you to yourself.” That is accurately what happened to Mara. The contemplative mood of Mara is just an ‘anti-chamber’ of her becoming full aware of her exploitative situation.

Furthermore, Mara’s contemplative status leads her to become ‘writer’, an artist then. Amma Darko relates the protagonist life of drug taker with that of artist. Artist cannot stand without being stimulated. By sniffing ‘snow’, Mara knows that she is completely hooked and demands it every day as if it were a meal. It reveals her real shape: “that she is oval shape” now. It reveals her need to write and share her trauma because some traumas are not sharable in safe and normal state of mind. To shed light on that contemplative mood renders by the psychotropic product use, Young Jock clarifies it in his book that: “The naive user does not experience a high at first; he may feel, it is true, slightly strange but that is all; he is unable to interpret the meaning of the physiological sensations that he is experiencing”²⁵⁶. The novice user may feel nothing at all has happened to him, he may feel totally cheated by the drug until the sophisticated user has indicated to him the likely effects that he may know he is in fact being affected by the drug. A situation very similar to this with has happened to Mara. It results in her sexually abused by many white people. It is a situation which has been arranged by her pimp husband to blackmail her later. With a distressed voice, she shares the experience this way:

Akobi returned some minutes later and brought me a glass of wine. Then I was left on my own again for a long, long while during which I finished off my wine and waited. Then something started happening to me. I was still conscious but I was losing control of myself. Something was in the wine I had drunk. It made me see double and I felt strange and happy and high [...] so high that I was certain that I could fly free. (Darko, 111)

This excerpt proves exactly the high mood of the first time drug taker as said by Young. Before this contemplative mood, the effects of the drug are physically unpleasant or at least ambiguous. Mara felt that “something started happening. She was still conscious but was losing control of herself”. She confirms that “something was in the wine” her husband brought to her to drink. Mara felt then high, so high that she could fly is to interpret the euphoric effect of the drug she took. According to Isbell and White’s research, Mara is called “evidence of the

²⁵⁶ Young, J. (1971). *The Drugtakers: The Social meaning of drug use*. London, Reading & Fakenham: Granada Publishing Limited, p. 37.

potency of the shot”²⁵⁷. Yet, this euphoric mood varies from the first user to the addict. It then depends on the person under pressure because when Mara has become hooked, she felt no more that kind of dizziness and sleepiness. As soon as she became use of it, her mental state stopped to show distortions, hallucinations, physical sensations which firstly she does not know how to interpret. She may think at first that her sanity has become impaired, that her mind is out of control. She regularly uses it to control her anxiety, extreme pain and endless trauma.

However, based on Sigmund Freud’s *Beyond the Pleasure Principle*²⁵⁸, the theorist of narrative traumas Judith Butler in *The Pleasures of Repetition* demonstrates that repetition itself is indicative of the subject’s inability to accept the present “The repetition is a vain effort to stay, or indeed, to reverse time; such repetition reveals a rancor against the present which feeds upon itself. [...] In effect, repetition is associated with the re-presentation of the past, and hence, it indicates a way in which the ego fails to inhabit present time.”²⁵⁹ Repetition concretizes and draws readers’ attention to writers’ message. Rightfully in the beginning of the novel Mara repeats and repeats her ‘liking of oval shape’ and at the end her ‘sniffing snow’, which is, following to Sigmund Freud and Judith Bulter’s method is therapeutic because if such excess is neither controllable nor even fully perceptible, it provokes an extreme anxiety that could be explained in endless and repetitive symptoms. So then, in the specific case of Mara, the symptoms are always there and the therapeutic remedy also. Judith Butler advises that the traumatized subject uses “repetition to repair the past because it is the past that has made the present uninhabitable.”²⁶⁰ Similarly, Caruth posits:

the wound of the mind [...] is not, like the wound of the body, a simple and healable event, but rather an event that [...] is experienced too soon, too unexpectedly, to be fully known and is therefore not available to consciousness until it imposes itself again, repeatedly, in the nightmares and repetitive actions of the survivor.²⁶¹

²⁵⁷ Isbell, H ; White, W. (1953). “Clinical Characteristics of Addiction”, *American Journal of Medecine*, no. 14, p. 558 in *The Drugtakers: The Social meaning of drug use*. London, Reading & Fakenham: Granada Publishing Limited, p. 38.

²⁵⁸ Freud, S. (1961). *Beyond the Pleasure Principle*. New York: Norton. Trans. James Strachey.

²⁵⁹ Butler, J. (1990). “The Pleasures of Repetition” in *Pleasure Beyond the Pleasure Principle*, (ed.) Robert A. Glick and Stanley Bone. (New Haven: Yale University Press), p. 272-73.

²⁶⁰ *Idem*.

²⁶¹ Caruth, C. (1996). *Unclaimed Experience: Trauma, Narrative and History*. Baltimore & London: The Johns Hopkins University Press, pp. 3-4.

On one hand, Amma Darko criticizes Europeans' way of having sex that seems masochistic. Etymologically the word pornography is from Greek origin '*pornographos*' which means 'writing of harlots', from *porne* (prostitute). *The Concise Oxford Dictionary* defines pornography as "the explicit description or exhibition of sexual activity in literature, film, which stimulate erotic rather aesthetic or emotional feelings"²⁶². The same dictionary defines masochism as "a form of perversion characterized by gratification derived from one's own pain or humiliation or the enjoyment of what appears to be painful or tiresome"²⁶³. All this forms a cocktail of sexual immortality on the body of the protagonist. The merit is that she does not hesitate to speak out to describe all that. What seems important we draw attention to is that Amma Darko's female character does not resist that male sexual invasion and 'colonization'. Moreover, Mara having sex with that European stands for a political symbol that when Western countries give their money to Africa, they use as they want its intimate resource, beating, bleeding, breaking, looting and burning all. Mara like Africa come finger broken.

What seems to be a part of the cause of those masochistic treatments against Mara by her best spender lies in Francis Boeuf's *La Soudanaise et son amant* (1924). He depicted an African woman's sexuality as that which is not dissimilar from animal since she has no passion and is deprived of intelligence. He wrote: "La sensibilité d'une africaine, autant que nous puissions en juger, ne dépasse pas les limites de l'instinct. Elle ignore la passion et la spéculation de l'intelligence. Sa force émotive n'est qu'un embryon non développé, durci, et qui est le produit d'un engourdissement millénaire [...]"²⁶⁴. Thus, Francis Boeuf and some of his fellows defended with no scientific proofs that an African woman is deprived of sensuality and does not even know what heart problem is. Then her European sexual companions would better be rude and bully as if they were having sex with 'an animal' as the European sexual partner of Mara did. That depiction of the African woman was shared by a generation of writers in the colonial period and Louis Charles Royer made his character René among them. He showed the black woman's skin with disgust and hatred: "Au contact de cette peau froide, il avait reculé comme

²⁶² *The Concise Oxford Dictionary of Current English* (1995). (1st Ed.) Fowler H. W. & Fowler F. G. (9th Ed.) Oxford University Press, Della Thompson. Print USA.

²⁶³ *Idem.*,

²⁶⁴ Boeuf, F. (1924). *La Soudanaise et son amant*. Paris : Albin Michel, p. 17 quoted in *Regards sur les Littératures Coloniales*. Afrique francophone: Approfondissements, Tome II. France & Montréal: L'Harmattan, 96-97. "The sensibility of an African woman, as we could judge it, is limited to instinct. She ignores passion and intelligence speculation. Her emotion is tiny, undeveloped, that is the result of millenary numbness". (My translation)

s'il venait de toucher un reptile. A l'idée de coucher avec une Noire, sa chair se hérissait"²⁶⁵. The skin and the nakedness of the black woman matter. Both look rather strange, eccentric and exotic according to the author of the excerpt. To compare a human's skin with that of an animal is the most humiliating and degrading comparison possible. Conversely, at the rescue of the black as having also the right to live, Frantz Fanon gives a rather vivid answer to that question of skin and sexuality of a black. He puts this way:

But to say that the mere fact of his skin, of his hair, of that aura of sensuality that he [the Negro] gives off, does not spontaneously give rise to a certain embarrassment, whether of attraction or of revulsion, is to reject the facts in the name of a ridiculous prudery that has never solved anything. [...] M. Salomon's study informs us that he is a physician. He should be wary of those literary points of view that are unscientific. The Japanese and the Chinese are ten times more prolific than the Negro: Does that make them sensual? [...] The Negro, M. Salomon, gives off no aura of sensuality either through his skin or through his hair. It is just that over a series of long days and long nights the image of the biological-sexual-sensual-genital-nigger has imposed itself on you and you do not know how to get free of it.²⁶⁶

Some French writers of the period made their 'white' characters have rude judgement like the African woman could not be classified as human being "parce qu'il n'avait jamais eu de femmes, rien que des femelles, Enny n'avait jamais été jaloux"²⁶⁷ or whenever, they are 'honoured' as human beings, the place is as concubine or prostitute. This image of black women both in society and literature was portrayed to emphasize their sexual prowess, insatiable sexual hunger, libido and absence of morality. They are like 'Black Bitch'. In Francis Boeuf's writing, we can see that black female characters were available just to satisfy the sexual lust of the white master and supposedly enjoyed the experience of ill-disguised rape. They could be used, abused and forced into acquiescence while the blame of the action could be placed on their shoulders as they were supposed to play the role of the temptresses and seductresses whose black charm, firm nipples and swaying wags ostensibly had entangled the unsuspected rapist. Then there was no apologize if while playing the role of temptress, the master loses one or two. They were just of

²⁶⁵ Royer, L. C. (1928). *La Maîtresse noire*, Paris: Les Editions de Paris, p. 43 quoted in Regards sur les Littératures Coloniales. Afrique francophone: Approfondissements, (Ed.) Jean-François Durand. Tome II. France & Montréal: L'Harmattan, p. 97. "At the contact of her cold skin, he coiled back as if he touched a snake. He felt shaggy at the idea of having sex with her". (My translation from French above)

²⁶⁶ Fanon, F. (1952). *Black Skin, White Masks*. (ed.) Paris: Seuil New York: Trans Charles Lam Markmann, Grove. First published in the United Kingdom (1986). Pluto Press 345 Archway Road, London N6 5AA This new edition published 2008, p. 156.

²⁶⁷ Sonolet, L. (1911). *Le Parfum de la dame noire*, p. 212 quoted in Regards sur les Littératures Coloniales. Afrique francophone: Approfondissements, (Ed.) Jean-François Durand. Tome II. France & Montréal: L'Harmattan, p. 96 "Because it had never been women, but rather females, then Enny was never jealous." (My translation from French above)

female sex to repeat Louis Sonolet's character word. All that above justifies the feeling of alienation with black female characters as it is said "Les négresses sont étrangères aux complications du coeur"²⁶⁸.

As a result of the above passages, the sexual submission and the naiveté of Mara may be understood as the political submission of a whole country (Ghana), a whole continent (Africa). Mara (Ghana) surrenders to the assault of the West because she is obliged not only by her husband, but because of the money the European gives. Mara herself confesses that the man "is one of my best spenders" (Darko, 2). Amma Darko also proves that males in any sexual relations do not have the knowledge and the ability to conquer female body, rather at any occasion they maltreat it. They think that violence and physical force solve sensual matters. It means their lack of sensuality and tact to manage female body because they are always betrayed by their sense of superiority and patriarchal culture. The question we are intended to ask is how many men of that shape come to Mara a day? After she was torn apart by her own husband who else cannot try to do this harm to her emotion? Amma Darko obviously mocks at the ignominious justification of domestic rape through this illustration from the protagonist:

So I don't know why he slept with me.
'He is a man, Mara, and when he has a risen penis he will sleep with anything that has a vagina and leave the regret for later,' said Osey's wife. [...] Why did he do it with me if he didn't want to? (Darko, 86-87; italic is mine).

In the above excerpt, we see Mara is surprised to undergo sexual assault from her husband in Germany because she thinks that the geography of her pain has changed. The geography always haunts the victims of bloody crimes, especially when it happens in a home or in a beloved neighbourhood. Those places become tainted by trauma and Mara knows that Accra is that haunted place she has already left behind, but now she is in Germany. To illustrate this assertion, the protagonist puts: "I mean, Akobi beat me a lot at home, yes, but somehow I identified beatings *like this with home*. That African also beat their wives in Europe somehow didn't fit into my glorious picture of European life. *I was in Europe, yes, but I did not know Europe*" (Darko, 73. Italic is mine). By displacing the violence to Germany, Amma Darko is

²⁶⁸ Reboux, P. (1920). *Romulus Coucou*. Paris: Flammarion, p. 13 quoted in Regards sur les Littératures Coloniales. Afrique francophone: Approfondissements, (Ed.) Jean-François Durand. Tome II. France & Montréal: L'Harmattan, p. 97. "Black women have no idea of heart problems". (My translation from the French version above)

showing another skill. She demythologizes Europe as the privilege place of redemption for marginalized subjects like women. Europe is thought to have been the first continent in which women struggled in the past to claim for their rights and have it. However, it is in this Europe women are abused, beaten by their husbands. Where is then the female liberation? The surprise and the disappointment are total in Mara's mind. The place where she thinks is 'heaven' is in real fact the place where is beaten, raped and put into prostitution by her husband.

In that vein, to Akobi, sex as tool of violence must be common and available things sharply present. For example, Akobi does not mind having sex with his wife in the company of his friends. He exercises his power of possession on her wife in the present of others. The geography here is not important for him. The important thing is the need to impose his desire. This overconcentration of phallus of Akobi has to do with his education in patriarchal environment. The naive Mara would voluntarily accept to be brutalized by her husband in Accra and then take it as part of her mother's counselling, her husband's frequent physical exercise and his ultimate right to dispose of her body. This rather defeatist conclusion of Mara is exactly that of Dongo in Calixthe Beyala's *Your Name Shall be Tanga* (Trans, 1996) and Raphael Confiand's *Mamzelle Libellule* (2000). On one hand, Calixte Beyala's character Dongo is a princess in the king's court. She was raped by a masked rapist²⁶⁹. Though she knew who is behind the mask, she refuses to give his name. As a result, she constructs in her mind that her body was definitely to be disposed of just like Mara who accepts to work as a good time girl. On the other hand, Adelise also surrenders her body to the Commander and thereby other penis in her. When the commander assaulted the protagonist, her dumb docility answers the sexual and vicious call:

C'est pourquoi le jour où le commandeur m'attrapa par une aile [...] se mit à me sucer les seins à travers ma robe et glissa sa main entre mes cuisses, je ne me débattis point. Je n'éprouvai aucune sensation. Ses mains prospectaient la surface de mon corps de la manière que l'eau de pluie, c'est-à-dire froides et râpeuses. Il me renversa dans l'herbe et me chevaucha, me pilonnant de toutes ses forces, mais je ne me mis pas à pleurer, ne gémiss pas ni ne tentai de résister²⁷⁰.

²⁶⁹ Beyala, C. (1996). *Your Name Shall be Tanga*. London: Heinemann, Print. Trans. from the French version Tu T'appelera Tanga (1988) by Marjolijn de Jager

²⁷⁰ Confiand, R. (2000). *Mamzelle Libellule*. Paris: Serpent à plume, p. 25.

This emotionless scene of sex between a slave and her master is similar to that described by Amma Darko with Mara and the German man, her best spender. Both of the victims did not participate, though the moment could oblige them to. Mara shares that: “and even when he puts me in pain and spits upon me and calls me a nigger fool I still offer him my crimson smile and pretend [...]” (Darko, 3). The crimson smile does not flicker because Mara feels an emotion for the man, but because it is part of her job. The sex is totally cold. Calixte Beyala’s poignant novel also provides a quite similar scene. The female character Adelise does not resist the commander’s sexual assault. She lets herself be raped, but does not take part in the pleasure. This act is significant. Like Dongo in Calixte Beyala’s novel, Adelise does not care when men dispose of her body after being raped by the commander. She does not complain. She shares her defeatist feeling this way: «Je me moquais d’ouvrir mes cuisses aux hommes [...]. Mon corps ne m’appartenait pas, je l’avais perdu au fil des jours, seul mon cœur demeurait mien»²⁷¹. Rape acts like psyche and soul destroyer. Rape inhibits the victim’s capacity to be herself or to think of a line to resist. To corroborate it, Monique Agenor²⁷² compares it in her *Comme un vol de papang*’ (1998) to male dragons unleashed against female intimacy.

Furthermore, and analogically, Mara, the protagonist’s mood after the domestic sexual violence is quite in contradiction with what she confides early:

[...] after all, mother had taught me that a wife was there for man one thing, and that was to ensure his well-being, which included his pleasure. And if demands like that were what would give him pleasure, even if just momentarily, then it was my duty as his wife to fulfil them. So that even those nights when he ordered me to sleep on the thin mat on the hard floor, even if I laid there and could not sleep and suffered a splitting headache the next day because of lack of sleep, I still regarded my suffering as part of being wife, and endured it just like I would menstrual pain. That he had bought me no new clothes and left me still with the only those I had come in from the village, and that in spite of this he had also forbidden me to sew any of the cloth he had presented me with as part of my dowry, I saw also as falling under ‘obey and worship your husband’ (Darko, 13).

Extending this idea, it may be easily argued that male dominated mainstream has forged a rather condoned representation of sexual assaults from men, yet this is not the case for the

²⁷¹ *Ibid.*, p. 71. “I did not care to offer myself to men. I do not own any more my body. I lost it day after day, only my heart remains”. (My translation).

²⁷² Monique Agenor was born in La Réunion in 1940. She left the isle the 60s to live in Paris. She wrote *L’Aieule de l’Isle Bourbon* (1993), *Bé-Maho* (1996) and *Comme un vol de papang*’ (1998) in *Genre et Migrations postcoloniales : Lecture croisée de la norme* (2013). Presses Universitaires de Rennes, p. 55.

representation of females, which has always been filtered by the hegemonic male gaze. Hence, the male representation of sensuality is confined in sexual penetration and thereafter the orgasm feeling. This is exactly the contrary of the need of women in marital situation. Yet, the obedience society places on women obliges them to cope with the challenge in silence. Because of that, Mara never complains. Mara thinks her marriage is worth more than her own life and that it is her duty to be her husband source of comfort no matter how. Mara usually accepts to sleep on the floor while Akobi, just after having sex with her, orders her to quit the mattress. While rethinking the concepts of manhood and womanhood, it is important to point out bell hooks asserting that recognizes the “biological differences without seeing them as markers of specific character traits” (Darko, 22). Male characters like Akobi think that penetration is enough for women. For Akobi, a sexual act is the finality of any love affair, not the beginning. It is the peak of the man’s selfish pleasure. These male characters do it because they think the orgasm is shared with their female partners. The passage of Mara’s complaining to Kanye proves that she does not agree with the method, but cannot assure that it changes because she recognizes her powerlessness as a woman. In such a society, women have been persuaded to see their sexual impulses in terms that suit men.... man's pleasure is paramount and women are merely vehicles for procuring this enjoyment. She lives under the shadow of her man from Accra to Hamburg, she is therefore regarded as second class citizen. The female character Mara is usually neglected as her opinion is never sought before decisions are taken even in matters that directly affect her.

Moreover, in some African settings, sex and its derived are hardly discussed. So the female character, Mara, knows that her request is a still born. In fact, in a patriarchal society, women are faced with all sorts of dehumanizing acts ranging from deprivation, negligence, maltreatment, marginalization, oppression, subjugation, exploitation, humiliation and even isolation, all of which emanate from aspects of the people’s culture. Those cultural attitudes plague seriously women’s mind, self-development potentialities and hinder their potentials to decide for their own. In Arab society, the Egyptian non-conformist female writer Nawal El Saadawi²⁷³ portrays a similar predicament. In her five-star book *Woman at Point Zero* (1983) to

²⁷³ Nawal El Saadawi is a leading Egyptian feminist, sociologist, medical doctor and militant writer on Arab women's problems. She is one of the most widely translated contemporary Egyptian writers, with her work available in twelve languages. Nawal El Saadawi was born in 1931 in Kafr Tahlia, a small village outside of Cairo. El Saadawi was raised in a large household with eight brothers and sisters. Her family was relatively traditional, El Saadawi was "circumcised" at the age of six, and yet somewhat

cite just this, Nawal El Saadawi shows the permanent ordeals of women in their marital homes. Women are considered as menial and exchangeable objects. To Nawal El Saadawi, almost all Egyptian women do live in nervous conditions, so much so all they want to express themselves violently. The following is one of the radical positions from Firdaus: “Every single man I get to know filled me with but one desire: to lift my hand and bring it smashing down on his face”. In her childhood, the protagonist, Firdaus, does not understand the similarity between her father’s beating her mother and his faith to God because the beating. She finds that it will be a very long way for women to achieve her dream of being accepted on the ‘ground zero’ if she does not fight her way no matter what happens to her pride. A woman in such a society has no self, no consciousness and no mind according to Nawal El Saadawi.

Women in Arab world comply with the rules of obedience because there seem to be no way to exit. In addition, literature, in that part of the world, had also been used to down crush the female characters and in that scope, Kolawole (1997) submits that most male writers in the early phase of African literature encouraged the marginalization of women. Chukukere (1995) confirms that the ideal female character created by male writers often acts within the framework of her traditional roles as wife and mother. Fonchingong (2006) backs up this notion by saying that social values are so strong that the respect and love which a woman earns is relative to her degree of adaptation to these roles. The intersection between life and writing is always at the heart of Barthes’s project; so much as he was fascinated by writing autobiography. That conviction led him write *Roland Barthes* (1975) to proof-show the connection between reality and literary writing. The conviction of the late French joins that of the British scholar and novelist C.S. Lewis who states that “Literature adds to reality; it does not only describe it. It enriches the necessary competencies that daily life requires and provides; and in this respect, it irrigates the deserts that our lives have already become”.

According to Ana Diez, “the sex scenes do not gravitate around an erect penis, but explore the sensual exchanges that display rarely seen forms of male sexual performance such as

progressive, El Saadawi's father insisted that all of his children be educated. Saadawi was interested in meeting the woman and visiting the prison, and her colleague arranged for her to conduct her research at Qanatir Prison in the autumn of 1974. No Arab woman inspires as much emotion as Nawal El Saadawi. No woman in the Middle East has been the subject of more polemic. Certainly, no Arab woman's pen has violated as many sacred enclosures as that of Nawal El Saadawi.

panting, gymnastics, foreplay, oral sex, clitoris sucking and tongues sucking”²⁷⁴. It is obviously a long sequence while the two partners caress each other and exchange a whole and intense moment of sexuality and sensuality. When the sexual act is deprived of all those connected sensuality before the penetration, it is called rape. As so, rape is classified as gender based violence against women. Rape is defined as “forcible male penile penetration of a female vagina”²⁷⁵. A more recent definition of that violence states: “the penetration, no matter how slight, of the vagina or anus with any body part or object, or oral penetration by a sex organ of another person, without the consent of the victim.”²⁷⁶ Rape is then a violent act usually committed by men and boys against women and girls without their consent. All feminists agree that rape is a grave wrong. However, in some countries, victims are not always seen as victims; rather they are accused of having favoured the act either through their behaviour or their sexy cloths. In fact, the accurate neglect may not lead people underestimate the crime. The condoning of rape by some societies contributes to its permanent perpetration. Marital rape seems to be more ‘justifiable’ by men as society is mainly male dominated. In such a situation, women are neither listened to nor believed when they complain of being harassed, insulted and raped by their own husbands. By depicting that moment of marital rape, Amma Darko explains that she does not want to be shy over that injustice. This allows her to express her anger. That is the reason why she talks about that horrible moment. Amma Darko writes the scope, the people in interaction and the setting. But most importantly, the author abridges writing and story, and writing and reality. This is in line with Selwyn Cudjoe’s statement “writing states the past as past and allows thus the emergence of the present and the reinvention”²⁷⁷.

How can it be humanely possible that a man who owes the female body, wanting to take it at time he feels like and meet the opposition of the woman? The conception of a woman’s body naked or not is represented as being owned by a man. A woman’s body is her husband’s property. The owner of that property assures its existence and its *raison d’être*. The society seems to give ‘green card’ to the man to deal with any woman in marital home who refuses to give that part of her body. Then rape is not a crime with this conception of female body. With this background, the predominance of male conception of female body is intricately linked with

²⁷⁴ Zecchi, B. (2006). ‘Women filming the male body: Subversions, inversions and identifications’, *Studies in Hispanic Cinemas* 3: 3, pp. 187–204, doi:10.1386/shci.3.3.187/1.

²⁷⁵ From The USA department of Justice (2012). www.justice.gov/opa/blog/updated

²⁷⁶ From The USA department of Justice (2012). www.justice.gov/opa/blog/updated

²⁷⁷ Yassine-Diab, N. (2014). *Aliénation et réinvention dans l’œuvre de Jamaica Kincaid*, Presses Universitaires de la Méditerranée, Université Jean Jaurès, p. 236.

the issue of gender inequalities. Rape is a crime and its perpetrator is a criminal no matter varied circumstances in which it occurs. It cannot be justified. Rape or any other violence causes lasting traumas on its victim always female.

5.1.3. Trauma and Sexual Violence

Women are not just men with breasts and tubes. Women are beings different from men in terms of anatomy and physiology (hormones, ovaries, clitoris, pregnancy) that deserve to be respected and even studied with intensity and interest. The difference between the two demands more care and attention while being handled. More so, women need more care and a more or less attention paid to women count in their life. For example, the psychological impact of sexual violence against women is more problematic in women than when applied to men. Additionally, the relevance of a drug is medically tested on male volunteers only before being released for sale in pharmacies. Pharmaceutical laboratories are not often preoccupied by the possible different negative impacts a drug can have on the female body.

The story's protagonist, Mara, lives in post-world war II Germany and is trying to forget the detriment of her experiences as a sexual slave, while also trying to build her life as an independent woman. Her two sons in thousand miles away, and on top of that she is being haunted by the ghost of her transformed identity. *Beyond the Horizon* epitomizes loss of innocence during the time of transatlantic slave trade, revealing the brokenness that came with its experiences, especially for women. This novel is one of the first historical writings by Amma Darko and another example of a black female writer revealing the struggles faced by African women in a foreign country to survive by offering the most part of her body. Sean P. O'Connell *et al* accurately note that:

The testimony of her narrative confirms that she acknowledges a sense of guilt, since she is certainly violating the value she learnt as a child in the village of Naka. Nonetheless, her isolation is a foreign culture and a degree of innocence on her part contributes to her disastrous circumstances²⁷⁸.

The same narrative of body disposal and sexual violence are also portrayed in Alice Walker's *The Color Purple* (1982). The female character, Celie, is repeatedly raped and beaten

²⁷⁸ O'Connell, S. P. & Odamtten, V. (2007). "Licit Desires, Alien Bodies and the Economics of Invisibility in Amma Darko's *Beyond the Horizon* and Stephen Frears' *Dirty Pretty Things*" (Ed.) in *Broadening the Horizon: Critical Introductions to Amma Darko*. UK, London: Ayebia Clarke Publishing, Print, p. 50.

by her abusive father, having two children by him. Throughout the novel, incidents of abuse and sexuality's questioning become apparent themes. Alice Walker's novel, like Maya Angelou's works²⁷⁹ and Toni Morrison²⁸⁰, reveal the struggles of African American women during a particular time in slavery due to their sub-human status in society. Despite loss of innocence, these authors suggest through their writing the black woman's ability to find a reason to live despite adversity.

Further, sexual assaults like rape have nothing justifiable. Penis is like an armed gun in the hands of a criminal. When it is raised on a woman without her consent, it is like charged with munitions for a harmful purpose: female destruction. Men are then latent criminals and can be dangerous as soon as they use their penis to terrorize and dominate women. The regular use of that weapon by Akobi has just replaced the hands used to slap and beat the female character Mara while in Accra. In fact, nothing has changed for Mara, the slave. She is still under dominion, servitude and control in Germany. This is profoundly the description of a relation between a master and a slave. To the question, why does the 'master' use violence to delineate his territory and to subjugate the colonized? The answer is the necessity to settle a hierarchy, a gap, a relation of fear and terror between him and his slave and the impossibility for the 'slave' to complain. Reporting a rape is still taboo in some countries. It is for this reason that both perpetrator and victim enter a conspiracy of silence. Incidents like rape are hidden because of the consequences in one hand and gossips of surrounding people in the other hand. The female victims are even punished and rejected by family, isolated and ostracised by friends.

Added to their mental state, these women live in nervous conditions that make them appear as if they were the verge of tears every day. Sometime their shaky and unstable mental health makes them think that it is their fate to be raped and abandoned. For example, Mara always refers to karma. They need support, but none comes. Alone, these psychologically wounded die of shame and anger. The answer leads us to two Caribbean scholars Frantz Fanon and Maryse Condé who wrote on violence and silence of a colonizer or a slave. By violence

²⁷⁹ Maya Angelou was born Marguerite Annie Johnson (April 4, 1928-May 28, 2014) African-American, Author, Civil Rights Activist, Poet Maya Angelou is a poet and award-winning author known for her acclaimed memoir *I Know Why the Caged Bird Sings* (1969), *Give Me A Cool Water 'Fore I Die* (1971) and her numerous poetry and essay collections. She also wrote *All God's Children Need Travelling Shoes* (1986), *A Song Flung to Heaven* (2002).

²⁸⁰ Toni Morrison is Chloé Anthony Wofford (February 18, 1931-) African-American, Author, Playwright, Literary critic. Toni Morrison is a Nobel Prize Literature in 1993- and Pulitzer Prize-winning American novelist. Among her best known novels are *The Bluest Eye* (1970), *Sula* (1973), *Song of Solomon*, (1977), *Tar Baby* (1980), *Beloved* (1987), *Paradise* (1998), *Love* (2003) and *A Mercy* (2007), *Home* (2012) and a non-fiction book *What Moves at the Margin* (2008). She has also written a few children's literature. From <http://www.biography.com/people/toni-morrison-9415590>

from the master, the slave is mindful to his space, a very tiny one. He and his family also know their environment, their rock stone like bed, their thatch homes full of mice, mosquitoes and other small nasty beasts. The slave discovers in his thoughtful nights that all he must do to save his life is silence.

Hence, muteness means silence, voice that is uttered and unheard. Carole Boyce Davies and Elaine Savory Fido, co-editors of *Out of the Kumbula, Caribbean Women and Literature*, describe it as: “the inability to express the position in the language of the ‘master’ as well as the textual construction of woman as silent. Dysphonia also denotes articulation that goes unheard”²⁸¹. Mara does not complain or argue with Akobi when he orders to remove her trousers “as loud as music would allow” (Darko, 83-84) because her articulation goes unheard. She was obliged to talk to her crony Kaye. Frantz Fanon provides the rarest and the deepest insight into the relationship between black men and their wives, black or white of both sexes. Unlike writers of the same period, Frantz Fanon wrote about the black woman, but he did so selectively and ambivalently. The Martinican writer has a strong contemporary echoes and it is still relevant to the present days. However, with the straightforwardness the world knows of the psychoanalyst, Frantz Fanon argues in his renowned book:

I do not come with timeless truths; fervor is the weapon of choice of the impotent; the black man wants to be white, the white man slaves to reach a human level. We are left with little doubt we are confronting a great deal of anger. The resentment takes us to a particular place: a zone of non-being, an extraordinary sterile and arid region, where black is not a man, and mankind is digging into its own flesh to find meaning.²⁸²

So far, to keep up the ultimate use of violence, the Cameroonian-French writer Calixte Beyala explained in an interview, “I do not see how a political scene is less shocking than an erotic scene. A woman sold or prostituted; a dictator who goes in the street, meets a man and shoots him in the head. They are exactly the same thing; one should not separate the two worlds. The human being is deeply touched in the spirit [...] there is no special rule for a man and disrespect for a woman. Ateba [a female character] is no different from a political prisoner”²⁸³.

The matriarch Ama Ata Aidoo also sets her feminist voice to condemn rape in domestic

²⁸¹ Davies, C. B. & Fido, E. S. (1990). *Out of the Kumbula, Caribbean Women and Literature*, Trenton, NJ: Africa World Press, pp 399. ISBN-13: 978-0865430433

²⁸² Fanon, F. (1967). *Black Skin, White Blacks*. (Trans) London: Grove Press.

²⁸³ Matateyou, E. (1997). *An Anthology of Myths, Legends and Tales from Cameroon: Storytelling in Africa. Research in African Literatures* 31.3, Lewiston: Mellen, 256 pp. ISBN 0-7734-8517.

sphere in her literary work. Ama Ata Aidoo captures this marital rape incident like this:

[...] Oko flung the bedcloth away from him, sat up, pulled her down, and moved on her. Esi started to protest. But he went on doing what he had determined to do all morning. He squeezed her breast repeatedly, thrust his tongue into her mouth, forced her unwilling legs apart, entered her, plunging in and out of her, thrashing to the left, to the right, pounding and just pounding away. Then it was all over. Breathing like a marathon runner [...], he got off her and fell heavily back on his side of the bed.²⁸⁴

Far from accepting the rapist act, Ama Ata Aidoo is portraying just the incident. This incident is more than a marital rape. In the same vein, with Amma Darko, the idea of having sex with ‘*anything*’ that has vagina, makes Amma Darko’s male characters act like mere animal in front of female sex. So when men are raised, they have no control of themselves unless they find ‘anything that has vagina’. Amma Darko denies to her male characters’ brain and reason that lead to self-control and discernment. The above passage is illustrious. Another example is Osey in the train from East Berlin to Hamburg. He nearly rapes Mara in a train. The autodiegetic narrator depicts the sexual assault she has been victim of from the shameless character, Osey, smuggling her in Germany, the ‘Promised Land’. Mara’s sexual assault rings as follows “Are you wearing something under your sweatshirt? [...] What are wearing under your sweatshirt? [...] Osey suddenly shoved his hand into my sweatshirt from below, causing me to spring up like I was on fire” (*Ibid.*, 64-65). The way to ‘Promised Land’ is paved with dangerous deeds and the proof is shown here with Osey sexual assault on his friend’s wife whom he was just ordered to smuggle in Germany, not to rape. As if Osey does not finish being bad, he recognizes his forfeiture of having frightened the elderly lady in the following dialog:

‘I did nothing. I just *grinned*,’ he replied, still grinning.
‘So why did she leave?’ I queried.
‘Because she fears monkey *grin*,’ Osey replied, still grinning.
‘Whose monkey *grin*?’
‘My monkey *grin*,’ and he uttered a loud laugh.
‘You have a monkey *grin*?’ I asked naively.
‘No, but she thinks I have a monkey *grin*.’ (Darko, 64, italics mine)

Not putting aside the fact that Africans never show disrespect to elderly people, we would want to analyse the grammar rule of repetition used by Amma Darko. The authoress’s

²⁸⁴ Aidoo, A. A. (1977). *Our Sister Killjoy or Reflections from a Black - Eyed Squint*. Harlow, Essex: Longman Group Ltd, p. 13.

repetition of the grammatical word 'grin' lies for a very specific purpose and according to David Lodge this has nothing to do with "traditional rhetoric, but partly literary and partly philosophical. He thought that "fine writing" falsified experience, and strove to "put down what really happened in action, what the actual things were which produced the emotion that you experienced" by using simple denotative language purged of stylistic decoration"²⁸⁵.

Concomitantly, Amma Darko's emphasis is to draw attention to the abnormal status of the face of Osey suddenly. To grin in *Merriam-Webster's Learner Dictionary*, is therefore "to draw back the lips so as to show the teeth especially in amusement or laughter; *broadly* to smile". Exactly our facial expressions are the way our brains move the muscles in our faces to express the way we feel. For example, we raise our eyebrows in surprise, we lower our eyelids in shyness, and we smile with happiness. That last facial expression is the one we most like to experience ourselves as well as to see in others according to the Dictionary. The facial expression 'grin' is usually attributed to monkey and thus, no animal has more human-like facial expressions than our close relative the chimpanzee, generally called monkey.

The prominence here is that animals' world is very tricky and difficult to size, in spite of that, racists regrettably attribute those 'monkey-grins' to Africans of sub-Saharan desert and Osey exploits this unfortunate information to scare the German elderly woman. But in the collective representation of most of Europeans and in line with Frantz Fanon anticolonial writing, "a Negro is a Negro; but in the unconscious there is the firmly fixed image of the nigger-savage"²⁸⁶. What does the black man represent in the eye of other people? In many places, the black man is rejected since black has a bad connotation ranging from danger, evil, bad omen, fear and shadow. Black also represents poverty, to illiteracy and wildness. For example, people say 'black magic' to mean the worst and dangerous one. Nothing good is of black colour. The colour black is the sign of Satan himself. People wrongly think that because the commentaries are kept to maintain African people head under water, begging for mercy every time. For example, we say black anger, blackmail, black book, black flag, black list, black beast, black oil. Black depression means the worst of the depression. Black stands for horrible and black night means the most dangerous night and black mind stands for a pessimistic one.

²⁸⁵ Lodge, D. (2011). *The Art of Fiction*, UK/London: Vintage Random House, p. 91.

²⁸⁶ Fanon, F. (1952). *Black Skin, White Masks*. (Trans.) Grove Press, p. 154.

Black also means dirty, filthy, grimy, grubby, impure, unclean, to cite a few. Black art means belief in magic spells or occultism.

Nowadays, black symbolises illegal migration and the worst part of population displacement. In this regard, some people shake aside the fact that many other populations migrated before Africans (Jews, Irish, Italians, Frenchs, Armenians, and Mongolians) flee social and economic uncertainty, stagnation, war, permanent adversity due to unfair resource distribution. Additionally, it is unfair to qualify an immigration as illegal, but the right term is to our opinion undocumented immigration. Regrettably, western Medias, politicians and other controversial debaters do not stop calling migrants from African countries and countries like Haiti, Cuba, Syria, The Yemen, and Iraq illegal in order to grant a demonic aspect to the phenomenon. In the process of globalization, black people are mostly unaccepted in their movement to elsewhere since Africa has long been the continent of stereotypes and its people objectified. These representations all too often are what Westerners believe is reality. For all too many, Sub-Saharan Africa is the “dark continent”, a culturally monolithic land full of poverty, disease, war and famine. For example, during Biafra’s war, many pictures were taken to prove how children were starving, but no picture presented who sold the weapons.

Developed countries’ capitalistic greed and African leaders’ blind desire to cling on power lead them to the extreme. So when Africans start killing each other, they are called uncivilised. All along with biased reports, the African continent is represented as a place of savagery and superstition; as a place devoid of humans. In any case, the continent receives very little detailed or positive coverage. This is in line with all that some Europeans have been doing to erase African history. One of the vivid and long standing stereotypes on the colour black is that many Africans fear to have their stay denied in some western countries. The cause of these stereotypes lies in 1492 when Christopher Columbus discovered a land he mistakenly named West Indies. From this discovery, started the most important human displacement in history that is Transatlantic Slave Trade. West Europeans conquered and colonized the other part of the world. This placed Europeans on the top of all the other people in the world because of the richness and fame it brought. So they shaped the rest of the world’s history the way they wanted it to be as they controlled information and the discourse around the information. In the name of jungle law and African loss of power, a huge part of their history was erased following Lord Macauley’s counsel. Among these information, we have biased reports such as ‘India or Africa

has no civilization' and the discourse around is that 'it was Europeans who brought light and humanity to the African savages and cannibals. Such discourses are still prevailing in some European countries since many of them do not teach African history in their schools and universities. The lack of right information maintains the fear of black people more intensely in some Europeans' collective mind.

For Amma Darko, racial problem is physical and visible like an anecdote of two women of different skin colour talking about gender bias: one is black and the other white. The white woman says:

when I look in a mirror, I see a woman. The black woman says in her turn: "When I look in a mirror, I see a black woman. So you see, struggles are different". Like privilege, racial problem may be invisible sometimes. Privilege is invisible to those who have it. The white woman has the privilege to be white as men have the privilege to be men in patriarchal society²⁸⁷.

In the light of the above-mentioned, we realize that Amma Darko emphasizes the representation of the face to "create a representation of the privacy or the inferiority of a subject"²⁸⁸. In fact, the movement of facial representation in literature makes the invisible visible. That is Osey by starting grinning materializes what was invisible to visible: the common belief that an African is a monkey, biasing the evolutionist theory of human being of Charles Darwin.

The character does not dislike the German woman as she thinks, but her presence in that very wagon of the train is at stake. Osey is just in want to startle her in order to have space to sexually assault Mara. He succeeds in his act by using to his benefit a popular cliché known in Europe: 'Africans grin like monkey'. He draws then to his side this racial stereotype at the right moment. Osey's words toward the woman cannot do, but his facial expressions do it remarkably. This demonstrates that a human face is the principal point of contact with the others. It can more or less express our mood and emotion. "Il s'exhibe et s'offre à la lecture. [...]"

²⁸⁷ TED Talks : "Why Gender Equality is Good for Everyone, Men included", Michael Kimmel.

²⁸⁸ Gaspari, F. (2016). *L'écriture du Visage dans les littératures francophones and Anglophones*: De l'âge classique au XXI^e siècle. L'Harmattan, Espaces Littéraires, p. 22.

il devient figure”²⁸⁹, c’est-à-dire “représentation de l’homme de l’extérieur intérieur” (Courtine & Haroche : 1988, 43).

The other side of the predicament is the recurring matter of the racial issues and biased clichés on African immigrants as thieves, murderers, liars and lazy apart from their being ‘monkeys’ and uncivilized. Here lies an example: “When I first met your brother, Mara, he was very lazy, a very lazy African man” (Darko, 98-9). However, the timid reaction of Mara highlights also cliché from the periods of transatlantic slave trade to colonization: “At first I didn’t understand, because here we hear always that African people are hard workers and love hard work because God made them especially for the hard work of the world [...]” (Darko, 99).

The stereotype of Africans perceived as ‘dumb hard working’ people took its origin in the time of the slaves trade when the capitalistic ideas of space and lands conquest grew stronger and stronger. The first people the slaves’ merchants and slave-drivers employed in the plantations in West Indies and the Americas were the natives Indians. Unfortunately, it did not prosper because these natives died from unknown diseases and of overtiredness. When it became clear that Indians were dying out too quickly to be useful labourers, settlers turned to the transatlantic slave trade. There came the idea to go to fetch Africans who were likely to work in difficult and nervous conditions in similar tropical climate like that of the West Indies and the “New World”²⁹⁰. Nobody knows the exact number of driven souls from Africa for four hundred years because slave traders would often record fewer slaves than they actually transported to keep insurance costs down as declared by Elikia Mbolo.

Settlers reaped huge profits from African slaves who were imported to provide labor to maintain the colonies. Plantation slavery soon spread throughout the Americas, providing agricultural production for the colonizers at very little cost. The Senegalese curator, the late Joseph Boubacar N’Diaye while presenting his book *Il Fut un Jour à Gorée* (2006) called it “African forgotten holocaust”²⁹¹. While some scholars do not declare the exact number of African slaves driven during the Trans-Atlantic Slave, W. Whatley estimated that about “twelve

²⁸⁹Gaspari, F. (2012). “Morsels for the Gods”: l’écriture du visage dans le roman britannique (1839-1900). Paris: Michel Houdiard.

²⁹⁰ From Christopher Columbus while he discovered the land now called USA. Christopher Columbus is celebrated in much of the United States on October, 12, since 1971, though the explorer was hauled back in Spain in chains to serve in prison for his misdeeds and torture sessions on Indians natives. Columbus Day is a day of parades, pageants and retail shopping bargains across the nation. Schools close and government employees get the day off

²⁹¹ Retrieved from INA Talks Shows by France 2 Television’s ‘On n’est pas couché’ in 2006.

million and half were embarked as slaves towards the Americas between the turn of the sixteenth century and 1866”²⁹². The trade did not stop until four centuries passed because it was a profitable economic activity for both European buyers and African sellers. In fact, the magnitude required a system for ensuring the capture and supply of slaves which was another feature setting the African slave trade apart.

Extending the idea, Mara and the Giant Man situation might be understood as a relationship between Africa and Europe, in terms of trade. The relation is always unbalanced implying then a no love relationship, not even a hint to share, especially from Europeans. The ‘Giant Man’ comes for his unique and selfish sexual ecstasy regardless the pain of the woman, a relief he cannot afford with his female fellow at home. Amma Darko illuminates how the female body becomes the site of both abuse and resistance by outlining the narrative trajectory of female bodies through space. Global theorist Anthony Giddens describes how “capitalism has been such a fundamental globalizing influence precisely because it is an economic rather than a political order”²⁹³. Capitalism works among, rather than within, national political structures, “it has been able to penetrate far-flung areas of the world” (Giddens, 184). In her novel, Amma Darko traces Mara’s movements in global space. In doing so, Amma Darko portrays Mara as both humanized subject and commodity within the capitalist system contributing to “local and international discourses about the abuse of women in the transnational sex trade”²⁹⁴. Amma Darko constructs Mara’s body as a producer for the transnational flow of capital from Europe to Africa. That means a part of the money she earns from her body trade is sent to her parents in Accra to make them believe that she really finds a decent work. The other interpretation is that naturally a slave’s forced labour in a plantation does produce flow cash to his owner. The principal pocket in which the flow enters is that of Akobi who represents here the slave merchant.

Structurally, the novel serves as a map, for the movement of capital and information to and from different physical locations through the movement of female bodies; however, through

²⁹² Whatley, W ; Gillezeau R. (2011). The Impact of the Slave Trade on African Economies, in: Rhode P., Rosenbloom, J. ; Welman, D. (eds), *Economic Evolution and Revolution in Historical Time*, Stanford: Stanford University Press.

²⁹³ Giddens, A. (1994). "From the Consequences of Modernity." *Colonial Discourse and Post-Colonial Theory: A Reader*. Patrick Williams and Laura Chrisman, Eds. New York: Columbia UP, 181-90.

²⁹⁴ Higgins, M. E. (2006). “Transnational, Transcultural Feminisms? Amma Darko’s Response in *Beyond the Horizon*” *Tulsa Studies in Women’s Literature*. Vol. 25, No. 2 (Fall 2006), pp. 307-322.

the particularity of Mara's experience, Amma Darko also outlines ways in which females may use their bodies to resist exploitation. The decision to resist against the oppressor and the capitalist comes in four important and symbolic steps. The first is when she "began to wonder. Why couldn't I take control of my own life" (Darko, 118). The second is when she invites Gitte to know her version of the story in an "obscure Italian parlour" (Darko, 121) and the third is when she decides to write the whole story of her life after the insightful investigation eyes of "Gerhardt Strauss, private detective for all cases" (Darko, 132) and finally posts it to inform the world (Darko, 138). These steps are typical to Amma Darko and come to clear the way to any women in patriarchal society.

This perspective of Amma Darko proves her clear cut touch of feminism which differs from her counterparts such as Efua T. Sutherland and Ama Ata Aidoo. Efua T. Sutherland is recognized here for her innovative use of Anansesem (folktales) and Ama Ata Aidoo for Anowa's independence and agency in her choices. It may have been very difficult for Efua T. Sutherland to get straight with people who were entirely tied to their patriarchal privileges to listen, read and understand her writing as feminist. However, her texts required attention of male readers in a 'chauvinist' Ghana. They also required difficult questions about how and why she thought male should leave or share those privileges with their women in Ghana. Both female writers impact their environment for having thought of ways and means to empower Ghanaian women no matter what it costs. Their innovation sparks progress in the way Ghanaian men should treat their female counterpart in society and gives diversity to Ghanaian feminism. They provide the readers with tangible and familiar examples from popular culture and daily life experience. They have the merit to be the first Ghanaian female writers to try to bring a feminist perspective to conversations with people who might have never considered how feminist histories and theories affect them. Further, they might never have imagined that one day those ideas considered 'aliens' to African cultures to be transported in Ghanaian cultures by even Ghanaian women.

On another hand, they make a damageable confusion between sexuality and violence, between having fun and killing a pig, giving oneself pleasure and slaughtering, though we know that some people find their libido in these masochistic games of '*bleed me before*'. In this way, Amma Darko illustrates their Machiavellian desire through her homodiegetic protagonist:

The injury was made to me by one of my best spenders, a giant of a man but [...] he imagines me to be her, orders me to shout I am her, and does horrible things to me like I never saw a man ever do a woman before in the bushes I hail from. And even when he puts me in pain and spits upon me and calls me a nigger fool I still offer him my crimson smile and pretend he's just called me a princess (Darko, 2-3).

Amma Darko exposes all that wrong made on a female body by a masochistic just because he has money and wants meta-ecstasy for his own without imagining one minute that he is with a human not a mere animal. By emphasizing on this scene, the authoress condemns it and appeals for more humanity with African prostitutes in European countries. Yet, she reveals the paradigm of female power over male characters through the man, though giant and filled with rage of revenge, "lack the guts even to pull her hair" (Darko, 3), but imagines someone else being her. This is really a proof of powerlessness. The emphasized message is that women have remained the possessions of men and counted among their property. Therefore, Amma Darko turns the means of violence against the formal and natural bearer.

At last, the feminist perspective typical to Amma Darko is to prove that women are not going to be all-giving and all-enduring. The woman as a dutiful slave for a man will not last now that the woman is claiming for her right position in the community. Amma Darko finds a way for the protagonist to revenge against the patriarchal society that renders her traumatized. She writes back to denounce the phallocracy and its violence as method of maintain women under its rule.

6. Amma Darko's Special Touch

Amma Darko writes for two different purposes. The first is to narrate what she thinks is going on around her and the second is the means by which it occurs in her society. The fast changing of attitudes around Amma Darko is explained in her special touch of describing social predicaments. She is not that prolific user of Ghanaian proverbs, but she is influenced by stay in Germany and the rapid urbanization that occurred in her home town. Amma Darko's way of writing is slightly different from that of her former compatriots like Efua T. Sutherland and Ama Ata Aidoo. We mean here by 'special touch' the way Amma Darko means to depict her own understanding of what is around her.

6.1. Trauma, Globalization and Poverty

It is quite important to clarify the concept of globalization and its implications in African countries' development. S. T. Akindele defines globalisation as “a planetary new order of marginalisation of the African continent. Its universalization of communication, mass production, market exchanges and redistribution, rather than engendering new ideas and developmental orientation in Africa, subverts its autonomy and powers of self-determination. It is rather by design than by accident that poverty has become a major institution in Africa despite this continent's stupendous resources”²⁹⁵.

6.1.1. Trauma and Globalization

In the 1990s, the World Bank report confronts the implication of a new order in developing countries debt burden. In the process, they assure that many African families will be dislocated because of poverty and their insufficient livelihood. The World Bank reports that “globalization has disintegrated or disarticulated the industrial sector of most, if not all polities in Africa. This has been particularly evident in the areas of cost of production which has become uncomfortably high in most of the developing countries; also in the lack of government's incentives to encourage local production; subversion of local products through high importation, currency devaluation; and depletion of foreign reserves. This clearly raises the problems of marginalization which, according to Ake (Ake: 1996, 114), is, in reality, the dynamics of under development - the development of under development by the agents of development.

In Ake's perceptive, the physical manifestation of these negative impacts is the replacement of the traditional economy in African countries that was founded on fishing, farming and hunting for economic sustenance with a petrol-dollar economy. Thus, as a matter of fact it leads to a decrease of agricultural productivity and fishing in the areas, leading to the prevalence of poverty which was put above the national average. One of the direct consequences of this decrease of agricultural productivity is that in a country like Ghana, most of the rural people migrate to urban areas for work and having formerly nowhere to live, they start settling at the peripheral areas. They create slums like that of 'Sodom and Gomorrah' in Amma Darko's

²⁹⁵ Akindele, S.T.; Gidado, T.O., & Olaopo, O. R. (2002). “Globalisation, Its Implications and Consequences for Africa”, Department of Political Science, Obafemi Awolowo University.

third novel *Faceless*. The name of this slum freezes any reader, ‘Sodom and Gomorrah’. The evocation of the two names freezes any Old Testament reader.

In *The Housemaid*, the principal message is about African women and girls’ conditions in urban areas. It is explicitly about women’s exploitation in urban cities. It is also about tradition and modernity. Through its title, the novel designates a human being, specifically a female servant who cleans rooms and does other chores in a house, one may wonder why the author does not choose a name instead like “*The Life of Tika* or *The Life of Efia*” or like the prolific Nigerian Cyprian Ekwensi’s *People of the City* (1954) and *Jagua Nana* (1961), all about city life, crimes and cute scenes of sex. At its publication, some information carried that Ireland²⁹⁶ banned Ekwensi’s first novel special for indecency and questioned the author literary career. This poses the problem of writer as teacher dear to Achebe, though sex in some African novels should not be taken as necessarily pornography but a kind of body desire, discovery, freedom seeking or barrier breaking. When this sexual relationship happens in a dream it is another psychological or metaphysical interpretation. Sexual relationship in literature can also be politically regarded as a sign of dominance and hypnotism of a sex (male power) over another (female) or in term of rape like in Emecheta’s *The Rape of Shavi* (1983), the woman as the African continent and the rapist symbolically the colonizer. This representation will be developed later in our analysis.

As far as Amma Darko’s point is concerned, her choice stems from the emphasis she wants to lay on the nature of the work of a housemaid rather than on the individual performing the task. Amma Darko has also tried to work as a domestic in Germany, then she knows well what she is talking about. Being domestic or housemaid is a menial job what does not accord any respect and a black to do that job in a white man’s’ country is more humiliating. The case of Ferdinand Oyono’s *Houseboy* (1956) is a proof-based experience of the daily humiliation of Toundi at the opulent whites’ Residence to serve the Commandant, his wife and their friends after the death of the priest Gilbert.

Through the entitling process, the novelist is bringing into sharp focus this lack of respect for the group of people who are designated. This argument is supported by the fact that in the body of the text a synonym for ‘housemaid’, ‘house-help’ or ‘domestic’, which does not

²⁹⁶ Country located in the north of England and has a capital Dublin.

have the negative connotation of the first one, is not used by the author. By its structure, then, and as the reader's first encounter with the text, the title raises questions that can arouse the interest of the reading public in the text: Who is the housemaid? What is her character intended for? Where does she come from? What does she do? Why does she do it? How does she do it? Is this name chosen deliberately?

In this very sense, Taha posits it as follows: "The title sparks numerous questions, reflections, sensations, expectations and guesses which can find a consensual answer only in the body of the text, or more precisely with the help of the body of the text" (Taha, 2000). Through the titling process, we believe that Amma Darko has fulfilled the functions of the title embedded in Hoek's definition which is the designation of the book, indication of its content, and appeal to a readership. It has provided the reader with a means of internal reference to the body of the text and helped to identify the focus and intention of the writer: a housemaid.

6.1.2. Fictionalization of Poverty

In *The Housemaid*, Amma Darko fulfils her role of fiction writer by creating Osiadan, a small fictional village as a microcosm of the wider national trauma of chaos, suspicion, and silence imposed on the female dwellers who attempt to defy the order of oppression and subjugation, the very system which maintains an atmosphere of poverty and relegation. The narrator gives a background within which poverty prevails at its crowning rate compelling little children, at what age must be at school, to become scavengers and baby-sitters, whose findings come to be worth for a whole family:

[...] two boys scavengers searching the rubbish dump as usual for anything that might be useful, spotted a red plastic bag and made a grab for it. [...] some beige nylon underwear and a faded cover cloth. All of these were stained with plenty blood and other fluids the two scavengers could make no sense of. But they took it all anyway, because they had across finds in worse states which had turned out good and useful (Darko, 5).

According to Jayne Cortez, poet and president of the Organization of Women Writers of Africa, "Black women writers from around the globe have been struggling against racism, exploitation, gender oppression, and other human rights violations²⁹⁷". She continues, "The

²⁹⁷ Cortez, J. (2004). Remarks given at Yari Yari Pamberi Conference, New York University Press.

psychological and physiological consequences of globalization have been a major part of the subject matter of the contemporary African writer. In relation to Africa and African culture, the international slave trade and colonialism forced significant contact with globalization in its early manifestations. Black women writers want to participate in global decisions concerning survival and the future of humanity. They need access to the progress of globalization”²⁹⁸. In *Faceless*, the third novel by Amma Darko, a female character compares poverty to a foe, that cunning and furious animal of African savannah. The comparison of poverty to a foe lies in its manner to devour very quickly its victims alive.

In *The Housemaid*, mother’s interest and daughter’s interest are divergent and parallel. Like Tsitsi Dangarembga’s *Nervous Conditions* (1988) central protagonist, Tambudzai, the adolescent Bibio’s burning desire is to go to school no matter how cost avoid being “a mini-version of Mami Korkor, as she finds in her no acceptable model of womanhood.”²⁹⁹ Bibio attacks her mother accusingly “You should have sent me to school to learn some manners then. But since you rather let me stay home to play mother to you and your friends’ sons-boys I’m only three years older than where else can I learn my manners but in the streets? (Darko, 11)” that of her mother Mami Korkor is to make of money in Odiadan market, “It was at this point that Mami Korkor, a fresh-fish hawk, emerged from the market very exhausted, and headed for home” (Darko, 10). Amma Darko rejects motherhood as the female way of societal fulfilment which can earn respect. One can obviously notice how Mami Korkor is overwhelmed since she is alone in the breeding of her progeny. In this light, Abiodun Olayiwla rightly emphasizes to support the little and innocent girl:

Bibio’s rage is couched in her desire for a role model to cling to which she does not see in her mother because of her inability to fire deadly shots at the system that oppresses her and creates absence of nuggets of life that can give her hope. She feels her mother’s disappointment and her mother’s humiliation has a domino effect on her life³⁰⁰.

²⁹⁸ Cortez, J. (2004). Remarks given at Yari Yari Pamberi Conference, New York University Press.

²⁹⁹ Bungaro, M. (2007). “Victims and/or Victimisers? Women’s De(Con)structive Power in *The Housemaid*.” (Ed.) Vincent O. Odamtten, *Broadening the Horizon: Critical Introductions to Amma Darko*. UK, London: Ayebia Clarke Publishing, Print, p. 33.

³⁰⁰ Abiodun, O. & Adekunle, O. (2013). “Mothering Children in Africa: Interrogating single parenthood in African literature”, *Cadernos de Estudos Africanos* [Online], 25 | 2013, posto online no dia 11 Julho 2013, consultado o 16 Dezembro 2014. URL : <http://cea.revues.org/880> ; DOI : 10.4000/cea.880

For this reason, Amma Darko describes the two different and parallel worlds existing in Ghana after independence. In one side, we have the small world of poor people represented here by Mami Korkor and her alike and in the other that of rich people or those Ghanaian who have tried to come out of the system. In the world of poor people, Amma Darko highlights female powerlessness to subvert patriarchal grip that renders Ghanaian women dependent and head down. To stand on their feet and resist against the prevail order, Ghanaian women must be educated or have money, a condition which Mami Korkor and unfortunately her daughter do not fulfil and which Bibio wants to avert. The oppressive hands of tradition still exit in Ghanaian contemporary societies? Then, in diverse works of African female writings and in African patriarchal societies, everything evil often tends to be viewed as fault of the women, including poverty and children's education. They also suffered from stress as a result of thwarted male ambitions.³⁰¹

In that microcosm of diverging desires and powerlessness, where some Ghanaian women sweat hard from morning to dawn to get very few for their family, other just from 'corners to runabouts' get the maximum with bread and butter on their table by using their "genital power"³⁰². Life is unjust to poor people in cities. Amma Darko illustrates it this way:

And the man felt his obligation to his unborn child transcending his loyalty to his wife. He left her. 'I will live the rest of my life for you and our child,' he promised Sekyiwa. 'I will set up in business. I will make you rich. I will invest every pesewa that crosses my hand in you. So that one day, when I am old and no longer working, you can take care of me and our child (Darko, 18).

Amma Darko pins down the matter of motherhood in present Ghanaian society and commenting on situations encountered by women of these two different worlds, Filomina Steady highlights the issue of motherhood and how it can hinder or give opportunities to African women's personal empowerment, along with various other factors:

³⁰¹ Watchell, E. (1977). 'The Mother and the Whore: Image and Stereotype of African Women'. In *Moja* 1 (2): pp. 31-48.

³⁰² Diabate, N. (2011). "Genital Power: Female Sexuality in West African Literature and Film", University of Texas at Austin, p.2. As defined here, "genital powers" refer to a range of genitally centered practices that women and female characters use to resist male domination. Using anthropological and folk media, I explore public undressing also known as genital cursing and genital strike as examples of genital powers. Since to speak about the body and more specifically to position women's genitals as a possible site of resistance is challenging in the West African context, the chapter analyzes the trope of the hypersexualized black female body in the racist colonial ideology, the theoretical instability of the body as a material entity, and the heteropatriarchal framework of the postcolonial nation states as some of the arguments against this project.

[T]he black woman's situation is different and amongst the things that make her situation different is the lack of choice in motherhood and marriage [...] enforced silence and a variety of other forms of oppression intrinsic to various societies which still plague African women's lives and must inevitably be at the crux of the African feminist theory (quoted in Boyce Davies and Adams Graves, 7).³⁰³

In fact, the African traditional view of womanhood configures the social construction of African woman and the role-participant carved for her. In view of this, in virtually every place and time, two words have been employed to denote and qualify the African woman: marriage and maternity. So in many African societies, marriage and maternity lie for the same purpose because when a woman gets married, she is entitled to bear children as a result of her marriage. In *Beyond the Horizon*, the homodiegetic narrator confines it to illustrate the concept's anchorage deeply to African people's mind: "I don't know, I don't know [...]. When he married me, I thought all the time he slept with me that he was doing it so that I would bear him a son" (Darko, 86). The message is clearly-cut and completely understood. It is like: 'Woman, you are here to bear babies, especially sons'. Hence, the more a woman has children mainly sons, the more she seems to have her place in her husband's family.

In this sense, Ngcobo believes that generally, Africans take motherhood to be all about children, as she put it: "every woman is encouraged to marry and get children in order to express her motherhood to the full. The basis of marriage among Africans implies the transfer of the woman's fertility to the husband's family group"³⁰⁴. The fertility is then a key factor of a union between a man and a woman. Generally, from the man's family, relatives and occasionally some friends, some volunteers investigate the surrounding of the bride's family to see whether there had fertility troubles in the past. Focusing on the various above-mentioned issues by Filomina Steady and Ngcobo, Amma Darko's novel unmistakably shows that motherhood as traditionally conceived needs to be addressed so that Ghanaian women can realize their potential and overcome that which hinders their personal development. Amma Darko is somewhat saying this: 'Yes, motherhood is important, but a woman is not only made for that'. Mami Korkor can be good to her little Bibio if only she had children as less as possible and then could concentrate

³⁰³ Davies, C. B. (1986). Introduction. *Ngambika: Studies of Women in African Literature*. Trenton, NJ: Africa World Press, pp. 1-23.

³⁰⁴ Ngcobo, L. (1988). "African motherhood: Myth and Reality." *Criticism and Ideology*. (Ed.) Kirsten Holst Petersen. Upp Sala: Scandinavian Institute of African Studies, p. 140-49 in Akujobi, Remi's "Motherhood in African Literature and Culture". *CLCWeb: Comparative Literature and Culture* 13.1 (2011), Purdue University Press, p. 3.

on their education. According to Hendrick and Lewis, it is important that African female writers especially strive “to reclaim traditional African heroines with a view to constructing an affirmative matrilineage”³⁰⁵.

In fact, the possibilities of women’s empowerment are limited in this novel, as a result of many hindrances Amma Darko’s characters encounter in their lives, particularly those related to motherhood. The authoress highlights the extent to which women in Ghanaian societies acquire happiness through motherhood, but also the way in which they suffer as a result of the societal and cultural pressures placed upon them to become mothers. It is a well-known conviction in Africa that motherhood brings joy, but Amma Darko emphasizes the fact that there can be a complete absence of happiness in motherhood. Therefore, motherhood has almost no joy to join the ironic concept of the joys of motherhood as depicted in Emecheta’s *The Joy of Motherhood* (1979). Buchi Emecheta and Amma Darko, though not being writers of the same generation, agree on the way it can cause sadness and suffering to women, with the potential to hinder their capacity for attaining a sense of self-worth, self-fulfilment and empowerment; and how, in this and other respects, it can serve to further patriarchal systems of control over women’s lives. Mami Korkor’s powerlessness to send her little Bibio to school as we have said earlier derives from the number of children she has to feed with no help from their irresponsible, nameless and good for nothing father. The most important thing for these kinds for men is their sexual satisfaction that they selfishly deny to women. They are the living materials used by patriarchy to continue its hegemony in Ghanaian households. Bungaro asserts that:

The interface in these ambiguities in the universe of *The Housemaid* can be visualized thus: Bibio and Mami Korkor, Efi, her mother and the grandmother, Tika and Sekyiwa. The scenario pictured in these demarcations is the daughter’s repulsion toward the mother³⁰⁶.

The main relationship in the novel between mother and daughter seems that of an inevitable clash and mistrust in a closer look. The relation is played out in terms of power and domination, the mother portrayed as cold, powerless and calculating. Furthermore, the outcome is that “the mother is represented as a failure” (Darko, 70). Bibio first gives us the inkling of a

³⁰⁵ Hendricks, C. ; Lewis, D. (2004). Voices from the Margins. *Agenda* 60 (2): pp. 60-74.

³⁰⁶ Bungaro, M. (2006). “Mothering daughters and the other side of the story in Amma Darko, Ama Ata Aidoo and Nozipo Maraire”. In Emenyonu, E. N. (Ed.), *New directions in African literature*. Special issue of *African Literature Today*, 25, pp. 67-81.

battered relationship accusing overtly her mother to be a willing victim of the system inducing her offspring in that intricacy. She is frustrated with the life she is consigned to live.

In *The Housemaid*, Amma Darko illustrates: “Sekyiwa had always known that Tika blamed her for the death of her father. She tried to buy her forgiveness. Tika saw her mother’s turmoil and relished it. Somehow, her mother’s desperation for her forgiveness eased the memory of the grave sadness in her father’s face when she saw him for the last time” (Darko, 21). Ketu H. Katrak states that women writers such as Ama Ata Aidoo and Amma Darko play a significant role in women’s literature, by exploring new possibilities for women and women’s writing:

Women writers’ uses of oral traditions and their revisions of Western literary forms are integrally and dialectically related to the kinds of content and the themes they treat. Women writers’ stance, particularly with regard to glorifying/denigrating traditions, vary as dictated by their own class backgrounds, levels of education, political awareness and commitment, and their search for alternatives to existing levels of oppression often inscribed within the most revered traditions. Their texts deal with, and often challenge, their dual-oppression-patriarchy that preceded and continues after colonialism and that inscribes the concepts of womanhood, motherhood, traditions such as dowry, bride-price, polygamy and a worsened predicament within a capitalist economic system introduced by the colonizers. Women writers deal with the burdens of female roles in urban environments (instituted by colonialism), the rise of prostitution in cities, women’s marginalization in actual political participation (Ketu Katrak, 2006: 240).

In this extract, Ketu Katrak discusses various forms of oppression, a number of which are patriarch, bride price and polygamy. Moreover, she mentions women’s quests for self-actualization. The four primary novels under study provide us with insight into ways in which some women are able to attain empowerment, as illustrated in Ketu Katrak’s words “search for alternatives”³⁰⁷, whilst others are unable to do so. However, despite concerted efforts to empower women especially in postcolonial societies and states, many women have not been emancipated from various forms of psychological, emotional, physical oppression and sex-role stereotyping and Mami Korkor is among these women having in charge four children without the help of her husband as if she was respecting the popular saying: ‘You give birth to a child.

³⁰⁷ Katrak, K. H. (2006). “Decolonizing Culture: Toward a Theory for Postcolonial Women’s texts” in Ashcroft, Bill; Gareth Griffiths & Helen Tiffin (Ed.). *The Post-Colonial Studies Reader*: London & New York: Routledge, p. 239-41.

God will take care of it'. As for the little boys of Mami Korkor, the narrator puts like this "They still go scavenging on the rubbish dump? [...]. Not a pesewa came from their father. But Bibio, the young girl who speaks words above her age, had a different view. She cannot understand the good reason "Why, after making Nereley with him, when you realised how irresponsible he was, did you go ahead to make Akai, me and Nii Boi as well?" (Darko, 11).

The frustration of the little girl is obvious and the confrontation also inevitable. In confronting her mother, "Bibio adopts the double role of judge and aggressor"³⁰⁸. Because of a mother's accepting the status quo, a number of people depending on her have to bear the consequences of the decision. Mami Korkor's boys scavenge in search for garbage and third-hand clothes to be recycled. Those young boys on the street also pose the problem of homeless children and implicitly the rapid and wild development of urban centres in contemporary Ghana. This is one of the serious thematic portrayed in Amma Darko's third novel *Faceless*. This novel describes the persistence of Amma Darko's preoccupation about women's welfare and economic emancipation in fast growing Ghana that is giving no opportunity and having no pity on people whose chance grows thinner and thinner.

6.1.3. Trauma and Motherhood

Being a mother in a patriarchal setting is a very important role. Rules are clearly set to women before they grow to adulthood. In that setting, mothers love mostly their children than themselves. They accept even to be crushed down for their children to survive. When they do not get any, they are also ready to do all they can to have one. As soon as they get inside their marital house, the pressure from in-law is unavoidable. The race to be mother becomes a life priority, an accomplishment for young married women. The pressure's good result testifies that the bride comes from a good family. This necessity and urging need of life giving may become a danger to women. It becomes disturbing when, months after a woman arrival in her groom's house, no pregnancy occurs. This psychological stress is inevitable a burden to women's development. That is why female writers bring attention on this tragedy in women's realm.

³⁰⁸ Bungaro, M. (2007). "Victims and/or Victimisers? Women's De(Con)structive Power in *The Housemaid*." Ed. Vincent O. Odamtten, *Broadening the Horizon: Critical Introductions to Amma Darko*. UK, London: Ayebia Clarke Publishing, Print, p. 33.

Further, the new direction the writers of the third generation have taken with their fiction is to denounce this pressure from society. It does not mean that women reject mothering as being a step in the human species regeneration, but it should be a joint and concerted decision. Thus, a focus on Amma Darko's writing proves that she strips off the Ghanaian traditional perception of motherhood since it becomes more and more a serious setback to women, an obstacle to their mental and economic self-fulfilment. Motherhood, when not prepared for, gets women into poverty and starvation; and poverty contributes to the deterioration of social habitat. Here female characters like Maa Tsuru in *Faceless* and Mama Korkor in *The Housemaid* deserve a life like that of women of MUTE NGO³⁰⁹. However, they are encircled and waved with scent of dirty, inelegance and impropriety. During a conversation with the critic James Adeola, Buchi Emecheta confesses this point "When writing about women, Buchi Emecheta says she tries to ask the following: "Why are women as they are? Why are they so pathetic? When you hear about traditional women who were very strong, you wonder, why are we today so pathetic, so hypocritical? (James Adeola, 42)"³¹⁰. Like Buchi Emecheta defends, Amma Darko knows that Ghanaians had valuable women such as Nana Yaa Asantewaa before. But today, patriarchy perfect plan is at work in many households so as to reverse the trend. When there is no food and no materials of first necessity, women who get pregnant because of fertile, and copious nights with irresponsible and good for nothing men, have to get ready for starvation. Irresponsibility get men "to release tension"³¹¹ with friends around glasses of "Akpeteshi"³¹² while their women go hungry at home for their evening meal. In this social setting, it is normal that Ghanaian women feel powerless to let go of their young progenies onto the street and even when they seem to come back after streets lords threatening them, single parents like Maa Tsuru try dissuade them:

Maa Tsuru began to cry. "Go away, Fofu," she managed between tears, "Go!" Fofu's face clouded fiercely. "Is history repeating itself here? Are you sacking me, mother? Because of him?" "No! No! I am not sacking you from here. Not from this room. Not from this house. I mean to say, go away. From Accra, if possible, Fofu. Go away, Go somewhere far away from here. (Darko, 21-2)

³⁰⁹ MUTE is an acronym which meaning is explained in *Faceless*, (2010) Sub-Saharan Publishers, p 38

³¹⁰ Adeola, J. (1990). *In Their Own Voices: African Women Writers Talk*. Portsmouth, NH: Heinemann.

³¹¹ Darko, A. (2010). *Faceless*. Accra: Sub-Saharan Publishers, p. 14.

³¹² *Ibid.*, it is a local palm wine, cheap and very appreciated by the middle class Ghanaians, p. 1 &123.

As for Maa Tsuru, she is unable to defend herself, through the awareness of her own guilt, in front of her daughter Fofu's accusations of having given birth to six children, without the slightest thought about their future. In shocking and lurid details, Amma Darko's narrative captures the horrid reality women and teenage girls endure. The aforementioned passage is a heart-breaking conversation between a mother and her daughter. To be good to her lover who cannot afford for many mouths in the household, Maa Tsuru urges Fofu to leave and go very far away from the home which should normally be a natural shelter, a milieu of protection and care anytime the little child tries to come back home:

she is always in the hurry to see my back. Sometimes I cannot help thinking that maybe she never has a smile for me. Sometimes I cannot help thinking that maybe she never has a smile for me because the man she made me with that is my father probably also never had a smile for her too"³¹³.

The real abandonment leads the protagonist to choose her way and not to become like her powerless mother. As a result, Fofu goes onto the street where she is alone but free, where she has to act and react as an adult, responsible for her life. Fofu is accepted and recognized as member of 'street children', her new tribe. On to the street, Odarley is Fofu's best friend with whom she shares a similar story. Odarley's mother, like that of Fofu, also has a new husband and children she'd had by him. So she resents Odarley because her father abandoned them and constantly accuses her daughter of stealing from her. So she drives Odarley out to live on the streets.

Meantime, Amma Darko does not only delve into the relation between male and female characters, but also women's exploitation by the social system, a crime and its particular investigation by women of an NGO helped by a Media presenter, since the government fails to play its primary roles. Before the NGO's inquisition, the little street girl asks sharply for the government's responsible action "Government! I said government. I want government" (Darko, 47). The peculiarity of Amma Darko's creative writing lies in three points: an innocent girl revealing overtly the inaction and absence of a whole government, an NGO to investigation a crime scene in replacement of the official institution (police) and the limit of the NGO in terms of finance. The street girl knows the reason why she is asking for the government's action to

³¹³ Anyidoho, K. (2010). "A New Landmark in Ghanaian Fiction: An introductory essay in *Faceless*". (Revised version) Accra: Sub-Saharan Publisher, p. xv.

help since street is a merciless enemy to youngsters like her senior sister, her friend and her. She also knows that she is talking to someone reliable. Luckily, “Fofu finds in Kabria, the social worker at MUTE, a valid gender model to look up to”. We read that Fofu collapses into the arms of Kabria and the latter responds by holding her close. This shows the spontaneous bonding between the two. The affectivity absent in the Maa Tsuru and Fofu relationship is seen in the Kabria/Fofu relationship because children need to be assured and cared for and parents must be present to offer that guarantee. We read earlier on that when “Maa Tsuru raised and pegged one corner of the curtain onto the line and entered the inner space, Fofu hesitated, then moved and sat down carefully at the farthest point from her mother. Something did not quite fit. Tears welled up in Maa Tsuru’s eyes” (Darko, 21).

Additionally, in another range of thoughts, the charismatic female members of the NGO know that it is not in their ability to further their investigation and also that they are in lack of materials like cars, money and men to rely on. For example, to investigate in the crime of Baby T, Kabria goes with her old Creamy, the mark of the car she drives to office, markets and in any other places in Accra. The car always breaks down to the misfortune of the combative woman. What Creamy is for is described in this line:

Finally, Creamy. The car had been in and out of every kind of workshop from Abeka to Zongo so many times and undergone all kinds of clinical and plastic surgeries, that it seemed to have grown immune to both. Creamy; a name Kabria held so dear to heart that she once shocked Adade with the extent of her passion when he dared put it to rest. It was after one of Creamy’s many plastic surgeries, which left it, so tattooed that it required urgent re-spraying. Unable to squeeze anything out her misery salary, she sought help from Adade. (Darko, 15).

Further, with Amma Darko, the lifeless and mutilated body of Fofu’s elder sister, appears near the beginning and triggers various enquiries: by Fofu, by an NGO that defends women, by the police, and by a local radio station. In *The Housemaid*, it is a dead female body that serves as the starting point of the narrative. This is to prove the marginal characters’ destiny. Women are depicted as marginal in Amma Darko’s novels, however their death does lead to change or must infer it in social attitudes toward them. On the other hand, so no sooner had they come at the police than they realized with great surprise that that kind of police station could assure neither security nor a good investigation. Here is the image of the police station:

The police station stood in a very busy area and was, simply put, a sorry sight. Broken windows, leaking drains, cracked walls and peeling paint greeted Vickie and Kabria. The officer behind the outdated front desk, who seemed very bored with his world, his job and his very own self too, responded to their loud and clear greeting with a sullen nod. [...]

“Look!” he bawled apparently giving no hoot any more about the FM station bit, “You think you can come here and teach me how to do my job? Do you have any idea at all what we go through here? We do our best within the available resources here. (Darko, 80-1)

The ineffectiveness of some State police officers takes everyone aback in this excerpt. This police lives as parasite as any intestinal worm can proceed in a human body; so their result. An officer instead of concentrating on the case of murder was with his lotto newspaper. He is at his leisure time while on duty because nothing compels him to do the best to help solve the case. However, it is difficult to blame him for the somehow negative attitude he shows towards the killing of the child because the provision of logistics for him to carry out his duties effectively is virtually non-existent. Further, the lotto newspaper on his desk is not to be neglected. The officer is reading the result of his previous betting and now calculating the probability that suggested numbers by specialists are right to win the jack pot. He is just feeding his irrational hope and dream for better life and social respect.

The shocking extract sounds an exaggeration from the novelist, yet it portrays the real malaise of Ghanaian society in general and police station in particular at present-day. Things fall so greatly apart that it is a common NGO specialized in social welfare which investigates criminal affairs in Ghanaian society, Amma Darko shows. The almost “surrealistic scenery of the rape act translates as vicious and relentless violations of the female body and desperate efforts of very young girls to defend their feminine space. The opening scene marks an attempt to crush the female body. This startling opening narrative signifies Amma Darko's artistic predilections.”³¹⁴ However, the surprising thing in the second novel by Amma Darko is how the little girl Bibio’s age could talk so incessantly to her mother with such an insulting tone and if it is not the authoress herself who replaces the adolescent. In actual fact, one really intends to ask such a question like: Why do you accept to bear so many babies to a man who ignores his primary responsibility?

³¹⁴ Awuyah, C. K. (2013). *Faceless: Amma Darko's Face for the Faceless*. Making Connections: Interdisciplinary Approaches to Cultural Diversity: March 2013, Vol. 14, No. 1, pp. 28-39.

In this sense, “Mami Korkor daily enhances her marginal status by accepting an irresponsible lover and multiple pregnancies without offering any resistance”³¹⁵. Her acceptance is denounced here by Darko. But in fact, Mami Korkor is a mere victim of the patriarchal system which obliges women to have husbands anyhow, anyway and to bear children as many as possible either the men help them or not. This form of oppression was pointed and denounced in Flora Nwapa’s *One is Enough* (1981). The protagonist Amaka refuses to stay in her husband home without a child as society particularly urges. She leaves Obiora and settles as a lonely but a cash woman, a rich trader. Mami Korkor hawks fish from morning to dusk to feed her four children. Fish hawking is not an easy job at all, that is why she feels depressed, tired and anxious at her arrival. Mami Korkor’s desire is not to discuss with her little girl, but to cook food, rest and get ready for another day. This impacts necessarily on her education as it could impact any other child confronted with the frequent absence of his parents. Mami Korkor recognizes that as she was taken aback and rebukes her child’s tone: “I don’t like your tone, Bibio,” she warned icily. [...] Mami Korkor was at a loss. Her daughter was growing up on the wrong side of the tracks, she knew. But how could she change things?” (Darko, 11). Nobody puts a gun to her head and obliges her to bear so many children. Had she stopped to Bibio, she might be free to bring her to adulthood with the means she has. The modern world is bound to free choice for everybody to be married or not, to bear children or not, which is not possible in traditional setting.

To back up Amma Darko’s idea about children’s mis-education in households where parents are “workaholic”³¹⁶ and illiterate, Bhushan and Ghao, two World Bank experts reported that “The wide range of gender gaps makes households headed by women more vulnerable to poverty than households headed by men” (Bhushan and Ghao)³¹⁷ and children are likely not to go to school or to dropout earlier in these households. Bibio and her junior brothers, Fofu, Odarley and their counterparts and lords of the streets are then living cases of the situation prevailing in Ghanaian post independent society.

³¹⁵ Bungaro, M. (2007). “Victims and/or Victimisers? Women’s De(Con)structive Power in *The Housemaid*.” (Ed.) Vincent O. Odamtten, *Broadening the Horizon: Critical Introductions to Amma Darko*. UK/London: Ayebia Clarke Publishing, Print., p. 33.

³¹⁶ Otu, W.; Appiah, E. E. ; & Addo, B. E. (2015). “Family Roles and Dual Career Marriages in Ghana: Benefits and Challenges to Emerging Families in Ghana” in *Journal of Historical Research Letter*, ISSN 2224-3178 (Paper) ISSN 2225-0964 (Online) Vol.26, p. 8-11.

³¹⁷ Bhushan, I. ; Shiyam, C. (1996). “Poverty Reduction among Female Headed Households in Ghana: Is it Real? World Bank, Ghana Country Team, Washington, D.C. in *Ghana, Gender Analysis and Policymaking for Development*, (ed), Shiyam Chao, pp. 1-2.

In her second novel, Darko proves that a reversal role and attitude can be described in a female creative writing through Tika's father. This sickly and morbid character leaves his first wife, a barren, just at the hearing of his young lover, Sekyiwa, gets pregnant of his dreamt child. However, as a doomed fate, as his libido begins fading, Sekyiwa begins looking for good sex from "young, good-looking male gold-diggers" (Darko, 18). She maltreats her husband till he dies. The following dialog shows the heart-breaking sequence of the old man's weeping "Tika leaned confused against the corridor wall. She had gone to find her father and ask why he was weeping. 'Did Mama beat you?' She had asked. 'No, her father had replied calmly" (Darko, 19).

This passage proves once more the male-bashing perspective of the writer. All the male characters of Amma Darko either they are finally in jail, or silenced by their work or their position. The authoress does not give them opportunity to defend themselves and talk. The same way, African male writers did not give to their female characters any chance and any voice. However, she recognizes that the concept of 'good mothering' is not the appendage of all women. Sekyiwa does not give much love to her daughter, the same does Mama Korkor, though sometimes they know what is good for their daughters like education, independence, respectability and reputation either by offering sex to men or by corruption.

At last, the chapter illustrates the trauma of Ghanaian women in patriarchal society is a permanent condition. We describe their daily sufferings and their struggles to get free from the harsh conditions. Amma Darko is a writer of the third generation who writes about phenomena in urban life. A classification in different categories like the one mentioned above can be criticized as limiting, and giving an illusionary image of the real scope of Amma Darko's literary production because she also ventures in history by mapping the Transatlantic Slave Trade that struck Ghana. But it is also a helpful tool to chart the changes the literature of a nation goes through. Each generation publishes within a certain time-frame, and seems to be characterized by an important event in history, so it would be evident to assume that each generation's literature is inherently influenced and determined by that event. However, the merit of Amma Darko is that she actively positions herself in contemporary Ghanaian literature and is one of the new feminist voices to reckon and her engagement as activist.

PART TWO: SOCIO-CULTURAL FACTORS CONTRIBUTING TO THE GENDER GAP

Chapter three: Culture of silence: a factor for gender gap enlarging

The present chapter is directed not only to solve cultural questioning, but also focuses on social and religious questions to answer by the means of literature. Therefore, we operate from the premises of patriarchal structures which engender socio-cultural and economic constraints and impede African women's progress, one of the multiple ways to let prevail and deploy poverty in the society. We say poverty because a woman who is obliged to keep silence is blocked from asserting herself socially, financially and intellectually. Then, the duties and activities assigned to a particular gender can demonstrate their respective position in the overall power structure in that particular society. In the respect, Amma Darko has no taboo in portraying the typical Ghanaian society after independence with all these limits sharpened and forever present against women to imply their subjugation. Women have to comply with the rule otherwise they are ejected from the society as deviant, and deviance has also its price: death. When patriarchal communities reclaim docility from women, it is foremost to lead them arm and legs bound to marriage. Subsequently the following chapter will not only deal with obedience, but also traditional marriage and other social conditions admitted as rites of passage to adulthood in traditional societies. By this means, the individual is granted the right to enter plainly into his destiny. Otherwise, choice is made for him/her to lead his/her life in the right direction that the community wants. Deviants are put aside and punished.

7. Obedience and traditional marriage in *Beyond the Horizon and Faceless*

Conceivably, it is fitting to begin this analysis by stating that reality in African cosmological view is steeped in African metaphysics or ontology which “does not see things as separate but ontologically linked with each other”³¹⁸. It is out of this thought-flow of African cultural and traditional embroidery that is carved the African woman’s construction in society. This socio-cultural over-decorated fabric of gender lays bare of any kind of ideology for gender inequalities. In Africa, womanhood can only be attained through motherhood and the latter

³¹⁸ Nwakaeze-Ogugua, I. (2007). Feminism and African cultural heritage. *Gender and behaviour*, 5 (1), 1022-1041 in Abiodun Olayiwola and Adekunle Olowonmi, « Mothering Children in Africa: Interrogating single parenthood in African literature », *Cadernos de Estudos Africanos* [Online], 25 | 2013, Online since 11 July 2013, connection on 12 October 2016. URL : <http://cea.revues.org/880> ; DOI : 10.4000/cea.880

comes after obedience and marriage. This thematic has long been used by many female writers in African literature to draw public and private attention.

Thus, like her ‘mentor’ in literature, Ama Ata Aidoo, Amma Darko’s current topics are related to social issues like marriage, motherhood, prostitution, female emotional and economic dependence, marginalization, submission, political and economic marginalization to cite these few. In our context, Amma Darko writes her own way and through a textual analysis, we see her representation of African women as they battle with the cleavages within the reality of modern day. Amma Darko creates her own experience, her own view of African women within society and drains a paradigm shift which locates the imbalances of the burdens on women’s shoulders. Throughout the study of the selected novels by Amma Darko, our perspective is that West African women are oppressed by many factors. Still, we emphasize their complicity in their own oppression. In what we can call ‘sabotage’ and during our overall analysis, we argue that modern African women themselves are principally responsible for the enforcing and perpetuation of female subjugation. By the means of oral literature, arranged marriages control female soul and mind in cultural rituals. To some extent, some women in Africa are not just victims but accomplices of their ordeals.

7.1. Obedience as mode of education

Amma Darko’s view is found in describing the traditional and modern Ghanaian women’s pains to explain the urging reasons for giving power to her characters. One of the portrayed pains is obedience in patriarchal settings. It is important to precise here that this subchapter is going to take into account the essence of the family that is traditional marriage. Marriage imposes that women should be subservient and docile to their husbands. Marriage is therefore defined as a recognized union of a man and a woman as husband and wife. That union is expected to last their whole life. It is one of the oldest rituals to be practiced even today in every part of the world. Marriage is an important part of the traditional African society and is one of the largely reflected issues in African literature. So, a woman who is engaged in a dubious union or an unrecognized union is referred to as a prostitute or commonly a woman who sleeps on the floor, a person of no fixed abode. Marriage then is more considered at the side of a woman than a man. Marriage’s specific purpose is to perpetuate the lineage and in the process, bestowing social status on the man before and the woman after. But this does not

impede the man from showing respect to the woman anywhere they live or they move to. Obedience does not mean enslavement then. In the Shona culture, from a tender age, the socialization process differentiates the girl child from the boy child. Shona males are socialized to view themselves as breadwinners and heads of households whilst females are taught to be obedient and submissive housekeepers. J. Charvet opines on the reason why society like this puts that kind of expectation on women. He states that the cause of such differentiation and discrimination is “the fact that society views women as sexual beings and not as human beings”³¹⁹. In this kind of marriage, the husband can have as many wives as possible and can also have extra-marital affairs as a bonus. When a scenario like this happens, it is the wife who is blamed for failing to satisfy her husband or for failing to cater for all his desire. In addition, married women, having now known the conditions, are expected to be sexually passive and submissive to their husbands, men are the initiators of sex and also set the conditions for the sexual encounter.

Considered within the same line of thought, Laretta Ngcobo asserts in her essay *African Motherhood-Myth and Reality* that the concept of marriage in African context is similar with any other community. As elsewhere, marriage amongst Africans is mainly an institution for the control of procreation. Every woman is encouraged to marry and get children in order to express womanhood to the full. The basis of marriage among Africans implies transfer of a woman’s fertility to the husband’s family group.³²⁰ The key element in that union is the intense respect of the man by the woman. That respect from the woman accords the man in public and in private his statute of head of the family, ruler of the ‘kingdom’. The union can be denuded of love, as we have said earlier, but it must be based on obedience and submissiveness. Docility or obedience is a word that is used to indicate submissiveness, compliance or passivity. The online dictionary defines obedience as “compliance to an order, request, mindful of rule or law or submission to another authority”³²¹. It manifests itself in almost all African societies in which women are expected to behave as “second sex”³²² or as “second-class citizen.”³²³ What has not to be skipped in obedience is hierarchy of power, status. Therefore, the person giving the order

³¹⁹ Charvet, J. (1982) *Modern Ideologies: Feminism*. London: J.M. Dent and Sons Limited.

³²⁰ Ngcobo, L. (1986). “African Motherhood-Myth and Reality”. *Criticism and Ideology: Second African Writers’ Conference*, Stockholm. Kirsten Holst Petersen. Uppsala: Scandinavian Institute of African Studies, 1988. Print, p. 141.

³²¹ Online dictionary 2017.

³²² de Beauvoir, S. (1972). *The Second Sex*. Great Britain: Penguin Books.

³²³ Emecheta, B. (1974). *Second Class Citizen*. New York, NY: George Braziller, Copyright, Inc.

has a higher status than the person receiving it. In the case of our study, a woman is the one receiving the order; therefore, she has to be all giving and all forgiving which is all that is expected from a woman in patriarchal society.

In *Beyond the Horizon* and *Faceless* Amma Darko introduces the vulnerability of women in Ghanaian societies through her female characters. Amma Darko is far too subtle, challenging and inventive a novelist to be usefully defined by negatives. Her works may seem at the first glance to stand apart from the preoccupations of many of her literary contemporaries. She points an accusing finger to these societies that educate women to generate a subservient mind. Marriage traces the responses to matrimony of women which is not the case of men. Regardless their own choice, women have to get ready to bear many children and produce substantial amounts of food or to become the source of income. As a matter of fact, the protagonist's speech demonstrates how a mother brain washes her own daughter to accept the choice being made by her father:

I remember the day clearly. I returned from the village well with my fourth bucket of water of the day when mother excitedly beckoned to me in all my wetness and muddiness, dragged me into her hut breathlessly told me the 'good news'. 'Your father has found a husband for you,' [...] 'a good man!' (Darko, 3-4)

Mara's mother does not hesitate a moment. She promptly places her daughter on the market of subjugation, the same way she has been placed years before accepting her daughter to become a monetary income, a woman with body and soul enchained, though her daughter was still in her teenage. She alienates her daughter; the same way she was alienated in Mara's father house. Mara's mother in doing so enters the long list of female accomplices of patriarchal subjugation. A similar scene of mother's complicity is described in R. Confiat's *Mamzelle Libellule* (2000)³²⁴. Like Mara's mother, Adelise, the protagonist's mother allows the Commander to dispose of her daughter of just fourteen years old in front of her. The story unfolds this way: "Quand le Commandeur rencontre Adelise pour la première fois, il caresse les seins de la jeune fille de quatorze ans devant la mère de celle-ci, tout en apostrophant cette

³²⁴ Raphael Confiat (born in 1951) He is a writer from the Martinique known for his literary commitment toward Creole literature. He studied English and Political science at the Science Po Aix.

dernière de ces mots: “Tu possèdes un sacré bout de femme [...]”³²⁵. The protagonist’s mother does not seem to be offended by the Commander’s vulgar comment. She keeps quiet, an attitude which opens the way to closer and sharper physical contacts from the Commander. Both mother and daughter share an attitude of stillness towards a male sexual commitment to pass on the law of subjugation. The silence gives way to another interpretation from the commander later.

The above mentioned passage underscores the hegemonic ideology of many African societies, and the way a woman is constituted as prisoner and object through the process. In African society emphasis is placed on two important things: women’s marriage to men because of the institutionalized heterosexuality and the concept of total obedience. The emphasis heterosexuality is taught since the little age of daughters. In some African societies, the rite of passage to this right to heterosexuality begins when the little girl undergoes excision or clitoridectomy. In Kenya, the removal was considered as being a symbol of pride. The same rite of passage is applied to young men through the prepuce’s removal to let loose the penis. This rite of passage imposed on women in Gikuyu’s tribe is described in Ngugi Wa Thiong’o’s *The River Between* (1965).

To Althusser, it is through this interpellation that an individual is constituted as a subject. The interpellation is successful only when the person (always a woman) recognizes and adopts what she is being told “as an ideology, thus believing her actions are predicated upon her own ideas, which of course, unknown to her, are subsumed in ideology”.³²⁶ This is almost what happens to women in all African patriarchal communities: their formatting to the notion of their subjugation. Unless the goat accepts that it is a ‘scapegoat’ that it believes in the doom and its being object of sacrifice. In the same light of thought, Beatrice Rangira Gallimore articulates this concern concisely in "*De l'aliénation à la réappropriation du corps chez les romacières de l'Afrique Noire Francophone*”:

In Africa, [...] it is through the body that society stabilizes and perpetuates itself. Thus, this body must be shaped, controlled and branded. The control of the body is translated through the verbal instructions regarding the way to maintain one's body, which is regulated by a code that determines good and bad behavior [...] society, and more precisely a patriarchal society, brands the

³²⁵ Confiant, R. (2000). *Mamzelle Libellule*, Paris, Serpent à plume, p. 29. “When, for the first time the Commander meets Adélise, he fondles her breasts before her mother and says: “You have a very nice bit of woman here!”. (My translation).

³²⁶ Althusser, L. (1971). “Lenin and Philosophy and Other Essays”. New York, NY: Monthly Review Press, Print.

female body in order to ensure total control over woman and to prepare her for her role as passive receiver (qtd in Cazenave, 126).

The female body is not just stripped of the sense of subjectivity but also of the organic life and in *Women, Culture and Society* (1985), Rosaldo and Lamphere explain that all contemporary societies are replete of male dominance's acts. They opine that there is no society that recognizes women's power over men's if this is not in fiction and drama. Everywhere women are silenced. Combined with other forms of oppression, expectations of this nature relegate women to the margins, forcing them to be passive, in order to be regarded as 'good' women and to be able to perceive themselves as such. At their young age and as a rite of passage, a good dose of folktales which portray the sad end of a disobedient daughter. Within the same line of thought, Vincent Odamtten puts:

[...] that the tone of 'bite your lip acceptance' really mourns the loss of her naiveté, a comfortable blindness that allowed her to accept her role as the obedient daughter. However, her experiences since her 'sale', that is marriage to Akobi, have systematically exposed the lie of obedience.³²⁷

The end of Amma Darko's *Beyond the Horizon* surprises us by not noticing the positive reward of the extremely obedient daughter, Mara, as portrayed again and again in traditional tales. What is accurate to all is that, from an African country to another, the final lesson is the same: the obedient daughter is rewarded by her parents, by the forest's spirit, by the ancestors' spirits or something related whereas the disobedient is punished either by the 'unknown man' or 'the skull', the 'snake transformed to a man' she gets married to. Some tales directly show that she dies of sorrows or is eaten by an animal on her way home. To prove that a novel that can be a tale-based record, J. Peck writes that:

Alongside the fact that novels look at people in society, the other major characteristic of the genre is that novels tell a story. In fact, novels tend to tell the same few stories time and time again. The story in a novel is almost a parable, a tale that makes a point, but in producing a novel the writer complicates the basic story by the addition of a great deal of detail.³²⁸

³²⁷ Odamtten, V. O. (2007). "Amma Darko's *Beyond the Horizon*: Vending the Dream and Other Traumas for the Obedient Daughter" (Ed.) in *Broadening the Horizon: Critical Introductions to Amma Darko*. UK/London: Ayebia Clarke Publishing, Print., p. 103.

³²⁸ Peck, J. ; Coyle, M. (1984). *How To Study Literature. Literary Terms and Criticism*. London: Macmillan Press Ltd, p. 100-101.

Like in *The Bride Price*, what lacks in the beginning of the novel *Beyond the Horizon* is this particular phrase to begin a tale: ‘Once upon a time’ to help solve the dilemma which Odamtten also recognizes:

Amma Darko takes the familiar folk tale of the disobedient daughter, a character we have seen in such works as Ama Ata Aidoo’s *Anowa* and Amos Tutuola’s *The Palmwine Drinkard*, and turns it on its head. We have instead tales of the obedient daughter. This is the young woman who, because of a sense of duty, wilfulness, naiveté or just plain ignorance, feels compelled to obey the rules, to play the game as her elders and betters have taught her, and yet, by the day’s end, the young woman finds herself still trapped in that neo-colonial hall of mirrors, never sure if the image seen is the real reflected.³²⁹

In the same vein of traditional folktales that shape women’s minds and inhibit their self-decision and choice, Amos Tutuola’s first novel *The Palm-Wine Drinkard*³³⁰ also evokes a Yoruba’s legend that described the odyssey of a devoted palm-wine drinker through a nightmare of fantastic adventure. The novelist uses a hypertext related to common Nigerian tales that give strong lessons of obedience to children. The lesson is that one should not to follow an unknown person to an unknown area. One has to be mindful to parents’ words.

Tales like those of Amos Tutuola and Werewere Liking are structured around children especially girls in patriarchal societies. The tails force them to comply with the rules and regulations in force and accept what the protagonist Mara calls all long in the novel “karma”³³¹, from Hindu philosophy which means to 'act'.

The Concise Oxford Dictionary of Current English defines it as the “sum of person's actions in one of his successive states of existence, viewed as deciding his fate for the next”. Karma is the differentia that characterizes human beings and distinguishes him from other creatures of the world. In this regard, the female character Mara, by putting “many things that happened in my marriage appeared to me to be matter-course things that happened in all

³²⁹ Odamtten, V. O. (2007). “Amma Darko’s *Beyond the Horizon: Vending the Dream and Other Traumas for the Obedient Daughter*” (Ed.) Vincent O. Odamtten, *Broadening the Horizon: Critical Introductions to Amma Darko*. UK/London: Ayebia Clarke Publishing, Print., p. 104.

³³⁰ Tutuola, A. (1952). *The Palm-Wine Drinkard* (New York: Grove, 1980) 9. Print.

³³¹ Karma is the law of moral causation. The theory of Karma is a fundamental doctrine in Buddhism. This belief was prevalent in India before the advent of the Buddha. Nevertheless, it was the Buddha who explained and formulated this doctrine in the complete form in which we have it today. Karma does not exist lurking in the past as a thing to punish or reward us, but exists and is created now, newly, in every second. We can create Karma with supposedly good intentions, as mentioned previously. <http://www.buddhanet.net/e-learning/karma.htm>

marriages and to all wives. I didn't see much difference from parent's marriage either, so why should I think differently just because I was living in the city? [...] 'Because he is a man.' (Darko, 12-13), thinks that all her life has already been declined in negative actions. She thinks she is then doomed for that kind of life.

In Amma Darko's case, Mara obeys candidly the words of her parents and follows Akobi, the unknown to Accra. We can understand the women's submissiveness in any social and religious spheres. In the Judeo-Christian communities, the Holy Bible firmly demands "Let a woman learn in quietness, in entire submissiveness. I allow no woman to teach or to have authority over men; she is to remain in quietness and keep silence in assemblies"³³². Women in the Islamic world are not spared from these restrictions as their identities are well hidden by their hijabs, veils, dresses and other physical and social constraints.

In actual fact, the scope of that dressing is implicitly to avoid malicious looks from men in search for lusts and desires; for female denuded bodies are usually subject of visual distraction and psychological desires. This exemplifies the stereotypically phallo-centric representation of male desire which expresses itself through the power to arouse and awaken. The narrative of this places the man in an active position which grants him the ability to exercise this power. In order for him to do this successfully, however, the only position which the woman can occupy in the narrative is one of passivity in which she must obediently reflect, follow, and fulfil the call of male desire because sexual arousal is inaccurately attributed to men. A number of physiological responses occur in the body and mind of a man as preparation of sexual intercourse and continue during the act. A woman's body also takes part in that arousal. Her awakening does not realise her existence as a woman in her own right, rather as the universal fantasy of a woman whose existence is only validated by her ability to remain desirable. This concept of feminine desirability is one which depends on her not having the power to assert her own desire because the female wish is not allowed to play an active role nor even to be expressed openly. The woman's allure and therefore her value depends on her remaining passive, silent, and horizontal, the patriarchal society argues.

Elsewhere in France, the feminist and prolific (Algerian born) writer, Helene Cixous, examines with insightful writings the supposed darkness of femininity as usually represented in

³³² 1 Timothy 2:11-12. Online Bible New version International.

literature. Dark is dangerous and people fear to go there like in forest. People do not see anything in the dark. The writer empowers female actions right from its origins “in the classical myth of the Medusa, which in turn had a profound influence on Freud’s psychoanalytic theories of female sexuality”³³³. In her historical “*The Laugh of the Medusa*”, the French-Algerian feminist Hélène Cixous discloses the subjugation of the female voice by exploring the myth of the Medusa and the various connotations associated with the “deadly” but otherwise ‘beautiful’ Medusa. Women should get back their right position in the society by taking the control of their body to change the meaning of history.

To Hélène Cixous, the women’s image has been misrepresented purposely by men in patriarchal societies. In this regard, Hélène Cixous posits that: “Men have committed the greatest crime against women. Insidiously, violently, they have led them to hate women, to be their own enemies, to mobilize their immense strength against themselves, to be the executants of their virile needs”³³⁴. Turning to women’s interpersonal experiences, that representation renders female body an object of attraction and desires as well as dreadful and bleak fears. In a series of women’s daily dairy, for example, looks from men raise the women’s awareness of their being spied on. Besides, some women repeatedly report that they have experienced unwanted sexual objectification within their own community. Therefore, in reaction to that, stereotypes against men have that when a man sees a woman, he thinks immediately of the bed and sex. That cliché can be ranged in the objectification theory. “Objectification theory”³³⁵ provides important framework to improve women’s lives in a socio-cultural context that sexually objectifies the female body and equates a woman’s worth with her body appearance and sexual functions.

To buttress all this point, we see that whenever Akobi wants to have sex with her, irrespective to her mental and physical conditions, he orders her to strip off her dress and he strips his and then in silence and a total submissiveness she accepts to be dived into for the pleasure of her man. After satisfying himself, he orders her to sleep on the floor when he, on the

³³³ Freud, S. (1955). ‘Medusa’s Head,’ in *The Standard Edition of the Complete Psychological Works of Sigmund Freud*, ed. and trans. by James Strachey in collaboration with Anna Freud, 24 vols. (London: The Hogarth Press), XXI (1940), p. 273-74.

³³⁴ Cixous, H. (1976). *The Laugh of the Medusa*, Trans. Keith Cohen and Paula Cohen: 875-893. Print. p. 5

³³⁵ Objectification theory postulates that many women are sexually objectified and treated as an object to be valued for its use by others in Fredrickson, B. L. & Roberts, T. (1997). Objectification theory: toward understanding women’s lived experiences and mental health risks. *Psychology of Women Quarterly*, 21, 173-206.

mattress, sleeps. In that light, sex is not a two-way affair convenience, rather a pleasure to be satisfied, an order and a unique delight: that of the man. As for the woman, obedience and respect are hers to avoid violence and repression. The female character Mara conveys in a true sense the message of her 'bitterness' as illustrated here:

He was lying on the mattress, face up, looking thoughtfully at the ceiling when I entered. Cool, composed and authoritative, he indicated with a pat of his hand on the space beside him that I should lie down beside him. I did so, more out of apprehension [...] Wordlessly, he stripped off my clothes, stripped off his trousers, turned my back to him and entered me. (Darko, 22)

The common point with Tutuola's storyline is the 'unknown' person that the obedient daughter follows and the narrator recognizes this unfortunately "I just didn't know him. I was living with this man and sleeping in one room with him and I just didn't know him" (Darko, 21). Importantly and rightfully, Amma Darko shows the reader that the mainstream of her narrative is not different from that of Tutuola and that of the common Ghanaians. Moreover, the narrator does not mention the man's name in the passage to show how strange her husband becomes. But the diverging point is that Mara is an obedient. The shape of mind goes along with how children are raised in patriarchal societies to adulthood. Like Chimamanda Ngozi Adichie, drawing from her own experience, she defines the male system as being that of a 'single story' during a TED talk given in the United Kingdom at TEDxEuston in 2012.

7.2. Patriarchy: The scope of the arranged marriage

What made women create feminist movements to seek to protect and promote women's interest in the 1970s in Africa is the enchaining and enslaving system of patriarchy. A patriarchal society is a male dominated society. It is an institution of male-rule and privilege that thrives on female subordination that is why most forms of feminism characterize patriarchy as a wicked social system of rule. That rule is oppressive to women because it is an exertion of male dominance over women in all fields. A patriarchal society consists of a male-dominated power structure throughout organized society and in individual relationships. Though patriarchy takes different forms in different cultures, its different belief is the same. In that social system the rights of women as human rights do not exist. The man is superior by nature, born to rule in all works of life, the woman, and inferior, born to be ruled and to serve the man. The daily life highlights how the woman must take a second place in society. In fact, she is meant only to be

seen and not to be heard. This age-long mentality portrays how patriarchy expands racism, sexism and classism. It underscores all forms of oppression where one set of human beings sees self as the norm and evaluates others as existing only for self.

Through the lines of the novel under study, while the protagonist is informed of her being ‘sold off’ by her father, Mara grins and bears it, for she does not resist when the ‘unknown person’. In fact, it is a cursory grin at the patriarchal and hegemonic system of rule. The result is her transportation first to Accra and secondly to Germany for her transformation. The groom asks her to come in Germany, the unknown world to her. The ultimate question we could ask is: why Germany and not England or USA or Zimbabwe or Uganda or Ukraine? Germany represents the immense forest where the skull like human headed the girl to and possessed her for life following the tale. Whether Mara is alive or died, her parents do not know. All that she has for them is material and hope is not that which she looks for. In real life and presently, Germany is the place where every African in illegal situation wants to go and live in. Better life, easy work finding in bars, shops, in houses is mirrored to them.

In fact, the *GTZ: Migration and Development, The Diaspora of Ghanaian in Germany* seeks to know the factual situation of Ghanaian in Germany and then put it: “The available statistics do not provide comprehensive figures for or permit demographic and socio-structural analysis of the Ghanaian Diaspora in Germany. In reporting on migration, detailed information on Ghanaians or on other African migrant groups is not separately evaluated due to the limited number of cases. The official statistics are based on the Ghanaian citizens living in Germany and do not include all persons with a Ghanaian migration background. Today, there is statistical evidence that nearly 40,000 persons with a Ghanaian migration background live in Germany. In 2007, 20,329 persons with Ghanaian citizenship were officially registered in Germany. 8,194 Ghanaian citizens became German citizens between 1980 and 2007. In addition, 9,729 children were born to German-Ghanaian couples between 1965 and 2006”³³⁶. This insightful research work discloses the strong trend of migration in Germany by Ghanaian since almost three decades. The reasons of this preference as we say are divers and sometimes personal. However, it is revealed that the relation between Ghana and Germany is a far remote one. Historians argue that “While historical relations between Germany and Ghana go back as far as the 17th century

³³⁶ Schmelz, A. (2009). “*GTZ: Migration and Development*”. Frankfurt: Published by Deutsche Gesellschaft für Technische Zusammenarbeit (GTZ) GmbH Economic Development and Employment Division Migration and Development Sector Project, Editing: Irina Kausch Kirsten Schüttler.

with the trade base established by Frederick William I in 1683, the long colonial relationship between Ghana and Great Britain has caused migration by Ghanaians to continue to focus on the colonial power even today”³³⁷. However, there is a long tradition of migration by Ghanaian in Europe in general, the prior reason having been the hope that Ghanaian independence brought to the whole world in 1957. This old relation between two countries could have led the writer prefer Germany to France or England. Then how all this could be arranged fictionally by a writer? Amma Darko proceeds by encounter in a village called Naka. To illustrate how oddly was the encounter and thus the marriage, the protagonist calls the circumstances in this mother-daughter dialog this way:

‘Who is he?’ I asked mother, ‘Father’s choice for me?’
‘Oh, dear child,’ mother said, ‘you know your father would consider it rude if I disclosed him to you before he did. Dress up,’ she urged me, ‘I am certain he will send for you soon.’ And he did. And made known to me that my chosen husband was the man named Akobi. And it astounded me, first, that man had settled on me as his wife, and second, that father had had the guts to approach his father to offer him his daughter. But I soon learnt that, yes, Akobi chose me as his wife, but it was his father who approached mine and not vice versa (Darko, 4).

In the excerpt, without a fuller understanding of these aspects of tradition we cannot apprehend the selfishness of Mara’s father who literarily ‘sold’ his daughter just because he was looking for an opportunity like that to take the bride price to get a new wife and then enhance his personality in Naka. What will happen to her later in this kind of marriage is her ‘karma’. Rather following the above definition of Karma, we understand that the protagonist believes firmly in the wrong side of the faith because patriarchal socio-cultural constraints let her believe so. The significance goes that karma is the logic of the fact that a wrong-doer gets wrong and a good doer good. Yet, Mara considers herself as a wrong-doer that is why she encounters all these problems in her marriage. She thinks that being a woman is having signed a contract with social problems. This attitude of Mara reveals the serious matters raise by gender inequalities in traditional communities such Naka and the alike. So tradition, in combination with socio-economic developments, has been perverted to suit patriarchy. Next it is clear that women have become material assets in the modern cash economy. For instance, this is shown through the

³³⁷ Schmelz, A. (2009). “*GTZ: Migration and Development*”. Frankfurt: Published by Deutsche Gesellschaft für Technische Zusammenarbeit (GTZ) GmbH Economic Development and Employment Division Migration and Development Sector Project, Editing: Irina Kausch Kirsten Schüttler.

naming of Nnu Ego which means ‘a great amount of money’ and Aku-nna that is father’s wealth.

Further to all this, the protagonist in Amma Darko’s novel believes that all this happens because Akobi “is a man” and he has the right to do so, because she has been formatted to accept as gospel order and that to become “a very good young woman” (Darko, 32), she has to close her eyes on her own ‘slaughtering’ regardless the warning of the elderly woman, Mama Kiosk (Darko, 22). The powerlessness of the protagonist against this force has already been portrayed in Buchi Emecheta’ *Joy of Motherhood*. Considering that Mara grows up in a family where the law of male worshipping is passed on children from generations over generations, it is cute that her ignorance and greenness play a decisive role. Rather she confirms it “I saw my mother worship my father daily, I saw, too, that father took ample care of her. But still I wasn’t going to let Mama Kiosk spoil my marriage for me.” (Darko, 14) This mind formatting leads Mara to respect her new lord’s word. She shares it this way “This man I call Oves. Formally, to others, he is Overseer. He is my lord, my master and my pimp. And like the other women on my left and right, I am his pawn, his slave and his property. What he orders, I do.” (Darko, 3)

In the light of this narrative, we are clearly directed to the negative impact of patriarchal teachings and stranglehold on women. Some women believe strongly that they are ‘slave’ and ‘pawn’. Added to this is their illiteracy in African societies. The highest trend of illiteracy is among women either in rural or urban centres. “Consequently, African women on the continent and the Diaspora become subjected to what is termed double patriarchy”³³⁸. Double patriarchy is a system under which sexism, the weapon of patriarchal power and its various manifestations, politically, socially and economically oppress women twice over. The agony of women in this kind of society stems from the fact that they are overshadowed by structures of patriarchal power added to their illiteracy. In that context, women are rendered almost transparent, even non-present. The hostile social climate that they live in renders them mute and marginal. They do not have a genuine status of their own, and they become, barely, a reflection of other, overpowering figures. They are victims of alienation, and they suffer from emotional anguish and host of other internal mental crises, as a result of the constraining forces of isolation. Amma Darko critical perspective denounces this behaviour of her male characters. Ama Ata Aidoo also

³³⁸ Ajayi-Soyinka, O. (1993). Black Feminist Criticism and Drama: Thoughts on Double Patriarchy <https://journals.ku.edu/index.php/jdtd/article/viewFile/1875/1838>, p 162.

condemns that attitude of Ghanaian patriarchal society. She recreates this most vividly through Anowa's incisive remark that "Someone should have taught me how to grow up to be a woman. I hear in other lands a woman is nothing. And they let her know this from the day of her birth... in order for her man to be a man, she must not think, she must not talk, Oo, why didn't someone teach me how to grow up to be a woman"³³⁹.

The last sentence of the quoted passage in *Anowa* indicates the moral and cultural bankruptcy of Ghanaian society in at stake. This is an overt accusation from Anowa against her society. Anowa like Maa Tsuru have no important training which could allow them to face their marital problem if it is not to keep silence in any circumstances with their husbands. Silence, in most cultures, is then identified as a female virtue, a position that is popularised by the Beti proverb in Cameroun which states that "women have no mouth."³⁴⁰ To enforce this, one of the earliest and most famous African works of literature *Things Fall Apart*, all that fails or that is weak is portrayed as female. Okonkwo, the protagonist regards his father like a 'woman', good for nothing, an improvident. Throughout his life Okonkwo avoids being taken the way people used to portray his father. This is why he tries all this lifetime to be the opposite figure, 'a man', a brave, a warrior and wishes his children even the female to be like him. His obsession with proving and preserving his manliness dominates his entire life. The narrator puts that "Okonkwo ruled his household with a heavy hand. His wife especially the youngest, lived in perpetual fear of his fiery temper, and so did his little children." (Achebe, 12) and he nearly shot the second. Afterwards when he feels sad about the whole incident he questions himself, "When did you become a shivering old woman... you, who are known in all the nine villages for your valor in war? Okonkwo, you have become a woman indeed" (Achebe, 59).

Above all, in *Beyond the Horizon* there is the necessity for parents to let the choice for their daughters as far as marriage is concerned because marriage is more and more an individual choice than collective. The fact that women do not have a say in such an important matter is a serious hindrance to their self-development. If Mara's parents have tried to know her view beforehand, they would know that Mara wanted to marry rather a man she knew in due time and loved. She would also want her family's moral support whenever there is a problem like that which made her flee from Accra to Naka when she was pregnant. Amma Darko is an Akan

³³⁹ Aidoo, A. A. (1970). *Anowa*. London: Longman, p. 52.

³⁴⁰ Okereke, G. E. (1998). "African Gender Myths of Vocality and Gender Dialogue in African Literature." *Gender and Development in Africa*. Ed. Mary E. Modupe Kolawole. Lagos: Arrabon Academic Publishers, p.135-158.

born, so she is bound with a matrilineage system where a descent group traces their ancestral lineages via the maternal (uterine) side of the group. This does not exactly flip patrilineal descent systems on their head, such that women are the more powerful gender, but it can somehow. Women often share power equally with men, and occupy some of the more powerful roles in society (often alongside men: example of the queen warrior Yaa Asantewaa). Matrilineal groups also pass wealth through the female line, and women often own or control land and production. The wealth stays at their dwelling, which often houses all living females in a matriline as well as many of the brothers, sisters, and, in some societies, husbands of that matriline. Male status and property pass through to their sister's sons, rather than their own. However, her merit is that she shows the system is “weighed down by the Akan law of inheritance under the matrilineal system. Although, descent is traced through the mother, the woman lives patrilocally.”³⁴¹ In this scope, while enslaved physically and mentally, Mara does not forget the story by her mother which lies for her attempt to contain and control her bitterness and anger in the strange ‘forest’. These moments of storytelling or games are intense moments of intimacy between Mara and her mother which represent the basis of her personal history. Mara inherits from her mother a sense of attachment to men, to father no matter what happens, no matter the hellish climate. Mara’s mother legates to her daughter her ‘no sense of self’ and her ‘no sense of fighting spirit’ against the symbol of patriarchal power. Mara’s mother is naive and legates it to her daughter the same way she has taken it from maybe her mother, Mara’s grandmother because young daughters learn from their mother either survival skills or subjugation mind. Mara’s trauma while with her mother forces her to become part of the male oppressive machinery. Instead of shielding her daughter from the oppressive machinery, Mara’s mother teaches her to be subject and deny herself. As example, the protagonist shares:

I have yet another handicap too, my little left finger. I think often of the games my mother used to play with them, my fingers. Childish games when I was her innocent naive child. ‘Give me your hand,’ she used to say. And I would give it to her. And she would take it, usually my left hand, and spread out my five fingers on her thighs, her coal-black thighs. And start the song: this one cries gaa gaa gaa, this one asks what is wrong, this one says maybe hunger, this one says let’s go take and eat, but thicky Tom thumb won’t agree, he says I’ll tell when father comes, and so small goes crying on gaa, gaa, gaa. Small was my little finger and it still cries, but no more for mother’s playful hunger. (Darko, 2)

³⁴¹ Opara, C. C. (1987). “Towards Utopia: Womanhood in the Fiction of Selected West African Writers”. (Ph.D Thesis). Arts. University of Ibadan, Nigeria.

The story also embeds in some part Mara's family history in which lies as the basis of her 'mental slavery' as she finally and unfortunately believes in her karma as a forever subjugated woman. The relation between Mara and her mother is ambiguous though. As an Akan born woman, she is the one to announce to her daughter the unfortunate news of marriage, her being sold off by her mother, a position which should be the contrary. Mara's mother should normally play a role of protection. We can say doubtless that Mara's mother succeeds in inculcating subjugation to her daughter which Ma Tsuru does not succeed in doing in *Faceless* and Ma Blackie with Aku-nna in Buchi Emecheta *The Bride Price*. It is then a clear relation of alienation from mother to daughter in *Beyond the Horizon*. It is what the Antigua writer Jamaica³⁴² Kincaid's *Lucy* depicts as 'maternal dogmatic' which lies for the fact that a daughter is likely to listen to mother than any other person in patriarchal societies. The Antiguan female writer points "You can run away, but cannot escape the fact that I am your mother, my blood runs in you, I carried you nine months inside me. How else was I to take such as statement but as a sentence for life in a prison whose bars are stronger than any iron imaginable?"³⁴³

Jamaica Kincaid's reference to prison is to depict the stranglehold of the philosophy of obedience in patriarchal communities, prison meaning a symbol of enclosing, enslaving, dogmatic ideas of subjugation and self-abandonment. Like Jamaica Kincaid's female character, Amma Darko renders her female character a 'surrendered person' who believes in fatality. She believes that nothing else can change her social situation because so hard is the system that renders her so pathetic and subdued. But in revenge in *Annie John* (1985), Jamaica Kincaid lets her character understand the role of her mother and describes Annie John's mother as wall blocking her autonomy and self-assertion:

Out of the corner of one eye, I could see my mother. Out of the corner of the other eye, I could see her shadow on the wall, cast there by the lamp-light. It was a big and solid shadow, and it looked so much like my mother that I became frightened. For I could not be sure whether for the rest of my life I would be able to tell when it was really my mother and when it was really her shadow standing between me and the rest of the world.³⁴⁴ (*Annie John*, 1997: 106-7)

³⁴² Born in Antigua in the West Indies, Jamaica Kincaid has cultivated a voice distinct from male Caribbean writers such as Derek Walcott and Caryl Phillips. Using life to inspire fiction, Kincaid often explores the complexity of mother-daughter relationships, the effects and aftereffects of colonialism, and alienation more generally. Her work also transcends Afro-centric and feminist perspectives. Her deceptively simple prose is marked by poetic lyricism, vivid imagery, and nonlinear time.

³⁴³ Kincaid, J. (1990). *Lucy*. New York, Farrar, Straus & Giroux, p. 90.

³⁴⁴ Kincaid, J. (1985). *Annie John*. Reading, Vintage, 1997, p. 106-7.

From the above passage, the protagonist's mother becomes a figure pursuing her like a ghost. Jamaica Kincaid transforms the protagonist's mother to a father to remind her of her purpose as a daughter. Here her mother is her nightmare, not her dream. The protagonist is afraid of her mother, a situation which is rather surprising. This denotes her being so pressurized that she is now like a fool. The feeling of a daughter should normally be confident and trusting in the presence of her mother, the mother being her accomplice. Similarly, in Islamic and Christian communities it is stated that a man is a woman's protector and the traditional belief prevails that the man is the head of the house, and therefore a woman ought to show utmost respect to him and be subjected to his orders. African women tend to repress themselves as a result of this, as Binetou and as do various key female figures in *So Long a Letter*. As women are regarded as part of a man's property, they are never in a position to disagree or fight back. This is evident in *So Long a Letter* (Trans. 1989), as Aunt Nabou makes sure that she instils submissiveness in young Nabou. Rama recalls this, saying; "Her aunt never missed an opportunity to remind her of her royal origin, and taught her that the first quality of a woman is docility"³⁴⁵.

This intransigent subjugation in that muslim society is portrayed in Ba's *So Long a Letter* (1980). She depicts women's subordinate status reinforced by longstanding patriarchal tradition in Senegal. Women are trained to be dutiful and expected to be submissive to their husbands. For example, Rama is required to relinquish a life of her own and live the life of the man who has married her, "giving up her personality, her dignity, becoming a thing in the service of the man who has married her" (Bâ, 4). She is expected to change her behaviour as well, in order to impress her family in-law. Thus, a woman is reduced to mere property, devoid of feelings and individual identities, as evident in the word 'thing'. Then, if they ever do display their own feelings, these are less important than those of their male companions. Another example of a situation of this nature is depicted in the Cameroonian writer Anne Tanyi-Teng's *Ewa and Other Plays* (1964), in which Ewa has no say in her marital home. Fonchingong observes that she is subjugated to the extent that she cannot learn any trade to further her education or empower her financial autonomy. Her situation is comparable to Mara's in this respect. Ewa sadly remarks to herself that "we are living in a man's world" (cited in Fonchingong, 139). In fact, women are not just living in a man's world, but in a dangerous and pitiless one. Amma

³⁴⁵ Bâ, M. (1980). *So Long A letter*. Trans. M. Bode-Thomas (1981). London: Heinemann, p. 29.

Darko's third novel *Faceless* depicts a society where its female characters are often terrified, oppressed and driven to physical and psychological disintegration by powerful and tyrannical males who embody patriarchal oppression and whose names recall their toxicity and their masochistic minds. Their names denote effectively the dangerousness of their intention against their female fellows. In the novel, "Amma Darko writes with urgency about the predicament of a cadre of very young children who eke out a living on the streets of Accra".³⁴⁶ The young characters are faceless on the asphalt streets and subjected to untold mayhems from the 'wicked' patriarchal system. The writer female alarms the Ghanaian authorities at the "plight of the street children who are among the most vulnerable in society and mostly in African societies where they are considered the wealth of a family"³⁴⁷. She lets the Ghanaian see with their eyes the true image of the faceless and to hear the cry of the voiceless.

The major point from which we can begin the analysis of the novel is its cover and its title. The cover of the novel *Faceless* represents a tricolour mask which goes from black to grey that symbolizes a face. The fact that it goes from a face to a mask attests to an extent the significance of the title. A mask is a device someone wears to cover or hide his face either for a ceremony, a ritual or during carnivals in West African regions. Sometimes masks are worn during kidnapping and wartime in traditional societies. According to *The Oxford English Dictionary* 'face' has an uncertain etymology. Some scholars refer it to 'facere' to make; others to the roots *fa* to appear, shine (fac-em: torch). From the Latin origin, face generally appears as the front part of the head, from the forehead to the chin. Then 'faceless' is said to something or someone that lacks face, or even courage, someone without identity. The latter significance of faceless matches a lot to the content because women depicted in Amma Darko's novel live under cover, masked, hidden and silenced by permanent ordeals beyond imagination. More so, Amma Darko's characters' names like Fofu, Baby T illustrate the significance of the title. The latter names seem to be picked as afterthoughts, rather than conscious choices reflecting certain values or aspirations. Fofu's others siblings are not named. This technique of Amma Darko mirrors her characters' defeated identity.

³⁴⁶ Awuyah, C. K. (2013). *Faceless: Amma Darko's Face for the Faceless*. Making Connections: Interdisciplinary Approaches to Cultural Diversity: March 2013, Vol. 14, No. 1, p. 28-39.

³⁴⁷ Awuyah, C. K. (2013). *Faceless: Amma Darko's Face for the Faceless*. Making Connections: Interdisciplinary Approaches to Cultural Diversity: March 2013, Vol. 14, No. 1, p. 29.

Besides, as we know Amma Darko as a complete artist, she points out in her novel all the cultural norms that veil Ghanaian women and oblige them to be voiceless and unassertive. “In this novel, Amma Darko defines feminine sexuality in terms of a complex trope of transformation from voicelessness to voice and movement beyond facelessness to attain face or personhood”³⁴⁸.

In *Faceless*, the message of submissiveness goes from a mother, a typical social conformist to her young daughters, Baby T in one hand and Fofo an anti-conformist. Amma Darko novel argues that Poison, Macho, Kwei and Nii Kpakpo fit the descriptions of a patriarchal terrorism and Maa Tsuru, Baby T, Fofo, Odarley and the others the suffering subjects of this excessive authority. These victims of paternal patriarchal authority claim their free space in the oppressive circumstances just like lions over lionesses in a jungle. It is significant to spot these broad patterns, so as see to which extent the use of literary detail makes the characters of this novel substantial and individual. Likewise, female characters are exploited in their different identities in the setting of the novel. In the narratives, women are wives, mothers, daughters or mistresses and these positions allow them to use the domestic space and the prescribed female identity to contest male power. Yet, most of them succumb to the silent pressure over their strong desire to speak and rebel against the status quo. So far, the title of this Amma Darko’s novel should be ‘*Fofo, The Street child Adventures*’ or ‘*A Woman’s Vending Dream*’ since the content depicts the filthy life of Maa Tsuru and her daughters in urban centres in contemporary Ghana.

In the novel, Maa Tsuru may be the most scornful woman ever seen, but the fact is that she was formatted to accept her fate and seek to be necessarily a woman with a husband if the latter loves and respects her former children, this is not a matter. In search of a lover, a condition which is imposed in patriarchal setting, Maa Tsuru lets loose of her off-springs onto the street: “She chose to spend the night on the old cardboard laid out in front of the provision store at the Agbogbloshie market place because it was a Sunday [...]. The reason was simply that if she hadn’t, she would have stood the risk of losing her newly acquired job of washing carrots at the vegetables wholesale market (Darko, 1)” because Agbogbloshie is a camp for refugees, run-away children and street lords. It is a place that certainly leads its dwellers in a downward spiral of moral decay. In the street, the little girl fourteen was obliged to leave her mother’s protection

³⁴⁸ *Idem.*,

to the street because her mother wanted to be the docile woman. Ogundipe-Leslie (1994) identifies oppression at the matrimonial level as one of the mountains that keep the African women in subordination. Any system of oppression draws much of its strength from the acquiescence of its victims, who accept their image and get paralyzed by a sense of helplessness. Female characters like Maa Tsuru and her daughter Baby T are acquiescent to exploitation and have not the guts to face their fate. Maa Tsuru and Baby T represent Ghana of weakness and intellectual lack of guts. They represent a site of inaction and gender inequalities. Amma Darko tries to dissociate this image of Ghana from that of Fofu who represents women of contestation and competition. Fofu represents the future at her encounter with education and hope giver, the team workers of MUTE.

The narrator does not reveal the circumstances of Maa Tsuru's marriage; instead the narrator highlights her lovers' absence that seems damageable to the children's education. She recognizes later her limitation against the social system and then confirms: "I have nothing better to tell you, child. And no money to give you too". Maa Tsuru cried, "I looked on and allowed something to happen that shouldn't have. My hands are tied. I have my finger between his teeth" (Darko, 25). Maa Tsuru knows that it was dangerous to leave her daughter Baby T in the hand of Mama Abidjan to become house help, nevertheless, she allowed it. She is bound to all the selfish desires of her lover (Kwei) and when she thinks she is released, she falls on the hands of the second lover (Nii Kpakpo), also absentee and violent. Kwei, the first lover of Maa Tsuru does not hesitate to repudiate her for having got pregnant as if getting pregnant, stops to be a matter of two dissimilar sexes. He becomes twitchy and violent to prove his anger and determination not to father the physiological state of Maa Tsuru. The following passage underlines the scene and justifies Amma Darko's sympathetic concern with women's matters:

Maa Tsuru was still spending the nights with Kwei. Neither of them took any precaution. They knew it could happen. They assumed and hoped it wouldn't. Then it did. Maa Tsuru picked seed for the third time. And their second son was still crawling. Kwei became a changed man overnight. "How?" he yelled at Maa Tsuru. "Why? Why did you let it happen?" As though he played no part at all in the making of it. (Darko, 121)

Kwei and his alike think that it is only of the responsibility of women to control their body physiology, to get pregnant and to bear male or female baby. In this sense, men plant the seed in a closed vacuum and women look after it by transforming it into being. In fact, modern

writers have returned to more traditional themes, albeit from a different angle. One of such themes considered by Amma Darko concerns superstition and mysteries. Despite the fact that Kwei was warned on the incurring danger if he engaged an intimate relationship with Maa Tsuru, he made it happen. He impregnated her for the fourth time. He then thought violence could help stop the trend. But he did not stop on that last violence scene above referred. He went from verbal to physical aggression. The most violent picture was when the pseudo 'gynaecologist', 'Dr' Kwei struck:

pounced on her like a cat on an unsuspecting mouse and began a vicious pounding spree. He pounded Maa Tsuru with his fists, landing the blows anywhere and everywhere and on every part of her pregnant body. [...] She began to bleed. Kwei grinned. He pulled her up by one arm, held her by the back of her neck and pushed her out of the house. He returned to Agboo Ayee and told all there that, with immediate effect, they had better start calling him Dr. Kwei. (Darko, 124)

Given the above fact of violence, it is clear to identify the perspective of Amma Darko which to pinpoint the extreme wickedness and hatred of her male characters toward the female ones. Kwei goes to celebrate something wrong with his friends without being blamed. In fact, the major and prevailing brain wash subject that is working in Maa Tsuru mind is a superstitious belief that states in the beginning that the man who fathers the pregnancy of her dead mother refuses at the right moment "when Tsuru's mother picked seed with her, the young man responsible, that is Tsuru's father, denied the pregnancy. Worse still, he insisted he had never even seen Tsuru's mother ever in his life" (Darko, 92). The anger of having been left alone with the pregnancy created a hatred for the young man which generates ill-wishes as soon as the baby is born "By the time the baby's shoulder burst through her and tore to shreds the lining of her womanhood, the malediction was on her lips. She was fading away, but wasn't going to go without a legacy. The cord was still uncut when she yelled that may her lover and his descendants after him, suffer in more ways and in more forms that he had made her suffer" (Darko, 93). This is probably the reason why Maa Tsuru is unable to do and have good things in her life and more unfortunately no one in her community tries to help overcome the evil because "nobody needs to take responsibility for any action once supernatural forces are thought to be at

play.”³⁴⁹ This is what the system’s actors want the community to believe. The silence of the community implies the on-going of the ‘slaughtering’. As it has been with Mara, so it is here with Maa Tsuru while she was endangered by Kwei’s battering: no reaction from her community.

The detail that worsened the superstition raised on Maa Tsuru’s life is that the pregnancy that our ‘self-named Dr’ Kwei thought was aborted as he saw blood bleeding during the fight, was not, still it was growing bigger and bigger and at rapid fast pace. What fuels Kwei decision to leave Ma Tsuru is the grip of traditional beliefs, Kwei’s mother being the corner stone of it all. She reminds over and over Kwei of her the superstitious invective and evil-speaking on Maa Tsuru. She believes in superstition based on her traditional beliefs and prohibits beforehand her son Kwei from his involvement with a cursed woman. Further, she knows that she has a strong influence on him. The domineering attitude over her son illustrates the complexity between mother and son has been demystified. The mother has a ‘castrating power’ over her son’s conjugal relationship. Witness her words:

“Twice in the past, I woke up in the morning and you were gone. This time, it is I asking you to go. Go! Kwei, go! Go far away from here. The number “five” has always been in conflict with the spirit of this family. She is carrying your fourth child. Have you noticed? I shall not sit down idly and watch you go on to make fifth child with her. I shall not allow you to bring such calamity to bear on this family. So go away. It is the only way to keep you away from her. Go away. And this time, please, stay away for good. For the sake of us all.” Two superstitions swords crossed paths. A cursed woman and the number five? It was time to escape. He had done enough harm to himself already. He had bedevilled his family enough through mixing blood four whole times with Maa Tsuru. Five times would be provoking the spirits of his family. It would be throwing a challenge to them to prove their potency. Doom would befall them all. Superstition found ground in another mind. (Darko, 126)

Kwei’s mother succeeds in saving her son from trouble either justifiable or not. In fact, nobody can the truth in a mystery, in a superstition. People’s mind is the problem and the shape of their mind has been made since centuries. So Kwei thought people were right when they gossiped around that a malevolent spirit is at work in Maa Tsuru’s life. The reality is that not because there is bleeding from a pregnant woman that does not mean that she loses her baby due

³⁴⁹ Antgsotinge, G.; Dako, K.; Denkabe, A. ; Yitah, H. (2007). “Exploitation, Negligence and Violence: Gendered Interrelationships in Amma Darko’s Novels” (Ed.) Vincent O. Odamtten, *Broadening the Horizon: Critical Introductions to Amma Darko*. London: Ayeibia Clarke Publishing, Print., p. 92.

to an abortion. An abortion may be voluntary and involuntary act due to many factors. Abortion according to “Sutter Health Palo Alto Medical Foundation” means “ending a pregnancy before the foetus (unborn child) can live independently outside the mother. If an abortion happens spontaneously before twenty-four weeks of pregnancy, it is called a miscarriage. An induced (or "therapeutic") abortion is caused deliberately in order to end the pregnancy”³⁵⁰. The last statement could be Maa Tsuru’s case. Even during or after a fight, sometimes the foetus does not come out in a one go. It fights for its life and resists even to Kwei’s brutality. That is what happened in the novel. But Kwei does not know that detail of pregnancy and abortion. The icing on the cake, he is just jobless, but easy doer Ghanaian, and ‘*akpeteshi-addict*’. It is then effortless for his mother to have control on him and mainly because he has no emotional and physical attachment to his children. The difficult conditions in which he lives further his desire to flee his social responsibility. Here lies one of the frequent and shocking invectives of Kwei’s mother: “Shut your big mouth up. You call yourself a man? You think you understand the world better than I do? [...] Idiot”! (Darko, 147).

The depiction of the scene discloses three wings of thoughts. The first is the extreme violence of male characters in Amma Darko’s novel, the second is the unawareness of female’s body physiology and the third is that all the female characters in the novel seem to be condemned by Amma Darko. For the latter point, we venture to say that Amma Darko seems too extremist and alarmist in the depiction of contemporary Ghanaian society which gives no chance to women either living alone or in households and who have to breed their children with no male support. She puts her female characters in such an excessive and desperate dependence on men that it seems somewhat an apocalyptic situation in Ghana. The question it raises in an academic reader’s mind is: ‘is no singled-woman living in peace in contemporary Ghana? For Amma Darko creates her characters so dependent on their men’s presence for physical protection and sexual nightly pleasures, that it leads them totally astray. They become mere silhouette of themselves with no decision to take to better their conditions. Even the family which likely contains the subjugation and the male fury like that of Kabria, sometimes the tension breaks through. Women are overwhelmed in Amma Darko’s novel. Amma Darko creates a serious tension for women and gives no social interface to poor ones like Maa Tsuru. The case of Kabria is less apprehensive though she has a present husband but absent minded and

³⁵⁰ Sutter Health Palo Alto Medical foundation <http://www.pamf.org/teen/sex/pregnancy/abortion.html>

a car which breaks down every day. Though Amma Darko declines honestly to see herself as ‘life image’ of Kabria, she nevertheless agrees that Kabria is very likable character. She confesses at a conference this:

I think the crux of the matter is here not whether I am Kabria or not. I like this character very much myself. I have been asked this same question by a number of interviewers. My only reply is that a character like Kabria deserves to be studied carefully and imitated by any woman who does not want to limit her roles to kitchen and the bedroom. (Personal communication, April 15, 2010).³⁵¹

Kabria epitomizes a successful woman who refuses to be defeated neither in bedroom and kitchen chores nor in her work with MUTE. This character of Amma Darko does not feel like having a problematic husband and three troublesome children (two daughters and a boy). Amma Darko simply employs this female character to exemplify the courage and dignity of women who harbour even in the direct circumstance in this case, a troublesome marriage. Kabria is the beacon light of hope of millions of Ghanaian women’s regeneration and rehabilitation. On the other hand, she thoroughly creates a nightmare in the other women’s passionate dreams if ever life in suburbs such as Sodom and Gomorrah or Agbogbloshie can make people dream. If ever poverty patrolling night and day like a foe, to recall Fofu’s word, does reach someone’s corrugated iron sheet in the slums and devours him. She purposely warns the reader at the very beginning of the novel, for no one can still have a dream such as Martin Luther King’s famous words³⁵² if ever he is pursued by dangerous, venomous and deadly sociopaths such as Poison³⁵³ and Macho³⁵⁴ who represent in fact the male domination. The author here does not want her female characters to have a long dream because it can turn into laziness and slowness. She wants action from them. ‘Life is not easy. Do not get too much trustee, women’, Amma Darko seems to say to her female fellows through fictional interposition. That is the reason why she

³⁵¹ An interview with Amma Darko on “What motivates her to write irrespective to her tight schedules at work” at her office at Internal Revenue, Kaneshie Branch, Accra, April 15, 2010.

³⁵² Reverend Martin Luther King, Jr’s speech “I have a Dream”, copyright 1963 at the ‘March on Washington’, 28/08/1963. Martin Luther King (born Michael King Jr/ January 15, 1929-April 4, 1968). He was an American clergyman and civil rights leader who was fatally shot at the Lorraine Motel in Memphis, Tennessee.

³⁵³ Poison is any substance which, introduced into or absorbed by a living organism, destroyed life or injures health, irrespective of mechanical means or direct thermal changes. Popularly applied to as substance capable of destroying life by rapid action, and when taken in a small quantity. Definition retrieved from “The Oxford English Dictionary” (Second Edition), 1989. Something toxic, that causes certain death. And the Medical Dictionary defines it as a substance that, on ingestion, inhalation, absorption, application, injection, or development within the body, in relatively small amounts, may cause structural or functional disturbance. Called also toxin and venom. *adj., adj* poisonous. <http://medical-dictionary.thefreedictionary.com/poison>.

³⁵⁴ Macho denoting or exhibiting pride in characteristics believed to be typically masculine, such as physical strength, sexual appetite, retrieved from <http://www.thefreedictionary.com/MACHO> and to “The Oxford English Dictionary” (Second Edition), 1989 is something masculine, male, virile and tough.

creates a still-born dream of a dreadful nightmare. Ghanaian women can never be satisfied if ever some of them are stripped of their basic right of love, decision and selfhood. They cannot be satisfied as long as singled-women are tagged to be prostitute. They cannot be satisfied as long as irresponsible men decide to abandon on their charge the long list of children they make together and be victims of unspeakable trauma.

In fact, there lies the specific reason why the female characters of Amma Darko live in ‘*nervous conditions*’ to borrow from the Zimbabwean writer Tsitsi Dangarembga. Amma Darko does not create her female characters like those of Ama Ata Aidoo’s Anowa, Zainab Alkali’s Li in *Stillborn* (1984) and Ada in Buchi Emecheta’s *Second-Class Citizen*. The female characters in her counterparts’ early creative writings are independent, autonomous and self-assertive as soon as they notice that their former social shape as house women and submissive does not fit their ideology and struggle. Still, the author does not allow some of her male characters to become conscious their lack of knowledge, which reinforces their superstitious beliefs. Kwei happened to believe what he *should* never let his mind consider. As a matter of fact, he abandons Maa Tsuru and the baby because he thinks that nothing binds him to them and further he is risking his life by continuing to sleep with this ‘Jezebel wife’ and Maa Tsuru really stands for Jezebel here in four ways. At the outset, like Jezebel was cursed by the prophet Elijah in the Bible³⁵⁵, Maa Tsuru was also under evil spell. Secondly, Jezebel was depicted as a heartless and bloody woman, Maa Tsuru was also heartless for having dumped all her children onto the streets to live her life with her lovers and having not even mourned her daughter’s death turned her into bloody. Thirdly, Jezebel loved to be covered with jewellery the same way Maa Tsuru loved monetary reward out of her daughter’s thigh work and her baby boys running errands. Finally, Jezebel suffered in the end, like Maa Tsuru. Religious beliefs are so strong in Africa and bind people to their roots culture though the Bible is an imported culture.

Our traditional religion is so powerful that if well managed can help curb so many outrageous incidences happening in our society. The insight in Fonchingong’s article lays out the right perception of marriage by Ghanaian society and it puts: “The heavy hand of tradition is visible in the marital institution. The intensity of marriage in the sociology of African life is heralded by Oriaku (1996). He posits that “[...] marriage both in real life and fiction, is perhaps, the most circumscribing factor in the life of an African woman”. Marriage acts as an avenue for

³⁵⁵ King James’ version 1 Kings 16:31; 18:4-19; 19:1, 2; 21:5-25; 2 Kings 9

violence and a plethora of injustice against women, a phenomenon Judith Newton and Deborah Rosenfelt (1985) call “the intersection of multiple oppressions”. For example, in Ama Ata Aidoo’s *Anowa*, Badua defines the traditional role of women “marry a man, tend a farm and be happy to see her peppers and her onions grow. A woman [...] should bear children many children so she can afford to have one or two die” (Aidoo, 12). As a custodian of tradition, he is emphatic “a good woman has no mouth and brain”³⁵⁶. This position is picked up by Kofi Ako who reminds his wife Anowa of her limits in their verbal tussle over the possession of slaves “who are you to tell me what I must do or not do?” (Aidoo, 29). “We all know you are a woman and I am the man” (Aidoo, 30). In the play, the joys of motherhood could be reaped by women who could give birth. Those who could not give birth were cut off from the group of the venerated. The following chapter tackles the topic of barrenness in traditional community.

Reversely, as Amma Darko likes it the most, to turn the head of common Ghanaian tales, she now humanizes the popular story of the tortoise and the birds whose greed brings everlasting curse on its shell from generation to generation. The narrator tries to explain why Maa Tsuru and her children are undergoing unceasing poverty and suffering which is related to the tortoise and its shell that is not smooth. This particular tale has been used in Chinua Achebe’s *Things Fall Apart*³⁵⁷. The tale goes that Tortoise befriends the birds. One day he convinces birds to invite him at their frequent feasts up in the sky. As they accept, Tortoise then begs each of them to give him a feature in order to have wings and fly like them, what they execute without knowing what the tricky tortoise lays out. At last the great day comes and Tortoise is the first to arrive at the meeting place. When all birds gather together, they set off in a body. Tortoise is very happy and voluble as he flows among the birds, and he is soon chosen as the man to speak for the party because he is a great orator. He sets off a tricky puzzle and eats a good part of the food before them. When they realize the malevolence, it is too late. Birds make the decision to take back their feature to punish Tortoise. To save the face, he lets himself go from the sky and falls on his hard shell. Tortoise breaks seriously his shell, but does not die. That is why Tortoise has a crooked shell. The retrieved lesson is to be honesty of friends. Honesty is better than malice.

³⁵⁶ Fonchingong, C. C. (2006). “Unbending Gender Narratives in African Literature”. *Journal of International Women’s Studies* Vol. 8 #1 November 2006, 135-147.

³⁵⁷ Achebe, C. (1958). *Things Fall Apart*. Edinburg: Heinemann, Pearson Education Limited, (ed) 2008, pp.77-8.

As a mediating process, Amma Darko's authorship can be understood within the dynamic of patriarchal aligning women on the margin so as to hold them subjugated, inferior and second-class. Once cursed, forever curse, it seems. In fact, this curse recalling maintains Maa Tsuru on the verge of poverty, inferior and disempowerment. She is weak, silent, passive and superstitious and wants her children also to lag behind, though she knows her pain when she was bringing Baby T, which the impact of patriarchal hold on Ghanaian women: to remain peripheral. Women in Amma Darko's *Faceless* are lumped together with children because it is generally accepted that they are unimportant creatures who have nothing significant to contribute to nation building. Amma Darko's description of Maa Tsuru seems to be her reaction against the system of women's silencing in traditional and urban communities. However, the critic made by Carmela Garritano on Amma Darko's literary carving is that "Darko writes a novel that proclaims itself as such and yet, simultaneously, destabilises the very conventions that define the novel. Her text, in its form and content, is a decidedly feminist one"³⁵⁸.

However, what is worth pinpointing according to us is that Amma Darko describes the early vulnerability of women in patriarchal societies and their unsecure stance. Definitely they undergo the harshness and pitilessness of the system which downgrades and maintains them as objects to manipulate. In different ways, women suffer the social constraints and patriarchal burden. Representative female characters of Amma Darko formulate the injustice environment in which Ghanaian women live, love and die. Women, as the novels prove rightfully, are still beasts of preys in the heavy hands of male characters like namely Akobi and Osey in *Beyond the Horizon*, Poison, Macho, Kwei and Kpakpo in *Faceless*. They are portrayed as active agents of patriarchy who poison the lives of women. Like vultures, they announce bad omen, terrible smelling of socio-cultural 'putrefaction' and political decomposition, though critic like Carmela Garritano reproaches to Amma Darko's writing not be politically engaged. In patriarchal society, mothering is the most important step of women's life to borrow from Ama Ata Aidoo's character Badua in *Anowa* "marry a man, tend a farm and be happy to see her peppers and her onions grow. *A woman...should bear children many children so she can afford to have one or two die.*" (Aidoo, 12, italic added). This opinion was also defended by Amaka's mother in *One is Enough* (1981) who advised her to forget men, to get be pregnant, have your children and live

³⁵⁸ Garritano, C. (2007). "Amma Darko's *The Housemaid* and the Gendering of Novel and Nation" (Ed.) Vincent O. Odamtten, *Broadening the Horizon: Critical Introductions to Amma Darko*. UK/London: Ayeibia Clarke Publishing, Print., p. 72.

an independent life. Take your sister Ayo as an example; even though she is not married, she has four children with a wealthy man who is in charge of their welfare. Just like mother hen could do to guide its little hens, Amaka's mother counsels and coaches her daughter. To this we might add that women in patriarchal societies have to struggle from the little age to adulthood because of the classic stereotypes as yoke on women's shoulders especially this kind of discrimination on female children.

8. Devaluation of the female child in *The Housemaid*

It is here necessary to clarify beforehand that in patriarchal societies, a son is believed to be more valuable than all daughters of a compound. In those societies, the verbal as well as the body language show that position right way. The traditional African society is a patriarchal society which is characterized by current and historic unequal power relations between women and men where women are systematically disadvantaged, subdued and oppressed. Thus the expectation placed on a son is inherent to his ability to 'plant the seed' for a new generation. In the three monotheist religions, the biased beliefs came from the origin: Adam's crooked rib. Yet, what these societies often forget is the 'receiver' of the seed.

The novel *The Housemaid* begins with an insightful illustration that will guide our analysis. Amma Darko puts "In Ghana, if you come into the world a she, acquire the habit of praying. And master it. Because you will need it, desperately, as old age pursues you, and mother nature's hand approaches you with a wry smile, paint and brush at the ready, to daub you with wrinkles." (Darko, 3). This is an insisting message of the narrator's perspective to tackle gender issues in Ghanaian society. These words indicate the extent to which girls are regarded as simple beings where investment in a wrong deed. The social conditioning arising from perspectives of this nature affects women from childhood onward. It is crucial to understand that Amma Darko indicates the preference of male to female and that women are asked to produce not only children, many children, but to bear sons in order to be perceived as a 'complete women'. Women seem fulfilled when they bear male children in such societies because the continued growth of the family name is impossible with a girl.

Yet, many women without male children are always exposed to insults. They are despised by almost all the community. Women feel incompetent and incomplete whenever they fail in their duty to bear male children. This infers that Efi's stillborn would have been of more

importance if it had come 'son'. The turmoil it would raise more insults against the possible mother more abusive. The narrative takes the reader into the intimacy of her female characters' minds. Girls are not really welcome in such societies. The significance attached to male children is evident as it occurs in a number of other African novels including Chinua Achebe's *Things Fall Apart* and Buchi Emecheta's *Joy of Motherhood*.

For instance, Okonkwo wishes that his favourite daughter Ezinma were a boy, he would have been happier because she has the right spirit; so much so that she began behaving like a boy (Achebe, 35-6; 52). In *Joy of Motherhood*, Nnu Ego was desperate to have male children in order to please her husband. The passage goes this way: "Hm I know, but I doubt if our husband will like them very much. One can hardly have one girl in a town like this, to say nothing of two" (Emecheta, 140). It is deeply disturbing that a woman, a mother, is made to feel like this about her own children. The novel indicates the boys' highly valuable place in families, while at the same time; girls seem not to belong to these families. Girls are expected to make life easier for her brothers and in order to achieve this, it is required that the girl should inherit the ability to do this, coupled with domesticity, from her mother. Nnu Ego tells her daughters to give up their lives by being forced into early marriage to generate income for their brothers. "But you are girls! They are boys. [...] When your husbands are nasty to you, they will defend you" (Emecheta, 197).

The sense we could make out of this is that in patriarchal settings, there is frenzied rush to male sex which sometimes runs traumatic to women and is not without consequence. As said, women want to have male children due to the importance attached to it. They are reminded as soon as they get pregnant. For example, in Yoruba's community when the man's father died, the first boy's name is '*Babatunde*' to recall the father's reincarnation to a boy. To figure out this consideration, we must go back to the definition of patriarchy.

Only when women belong to a very highly considered social class that they are respected. For example, in Chinua Achebe's *Things Fall Apart*, the only woman respected in Umuofia is Chielo, the priestess of the oracle of the Hills and Caves who is removed from the pale of normalcy, clothed in the mystic mantle of the divinity she can reprimand Okonkwo and even scream curses at him while the great Okonkwo was arguing with her. "Beware of exchanging words with Agbala' (the name of the Hill and Caves). Does a man speak when a god

speaks? Beware!”³⁵⁹ Though Agbala is a male, he is strongly associated with the female earth. Yet if Okonkwo is powerless before a goddess priestess he can at least control his own women. Chinua Achebe gives further illustration here:

The old man bore no ill-will towards Okonkwo. Indeed, he respected him for his industry and success. But he was struck, as most people were, by Okonkwo’s brusqueness in dealing with less successful men. [...] Without looking at the man Okonkwo had said: ‘This meeting is for men.’ The man who had contradicted him had no titles. That was why he had called him a woman (Achebe, 21).

However, from this early society described in *Things Falls Apart*, Amma Darko demonstrates that change have occurred slightly in women’s lives. She puts as a sign of surrendering to the ever matching chant of inequalities from generations to generations in Ghana:

Though some change has occurred in today’s Ghana as to the relationship between men and women due to women’s easier access to education and financial resources, even in families where women themselves are pursuing successful careers, they are still expected to arrange the childcare, do the bulk of the domestic work and all the domestic planning. From this point of view, nothing has changed. I can do my job, dedicate myself to writing, still when I come back home, I am no longer a worker or a writer. I am a wife and a mother.³⁶⁰

The question we intend to ask is what could be wrong with these seemingly illaudable values raised against women? Why should Amma Darko have come to realize that there were inadequate values for a writer to espouse in her protest against patriarchy so easily? Is this a defeatist writer? Nonetheless, the quotation illustrates the author’s view on devaluation of girl children. It is her ultimate position she has adopt throughout the novel: that of recording the consciousness of her own time as she has arranged in the opening. The novelist’s implicit claiming of the world’s hatred for women is clearly cut and accurate. Her project in this regard is to capture readers’ attention, yet the lines that followed the young narrator’s act of visionary appropriation can scarcely be said to have built up Amma Darko’s feminist voice.

³⁵⁹ Achebe, C. (1958). *Things Fall Apart*. Edinburg: Heinemann, (ed.) Pearson Education Limited 2008, p. 80.

³⁶⁰ Bungaro, M. (2007). “Victims and / or Victimisers? Women’s De(Con)structive Power in *The Housemaid*” (Ed.) Vincent O. Odamtten, *Broadening the Horizon: Critical Introductions to Amma Darko*. UK/London: Ayebia Clarke Publishing, Print., p. 30.

Indeed, nearly all the action of *The Housemaid* takes place in an urban centre, though it previously moves from Akataso village beforehand. In this sense, African women writers such as Amma Darko seem to reveal these tensions by showing that some of them are not pleased with their plight despite their apparent acceptance of societal expectations and impositions. In the novel *The Housemaid*, Amma Darko focuses on the shameful plan a whole family makes on the life of a little girl Efia to transform their misery to richness like a farmer can decide to sell a plot of his land and take the income to buy a cart for his cows to be more productive. Here is the very beginning of the meaning of the novel's title:

Efia's people went to one side and put their heads together as if there were hearing everything for the first time. When they rejoined the others, Papa Kaawire spoke, his eyes fixed on Tika. [...] It is important for me to be able to trust he enough not to have to worry about my home when I'm away. [...] If she can clean, wash, sweep and cook well. That's it. [...] He continued, 'So now can we also know how you intend to reward our child for her service? Eyes widened with interest.'³⁶¹

The result of the last sentence is that which Efia's family was waiting for: the reward for the service their child will offer. Obviously the other things appear to be of not less importance because the young girl parents kept nodding throughout the recitation of all will be her benefit. After these people know that something more interesting can come out of Tika's childlessness blackmailing, they plan back trickier and wicked that employs not only men, but also elderly women. Amma Darko emphasizes on this possibility to show that gender oppression can also come from women. As Bungaro accurately highlights it "Darko's point that both class and gender stratification contribute to the chaos charactering modern Ghana and often force the desperate individual, either man or woman, to search for questionable alternatives."³⁶²

Amma Darko insists on the active implication of some women in the gender inequalities in the Ghanaian society and her novel *The Housemaid* is an example. In fact, Amma Darko is only really willing to become one of the qualified spokeswoman for the victims under the aegis the broader view of the problem at stake. As we have seen in a previous chapter, Ghana is the first African country to have its independence, so writers like Amma Darko could mostly write

³⁶¹ Darko, A. (1998). *The Housemaid*. Edinburgh Gate, Harlow, Essex: Heinemann, p. 41.

³⁶² Bungaro, M. (2007). "Victims and / or Victimisers? Women's De(Con)structive Power in *The Housemaid*" (Ed.) Vincent O. Odamtten, *Broadening the Horizon: Critical Introductions to Amma Darko*. London: Ayebia Clarke Publishing, Print., p. 32.

about female oppression as a way to denounce the conditions prevailing in the new nation. So far, if we make the link of this literary engagement, writing about gender inequalities is like Nadine Gordimer's lifelong struggle against Apartheid in South Africa. The forms of suffering that colonialism inflicts on women are so accurate that there continue to be present in contemporary Ghana. But why colonialism is found as responsible for all this? Colonizers in that period were need of men, as brave and strong as possible for hard works in farms and rails ways construction, so much so that girls were not needed. This discrimination has been nourished for a long time in colonies.

The novel *Faceless* gives us an illustrated example of this preference "Mum, you don't understand," Ottu reprimands his parents as if he were not really treated the way it should be. He sees in other families how a boy is venerated. He reproaches, "he is also the only son. Just like me. And his grandmother said he is special. Veeeeery special. [...] "Yes, You see, by coming as a boy, he earned his mother plenty of respect and also ended her pains. [...] ensued that my friend's mother continued to bear more and more children till she bore a son" (Darko, 13). The quoted passage gives us more indication about the fact that the bearing of son can 'end a pain' a woman feels while bearing and she could be obliged to bear continuously if she has not born a son before. This serious affirmation comes from a little boy of seven years ago, but in reality it is Amma Darko's way of tell her society's facts and telling her pain. Amma Darko depicts a society where boys are 'veeeeeery special' and what of girls? Nothing?

While analysing her novel *The Housemaid*, we have the impression that Amma Darko has given up all hope of any type of redeeming factor in the Ghanaian society, because of its elderly people's defeatist mind against girl children. The psychological attitude of Amma Darko's characters is condemnable. Everyone exploits mostly girls in such a society and no one stands to correct this status of thing and sex is the recurring item in the male/female transaction though women are not only victims of the system. This winner/loser relationship is typical to Amma Darko. To highlight this relationship Amma Darko writes "Young, good-looking male gold diggers began to vie for her attention. Her husband's libido was waning anyway, so she gave in. She gave them money; they gave her good sex" (Darko, 18). The prevailing phallogocentric culture encourages gender inequalities in society and thus settles an atmosphere in which male characters seem reduce female to objects. Further, female characters who seek to resist its stranglehold on the traditional structures of family and marriage have to pay the price

of their most intimate part of their body or replace it by money. Even the little Akua, on Accra-Kumasi highway, armed with determination, knows that she has the price of her ambition with her driver, almost her father's age. The dialog illustrates

“For nearly three hours, she stood by the roadside asking for a lift. Eventually a contractor's truck stopped for her.
Where to? The driver asked curtly.
‘Kumasi.’
‘You have the money to pay me?’
‘No.’
(...) ‘I’m sure you’ll find help here,’ he assured her and drove away.
Akua did. There were many young girls here working as porters, who had bolted from home to seek greener pastures, just like her” (Darko, 30-1).

From the above dialog we observe that carefully Amma Darko warns us about her female character's ordeals in the city where she is going without the blessings of her parents. In fact, the female character Akua is fleeing from poverty which prevails in her village. She does not know that poverty exists even in town where she is going. But, as her mind leads her, she decides to move forward. Further, the driver represents an opportunistic and greedy male character who stands for the new Ghanaian society's 'builder'. He does not hesitate as if he was waiting for Akua to offer sex to cover the transport fees. The unnamed driver cannot live Akua without consenting to mate with her and life in Ghanaian contemporary society is built so. Nothing is free of charge and Akua is ready to pay the price of her ambition. She wants to leave Kataso to Accra where people told her, 'money floats at every roundabout.

Kataso here means the place of Akua's people status quo, where people live in confinement and where despair and poverty are every day's meals. In the description of what happened to Akua, "Amma Darko is cautious not to make it look attractive, and how did she do that? Through abhorrence of it; because the four-hour of silence that followed the journey describes a sense of mere usury. Little did the driver care about how penniless Akua will survive in a totally new environment. The sensitive nature of the driver is seen in the last words to her: "I'm sure you'll find help here."³⁶³ The disgraceful driver does not care the little girl he has sex with lose her way to a secured place, but his pleasure already satisfied, he drives his way and vanishes in the air like a ghost. Amma Darko shows how women surrender men's will and ego

³⁶³ Abeka, P. ; Marfo, C. ; Bonku, L. (2014). "An angle Seeing : Pornography and Profanity as Pharmakon in Darko's *Beyond the Horizon* and *The Housemaid*", in *Advances in Language and Literary Studies*, Australian International Academy Centre, Australia, vol.5, No 2, p. 112.

in patriarchal societies. Even in the religious sphere, a woman is expected to live in submission to her man/husband. Patriarchy uses silence as a weapon to expose its strategy of submission. The use of silence makes way to slavery which leads to acceptance of all social burdens. In that way, no woman living in such circumstances can ever think of her revolt. According to Leslie Ogundipe,

Women are shackled by their own negative self-image by centuries of the interiorization of the ideologies of patriarchy. Her own reactions to objective problems therefore are often self-defeating and self-crippling. She reacts with fear, dependency complexes and attitudes to please and cajole where more self-assertive actions are needed.³⁶⁴

Further, in the olden days, villages were presented as very good places where ran ‘life, goodness, fruits, meals’ for all. Nobody could be in lack of something in villages. The village microcosm is now changed and now in African literature writers no more write about this angelic face of the village. To show this new face traditional microcosm that has been corrupt by urban centres, Amma Darko is very cautious in her writing as she shows that women also exploit the situation by “exploiting the exploiter”³⁶⁵ Sex emerges from Amma Darko’s novel not as figure of shared entertainment and desired love from male and female characters, but as a locus of shame and annihilation of peripheral people. This is what Gayatri Spivak calls “subaltern.”³⁶⁶ For Gayatri Spivak a woman’s role in traditional societies is formatted to be second and inferior. A subaltern is defined in *The Chambers Dictionary* as “the military under the rank of captain, subordinate, having the status of a vassal”.³⁶⁷

To Gayatri C. Spivak between patriarchy and imperialism, subject-constitution and object-formation, the figure of the woman disappears, not into a pristine nothingness, but into a turbulent shuttling which is the displaced figuration of the ‘third-world woman’ caught tradition and modernization. These considerations would revise every detail of judgments that seem valid

³⁶⁴ Leslie-Ogundipe, M. (1984). African women, culture and another development. *Journal of African Marxists*. 5, pp. 35-36.

³⁶⁵ Marfo, C.; Abeka Y., Philomena & Bonku, L. (2015). “Exploiting the Exploiter: Some Violations of Society’s Expectations in *Beyond the Horizon* and *The Housemaid*”. (ed.) 3L: *The Southeast Asian Journal of English Language Studies* – Vol 21(1): 35 – 46 <http://dx.doi.org/10.17576/3L-2015-2101-04>

³⁶⁶ Spivak, G. C. (1988). “Can the Subaltern Speak?” Cary Nelson and and Lawren Grossberg (ed.), *Marxism and the Interpretation of culture*, London: Macmillan.

³⁶⁷ *The Chambers Dictionary* (1993). Chambers Harrap Publishers Ltd, Edinburg.

for a history of sexuality in the West”³⁶⁸. Further, we live in a world which has grown increasingly more sex demanding than before and bringing women to a primitive role even when the woman is educated, so then it would be normal for a woman to conform to these cultural constraints. Sex plays an ever determining role in human life, drives human reproduction and nature, manifests in various forms of identity, culture, race and genre.

Much as Amma Darko seeks to project this unfortunate phenomenon, her female characters’ sexual exploitation as one of the direct effects of the patriarchal stranglehold and moral decay in contemporary Ghana, she does not exonerate communities from blame. Although Akua and her alike really love sex and all the zest its can bring as the above dialog proves, Amma Darko’s disgust at this practice is a direct indication of her disapproval of the exodus of young and unqualified Ghanaian girls to urban centres, especially those who return to their villages with serious problems like unwanted pregnancies. The on-going of this phenomenon finds its source in the fact that only women are condemned, though it makes two to bear a baby. Amma Darko tries to correct this erroneous tag through a female character with sarcasm “You holy fool’ she roared. ‘You think the mother just sat there, opened her legs, and God above pushed the baby into her or what?’” (Darko, 7). But soon, she has been overpowered by men surrounding her. They justify the act by the fact that men are not the only beneficiary of sexual orgasms and then when it comes to punish a culprit, it maybe the woman as society proves her to be weak and “a whore, a demon, a Jezebel through and through” (Darko, 9).

The reference to Jezebel to call a woman is clear in Amma Darko’s male characters’ mind. The name reminds the Bible readers of a brave woman in sinful acts. Like the evocation of Sodom and Gomorrah means sexual immoralities and sinful acts, Jezebel is a beautiful, heartless woman, and unbending character with a bloody history in the Bible. According to the Book of Kings, Jezebel was the daughter of Ethbaal, king of the Zidonians, and both king and priest of Baal worshippers³⁶⁹. In evoking Jezebel’s story, Amma Darko not only shows the interpretive bad image of women Ghanaian men have on women; but also sets in motion the potent trope of repetition of the biblical story that highlights the dangerousness and weakness of women.

³⁶⁸ Spivak, G. C. (1988). “Can the Subaltern Speak?”. Cary Nelson and and Lawren Grossberg (ed.), *Marxism and the Interpretation of culture*, London: Macmillan.

³⁶⁹ 2 Kings 9 : 22 (King James version of Bible)

In the novel *The Housemaid*, through this singular act of her stillborn, Efua taps into a dominant Old Testament conceptualisation of beauty of catastrophe, misfortune, or radical degeneration or devaluation of being into bare life. Men have their stereotypes against women and women also have their arguments. For example, to the predicament of gruesome baby-girl's corps found on dirties, men chastise the mother and suggest clearly and drastically that when she is caught "her womb should be removed, cut in two, and given to her to swallow by the count of three" (Darko, 6). Women, on the other hand sympathize with "the poor baby's mother and criticize "the irresponsible man who go and impregnate the little girl" (Darko, 6). Amma Darko proves in doing this, the way national issues are discussed among common or well involved people in Ghana.

In writing this passage, Amma Darko proves the ignorance of the character Akua in contraception and women's health protection against undesired pregnancies and diseases such HIV/AIDS and other sexually transmitted diseases. She knows that having sex with a man can lead to such a state, but does not know or has not been taught on the way to prevent it, which is not just a verbal insurance from an opportunistic man. The driver's spontaneous acceptance here stands for the moral decay of elderly people in Ghanaian society as far as female sex and body are concerned. In a such a materialistic society, a man twice or three times older than Akua can accept to have sex with her and in an indecent place first of all as a sign of power over the little girl's body and soul and secondly as a way to prove her that nothing is free of charge. This is expressed as male perversion.

The issue has been tackled by Elizabeth Roudinesco in "history of perversion"³⁷⁰. Rousinesco argues that, to study perversion, "one should go beyond moralizing rejection; hence, one should remain historical, yet without falling into the trap of culturalist equanimity. In opposition, Sigmund Freud and Jacques Lacan take perversion as a structure of the subject, and the three main paradigms they explore are fetishism, sadism, and masochism. Perversion is a structure that can be approached genetically"³⁷¹. Freud gives a particular direction to the psycho analysis exclusive interest men feel for women as far as sex is concerned. He thinks that this particular point needs to elucidate. Amma Darko's sensitivity to sex seems to be the basis of her

³⁷⁰ Roudinesco, E. (2009). *Our Dark Side: A History of Perversion*, trans. Davis Macey, Cambridge and Malden, MA, Polity Press in *The Cambridge Introduction to Literature and Psychoanalysis* (2014)(ed) Rabaté, Jean-Michel, University of Pennsylvania, Cambridge University Press, p. 177.

³⁷¹ Ibid., p. 178.

art, her self-scrutiny and her analysis of her wider social and political ill contemporary Ghana indeed. The introspective character of Amma Darko's fiction was shaped by her early experience of isolation just after her university degree. Like Amma Darko, the young Efua experience yearned to be a housemaid, but following the menial income and the risk one takes, she stops the job, though she still felt an obligation to send money from Germany to Accra for her parents who did not seem to think to understand her predicament. To this we might add that Germany of Amma Darko's arrival in 1980s was that of a country ravaged by successive wars and discrimination of Jews, Blacks and others such as non-German. It would then be difficult to work as housemaid in such a hectic situation. Amma Darko, herself states this:

If you go abroad and return, you are worshipped irrespective of who you are [...] I did menial and didn't make very much money. I saw girls making so much more on prostitution. Their families were happy because they sent so much money back home. Some of mine thought I was a failure. This was something that needed to be told (28 May 1998).³⁷²

What is also important to note here is the association between Efua the housemaid in Accra and Amma Darko the housemaid and now writer. The detachment of Efua from her family and community is linked with Amma Darko's belief in the enlightened distance of the artist from his society. There is a deeper sense in which Amma Darko is invested in the posture of isolation of her principal characters to provoke the reader profound attention and compassion. All too often, her novels culminate in what one scholar has termed "an apotheosis of the ruthless political self"³⁷³. The ambivalence Amma Darko always shows in her writing, that is, perpetrator-victim or "victims/victimisers"³⁷⁴, counts and baffles while reading. The logic would be that someone helps women in dangerous predicaments without waiting for sex favour, but it is not. Male characters in Amma Darko's fiction want always to prove their virility everywhere, and to everyone. Further, the ignorance also proves that Akua is illiterate, what should normally not surprise the readers because Amma Darko previously describes the precarious environment of Kataso, an image not distant from all African village settings' tight spots. She puts it:

³⁷² Zak, L. A. (2007). "Amma Darko: Writing her Way, Creating a Writing Life". (Ed.) Vincent O. Odamtten, *Broadening the Horizon: Critical Introductions to Amma Darko*. UK/London: Ayebia Clarke Publishing, Print., p. 13.

³⁷³ Roberts, R. S. (2005). "No Cold Kitchen", Johannesburg: STE Publishers, p. 294.

³⁷⁴ Bungaro, M. (2007). "Victims and/or"? Women's De(Con)structive Power in *The Housemaid*. Ed. Vincent O. Odamtten, *Broadening the Horizon: Critical Introductions to Amma Darko*. UK/London: Ayebia Clarke Publishing, Print., p. 28.

Kataso, a village in the eastern hills, had no flowing water, no electricity, no entertainment centre, nothing. Only the chief owned a television set – old, black and white, and 100 per cent out of order. There would have been no power to run it, even if it had worked. It stood in the palace for decoration. A privileged few, who could occasionally afford batteries, owned pre-set radios, the kind imported from China in the 1960s; they were set permanently to the only radio station that had been at the time. Which therefore left sex as the only really affordable entertainment in Kataso. Everyone – young, old, mature and immature - indulged in it freely, making the two midwives the busier of the village professionals. (Darko, 29)

The psychology of young girls from the village and its alike is naturally the result of the financial and material conditions of its people. Besides, in discussing this theme of easy sex as the only affordable entertainment, Amma Darko subtly enters into politics and compares the period of the first Ghana president Kwame Nkrumah with present-day Ghana. She rightfully introduces the period of 1960 as politically and socially regarding than nowadays' social policy. People in the villages are still poor and take sex as first entertainment item, yet the social policy in force with the visionary Kwame Nkrumah tries to give a little satisfaction and attention to Ghanaians basic needs. At least people could pay for batteries and “pre-set radios” for information since Ghana was in cooperation in terms of trade with China. The political trend at the time was Communism and Ghana was a very active ally with the Soviet Union, China, Vietnam and the other communist nations. In other words, the political vision of the time was more accommodating than that prevailing in contemporary Ghana. That is the strength of the period. Amma Darko's disdain for the institutional decay of her country is more visible. The moral and political decadence goes tighter and together to oblige little young to make wrong decisions on one hand and hold people in poverty and promiscuity on the other hand.

According to Sigmund Freud, the use of sex is essentially for pleasure and Amma Darko's passage does insist on the lack of entertainment in villages which leads to this overuse of sex. It is then clear that Freud's definition of libido as “seeks to force together and hold together the portions of living substance”³⁷⁵ is somehow applied here for the passage reflecting ‘nervous conditions’ of the villagers especially women. As for Singer, he quotes Freud on the organic and adaptive nature of libido, to show that at no time did he forsake his biological model. Singer's conclusion regarding Freud's use of the libido is that it merely amounts to “an

³⁷⁵ Singer, I. (1987). *The Nature of Love* (Chicago, IL: The University of Chicago Press), p.111.

'idealization': a bestowing of importance upon an aspect of life that particularly quickens and enthral his imagination"³⁷⁶. He could have added that the problem with an idealized construct masquerading as scientific theory is that it is incapable of generating hypotheses that can be tested by experience; and that it is singularly impervious to the drag of disconfirming evidence in any case.

As a matter of fact, sex is the most accurate difference between men and women biologically and psychologically. In his early theories, Freud simply extended his views of male sexuality to women, viewing women as simply men without penises³⁷⁷. His male perspective of sexuality is understandable, but nonetheless problematic, as it marginalizes female sexuality. Female sexuality, according to early Freudian theory, is exactly the same as male sexuality up until the phallic stage of psychosexual development; since women don't have a penis, however, they experience penis envy, which is the jealousy little girls feel towards boys and the resentment towards their mothers (whom they blame for not having a penis). Though Freud didn't propose the 'Electra complex', it can be inferred from his theories that little girls switch their affections from their mother to their father in an attempt to "gain" a penis. Being female, they cannot come to identify with their father, however, and when they realize they cannot "gain" a penis, seek to have children instead.³⁷⁸

In this sense, the desire to compensate their lack of penis leads Amma Darko's characters such as Sekyiwa, Tika and Efia to indulge into sex trade to cover their need for money to build their personality. Although these above characters are factious, the fact that the narrator should treat them as if readers already know and meet them in reality, is an indication of Amma Darko's determination to use characterisation as a tool to broaden the scope of her attack against Ghanaian society. By virtue of the fact that the names of these characters suggest that they come from Ghana and from Zambia, South Africa or Germany, one can conclude that Amma Darko is not criticising only Ghanaians but Africans in general because lots of Tikas, Efiyas, Akuas and Sekyiwias are in all African countries to exploit or to be exploited. Here, Amma Darko's work often does not cringe when it comes to making her perspective clear in

³⁷⁶ Ibid., p. 110.

³⁷⁷ Cohler, B. J. & Galatzer-Levy, R. M. (2008). Freud, Anna, and the problem of female sexuality. *Psychoanalytic Inquiry*, 28, pp. 3-26.

³⁷⁸ Denmark, F. ; Paludi, M. A. (2008). *Psychology of women: a handbook of issues and theories* (2nd ed.). Westport: CT: Praegar Publishers.

reality. She humanises her characters, mostly females, to invite us to their socio-cultural and gender consciousness.

Hence, like in reality, the guilt of folks at home increases when Efiya was suspected of having left the dead body of a new-born baby on a dump and ran home as if nothing happened. The number of abandoned babies on dumps, thrown in toilets, in boreholes, either the whole body or the aborted parts of them, increases every day. People read it in the news, talk about it, however, nobody cares about that. This is what revolts Amma Darko and influences this part of her writing. She unearths this stinging and smelly part of the developing society, that society which grows unsocial and merciless. In the narrative, she puts “but no sooner were they at the edge of the thicket than they were confronted by a foul and pungent odour. The search gathered fervour. Then they stumbled upon it – the gruesome, decaying corpse of a new-born baby girl” (Darko, 4).

The emphasize the “corpse of a *newborn baby girl*” (italic mine) is very important here. This corroborates our position of girl’s undermining and devaluation in traditional societies. The psychological analysis gives us full right to accuse not only Efiya for having intentionally killed her baby because it comes ‘girl’, but also her parents, relatives and community. For Amma Darko as for Ama Ata Aidoo losing one’s baby girl is not as important as to ‘sell one’s body’. Both writers are convinced through their writings that women being unfruitful, dry and non-irrigated could be the same as to lose a baby girl notwithstanding the hardship of women in such African societies. They have no future so the writers prefer to render them shallow and unprofitable so as not to bear babies to see them suffering in the hands of their male counterparts. Once again, Ghanaian society is cruel to women and girls. They do not occupy secure positions in a patriarchal society which locates them underground.

In this sense, we said in a previous chapter that Ama Ata Aidoo renders Anowa the protagonist infertile this was in late 1970s and early 2010 her godchild, Amma Darko, makes Efiya lose her new-born girl. The depiction of women’s hardships is the same. The scope in which Ama Ata Aidoo was obliged to render Anowa ‘inoperative’ is the same with that of Amma Darko’s rendering Efiya’s baby girl a dead. If Ghanaian societies do not love baby girls, why continue to bear them? In their writing, both female authors do not give reason to Freud who wrote that women have sex just to have children and because the lack penis, they dive into

sex to compensate. The feminist Amma Darko proves in her way of writing that her female characters are sexually exploited their male ones. Ghanaian women can hardly escape this already woven spider's network against their body. First of all, Sekyiwa with her young age and gives hot 'spur of sex' to turn Tika's father to draw attention from his unproductive first wife. The passage goes this way:

At the age of twenty-two she began a clandestine affair with a married man twenty-four years her senior. His wife was barren and rumour had it that this was the result of an abortion she had had when they were courting. Then Sekyiwa got pregnant. And the man felt his obligation to his unborn child transcending his loyalty to his wife. He left her. (Darko, 18)

Amma Darko emphasizes the movement of the man in one of the shortest sentence in the novel: "he left her". To leave here corresponds to abandon and Amma Darko's recurring thematic depicts Ghanaian women effort to leave alone and their children in this pitiless contemporary urban centres. She reveals the heart-breaking difficulties of those women to be accepted as partly members of Ghanaian society and almost the clichés tagged on their identity with no taboos. Amma Darko portrays her female characters as subdue pawns to the current exploitation chess table made by patriarchal societies. However, as Fanon suggests in *Black Skin, White Masks* (1967) to black women's freedom that first "freedom requires an effort at disalienation"³⁷⁹ and, second, that developing an ability to explain the other to the self may usher in a world of harmonious cohabitation. It is the quest for '*disalienation*' which leads first of all Sekyiwa to treat as mere objects of sex her lovers: "By the third year, Sekyiwa had become one of the wealthy market mummies. Young, good-looking male gold diggers began to vie for her attention. Her husband's libido was waning anyway, so she gave in. She gave them good money; they gave her good sex." Balanced contract, we will say. That is how life goes on. Second, Tika also entered in business and understood that the end justifies the means. She then exchanges her sex for business favours. The stream of consciousness reveals that Tika has as many as possible male 'contractors' to sexually satisfy before having from them the necessary favours she needs.

³⁷⁹ Fanon, F. (1967). *Black Skin, White Masks*. New York: (Trans) Charles Lam Markmann, Grove.

Samuel, the son of an apostolic pastor, [...] Riad, the half-caste, shop owner with several outlets. Eric, the struggling musician. Mr Attui, the factor owner, who helped her get good credit rates on the goods she bought, who proved to be her one error. Samuel, Riad and Eric all had wife each, wore wedding bands, talked proudly about their wives and children, and wanted only lust from Tika. Attui, however, had two wives, with a total of twelve children between them, and two concubines. He was always insulting his wives, dropped two concubines when he met Tika, and made no bones about his desires to marry more women and add to his children. (Darko, 25)

The passage highlights the dark testament of men in patriarchal communities and Amma Darko knows that her female protagonist Tika is in charge of their exploitation to show that women also have soul, feelings and strategies to defend themselves. Before Amma Darko, many other females have tried to portray not only the stranglehold of patriarchy, but also the stratagems used by female characters. For example, many women like Sibò use sex as a means to control men, despite this practice. In that respect, she reminds me of T'Cheley, the daughter of an enterprising woman called Bernadette in Désiré Ecaré's *Faces of Women* or *Die Gesichter der Frauen* (1985). Contrary to her mother, her views are that women should use their sexual power to achieve their goals in a male-dominated society like the Côte d'Ivoire. In a similar context, Nko, the Nigerian female student in Buchi Emecheta's *Double Yoke*, finds herself involved in a sexual relationship with Professor Ikot to pass her exams. For example, the way to undermine female desire, lead some traditional societies to mutilate them. In this regard, while Sibò, Nko, Fili, and Aïcha Tambura are excised, only Fili and Aïcha see the procedure as traumatic. Furthermore, Nko and Sibò seem to accept tradition and do not recall bad memories. Yet, their exploits of sexual bargaining suggest some hidden scars that objectify sex as a tool that can be effectively used on men. The inference is that the effects sought to reduce the sexual appetite of women do not meet such expectations and the practice of excision in some African societies may create just the opposite results. In patriarchal communities, all the means are possible to reduce women to silence, to objects, to others and subalterns. From girls undermining to excision or any other downgrading acts, women are trapped with the stranglehold of ideology of submission, muffled tone and subjugation.

As a matter of fact, and unknowingly, Sekyiwa passes her legacy of subjugation onto her daughter to be the object in a game in which just like Mara in *Beyond the Horizon* will have only material things and no other decent things for her children. But here in the novel, the merit of Amma Darko is to turn Tika into barren. Some defeatists say that women are done and have

to surrender. But optimistic views, on the contrary, opine that women are mothers of creation by giving forth to the future, hope and voice. What if they are unable to satisfy this expectation of the society? This expectation, however, has inherent conflict in the sense that it carelessly assumes a problem-free life towards mothering. In *Beyond the Horizon* and *The Housemaid*, Amma Darko sharply condemns this traditional expectation on women by calling for a critical analysis of the nature of mothers, especially in contemporary times, where we encounter numerous instances of exploitation of mothers. Amma Darko seems not to be directing her critique to women but sarcastically addresses to Ghanaian patriarchal society that lets it happen. The failure of the society is at stake in her novels. It does not guarantee to its members especially women a safe and secured environment where gender inequalities should no more prevail, where phallogocentric ideas should not determine women's lives and circumstances. Amma Darko indicates righteously that there is no legislation to impose it because people want it to be so. Women have no choice, if it is not to be subordinate in silence. Prostitution, motherhood, poverty and suicide are not chosen by women, but imposed onto them as a burden. Amma Darko's desire is to use literature to teach mothers how to evade the trials of motherhood or to overcome these trials. Like a green ground can be fruitless, women can also be barren, still does the farmer lives forever that land to another without one day of the one he has left? Does he not come back on it with all his love and hope to check if it has changed? Does Ghanaian society accept this ultimate failure from women? The coming chapter will give us the clues about the social oppressive conditions that befall women in patriarchal societies.

Chapter four: Exploring the Social conditions of Amma Darko's Female characters

The novel under study scrutinises some cultural practices in African societies through characters' interposition. In fiction particularly, characters play perfectly or awkwardly the roles of human beings because fictional events depict real fact or events to which an author subverts to make another story. So, African societies emphasize motherhood as the prominent element in a man/woman union, barrenness is viewed as the 'no go' condition in patriarchal setting. No matter what life may serve, a woman is supposed to choose to live and give life to future generation. But barrenness resists this notion of what 'naturally' befalls women. From Flora Nwapa to Buchi Emecheta, from Efua T. Sutherland to Ama Ata Aidoo, the subject of the social conditions of women in patriarchal societies has intrigued female writers and then engendered the prevailing writing in their contemporary creative devices. Female writers depict imaginative situations to either indicate men's selfishness and ingratitude toward women or general oppressive attitude against women. In societies where all the rights are given to men over women, motherhood is a matter of price, desired and imposed by all, especially men. When a woman fails to bear a child for the regeneration of the human species, all the blame is on her and in these moments of suffering, the man does not show any kind of emotional support. Besides, when it happens that a man dies in a family, the woman becomes the first victim of oppressive practices of degrading cultures.

9. Barrenness and Widowhood practices in *Not Without Flowers*

In *The Concise Oxford Dictionary of Current English*, barren is something "unable to produce fruit or vegetation, unprofitable"³⁸⁰ and in human medical sciences the term 'barrenness or infertility' is defined as "not being able to get pregnant after at least one year of marriage. Women who are able to get pregnant but then have recurrent miscarriages are also said to be infertile"³⁸¹. Moreover, the World Health Organization definition based on twenty-four months of marriage to get pregnant is recommended as the definition that is useful in clinical practice and research among different disciplines³⁸² and sustain that the following "three factors, in order

³⁸⁰ *The Concise Oxford Dictionary of Current English* (1995). (9th ed.) Thompson, Della, Oxford University Press.

³⁸¹ Prasanta, K. D. ; Swarnali S. (2010). Psychological Aspects of Infertility. *British Journal of Medical Practitioners*, Volume 3, Number 3, p. 1.

³⁸² Idem.,

of importance for the women were, (1). “Having Children is a Major Focus of Life” (2). “The Female Role and Social Pressure” (3). “Effect on Sexual Life” The men in the study reversed the order of importance of factors 1 and 2. The third factor was equally significant to both men and women”³⁸³. It was also shown that women experienced their infertility more severely than men as the responsibility to regenerate the species bestowed upon them. Women then show a more intense desire to have a baby than men.

9.1. The African concept of barrenness depicted in *Not Without Flowers*

The achievement of parenthood and societal respect are evidence of virility and potency for a man and of femininity and a distinctive womanhood for a woman. In society, when people await offspring from a couple and it does not come, they are discouraged and point an accusing finger to the woman who is supposed to bear it. In Christian society, a woman can be compared with a tree which is supposed to bear fruit. People naturally await good fruits from good tree. In the Gospel of Mark, when Jesus Christ came in Bethany, an incident happened to shed light on what awaits any tree that does not bear fruit at the right time:

The next day, as they were coming back from Bethany, Jesus was hungry. He saw in the distance a fig tree covered with leaves, so he went to see if he could find any figs on it. But when he came to it, he found only leaves, because it was not the right time for figs. Jesus said to the fig tree, “No one shall ever eat fig from you again!”³⁸⁴

If it happens that a tree fails to bear fruits and is rejected or cast in fire, the same metaphor can be applied to an infertile woman in the society. She is considered as good when she can fulfill her natural and genetic capacity of reproduction. Still, if she fails, she is ostracized. In the same light, Fortes states that “A woman becomes a woman when she becomes able to bear children and continued childbearing is irrefutable evidence of continued femininity” (Fortes: 1978, 141). The primacy of motherhood to African women has been elucidated by Oduyoye thus:

³⁸³ <http://www.who.int/topics/infertility/en/>

³⁸⁴ The New Testament, Psalms and Proverbs: Good News Translation, Bilingual edition, United Bible Societies, Nairobi, Kenya, 2007, Gospel of Mark 11: 12-14.

Motherhood is a highly valued role open only to women but desired by both men and women as well as the society as a whole; it is the channel by which men reproduce themselves and continue the family name and it is the channel by which women actualize their psycho-religious need to be the source of life. Often, procreation is described as if women are simply “Objects of genetic and social transmission.”³⁸⁵

In the cosmology of African societies, children represent a connection to the ancestors and their birth represents a continuation of the family not only in physical but in religious terms. In a subsistence economy, they are also important in providing a labour force and economic success has been shown to be correlated with family size in that “it is the rich men who have large families and not the poor”, for example among the Hausa (Hill: 1972). In African traditional beliefs, bearing a child is to have a certain power of life and to belong to the ‘secret society of mother’ although it takes stages before a girl becomes ‘mother’. A woman’s dilemma lies therefore in her sense of failure she has been taught; she is the victim of reproaches, which, when voiced, make her feel all the guiltier and responsible for the hopelessness of a whole situation.

Getting to the definition of the term ‘power’ should be considered in two conceptual meanings of ‘energy, potency’ and ‘potential, drive, capacity’ according to Naminata Diabate (Diabate: 2011). Frustrated women’s capacity to stand up for themselves and to reclaim some space of agency complements the potency of the means of resistance. She suggests in “*Genital Power: Female Sexuality in West African Literature and Film*” that the inner strength necessary to use the genital, contrary to its conventional and ‘prescriptive’ uses, is quintessentially transgressive. The transgression is even more powerful when the agents live in challenging material and psychological conditions, where their bodies’ naked lives are constantly marked for death. Whether produced out of limited options or deliberately acquired, genital power introduces ruptures and reversals in what seems like an interrupted and uncontested march of male-dominated values and practices. In patriarchal societies, the cultural mind-set of women leads them to be pressured by the necessity of having children which perpetuates sexual inequalities and renders them vulnerable.

³⁸⁵ Oduyoye, M. A. (2004). *Daughters of Anowa: Africa Women and Patriarchy*. New York, Orbi Books, pp. 141/142.

A barren in African society is considered as being not a completed and fulfilled woman. For Sarpong, motherhood “is the principal if not ultimate end of marriage.”³⁸⁶ The greatest misfortune to befall a Ghanaian woman is to be barren. Barrenness is considered as an anathema on a woman particularly in a rural setting. In the same scope, when a man is impotent, society considers him as a ‘woman’, meaning that he is weak and having no title. Amma Darko here tells the story of women who live in marital homes, but confronted with childlessness and finally ends up as wives in polygamous family and yet have to cope with not only with their present situation, but also with their being relegated as useless and mere ‘object’. Amma Darko illustrates:

It was all about their childlessness and his reluctance and persistent refusal to subject himself to fertility tests and possible treatment, if he were found out to be the guilty one. His wife had concluded that it had to do with the male ego complex. That the very suspicion that he could be the one responsible for their childlessness would dent his self-esteem as a complete man. His wife has a point, but that was only part of the reason for his reluctance. The greater part of it was his mother. [...] The fear and sadness of being seen as the mother of an incomplete man, a man whose ability to inseminate his wife was being called into question; an insult to his manhood and to the womb that carried him for nine months. (Darko, 40-1)

Following the above excerpt, it is clear that Ghanaian society is not ready to accept a man as being the culprit of a childless family and the mother of the suspected man as well. Seeking for the legendary solidarity of women, Aggie tries to negotiate her husband’s mother help to elucidate the affair, which renders things psychologically harder for her. As we say, it is difficult for a mother to collaborate in such an important affair which later will bestow upon her as the guilty-second person. The inference is that when her “learned and respected and adorned son” (Darko, 41) will be definitely designated as incapable of performing what she herself called “Nature’s free magical acts” (Darko, 41), the guiltiness charges will befall on her as being unable to bear a ‘complete man’ and the fear, sadness and judgment from neighbouring gossips and all her community. So much so that it would be better to hide the truth to people and let them believe the woman is the matter.

As a Ghanaian proverb states “A woman is a flower in a garden, her husband is the fence around it”. This very proverb has its consequence on women as well as their environment so

³⁸⁶ Sarpong, P. A. (1974). *Ghana in Retrospect*. Tema, Ghana Publishing Corporation, p. 69.

much as that nothing gives great joy to women more than their opportunity to have a husband and their ability to bear children. To the African woman, the scent of motherhood beckons at the altar, when she walks down that isle or go through the traditional marriage ceremony. Equally and to back up this idea, Helen Chukwuma puts that

the female character in African fiction is a facile lack-lust human being, the quiet member of the household, content only to bear children, unfulfilled if she does not, and handicapped if she bears only daughters. In the home, she was not part of the decision-making both as a daughter, wife and mother even when the decision affects her directly³⁸⁷.

Culture then solidifies the expectation of every woman in the sense that once she gets married; the next is a pregnancy and the birth of a baby. In that scope, some women are so desperate that they commit the worst for their life. In Sefi Atta's *Swallow* (2008), she discloses this: "I think my father's brother is my real father, Brother Tade. You know that if a woman is infertile she can't hide it. If a man is sterile, no one has to know. Understand? The wife finds someone else to father her child, and keeps the whole thing a secret"³⁸⁸. What comes out of Tolani's confession is the cultural stranglehold about women's liberty to share their problem, but the contrary to men. Women must hide their sterility, but men can share it and be helped by other men in bed.

The double expectation of women in some households is too strong and severe. They must bear offspring and also cover the way it comes up because of the desperate need to secure their marital position. This also leads most of Baba Segi's wives in Lola Shoneyin's *The Secret Lives of Baba's Segi's Wives* (2010) to hold up the secret of their adultery to Baba Segi. Thus, just like Tolani's father, Baba Segi is sterile, but no one divulges it until the day of discovery. Forced mothering propels mostly women into sexual immoralities, an attitude that contrasts with the cultural norms in Africa, but the Bible gives us further records about what happens to childless women. The narrative in the first Book of Samuel, barren or childless women are usually mocked at by those who have. The narrative goes this way: "Because the LORD had closed Hannah's womb, her rival kept provoking her in order to irritate her. This went on year after year. Whenever Hannah went up to the house of the LORD, her rival provoked her till she

³⁸⁷ Chukwuma, H. (2003). "Voices and Choices: The Feminist Dilemma in Four African Novels." *Feminism in African Literature: Essays on Criticism*. (Ed.) Helen Chukwuma. Port Harcourt: Pearl Publishers.

³⁸⁸ Atta, S. (2008). *Swallow*. Lagos: Farafina, p. 184.

wept and would not eat”³⁸⁹. It is the daily common lot of barren women not only in the ancient times of biblical events, but also in contemporary time like that depicted in Flora Nwapa’s *Efuru* (1966). We see clearly that when a woman fails to fulfil this social role, her female identity is seriously threatened as tradition dictates that if a woman is childless, then she is not a woman. In that scope, the author personally confesses that:

The problem that a woman faces in the world in the pain of not being able to bring forth a child from her womb, something no man can yet perform! The pain is great if she is denied this function and this is why the theme of barrenness is explored by many African writers particularly the female ones³⁹⁰.

She seems to suggest that greed, rather than poverty, drives the typical new Nigerian and Ghanaian who takes to making ends meet through irremissible means. This raises a serious question of economic difficulties of African countries in postcolonial era. Bretton Woods’ institutions such as World Bank and International Monetary Fund require that Africa has to meet some recommendations in order to benefit from the institution. All these measures impose a visible austerity on families and bring along with a permanent poverty in households. What we unfortunately notice is that the budgets of poverty targeted programme become smaller and smaller, so are the transfer values limited in mostly African countries leading to all that we have said above.

Against these social backdrops, Amma Darko ridicules this assumption of society through Dina when she states: “If nothing at all, the notion is that it proves her to be a complete woman. Physically, socially, spiritually and emotionally, procreation is considered to be a woman’s obligation to the ultimate essence of life itself” (Darko, 96). But Amma Darko puts rightly and subtly that in some countries, women can decide not to have children because their society backs them up emotional. For example, 5th Wife, as the favourite wife of Pesewa, is just in need of emotional and financial needs. She puts it herself: “I know it sounds unbelievable to many, but I did. It wasn’t due to any strong body chemistry or his electrifying touches. It has nothing to do with compatibility in bed or any extraordinary sexual fulfillment. I need emotional

³⁸⁹ New International Version (NIV) Holy Bible, New International Version®, NIV® Copyright ©1973, 1978, 1984, 2011 by Biblica, Inc.® Used by permission. All rights reserved worldwide.

³⁹⁰ Nwapa, F. (1998). “Women and Creative Writing in Africa”, Nnaemeka Obioma. *Sisterhood, Feminism and Power: From African to the Diaspora*. Trenton (NJ): Africa World Press, p. 89-90.

security and he offered it in abundance, with the added advantage of financial security too. He treated me like a queen” (Darko, 91). The same situation of infertile is found in Sefi Atta’s *Everything Good Will Come* (2005) where one of the female character Sheri, becomes infertile as a result of self-aborting pregnancy. The pregnancy comes after a gang rape in a park. The narrator proceeds on: “Sheri was lying in the seat. Her knees were spread apart. The boy in the cap was pinning her arms down. The portly boy was on top of her. His hands were cramped over her mouth. Daramola was leaning against the door”³⁹¹. Sheri is raped, devalued, ruined and is robbed of her *womanity* and pride. Further, Sheri becomes the mistress of a powerful male character who does not require her to have children. Sheri lives the same predicament like 5th Wife in Amma Darko’s fiction. Unfortunately, what is sought commonly in African patriarchal societies, is none of what 5th Wife or Aggie think is necessary in their marital home. Failure to conduct this natural progression brings so much anguish, shame and despair to the family but much more to the woman affected and the society does not put the blame on the man because ‘he is the fence’. Culture frowns then on a woman who fails to conceive within the first two years of the marriage and Aggie’s case is a perfect example. Therefore, Amma Darko uses a formal test to diagnose the childlessness source between the two.

Yet, traditionally, a lot of women have died from taking concoctions of unknown ingredients, both bitter and sweet, all in an effort to treat the condition from dubious medicine or religious men. Some have been made to bath in rivers and to gulp gallons of holy water all in the hope of cleaning and cleansing the blocked fallopian tubes. Other have been asked for huge amount of money for electrifying prayers in dubious prayers camps up springing like mushrooms in Ghanaian urban centres as well as in other African cities. Trapped in these conditions, Amma Darko’s female characters believe that biblical gospels with new prophets in Accra and other neighbouring cities could help them save their households and social stances. Helplessly they dive into an endless river of hope, thinking that an overnight social and financial change will drill from the sky to wake them up from their long contemplation. The beliefs grow night and day through gospels of prosperity and electrifying prayers led by a so-called prophet, a self-made man of God. Amma Darko’s female characters strongly believe that the spiritual world is what hinders them from being in peace in their household. They try by any means to cure their failure and misfortune in church. In actual facts, women outnumber men in churches

³⁹¹ Atta, S. (2005). *Everything Good Will Come*. Lagos: Interlink Books, p. 68.

in Africa because of their particular problems about their households, their husbands, their trades, their fear to lose their husbands, their children to name a few. Because of these above cited wants, women seem to more likely to believe in miracles by these men of God.

Conversely, to defend their ego, some men do not take kindly what seems to be a delay or incompatibility in producing a son, a legatee for the family name and then leave their wives to face alone the communal pressure. Pregnancy is no more the happiest times for a woman under pressure of having a male child. Further, some women suffer from a gynaecological delay in getting pregnant because of their psychological and social conditions. Another example is that a woman who, at her first birth, suffers from pre-eclampsia, a condition or pregnancy characterized by high blood pressure and protein in the urine, will hesitate and think twice before having another pregnancy. The trauma of her previous pregnancy with the illness will haunt her for a long time.

By contrast, other men, avoiding critics and mockeries from their families and relatives have either abandoned their wives outright or married second wives, or worse still maintained a concubine on the side. Despite the concerns raised by the above critic, it must be put on record again that the labelling of female writers' works as seeking the selfish interests of women and devoid of serious issues to trigger desired change or development in society is rather unfair. Available evidence indicates that some female works have gone beyond female issues to present issues relating to the larger society. Remarkably, even some of those who dismiss women writers' works as self-seeking do agree, though reluctantly, that some of the female authored works that have appeared over the years have presented issues of national or societal interest. Molara Ogundipe Leslie, for instance, despite all her arguments that the "female writer is concerned about telling the truth about the female experience, also adds that the female writer should be committed to her third world reality and status"³⁹² which is the concern of Amma Darko. Amma Darko's novel offers updated insights into Ghanaian women's predicament in fast-changing and increasingly unstable environments where women are simultaneously victims and accomplices of their situation. Kum Kum Sangari argues that the term "third world" not only designates specific geographical areas, imaginary spaces. It is "a term that both signifies and blurs the functioning of an economic, political, and imaginary geography able to unite vast

³⁹² James, S. M. & Busia, Abena P. A. (1993). *Theorizing Black Feminism: The Visionary Pragmatism of Black Women*. London & New York: 1st Ed, Routledge.

and vastly differentiated areas of the world into a single ‘underdeveloped’ terrain (Sangari 1990, 217³⁹³). Scholars such as Chandra Mohanty, Gayatri Spivak, Sara Suleri, Edward Said, to name a few, have amply discussed about the issues and its aftermaths on the former colonised. One of the aftermaths is referred to by Amin who writes that “in 1960s, in Annual Per Capita Growth rate in gross domestic product (GDP) in Sub-Saharan Africa did not exceed 1.3%, before falling to 0.8% in the 1970s, and almost to nil in the first half of 1980s”³⁹⁴.

In *Not Without Flowers*, Amma Darko uses her literary work to bring to limelight what is the pressure and stress in many childless Ghanaian homes. Aggie, one of the members of MUTE’s workers has married Idan for years. She loves her job with a passion that sometimes left her husband feeling jealous, but she also loves her husband. The particularity here is that the love Amma Darko highlights comes from the woman because women are supposed to be more giving and more loving than men. The male character’s desire is not yet completely fulfilled with a child and his woman would rather choose self-sacrifice manner so as her family structure remains intact. The conflict between duty to the family and personal fulfilment will always resolve itself through self-sacrifice and submission to the pattern of society. Much like other female writers who have burst onto the literary scene over the centuries, it is expected that Amma Darko would write from a female point of view. Among other things, issues concerning women such as the injustices against womanhood, the need for gender equality and the empowerment of the female, are bound to emerge in the fictions.

Amma Darko prefers to act like a camera, recording her female character Aggie’s emotions and situations with realism and sensitivity without allowing her to leave her husband house. The picture shows the fact that tradition is deeply ingrained in society. Childlessness reinforces Aggie’s docility because even Ghanaian educated women live in community that formats them to accept the diktat of the system. She faces patiently not only her husband’s refusal to undergo the test in a hospital on one hand, but also the family’s pressure to have a grandson in the other. At the first time, the attitude impacts her husband’s gratitude. He puts “My wife has finer taste” (Darko, 77). Though Idan presents his wife as having a finer taste, he does not hesitate to involve in an extra marital sexual relationship. This conception of

³⁹³ Sangari, K. (1990). The Politics of the Possible. In *The Nature and Context of Minority Discourse*. Eds. A JanMohamed and D. Lloyd. New York: Oxford University Press, pp. 216-45.

³⁹⁴ Amin, S. (1990). *Maldevelopment: Anatomy of Global Failure*. London and Tokyo. Zed Book United Nations University Press, p. 7.

masculinity expression also proves itself with other men in the text. Alongside, the reader is shown the project of Idan to deal with the problem, his self-esteem dictates a position which discards any attempt to accept the test in hospital. This implies that the blame of his childlessness shall befall on the woman and then her emotional pain cutter, an attitude which Amma Darko describes as follows:

Aggie slumped down on the low stool under the shady palm tree in the middle of the compound of their home, to begin her regular Saturday morning washing. She was tense. The waiting was killing her. The expectation of it, knowing it would happen anytime soon, was devastating. For the past few weeks, it had been happening every Saturday morning (Darko, 104).

Aggie is neglected and stigmatized by her husband in a crucial moment, in spite of the long time they have spent together as student at the university. Once together, Aggie is defined but as the 'other'. This feeling of 'Otherness' worsens her physiological and psychological condition. To illustrate it, the narrator shows a case when Aggie suffers from stomach contractions which makes her extremely agonize. She faces alone her ailment. Fortunately, enough, she finds the needed moral support from her sisterhood with the other MUTE. Sisterhood works as an antidote to women's suffering Amma Darko seems to show. Together, MUTE's female workers sit and discuss their respective household issues, give each other some advice and share experiences. But Aggie's problem sounds more serious. Any time, her husband is present, as soon as the "telephone buzzed, Idan rose like a zombie from the armchair" (Darko, 105). The reference to a 'zombie' to call Idan is his absence-minded at home and his pathetic psychological status with his wife. Idan is no more a human, but a living-dead. He is not conscious of all that he is doing. People say a man in love is more dangerous than a woman and Idan's case illustrates this so well. Then Amma Darko reveals:

He strode to the bedroom for his mobile phone. Leaving it there was also part of the ritual. She was yet to figure out why he did that. Why he always left his mobile phone in the bedroom when waiting for the two signature buzzes on the landline. [...] Because if the mobile phone was beside him in the living room, where the landline was, and upon the signal, he proceeded to the bedroom to make the call, it would look suspicious. (Darko, 105)

In the novel, Amma Darko makes her character Aggie act as a woman with no willpower to defend herself. She witnesses in silence as if it was normal to suffer. She stands by the door and listens to the phone call, but comes back to her washing to digest the gunshot pain, "ripping

the insides apart. The immediate impact; momentary deadness, then the maddening pain. The pain swiftly returned inside Aggie's chest. That must be how a gunshot felt. She began to tremble, at first mildly, then violently" (Darko, 106).

In Amma Darko's fiction, Aggie's husband comes to be a device of adultery with suspicious eyes of a childless woman. This attitude is condoned by Ghanaian society because women continue to be the weaker element on the social tablet. A similar case is discussed in *One is Enough*, where Flora Nwapa's narrative explores a female character's options in the face of subjugation and victimization. The story further highlights, the paramount issue of childlessness in marriage. Amaka, after six years of marriage without children, left her marital home and her adulterous husband who had fathered two sons with another woman unknown to Amaka. Her city refuge opened up vistas in self-fulfilment due to her courage, industry and tenacity. In the permissive environment of the city, she became the mother of twin sons. But she would not marry the twins' father preferring her new freedom because she said "one marriage is enough for a lifetime". Buchi Emecheta in her novel *Joys of Motherhood* presents to us the character of Adaku who in her marriage to two brothers had two daughters. Her position in the polygamous home was not assured because she had no son as her co-wife Nnuego. She walked out of her marriage into prostitution to make money to ensure the future of her daughters. Half of her decision has been inducted by her society, which forces her to do so as she is not fulfilled by offspring.

For example, in *Remembering: A Study in Experimental and Social Psychology*, P.C. Bartlett argues that while there is no proof that the social group has a mental life over and above that of its individual members, there is no doubt that the group functions in a particular way which directs the mental lives of the individual members (Bartlett: 298, 300)³⁹⁵. The individual may be seen as the product of his or her cultural history. Paul Connerton concurs with Bartlett, stating in "How Societies Remember" that "the narrative of our life is part of an interconnecting set of narratives; it is embedded in the story of those groups from which individuals derive their identity" (Bartlett, 2). Personal memory and cultural memory are thus not clearly separated. We internalize the cultural memories of which we are a product, and our pasts, both culturally and individually, determine who and what we are. The control of a society over memory is a means

³⁹⁵ Bartlett, F. C. (1932). *Remembering: A Study in Experimental and Social Psychology*. London: Cambridge UP, in Catriona Cornelissen's *Negotiating Cultures: Modes of memory in novels by African women (1997)* (Ed.) Toronto University Press, p. 2.

of retaining power and authority. While then retaining Aggie's memory to fight and conquer back her husband, because she thinks she is not in the right position to do so, Aggie accepts to be the 'other' and the subjugated then the authority is away. Amma Darko confirms this by putting "Idan gave an excuse of meeting somebody at the office for a discussion, and drove straight to Randa's hall. [...] They ended up in a rest house on the eastern outskirts of Accra. But it was always Randa who dictated whether or not they could be together. Idan went along with it, dazed, besotted and overwhelmed" (Darko, 114-15). Because of her pain, she "stopped the washing, leaned against the palm tree and burst into tears" (Darko, 115), Aggie has to bear the stranglehold of the patriarchal system. Her only escapism is her friendship with other women of MUTE.

From a feminist point of view, it is clear that Amma Darko in *Not Without Flowers*, regards sisterhood as one of the major outlets to women's problems. Although no attempt is being made to label Amma Darko as a feminist, her commitment to finding solutions to women and children's problems in contemporary Ghana draws her close to Ama Ata Aidoo in this particular instance. Significantly, Aggie's unbreakable friendship with Dina and the other workers can be seen as a deliberate attempt by Amma Darko to suggest that one of the ways to attain women's emancipation from the shackles of patriarchy is through sisterhood, a bond unbreakable by class, race, education, colour, religion or geographical differences. Of course, Amma Darko does not apply the radical 'therapy' of her female counterparts such as Flora Nwapa, Buchi Emecheta. She rather creates her own female characters in *Not Without Flowers* who most of the time failed to run away from their marital homes.

Yet, as a wife does, she conforms to the role, married to a man who wants a child, but no pregnancy occurs after seven years. Therefore, she lacks the power to change the circumstances of her life. Amma Darko justifies her way of portraying her characters in dilemma "I take the trouble to investigate the realities. When I write about Sodom and Gorrumah *for example* [...]. I want it to be authentic, because Sodom and Gomorrah does exist in Accra. So scenes have to be authentic" (Higgins, 112). She is then fully engaged according to Gervase Angsotinge in what she "portrays with fidelity and without idealization, the essence of everyday 'normal' Ghanaian life, with some exaggeration, even sensationalism in order to establish a motif that then mediates

the realistic concerns of the writing.”³⁹⁶ Every aspect of daily life becomes a reproach to the woman. Her situation is not improved by the fact that her husband is not averse to undermining her position by voicing his criticism directly though. At that very moment in a childless woman’s life, it can be like “a series of roads of all descriptions, and those who go far are those who, ignoring the possibility of accidents, learn to drive fast”³⁹⁷. It matters to Aggie that to drive fast means to learn to bear the humiliation and find her way to self-exalt and motivation, which is difficult but not impossible.

As for the family of Ntifor/Kakraba-Penyin the situation is totally different. Amma Darko gives way to what is her special touch of solving female gender inequalities and situation of lack and frustration. The household of Ntifor has been childless for a while and the head of the family marries another woman. What Amma Darko does not precise here are the moment of Kakraba’s arrival in Ntifor’s home. What is appreciable then is her being not a rival to the first wife but a co-wife to help each other in household. Nonetheless, the psychological pain is still pending because a woman likes a minimal possibility to share her husband with another regardless her social fault or inability. The character Penyin³⁹⁸ is Agya Ntifor’s first wife who has fallen childless and the question raised by the character is this: “I thought of how often you may have wondered about whether he would have taken you on as his second wife had I been able to bear him children” (Darko, 159). And really should Ntifor get another wife if Penyin had been able to bear children at first? What makes progress in patriarchal societies is for the ‘bread winner’ to get as many as wives in his household to enlarge his authority. The quality of Amma Darko is that which makes her fiction not just reading matter, but also her ability to knit life experiences into art. There is an effort to make the incidents as realistic as possible not just in context but in form and style. In the context, Ntifor would want to have children as many as possible then.

Left with no choice, she has to accept a new wife’s coming. Mena Kakraba then come and bears children to their common husband. Though Penyin has been told she also is the

³⁹⁶ Angsotinge, G.; Dako, K.; Denkabe, A. & Yitah, H. (2007). “Exploitation, Negligence and Violence: Gendered Interrelationships in Amma Darko’s Novels” (ed.) Odamtten, Vincent, O. *Broadening the Horizon: Critical Introductions to Amma Darko*. UK/London: Ayebia Clarke Limited Publishing Print, p. 83.

³⁹⁷ Busia, A. (1990). “Parasites and Prophets: The Use of Women in Ayi Kwei Armah’s Novels” (ed.) *Ngambika: Studies of Women in African Literature* (ed.) Davies Caroles Boyce & Graves Anne Adams. Trenton, New Jersey, Africa World Press, Inc, p. 91.

³⁹⁸ In Ghanaian naming chart, Penyin is given to the baby who comes before the twins. He or she is twin’s elder (Akan and Fante people).

mother of the children, the sorrow and the physical pain runs uncontrollable. Just like Aggie, Amma Darko does not make her childless female character Penyin walk out of her marital home. In Penyin's case, her husband marries another woman for the sake of heritage. As for Aggie's situation, Idan is engaged in a 'money for sex' situation with a girl outside. Young women, as they are no more "looking for a long-term affair, they accept to go in for one with lowest risk of an expectation of having child" (Darko, 78). So the contract is clearly termed for "sexual fantasies and desires that probably appall his 'ringed' better half at home. In return for which he also provides her with the financial security she craves for: a win-win situation" (Darko, 79).

The reason why a woman has to undergo frustrating moments of barrenness is because she has a highly important responsibility. This persuades us to argue that there is a message the writer is trying to communicate. Amma Darko's text exposes a simple fact that the unfair balance of power has not only led to frustration on the part of the oppressed. She paints a picture of women that are meant to be seen and not heard like a piece of decorative china doll. Despite a number of possibilities to tackle the matter it fails to receive adequate attention in patriarchal society like Ghanaian one. Our contribution delves into the challenges faced by female as well as how female characters' experiences are at work here. As opposed to Aggie and Idan's family, where Aggie found herself caught by a web woven by an unknown called Randa to tame the frustration of Idan, Amma Darko creates a situation of an accepted polygyny with Ntifor. The reason is the same: a childless family could not stand without offspring, so even as being against bigamy because of its intricate impact on the household and on its resulting children; Amma Darko conducts the reader to accept it this time.

Though the writer proves that it is affordable in villages, the female Penyin is not emancipated. We can see how she fears every movement of their husband while being visited by the teacher. She becomes a spy and psychologically watchful. For Penyin, the only consolation is to be watchful so that another rival does not come in the household to overthrow her. She is content at least to be the first wife and in real the second in importance, Kakraba being the one who bears Ntifor's children. Through this character, Amma Darko shows us that the psychological mind of a childless woman in a polygamous family is traumatic and "all still suspicion" (Darko, 154). It is also mentioned that Amma Darko depicts a woman who is not at

ease. Penyin “became alarmed. Her voice was low and intense. Penyin circled round and round and round and came to an abrupt halt” (Darko, 155).

Penyin’s attitude as seen above proves that she recognizes the true danger in which she is if their husband takes the third wife embodied by the nameless teacher. She becomes then the subject that reproduces the ruling ideas and practices. Her fury manifests itself in “loud a wheezing” (Darko, 155). Though Penyin has been certainly prepared to accept situation of that kind, she remains alarmed and impatient to see the end of all the story that links Ntifor with the stranger. Kakraba’s confirmation of her suspicion makes her explode:

Suddenly Kakraba decided that she knew what all this was leading to. “I think Ntifor wants her for his third wife. A brief period of silence elapsed. Then Penyin shot out abruptly,
“Do you think he will be having children with her? Isn’t she too old to begin to have children? [...] “If he marries her, I don’t see why not, even with his over seventy years. She doesn’t seem to me to be even forty years yet. Do you think she would let her babies turn into blocks in her womb? She will definitely want to have children with him. (Darko, 156)

On the one hand, the above passage reflects both women’s fear to have in another woman with children. But Penyin incarnates more this fear and anxiety. What we surprisingly notice is the normal confrontation between Penyin and Kabraka as it could be with female rival. Amma Darko creates both female characters without this hatred and rivalry feeling. Whenever the childless character feels “a little jealous” (Darko, 160), because she is human, her co-wife opposes love and sisterhood to share the title of ‘mother’ together. This is to be seen in her usual “our children” which does not exist in real childless and polygamous family. Although Penyin does know that it is her co-wife who has “creases and folds and marks of childbirth are her belly”, she is happy and grateful for this complicity and togetherness. The children I bore with him belong to us all. Our children, Penyin” (Darko, 160). But what Penyin cannot contain is the pain “of having to share Ntifor” with her young rival years ago and the dialog goes like this:

“Pain?” said Kakraba, amazed. She was confounded, “You never talked about any pain, Penyin.”
“Oh Kakraba, why do we normally shed tears. When I talked about the tears I shed in those final days I knew I was having him to myself alone for the last time, do you think it was for fun and joy?”
“Sometimes we shed tears because we are happy, Penyin, don’t we?” Kakraba muttered sadly.

“I know,” Penyin conceded, “But the tears I shed then was for the pain I felt” (Darko, 158).

All over the above dialog, Amma Darko uses many times the word ‘*pain and tears*’. The repetition of these two words is significant as it puts emphasis on the right psychological status of mind of the woman. Here it is the regularity of her pain and her burning heart that writer is showing, which surprises her co-wife. The prominent psychiatrist and theorist Frantz Fanon confirms in his ever famous book *Black Skin, White Masks* that similar psychological predicament can be seen in extremely deceived people. He argues that sometimes people hold a core belief that is very strong. When they are presented with evidence that works against that belief, the new evidence cannot be accepted. It would create a feeling that is extremely uncomfortable, called cognitive dissonance. And because it is so important to protect the core belief, “they will rationalize, ignore and even deny anything that doesn't fit in with the core belief”³⁹⁹. Penyin’s state of mind is that described here by Frantz Fanon and no amount of money can erase this pain. Penyin is in despair because of her childlessness and nothing can stop such a feeling. Amma Darko gives her no way to escape. She is condemned to behave in what Frantz Fanon called “neurotic orientation”. It is a state of permanent anger and anxiety which ‘is not a spontaneous phenomenon’. It is an anger borne out of grinding experience, painfully long self-analysis, and even longer thought and reflection. As such, it is a guarded anger, directed at a specific, long term desire.

According to Psychology Online Dictionary, neuroticism is “an umbrella term used to describe a range of meanings. For example, neuroticism could detail a state of neurosis whilst neuroticism is also one of the five personality models, which is characterized by a chronic level of emotional instability”⁴⁰⁰. So a childless woman in such society is in an enduring anger and pain. Her rescue is the task of a healer like that of Ayi Kwei Armah’s ‘historical reconstruction’ and not Teacher and her prophet Zeckaria, Abed Nego in *Not Without Flowers*. Just like in *The Healers*, where Ayi Kwei Armah reinvents again the story of the fall of the Ashanti Empire to negotiate the scramble, portioning and destruction of African continent, the hired prophet in Amma Darko’s novel arouses indignation and depicts another ‘scramble’ for African people’s wealth, especially market women of Accra, through the gospel ‘gift for pious heart’ or “visa grant through electrifying prayers” (Darko, op.cit. 250). These prophets are not mere than

³⁹⁹ Fanon, F. (1967). *Black Skin, White Masks*. Trans. Charles Lam Markmann. (1986) New York: Grove.

⁴⁰⁰ Psychology Dictionary, consulted 14/09/2016.

dreams vendors and manipulators benefitting from their victims' spiritual blindness and loss. Amma Darko confesses that though people seem to notice the treachery, they still believe these fake prophets because of their burning desire of overnight miracle like that of Jesus-Christ with five loaves breads and two fishes which became an overwhelming food to feed thousands of hungry people⁴⁰¹. The illustration lies as follows:

He nearly betrayed himself. It was the excitement. That nearly got him talking like Raja Hey. A whole Prophet Abednego of God? [...] He was overwhelmed and paralyzed by the Prophet Abednego on Bright FM. [...] "Yes. He had a revelation. It was a number of our family. One of those bad old women. Unfortunately, the pastor couldn't see her face in the revelation, only her feet. In the revelation the witch had used her huge ugly evil feet to stamp on my German visa..."

Inside your passport?

No. in the spirit.

"The German visa has a spirit?"

"Ei! Don't you know? Ei! Then you don't know what is happening!

"So the pastor who had the revelation, what did he do about it?"

"...He tried prayers and fasting. He made me even fast too and rinse my face three times a day with holy water [...]"

"To enable the visa officer to see your real face instead of the worms and cockroaches?"

"Yes."

"And?"

"Failure."

"It didn't work? All the prayers and fasting and holy water?"

"It was the pastor. He wasn't strong. Not knowing people had even been complaining about him. He always gets revelations, no miracle. Not even one single miracle has been credited to him (Darko, 250-51).

We select this long dialog to let proofread how these ordinary 'lottery players' disguised in Prophets bargain their perfidy and seduction alongside with their insignificant biblical passages' knowledge. They play with their followers' faith in them and take their ignorance as an advance to strike. The phenomenon is on its highest pick these times in almost all African countries.

Here with Amma Darko's use of a self-made prophet (a gospel trader) to refer to the up spreading phenomenon of evangelical revival in all Ghanaian urban centres is a diagnosis of all the interpretation around any unusual situation. When people live in an environment where any

⁴⁰¹ Holy Bible, New International Version®, NIV® Copyright ©1973, 1978, 1984, 2011 by Biblica, Inc.®

single and unusual situation is interpreted being mysterious, therefore predicaments like these befall them. Women seem to be more likely to fall in this trap. All this mystery militates against the women's well-being as they journey through life's winding cycles dictated by culture. For instance, when Kakraba attempts to feel Ntifor's boil to enable her diagnose what it could be, she is branded a witch for her knowledge and concern (Darko, op. cit. 161). In the text, Ntifor calling his second wife a witch could be interpreted as her being probably responsible for her co-wife's physiologically unable to bear children. The concern is that instead of being appreciated for her often timely contributions, she is misunderstood and branded witch. This attitude of Ntifor seems to be that of many African people in a mysterious situation. But the question to ask is why were mostly women and female children witches?

In patriarchal societies, to be called a witch is no easy matter. It spells certain death for the accused-usually being burnt alive, stoned to death, or in rare instances banishment. This accusation is strategic in fact. The fear of being thus branded kept young people from criticizing the 'elders', the male ruling class and the poor from showing open resentment to the 'well to do'; rank and file tribesmen from challenging the status quo, and women from challenging male domination because those who threatened the existing order of things in any form were branded as witches. That is to say, it was used to strengthen patriarchy. As for example, we have Ntifor and his wife in the present novel and Okonkwo and his wife in Achebe's *Things Fall Apart*. Every African knows or gives the impression to know how powerful the members of these secret societies are. However, when seen through, it can happen to anyone in society to enquire the health situation of a beloved and as a result, being branded a witch for the fear of it is permanent and is in the collective mind. As done in the past, protection from witchcraft has always been a common concern. Such protection is sought from traditional priest and medicine men as that mentioned in *Beyond the Horizon* while Mara is about to travel. The word from these people is taken gospel truth.

In consequence, taking clue from this, we can see that female curiosity is hammered down through that stratagem of branding her witch. Since a witch is said to cause harm to members of her family or community, in a closely-knit commune she is viewed as especially dangerous. Fear to endure the dehumanizing practices always forces the women to step back to their position as second and to remain reluctant to question the ruling order.

In fact, this implies that the experience and the frustrations of seeing beloved ones plunge into trouble may be a reason why women quickly offer their help in such situations. Like the historical circumstance in which Yaa Asantewaa, the Queen Mother of Ejiku (a historically famous Akan warrior of the pre-colonial era we referred to in our first chapter and also in historical events that foster Amma Darko's writing) offered her help to her brother, the King of Ashanti while in difficulty before the British invaders. Historians record that Yaa Asantewaa sees that some of the chiefs are likely to coil back for fear of being killed or being defeated and taken as slaves. Others say that there should be no war because war against the British Empire will leave their wives widows and their children orphans forever. They should rather go to beg the Governor to bring back the Asantehene King (Nana) Prempeh. Then suddenly Yaa Asantewaa stands up and speaks out a word of courage and full of motivation. "We the women will. I shall call upon my fellow women. We will fight the white men. We will fight till the last of us falls in the battlefields"⁴⁰². This word of hers saves the face of a whole kingdom.

All in all, barrenness is one of the most revered prejudices on the African continent because it removes from women the power to bring forth to life. In marriage, the most valued item is motherhood and mothering. When it comes to lack, the consequence befalls women as being at the cause of it.

9.2. African People's cosmological foundation of Death, Suicide and Widowhood

From ancient times, Africans have marked the transition of life cycle, from birth to death, with rites of passage. Through these 'journeys of the spirit', people are able to transcend the everyday concern to connect with their own spirit and with the spiritual world. Rites of passage have values for both the individual and the community. The ceremonies give an identity to the community that feels part of the world, the cosmology. African cosmology views death as a passage from the visible to the invisible (King: 2013)⁴⁰³. Death is natural but sometimes can be provoked by wicked people, always enemies of the family and the community. Death is then considered as a transition from a physical status to a spiritual one. As soon as the departed join the spiritual world they become ancestors, but through a long process of funeral rites. Here the

⁴⁰² The historical words of Yaa Asantewaa before Ghana Empire would collapse in the hand of the British Empire.

⁴⁰³ King, L. M. (2013). In discourse—towards a Pan-African psychology: Drum rolls for a psychology of emancipation. *Journal of Black Psychology*, (39), 223-231.

mode of death has all its significance. The departed are more likely to defend the living descendants. That is why there is a cult for dead people in Africa.

For example, in the history of the ancient Egypt, Pharaohs conserved their departed beloved by mummifying their bodies as they believed the soul would recognize and join the body for an eternal life. They also believed that beloved like Pharaohs would be happy to be buried with their personal belongings such as jewellery, clothes and other values. In some kingdoms, it was almost welcome that wives of the departed kings followed them in eternal life and love. Their view of an afterlife was then clear. Thus, it was important that the body be in good shape to reach the place. To be in accordance with the Senegalese poet Birago Diop's poem: "Deads are not dead. [...] There are in the wind. There are in the water, [...]"⁴⁰⁴. In this way, dead people are venerated because of their spiritual power over the living. The belief is widespread in Africa because of its foundation in collective memories. Christians, Muslims or Voodooists, people believe in the rites which permit the deceased to join the spiritual cosmology by formally separating them from the physical world. While in Egypt, the Greek Herodotus observed this on Egyptian mourning and burials that reads this way:

Whenever any household has lost a man who is of any regard amongst them, the whole number of women of that house forthwith plaster over their heads or even their faces with mud. Then leaving the corpse within the house they go themselves to and fro about the city and beat themselves, with their garments bound up by a girdle and their breasts exposed., and with them go all the women who are related to the dead man, and on the other side the men beat themselves, they too having their garments bound up by a girdle; and when they have done this, they then convey the body to the embalming.⁴⁰⁵

In order to become immortal, the Egyptians believed, a dead person had to get to the afterlife, and that was not easy or simple. When a person died, his soul left his body. The soul would then return and reunite with the body after it was buried. However, "the soul needed to be able to find and recognise the body in order to live forever. To that end, the body had to be carefully prepared and stored for eternal life. Moreover, the journey itself was fraught with perils, and to reach the destination, a dead person needed ample provisions and the help of ritual

⁴⁰⁴ Diop, Birago, *Le souffle des Ancêtres* (du recueil *Leurres Et Lueurs*, 1960, éd. Présence africaine). The author Birago Diop was born in 1906 and died in 1989.

⁴⁰⁵ Herodotus (2012, January 18). Herodotus on Burial in Egypt. *Ancient History Encyclopedia*. Retrieved from <https://www.ancient.eu/89/>

and magic spells”⁴⁰⁶. They buried their dead parents, relatives and kin in pots and ceramics, not because of their financial status not because Egyptians saw a symbolic connection between pots and wombs. They think that while the soul would return to reunite with the body, it needs a proper milieu like womb and pots can make it unmistakably. The Egyptians we are referring to here are, according to the evidence based-proofs of Professor Cheikh Anta Diop⁴⁰⁷, not “a part of Asia or Europe as some people continue to proclaim to this date, but a distinct African nation”⁴⁰⁸. Yet, some European historians, ethnologists and archaeologists while digging out artefacts were confronted with the manifest reality of the African continent being the first to have produced historical materials used by Europeans. They decided to rewrite the truth to their advantage. For Cheikh Anta Diop, there lies the point of depart of biased history which referred to events to the detriment of African people to this date. Shaking that truth aside, some Europeans continue to blame the African continent for its technological backwardness and economic retardation.

Extending the idea of rituals in Africa, it may be argued that some rites are strictly private and secrete where initiated can communicate with them to know the reason of their depart, depending on the community and others are public with sacrifices, offerings, and any kind of celebrations with masquerades like the Yoruba in Nigeria and Benin and the Bete in Cote d’Ivoire with serious sequences of mourning to praise the departed. Since the mortuary and mourning roles are distributed to women to express their displaced and delayed grief, the more they are secluded and harshly treated, the more the grief is expressed. Quoting Herz (1960) Osei-Mensah (1999) explains that:

The premise here is that grief is an inevitable response to death among those for whom the deceased was a valued or loved person. Visible expressions of grief take conventionalized forms such as the dirges already alluded to and occur in predictable contexts, [...]. Alternatively, funerals provide opportunities for individuals to express grief over their own impending deaths;

⁴⁰⁶ <https://arstechnica.com> : Ancient Egyptians « pots burials » are not what they seem.

⁴⁰⁷ Cheikh Anta Diop was born in the town of Diourbel in Senegal, on the West coast of Africa in 1923. His birthplace has a long tradition of producing Muslim scholars and oral historians. This is where his inspiration and interest in history, the humanities and social sciences from an African point of view began. After the publication of his first book *Nations Negres et Cultures* (1954) that had been rejected as a PhD thesis at the Sorbonne in Paris, he became one of the most controversial of present day African historians.

⁴⁰⁸ Clarke, J. H. (1974). Cheikh Anta Diop and the New Light on African History. Indiana University Press. *Transition*. No 46 (1974), pp. 74-76.

that is, the felt uncertainty about the nature and types of death that await them.⁴⁰⁹

In this scope of increasing grievance and discrimination, women suffer especially because of oppressive cultural traditions, many of which still persist in modern African societies. The scholar, poet and prolific feminist critic Ogun-dipe-Leslie identifies traditional customs as mountains on the back of African women (cited in C. Boyce Davies & Anne Adams Graves: 7). The oppression extends to, but not limited to, patriarchy, polygamy, widowhood, arranged early marriages, sacrificial marriages for the benefit of male children. Till now, it is widely believed that women should stay at home and wait for their husbands to come with arms full with food and that women should follow and worship their husbands to death. For example, women should stay at home and follow dumb and deaf the rites of widowhood when their husbands happen to die. In the olden day, it was honourable to see women die or accept to be buried alive with their departed husband like the practice of *suttee* or *sati* in the olden India⁴¹⁰. Many African communities practised the ritual before. A widow is definitely a woman who loses her husband or her partner through death. In our study, marriage is that customary union between a man and a woman that first purpose is to have children. A loss of a husband is a devastating and traumatic moment for a woman whether from South Africa, Senegal, Mali, Kenya or elsewhere. Then upon the man's death, the woman is expected to undergo some rites to prove her attachment to the deceased. Africans show their belief that departed relatives continue to live and show interest in the living. Then, families may show their belief by building shrines for the departed and placing bits of food or drink on their graves. These are act of respect for the departed that some communities in Africa amount to worshipping.

This is why foreigners wrongly called superstitious African religions. Superstition is a readiness to believe and fear something without proper grounds. In African religion, beliefs are based on deep superstitious beliefs and practices, but this is not the core or main part of their religion. This African heritage lasts since their forefathers' readiness to keep and perpetuate it. It is the product of the thinking and the experiences of these forefathers and mothers of former

⁴⁰⁹ Osei-Mensah, A. (1999) Women's Roles in the Mourning Rituals of the Akan of Ghana Author(s): Source: Ethnology, Vol. 38, No. 3, pp. 257-271 Published by: University of Pittsburgh- Of the Commonwealth System of Higher Education Stable URL: <http://www.jstor.org/stable/3773817>

⁴¹⁰ This is similar to that practised in the olden India where Hindu women to self-immolate to prove their eternal love to their departed husband. The practice is named sati or suttee, the burning to death of a widow on her husband's funeral pyre. Today, the practice is outlawed and illegal in India. Yet, it occurs up to the present day and is still regarded by some Hindus as the ultimate form of womanly devotion and sacrifice. <https://hashgar.com.au> the practice of sati.

generations going back thousands of years. All this is replete of symbolism and full of profound meaning. This profound meaning of all proves that a dead is not just a body without life, but more than that.

Customarily, no one disapproves of that because death is always shocking to those closely associated with the dead person and whether it comes after a long illness or it is sudden and violent, it is an awesome event, and a challenge to the emotional and spiritual understanding of every individual. Elderly women living alone with an aged husband may feel redundant once that husband dies and there is no longer a companion to care for. The shock continues when women are forced to undergo widowhood practices to prove that they are still in love with the departed, cannot stand their eternal depart or have nothing to do with their death. All communities try to make acceptable the enigma of death, less fearful, but women have to pay the absolute price. For all women, the death of a husband or a partner has an extra significance because it represents not simply the vanishing of a partner, a friend and a breadwinner but it also results into a radical change in a woman's social status and lifestyle. Since the role of literature is to depict people's reality by interfering characters, these social realities are used to demonstrate its connection to people. Literature is not positioned at a remove from society. It then has the power to change readers' ways of viewing the world by obliging their attention on cultures, norms and values.

As a result, many dreadful images are made around widowhood practices in Africa and unfortunately relayed by several scholars in their research topics. Ranging from the unpleasant treatments of widows, denial of basic hygiene, outlandish and costumes and dressing code before and after the interment to cite only these, widowhood rites have been blamed and rejected by a set of writers whereas others think that the rites mark a new beginning in the woman's life. Mariam Bâ (1981) describes this period as a dreadful moment for African women and points the patriarchal nature of many African communities as being responsible for the perpetuation of the practice. Oduyoye (1997) calls it extremely intense period which engages the life and the safety of the woman⁴¹¹. George Tasié corroborates this in his "African Widowhood Rites: A Bane or Boom for the African Woman" by quoting these different stances: "The rituals attached to this

⁴¹¹ Oduyoye, M. A. (1997). "Women and Ritual in Africa" in M. A. Oduyoye and M. R. A. Kanyoro (eds.) *The Will to Arise*. New York: Orbis Books.

transition have also been variously described as harmful (Chima: 2006), odious (Pius: 2007), as well as, inhumanity to the humanity of women”⁴¹².

As African women continue to undergo tremendous social ordeals, female writers provide with an appropriate response by identifying the plights and communicating with no retain. The indignation leads to writings such as those of Amma Darko whose stance about widowhood remains ambiguous though to us. In *Not Without Flowers*, Amma Darko writes, as usual, about women’s hardship in patriarchal communities. She gives way to imagination to describe her counterparts’ ordeals. As far as widowhood practice is concerned, Amma Darko makes it a compelling and a devastating one. The situation of agony often constitutes a crisis situation for the widow. For example, in the text, she presents a nameless female character who gets married with Pesewa who already has four wives in his mansion. In her situation, she knows that unless she engages in such a relationship with Pesewa, that she can one day be respected by the society. So as often, gossips rise all over the corners as “many often wondered why she chose to marry Pesewa. Many concluded she did it just for money. Only she knew the situation in which she had been. And only she knew that marrying Pesewa was the only option that she had” (Darko, 260). Because

In marrying Pesewa, she did become attached, albeit one of many wives but it still qualified her to take the title of wife; someone to whom a man is married. And it brought to an end that living hell of having to constantly deal with those unscrupulous men [...] Men who defined ‘single’ as synonymous with ‘lonely’ and thus ‘available’ [...] (Darko, 260).

As Ghanaian society urges young women to marry no matter how and no matter what, 5th Wife complies with this social rule so as not to be suspected as a prostitute. The second reason is that the pressure to produce children with a man as early as a year after the marriage will be reasonable, Pesewa having already a ‘running stream’ of children in his home. Amma Darko’s mentioning the circumstance in which the young girl in secondary school got pregnant, is to let the reader know the method by which 5th Wife’s pregnancy was removed to her misfortune. The removal was necessitated because of the condition in which it was growing: ‘an ectopic pregnancy’. Amma Darko shows that the abortion complicated in severe anaemia; so that it demanded the removal of her fallopian tubes, which represent the symbol of womanhood.

⁴¹² Tasie, G. (2013). “African Widowhood Rites: A Bane or Boom for the African Woman” in *International Journal of Humanities and Social Science*, Vol. 3 No. 1, pp. 155.

The mutilation of that female symbol is Amma Darko's attempt to transform her character into an insensible woman at the beginning of the chapter. She succeeds in making her a male-female character, a '*female eunuch*' to borrow the word from the Australian prominent and controversial female non-fiction writer Germaine Greer⁴¹³. The female author was critical both of the idea that emancipation can be achieved by women adopting male roles, thus physical transformation is the starting point. She did not believe in the possibility of women's self-determination within nuclear family. The choice of the group of words 'ectopic pregnancy' in collocation with women like 5th Wife dreams suggests that it is not her choice to let go of her dreams; the situation she meets in her marriage forces her to shake aside her dream. The remove of the tubes also represents the character's decision not to be subjugated and her rejection of being 'colonized' or possessed by the possible father of the future baby. If there is no womb, then no pregnancy can occur, and no baby will be expected. As a matter of fact, if there is no baby, there will be no father, implying no 'subaltern' relation between the mother (now 5th Wife) and the man.

It is significant for Amma Darko to create a female character totally free from any social engagement like Ama Ata Aidoo creates in her playwright Anowa a free woman. "Anowa does not have children, a literary position that we perceive as an assertion of female agency, an act of resistance in the form of a woman withholding her productive capabilities in a socio-economic context in which the fruit of the female womb is abused by unscrupulous males"⁴¹⁴. Though Amma Darko seems to minimize the loss of the baby, she knows that it is important that the 'to be 5th Wife' should not have an offspring before her marriage with Pesewa, the rich man, to carry her dream to the end. Early in the novel, 5th Wife is presented as a very intelligent woman by the Presenter of GMG, which is the time in Amma Darko's novel that she is portraying a character 'beautiful and intelligent'. The role is then carrying in purposely very significant. She

⁴¹³ Greer, G. (1970). MacGibbon and Kee: London. Although the word "eunuch" is defined as "a castrated male person," Greer claims that it is the woman who is castrated. Frigidity in women, unconnected with any frigidity or impotence in men, lies at the bottom of the joyless sexual relations between the sexes today. The book is a contribution to the continuing dialogue on the problems of women's liberation. Germaine Greer, the author, is from Australia, received her Ph. D. in Cambridge, and is now living and teaching in England. Her best-selling book has had an impact like that of Kate Millett's *Sexual Politics* - but there the comparison ends. Millett's indictment of patriarchal male supremacy and the glorification of sexual brutalities against women by famous male authors made her unpopular with male reviewers. <https://www.marxists.org/archive/reed-evelyn/1971/female-eunuch.htm>

⁴¹⁴ Horne, N. B. (2010). Sexual Impotence as Metonymy for Political Failure: Interrogating Hegemonic Masculinities in Ama Ata Aidoo's *Anowa*. In *Masculinity in African Literary and Cultural Texts*. (ed) Helen Nabasuta Mugambi & Tuzyline Jita Allan. Oxford: Ayebia Clarke Publishing Limited p. 178.

is credited with the modern knowledge so that the reader expects a change in her way of tackling social predicaments. Education here gives way to science and then to logic.

To see whether Amma Darko is right with her definition of ectopic pregnancy, questions like, what are the symptoms of ectopic pregnancy? How is an ectopic pregnancy treated? According to “Planned Parenthood”, there is a serious risk for a woman to carry on an ectopic pregnancy. It can result in serious complication like: “very early in pregnancy, ectopic pregnancies seem like normal pregnancies. A woman may have a missed period, breast tenderness, fatigue, and nausea”⁴¹⁵. And really ectopic pregnancy is treated either by surgery or by medicine. According to “Planned Parenthood”, “The medicine methotrexate can be used to end a tubal pregnancy. Surgery can remove the pregnancy. Sometimes it is necessary to remove the tube with the pregnancy. This is called a salpingectomy. The tube may be removed through an opening in the abdomen. This is called an open procedure. It can also be removed through a small incision near the navel, using a laparoscope”⁴¹⁶. The reference to this “ectopic pregnancy” is significant for the author of the novel wants to prove the burden on a woman’s shoulders as very heavy. As much as she is undermined when born in a patriarchal society, is at risk when she gets pregnant at an early age (teenage) which can result to an ectopic one or the pregnancy is conducted to term, the woman can bear a still borne. A Ghanaian woman is then surrounded by social, economic and cultural constraints totally against her emancipation.

In addition, Amma Darko disapproves of unprotected sex by teens in schools which she thinks is a consequence of moral decay of parents and society. Amma Darko seems to say that when teens recur to unsafe or unprotected sex, they can lose the sanity and the purity of their body. Then keeping it safe is normally what should be done with all teens. In another way, Amma Darko disapproves of the abortion that could result in complication like that of the young 5th Wife. Ghanaians are more content with the birth of a child than his education to adulthood and here the conscience rising is significant to Amma Darko. She teaches by experience in her texts. The literary realism of Amma Darko brings to limelight what is obtainable in many African homes. Further, Amma Darko’s representation of the rich Pesewa is to show the masochistic mind of some male characters. He thinks that female bodies are like mere ‘goods’ that one can buy in a market when one feels in need of them. He has money his approach of

⁴¹⁵ See more at: <https://www.plannedparenthood.org/learn/pregnancy/ectopic-pregnancy#sthash.UtQw7LfW>

⁴¹⁶ See more at: <https://www.plannedparenthood.org/learn/pregnancy/ectopic-pregnancy#sthash.UtQw7LfW.dpuf>.

getting married is totally uncommon. His radical method is that “if he wanted a woman, he simply made her his wife” (Darko, 57). These words indicate the extent to which Amma Darko’s writing is attentive to male dominance misdeeds while having money. This excerpt makes sense with Lazarus Miti’s idea that “A real African man deserved more than one wife. It was a sign of manhood and a measure of wealth”⁴¹⁷. Men like Pesewa regard polygamy as means to elevate their social status. Amma Darko’s egocentric character thinks that everything can be at his disposal as he has money. He can ‘buy’ his women anytime he is pleased. He has no limit to his selfish ambition.

When there is such a saying, a perception, then there is something wrong with that culture and that is when you want to change it. Unfortunately, the man died by committing suicide one night as he erroneously thought his 5th wife committed adultery and was infected by HIV/AIDS. A woman becomes widow when her husband dies, the circumstances in which he dies are not here important. It is from this point of death of the husband that a woman begins to go through the rituals associated with widowhood. However, there are a lot of similarities in the rituals undergone by widows. These practices, we define as sets of expectations as to actions and behaviour of the widow, action by others towards the widow, and rituals performed by, or on behalf of the widow from the time of the death of her husband. The social status of the man is significant. When he is an ordinary man, his “wife is expected to go into traumatic wailing immediately, to beat her chest, fling around her arms and go into falling down. Other women surround her immediately and restrain her and force her to sit down on the ground where they sit around her”⁴¹⁸. This ritual is widespread in many African societies. Later phases of these practices include issues of inheritance, the status of the widow, the remarriage of the widow and levirate relationships⁴¹⁹.

In *Not Without Flowers* as the title bears it so well and foreshadows later events, in no family obviously no important man can be buried without flowers. The title refers to the importance of flowers while burying a dear person regardless the circumstances. The title is very significant in that it gives a crisp summary of the novel’s content, as we have demonstrated earlier. It is for the very reason of ensuring a funeral with flowers which makes Ma’s children

⁴¹⁷ Miti, L. M. (1999). *The Prodigal Husband*. Cape Town: Kwela, p. 7.

⁴¹⁸ Amadiume, I. (1987). *Male Daughters, Female Husband's: Gender and Sex in an African Society*, London, Zed.

⁴¹⁹ Henderson, R. N. (1972). *The King in Every Man: Evolutionary Trends in Onitsha Igbo Society*. Yale University Press.

act the way they did. The explanation has been given by Kweku in his answer to Beam's question in a conversation:

"Yes. Cora started having a haunting, vivid recurring dream, in which Ma had died and had been buried. We held a funeral for her but her spirit remained restless, hovering the earth and shedding tears because of what we, her children had done."

"In Cora's dreams, we held a fine funeral for Ma, a funeral with flowers!"

"What?" Beam recovered instantly from his speechlessness.

"Yes. A fine funeral, with flowers at her bedside, flowers in church, wreaths on her grave."

"Yes. Flowers."

What is it with flowers? And in which part of this world is a funeral held without flowers?"

Be it a single white rose, a bunch of rich red roses, a carpet of bougainvilleas, a field of sunflowers, violets...whatever...our mother sets eyes on them, and she is sparked off.

How could we have a funeral without flowers for her when she died? (Darko, 35-6)

It is sometimes insane to think that a funeral can take place without flowers, yet it can happen. In Africa, death by suicide is as dishonourable as upsetting to the family and the relatives. Dead people in that way cannot be celebrated with flowers. Once more, Amma Darko uses a metaphor flowers symbol this time not to refer to flowers given to someone while in love but that which help to get to Pesewa's dishonourable death. In the narrative, after the death of Pesewa, the matter raised is the refusal by 5th Wife to undergo the practice of widowhood so as to be 'given' at the end to one of the deceased's brother to inherit her. The narrator tries to explain this status of thing by leading us to the foundation of the concept of marriage in such societies undertaken by their forefathers. First of all, marriage is

A union not just between the man and the woman entering into the union, but the two lineages to which they belong respectively. So a woman taken on a wife by a man, becomes a wife or one of many wives of the lineage to which the husband belongs. That does not imply that she can be shared and tossed about between the men of the lineage. Her husband is her caretaker for the lineage. And with him, she carries out the marital obligation of procreation. The children produced from the union, belong to the lineage. The physical death of her husband, does not sever her marital union with the lineage. His physical absence in the world, only calls for his replacement by another of the lineage. (Darko, 93)

In this vein, it is quite normal for a woman like 5th Wife to undergo such a practice and she does not object. While proceeding in the practice, questions like these are asked: “how are we sure she has no hand in the husband’s death by any means?” “Is she involved in any conjugal relationship?” “Is she planning to have more children?” “Will she return to her family after the period of mourning?” “How much is she entitled to from her late husband’s estate?”⁴²⁰ The lives of widows in Ghana and other African countries run through a number of unimaginable phases, but the reality is that many widows had nothing to do with their husbands’ death like the present case of 5th Wife. Many live without spouses for the rest of their lives, many of them are just victims, especially the older ones do not even think of having children after their husbands’ death rather, they are concerned with how to raise the children they already have and in most cases, many of these widows are left with little or nothing as inheritance. The nameless woman, 5th Wife’s fear lies in these untold implications hidden by her in-law. She thinks that “her sisters-in-law are looking for an opportunity to maltreat her. They never liked her from the start, for obvious reasons” (Darko, 63). The narrator further explains in these lines that:

5th Wife would gladly and willingly go through with the purification rite if only it is one that will ensure the solace and happiness of their late husband’s soul,” she began. “5th Wife is not coming out of hiding because she is convinced that the intentions of her sisters-in-law is to use the purification rite only as an excuse to maltreat her. She is aware of plans by her sisters-in-law to get one of her late husband’s brothers to sleep with her as part of the purification rite and by it, seal the ritual for a levirate union. (Darko, 190)

The above mentioned passages clarify the fear of the woman which leads her to hide herself. This is due to the fact that 5th Wife is “very educated” as repeated by Dina, one of MUTE active female workers. Firstly, as the youngest wife of Pesewa, 5th Wife knows that she is sexually ‘desired’ by her male in-laws and the moment is right to be trapped by the widowhood practices. Secondly, as an educated, she is aware that widows go through a lot of hardship that stems from the society, the husband’s family and from tradition. Amma Darko shows us how the plight of widows in Ghana and how gender and its attendant problems impede on the woman’s social standing and general development in society like that which impede Ma

⁴²⁰ Akujobi, R. (2006). “Yesterday you were divorced. Today I am a widow”: An Appraisal of widowhood practices and the effects on the psyche of widows in Africa. Ogun State University (Nigeria), p. 6.

Blackie in Buchi Emecheta's *The Bride Price* from going out and vacating in her trade. Mariama Ba's novel, *So Long a Letter* also points out how the African woman handles widowhood and how the African society perceives the widow.

In their main lines, the situation of female characters like Ramatoulaye Fall and Ma Blackie depict widows as silent victims, and pinpoint the gender inequalities they suffered as well as the oppressive structures that give rise to oppressive traditions. Ma Blackie is compelled to nine months of confinement with a firm banning to change her black rag clothes. She was not allowed to bath nor sleep on her mat but on the bare floor. Mariama Bâ brings to light the situation of women in a Muslim society, the religious tenets and social conventions which serve to keep women subject and silent. The widow's attempt to contest her condition is met with rigid resistance. In conclusion, widowhood throughout is "a period of hardship and deprivation as it includes varying degrees of physical seclusion for ritual purification"⁴²¹. Thus, for fear of facing a possible female uprising that could overthrow patriarchal power, men erected cultural and social constraints. At the end of the exclusion begins the practice of woman inheritance which is also a very tough condition. The story of *So Long a Letter*, revolves around Ramatoulaye Fall, a widow with twelve children who writes a letter to her friend Aissatou in which she narrates major events in her life. Her husband Modou, died of a heart attack four years after he marries a second wife Mariama Bâ and Buchi Emecheta maintain that there is a real need to revisit some of our customary practices in African tradition towards women. Rama and Amaka are women who express their self-freedom and self-assertion in their respective society. They represent the model in the eyes of the female writers. It is incumbent on all the female folk to rise up against the ignominious act whereby women are down grading themselves to reclaim their right to be free in their own choice, their own style of life. As long as a man has the right to choose a new woman after the death of the first, so does a woman. A woman needs to be courted and seduced, but not to be inherited with the intention to frustrate her.

In the same light, Amma Darko makes 5th Wife speak out her fears by opposing to the merciless and callous face of widowhood. She advocates its total elimination from Ghanaian societies. As indicated, Amma Darko points out that its elimination is posterior to its tracking

⁴²¹ Potash, B. (1986). *Widows in African Societies: Choices and Constraints*, California, Stanford University Press.

down by “no less an institution as the media to render the perpetrators “more conscious of their actions” (Darko, op. cit. 65). This particular concern is also portrayed in Ifeoma Okoye’s *The Trial and Other Stories* (2005). The author gives the reasons why Igbo women fear this moment when the widowhood practices are set up against their life and their right as human beings. In the short story, Ifeoma Okoye denounces the burdened practices in widowhood. She names the practice as a daily humiliation towards the female protagonist Anayo wrongly accused to have poisoned her husband Zinuzo: “As Anayo stepped in the Obi, the women’s eyes hit her like a thousand arrows” (Okoye, 44). At the end of the Obi (a traditional women’s gathering), the protagonist is condemned to submit to the practice. Like 5th Wife does, Anayo holds the ground and refuses to submit to the trial of getting her deceased husband’s fingers in a glass of water and then let her drink it whole before the assembly. Surprisingly, “not one woman spoke for her” (Okoye, 48) when she stood, waiting for the educated amongst the group to support her. According to Sunday Anozie, widowhood engenders many degrading practices towards Igbo women:

Le veuvage est un état d’une importance capital dans l’éthique socio-traditionnelle des Ibos. Placée dans cette situation par un décret absolu, la femme ne peut que se rendre compte des nouvelles limites de son comportement éthique et de conduite sociale. Bien que conservant le droit de se remarier, mariage qui comportera bien entendu beaucoup plus de retenue dans les cérémonies et moins de dépenses que le premier, la veuve est soumise à la contrainte d’interdits et, surtout pendant les deux premières années de deuil, sa vie subit un véritable effacement social. Toute sa réputation individuelle dans sa communauté villageoise en dépend autant que de son intégration continue dans la protection du groupe, à son tour, attend d’elle un conformisme presque idéal à l’éthique traditionnelle.⁴²²

In fact, we notice that traditional practices are meant to restore African dignity and cultural pride, but around it stand many abuses and deviations. Women are encouraged not to be bold and assertive and not to dare to question in marriage when they have to and to have initiative to build. The point raised by Amma Darko is that a widow should have the privilege to decide for her freedom and liberty. Tradition should not decide for widows, already lamenting for the departed husbands. Ifeoma Okoye and Amma Darko want women to have a revolution in their consciousness to affect mainstream thinking around themselves and their country. They should equally take tangible steps to show their dissatisfaction and stand against any practice

⁴²² Anozie, S. O. (1970). *Sociologie du roman africain*. Paris: Editions Aubier-Montaigne.

that degrade them. The question of media is raised here by Amma Darko to show its social help to people especially to the women. Apart from being a political action, working with the media is an activism. The African women know the importance of this to move things forward in society. In this scope, we do not want to cite again the place taken by women during African revolution from Algeria to Sudan, from Ghana to Zimbabwe and South Africa. They knew how men needed them and they did not hesitate to join their brave hands. Many male and female narratives relate their forever known activism⁴²³. The emerging female counter-power induces implicitly the redistribution of the political geography. Women become force to reckon as their militancy influences more and more other women and comfort women like Daba in Cheick Hamidou Kane's *Les Gardiens du temple* (1996) to move forward.

Hegemony, subjugation and subservience are all factors of patriarchy. Predominance and control of one group over another in order to conquer, control, make submissive and less important. We conclude by stating that women in Ghana and other African countries face endless physical and psychological sufferings that inhibit their lifestyle and decision-making. Amma Darko's focus upon human sentiments and her focus upon women dehumanization are related. What is universal in her fiction is intimately related to her humanizing of the local. Readers will find matters of weight engrained in the detail of Amma Darko's work, reflections on art, history, experience, psychology, emotion, sex, power, and politics. Like her counterpart Ama Ata Aidoo, Amma Darko combines these issues so well, or communicates them so intelligently and elegantly. She gives way to her imagination and writes about what should be normal in childless homes in Ghana and accepts a childless home to be polygamous to fill all the present women with joy and happiness. However, she condemns polygamy which involved in multiple sex partners which is at the origin of the spread of HIV/AIDS and other sexually transmitted diseases. Amma Darko encourages therefore fidelity in marriage whether polygamous or monogamous.

10. Polygamy and Unfaithfulness in *Not Without Flowers*

The present chapter discusses two social issues prevailing in all earthly communities. Polygamy or polygyny works in pair with unfaithfulness. Polygamy is then the result of unfaithfulness in a monogamous marriage. Both become sometime cultural because younger

⁴²³ Lopez, H. (1997). *Le Lys et le Flamboyant*. Paris : Le Seuil, p.346; Doumbi F. (1984). *La Retraite anticipée du Guide Suprême*. Paris: L'Harmattan, p. 26-27.

generations continue the practice. A kind of sexual identity is even built through polygamy and unfaithfulness. Hence, while the Bible is silent about the issue, the Holy Qur'an verses on polygamy are included among the 176 verses that comprise this surah that distinctly addresses the subject of women: "[...] marry women of your choice, two or three or four; but if you fear that you shall not be able to deal justly with them, then only one" (Qur'an 4: 3). With this passage, Islam has settled the issue. Men in Islamic community can get married up to four wives, if some important conditions are met. It seems that Islam does not impose nor restrict to men the fact of having as many wives as possible, but avoid men to be in relationship with a woman or a concubine irrespective to the law.

Knowing that men are more likely to be led by the desire of having much pleasure and lust, it is important to limit all that. Hence, despite the appearance of polygamy and unfaithfulness to be male-related issues and then rejected by women, both have well been developed and preferred and occasionally accepted by women for a long time. Some women's propensity of being in polygamous unions is high, especially when like, second and 5th wives, they want to hide outside lovers and treachery or unfruitful status. These two have a very long history of destruction of households. The stress Amma Darko makes on the number (second, third, fourth, 5th) of Pesewa's wives is her implicit approach to demonstrate her disapproval of polygamy in society. It makes two to call on oneself problems like those of Pesewa. Amma Darko does not even attempt to give a name to the wives after the first of Pesewa. As a valued and cherished system, both social plights resist the strong and economic idea of monogamy, though imported. Amma Darko seems to write in the novel under scrutiny that monogamy is good for urban areas and that faithfulness can be found in polygamy. To the later, Amma Darko gives us the example of Ntifer's household where he only gets the second wife, Mena Kakraba, to help fill his home of children as his first wife, Mena Penyin, could not bear a child. As a mother, Mena Kakraba makes Ntifer a proud father then. For the second example, Amma Darko shows how an educated woman like 5th Wife accepts to live in polygamous situation with Pesewa. 5th Wife then imposes her way in the polygamous household.

On the other hand, educated men can also be driven by cheap sex to have many female sexual partners. In this way, some young and good-looking girls are ready to commercialize their body like cash madam in search for contracts. Yet, what is worth to highlight is the uniqueness of this chapter because we cannot disconnect polygamy from unfaithfulness and vice

versa. So when sex and attention come to lack in a couple, they can lead to unfaithfulness or adultery. The case of Pesewa's 2nd wife is evocative. Adultery is another widespread socio-related issue. Before becoming polygamous, a man must be unfaithful to his first marital situation and Amma Darko explicitly disapproves of that social plight. In her work, Amma Darko spares no detail to condemn it by interposing characters to make her message a fiction. Consequently, the chapter focuses on the depiction of the plight in the writings of Amma Darko because various sociological studies have shown that men, more than women are often the recipients of that. But this ingeniously has been foregrounded in the literary sphere and this is what the present research sets out to find in the works of Amma Darko.

10.1. African Polygamy depicted in *Not Without Flowers*

According to *The Chambers Dictionary*, 'poly' means several, many and 'gamy' stands for marriage. So polygamy is defined as "the rule, custom, or condition of marriage to more than one person at a time, or (now rarely) in life; sometimes used for polygyny, mating with more than one in the same breeding season; occurrence of male, female"⁴²⁴. Then polygyny is defined as "the state or the practice of having more than one wife or female mate at a time"⁴²⁵. Despite the fact that the number of wives is emphasised with the term polygyny, we choose polygamy because it seems to be more in use and more familiar to most readers. So plural marriage has been practiced for much part of history in many parts of the world. While it is said that two or three wives with one husband, they could develop strong sisterly love it is in fact frequent quarrels that spring off every day. Strong rivalry, jealousy and hatred lead to recurrent clashes verbal commotion the day long and then to fights. In several sub-Saharan countries, more than 10% of married women are in a polygamous union (Tertilt: 2005). It is not only a type of marriage; it is a value system.

Polygamy has long time been practiced because it has coexisted with the primitive system of agriculture in which women tackle most of the farm tasks. Primarily when a young man got married, he cleared a new farm and later her children to grow. It was in that scope that men were really motivated to have many wives and children because all these armadas would serve as cheap labour on the field. For example, in Chinua Achebe's *Things Fall Apart* (1958),

⁴²⁴ The Chambers Dictionary, edited by Chambers Harrap Publishers Ltd, Edimburg, EH7 4AZ, 1993

⁴²⁵ <https://www.merriam-webster.com/dictionary/polygyny>

Nwakibie is renowned because he has three big barns of yams, nine wives and thirty children and a honourable title in society. He is the opposite of Unuka Agbala, the lazy. Further, Okonkwo, the warrior is respected by his dearest Umuofia because of his hardworking temper. He can afford all these women because he is strong (Achebe, 21). Hard work then can earn people a return like having the right of getting many wives in one's household like in Elechi Amadi's *The Concubine*. However, no matter how advantageous polygyny could be, its inconveniences are many. For example, it has been pointed as being the "cause of Africa's low savings rates (Tertilt, 2005), high incidence of HIV (Brahmbhatt *et al.*, 2002), high levels child mortality (Strassmann), and of female depression (Adewuya *et al.*, 2007).⁴²⁶

Hitherto, before we go further in the development of this subchapter, it is vital to recall the utmost meaning of marriage in African setting because polygamy does not occur in a vacuum. Polygamy takes its source and resource from cultural practices and gender inequalities occurring in the community. Like diseases related to malnutrition are linked with poverty, polygamy uses the fertile ground of marriage to amplify its woeful consequences. As marriage is defined as union primarily between two families, two communities and secondarily between a man and one or many women, no one stops a man from taking as many as possible to fill up his household. In African setting, two things are worth to highlight in a marriage: the blessed union by both families and the woman to conceive the future generation.

This subchapter, by means of close analyses of some selected passages, reveals that, despite all the struggles for liberation and assertion for women, values highly regarded in modern societies, polygamy is a prevailing sign of male dominance today and Ghana is not afar. Amma Darko's *Not Without Flowers* (2007) revolves around the story of three generations of women: Aggie, Ma, and Pesewa's wives. Amma Darko proposes in the novel that monogamy is not such a bed of roses that is the reason why she creates a female character who refuses to be in a monogamous situation because Amma Darko thinks that it is a subordination position. This is exemplified in *One is Enough* (1981) when Amaka refuses the church father's proposal to marry her. She expresses herself in unequivocal terms as she declares:

⁴²⁶ Fenske, J. (2011). African polygamy: past and present in LSR Research online, p. 1

I don't want to be a wife [...] a mistress, yes with a lover, yes of course, but not a wife. There is something in that word that does not suit me. As a wife, I am never free. I am a shadow of myself. As a wife, I am almost impotent. I am in prison, unable to advance in body or soul. Something gets hold of me as a wife and destroys me. (Nwapa: 1981: 132)

Here the meaning and the inner resolve of the character can be seen in the repetition of the word 'wife' that we highlight in italics. Amaka refuses to go back to subordination and voicelessness. She chooses to be wild and dangerous, and her ultimate choice proves it. Amaka chooses to be a mistress because a wife is a victim of circumstances and what she is demonstrating is a reaction to the oppressive life of wife. Her experience shows that being a wife is to lose one's freedom and autonomy. In the same light and desire to have a character like that of Nwapa, Amma Darko subverts the attack on monogamy by presenting a new type of protagonist. The image Amma Darko wants to show of 5th Wife is that of a free, young and progressive woman who are out to recreate new life of her own. She is persuasive and determined to achieve what she sets her eyes on. Education is important in women's lives because it empowers them. Ramatoulaye, Aissatou, Amaka and 5th Wife are created educated woman so she is persuasive and determined. 5th Wife in her turn makes a rather calculated and rational choice by accepting a polygamous family because of her early loss of fallopian tubes due to an ectopic pregnancy in secondary school. She gets married to the rich Pesewa who has already four wives. A similar decision is made by the female narrator in Lola Sholaneyin's *The Secret Life of Baba Segi's Wives* (2010). The protagonist, Bolande, despite her university graduation, accepts to become the fourth wife of Baba Segi, a rather successful Nigerian businessman who sells construction material. But this comfortable life of hers comes to an end when her secret is discovered by Iya Segi. As we can see, Lola Shoneyin's discloses the women's morality in a polygamous household. The affront to moral standard demonstrated by individuals, as seen in *The Secret Lives of Baba Segi's Wives*, is unacceptable because it is an affront to the ideological conscience of the Yoruba state. As we empathise with the individual characters in the text, we should be guided by our commitment to social order which is necessary for a balanced state.

Then, coming back to Amma Darko's writing, Pesewa as a noun lies for the name given to a Ghanaian cents coin and then by calling a male character 'Pesewa', it implies that the character is rich or full of money. The character Pesewa valuably represents the name given to

him. He thinks that money can purchase everything around and he feels happy to have “They were all taboo to Pesewa; lovers, girlfriends, chicken-soups, concubines. If he wanted a woman, he simply made her his wife.” (Darko, 57) Pesewa has then no time for the syndrome of chicken-soup or concubines (Darko, 65). He usually takes what he desires no matter what and how it costs. Amma Darko draws our attention to the way Pesewa dives in women collection like a rich collects car, jewelleryes and other important belongings in his cupboard. He establishes his fame upon his capacity to get women to fill his household.

In fact, Pesewa’s patriarchal heritage and traditional mentality forge him not to feel any remorse while behaving like a macho and egocentric with female gender. He does not communicate with his wives to announce the arrival of a new wife because he thinks they do not exist as human beings, but objects with vaginas, where to plug for his self-centred sexual enjoyments. That is what proves that he is a man, a real man in force and society does give him all the power to do so. He is seen as the archetype of a common Ghanaian living in the city with a certain purchase power. Pesewa represents the model of marginalization and objectification perpetrator in society despite his chilly appearance. Marginalization is the social process of being relegated to the fringe of society. Just like Pa, Pesewa is presented as a character whose life is ruled by an overriding passion to become successful and powerful by the number of wives he possesses. His obsession with proving and preserving his manliness dominates his entire life.

Further, to balance and even to overthrow that male power, the author creates 5th Wife. By chance 5th Wife, an educated young woman, is with a husband rather twice older than her, but with whom she is emotionally and romantically involved. Amma Darko draws the reader’s attention to the fact that in a union, the important parameter is the positive mind of the woman. Here, 5th wife seems to be happy and contented with her polygamous husband. The case of 5th wife and Pesewa is not a sugar-daddy and a young girl, but a case of real polygamy with a unique household for every woman apart from the 5th Wife, the youngest.

It is worth reminding the readers that polygamy prevails in Africa as a cultural value until the 19th century when European missionaries set foot in the continent, the Bible in their hand to see as sinful all this way of life. They argued that communion takers could not act in such a sinful and unpleasant way. Therefore, having more than a wife is not accepted by the God of White men and by implication, any new born, in search for heavenly made blessings has

to depart himself from earthly made richness and pleasures. Missionaries at the time emphasized the dangers like going in hell, losing God's spiritual advice and presence that Christians may be sentenced to if they still practiced their degrading culture. In that way, polygamy is forbidden to Christians then, apart from some Hebrew patriarchs such as Abraham (three wives⁴²⁷), Moses (Two wives⁴²⁸), Jacob (four⁴²⁹), David (eighteen⁴³⁰) and Solomon (seven hundred⁴³¹) to whom God Himself allowed more than one wife according to the Bible. As we have said earlier, people get married with many wives in prevision of their farm's flowering for the number of hands in need.

The present subchapter offers a critical reading of *Not Without Flowers* (2007) and observes that Amma Darko develops many growing social issues by seeking to challenge prevailing and traditional views of motherhood, patriarchy and female subjugation. Amma Darko writes about social sticky situations among which the phenomenon of sugar-daddies or sugar-mummies. Amma Darko condemns this phenomenon and urges for a critical analysis of a concept of new motherhood. In considering the painful realities of African women, Amma Darko gives ways to her feminist sentiments as she projects her ideological stance as female sex being the most unfortunate victim in postcolonial crises.

In *Not Without Flowers*, just like interest, sex leads life of those who fall in its dangerous and endless network. Sex can get people killed, bankrupted, put in jail, personally ruined to rephrase Edna Buchanan's saying (Darko, 20). On the top of it all, it enslaves the older man and consumes his consciousness to madness. The older man has no eyes for anyone except his chicken-soup. All that she asks is given to her to the deepest fancies. The older man is ready to treat the university girl like a queen and craves her with emotional security and abundance. Amma Darko also demonstrates that when sex comes to lack in a couple, it leads to its dislocation especially in a household of several wives. As far as polygamy is concerned, it is good whenever it serves a noble cause like filling the gap of childlessness. The emphasis of Amma Darko lies here with Ntifor's wives: "Yes. You were a young girl and you knew he made you his second wife for the sake of procreation" (Darko, 159).

⁴²⁷ Holy Bible International, Genesis 16: 1 ; 16 : 3

⁴²⁸ Exodus 2 : 21 ; 18 : 1-6

⁴²⁹ Genesis 29 : 23

⁴³⁰ 1 Samuel 18: 27; 25: 39-44

⁴³¹ 1 Kings 11: 3

In Ghana as well as other African countries, procreation is the most common expectation governing marriage. A woman's ability to secure her marriage lies in her capability to give birth as if procreation were a woman's obligation to its deepest essence. Yet, to borrow from science of reproduction, we know that it makes two of different sexes to have human offspring. Even though, polygamy can serve for procreation like with Agya Ntifor and his two wives, it is worth mentioning that envy and fear are not too far. Mena Kakraba's value in Agya Ntifor's house lies on her childbearing abilities, yet both women fear the intrusion of Teacher who is in fact Cora, Bible in hand for a pseudo research. Kakraba confesses her tight spot any time Teacher is alone with their husband in his room, "It's the woman. That teacher from the city who claims to be doing some research work with him. She was here again. She came when you had gone to the market for the dry plantain leaves for your Fanti kenkey business" (Darko, 151). Whenever Teacher comes in Agya Ntifor's house, Penyin and Kakraba are troubled and anxious because of the dating possibilities. They all are mindful that the more regular a woman meets a man for causeries and shared interests, the more they get together and close. And this togetherness can engender sympathy and then love or more or less affection to each other. The quotation proves it well: "What if the strange teacher actually becomes our rival? If she proves capable of bearing children with our husband and goes ahead to do just that, have you thought of the implication?" (Darko, 151). The capacity of childbearing comes back again to demonstrate that women are conscious of the first-hand and significant role that society assigns them.

In a heterogeneous society, the sugar daddy phenomenon is considered as polygamy as far as its aspect of multiple partners concerned. This is one the worst social realities with regard to family life that negatively affects most African women in their being yoked forever to difficulties. The growing quandary of sugar daddy or sugar mummy is to be addressed by all means because it is one of the first root-causes to the pandemic HIV. Amma Darko also paints the picture of the way HIV positives should be viewed by society, not like pariahs but part and parcel of the society building. Amma Darko seems to say that no one is protected against the dreaded infection, if someone outdoor is still at risk.

The special touch of Amma Darko lies in the fact that she presents the situation of polygamy as not being bad, but full with happiness and relaxation for the woman in the first hand. On the other hand, she presents a generational sexual relation between men and women in her text to point out the social reality prevailing in modern Ghana in a changing cultural context.

Men and women accept to change sexual pleasures to have money and other privileges. Men and women flirt into a sexual relationship totally denuded of love and self-respect. The relationships are characterized by large age and economic asymmetries between partners and which ended in unsafe sexual behaviour, main factor in the spread of HIV. The equation is very simple: a young and attractive secondary or university girl signs up for sugar dating with an older and well-off man in which he provides gifts and money and a young man does it with an older woman in need of good and strong sex. The bolt from the blue in the case is that the young girl knows that the man is married but flirts for a sex-money relationship, not for love. Amma Darko calls the phenomenon not prostitution but sugar-daddy or sugar mummy syndrome. By its nature, polygamy promotes multiple sexual partners. In Sue Nyathi's recent novel *The Polygamist* (2012) Jonasi, the husband of Joyce and Matipa, has Essie, his childhood love, as his mistress. Nevertheless, having these women in his life does not prevent him from sleeping with other women and again, the bond that a couple should have is weakened and because of the number some remain unsatisfied by the only one husband.

In this scope, the chicken-soup “fulfils for him those sexual fantasies and desires that probably appal his ‘ringed’ better half at home. In return for which he also provides her with the financial security she craves for: a win-win situation” (Darko, 79). In that so called partnership, “the sugar daddy adds to that energy with the time and attention he showers on with his lack of love and attention and empathy for her, further depleting whatever little reserve the wife may have had” (Darko, 80). It is also called in its light shape concubinage. It is a parasite system that drains the maximum finances from the engaged and then exposes him at a risk of HIV and sexual transmitted diseases. Amma Darko gives further description of the recurrent tasks assured by the engaged sugar daddy:

Cuddling; the sugar daddies pamper their chicken-soups and spoil them, and who doesn't want to pampered and spoiled? They don't only shower them with cash and presents, but with lots of attention too. Sex is a strong emotionally addictive enticement. (Darko, 79)

In the novel under study, the sex-for-money engagement ruins completely Pa, leaving him with a huge debt and a desire to commit suicide. This extramarital relation of Pa with Aggie renders Ma (Pa's wife) mentally sick because of Pa's permanent absence and neglect. “Ma was crying because Pa was not sleeping beside her on the bed” (Darko, 120). Randa decides to

avenge the whole by befriending Idan, Aggie's husband. From this position, she takes the total possession of Idan and the complete neglect of Aggie by Idan. Our subchapter on Randa and her sister will give more detail about their attitude and psychological stance in the novel. Hence, we need to that this syndrome of concubinage has a bitter reverse on Aggie because she bears no child to her husband Idan. We know how revered is a child in African motherhood and the importance revolves this. Moreover, Randa is HIV positive, a disease she carries through her relationship with Dam, her fiancé. She generously spreads first to Idan and subsequently to Aggie. Amma Darko proves through these lines her feminist stance about the male pathology of many female sexual partners having. She warns all the Ghanaian and African society that the retribution for all this is twofold; either the man falls sick with HIV and commits suicide or is completely ruined. Yet, in this representation, men are shown as a threat to women's health and welfare. That is the reason why the emphasis of Edna Buchanan (Darko, 20) in the beginning of the novel has all its sense as the caution message to those want to try it.

Further, the scapegoat of all the mess is well indicated in the text: Agnes. For Ma, Aggie is the cause of Ma's aversion and severe paranoia for flowers as Aggie loves being called Flower by Pa. The hatred is so harsh and general that all that grows in her garden must be cut off to obey her interior voice. The passage gives us much insightful idea on the prevailing loathe:

Following the orders that the voice was issuing inside her head, Ma surveyed the compound, taking in all the varied and beautiful flowers that were in plentiful bloom. (...) Ma Froze. She stared at the purple lily in her hand, severed from its stem. Blood. Where was the blood? The blood must be somewhere, Ma panicked. She couldn't trace the blood. She whirled around. No blood. She sniffed into the air, searching for a scent of the blood. No scent. She began to tremble. She had failed. The voice had ordered for blood. Where was the blood?

Whoosh! Whack! Whoosh! Whack! Blood! (Darko, 169-70)

Then the first punishment issued on Aggie's head for having been the main cause of Pa's financial, physical and mental annihilation begins during her wedding day. So Ma like a maharishi⁴³², forecasts a curse that it will rain on that very day because she (Ma) sheds hot tears during the time of Pa and Aggie relationship. Marital bed being sanctuary, grubby and polluted sexual encounter must not be played on. Ma wishes with all herself that the exploiter of her

⁴³² It means spiritual leader in India and Pakistan regions.

husband must endorse all the responsibility of her act. The role of wife should normally be difficult to play, irrespectively Ma tries and even succeeds so artistically. She prays for her husband everyday they meet but with no word to share. She tries to bring him back to reason by crying desperately. On the contrary, in Mariama Bâ's *So Long a Letter*, Rama does not know that her her Modou's desire to have a second wife. The news of her husband's taking on another wife takes her by surprise. This information erases in a second twenty five years of happy marriage. Rama is traumatized by this betrayal of her husband who, while alive, has many secrets to hide. All these revealed secrets injure psychologically the poor Rama. She is so desperate that when she meets Daouda Dieng, she turns off his proposal of marriage. After days of careful consideration, Rama concludes that she respects and admires Daouda, she doesn't love him. She writes a letter of explanation, telling Daouda that she also feels uncomfortable coming between him and her first wife, a pain she knows firsthand. Like Flora Nwapa's *One is Enough*, Mariama Bâ's *So Long a Letter* grapples with changing social climates and the important roles women take in them.

In *Not Without Flowers*, it is important to state here that the author's position is quite different from the other female feminists. Taking differently each female character bears a special mark from the author. This is the reason Amma Darko leads Aggie into polygamy to liberate all the vengeful spirits to clash with Aggie's destiny. The attack is launched in an enclosed envelope out of which flipped through NEMESIS, the Greek word for retribution, punishment. Aggie should reap what she takes years to sow. Like a boomerang effect, Aggie should suffer to the same extent to which she made Ma suffer. Amma Darko appropriates a biblical passage which states: "For with whatever judgment you judge, you will be judged; and with whatever measure you measure, it will be measured to you"⁴³³. To appreciate how much this is a statement of positive or negative income from an action, we have to keep step with Aggie as she traverses Amma Darko's forged story of polygamy, as gender issue in a post-independent Ghana. Born at the very year of Ghanaian independence, she witnesses all the ups and downs of her dear country and the growing gender outbreak inequalities and all subsequent related events in her personal life.

In her narrative, Amma Darko sheds light to the inner causes that fertilize men's desire to look for other sexual fantasies while still living in couple. In fact, at a time of their life, some

⁴³³ Holy Bible International, Mathew 7 : 2-3.

women think that sex is no more the essence of marriage, so much so that they stop putting spices in their relationship and craving for sex with their husband. Amma Darko shows that it is a big mistake from women. Ma's devotion to romance wanes and blazes off while at the same time, Pa is in need of fantasies and new patterns. The following passage is a dramatization of Pa's desire for a sex-life laced with assortment and not the ordinariness. Pa confesses:

When she gets into bed with me, all she wants to do is to go to sleep," he complained to his friend. "And on the rare occasion that she gives in to me, she leaves me feeling like the whole activity was just another household chore. It is becoming too frustrating and difficult to bear.

Pa's frustration gradually developed into a tension that was waiting to erupt. Everyone lusts in the heart one time or the other. Some suppress and keep it in check. Initially, just occasionally. Then gradually it gathered momentum. Eventually it became a pre-occupation. The absence of nurturing and intimacy began to eat him up. He began to fantasize about sex with another woman and felt guilty about it. (Darko, op. cit. 328)

On the one hand, Amma Darko warns wives who take for granted their outlook on sexual life once they begin to make babies and ageing. They must wake up and avoid routine in bed because enemies are outside waiting for a mistake. The awaited can come from the women. For example, Ma being more interested in her business of shop and her last born than the nightly sexual demand of Pa. "She lost energy for everyone else" (Darko, 327). On the other hand, Pa frequent temptation grows bigger and bigger because his wife fails to perceive the signs of his desire to be sexually nurtured and cared for not knowing that his wife seems to understand quicker and easier the burden of ageing. It takes a long time for Pa to understand that her is no more look attractive and good-looking, and cannot respond to his urging sexual desires.

The extract reveals the inner mind of a man of an age who does not know that while ageing, the libido in man and woman declines, so that the former volcanic fires in both of them wane completely to a small flame. This does not mean that one of the partners should go and check for it outside the marital bed. What begins like a volcanic heat at its hottest eruption must cool itself by the side of the mountain. So, Pa has not to look for romance with other woman, but tries to explain his burning desires to Ma for conciliation for Ma's failure to play the naughty girl in her sexual intercourses is not her fault. Ma fails to play a silly girl role in her own bed because of the society that teaches no woman about what awaits her in a marital

situation. The situation worsens because of the lack of communication between the two. A husband and a wife in bed must feel free to discuss, and each of them receive adequate sympathy and understanding of a husband's frustration or a wife's will not to be disturbed. In the case of Ma, she starts praying and then realizes that all the interest of her husband toward her has been devoured by Aggie's presence.

The pain to see her husband with another woman transforms. Ma is reluctant to challenge Pa physically; as a result, she whacks flowers off as if she were in a real battle against Aggie. She loses all the control of her mind and mood any time she seems in virtual confrontation with her rival. This worsens her mental status. In this case, polygamy is depicted as a scope of exploitation. The women who choose to be in polygamy are only junior wives (respectively 2nd, 3rd, 4th and 5th Wives) who purposely involve themselves in these relationships at the expense of the joy and security of senior wives (1st wife and Ma), who never seem to choose polygamy marriage as what is good for them. Polygamy is forced upon them, often secretly, and they suffer severely when they find it out. For example, the first wife of Pesewa was not informed that Pesewa would take on the second, the third, the fourth and the fifth wives in their home. Then when it happened she felt furious, betrayed and confused, but not like the first wife of Baba Segi in Lola Shoneyin's *The Secret Lives of Baba Segi's Wives* (2010). Craving to get back her favourite place in Baba Segi's house, she does not stop at nothing to protect that position. This position of Lola Shoneyin and Amma Darko seems not to be that of Mariama Ba. The late Senegalese female writer denounces polygamy, yet she does not make way to jealousy at that extent in the novel, *So Long a Letter* (1981) since these novels are written in different era. Today, women have relatively opportunities to have their decision reckoned in their household, although we can shout victory at this step of the struggle.

Further, talking about women's deception before polygamy, we see how the entry of the third and the fourth wives takes the second wife by surprise. The third is also surprised when the fourth and the fifth come in. Like most junior wives on the verge of acquiring seniority, the bitterness of their own medicine is unbearable, yet they should drink the cup of neglect and abandon. Junior wives thus seem to possess the advantage of choosing to be in polygamous relationships, while senior must recognize the powerlessness of their position. Ma and the wives of Pesewa are powerless to stop Aggie and the 5th wife to come and share their intimate

property. The realist African novel focuses in detail on people's experiences and thus uncovers the emotional dynamics of typically real situations.

Amma Darko finally demonstrates symbolically that by abandoning himself to the inside fire, Pa destroys himself, his job and his household because fire consumes, destroys, and devastates all around itself. The headline is written this way: "The implication! Loss of job! Destruction of his family! Eternal humiliation!" (Darko, 332) Pa's situation with the young and attractive Aggie turns to obsession and madness when his mind fills up with flowers, yellow flowers. It is "an unending expanse of yellowness, like her skirt. Pleasing. Like her. She was brightness. She was a sunflower and more. A rose" (Darko, 333). Aggie symbolizes the uniqueness, purity, love, beauty, and all the characteristics of the *femme fatale* portrayed as being a woman that entices men into perilous and compromising by way of charisma and mystery. Female characters like that have been used in many novels not only in Africa, but only the West. Aggie's involvement from mild flirtation to passionate and regular sex defines our position. She leads her lover to compromising and dangerous situations. Aggie is beautiful and captivating yet capable of the most abysmal wreckage. In the end, Pa notices to his loss that Aggie has neither been a sunflower nor a yellow rose, but a sentimentally poisonous mushroom on his way for life and lust. She is the forbidden *Santrofi* bird Ghanaians never like to take at home. Amma Darko does not introduce this female character in the narrative to add more sex appeal and a motivating factor to men, but to denounce the roles taken by some women at times. Nonetheless, the portrayal lies within a patriarchal system of objectification and female disempowerment. But, when applied to Amma Darko's feminist approach, we do not think that the author wants to belittle one of her female characters. Instead, Amma Darko demonstrates through Aggie that women can dominate men. Aggie is the key of all Pa's sexual drive and failure that threatens the very core of manliness. Then, when it becomes unbearable, she tries successfully to liberate herself from her role. She becomes a domineering character, nasty and unkind.

In *Not Without Flowers* (2007), Amma Darko uses many instances to portray Africa's decaying mores. Amma Darko gives way to her imagination to prove by her feminist voice the approach to deal with contemporary plight of sugar-daddy and sugar-mummy in Ghana and, by extension, in Africa. She uses common experiences of common Ghanaians' daily life to prove her position. Amma Darko's ability to render the realistic in her characters is to create real life

scenes. People like Pa and Ma fill up Ghanaian cities every day and night either to satisfy their blazing libido or to be hooked with and really get mixed up fast. The syndrome of sugar-daddy and sugar-mummy is a social issue which causes lie on poverty, scramble for sexual fantasies and money-guided love affairs. This is especially remarkable, because African women live within a dominant male culture that oppresses and devalues them. Undoubtedly, the African woman does experience these oppressions in various forms and in various spheres of life. Moreover, continued male dominance and sexism is legitimized only to the extent that people refuse to dismantle such oppressive constructs in our current conceptualizations of identity having accepted at the beginning of the dissertation that culture is alterable.

In Amma Darko's narrative, Aggie is presented as exploiting the exploiter and in return Randa exploiting Idan. The complex nature of the plot is seen as reflecting the lives of the female characters in the story. The female characters in the narrative have to confront their past when the whole exploitative system fails to enrich their lives and diminishes their value as well. The present then becomes a struggle, a struggle meant to expose mistakes of the past. In fact, Pa wants to exploit the young university girl, but falls in her web, then like a spider attacks its victim and sucks their intern organs, Pa sees all his finances go through expenses demanded by Flower. In characterizing Agnes and her exploitative temperament, Amma Darko uses particular linguistic registers that reveal that Agnes or Aggie embodies a parasite in the very soul of Pa and Randa the vengeful spirit of Ma to condemn Idan, Aggie's husband to become infected with HIV virus. Yet, what troubles the reader in the narrative is that Ma and Pa's children never blame Pa for having neglected their mother for another woman else. Despite this, they concoct a plan of NEMESIS (Darko, 131) with the help of Kofi Poku, with many nicknames (Darko, 235), a former dog chain seller, now a hired prophet, Zechariah Abednego⁴³⁴ to punish Aggie as the patriarchal instances teach them to seek vengeance from the woman, not the father's extramarital affairs which cause the pain. Ma's children forget the yellow inscription on the light blue Benz bus which reads "VENGEANCE IS GOD'S" (Darko, 116). The biblical reference to God's vengeance is true and should normally lead Ma's children to patience and forgiveness. The true biblical reference states the following: "It is mine to avenge; I will repay. In due time their foot slip; their day of disaster is near and their doom rushes upon them."⁴³⁵ Or in New Testament, it is formulated like this: "Never take revenge, my friends, but instead let

⁴³⁴ Abednego is the common nickname Ghanaians give to men of God to mock at them.

⁴³⁵ New International Version, Deuteronomy 32: 35.

God's anger do it. For the scripture says, "I will take revenge, I will pay back, says the Lord"⁴³⁶. Instead, the children are trapped and blinded by their anger and burning desire to avenge their suffering mother.

Once again, Amma Darko recalls Greek and Roman mythology in her writing as to corroborate Dr Cheikh Anta Diop's thesis on African history which cannot be dissociated with that of the other world and vice versa. Cheikh Anta Diop vehemently defends that Greek history is that of Roman and Roman the Greek. Then Greek history is that of African because these two people share Mediterranean borders which were under the complete influence of Egyptians and before Egyptians could control, there were Ethiopians. So Roman and Greek mythology is linked with that of Egyptians where fate is an invisible hand which leads people's lives in secret. Amma Darko uses that invisible hand in her first fiction *Beyond the Horizon* while talking about Mara's destiny to suffer. Karma is the word used by Buddhists in Japan, India and Chin to mean fate. Talking our cue from what is said, we know that Destine as her name seems to suggest believes in Karma as she proves: "I believe in fate. Karma". [...] "I believe that one way or the other, we always pay for our misdeeds." Karma acts like a natural revenge. Therefore, we reap what we sow as Amma Darko declares, "Karma teaches that conditions of a person's on-going life are the results of deeds from a previous life" (Darko, 220).

Then, as if really present conditions are guided by past events, the gossip newspaper "Talk let Talk" announces the story in the roughest way it has been told, heart-breaking news:

She was holding a copy of the hot gossip paper "T&T – the abbreviation for "Talk let Talk".

"Maa Cherie," she called, "the vendor just brought your paper, shiee...the T&T people, they are magicians, oh! How do they get their information? Look at their front page headline." [...]

"Yes. Shiee, Madam look; they say only his 5th Wife tested negative. The older four wives have all tested positive for the AIDS virus." [...]

"Shiee!!!" Fingers howled again as she left her madam's tiny office, still not believing what she had just read in T&T, "All four older wives HIV positive?" (Darko, 234)

⁴³⁶ The New Testament, Psalms and Proverbs. Good News Translation, Bilingual Edition, United Bible Societies (2007), Nairobi, Kenya. Romans 12: 19.

On the one hand, by creating this kind of newspaper, T&T it is called, the author highlights the existence of some unethical journalists, wolves in sheep's clothes. Any information is good to be released in the form that it has been heard either for a good or a bad purpose. There is no form of investigation beforehand, even to save the face of the concerned as professionals can manage. That is what some medias come to be in African countries. Instead of promoting good manners, they are more assertive in making money. That kind of media is more focus on women's as sex objects and housewives and little attention given to working women. They act as mere media-enterprise rather than promoting social welfare. Its effect has expanded and is influencing the way people are arranging their priorities and interests. In fact, it is influencing how people formulate their knowledge, attitudes, stands and practices. Shifting the portrayal of women in a more positive and realistic manner could be accomplished by the influence and efforts of omen working within the media. That is why the author portrays the worse side of it to raise the reader's awareness. The author wants the reader to draw by himself the conclusion of what should be the role of media. By launching such delicate information among the population, the media proves that it is not professional, but is in search for sensational news. The journalists of that house may love spectacle-news rather than good information. An HIV-infected is not a malaria patient. Data delivery in HIV case management should be more protected.

In doing this, the concerned becomes definitely ostracized by his friends and society so far the information is about his or her disclosed serology, particularly HIV virus, tuberculosis or any other communicable diseases. Amma Darko shows the way of denunciation of dishonourable attitudes. The opposite example is the Harvest FM, GMG producer, Sylv, Muff and his group. In the role of information givers, journalists should go for the real ones and confront them before releasing. It may be the same journalist, Sylv Po, the author uses in her previous novel *Faceless*.

On the other hand, all this falls in an intricate interwoven spider web. All the female characters of Amma Darko are related by an invisible line and especially by shared sex. Dam's obscure activities were unknown to Randa. She suspects that he is not the son of an affluent businessman, yet she does not investigate thoroughly. In fact, Dam, the young man of about thirty years old, is at the centre of this muddy muddle. He is among the young and good-looking men who target wealthy and sexually unfulfilled middle aged women in urban cities like Accra, Ibadan, Dakar, Bamako, Kampala, Kigali and Cotonou to cite only these few for cash for sex

affairs. Unfortunately, Dam is an HIV positive who meets and provides paid sex for Pesewa’s second wife. The relation is purely cash for sex affair as Pesewa begins to look for another new wife. As a result of the second wife’s sexual activities with Dam, she is infected and in return infected Pesewa. Dam infected Randa who infected Idan, Aggie’s husband. In this way, Aggie being in marital contact with Idan, she is infected. This tricky relation is drawn in the graphic below to explain the unbridled and ambivalent HIV connection relating these characters.

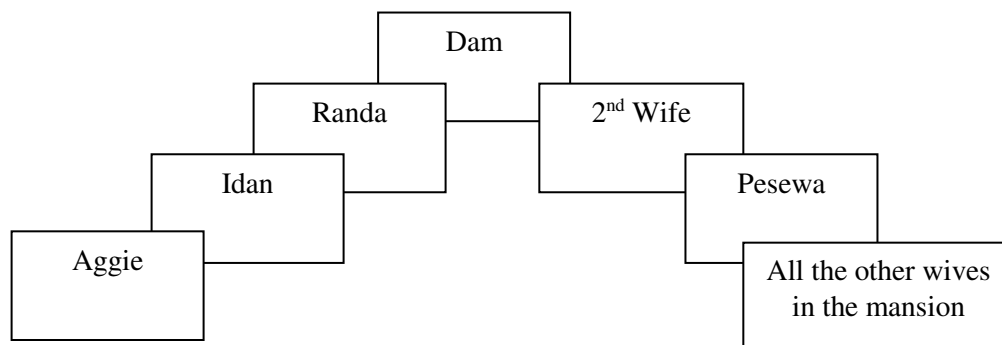

A chart showing the way the HIV/AIDS virus has been transmitted from a person to another as described by Amma Darko.

While reading through the diagram, we come face-to-face with another enlightened instance of literature of quality describing a social reality of HIV virus havoc. As one cannot recognize an HIV positive just after his look, Amma Darko gives the reader a clue: fear good-looking, young and prostitute men. As clear as it can be, young men like Dam fill up the cities nights and days in search for vaginas to lay their infected ‘eggs’ like eight-legged arachnids laying theirs in their victims’ bodies to transform them. And likewise, the victims are really transformed to be another arachnid and the circle expands. Amma Darko seems to say: Beware, several Dams and their alike are every corner in our cities and rural areas with their penises like to pump in any female body their dangerous manhood infested fluid. People like Dam are able to disappear into thin air whenever their real image of dangerous men is uncovered. “No one knew where he had gone. His mobile phone was also switched off” (Darko, 291).

Further, the incurable HIV shatters all the dreams of Randa, Aggie, Idan, Pesewa and his mansion. Most become infected with HIV through sex, which unfortunately carries moral stigma. Some people will say that it is their Karma, the result of their moral deviance which receives punishment from above or they are born to suffer, for in their former lives they made

some mistakes that they are obliged to pay in a way or another. What we do understand in Amma Darko's method is that she responds to the Ghanaian male writers who have been portraying women as loose, dangerous, weak and dependent on men. This unjust portrayal has been worsened by the prevalence of HIV/AIDS. Women have been depicted as vectors in the spread of the virus, thus perpetuating sexist ideologies in Ghana and all over Africa. These sexist ideologies rang from accusing miniskirts wearers on the road as being prostitutes to taking them as responsible of HIV/AIDS spread. The work of Amma Darko presumes the decision of African female writers to do better in the depiction of their female characters, so their presentation differs, while the accusing finger change its direction. With female writers, women are no more on the accused bench waiting for the verdict from male writers like Cyprian Ekwensi (*People of the City* and *Jagua Nana*), Elechi Amadi (*The Concubine*), Ngugi wa Thiong'o (*Petals of Blood*), to name only a few. They can now reckon on the new approach of writing prevailing social plights. Female writers then approach the gender equation in a variety of ways as they attempt to reserve aspects of female marginalization. Often they struggle to restore women to their rightful place.

In her mock epistolary work, the writer installs what we call 'do-me-I-do-you' relation between male and female characters. Amma Darko want to show that in polygamy, falsehood and dishonesty represent the foundation for at the beginning of Pesewa's marriage with his first wife, "other wives were never envisaged" (Darko, 269). The additional pain that the first wife has to bear is that of sharing his intimacy with more women. As the first wife is a good Christian, she confides her situation in God. In a polygamous household, the reign of the favorite wife has its expiration date, just the time the man dates another woman for his bed. As a matter of fact, at a certain level in the text, there is no more a win-win partnership between the two, but a 'hit and run' question. The expression 'hit and run' refers to the quickness of effect and the malevolent intention of their relationship rather than for permanency and real love. Charles Marfo *et al* defend that in Amma Darko's novels "mothers are portrayed in their real complex natures as nurturers with potential to exploit even their own daughters"⁴³⁷. Additionally, Amma Darko carves out her novels in a way that her female characters use sex as a strategy to survive their social and financial predicaments. That is the reason why the female

⁴³⁷ Marfo, C. ; Yeboa Abeka, P. & Bonku, L. (2015). "Exploiting the Exploiter: Some Violations of Society's Expectations in *Beyond the Horizon* and *The Housemaid*" in 3L: The Southeast Asian Journal of English Language Studies – Vol 21(1): 35 – 46 <http://dx.doi.org/10.17576/3L-2015-2101-04>.

exploiter in *Not Without Flowers* finally saps deep dry her exploiter's pocket: "Then Flower began to demand payment for that too, because the time spent on the telephone with him was time lost to studying" (Darko, 341). In so doing, she ruins his psyche so that he "resorts to a heavy alcohol intake to numb the aches in his body while waiting for Flower to dictate their next encounter" (Idem). Pa is completely hooked on the sex, drug and alcohol combined copious encounters. All this makes him high and a young man again; sexually active. He becomes a helpless puppy on a mere command of Flower. Here Amma Darko's fiction presents Flower as it presents many other junior wives as holding advantageous positions as new occupants of husband's heart and attention. They often inconspicuously enjoy the challenging threat they impose on the vulnerable senior wife. Subtly, they monopolize the husband's affections.

Pa's sizzling and volcanic spurs are quenched, but he must pay the highest bills: "he went borrowing to meet her demand. And it continued that way. Soon, he owed the bank and owed the company he worked for. And still she demanded. And because he could neither borrow from the bank or his company again, he resorted to selling his personal items" (Darko, 324). She decides to end the game, her marionette being totally hooked, does not bear the end of the silly movie: "[...] Oldie! Not sex and our next encounter. Money!" (Darko, 347). He ends his own life by committing suicide, but before that, he calls Flower and accepts to play the horrifying game now: "I am about to play it". "He picked one dining chair and went out again to the mango tree. He had already marked where to place the chair. He had planned well [...] he touched the noose. He liked its feel. He drew it tighter around his neck. Oldie?" (Darko, 357-58). Pa is a man lost in his own devices relying on his own intelligence to survive the web woven by the rampant flower. Amma Darko learns from Epicure that not all the pleasures are left quenched, some should be left aside. Overcome by his own nervous condition, he is just trapped and lonely as the women around him. He begins alone, fights alone and dies alone. In African spiritual cosmology, Pa will not be accepted in the *Ogboni in conclave*⁴³⁸ because suicide is not tolerated.

Critically, we realize that Amma Darko makes a justice for her female exploited characters, like she makes for Mara in *Beyond the Horizon* and for Baby T and Fofu in *Faceless*. The female character in *Beyond the Horizon* gives remorselessly the hardest blow to her husband exploiter by giving essential information to Gitte which splits apart Akobi's lifestyle in

⁴³⁸ The assembly of elders in Yoruba land in Wole Soyinka's *The Interpreters*.

his El dorado. In a letter to Gitte, Mara exposes to her all of Akobi's relationship with his lover, Comfort. The end of the gentleman Akobi is summarily presented thus:

Akobi is in jail here in Germany. He attempted to sneak out while still owing money to the bank and a couple of mail order houses and was caught. I am sure he wanted to follow Comfort when she got deported. Everything he and Gitte owned has been taken by the bank. Gitte has divorced him and returned to her family. (Darko, op. cit. 138-39)

The literary position of Amma Darko in the novel under scrutiny and even in all the others is poignantly feminist and carries out along. Amma Darko succeeds in making the readers sympathize with the wives, the women in pain because her exploration of their emotional traumas enables the readers to identify with their permanent suffering. Amma Darko reduces to zero all the men who attempt to violate the integrity of any woman in her text. She creates educated female characters, 5th Wife and Aggie, like her Senegalese writer, Mariam Bâ, creates Ramatoulaye in *So Long a Letter* as we show earlier. In fact, education and mental engagement become very important means of empowerment for women like 5th Wife in Amma Darko's fictional reality. The female character of Mariam Bâ succeeds in bursting out the pre-established norms of an Islamic society and campaigns as representative of the oppressed women under polygamous set-up. Mariam Bâ "condemns polygamy by highlighting and exposing the many ugly sides of the practice"⁴³⁹. Both novelists demonstrate that polygamy deprives the female spouses of their rights to enjoy the presence of their husbands, the time they should spend to discuss with them and their offspring. When men decide to be in a polygamous union, their senior wives are typically reminded of the position they hold and of how major it is for them to subdue their emotions in order to maintain their dignity and uphold their family's good name.

A woman who openly displays emotions of jealousy or any form of defiance is made to believe that she is disgracing her status and her family. In the last case, Amma Darko plays it right by making the second wife of Pesewa very jealous. When she comes in Pesewa's mansion, she is taken as the favourite not knowing that it has an expiration date which is the date when the third wife enters the mansion. When the date of expiration comes, she does not accept it and goes for extramarital affairs. The disgrace befalls her: HIV/AIDS as a severe bill of her extramarital love affairs. Yet, what is worth noting is that the side of the story in which the man

⁴³⁹ Akano, R. K. (2014). *So Long a Letter: Understanding the Missionary Narrative of a Polygamy Victim in Journal Of Humanities And Social Science*, pp. 22-27.

is an equal accomplice is often ignored because society seems ready to forgive men more than women for the behaviour that results in HIV and AIDS. Pesewa's relatives incriminate first of all 5th Wife because she is the most likely to do so for her age and beauty, and yet it is the husband who has five wives. He does not follow up the Apostle Paul's advice concerning the number of wife a Christian should have "But, because of sexual immoralities, let each man have *his own wife*, and let each woman have her own husband. Let the *husband render to his wife* the affection owed her, and likewise also the wife to her husband. (1 Corinthians 7: 1-3, emphasis mine)

If Pesewa had read once the Apostle's word, he would not have been in graveyard now. In fact, Pesewa's suicide is related to his positive serology to HIV/AIDS, a disease transmitted to him by his second wife due to her affair with Dam. If Pesewa had not taken the third wife, the second would not have felt neglected, and then would not have made the choice of a man outside her bed to provide her with good and potent but unfortunately infected sex. At last, Pesewa might have been alive. Pesewa does not want to fail in his ordained mission of chief, provider of wealth and he cannot stand malevolent looks from society. Amma Darko is thus advocating conjugal fidelity in marriage either polygamous or monogamous. Yet, the stereotypes against women's body are upsetting. It seems to carry danger and diseases. All this is a result of the gendered nature of HIV and AIDS, where women's body is often regarded as being diseased, therefore dangerous. However, the stigmatization of AIDS victims is criminal according to Amma Darko (Darko, 195).

Patriarchy is a system of exploitation and according to Amma Darko, all system of female exploitation must be combated to the end. In suggesting this point, Amma Darko joins Gayatri C. Spivak in denouncing the vulnerability of women in patriarchal society. The Indian critic submits this way "the subaltern has no history and cannot speak, the subaltern as female is even more deeply in the shadow"⁴⁴⁰. This is women's position in a male dominated society as well as in a colonised one. Women are twice under siege.

There exists then a dialectic force at work in all African societies where values and traditional norms try to maintain women's head downward, female writers push it high by speaking on their behalf. A community where women have no overt social and political power,

⁴⁴⁰ Spivak, C. G. (2006). Can the Subaltern Speak? In Ashcroft, Griffiths & Tiffin (eds): pp. 28-37.

one strategy left to women is influencing men. Through this merciless fight, Amma Darko suggests her way to destroy patriarchy which is formulated in the way Pa has been financially sapped to suicide and Idan VIH/AIDS virus infected. In so doing, the writer's offensive perspective is feminist, but embodies her own approach. In doing so, Amma Darko wants her female counterparts to propose another directive of struggle which teaches women how to fight together gender oppression with means like sisterhood and sharing information. Forming groups to attain a purpose is Amma Darko's feminist process by which African women under patriarchal yoke acquire energizing power. Empowerment is not easy as it requires considerable fortitude and emotional, psychological and at times physical strength and some parental supports. However, like the question of Nnu Ego in Buchi Emecheta's *The Joys of Motherhood*: "God, when will you create a woman who will be fulfilled in herself, a full human being, not anybody's appendage?"⁴⁴¹. Amma Darko shows, as we have said above, that not every woman embodies the spirit of exploiting other husbands. This is noticed in Ntifor's house where Mena Penyin and Mena Kakraba live together to strengthen the idea to sisterhood, very important to Amma Darko. For instance, Mena Penyin is the wife who does not bear children could end up in psychiatric asylum, rather sisterly action takes over and she nearly clobbers Teacher out of their compound. The bond here ensures a rather good relationship between both, irrespective their sharing the same man. This team work is rather idealistic, but it fortunately engenders a house of no "no discord, no suspicion, no squabble, no innuendos, no 'song lashing'" (Achebe, 14). Yet, feminist writers show that polygamy inhibits women in so many ways, especially if they are not educated.

The majority of educated women have the scientific knowledge and thus are prudent to get into that spider-woven network to lose themselves. They prefer monogamy. However, when it comes to be interested by a rich man like Pesewa, they do it purposely like Bolande in Lola Shoneyin's *The Secret Lives of Baba Segi's Wives* (2010). In many instances, African female writers tell stories of women's empowerment in African context. Even the female characters who fail in fiction are shown as examples but not to follow. Finally, African female writers portray their own backgrounds and their own experiences as women creatively, delving deeper into the lives of women in an intimate and authentic way, whether as feminists or defenders of traditional norms and values.

⁴⁴¹ Emecheta, B. (1979). *The Joy of Motherhood*. London, Heinemann, p. 186.

All in all, the norms and practices that oppress women continue to be perpetuated in societies because of the women who endorse and help further these forms of oppression. Naturally, when a woman is denied a voice and is oppressed, she becomes helpless and seeks for attention elsewhere. The next section will examine another level of oppression that works hand in hand with polygamy.

10.2. Unfaithfulness in *Not Without Flowers*

Unfaithfulness or infidelity is a violation of the commitment to sexual loyalty by one or both members of a committed relationship. Unfaithfulness refers to a breach of the expectation of sexual exclusivity. It can take various forms, including sexual infidelity and emotional infidelity. Although attitudes differ between men and women and across cultures, unfaithfulness or extramarital sex constitutes a serious act of betrayal within couples. The consequences vary from mental and emotional suffering to the termination of the former relationship. Extramarital sex or adultery is a specific kind of infidelity in which there is a betrayal of marital sexual exclusivity. In case of polygamy or polygyny, sexual relations occur with more than one partner. Still, before it results in several sexual partners' possession, the man in question is unfaithful to his first wife or partner.

In an African context, unfaithfulness or infidelity or cheating is thought to be a male related syndrome, but in some circumstances women do have sex outside their marriage. This form of infidelity is called philander, adultery or an affair. The modern law allows the partners to divorce. The main reasons for women to have sex affairs outside their marital homes are portrayed in *Not Without Flowers*. Male unfaithfulness constitutes another form of oppression against women. Men's wrong doing are condoned because society perceives it as braveness and manliness expression. This leads to gender oppression which results in women's dehumanization and objectification.

When a household contracts the syndrome of infidelity, peace goes out-door and the first person to be affected is the woman. What makes the novel under scrutiny one of the best of Amma Darko is that she discloses one of the most heart rending descriptions of the social context of this exploitation occurring nowadays. Infidelity can result in HIV/AIDS infection. It can also result in families' disintegration, the victims' financial breaking down and

impoverishment. The narrative shows among others issues, the victims' depression, and suicide. Pa, Kweku's father, starts being unfaithful when he feels not cared for by his wife, Ma. However, the malaise of the couple comes from the fact that Ma thinks her shop business is highly important than caring for her husband. She becomes deeply involved her financial activities than to care for an old man's growing sexual desires so that the desires come to be volcanic spurs. All this engenders her tormenting nightmare. Male characters engage in infidelity mainly because they want to live up to societal patriarchal expectations and because it is perceived as manly to do so. Charles Fonchingong provides further evidence by submitting that traditional African marriage acts as a conduit for injustice against women throughout its norms which dehumanize women by reducing them to second-class citizens. These norms, conversely, have no mercy on unfaithful women who are returned to their parents, immediately replaced or beaten to death.

Many unfaithful women in various other African societies suffer in a similar way. As society forged if days ago, women are not only forced to find their identity through their role as mothers, but they are also identified in relation to men, as wives, then silenced and voiceless. As so, nothing can stop the male ascending hegemony over women.

As a result, Pa launches his search for a fresh female soul to quench his sexual fantasies and falls this time on "a petal of Flowers, with a capital F" (Darko, 11). Amma Darko describes briefly the physical personality of Flower like: "She had looks that pleased the sense, she who came to take charge and control of his emotion; she who came town and possess him and who came to be his fetish and obsession" (Darko, 325). The author places these words to draw an erroneous image of Flower to the reader. Amma Darko does not write that the character is beautiful and good-looking, but beats round the bush. She means it, but in other way to oblige scornful looks on Flower. The female character seems to be the perfect scapegoat here. From an exploiter, Flower becomes fetish, an obsession. A fetish in African context of spiritual cosmology is a deity to worship because of its wrath. Thus, the encounter between Pa and Flower engenders the loss of the joy of a whole family.

Generally, flowers, as plants, have played a key role all throughout human history. We find out that "Some types of flowers were used as food and continue to be used as food until the

present day, others have properties and are used as medicine”⁴⁴². The last property of flowers is the one Pa misuses to his decadence, which is flowers as an obsession. We understand that Ma’s depression is rooted in Pa’s unfaithfulness. At a complete loss to how to get back Pa’s love and presence in the marital bed, Ma begins to be absent-minded. Infidelity creates in a couple loneliness and vulnerability for both the victim and the perpetrator. The more she bends over her mind's eye that her husband may be somewhere downtown with his lover Flower with her attractive petals, the more she suffers in her psyche. Amma Darko depicts the woman permanent pain through the following sequences:

But Randa continued to dream about Ma crying.
She had woken up. Yet she could still hear Ma crying.
Ma was actually crying. What was happening? The dream was unfolding
before her eyes. She called Ma, but Ma didn’t respond. Maybe Ma didn’t hear
her. Her voice was too frail. She called again. Ma still didn’t respond.
Ma was asleep. Why was Ma asleep and crying? Pa should know!
Ma was crying because Pa was not sleeping beside her on the bed. (Darko,
120)

The meaning of Ma’s facial expression is important and the repetition snatches our attention. Amma Darko places the word ‘crying’ most of the time to catch the reader’s compassion and to lead him to be part and parcel of her cause. The first question the reader asks can be “why all this is happening to this woman?” and the answer is because Pa loses control over his sexual drive to consider life without Flower as worthless in African context of love and courtship. We do not mean that Africans are not accustomed to flowers as important plants in their life. In dating, giving or using flowers is rare in African context.

In marriage, unfaithfulness creates a long and enduring period of pain. Ma cannot imagine, irrespective to the number of years she spends with her husband, that she can one day be subjected to sorrow of this extent: “Ma had been married to him for too long not to notice” (Darko, 339). This passage demonstrates that infidelity is not only with young and middle-age couples, but also strikes in old age. “Pa’s frantic pretentiousness and his clumsiness began leaving Ma feeling debased and degraded” (Darko, 339). Her self-esteem leaves her day after day. Amma Darko does not spare any word of criticism against African tradition. This indicates the fact that her feminist perspective can be related to some aspects of postcolonial discourses. This bears out Ashcroft, Tiffin and Griffiths’s comment:

⁴⁴² The Role of Flowers in Our Life : www.islandrose.net

Feminist and post-colonial discourses both seek to reinstate the marginalized in the face of dominant, and early feminist theory, like early nationalist post-colonial criticism, sought to invert the structures of domination, substituting, for instance, a female tradition or tradition in a place of a male-dominated canon. But like post-colonial criticism, feminist criticism has now turned away from such simple inversions towards a questioning of forms and modes, to unmasking the assumptions upon which such canonical constructions are founded, moving first to make their cryptic bases visible and then destabilize them.⁴⁴³

In this respect, feminists like Amma Darko seek to reinstate the marginalized by focusing on the experiences face by her female characters despite the tiny possibilities for ways out. Hence, when it comes to blame someone for the rich Pesewa's death, accusing fingers are pointed toward the youngest wife, 5th Wife. People, wrongly accuse her of having either poisoned, or infected Pesewa. The parents-in-law allude that 5th Wife has extramarital sex with her probable young lover and consequently gets infected. The fact is that having been neglected by Pesewa for his third and fourth wives, second wife engages herself in a sex-for-cash relationship which unfortunately results in infection with HIV virus. By contrast, Pesewa's second wife lacks the possibilities to which Mena Penyin has access.

Amma Darko highlights the misdeeds of some women in societies and how they can become victims of society's injustice. Amma Darko brings women's lives to the fore within a literary context. In fact, the second wife can save herself from doing this if she has been accepted beforehand by the first wife. For Pesewa women lose their value as soon as they step in his mansion because appealing less sexual appetite. Only the second wife seems to calculate what is good to do for her freedom to keep her sanity. She makes the decision to be satisfied outdoor. Taking clue of the preceding, Monica Bungaro points out,

Amma Darko's bluntness and frankness in naming and exposing the malaise of her society makes her one of the most militant writers on the contemporary African literary scene. [...] Darko realises that women's histories and experiences cannot be understood by referring to an abstract ideal of feminist consciousness, but can only be addressed by considering the complex

⁴⁴³ Aschcroft, B. ; Griffiths, G. ; Tiffin, H. (1989). *The Empire Writes Back. Theory and Practice in Post-Colonial Literatures*. London and New York: Routledge, pp. 175-76.

interplay between the social and material conditions affecting women's lives.⁴⁴⁴

Life is not easy for Amma Darko's female characters. Most of the time, if they are depicted as being subjugated and ready to be beaten, barred from any say in the communal decision-making process, abused by the dominant force in the society. The critique does not seem to be directed in fact at women who make the mistake to be in the wrong place at the wrong time, but at the men who are favoured by their gender power. However, materialistic instincts of some women to exploit are also pointed out as situations to avoid while women seek respect and help from their counterparts and from the society. In *Not Without Flowers*, Flower has been badly treated because she causes havoc through her money-oriented love to men. To be desperately loved by married men is her leitmotiv, subsequently she succeeds in causing depression and suicide in her own family and then in the community.

Unfaithfulness, according to Amma Darko, brings disease which is an expected punishment to any defiant behaviour. Amma Darko suggests 'one man, one wife' society where unfaithfulness may occur only in a restricted framework. Infidelity can occur to fill the gap of childlessness in a household. Ntifor's example is here pointed out as the model in service of motherhood and childbearing. This sort of model happens most of the time in non-materialistic environments where both women accept each other and take each other not as rivals, but as sisters united by the same man. This model is that displayed in the case of Flora Nwapa's *Efuru*. The female author presents a female character, an eponym, whose inability to bear life in her womb, poses a serious matter to her marriage. However, as to rescue and alleviate her, Flora Nwapa creates an Ugwuta-Igbo woman out of the usual conservation and rhetoric of Igbo, Ogea. She is a little child of ten years old to be in companion with Efuru, a financially succeeding woman, but still no child.

In essence, the image of women is usually objectified and taken as vacuum used for procreation. The roles are focused on their domestic and biological roles, the economic parts played notwithstanding. The advert of this fact in limiting women's roles is quite obvious. This is the reason why in female novels, women writers also limit their male characters either in their

⁴⁴⁴ Bungaro, M. (2007). "Victims and/or Victimisers? Women's De (Con)strutive Power in *The Housemaid*." Ed. Vincent O. Odamtten, *Broadening the Horizon: Critical Introductions to Amma Darko*. UK/London: Ayeibia Clarke Publishing, p. 44.

sexual satisfaction or their ability to make a woman pregnant. It is the case of Idan. Idan, a sexually unfulfilled, tries to satisfy himself outside the marital bed. He submits to the call of his lover this way: “Randa had called. And when Randa called, Idan went running” (Darko, op.cit. 107). His madness goes to an extent that “he had refused to eat for one reason or the other. It wasn’t the first time Aggie suspected infidelity on Idan’s part, but in the past, Idan always made it a point to be home in time to have dinner together with her” (Darko, 172). Amma Darko highlights the responsibility of husbands in general through her male characters. To showcase, the author portrays situations where Idan’s reason is readymade, “the reason was always their failure to conceive” (Darko, 172). Therefore, the lover uses the breach by expecting that she can have a play right through. The pressure lies only on woman’s chest as she becomes lonely for her dinner time or stays alone in their marital bed, her body twisting violently. At the same time, her husband may be with his lover for pretty good time discussing and being nursed. As Maa Tsuru in *Faceless*, Aggie is unable to defend herself through the awareness of her own past guiltiness. The smell of Destine’s perfume must confront Aggie’s past. The feeling of guilt and silence satisfy the proponents of unfaithfulness and reinforce patriarchal system in communities.

According to the dictate of African tradition, a woman is a good wife when she observes the status quo by, for example, not challenging her husband and looking for compromises. She must worship her husband. In this framework, the South African writer Ngcobo emphasises this point, noting that “this is a widespread tendency in patriarchal communities, when she states that an African girl is born to fulfil a specific role, for she is trained to be a suitable wife from a very early age”⁴⁴⁵. Yet, unfaithfulness is a gender-based violence, a social and psychological persecution against women. The feeling of rejection becomes more accurate and the pain cuter when the woman at home notices that the unfaithfulness of her husband is producing a fruit. Amma Darko points out: “Maybe it wasn’t so bad after all, he considered. Aggie was going to have to accept it, that it was her womb that was to blame after all. She would have to accept his baby. HIS BABY! It smelt, felt and tasted good on all of his senses. A child! A baby! His baby!” (Darko, 209) Finally, the society wants the poor Aggie has to cope with all this, since all the blame is on her while, in fact the misdeed comes from the man. The deep psychological wound does not allow Aggie to accept such a betrayal from her husband. As a result, and like a

⁴⁴⁵ Ngcobo, L. (2007). African Motherhood: Fact and Fiction. In Mariani, Philomena (ed). *Critical Fictions: The Politics of Imaginative Writing*, Seattle Bay Press, pp. 194-199.

normal human being, she bursts forth her pain from her chest “Suddenly Aggie roared with laughter and then convulsed into tears” (Darko, 222). In effect, infidelity undermines the betrayed partner’s sense of security and stability in a relationship; the emotional impact may be severe, including depression, anxiety, rage, symptoms of post-traumatic stress disorder and decreased self-esteem according to the psychiatrists.

Moreover, Randa is cheated on by her good-looking fiancé since the debut of their relationship. A similar case is portrayed in Sharai Mukonoweshuro’s *Days of Silence* (2000) where Grace’s late husband and Tsitsi’s former boyfriend infected her. In both relations, male characters are blamed for having infected their female friends. It means that in a heterosexual relation, the easiest way to be infected is for the female characters to be sharing infected male partners. That is why in *Not Without Flowers*, Amma Darko uses an infected male character, Dam from whom the disease spreads. For instance, Dam declares that he is the son of a renowned business man in the city. This social condition may justify his relatively well-off financial situation, but in fact the essential of his occult financial achievement comes from his activities of pimp and his sexual acquaintances with middle-age women sexually unfulfilled. Among these female characters we have Pesewa’s second wife. If Dam had not been exchanging his body for money with a multitude of female partners, his girlfriend and second wife would not have been infected. Moreover, Pesewa would not have ended his life. The story unfolds that there is surely:

The young man suspected of infecting the second wife with the AIDS virus. He paraded as a businessman. He was rich, had hordes of girlfriends and was indeed a male prostitute. Since he got wind that his story was due to appear in the T & T to blow his cover, he had disappeared. His picture had been published to enable all who have had sex with him to go and test for the AIDS virus. (Darko, op.cit. 299)

From the passage, we notice the unsophisticated and cruelty of the gossip newspaper T & T. The newspaper breaks the basic law about information and investigation in journalism. Unless they want to be sued to justice, they could not relay news like these with the picture of just a suspected person. The confidentiality over the result about AIDS virus or any resulted disease and the impact on the psyche of the concerned make it worth to be prudent and wise about a cover blowing. However, the newspaper bears rightly its name as ‘gossip newspaper’. As a matter of fact, the release of the news works like a massive destruction weapon:

Randa sat there numbed. She couldn't speak. She wanted to say something. She tried to, but her jaw wouldn't budge. The numbness invaded her whole body. She attempted to raise one leg. It failed her. Then suddenly, like a light switch turned back on with a click, the energy flooded back in huge waves, overpowering its space. She yelled [...]. She yelled again. And yelled again. [...]. The pain was excruciating. (Darko, 299)

The inner and remorseful thought of Randa will completely focus on the day she meets Dam, loves him and has sex with him because the pain is too great to stand. We see through the passage that Amma Darko is condemning unprotected sex among young men and women. Unprotected sexual relations have tremendous consequences on lives. The harm is done, and the cup served. Idan's infidelity with Randa results in Aggie being infected with HIV/AIDS. The fear of HIV and AIDS is aptly captured in *Not Without Flowers*, but individuals do not know how to overcome the plight. Amma Darko does not suggest the way of protection here, but empowers mentally women to support the situation once infected and invites people not to shun infected. The reaction of Randa when she hears her boyfriend's HIV positive serology through the gossip newspaper shows that she is afraid of being stigmatized by society if her condition becomes obvious. "She sat numbed and couldn't speak. [...]. The pain was excruciating" (Darko, 299). In this whole path, what Amma Darko succeeds in doing here is to capture society's different responses to the virus, with emphasis falling on both her male and female characters. The source of infection is now known but the culture that perpetuates social bias manages so that women come worse off. The discourse on HIV and AIDS is gendered, that is why women like Randa and second wife are depicted as whores endangering the world though, in the case of second wife, it is obvious that "she apparently needed more sex than her husband could offer her as one of five wives" (Darko, 298). According to Gikandi and Mwangi, (2007, 23), "the AIDS and HIV motif has been employed, especially in the 1990s, to inject sensation into literary texts: the infection has been ascribed to negative characters as a form of punishment in the texts' moral scheme."⁴⁴⁶ Amma Darko is opportunely among these African writers who choose the literary sensational to sensitize her readers on the growing pandemic VIH and AIDS in her society. She points out this "the fear of the disease was more destructive than the disease itself" (Darko, op. cit. 265).

⁴⁴⁶ Gikandi, S. ; Evans, M. (2007). *The Columbia Guide to East African Literature in English Since 1945*. New York: Columbia University Press.

Amma Darko leaves open-ended the issue of how the infected women live their respective life. She does not seem ready to pass judgement on which kind of life they would live in a society which does not cope with HIV and AIDS infected. What is clear to Amma Darko is that HIV and AIDS does not imply that one is destined to die right away. In spite of testing positive, one can live with it in the sense of taking control of oneself like the following extract illustrates “the first wife had come out of hiding and moved in with her four HIV positive rivals, to the amazement of the Pesewa family, most of whom were scared to death of even placing a foot on the steps of the quarters where the women had been confined” (Darko, 318). One by one relatives, friends and neighbours sway off and then “the number of people entering the quarters had reduced drastically. The servants who brought them their food wouldn’t look into faces” (Darko, 265). This fear is based on three facts: the wrong image people have on the disease and its ways of transmission and the non-existence of drug or vaccine to cure it. By emphasizing the way the four wives are isolated and treated as pariahs and secluded as mere thieves, remembering their glorious past, Amma Darko wants to make VIH/AIDS a universal talk, a universal preoccupation and a subject of frequent discussion on media and with NGO. As not to jump into hasty conclusion, we will see in our last chapter of characterization the reason why most of the implicated female characters are nameless. Amma Darko’s technique is rather special in the way that it can be anyone to contract VIH virus in actual facts. In reality, the rich Pesewa’s mansion is like a whole Ghanaian society.

At last, Amma Darko depicts female characters that refuse to be defeated by oppressive customs and culture. She subverts the traditional way of women’s all-accepting attitudes and gives way to an opportunity to take on decisions. This is also the way Ifeoma Okoye deals with her female characters in *Behind the Cloud* (1982). Ifeoma Okoye sets out to redeem the humiliating images of women in the African setting. She presents the Nigerian women as dignified and capable of other good odds than mothering. Finally, we see that *Not Without Flowers* is built around a powerful narrative because of its characters who fight gender oppressive and prevail against it the face of considerable events.

In actual fact, this means that no battle is won without suffering, brimstone smell and wounds. Beyond all that, no battle is defeated without a vision and determination from the concerned. Dignity and harmony in a society depend on both men and women, for a man cannot live free while a woman is a slave, wounded and lagging behind. These injuries can occur at any

time of life with known reasons or not. Social injuries against women last for their lifetime and leave definitely some sequels. Marriage is the only social institution where, biologically at least, women are as dependent on men as men are on women. No one can be left behind since human species regeneration is as important as life and humanity preservation. If we agree that marriage is the site of a collective realization and fulfilment of individuals, men and women, then when one element of the chain lacks to fulfil his role because of his ego or his mood, the consequence is felt at the end of the chain. One final small point can be made. The strangely mixed presentation of the situation of women and men, lacking to fulfil their ultimate and expected role, part solemn, part ludicrous, may strongly be deliberately misleading tactic on Amma Darko's part. It is a promise that the author cares about her characters' emotional and physical feelings. Feelings are as important as bearing and giving life. This is what leads African writers to pen down the day-to-day unanswered questions of their counterparts by developing all sorts of techniques to make their characters powerful or marginal; weak or strong. Other authors give a metaphysical power to their characters. All this depends on the author's ability to make the story more real. The following subchapter gives right insights on these social indicators.

11. Premonition, Mood disorders and Witchcraft in *Not Without Flowers*

African literature is replete of social topics like premonition and mood disorders discussed by writers in search for answers from the society. They write about society's plights the way they appear to them. As being former colonized, their wretched and nervous conditions have pushed some of them to tackle society's problems with special literary techniques. They have used premonition and/or mood disorders and as narrative technique to treat more vividly and more accurately their literary message. One of the dreadful topics that African writers dare not to step in is witchcraft which seems to be reserved to the initiated. This spiritual aptitude is wrongly or rightly attributed to women. While reading Amma Darko's *Not Without Flowers*, we realize that these social conditions are shaped to undermine, ostracize and demolish female counterparts. The present subchapter is going to show proof of it.

11.1. Premonition and Mood Disorders: NEMESIS Therapy

The most commonly quoted definition of health is that given by the World Health Organization (WHO) over half a century ago. It defines health as "a state of complete physical,

mental and social well-being and not merely the absence of disease or infirmity” (WHO, 2-3). However, commonly, each human community has its own mythology, philosophy and cultures which deal with one situation or another. The way Africans tackle their health predicament is different from that of Europeans. “As there is an African way of understanding God [...] in the same way, there is an African way of understanding the world, the visible world around us – the cattle, trees, people and cities as well as the unseen world, the supernatural world of spirits, powers, and diseases” (Oduro *et al.* 2008:9)⁴⁴⁷. Life in African religious beliefs is conceived on the basis of maintaining the necessary balance between the visible and the invisible. Then, problems and great catastrophes happen undoubtedly when the individual fails to give surety to this balance. So, the African conception of humanly conditions like premonition and mood disorders are different from that of the European one. They are sure that there are diseases that modern medicine cannot treat and above all behind each disease ambushes an evil spirit which can strike the deadly punch whenever the ailing does not apply the precise antidote. That is why they prefer to go to traditional herbalists for help. This is in line with Oyedele S. Jegede’s insight essay in “The Yoruba Cultural Construction of Health and Illness” which begins on a lighter note that:

For the Yorubas every plant, animal and natural The Yoruba Cultural Construction Of Health And Illness phenomenon is a carrier of the divine. God is the source and the ultimate controller of the vital forces, but the deities are the intermediaries between man and God. (...) For the Yorubas, nature is not an impersonal object or phenomenon: it is filled with religious significance. The invisible world is symbolized or manifested by visible and concrete phenomena and objects of nature.⁴⁴⁸

It suggests that whatever happens to people in life is ordered from a possible supernatural dominion and it is necessary to return to specialists like traditional medicine men, Ifa priests and other traditional healers to make it out. In the Yorubas’ spiritual cosmology and in others, no event is natural if it does not fall on one’s ‘*inner head*’ according Jegede (1994)⁴⁴⁹. That is the reason why the Most High Spirit gives a part of his power to traditional healers on

⁴⁴⁷ Oduro, T., Hennie P., Nussbaum S. ; Brain B. (2008). *Mission in an African way: A practical introduction to African instituted churches and their sense of mission*, Christian Literature Fund and Bible Media, Wellington.

⁴⁴⁸ Jegede, O. S. (2002). “The Yoruba Cultural Construction Of Health And Illness”. In *Nordic Journal of African Studies* 11(3): 322-335, p. 2.

⁴⁴⁹ Jegede, A. S. (1994). ‘*Aisan*’ as a social term in the Nigerian perspective on illness. Award- winning paper for the second worldwide competition for young sociologists for the International Sociological Association *African Culture and Health*. Ibadan: Stirling-Horden Pub.

the earth to find out the cause and apply the appropriate therapy. Good health, for traditional African belief is related to ancestors and living spirits in accordance with values and cultural norms in society.

The challenge here is to prove how Amma Darko uses not only mood disorders as cause-consequences of past events that justify the prevailing of NEMESIS therapy, but also that in some cases, mood disorders or premonition condition are given to female characters to make them become wiser. It is also to probe that the author uses this marginality to celebrate the culture of resistance while opposing madness to sanity in her novel. Amma Darko's insane characters are all capable to get through their way to warn their community about bad omen. The mental health condition of Amma Darko's female characters is not to be seen as ordinary insanity, but as wisdom. The narrative sheds light on the author's recurring use of biblical references either to turn head to or to plain use.

Once again, taking cues from the preceding, we notice that a psychologically suffering woman in Amma Darko's novel can be a wise and farsighted woman who has at her disposal the power to forecast good or bad omen. Just like Edward Said creates the concept of marginality to draw people's attention to the colonized's feeling of being on the edge, Amma Darko ingeniously invents her own stream of assumptions in the mind of the reader. She assists him to allude without having to explain the significance. We keep in mind the following comment on Amma Darko which states:

Darko's independent nature has helped her cope. She credits no one particular person with helping her on her way, nor has any writer given her writing advice. Fiercely, self-reliant and sure of her narrative gift, without 'anxiety of influence', she sees herself as one who forges ahead without the need or time for guidance.⁴⁵⁰

Amma Darko demonstrates through her narrative technique her use of embarking suspense. The unanswered questions in her text point out her ability to arouse the curiosity of her readers. Initially, Amma Darko starts the eleventh chapter by writing about a woman's inheriting "the gift of premonition from her mother because her mother, when she was still alive, used to also feel that way about thoughts sometimes" (Darko, op. cit. 166). In Amma

⁴⁵⁰ Zak, L. A. (2007). "Amma Darko: Writing Her Way, Creating a Writing Life". In Vincent O. Odamtten's (ed.) *Broadening the Horizon: Critical Introductions to Amma Darko* (UK: Ayeibia Clark Publishing Limited), p. 17.

Darko's text, the use of women is purposely done as the author wants her female characters to be above all situations, the gift of premonition signifying the knowledge of future actions in society. In fact, the premonition is defined as the aptitude to feel that something is going to happen in the future.

According to the online *Cambridge Dictionary*, premonition is "a feeling that something unpleasant will happen"⁴⁵¹. In our analysis, we assimilate this aptitude with depression, a health condition in which the patient feels and hears voices since both seem to have an element in common: hearing voices. As for depression, it is "a psychological disorder that can affect everyone at workplace, but abroad as well. Depression has become so common that it has been referred to as the common cold of mental illness and has become the world's number one public health problem"⁴⁵². The effect of this situation of premonition causes fear and people's reluctance to believe her. As a matter of fact, the premonition status of a person can lead people to assimilate her with a bad person. Learning from this possibility, the author juxtaposes: "He claimed to have received a revelation to the effect that it was the collective blood of the old woman's victims who she chewed up in the spirit and whose premature deaths she caused in the physical, that was boiling inside her head" (Darko, 166).

The suspected voices which are heard by Ma seem to be those which are present in the condition of mental illness called mood disorders. Ma follows "orders that the voice was issuing inside her head, Ma surveyed the compound, taking in all the varied and beautiful flowers that were in plentiful bloom. Then she turned like a zombie back into the house [...]" (Darko, 169). Pa's inability to control his sexual hot spurs makes Ma a possible mood disorders patient. Regardless of the method Amma Darko uses, the permanent hallucinations of Ma allow her to feel beforehand the treachery of Pa and in the second hand to reveal the truth on the on-going event. Her 'invented' mental condition allows her to feel the presence of Flower and then to vow to death all this kind of plant symbolizing the rival. The sequence of death sentence is illustrated like this "Ma froze. She stared at the purple lily in her hand, severed from the stem. Blood. Where was the blood" (Darko, 170). So far, if the act in itself proves a serious madness, what comes out of the action is Ma's fighting with a visible sword against Pa's lover to drill out the essential of her life; that is blood. Ma's severing all the flowers in the garden represents her

⁴⁵¹ Cambridge Dictionary.

⁴⁵² Bender, K. ; Furman, R. (2003). The Social Problem of Depression: A Multi-theoretical Analysis. 30 in *Journal of Sociology and Social Welfare* 123 at 123.

resistance against the oppressor. If the oppressor fails to have blood in her vessels, then she is dead. That is the purpose of the resistance. Ma is still in search for the right blow to give to her opponent to knock her out. The voice is then not wrong by insisting on flowers as her dilemma.

In fact, Ma suffers all the effect of patriarchal domination perpetrated by Pa and the neglect of the community as not taking as serious the word of a kind of person. Ma has to whack the maximum of these plants to feel at ease. This serves to celebrate the freedom and assurance through the death of the enemy and all sorts of parasites damaging her household's peace. The silence that grips her children while looking her cutting down flowers means that the children are also in want of their mother's mental peace. Moreover, the power of premonition given to Ma is a way to empower her as she has no modern education like 5th Wife. We draw attention to this paradigm in order to illustrate the capacity of educated women to escape more quickly to male oppression unlike the uneducated ones. The theme of women's education fits so well with many African female writers such as Flora Nwapa's *Amaka*, Mariam Bâ's *Rama* and Aissatou. Education also crafts women new identity and the aptitude to reason and not to fear while trouble is ahead.

Just like a psychiatric doctor, Amma Darko takes her readers through the world of a mental sickness before the disease gains all her character's mind. We take the clues from her own acknowledgement where she thanks the staff of "the Accra Psychiatric Hospital" for having allowed her to visit the patients to measure the extent to which these people are special in or out their sickness. She was taken aback when she went at the Hospital. She confesses this: "I did some research work at the Accra Psychiatric Hospital [...] I was shocked to find out how many women were there due to the emotional abuse they suffered at the hands of their spouses who were having affairs with young women their daughters' ages.⁴⁵³" In the fiction, Ma undergoes a very traumatic situation so that all that she can do is to be mentally and spiritually above. First of all, "Ma's prayers were silent. She would go down on her knees in front of her bed and pray quietly to God and beg God to please erase the pain" (Darko, op. cit. 338). Then when it degrades to a worse level, her prayers "took on a hoarse and angry tone. Sometimes she became so muddled up she wondered to herself what exactly it was she was praying to God about, and what she wanted. Each day became more confusing" (Darko, 342).

⁴⁵³ Odamtten, V. O. (2007). "Beyond the Comfort Zone: Relations Between African Writers and Audience", in *Broadening the Horizon: Critical Introductions to Amma Darko* (UK: Ayeibia Clark Publishing Limited), pp. 9-10.

In other words, Ma's nervous and disturbed conditions are to be understood as the widespread conditions of lots of women in any post-independent African countries. Amma Darko's *Not Without Flowers* fulfils then a political function. There is a hidden link between patriarchal exploitation against the female folk and the situation occurring in African countries. If read this way, Pa represents African leaders who waste permanently their countries' money into their fantasies and the poor people symbolized by Ma. The voices that Ma usually hears are those of the people claiming to resist the oppressor. The voices wish to avenge all the shattered money and properties for fans, sex and trips all over the world while the people are suffering plain and pure poverty. Amma Darko is not the first Ghanaian writer to use voices in her novel. Voices are also used in Ayi Kwei Armah's *The Beautiful Ones are Not Yet Born* (1969). The present writer's novel is about corruption that accompanies most of the time power. Ian Milligan writes that "It is about the temptations which may be offered to politicians and the sense of estrangement which a man may feel from a society which too readily accepts injustice. Armah's voice is harsh and accusatory, but impressive". So when there is serious events to denounce, writers let intervene voices. Two voices are engaged in Armah's novel: the voice of the first man obliged to pay a bride and that of the man who behaves in a peculiar way to be identified as an insane. Like in Armah's, Amma Darko's prose draws no particular attention, till the repetition of some simple words draws finally curiosity. Voices in Armah's case and those of Amma Darko's expressed a symbol a social insecurity and decay. The new society where Africans have to live is not secured. Just like that depicted in Chris Abani's *Song for Night* (2006).

Amma Darko demonstrates to a large extent that fiction reflects the tensions within the society and that literature is in the service of the community. The author knows through her experience of tax woman that Ghana has serious difficulties to balance the annual budget, in spite of that, leaders take it for granted. They vacate with their lovers and acquaintances to satisfy their lust and funs while the people is under pressure and under depression.

Besides, when analysed accurately, Amma Darko's narrative depicting Ma's depression or mood disorders is the sane reply to Pa's decision to cooperate with the invading force. Ma fights for her life, her sanity, her liberty and that of her children against external and internal subjugation inclinations. To borrow from Christian Delacampagne, we would argue that Ma's

resistance is “contre-acculturatrice”⁴⁵⁴, which is expressed through the violence against colonisation machinery. This fictional work of Amma Darko delves far beyond the spatial and temporal scope of betrayal and draws its importance from colonial resistance fights against the European settlers and the Africans and the Africans against and their brothers Africans. Ma has to fight patriarchy represented by the society and its norms and then prepares her reply against colonial and subjugation forces. All this is overwhelming and exhausting for a woman. Like Ngugi wa Thiong’o’s *A Grain of Wheat* (1967) paying tribute to his people revolt in the pre-colonial time and thereafter for independence, Ma is the leader of a kind of home guerrilla not permitting her land to be violated and her people to be acculturated. Ma accepts to play her part in fighting here and now with her weapon so that her country pays her tribute. Ma knows clearly what she is fighting against: Flower and for her Pa to come back. As a matter of fact, Ma can be the second hero of the narrative if she succeeds in winning and bringing Pa back. But we all know what happened in the history of colonisation. The inside force lends a hand with the external one to bring about the resistance which leads to Ma’s psyche complete degradation. Her pathology reveals the cause of her alienation, the same way it is an indispensable reaction against the disease that stands here for colonisation. Hence, despite the fact that in African literature some characters may be chosen to play these unfortunate roles of depressed, mental alienated, we are sure that through these unusual characters the authors express the pertinence of their discourse.

In Gabriel Okara’s *The Voice* (1964), the male character Okolo, because of his subversive discourse, is taken as a mentally sick by the community. Creatively, the author makes him drown in a river to symbolize purification. The rite of purification diverges from an author to another. From a female perspective, the ritual in Flora Nwapa’s *One is Enough* stands for the protagonist’s having sex with a priest. The symbolic making love with a man of God changes Amaka’s standing. She changes from a mocked and kicked off barren to a mother of twin and then refuses to marry any man again. In the same view point, her female countrywoman, Buchi Emecheta writes about the death of her female character in *The Bride Price* as an ultimate rite of cleanliness. It means that one girl is worth dying to save the whole village. Aku-Nna succeeds in giving forth to a new generation. Aku-Nna is carved in an image

⁴⁵⁴ Delacampagne, C. (1978). “Introduction à une ethnopsychanalyse du messianisme”, In *La Violence Actes du Colloque de Milan*, Union Générale d’Editions, p. 345.

of a scarf which death will save the people. The symbol lies there and brings along traditional and Christian beliefs. The author proves the traditional assertion that blood is thicker than water.

In the same vein, the symbolism stands also for Ma's whacking off all the flowers to purify her garden. The psychiatrist Tobie Nathan⁴⁵⁵ appreciates the African traditional way of tackling mental sickness in the sense that it reintegrates the patient in his family after the therapy. The method is different from that of European where the depressed is ostracized and isolated from the community forever. These characters in African literature can also hold a complete wisdom and intelligence like in Wole Soyinka's play *Madmen and Specialists*⁴⁵⁶ (1974). The play presents a stark confrontation between good and evil forces. Good is defined as creative, beneficent and humane; and evil as destructive, sadistic and reductionist. The same thematic has been dealt with by the prolific Ghanaian writer now living Senegal, Ayi Kwei Armah. In his novel *The Healers* (1979)⁴⁵⁷ the narrator insists on the reintegration of African fundamental and important values to heal Asamoah and Araba Jesiwa. The African traditional therapy is not to be thrown away according to Ayi Kwei Armah. So if it were in Ayi Kwei Armah's *The Healers*, Ma would not be taken to a prayer camp in order to be whipped savagely but to a traditional seasoned therapist for treatment.

Hence, in *Not Without Flowers* at the debut of the pathology, her children, Kweku and Cora, do not understand the reason why it necessitates all that commotion, still, the more the coloniser's strategy hangs down, the more the reaction. Ma's action to get rid of Flower incarnates a whole movement of liberation like the Mau Mau's revolt, the Fanti and Akan reaction against colonisation. As we have earlier opined, Ma is sane in her insanity more than Pa's blank foolishness to leave all his possessions to a stranger (the colonizer). Her ostensible psychosis denotes the hostility of the people against the colonial administration which is set to loot and devastate the land with their gun (penis) and ideologies (the provocative beauty of Flower). This behaviour finds its explanation in Frantz Fanon's *Black Skin, White Masks* (1952) and *The Wretched of the Earth* (1968). Frantz Fanon defends the necessity for the colonized to rebel against the colonizer, point out the foolishness of him. According to Frantz Fanon, it is the

⁴⁵⁵ Tobie, N. ; Stenger I. (1999). *Médecins et Sorciers*, Paris, Sanofi-Synthélabo.

⁴⁵⁶ *Madmen and Specialists* is considered Soyinka's most pessimistic play, dealing with man's inhumanity and pervasive corruption in structures of power. It was conceived while Soyinka was imprisoned during the Nigeria Civil War.

⁴⁵⁷ Armah, A. K. (1979). *The Healers*, London, Heinemann.

colonizer who embodies the insanity that engenders trauma in the colonized. As a result, the reaction justifies Ma's commitment to attack and defend her integrity and that of her country (her household). She can control the sword's movement in the garden and direct the attacks against the rival. She also knows when she fails following the orders of the voice. Amma Darko illustrates: "Still, no blood. Failure. [...] Failure! Failure! Failure!" (Darko, 171). Ma's failure to finish Flowers seems to be tragic, but the narrator creates a possible escape.

Furthermore, Pa does not know until his suicide the dangerousness of his teamwork with the intruder. The female character Flower in the narrative strategizes tenderly but surely using her beauty and sexual capacity (ideologies) to trap some African leaders, Pa. She averts completely medusa-like his attention from his family. Subsequently, he abandons his nation in total suffering. In conclusion, we see that Amma Darko's narrative, just like her first novel *Beyond the Horizon*, turns head to the real historical event which happened to Fanti, Ewe and Akan people to the capsizing the whole kingdom. The kingdom turns to be Ghana, a mere colony, a vast land of wealth and knowledge but subjugated, surrendered people. What maintains its people in life is the story of glorious past events; loss of power provides anxiety and anger. Ma survives the hurricane which is about to devastate her life, but turns to a mere figure, frail, weak and alone like Akan, Fanti and Ewe kingdoms have turned desolate, wreck, ravage after their being conquered one after the other by the British Empire.

Taking cue of the preceding, we understand that Ma's disguised mental sickness is to be understood as the social and financial condition of an entire country, the whole African continent. From Dakar to Khartoum, from Lagos to Johannesburg, from Kampala to Cairo, the conditions are the same, overwhelmed and sorrowful. This reminds us of Frantz Fanon's historical phrase about the African continent's condition: "The condition of native is a nervous condition" in *The Wretch of the Earth*. The people of these different African countries become dejected because their leaders like Pa and his alike neglect them and prefer to have enjoyments outdoor. The inter-disciplinary role of literature is at stake with Amma Darko. The novelist makes literature speak to science and vice versa. This innovative literary technique is in fact her special touch. Amma Darko knows how the people's voice can be commanding when they are angry against the leaders. They can transfer this anger to anything or anyone that is associated with her current depression. Ma fights her oppressors who are flesh and bones her husband and his lover by the interposition of her garden's flowers. What she fails to do is to protect herself

and therefore defend her integrity, she can do it to the plants in her immediate surroundings. Sometimes, the similar rituals happen so that people are told in common beliefs to whip the trees, to give some punches in water to make vanish their wrath against a situation. Amma Darko goes on this way:

Following the orders that the voice was issuing in her head, Ma surveyed the compound, taking in all the varied and beautiful flowers that were in plentiful bloom. [...] A purple beauty, royal, graceful, feminine.

The knife was in Ma's hand and the voice was screaming blood. The previous day stayed away from inside her head.

Ma's feet came crushing down on a rose. Then another rose. Then a sunflower and another sunflower and a hibiscus. One foot after the other.

Crush! Crush! Crush!

Pa never gave Ma the middle name: Flower (Darko, 171).

The last sentence of the excerpt means that leaders pay no attention to their people's basic needs, even when they are depressed and live in nervous conditions. To make it worse for the wretched, Ma's depressed condition has been transposed to her daughter Cora and scattered her marriage as well. A depressed family can produce only depressed and mental fool children according to Amma Darko's writing. It means that the nervous conditions of parents can impact the psyche of their children. That is to say when the nation suffers from depression via a structural adjustment because of its financial and social conditions as highly indebted, underdeveloped and low income country, this implies the nation's children (Cora) are also suspected as depressed, mentally and economically poor and treated as so. Cora, as she is the one to bear the cross of shame and dust, is disqualified to marry Affuls, a rich and notable family. Getting marriage becomes a very serious matter when it comes to be a royal versus an ordinary family. This means that it is difficult for a poor family to be engaged for a life contract with a wealthy one because of the social gap. Consequently, between Affuls and Cora's family, there is social 'no-go'. The union is not worth daring as the risk is too high. Nana Afful's family refuses his marriage for two factors: the first is the depression of Cora's mother and the second Cora's father suicide (Darko, 124). The latter's family represents a family of mental dilemma. Cora is then likely to end either into mental health hospital or in graveyard and maybe the children she will bear for Affuls will be infected with the grain of mental sickness. The narrator's investigation is themed this way: "Nana Afful's family didn't want Cora in their family. Kweku was the appropriate person to convey that message to, and this he had done. If Kweku wanted the issue to be dealt with quietly and peacefully, then he was advising Kweku on

behalf of Nana Afful's family, to encourage Cora to initiate and instigate the break-up with Nana Afful" (Darko, 124). In fact, when a girl marries into a family of higher social status, she raises the fortunes of her immediate family by giving them access to economic and political power; but this power is never firmly secured until she has produced a baby, especially a boy. So the fear of the Affuls is to see that the regeneration of their species by the help of Cora's womb would be biased because she is a family of a mental sickness.

From the above extract, we see how analogically the narrator gives reason to Affuls as, just after the break-up, "Cora never recovered from that break-up with Nana Afful. She lapsed into deep depression and let herself go" (Darko, 124). In this way, Amma Darko discusses the social gap between families in the 21st century Ghanaian society. She highlights the possibility that some parents pass their illness on their children as if hereditary. However, the question raised is this: Is depression hereditary in actual fact? And Psychiatrists acknowledge that

depression tends to run in families, and yet there are plenty of examples where two clinically depressed parents can produce a child free from depression. What there seems to be is a general tendency toward depression within certain families; whether that is purely genetic code or not remains to be proven. If a parent or sibling has suffered from depression of some sort, other family members sharing the same blood are understandably concerned that they may also endure depression at some time in their lives. When family members witness and/or support a person with depression, it is logical that they should fear it for themselves.⁴⁵⁸

For example, a child living with depressed parents, may copy a number of abnormal behaviours and encompass these behaviours in his daily habits. He may want to set fire to his bed, destroy the house's carpet. Thus, it is quite possible that writers collaborate with scientists to come up with solutions to sickness like mental instability. The mentally instable may hear effectively urging, commanding and even paralysing voices. They may seem tormenting the sick at any moment. The victim may smile when there is no joke or shout when there is no subject of anger. Like Ma the victim is comparable to a robot whose moment is dictated by button somewhere. The victim is influenced and overwhelmed. The depicted symptoms here illustrate the effectiveness of Amma Darko's writing after her visit in the 'Acknowledgment' of the novel: "Mrs Alice Allotey, the current President of the Ghana Registered Nurses Association, and a good friend of my very supportive sister, Cecilia, also paved the way for me to interact

⁴⁵⁸ Read more <http://depressiond.org/is-depression-hereditary/>

with some staff of the Accra Psychiatric Hospital. (Darko, 9)” The passage points out the author’s strong desire to underscore a scientific truth in her fiction. She went to Accra Psychiatric hospital to dig out fresh news about the illness to confirm our point about literature, fiction and social reality.

Here, the evidence is going to be particularly accurate, for just like the way she deals with HIV and AIDS virus, Amma Darko wants the community to accept mental disorders patients. In fact, people do not take mental sickness as being a simple disarray like malaria, tough or eyes irritation, but God’s punishment from above against misdeeds. Then when it happens, the first place to go is to consult traditional healers, priests or anywhere else to find secured help and advice. That is what leads Amma Darko’s characters to go to the prayer camp called Whip to Conquer Satan (WCS). At the camp, the way these gospel-entrepreneurs treat mental health patients causes scare and therapeutic pity. They remove from their body and soul the tiny humanity remaining and reduce them to mere shadowed figures because they portray them as being possessed by evil spirits. The horrible act of whipping these figures of their own consist of “make the physical body an uncomfortable abode for the evil spirit to continue its occupation” (Darko, 31). The black sin is severed by several lashes like that of the Christ himself for it is conceived and born wretched. He has to pray the price of his inferiority as Frantz Fanon pointed with sarcasm “Sin is Negro as virtue is white”⁴⁵⁹. So in black and sick body, there can be no slightest of virtue. From hair to toes, it embodies sins and dirt. The depicted image reminds of the former slaves enchained in the slave merchants’ ships and obliged to sleep naked on rocks as pillow. As a matter of fact, the patients in there must be “saved through torture” (Darko, 12). The word ‘torture’ is plain and simple. Therefore, the mental patients undergo dehumanizing torments in order to diagnose the specific spirit in question:

There was no pillow for her head [...] about sixty, skeletal features, completely bald... Around each of her ankles was an iron ring hanged to a thick iron chain [...]

It was hooked through a hole in huge blunt iron rod buried into the concrete floor in the centre of the hut. There were other metal hooks in the hole from the other chained ankles. No wonder the wooden door was never locked. There was no need to.

⁴⁵⁹ Fanon, F. (1961). *Black Skin, White Masks*. (Trans.) Charles Lam Markmann, Pluto Press (1986), p. 106.

The frail woman stank of stale urine...They tiptoed to the next figure, also bald and huddled on a mat with no pillow. The ankle was also chained...They moved onto the next and the next, all women, all old, and bald, all frail and chained, all haggard and stinking of stale urine. (Darko, 27-8)

The narrator's comment is desperately sarcastic against the prayer camp and their way of tackling the issue. Figures here and there, metallic hooks in the hole to retain their frail ankle enchained, night and day rolling in their own urine, nowhere to go. The narrator's description is terrible and takes a back. Only concrete heart can do that in that prayer camp. There is not humanity in there. God has surely gone from these camps and leave his holy place to Satan himself, for they resort to whip these frail figures to conquer Satan. The conduct of these so called Christians and self-made prophets corroborates the biblical reference above about human wisdom as foolishness in God's eyes. The most disappointing act, the most disabling decision from the frail figure's parents is to send her to a prayer camp instead of sending her in psychiatric asylum for clinical cares with specialists of mental health. Yet, to understand their decision, we must seek the possible reasons in the cultural and religious foundation of her people.

In African religious cosmology, the spiritual world has always been considered as the highest and secured place for welfare conception. As positive elements like rain, sunshine, moonlight come from above so are sicknesses, bad harvests, misfortunes, and thunder. Therefore, in the collective memory, people are basically sure that all this is under the watchful control of spirits. That is the reason why they refer to the above force whenever they are in danger and thank them in happiness. In this light, African people do not systematically go to hospital when they are ill, but seek help from the representatives of the spiritual world: the healers who abridge between the spiritual world and humankind. These people undoubtedly uphold the knowledge and the secret of spirits and can tame the dreadful ones. African traditional beliefs motivate for example Ntifor and his wives to seek help from the seasoned herbalist, Opanin, before any consultation else. The faith also pushes Madume and Emenike to go to Anyika for help in Elechi Amadi's *The Concubine*. It is the same conviction which leads Okonkwo to Ogbuefi Ezeuder to seek for spiritual assistance in *Things Fall Apart*. As pointed out by Maclean (1974), "the real value of African medicine lies not in its materials but in the methods and concepts which underlie their use. It is characterized by its ability to supply

meaningful answers to questions which are relevant to patients and practitioners alike”⁴⁶⁰. However, Africans encountered with Europeans during the colonial time has changed almost all their spiritual faith. The colonial masters through their religious missionaries have obliged Africans to praise foreign spirits mentioned in Bible. The prolific and ever renowned African literature personalities, Chinua Achebe and Wole Soyinka have respectively offered a more perceptive study about the unfortunate result of the new religion on Africans from the colonial era to present day.

Having been robbed off their material resources and cultural identities as well, the now Christianized Africans must pray a white God⁴⁶¹ who has a son Jesus Christ and in their service all the saints in replacement to their black and pitiless gods and deities such as Egwugwu (spirit of dead), Shango or Hèvioso (god of thunder and storm), Ogu (god of iron and weapons), Toxosu or Abiku (god of malformed babies), Sakpata (god of earth) to cite only these few which they have been invoking and celebrating before the Europeans setting foot in Africa for their God ordained missions. This spiritual alienation dwells in their very soul from that moment and induces the introduction of new ways of worship in African communities. Africans encounter with Europeans have produced more negative transformations than ever according Cheikh Anta Diop, Kwame Nkrumah and Ayi Kwei Armah to name just a few. Thereafter have begun crusades, prayers camps, cleansings prayers, prayers for visa, prayer for marriage, prayers for protection, and prayers for this or for that have sprung like mushrooms all over any African post-independent country. In the remote villages of our post-colonial countries are built churches to save souls from perdition and sinful behaviours. Heaven above accepts to forgive extreme sins no more after goats, sheep, and cows sacrifices, but by offerings, tithe and electrifying prayers especially in camps, at beaches. Consequently, African people direct their spiritual requests to and in these new churches like Whipping to Conquer Satan which function in absolute violation of basic human rights. The owners of these uncompleted brick houses or open-air churches believe that the more the patients are tormented, the quicker they are healed. This belief has been focused on in Amma Darko’s writing to highlight its inaccurate side. The narrative then shows that the more the patients are tortured, the more they become sick. Ma is

⁴⁶⁰ Maclean, U. (1974). *Magical medicine: a Nigerian case study*. England: Penguin Books

⁴⁶¹ Ayi Kwei Armah has also written about a white God worshipping by African in *Two Thousand Seasons* (1973). The novel provides a survey of the history of Africa from the past to the future. It chronicles the life of the African people confronted with cultural, religious, economic and social enslavement. The writing calls for struggle for the liberation of the land.

just a shadow of herself in the camp with many other figures stinking of stale urine, frail, bald, weak and chained. The inhumane conditions in which live these innocent souls are worth depicting as that of the Nazis with their euphemistic language to disguise the true nature of their crimes. They used the term “Final Solution”⁴⁶² to refer to their plan to annihilate the Jewish people. The Nazis established ghettos (camps) in Warthegau (an area of western Poland annexed to Germany) to isolate the Jewish people. To corroborate the point, Professor Kwesi Yankar carries on with a kind of despondency in his tone that “in the 21st century Africa descends further into the abyss of barbarism” (Darko, 11) and nonsense. Along with Amma Darko’s position, the Nigerian patriarch, Wole Soyinka, has already criticized such a practice, Christianity’s stinging deviances in his satirical play *The Trial of Brother* (1964). *The Trial of Brother* ridicules such religious chimera by exposing to daylight self-made prophets in quest for fame and wealth taking advantage from people’s needs of spiritual protection against malicious and invisible powers. Conversely, Ama Ata Aidoo subscribes to the impossibility of replace African tradition with another. During her interview entitled ‘Facing the Millennium’, Ama Ata Aidoo defends this unalterable Pan Africanist position of hers:

Well, then, there is no replacement. I mean, I think that we are looking at a society which by and large, has been in a process of collapse and disintegration, as a result of colonial intervention for some time. That is, if we are looking at it in terms of very original traditional structures. [...] We don’t have to let everything collapse. What we need is a certain measure of energy. [...] Like making the education system meaningful, [...]. Like tackling the issue of African languages and what we want to do about that.⁴⁶³

Amma Darko’s *Not Without Flowers* gives an appropriate mirror-reflected image of the post-colonial society with all the prevailing social plights. She writes with no subject retained about what Ghana comes to be in contemporary period. To reinforce the position, we find useful to quote Rudine Sims Bishop’s insightful point:

Books are sometimes windows, offering views of worlds that may be real or imagined, familiar or strange. These windows are also sliding glass doors, and readers have only to walk through in imagination to become part of whatever world has been created or recreated by the author. When lighting conditions

⁴⁶² Aly, G. (1999). *"The Final Solution": Nazi Population Policy and the Murder of the European Jews*. London: Arnold and Breitman, Richard (1991). *The Architect of Genocide: Himmler and the Final Solution*. New York: Knopf.

⁴⁶³ Azodo, A. U. (1996). Interview with Ama Ata Aidoo: Facing the Millennium, Hauppauge, New York, p. 4.

are just right, however, a window can also be a mirror. Literature transforms human experience and reflects it back to us, and in that reflection we can see our own lives and experiences as part of the larger human experience. Reading, then, becomes a means of self-affirmation, and readers often seek their mirror in books.⁴⁶⁴

Amma Darko's commitment to a special type of writing finds its analogy in the above extract. A book is the door to outside world and rightly the mirror of society. What is then writing in books is a replication of the on-going life in the society. It can also reveal one society to outside world. African women's literature can act as a mirror, reflecting African cultures to Africans, and how it can serve as a window and a door, revealing African cultures to those outside of them in whole or in part. For example, through the plumes of Jamaica Kincaid, Mariama Bâ, Buchi Emecheta, people respectively know about the West Indies, Senegal, and Nigeria to cite only these few writers at the right moment these women wrote their books or past events. So the novel propounds the position of the author of *Not Without Flowers* traceable in her expository writing and her belief in African women's redemption plays a part therein. Amma Darko discusses overtly all the social issues by the help of premonition, superstitions and dreams. Most of these dreams and beliefs are at the heart of the plot in her novels principally *Not Without Flowers*. Some traditional beliefs are hard to remove. In the society where mother and father are very revered, that same society leaves them to wolf-park and wild dogs' wrath because of a simple dream, superstition, curses, as well as humour that come with her society. In this light, they may be accused of being dangerous, night wanderers, blood suckers, soul drivers, destine breakers, flyers on broom, witches. Amma Darko refers to these social issues in her writing to draw the reader's attention to the fact that much of the accusations have no proven basis. People especially women are blamed of being witches because of their age, but essentially because women in society should not be assertive and authoritative. As soon as they start seeking for their place, they become 'ndichie' to borrow from Okonkwo in Chinua Achebe's *Things Fall Apart*.

⁴⁶⁴ Sougou, O. (2001). Review Articles (Ayi Kwei Armah) Armah's Politics in *Osiris Rising: The African Diaspora Reversing the Crossing*, in *Identity, Culture and Politics*, Volume 2, Number 1, pp. 79-86.

11.2. Witchcraft depicted in Not Without Flowers

To introduce the subchapter, we find it right to underscore Amma Darko's insightful point in the first chapter in *The Housemaid* (1998):

In Ghana, if you come into the world a she, acquire the habit of praying. And master it. Because you will need it, desperately, as old age pursues you, and mother nature's hand approaches you with a wry smile, paint and brush at the ready, to daub you with wrinkles.

If on top of this, your children, waging a desperate war of their own for economic survival, find themselves having too little time for you, count you among the forsaken and forgotten; and if, crowning it all, cash, fine sweet cash, decides it doesn't really fancy your looks and eludes you in all nooks, crooks and crannies, then know for sure that you are on route to qualifying grandly as a witch.⁴⁶⁵

What must be mentioned is that Amma Darko's present masterpiece focuses on the dilemmas plaguing African societies. From marriage, polygamy, male and female prostitution to unfaithfulness and HIV/AIDS virus infection, the Ghanaian female author lays bare her young but productive imagination to point out the oppressive nature of African societies toward women in general and Ghanaian women in particular. Accurately, Amma Darko depicts "a world replete with family crises, triggering nightmares, premonitions, mental disorders, suicide, promiscuity and ultimate infections: HIV/AIDS" (Darko, p. 11). African women live in a turbulent world tightly holds up by cultural norms. In fact, the title of the fourth novel by Amma Darko can bear without difficulty Chinua Achebe's novel title *No Longer at Ease* because of the remarkable literary level of the author and the pertinence of what is written.

As the plot of the novel unfolds, it becomes evident that the issue of gender inequalities and its destructive effects stand tall among all the other themes. The female characters of Amma Darko have to where to run to for protection. The nightmares become true because the persistent premonitions are just forthcoming dreams. Vivid images and shadows seen in the dark are actual signs and symptoms. It is a spiritual power given solely to women, initiated women. These initiated become revered and dreadful since the power is tough and pitiless to deviants. Chinua Achebe's *Things Fall Apart* calls them 'ndichie' meaning one of the elder of the society. In fact, this points out that African patriarchal society limits women's capacity to take part in

⁴⁶⁵ Darko, A. (1998). *The Housemaid*, Heinemann, Edinburgh Gate, Harlow, Essex, p. 3

discussions and making decisions even the commonest. This means that women never have much say in community matters in many traditional African societies, and in most instances they tacitly accepted or were brainwashed into accepting their inferior status. In *Anowa* (1970) by Ama Ata Aidoo, Kofi Ako reminds his wife Anowa of her limits in their verbal divergences over the possession of slaves, stating “[w]e all know you are a woman and I am the man” (Aidoo, 30). This shows that women’s voices are often silenced and are supposed to be heard only in the private domain of the home, while men operated in the foreground. Conversely, when women begin to take part in overt discussions with men or with other women in society, they are rapidly attributed an invisible power which stands for their belonging in secret society of night wanderers, blood suckers, destiny breakers, dreams breakers. They belong to witchcraft that is why they dare to talk or respond in public, behaviour contrary to the norm. Before we know the challenge that witchcraft induce, we must define it, explore the status and function in contemporary Africa.

Moreover, we have to explore why and how psychology should investigate the role of witchcraft belief in Africa and how it constitutes a gender bias against African women especially. The English dictionary defines witch as wizard, sorcerer and emphasizes unfortunately that it is “a woman practicing the black arts, an ugly old woman, crone or hag, one supposed to possess supernatural powers especially by compact with the devil or a familiar, a magic spell; a hex”⁴⁶⁶. Thus, witchcraft by the same dictionary is “an act or instance of employing: sorcery especially with malevolent intent, a magical rite or technique; the exercise of supernatural powers, alleged intercourse with the devil or with familiar; an irresistible influence or fascination, charm, enchantment”⁴⁶⁷. The definition of witch exhibits the gender bias and stigma that has occurred historically in association witchcraft with women. Yet, what is worth noting is that a dictionary is a fine product of popular understanding, primary gossips, rumours or investigations in cultures by men either professional or not. Therefore, the focus on women as depicted in the English dictionary comes out of the popular recognition that a witch should be a woman and not a man. For example, the use of ‘*ndichie*’ by Chinua Achebe’s Okonkwo to characterize his first wife’s audacity as she raises her voice before him and that of Ntifo to his wife, Mena Kakraba (Darko, 161) is a simple and plain primary stereotype toward

⁴⁶⁶ Webster’s Third New International Dictionary of the English Language, Unabridged, Springfield, Mass.: G & C. Merriam Company, Publishers, 1996.

⁴⁶⁷ Webster’s Third New International Dictionary of the English Language, Unabridged, Springfield, Mass.: G & C. Merriam Company, Publishers, 1996.

women who are assertive. The *modus operandi* reflects obviously the misconception of women's capacity to guess, to be concerned in the on-going problems or well-being of loved one around them and have supernatural power. In the modern women's studies, the French philosopher and poet Hélène Cixous lays bare the foundation of the female need of breaking the long silence in her historical treatise *Le Rire de la Méduse* (1975) translated *Laugh of the Medusa* in 1976 by Paula Cohen and Keith Cohen. Hélène Cixous insists in her writing that a woman must write woman and a man, man to be right in her depiction.

In writing this way, Hélène Cixous finds back her pleasure, her senses, her organs, her immense bodily territories which have been kept under seal by the hegemonic presence of men. In the male constructed society, even the instinct of mother is denied to women. In medieval era, any woman accused of premonition or invoking any strange spirit was executed in public. For example, the story of Joan of Arc, the virgin of Orleans, is still present in the historical annals as having been a sad scapegoat of the past witch hunt. She has been executed in May 1431 at Rouen (France), among other reasons is because the church (influenced by the English) has not been prepared to accept in one hand a woman with such power and on the other, a woman to be at the top position of military decision making instances. The virgin was accused not of witchcraft but of gift of premonition, heresy, apostate and lie. No one dares to defend her because it is not easy to protect a person branded witch at that time.

As an African say goes that mothers care more than fathers, so a person has only a mother, but can have many fathers. Meanwhile, one sees that the functions of a witch are clear ranging from torturing, killing, destroying, transforming in the ghastliest ways. The motives for inflicting these ailments to their rivals and relatives may include jealousy, envy, cruelty, malice, possessed spirit, spirit under demonic influence. Some of these causes are consequences of unfaithfulness, and past misdeeds which reward is NEMESIS. To the latter point, an overwhelming African theory carries that evil spirits can decide to avenge against someone's past misdeeds. Perhaps he or she promises his or her faithfulness to a spirit (water spirit for example) in exchange of marriage, a good husband or wife, and offspring. Now that he or she has all that, he or she makes up his or her mind. Some overnight wealthy Africans are accused to have made that kind of pact. At the first, they accept to give their part of the long list of promises, but days passing it becomes difficult for them to fulfil their part of the obscure deal. Accusation of witchcraft always precludes a negative assessment. Old women in Amma Darko's

Not Without Flowers are in danger for they can be branded witches if people feel like suspecting them. What Amma Darko seeks to debunk is the patriarchal view of old women in post-colonial society.

Subsequently, in the collective memories, all Africans believe in witchcraft, demon, evil spirits and the paranormal even when they receive modern education and are deeply involved western religious beliefs. This principle leaks out in songs, tales, legends and all sorts of oral literary devices because of African traditional epistemology. When someone fails his exam or falls sick in a suspicious way, accusing fingers are pointed toward old women around, family curses, demons or far-off alliances with evil spirits. They do not take responsibilities for their failures and shortcoming. In both Europe and Africa accusations of ‘*maleficium*’ or its equivalent fall most heavily on women. With their magic power, witches can transform a course of life of one or many people.

For example, in the Greek Legend *The Odyssey* by Homer after drinking a potion from Circe, a very attractive woman, Odysseus’s men were all turned into pigs. Odysseus saved them by the help of Hermes, the legend supported. The woman tried to entice the captain, for no avail. There has been no shortage of explanations for this misogynistic aspect of the witch craze all over the world. In fact, mostly the emphasis is made because of the vulnerability and stigmatization of women, particularly the older ones without husbands who are recurrently suspected. People accuse the witch to have the power to destroy the life power of the victims. The feeling is therefore directed to middle age and old women because of their physical aspect and if above all they have a power of premonition and someone in their family dies, the puzzle is then settled; they are branded witches for life. Witchcraft evokes and reinforces image of ignorance, backwardness, primitiveness and underdevelopment. In *Not Without Flowers*, Idan’s grandmother who died two decades ago, has a gift of premonition which is assimilated with witchcraft power in action. As we highlighted earlier, it is the gift of premonition which helps her sense bad omen in her family, but at that time nobody suspects it as being dangerous until her own nephew, a self-proclaimed and self-taught pastor, insinuates that “the old woman was a witch” (Darko, op. cit. 166). The narrator points it sarcastically to show the society’s position about witchcraft heritage which is similar to the fate of the medusa, beautiful, wicked and to be feared for:

It was in the family. Sisi was a witch who wanted to transfer the witchcraft to her two granddaughters, they argued. *No male in their family had been declared a wizard so it had to be the females who inherit it.* The two granddaughters had refused the witchcraft [sic] for which reason Sisi had made them pay their respective retardation and deformity. [...]. *She proclaimed herself a witch seeking exorcism and announced that indeed, she and Sisi belonged to the same worship group in the underworld of witches. She revealed that Sisi had been ordered by the underworld queen to transfer her witchcraft to Efe and direct Efe to use it to destroy her husband and his family. [...]* Efe packed her things one morning after her husband had left for work and returned home to Sisi with her two sons and their daughter the hunchback. (Darko, 202-03, Italics mine)

The reason of the hunt is diagnosed: Sisi, the witch is ordered to pass her satanic power on the future generation and especially females and it urges to stop it. People suspecting have no proof, but are convincing. From that very time, the whole family descends into a deep moral abyss as not knowing if they are right or wrong about the suspicion. Thus, Ofofu corroborates that “This spells a clash of cultures and religions; the African versus the Western culture; Christianity versus Traditional Religion.⁴⁶⁸” The clash of cultures and religions has been one of the central thematic with many African writers since independence in Africa. Europeans set foot on the continent with their park of missionaries in order to debilitate African existing religious beliefs which pay tribute to elderly people. They brainwashed the first Africans with their cultural and religious norms. Bible has severely reprimanded his people in the book of Deuteronomy:

when you enter the land the Lord your God is giving you, do not learn to imitate the detestable ways of the nations there. Let no one be found among you who sacrifices their son or daughter in the fire, who practices divination or sorcery, interprets omens, engages in witchcraft, or casts spell, or who is a medium or spiritist or who consults the dead. Anyone who does these things is detestable to the Lord.⁴⁶⁹

The subversive accusation of the youngster and self-ordained man of God also poses a problem generation conflict since the younger generation seems to pay no respect to the older one. In the olden time, it could not be possible for this young man to come and proclaim the supremacy of another religion in the house of his grandfather without showing proof of his

⁴⁶⁸ Ofofu, J. D. (2013). “The Feminist Voice in Contemporary Ghanaian Female Fiction: A Textual Analysis of Amma Darko’s *Faceless* and *Not Without Flowers*” in *Research on Humanities and Social Sciences* Vol.3, No.1, p. 180.

⁴⁶⁹ Bible International Version, Deuteronomy 18 : 9-12.

allegations; punishment comes after. For example, the news of Idan's grandmother being a witch goes round to reach the ears of Affuls who fear to have as wife for their dearest son, a woman from such a bewitched and demoniac family. People think that being Christians give them right to belittle their former cultures. The question which Affuls and the alike may ask is what if it was the grandmother witchcraft that transformed the destiny of her own daughter and that of her husband who committed suicide? A family replete of witch and mental sick must be feared anyway. Here again, Amma Darko seizes the opportunity to hammer on one serious social problem that is gradually tearing the Ghanaian and by extension African society apart: the growing phenomenon of new Christian religions.

Amma Darko's novel sheds light on the harmful impact of these religions over African families. To proclaim with no real proof that a revered grandmother is a witch and by extension that she is one to instigate her grandchildren's misfortune is the most deviant conclusion a man of God can make. However, in contemporary Africa, we have many Affuls as "African cosmology is characterized by a preoccupation with good and evil spirits. The principal evil is attributed to witchcraft, since it is held that all evil forces can be in league with witches to effect an evil act"⁴⁷⁰. An argument can be made that if an African has been treated with modern medicine when he is sick, he will not be cured since the common belief is that he is bewitched. The better way for the sick or his parents have to do is to seek help from a witchdoctor or an herbalist. The sooner they go, the faster he may be healed. As a matter of fact, when a boil appears on Ntifor's leg, it is suspected as "one of those evil ones" (Darko, op. cit. 160). Witch action is suspected anytime there is an unexplainable question. The negative aspects include that of Ma's depression which can be explained as a curse or an overnight attack from her rival Flower because a polygynous situation provides jealousy and envy among women.

The only place Ma's children can use is the prayers camp because of their Christian faith. Even Kweku, the elder of the family, who went to modern school, cannot know that many of the symptoms taken as attack from witchcraft or spirit possession can be explained away by medical sciences. In such cases repeated sessions of deliverance worsen the person's conditions. In these prayers camp the admitted are subjected to sequential whippings to make the body an uncomfortable space for the evil spirit to continue its stay. These prayers camps flourish all over

⁴⁷⁰ Onyinah, O. (2012). Pentecostal Exorcism. Witchcraft and Demonology in Ghana. Blandford Form: Deo Publishing quoted in Witchcraft Concepts in West-African Pentecostal Literature, Bachmann, Judith, GloPent Conference, London, pp. 3-4.

Ghana and other post-independent countries today since it does not necessitate any training, certificate or formal recognition from a body of Christians. Unemployed and opportunists like Raja Hey alias Who Killed Lucy and the grandmother's nephew, who have strong personality can easily claim spiritual encounters and strive after modern wealth at the expenses of the poor innocent believers. They adopt all kind of ways to convince people that they are wasting time and money, and then suggest their whipping camp. Nevertheless, other people erect some camps, which have nothing to do with the treacherous ones, where there are no whippings sessions, but are left to their own fate. For example, we have from the International NGO ActionAid's Report "*Condemned Without Trials: Women and Witchcraft in Ghana*" the following:

In northern Ghana hundreds of women accused of witchcraft by relatives or members of their community are living in 'witch camps' after fleeing or being banished from their homes. The camps, which are home to around 800 women and 500 children, offer poor living conditions and little hope of a normal life. [...] The six 'witch camps' of Gambaga, Kukuo, Gnani, Bonyase, Nabuli and Kpatinga are located close to or even within 'ordinary' towns or villages and all are in remote areas of northern Ghana. They are not fenced off but residents and those outside are very aware of where the camps' boundaries lie.

*The camps consist mainly of mud huts with flimsy thatched roofs. Food supplies are inadequate and, in some camps, women have to walk several miles to collect water.*⁴⁷¹ (Italics mine)

The overall characteristics of these accused of witchcraft are in majority illiterate, poor, relatively old, and abandoned and most of the time from villages where the belief and the fear are still present. Those who reach the camp, after being accused, according to the report, are lucky because others are trampled and set on fire by their own relatives. In our context, the narrator does not focus on the time when Ma's children accept to admit her in the camp. What is clear is that the more these admitted figures are illiterate and poor, the more society isolate them. Like leprosy and Buruli ulcer, witchcraft seems to be for destitute. "There are whipped, chained, thrown in filth and squalor in the name of exorcising the devil" (Darko, 12). However, the admission to that house of horror demonstrates that people are desperate about the ailment of their beloved. Thus any solution presented to them is welcome. It is for example like when someone is suffering from a severe stomach-ache and his parents offer him a forged concoction

⁴⁷¹ ActionAid International 2012 Report "*Condemned Without Trials: Women and Witchcraft in Ghana*", Johannesburg, South Africa.

based on herbs mixed up with mud. The patient will take it immediately before detecting that it has nothing to do with his complaint. Furthermore, “the stigma that mental disease attracts can be crippling, made worse if it points to a family history” (Darko, 12-13). In this way, the sooner it is healed, the better for everyone for no family want to be pointed as developing that disorder or its alike.

On the other hand, a belief either traditional or modern becomes awkward when it allows abuse on its own children for the sake of money or individual reputation. Amma Darko seizes occasions to reveal her feminist perspective by uncovering women’s hell like conditions in patriarchal societies. Amma Darko thinks that all these embarrassing conditions prevail because people decide not to talk about and the silence nourishes the mess. To shed light on the situation, Amma Darko suggests that media and NGO must help in the feminist struggle. Her appeal is similar to that of her Nigerian female counterpart Chimamanda Adichie Ngozi (TeDx Talk, 2012⁴⁷²). Chimamanda Ngozi Adichie suggests that women should reckon with the help of men in their struggle against social forces of stagnation and status quo. Therefore, the role of these social structures is to fetch information and documentation to empower women and the population. In fact, Amma Darko shows the very role of these institutions by already laying it forth through her own pen and notebook. Amma Darko herself confesses the important role of writing and therefore of literature:

Sometimes when I’m very depressed, that’s when the urge comes ...It’s when I’m under pressure or when I’m going through bad times I write a lot. Because then I have to write to survive. And when things are so smooth, I don’t know, maybe it kills the urge or dampens it a little (3 December 1999).⁴⁷³

Amma Darko clearly points out in the above extract that she writes to feel free and to cure her own depression and that of female counterparts in Ghana and in other African countries. The role Amma Darko assigns to literature is that of a psychologist, psychiatrist or a social worker can do, that is to discuss prevailing abuses and gender inequalities and help find solutions through convincing characters.

⁴⁷² Ted Talks. The Danger of a Single Story. Chimamanda Ngozi Adichie. March 28, 2012. <http://www.ted.com/talks/chimamanda_adichie_the_danger_of_a_single_story.html>

⁴⁷³ Odamtten, V. O. (2007). “Amma Darko: Writing Her Way, Creating a Writing Life”, in *Broadening the Horizon: Critical Introductions to Amma Darko* (UK: Ayebia Clark Publishing Limited), p. 14.

Throughout the novelist's writing, the reader's attention is drawn to social issues particularly gender inequalities plaguing women's day-to-day life in patriarchal society. Amma Darko seems to continue the gender struggle where her Ghanaian female counterparts stopped years ago. Shockingly, the narrative exposes old women's life in a society which has no eyes for their possibility and capability to share their knowledge, but all that they can share according to the stereotypes is witchcraft and their dangerous gift of premonition. For example, Sisi the old woman is branded witch ready to pass her supernatural legacy on her grandchildren and because of the suspicion none of his relatives and kin has to visit her again. The detection of her fourth grandson's hunchback provokes all the polemic. Then, who will celebrate with the coming generation the history and legends of the community if all the old age is feared this way? As the say goes who will dance if everyone wants to beat the drum? Amma Darko leaves the question unanswered and trotting in the reader's mind.

Further, when it comes to blame someone of having induced unfaithfulness, once more in patriarchal society, women are the first to be accused and to be suspected as infertile or to be at the cause of the conjugal issue. The view that it makes two people of different sexes (male and female) and physiologically normal to reproduce is let aside. Traditional opinion is that women are the mother of creation; therefore, as soon as a man and a woman get together a year later pregnancy should occur. Amma Darko proves by and large in her text that in a household, a woman can suffer from serious health impairment history like womb amputation which can eternally block her from childbearing. Other hormonal decline or higher pick can delay the pregnancy occurrence. When the cause happens to be from the woman, society quickens to point accusing fingers and lays the blame. However, when it is the man who has the problem, society protects him and then puts it on the back of the nature or witchcraft. Extending the idea, Amma Darko exposes the pain of women in such predicaments where great expectations are put on their ability to bring forth to children and to regenerate human species all over the earth to fulfil God's assignment.

When women feel sexually unfulfilled as a result of their living in polygamous households, they are emotionally in danger since it is impossible for them to ask for more sex and more attention, lest they are branded prostitutes or names alike. Like Pesewa's first wife does in the narrative, society wants all women to keep their sexual unfulfillment under double lock as a yoke to bear silently and not to explore outside. As soon as second wife starts peering

around the possibility to satisfy her voluptuous desires out of her marital bed with potent and young men, 'evil spirits of infection' come knocking at her door. This is Amma Darko's way of condemning not only polygamy to show the financial status of the man, but also his unfaithfulness. Had Pesewa not taken on many wives after his docile first one, he would not have been infected with HIV virus. No one is saved in Amma Darko's narrative since the same sanction is applied to Pa and Idan. Ma resists to the oppression as a result of her husband's extra conjugal love affairs with a very attractive university girl. Flower hooks on Pa's pockets and drains them dry to his loss. Ma has to manage the stereotype against mental sickness patients in society after having settled her conflict with Flower. In presenting Ma's mental health state, Amma Darko wants society to be more flexible and more regarding irrespective to people's fear to be contaminated. Mental depression and its alike are not like some skin diseases to be contracted when the patient greets a safe partner. Also, a family with mental disease history does not produce eternally patients of that kind. This may happen, but the probability to occur is very tiny. To write with evidence based-proofs, Amma Darko pays a prior visit to the staff of the Accra Psychiatric Hospital and also reads textbooks and other materials given by the Psychology Department of the University of Ghana to be sure of what she communicates. In doing so, Amma Darko does want to apply an unmistakable therapy to the disease and to the possible stereotypes coming along. Amma Darko does not fail. Thus, she links successfully literature to medical sciences.

Polygamy and unfaithfulness are two social conditions that work together in the narrative. When both find place in a household, peace goes through a window. The story unfolds on Pesewa's peaceful mansion troubled by the intrusion of second wife. As it was put earlier, second wife is unsatisfied sexually and then starts looking outside to cool herself. She is blamed for having opened the mansion to HIV/AIDS virus which leads to Pesewa suicide since he cannot cope with people's gossips and scornful looks at the breaking news. Second wife's infection news leak out down town and people start fearing to come and purchase items in her good and well-stocked shop. All the servants and friends who flowed in Pesewa's mansion disappear for fear of being contaminated. This raises the interrogation of how HIV-infected patients are treated in society. That lack of more information and public campaigns related to the mode of contamination make people translate their fear and anger against the patients. Therefore, Amma Darko calls on the community's cooperation and consideration to cater a more human regard toward these people in need.

Extending the idea, Amma Darko administers her therapy as a professional tax woman to set right the numerous ailments of African society against women's fellows. One of her therapy is to find necessary and significant Ntifor's taking on a second wife in order to fill the gap left by his first wife barrenness. The novelist means that whenever it is absolutely needed for a man to take on a new woman to help solve childbearing expectation, the man can be allowed to with a strictly controlled number. The man has also the duty to ensure equality and stability in the household. In this way, both women cannot see each other as rival, but as sisters bound to share the same cradle of command and sexual pleasures. All these tactful details are indeed a true reflection of realities in society.

PART THREE:
**THE FACETS OF AFRICAN FEMINISM: AMMA
DARKO'S TOUCH OF CHARACTERIZATION**

Amma Darko writes about women's lives, issues, and concerns within the traditional and urban culture of Ghanaian society. As she explores many of the characteristics of her social group, she posits the women's desire for change, choice, and acceptance within a society in which they wish to participate fully as human beings and not just as women traditionally expected to participate in a limited, culturally-defined way. The female characters in Amma Darko's novels speak to the needs of collective and individual female identity within their culture. They seek love and respect from the community and acceptance of the choices they make, though some compromise themselves. Most of the time, as bell hooks writes

Males as a group have and do benefit the most from patriarchy, from the assumption that they are superior to females and should rule over us. But those benefits have come with a price. In return for all the goodies men receive from patriarchy, they are required to dominate women, to exploit and oppress us, using violence if they must to keep patriarchy intact⁴⁷⁴.

This is why as Amma Darko's works evolve, her female characters become more independent, self-styled and sometimes more aggressive. Increasingly, they are women with a mission and those who have a real mission are empowered either by their early education or by a new event. Unlike her female counterparts who write about the clash between modernity and tradition, Amma Darko writes about women's education as one of the foremost issues on women's agenda because education brings along self-confidence, self-reliance, gender issues awareness, women's rights awareness for emancipation. Amma Darko portrays her male characters as ignorant of women's rights and needs to have their say in the household's ongoing life. The authoress wants definitely people to change their view on male power which earns them respect and fame. A man, according to Amma Darko, should be different and should change: "Who is a good man if not the one who eats his wife completely, and pushes her down with a good gulp of alcohol? In our time, the best citizen was the man who swallowed more than one woman, and the more, the better. So our warriors and our kings married more women than other men in their communities"⁴⁷⁵. On the other side, Amma Darko is perhaps saying to the men folk that if they want to be at peace in their marriage, then they have to marry one wife and be faithful to her. Thus there are many different perspectives on gender-based oppression and possible avenues for countering it that we will explore throughout Amma Darko's novels.

⁴⁷⁴ Hooks, b. (2000). *Feminism is for Everybody: Passionate Politics*. Cambridge: South End Press, p. 8.

⁴⁷⁵ Aidoo, A. A. (1993). *Changes: A Love Story* (New York: The Feminist Press), p. 109.

Further, the word ‘empowerment’ is not of distant etymology with emancipation. It became widely used and popularised by the ‘Draft Platform of Action’ of the Beijing Declaration of 1995. Empowerment suggests the giving of power to someone who has been deprived of it once, someone who will remain vulnerable without that power, someone whose hope for justice and fairness seems hinged only on the possession of that power. This power has to be wrested from a despot, in this case, man. The power has been given to him by his patriarchal society. That power also promises to be a magic potion for all sexual problems: inequality between the sexes, under-representation. All these features underscore the origin of sexual conflict embedded in the psyche. The obvious conflict that began in the olden times and continues up to today seems to be the one thread that runs through the intellect of the social development worldwide. Women seek power by all means and ways. Any opportunity is a possible path of voice. When women seek for recognition and they find the pathway conducting to it through literature, they are on the top with all their saint anger.

Women portray female characters in their creative writing to give sense to their life. Amma Darko reacts eagerly once against the precarious living conditions of women of contemporary Ghana and justifies her writing as an accurate rejection of the status quo. Amma Darko’s writings speak and seek to both present and alter reality. The authoress employs male and female characters, good and bad, naïve and cunning, silent and assertive to demonstrate her point of view. She constructs meaningful status to her characters and makes to the reader understand the sense of her literary philosophy. Amma Darko’s literary approach is in the same line with Magie Humm’s view according which, “the word feminism can stand for a belief in sexual equality combined with a commitment to transform society”⁴⁷⁶. It is that sense of society’s transformation which leads Amma Darko’s technique of characterisation. Characters study requires that the reader brings together the major traits such as the names, the title, the physical appearance, the clothing, the speech, the actions and the setting where the characters live. We agree with this insightful emphasis which writes that “Feminists critics are [*mostly*⁴⁷⁷] interested in exploring how men have exercised such power so widely in society, but also how

⁴⁷⁶ Humm, M. (1992). *Feminisms: A Reader*. New York: (ed). Harvester Wheatsheaf.

⁴⁷⁷ This word is ours.

women's experiences of selfhood have been affected by the power exercised over them. What capacities in women have been deemed "unnatural" and therefore punished if demonstrated?"⁴⁷⁸

The means by which these questions can be relatively answered is characterization. Characterization is the means by which the author gives a full sense to her feminist position in her narrative. Characterization also allows an author to put souls in factious bodies like those of characters and these latter are what attract mostly readers to novels. It gives the physical and psychological description of the character, but sometime women do not simply seek to point out victimization from other women. They want to persuade and have recognition that women also can raise attention financially and socially throughout solid and well-constructed narratives. We have already mentioned the narratives that describe Anowa's life in Ama Ata Aidoo's *Anowa* and Amaka in Flora Nwapa's *One Is Enough*. These early feminist works consist of point out those blind spots, raising women's consciousness of their own oppression, and tracing how and why they have been trapped in social intricacies; citing then poverty, their inaction to fight back, their fear to get together for serious actions against these odds. In that range of female writers rises a new one that is Amma Darko. In examining her female characterization, Vincent Odamtten, Professor of Literature at Hamilton College, confirms that

[...] Darko was able to carve out the space and time from which she could write the kind of narrative about the sort of people she knew and met. Unlike her literary predecessors, who often wrote about individuals torn by contradictions of negotiating the highways and byways of tradition and modernity, [...] she rejected such self-absorbed characters.⁴⁷⁹

In so doing, she addresses women's predicaments in patriarchal societies. The eminent new Ghanaian literary voice, the author of five novels uses a special touch to show her commitment to women's autonomy, but we select only four for our study. Amma Darko focuses her attention on women and what they go through in life, their love for the family, their absolute respect for their husbands even when they treat them shabbily and how some of them were able to say stop to all forms of discrimination. Our aim in the following chapters, after differentiating the characters of each novel, that round, flat, protagonist, antagonist, autodiegetic, major and minor, will be to analyse the role assigned to each of them. We will also mention the

⁴⁷⁸ Hall, D. (2001) *Literary and Cultural Theory: From Basic Principles to Advances Applications*. Boston-New York: Houghton Mifflin Company, p. 203.

⁴⁷⁹ Odamtten, V. O. (2007). "Beyond the Comfort Zone: Relations Between African Writers and Audience", in *Broadening the Horizon: Critical Introductions to Amma Darko* (UK: Ayeibia Clark Publishing Limited), p. 5.

psychological state of each character depicted in the novels, the link between their name and their attitude and acts, the way they conduct their speech in the invented but realistic setting and finally how they bear the significance of their traditional Ghanaian names. In the light of this, we agree with the insight of Vincent Odamtten who states:

Despite a style that has been characterized as direct and straightforward, her narratives have an irony of tone and are set against a complex sociological background. Indeed, she is remarkable for her ability to build a multiplicity of narratives and psychological perspectives into a given story, which is perhaps predictable.⁴⁸⁰

This means that our task in this chapter will investigate these issues as we intend to take into account the maximum of the female characters in the fiction under consideration because the protagonists in the novels are all women. Indeed, literary writings provide invaluable and intriguing sources of data that we can use to address these gender-based issues. As Jessica Holt pinpoints “Feminist artists appropriated familiar images of women and used them as a means to propel their agenda. When depicted by women, the female body became a powerful weapon against the social constructs of gender”⁴⁸¹. Through these characters we shall learn about truth, lie, plight, goodness, dishonesty, fears, obsessions, motives in society. What characterization and narrator comments help discover the gender belief systems in Amma Darko’s and other female writers’ texts? The following lines highlight the perspective of all that is above pointed.

⁴⁸⁰ Odamtten, V. O. (2007). “Beyond the Comfort Zone: Relations Between African Writers and Audience”, in *Broadening the Horizon: Critical Introductions to Amma Darko* (UK: Ayebia Clark Publishing Limited), p. 6.

⁴⁸¹ Holt, J. “The Changing Representations of Women: The Art of Hannah Wilke, Lynda Benglis, and Cindy Sherman” <http://www.brooklyn.cuny.edu/pub/departments/bcurj/pdf/HoltJessicaART.pdf>

Chapter five: Female characters' roles in Amma Darko's novels

In fiction, authors use many different types of characters to illustrate their plot and to interest their audience. The words of Akua Agyeiwaa Manieson, a “character is the representation of a person in a narrative or dramatic work of art (such as novel, play, or film). Since the nineteenth century, the art of creating characters, as practiced by authors or, has been characterisation”⁴⁸². In this way, characterisation is the process by which the writer reveals the personality of a character either directly or indirectly.

In writing her own stories, Amma Darko presents different types of women transformed by their assigned roles; naive women, good women, illiterate women, educated women, subjugated women, dangerous women. Furthermore, names given to characters in her narratives also transform their lives and render them active or passive. Characters have long been regarded as fictive people. To understand characters, readers tend to resort to their knowledge about real people. In this framework, an anthropological, biological or psychological theory of persons can also be used in character analysis, as for example in Sigmund Freud's analysis of *Hamlet* where he claims “I have here translated into consciousness what had to remain unconscious in the mind of the hero”⁴⁸³. The names serve a particular function in the text and mediate the specific choice bestowed to the characters by the writer. The names also contribute to the understanding of a part or the whole message conveyed in a fiction. When it occurs that a writer gives a proper name to a character from a socio-cultural or religious origin, this can serve a specific purpose as well as to incarnate an identity, a history or just a simple choice.

In the process of writing, a writer can thus choose a name for just the pleasure to have it in his story. In this light, Amma Darko's use of proper names from European culture in her novels shows in fact the influence of colonisation on Ghanaian culture. The attitude of giving a European name to an African in Ghana proves the extent to which Ghanaians are acculturated. One of the examples of proper names is Comfort and Vivian in *Beyond the Horizon*, Agnes in *Not Without Flowers*. In this scope, we agree with Ayodele Allagbe who submits that “[...] once these names are deployed in literature, their function is no longer indexical or deictic but rather specific. This is to say, these names carry specific meanings which integrate and imprison the

⁴⁸² Manieson, A. A. (2011). *Interpretation and Analysis of Purple Hibiscus*, Accra: Akua A. Manieson Publisher, p. 20.

⁴⁸³ Freud, S. ([1900] 1950). *The Interpretation of Dreams*. New York: The Modern Library. 1900] 1950: p.164).

characters in the fictional world”⁴⁸⁴. In the same light if thought, Peace Ibala points out that “It is common critical knowledge that the basis of fictional writing is character creation, perhaps nothing else. Characters not only add depth and complexity to the novels by giving readers perspectives of situations, but keep the readers engaged at all times”⁴⁸⁵. In the similar vein, Ogaga Okuyade puts that “The development of the protagonists is usually physical and psychological, each stage corresponding to their major areas of abode in the novels, since the environment in which they find themselves influences their worldviews at any given time”⁴⁸⁶.

Either with African words or European, Christian or Muslim, characters’ names in novels are evocative and significant. Characters’ names reinforce traits, sometimes through their acoustic and metaphoric value. Names can also be of a semantic connection. Characters’ frequent actions, the physical shape and behaviour in a novel as we say, can determine their name. For example, Unuka Agbala in Chinua Achebe’s *Things Fall Apart* (1958) is portrayed as a lazy man and the name proves it well and then Piggy, the fat boy in William Golding’s *Lord of the Flies* (1954).

In *The Housemaid*, the author takes on the challenge by using only Ghanaian cultural naming chart to illustrate her attachment to her culture. We have for example Efia, Tika and Akua to cite only these few. In African setting, names are given a spiritual power because of their vibration that echoes the ethnic lineage. A name is not just a name in Africa. A child’s name reflects the aim his parent wants his life to be guided. A name can also reveal the family’s history, a famous king or warrior’s name and the circumstances (joy or sadness) in which the child is born. That is why a name that befalls a child is attributed after a spiritual consultation which compels each member of the family to accept it. This practice stretches back thousands of millions of years in Africa. The practice echoes the spiritual essence of Africans at the beginning of time. For example, names of Yoruba or Fanti or any other African communities are not given for joke, but out of a meaningful basis for a meaningful purpose. Either they are emotional or spiritual.

⁴⁸⁴ Allagbe, A. (2016). “Character Naming and Authorial Attitudes in Contemporary African Literature” in *Research on Humanities and Social Sciences* ISSN (Paper) 2224-5766 ISSN (Online)2225-0484 (Online) Vol.6, No.4, p. 1.

⁴⁸⁵ Ibala, P. (2013). “Inflationary and Deflationary Characterization in the Novels of Ayi Kwei Armah” in *Research on Humanities and Social Sciences* ISSN 2222-1719 (Paper) ISSN 2222-2863 (Online) Vol.3, No.17, p. 1.

⁴⁸⁶ Okuyade, O. (2010). “Trying to survive: Growth and transformation in African female narratives”. *California Linguistic Notes* Volume XXXV No. 1.

In opposition, another school of thought pictured character as mere words or a paradigm of traits described by words. A well-known example of this “approach is Barthes’s *S/Z*⁴⁸⁷” in which one of the codes, “voices,” substitutes for person, understood as the web of semes attached to a proper name. In this view, a character is not to be taken for anything like a person, yet on closer examination these semes correspond to traditional character traits. (Barthes, Roland, *idem*).

In this dissertation, we agree with David Lodge’s school of thought and sustain that in a real life, a character is a flesh-blood-and-bones person, someone who sees people and whom people can see, hear and discuss with. This means that in Ghanaian cities we can meet and discuss with many Maras, Poisons, Maa Tsurus, Kofi Pokus, Sylv Pos, Dianas, Vickys, Pesewas and Pesewa’s wives, to cite only these few. The narrator or the character has then a voice, a soul given by the writer. We can hear all these voices while reading throughout the novels. Amma Darko then creates a real but fictional life around the novel. Amma Darko sets most of her fictional works in Ghana, a post-colonial country which is a male-dominated community where names are supposed to be very meaningful due to the prevailing gender inequalities, the colonial history and the past glorious history of the country. For example, since the independence of Ghana from the British Empire, there is a resurgence of historically meaningful names of warriors like Poku, Nana, Asantewaa, Komfo, among others, given to babies born from that moment to this date. Therefore, the ideas from Latimer (1989) and Bamisaye (1997) that view that naming and nicknaming in literary devices do not denote anything and do not carry any semantic relevance are both rejected in our thesis. On the contrary, we agree with the fact that African names used in narratives and discourses written by Africans are full of sense as submitted by Ogunwale Joshua Abiodun *et al* (2015).⁴⁸⁸

As we have pointed earlier, literature is the channel by which social, economic and cultural messages are conveyed and Amma Darko also illustrates this function in her novels. Her first novel, *Beyond the Horizon*, has been so much influenced by her stay in Germany and the second turns out to be on her early years as young girl in Ghana listening to grandmothers’

⁴⁸⁷ Barthes, R. ([1970] 1974). *S/Z*. New York: Hill & Wang.

⁴⁸⁸ Ogunwale, J. A. ; Bamigbade , Oluwafemi, E. (2014). “*Linguistic Alienation and Culture Subversion as Sociolinguistic Factors for Name Dropping and Change among the So-Called Yoruba Elites*” in IOSR Journal Of Humanities And Social Science (IOSR-JHSS) Volume 19, Issue 11, Ver. I (Nov. 2014), PP 42-53 e-ISSN: 2279-0837, p-ISSN: 2279-0845.

stories and traditional tales about young girls who fled from their home. As for her third novel *Faceless*, Amma Darko conveys three important messages to her society. The first is the impact of rapid urbanisation on poor families in Ghana which brings along street children plights. The second is the necessity of revolt of youth against the inaction of the Ghanaian government about the phenomenon of street children and the last is the consequence of the first two points above which is the survival of the juvenile urban prostitution in Ghanaian cities and by extension in the other African cities. The fourth novel draws the community's attention to social and not yet solved issues like polygyny, unfaithfulness, female depression due to their husbands' neglect, the recurring plight of HIV/AIDS and its consequences on the probable infected. In writing such a fiction, Amma Darko does insist on the growing syndrome of male prostitution in Ghanaian cities which also havocs in the population. In her fiction, contemporary Ghanaian female writer Amma Darko captures the very ideals that spring from the hearts and souls of today's African women. In the African developing nations, women experience transitional times in their respective cultures where traditional norms still prevail. Consequently, they have to execute some roles that are prescribed by male-dominated societies. However, modernization (education) progressively brings about social changes that boost women's need for a free choice of roles. At the same time, women expect society to give them equal opportunities and to help them reach their potential. This desire is portrayed in the author's making her female characters get together in sisterhood either in a form of NGO like MUTE or in family circles. Togetherness brings about the fences of ostracism and discrimination.

12. Female Characters' depiction

Amma Darko's protagonists are mostly women and each of them has a particular role and ability in the narrative process. Some are dynamic and others static. Some are round and others flat characters fulfilling the feminist purpose of the writer. Here is the sampling of the major characters in *Beyond the Horizon* (1995), Amma Darko's first fiction.

12.1. Main characters in *Beyond the Horizon*

As they are defined, main or major characters in a fiction are central and vital to the development of the plot and the resolution of the conflict or to the understanding of the message. The plot therefore revolves around these characters. The names given to these characters are chosen purposely. David Lodge corroborates this by pointing out that "In a novel,

names are never neutral. They always signify, if it is only ordinariness. Comic, satiric or didactic writers can afford to be exuberantly inventive, or obviously allegorical, in their naming. [...] The naming of characters is always an important part of creating them, involving many considerations and hesitations, which I can most conveniently illustrate from my own experience.⁴⁸⁹ Sometimes it occurs that the major character is the one who narrates the event, roughly a first-person narrative as opposed to that of the third-person. This kind of narrator is called homodiegetic for the first and heterodiegetic for the second (G. Genette, 1980 [1972]). The appreciation of the novel by the audience depends on the full understanding of the ability of these characters to play their role as entertainers and message conveyers and make it as real and glowing as possible.

12.1.1. The life of Mara in *Beyond the Horizon*

In *Beyond the Horizon*, the principal character's name is Mara, a pure prototype of a girl educated with the rule and regulation of traditional norms. She is of kinky hair and sometimes Afro-combs it. The emphasis of her hair is put to mean the character's cultural authenticity while living in her village. She stops plaiting her hair while in Hamburg maybe because no one helps her do it. But, African women's plaiting hairstyle represents a symbol of identity especially when they are abroad. What is interesting here is that African women's hair is braided naturally to show the beauty of being in contact with nature and history. In the ancient time, in Africa braiding one's hair is made to encourage healthy hair growth by minimizing damage and breakage from everyday activities. These daily common activities include carrying water from wells or river to home and carrying dry wood from neighbouring areas for sale. So it is important to have an adapted hairstyle. It also minimizes the amount of time required for daily hair care routine. Women's hair is hydrated through such technique. Braids could communicate the woman's marital, social, tribal, or other status. During an interview in April 2013, the Award-winning African author Chimamanda Ngozi Adichie tells during a show why her latest book *Americanah* (2014) mirrors some of the central issues of her own life: race, immigration and the power of hair. The novel's cover page portrays that power of hair so much. Then, she adds that hair has a political power on its wearer's head and implicitly to the environment where that African lives. Hair is a central and important part of Africans' lives. The female author

⁴⁸⁹ Lodge, D. (1992). *The Art of Fiction*, Vintage Books: London, p. 37.

argues during a conversation with Synne Rifbjerg that “if Michelle Obama had worn her hair in a natural black hairstyle, Barack Obama would not have been elected as US president, because many white Americans would fear them as radical, Black Panther, difficult. Whether a black woman wears her hair natural or in weave, she is always criticized and can’t win”⁴⁹⁰. Hence, hair is a serious issue in black women’s lives, especially because it can have implications beyond the aesthetic level like that narrated by Chimamanda Adichie. Yet, African hair is rich with symbolic meaning especially with women of African descent. The novelist admits also during the show that “hair is not just hair”⁴⁹¹. Hair is a woman’s life, love and expectation. Through a woman’s hair lies her profession and even her future aspiration. The power of African women’s hair inspires Chimamanda Adichie Ngozi’s *Americanah*.

In our context, Mara’s ending her afro hairstyle represents her being transformed by her new environment in Hamburg. She becomes “culturally bleached”⁴⁹² and fragmented. This is not only because of her physical exile and mental exile, but also because of trauma as being black. Several traumatizing events happen and direct Mara to her choice. As announced in the chapter of this thesis, the narrative presents the reason why Mara is traumatized and is in search of her lost identity. Analysis by Elisabeth Waites is very insightful in the ground. She explains that there is process of fragmentation which results from trauma. She continues and posits that trauma leads to divers forms of disorganization and fracture in social relations⁴⁹³. Many African women stop such hairstyle while abroad because they think it is rustic and ugly to have it. Natural black hairstyles are stigmatized when they are worn by black people. Negative cultural and social connotations are attached to the natural hair of black women; dreadlocks are on the top. Black hair is seen as ‘bad hair’. There is a strong meaning attached to this hairstyle. Black hair stands for an identity; as a result, Mara loses her physical and cultural identity. This clearly explains that something is rotten in Mara’s life. Normally, African women are expected to be African and not half African and half European or Indian. This has also been the point of the matriarch Ama Ata Aidoo in *The Girl who Can* (2002). The story begins this way:

⁴⁹⁰ Chimamanda Adichie’s conversation with Synne Rifbjerg in 2014. <https://youtu.be/b8r-dP9NqX8>

⁴⁹¹ A talk show at International Sunrise Channel interview with Chimamanda N. Adichie. [sunrise@channelstv.com / https://youtu.be/WWuRA61N8jA](https://youtu.be/WWuRA61N8jA)

⁴⁹² Nozipo, M. (1996). *Zenzele*. New York: Delata Books, p. 15.

⁴⁹³ Horvitz, M. D. (2000). *Literary Trauma: Sadism, Memory, and Sexual Violence in American Women’s Fiction*. Albany & New York: State University of New York Press, p. 5.

The piece, she swore, would keep its shape, its texture, for years and years and years. ‘Pliant and pliable, you can plait, perm and pleat, roll it up a bun, flatten for the early twentieth century look, or just curl it up for a Louis Quatorze,’ Oh yes. She knew them all: all monarchs of Europe, and their wives and mistresses, who had given their names to coiffures. [...] I had declined in the only way I know how, pleaded my perennial poverty, [...]. A mop of silky hair: lovingly grown, diligently fed, nursed, and pampered to yield its best in brilliant black sheen that breathes and glows like a sated mamba, then cut [...]⁴⁹⁴

The narrator helps us recognize monarchs, their wives and mistresses with their hair. Hair is not just that natural cover to protect human beings’ head, especially to women. Hair symbolizes a cult and a culture. Historically however, black women have undergone many pressures that shaped their hair choice in many ways. This is why the narrator prefers to choose a style she can afford, despite her craving for a “brilliant black sheen that breathes and glows like a sate mamba” (Aidoo, 2). More, by the channel of the colonial contact which, day in day out, portrays white women’s straight hair as beauty in person, women of other regions, chemically treat theirs and finally lose the primary and natural kinky style like some African and African-American female Pop Stars. Cheryl Thompson and Cynthia L. Robinson share with us the reason why some Africans have to alter their natural either to please or to surrender to a code, that very code to which Mara surrenders. Thompson writes that: “However, despite their looser hair texture, house enslaved Africans still had to take a step further in order to be presentable as white masters had control over them and forced them to have an image as close to white as possible”⁴⁹⁵.

In the foregoing reason, Amma Darko indicates Mara’s end in Germany after having changed her natural hairstyle, accepted forever to continue her shameful work. Extending the idea, we see Mara telling her own poignant story by journeying us through her life from Naka, a fictional village in Ghana to Accra and then to Hamburg in Germany. Before being ensnared in a hasty and disastrous marriage urged by her materialistic father, there has been no period of courtship. The period of courtship is that during which the bride and the groom come to know each other. They have time for conversation and to invest each in what will be their future

⁴⁹⁴ Aidoo, A. A. (2002). *The Girl Who Can*. South Africa: Heinemann, p. 1-2.

⁴⁹⁵ Thompson, C. (2008). *Black women and identity: What's hair got to do with it?* Michigan Feminist Studies, 22(1) ; Robinson, C. (2011). *Hair as race: Why “Good hair” may be bad for black females*. Howard Journal of Communications, 22(4), 358-376.

marriage. It is a period of dream ‘par excellence’. It is when this relationship becomes so comfortable, so joy-filled, that whether or not embark on marriage becomes a conversation, itself filled with joy. All this joy fills the groom and the bride’s life everlastingly. In the animal realm, the courtship is the period when the female chooses a father for her future offspring. It displays the significance of the period. Jean-Paul Sartre and Jacques Lacan argue that it is the period of narcissist and emotional investment where both sexes develop each other’s sexual desires and wishes. For example, in the jungle, what can be called courtship with the lions is the moment when the lioness chooses among the available lions the stronger one to mate with, to assure her security and that of her cubs. Most of the time, this period last more than a week before the lioness can accept mating. With birds, courtship is a moment for the males to parade with their multicolour features singing around to draw their female partners’ attention. Courtship is then a period of males and females physical and emotional connection. If it does not occur in a relationship, it seems that a crucial stage has been stepped over.

In *The Bride Price* Buchi Emecheta explains that the traditional and passionate activity which is courtship is significant in the sense that it helps solidify a liaison in Igbo community. The same activity is also described in Margaret Ogolo’s *The River and the Source* (1994). As soon as they are allowed to move to the girl’s house, men of the same age group come every evening as Ogolo depicts that: “The suitors came tumbling over each other, all of them men or sons of men with ability, from good families without a shadow of *juok* or witchcraft, madness, habitual thievery, laziness or any other undesirable trait against them”⁴⁹⁶. Love does not seem to be significant during the process of courtship. While coming in the house to visit the young and marriageable girl, the decision to choose one of the men to the girl is made by the father. As soon as it is made, all the other go. Likewise, Buchi Emecheta portrays a similar process in her fiction. The process sometimes can be interrupted by some men’s brutality toward Aku-Nna, Ezekiel Odia’s daughter. As for example, Chike Ofulue and Okoboshi Obidi are stopped and sacked from the house because of a fight. Aside from the difficulties she has because of her father’s death, the little girl faces the cultural mission as a female in society which is to get married to someone who can afford the expected amount of money and valuables to help Okonkwo get the higher title of the village.

⁴⁹⁶ Ogolo, M. (1994). *The River and the Source*. Nairobi : Focus Publishers, p. 15

In the novel under study, Mara and her husband have met nowhere before, not even during a festival. The narrative seems to prove that Mara's father is a kind of person who usually pushes his offspring into hazy marriages. Mara's mother passes the law of subjugation and submission onto her own daughter, the same way she had been eaten up by patriarchal system at her younger age. Mara's father, the slave owner-like, has no pity on her properties. Whenever his mercantile profit urges him, he chooses a young slave to sell for his personal affairs. The home of Mara's father represents plantation where slaves work for a foreman like the time of slave trade. After selling off his daughter, the bride price he earns gives him opportunity to enhance his ego highly over his wives and children. The protagonist condemns the traditional method of marriage this way: "I don't know why of all the eligible women in the village his father chose me. I only know that the choice, for my father, could not have come at a better time. A man he owed money had come and forcefully claimed his debt in the form of eight of eleven father's goats. So my dowry came in handy" (Darko, p. 6). Additionally, Mara's mother, an ambivalent woman, plays the negative role of mother toward her daughters. Buchi Emecheta reports a similar predicament with the protagonist in *The Joy of Motherhood*. Agbadi, the father of Enu Ego, starts arranging another marriage to his daughter without her knowing just after Amatokwu sacks her away as a result of her recurring failure to get pregnant. The decision of marriage in a patriarchal society rests completely in the hands of the father, the uncle and the stepfather of the daughter and not the other way round. Likewise, when in *The Bride Price* by the same authoress, the little Aku Nna decides to choose Chike Ofuelu, the disapproval befalls straightaway. In *A Woman at Point Zero* by the dissident Egyptian Nawal El Saadawi, it is the uncle of the protagonist Firdaus to organize her wedding with the elderly and widower Sheikh Mahmoud, he chooses for her. The uncle's university education does not hinder him from taking advantage from that cultural norm. He also agrees to take the dowry from the arranged marriage.

In our context, Mara falls in the hand of a violent, misogynistic and egocentric husband. Being a member of Naka, a village in an African country, Mara has to comply with the rule of silence and acceptance of all the decision from her parents. Mara lives in a community that relegates women to subaltern. In this way a subaltern cannot speak as the insightful and historical essay by Gayatri C. Spivak proves so well. Hence, Mara's self is disbanded in this system which gives no opportunity to women and girls. In that social structure, women and girls are considered as tool for economic accomplishment. Once in Accra,

her predicament within the marriage is understood as a fate. Worse, tradition has fashioned her comprehension of her degrading situation. She is deprived of all rights. Therefore, she cannot actuate her proper desires. The protagonist is victim of physical and moral tortures whenever she shows an impulse of freedom. Her social, economic and moral fulfilment is hindered by the rapaciousness of that tradition.⁴⁹⁷

She is in charge of keeping the house clean and secured, the same house which lodges comfortably cockroaches, spiders, wasps and other rampant insects. She is obliged to fix the broken parts with pieces of bricks and clay she takes here and there. Mara is presented here as an entrepreneur determined to have her shabby-shelter cleaned and somehow secured. Yet, Mara's silence over her husband's wickedness favours the continuity of her predicament. She is regularly beaten up, kicked, knocked, trodden over, slapped (Darko, 20), denigrated, sexually and verbally abused, but she continues to strive to cook for him because society urges her to do so without complaining. Akobi usually beats the hell out of her as she symbolizes his punch ball. For Mara, a good woman⁴⁹⁸ is who accepts to be killed by her man to save the face of patriarchal society's misdeeds. This proves so much what has been said by a character in Ama Ata Aidoo's novel: "A good woman was she who quickened the pace of her own destruction. To refuse, as a woman, to be destroyed, was a crime that society spotted very quickly and punished swiftly and severely"⁴⁹⁹. Mara is beaten every day for the slightest disagreement and mistake.

In Accra, Mara becomes the perfect scapegoat of the tradition with arms and legs bound. When it comes to have sex with her man, the sequence is purely a slaughtering and just after the act, if we can call it so, she is brutally ordered to lie down on the bare floor for the man to feel the pleasure of the mattress alone. If the narrative has ended in Accra, we would suggest the author to change the title to the novel and have it anew like *In The Ditch* to borrow from Buchi Emecheta's novel. Living in an abandoned room in the outskirts of Accra with a loose thatch which she shares with thousands of cockroaches and fat mosquitoes is accurately to reside in the ditch and Amma Darko emphasizes intentionally the "cluster of shabbily-constructed corrugated-iron sheet shelters" (Darko, 8), dried-grass mattress, an old three-legged centre-table, open gutters never drained to point out the economically precarious life of Mara in Accra.

⁴⁹⁷ M'Bra, K. (2016). "The African Post-independent Legacy and the Objectification of the Woman in Amma Darko's *Beyond the Horizon*" in *Germivoire*, ISSN 2411-6750.

⁴⁹⁸ You are a good woman, Greenhorn, a very good woman, *Beyond the Horizon*, Edinburg: Heinemann, p. 32.

⁴⁹⁹ Aidoo, A. A. (1993). *Changes: A Love Story* (New York: The Feminist Press), p. 110.

Mara accepts to live in a real wretched condition in Accra thinking that one day her condition will improve. One cannot ask for a more detailed description to feel the ditch image in one's mind. In fact, a ditch is a place where people find insects, all sorts of rampant, rats, and other putrefied dirties. It is dirty water passage and in most African countries people throw any kind of wastes in. However, the dutiful 'greenhorn' accepts to live in it not knowing all the risks she is taking. Mara does not know that she can make it change as traditional cultures annihilate women folks' will to break through. The female protagonist is one of these women who are stuck to the cultural status quo. The more women live in the African socio-cultural jail; the more patriarchal system hangs down on its golden throne. Further, though living with a man who is supposed to work as clerk in ministries, she is obliged to throw the surrounding people's rubbish garbage to live and her shameless husband comes to eat the cooked food. Mara is a slave, a good to be sold off anytime the master is pleased. This spontaneous desire to sell a slave and replace her by another is portrayed in Alex Haley's *Roots* (1976) a very poignant and heart-breaking book which mapped the hazardous and miserable living conditions of slaves in their masters' homes and plantations. *Roots* is a work of imagination rather than strict historical scholarship. Conversely, its striking point resides in the likely real approach to the history of the slaves and also that it recaptured everyone's attention.

Slaves in Alex Haley's novel are ordinary living 'animals' without soul in the service the white masters whose chieftaincy is ordained by God Himself. Then, when a master decides to punish a slave he judges stubborn or rebellious, it can take a day or a week of beating in the hands of a merciless foreman. The slave, tied to a tree, is beaten to the last strength of the foreman. The act annihilates any sense of upheaval in the slave's mind. A slave who starts again is punished to death and shown off to everyone. The permanent violence in the plantations and even at home conditioned and limited psychologically the slaves. Sometimes rape and other forms of sexual abuses come to cap it all. Silence and hard work in the plantations consolidate the masters' power. Violence and power over the slaves were at that moment a political expression. More than an attitude during the period, violence denotes a particular critical orientation to apprehend the present relationship between a colonizer and a colonised.

As a matter of fact, Hook Derek quotes Edward Said's (1978) insightful distinction between the two by suggesting that "colonialism is the physical, material and typically violent practice of dispossessing people of their native territory. Imperialism, by contrast, is the broader

theoretical and ideological basis that attempts to justify such actions.⁵⁰⁰” This, incidentally, is a helpful way of understanding how the legacy of colonialism continues into the post-colonial era to the present day and renders African women submissive. The term colonialism here is to be understood as the strategy or all means that a person or a group of people set in order to take control of someone’s mind or valuables like body or territory. The issue of colonialism is mostly related to patriarchy because both aim at other people’s mind taking over and dictating new ideals and philosophy. Colonialism acts like a system that controls with a stranglehold people in their own country, the same does patriarchy in society. Whether the colonised likes it or not, he has to collaborate with the new ruling order. Along with this challenge, Amma Darko’s merit is to write about the issue in order to demystify it and destroy its prevailing prestige and power. Taking clues of this, we see the permanent violent poured on her by the colonial master of her body:

When I didn’t bring him the bowl of water and soap in time for washing his hands before and after eating, I received a nasty kick in the knee. When I forgot the chewing stick for his teeth, which he always demanded be placed neatly beside his bowl of served food, I got a slap in the face. And when the napkin was not at hand when he howled for it, I received a knuckle knock on my forehead. [...]

He grabbed my left ear between his thumb and forefinger and, with my body slanted halfway towards him, my ears burning hot in pain, walked slowly and steadily with back into our room. By the time he released me my left had gone numb. (Darko, 19)

The extract above vividly enables us to infer the ordeals of a slave (a colonised) in the hands of a pitiless master, but not a wife with her husband. A wife/husband relationship does not exist between the two from the beginning to the end of the narrative. There is no hint of love or respect flickering in that excerpt. This kind of scene happens only when the woman is treated like a slave and ready to be conditioned. Despite the fact that it is a fiction, one is sized with compassion to the slave in the plantation in the presence of a foreman shouting an order for instance: ‘The work must be properly done as the plantation ready before the next summer for harvest’. The slave here has no will, only her body numb and scared. Now trained to be a subject and submissive, Mara is ready to be sold off the same way a slave was mentally

⁵⁰⁰ Hook, D. (2004). Frantz Fanon, Steve Biko, ‘psychopolitics’ and critical psychology [online]. London: LSE Research Online, pp. 84-114.

prepared in the Elmina Castle, in Gorée Island or in Ouidah to be taken off. The slave waits for his turn to be examined (teeth and breasts for women). He or she gets only a rock stone as a pillow and the cold ground the bed. The slightest idea of resistance is then powerfully neutralised in the shell. In the dark hours of the Transatlantic Slave Trade, the master (always white) can sexually have any of his female slaves. This sexual prerogative remains after the abolition of the Transatlantic Slave Trade. This explains the conception feminine dispossession. Violence and rape are the tools of this amputation in plantations. Mara tries a delayed physical transformation thinking it can change the direction of her fate with her master. Then she develops a standard she hopes will make him be proud of her. The standard goes this way:

I needed plenty changes outside me still, I knew, but I had started and made significant strides and was content with my steady progress. For instance, I no longer wore African clothes, neither new nor old. No! I wore dresses, European dresses [...] You know, it sounds nothing special, said just simply: I no longer wore dresses. But it was something special. It was an outward transformation and it was a thrill, a very special and subjective thrill. [...] She looks at herself in a mirror and she asks herself, Why didn't I do this before? That was what I asked myself too: why didn't I start wearing dresses when Akobi was here? It was such a transformation and I would have passed better into his world, his modern world. It probably would have made him take me to his farewell party and to the airport and there probably would never have been the need for Comfort's intrusion into his life. (Darko, 48-9)

An overdue dressing standard cannot change her inferior social position attributed to her by society. For Akobi, Mara does not fit him and it is definitely his final decision from the beginning. A slave cannot suit a master's bed, but just in a corner for some minutes' fun. For those who strive to understand and reduce the inequalities between men and women, the passage operates in a way to remind them that there are still many rivers to cross. The system strives to perpetuate itself by decreeing that certain spaces, sometimes invisibles, but existing and persisting. The gap breaks heart because of its long lasting impacts on its victims. That is why the master calls for a woman (Comfort) suitable and comfortable to his class in his eyes. Mara has lost right from the start by being made wife of a man who does not love her. She is dispossessed at the very time her mother begs her to accept the man. In R. Confiant's *Mamzelle Libellule* (2000), the dispossession is also proven through the female character Adélise when she is repeatedly raped by the Commander. The setting here portrays a world of exploitation felt by the little Adélise. The plantation like Germany represents a patriarchal world through the system

of male-dominance and then colonial that both represent. Germany for Mara and the plantation for Adelise represent the world of male power expression. All this motivates unfortunately what Adelise and Mara do with their respective body. What links both female characters is their body being used by their master and their telling the story as homodiegetic character. Adelise and Mara both represent disconnected women through their lost body and by extension their culture. Adelise and Mara's situation demonstrates how patriarchal society compels women to subject themselves to men through body exile. Without an identity, Mara is exploited by men verbally or physically. Having no authority to protect herself, she has only one way to escape from this status of public property, to become a private property of a man in Germany. It means that when a woman loses track of her body, the loss extends to her culture. Therefore, when a woman loses track of her culture (body/her identity), she becomes a prostitute.

Once deported in Germany, the homodiegetic character becomes a dumb ready to fetch money for her owner like husband through her body selling. In fact, Mara thinks that her coming to Hamburg is the logic fulfilment of a previous promise which was promised by her husband before leaving Accra. There lies an underground Machiavellian strategy to trap her into prostitution and further exploit her. The plan lies in many steps, the first being to make Mara drink a glass of wine laced with some weakening substance; the second is to tape-proof the moment Mara, the greenhorn turns red and polluted. Mara recounts the horrible scene:

Briefly, when they opened the door to the other room, I heard voices, many male voices.

Akobi returned some minutes later and brought me a glass of wine. Then I was left on my own again for a long, long while during which I finished off my wine and waited. Then something started happening to me. I was still conscious but I was losing control of myself. Something in the wine I had drunk, it made me see double and I felt strange and happy and high... so high that I was certain that I could fly free. Then suddenly, the room was filled with people, all men and they were talking and laughing and drinking. And they were completely naked! There must have been at least ten men for what I saw was about at least twenty images. Then they were all around me, many hairy bodies and they were stripping me, fondling me, playing with my body, pushing my legs apart, wide, wide apart. As for the rest of the story I hope the gods of Naka didn't witness it. (Darko, 111)

The gods of the protagonist's village are supposed to omnipresent, omniscient, yet, because of the bitterness of what happened they would prefer to close their eyes or choose to be

absent in the place. If a human act obliges a spirit (stronger than human) to lose one of his potentiality, then it means the act is so ugly, painful, condemnable and awful. What the Mara is explaining is her profound resentment against the act. Sexual violence is one of the most horrific weapons in a non-organized house and in wartime. Rape is used to demoralize the victim and then facilitate the crime or the imposition. That is why it mostly occurs in warfront. Amma Darko describes in fact the saddest face of women taken of animals and mere goods by their husbands. This is the second and ugly face of the impact of patriarchy. She portrays the millions of Ghanaian women who have been betrayed by their husbands and taken for granted in another country. In a colonized land, it is frequent to dream of another land where to escape to feel better, but this land also can be dangerous and even harsher than the first. Beyond all this, some writers decide to write about historical events like in Buchi Emecheta's *The Rape of Shavi*. Furthermore, we see that Buchi Emecheta, after having turned her writing in more political meaning, comes back in *The family* (1990) to a metaphor of rape. She presents rape in its natural scope that is in a traditional setting where rape is a taboo and where the victim cannot report the rapist. Gwendolen is sexually molested by her daddy, but daddies do not have sex with their daughter. If raping among young men is a manner to prove one's manhood and domination over a girl or an aggressive expression of the sexual unrepressed desire, what about a father's raping his daughter? This is incest and it is not the African culture. Fathers do not turn their sex against own their daughters. But postcolonial madness leads them to. Nevertheless, Gwendolen never complains to someone about that. Shortly after this, Winston also rapes her and justifies that "her "flimsy gymslip... [And] her young bosom taunted him" (Emecheta, 16). Gwendolen's genitors fail to show her the appropriate love and protect she deserves in her childhood.

In the case of *Beyond the Horizon*, Mara's exploiters take the proof to blackmail and coerce her into her body sale. This account of Mara's life is also the account of Africa, as continent and that of Ghana as country, both raped by intruders and on whom the rapists impose silence and unbalanced trade cooperation. The female body here is a tool of mercantile profit like that of a slave. Mara's body represents metaphorically the African continent being entered without any permission and taking off the maximum profit from her. The process of women's victimization is at work in Amma Darko's feminist writing. This is a form of colonisation of the African continent through Mara's body. The blackmail is IMF and World Bank's annual letters for resource adjustments in order to control African countries. However, as horrible as a rape can be portrayed, it is not the only outrage against the continent. The exploiters' rape leads the

continent into a permanent prostitution as these high financial world structures coerce the African continent to concessions. The allegorical situation of rape is also illustrated in Buchi Emecheta's *The Rape of Shavi* (1983). Buchi Emecheta's fiction is an allegorical story in which a collision between Westerners and tribal members imperils the stoic traditionalism of the Africans. The Europeans violating the peaceful, idyllic and isolated village of Shavi, bring alongside with them corruption and desolation which ruin Shavi's ever revered customs. In the novel, the author questions what is exactly 'civilization' if it does not pay any respect to others' cultures and ancestral good norms?

As a result, at the beginning of the novel, Mara's body changes its shape to oval. This surely implies the physical degradation of the African continent in the 21st century. The overuse of the highly key resources of the African country in an unbalanced trade results in what becomes of the continent at the present days. The African continent is highly indebted to its marrow. Poverty becomes permanent all over the continent. Then, it is the same exploiters who engender that kind of financial and social situation who, in return, accuse the continent of lagging behind. They treat the continent as if not knowing what happened in the past and is still happening today inside and outside the continent. Today the continent hosts war zones especially in countries where ground resources are highly concentrated and exploited by what the late Nigerian activist and musician Fela Kuti Anikulapo calls 'International Thieves Companies'⁵⁰¹. These international enterprises operate by the help of European governments to exploit oil, forestry and other ground resources out of Africa with menial economic gain to the populations. The politically engaged and popular singer denounced the rampaging nature of multi-national companies operating on the continent as well as Africa's dependency on aid, its debt and its increasing poverty in the absence greater economic and political policies. The recurring idea of Biafra's secession is nurtured out of that injustice. It is from that little that the State authorities collect what seems to be their part and leave the low for the State's affairs. They leave Africa emptied handed after promising him development through biased joint partnerships.

In our context, the unbalanced relationship between Mara and her white and black exploiters illustrates the prevailing liaison between Africa and Europe where we can see how

⁵⁰¹ From his song in 1970s, ITT which is defined as International Thief Thief. He referred to international companies which settled in Nigeria to exploit the country's ground and off shore resources without giving the right share to the nation.

Africa is still crushing and crumbling under the weight of titanic-like debts, ever mounting structural adjustments and monetary devaluation. Some Europeans who do not come across that severing of the continent's resources think that Africa refuses to make its development from within. It is from this overuse of the African continent that come the African new bourgeoisie embodied by Akobi and the alike. Walter Rodney's book *How Europe Underdeveloped Africa* (1973) also corroborates this line of thought when he observes that Europe and its invading forces embody the core causes of the African continent's economic and social retardation since Christopher Columbus's discovery of the New World. According to the historian, the evident gap between the West and Africa is not only great, but it is increasing. Then "many people have come to realise that the developed countries are growing richer quite rapidly, while underdeveloped countries for the most part show stagnancy or slow rates of growth"⁵⁰². The simple reason is that the West impoverishes the African continent by taking away all its resources and then like blood functions in vessels, these raw materials serve the sole interests of Europe to develop and maintain its rhythm of progress in detriment of Africa who, by contrast, lags behind with its permanent issues such as poverty, wars, civil uprising against local political leaders, wrong imprisonment of opposition leaders and natural catastrophes to name only these few.

Further, in our context, Mara realizes that the shift of space (from Accra to Hamburg) is not a promised achievement, but a calculated strategy to oblige her to dive into the river of prostitution the same as beast of burden, dumb-blind-naive. While reading throughout the novel, we are turned off by the inhumane conditions imposed onto Mara by people she knows and lives with in Accra. Easy money turns these people's head away from decency, goodness and humanity. The one to be blamed here is Akobi, Mara's supposed husband. Mara's husband becomes a monster, a hook worm in quest for human blood. What Amma Darko conveys is the crudest criticism of what her dearest people have become after colonial time. Their mind has been corrupted and polluted by capitalistic thinking of 'cash and carry' to an extent that they can sell their beloved ones for money, properties, and fame just like what they did in the ancient and dark times of the Transatlantic Slave Trade. This African past is thoroughly present in the collective mind and memory. The present female character travails through a hard road full of dangers, suspense, fear and hope, though a very tiny hope is drawn from the novel.

⁵⁰² Walter, R. (1973). *How Europe Underdeveloped Africa*. Bogle-L'Ouverture Publications, London and Tanzanian Publishing House: Dar-Es-Salaam, Transcript from 6th reprint, p. 28.

In Germany, where Mara thinks it should be a haven full of wonders, her ordeals become harder and harder, her body scarred with pain, her finger broken and bent which is far beyond her imagination (Darko, 2). She is completely unconscious of the racial and gender issues waiting for her. Here, the author purposely moves from a setting to another. The shift of setting deals with the Bakhtinian term “chronotope”, which intimately links setting with genre, plot and temporality. This is with no wonder the case of Amma Darko. She wants the principal character to be defamiliarized with her previous setting so precisely to draw our attention to its significance. Then, the experience of the diasporic situation of Mara is worth the compassion from a whole nation. Her real migration situation has then nothing to do with what she thinks. Mara’s situation symbolises then that of a slave imported for hard and draining works of plantations. Mara is a slave of modern times. The female character seems to have no hope for a better future, then in a final move of disillusionment as the slaves did at Ouidah bay, she forces herself to forget all around her and buries herself neck-deep into ‘snow’ sniff to her morrow. The only way to resist her oppressor is to prostitute herself and find a strategy to strike back. In this resolution, all that she has for two male children is material. What seems also surprising is that, at the end of the narrative, Mara only mentions male names like “I have sent my eldest brother”, “and send the video tapes to him for my two sons”, “My third brother, too, I sometimes see in my daydreams” (Darko, 140).

In fact, Mara begins to display tendencies of her resentment and discount for her geography. In our context, geography can mean spatial and at the same time psychological. This obliges the protagonist to think about her social status and her gender. Her offspring represents her compensatory gift from the union we are right to call a ruining one. Mara and her two children are well-provided at least with material things though she seems unsatisfied about that situation. We expect Mara to challenge her status quo and fight once more to change it, but the novel is at its end already. Mara’s dream is not totally complete to boost her image as a liberated woman beyond the horizon. She is not autonomous as she thinks she will perhaps become when the perpetrators will be in jail. Mara is still a whore, sex provider for men who are not contented with the women they have at home. Her finances are still linked to her body prostitution. This renders Mara unfulfilled. The appealing echo of Mara’s voice is quite audible at the end of the novel. Living abroad is a price to pay for her children to feel at ease and to be enhanced from their marginality. She projects a wrong image of her conditions abroad, an attitude which is

quite what of that of many others before her. The little Akua embodies that characteristic in *The Housemaid* where during the village's festival; she comes with a grey T-shirt on the front of which is written "I'm insured by the Mafia" (Darko, 33) to beam with pride in the village. The narrator shares that "This is what it took for Akua to qualify as one of the soon-to-be-envied-a returnee" (Darko, 33). The returnee amazes and diffuses wrong images of towns through stories of "traffic lights, fly-overs, the latest cars on the streets and exotic events" (Darko, 33), but she does not share with them the secret of her ultimate recurs to sex to bribe the truck driver and workers at the building sites. Mara's bitterness also hides a probable dislocation of her family. Mara, the slave, knows that she will never return to her village nor see her children. This unpleasant conclusion of her life marks the disillusion which echoes the disillusion of a whole nation. Amma Darko skilfully refers to Ghana as a post-colonial country disenchanted. Poverty and wreck condition come to be hereditary in post-colonies and the concept of town is here associated with depravation and pathetic living conditions.

In Ama Ata Aidoo's "Cut me a Drink" (1995), a similar portrayal is made to project a progressive loss of traditional values in urban settings. Mansa does not care about what people can say or think of her strange behaviour in town now that she has left her village. Mansa prostitutes herself and her family comes out of her mind. She becomes strange and alien in the eyes of her brother, the narrator who tells the community the radical transformation of her sister. Mara and Mansa share three specific characteristics which are the catalyst of their similarity. The first is the setting, the second the profession and the third the result from the two mentioned elements which is the physical and mental transformation. Here, the feminist critique of gendered social practices and relations is aimed ultimately at effecting social transformation. The social status quo is contested in favour of a feminist humanist vision of a just society.

Besides, to substantiate all this, Fowler R. (1986) draws attention to the fact that literary critics demystify and clarify what writers have encoded in a more or less complex language with a view to facilitate the task to readers⁵⁰³. They also point out good or bad aspects of the work they criticize. In this vein, we highlight in Amma Darko's narrative the importance of her way of writing in the sense that she especially turns head to common stories, tales or takes her inspiration from biblical references everyone knows to construct her plot or a part of it. She uses these references to convey her message. The particularity of Amma Darko in this novel is that

⁵⁰³ Fowler, R. (1986). *Linguistic Criticism* (1st ed.). London: University Press.

she places Mara at the heart of events and actions to properly convey her striking message. When reading her writings, we are evidently offered occasions to be part of the struggle in society regardless the gender because gender issues concern everyone. In a discourse, gender issues are usually sensitive; this is because they always engender controversies. In the novel, Amma Darko goes freely on the top of her art of imagination because:

to create a story in one's head and tell it in the form of writing is not always only for the pleasure of it, writing is an outpouring. So sometimes it is also therapeutic. To have someone else enjoy it, identify with it, laugh or cry along with it is a bonding between writer and reader. My audience [the readers] rejuvenates me. By virtue of who they are, they tell me that something I created for myself is also good for them and worthy of their time and money⁵⁰⁴.

In the same light of thought, Mara, the name of this female character, is rightly chosen to mean much in the text. In Bible, Mara recalls something of bitter taste, acrid and full of sorrow. For example, in the book of Exodus when God calls back his people from Egypt to the Promise Land, we can read:

Moses led Israel onward from the Red Sea, and they went out into the wilderness of Shur; and they went three days in the wilderness, and found no water. When they came to *Marah*, they couldn't drink from the waters of Marah, for they were *bitter*. Therefore its name was called *Marah* [*Marah means bitter.*]⁵⁰⁵ (The italic emphasis is mine)

Actually, nobody can deny the importance of water to human kind. A human being is made 70% of water, science reveals. A man can then stop eating for three days or more, but impossible for him not to drink for three days. Death comes straight knocking at the door. So, after the wilderness, Moses has to lead his people to drink water, unfortunately it is undrinkable. Mara represents once again bitterness. That is why, to continue in the biblical reference, Yahweh orders Moses to go ahead and find another source of waters to quench the urging thirst of the people. The present shift of direction in Bible which makes Moses change his direction to another also motivates Amma Darko's present writing. Mara goes from a typical working wife to a prostitute in order to cater to the needs of her husband and his lover. The metamorphosis

⁵⁰⁴ Odamtten, V. O. (2007). "Beyond the Comfort Zone: Relation Between African Writers and Audience", in *Broadening the Horizon: Critical Introductions to Amma Darko* (UK: Ayebia Clark Publishing Limited), p. 5.

⁵⁰⁵ Exodus 15 : 23-25. Douay-Rheims American Edition, 1899.

made by the writer's feminist approach also helps her reconsider the situation and take control of her life. She has to fix up "The body being used and misused belonged to me [...]. So why should the money I made go to him?" (Darko, 118).

Here, Amma Darko deserves some approval for not displaying her feminism like a poster before her audience. She delicately drives her gender ideology into the core of her story giving the freedom to her reader to detect the central ideology concern. As a matter of fact, Amma Darko serves this purpose by deconstructing the stereotypical image of the submissive, passive and all-forgiving African woman. She portrays her female characters stronger in mind for she really knows African women's trauma since she meets some of them while in Germany in 1980s.

Further, she represents the biblical woman who has lost most valuables for emptiness, voidance and loneliness. Amma Darko subverts many biblical passages and names to write her way. She turns head to some biblical passages in order to write her own story and the use of these passages has much to do with intertextuality. Julia Kristeva is the first to use the technique in her *Word, Dialogue and Novel* (1966). She describes the Backtinian idea that "any text is constructed as a mosaic of quotations; any text is the absorption and transformation of another"⁵⁰⁶. In other words, intertextuality is then "a universal phenomenon that elucidates the communicative interconnections between a text and the other text and context"⁵⁰⁷. In her *Bound-Text* (1967) Julia Kristeva deals with the process of creating a text outside the already present discourse. For Julia Kristeva, "a text is a practice and productivity. Therefore its intertextual position symbolizes its configuration of words and utterances that already existed making a text 'double voiced'⁵⁰⁸. In the line with the above detailed definitions, we understand from the present narrative that Mara's life seems to refer to that of a female biblical character with a poignant which story is similar to that of Mara. In the biblical passage, the woman's name is Naomi who once has had two male children before moving to another town for a better life. Once there, unfortunately she loses both of them. In fact, while implicitly interconnecting both texts, Amma Darko subtly alters the original text by mixing up her own fiction. Henceforth, the message stands this way:

⁵⁰⁶ Hodges, A. (2015). "Intertextuality in Discourse". UK: Carnegie Mellon University, p.44.

⁵⁰⁷ P. Prayer, ElmoRaj (2015). "Text/Texts: Interrogating Julia Kristeva's Concept of Intertextuality", In Research Journal of Humanities and Social Sciences. Vol 3, pp. 77-80.

⁵⁰⁸ Ibid., p. 78.

So they two went until they came to Bethlehem. It happened, when they were come to Bethlehem, that all the city was moved about them, and [the women] said, Is that *Naomi*?

She said to them, “*Don’t call me Naomi, call me Mara*; for the Almighty has dealt very bitterly with me.

I went out full, and Yahweh has brought me home again empty; why do you call me *Naomi*, seeing Yahweh has testified against me, and the Almighty has afflicted me?”⁵⁰⁹ (*Italic is mine*)

The above extract allows us to discover the concealed choice of Amma Darko to give that pseudonym to her principal character in the storyline. The pseudonym Mara means then bitterness and the female experiences it in full. Her innocence leads her right away in an abyss. In the biblical story, Naomi (meaning the lovable, the delightful) lived a peaceful life with her husband Elimelech along with their two sons, Mahlon and Chilion. But her husband died and she decided to move to another city. Unfortunately, the two sons died leaving their wives Orpah and Ruth and Naomi, their mother. Similarly, in the present plot Mara has also two, yet too young to marry. However, she loses them in the sense that she cannot return home to Ghana to see them. She is contented in sending them money and “material things are all I can afford them. As for myself, there’s nothing dignified and decent left of me to give them” (Darko, 140). Mara’s only hope lies on her two children’s life out there in Accra with “all the things” (Darko, 139) she sends to her family. Mara’s motivation is the love for her children just like that of Naomi. The latter’s feeling to have her children’s wives beside her comforts her and engenders her *raison d’être* and the former’s joy is to see her young children growing and going to school. Naomi is full of bitterness of because she loses her most valuable beings like Mara loses the greenness of her black body, the beauty of her kinky and plaited hair and the beauty of her body being given to only one man. Her natural and prior shape changes to an oval and deformed one due to its overuse. Mara like Naomi fears to return home and hear her people asking like Naomi’s people in Bible. Now that her consciousness returns, she feels ashamed to go back home and see people gossiping around her physical change to a polluted and degraded body with flabby and flat tissues like breasts on her chest because her people know how beautiful she was before leaving to Hamburg. She cannot return home to hear all that. The effect that a ‘been-to’ has on the others is usually the cute physical aspect and financial relatively good shape that with which they return to impress the village. However, Mara cannot afford that cute physical

⁵⁰⁹ Bible International Version, Ruth 1 : 19-21

shape since what is left over is an worn-out body and a degraded mind due to her overuse of drug and other psychotropic substances. The choice of that very name participates in the autodiegetic narrator's marginality predispositions. In that range of idea, Jean Starobinski declares that "lorsqu'un homme se masque ou se revêt d'un pseudonyme, nous nous sentons défiés. Cet homme se refuse à nous. Et en revanche nous voulons savoir⁵¹⁰". Since Mara and Amma Darko share the same life experience and destiny, Mara's pseudonym gives us a clue about the author's future life and literary position. However, very wisely, Amma Darko does not hide in that approach of pseudonym using. She reveals her own identity to us. She does not want to use Ken⁵¹¹ Bugul's approach by veiling her identity.

Actually, when someone from an under-developed country travels to any western country, people expect he returns wealthy and healthy. The case of Mara will be unusual and different if she comes back home. That is why she reconsiders her trip back to Naka. Therefore, what remains is to pretend that everything is alright beyond the horizon. She wants her people to continue to see Europe as a fascinating place of paradise for the post-colonial subject. Mara knows now the truth. In the similar vein, Asempasah Rogers *et al*, submit that

by invoking Naomi's story Darko not only constructs an interpretive community; she also sets in motion the potent trope of repetition and difference that highlights the parallels and, especially, the differences of the conceptualisation of the source of bitterness of the tough situation Mara is confronted with in Germany⁵¹².

Taking cue from this, it is important to underscore the effort of the author of superposing both stories as if it were a repetition of history or historical events in a fictional narrative. Both women share an extreme situation of bitterness and affliction. Naomi is forced to leave her homeland to Moab just like Mara is imported to Germany, a foreign country. We also emphasize the place where the protagonist is imported to since Germany has been twice ravaged by World War II and by Cold War. The ravages of all these confrontations thus become a symbol of European cultural indecency and a justification for the rejection of western values. So insidiously, in choosing this destination for her female character, the writer foresees the

⁵¹⁰ Jean Starobinski, cité par Gérard Genette dans *Seuils*, Paris, Seuil, 1987, p. 53

⁵¹¹ Ken Bugul is the pseudonym of Mariëtou Mbaye born in 1947 in Malem-Hodar in Senegal. Ken Bugul means "the one that no one wants" in Wolof. She is educated under the French system and receives a scholarship to study in Belgium. Ken Bugul writes an autobiographical novel entitled *Le baobab fou* (1984).

⁵¹² Asempasah, R. ; Sam, A. C. (2016). "Reconstructing the self: Of Names, Discourses and Agency in Amma Darko's *Beyond the Horizon*". In *International Journal of Humanities and Cultural Studies*, Vol. 2, Issue 4, p. 5.

rejection that should be hers because of the transposition of trauma, fear and hatred noticed during and after any physical and military confrontation. Amma Darko implicitly shows that being savage is not a question coming from Africa, but a question of circumstance and belligerent environment, and Germany offers all that approach.

One of the significant steps of Mara lies in the above decision to break the ice when things fall apart. She breaks into her mind prison wall which helps ruin down under the system that subjugates her. Achieving the goal of patriarchal system decline is not an easy task. It takes strategy. Mara befriends her 'co-worker' and the German woman. The advice from the female folk engenders courage and motivation in her. Sisterhood is at stake here without racial barrier to set women free from their captivity. Mara "is not just a prostitute⁵¹³", and that village innocent girl becomes a writer, pen in hand to denounce her afflicted conditions to German authorities at the encounter of a friend Kaye. However, the plan to escape is not to freedom, but to another tough horizon, to paraphrase Mara, "once a prostitute, always a prostitute" (Darko, 119). A close analysis of Mara's attitude from the beginning to the end of the narrative, discloses the impact of her traditional education in Naka on her psyche and her aptitude to make a decision. She is educated to be obedient and respect word to word her husband's desires. She is like all the other girls and women of the village, trained to be respectful to the graveyard.

The uneducated Mara is also presented as superstitious (like many Africans) for before her departure to Germany she believes the village foreseer. In fact, the man forecasts that Mara's life will be bright and "no grain of harm, would ever come to (her) in Europe. All was going to golden for (her)...(she) would bring honour to Naka" (Darko, 55). None of this comes true. The narrative shows the contrary to the reader. However, we are rather doubtful and prudent to blankly reject all that the medicine man foresees about the future of Mara beyond the horizon. Then the question to ask the medicine man, if he were blood and bones present, is to know what he means by 'no harm would ever come' to her and she will return 'with wealth and bring honour to Naka'. These words from a man of unseen world can be parables and hidden meaning. Mara does not die of her ordeals; she survives. She transforms even herself to a writer and uses prostitution as a weapon of resistance as to be in accordance with Nawal Al Saadawi's

⁵¹³ Marfo, C. (2015). "Exploiting the Exploiter: Some Violations of Society's Expectations in *Beyond the Horizon* and *The Housemaid*" in 3L: The Southeast Asian Journal of English Language Studies – Vol 21(1): 35 – 46 <http://dx.doi.org/10.17576/3L-2015-2101-04>.

assertion: “If you are creative, you must be dissident”⁵¹⁴. Amma Darko follows the pathway of that dissidence to express her sense of revolt and the pain of many years of loss and dispossession.

Mara unveils her mask of weakness and commands her clients’ slightest sexual desires. She becomes a dissident as recommended by the Egyptian writer and feminist. At the command of her business, Mara leads “them on sinful rides through the back doors of heaven and retu[rns] with them back on earth” (Darko, 131). She creates in each of her clients a dependence, a want for only her body, as if there would be no sexual pleasure in her absence. She needs their money as they need her sex. Mara succeeds in transforming the one-way contract to an interdependent trade between Africa and Europe. Literature can create that balanced trade between Africa and Europe. Mara, the Naka village girl takes over and heads win-win commercial negotiations. In fact, a transformation within a post-colonial context is currently relevant, especially for a woman from a former colonial country, who is in need to have an exciting transformation in world history. The change motivates her to ling on and to stay alive. Then she is able to send materials things to her children and her family. Is that what the medicine man foresees? One never knows. But it is too late for Mara to see red where there is red and blue where there is blue as many times she rules out the possibility to see with her real eyes. A subaltern cannot see then. This is in line with Amma Darko’s purpose in her writing. She

rejected [...] self-absorbed characters. Instead, she wrote about the experiences of ordinary people, not the ones who won scholarships to go abroad, not the ones whose journey to Europe could be described as a Season of Migration to the North, but the ones who were too poor or unfortunate to know anything other than what society made apparent⁵¹⁵.

In fact, Mara’s representation in *Beyond the Horizon* reveals two principal aspects. The first is that Amma Darko shares in one hand her own part of the Transatlantic Slave Trade by choosing fictional characters to description past events in the memory of Africans. In the past, one of the techniques of slaves’ owners is to forbid any contact with other slaves in the plantation or at home so as not to let the slave make friend and feel at ease. In this sense, Mara is made feel frightened permanently. On the other hand, Amma Darko lays bare, with the

⁵¹⁴ See <http://citizenactionmonitor.worldpress.com/nawal-el-saadawi>.

⁵¹⁵ Odamtten, V. O. (2007). “Beyond the Comfort Zone: Relations Between African Writers and Audience”. In *Broadening the Horizon: Critical Introductions to Amma Darko* (UK: Ayebeia Clark Publishing Limited), p. 5.

greatest compassion, the ordeals of a woman in patriarchal society where her words do not count. The trials double when the woman is illiterate and dumb, obedient to traditional norms.

Further, Amma Darko's round character appears at the beginning as naive and then in the end is transformed into a strategic and cunning woman, a professional prostitute taking control of her destiny. Mara is to make use of her brain more than her thigh and her genital. Icing on the cake, Mara becomes a writer, writing now her own story. In becoming a writer, she comes appropriate her adulthood who has suffered when she was green and innocent. She emerges as a full grown up in order to assume her power. Mara looks in the eye of men and speaks in commanding language. This takes her a long way of suffering. The end of the story seems to be the personal history of Amma Darko, though she refuses that alternative in an interview she has with Patrick Muana. She argues this way:

When *Beyond* [...] came out in German, many assumed it to be my personal experience. When they got to know Amma Darko and realised that I couldn't be Mara, they set out on a search hunt for who Mara was in reality. I felt flattered somehow to have created a story that seemed so real that people felt it simply had to be a particular someone's real life story. Mara is just Mara: a woman character in my story. She does not embody any one woman's life...though she could be; who knows? But I think that every aspect of her reflects someone's disposition and real life experience⁵¹⁶.

In fact, what is significant to consider is that the story depicts the real life of many African female migrants in search for better life far beyond the borders of her country. Here we argue that Mara is not just Mara, a female character, but the life of all maltreated women in the world, agonising in search for a place in society. Mara is real since literature is in active service of society. In Mara's grilling challenge and contest of meaning dissemination and production of truth of herself, reason invariably tends to defeat dogma inculcated in her mind while younger. It means that so far Mara upholds common sense or reason now, but at what price we can ask rightly. The physical appearance of Mara's liberty is deformed and unstable because of her using of snow, an opioid. Snow here stands for Mara's attempt to stop being a woman since everybody knows the kind of people who sniff it. Drugs and alike are directed to men to show their power and their masculinity. Snow is what masturbation is for Xuela in Jamaica Kincaid's *The Autobiography of My Mother* (1996). The narrator in *The Autobiography of My Mother*

⁵¹⁶ Interview on the book *'Beyond the Horizon'* Citation: Darko, Amma. "Beyond the Horizon: Feminist Urges and Faceless Women?" E-mail to Patrick K. Muana. 21 July 2003.

reveals one of her intimate instances of her inner body exploration with her fingers to feel physically and mentally satisfy. While masturbating herself, Xuela feels high like snow lifts Mara to her highest physical form to do her job. Xuela shares this: “[...] in private, then as now, my hands almost never left those places and when I was in public, these same hands were always not far from my nose, so I enjoyed the way I smelled, then and now”⁵¹⁷. Xuela wants to see herself in action and satisfying herself sexually. She wants to be a man, enjoy her own powerful odour. Anytime she has the occasion, she takes off her cloth and goes on enjoy her own private places with her fingers. However, before Jamaica Kincaid could refer to her female protagonist desire to transform into a man, Maryse Condé’s *Moi, Tituba sorcière...Noire de Salem* writes about Tituba and her discovery of her own body as interesting to enjoy. She does it herself frequently. The autodiegetic female character, Tituba puts this:

J’ôtai mes vêtements, me couchai et de la main, je parcourus mon corps. Il me sembla que ses renflements et ses courbes étaient harmonieux. Comme j’approchais de mon sexe, brusquement il me sembla que ce n’était plus moi, mais John Indien qui me caressait ainsi. Jaillie des profondeurs de mon corps, une marée odorante inonda mes cuisses. Je m’entendis râler dans la nuit.⁵¹⁸

The two excerpts above prove to which extent the female characters of both creative writers want a change outside to induce that of inside. Therefore, they dive into masturbating themselves to feel the gap of their physical need. Xuela and Tibula’s masturbating is not to be understood as a simple sexual need, but beyond that. They want a physical transformation for their ‘selves’ into men. Both possess their body with determination and repeatedly they express the desire. The difference between the couple Xuela/Tituba and Mara is that, Mara has already several men for her body. Now all that she needs is the snow to feel atop. She lifts her men to seventh heaven and come back by the help the snow. With the help of the snow, Mara can stand side by side with her men and even with her new master. Men are no more to be feared, but mere objects of income and material stuffs. Mara pulls all her men into competition to gain her favour. That is the reason why she selects one of them as being her best expender for whom every fantasy is allowed. That male character is the one that expends much on her, but also the only one to beat and torture her. These white hands truly pick the fruit, reap the grain, milk the cows and shear the sheep. What remains is a left over, broken fingers and shameful body. All this is allowed to him because she is a slave, a land no one owns.

⁵¹⁷ Kincaid, J. (1996). *The Autobiography of My Mother*. New York: Farrar, Straus & Giroux, 58-9.

⁵¹⁸ Condé, M. (1986). *Moi, Tituba sorcière...Noire de Salem*. Mercure de France: Saint Armand, p. 30

The crucial point is that the relationship between a coloniser and a colonised, a dominant and a dominated and that between a conqueror and a conquered is inversed and burst into by Mara. She allows her best expender to express himself since he cannot do in his own household where he is a mere shadow of himself (Darko, 2). This is what Africa has been doing since. However, Mara succeeds in enslaving the giant man, a finality which gives credit to Amma Darko's radical and typical feminism. Then, to Amma Darko's approach, a master who depends so greatly on his slave is not a master, but also a slave. In trying to enslave Mara, the unnamed giant man also puts the enslaving chain on himself. Thus, Africa is as in need of Europe as Europe is of Africa. Both are in chain. By exploiting the African continent, Europe creates an addiction to its ground resources and thus enslaves its own continent. The unnamed giant cannot fulfil himself sexually if he does not go to Mara, the only one ready to accept all his deviant funs. For the giant man, Mara is what the ground resource of some countries is for telephone batteries makers. Huge international firms need a material from some African countries' ground before completing telephone batteries. From this, emerges the necessity for Africa to survive and keep on surfacing.

In light of these reflections of stolen ground resources, we see Amma Darko's feminist approach which creates this story to remind the African women physical and spiritual representation. It also reminds of women body's vulnerability, yet highly needed. African women symbolize the African continent irrespective to where they live and are born. Traditionally, African women's body serves in African female writers' novels as a metaphorical act of rape perpetrated against the African continent for many years. Therefore, like in Buchi Emecheta's *The Rape of Shavi* (1983), Leonora Miano's *Contours du jour qui vient* (2006) and Toni Morrison's *Beloved* (1988), Amma Darko writes metaphorically about the African continent being betrayed, raped, beaten, torn apart, but still standing up for new and future challenges. The brilliance of the African continent survival is that she finds a way to reclaim her right for freedom. She turns the social and financial conditions prescribed for her by the slave trade, colonization and neo-colonization, into something else, something to be desired. Argued this way, Amma Darko's approach forces all the male characters to kneel down and bow for respect. Even the strong and giant European man cannot talk to his wife and then with that loathe and rage. Consequently, he takes on Mara as a replacement target to feel sexually and mentally contented.

Meaningfully, Mara's keeping quiet while the masochist is at work on top of her is not a sign of subjugation, but a sign of supremacy; for Mara is at control of all his wants and movements. Obviously, one can see that Mara is in agony to allow the weak man feels the pleasure he loses with his own wife. Mara helps the man to let loose his animal instincts. She is then a psychoanalyst healing the giant man. Like a psychoanalyst or a psychiatrist in real, she makes the man talk like a parrot about his wife and his unfulfilled life. Through the man's psychological recklessness, Mara finally knows that men from Africa to Europe have a common denominator which is pleasure from a woman no matter what. So she manipulates them knowingly. The European man is just like a mere doll in the hands of Mara, now a professional prostitute. Mara sees prostitution as the only job she can do and be satisfied. She knows how to entice her men in the job. The narrator shares this: "And even when he puts me in pain and spits upon me and calls me a nigger fool I still offer him my crimson smile and pretend he's just called me a princess" (Darko, 3). The part of the professional prostitute job is to let the giant man feel at ease, just like a psychiatrist can do with a patient. Mara takes over the way Amma Darko wants her to do. What the narrator fails to say after the giant man goes back home is to give the detail of Mara's mind. Mara would laugh at him and share this: 'In my hands a man is like a playful doll. I know how to manipulate them now'. This could be the missing detail of the narrator.

In other words, Mara stands to win out over her people's dogmatic tendencies, but her bitterness is everlasting like that of the African continent. Amma Darko shows in the fiction that Africa will remain alive, but hooked on analgesic and hallucinogen products like IMF and World Bank structural adjustments. What Mara does while with her male clients has nothing to do with making love, but subdued signs of resistance. This reminds us of what Martinican author and politician Aimé Fernand Césaire says referring to the African continent's economic retardation: "Le malheur de l'Afrique, c'est d'avoir rencontré la France sur son chemin"⁵¹⁹.

Mara's conditions in *Beyond the Horizon* teach us the tough life of women in patriarchal society, their burdens with disrespectful husbands. All this added to their innocence can lead them to other harder situations. Mara's life in Germany depicts that of illegal immigrants who

⁵¹⁹ Aimé-Fernand-David Césaire was born in Basse-Pointe in Martinique in June 1913. He died in April 2008. His notable works are: *Return to My Native Land* (1939), *Cutthroat Sun* (1948), *The Tragedy of King Christophe* 1963 and *A Season in the Congo* (1966). He was the first to coin the term "Négritude" to refer an influential movement to restore the cultural identity of black Africans. My translation of Aimé Césaire assertion above "The African continent problem lies on its past encounter with France".

embark onto dangerous journeys far away from their homeland for a better life when they follow dumb and doomed a 'dear' friend to Europe, a supposed paradise. Like Mara, when they set foot in Europe, most of these illegal migrants are of course disillusioned.

Finally, in the narrative, the author's moving Mara from place to place justifies the assertion that a colonized has no place to dwell. Very often the notion of site generates many writings from African writers. The sense of place is continuously a great deal to a slave and mostly to a colonized. The point is, of course, that he or she must bear in mind that he or she is a soul of no territory since this notion of territory is tributary to that of power. Places are not just made metaphorically expressive in Amma Darko's work, but are also conceived of as ideologically productive. Then, we can see that Mara has been more independent when she was at Naka than anywhere else. Needless to say, this geographical set-up has a negative and everlasting impact on Mara's life. There lies also a political connotation in that sense of Mara's frequent displacement. Yet there are some reasons to say that Mara's life throughout the narrative comes once more to prove that literature is fairly in service of the society and coincides with reality.

12.1.2. Mama Kiosk, a metaphor of African eternal spirit

The name of this female character symbolizes old age, a category of age revered by Africans. Mama stands for mother in term of affection. In some African countries, mothers are called Nana or Maa or Maami to give to noun its whole sense of emotion, sensitivity and spirituality. Old age in Africa represents wisdom and incarnates respect. In a traditional assembly, old age speaks the last to close the debate and the decision wins through. Their speech is often based on their knowledge and experience. Years and routines give them hidden skills and perhaps spiritual technique to tackle problems. Bible many passages submit that people should vow respect upon old age and parents to benefit from their skilled and experienced advice (Exodus 20: 12, Proverbs 1: 8, Ephesians 6: 1-4, Colossians 3: 20, Hebrews 13: 17). The Qur'an also has passages about respecting parents and old people in order to have the Lord's clemency and to live a peaceful live. Old age is then very much quoted in the eyes of the Lord and that of the society too.

Besides, the female character at stake begins to be mentioned in chapter two when the homodiegetic narrator moves from Naka to Accra in her gutter like home. The narrator shares

the moment: “Mama Kiosk was what people called her because she owned a kiosk at the main lorry station in which she retailed cigarettes, sweets, and iced water. Her home was not Alhaji’s but her own. It wasn’t all corrugated-iron sheets but part blocks” (Darko, 10). Mama Kiosk, as the name sounds is a very simple woman. Amma Darko does not give any precision about her education but rather emphasizes her simplicity and directness over complex subjects.

Old age is so important in African traditions that writers mention as soon as the occasion is presented. For example, in Ama Ata Aidoo’s *Anowa* their words are so significant and full of wisdom. The result is immediately felt when some people shake their words aside to follow nonsense. This means grandmother’s word means business and represents bright light along on the pathway as Werewere Liking submits (2000)⁵²⁰. Ayi Kwei Armah also uses old age in his historical and metaphorical novels *Two Thousand Seasons*, *The Healers* and *Osiris Rising*. In the narratives, one is sized by the constant invocations of old age memory through ancestors and through some living characters which epitomize the bridge between the past and the present. Ogede puts rightly this about Ayi Kwei Armah’s literary commitment:

Two Thousand Seasons, *The Healers*, and *Osiris Rising* mark significant stages, both in the development of Armah’s ideological orientation and in his novelistic technique. Their most important achievement lies in their ability to delve deep into Africa’s past, to show how history and myth collide to give rise to fresh visions of order, and especially in his fourth novel *Two Thousand Seasons*, Armah shows afresh what ingenious use a modern writer can make of oral materials.⁵²¹

Ayi Kwei Armah’s commitment to valuable past events forces him to espouse a literary technique which recalls the necessary place of old age in his narrative. Ayi Kwei Armah uses these characters to remind significant values of African cultures to the present generation. Before the generation of Ayi Kwei Armah could disclose the old age reputation, writers like Leopold Sédar Senghor, Abdoulaye Sadju and Ahmadou Kourouma open the floor with their lyric poems and prose to praise Mother Africa’s magnificent deeds, and her treasured advice. This pathway is which Amma Darko also follows in her present writings with the difference that her perspective is feminist. In this light, Mama Kiosk represents African consciousness that can

⁵²⁰ Werewere, L. (2000). *It shall be of Jasper and Coral*, (Trans) Charlottesville, London: University of Virginia. From the French version (1983). *Elle sera de jaspe et de corail*, Paris, L’Harmattan, p. 151.

⁵²¹ Ogede, O. (2000). “Three Backward Glances. Roads to Freedom in the Late Novels (*Two Thousand Seasons*, *The Healers*, and *Osiris Rising*)”, Ayi Kwei Armah. *Radical Iconoclast: Pitting Imaginary World against the Actual* (Athens : Ohio University Press), p. 95.

see afar bad omen. She is the only one to notice that Mara's husband is a dangerous man, selfish and egocentric with a flat nose to cap it. She portraits Mara's husband this way: "And that Ministries man with a flat nose, is that your husband?" (Darko, 10). In the same vein, Naana Banyiwa Horne pinpoints that

The centrality of the grandmother figure in black literature mirrors her central role in black society, African, Caribbean, and African-American, making the neglect by scholars and critics all the more disturbing. For, perhaps no figure represents so clearly the way in which traditional sources of cultural wisdom have been ruthlessly erased within dominant profit economics⁵²².

In the scope, it is meaningful for Amma Darko to engage bridge between the two generations. The world depicted by Amma Darko is that in which prevails high exploitation and social decay where older people like Mama Kiosk have to intervene in order to direct the good way to youth. The present generation needs a source of inspiration and guidance to find the way out of the oppression from the male-dominated society. Grandmothers like Mama Kiosk resist all sorts of oppressions and claim their wisdom and enlightenment over any circumstances. Additionally, no precision is made on her having children. This is also from the skill of the writer to prove that Mother Africa is productive and mother of all children and so, does not need a specific one. All the children of any African country are her own.

The most significant emphasis the old woman makes towards Mara is this: "do you work? You want work? Now? (Darko, 10)" The old woman knows what is useful in the life of a young woman like Mara to be independent from a man in a hostile city of Accra. Work frees people from beseeching and brings respect on the one who has it. The old woman has a kiosk and it seems to be engendering happiness and a full joy. In fact, Mama Kiosk is Amma Darko's technique of representing the image of goodness of Africa and by extension that of African woman in contemporary patriarchal society. Furthermore, the spiritual cosmology of many sub-Saharan African communities (communities sharing the Bight of Guinea) gives a revered place to female spirits. The chief deity is the goddess of Earth that dominates. The image of that deity influences the lives of people all around. She is the mother of human mankind and then washes over its people. African female writers like Flora Nwapa catalyse the existence of that sea or

⁵²² Horne, N. B. (2007). "Sage, Muse, Crone: The Grandmother in Amma Darko's Novels", in *Broadening the Horizon: Critical Introductions to Amma Darko* (UK: Ayeibia Clark Publishing Limited), pp. 111-12.

lake goddess in their writing. Flora Nwapa describes the spirit as beautiful, powerful and wealthy. This camouflaged Mother Africa symbolizes fertility, purity, love and kindness. That is why Mama Kiosk spontaneously offers her help to Mara, the first and simple one she has in her hand. Then after, she suggests Mara that it is very important a woman not wanting to be completely dependent to her husband finance should “take up hawking boiled eggs to travellers at the lorry station where she had her kiosk because it was a very popular snack with them” (Darko, 18). Mama Kiosk wants the innocent Mara to be empowered financially and then have her own word to say, not waiting every time her ‘flat-nose-ministries-man to fetch for money for her daily expenses and for cooking.

In Accra, it is Mama Kiosk who uncovers Mara’s innocence as she calls her (Mara) greenhorn. That innocence of her leads her man not to consider her sensitive and intelligent enough to understand situations around. In urban centre, Mama Kiosk represents Mara’s mother and watches over her. Just by allowing her to discuss her inner issues with her Mama Kiosk places Mara’s mind above water. Mara quickly sees a substitute mother in her and more and more emotionally dependent on Mama Kiosk. She is called “Johnnie-just-come” or “villager in town” by Mama Kiosk to divulge her attitude of new comer in urban area. One could easily be misled and take her as a supporter of the patriarchal system, however the contrast is sharp. Mama Kiosk strikes again by disclosing after having heard of the trials of Mara with the hand of her husband:

Your husband is one of those men who have no respect for village people,’ she said once. Tradition requests that the wife to respect, obey and worship her husband but it asks, in return, care, good care of the wife. Your husband neglects you and yet demands respect and complete worship from you. That is not normal” (Darko, 13).

The above excerpt shows that Mara is in the school of life and Mama Kiosk the teacher. She teaches the greenhorn what marital life should be. Mama Kiosk draws the analogy between living a martial better life and the respect a husband should have to his wife. Then likewise, when a man buys a cloth for himself, he must buy it to his wife if he wants really to care for her and be part of her life. This advice of Mama Kiosk is similar to that of the Apostle Paul to Ephesians who insists on the love a husband should have to his wife: “Husbands, love your

wives, even as Christ also loved the church, and gave himself for her”⁵²³. In this scope, love shares and forgives. Mama Kiosk wants, in her teachings and life knowledge, Mara to recognize that her ministries man is not only complex but also “a bad husband [...]. This your Ministries man, he has also got something inside his head. I only hope that he won’t destroy you with it before you start seeing with your eyes like I do” (Darko, 13; 17). The old woman rightly forecasts more than the medicine man what awaits Mara in the future with her Ministries man, the flat nose. If Mara marked these words of Mama Kiosk, she would stop the relation. Mama Kiosk puts it “To tell you the truth, Greenhorn, if I was you, now that he’s gone I would forget him and start thinking wholly about yourself and your son. That is what you must do” (Darko, 45-6). What kind of warning there can be to raise Mara’s awareness on her future with her Ministries man?

For Mama Kiosk, Mara’s husband is not a reliable man and a representative of cultural norms a woman cannot live with him. This is surely true since at hearing of his wife’s pregnant, he gets completely angry and roars lion-like. The old woman is aback and puts: “What African man got angry because his wife was carrying a baby? And the first baby at that?” (Darko, 17). In doing this, Mama Kiosk, the spirit African mother reveals her real position about marriage. It is important to note how consistently Amma Darko portrays the character’s involvement to financially empower Mara and renders her more liberal. She counsels Mara rightly on “what to do and what not to do” (Darko, 23). Further, she is available and dependable to indicate what traditional herbal concoction to use and which not to use for an easier birth. Mama Kiosk is a good grandmother irrespective to her illiteracy. Had Mara listened to her words and advice very soon, her ordeals would not have been so great and unfixable. In spite of all that, Mama Kiosk, the Mother Africa, the spirit of the African forest, is still in contact with Mara, the African lost soul beyond the horizon. In fact, Mara’s tale is also the story to be taken as a red line beyond which girls should not pass if they wash out old age counsels. In real, in the streets of European countries we cannot stop seeing thousand over thousand over African young girls in search for green pastures and unable to return to Africa, their homeland.

12.1.3. Kaye, an angel of God

⁵²³ King James Bible, Ephesians 5, 25.

The name Kaye is used to female child in English speaking countries. Kaye seems to be of Greek origin. It may mean pure, clean and beautiful and we know the heart of an angel is supposed to be pure and clean of dirty. This female character's name is the first time mentioned at the beginning of the chapter fourteenth of the narrative, just after Mara's fate is double locked. The video showing her sexual sequence with a multitude of white men changes her decision to be remained 'green'. Kaye is an African woman and "a stunning black beauty and the wife of the good-looking man who was the owner of Peepy" (Darko, 116). The narrator reveals no further information about her education. She is likely a wife to Pompey. She becomes a professional prostitute "when time and interest allowed" (Darko, 116). Kaye is posted as Mara's day and night bodyguard to teach her the skills of the job and then watches over her. She has a similar smuggling history with Mara with a slight difference that it is her boyfriend, not her husband, full of dreams who sells her off with the technique of blackmailing her with pictures "he had clandestinely taken of her in action with different men" (Darko, 117). In her prison, Kaye manages to let her people believe that she finds a well-paid job and that she will return home very soon, yet she sends them all that they ask for to feel at ease.

Besides, she becomes a good and Mara's trustee friend in the sense that her encounter provokes in Mara a real sense of transformation (Darko, 118). Kaye is the courageous woman who elaborates and puts into motion with Mara a plan to escape from their prison like business in which they gain nothing than physical and emotional sufferings. Both can quit the stranglehold of their pseudo husbands, these rigid men who love only the flowing cash that their sex work yields. Their wives' bodies suffering under other men's foot kicks, spitting, slaps and all sorts of violence do not seem to draw a slightest emotion and a single attention. This implies her convincing Pompey to accept Mara's fake body destruction:

She's been destroyed down there, [...] It was that Italian who came to see her for the first time yesterday. He almost completely destroyed her. I think her decision is wise. After all, that's her capital and she must take care not to lose it, which is what will happen if she doesn't slow down. (Darko, 119).

From this point of view, Kaye symbolizes an angel of God in the sense that she becomes Mara's accomplice and thinks that the risks are worth taking to be liberated from the bondage. Just like Mama Kiosk in miniature, Kaye is a good counsellor though in her robe of whore. She is the only one to courage Mara to stick to her focus to run away from Hamburg to another

horizon. Kaye, the angel induced a complete change in her friend of misfortune and finally asks one day: “You are no more you, Mara. You’ve changed.” Unlike the biblical Naomi, Mara objects: “No, Kaye. I’m still me. I have just understood the world better” (Darko, 127). In fact, the change here is not physical as Kaye supposes, but psychological. Mara takes definitely control of her psyche, a decision which induces her better understanding of the situation and the world.

12.2. Female secondary characters

As the plot unfolds, one comes across some characters which roles and actions let us categorize them as secondary. It does not mean that the characters depicted here are not as important as those called major or principal. It is their roles in the plot which are categorized as secondary. The story could be told without them; it would just be harder. Thus, it is the interaction between the two that helps understand partly or completely the story and help move the plot forward. Characters have physical appearance as the writer has to describe them in a way or another. At that time, characters come out of shadow and become visible, physical in our mind. Fiction adaptation to movie uses this part of characters to show them off through a screen. Commonly, when a story is written, it is for the potential reader to spend hours or even days with the characters in the novel. Reading is then a devotion that no one wants to share in companion with real people. So the conveyed message has to be interesting to attract the reader. By the help of all characters in the fiction, the writer can reach that goal. Amma Darko’s *Beyond the Horizon* is replete in actual fact with secondary characters. The story is interesting because of the role of these characters. Among others, we have Gitte, the German woman, Comfort and Mara’s Mother. The depiction of these characters also determines the understanding of the novel with no doubt.

12.2.1. Gitte, the white female innocent

The first point which draws the reader’s attention is that Gitte is a German native and wife of Cobby because of the link of official marriage. This white female character is portrayed as fat, not pretty and shy. All these physical traits give her no chance to have a boyfriend except one day a man like Akobi or Cobby to take advantage of this in kissing her for the first time. It is pretty obvious that the characterization of the white woman is completely unfavourable. Gitte is given no peculiarity apart from being described as ugly and overweight. Gitte’s depiction

corresponds to a metaphoric transposition of the West's devouring of Africa's material resources. Right from the start, Amma Darko uses a deflationary characterization to destroy the self-esteem or confidence of the female character. The recourse to such characterization becomes very customary in African literature.

In presenting the female character that way, Amma Darko reveals a significant hint in the women's world that is the importance young girls attached to kissing at teenage. Being kissed at her nineteenth seems so central to put Gitte's head in the clouds. All the occasion being needed to experience sex with a man, she immediately accepts the bid from Akobi, the opportunist. She completely falls in love with him and marries him because she thinks the relationship between them is a serious one. The latter marries her with the hidden intention to acquire residency papers which could help him live in Germany in peace and realize his selfish dreams. Rightly enough, the woman's family guesses Cobby's tricky attitude and warns Gitte not to be a 'Negerfrau' (Darko,81). Unfortunately, first sight love blinds her brain eyes and numbs her rationale to see. Otherwise, why do Gitte's parents forbid her to get married with a black man? Frantz Fanon has given a consistent comment on the answer in his analysis along with the fear of the Negro and his seeming sexual eccentricity. Frantz Fanon comments that "the father revolts because in his opinion the Negro will introduce his daughter into a sexual universe for which the father does not have the key, the weapons, or the attributes [...]"⁵²⁴ Frantz Fanon's analysis unveils the inner thought of Gitte's father. He personifies the otherness of her daughter's boyfriend. He would not have refused the friendship if it had been a boyfriend of his race, if Cobby had been a non-black. Cobby's African origin matters here. However, the father (of pure German blood) is unable to emphasize blatantly his racism toward a non-white, an ideology of race supremacy. The union between a non-white from Africa and a pure white engenders a mixed blood offspring. Gitte's father cannot stand this result. Further, he is afraid of losing her daughter because of the black man's potency, but let us not jump into conclusion because Amma Darko's writing proves far along the contrary in terms of the African sexual value. This attitude of Amma Darko is in line with Frantz Fanon's blatant argument on a possible castration of the black man. The man will soon be responsible for the conflict between the racist and introverted father and his daughter.

⁵²⁴ Fanon, F. (1967). *Black Skin, White Masks* (Trans.). London: Grove Press, Inc, p. 127.

Gitte becomes the white woman who accepts a black man for love and attention. People often think that when a white woman falls in love with a black man, automatically it calls for a romance. They also think that she is dragged by the black man's virility. Our position is justified by the prolific Frantz Fanon's phrase that states: "Our women are at the mercy of the Negroes. For the sexual potency of the Negro is hallucinating. That is indeed the word: This potency *must be* hallucinating"⁵²⁵. Throughout the novel, the narrator does not mention any passage looking like a romantic love between Gitte and Cobby. She simply loves him because he is the first man to dare to break into the fence of her heart, first sight bump love. What is worth noting here is that Cobby does not dare to beat the woman because of her 'whiteness', her European skin colour and the seeming superiority that Akobi remarkably considers. For example, at the sight of the white woman, the poor Cobby can neither raise his voice nor protest. In fact, the colour white is for the master and black for the slaves. Gitte is the master and her black man the servant in this relationship. Even Mara is surprised to notice her constantly strong and commanding husband become subservient and subjugated in Germany. Both live together but no pregnancy occurs, but not because Gitte is unproductive. Amma Darko does not make Gitte conceive for it will be of no avail. During his relationship with Gitte, the black man's manhood (penis) seems sterilized and annihilated. This also uncovers the difficult and impossible relationship between Africa and Europe as the relationship is often unbalanced. As the bond between a master and a slave is usually problematic, so is that of the two. It corroborates Jorge Manuel, one of Ayi Kwei Armah character's assertion "an African in love with a European is a pure slave [...] with the heart of a slave, with the spirit of a slave"⁵²⁶. Throughout the narrative discourse we understand that interracial sexual relationships are doomed to failure no matter their attempt to consolidate. The contact between a white woman and a black man results in the emasculation of the black man. In the novel, examples such as Jorge Manuel, Solo, Modin Dofu, Ndugu Pakansa are all undone by their white women. This seems to set in motion in the novel an allegory between Africa and the West in term of sex and politics which can never work in fact. Amma Darko's German female character's relationship with her African sex provider depict the disposition of blacks and whites as being in love with African sexual superiority versus white women's frigidity. To compensate, Gitte offers herself to Cobby expecting him to liberate her from her sexual clogs.

⁵²⁵ Fanon, F. (1967). *Black Skin, White Masks* (Trans.). London: Grove Press, Inc, p. 122.

⁵²⁶ Armah, A. K. (1972). *Why are We So Blest ?* London: Heinemann, p. 255.

In the light of the foregoing, Amma Darko's portrayal enables us to get into the deep inside of this character psyche as a desperate white young woman in need of a husband to conform to her generation's desire. Indeed, some migrants attach themselves to middle aged-women, divorcees, old women or women with physical disabilities to express their purposed love though some of them are sincere in their attitude. For others, the game is usually fairly thought. Gitte is among these women who dive into the river and then are sweetly ensnared in the mesh. As a fiction writer, Amma Darko is not justifying the character's choice, but presenting a trustworthy picture of women's decision before their social dilemmas in gender inequalities' complex context. As biology teaches us, women all over the world are in some way timed because of their hormonal system which stops functioning at a time, almost fifties to sixties. Therefore, they need to have, if they want, a husband and children at a defined interval of their life. By adopting this critical tone toward Gitte's attitude and by extension toward European society, Amma Darko tries to awaken female sensibility to the importance of their choice and their taking control of their life. This should not necessarily be in blind accordance with the social diktat. The authoress renders accountable her characters' choice to act or not to act.

Hence, like Mara, Gitte falls also in the sticky and neatly woven lies of Cobby or Akobi, the pseudo prince of Ghana with an imaginary palace. Furthermore, as bigamy is a crime in Germany, Gitte does not know that she hosts her rival from an outskirts village in Ghana. When all the lies are discovered thanks to the letter posted by Mara, the innocent German woman divorced and returned to her family. She becomes very anxious as a result of the loss of her belongings. This final description of the character discloses Amma Darko's feminist perspective to make by all means her female characters strong and stands firm after their social '*tsunami*'. Now that Gitte loses weight, she becomes transformed and anew and maybe given another opportunity to have a good and respectful husband. Amma Darko's experience epitomizes a host of contemporary issues for today's African and European women in the sense that she empowers her female characters no matter what ordeals they experience in the male-dominated society. Monica Bungaro insightfully submits that "Darko's highlights the idea that victims must accept some of the responsibility for their victimisation especially when they foolishly

agree to participate in the exploitation of other women by permitting themselves to be dominated”⁵²⁷.

The portrayal of this female character by Amma Darko unveils the fact that gender inequalities issues have no limits, no borders and that patriarchy is not confined to African physical limits only. What is rather important is the capacity of reaction that the writer offers her female characters either through their modern education, their parental interference, their friends’ assistance (sisterhood) or their audacity to elaborate ways out of their tough situations.

12.2.2. Comfort, the comfortable traitor

Comfort works as a typist in the same ministry as Akobi. She hails from Sumanyi. She is described as sophisticated, young, tall, brown, hairy and beautiful. Comfort uses bleaching skin soaps and skin-lightening creams. Amma Darko’s emphasis the use of these manufactured products by Comfort is to demonstrate that the character has a serious problem of identity and self-love. Years in city allows her to shake aside her inexperience. She is the type of girl Akobi loves, but at the time when he was working at the ministries, the latter’s pocket could not afford that genre of woman, big-eyed, lover of sliver metallic Pontiac and its similar. So he postponed his desire to have her.

After that, she re-evaluates her position when she hears that the Naka’s born boy, her ministries clerk is about to travel to Germany and we know how Europe can fascinate any African in loss of identity. The night prior to his departure, Comfort accepts the proposal of Akobi to have good time in exchange for her coming in Germany as his sanctified guest. Amma Darko portrays Comfort as a frivolous, cupid character and a very skilled calculator. As to play the part of his promise, Akobi sends his smuggler like friend to fetch Comfort to Germany. Akobi rents a complete apartment for her alone. This shows how Comfort influences her lover’s life down to his marrow. She is his spoilt machine at the click of her eye brow. She is taken all over the place (Darko, 131) and is the centre of all attraction. Her materialistic instincts can be linked with her attitude of rejecting her African origin by using bleaching skin to become white. These instincts are beyond her dignity and morals. As to agree with Monica Bungaro, “Darko’s

⁵²⁷ Bungaro, M. (2007). “Victims and/or Victimisers? Women’s De(Con)structive Power in the *Housemaid*”, in *Broadening the Horizon: Critical Introductions to Amma Darko* (UK: Ayebia Clark Publishing Limited), p. 29.

novels offer updated insights into women's predicament in fast-changing and increasingly unstable post-colonial environment and contexts where women are simultaneously victims and accomplices of/with the on-going system"⁵²⁸.

Extending this idea, we argue that Comfort is the perfect partner in crime impeached in the degradation of another woman. Patriarchy needs traitor among the female fold to perpetuate its domination against women and Comfort is characterized by these traits. She also collaborates indirectly with the coloniser in exploiting her own blood. This manner of acquiring wealth finally compromises her integrity. For the sake of justice, she is deported to Nigeria. The choice of Amma Darko to make Comfort be expelled back to Nigeria is in accordance with the objective to punish her as she instigates Mara's deportation to Germany. In fact, if Mara is obliged to stay forever in Munich in bitterness, then those who bring on this condition must also suffer the absence of their parents and relatives. More importantly, Amma Darko urges readers to believe that the resolution to expel Comfort in Nigeria, and not Ghana, is at the same level with Mara's loss of faith to return one day to Ghana.

12.2.3. Mara's mother, the co-conspirator

There is an African proverb which states that when a witch strikes fatally in a house, it means that he /she has been shown the way to enter the house easily by someone within. And another teaches that it is only a cracked brick wall that hosts a lizard. In the novel, Mara's mother is described as traditional woman with no contact with urban or modern world. She has also been subjected to similar conditions of marriage by her parents. So to pass it onto her female children is just a matter of timing. Mara's mother, with no precision on her real name, operates within the dictate of the cultures and more importantly within the scope of patriarchy. The system in which Mara and her mother evolve is that of a "moral system of family values and parental obedience"⁵²⁹. Then, Mara has to follow at the letter her mother's advice to be subservient and a good daughter.

⁵²⁸ Bungaro, M. (2007). "Victims and/or Victimisers? Women's De(Cons)tructive Power in the Housemaid", in *Broadening the Horizon: Critical Introductions to Amma Darko* (UK: Ayebia Clark Publishing Limited), p. 29.

⁵²⁹ O'Connell, S. P. ; Odamten, V. (2007). "Licit Desires, Alien Bodies and the Economics of Invisibility in Amma Darko's *Beyond the Horizon* and Stephen Frears' *Dirty Pretty Things*", in *Broadening the Horizon: Critical Introductions to Amma Darko* (UK: Ayebia Clark Publishing Limited), p. 53.

Mara and her mother are two female characters that cannot be dissociated because former's difficult life as narrated starts because of an imprudent advice from the latter. As a matter of fact, Mara still remembers the circumstance: "I returned from the village well with my fourth bucket of water of the day when mother *excitedly beckoned* to me in all my wetness and muddiness, *dragged me* into her hut and *breathlessly* told me the 'good news'. (Darko, 4, emphasis mine)" The excitation of Mara's mother hints of a good news, but it is not. This woman in service of patriarchy continues her work: "Your father has found a husband for you, [...], *a good man!*" (Darko, 4, italic is mine). The woman's attitude raises many interrogations like for example: "A good man, how can she be so sure about his goodness? A man she does not know! Or just because Mara's father recommends him? This lets us understand to which extent patriarchy is deeply embedded in the collective mind of people.

Furthermore, the woman educates her daughter in such a way that only the marks of her traditional training remains in her brain. The trainings are done in a way that daughters of such setting are made dumb and doomed. Mara's mother succeeds in doing that in accordance with the cultural norms of the village Naka that represents here the whole traditional Ghana. In doing this, Mara's mother connives with the ruling system to sell off her daughter. She fails to protect her from the system. In fact, through the depiction of this mother, Amma Darko shows that mothers in these settings have no choice. The system holds them as victims as well as their daughters. What illustrates it is that as mother, it is a day of the agreement between bot fathers that the latter is informed about her own daughter's taking off as wife by a neighbouring family. The second point is that Mara's mother may have certainly been taken away the way her daughter is being married off. Freedom and autonomy within the rank of the oppressed do not exist at all. What prevails is submissiveness. However, the mother's teaching in some way must not be rejected systematically as Mara also recognises as moral values "*As for the morals of life my mother brought me up by*, I have cemented them with coal tar in my conscience. (Darko, 131, emphasis mine)" She knows that her mother's teachings are significant and remind her of her origin as an African. Mara's mother is obliged to conspire against her own blood to save the face. Mara's mother fails to protect her daughter while in danger. That protection should normally be her first and foremost concern because in African context: "A man belongs to his fatherland when things are good and life is sweet. But when there is sorrow and bitterness he

finds refuge in his motherland. Your mother is there to protect you”⁵³⁰. This is what mother’s role should be and this mother fails to secure her little child from the hands of a potential predator, Akobi. Yet, the weight of tradition and the fear to be disowned by her husband if she opposes herself against the marriage subdue her ultimate role of mother.

Yet, Amma Darko’s female characters’ portrayal in her first novel shows her realistic commitment about African women’s rehabilitation. The portrait serves as her feminist technique to empower the oppressed females. She also shows that oppression has no borders, limits. She propels the significance of focusing on female togetherness for a joint activism in order to arrive at creative solutions to discharge their burdens and this way to give a brighter future for the future generation either female or male. The following subchapter will focus on the second novel by Amma Darko. Its intrigue raises the issues about modernity and tradition, the decay of the post-colonial Ghanaian society and money greed of people who are supposed to be above suspicion.

13. Female characterization in *The Housemaid*

The novel under discussion is particularly special in the sense that it unveils all along its pornographic and sex free sides. In this category of African writers who do not fear these sexual scenes we have the Ghanaian male writer Cyprian Ekwensi in his *Jagua Nana* (1961). If sex in *Jagua Nana* is a matter of social and moral debauchery, Amma Darko uses these images as a means of resistance and power control of her female characters over the male. Amma Darko proves that female genitals have strong control over any of her male characters. In doing this, Amma Darko can be branded as an adept of hedonist theories⁵³¹, though African female writers seem not to give themselves this liberty in literature. African women authors decide to discuss the problems African women face in society by uncovering the hidden truth. Many of them have been severely criticized for being too bold in their portrayal of women characters in their novels. Others are blankly attacked for portraying female characters so strong to defeat male characters. Though African society is still a very dominated world, some female writers dare to speak out

⁵³⁰ Achebe, A. (1958). *Things Fall Apart*. New York: Anchor Books (ed. 1994).

⁵³¹ The word ‘hedonism’ comes from the ancient Greek for ‘pleasure’. Psychological or motivational hedonism claims that only pleasure or pain motivates us. Debate about hedonism was a feature too of many centuries before Bentham, and this has also continued after him. Other key contributors to debate over hedonism include Plato, Aristotle, Epicurus, Aquinas, Butler, Hume, Mill, Nietzsche, Brentano, Sidgwick, Moore, Ross, Broad, Ryle and Chisholm. Retrieved from <https://plato.stanford.edu/entries/hedonism/>

about the conditions of women in Africa. Like Buchi Emecheta, Grace Ogot, Flora Nwapa, Amma Darko dares to have her say in the debate. She portrays her female characters' ordeals in the hand of men to demonstrate the necessity of the African women to take over. Like a psychoanalyst, Amma Darko shows her female characters the right way to set the upheaval. In the same vein, Amma Darko's characters role cues a direct categorisation when the narrative unfolds. The following lines give us the clear-cut way of it.

13.1. Main characters' depiction

When reading throughout the novel in discussion, we find as major characters the following ones due to the predominance of the role they play:

13.1.1. Madam Sekyiwa, the doomed manipulator

Madam Sekyiwa is an illiterate, unfaithful and mother of Tika. She is an opportunist character that takes advantage of her lover's wife unfruitfulness and gets pregnant at the age of twenty-two. Her pregnancy ends her lover's peaceful household. Sekyiwa is twenty-four years his junior. Despite this gap of age, Madam Sekyiwa is described very influential over her lover so that he gets the resolution to set her up in business and make her rich as a result of "his obligation to his unborn child" (Darko, 18). As soon as she gets contentedly and completely what she is in quest for, she gets quickly rid of the old man who has induced all the richness. The man dies and the responsibility of this death is forever recognized by her daughter Tika who eyewitnesses the frequent scenes of their conjugal disputes. Just after that she turns her attention to young and strong men of the surrounding.

Furthermore, Madame Sekyiwa is portrayed as an irresponsible mother who prefers to focus on her business and several profitable business encounters instead of watching over her daughter. Amma Darko changes the common roles of women in African female writings, for frequently audience awaits the victims to be women and men the violence's perpetrators. As far as Amma Darko's present fiction concerned some victims are male characters. In that scope, we agree with Monica Bungaro who submits that "Not surprisingly then, *The Housemaid's* world is a world composed primarily of women and in which men intervene only as passing characters,

official or transitory lovers, drunken or weak fathers, and/or oppressors”⁵³². In Amma Darko’s narrative, the psyche of Madam Sekyiwa stands for that of a manipulator as she uses her attractive feminine attributes to influence her lover. Implicitly, she builds up her own daughter’s life the same way she has built up hers. In this scope, she recruits an experienced friend in business to teach Tika the fundamentals and then helps her daughter with a good cheque as assets to start her own trade. This attitude recalls in our mind the Nigerian Cyprian Ekwensi’s two novels *Jagua Nana* (1961) and *Jagua Nana’s Daughter* (1986) portraying their female protagonists as being *femme natale*. Both are described as being temptresses like Eve in Eden garden.

In this doing, Sekyiwa pushes her single daughter on the way of cash-money-sex system. Women in that system get ready to entice men in order to get several favours from them. Like the village people gossip, a daughter of a whore is a whore. Yet, all the way, Madam Sekyiwa seems to be a complex character in the sense that in an ultimate extract, she tries to persuade Tika not to abort: “So I am still begging you. Please reconsider aborting this baby. I beg you. But Tika did not reconsider. She ended the pregnancy. She [Sekyiwa] was devastated” (Darko, 27).

The character’s changing attitude redeems her and converts her to a semi good character. Amma Darko tries to correct the first portrayed image she gives the reader about Madam Sekyiwa. Monica Bungaro insightful opinion describes rightly the female writer literary stance on her female characterisation:

Darko’s rhetoric of realism conceals certain ironies and is a strategy of narration which presents women in shifting, changeable, positions as a way of countering their static definitions in a patriarchal society, though the protagonists’ actions and choices mostly shift in relation to a pragmatic sense of their own needs as persons and as women⁵³³.

Extending the idea, we realise that Abena Busia also writes about similar characteristics in “Parasites and Prophets: The Use of Women in Ayi Kwei Armah’s novels” (1996). It goes this way “there are basically two traditions of oppositions governing the portrayal of women in

⁵³² Bungaro, M. (2007). “Victims and/or Victimisers? Women’s De(Con)structive Power in *The Housemaid*”, in *Broadening the Horizon: Critical Introductions to Amma Darko* (UK: Ayebia Clark Publishing Limited), p. 31.

⁵³³ Bungaro, M. (2007). “Victims and/or Victimisers? Women’s De(con)structive Power in *The Housemaid*”, in *Broadening the Horizon: Critical Introductions to Amma Darko* (UK: Ayebia Clark Publishing Limited), p. 46.

the novels which concern us here: women as wholesome whores or victimized or virtuous virgins, and women as nurturing earth mothers or destructive Jezebels”⁵³⁴. While following the progress of Amma Darko’s female characters in the present novel, we come to the point that they are transformed from parasite like Sekyiwa to good people who have greater influence on the male characters in the texts. Madam Sekyiwa is among the strong and courageous female characters that succeed in imposing their will on their weak husband. Amma Darko subverts her male characters’ natural dominion to the benefit of the females’. In Amma Darko’s novel under study, the weaker sex is that of the male, dominated and crushed by the female one. The technique is that of Amma Darko made to empower her female characters for it is important for African women writers to promote themselves and to band together.

The character Madame Sekyiwa represents the fullness of what Ghanaians have become in post-colonial time as in many African writings a nation is represented as a woman and her children the people of the nation. The symbol of a woman of that age, young and attractive stands for Ghana nation. The prostitution means here the people’s mind perversion after the nation is colonised by Europeans. The time it takes for the mother (Mother Ghana) to recognize her mistake, her daughter (the future generation) has also been corrupted by the same plight of cash-sex for business and stranger’s alien behaviour. Her daughter’s mind and body have already been polluted by many people that symbolised capitalism. Madam Sekyiwa loses her daughter because of her fault, the same way Africa loses its lands and power because of colonial and neo-colonial forces. Here we notice how meaningful Amma Darko directs her characterization and the credit it is important to pay to her writing Africa contemporary ordeals related to its past unsolved issues. To sustain this, Carmela Garritano states that “The novel, in its re-enactment of the struggles of women living in contemporary Ghana, posits a discursive relationship between the nation and the bodies of women and presents a stinging critique of the failures of the Ghanaian nation”⁵³⁵.

In the narrative, the successive failures of the nation stand for that of Madam Sekyiwa to educate her daughter for a life without corruption and her body pollution. She also fails to be

⁵³⁴ Busia, A. (1996). “Parasites and Prophets: The use of Women in Ayi Kwei Armah's Novels” *Ngambika: Studies of Women in African Literature*. Ed. Davies, Carole Boyce and Graves, Anne Adams. Trenton, N.J.: Africa World Press. Print.

⁵³⁵ Garritano, C. (2007). “Amma Darko’s *The Housemaid* and the Gendering of Novel and Nation”, in *Broadening the Horizon: Critical Introductions to Amma Darko* (UK: Ayebia Clark Publishing Limited), p. 72.

together like one, which should be the normal relationship between a mother and her daughter. The complicity we are talking about is suggested in Jamaica Kincaid's *At the Bottom of the River* (1992). The West Indies female writer points out:

We greeted each other at first with great caution and politeness, but as we walked along, our steps became one, and as we talked, our voices became one, and we were in complete union in every other way. What peace came over me then, for I could not see where she left off and I began, or where I left off and she began.⁵³⁶ (*Italic is mine*)

The collusion which should prevail between a mother and her daughter is that depicted in the above extract with Kincaid's narrator. That nourished affinity full of love, oneness and sisterhood is the relation that should be manifested for the harmony of the family. Besides, Sekyiwa is blamed for having failed to reason her daughter when she decides to abort. Amma Darko wants women to feel guilty and to wait for the sentence when they fail to play their role of educator, so that any mother who copes with corruption has to be isolated from the society. As a matter of fact, Madam Sekyiwa, in the end of the narrative is left alone with all her wealth, but wrinkled, and cramped. The image symbolises Ghana as well as Africa, running dry or means, her children not willing to look for her. The end of the narrative leaves us on our greed as it does not show the way out of the abyss. Also it does not attempt to give a hope for change, a resolution of past dilemmas for the pain, the anger and the fear are still present in the collective memory of each African and there is still a long way to go.

13.1.2. Tika, a model of female revolutionary?

Amma Darko seems to have subverted the original name Sika to Tika, a name often given to baby girls. The proper name Sika is used by the peoples from Ghana, Togo and Benin. Sika means 'gold', 'valuable' 'precious' in naming chart of these different peoples. The name of the baby girl reminds readers of the circumstances of her birth. Sika or Tika may have been given by her father because of the preciousness of the baby. Tika is a middle age female character of thirty-five years old. It is important to mention that at that age, in actual fact, Tika has not really much luck to the first wife of any of her lovers. People think and are right that, at that age, a woman may have an important number of lovers who, either fail to have her as wife

⁵³⁶ Kincaid, J. (1992). *At the Bottom of the River*, New York, Penguin, pp. 59-60.

or do not appreciate her behaviour. They think she is sent away from the first husband, then it is difficult to make her real wife, but a good time woman can do.

In the narrative, while very young Tika is the only one to call the old man ‘father’, her first wife being barren as the narrative informs. Tika’s father hails from Kataso, a poor farming and fictional village in the Eastern Ghana with no flowing water, electricity, no entertainment centre, nothing. The village is targeted as where many of the shoe-shine boys, truck pushers, and hawkers, dog chain retailers head from. While young, Tika has seen many times her father weeping because of the frequent argument he has with Madam Sekyiwa. On page 19, the word “*cuddled*” is put to symbolise Tika’s father attempt to assure her his love. However, the psychological state of the old man is completely low due to the hubbub around. Moreover, the group of words “*little smile*” is surely associated with the man’s mood. The little smile that flickers on his face does not betray Tika. She knows that something is happening around her and her mother is the reason. The little Tika keeps all this in her mind as a negative aspect of motherhood. She is not able to know the truth from her because of the gap between the two. The lack of maternal love is here materialised through the line: “It had been even more glaringly clear on those free Saturdays when her mother had not taken her to the shop” (Darko, 19). The lack of time for her baby works as a concrete boundary in a mother/daughter relationship and definitely separates the two. Tika grows in a loveless family. The teenage of Tika copes with absence and void and more so when her father dies. The pathetic relationship between mother and daughter is the direct consequence of the father’s eternal absence since Tika retains from father delightful moments. The narrator points it: “On such days her father had become a completely different person, playing and laughing with her” (Darko, 19). In fact, the presence of the father is always that of a guide and a protector, a subject of cheeriness. The analogy it seems to disclose is that of Mother Africa with her daughter as we know that African literature always refers to its colonial past. African writers always depict in their writing either the admiration they have to Mother Africa or their anger to her alienation which is today implying her children’s modern estrangement.

The accuracy of the narrative places the narrator as the family’s friend since she guesses the event and the psyche of the little girl and her resentment and disappointment towards her mother. In this context, it is sure that the loss of a dear person can be psychologically devastating, and makes the vanishing of his specific role as father and husband. The loss of

Tika's father creates a gap that favours her copying on her mother. As a matter of fact, Tika has become for a moment a double version of her mother by sleeping with men for business arrangements. It symbolises her enslavement and dependence to men which would please her mother and creates a better contact.

On the other hand, chapter two of the story depicts the young Tika as a perfect reflected image of her mother. The novel presents her as a cash madam, a successful market woman, single, attractive and "childless at the ripe old age of thirty-five" (Darko, 17). She lives with her maid and moves very frequently because of her business. Through the character, Amma Darko wants to point out the unsympathetic side of business doing in African cities. When a woman engages in business in urban centres, her body has to suffer in the hands of the macho who think that only a woman in search for men can do business because for a long time business has been considered as men's issues. Additionally, no contract, most commonly, is signed if the woman in business does not use her genital power. Gender-based constraints and the cultural cult of domesticity have hindered women to develop their business skills for many decades. Some men are totally against women's involvement in business thinking that their place is defined at home in kitchen and at the backyard rearing children. They argue that the biology of sex determines that women are limited to the home and children, and must play a subordinate role in the economy (Deckard, 1983)⁵³⁷. Knowingly, Owuraku, her boyfriend does not approve of her business as the risks factors are colossal. The same tribulations have already been depicted in Flora Nwapa's *One Is Enough* (1981). In the narrative, when Amaka decides to settle in Lagos for the sake of her business, many times she has been obliged to have sex with many men at important administrative positions either to facilitate the import of her goods or the intervene in administration to help. Like Amaka, Tika exploits the men who, in exchange of their administrative facilities, ask for sex. Urban cities in contemporary African female novels seem to be merciless to female characters. In fact, this idea denotes what post-colonial African countries have become on their way to modernity. In patriarchal societies, men use cultural and religious norms to abuse women in society and deny them any dignity. This kind of violence is not just an argument, but a pattern of coercive control that men exercise over women. Women's abusers use physical and sexual violence, threats, emotional as a technique of domination. For

⁵³⁷ Deckard, B. S. (1983). *The Women's Movement: Political, Socio-economic and Psychological Issues*. Harper & Row Publishers, NY.

their personal comfort, men build social myths around their personality, then they forget to bring along with all this, humanity and sociability to their female counterparts.

Tika fails at school and loses her boyfriend at the same way. Then possessed by a success spirit obtained from her mother, she launches her business to prove to her boyfriend that a failure in school does not mean failure in business. On her way to celebrity and success, she is obliged to deal with the different sexual partners such as “Samuel, Riad, Eric and Attui” (Darko, 25). From each of these male characters, Tika awaits a particular help. From Samuel, the customs officer, Tika is able to smuggle goods from Togo to Ghana. From Riad, Tika is able to sell her goods fast since he is a big shop owner. Through Eric, the musician, Tika’s name remains on the favoured customers list of the Ghana Commercial Bank because the manager is Eric’s older brother. Attui, the factory owner, helps her get good credit rates on the goods she buys. No wonder she sees them more as business partners than lovers. All their business transaction usually lands in Tika’s bed and the noise to be overheard by Efiya, where sometimes she has to lie to other partners who unfortunately come to visit or to make their transaction also (Darko, 50). In fact, Amma Darko demonstrates how women are marginalized and sexually exploited by men in society not only when they decide to be on their own, but also when they accept to be subjugated. The writer also shows the parallel which proof shows that some women are not completely victims of that practice, but participate in its reinforcing. The latter presentation demonstrates how complex is Amma Darko’s feminism as she uses nuanced strategies to lay bare her narrative. This needs to be highlight as soon as we deal with the writer’s technique. Therefore, we decide in our analysis to let the writer’s creative writing speak freely. What is worth mentioning here is the way the narrator presents the present female character so as to blame women’s actions. So while Tika engage herself in this trade, she finally gets pregnant to one of her business associates and comes up to end it being haunted by her parents’ failed marriage. For Tika, getting married with a one of the partners means the end of her liberty, autonomy and power to control men sexually. In spite of her mother’s interference, Tika terminates the pregnancy which results in complications that oblige the doctor to remove her womb. The removal of Tika’s womb stands for two different but chief aspects. On one hand, a womb is the part of female body where is formed and developed the foetus that grows to a baby. A woman carries on in her womb the future generation as soon as she is pregnant. It is thus an important part of human anatomy that helps make the difference between a woman and a man. The removal of this organ is instrumental to the need of Amma Darko to transform her

female character to a male one in accordance with the need of the late father to have a baby boy. African society prefers to have a boy because of the common beliefs around a boy. The joy of the household depends on the gender of the baby. People feel happy and blessed when it is a male child and the family falls in despair when a girl is born. On the other hand, the author does not want the perpetuation of prostitution from the Tika's womb.

As people of Kataso mockingly say 'a daughter of a prostitute soon and surely becomes prostitute' and so the cycle continues. Wrong doing will be forever stuck on the family and by extension to the female world. The writer's humanistic reason is to stop the cycle very soon as mother and daughter's behaviour contradicts the slightest reason of mothering. To make it worse "on no occasion does Tika reflect on her abortion, once she has got through it and the only marks she bears seem to be physical rather psychological"⁵³⁸. Further, the expectation people have over a womb is to bear babies in order to perpetuate the patriarchal system. Amma Darko does not want her female character to fall into this perfidy and be trapped forever like her mother and all the other women in urban cities and in Kataso, more babies but no food to give them. In this way, the cycle of poverty and promiscuity continues.

In the same line of idea, we can understand as a metaphor, Amma Darko's decision to let Tika abort. Tika refuses to become the third wife Attui. Tika refuses to be enchained as Attui's wife or anyone else. To become Attui's wife, the factory owner means to accept to become slave and subjugated. Tika does not want to fall neither under the control of colonial power nor patriarchal one. The removal of the pregnancy constitutes the liberation of her body from being owned by a man and conjugal commitments required by society. Tika bursts into the common traditional theory that motherhood brings joy; a theory that motivates Buchi Emecheta's writing *Joy of Motherhood*. For Tika, no enjoyment can come out of motherhood and she has her mother as an example of failure. Tika's sole desire is to take an entire control of her body and uses it as she is pleased and a pregnancy is interpreted not as a means of happiness but a hindrance to freedom. The re-appropriation of the female character's body is a metaphor of patriarchal hegemonic and colonial history. Amma Darko is making a severe diatribe against two evils in force in Ghanaian society: colonialism and patriarchy. We do agree with that form of resistance that conveys the diatribe against the two major evils.

⁵³⁸ Bungaro, M. (2007). "Victims and/or Victimisers? Women's De(Con)structive Power in the Housemaid", in *Broadening the Horizon: Critical Introductions to Amma Darko* (UK: Ayebia Clark Publishing Limited), p. 38.

In fact, Tika's portrayal is the improved version of her mother Sekyiwa in the sense that she has gone to school. Education enables her to discover the treacherous attitude of her housemaid's family to take hold of her wealth. Her education and sharpness help her succeed more than her mother and leave her mother's house to her own apartment. The author portrays her humanistic side as she insists to help her maid become a seamstress and buy her a sewing machine. She proves before Teacher that she is a woman of word in spite of her decision to send the maid back to her village:

‘I certainly will not keep her,’ Tika replied, ‘but I will continue to care for her while she is in Kataso. And one day, when her baby is old enough to be left behind, and circumstances allow it, I might still decide to put her through her dressmaking training. Because in spite of what she has done, the fact remains that she has served me well during her short stay with me. (Darko, 77)

Once again, Amma Darko highlights the importance of female togetherness in difficult times. Sisterhood and education are two core traits which empower female characters and in real life also. Teacher being with Tika to format her while taking major decision transforms definitely her personality not only towards the other, but also to herself. Tika appropriately fulfills the invisible naming of her name, Sika, the valuable. She refuses to be like her mother. She refuses to be judged only by her aptitude of motherhood and not by her real capacity of being herself with no social constraints. Sika or Tika is a revolutionary after going through the school of life with Teacher.

13.1.3. Teacher, the transformer

Being a teacher has always been a valuable profession. That is why people rightly give to a give the name of nation's educator. Like Tika, Teacher, a nameless female character comes from Kataso, a real symbol of ambient poverty. She starts going to school at an advanced age and mockingly her classmates call her 'class mother' and her teachers 'school madam'. She holds on all the way to her graduation. Amma Darko puts this female character to prove to the reader that not all her female characters are money lovers and overnight wealth seekers. Teacher seems then to be the only one character that really knows that victory comes after hard work. Based on this, Teacher seems to be more independent and emotionally strong to support the

other female characters. For example, Teacher supports Tika when she is in hospital (Darko, 39) and the one who advises her on her maid and her family. Teacher plays the role Tika's mother is bound to play if she were not suspected to be in collusion with male dominance.

Besides, because of her profession and her aptitude to find solution to others' problems around her, Teacher is profoundly respected by the community. She influences positively Tika and directs her to a better life. The attitude of this female character of Amma Darko reminds us of that Chinua Achebe wants the writer to be. Chinua Achebe urges African writers to be professional and a good image to the society, a model to listen to. The present female character tries by all the best to be a professional. The portrayal of Teacher proves so much that money is just a mean to help purchase items one's needs, but not a master to worship. Money is then what one gets after honest work. Amma Darko creates that female character in opposition to Tika who thinks endlessly that money is power instead of education.

13.1.4. Efia, scapegoat of manipulation

The name is given to a Friday's born baby girl in the Fante naming chart. Some change Efia to Efua like Efua Sutherland, the prolific Ghanaian poet and critic. The name seems to have more than one origin. Swahili also give this name to their new born to means 'Mercy' or 'Protection'. At that time the name changes to Afua. People may ask why a Ghanaian ethnic name can be given to a Swahili new born because they may think that a particular given name must pertain to a specific origin or social group in Africa. People think that Africa is divided into separated ethnic groups that have no historical and linguistic link, but this is wrong. Further, some African parents are proud to give their descendants names of other national or ethnic group, a practice spread all over the African continent today. This wake paints the Africanity or pan Africanism wanted by the pioneers such as Kwame Nkrumah (Ghana), Jomo Kenyatta (Kenya), Julius Nyerere (Tanzania), Modibo Keita (Mali), Sékou Touré (Guinea) to name only these few. These African names enable Africans to survive in this globalisation.

The novel under discussion revolves around Efia, the housemaid. It is her job in the city which confers the title to the novel. Efia like Teacher and Tika is from Kataso. She is illiterate and naive. She is targeted to be the maid of Tika in her apartment, to help Tika in the house chores. The novel discloses her apparition in the narrative after Tika's admission to hospital due

to the removal of her womb after a complicated abortion. In the narrative, Efia's mother and grandmother negotiate with the little naive girl to get pregnant and incriminate one of the sexual partners of her Madam. She does not question her parents on the way she can make it. The traditional dumb respect vowed to one's parents is implicitly questioned here. Old people are supposed to stay above all contemporary factors of psyche's pollution and corruption. It is that difference that propels them to admiration by youth. Here instead, their complicity sets in motion a dark plan of disastrous consequences. So like a goat of pasture, she deploys the stratagem to the letter once in Tika's house as told. She becomes in a straight line the accomplice of the greediness of her people who expect that their becoming wealthy depends on Efia's succeeding in holding up Tika's wealth.

Throughout Efia's depiction, Amma Darko condemns all form of the exploitation of destitute in society. The concept of housemaid is in fact the modern time's slavery in African urban centres consisting in fetching from rural areas young girls at the age to go to school to work for well-off families in towns. Interesting jobs and money-spinning salaries are mirrored to them or to their family. It is promised to these poor people that their offspring will be sent to school, in apprenticeship or training like dress making, hair dressing, food sale in shops after a moment. A part of their earning can served to that purpose. The specific mention is that all these trainings will surely help them change their social status and lead them to stay in town. In return, they can help other members of their families to become independent. These young people are exported outside their home countries to nearby countries or to Europe, Southern and Middle East Asian countries and in Gulf countries where oil and money spill out of the ground for free. Often, it is a promise of death at the non-return gate. They are thus expected to return very rich with money flowing in their pockets and in their bank account to feed the village. Then a whole village places great expectations over their children just like Naka does with Mara while leaving for Hamburg. Innocently, Mara like Efia and Akua think that in town "All was going to be golden for me there and, though I was going there poor, I would return with wealth and bring honour to Naka" (Darko,55). This calls for African understanding about the phenomenon of illegal immigration from Africa to Europe or other countries in the world. As Mbugua Nganga points out, "Many people from poor African countries embark on the dangerous journey for Europe, in hopes of a better life"⁵³⁹. Once in the El Dorado like city,

⁵³⁹ Nganga Mbugua qtd in Gbaguidi, C. (2014) "African Illegal Immigrants' Disillusionment in Europe: a Study of Amma Darko's *Beyond the Horizon*" in *Revue du CAMES, Lettres, Langues et linguistique*, numéro 2, p. 2.

some find their way through, whereas others are completely disenchanted, but they hold on, not giving up to their last breath. They think that the issue of unemployment is a distinctive feature of the African continent. At this point, Amma Darko deserves much credit for raising through her creative writing her readers' consciousness on the control of their own destiny in their hometown and not in other people's. Like the proverb that carries that 'a bird in hand is worth two in bush'.

This is Amma Darko's way of warning the Ghanaian society of what will become of their daughters if they do not stop this sort of exploitation. On the top of it, the exploitation is perpetrated by well-off women or family to poor women or young girls. In doing this, Amma Darko shifts the African female writers' ordinary denunciation from patriarchal system misdeeds to an inside-threat condemnation. In contemporary times, women become dangerous to their own counterparts. They compromise their female counterparts' freedom by coercing them to slavery and social bondage. Women suffer in the hands of other women for the sake of traditional norms. In effect, subtly the female author highlights the consequences of rapid social mutations such as globalisation and urbanisation occurring in African countries. In the frenzied race to wealth and social fame, many African families are ready to exchange their integrity and dignity to seeming financial stability and sustainability. Efia is the evidence of that change of mind where people should more practice collectiveness and not individualism. Thus, the instigators of African social and financial problems are not only the colonisers, but also some Africans. For example, Efia becomes pregnant because of her need of imitation, her visionless desire to cover pecuniary wishes and her want to achieve what she is told by her parents.

Besides all this, Efia is just like a pawn of her grandmother and mother strategy to get hold of the woman's wealth. Amma Darko discloses that some women collaborate to the strengthening of the patriarchal system stranglehold against other women. Above all this, Efia, meaning 'protection' in Swahili, is superstitious like all other girls born in a traditional setting such as Kataso. The belief comes forth when she loses her infant, a stillborn. A stillborn is to mean that Efia, her mother and grandmother's dream to make easy money is impossible.

13.1.5. Akua, the symbol of contemporary social failure

Akua is a Fante name given to Wednesday born babies in the Ghanaian naming chart. Akua hails from Kataso, the same fictional village with Teacher and Efia. Akua is an illiterate

who has heard so much of the goodness of Kumasi. She has then in mind that Kumasi, like all Ghanaian cities, can transform a little unhappy girl like her to a rich and famous one. So decidedly, one day she makes up her mind to move to Kumasi minimizing all the risks and “armed only with her determination to make it to the city” (Darko, 30). Economic migrants and refugees have an ironed determination to walk forward to their goal not fearing to cross rivers, mountains and oceans. These migrants flee callous conditions and social stagnation prevailing in their homelands to safety and maybe to green pastures. Kataso is similar to all African rural areas where poverty is present all around, a situation which gives no hope to youth. Kataso economically disempowers its rural dwellers as it gives no opportunity to them. The situation has its roots in colonialism. The British system of indirect rule in colonial Ghana, with its emphasis on semi-autonomous territories governed indirectly through local chiefs, promoted ethnic allegiance among the different ethnic groups in the area that later formed Ghana. Such ethnic fidelity and the consequential suspicion of one ethnic group by another remain major problems that Ghana has faced since its independence in 1957. These problems led to the 1966 military coup that later culminated in frequent coups, a moment when the minorities felt not only marginalised but also rejected by the central government in Accra. Many of them decided to move for green pasture beyond the borders of their villages. Akua’s departure to Kumasi does not meet the same enthusiasm and expectation like Akobi and Mara’s because of the way she moves. She moves just the way a disowned child can leave a house. She tiptoes and runs away because she is sure of not having the complete back up of her parents.

In Akobi and Mara’s case, their travel to Germany was a whole village’s affair. Even the gods of Naka were excited to the idea of their trip to where human eyes cannot see. That is why they have been asked to clear up the visible and invisible paths, to help make duly sacrifices which should open the sky to let in the ‘proud to be leaving young man’, Akobi. Mara also leaves Naka with all blessings from medicine men. In Naka, some of the villagers make generous contributions to the trip and Akobi’s father sells his land to cap it all. In fact, Amma Darko emphasizes all these details to show the misconception of the West by the less fortunate people like ours. It takes even a whole year of saving or even more than that for people to get ready for the trip. However, for Akua it takes just a night of resolution as the prevailing poverty urges. No wonder, there is nothing that can stop the determined Akua to move because no one can entertain a man or a woman who has no food. Akua’s attitude confirms the assertion that ‘a

hungry man is an angry man'. Akua is hungry, that hunger makes her run away to Kumasi for food no matter the risk.

Besides, the ultimate need for some of Amma Darko's characters to move out of their ordinary space to another has to do with the need for any colonised to free himself or herself from the yoke of the colonial enslavement, the new space being a place of liberty. The colonised thinks of his reinvention in another place. A change of space though painful means a lot to the female writer since she has once moved from Ghana to Germany and then has experienced the psychological void it creates. This is in line with Louise Allen Zak's writing about Amma Darko: "Darko was shocked when she arrived in Germany [...]"⁵⁴⁰. The example of the void is for the most part depicted in *Beyond the Horizon*. As far as *The Housemaid* is concerned, the little Akua knows that ambushes are on her way fulfilment and she gets ready to overcome them all. Her exile allows her to flee from the colonial oppression and have her life anew in Kumasi. The risk is worth taking because she does not want to finish her life like the others in the village. In fact, it is the lack of the minimum that teaches her to have ambition to go forward. Then, she also knows that "If you go abroad and return, you are worshipped irrespective of who you are"⁵⁴¹. This is what usually happens in underdeveloped countries where the feeling of running away from a suffocating home is the most shared feeling in people especially the younger.

Conversely, the idea to move necessarily out of the rural place to an urban one seems to be the portrayal of the colonial legacy. In fact, when the Europeans first set foot in Africa, they came with their ordained mission of civilisation teaching African people that their ordinary living conditions are very weak and that they were also barbarous and savage. Then Africans should accept modern ideologies thought in Europe and given to Africans though the settings are not the same. Africans were then brainwashed and became aliens with imported ideas on their own continent. They think of urbanisation, globalisation and 'Europeanization' of Africa though sometimes all these concepts do not fit Africa. Colonisation destroys Africans' 'raison d'être', personality and way of life. It renders their mind alien and turns to white to agree with Frantz Fanon's historical anti-colonial writing *Black Skin, White Mask*. African brains turn

⁵⁴⁰ Zak, L. A. (2007). "Amma Darko: Writing Her Way, Creating a Writing Life." (Ed.) Vincent O. Odamtten, *Broadening the Horizon: Critical Introductions to Amma Darko*. UK, London: Ayebia Clarke Publishing, Print, p. 13.

⁵⁴¹ Zak, L. A. (2007). "Amma Darko: Writing Her Way, Creating a Writing Life." (Ed.) Vincent O. Odamtten, *Broadening the Horizon: Critical Introductions to Amma Darko*. UK, London: Ayebia Clarke Publishing, Print, p. 13

‘white’ inside. They begin to think that villages are evil and poor places, and urban centres are better places where to feel more Europeanised, more globalised, but completely alienated. That is what has pushed many Africans to move out of villages to large cities for a hypothetical better life.

In actual fact, For Akua, Kumasi does not only represent a place of liberty, but also a place of self-fulfilment in terms of economy and material property. Although in the past, there were many big and flourishing cities such as Gao and Timbuktu in Mali Empire, Kumasi the capital of Asante Kingdom, Benin City in Nigeria and Kilwa City in Tanzania to cite these few. All these African cities existed in the past and were crowded with people coming from everywhere for trade, science and knowledge. Records make it that fire was set to cities’ valuables like libraries, books, architecture drawings and totally destroyed during the European Scramble for Africa. From that time on, no recovering action has been possible. For example, here is a comment of Marie-Joseph Bonnat (1869-1874) edited by Claude-Hélène Perrot which confirms the richness of the Capital-City Kumasi (Ashanti Kingdom) and surely that of the other cities. The historian and humanist, Marie-Joseph Bonnat, wrote this: “Je crois que l’Afrique est capable de faire de grandes choses aussi bien que l’Europe. Oh ! Si le christianisme prenait dans un beau et riche pays comme celui-ci »⁵⁴². Marie-Joseph Bonnat wrote about what he saw at that time, the greatness of a whole country which he honestly wished could make it as well as Europe. Marie-Joseph Bonnat was detained by Ashanti people and fortunately was liberated during a conflict which opposed English army to Ashanti. Despite that unfortunate experience, Marie-Joseph Bonnat came back to Gold Coast to live and die. That Ghana was great and its contemporary people have the challenge to make it great again and to let Osiris rise to borrow from Ayi Kwei Armah’s sixth novel title *Osiris Rising* (1995). Thus, just like *Osiris Rising* takes its narrative construction from the roots of African history the Isis-Osiris myth cycle, African writers are called for the same move to their source. To succeed in that challenge, writers must refer not only to its past in their texts and make the connection between history and literature and literature to society, but also to restore its image long time destroyed by erroneous writings. Amma Darko is among these African female writers who decide to use highly history their writings.

Further, Amma Darko focuses on the very passage where Akua pays the price of her decision to flee from poverty and social stagnation; she brings to light her dream to make money

⁵⁴² Wauthier, C. (1996). Mémoires de la Société des Africanistes, pp. 30-1.

either with her arms or with her sex if needed. She proves it immediately on her way to Kumasi. The dialog unfolds this way:

The driver: Where to?

Akua: Kumasi.

The driver: You have the money to pay me?

Akua: No.

The driver: So you won't pay me?

Akua: Unbuttoned her blouse

The driver: Eyes blazed with consent

Akua: Removed her pants

The driver: Grinned, and stopped the truck in a secluded bend.

Akua: But don't make me pregnant.

The driver: I won't and he covered her nipples with his lips. He sucked and fondled her body.

Akua: She liked it and did the same for him. (Darko, 30-1)

The extract shows the graduation of intensity during the terrible sex crime between a young girl and a man of her father's age, a sex predator. The first word of temptation is 'unbuttoned the blouse'. In this sense, Akua expects her naked body impacts the driver and it rightly does. Then, the result is felt immediately because the driver's 'eyes blazed' of interest to what is expected to be the next item. Gradually the intensity grows up when Akua 'removed her pants'. The narrator keeps the passion on that the driver 'grinned and stopped' the car. What remains to form a complete cocktail is the blazing penis of the driver that the narrator does not mention. The truck driver is an opportunist who in fact, can give a ride to the little Akua devoid of reward. The passage describes the growing materialistic greed in globalised and capitalist African urban centres. Akua is a victim of the macho system that gives nothing for free. So hoping to get to the other side of the 'river', Akua has to pay the ultimate price. As she has no money, sex is the right exchange object to bribe the driver who does not even care for his own sexual security. We can see that the narrator does not mention any condom use. One of the sentences of Akua proves it: 'But don't make me pregnant'. In the sequence of events, Akua is shown as the prototype of the scapegoat of the system of immigration.

The story of the little Akua is similar to that of any immigrant in real life. In this way, it highlights Amma Darko's own life story since she also migrated to Germany for a better life years ago. The ordeals of immigrants are unimaginably dark and hard to tell. They have to accept conditions shaped in hell and dictated by devil itself. When talking about immigrants,

people deploy the utmost of their animosity that dwells in them to treat human beings like them. Some are literally killed and their dead bodies abandoned, others are taken as trophy for sexual slavery for themselves, their wild dogs in house or taken as servants for forced labours. The life of these little and pretty people down in the African cities or in other countries is incredible.

For instance, the narrator points out that “Like her mates, Akua had no regular home. They lived in unfinished buildings; when final completion work started, they moved out. Thanks to bribes of cash and sex, workers at the building sites regularly tipped them on the next place available for occupation” (Darko, 32). The above scene of sex is purposely placed by the author to blame her male characters of being sexual predators against their own daughters that the future generation. Amma Darko seems to be completely upset against the situation where young girls and women have to exchange their body to having a lift to a place where they wrongly think is a greener pasture. They become the potential victims of this globalised world where money leads all and all is built around money and sex. To give a lift to a young girl like Akua cannot necessitate asking for sex, but contemporary Ghanaian society is built like that. In society, someone who has a parcel of power often abuses. The driver shows the case of the imbalanced commercial trade between two worlds in action. In so doing, the system is burst out by individualism and materialism embodied by men and their sexual greed and predation. The social system seems to be at the mercy of ‘give-me-I-give-you’ system. No assistance is free of charge for the sake of good manners and humanity. The transition from tribal system to socialist or democratic one is lost and people have to pay the price especially weak and destitute people.

The extract also highlights that the modus operandi is too clear to be understood by both actors. First, what Akua requires is not to be pregnant since she knows how being single with a pregnancy can jeopardise her dream of making money in the city and come back respected and envied in her home village. The second element that draws our attention is the spontaneous answer “*I won't*” of the driver to calm down the little Akua already stark-naked and waiting as if he were sure the girl to ask a question. The third point arises from the second. The attitude of the driver proves that he is used to that kind of predicaments on his way to Kumasi. The simultaneous answer is a ready-made reply of a person accustomed to circumstances like this one. The scope connotes that the old man is not at his first strike. Then, after this word of assurance from the driver, there is other word than his action. He starts fondling and sucking her nipples and body with his lips. Amma Darko succeeds in drawing the reader's compassion

toward the little girl and by extension to all the girls of Akua's age. Parents have to be revolted after reading this excerpt from the novel. But in fact, the more Amma Darko writes about her female characters' poignant ordeals, the more she expects to raise people's attention on what is now important to do and the next step to make to stop the slaughtering, the social down falling.

The fourth aspect that raises our attention is the material used for the transport: a truck. The narrator uses a truck because it is less comfortable than an automobile. Trucks are designed mostly to transport cargo, heavy luggage and goods like meats, fruits and vegetables. Trucks vary greatly in size, power and configuration. Then, smaller varieties may be similar to some automobiles. Roads and buildings' contractors use trucks to move their specialized equipment. If a truck is used in the present narrative, it is for two reasons. The first is to raise our awareness on the female character's determination to leave no matter what happens and with the first means of transportation which helps her to move. When home suffocates, nothing can stop the desire to leave immediately and the quest for liberty. By the means of that truck starts the female character's quest for freedom. There should be a sign of relief at the sight of the truck. The trailer comes with an illusory hope to the girl. Akua will sooner or later know that freedom is illusory in this capitalistic world since she is obliged to exchange her body with the driver and this way of payment continue in town. This sort of illustration is also found Ken Bugul's *Cendres et Braises* (1994) and *Riwan ou le Chemin de sable* (1999). In these two novels, Ken Bugul constructs her female characters' lives and movements in a circle of interdependent elements and actions that oblige the later to come to their traditional milieu. According to the author, her female characters cannot find peace if they live out of their traditional spheres. For example, if they live Africa to Europe or their village to town. Ken Bugul's female characters are then finally trapped in a sort of circle in their quest for liberty. For example, a Muslim female character travels to Europe for emancipation leaving because of the social and religious constraints, but she is finally trapped by the same constraints.

In the above extract, the exhibition of sex is a scene denuded of pleasure. It is a means of resistance and Akua knows that not the offering of her body is significant, but what good derives from the offer which is the ride to Kumasi. In the similar vein, Dako et al (2006) is convinced that the author purposely uses pornography in her writing. He submits that:

Darko's use of pornography and profanity [...] exhibits a kind of resistance that manifests in her desire to fight prostitution with its cores allies of

pornography and profanity. Injecting decency in her shared gender through the use of indecent pictures and language throws into focus the devastating effect that prostitution has on women's image and health. This angle of telling the whole truth about prostitution-i.e. making it look and sound so repulsive to warrant immediate redemptive action, is not only arresting but also calculating.⁵⁴³

The above passage shows us that Amma Darko elaborates on the stinging and poignant side of prostitution in order to teach people about the phenomenon's havoc on the population. Likewise, the author tells about the phenomenon of migration to indicate the extent to which it triggers people's expectation to have their life changed. Greener pastures are what they look for, but it changes to nightmare. Thousand over thousands of migrants are ready to do that to escape from the hellish danger their country represents. The narrative pities the hectic life of immigrants and horrible journey each of them is forced to make. For example, the world received in September 2015 the shocking and full horror picture of the Syrian boy which shows tragic plight of refugees and migrants. The boy found lying face-down on a beach near Turkish resort of Bodrum was one at least twelve Syrians who drowned attempting to reach Greece. This is in fact the living reminder of the danger poor people are taking in search of a better life. While full of determination they all know that the end justifies the means. Their courage to cross fraudulently other countries' borders by breaking the rules and regulations is not what they want to do, but they are obliged to make it happen because of many unworthy employment policies of governments all over the world.

Yet, others flee their country because it becomes a battlefield, a field of weapons' confrontation. Adversity and enmity drown people's humanity and make them simply animals. This hostility is born out of people's want of power and prominence. This corroborates the English philosopher Thomas Hobbes of Malmesbury⁵⁴⁴ (1588-1679) opinion about human nature in *Leviathan* (1651). Thomas Hobbes view of human nature leads him to develop his vision of an ideal. He believed that the nature of humanity leads people to seek power. Consequently, when two or more people want the same object, they become rival or enemies

⁵⁴³ Abeka, P., Marfo, C. ; Bonku, L. (2014). An Angle of Seeing: Pornography and Profanity as Pharmakon in Amma Darko's *Beyond the Horizon* and *The Housemaid*. *Advances in Language and Literary Studies*, Vol. 5, No 2, p. 108.

⁵⁴⁴ Thomas Hobbes born April 5, 1586 at Westpoint and died in December 4, 1679 at Harwick Hall, Derbyshire. He was an English philosopher, scientist and historian, best known for his political philosophy, especially as articulated in his masterpiece *Leviathan* (1651). Hobbes was one of the prolific scientists of his time. In metaphysics, Hobbes defended materialism, the view that only material things are real.

and attempt to destroy each other. Thomas Hobbes believed that this state of war and permanent trouble is the natural state of human beings and that harmony among human beings is artificial. Then, the visible state of peace is factual and basically unstable. That is why everywhere, people are in trouble and their surroundings so devastated. Out of this state of power desire come strategies such as other people enslavement and colonization. No surprise, we know that all this leads to devastation and desolation of the countries where all this happened in the past. In our context, the little Akua is from one of these countries where both of these events occurred. Among these devastated countries are the Sub-Saharan that are still paying the price of these evil events. In these Sub-Saharan countries, the colonial pact added to its intricacies force many African young people to dare to move and reach countries beyond the horizon. Among others, the little pretty being Akua must decide to live in her village and finish like the other mates or spread her wing and fly away and have an opportunity to regenerate in Kumasi no matter how. Akua's life in Kumasi is similar to that of Efia's as housemaid in Tika's house and also Mara's life in Accra living in her iron corrugated sheet house. As we have mentioned earlier, Efia has to strive in the daytime for the house chores and during the nights to replace Tika with her business partners. As for Mara, in the morning time she must carry out her normal duties such as fetching water for Akobi's bathing and wait his return to carry back home the sponge and basket, just after Akoki's departure to office, Mara must clean the house and throw dirties for neighbours. Then she has to go to hawk her boiled eggs at the nearby station. In the evening, Mara has her normal duties to follow strictly. Failure to carry out one of these tasks generates her master's anger materialising with blows and slaps.

Thus, if we assume that Akua and Efia (younger generation) are to be taken as a whole nation, then they have to give themselves to many sexual partners for commercial affairs and when we say 'commerce', we unfortunately refer to a biased business between well-off and destitute people, the most unfair exchange the world has ever witnessed. The situation, common to almost all African post-colonial countries, describes the significance of intercourses in the discourse in post-colonial context. Then, most of the time, African writers refer to sexual intercourses as being an evidence based proof of male-oriented dominance and the colonial aftermaths still prevailing in those countries. Extending the idea, Robert Young quoted by Vincent Odamtten submits insightfully on the characterization of "colonial desire" this way:

Sexuality is a direct and congruent legacy of the commercial discourse of early colonial encounters, the traffic of commerce and the traffic of sexuality being complementary and intertwined economic and sexual exchange more intimately bound up, coupled with each other, from the very first. The history of the meanings of the word 'commerce' includes the exchange both of merchandise and of bodies in sexual intercourse⁵⁴⁵.

In this context, there is a permanent combination between commercial exchanges and erotic or sexual desires and also between material needs from a specific group and their sex exchange. Mara, Akua and Efiya's approach towards their body exchange is obviously a desperate sign a survival amidst that group of people. There is no way getting straight with one own desire without putting on the table one's part of transaction. This body business also proves that people have to bear in their mind that the higher the dream, the higher the price and the part given for the transaction in question. These pretty little beings know how to manage it or they have been forced by their environment to master very quickly the way it works in concrete jungle like their society.

Further, the portrayal of Akua pinpoints the fact that it is important for Akua to leave her village to Kumasi because of the image the returnees (been-tos) give of the city and the failure for the village to create hope for its youth. The narrator puts it: "At home for the festival that first year, Akua dazzled her people with tales of traffic lights, fly-overs, the latest cars on the streets and exotic events such as visiting foreign musicians. And finally when it got to 'showtime', she joined the crowd of returnees to Osiadan proudly" (Darko, 33). Akua does not mention the degrading conditions in which she lives and her sexual show times with different workers in order to get a corner where to sleep. She will never become that rich woman since she thinks that going to city infers fortune for free. Does Africa's prostitution all that time alongside with all its ground resources cheaply taken away by International Companies and its money borrowing IMF and World Bank induce development? It has never been, not even a little hint of it. The aid Western countries granted to African countries can never infer development because of the ways and their intricacies. In that vein, during an interview with CNN, the President of Rwanda, Paul Kagame, calls this kind of aid "dead aid which cannot induce any development in Africa, but Africa should take serious responsibility and accept its failure to go

⁵⁴⁵ Odamten, O. V. (2007). "Amma Darko's Beyond the Horizon: Vending the Dream and Other Traumas of the Obedient Daughter" (Ed.) Vincent O. Odamten, *Broadening the Horizon: Critical Introductions to Amma Darko*. UK/London: Ayebia Clarke Publishing, Print., p. 110.

forward”. He then proposed a “free opportunity of transaction with any foreign country without restriction”. He warned that controlling African countries’ business transaction would not help them develop. This point has also been raised by the Zambian economist Dambisa Moyo⁵⁴⁶ on ABC in May, 2009. She advocates that Europe and the other western countries should stop sending aid to Africa because it impedes its development. Aid does make any one to come out of poverty, she defends. However, the final point of the international economist is that the best for Africa is to have China as the replacement business partner to Europe, which is absolutely not our point of view. In fact, documents in economics reported that China was rather “poor country”⁵⁴⁷ and mainly an agrarian society in the 1960s when most of African countries were getting their independence. We do not deny that China’s spectacular rise over the past half century is one of the most striking examples of the impact of opening an economy up to global markets particularly in 1979 (when economic reforms began in China)⁵⁴⁸. Over that period, China has undergone a shift from a largely agrarian society to an industrial powerhouse. From that power up to now “China has been among the world’s fastest-growing economies, with real annual gross domestic product (GDP) growth averaging nearly 10% through 2016”⁵⁴⁹. However, the acceptance of China as the principal commercial partner with African countries would be, to our point of view, the last and deadly blow that the African leaders would make against the continent’s development.

To our opinion, what is important is the sovereignty that each African country should have in terms of free choice to get any business partner it desires or a large variety among which to make its choice. There is finally no hope that a well-adjusted exchange would come out of that partnership as it has never been. What could make it change is the determination of African countries to have their own industries and consume their own manufactured products. Our point of view is that the control from these international institutions keeps African countries’ head under water and debts suffocate them extremely. As a result, the African continent is under-

⁵⁴⁶ Dr Dambisa Moyo is a pre-eminent thinker, a Zambian born international economist who influences key decision-makers in strategic investment and public policy. She is respected for her unique perspectives, her balance of contrarian thinking with measured judgment, and her ability to turn economic insight into investible ideas. She holds a PhD in Economics from Oxford, a Masters from Harvard, and is recognized for fresh and innovative ideas as the Author of three (03) New York Times Bestselling Books.

⁵⁴⁷ The world bank, *World DataBank, Poverty and Inequality Database*. Extreme poverty is defined as those living on less than \$1.25 per day on a purchasing power parity basis.

⁵⁴⁸ Morrison, W. M. (2017). *China’s Economic Rise: History, Trends, Challenges, and Implications for the United States*. Congressional Research Service (CRS Report), p. 1.

⁵⁴⁹ Morrison, W. M. (2017). *China’s Economic Rise: History, Trends, Challenges, and Implications for the United States*. Congressional Research Service (CRS Report), p. 1.

developed and at present exceedingly indebted. Akua's social situation depicts that of destitute people on one hand and rich one the other hand and by extension that of Africa and the West.

Akua represents here Africa and its people and her story illustrates the class social struggle, where rich people manage their best to keep under yoke their poor servants, housemaids, drivers, gardeners. Irony of this kind is common in novels where people take themselves terribly seriously, but should be laughed at. In fact, "the point is that for these characters their predicaments are serious, but viewed from another angle their lives are absurd"⁵⁵⁰. The emphasis so far has been on Akua's imprudent behaviour in Kumasi in search for instant wealth. She publicly ridicules herself while obliged to give herself from worker to worker to find unfinished shelter night by night, yet she clings on to the end which is not foolish to take into account. Her action must not be dismissed for its foolishness, but understood as a rather desperate call for help from a drowning in poverty's water and lost in the middle of an endless forest.

Throughout the narrative, on one hand, we make out that Amma Darko condemns that kind of mistreatment of weak people. The author makes show of the dialectic struggle between poor and rich people, poor being always under the tyranny of the well-off. Amma Darko writes about the gap to illustrate the permanent warfare between both classes. The female author militates for an equalitarian society where the fact of having power (financial and political) at one's disposal must not lead people to misuse it. On the other hand, Akua's story adopts African way of telling tale. The missing element is the traditional opening such as 'Once upon a time...'. African oral literature is replete of interesting tales referring to youth's braveness and misfortune like that of Akua and her mates. In fact, Amma Darko like the other African writers who make use of African tales to illustrate their creative message force their readers' admiration by making them rediscover what is ordinary. This is in line with the South African Njabulo Ndebele's idea in "The Rediscovery of the Ordinary: Some New Writings in South Africa" who makes this discerning remark that:

Subtlety is avoided: what is intended is spectacular demonstration at all costs. What matters is what is seen. Thinking is secondary to seeing. Subtlety is secondary to obviousness. What is finally left and what is deeply etched in our minds is the spectacular contest between the powerless and the powerful.

⁵⁵⁰ Peck, J. ; Coyle M. (1984). *How to Study Literature*. London: MacMillan Press Ltd.

Most of the time the contest ends between in horror and tragedy for the powerless.⁵⁵¹

Taking cue from the above remark, we understand that Amma Darko wants to raise people's awareness on Ghanaian social problems which have some solutions in their ordinary tales. Amma Darko wants Ghanaians to replace their tales in their context to find their way out of their present predicaments. Aside from its ludic side, African tales teach social norms and good manners. The tales condemn all forms of exploitation of the poor by the rich and reinforce unity among the exploited. Further, what is also important to mention as the narrative unfolds is the feeling of satisfaction when the little Akua comes back for Kataso yam festival though "life as a porter in Kumasi was not what a normal person would call living. It was survival" (Darko, 32). However, Akua knows that one bird in hand is better than two in bush and that "The adulation she would receive in Kataso would make all her sweat and humiliation sweet" (Darko, 32). At her return for Yam festival, Akua will receive warmed welcome and envying eyes from all her people as she becomes an envied 'been-to'. In fact, Amma Darko depicts the feeling from the deep inside of the Diaspora's psychological construction and the feeling of success they have while back home. The sweetness it creates obviously turns nice their frustration, mortification and alienation.

In *The Housemaid*, Amma Darko presents a credible and reliable image of what happens to women when they move beyond the borders of their country for a better life because nationals fail to make it possible at the different places a policy to keep youth hoping for a change. The reader can feel Amma Darko's resentment against them. She writes to lay blame on their fail to redistribute the national wealth equitably in contemporary Ghana. For example, in some villages people lack the minimum to feel at ease and only "a privileged few, who could occasionally afford batteries, owned pre-set radios, the kind imported from China in the 1960s" (Darko, 29). Sex becomes the only centre of entertainment. Then "everyone – young, old, mature and immature – indulged in it freely" (Darko, 29). Ghanaian youth has to prostitute all over the streets in modern cities to show the failure of the national authorities to figure out the real social problems of their people.

⁵⁵¹ Njabulo S. N. (1994). "The Rediscovery of the Ordinary: Some New Writings in South Africa" in *South African Literature and Culture: Rediscovery of the Ordinary* (Manchester and New York: Manchester University Press.), p. 46.

14.2. Female secondary characters

For the sake of the understanding of the story in its wholeness, the reader also needs the characters we now qualify as secondary. Though being as important and necessary as the first studied, the female characters in the present novel that we categorise as secondary help balance the plot. Ranking these female characters, we have by priority as follows:

14.2.1. Mami Korkor, the symbol of female powerlessness

Mami and Mama are names commonly given to women of a certain age to represent their old age. Its real writing should be ‘*Maame*’ to be correct with Ga or Ashanti people pronouncing it. The woman’s name is mentioned right from the start in the first chapter of the novel. The proper name Korkor, from Ga language ⁵⁵², may be given to refer to the woman’s proper name. The practice is widespread in black African countries where names of mothers’ first children are called. Mami Korkor is illiterate, single and a poor fresh-fish hawker. In Ghana, according to Ghana Statistical Service (GSS), the 2000 census reports that “45.7% of the adult population is not literate. The level of illiteracy is however higher for females than males”⁵⁵³. That evidence based-proof from the GSS shows that there are many Mami Korkors flesh and bones in Ghanaian society who have never been to school. Amma Darko’s depiction is based on the GSS’s scientific trend. This shows how literature can be in service of society by revealing, but fictionally the living reality of Ghanaian women. Yet, as the situations get harder and harder in present days, more Ghanaian women are getting out of their homes to work for their own, unfortunately hawking is menial enough to feed all the waiting mouths in Mami Korkor’s house. In “*The Role of Women in Ghana’s Economy*”, Nora Judith Amu reports that:

women are predominant in all the sub-sectors namely farming, processing and distribution. As farm owners, farm partners and farm labourers, women are estimated to account for 70% to 80% of food consumed in Ghana. The

⁵⁵² Ga is the name of a tribe in Ghana and also a language spoken in the South-eastern Ghana and around the capital Accra. The Ga population are estimated to be well over 300.000 in the whole of Accra. Ga is the Kwa language, a part the Niger-Congo family. It is close related to Dangme and together they form the Ga-Dangme branch within Kwa. The origin of the Ga speaking ethnic group stems from the 16th century when the Ga people migrated from the East Nigeria. The Ga people had been the last to settle in Ghana. They had ancestral link with the Yoruba in the tonality and cognates. Retrieved from “The history of the Ga Peoples”.

⁵⁵³ Amu, N. J. (2006). *The Role of Women in Ghana’s Economy*. Fredrich Ebert Stiftung, Ghana, ISBN 9988 - 0 - 2606 - 4, Print and design by O’mens Graphix, p. 24.

predominant role of women in agriculture has enabled most women farmers to become increasingly responsible for the educational and other material needs of their wards, especially for female headed households⁵⁵⁴.

She is from Braha, a small fictional village near Kumasi. In Ashanti language Braha means ‘*come here*’. When someone comes to a new place, he sees people and their culture. Then come here to see our culture is in the same line with what the writer tries to show in her fiction. To be close to the reality of the country, in Kumasi the foremost language spoken is Ashanti. That is surely why the writer tries to stick to names and nouns from her language. Mami Korkor has four children of whom none is at school. She has a boy who is among the scavengers that find the horrible dropped wrapper of the stillborn. With an indirect consent her boy (Nii Boi) has to scavenge searching in “the rubbish dump for anything that might be useful” (Darko, 5). Mami Korkor has no financial support from her husband. According to Leavitt (1971) “the most important clue to a woman’s status anywhere in the world is her degree of participation in economic life and her control over property and the product she produces”⁵⁵⁵. In this very scope, Mami Korkor has to sell from dawn to dusk to feed herself and her children, which is the foremost reason why her children do not go to school. Her absence also influences her children’s education.

In fact, Amma Darko chooses the female character to point out the rather difficult life for a single, poor, uneducated and mother of four children either in a village or in an urban centre in contemporary Ghana. Life is tough and merciless for women who have no moral and financial supports of their husbands. They live in a nervous condition and their children also. Like Mami Korkor, many other women have to go to hawk in the same conditions before they have food for themselves and their children. The situation of Mami Korkor proves rightly the marginality of women in post-colonial African countries which forces women to live wreck. She does all her best to move from the margin to the ‘centre’, but regrettably she notices no change because no one gives her opportunity. Opportunity, as the African American actress, Viola Davis, says during the Emmy Awards in 2015 is what distinguishes a woman of colour and a white. Mami Korkor meets no one to give her lift. She is then blamed by her little girl child Bibio. The little girl blames harshly her mother this way: “Too bad. You should have sent me to school to learn

⁵⁵⁴ Amu, N. J. (2006). *The Role of Women in Ghana’s Economy*. Fredrich Ebert Stiftung, Ghana, ISBN 9988 - 0 - 2606 - 4, Print and design by O’mens Graphix, p. 10.

⁵⁵⁵ Amu, N. J. (2006). *The Role of Women in Ghana’s Economy*. Fredrich Ebert Stiftung, Ghana, ISBN 9988 - 0 - 2606 - 4, Print and design by O’mens Graphix, p. 15.

some manners then. But since you rather let me stay at home to play mother to you and your friend's sons-boys I'm only three years older than-where else can I learn my manners but in the streets?" (Darko, 11). There is no way to convince Bibio. Being a member of that system, Mami Korkor is unable to stop her marginality since every day she is more and more pushed into poverty and other harsh conditions. Further none of her offspring is at school to be empowered in the future and then help her change her situation.

In this vein, we agree with Monica Bungaro who submits that "It is clear that Mami Korkor feels guilty for failing to meet her daughter's needs⁵⁵⁶" that is why she starts insulting her and blaming her absentee and irresponsible father this way: "Not a pesewa⁵⁵⁷ came from their father" (Darko, 11). Mami Korkor is a defeated and on the top of all, she is an exploited mother by her husband and by the patriarchal system which encourages motherhood at all venture. If we consider Ghana as Mami Korkor, then we can assume that it is the future of a whole nation which is endangered. The nation is then exploited by an imperceptible colonial master here represented by Bibio's father, an absentee man who does not assure his full responsibility as protector, educator and 'bread winner' of the family as his contribution is needed to balance the family's revenue. Fresh-fish hawking income is not sufficient to feed five mouths. The emphasis made by Amma Darko about Mami Korkor's menial job is to show that there exists in Ghana a potential productive human capital in the form of women, which needs encouragement and opportunity. In the same vein, Ghana as a nation lacks all opportunity to become bigger and bigger because of its past. Ghana will not move from his poverty if not given opportunity to change its citizens' social and economic situation. Just like Mami Korkor, Ghana is defeated and lost.

Further, in one hand, we remark that Mami Korkor is the opposite version of Maa Tsuru in *Faceless*. The latter stays at home and lives on what her children bring home from garbage dump and her female from prostitution and streets. Both of them share a large number of children among whom boys are assigned to scavenge and bring materials to sell. In the other, Mami Korkor is the illiterate form of Kabria in *Faceless*. Both female characters wake up in the morning, come back in the evening to make ready the evening meal for their stubborn children. Mami Korkor is alone facing her trials Mami Korkor's person needs "adequate investment in the

⁵⁵⁶ Bungaro, M. (2007). "Victims and/or Victimisers? Women's De(Con)structive Power in *The Housemaid*", in *Broadening the Horizon: Critical Introductions to Amma Darko* (UK: Ayebia Clark Publishing Limited), p. 33.

⁵⁵⁷ Pesewa is the smallest silver currency like European's cents used in Ghana.

form of education and skill training and to provide the requisite guidance and capital needed to apply this potential to actual productive activities”⁵⁵⁸.

Additionally, from the beginning as it is shown the mother has been exploited mercilessly like Ghana is being monetarily, financially and psychologically exploited with no intervention from outside. Its ground resources serve to enrich other western countries and Ghana as a nation is poor and its children uneducated. Other Ghanaians have to leave and settle in other countries for a better life. Unfortunately, Amma Darko gives no way out for this female character. For her boy (Nii Boi) being scavenger and her daughters uneducated means that the cycle of poverty is set in motion. No one in that family can ever stand on his feet to resist because there is no tool of empowerment, at least at the present time. Who among the children can take the challenge to fight back, Nerely, Akai, Nii Boi or Bibio? Amma Darko, through this character depicted a dark future for a nation, if nothing is done to address the present time difficulties.

14.2.2. Bibio, a young revolutionary

Bibio is three years old. She is born to an irresponsible father whose name is not mentioned throughout the narrative. Bibio is a little girl who has to cope with the early absence of her two parents. Her mother, a fresh-fish seller, has to hawk from morning to evening to find what she must feed them with. The extreme poverty in which Bibio, the last of a family of four, is born justifies the fact that she does not go to school because her mother cannot afford it. She blames her for that “You should have sent me to school to learn some manners then” (Darko, 11). The little girl is conscious that education no matter how tiny is important in a woman’s life. Education is the key determinant to have knowledge which helps liberate from ignorance and even poverty. Education is a weapon for achieving self-actualisation and fulfilment. It is the key that opens the doors to women. That is why Bibio focuses on her going to school like Tambu in Tsisti Dangaremgbá’s *Nervous Conditions* (1988). In the narrative, Tambu’s father does not consider significant a woman’s sending to school and puts this: “[...] of a woman who remains in her father’s house? ...She will meet a young man and I will have lost everything”⁵⁵⁹. This father thinks that the better investment is to educate male children, given the custom whereby a

⁵⁵⁸ Amu, N. J. (2006). *The Role of Women in Ghana’s Economy*. Friedrich Ebert Stiftung, Ghana, ISBN 9988 - 0 - 2606 - 4, Print and design by O’mens Graphix, p. 25.

⁵⁵⁹ Dangaremgbá, T. (1988). *Nervous Conditions*. United Kingdom: The Women’s Press, p. 30.

woman joins her husband's family after marriage and wastes the investment in giving birth, staying at the kitchen and cooking food for the family. As these common tasks of a woman do not require her obtaining a university degree, he discharges his daughter's intellectual capacity as of little use to him. Finally, a White woman, Doris, and her husband pity Tambu and give Matimba, the Sunday's school teacher, ten pounds sterling to pay for her education. A similar situation is depicted by Kaine Agary's *Yellow-Yellow* (2006). Agary reveals a society that denies the woman something to desire, something to look out for, to make, achieve and something to give. In *Yellow-Yellow*, Zilayefa is the central character in the novel. Her mother, Bibi, is an Ijaw-Nigerian woman⁵⁶⁰, a highly destitute mother who cannot afford her daughter's education. In the discourse, unlike Mami Korkor, Bibi is convinced that education is very important to women in society. She therefore dismisses her own basic needs and makes sure her daughter get educated because she sees in her daughter a tool of self-realisation, which is not seen in Mami Korkor's mind-eyes.

Furthermore, the roughness in Bibi's speech must draw the reader's attention for her articulate revolt is unlike for a baby of three years old. At three years of age, Bibi is capable of thinking so deeply and neatly, at least more than her subdued mother because age does not define maturity. She knows that school is par excellence the place where people are taught good manner and that reading from books at school gives people skills to find out ways to build up capacity. A school is where you are sent to learn to treat people and where you are taught to be treated well. All the way, in African culture small children are permitted to talk neither in assembly nor to their senior the way she talks to her working mother, struggling woman. In spite of all this, the blame is not to be put on the little girl. She is aware of the total poverty around and knows that her lonely mother is unable to tackle it all. She does not want to become in future Mami Korkor in miniature. Children copy and learn by example and when Bibi looks around, all that she finds is her defeatist and poor mother that she does not want to resemble. She has no one to particularly admire and cannot also understand why her culture is so selective about biology's use as reasons for social norms. She cannot why gender roles are so sharply cut and defined in her society.

⁵⁶⁰ Ijaws are the predominant indigenous people in the Niger Delta who moved to the Delta over 7,000 years. The Ijaw is the anglicised version of Ijo or Ejo, a variation of Ujo or Ojo the ancestor who gave the Ijo people their name. Ijo believe that they are from Benin since they share the same traditional stories, tales and legends, but the language is far not the same. Then if Ijo originated from Benin, they might have left the land far earlier than any other tribe migrating from Benin. From: www.ijawinnigeria.com

For example, in many African cultures, children belong to their father, no matter what happens. We use biology to explain the privileges that men have, the most common reason being men's physical superiority. Then, why men should not assert their responsibility over their offspring and take on their duty to care for them? When Bibio stays at home instead of going to school, why that father does not come out of his hiding and claim for his daughter and puts her to school? When then is he obliged to flee while this part of his responsibility is at stake? Consequently, it is necessary to figure out the solutions with no delay. Social norms are created by human beings and when they do not fit, they have to be changed. In the same scope, Monica Bungaro emphasizes the pressing need for a daughter to reject her situation:

Bibio rejects the idea of being a mini-version of Mami Korkor, as she finds in her no acceptable model of womanhood. The daughter then attacks the mother as the tool of patriarchy, accusing her of colluding with the same power structures she is supposed to challenge. Bibio's hostile attitude towards her mother finds its main reason in her rejection of a life she is condemned to live because of her mother's mistakes. She feels rage at her mother's powerlessness because of her intense identification.⁵⁶¹

The little girl wants to move off from her powerless mother and the only way is to strike the direct responsible of her permanent ordeals. She wants to be herself and not another person, a self dictated by her mother's present social conditions. She wants to be the best version of herself. She wants her life to be what she desires it to be and not the result of her mother's lack of financial means and her invincible father dictate. Bibio's attitude teaches the girls of her age and above to fend for themselves and to love to ask questions to their mothers and older people no matter the outcome. Bibio never sees her father, the one who should direct and empower her with his presence. This means that her mother represents the patriarchal danger she has to fear. Bibio is a revolted youth against her lethargic parents, her mother first. Bibio's depiction is a direct forewarning to parents (Ghanaian and African authorities) of an imminent revolt of youth if they do not play their part of responsibilities which lie in two points: education and protection. These two are the basic points a responsible nation or continent should give to its citizens, its children. Amma Darko asserts through Bibio that a Nation has to define priorities for the well-being of its people especially women and youth. Then a nation should elaborate strategies to help women resist the ideology of gender inequalities. Bibio is thus a response to societal spells

⁵⁶¹ Bungaro, M. (2007). "Victims and/or Victimisers? Women's De(Con)structive Power in the Housemaid", in *Broadening the Horizon: Critical Introductions to Amma Darko* (UK: Ayebia Clark Publishing Limited), p. 33

that have suppressed youths from self-discovery and education. Women have not to be distracted from the significant points to resist male imperialism.

The feminist has to be sensitive to women cases in all form in patriarchal society. This is in line with Acholonu's observation that "African feminism has to be sensitive to ever-increasing threat of starvation faced by millions of African children and the third world. A threat directly connected with the exploitation of the third world by world powers in Europe and America"⁵⁶². Aside from all this, patriarchy has also the possibility to use women to jeopardise their move to self-assertion and self-development.

14.2.3. Efia's grandmother, the conspirator

The character is the mother of Maami Amoakona, Efia's mother. She is in the exception of Amma Darko's old age depiction. She is dishonest and is suspected of collusion with the force of subjugation. In the story, the reader's attention is drawn to her tactic to manipulate the whole family to her materialistic end. She is illiterate and poor. As a matter of fact, she thinks that the only way to get rich is to take control of another person's wealth. To bring to light her plan, she calls for her granddaughter to get pregnant to one of Madam Tika's sexual visitors. If the plan goes to the letter, Tika will adopt the child as she has none and then Efia's family will claim for a part of Madam Tika's fortune as an element of the deal. The grandmother thinks that it is the only occasion for her to get rich by exploiting her female counterpart, a way to escape from the wretch conditions.

There is a concealed but pervasive vision of the grandmother which traces down its origin from the two contacts of Africa with Europe. These two events trace down the history of Africa being underdeveloped till now. The Transatlantic Slave Trade which drove millions over millions of brave Africans out of their land, was the first event and the second was colonisation, which form a "chapter unpleasant to look back upon"⁵⁶³. Colonisation left devastating consequences on the colonised bodies and souls. Besides this, the self-appointed civilisers of the backward peoples set up social hierarchies and continue to exploit their former colonies' territories. African people are left empty-handed. As a result of all this, there exist villages like

⁵⁶² Acholonu, C. O. (1995). *Motherism: An Alternative to Feminism*. Owerri: Afa Publications, p. 90.

⁵⁶³ Dubois, W.E.B. (1976). *The Souls of Black Folk*. In Martin Luther King Day. Print, p. 76

Kataso completely stripped of the basic to survive. What remains, getting rid of their integrity and moral values, is to make use of the slightest occasion which comes to them.

Furthermore, the narrative shows the influence of the grandmother on her daughter and her offspring. Amma Darko shows in the plot the extent to which poverty can make unexpected people become dishonest and dangerous to society. In the same vein, the environment in which the grandmother grows and lives is Kataso, that poor village in the eastern hills with no social infrastructures. Culturally in Africa, a grandmother embodies respect, honesty and righteousness, natural quality that she lacks as dragged to the bitter edge of the capitalistic tide. Obviously, it is a forgotten place where all the vices are nourished and developed by its people since poverty has set its 'generous' feet there since 1960. The only signs of modernity are pre-sets radios and batteries imported from China when Ghana was deeply involved in socialism inspired by China's former revolutionary president Mao Zedong.

Amma Darko's characterization discloses the transformation of Ghanaian society even to old age in the remotest village. Efia's grandmother represents the decadence of a nation from its roots, its most important part which should sustain the tree while being rocked by social events. Corruption of Ghanaian society has reached the deepest component. This means that no fraction of the Ghanaian society is put aside from the modern change.

14.2.4. Efia's mother, the dumb witness

She is the mother of Efia. Her proper name seems to be Amoakona. Efia's mother is subjugated by her mother. She is obedient and respectful to her mother to the letter. As she accepts the conspiracy of her mother, she becomes her co-conspirator. She encourages her own daughter by her silence to get pregnant while working as housemaid in Tika's apartment. Efia's mother is the image of the despair and disarray of Ghanaian contemporary society in the sense that as a mother, she accepts to endanger her own daughter for her selfish profit.

Efia's mother is the prototype of a subjugated woman, a type of woman patriarchy likes. She has many children from her drunken husband and manages to feed them all. Like her mother, the present female character colludes with the force in duty. Here women's

“materialistic instincts are shown to prevail over dignity and morals”⁵⁶⁴. Efia’s mother is double fold of her mother, a typical woman blinded by patriarchy. She is the dumb witness her own ordeals and that of her daughter.

15. Amma Darko’s female characterization in *Faceless*

The third novel by Amma Darko portrays African growing urban centres’ new syndrome that is street children. The novel seems to be the prolonging of the second which documents its readers on the movement of people from their denuded and poor villages to cities. Then the right consequence of the exodus is the mismanagement of their housing. In cities, they have no regular home. They live in either unfinished buildings or in slums all around the big cities. They live like wretched in hell. Families, relatives and friends also leave the villages in order to fulfil their Kumasi or Accra dream like illegal migrants realize their American dream. As a matter of fact, the lack of means coerces some parents to accept to see their children onto streets to scavenge in rubbish and other make up their mind to dump them straight. Streets become their natural homes, places where they are born, grow up and even die. In the streets, rape is for some their first sex experience. On the streets, their body become a means of business-related exchange, that is sex for food or sex for security. In this way, having sex stops to be a matter of pleasure, but a weapon to resist and survive. The change of a body to a tool of survival has also been discussed in Raphael Confiant’s *Mamzelle Libellule* (2000). The young Adeline lets Raphael Confiant’s male characters dispose of her body as a way to resist the commander. The desire to control male characters invades her mind when she is sexually assaulted by these people.

Consequently, the severe mental pain pushes most of the victims of rape into prostitution and high way gangsters at their innocent age. By the means of fiction, Amma Darko sheds light on serious and bitter social issues in Ghana society and by extension in Africa. Amma Darko fictionalises her resentment against Ghanaian nationals for not assuming their responsibilities. Her interposing of major and secondary characters in her narrative does not prevent readers to decode her appeal for revolt. Amma Darko’s third novel *Faceless* seems then to be the second

⁵⁶⁴ Bungaro, M. (2007). “Victims and/or Victimisers? Women’s De(Con)structive Power in the Housemaid”, in *Broadening the Horizon: Critical Introductions to Amma Darko* (UK: Ayebeia Clark Publishing Limited), p. 34.

So Long a Letter, this time from a Ghanaian woman who, but has not yet committed suicide⁵⁶⁵. Amma Darko's story should normally begin this way: "To the Ghanaian nationals, this is what Ghanaian children come to be because of your repeated mismanagement [...]". In this light, the roles the writer gives to her female characters are many folds that is the reason why we categorise some as main and other secondary though all of them are very significant to unfold the conveying message.

15.1. Main female characters' portrayal

Contrary to her first novel *Beyond the Horizon*, Amma Darko presents largely *Faceless* through the third person narrative. It is a story of the experiences and efforts by both the freedom fighters and the masses during the struggle for liberty and what they ultimately got out of it. It portrays the callous life of little street girls who act some as help to investigate as a co-journalist in a death affair and other in the prostitution of street children's coming from in poor families in African settings.

15.1.1. Fofu, a model of youth revolt

Fofu is the protagonist in the fiction. She is illiterate like the other girls of her age in the streets. She is a 'professional street girl' though street has no womb to produce a human being. The concept is inappropriate, yet used in Amma Darko's third novel to indicate the place where these children live permanently. Fofu is a girl of fourteen years old, but acts like someone who has more than that because the street where she lives has no time for crying babies, 'greenhorns', and immature dwellers. The street seems to be a military camp for Fofu and her friends. It trains them and brings about their fear to go ahead. The street gives them the full determination to dream like normal children living under roofed and furnished houses.

Fofu's portrayal in the narrative is not to be taken as a simple story of a girl who runs away from her parents and settles onto the street for facilities, for streets in any country do not give any easy situation to its consented or forced dwellers. Life as we can see is very tough and

⁵⁶⁵ The statement of suicide may shock some people and others may not understand why we draw this analogy. In fact, it is said that just after Mariam Bâ published her novel *So Long a Letter*, she had been pressurised by her society to an extent which forced her to commit suicide in order to stop facing critique from the very people she wrote the letter to. Mariama Bâ was not understood by the Senegalese society of that time. We apologise if the statement shocks. This is not our intention. We do respect Senegal and its lovely people. The analogy is then about Amma Darko who also seems to have written a letter to the Ghanaian people, but has not yet committed suicide.

merciless for anyone who lives in the street, and children are the first to suffer the severity of this milieu. Fofu is dumped out of her home for the sake of her mother's love with a new lover, Nii Kpakpo, an unemployed and a professional liar. Since then, the little girl settles at the most dreadful city Sodom and Gomorrah (Darko, 65), a few kilometres away from her home (Darko, 20). While in the street, Fofu is transformed because street attracts its new victims, entices them with glittering objects and menial jobs and finally acts like a serial killer. At that time, street is as merciless as Satan's hell. It also transforms little girls into mature women ready to be sexually consumed by adults of two and even three times their age. Equally while on the streets, these little pretty beings act and behave beyond their age since living down in slums and near dirty garbage render them more active to survive and keep themselves above the surface. The narrator approves it "Life on the streets made mixed up persons out of children" (Darko, 21). Moreover, life proves its mercilessness when little girls such as Fofu meet a wicked street lord in want of someone to fill his sexual pleasures. Then, Fofu:

was smiling still her dream and doing it comfortably in the toilet with a roof when she felt the light pressure on her breast under the weight of a pair of hands that were definitely not the Lord's. The hands began to play around her bosom. Slowly she began her descent from dream to reality. She felt a squeeze, which jolted her very rudely into full awakening. She opened her eyes slightly. Someone was kneeling over her. She opened her eyes a little. It was a man. [...] The hand travelled gradually and purposefully down to her stomach. (Darko, 3)

From the extract, the intention of Amma Darko is to demonstrate that Fofu, the little girl, uses more her brain than the male character in action. She defeats the street's lord, the poison of the street who reigns as a king. We will analyse later how that onomastic name, Poison, serves in didactic purpose for the writer to draw our attention to streets' high lethality for anyone that ventures to settle there. To the character Fofu, Amma Darko gives all the authority that remains to women on earth. She is the spear head of a struggle for liberty and freedom of action of women. Fofu preserves her integrity against the street's lord as his intention is to rape. The failure to rape symbolises the failure of the coloniser to corrupt Fofu's body. Amma Darko does not want to present Fofu as a weak and helpless character whenever challenges are. Fofu then fights back as violently as the circumstance shows off as "her guts led her on" (Darko, 4). Fofu strikes back a heavy blow to free herself. Her audacity to fight the representation of male supremacy symbolises the opportunity of women's liberation from social yoke. Long-time maintained in chain of enslavement, Amma Darko finds the right time to show them the way of

freedom. Male stranglehold is tough and merciless, but women can free themselves by acting. This is just a question of courage and experience, both empowering women in society. The protagonist shows the tactic to all women in such a situation on the African continent and beyond. In this vein, we agree with the three Australian prominent scholars Ashcroft, Griffiths & Tiffin (1995) who posit that many of African literary devices interrogate colonial ideology. The comparison of this idea with Amma Darko's depiction of Fofu is her standing as the colonised in quest for independence on the one hand. Fofu has to run away from what represents in her eyes the place of dream's imprisonment which is her mother and her normal home. But unfortunately, she comes to hide in the den of a wild animal ready to eat off all little beings next to its large opened mouth. Miles away from her mother, Fofu can set in motion all her dream of liberty and pays the price. Fofu is faceless like her other mates of misfortune and continues to be while at home with her faceless and powerless mother. On the other hand, the street symbolizes the place which can turn her present fear and permanent nightmare to dream and from dream to real fact. In that scope, the narrator creates a sudden encounter in the very market of Sodom and Gomorrah which changes her fate. This hides a metaphorical significance that it is from darkness that comes out the light which shows the direction of freedom. Bad experience can prepare people to a successful life. Fofu's case is an evidence based-proof.

As a matter of fact, in the market where Fofu has to work or steal to feed herself, she disguises in a boy's clothes and attempts to steal the purse of the woman who will later be her liberator, an angel of God who dares to descend in hell to save her. The woman of MUTE (an acronym which does not stand for silence, but the contrary) notices the condition in which she lives; therefore, feels a personal and urging responsibility to help her. Amma Darko proves this way that only a woman can be sensitive toward a child on the street and proposes her help. The coincidental meeting between an educated and sensitive woman of the middle class of Ghana and a poor street girl can change definitely the status quo to a break through. The literary pragmatism of Amma Darko sets free the captive. It is this perspective of Amma Darko's writing that empowers African women. A closer look demonstrates the writer's own voice and her own hand to move what seems to be static and stagnating. While writing, Amma Darko plays a game on a chessboard and holds the winner's warrant. As a result, Fofu divulges her authentic identity (from boy to girl) and asks to meet government because consistent actions should be taken by political and administrative authorities of contemporary Ghana to help eradicate the plight. The new identify of Fofu represents that of any woman who encounters new

situation of change. A woman lets people discover her new self as occasion allows her to. Fofu joins the squad of engaged women whose mission is to document Ghanaians on special information necessary for their life and very particularly to investigate in the murder of the senior sister of their now informant. If Fofu does not move from the margin to the centre, she will still live among the thousands of children in the street and still take on her wreck and unstable life. Today it is not about Fofu, but it is about Odarley and the others working as *kayayooos*⁵⁶⁶ who stay in the pitiful situations all over the world because the street children syndrome does not only occur in Africa. Street children do exist in other countries in the world where parents bored by the burden of keeping them, force them onto the streets to feel free. However, what can differ is the system set by ordinary people, NGOs and nationals to manage it.

The “street-wisened⁵⁶⁷” Fofu’s dream comes true as soon as she meets an educated and engaged woman in the social cases management. The ordinary role of her NGO turns to that of the police, the very institution in charge of investigation which has no substantial funds from the government. Then, what is worth noting as literarily wonderful is what Amma Darko makes symbolically of a simple NGO which turns to the Federal Bureau of Investigation (FBI) to look into an affair of murder in the most dangerous slum located in the centre of Accra. In actual fact, in no country an NGO can act in replacement for police or any other department of case investigation for interior security. An NGO can document national police of what it notices on the ground, but never substitute itself to police. To exceptional situation, the writer adapts exceptional remedy. The shantytown, settled some years ago, grew bigger and bigger just because of the negligence of the formal national policy to find the right exit out of the labyrinth. So, what should enforce the exceptional situation is the neglect to carry out an investigation to settle the case of murder and to find out the culprit. However, the condition of the national police cannot make happen. Everything with that police is upside down and even a decade of rehabilitation cannot change any situation. The decadence of national police has remote causes deep-rooted in colonial time. Ghana, a former great and wealthy empire in what corresponds to the medieval time in Europe, suddenly becomes poorer and poorer just after westerners set back

⁵⁶⁶ The last chapter of our work will deal with the meaning of Ghanaian nouns.

⁵⁶⁷ Higgins, M. E. (2007). “Ngambika and Grassroots Fiction: Amma Darko’s *The Housemaid* and *Faceless*.” (Ed.) Vincent O. Odamtten, *Broadening the Horizon: Critical Introductions to Amma Darko*. UK, London: Ayebia Clarke Publishing, Print, p. 68.

in the 1960s. What is also overwhelming is when a country of such a golden glory is unexpectedly declared by the former colonial master to be indebted to its marrow, not able to well-pay its national workers and unable to sustain its own development without borrowing from IMF and World Bank. Consequently, we see national police highly reluctant to inspect further in murder case or any other case. A death case, for this police in paper, is an ordinary case of robbery or traffic lights jump. Nothing means business for that deserting police. Police are in the image of national authorities who do not equally take anything serious and provide no fitting results.

Further, while constructing the narrative, Amma Darko fails to make this novel a case of homodiegetic narration where Fofu tells her own journey to the street and from the street to the realisation of her dream, her dream to ease herself one day in a real toilet in a roofed house. In our opinion, making a narrative homo(auto)diegetic can help draw more attention to the plot like the reading of the first novel *Beyond the Horizon*. Homodiegetic texts which refer to self-experience seem to be more sensitive and more focalizing than heterodiegetic texts. It appears in homodiegetic texts that the narrator seems to play more deeply his role in his own narrative than in any other texts. For example, a narrator who relates that ‘he is transformed into a lion to defend his own village people after having been attacked by rivals and then can regain his human features through many occult rituals like a midnight-bathing and drinking an unnamed herbal concoction mixed with the rivals’ blood in an old and smelly calash’. A story like this focalizes more our attention than any other one.

In fact, the “I” narrator is deeply involved in the actions of narratives and contributes very effectively to the plot of the narratives. In most of the cases, when a writer uses what Mawuli Adjei names as “narrative subjectivity”, it is with no doubt to draw attention on the particularities of the story or the plot. This subjectivity has also been used in some of Ama Ata Aidoo’s fiction such as *Our Sister Killjoy* and *A Girl Who Can* where she narrates her stories through characters that are part of the narratives and relates the stories from their subjective points of view. The intrigues are constructed around these characters and it is through their skilful mouth that the female writer delivers her message. However, there may be various reasons that motivate writers like Amma Darko’s choice for a narrative in the third person in *Faceless* where the narrator leaves no traces of his or her identity. Our point has already been backed up by Gérard Genette, the French literary theorist, defending that this kind of narrative is

“employed in texts that simulate a neutral position or historical objectivity”⁵⁶⁸. This is with no doubt what Amma Darko wants in this very writing.

What Amma Darko stresses here in the narrative is the capacity of her female character to get up when she falls down. Then, Fofu’s rescue from the street demonstrates the rising sun ahead for youth. Ghanaian youth is going to be strong. This attests certainly that there is in the novel a reluctance to believe in total loss and waste of humanity, given to its more positive expression in Fofu’s face while in the house of rescue. She feels free and secured to talk about her plight and let her rescuer plan for her future. This corroborates Bob Marley’s point which goes this way “When youth is saved, it grows stronger and stronger”⁵⁶⁹. Nevertheless, what remains uncertain is the future of her family because what can befall her junior brothers or even her mother then happens indirectly to Fofu.

Hence, the assigned role to Fofu in the fiction hides that of the importance of youth education and female collective cooperation. Amma Darko insists on that alternative in her writings. Togetherness helps her female characters to stand against oppression, subjugation and fear either in traditional or urban settings. Amma Darko tries to demonstrate through creative writing that male oppression ceases as soon as women come together to repress it. Amma Darko women’s acting together annihilates the street lord’s lethality and toxicity, Poison and the brutality of his acolyte, Macho. Fofu is now to have her dream fulfilled like going to toilet and to bath in a roofed home every day, feel the softness of a mattress, the love of people around, counselling of elders and finally a way to become schooled for her people’s empowerment. Additionally, what can ultimately draw our attention is the clear emphasis and the didactic significance of Amma Darko’s naming technique especially the male characters. A subchapter in our thesis will deal with that accurate technique of the writer.

15.1.2. Baby T, the doomed

Her real name is Tsuru. She is the one at conception when Kwei, the father pounces on her mother and gives her several blows in punishment of her getting pregnant. Her mother bleeds, but does not abort. This woeful event obliges the mother to give her the name Tsuru that means ‘Patient’. She is a girl of about sixteen years old and first born to an absentee and

⁵⁶⁸ Genette, G. (1983). *Narrative Discourse Revisited*. Ithaca: Cornell UP, p. 53.

⁵⁶⁹ From the song 400 years, Bob Marley and the Wailers (1973).

irresponsible father. Like the other female characters in the narrative, Tsuru does not go to school certainly because of the extreme poverty which reigns in her family. Baby T, as she is named, is born in a particular condition of superstition which impacts seriously her mother's psyche towards her. The ordeals of the little creature begin from her mother's womb as she seems to be cursed while coming out of her mother. In doing so, Amma Darko recalls how some customs in Africa can be a hindrance to people's psychological and therefore social commitment.

Baby T has nearly been assaulted by her stepfather Nii Kpakpo when she was about twelve. The coming extract reveals mostly the issues about Amma Darko's female characters' bodies in general. Women have to suffer in hand of macho dominance society from their birth to death. The narrator discloses:

Kpakpo tiptoes over to Baby T and tapped her on the shoulder. Baby T sprang up, still drowsy, Kpakpo beckoned her to follow him. It all seemed like a scene in a zombie film. Baby T rose. Kpakpo beckoned again, impatiently, forcefully. Baby T walked slowly, like there was no life in her. She followed him [sic] behind the curtain. [...]. Kpakpo took Baby T's hand and sat on the bed. He placed Baby T before him and signalled her to remove her dress. Baby T obeyed as though in a trance. He savoured Baby T's maturing body hungrily with his eyes. Then he brushed the back of one hand over Baby T's breast and drew down her pants. They fell on the floor. [...] Kpakpo stripped naked in frenzy, filled with an urgency so wrong, by Baby T's nakedness. (Darko, Revised version 2010, 133- 34)

Taking cue from the above extract, we can see that Baby T's portrayal serves as a metaphor to female social burdens prevailing in contemporary globalised Ghanaian society of the 21st century. The post traumatic impact of rape or any kind of sexual assault on the psyche of a child is that long term drawbacks. Alongside with physical consequences, a rape can hold back the psychological ability of a victim. In this scope, Baby T is forever traumatised by this attempt from a man she calls 'father', a member of her family, the lover of her dear mother. As if the failed rape is not sufficient, Nii Kpakpo connives with a male character whose name sounds 'uncle', Onko, a very trustee friend of the family to rape her and leave him the rest of the affair to be intricately woven for the little baby to be accused of giving her body to men two or three times older than her for free. The result of this irreversible connivance serves Kpakpo as the start of a dark traffic of Baby T's body to men through his contact in the city. The silly act

brew in this way in the head of Onko comes forth. The concocted lie of her giving her body to men is very arranged for every to believe. Baby T is dropped by her family and even by her mother.

Baby T is taken away by a former professional sex worker, Maami Broni, to exercise under the close watching eyes of the street lord, a heartless pimp of a deadly bite. Maa Tsuru receives monthly financial compensation of her daughter's prostitution. Baby T is sold off by her own family to feel socially considered. Amma Darko portrays women's bodies not only as objects to merchandise and from whose body profits are earned, but also that of a deep representation of colonisation. The coloniser exploits the body of his or her servant in order to get rich and at this position Amma Darko indicates Maa Tsuru and Kpakpo as the accused. As Baby T's body is polluted by the colonisers' penises, Amma Darko's fictional decision makes the character die through murder like the slave's body is crushed by a simple desire of her owner. The coloniser can make use of his servant's body and then when bored, he can decide to kill her. Baby T pays a very high price for her stubborn resistance and her defiant attitude toward her coloniser. Baby T's resistance against her commander-in-chief is to express the slave resistance to accept the wretched condition. Amma Darko is convinced that a slave has to break through. Thus, Baby T's death symbolises the coloniser's defeat to continue his trade as the pimp angrily mells "Why would I kill a girl who was making lots of money for me?" [...] I am a business man. You may not like what I do but that is what I do. It is my business. Why would I so foolishly and carelessly jeopardise it by killing one of my girls?" (Darko, 173).

In an ultimate attempt to conceal her real identity, her hair is shaved bald. The feminist voice in Amma Darko's creative writing stops the inhumane trafficking and defeats the male supremacy. So if the slave dies, the trade will stop and the trafficker's source drains off. It rightly happens the way the authoress makes it. Baby T's death is not to be mourned because her sacrifice helps save many others street girls. That is why neither her junior sister (future generation) nor Naa Yomo (old generation) regret her loss. Baby T's death is decoded as Amma Darko's way to refer to the biblical holocaust. This time, it is not the person who offers that is rewarded, but the person who decides to offer himself for the good of society. In terms of sacrifice, one is enough and it is Baby T's body. Her soul is not taken off by the perpetrator because Onko does not succeed in doing what he has in mind. The failure also exposes the limitations of traditional medicine practitioners. His request is one of the strangest, but it is to

uncover his exploitative technique over those who come to him for enchantment or to bewitch others. However, finally he helps MUTE female workers by providing satisfactory and significant information that helps decipher the mystery.

While portraying the female character, Amma Darko depicts with realism throughout her work the living conditions of destitute and miserable people in contemporary Ghana. Their silence echoes so loud in the feminist heart of Amma Darko. Their fate is didactically proposed as so to let them move forward. Hence, Amma Darko uses her position as tax woman to divulge what commonly happens to marginal people. They live in nervous conditions and die just behind a kiosk, but no local or central authority cares. To make it clear that people have to care about others' disappearance, Amma Darko creates circumstances to some NGO and dynamic women to launch the investigation in replacement to real authorities, to real government who is busy on other fields. The positive result of the investigation is the final reward that the society can give to its children that are assaulted, abused and murdered: to make justice survive!

15.1.3. Kabria, a sensitive female character

Kabria is a sensitive and a hard working mother of three children ranging from seven to fifteen years old. Kabria is married to Adade, an architect. Kabria is one of the passionate members of the all-female dedicated NGO which helps dig out the many buried voices of the faceless and voiceless cases among which Baby T's and Fofos. Every day, Kabria has to cope with the frequent caprices of her children before and after their school and sometimes with her old fashion and breaking up car, 'Creamy'. She has to lend money from her 'World Bank' husband to fix up her 1975 Volkswagen Beetle automobile. In spite of her husband's seeming tough personality, she knows how to manage him. Rather than words and frequent disputes, Kabria resorts to action with him. Insightfully, Philomena Yeboah A. Okyeso points out that:

Her action can be metaphorically compared to a coup-d'état through which a de jure authority supersedes a de facto one. The metaphorical reference to a coup-d'état used by Darko here suggests that mothers, when faced with trials such as these, are capable of employing creative strategies to attain their goals.⁵⁷⁰

⁵⁷⁰ Okyeso, Yeboah P. A. (2013). "A Street Child's Revolt Against Her Mother and Society: Lessons from Amma Darko's *Faceless*" in *Journal of Global Initiatives: Policy, Pedagogy, Perspectives*, Vol. 8, No 1, p. 10.

Symbolically, Kabria, the middle class woman, represents Ghanaian women who work harder and harder in order to earn the tiniest portion of the family's revenue. Then, while back home Kabria feels frustrated to go on cooking for the whole kinfolk and not given any occasion to socialise by "releas[ing] the tension (Darko, 14)" like her husband; for African women have been domesticated by tradition and are "expected to look up to their men folk as towers of strength and sources of inspiration, guidance and succour"⁵⁷¹. Society does not value women's hard work until they ascertain that they are married. The following logic is that society degenerates women who are not married and constantly reminds them of how unfulfilled they are without a man in their life even when these women are contributing a lot to the society. This is unfortunately what traps Maa Tsuru into poverty, denigration and compromising. What matters to society is only to know if the woman is married. The other element is not important. No one cares for the hard work of an unmarried. Her achievement is not considered because people around her think wrongly that she is prostituting herself to have all that. Still, some economic trends prove that women in some African countries work as much as men do. In South Africa, a 1998's economic survey showed that 33% women worked in informal sector as opposed to 18% of men⁵⁷². This rang of women working in that informal sector, while back at home have to complete the house chores and care for their children, because being unmarried does not mean not having a child. To be recognized by their society, women have to work harder and harder not only for their own, but also their household.

In this light, Kabria represents the marginalised woman in her household whose expectation is to breed alone the children, stay in the kitchen for family food and stripped herself naked in bed when sexually needed. After all this effort, she is not even seen as a positive contributor to the household and society's development. Kabria is at loss in this patriarchal society which gives no place for its women. It is a long since that male-oriented world invented gender roles. Though, we know that only breastfeeding should be a female assignment. This disguised enslavement is a salient method to block the African woman from asking for more attention and more rights. It must be noted, nonetheless, that the expected social change cannot occur without the women's full participation in the struggle. In that case, Kabria is the literary example to follow, though it remains that Kabria be more assertive about her

⁵⁷¹ Johnson, R. (1990). *Womanism and Feminism in African Letters: A Theoretical Perspective*. The Literary Criticism vol xxv, p. 25.

⁵⁷² <https://www.internationalbudget.org/wp-content/uploads/Women-and-Tax-in-South-Africa.pdf>. Consulted on August 2nd, 2018

husband's active participation in the house chores and children's care. Gender roles are so sharply conditioned in her household. Though they are very difficult to unlearn, Kabria, a learned woman and one of the best MUTE workers, knows well how to manage. This is made to bring about gender barriers and step down the fences and go forward. Home has no traffic lights where women should stop when they turn red and wait for men to go after the green lights.

In that very scope, if we agree that literature is the criticism of current life in society, then Mary Ellen Higgins is right to put that "Darko's novels can be read as a valuable contribution to an alternative, grassroots library –an alternative library, like a conventional one, raises awareness and contributes to the production of knowledge"⁵⁷³. Really, Kabria's assignment with the other female characters working for an NGO whose name is quite contrary to its actions in the ground struggles to find solution to forsaken cases in the Ghanaian society. As we know, library gives documents to set in motion and revive people's knowledge. This knowledge brings about people's ignorance especially that of women in society. Education helps the African women stand on their feet against marginalisation, not condescendingly, but very tactfully like Kabria does with her husband. It means that education empowers the African women and silence is no more the virtue.

Wifehood and womanhood cease to be the principal components of the African women's lives, but part of the rights. It is not the major required element which should help them have access to recognition. African women can claim for their right to have a job, then a well-paid job. They can claim for their right to drive cars which their male counterparts use to drive. They can ask their husband not to help them give ride to their children to school, but to do most of the time, because being parent is a one way command. Men should also give ride to their children. This way of education and child care is far from being a babysitting role assigned to men. A babysitting role is played by someone who is not directly concerned by the welfare, well-being and the future of the baby. It is not his or her primary responsibility. He or she fulfils the role to be later paid. But, a man (husband) has the obligation to keep a watchful eye on his children. After doing this, a man should not wait for any reward or any special gratification or praise. The

⁵⁷³ Higgins, M. E. (2007). "Ngambika and Grassroots Fiction: Amma Darko's *The Housemaid* and *Faceless*." (Ed.) Odamtten Vincent O., *Broadening the Horizon: Critical Introductions to Amma Darko*. UK, London: Ayebia Clarke Publishing, Print, pp. 69-70.

responsibility belongs equally to the man and the woman, whether by circumstance or by choice. This is not an option, but a necessity. Share child care equally is not a fifty-fifty role as we commonly say. Ignorance is losing power and space in the African women's realm due to the African female's education.

Besides, Kabria's depiction sheds light on women's conditions in male dominated societies, where educated women strive to get good and well-paid job like men, and fail to have the same wages because of the gender inequalities nourished by educated men also in African societies. For example, Kabria never has time to socialise, not because she does not want, but it lies in her busy day work couples with the necessity to attend to her children. Kabria is a university-graduated like her husband, but conforms to her subservient social role assigned to her by her people's culture. In the same thread of thought, she has to cope with her menial salary. Women have as much right as men to get access to good jobs and have opportunities to entertain themselves with her female friends and co-workers. We cannot rule out the possibility that Amma Darko is in fact writing her own history as a tax woman working at the Ghanaian Revenue Office where women have no well-paid salary although they have to risk at the same level and purchase in the same market. Like Kabria, Amma Darko is also a three-children-mother. Both Amma Darko and Kabria all work in a cosmopolite and very busy capital-centre, Accra. In that vein, Monica Bungaro confides what Amma Darko herself affirms during an interview:

Though some change has occurred in today's Ghana as to the relationship between men and women due to women's easier access to education and financial resources, even in families where women themselves are pursuing successful careers, they are still expected to arrange the childcare, do the bulk of the domestic work and all the domestic planning. From this point of view, nothing has changed. I can do my job, dedicate myself to writing, still when I come back home, I am no longer a worker or a writer. I am a wife and a mother⁵⁷⁴.

When Kabria comes back home, she is no more that MUTE worker but a housewife striving for the welfare of her three children and her husband who usually returns home very late. Adade the husband never cares about that because society grants him the title of

⁵⁷⁴ Bungaro, M. (2007). "victims and/or Victimisers? Women's De(Con)structive Power in *The Housemaid*" (Ed.) Vincent O. Odamtten, *Broadening the Horizon: Critical Introductions to Amma Darko*. UK/London: Ayebia Clarke Publishing, Print., p. 31.

‘untouchable’. All that he is sure of is to see his meal ready-made and waiting for him on the dinner table. Amma Darko, the writer is deeply connected with her female character Kabria. No wonder, here we are with a case of a female writer who chooses to write about herself, her life experience and her great expectations towards society by using among others only one character. The choice really matches. Further, it is quite the same distance that Kabria and Amma Darko make to reach their respective office. Amma Darko presents Kabria as more than just a woman. She is the type of woman Amma Darko wants every African woman to be. She is the guarantee of the well-being of African society today and in the future. Although Kabria comes to be victim of Adade’s concrete heart over some issues, she stands on her feet to resist and the female writer gives her all the means to overcome any attack. Then, nowhere in the novel, does Kabria define herself as being Mrs Adade, which should be the norm. Kabria proves that she is not successful woman because of her husband. She is because she deserves it throughout her hard work. In doing this, Amma Darko is an unflinching critic of patriarchal customs within Ghanaian culture. All this aside, it is clear that a man cannot be free with a woman enchained in his backyard crying for help. Amma Darko seems to remind it to contemporary Ghanaian society.

15.1.4. Dina, the enlightened MUTE founder

The female character is a university graduate and the founder of MUTE. Diana spends four years in a marital status, but no pregnancy occurs. Unlike Kabria, Diana’s husband existence is not underscored during the course of the novel. Likewise, the narrator does not mention that she is barren. This does not hamper her from being very active. Dina creates a library to fill the gap in social cases because of a frustration during her dissertation. The narrator gives more stress on the scope which lays bare to Diana’s human library “[...] Dina fondly referred to as: The Alternative Library. Every social, gender and child issue was the interest to MUTE. Their sources were newspapers, magazines, radio, television, hearsay, gossip, telephone calls, and observations” (Darko, 38). As a special NGO, MUTE is invested to look into abandoned cases among the population. It is the right role of an NGO, but not to substitute to a police. In fact, the creation of the NGO seems to be the feminist approach of Amma Darko because of the NGO is led by all-female characters and University of Ghana graduates. In this vein, it is significant to note that Molaria Ogundipe-Leslie in “The Female Writer and Her Commitment” (1987), an article featured in *Women in African Literature Today*, writes that

“Feminists have posited that the woman writer has these two major responsibilities: first, to tell about being a woman; secondly, to describe reality from a woman’s view, a woman’s perspective”⁵⁷⁵. For Molaria Ogundipe-Leslie as well as Amma Darko, it is necessary to correct the erroneous perception of African woman’s partaking in the construction of the society, so all the means are noteworthy. All the female writers’ contribution of is needed to walk back up the hill by writing the real ordeals of women in patriarchal societies. The African female writers carve out the identity of themselves thereby providing evidence of their wretched living conditions. Their literary discourses are then oriented to the African women’s reinvention and the rehabilitation. The social power should be concentrated in the hands of woman to balance the decision control. Diana and her female co-workers know what Amadou Hampate Bâ says about old people as being human libraries and then warns on their passing away as a serious loss for society. That is the reason why Diana and her colleagues proceed in recording the Ghanaian old age knowledge.

The female character, Diana, incarnates that renovation of the African woman. Her humanistic action of women’s reinvention is disguised in her research that leads to the protagonist rehabilitation. Amma Darko uses this female character to point out African women’s determination to invent new selves and fight against stereotypes like childlessness, jobless in male dominated society. Diana is a daring female character by whom other female characters are empowered. Diana works hand in hand with Kabria, Vickie and Aggie, all enterprising women for the good of society. All these female characters of Amma Darko share two criteria which are education and togetherness, two social aspects very significant in female empowerment. The activism of these female characters proves that women are no more the second sex the French writer Simon de Beauvoir writes about. They fight to let themselves heard and reckoned in society. Efforts are made to show African women are rated based on the real and good women of MUTE. The acronym MUTE is a work place where female mental and intellectual capacities meet for the sake of other women. MUTE is not to be taken therefore as silence but as place of opportunity of TALK and LET TALK. While these female characters are making themselves heard no matter what happens, there are others who refuse to talk and move from the margin to the centre. Their ‘Otherness’ is rooted in their spine, so the yoke is double locked around their neck. They remain submissive and silent because of the system.

⁵⁷⁵ Tidorchibe, E. T. (2014). The Generational link between Ama Ata Aidoo and Amma Darko, Kumasi University, Unpublihsed Thesis, p. 10.

15.1.5. Maa Tsuru, the manipulated and selfish mother

The female character Maa Tsuru is illiterate and she lives in the famous and the biggest slum in the centre of Accra, Agbogloshie. She mothers four children with Kwei among whom Fofu, the protagonist and Baby Tsuru after whom she has the name Maa Tsuru. Kwei, the father of her first four children (two girls and two boys), fades away one day from the household for fear of the consequence of a superstitious belief held on Maa Tsuru's life right on the day of birth by her mother. It is explained that it is the curse which turns her psyches barren. All that she does is unproductive and void. The only parental function that Maa Tsuru fulfils is to bear in her womb for nine months her offspring. The other functions like protection, education, initiation are not her concern. Maa Tsuru also clings on that superstition and refuses to move forward from the periphery in her mind to the centre, to a new realisation of herself. More and more she hides behind the alibi of her curse to stop cater for her children's ultimate need for protection. For fear of people's tittle-tattles, Maa Tsuru accepts into her single-place room an unemployed lover and a scammer named Kpakpo, an action which hastens all her children onto the street to survive on their own. She also bears two sons to Kpakpo. As the story unfolds, Maa Tsuru becomes a bitter mother and even identifies herself as a 'leper' because of her evident weakness over her life and that of her offspring. A Ghanaian saying well illustrates Maa Tsuru's attitude toward her daughters in Ama Ata Aidoo's plays that "Before the Stranger could dip his finger into a thick palm-nut soup; it is a townsman who must have told him to"⁵⁷⁶. The townswoman here stands for Maa Tsuru whose silence implicitly directs Mami Broni and Mama Abidjan, both dark business women to her innocent girl. The attitude also refers to the historical implication of Fante, Akan and Ashanti people into the slave trade in Ghana.

In fact, *Faceless* shows Amma Darko's subscription to the modern form of Transatlantic Slave Trade where mothers and fathers in quest for overnight wealth, sell off their offspring to the slave-drivers. As it has been for her first novel, *Beyond the Horizon*, Amma Darko rewrites history to denounce its damaging consequences on the African continent from generations to generations. In that range, Kofi Agyekum⁵⁷⁷ posits in his *Introduction to Literature* that

⁵⁷⁶ Aidoo, A. A. (1989). "Two Plays: *The Dilemma of a Ghost* and *Anowa*" (New York: Longman Publishers), pp.50-52.

⁵⁷⁷ Kofi Agyekum, popularly called Opanyin Agyekum was born on March 21, 1954. He graduated from Legon in 1989 with a first class in Linguistics and Russian, and was appointed a Teacher Assistant at the Department of Linguistics in the same year. His thesis 'Akan Verbal Taboos in the Context of the Ethnography of

literature is “a representation of life experience and reality of the world through linguistic creativity and imagination”⁵⁷⁸. If we agree with Kofi Agyekum’s definition of literature, so shall we appreciate positively Amma Darko’s insightful success in intertwining history and literature, both affecting every aspect of each African life. Then, when the occasion is offered, African writers do not stop writing about the horror of the most humiliating human trade and also colonialism and its heart-breaking and everlasting implications on the African continent. Extending the idea, we see how Africa as a mother shuts down her eyes on her children exploitation of the marrow. Africa becomes the perfect partner in crime during the trade where her children are sexually abused and even murdered by the slave-drivers. Maa Tsuru does not care while being monthly paid by her business partners and even when she receives “the thick wad of notes in her hand (Darko, op. cit. 138). Her gaze during the monetary exchange with Onko, the rapist, is furtive enough to be sorrowful “worry and hopelessness in her eyes and another not so easily discernible” (Darko, 138). The passage draws our attention to the fact that Maa Tsuru is shocked as can be a mother who loses her child’s virginity after a rape and is ready to complain to police for justice. Maa Tsuru’s silence over the crime makes her fully engaged and accomplice of the offence. Maa Tsuru’s face expression in this part of the narrative is associated to that of an innocent and defector. It seems that a machine stronger than her utmost love for her children coerces her to do wrong to her daughters. The above extract justifies so much the position as she seems not to reject the thick wad of money she is being given by the rapist to buy her silence.

The action is worth a monetary transaction between a condemnable male character and Maa Tsuru. The situation can be compare with the shocking silence of modern African leaders and the recurring illegal migration issues. In this day and age in Libya, hundreds of young Africans are sold as slaves without the African leaders’ firm reaction not to verbally condemn as usual, but to take actions and mean business. Yet, their inaction lasts the slaughtering. So far, Maa Tsuru’s silence helps deteriorate the physical and psychological state of her children and allows the oppressors to intensify the abuse. Her entire life with her different lovers is devoted to sex, lies and beatings, regardless of this; she still protects these lovers against her children. Maa Tsuru seems unable to rid of that status. Unlike Mara in *Beyond the Horizon*, Maa Tsuru

Communication’ was one the best in his department. He returned to Ghana in July 1996 and started his career as a Lecturer at the Linguistics Department of the University of Ghana.

⁵⁷⁸ Agyekum, K. (2007). *Introduction to Literature*, Media DESISGN, Accra, p. 2.

fails to take control of herself. She does not re-appropriate her body as a tool, a means to retaliate. She conforms herself to the diktat of society.

In reality, of course, Maa Tsuru is manipulated by her lover Kpakpo and felt bound to the social norms prevailing in the community. Maa Tsuru is raised to be subservient to the traditional dictate. This proves so much her immaturity despite her advanced age. The characterization is in the line with Wollstonecraft's point about women's compliance which reads "The woman who has only been taught to please will soon find that her charms...cannot have much effect on her husband. Will she then have sufficient native energy to look into herself for comfort, and activate her dormant faculties or is it more rational to expect that she will try to please other men?"⁵⁷⁹. In patriarchy as Amma Darko portrays, women are in a warfront and have to fight for their life, but Maa Tsuru seems not dedicated to the struggle. She does not combat the traditional perpetrator. Instead, she collaborates with him and gives him full access to her mind vessels and then to her marrow. She is confused by traditional irrational belief about fate and misfortune. Nobody dares to help the female character for people of Sodom and Gomorrah think strongly that supernatural forces are at play in her life. Maa Tsuru becomes completely subservient to the diktat of society. Where angels fear to tread, human beings must be cautious. Therefore, Maa Tsuru is a tragic example of the worst fate that can befall a Ghanaian woman. Amma Darko also corroborates that "I take the trouble to investigate the realities. When I write about Sodom and Gomorrah ...I want it to be authentic, because Sodom and Gomorrah does exist in Accra. So scenes have to be authentic"⁵⁸⁰.

Amma Darko's responsibility to write a fiction not too far from reality is denoted in the presentation of each of her female characters. These characters' portrayal reveals the author wish to stick to real life. Maa Tsuru's failure to save the most substantial part of herself symbolises the predicted failure of each illiterate woman to succeed in patriarchal system without taking action and being helped by others with tangible strategies. Her powerlessness is contagious. Maa Tsuru is the duplicate version of Mami Korkor in *The Housemaid*. They are the twin version that Fofu and Bibio dislike respectively. Fofu does not want to build up her life the

⁵⁷⁹ Wollstonecraft, M. (1975). *A Vindication of the rights of woman*. New York: W.W. Norton, p. 195.

⁵⁸⁰ Angsotinge, G. (2007). "Exploitation, Negligence and Violence: Gendered Interrelationships in Amma Darko's Novels", in *Broadening the Horizon: Critical Introductions to Amma Darko* (UK: Ayebeia Clark Publishing Limited), p. 83.

way her mother does and Bibio loathes this all accepting way of her mother. Yet sometimes, Fofo bides and tries to reconsider her radical position toward her mother. Here the narrator explains “Deep down inside her, she felt some affection for Maa Tsuru. Yet an overpowering urge to hate her also consumed her sometimes” (Darko, 20). Towards Maa Tsuru, Fofo has mitigated feelings to attest her guiltiness and at the same time her innocence. The same way we can clear her up of all the charges.

In spite of this, we are convinced that her responsibility is absolutely engaged. Comparing the situation with the rule of jungle, Maa Tsuru is the lioness assigned to protect her cubs no matter what happens in the forest. If she leaves them unprotected, they will be eaten off by other wild animals around. They can be trodden on by buffalo bulls and elephants. In the text, the forest symbolizes the street where live the unprotected cubs (Maa Tsuru’s children). That wild and merciless bush where fierce animals are waiting to devour all that is left behind. Further, in some extreme cases, a lioness can hide her cubs and faces rivals and intruders. In other cases, she runs away, but with her cubs to safety. In this very chronicle, Maa Tsuru fails to play her natural role like a lioness, an animal assigned to protect her little ones. In actual fact, if the NGO or any person else has gone to court to complain against that neglecting mother and claimed for justice for X (an unknown person), Maa Tsuru will certainly be charged of negligent homicide. Ironically, while getting rid of the maternal weighted load (her children), she ends up unfortunately in a hell like cycle which she does not recognise as a hazardous one.

All the same, a woman in a patriarchal setting is raised to accept as gospel true all that she is taught. Mara is a fair illustration of that dumb obedience. For example, when women in such society are being beaten by their husbands, the traditional expectation is that they remain quiet as a sign of respect to men. The case of Kwei’s beating her illustrates this. Complete silence is expected of women at home. Since they are viewed by the society as appendages to men, subservience therefore is demanded from them. Women’s place according to C. Opara is “a quiet member of the home whose rightful place is to cook the meals in the home and bear children [...]”⁵⁸¹. In Ghana and by extension in other African countries, live countless Maa Tsurus flesh and bones entirely controlled by patriarchal system. Maa Tsuru is definitely among the female characters manipulated by the system and almost annihilated under their burdens. All

⁵⁸¹ Opara, C. (1987). *Towards Utopia: Womanhood in Fiction of Selected West African Writers*. PhD Thesis in the University of Ibadan, p. 87.

that Maa Tsuru thinks of is her sole and meaningless effort to survive in the traditional system. To Maa Tsuru, there is no way out of that hell. Then like a bird, Maa Tsuru is imprisoned into an endless cage. She becomes the woman society wants her to be, blindly subservient and asking no question to challenge her lover.

Taking cue from that, we are tempted to change the title of the present novel and give another that suits well Maa Tsuru and her children's social conditions. We can shift to that of the Beninese writer Olympe Bhely-Quenum's *Un Piège sans fin* (1960) translated into English as *Snares without End* (Longman, 1981). In *Faceless*, the narrative is built up with so much tricky suspense which calls for our attention to the end. Moreover, the depiction of the female character proves her selfishness to an extent that, when her children have been in need of her attention, she does not care for them. Now that Fofu changes her physical aspect, "Maa Tsuru made to embrace Fofu" (Darko, 156) yet, the reaction of the little being is quiet normal, "Fofu went rigid" (Darko, 156) as she is full of wrath. The rejection of the mother's hands appears symbolic and meaningful. It conceals a weary attitude of the little girl which seems to be right. Maa Tsuru does not come up to hide her implication in the prevailing trials of Fofu. Maa Tsuru's representation in the mind of Fofu is not too far from a traitor, then she wants to conceal, but Fofu makes a move to stop her in front of the MUTE workers. Fofu does not forgive her mother for having dumped Baby T, her brothers and her on the street and abandoned them just like one can leave off dirty garbage.

Between her offspring and her, Maa Tsuru does not create a trusting climate, but before Kabria and Sylv Po, she hides her image of defeated mother. The opposing situation happens with the female protagonist in Jamaica Kincaid's *At the Bottom of the River* (1983). In the novel, it is the protagonist who offends her mother and begs for pardon. The narrator puts this way:

Immediately on wishing my mother dead and seeing the pain it caused her, I was sorry and cried so many tears that all the earth around me was drenched. Standing before my mother, I begged her forgiveness, and I begged so earnestly that she took pity on me, kissing my face and placing my head on her bosom to rest.⁵⁸²

⁵⁸² Kincaid, J. (1983) *At the Bottom of the River*. New York, Penguin, 82p.

The attitude of the protagonist in Kincaid's narrative denotes the feeling of repentance. The character is therefore strategic toward her mother in order to make herself accepted. It shows that the character is simple and open-minded. She offends and then begs for pardon, which should be the attitude of Maa Tsuru toward her angry little girl, but she shrugs it away when Fofu rejects her hands. After all this, our accusing finger is also directed to society that abandons that singled mother who becomes unfortunately the father and the mother of these children. As Ms Kamame shares, when the load is too heavy on our, we naturally abandon it. Maa Tsuru starves before the society which lifts no hand to help her while in difficulty. Yet, that society surprisingly waits for wonders from that wounded mother. The attitude of Maa Tsuru's society brings to mind J. M. Coetzee's sardonic denunciation of the political geography of apartheid in a 1986 essay:

If people are starving, let them starve far away in the bush, where their thin body will be a reproach. If they have no work, if they migrate to the cities, let there be roadblock, let there be curfews, let there be laws against vagrancy, begging, and squatting, and let offenders be locked away so that no one has to hear or see them. If the black townships are in flames, let cameras be banned from them.... Certainly there are many lands where prisons are used as dumping-places for people who smell wrong and look unsightly and do not have the decency to hide themselves away. In South Africa the law sees to it as far as it can that not only such people, but also the prisons on which they are held, become invisible.⁵⁸³

If we apply Coetzee's touching denunciation, we are sure it matches the society where Maa Tsuru lives. It has eye for her slightest mistakes, but not for her personal needs to feel amidst human beings. Maa Tsuru is left alone, and then she decides wrongly the direction to take. Further, as it is clearly understood, apartheid operates from day to day as a means of upsetting people, so does poverty by decreeing the state of mind in Agboghoshie. Maa Tsuru has then no choice, if it is not to surrender and face the reality around her. She is poor, so she remains poor to the end because no one comes to her rescue and also that she does not take action to come out of it. Besides, throughout the novel, we see that Maa Tsuru is all about what a woman should not do before being adorable and likeable to men. Maa Tsuru tries to be likeable to her men to the end. As a result, she fails to keep a watchful eye on her offspring. This is the most dangerous aspect of wanting to be nice all the time because it is a false feeling.

⁵⁸³ Coetzee, J. M. (1992). *Doubling the Point: Essays and Interviews*. Ed. David Attwell. Cambridge: Harvard University Press, p. 361.

Society obliges Maa Tsuru to be nice and good, but does not teach Kwei and Kpakpo the same. These two sexual predators capitalize on this. They know that Maa Tsuru will not complain and not try to change it. She is kind to them and normally she deserves it from them and other people also. On the contrary, the moment she needs their kindness, they flee and shake off the dust of their feet. This is also what happens to her companion in misfortune, Mami Korkor. Both women fail to be honest and brave. During their ordeals, they never speak their mind to say what they really want and think. Very shortly in the novel, Mami Korkor talks about her invisible husband, but does not further her resentment in front of her inquisitive daughter.

What she importantly fails to be is assertive and challenging. She fails to order both men who make her pregnant to come to fulfil their role of father either willingly or by force. This is not an option, but a natural order. Maa Tsuru should even threaten both of them if they fail to have their responsibility done. To us, being single is not the problem, but being single with a herd of children to educate is a great deal.

Apart from the characters we select as principal and around which revolves the plot, we also categorise others as secondary. Our study needs the presence and actions of these characters to understand the complete story.

15.2. Secondary female characters

The secondary female characters around who revolves the plot are as tough as the principal. Amma Darko's creative writing does not shake aside the power given to each of her female characters in the narrative. Each of them has its role and importance in the text and the presence helps understand more overtly the suspense. In the present fiction, the relation between the principal characters and the secondary is thicker than water. That is the reason why the study related to major characters cannot be dissociated with secondary ones.

15.2.1. Naa Yomo, Mother Africa's spirit

Naa Yomo is a very old female character of about eighty-seven years old. 'yommo' is from Twi (a local language spoken in the southern part of Ghana) vocabulary to mean black hair dye. The 'yommo' is used by old people from Ghana to Nigeria to hide their grey hair. The black hair dye allows them to change the grey hair to black. In the novel, Naa Yomo is

presented as a wise woman and throughout her depiction by Amma Darko, she is illiterate. The emblematic figure of the grandmother of one and all, named Naa Yomo presides over all the comings and goings in her slum area, and is an inexhaustible source of local information. As she is the oldest member of her family, she has a broadened knowledge of the history of Ghana and its people. All said above about Mama Kiosk in *Beyond the Horizon* can be applied to Naa Yomo. She plays the role of traditional preserver in the extended family. She survives many perilous events as her age permits and even that of the 1939's seismic activity. As most of the African old age, Naa Yomo may have been impacted by oral tradition and a strong traditional culture. Naa Yomo may be a contemporary version of the renowned and revered Yaa Asantewaa, the guardian of Ashanti tradition. Therefore, Naa Yomo seems to have been profoundly influenced by the people she grows up with or whose legend she has been told.

One of the points that can draw our attention is that Naa Yomo loses five of her eleven born children, however, she has not been suspected of witchcraft by her community. Naa Yomo has never been declared witch and blamed for all the death of five of her children since there is no young witch in Ghanaian culture. In spite of the loss, she still embodies wisdom and her ultimate medium role helps MUTE worker to have access to the history of Maa Tsuru's family and society as a whole. Amma Darko's Ghana is profoundly distorted and confounded, but Naa Yomo is charismatic while carrying on her role of teacher. She is the opposite version of Efia's grandmother in *The Housemaid*. She educates and defends moral virtue. When young people of her community fail to show her respect, she promptly recalls them to good manners to have toward old age. For example, the narrator signals in a sequence:

If the washing woman did not appropriate her courtesy for whatever reason, Naa Yomo obviously expected it, for whatever reason. Odarley went over and greeted her politely. Naa Yomo responded and asked how she was doing [...]. Having been briefed by Odarley on the way, she greeted no one else aside Naa Yomo when she entered the house (Darko, 19-20).

In this regard, the younger generation has a lot to learn from this person as being the living spirit of Mother Africa, flesh and bones, with her people. Her presence stands for the need of Ghanaian to be guided, to be taught of the treasure which old age symbolizes in Africa. Naa Yomo can be compared to Ie, the old woman in Leonora Miano's *L'intérieur de la Nuit* (2005). The old woman does not understand the reason why the group of these good for nothing chooses

to come and disturb the villagers of Eku in the night. Then, she decides to what all the men present cannot do:

Alors, la doyenne des femmes d'Eku mit son vieux corps debout. [...]. Isilo la regarda, et elle le regarda aussi, du haut de ses cinquante années d'expérience des humains. Elle n'avait pas peur. Tout ce qui émanait d'elle, c'était la force, l'importance qu'elle accordait à sa propre personne, et un certain agacement. [...]. Elle ouvrit la bouche, ce fût d'une voix grave aux accents traînants qu'elle demanda aux étrangers d'en venir au fait. [...]. Je détestait qu'on se moquât d'elle.⁵⁸⁴

The excerpt shows that only that old woman stands and discusses with the young armed rebels in the nearby hills who comes to defend an imaginary African cause. Like the other villagers, Ie believes that what has to happen always eventually come to pass, but there must be someone to tell the truth to these agitated adolescents. Despite the militia brutality, Ie succeeds in negotiating with them to save young girls, nurturing and pregnant women and babies from the carnage. The attitude of the old Ie like that of Naa Yomo demonstrates that no one has to accept fatalism and imperialism in any forms. Further, in a postcolonial nation or in a community, the old age presence has to dissuade malevolent and destructive intentions from the young and undisciplined. Leonora Miano's indirect point of view demonstrates that colonialists' culture invaded the domestic sphere by transforming African men into monsters who treated their wives like scum, their offspring and junior brothers like mere animals and meat to feed on. Fortunately enough, there are still people (guardians of tradition and order) who know how to dare to say their words and require respect in the community.

The above consistency matches with Amma Darko's taking Naa Yomo as the eye that sees all around. She points that the family home foundation "was built by an honourable man [...]" (Darko, 89). Naa Yomo hails from a family whose members have integrity as virtue and hold on it. In fact, to the old woman, home does not mean the concrete structure in which one beds, cooks and eats, but home like mind solidified by cultural knowledge and wisdom. Naa Yomo obtains years after years her life experience which does not unfortunately prevent her great-great-great grandchild or grandniece to have streets as their home, market places as their beds and rock stones as their cushions. In fact, Naa Yomo pities the falling apart of tradition that witnesses her birth and of which she is proud. The causes of the prevailing condition have to be sought in the past. She associates the present plight to "the Atlantic Slave Trade and the

⁵⁸⁴ Miano, L. (2005). *L'Intérieur de la Nuit*. Paris: Plon, pp. 99-101.

trafficking in human beings”⁵⁸⁵ and the degradation of African culture by colonisation. The portrayal of Naa Yomo fits so much the image to Mother Africa shown in Negritude’s writings by its pioneers namely Aimé Césaire, Leopold Sedar Senghor, Leon Damas, Paul Hazoume, , Ahmadou Kourouma, Camara Laye, Ken Bugul, Aminata Sow Fall.

In fact, Naa Yomo represents a myth, an African version to praise good people. As corroborated by Molefi Asante “[. . .] myth becomes an explanation for the human condition and an answer to the problem of psychological existence in a recent society”⁵⁸⁶. This declaration praises the value of myth in society and obliges it to keep looking ahead. The reader knows that nowadays it is quite exceptional to meet wise people like Naa Yomo as contemporary Africans live in materialistic world like the West.

Naa Yomo represents the symbol of the female spirit that guides African people and settles their mind to good manners, better life and hope. The character has not received any modern education, yet she is more informed than any other one. Naa Yomo keeps in her mind important historical events to be known by every African. Juliana D. Ofosu upholds our position this way: “Darko as a result, beckons on the society to give some credit to the voice of elderly women who are embodiments of African tradition”⁵⁸⁷. Naa Yomo stands for the human library that Diana is in need of. She acts like a historian and a national self-definition as she takes up a task of remembering the glorious past to a whole community. She also gives a point of view of an alerted and enlightened person while Amma Darko presents her a personal finding for her strong desire to build up an event to “never forget” linked up with the historian’s project, as well as with the trauma theory. Naa Yom’s encounter with the members of MUTE subscribes in the same framework as the mission of Diana while setting in motion her Alternative Library. The MUTE mission is

categorizing their information under a regular library system may be awkward and untenable. But gathering and documenting them is critical for us as a people philosophically, psychologically and sociologically. The MUTE Alternative Library concept would place this information under an orderly and

⁵⁸⁵ Horne, N. B. (2007). “Sage, Muse, Crone: The Grandmother in Amma Darko’s Novels”, in *Broadening the Horizon: Critical Introductions to Amma Darko* (UK: Ayebia Clark Publishing Limited), p. 131.

⁵⁸⁶ Asante, K. M. (1987). *The Afro-Centric Idea*. Philadelphia. Temple University Press, p. 98.

⁵⁸⁷ Ofosu, J. D. (2013). “The Feminist Voice in Contemporary Ghanaian Female Fiction: A Textual Analysis of Amma Darko’s *Faceless* and *Not Without Flowers*” in *Research on Humanities and Social Sciences*, Vol.3, No.1, p.3.

classified system, to enhance accessibility and worth. That is how I intend to tackle the topic to fit into my course of study⁵⁸⁸.

In this quote it is possible to find a concern for both the personal quest for identity and that of the community. Indeed, it seems that for Amma Darko both are closely intertwined. The encounter also helps record old age life experiences to avoid their loss and erosion. The writer succeeds rightly in recreating the needed national spirit within an old female character. In protecting African core values, Diana and her female MUTE workers are sure to avoid what Ahmadou Hampate Bâ says of African elderly people: “An old man who dies is equal to a burning library”⁵⁸⁹. This is quite what Ama Ata Aidoo’s *Anowa* (1970) also shows while presenting old age counselling young people. The African continent must reconstruct its history by accepting its past and facing its future with dignity. Hence, Amma Darko and her MUTE NGO’s lesson remind the new generation of their identity and integrity anytime their consult in that documentation centre.

15.2.2. Ms Kamame, a social model

The introduction to the female character Ms Kamame appears in the first book of the novel *Faceless*. The social scientist name is also mentioned in *Not Without Flowers* (Darko, 90). She encodes the modern empowered woman as Amma Darko depicts in her writings. When a woman is educated, she is strong and self-confident. Like Diana, Ms Kamame is the founder of an unnamed NGO that carries out a research on street children syndrome. Her NGO’s ambition is to direct an “awareness campaign at those women and girls of our society who are more likely to neglect their children and make street children out of them” (Darko, 111). She is then called upon as a professional in social affairs by Sylv Po, the producer of Good Morning Ghana (GMG) show to discuss about the issue. As if it were Amma Darko herself, Ms Kamame presents with an authorial voice the situation of abandoned children onto the streets in Ghanaian urban centres and by large in African cities. We find that plight in Addis Ababa, Nairobi, Kampala, Lagos, Johannesburg, Gaborone, Abidjan, Dakar, Bamako, Luanda and Juba, to cite these few. For Ms Kamame, one of the phenomenon’s causes “*appears to be poverty [...]* because there are some very poor parents we encountered who in spite of their situation, were not allowing their children out onto the streets” (Darko, 2010, 108, italic is mine).

⁵⁸⁸ Darko, A. (2007). *Not Without Flowers*. Legon, Accra: Sub-Saharan Publishers, p. 217.

⁵⁸⁹ Translated from Ahmadou Hampate Bâ’s famous assertion: «Un vieillard qui meurt est une bibliothèque qui brûle ».

Ms Kamame is a skilled professional of street children predicament. During the show, she gives in detail the cause, the consequences and the ways out. She points out that “the phenomenon appears to be less prevalent in our villages” because individualism is not rooted. Then whenever the child is in trouble in his family, other mate family can come to rescue to save the face, an attitude which does not reign in urban cities. This raises the capitalistic self-hood and individuality which is settled by colonialism. Most of African urban centres seem to suffer from the globalisation syndrome. The legendary friendship and brotherhood that characterized Africans in the past is no more the priority in post-colonial Africa. The globalised African cities promote mono-parental and nuclear families which are completely different from the former extended and polygamous families.

Additionally, Ms Kamame seizes the occasion to suggest African Parents Planned Parenthood and its benefits. This can help many parents know exactly the time when their children come to life through an accurate scheduling. The planning helps them not to fall in a short resource of their upbringing. Planned Parenthood aims at solving the issue of uncontrolled births which lead in some circumstances to street children syndrome. The street child of today is the adult of tomorrow, the leader or the gangster of the future Africa. Then the case has to be well-managed, Amma Darko warns through Ms Kamame. The feminist voice of Amma Darko epitomises about the issue as being as important as constructing our future life. If we fail to manage the present cases, then we fail to build a peaceful future.

15.2.3. Mama Abidjan, the female conspirator

The present female character Mama Abidjan stayed in Abidjan. Right from the start, Maa Tsuru does not trust this middle age woman for her former job as prostitution in Ivory Coast. Mama Abidjan adopts here the tools of the male oppressor. She exploits young and naive girls on a monetary purpose. Like some Fante, Ashanti and Akan at the Transatlantic Slave Trade and colonial times, Mama Abidjan collaborates with the slaves’ merchants in order to exploit her own fellow for wealth and fame. Amma Darko blames this female character because of her implication in the exploitation of Baby T. Subsequently, Amma Darko’s feminist approach unfolds in the way that when a female character is involved in a simple or complex conspiracy against her own gender like Comfort encouraging Akobi to import Mara in *Beyond the Horizon* and Efia’s grandmother in *The Housemaid*, the punishment is high as that inflicted

to male characters. For the writers, what these female characters deserve is the most severe penalty that can exist in criminal law files.

Mama Abidjan symbolises what becomes of middle age female Ghanaians who still collaborates with oppressors or represent a new version of oppression. The female writer intends to call on her female counterparts to act responsibly so as to ensure social stability and consistency that engenders a real social change and thereafter development. Women need to work hand in hand to improve their conditions in society.

15.2.4. Maami Broni, the co-conspirator

The Ghanaian word ‘*obrouni*’ stands for a dark skinned person from beyond the horizon. This means in our context that Maami Broni is a dark skinned woman like Mama blackie in Buchi Emecheta’s *The Bride Price*. Additionally, no one knows where the woman is from. These two characteristics force people to call her Maami Broni, the black-skinned woman whose origin is unknown. People do not know where she hails from. Maami Broni is also a middle age woman who works in a brothel owned by the most dangerous male character in Amma Darko’s present text. This female character Maami Broni works hand in hand with a former professional of prostitution, Mama Abidjan, to exploit other female characters. She is the one that takes away Baby T promising Maa Tsuru to put her in seam apprenticeship, but conversely, coerces her into prostitution. The reason is that Maami Broni she has been lied to that the little girl likes sex and gives herself free of charge to men very far beyond her age. Any time, she shows up, it means money is around. The narrator discloses “Maami Broni came to symbolise the arrival of an envelope containing money, whenever she showed up in the house. It brought a smile to Kpakpo’s face and a wince to Maa Tsuru’s, who nevertheless never turned it down” (Darko, 143). Maami Broni pays frequent visits to dispatch what comes out of Baby T’s prostitution contract in her brothel.

Maami Broni knows that prostitution is a very difficult job, then she introduces to her new recruited the use of marijuana to help fade the pain and the anxiety. The chemical containing in the marijuana’s seeds (*cannabinoids*⁵⁹⁰) make people ‘high’. The marijuana plant contains more than hundred cannabinoids. Scientific studies carry that when treated in laboratory, the ‘*devil’s leaf*’ or ‘*wee (d)*’ can be used to treat certain conditions such as

⁵⁹⁰ National Institute on Drug Abuse. <http://www.drugabuse.gov>.

childhood epilepsy, a disorder that causes a child to have violent seizures. Other studies carry that marijuana alters seriously its users' mind and damages the brain natural capacity.

In the narrative, when the situation becomes worse and worse, Maami Broni shows up to make some important revelations that help elucidate Baby T's affair and dismantle the brothel. Maami Broni cooperates with the oppressor at the time when the business flows fresh cash. As soon as the stench of Baby T's dumped body begins stinging, she surrenders and reveals all the secret of the business. The narrative does not mention that Maami Broni regrets her action and asks for forgiveness. In other words, if the circumstances present once again, she can take up again her collaboration. Amma Darko pins down this female character to show the extent to which the male oppressors need collaboration and it does find among female fellows to perpetrate and perpetuate the domination. In the same way, the coloniser needs collaboration before he sets up in motion his machine of colonisation.

To conclude this part of Amma Darko's characterization, we see that the female writer seizes the right edge of women's trials in contemporary Ghana and by extension in other African countries. Women live in wreck conditions and have to keep on surface if the high flood of their burden does not drag them completely down. Amma Darko proves her artistic skills in creative writing and her right to claim for a memorable position in the pantheon of Ghanaian female writers, one the youngest of the third generation writers such as Chimamanda Ngozi Adichie, Sefi Atta (Nigeria), NoViolet Bulawayo and Tsitsi Dangaremba (Zimbabwe).

Much like other African female writers of the first and second generations, Amma Darko bursts into the existing male domination structure through her literary device. To make the balance, Amma Darko creates in all her novels dangerous, violent, frivol and insensible male characters in one hand and on the other hand, female characters crawling under the burdens of their stereotypes and almost blocked by cultural norms. Women and girls have to strive twice than men and boys before reaching the normal standard in these settings. There urges a "challenging reconfiguration of national realities in which the feminine is neither essentialized and mythologized nor marginalized, but unapologetically central to the realist representation of a recognizable social world"⁵⁹¹. Amma Darko writes her own way and idea about women as her

⁵⁹¹ Bryce, J. (2008). "Half and Half Children": Third-Generation Women Writers and the New Nigerian Novel in Project MUSE, Today's research. Tomorrow's Inspiration. Indian University Press, Research in African Literatures, volume 39, Number 2, pp. 49-67.

strict desire orders without altering the slightest reality. In this view and subsequently, in *Not Without Flowers*, Amma Darko goes on, after getting the right temperature of women in existing ghettos, in the Ghanaian streets and poor villages, writing her female characters' ordeals in a wealthy mansion, the stereotypes HIV/AIDS infected patients suffer in society, the overt risks of infection even married people can have.

The necessity of change sets the tone for female writers like Amma Darko to attempt to examine the kind of relationship between their fictional work and the outdoor reality in term of gender inequalities prevailing in Ghanaian society. In this way, Amma Darko writes her contemporary society by using her characters' ordeals. She depicts Ghana after independence and the promotion women get in living in such a society.

Finally, the striking feature in Amm Darko's writings is the way she uses some of her female characters to solve a social issue. The novel cynically criticizes polygamy as we have earlier, society's hypocrisy towards women suffering. The only one woman who escapes lampooning is the 5th Wife.

4. Female characters' portrayal in *Not Without Flowers*

Amma Darko's present novel deals with a strong lust for revenge from a family and also sets up to expose some social evils and issues within the Ghanaian society. Amma Darko writes about the women's ordeals within that society and her contribution to heal the profound wound that has remained ailing for years. The way the female writer presents these gender issues finally proves that there are no more targeted to women only, but there becomes a national issue to cure. This is reason why we back up that Amma Darko writes from a feminist perspective. It is a kind of approach which gives power to woman or depicts women's plights in a fictional male dominated society. She also feels the urge to discuss other pertinent issues. There is evidence that most of Amma Darko's female characters' depiction seeks to address certain challenging issues of Ghanaian society added to the necessity for the female characters to be accompanied by some dependable male characters, though the writing is from the female perspective. We think that there lies the reason why Amma Darko's story gains recognition and patronage in mainstream literature.

16.1. Main characters' portrayal

Amma Darko's fourth novel *Not Without Flowers* revolves around some female characters that play particular roles in the narrative. Like the other novels by the author, major and secondary characters are needed to lay bare of the plot and thereby the message to society. One remarkable element in the present narrative is the realism with which the narrator (Third person) relates each story and then to form a whole interesting national social plight exposure.

The novel presents a story of unsuccessful relationships and their traumatic results on victims, their families, on society as a whole. The severe pains, agonies, clashes, nightmares, dreams, hope, fear and the burning desire of vengeance characterize each chapter of the novel and render it special and interesting to read. The suspense in the plot emerges right from the start while the narrator begins uncovering sensible information on the mental sickness of Ma which conducts her to a dubious prayer's camp. The prologue gives a perspective of what awaits us in the very detail of the chapters. Beam the journalist, a benevolent farmer, his son and Kweku, Cora and Randa attempt, as a commando, to rescue their mother. What is left of the woman after long and exhausting sessions of whippings in WCS, is a frail figure, a shadow in stingy stale urine of the days before. The revelation shows the shocking aspects of contemporary Ghanaian society. Moreover, it describes what is left of the ancient Ghana Empire and the Fante Kingdom after the European missionaries and administrative governors' departure. In doing this in her real documentary piece, Amma Darko seeks to give a voice to the thousands of voiceless and a face to the millions of faceless of society.

16.1.1. 5th Wife, a model of African modern woman

As we have mentioned earlier, Amma Darko's female characters constantly share their life swayed between tradition and modernity. As far as this female character is concerned, we see the constant influence of tradition and even its wicked use to hinder women's development. The mention of this character is mostly in the author's intention to impact that culture and endure perhaps its change. *Not Without Flowers* reveals by and large the though predicaments of a young and beautiful widow in a patriarchal society. In fact, the present plot does not start with this female character, 5th Wife. The female character's name is mentioned in the novel's third chapter of in a discussion between two male professional journalists in prelude of their morning show. The symbolic number five confers to the woman the 5th position among the women

conquered by the rich Pesewa. Amma Darko refers then to the character's position to make her nameless. Sometimes, authors spend hard time to have names for their characters because of the role they want the characters to play. Using this literary device, a character can be identified by a number, a letter, job, or common trait to present a hidden meaning. 5th Wife is perfectly in the case. Novels or stories with nameless characters called 'dystopian'⁵⁹². Leaving a character unnamed is also a way to demonstrate that the character is experiencing a personal crisis of identity and keeps his identification vague. It can be anyone then. So a name given to a character rather can dramatically affect the environment and even gives a new direction to the plot. For example, a name such as Poison in *Faceless* gives a full sense to what the author wants as far as our view toward the character is concerned. The more a character's name focuses our attention, the more interesting the reading of the narrative. By making a character nameless, the author prevents any an unconscious identity attachment of a living person. More importantly, nameless characters provide a mirror into our own lives while trying to represent their own simultaneously. Hence, Amma Darko wants to prove, above all, that all her nameless characters are lost and changing identity.

However, the narrative portrays 5th Wife as a young woman at her thirties and described as being attractive, well-built and open-minded. The female character is like 'Akwaba doll', a symbol of a true Ghanaian loveliness as she possesses legendary Ghanaian feminine beauty, yet she does not epitomise normative femininity expected by traditional society. She defies the traditional expectations her society holds of women. Because of this impairment, 5th Wife makes up her mind to accept the first offer of marriage from any the wealthy and already married man of the surrounding. The marriage here is a refuge to escape geographically from the impairment, but not psychologically. The female character Bolande in Lola Shoneyin's *The Secret Lives of Baba Segi's Wives* (2010) accepts also that sort of marriage. Just like 5th Wife, Bolande hides a physiological impairment due to a rape that resulted into a pregnancy and then she aborts at the age of fifteen years old. She says, "Mama, you were living with an empty shell. Everything was scraped out of me. I was inside out" (150). In this situation, the Alao household seems to provide Bolanle with the comfort she needs to become whole. Baba Segi's home is a troubled place within which to escape and to heal, but it is less troubled than the world outside. Taking as

⁵⁹² British philosopher John Stuart Mill first used the term 'dystopia' as early as 1868. The dystopian stories are often stories about survival, their primary theme is oppression and rebellion. The environment plays important role in dystopian depiction. The dystopian depiction is imaginary. It is characterized by a focus on negatives, usually frightening facts.

a broken egg, she needs to recover in a house where childbearing is not the first hand necessity. Similarly, 5th Wife's choice to start anew in a polygamous family is very clear. When the woman and her polygamous lover get together, 5th Wife coerces him to use condom while having sex, an attitude almost uncommon in a marital relationship since condom use is irregular among married couples for various reasons including the desire to have children and the widespread association of condoms with infidelity and lack of trust.

Yet, Amma Darko's character makes it usual and compulsory for the on-going of the special side of the plot and the message. 5th Wife strongly believes that married women's vulnerability to HIV is as higher in a polygamous relationship as in unmarried one. Her economic dependence to her emotional and financial provider does not make it difficult to express her desire to have safe sex with him. In fact, what the narrative presents tactfully is that 5th Wife refuses to have unprotected sex with the frivolous Pesewa.

In fact, what predisposes 5th Wife to this attitude toward her husband is her modern education and the fact that she has once suffered from the consequence of an unprotected sex at the age of eighteen (Darko, 261). The unprotected sex has an irreversible consequence on the woman. She becomes childless due to the removal of her womb as a result of an ectopic pregnant. This is the reason that motivates her to be with the already-married-to-four Pesewa. Without pretending to be a psychiatrist, Amma Darko goes beyond a fictional presentation to prove the severe trauma a woman can feel after having lost her capacity to bear and bring forth as a result of her past unprotected sex affair. 5th Wife honestly confirms when questioned about her relationship with the rich, old and polygamous Pesewa:

I know it sounds unbelievable to many, but I did. I wasn't due to any strong body chemistry or his electrifying touches. It had nothing to do with compatibility in bed or any extraordinary sexual fulfillment. I needed emotional security and he offered it in abundance, with the added advantage of financial security too. He treated me like a queen. (Darko, 91)

This Amma Darko's female character's attitude contrasts rather sharply and clearly with that of Mara in *Beyond the Horizon* in the sense that 5th Wife shapes right from the start what visibly leads her to Pesewa's. The financial security the middle age woman needs is in Pesewa's pocket, but in Mara's case nothing leads her to Akobi's if it is not just a hypocrite reaction of her powerless mother. A mother like Mara's cannot challenge her husband because of the

environment where she has grown up. Above all, all women expect to be treated as special and Pesewa can do that. The slightest difference between 5th Wife and Kabria in *Faceless* is that the former is made lose her womanhood. Apart from the point, Kabria and 5th Wife are the kind of women Amma Darko loves. They are assertive, intelligent, resistant and always seeking to have their say in the on-going of their marital life and that of their partner. Both female characters are strategic and wilful to go forward in society. Thus, taken alone, 5th Wife tactically hides her barrenness as her husband has already had a running stream of children in his well-built castle. Further, in home purchased by Pesewa, a remote place from Pesewa's lodge, 5th Wife imposes her will to have protected sex with her husband for she is "the favourite wife, and for as long as she remained that, pending the arrival of a possible sixth wife, 5th Wife stood by her demand that Pesewa use it" (Darko, 262). Sometimes and cautiously, "she also kept some female condoms on hand" just in case Pesewa refuses to use his. 5th Wife clearly demonstrates that women also can manipulate or in other words have control over men in patriarchal society. Ultimately women can have the power to decide whether or not a man enjoys freely the sex act. It is that insignificant act of resistance that must be celebrated. If a woman withholds joy, a man's ego is deflated. 5th Wife becomes a good example of women who can recreate themselves and emerge with advantages over the men they interact with. In fact, we can see clearly that the way of exercising a male control over his wife is when he has unprotected sex with her. In that unsecure relationship, her watchful attitude saves her from being an HIV/AIDS-infected. It is the only reason why she was negative while her four other rivals were all carrying the AIDS virus" (Darko, 263).

The story reveals that as soon as Pesewa gets evidence of his infection, he suspects his fifth wife. Consequently, he takes his own life to save the face from people's tittle-tattles. In this doing, the first suspected person is 5th Wife for the sole reason that she is the younger of all Pesewa's wives and then the only one that can be in need of more attention and more sex, which Pesewa is more and more unable to afford. All Pesewa's mansion members and his relatives form a cabal against 5th Wife. They pester her after Pesewa's decease. For fear of being married off to her late husband's brother (Darko, 90) and then imposed upon the debasing practice of widowhood, she leaves the mansion her late husband bought for her and hides herself elsewhere for safety. However, as the mystery behind Pesewa's death slowly unfolds by the help of MUTE and the male journalists as well, it becomes obvious that the woman in cause is Second Wife. She desperately and frenziedly decides to buy good but infested sex from outside (Darko, 274).

5th Wife is then cleared of all suspicion due to the strategy that MUTE, the media and herself use during the case management. We live in an unfair world and this female character believes strongly that when someone creates to himself an opportunity to survive, he or she must strive to maintain it no matter what happens.

Once again and like their professional investigation undertaken in *Faceless*, MUTE helps clear up 5th Wife's case with dexterity, thus saving a woman from undergoing cultural atrocities. This disguised sisterhood is the way Amma Darko urges all Ghanaian women to behave in order to boot out of their yard traditional ordeals and by extension patriarchy. This is her special approach of feminism back up by Oyeronke Oyewumi. She echoes the same concern about the necessity for the globalization of sisterhood among African women. She wants African women scholars and writers to adapt feminism to sisterhood and then defines sisterhood this way:

'Sisterhood', just like the term 'feminism' demands theorization because, although its origins are very much tied to a specific culture, its intended application is ultimately transglobal. What meaning does it carry as it crosses boundaries, if indeed it ever does cross boundaries? Should it carry the same meaning? Can it carry the same meaning, given that words are informed by specific cultural assumptions and histories? What exactly are the implications of the cross-cultural use of 'sisterhood', given that the meaning shifts depending on a host of factors. [...] It is also pertinent to question whether the desired relationship apparent in the use of 'sisterhood' by white women is matched by the desire of other women to relate to them and others in that way⁵⁹³.

To Oyeronke Oyewumi's point of view, African sisterhood which should be understood as totally contrary to western feminism is shaped to answer the many unsolved questions applied to African way of tackling gender problems since many African scholars think that feminism is predominantly a westernized experience that shakes aside the realities and culture of Black women. The issues of colour and culture between the west and 'other' are crucial while theorizing African feminism. In the same vein, Filomina Chioma Steady defines African feminism as focusing much and particularly on female autonomy and cooperation, African mothering specificity, children bearing necessity, cultural centrality and kinship⁵⁹⁴. In fact,

⁵⁹³ Oyewumi, O. (2001). 'Ties that (Un)Bind: Feminism, Sisterhood and Other Foreign Relations' in *Jenda: A Journal of Culture and African Women Studies*, 1, 1, p. 3.

⁵⁹⁴ Chioma Steady, F. (1981). *The Black Woman Cross-Culturally*. Cambridge, Massachusetts: Schenkman Publishing Co., p. 28.

African feminism as portrayed by Filomina C. Steady is not antagonistic to men, but challenges them and reminds them constantly of their prominent role as women's protectors in society. Men should then be reckoned by women during their struggle.

In our context, the nameless character is to show the specific role assigned to her in the story. In fact, by giving the character no name, Amma Darko wants to demonstrate that her role in the novel could be that of any woman in society. If empowered, 5th Wife's wise attitudes can be embodied by any Ghanaian woman or African woman in general. We have said above that polygamy and extramarital sex are some core factors that lead families to HIV/AIDS virus infection. The low literacy and ignorance of self or partner's HIV status are also risks factors which can turn a whole peaceful family to the most feared one in society. As we see, the infection can spring from any member within the family and this is what Amma Darko wants to demonstrate in the plot. What help 5th Wife overcome the predicament is her education level and her ability to let her word heard by her late husband. To be empowered within their families, women should begin marking their footprints early in their relationships with their lovers, their boyfriends, their husbands to be.

16.1.2. Ma, the defender of her household

The present story revolves also around this female character Ma, a familiar way to call mother and the clipped form of Mama or mother. Like 5th Wife, Ma is also an unnamed female character in the narrative. As well as 5th Wife, Ma shares the same purpose of choice and suffers from similar identity crisis. Ma is married to Pa, a senior officer for a private company. Out of the union come three blessed children (Kweku, Cora and Randa). Ma marries a devotee husband until the birth of the third child. Then Ma begins involving in her business and leaves Pa with his need of attention. Despite the fact that Ma is partially responsible for Pa's extramarital love affair, Amma Darko gives no reason to her male characters to have a second wife. As life within the couple evolves, Ma becomes sick and is admitted to a psychiatric hospital where the sickness is under control due to the appropriate medication. Yet, before being admitted to the psychiatric hospital, Ma unconsciously revenges on the flowers in her garden. The violence lets loose of her hatred for the person because Pa calls his young and attractive female lover, Flower. The narrator relates as follows:

Following the orders that the voice was issuing inside her head, Ma surveyed the compound, taking in all the varied and beautiful flowers that were in plentiful bloom. Then she turned like a zombie back into the house and into the kitchen and stood before the drawer containing the assortment of knives. She took an instant liking to the smooth sharp meat slicer. [...]

Ma glanced around with glazed eyes. Then one hand sprang forward and held the purple lily. [...]

The knife was in Ma's hand and the voice was screaming blood. [...]. Today the voice was back. She was holding the purple lily and the voice was...

Blood!

"Whoosh!" The voice sounded. "Whack!" it yelled. "Whack!" [...]

One after the other, the blooming flowers feel. [...]

Flower.

Pa never gave Ma the middle name: Flower. (Darko, 169 ; 170-71)

From this point, we see that Ma's mental sickness is understood as having been provoked by her husband's frequent infidelity with a young and bewitching university girl called Flower. She then uses her religious faith which teaches that it is when a Christian is in trouble, an answer is given from above: "And when she prayed, it was no longer only for the easing of the pain in her heart, but also for the survival of her mental faculties, because she began to feel and sense it slowly and gradually slipping away" (Darko, 339). One could believe that Ma gives right to the stereotypes that people stuck on women: hysteria. Women are described in terms of instability. This characteristic is portrayed over and over in male literature according to Sigmund Freud's perspective on women⁵⁹⁵. Pa usual absence leaves Ma in confinement characterized by her present hysterical which has nothing to do her feeling of being inferior to Pa. The old and abandoned woman seeks for a spiritual resort. Faith in God becomes her refuge. Yet, her faith does not hamper her from hearing voices. Ma's mental health, in fact, is explained by a female psychoanalyst, Caren Horney. In her book "Self-Analysis" written in 1942, Caren Horney⁵⁹⁶ outlined her theory of neurosis, describing different types of neurotic behaviour as a result of overusing coping strategies to deal with basic anxiety. These behaviours

⁵⁹⁵ In 1935, Sigmund Freud wrote a paper entitled "The Psychological Consequences of the Anatomic Distinction Between the Sexes". This Freud's theory about women raised many controversies during his life time and even after his death. Some psychoanalyst do not know Freud's motivation as he (Freud) had been really loved by his mother. His was the first son of his mother in the family, his father having had already two boys in other marriage. <https://www.verywellmind.com/how-sigmund-freud-viewed-women-2795859>

⁵⁹⁶ Psychoanalytic theorist [Karen Horney](#) developed one of the best-known theories of **neurosis**. She believed that neurosis resulted from **basic anxiety** caused by interpersonal relationships. Her theory proposes that strategies used to cope with anxiety can be overused, causing them to take on the appearance of needs. According to Horney, basic anxiety (and therefore neurosis) could result from a variety of things including, ". . . direct or indirect domination, indifference, erratic behavior, lack of respect for the child's individual needs, lack of real guidance, disparaging attitudes, too much admiration or the absence of it, lack of reliable warmth, having to take sides in parental disagreements, too much or too little responsibility, over-protection, isolation from other children, injustice, discrimination, unkept promises, hostile atmosphere, and so on and so on" (Horney, 1945). <https://www.verywellmind.com/horneys-list-of-neurotic-needs-2795949>

include such elements as the neurotic needs for power, prestige, and affection. This explains Ma's state of mind when Pa abandons her for another woman. Ma's anxiety grows bigger and bigger during of the period of Pa's absence. She feels losing control over her husband, losing her primary privilege as wife. This makes her mind restless and her heart bleed for the very fact something is wrong in her household. It is a clear indication of her emotional involvement in her husband's life because of their long period together.

We can throughout the above analysis that Ma's sickness is a spiritual-based issue and thus cannot be exorcized by prayers. As a matter of fact, the voices which order Ma to put an end to all the flowers around represent the resisting force which holds the ground against all this confusion in society. Yet, she follows instantly their instructions and the voices become her friends. She feels reluctant to speak to no one else apart from the voices. The voices have a social conversation with a real existing person. Ma is filled with a great sense of failure, whenever blood does not come out of the flowers' stems severing. But, who is Flower, the reader would ask. Flower is the pet name given by Pa to his lover who is only a year older than Kweku (a Wednesday male born), Pa's son. Ma's being forsaken by her husband to Flower creates a depression and constant mood disorders whenever she hears the mention of flower. What worsens Ma's mental instability is Pa's suicide due to Flower's voracious greed that devours his wealth. Ma is then led to a prayer camp to be cared for as she carries all the alienation of an entire nation. The deviation which has been made by missionaries in the colonial time is now on its active stage. Ma's sick body stands in fact for the whole Ghanaian nation's agonizing body, wounded, plagued with debts, confused, corrupt with depression and in serious need of a therapy that none of her children makes out. Finally, her body depicts the outcome of all this mental violence engendered by governmental mismanagement, money embezzlement and physical carelessness. Here, there is a recreation of the effects of stress on life in the form of grotesque and socially, emotionally and physically handicapped.

Furthermore, what comes under the full glare of Amma Darko's criticism is the concept carried out by imported religions. The admission of Ma to a prayer camp in the outskirts of Accra is an opportunity for Amma Darko to shed light on the plight related to the upspring religions all over postcolonial African cities. In his work, Amma Darko criticizes the dubious religious people just like Wole Soyinka does with Lazarus in *The Interpreters* (1965). Five years after Nigeria got its political independence, Wole Soyinka writes about the vice in the Nigerian

society. The main characters thus serve as types, allowing the author to explore the excesses and growing disillusionment of the educated elite of the postcolonial Nigeria.

In essence, Amma Darko wants us to know that mental sickness is not all related to spirits or demons. Before writing this position, Amma Darko pays visit to the “staff of the Accra Psychiatric Hospital” (Darko, 9) to know more about the ailment, its process of treatment and its social implications. Like HIV-infected patients, mental sickness patients are ostracised during and after the ailment. That is why people fear to refer to it. The narrator puts it this way:

Don't start referring to mother's situation as mental. Do you know what you are doing? Kweku, what if Elsie also goes to discuss it with other people? Do you know what people will begin to say about us? About this family? They will say that Ma is going mad. That is how easily people conclude such situations. (Darko, 343)

The question addressed to Kweku derives from the ordinary question relatives ask when they hear that someone of their family is mentally sick: ‘what will the neighbours say?’ In fact, society fears not only the patient but also her children because the analogy is easily made. It is a taboo in many societies. The fear to declare one's parent mental sickness hails from colonial time where mental patients were treated as criminal and put in jail. The trauma and the stress people resent while seeing their dear parents in prison switches others will to tag their house as lodging a mental sick. The memory of that sad misconception subsists in the collective mind of post-colonial Africans. People think that they can pray mental sickness away. They strongly believe that the discovery or worship of Jesus Christ is accompanied by an unexplainable euphoria. Then, many have become adept at putting on these performances, by faith, even when they are dying inside, but most cannot pretend, so they are dragged to exorcisms and deliverances. Yet, one of the problems is that most African countries do not have the number of specialists required to deal with the magnitude of the problems.

Normally, like people spontaneously go to consult in these modern days their dentists, their bank account manager, the physicians, their designers, their Facebook or Twitter account fixer, so must they try to have by their side their psychiatrists. Yet, it is almost difficult and puzzling to go and visit even infrequently the doctor who manages mental issues, for stigmatisation comes knocking at the door very soon. People are not yet ready to tolerate in their surrounding mental patients, though not knowing really who are and who are not. If most of

Africans live without knowing that they need a psychiatrist, firstly, it is because of their financial and social status. In that part of the world, several people cannot afford two meals per day. Thus, it is rather puzzling to ask them to go for a visit to a psychiatrist per year. Secondly, the visit which is affordable may be that towards an herbalist or a prophet of a camp if the spirit of the patient has not yet been polluted beyond healing by the doctor's chemical modern fusions.

The novel displays the proof-based evidences about social issues embodied by prayers camps in postcolonial African countries. Hence, the owners of famish places like Whipping to Conquer Satan or We Conquer Satan spread false information on ordinary health disorders as being of demonic causes. This is in fact to trap people as they expert to influence mentally the patients and their parents. Thus, when people admit their patients in the prayers camps, these owners dump their mental sick like Ma in unhygienic conditions to worsen the situation. The isolated place which should normally participate in the disease's cure amplifies Ma's ailment and worsens her emotional and physical health conditions. These insecure places provoke fear and mitigate feelings not only in the patients, but also in the patients' relatives. A similar situation has also been described in Ahmadou Kourouma's *The Sun of Independence* (1970) where Salimata remembers when she was in Tiecoura, the healer's hut, feeling abandoned by her parents, her relatives and all the community. Here, the healer's hut which should be replete of spiritual security turns to be dangerous and scary. The narrator puts:

isolée, réduite, encombrée, grouillante de margouillats. A l'intérieur le fétiche dominateur était un masque épouvantable qui remplissait une grande partie ; une lampe à l'huile flambait, fumait et brillait juste un peu pour maintenir tout le mystère. Le toit de paille, de vieille paille noire de fumée était chargé de mille trophées : pagnes, panier, couteau, etc. Sur la nuit, sur la brousse, sur les mystères s'ouvrait la porte, elle aussi très petite et à laquelle pendait une natte⁵⁹⁷.

A cabin of that kind, isolated, full of little and abandoned things, lizards and other rampant, can never assure security for many reasons like that isolated place where Ma is secluded for her sickness. Both places have many similarities in terms of place of torture and inhumanity. The hut serves as a place where Salimata is secluded and raped, so it can only symbolize a house of oppression and suffocation. It is the starting block of the female character social and physical enslavement.

⁵⁹⁷ Kourouma, A. (1970). *Le Soleils des Indépendances*, Paris Seuil, p. 36.

The new religions take advantage from people's ignorance to sell dreams to poor and illiterate. In the prayer camp, the patients are left in completely poor conditions; even the basic human right is not met. When the rescue mission arrives there, the description of the place has that:

On the floor, where the farmer's son had pointed, was a figure. She was frail and huddled on a mat on the bare floor, fast asleep. There was no pillow for her head. Kweku shone the torchlight on her face. She was about sixty, with skeletal features, and completely bald, the hair on her head having been shaved off. Around each of her ankles, was an iron ring linked to a thick iron chain. [...] It was hooked through a hole in a huge blunt iron rod buried halfway into the concrete floor in the center of the hut. There were other metal hooks in the hole from other chained ankles. (Darko, 27)

Yet, many people are easily tricked by these '*pray-for-me-men of God*'. Ma's children are one of the victims of these criminals, though well-educated. This comes to show the extent to which Ghanaian society allows fake men of God to destroy innocent lives. To stop it, a commando mission successfully conducted by Kweku gets Ma out of the camp luckily. The most absurd of the impacts of the flowing imported religions on Africans psyche is that they believe that the most beloved parents are possessed by demons which should be delivered through bodily pains in doubtful camps. These camps are supposed to bring light to darkness. What impacts should be physical acts on spiritual beings, knowing that spirits live in unseen world? We know that questions are not welcomed in such assemblies as the gospel-entrepreneurs revere to be discovered. Unfortunately, the amount of superstitions in Africa rises higher at the advent of Christianity. Christianity has not completely taken hold of Africa. Nevertheless, the gospel-entrepreneurs still work for the resisting areas to surrender totally. But this time the enchanters do not pursuit the primary objective of the religion which is the salvation of lost souls. They convince their victims through their ordinary gospels of prosperity, eternal offerings and tithe giving, all this to go to heaven. According to these entrepreneurs, heaven going depends on the believer's tithe offering, his self-abandonment to God and his detachment from earthly materials. At the last resort, the introduction of this religion sees the rate of Africans' loss identity increases significantly. This point is sustained by Viera Pawlikova-Vilhanova who declares that:

Cultural contacts with the West were no doubt led by the missions and were defined above all by their intention to transform African societies. [...] They took from it its conventional features, building churches and schools in the Europeans style and imposing the habits and ethos of the Western Christian civilization on their converts⁵⁹⁸.

In short, the passage above demonstrates how perfectly African people have been dispossessed of their culture and then given back imported and westernized behaviours. The loaves that remain are abandoned because Africans think that they are useless or demonic. The deprivation has been completed by colonization and neo-colonization throughout music, dressing, education and the use of their own language without borrowing words from western languages. In that way, missionaries proved as confronted by some resisting areas the superiority of their own civilization. Huge Christian “propagandas were in the most region of sub-Sahara were introduced to reach the outskirts of villages. Missions of all denominations disseminated education in their attempt to win converts and to train African catechists”⁵⁹⁹. More importantly, in the same range of African or other continents cultures’ sabotage, this is what Lord Macaulay’s *Minute to Parliament* proposed to the British Empire in 1835:

I have travelled across the length and breadth of India and I have not seen one person who is beggar, who is a thief, such wealth I have seen in this country, such high moral values, people of such caliber, that I do not think we would ever conquer this country, unless we break the very backbone of this nation, which is her spiritual and cultural heritage and therefore, I propose that we replace her old and ancient education system, her culture, for if the Africans think that all that is foreign and English is good and greater than their own, they lose their self-esteem, their native culture and they will become what we want them, a truly dominated nation⁶⁰⁰.

The passage above discusses the proposed technique which should bring about the pillar of African ancient and great civilization and help the British Empire dominate Indians and with no wonder Africans. The British Empire accepted to finance Lord Macaulay’s method of destruction from the 18th to the 19th century through the system of first the Missionaries, after the Merchants (Consuls) and at last the Militaries (invading armies). Missions had a special role

⁵⁹⁸ Pawlikova-Vilhanova, V. (2007). Christian missions in Africa and their roles in the transformation of African societies, *Asian and African Studies*, 16, 2, pp. 249-60.

⁵⁹⁹ Pawlikova-Vilhanova, V. (2007). Christian missions in Africa and their roles in the transformation of African societies, *Asian and African Studies*, 16, 2, pp. 249-60.

⁶⁰⁰ Lord Macaulay’s Address to the British Parliament on 2nd February 1835.

to play in many colonial situations. Missionaries were crucial and precursors of imperialism and of what would later be termed ‘The Scramble for Africa’. From that perspective, the African continent, like a big cake, had been torn into pieces. Each of the developed nations had its share. Big nations had the biggest parts of it and Africa had been dispossessed of its valuable and intimate part. For Macauley, the British Empire, after subverting others’ civilization, may finally get a class of Indians or Africans in flesh, bones, blood and colour, yet English in taste, opinions, in morals, attitude and inner mind. What happened later has the most dramatic and negative impact on the African continent than could be any incurable disease. This emphasizes the damaging impact of missions on Africa and its people.

As a matter of fact, the African continent substituted its civilization to that of the West. This reminds us of the incident of gloves wearing in Wole Soyinka’s *The Interpreters* (1965). The pseudo-intellectual, Ayo Faseyi, orders his wife, Monica, to wear gloves to a party (Professor Oguazor’s) for simple requirements. In the range of mental disorientation, what is more salient is that even those in traditional dresses at the party also wear gloves (Soyinka, 147). In other words, Africans, Indians and other colonized people learned to be hybridized because the British Empire succeeded in making it so in order for their domination to work. The West succeeds in making a large number of Africans what a character in *The Interpreters* calls “the new black Oyinbos⁶⁰¹” (Soyinka, 112). This hybridity does not fit Africans most of the time. As for religious beliefs, Africans become Roman/Jew outside and animist/fetishists inside. They become ambivalent and from two separated worlds. They become new specimens in their old body and their mind subverted definitely by the Europeans’ cultures which do not fit African civilization model. But they rather surrender to this imported ideal reluctantly. Thus, as paradoxical as it may sound, most of Africans, even with their new born Christian philosophy, believe that behind an ailment hides a spirit and then it is necessary to conjure the fate by sacrifice. By contrast, in our context, Ma’s depression is to be understood as the saint revolt against her husband frequent absenteeism at home for his lover, Flower. Ma also revolts against polygamy plaguing many African men in urban and rural settings. The extreme reaction against the social plight can be taken as insanity to the common reader. Ma needs to vent her frustration and talk to get loose of her anger, an opportunity which is not given to her. The feel becomes violent and urging. Ma’s depression as a consequence of her loneliness can be compared with

⁶⁰¹ Oyinbo is a Yoruba word for a white man. The word is commonly used in Pidgin English in Nigeria.

that of Mara in Germany. Mara is abandoned by her husband, but soon she befriends Kaye and together both get a planning to escape and start their own business. That is what saves Mara from depression and avoid her to sojourn in an asylum. In some narratives, when characters find themselves in loneliness and new and strange space like Europe, anxiety becomes their lot as they lack to have friends. In Ken Bugul's *Cendres et Braises* (L'Harmattan, 1994), the female character, just like Mara, travels to France with her friend Y, but falls in solitude as the latter abandons her a hotel room. She sits all the day in the hotel room waiting: "Je passais toutes mes journées à attendre. Attendre un coup de téléphone, attendre un coup à la porte. Quand Y apparaissait, c'était la délivrance"⁶⁰². To top it, the protagonist's solitude in France becomes a nostalgia where she dreams of her homeland and craves to see again her friends and parents (Bugul, 37). Still, in most African societies, solitude is not tolerated even for old people. When it happens that somebody usually isolates himself for some reasons, the community questions him and then as stated in Leonora Miano's *L'Intérieur de la nuit*,

A Eku comme partout en Afrique, les moindres marques d'individualisme étaient considérées comme des attitudes inhumaines, et si on observait quelque penchant pour la solitude chez une personne, on la menait chez le guérisseur. Il fallait être malade, certainement envoûté ou possédé par un mauvais esprit, pour aimer être seul.⁶⁰³

Loneliness in most African cultures is portrayed as being a bad attitude and we see that solitude in any form is totally abhorred by communities and people then understand that the person needs help, first from his peers and from above. Dr Dieudonné Gnonlonfoun, a neurologist at the University Hospital of Cotonou in Benin confirms that it is highly important for a mental disease patient to have people around him and to talk with. The presence of his peers around gives him or her self-assurance and proves him or her that he or she is not abandoned⁶⁰⁴. The element that can worsen his or her health condition is the feeling of loneliness and isolation. Loneliness is a factor that favours the disease. The neurologist concludes that depression is a disease of loneliness and that many untreated depressives lack friends because it saps the vitality that friendship requires. It confines its victims in an impenetrable cover, making it hard for them to speak or hear words of comfort. Mental sickness

⁶⁰² Bugul, K. (1994). *Cendres et Braises*. Paris: L'Harmattan, p. 62.

⁶⁰³ Miano, L. (2005). *L'Intérieur de la nuit*. Paris : Plon, p. 172.

⁶⁰⁴ We are not referring to the presence of the whole village, but strictly his relatives and pet friends.

can become physical while untreated. Hence, as soon as people understand the need, Ma's craving to speak and be cared for are satisfied.

In trying to understand Ma's psychological attitude in the narrative, we can understand that her reaction responds to a social malaise created by despair, loneliness and absence of romance in her household. Women need to be cared for emotionally and sexually. At a certain time of her life, Ma lacks all that, so her romantic revolt is to fill the gap. In the same range of thought, with some African male writers, the social malaise depicted in their different writings has to do with nostalgia (Aimé Césaire), anxiety (Léon Gontran Damas), African miseries (Ahmadou Kourouma), cultural conflict and the oppressor's tyranny (Mongo Beti).

Finally, she asks her children to bring some flowers "to smell the delightful perfume of a bunch of beautiful yellow roses" (Darko, 367). This attitude denotes that the conflict between Flower and Ma is now over; hence her traumatic experience stands for the novelist's specific way to fight against discrimination. The period presents that of her loss of humanity and thus her loss of identity. During that period of loss, Ma's behaviour can be assimilated to that of animal as only her nose and eyes function, but her capacity to reasoning is lost. Moreover, Ma's behaviour toward Flower is explained as a kind of self-reinvention as a process of trauma's healing. This process is discussed by many psychiatrists, literary critics, philosophers namely Descartes, Hume, Locke, but especially Jung, Freud, Foucault and Deleuze. Then, until Ma does not finish the process of her self-rehabilitation, she will still be melancholic and a ghost of herself. McCann and Pearlman state in *Psychological Trauma and the Adult Survivor* (1990) that:

The process of healing and transformation must ultimately result in renewed developmental progression, a process in which the self-capacities and resources are strengthened, psychological needs are balanced, and schemas are adjusted to incorporate new information in a way that enables the individual to experience pleasure and satisfaction in his or her life.⁶⁰⁵

Here, Ma's notion of maturation is very interesting as the process of her healing is completed, not in a camp of prayer, but by herself accompanied by her beloved. Her former pleasure of flowers' smelling comes back. She comes back in life. The end of the novel mirrors

⁶⁰⁵ McCann, I. ; Lisa and Pearlman, L. A. (1990). *Psychological Trauma and the Adult Survivor; Theory, Therapy, and Transformation*. New York: Brunner-Routledge, p. 6.

hope to younger and future generations and forecasts that no conflict can last long when chances are to end it. As McCann and Laurie Anne Pearlman defend: “The development of a stable and cohesive self and the internalization of positive self and other representations depend upon empathy”⁶⁰⁶, Ma encounters the light of stability by accepting a positive mirroring, an idealizing of Flower. Her decision to smell a bunch of flowers beams light and peace in her trauma. However, Ma has to face the stigmatisation of victim of mental sickness by society as well as the stingy reality of Pa’s death by suicide. Death by suicide is not an easily accepted fate in most African societies. This awaiting struggle is justified by her head still buried in the pillow and her eyes firmly closed. Ma is convinced that the next struggle will not be that easy. She will have to face the accusing eyes of the neighbours, the reproachful comments of her in-laws and the doubt of her own children blaming inside themselves that she could have done the best to save their father from that unhappy and shameful end. That is why they decide to avenge their father’s death. Ma’s female children adopt a five-fold plan calculated to punish Aggie and rob her of all joy. Further, as we know, when a man dies in almost all human communities, it is his wife who is the first person to be indicted. Finally, Ma’s portrayal informs of trauma writing as it can be seen in female novels such as Nawal El Saadawi’s *Woman at Point Zero* and Flora Nwapa’s *Efuru*. Ma’s madness reflects a body malaise and confusion between real and unreal. It also explains a national malaise in a point that the more the pain, the harsher the reaction of the victim. Ma’s memory does not trick her, she is not dreaming. It just explains that trauma, an element related to darkness can be fought against by the help of light, smile and friendship and to mental confusion we can oppose life and light.

16.1.3. Aggie, boomerang’s victim

Aggie’s real name is Agnes, a university pretty girl. She is one the MUTE female workers. She gets married to Idan. Before her marriage, Aggie (Agnes) while at the university, meets Pa (the clipped form of Papa) for permanent exciting love affairs. The old man calls her Flower. Their love affair causes Pa’s family dislocation and by extension, Ma’s mental sickness. After draining dry Pa financially, she raises her voice toward him the rudest way, “*Money!* Flower screamed into the telephone, “That is what I want us to talk about, *Oldie!* Not sex and

⁶⁰⁶ Ibid, 18.

our next encounter. *Money!* [...] Pain shot through Pa's heart and numbed him. *Oldie again?*" (Darko, 347, Italics mine).

The extract shows the roughness of the message Aggie sends to her old lover to break the relationship. Since Pa is completely hooked to sex with the young and attractive and cannot live without her, he commits suicide to cap it all to the misfortune of his family. Now the boomerang effect comes through her door to her bedroom and settles down. After seven years of marriage with Idan has no child to comfort her place in her marital home since motherhood the first barometer that allows the test a woman in patriarchal setting. To fill the gap, Aggie's husband begins seeing a young and attractive girl. This causes a psychological devastation on Aggie. Her marriage is ruined as she has also ruined someone else's while younger.

The depiction of this female character is set out to show the causes and effects of boomerang. Amma Darko wants people to know that good deeds harvest good and bad deeds misfortune. Aggie by her materialistic behaviour destroyed in the past a whole family and the boomerang effect befalls her the same way. Aggie gets herself infected through her husband as the latter is engaged in a clandestine relationship with an HIV-infected lover, Randa who joins forces with Cora to fight Flower (Aggie) and her parents. The latter female character, Randa, is the daughter of the old man from whom she snatches a huge amount of money while being a university student. Randa disguises in Destine to avenge by ruining her marriage while her senior sister, Cora (teacher) works to break the marriage of her parents in a remote village. Ma is being revenged through the hands of her daughters.

Further, this equally exposes society's tolerated attitude toward men's polygamy or syndrome of sugar-daddy and Amma Darko blames society for this position. For the same reason, J. D. Ofori submits rightfully that "The feminist voice protests society's bias against women and criticizes it for seeing very little wrong with adulterous men whilst strongly kicking against adulterous women"⁶⁰⁷. Moreover, when a female character is totally blinded by her irreversible desire to avenge, fate can lead her to a distressed end. In this vein, Amma Darko's upcoming character is involved in this unhappy end because of her heartlessness and the fact of she is still walking on past events' grievances.

⁶⁰⁷ Ofori, J. D. (2013). "The Feminist Voice in Contemporary Ghanaian Female Fiction: A Textual Analysis of Amma Darko's *Faceless* and *Not Without Flowers*" in *Research on Humanities and Social Sciences* Vol.3, No.1, p. 4.

16.1.4. Randa, the lost

The first chapter of the novel commences with her fake collision into Idan. Randa is the last of a family of three children. She is a beautiful university student. Her desire is to complete her study and becomes Dam's wife. Randa's hidden name is Destine at MUTE pretending to be carrying out a research in order to come face to face with Flower. Randa is the author of the catalysing word 'NEMESIS' to ruin Aggie's marital life the same way Flower has ruined her family's. Her uncontrolled desire to revenge straightforwardly ruins her own life. Randa dumps revengefully into the life of Aggie's husband. Whenever Randa calls Idan, "She became his proverbial *Santrofi* bird. Captured by him in the forest, he was neither able to bring her home nor abandon her in the forest" (Darko, 107). As their relationship evolves, Randa pretends to be pregnant in order to fulfil the utmost desire of Idan to father a child, a joy he has not seen for seven years of marriage with Aggie. The effect is instant. Idan becomes completely subjected and cannot stop answering to her slightest call and fantasy. But to Sigmund Freud, fantasy is not of constant characteristic, then "fantasy is thus both understood in opposition to reality and seen as a systematic unconscious construction that underpins"⁶⁰⁸. This defines so much Randa's position in the story since their love affair is based on lies; there is no way for it to be taken serious. As the love affair evolves, Randa breaks it by shrieking the rude and harsh parting words this way:

Get it inside your head Idan. Let it finally get in there and stay there. I am not pregnant with your child. You did not make me pregnant. I am not carrying your baby or any other man's baby for that matter. [...]. Tell them that. I am not your girlfriend. I was never your girlfriend. [...] The game is over. Finished. So leave me alone! (Darko, 289).

The excerpt shows the extent to which the female character manipulates the victim. She does not care about the psychological consequence of the break. The hope that her fake pregnancy engenders in her sugar-daddy's mind all fades as soon as the news is launched aloud in his ears. Desperately, Idan tries to make Randa reconsider her decision, but in vain. The narrator confirms: "Randa please...for the last time....Tears welled up in Idan's eyes" (Darko, 290). It proves Idan's inner feeling of despair and betrayal. All his hope to have a child wipes away in a clip of second. Yet, the hidden secret is that Idan cannot make pregnancy occur in a

⁶⁰⁸ Rabaté, J.-M. (2004). *The Cambridge Introduction to Literature and Psychoanalysis*, New York, NY, USA, Cambridge University Press, p. 220.

woman because of his manhood's emptiness. Idan is sexually diluted and of no use. Traditionally, a man has power when his manhood functions. That part of a man subordinates all women who come on his way, which unfortunately lacks in Idan. Thus, power in that relationship is not equally shared, but shifts to her lover's side. Randa is now the one who takes over the direction of all his feeling and even life. That is why he literally loses the control of all.

At MUTE, Randa sets up her NEMESIS agenda, but her perfume betrays her presence. The scent evokes that of Idan's infidelity and alerts Aggie's fifth sense this way: "Her perfume, Dina. She has been using it just these past few days, and I can't stand it" (Darko, 130). Aggie cannot stand this scent because it is that of Randa, Idan's lover. The perfume is customary to Aggie. Randa does not give an opportunity to MUTE workers to argue with her. She disappears from her work place the day her disguised nature is disclosed.

In fact, Randa does not love Idan. She keeps in secret her relation with Dam, her boyfriend who unfortunately is a male prostitute. Unluckily, she bumps into T&T gossips newspaper uncovering Dam's HIV-infection. This means that she is inevitably infected having had unprotected sex with him. From Randa's misfortune, Amma Darko teaches us the various ways through which people can get infected with the HIV virus, essentially while they have several sexual partners and unprotected sex with all of them. The writer shows the primary elements in a relationship allowing us to be cautious during sexual interactions and advises protected sex while in doubt. Randa loses all because she is not prudent and blindly works to the danger. Randa's HIV infection will have serious consequences on her life and that of her surroundings. Generally speaking, "HIV/AIDS can lead to poverty affecting particularly women and young people and can halt or reverse socioeconomic development of a country"⁶⁰⁹. Randa's need of the hour is the social and psychological support that her family must give her. Surrounding people's look changes toward an HIV infected patient when finally, an individual is diagnosed the sickness. Their facial expression indicates a blaming one, which should not be according to the female writer. Amma Darko talks about the plight to induce the reduction of the stigmatization and discrimination and the increase of the need for care. HIV patients need to be cared for and loved to survive, but this revolution in behaviour requires an intensive education

⁶⁰⁹ Taraphdar, P. ; Guha, Rray T. (2011). "Socioeconomic consequences of HIV/AIDS in the family system, Nigerian Medical Journal": *Journal of the Nigeria Medical Association*, 52 (4), p. 1.

and large communication. It also requires teachings on the subject in primary and secondary schools.

16.1.5. Cora, a ‘bad teacher’

The prologue adjunct to the novel starts with her name Cora. It shows her fear while Kweku (her senior brother), Beam, the journalist and the others were at hand to descend in the prayer camp to rescue Ma, her sick mother. Cora is thirteen years older than Randa. She is well-groomed and attractive. The first point about Cora is her masking her look with a huge Blonde Afro wig to attack Idan, Aggie’s husband on the way. The dark plan starts when she calls Idan’s office and speaks to him in a rude manner, all this being very calculated. Then, we see how all this is set in motion without any suspicion from Idan:

THE BLONDE-AFRO-WIGGED woman plagued Idan. The feeling that she was after him for something was nagging him. He knows her from nowhere, but did she know him from somewhere? As far as he was concerned, she had bumped into him or they had bumped into each other in the office corridor. She tried to get him interested in her. Love at first sight? Lust at first bump? What would make a woman stoop so low as to force herself on a man who obviously didn’t want her and humiliate herself to that extent? (Darko, 70)

Amma Darko uses here suspense and mystery to unfold the narrative with her character named teacher. When all her intricate web functions, Cora calls for her junior sister Randa to finish the work while she pretends to a university researcher before Aggie’s family. The incident of Randa pretending to have been bumped by Idan is just a false pretence. Then, Cora comes again to become a teacher to set in motion the second plan which is to destroy Aggie’s parents. The ‘t’ of teacher in the novel is written with a small ‘t’ throughout the novel. This point strikes our awareness. The profession Teacher is a noble one and whenever it is noted in a literary device, it is ‘worshipped’ like Teacher in the second novel, *The Housemaid*. Some specialists in didactics say that there is no bad teacher. Generally, teachers educate and raise their pupils and students’ awareness. To be respected by community, teachers do not teach nonsense. Through their coaching, the students are led on the good way and attitudes to have in society. However, here, the role played by that teacher is worth denouncing. This female character is at the second position after Kweku in Ma and Pa’s family. She is a teacher. Before she accepts to connive with her junior sister to harm Aggie’s family down in a village, she befriends Nana Afful and intends to be her wife forever. Unfortunately, society’s stereotypes against mental sickness

derail her marriage with Afful, a royal blood. The mental history of Cora's family destroys her love affair absolutely.

It followed Nana Afful declaration to his family that he and Cora were seriously discussing marriage. His family apparently hoped it wouldn't get to that. There were royals and it was taboo that Nana Afful would marry a woman of a family with a history of suicide. [....]. By all means, it would pop up to the surface sooner than later (Darko, 123).

What the extract unfolds is that the Affuls fear to have in their family a woman whose mother suffers from mood disorders and her father who committed suicide. When a family is labelled as suffering from a particular inherited disease, people tend to avoid its members in every situation. Nobody would want to neither marry into such a family nor maintain a friendship with a member of that family. The collective beliefs on mental disorders are deep rooted in the collective mind. Without any scientific based-proof, people predict that a family where one of the parents suffers from mood disorders or commits suicide, the children are surely exposed the eventuality of all this. Amma Darko seizes the occasion to demonstrate that mood disorders or mental sickness are not communicable diseases and "like any disease, it can be cured" (Darko, 123). Thus, Cora's mother mental condition cannot be passed on Cora or the other children. Most essentially, Amma Darko uses this episode to show case to people who still believe that mental sickness is a contagious disease. The repetition of false news does not make it true, but it renders it more false. In this case, people's ignorance worsens all about the disease.

Further, as the story evolves, Amma Darko draws our attention to Cora's stigmatization by her community about her parents' former health conditions. Cora's broken love affair engenders her "broken heart and lapsed into depressed" (Darko, 124). This new situation of Cora was about to give reason to gossipmongers about how "Ma landed where she was" (Darko, 124) and about the communicability of mental sickness within a family. However, it is her life-threatening situation similar to that of Ma which leads her to depression. There is nothing to do with the disease's transmission to another person, be him or her a member of the family. Cora then realises that all her family's problem is related to her father's venturing in an extramarital love affair with Aggie (Agnes). She and her siblings decide to take revenge. The plan in motion is to allow Cora to go to Aggie's parents and claim to carry out a university research on polygamy and that Aggie's family can be the right case.

The beginning of Cora's story seems to reflect an effective university research or evangelizing mission to cure Aggie's father's leg. But soon the mask falls down. Amma Darko's depiction of Cora with Bible in hand reveals the secret story of African missionaries on their own land. On the one hand, the writer wants us to know the disguised mission of evangelisation in Africa. The mission is to brainwash Africans while their most important resources are taken away. In that vein, by bringing Christianity in Ntifor's house, Cora tries to divide his house and reign as the only one bearer of right teachings and secret news. The former and ever revered President of Kenya, Jomo Kenyatta rightfully mentions about Christianity and its way of taking hold of Africans' mind "When the missionaries arrived, the Africans had the land and the missionaries had Bible. They taught us how to pray with our eyes closed. When we opened them, they had the land and we had the Bible"⁶¹⁰. This reveals exactly what will have happened to Ntifor's first wife if the second does not decide to chase Cora away.

NEMESIS is in its active motion. Destine, her disguised sister Randa uses at MUTE. Cora, the teacher wants to work for Aggie's family dislocation. During her first visit to the family, she scrutinizes all corners to take into account the slightest information. Cora notices that Ntifor develops a sour on his leg. Insightfully, she comes up to recruit a fake man of God to announce that the affliction is spiritual, a sour commanded by demons. As many Africans think any affliction or disease is ordered from the unseen world, some malevolent people take advantage of this and use them to terrorise and make money. The cooked strategy is to make Ntifor believe that the only way to heal his leg's affliction (Buruli ulcer) is to divorce his second wife, Mena Kakraba, the mother of his children, the mother of Aggie. She nearly succeeds in dislocating the family. Soon, the trickery is discovered and the malevolent teacher is welcome with pestle blows because Ntifor's sour is not caused by demons and evil spirits, but bacteria (Darko, 252).

One has, however, to admit that not all the female characters in *Not Without Flowers* have the same importance in terms of the role to play. Given to some intrinsic aspects of these roles, these female characters are offered an opportunity to complete what the major ones have already made. Both categories of characters are linked to life and are assigned roles to make the

⁶¹⁰ One of the most used citations of Mzee Jomo Kenyatta. Jomo Kenyatta (1897-1978) was a Kenyan anti-colonial activist and politician who governed Kenya as its Prime Minister from 1963 to 1964 and then as its first President from 1964 to 1978. He was the country's first black head of government and played a significant role in the transformation of Kenya from a colony of the British Empire into an independent republic.

plot understood to all. In that range of idea, Amma Darko makes some female characters secondary, knowing that the protagonist and her surrounding have already played their part of action.

16.2. Secondary female characters

As presented above, Amma Darko assigns a range of roles to her female characters that help understand the plot. These secondary characters are presented as follows:

16.2.1. Mena Kabraba and Mena Penyin: The African sisterhood

Scholars and many female writers argue that polygamy is an extremely negative social plight reigning in male dominated societies. Then, feminism has been a considerable force in helping set the stage for women's advancement in that kind of society. The Senegalese female writer Mariama Bâ has elaborately documented Islam world's position about women and polygamy in her historical *So Long a Letter* (Trans. 1989). In that novel, Mariama Bâ rejects polygamy as a way to enslave women in patriarchal society. The significance of Mariama Bâ's exposition of polygamy hinges on the fact that it discloses the evil hidden agenda of its contemporary practitioners and reveals the faulty logic behind it. In the similar vein, Flora Nwapa's *One is Enough* (1981) also presents a female protagonist that challenges verbally her husband's taking on a second wife. As a result, she parks all her belongings out of her marital home. Amazingly enough, this female character self-fulfilment occurs when she leaves her marital home to settle alone in Lagos. The very premise of such revolt lures in the mind of many other female writers in order to liberate people through literature. In that very context, Amma Darko's *Not Without Flowers* launches the debate again in her own way. She demonstrates that polygamy can sometimes be recommended to serve a specific purpose even in a highly misogynistic society.

To understand the context in which Amma Darko writes about the seemingly good side of polygamy, it is important to illustrate the fictional scope: "Yes. *You were a young girl* and you knew he made you *his second wife* for the *sake of procreation*. I thought of how often you may have wondered about whether he would have taken you as *his second wife* had I been able to *bear him children*" (Darko, 159; italics are mine). In fact, the story discloses that Agya Ntifer's first wife is infertile without emphasizing the circumstance which makes her

unproductive. The narrator's choice to make Ntifor's first wife infertile is not precise in the story. However, it helps deliver the message of the possibility to have peace in a family of two wives. In fact, motherhood and mothering are two realities of great importance in traditional settings, not only in Africa but also in other part of the world. We demonstrate it in our earlier chapter above. This social reality has also been depicted in many female writings alongside with their ordinary burdens in society. Moreover, Ntifor lives in a rural area where more hands are needed to keep his farm works going on. The failure to produce the working hands can motivate the man to marry another woman. At that point, here it is '*for the sake of procreation*'. Both female characters agree to live in house like Pesewa's first four women. The difference between Pesewa's mansion and Ntifor's house is that the first is a monetary based-marriage and the second a 'true love' with an accurate objective: to bear children. The two wives of Ntifor do not consider one other as rival, but bound by the same womb and destined to manage their problems together. For example, the second wife allows the first to consider her children as hers. The aim of letting them together is to oblige communication and collectiveness. Sometimes, as human with feelings and fears, the first wife feels frustrated to have not succeeded in bearing Ntifor's legatees, but is immediately appeased by the second. Ordinarily in a polygamous marriage, it happens that a wife claims for more privileges than the other and then fires up the already magmatic atmosphere among them. The situation leads straight down to jealousy and fight if not better managed. Yet, Amma Darko's intention is to show the intimacy and joint work that help overcome challenges.

For example, the challenge of both women is the frequent presence of a woman called teacher for the sake of a research. The presence becomes a concern and grows to a permanent upsetting. For less than that, teacher can one day or another be on the list of the rivals and destroys the peaceful climate in the family. On one hand, because of her young age, her good looking aspect and her modern knowledge, she can better manage the sexual needs of their husband, Agya Ntifor. So far teacher begins to have a deep and striking influence on Ntifor (Darko, 254). As a result, she is insidiously stirring their husband, by the help of a fake prophet of hundred names, to send Kakraba back to her family, in order to be baptized into a church (Darko, 257) because his polygamous marriage is a sin before the Almighty God. Ntifor cannot be administered the holy sacrament if he remains non-baptized. Both women's challenge grows more and more powerful and troublesome. However, the more the concern grows in intensity, the thicker their togetherness. For example, at the same moment, Kakraba calls her children that

of the two, “I’ll send for *our* daughter Penyin” (Darko, 259, italic is mine). Possessive pronoun used here ‘our’ is to avoid repeating information that is already clear. In general, it makes the sentence less confusing because the same information is not being repeated. The pronoun ‘*Our*’ placed by the narrator means indeed that the daughter is for both Penyin and Kakraba.

To epitomize her own regard on motherhood, Amma Darko demonstrates that there is a possibility for two women to be mother of the same children. Strategically, in the traditional African setting, to have peace in a polygamous home, it is important to bring both women to accept to share significant values and items like their children as they are already sharing the man.

As a final point, an idea comes in the mind the first wife as if she were the one to be sent away. She knows that she will be fragile and weak over managing the household if Mena Kakraba is sacked just a holy sacrament from a fake prophet and a bad teacher. Then she decides to play it her own way. The space is too tensed, since she is “Holding the largest fufu pestle from the kitchen like a spear, Mena Penyin did not look an iota less than a warrior. Her face was furrowed in anger and her breathing was hard and sharp” (Darko, 304). She pursues the teacher with a pestle like a thief since this kind of teacher “deserved the largest pestle in this house. One blow was all she would have needed to be on her way to her maker” (Darko, 305). The coalition of the female characters discovers the treacherous attitude of the teacher and treats her the way a thief deserves. This evidence based-proof shows how important sisterhood in front of challenges. The feminist bonding like that between Ramatoulaye and Aissatou in Mariama Bâ’s *So Long a Letter* helps both survive while in danger in a male-dominant society. Likewise, the feminist voice in Amma Darko’s *Not Without Flowers* seems to be an overt and long letter sent to contemporary female counterparts and to Ghanaian society. Amma Darko urges through her oriented writing that whenever trouble comes ahead, women should stand still and thick together because “the hotter the battle, the sweeter the victory” (Bob Marley, *The Heathen*, 1977).

16.2.2. First wife, an enduring and hearty woman

As the name may direct, the present female character is Pesewa's first wife. Meaningfully, the author plays a very important part in the naming process of all her characters. Here, first wife has no proper name like 5th Wife. First wife shares the mansion with the other three wives and being assembled by the same fate, they have no capital 'w' like 5th Wife. The special mention about first wife is that she is a fervent Christian. The situation is quite good with her husband, a young farm hand in the period. "Together they dreamt about a future that would be filled with everlasting love, children and the comforts of life. Other wives were never envisaged" (Darko, op. cit. 269). The narrator continues further that "by virtue of her faith, first wife deemed herself Pesewa's only true, and the one qualified to pray for him and ask for that forgiveness of his soul by God," (Darko, 269). Nevertheless, as years count down, the now rich Pesewa makes the contrary resolution. Of course, the prevention through prayers falls useless.

In fact, the forthcoming events justify the reason why Amma Darko makes her female character a fervent Christian who fortunately enough reads that the Bible forbids suicide by considering it as sinful. Christian faith condemns suicide and people who commit suicide are sinful to God. Pesewa believes in God, but not as fervent as her wife. So one day, as if responding to a mysterious call, there he is with a second wife. Pesewa intends to bring an illusory intimacy into his mansion between the two women by taking on "a very close friend to the first wife" (Darko, 270), but nothing avails. Then, consecutively and uncomplainingly, first wife sees after her, three other wives in the mansion and the fourth in another house without wincing an inch of intention to leave the mansion. She keeps quiet all the time to the end. Keeping silence in literature is another fierce topic of debate. Silence in literature is as communicative as anger, noise and crying. Adam Jaworski writes in *The Power of Silence: Social and Pragmatic Perspectives* (1993) that: "silence is a rich and powerful tool of communication". To him, silence is "a legitimate part of the communicative system comparable with speech"⁶¹¹. First wife having not claimed for any position after having noticed Pesewa's betrayal is a communicative value. The silence is a valuable tool that Iya Segi does not use. Contrary to our character in study, she expresses her anger and claims for her inalienable right as first wife in Baba's Segi mansion in Lola Shoneyin's *The Secret Lives of Baba Segi's Wives*.

⁶¹¹ Jaworshi, A. (1993). *The Power of Silence: Social and Pragmatic Perspectives*. Newbury Park, CA: SAGE Publication, Inc, p. xii

Silence, as a concept, also occurs in Flora Nwapa's *This is Lagos and Other Stories* (1971) when Jide meets Miss Gobi in London. The narrative here emphasizes the simplicity in Miss Gobi's attitude: "We danced and we talked. I was beginning to like her. She was cheerful and easy. She was not inhibited in any way" (Nwapa, 21). However, silence also befalls in other circumstances to show the trauma of/in someone. Jide's meets another woman and then appreciates: "Maria, poor girl. It wasn't her fault. She is insane. She went off her head in London. She was in the asylum for nearly a year [...] Her husband was cruel to her so it entered her head" (Nwapa, 27). The first wife feels betrayed by her husband and then enters in a traumatic and lethargic silence. This is in fact what traditional society wants from women. The more the social winepress presses, the more women get muzzled. There is a haunting regret and self-victimization that oblige the first wife to retreat. This is why the first wife chooses involuntarily to stay silent and barricades herself behind her faith in God. Ma, on the contrary, refuses to surrender to this culture and fights her way through no matter what happens to her mental health. It is striking how both women undergo the same situation, but each of them has a different approach. The point is that past and present events can erode the women's self-esteem and cause irreversible psychological damages. Therefore, it is difficult for these victims to open their heart to the first to come. This particular psychological and painful condition limits her from being physically active in the mansion. She stops struggling for herself.

Still, mostly women in monogamy image polygamy negatively and cannot stand sharing their husband with other women and in the same household. Then, despite her distress, first wife clings on her Christian faith which helps her not to be depressed. This does not mean that she agrees with a polygamous marriage. No woman really loves to be detached from the first love she has to her husband and then to be bothered by any other woman. Since the dawn of the time, women generally harbour to share their husbands with other women for many reasons. For example, as soon as another woman intrudes in a household, there comes forth a closed and overt conflict like who will grow in seduction, in having much time with the man, who will have priority to do this and that. Hatred, jealousy and suspicion become the most shared item in a polygamous family. The prospect to share Pesewa with other women pains her. As a result, she implores God as if she were in front of Him and God responds to her insisting appeal. Her sorrowful heart becomes peaceful. The narrative does not really focus on the climax that reigns in the mansion, but his family home is clearly not designed to encourage togetherness. It is rather a place where the occupants are somehow subordinate to their rooms, a place where they

do not exactly live, where they seem to be just visitors as Pesewa consults them for nothing and on nothing. The first wife and the other women are present just to notice change.

As if her sorrows do not suffice, the mansion floods with HIV-AIDS due to second wife sexual untamed appetite. Facing the disease mismanagement, the news of her HIV status had driven away their relatives and friends. As a matter of fact, the mansion becomes a place of mourning and horror like a cemetery. Amma Darko shows to highlight the extent to which people's lack of knowledge about HIV/AIDS can help them discriminate patients. So far, people wrongly think that while purchasing their items or while greeting an HIV-infected patient in the mansion as ordinary, they will contract the virus. In fact, the AIDS epidemic brings with it a large range of stigma. Generally, when it strikes in a specific environment, all their surrounding people fear its uncontrollable outbreak. This reaction is quite normal, because no one wants to die and fear of the unknown can cause people and communities to panic. Most people need quick answers, and they need to know how to avoid it themselves. When there are few answers, people often speculate and as a result fear and rumours start to spread. Rumours are counter-productive. They put walls up between people and contribute to the problem rather than solving it. In case of HIV/AIDS, infected people are stigmatized on multiple levels. There are many people who think that HIV is a common disease like chicken pox or any skin disease contracted just after physical contacts. Rumour like this can spread and this is Pesewa's mansion case. The flux of people coming in the mansion drastically decreases because of the fear of being infected. However, more meaningfully Amma Darko's writing about the disease lies on her pointing an accusing finger at unfaithfulness and polygamy as two male-related syndromes.

Both of these social syndromes are most of the time the cause of HIV infection. Multitude of sexual partners like in polygamy case leads with no doubt to HIV infection and any other dreadful sexual transmitted diseases. In doing this, Amma Darko unleashes her feminist voice that protects and gives power to female characters in her text. She blames her male character for having been led by his sexual appetite and his selfish desire to prove his manliness since it is said that "if he wanted a woman, he simply made her his wife" (Darko, 57). This is Pesewa's way of proving his wealth and his sexual intransigence. Pesewa does not care about his own health. If he desires a woman, he takes her on. Had Pesewa kept only one wife, he would not have infected by AIDS virus. The patient and good female character, first wife, is infected, but it does not mean that death will come overnight to take her go. First wife has many

days, many months and many years to spend with her children. First wife keeps her head above water to prove her strong faith in God that gives her endurance and an ironed heart to support all. Among her rivals, the only friend she has is 5th Wife for she sees in 5th Wife the sign of what she would be if she attended school. First wife backs up in silence the struggle of 5th Wife against culture. As rightfully said, Doris Nyanta et al postulate that “the concept of culture lends itself as an alibi to perpetuate the domination of men over women”⁶¹². Then, the sets of constraints made by men are bound to be broken by a collective action of women in society. Some bend the rules by their side by interpreting the norms as wrongly as possible. So far, 5th Wife’s victory is absolutely first wife’s and by extension that of the other women in such a predicament. Amma Darko’s depiction of the present female character shows that there are women who stand strong in mind during their day of ordeals. First wife being nameless proves that there are many first wives all over Ghana and by extension in all African countries.

16.2.3. Second wife, the lost

Like the first, the second wife is intentionally an unnamed female character. The number proves her position in Pesewa’s mansion. Also, the universality of the disease forces Amma Darko to use many nameless female characters in the plot. Second wife is a close friend of first wife. She is aggressive and ambitious by nature. That mood of hers may have pushed her in the hand of the rich Pesewa. While she enters with enthusiasm Pesewa’s home, she forgets that “the reign of the favorite wife in a polygamous marriage is always like a passport. It expires” (Darko, 272). Hereafter, her reaction when she hears about her husband’s taking on the third and the fourth wife proves that polygamy is not really cherished by women if it is directly related to them. Second wife is the one who breaks into Pesewa’s quiet castle. The idea is to show that some women are ready to tread in an already peaceful and monogamous family if ever their selfish ambition is fulfilled. Her presence then converts the monogamous to a polygamous family with its large range of perils which the narrative unfolds.

Second wife’s dominion termination comes as quickly as her entering in Pesewa’s bed. Her jealousy grows bigger and bigger and destroys her capacity of self-control. “Her jealousy waned and shrank. By the time it got to the turn of the third wife to do her crying with the

⁶¹² Nyanta, D., Ankrah, G. K. ; Opoku K. (2017). “Culture: A vessel for female subordination in three African novels” *European Journal of Social Sciences Studies* ISSN: 2501-8590 ISSN-L: 2501-8590, p. 4.

arrival of their husband's fourth wife [...]” (Darko, 272). She makes an end to her emotion toward Pesewa so that whenever she is in his bed, she seems to be “obliged dutifully like a soldier summoned to war. She began to look forward to getting out of his bedroom fast” (Darko, 272).

On the one hand, we see that second wife cannot stand sharing in the castle her dearest husband with two other women as the first wife does, but reluctantly. As a matter of fact, she makes the worst decision of her life to get good sex outskirts of the marital circle. On the other hand, second wife making money from her shop business swells her ego and intoxicates her capacity of cooling down her temper. The narrator confirms it this way:

Gradually a kind of emotional osmosis began to manifest itself. An in and out flow. A loss of endearment to the husband she shared with two other women added to the gain of the intoxicating power that her social and financial freedom and independence from her successful trading business gave her. (Darko, 273)

Throughout second wife's attitude, Amma Darko demonstrates that some women can be completely influenced by their social and financial transformation. The financial independence changes second wife and turns her to an indifferent woman. As her jealousy wanes and shrinks, the temptation to look for another sexual energy from above the mansion's wall grows. As a result, second wife befriends Dam, a male prostitute (a gigolo) who is the boyfriend of Randa. Second wife recruits him for paid sex to fill up the gap left by her husband busy with his newly conquered wives. She cheats on her husband and on the other women in the mansion. At that moment, second wife takes over, controlling her pleasure and is contented to have men at her disposal instantly at a clip of her fingers. This feeling encourages her to continue. Yet, suddenly she sinks as quickly as she comes in Pesewa's manor. Her reign is over. As a result, she contracts the incurable HIV virus. For a long time, polygamy has always been related to male attitude, as it involves having many sex partners. One of the causes of HIV wide spread in urban cities like Accra lies in the number of sexual partners and Amma Darko is right to writer about polygamy as one of the agents for the HIV-AIDS spread.

The writer is fully aware of the implication of women in the prevailing predicament. She highlights that women are to be blamed for having multiple sex partners and still remain in their conjugal home. There is no other term to name this act than prostitution. The focus on all this is

very much the role of women, but not in an impartial style. In feminist writings, we expect to have automatically consigned victimhood to female characters by emphasising their hardship in a male-dominated society. Hitherto, some female characters can become impatient and dangerous if their needs are not quenched on time. Second wife is not first wife who, in the crucial moment of trials, relies on her Christian faith to stand firm. She has a boiling temper which leads her astray. Now she is infected by Dam, her good sex provider. Therefore, she contaminates Pesewa, who in return infects the other women in the mansion with the not yet curable AIDS disease. This is where the wheel seems to come full circle. Therefore, by treating Dam as a sexual object for her adulterous pleasure, second wife dehumanises herself and Dam. Her embarrassment and horror at Dam's VIH infection may thus be seen as a deserved punishment. But it is to be noted that second wife can be justifiably regarded as a victim of Pesewa unavailability to be there for her own.

The final responsibility for the disastrous mess of his family thus rests squarely with Pesewa as Amma Darko ascribes. Her feminist approach is to accuse her male characters of being the full culprits of women's ordeals. The guilt befalls them because of their blind fight to control and subjugate female characters we could say. Amidst the turmoil, commotion and tensions, blaming over blaming, Amma Darko sets out to inform us that HIV gains space among human kind because of our irresponsible attitude. Male greed over sex and particularly unprotected sex with several is to be blamed in society. The writer writes about society's negative attitude toward victims of the disease. She also raises awareness about the narcissistic personality of some women in African society. What drives Pesewa's second wife to Dam is sex and her selfish desire to be owned by someone else. She exploits the young Da without seeking for the consequences. The consequences are the results that her damaging behaviour has on her family. That is why Pesewa commits suicide out of society's stigmatization. Life would be difficult to live for Pesewa if he does not disappear amongst the accusing eyes and gossiping mouths.

With great relief to all, Amma Darko exposes the suspected weapon which is the men's restless penis. Amma Darko implies that a penis is like a weapon of massive destruction if not disciplined. In this way, penises of Pesewa and Dam are suspected to be dangerous and dragging evils along while erected. Amma Darko's male-bashing (to borrow from Adjei Mahuli: 2009) draws our attention to the fact that polygamy working in pair with unfaithfulness brings

sicknesses in peaceful households and besides, when polygamy breaks into a mansion to settle down, it is because the entrance is opened by the owner of the house. As a matter of fact, if Pesewa has just remained monogamous with his dutiful and hearty first wife, no person would be infected.

Taking cue from this, we realize that Amma Darko is on duty for feminism. She puts her female characters at the centre of the message. Thereafter, she blames the male characters to be the causes of female characters' frequent trials in society. African society is a patriarchal society, characterized by current and historic unequal power relations between men and women where women are systematically disadvantaged, subdued and oppressed. Amma Darko cannot stand discrimination, so she creates her female characters empowered for fear of the house inside division. The threat to feminist identity is clear; then the situation must be subverted to overthrow the men and consequently move from the margin to the centre. In this regard, in her essay "*Placing Women's History in History*", Elizabeth Fox-Genovese⁶¹³ corroborates that feminist writings shape the female history by recognising their special role in the story. Based on this evidence, feminist identity is the identity of women. That is the reason why all women view feminism as the way *par excellence* for their liberation. However, before the liberation is fulfilled, it is important for women to have by their side with no doubt elderly women because of their life experience must help tackle contemporary issues.

16.2.4. Akatasia's grandmother, the symbol of old age

The name Aberewa is an Ashanti word meaning 'Old lady' or 'Old woman'. Aberewa's portrayal shows a staunch defender of African tradition. This denotes that a character's name is given purposely by a writer and on top of it all when it is to satisfy gender struggle and imbalance power. To be counted among the old age, a woman should be of the characteristic: "les plus âgées. Celles qui ne voient plus leur sang depuis de longues nuits. Celles que le clan considère désormais comme les égales des homes »⁶¹⁴. The fact that the author makes the character a grandmother is also aimed to share her life experience with her grandchildren. For example, Aberewa cannot stand rebuking Akatasia "at the sight of Akatasia. It was horrible enough that the dress was way up above Akatasia's knees. [...]. Thighs exposed to their possible

⁶¹³ Fox-Genovese, E. (1982). "*Placing women's history in history*". *New Left Review*, 133, pp. 5-29.

⁶¹⁴ Miano, L. (2013). *La Saison de l'ombre*. Paris: Grasset, p. 11.

uppermost part and her bosom on such free display?" (Darko, 174). Colour has symbolic meaning in African culture and each colour vehicles special information when worn or displaced at significant places or situations. That information is not known by Akatasia. This is the reason why she sees no indecency in wearing a black dress and a skirt to expose her thigh and shape to the public. On the contrary, the old woman takes it completely wrong and disrespectful. According to Aberewa's traditional belief, dressing in black rises the gods' wrath against its bearer because the colour is used for funeral in almost all parts of Africa. It does not mean that black colour is loathed in African culture, but the using is destined to sorrowful and mourning events.

As a result, black is associated with death, evilness, darkness, scary and every other thing negative. That is why many people do not like to be associated with black. The old woman cannot understand why Africans should blindly copy Europeans' ways of life such as marriage, dressing style and culinary habits. For example, in western countries, marriage is just an engagement between man and woman where black dresses are allowed. In this important process, none of families interfere. The narrator explains that "Aberewa had heard that engagements in Europe often took place solely between the man and the woman intending to marry. Sometimes even at a dinner in a restaurant" (Darko, 174). Through the eyes of Akatasia, we see that Africa and Europe have fundamental differences in cultural values. If Europeans can wear black dresses to weddings and outdoorings, this is quite difficult in Africa. If Europeans can wear miniskirts accepted by millions of people, that attitude is reprimanded or misunderstood in Africa since miniskirts show intimate curves of women and satisfy the greedy eyes of inquisitive people.

Akatasia wants to behave like Londoners without knowing that the black colour calls for gods' wrath in African setting. Amma Darko uses that female character for the same purpose as for the old female characters in her former novels. Like Mama Kiosk in *Beyond the Horizon* and Naa Yomo in *Faceless*, Aberewa is the representative of female decency and old age consciousness. Aberewa's depiction in the novel denotes Amma Darko's own fear to see the core of African cultural values to erode, fade and disappear because of the globalisation as many are seriously influenced by today's distraction. Some Africans copy European reality and make use of it without separating the wheat from the chaff, and some of the chaff is just difficult to cope with. Aberewa foresees bad omen upon the black dress wearing for a joyful occasion. But

her people copy down England in “black trousers, black skirts, black jackets, black everything” (Darko, 174). But the old woman keeps it for herself for fear of being branded witch like Sisi or admitted to a prayer camp like Ma. “After which she would be lucky not to be declared a witch” (Darko, 175). The writer’s stress on ‘*lucky*’ is here ironical to prove how people fear the misunderstanding people can have about their premonition in African setting. This indicates the extent to which old age is respected in Africa. In several African societies, some proverbs corroborate the reverence due to elders which literarily mean: “An elder does not tell lies”, “What comes from an elder’s mouth is full of wisdom”. Elders are then respected because of their life experience and their knowledge of the way to live a relatively perfect life and breed youth to respectful manners. All this put together proves that old people have in their mouth what some community named as ‘divine words’; that is why they do not speak nonsense in assembly or any other place. The consistency of their words demonstrates what happens next to Aberewa.

Thus, unfortunately, three days after the traditional de *luxe* white Christian marriage, he is hit down by a truck and dies instantaneously. As a result, the marriage is ruined. Had the old woman premonition been considered beforehand, Akatasia’s parents would have allowed Aberewa to perform the related traditional rite. In doing that, Amma Darko draws the reader attention to the importance of caring for elderly people because they represent experience, traditional culture and have their own understanding of situations and forthcoming events.

16.2.5. Pesewa’s sisters, the reflection of patriarchy

Patriarchy is a social system which puts forward males as the most important elements. Patriarchy “is an institution of male rule and privilege that thrives on female subordination that is why most forms of feminism characterize patriarchy as a wicked social system of rule that is oppressive to women because it is an exertion of male dominance over women”⁶¹⁵. In such a society, the power is controlled by men and its exercise absolutely influences women’s freedom to get into the intimate circle of decision making. Women are silenced in such a society. So far, to propagate the overwhelming rite and pass the law over the future generation, patriarchy needs to establish its rule by the help of other women. Pesewa’s sisters are among these women

⁶¹⁵ Ifechelobi, J. N. (2014). “Feminism: Silence and Voicelessness as Tools of Patriarchy in Chimamanda Adichie’s *Purple Hibiscus*” In *African Research Review: An International Multidisciplinary Journal, Ethiopia, Vol. 8(4), Serial No. 35:17-27* ISSN 1994-9057 (Print) ISSN 2070--0083 (Online) DOI: <http://dx.doi.org/10.4314/afrrrev.v8i4.2>

representing the system. That is the reason why 5th Wife “was wary of especially Pesewa’s sisters” (Darko, 149) and would not be in security, if not escorted by any member of MUTE.

Pesewa’s sisters allege that 5th Wife is the one who causes their brother’s death. Thus, in that critical moment in traditional setting, widowhood practices are performed to make sure that the suspected wife is finally guilty or not. Additionally, Pesewa’s sisters do not appreciate their brother’s youngest wife since they think she is too spoiled and is taking too much time to produce. She bears no child, but is the only one to inflict a battery of conditions to their brother. The sisters consider their brother’s attention toward 5th Wife overwhelming and too strange to stand. The fact that the young lady in return imposes her rule of condom use in a marital home is not understood by the sisters of her husband. The question we can actually ask is the reason why these women are so rude to 5th Wife. The possible answer lies in the fact that many in-laws think that they are in their right to interfere in the marital affair of their relative or siblings. Jealousy also leads them to make hasty but wrong decisions. Thereafter, she may not deserve any recognition as one of their late brother’s wife. They reproach that “She has flouted tradition with impunity by failing to subject herself to any widowhood purification” (Darko, 149). Besides, they think that, before the eternal departure of their brother Pesewa, 5th Wife struggles to monopolise her husband in detriment to the other four. Nevertheless, the truth is that “5th Wife insisted and always ensured that their late husband met his intimate obligation to share his bed with each and every one of them in the fairest possible manner [...]” (Darko, 189).

On top of this, these female characters connive to get the youngest of Pesewa’s wives “to be married to Pesewa’s brother” (Darko, 189), a tricky plan which will be sealed as soon as 5th Wife accepts to undergo the ritual of widowhood. In the concealed plan of the female characters, Pesewa’s brother in question will try to sleep with 5th Wife as part of the deal and then sets in motion “a levirate union” (Darko, 190) for sure. That is the second reason why 5th Wife does not show off from her hideaway and frequently sends her representative to speak on her behalf.

The point Amma Darko raises throughout these female characters is the astonishing determination to enslave their counterpart. In the same vein, the development above sustains that patriarchy needs some active collaboration to pass tradition on future generation. Further, it in almost all African cultures, in-laws never get straight with the bride’s family because that

their son is over spending money on his wife than he may do on his own family. His decision is also more influenced by her wife's family than his. Therefore, all lies and trickeries are ready made to reason him. They also fear that wives monopolise or get away with their brother's properties after his death, so it is important to keep her within the family and then they will not take long to control it. The scenario is already fraught to dispossess 5th Wife of what she can claim to possess.

Pesewa's sisters personify the female agents of traditional mores that use culture to take over people's property. They also co-opt other women to work against 5th Wife. Therefore, they will rejoice if 5th Wife is condemned and imposed to undergo the widowhood practice and at the end given to Pesewa's brother since they have no respect for her. Fortunately, enough for 5th Wife, their allegations are swayed off by proof-based evidence given by the spokesman of 5th Wife's family backed up by the spokesperson of Pesewa's family. Due to the patriarchal nature of the African society, the African woman is considered as both physically and intellectually inferior to men. For instance, because she is perceived as inferior to men she must recognize and accept her ordained secondary position without questions, an approach rejected by 5th Wife.

In consequence, we see that the portrayal of these female characters focuses our attention on women's general ordeals perpetrated by other women. This story demonstrates that it is not only men who endanger women in society. In fact, some women can equally be co-opted by patriarchal structures. For example, Pesewa's sisters represent a threat to 5th Wife. Put differently, this story is one in which the author expands the notion of gender revealing that there are women who act as men and that the consequence of the actions are negative to other women. Amma Darko presents in her novels two types of women, the virtuous women and the dangerous ones. Out of this writing, we see Amma Darko follows Ama Ata Aidoo's footpath because of her use of history and society's reflection in her writings. Amma Darko uses a complex feminism to portray her female characters. She uses deflation against her male characters which is a literary attitude similar to that of her female Ghanaian counterpart.

Additionally, Amma Darko's conception of African culture disdains practices that enslave and mute female folks in patriarchal society. The writer tries to pinpoint out that suffering women mostly fail from the lower strata, although the circle of violence is stretched in all the sections of society. Women are sexually assault, brutally murdered, raped and

deliberately subjected to all kind of violence in the name of religion or culture. Women's innocence has been sometimes exploited to their detriment. Women suffer in silence with no humane hand to them rescue. Amma Darko's female characters by large do not accept their self-effacement, self-erasure which insidiously demean their value for so long time. What makes women suffer in society is that men make the rule to allow others to follow. This is what is documented in literature generally, but these female characters also make theirs for some males to comply with. In Amma Darko's fictional works, a few men believe in women's value in society and help them carve out dignified images for themselves. Then, she carves out the space and time to these women to empower themselves as she rejects plainly self-absorbed female characters in her texts.

Hence, Amma Darko presents her version of African feminism which stands on human library documentation and accepts to collaborate with men of good behaviour. This is in line with Bungaro's (2006) observation that fiction, especially African women's writing, explores the dynamics of power in African societies and the resultant tension and conflict which ensue from such complexities. Based on this, Amma Darko's novels question the extreme and erroneous aspects of traditionalism and culture that are stifling to women. She also suggests an intelligent shift from traditional norms of nationhood and from individualistic, capitalistic mind orientation to togetherness, media being the channel for all. Amma Darko opposes her legendary sisterhood, collectiveness and mass media communication to the African women's ordinary plights in society. In the same light of thought, the forever contemporary Frantz Fanon, while describing the universal quest for recognition in the last chapter of his psychoanalytic analysis, opines that:

Man is human only to the extent to which he tries to impose his existence on another man in order to be recognized by the other, that other will remain the theme of his actions. It is on that other being, on recognition by that other being, that his own human worth and reality depend. It is that other being in whom the meaning of his life is condensed (Black Skin, White Masks, 216-17).

In spite of Frantz Fanon's passing away just over fifty years now, his historical writings for Africa in these early years are still pertinent. It still keeps it up because he posed fundamental questions to the core issues that Africans from a generation to another have not yet fully responded to. On the one hand, Frantz Fanon's writing discloses skilfully colonialism's

strategy and its consequences on the African continent. On the other hand, the excerpt gives sense to what have ever been the African male authored creative writings that have depicted only the way to control women in society. In such an environment, women are confronted to cultural norms shaped by men to debase their assertiveness and keep their head always bowed. Tough conditions are invented to prove women's eternal obedience. Then it comes as no surprise that the male authored African literatures write about the male characters' power in action and thus the female characters as the 'theme of their actions. The female characters just appear to assist as second hand characters and figurants with predefined roles and places.

Today, African women have the full opportunity to write back and correct the image long time portrayed by male writers. They subvert the attack by empowering their female characters and bashing the males or making them passive. Other female writers depict their male characters as very weak, obedient and irresponsible. With female writers, the girl babies are no more drowned in the river, the baby buried alive with the lord, burned alive on the funeral pyre, burned as witch at the stake, stoned to death for adultery, beaten, raped, bartered, bought and sold. But, if all this occurs in their writings, the female writers create occasions for these women to retaliate either softly or harshly. Now the women depicted in novels like those of Amma Darko defend their lives, their existence, their words and those of the next generation. The African women in Amma Darko's fiction are renewed and are created to keep their heads high. The African women have their place and space through the mighty plume of women such as Amma Darko. When we say plume, we are not only referring to the tool that helps write, but also the plume which stand for a phallic object. A plume is erected as a penis can be fierce and daring while rising up. Now that some women realize that it is important to be conscious about the prevailing trend, they set in motion a process of women's self-restoration economically, morally, spiritually and physical and we are sure that through literature they are succeeding in making themselves atop and anew. Therefore, hostile environments to women writers, women's experience and literature written by women are getting straighter and straighter with giving women chance and occasions; no wonder that one day the trend will significantly change because as we have said earlier, there is no man free if his woman is enchained next to him.

The following chapter give an overview of Amma Darko’s way of depicting by proving as she uses to say “women are going to be all-giving, all forgiving”⁶¹⁶. They have to react having given the opportunity to, to be in the same line of thought with the Afro-American actress, Viola Davis⁶¹⁷ at the 67th Emmys Award in 2015.

⁶¹⁶ Ayinne, R. A. (2004). *Emerging Issues in Amma Darko’s Novels: Beyond the Horizon, The Housemaid and Faceless*. Undergraduate Long Essay, Department of English. Legon: University of Ghana.

⁶¹⁷ Viola Davis’s speech at the 2015 Emmys & why Pop Culture Matters: “The only thing that separates women of colour from anyone else is opportunity.” Viola Davis is the first black winner of the Emmy for best actress

Chapter six: Masculinity under Amma Darko's Deconstruction

Before the rise of the African wing of feminism and its other divisions in the sixties, African literature was abounding with male-authored writings that celebrated their male characters. African literature was filled up with references to male characters' braveness and audacity from legends, tales and traditional songs. The writers referred to male epic battles, warfare bravery, values attached to male activities during field and harvest works. The first African writers to display this trend are Chinua Achebe, Ngũgĩ wa Thiong'o, Elechi Amadi, Ayi Kwei Armah, Cyprian Ekwensi to name just a few. Female characters which venture in these texts were shadowed and relegated to the second rank for menial roles. Besides, if they chanced to be in male-authored fictions as main characters, they were presented as sex objects to men and their participation is just figurative, though the significance of women in the African oral tradition cannot be contested. For example, in Peter Abrahams's *A Wreath For Udomo* (1979), the male character Tom Landwood shows his point of view on male supremacy and capacity of doing things without any help from women. He sees women as unworthy to trust as this comment shows: "You don't take women seriously, but they are useful"⁶¹⁸. In that period what was valuable was men's brawn and brain to organise riots and assemblies for some new born African countries. Women were therefore put aside. In *Contemporary African Literature and the Politics of Gender* (1994) Florence Stratton criticises Gerald Moore, Eustache Palmer, and Eldred Jones for inaccurate evaluations of women's novels⁶¹⁹. According to Stratton, Eustache Palmer's *An Introduction to the African Novel* (1972) refers only once to one woman writer and labels Flora Nwapa as "an inferior novelist"⁶²⁰. This demonstrates how unprofessional and biased some renowned critics deal with novels written by women in African contexts.

Hence, when African female folks enter the room on their own, they shift the trend of female identity portrayal. In this light, African women writers such as Grace Ogot, Flora Nwapa, Buchi Emecheta, Ama Ata Aidoo, Nawal El Saadawi, Mariama Bâ, Leila Aboulela, Chimamanda Ngozi Adichie, Sefi Atta, Amma Darko to cite these few starts a new technique of writing in order to improve people's views on female characters. Women writers give other stimulating roles to their female characters to correct the role image long time portrayed by male

⁶¹⁸ Abrahams, P. (1979). *A Wreath For Udomo*. London: Faber & Faber, p. 45.

⁶¹⁹ Stratton, F. (1994). *Contemporary African Literature and the Politics of Gender*. London: Routledge.

⁶²⁰ Palmer, E. (1972). "Chinua Achebe: *Things Fall Apart*", in *An Introduction to the African Novel*. London: Heinemann, p. 61.

authors. The roles played by women in fiction from that time onwards change definitely. In these writings, the female characters are depicted in a way to redefine and re-empower the female image. They subvert the tradition of male writing in which female characters are often relegated to the margin of the culture and confined to the domestic and private sphere.

In that regard, some African female scholars suggest an African specific theory that takes into account the African gender discourse, like the scholar C. O. Acholonu (1995) who recommends an African section of alternative feminism named Motherism⁶²¹. The proposed feminism is motherhood centred theory whereas Molaria Ogundipe-Leslie (1994) urges for a theory centred on African women's social transformation⁶²². Gender is a social construction and communities around the world use various cultural practices to teach their young people the norms of acceptable gender roles. For example, if in Igbo community, proverbs are cardinal strategies for acculturating young men into what society expects from them, in Kikuyu society wild animal hunt is the way to bring up young men to maturity. Taken differently, we see that each culture works to shape their younger generation's mentality to toughness, self-control, respect given to old age and strangers, generosity, togetherness and love. These values survive with difficulty during and after the African continent met Europeans' civilization centuries ago. African wild and pure lands surrender and become colonies, dominions of the West.

Then, post-colonial literature reveals the new identity of African women by promoting their actions and their field movements. These writers stand to reason through their characters and subvert the male power. This idea is in accordance with the definition of fiction in *Faits et Fiction: Pour une frontière* (2016): "La fiction est, en effet, aujourd'hui un champ de bataille, ce qui a presque toujours été le cas, même si les modalités et les acteurs des conflits diffèrent"⁶²³. The female characters are chosen for a specific purpose which is in line with these female writers' trend to overthrow the males. Characters serve as conduits for their expression on society. They constitute the ground on which the writers raise a part or a whole community's awareness on past, present and future events. Society represents to literature a field of expression as well as characters symbolize the firewood through which the writer conveys his message. Characters' names are important to choose. Naturally, names call to mind the direction the writers want to give to their message and also unveil the approach. In that tendency,

⁶²¹ Acholonu, C. O. (1995). *Motherism: An Afro-Centric Alternative to Feminism*. Owerri: Afa Publications.

⁶²² Ogundipe-Leslie, M. (1994). *Recreating Ourselves*. Trenton: Africa World Press, p. 1.

⁶²³ Lavocat, F. (2016). *Faits et Fiction: Pour une frontière*. Paris: Editions du Seuil, p. 14. "Fiction, to this date, is like a battle field, even though the modalities and the actors change". (My translation)

masculinity is worth emphasizing for scholar studies, because it looks like female writers are just taking revenge of their having been shaken aside by male writers. Hence, several African feminists develop their own technique which reveals clearly their approach. The following lines discuss Amma Darko's writing approach. But most outstandingly, the following lines draw a particular attention to the fact that Amma Darko is not only concerned with women's gender issues but also on society specific issues.

Characters' names as we say are not just given to fill a fiction's writing rule in literature. In David Lodge's *The Art of Fiction* (2011), it is insightfully argued that the true secret of characters' naming is never neutral in fiction, nor given for the simple reason to give a name, even when the author (male or female) chooses them nameless. It is usually purposely. David Lodge posits that

They always signify, if it is only ordinariness. Comic, satiric or didactic writers can afford to be exuberantly inventive, or obviously allegorical, in their naming. Realistic novelists favour mundane names with appropriate connotations (Emma Woodhouse, Adam Bede). The naming of characters is always an important part of creating them, involving many considerations, and hesitations, which I can most conveniently illustrate from my own experience.⁶²⁴

In disclosing the clue of fiction characterizing, what remains is each writer's ability to use a name and the way to use it in his writing. As far as Amma Darko is concerned, *Broadening the Horizon: Introduction to Amma Darko Fiction* (2007) concentrates its analysis on women characters as 'victims of patriarchal violence' as well as women participating in the violence against their own sisters. Amma Darko equally portrays the majority of her male characters with a disdainful manner that to point out that all the blame is on their oriented and materialistic society they build for their own. By portraying their male characters so severely responds to the trend of African female literature to empower female characters in general and African women in particular. Amma Darko's contribution to the prevailing tendency highlights mainly the danger associated with women's sexuality, women's assertiveness and power to lead and guide their own decision in patriarchal societies. Exposing women's permanent traumas is the motivation of third generation women's writers. The male characters by Amma Darko are all of different background, yet there are identical on their role which mainly is to subjugate their

⁶²⁴ Lodge, D. (2011). *The Art of Fiction*. London, Great Britain: Vintage Random House Ed. (First published) Martin Secker & Warburg Ltd 1992, p. 37.

wives and daughters. Amma Darko's male characters pull down the female folks and do not allow them to emerge and assert themselves. The settings presented in the author's literature only provide to male characters, the background within which these charges are undertaken. In some novels by women's writers, the setting is extended to the whole country where women are silenced under the yoke of their white or black masters. This proves that domestic violence silences more rapidly and accentuates women's subject being to object. In some African communities, the family's head never calls his wife by her name, but rather the name of his son. For example, the father says "mother of X or mother of Y, if the X or the Y are of male sex, but does not call her by his daughter's name. The female gender does not count. We refer to gender here because some feminists seem to make a strict difference between sex and gender. According to Christine Delphy, "le genre précède le sexe, par sa capacité normative il impose une dichotomie des sexes largement construite socialement, en particulier par le discours médical"⁶²⁵. Some people in traditional settings go further to consider their wife as their enemy. They think that women are the uncompleted form of men; so that there is no consideration to give them. Some passages of the Qu'ran and the Bible reinforce their belief. In the Bible, the passage reads this: "Then the Lord God made a woman from the rib he had taken out of the man, and he brought her to the man" (Genesis 2: 22). The Hadith of woman being created from a bent rib goes like this:

And I command you to take care of the women in a good manner for they are created from a rib and the most crooked portion of the rib of its upper part; if you try to straighten it, you will break it, and if you leave it, it will remain crooked, so I command you to take care of the women in a good manner. (al-Bukhari, Muhammad bin Isma'il, as-Sahih, Hadith 5186)

So, some Muslim scholars defend that the Hadith means that Allah Almighty first created Adam and then Eve from his rib. Other scholars interpreted the Hadith differently stating that the example of a woman is like a rib which appears to be bent, but the real beauty of it is in being crooked. If one tries to straighten it, it will break. We think that these biblical and quranic passages are wrongly used to harden the living conditions of women in households. Due to this bent form, some think women are different from them in terms of nature and quality. They also think that due to this crookedness, women are naturally weak and easily breakable. Women are then denied their right in decision-making and speech.

⁶²⁵ Delphy, C. (2001). « Penser le genre », *L'Ennemi principal*, tome II, Paris : Syllpse.

This is an example of a typical domestic violence. Violence has nothing to do with that which prevailed between the white settlers and the black native or the black and the white South Africans at the time of apartheid. Thus, women have to struggle to be seen and heard. In Amma Darko's different texts, we are made aware of intricacies in the relationships between men and women and ultimately, the fact that the gender debate continues as much in art as in real life. Amma Darko's literary position allows the reader to examine how far people have come in the past few decades of intense debate in gender studies. Extending the idea of debate, the following chapter aims at bringing in light the sort of male characters Amma Darko presents in her novels. Amma Darko's position is in line with that of Valérie Magdelaine-Andrianjafitrimo in "Avatars de la mère: Genres, diaspora, migration et créolisation dans deux romans mauriciens, *Salogi's* de Barlen Pyamootoo⁶²⁶ et *Le Sari vert* d'Ananda Devi"⁶²⁷ : « les personnages masculins s'inscrivent dans une temporalité dynamique et ouverte alors que les femmes demeurent les vestales d'un monde qui ne subsiste que par la foi et le dévouement qu'elles lui manifestent »⁶²⁸. This point is also that of Gayatri C. Spivak who depicts in her essay the situation where women while being maintained under the cultural and social yoke reflects the image of the subaltern (always a woman) that cannot speak⁶²⁹. The subaltern condition forces some women to succumb to community's despair while others survive disastrous experiences. Those who survive may be traumatised in silence for life. It is difficult for these female subalterns to speak in that condition. Similarly, Amma Darko illustrates in her own way the attitudes of her diverse male characters that keep below the surface the body of their female counterparts in order to feel strong, respected and revered. Amma Darko's characterization raises awareness on the on-going harsh condition of women in society. The denunciation of such a condition functions as a call for resistance against oppressive cultural norms and male-oriented systems. Amma Darko succeeds in describing her male characters the way that suits the best for her perspective. While portraying the characters, the author skilfully makes use of tone, the structure of her narrative, the names' meaning, the context, the setting to communicate and draw our awareness toward the prevailing situation.

⁶²⁶ Pyamootoo, B. (2008). *Salogi's*. Paris: L'Olivier.

⁶²⁷ Devi, A. (2009). *Le Sari vert*. Paris: Gallimard.

⁶²⁸ Devi, A. (2009). *Le Sari vert*. Paris: Gallimard.

⁶²⁹ Spivak, G. C. (1988). "Can the Subaltern Speak?" *Marxism and the Interpretation of Culture*. Eds. Cary Nelson and Lawrence Grossberg. Urbana and Chicago: University of Illinois Press, Print.

17. Male characters' depiction in Amma Darko's novels

Figuratively many critics have shown that Chimamanda Ngozi Adichie is the literary daughter of Chinua Achebe, not only for having stayed in his house, but also for having used much of his technique to depict with simplicity the environment, the actions and the events in her novels. The language used has also been emphasised as being that of Chinua Achebe. Thus, this sort of remark could be applied to Amma Darko's method and that of her senior in literature Ama Ata Aidoo. As we have already mentioned, both writers are of Fanti origin, so they have been raised with quite the same cultural, social and religious realities. For example, Ama Ata Aidoo presents Eulalie in *The Dilemma of a Ghost* as a naïve female character; as well Amma Darko depicts Mara as a naïve woman. Ama Ata Aidoo also presents Sissie in *Our Sister Killjoy* as a female character who leaves from a less developed country (Ghana) to head to Germany and Amma Darko makes Mara also travel to Germany comfortably. She then discovers how her compatriots live like wreck and have even to earn menial before surviving. Several other points like geography and history unite both sisters in joy. All these points give us the right to maintain that Amma Darko and Ama Ata Aidoo are from the same '*literary womb*'. It is evident that the way Ama Ata Aidoo depicts her male characters in her writings influences intensely the vision of Amma Darko. They are both aware of Georg Lukacs's observation on a complete characterisation which necessarily is related to ideology, and that ideology is then a highest form of consciousness. Ignoring it, a writer excludes what is important in delineation of character. In fact, Amma Darko continues with the concerns Ama Ata Aidoo presents in her works in line with all that prevails in postcolonial African countries. To describe the existing situation in African women's fiction, Deepika Bahri points out that "Postcolonial feminists repeatedly draw attention to the nexus between colonialism, patriarchy, and capitalism"⁶³⁰. This is evidently the case of Amma Darko's writings.

Patriarchal system's stranglehold added to colonialism impacts on Ghanaians draw Amma Darko's consciousness by coercing her to depict her male characters so harshly that one could think that in real life, men have a personal problem with the writer. Amma Darko proposes her male characters appropriate female narrative elements as a means of helping them to empower themselves. Amma Darko writings want the reader to journey freely in the mind of

⁶³⁰ Bahri, D. (2009). "Feminism and Postcolonialism in a Global and local frame" in: Vents d'Est, Vents d'Ouest: Mouvements de femmes et féminismes anticoloniaux. Genève: *Graduate Institute Publications*, p. 197.

her female characters and the share with compassion their burdens in society. Her feminist approach makes her depict her male characters as poisonous, pitiless, dangerous and macho so much so that it is urgent for women not to be any more all giving and all pardoning. According to Catherine Frank the time has come for female characters in women's writings to slay the dragon representing patriarchy and take over (1987: 14-15). The dragon Catherine Frank refers to stands mainly for the double yoke of patriarchal system and colonial heritage which rank women as second in society. The dragon refers to masculinity's stranglehold since this mythological animal (as huge as a dinosaur) is supposed to get physical strength. This representation may not be the same in all countries. It reminds us of an African-American's song "*Unleashed the Dragon*"⁶³¹. A dragon is usually taken as a gigantesque animal (a penis) capable of spitting fire (sperm) which represents manhood and male sexual dexterity.

In effect, Amma Darko's first novel *Beyond the Horizon* (1995) is set in Naka, a fictional village in Ghana, then in Accra and finally in Hamburg and Munich in Germany. The plot revolves around the principal male character Akobi Ajaman who embodies Ghanaian's martial ethos. He is a ministry clerk, the first boy of Naka to reach that education level. In Accra, Akobi is presented as beast of prey, violent and exploitative. Akobi opts to be the roaring lion and strives at all times to live up to what he considers to be the appropriate image of a man in his patriarchal society. In so doing, he regularly beats his '*wife*' and does not consider her presence beside him. Here we italicise the word wife to emphasize the vanity it represents in Akobi's eyes. Thus, he embodies a type of successful masculinity, an attitude which will be later subverted by the novelist by introducing elements which show that Akobi does not fully understand the details of his culture. The villain, Akobi, makes his violence permanent and more skilled as he sharpens his 'home gun' this way against another human being:

He was *lying on the mattress*, face up, looking thoughtfully at the ceiling when I entered. Cool, composed and authoritative, *he indicated with a pat of his hand* on the space beside him that *I should lie down beside him*. [...] Wordlessly, *he stripped off my clothes* [...] turned my back to him and

⁶³¹ Mark Althavean Andrew's stage name is Sisco. He is R&B singer. He released the *Unleashed the Dragon* in November 1999 and justified it as the period when no African-American artist male's song was enjoyed by the public. It was the time when women singers such as Destiny Child's was bobbling on the top of ten drilling millions dollars. So, he unleashed the dragon to attach and to prove the manliness of male singers. Really, after that song, many R&B found their way through. In 2001, he sang *Return of Dragon* (Platinum) and recently *Last Dragon* in 2015.

entered me. Then *he ordered me off the mattress [...]*” (Darko, 22, italics mine).

The above passage draws our attention to the cold-bloodedness of Akobi and raises an important question: how can a man, just after having sex with a woman, his supposed *wife*, orders her, one second later, to get off and sleep on a far-off concrete floor? This attitude is far beyond a human mind's eye. The technique Amma Darko employs here is named deconstruction. The deconstructionist theory school originated in France in the 1960s by the French philosopher, Jacques Derrida, when he presented a series of papers to dispute the metaphysical assumptions of western philosophy from the classical period to contemporary times. Deconstruction which does not mean destruction is a complex body of philosophical, literary and cultural principles. Deconstruction means an analysis of a reading, a revolutionary way of reading. It is then more a reading technique than a literary theory. According to *A Dictionary of Critical Theory*, “deconstruction is best described as a theory of reading which aims to undermine the logic of opposition within texts” (London: 1996, Blackwell, 4). Actually, deconstruction aims to show how texts unravel themselves, particularly displaying how the privileged item in a binary pair can be reversed and subverted. The technique is mostly used by feminists and Marxists in their writings.

So clearly speaking, when the above reading device is applied to Akobi's attitude and deeds, it appears that the male character has no love and not a slight attention for women in his heart. His personality is full of hatred towards women that is why he treats them as mere slaves. The relationship between Akobi and Mara could be compared to that between a master and his female slave. He gives himself the pleasure to explore her body sexually anytime he feels like with no verbal or physical challenge from the slave. Akobi has nothing in mind, except to feel powerful in front of his slave. In that very society, the only important trait that is expected of a woman is submissiveness to the husband. Mara is Akobi's land and property. What comforts Akobi's position is the culture that portrays a man as the head of the family and the master of his wife. Akobi is the master of the land in the sense that he is usually in the position of controlling the slightest movement of Mara. Akobi is the villain who messes thoroughly Mara's life. The female writer also depicts the physical impairment of Akobi which could be one of the reasons why he is rude and pitiless. She writes that he is of “big flat nose” (Darko, 10), which means that he is not good looking. He has an unstable personality; that is why he gets angry

every time for no sustainable reason. Akobi is heartless with Mara the same way technique the master or his foreman could be with his slaves. The portrayal of this male character proves Amma Darko's radical feminist perspective which draws the line between male and female in patriarchal society: men as villain and women as victims.

Actually, the monetary exchange that equals to the land's value (the body for sale) is simply the dowry given. The environment in which Akobi is raised also impacts him negatively. Akobi is influenced by what he sees and hears every day about men and women within his family and his community. Within his family, the person he sees in action every day is his father, his mother is never mentioned. Akobi's body is colonized by his family or community's patriarchal gangrene. That colonial-patriarchal context reduces women to men's sexual objects. As we say the narrator does not refer to Akobi's mother whose presence can to some extent inverse the inclination. Besides that, Akobi Ajaman becomes a more conniving man in terms of domestic violence against his *wife*. Therefore, the majority of the narrative refers to Akobi's violence against Mara. He exploits her innocence toward him so that Mara has grown used to that permanent harshness. Akobi seems to come from a different planet since his attitude toward Mara is so rude and brutal. This makes both of them live in two different worlds. Through the lens of gender and from a feminist perspective, Mara is the angel that ventures into hell not for a simple visit, but rather a long stay. Mara tells one of her first bitter experience with Akobi:

It was natural that after I had woken up first at dawn, and made the fire to warm up water for Akobi, and carried a bucketful of it with his spongebag to the bathhouse for him, and returned to wake him up to tell him his bath was ready-it was natural that I also had to stand outside while he bathed just in case some soap suds should go into his eyes and he should need me. Moreover, it was me who always carried back the buckets and the bathing accessories and saw to the drying his towel ready for next morning since he hated wet towels touching his skin.

It was natural, too, that when he demanded it, I slept on the concrete floor on just my thin mat while he slept all alone on the large grass mattress since, after all, mother had taught me that a wife was there for a man for one thing, and that was to ensure his well-being, which included his pleasure. And if demands like that were what would give him please, even of just momentarily, then it was my duty as his wife to fulfil them. (Darko, 12-13, italics mine)

Added to the permanent violence Akobi Ajaman exercised on his *wife*, he decides not to cater for her basic needs: "That he had bought me no new clothes and left me still with only

those I had come in from the village, and that in spite of this he had also forbidden me to sew any of the cloth he had presented me with as part of my dowry” (Darko, 13). ‘Mr’ Ajaman is here like the biblical giant Philistine Goliath, ordering the little David to come and fight because he thinks David is unqualified and very young for that. Not to cater for one’s wife needs to wear new and good cloth to feel cared for and loved seems to be a forbidden task. ‘Mr’ Ajaman is cruel and ignorant to believe that showing love for a woman is to demonstrate one’s weakness. ‘Mr’ Ajaman thinks erroneously that all this falls in the command of tradition and culture. His phobia lies on the fact that he fears to be considered weak if he feels more affective and kind toward his wife. This fear describes his relationship with his wife and then with their neighbours. He considers himself as being a patriarch and in this sense, he rules his household with a firm hand. While in Accra, Akobi exercises unchallenged authority over his wife; not even the presence of Mama Kiosk stops his wrath and makes him reconsider his manners.

In Germany, Akobi changes his name to Cobby, to a Europeanized name. As we know that a name bears one’s cultural identity, its change proves that the bearer wants to change his identity and conform to the milieu where he lives now. Many Africans change their name because they think it is too traditional and rustic to allow them benefit all the possible privilege a new name can give. The process of a name changing occurs when the first seems to recall a negatively past event. In Africa, some countries or cities change their former name to another to remove all traces of colonial rule, or to reflect the ideology of the government in power. For example, present-day Zimbabwe was known as southern Rhodesia, named after British colonist and businessman Cecil Rhodes. It is widely believed that Zimbabwe is a compression of the words ‘dzimba’ and ‘dzamabwe’ (meaning House of stones) in the Shona language, the most spoken in the country. Present-day Benin was until 1975 called Danxomè (literally it means “in the belly of the snake”), named after the famous southern kingdom led by its last and most revered King Gbê Hanzin (literally “the world holds an egg”). French government exiled the King to Martinica and then to Algiers after his defeat in 1896. Other African countries changed their name such as Upper-Volta to Burkina-Faso by Thomas Sankara in 1984. Gold Coast was also changed to Ghana in 1957 by Kwame Nkrumah. Tanganyika-Zanzibar changed to Tanzania in 1965, and finally Leopoldville to Zaire with President Mobutu Sese Seko. Then in 1996 when Mobutu was deposed, the new government led by Laurent Kabila returned the country to its old name, Congo.

If we mention the above scope in which countries change their former name, so it is mainly because the name's significance is not shared by the majority of people of that country. The change may occur as it reveals a not-accepted past of the people of the country. The transformation from Akobi to Cobby is correlative of something else far more important concerning the subjective behaviour of himself. Akobi has a real problem of identity double with a personality disorder. Akobi is an unstable human being and an opportunistic person who believes that he can fool people. For Frantz Fanon, this attitude of some Africans justifies their psychological alienation. Cobby's attitude in and out of Africa proves that he loses what we can name 'the national motive' of his race that lies in his superego (morality). Cobby highly estimates his personality of making other people suffer to prove himself that he is at the control. This defiant attitude of some human beings is discussed by Sigmund Freud. To Sigmund Freud, the superego develops during the first five years of life in response to parental punishment and approval. This development occurs as a result of the child's internalization of his parents' moral standards, a process greatly aided by a tendency to identify with the parents. This clearly explains Akobi/Cobby's social deviation toward women since the man grows in a family where his father has no respect for his wives and daughters. Akobi/Cobby identifies himself to his father. Since he is as ambitious as his father, he gives himself all opportunities which can allow him to ascend. He makes use of the Greek philosopher's, Protagoras⁶³², say in *Truth*: "Of all things the measure is Man". Cobby takes this viewpoint as his and sets it up in all his deeds and attitude towards women mostly.

In Germany, Cobby finds a more destructive weapon against his subservient *wife*, Mara. The narrator shows us that he transforms no remorse his own wife into a prostitute. He rules his plan at the letter. Cobby becomes a pimp, an exploiter of his *wife's* sexual lucrative activity. Together with his partner, they order their *wives* to work in brothels and bars. The women are imposed to take on more and more men for much money in their husbands' bank accounts. Amma Darko depicts her male characters' inner capitalistic greed which leads them to that extreme choice. Cobby and Osey think that the women beside them are nothing but cash cows or just a conduit whereby, in one hand, they can earn citizenship paper and in the other hand,

⁶³² Protagoras of Abdera (c.485-415 BCE) is considered the greatest of the Sophists of ancient Greece and the first to promote the philosophy of subjectivism, arguing that interpretation of reality is relative to the individual. The same view was earlier promoted by the Chinese philosopher Teng Shih (6th century BCE) but Protagoras was the first to teach this view in Greece through his position as a Sophist. A Sophist was a teacher of rhetoric, politics and logic who served as a private tutor to the youth of the upper classes. Protagoras wrote many works, the most important being *Truth* and *On the Gods*. Source: ancient.eu.

gain wealth and live peacefully. They can then live the European dream. In this sense, Amma Darko's male characters either are presented as female exploiters, macho and pure chauvinists or smugglers and rapists. This is in line with Mawuli Adjei's view about Amma Darko's representation of Akobi "he is a predatory monster, a raging matador driven by atavistic instincts of blood and gore. He is a sadist who enjoys inflicting pain on his wife, without revealing a modicum of human feeling"⁶³³.

While analysing male characters, we find out that Akobi has never ever shown disrespect to his white woman, Gitte. This attitude is also portrayed by Amma Darko to pinpoint the difference between Akobi with Mara and Akobi with Gitte. In fact, the sub-conscience of millions of Africans or people from African descent have been built to accept more what is white to be good and angelic, but the contrary with black or dark. Akobi keeps deep in his mind this inferiority of his own skin colour and then deploys it while confronted to choose. Frantz Fanon reveals a similar subjectivity of black man in his first book *Black Skin, White Masks*. The Martinican psychoanalyst tried to resolve the issue of being a black man in a white world investigate the psychology of colonialism. The book examines how colonialism is internalized by the colonized and how an inferiority complex is inculcated. Profoundly, the book proves right from its introduction that the author has also been tormented by personal challenges in that white and hostile world. It states that: "This book should have been written three years ago.... But these truths were a fire in me then. Now I can tell them without being burned"⁶³⁴. The manner with which he treats Gitte is completely different from which he treats Mara, a woman of his skin colour and from his country. The feeling of inferiority becomes unconsciously part and parcel of Akobi's DNA⁶³⁵. It is an adopted colonial deviant mind which results in a lost of identity and a lower self-esteem. As son of a former colonised, Akobi loses the very significant part of his cultural roots, his identity. This is specific to any African. This is very hard for an African or a man of African descent to overcome that kind of feeling. Surely, the character Akobi can be compared with the male character Jean Veneuse in Frantz Fanon's *Black Skin, White Masks* that we have mentioned earlier. Frantz Fanon argues that racism has such a powerful impact on people's psychology that even seemingly unrelated issues are often

⁶³³Adjei, M. (2009). "Male-bashing and narrative subjectivity in Amma Darko's first three novels", in *SKATE Journal of Literary Studies*, vol. no. 1. pp. 47-61.

⁶³⁴ Fanon, F. (1952). *Black Skin, White Masks*, p. 9

⁶³⁵ DNA is deoxyribonucleic acid; a nucleic acid that is the main constituent of the chromosomes of all organisms (except the viruses). It contains the genetic code and transmits the hereditary pattern.

traceable back to race in some way. Then, men of colour such as Akobi Ajaman and Jean Veneuse desire white women because, through their being loved by white women, these black men feel recognized by the world as white and closer to the white ideal that racist culture upholds. In Frantz Fanon's text, Jean Veneuse seeks a permission from a white man to allow him to be with a white woman since he thinks he is not white enough in his heart and his mind to be her lover. Likewise, Akobi Ajaman arranges to be in a place where many white men are present to kiss Gitte. The eye glances of all these people present afford him an approval to have Gitte. This attitude would not be the case of a white man with a black woman. If we take into account Frantz Fanon's therapy, we would check the health state of Akobi as being a neurosis like that of Jean Veneuse.

Further, to Amma Darko's, male characters such as Akobi or Cobby Ajaman who cannot take over that feeling of loss have their place out of society. Their place is then in jail to reprocess their behaviour. Cobby is arrested as he tries to sneak out of the country, Germany. The verb used the present sentence "He attempted to sneak out [...] and was caught." (Darko, 138) shows that Cobby is conscious of being guilty for having transgressed the law not only by having enslaved a woman, Mara, but also by still owing the bank which lends him money. In that case, we can see that the man makes himself an outlaw, so only a tentative to invade is the option left. A slave or a culprit thinks about invasion in his quest for freedom. At that very moment, the male protagonist considers himself as a slave since his guilty mind does him a trick. Not even his 'sex-acquired-German-citizenship' helps him save the face by not being jailed. Cobby should feel alone and weakened in jail because his masculinity and his permanent strength were defined by the presence of Gitte and Mara.

Further, the jail, in a geographical context, stands for a place of silence, confinement and sorrow where criminals and outlaws go. People are jailed because of their misdeeds in society. Then, a jail is a place of correction and rehabilitation. In African literature, prison evokes a metaphorical place of reality and literary creation. The evocation of prison here can be a life experience of the author or a friend of hers. Amma Darko does not describe the atmosphere which prevails in the prison, but African writers like Wole Soyinka and Ngũgĩ wa Thiong'o do. To Wole Soyinka, a prison is a tragic place of physical and moral confinement with dirty walls

and corrugated doors⁶³⁶. In this sense, Cobby's symbol of strength which represents here his freedom to get his wife and girlfriend tortured is weakened and even defeated. The emphasis about Cobby's material loss and his German wife's departure is also very important. The autodiegetic narrator stresses that: "Everything he and Gitte owned has been taken by the bank. Gitte divorced him [...]" (Darko, 138). This stress means that all that Cobby earns or makes by his hands is lost and then the symbol of capitalism is destabilized. As for Ngũgĩ wa Thiong'o, in his famous *Detained: A Writer's Prison Diary* (Heinemann, 1981), jail is where all kind of accusations are placed on the detained so as to frustrate him in a political context. Like Wole Soyinka, Ngũgĩ wa Thiong'o is imprisoned for his opinion in Kenya while Daniel T. Arap Moi was the Prime Minister with Nze Jomo Kenyatta as President. The kind of prison Wole Soyinka and Ngũgĩ wa Thiong'o were sentenced to is not that mentioned by Amma Darko and where Cobby should stay and may be die. The formers are wrongly accused while Cobby is a criminal.

Moving away from the formal features of texts, we see that the author succeeds in fulfilling the task of male isolation for the benefit of her female character and for society. That is why Akobi has been indicted and put in jail far from his hometown. An analogous story is described in Nawal El Saadawi's *Woman at Point Zero*. According to Marilyn Slutzky Zucker:

Firdaus, the hero of Nawal El Saadawi's 1975 novel/fictional (auto)biography, *Woman at Point Zero*, offers a scathing indictment of her culture's masculinities that damage political, religious, social and family life. About to be hung for the murder of her pimp, Firdaus attacks all men of her society for their pervasive and corrupting power-detail and perspective on masculinist principles organising Egyptian culture, principles that directly influence the way people conduct their lives⁶³⁷.

Here then, the passage proves that the female character in question does not fulfil the conventional female role that is to silence and let the family's head do what society assigns him. A woman committing murder is particularly rare in a patriarchal system. It transgresses all cultural norms. It also contrasts with all those people who are used to witness murder cases in that society. Likewise, in Amma Darko's text, a woman is not assigned the role of denouncing her husband's misbehaviour. She has to take all as heavenly ordained or her karma. Firdaus and

⁶³⁶ Soyinka, Wole (1987). *Cycles Sombres*. Paris: Silex Editions, p. 63.

⁶³⁷ Slutzky Zucker, M. (2010). Killing the Pimp: Firdaus's Challenge to Masculine Authority in Nawal El Saadawi's *Woman at Point Zero*. In *Masculinity in African Literary and Cultural Texts*. (ed) Helen Nabasuta Mugambi & Tuzyline Jita Allan. Oxford: Ayebia Clarke Publishing Limited p. 237.

Mara's action toward their respective husband bring about the general judgment of men's superpower in society. This presupposes that some women can stand against their men and claim for new conditions and social recognition. Akobi, the strong man like his father, ends up in jail indicted because of his irrationality against two innocent women, Gitte and Mara. Akobi's final portrayal shows the way feminists like Amma Darko want patriarchy to end up. However, the other male who should be equally inducted is Akobi's father for having formatted his son in his image.

In the narrative, Akobi's father is an unscrupulous undertaker whose best moment to see his business highpoint is during the outbreak of cholera in the village and its surrounding. He makes his money from people's death and does not feel any repentance. He is then as heartless as his son who makes his fortune from his own wife's prostitution. Actually, Akobi's father behaves like gun manufacturers whose activities flow when people are in need of guns for protection and security. Huge gun manufacturers are happy when African countries wave internal armed conflicts which last for many years. Their machine guns are bought at high price to make them well-off and influential. Therefore, the feeling of power comes when people are armed. A gun being a phallic object because of its shape, people feel secured when they take it on themselves. They do not care about what could become of the people in these countries where these clashes rise perpetually. We could not, for the same of respect, mention these African countries where internal conflicts and gun shootings become part and parcel of people's daily routine, so much so that when a day ends without gunfire or a bomb blast, people think that something lacks in their lives.

In Akobi's father context, cholera prevailing in Naka is like war waved in a country and invisibly backed up by suppliers. Likewise, Mara's father makes his reputation out of his daughters' marriage with people he knows they can afford huge bride prices. He feels no pain to see his daughters becoming all miserable in their chosen marital households. None of his daughters challenge him before on that fact for as a motif that runs throughout the narrative, anybody who expresses or stands for different views or who challenge the hegemonic posture, are accused of subversion or rebellion against patriarchal authority and is made regret or repent. According to Mara's father, women do not count in society. Then as subordinates, they are not even expected to have an opinion on this issue of power. In that setting, the master and slave relationship is clearly asserted. Also, in such a setting, the social stratification is clearly based on

wealth, knowing that the master firmly believes that his wealth derived from his own hard work. He does not consider the diligent and exhausting work of peasant cultivation of food, and cash crop and trading.

Implicitly then, like the colonial power, Amma Darko's male characters disrespect their female slaves since they seem to be given a supernatural right to literally down press them and even rape them with no repentance. That is the rhetorical question Percy Bysshe Shelley poses in *The Revolt of Islam* (II, XLIII, 1). Naturally there is no man that can be free if his woman is enchained. So a man has to live peacefully with a woman as both are created to be together as one. That is the reason why in Genesis 2: 22, God decides to crook the rib of the man to make a woman. Both share the rib. This is to say that the liberation of a woman is concomitant with socio-political change and that the role of the woman in bringing about such change is undeniably important, be her Ghanaian, Liberian, Sudanese, South African or from any other country deadlocked by socio-political stagnation. Then a woman should understand and use her body as a political tool against man-made society in order to rise up or keep surfacing. Her body becomes a political ground, inscribed and constituted by power relations.

All the way, what is noteworthy is that violence begets violence and thus, the circle of violence continues in an endless row. The African woman does not need to engage a merciless battle to destroy all the male folk since her struggle is a marathon for a final crown. The female struggle should not be understood as a trend of physical revenge between men and women, but a debate on sustainable ideas, society management, cultural and mental substantial change. Amma Darko's female characters do not strive to justify their second position as Simone de Beauvoir ironically reveals, but seek for their place, not at the bottom of the room and the kitchen.

Before we can present the male characters in *The Housemaid*, it is worth taking clue from the following insightful point that "From girlhood to womanhood, the African woman has had to contend with many issues that militate against her 'being' as she journeys through life's winding cycles dictated by culture"⁶³⁸. The Ghanaian female writer provides us with the personal struggle of women who decide to establish their life in a male-dominated society. In essence, it is a detective story revolving around the mystery of a dead baby, the novel depicts

⁶³⁸ Ofosu, J. D. (2013). "The Feminist Voice in Contemporary Ghanaian Female Fiction: A Textual Analysis of Amma Darko's *Faceless* and *Not Without Flowers*" in *Research on Humanities and Social Sciences* Vol.3, No.1, p. 1.

women who turn against and manipulate each other, largely because of the lack of education and opportunities afforded them by a patriarchal society. Amma Darko seizes the opportunity to hammer on serious social issues in Ghanaian society working against women autonomy. To balance the current tendency, Amma Darko creates a story around two female characters where all the male characters are presented as being weak, irresponsible and good for nothing or unable to care and cater for women's needs. When the narrative unfolds, we can notice that some male characters are named and others are not. This depends on the degree of their irresponsibility in the story. Amma Darko gives Christian names to some of the male characters for two reasons. The first is to show the extent to which Christianity is embedded in West African culture and the second linked to the first, is to demonstrate that men do not respect the biblical recommendations required for a Christian as ordered by the Bible "But, because of sexual immoralities, let each man have his own wife, and let each woman have her own husband. Let the husband render to his wife the affection owed her, and likewise also the wife to her husband" (1 Corinthians 7: 2-3).

First of all, Tika's father, an old man of the double of his lover's age, is presented sick and manipulated by Sekyiwa, a "100 per cent illiterate, stinking rich and riddled with guilt" (Darko, 18). He is a self-actualised intellectual. In actual fact, he represents the common Ghanaian man who received a modern education and gets through to his own way of doing business, however his manly power is subverted in the sense that he is presented very weak to place his word in contradiction to his second wife. He is not presented as being the dominant power in the narrative. This seems to say that masculinity does not have any humanity when it is expressed in its full form and force. He is presented dishonourable in order to be an effective instrument in the hands of Sekyiwa. While presenting Tika's father as weak in his own household, Amma Darko subverts the ordinary idea on masculinity (strong and authoritative). Consequently, in the end, we have in mind that masculinity is not to be taken "as a generic metaphor for socially diffused power in a roughly Foucauldian sense and femininity as a metaphor for weakness, or, likewise, simply identifying masculinity with violence"⁶³⁹. It is also clear that the reader feels sorry for the sorrowful end of that male character in the narrative.

⁶³⁹ Downing, J. D. H. (2010). Masculinity in Selected North African Films: An Exploration. In *Masculinity in African Literary and Cultural Texts*. (ed) Helen Nabasuta Mugambi & Tuzyline Jita Allan. Oxford: Ayeibia Clarke Publishing Limited p. 116.

In one hand, that male character's unfortunate end of life lies in that he comes across that blooded woman who drains dry his pockets and leaves him to die destitute and full with the sorrow for not having cared for his first wife though she was barren due to an abortion he ordered her while dating. To the narrator, it is his responsibility if the woman does not conceive. He has to bear the burden with her. The woman fulfils her part of the engagement by respecting him, but he is in need of a baby. Then he started a clandestine love affair with at that time the twenty-two years old Sekyiwa. On the other hand, Tika's father dies wreck by the flick of a switch because he does not feel his obligation to his first and unfortunate wife. He leaves her and settles with the young one accepting to set her up in business.

According to Amma Darko, men who do not respect their word to be with their wives in good terms and during misfortune are worth being exploited by other women. Amma Darko seems to be contracting his former position. She wants her male characters to respect the female ones, but at the same time, makes them beaten by their women because they feel dutiful to these women. The example of Tika's father is really seizing and disappointing. This contradictory stance of Amma Darko may raise interrogations from the reader like, 'why a man like that should be cheated on? Is not the kind of man, feminists want in society? Amma Darko's position is like that of a woman who wants to eat a cake and still have it. So if it is not good to have men like Akobi and Osey as husbands or boyfriends, then it shall be good to have a man like Tika's father. So far, prior to his death, the narrator shows us that the old man tries reconciliation. Yet he is met with the millions of insults she knows under the sun. The woman puts angrily: "Bury any shred of hope you have for a possible reconciliation down a million-mile pit! And make sure too that for as long as both of us live, you never across my way or step on my shadow" (Darko, 20). In a patriarchal society, men can also be abused and downtrodden because of their physical appearance, sensitivity, weakness and excessive love for the others. Nsorhwe illustrates that male character that cares for his wife's children though not his. Amma Darko concentrates especially on his physical appearance which puts him out of any list of candidates to seduce a woman. The first girl he approaches feels it as an insult. His two sexual contacts with Tika are strictly made in the scope of his position as bank manager. Tika wants an overdraft from his bank while being with him. Men such as Samuel (the son of an apostolic pastor), Riad (a half-caste shop owner) and Attui (a factory owner) use their position and money to exploit women. Tika's sex facilitates that business. Here Amma Darko unveils her male characters' corrupt mind and sexual avidity in society. Everything men need is to overtake

women's body and dominate it with their greedy sex. But, some women are ready for the game. Further, Amma Darko subverts the concept of fatherhood by comparing the compliant Nsorhwe to the drunken Efia's father and the absentee Bibio's father. Then, the title of father is attributed to men who really care for children either theirs or for other people. To Amma Darko's description, Bibio and Efia's respective fathers do not deserve any title of father as they do not contribute to the welfare of the offspring. So, to the female writer, the title father is not necessarily given to the biological male engender, but it can also be attributed to any male character who gives love, attention, respect and time to a child. The biological way of genes giving does not matter here. This is why Nsorhwe is not to be blamed at all for his action in the text; whereas, the others are totally guilty for having left their children and their wives to face alone these social and financial tough conditions. These dishonest fathers imagine desperate and opportunistic ideas employ to enslave women in society.

From the passage above, we realise that Amma Darko places herself at the radical wing of feminism which takes man as enemy. Her desire is to deconstruct her male characters as pointed by Adjei (Adjei: 2009, 48). Mawuli Adjei submits his view point this way:

The result is that, taken together, there is not a single man of honour in her first three novels. The principal male characters are irresponsible fathers and husbands, drunkards, rapists, exploiters, predators and monsters. They are presented as though they are totally detached from the general social malaise and moral decadence, but are rather congenitally, inherently and pathologically predatory, sexually depraved, perverse and evil⁶⁴⁰. (Italics mine)

Amma Darko's literary stance is completely radical and anti-patriarchal. Therefore, as if being at warfare, while taking down their enemy or if the enemy surrenders, women's army does not have to save the enemy's life, instead to shoot him down. The female writer makes of Tika's father irresponsible, always drunken and saying nonsense most of the time.

Secondly, Owuraku, a boy of eighteen, is the adolescent friend in love with Tika. As we know how love at that age functions, the narrator reminds the reader of how much Tika invested of herself in this love, yet, when it fails, she "switched her emotions into neutral" (Darko, 17). Tika's boyfriend succeeds in his exam and qualifies for the sixth form, whereas Tika misses it.

⁶⁴⁰ Adjei, M. (2009). "Male-bashing and narrative subjectivity in Amma Darko's first three novels", in *SKATE Journal of Literary Studies*, vol. no. 1. p. 48.

Further, when Owuraku walks up to university empty-pocket, Tika becomes a cash market woman with plenty of money. Here the common trend about man being the main source of income is burst out by the feminist writer; so much so that, if the university man needs money for his expenses, he has to accept to be the *second sex* under the power of the woman. The writer proves that not only women are beast of burden in society. In doing this, Amma Darko succeeds once more in subjugating what long time has been considered the first to second position. The authoress empowers Tika by giving her the opportunity to grow up socio-economically and when women are economically strong, they are mentally strong to claim for their position and fight then to maintain that social stance. Owuraku's position is that depicted in Chinua Achebe's *Morning yet on Creation Day* (1975) where it is argued that "the worst thing that can happen to any people is the loss of their dignity and self-respect"⁶⁴¹. Owuraku refuses to bow down before his girlfriend's indecent proposal and accept to be cheated on. He does not want to exchange his self-esteem to money made out of prostitution. He bangs the door after him and breaks the relationship. The narrator shares the moment:

The way your woman has become your provider, she could be hijacking your manhood, while you have no control over her womanhood at all! [...]
Owuraku launched straight into an attack. [...].
He thought Tika would break down and beg for forgiveness. Instead she snapped defensively. [...]
In fact, until she got into it, she had not realised that business could entail so much unpleasantness. [...] And she needs to perform well because she wanted to prove, to Owuraku especially, that her failure had ended with her exams. (Darko, 23)

In actual fact, Owuraku's attitude proves that some men can be exceptionally intransigent about their self-esteem in front of easy money. Owuraku knows that money is good, but it cannot replace a man's pride. If the debut of their relationship is so problematic and full of treachery, they had better end it at that point, once and for all. This male character is presented completely different from Nsorhwe, the wilful and all forgiving man. Owuraku is among those men who think that sex and relationship are connected. He does not want to cope with his primary love and his lover's treachery. Put another way, Owuraku knows that male sexual desire tends to be driven by physiological rather psychological factors; so much so that women need solid reasons before cheating. Then, if Tika is a money-driven woman, Owuraku had better stop

⁶⁴¹ Achebe, C. (1975). *Morning Yet on Creation Day*. London: Heinemann Press.

wishing to live with a female psychopath and sexually deviant. Amma Darko uses also some particular male characters to describe men irresponsibility in society.

Mami Korkor's husband is an invisible character in the novel. He is depicted as an irresponsible man who impregnates four times the devoted Mami Korkor without feeling the duty toward his born children to help them have a decent life. But in fact, Amma Darko warns us on the sexual hyperactivity of men from these two villages in her texts. As there are no places for entertainment, then the affordable item left for them is sex. This implies in a straight line the number of abandoned children we can notice throughout the text. The narrator does not emphasize his existence, but points out one of the negative impacts of his irresponsibility and his permanent absenteeism on his children. That is to say, his "[...] daughter was growing up on the wrong side of the tracks" (Darko, 11). There are similar creatures in Amma Darko's *Faceless* where she catalogues young girls who do not have access to formal education as a result of defected parenting. Two girls, Baby T, Fofu of the same family and Odarley their friend fail to get educated in contemporary Ghana. Their innocent youth is spent on the street. They have to survive at the mercy of people and also support their parents at home. These little beings are under duty on the street. Unlike, Mami Korkor's husband the first two girls' father name is known. Hence, the fact that the male character is not named in Amma Darko's text proves that it can be anyone in society. Patriarchal society is pointed particularly as being dangerous to women.

In *Housemaid*, another weakened male character is Efi's father who lives in Kataso with Efi's mother and grandmother. One of the most important steps of Amma Darko is to point out the financial and social statute of people living in that village. The village is portrayed as lacking the minimum and in that vein it gives no opportunity to its inhabitants mostly the men who are supposed to be head of their family. The narrator highlights: "Kataso, a village in the eastern hills, had no flowing water, no electricity, no entertainment centre, nothing" (Darko, 29). Efi's father is described as an irresponsible, useless and absent-minded as he is drunk all the daylong and 'fast asleep on a wicker mat inside the hut' (Darko, 40). Efi's father is then a good for nothing man as he loses his power and his privilege of being his family's head, the chief commander. Nobody considers him since anytime he speaks it is for a nonsense. Efi's father who fails to be the head, becomes the footstool of the whole family. With regret, Efi's mother puts that it is the local made whisky that rinses his mouth every morning either from a bottle

under his bed or at the bar ‘Kill-Me-Quick’, the very place where Kwei the bully goes to proclaim his being a Dr. Both defeatists have a place and a tradition in common: the place where to drink and an irresponsible behaviour toward themselves and with others. Efia’s father and Kwei will not move their single finger while sighting women in danger. Their problem is to release their tension every day with their friend. The attitude is not also too far from that of Adade. He gives himself a right to drink with his friends before going back home. Time and again, Adade does not feel guilty or blaming himself when he leaves only his wife at the frontline of the family chores day in, day out.

In the perspective of male characters’ deconstruction in Amma Darko’s writings, Mawuli Adjei (2009) insightfully postulates that:

Darko employs a highly subjective female viewpoint which is expressed through verbal violence or language which is deflationary and condemnatory of men, including insults and curses; the caricaturing of male characters; the muting and banishment of male characters; creating assertive female protagonists who defy male dominance in words and deeds; creating female characters who are repositories of knowledge and wisdom and who act as commentators and counsellors expressing the female viewpoint; female counter-forces based on group solidarity; and through authorial intrusion in terms of sympathy and empathy.⁶⁴²

We notice that it is Efia’s grandmother and mother who set the discussion of the girl’s transfer to Kumasi to become Tika’s housemaid. The slightest word of Efia’s father is to ask the amount of money to earn from that placement operation. He seems not concerned about his daughter’s life in the city. What is important for him is what to gain instantly. The decision making is for Efia’s mother. The narrator states: “Her father will be told everything when he wakes up” (Darko, 42). But in fact, the usually drunken father does not object any of his wife’s decision as he is every day out of order. Being powerless because of his state, the woman takes over so as the man becomes her servant. In Amma Darko’s perspective, the woman’s action is taken as a heroic one which the narrator does not fail to highlight. In the context of Efia’s father, the choice to become weak makes perfect sense. Because men always use women’s body to satisfy their own pleasure; then by now, women decide to get paid for what has always been taken for granted. Amma Darko humiliates her male characters in different ways to fulfil her

⁶⁴² Adjei, M. (2009). “Male-bashing and narrative subjectivity in Amma Darko’s first three novels”, in *SKATE Journal of Literary Studies*, vol. no. 1. p. 50.

female characters' ardent desire to be on power no matter what happens. This corroborates Vincent O. Odamtten's point of view that: "A writer like Amma Darko, who is willing and able to move beyond the comfort zone, deserves a reader who is engaged and is also willing to move beyond the comfort zone"⁶⁴³. Amma Darko moves then her male and female characters further than what is commonly read in African fictional writings. She succeeds in creating her own type of writing fiction that carries us out of our possible sorrows and to put us in a new world. The writing forces us to express our compassion, our passion and our joy. Amma Darko gives way of her point of view demonstrating that women are in danger and also endanger other women. She also presents some men weakened by their incapacity to participate in the positive movement of society.

In situations where women have their husbands silent, on their knees and speechless, it is considered most often as a serious breach of accepted cultural practices. Women in such a society are too assertive and bold in expressing their opinion without waiting for those of their men. A society where men like Efia's father do not have their say is considered as alien and fallen apart, the normal role of men being at the front. They are naturally considered the spear head, not the back of it. Efia's father is a broken man, the reverse of what is presently seen in society. He is transformed into a shadow, a mere male doll. A similar defeated male character is also portrayed in Leonora Miano's *L'Intérieur de la nuit* (2005). In this novel, Eke, the male character, is presented as being someone who loses his phallus and manliness because « au cours des trois derniers mois de sa grossesse (sa femme) avait dû garder le lit, transformant son mari en femme »⁶⁴⁴. Eke becomes a woman at home because of his marginal behaviour. What deconstructs this male character lies in this line as follows: « L'autre jour, Eké ne s'est pas contenté de l'accompagner à la source. Il est allé à sa place ! Comme une femme ! » (Miano, 17). Some perceive his weakness even in his physical traits. First, they think his voice is womanly. It is denuded of authority and secondly: "il avait exprimé son refus d'une voix de miel" (Miano, 19), and his look is compared to a source of water, cool and inoffensive.

⁶⁴³ Odamtten, O. V. (2007). "Beyond the Comfort Zone: Relations Between African Writers and Audience" (Ed.) Vincent O. Odamtten, *Broadening the Horizon: Critical Introductions to Amma Darko*. UK/London: Ayebia Clarke Publishing, Print., p. 11.

⁶⁴⁴ Miano, L. (2005). *L'Intérieur de la nuit*. Paris: Plon, p. 19. Translated into English as "Dark Heart Of The Night". Lincoln : University of Nebraska Press, 2010. The author seems not to agree with the title and foreword in the English version of *L'Intérieur de la nuit*. She thinks it sounds like Joseph Conrad's novel *Heart of Darkness* and the story narrated is far beyond what she portrays in the French one. She recommends the Nebraska University to remove it. This is why our references are mainly taken from the French version.

These elements depict so much that this male character is in identity crisis. In a man's world that must be materialized with men staying at home to see their women go and fetching water at the source, doing manly works such as farming, driving a boat, fishing to cite only these few, Eke is none of this. His work seems to be very simple and close to that of a woman. He even accepts to replace his wife in her field of work like fetching water and caring for Ayane, their daughter. Women around, throughout their gossips, seem to shout: 'this is not your work to Eke'. This mode of portrayal is generally that of other female writers' novels. According to Leonora Miano, what reduces male characters' sexual traits reside in their living in urban centres, because well-built, strong and authoritative male characters live in villages, enforced by their physical works. Amma Darko takes an opposite stance since she describes Efi's father as being in village where there is no work for men like him. Then, he occupies himself by drinking all the day long at the local gin place. This village/city opposition displays a sense of a topographic opposition. It is an opposition between two different spaces. Both represent the permanent clash between tradition and modernity in African literature, accusing each of what should be if there was no change. As a final point, representing a male character this way proves that some men can be marginal in a male-oriented society and their behaviour can tread down the social and cultural norms known by all.

Further, Amma Darko portrays more and more male characters in her fictional works to lay bare of her perspective to women's empowerment through literature. That is, the more she undermines or subverts her male characters' power, the more her female ones take over. The long-time marginalization of women in society makes all this happen in female writing. The female writers are taking revenge.

Therefore, in the third novel, *Faceless*, the feminist perspective is also emphasized because of the assertiveness of the female characters to the detriment of the male ones. All the male characters except the male journalist, a simple figurant, are irresponsible, violent and restless. The setting gives all the clues about the prevailing danger. Actually, the author sets the plot of *Faceless* in a suburb of Accra named Sodom and Gomorrah. The two cities evoke fear and denote a great level of sin, danger, insecurity and all sorts of sexual immoralities. By introducing the biblical historical 'Sodom and Gomorrah', Amma Darko wants to infer our attention on the prevailing confusion in African post-colonial cities due to its authorities' failure to take action and well-organised plans. The setting also denotes the permanent poverty and

dirtiness all around. We may think, for instant, that these kinds of settings are common to many African authors either male or female. This description is also applicable to John Maxwell⁶⁴⁵ Coetzee's second novel, *In the Heart of the Country* (1977) in which places like "Armoede" means poverty which reminds of the country's morbid place names like Verlatenheid (Desolation), Weenen (Weeping), Lydenburg (Town of Suffering), the list could be extended. But this reality effect is undercut by the all too perfect and all too allegorical match between the name and the scene or between the name and the deed.

Likewise, the male characters' names are so much venomous that they call to mind terror and cruelty prevailing in such society. Amma Darko also uses these male characters' names as a tool for her didactics. Like Christians fear the name of these two cities, Amma Darko wants us to have apprehension on these cities in her fiction. These cities can stand for any post-colonial cities in Africa. According to Ayodélé Allagbé (2016), Amma Darko wants:

to create a strong symbolic image therein. The image she creates here is that of a place where the people (male and female alike) therein are submitted to abject and rampant poverty expressed by such aspects as lack of basic social amenities, squalid environment, human suffering, joblessness.⁶⁴⁶

Amma Darko's discourse is expressed through the scenes and the characters (male and female) in the novel *Faceless* narrative which seems to be more seizing and more poignant as to calls for more attention and compassion than *The Housemaid*. The writer offers a story of a post-colonial society that has grown tragic and cruel for many reasons. On one hand, she depicts

⁶⁴⁵ John Maxwell J.M. Coetzee was born on 9th February, 1940. He is a South African novelist, essayist, linguist, translator and recipient of the 2003 Nobel Prize in Literature. His first published book was *Dusklands* (1974), and this was followed by several further novels including *In the Heart of the Country* (1977), winner of the Central News Agency (CNA) Literary Award and filmed as *Dust* in 1985; *Life & Times of Michael K* (1983) and *Disgrace* (1999), both winners of the Booker Prize for Fiction; and *Elizabeth Costello: Eight Lessons* (2003). More recent novels are *Slow Man* (2005) and *Diary of a Bad Year* (2007). J. M. Coetzee also writes non-fiction. *White Writing: On the Culture of Letters in South Africa* (1988) is a collection of essays on South African literature and culture, and *Doubling the Point: Essays and Interviews* (1992) is a collection of essays and interviews with David Attwell. His books *Boyhood: Scenes from Provincial Life* (1997); *Youth: Scenes from Provincial Life II* (2002); and *Summertime* (2009) form a trilogy of fictionalized memoirs. *Summertime* was shortlisted for the 2009 Man Booker Prize for Fiction and the Commonwealth Writers Prize (South East Asia and South Pacific region, Best Book) and the Australian Prime Minister's Literary Award. J. M. Coetzee is also a translator of Dutch and Afrikaans literature. He emigrated to Australia in 2002, where he has an honorary position at the University of Adelaide. He was awarded the Nobel Prize for Literature in 2003 and knighted in the Order of the Dutch Lion in 2010.

⁶⁴⁶ Allagbe, A. A. (2016). "Character Naming and Authorial Attitudes in Contemporary African Literature" in *Research on Humanities and Social Sciences*, Vol.6, No.4, p. 25.

a fictional place where most of the fathers lose control over their children or most children do not see their fathers as protectors and educators anymore. The welfare of these little pretty beings is no more their fathers' concern. On the other hand, individualism becomes more and more the rule and regulation in such remote villages. This destroys the core elements of human foundation. Like in the jungle where the male leopard, after mating with the female one, never returns to see its cubs' health state, fathers in *Faceless* are insensitive and stripped of compassion toward their wives and their children. The fast growing society transforms each father into zombie, the more they suck blood from their offspring, the more they grow demanding. This developing African society removes the essence of traditional society which lies in collectiveness, togetherness and sense of responsibility. Fathers fight for their own life ignoring the surrounding mass distress.

In the narrative, male characters like Adade ignore one of the fundamental needs of their children which is to create a permissive environment of discussion, confidence and protection. Adade, Kabria's hard working husband, cares for his offspring financially, but fails to do it emotionally, while Kwei fails the two completely in both. Adade is a selfish and egocentric husband who cares only for his external image through his well-paid job and his nice car leaving that of his wife always breaking down, Creamy. The author compares Creamy's unstable state with that of a human being. Kabria's car has undergone several surgeries and other mechanical mending that the scars are still visible on it. Amma Darko forces us to imagine how that hard working woman's car is. Unfortunately, it does not draw her husband generous attention. Through the male character, Amma Darko portrays an objective reality in society. A man who fails to care for his wife, the mother of his children, is worth criticism added to the fact that Adade is more focused on his own social achievement than of that of both. He is selfish and imbued of his personality and never asks to know his children's school realisation. In this scope, according to Mary Higgins, Adade epitomizes "the World Bank and IMF"⁶⁴⁷ lending to the underdeveloped countries the minimum which does allow them to free themselves. These underdeveloped countries are still owning and still crushing under the huge weight of loans and structural adjustments. Adade's concern is to come home, after having released his tension with his friends, to find food already cooked. It is worth noting that Adade's role is that regularly

⁶⁴⁷ Higgins, M. E. (2007). "Ngambika and Grassroots Fiction: Amma Darko's *The Housemaid* and *Faceless*" (Ed.) Vincent O. Odamtten, *Broadening the Horizon: Critical Introductions to Amma Darko*. UK/London: Ayebia Clarke Publishing, p. 68.

noticed in Akan society and by extension in any patriarchal society. Our point is that women do not need to be revered. They need to be treated as equal human beings because being together with a man is not an achievement, but a resolution coming from both side. Marriage is not a female life aspiration.

The patriarchal ideal is necessarily phallic and unperturbed. In this vein, Adade's behaviour takes its roots from the natural construction of a masculine identity. He does not interfere in any of the conversations between Kabria and their children within his household, as he thinks it is his wife's role to do that. He is always off all talk; therefore, he is off the detail of his offspring's reality. He is the man of the household, the bread winner. Being such a man, translates into making himself the dominant one in the household and so reducing his wife to subordinate status. In doing so, he gains more power to make unilateral decisions while everything is upside down. Adade builds himself into a powerful patriarch, having the exclusive right to keep silence at the right moment when his word is needed. He also has the excuse to return from office at an unearthly hour.

Additionally, by not attending to his wife's frequent worries, Adade indirectly coerces his wife into giving up work to become a stay-at-home wife. Similar imposition has been made by Kofi Ako to Anowa in Ama Ata Aidoo's *Anowa* as he exploits the slaves' labour to make money. Both male characters present some striking similitudes though. The manipulative and exploitative aspects in Kofi Ako can also be seen in Adade as he accepts to lend money to his wife like the World Bank does to low income countries. The money lent is immediately transformed into salaries for expatriates and for contracts for international companies. At the end of that financial operation, these low income countries become poorer and poorer, crutching under the weight of their elephant like debt. Adade is rightly indexed here. His obsession with social change is evident in his insistence to have his car anew and his cloths ironed. In that process, he has no compassion to see his wife as a housemaid, a driver, a cook, and to cap it all a mortgagor. In the same vein of male characterization, Amma Darko presents more and more wicked and of concrete heart male characters. The fact is that the author wants to demonstrate the traumatic outcome of neglect from genitors in society. The depiction of this male characters calls for compassion to all women in such a situation in the world. The male character Kwei epitomizes the failed father pushed forward and backward by several other ideas such as absurd superstitions and his mother's pressure.

Indeed, in the beginning, Kwei thinks that he has nothing to do with his wife's pregnancy and orders a quick abortion. As the woman is not complying, Kwei, the self-made gynaecologist, urges his friends of *akpeteshie* to call him 'Dr.' Kwei at Kill-Me-Quick, after a fierce altercation with his wife (Darko, 124). Kwei pounces, pounds, pounds and pounds the belly of his wife thinking that as much as he lays his rounded fists on the woman's belly, he will get the pregnancy aborted. Our accidental *Dr* falls into the cultural trap of superstition cooked by society. He thinks that he is in danger if he cares too much for his wife and children. In doing so, Kwei symbolises the male irresponsibility refusing to take part in the welfare of the family and by extension in the community's well-being. Thus, he drops down all his moral and financial duties toward his family and vanishes for a long period of time. He reappears very violent and with many bodily scars.

In fact, what makes potential Kwei's belief in superstition is the story he is told about Maa Tsuru's father who impregnates Maa Tsuru's mother and rejects it. Naa Yomo puts this way: "When Tsuru's mother picked seed with her, the young man responsible, that is Tsuru's father, denied the pregnancy. Worse still, he insisted he had never even seen Tsuru's mother ever in his life" (Darko, 92). The passage from the oldest woman of the family justifies how much irresponsible is Tsuru's father. The villain lies to his mother that he has never seen the girl before, an attitude not only selfish of him, but also immature. The denial to recognise the pregnancy leads then Maa Tsuru's mother, full of resentment, to spell the baby while his "shoulder burst through her and tore to shreds the lining of her womanhood" (Darko, 93). Amma Darko is able to penetrate the psyche of a wounded woman and display on a screen her mother to curse a man and all his belonging. The author displays the spiritual power a woman has to give life or to destroy it. She writes this to show the power of retaliation of a woman while feeling frustrated, debased and disappointed.

Additionally, the second aspect that determines Kwei's decision to flee from Maa Tsuru is the role his mother plays in the divulging of the superstition. Kwei's mother does not stop reminding her son that it is dangerous and hazardous for him to care for a cursed woman. Consequently, when we care for someone who is cursed, we have a huge probability to be cursed in return or to carry away the thousands of demons behind the spell. For the woman, behind every curse lies an evil spirit watching anyone who is about to help decipher the malediction. That argument is the reason why "Superstition found fertile ground" (Darko, 126)

in Kwei's mind and obliges him, though not wanting to, to disappear forever from Maa Tsuru's life. The social problem Amma Darko is referring to is the transmission of taboo and superstition in African society from generation to the next. Kwei runs away to save his life as quickly as the character Forrest Gump in the movie of the same name *Forrest Gump* (1944). In the movie, the major character takes off any time he is confronted with tough situations to which he has no quick answer or any time he is told to run off to save his life.

Mostly, it is the father's role to be in charge of his offspring's protection, education, and initiation. However, the narrator does not inform us of the existence of Kwei's father which is quite surprising. If we assume that Kwei's father also gets himself overwhelmed by a long-standing fallacy of his family or his wife's family, therefore the result is that he transmits unconsciously the gene of irresponsibility to his son, Kwei. Implicitly, it means that if a father is irresponsible, it is probable that his son becomes irresponsible by the same token. Such a possibility comes rightly true with Akobi and his father in Amma Darko's *Beyond the Horizon*. Akobi's father is an unscrupulous business man who makes profit from his mates' death in cholera outbreak. His son also decides to sell off his own wife's body to make money and get rich to achieve his selfish dream. Kwei's father is never present to care for Kwei and his mother. That is why the mother plays the role in replacement. There is no denying the fact the more Kwei stays with his mother, the more he attaches emotionally to her. Subsequently, the more Kwei leaves with his mother, the more he gets mentally intoxicated by the woman's fallacies. In that very scope, the psychoanalyst Sigmund Freud defines this trend as the Oedipus complex in 1910. Sigmund Freud explains the theory as a child unconscious desire for the opposite sex parent as a necessary stage of psychosexual development. Sigmund Freud's theory is backed up by Ernest Jones in *Hamlet and Oedipus* (1949). The question raises in Ernest Jones's work is whether:

Hamlet should want to kill his uncle or his mother, whose hurried remarriage hints at her guilt, a guilt akin to "incest" in the language of the time. If "incest" is a perversion shared by Gertrude and Hamlet, albeit with different meanings, then Hamlet's task may be different from the injunction issued by the ghost. Fundamentally, Hamlet has to be understood within the structure provided by Sophocles. Oedipus indeed kills his father and sleeps with his mother, while Hamlet dithers and postpones the revenge expected from him. His inhibition stems from his unconscious recognition that his uncle has accomplished before him what he most intensely desires: to kill his father and

marry his mother. This theory is posited as a cornerstone of psychoanalytical dogma and should escape any reproach of “psychologization” because of it derives from an unconscious structure.⁶⁴⁸

The Freudian interpretations lay bare the foundation of modern psycho-analysis since they help explain the inner desire of people. This is because “The Freudian psychology is the only systematic account of the human mind which, in point of subtlety and complexity, of interest and tragic power, deserves to stand beside the chaotic mass of psychological insights which literature has accumulated through the centuries”⁶⁴⁹. which, maybe deferred in Kwei, pushes him to blankly believe the allegations of his mother. Like Hamlet, Kwei is certainly preparing a tragedy, not in killing his father and sleeping with his mother, but another form tragedy. Maa Tsuru is the feminine side of Hamlet. Kwei can then be a mentally malformed child right from the start whose complete transformation happens when he has already taken on Maa Tsuru as wife. This leads him to permanently refer to his mother’s advice before performing any action in his own household. As his mother’s allegation becomes insisting, Kwei follows the maternal directive like a soldier on duty. Once more with Amma Darko, fathers are either absent when their presence is required and violent and brutish when they have to be soft and lovely. In Chinua Achebe’s *Things Fall Apart*, Okonkwo flees his father’s home to get initiated elsewhere. In that very case, it is because the father (Unuka) has nothing good to give to his son apart from his flute. Okonkwo’s father is known beyond the borders of their village. In this absence of Kwei’s father, his mother takes control of all.

In fact, this character is the reflected image of Akobi in *Beyond the Horizon* who never seeks to know about his two children left in Accra. They are also similar in the sense that they rebuke their respective wife of getting pregnant though it requires two (male and female sexual contact) to have a child. If Kwei is a woman barterer and highly superstitious because of his Oedipus complex, then Kpakpo and Onko are the most wanted violent and brutish male characters in the plot. At the head of this squad of risky male characters, we have Poison and Macho, the street’s lords.

⁶⁴⁸ Rabaté, J.-M. (2014). *The Cambridge Introduction to Literature and Psychoanalysis*, New York: Cambridge University Press, pp. 30-1.

⁶⁴⁹ Lodge, D. (1972). *20th Century Literary Criticism: A Reader*. London: Longman Group LTD, p. 276.

Like Kwei, Nii Kpakpo is worth all our criticism as being depicted as an unemployed and a scammer who lies to Maa Tsuru that he is getting ready to work with a big factory and by that way he needs just for a few time somewhere to rest his head until the hard period passes. This allows him to tread into the woman's life. Maa Tsuru also does not care about her being once bitten before by her first lover. She does not care about the proverb that cautions as "one bitten twice shy". Maa Tsuru's callous situation with Kwei does not serve her as a lesson. As soon as Kpakpo steps in the house and gains his lover's attention and confidence, he attempts to rape the older of the woman's children, Baby T, but he retracts himself. The narrator tells the scene this way, Kpakpo "tiptoed over to Baby T and tapped her on the shoulder, Baby T sprang up [...]. Kpakpo stripped naked in frenzy, filled with an urgency so wrong by Baby T's nakedness. [...] He didn't do it. Her voice sounded like coming from outside of her" (Darko, 133-34). Then after that failed operation, he orders Maa Tsuru to sack all her children as the only condition for him to become her full sex provider. Additionally, to this condition, all night long, their love making pantings discomfort the little beings who decide to leave before it grows worst. Unfortunately, later while confronted with the accusation, the rogue claims that it was Baby T who first started tempting him. In any case, Kpakpo, the unsuccessful paedophile, takes revenge by conspiring with two women (Maami Broni and Mama Abidjan), all former prostitutes and female pimps to carry away Baby T for more training. The materialistic mind of Kpakpo is then at work. He earns much money out of the little girl's prostitution. Baby T's prostitution justifies the miracle of the chop money Kpakpo starts providing. When discovered, he quickly lays off his presence with Maa Tsuru's and like Kwei, he unceremoniously vanishes in the air leaving the woman with more worries and with two more mouths to feed. A man who is just interested in feeding off the sweat of his stepdaughters deserves a long stay in jail like Akobi gets indicted for life penitence verdict. Amma Darko portrays this male character to demonstrate how generally men see women as available sex object and useless commodity after satisfying their selfish pleasure. The narrative unfolds a family tragedy from the start to the end.

What makes more sense to illustrate as tragic is the attitude of Onko toward the family that calls him uncle. This means that the male character Onko is probably from the little girls' father family. This means that he is a close member or relative of the family. That fact that Onko hails from their father's family calls for two aspects. The first is the reliance all the girls have toward this man and the second is less interesting. Onko may be Kwei's junior brother. Then, he has the same blood constituent as Kwei. But Kwei is disrespectful to women and superstitious,

so is Onko. As the narrative unfolds Onko, that sexual predator sneaks, stalks and succeeds in defiling the little Baby T, a girl around twelve years old at the time. The narrator corroborates it this way: “Onko, [...] Mother, Baby T muttered once more, It was Onko” (Darko, 137). The defiler thinks that his forfeiture can be veiled if he buys the girl’s mother silence and forces her to drop the matter and spare him all the trouble around. Then, he proceeds in bribing the woman, an already defeated, pitiable and broke woman of six children. In such a condition, no one can put in front his morality and refuse the thick wad of money. Of course, Maa Tsuru quickly accepts. As if not satisfied, Onko leagues up with Poison, the dangerous street lord to have Baby T as his personal prostitute, where to put his bad harvest and defiling penis. The negotiation fails and Baby T gets her head smashed like the melon fruit. Baby T’s murder sounds as parental neglect supreme act in patriarchal society which has no eyes and no attention for female descendants. Moreover, her assassination sounds like the defeat of mildness and compassion in society.

As a result, a patriarchal society grows with no time for weak and innocent people. Jungle-like, it grows modernized, globalized and urbanized with less moral and humane characteristics. In such society, people do not complain when they notice a cracked body behind their house. For example, in *Faceless*, the kiosk owner does not complain to police station after discovering an unanimated body. They find it normal and ordinary and perhaps because the owner fears punishment from street-lords. Hence, while Baby T’s death does not represent a great loss to society, it also means less to national police. Her loss illustrates the younger generation’s life being brutally switched day in, day out without society’s feeling concerned. Mercilessly, patriarchal society grows wild, ready to devour any soul at loss in the street. The author describes objectively what happens to street children to raise our kindness and compassion towards these pretty beings. Amma Darko succeeds in painting objectively the situation as she works as tax collector whose office is just next to the capital Centre’s big market where she can have a broadened view. Thus, she knows by experience how statistics are highly managed in this field to find out the lower and the higher tendency of development index and also where social issues rise from. These issues run unnoticed in contemporary society because national authorities leave their eyes closed on them. The same agonizing society has been depicted in George Orwell’s *Animal Farm* (1945) where the more violent people become, the more they assure their lives in society. Grievances are frequent and irremediably the weapon of the stronger. Weak people are switched off to give place to the stronger and pitiless character.

The British author George Orwell describes a society deprived of humanity where hit-and-run climax reigns permanently. The only respected people are those able to fight, to bite and to kill. Then, if someone sees his mate dead, he does not complain, rather he waits his turn to be killed or kill before the rival come at door. Mercilessly, patriarchal society grows wild and risky.

Henceforth, following this development, it is worth re-mentioning that Amma Darko works as tax collector whose office is just next to the capital centre's big market, yet her "independent nature has helped her cope. She credits no one particular person with helping her on her way, nor has any writer given her writing advice"⁶⁵⁰. Further, during an interview, Amma Darko explains: "I write little things, and when I finally decide on a story line, there're there. As I am writing a story, I also collect ideas"⁶⁵¹. Therefore, we see how the author collects ideas the way she collects tax in her office. It comes freely and fluently. Thus, she knows by experience how statistics are rightly managed in this field to find out the lower and the higher tendency of development index. Upside becomes the place and the place is unnoticed in such society since national authorities consent unconsciously that people tricky morality takes over with their guns (penises). Awkwardly, pretty little beings that should normally be protected from predators are left outdoor in merciless hands and no government finds prior to seek solutions to the heart-breaking situation. With that trend, people will live to bury their daughters. Like Kpakpo, Onko is a sexual predator, a dangerous man and worth to be sacked out of community. However, more than Akobi, Amma Darko thinks that Onko does not deserve prison. As a result, he ends up his life by committing suicide.

In many African societies, death by suicide is the utmost shameful death since people think the perpetrator rests eternally in damnation with demons. Consequently, Onko deserves to be in hell according to the oldest woman of the family, Naa Yomo. The suggestion of Naa Yomo is in the same line of thought with Jacques Lacan who reconciles with Sigmund Freud's Oedipus complex theory, but who suggests a more radical way to terminate with male phallus violence. Jacques Lacan proposes "a castration to resolve the Oedipus complex"⁶⁵². Jacques Lacan views then literature and psychoanalysis as two fields forced to walk side by side. So far,

⁶⁵⁰ Odamtten, V. (2007). "Beyond the Comfort Zone: Relations between African Writers and Audience" (Ed.) Vincent O. Odamtten, *Broadening the Horizon: Critical Introductions to Amma Darko*. UK/London: Ayeibia Clarke Publishing, Print., p. 17.

⁶⁵¹ Idem, p. 16.

⁶⁵² Rabaté, J.-M. (2014). *The Cambridge Introduction to Literature and Psychoanalysis*, New York: Cambridge University Press, p. 44.

some writers then use “psychopathological characters” on (their) stage to depict the extent to which society goes astray. These characters all “suffer from universal affliction, because all of us have supposedly been determined on way or the other, by the Oedipal predicament”⁶⁵³. As being brought up in a patriarchal society, Onko and then Poison are at loss because of their complex. They deserve to be castrated and it is this form of castration that the author suggested by making Onko completely disappeared through the most humiliating death. As far as Poison is concerned, the author proposes another method to deal with him.

Before the active principle of his toxicity can start functioning to his loss, the left-handed Poison was a shy boy, a very soft spoken, but covered with scars. The scars that cover his skinny body are tributary to the extreme brutality of his stepfather which transformed him into a dangerous and venomous boy. Our question could be why does his stepfather always beat him, since the narrator does not mention a sequence of his wrongdoing? We have an answer from the psychoanalyst Sigmund Freud who submits this:

Freud shows that the fantasy can be decomposed into three successive stages. There is first the figure of the child who fantasizes about possessing the father’s exclusive love. The child’s fantasy is that the father beats another child who is hated by the subject. In this figure, the father beats the rival of the child, which generates pleasure because it confirms the incestuous father-child link. In the second figure, the subject is in the position of the beaten child, which corresponds to a masochistic enjoyment of the humiliation felt. In the third figure, the father is replaced with any authority figure, and the beaten child is an anonymous and male third party. In this sadistic variation, the subject is sexually excited by the vision of a child or children being beaten. The last fantasy is more autoerotic, a conscious daydream.⁶⁵⁴

Poison’s case is that of the third figure where his stepfather enjoys beating a shy and reclusive child to satisfy his masochistic and Machiavellian sexual fantasies. For that reason, Poison’s stepfather beats him for a masturbatory purpose. This justifies the consistency and the regularity in the boy’s beating. What counts is the satisfaction which comes out of the beating since the narrator does not mention the cause of the permanent beatings. This is an onset of male perversion depicted by Amma Darko. The female writer does not go further in detail, which is included in her technique. She uses freely synecdoche, a technique of writing which functions in

⁶⁵³ Ibid., p. 46.

⁶⁵⁴ Rabaté, J.-M. (2004). *The Cambridge Introduction to Literature and Psychoanalysis*, New York, NY, USA, Cambridge University Press, pp. 57-8.

a way that parts are made as a whole. Briefly, synecdoche or allegory is a metaphor that usually teaches a lesson. The technique is used to comment on some aspects of society in effort to change, accept or criticize it. For example, William Golding's *Lord of The Flies* is an allegory which criticizes civilization's conflict and Ngũgĩ wa Thiong'o's *River Between* condemns the Christian missionaries' deviation of in the former British colony of Kenya, the unchanging land of Kikuyu. The narrative shows how religion which should be used as an entity of freedom serves to brain wash African people. Religion serves to dispossess Kikuyu's fertile land and mind. It enslaves Kikuyu as well as Cameroun people in Ferdinand Oyono's *Houseboy* (1966). The novel insightfully depicts life of colonized people in their own homeland having to word to place to defend themselves before white settlers who think that black people have no feelings and no soul. At the same time and providentially only one of them, Father Vandermeier, proves to be Toundi's benefactor, but he meets an untimely death through a road accident and the protagonist becomes alone having nowhere to go. Toundi cannot go back home as he flees his father's blows to come to the white missionary. While with the missionary, the rural African boy encounters a white world that gives no chance for Africans in colonial Cameroon.

In *Faceless*, what is written about Poison's stepfather draws our attention to his psychology. The man is deep rooted in sexual perversion and mental instability. As a matter of fact, beating is just a subterfuge of his. He beats the poor and reclusive boy to make his own transition into a full satisfied sexual predator. Significantly, the stepfather disguises his homosexual as well as his masochistic tendencies, as he knows the crackdown homosexuals are confronted with in African societies' intolerance. He hides himself to commit the forfeiture on the boy. In that sense, Sigmund Freud offered some insightful observations and necessary principles which modern theories in psychology and therapies continue to develop though they seem to be very ambivalent today.

On the one hand, to illustrate homosexuality in society, in Sigmund Freud's "Anonymous Letter to an American Mother" in 1935, the psychoanalyst defends that "homosexuality is nothing to be ashamed of, no vice, no degradation, it cannot be classified as an illness: we consider it to be a variation of the sexual function produced by a certain arrest of sexual development"⁶⁵⁵. Then he assured the mother to whom he answered that "Many highly

⁶⁵⁵ Freud, S. (1922). Anonymous (Letter to an American mother). In E. Freud (Ed.), London: Hogarth Press, 1960, pp. 423-424.

respectable individuals of ancient and modern times have been homosexuals, several of the greatest men among them. So it is not a social deviancy or behaviour to be afraid of. On the other hand, Sigmund Freud's controversial explanation for homosexuality is that "the attachments formed with parental objects in early childhood shape adulthood expressions of sexuality and that homosexuality is the result of an abnormal pattern of attachment to the parental objects"⁶⁵⁶. The group of words 'abnormal pattern' draws our attention to the fact that Sigmund Freud is indicating homosexuality as pathology, an abnormality, a sickness. Sigmund Freud's second explanation about homosexuality may lie in the fact that human natural reproductive process consists of a human male injecting seminal fluid discharged from his penis into the vagina of a human female. This leads to fertilization of the eggs within the womb of the female and eventual birth of a human child. This natural reproductive process of the human species determines the psychological and physiological characteristics of men and women. All this is accompanied by strong emotions of attraction to the opposite sex, love, desire to possess or to belong, envy, jealousy, protectiveness. Often people find it difficult to resist or control these feelings. So what is homosexuality? It is an attitude in the course of which a person satisfies his sexual instincts and emotions by interacting with another person of the same sex, there lies the abnormality Sigmund Freud was referring to. In fact, the anal passage is meant for discharge of the human faeces after products digestion, not for childbirth and a finger or tongue cannot make a woman pregnant. Then homosexuality is a behaviour not a physiological characteristic and some psychoanalysts maintain that it is an abnormal behaviour of normal people.

In that sense, the complex the man feels leading him to hide his sexual inclination impacts his mood toward the little boy. The question the behaviour raises is what it may be if Poison were a little girl? The first and immediate answer is that the stepfather's action is similar with that of Nii Kpakpo towards the poor and innocent Baby T. Poison's stepfather may change into a paedophile, which is also a sexual deviation. Our point of view may not be shared by others, but we are talking of African society which cannot stand any other plight. Taking this into account, we realize that the stepfather (a paedophile) will fall in an intricate web of sexual and incestuous depravity. He will try to rape or will succeed in raping the young girl, Baby T and many others if given to the occasion. Further, in post-colonial settings, sexual desires refer

⁶⁵⁶ Freud, S. (1922). Anonymous (Letter to an American mother). In E. Freud (Ed.), London: Hogarth Press, 1960, pp. 423-424.

commonly to biased relationship between men on power and subjugated women. Therefore, Baby T being crushed under prostitution's yoke or under sexual servitude is just a reflected image of a national issue which puts an end to destitute people's dream to be free. Then, women who resort to their body as a site of commercial exchange force understand the various subjectivities in the postcolonial space.

The character's specificity shows that the stepfather setups Poison's mind to that of a merciless masochistic. It lays out the way Poison behaves afterward. This perversion engenders the rebirth of another perversion. That is the reason why other street boys call him Poison 'lord'. This nickname is attributed to him because of his bloodiness. He matures in an environment where the only subject which he is taught is violence and bitterness. He then projects this entire wrath onto his potential victims. The unnamed stepfather transforms the little shy boy into a poisonous portion and at no time does Poison plead for mercy. Poison passes successfully the rite of passage by proving his manliness. When referring to manliness, it is worth noting that danger overcoming is one of the African rites of passage which qualify a boy to maturity. For example, boys of Poison's age group are separated from their families and taken to a secluded area on the outskirts of the village under watchful eyes of a wise man. They undergo a sustained period of formal instructions and then are sent away with a firm recommendation that they should bring back home dead bodies of wild animals to prove their braveness. At the end, a celebration marks their passage to adulthood. A similar rite occurs unfortunately with Poison. He holds out against the whips of his stepfather. Poison becomes mature, but rather in wicked deeds and misconducts. In actual fact, the evocation of the chemical substance inspires fear and fright which is the same with the evocation of the boy's name in the street. In line with this we have:

[He] landed in bad company on the streets the moment he landed there. Within days, he had mattered in car tape-deck thefts. The more he stole, and got away with, the more confident he became. [....]. By age fifteen, Poison had mattered the intricacies of pimping enough to have a go at it on his own. He had no problem at all forming his gang. He had made a mark and a name on the streets already. (Darko, 169)

In his realm of pimp, the more brutal the pimp, the more respected and revered he is by his prostitutes and the surrounding challengers. Some prostitutes choose to work under a pimp who had a history of murderer or prisoner, a merciless supervisor who can beat to death a

prostitute who becomes unmindful to his strict instructions. Poison is able of doing all that. The depiction of that male character raises two issues. The first is how to take care of children and the second is how children strive to succeed in society, but fail for lack of moral support. The more children are taken care of without any physical or verbal violence, the more they get well-educated and become good for society. Poison fails to become a good man because he met previously on his way a wicked and unstable man, his stepfather. If Poison flees from home like Okonkwo does, it is to become the opposite version of his stepfather. Then, the same way Okonkwo runs out of Unuka's home to become a renown wrestler, a good warrior and successful farmer, Poison flees because his stepfather also fails to play at least a single of the five functions of a father as directed by Yvon Dallaire. The Canadian psychologist, Yvon Dallaire classifies the five functions of a father this way: protection, education, initiation, separation and affiliation. Like Kwei and Kpakpo, Poison's stepfather fails to get straight with his duty of father. In beating frequently the young and shy boy, he succeeds in destroying the slice of humanity in creation in him. The stepfather sets in motion in him the hidden chemical and toxic active principles. Then, the wary boy becomes a social bomb. He becomes a pitiless street lord because no one gives him chance to be good even society where he lives. Abused young males, in particular, are also more disposed to become abusers themselves. As if this was a spell, Poison becomes successfully a complete abuser.

The beginning of the novel *Faceless* demonstrates widely Poison's inclination to rape and sexual abuse. He knows that he lives in Sodom and Gomorrah, a township and a place of a dreadful and sinful reputation, so he never goes out without his self-reliant weapon which is his penis. Poison uses his penis (genital power) as a tool to control his harem and the surrounding's women. Therein, just like a gun that assures to his carrier a kind of mental reliance, Poison's penis functions the same way. The narrator confides this:

She felt the light pressure on her breast under the weight of a pair of hands that were definitely not the Lord's. [...]

She felt squeeze [...].

She opened her eyes slightly.

She opened her eyes a little. It was a man. [...]. She stiffened, closed her eyes again and remained still. Instinct guided. Her heart pounded violently, threatening to explode inside her chest. [...]

A man who used to be the leader of the bullies like Macho now was. [...]. Fofu let out a cry and began to kick her hands and legs wildly in the air. [...].

Poison successfully captured her legs between his kneeling thighs. You want to live?
[...]
Poison grinned like the devil himself. [...]
Poison pushed up her dress and scowled at the sight of her underpants.
Poison muttered an obscenity.
Poison unbuckled his belt.
Poison was swaying above her. (Darko, 3-4, italics mine)

On the one hand, the excerpt demonstrates how insisting the narrator about Poison's wickedness toward the other street survivors is. As a lord in real, he imposes his law upon his vassals and in his surroundings. He beats and tortures those who resist and rapes those he wants. His menu of terror is diverse in relation with his anger and eager to harm his opponents whether female or male. The menu ranges from squeezing the victims, strangling and threatening to kill them. The repetition of the noun 'poison' (six times) is intentionally made. The narrator wants to make it clear that it is the most harmful chemical substance and the street boy all together in one person she is referring to. As a dangerous chemical substance, poison has attracted many chemical studies and is integrated in many literatures. Poison is a "natural or synthetic substance that causes damage to living tissues and has an injurious or fatal effect on the body, whether it is ingested, inhaled, or absorbed or injected through the skin"⁶⁵⁷. In this sense, the character Poison carves right from the start an identity to set his noxiousness up on the street. He is a king, a landlord and a king is revered, feared because of his capacity of nuisance and worshipped likewise. Like a dictator, he rules and cannot stand any opposition. Then, poisoning involves the substance, the poisoned organism, the injury of cells and the symptoms and signs or death. Apart from the poison which stands for the character himself, the other three elements are present in the surrounding of Poison. To assert his worth, masculine force and authority, Poison proves to his rivals (male and female) that he is the lord of that corner of the street and that he is ready to defend his properties tooth and nail. He is also ready to terminate any resisting opponents. He proves that he is the evil they should avoid and the poison they should not drink. For example, when the female character Baby T is exposed to the toxic chemical's wrath, the result is known by all the other streets dwellers: smashed head. Wrath and violence disrupt the girl's structure and function. The toxicity is so severe that Baby T dies just few minutes after.

⁶⁵⁷ Toxiological Chemistry (2009) Universitatis Medicinalis Leopoliens Sigillum, p. 3.

Violence is what Poison knows the best as he has been opposed to it since his childhood. Like a warrior then, Poison wages attacks especially against his rivals and women to subjugate respectively as vassals and prostitutes. This is because men in a patriarchal system affirm their power over their peers and their women. These men speak violently to women in order to get them influenced. We think that more than the means itself, Poison's ability to display that authoritative violence and that hatred towards women deserves our recognition and all that reminds us of his stepfather is fought. Poison does not accept weak people in his surroundings because his stepfather is a weak and a defeated person. Therefore, Poison struggles to maintain himself atop, but finally he is also defeated by some women's joint hand working. The women of MUTE mute his strength and reduce his wrath. His annihilation comes quickly after that. Poison, a young man who fights his way through to the top of his business falls down like a stone on the ground because of his constant and permanent failure to respect his society's norms and values. Poison is a man to be put aside like Akobi and his mates.

On the other hand, rape stands for the violation of an intimate territory or identity. Some African female writers are the recipients of roots and collective memory as they insightfully play their role in the construction of national identity. So, in a context where all bodies are believed to be socially constructed to accept change, one wonders to what extent male bodies can be subverted in a female text. However, many radical feminists maintain in their writings that national lands in African belief are more likely to be related to women's bodies than those of men. It is women's bodies that receive seeds, conceive them and bring them to life. In that process, male bodies do nothing more than to release the seed (the semen). They have no more role other than to fecund the already fertile wombs (lands). Among these female writers, Buchi Emecheta writes about rape as the violation of national borders of a fictional village named Shavi. In *The Rape of Shavi* (1985), the female writer shows how rape can be organized in order to deprive a whole community of its integrity and dignity. Shavi's borders become widely opened to Western alienation as soon as the Western settlers set foot in the village. With that arrival, Shavi (female entity) ceases to be respected and her children start to be enslaved by the white settlers. As a matter of fact, if we assume that a woman's body stands for a whole territory, therefore the narrative in *Faceless* showing Poison attempting to rape Fofu means that the toxic boy is about to disrupt the intimate border of the little street girl. If Poison succeeds in raping Fofu, then she will be enslaved forever. In that sort of awful desire, Jacques Lacan is in debt to Sigmund Freud's analysis of sadism and masochism. Jacques Lacan deals with the desire as a

concept called “the cruelty of the superego”⁶⁵⁸ which Sigmund Freud developed in 1924 in “The Economic Problem of Masochism”. This is the genesis Sigmund Freud states:

This super-ego is in fact just as much a representative of the id as of the outer world. It originated through the introjection into the ego of the first objects of the libidinal impulses in the id. namely, the two parents, by which process the relation to them was desexualized, that is underwent a deflection from direct sexual aims. Only in this way was it possible for the child to overcome the Oedipus-complex. Now the super-ego has retained essential features of the introjected persons, namely their power, their severity, their tendency to watch over and to punish.... The super-ego, the conscience at work in it, can then become harsh, cruel and inexorable against the ego which is in its charge.⁶⁵⁹

The portrayal of Poison in the end must draw our compassion because of his history in violence. Like a child engaged at warfront, Poison grows up in violence and develops a resistance which drags him to violence although not destined to. As a matter of fact, the reader notices that Poison regrets all that intricate end of Baby T, his loveliest and overpriced prostitute. In the field of violence, Poison’s life story is like that of the male protagonist in Ken[ule] Saro-Wiwa’s *Sozaboy* (1985). Ken⁶⁶⁰ Saro-Wiwa’s novel connects the reader with the intimacy of civil war horror and mercilessness. *Sozaboy* is developed in the Nigerian Pidgin English (commonly spoken Nigerian English), but intensely depicts the inconsistencies and confusions of war. Mene, the protagonist looks confused and frightened while at warfront. The narrator unveils: “And I know say my life don begin spoil small small. Before dis time, I no know wetin to die mean. All my life just sweet dreams. Now today today, I don see say life no be as I dey see am before. I know say wickedness plenty. And I know say my life must change one time”⁶⁶¹.

As a matter of fact, while assigning that sort of role to her male character into her literary scene, Amma Darko wants to create a binary opposition of master and slave relationship which her writing describes most of the time. It seems definitely that the presentation of the population

⁶⁵⁸ Rabaté, J.-M. (2004). *The Cambridge Introduction to Literature and Psychoanalysis*. New York: NY, USA, Cambridge University Press, p. 184.

⁶⁵⁹ Freud, S. (1924). “*The Economic Problem in Masochism*,” New York, NY, USA, Cambridge University Press, pp. 197-198.

⁶⁶⁰ Kenule Saro-Wiwa was a Nigerian environmental and political activist. He was a writer of satirical novels, civil rights activist born in October 10, 1941. His death was ordered by multinationals which ravage his home country’s ground resource like oil, but give nothing in return to help solve water issues in the surrounding areas. His assassination was led by General Sani Abacha’s military regime in November 10, 1995.

⁶⁶¹ Saro-Wiwa, K. (1985). *Sozaboy*. Nigeria: Saros International Publishers, pp. 111-12.

in *Faceless* is so shaped: master/slave and unfortunately some stay slave at the end of the story. Referring to war, its aggressiveness and its main purpose of subjugating other people, Frantz Fanon writes in his second book *The Wretched of the Earth* (1961) that: “Individualism is the first to disappear [...]. Henceforward, the interests of one will be the interests of all, for in concrete fact everyone will be massacred – or everyone will be saved”.⁶⁶² Poison as well as Mene live the same ‘*now today today*’ life, having nothing to fear and nothing to lose, for it needs little skill in psychology to be sure that both of them are highly gifted, had society tried to handle them their turn. Both would be good men in their respective society. That, more or less, is how the story would run. Instead, in *Sozaboy*, Mene says he does not know what death is; Poison does not know what parental love is. Each of them loses their childhood because of adult’s long-lasting violence over them. Then they lose track of themselves and grow up on the wrong side of the tracks. This is reinforced by the image many African societies have on male children’s social construction. These societies expect male children to be strong physically and mentally before being granted the stature of men. With their little age, they are considered full grown-ups who have voice preponderance over women if the family has only them. In that regard, Mene and Poison are generally constructed to lead without necessarily having that strong mental capability.

Extending the idea, we see that Poison is indicted of murdering Baby T though claiming at first his innocence. Amma Darko echoes throughout the narrative that those who benefit from the prostitution of other people have to pay the highest price of their life. Either they stop before it explodes or they accept the final solution of the law of justice. That law according to Amma Darko’s writing can be led by an NGO. While Poison stayed with his stepfather’s in a two by four room which he has to share with five of his siblings, his mother and the man, he is not given the opportunity to go to school in order to get educated. The room is like a prison where Poison, the shy boy gets bored. The permanent boring makes him feel like he does not belong to there. Then his sole feeling is to flee from the hell like home to where he gets security. The narrator does not give the reader any emphasis about Poison’s stepfather school level. He is an illiterate who makes his children likewise. He is presented as violent and brutish. Had Poison gone to school, he would not have landed in bad company or rather the percentage of his landing there will decrease. This also raises the financial status of the stepfather though as Ms Kamame

⁶⁶² Fanon, F. (1963). *The Wretched of the Earth*. New York: Grove Press, Print, p. 47.

places that there are some poor parents who do not dump their children onto the streets and further do their best for their education. Poison's stepfather misses to do that. Amma Darko reiterates her position of parental responsibility over children and parental neglect. Nothing can justify parental neglect, not even poverty because children do not choose to be born in a family that has nothing to give them.

Amma Darko like a psychologist with the proficiency of a social worker diagnoses the evil of modern and globalised African society. In that globalised society, the question of secured family seems forgotten or put asunder. There is no more the feeling of belonging to an extended family since modern individualism brainwashes people. Globalisation isolates each family and deters the meaning of it. Several dislocated families live clumsily to survive in harsh conditions. However, what seems rather astonishing, it is that none of these families in difficulties want to move from the claims and the tyrannies of these fast growing cities. As a matter of fact, several writers have proposed that colonialism and neo-colonialism and their accompanying poverty and powerlessness, have prevented men from exercising their role as providers for women and children in their extended families. Moreover, rapid urbanisation leads the village people to believe that urban places are where they should come for greener pasture. They move from their ordinary places to urban centres for menial jobs. It poses also the issue of family migration to cities which leads to slums and while not well managed, it induces highway robbery, prostitution and promiscuity, a phenomenon of street children. These are the modern unsolved problems of big cities in Ghana and African post-colonial countries. This evokes once again the significant and relevant work by Frantz Fanon about *wretched* conditions of African people. While African people expected to be free and have the opportunity to use their ground resources after the bitter and sad periods of the Trans-Atlantic Trade, colonial period that depopulated the continent, they are now enslaved by their own African leaders on the continent. The political leaders are not truly interested in the welfare of their people. The situation makes double wreck condition of Africans.

As a result, they squandered their national resources maintaining themselves in power and eliminating their real and imagined enemies. It results in that social and economic desolation in cities as well as in villages. Parents like the stepfather of Poison have to capitulate under the weight of that permanent misery as conditions get harder and harder for them. The professional Ms Kamame puts it rightly that "if you are carrying a load and you begin to feel the

first cracks of tension in the neck, what thought comes to your mind? Unload” (Darko, 109). That is what happens with Poison’s stepfather in that two by four room with Poison’s mother, Poison and five of his siblings. The picture seems to be that of common families in Africa. Children should not be perceived as load, but rather taken as joy. However, when the number produced also becomes a hindrance, families overwhelmed by poverty can decide to unload as they feel the crack in their neck. These children do not ask to come to life, yet have to pay the highest price.

If Amma Darko writes about these social plights, it is because they are prevailing and happening at the present time. Gervase Angsotinge quotes in her critical article some of Amma Darko’s words during an interview Ellie Higgins. She states: “I should think that if a country is going through a crisis, and people are writing around that time, they will be drawn to writing stories that would deal with those crises...”⁶⁶³. These plights are right now prevailing in almost all African large cities as contemporary and unanswered issues. Amma Darko has opted for an approach which pinpoints the distortions in post-colonial Ghana and suggests the remedies. The suggestions she makes introduce positive and peaceful ways to improve the current situation and trigger a social reconstruction. Her works are impregnated with a touch of realism. The plots, the characters, the language (Ghanaian words and Ghanaian English), the settings in a straight line refers to the Ghanaian society and people. Amma Darko faithfully reproduces Ghana’s reality using her creative skills to add more literary value to her works.

The sentiment of writing on and against the edge of African women leads the writer to sign that specific narrative technique. Taking into account bell hooks and Edward Said points of view about marginality, Amma Darko fully refers to women’s varied forms of burdens inferred by patriarchy, colonialism and Transatlantic Slave Trade. In actual fact, the broadness of Edward Said’s approach to literature eludes easily the categorisation since identity and its construction are the concern of Said. That is why we need literature to be aware of the impact of our inner fantasy on our lives. In fact, literature creates fictional heroes with whom we can identify or not. We can identify all the more with the figure of the hero because, despite all the dangers braved, nothing can happen to the hero. When the hero overcomes all the dangers, he satisfies the fantasies of the reader.

⁶⁶³ Angsotinge, G.; Dako, K., Denkabe, A. & Yitah, H. (2007). “Exploitation, Negligence and Violence: Gendered Interrelationships in Amma Darko’s Novels” (Ed.) Vincent O. Odamtten, *Broadening the Horizon: Critical Introductions to Amma Darko*. UK/London: Ayeobia Clarke Publishing, Print., p. 80-1.

A noteworthy framing device is that all Amma Darko's male characters in *Faceless* are at loss. They either prey on the young female characters to dispossess them after having controlled Sodom and Gomorrah, the most devastated environment. An abusive and scammer like Kpakpo has to cope with brutal and vicious parasites and poisonous like Poison and Macho to succeed in exploiting and murdering an innocent girl like Baby T. In *Faceless*, the male characters are no longer at ease as their strategy is uncovered. They are the cause of the female characters' tragedy at all expenses. Some have to wait for the verdict and other have to be denounced by media. In that mess, Amma Darko has the merit to portray a last category of male characters that embody Sylv Po, the GMG producer at Harvest FM, a correct male character who helps MUTE's female workers conduct the investigation from the beginning to the end. Sylv Po is muted as soon as he helps MUTE to find out its investigation. Despite his professionalism, his actions toward the woman and the girl causes in the novel are shadowed by those of MUTE. His energy and participation remind us of the crucial role of the private German detective Gerhardt in *Beyond the Horizon* who helps Mara have the real information on the double life of Akobi or Cobby comforting himself with Comfort with money earned by Mara's prostitution. That information drags Cobby directly into jail and Comfort to being deported. The detective Gerhardt tackles perfectly and professionally Mara's investigation. Gerhardt's depiction demonstrates that not all men identify themselves to John Wayne in *Angel and the Bad Guy* (1947).

The portrayal of male characters in *Not Without Flowers* illustrates several of the most salient models of African masculinities that inform later representations by other Ghanaian female writers. Being a man in a patriarchal society is defined by a cluster of traits such as violence, control, strength to name a few. These ordinary traits secure the male supremacy as illustrated in *Things Fall Apart* (1958). Okonkwo is a big man, rich, a good wrestler, a hard worker and a polygamous. In a wrestling match he has earned the nickname of Amalinze the Cat for his physical prowess and then gains his second wife. He is the antipode of his father Unuka *agbala*. He particularly dislikes the effeminates living in his dear Umuofia. The physical representation of a man is central to his identity. Okonkwo appears strong and feline. These physical characteristics do not transpire in African female writings. When they appear, it is most of the time to the detriment of the characters. The masculine identities are in total transformation, whereas older expressions of African manhood are combatted by female writers. If one does not pay attention while reading *Not Without Flowers*, much focus will be on the

female protagonist and little devoted to exploring the life of the male characters. Amma Darko succeeds in impressing upon the reader the symbiotic nature of the relationship femininity and masculinity and womanhood and manhood, femaleness and maleness. From Amma Darko's point of view, male characters are depicted in a dual role: either they are exploiters or exploited, irresponsible or responsible husbands, fathers and men in society. In the narrative, male characters such as Pesewa, Pa, Idan and Dam are unified by the same sexual fantasies and the same failure.

Pesewa is described as a successful farmer who made money very luckily. It is then his new status of rich man that drags him into polygamy. He is a self-disciplined in his principle of polygamy. Any woman that pleases him is married off purely and simply. The narrator confides "They were all taboo to Pesewa; lovers, girlfriends, chicken-soups, concubines. If he wanted a woman, he simply made her his wife" (Darko, 57). Pesewa is selfish and imbued of his personality and his wealth taking all women as goods to purchase. He is the typical of men who drastically change their behaviour when they get their social status changed, for he has assured his first wife that he would not take on any other woman except to live, to grow old and to die by her side. Then as soon as he has plenty of money, he makes up his mind and takes on four others. The first four live in his mansion near Tantra Hill and the fifth, the favourite with special treatment, lives in a "rented and furnished at Sakumono" (Darko, 64) before he can finish her own house at Taifa. The narrator says that Pesewa well treats all his wives, a statement which is not completely verified since the first wife feels so desperate that she confides herself to God worship and forgets about her being forsaken. The second is so much unsatisfied, despite her big and well-stocked shop, that she makes up her mind and starts giving herself to a young and more available to feel alive and sexually cared for. What Pesewa assures is his domination over his wives through his sporadic conjugal visits in the respective bed of his female slaves. Pesewa proves himself a man among men capable of affording all these women in his mansion (harem, slaves vacuum) and even outside the vacuum. He is a slave master just like Okonkwo is in Chinua Achebe's *Things Fall Apart*. He draws a line between his physical pride of having all these women and his heartfelt love. Pesewa acts like an imperialist in his decision to conquer and dominate. Hence, the experiences of his wives are similar to those of colonized subjects. Any subject who accepts to come along with Pesewa is put in prison, the mansion of Pesewa. A mansion here must be compared to a prison with tall block of walls from where no slaves (the wives) could escape. The only difference is that Pesewa does not have her wives work for him

like a foreman can do in sugar canes plantations. They reside in the mansion mainly for a reproduction purpose and for Pesewa's masculine prestige. This is what makes Amma Darko's approach a feminist one. Feminists unveil the conditions and the position of women within their societies. As Bill Ashcroft et al define the scope in which it acts this way, "feminism has often been concerned with the ways and extent to which representation and language are crucial to identity formation and the construction of subjectivity"⁶⁶⁴. While imperial power and language (tongue) are used in patriarchal settings as channel to women's domination and subjugation, language is also deployed to subvert it. This makes the power balanced.

As stated above then, Pesewa does not realise that his debauchery can lead to his loss. He trusts all his five wives and cannot imagine that HIV/AIDS breaks his secured mansion's fences. When he notices the infection, he decides to commit suicide for fear of being subject of people's gossips. But in fact, Pesewa's death by suicide is Amma Darko's technique to prove that male characters represent the failure in society. In that way, she portrays Pesewa as a man who does not only want wives and children all around him like a harem, but also is excessively submerged by the feeling of supremacy and stranglehold. Pesewa's depiction answers Amma Darko's redefinition of gender and sexuality within the historical, political and economic context. Pesewa's sexual potency in having all these women because of his wealth in his harem corresponds to the hegemonic masculinity. He exploits and dehumanises the fruit of his (slaves) women's wombs in his quest of power and social recognition. Pesewa pays the highest price for that choice, a choice which leads to end his life. Like Mariama Bâ in *So Long a Letter*, Ama Ata Aidoo in *Anowa*, Amma Darko deflates hegemonic masculinities in her writing. Before Amma Darko's prologue in *Not Without Flowers*, we are warned about the irrevocability of what sex makes of men in society. The excerpt from Edna Buchanan is a clear-cut passage of what is awaiting us throughout the novel. It states that "Sex gets people killed; put in jail; beaten up; bankrupted and disgraced; to say nothing of ruined-personally, politically and professionally [...]".⁶⁶⁵

⁶⁶⁴ Ashcroft, Bill et al (2007). *Post-Colonial Studies. The Key Concepts*. Second edition. New-York: Routledge Taylor and Francis Group, p. 93.

⁶⁶⁵ Edna Buchanan – *The Corpse had a Familiar Face in Not Without Flowers* (2007), p. 20.

The counsel that is hidden in the above mentioned passage leads us to the second male character in the plot, Idan in *Not Without Flowers*. His portrayal also answers to the question of men's fantasies' problematic. Idan marries his university sweetheart who took good care of him while studying (Darko, 71), however he has a very serious problem about his manhood. Idan is described as impotent and not capable of making a woman pick a seed of fecundity. When it happens that a man fails to express his virility, it is said that he is emasculated. According to the dictionary, emasculation is the process of depriving someone of virile or procreative power by way of castration. In the traditional understanding of impotency, Idan is unable to attain a respected standing in society even though he provides wealth to his family. The society where Idan hails from takes as sacrosanct masculinity in term of ability to make pregnant a woman regenerate the human species. Unfortunately, like Kofi Ako in Ama Ata Aidoo's *Anowa*, Idan is incapable of impregnating a woman even if the latter is left naked for a whole year in his bed. He cannot give that joy to any woman, but society condones that lack as it comes from the man of the family. Idan contrasts rather with Pesewa whose fame rested on solid personal achievements in terms of the number of children he has. Pesewa believes in his phallic masculinity as a power to reckon. Unlike Pesewa who demonstrates his testicular authority, Idan fails in getting straight with his own marital affairs. He has neither the courage to talk about his outside sexual affair, nor to take the girl at home like Pesewa. Therefore, his sexual frustration and social unfulfillment lead him to accept an outside relationship with the young university girl named Randa, a relationship which destroys Idan. In the range of love affairs that inflict self-devastation to characters, we have Pa's heart matter with the attractive Flower.

Pa's depiction is in the scope of men's choice to experience a mid-life crisis as a way to upgrade their public standing as masculine. Amma Darko describes that male hypersexual activities can lead them astray like it conducts Pa into the graveyard. Pa, like his compatriot in misfortune, Pesewa, commits suicide as he is psychologically and economically overwhelmed by his sexual affair with Flower. He, the senior officer at his workplace, now emptied-pocket, cannot stand failing since he is already hooked to the numerous sexual fantasies granted by Flower. He sells many of his expensive belongings to be atop with Flower's overpowering desires of material items. The narrator's voice puts:

And God knows how fervently he prayed over the gold wristwatch. [...]. The voice at the other end quivered with excitement when he was told what was on offer for sale this time. A twenty-two carat gold wristwatch? Two valuable kente cloths; the cuff links, two silver and one gold pair; plus other items he had apparently sneaked out of the house without his wife's knowledge. Like the beautiful silver ice bucket. The buyer had been in the business for a long while. And the cardinal rule was never to ask a seller why he was trading away something obviously and undoubtedly so valuable. He repeated to the seller, "Do you really mean a twenty-two carat gold wristwatch? (Darko, 320-21).

Pa is ruined from the first day he meets Flower. Moreover, he is overwhelmed by all the loans he contracts from his office's accountant. The narrator indicates: "(...) just like his office accountant was also demanding. The bank was deducting so much from what he owed them that the balance from his monthly salary was never enough to also deduct payment for what he owed the company" (Darko, 350). Pa's tremendous attitude to make his mistress blissful can be compared to Koomson's in Ayi Kwei Armah's *The Beautiful One are Not Yet Born*. Koomson diverts the public money to meet his new craving just as he did in the case of the scholarship for Regina's course. As a rebel writer, Ayi K. Armah's argument is that this kind of misplaced priority in the use of public fund adds to the suffering and disenchantment of the people. The similar case is thus portrayed in Pa's debts and loans and his incapacity to pay the long list of bills and other expenses at home. The crux of the matter in Ayi Kwei Armah's novel and that of Amma Darko is that Africa's prospects for a better life, a better future are very bleak on the account of her leaders' inordinate greed and concupiscence. Moral uncertainty, absence of clear social goals and the total disengagement of the political leaders form for sure bombs after bombs that will soon explode.

Further, sex functions as a hard drug while people are really hooked on it. Amma Darko's portrayal of the mistakes that lead to Pa's helpless state is meant to subvert the stereotypical notions about the hegemonic masculinity. Amma Darko's male characters are under pressure because their manhood supremacy is overthrown and dented. Masculinity is under attack in Amma Darko's novel. The female writer presents masculinity as a notion in which many excesses are condoned by society since these male characters live in a patriarchal setting. Then, Pa is presented as social and financial victim of the pitiless system which takes them as goods. When describing the young man, Amma Darko poses the issue of men as slaves

obliged to exchange their body to money or materials to survive, an attitude long time supposed to be female.

Fathers, men and husbands, most of the time, are presented as exploiters or deserters, so that the female characters of Amma Darko have to look for methods to overcome their powerful and thick woven network. Amma Darko's male characters are portrayed defeated. The notion of husband and father is at loss with Amma Darko. The example here is the way Pa, Idan and Pesewa have been described. The distinctive feature of Amma Darko's male characters is that they are wicked, selfish, masochistic, drunk, dominant, sexist, and brutal, so that the only punishment they deserve is death, dishonour and highest shame for having dispossessed the female characters. Pesewa and Pa's suicide, in Amma Darko's writing, serves as metonymy for male characters' failure to cope with tough predicaments in society, in particular the failure of African male leadership and self-control. The writer wants to say that masters are virile patriarchs who beget many children, yet cannot stand unpleasant circumstances.

Taken as the body of the whole ancient Gold Coast, Amma Darko's female characters' bodies are abused, raped, exploited and dispossessed by the male ones. In that process, marriage corresponds to conquest and exploitation of a body, a land, a space. That is the reason why most of the female characters' bodies are wreck and devastated. Throughout Amma Darko's writing, the male characters are ravers, rapists and colonisers stealing from the female body (The National Land). It is that conception of female body as land that motivates the writer to create her own female characters as strong as possible. Then, one of the significant elements of these female characters lies in the mastering of that land's power and borders to resist invaders. The harsher the male forfeit, the tougher the female resistance. Regarding of the validity of this thesis of national land, we are sure that the issue of land is also that of frontier. A boundary is then a limiting zone to distinguish one space, one land or one nation from another. The concept is as older as the theory of a land possession by its first occupant. So if a land (a woman's body) is considered as being her property and its boundaries guaranteed, then any non-authorized interference should be considered as rape and a violation against the woman. However, the cartography of a woman's space is not secured in patriarchal societies since the fence between the space and the space's owner is very tiny and sometimes non-existent.

In these societies, men affirm their manhood through power over their peers and their women. Everyday speech revolves around virility and courage. Men speak violently and maintain that such is the way of men. That power of men can be completely destroyed or subverted if they are overpowered by other men or women who use the same means more effectively or more strategically. The virility along with violence makes the basis of patriarchal society. Amma Darko writes her way with no taboo in order to defeat the beast. So female writers like Amma Darko knows that when the writer removes from masculinity its power, it does not exist or it weakens, fades and dies. That is the case of the male characters in Amma Darko's novels. The characters portrayed by Amma Darko follow her feminist perspective in the sense that it induces for the female ones the re-appropriation of their 'selves' and taking of power without being physically and mentally sick of that power. That skilful ruling is on the crossroad of Amma Darko's typical feminism. In this process of self-redefinition, the female characters have to empower themselves through education and sisterly assistance and then by engaging in a relationship where they are at the command to avoid to be ruled out or manipulated by male characters like Akobi, Osey, Idan, Kwei, Poison and their alike. Amma Darko does not refer to heterosexual marriage as a social act that imprisons and empoisons her female characters like her seniors in literature such as Flora Nwapa in *One is Enough* or Buchi Emecheta's *In the Ditch* and her female compatriot Ama Ata Aidoo's *Anowa*. All the same, Amma Darko focuses on relationships where women can feel fulfilled emotionally, mentally and financially like 5th Wife in *Not Without Flowers*. She emphasises that marriage rip of love and respect surely ends up by endangering the woman and even her children like that of Mara and Akobi or that of Maa Tsuru and Kwei/Kpakpo. Life of women like Maa Tsuru is full of pleasure and insincerity; as if the pleasure calls for insincerity and lies. Also women can be endangered because of other women that want to pass on traditional customs on new generations. They represent traditions and want them to be perpetuated no matter how. Further, Amma Darko seems to forbid to her female characters to fall in love for fear of being insane like Ma in *Not Without Flowers*.

Eventually, Amma Darko's novels get male characters are all portrayed very unkindly. Her depiction of male characters has a deep significance beyond the symbolic level. The female writer engages gender ideologies while exploring, in intricate ways, issues that cut to the heart of normative masculinities and femininities in her depiction and in underscoring the symbiotic nature of the relationship between her characters. She bases her novels' style on her personal

resentment against Ghanaian men. Hegemonic masculinity is portrayed as repugnant and crumbling. It deforms the very men who uphold it, yet it is an entrenched value that is difficult to change. None of Amma Darko's male regrets their inhumane attitude toward females though they (male) have love to give and to share. Hegemonic masculinity leads Amma Darko's male characters astray and the following Ghanaian proverb illustrates well the situation: "when a fly refuses discretion, it is buried with a cursed body". In the present context, the fly stands for the masculinity and the cursed body men. Male characters' disgraceful conducts throughout the novels are represented as power abuse and also the use of feudal possession to degrade the powerless. In the described society male characters misunderstand their position by asserting their strength over women and by imposing their rapacious virility on the most defenceless among them. Instead of caring their wives and partners, male characters take the female obedience as granted and continue the mistreatment. Nonetheless, it is important to bring this devastatingly misogynistic and sexist culture into the drowning rooms in order to cleanse society of male disgrace. Culture is what prevails when a man loses all around him, but it can happen that a part of culture becomes a hindrance to man's progress. According to Matthew Arnold in *Culture and Anarchy* (1932), "culture is a study of perfection (...)." ⁶⁶⁶ Referring to perfection, Matthew Arnold defends that culture can be, among others, related to religion as the latter seeks God's will to prevail in society. If God's will must prevail (who is an abstract and invisible entity), then it is worth noting that no God asks man to be so brutish and rude towards his female counterpart since Africans believe strongly in his limitless magnanimity. God, an entity of such fairness, cannot be associated to that brutality and intolerance.

Consequently, men's position demonstrates that they do not understand the intricacies of their culture or more importantly do not understand how their culture wants them to behave towards the other gender in society. That is why the respect men command from all the other members is more consistently about their maintaining on power with strong rule and not drawing an opportunity to share that power. Much as society provides support for men in time of need, it also expects men to see for their women when they have the means. Yet, as men get all this wrong, women have to provide for their own means to support one another while in need. Then, women have to write about women in order to sustain moral, spiritual and mental support. The empowerment women should provide to raise their fellows' head above water is to

⁶⁶⁶ Arnold, M. (1932). *Culture and Anarchy*. Wilson, J. D. (ed.), Cambridge University Press, London, pp.241

write about women's present and future regeneration and the possibility they have to take over social and financial power in society. Amma Darko writes by and large about these occasions in her novels. She discloses all the clues for women to overcome their present conditions and to rule not by shedding blood, but by having their say in their household and being strong mentally. In that range of support providing, the female characters such as Kabria, Dina, the actualized version of Mara and 5th Wife are the reflected image of Amma Darko herself. These characters' resemblance with the female writer is too striking and original. It does not foreshadow that Amma Darko writes an autobiography, but she attributes herself a very specific part to play by embodying a female character in each of her text. Her relationship with these characters is beyond literary bounds to become an affiliation. She creates in her fiction a singular and special intimacy with her female characters which is not seen in her female counterparts' writings. With her male characters, a close look makes us understand the extent to which grows her resentment against the hegemonic maleness which forces all of her male characters to deploy signs and strategies to subject, to conquer and enslave. The bitterness that her writings display indirectly senses the concealed request of the female writer. Amma Darko's texts are many times ambiguous and contradictory for sometimes she proposes a breakthrough and another time she wants them to be submissive. In actual fact, the writer proposes that women should not be alone to let people gossip around their hidden nocturnal activities as prostitute. Society usually targets lonely women as being prostitutes and barren women as being useless. Then at their marriageable age, they must get married and bring forth to male children at any cost.

Further, Amma Darko wants them to undertake any activity to finance their autonomy and self-government. She wishes that the female folk be at the battle front because no one else would do that for them. Her desire is to see women assisting each other in an intimate sisterhood and togetherness. In doing so, Amma Darko teaches life by writing fiction and shares her knowledge. Ghana and women are strongly at the centre of her imagining, but she also writes about a few of her personal experiences made abroad.

For some reasons, one is likely to push the comparison further by noting that Amma Darko's own life story is at stake in her writing. As a motif that runs throughout her novels, what is not to be shaken aside is that Amma Darko was obliged to leave her country in the 1980s not because she wanted to, but the situation was so explosive and replete with coups that

the younger Amma had to leave Ghana to a greener pasture. That unstable socio-political situation in her dearest Ghana was the fact of men. Her shock for having been obliged to leave her motherland at a period of time remains in her mind. Additionally, while abroad she worked to earn but menial in post-war Germany where black women faced racism and other stereotypes. Her return to Ghana is like the one depicted in Peter Abrahams' *Return to Goli* (1953). Amma Darko returns to Ghana to find her country under siege of structural adjustments, IMF and World Bank loans which block it from breathing and moving. In that under siege Ghana, spring out of the earth new plights and challenges which force Ghanaians to surface. All these sufferings motivate Amma Darko to write her way using a special technique. That specific literary technique in the female writer's texts draws our attention and makes us write about. The use of metaphor helps the writer's story telling method and broadens the reader's opinion over her capability to convince. Furthermore, the use of some Ashanti or Akan words without any glossary expresses her socio-linguistic identity uniquely African.

18. Amma Darko's narrative technique

Writers, novelists or poets use language as tool to communicate. Novelists use it to describe their characters' appearance, actions, habits, thoughts, feelings and fears. In African settings, orality is often used in written texts. In African cultures, the ever used and commonest genres are tales and legends around which many people gather to share experience and values. It is a technique of knowledge and wisdom transmission between the older and younger generations. Proverbs in African literature are literary devices used to enhance the relevance of orality in the written form of literature. African linguists' eloquence is proved through his easy way of employing proverbs to illustrate his message. That is the reason why Chinua Achebe puts rightfully that "proverbs are the palm-oil with which words are eaten" (Achebe, 5). The metaphor of words as food illustrates the highly agricultural nature of Igbo society in the time of the novel's writing. The same value placed on food is awarded to words which induces society interaction. This explains the high meaning of words in Africa. The narrative also gives us the opportunity to realise the extent to which literature is in the service of society. It attempts to show how characters' actions and interactions affect in actual fact the on-going of the writing. It means that writers especially those of Africa are the tools of their society. Writers derive their thematic preoccupations from society. More consistently, the novel becomes the shadow of society that produces it. Fortune or misfortune of the peoples does not change because of the

new millennium or a new century; hence literature remains the mirror of society, literature's source of inspiration. Both are interdependent and interconnected. This corroborates the Nigerian critic and feminist activist Helen Chukwuma's idea that reads: "the novelist does more than simple story telling in a beautiful manner, he arouses in the reader a true sense of himself, evoking his past and linking it to the present"⁶⁶⁷. This is made through significant tools like proverbs, tales and legends.

The prominence of proverbs, tales and other literary genres are also noticed in Fante and Akan communities in Ghana. In Igbo community like that of Akan in Ghana, tales are told in family at moonlight nights. Throughout that traditional journey are present, old men, old women, young men and children of all age. Other stories are told in public places to have the attention of a large number of people. According to Birago Diop "Le roman n'est qu'un conte plus ou moins « délayé » et « dilué » où la personnalisation des sujets et des objets amortit les caractères majeurs des « Types » (bêtes, choses et gens) des récits"⁶⁶⁸. This goes in line with Roger Mercier's statement on African literature as being replete of orality in all its wholeness⁶⁶⁹.

Further, when focusing on the author's writing technique, we fortunately realize that she makes use of flashbacks to emphasize her language mastery. The use of flashback either at the beginning of the story or at the end of it helps the writer draw the attention to different facets of the stories. In fact, while reading a story, it is important to recognise a flashback. According to the online dictionary:

Authors use flashbacks as a means of adding background information in the present events of their story. They interrupt a specific event within their story by using events that have already occurred or that have not been presented. This gives the reader added information about a character's past, including his or her secrets, inner or external conflicts, or significant events that affected his or her life. If the author is able to do this well, the reader will begin to convey reasoning for the actions of the characters throughout the story and develop a better understanding of present events. This also helps the author create a

⁶⁶⁷ Chukwuma, H. (2003). *Accents in the African Novel*. Lagos: Pearl Publishers.

⁶⁶⁸ Diop, B. (1985). « Entretien avec Bernard, *Notre Librairie* N°81, p. 65. « Le roman n'est qu'un conte plus ou moins « délayé » et « dilué » où la personnalisation des sujets et des objets amortit les caractères majeurs des « Types » (bêtes, choses et gens) des récits. My translation : "a novel is a more or less illustrated tale where the characterisation replaces the use of animals or things in traditional tales which always sums up all the other genres to illustrate positive and negative aspects of past civilization or civilization in change"⁶⁶⁸. (My translation)

⁶⁶⁹ Mercier, R. (1974). « La Littérature négro-africaine et son public ». In *Revue de littérature comparée* N° 191-192, pp. 398-408.

theme for the story and increase the emotional impact it will have on the reader.⁶⁷⁰

One might say that in literature, flashbacks are past events that the writer inserts in an already going narrative in order to make it more understandable, more vivid and attractive. A flashback gives a background to a narrative and places a current action in a context. Dreams and memories are techniques used to represent flashbacks. In the beginning of *Faceless*, Fofu's dream opens the narrative with her unfortunate encounter with the street lord. In the same vein, Amma Darko presents the overused and deformed body of Mara in *Beyond the Horizon* before the narrative can unfold the intricacy of the whole story. It reads: "I am sitting here before my large oval mirror. [...] I am staring painfully at an image. My image? No! -- what is left of what once used to be my image" (Darko, 1). While placing the flashback in the beginning, the writer motivates the reader to know what happens to the character. Then, reading the whole narrative provides many useful details and elements partly or already mentioned above.

In *Not Without Flowers* also, when Randa was a very little girl dreams a lot of the time about Ma's crying and her having a problem with Pa. This is to place us in her own mind and locate current events as cause-consequences of what happened in the past. *Not Without Flowers* seems to be a novel of flashbacks. However, Amma Darko's male characters' portrayal, her technique of language and flashbacks match well with the representation she makes of postcolonial Ghana and by extension of postcolonial Africa. This fits with the long debate engaged by the majority of African writers such as Ama Aidoo, Buchi Emecheta, Ngũgĩ wa Thiong'o, Ayi Kwei Armah, Doris Lessing, Nadine Gordimer, Nawal El Saadawi, to name these few. The author deals with social principal issues of postcolonial Africa. African people are still traumatised and fragmented because of colonisation's long terms aftermaths and the neo-colonialism which bring alongside permanent consumerism ideology, globalization, urbanization, subverted schooling and all thinking in western languages.

Taking into account the above thesis, we have it that neo-colonialism (the new and disguised form of imperialism⁶⁷¹) lies in the fact that the African elites claiming for political

⁶⁷⁰ <http://study.com/academy/lesson/what-is-a-flashback-in-literature-definition-examples.html>

⁶⁷¹ Imperialism refers to the formation of empire in which one nation has extended its domination over one or many neighboring nations. Edward Said (Said 1993: 8) also defines this term as the 'practice, theory, and the attitudes of a dominating metropolitan centre ruling a distant territory, a process of colonialism, which is implanting

independence from the British Empire or France and other colonial powers without having previously ideas about economic governance, have no other choice than to surrender economically. The economic power is still largely retained by Europeans and expatriates in African countries. This economic stranglehold of the West obliges the African continent to turn out to be a huge mass of consumers forever importing. The system also consists in appointing or helping financially an African leader who is body and soul devoted to the West's crucial orders. By appropriating foreign economic strategies, African leaders have to surrender their ground resources. All that the leaders want may be ordered from the country of his helpers. They may become leaders who rule without legitimacy, embezzle from the already agonizing state and hide it in European bank without being denounced. Amma Darko's representation of Ghana and Africa is strictly tied to what everyone sees everyday happening. She uses literature to depict recurring and permanent realities. This attitude of hers gives us the right to call her a 'Teacher' as Chinua Achebe defines it.

Apart from this, we cannot fail to highlight her purposed and deliberate choice of settings. Amma Darko's settings are necessary tools in her way of writing about women's ordeals in society. Some of the settings in Amma Darko's texts are realistic or seem to be real because of their relevance as public and common places in Ghana. The same method of settings' tangibility has already been adopted in novels such as *Maimouna*, *Things Fall Apart*, *Idu*, *Purple Hibiscus* to name just a few. Each of these novels uses ordinary places existing in their country or the neighbouring ones to illustrate their message. Others are fictional spaces brought into play by the author to symbolise a village setting or an urban. All these settings start existing as soon as the characters and surely the different protagonists begin to live in and acting inside each of the settings. This does not shake aside the use of language to make this entire match with the first aim of the writer: to communication. As Raymond Jean argues: "Le langage n'a rien d'éminent ni de prestigieux s'il tourne à vide. Rien en littérature ne peut se constituer sans lui. Mais il ne constitue pas tout par lui-même. Il n'a de force et de richesse que s'il tient le réel serré dans ses mailles »⁶⁷². Literature, language, reality and setting are then undissociable factors.

settlements on a distant territory'. Retrieved from Ashcroft, B. (2007). *Post-Colonial Studies. The Key Concepts*. Second edition. New-York: Routledge Taylor and Francis Group, p. 111.

⁶⁷² Jean, R. (1965). *La Littérature et le Réel*. Paris: Edition Albin Michel, p: 13.

Stylistically, when the author associates a village's way of life with that of a city (Naka/Accra and Kataso/Kumasi for example), it is to raise consciousness on a potential transformation either in the protagonists' lives or that pertaining to the settings. For a long time, villages in African literature have been depicted as space of safety, liberty, collectiveness and where songs, tales, legends under bright moonlights are told for the community's delight, but some events make over all that joy to desolation and melancholy. The villages described by Amma Darko are those semi-primary villages not totally like Chinua Achebe's Umuofia depicted in *Things Fall Apart*. The villages in Amma Darko's texts are postcolonial ones devastated by western ideology, synthetic products, and mostly by neo-colonialism.

In fact, the ultimate transformation of these villages creates in all its residents an urging need to leave for other places, particularly towns, where unfortunately there is no security. Violence and self-interest take over in cities along with other terrible social issues. For example, we have places such as Sodom and Gomorrah in *Faceless*, Accra with its iron corrugated sheets where dwellers have to sleep with cockroaches, ants and insects in *Beyond the Horizon*. For the former, anyone who once reads the complete version of the Old Testament or specially the Book of Genesis may encounter that renowned city's name and the peculiarity of what happened there. In that very city, danger was permanent and awesome all the citizens. In the latter, 'Johnny-just-come', new comers have to find necessarily cheapest places in Accra where to spend their night. These torn out and dirty places depicted the kind of life they live, their first preoccupation being to be recognized as living in large cities. No one predicts what can happen in the next moment of the story. This uncertainty makes the city particularly revered. Amma Darko illustrates how deeply entrenched is the issue in African globalized cities. Repeatedly in her texts, we notice that she finds herself at a point of tension, aware that her writing both challenges the conventional view of what is appropriate for her characters and encroaches on what some see as a male preserve. This lasting danger is also described in Amos Tutuola's *The Palm Wine Drunkard* where the hero looks for his palm wine tapster in a strange bush of wonders and dangers. In *The Palm Wine Drunkard* at the invocation of the hero's future encounter with 'Death', he is scared to his marrow, quivering since it is unsafe to meet physically 'Death'. As in the setting where the protagonist faces several creatures, Amma Darko's third novel is built around a female protagonist who settles her dwelling in the street by force of circumstances. She treads where angels and frail heart people refuse to go. Sodom and Gomorrah's streets symbolize places where children are tortured, raped and murdered. These

streets epitomize the same risky places as those described in *The Palm Wine Drunkard*. In Sodom and Gomorrah, fear is the most shared item every night and every day like distrust in *The Housemaid*. In *The Housemaid*, where suspicion and mistrust are common and then the first to strike has right to do it to survive.

In *Faceless* the character similar to Death is the male character Poison, the cruel street's lord. In the street, no one dares to challenge him. He is as brutal and un pitying like his friend in crime, Macho. Both together symbolize the street terror. The narrator points it out "Poison, in addition to this single act of extreme brutality, gained more fame in his world with his loud-mouthed acknowledgement [...], his life was not on the right track [...]" (Darko, 170). With these two male characters around, the street becomes a prison and simultaneously hell-like for the other street boys and girls. The streets of Sodom and Gomorrah and Agbogloshie market incarnate also places of confusion. By definition, confusion means ruin and defeat. That confusion is exploited by the machos to rule and reign. None of these little beings find alone the way out the predicament except providentially enough the protagonist Fofo rescued by MUTE's intervention. Similar confinement is described in Abdoulaye Sadjı's *Maimouna* (1985). In the novel, Dakar symbolises the place of fantasies and enchantment. Dakar city also represents a place where prevails jungle law which provokes Maimouna's loss like Sodom and Gomorrah that witnesses without a word Baby T's murder. The same sin city is about to see that of Fofo. The two African cities become inhumane, pitiless, and devouring children, especially the female ones. These urban centres become cruel to borrow from the Cameroonian Mongo Beti's novel title *Cruel City* (1954). The severity depicted in these cities originates from people's heartlessness and individualism and traditional values go. As if imposed by an invisible hand, all African postcolonial cities beget this desolation sign. This moral devastation is also depicted in Cyprian Ekwensi's *Lokotown and Other Stories* (1966). Loko, a small and peaceful town soon transformed into a dangerous place full of rotten women who never marry because of its rapid urbanization. Loko becomes a glittering city full of lust, sexual libertinage and material appetite. It is the casualty of white washing Africa and the discrediting of everything ancient African. The decimation of African languages and culture wreaked harvest on the collective psyche of African thought and advancement. Languages loss denuded African people of their pride, history and way of life. In this regard, Africans spend half their time learning and mastering their former colonial masters' languages and cultures to the detriment of their overall well-being. Then from earth spring urban large centres that pressurize inhabitants mind leading them

to desire more and more from that model of society. African cities after their contact with the West since the 19th century continue to lose the ancient and famous togetherness and collectiveness to western individualism and eccentricity.

By and large, it is commonly remarked in African culture that fear, hope, despair, anger, braveness, to cite these few emotional traits are portrayed in songs, tales and legends. In the range, we also have proverbs which give a wide view of wisdom and knowledge of the continent. African oral literature is replete of the essential of the continent productiveness and its partaking in the development of the world in terms of arts. African novelists write about their peoples' fear and interrogation while facing all the postcolonial transformation which imparts negatively though their lives. Throughout the prevailing uncontrollable and extraordinary change, we think that the colonial masters are still present and at work, but now disguised in concepts like urbanisation, globalisation and international fund structures. It is the greediest part of the Western capitalism. The colonial master's sense continues down in African cities and this trend is shown through literature. The African cities witness several families' dislocation due to fathers' frequent absences at home because colonialism utilizes more male power than female in works such as railways, harvest in plantations, wild animals hunting, wells digging for water, trees cutting and warfront soldiers. Thus, colonial time consciously enhanced brawn power since muscles are more needed in such physical works. If families want to live in urban centres, then they have to adapt themselves or disappear. Efia's family in *The Housemaid* and that of Fofu in *Faceless* are forced to dissolve definitely. We clearly understand that the advent of colonialism and afterward neo-colonialism worsens the African families' conditions particularly the women's, condemning them to second roles where they are neither seen nor heard. In these settings, women have to struggle to feed themselves and feed their offspring. All this creates with no doubt families' dislocation and favours the appearance of street children in urban centres. Life experience in street is mostly at stake in that novel. In *Faceless*, the writer does not go around the pot to portrayal the conflict that bedevils mother-daughter bound in patriarchal society. Through that channel, Amma Darko addresses other issues such as irresponsible parenting, government indifference and youth neglect, police inefficiency in Ghana and in many African countries to further a murder investigation.

In Amma Darko's narrative, we emphasize the contribution to the understanding of what distinguishes her way of writing. Amma Darko's narrative technique is not that simple, though it

expresses fluently the socio-cultural realities of community and sometimes the imaginary settings. Amma Darko uses freely some Ghanaian words without giving to the non-Ghanaians the opportunity to know the right meaning in the context. For the sake of her national and cultural identity, Amma Darko does not offer a list of these words' significance. It is her special touch in writing fiction and uncovering national history. In each of her novel, many words are used which require a glossary. However, we share the view of Carmela Garritano who submits as follows "Darko's narrator speaks to the reader with a degree of familiarity and, [...] places herself in close proximity to this reader in time and space. [...]. Darko also assumes that her reader has a certain degree of insider knowledge"⁶⁷³.

A close analysis of Amma Darko's narratives, unveils her facility to use Akan and Ashanti words to convey easily her message. It also demonstrates that Amma Darko is well-rooted in her native tradition as well as filled in her feminist approach of denouncing contemporary Ghanaian women's trials. She does allow or leave herself to any boundary like her national language. In this doing, she differentiates herself from Ama Ata Aidoo who usually provides a glossary to her readers in *Changes* (1993). The father of African literature in English, Chinua Achebe provides also a list of Igbo words in his historical and ground making novel *Things Fall Apart* (1958). Randomly taken, we can name Ousmane Sembene's *The Money-Order* (1965), *The Interpreters* (1965), Abimbola Lagunju's *Days of Illusions* (2005) and Leonora Miano's *La Saison de l'ombre* (2013). The former provides a list of Wolof words while the latter that of Yoruba words to make people understand the literal meaning and the context. Any reader that encounters a Wolof or a Yoruba word while reading these two novels can go back to the glossary to know the significance. That is how Ousmane Sembene, Wole Soyinka and Abimbola Lagunju want their texts to be understood and by the same token to let the Wolof and Yoruba culture spread.

Using a glossary to explain African words in African literature also poses a problem of readership. It is impossible to rule out the dialogical emphasis the glossary raises when put in an African novel in front of a foreign audience. After all, it is normal that an African writer seeks audience from beyond the horizon to satisfy a want of critical reading, view and response from others. For Vincent Odamtten, "the accessibility of Darko's language does not preclude the use

⁶⁷³ Garritano, C. (2007). "Amma Darko's *The Housemaid* and the Gendering of Novel and Nation" (Ed.) Vincent O. Odamtten, *Broadening the Horizon: Critical Introductions to Amma Darko*. UK/London: Ayeibia Clarke Publishing, Print., p. 79.

of humour and irony in her work, and these qualities serve to temper her unflinching presentation of stark circumstances and human suffering and folly. Indeed, she sees the use of humour as being inherent in the Ghanaian narrative tradition and crucial to her relationship with the reader”⁶⁷⁴. So, the writer’s relationship with a potential reader either African or Westerner is created by the humour in the text and reading it should satisfy the reader’s desire to relax. As Amma Darko herself says “A story must be enjoyed. Even when it’s a sad one and bogging down the reader’s emotions, the reader should be helped to balance”⁶⁷⁵. The excerpt emphasizes the role of humour in the reader of a novel makes the message more interesting. The language used, the spiralling and overlapping pattern of events and the perspective to see the end of it all attract the reader and reinforce his sense of want to read more from that specific author. That is how a novel makes and builds a national and international reputation to the writer.

Further, the fact that Amma Darko does not offer that list of Ashanti or Akan words and their sense illustrates the necessity to force far-off readers and non-speakers of Fanti to seek for the meaning or get taught as Leo Viktor Frobenius⁶⁷⁶ advises his European fellows to do as far as African languages are concerned. While doing his early research on African languages and cultures and their interaction with the world, the German explorer and ethnologist learnt a large range of local languages of the people whose cultures he studied. Part of his research led him to city of Ilé-Ifè in Nigeria to dig out the lost civilization of Atlantis. This is because the city has all the makings and trimming of Atlantis. That technique allowed him to be really part of them and their mode of living. Amma Darko intersperses words from Ghanaian languages directly in her English texts without transition. A close reading of Amma Darko’s texts illustrates some grammatical and lexical specificities that render her writing not only drawing attention to her post-colonial history, but also her capacity of writing her way. The phonetic transcription of her maternal language (The Fanti) has also been used, which renders visibly the introduction of some Fanti words in her English texts. Ashcroft defines this linguistic intersection and this superposition of two different languages as the specific characteristic of a post-colonial literature:

⁶⁷⁴ Odamtten, V. O. (2007). “Beyond the Comfort Zone: Relations Between African Writers and Audience” in *Broadening the Horizon: Critical Introductions to Amma Darko*, p. 7.

⁶⁷⁵ Idem, 7.

⁶⁷⁶ Frobenius, L. V. (1936). *Histoire de la civilisation africaine*, Paris : Gallimard. Leo Frobenius (1873-1938) was an eminent German explorer and anthropologist on prehistoric art. He published “African Genesis: Folk Tales and Myths of Africa” a year before his death. The text is buttressed with maps and illustrations.

One of the most interesting features of post-colonial literatures is that kind of writing which informed by the linguistic principles of a first language or an English moulding itself out of a peculiar (post-colonial) relationship to place. This is an “overlap” of language which occurs when texture, sound, rhythm and words are carried over from the mother tongue to the adopted literary form. And it is the intersection of language which many writers propose as the distinguishing feature of post-colonial literature⁶⁷⁷.

This has to do what Gates (Gates: 1988, 131) names as “*the oral within the written*” which means to use the language of the oppressor to reconstruct one own in order not to be dispossess culturally and then gain back the lost power that one’s own language had before the arrival of the European intruders. The technique characterises most of the post-colonial African countries, Indian, South American and others. Gates explains that in those literatures, the reader either comes across two languages like Yoruba and English, Spanish and French or the ‘black vernacular’ and standard English. It is a ‘crossroad’, a mixing of two languages and two cultures. Similar technique has been used by her senior in literary writing, Ama Ata Aidoo as said above. In *Change: A Love Story*, Ama Ata Aidoo makes use of Ghanaian words like *wahala* to designate the matrimonial quarrel amid Opokuya and Kubi over who will take their only car on a particular day (Aidoo, 9). The word *comot*, a typical Ghanaian word followed by *kabisa* to mean that the marriage between Ali Kondey and Esi Sekyi is finally over (Aidoo, 159). Amma Darko uses the same method in her novels. For example, in *Not Without Flowers*, the words *wahala* (Darko, 99 and 242), *Kwasea* (Idem), *Mpesempese* (Darko, 187), in *Faceless* the word *Akpeteshie* and *devil’s leaf* which takes after the typical Ghanaian English *flabberwhelmed* used by Ama Ata Aidoo to specify a fusion between the English words ‘flabbergasted’ and ‘overwhelmed’. The use of these composed words in a text proves the author’s language skills connected with her desire to snatch our attention to her message and sets the reader’s humour. As no one knows these words before, their encounter in novels raises attention and curiosity to go and seek for the meaning in dictionary. Humour makes the author of the novel be heard. These words invented by a non-native of the language raises the question of the capacity of a non-native to manipulate a foreign language to the way she wants. Humour helps people who deploys it “to resist victimhood and enact a psychological rebellion against the circumstance of colonialism and its legacies, and facilitates a sense of community through

⁶⁷⁷ Ashcroft, B.; Griffiths, G. & Tiffin H. (1989). *The Empire Writes Back: Theory and Practice in Post-Colonial Literatures*. London: Routledge, p. 4.

laughter among both those who deploy it and those who enjoy it as audience members”⁶⁷⁸. Humour seems then to be a particular value for contesting colonialism and its legacies in Africa. The way a Westerner is surprised to encounter a new and invented word while reading an African novel is the same when an African encounters African words in that novel. Little attention has been paid to African words in African novels as it has also been paid to new invented words. So, Amma Darko wants to be among these African female writers to revive this sense of humour in her texts. It is better to laugh in order to repulse traumatic experiences of many horrific events of the past and present world and feel free to act and express oneself. Humour plays a role of healing wounded soul and is represented as a way of displacement and a form of empowerment. The transformation of African literatures from its traditional form to high standard has its own well-founded historical reasons here. Folklores, tales and legends are the whole retailers of the laughter people are in search for while listening or reading, a technique which has just been transposed in African written texts. In fact, African written texts transform just abstract narrative to expressive and intellectual discourse and in this respect, it seems hard to these categories of writers to depart from the foundation of their *raison d’être*, of their art. In their writings then, verbal arts share common features with modern fiction simply because both are meant for teaching and entertaining through the medium of language and images. The literate world has inherited this diversity of knowledge and now makes use of it in its blended form.

In search for new ideas, new grounds for humour and entertainments, African writers go back to their roots and fetch the fresh cream of it to quench their audience thirst. Like African everlasting diamond fields and gold mines, contemporary African writer go for ground work to fish out the best of the tales to adapt in their writings. Thereby, just like her Ghanaian counterpart, Ama Ata Aidoo, Amma Darko makes use of African words to set laughter in the reader either African or Westerner. In lines below, we establish an explanation of some of African words used by Amma Darko in the novels on which we focus our analysis. In the assessment of our analysis, we choose to clarify and interpret the context in which some of these African words are used in the texts and in common life in Ghana or in any other African country. The use of African words fulfils straightforwardly the need to use formal criteria on the basis of traditional standard. African writers deploy their English, French and Spanish language

⁶⁷⁸ Holoch, A. M. (2012). *The Serious Work of Humor in Postcolonial Literature*, Thesis, Iowa University Press, p. 1.

competence by combining these foreign languages with their indefectible love for their mother tongue wrongly named as vernacular.

Furthermore, Amma Darko's aptitude to shift from English to her native language is called heteroglossia which helps her much in her feminist perspective and her characterisation. Heteroglossia clearly includes the interacting of languages and speech acts. Heteroglossia is defined as a base condition leading the operation of meaning in any utterance. The prolific Russian critic, essayist and literary theorist Mikhail Bakhtin⁶⁷⁹ provides an insightful overview on that theory. The critic rejects rigid systems of thoughts that could not account for what he terms 'heteroglossia': the polyphony of languages and perspectives that make up modern society and are reflected in its art. For Mikhail Bakhtin, a novel can become a site of heteroglossia because of it can represent multiple speech-genres. Then the use of that system if a novel can be political. That political engagement is seen in many post-colonial writings in African literature as having its core roots in colonialism. The colonisers refuse to grant a statute of language to languages spoken in their former colonies on the African continent and in India. Some keep calling them pejoratively '*dialect*'. So when a native has the opportunity to write, he or she writes by paying tribute to his or her language to prove and showcase of its cultural potency. This is in line with Maryse Condé's historical statement about the power of the language. She reminds us that "Language is a site of power; who names controls. Politically and economically alienated colonized are first colonized linguistically [...]"⁶⁸⁰. Language is then a mode a resistance to the linguistic control of the colonial power. The writer is sure that in deconstructing the colonizer's language, the colonized is making the first step of linguistic liberty. That is why Amma Darko does not provide any glossary in her novel. She knows that her ideas and message while writing in English will be worldwide. Hence, she is convinced that her identity is safe and can be tracked down by watchful readers. As Ashcroft, Griffiths and Tiffin remind us, former colonised are heteroglossic or polyglossic communities and colonization's drawbacks are still visible in these countries. The critics declare that:

⁶⁷⁹ Mikhail, Bakhtin (1895-1975) was born in Oryol, south of Moscow in Russia. He grew up in Vilnius in Lithuania and the Russian port city Odessa. He attended Novorossia University and later transferred to St Petersburg University from which he graduated in 1918. He was a Russian literary theorist and philosopher of language whose wide-ranging ideas significantly influenced Western thinking in cultural history, linguistics, literary theory and aesthetics. Because of Stalinist censorship, he often published works under the names of friends including *Freydizm* (1927; *Freudianism*); *Formalny method v literaturovedeni* (1928; *The Formal Method in literary Scholarship*). He was especially known for his work on the Russian writer Flyodor Dostoyevsky (1929) retitled *Problems of Dostoyevsky's Poetics*.

⁶⁸⁰ Condé, M. (1995). "Language and Power: Words as Miraculous Weapons", *College Language Association Journal*, n° 39.1, pp. 18-25.

There are three main types of linguistic groups within post-colonial discourse: monoglossic, diglossic and polyglossic. Monoglossic groups are those single-language societies using English as a native tongue [...]. Diglossic societies are those in which bilingualism has become an enduring societal arrangement [...]. Polyglossic communities occur principally in the Caribbean where a multitude of dialects interweave to form a generally comprehensive linguistic continuum. (Ashcroft, Griffiths, Tiffin: 1989, 39)

In that context, several post-colonial critics have highlighted the power of language. Ngùgì wa Thiong’o views language as means of spiritual assimilation. He names it as “spiritual subjugation” and his comments prompt this way: “In my view language was the most important vehicle through which that power fascinated and held the soul prisoner. The bullet was the means of the physical subjugation. Language was the means of spiritual subjugation”⁶⁸¹. Further, his comments go far by assimilating language as an instrument of domination. Ngùgì wa Thiong’o points that “The domination of a people’s language by the languages of the colonising nations was crucial to the domination of the mental universe of the colonised” (Ngùgì: 1986, 16). In other words, the fact Amma Darko shows the aesthetic of Ghanaian language in her novels demonstrate the poetic which resides in African languages and to borrow from Jean-Claude Blachère⁶⁸² (Blachère: 1993, 116), it is “négrification de l’écriture romanesque” as well as the oral forms of narrative.

Extending this idea, it may be argued that Ngùgì wa Thiong’o is sure that the mission of a writer is as high as that of an educator and above just an idea of writing to inform or to condemn. He thinks that a choice has to be made between two opposing aesthetics, the aesthetic of oppression, exploitation and acquiescence with imperialism, and the aesthetic of liberation (Ngũgĩ: 1981, 83). In our context, Amma Darko is on the way of writing an aesthetic of independence. Amma Darko’s writing subverts patriarchy and colonialism. She represents history and society. As for history, Amma Darko presents African history as an open wound of oval shape, deep and hard to cure. The wound is the one which began in 1492 when Christopher Columbus discovered the New World. From that day started what became an international and

⁶⁸¹ Ngùgì, w. T. (1986). *Decolonising the Mind: the Politics of Language in African Literature*. London: James Currey, p. 9.

⁶⁸² Selon Jean-Claude Blachère, «la négrification consiste en l’utilisation, dans le français littéraire, d’un ensemble de procédés stylistiques présentés comme spécifiquement négro-africains, visant à conférer à l’œuvre un cachet d’authenticité, à traduire l’être-nègre (...). Ces procédés s’attachent au lexique, à la syntaxe, aux techniques narratives ». cited in Ehora, Effoh Clément (2013). *Roman africain et esthétique du conte*. Paris: L’Harmattan, p. 72.

organized trafficking in human beings by other humans to gain wealth and nobility. Actually, most of present economic and social problems faced by the African continent started from that unfortunate trafficking. Consequently, again and again, African writers of all horizons make use of that historical incident to express their anger, trauma and fear about what happened to their forefathers⁶⁸³. However, what none of these writers mention or hardly mention in their texts is the human trafficking that took place at the oriental coast of Africa⁶⁸⁴.

As a matter of fact, the history of the majority of her female characters seems to be Amma Darko's own history and even that of a whole nation. Some of her female characters embody her spirit and soul and then talk freely about herself. The fact that Amma Darko insists on the oval shape, the material things that Mara can only provide and a simple execution destiny of the autodiegetic female character seems to prove an idea of endless beginning of historical events. This is a reopening of past and still uncured wound since 1492. The prevailing problems of Africans have their source from that year up to today. Globalisation and urbanisation are new deep wounds opened from the African continent's contact to Europe through Transatlantic Slave Trade and later colonisation⁶⁸⁵. Every day seems to perpetuate the colonial logic which is to maintain Africa under the yoke of an unexplainable karma. By and large, we are sure that Amma Darko's characters consciously bear a more traditional role for women while others stand a more flexible view, and some female characters like Mara, Fofo, Efia, 5th Wife show changes in their views and actions in the novels.

Fortunately, the growth and development of modern African literature places traditional oral poetics is playing a very important role. That is why novelists like Amma Darko expect while writing that these possessions of the African oral tradition will nurture their novel form. Therefore, Amma Darko uses African words as a way to communicate the African oral tradition within the frame of the western novel. She weaves Ghanaian ordinary interjections, words and insults into the fabric of her stories which makes her writing stranger and enlightened. This justifies the use of some words in Amma Darko's novels.

⁶⁸³ Ramadanovic, P. (2001). *Forgetting Futures: On Memory, Trauma, and identity*. Lanham: Lexington Books, p. 97.

⁶⁸⁴ Less well-known is a system that went on for centuries longer, but which took place across its opposite ocean mass, the Indian Ocean. The Indian Ocean slave trade encompassed Africa, Asia and the Middle East, with people from these areas involved as both captors and captives. Yet, why writers never talk about it?

⁶⁸⁵ We do not set apart the fact that there was the form of colonisation started by Arabs which was more religious than economic. Historical studies documented that Alexandria in Egypt fell in the hands of Arabs in 643 CE and in 698 CE Carthage to ensure their political influence in Africa around the Mediterranean. They were more seen as saviours from the oppressive rule of the Byzantine (Greco-Roman domination). Africa is still suffering all these different forms of colonisations because no form of colonisation is good.

The word '*wahala*' is a Hausa word to mean 'suffering', 'problem', 'quarrel'. The nickname is given to the enigmatic preacher of the street who "engaged Raja as his assistant with the main duty of keeping an eagle eye on the collection money people would donate, because some people were really bad" (Darko, 242). The word becomes a borrowing for many sub-Saharan communities from Senegal to Nigeria. This proves the nomadic attitude of Hausa before and after the colonisation of Africa. The communities of this part of Africa (West Africa) have many words and expressions that they share. The cultures seem to be the same with just some slightest differences either in the approach or in the implementation. The negative consequences of the Scramble for Africa and its colonisation come to stop the effort of integration of these languages in a cohesive microcosm. These negative aspects of the Scramble also give way to writings such as Amma Darko who portray her male characters as being useless and good for garbage. The following word explains that uselessness in a Ghanaian word.

'*Kwasea*' is an Akan word to label a person of no use, an idiot. It is an insult. The woman who uses the insult means that the man in front of her is useless, senseless. Amma Darko's male-bashing continues and once more it is a female character who treats a male as being unusable. But fortunately enough, the insult does not stop the male character to continue to blame the "crazy educated Ghanaian women who think more white than black in their black skins" (Darko, 242). That expression reminds us of Frantz Fanon's creative and anti-colonialism analysis in *Black Skin, White Masks*. The man condemns Western forces in motion to alienate Africans. It reads: "They started it all" (Darko, 242). The man thinks but mistakenly that the practice of condom underscores the potential and natural power of a man over a woman in a household. According the man, patriarchy is in danger if men continue to obey women's desire by taking on European way of contraception.

Amma Darko's use of the word '*mpesempese*' replaces in fact the expression Rasta man she uses on the page before which states this "Rasta man gained the attention of the man in the light blue shirt" (Darko, p. 186). Amma Darko draws the reader's attention to what we all know about people like that. Rasta men identify themselves as being from a holy land and ordain by God (Jah) to guide the people. The indicated land's flag colour is 'red, yellow and green' which is mentioned by Amma Darko above as the T-shirt of the man. The word 'rasta' is the clipped

form of Rastafari⁶⁸⁶. Generally, when people hear of Rasta, they relate it to the Jamaican singer Bob Marley, Marijuana smoking, the selling of cultural artefacts and the listening of reggae music. The use of drug can be just an excuse. It is a philosophy which finds its roots in the Old Testament (Book of Numbers 6: 5-6). In the doctrine, the adherents consider their body as being a temple of God (Jah). That is why they leave their hair uncombed for many years and use marijuana as the holy herb to perfume and cleanse the temple. They consider themselves more illuminated than any other ordinary people. Although these people consider themselves more open-minded and highly enlightened in terms of spirituality and knowledge as being God's (Jah) chosen people, what that 'mpesempese' man says next cannot be of him. The sentence reads "Every fiscal year we go to them, cup in hand, before we are able to balance our budget" (Darko, 86). What is important to mention though is that the authoress is a tax woman who works for the Ghanaian Revenue Office in Accra. She is more likely to know what happens to Ghana before the budget can be balanced at the beginning of each fiscal year. That news is highly confidential to be on the lips of an ordinary street and news scavenger.

Further, we have the use of the expression 'Charlie wotee' in both *Not Without Flowers* and *Faceless*. These Ghanaian expressions are employed on page 306 in *Not Without Flowers* and on the fifth page in *Faceless*. The expression is more comprehensible in *Faceless* than in *Not Without Flowers*. The sentence states: "Odarley followed, pausing briefly by the door to fish out her *Charlie wotee* from a bunch. She slipped in her feet and stepped out with Fofu" (Darko, 5). The expression then means ordinary, simple and multi-coloured plastic shoes that people wear in their room to go to bath or to toilets. *Charlie wotee* is an Akan expression to indicate these popular shoes. People who have less means use them only for toilet and bathroom, but also for market and other places. They are useful and cheap.

Besides, in the same novel, the narrator uses another strange expression such as *devil's leaf*. It is a word to word translation which means marijuana. In the same novel, it is also called 'wee'. "The vulcaniser seemed to know a lot. He said many of the area's wee smokers take turn with her when they are *high*" (Darko, 39). It is called *devil's leaf* or 'wee' (shortened form of *weed*). The user of the leaf feels *high* because of its analgesic function without loss of consciousness. Due to that function, the leaf acts as a painkiller. The leaf contains a substance categorized as a drug. It inhibits the possible pain that a person can feel while doing something

⁶⁸⁶ Blog: ras-highsay.skyrock.mobi.

hard. The leaf is introduced to Baby T for the same function just like the *snow* is given to Mara to relief her pain for the user knows the active principles of marijuana and cocaine. The ingestion of the leaf has an analgesic effect on the subject just like of the ingestion of Jastram flower by Adelise in *Mamzelle Libellule* (2000). People who take it act like fool that is why the woman shouts out “Or is it some of those [sic] your stupid drugs and the *devil’s leaf* working you up?” (Darko, 28) Another word taken from the Ghanaian language is *Akpeteshie*. The word is used by the countries sharing the bight of guinea. From the start the word is ‘*patash*’. *Akpeteshie* is a local gin taken out of the palm wine and distilled for several hours. It can also be removed from fermented sugar canes. The gin is the most used whisky during traditional festivals and celebrations in many West African countries.

The following word borrowed from the Ghanaian vocabulary is *tro-tro*. It is the public and most used means of transportation in Ghana. It is taken by people who have less means to buy a car. It goes like this: “what do they do to those pupils who come by *tro-tro* and on foot?” (Darko,35). Here, Kabria wants her children to not be flabbergasted and ashamed to take that kind of public taxi if her car continues to break down. Children like Kabria’s can consider themselves fortunate enough to come to school by car since others go on foot and by public transport. In effect, some people do not like to take *tro-tro* because the drivers do not respect the road code. Among other penalties, they stop abruptly wherever potential clients call for them. According to the Ghanaian National Ambulance Service, “*tro-tros* are the most associated means of transportation in road traffic accidents in Ghanaian cities”⁶⁸⁷. The trend in the national statistics accuses this public transportation of disrespecting the slightest mode of driving and parking cars and buses on the roads. Further, traffic jams due to permanent accidents and breakdowns account for the tendency. Damages on traffic lights are also on the list of the charges against *tro-tro*.

Another borrowed word from Ashanti vocabulary is *fos* to mean second-hand. It infers the financial status of the man who is indicated as wearing a *fo* of something. The word has been used in *Faceless* (Revised version, 2010, 41,) and in *Not Without Flowers*. It states as follows “A man mercilessly trailed by the too well known scent of ‘*fos*’, approached them out of the blue [...]. The man was in the true sense of the word, *fos* – full. *Fos* trousers, *fos* shirt, *fos* cap,

⁶⁸⁷ Dr. J. Plange Rhule the president of the GMA’s Speech at the 4th annual public lecture of the Ghana Medical Association (GMA), on the theme “Carnage on our roads - The impact on the Health of the Nation” (2003). Blog by Ransford Ocansey.

fos socks, *fos* shoe” (Darko, 237). The narrator makes use of the word to point to the man who wears currently second-hand of everything. Here is an illustration: “Fine. I’ll help you! *Fos* man assured them, I help people especially young guys like you from my tribe” (Darko, 238). The wearing of *fos* also proves its wearer’s alienation. He is from a class that cannot afford him the specific wearing he likes but he keeps on surface with his all *fos*, brand new second-hand of all. In cities, what seems to be significant is that people display, what they pretend to be. They want to appear socially good and nice to others, but their inner attitude shows a profound malaise. This kind of people are everywhere in the world. Further, the next word is also commonly used in Ghanaian daily conversation and mostly in and around market places.

Kayayoo (*Faceless*, 42 and 168) is also a borrow word from Hausa like *wahala*. It means a ‘porter’, a truck pusher. When he pushes the truck, he usually shouts ‘*agoo...agooo*’ (*Faceless*, p. 44) at people in markets while dragging baggage toward stations or to customers’ cars. In fact, it is an onomastic word which signifies ‘give space, please, give space’. The word can also mean ‘please, please’ like in the following “*Agoo...agoo...agoo* [...] Is anyone home? *Agoo!* Papa Driver called out loud” (Darko, 316). The word is used in many West African countries, especially in markets and public and crowded places. In the same vein, Mary Higgins submits that “Darko’s second published novel, *The Housemaid* and her third published novel, *Faceless*, feature characters who work as *kayayoo*s, or porters, in the marketplace. These symbolic porters make a living by transporting other’s loads”⁶⁸⁸. In fact, Amma Darko casts a critical glance at this unfair use of these children at work, which is against the “Convention on the Rights of the Child”⁶⁸⁹. The declaration is clear, but parents are also obliged to dump their children because of their destitute conditions. Those children have to work hard to feed themselves and their parents left behind. Consequently, one step is to write a convention and another is to help people have encouraging conditions to stop children’s works.

After the present word, we shift to a more delighting one which occurrence makes people happy. Among events which delight people, we have more importantly celebrations through a dance. Oxford online Dictionaries defines dance as rhythmical and aesthetic moves to music typically following a set sequence of steps. Then, it is obvious that people dance to

⁶⁸⁸ Higgins, M. E. (2007). “Ngambika and Grassroots Fiction: Amma Darko’s *The Housemaid* and *Faceless*”. in *Broadening the Horizon: Critical Introductions to Amma Darko* (ed.) Odamtten V. O. UK/London: Ayebia Clarke Publishing Limited, p. 59.

⁶⁸⁹ Convention on the Rights of the Child adopted by General Assembly resolution 44/25 of November 1999.

express their happiness and joy for events like baby birth, naming ceremony, harvest time and folktales' times to bring people together and forge a place where mind and body interact. In Africa, dances which represent a sharp affirmation of cultural beliefs, are purposely oriented each time to express creative skills, male power, sexuality, female submissiveness, mournful events to cite a few. In Ghanaian dances, some traditional rhythms such as 'Kpatsa, Adzewa, Tokpe, Adowa'⁶⁹⁰ and *Mapuka* express people's state of mind and body at the moment of its performance. Each dance reflects the ethnic groups' culture. Ghanaian dances are nowadays re-appropriated to build a national unity and pride.

Mapuka is a Ghanaian dance that consists in wagging one's buttocks to show its nice shape and how it can move excitedly. It is a very sexy dance. In our context, the narrative describes Kabria's emotional condition while she meets Fofu who disguises like a boy in the market. At Kabria's remarking that the thief is not a boy as she thinks, she is shocked and then wants to shake her whole body as if dancing *mapuka*. The narrator puts this way "Kabria wanted to laugh and cry and do the mapuka all in one" (Darko, 47). Here Kabria does not want to shake her buttocks in order to show the market women their nice shape, but want to move as a sign of surprise and astonishment about the situation. The sentence which follows illustrates her surprise to see a girl so skilled and so courageous: "*A girl who posed as a boy to steal my purse? Do you have a name? Yes. Fofu*" (Darko, italic is mine). Generally, in public places like markets, people are sure to bump into thieves (always male thieves) trying to steal their purse, their wristwatch, their cap, their bags or any other items on them. Kabria's astonishment is twofold. Firstly, it comes from the thief's gender and secondly the completely hostile environment. Usually, a thief is known to be of male gender, not the contrary. Then, how come a girl comes a thief and above all in a market? This could be Kabria inner interrogation.

So, if all this unfortunate encounter forces Kabria to move her whole body, it may be for a good reason. As we said earlier that dances are performed for happy events, it happens during the crowning of an honourable or knowledgeable man in traditional settings. Thus, stylistic elements of the dance are employed to better adapt the dance to the event. In all, *Mapuka* is an exaggerated twisting that happens with the buttocks when walking. *Mapuka* in its twisting movements of buttocks show its flexibility and its control deserves its recognition when it occurs during *Nkosoohenes*' crowning moment as performed only by young women. The

⁶⁹⁰ All these cited rhythms are Ghanaian dances performed by different geographical parts of the country.

twisting of the buttocks around the central axis displays their feminine enticing shapes. It is a movement of high energy due to the drums beating patterns employed or the music played. As *Nkosoohenes* are prominent chiefs although being strangers, their enthronement celebration deserves a good dance like *Mapuka*.

Nkosoohene is said of a crowned foreigner in Ghanaian culture. It is an honorific title attributed to a European, not qualified to become king in an Ashanti kingdom, but who contributes to the development of an area where he dwells. The man may marry a Ghanaian woman to be offered the title. The narrator puts it “A love so strong that, was Ghana-time human, he would undoubtedly have been crowned *Nkosoohene*” (Darko, 48). *Nkosoohene* is a traditional title given to a stranger to motivate him for all his actions toward Ghanaian society’s progress. While having a foreigner crowned *Nkosoohene*, trespassers can express their surprise nowadays because of the Ghanaian re-affirmation of nationalism, people are more and more reluctant to attribute these traditional titles foreigners. If then it happens, people have interjection words like *Tweaaaaa* to give way to their astonishment.

Tweaaaaa! is an exclamation used to mock at a person who pretends to do something which visibly he or she cannot. For example, someone who challenges to eat up a whole elephant or who pretends to lift up a car with his fingers can meet that interjection mixed with scornful looks from his mates. The context in which the word is used is this: “Maa Cherie got the message fast. The first customer she tried to convince to book an appointment in the spirit of time consciousness, clucked her tongue in utter dismay, [...] reserving her comments to herself. [...]. The second customer handed her a big surprise on a silver platter: “*Tweaaaaa*” (Darko, 49). The sarcastic word is about Maa Cherie who wants her female customers to behave like American women now by booking their respectively appointments beforehand, ignoring that Ghana is not America and Accra not Chicago or Las Vegas. The word *Tweaaaaa* makes out the impossibility to have that quick change in Accra since the customers come to Maa Cherie’s hair salon not only for their hairdo, but also for gossips and sterile discussions. Fortunately enough, Maa Cherie understands the message fast and “promptly shelved her progressive thoughts. She never brought the matter up again” (Darko, 49). In Ghanaian culture, many other words are used by people to make themselves understood by the audience who knows the sense. The introduction of these expressions helps know the words utterer’s status of mind of the moment. It also shows the beauty and the rich vocabulary of the language. Without being too long, the

utterer makes himself understood by his receiver. Among Ghanaian ready-to-wear shortened expressions which mean a lot, we have *Adweaaaa...eduro no akye no* used by one of Amma Darko's male characters in *Not Without Flowers*.

Adweaaaaaeduro no akye no is a readymade Ashanti expression which means: "Have I not warned you?" People listening to the radio seem to suspect 5th Wife of hiding the truth. In fact, to understand it, we have to go back to the sentence prior to that of the shirtless young guy. 5th Wife carelessly puts: "If producing children for the lineage is their major reason for wanting me to marry my late husband's brother, *then the truth had better come out [...]*" (Darko, 94, italic is mine). In that vein, the Harvest FM listeners think that the woman hides some important information to her late husband and her in-laws that she is now about to disclose. That is why the shirtless young man utters: "*Have I not warned you!*" (Darko, 94). In the same register, we have another Ghanaian expression "*Oyiwa! Ena eda ho no!*"

"*Oyiwa! Ena eda ho no!*" like the above expression are used by unnamed male characters. The expression '*Oyiwa! Ena eda ho no!*' comes after 5th Wife reveals on Harvest FM the reason why she gets married to Pesewa, which concerns her permanent impossibility to conceive and then the opportunity to be lavished with valuable and attention. It is the news which obliges the unnamed man to say 'Have I not told you!' *that the woman is insincere right from the start!* (Darko, 95). The expression '*knickerbockers*' is also a popular word that stands for baggy shorts usually put on by men.

Further, in Ghana there is a more particular reason for writers to deploy national words in their texts which is the great sense of nationalism and independence. Ghanaian political authorities have established music and dance in Ghana's educational curriculum. This is another step towards preserving culture, a step which instils pride and national love. Therefore, the national syllabus points directly the ways and means by which any experienced Ghanaian can make himself understood either through his ethnic dance performance or his national language competence. This reminds us of what Chinua Achebe says about proverbs mattering by Africans which should be taken as oil to eat words. Proverbs like national words and idioms touch not only the user's spirit and the soul but also the reader's and the listener's. Without these words in Amma Darko's novels, we cannot see the extent to which spread the authenticity and originality of the female writer's patriotism despite her long stay abroad. Beyond this primary level, the

female writer demonstrates her attachment to her motherland's culture and arts. While using these Ghanaian words, unlike the ordinary storyteller, Amma Darko makes no improvisation. She utilizes words at their right places to draw attention to her right to have them as her own. She employs them freely as a bird can sing freely, but not like a *Santrofi* which announces bad omen to people.

Santrofi bird is an attractive bird in bush. Because of its demonic power, Ghanaian old age uses it in proverb to warn youth on catching the bird or even laying their eyes on. They think that the sight of it yields curse and long-term problems. Ghanaians believe that the bird is demonic. In our context, Randa symbolises the *Santrofi* bird. The narrator rightly emphasises: "Randa [...] came to possess and occupy and ceaselessly his mind. She became his proverbial *Santrofi* bird. Captured by him in the forest [...]" (Darko, 107). Idan does not pay attention to the old age warning about the bird, so he may rip what he sows. He places his eyes on the bird in its dwelling despite the caution, now "he was neither able to bring her home nor abandon her in the forest" (Darko, 107). The long-standing malediction without doubt befalls him and when Ghanaians talk about bad omen, they mention death and the invisible forces working in pair with it. When it happens to qualify a tragic situation in which occurs human blood and scattered flesh, Ghanaians make use of the word '*Basaa*'. The word is also used when unpredictably fruits and vegetables spackled heavily on the ground and break.

Basaa is a Twi word which stands for mess, confused, bad and not proper. In our context, the narrator talks about Baby T's split head with blood and brain scattered all over the floor as follows "*Den I look well again. Den straight, I seeings dat it is Fati. Her face makes basaa. You cannot look long even*" (Darko, 114). The word is also used by other Ghanaian language speakers. The state of mess can recurrently be noticed in a place like *Agboo Ayee* during intense fights between drunken people.

Agboo Ayee in *Faceless* is the equivalent of Kill-Me-Quick in *The Housemaid*. The narrator puts as follows: "[...] He didn't go to Kill-Me-Quick. He drank just the quarter bottle under his bed ((Revised version, 2010, 58). It is a public place where men and women gather to discuss nonsense and drink the local and traditionally made gin called *Akpeteshie*. People who are usually present in such place wear in the same uniform of *Kaba* blouse. The word *Kaba* means a robe of low price made by seamstresses of poor areas in Ghana. So when villagers send

their female children in big cities for works, they expect these daughters to be put in workshops to learn seaming *kaba* but unfortunately the daughters may indeed be busy building a clientele of their own in prostitution. (Revised version, 2010, 189). The word is also used in *Not Without Flowers* this way to prove that *kaba* is a dress commonly put on by destitute Ghanaian women: “She grabbed her *kaba* blouse and wrenched it off her body” (Darko, 255). When a Ghanaian woman wears *kaba*, we can imagine the class to she belongs because of the linen’s cost. Thus, if men or women who set up unconsciously their residence in *Agboo Ayee* murder their mate due to their ethylic status, they can buy *Wawa* wood to make his coffin.

Wawa is a tree. That type of tree is used for cheap wooden item such as chair, table and coffin. Carpenters employ that kind of tree when people cannot afford the other types of wood like ebony, cashew, maple, teak, redwood. In our context, the narrator wants to draw the reader’s attention to the financial status of Cityman and also the fact he (dead) has no relatives or kin where he dies to afford a costlier coffin as many Africans like to have for their dead parents. In Africa, coffin trade is a very lucrative business. In our case, people who find Cityman’s body cannot afford more than that. The narrator carries on this way: “Cityman’s body was washed ashore at the beach. Cityman found his final resting place at Mile Eleven, in a *wawa* coffin, sharing his grave with seven other bodies of unknowns and unclaimed in similar *wawa* coffins (Darko, 239). The death of the poor Cityman raises serious interrogations about homosexuality in Africa. The narrator focuses on the fact that those prefer to have sex with fellow men are “some white people” (Darko, 238) who trap young and unemployed Africans for the job. They also have some African spokesmen to negotiate the business. That transaction seems to be similar with that of Transatlantic Slave Trade in the olden and dark days. The implication of African fellows in the trade is completely proven. Here the connection man at the *beach* is embodied by “a guy in an obscenely tight pair of indigo swim pants and wearing two gold chains with no pendants” (Darko, 239) who meets Raja Hey and his friend. The emphasis of the narrator about the expression “*at the beach*” is also very important as to direct the reader’s attention on what have seen affirmed above. The beach is the slaves’ destination when Asanti and Fanti slave traders collected them from inner villages. They were put like mere goods inside Elmina Castle.

Secondly, Cityman, the slave is found dead ashore at the beach. This stands for the common place where slaves died if they were found useless or when they rebelled against their

furious masters. As if Amma Darko maps once again the historical trade of Africans, Cityman is buried in a grave with seven of other unknown bodies. Beach and ocean represent a landscape of African history pertaining to Transatlantic Slave Trade. Beach symbolizes the last place where slaves stop thinking of their homeland, wives, children and belongings. When the long slaves' coffles reached a beach, they knew that any hope to escape or to be released was lost. In the 1990s in Ouidah, a Benin's city involved in the slave trade at that time, a cemetery at the borough called *Zomatchi* (which means in the local language 'the flame cannot stop burning') thousands over thousands of bones, skulls and other human body parts have been discovered and dated to the period of Transatlantic Slave Trade. The hole has served as a collective grave for worn-out and deceased slaves as a result of their exhaustion or killed because of their bad and rebellious temper. It has been affirmed that some of them have been buried alive as found useless for the slave drivers. The practice may have been also done at Elmina Castle and Gorée Island. All these departed souls have been celebrated during the International Festival Ouidah 1992 financed by the State House and some volunteers from African Diaspora. Striking and haunting marks of that trade are still present in Africans' collective memory as if it happened a few days ago.

Thirdly, the narrative informs us that the poor Cityman was buried with seven of other unknown and unclaimed bodies and the number seven used by the writer draws our attention. Then, we try to investigate on the real significance of the number. According to the *Oxford Advanced Learner's Dictionary of Current English*, a number is a word or symbol that represents an amount or a quantity. Then the notion of numbers and counting dates back to prehistory, and all societies have some system of counting. The number seven (*seven of other unknowns and unclaimed bodies*) has much emphasis in mythology. Consequently, the fact that Amma Darko puts together with Cityman seven other justifies her beliefs in Cityman's innocence and young age to die and also her belief in numbers' interpretation in African spiritual cosmology and symbols mythology. The world is then an association of number, symbols and signs visible and invisible.

To end with the list of the Ghanaian words used in Amma Darko's novels, while reading *Not Without Flowers*, we come across a popular work song which literal translation stands as follows:

Yoo ko mli nshi kelekele ye Africa ...
 There is a woman selling small slices of fried plantain in Africa
 Mli nya bi Mami kaple ke yahe eko ...
 I am going to ask my mother for a penny so I can buy some
 (3) Be ni mi she dze me le ake eta ...
 When I got there they said the small slices of fried plantain were finished
 (4) Eta ...hop...kelekele eta...
 It is finished; the small slices of fried plantain are finished.

Amma Darko, apart from being a novelist doubles her aptitude in poetry. This ability makes her writing more attractive and worth reading. Related to the above passage is how Amma Darko can revive a popular but almost forgotten work song. The aforementioned song is used as an intertext in the novel. In the past, it was sung to motivate men at work in harvest time. Amma Darko makes use of that song for many reasons. Before mentioning those reasons, we try to make a distinction between the categories of songs which can interest a novelist in a fictional text. For the Ivorian Effoh Clément Ehora, there are two different kinds of songs that an African writer can use in a fiction to raise awareness on African cultural productivity. Effoh Clément Ehora carries out his point of view this way:

Les textes poétiques souvent convoqués en contexte d’oralité dans le roman africain sont les chants, les prières, les incantations et les paroles de libation. Le chant, en tant que pièce en vers divisée en stances reliées généralement par un refrain, est un texte poétique. On en distingue deux types dans les romans : les chants lyriques et les chants rituels qui sont exécutés à l’occasion des fêtes ou cérémonies traditionnelles telles que les noces, les commémorations, les libations.⁶⁹¹

If we relate the above definition to Amma Darko’s traditional work song, we realize that songs follow specific purposes. First of all, the song in italic lets us know that it is a language other than English and the emphasis is worth making. It also matches with Chinua Achebe’s advice to African writers in his essay *Morning yet on Creation Day* (1975) that they should use English in a way that brings out their message best without altering the language to the extent that its value as a medium of international exchange will be lost. The writer should aim at fashioning out an English which is at once universal and able to carry their peculiar experience. Chinua Achebe accomplishes this by innovatively introducing Igbo language, proverbs,

⁶⁹¹ Ehora, E. C. (2013). *Roman africain et esthétique du conte*. Paris: L’Harmattan, p. 67.

metaphors and ideas into a novel written in English. Chinua Achebe, in a speech entitled 'The African Writer and the English Language' (1975), says this: "Is it right that a man should abandon his mother for someone else's? It looks like a dreadful betrayal and produces a guilty feeling. But for me there is no other choice. I have been given the language and I intend to use it" (Achebe: 1957, 62). He also agrees that a writer should write for a social purpose. Rightly then, Amma Darko follows this footsteps like a good trainee since oral tradition implies a situation in which transmission is carried out by word of mouth through a direct contact of individuals in society. To assure this transmission, people set celebrations such as age group party, family frequent enjoyment where grownups, children and old age come together to share their culture. Such values are usually expressed through songs performed in public. Good performers are granted awards like plots of land (material) and social respect (immaterial). By the mouths of mothers in Africa, riddles, poems, proverbs and songs are inculcated to children and young adults. This practice is more and more eroding because of the western model of culture and education.

In this regard, the popular work song here depicts Dina's daily working routine. Dina, the female character in *Not Without Flowers*, a former University girl, from the opening of the morning exercise with her rope starts singing a modern song like "Mary had a little lamb, [...]" (Darko, 182), then she makes up her mind. Dina makes "a revolt of the conscience" (Darko, 182). The western verse sung by Dina is in connection with the factors that impact the people of her country, the British former colony. The verse reminds Dina of Ghanaian colonial legacy on her psyche and by extension to that of a whole nation. It means years after colonization, Dina as a colonised entity continues to be alienated if she carries on singing that "Mary had a little lamb" song (Darko, 182). Further, the verse teaches how to be docile and submissive to a master. The word lamb means then an object of sacrifice. A lamb shall accept its destiny which is to be unfairly accused, to be slain and to serve as an offer to a deity. It points out the biblical reference of Jesus as a lamb and Mary as his mother. Then, a former colonised like Dina should, like a lamb, accept her destiny which is to stay submissive all the time.

By highlighting this, Amma Darko exposes issues that have been long time suppressed and ignored among which is the cultural alienation of Africans intellectuals. This, incidentally, is a helpful way of understanding how the legacy of colonialism continues into the post-colonial era, "because quite clearly, imperialism as an ideological form of cultural and economic

dominance continues far beyond the cessation of formal colonial rule” (Said: 1978; 1993). Due to this legacy, Africans have to make a psychological revolution before succeeding in confronting the colonial established order.

Extending this idea, we understand that the process of teaching European songs and rhymes in African schools is in line with transforming and subjugating Africans’ mind and psyche. In this scope, Edwin Smith well illustrates the trend in his famous book *The Golden Stool* (1926). He writes:

The first method begins by destroying the institutions, traditions, religion of the people and then superimpose upon the native ruins whatever the conquering governing power considers to be the better administrative system. The other method is to graft our higher civilization on the soundly rooted native stock, bringing out the best of that is in the native tradition, and moulding it into a form consonant with our modern ideas and higher standards⁶⁹².

Western settlers succeeded in erasing at last the most significant part of African culture and civilization before introducing theirs. The process has been through space and time. It has required patience and treachery. Finally, things fall apart. African people become anew mastering other peoples’ languages, songs, tales and proverbs like the one Dina tries to sing. The song maps the inner malaise of a post-colonial entity like Dina. That new condition of colonization is evoked in Kwame Nkrumah’s *Neo-Colonialism, The Last Stage of imperialism* (1965). In his detailed study of neo-colonialism in Africa, Kwame Nkrumah, one of the greatest figures of twentieth century, explains the stranglehold of foreign monopoly that perpetuates poverty in Africa this way: “The essence of neo-colonialism is that the State which is subject to it is, in theory, independent and has all the outward trappings of international sovereignty. In reality its economic system and thus its political policy is directed from outside”⁶⁹³. This is how African countries’ economic and political conditions have been programmed by the former colonizers to continue yielding money, social and economic stability to them (Europeans). The process of African expropriation out of their own lands, their properties and their cultures is a very disguised one. Used in this sense, neo-colonialism is a structured relationship of a new

⁶⁹² Smith, E. W. (1926). *The Golden Stool: Some Aspects of the Conflict of Cultures in Modern Africa*. London: Edinburg House Press. Holborn Pub, p. 186.

⁶⁹³ Nkrumah, K. (1965). *Neo-Colonialism, The Last Stage of imperialism*. New York: International Publishers, p. ix.

domination of where the former dominants are still ruling and the dominated still under the yoke of the former master. The independence granted was just a subterfuge, a mirage to lure African liberation fighters. That illusion of independence is the system which drags Amma Darko's female character Dina to school to learn European songs in an African place of knowledge.

At the last resort, Dina is taught realities that have nothing to do with hers. She is taught a complete submission to foreign songs while at school, but while playing at home, Dina uses certainly her maternal language with "words through riddles, proverbs, transpositions of syllables, or through nonsensical but musically arranged words"⁶⁹⁴. This is in line with Lawrence Bamikole's submission "Societies that have been colonized are negatively affected in many ways, most important of which is the erosion of their cultural values"⁶⁹⁵. The national rhyme has no place in imperialist system which takes over Africans' mind and psyches. It is called vernacular and treated as an obscene rhyme because subalterns cannot make good rhymes. Everything good hails from the West. In the range of reaction, Frantz Fanon gives us insightful analysis about the way the former coloniser acts to subvert African people's mind in *Black Skin, White Skin*, so that African people think that the best for them is to conform or get conformed to Western models.

In such a situation, what is fundamental for Africans is to consciously start a change like Dina's "revolt of conscience" (Darko, 182) and then honour national songs and cultures more often than other nations' rhymes. These rhymes have no similar cultural realities with those of Africans. The narrator illustrates the point as follows: "The lamb with fleece as white as snow taking charge of an exercise routine on grounds upon whose surface no snow had ever fallen" (Darko, 183). Africans should stop importing solutions from beyond their borders which do not fit their national problems.

By the same token, Homi K. Bhabha has conceptualised linguistic and socio-cultural hybridity in postcolonial terms, as the site of the enunciation of cultural differences in the grey zone of interaction between oppressor and oppressed, between coloniser and colonised, which makes possible resistance and survival⁶⁹⁶. Yet, before the Indian literary critic, Homi K. Bhabha,

⁶⁹⁴ Ngugi, W. T. *The Language of African Literature*, p. 286.

⁶⁹⁵ Bamikole, L. (2012). "Nkrumah and the Triple Heritage Thesis and the Development of African Societies". In *International Journal of Development, Humanities and Technology*, Vol.2, No2, p. 1.

⁶⁹⁶ Bhabha, H.-K. (1994). *The Location of Culture*. London / New York: Routledge, pp.17-18.

develops his idea, Edward Said has tried to pinpoint the foundation of that hybridity in his well-known *Orientalism* (1978). Edward Said unmask the unholy nexus between knowledge and power in the mapping of the “Orient” that abetted the colonial enterprise. His *Orientalism* examines “the ways in which colonial discourse operates as an instrument of power, initiated what came to be known as colonial discourse theory”⁶⁹⁷. The notion is later termed “Post-colonial Theory” and backed up by contemporary critics like Gayatri C. Spivak, Homi K. Bhabha, Ngũgĩ wa Thiong’o to name just a few. His criticism touches the foundation of Western civilisation in relation with former colonised peoples’ literary creations. The juxtaposition of two or more cultures within an identity creates the capacity of using either both cultures or one. That permanent alternative to African languages will continue to find its path in African literature. For example, it occurs in African fiction that the way dialogues and conversations are often represented as transcriptions in English of what is naturally done in local languages. In that case, literature is in the service of society in the sense that it mirrors the reality occurring in that society. Other African writers try to find another way to express themselves by adopting a rotten language called pidgin, a non-standard English as a technique of writing fiction. In this mirror, we have writers like Ken Saro-Wiwa’s *Sozaboy* and Brian Chikwava’s *Harare North* and even the Nigerian poet Odi Ofeimun’s *London Letter and Other Poems* (2000). A Nigerian reader of *Sozaboy* may not be surprised of the language used because he or she is used to, yet a reader from Ireland, Zimbabwe or South Africa will be shocked and amused. This is the same shock with *Harare North* in Liberia, New Zealand or Jamaica. According to Barrie Rhodes the “standard” is a human choice that could have been otherwise (like driving on the right or left). It is not in any intrinsic way better or worse than other dialects. Further, when writers use that sort of language, readers think that it is to show his own educational limit like that of Amos Tutuola’s *The Palm Wine Drunkard* (1952), but in fact, writers like Chinua Achebe places some of their protagonists (Chief Nanga in *A Man of the People*) in this position to reach a specific and national audience. Ken Saro-Wiwa wants to reach that same readership while narrating Biafra’s war in his novel. The narrator says:

⁶⁹⁷ Ashcroft, B. et al (2007) *Post-Colonial Studies. The Key Concepts*. (2nd Edition). New-York: Routledge, p. 37.

The man with fine shirt stood up. And begin to talk in English. Fine fine English. Big words. Grammar. Fantastic. Overwhelming. Generally. In particular and in general'. Haba, God no go vex. But he did not stop there. The big grammar continued. Odious. Destruction. Fighting. I understand that one. Henceforth. General mobilisation. All citizens. Able bodied. Join military. His excellency. Powers conferred on us. Volunteers. Conscription'. Big words. Long long grammar. Ten heads. Vandals. Enemy'. Everybody was silent. Everywhere was silent like burial ground. Then they begin to interpret all that long grammar plus big words in Kana. In short what the man is saying is that all those who can fight will join army. (*Sozaboy*, 46-7).

On the one hand, when that kind of language is spoken to people who are used to, they feel at ease to listen and understand the speech. But when they are not, it becomes very boring and shocking. The case of the soldier boy reveals it the dichotomy so clearly. Rightly with Chinua Achebe's *A Man of the People*, we see that the writer displays this linguistic technique to prove that different situations and role shifts demand fitting language code for operative communication. This is an example with Chief Nanga speaking: "You call this spend? You never see some thing my brother. I no de keep aniti for myself, na so sotroway. If some person come to you say I wan make you Minister "make you run like blazes commot. Na true word I tell you..."(Achebe, 16) and the same Chief Nanga speaking in Standard English to Odili Samalu, a postgraduate who studies overseas: "If you come as soon as you close, you can stay in my guest room... you can live by yourself and do anything you like there"(Achebe, 20). On the other hand, the author does fail to combine the ordinary life to literary experience and politics. Chinua Achebe's novel becomes reflectors of history in making.

Hence, in our context, Amma Darko's characters' predicaments are not so demanding to this extent. This is why they manage with the Standard English without mixing up to pidgin. Dina psyche's rings a revolt against the foreign song satisfies the above conditions like that of Modin, a Harvard-educated, in Ayi Kwei Armah's *Why Are We so Blest?*

In the narrative, Modin drops the western oriented ideology school when he realises that educational system in a postcolonial country is trapped in a woven net in order to allow its subjects' alienation and acculturation endlessly. Thus, the colonial indoctrination lies in the form of teaching mechanism in postcolonial schools. Modin thinks that the Western educated Africans are half-poisoned by the oppressor's values which actually hinder the African revolution process. Throughout the writing, the narrator seems to suspect school (the way it is

built in former colonies) as serving an imperialist purpose. Similarly, presented this way, Amma Darko shows the extent to which her novels are politically engaged like her male counterpart Ayi Kwei Armah in *Fragments* (1969). Additionally, the novel combines fiction to facts and can be perceived as faction, which means a sub-division of literature that fictionalizes facts and realities. The present point is in line with that of Vincent O. Odamtten who states that:

Yet the fact remains that the writer, whether on the Continent or in the Diaspora, struggles to give artistic form to our collective needs and to describe the often half-perceived possibilities and dangers, even as she outlines a safe harbour far from the storms of a homogenising globalisation⁶⁹⁸.

Vincent Odamtten's idea above echoes properly in the environment where it should be. African writers take on their hybridity ability into account and write by using it. From that perspective, we notice that all the Ghanaian words in Amma Darko's texts demonstrate the hybrid colour of her texts and her tough predicaments as a postcolonial writer. She is obliged to use the former colonisers' language to convey the message to her people and beyond the horizon. This does not mean that she fails in conveying the quintessence of the message or to compromise her mission as African literature writer of the third generation. This surely corroborates Kwaku Asante-Darko's opinion about language used in post-colonial writings:

The choice to imitate foreign languages and cultures in African literature will continue to provide a unifying center for the myriad of African languages and cultures for which the political and legal implications of a return to pre-colonial multilingualism and culture diversity are neither desirable nor possible⁶⁹⁹.

The similar statement has been defended by the South African poet and novelist Ezekiel Mphahlele (1919-2008) about the use of French and English as means to convey an African writer's message worldwide. Hitherto, Amma Darko seizes the necessity not to wipe away her own culture and her identity as African. Hence, the female author's texts justify their importance in the sense that they raise our awareness and consciousness of language power of subversion. Language vehicles people's ideology and most essentially it carries out people's real motivation and their need to dominate others. Language assists or contributes to the way some people are

⁶⁹⁸ Odamtten, V. O. (2007). "Beyond the Comfort Zone: Relations Between African Writers and Audience". In *Broadening the Horizon: Critical Introductions to Amma Darko* (UK: Ayebia Clark Publishing Limited), p. 1.

⁶⁹⁹ Asante-Darko, K. (2000). "Language and Culture in African Postcolonial Literature." *CLCWeb: Comparative Literature and Culture* 2.1. <http://dx.doi.org/10.7771/1481-4374.1062>

dominated. This shows that the new configuration of a former colonised engenders eternally an alienated mentality if determinedly he does not reconsider his mind and ride back to his culture.

Thus, if we look closer to Amma Darko's literary attitude, it is similar to the Negritude pioneers' protest against racism and the domination of a people over another. That francophone pan African movement was an elitist gathering that probed many African and university men and women in politics and literature to denounce the African people living conditions. The prejudice of being dominated characterized the pioneers of African literature. In other words, bitterness and rancour trail the work of the female writer and her writing is socially relevant. The movement did not receive the same enthusiastic appraisal from the Anglophone world. One of the greatest African literary critics from Nigeria, Wole Soyinka, criticised the essence of its foundation. The Nigerian Nobel Literary prize winner, Wole Soyinka, disagreed with the Negritude approach in "asserting Africaness as he euphemistically proposes tigritude"⁷⁰⁰. Wole Soyinka proposes a counter-motion to Negritude⁷⁰¹ that he calls *tigritude*. The *tigritude* is a coined word from the satire writer who called these negritude pioneers to imitate a tiger's attitude towards its prey. A tiger symbolizes the African people and its prey the former colonisers. Thus, between the two African writers sets a dialogue that creates a startling balance between Léopold Sédar Senghor and company offering confident and, perhaps, too serious exultations over the Pan-African focus of the literary movement Negritude, a black intellectual philosophy founded in France in 1930 and Wole Soyinka providing a wry dissection of the movement's triumphs and failing. As a result, what is important is the contribution of both in African development irrespectively to their philosophical and conceptual differences. The African continent needs all the hands from its children to reconstruct its past, to face its present and build up the future. The continent is rich of its people and of its ground resources to fit the challenges of the coming years, decades and centuries.

In this trend, Amma Darko does not want to shy away her country's cultural richness in meaningful rhymes, in versification, in tribute paying to African authentic items and significant musicality. Simply put, only African educated brains like Dina have the power to turn the

⁷⁰⁰ Ariole, V. C. *Negritude and Tigritude: An Analysis of Language Contents for Development Purposes*. Lagos

⁷⁰¹ The coined word Negritude was invented by Aimé Césaire in 1936 who meant this while creating it: "La simple reconnaissance du fait d'être noir, et l'acceptation de notre histoire et de notre culture." (*Liberté* 3, pp 269-210.) The word was first used in Léopold Sédar Senghor's *Le Portrait*: "Il ne sait pas encore l'entêtement de ma rancœur aiguisé par l'Hiver ... Je suis d'autant plus libre de défendre le terme, qu'il a été inventé non par moi, (...) par Aimé Césaire."

tendency around since they know the magnitude to which the colonial legacy has developed. Then they must militate for its skipping aside to embrace what is genuinely African. Dina's attitude proves with great insight the necessity for Africans to return to their cultural root for the sake of their identity rather than to continue to be imbued of foreign cultural reality. Taking into account the song, we all know that Ghana has never witnessed a snow fall, therefore there is no way singing a song which pays tribute to snow in a country where the average temperature in the shade varies between thirty and thirty-eight. Most importantly, African countries have different rain and heat seasons to Europeans'. Moreover, the woman that sells *kelekele* (slices of plantain) should be proud of her *kelekele* wherever she lives. Amma Darko succeeds in creating a want to become nationalist, and in the same vein, to know more about the poem, the author of that anonymous song and above all the Ghanaian words to size the aesthetics of the language.

In fact, the novelistic look of hybridity concerning culture and language, by Amma Darko, can be interpreted as a way of conveying the complexities of postcolonial experiences, simultaneously exposing the peaceful overlapping of practices from different cultures. As for Walter Ong quoted by Emmanuel Obiechina, "the first discovery is that the oral culture does not immediately disappear by the mere fact of its being in contact with writing, nor does the literature of the oral society disappear because of the introduction of written literature"⁷⁰². The dynamism of orality is not absorbed by the introduction of the written form of literature; rather it enhances it. African orality needs the written form of literature and vice versa. The French critic Jacques Chevrier gives an opposite assertion by declaring:

A une civilisation de l'oralité se substitue donc progressivement une civilisation de l'écriture dont l'émergence est attestée par l'apparition d'une littérature négro-africaine en langue française. Cette littérature, dont les premières manifestations remontent à 1921, s'est affirmée dans les années qui ont précédé l'accession à l'indépendance des États africains et elle s'est déployée dans plusieurs directions⁷⁰³.

What is worth noting in Jacques Chevrier's statement that conjectures a possible vanishing of African orality which progressively gives place to a written literature, as if the European written form of literature is more interesting than African orality. It does not match to

⁷⁰² Obiechina, E. (1992). "Narrative Proverbs in the African Novel" in *Oral Tradition* 7/3, pp. 197-230.

⁷⁰³ Chevrier, Jacques (1984). *Littérature nègre*. Paris: Armand Colin, p. 25. « To the civilisation of orality is substituted progressively a written form which emerges. The rising of that written literature is certified by the Negro-African literature in French in 1921 and then asserts itself in the years of independence of African countries to this date". (My translation)

our sense. The written literature rather helps integrate African metaphors, legends, proverbs, images and allegorical symbols. None of the two literatures works to subordinate one another. In African context, the written literature needs the oral as the orality needs the written form to expand and makes itself known. This fact is corroborated this way « La littérature, étant la transcription organisée de la pensée humaine, est d’abord pensée avant d’être orale ou écrite. En Afrique et ailleurs la signification est certainement la même dans la forme »⁷⁰⁴. In this scope and according to Ngũgĩ wa Thiong’o African mind is worth decolonising before he can realise the hazardous trend of colonial legacy in his mind⁷⁰⁵. As Ashcroft et al (1995) warn: “All post-colonial societies are still subject in one way or another to overt or subtle forms of neo-colonial domination, and independence has not solved this problem” (Ashcroft, 2). It is also important to realise the significance of this caution in the sense that the damage done to African cultures by colonialism is somewhat irreversible. It is on this basis that Ngũgĩ Wa Thiong’o urges Africans intellectuals to counterattack the new domination embodied by imperialism by writing in their own language because knowledge does exist in African languages. As a matter of fact, he starts writing in Gikuyu to reach a larger but national audience. The novel *Devil on the Cross* (1980) was first written in Gikuyu as *Caitani Mutharabaini*. The rebel writer tries also many other writings such as *Matigari Ma Njirungi* (1986), and *MurogiWaKagogo* (2004). Since 1978 Ngũgĩ wa Thiong’o has not the only African writers to decide this. Other African writers have had their works translated into English among whom Nawal El Saadawi. She writes in her native Egyptian Arabic language which lifts her to the generality of women in the whole Maghreb. The aesthetic of a language quickly shows off when the message is written one own’s language. The case of Nawal El Saadawi is an example among others since people have mostly been schooled in Arabic language with some little differences from Morocco to Algeria, and from Tunisia to Egypt. To stop imperialism, African writers have then to stop conveying their message of their mind’s decolonization in their former masters’ languages.

In this vein, Edward Said (Said: 1978; 1979) rightfully makes the difference between colonialism and imperialism. According to him, colonialism is physical, material and particularly brutal against the oppressed people, whereas imperialism is theoretical, ideological and cultural. Imperialism is the soft and mild version of colonialism since it continues to devastate colonial territory far beyond the former boundaries of colonialism. Former colonial

⁷⁰⁴ Ainamon, A. (2016). “Conflits Culturels et Littératures en Afrique”. Bari University Press, p. 11.

⁷⁰⁵ Ngũgĩ, W. T. (1986). *Decolonizing the Mind: The Politics of Language in African Literature*. London: J. Currey.

territories consume to enrich former colonial masters' territories, but do not complain. To that lethargy from post-colonised, Frantz Fanon opposes a legal fight and puts "To fight for national culture means in the first place to fight for the liberation of the nation, that material keystone for culture which can develop apart from the popular struggle"⁷⁰⁶.

This is the reason why Ngũgĩ wa Thiong'o recommends vehemently a new way to tackle the issue. So far, before Ngũgĩ wa Thiong'o suggested this trend, Thomas Mofolo (1876-1948) wrote *Moeti oa bochabela* (1907), *Pitseng* (1910) and in the same year *Chaka* in Xesoto while the Nigerian Daniel O. Fagunwa's *Igboju odè inu irumalè* was translated into English as *The Forest of Thousand Demons* (1968). The rhymes and the vibes are so vivid to prove the root of a civilisation and the *raison d'être* of contemporary African people. These writings make evident of the originality and authenticity of the aesthetics in African languages. What is possible in European languages is also possible in African ones. The step of African intellectuals is the necessity to decolonise their mind. African languages are also worth learning and teaching. They should walk then side by side with other languages. Then if the storyteller is well-rooted in those African rhetorical symbols, the message or the story is delightedly enjoyed like a good soup with the appropriate pepper and other bitter ingredients. It is like Achebe's palm-oil with which words are eaten. The fiction writer takes her story from what happens around her that she mixes with her own imagination to make it more digest delightfully. Through that mechanic, the storyteller shows the richness of her culture. In that scope, many scholars try to find a good and simple definition to culture that synthesize all the aspects.

As a result, Margaret Mead (Mead: 1953, 13) postulates that culture referred to "the whole complex of traditions behaviour which has been developed by the human race and is successively learned by each generation"⁷⁰⁷. If taken so, then, Amma Darko's fictional writings are culturally rich and divers, despite the complexity of her feminist approach. Taboo subjects are discussed in her fiction without being truly direct. For example, during sexual scenes, Amma Darko prefers to refer to that act as 'entering' the female character's body or making allusion like 'the thing' rather than writing 'penis'. These four examples illustrate the caution in the use of language particularly the use of words: the first is this: "Wordlessly, he stripped me off my

⁷⁰⁶ Ashcroft, B.; Griffiths G. & Tiffin H. (1995). *The Post-Colonial Studies Reader*, p. 154.

⁷⁰⁷ Mead, M., M'ettraux, R. (1953). *The Study of Culture at a Distance*. University of Chicago Press, p. 13.

clothes, stripped off his trousers, turned my back to him and *entered* me” (Darko, 22, italics mine). The second reference to sex without mentioning the word penis is this: “Then he took my jeans, spread them on the bathroom floor, and knelt down. I felt him *enter* me from behind and the second he was out of me again and demanding hastily to know whether I had taken something against pregnancy” (Darko, 84, italics mine). Thirdly, the narrator puts with disgust: “Vivian, who taught you to rub Osey’s *thing* in your hands and put it in your mouth?” (Darko, 90; italics mine). The fourth example goes like this in *Not Without Flowers*: “When I wanted to be *intimate* and *he didn’t*, I accepted it without qualms because I had no reason to feel he neither wanted nor desired me” (Darko, 272; italics mine).

The reference to that kind of abstraction can surprise the reader of European culture. It can seem grotesque because they are used to mention sex as freely as possible. Whereas, in most of African writings, taboo words like *penis* or *vagina* are rarely mentioned because of the attention and the reverence Africans give to them. The technique from female writer is to remove the sensibility or the excitement which comes out of the act. African female writers sometimes use metaphors. For example, when in a narrative, the writer refers to a waning flower; she may be talking about a male castration or weak manhood colonised by diseases. What matches well with penis in African literature is its reference to a wooden living object. So far, men and women refer to the male sexual organ as a tail because of its reverence. So if a character refers to the male sexual organ as penis, this may be the author’s wish to make loose that character’s mental alienation. In African literature, writers do not talk about sexual organs (penis and vagina) so crudely and so abruptly. Is it really because of their reverence or the shame their reference provides? Why simple organs should not be mentioned the same way we mention our eyes, our legs and our stomach? Why particularly this part of the human body may not have a name in literature, though literature is *par excellence* a tool that teaches norms and values? This indirect reference to sex occurs in the Mandingue culture, the former Sundiata Keita’s Mandingue society, where manliness is the social barometer for all and in all. Then, writers transfer the shame they feel in their society in literature by not being rude and impolite. They inherit that shame from their people and do not free themselves from it until they become writers.

This is why Africans have many euphemisms to describe it as it is difficult in many cultures to make sexuality or any other intimate body part an approved subject in public. This is

why they take in impolite and vulgar. It is much more about avoiding being that vulgar in public than a reverence vowed to the organ. As people await their daily discussion to be mindful to these norms, they are surprised to find this vulgarity in novels. This surely leads the patriarch Chinua Achebe to treat Ayi Kwei Armah's *The Beautiful Ones Are Not Born* as having not respected this norm. He considers Ayi Kwei Armah an outright pessimistic author, bound to aesthetic and philosophical canons that utterly western. He goes further and treats the Ghanaian's writer as having written an existentialist novel à la Camus⁷⁰⁸, the French writer. In fact, in the narrative, Ayi Kwei Armah demonstrates his eloquence and establishes right from the start his trademark as a moral writer in a decaying Africa. Although the writer uses an unconventional language, this seems not to be vulgar. The Oxford Advanced Learner's Dictionary (2006:1648) defines vulgar as "not having or showing a good taste; not polite, elegant or well behaved". This position is comforted by Alexander Dakubo Kakraba who submits that Ayi Kwei Armah uses it:

to serve as an electroconvulsive tool. In other words, it is intended to shock the reader to calculatingly draw his or her consideration to the dreadfully shocking and repulsive things and behaviors like corruption, materialism, moral degeneration, filth and the pervasive moral, spiritual and physical decadence in the society so as to effect a change⁷⁰⁹

Ayi Kwei Armah uses cruder, ruder and somewhat 'impolite' language by referring to 'VAGINA SWEET' through the mouth of the narrator. A similar rude image is described in Wole Soyinka's *The Interpreters* and even later Chinua Achebe himself in *A Man of the People* (1966) to draw the reader's attention to African political leaders' insatiable greed in Nigeria after independence. This is a kind of venom to cure venom. These writers employ rude and insulting words to point the rapid putrefying African society after the independence. Even Cyprian Ekwensi's *Jagua Nana* and *People of the City* have never been so crude. Ayi Armah's narrative is one of the first to portray deliberately and bluntly the canal parts of human body by using words like 'shit', 'juicy vaginas', 'fuck', 'arsehole'. For the write, it is an emergency to point blatantly the human body parts which are causing all contemporary African social issues

⁷⁰⁸ Albert Camus was a French philosopher born in Algeria in November 1913. He was known after his novel *The Outsider* or *The Stranger* (1942) and his essay *The Rebel* (1951). He was considered to be existentialist during his life, what he absolutely rejected. He won the Price Nobel in Literature at the age of 44, which propels him as the second youngest recipient in history after Rudyard Kipling at the age of 42. Albert Camus died during a car accident in January 1960.

⁷⁰⁹ Kakraba A. D. (2011). Ayi Kwei Armah's Vulgar Language in the *Beautiful Ones are not Yet Born*, a Therapeutic Tool in *Current Research Journal of Social Sciences* 3(4): 306-313, 2011 ISSN: 2041-3242, p. 1.

after those of transatlantic slave trade, colonialism and neo-colonialism. Rather than portraying the characters without their organs, “Armah’s prophetic harsh voice will continue to echo in his readers’ ears”⁷¹⁰.

Nonetheless, in some African writings, emasculation can be metaphorical in the sense that it does not mean the removal of the organ. It can mean a political incompatibility or social incompleteness. This incompleteness is evoked in Ousmane Sembene’s *Xala* (1976) where after the El Hadji’s wedding, he is unable to consummate his marriage with N’Gone, his third wife. Obsessed by this sexual loss, he believes to have been cursed with xala, a condition which leaves him impotent. When this body part suffers, things fall apart in men’s world. That is why El Hadji Abdou Kader Beye agrees desperately that diseased beggars spit upon him to have back his potency.

What is also central to mention is that Amma Darko, the authoress is by the same token the narrator of the story. Although, this seems to be party and judge, it does not intrude in the story telling. In that way, the attentive reader has to care about the author’s intention and voice as presented by the narrator. First, in *Not Without Flowers*, the *mpesempese* (Rasta man) talking about fiscal year, balance budget and all the extremely confidential information about financial arrangements between the Ghanaian authorities and the West is not something popular. That account is rather strange from a man like him (Darko, 186). Secondly, when Fofu, the street girl insists to meet and talk to government (*Faceless*, 47). In actual fact, the teenager cannot know that it is the government of her country that fails in his statement’s obligation to offer the required protection to his citizens. So far, Fofu breaks into all the patriarchal system with her courage. She stands off her father’s absence and her country’s government inaction. In the narrative, the government stands partly for Fofu’s real father who decides to be absent right from the start. She dares to raise her voice against her father in a way that does not directly confront him. Fofu, the revolted child, talks about the government of her country because her suffering hails from a source beyond her father’s absenteeism which can be embodied in that government. Thirdly in *The Housemaid*, the little Bibio, rebuking her mother for her indecision and passivity for so long time is, to name just these few examples, the authoress’s own voice and opinion. The little Bibio cannot understand why her mother accepts to go on bearing child

⁷¹⁰ Kakraba A. D. (2011). Ayi Kwei Armah’s Vulgar Language in *The Beautiful Ones are not Yet Born*, a Therapeutic Tool in *Current Research Journal of Social Sciences* 3(4): 306-313, 2011 ISSN: 2041-3242, p. 8.

over child with a man (similar to Fofu's father) who definitely refuses to play his part of the game which is to care for his family. Bibio lacks to say 'Mother, nobody obliges you to continue bearing children with him' as you know that he cannot afford the slightest of the livelihood. This is to say that a father's presence makes events different in a household. For example, in Chimamanda Adichie's *Purple Hibiscus*, the protagonist, Kambili, tongue seems to be burnt and her gesture and movement very calculated while in front of her father, Eugene. Kambili struggles to speak, but her tongue is lumped and tied. It is only when "she is alone with Jaja that the bubbles in her throat let her word come out" (Adichie, 154). Still, even when both are together, while they realize the slightest presence of their father, their communication revolves around meaningless topics. Their father's presence impacts the children's communication and that of their mother, Beatrice who speaks "the way the bird eats, in small amounts, (Adichie, 20) in a low voice (Adichie 8; 13).

Finally, Amma Darko's presentation of *Beyond the Horizon* and *Faceless* helps us distinguish easily the main female characters despite the fact that in *Faceless* the story is told by using the third person pronoun. Amma Darko's plots all focus on society, particularly that of Ghana. An African reader cannot miss all these physical and real settings like Accra, Kumasi, Korle Bu and its renown University Hospital to cite just these few. Amma Darko makes her characters so involve to each other to constitute a real life event. The technique is to help the reader make an easy assimilation of the conveyed message through the skilled eyes of the writer. The plot in *Faceless* contrasts with that of *The Housemaid* in the sense that, in spite of its third person pronoun, does not allow the reader to get easily through to the main female character. To unfold the link between two or many characters, the female writer easily and dexterously can move from a character to another. For example, Fofu's kinship with Maa Tsuru is easily known when the story starts and Fofu begins talking with her. The technique also allows us to set mentally analysis and find out the similarities and dissimilarities between characters. Despite the fact that the exercise seems more demanding and puzzling, there is strong affinity, a blood relationship between female characters in each of the author's fiction. The author partly narrates her personal nightmare about Ghana and the Ghanaian women's ordeals. She feels concerned and falls in a long and carrying nightmare. She is not telling a story, but recounting what she dreams of last night in her bed. Amma Darko makes it trickier in her fourth novel, *Not Without Flowers*. One cannot make out the link the between characters so easily because the writer decides to be more complex in her narrative and her technique. For example, before the reader

knows what happened so that Ma is mentally sick, he has to read more than the half of the novel and he has to read to the end before finding that Ma finally gets straight with the haunting nightmare of flower. Moreover, the novel requires more attention from the reader to make out the ending note about the first, second wife and 5th Wife and the other members of the mansion. What Cora and her sister Randa make of their boiling desire of revenge is hidden in the lines at the bottom of the novel. The plot in *Not Without Flowers* seems to be a metadiegetic narrative with many sequences, but only one moral. However, similar to the other novels by Amma Darko, urban centres in *Not Without Flowers* are presented as unforgiving and full of heart-breaking instances either for men or for women and children where danger stalks in every corner and ready to flush out to attack its victims. In urban centres, every shadow, every hole can bear a possible danger. Amma Darko urges not to trust anyone in the modern and globalised urban centres in Ghana and this extends to any other African countries.

CONCLUSION

This thesis aimed to probe the question of whether Amma Darko has a different view in portraying her female characters in her creative writings and whether these writings can be used for women's empowerment. This research has focused upon three main parts; all subdivided into balanced chapters which help tackle the undertaken analysis taking into account four of Amma Darko's novels which are *Beyond the Horizon* (1995), *The Housemaid* (1998), *Faceless* (Revised 2010) and *Not Without Flowers* (2007). The introduction offers background information to the problematic, a review of Ghanaian history has been made in terms of historical events which surely determined Ghanaian contemporary literature. The literary critical tools were presented such as feminist, dialogic theories in relation to African literature and more specifically to Ghanaian writings. The first chapters of the first part have focused upon the main reasons why Amma Darko has started writing her our way and her early literary influence. The second part has dealt with the major themes the novels have raised and the literary tools which have helped us lay bare our analysis. In the third part, we have dealt with Amma Darko's different characters around which have revolved the plot and the novelist message.

All Amma Darko's novels have identified Ghanaian women as having come a long way over the years from voicelessness to voice even though they have faced many difficulties. With women's voices becoming louder and unflinching from *Beyond the Horizon* to *Faceless* and *Not Without Flowers*, Amma Darko's women attain noteworthy levels of self-consciousness and personal identity. Some of Amma Darko's women find respect, others happiness while taking control of their bodies as language empowers them, others struggle to move from voiceless to voice, but due to cultural constraints, they have failed. Finally, others do not try to make a move as being deeply brainwashed and having completely lost their mental power to fight. The novelist advocates a range of solutions or compromises through her characters. This makes her works reflect her strong wish to open the opportunities of collaboration between individuals of different ages, education, regions, and sexes as all these different facts must help them make choices. Tradition, gender issues, colonialism and post-colonialism confuse the many changes in the lives of Ghanaian women and men and Fante and Asante's culture that Amma Darko tries to emphasize in her works as it was demonstrated.

Hopefully, this work has shown how much Amma Darko's novels have revealed the extent to which literature is in the service of society, entertaining readers with legends, tales and myths. According to the novelist and critic Chinua Achebe, literature should be useful, that is, it should be politically and socially committed. Indeed, literature must serve society as society provides the necessary materials for its essence. It mirrors society and its mannerisms. It is interpreted as reflecting norms and values, as revealing class issues and "a diseased society which cannot control or take care of its children"⁷¹¹. For example, a street boy tells a reporter that "My dream, is to go home one day to visit my mother and see a look of joy on her face at the sight of me. I want to be able to sleep beside her. I wish her to tell me she was happy I came to visit her" (Darko, 26). If parents fail to cater for even one of their roles toward their children, they can be considered as being negligent; this is one of the messages sent by Amma Darko who pinpoints the recurring irresponsibility of parents in contemporary African countries and furthers the point that giving life to children is not the end of the pathway. What is also important is the care around these beings. The parents' inattention poses another question about forced parenthood. In most patriarchal societies, parents are compelled to have children, though not being able to care for themselves. Therefore, when parents cannot cater for their children's slightest needs, society does not provide them. If home does not sustain necessary wishes of its members, the solution is to seek for greener pastures. This is why Amma Darko confesses that: "Home was suffocating me"⁷¹².

This psychological disturbance obliges her and therefore some of her characters to exile. This shows how Amma Darko's personal life inspires the construction of her characters. The novelist personal move out of her country can be interpreted as being a choice to make her own life brighter. This wish makes her depict some of her female characters as having also a range of choices and decisions to make. The possibilities of choices lie in personal experiences and reflect expectations. Looking through the prism of the experience, surely the reader is embarked in a feverous journey with the growing plight of street children not only in Ghana, but also in almost all globalized African towns. Beyond Amma Darko's documented protestation about this confrontation in *Faceless*, the novelist crafts a poetically captivating eyewitness account of the

⁷¹¹ Awitor, E. F. (2014). "Social Tragedy in Amma Darko's *Faceless*: Plight of Street Children" in *IISTE* vol. 4, n°27, p. 1.

⁷¹² Odamtten, V. (2007). *Broadening the Horizon: Critical Introductions to Amma Darko*. UK/London: Ayebia Clarke Publishing, Print., p. 12.

conflict in *The Housemaid*. Both *The Housemaid* and *Faceless* tracks down the rural exodus of population in search of jobs, shelters and dreams to fulfil in these fast-growing cities. As soon as they come, they face the hard reality in these cities and have to reinvent themselves in the peripheries to survive. This reminds us of Thomas Fouquet's approach of "citadinité subalterne". He posits that :

l'approche en termes de citadinité subalterne ne se résume pas à une conception statique de situations de subordination ou de relégation dont l'espace urbain serait le simple contexte physique et historique. En partant de l'idée que la ville est également un haut-lieu d'acquisition de ressources, de saisissement, d'occasions de production imaginaires, mais aussi de contestations plus ou moins directes ou détournées, il s'agit alors de penser ensemble des situations de domination et de manières de les négocier sous l'angle heuristique qui s'en dégage [...] ⁷¹³.

Amma Darko wants to dig out the cosmopolite aspects of these new and colourful spaces in post-colonial countries where misery dwells in permanence, danger patrols and death toll higher. Amma Darko shows the sourness of African cosmopolitan cities which proves that parents, society and subsequent governments in Ghana have failed to satisfy the basic needs of these little and innocent beings at the right time. What these succeeding governments fail to do lies in psychological and moral supports toward this category of citizens. In Thomas Fouquet's article some African countries tried it in the past, yet due to some political reasons they failed: "Après les indépendances, certains Etats s'essaient également au contrôle de l'exode rural, comme la Guinée de Sèkou Touré ou la Tanzanie de Julius Nyerere, en partant d'une valorisation morale des campagnes" ⁷¹⁴.

A decayed Ghana has already been portrayed in Ayi Kwei Armah's *The Beautiful One Are Not Yet Born* (1968), *Fragments* (1969) and *Healers* (1978). In the first novel, Ayi Kwei Armah depicts a Ghanaian society in a rotten, stench and insulting words in order to raise the alert, but in vain. He reveals in rough images the regime of Kwame Nkrumah who fails to assist the mass in almost all domains. The presence of excrements represents metaphorically the decadence of the dreamt Ghana by its political leaders. This proves the rather pragmatic sense of African literature while delving in social reality by the interposition of characters. In this regard,

⁷¹³ Fouquet, T. (2018). « Subalternités et citadinités en Afrique : une tension heuristique » in *Citadinités subalternes en Afrique*. Paris : Karthala, p. 7.

⁷¹⁴ Fouquet, T. (2018). « Subalternités et citadinités en Afrique : une tension heuristique » in *Citadinités subalternes en Afrique*. Paris : Karthala, p. 7.

Philip Whyte points out that “Les romans d’Armah se trouvent donc au cœur de ce qui demeure l’une des problématiques majeures de la littérature africaine contemporaine, à savoir la dualité d’une écriture et d’une pensée écartelée entre deux conceptions de l’univers : l’occidentale et l’africaine, la modernité et la tradition. [...]”⁷¹⁵ The same duality is portrayed in Amma Darko’s *The Housemaid* (1998) and *Not Without Flowers* (2007) where modernity with its glittering thoughts clashes with traditional values and moralities. This conflict between tradition and modernity also translates as the conflict between rural values and urban ones. Among the attractions in the city depicted in *The Housemaid* are modern sophistications like traffic lights and variety, sexual freedom for teenagers and adults and the availability of glamorous consumer items.

Besides, Amma Darko engages in the struggle side by side with most African women to contest social inequalities, sexual and sexist discriminations. The novelist underscores the reasons of her participation in the struggle and the process paints a picture of the devastation and traumatizing experience of women (survivors) in patriarchal societies. The stories in Amma Darko’s novels encapsulate the involving stages of her own experience as a Ghanaian woman and thereafter as a feminist. She makes us pity the intellectual barrenness of her male characters and their deliberate attitude which has turned the women’s world into a wasteland and that of their children into a desperate and merciless milieu. Reading literature nurtures one’s intellectual capacity and keeps one aware and enlightened to get closer to other people. Some renowned literary works such as The Bible, Qu’ran and Japanese Buddha’s teachings amongst others, provide society with guiding principles of life and to another extent spiritual protection and security. When writings are well-built like that of *Beyond the Horizon* and *Faceless*, readers tend to associate themselves with the emotions portrayed in these works and become emotionally involved in them. The reception of literature can have a deep impact on the readers’ minds and in turn, their lives. As a matter of fact, literature is a vast field which has language as backbone and as its pair companion. It can be any language. In so doing, literature serves community just causes and gives it the right to keep their collective memory’s conservation. Amma Darko shares with us a remote country’s history and aesthetic and teaches us how to behave once in that country or region. Realist texts can provide imaginative representations of specific historical moments, events or periods. In this respect, literature is used to reveal

⁷¹⁵ Whyte, P. (2003). *L’Imaginaire dans l’Ecriture Ayi Kwei Armah : L’Evolution d’une forme. Vol. 1 : A la recherche d’une forme*. Paris: L’Harmattan, p. 8. “Armah’s novels”.

historical events and moments to the reader. From that perspective, it is important to situate the reality in a literary text knowing that fiction is in its full form imaginative.

This study has demonstrated that while portraying women's ordeals in society, Amma Darko no longer wants her female characters to accept being confined to roles of mere witness and silenced which are typical traits in patriarchal and traditional society. As Ifechelobi, J. N. states that:

A patriarchal society is a male dominated society. It is an institution of male-rule and privilege that thrives on female subordination that is why most forms of feminism characterize patriarchy as a wicked social system of rule that is oppressive to women because it is an exertion of male dominance over women. The underlying factor in patriarchy is power and status⁷¹⁶.

Once more, this clarifies the most relevant action of African female writers on their joint action. In fact, as the issue that bothers women in society is found, then the second step lies in strategy elaboration to overtake it. This is in line with the opinion of the British scholar and novelist, Clive Staples Lewis who points out that literature has the power to change our lives and declares that "Literature adds to reality, it does not simply describe it. It enriches the necessary competencies that daily life requires and provides; and in this respect, it irrigates the deserts that our lives have already become"⁷¹⁷. Whatever it may be, reality comes right at surface while reading fiction which traces or not historical, cultural or sociological events of a community. People who read fiction know, with the interposition of characters and settings, what happened. Reality catches eagerly people whose past is portrayed in the book. But unfortunately, fiction also vents the single imagination of their writers and continuously exposes a number of created happenings which reveal the anti-thesis between the world as it is, and the world as the writers have imagined it. Rightly, many events in *The Housemaid*, *Faceless* and *Not Without Flowers* may not have happened this way or even more they may never have occurred. Amma Darko's creative writing uses social realism to emphasize the prevailing issues that many may ignore. While some of her compatriots like Ayi Kwei Armah and the late Kofi Awonoor concentrate mostly on political messages, Amma Darko privileges social concerns. She adds to her writing a point of an individual's emancipation which joins Frantz Fanon's quest for endless creation as he states that he lives in the world that moves every time, therefore

⁷¹⁶ Ifechelobi, J. N. (2014). "Feminism: Silence and Voicelessness as Tools of Patriarchy in Chimamanda Adichie's *Purple Hibiscus*" in *AFFREV: An International Multidisciplinary Journal*, Ethiopia, Vol. 8(4), Serial No. 35, p. 2.

⁷¹⁷ Lewis, C. S. (n.d.). AZQuotes.com. retrieved April, 21, 2018, from AZQuotes.com web site: http://www.azquotes.com/author/8805-C_S_Lewis

he also is in an endless creation. This does not necessarily mean that Amma Darko adopts all the ideas of the Algerian of Martinican origin revolutionary, Frantz Fanon, in her writings.

The genuine portrayal of what is the writer's contribution to African cultural image recreating has been built upon long literary traditions, both oral and written. Thus, to fashion a counter-writing and to correct the erroneous image elaborated by male writers, African women writers namely Flora Nwapa, Buchi Emecheta, Ama Ata Aidoo, Grace Ogot, Zaynab Alkali, Nawal Al Saadawi, Mariama Bâ and Amma Darko started writing from their own perspective. These female writers positioned women at the centre of their plot and the message of women's struggle to stay or to come to the centre is clearly displayed. Their courageous and tactical leadership led to the wresting of literary independence of women from male writers. The passion and quest of women to let truth arise prompt their opponents to brand them dreamers and megalomaniac. However, if it is better that history be written by a historian and a house built by a trained engineer, then it is also better to leave women to write their own life stories in order to reach the maximum rate of truth.

Consequently, for the sake female rehabilitation, women would hold the ground before all dominating forces in society through literature. In this sense, this thesis has argued that Amma Darko portrayed most of her female characters brave and mentally fit for the job. In this doing, she recreates her national identity in her present context. She constructs female characters who challenge the status quo in their cultures. More, Amma Darko gives her own point of view on female freedom and independence. Her writings demonstrate insightfully the working pair literature and society, history and literature and finally history and persisting trauma. Abdelkader Djemaï submits that “J’aime que la littérature, particulièrement le roman qui n’est pas un essai, un ouvrage technique, un tract ou un éditorial, m’apprenne des choses, me fournisse des connaissances, des informations, des détails intéressants”⁷¹⁸.

The present passage sheds light on the contribution of history writing in African literature which must be encouraged. Novels can cater for the reader's need of historical information and also for fun. Amma Darko is conscious of that need, a vision which allows her to use history in her fictional creation. Additionally, the use of history in fiction allows

⁷¹⁸ Djemaï, A. (2017). “Quand le roman raconte l’Histoire” in *La Représentation de l’Histoire dans les Littératures et les Arts Africains*. Alger: ENAG. p. 275.

addressing the resulted trauma to be healed or just to be known. When a trauma is spoken or written, the victim does not remain a silent individual. While a novelist may spend his time mentioning the traumatic results of transatlantic slave trade and colonialism on the African continent for example, the historian may not, but he can emphasize explaining his choice and his source. The novelist writing technique stands to raise the alert on the necessity not only to keep history rewritten with the right event, but also events which can entertain the reader or draw his compassion.

Moreover, Amma Darko's use of heterodiegetic or autodiegetic narrators in her novels helps propel more the compassion and gather more readers for females' cases. She delivers a sarcastic and didactic message to society about gender issues and post-colonial impacts on Ghana. As far as male domination is concerned, she uses an antidote known to all almost all feminists which is deconstruction. She portrays some male characters as being dangerous, enemies although some of them inspire respect and comprehension due to their traumatic past. However, she does not develop an anti-male attitude. She coerces tactfully her male characters to join the female movement otherwise they are left aside. As for the post-colonial resistance, Amma Darko describes Ghanaian big cities and villages' aspects which deeply reveal the negative impacts of colonialism.

Stated in other words, the novelist makes insidiously a comparison between post-colonial big and newly urbanized cities and archaic and abandoned villages. This two-fold image promotes people's segregation and space's fragmentation. The image shows also the heteroclitite and ghetto-like characteristics of cities and villages. There is a visible border between cities and villages in post-colonial countries in Africa and even within the cities as "colonialism inevitably produces in the colonized society a period of chaos during which old values no longer apply and the new ones have not yet been found"⁷¹⁹. After the period of colonization, there remains no awareness of belonging to here or there. Particularly, big cities represent no more spaces of identity like previously in pre-colonial villages. In these devastated cities and villages, because of their colonial past, Amma Darko presents some of her female characters as reflecting hope, aspirations and inspirations to destitute people as they try by all

⁷¹⁹ Campu, A. (2013). Tradition versus modernity in Chinua Achebe's *No Longer At Ease*. Bulletin of the Transilvania University of Braşov • Series IV • Vol. 6 (55) No.2.

means to part with all enslaving cultural norms. The author's correlation of the African continent present-day difficulties and its past is interrelated.

It is obvious that Amma Darko wants to delve into the Ghanaian past to force an awareness about all that happened to the forefathers on their own Fante and Asante lands which now has become Ghana. To explain the state of mind of former colonizers, Bill Ashcroft *et al* state in *The Empire Writes Back* (1989) that "more than three-quarters of the people living in the world today have had their lives shaped by the experience of colonialism"⁷²⁰. Though there was a political change, many African nations obtained their independence, however they are still in confusion about their culture and identity. The confusion of identity and culture is also argued by two of the famous theorists in the field: Frantz Fanon⁷²¹, the Indian-English Homi K. Bhabha⁷²² and the Palestinian-American Edward Said⁷²³.

As a result, the modern African female writer has been indirectly assigned the role to write about her society's realities, not by idealizing it, but writing the truth. Art is then the only means which helps display one's people's reality. Yet, writing about real events can be a tough and bias issue for a novelist as the German philosopher Friedrich Nietzsche (1844-1900) thinks that "what can be thought must certainly be a fiction"⁷²⁴. It means that any time a novelist or a creative writer writes about an event he certainly adds his own point of view which weakens the real events. Fiction, as it is made up by the writer's sole desire is not possible to apprehend as facts can be traced down easily. But we access reality through fiction insofar as we tell ourselves a story about it. Embarked in this desire to communicate with a potential reader, a novelist can write about his personal life experience. This act is called an autobiography and *Beyond the Horizon* could be included in this kind of literary genres. In his "Introduction" to *Autobiography as a Writing Strategy in Postcolonial Literature*, Benaouda Lebdaï argues that:

⁷²⁰ Ashcroft, B., Griffiths, G. & Tiffin, T. (1989). *The Empire Writes Back: Theory and Practice in Post-Colonial Literatures*. London: Routledge.

⁷²¹ Fanon, F. (1963). *The Wretched of The Earth*. Trans Constance Farrington. New York: Grove Press.

⁷²² Bhabha, Homi .K. (1994.) *The Location of Culture*. London: Routledge Print.

⁷²³ Said, E. (1978). *Orientalism*. London: Routledge.

⁷²⁴ <https://www.iep.utm.edu/nietzsch/>

Through self-telling, black authors clearly affirm and reveal their individuality, their personality and the reconstruction of their lives, all with a genuine impact on ‘literality’ and politics. More than a mere representation of one’s life, autobiographical writings are a powerful quest for identity, for self-knowledge, and self-recognition particularly meaningful in colonial and postcolonial times⁷²⁵.

A feature which distinguishes a simple fiction from an autobiography lies therefore in quest of the writer’s own self. It means that autobiographies have to follow a specific line of writing that fiction does not have. Yet, as reviewed throughout the analysed novels, Amma Darko is not only concerned by gender issues which are real facts in African society, but also other affecting issues such as the clash between globalization, urbanization and tradition. The thematic concerns raised by Amma Darko leave no one in doubt that she is a writer of her time. Amma Darko is not just interested in the fame provided by writing history, culture, gender issues and a struggle of a female protagonist against all odds and her society, but she uses Medias and Non-Governmental Organizations to condemn the negativities of her society, her national authorities and male misconception of female bodies and social partaking. The novelist projects the commitment of women, through fiction, to the exposition of many traditional tenets that champion female subordination in patriarchal societies, keep them mute and limit their involvement in the socio-cultural space. She clearly portrays the female characters, usually the protagonists, as greatly subjugated by their male counterparts. This is the case in all the four novels under study in this thesis. Undoubtedly, the subordination of women does no good to women in particular and society at large. Hence, this socio-cultural construct should be kept at bay if not eradicated. Also, tolerating injustice means to accept being silent forever. Women stand therefore in an ambiguous stance which is typically human. Amma Darko’s female characters’ assertiveness makes a clear cut of Ghanaian women’s position.

Additionally, Amma Darko’s omniscient narrators present events as simply as they occur in society which allows to perceive the writings as being inscribed in social realism. This kind of approach deals with themes related to society and the relation between society and human beings’ problems. Thus realist novels describe life as it truly is even though characters are interposed. It is a kind of writings which try to remove the romanticism and portray reality the way it is as it takes subject matters from daily life. It deals with problems and solutions

⁷²⁵Lebdai, B. (2015). *Autobiography as a Writing Strategy in Postcolonial Literature*. Cambridge: Cambridge Scholars Publishing.

applicable to real life and contemporary culture. These well-informed narrators help her present African women's tough predicaments in patriarchal society. According to Amma Darko, the female gender matter in such society and it is the reason why she takes on the advocacy of the down-trodden and voiceless throughout her writings. She thus symbolizes Ghanaian women through her female characters and gives them the major roles. She enhances literarily their social and economic independence to the disadvantage of her male characters that she represents as void of humanity, pitiless and brutal. The male characters in Amma Darko's novels epitomize patriarchal rough treatment towards women who in turn are peacefully in quest for protection, companionship, love and pleasure to fulfil. Some of the revealed thematic preoccupations include the issues of motherhood, abandonment of social roles, polygamy, wife-inheritance and barrenness. There is no doubt that in the portrayal of African men, their virility and masculinity are extremely hurt. This is in fact the novelist's ideological position. As George Lukacs states:

Characterization that does not compass ideology is not complete. Ideology is the highest form of consciousness; ignoring it, a writer eliminates what is important in delineation of character. A character's conception of the world represents a profound personal experience and the most distinctive expression of his inner life, (ideology) at the same time it provides a significant reflection of the general problems of his time⁷²⁶.

Amma Darko appears to be aware of George Lukacs's observation about a novelist's characters which should reflect his ideology while writing. The merit of Amma Darko is to construct most of her female characters holding the ground and refusing to continue being victims of male-oriented society's obligations which hinder their social and economic rise. She also portrays women as being perpetrators of their counterparts' unpleasant predicaments and down falling. Other women symbolize their own threat since being at the margin does not bother them.

The analysis throughout this study has shown the difference between Amma Darko and many other African female writers in the sense that she does not turn the oppressed into saints. In the quest for liberty and space for their own, some women hurt others and block them from attaining their own point of independence. Amma Darko presents this point as existing in

⁷²⁶ Lukacs, G. (1962). *The Historical Novel*: A Peregrine Book. Harmondsworth: Penguin Books Ltd, Merlin Press Ltd.

women's realm, a major element that hinders women's sisterhood to express itself and progress. Women fear women because women become a problem to their counterparts. This reveals that female misogyny exists and to avoid mentioning it is to create opportunities for anti-feminists to disgrace the theory. This is why the writer anticipates and presents situations where women tread down and enslave other women. Some women cheerfully raise their voice saying 'they are not feminist and that they would never be'. Women are as human as men are and not all women are feminists as not all men are misogynists. What is important is the necessity of feminism expansion.

The reader is convinced that the use of these female characters provides a broadened view of African literature's prominence which depicts women's conditions in a capitalistic society as described in *Beyond the Horizon*. Amma Darko makes an attempt to correlate the ordeals of her female characters with those of Ghanaian women in real life as she makes it in the third novel, *Faceless*. She illustrates fictional society with great realism. She illustrates the struggle of the oppressed to tell their story, to address the present and reconstruct the future. This comforts Williams Abraham's ideas when he states that:

When critics like Gombrich say that the African artists were incapable of realistic representation, they quite miss the point of African art. If they seek life-like representation, they should turn to secular art, the art which was produced for decorative purposes or the purposes of records, rather than moral art, the art whose inspiration is the intuition of a world force⁷²⁷.

Without doubt Amma Darko's novels depict mostly women's craving for self-transformation. Some of her female characters refuse to accept the status quo and strive hard to come out of the predicament that renders them weak, submissive and dumb-docile. Some of Amma Darko's women struggle to have their words heard and their actions reckoned in society because they think that chances and choices are. In one way or another, Amma Darko's women also want men to share child care with them. Amma Darko's matrilineal origin could be the possible reason why her novels are mostly exposing women's trials in patriarchy as women are raised to think that being born female means being inferior to men and having no right in society.

⁷²⁷ Abraham, W. (1962). *The African Mind*. London: Weidenfeld and Nicolson. A classic text of African philosophy, p. 113

For this reason, Amma Darko gives crucial roles as catalyst elements of change to some of her female characters and therefore she asks more from them. She conceives a sort of feminism that fits her own social, cultural and economic point of view about women. This feminism represents female characters as leading individuals of their family and that its welfare depends on their intimate decision to win or to lose. Through the lens of our methodology, we can rightly conclude that Amma Darko's feminism is much in quest for women's identity reconstruction and women's place reinvention than her own personality enhancing through literature. Through this sort of feminism, Amma Darko contests the various codes which tilt towards patriarchy and undermine the values of women in African society. This is why Amma Darko constructs female characters such as 5th Wife who surpasses all the other wives of the patriarch Pesewa. The others symbolize marginality and submissiveness. 5th Wife in *Not Without Flowers* as well as Kabria in *Faceless* represent self-realization, female self-motivation and independence. The author and this female character "leave the border"⁷²⁸. The border evokes to Amma Darko the feeling of weakness, powerlessness, cry, weeping and despair; that is why she struggles to put them away out of it. Amma Darko's female characters, heroines of most of her works, are characterized by traits that are attributed to male gender: authority, independence, strength and courage. This remodelling of female and male genders is apprehended in most of her novels and gives way to a particular hybrid aesthetic. This hybridity is appropriated in Amma Darko's writings mainly as her former colonized woman's capacity of conquering the former master's language (English) and also her traditional language (Akan).

By and large, Amma Darko succeeds in drawing the readers' attention to the nature and the extent of the specific values which represent the backbone of African cultures and identity as André-Patient Bokiba's statement confirms: "l'identité s'affirme par le langage, il n'y a point d'identité qui ne se dise, ne s'exprime"⁷²⁹. This identity is essential for human beings' cultural existence in this world of competition.

Additionally, we have analysed Amma Darko's writing style which is simple and does not make the reader regret his choice while reading. Homi Bhabha elaborates on the concept of hybridity as a result of post-colonialism. The term negates hierarchical nature of language and

⁷²⁸ Miano, L. (2012). *Habiter la frontière*, Tête à tête, 1 vols (Paris : l'Arche). p. 31 (my translation)

⁷²⁹ Bokiba, A-P. (1998). *Ecriture et identité dans la littérature africaine*. Paris: L'Harmattan, p. 10.

propels linguistic and cultural exchange as “all forms of culture are continually in a process of hybridity”⁷³⁰. The major concern of Amma Darko in her first three novels is to construct a coherent and simple narrative which can be understood by all. This wish lies in the simple grammatical style and the message delivered by each of the characters not too long. Such a style through simplicity draws the reader’s interest. Ama Ata Aidoo’s *The Girl who Can* (1997) is also written with the same simplicity which proves both female novelists and compatriots interconnected and concerned in reaching their relationship.

Yet, and despite such as strategy, it is not what transpires in Amma Darko’s fourth novel, *Not Without Flowers*, which cuts short with the novelist’s current simplicity to a more complex style. *Not Without Flowers*’ lines are not digestible. The characters’ presentation repulses the reader although the beginning with a long flashback can entice and draw his attention. In terms of length, the novel is almost three times the volume of *Beyond the Horizon* and four that of *The Housemaid*. She may not be that ready to take into account critical perspectives of literary critics who have analysed her first writings. Yet if we consider William Labov’s definition of narrative who states that “narrative is a genre particularly given to the use of details since it is by definition devoted to describing events that take place in scenes [...] which provide background information”⁷³¹, then we understand here Amma Darko’s particular concern with the current novel. Details are what make the narrative thicker and opaque, which in fact confuses the reader’s understanding of the message at a glance. Almost all the characters’ psychology is clouded with darkness as the narrative is complex.

All this put aside, *Not Without Flowers* unearths an old conflict that opposed traditional religions to Christianity in African post-colonial countries and also clashes the long standing concept of polygamy. The writing does not disclose a bloody clash throughout the story; still it criticizes the Christian foundation of body deprivation in Africa. In fact, it is the background of Christianity’s introduction in Africa which is problematic. Yet, we do not reject the positive aspect of education based on holistic human development, a positive point taken on by Christianity. Religion has acted as the catalyst element for African invasion and colonization and the President Jacob Zuma cited in this way says that “Christianity, introduced by European

⁷³⁰ Rutherford, J. (1990). *The Third Space: Interview with Homi Bhabha*. Identity, Community, Culture, Difference. J. Rutherford. London: Lawrence and Wishart: pp. 207-221.

⁷³¹ Labov, W. & Waletzky, J. (1967). Narrative analysis: Oral versions of personal experience. *Essays on the verbal and visual arts*, ed. by June Helm. Seattle: University Of Washington Press, p. 12-44.

missionaries mainly in nineteenth century, has destroyed the safety net for orphans, elderly people and the poor”⁷³². The religious dogmatism imposed on Africans turns to be fanatic and culturally depriving. Amma Darko disapprove of, not only the method of its introduction, but also its implementation on the ground. Amma Darko implicitly and tactfully suggests a new assessment of church and religious dogma’s place in African society, still she does not urge for a return to traditional religious values like her counterpart Ayi Kwei Armah through his historical novel *The Healers*.

It appears that Amma Darko does not see herself as a feminist, her writings prove it so obviously. She does draw an invisible, dialectic and binary world between men and women which gives way to a tangible struggle for women of the margin to move to the centre. Amma Darko’s view point in the narrative is that prostitution is initially a foreign threat against women’s welfare and that consistently deviant attitudes are inherent to colonial masters’ arrival and their sexual needs.

Finally, after having placed women at the centre of her discourse, Amma Darko’s wish is to make all of them aware of “the danger of a single story”⁷³³ as stated by the Nigerian novelist Chimamanda Ngozi Adichie. Women represented here have already the courage to challenge society. All that they need now is the opportunity to get together and to move the long standing mountains of stereotypes out of their way. Just like Ama Ata Aidoo, Aminata Sow fall, Mariama Bâ, Doris Lessing, Nadine Gordimer, Nawal El Saadawi, Assia Djebar to name these few, Amma Darko replaces Ghanaian women in their historical place. She brings to the surface their experience and daily resistance to all male ideologies in society. Most of Amma Darko’s women realize that they can take control of their own lives and have choices.

Amma Darko’s didactic purpose teaches the protagonists’ new sacrifices to the reader. She adopts a low-key approach in her feminism as a sign and symbol of her own humility. Although the narratives are told in her own view point, she does make it like an ordinary woman by (re)fencing and reinforcing women’s garden. The analysis of Amma Darko’s female and male characters reveals that the novelist’s concern must be more than binary because she does

⁷³² Smith, D. (2011). Jacob Zuma blames Christianity for breakdown of South Africa traditions, *The Guardian*, Wednesday 21 December 2011, 17.02 GMT.

⁷³³ Adichie, Chimamanda N. (2009). “The Danger of a Single Story”. TED TALK, www.ted.com

not present all her female characters as being subjugated by their men or the male-oriented society. This technique has what most of the time been used in realistic novels in order to let characters express their inner thoughts. The characters' motion and thoughts have to be different from those of the novelist. It is then an established fact that the pattern of language also helps discover Amma Darko's pro-woman position notwithstanding the origin of Amma Darko which is Ghanaian, one of the last matriarchal systems prevailing in men's world.

This thesis has underscored that Amma Darko's novels are socially oriented in the sense that Ghanaian social issues are mainly addressed in her creative writings. Therefore, she creates a new form of advocacy to help address Ghanaian women's questions. This shows that African female writers predictably continue to raise the challenge of remaining committed to their community. African female literature gets women ready to speak up, to transcend the margin and to get out of these conditions. This propels Amma Darko to portray some of her female characters as bearing hope and future brightness. Society is left limb and rocking when women, one of the components of society, are still slaves in men's homes. As a matter of fact, men cannot be free, if women are still silent and hands bound. This is the say that freedom of women is concomitant with the socio-political change and that is what Amma Darko tries to bring about in her different novels. Amma Darko has the merit to display the important roles of women in patriarchal societies and represent her female characters as no more being the silenced and voiceless members of society.

We have finally put the thesis as a whole in a perspective, which unearths the main issues of African women's trauma, alienation and reinvention the best way that these themes can better be portrayed and understood. One reason for this method is that Amma Darko's novels give extensive background information about Ghanaian women's ordeals and difficult conditions in contemporary period. Yet women's struggle itself is slowed down by other women's decision to make them fail as many female revolutions in Kwame Nkrumah's country have failed because of internal and external betrayal. Another reason is that Amma Darko as a professional tax-woman knows to a great extent the difficult predicaments brought by globalization and urbanization in African postcolonial countries. In choosing to write on such issues, we are sure that the novelist uses a great deal of realism as she takes social reality to deploy her imagination. More, Amma Darko attaches high significance in the implicit lesson her message brings alongside with the didactic and radical perspective. Past and present lessons are

normally used to well construct the future of a nation which has suffered for a long time because of its military and economic instability. If ever Amma Darko is indebted to her literary female and male counterparts, it is also important to note that Amma Darko's merit is to write about new issues that Ghanaian women are confronted with these days. Thus, in her own way of pointing out the danger in a single story, she emphasizes that unless these cultural norms are revisited and revised, Ghanaian women will still live in the illusion to see a better future for themselves and their female children. This thesis is, in the angle of literary studies in English, the first long analysis of Amma Darko's selected works through a feminist approach and in that sense it contributes to the critical studies on Ghanaian literature in a postcolonial lens.

BIBLIOGRAPHY

1. Amma Darko's Novels

Darko, A. (1995). *Beyond the Horizon*. London: Heinemann.

----. (1998). *The Housemaid*. London: Heinemann.

----, A. (2010). *Faceless*. Accra: Sub-Saharan Publishers (Revised version).

----. (2007). *Not Without Flowers*. Accra: Sub-Saharan Publishers.

2. Secondary sources:

Abani, C. (2007). *Song for Night: a Novella*. New York: Akashie Books.

Abrahams, P. (1953). *Return to Goli*. London: Faber & Faber.

Abrahams, P. (1979). *A Wreath For Udomo*. London: Faber & Faber.

Achebe, C. (1958). *Things Fall Apart*. Oxford: Heinemann Educational Publishers.

-----.. (1966). *The Man of the People*. Oxford: Heinemann Educational Publishers.

-----.. (1975). *Morning Yet on Creation Day*. London: Heinemann Press.

-----.. (1973) "African and Her Writers." *The Massachusetts Review*.

Adichie, C. (2009) *Purple Hibiscus*. Yaba, Lagos: K-Alfa Publisher.

-----.. (2006). *Half of a Yellow Sun*. New York: Anchor Books.

-----.. (2004). *A Private Experience*. New York: Fourth Estate.

Agary, K. (2006) *Yellow-Yellow*. Lagos: Dtalkshop Publishers.

Agenor, M. (1998). *Comme un vol de papang'* in *Genre et Migrations postcoloniales : Lecture croisée de la norme* (2013). Presses Universitaires de Rennes.

Aidoo, A. A. (1970). *Anowa*. London: Longman.

-----.. (1977). *Our Sister Killjoy or Reflections from a Black - Eyed Squint*. Harlow, Essex: Longman Group Ltd.

-----.. (1993). *Changes: A Love Story* (New York: The Feminist Press).

- (1995). "Cut Me a Drink" in *No Sweetness Here and Other Stories*. New York: The Feminist Press.
- (1997). *The Girl Who Can*. Accra: Sub-Saharan Publishers.
- Amadi, E. (1966). *The Concubine*. London: Heinemann, AWS.
- Armah, A. K. (1968). *The Beautiful Ones Are Not yet Born*. London: Heinemann.
- (1969). *Fragments*. London: Heinemann.
- (1972). *Why Are We So Blest?* London: Heinemann, AWS.
- (1973). *Two Thousand Seasons*. London: Heinemann.
- (1979). *The Healers, An Historical novel*. London: Heinemann, AWS. First publication : East African Publishing House, 1978.
- (1995). *Osiris Rising, A Novel of Africa Past, Present and Future*. Popenguine (Sénégal): Per Ankh.
- Atta, S. (2005). *Everything Good Will Come*. Lagos: Interlink Books.
- (2008). *Swallow*. Lagos: Farafina.
- Bâ, M. (1980). *So Long A letter*. (Trans.) M. Bode-Thomas (1981). London: Heinemann.
- Beyala, C. (1996). *Your Name Shall be Tanga*. London: Heinemann. Translated from the French version *Tu T'appelera Tanga* (1988) by Marjolijn de Jager.
- Cixous, H. (1976). *The Laugh of the Medusa*, (Trans) Petroleuse Press.
- (1976). *The Laugh of the Medusa*, Trans. Keith Cohen and Paula Cohen.
- Confiant, R. (2000). *Mamzelle Libellule*. Paris: Serpent à plume.
- Coetzee, J. M. (1977). *In the Heart of the Country*. New-York: Penguin.
- (1992). *Doubling the Point: Essays and Interviews*. Ed. David Attwell. Cambridge: Harvard University Press.
- Dangaremgba, T. (1988). *Nevrous Conditions*, United Kingdom: The Women's Press.
- Djebar, A. (2004). *So Vast the Prison*. London: Betsy Wing
- Doumbi F. (1984). *La Retraite anticipée du Guide Suprême*. Paris: L'Harmattan.
- Golding, W. (1954). *Lord of the Flies*. London: Faber & Faber.

- Ekwensi, C. (1954). *People of the City*. London: Andrew Dakers.
- (1961). *Jagua Nana*. (First Edition) London: Hutchinson & Company.
- (1966). *Lokotown and Other Stories*. Trenton: Africa World Press (ed. 2004)
- El Saadawi, N. (1983) *Women at Point Zero* London: Zed Books Ltd.
- , N. (1985) *God Dies by the Nile* London: Zed Books Ltd.
- Emecheta, B. (1976). *The Bride Price*. New York: Allison & Busby George Braziller.
- . (1979). *The Joy of Motherhood*. London, Heinemann.
- . (1982). *Double Yoke*. London: Ogwugwu Afor Press,
- . (1983). *The Rape of Shavi*. New York (USA): George Braziller Inc.
- .(1990). *The Family*. New York: George Braziller Inc.
- Ogolo, M. (1994). *The River and the Source*. Nairobi: Focus Publishers.
- Kennedy, D. (1988). *Beyond the Pyramids*. HarperCollins Publishers Ltd; New Ed edition (1989).
- Kourouma, A. (1970). *Le Soleils des Indépendances*. Paris: Seuil.
- Kincaid, J. (1985). *Annie John*. Reading: Vintage, 1997.
- (1990). *Lucy*. New York: Farrar, Straus & Giroux.
- (1992). *At the Bottom of the River*. New York: Penguin.
- Lessing, D. (1950). *The Grass is Singing*. (First edition) UK: Michael Joseph & Thomas Y. Crowell Co.
- Lopez, H. (1997). *Le Lys et le Flamboyant*. Paris : Le Seuil.
- Miano, L. (2005). *L'Intérieur de la Nuit*. Paris: Plon.
- (2006). *Contours du jour qui vient*. Paris: Plon.
- (2012). *Habiter la frontière*. Tête à tête, 1 vols (Paris: l'Arche).
- (2013). *La Saison de l'ombre*. Paris: Grasset.
- Miti, L. M. (1999). *The Prodigal Husband*. Cape Town: Kwela.

- Morrison, T. (1988). *Beloved*. New-York: Penguin Books.
- Nyathi, Sue (2012). *The Polygamist*. Johannesburg: L-Media & Publishing LLC
- Nwapa, F. (1966). *Efuru*. London: Heinemann.
- . (1986). *One is Enough*. Nigeria: Tana Press. Rpt. Trenton, N.J.: Africa World P.
- Nozipo, M. (1996). *Zenzele*. New York: Delata Books.
- Okara, G. (1964). *The Voice*. London: Heinemann Educational Books Ltd.
- Okoye, I. (1982). *Behind the Clouds*. Harlow Essex: Longman.
- Oyono, F. (1966). *Houseboy*. (Trans) John Reed. London: Heinemann.
- Saro-Wiwa, K. (1985). *Sozaboy*. Nigeria: Saros International Publishers.
- Sembene, O. (1976). *Xala*. Westport: Lawrence Hill and Company.
- Shoneyin, L. (2010). *The Secret of Life Baba Segi's Wives*. Abuja: Cassava republic Press.
- Soyinka, W. (1964). *The Trial of Brother Jero*. In *The Jero Plays*, Ibadan: Spectrum Books. Ltd.
- (1965). *The Interpreters*. London: Heinemann.
- (1974). *Madmen and Specialists*. Oxford: OUP Print.
- (1987). *Cycles Sombres*. Paris: Silex Editions.
- Thiong'o W. N. (1967). *A Grain of Wheat* (1st Ed). London: Heinemann, AWS.
- (1972). "Homecoming". London: Heinemann Educational Publishers.
- Tutuola, A. (1952). *The Palm Wine Drinkard*. London: Faber & Faber.
- Walker, A. (1982). *The Color Purple*. New-York (USA): Harcourt Brace Jovanovich Publishers.
- Werewere, L. (2000). *It shall be of Jasper and Coral*, (Trans) Charlottesville, London: University of Virginia.

3. Articles on Amma Darko

- Abeka, P., Marfo, C. & Bonku, L. (2014). "An Angle of Seeing: Pornography and Profanity as Pharmakon in Amma Darko's *Beyond the Horizon* and *The Housemaid*". *Advances in Language and Literary Studies*, Vol. 5, No 2. ISSN: 2203-4714.

Adjei, M. (2009). "Male-Bashing and Narrative Subjective in Amma Darko's First Three Novels." *SKASE Journal of Literary Studies* Vol.1.No1.

Anyidoho, K. (2010). Amma Darko's *Faceless: A New Landmark in Ghanaian Fiction*, an Introductory Essay, (ed.) Accra: Sub-Saharan Publishers.

Annin, F. A. (2013). Critical Overview Of Amma Darko's *Faceless*- A Review *IOSR Journal Of Humanities And Social Science (IOSR-JHSS)* Volume 16, Issue 5 (Sep. - Oct. 2013) e-ISSN: 2279-0837, p-ISSN: 2279-0845.

Ayinne, R. A. (2004). Emerging Issues in Amma Darko's Novels: Beyond the Horizon, *The Housemaid* and *Faceless*. Undergraduate Long Essay, Department of English. Legon: University of Ghana.

Allagbé A. A. (2016). "Character Naming and Authorial Attitudes in Contemporary African Literature". In *Research on Humanities and Social Sciences*. Vol.6, No.4, ISSN (Paper) 2224-5766 ISSN (Online) 2225-0484 (Online).

Asempasah, R. & Sam, A. C. (2016). "Reconstructing the self: Of Names, Discourses and Agency in Amma Darko's *Beyond the Horizon*". In *International Journal of Humanities and Cultural Studies*, Vol. 2, Issue 4.

Ayinne, R. A. (2004). *Emerging Issues in Amma Darko's Novels: Beyond the Horizon, The Housemaid and Faceless*. Undergraduate Long Essay, Department of English. Legon: University of Ghana.

Awitor, E. F. (2014). "Social Tragedy in Amma Darko's *Faceless*: Plight of Street Children" in *IISTE* vol. 4, n°27.

Awuyah, C. K. (2013). *Faceless: Amma Darko's Face for the Faceless*. Making Connections: Interdisciplinary Approaches to Cultural Diversity: March 2013, Vol. 14, No. 1.

Bungaro, M. (2007). "Victims and / or Victimisers? Women's De(Con)structive power in *The Housemaid*". In *Broadening the Horizon: Critical Introductions to Amma Darko* (UK: Ayebia Clark Publishing Limited).

Cakpo-Chichi-Zanou, L. C. ; Gbaguidi, C. & Djossou, A. (2017). "Amma Darko's Contribution in *Beyond the Horizon* to Contemporary Gender Portrayals" in *Africology: The Journal of Pan African Studies*, vol. 10, n°1.

Cakpo-Chichi-Zanou L. Cl. & Djossou, A. (2015). "The Phenomenon of Street Children in Amma Darko's *Faceless*" in *Research on Humanities and Social Sciences* ISSN (Paper) 2224-5766 ISSN (Online) 2225-0484 (Online), Vol.5, No.18.

Dako, K., A. Denkabe, and H. Yitah. (2006). "Pawns and Player: The Women in Amma Darko's Novels *Sex and Gender in an Era of AIDS*". Eds. Christine M. Oppong, Yaa P. A. Oppong, and Irene K. Odotei. Accra: Sub-Saharan publishers. Print.

Garritano, Carmela (2007). "Amma Darko's *The Housemaid* and the Gendering of Novel and Nation", in *Broadening the Horizon: Critical Introductions to Amma Darko* (UK: Ayebia Clark Publishing Limited).

Gbaguidi, C. (2013). "Misandry in Amma Darko's *The Housemaid*," in *Safara: Revue Internationale de Langues, Littératures et Cultures*. Saint Louis: Université Gaston Berger/Sénégal, N°12, ISSN 0851-4119.

Higgins, M. E. (2007). "Ngambika and Grassroots Fiction: Amma Darko's *The Housemaid* and *Faceless*." (Ed.) Vincent O. Odamtten, *Broadening the Horizon: Critical Introductions to Amma Darko*. UK, London: Ayebia Clarke Publishing, Print.

Koussouhon, L. A. ; Akogbeto P. A. ; Allagbe A. A. (2015). "Portrayal of Male Characters by a Contemporary Female Writer: A Feminist Linguistic Perspective". In *International Journal of Advanced Research* ISSN 2320-5407 (2015), Volume 3, Issue 12.

Nyanta, D.; Ankrah, G. K. & Opoku K. (2017). "Culture: A vessel for female subordination in three African novels" *European Journal of Social Sciences Studies* ISSN: 2501-8590 ISSN-L: 2501-8590.

M'Bra, K. (2016). "The African Post-independent Legacy and the Objectification of the Woman in Amma Darko's *Beyond the Horizon*" in *Germivoire*, ISSN 2411-6750.

Marfo, C. ; Yeboa A., P. & Bonku, L. (2015). "Exploiting the Exploiter: Some Violations of Society's Expectations in *Beyond the Horizon* and *The Housemaid*" in *3L: The Southeast Asian Journal of English Language Studies – Vol. 21 (1)* <http://dx.doi.org/10.17576/3L-2015-2101-04>.

Odamtten, V. O. (2007). *Broadening the Horizon: Critical Introductions to Amma Darko* (UK: Ayebia Clark Publishing Limited).

Ofori, J. D. (2013). "The Feminist Voice in Contemporary Ghanaian Female Fiction: A Textual Analysis of Amma Darko's *Faceless* and *Not Without Flowers*" in *Research on Humanities and Social Sciences* Vol.3, No.1.

Okyeso, Yeboah P. A. (2013). "A Street Child's Revolt Against Her Mother and Society: Lessons from Amma Darko's *Faceless*" in *Journal of Global Initiatives: Policy, Pedagogy, Perspectives*, Vol. 8, No 1.

Osei, C.; Addei, C. (2013). "The Effects Of Child Abuse On The Victims And The Community – A Critical Analysis Of Amma Darko's *Faceless* And Lawrence Darmani's *Grief Child*". *IOSR Journal Of Humanities And Social Science (IOSR-JHSS)* Volume 16, Issue 4, e-ISSN: 2279-0837, p-ISSN: 2279-0845. www.Iosrjournals.Org.

Palmer, F. (2009). *Beyond Freedom and Constraint: Alternative Intimacies in the Novels of Yvonne Vera, Calixte Beyala and Amma Darko*: Columbia University Press.

Umezurike, U. P. (2015). "Resistance in Amma Darko's *Beyond the Horizon* and Chika Unigwe's *On Black Sisters' Street*". *An International Journal of Language, Literature and*

Gender Studies (LALIGENS), Ethiopia Vol. 4 (2), Serial No 10, May, 2015: 152-163 ISSN: 2225-8604(Print) ISSN 2227-5460 (Online).

4. Critical works

Abraham, W. (1962). *The African Mind*. London: Weidenfeld and Nicolson. A classic text of African philosophy.

Abdulla, A. K. (2001). "Rhetorical repetition in Literary Translation", *Babel*, Volume 47, Number 4, John Benjamins Publishing Company. ISSN 0521-9744 (Print); ISSN: 1569-9668 (Online).

Achebe, C. (1988). "The Novelist as Teacher", *Hopes and Impediments: Selected Essays, 1965-1987*. London: Heinemann.

Acholonu, C. O. (1995). *Motherism: An Alternative to Feminism*. Owerri: Afa Publications.

Adelugba, D. (1976). "Language and drama: Ama Ata Aidoo", *African Literature Today* 8.

Adesanmi, P. & Dunton, C. (2005). "Nigeria's Third Generation Writing: Historiography and Preliminary Theoretical Considerations", *English in Africa*.

Adogame, A. "Editorial: Religion in African Literary Writings" in *Studies in World Christianity*.

Afisi, O. T. (2010). "Power and Womanhood in Africa: An Introductory Evaluation" in *The Journal of Pan-African Studies*. Vol 3, No 6.

Ajayi-Soyinka, O. (1993). *Black Feminist Criticism and Drama: Thoughts on Double Patriarchy* <https://journals.ku.edu/index.php/jdtc/article/viewFile/1875/1838>.

Akachi, E. T. (2008). *Artistic Creativity: Literature in the Service of Society*, University of Lagos.

Akano, R. K. (2014). *So Long a Letter: Understanding the Missionary Narrative of a Polygamy Victim in Journal Of Humanities And Social Science*.

Akujobi, R. (2006). "Yesterday you were divorced. Today I am a widow": An Appraisal of widowhood practices and the effects on the psyche of widows in Africa. Ogun State University (Nigeria).

Akindele, S.T.; Gidado, T.O., & Olaopo, O. R. (2002). "Globalisation, Its Implications and Consequences for Africa", Department of Political Science, Obafemi Awolowo University.

Allan, J. T. (1995). "Womanist and Feminist Aesthetics". Athens & Ohio: Ohio University Press.

Ama, B. (2008). "The Legacy of Kwame Nkrumah in Retrospect" in *The Journal of Pan African Studies*, Vol. 2. No.3.

Amadiume, I. (1987). *Male Daughters, Female Husband's: Gender and Sex in an African Society*, London, Zed.

Amase, E.; Kaan, N. & Aondover, C. (2013). "African Literature and English Language: A Political Literary Discourse" in *International Journal of Humanities and Social Science Invention* ISSN (Online): 2319 – 7722, ISSN (Print): 2319 – 7714 www.ijhssi.org Volume 2 Issue 3.

Amu, N. J. (2006). *The Role of Women in Ghana's Economy*. Fredrich Ebert Stiftung, Ghana, ISBN 9988 - 0 - 2606 – 4, Print and design by O'mens Graphix.

Ankersmit, F. (2010). Truth in History and Literature. *Narrative* 18(1), 29-50. The Ohio State University Press. Retrieved August 10, 2018, from Project MUSE database.

Anozie, S. O. (1970). *Sociologie du roman africain*. Paris: Editions Aubier-Montaigne

Asante-Darko, K. (2000). "Language and Culture in African Postcolonial Literature." *CLCWeb: Comparative Literature and Culture* 2.1. <http://dx.doi.org/10.7771/1481-4374.1062>

Asante, M. A. (1991). The Afro-Centric Idea in Education *Journal of Negro Education*, Vol.60, No 2.

Aschcroft, B. ; Griffiths, G. & Tiffin, H. (1989). *The Empire Writes Back. Theory and Practice in Post-Colonial Literatures*. London & New York: Routledge.

Ashcroft, Bill et al (2007) *Post-Colonial Studies. The Key Concepts*. (2nd Edition). New-York: Routledge.

Atta, B. (1975). "Hero-Worshipping in the African Novel: The Case of Ayi Kwei Armah and Others" (*Asemka* N° 3, September 1975).

Bamikole, Lawrence (2012). "Nkrumah and the Triple Hertiage Thesis and the Development of Africana Socieites". In *International Journal of Development, Humanities and Technology*, Vol.2, No2.

Barrois, C. (1994). "La psychologie du guerrier", in *Sciences Humaines*, n° 041.

Bartlett, F. C. (1932). "*Remembering: A Study in Experimental and Social Psychology*". London: Cambridge UP, in Catriona Cornelissen's *Negotiating Cultures: Modes of memory in novels by African women* (1997) (Ed.) Toronto University Press.

Bender, K. & Furman, R. (2003). "The Social Problem of Depression: A Multi-theoretical Analysis". In *Journal of Sociology and Social Welfare* Vol. 30, 123 at 123.

Bœuf, F. (1924). *La Soudanaise et son amant*. Paris : Albin Michel in Regards sur les Littératures Coloniales. Afrique francophone: Approfondissements, Tome II. France & Montréal: L'Harmattan.

Bressler, C. E. (2007). *Literary criticism: An introduction to theory and practice*. New Jersey: Pearson Education Inc.

Busia, Abena (1989-90). "Silencing Sycorax: On African colonial discourse and Unvoiced Female". *Cultural Critique*, vol.14.

Butler, J. (1990). "The Pleasures of Repetition" in *Pleasure Beyond the Pleasure Principle*, (ed.) Robert A. Glick and Stanley Bone. (New Haven: Yale University Press).

Campu, A. (2013). Tradition versus modernity in Chinua Achebe's *No Longer At Ease*. *Bulletin of the Transilvania University of Braşov • Series IV • Vol. 6 (55) No.2*.

Charvet, J. (1982) *Modern Ideologies: Feminism*. London: J.M. Dent and Sons Limited.

Chioma Steady, F. (1981). *The Black Woman Cross-Culturally*. Cambridge, Massachusetts: Schenkman Publishing Co.

Chioma Steady, F. (1981). *The Black Woman Cross-Culturally*. Cambridge, Massachusetts: Schenkman Publishing Co.

Chukwuma, H. (1994). *Feminism in African literature*. Enugu: New Generation Books.

Cloete, N. (1998). Women and transformation: A recurrent theme in Head and Ngugi: *Literator*, 19 (2) ISSN 0258-2279. Sovenga: University of the North.

Cohler, B. J. & Galatzer-Levy, R. M. (2008). Freud, Anna, and the problem of female sexuality. *Psychoanalytic Inquiry*, 28.

Davies, C. B. ; Fido, E. S. (1990). *Out of the Kumbla, Caribbean Women and Literature*, Trenton, NJ: Africa World Press.

Davies, C. B. ; Fido, E. S. (1993). African Women Writers: Towards a Literary History In: Owomoyela, O. (ed). *A History of Twentieth Century African Literatures*. Lincoln, Nebraska: University of Nebraska Press.

Davies, C. B. (1986). "Introduction: Feminist Consciousness and African Literary Criticism." *Ngambika: Studies of Women in African Literature*. (Ed.) Carole Boyce Davies and Anne Adams Graves. Trenton, NJ: Africa World Press, pp.1-23.

Davies, C. B. (1986). Maidens, Mistresses and Matrons: Feminine Images in Selected Soyinka Works. In DAVIES, C. B. and GRAVES, A. A. (eds.). *Ngambika Studies of Women in Africa*. Trenton, NJ: Africa World Press.

- Denmark, F. & Paludi, M. A. (2008). *Psychology of women: a handbook of issues and theories* (2nd ed.). Westport: CT: Praeger Publishers.
- Deckard, B. S. (1983). *The Women's Movement: Political, Socio-economic and Psychological Issues*. Harper & Row Publishers, NY.
- Delacampagne, C. (1978). "Introduction à une ethnopsychanalyse du messianisme", In *La Violence Actes du Colloque de Milan*, Union Générale d'Éditions.
- Djemaï, A. (2017). "Quand le roman raconte l'Histoire" in *La Représentation de l'Histoire dans les Littératures et les Arts Africains*. Alger : ENAG.
- Dutton, R. (1984). *An Introduction to Literary Criticism*. Essex: Longman.
- Eagleton, M. (2011). *Feminist Literary Theory: A Reader*, Third Edition. India: Mary Eagleton: Wiley-Blackwell Publishing Ltd, Pondicherry.
- Felman, S. (1992). "Education and Crisis, or the Vicissitudes of Teaching" Felman, Shoshana and Laub, Dori. *Testimony: Crisis of Witnessing in Literature, Psychoanalysis, and History*. New York: Routledge.
- Fenske, J. (2011). "African polygamy: past and present" in London School of Economics (LSE) Research online.
- Fonchingong, C. C. (2006). "Unbending Gender Narratives in African Literature". *Journal of International Women's Studies* Vol. 8 No.1, pp. 135-147.
- Forrester, V. (2011). 'What Women's Eyes See'. *New French Feminisms in Feminist Literary Theory: A Reader* (ed.) Eagleton, Mary. *Feminist Literary Theory: A Reader*, (Third Edition). India: Mary Eagleton: Wiley-Blackwell Publishing Ltd, Pondicherry.
- Fortier, M. (2002). *Theory/theatre: An introduction*. London: Routledge.
- Fouquet, T. (2018). « Subalternités et citadinités en Afrique : une tension heuristique » in *Citadinités subalternes en Afrique*. Paris: Karthala.
- Frank, K. (1984). "Feminist criticism and the African novel". In J. Durosimi & E. Palmer (Eds.) *African Literature Today*, Ibadan: Heinemann, vol.14.
- Frank, K. (1987). *Women Without Men: The Feminist Novel in Africa*. In DUROSIMI, E. et al. (ed.). *Women in African Literature Today*. Trenton, NJ: African World Press.
- Freud, S. (1922). Anonymous (Letter to an American mother). In E. Freud (Ed.), London: Hogarth Press, 1960.
- Giddens, A. (1994). "From the Consequences of Modernity". *Colonial Discourse and Post-Colonial Theory: A Reader*. Patrick Williams and Laura Chrisman, Eds. New York: Columbia University Press.

Green, R. (1987). "From *The Lying Days* to *July's People*: The Novels of Nadine Gordimer," *Journal of Modern Literature*, 14, 8).

Harris J. (1987). The plural text/the plural self: Roland Barthes and William Coles *College English*, 49 (2) (1987).

Helen, G. (2001). "Postcolonial Play: An Anthology". London and New York: Routledge, Taylor & Francis Group.

Henderson, R. N. (1972). *The King in Every Man: Evolutionary Trends in Onitsha Igbo Society*. Yale University Press.

Hoek, L. H. (1981). *La Marque du titre: Dispositifs sémiotiques d'une pratique textuelle* (Approaches to Semiotics; Paris: Mouton de Gruyter, 1981), quoted in Gérard Genette, "Structure and Functions of the Title in Literature," *Critical Inquiry* 14 (Summer 1988).

Holoch, A. M. (2012). *The Serious Work of Humor in Postcolonial Literature*, Iowa: Iowa University Press.

hooks, b. (1997). "*Feminism: A Movement to End Sexist Oppression*". *Feminisms*. (Ed.) Sandra Kemp and Judith Squires New York: Oxford University Press.

----- (1984). *Feminist Theory: From Margins to Centre*. Boston: South End.

----- (2000). "Feminist Theory: From Margin to Centre". Cambridge. MA South End Press. Print (1st Ed) 1984.

----- (1998). 'Black Feminism: Historical Perspective' in *Call and Response: The Riverside Anthology of African American Literary Tradition*. Liggins Hills et al. (eds). Boston: Hughton Miffling Company.

Hook, D. (2004). Frantz Fanon, Steve Biko, 'psychopolitics' and critical psychology [online]. London: LSE Research Online.

Horvitz, M. D. (2000). *Literary Trauma: Sadism, Memory, and Sexual Violence in American Women's Fiction*. Albany & New York: State University of New York Press.

Hopkins, P. (1900). *Contending Forces: A Romance Illustrative of Negro Life North and South* (Boston: Colored Co-operative Publishing House in *Feminist Literary Theory: A Reader*, (2009). (Third Edition). Pondicherry, India: Mary Eagleton: Wiley-Blackwell Publishing Ltd.

Humm, M. (1992). *Feminisms: A Reader*. New York: Harvester Wheatsheaf.

Ifechelobi, J. N. (2014). "Feminism: Silence and Voicelessness as Tools of Patriarchy in Chimamanda Adichie's *Purple Hibiscus*" in *African Research Review, An International Multidisciplinary Journal*, Ethiopia Vol. 8(4), Serial No. 35, September, 2014:17-27 ISSN 1994-9057 (Print) ISSN 2070--0083 (Online).

Isbell, H.; White, W. (1953). "Clinical Characteristics of Addiction", *American Journal of Medecine*, no. 14, p. 558 in *The Drugtakers: The Social meaning of drug use*. London, Reading & Fakenham: Granada Publishing Limited.

James, S. M. et al. (1993). *Theorizing Black Feminism: The Visionary Pragmatism of Black Women*. London & New York: (1st Ed), Routledge.

Jaworshi, A. (1993). *The Power of Silence: Social and Pragmatic Perspectives*. Newbury Park, CA: SAGE Publication, Inc.

Kakraba A. D. (2011). Ayi Kwei Armah's Vulgar Language in *The Beautiful Ones are not Yet Born*, a Therapeutic Tool in *Current Research Journal of Social Sciences* 3(4): ISSN: 2041-3242.

Kaufmann, J. C. (2004). *L'Invention de soi. Une théorie de l'identité*, Armand Collin in *Identité (s) : L'individu, le groupe, la société* (2016). Editions Sciences humaines.

Kennedy, D. (1988). *Beyond the Pyramids*. HarperCollins Publishers Ltd; New Ed.

King, L. M. (2013). In discourse—towards a Pan-African psychology: Drum rolls for a psychology of emancipation. *Journal of Black Psychology*, 39, in "the African Conception of Death: A Cultural Implication" Lesiba Bolayi & Molebogeng Makobe-Rabothata. South Africa: University of South Africa.

Klimkova, S. (2015). Ngugi Wa Thiong'o, 1978 quoted in History and fiction: Ngùgì wa Thiong'o's vision in *Seria Filologicsna, Studia Anglica Resoviensia* 12, Constantine the Philosopher University in Nitra.

Kolawole, M. E. M. (1987). "Womanism and African Consciousness". Trenton, New Jersey: African World Press.

Labov, W. & Waletzky, J. (1967). Narrative analysis: Oral versions of personal experience. *Essays on the verbal and visual arts*, ed. by June Helm. Seattle: University Of Washington Press.

Lazar, M. (2007). 'Feminist Critical Discourse Analysis: Articulating a Feminist Discourse Praxis', *Critical Discourse Studies*, 4: 2.

Lazarus, N. (1990). *Resistance in Postcolonial African Fiction*. New Haven: Yale University Press.

Lazarus, N. (1997). *Ama Ata Aidoo: Independence and Disillusionment in Postcolonial Ghana in African Post-colonial Literature in English*.

Lebdai, B. (2015). *Autobiography as a Writing Strategy in Postcolonial Literature*. Cambridge: Cambridge Scholars Publishing.

Lindfords, B. (1999). *Nadine Gordimer Revisited*, Twayne's World Authors Series, *African Literature*, Bernth Lindfords, Editor, University of Texas at Austin.

Little, D. (2008). "Philosophy of History", The Stanford Encyclopedia of Philosophy (Edition), Edward N. Zalta. <<http://plato.stanford.edu/archives/fall2008/entries/history>>.

Maclean, U. (1974). *Magical medicine: a Nigerian case study*. England: Penguin Books.

Manieson, A. A. (2011). Interpretation and Analysis of *Purple Hibiscus*, Accra; Akua A. Manieson Publisher.

Mannoni, O. (1951). "La Plainte du Noir", *Esprit*, n° 179. 0-7734-8517.

Matateyou, E. (1997). "An Anthology of Myths, Legends and Tales from Cameroon: Storytelling" in *Africa. Research in African Literatures* 31.3, Lewiston: Mellen, 256 pp. ISBN

Milligan, I. (1983) "The Novel in English: An introduction". Hong Kong: The Macmillan Press LTD.

Morrison, W. M. (2017). *China's Economic Rise: History, Trends, Challenges, and Implications for the United States*. Congressional Research Service.

Moyo, D. (2009). *Dead Aid: Why Aid is not Working and How There is Another way for Africa*. New York: Farrar, Straus and Giroux.

Nabasuta Mugambi H. & Tuzyline J. A. (2010). *Masculinity in African Literary and Cultural Texts*. (ed). Oxford: Ayebia Clarke Publishing Limited.

Nair, S. (1995). "Melancholic Women: The Intellectual Hysteric (s) in *Nervous Conditions*". *Research in African Literatures*, 26.

Ngũgĩ, w. T. (1981). *Detained: A Writer's Prison Diary*. Nairobi: Heinemann Educational Books.

Nkosi, L. (1981). *Tasks and Masks: Themes and Styles of African Literature*. Essex: Longman.

Nwankwo, C. (1990). "The Oral Foundation of Nigerian Written Poetry." In E. Emenyonu (ed.). *Literature & Black Aesthetics*. Ibadan: Heinemann.

Oduyoye M. A (1997) "Women and Ritual in Africa" in M. A. Oduyoye and M. R. A Kanyoro (eds.) *The Will to Arise*. New York: Orbis Books.

Ogede, O. (2000). "Three Backward Glances. Roads to Freedom in the Late Novels (*Two Thousand Seasons, The Healers, and Osiris Rising*)", Ayi Kwei Armah. *Radical Iconoclast: Pitting Imaginary World against the Actual* (Athens : Ohio University Press).

Ogundipe-Leslie, M. (1984) *African Woman Culture and Another Development* .Journal of African Marxists. London: Heinemann.

Ogundipe-Leslie, M. (1987). "The Female Writer and her Commitment" in Jones, E.D., Palmer, E. and Jones, M., *Women in African Literature Today* 15, London & New York: James Currey.

- Ogundipe-Leslie, M. (1994). *Recreating Ourselves*. Trenton: Africa World Press.
- Ogundipe-Leslie, M. (1993) *African Women, Culture and Development. Theorizing Black Feminism*. London: Routledge.
- Ogundipe-Leslie, M. (1994). *Recreating Ourselves: African Women and Critical Transformations*, Trenton, New Jersey: Africa World.
- Ogunwale, J. A. & Bamigbade, O. E. (2014). “Linguistic Alienation and Culture Subversion as Sociolinguistic Factors for Name Dropping and Change among the So-Called Yoruba Elites” in IOSR Journal Of Humanities And Social Science (IOSR-JHSS) Volume 19, Issue 11, Ver. I, e-ISSN: 2279-0837, p-ISSN: 2279-0845.
- Okpewho, I. (1992). *African Oral Literature: Backgrounds, Character, and Continuity*. Indiana University Press.
- Okri, B. (1996). *Dangerous Love*. London: Phoenix House, quoted in Akachi Ezeigbo’s Artistic Creativity: Literature in the service of Society (Feb, 2008), University of Lagos Press.
- Ong, W. J. (1982). “Orality and Literacy: The Technologizing of the World”. London: Aidoo, Ama Ata (1998). “African Women Today” in Sisterhood Feminisms & Power: From Africa to the Diaspora, O. Nnaemeka, (ed.) (Trenton, New Jersey: Africa Wide Press).
- Opoku-Agyemang, K. (1996). *Cape Coast Castle: A Collection of Poems*. Accra: Afram Publications (Ghana) Ltd.
- Osei-Mensah, A. (1999) Women's Roles in the Mourning Rituals of the Akan of Ghana Author(s): Source: *Ethnology*, Vol. 38, No. 3, pp. 257-271, University of Pittsburgh- Of the Commonwealth System of Higher Education Stable URL: <http://www.jstor.org/stable/3773817>
- Oyewumi, O. (2001). ‘Ties that (Un)Bind: Feminism, Sisterhood and Other Foreign Relations’ in *Jenda: A Journal of Culture and African Women Studies*, vol1, No1.
- Palmer, E. (1972). *An Introduction to the African Novel*. London: Heinemann.
- Parry, B. (1987). ‘Problems in Current Theories of Colonial Discourse’ *Oxford Literary Review* 9 (1&2) in *Post-Colonial Studies Reader* (ed.) Bill Ashcroft, Gareth Griffiths & Helen Tiffin.
- Peck, J. ; Coyle, M. (1984). *How to Study Literature: literary Terms and Criticism*. Hampshire & London: MacMillan Press Ltd.
- Potash, B. (1986). *Widows in African Societies: Choices and Constraints*, California, Stanford University Press.
- Prasanta K. D.; Swarnali S. (2010). Psychological Aspects of Infertility. *British Journal of Medical Practitioners*, Vol 3, No 3.

- Ramadanovic, P. (2001). *Forgetting Futures: On Memory, Trauma, and identity*. Lanham: Lexington Books.
- Reboux, P. (1920). *Romulus Coucou*. Paris: Flammarion, in Regards sur les Littératures Coloniales. Afrique francophone: Approfondissements, (Ed.) Jean-François Durand. Tome II. France & Montréal: L'Harmattan.
- Roberts, R. S. (2005). "No Cold Kitchen", Johannesburg: STE Publishers.
- Robinson, C. (2011). *Hair as race: Why "Good hair" may be bad for black females*. Howard Journal of Communications, 22(4).
- Roudinesco, E. (2009). *Our Dark Side: A History of Perversion*, trans. Davis Macey, Cambridge and Malden, MA, Polity Press in *the Cambridge Introduction to Literature and Psychoanalysis* (2014)(ed) Rabaté, Jean-Michel, University of Pennsylvania, Cambridge University Press.
- Royer, L. Ch. (1928). *La Maîtresse noire*, Paris: Les Editions de Paris in Regards sur les Littératures Coloniales. Afrique francophone: Approfondissements, (Ed.) Jean-François Durand. Tome II. France & Montréal: L'Harmattan.
- Said, E. (1978). *Orientalism*. London: Routledge.
- (1994). *Culture and Imperialism*. New York: Alfred A. Knopf.
- Sander, R. and Lindfors, B. (2006). (eds) "Ngugi Wa Thiong'o Speaks". Nairobi: James Currey Oxford.
- Sangari, K. (1990). The Politics of the Possible. In *The Nature and Context of Minority Discourse*. Eds. A JanMohamed and D. Lloyd. New York: Oxford University Press.
- Sicherman, C. M. (1989). Ngugi wa Thiong'o and the Writing of Kenyan History in *Research in African Literatures*, Vol. 20, No. 3 (Autumn, 1989), Indiana University Press.
- Singer, I. (1987). *The Nature of Love* (Chicago, IL: The University of Chicago Press).
- Sonolet, L. (1911). *Le Parfum de la dame noire*, in Regards sur les Littératures Coloniales. Afrique francophone: Approfondissements, (Ed.) Jean-François Durand. Tome II. France & Montréal: L'Harmattan.
- Spivak, C. G. (2006). "Can the Subaltern Speak?" In Ashcroft, Griffiths & Tiffin (eds).
- Sougou, O. (2001). Review Articles (Ayi Kwei Armah) Armah's Politics in *Osiris Rising: The African Diaspora Reversing the Crossing*, in *Identity, Culture and Politics*, Volume 2, N° 1.
- Stratton, F. (1994). *Contemporary African Literature and the Politics of Gender*. London: Routledge.

Subbah, M. (2016). "Shock in War-Gothic: Exploring War Shock and Trauma in Pat Barker's Another World" in *Journal of Literature, Languages and Linguistics*, ISSN 2422-8435, Vol.21.

Tasie, G. (2013). "African Widowhood Rites: A Bane or Boom for the African Woman" in *International Journal of Humanities and Social Science*, Vol. 3 No. 1.

Thiam, A. (1978). *La Parole aux Négresses*, Paris, Denoel/Gonthier, I & II.

Thompson, C. (2008). *Black women and identity: What's hair got to do with it?* Michigan Feminist Studies, 22 (1).

Tobie, N. ; Stenger I. (1999). *Médecins et Sorciers*. Paris: Sanofi-Synthélabo.

Trier-Bieniek, A. (2015). *Feminist Theory and Pop Culture*. (Ed.) Adrienne Trier-Bieniek Valencia College, Orlando, USA, Vol. 5. Sense Publisher, Rotherham.

Uchida, A. (1992). When difference is dominance: A critique of the anti-power-based cultural approach to gender differences. *Languages in Society*, 21.

Van der Merwe, C.; Gobodo-Madikizela, P. (2007). *Narrating our Healing: Perspectives on Working through Trauma*. Newcastle; Cambridge Scholars Publishing.

Vinogradona L. N. & Tolstaja, S. M. (1995). "Priglasenie", Slavjanskaja mifologija, Moscou, 325-326. In *Le Chemin, la Route, la Voie: Figures de l'Imaginaire occidental à l'époque moderne*, Presse de l'Université Paris-Sorbonne (ed.), (2005) Marie-Madeleine Martinet, Francis Conte, Annie Molinié, Jean-Marie Valentin.

Wade, M. (1978). *Nadine Gordimer*. Ibadan: Evans Brothers.

Whatley, W ; R. Gillezeau (2011). The Impact of the Slave Trade on African Economies, in: Rhode P., Rosenbloom, J. and Welman, D. (eds), *Economic Evolution and Revolution in Historical Time*, Stanford: Standfort University Press.

Weedon, C. (1987). *Feminist practice and post-structuralist theory*. Oxford: Basil Blackwell Ltd.

Whyte, P. (2003). *L'Imaginaire dans l'écriture Ayi Kwei Armah : L'Évolution d'une forme. Vol. 1 : A la recherche d'une forme*. Paris: L'Harmattan.

William, L. A. (1988). *To Tell a Free Story: The First Century of Afro-American Autobiography, 1760-1865* (Urbana).

Wilson-Tagoe, N. (2002). "Ama Ata Aidoo in Conversation". In *Wasafiri* 37 (Winter).

Chatman, S. (1978). *Story and Discourse: Narrative Structure in Fiction and Film*. Ithaca, New York: Cornell University Press.

Wright, D. (1990). *Ayi Kwei Armah and the Significance of His Novels and Histories*, in the *International Fiction Review*, Northern Territory University Australia.

Woods, T. (2007). *African Pasts: Memory and History in African literatures*. Manchester: Manchester University Press.

Zazzo, R. (1973). "La Genèse de la conscience de soi", *Psychologie de la connaissance de soi*, symposium, Puf, in *Identité (s) : L'individu, le groupe, la société* (2016). Auxerre: Editions Sciences humaines.

Zecchi, B. (2006). "Women filming the male body: Subversions, inversions and identifications", *Studies in Hispanic Cinemas*. Vol. 3: No 3, doi:10.1386/shci.3.3.187/1.

Zéraffa, M. (1971). *Roman et société*. Paris: P.U.F.

5. Historical books:

Nkrumah, K. (1966). *Neo-Colonialism, The Last Stage of imperialism*. New York: International Publishers.

Walter, R. (1973). *How Europe Underdeveloped Africa*. London and Dar-Es-Salam: Bogle-L'Ouverture Publications, Publishing House: Dar-Es-Salaam, Transcript from 6th reprint.

6. Books of Critical Analysis and Post-colonial writings

Acholonu, C. O. (1995). *Motherism: An Afro-Centric Alternative to Feminism*. Owerri: Afa Publications.

Agger, B. (1998). *Critical Social Theories: An Introduction*. Boulder: Westview Press.

Aly, G. (1999). "*The Final Solution*": Nazi Population Policy and the Murder of the European Jews. London: Arnold

Arnold, M. (1932). *Culture and Anarchy*. Wilson, J. D. (ed.), Cambridge University Press, London, pp.241

Barthes, R. ([1970] 1974). *S/Z*. New York: Hill & Wang.

Barthes, R. (1977). *Image, Music and Text*. Trans Stephen Heat. London: An imprint of HarperCollinsPublishers, Fontana Press.

Barthes, R. & Hamon, P. (1982). *Littérature et Réalité*. Paris: Edition du Seuil.

Bokiba, A-P. (1998). *Ecriture et identité dans la littérature africaine*. Paris: L'Harmattan, p. 10.

Braeckman, C. (1994). *Rwanda. Histoire d'un génocide*. Paris: Fayard.

Breitman, Richard (1991). *The Architect of Genocide: Himmler and the Final Solution*. New York: Knopf.

Butler, J. (2008). "Violence, Nonviolence: Sartre on Fanon" in Jonathan Judaken, *Race After Sartre: Antiracism, Africana Existentialism, Post-colonialism*. (New York: State University of New York Press) p. 216. ☒

Caruth, C. (1996). *Unclaimed Experience: Trauma, Narrative and History*. Baltimore & London: The Johns Hopkins University Press.

Chatman S. (1978). *Story and Discourse, Narrative Structure in Fiction and Film*, Ithaca & London: Cornell University Press

Chevrier, J. (1984). *Littérature nègre*. Paris: Armand Colin.

Coquery-Vidrovitch, C. (1993). *Histoire des villes d'Afrique noire. Des origines à la colonisation*, Paris : Albin Michel, 412 p.

Derrida, J. (1974). *Of Grammatology*. (Trans.) Gayatri Chakravorty Spivak. Baltimore: The John Hopkins University Press, Print.

Diderot, D. (2004). *Jacques le Fataliste et son maître in Contes et romans*. Edition de Michel Delon. Paris : Gallimard, coll. "La Pléiade".

Dossou-Yovo, N. (1997). « *Individu et Société dans le Roman Nègro-Africain d'expression anglaise de 1939 à 1986* ». Edition L'Harmattan. Paris: Collection Etudes Africaines. ISBN: 2-7384-5785-1

Dubois, W.E.B. (1976). *The Souls of Black Folk*. In Martin Luther King Day. Print.

Ela, J-M. (1983). *La ville en Afrique Noire*, Paris: Karthala, 219 p.

Ehora, E. Cl. (2013). *Roman africain et esthétique du conte*. Paris: L'Harmattan.

Fanon, F. (1961). *Black Skin, White Masks*. (Trans.) Charles Lam Markmann, Grove Press Inc, (Trans. 1986).

Fanon, F. (1961). *The Wretched of the Earth: A Negro Psychoanalyst's Study of the Problems of Racism & Colonialism in the World Today*. (Trans. 1968, New York: Grove Press, Inc.).

Fowler, R. (1986). *Linguistic Criticism* (1st Ed.). London: University Press.

Freud, S. ([1900] 1950). *The Interpretation of Dreams*. New York: The Modern Library.1900] 1950: p.164).

Freud, S. (1961). *Beyond the Pleasure Principle*. New York: Norton. Trans. James Strachey.

Freud, S. (1961). *Introduction to Psychoanalysis*. Paris: Payot.

Gaspari, F. (2012). "Morsels for the Gods": l'écriture du visage dans le roman britannique (1839-1900). Paris: Michel Houdiard.

- Gengembre, G. (2006). *Le Roman historique: 50 Questions*. Paris: Klincksieck.
- Genette, G. (1987). *Paratext: Threshold of Interpretation*, (trans.) Jane E. Lewin (*Seuils*, 1987; Cambridge: Cambridge University Press).
- Gibaldi, J. (1997). *MLA Handbook for Writers of Research Papers, Theses, and Dissertations*. New York: The Modern Language Association of America.
- Gikandi, S. & Evans M. (2007). *The Columbia Guide to East African Literature in English Since 1945*. New York: Columbia University Press.
- Greer, G. (1971). *The Female Eunuch*. New York: McGraw-Hill.
- Hamon, P. (1977). « Pour un statut sémiologique du personnage ». In : *Poétique du récit*. Paris: Seuil.
- Hatzfeld, J. (2002). *Dans le nu de la vie*. Paris: Seuil.
- Hooks, b. (2000). *Feminism is for Everybody: Passionate Politics*. Cambridge: South End Press.
- Jean, R. (1965). *La Littérature et le Réel*. Paris: Edition Albin Michel
- Laplanche, J. (1967). *Vocabulary of Psychoanalysis*. Paris: P.U.F.
- Lavocat, F. (2016). *Faits et Fiction: Pour une frontière*. Paris: Editions du Seuil.
- Lodge, D. (1992). *The Art of Fiction*. London: Vintage Books.
- Lodge, D. (1972). *20th Century Literary Criticism: A Reader*. London: Longman Group LTD.
- Lottinville, S. (1976). *The Rhetoric of History*. Norman: University of Oklahoma Press.
- Lyotard J-F. (1991) “The Inhuman”, Cambridge: Polity Press.
- Lukacs, G. (1962). *The Historical Novel: A Peregrine Book*. Penguin Books Ltd, Harmondsworth, Middlesex, England, Merlin Press Ltd.
- McCann, I. ; Lisa and Pearlman, L. A. (1990). *Psychological Trauma and the Adult Survivor; Theory, Therapy, and Transformation*. New York: Brunner-Routledge.
- N’Diaye, T. (2008). *Le Génocide voilé : Enquête historique*. Paris: Gallimard.
- Ngugi, W. T. (1986). *Decolonising the Mind: the Politics of Language in African Literature*. London: James Currey.
- Ngugi, W. T. (1997). “Writers in Politics”. Nairobi: East African Educational Publishers.
- Radford, J. (1975). *Norman Mailer: A critical study*. London: The Macmillan Press Ltd.

Renate, Z. (1974). *Frantz Fanon: Colonialism and Alienation*. (New York: Monthly Review Press).

Ryan, M-L. (2004). *Narrative across Media: The Languages of Storytelling*. Lincoln & London: University of Nebraska Press.

Sartre, J.-P. (1948) *Qu'est-ce que la littérature?* Paris: Gallimard. *What is Literature?* (Trans) Bernard Frechman, New York: Philosophical Library.

Selden, R.; Widdowson, P. & Brooker, P. (2004). *A Reader's Guide to Contemporary Literary Theory*, (Fifth Edition), Routledge.

Teitelbaum, H. (1966). *How To Write a Thesis: A Guide to the Research Paper*. New York: Monarch Press.

Toxiological Chemistry (2009) Universitatis Medicinalis Leopoliens Sigillum.

William, L. Andrews (1988). *To Tell a Free Story: The First Century of Afro-American Autobiography, 1760-1865* (Urbana).

Wollstonecraft, M. (1975). *A Vindication of the rights of woman*. New York: W.W. Norton

Young, J. (1971). *The Drugtakers: The Social meaning of drug use*. London, Reading & Fakenham: Granada Publishing Limited.

7. Webiography

ActionAid International 2012 Report “*Condemned Without Trials: Women and Witchcraft in Ghana*”, Johannesburg, South Africa.

Magma,W. *The Dynamics of African Literature and its Criticism: Perspectives from Zimbabwe*.

<http://www.biography.com/people/toni-morrison-9415590>

<https://www.bps.ac.uk/about/about-pharmacology/what-is-pharmacology>

British Pharmacological Society, *Today's science, Tomorrow's medicine*.

www.justice.gov/opa/blog/updated

<https://www.bps.ac.uk/about/about-pharmacology/what-is-pharmacology>

http://www.bbc.co.uk/worldservice/arts/features/womenwriters/aidoo_life.shtml

<http://www.bachelorandmaster.com/criticaltheories/colonialist-criticism.html#WOCZdM6cHIU>”.

Ted Talks. The Danger of a Single Story. Chimamanda Ngozi Adichie. March 28, 2012.
http://www.ted.com/talks/chimamanda_adichie_the_danger_of_a_single_story.html

Smith, David (2011). Jacob Zuma blames Christianity for breakdown of South Africa traditions, *The Guardian*, Wednesday 21 December 2011, 17.02 GMT. <http://www.guardian.co.uk/>

Goredema, Ruvimbo (2009). African Feminism:

The African woman's struggle for identity.

http://reference.sabinet.co.za/webx/access/electronic_journals/ayor/ayor_v1_a5.pdf

<http://www.blackhistoryheroes.com/2010/05/queen-mother-nana-yaa-asantewaa.html>

Ndabayakhe, V. (2013). Attitudes Towards polygamy in select African Fiction.

Lewis, C. S. (n.d.). AZQuotes.com. retrieved April, 21, 2018, from AZQuotes.com web site:
http://www.azquotes.com/author/8805-C_S_Lewis

<http://www.ecology.com/2011/11/15/animals-smile/>

Sarah B. Weir & Trystan L. Bass. (2011). Can Animals Smile?

<https://sumansutra.wordpress.com/2011/10/05/animal-can-smile/>

<http://www.empower-yourself-with-color-psychology.com/color-blue.html>

<http://www.webmd.com/skin-problems-and-treatments/guide/leprosy-symptoms-treatments-history>

Source: Commission of the European Communities: Eurostat, Netherlands Interdisciplinary Demographic Institute (NIDI). 2001. Push and Pull Factors Determining International Migration Flows, "Why and Where: Motives and Destinations."

Haris Braden Joyce: African And African-American Traditions In Language Arts no website
<http://www.pps.k12.or.us/district/depts/mc-me/essays.shtml> do PPS Geocultural Baseline Essay Series, p, 5.

Aliyu Ibrahim, A Socio-Semiotic Interpretation of Ama Ata Aidoo's *Anowa*, p. 7.
www.unilorin.edu.ng/publications/aliyu-ibrahim/

Sarpong, Peter Akwasi (1974). *Ghana in Retrospect*. Tema, Ghana Publishing Corporation

Pyper, Cecilia (2010). ScienceDaily, University of Oxford

Oduro, T., Hennie P., Nussbaum S. & Brain B. (2008). *Mission in an African way: A practical introduction to African instituted churches and their sense of mission*, Christian Literature Fund and Bible Media, Wellington.

Onyinah, O. (2012). Pentecostal Exorcism. Witchcraft and Demonology in Ghana. Blandford Form: Deo Publishing quoted in *Witchcraft Concepts in West-African Pentecostal Literature*, Bachmann, Judith, GloPent Conference, London.

Pawlikova-Vilhanova, V. (2007). Christian missions in Africa and their roles in the transformation of African societies, *Asian and African Studies*, 16, 2. Source: blog

Thesis:

Brown, L. (1981). *Women Writers in Black Africa*. Westport: Greenwood Press.

Diabate, N. (2011). *Genital Power: Female Sexuality in West African Literature and Film*. University of Texas at Austin. Published PhD Thesis.

Leddai, B. (2001). « Signes et Symbolique de la révolte existentielle dans les personnages d'Ayi Kwei Armah ». Université de Lille : Atelier de production des thèses.

Mears, M. D. (2009). *Choice and discovery: An analysis of women and culture in Flora Nwapa's fiction*. University of South Florida, Published Thesis. Scholar Commons.

Neupane, S. P. (2010). *Construction of Community as the Cause of Communal Violence: A Study of Adichie's Half of a Yellow Sun*. Tribhuvan University in Kathmandu. Published Thesis.

Opara, C. (1987) *Towards Utopia: Womanhood in Fiction of Selected West African Writers'*. PhD Thesis in the University of Ibadan.

Sinclair, T. J. (2012). *Beyond their control: The Disempowerment of women in Middle Eastern and African literature*. East Carolina University, Unpublished Thesis.

Tidorchibe, E. T. (2014). *The Generational link between Ama Ata Aidoo and Amma Darko*, Kumasi University, Unpublihsed Thesis.

Yassine-Diab, N. (2014). *Aliénation et réinvention dans l'œuvre de Jamaica Kincaid*, Presses Universitaires de la Méditerranée, Université Jean Jaurès.

Dictionaries:

Barrow, Robin & Milburn, Geoffrey. (1990). *A Critical Dictionary of Education Concept*. (2nd Edition). New York: Harvester Wheatsheaf.

The Cambridge Dictionary.

The Concise Oxford Dictionary of Current English (1995). (1st Ed.) Fowler H. W. & Fowler F. G. (9th Ed.) Oxford University Press, Della Thompson. Print USA.

Gikandi, S. (2003). *The Routledge Encyclopedia of African Literature*, (ed.) USA, New York, NY and Canada, Routledge 10016.

Oxford Advanced Learner's Dictionary of *Current English* (2015) (ed. 9th) Oxford University Press.

Webster's Third New International Dictionary of the English Language, Unabridged, Springfield, Mass.: G & C. Merriam Company, Publishers, 1996.

Interviews:

Adichie, Chimamanda N. (2009). "The Danger of a Single Story". TED TALK, www.ted.com

Aidoo's interview with Wangui wa Goro, in [Royal African Society](#)'s annual *Africa Writes* Festival, August 2014.

Amma Darko's interview on "What motivates her to write irrespective to her tight schedules at work" at her office at Internal Revenue, Kaneshie Branch, Accra, April 15, 2010.

Azodo, A. U. (1996). Interview with Ama Ata Aidoo: Facing the Millennium, Hauppauge, New York.

Behrent, M. (1997). Ama Ata Aidoo: Independence and Disillusionment in Postcolonial Ghana in *African Post-colonial Literature in English*.

Buchi Emecheta in a 1989 interview. Cited in Juliana Makuchi Nfah-Abbenyi, *Gender In African Women's Writing. Identity, Sexuality and Difference* (Bloomington and Indianapolis: Indiana University Press, 1997), p. 7.

Interview of Sidiwe Magona with Karin Orantes in *Trauma, Memory, and Narrative in South Africa: Interviews*, (ed.) Ewald Mengel, Michela Borzaga & Karin Orantes (Matatu 38; Amsterdam & New-York: Editions Rodopi, 2010), p. 36.

Holt, J. "The Changing Representations of Women: The Art of Hannah Wilke, Lynda Benglis, and Cindy Sherman"

<http://www.brooklyn.cuny.edu/pub/departments/bcurj/pdf/HoltJessicaART.pdf>

Rutherford, J. (1990). *The Third Space: Interview with Homi Bhabha. Identity, Community, Culture, Difference*. J. Rutherford. London: Lawrence and Wishart: 207-221

Micere, M. (2010). *A Conversation: Ama Ata Aidoo with Micere Mugo*. Interview, Brown University.

Muana, P. K. (2003). Interview. "Amma Darko." *Beyond the Horizon: Feminist Urges and Faceless Women? Professional African Women with Class and Style*. Web. 29 March, 2008. www-English.tamu.edu/pers/fac/muana/DarkoInt.doc. Web.

[Royal African Society](#)'s annual *Africa Writes* Festival, August 2014

