



HAL
open science

On the interaction of cooperation techniques with channel coding and ARQ in wireless communications

Faton Maliqi

► **To cite this version:**

Faton Maliqi. On the interaction of cooperation techniques with channel coding and ARQ in wireless communications. Other. Université Paris Saclay (COMUE); Universiteti i Prishtinës (1999-..), 2017. English. NNT : 2017SACLS576 . tel-02179745

HAL Id: tel-02179745

<https://theses.hal.science/tel-02179745>

Submitted on 11 Jul 2019

HAL is a multi-disciplinary open access archive for the deposit and dissemination of scientific research documents, whether they are published or not. The documents may come from teaching and research institutions in France or abroad, or from public or private research centers.

L'archive ouverte pluridisciplinaire **HAL**, est destinée au dépôt et à la diffusion de documents scientifiques de niveau recherche, publiés ou non, émanant des établissements d'enseignement et de recherche français ou étrangers, des laboratoires publics ou privés.



NNT : 2017SACLS576

THÈSE DE DOCTORAT

DE
L'UNIVERSITÉ PARIS-SACLAY

EN CO-TUTELLE AVEC
L'UNIVERSITÉ DE PRISTINA

PRÉPARÉE À L'UNIVERSITÉ PARIS-SUD
AU SEIN DU LABORATOIRE DES SIGNAUX ET SYSTÈMES (L2S)

ECOLE DOCTORALE N° 580
Sciences et Technologies de l'Information et de la Communication (STIC)
Spécialité de doctorat : RÉSEAUX, INFORMATION ET COMMUNICATIONS

Par

M. Faton MALIQI

**On the interaction of cooperation techniques with
channel coding and ARQ in wireless communications**

**Thèse présentée et soutenue à Gif-sur-Yvette,
le 19 Décembre 2017 :**

Composition du Jury :

M. Philippe CIBLAT	Télécom ParisTech	Président du jury
M. Pierre DUHAMEL	L2S/CNRS/CentraleSupélec	Directeur de thèse
M. Ilir LIMANI	Université de Pristina	Co-directeur de thèse
Mme Marie Laure BOUCHERET	ENSEEIH Toulouse	Rapporteur (absente)
M. Didier LE RUYET	CNAM	Rapporteur
Mme Elena-Veronica BELMEGA	ETIS/ENSEA	Examinatrice
Mme Francesca BASSI	ESME-Sudria	Invitée, co-encadrante

To my parents,

To my beloved wife, Teuta,

To my sweet daughters, Dina and Jora

Acknowledgements

I have always liked acknowledgements, as this is a sign that people love each-other, cooperate, support and understand each other. There are few weeks up to my PhD defense, and I remind the time passed during these three years. A lot of work has been done and a lot of memories have remained. I would consider the most difficult period of my life so far, a challenge where in the end the courage wins over the despair and the success over the failure. I could not have finalized successfully this "journey" without the people that I would like to thank as follow.

First of all, I would like to thank the staff of French Embassy in Prishtina, who have supported, financed and organized my trips in Paris during these three years. I would be grateful for entire my life.

Secondly, I would like to thank my supervisors, Pierre Duhamel and Francesca Bassi, for their endless support, supervision and patience during this time. This co-supervised PhD, with periods and trips come-and-go between Prishtina and Paris have not been easy for neither part. Thank you that believed on me, beside all the difficulties.

I am grateful to Professor Ilir Limani, whom I attribute the merits for involving me in academic life. I would like to thank him for cooperation, discussions, suggestions, and for his consideration during my absence in teaching and evaluation processes in University exams in Prishtina.

I would like to thank all colleagues and friends from the Laboratory of Signals and Systems (L2S) and Supelec for the time and moments spent together. In particular, I would like to thank my friend Hong Nhat Nguyen who was the first whom I met at L2S, and with whom we have shared the best and the most important discussions. Also, at the most difficult times, then where the "marathonomac" losses his powers, a major courage I had gotten from my friend, Paulo Prezotti, with whom we have shared many discussions and tennis games. Thank you Paulo. You are a good friend.

A proverbial phrase says: "when life gives you lemons, make lemonade". Therefore, I am happy that my dream to know my father Mejdi, whom I lost when I was 2 years old, I converted to the main motivation to follow his journey. I wanted to know more about telecommunications, like he did. I wanted to live, in his behalf ...

I begun with the motivation gotten from my father, and then I continued with the desire to make my mother Sevdije proud, whom I dedicate a large part of my success. She is a hero, who took care alone for the family. I would like to thank my brother Artan, too, for his constant support and courage.

The most important thank goes to my wife Teuta, and to our daughters, Dina and Jora. I missed you every moment, but you have supported and pushed me forward every moment. Dina and Jora, you are the joy of my life. In you, I found the true meaning of life. In you, I found home. In you, I found myself. Teuta, you stand behind every success of me. More than for that, I would like to thank you for unconditional love and for giving birth to our sweet daughters. Thank you that you take care of the family and make us happy every day. This PhD is not written well enough to dedicate it to you. The life doctorate that we are writing with our daughters, it is better.

Résumé de la thèse

Les communications mobiles se caractérisent par une demande accrue de services basés sur Internet (voix, données vidéo). Aujourd'hui, les services vidéo constituent une grande partie du trafic Internet et, d'après un rapport de Cisco, 75% du trafic mondial de données mobiles sera basé sur la vidéo d'ici 2020. Cette demande de plus en plus constante dans la prestation de services Internet, a été le principal moteur du développement du réseau cellulaire numérique 4G, où les services à commutation de paquets sont la principale cible de conception. En particulier, l'ensemble du système doit assurer des débits de données de pointe élevés pour l'utilisateur et un faible retard dans la livraison du contenu, afin de prendre en charge les applications en temps réel telles que la diffusion vidéo et les jeux vidéo en ligne. Ces besoins ont motivé, au cours de la dernière décennie, un intérêt croissant et une recherche renouvelée et dans la technologie d'accès radio sans fil.

Le canal sans fil peut fournir un débit de données limité, en raison de divers phénomènes physiques tels que l'affaiblissement de propagation, la décoloration, les interférences, etc., qui affectent considérablement la qualité du signal reçu. Ces phénomènes peuvent être contrastés en utilisant des techniques de diversité coopérative (transmission du même signal à partir de stations multiples) et en utilisant des techniques de diversité temporelle (retransmission du même signal de la même station). La stratégie de diversité coopérative nous permet d'utiliser les relais comme nœuds alternatifs pour retransmettre le même signal vers la destination, alors que la stratégie de la diversité temporelle repose sur le protocole requête automatique de répétition (ARQ). Les deux techniques appliquées uniquement apporteront des améliorations, mais nous voulons vérifier si l'application conjointe de ces deux techniques apporte des améliorations plus élevées. Ainsi, notre objectif dans cette thèse est d'étudier l'interaction entre les protocoles de relayage et l'ARQ en présence du codage canal. Bien que cette interaction a été étudiée à partir de différentes perspectives dans la littérature et principalement pour les couches supérieures, nous nous concentrons, dans notre étude, sur la couche physique (PHY) et la couche de contrôle d'accès au support (MAC), en ce qui concerne la conception des outils de traitement numérique du signal (DSP).

Pour l'analyse théorique de ces systèmes, on utilise différents outils, mais dans notre analyse, nous nous concentrons sur les Machines à états finis (FSM) et les Chaînes de Markov à un nombre fini d'états (FSMC), qui représentent des moyens systématiques d'analyser les protocoles de coopération. Dans la plupart des publications, on considère généralement le cas lorsque le relais fonctionne en mode Décodeur-et-Transférer (DCF) ou Amplifier-et-Transférer (AF). Mais, en mode DCF, il est nécessaire de mettre en œuvre des algorithmes complexes pour le décodage au relais, et en mode AF, le relais, amplifie non seulement le signal utile mais aussi

le bruit. Par conséquent, en raison de sa simplicité de mise en œuvre, dans notre étude, nous nous concentrons principalement sur le mode Démoduler-et-Transférer (DMF), selon lequel le signal reçu par le relais est démodulé / ré-modulé puis est transmis à la Destination . En outre, une courte analyse du mode DCF a été menée.

L'interaction entre les deux techniques a été souvent étudiée à l'aide de protocoles déterministes, mais dans notre analyse, nous nous concentrons sur les protocoles à la fois déterministes et probabilistes. Jusqu'à présent, les protocoles probabilistes, où l'action à exécuter ensuite (quel nœud retransmet l'information) est choisie avec une probabilité donnée, ont été principalement proposées pour des couches supérieures des systèmes de communication, alors que dans notre thèse, nous discutons des protocoles probabilistes sur la couche physique et la couche MAC, qui donnent une meilleure idée de l'analyse et de l'optimisation des performances. Les protocoles probabilistes ne contiennent que deux paramètres qui peuvent être optimisés pour les meilleures performances. Pour le décodeur de type I, nous avons effectué l'optimisation via un FSMC à six états, tandis que pour l'optimisation du décodeur de type II, nous avons utilisé un FSMC avec un nombre d'états plus élevé, mais qui est toujours très efficace et permet une prédiction rapide de la performance.

Grâce à l'analyse d'optimisation, nous avons pu trouver l'emplacement optimisé du relais pour les deux types de décodeurs. Nous rappelons qu'en mode DMF, l'emplacement optimisé explique le compromis entre les erreurs de démodulation sur le canal S-R et la capacité du relais à réussir sur la distance R-D restante. Comme dans différents types de réseaux, le relais peut être fixé, par ex. dans les Réseaux Locaux Sans Fil (WLAN), ou un nœud mobile, par exemple Véhiculaire Ad-Hoc Network (VANET), alors l'information de la meilleure localisation du relais peut être très bénéfique.

Structure de la thèse

Cette thèse est organisée en six chapitres. Le chapitre 1 contient une introduction aux tendances et aux exigences des systèmes de communication sans fil qui stimulent l'évolution et le développement de nouvelles générations de communications mobiles. On a également fourni un aperçu des techniques qui ont été utilisées dans les technologies récentes pour atténuer la communication dans les chaînes sans fil, en mettant l'accent sur l'interaction entre deux techniques principales, qui est l'objectif principal de cette étude. Une revue de littérature connexe est également fournie.

Au chapitre 2, on donne un aperçu des techniques de diversité temporelle et des techniques de diversité coopérative. Une description de tous les liens physiques est discutée, ainsi que la description des récepteurs. On discute des principales politiques de la technique H-ARQ et des différents types de décodeurs. À la fin du chapitre, on introduit les paramètres de performance que nous allons utiliser tout

au long de la thèse.

Dans le chapitre 3, on fournit une analyse détaillée des protocoles déterministes pour un réseau coopératif contenant une source, un relais et une destination. Un aperçu des Machines à états finis (FSM) et des Chaînes de Markov à l'état fini (FSMC) est présenté, et on montre comment ces outils peuvent être utilisés pour modéliser les comportements des protocoles. L'analyse est répétée pour le relais fonctionnant en mode DMF et en mode DCF et pour la destination équipée du décodeur de type I et de type II. L'analyse est validée avec des résultats numériques, où les résultats de la simulation sont comparés aux résultats théoriques.

L'analyse FSMC des protocoles déterministes fournis au chapitre 3 montre que les calculs pour l'évaluation des performances deviennent lourds à mesure que le nombre d'états augmente, ce qui est lié au nombre de noeuds, au nombre de re-transmissions et au mode de fonctionnement du relais. Par conséquent, dans le chapitre 4, on fournit une analyse des agrégations d'état dans la chaîne de Markov. Les principales définitions et les propriétés des chaînes de Markov sont discutées, ainsi que des détails sur la façon dont l'agrégation de l'état est effectuée. Le processus d'agrégation de l'état est illustré par des exemples pratiques décrits au chapitre 3.

Outre la réduction des calculs que nous obtenons de l'agrégation des états, des FSMC simplifiées, on peut en déduire davantage d'informations. Étant donné que pendant l'agrégation des états, nous avons gardé la structure des états de sorte que le nombre d'actions de l'émetteur reste le même, alors nous avons exploré l'idée d'associer les FSMC simplifiés aux protocoles probabilistes. Par conséquent, dans le chapitre 5, on fournit une analyse du protocole probabiliste pour les deux types de décodeurs, type I et type II. À la fin de ce chapitre, la performance du protocole probabiliste optimisé est comparée à un protocole déterministe de référence. Un autre protocole probabiliste est également introduit.

Dans le chapitre 6, on pose la question du problème de la sélection de relais dans les réseaux coopératifs, où dans un environnement avec plusieurs relais, un seul relais serait choisi pour faciliter la communication entre une source et une destination. Sur la base d'un critère proposé, cette question est discutée dans deux perspectives: choisir le meilleur emplacement du relais en moyenne, et choisir le meilleur relais instantané pour la coopération. De plus, le critère proposé est également comparé au critère de référence dans la littérature.

Contributions de la thèse

Les principales contributions de cette thèse peuvent être résumées comme suit:

- Un cadre FSMC est proposé pour évaluer la performance des protocoles déterministes. Conformément à la représentation FSMC, on propose également une

façon unique d'obtenir des métriques de performance en utilisant à la fois une approche combinatoire et une analyse de l'état d'équilibre. Une autre façon d'obtenir le vecteur d'état stable est introduite;

- L'analyse principale de ce travail constitue sur le cas où le relais fonctionne sur le mode Démoduler-et-Transférer (DMF), ce qui n'a pas été publié auparavant. Ceci est intéressant car dans ce mode, le relais aurait toujours quelque chose à retransmettre, mais l'analyse est complexe car nous devons compter pour les erreurs de démodulation sur le relais. Pour évaluer les probabilités nécessaires à l'analyse théorique, on a fourni des algorithmes et des analyses permettant d'obtenir ces résultats en utilisant des simulations Monte Carlo;
- Une autre contribution peut être considérée comme l'application de l'agrégation de l'état dans la chaîne de Markov. L'agrégation des états n'est pas quelque chose de nouveau, mais cette application concernant l'évaluation des performances des protocoles de communication n'est pas publiée auparavant. En outre, les règles selon lesquelles nous avons choisi d'agréger les états avec les mêmes actions sont une bonne idée;
- La contribution principale peut être comptée à l'introduction de protocoles probabilistes pour la couche physique (PHY) et la couche MAC, c'est l'idée d'associer le FSM simplifié aux protocoles correspondants. Ces protocoles probabilistes que nous avons exprimés en fonction des paramètres dont les valeurs peuvent être évaluées pour imiter la performance des protocoles déterministes. En outre, les protocoles probabilistes sont plus faciles à optimiser car ils n'ont que deux paramètres à ajuster pour trouver les meilleures performances;
- Une autre contribution est la sélection du relais basée sur un critère proposé. Ce critère est utile pour déterminer la position optimale du relais en moyenne et choisir le meilleur relais instantané pour la coopération. En appliquant ce critère, nous avons montré que la performance s'améliore par rapport à l'application des critères de référence ou lorsqu'aucune sélection de relais n'est appliquée.

Contents

List of figures	xii
List of tables	xiii
List of publications	xv
1 Introduction	1
1.1 Thesis motivation	1
1.2 Thesis structure	3
1.3 Thesis contributions	4
2 HARQ transmission system in a cooperative network	7
2.1 Introduction	7
2.1.1 Time diversity techniques (ARQ)	8
2.1.2 HARQ: ARQ combined with channel coding in physical layer	8
2.1.3 Cooperative diversity techniques	9
2.2 System model	10
2.2.1 Source-Destination link	11
2.2.2 Source-Relay-Destination link	12
2.3 Type-I HARQ	13
2.3.1 Destination receiver	13
2.4 Type-II HARQ	17
2.4.1 Destination receiver	17
2.5 Performance metrics definition	17
3 Deterministic HARQ protocol for a cooperative network S-R-D	19
3.1 Introduction	19
3.1.1 Finite State Machines (FSM)	20
3.1.2 Finite State Markov Chain (FSMC)	21
3.2 S-R-D protocol, DMF mode	23
3.2.1 Communication protocol	23
3.2.2 Description of the transmitter using a FSM	24
3.2.3 Performance evaluation using FSMC, Type I decoder	24
3.2.4 Alternative way to obtain the steady state vector	26
3.2.5 Performance evaluation using FSMC, Type II decoder	27
3.3 S-R-D protocol, DCF mode	29
3.3.1 Communication protocol and its representation via FSM	30
3.3.2 Performance evaluation using FSMC	32
3.4 Numerical results	33
3.4.1 Simulation of the protocol, DMF mode	33

3.4.2	Simulation of the protocol, DCF mode	38
3.5	Conclusions	40
4	State aggregation on the FSMC	43
4.1	Introduction	43
4.2	Aggregation method of Markov Chain	44
4.3	State aggregation for HARQ on a S-D link	47
4.4	State aggregation for HARQ on a S-R-D network, DMF mode	48
4.5	State aggregation for HARQ on a S-R-D network, DCF mode	52
4.6	Conclusions	52
5	Probabilistic HARQ transmission protocols for cooperative networks	55
5.1	Introduction	55
5.2	Association of simplified FSMC with a probabilistic protocol	56
5.2.1	A general simplified FSM	56
5.2.2	Parameter optimization for the probabilistic protocol	58
5.3	Probabilistic protocol, type I decoder	59
5.3.1	Numerical results	62
5.4	Probabilistic protocol, type II decoder	68
5.4.1	The probabilistic protocol with Type II decoder with limited buffer	68
5.4.2	Description of the probabilistic protocol with a limited-buffer Type II decoder using a FSMC	69
5.4.3	Numerical results	73
5.4.4	Comparison with a referent deterministic protocol	77
5.5	Alternative probabilistic protocol	81
5.5.1	Numerical results	83
5.6	Conclusions	85
6	Relay selection in cooperative networks	87
6.1	Introduction	87
6.2	Selecting the optimal position of the Relay	88
6.2.1	Criterion for choosing the optimal position of the Relay	91
6.3	Selecting the best instantaneous Relay	98
6.3.1	Comparison of criterion ρ_c with a referent criterion	99
6.4	Conclusions	102
7	Conclusions and further perspectives	103
7.1	Conclusions	103
7.2	Further work considerations	104
	Bibliography	111

List of Figures

2.1	General scheme of HARQ system	9
2.2	S-R-D network	10
3.1	General structure of FSM	20
3.2	Graph of state transitions	21
3.3	FSM of the transmitter of the deterministic protocol	25
3.4	FSMC of the transmitter of the deterministic protocol, DMF mode	26
3.5	Comparison of $\pi_{[A,B]}$ for different values of A and B	29
3.6	FSM of the transmitter of the deterministic protocol, DCF mode	30
3.7	Comparison of PER with 4 copies and with 6 copies, type I and type II	34
3.8	Goodput with 4 copies and with 6 copies, type I and type II	34
3.9	Comparison of PER for various N_S and N_R , type I and type II	35
3.10	Comparison of PER, $N_S = 1$ and $N_R = 3$, various location of the Relay	36
3.11	Comparison of PER, $N_S = 2$ and $N_R = 1$, various location of the Relay	37
3.12	Goodput for various N_S and N_R and for various location of the Relay	37
3.13	Comparison of PER, various location of the Relay, DCF mode	38
3.14	Comparison of Goodput, various location of the Relay, DCF mode	39
3.15	Comparison of average number of transmissions, various location of the Relay, DCF mode	40
4.1	Original FSMC	44
4.2	New FSMC by aggregating states of the original FSMC	45
5.1	Probabilistic protocol represented by FSM on the transmitter	56
5.2	Monte Carlo simulation of probabilities $\pi_{1,0}$ and $\pi_{0,1}(k)$, various d_{SR}/d_{SD}	60
5.3	FSMC representing the probabilistic protocol, Type I decoder	61
5.4	PER achieved with deterministic and probabilistic protocol, type I	63
5.5	\bar{T} achieved with deterministic and probabilistic protocol, type I decoder	63
5.6	Optimization for various γ and β , $d_{SR}/d_{SD} = 0.50$, $E_b/N_0 = 5$	64
5.7	PER achieved with corresponding \bar{T} , best γ and β , $d_{SR}/d_{SD} = 0.50$	65
5.8	Optimized PER, $d_{SR}/d_{SD} = 0.50$, $\bar{T}_{\max} = 2.5$, Type I decoder	66
5.9	Optimized PER, various d_{SR}/d_{SD} , limited $\bar{T} = 2.5$, Type I decoder	67
5.10	FSMC representing the probabilistic protocol with limited buffer $C_{\max} = 4$	70
5.11	PER of the deterministic and probabilistic protocol, type II decoder	73
5.12	\bar{T} of the deterministic and probabilistic protocol, type II decoder	74
5.13	Optimization results for various γ and β , $d_{SR}/d_{SD} = 0.50$, tupe II decoder	75
5.14	Comparison of PER with corresponding \bar{T} , type II decoder	76
5.15	Comparison of PER with corresponding Goodput, type II decoder	76

5.16	Optimized PER, $d_{SR}/d_{SD} = 0.50$, $\bar{T}_{\max} = 2.5$, type II decoder	77
5.17	Optimized PER, various d_{SR}/d_{SD} , limited $\bar{T} = 2.5$, type II decoder .	78
5.18	Optimized Goodput, various d_{SR}/d_{SD} , limited $\bar{T} = 2.5$, type II decoder	78
5.19	PER achieved with deterministic and probabilistic protocol, type II .	80
5.20	\bar{T} achieved with deterministic and probabilistic protocol, type II . .	80
5.21	Goodput achieved with deterministic and probabilistic protocol, type II	81
5.22	Scheme of the alternative probabilistic FSM	82
5.23	Comparison of PER achieved with probabilistic protocol and alternative protocol	83
5.24	PER versus the energy spent on the transmitter for both protocols .	84
5.25	Goodput versus β at probabilistic protocol and alternative protocol .	85
5.26	PER versus β at probabilistic protocol and alternative protocol . . .	86
6.1	Demodulation of bit errors for the entire link S-R-D, various d_{SR}/d_{SD}	90
6.2	PDU error probability after demodulation at D, various d_{SR}/d_{SD} . .	90
6.3	PDU error probability after decoding a single copy from Relay, various d_{SR}/d_{SD}	92
6.4	Average absolute value of the LLR per coded bit at the Destination, various d_{SR}/d_{SD}	93
6.5	The value of $ \bar{\Lambda} $ by varying the rate of errors ϕ_{SR} on R, various d_{SR}/d_{SD}	94
6.6	Comparison of proposed criterion for various d_{SR}/d_{SD}	95
6.7	Comparison of $\phi_{SRD,k}$ for various channel code rate R_c , various d_{SR}/d_{SD}	96
6.8	Average absolute value of the LLR per bit, various channel code rate R_c , various d_{SR}/d_{SD}	96
6.9	Comparison of ρ_c for various code rate R_c , various d_{SR}/d_{SD}	97
6.10	Comparison of $\pi_{0,1}$ and $\pi_{1,0}$ for various code rate R_c , various d_{SR}/d_{SD}	98
6.11	Comparison of $\pi_{0,1}$ achieved with both criterions	100
6.12	Comparison of PER achieved with both criterions	101
6.13	Comparison of Goodput achieved with both criterions	102

List of Tables

2.1	Code rates with corresponding punctured matrices	11
3.1	Definition of states in the FSM of the transmitter	24
3.2	Definition of states in the FSM of the transmitter, DCF mode	31
5.1	Definition of states in the probabilistic FSM	57
5.2	Definition of states in the FSMC of the transmitter, type I decoder	61
5.3	Optimized values of γ and β , various d_{SR}/d_{SD} and E_b/N_0 , type I decoder	67
5.4	Definition of states in the FSMC of the transmitter, with a limited buffer on the receiver	69
5.5	Optimized values of γ and β , various d_{SR}/d_{SD} and E_b/N_0 , type II decoder	79
5.6	Values of γ and β for each point of E_b/N_0 , in the comparison of probabilistic with deterministic protocol	79
5.7	Definition of states in the alternative probabilistic protocol	82

List of publications

- Faton MALIQI, Francesca BASSI, Pierre DUHAMEL, Ilir LIMANI, "*Simplified Analysis of HARQ Cooperative Networks Using Finite-State Markov Chains*", EUSIPCO 2017, Kos, Greece (published);
- Faton MALIQI, Francesca BASSI, Pierre DUHAMEL, Ilir LIMANI, "*A Probabilistic Retransmission Protocol on a Relaying Network*", IEEE PIMRC 2017, Montreal, Canada (published);

Introduction

Contents

1.1	Thesis motivation	1
1.2	Thesis structure	3
1.3	Thesis contributions	4

1.1 Thesis motivation

Nowadays, mobile communications are characterized by a fast-increasing demand for internet-based services (voice, video data). Video services constitutes a large fraction of the internet traffic today. According to a report by Cisco [VNI 2017], 75% of the world's mobile data traffic will be video-based by 2020. This ever-increasing demand in delivering internet-based services, has been the main driver for the development of the 4G digital cellular network, where packet-switched services are the primary design target. In particular, the overall system needs to ensure high peak data rates to the user and low delay in the delivery of the content, in order to support real time applications such as video streaming and gaming. This has motivated, in the last decade, a renewed and raising interest and research in wireless radio access technology.

Communication systems typically experience higher Bit-Error-Ratio (BER) for communications over wireless channels than in wireline channels due to the effects of fading and interference that is experienced in wireless channels. In latest technologies, these effects are opposed using Automatic Repeat re-Quest (ARQ) protocol, which consist on the retransmission of the same signal from the same node. But, in order to combat the deleterious effects of high BERs on the services offered to subscribers and at the same time to avoid the retransmissions of erroneous data blocks by the transport layer's error-control mechanism, the ARQ protocol is typically combined with channel codes at the physical layer, which is known as Hybrid Automatic Repeat re-Quest (HARQ) protocol [Ngo 2014]. Another improvement for communications over wireless channels is achieved when Relays are used as intermediate nodes for helping the communication, which is known as cooperative communication [Nosratinia 2004]. Both techniques, cooperation and HARQ, if individually applied, significantly improve the performance of the communication system. One

open question is whether their combination would bring the sum of the singular improvements, or be only marginally beneficial.

For the combination of these two techniques can be found many studies in literature: an outage probability analysis of HARQ on a cooperative network is conducted in [S. Tomasin 2007], a scheme with multiple Relays is studied in [Zhao 2005], an analysis from the perspective of energy efficiency is conducted in [I. Stanojev 2009], an analysis from the perspective of information theory is conducted in [M. S. Fazel Falavarjani 2010], etc. In our thesis, we are focused mainly to study this interaction on the physical (PHY) layer and medium access control (MAC) layer, using example protocols on a S-R-D network.

For theoretical analysis of these systems there are used different tools, but in our analysis we focus on Finite State Markov Chain [Hennie 1968]. Markov models have been extensively used in the HARQ literature as a tool for performance prediction, both for Type I [Zhang 1999] and Type II [Zorzi 1995, Badia 2008] point-to-point protocols. They have been widely employed also in the analysis of cooperative networks, *e.g.*, Markov chain models are employed to describe specific network topologies, as in [Hassan 2011] or [Hassan 2014] for multi-hop networks. In [Luo 2014] FSMCs are developed to assist the design of cooperative systems with amplify-and-forward relaying, while Markov decision processes are used to assist relay selection in [Shirazi 2009, Babich 2012, Li 2014]. Similar frameworks are also proposed in [D. Xu 2016] for studying a bursty service model in a cooperative network with ARQ when the transmitting node is saturated with a current copy because the process of retransmitting the packet is still ongoing and a new packet arriving on the transmitter will be discarded resulting in a packet loss, and in [Q. Li 2015] for the performance analysis for a cooperative two-path Relay channels, where on the same time-slot are allowed to transmit simultaneously both Source and Relay. One example of Markov models used in schemes coupling ARQ and cooperation is studied in [Dianati 2006]. In most of the literature, there is usually considered the case when Relay works on the mode Decode-and-Forward (DCF), but there are also cases when Relay is considered to work on the mode Amplify-and-Forward (AF) like one in [M. S. Fazel Falavarjani 2010] where Source participates in all the retransmissions while Relay retransmits only if its normalized accumulative mutual information is not lower than a certain threshold. An analysis is conducted when Relay works on DCF mode, but our study is more emphasized on the case when Relay works on Demodulate-and-Forward (DMF) mode [Yang 2009] due to its simplicity in implementation and due to the fact that Relay in that case would have always something to retransmit.

Usually, the interaction between the two techniques has been studied using deterministic protocols, like in [Krikidis 2007], but in our analysis we will focus on both, deterministic and probabilistic protocols. So far, probabilistic protocols, where the action to be performed next (which node will retransmit the information)

is chosen with a given probability, have been mainly proposed for higher layers of communication systems, like in [A. Lindgren 2003] where there is proposed a probabilistic routing protocol where the decision of packet forwarding from one node to another is based on a probabilistic metric that is introduced to help in the decision, and which metric is updated each time one node encounters the other, or like in [Fukuyama 2009] where the communication is based on an algorithm that pre-computes the probability that the communication is possible between a specified source and destination. In contrast, this thesis studies probabilistic protocols on the physical layer and MAC layer, which give more insight on the analysis and performance optimization. The probabilistic protocols contains very few parameters (only 2) that can be optimized for best performance. Note that these parameters can be computed to mimic the behavior of a given deterministic protocol, and that the result of the optimization can only improve over this one. Moreover, the performance of our optimized probabilistic algorithm is checked against results of the literature [Krikidis 2007].

1.2 Thesis structure

This thesis is organized in seven Chapters. Chapter 1 contains an introduction to the trends and demands in wireless communications systems which drive the evolution and developing of new generations of mobile communications. There is also provided an overview of techniques that have been used in recent technologies to mitigate communication in wireless channel, emphasizing the interaction between two main techniques, which is the main goal of this study. A related literature review is also provided. In the end of this Chapter, a thesis structure and thesis contributions are summarized.

In Chapter 2, there is provided an overview of time diversity techniques and cooperative diversity techniques. A description of all physical links is discussed, as well as description of the receivers. There are discussed main policies of H-ARQ technique and different types of decoders. In the end of the chapter, there are introduced the performance metrics that we will use throughout the thesis.

In Chapter 3, there is provided a detailed analysis of deterministic protocols for a cooperative network containing one Source, one Relay and one Destination. An overview of Finite State Machines (FSM) and Finite State Markov Chains (FSMC) is introduced, and there is shown how these tools can be used to model behaviours of the protocols. The analysis is repeated for the Relay working in Demodulate-and-Forward (DMF) mode and Decode-and-Forward (DCF) mode, and for Destination equipped with type I and type II decoder. The analysis is validated with numerical results, where the simulation results are compared with theoretical results.

FSMC analysis of deterministic protocols provided in Chapter 3 shows that the computations for performance evaluation become heavy as the number of states increase, which is related to the number of nodes, number of retransmissions and the working mode of the Relay. Therefore, in Chapter 4 it is provided an analysis of state aggregations in Markov Chain. Main definitions and properties of Markov Chains are discussed, as well as details on how the state aggregation is performed. The state aggregation process is illustrated with practical examples that were described in Chapter 3.

Beside the reduction of computations that we get from the state aggregation, from the simplified FSMCs there can be inferred more information. We have also explored the idea of associating the simplified FSMCs with probabilistic protocols. Therefore, in Chapter 5 there is provided an analysis of probabilistic protocol for both types of decoders, type I and type II. In the end of this chapter, performance of the optimized probabilistic protocol is compared against a referent deterministic protocol. An alternative probabilistic protocol is also discussed.

In Chapter 6 there is discussed the issue of Relay selection in cooperative networks, where in an environment with multiple Relays only one Relay would be chosen to help the communication between a Source and a Destination. Based on a proposed criterion, this issue is discussed in two perspectives: choosing the best location of the Relay in average, and choosing the best instantaneous Relay for cooperation. Moreover, the proposed criterion is also compared against the referent criterion in literature.

Chapter 7 draws conclusions and future works.

1.3 Thesis contributions

The main contributions of this thesis can be divided in five parts as follow:

- A FSMC-based framework is proposed for evaluating performance of the deterministic protocols. In line with FSMC representation, there is also proposed a unique way of obtaining performance metrics using both, combinatorial approach and steady state analysis. An alternative way of obtaining the steady state vector is introduced;
- The main analysis of this work constitutes on the case when Relay works on Demodulate-and-Forward (DMF) mode, which is something that has not been published before. This is interesting since in this mode the Relay would have always something to retransmit, but the analysis is complex as we need to count for the demodulation errors on the Relay. For evaluating the probabilities needed for theoretical analysis, there are provided algorithms and analysis how these can be obtained using Monte Carlo simulations;

-
- Another contribution can be counted the application of state aggregation in Markov Chain. The state aggregation is not something new, but this application with respect to performance evaluation of communication protocols is something that has not been published earlier. Moreover, the rules according to which we have chosen to aggregate the states with the same actions is shown to be an interesting idea;
 - The main contribution can be counted the introduction of probabilistic protocols for physical (PHY) layer and MAC layer, which came as an idea of associating the simplified FSM with corresponding protocols. These probabilistic protocols we have expressed as a function of parameters whose values can be evaluated to mimic performance of deterministic protocols. Moreover, probabilistic protocols are shown to be easier to optimize as they have only two parameters to adjust for finding the best performance;
 - Another contribution could be counted the issue of Relay selection based on a proposed criterion. This criterion is shown to be useful in determining the optimal position of the Relay in average, and choosing the best instantaneous Relay for cooperation. By applying this criterion, we have shown that the performance improves when compared to the application of referent criterions or when no Relay selection is applied at all.

HARQ transmission system in a cooperative network

Contents

2.1	Introduction	7
2.1.1	Time diversity techniques (ARQ)	8
2.1.2	HARQ: ARQ combined with channel coding in physical layer	8
2.1.3	Cooperative diversity techniques	9
2.2	System model	10
2.2.1	Source-Destination link	11
2.2.2	Source-Relay-Destination link	12
2.3	Type-I HARQ	13
2.3.1	Destination receiver	13
2.3.1.1	Reception from Source	13
2.3.1.2	Reception from Relay, DMF mode	14
2.3.1.3	Reception from Relay, DCF mode	16
2.4	Type-II HARQ	17
2.4.1	Destination receiver	17
2.5	Performance metrics definition	17

2.1 Introduction

Compared with the wireline channel, the wireless channel can provide limited data rate, due to various physical phenomena (pathloss, fading, shadowing, interference) greatly degrading the quality of the received signal. Channel fading, caused by multipath propagation, is in particular able to disrupt the entire communication. This phenomenon can be contrasted using time diversity techniques, which are based on the repetition of the same signal from the same node, and using cooperative diversity techniques [Nosratinia 2004], which are based on the transmission of the same signal from multiple stations. Both strategies are incorporated in the LTE-Advanced standard, which relies on Hybrid Automatic Repeat reQuest (HARQ) technology, and allows the presence of relay nodes.

Diversity techniques are able to increase the reliability of the wireless channel, usually at the cost of a reduction in spectral efficiency. In cooperative schemes, physical layer network coding has been proposed, more recently, as an effective solution to reduce this effect. In this context, there is important to study the interaction between time and cooperative diversity, in presence of physical layer network coding, which is one of the objectives of this work. This study interaction can be of interest in the context of the definition and standardization of next generation digital cellular networks.

2.1.1 Time diversity techniques (ARQ)

Time diversity is attained by the exploitation of the data-link layer feedback channel, used to exchange control messages from the destination to the sender. In an Automatic Repeat reQuest (ARQ) scheme the receiver is able, thanks to an error detection code inserted in the information packet, to detect whether the received data are corrupted, and to demand retransmission via the feedback channel until correct decoding or until the predefined number of retransmissions has been exhausted. The feedback channel is assumed to be ideal and error-free.

There are three main types of ARQ protocol [Ngo 2014]:

- *Stop-and-wait ARQ*: According to this policy, the transmitter sends a packet and waits for an acknowledgements (ACK) from the destination. If ACK is received then a new packet will be transmitted, but if a negative-acknowledgement (NACK) is received then the same packet is retransmitted.
- *Go-Back-N ARQ*: According to this policy, the transmitter can send a number of packets specified by a window size N , before requiring an ACK. The receiver observes the packet index and will send a NACK only if the index of the packet is not on the order as it was expected. If a NACK is issued, then all the following packets starting from that index are discarded at the receiver, and the transmitter retransmit the following N packets starting from the last ACK-ed packet index. Otherwise, if an ACK is missing at the transmitter, then all the packets that belong to the specific window will be retransmitted.
- *Selective Repeat ARQ*: This policy can be considered as a special case of the policy Go-Back-N ARQ, where the transmitter will continue to transmit new packets even if a specific packet is missing, and as a result only those missed packets will be retransmitted.

In our work we will consider ARQ governed by *Stop-and-wait* policy.

2.1.2 HARQ: ARQ combined with channel coding in physical layer

In modern architectures ARQ is usually combined with Forward Error Correction (FEC) [Hagenauer 1996] code at physical layer, resulting in Hybrid ARQ (HARQ)

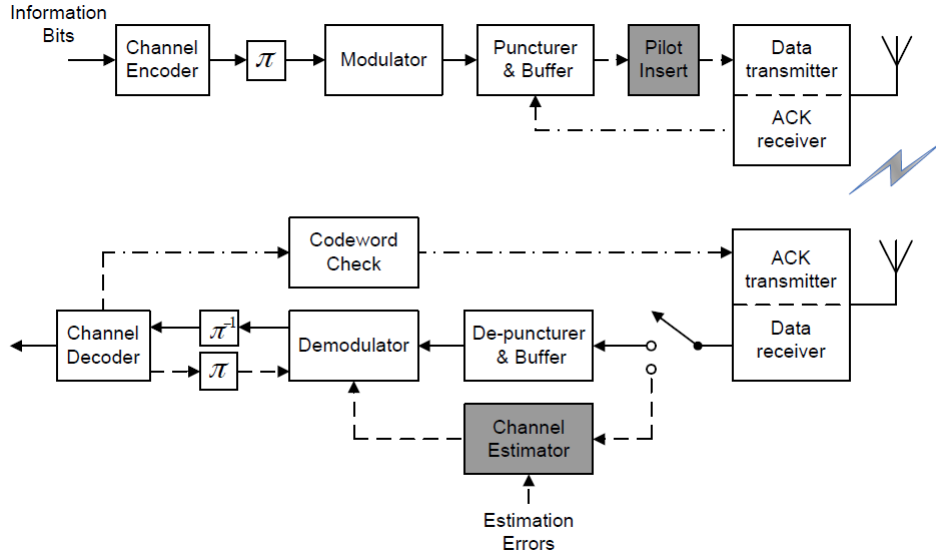

Figure 2.1: General scheme of HARQ system

schemes. This combination was first introduced by [Wozencraft 1960] and [Wozencraft 1961]. The main advantage provided by HARQ is the ability to provide implicit adaptation of the error protection mechanism to the instantaneous radio link quality. The general scheme of the HARQ system is shown in Figure 2.1 [Ngo 2014].

2.1.3 Cooperative diversity techniques

Cooperative diversity is attained by the exploitation of special nodes in the network (the Relays), willing to help the communication between a Source and a Destination by repeating the message broadcast by the Source. The working mode of the Relay can be divided into two broad categories [J. N. Laneman]: analog relaying and digital relaying. In analog relaying, referred to also as Amplify-and-Forward (AF) mode, the Relay simply amplifies the received signal (including the noise) and broadcasts again. By contrast, in digital relaying, referred to as Decode-and-Forward (DCF) mode, the Relay first decodes the Source message, re-encodes it, and forwards it to the destination, thus removing the effects of the noise on the Source-Relay link. Full diversity gain is attained when the Relay is able to check whether the Source message has been correctly received via a Cyclic Redundancy Check (CRC) code [T. V. Ramabadran], and to avoid forwarding in case of errors. But, beside these two main working modes, there are also other simpler and so effective working mode of the Relay, such as Demodulate-and-Forward (DMF) mode [Yang 2009], where Relay receives the information, demodulates it (thus separating the noise from the useful signal) and forwards it to the Destination. In this way, we avoid the use of complexity and energy consuming algorithms that DCF mode involves on the Relay. Therefore, in most of our work we have considered the Relay in DMF mode.

We note that beside its simplicity in implementation, working on DMF mode has also its drawback, since by only demodulating/remodulating the signal on the Relay there is not checked the integrity of the copies that are forwarded and therefore for the overall performance we need to consider also the effects of demodulation errors on the Relay.

2.2 System model

In our work, the reference network is composed of one Source (S), one Relay (R) and one Destination (D), as it is shown in Figure 2.2.

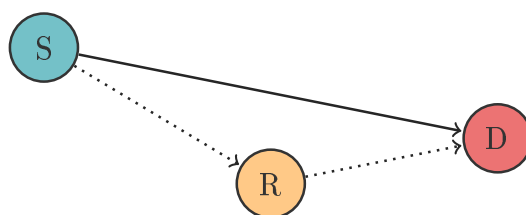

Figure 2.2: S-R-D network

The Source generates the information in packets, named here as PDU (Protocol data unit). Each PDU has a length of L information bits. Then, to each of these PDU's there is attached a sequence of detection code which is used for error detection on the destination. This detection code sequence is a Cyclic Redundancy Check (CRC) code [T. V. Ramabadran] applied to each PDU separately, denoted here as $CRC-G$ which is of length G bits. The selection of generator polynomial depends on the length of L , which in our case of $L = 1000$ bits we are using $CRC-24$ given with:

$$CRC - 24 = x^{24} + x^{23} + x^{14} + x^{12} + x^8 + 1 \quad (2.1)$$

So, after adding the CRC -remainder to the PDU, we will get the vector \mathbf{m} of length $L_1 = L + (\text{length of } CRC \text{ remainder}) = L + G$. After that, the vector \mathbf{m} is encoded using Rate Compatible Punctured Convolutional (RCPC) code [Hagenauer], with mother code being convolutional code [Lajos Hanzo 2011] with $R_c = 1/3$, with constraint length $K = 7$, with memory $E = 6$, and with generator polynomials in binary form $g_1 = 1011011$, $g_2 = 1111001$ and $g_3 = 1100101$. The puncturing period is taken $O = 8$, while the puncturing matrices used for generating the rates $R_c \in \{8/9, 4/5, 2/3, 4/7, 1/2, 4/9, 4/10, 1/3\}$ are found in [Hagenauer] and rewritten in Table 2.1.

Finally, the coded sequence in the output of the channel encoder, \mathbf{c} , is modulated using M -QAM modulation thus giving the vector \mathbf{x} in the output of the modulator. Each modulated symbol in vector \mathbf{x} represent $k = \log_2(M)$ bits of vector \mathbf{c} , and here are represented in complex plane with the real part of each symbol taking any of the

Table 2.1: Code rates with corresponding punctured matrices

$R_c = 8/9$	$R_c = 4/5$	$R_c = 2/3$	$R_c = 4/7$	$R_c = 1/2$
11110111	11111111	11111111	11111111	11111111
10001000	10001000	10101010	11101110	11111111
00000000	00000000	00000000	00000000	00000000
$R_c = 4/9$	$R_c = 4/10$	$R_c = 4/11$	$R_c = 1/3$	
11111111	11111111	11111111	11111111	
11111111	11111111	11111111	11111111	
10001000	11001100	11101110	11111111	

values $x_{Re} \in \pm(2l-1)$, and imaginary part taking any of the values $x_{Im} \in \pm(2l-1)$, for all possible combinations of $l \in \{0, 1, \dots, \sqrt{M}/2\}$, with M being the constellation size. In our analysis we are going to use constellations for $M = 4, 16, 64$ and 128 .

The number of symbols in vector \mathbf{x} is given with the expression:

$$n_s = \left(\frac{1}{R_c} \right) \frac{L_1}{\log_2(M)} \quad (2.2)$$

where the ratio:

$$n_c = \frac{L_1}{R_c} \quad (2.3)$$

represent the number of coded bits.

We assume that Source, Relay and Destination are synchronized, and thus operating in time-slots of duration τ_t . If we denote the duration of a single symbol with τ_s , then the number of symbols transmitted at one time-slot of the channel is given with the expression:

$$s_t = \frac{\tau_t}{\tau_s} \quad (2.4)$$

Therefore, the number of time-slots needed for transmission of modulated vector \mathbf{x} is given with:

$$N_{ts} = \frac{n_s}{s_t} \quad (2.5)$$

2.2.1 Source-Destination link

The communication channel between the Source and the Destination is modeled as Gaussian channel, which for time-slot t takes the form:

$$\mathbf{y}_{SD,t} = \sqrt{E_s} l(d_{SD}) \mathbf{x}_t \mathbf{h}_{SD,t} + \mathbf{w}_{SD,t} \quad (2.6)$$

where, multiplication between vectors is element-wise operation; $\sqrt{E_s} \mathbf{x}_t$ is the vector of modulated symbols with energy $E_s = k \cdot R_c \cdot E_b$ in time-slot t ; E_b is the energy per

information bit; $l(d_{SD})$ is the path-loss factor which depends on distance between the Source and the Destination, d_{SD} , and is given with the expression $l(d_{SD}) = (d_{SD})^{-\alpha}$, with α being the path-loss exponent; $\mathbf{w}_{SD,t}$ is the vector of white complex noise, $\mathcal{CN}(0, N_0)$, with N_0 being the noise spectral density; $\mathbf{h}_{SD,t}$ is the Rayleigh fading complex coefficients in time-slot t with zero-mean and unit variance, $\mathcal{CN}(0, 1)$, whose probability density function (pdf) is given with [D. Tse 2005]:

$$P_{\text{df}}(r) = \frac{r}{\sigma_{h,SD}^2} \cdot \exp \left\{ -\frac{r^2}{2\sigma_{h,SD}^2} \right\} \quad (2.7)$$

The fading coefficients are assumed to be perfectly known at the receiver, and in our analysis we are going to consider the case of block-fading (when fading coefficients do not change within a block of symbols).

2.2.2 Source-Relay-Destination link

As the Source broadcasts the signal on the wireless channel, beside the Destination there is also the Relay who receives this signal. The channel S-R is assumed to be Gaussian channel which adds white complex noise, $\mathcal{CN}(0, N_0)$, to the transmitted signal. The channel also experiences Rayleigh fading with complex coefficients, $\mathcal{CN}(0, 1)$. We repeat here our assumption that all the nodes (Source, Relay and Destination) are synchronized. So, the received signal on time-slot t on the Relay takes the form:

$$\mathbf{y}_{SR,t} = \sqrt{E_s l(d_{SR})} \mathbf{x}_t \mathbf{h}_{SR,t} + \mathbf{w}_{SR,t} \quad (2.8)$$

where, all the quantities are defined in previous subsection with the difference that here we deal with link S-R. For our numerical results and analysis we consider various positions of the Relay normalized to the distance S-D, d_{SR}/d_{SD} .

Now, the transmitted signal from the Relay toward the Destination depends on which mode does the Relay works, DCF or DMF. In Decode-and-Forward (DCF) mode, the received signal on the Relay is initially demodulated, decoded and CRC is checked, and Relay will be allowed to re-encode, re-modulate and forward the signal only if it contains no error. This means that the forwarded symbols from the Relay toward the Destination are exactly the same as those broadcast from the Source, and therefore the received signal on time-slot t of the channel R-D takes the form:

$$\mathbf{y}_{RD,t}^{DCF} = \sqrt{E_s l(d_{RD})} \mathbf{x}_t \mathbf{h}_{RD,t} + \mathbf{w}_{RD,t} \quad (2.9)$$

But, if the Relay works on Demodulate-and-Forward (DMF) mode, then the situation is different. In this case, the Relay only demodulates the received signal, then re-modulates and forwards the symbols toward the Destination. Since in this case the sequence is not decoded and CRC is not checked, then it may happen that the transmitted symbols from the Relay are not the correct ones because of the errors during the demodulation. As a result, the forwarded symbols, $\tilde{\mathbf{x}}$, are only

estimates of the original symbols, \mathbf{x} , broadcasted by the Source, and the received signal on the channel R-D at time-slot t takes the form:

$$\mathbf{y}_{RD,t}^{DMF} = \sqrt{E_s l(d_{RD})} \tilde{\mathbf{x}}_t \mathbf{h}_{RD,t} + \mathbf{w}_{RD,t} \quad (2.10)$$

where, the channel R-D is assumed to be Gaussian channel which adds white complex noise, $\mathcal{CN}(0, N_0)$, to the transmitted signal. The channel also experiences Rayleigh fading with complex coefficients, $\mathcal{CN}(0, 1)$.

2.3 Type-I HARQ

In the following two subsections we will describe how the Destination receiver works. According to the HARQ protocol, the receiver decodes the last PDU and checks CRC: if there is no error found, then it sends an ACK to the transmitter and a new PDU will be transmitted, but if an error is found then a NACK is sent and a new retransmission is asked. When only the last received copy is used for decoding, then this is known as Type I HARQ [Comroe].

2.3.1 Destination receiver

2.3.1.1 Reception from Source

On the receiver side, the demodulator performs soft demodulation by calculating the Log-likelihood ratio (LLR) of each coded bit and feeds these values into the Viterbi decoder who performs soft decoding. Considering that we have n_s channel samples each of them representing k coded bits, the LLR for i^{th} coded bit of the n^{th} received symbol, $y_{SD,n}$, is calculated with the expression:

$$\Lambda_{n,i} = LLR(c_{n,i}) = \log \frac{p(y_{SD,n} | c_{n,i} = 0)}{p(y_{SD,n} | c_{n,i} = 1)} \quad (2.11)$$

where, $i \in \{1, 2, \dots, k\}$ and $n \in \{1, 2, \dots, n_s\}$. The likelihood functions of each of the k coded bits of the n^{th} received symbol having one copy of the received signal from the source, are calculated with the expressions:

$$\begin{aligned} p(y_{SD,n} | c_{n,1} = 0) &= \sum_{\forall c_{n,i} \in \{0,1\}, i \neq 1} p(y_{SD,n} | c_{n,1} = 0, c_{n,2}, \dots, c_{n,k}) \\ &= \frac{1}{\pi N_0} \sum_{\forall x_n, \text{ where } c_{n,1} = 0} e^{-\frac{\|y_{SD,n} - \sqrt{E_s l(d_{SD})} h_{SD,n} x_n\|^2}{N_0}} \end{aligned} \quad (2.12)$$

$$\begin{aligned} p(y_{SD,n} | c_{n,1} = 1) &= \sum_{\forall c_{n,i} \in \{0,1\}, i \neq 1} p(y_{SD,n} | c_{n,1} = 1, c_{n,2}, \dots, c_{n,k}) \\ &= \frac{1}{\pi N_0} \sum_{\forall x_n, \text{ where } c_{n,1} = 1} e^{-\frac{\|y_{SD,n} - \sqrt{E_s l(d_{SD})} h_{SD,n} x_n\|^2}{N_0}} \end{aligned} \quad (2.13)$$

$$\begin{aligned}
 & \qquad \qquad \qquad \vdots \qquad \qquad \qquad \vdots \qquad \qquad \qquad \vdots \\
 p(y_{SD,n} | c_{n,k} = 0) &= \sum_{\forall c_{n,i} \in \{0,1\}, i \neq k} p(y_{SD,n} | c_{n,1}, c_{n,2}, \dots, c_{n,k} = 0) \\
 &= \frac{1}{\pi N_0} \sum_{\forall x_n, \text{ where } c_{n,k} = 0} e^{-\frac{\|y_{SD,n} - \sqrt{E_s l(d_{SD})} h_{SD,n} x_n\|^2}{N_0}} \quad (2.14)
 \end{aligned}$$

$$\begin{aligned}
 p(y_{SD,n} | c_{n,k} = 1) &= \sum_{\forall c_{n,i} \in \{0,1\}, i \neq k} p(y_{SD,n} | c_{n,1}, c_{n,2}, \dots, c_{n,k} = 1) \\
 &= \frac{1}{\pi N_0} \sum_{\forall x_n, \text{ where } c_{n,k} = 1} e^{-\frac{\|y_{SD,n} - \sqrt{E_s l(d_{SD})} h_{SD,n} x_n\|^2}{N_0}} \quad (2.15)
 \end{aligned}$$

Then, the LLR's of each coded bit, $c_{n,i}$, of the n^{th} symbol are translated into LLR vector $\mathbf{\Lambda}$ with indexes $k \cdot n - (k - i)$. The Viterbi decoder gets the LLR vector, and in the output it gives the estimated vector $\hat{\mathbf{m}}$, which contain the estimated data bits of the PDU together with CRC remainder. Then, to the sequence $\hat{\mathbf{m}}$ it is performed CRC for checking the errors, and the destination sends ACK if no error is found, and otherwise it send NACK if errors are detected.

2.3.1.2 Reception from Relay, DMF mode

When the Relay is working on mode Demodulate-and-Forward (DMF), according to which it demodulates, re-modulates and forwards the signal to the Destination, we need to count for the errors that may occur during the demodulation process on the Relay. Based on the channel observations \mathbf{y}_{RD} , the destination demodulator calculates the LLR of each coded bit based on the expression:

$$\Lambda_{n,i} = LLR(c_{n,i}) = \log \frac{p(y_{RD,n} | c_{n,i} = 0)}{p(y_{RD,n} | c_{n,i} = 1)} \quad (2.16)$$

where, the likelihood function of i^{th} coded bit of the n^{th} symbol is given as:

$$\begin{aligned}
 p(y_{RD,n} | c_{n,i} = 0) &= \sum_{D_R \in \{0,1\}} p(y_{RD,n}, D_R | c_{n,i}) \\
 &= \sum_{D_R \in \{0,1\}} p(y_{RD,n} | D_R, c_{n,i}) \cdot p(D_R | c_{n,i}) \quad (2.17)
 \end{aligned}$$

where, D_R is a parameter which takes the value $D_R = 0$ when the Relay did not correctly demodulate the symbol from Source, and the value $D_R = 1$ when the Relay did correctly demodulate the symbol. Consequently, the likelihood function takes the form:

$$\begin{aligned}
 p(y_{RD,n} | c_{n,i}) &= p(y_{RD,n} | D_R = 0, c_{n,i}) \cdot p(D_R = 0 | c_{n,i}) + \\
 &\quad + p(y_{RD,n} | D_R = 1, c_{n,i}) \cdot p(D_R = 1 | c_{n,i}) \quad (2.18)
 \end{aligned}$$

We see that the total likelihood function is marginalized over both cases of the value of D_R . So, the likelihood functions for the 1st coded bit of the n^{th} symbol, $c_{n,1} = 0$, are given with the expressions:

$$\begin{aligned} p(y_{RD,n} | D_R = 0, c_{n,1} = 0) &= \sum_{\forall c_{n,i} \in \{0,1\}, i \neq 1} p(y_{RD,n} | D_R = 0, c_{n,1} = 1, c_{n,2}, \dots, c_{n,k}) \\ &= \frac{1}{2\pi\sigma_{RD}^2} \sum_{\forall x_n, \text{where } c_{n,1}=1} e^{-\frac{\|y_{RD,n} - \sqrt{E_{s1}(d_{RD})} h_{RD,n} x_n\|^2}{2\sigma_{RD}^2}} \end{aligned} \quad (2.19)$$

and

$$\begin{aligned} p(y_{RD,n} | D_R = 1, c_{n,1} = 0) &= \sum_{\forall c_{n,i} \in \{0,1\}, i \neq 1} p(y_{RD,n} | D_R = 1, c_{n,1} = 0, c_{n,2}, \dots, c_{n,k}) \\ &= \frac{1}{2\pi\sigma_{RD}^2} \sum_{\forall x_n, \text{where } c_{n,1}=0} e^{-\frac{\|y_{RD,n} - \sqrt{E_{s1}(d_{RD})} h_{RD,n} x_n\|^2}{2\sigma_{RD}^2}} \end{aligned} \quad (2.20)$$

while the likelihood functions for both values of D_R for the 1st coded bit of the n^{th} symbol, $c_{n,1} = 1$, are given with the expressions:

$$\begin{aligned} p(y_{RD,n} | D_R = 0, c_{n,1} = 1) &= \sum_{\forall c_{n,i} \in \{0,1\}, i \neq 1} p(y_{RD,n} | D_R = 0, c_{n,1} = 0, c_{n,2}, \dots, c_{n,k}) \\ &= \frac{1}{2\pi\sigma_{RD}^2} \sum_{\forall x_n, \text{where } c_{n,1}=0} e^{-\frac{\|y_{RD,n} - \sqrt{E_{s1}(d_{RD})} h_{RD,n} x_n\|^2}{2\sigma_{RD}^2}} \end{aligned} \quad (2.21)$$

and

$$\begin{aligned} p(y_{RD,n} | D_R = 1, c_{n,1} = 1) &= \sum_{\forall c_{n,i} \in \{0,1\}, i \neq 1} p(y_{RD,n} | D_R = 1, c_{n,1} = 1, c_{n,2}, \dots, c_{n,k}) \\ &= \frac{1}{2\pi\sigma_{RD}^2} \sum_{\forall x_n, \text{where } c_{n,1}=1} e^{-\frac{\|y_{RD,n} - \sqrt{E_{s1}(d_{RD})} h_{RD,n} x_n\|^2}{2\sigma_{RD}^2}} \end{aligned} \quad (2.22)$$

On the equation (2.18), the term $p(D_R = 0 | c_{n,i})$ represent the probability that a coded bit is demodulated with error on the channel S-R, ϕ_{SR} . Since in our work we use M-QAM modulation technique, then initially we may evaluate the average probability that a symbol is demodulated with error on the channel S-R, which is given as [Rao 2015]:

$$\tau_{SR} = \int_0^\infty \tau_{SR}(\Gamma) \cdot P_{\text{df}}(\Gamma) d\Gamma \quad (2.23)$$

where, Γ is the instantaneous SNR, $P_{\text{df}}(\Gamma)$ is the probability density function of Γ , and $\tau_{SR}(\Gamma)$ is the demodulation error rate of a symbol at a given instantaneous

SNR Γ which is given as [K. Pahlavan 2005]:

$$\tau_{SR}(\Gamma) = 4 \cdot Q\left(\sqrt{\frac{3 \cdot \Gamma}{M-1}}\right) = 4 \cdot Q\left(\sqrt{\frac{3 \cdot E_s \cdot l(d_{SR}) \|h_{SR,n}\|^2}{(M-1) N_0}}\right) \quad (2.24)$$

Then, considering that we use the rectangular constellation based on Gray coding, we may assume that the bit error probability is k -times smaller than the symbol error probability [K. Pahlavan 2005], and in this way we get the parameters $p(D_R = 0 | c_{n,i})$ and $p(D_R = 1 | c_{n,i})$ that we need for evaluation according to equation (2.18), as:

$$\phi_{SR} = p(D_R = 0 | c_{n,i}) \simeq \frac{\tau_{SR}}{k} \quad \text{and} \quad p(D_R = 1 | c_{n,i}) = 1 - \phi_{SR} \quad (2.25)$$

The Destination does not know the channel coefficients S-R, but it knows the statistics of the channel S-R and the position of the Relay, which is sufficient information to evaluate the parameter ϕ_{SR} . We note here that to evaluate this parameter ϕ_{SR} , in our case we have used Monte Carlo simulation [Kalos 2008].

Having discussed the way to obtain the LLR for the 1st coded bit of the n^{th} symbol, on the same way there can be obtained also the LLRs for all other $k-1$ coded bits of the n^{th} symbol, and then the procedure is repeated for all the symbols of the received sequence. Finally, we obtain a LLR vector $\mathbf{\Lambda}$ of the whole received sequence, where the i^{th} coded bit of the n^{th} symbol is represented with index $k \cdot n - (k - i)$. Then, this vector $\mathbf{\Lambda}$ is fed into the Viterbi decoder for soft decoding.

2.3.1.3 Reception from Relay, DCF mode

We discussed earlier that when the Relay works on the mode Decode-and-Forward (DCF), the forwarded signal from Relay does not contain any error as its integrity is checked using CRC. Therefore, on the Destination demodulator, the LLR of i^{th} coded bit of the n^{th} symbol can be evaluated using equation (2.16), while the likelihood functions for the 1st coded bit of the n^{th} symbol are given below:

$$\begin{aligned} p(y_{RD,n} | c_{n,1} = 0) &= \sum_{\forall c_{n,i} \in \{0,1\}, i \neq 1} p(y_{RD,n} | c_{n,1} = 0, c_{n,2}, \dots, c_{n,k}) \\ &= \frac{1}{\pi N_0} \sum_{\forall x_n, \text{ where } c_{n,1} = 0} e^{-\frac{\|y_{RD,n} - \sqrt{E_s l(d_{RD})} h_{RD,n} x_n\|^2}{N_0}} \end{aligned} \quad (2.26)$$

$$\begin{aligned} p(y_{RD,n} | c_{n,1} = 1) &= \sum_{\forall c_{n,i} \in \{0,1\}, i \neq 1} p(y_{RD,n} | c_{n,1} = 1, c_{n,2}, \dots, c_{n,k}) \\ &= \frac{1}{\pi N_0} \sum_{\forall x_n, \text{ where } c_{n,1} = 1} e^{-\frac{\|y_{RD,n} - \sqrt{E_s l(d_{RD})} h_{RD,n} x_n\|^2}{N_0}} \end{aligned} \quad (2.27)$$

In similar way there can be evaluated also the likelihood functions for other $k-1$ coded bits of the n^{th} symbol.

2.4 Type-II HARQ

When the Destination decoder issues a NACK based on the detected errors, then the decoding would be more effective if the receiver stores the current copy on the buffer and uses it together with other incoming copies. This procedure is known as Type II H-ARQ or as soft combining at the receiver, and comes in many flavours: with Chase combining [Chase 1985] there is retransmitted always the same sequence of coded bits, while with Incremental redundancy combining [Pursley] at each retransmission only a set of additional parity bits is retransmitted, according to Table 2.1. For our numerical analysis we have considered Chase Combining.

2.4.1 Destination receiver

Let us consider that the Destination is combining A copies from the Source and B copies from the Relay. Then, the resultant combining likelihood function of all the received copies $p(y_n|c_{n,i})$, takes the form:

$$\begin{aligned} p(y_n|c_{n,i}) &= p(y_{SD,n}(1), \dots, y_{SD,n}(A), y_{RD,n}(1), \dots, y_{RD,n}(B)|c_{n,i}) \\ &= \prod_{a=1}^A p(y_{SD,n}(a)|c_{n,i}) \cdot \prod_{b=1}^B p(y_{RD,n}(b)|c_{n,i}) \end{aligned} \quad (2.28)$$

where, $p(y_{SD,n}|c_{n,i})$ and $p(y_{RD,n}|c_{n,i})$ are likelihood functions of copies coming from the Source and from the Relay, respectively. Of course, for the copies coming from the Relay there needs to be distinguished the cases of DMF and DCF mode, when substituting on equation (2.28). The LLR of i^{th} coded bit of the n^{th} symbol on the demodulator can be evaluated as follow:

$$\Lambda_{n,i} = LLR(c_{n,i}) = \log \frac{p(y_n | c_{n,i} = 0)}{p(y_n | c_{n,i} = 1)} \quad (2.29)$$

2.5 Performance metrics definition

For performance evaluation of the interaction between HARQ and Relaying, we have chosen the following performance metrics: the proportion of PDUs that were transmitted but non-acknowledged by the destination, denoted by PER; and, the average number of transmissions per PDU, denoted by \bar{T} . Let us denote here with ν - the total number of information PDUs sent by the Source during the operation time, with ν_t - the number of information PDUs that have been transmitted exactly t times during the operating time, with σ - the total number of information PDUs that were ACK-ed at the Destination during the operation time, and with N_{max} - the maximum number of transmissions per PDU from both Source and Relay. So, the chosen performance metrics take the form:

$$PER = 1 - \frac{\sigma}{\nu} \quad (2.30)$$

$$\bar{T} = \frac{1}{\nu} \sum_{t=1}^{N_{max}} t \cdot \nu_t \quad (2.31)$$

But, since an increase on the number of retransmissions results on the decrease of PER, than we introduce another performance metric named as *Goodput*, that accounts for the trade-off between PER and \bar{T} , and is defined as the number of successfully delivered information PDU's per unit of time, $[PDU/tu]$. Assume that the transmission of one PDU over the channel takes 1 time unit. The *Goodput* is defined as:

$$G = \frac{1 - PER}{\bar{T}} \left[\frac{PDUs}{tu} \right] \quad (2.32)$$

We note here that in simple examples we can evaluate the above performance metrics using combinatorial approach, but as the protocol gets more sophisticated or the number of nodes on the network increases, then it would be very difficult to use combinatorial approach for evaluating the performance metrics of the protocol.

Deterministic HARQ protocol for a cooperative network S-R-D

Contents

3.1	Introduction	19
3.1.1	Finite State Machines (FSM)	20
3.1.2	Finite State Markov Chain (FSMC)	21
3.2	S-R-D protocol, DMF mode	23
3.2.1	Communication protocol	23
3.2.2	Description of the transmitter using a FSM	24
3.2.3	Performance evaluation using FSMC, Type I decoder	24
3.2.4	Alternative way to obtain the steady state vector	26
3.2.5	Performance evaluation using FSMC, Type II decoder	27
3.3	S-R-D protocol, DCF mode	29
3.3.1	Communication protocol and its representation via FSM	30
3.3.2	Performance evaluation using FSMC	32
3.4	Numerical results	33
3.4.1	Simulation of the protocol, DMF mode	33
3.4.2	Simulation of the protocol, DCF mode	38
3.5	Conclusions	40

3.1 Introduction

In this chapter we will provide an analysis of HARQ protocols for cooperative network containing one Source, one Relay and one Destination, as it is shown in Figure 2.2. For studying this interaction, we need to define how the protocol works, which rules are applied and which is the (re)transmission order. Usually, the order of (re)transmissions for each node is pre-determined, and we refer to these protocols as *deterministic protocols*.

Defining how the deterministic protocol works, we then can simulate the protocol, but this is not sufficient as we need to provide theoretical analysis for its

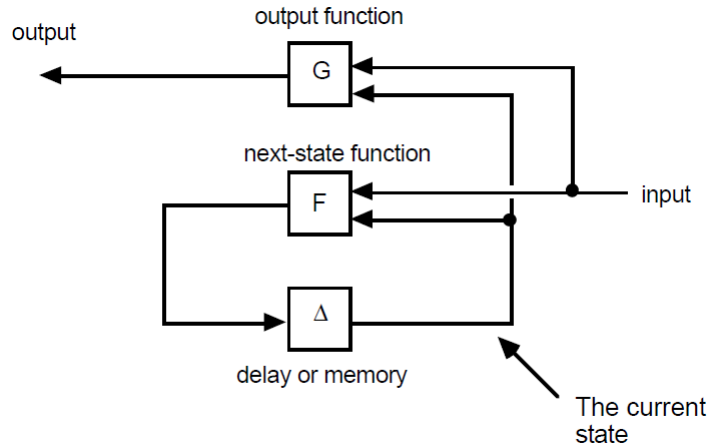

Figure 3.1: General structure of FSM

performance prediction and optimization. Therefore, in this chapter we also introduce Finite State Machines (FSM) and Finite State Markov Chains (FSMC) as tools that we will use for performance prediction and optimization. We will provide the analysis for both types of the Destination decoder, Type I and Type II decoder, and for two types of Relay mode, DMF and DCF. In the end, we will also compare simulation analysis with theoretical prediction.

3.1.1 Finite State Machines (FSM)

Finite State Machine (FSM) is a mathematical model that finds many applications. It has a finite number of states, where each *state* represent a certain event or information. The machine has an *input* and an *output*, and it can change its state from one to another to which change we refer as *transition*. State transition depend on two factors: on the current state and on the observed information of input, based on which it produces an output information or action and transits to another state.

To capture the behavior of FSM, there are various representations, but we stick to its modeling via graph representation as it is shown in Figure 3.1 [Keller 2001], where F represent the next-state or state-transition function, and G represent the output function. The meaning of these functions can be written as follow:

- $F(q,X)$ is the state to which the machine goes when it is currently in state q and X is read;
- $G(q,X)$ is the output produced when the machine is currently in state q and X is read.

3.1.2 Finite State Markov Chain (FSMC)

A Markov Chain is a random process for which the future (the next step) depends only on the present state, and it has no memory how the present state was reached. If with n , $n \geq 0$, we denote the time index, then with X_n we denote the state of the Markov Chain which is an integer valued random variable at time n . In general, the set of possible values for the random variable X_n is finite, $\{1, \dots, M\}$. The definition of Markov Chain is given as follow [Gallager 2014]:

Definition 3.1. *A Markov Chain is an integer-time process, $\{X_n, n \geq 0\}$ for which the sample values for each random variable $X_n, n \geq 1$, lie in a countable set \mathcal{S} and depend on the past only through the most recent random variable X_{n-1} . More specifically, for all positive integers n , and for all i, j, k, \dots, m in \mathcal{S} ,*

$$Pr \{X_n = j \mid X_{n-1} = i, X_{n-2} = k, \dots, X_0 = m\} = Pr \{X_n = j \mid X_{n-1} = i\} \quad (3.1)$$

Furthermore, $Pr \{X_n = j \mid X_{n-1} = i\}$ depends only on i and j (not n) and is denoted by

$$Pr \{X_n = j \mid X_{n-1} = i\} = P_{ij} \quad (3.2)$$

If in the Markov Chain the number of states is finite, then we talk about Finite State Markov Chain (FSMC). For simplicity, the equation (3.1) can be written as

$$Pr \{X_n \mid X_{n-1}, X_{n-2}, \dots, X_0\} = Pr \{X_n \mid X_{n-1}\} \quad (3.3)$$

where, X_0 represent the initial state that has an arbitrary probability distribution.

Markov Chains are usually described by a graph that represent the state transitions associated with corresponding probabilities. Let us consider an example of FSMC with $M = 5$ states, as shown in Figure 3.2.

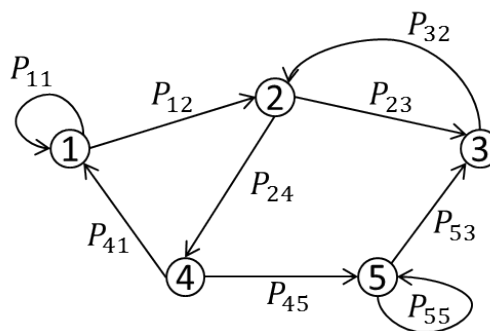

Figure 3.2: Graph of state transitions

Then, the finite-state Markov chain of Figure 3.2 can be described by a state-

transition matrix P of dimensions $M \times M$ as follow:

$$P = \begin{bmatrix} P_{11} & P_{12} & 0 & 0 & 0 \\ 0 & 0 & P_{23} & P_{24} & 0 \\ 0 & P_{32} & 0 & 0 & 0 \\ P_{41} & 0 & 0 & 0 & P_{45} \\ 0 & 0 & P_{53} & 0 & P_{55} \end{bmatrix} \quad (3.4)$$

In general, in a directed graph $G = (S, E)$, where S is a set of states and $E \subseteq S \times S$ is a set of edges on the graph, we may classify states of the finite-state Markov chain based on the following definitions [Gallager 2014], [A. Gambin]:

Definition 3.2. *Two distinct states i and j communicate (abbreviated $i \leftrightarrow j$) if i is accessible from j and j is accessible from i . The communication can be done via one or more intermediate states.*

Definition 3.3. *For finite-state Markov chains, a recurrent state is a state i that is accessible from all states that are accessible from i (i is recurrent if $i \rightarrow j$ implies that $j \rightarrow i$). A transient state is a state that is not recurrent.*

Definition 3.4. *A strong component of graph G is any maximal subgraph C , with the property that $i \rightarrow j$ for any two states i, j of C .*

A strong component is *absorbing* if it has no outgoing edges. Strong absorbing components are also called *closed classes* in the sequel. An underlying graph of each Markov chain has at least one strong absorbing component.

Definition 3.5. *A Markov chain is called an ergodic chain if it is possible to go from every state to every state (not necessarily in one move).*

Ergodic Markov chain has the property that the probability distribution of being in each state of the chain at time moment n becomes independent of the starting state i as $n \rightarrow \infty$. Let us denote with \mathbf{p}_0 the vector corresponding to the probability distribution of the initial state. If the chain starts deterministically in State 0, then \mathbf{p}_0 takes the form:

$$\mathbf{p}_0 = [1 \ 0 \ 0 \ 0 \ \dots \ 0 \ 0 \ 0] \quad (3.5)$$

Then, the probability of being in each state at time $n = 1, n = 2, \dots$, at time n , respectively, is given with the expression:

$$\mathbf{p}_1 = \mathbf{p}_0 \cdot P, \quad \mathbf{p}_2 = \mathbf{p}_0 \cdot P^2, \quad \dots, \quad \mathbf{p}_n = \mathbf{p}_0 \cdot P^n \quad (3.6)$$

If we continue on this way for a long time, then we see that:

$$\lim_{n \rightarrow \infty} P^n = P^{n+1} \quad \Rightarrow \quad \lim_{n \rightarrow \infty} \mathbf{p}_n = \mathbf{p}_{n+1} \quad (3.7)$$

and therefore:

$$\mathbf{p}_{n+1} = \mathbf{p}_n \cdot P = \mathbf{p}_0 \cdot P^{n+1} \quad (3.8)$$

The above relationship comes from the property of eigendecomposition, where it is shown that for a square matrix P there exist a vector \mathbf{p} which is called the eigenvector of P , and a λ which is called the eigenvalue of P , that fulfill the relationship [J. Defranza 2009]:

$$P \cdot \mathbf{p} = \lambda \cdot \mathbf{p} \quad (3.9)$$

The number of eigenvalues and eigenvectors depend on the order of the matrix, but the eigenvector which is associated with the eigenvalue $\lambda = 1$ is known as the steady-state vector, \mathbf{p} of the state transition matrix P , and the relationship can be written as:

$$\mathbf{p} \cdot P = \mathbf{p} \quad (3.10)$$

In other words, the steady state probability p_k represents the fraction of time that the Markov Chain spends in state k [Gallager 2014], and p_k^{-1} represents the expectation of the recurrence time on state k . As we will see later, the property from equation (3.10) we will use for our theoretical performance analysis of the protocols.

3.2 S-R-D protocol, DMF mode

3.2.1 Communication protocol

The protocol determines the role of each node on the communication network. Considering the topology of cooperative network of Figure 2.2, we can define many different protocols, but we will consider an example of HARQ protocol with the following rules: As soon as the first PDU is in the buffer, the source S broadcasts the channel coded packet, which is received by both D and R. D attempts decoding and issues the control message (ACK if decoding is successful, NACK if a decoding error is detected), received by both S and R. In case of ACK message, S proceeds with the transmission of a new information PDU. In case of NACK message, the protocol enters in the retransmission phase, where R and S retransmit in a deterministic order. A retransmission is performed every time that D issues NACK and the maximum number N_{\max} of transmissions for the same PDU has not been reached yet. The retransmission order is determined by the following rules: 1) R performs the first retransmission of the current information PDU; 2) R is allowed to retransmit N_R consecutive times after each (re)transmission by S, after which the control of the channel goes back to S; 3) S transmits the same PDU a maximum of N_S times (this includes the first transmission). Each PDU is then allowed a maximum number of $N_{\max} = N_S \cdot N_R + N_S$ transmissions. S will proceed with the transmission of a new PDU any time that D issues an ACK, or after the N_{\max} -th failed transmission of the same PDU.

Table 3.1: Definition of states in the FSM of the transmitter

State name	State definition	Next action
0	$t_S=0, t_R=0, W=ACK$	ST
1	$t_S=0, t_R=0, W=NACK$	ST
2	$t_S=1, t_R=0, W=NACK$	RRT
3	$t_S=1, t_R=1, W=NACK$	RRT
...
N_R+2	$t_S=1, t_R=N_R, W=NACK$	SRT
N_R+3	$t_S=2, t_R=0, W=NACK$	RRT
N_R+4	$t_S=2, t_R=1, W=NACK$	RRT
...
$N_S N_R + N_S$	$t_S=N_S, t_R=N_R-1, W=NACK$	RRT

3.2.2 Description of the transmitter using a FSM

As described at the beginning of this Chapter, FSM can be used to model many practical situations. We can use it to model our deterministic protocol, too. In our case, the FSM enters a state in each time-slot. The state determines the action that is going to be taken during the time-slot. The outcome of the action determines the transition to the next state. The definition of the states for the considered protocol is given in Table 3.1. At the beginning of the time-slot, let t_S denote the number of times S has already transmitted the current PDU; t_R the number of times R has already transmitted the current PDU after the last transmission from S; and W the last control message issued by D. Each possible combination of the values of the parameters t_S , t_R and W defines a state. Notice that the combinations such that $\{1 \leq t_S \leq N_S, 1 \leq t_R \leq N_R, W = ACK\}$ are not possible, since $W = ACK$ forces the transmission of a new PDU. Each state is associated with one of the possible actions: ST (Source Transmits a new PDU for the first time), SRT (Source Retransmits the current PDU) or RRT (Relay Retransmits the current PDU). The protocol starts in State 0 (if the previous PDU was ACK-ed) or in State 1 (if the previous PDU was NACK-ed) where a new PDU is transmitted for the first time. The scheme of the possible state transitions in the FSM is given in Figure 3.3.

3.2.3 Performance evaluation using FSMC, Type I decoder

Since the state transitions of the FSM depends only on the last input (ACK or NACK) from the Destination, and since these inputs are associated with probabilities, then this FSM has a Markov Chain [Norris 1997] property. That is, by knowing that the decoding result on the receiver depends on the channel conditions, and assuming that the channels S-D, S-R and R-D are independent, then we can evaluate the average probabilities that the decoder issues NACK. Let us define here with $\pi_{[1,0]}$ the probability that D issues NACK after decoding the last copy received

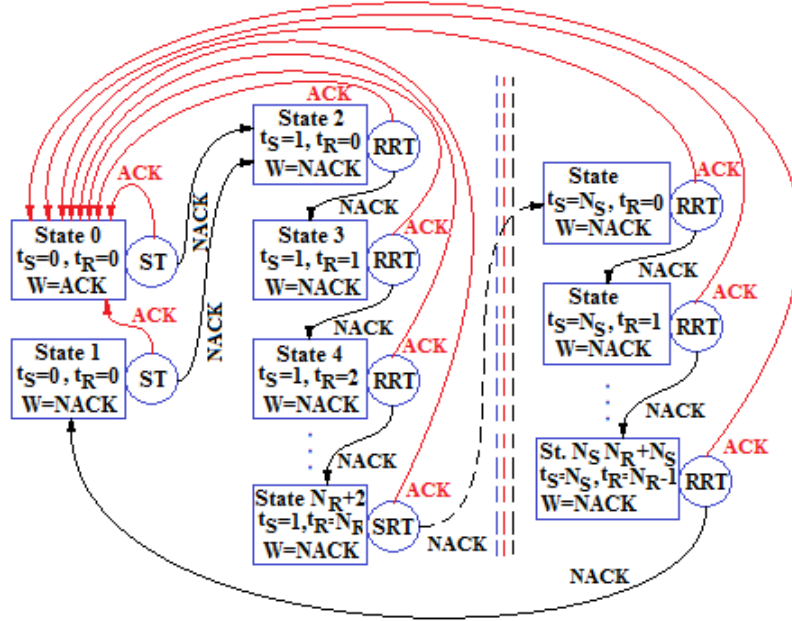

Figure 3.3: FSM of the transmitter of the deterministic protocol

from S, and with $\pi_{[0,1]}$ the probability that D issues NACK after decoding the last copy received from R. Then, the considered protocol can be described by the Finite State Markov Chain (FSMC) shown in Figure 3.4, with state transition matrix P , of size $(N_S \cdot N_R + N_S + 1) \times (N_S \cdot N_R + N_S + 1)$:

$$P = \begin{pmatrix} 1 - \pi_{[1,0]} & 0 & \pi_{[1,0]} & 0 & \cdots & 0 & \cdots \\ 1 - \pi_{[1,0]} & 0 & \pi_{[1,0]} & 0 & \cdots & 0 & \cdots \\ 1 - \pi_{[0,1]} & 0 & 0 & \pi_{[0,1]} & \cdots & 0 & \cdots \\ \vdots & \vdots & \vdots & \vdots & \ddots & \vdots & \ddots \\ 1 - \pi_{[1,0]} & 0 & 0 & 0 & \cdots & \pi_{[1,0]} & \cdots \\ \vdots & \vdots & \vdots & \vdots & \ddots & \vdots & \ddots \\ 1 - \pi_{[0,1]} & \pi_{[0,1]} & 0 & 0 & \cdots & 0 & \cdots \end{pmatrix}. \quad (3.11)$$

The element $[P]_{ij}$ represents the transition probability from State i to State j . For numerical results, the probabilities $\pi_{[1,0]}$ and $\pi_{[0,1]}$ are evaluated via Monte Carlo simulation [Kalos 2008].

Having the probability transition matrix P , then according to equation (3.10) we can evaluate the steady state vector of the protocol FSMC, and use it to obtain the values of performance metrics (2.30) to (2.32) that describe the protocol. Since p_k^{-1} represents the expectation of the recurrence time on state k , then the average

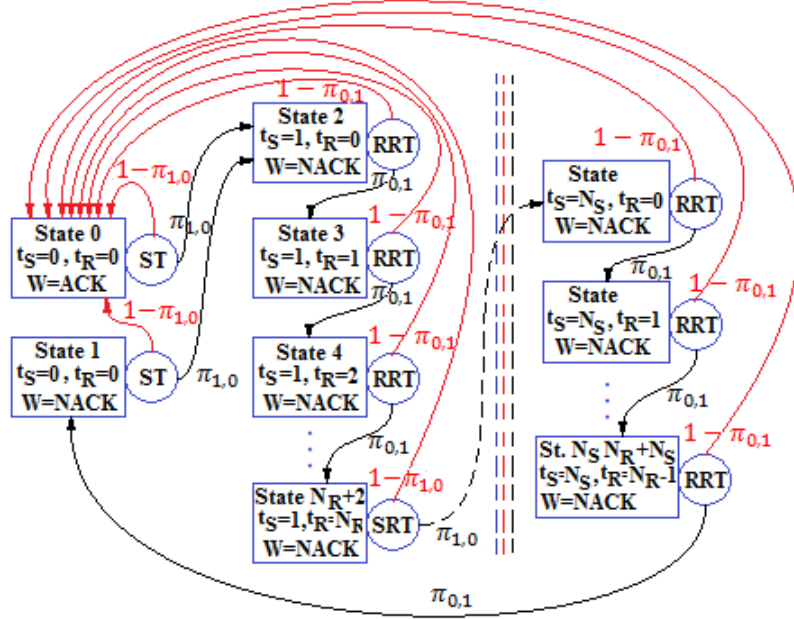

Figure 3.4: FSMC of the transmitter of the deterministic protocol, DMF mode

number of transmissions per PDU, \bar{T} , and PER, respectively, can be obtained as:

$$\bar{T} = E[\text{recurrence time on the initial state}] = \frac{1}{p_0 + p_1} \quad (3.12)$$

$$PER = \frac{p_1}{p_0 + p_1} \quad (3.13)$$

Substituting (3.12) and (3.13) into equation (2.32), the Goodput take the form:

$$G = R_c \cdot \frac{1 - PER}{\bar{T}} \left[\frac{PDU_s}{tu} \right] = R_c \cdot p_0 \left[\frac{PDU_s}{tu} \right] \quad (3.14)$$

3.2.4 Alternative way to obtain the steady state vector

Thanks to the structure of the matrix P , the steady state vector \mathbf{p} can be also evaluated using a combinatorial approach. The states of the FSMC are visited in paths starting from State 0 or State 1 and going back to State 0 or State 1. Even if different paths may have different lengths, they share the property that State i , $\forall i > 2$ is always reached from State $i - 1$ (State 2 can be reached either by State 0 or 1). Define c_k as the probability of accessing State k for the first time during one of these paths. It is evaluated as

$$c_0 = \sum_{t_S=1}^{N_S} \left(\sum_{t_R=0}^{N_R} \pi_{[1,0]}^{(t_S-\alpha)} \cdot \pi_{[0,1]}^{(t_S-1)N_R+t_R-1+\alpha} \cdot (1 - \pi_{[1,0]})^\alpha \cdot (1 - \pi_{[0,1]})^\beta \right), \quad (3.15)$$

$$c_1 = \pi_{[1,0]}^{N_S} \cdot \pi_{[0,1]}^{N_S N_R}, \quad (3.16)$$

$$c_{([t_S-1]N_R+t_S+t_R)} = \pi_{[1,0]}^{(t_S-\alpha)} \pi_{[0,1]}^{(t_S-1)N_R+t_R-1+\alpha}, \quad (3.17)$$

where $\alpha = 1$ if $t_R = 0$ and $\alpha = 0$ otherwise; and $\beta = 0$ if $t_R = 0$ and $\beta = 1$ otherwise. The steady state probability p_k can be expressed as a function of the vector \mathbf{c} as

$$\begin{aligned} p_k &= \Pr(\text{being in steady state } k) \\ &= \Pr(\text{access state } k \mid \text{current path}) \\ &= \Pr(\text{access st. } k \mid \text{access st. } i \in \{0, 1, \dots, N_S N_R + N_S\}) \\ &= \frac{c_k}{\sum_{i=0}^{N_S N_R + N_S} c_i}. \end{aligned} \quad (3.18)$$

We note here that the result in (3.18) it is observed independent of any reference or literature, and later discovered by the author that this seems to be among the "most often rediscovered result in probability theory" [Aldous 2002]. This result is represented by the following theorem [A. Gambin]:

Theorem 3.1. (Markov chain tree theorem) *If the underlying graph of a markov chain has exactly one absorbing strong component, then the stationary distribution is given by:*

$$p_i = \frac{\omega(\mathcal{F}(i))}{\sum_{j \in S} \omega(\mathcal{F}(j))}, \text{ for } i = 1, \dots, s \quad (3.19)$$

where, with $\omega(\mathcal{F}(i))$ there is represented some (multiplicative) weight of a tree (forest, \mathcal{F}) ending at state i . For more details, the interested reader can refer to [A. Gambin].

3.2.5 Performance evaluation using FSMC, Type II decoder

When the decoder saves the previous erroneous copies to combine with new incoming copy for decoding, this is known as Type II decoder as described in section 2.4. Performance analysis of the protocol in this case remains almost the same with the case of type I decoder provided in previous subsection, with the difference that here change only the probabilities on the transition matrix. Let us define here with $\pi_{[A,B]}$ the probability that D fails in decoding the current PDU, based on A copies received from S and B copies received from R, knowing that previous decoding with less copies has been unsuccessful. We note here that Relay forwards the last demodulated copy from Source. Then, the probabilities $\pi_{[A,B]}$ can be evaluated via Monte Carlo simulations according to the Algorithm 1. A simulation example of probabilities $\pi_{[A,B]}$ on a fully-interleaved channel for some values of A and B is shown in Figure 3.5. As we see from the plots, $\pi_{[1,2]}$ is interestingly lower than $\pi_{[1,3]}$

and $\pi_{[2,2]}$ for $E_b/N_0 > 1$! This has the following explanation: with $\pi_{[1,3]}$ and $\pi_{[2,2]}$ we jump to the fourth copy only if we fail with the first three copies, that means that the first three copies are very bad, so even if the fourth copy is better it has more probability to fail than to succeed (as the overall information is still bad), while in the case of $\pi_{[1,2]}$ we jump to the third copy only if we fail with the first two copies and thus the overall information after the third copy is more balanced between succeeding and failing thus having lower ratio of failures, compared to the cases when we have failed previously with more copies.

Algorithm 1: Evaluation of probabilities π_{AB}

```

Define  $A, B$  ;
 $v_{ACK} = 0; v_{NACK} = 0$  ;
while True do
     $t_S = 0; b = 0$ ;
    Generate a new PDU;
    while  $t_S < A \ \& \ CRC\_flag=NACK$  do
        Source.Transmits();
        Append copy on the buffer;
        Calculate.LLR;
        Decode.LLR;
        Check.CRC;
         $t_R = 0$ ;
        while  $t_R < N_R \ \& \ CRC\_flag=NACK \ \& \ b < B$  do
            Relay.Transmits();
            Append copy on the buffer;
            Calculate.LLR;
            Decode.LLR;
            Check.CRC;
             $b = t_S \cdot N_R + t_R + 1$ ;
             $t_R ++$ ;
        end
         $t_S ++$ ;
    end
    if  $t_S = A \ \& \ b = B \ \& \ CRC\_flag=ACK$  then
         $v_{ACK} ++$ ;
    end
    else if  $t_S = A \ \& \ b = B \ \& \ CRC\_flag=NACK$  then
         $v_{NACK} ++$ ;
    end
end
Evaluate:  $\pi_{AB} = v_{NACK} / (v_{ACK} + v_{NACK})$ ;
    
```

Having defined and evaluated the probabilities $\pi_{[A,B]}$, then the probability tran-

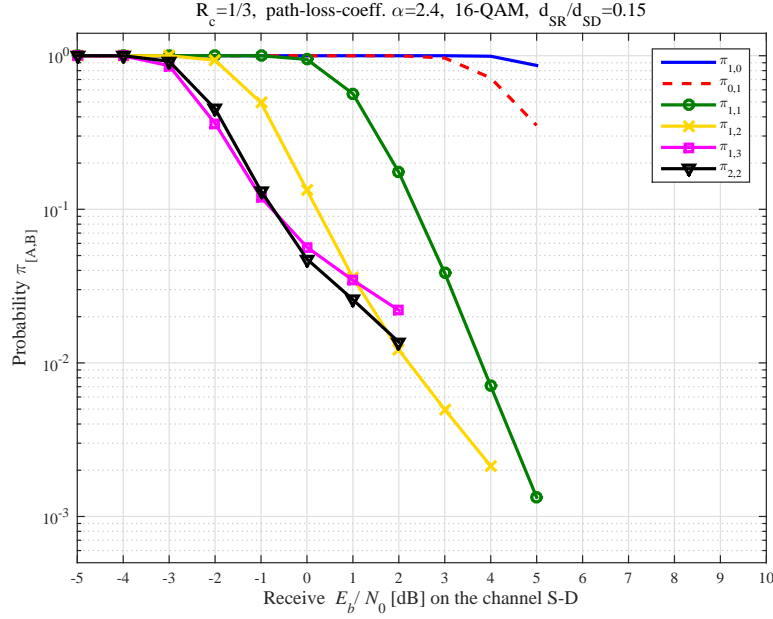
Figure 3.5: Comparison of $\pi_{[A,B]}$ for different values of A and B

sition matrix of the FSMC of the protocol with type II decoder takes the form:

$$P_{II} = \begin{pmatrix} 1 - \pi_{[1,0]} & 0 & \pi_{[1,0]} & 0 & \cdots & 0 & \cdots \\ 1 - \pi_{[1,0]} & 0 & \pi_{[1,0]} & 0 & \cdots & 0 & \cdots \\ 1 - \pi_{[1,1]} & 0 & 0 & \pi_{[1,1]} & \cdots & 0 & \cdots \\ \vdots & \vdots & \vdots & \vdots & \ddots & \vdots & \ddots \\ 1 - \pi_{[1,N_R]} & 0 & 0 & 0 & \cdots & \pi_{[1,N_R]} & \cdots \\ \vdots & \vdots & \vdots & \vdots & \ddots & \vdots & \ddots \\ 1 - \pi_{[N_S, N_S N_R]} & \pi_{[N_S, N_S N_R]} & 0 & 0 & \cdots & 0 & \cdots \end{pmatrix}, \quad (3.20)$$

Once we have the probability transition matrix P_{II} , then the steady state vector can be obtained via equation (3.10), which can be used to evaluate performance metrics as discussed earlier.

3.3 S-R-D protocol, DCF mode

Having provided the analysis of the protocol for the case of Relay working on DMF mode, now we turn to the analysis of the same protocol when Relay works on the mode Decode-and-Forward (DCF), where Relay demodulates, decodes and if no error is found then it re-encodes, re-modulates and forwards the message to the Destination. In this case, the message received from Relay on the Destination is free of demodulation errors on the Relay.

3.3.1 Communication protocol and its representation via FSM

Let us consider the same deterministic protocol as discussed on previous section, where for each of N_S (re)transmissions from the Source, Relay is allowed to perform up to N_R successive retransmissions. Of course, a retransmission is asked any time that the decoder issues a NACK. But, contrary to the DMF mode when Relay always can retransmit when it is asked, here at the DCF mode the retransmission of the Relay does not depend only on the request, but also from the fact if it has correctly decoded or not (via CRC check) the copy received from the Source. The Relay will try to decode any of the (re)transmissions from the Source, and in case of successful decoding it will keep the right to (re)transmit up to N_R successive retransmissions (if needed) after each of the remaining (from maximum N_S) (re)transmissions from the Source. But, if the Source has (re)transmitted and both, the Destination and the Relay, did not decode correctly the copy, then it would be again Source who will retransmit. Therefore, in case of a continuous NACK from D, the minimum number of transmissions per PDU can be $N_{min} = N_S$ (in case R never retransmits because it could not decode the copy from S), and the maximum number of transmissions per PDU can be $N_{max} = N_S \cdot N_R + N_S$ (in case R decodes the copy during the first transmission from S).

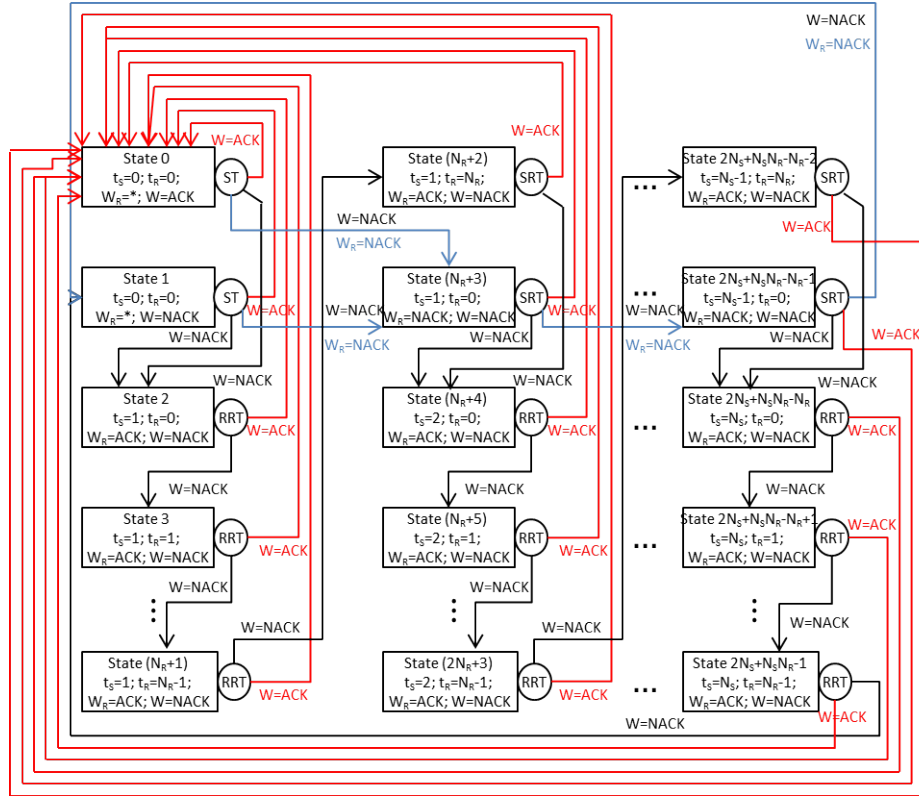

Figure 3.6: FSM of the transmitter of the deterministic protocol, DCF mode

The condition of having a correct copy on R for a retransmission implies a new parameter for defining the states of the FSM, and obviously the number of states on the FSM increases compared to the case of DMF. Let us keep the same parameters, t_S , t_R and W under the same definitions as provided earlier, and add here a new parameter, W_R , that represents the control message (ACK or NACK) resulting from the decoding of received copy on R. Then, the state definitions of the FSM is given in Table 3.2, while the state transitions is shown in Figure 3.6.

Table 3.2: Definition of states in the FSM of the transmitter, DCF mode

State name	State definition	Next action
0	$t_S=0, t_R=0, W_R=*, W=ACK$	ST
1	$t_S=0, t_R=0, W_R=*, W=NACK$	ST
2	$t_S=1, t_R=0, W_R=ACK, W=NACK$	RRT
3	$t_S=1, t_R=1, W_R=ACK, W=NACK$	RRT
⋮	⋮	⋮
N_R+1	$t_S=1, t_R=N_R-1, W_R=ACK, W=NACK$	RRT
N_R+2	$t_S=1, t_R=N_R, W_R=ACK, W=NACK$	SRT
N_R+3	$t_S=1, t_R=0, W_R=NACK, W=NACK$	SRT
N_R+4	$t_S=2, t_R=0, W_R=ACK, W=NACK$	RRT
N_R+5	$t_S=2, t_R=1, W_R=ACK, W=NACK$	RRT
⋮	⋮	⋮
$2N_R+3$	$t_S=2, t_R=N_R-1, W_R=ACK, W=NACK$	RRT
⋮	⋮	⋮
$2N_S+N_S N_R-N_R-2$	$t_S=N_S-1, t_R=N_R, W_R=ACK, W=NACK$	SRT
$2N_S+N_S N_R-N_R-1$	$t_S=N_S-1, t_R=0, W_R=NACK, W=NACK$	SRT
$2N_S+N_S N_R-N_R$	$t_S=N_S, t_R=0, W_R=ACK, W=NACK$	RRT
$2N_S+N_S N_R-N_R+1$	$t_S=N_S, t_R=1, W_R=ACK, W=NACK$	RRT
⋮	⋮	⋮
$2N_S+N_S N_R-1$	$t_S=N_S, t_R=N_R-1, W_R=ACK, W=NACK$	RRT

The state name or index, z , associated with the retransmission from Relay is modelled as a function of t_S and t_R , as follow

$$z = 2t_S + (t_S - 1)N_R + t_R, \quad \{1 \leq t_S \leq N_S, 0 \leq t_R \leq N_R - 1, W_R = ACK\} \quad (3.21)$$

while the index z of the states associated with the retransmissions from Source when Relay confirms that it has the correctly decoded copy on the buffer $W_R = ACK$, is modelled as a function of t_S and t_R , as follow:

$$z = 2t_S + (t_S - 1)N_R + N_R, \quad \{1 \leq t_S \leq N_S, W_R = ACK\} \quad (3.22)$$

and the index z of the states associated with the retransmission from Source when Relay confirms that the decoded copy contains an error $W_R = NACK$, is modelled as follow:

$$z = 2t_S + (t_S - 1)N_R + N_R + 1, \quad \{1 \leq t_S \leq N_S, W_R = NACK\} \quad (3.23)$$

We note that:

- all states with index $z \in \{2, \dots, 2N_S + N_S N_R - 1\}$ are associated to the z -th transmission of the current PDU;
- the states with index $z = 0$ or $z = 1$ are associated with the first transmission of the current PDU.

3.3.2 Performance evaluation using FSMC

Since we can describe the state transitions of Figure 3.6 with corresponding probabilities, then we can model the behaviour of the protocol via FSMC. Let us keep the same notation and the definitions for probabilities $\pi_{[1,0]}$ and $\pi_{[0,1]}$ representing the probability that D issues NACK after decoding the last copy received from S and from R, respectively. In addition to this, let us denote with α_R the probability that R cannot decode correctly the copy coming from S. Then, for the case of type I decoder, the probability transition matrix takes the form:

$$P_{DCF} = \begin{bmatrix} 1 - \pi_{1,0} & 0 & (1 - \alpha_R) \pi_{1,0} & 0 & \cdots & \alpha_R \pi_{1,0} & \cdots & 0 & 0 & \cdots \\ 1 - \pi_{1,0} & 0 & (1 - \alpha_R) \pi_{1,0} & 0 & \cdots & \alpha_R \pi_{1,0} & \cdots & 0 & 0 & \cdots \\ 1 - \pi_{0,1} & 0 & 0 & \pi_{0,1} & \cdots & 0 & \cdots & 0 & 0 & \cdots \\ \vdots & \vdots & \vdots & \vdots & \ddots & \vdots & \ddots & \vdots & \vdots & \ddots \\ 1 - \pi_{0,1} & 0 & 0 & 0 & \cdots & \pi_{0,1} & \cdots & 0 & 0 & \cdots \\ 1 - \pi_{1,0} & 0 & 0 & 0 & \cdots & 0 & \cdots & \pi_{1,0} & 0 & \cdots \\ 1 - \pi_{1,0} & \alpha_R \pi_{1,0} & 0 & 0 & \cdots & 0 & \cdots & (1 - \alpha_R) \pi_{1,0} & 0 & \cdots \\ 1 - \pi_{0,1} & 0 & 0 & 0 & \cdots & 0 & \cdots & 0 & \pi_{0,1} & \cdots \\ \vdots & \vdots & \vdots & \vdots & \ddots & \vdots & \ddots & \vdots & \vdots & \ddots \\ 1 - \pi_{0,1} & \pi_{0,1} & 0 & 0 & \cdots & 0 & \cdots & 0 & 0 & \cdots \end{bmatrix} \quad (3.24)$$

In similar way, for the type II decoder, we can evaluate the probabilities $\pi_{[A,B]}$ and obtain the probability transition matrix. The number of states remain the same as with type I decoder, but we need to be carefully when we evaluate the probabilities $\pi_{[A,B]}$ and pay attention to the fact that the Relay can decode correctly or not the incoming copies during any of the (re)transmissions from the Source. Once Relay decodes it correctly, then it keeps on the buffer and ignores the other incoming copies of the same PDU, until either this PDU is ACK-ed on the Destination or the maximum number of transmissions for this PDU is reached.

3.4 Numerical results

In this section we present numerical analysis of deterministic protocol using simulations and FSMC, for both types of decoders. The physical layer analysis of the links and receiver are discussed in Chapter 2. In our case, we consider Convolutional Coding with code rate $R_c = 1/3$, and we consider 16-QAM modulation. Each information PDU is of length 1000 bits. The average energy per modulated symbol is the same at S and R, $E_s = 1$, and as a result the transmit E_b/N_0 is the same on the channels S-D and R-D. The path-loss exponent is $\alpha = 2.4$. We assume that we know the propagation conditions on the channels S-D, S-R and R-D, where we assume block fading according to Rayleigh distribution and also impaired by complex Gaussian noise with noise density N_0 . The probabilities $\pi_{1,0}$, $\pi_{0,1}$ and $\pi_{[A,B]}$ are evaluated using Monte Carlo simulations.

3.4.1 Simulation of the protocol, DMF mode

Let us consider the case when Relay works on the mode Demodulate-and-Forward (DMF). Initially, we want to show that we can use our theoretical framework for performance prediction of the protocol. In Figures 3.7 and 3.8 we have considered a performance prediction for the protocol with 4 copies and with 6 copies, respectively. In Figure 3.7 there is shown the comparison of PER achieved with simulation and with theoretical analysis via FSMC. As we may see, the performance is predicted accurately, and as it is expected, increasing the maximum number of transmissions per PDU, decreases PER. Also, as it is expected, type II decoding outperforms type I decoding, and the gain can go up to over 5 [dB].

In Figure 3.8 there is shown the comparison of Goodput (expressed in % of maximum Goodput) as a function of receive E_b/N_0 on the channel S-D, achieved with theoretical analysis and with simulation. We note here that since we use channel coding with code rate R_c , the maximum value that Goodput can take according to equation (2.32) is $G = R_c$. From Figure 3.8 we see that increasing the maximum number of transmissions per PDU brings higher Goodput, too. But, we see that when the channel is bad, we have higher difference of Goodput achieved with 6 copies compared to the Goodput achieved with 4 copies, and as the channel improves this difference becomes smaller and smaller. This means that in a good channel most of the PDUs get acknowledged with very few transmissions.

One important aspect on the analysis is performance optimization. This means that we want to keep fixed the maximum number of transmissions, and we check for which combination of N_S and N_R we get the best performance. We remind here that the maximum number of transmissions per PDU is $N_S + N_S \cdot N_R$. For the case of 4 copies we get two possibilities: 1) $N_S = 1$ and $N_R = 3$; and, 2) $N_S = 2$ and $N_R = 1$. For the case of 6 copies we get three possibilities: 1) $N_S = 1$ and $N_R = 5$; 2) $N_S = 2$ and $N_R = 2$; and, 3) $N_S = 3$ and $N_R = 1$. The comparison of various N_S

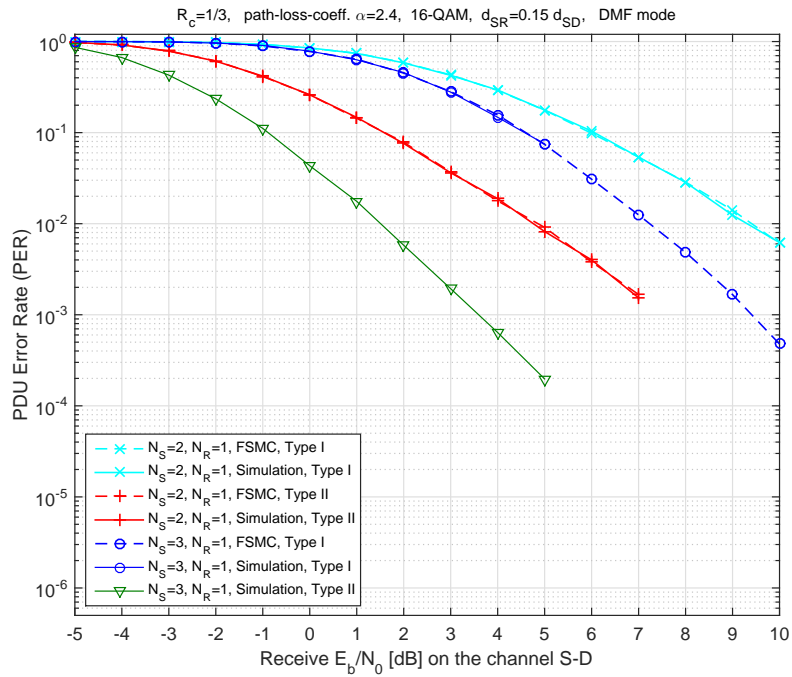

Figure 3.7: Comparison of PER with 4 copies and with 6 copies, type I and type II

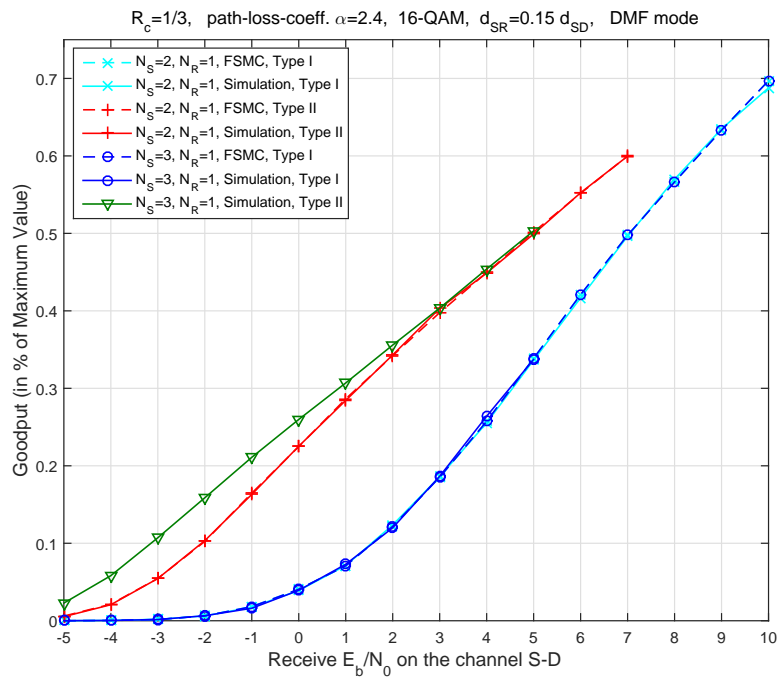

Figure 3.8: Goodput with 4 copies and with 6 copies, type I and type II

and N_R for both cases, 4 copies and 6 copies, for both types of decoders, type I and type II, is shown in Figure 3.9, where the PER is compared versus receive E_b/N_0 on the channel S-D. As we may see, the best performance it is achieved when we set the value of $N_R = 1$, which means that we do not allow more than one successive retransmission from Relay. Since the Relay could forward an erroneous copy due to the demodulation errors on the copy from the Source, then we should allow the Relay to refresh its own demodulated copy from the Source before the next retransmission.

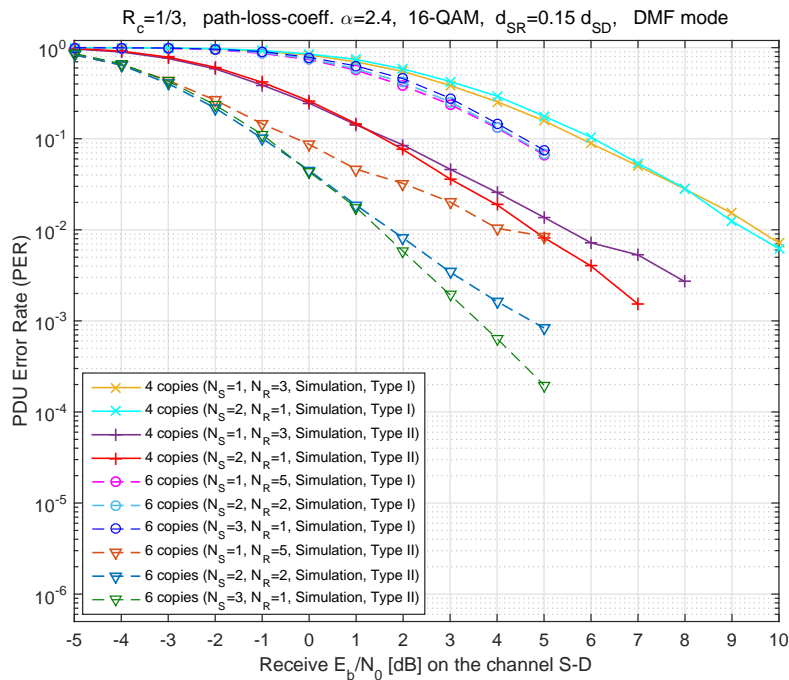

Figure 3.9: Comparison of PER for various N_S and N_R , type I and type II

Since the above analysis are considered for the case when Relay is located close to the Source ($d_{SR}/d_{SD} = 0.15$), we want to check what happens when Relay is located to other positions with respect to S and D. Therefore, in the following Figures we have compared performances when Relay appears at distances $d_{SR}/d_{SD} \in \{0.15, 0.35, 0.50, 0.85\}$. In Figure 3.10 there is compared PER when we have only one transmissions from S and three retransmissions from R (associated with $N_S = 1$ and $N_R = 3$) for various locations of the Relay. As we may see from the Figure, the highest performance it is achieved when Relay is located close to the Source, as in this case it suffers from less demodulation errors compared to other locations of the Relay. This location of the Relay seems to be the best for both types of decoders.

In the other hand, when we compare performance of the protocol with $N_S = 2$

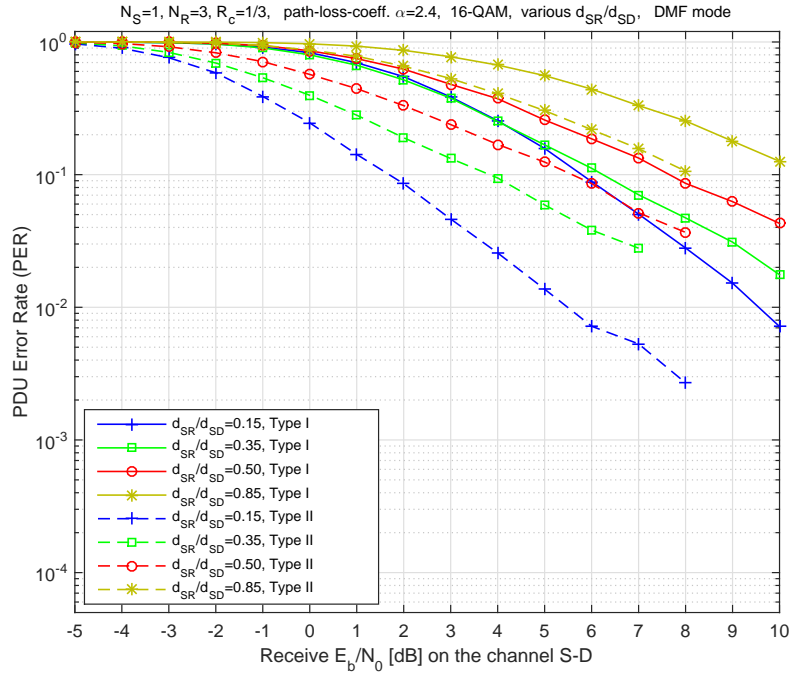

Figure 3.10: Comparison of PER, $N_S = 1$ and $N_R = 3$, various location of the Relay

and $N_R = 1$ (for every transmissions from S, R is allowed to retransmit once) for various location of the Relay, the situation is different. From Figure 3.11 we see that the best performance it is achieved when Relay is located at distance $d_{SR}/d_{SD} = 0.35$. As we may see, the performance improves as Relay moves from the position of being close to the Source up to location $d_{SR}/d_{SD} = 0.35$ where it gets its maximum performance, and then the performance decreases as Relay approaches the Destination. We note here that the optimized location of the Relay accounts for trade-off between the demodulation errors on the Relay and the probability of success on the remaining distance R-D.

In Figures 3.10 and 3.11 we have compared achieved PER, but we have still not provided any comparison for the average number of transmissions per PDU, \bar{T} , which is important metric, too. But, since we have introduced the metric of Goodput that counts for trade-off between PER and \bar{T} , then in Figure 3.12 we have shown comparison of Goodput for various values of N_S and N_R , and for various location of the Relay. As observed also at the comparison of PER, similarly, for the case of $N_S = 1$ and $N_R = 3$ the optimized location appears at $d_{SR}/d_{SD} = 0.15$, while for the case of $N_S = 2$ and $N_R = 1$ the optimized location appears at $d_{SR}/d_{SD} = 0.35$.

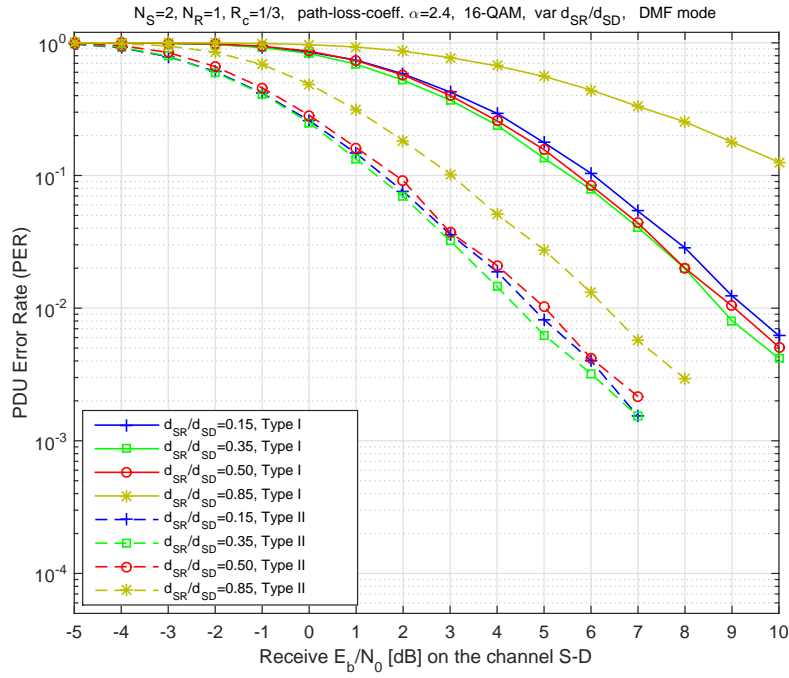

Figure 3.11: Comparison of PER, $N_S = 2$ and $N_R = 1$, various location of the Relay

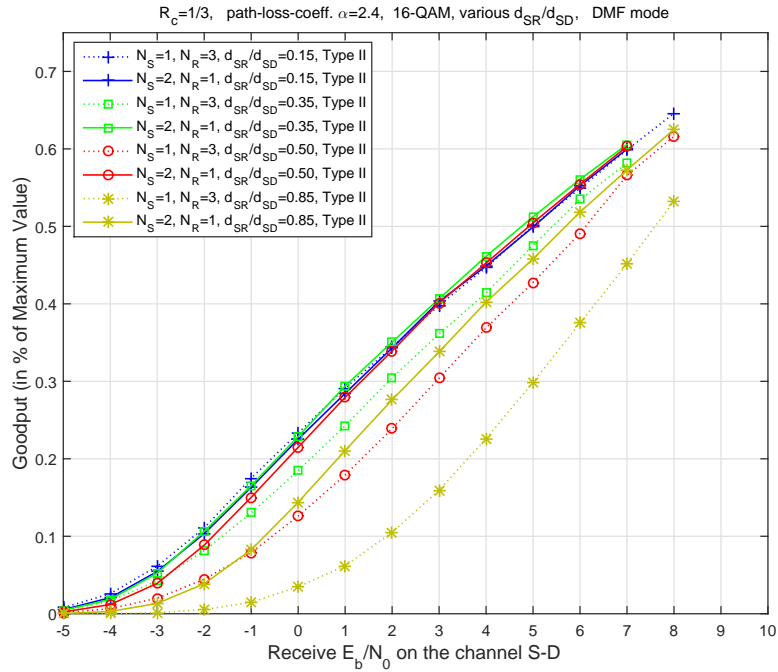

Figure 3.12: Goodput for various N_S and N_R and for various location of the Relay

3.4.2 Simulation of the protocol, DCF mode

Let us now turn to the case when Relay works on Decode-and-Forward (DCF) mode. As mentioned on Chapter 2, the Relay in this mode receives the sequence, demodulates, decodes and uses CRC for detection of possible errors, and the Relay would be allowed to retransmit only if it has the correct copy. Because of that, this mode brings higher diversity than the Relay working on DMF mode, but this implementation has higher cost due to the requirement of employing complex decoding algorithms and more consuming energy.

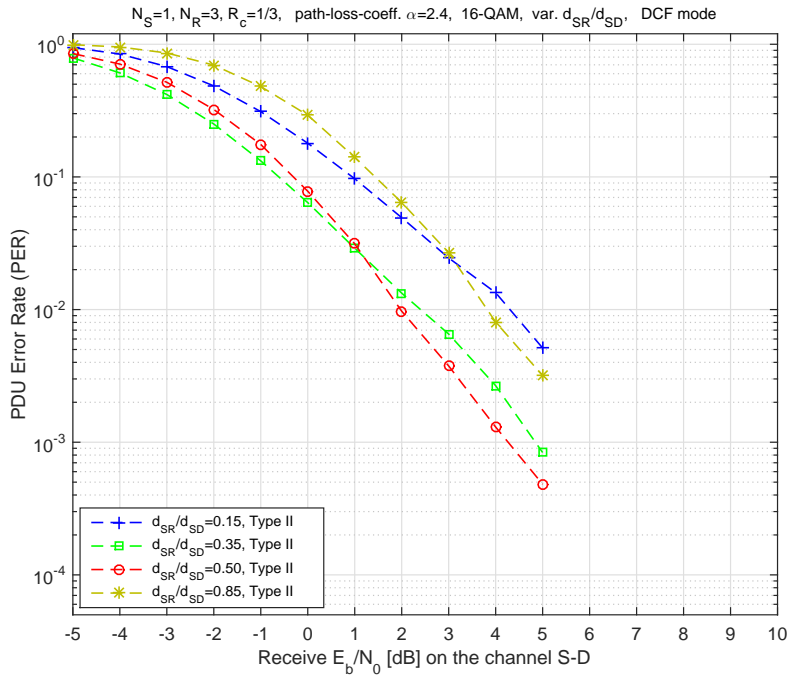

Figure 3.13: Comparison of PER, various location of the Relay, DCF mode

Since the channels S-D and R-D suffer from noise of the same distribution and same noise spectral density N_0 , and considering that Relay would have the correct copy to retransmit, then in this case the grant of retransmission always should be given to the Relay as it has shorter distance (compared with Source) toward the Destination. Let us consider the case when the maximum number of transmissions per PDU is limited to 4, according to the following (re)transmission strategy: the first transmission always belong to the Source, and all the remaining retransmissions (from total of 4 transmissions per PDU) belong to the Relay as soon as it is able to decode correctly the copy coming from the Source. At any time that Relay could not decode the copy from Source, then it would be Source who will retransmit again, and the cycle repeats until either an ACK is issued from D or the limit of

maximum number of transmissions per PDU is reached (in this case 4). So, Relay can retransmit the same PDU in maximum 3 times, and in minimum 0 retransmissions (in the case when it could never decode the copy from S). The comparison of PER for various location of the Relay is shown in Figure 3.13. As we may see, as the channel is bad the best performance it is achieved when Relay is located at distance $d_{SR}/d_{SD} = 0.35$, while as the channel improves ($E_b/N_0 > 1$) we see that the best performance it is achieved when Relay is located in the middle of distance S-D ($d_{SR}/d_{SD} = 0.50$). Once again, the optimized location counts for the trade-off between the ability of the Relay decoder to decode correctly the copy from Source, and the probability to succeed on the remaining distance R-D. It is interesting that when the channel is bad, the worst location seems to be $d_{SR}/d_{SD} = 0.85$ (when Relay is located close to the Destination), but as the channel improves we see that the performance achieved at this location outperforms the case when Relay is located close to the Source. This is reasonable as an improve on the channel conditions increases the chances of correct decoding on the Relay, and the probability of success on the channel R-D is high as the distance is very short. The same behaviour and tendency as with PER we observe when we compare the Goodput, as it is shown in Figure 3.14.

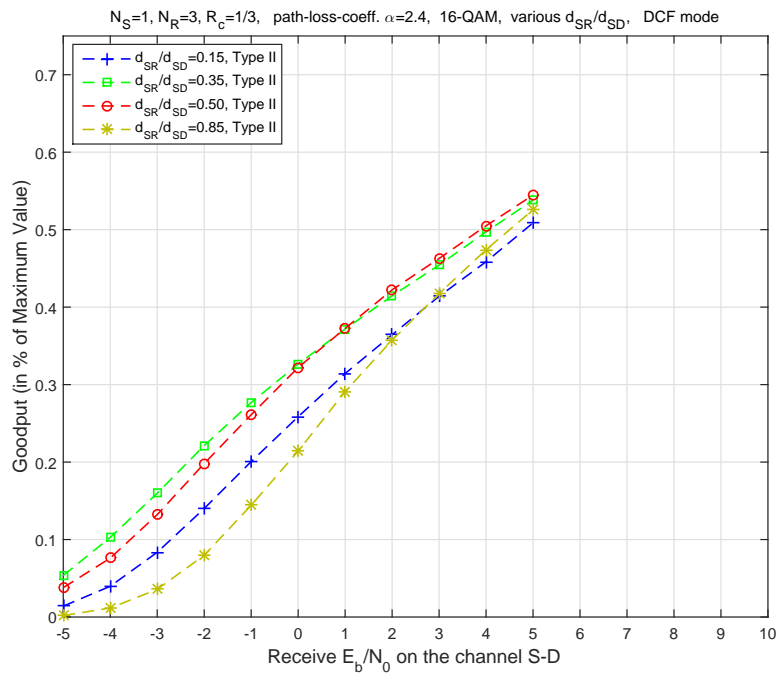

Figure 3.14: Comparison of Goodput, various location of the Relay, DCF mode

In addition to Figures 3.13 and 3.14 for comparison of PER and Goodput, respectively, in Figure 3.15 we have shown the comparison of total average number of

transmissions per PDU, \bar{T} , and also the average number of transmissions performed by S and R, respectively, that will bring more information on drawing conclusions related to the behaviour of the protocol for various location of the Relay. As we may see from this Figure, when the channel is bad the lowest \bar{T} it is achieved when Relay is located at distance $d_{SR}/d_{SD} = 0.35$, while as the channel improves we see that Relay at location $d_{SR}/d_{SD} = 0.50$ behaves slightly better.

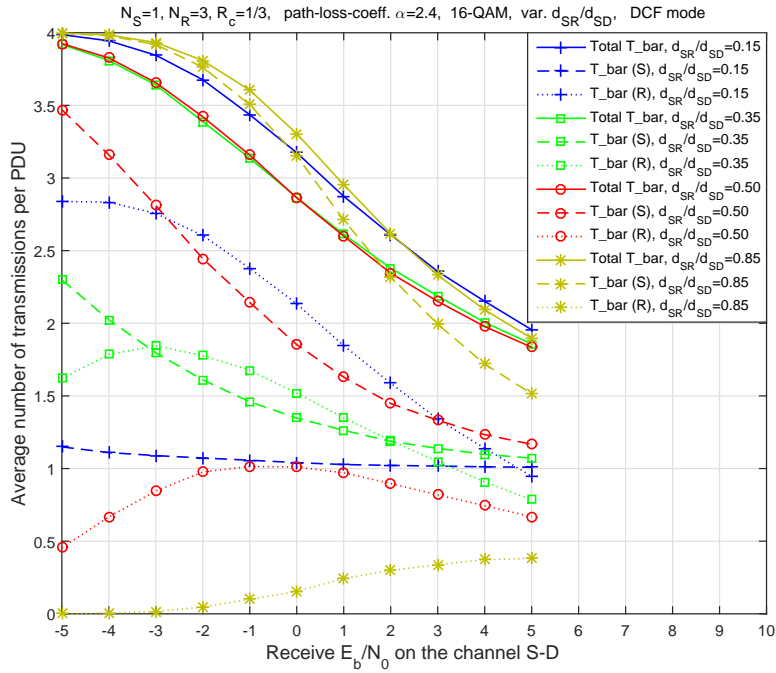

Figure 3.15: Comparison of average number of transmissions, various location of the Relay, DCF mode

3.5 Conclusions

In this Chapter we have introduced a deterministic protocol on a cooperative network containing one Source, one Relay and one Destination. We have introduced a framework for performance evaluation of this protocol, that can be applied very easily to other deterministic protocols, too. We have shown that Finite State Machines (FSM) and Finite State Markov Chains (FSMC) are very efficient tools for modeling the behaviours of communication protocols, and predict their performance. We have provided analysis for both types of decoders, type I and type II, and also for both working modes of the Relay, Demodulate-and-Forward (DMF) mode and Decode-and-Forward (DCF) mode. Thanks to the structure of the probabil-

ity transition matrices of these protocols that contain trees, we have proposed an alternative way for obtaining the steady-state vector which is needed for evaluation of performance metrics. Numerical results show that the theoretical prediction matches very accurately with simulation results. Here is also addressed the optimization of deterministic protocols by trying any possible combination of the number of retransmissions among the transmitting nodes, when the total maximum number of transmissions per PDU is limited. Similar optimization procedures are performed for various locations of the Relay, based on which there is also found the optimized location and optimized values of protocol parameters.

State aggregation on the FSMC

Contents

4.1	Introduction	43
4.2	Aggregation method of Markov Chain	44
4.3	State aggregation for HARQ on a S-D link	47
4.4	State aggregation for HARQ on a S-R-D network, DMF mode	48
4.5	State aggregation for HARQ on a S-R-D network, DCF mode	52
4.6	Conclusions	52

4.1 Introduction

In Chapter 3 we have seen how we can apply Markov Chain (MC) to model behaviour of the deterministic communication protocols and evaluate its performance. But, the applications of Markov Chains are much more than that: it finds wide range of application in Computer Science, too. The Google Company uses a MC based algorithm called PageRank (PR) that is used for ranking the websites in their search engine results [Brin 1998]. Other applications in Computer Science include the use of MC to locate bottlenecks in communication network and to assess the benefit of increasing the number of CPUs (Central Processing Unit) in multiprocessor systems [Stewart 1994]. But, beside the applications of MC in Telecommunications, Computer Science and other areas of engineering, MC finds application in other disciplines, like biology, genetics, agriculture, economics, etc [Dayar].

In some applications, it is very common that for modeling some behaviours there are needed a large number of states. As a result, it is not always easy to evaluate the steady state vector (3.10) that is needed for performance evaluation or gathering needed information, because the computations become very heavy. Therefore, to avoid the problem of heavy computations, there is proposed the aggregation of states in Markov chain which has been subject of interest for many years [Sterck 2008]. To this, it has helped the fact that the transition matrix of Markov chain are often sparse and possess specific structure [A. Gambin].

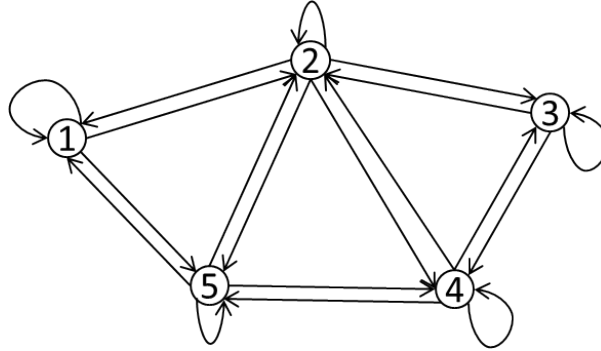

Figure 4.1: Original FSMC

In this Chapter we will show how can be done the aggregation of states in a general ergodic Markov chain. Then, we will show how we can apply this method on aggregating the states of FSMC for our deterministic protocols in S-R-D network discussed in Chapter 3.

4.2 Aggregation method of Markov Chain

Consider a FSMC (\mathcal{S}, P) defined by a state set $\mathcal{S} = \{1, \dots, L\}$ and a transition matrix P . We want to aggregate multiple states of (\mathcal{S}, P) to obtain a new FSMC (\mathcal{T}, Z) with state set $\mathcal{T} = \{1, 2, \dots, M\}$, with $M < L$, and transition matrix Z . For better understanding on how the aggregation process can be done, we consider an example with $L = 5$ and $M = 3$. In Figure 4.1 it is shown the original FSMC with five states. We consider that the chain is ergodic, i.e. from every state it is possible to go to every other state, not necessarily in one move. The transition probability from State i to State j it is denoted with P_{ij} . Then, the transition matrix P of the original FSMC takes the form

$$P = \begin{bmatrix} P_{11} & P_{12} & P_{13} & P_{14} & P_{15} \\ P_{21} & P_{22} & P_{23} & P_{24} & P_{25} \\ P_{31} & P_{32} & P_{33} & P_{34} & P_{35} \\ P_{41} & P_{42} & P_{43} & P_{44} & P_{45} \\ P_{51} & P_{52} & P_{53} & P_{54} & P_{55} \end{bmatrix} \quad (4.1)$$

We want to obtain a new FSMC with three states that is obtained by the following rules:

- *State 1* of the original FSMC is not aggregated, and on the new FSMC it gets renamed as *State 1'*;
- *States 2, 3 and 4* are aggregated to a single new state, that is named *State 2'* on the new FSMC;

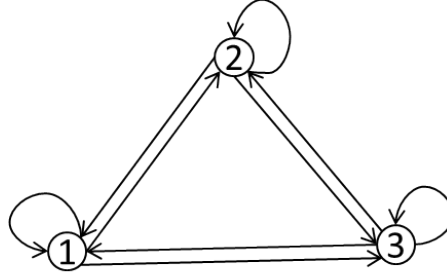

Figure 4.2: New FSMC by aggregating states of the original FSMC

- State 5 of the original FSMC is not aggregated, and on the new FSMC it gets renamed as *State 3'*

The new FSMC that is obtained by aggregating the states of the original FSMC now can be drawn as in Figure 4.2, with a transition matrix Z :

$$Z = \begin{bmatrix} Z_{1'1'} & Z_{1'2'} & Z_{1'3'} \\ Z_{2'1'} & Z_{2'2'} & Z_{2'3'} \\ Z_{3'1'} & Z_{3'2'} & Z_{3'3'} \end{bmatrix} \quad (4.2)$$

During the aggregation process, we are interested in imposing the following constraint on the steady state vectors \mathbf{p} and \mathbf{z} of the FSMCs (\mathcal{S}, P) and (\mathcal{T}, Z) , respectively. Let I be the state in (\mathcal{T}, Z) resulting from the aggregation of the set of states $\mathcal{I} \subseteq \mathcal{S}$ of (\mathcal{S}, P) . Let J and \mathcal{J} be defined similarly. Then the steady state probability z_I of state I is the sum of the steady state probabilities p_i , $i \in \mathcal{I}$

$$z_I = \sum_{i \in \mathcal{I}} p_i. \quad (4.3)$$

Once the aggregation rules are defined, then the main task in the aggregation process is to evaluate the transition probabilities on the new FSMC. Apparently, these new transition probabilities, Z_{IJ} , can be evaluated by the original transition probabilities, P_{ij} , which we assume that we know. Let us consider that we want to show the evaluation of probability $Z_{2'2'}$ and then the other probabilities can be obtained in similar way. Thus, the probability $Z_{2'2'}$ can be written as:

$$Z_{2'2'} = \frac{Pr[2', 2']}{Pr[2']} \quad (4.4)$$

Considering that the new state named as *State 2'* is composed of the original states *State 2, 3 and 4*, then the transition probability $Z_{2'2'}$ can be rewritten as:

$$Z_{2'2'} = Pr[\{2, 3, 4\} | \{2, 3, 4\}] = \frac{Pr[\{2, 3, 4\}, \{2, 3, 4\}]}{Pr[2, 3, 4]} \quad (4.5)$$

The expression on the numerator can be expanded as:

$$\begin{aligned} Pr[\{2, 3, 4\}, \{2, 3, 4\}] &= Pr[2, 2] + Pr[3, 2] + Pr[4, 2] + Pr[2, 3] + Pr[3, 3] + \\ &+ Pr[4, 3] + Pr[2, 4] + Pr[3, 4] + Pr[4, 4] \end{aligned} \quad (4.6)$$

while, the expression on the denominator can be expanded as:

$$Pr[2, 3, 4] = Pr[2] + Pr[3] + Pr[4] \quad (4.7)$$

Then, by applying Bayes' Theorem to each component of equation (4.6), we get:

$$\begin{aligned} Pr[2, 2] &= Pr[2] \cdot Pr[2|2], \quad Pr[3, 2] = Pr[2] \cdot Pr[3|2], \quad Pr[4, 2] = Pr[2] \cdot Pr[4|2] \\ Pr[2, 3] &= Pr[3] \cdot Pr[2|3], \quad Pr[3, 3] = Pr[3] \cdot Pr[3|3], \quad Pr[4, 3] = Pr[3] \cdot Pr[4|3] \\ Pr[2, 4] &= Pr[4] \cdot Pr[2|4], \quad Pr[3, 4] = Pr[4] \cdot Pr[3|4], \quad Pr[4, 4] = Pr[4] \cdot Pr[4|4] \end{aligned} \quad (4.8)$$

We repeat here that the term $Pr[j|i]$ is interpreted as *Probability (transitting to State j / knowing that we are on State i)*, which probabilities for the original FSMC are assumed to be known. Moreover, the equation (4.7) can be interpreted as the *Probability of being in new state 2'* or equivalently *Probability of being jointly in the original States 2, 3 and 4*. In other words, these probabilities represent the steady-state probabilities of being in the corresponding states, and therefore can be substituted with the following equation:

$$Pr[2, 3, 4] = p_2 + p_3 + p_4 \quad (4.9)$$

Then, in general case, the elements of the simplified transition matrix Z can be obtained with the following expression [Sterck 2008]:

$$Z_{IJ} = \frac{\sum_{i \in \mathcal{I}} p_i \left(\sum_{j \in \mathcal{J}} P_{ij} \right)}{\sum_{i \in \mathcal{I}} p_i}. \quad (4.10)$$

The same operation can be described in more compact form as follows. Define the binary matrix T of size $M \times L$, and such that

$$T_{Ii} = \begin{cases} 1 & \text{if original state } i \text{ absorbed in new state } I \\ 0 & \text{otherwise.} \end{cases} \quad (4.11)$$

Then,

$$Z = T^T P \text{diag}(\mathbf{p}) T \text{diag}(T^T \mathbf{p})^{-1}. \quad (4.12)$$

where the superscript T represent the *matrix transpose operation*.

We note here that since the state aggregation process requires the knowledge of the steady state vector of the original FSMC, then the solution of reducing size of the matrix does not seem the best one on the first sight, because one of the

reasons behind the state aggregation is to avoid heavy calculations to obtain the steady state vector. But, since the transition matrixes that we are dealing with are most of the time with sparse structure, then we can apply the alternative way to obtain the steady state vector as described in subsection 3.2.4. Moreover, behind the reasons for state aggregation could be not only the reduction of heavy computations for obtaining the steady state vector, but also to get more information about the process that Markov chain has been used to model. As we will see later on the next chapter, from the state aggregation process we can associate many ideas that could be applied in many situations that shows improvement compared to the original idea before aggregation.

4.3 State aggregation for HARQ on a S-D link

Let us consider the case when we use FSMC for modeling only the communication between the Source and the Destination. In this scenario, it will be only Source who will (re)transmit. Considering that the maximum number of transmissions per PDU is an arbitrary number N_S , the transition matrix $P_{S,I}$ for the case of type I decoder, in line with representation (3.11), takes the form:

$$P_{S,I} = \begin{bmatrix} 1 - \pi_{[1,0]} & 0 & \pi_{[1,0]} & 0 & \cdots \\ 1 - \pi_{[1,0]} & 0 & \pi_{[1,0]} & 0 & \cdots \\ 1 - \pi_{[1,0]} & 0 & 0 & \pi_{[1,0]} & \cdots \\ \vdots & \vdots & \vdots & \vdots & \ddots \\ 1 - \pi_{[1,0]} & \pi_{[1,0]} & 0 & 0 & \cdots \end{bmatrix} \quad (4.13)$$

The states of the transition matrix are indexed from 0 to N_S , and as explained earlier, *State 0* and *State 1* represent the initial state after the last PDU is ACK-ed and NACK-ed, respectively. This split is applied in order to make possible the evaluation of performance metrics, and in order to keep unchanged the performance metrics on the simplified FSMC, we will not touch the initial states during the aggregation process. In other words, we will aggregate only the states associated with the retransmissions, i.e. we will aggregate the *States 2, 3, ..., N_S* to a single state, named here as *State 2'*. So, the resulting simplified transition matrix will contain only three states. Following the equation (4.10) for evaluation of transition probabilities on the new FSMC, the simplified transition matrix $Z_{S,I}$ takes the form:

$$Z_{S,I} = \begin{bmatrix} 1 - \pi_{[1,0]} & 0 & \pi_{[1,0]} \\ 1 - \pi_{[1,0]} & 0 & \pi_{[1,0]} \\ Z_{2',0'} & Z_{2',1'} & Z_{2',2'} \end{bmatrix} \quad (4.14)$$

The elements $Z_{2',0'}$, $Z_{2',1'}$ and $Z_{2',2'}$ are probabilities that are obtained as a result of aggregation, but in order to link every state transition of the new FSMC with

parameter $\pi_{[1,0]}$, we can rewrite it on the following form:

$$Z_{S,I} = \begin{bmatrix} 1 - \pi_{[1,0]} & 0 & \pi_{[1,0]} \\ 1 - \pi_{[1,0]} & 0 & \pi_{[1,0]} \\ 1 - \pi_{[1,0]} & \alpha \cdot \pi_{[1,0]} & (1 - \alpha) \cdot \pi_{[1,0]} \end{bmatrix} \quad (4.15)$$

where, α is a parameter that link the original transition matrix (4.13) and the simplified transition matrix (4.15), and for equivalence between the two matrixes takes the form:

$$\alpha = \frac{\pi_{[1,0]}^{N_S-1}}{\sum_{k=1}^{N_S-1} \pi_{[1,0]}^{N_S-k}} \quad (4.16)$$

With α evaluated with equation (4.16), it is guaranteed that the relationship (4.3) between the two steady state vectors holds.

4.4 State aggregation for HARQ on a S-R-D network, DMF mode

Let us consider that we have a scenario of cooperative network containing one S, one R and one D, when R works in DMF mode. As explained on Chapter 3, the deterministic protocol with arbitrary number of maximum transmissions from S, N_S , and with arbitrary number of maximum successive retransmissions from R for each transmission from S, N_R , can be described by a FSMC and represented with a transition matrix of dimensions $(N_S \cdot N_R + N_S + 1) \times (N_S \cdot N_R + N_S + 1)$, which for the type I decoder takes the form:

$$P_{R,I} = \begin{bmatrix} 1 - \pi_{[1,0]} & 0 & \pi_{[1,0]} & 0 & \cdots & 0 & \cdots \\ 1 - \pi_{[1,0]} & 0 & \pi_{[1,0]} & 0 & \cdots & 0 & \cdots \\ 1 - \pi_{[0,1]} & 0 & 0 & \pi_{[0,1]} & \cdots & 0 & \cdots \\ \vdots & \vdots & \vdots & \vdots & \ddots & \vdots & \ddots \\ 1 - \pi_{[1,0]} & 0 & 0 & 0 & \cdots & \pi_{[1,0]} & \cdots \\ \vdots & \vdots & \vdots & \vdots & \ddots & \vdots & \ddots \\ 1 - \pi_{[0,1]} & \pi_{[0,1]} & 0 & 0 & \cdots & 0 & \cdots \end{bmatrix}. \quad (4.17)$$

As we have explained earlier, each state of the FSMC it is associated with an action from the transmitter (ST, RRT or SRT). Therefore, in our analysis we want to aggregate only the states with the same actions, according to the following rules:

- State 0 and State 1 remain unchanged and are not aggregated;
- States associated with action *Relay Retransmit (RRT)* within each cycle¹ are aggregated to separate states: States of the first cycle with indexes $\{2, 3, 4, \dots, N_R +$

¹A cycle means a round of successive retransmissions from R after a (re)transmission from S.

1} are aggregated into a single state named here as *State 2'*, States of the second cycle with indexes $\{N_R + 3, N_R + 4, \dots, 2(N_R + 1)\}$ are aggregated to another single state named *State 4'*, and the process is repeated within each cycle in the same way;

- States associated with action *Source Retransmit (SRT)* are only rearranged within the transition matrix and change only the indexes: i.e. *State* $N_R + 2$ at the original FSMC now is renamed as *State 3'*, and the process continues on the same way.

After the aggregation, the transition matrix takes the form:

$$Z_{R,I} = \begin{bmatrix} 1 - \pi_{[1,0]} & 0 & \pi_{[1,0]} & 0 & 0 & 0 & \cdots & 0 \\ 1 - \pi_{[1,0]} & 0 & \pi_{[1,0]} & 0 & 0 & 0 & \cdots & 0 \\ \rho_1 & 0 & \rho_2 & \rho_3 & 0 & 0 & \cdots & 0 \\ 1 - \pi_{[1,0]} & 0 & 0 & 0 & \pi_{[1,0]} & 0 & \cdots & 0 \\ \rho_1 & 0 & 0 & 0 & \rho_2 & \rho_3 & \cdots & 0 \\ \vdots & \vdots & \vdots & \vdots & \vdots & \vdots & \ddots & \vdots \\ 1 - \pi_{[1,0]} & 0 & 0 & 0 & 0 & 0 & \cdots & \pi_{[1,0]} \\ \rho_1 & \rho_3 & 0 & 0 & 0 & 0 & \cdots & \rho_2 \end{bmatrix} \quad (4.18)$$

where, ρ_1 , ρ_2 and ρ_3 are probabilities that are obtained as a result of aggregation. But, in order to link these probabilities with parameter $\pi_{[0,1]}$, we can rewrite it on the following form:

$$Z_{R,I} = \begin{bmatrix} 1 - \pi_{[1,0]} & 0 & \pi_{[1,0]} & 0 & 0 & 0 & \cdots & 0 \\ 1 - \pi_{[1,0]} & 0 & \pi_{[1,0]} & 0 & 0 & 0 & \cdots & 0 \\ 1 - \pi_{[0,1]} & 0 & (1 - \gamma) \pi_{[0,1]} & \gamma \pi_{[0,1]} & 0 & 0 & \cdots & 0 \\ 1 - \pi_{[1,0]} & 0 & 0 & 0 & \pi_{[1,0]} & 0 & \cdots & 0 \\ 1 - \pi_{[0,1]} & 0 & 0 & 0 & (1 - \gamma) \pi_{[0,1]} & \gamma \pi_{[0,1]} & \cdots & 0 \\ \vdots & \vdots & \vdots & \vdots & \vdots & \vdots & \ddots & \vdots \\ 1 - \pi_{[1,0]} & 0 & 0 & 0 & 0 & 0 & \cdots & \pi_{[1,0]} \\ 1 - \pi_{[0,1]} & \gamma \pi_{[0,1]} & 0 & 0 & 0 & 0 & \cdots & (1 - \gamma) \pi_{[0,1]} \end{bmatrix} \quad (4.19)$$

where, γ is a parameter that links the matrixes (4.18) and (4.19) and is expressed as:

$$\gamma = \frac{\pi_{[0,1]}^{N_R}}{\pi_{[0,1]} + \pi_{[0,1]}^2 + \pi_{[0,1]}^3 + \cdots + \pi_{[0,1]}^{N_R}}, \quad (4.20)$$

So far, we have aggregated only the states associated with action RRT within each cycle, and as a result for each cycle we have only two states, one associated with action SRT and another associated with action RRT. But, since even within each cycle the action is associated with the same node, then we can make another aggregation which we call as *phase 2 of aggregation* such that:

- We aggregate all the states with the action RRT among all cycles to a single state which we will call *State 2''*;

- We aggregate all the states with the action SRT among all cycles to a single state which we will call *State 3''*.

So, the final simplified transition matrix will contain only four states and can be written in the following form:

$$Z_{R,I} = \begin{bmatrix} 1 - \pi_{[1,0]} & 0 & \pi_{[1,0]} & 0 \\ 1 - \pi_{[1,0]} & 0 & \pi_{[1,0]} & 0 \\ 1 - \pi_{[0,1]} & \gamma \cdot \beta \pi_{[0,1]} & (1 - \gamma) \pi_{[0,1]} & \gamma (1 - \beta) \pi_{[0,1]} \\ 1 - \pi_{[1,0]} & 0 & \pi_{[1,0]} & 0 \end{bmatrix}. \quad (4.21)$$

where, we see that as a result of second aggregation we have obtained another parameter, β , that links matrixes (4.19) and (4.21) and is expressed as:

$$\beta = \left(1 + \sum_{t_S=1}^{N_S-1} \left(\frac{1}{\pi_{[1,0]}^{t_S} \cdot \pi_{[0,1]}^{t_S \cdot N_R}} \right) \right)^{-1}. \quad (4.22)$$

As we will see on the next Chapter, the parameters γ and β we can associate with a meaningful definition that allows new ideas and new protocols to be applied.

Let us now turn to the case of type II decoder. The probability transition matrix of the same scenario and same protocol in this case takes the form:

$$P_{R,II} = \begin{bmatrix} 1 - \pi_{[1,0]} & 0 & \pi_{[1,0]} & 0 & \cdots & 0 & \cdots \\ 1 - \pi_{[1,0]} & 0 & \pi_{[1,0]} & 0 & \cdots & 0 & \cdots \\ 1 - \pi_{[1,1]} & 0 & 0 & \pi_{[1,1]} & \cdots & 0 & \cdots \\ \vdots & \vdots & \vdots & \vdots & \ddots & \vdots & \ddots \\ 1 - \pi_{[1,N_R]} & 0 & 0 & 0 & \cdots & \pi_{[1,N_R]} & \cdots \\ \vdots & \vdots & \vdots & \vdots & \ddots & \vdots & \ddots \\ 1 - \pi_{[N_S, N_S N_R]} & \pi_{[N_S, N_S N_R]} & 0 & 0 & \cdots & 0 & \cdots \end{bmatrix}, \quad (4.23)$$

Following the same rules of aggregation like for the case of type I decoder, by aggregating states with the same actions, the simplified transition matrix takes the form:

$$Z_{R,II} = \begin{bmatrix} 1 - \pi_{[1,0]} & 0 & \pi_{[1,0]} & 0 \\ 1 - \pi_{[1,0]} & 0 & \pi_{[1,0]} & 0 \\ Z_{20} & Z_{21} & Z_{22} & Z_{23} \\ Z_{30} & 0 & Z_{32} & 0 \end{bmatrix} \quad (4.24)$$

where, Z_{20} , Z_{21} , Z_{22} , Z_{23} , Z_{30} and Z_{32} are probabilities with respect to other states that are obtained as a result of aggregation, using equation (4.10). The matrix can be expressed also in the following form:

$$Z_{R,II} = \begin{bmatrix} 1 - \pi_{[1,0]} & 0 & \pi_{[1,0]} & 0 \\ 1 - \pi_{[1,0]} & 0 & \pi_{[1,0]} & 0 \\ 1 - \pi_{[RF]} & \gamma \cdot \beta \pi_{[RF]} & (1 - \gamma) \pi_{[RF]} & \gamma (1 - \beta) \pi_{[RF]} \\ 1 - \pi_{[SF]} & 0 & \pi_{[SF]} & 0 \end{bmatrix}. \quad (4.25)$$

4.4. State aggregation for HARQ on a S-R-D network, DMF mode 51

where, $\pi_{[RF]}$ and $\pi_{[SF]}$ represent the *average* probability of failure in decoding at D after the reception of a retransmission from R and from S, respectively. These probabilities and the parameters γ and β in this case follow the relationship:

$$\pi_{[RF]} = Z_{21} + Z_{22} + Z_{23} \quad (4.26)$$

$$\pi_{[SF]} = Z_{32} \quad (4.27)$$

$$\gamma = \frac{Z_{21} + Z_{23}}{Z_{21} + Z_{22} + Z_{23}} \quad (4.28)$$

$$\beta = \frac{Z_{21}}{Z_{21} + Z_{23}} \quad (4.29)$$

The aggregated probabilities on matrix (4.24) can be obtained also using combinatorial approach, as follow:

$$Z_{20} = \frac{\sum_{1 \leq t_S \leq N_S} \sum_{1 \leq t_R \leq N_R} [p_{[(t_S-1)N_R+t_S+t_R]} \cdot (1 - \pi_{[t_S, (t_S-1)N_R+t_R]})]}{\sum_{1 \leq t_S \leq N_S} \sum_{1 \leq t_R \leq N_R} p_{[(t_S-1)N_R+t_S+t_R]}} \quad (4.30)$$

$$Z_{30} = \frac{\sum_{2 \leq t_S \leq N_S} [p_{[(t_S-1)N_R+t_S]} \cdot (1 - \pi_{[t_S, (t_S-1)N_R]})]}{\sum_{2 \leq t_S \leq N_S} p_{[(t_S-1)N_R+t_S]}} \quad (4.31)$$

$$Z_{21} = \frac{\prod_{1 \leq t_S \leq N_S} \left(\prod_{(t_S-1)N_R \leq t_R \leq t_S \cdot N_R} \pi_{[t_S, t_R]} \right)}{\sum_{1 \leq a \leq N_S} \left\{ \prod_{1 \leq t_S \leq a} \left(\prod_{(t_S-1)N_R \leq t_R \leq (t_S-1)N_R + c_{(a, t_S)}} \pi_{[t_S, t_R]} \right) \right\}} \quad (4.32)$$

$$Z_{22} = \frac{\sum_{1 \leq a \leq N_S} \left\{ \prod_{1 \leq t_S \leq a} \left(\prod_{(t_S-1)N_R \leq t_R \leq (t_S-1)N_R + b_{(a, t_S)}} \pi_{[t_S, t_R]} \right) \right\}}{\sum_{1 \leq a \leq N_S} \left\{ \prod_{1 \leq t_S \leq a} \left(\prod_{(t_S-1)N_R \leq t_R \leq (t_S-1)N_R + c_{(a, t_S)}} \pi_{[t_S, t_R]} \right) \right\}} \quad (4.33)$$

$$Z_{23} = \frac{\sum_{1 \leq a \leq N_S-1} \left\{ \prod_{1 \leq t_S \leq a} \left(\prod_{(t_S-1)N_R \leq t_R \leq t_S \cdot N_R} \pi_{[t_S, t_R]} \right) \right\}}{\sum_{1 \leq a \leq N_S} \left\{ \prod_{1 \leq t_S \leq a} \left(\prod_{(t_S-1)N_R \leq t_R \leq (t_S-1)N_R + c_{(a, t_S)}} \pi_{[t_S, t_R]} \right) \right\}} \quad (4.34)$$

with $b_{(a, t_S)}$ and $c_{(a, t_S)}$ being coefficients that depend on a and t_S and take the following values:

$$b_{(a, t_S)} \in \{1, 2, \dots, N_R - 1\}, \text{ when } t_S = a \quad (4.35)$$

$$b_{(a, t_S)} \in \{1, 2, \dots, N_R\}, \text{ when } t_S \neq a \quad (4.36)$$

$$c_{(a, t_S)} \in \{0, 1, 2, \dots, N_R - 1\}, \text{ when } t_S = a \quad (4.37)$$

$$c_{(a, t_S)} \in \{0, 1, 2, \dots, N_R\}, \text{ when } t_S \neq a \quad (4.38)$$

4.5 State aggregation for HARQ on a S-R-D network, DCF mode

Let us now consider the same scenario, S-R-D network, when the Relay works on DCF mode. As explained earlier, the probability transition matrix in this case takes the form:

$$P_{DCF} = \begin{bmatrix} 1 - \pi_{1,0} & 0 & (1 - \alpha_R) \pi_{1,0} & 0 & \cdots & \alpha_R \pi_{1,0} & \cdots & 0 & 0 & \cdots \\ 1 - \pi_{1,0} & 0 & (1 - \alpha_R) \pi_{1,0} & 0 & \cdots & \alpha_R \pi_{1,0} & \cdots & 0 & 0 & \cdots \\ 1 - \pi_{0,1} & 0 & 0 & \pi_{0,1} & \cdots & 0 & \cdots & 0 & 0 & \cdots \\ \vdots & \vdots & \vdots & \vdots & \ddots & \vdots & \ddots & \vdots & \vdots & \ddots \\ 1 - \pi_{0,1} & 0 & 0 & 0 & \cdots & \pi_{0,1} & \cdots & 0 & 0 & \cdots \\ 1 - \pi_{1,0} & 0 & 0 & 0 & \cdots & 0 & \cdots & \pi_{1,0} & 0 & \cdots \\ 1 - \pi_{1,0} & \alpha_R \pi_{1,0} & 0 & 0 & \cdots & 0 & \cdots & (1 - \alpha_R) \pi_{1,0} & 0 & \cdots \\ 1 - \pi_{0,1} & 0 & 0 & 0 & \cdots & 0 & \cdots & 0 & \pi_{0,1} & \cdots \\ \vdots & \vdots & \vdots & \vdots & \ddots & \vdots & \ddots & \vdots & \vdots & \ddots \\ 1 - \pi_{0,1} & \pi_{0,1} & 0 & 0 & \cdots & 0 & \cdots & 0 & 0 & \cdots \end{bmatrix} \quad (4.39)$$

Following the same idea of aggregating the states with the same actions, the simplified transition matrix takes the form:

$$R_{DCF} = \begin{bmatrix} 1 - \pi_{[1,0]} & 0 & (1 - \alpha_R) \pi_{[1,0]} & \alpha_R \pi_{[1,0]} & 0 \\ 1 - \pi_{[1,0]} & 0 & (1 - \alpha_R) \pi_{[1,0]} & \alpha_R \pi_{[1,0]} & 0 \\ 1 - \pi_{[0,1]} & \gamma \beta \pi_{[0,1]} & (1 - \gamma) \pi_{[0,1]} & 0 & \gamma (1 - \beta) \pi_{[0,1]} \\ 1 - \pi_{[1,0]} & \alpha_R \alpha_S \pi_{[1,0]} & (1 - \alpha_R) \pi_{[1,0]} & \alpha_R (1 - \alpha_S) \pi_{[1,0]} & 0 \\ 1 - \pi_{[1,0]} & 0 & \pi_{[1,0]} & 0 & 0 \end{bmatrix}. \quad (4.40)$$

As we may see, the simplified transition matrix at DCF mode contains five states, one state more than at DMF mode. This is due to the conditioning whether the Relay did or did not correctly decode the copy coming from the Source. Parameters γ and β can be obtained on the same way as explained earlier. The parameter α_R is defined in Chapter 3 as the probability that the Relay could not decode correctly the incoming copy from the Source, while the parameter α_S is a new parameter that is obtained as a result of aggregation and depend entirely on the value of N_S . Since in our analysis we will focus more on the DMF mode, for the details on how to obtain this parameter can be followed on the same logical way how the other parameters are obtained on the last subsection.

4.6 Conclusions

In this Chapter we have addressed the issue of state aggregation in Markov Chain. Since in our case we have used FSMC for assessing performance of the protocols, we have shown how the state aggregation can be done mathematically and how it can be applied in our case. By choosing a strategy that only the states with the same

actions can be aggregated, we have shown that the simplified transition matrices can be used to evaluate very effectively performance of the protocols. The aggregation procedure is discussed for both, DCF and DMF, focusing more on the latter, and also for both types of decoders. Most important, the simplified transition matrices provided as a function of some new parameters allows association to some new protocols that will be introduced on the next chapter.

Probabilistic HARQ transmission protocols for cooperative networks

Contents

5.1	Introduction	55
5.2	Association of simplified FSMC with a probabilistic protocol	56
5.2.1	A general simplified FSM	56
5.2.2	Parameter optimization for the probabilistic protocol	58
5.3	Probabilistic protocol, type I decoder	59
5.3.1	Numerical results	62
5.4	Probabilistic protocol, type II decoder	68
5.4.1	The probabilistic protocol with Type II decoder with limited buffer	68
5.4.2	Description of the probabilistic protocol with a limited-buffer Type II decoder using a FSMC	69
5.4.3	Numerical results	73
5.4.4	Comparison with a referent deterministic protocol	77
5.5	Alternative probabilistic protocol	81
5.5.1	Numerical results	83
5.6	Conclusions	85

5.1 Introduction

In Chapter 3 we have discussed deterministic protocols and its representation via FSMC. Since the size of the matrix increases as the protocol becomes more sophisticated or as the number of nodes on the network increases, the performance evaluations involve heavy computations. As an alternative to reduce the complexity of computations and to get more information, in Chapter 4 we have introduced a way on how to aggregate states of the finite-state Markov chain of the deterministic protocol. Knowing that during the aggregation we were careful on aggregating only the states with the same actions, then even on the simplified transition matrix the number of actions remains the same. What changes here is that now some transitions become probabilistic. This structure of FSMC where each state is still

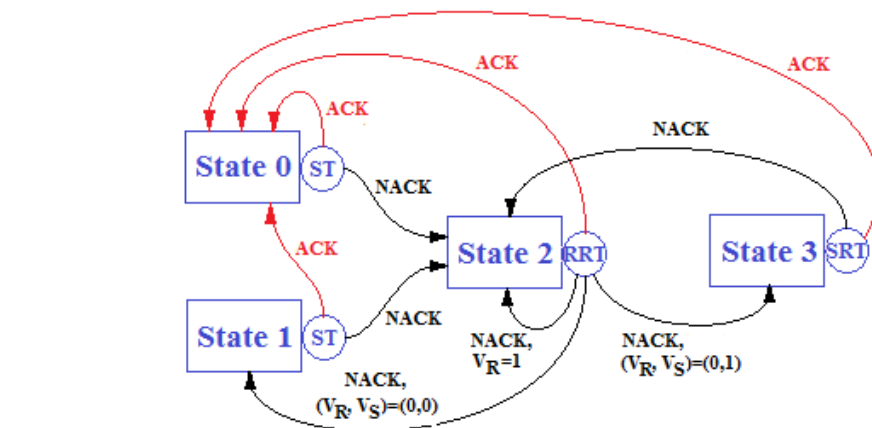

Figure 5.1: Probabilistic protocol represented by FSM on the transmitter

associated with an action, makes possible to associate it with a probabilistic protocol, i.e. the retransmitting node will be chosen probabilistically. As we will see, these protocols are easier to implement, analyze and optimize, such that their performance can never be lower than of deterministic protocols. In certain conditions, their performance exceeds those of deterministic protocols. We note here that in our analysis we will focus mainly on DMF mode, due to its simplicity in implementation. Moreover, in DMF mode the Relay would have always information to transmit and therefore it is more interesting to check to which node we should give the priority of retransmission. While, at DCF mode, any time that Relay has the correct copy, it should be given the right to retransmit due to its shorter distance with the Destination, as discussed in Chapter 3, section 3.4.2.

5.2 Association of simplified FSMC with a probabilistic protocol

5.2.1 A general simplified FSM

Let us take a look at the transition matrixes for both type of decoders, (4.21) and (4.25). We see that both matrixes are function of parameters γ and β . These parameters can be obtained by the aggregation procedure for type I and type II, respectively, and to which we can give the following interpretation: γ , is the probability that the Relay will not retransmit in the next time-slot knowing that it performs the current retransmission, and β , is the probability that the Source will not retransmit in the next time-slot, knowing that in the current time-slot the Relay is transmitting and will not be allowed to transmit in the next time-slot. Then, the probabilistic protocol for both types of decoders can be described by the FSM in Figure 5.1. As we may see from the FSM scheme, the transitions from States 0 and 1 are determined by the observed control message issued by D (ACK or NACK) only.

Table 5.1: Definition of states in the probabilistic FSM

State name	State definition	Next action
0	W=ACK	ST
1	$V_R = 0, V_S = 0, W=NACK$	ST
2	$V_R = 1, V_S = 0, W=NACK$	RRT
3	$V_R = 0, V_S = 1, W=NACK$	SRT

The transitions from States 2 and 3 depend hence on the observed control message but also on the realization of two random variables, V_S and V_R . The variable V_R is Bernoulli distributed, with parameter γ . The variable $(V_S|V_R = 0)$ is Bernoulli distributed, with parameter β , and the variable $(V_S|V_R = 1) = 0$ with probability 1. The definition of states on the FSM according to the values taken by V_R and V_S is given in Table 5.1.

The probabilistic protocol described by the probabilistic FSM in Figure 5.1 works as follows. The first transmission of a new information PDU is performed by S. In case retransmissions are needed the following rules are applied.

1. The first retransmission after any (re)-transmission by S is performed by R;
2. if R is retransmitting, the next action is determined by drawing (V_R, V_S) : for $V_R = 1$, R is allowed to retransmit in the next time slot (probability $(1-\gamma)$); for $(V_R, V_S) = (0, 1)$, S is allowed to retransmit in the next time-slot (probability $\gamma(1 - \beta)$);
3. neither R or S are allowed to retransmit in the next time slot (probability $\gamma \cdot \beta$), where $(V_R, V_S) = (0, 0)$. In this case, the current PDU is lost, and S transmits a new PDU for the first time.

Since the States 0 and 1 have been excluded from grouping, and because of the constraint (4.3) imposed in the aggregation procedure, one has that $z_0 = p_0$ and $z_1 = p_1$ for Type I decoder, if the values of parameters γ and β are evaluated properly from the state aggregation procedure of the deterministic protocol with parameters (N_S, N_R) . This equivalence is assured also from the fact that the probabilities of success from S and R, $(1 - \pi_{[1,0]})$ and $(1 - \pi_{[0,1]})$, respectively, remain constant independent of the values of γ and β , because the decoder has no memory. Therefore, knowing these facts, we can conclude that for the case of type I decoder, the probabilistic protocol is at least as good as the deterministic one.

Let us now turn to the case of type II decoder. Since in this case the decoder has memory of the previous copies of the same transmitted PDU, then the probabilities of success from S and from R, $(1 - \pi_{[SF]})$ and $(1 - \pi_{[RF]})$, respectively, depend on the values of γ and β , and this imposes that $z_0 \approx p_0$ and $z_1 \approx p_1$. This means that

for the case of type II decoder, with proper values of γ and β obtained from the aggregation procedure, the performance of the probabilistic protocol can be close to the performance of the deterministic protocol.

Concluding that the performance of probabilistic protocol can be at least as good as of the deterministic one, hence, for our numerical analysis we will focus more on the optimization of the probabilistic protocol.

5.2.2 Parameter optimization for the probabilistic protocol

Having established that the probabilistic protocol for type I decoder is always at least as good as the deterministic protocol, and very close for the case of type II decoder, we turn to the problem of finding the best values of the parameters γ and β in order to optimize the performance. Since the goodput G represents the trade-off between PER and the average number of transmissions per PDU \bar{T} , we want to satisfy the criterion:

$$\max_{\gamma, \beta} G = \max_{\gamma, \beta} R_c \frac{1 - PER}{\bar{T}}. \quad (5.1)$$

Depending on the propagation quality of the physical channels, we can identify two regimes:

1. **Bad medium:** in this regime it is rare event that a PDU can be successfully decoded with few transmissions, therefore decreasing the probability $\gamma \cdot \beta$ of dropping a non-acknowledged PDU causes \bar{T} to increase and PER to decrease. In this region varying the values of γ and β affects the trade-off between PER and \bar{T} .
2. **Good medium:** in this regime it is a rare event that a PDU cannot be successfully decoded with few transmission. Therefore, decreasing the probability $\gamma \cdot \beta$ of dropping a non-acknowledged PDU causes PER to decrease without increasing \bar{T} . Then, since there is no trade-off to be achieved, choosing $\beta \rightarrow 0$, *i.e.* make the drop an almost impossible event, becomes the optimum strategy.

We are hence interested to address the optimization problem (5.1) in the first regime. The problem of identification of the two regimes we will discuss in the subsections of numerical results.

We consider the case of Type I decoder first. Since the decoder processes only the most recent received copy, in (4.21) the average probability of ACK after a retransmission from S, $(1 - \pi_{[1,0]})$, remains constant on each retransmission. We have also assumed that the average probability of ACK after a retransmission from R remains constant, $(1 - \pi_{[0,1]})$. Though this assumption holds in many situations, we will see later that when Relay works on the DMF mode this assumption does not hold at every location of the Relay, because we need to count also for the errors

during the demodulation/re-modulation on the Relay as a result of which the probability $\pi_{[0,1]}$ does not remain constant on successive retransmissions, and especially when the Relay is far from the Source. As a result, we cannot use the aggregated FSMC in (4.21) for performance evaluation at any situation. Therefore, to perform performance prediction and optimization for a wider range of values of (γ, β) for a general case, we have proposed a FSMC model that we will introduce on the Section 5.3.

We now turn to the case of Type II decoder. Since the decoder has memory, in (4.25) the average probabilities $(1 - \pi_{RF})$ and $(1 - \pi_{SF})$ are statistically dependent, via two combinatorial relationships, on the parameters γ and β . For example, for $\beta \rightarrow 1$ the parameter $(1 - \pi_{RF})$ depends only on γ , and can be evaluated as

$$(1 - \pi_{RF}) = \pi_{[1,0]}(1 - \pi_{[1,1]}) + \pi_{[1,0]}(1 - \gamma) \sum_{k=2}^{\infty} \pi_{[1,k-1]}(1 - \pi_{[1,k]}). \quad (5.2)$$

As a result of dependence on parameters γ and β , the matrix (4.25) cannot be used for performance prediction at any situation, because the probabilities will vary according to the number of copies on the decoder. It is clear from (5.2) that the parameters $\pi_{[A,B]}$ for high values of A and B are needed to evaluate good approximations of the combinatorial functions expressing $(1 - \pi_{RF})$ and $(1 - \pi_{SF})$. But, even in this case, on the Subsection 5.4 we have proposed a FSMC model that can be used to predict and optimize very closely performance of the probabilistic protocol.

5.3 Probabilistic protocol, type I decoder

So far, we have introduced the probabilistic protocol, we have discussed how it works and we have modeled it using FSM. But, we need also to have a FSMC that can be used to predict its performance for any situation. For the current FSMC in (4.21), as we have stated earlier, when we have evaluated the probability $\pi_{[0,1]}$ via Monte Carlo simulations, we have assumed that the probability that R fails on its retransmission, $\pi_{[0,1]}$, remains constant independent of how many times successively it has been retransmitting. But, we have observed that for DMF mode this assumption does not hold at every location of the Relay. In other words, the probability that R fails on its first re-transmission, $\pi_{0,1}(1)$, in general would not be the same with the probability that R fails on its second re-transmission, $\pi_{0,1}(2)$, and so on ... To get an idea how do these probabilities change for various location of the Relay, we have simulated them using Monte Carlo simulations, and we have shown them in Figure 5.2. As we may see, as R is located close to S, the probabilities of failure from R for the k -th time, $\pi_{0,1}(k)$, change very slowly as k increases, while as R moves further toward the D, then the probabilities $\pi_{0,1}(k)$, change more rapidly as k increases. Therefore, the matrix (4.21) can be used for very close performance prediction only on the case when R is located close to S.

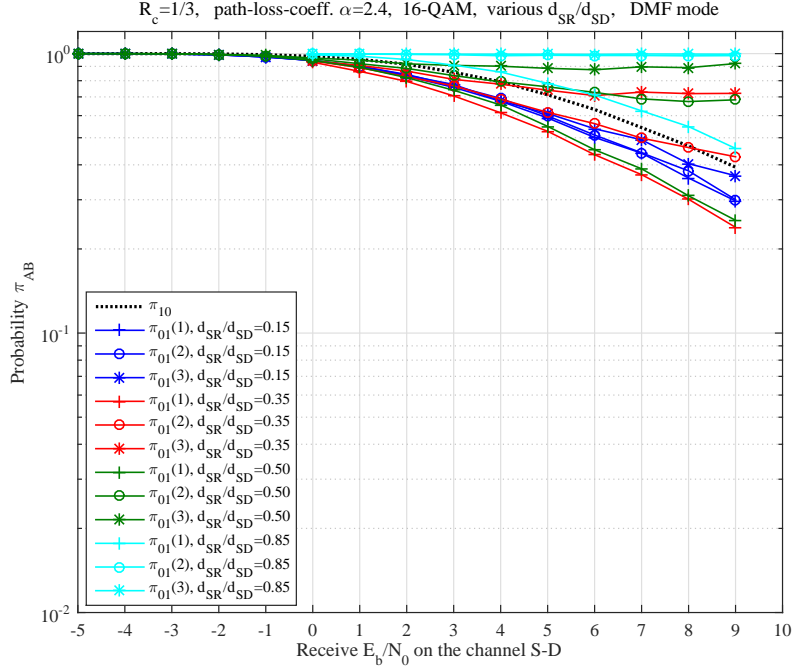

Figure 5.2: Monte Carlo simulation of probabilities $\pi_{1,0}$ and $\pi_{0,1}(k)$, various d_{SR}/d_{SD}

The curves in Figure 5.2 shows us that for exact performance prediction via FSMC, we need to evaluate the probabilities $\pi_{0,1}(k)$ averaging not only over the path S-R-D, but also over the path R-D with a single demodulated copy on the channel S-R, because Relay may or may not have the correct demodulated information to forward. Moreover, this fact tells us that the exact evaluation of probabilities $\pi_{0,1}(k)$ depend on γ , and this is not something we would want. Therefore, we want to develop a FSMC model where the probabilities $\pi_{0,1}(k)$ would not depend on γ and at the same time to allow us a very close performance prediction for any value of γ and β , which we will discuss as follow.

Since the probabilities $\pi_{0,1}(k)$ change very slowly when R is located close to the S, and they change more rapidly (with the upper-bound probability close to 1) as R approaches the D, then we propose to keep track on probability evaluation up to the third successive retransmission from R and then we may assume that after the third retransmission the probability of failure for the k -th retransmission ($k > 3$) remains constant, that is:

$$\pi_{0,1}(k) \approx \pi_{0,1}(3), \quad k > 3 \quad (5.3)$$

In this way, we consider that the performance prediction via FSMC will be very close to the exact prediction.

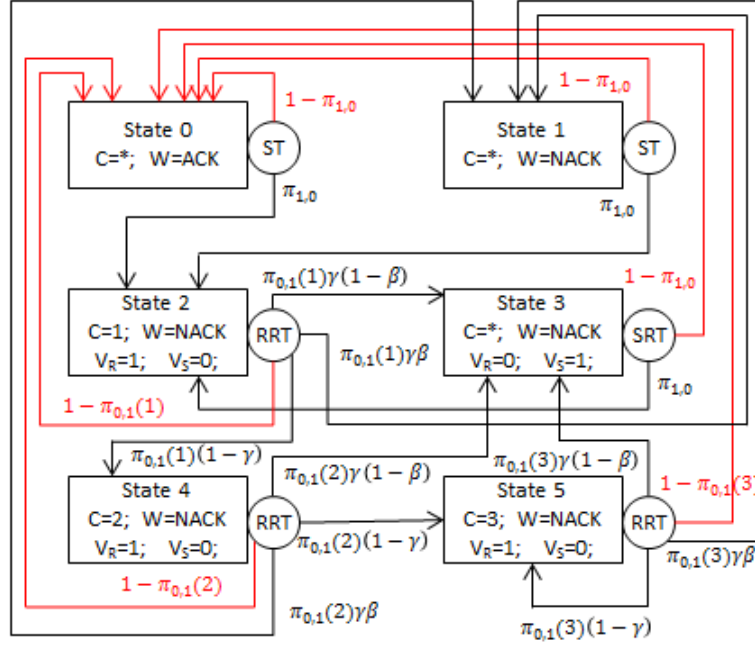

Figure 5.3: FSMC representing the probabilistic protocol, Type I decoder

Under the assumption (5.3), the proposed FSMC is given in Figure 5.3, with the state definitions shown in Table 5.2. As we may see, the parameters of state definitions V_S , V_R and W remain the same as defined for Table 5.1, while here we have added one more parameter, C , which counts the number of successive retransmissions from R after the RRT current action is performed.

Table 5.2: Definition of states in the FSMC of the transmitter, type I decoder

State	State definition	Action
0	$C=*$, $W=ACK$	ST
1	$C=*$, $W=NACK$	ST
2	$C=1$, $V_R = 1$, $V_S = 0$, $W=NACK$	RRT
3	$C=*$, $V_R = 0$, $V_S = 1$, $W=NACK$	SRT
4	$C=2$, $V_R = 1$, $V_S = 0$, $W=NACK$	RRT
5	$C=3$, $V_R = 1$, $V_S = 0$, $W=NACK$	RRT

Following the state transitions with corresponding probabilities on Figure 5.3, then the state transition matrix for type I decoder, $Z_{P,I}$, now takes the general form

of dimensions 6×6 :

$$Z_{P,I} = \begin{pmatrix} 1 - \pi_{1,0} & 0 & \pi_{1,0} & 0 & 0 & 0 \\ 1 - \pi_{1,0} & 0 & \pi_{1,0} & 0 & 0 & 0 \\ 1 - \pi_{0,1}(1) & \gamma\beta\pi_{0,1}(1) & 0 & \cdots & \cdots & \cdots \\ 1 - \pi_{1,0} & 0 & \pi_{1,0} & 0 & 0 & 0 \\ 1 - \pi_{0,1}(2) & \gamma\beta\pi_{0,1}(2) & 0 & \cdots & \cdots & \cdots \\ 1 - \pi_{0,1}(3) & \gamma\beta\pi_{0,1}(3) & 0 & \cdots & \cdots & \cdots \end{pmatrix} \quad (5.4)$$

This FSMC description of probabilistic protocol with Type I decoder allows easy optimization for each value of γ and β .

5.3.1 Numerical results

Here we present the numerical analysis of probabilistic protocol with type I decoder using simulations and FSMC. The physical layer analysis of the links and receiver are discussed in Chapter 2. In our case, we consider Convolutional Coding with code rate $R_c = 1/3$, and we consider 16-QAM modulation. Each information PDU is of length 1000 bits. The average energy per modulated symbol is the same at S and R, $E_s = 1$, and as a result the transmit E_b/N_0 is the same on the channels S-D and R-D. The path-loss exponent is $\alpha = 2.4$. We assume that we know the propagation conditions on the channels S-D, S-R and R-D, where we assume block fading according to Rayleigh distribution and also impaired by complex Gaussian noise with noise density N_0 . The probabilities $\pi_{1,0}$ and $\pi_{0,1}(k)$ for FSMC representation are evaluated using Monte Carlo simulations.

Initially we want to show that we can evaluate the parameters γ and β from the simplification algorithm, such that the performance of probabilistic protocol to be equivalent with that of deterministic protocol. Let us consider the case of having deterministic protocol with $N_S = 2$ and $N_R = 1$, and the values of γ and β are evaluated accordingly with equations (4.20) and (4.22). Figure 5.4 shows the comparison of the PER as a function of receive E_b/N_0 on the channel S-D, achieved with the deterministic and probabilistic protocol. The prediction via FSMC model (4.21) is very accurate with respect to the simulated performance.

Figure 5.5, left y axis, depicts \bar{T} predicted and simulated. Notice that in the probabilistic protocol no maximum number of transmissions per PDU is imposed. In Figure 5.5, right y axis, we show the proportion of PDUs that get transmitted more than N_{max} times, *i.e.* exceed the maximum number of retransmissions allowed by the deterministic protocol. As expected, this proportion decreases as the channel improves.

But, in our analysis we are interested on the optimization of probabilistic protocol for any value of γ and β using FSMC analysis, as stated on equation (5.1). Let us initially perform analysis at the case when Relay appears at equal distance from

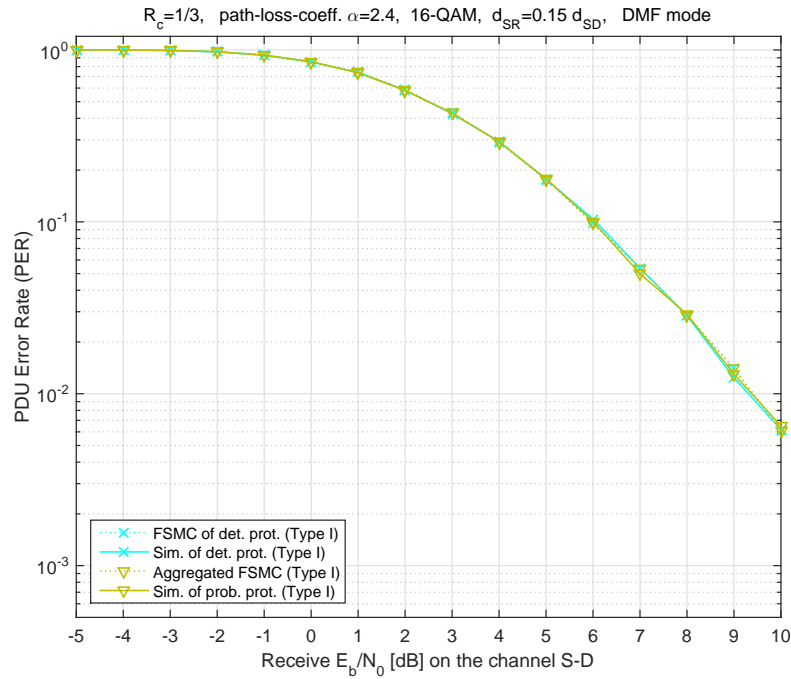

Figure 5.4: PER achieved with deterministic and probabilistic protocol, type I

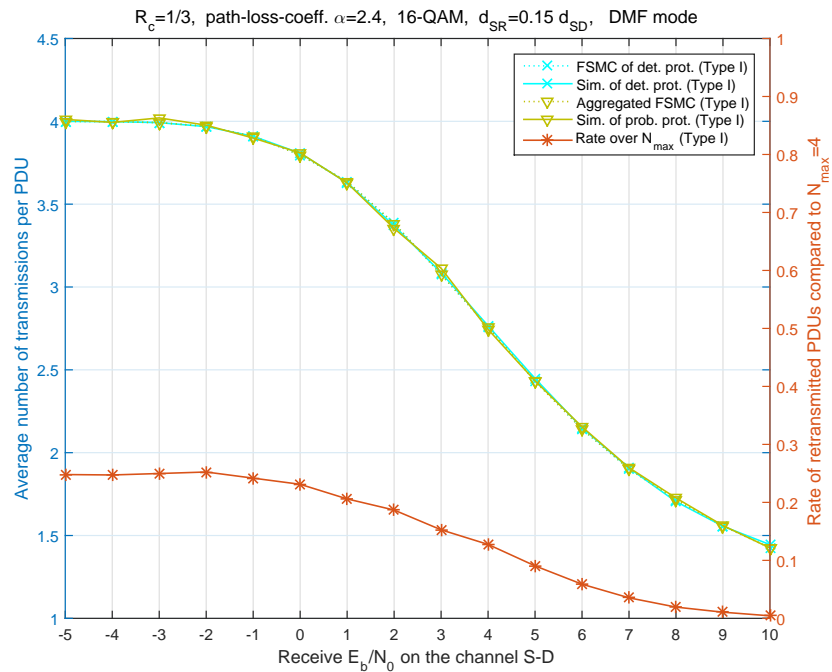

Figure 5.5: \bar{T} achieved with deterministic and probabilistic protocol, type I decoder

S and D, respectively, $d_{SR}/d_{SD} = 0.50$, and then we extend the analysis to other locations of the Relay. The optimization procedure is as follow: we consider various values of γ , then we keep its value fixed and we vary the value of β by continuously decreasing it (the decrease of β means the increase of number of retransmissions). Since the same procedure follows for each point of E_b/N_0 , one example of optimization for $E_b/N_0 = 5$ is shown in Figure 5.6.

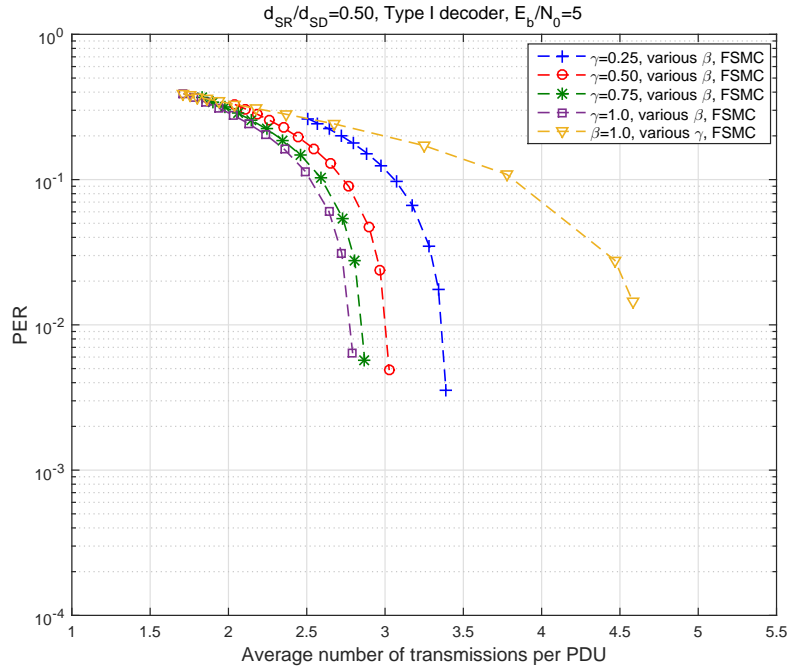

Figure 5.6: Optimization for various γ and β , $d_{SR}/d_{SD} = 0.50$, $E_b/N_0 = 5$

From Figure 5.6 we see the tendency that the best performance it is achieved if we do not allow R to retransmit twice in a row (by setting $\gamma = 1.0$), as in this way we allow R to refresh the demodulated copy from S before it can perform the next retransmission. Following this tendency, then in Figure 5.7 there is shown the comparison of PER vs corresponding \bar{T} , for various points of E_b/N_0 when $\gamma = 1.0$ and continuously decreasing β . As we may see, performance prediction of the probabilistic protocol via the FSMC analysis is accurate.

From Figure 5.7 we can define the presence of bad and good mediums described in Section 5.2.2. As we may see, the PER decreases as the value of β decreases. But, we see that after some point, further decrease of β allows decrease in PER but \bar{T} and Goodput remain unchanged. We refer to this as *saturation point*. Therefore, in our analysis we are interested to make the optimization before the \bar{T} reaches the saturation point.

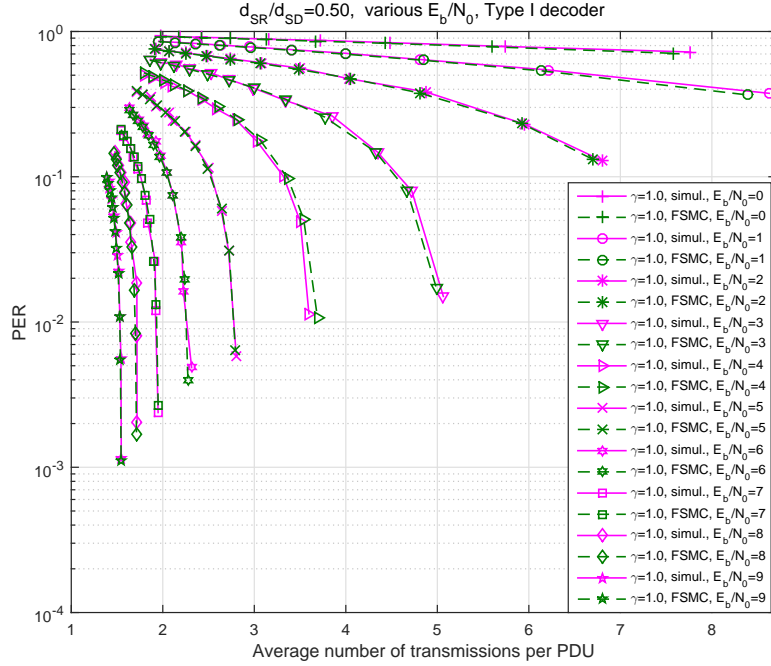

Figure 5.7: PER achieved with corresponding \bar{T} , best γ and β , $d_{SR}/d_{SD} = 0.50$

Let us consider that we set up $\bar{T}_{\max} = 2.5$, and we want to optimize for $\bar{T} \leq \bar{T}_{\max} = 2.5$, by keeping the Relay at the same distance as earlier, $d_{SR}/d_{SD} = 0.5$. We want to compare the following three cases: 1) we set the value of $\beta = 1.0$ (meaning that S performs only the first transmission and the rest are performed by R), and we select on the FSMC the value of γ that meets the optimization criterion in (5.1); 2) we set the value of $\gamma = 1.0$ (meaning that R is not allowed to retransmit successively two times), and we select on the FSMC the value of β that meets the optimization criterion in (5.1); 3) we set the value of $\gamma = 0.5$ (meaning that we allow more successive retransmissions from R), and we select on the FSMC the best value of β that meets the optimization criterion in (5.1). We note that the optimization is performed independently for each point of E_b/N_0 . The optimized PER from this comparison is shown in Figure 5.8. As we may see, the best performance it is achieved if we allow R to refresh its own demodulated copy from S before the next retransmission (associated with $\gamma = 1.0$), which was also seen in Figure 5.6.

After discussing the results when Relay is located at distance $d_{SR}/d_{SD} = 0.50$, we want to check what happens if the Relay appears at other locations, by keeping the constraint $\bar{T}_{\max} = 2.5$. Therefore, we have performed the same optimization analysis like we did for the case of $d_{SR}/d_{SD} = 0.50$, and we have plot the best curves at each location of the Relay. The following comparison is provided in Figure

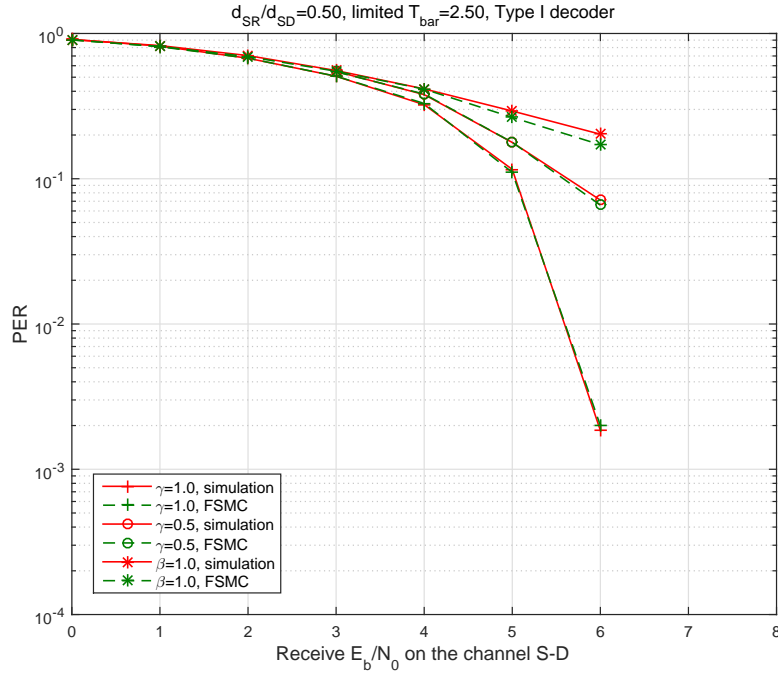
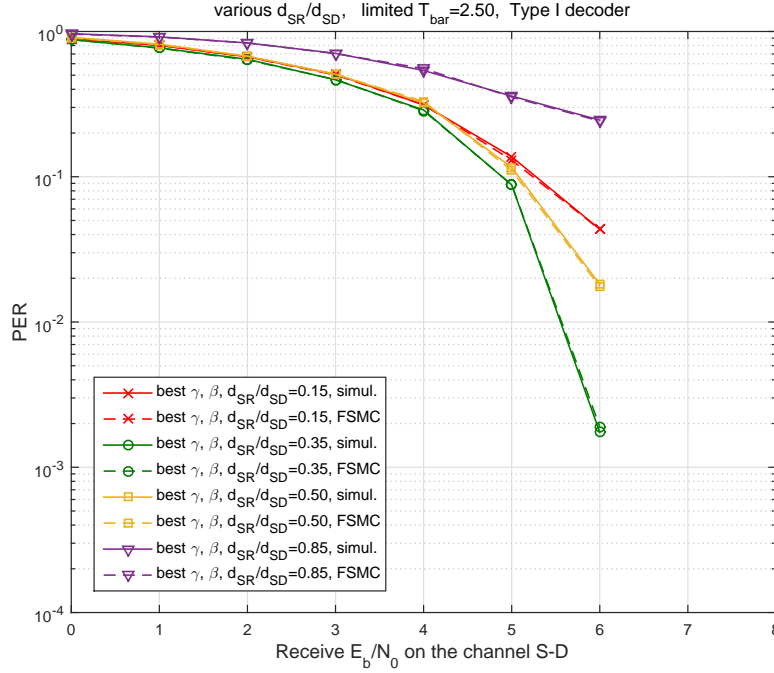

Figure 5.8: Optimized PER, $d_{SR}/d_{SD} = 0.50$, $\bar{T}_{\max} = 2.5$, Type I decoder

5.9 where there is shown the comparison of PER as a function of various points of receive E_b/N_0 on the channel S-D, with the best γ and β at each corresponding location of the Relay. The details of the values of γ and β for each location of the Relay are shown in Table 5.3.

As we may see from Table 5.3, as the Relay is located close to the Source, for the lower points of E_b/N_0 the best performance it is achieved if we allow only Relay to perform successive retransmissions (associated with $\beta = 1.0$) and as the channel improves then the best performance it is achieved with $\gamma = 0.5$ and at the same time by leaving some probability that Relay refreshes its own demodulated copy from Source (associated with $\beta < 1$). As the Relay moves further away from the Source and when the received power of signal is equal or higher than the power of noise, we see that the best performance it is achieved if we do not allow Relay to retransmit successively more than one time (associated with $\gamma = 1.0$), and we push Relay to refresh its own demodulated copy from Source before the next retransmission (associated with $\beta < 1$).

As we see from Figure 5.9, the highest performance it is achieved when the Relay is located at distance $d_{SR}/d_{SD} = 0.35$. This means that as we move from Source toward the Destination, the performance improves up to distance $d_{SR}/d_{SD} = 0.35$, where it has its maximum performance, and then the performance decreases as the

Figure 5.9: Optimized PER, various d_{SR}/d_{SD} , limited $\bar{T} = 2.5$, Type I decoderTable 5.3: Optimized values of γ and β , various d_{SR}/d_{SD} and E_b/N_0 , type I decoder

E_b/N_0	d_{SR}/d_{SD}			
	0.15	0.35	0.50	0.85
0	$\gamma = 0.6315$ $\beta = 1.0$	$\gamma = 0.6280$ $\beta = 1.0$	$\gamma = 1.0$ $\beta = 0.7740$	$\gamma = 1.0$ $\beta = 0.7845$
1	$\gamma = 0.5960$ $\beta = 1.0$	$\gamma = 0.5845$ $\beta = 1.0$	$\gamma = 1.0$ $\beta = 0.7440$	$\gamma = 1.0$ $\beta = 0.7665$
2	$\gamma = 0.5335$ $\beta = 1.0$	$\gamma = 0.5220$ $\beta = 1.0$	$\gamma = 1.0$ $\beta = 0.6895$	$\gamma = 1.0$ $\beta = 0.7325$
3	$\gamma = 0.4390$ $\beta = 1.0$	$\gamma = 0.50$ $\beta = 0.8840$	$\gamma = 1.0$ $\beta = 0.5950$	$\gamma = 1.0$ $\beta = 0.6710$
4	$\gamma = 0.3065$ $\beta = 1.0$	$\gamma = 1.0$ $\beta = 0.4195$	$\gamma = 1.0$ $\beta = 0.4555$	$\gamma = 1.0$ $\beta = 0.5850$
5	$\gamma = 0.50$ $\beta = 0.3495$	$\gamma = 1.0$ $\beta = 0.1610$	$\gamma = 1.0$ $\beta = 0.1940$	$\gamma = 1.0$ $\beta = 0.4350$
6	$\gamma = 0.50$ $\beta = 0.1670$	$\gamma = 1.0$ $\beta = 0.005$	$\gamma = 1.0$ $\beta = 0.0445$	$\gamma = 1.0$ $\beta = 0.3915$

Relay moves closer to the Destination, due to the high number of demodulation errors. In other words, the optimized location accounts for a trade-off between

the demodulation errors on the channel S-R and successful re-transmissions for the remaining distance R-D, which in our case appears to be in 1/3 of the distance S-D.

5.4 Probabilistic protocol, type II decoder

As it was argued earlier, performance prediction of the probabilistic protocol for Type II decoder using $(\mathcal{S}', Z_{R,II})$ is not possible since the probabilities π_{SF} and π_{RF} depend on the parameters γ and β . In the other hand, because of these dependence, an exact performance prediction it is not possible since the number of copies on the decoder can be very large, and as a result the FSMC analysis will become too complex. We are hence interested to get a FSMC model that provides good approximations of the performance of the probabilistic protocol using alternative strategies.

5.4.1 The probabilistic protocol with Type II decoder with limited buffer

In this section we consider a variation of the Type II decoder that can simultaneously process at most C_{\max} received packets. We express this by saying that D has a buffer limited to C_{\max} entries. The probabilistic protocol described by the FSM in Figure 5.1 runs without alterations. At the destination, the received copies are stored in the buffer. If the buffer is filled to capacity C_{\max} but a new copy is received, this overwrites one of the existing items in the buffer. We impose the rule that a packet from S can overwrite only packets from S, and a packet from R can overwrite only packets from R. The packet to be replaced is chosen as the one with the worst quality.

The limited buffer Type II decoder is the standard Type II decoder for $C_{\max} \rightarrow \infty$. We make the assumption that, at least for C_{\max} big enough, the limited buffer decoder approximates well the performance of the standard decoder. This assumption is verified by the numerical results in Section 5.4.3.

For the overwriting process in the buffer, we need to rank the received sequences in order to overwrite the worst. Notice that sometimes the incoming copy could be worse than the worst copy on the buffer: even in this case we choose to overwrite the worst copy. The ranking of the received sequences is based on the *a posteriori* probabilities of the coded bits, which can be evaluated as it follows:

$$\begin{aligned} p(c_{i,n} = 0 | y_n) &= \frac{p(y_n | c_{i,n} = 0)}{p(y_n | c_{i,n} = 0) + p(y_n | c_{i,n} = 1)} \\ p(c_{i,n} = 1 | y_n) &= \frac{p(y_n | c_{i,n} = 1)}{p(y_n | c_{i,n} = 0) + p(y_n | c_{i,n} = 1)} \end{aligned} \quad (5.5)$$

where i is the index of the coded bit of the n -th symbol, and

$$p(y_n) = p(y_n | c_{i,n} = 0) p(c_{i,n} = 0) + p(y_n | c_{i,n} = 1) p(c_{i,n} = 1) \quad (5.6)$$

Table 5.4: Definition of states in the FSMC of the transmitter, with a limited buffer on the receiver

State	State definition	Action
0	CO=*, W=ACK	ST
1	CO=*, $V_R = 0, V_S = 0, W=NACK$	ST
2	CO=S, $V_R = 1, V_S = 0, W=NACK$	RRT
3	CO=SR, $V_R = 0, V_S = 1, W=NACK$	SRT
4	CO=SR, $V_R = 1, V_S = 0, W=NACK$	RRT
5	CO=SRS, $V_R = 1, V_S = 0, W=NACK$	RRT
6	CO=SRR, $V_R = 0, V_S = 1, W=NACK$	SRT
7	CO=SRR, $V_R = 1, V_S = 0, W=NACK$	RRT
8	CO=SRSR, $V_R = 0, V_S = 1, W=NACK$	SRT
9	CO=SRSR, $V_R = 1, V_S = 0, W=NACK$	RRT
10	CO=SRRS, $V_R = 1, V_S = 0, W=NACK$	RRT
11	CO=SRRS, $V_R = 0, V_S = 1, W=NACK$	SRT
12	CO=SRRR, $V_R = 0, V_S = 1, W=NACK$	SRT
13	CO=SRRR, $V_R = 1, V_S = 0, W=NACK$	RRT

and where, $p(c_{i,n} = 0) = p(c_{i,n} = 1) = 1/2$.

Then, we define B_s as the belief that hard demodulation of the received sequence with N symbols and k coded bits per symbol would produce the correct sequence of coded bits. This metric takes the form

$$B_s = \sum_{n=1}^N \left(\sum_{i=1}^k \bar{p}(c_{i,n} | y_n) \right), \quad (5.7)$$

where $\bar{p}(c_{i,n} | y_n) = \max\{p(c_{i,n} = 0 | y_n), p(c_{i,n} = 1 | y_n)\}$ for each coded bit of each symbol of the received sequence. A sequence with the higher value of B_s represents a better sequence. The worst sequence in the buffer is the one with the smallest B_s .

5.4.2 Description of the probabilistic protocol with a limited-buffer Type II decoder using a FSMC

In this section we derive a FSMC able to predict the performance of the probabilistic protocol with limited-buffer Type II decoder. The states of the FSMC are defined according to the rules regulating the access to the channel in the probabilistic protocol and according to the possible filling levels of the decoder buffer. In particular, we wish to consider i) how many copies from S and from R are in the buffer ii) the order with which the buffer has been filled for the first time. The reason why we wish to account for the order of arrival is related to the DMF mode of the relay. The relay always retransmits the most recently received message, without checking for

its integrity. This implies that a retransmission pattern alternating retransmissions from S and R produces is the most effective strategy to increase diversity. As a consequence the average probability of success in decoding at the destination depends not only on the number A of copies received from S and the number B of copies received from R, but also on their order.

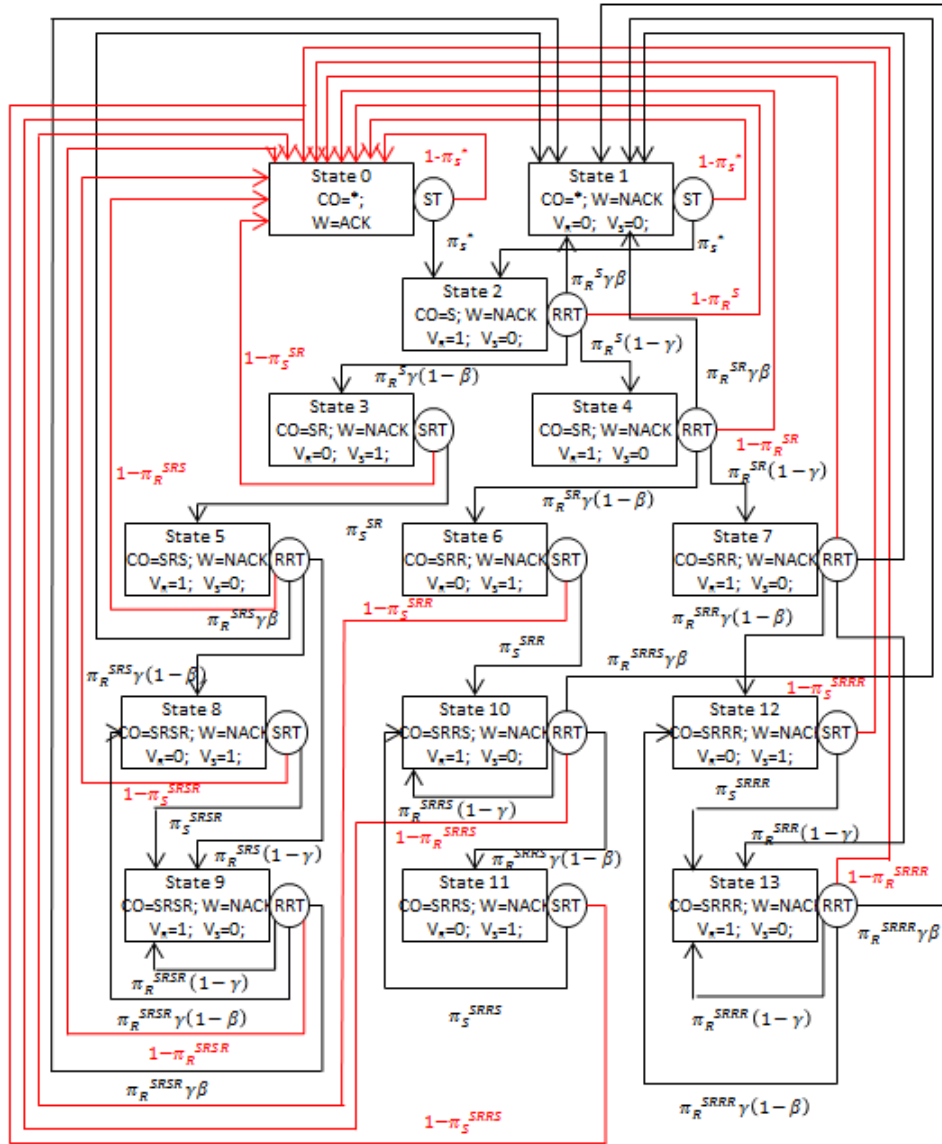

Figure 5.10: FSMC representing the probabilistic protocol with limited buffer $C_{\max} = 4$

For the case of $C_{\max} = 4$, the definition of states on the FSMC is given in Table 5.4, while the scheme of FSMC is shown in Figure 5.10. The states are defined

according to the value of the parameter CO (Copy Order), representing the order with which the packets have filled the buffer, before the current time-slot; of the control parameters (V_R, V_S) regulating the next access to the channel; of the latest control message W . Notice that as usual State 0 and State 1 correspond to the first transmission of a new PDU, after successful acknowledgement or after a drop, respectively. The number of states increases with the size of the buffer C_{\max} . For size $C_{\max} = 4$ the number of states is 14, for $C_{\max} = 5$ the number of states is 23 and for $C_{\max} = 6$ the number of states is 37.

Denote by $(1 - \pi_S^{\text{co}})$ the average probability of successful decoding at D, when the current transmission is performed by S and the buffer has configuration CO=co just before the transmission happens. Define π_R^{co} similarly. Let Q be the transition matrix of the FSMC with state set defined by Table 5.4. It has the following form:

$$Q = \begin{pmatrix} (1 - \pi_S^*) & 0 & \pi_S^* & \cdots & \cdots \\ (1 - \pi_S^*) & 0 & \pi_S^* & \cdots & \cdots \\ (1 - \pi_R^S) & \gamma \cdot \beta \pi_R^S & \gamma(1 - \beta) \pi_R^S & \cdots & \cdots \\ (1 - \pi_S^{SR}) & \gamma \cdot \beta \pi_S^{SR} & 0 & \cdots & \cdots \\ \vdots & \vdots & \vdots & \ddots & \vdots \\ (1 - \pi_R^{SRRR}) & \gamma \cdot \beta \pi_R^{SRRR} & 0 & \cdots & \cdots \end{pmatrix}. \quad (5.8)$$

Notice that the average probabilities $(1 - \pi_R^{\text{co}})$ and $(1 - \pi_S^{\text{co}})$ relative to filling patterns co strictly shorter than C_{\max} do not depend on the parameters γ and β . This is not true when we consider the probabilities $(1 - \pi_R^{\text{co}})$ and $(1 - \pi_S^{\text{co}})$ for filling patterns co of length C_{\max} . In this case the current retransmission will certainly result in the overwriting in the buffer. The probability $(1 - \pi_R^{\text{co}})$ is defined as the expected probability of success after the current transmission from R overwrites an element in the buffer. Let \mathbf{W}_R be the number of substitutions that have happened in the buffer before the current time-slot, and let $q_R(\mathbf{w})$ be the probability $\mathbb{P}(\mathbf{W}_R = \mathbf{w})$. Then the average probability $(1 - \pi_R^{\text{co}})$ is defined as

$$(1 - \pi_R^{\text{co}}) = \sum_{\mathbf{w}} ((1 - \pi_R^{\text{co}}) | \mathbf{W}_R = \mathbf{w}) q_R(\mathbf{w}). \quad (5.9)$$

Notice that the probabilities $q_R(\mathbf{w})$ are functions of the parameters β and γ . In order to eliminate this statistical dependence, we choose to approximate (5.9) as follows

$$(1 - \pi_R^{\text{co}}) \approx ((1 - \pi_R^{\text{co}}) | \mathbf{W}_R = 1). \quad (5.10)$$

where, $\mathbf{W}_R = 1$ means that on the buffer there is performed only one overwriting, and the expression (5.10) provides the approximation that the probability of success from R after performing $\mathbf{W}_R > 1$ overwritings remains unchanged compared to the probability of success after $\mathbf{W}_R = 1$ overwriting. With this approximation, then all the probabilities in (5.8) are independent on γ and β and can be evaluated using Monte Carlo simulations. An example is Algorithm 2, where $\pi_Y^{C_{\max}}$ represent the

Algorithm 2: Evaluation of probability $\pi_Y^{C_{\max}}$

```

Define size of the buffer,  $C_{\max}$  ;
 $v_{ACK} = 0$ ;  $v_{NACK} = 0$  ;
while True do
     $t_S = 0$ ;  $b = 0$ ;
    Generate a new PDU;
    while  $t_S < N_S$  &  $CRC\_flag=NACK$  &  $t_S + b < C_{\max}$  do
        Source.Transmits();
        Evaluate quality of the copy  $P_S$ ;
        Append copy on the buffer;
        Calculate.LLR;
        Decode.LLR;
        Check.CRC;
         $t_r = 0$ ;
        while  $t_r < N_R$  &  $CRC\_flag=NACK$  &  $t_S + b < C_{\max}$  do
            Relay.Transmits();
            Evaluate quality of the copy  $P_S$ ;
            Append copy on the buffer;
            Calculate.LLR;
            Decode.LLR;
            Check.CRC;
             $b = t_S \cdot N_R + t_r + 1$ ;
             $t_r ++$ ;
        end
         $t_S ++$ ;
    end
    if  $CRC\_flag=NACK$  then
        NodeY.Transmits();
        Evaluate quality of the copy  $P_S$ ;
        Replace the worst copy on the buffer;
        Calculate.LLR;
        Decode.LLR;
        Check.CRC;
        if  $CRC\_flag=ACK$  then
             $v_{ACK} ++$ ;
        else
             $v_{NACK} ++$ ;
        end
    end
end
Evaluate:  $\pi_Y^{C_{\max}} = v_{NACK} / (v_{ACK} + v_{NACK})$ ;

```

average probability of failing successively up to A copies from S and B copies from R , and after the worst copy from node Y is replaced one time. This FSMC description of the probabilistic protocol with limited-buffer Type II decoder hence allows to easily optimize the parameters γ and β using the same procedure considered in the case of Type I decoder.

5.4.3 Numerical results

For theoretical and simulation results of type II decoder, we use the same parameters as described for the numerical results of type I decoder in Section 5.3.1. Like for the case of type I decoder, where we have shown the equivalence between the probabilistic and deterministic protocol if the values of parameters γ and β are evaluated from the aggregation algorithm, we want to show that even for the case of type II decoder the performance of probabilistic protocol can be very close with that of deterministic protocol if parameters γ and β are evaluated from the aggregation procedure. We consider the case of deterministic protocol with $N_S = 2$ and $N_R = 1$, and then the parameters γ and β are evaluated accordingly. In Figure 5.11 there

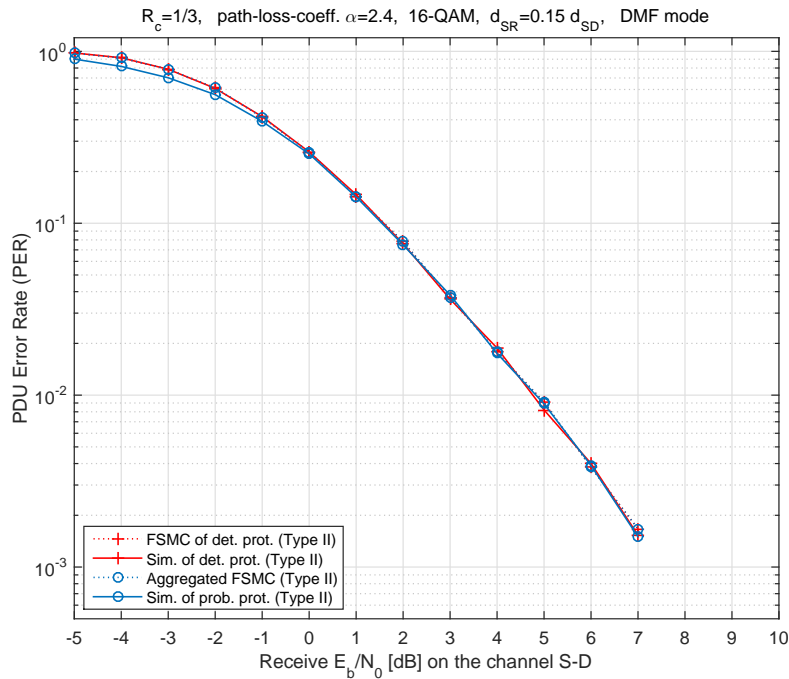

Figure 5.11: PER of the deterministic and probabilistic protocol, type II decoder

is shown the comparison of the PER as a function of receive E_b/N_0 on the channel S-D, achieved with the deterministic and probabilistic protocol, while in Figure 5.12, in left y axis is depicted \bar{T} predicted and simulated, and in right y axis, it is shown the proportion of PDUs that get transmitted more than N_{max} times, *i.e.*

exceed the maximum number of retransmissions allowed by the deterministic protocol. As expected, this proportion decreases as the channel improves. The prediction of the FSMC model is very accurate with respect to the simulated performance. The small mismatch of the probabilistic protocol with Type II decoder comes at the very bad region of the channel, where the deterministic protocol has very high PER. This mismatch has the following interpretation: while at the deterministic protocol decoding with maximum 4 copies we fail almost all the time, at the probabilistic protocol the maximum number of transmissions is not limited, and for the cases when the decoder has more than 4 copies it brings better decoding result. At the same time, since γ and β are evaluated from the aggregation procedure, the average number of transmissions (\bar{T}) achieved with probabilistic protocol never exceeds the average number of transmissions (\bar{T}) achieved with deterministic protocol. This behaviour of the probabilistic protocol shows advantage over deterministic protocol at this region of the channel.

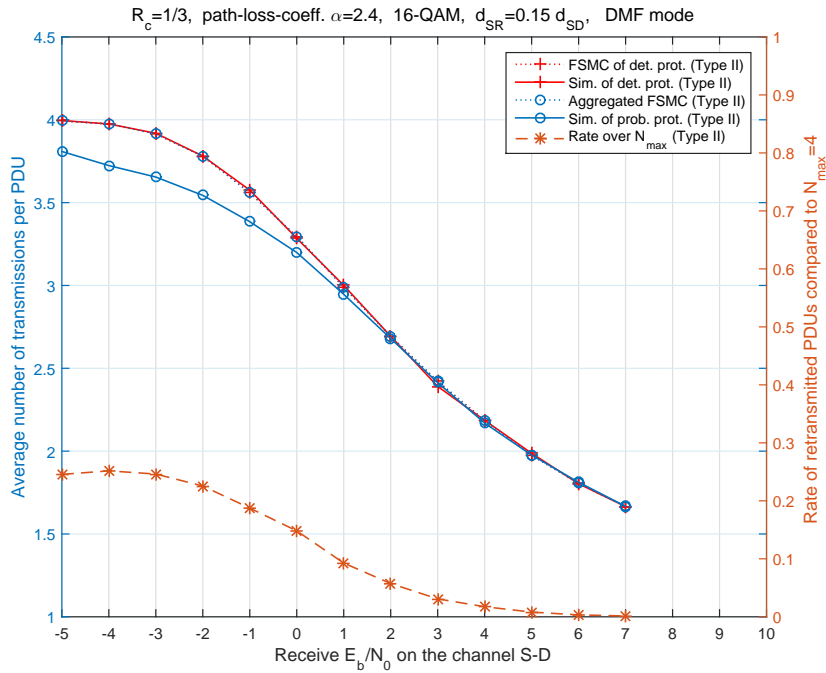

Figure 5.12: \bar{T} of the deterministic and probabilistic protocol, type II decoder

Let us now turn to the performance optimization of parameters γ and β using FSMC transition matrix of the probabilistic protocol with limited buffer. Like we did on the case of Type I decoder, the same procedure we follow also for the case of Type II decoder. Initially, we stick to the location of Relay at distance $d_{SR}/d_{SD} = 0.50$. The results of the optimization procedure for various values of γ and β for few points of E_b/N_0 are shown in Figure 5.13, where PER is expressed

vs. average number of transmissions per PDU, \bar{T} .

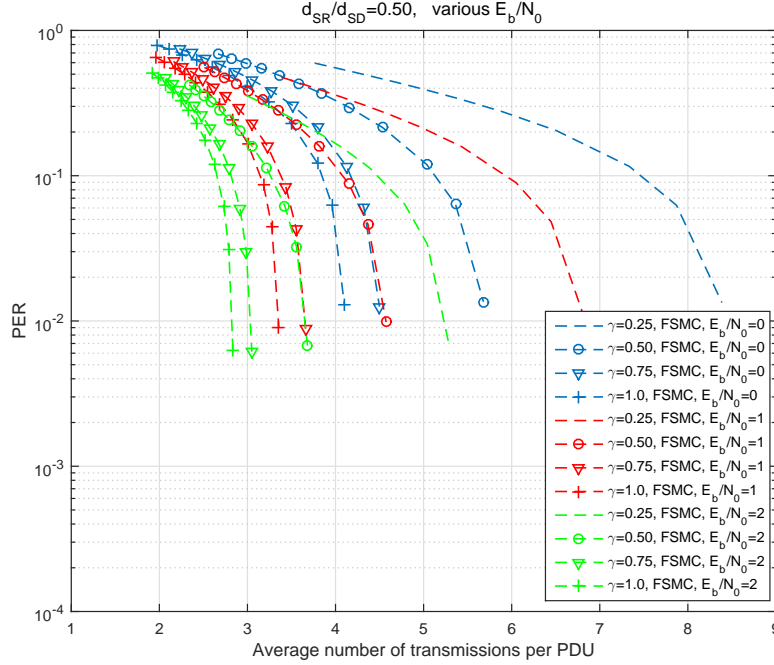

Figure 5.13: Optimization results for various γ and β , $d_{SR}/d_{SD} = 0.50$, tupe II decoder

From Figure 5.13 we discover that even on the case of Type II decoder there is tendency that the best performance it is achieved if we set $\gamma = 1.0$. Following this tendency, then in Figures 5.14 and 5.15 there are shown the comparison of PER vs corresponding \bar{T} and Goodput, respectively, for various points of E_b/N_0 when $\gamma = 1.0$ and continuously decreasing β . As we may see from both Figures, performance prediction of the probabilistic protocol via the FSMC analysis is accurate, except for high levels of noise on the channels. Here we can also define the presence of bad and good regimes described in Section 5.2.2, and the *saturation phenomena*. Like on the case of Type I decoder, we are interested to make the optimization before the \bar{T} reaches the saturation point.

Keeping the constraint that $\bar{T} \leq \bar{T}_{\max} = 2.5$, then the comparison for various values of γ and β is shown in Figure 5.16. Even here, there is confirmed that the best performance it is achieved if we allow R to refresh its own demodulated copy from S before the next retransmission (associated with $\gamma = 1.0$).

In the end, we perform the same optimization procedure at the other locations of the Relay by keeping the constraint $\bar{T}_{\max} = 2.5$, and the best curves at each

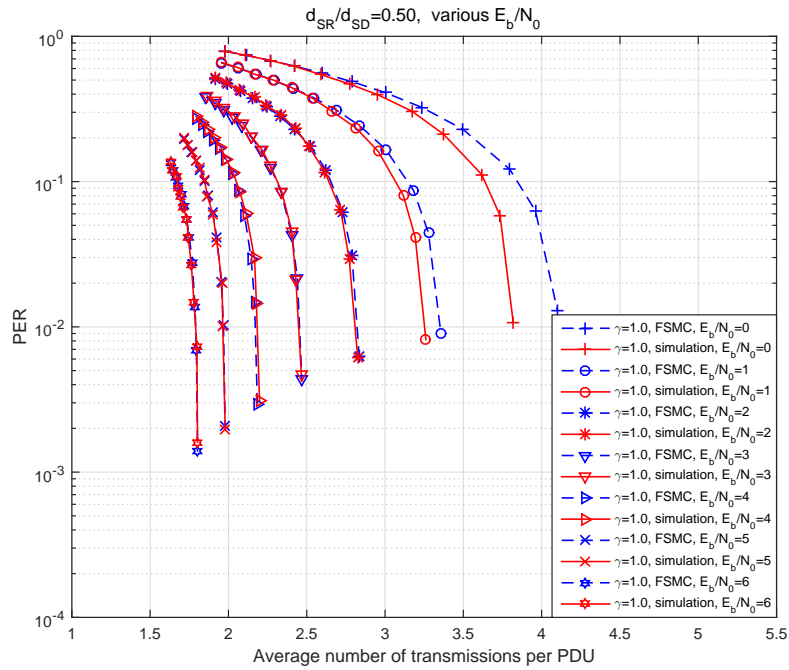

Figure 5.14: Comparison of PER with corresponding \bar{T} , type II decoder

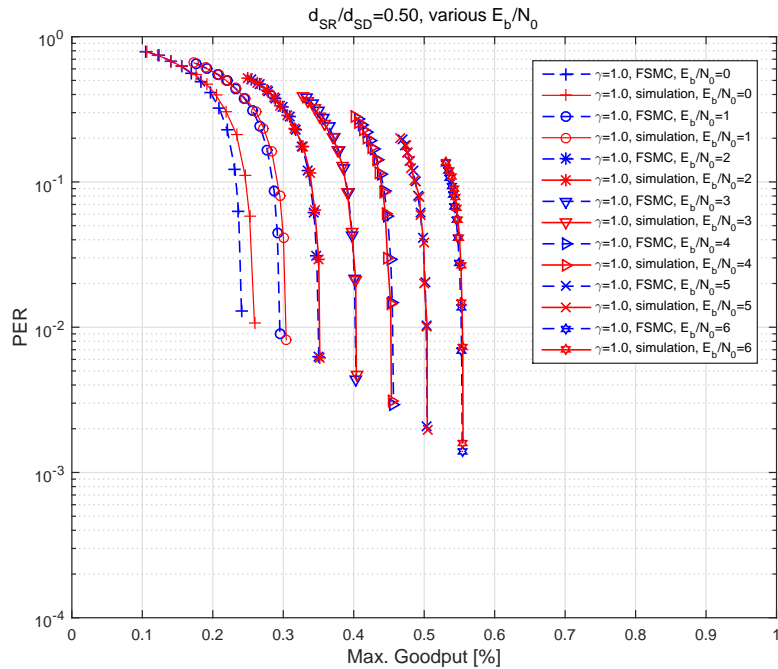

Figure 5.15: Comparison of PER with corresponding Goodput, type II decoder

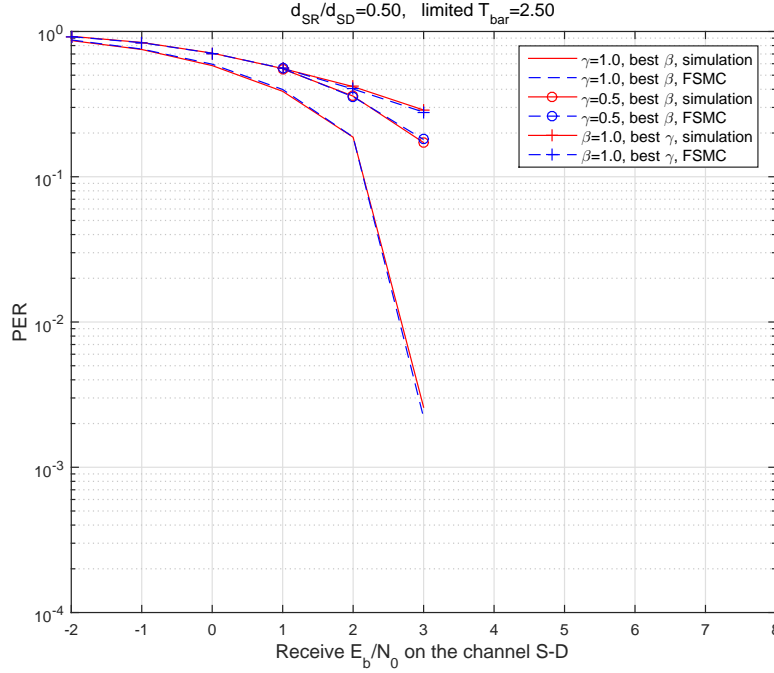

Figure 5.16: Optimized PER, $d_{SR}/d_{SD} = 0.50$, $\bar{T}_{max} = 2.5$, type II decoder

location of the Relay are shown in Figures 5.17 and 5.18, where there are shown the comparison of PER and Goodput as a function of various points of receive E_b/N_0 on the channel S-D, respectively. The results confirm that even on the case of Type II decoder, the highest diversity it is achieved when Relay is located at distance $d_{SR}/d_{SD} = 0.35$. The details of the optimized values of γ and β for each location of the Relay are shown in Table 5.5.

5.4.4 Comparison with a referent deterministic protocol

In order to show how the performance of probabilistic protocol stands compared to other published deterministic protocols, we have considered the protocol published in [Krikidis 2007] as a reference for comparison, and we have considered the case of Type II decoder for both protocols. Though the author considers the Relay mode Amplify-and-Forward (AF) in a situation with K -Relays, only one of the Relays is allowed to retransmit. Since in this case there is not checked integrity of the copy that Relay has to forward, then we can adapt this protocol to our example network S-R-D when Relay works on DMF mode. The author considers the limit of maximum number of transmissions per packet to 3, and tries all possible combinations for finding the best performance: (3 direct, 0 Relay), (2 direct, 1 Relay), and (1 direct, 2 Relay). We have simulated all these scenarios and we have compared its performance with the probabilistic protocol in the following way: we have chosen

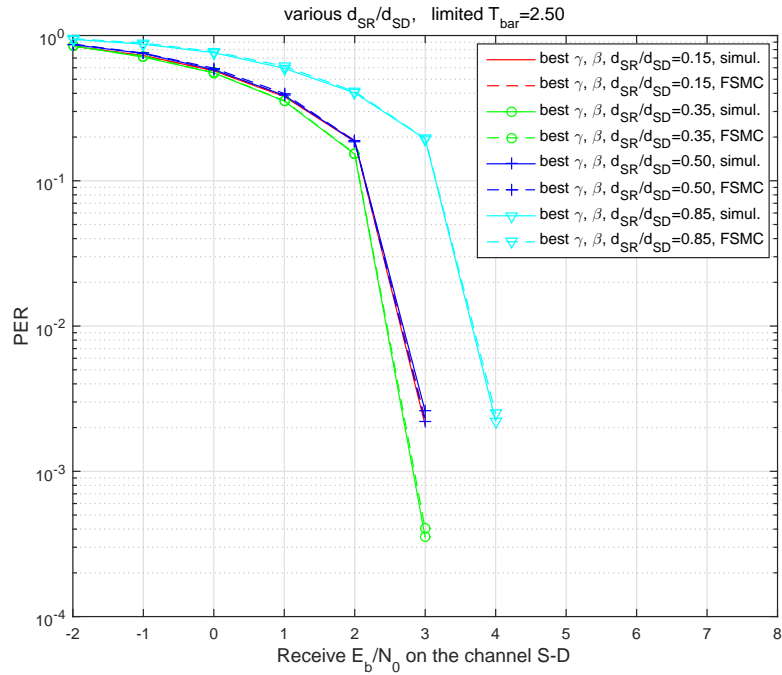

Figure 5.17: Optimized PER, various d_{SR}/d_{SD} , limited $\bar{T} = 2.5$, type II decoder

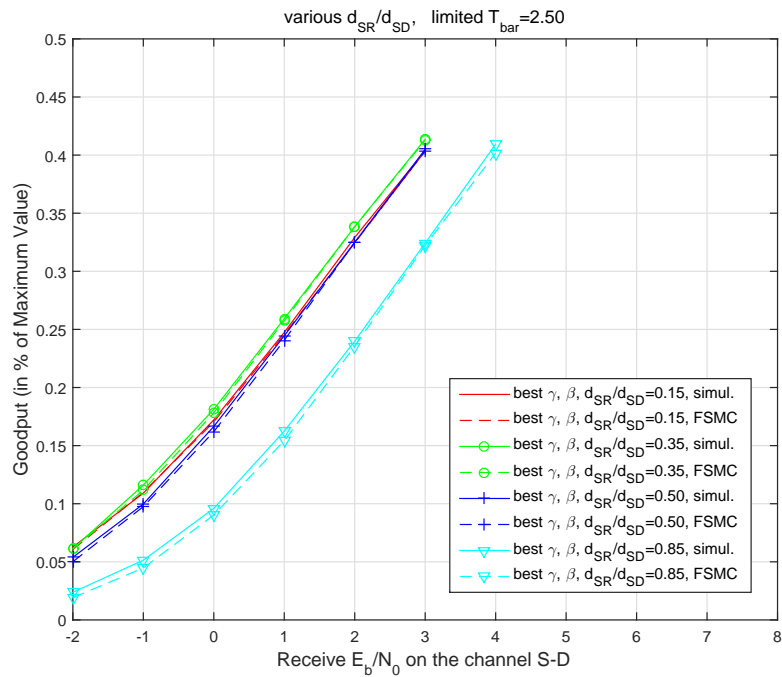

Figure 5.18: Optimized Goodput, various d_{SR}/d_{SD} , limited $\bar{T} = 2.5$, type II decoder

Table 5.5: Optimized values of γ and β , various d_{SR}/d_{SD} and E_b/N_0 , type II decoder

E_b/N_0	d_{SR}/d_{SD}			
	0.15	0.35	0.50	0.85
-2	$\gamma = 1.0$ $\beta = 0.76$	$\gamma = 1.0$ $\beta = 0.7595$	$\gamma = 1.0$ $\beta = 0.7670$	$\gamma = 1.0$ $\beta = 0.7850$
-1	$\gamma = 1.0$ $\beta = 0.7165$	$\gamma = 1.0$ $\beta = 0.7160$	$\gamma = 1.0$ $\beta = 0.7265$	$\gamma = 1.0$ $\beta = 0.7655$
0	$\gamma = 1.0$ $\beta = 0.6485$	$\gamma = 1.0$ $\beta = 0.6410$	$\gamma = 1.0$ $\beta = 0.6575$	$\gamma = 1.0$ $\beta = 0.7250$
1	$\gamma = 1.0$ $\beta = 0.5255$	$\gamma = 1.0$ $\beta = 0.5045$	$\gamma = 1.0$ $\beta = 0.5360$	$\gamma = 1.0$ $\beta = 0.65$
2	$\gamma = 1.0$ $\beta = 0.3230$	$\gamma = 1.0$ $\beta = 2795$	$\gamma = 1.0$ $\beta = 0.3230$	$\gamma = 1.0$ $\beta = 0.5175$
3	$\gamma = 1.0$ $\beta = 0.005$	$\gamma = 1.0$ $\beta = 0.001$	$\gamma = 1.0$ $\beta = 0.005$	$\gamma = 1.0$ $\beta = 0.3050$
4	————— —————	————— —————	————— —————	$\gamma = 1.0$ $\beta = 0.005$

to take as a reference the lowest and highest \bar{T} achieved with deterministic protocol from the three different simulated cases, and then we checked on the FSMC and by simulations on which is the best PER and Goodput that we can get with probabilistic protocol, by keeping the constraint of lowest and highest \bar{T} , respectively. The comparison is performed for each point of E_b/N_0 , and the details of the corresponding values of γ and β are given in Table 5.6.

Table 5.6: Values of γ and β for each point of E_b/N_0 , in the comparison of probabilistic with deterministic protocol

E_b/N_0	lowest \bar{T}	highest \bar{T}
-2	$\gamma = 0.995, \beta = 0.6$	$\gamma = 0.9975, \beta = 0.59$
-1	$\gamma = 1.0, \beta = 0.5525$	$\gamma = 0.995, \beta = 0.5325$
0	$\gamma = 0.9975, \beta = 0.5025$	$\gamma = 0.9975, \beta = 0.45$
1	$\gamma = 0.995, \beta = 0.4425$	$\gamma = 1.0, \beta = 0.35$
2	$\gamma = 0.9975, \beta = 0.3650$	$\gamma = 0.9975, \beta = 0.24$
3	$\gamma = 1.0, \beta = 0.3225$	$\gamma = 0.9925, \beta = 0.11$
4	$\gamma = 0.9950, \beta = 0.28$	$\gamma = 1.0, \beta = 0.03$
5	$\gamma = 1.0, \beta = 0.2625$	$\gamma = 1.0, \beta = 0.005$

The comparison of PER as a function of receive E_b/N_0 on the channel S-D is shown in Figure 5.19. As we may see, the probabilistic protocol can be optimized easily by using the FSMC analysis such that its performance outperforms the deterministic protocol for both cases: achieved with the lowest \bar{T} and with the highest \bar{T} , respectively. We note that the highly better performance of the probabilistic

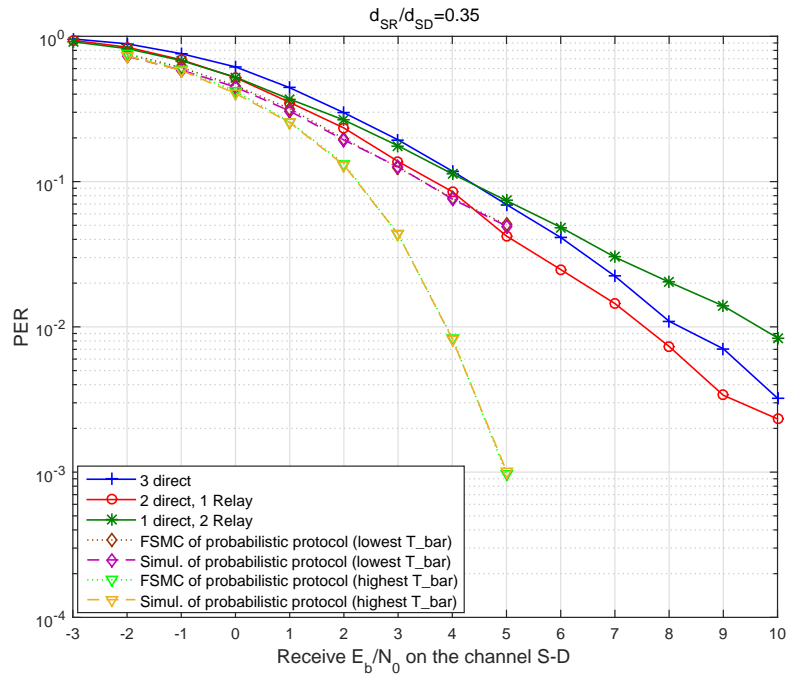

Figure 5.19: PER achieved with deterministic and probabilistic protocol, type II

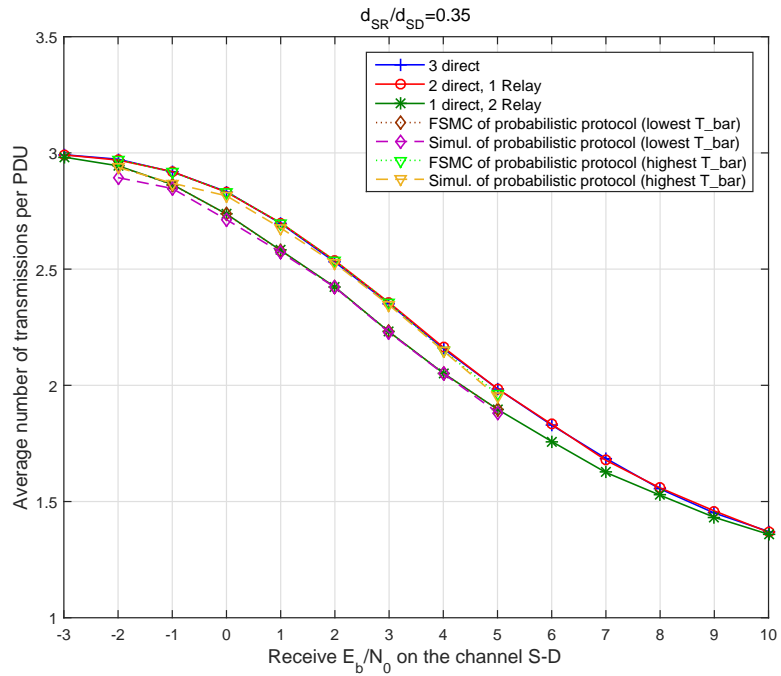

Figure 5.20: \bar{T} achieved with deterministic and probabilistic protocol, type II

protocol achieved with the highest \bar{T} at the very good channel comes due to the fact of *saturation property* discussed in previous subsection, and this is another advantage of probabilistic protocol, as we can just increase slightly the \bar{T} and improve significantly the PER. This is possible because we can adjust the values of parameters γ and β to achieve any value of \bar{T} , while at the deterministic protocol we have limited choices, i.e. for limited maximum number of transmissions to 3, we have only 3 possible \bar{T} -s that could be achieved. The comparison \bar{T} and Goodput as a function of receive E_b/N_0 on the channel S-D are shown in Figures 5.20 and 5.21, respectively, where the results confirm that a better performance it is achieved with the probabilistic protocol.

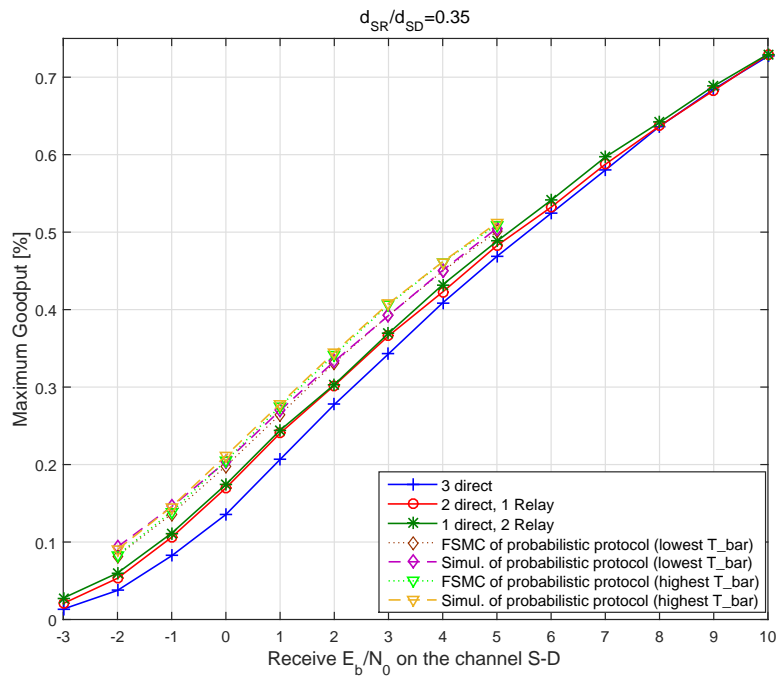

Figure 5.21: Goodput achieved with deterministic and probabilistic protocol, type II

5.5 Alternative probabilistic protocol

Performance of the probabilistic protocols described previously clearly outperform performance of deterministic protocols. In this section we wish to investigate whether the improvement is due to the fact that in the probabilistic protocol no maximum delay is imposed, contrary to what happens in the deterministic protocol. In order to make this comparison, we test what happens if we limit the maximum number of retransmissions in the probabilistic protocol. We call this the alternative probabilistic protocol. In this section we analyze the same probabilistic FSM as discussed in

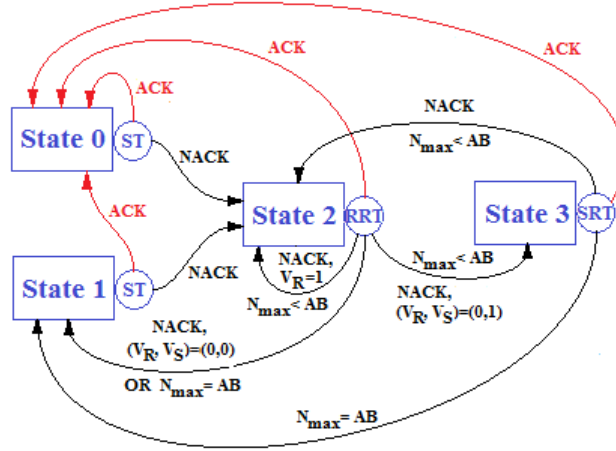

Figure 5.22: Scheme of the alternative probabilistic FSM

section 5.2, where the maximum number of transmissions per PDU N_{\max} is limited. We note that the working principle of FSM remains the same as discussed on section 5.2, with the only change that here after each failed retransmission, the FSM checks whether the maximum number of transmissions N_{\max} for the same PDU is not reached: if yes, then the next action would be chosen by the realization of random parameters V_S and V_R , as discussed previously. The retransmission of the same PDU is dropped if one of the following is observed: the PDU is ACK-ed by D; V_S and V_R take the values ($V_S = 0, V_R = 0$); or, $AB = N_{\max}$ is reached. The distribution of parameters V_S and V_R remain the same as discussed previously, as well as the definition of parameters γ and β which remain under the same definition. For definition of states at this new FSM, beside the old parameters of the previous FSM, we need the counter AB for counting the number of transmissions for the same PDU and can take the values from 0 to N_{\max} . Having defined all the parameters, then the definition of states in this new FSM can be represented as shown in Table 5.7, while the modified scheme of the FSM implemented on the transmitter is shown in Figure 5.22.

Table 5.7: Definition of states in the alternative probabilistic protocol

State name	State definition	Next action
0	$W=ACK$	ST
1	$(V_R = 0, V_S = 0) \parallel (AB = N_{\max}), W=NACK$	ST
2	$(V_R = 1, V_S = 0) \&\& (AB < N_{\max}), W=NACK$	RRT
3	$(V_R = 0, V_S = 1) \&\& (AB < N_{\max}), W=NACK$	SRT

5.5.1 Numerical results

For simulation of alternative probabilistic FSM we use the same parameters as described for the numerical results in Sections 5.3.1 and 5.4.3. We consider the Relay on DMF mode, and the receiver is equipped with type II decoder. We will consider various values of N_{\max} , and we will also compare its performance with the probabilistic protocol with unlimited number of transmissions.

Let us consider the same example as shown in Figure 5.17, by focusing only on the optimal location $d_{SR}/d_{SD} = 0.35$. We want to keep the same constraint $\bar{T} = 2.50$, and the same values of γ and β shown in Table 5.5. Then, the comparison of simulation results for the two protocols is shown in Figure 5.23, where the PER is given as a function of receive E_b/N_0 on the channel S-D. As the number of maximum number of transmissions at alternative protocol increases, its performance approaches the performance of probabilistic protocol, but even with $N_{\max} = 5$ its performance is still lower than of probabilistic protocol.

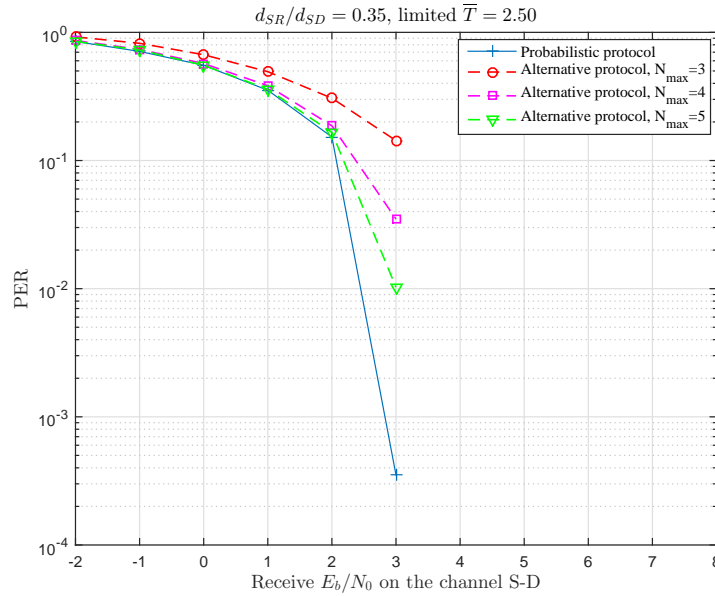

Figure 5.23: Comparison of PER achieved with probabilistic protocol and alternative protocol

Comparison of PER as a function of total E_b/N_0 spent from the transmitter is shown in Figure 5.24. We remind that the total energy spent from the transmitter accounts also for the energy of every retransmission. In this representation we see that the performance of alternative protocol with $N_{\max} = 5$ approaches even more to the performance of probabilistic protocol, except above $E_b/N_0 > 6$ which tells

that the probabilistic protocol enters earlier on the saturation phase and therefore it shows higher performance.

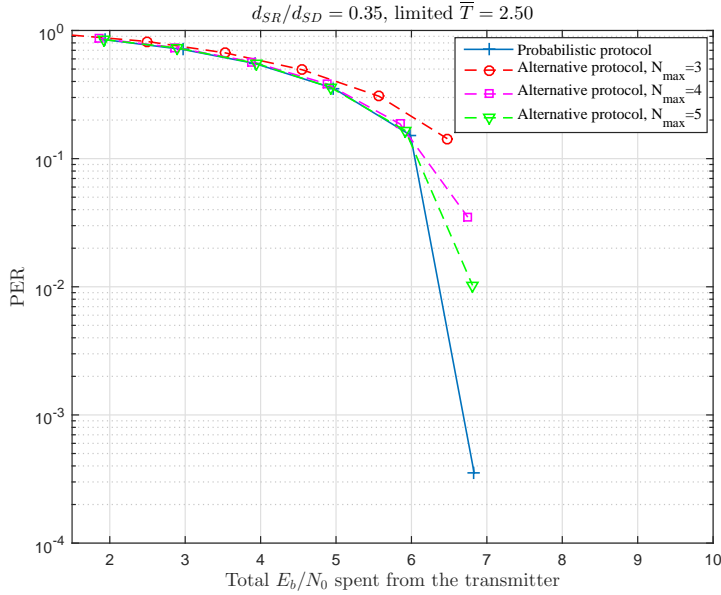

Figure 5.24: PER versus the energy spent on the transmitter for both protocols

From the above analysis we can conclude that limiting the maximum number of transmissions per PDU while using the probabilistic protocol determines a loss in performance.

To check that this loss cannot be compensated by varying the values of the parameters β and γ away from the optimal values found in the case of the probabilistic protocol, we consider the following. Referring to the analysis in section 5.4.3, we want to keep the optimized location of the Relay ($d_{SR} = 0.35 \cdot d_{SD}$) and we compare how the performance of the two protocols vary with the parameters γ and β . We perform the comparison for one point of E_b/N_0 , and the comparison for other points of E_b/N_0 can be done on the same way.

Since an increase in \bar{T} reflects on the decrease of PER, then we want to compare both protocols in Goodput, which represents the trade-off between \bar{T} and PER. Therefore, in Figure 5.25 we have shown the comparison of Goodput achieved with both protocols for various values of β , when $\gamma = 1$. As we may see, for any given value of β the performance of the probabilistic protocol is higher than of the alternative probabilistic protocol. Moreover, the gap between the best performance achievable by the alternative probabilistic protocol and the best performance achievable with the probabilistic protocol decreases as N_{\max} increases.

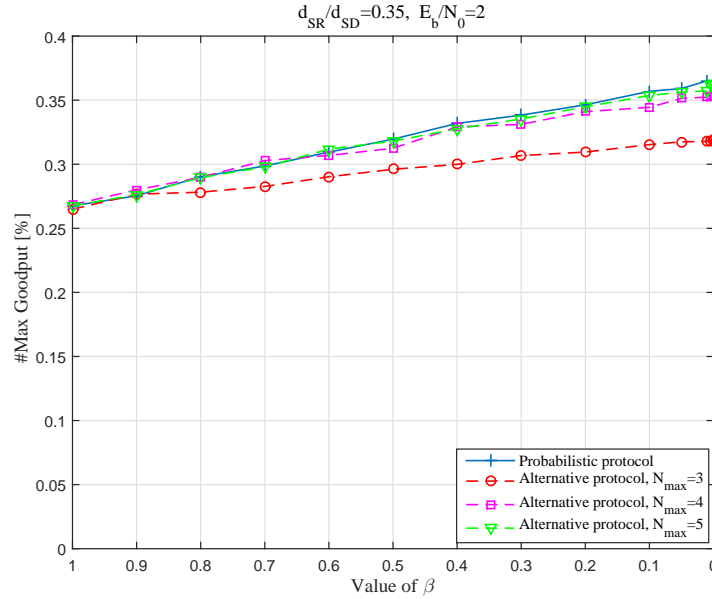

Figure 5.25: Goodput versus β at probabilistic protocol and alternative protocol

The performance comparison as a function of β can be shown also from the perspective of PER, as in Figure 5.26. As expected, the PER decreases as β decreases, where we see that the lowest PER it is achieved with probabilistic protocol. We may see that as N_{max} increases, the PER of alternative protocol approaches the performance of the probabilistic protocol.

From the above analysis we can conclude that limiting the maximum number of transmissions per PDU is a characteristic of deterministic protocols that makes them perform worse than the probabilistic protocol.

5.6 Conclusions

In this Chapter we have shown that since during the state aggregation the number of actions do not change but only some transitions become probabilistic, then we can associate these transition matrixes with a four-states FSM. State aggregation has imposed new parameters (γ and β) to appear, which can be used to introduce a protocol. Since the choice of retransmitting node and the number of retransmissions per PDU will depend on some probabilities, then we refer to this protocol as probabilistic protocol. As belong to performance prediction of this protocol using FSMC, for the case of type I decoder we have shown that a four-states transition matrix can be used to evaluate performance of the protocol in some cases. But, since in DMF mode the average probability that Relay fails on its transmission needs to count not only the probability of success on the channel R-D, but also the integrity of the copy

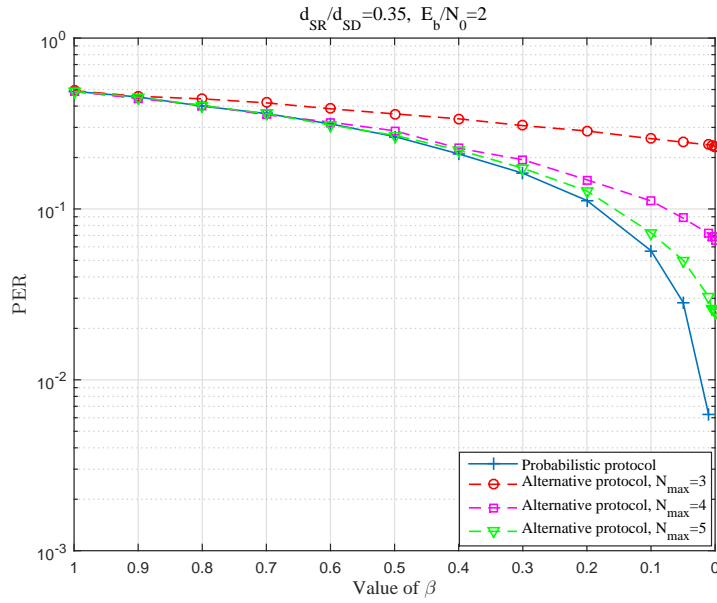

Figure 5.26: PER versus β at probabilistic protocol and alternative protocol

on the channel S-R, then for a general case and for any location of the Relay we have introduced a new six-states FSMC that can be used very effectively to predict performance of the probabilistic protocol for type I decoder. In similar way, for the type II decoder we have introduced a FSMC with a larger number of states, but which is still very effective and which allows fast and very close prediction of the probabilistic protocol. Moreover, in both types of decoders, it is shown that these FSMCs can be used to optimize performance of the protocol for various locations of the Relay by adjusting the values of only two parameters. Comparison of the deterministic and probabilistic protocols show that the probabilistic protocol outperforms the deterministic. In the last section of this Chapter we have introduced the alternative probabilistic protocol, where the maximum number of transmissions per PDU is limited. The comparison with the performance achievable with the probabilistic protocol confirms that limiting the maximum number of transmissions, as done in the deterministic case, degrades the achievable performance.

Relay selection in cooperative networks

Contents

6.1	Introduction	87
6.2	Selecting the optimal position of the Relay	88
6.2.1	Criterion for choosing the optimal position of the Relay	91
6.3	Selecting the best instantaneous Relay	98
6.3.1	Comparison of criterion ρ_c with a referent criterion	99
6.4	Conclusions	102

6.1 Introduction

In this chapter we will discuss the issue of selecting the best Relay to cooperate in the reference setup considered so far. In previous chapters we have seen that we can have significant benefits by using Relay nodes to communicate between a Source and a Destination. In our analysis, we have also seen by simulations that in average the highest diversity by using Relay we have when Relay is located around the position $d_{SR}/d_{SD} = 0.35$. For the Demodulate-and-Forward (DMF) mode, we have also discussed that the optimal position of the Relay accounts for the trade-off between the demodulation errors on the distance S-R, and the ability of Relay to succeed on the channel R-D. We want to develop a criterion that shows us which position of the Relay brings the best performance. We remind here that the Relay could be either a fixed node, *i.e.* in Wireless Local Area Networks (WLAN), or either a moving node, *i.e.* in Vehicular Ad-hoc Networks (VANET). In a multi-node network, it is very important to know how to select the best Relay to cooperate. If there will be only one Relay to be chosen for cooperation and if its position would be fixed, than we should have a criterion that shows which is the best position of the Relay in average. But, if there would be many Relay candidates between the Source and the Destination, then we should have a criterion to choose the best instantaneous Relay to cooperate, where the positions of Relays could vary based on the instantaneous quality of the channels S-R and R-D. Similar literature for Relay selection have been discussed a lot, like in [Liu 2013] where there are proposed two retransmission schemes in which the Relay is chosen by comparing its SNR on the

link S-R with a simulated threshold, or like in [Wided Hadj Alouane 2012] where the Relay working on DMF mode is chosen by comparing its SNR with another threshold. In contrast, in our work we will focus on Relay selection based on the absolute values of LLRs and the probabilities of demodulation errors per coded bit.

We assume that we know the propagation conditions on the channels S-D, S-R and R-D, where we assume block fading according to Rayleigh distribution and also impaired by complex Gaussian noise with density N_0 . We consider Convolutional Coding and 16-QAM modulation. Each information PDU is of length 1000 bits. The average energy per modulated symbol is the same at S and R, $E_s = 1$, and as a result the transmit E_b/N_0 is the same on the channels S-D and R-D. The path-loss exponent is $\alpha = 2.4$.

6.2 Selecting the optimal position of the Relay

Let us focus initially on the analysis of a system working without channel coding. Then, the first thing that we want to analyze is to check what happens with the demodulation errors on the channel S-R-D. Since the Relay works on the mode Demodulate-and-Forward (DMF), we need to account for the fact that the Relay may not forward the correct information to the Destination, due to the demodulation errors. Therefore, the demodulation symbol errors at the Destination for the entire link S-R-D occur when:

- The symbol on the channel S-R is received correctly and the symbol on the channel R-D is received in error, or
- The symbol on the channel S-R is received in error and the symbol on the channel R-D is received correctly.

Denoting the probability of symbol error after demodulation on the channel X-Y with τ_{XY} , then the probability of symbol error after demodulation on the two-hop link S-R-D is given [Tairan Wang 2007]:

$$\tau_{SRD} = (1 - \tau_{SR}) \cdot \tau_{RD} + (1 - \tau_{RD}) \cdot \tau_{SR} \quad (6.1)$$

Probability that a symbol is demodulated in error on the channel X-Y with fading coefficients h_{XY} and when M-QAM modulation is used, is given with [K. Pahlavan 2005]:

$$\tau_{XY}(\Gamma) = 4 \cdot Q \left(\sqrt{\frac{3 \cdot \Gamma}{M-1}} \right) \quad (6.2)$$

where, Γ is the instantaneous SNR and it is given with $\Gamma = \frac{E_s \cdot l(d_{XY})}{N_0} |h_{XY}|^2$.

Channel coefficients h_{XY} follow Rayleigh distribution, while h_{XY}^2 follow chi-square distribution. Then, the probability density function $P_{\text{df}}(\Gamma)$ is given with [Rao 2015]:

$$P_{\text{df}}(\Gamma) = \frac{1}{\bar{\Gamma}} \exp\left(-\frac{\Gamma}{\bar{\Gamma}}\right) \quad (6.3)$$

where, $\bar{\Gamma}$ is the average receive SNR on the channel X-Y and it is given as:

$$\bar{\Gamma} = \frac{E_s \cdot l(d_{XY})}{N_0} \text{E} \left[|h_{XY}|^2 \right] = \frac{E_s \cdot l(d_{XY})}{N_0} \quad (6.4)$$

since the variance is $\text{E} \left[|h_{XY}|^2 \right] = 1$.

Now, averaging over all possible instantaneous SNRs, Γ , we obtain the average symbol error rate after M-QAM demodulation on the channel X-Y as [Rao 2015]:

$$\tau_{XY} = \int_0^\infty \tau_{XY}(\Gamma) \cdot P_{\text{df}}(\Gamma) d\Gamma \quad (6.5)$$

Considering that we use the rectangular constellation based on Gray coding, then we may assume that the bit error probability ϕ is k -times smaller than the symbol error probability τ , and therefore the two probabilities are related as [K. Pahlavan 2005] $\phi_{XY} = \tau_{XY} / \log_2(M)$.

The error probabilities for information bit after the demodulation for the entire link S-R-D, ϕ_{SRD} , counting for errors on the channels S-R and R-D, for various positions of the Relay, are simulated and compared as shown in Figure 6.1. The results are shown for few points of receive E_b/N_0 on the channel S-D. As we may see from the Figure, the lowest rate of demodulation errors we have when the Relay is located in the middle of link S-D, $d_{SR}/d_{SD} = 0.50$.

Since channel coding is not used, than an ACK-ed PDU would mean the one which has all the symbols received correctly. Reminding that with $\tau_{XY}(\Gamma)$ there is denoted the instantaneous probability that a symbol on the channel X-Y is demodulated in error, then for the fully-interleaved channel (each transmitted symbol experiences different fading over the channel) the probability that a PDU transmitted from the Relay is received in error at the Destination is denoted with $\theta_{[0,1], \text{fully}}$ and is given as [Paul Ferrand 2013]:

$$\theta_{[0,1], \text{fully}} = 1 - (1 - \text{E}[\tau_{SRD}(\Gamma)])^{n_s} \quad (6.6)$$

where, n_s is the number of symbols needed to transmit a PDU. On the other hand, when we have block-fading (the symbols in a PDU experience the same or similar fading states), then the probability $\theta_{[0,1], \text{block}}$ is given as [Paul Ferrand 2013]:

$$\theta_{[0,1], \text{block}} = 1 - \text{E}[(1 - \tau_{SRD}(\Gamma))^{n_s}] \quad (6.7)$$

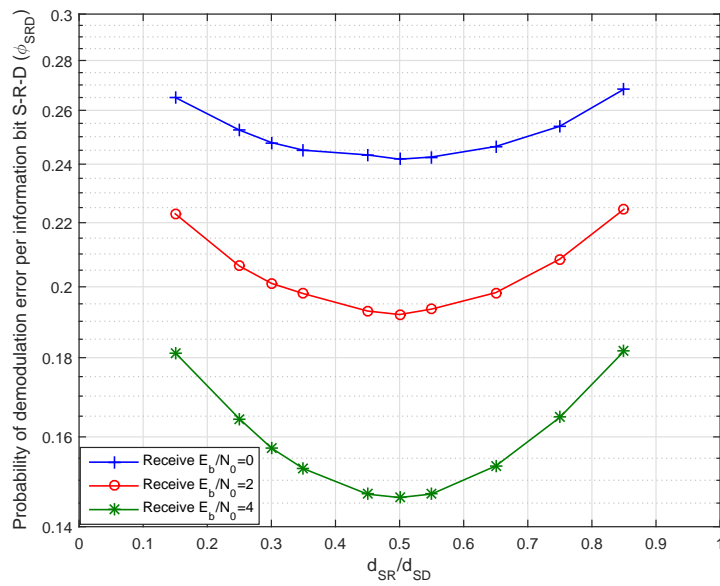

Figure 6.1: Demodulation of bit errors for the entire link S-R-D, various d_{SR}/d_{SD}

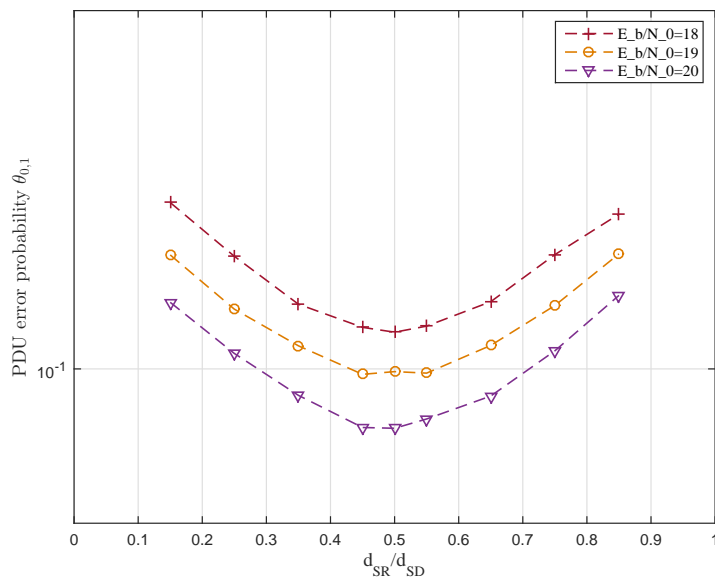

Figure 6.2: PDU error probability after demodulation at D, various d_{SR}/d_{SD}

Keeping the same channel conditions and simulation parameters as in previous Figures, then on Figure 6.2 there is shown the PDU error probability after demodulation $\theta_{[0,1], \text{block}}$. As we may see from the Figure, the lowest probability of

demodulation error for a PDU it is achieved when the Relay is located in the middle of distance S-D.

From Figures 6.1 and 6.2 it can be seen that the lowest rate of demodulation errors it is achieved when Relay is located in the middle of link S-D. Since we need to account for demodulation errors on both hops, S-R and R-D, as given on equation (6.1), than it can be inferred that the demodulation performance it is symmetrically around $d_{SR}/d_{SD} = 0.50$. This means that the rate of demodulation errors on the link S-R-D when Relay is in distance d_1 from the Source is equal with the rate of demodulation errors on the link S-R-D when Relay is in distance d_1 from the Destination. At $d_{SR}/d_{SD} = 0.50$, both hops S-R and R-D experience the same rate of demodulation errors simultaneously, which shows to be the best compromise between the two hops.

Let us now focus on the case when we use convolutional coding with code rate $R_c = 1/3$. We remind here that since E_b/N_0 represent the ratio per information bit and the transmitted sequence is encoded with code rate $R_c = 1/3$, then the true E_b/N_0 on the plot can be represented via the ratio per coded bit, E_{cb}/N_0 , using the relationship $E_{cb} = E_b R_c$. In Figure 6.3 there is shown the average probability that a single PDU from the Relay is decoded with error at the Destination. The simulation is performed for various positions of the Relay, and for the same points of E_b/N_0 like in Figure 6.1. As we may see from Figure 6.3, the lowest probability of decoding errors for a PDU is achieved when Relay is located between $d_{SR}/d_{SD} = 0.30$ and $d_{SR}/d_{SD} = 0.35$. This is interesting as it shows that the optimal position of the Relay when an error correction decoder is used, does not correspond with the optimal position of the Relay without channel coding. In other words, even though at the location $d_{SR}/d_{SD} = 0.50$ we experience less demodulation errors than at any other location, it seems like at the location around $d_{SR}/d_{SD} = 0.30$ the decoder is more able to correct the demodulation errors than at $d_{SR}/d_{SD} = 0.50$. Since intuitively one expects that the optimal location to be there where less demodulation errors are experienced and since the decoding results show the optimal location somewhere else from the initial expectation, than our focus is to find a criterion that shows us the optimal position of the Relay before the decoding is performed. Of course, the initial analysis will be performed for the same example setup as in previous analysis, i.e. the same modulation scheme, the same channel coding scheme, the same channel conditions, the same PDU length, the same value of path-loss exponent, etc. Then, we will see if the same criterions hold also for other cases and other scenarios.

6.2.1 Criterion for choosing the optimal position of the Relay

As we have seen earlier, for choosing the optimal position of the Relay when we use channel coding we cannot focus only on the demodulation errors. Therefore, since we observe received sequences on the channel R-D and the Destination knows the statistics of the channel S-R, then we may evaluate the Log-likelihood ratio

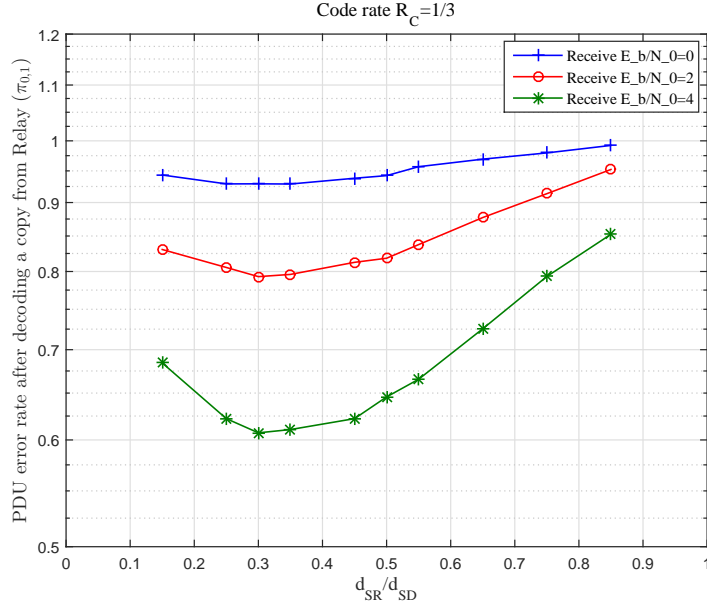

Figure 6.3: PDU error probability after decoding a single copy from Relay, various d_{SR}/d_{SD}

(LLR) for each coded bit at the Destination, as explained in section 2.3.1.2. Using logarithmic properties, then the expression for the LLR of the k^{th} coded bit of the n^{th} symbol on the link S-R-D can be rearranged in the form:

$$\Lambda_{k,n} = \log \left\{ \exp^{-Y_{0,RD}} - \tau_{SR} [Y_{0,RD} - Y_{1,RD}] \right\} - \log \left\{ \exp^{-Y_{1,RD}} + \tau_{SR} [Y_{0,RD} - Y_{1,RD}] \right\} \quad (6.8)$$

where,

$$Y_{0,RD} = \frac{\left\| y_{RD,n} - \sqrt{E_s \cdot l(d_{RD})} \cdot h_{RD,n} \cdot x_0 \right\|^2}{N_0} \quad (6.9)$$

$$Y_{1,RD} = \frac{\left\| y_{RD,n} - \sqrt{E_s \cdot l(d_{RD})} \cdot h_{RD,n} \cdot x_1 \right\|^2}{N_0} \quad (6.10)$$

and where, x_0 is the symbol associated to bit 0, and x_1 is the symbol associated to bit 1. For M-QAM modulation, we have shown in section 2.3.1.2 that for these symbols we use marginal probabilities among the M-QAM symbols with particular bit k equal 0 or 1, respectively.

It is known that the sign of an LLR value denotes the detected bit result and its absolute value denotes the degree of confidence [Sklar 2001]. Therefore, a higher absolute value of LLR represent a higher confidence that the decoding decision would be correct. Therefore, initially we evaluate the sum of absolute values of each LLR of the whole sequence of coded bits, and then we evaluate the average absolute value

of LLR per coded bit by dividing the sum with the number of coded bits n_c of the sequence as:

$$|\bar{\Lambda}| = \frac{\sum_{i=1}^{n_c} |\Lambda_i|}{n_c} \quad (6.11)$$

where, $n_c = L_1/R_c$. Notice that the measure $|\bar{\Lambda}|$ is evaluated before Destination performs channel decoding, and hence does not represent a measure of the confidence in value of the information bits, but a measure of the confidence on the coded bits. The simulation of $|\bar{\Lambda}|$ for various location of the Relay and for $E_b/N_0 \in \{0, 2, 4\}$ is shown in Figure 6.4.

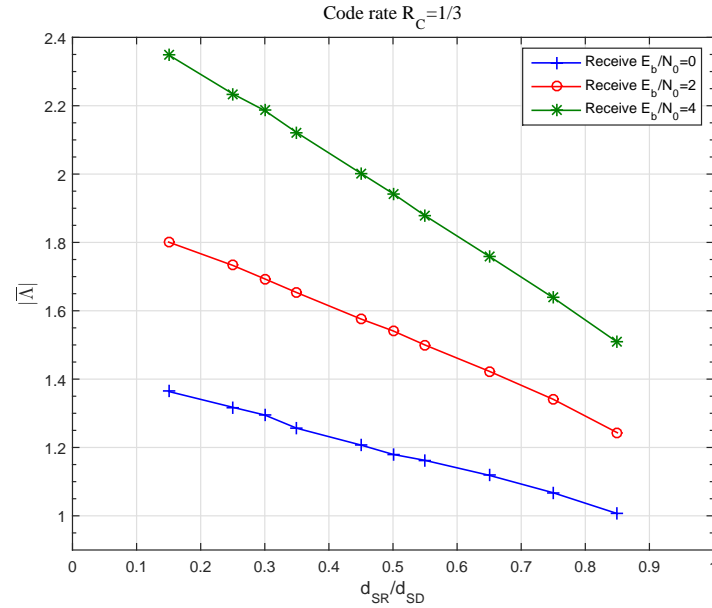

Figure 6.4: Average absolute value of the LLR per coded bit at the Destination, various d_{SR}/d_{SD}

As we may see from Figure 6.4, the value of $|\bar{\Lambda}|$ is higher when the Relay is located close to the Source. As the Relay gets further from the Source, the value of $|\bar{\Lambda}|$ decreases from effect of the potential error demodulation at the Relay, as visible from the following experiment. Now, let us consider the same case as in Figure 6.4 for $E_b/N_0 = 2$. We want to compare the case when Relay has no demodulation errors at all, with the cases when the demodulation errors on the Relay are added proportionally step by step up to the real value of errors. In this case, we want to compare how the curve of $|\bar{\Lambda}|$ is changing depending on the rate of demodulation errors on the Relay. The corresponding comparison by simulation is shown in Figure 6.5. As we may see from the plot, when the Relay does not suffer from any demodulation error, then the value of $|\bar{\Lambda}|$ is exponentially increasing as the Relay approaches the Destination. But, as the rate of demodulation errors on the Relay increase, the highest decrease on the value of $|\bar{\Lambda}|$ it is experienced at the locations

close to the Destination. Moreover, we see that when we increase the rate of demodulation errors on the Relay up to its real value, the value of $|\bar{\Lambda}|$ becomes higher at the location close to the Source. This plot is a good example which shows how much the demodulation errors on the Relay affects the value of LLR on the Destination.

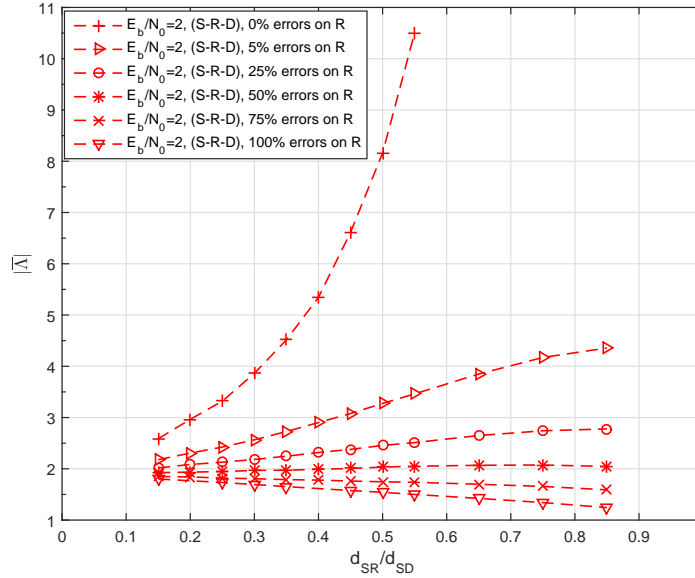

Figure 6.5: The value of $|\bar{\Lambda}|$ by varying the rate of errors ϕ_{SR} on R, various d_{SR}/d_{SD}

Having only the measure (6.11) does not give us any information about the optimal position of the Relay. A criterion for choosing the optimal position of the Relay may take into account both measures, $|\bar{\Lambda}|$ and ϕ_{SRD} . Researching into this direction, we have observed that the ratio between the two, $|\bar{\Lambda}|$ and ϕ_{SRD} , which we call as *ratio of confidence* ρ_c , tells us the best compromise between the two measures and hence the optimal position of the Relay. Defining this ratio as a metric, then the criterion for choosing the optimal position of the Relay would be the one which produces the highest value of the ratio ρ_c , as

$$\max_{d_{SR}/d_{SD}} \rho_c = \max_{d_{SR}/d_{SD}} \frac{|\bar{\Lambda}|}{\phi_{SRD}}. \quad (6.12)$$

We consider that as high as the ratio ρ_c is, we have higher confidence that the errors could be corrected in the decoder.

In Figure 6.6 there is shown the applied criterion for various positions of the Relay. As we may see, this criterion works perfectly and it is in line with the behaviour of decoding probability of Figure 6.3. The results confirm that between $d_{SR}/d_{SD} = 0.30$ and $d_{SR}/d_{SD} = 0.35$ there is achieved the optimal position of the Relay. This is confirmed for various points of E_b/N_0 , where we see that the ratio ρ_c

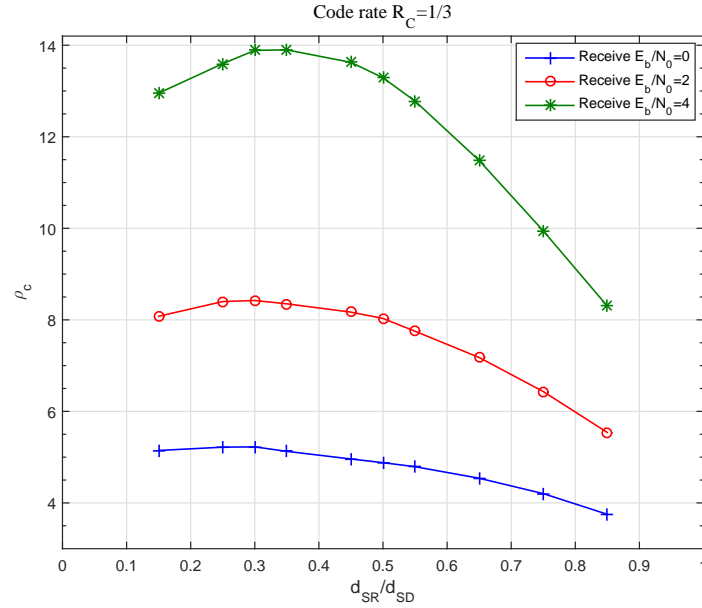
Figure 6.6: Comparison of proposed criterion for various d_{SR}/d_{SD}

increases as the channel improves.

Since in the above Figures we have used the Convolutional Code with code rate $R_c = 1/3$, we want to check what happens if we change the code rate, i.e. whether the optimal position of the Relay changes or remains the same. Considering the same ratio of E_b/N_0 per information bit for each case of different code rate, in Figure 6.7 there is shown the comparison of coded bit error probability ϕ_{SRD} during the demodulation for the entire link S-R-D for various code rates and various position of the Relay. As we may see from the Figure, as the code rate decreases, the probability of demodulation error per coded bit increases. This happens because the energy per information bit E_b is constant, and the energy per coded bit E_{cb} decreases as the code rate decreases. Moreover, on the same plot there are shown the curves of demodulation errors for the direct link S-D. We may see that for the same channel code rate, the demodulation errors on the S-R-D link are always lower than on the direct link S-D.

On the other side, we want also to check what happens if the same scenario of Figure 6.7, we compare from the perspective of the average absolute value of the LLR per bit, $|\bar{\Lambda}|$. This comparison is shown in Figure 6.8. We see that the comparison is extended not only for various positions of the Relay, but also there is compared with the direct link S-D. Interestingly, the value of $|\bar{\Lambda}|$ is higher for the direct link than for the relaying link, and this difference is smaller as the channel code rate decreases. Moreover, the value of $|\bar{\Lambda}|$ is monotonically decreasing as the

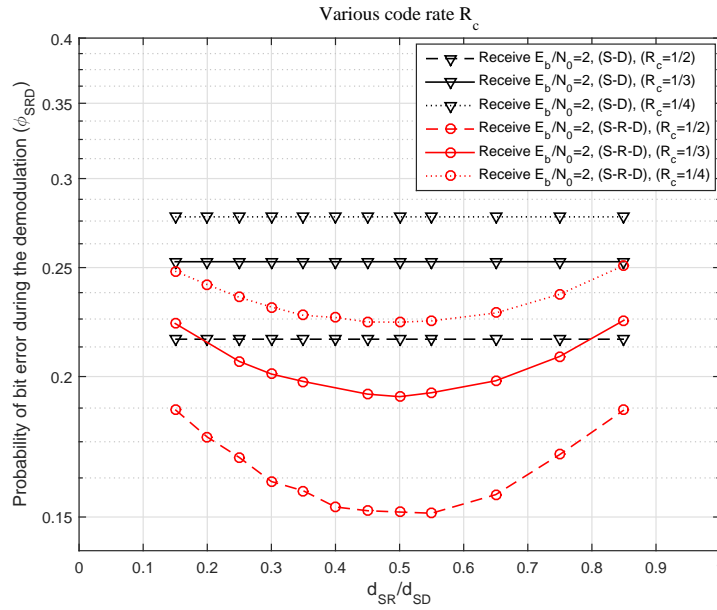

Figure 6.7: Comparison of $\phi_{SRD,k}$ for various channel code rate R_c , various d_{SR}/d_{SD}

Relay moves further toward the Destination.

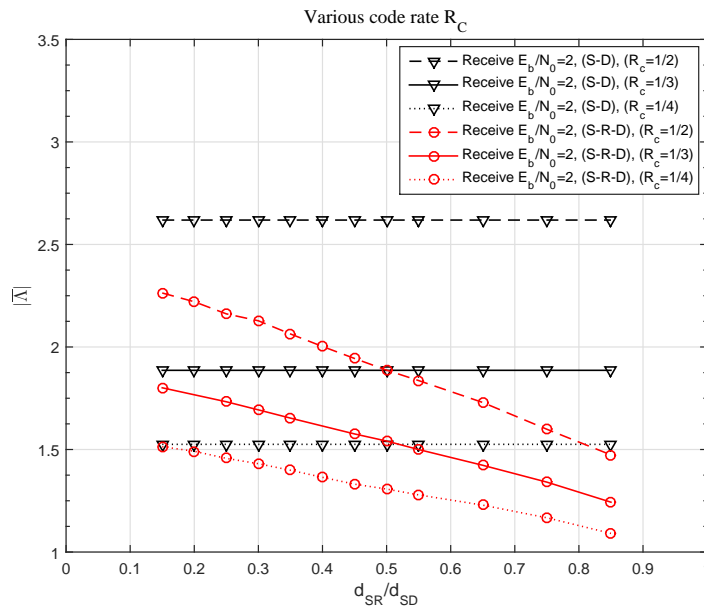

Figure 6.8: Average absolute value of the LLR per bit, various channel code rate R_c , various d_{SR}/d_{SD}

Figures 6.7 and 6.8 confirm once again that we cannot rely entirely only on one metric, $|\bar{\Lambda}|$ or ϕ_{SRD} , and therefore the rate between the two, ρ_c , it is necessary to be used for determining the optimal position of the Relay. In Figure 6.9 there is shown the comparison of proposed metric ρ_c for both links S-D and S-R-D, for various code rate and various position of the Relay. As we may see from Figure 6.9, the comparison shows that the value of criterion ρ_c is higher as the code rate is higher, due to the reason explained earlier: each curve is represented as a function of the same receive E_b/N_0 per information bit, which means that the ratio E_{cb}/N_0 per coded bit is higher as the code rate is higher. Moreover, the comparison shows that the optimal position of the Relay is achieved around the location $d_{SR}/d_{SD} = 0.30$.

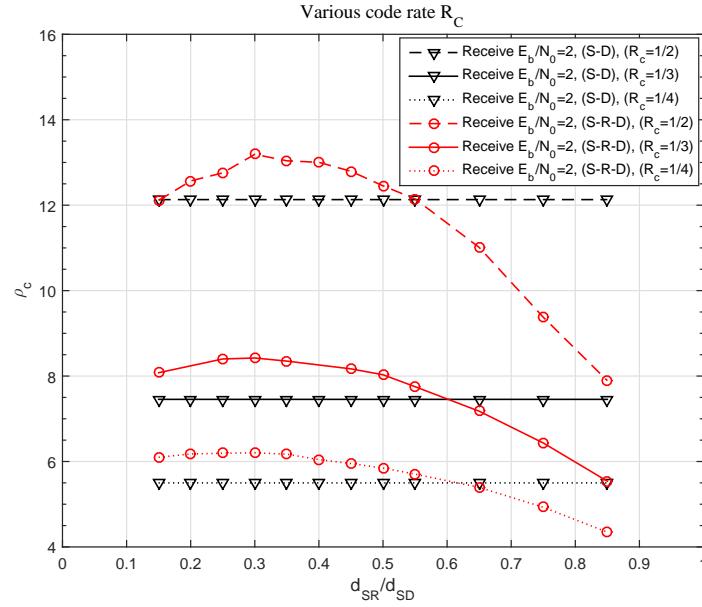

Figure 6.9: Comparison of ρ_c for various code rate R_c , various d_{SR}/d_{SD}

To ensure that the criterion is working properly, in Figure 6.10 there is compared the probability that a single PDU from Relay is decoded with error at the destination $\pi_{0,1}$, for various code rates and for various positions of the Relay. As we may see, for any channel code rate the optimal value of the criterion ρ_c from Figure 6.9 corresponds with the optimal position of the decoding results shown in Figure 6.10, which appears at around $d_{SR}/d_{SD} = 0.30$. Moreover, on Figure 6.10 there is shown also the comparison of probability of decoding error for a single PDU on the channel S-D, $\pi_{1,0}$. Both probabilities, $\pi_{1,0}$ and $\pi_{0,1}$, achieve the lowest value for the code rate $R_c = 1/3$.

We also note that from the comparison of Figures 6.9 and 6.10, we see that the

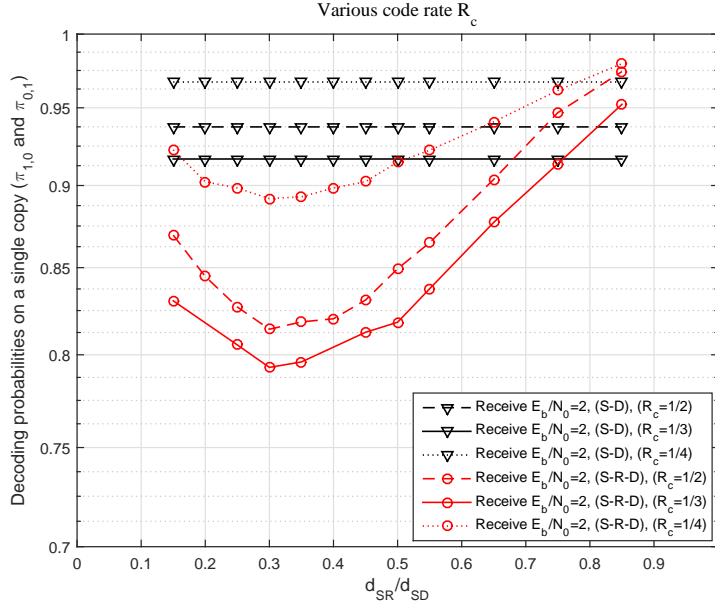

Figure 6.10: Comparison of $\pi_{0,1}$ and $\pi_{1,0}$ for various code rate R_c , various d_{SR}/d_{SD}

ratio of confidence ρ_c can be used not only to determine the optimal position of the Relay, but also to compare the link S-D with the link S-R-D which shows very closely the diversity that we may have by using the Relay.

6.3 Selecting the best instantaneous Relay

In previous subsection we have discussed the issue of choosing the optimal position of the Relay in average. For analysis, we have considered that we have observations of the received symbols on the channel R-D, and we consider that the Destination knows the statistics of the channel S-R. Based on a proposed criterion and using numerical analysis, we find the optimal position of the Relay in average. This information can be used when we try to select the best instantaneous Relay in a scenario when we have multiple candidate nodes to cooperate between a Source and a Destination.

The optimal position of the Relay may depend on many parameters, i.e. demodulation scheme, channel coding scheme, Relay mode, etc., but for our example situation when Relay works on DMF mode, we have seen that in average the optimal position of the Relay appears around $d_{SR}/d_{SD} = 0.30$, where it accounts the best trade-off between the demodulation errors on the channel S-R and the path-loss impact on the channel R-D. But, when we have multiple Relays and we have to choose only one of them, then we need to have a criterion that helps us to choose the best instantaneous Relay to cooperate. In our analysis, we will be helped by

previous analysis about the optimal location of the Relay, and we will also use our criterion ρ_c for choosing the best Relay.

6.3.1 Comparison of criterion ρ_c with a referent criterion

The problem of Relay selection has been treated a lot on the literature, where various criterions have been proposed. On [Alexan 2014] there is proposed a criterion based on the average absolute value of Log Likelihood Ratio (LLR) $|\bar{\Lambda}|$. On a scenario where Relay works on DMF mode, the best Relay it is chosen the one which has the highest $|\bar{\Lambda}|$ among the candidate Relays, and then this value it is compared with the value $|\bar{\Lambda}|$ of the channel S-D. Since when Relay is located close to the Source it has most of the time $|\bar{\Lambda}_{SR}| > |\bar{\Lambda}_{SD}|$, then we assume that the condition for activating a Relay in [Alexan 2014] it is fulfilled most of the time. Moreover, the authors in [Alexan 2014] consider a random distribution of Relays, but in our case we want to perform the comparison of our criterion with the referent criterion on the link S-R targeting the Relays distributed around the optimal location obtained in previous subsection. According to the selection procedure, with our criterion we will select the Relay which has the highest ρ_c among the candidate Relays, and with the referent criterion we will select the Relay which has the highest $|\bar{\Lambda}|$, and we compare performance of the two. The implementation of these criterions requires that calculations of ρ_c and $|\bar{\Lambda}|$ needs to be done, and an exchange of this information is needed. For this problem we consider that in some communication standards like IEEE 802.11 there exist RTS (request-to-send) and CTS (clear-to-send) messaging communication between the nodes, and we assume that these messages may be modified to exchange the required information of ρ_c and $|\bar{\Lambda}|$ between the nodes. Practically, we consider that the Source broadcasts the PDU which is received by the Destination and by the Relays. Each of the Relays calculate the corresponding ρ_c and $|\bar{\Lambda}|$ and forwards it to the Destination via RTS message. Then, the Destination compares which Relay has the highest value of the metric (ρ_c or $|\bar{\Lambda}|$) and if a retransmission is needed, then the Destination broadcasts NACK to the Source and the Relays in paralel with CTS message, by showing also the decision which node will retransmit the PDU.

In a scenario of having multiple Relays between a Source and a Destination, we consider that we should target the Relays which are located around $d_{SR}/d_{SD} = 0.35$. In this location, we want to compare both criterions. In Figure 6.11 there is compared the probability that the destination decoder issues NACK on a single copy received from Relay for the following cases: when we have only 1 Relay appearing at that particular location, when we have 2 Relays (only one is chosen) at that location, and when we have 3 Relays (only one is chosen) at that location. Both criterions are compared for the cases of having more than one Relay. As we may see from the comparison, both criterions applied for choosing the best Relay, show better performance than having only a single Relay. Moreover, as the number of

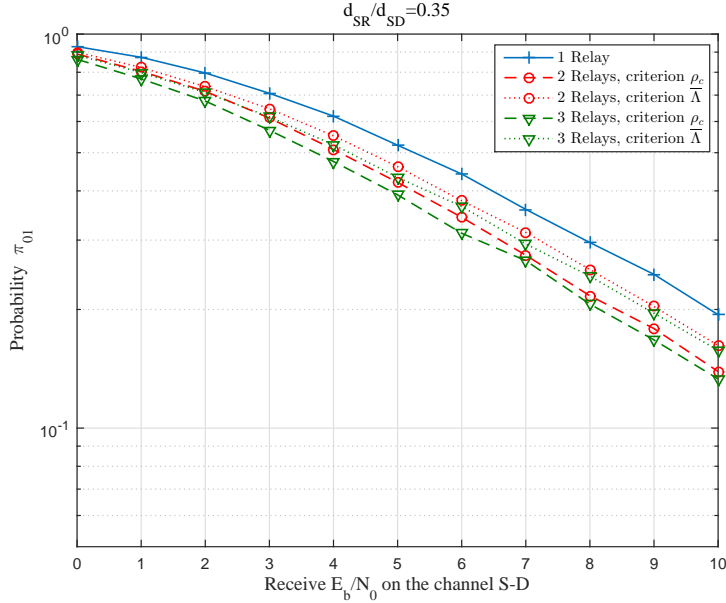

Figure 6.11: Comparison of $\pi_{0,1}$ achieved with both criteria

appeared Relays at that location increases, the performance improves, as we have more choices. In each case, we see that the performance achieved with our criterion ρ_c is better than with the referent criterion $|\bar{\Lambda}|$.

Let us now consider that we want to take into account also the link S-D for analysis. As discussed in section 2.3.1.2, the LLR of the k^{th} coded bit of the n^{th} symbol for the direct link S-D can be rewritten as:

$$\Lambda_{k,n} = \frac{\left\| y_{SD,n} - \sqrt{E_s \cdot l(d_{SD})} \cdot h_{SD,n} \cdot x_1 \right\|^2}{N_0} - \frac{\left\| y_{SD,n} - \sqrt{E_s \cdot l(d_{SD})} \cdot h_{SD,n} \cdot x_0 \right\|^2}{N_0} \quad (6.13)$$

Then, since the destination decoder performs Chase combining, then for the case of having multiple copies to be combined at the Destination, the LLRs of all the copies are added per coded bit for a better decoding. We remind that the LLR for the link S-R-D is given previously with equation (6.8). We also assume that the best position of the Relay chosen from the previous analysis based on a single copy from Relay, remains also as the optimal position for the case of combining to the decoder. This can be seen also from the numerical analysis on Chapters 3 and 5.

Let us now consider that we have a communication protocol where the maximum number of transmissions per PDU is limited to 2. Then, we want to compare the following cases: 1) both transmissions come from the Source; 2) first transmission comes from the Source, and one retransmission comes from the Relay (only 1 Relay

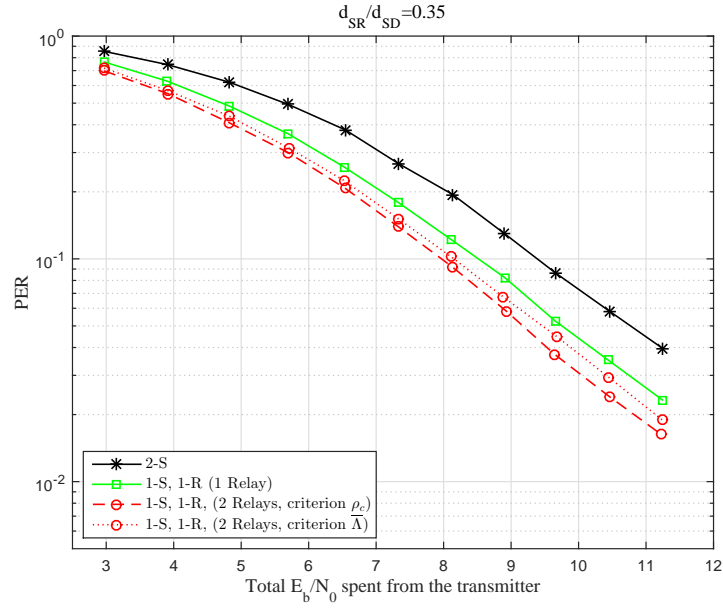

Figure 6.12: Comparison of PER achieved with both criteria

available on that location); 3) first transmission comes from the Source, and one retransmission comes from the Relay (2 Relays available on that location). For the latter case 3) we also compare performances achieved with both criteria. The aforementioned comparison is shown in Figure 6.12, where the PER is represented as a function of total E_b/N_0 spent from the transmitter. The total transmit E_b/N_0 considers the average energy per information bit spent by the protocol, including all retransmissions. As we may see from the plot, in any case, by using the Relay we have better performance than having both transmissions from the Source. As expected, applying a criterion for choosing the best Relay in a multi-node network, brings better performance than having only a single Relay. Moreover, we see that the performance achieved when we apply our criterion for Relay selection, is better than on the case when the referent criterion is applied.

We want also to compare the same scenario from the perspective of Goodput. This comparison is shown in Figure 6.13, where Goodput is shown as a function of total E_b/N_0 spent from the transmitter. We reconfirm that the Relay is beneficial to use, and also we reconfirm that the performance is better when selection criteria are applied in a scenario with more than one Relay. Even on the context of Goodput, we see that our criterion ρ_c performs better than the referent criterion.

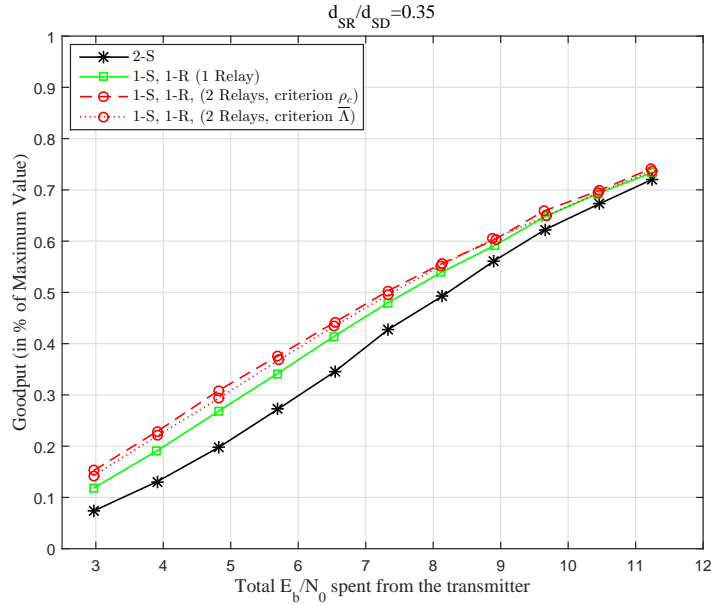

Figure 6.13: Comparison of Goodput achieved with both criteria

6.4 Conclusions

In this Chapter we have discussed the issue of Relay selection in cooperative networks. A Source can communicate with a Destination with the help of a Relay, but in a scenario where multiple nodes are candidates that can help the communication between a Source and a Destination, it is important to know how to select the best Relay to cooperate. Therefore, our analysis is focused in two parts: the issue of selecting the best position of the Relay in average, and the issue of selecting the best instantaneous Relay. On the first part, the analysis is focused on two measures: the absolute value of LLR on the coded bits at Destination and the probability of demodulation errors of the coded bits at the Relay. Since in most of our work the Relay is considered to work on DMF mode where Relay may not forward always the correct symbols toward the Destination, then it is observed that a useful criterion for selecting the best location of the Relay can be defined as the ratio of the two measures. This criterion provides a good prediction of the optimal position of the Relay. Moreover, it can be used to compare the PDU error probabilities $\pi_{1,0}$ and $\pi_{0,1}$ which helps in determining whether relaying should be activated or not. On the second part, we have considered the problem of choice of the best instantaneous Relay among a co-located group. If the instantaneous channel is known, the proposed criterion can be used to select the best Relay. We have compared our criterion with a referent criterion, and the performance achieved by applying our criterion is higher than with the referent criterion.

Conclusions and further perspectives

Contents

7.1	Conclusions	103
7.2	Further work considerations	104

7.1 Conclusions

In this thesis we have given an analysis of the HARQ protocol on a cooperative network containing one Source, one Relay and one Destination. On this S-R-D scenario, we have considered an example protocol and we have shown how to evaluate the performance of communication protocols using Finite State Machines (FSM) and Finite State Markov Chains (FSMC), for both types of decoders (type I and type II) and for both working modes of the Relay (DMF and DCF). Then, we have seen that as the protocol gets more sophisticated or as the number of retransmissions increases, the FSMC analysis becomes more complex. To solve this problem, we have given a method for simplifying the FSMC of a deterministic protocol using state aggregation. Since during the aggregation we grouped only the states with the same actions and as a result the number of actions remains the same, then we have shown that the simplified FSMC can be associated with a probabilistic protocol that in general case and for both types of decoders can be described via four-states FSM that contains only two parameters that can be used to choose probabilistically the retransmitting node and determine the average number of transmissions per PDU.

Performance prediction is an important issue of communication protocols. The frameworks proposed for performance evaluation are shown to predict accurately performance of the actual systems for both protocols: deterministic and probabilistic. This allows to optimize the parameters of the communication protocols in both cases. The attention is focussed then on the probabilistic protocols, which are very simple in implementation. Most importantly, it is shown how a single probabilistic protocol can emulate a variety of deterministic protocols, which would require separate descriptions, simply by the tuning of very few parameters.

For type I decoding, there is proposed a six-states FSMC that can be used to predict almost exactly performance of the probabilistic protocol. Via this FSMC, there is addressed also the issue of performance optimization, providing thus optimized values of γ and β for various locations of the Relay. For type II decoding, there is proposed a FSMC with higher number of states but which is still very effective and allows fast prediction of the performance. The optimization can be performed very easily by adjusting only two parameters that bring the best performance for any location of the Relay. Moreover, by choosing proper values of probabilistic parameters γ and β , we can emulate many deterministic protocols.

Via optimization analysis we were able to find the optimized location of the Relay for both types of decoders. We remind here that in DMF mode, the optimized location accounts for trade-off between the demodulation errors on the channel S-R, and the ability of Relay to succeed on the remaining distance R-D. Since in different types of networks the Relay can be either fixed, e.g. in Wireless Local Area Networks (WLAN), or a moving node, e.g. Vehicular Ad-Hoc Network (VANET), then by using a proposed criterion we have discussed the issue of choosing the optimal location of the Relay in average, and the issue of choosing the optimal instantaneous Relay to cooperate. The proposed criterion is compared against a criterion of literature and the performance achieved by applying our criterion is higher.

7.2 Further work considerations

As directions for future work can be considered the following cases:

- The analysis shown in this thesis can be repeated for the case of various assumptions for Channel State Information (CSI);
- The same tools developed and used in this work, can be applied for more complex cases, i.e. by increasing the number of nodes on the network;
- The analysis could be extended on the case when a Rate-Compatible Punctured Convolutional Code (RCPC) will be used as a channel code, and Incremental Redundancy (IR) will be applied as a combining method on the receiver;
- The criterion discussed in Chapter 6 for selecting the best instantaneous Relay is mainly based on the assumption that the best Relays in average are located around $d_{SR}/d_{SD} = 0.35$ and therefore in our analysis we have targeted the Relays in that region. But, as a future direction could be to generalize the criterion for more general situations, where the best instantaneous Relay could appear also at other locations.

List of Acronyms and Nomenclature

LIST OF ACRONYMS

ACK	Acknowledgement
AF	Amplify-and-Forward
ARQ	Automatic Repeat re-Quest
BER	Bit Error Rate
CPU	Central Processing Unit
CRC	Cyclic Redundancy Check
CSI	Channel State Information
CTS	Clear-to-Send
D	Destination
DCF	Decode-and-Forward
DMF	Demodulate-and-Forward
DSP	Digital Signal Processing
FEC	Forward Error Correcting
FSM	Finite State Machine
FSMC	Finite State Markov Chain
HARQ	Hybrid Automatic Repeat re-Quest
IR	Incremental Redundancy
LLR	Log Likelihood Ratio
LTE	Long Term Evolution
MAC	Media Access Control
MC	Markov Chain
NACK	Negative Acknowledgement
PER	PDU Error Rate
PDU	Protocol Data Unit
PHY	Physical

PR	Page Rank
QAM	Quadrature Amplitude Modulation
R	Relay
RCPC	Rate Compatible Punctured Convolutional
RRT	Relay Retransmits
RTS	Request-to-Send
S	Source
SRT	Source Retransmits
ST	Source Transmits
VANET	Vehicular Ad-Hoc Network
WLAN	Wireless Local Area Network

NOMENCLATURE

L	Length of information bits in a PDU
G	Length of CRC code
L_1	Length of PDU after CRC code is added to information bits
R_c	Code rate
K	Constraint length at RCPC code
O	Puncturing period at RCPC code
E	Memory at RCPC code
M	Constellation size of modulation
k	Number of bits in a modulated symbol
\mathbf{m}	Vector containing information bits + CRC code
\mathbf{c}	Vector containing coded bits of PDU (after coding vector \mathbf{m})
\mathbf{x}	Vector containing modulated symbols of PDU
n_s	Number of symbols in vector \mathbf{x}
n_c	Number of coded bits in vector \mathbf{c}
τ_t	Duration of time-slot
τ_s	Time-duration of symbol

s_t	Number of transmitted symbols in a time-slot
N_{ts}	Number of time-slots needed for transmission of modulated vector \mathbf{x}
E_s	Average energy per modulated symbol
E_b	Energy per information bit
\mathbf{x}_t	Vector of modulated symbols at time-slot t
d_{XY}	Distance between nodes X and Y
$l(d_{XY})$	Path-loss factor on the path $X - Y$
α	Path-loss exponent
M	Constellation size of modulation
$\mathbf{w}_{\mathbf{X}Y,t}$	Vector of white complex noise components on the channel $X - Y$ at time-slot t
N_0	Noise spectral density
$\mathbf{h}_{\mathbf{X}Y,t}$	Vector of fading complex coefficients on the channel $X - Y$ at time-slot t
$\mathbf{y}_{\mathbf{X}Y,t}$	Vector of received symbols on the channel $X - Y$ at time-slot t
$\sigma_{h,XY}^2$	Variance of fading channel coefficients on the path $X - Y$
$\sigma_{w,XY}^2$	Variance of noise channel coefficients on the path $X - Y$
$c_{n,i}$	i^{th} coded bit of n^{th} symbol
$\Lambda_{n,i}$	Log-likelihood ratio of i^{th} coded bit of n^{th} symbol
$p(y_{XY,n} c_{n,i})$	Likelihood function of the n^{th} received symbol on the channel $X - Y$, knowing i^{th} coded bit of n^{th}
$\text{Pdf}(\cdot)$	Probability density function
$\hat{\mathbf{m}}$	Estimated vector of \mathbf{m} after decoding at the receiver
τ	Probability that a symbol is demodulated with error
ϕ	Probability that a bit is demodulated with error
A	Number of copies combined from the Source
B	Number of copies combined from the Relay
D_R	Control parameter that shows if Relay has correctly demodulated the copy from Source
\bar{T}	Average number of transmissions per PDU
ν	Total number of information PDUs transmitted during the operation time

ν_t	Total number of information PDUs that were transmitted t -times during the operation time
N_{\max}	Maximum number of transmissions per PDU
σ	Total number of information PDUs that were ACK-ed during the operation time
G	Goodput
P	Probability transition matrix of the deterministic protocol, type I decoder
\mathbf{p}	Steady state vector of matrix P
λ	Eigenvalue
N_S	Maximum number of times that Source can transmit the same PDU
N_R	Maximum number of times that Relay can retransmit the same PDU for each (re)transmission from Source
t_S	Counter of the number of transmissions of the same PDU from Source
t_R	Counter of the number of transmissions of the same PDU from Relay after each (re)transmission from Source
W	Last control message by the Destination
P_{ij}	Transition probability from state i to state j
$\pi_{[1,0]}$	Probability that Destination issues NACK after decoding the last copy from Source
$\pi_{[0,1]}$	Probability that Destination issues NACK after decoding the last copy from Relay
P_{II}	Probability transition matrix of the deterministic protocol, type II decoder
W_R	Control message of decoding at Relay
c_k	Probability of accessing state k
$\pi_{[A,B]}$	Probability that D fails in decoding the current PDU, based on A copies from S and B copies from R, knowing that previous decoding with less copies has been unsuccessful
E_b/N_0	Ratio of energy to noise per information bit in [dB]
z	Index of the states at FSM representation of deterministic protocol, DCF mode
α_R	Probability that R cannot decode correctly the copy coming from S

T	Binary transition matrix used for transforming the original transition matrix to the aggregated transition matrix
$P_{S,I}$	Probability transition matrix of the deterministic protocol on a S-D path, type I decoder
$Z_{S,I}$	Simplified transition matrix of $P_{S,I}$, type I decoder
α	Probabilistic parameter that links matrices $P_{S,I}$ and $Z_{S,I}$
$P_{R,I}$	Probability transition matrix of the deterministic protocol on a S-R-D network, type I decoder
$Z_{R,I}$	Simplified transition matrix of $P_{R,I}$, type I decoder
γ	Probability that R will not retransmit in the next time-slot knowing that it failed previously
β	Probability that S is not allowed to retransmit on the next time-slot after R failed previously and after it is not allowed to retransmit one more time
$P_{R,II}$	Probability transition matrix of the deterministic protocol on a S-R-D network, type II decoder
$Z_{R,II}$	Simplified transition matrix of $P_{R,II}$, type II decoder
$\pi_{[RF]}$	Average probability of failing when R retransmits, combining all previous copies on the decoder
$\pi_{[SF]}$	Average probability of failing when S retransmits, combining all previous copies on the decoder
P_{DCF}	Probability transition matrix of the deterministic protocol on a S-R-D network, type I decoder, DCF mode
R_{DCF}	Simplified transition matrix of P_{DCF} , type II decoder, DCF mode
V_S, V_R	Control random variables for defining the states on the four-states simplified FSM
$\pi_{0,1}(k)$	Probability of failing from R for the k -th successive time
C	Counter of the successive number of retransmissions of the same PDU from R
$Z_{P,I}$	Probability transition matrix of the probabilistic protocol, type I decoder
C_{\max}	Size of the buffer at the decoder
B_s	The belief that hard demodulation of the received sequence would produce the correct sequence
CO	Parameter that represent the order with which the packets have filled the buffer

π_S^{co}	The average probability of decoding failure at D, when the current transmission is performed by S
π_R^{co}	The average probability of decoding failure at D, when the current transmission is performed by R
Q	Probability transition matrix of the FSMC representing the probabilistic protocol with limited buffer, type II decoder
\mathbf{W}_R	Number of substitutions that have happened in the buffer before the current time-slot
$q_R(\mathbf{w})$	Probability that on the buffer there are substituted w copies
π_Y^{Cmax}	The average probability of failing successively up to A copies from S and B copies from R, and after the worst copy from node Y is replaced one time
$ \bar{\Lambda} $	The average absolute value of LLR per coded bit
ρ_c	Rate of confidence per coded bit (at the proposed criterion)

Bibliography

- [A. Gambin] P. Krzyzanowski A. Gambin and P. Pokarowski. *Aggregation algorithms for perturbed Markov chains with applications to network modeling*. Journal on Scientific Computing, Society for Industrial and Applied Mathematics (SIAM), vol. 31, no.1, pages 45–73. (Cited on pages 22, 27 and 43.)
- [A. Lindgren 2003] A. Doria A. Lindgren and O. Scheln. *Probabilistic routing in intermittently connected networks*. In ACM SIGMOBILE mobile computing and communications review, volume 7, pages 19–20, 2003. (Cited on page 3.)
- [Aldous 2002] David Aldous and James Allen Fill. *Reversible markov chains and random walks on graphs*. Unfinished monograph, recompiled 2014, 2002. (Cited on page 27.)
- [Alexan 2014] Wassim Alexan and Ahmed El Mahdy. *Relay Selection Based on the Log Likelihood Ratio for Cooperative Communication Networks*. In Signal Processing: Algorithms, Architectures, Arrangements, and Applications (SPA), pages 149 – 153, 2014. (Cited on page 99.)
- [Babich 2012] F. Babich, A. Crismani and L. Hanzo. *Relay selection schemes relying on adaptive modulation and imperfect channel knowledge for cooperative networks*. In Proc. IEEE Int. Conf. on Communications (ICC), 2012. (Cited on page 2.)
- [Badia 2008] L. Badia, M. Levorato and M. Zorzi. *Markov Analysis of Selective Repeat Type II Hybrid ARQ Using Block Codes*. IEEE Transactions on Communications, vol. 56, no. 9, 2008. (Cited on page 2.)
- [Brin 1998] Sergey Brin and Lawrence Page. *The Anatomy of a Large-Scale Hypertextual Web Search Engine*. Seventh International World-Wide Web Conference (WWW 1998), 1998. (Cited on page 43.)
- [Chase 1985] D. Chase. *Code combining: A maximum-likelihood decoding approach for combining an arbitrary number of noisy packets*. IEEE Transactions on Communications, vol. 33, no. 5, 1985. (Cited on page 17.)
- [Comroe] R. Comroe and D. J. Costello. *ARQ schemes for data transmission in mobile radio systems*. IEEE Journal on Selected Areas of Communication, vol. 2, pages 472–481. (Cited on page 13.)
- [D. Tse 2005] P. Viswanath D. Tse. *Fundamentals of wireless communication*. Cambridge University Press, 2005. (Cited on page 12.)
- [D. Xu 2016] Y. Yao Ch. Zhang D. Xu Ch. Yang and B. Xia. *Performance Analysis of Bursty Service in Relay Systems with ARQ Protocol*. In IEEE International

- Conference on Wireless Communications & Signal Processing (WCSP), pages 1–5, 2016. (Cited on page 2.)
- [Dayar] T. Dayar and W. J. Stewart. *Quasi-lumpability, lower-bounding coupling matrices and nearly completely decomposable Markov chains*. SIAM Journal on Matrix Analysis and Applications, vol. 18, pages 482–498. (Cited on page 43.)
- [Dianati 2006] M. Dianati, X. Ling, K. Naik and X. Shen. *A Node-Cooperative ARQ Scheme for Wireless Ad Hoc Networks*. IEEE Transactions on Vehicular Technology, vol. 55, no. 3, 2006. (Cited on page 2.)
- [Fukuyama 2009] J. Fukuyama. *A Probabilistic Protocol for Multi-Hop Routing in VANETs*. In ICC Workshops, 2009. (Cited on page 3.)
- [Gallager 2014] R. G. Gallager. *Stochastic processes, theory for applications*. Cambridge University Press, 2014. (Cited on pages 21, 22 and 23.)
- [Hagenauer] J. Hagenauer. *Rate-compatible punctured convolutional RCPC codes and their application*. IEEE Transactions on Communications, vol. 36, no. 4, pages 389–400. (Cited on page 10.)
- [Hagenauer 1996] J. Hagenauer. *Forward error correcting for CDMA systems*. In IEEE International Symposium on Spread Spectrum Techniques and Applications Proceedings, 1996. (Cited on page 8.)
- [Hassan 2011] S. A. Hassan and M. A. Ingram. *A Quasi-Stationary Markov Chain Model of a Cooperative Multi-Hop Linear Network*. IEEE Transactions on Wireless Communications, vol. 10, no. 7, 2011. (Cited on page 2.)
- [Hassan 2014] S. A. Hassan. *Performance Analysis of Cooperative Multi-hop Strip Networks*. Wireless Personal Communications, vol. 74, no. 2, 2014. (Cited on page 2.)
- [Hennie 1968] Frederick C. Hennie. *Finite-state models for logical machines*. Wiley, 1968. (Cited on page 2.)
- [I. Stanojev 2009] Y. Bar-Ness I. Stanojev O. Simeone and D. H. Kim. *Energy efficiency of non-collaborative and collaborative Hybrid-ARQ protocols*. IEEE Transactions on Wireless Communications, vol. 8, no. 1, pages 326–335, 2009. (Cited on page 2.)
- [J. Defranza 2009] D. Gagliardi J. Defranza. *Introduction to linear algebra, with applications*. McGrawHill, 2009. (Cited on page 23.)
- [J. N. Laneman] D. N. C. Tse J. N. Laneman and G. W. Wornell. *Cooperative diversity in wireless networks: efficient protocols and outage behavior*. IEEE Transaction on Information Theory, vol. 50, pages 3062–3080. (Cited on page 9.)

- [K. Pahlavan 2005] A. H. Levesque K. Pahlavan. *Wireless information networks*. Wiley, 2005. (Cited on pages 16, 88 and 89.)
- [Kalos 2008] Malvin H. Kalos and Paula A. Whitlock. *Monte carlo methods*. Willey-SCH, 2008. (Cited on pages 16 and 25.)
- [Keller 2001] Robert M. Keller. *Computer science: Abstraction to implementation*. Harvey Mudd College, 2001. (Cited on page 20.)
- [Krikidis 2007] I. Krikidis. *Distributed truncated ARQ protocol for cooperative diversity networks*. IET Communications, IET Journals & Magazines, 2007. (Cited on pages 2, 3 and 77.)
- [Lajos Hanzo 2011] B. L. Yeap R. Y. S. Tee Soon Xin Ng Lajos Hanzo T. H. Liew. *Turbo coding, turbo equalisation and space-time coding: Exit-chart-aided near-capacity designs for wireless channels*. Willey, 2011. (Cited on page 10.)
- [Li 2014] Y. Li, P. Wang, D. Niyato and W. Zhuang. *A hierarchical framework of dynamic relay selection for mobile users and profit maximization for service providers in wireless relay networks*. *Wireless Communications and Mobile Computing*, vol. 14, no. 12, 2014. (Cited on page 2.)
- [Liu 2013] Ye Liu and Chi Wan Sung. *Network-coded retransmissions in wireless demodulate-and-forward relay channels*. *EURASIP Journal on Wireless Communications and Networking*, 2013. (Cited on page 87.)
- [Luo 2014] Y. Luo, R. Zhang, L. Cai and S. Xiang. *Finite-state Markov modelling for wireless cooperative networks*. *IET Networks*, vol. 3, no. 2, 2014. (Cited on page 2.)
- [M. S. Fazel Falavarjani 2010] R. Hoshyar M. S. Fazel Falavarjani and R. Tafazolli. *Performance Evaluation of A Flexible Amplify and Forward (AF) Combined with HARQ*. In *21st Annual IEEE International Symposium on Personal, Indoor and Mobile Radio Communications*, pages 488–493, 2010. (Cited on page 2.)
- [Ngo 2014] H. Anh Ngo and L. Hanzo. *Hybrid Automatic-Repeat-reQuest Systems for Cooperative Wireless Communications*. *IEEE Communications Surveys & Tutorials*, vol. 16, no. 1, 2014. (Cited on pages 1, 8 and 9.)
- [Norris 1997] J. R. Norris. *Markov chains*. Cambridge University Press, 1997. (Cited on page 24.)
- [Nosratinia 2004] A. Nosratinia, T. E. Hunter and A. Hedayat. *Cooperative communications in wireless networks*. *IEEE Communications Magazine*, vol. 42, no. 10, pages 74–80, 2004. (Cited on pages 1 and 7.)

- [Paul Ferrand 2013] Claire Goursaud Paul Ferrand Jean-Marie Gorce. *Approximations of the packet error rate under slow fading in direct and relayed links*. In Research Report, HAL Id: hal-00834904, RR-8316, INRIA, 2013. (Cited on page 89.)
- [Pursley] M. B. Pursley and S. D. Sandberg. *Incremental redundancy transmission for meteor-burst communication*. IEEE Transaction on Communications, vol. 39, pages 689,702. (Cited on page 17.)
- [Q. Li 2015] A. Pandharipande T. Han J.Zhang Q. Li M. Yu and X.Ge. *Cooperative Two-Path Relay Channels: Performance Analysis Using A Markov Framework*. In IEEE International Conference on Communications (ICC), pages 3573–3578, 2015. (Cited on page 2.)
- [Rao 2015] K. Deergha Rao. Channel coding techniques for wireless communications. Springer, 2015. (Cited on pages 15 and 89.)
- [S. Tomasin 2007] M. Levorato S. Tomasin and M. Zorzi. *Analysis of outage probability for cooperative networks with HARQ*. In IEEE International Symposium on Information Theory (ISIT), pages 2716–2720, 2007. (Cited on page 2.)
- [Shirazi 2009] G. N. Shirazi, P. Kong, and C. Tham. *Markov decision process frameworks for cooperative retransmission in wireless networks*. In Proc. of the IEEE Wireless Communications and Networking Conference (WCNC), Budapest, Hungary, 2009. (Cited on page 2.)
- [Sklar 2001] B. Sklar. Digital communications: Fundamentals and applications. Prentice-Hall, 2001. (Cited on page 92.)
- [Sterck 2008] H. De Sterck, T. A. Manteuffel, S. F. McCormick, Q. Nguyen and J. Ruge. *Multilevel adaptive aggregation for Markov Chains, with application to web ranking*. SIAM Journal on Scientific Computing, vol. 30, no. 5, 2008. (Cited on pages 43 and 46.)
- [Stewart 1994] W. J. Stewart. Introduction to the numerical solution of markov chains. Princeton University Press, 1994. (Cited on page 43.)
- [T. V. Ramabadran] S. S. Gaitonde T. V. Ramabadran. *A tutorial on CRC computations*. IEEE Journals & Magazines, vol. 8, no. 4, pages 62–75. (Cited on pages 9 and 10.)
- [Tairan Wang 2007] Georgios B. Giannakis Tairan Wang Alfonso Cano and J. Nicholas Laneman. *High-Performance Cooperative Demodulation With Decode-and-Forward Relays*. IEEE Transactions on communications, vol. 55, no. 7, 2007. (Cited on page 88.)

- [VNI 2017] Cisco Mobile VNI. Global mobile data traffic forecast update, 2016-2021, white paper. <https://www.cisco.com/c/en/us/solutions/collateral/service-provider/visual-networking-index-vni/mobile-white-paper-c11-520862.html>, 2017. (Cited on page 1.)
- [Wided Hadj Alouane 2012] Nouredine Hamdi Wided Hadj Alouane and Soumaya Meherzi. *Accurate BEP of Adaptive Demodulate-and-Forward Relaying over Rayleigh Fading Channels*. In IEEE Symposium on Computers and Communications (ISCC), pages 129 – 131, 2012. (Cited on page 88.)
- [Wozencraft 1960] J. M. Wozencraft and M. Horstein. *Digitalised communication over two-way channels*. In The Fourth London Symposium of Information Theory, 1960. (Cited on page 9.)
- [Wozencraft 1961] J. M. Wozencraft and M. Horstein. *Coding for two-way channels*. In tech. rep., Research Laboratory of Electronics, M.I.T., 1961. (Cited on page 9.)
- [Yang 2009] Y. Yang, H. Hu, J. Xu and G. Mao. *Relay technologies for Wimax and LTE-Advanced mobile systems*. IEEE Communications Magazine, vol. 47, no. 10, 2009. (Cited on pages 2 and 9.)
- [Zhang 1999] Q. Zhang, T. F. Wong and J. S. Lehnert. *Performance of a Type-II Hybrid ARQ Protocol in Slotted DS-SSMA Packet Radio Systems*. IEEE Transactions on Communications, vol. 47, no. 2, 1999. (Cited on page 2.)
- [Zhao 2005] B. Zhao and M. Valenti. *Practical relay networks: A generalization of hybrid-ARQ*. IEEE Journal on Selected Areas in Communications, vol. 23, pages 7–18, 2005. (Cited on page 2.)
- [Zorzi 1995] M. Zorzi and R. R. Rao. *Throughput analysis of ARQ selective-repeat protocol with time diversity in Markov channels*. In Proc. of IEEE Global Telecommunications Conference (GLOBECOM), 1995. (Cited on page 2.)

Titre : Interactions de la coopération, des techniques ARQ et du codage canal dans le contexte des communications sans fil

Mots clés : Techniques de coopération, ARQ, Codage canal, Relais

Résumé : De nos jours, les communications mobiles sont caractérisées par une demande croissante de services basés sur Internet. Les services vidéo représentent une grande partie du trafic Internet aujourd'hui. Selon Cisco, 75% du trafic mondial de données mobiles sera constitué par données vidéo d'ici 2020. Cette demande toujours croissante a été le principal moteur du développement du réseau cellulaire numérique 4G, où les services numériques à commutation de paquet sont la principale brique de conception. En particulier, le système global doit assurer à la fois hauts et bas débit de transmission, et fournir des garanties de temps réel, par exemple dans le cas du streaming vidéo ou des jeux en ligne. Cela a motivé, dans la dernière décennie, un intérêt renouvelé dans la technologie d'accès radio.

Le canal sans fil est affecté par divers phénomènes physiques, comme les Chemins multiples, le shadowing, l'évanouissement, l'interférence, etc. Dans les technologies les plus récentes, ces effets sont contrastés en utilisant le protocole ARQ (Automatic Repeat reQuest), qui consiste à retransmettre le même signal depuis la source. Le protocole ARQ est généralement combiné avec des codes de canal au niveau de la couche physique, qui est connu comme HARQ (Hybrid ARQ). Une autre technique pour améliorer la communication entre une source et une destination est la communication coopérative, où un relais est utilisé comme nœud intermédiaire. La communication coopérative et le HARQ, si appliquées individuellement, améliorent considérablement les performances du système de communication. Une question ouverte est de savoir si leur combinaison apporterait la somme des améliorations singulières, ou si ne serait que marginalement bénéfique.

Dans la littérature on peut trouver de nombreuses études sur la combinaison de ces deux techniques, mais dans notre thèse, nous nous concentrons principalement sur cette interaction

à niveau de la couche physique (PHY) et de la couche de contrôle d'accès (MAC). Nous utilisons des exemples de protocoles sur un réseau composé de trois nœuds (source, destination et relais). Pour l'analyse théorique nous nous concentrons sur les Chaînes de Markov à états finis (FSMC). Nous abordons le cas où le relais fonctionne en mode Decode-and-Forward (DCF), très commun dans la littérature, mais notre analyse se concentre de manière plus accentuée sur le cas où le relais fonctionne en mode Demodulate-and-Forward (DMF), en raison de sa simplicité d'implémentation et de son efficacité. Ce cas est beaucoup plus rarement abordé dans la littérature disponible, à cause de la complexité supérieure demandée par son analyse.

Habituellement, l'interaction entre les deux techniques a été étudiée dans le cas de protocoles déterministes, mais dans notre analyse, nous nous concentrerons sur les protocoles déterministes et probabilistes. Jusqu'à présent, les protocoles probabilistes, où le nœud retransmetteur est choisi selon un modèle probabiliste, ont été principalement proposés pour des couches supérieures du système de communication. Au contraire, cette thèse étudie des protocoles probabilistes sur la couche PHY et sur la couche MAC, qui permet de mieux analyser et optimiser les performances. Le protocole probabiliste ne contient que deux paramètres, qui peut être optimisé pour de meilleures performances. Ces paramètres peuvent être calculés pour imiter le comportement d'un protocole déterministe donné, et ses performances optimisées ne peuvent que s'améliorer par rapport à celui-ci. De plus, les performances du protocole probabiliste est comparées aux résultats présentés en littérature, et la comparaison montre que notre protocole fonctionne mieux.

Enfin, la question de la sélection des relais est également abordée. Nous proposons un critère pour opérer le choix du relais à utiliser, en cas de plusieurs candidats. La performance obtenue par ce critère est comparée à celle obtenue avec les critères de référence dans la littérature.

Title : On the interaction of cooperation techniques with channel coding and ARQ in wireless communications

Keywords : Cooperation techniques, ARQ, Channel coding, Relaying

Abstract : Nowadays, mobile communications are characterized by a fast-increasing demand for internet-based services (voice, video data). Video services constitutes a large fraction of the internet traffic today. According to a report by Cisco, 75% of the world's mobile data traffic will be video-based by 2020. This ever-increasing demand in delivering internet-based services, has been the main driver for the development of the 4G digital cellular network, where packet-switched services are the primary design target. In particular, the overall system needs to ensure high peak data rates to the user and low delay in the delivery of the content, in order to support real time applications such as video streaming and gaming. This has motivated, in the last decade, a renewed and raising interest and research in wireless radio access technology.

Wireless channel suffers from various physical phenomena like path-loss, shadowing, fading, interference, etc. In the most recent technologies, these effects are contrasted using Automatic Repeat re-Quest (ARQ) protocol, which consist on the retransmission of the same signal from the same node. ARQ protocol is usually combined with channel codes at the physical layer, which is known as Hybrid Automatic Repeat re-Quest (HARQ) protocol. Another improvement for communications over wireless channels is achieved when Relays are used as intermediate nodes for helping the communication between a Source and a Destination, which is known as cooperative communication. Both techniques, cooperation and HARQ, if individually applied, significantly improve the performance of the communication system. One open question is whether their combination would bring the sum of the singular improvements, or be only marginally beneficial.

In the literature we can find many studies for the combination of these two techniques, but in our

thesis we focus mainly on this interaction at the level of the physical layer (PHY) and the medium access control layer (MAC). We use example protocols on a network of three nodes (Source, Destination and Relay). For the theoretical analysis of these systems we focus on Finite State Markov Chains (FSMC). We discuss the case where Relay works in Decode-and-Forward (DCF) mode, which is very common in the literature, but our analysis focuses more strongly on the case where the Relay works in Demodulate-and-Forward (DMF) mode, because of its simplicity of implementation and its efficiency. This case is much more rarely addressed in the available literature, because of the higher complexity required by its analysis.

Usually, the interaction between the two techniques has been studied using deterministic protocols, but in our analysis we will focus on both, deterministic and probabilistic protocols. So far, probabilistic protocols, where the retransmitting node is chosen with a given probability, have been mainly proposed for higher layers of communication systems, but, in contrast, this thesis studies probabilistic protocols on the physical layer and MAC layer, which give more insight on the analysis and performance optimization. The probabilistic protocols contains very few parameters (only 2) that can be optimized for best performance. Note that these parameters can be computed to mimic the behavior of a given deterministic protocol, and the result of the probabilistic protocol after optimization can only improve over this one. Moreover, the performance of our optimized probabilistic protocol is checked against results of the literature, and the comparison shows that our protocol performs better.

In the end, there is also discussed the issue of relay selection. In a scenario of several candidate Relays, we propose a criterion for choosing the best Relay. The performance obtained by this criterion is compared to that obtained with the reference criteria in the literature.

