



HAL
open science

Effets des régimes hyperprotéiques et des métabolites bactériens dérivés des acides aminés sur la muqueuse du gros intestin

Martin Beaumont

► To cite this version:

Martin Beaumont. Effets des régimes hyperprotéiques et des métabolites bactériens dérivés des acides aminés sur la muqueuse du gros intestin. Médecine humaine et pathologie. Université Paris Saclay (COmUE), 2016. Français. NNT : 2016SACLA011 . tel-02303264

HAL Id: tel-02303264

<https://theses.hal.science/tel-02303264>

Submitted on 2 Oct 2019

HAL is a multi-disciplinary open access archive for the deposit and dissemination of scientific research documents, whether they are published or not. The documents may come from teaching and research institutions in France or abroad, or from public or private research centers.

L'archive ouverte pluridisciplinaire **HAL**, est destinée au dépôt et à la diffusion de documents scientifiques de niveau recherche, publiés ou non, émanant des établissements d'enseignement et de recherche français ou étrangers, des laboratoires publics ou privés.

NNT : 2016SACLA011

THESE DE DOCTORAT
DE
L'UNIVERSITE PARIS-SACLAY
PREPAREE A
AGROPARISTECH
(L'INSTITUT DES SCIENCES ET INDUSTRIES DU VIVANT
ET DE L'ENVIRONNEMENT)

ECOLE DOCTORALE N° 581
Agriculture, alimentation, biologie, environnement et santé (ABIES)

Spécialité de doctorat : Sciences de la nutrition

Par

M. Martin Beaumont

Effets des régimes hyperprotéiques et des métabolites bactériens dérivés
des acides aminés sur la muqueuse du gros intestin

Thèse présentée et soutenue à Paris, le 8 novembre 2016

Composition du Jury :

Mme Bernalier-Donadille Annick	Directrice de recherche	UR454	INRA	Rapporteur
M. Pierre Fabrice	Directeur de recherche	UMR1331	INRA	Rapporteur
M. Bado André	Directeur de recherche	U1149	INSERM	Examineur
M. Darmaun Dominique	Professeur	UMR1280	INRA	Examineur
M. Tomé Daniel	Professeur	UMR914	INRA	Président du jury
M. Blachier François	Directeur de recherche	UMR914	INRA	Directeur de thèse

NNT : 2016SACLA011

THESE DE DOCTORAT
DE
L'UNIVERSITE PARIS-SACLAY
PREPAREE A
AGROPARISTECH
(L'INSTITUT DES SCIENCES ET INDUSTRIES DU VIVANT
ET DE L'ENVIRONNEMENT)

ECOLE DOCTORALE N° 581
Agriculture, alimentation, biologie, environnement et santé (ABIES)

Spécialité de doctorat : Sciences de la nutrition

Par

M. Martin Beaumont

Effets des régimes hyperprotéiques et des métabolites bactériens dérivés
des acides aminés sur la muqueuse du gros intestin

Thèse présentée et soutenue à Paris, le 8 novembre 2016

Composition du Jury :

Mme Bernalier-Donadille Annick	Directrice de recherche	UR454	INRA	Rapporteur
M. Pierre Fabrice	Directeur de recherche	UMR1331	INRA	Rapporteur
M. Bado André	Directeur de recherche	U1149	INSERM	Examineur
M. Darmaun Dominique	Professeur	UMR1280	INRA	Examineur
M. Tomé Daniel	Professeur	UMR914	INRA	Président du jury
M. Blachier François	Directeur de recherche	UMR914	INRA	Directeur de thèse

Effets des régimes hyperprotéiques et des métabolites bactériens dérivés des acides aminés sur la muqueuse du gros intestin

Mots clés : protéines alimentaires, microbiote intestinal, métabolites bactériens, muqueuse du côlon

Résumé : Les régimes hyperprotéiques sont couramment consommés mais les conséquences au niveau du gros intestin sont peu connues. L'objectif de la thèse était d'étudier les effets des régimes hyperprotéiques et des métabolites bactériens dérivés des acides aminés sur la muqueuse du gros intestin

Une série d'expérimentations animales et *in vitro* a permis de montrer que deux métabolites bactériens dérivés des acides aminés (le sulfure d'hydrogène et le *p*-cresol) sont toxiques pour l'épithélium lorsqu'ils sont présents en concentration élevée. Les résultats obtenus lors d'une étude clinique montrent que la quantité et la qualité des protéines alimentaires n'ont pas d'effets marqués sur la composition du microbiote fécal mais modifient les concentrations fécales et urinaires en métabolites bactériens.

Ces modifications de l'environnement luminal du gros intestin n'étaient pas associées à une augmentation de la cytotoxicité des eaux fécales *in vitro*. Néanmoins, dans la muqueuse rectale, l'augmentation de l'apport en protéines a régulé l'expression de gènes impliqués dans le maintien de l'homéostasie et ces effets étaient distincts en fonction de la source de protéines utilisée. Toutefois, le niveau d'apport en protéines n'a pas eu d'effet sur les paramètres inflammatoires et histologiques dans la muqueuse. Ces résultats ont été complétés par une étude chez le rat montrant qu'un régime hyperprotéique modifie le transcriptome dans les colonocytes mais n'a pas d'effets délétères en termes d'intégrité de l'ADN, de renouvellement de l'épithélium et de fonction barrière.

Effects of high-protein diets and of amino-acid derived bacterial metabolites on the large intestine mucosa

Keywords: dietary protein, gut microbiota, bacterial metabolites, colonic mucosa

Abstract: High-protein diets are frequently consumed but the consequences for the large intestine are not well described. The objective of this thesis was to evaluate the effects of high-protein diets and of amino acid derived bacterial metabolites on the large intestine mucosa. Animal and *in vitro* studies showed that two amino acid derived bacterial metabolites (hydrogen sulfide and *p*-cresol) are toxic for the epithelium when present at high concentration. The results obtained in a clinical trial indicate that quantity and quality of dietary protein do not have major effects on the fecal microbiota composition but modify the fecal and urinary concentration of bacterial metabolites.

These changes in luminal environment were not associated with an increase in fecal water cytotoxicity *in vitro*. Nevertheless, in the rectal mucosa, the increase in protein intake regulated the expression of genes implicated in homeostatic processes and these effects were modulated by the source of protein. However, the level of protein intake had no effect on immune and histological parameters in the mucosa. These results were completed with a study in rats showing a clear transcriptome profile in colonocytes induced by a high-protein diet but that was not associated with detrimental effects in terms of DNA integrity, epithelial renewal and barrier function.

REMERCIEMENTS

Je tiens d'abord à remercier Annick Bernalier-Donadille et Fabrice Pierre d'avoir accepté d'être les rapporteurs de cette thèse ainsi que André Bado et Dominique Darmaun d'avoir accepté d'en être les examinateurs.

Je remercie Daniel Tomé et Gilles Fromentin de m'avoir permis de réaliser mon doctorat dans le laboratoire qu'ils dirigent.

Je remercie chaleureusement mon directeur de thèse, François Blachier, pour son encadrement quotidien, son écoute et son enthousiasme pour notre projet de recherche. Je lui suis très reconnaissant de la confiance et de la liberté qu'il m'a accordées pour mener ce travail. Je remercie également ma co-encadrante de thèse, Anne-Marie Davila, pour ses conseils, son implication dans les expérimentations ainsi que de m'avoir permis d'intervenir dans ses modules d'enseignement.

Merci à Mireille Andriamihaja pour son soutien permanent sur les plans scientifiques et techniques. Je remercie Annaïg Lan pour son encadrement, son écoute et son suivi de l'ensemble de mon travail ainsi que de m'avoir confié des enseignements. Je remercie Nadezda Khodorova pour son aide précieuse avec le GC-MS et l'HPLC. Merci aussi à Marion Oberli, Lucie Armand, Marta Grauso, Catherine Chaumontet, Patrick Even, Jean-François Huneau, Corinne Delteil, Morgane Dufay et Nicolas Trépié pour leur participation aux expérimentations. Je remercie Boris Benoit et Raphaël Magiorre pour leur aide au cours de leurs stages. Merci à l'ensemble des membres du laboratoire pour leur aide scientifique, technique et logistique.

Je remercie Robert Benamouzig d'avoir permis la réalisation de l'étude clinique au centre de recherche des volontaires qu'il dirige à l'hôpital Avicenne de Bobigny. Je suis très reconnaissant à Nils Steuer pour son implication lors de cette étude. Je remercie également Marie-Claude Amard pour le recrutement des volontaires, l'organisation et la réalisation des prélèvements. Merci également à Gheorghe Arinei pour son aide dans l'organisation et la réalisation de l'étude. Je remercie aussi Aurélie Belvaux et Katia Spiczzonek pour le suivi diététique des volontaires.

A Toulouse, je remercie Marc Audebert de m'avoir accueilli au laboratoire Toxalim et pour son encadrement lors des expériences de génotoxicité. Merci aussi à Laure Khoury pour ses précieux conseils techniques. A Reading, au Royaume-Uni, je remercie Sandrine Claus de m'avoir accueilli dans son laboratoire et pour son encadrement lors des expériences de métabolomique. Merci également à Giulia Macano pour son aide avec la RMN et à Olivier Cloarec pour son enseignement en statistiques

multivariées. A Valence en Espagne, je remercie Yolanda Sanz et Kevin Portune pour l'analyse de la composition du microbiote. Je remercie également Florent Dumont pour les analyses statistiques des données de transcriptomique de l'étude clinique. Merci à Nathalie Kapel de m'avoir accueilli dans son laboratoire pour le dosage de la calprotectine. Merci à Frédéric Bouillaud pour ses conseils scientifiques sur le H₂S et les mitochondries. Je tiens également à remercier tous les membres du projet Alias dans le cadre duquel cette thèse a eu lieu.

Ce travail de thèse a été réalisé dans une ambiance joyeuse et détendue et je remercie toutes les personnes qui y ont contribué. Le doctorat a aussi été une période très réussie sur le plan gastronomique, surtout grâce à Mireille avec les gâteaux glissés dans la poche de la blouse, les samossas et le rhum de Madagascar mais aussi lors des repas de Noël et des barbecues. Les déplacements en congrès ont été l'occasion de festivités mémorables à Bruxelles, Marseille, Lille et Paris.

Merci aux thésards Ambre, Caroline, Clélia, Gabrielle, Marion, Olga, Sandra, Simon et Tristan pour les très bons moments passés ensemble dans notre bureau à manger des gâteaux, sur notre terrasse au soleil, à la salle d'escalade, chez les uns et les autres pour les repas thésards... Merci aussi pour votre solidarité précieuse.

Enfin, c'est d'abord grâce à mes proches, famille et amis que ces trois années ont été réussies : Merci !

SOMMAIRE

Abréviations	8
Contexte de réalisation de la thèse	9
Publications et communications	10
Introduction générale	12
Introduction bibliographique	14
1 Besoin, apport et digestion des protéines	14
1.1 Besoin et apport en protéines.....	14
1.2 Digestion des protéines.....	17
1.3 Pertes d'azote au niveau de l'iléon terminal.....	18
1.3.1 Digestibilité des protéines et pertes iléales azotées	18
1.3.2 Effets de la quantité de protéines ingérées sur les pertes iléales azotées.....	20
2 Physiologie du côlon et de son épithélium	22
2.1 Organisation et renouvellement de l'épithélium du côlon.....	22
2.2 Fonction barrière de la muqueuse du côlon.....	24
2.2.1 Cohésion de l'épithélium et perméabilité intestinale.....	24
2.2.2 Rôle protecteur du mucus	26
2.2.3 Rôle des cellules épithéliales dans l'immunité	27
2.3 Métabolisme des colonocytes, stress oxydant et dommages à l'ADN	27
2.3.1 Rappels sur le métabolisme mitochondrial	27
2.3.2 Métabolisme énergétique des cellules épithéliales	29
2.3.3 Stress oxydant et métabolisme du glutathion.....	30
2.3.4 Intégrité de l'ADN	31
2.4 Maladies inflammatoires chroniques intestinales.....	32
3 Composition et activité métabolique du microbiote intestinal	34
3.1 Composition du microbiote intestinal.....	34
3.1.1 Variabilité de la composition du microbiote intestinal	35
3.1.2 Effets de l'alimentation sur la composition du microbiote intestinal	35
3.1.3 Effets de l'apport en protéines sur la composition du microbiote	36
3.2 Activité métabolique du microbiote	39
3.2.1 Dégradation des glucides indigestibles par le microbiote.....	40
3.2.1.1 Production d'acides gras à courtes chaînes à partir des glucides.....	42
3.2.1.2 Effets des acides gras à courtes chaînes sur la muqueuse du gros intestin.....	42
3.2.2 Dégradation des protéines par le microbiote.....	43
3.2.2.1 Acides gras à courtes chaînes issus de la fermentation des acides aminés.....	44
3.2.2.2 Ammonium issu de la désamination des acides aminés.....	51

3.2.2.3	<i>Métabolites issus de la dégradation des acides aminés aromatiques.....</i>	54
3.2.2.4	<i>Amines et polyamines issues de la décarboxylation des acides aminés</i>	60
3.2.3	Sulfure d'hydrogène bactérien et muqueuse digestive	62
3.2.3.1	<i>Production de sulfure d'hydrogène par le microbiote intestinal.....</i>	62
3.2.3.2	<i>Détoxication du sulfure d'hydrogène par les colonocytes.....</i>	65
3.2.3.3	<i>Effets du sulfure d'hydrogène sur la muqueuse du gros intestin.....</i>	66
3.2.3.4	<i>Sulfure d'hydrogène et maladies inflammatoires chroniques intestinales</i>	67
3.2.4	Toxicité de la dégradation des acides aminés par le microbiote.....	68
4	Effets de l'apport en protéines sur la muqueuse du gros intestin.....	70
4.1	Effets de l'apport en protéines sur les caractéristiques des contenus luminaux du gros intestin	70
4.2	Effets de l'apport en protéines sur la muqueuse du côlon.....	70
4.2.1	Effets de l'apport en protéines sur le métabolisme énergétique des colonocytes	71
4.2.2	Effets de l'apport en protéines sur le stress oxydant et les dommages à l'ADN dans l'épithélium du côlon	72
4.2.3	Effets de l'apport en protéines sur le renouvellement de l'épithélium colique ..	73
4.2.4	Effets de l'apport en protéines sur les réponses immunitaires dans la muqueuse du côlon.....	74
4.2.5	Effets de l'apport en protéines sur la fonction barrière du côlon.....	74
4.2.6	Mécanismes potentiellement impliqués dans les effets des régimes hyperprotéiques sur la muqueuse du gros intestin	76
4.3	Apport en protéines et maladies inflammatoires chroniques intestinales.....	77
	Justification des travaux de thèse.....	78
	Objectifs de la thèse et démarche expérimentale.....	79
	Etude 1 : Effets du sulfure d'hydrogène sur les colonocytes de rats et adaptation à un régime hyperprotéique	82
	Etude 2 : Génotoxicité du <i>p</i>-cresol sur les colonocytes <i>in vitro</i>	96
	Etude 3 : Effets d'un régime hyperprotéique sur l'épithélium du côlon chez le rat	106
	Etude 4 : Effets de la quantité et de la qualité des protéines alimentaires sur la composition du microbiote intestinal, sur les métabolites bactériens et sur la muqueuse rectale chez l'homme en surpoids.....	142
	Discussion générale et perspectives.....	196
	Bibliographie	206
	Annexe	221

ABREVIATIONS

3-MST : « 3-mercaptopyruvate sulfurtransferase »
AA : acide aminé
AGCB : acide gras à chaîne branchée
AGCC : acide gras à courte chaîne
ANC : apport nutritionnel conseillé
CBS : cystathionine- β -synthase
CH₄ : méthane
CSE : « cystathionine- γ -lyase »
ETHE1 : « dioxygénase ethylmalonic encephalopathy »
FCCP : « carbonyl cyanide p-trifluoromethoxyphenylhydrazone »
GSH : glutathion réduit
GSSG : glutathion oxydé
H₂S : sulfure d'hydrogène
HIF : « hypoxia inducible factor »
HP : hyperprotéique
IFN- γ : interféron- γ
IL : interleukine
iNOS : « inducible nitric oxide synthase »
JAM : « junctionnal adhesion molecule »
MC : maladie de Crohn
MCT1 : « monocarboxylate transporter 1 »
MICI : maladie inflammatoire chronique intestinale
MPO : myéloperoxydase
MUC : mucine
NF- κ B : « nuclear factor- κ B »
NH₄⁺ : ammonium
NO : « nitric oxide »
NP : normoprotéique
PRR : « pattern recognition receptor »
PTGS2 : « prostaglandin-endoperoxide synthase 2 »
RCH : rectocolite hémorragique
ROS : « reactive oxygen species »
SIgA : immunoglobulines A sécrétoires
SMCT1 : « sodium monocarboxylate transporter 1 »
SQR : « sulfide quinone reductase »
SRB : « sulfate reducing bacteria »
TGF- β : « transforming growth factor- β »
TLR : « toll-like receptor »
TNF- α : « tumor necrosis factor- α »
TST : « thiosulfur transferase »
ZO : zonula occludens

CONTEXTE DE REALISATION DE LA THESE

La thèse présentée dans ce manuscrit a été menée dans le laboratoire dirigé par Daniel Tomé : « Physiologie de la Nutrition et du Comportement Alimentaire » (PNCA), UMR0914, INRA, AgroParisTech, Université Paris Saclay. L'objectif des recherches du laboratoire est d'analyser les effets nutritionnels de l'apport en protéines dans différentes situations physiologiques ou physiopathologiques. Cette thèse s'inscrit dans le projet de l'équipe « apport protéique et adaptations intestinales » dirigée par François Blachier. La bourse de thèse a été financée par le Labex ALIAS (Aliment, Alimentation et Santé) dans le cadre de l'université Paris Saclay. Les expérimentations ont été financées principalement par le programme européen « My New Gut » dont l'objectif général est d'étudier les liens entre alimentation, microbiote et santé. Ce travail de thèse a été encadré par François Blachier (directeur de thèse) et Anne-Marie Davila (co-encadrante de thèse).

PUBLICATIONS ET COMMUNICATIONS

Publications

Andriamihaja, M., Lan, A., **Beaumont, M.**, Audebert, M., Wong, X., Yamada, K., Yin, Y., Tomé, D., Carrasco-Pozo, C., Gotteland, M., Kong, X., Blachier, F., 2015. The deleterious metabolic and genotoxic effects of the bacterial metabolite p-cresol on colonic epithelial cells. *Free Radic. Biol. Med.* 85, 219–227.

Beaumont, M., Andriamihaja, M., Lan, A., Khodorova, N., Audebert, M., Blouin, J.-M., Grauso, M., Lancha, L., Benetti, P.-H., Benamouzig, R., Tomé, D., Bouillaud, F., Davila, A.-M., Blachier, F., 2016. Detrimental effects for colonocytes of an increased exposure to luminal hydrogen sulfide: The adaptive response. *Free Radic. Biol. Med.* 93, 155–164.

Portune, K.J., **Beaumont, M.**, Davila, A.M., Tomé, D., Blachier, F., Sanz, Y., 2016. Gut microbiota role in dietary protein metabolism and health-related outcomes: the two sides of the coin. *Trends in Food Science and Technology*. DOI: 10.1016/j.tifs.2016.08.011.

Beaumont, M., Andriamihaja, M., Armand, L., Grauso, M., Jaffrézic, F., Laloë, D., Moroldo, M., Davila, A-M, Tomé, D., Blachier, F., Lan, A. Epithelial response to a high-protein diet in rat colon. Article soumis.

Beaumont, M., Portune, K.J., Steuer, N., Lan, A., Mancano, G., Audebert, M., Dumont., F., Khodorova, M., Andriamihaja, M., Airnei, G., Tomé, D., Benamouzig, R., Davila, A.M., Sanz, Y., Claus, S.P., Blachier, F. Quantity and quality of dietary protein alter the metabolites produced by the gut microbiota and impact rectal mucosa gene expression in overweight humans. Article en préparation.

Communications orales

XXIII^{ème} CECED (club d'étude des cellules épithéliales digestives), mars 2016, Lille, France.

Beaumont, M., Steuer, N., Claus, S., Lan, A., Khodorova, N., Andriamihaja, M., Arinei, G., Tomé, D., Davila, A-M., Benamouzig, R. et Blachier, F. La quantité et la qualité de l'apport protéique modifient l'activité du microbiote intestinal et le transcriptome de la muqueuse rectale.

10th symposium INRA/Rowett on gut microbiology, juin 2016, Clermont-Ferrand, France.

Beaumont, M., Steuer, N., Claus, S., Mancano, G., Dumont, F., Khodorova, N., Andriamihaja, M., Arinei, G., Tomé, D., Lan, A., Davila, A-M., Benamouzig, R. and Blachier, F. Quantity and quality of protein intake alter gut microbiota activity and impact large intestine mucosa in overweight humans

Posters

Journées francophones de nutrition, 2014, Bruxelles, Belgique.

Beaumont, M., Andriamihaja, A. Lan, N. Khodorova, A-M. Davila, M. Grauso, L. Lancha, A. Lancha, D. Tomé, F. Bouillaud, F. Blachier. Régime hyperprotéique, sulfure d'hydrogène bactérien et cellules épithéliales coliques.

Journées francophones de nutrition, 2015, Marseille, France.

Beaumont, M., Steuer, N., Grausso, M., Marsset-Baglieri, A., Lan, A., Andriamihaja, M., Arinei, G., Tomé, D., Davila, A-M., Benamouzig, R. et Blachier, F. Un régime isocalorique riche en protéines animales ou végétales entraîne une modification de la composition luminale dans le gros intestin associée à un changement du profil transcriptomique dans la muqueuse chez des volontaires en surpoids.

Congrès de l'ESPEN (european society for clinical nutrition and metabolism), 2015, Lisbonne, Portugal.

Beaumont, M., Andriamihaja, M., Lan, A., Khodorova, N., Audebert, M., Grausso, M., Tomé, D., Bouillaud, F., Davila, A-M. et Blachier, F. The bacterial metabolite hydrogen sulfide is more abundant in large intestine of rats fed high protein diet and inhibits colonocyte respiration in association with pro-inflammatory but not genotoxic effects

4th international conference on hydrogen sulfide biology, 2016, Naples, Italie.

Beaumont, M., Andriamihaja, M., Lan, A., Khodorova, N., Audebert, M., Blouin, J-M, Grauso, M., Lancha, L., Benetti, P-H., Benamouzig, R., Tomé, D., Bouillaud, F., Davila, A-M., Blachier, F. Detrimental effects of gut microbiota-derived hydrogen sulfide on colonic epithelial cells and adaptive responses to a high-protein diet in rats

INTRODUCTION GENERALE

En France, la consommation moyenne de protéines est environ 1,7 fois supérieure aux apports nutritionnels conseillés (ANC) (1). Lors des régimes hyperprotéiques (HP) suivis dans un but d'amaigrissement, l'apport en protéines peut atteindre jusqu'à 4 fois les ANC (2). Il est estimé que ce type de régime serait suivi par des millions de personnes dans le monde (3). Chez les individus en surpoids ou obèses, les régimes HP sont généralement considérés bénéfiques puisqu'ils induisent une perte du poids et une amélioration de divers paramètres métaboliques, au moins à court terme (4). Néanmoins, le niveau d'apport maximal en protéines non délétère pour la santé n'est pas connu. Il est donc nécessaire d'étudier les risques potentiellement associés à un apport élevé en protéines afin d'évaluer le rapport bénéfices / risques de ce type de régime. En particulier, les effets d'un apport élevé en protéines au niveau du côlon sont peu connus.

La digestion des protéines est un processus très efficace puisqu'entre 90 et 95% de l'azote des protéines alimentaires est absorbé dans l'intestin grêle (5). Cependant, une dizaine de grammes de protéines et de peptides (alimentaires et endogènes) non digérés parviennent chaque jour au niveau du côlon (6). Le catabolisme des protéines par les bactéries du microbiote intestinal entraîne la production d'une grande diversité de composés actifs sur la muqueuse du côlon, certains étant bénéfiques alors que d'autres peuvent s'avérer délétères lorsqu'ils sont présents en concentration excessive (7). Cependant, les effets de ces métabolites bactériens sur l'épithélium ont été peu étudiés ou de manière incomplète. Lors d'un régime HP, la quantité de protéines et de peptides non digérés parvenant dans la lumière du côlon augmente (8). Des études chez l'animal montrent qu'un apport élevé en protéines entraîne des modifications de la composition luminale en bactéries et en métabolites bactériens associées à une perturbation de l'homéostasie de la muqueuse colique (9–11). Quelques études chez l'homme montrent également que l'apport en protéines modifie la composition luminale en métabolites bactériens (12,13) mais les conséquences de ces modifications pour la muqueuse du côlon n'ont jamais été étudiées de manière directe. De plus, le rôle au niveau du gros intestin de la source de protéines utilisés lors des régimes HP n'a été que peu étudié chez l'animal et jamais chez l'homme. Pourtant, les effets des protéines animales et des protéines végétales pourraient être distincts en raison de leurs différences de digestibilité et de composition en acide aminés.

L'objectif de cette thèse était d'étudier les effets de la quantité et de la qualité de l'apport en protéines sur les caractéristiques de l'environnement luminal du gros intestin (composition du microbiote, métabolites bactériens) ainsi que les conséquences de ces modifications éventuelles sur la muqueuse du côlon. Ce manuscrit débute par une introduction bibliographique présentant d'abord les notions de besoin et d'apport en protéines ainsi que les processus permettant leur digestion et l'absorption des composés azotés. Ensuite, les notions de physiologie de la muqueuse du côlon

nécessaires à la compréhension des résultats obtenus lors de la thèse sont présentés. La partie suivante décrit la composition et l'activité métabolique du microbiote intestinal. La production de métabolites bactériens dérivés des acides aminés est particulièrement détaillée ainsi que leurs effets sur l'épithélium. La dernière partie présente les conséquences pour la muqueuse du côlon d'une modification de la quantité et de la qualité de l'apport en protéines.

L'introduction bibliographique est suivie d'une présentation des travaux de thèse. Les démarches expérimentales et les résultats obtenus sont ensuite présentés sous forme d'articles publiés ou rédigés pour soumission. Le manuscrit s'achève par une discussion des résultats obtenus.

INTRODUCTION BIBLIOGRAPHIQUE

1 **Besoin, apport et digestion des protéines**

1.1 Besoin et apport en protéines

Les protéines sont des macromolécules constituées d'une séquence d'acides aminés (AA, molécules organiques comportant un groupement carboxyle et un groupement amine). Vingt AA entrent dans la composition des protéines (Figure 1). D'autres AA sont présents dans les tissus mais ne sont pas utilisés pour la synthèse protéique. Tous les AA sont considérés essentiels, c'est-à-dire qu'ils participent à des fonctions biologiques obligatoires pour l'organisme. Neufs AA sont indispensables (Figure 1) puisqu'ils ne peuvent pas être synthétisés par l'homme ou, du moins, pas à une vitesse suffisante pour assurer le maintien des fonctions biologiques associées. Certains AA dits « non indispensables » sont considérés conditionnellement indispensables dans la mesure où leur synthèse endogène peut s'avérer insuffisante pour assurer le besoin dans certaines situations (arginine, proline, cystéine, glycine) (14). Les AA alimentaires sont également la principale source exogène d'azote et de soufre (15). Les protéines alimentaires sont d'origine animale (viandes, produits laitiers et œufs) ou végétale (graines issues des produits céréaliers et des légumineuses) (1). Généralement, les produits animaux sont plus riches en protéines que les produits végétaux. De plus, la teneur en AA indispensables est plus élevée dans le cas des protéines animales et certains d'entre eux sont limitants dans le cas des protéines végétales (lysine pour les céréales et AA soufrés pour les légumineuses). Les protéines animales sont donc généralement considérées comme étant de meilleure qualité nutritionnelle que les protéines végétales.

Les protéines de l'organisme sont en renouvellement constant. Chez l'homme adulte ingérant entre 80 et 100 g de protéines alimentaires par jour entre 250 et 300 g de protéines corporelles sont renouvelées chaque jour, soit 2,5% environ de la masse protéique totale (1). Les pertes en AA et en azote se distribuent entre les pertes intestinales (25-30% : sécrétions endogènes et exfoliation cellulaire), les pertes par désamination oxydative des AA entraînant majoritairement le transfert de l'azote sur l'urée et son excrétion urinaire (70-75%) ainsi que les pertes diverses minoritaires (1-5%). L'apport en protéines alimentaires permet de compenser ces pertes quotidiennes.

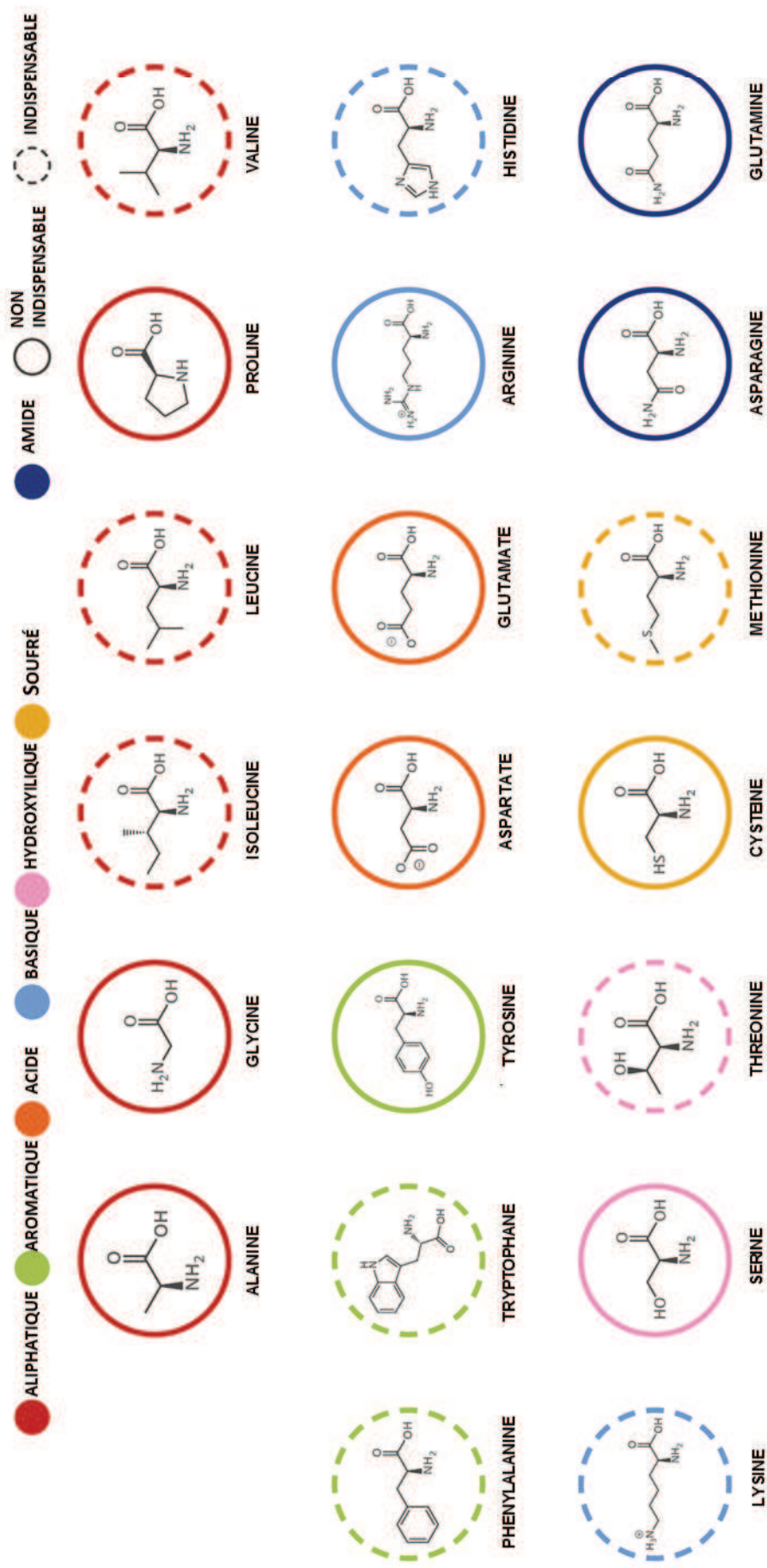

Figure 1 : Structure des 20 acides aminés protéinogènes. Les acides aminés indispensables sont entourés par des cercles en pointillés. Les couleurs indiquent les propriétés chimiques des acides aminés. D'après Compoundchem.com.

Le besoin nutritionnel en protéines correspond à la médiane du besoin dans la population. L'apport nutritionnel conseillé (ANC) en protéines est égal à la valeur permettant de couvrir le besoin de la plus grande partie de la population (besoin nutritionnel + deux écart-types) (Figure 2). Il est important de souligner que cet ANC, dans le cas des protéines, correspond à une valeur minimale de sécurité et non à un niveau de consommation à ne pas dépasser (1). Le besoin nutritionnel en protéines est de 0,66 g/kg/j et l'ANC est de 0,83 g/kg/j. En raison du manque de données disponibles, il n'existe pas de limite supérieure de sécurité (limite au-delà de laquelle il apparaît un risque lié à une surconsommation de nutriment) d'apport en protéines mais deux seuils ont été proposés : élevé (entre 2,2 et 3,5 g/kg/j) et très élevé (supérieur à 3,5 g/kg/j). Ces seuils ont été déterminés par rapport à la capacité de synthèse d'urée par le foie (uréogénèse), afin d'éviter une intoxication par une accumulation d'ammonium (1). Ces données ne concernent que l'adulte jeune et en bonne santé, les recommandations peuvent être différentes dans certaines situations physiologiques ou pathologiques mais ne sont pas décrites ici.

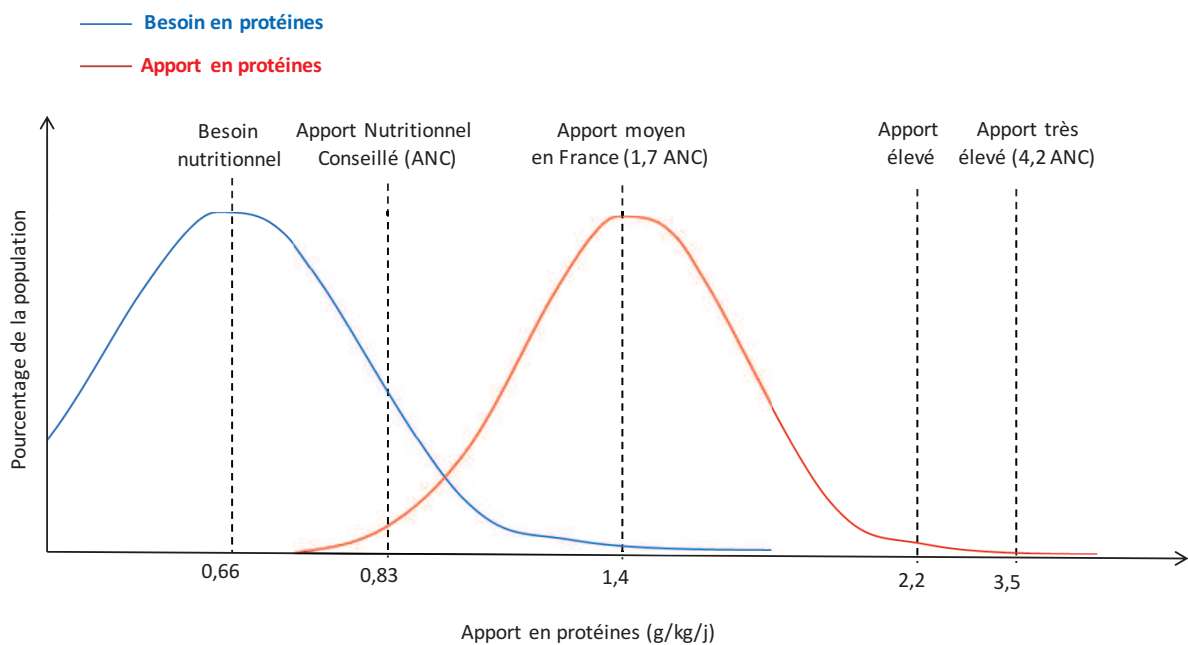

Figure 2 : Représentation schématique du besoin et de l'apport en protéines dans la population. D'après (1).

En France, l'apport moyen en protéines est d'environ 105 g par jour chez les hommes et 82 g par jour chez les femmes (1). Cela correspond pour les deux sexes à 1,4 g/kg/jour et environ 17% de l'apport en énergie. L'apport moyen dans la population française représente donc environ 1,7 fois l'ANC (Figure 2). Les plus grands consommateurs de protéines (95^{ème} percentile) atteignent 2,1 g/kg/j (152 g/j chez les hommes et 119 g/j chez les femmes), soit 2,5 fois l'ANC et représentant 21,8% de l'apport en énergie. Les apports maximums atteignent 30% de l'apport en énergie et chez les sportifs, l'apport en

protéines est plus élevé que dans la population générale (1,8 à 2,1 g/kg/j). Chez les personnes pratiquant un régime amaigrissant, l'apport en protéines est supérieur à celui de la population totale dans environ 80% des cas (2). Par exemple, dans le cas du régime « Dukan », l'apport en protéines peut atteindre 3,5 g/kg/j soit environ 4,2 fois l'ANC et plus de 50% de l'énergie apportée par les protéines (2). Des données récentes suggèrent que plusieurs millions de personnes dans le monde consomment des régime HP amaigrissants (3). Lors de la consommation ces régimes, les protéines apportent généralement entre 25 et 30% de l'énergie (4). Les régimes HP favorisent la perte de poids et éventuellement son maintien, au moins à court terme (16,17). La plupart des études montrent que les régimes HP entraînent une augmentation du ratio masse maigre / masse grasse ainsi qu'une amélioration de certains facteurs de risques cardio-métaboliques (tension artérielle, glycémie, insuline, triglycérides, cholestérol) (16,18). Cependant, l'amélioration de ces paramètres lors de la consommation des régimes HP est débattue et serait principalement liée à la perte de poids. De plus, les bénéfices à long terme restent discutés et l'interprétation des résultats de ces études de longue durée est souvent délicate en raison des problèmes de compliance des participants (18).

1.2 Digestion des protéines

Dans ce paragraphe, les principales étapes de la digestion des protéines sont rappelées brièvement. La digestion des protéines débute dans l'estomac où la sécrétion d'acide chlorhydrique contenu dans le suc gastrique participe à la dénaturation des protéines et à l'activation des pepsinogènes sécrétés par l'estomac en pepsine (enzyme à l'activité endopeptidase) (Figure 3). La digestion des protéines se poursuit dans l'intestin grêle à partir du duodenum où se déversent les sécrétions pancréatiques contenant des endopeptidases et des exopeptidases. Cette étape aboutit à l'accumulation dans la lumière d'AA libres et d'oligopeptides. Les peptidases de la bordure en brosse des entérocytes dégradent les oligopeptides en AA libres ou en di- et tri-peptides. Jusqu'à l'iléon terminal, les AA libres franchissent la membrane apicale des entérocytes principalement par une série de transporteurs spécialisés présents à la surface des entérocytes, alors que les di- et tri-peptides utilisent le transporteur PEPT-1. Il est généralement admis que la capacité d'absorption des oligopeptides et des AA par l'intestin grêle n'est pas un facteur limitant, même en cas d'apport élevé en protéines (19). La digestion des di- et tri-peptides est achevée dans le cytoplasme des entérocytes et les AA sont alors transportés dans la veine porte sauf pour une partie des AA utilisés directement par l'épithélium (20).

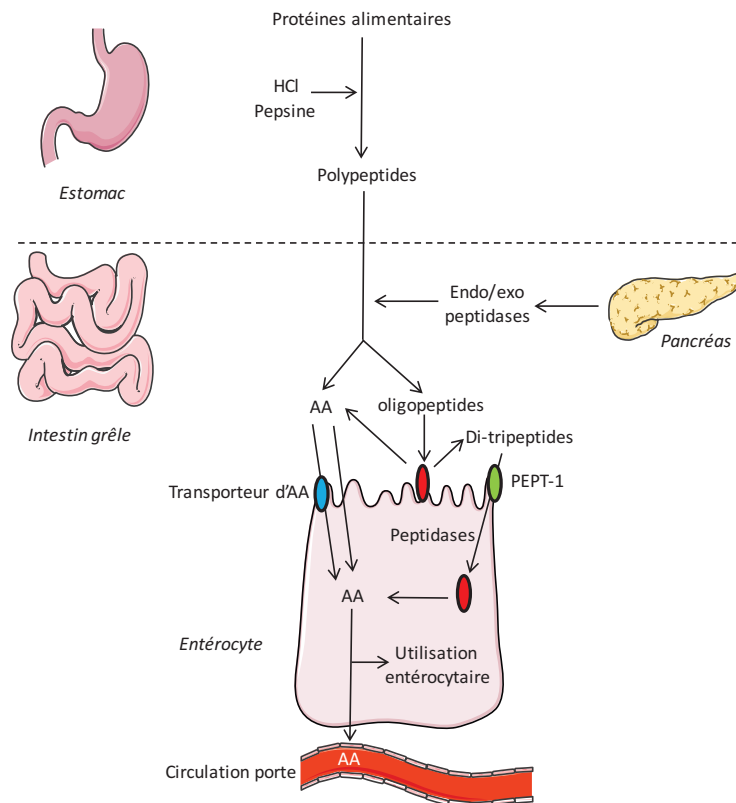

Figure 3 : Représentation schématique de la digestion et l'absorption des protéines. AA : acides aminés. Les peptidases sont représentées en rouge.

1.3 Pertes d'azote au niveau de l'iléon terminal

1.3.1 *Digestibilité des protéines et pertes iléales azotées*

Bien qu'il s'agisse d'un processus très efficace, la digestion des protéines n'est pas complète. La digestibilité des protéines (ou de l'azote) représente le pourcentage de protéines absorbées par rapport à la quantité de protéines ingérées ($\text{Digestibilité (\%)} = \frac{\text{quantité de protéines absorbées}}{\text{quantité de protéines ingérées}} \times 100$). La digestibilité oro-fécale de l'azote ne représente pas un marqueur pertinent de digestibilité de l'azote, car la majorité de l'azote fécal est sous forme bactérienne (21). De plus, il n'y a pas d'absorption significative d'AA dans le côlon chez l'homme (excepté pendant la période néonatale) (22), les AA arrivant dans le côlon représentent donc des pertes nutritionnelles bien que l'azote puisse être réabsorbé sous d'autres formes (voir 3.2.2.2) (21). Pour ces raisons, la digestibilité des protéines est estimée par la mesure de la proportion d'azote alimentaire absorbé jusqu'à l'iléon terminal (digestibilité iléale) par rapport à l'azote ingéré.

En raison de la difficulté d'accès à l'iléon terminal chez l'homme, une série d'études a été menée chez des sujets iléostomisés (iléon terminal relié chirurgicalement à la paroi de l'abdomen) chez qui l'accès aux effluents iléaux est direct. Chez ces sujets, environ 1 g d'azote (correspondant à environ 6 g de protéines) est excrété chaque jour dans le gros intestin lors d'un régime sans protéines alors qu'environ 2 à 3 g d'azote (correspondant à environ 12 - 18 g de protéines) sont excrétés lorsque l'alimentation contient des protéines (6,23). Les pertes iléales d'azote sont donc d'origine endogène et alimentaire. La plupart de l'azote endogène est contenu dans les sécrétions digestives (enzymes pancréatiques), le mucus et les cellules épithéliales exfoliées (23). L'azote excrété au niveau de l'iléon terminal se trouve principalement sous forme de protéines (50%) et de peptides (30%) mais aussi sous forme d'AA (10%), d'urée et d'ammonium (5%) (6). Une des principales limites des études sur les sujets iléostomisés est l'adaptation de l'iléon présentant des caractéristiques de gros intestin (morphologie, colonisation par des bactéries) (21).

Plus récemment, l'utilisation de sondes naso-iléales a permis de récupérer des effluents de l'iléon terminal chez des volontaires en bonne santé. Cette technique a confirmé que la majorité de l'azote iléal provient des pertes endogènes (1 à 2 g/j) et que les pertes alimentaires représentent entre 0,7 et 1,2 g/j (Figure 4) (5). La méthode des sondes naso-iléales a également été utilisée pour déterminer la digestibilité de protéines alimentaires marquées à l'azote ¹⁵N afin de distinguer l'azote alimentaire de l'azote endogène. Les protéines animales sont généralement très digestibles (environ 94% pour les protéines de lait et de viande) (24,25). Chez le rat, la digestibilité des protéines de lait est encore plus élevée : 95% pour les caséines et 98% pour les protéines de lactosérum (26). Les protéines végétales sont généralement moins digestibles que les protéines animales (environ 89 - 91% pour les protéines de soja, pois et blé) (27-29). Cela signifie que davantage de protéines et de peptides non digérés ou partiellement digérés entrent dans le côlon lors de la consommation de protéines végétales. Enfin, il est important de considérer qu'au sein d'une protéine, tous les AA n'ont pas la même digestibilité (5).

La digestibilité des protéines peut être modifiée par le traitement technologique utilisé lors de la préparation des aliments. Par exemple, la cuisson des œufs entraîne une augmentation importante de la digestibilité des protéines (30). Au contraire, dans le cas de la viande de bœuf, une cuisson prolongée à haute température la diminue légèrement (25). La structure de la matrice alimentaire contenant les protéines peut également influencer leur digestibilité. En effet, chez des sujets iléostomisés, la quantité d'azote excrétée dans les effluents (iléaux) est plus élevée dans le cas de purée de soja que dans le cas de graines de soja intactes, indiquant un effet de la structure de la matrice alimentaire contenant les protéines (23). Enfin, la digestibilité des protéines peut aussi être modifiée en raison de facteurs endogènes, notamment dans les cas de pathologies perturbant la digestion des protéines (31).

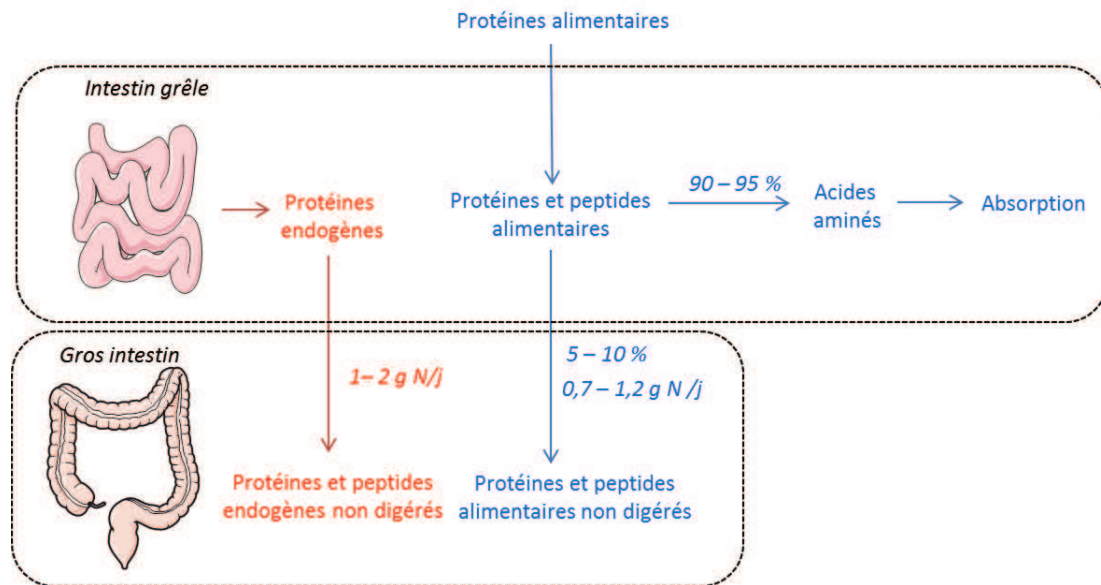

Figure 4 : Représentation schématique du passage de l'iléon au gros intestin de l'azote issu des protéines alimentaires et endogènes. g N/j : gramme d'azote par jour.

1.3.2 Effets de la quantité de protéines ingérées sur les pertes iléales azotées

Une méta-analyse a regroupé les résultats de 9 études d'intervention nutritionnelle chez des sujets iléostomisés chez qui le contenu en azote a été mesuré dans les effluents et dans l'alimentation. La quantité d'azote dans les effluents iléaux est positivement corrélée à la quantité d'azote ingérée (Figure 5) (6,8). Ce résultat montre que plus l'apport en protéines alimentaires est important, plus la quantité de protéines échappant à la digestion dans l'intestin grêle est élevée. Néanmoins, à partir de ces données, il est impossible d'exclure l'hypothèse qu'un apport élevé en protéines augmente la sécrétion d'azote endogène. Dans un modèle de mini-porcs équipés d'une canule au niveau de l'iléon terminal et nourris avec des protéines de viande de bœuf marquées à l'azote ^{15}N , la quantité cumulée de ^{15}N dans les effluents iléaux est plus élevée lors d'un apport important en viande (135 g) que lors d'un apport plus faible (65 g) (32). En revanche, les pertes endogènes d'azote ne sont pas modifiées par le niveau d'apport en protéines dans ce modèle expérimental (32). Deux études ont également montré que le niveau d'apport en protéines ne modifie pas la digestibilité des protéines (environ 94% pour les protéines de viande étudiées) (32,33). Ainsi, dans la gamme d'apport en protéines testée dans ces études, le pourcentage de l'azote des protéines ingérées parvenant dans le côlon est constant (environ 5%), quelque soit le niveau d'apport en protéines. Ce résultat suggère que la digestion et l'absorption des protéines dans l'intestin grêle ne sont pas des facteurs limitants mais que certains motifs peptidiques sont résistants aux enzymes protéolytiques humaines.

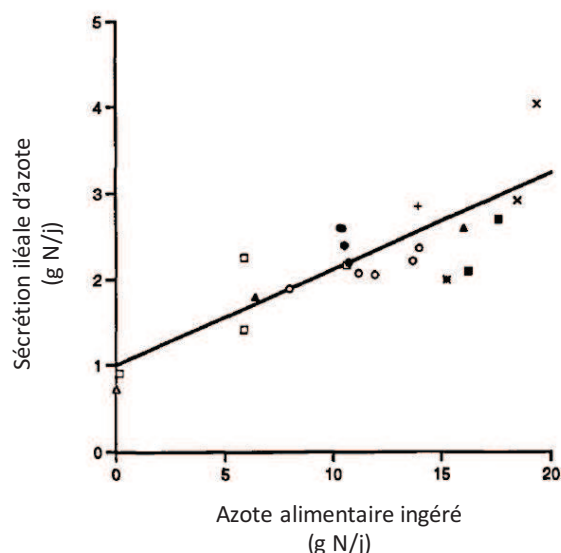

Figure 5 : Corrélation entre le niveau d'apport alimentaire en azote et l'excrétion iléale d'azote chez des sujet iléostomisés. D'après (8).

En résumé

- En France, l'apport en protéines est supérieur (1,7 fois) à l'ANC et la limite supérieure de sécurité n'est pas connue.
- L'apport en protéines peut atteindre jusqu'à 4 fois les ANC lors de la consommation des régimes HP amaigrissants.
- La digestibilité des protéines est élevée (90 - 95%) et est supérieure pour les protéines animales que pour les protéines végétales.
- Environ 12 g de protéines et peptides (endogènes et alimentaires) arrivent chaque jour dans le gros intestin et cette quantité augmente lors d'un apport élevé en protéines.
- La digestibilité des protéines ne dépend pas du niveau d'apport en protéines.

Les données présentées dans cette première partie montrent que des protéines alimentaires et endogènes non digérées ou partiellement digérées parviennent dans la lumière du côlon. Les parties suivantes décrivent leur dégradation par les bactéries intestinales et les conséquences de cette activité métabolique pour la muqueuse du côlon. Dans un premier temps, les notions de physiologie du côlon nécessaires à la compréhension et à l'interprétation des résultats obtenus lors de la thèse sont présentées.

2 Physiologie du côlon et de son épithélium

Chez l'homme, le gros intestin (environ 1,5 m de longueur et 6 cm de diamètre) est divisé en six régions anatomiques : cæcum (très développé chez les rongeurs contrairement à l'homme), côlon ascendant, côlon transverse, côlon descendant, côlon sigmoïde et rectum (Figure 6 A). La paroi du côlon est constituée de la muqueuse (épithélium, *lamina propria* et musculaire muqueuse), de la sous-muqueuse, de la musculuse et de la séreuse (Figure 6 B). Le gros intestin reçoit les effluents de l'iléon terminal contenant de l'eau, des électrolytes ainsi que des résidus alimentaires et endogènes non digérés. Le pH du contenu luminal augmente du cæcum (pH 5,7) au rectum (pH 6, 7) (34) et le temps de transit est considérablement plus lent que dans l'intestin grêle (environ 60 heures chez l'homme) (35). Par ailleurs, il existe un gradient radial de concentration d'O₂ dans le côlon : de l'O₂ est présent en faible concentration au niveau de l'épithélium alors que le centre de la lumière est strictement anaérobie (36,37). Cet environnement est propice à la colonisation du côlon par de très nombreuses bactéries (voir 3.1).

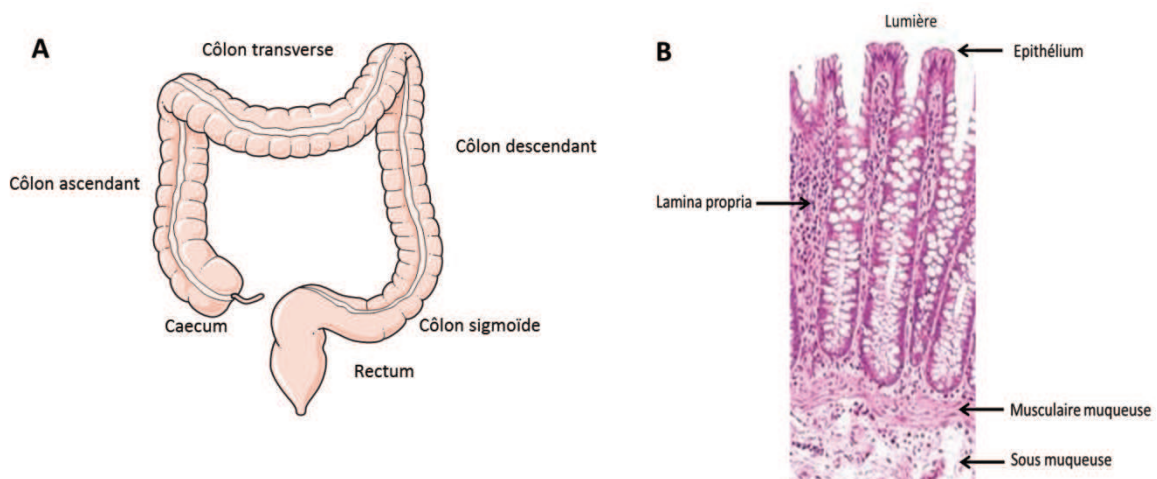

Figure 6 : A - Représentation schématique de l'anatomie du gros intestin. B - Photographie d'une observation au microscope d'une coupe de paroi de côlon humain (coloration hématoxyline & éosine). Les parties les plus externes de la paroi du côlon (musculaire et séreuse) ne figurent pas sur cette illustration.

2.1 Organisation et renouvellement de l'épithélium du côlon

L'épithélium du côlon est constitué d'une monocouche de cellules (colonocytes) reposant sur la *lamina propria* et répartie entre la surface (épithélium de plateau) et des invaginations tubulaires appelées cryptes (Figure 7 A). La présence dans le contenu luminal colique de composés toxiques est associée à un renouvellement très rapide de l'épithélium (38). Les cellules épithéliales matures sont

exfoliées au niveau de l'épithélium de plateau lors d'une forme d'apoptose appelée anoïkis. La mort cellulaire est induite lors du détachement des cellules de la matrice extracellulaire (voir 2.2.1) par l'activation de voies de signalisation dans lesquelles les mitochondries jouent un rôle central et aboutissant à l'activation des protéines caspases (39). La division régulière de quelques cellules souches pluripotentes situées dans la partie inférieure des cryptes permet de compenser la perte des cellules exfoliées. Ces cellules souches sont à l'origine de cellules appelées progénitrices (« transit amplifying cells »). La division des cellules souches est qualifiée d'asymétrique puisqu'elle aboutit à la formation de deux cellules aux caractéristiques distinctes : une cellule progénitrice et une cellule souche. Ce processus permet de maintenir constant le nombre de cellules souches dans les cryptes (40). L'activité de ces cellules est finement régulée par de nombreux signaux paracrines (cytokines, facteurs de croissance) dérivés des cellules avoisinantes (cellules épithéliales et fibroblastes sous-jacents) formant un microenvironnement complexe appelé « niche des cellules souches » (38).

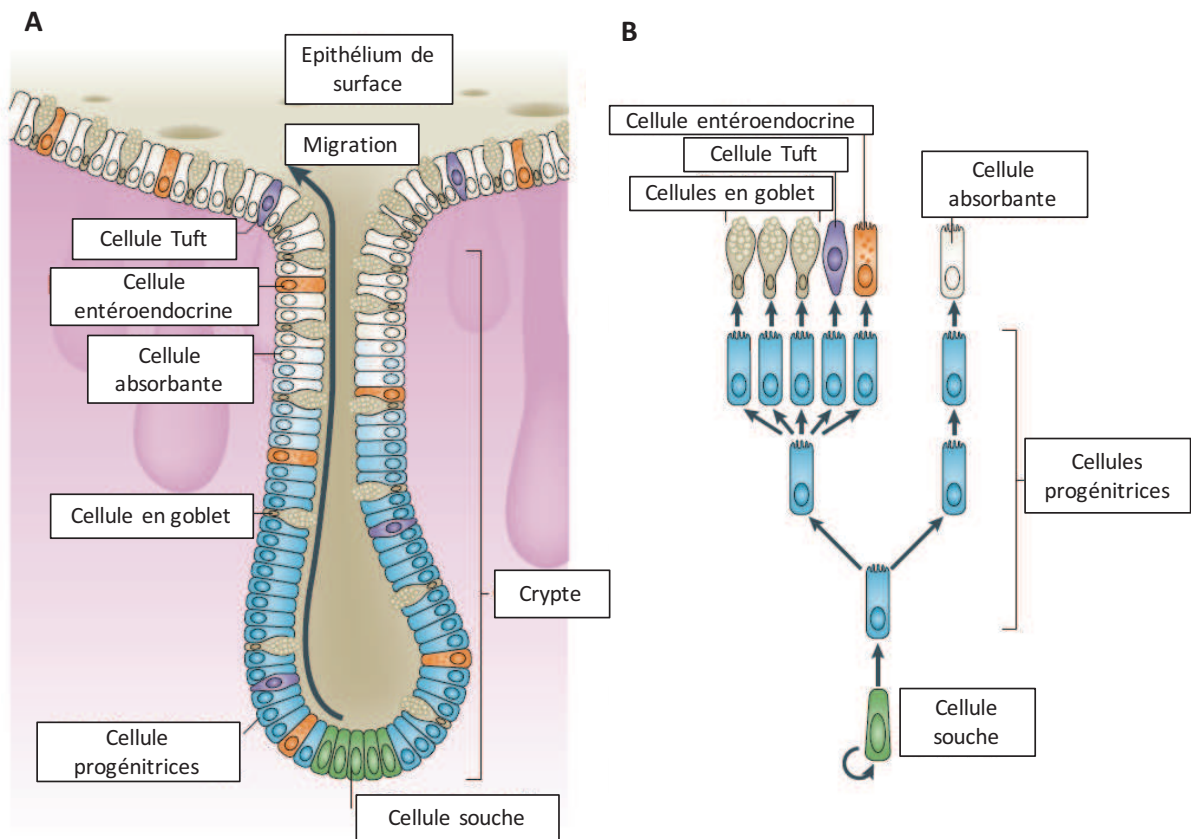

Figure 7 : A - Représentation schématique de l'organisation et du renouvellement de l'épithélium du côlon. B - Représentation schématique des voies de différenciation des cellules épithéliales coliques. D'après (38).

Les cellules progénitrices prolifèrent très rapidement dans la moitié inférieure des cryptes et migrent vers la lumière (38). Ainsi, les protéines jouant un rôle dans la prolifération des cellules épithéliales telles que PCNA (« proliferating cell nuclear antigen ») ou Ki67 sont exprimées uniquement à la base des cryptes et sont utilisées comme marqueurs de la prolifération (41). Dans la moitié supérieure de la crypte, les cellules se différencient en quatre types cellulaires (Figure 7 B) ; des cellules absorbantes (80% des cellules épithéliales) et des cellules sécrétantes : cellules en gobelet (16%) ainsi que, de manière minoritaire, des cellules entéroendocrines productrices d'hormones et des cellules tufts impliquées dans les réactions antiparasitaires (40). Le rôle de ces deux derniers types cellulaires ne sera pas davantage détaillé dans le manuscrit. Une fois différenciées, les cellules épithéliales sont polarisées selon un axe baso-apical contribuant à l'acquisition de leur forme et à l'organisation des transports intracellulaires (voir 2.2.1) (42). Au pôle apical des cellules absorbantes, la membrane plasmique présente des microvillosités formées principalement par des filaments d'actine. Cette caractéristique morphologique permet d'augmenter la surfaces d'échange et ainsi de favoriser l'absorption d'eau et le transport d'électrolytes par ces cellules. Le cycle complet de renouvellement de l'épithélium (de la division asymétrique des cellules souches à l'anoïkis) dure entre 5 et 7 jours (38). L'homéostasie épithéliale résulte donc d'un équilibre dynamique entre prolifération, différenciation et apoptose maintenu tout au long de la vie (40).

2.2 [Fonction barrière de la muqueuse du côlon](#)

Située à la frontière entre les milieux extérieur (lumière de l'intestin) et intérieur, la muqueuse du côlon joue un rôle de barrière face aux composés luminaux potentiellement toxiques (bactéries, métabolites, toxines, etc.). Néanmoins, cette barrière doit être partiellement et sélectivement perméable puisque l'épithélium est une surface d'échange (eau, électrolytes, etc.). Le rôle de l'épithélium dans la mise en place et le maintien de cette fonction barrière sera détaillé dans les paragraphes suivants.

2.2.1 *Cohésion de l'épithélium et perméabilité intestinale*

Des interactions protéiques entre les cellules épithéliales adjacentes et entre les cellules épithéliales et la matrice extracellulaire sous-jacente (appelée lame basale) assurent la cohésion de l'épithélium (Figure 8). Le contact entre les cellules épithéliales adjacentes inclut trois complexes protéiques situés au niveau de la membrane latérale (desmosomes et jonctions adhérentes) et au niveau du pôle apical (jonctions serrées) (43,44). Les desmosomes sont formés par des interactions protéiques entre les desmoglécines, desmocollines, desmoplakines et les filaments de kératine (45). Les jonctions adhérentes sont formées par des complexes protéiques impliquant notamment les protéines transmembranaires cadhérines et nectines liées à des protéines cytoplasmiques (caténines) et aux filaments d'actine (42). Enfin, les jonctions serrées sont formées par des protéines transmembranaires

(claudines, occludines, « jonctionnal adhesion molecule » (JAM) et tricellulines) interagissant avec des protéines cytoplasmiques (zonula occludens, ZO) et les filaments d'actine (42). Le rôle des claudines est complexe puisque certaines d'entre elles renforcent la fonction barrière (claudines 1, 3, 4, 5 et 8) alors que d'autre la diminuent (claudines 2, 7, 10 et 12) (45). Ces jonctions serrées sont les principaux régulateurs de la perméabilité paracellulaire (voir ci-dessous) (44). Au pôle basal, les cellules épithéliales adhèrent via des intégrines à la lame basale constituée d'un réseau complexe de protéines (collagène, laminine, protéoglycans, fibronectine et tenascine-C) sécrétées par les cellules épithéliales elles-mêmes et par les cellules mésenchymateuses situées dans la *lamina propria* (46).

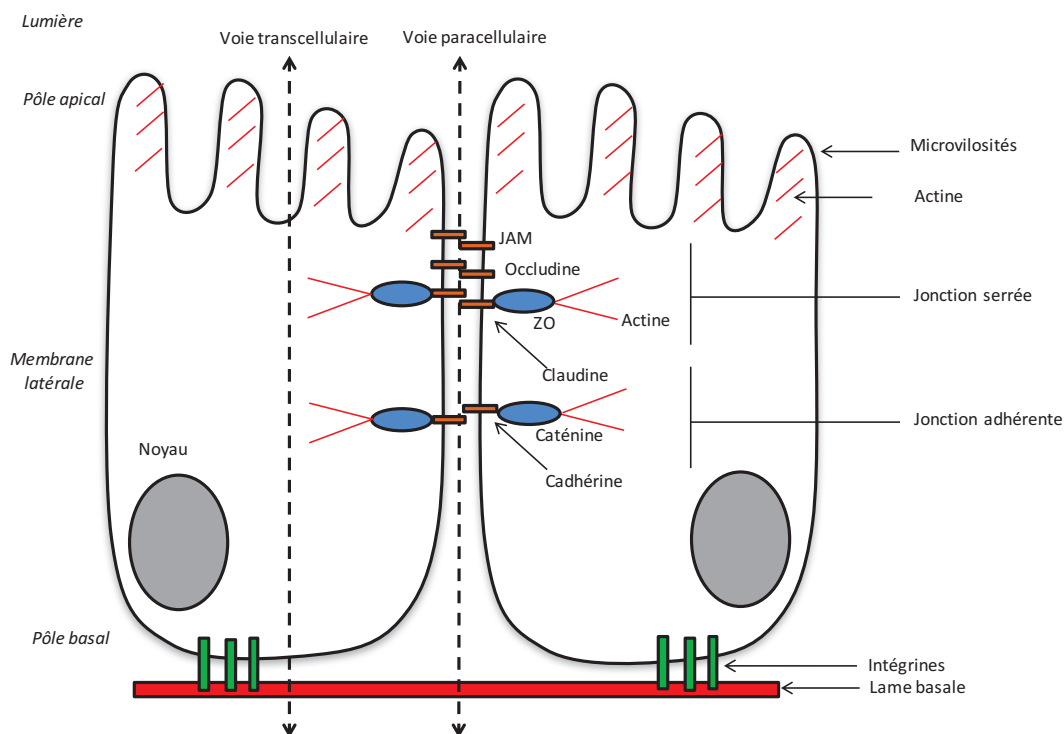

Figure 8 : Représentation schématique simplifiée de la polarisation et de l'adhésion des colonocytes ainsi que des deux voies de transport au travers de l'épithélium. Les desmosomes ne sont pas représentés sur cette figure. JAM : « jonctionnal adhesion molecule », ZO : zonula occludens. D'après (42,43,46).

L'adhésion cellulaire joue un rôle clé dans la régulation des processus de prolifération, de différenciation, de polarisation et d'anoïkis des cellules épithéliales (42–44). L'adhésion des cellules épithéliales est également essentielle au maintien de la fonction barrière de la muqueuse du côlon face aux composés luminaux. Cette barrière est sélective puisque certains composés de petites tailles sont absorbés (eau, électrolytes, métabolites) alors que les composés de plus grandes tailles (bactéries, protéines, etc.) ne franchissent pas ou très peu l'épithélium. Il existe deux voies de passage des composés luminaux au travers de l'épithélium : la voie paracellulaire (diffusion entre les cellules, molécules de faible poids moléculaire <10 kDa) et la voie transcellulaire (diffusion ou endocytose au niveau de la membrane apicale des cellules, molécules de haut poids moléculaire >10 kDa) (Figure 8) (43). Une

diminution de la résistance électrique transépithéliale ou une augmentation du flux transépithélial de petites molécules (sucres tels que le dextran ou le mannitol) sont des marqueurs d'une augmentation de la perméabilité paracellulaire (47). Le passage transépithélial de molécules de poids moléculaire plus important (protéines telles que la « horse-radish peroxidase » ou la β -lactoglobuline) est un marqueur de la perméabilité transcellulaire. Les cytokines régulatrices « transforming growth factor- β » (TGF- β) et interleukine-10 (IL-10) diminuent la perméabilité intestinale alors que les cytokines pro-inflammatoires interféron- γ (IFN- γ), IL-1- β et « tumor necrosis factor- α » (TNF- α) l'augmentent (43,45). Pour résumer, l'adhésion cellulaire est un facteur essentiel de l'homéostasie de l'épithélium puisqu'elle participe au contrôle de la perméabilité épithéliale ainsi qu'au renouvellement de l'épithélium.

2.2.2 Rôle protecteur du mucus

Les mucines sont des glycoprotéines (plus de 50% de leur masse est glucidique) liées entre elles par des ponts disulfures (48,49). Dans l'épithélium, les cellules absorbantes expriment des mucines transmembranaires (MUC1, 3, 4, 12, 13, 16 et 17) formant une structure protectrice appelée glycocalyx. De plus, les cellules en gobelet sécrètent des mucines dans la lumière intestinale (MUC2, 5AC et 6). Dans le côlon, le mucus forme un gel réparti en deux couches, principalement constituées de MUC2 (Figure 9) (48,49). La couche interne est dense, attachée à l'épithélium, d'une épaisseur de quelques centaines de micromètres chez l'homme, ne contient pratiquement pas de bactéries et est renouvelée en une heure environ (48,49). La couche externe est lâche (suite à l'action d'enzymes protéolytiques), non attachée et est colonisée par des bactéries. Le mucus contribue à la fonction barrière en limitant les contacts entre l'épithélium et les bactéries mais aussi en diminuant le stress mécanique exercé sur l'épithélium par les contenus luminaux (48,49). Le rôle protecteur du mucus est illustré par le développement spontané d'une inflammation intestinale chez les souris déficientes en *Muc2* (50). En conclusion, les mucines forment la première ligne de défense de la muqueuse face aux composés luminaux potentiellement toxiques.

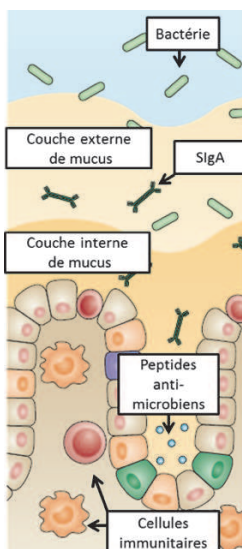

Figure 9 : Représentation schématique de différents acteurs de la fonction barrière dans le côlon : mucus, peptides anti-microbiens, immunoglobulines A sécrétoires (SIgA) et cellules immunitaires de la *lamina propria*. La cohésion de l'épithélium est également un facteur essentiel de la fonction barrière. D'après (46).

2.2.3 Rôle des cellules épithéliales dans l'immunité

A l'interface entre les milieux intérieur et extérieur, les cellules épithéliales jouent un rôle de sentinelles et détectent des composés bactériens (51). Cette reconnaissance est effectuée par des récepteurs spécialisés « pattern recognition receptors » (PRR) (« toll-like receptor » (TLR), par exemple) dont la stimulation par des motifs moléculaires bactériens active notamment des voies de signalisation en amont du facteur de transcription « nuclear factor- κ B » (NF- κ B) (51). La translocation nucléaire de NF- κ B active la transcription de gènes de peptides antimicrobiens (défensines par exemple) et de cytokines régulant l'adhésion cellulaire (voir 2.2.1) ainsi que le recrutement et l'activité des cellules immunitaires dans la *lamina propria* (lymphocytes, neutrophiles, etc.) (Figure 9) (51). En particulier, NF- κ B régule l'expression de l'enzyme « inducible nitric oxide synthase » (iNOS) générant des quantités élevées (μ M) de monoxyde d'azote (NO) en situation d'inflammation (52). Lorsqu'il est présent à des concentrations importantes, le NO a des propriétés antibactériennes mais il peut également être toxique pour l'épithélium (voir 2.3.3) (53). Au-delà de son rôle dans l'immunité, NF- κ B régule la survie cellulaire et l'intégrité de la fonction barrière, il s'agit donc d'un acteur central de l'homéostasie épithéliale (54). Les colonocytes contribuent également au transport par transcytose des immunoglobulines A sécrétées (SIgA) produites par les plasmocytes (lymphocytes B différenciés) dans la *lamina propria* (Figure 9) (55). Une fois sécrétés dans la lumière, ces anticorps se lient aux bactéries et contribuent à leur maintien à distance de l'épithélium (55). En conclusion, la muqueuse du côlon est caractérisée par un état d'inflammation à bas bruit permettant de limiter les contacts avec les bactéries tout en évitant d'endommager l'épithélium (51). Un déséquilibre de ce niveau de stimulation du système immunitaire peut conduire à une rupture de l'homéostasie de l'épithélium.

2.3 [Métabolisme des colonocytes, stress oxydant et dommages à l'ADN](#)

Le renouvellement constant des cellules épithéliales, la synthèse de mucines, le transport d'eau et d'électrolytes sont des processus coûteux en énergie (56,57). L'efficacité du métabolisme des colonocytes est donc essentiel au maintien de l'homéostasie de l'épithélium du côlon.

2.3.1 Rappels sur le métabolisme mitochondrial

Une des fonctions principales des mitochondries est de produire de l'ATP, la principale source d'énergie utilisée dans la cellule. Les mitochondries sont des organites possédant deux membranes (l'une interne et l'autre externe) délimitant deux compartiments : la matrice mitochondriale et l'espace inter-membranaire. Les électrons issus de l'oxydation des substrats énergétiques (voir 2.3.2) sont transférés dans la chaîne respiratoire au niveau du complexe I situé dans la membrane interne mitochondriale (Figure 10) (58). Le transport des électrons par des transporteurs membranaires grâce à

une succession de réactions d'oxydoréduction le long de la chaîne respiratoire aboutit à la réduction d' O_2 en H_2O au niveau du complexe IV (cytochrome c oxydase). L'énergie libérée par ce transfert d'électrons permet le pompage de protons de la matrice mitochondriale vers l'espace inter-membranaire au niveau des complexes I, III et IV. Le retour des électrons de l'espace inter-membranaire vers la matrice a lieu principalement au niveau de l'ATP synthase. Cette enzyme utilise la force proton motrice pour synthétiser de l'ATP. Cette synthèse d'ATP directement liée à la consommation d' O_2 est appelée phosphorylation oxydative.

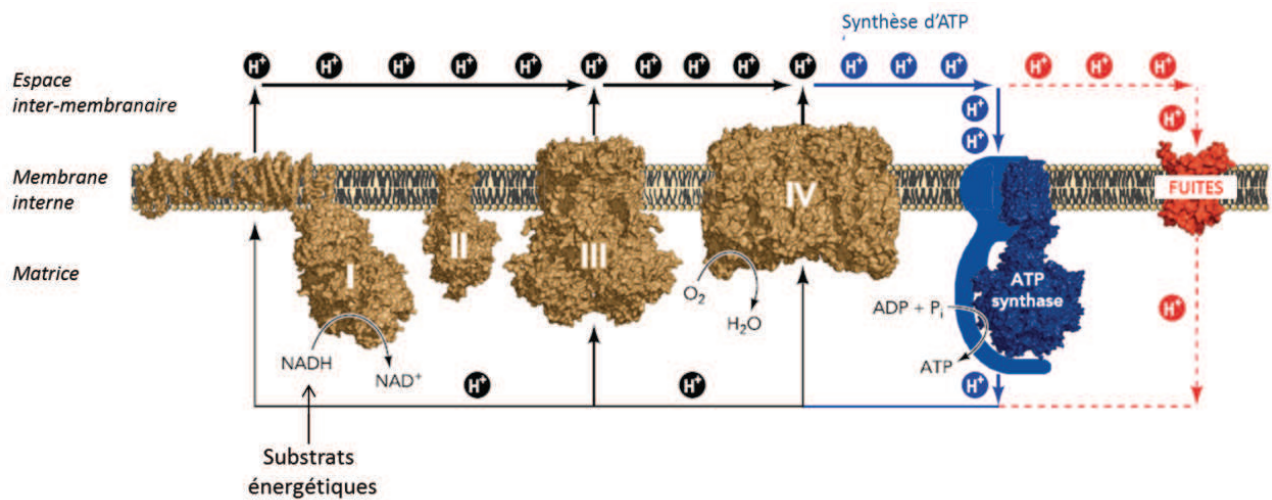

Figure 10 : Représentation schématique de la chaîne respiratoire mitochondriale et des flux de protons. D'après (59).

Le fonctionnement de la chaîne respiratoire peut être estimé par la vitesse de consommation d' O_2 « basale » appelée stade 3. La membrane interne mitochondriale n'est pas entièrement imperméable et cela entraîne une fuite de protons (depuis l'espace inter-membranaire vers la matrice) non couplée à la synthèse d'ATP (Figure 10) (59). Une augmentation des fuites de protons (ou du « découplage ») entraîne une diminution du rendement énergétique de la chaîne respiratoire mais permettrait également de limiter la production d'espèces réactives de l'oxygène (ou « reactive oxygen species », ROS) (voir 2.3.3). Les fuites de protons sont mises en évidence par la mesure de la consommation d' O_2 en présence d'oligomycine, un inhibiteur de l'ATP synthase. En effet, dans ce cas, la consommation d' O_2 est liée uniquement aux fuites de protons. Enfin, la réserve respiratoire des cellules représente la capacité maximale de la chaîne respiratoire à transporter des électrons et est estimée par la mesure de la consommation d' O_2 en présence d'un agent découplant tel que le « carbonyl cyanide p-trifluorométhoxyphénylhydrazone » (FCCP). Cette réserve respiratoire correspond à la capacité maximale à oxyder les substrats énergétiques lors de leur accumulation. En résumé, la fonction mitochondriale peut être évaluée via les mesures successives de la consommation d' O_2 par les cellules

au stade 3 (respiration basale), en présence d'oligomycine (fuites de protons) puis en présence de FCCP (capacité respiratoire) (58).

2.3.2 Métabolisme énergétique des cellules épithéliales

Les colonocytes ont la particularité de disposer de substrats énergétiques provenant de la circulation sanguine au pôle basal (glutamine et glucose principalement) mais aussi du pôle apical (métabolites produit par les bactéries) (Figure 11 A) (57). Le butyrate, un acide gras à courte chaîne (AGCC) produit par les bactéries intestinales (voir 3.2.1.1), est la principale source d'énergie (70%) pour l'épithélium du côlon. Sa dégradation lors de la β -oxydation et du cycle de Krebs dans la mitochondrie fournit des électrons à la chaîne respiratoire (57,60). Certains métabolites bactériens (voir 3.2.2) et endogènes peuvent inhiber la chaîne respiratoire mitochondriale et ainsi entraîner une diminution de la production d'ATP dans les colonocytes (7). Par exemple, des concentrations élevées de NO inhibent le complexe IV de la chaîne respiratoire (61). Un déficit en énergie dans les colonocytes peut s'avérer délétère pour l'homéostasie de l'épithélium (62).

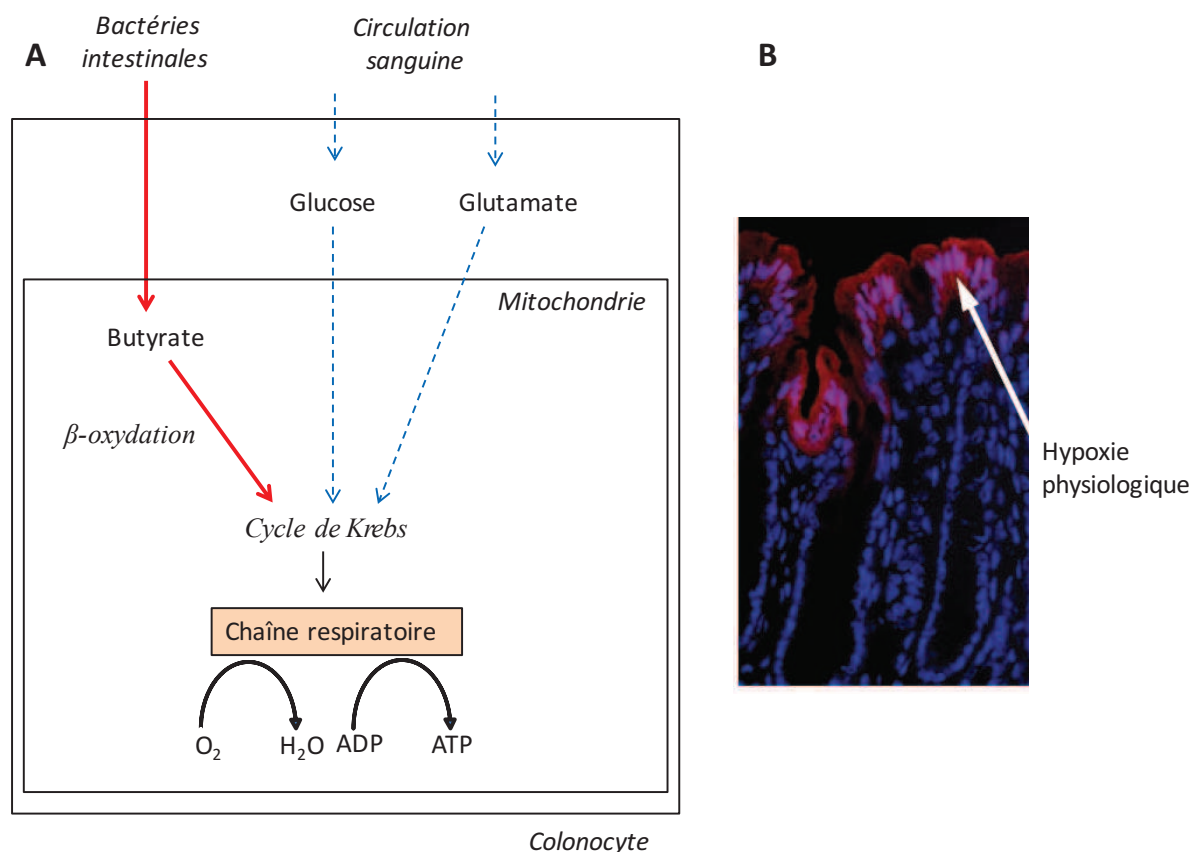

Figure 11 : A - Représentation schématique simplifiée du métabolisme des colonocytes. D'après (56,60). B - Le marquage au 2-nitroimidazole (indicateur de l'hypoxie, en rouge) dans la muqueuse du côlon de souris illustre l'hypoxie physiologique caractéristique des cellules de l'épithélium de plateau. Les noyaux des cellules sont colorés en bleu. D'après (63).

En raison de la proximité avec la lumière du gros intestin (anaérobie), les colonocytes sont exposés à des concentrations d'O₂ nettement inférieures à celles mesurées dans d'autres tissus et possèdent des caractéristiques métaboliques uniques adaptées à cet environnement particulier (« hypoxie physiologique ») (Figure 11 B) (36,63). Le facteur de transcription « hypoxia inducible factor 1 » (HIF1) est le principal régulateur de l'adaptation à l'hypoxie et joue un rôle clé dans l'homéostasie de l'épithélium (63). Une diminution de la concentration d'O₂ entraîne une stabilisation de la sous-unité HIF1 α qui se lie à la sous unité HIF1 β dans le noyau où ce complexe régule l'expression de gènes impliqués dans la fonction barrière (mucines, peptides anti-bactériennes, iNOS, etc.) (63).

2.3.3 *Stress oxydant et métabolisme du glutathion*

Les ROS sont des molécules dérivées de l'oxygène (anion superoxyde (O₂⁻), peroxyde d'hydrogène (H₂O₂) et radicaux hydroxyles (HO[•])) pouvant oxyder d'autres molécules (64). La chaîne respiratoire mitochondriale est une source importante de ROS, en particulier lorsqu'elle est inhibée au niveau des complexes I et III de la chaîne de phosphorylation oxydative (64). Certaines enzymes telles que la NAD(P)H oxydase et la xanthine oxydase peuvent également produire des ROS. En présence de signaux pro-inflammatoires, les cellules épithéliales et certaines cellules immunitaires telles que les macrophages et les neutrophiles produisent des quantités importantes de ROS, permettant de lutter contre les bactéries (51,65). Néanmoins, en quantité excessive, les ROS entraînent un stress oxydant causant des dommages aux protéines, aux lipides et à l'ADN des colonocytes (voir 2.3.4) (66). De plus, la réaction du NO (produit notamment par iNOS) avec les ROS peut conduire à la formation de peroxynitrite (ONOO⁻), un puissant agent oxydant et nitrosant (52).

Il existe divers mécanismes de défenses anti-oxydantes dans l'épithélium tel quel les superoxide dismutases, les catalases et le glutathion (37). Ce dernier (γ -glutamyl-cysteinyl-glycine) est un métabolite présent à des concentrations millimolaires existant sous une forme oxydée (GSSG) (minoritaire en conditions physiologiques) et sous une forme réduite (GSH) (67). Le métabolisme du glutathion implique diverses enzymes (« glutathione reductase », « glutaredoxin », « glutathione peroxidase » et « glutathione-S-transferase ») jouant un rôle important dans le contrôle du stress oxydant et dans la détoxification de xénobiotiques. Les enzymes du métabolisme du glutathion sont surexprimées dans les cellules épithéliales différenciées, correspondant à une protection anti-oxydante accrue au niveau de l'épithélium de plateau (67). Le rôle protecteur du métabolisme du glutathion est illustré par les pathologies digestives associées à une perturbation de l'activité des enzymes utilisant le glutathion (68).

2.3.4 Intégrité de l'ADN

Des dommages à l'ADN des colonocytes peuvent être provoqués par le stress oxydant causé par les cellules épithéliales elles-mêmes ou par les cellules immunitaires (69). Les bactéries du microbiote peuvent également induire des cassures de l'ADN dans l'épithélium de manière directe, via des métabolites génotoxiques, ou de manière indirecte, via l'induction d'un stress oxydant (69). Il existe différents types de dommages à l'ADN : cassures simple brin, formation d'adduits, oxydation, alkylation, mésappariement de bases et pontages intra et inter brins (70). Les cassures double brin subséquentes reflètent globalement les atteintes à l'intégrité de l'ADN et entraînent la phosphorylation de l'histone H2AX (γ H2AX désigne la forme phosphorylée) dont la quantification est utilisée comme marqueur de génotoxicité (71). Une autre méthode courante de détection des dommages à l'ADN est le test des comètes (ou « single-cell gel electrophoresis »). Il s'agit d'une électrophorèse de l'ADN nucléaire dans un gel d'agarose, les cassures de l'ADN entraînant sa migration sous forme de comètes (Figure 12) (72). L'endommagement de l'ADN peut induire la mort cellulaire par apoptose (73). Différentes voies de réparation de l'ADN sont impliquées en fonction du type de dommages (principalement : « nucleotide excision repair » : NER, « mismatch repair » : MMR, « base excision repair » : BER, « homologous recombination » : HR et « non-homologous end joining » : NHEJ). Des erreurs lors de la réparation de ces cassures peuvent entraîner l'apparition de mutations entraînant potentiellement une perte de fonction de certains gènes essentiels au maintien de l'homéostasie épithéliale, notamment lorsqu'elles touchent les cellules souches. Pour cette raison, une augmentation des dommages à l'ADN ou une diminution de leur réparation peut avoir des conséquences pathologiques (70).

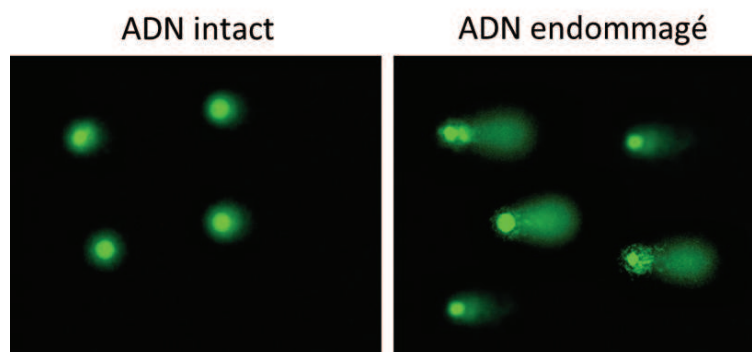

Figure 12 : Photographies d'observations au microscope de l'ADN (coloré en vert) issu de cellules dont l'ADN est intact ou endommagé après électrophorèse lors du test des comètes. D'après Cell Biolabs INC.

2.4 Maladies inflammatoires chroniques intestinales

Certaines caractéristiques des maladies inflammatoires chroniques intestinales (MICI) sont décrites ici en tant qu'exemples de perturbations de l'homéostasie de l'épithélium du côlon associées à une situation pathologique.

Les deux principales formes de MICI sont la maladie de Crohn (MC) pouvant atteindre l'ensemble du tractus digestif et la rectocolite hémorragique (RCH), atteignant uniquement le gros intestin. Ces pathologies sont caractérisées par une inflammation chronique de l'intestin alternant entre des phases de poussées (phases actives de la maladie) et des phases de rémission. L'étiologie de ces maladies n'est pas entièrement comprise mais implique des facteurs génétiques prédisposant à une réaction immunitaire excessive en réponse aux bactéries intestinales (74). Le rôle de l'environnement (et de l'alimentation en particulier) dans ces pathologies est illustrée par l'augmentation de leur incidence lors de migrations depuis les pays en développement vers les pays occidentaux (74). Le tableau 1 présente des exemples de caractéristiques observées lors des MICI concernant les paramètres de physiologie de l'épithélium du côlon décrits dans les paragraphes précédents. Ces données permettent d'illustrer qu'une rupture de l'homéostasie de l'épithélium du côlon est associée à des pathologies digestives telles que les MICI.

Tableau 1 : Exemples de perturbations de l'homéostasie de l'épithélium du côlon observées lors des maladies inflammatoires chroniques intestinales (MICI). ↑ : indique une augmentation, ↓ : indique une diminution.

Paramètre	Observation dans l'épithélium lors des MICI	Référence
Perméabilité	↑ Perméabilité, perturbation des jonctions serrées	(51)
Mucus	↓ Sécrétion de mucus	(75)
Immunité innée	↑ Activation de NF-κB	(67)
Métabolisme	↓ Oxydation du butyrate, ↑ hypoxie	(62,63)
Stress oxydant	↑ ROS, GSSG, iNOS	(67,76)
Intégrité de l'ADN	↑ Dommages à l'ADN	(77)

En résumé

- Le renouvellement constant de l'épithélium du côlon nécessite le maintien d'un équilibre entre prolifération, différenciation et apoptose.
- La couche de mucus limite les contacts entre les bactéries intestinales et l'épithélium du côlon
- La cohésion de l'épithélium garantit le contrôle de la perméabilité intestinale.
- Les colonocytes jouent un rôle de sentinelles et régulent l'activation du système immunitaire de la muqueuse.
- L'épithélium du côlon a un besoin élevé en énergie en raison de son renouvellement rapide et des processus d'absorption des électrolytes.
- Les substrats énergétiques des cellules épithéliales sont d'origine luminale (AGCC) ou artérielle (glutamine, glucose).
- Une dysfonction mitochondriale ou des signaux pro-inflammatoires induisent la production de ROS pouvant causer en particulier des dommages à l'ADN.
- Les mécanismes de lutte contre le stress oxydant et de réparation de l'ADN sont indispensables au maintien de l'intégrité cellulaire.

La partie précédente présentant des aspects importants de la physiologie du côlon est suivie de la description de la composition et de l'activité métabolique de la communauté bactérienne qui y réside. Ce chapitre détaille particulièrement les interactions entre les protéines présentes dans la lumière du côlon et les bactéries ainsi que les conséquences pour l'épithélium de l'exposition aux métabolites bactériens dérivés des AA.

3 Composition et activité métabolique du microbiote intestinal

3.1 Composition du microbiote intestinal

Le microbiote de l'homme désigne l'ensemble des microorganismes dont l'habitat est le corps humain (78). La plupart des bactéries du microbiote résident dans le côlon (10^{11} bactéries/g de fèces, soit environ 10^{13} bactéries au total dans le côlon) (79). Ces bactéries composent la grande majorité (97%) du microbiote intestinal mais le côlon est également colonisé par des archées (2%), des eucaryotes et des virus (80,81). La difficulté de culture de ces bactéries (anaérobies strictes en majorité) a longtemps limité la connaissance de cet écosystème. Le développement récent des méthodes moléculaires basées sur le séquençage du gène de l'ARN ribosomal 16S ainsi que sur le séquençage complet du génome bactérien collectif (métagénome) a permis une avancée considérable dans la connaissance de la composition du microbiote intestinal. Environ 1000 espèces bactériennes différentes ont été détectées dans les fèces humains et chaque individu serait porteur de quelques centaines d'espèces différentes (82). Les deux phyla bactériens dominants du microbiote sont les Firmicutes et les Bacteroidetes, représentant à eux deux environ 90% de la diversité phylogénétique (Figure 13) (82,83). Les phyla sous-dominants sont les Actinobacteria, Proteobacteria, Verrucomicrobia, Synergistetes et Fusobacteria. Dans les différents phyla, les genres bactériens dominants sont *Ruminococcus* et *Clostridium* (Firmicutes), *Bacteroides* et *Prevotella* (Bacteroidetes), *Collinsella* et *Bifidobacterium* (Actinobacteria), *Escherichia* et *Desulfovibrio* (Proteobacteria) ainsi que *Akkermansia* (Verrucomicrobia) (84).

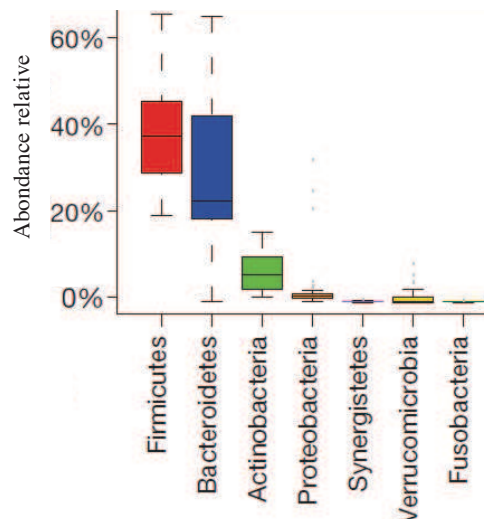

Figure 13 : Abondance relative des phyla bactériens du microbiote fécal humain. D'après (81).

3.1.1 Variabilité de la composition du microbiote intestinal

Le microbiote intestinal est un écosystème complexe et dynamique dans lequel quelques espèces sont dominantes et de nombreuses espèces sont présentes en faible proportion. La composition du microbiote est dépendante de nombreux facteurs provenant de l'hôte (peptides anti-microbiens, SIgA, temps de transit) mais aussi des autres membres du microbiote et de l'environnement luminal (potentiel d'oxydoréduction, pH, concentration d'O₂, disponibilité des résidus alimentaires) (78,85). Ainsi, la composition du microbiote varie en fonction du site anatomique dans le côlon selon un axe longitudinal (proximal-distal) mais aussi selon un axe radial (lumière-muqueuse) (78). Par exemple, le microbiote associé à la muqueuse du côlon est enrichi en Actinobacteria et Proteobacteria par rapport au microbiote luminal probablement en raison de la plus grande tolérance à l'O₂ des bactéries appartenant à ces deux phyla (36). La plupart des études chez l'homme sont basées sur l'analyse du microbiote fécal en raison de la simplicité d'échantillonnage mais l'analyse de la composition du microbiote associé à la muqueuse est également intéressante en raison des potentielles interactions privilégiées entre ces bactéries et l'épithélium.

La composition du microbiote intestinal est caractérisée par une très grande diversité interindividuelle (83,86) mais, chez un individu donné, la composition en bactéries est relativement stable au cours du temps (87,88). Néanmoins, la composition bactérienne peut être ponctuellement modifiée, par exemple lors d'un traitement aux antibiotiques, mais le microbiote est qualifié de résilient, c'est-à-dire qu'après une perturbation il y aurait un retour spontané et rapide à la composition d'origine ou au moins à un nouvel état d'équilibre (78). Malgré l'importante variabilité interindividuelle dans la composition du microbiote, il existe des similitudes taxonomiques partagées par la plupart des personnes. Une cinquantaine d'espèces bactériennes sont partagées entre les individus sains (82,89). Plusieurs études ont suggéré que la composition du microbiote fécal humain pouvait être classé selon deux ou trois catégories distinctes (nommées entérotypes) identifiables par l'abondance d'un des trois genres suivants : *Bacteroides*, *Prevotella* ou *Ruminococcus* (81,86). Cependant, cette notion d'entérotype pourrait refléter une volonté de simplification excessive, la notion d'entéro-gradients étant probablement plus exacte (90). Enfin, une perturbation de la composition du microbiote intestinal (dysbiose) a été observée chez les personnes souffrant de pathologies digestives et métaboliques (82,88,91).

3.1.2 Effets de l'alimentation sur la composition du microbiote intestinal

La composition globale du microbiote intestinal est associée aux caractéristiques de l'alimentation à long terme (à l'échelle de plusieurs années). Par exemple, l'entérotype *Bacteroides* est associé à un régime riche en protéines et en lipides alors que l'entérotype *Prevotella* est associé à un

régime riche en glucides (86). Un changement d'alimentation à court terme (de quelques jours à quelques semaines) modifie également la composition du microbiote intestinal (92). La plupart des études chez l'homme ont porté sur des suppléments en glucides indigestibles résultant généralement en une augmentation de l'abondance de bactéries considérées bénéfiques (*Bifidobacterium*, *Lactobacillus*) (93). Dans la plupart des cas, un changement d'alimentation à court terme n'affecte que certains groupes bactériens et l'individu reste le principal facteur déterminant la composition du microbiote (94,95).

Les substrats disponibles pour le microbiote dans le gros intestin sont d'origine endogène et alimentaire. La principale source de variabilité dans la disponibilité de ces substrats est l'alimentation puisqu'elle détermine la quantité et la qualité des résidus alimentaires non digérés et utilisables par le microbiote. Les groupes bactériens les plus adaptés aux substrats disponibles seraient favorisés. Ainsi, il est envisageable que les bactéries dominantes, les plus flexibles métaboliquement, ne soient pas affectées par les changements alimentaires (96). L'alimentation pourrait également réguler la composition du microbiote par d'autres mécanismes tels que la modulation de la sécrétion d'acides biliaires, d'enzymes digestives ou encore de mucines (95). Ces changements induits par l'alimentation sont très rapides (dès l'arrivée des résidus alimentaires dans le côlon) mais sont réversibles en quelques jours après l'arrêt du régime testé (92,94). Enfin, la modification de la composition du microbiote suite à un changement alimentaire dépend clairement de la composition initiale du microbiote de chaque individu (96). Chez l'homme, environ 10% de la variabilité de composition du microbiote serait expliquée par l'alimentation à court terme alors que chez la souris la variance expliquée par l'alimentation atteindrait 60% en raison de la plus grande homogénéité génétique, du meilleur contrôle des conditions expérimentales et du nombre élevé de réplicats biologiques (95).

3.1.3 *Effets de l'apport en protéines sur la composition du microbiote*

Le tableau 2 présente les effets de l'apport en protéines sur la composition du microbiote intestinal. Chez l'homme, une modification de la composition du microbiote a été observée seulement dans le cas où l'apport élevé en protéines est combiné avec une diminution importante de l'apport en fibres. Dans ces conditions, il semble y avoir une diminution du nombre de bactéries totales et une diminution de l'abondance de genres bactériens connus pour être favorisés par un apport élevé en fibres (*Roseburia*, *Eubacterium*, *Bifidobacterium*) (96). Il est donc probable que les effets observés ne soient pas liés à l'augmentation de l'apport en protéines mais plutôt à la diminution de l'apport en fibres.

Tableau 2 : Effets de l'apport en protéines sur la composition du microbiote intestinal. CO = schéma expérimental en cross over, % E : pourcentage d'énergie apportée par les protéines, % MS : grammes de protéines pour 100 grammes de matière sèche, g/j : grammes de protéines par jour, ↓ indique une diminution, ↑ indique une augmentation, = indique une absence d'effet, DGGGE : électrophorèse sur gel en gradient dénaturant, FISH : « fluorescence *in situ* hybridization ».

Espèce	Durée	Apport en protéines	Source de protéines	Apport en fibres	Méthode	Effet sur la composition du microbiote	Référence
Humain n=17 (CO)	28 jours	13 % E 28 % E 29 % E	Mixte	21,9 g/j 12,8 g/j 8,8 g/j	FISH (Fèces)	Témoïn ↓ bactéries totales ↓ bactéries totales, <i>Bacteroides</i> , <i>Roseburia/Eubacterium rectale</i>	(12)
Humain n=20 (CO)	28 jours	94,4 g/j 127,2 g/j 119,5 g/j	Mixte	27,9 g/j 11,7 g/j 6,1 g/j	FISH (Fèces)	Témoïn ↓ Bactéries totales, <i>Bifidobacterium</i> , <i>Roseburia/Eubacterium</i> ↓ Bactéries totales, <i>Bifidobacterium</i> , <i>Roseburia/Eubacterium</i>	(97)
Humain n=20 (CO)	2 semaines	12 % E 15 % E 27 % E	Mixte + protéines de lait	16,3 g/j 15,4 g/j 17,4 g/j	DGGGE (Fèces)	Pas de différences de profil bactérien	(13)
Humain n=91	8 semaines	24 % E 35 % E	Mixte	31,5 g/j 13 g/j	Culture (Fèces)	Témoïn ↓ Bifidobacteria	(98)
Porc n=8	20-23 jours	15 % MS 20 % MS	Protéines de soja	15 % MS 15 % MS	qPCR (Côlon)	Témoïn ↑ <i>Clostridium leptum</i>	(99)
Porc n=6	100 jours	13 % MS 16 % MS	Protéines de soja	16 % MS 14 % MS	Séquençage 16S (Cæcum)	Témoïn = diversité, ↑ <i>Lactobacillus</i> , ↓ <i>Peptostreptococaceae</i> , <i>Lachnospiraceae</i>	(100)
Porc n=6	100 jours	13 % MS 16 % MS	Protéines de soja	16 % MS 14 % MS	Séquençage 16S (Côlon)	Témoïn = diversité, ↑ <i>Streptococcus</i> , <i>Sarcina</i> , <i>Peptostreptococaceae</i>	(100)
Rat n=4-7	2 semaines	14 % MS 53 % MS	Protéines de lait totales	5 % MS 5 % MS	qPCR (Cæcum)	Témoïn ↑ Diversité, ↓ <i>C.cocoides</i> , <i>C. leptum</i> , <i>F.prausnitzii</i>	(11)
Rat n=4-7	2 semaines	14 % MS 53 % MS	Protéines de lait totales	5 % MS 5 % MS	qPCR (Côlon)	Témoïn ↓ Diversité, bactéries totales, <i>C. cocoides</i> , <i>C. leptum</i> , <i>F.prausnitzii</i>	(11)
Rat n=10	6 semaines	20 % MS 45 % MS	Caséines	5 % MS 5 % MS	qPCR et séquençage 16S (Côlon)	Témoïn ↑ Diversité, <i>Lawsonia</i> , <i>Bacteroides</i> , <i>Parabacteroides</i> , <i>Escherichia/Shigella</i> , <i>Enterococcus</i> , <i>Streptococcus</i> , <i>Eubacterium</i> , <i>Lactococcus</i> , <i>Lactobacillus</i> , bactéries sulfato-réductrices ↓ <i>Actinobacteria</i> , <i>Acidobacteria</i> , <i>Sporobacter</i> , <i>Bifidobacterium</i> , <i>Ruminococcus</i> , <i>Akkermansia</i> , <i>R. bromii</i> , <i>F. prausnitzii</i>	(101)

Chez l'animal, des résultats très divers et souvent contradictoires ont été obtenus (Tableau 2). En cas d'apport élevé en protéines, la diversité du microbiote est soit augmentée soit diminuée ou encore inchangée en fonction du modèle (rat ou porc) et du segment étudié (cæcum ou côlon). Les caractéristiques des régimes testés pourraient expliquer en partie cette diversité de résultat. En effet, la source de protéines, le niveau d'apport et la durée des études varient considérablement, il est donc difficile de les comparer. La comparaison des genres bactériens affectés par les régimes HP lors des différentes études permet difficilement d'identifier des tendances claires. Les effets les plus convaincants d'une augmentation de l'apport en protéines concernent l'augmentation de l'abondance de *Lactobacillus* et *Streptococcus* ainsi que la diminution de l'abondance de *Faecalibacterium prausnitzii*. Cette dernière espèce bactérienne est considérée bénéfique pour la santé de l'intestin en raison de ses propriétés anti-inflammatoires (102), la diminution de son abondance pourrait donc avoir des conséquences délétères. Peu d'études présentées ici ont utilisé des techniques non ciblées (séquençage), il est donc possible que les groupes bactériens sensibles au niveau d'apport en protéines n'aient pas été identifiés.

Quelques études chez l'animal montrent que la source de protéines peut également influencer la composition du microbiote intestinal. Chez des hamsters nourris avec des protéines de lait, la composition du microbiote est moins diverse que dans le cas des protéines de soja et est associée à une plus grande abondance dans le cæcum des familles Bacteroidaceae et Porphyromonadaceae et une moindre abondance des familles S24-7, Bifidobacteriaceae et Lachnospiraceae (103). Chez le rat, la source de protéines (lait, bœuf, porc, poisson et soja) modifie la composition du microbiote au niveau des phyla et il existe une plus grande proximité taxonomique entre les animaux nourris avec les protéines de porc, de poisson et de bœuf (dominé par les Firmicutes) d'une part et ceux nourris avec les protéines de soja et de caséines (dominé par les Bacteroidetes) d'autre part (104). Ici encore, la disparité des protocoles expérimentaux et des modèles étudiés ne permet pas de décrire clairement l'effet de la source de protéines sur la composition du microbiote intestinal. De plus, cette question n'a jamais été étudiée chez l'homme. En conclusion, les données de la littérature suggèrent que la quantité et la qualité de l'apport en protéines influencent la composition du microbiote mais ces effets restent à détailler.

En résumé

- Le microbiote intestinal humain est principalement composé de bactéries appartenant aux deux phyla Firmicutes et Bacteroidetes.
- La composition du microbiote est stable au cours du temps chez un individu mais très variable d'un individu à l'autre.
- L'alimentation régule la composition du microbiote et le niveau d'apport en glucides indigestibles est un facteur déterminant.
- Les effets de l'apport en protéines sur la composition du microbiote ne sont pas clairement définis mais la quantité et la source de protéines semblent jouer un rôle.

3.2 [Activité métabolique du microbiote](#)

Une relation mutualiste s'est établie au cours de la co-évolution entre le microbiote et son hôte. L'hôte procure un environnement relativement stable et fournit des résidus endogènes (mucines, enzymes digestives, cellules épithéliales exfoliées) et alimentaires servant de substrats aux bactéries du microbiote (qualifiées de « commensales ») qui, en retour, contribuent à la physiologie de l'hôte. Le microbiote participe notamment à la récupération d'énergie à partir des aliments non digérés, à la synthèse de vitamines et d'AA (dont la contribution à la nutrition de l'hôte reste discutée), à la maturation de l'épithélium intestinal et du système immunitaire ainsi qu'à la lutte contre les microorganismes pathogènes (20,41,105).

Le génome collectif bactérien ou « métagénome » contient environ 500 fois plus de gènes que le génome humain et certains d'entre eux apportent à l'hôte des capacités métaboliques supplémentaires et complémentaires aux siennes (106). Le microbiote aurait une capacité métabolique comparable à celle du foie (107) et il est estimé que plusieurs centaines de métabolites bactériens seraient ainsi ajoutés au métabolites humain (108). Malgré la grande diversité interindividuelle de composition du microbiote, les fonctions métaboliques et les métabolites produits par les bactéries sont très conservés entre les individus (89). Le microbiote est caractérisé par un degré important de redondance fonctionnelle, c'est-à-dire que de nombreuses bactéries sont capables de réactions métaboliques similaires (107). L'activité métabolique du microbiote dépend de la composition en bactéries et de leur abondance mais aussi, et probablement principalement, de la concentration des substrats disponibles (96,109,110). Des données récentes suggèrent d'ailleurs que, chez l'homme, l'alimentation régule davantage l'activité métabolique du microbiote que sa composition taxonomique (95,112). Les paramètres de l'environnement luminal

du côlon (pH, température, concentration d'O₂, temps de transit) contrôlent également les activités métaboliques bactériennes (85,107,109). Le métabolisme collectif du microbiote intestinal forme une chaîne trophique dans laquelle s'établissent des interactions de natures diverses (compétition, commensalisme, mutualisme) (96,109,110). Les principaux substrats disponibles pour le microbiote dans le gros intestin sont les glucides et les protéines (Figure 14). De petites quantités de lipides alimentaires sont retrouvées dans les fèces mais leur utilisation par le microbiote a été très peu étudiée (111).

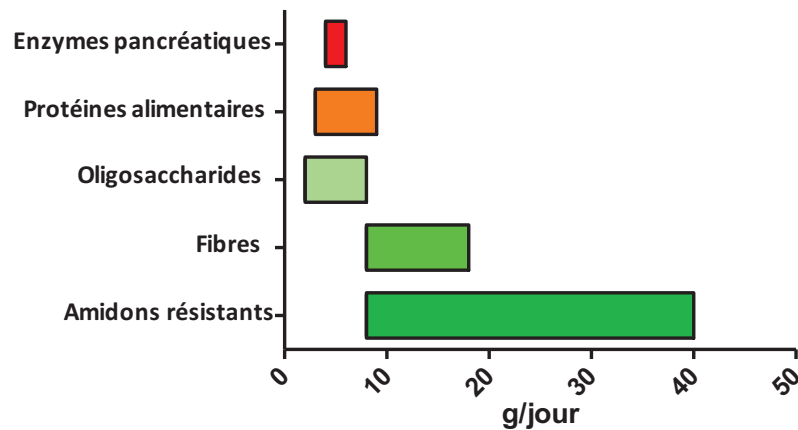

Figure 14 : Substrats disponibles pour le microbiote dans la lumière du gros intestin. D'autres sources de protéines endogènes telles que les mucines et les cellules exfoliées sont certainement importantes mais n'ont pas été quantifiées. g/jour : grammes par jour. D'après (109).

L'objectif de la partie suivante est de décrire la production de métabolites bactériens dérivés des glucides et des protéines ainsi que leurs principaux effets sur la muqueuse du gros intestin. Dans un souci de concision, les effets de ces métabolites sur les organes périphériques ne sont pas décrits.

3.2.1 Dégradation des glucides indigestibles par le microbiote

L'alimentation apporte des glucides non digestibles (entre 20 et 60 g par jour) appartenant à trois catégories : polysaccharides structuraux (fibres), oligosaccharides et amidon résistant (Figure 14) (96,97). Ces composés sont principalement issus des céréales, des fruits et des légumes et parviennent non digérés au niveau du gros intestin. Des sécrétions de glucides endogènes s'ajoutent à ces sources alimentaires, notamment lors de la sécrétion des mucines dont la glycosylation importante contribue à la disponibilité en glucides dans la lumière du côlon (96). La dégradation et la fermentation des glucides par le microbiote a lieu principalement dans la partie proximale du gros intestin où ces substrats sont abondants (Figure 16) (109). Les glucides présents dans la lumière du côlon constituent la principale source d'énergie pour la majorité des bactéries intestinales (35,96). Bien qu'une grande diversité de substrats glucidiques soit utilisée par le microbiote, il y a relativement peu de produits terminaux

correspondant à leur utilisation (35). Une représentation schématique du métabolisme des glucides par le microbiote est présentée sur la figure 15. Les glucides indigestibles sont d'abord hydrolysés par des bactéries exprimant des enzymes hydrolytiques et appartenant notamment aux genres *Bacteroides*, *Bifidobacterium*, *Ruminococcus* et *Roseburia* ainsi que certaines espèces des genres *Clostridium*, *Eubacterium* et *Enterococcus* (110,112,113). Ensuite, les produits d'hydrolyse des glucides complexes sont fermentés en acides gras à courtes chaînes (AGCC), les métabolites bactériens les plus importants quantitativement dans l'intestin. Les gaz dihydrogène (H₂) et dioxyde de carbone (CO₂) sont également des produits majeurs de la fermentation des glucides et une concentration trop importante en H₂ inhibe les réactions de fermentation (114,115). Le H₂ est utilisé par les bactéries hydrogenotrophes : méthanogènes productrices de méthane (CH₄), sulfatoréductrices productrices de sulfure d'hydrogène (H₂S) et acétogènes productrices d'acétate. La fermentation des glucides peut également produire du lactate, du succinate ou de l'éthanol mais ces intermédiaires métaboliques ne s'accumulent normalement pas dans la lumière intestinale en raison de leur utilisation par d'autres bactéries (109).

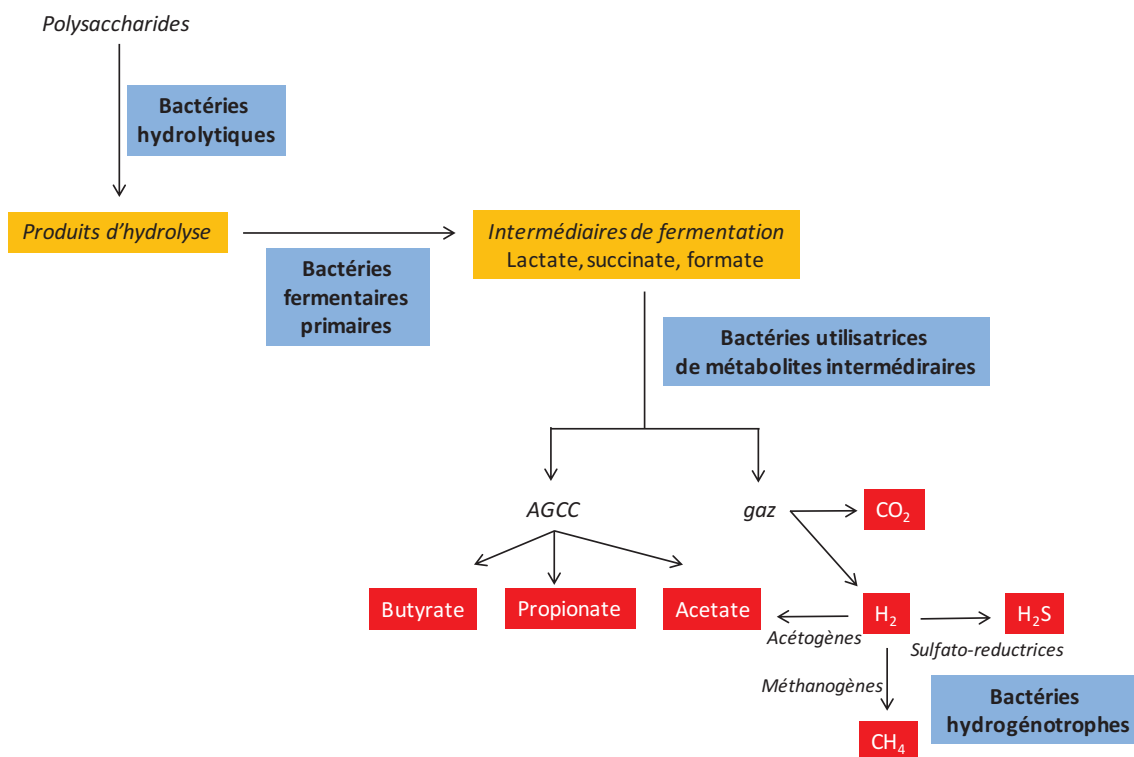

Figure 15 : Représentation schématique du métabolisme des glucides par le microbiote intestinal. Les bactéries peuvent appartenir simultanément à plusieurs des catégories décrites dans les rectangles bleus. D'après (109,110).

3.2.1.1 Production d'acides gras à courtes chaînes à partir des glucides

La fermentation des glucides par les bactéries intestinales produit principalement trois AGCC (90 - 95% des AGCC totaux) : acétate, propionate et butyrate à une concentration fécale totale d'environ 100 mM chez l'homme (ratios molaires : 60/20/20, respectivement) (35,116). L'importante production d'AGCC dans le côlon proximal entraîne une acidification du pH du contenu luminal (35). Plus de 95% des AGCC produits par les bactéries sont absorbés par l'épithélium passivement ou via les transporteurs « monocarboxylate transporter 1 » (MCT1) et « sodium monocarboxylate transporter 1 » (SMCT1) (35,117). Ainsi, et de manière générale pour tous les métabolites bactériens absorbés par la muqueuse, la concentration fécale est la résultante nette de la production et de l'utilisation par le microbiote ainsi que de l'absorption par la muqueuse. La concentration luminale d'un métabolite ne reflète donc pas directement l'exposition de l'épithélium à ce composé. De plus, les concentrations fécales souvent rapportées dans les études chez l'homme ne reflètent que les concentrations dans la partie la plus distale du gros intestin. Le butyrate est oxydé quasiment totalement par les cellules épithéliales (voir 2.3.2) alors que l'acétate et le propionate sont peu oxydés par les colonocytes et sont transportés dans la veine porte et oxydés dans les tissus périphériques (117). Ainsi, les AGCC pourraient contribuer jusqu'à 10% à l'apport énergétique quotidien de l'homme (118). Les bactéries intestinales sont plus ou moins spécialisées dans la production de l'un des trois principaux AGCC (96,110). L'acétate est produit par la plupart des genres bactériens prédominants du microbiote : *Bacteroides*, *Clostridium*, *Bifidobacterium*, *Ruminococcus*, *Eubacterium*. Le propionate est produit principalement par les *Bacteroides* ainsi que *Propionibacterium* et *Veillonella*. Le butyrate est produit en majorité par des espèces du genre *Eubacterium*, *Roseburia*, *Faecalibacterium* et *Coprococcus*. Chez l'homme, la concentration fécale de butyrate est effectivement corrélée avec l'abondance de ces genres bactériens (92,97).

3.2.1.2 Effets des acides gras à courtes chaînes sur la muqueuse du gros intestin

Les effets sur la muqueuse des AGCC, et en particulier du butyrate, ont été très étudiés et les principales conclusions sont résumées brièvement ici. Ces métabolites agissent principalement via deux mécanismes : l'inhibition des histones déacétylases (enzyme de régulation de l'expression génique) et la stimulation de récepteurs couplés à des protéines G (GPR41, GPR43 et GPR109A) (117). En plus de son rôle essentiel de substrat énergétique pour l'épithélium (voir 2.3.2) (57), le butyrate est impliqué dans le contrôle de la prolifération et de la différenciation des cellules épithéliales, joue un rôle protecteur contre le stress oxydant et participe au maintien de la fonction barrière du côlon (107,119). Le butyrate régule également l'immunité dans la muqueuse en favorisant la génération de lymphocytes T régulateurs (120). En raison de ces propriétés, le butyrate pourrait contribuer au rôle protecteur des fibres dans les pathologies digestives (121). Les effets du propionate et de l'acétate sont généralement moins marqués mais ils sont également considérés comme bénéfiques pour la muqueuse du côlon.

3.2.2 Dégradation des protéines par le microbiote

Il est estimé qu'environ 12 g de protéines et peptides d'origine alimentaire ou endogène entrent dans le gros intestin chaque jour (voir 1.3) (Figure 14) (109). Généralement, les bactéries lumineales utilisent prioritairement les glucides comme source d'énergie. Au contraire, les bactéries associées à la muqueuse sont majoritairement protéolytiques et utilisent principalement les protéines produites par l'épithélium (36). La dégradation des protéines (également appelée putréfaction) a lieu préférentiellement dans la partie distale du gros intestin où les glucides sont plus rares et où le pH est proche de la neutralité (Figure 16) (109,122). Un temps de transit lent favorise également la dégradation des protéines par le microbiote intestinal (85) probablement en raison de l'épuisement des glucides disponibles pour le microbiote lors d'une stase prolongée.

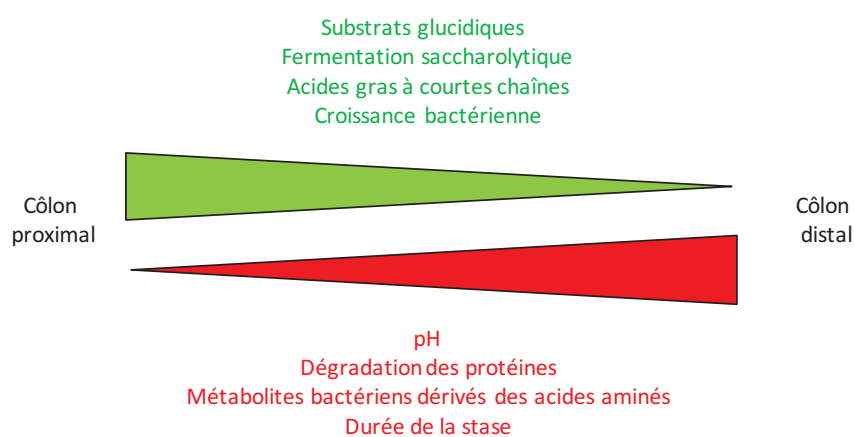

Figure 16 : Représentation schématique des caractéristiques de l'environnement luminal colique en fonction de la localisation anatomique. D'après (109).

La dégradation des protéines par le microbiote débute par une étape d'hydrolyse extracellulaire par des peptidases (Figure 17) (35). Le gros intestin contient en effet une quantité importante de protéases d'origine bactériennes, leur activité étant très diversifiée en termes de substrats (35). De nombreuses bactéries réalisent l'étape de protéolyse : *Bacteroides*, *Clostridium*, *Fusobacterium*, *Streptococcus*, *Lactobacillus*, *Peptostreptococcus*, *Actinomyces*, *Propionibacterium*, *Actinomyces*, *Peptococcus*, *Ruminococcus*, *Bacillus*, *Staphylococcus*, *Megasphaera* et *Acidaminococcus* (109). Les AA libérés lors de la protéolyse dans la lumière du côlon ne sont pas absorbés par l'homme adulte et sont donc disponibles pour les bactéries (7). Les AA permettent de fournir de l'azote nécessaire à la croissance des bactéries saccharolytiques mais aussi des AA comme substrat énergétique pour les fermentations des bactéries asaccharolytiques (35). Une grande diversité de bactéries sont capables d'utiliser les AA comme source d'énergie : *Enterobacteria*, *Clostridium*, *Peptostreptococcus*, *Campylobacter*, *Fusobacterium*, *Eubacterium* ainsi que certaines bactéries sulfato-réductrices (123).

Certains genres bactériens n'utilisent pas ou peu la fermentation des glucides, ce sont des fermenteurs obligatoires des AA : *Peptococcus*, *Acidaminococcus*, *Veillonella* et *Eubacterium* (35). Le catabolisme des AA par les bactéries intestinales implique principalement des réactions de désamination et de décarboxylation (Figure 17). La dégradation des protéines par le microbiote conduit à la production d'une plus grande diversité de métabolites que la dégradation des glucides : des AGCC, des amines, des composés aromatiques et des gaz (H_2S , H_2 , CO_2) (35). Comme évoqué pour la fermentation des glucides, la concentration de H_2 doit rester faible pour que certaines réactions de fermentation des AA puissent avoir lieu, indiquant l'importance des microorganismes hydrogénotrophes dans la régulation du métabolisme des protéines par le microbiote (voir 3.2.1) (35).

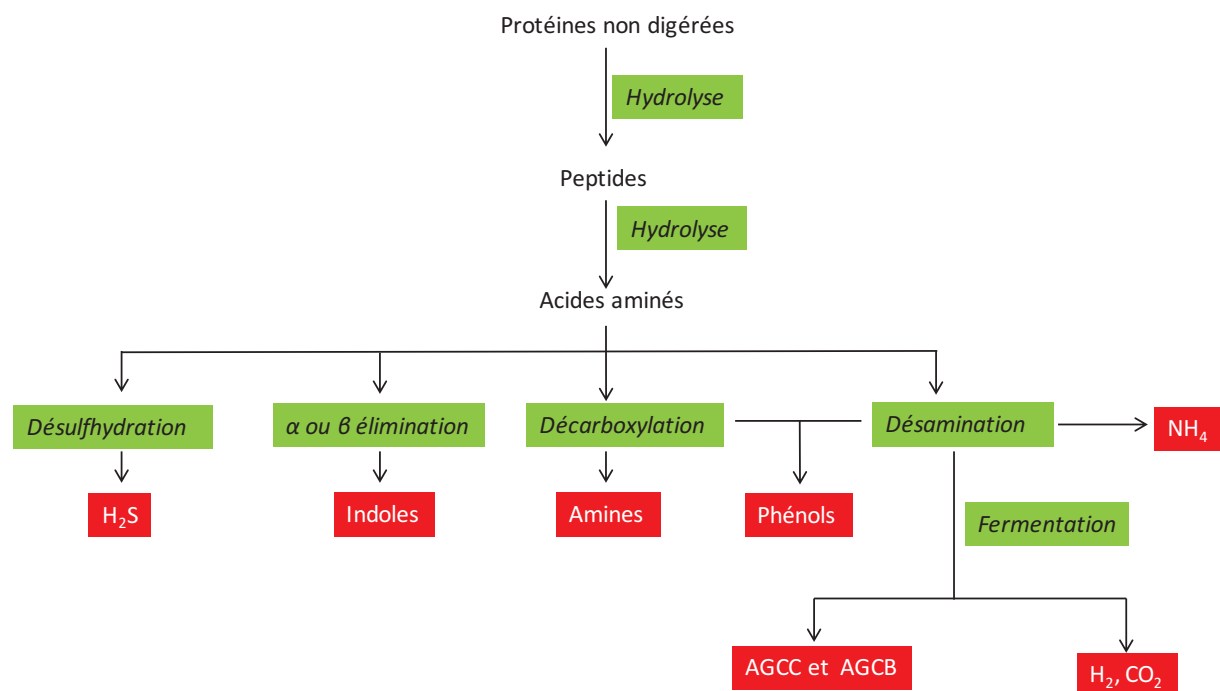

Figure 17 : Représentation schématique du métabolisme des protéines et des acides aminés par le microbiote intestinal. AGCC : acides gras à courtes chaînes, AGCB : acides gras à chaînes branchées. D'après (109).

3.2.2.1 Acides gras à courtes chaînes issus de la fermentation des acides aminés

Les AGCC sont quantitativement les produits de fermentation des protéines les plus importants (30% des substrats protéiques) (35,111). Les mêmes AGCC que ceux issus de la fermentation des glucides (acétate, propionate et butyrate) peuvent être produits par le microbiote à partir des AA précurseurs présentés sur la figure 18 lors de réactions de désaminations suivies de fermentations (Figure 17) (7). D'autres AGCC sont produits par le microbiote spécifiquement à partir des AA. Le valérate est

un AGCC produit par le microbiote à partir de la proline (124). Les AA branchés valine, leucine et isoleucine sont métabolisés en AGCB (isobutyrate, isovalérate et 2-méthylbutyrate, respectivement) (35,116). Les AGCB ne sont pas produits par le métabolisme humain, leur concentration fécale est donc couramment utilisée comme marqueur de la dégradation des protéines par le microbiote (122). La concentration totale des AGCC dérivés des AA est généralement inférieure à 10 mM. La proportion relative en AGCC dérivés des AA est plus importante dans le côlon distal (7,5% du total des AGCC) que dans le côlon proximal (3,4%) (Figure 16) (35).

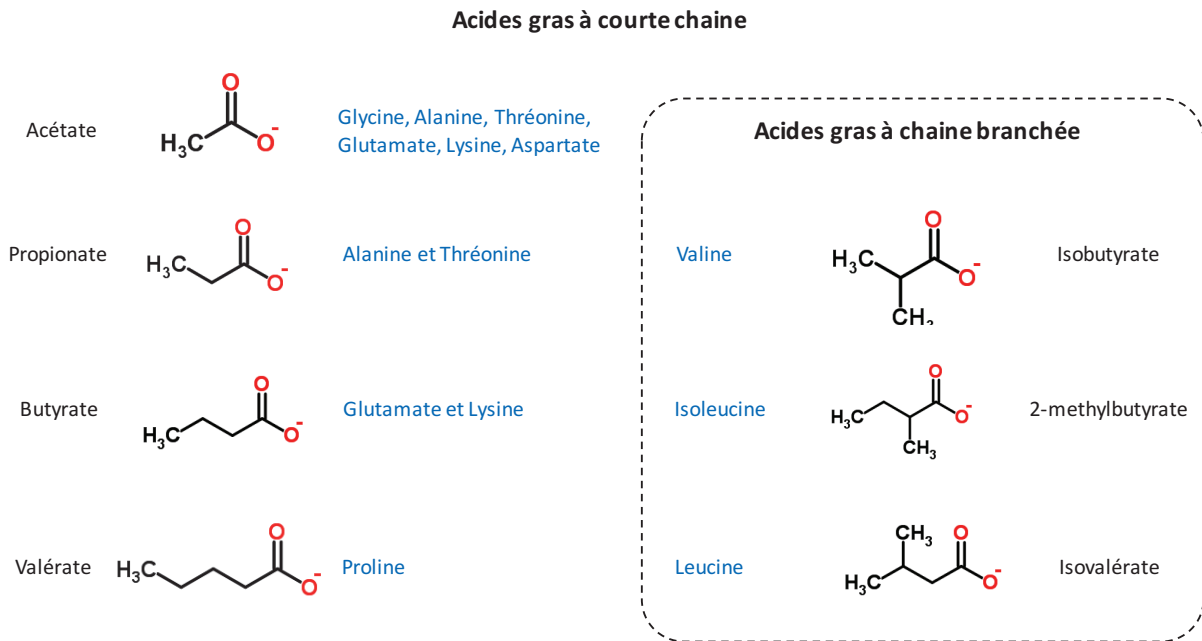

Figure 18 : Structure des acides gras à courtes chaînes produits par le microbiote intestinal à partir des acides aminés. Les acides aminés précurseurs sont écrits en bleu. D’après (7).

Les effets de l’apport en protéines sur la concentration totale d’AGCC sont décrits dans le tableau 3. Globalement, si l’apport en fibres n’est pas modifié, la concentration totale en AGCC n’est pas ou peu affectée par une augmentation de l’apport en protéines. Ce résultat est cohérent avec la faible contribution des AA à la production d’AGCC. Cependant, une étude chez le porc a montré qu’une augmentation de l’apport en protéines de soja augmente la concentration totale en AGCC (99) suggérant une modulation potentielle des effets des régimes HP par la source de protéines. Néanmoins, une autre étude avec des protéines de soja n’a pas confirmé ce résultat dans le cas d’une augmentation plus modeste du niveau d’apport en protéines (+ 3% *versus* + 5%) (100). D’autres études montrent que la combinaison d’un apport élevé en protéines et d’un faible apport en fibres (<15 g/j) entraîne une diminution de la concentration totale en AGCC, probablement en raison de la moindre production d’AGCC à partir des glucides indigestibles.

Les effets de l'apport en protéines sur la concentration de butyrate sont décrits dans le tableau 4. La concentration de butyrate diminue lorsqu'un apport en protéines élevé est associé à un apport en fibre faible (<15 g/j) probablement pour les mêmes raisons que pour la diminution des AGCC totaux. Par ailleurs, ce type de régime affecte davantage le butyrate que l'acétate et le propionate (12). Au contraire, lorsque l'apport en fibres n'est pas modifié, la concentration de butyrate n'est généralement pas affectée sauf dans une étude chez le rat (101,125). Il est intéressant de constater qu'il s'agit de la seule étude utilisant des caséines comme source protéique. Il est donc possible que la source de protéines utilisée module les effets des régimes HP sur la concentration en butyrate.

Les effets de l'apport en protéines sur la concentration des AGCC dérivés spécifiquement des AA sont décrits dans les tableaux 5 (isovalérate), 6 (isobutyrate) et 7 (valérate). Les effets de l'apport en protéines sur la concentration de 2-méthylbutyrate n'ont pas été étudiés. Dans la majorité des études, les concentrations en isovalérate et isobutyrate augmentent lors d'un apport élevé en protéines, quel que soit l'apport en fibres. Cependant, une étude chez l'homme a observé une diminution de la concentration fécale en isovalérate probablement en raison de la diminution très marquée de la concentration totale en AGCC observée simultanément (Tableau 3). Une étude chez le porc a montré que l'apport en protéines semble particulièrement affecter la concentration de ces AGCB dans le cæcum par rapport au côlon (Tableau 5 et 6) (100). L'absence de cæcum développé chez l'homme est une limite à l'extrapolation de ces résultats. La concentration de valérate semble moins sensible au niveau d'apport en protéines que les deux AGCB décrits précédemment (Tableau 7) mais les raisons expliquant ces différences ne sont pas connues. Il semble donc que les AGCB soient de meilleurs marqueurs de la fermentation des protéines. Une seule étude a montré que la source de protéines peut également modifier les concentrations des AGCC chez le rat, probablement en raison des différences de composition en AA et de digestibilité (104).

Les effets des AGCC dérivés spécifiquement des AA (isobutyrate, isovalérate, 2-méthylbutyrate et valérate) ont été peu étudiés au niveau de l'épithélium intestinal. Lors d'une déficience en butyrate, l'isobutyrate est oxydé dans les colonocytes en 3-hydroxyisobutyrate (7). L'isobutyrate pourrait donc être utilisé comme source d'énergie secondaire par les colonocytes. Des données suggèrent également que les AGCB participent à la régulation des mouvements ioniques (7). Il a aussi été montré *in vitro* que l'isovalérate et l'isobutyrate sont cytotoxiques à des concentrations élevées (environ 10 mM) et probablement extra-physiologiques (126). Enfin, le traitement *in vitro* de cellules épithéliales Caco-2 avec des AGCB (5 - 20 mM) limite de manière dose-dépendante la diminution de la résistance transépithéliale induite par l'exposition à des cytokines pro-inflammatoires (127). Les AGCB pourraient donc contribuer au maintien de la fonction barrière de l'épithélium du côlon.

Tableau 3 : Effets de l'apport en protéines sur la concentration totale en acides gras à courtes chaînes. CO = schéma expérimental en cross over, % E : pourcentage d'énergie apportée par les protéines, % MS : grammes de protéines pour 100 grammes de matière sèche, g/j : grammes de protéines par jour, ↓ indique une diminution, ↑ indique une augmentation, = indique une absence d'effet, # valeur lue sur histogramme.

Espèce	Echantillon	Durée	Apport en protéines	Source de protéines	Apport en fibres	[Acides gras à courtes chaînes totaux]	Effet d'une augmentation de l'apport en protéines	Référence
Humain n=20 (CO)	Fèces	2 semaines	12 % E	Mixte	16,3 g/j	378,5 mg/L (a)	=	(13)
			15 % E	+ protéines de lait	15,4 g/j	309,3 mg/L (a)		
			27 % E		17,4 g/j	365,3 mg/L (a)		
Humain n=5 (CO)	Fèces	1 semaine	15,4 % E	Mixte	18,9 g/j	97,7 mM (a)	=	(128)
			23,8 % E	+ protéines de lait	17,2 g/j	115,4 mM (a)		
Humain n=4 (CO)	Fèces	2 semaines	62,7 g/j	Mixte	23,4 g/j	65,7 mM (a)	=	(129)
			136 g/j		21,8 g/j	57,7 mM (a)		
Humain n=17 (CO)	Fèces	28 jours	13 % E	Mixte	21,9 g/j	108,3 mM (a)	↓	(12)
			28 % E		12,8 g/j	100,6 mM (a)		
			29 % E		8,8 g/j	73,59 mM (b)		
Humain n=20	Fèces	28 jours	94,4 g/j	Mixte	27,9 g/j	113,6 mM (a)	↓	(97)
			127,2 g/j		11,7 g/j	73,7 mM (b)		
			119,5 g/j		6,1 g/j	56,2 mM (b)		
Humain n=16-17	Fèces	12 semaines	90,4 g/j	Mixte	33,8 g/j	Environ 35 mmol/24h #	=	(130)
			133,4 g/j		42,8 g/j	Idem		
Humain n=9I	Fèces	8 semaines	24 % E	Mixte	31,5 g/j	114,5 mM (a)	↓	(98)
			35 % E		13 g/j	86,4 mM (b)		
Rat n=8	Cæcum	4 semaines	15 % MS	Caséines	5 % MS	81,1 µg/g (a)	=	(125)
			25 % MS		5 % MS	127,0 µg/g (a)		
Porc n=8	Côlon	20-23 jours	15 % MS	Protéines de soja	15 % MS	95,1 mM (a)	↑	(99)
			20 % MS		15 % MS	120 mM (b)		
Porc n=10	Côlon	7 jours	15 % MS	Mixte	13 % MS	77,6 mM (a)	=	(131)
			22 % MS		11 % MS	71,6 mM (a)		
Porc n=6	Cæcum	100 jours	13 % MS	Protéines de soja	-	133,6 mM (a)	=	(100)
			16 % MS		-	129,7 mM (a)		
Porc n=6	Côlon	100 jours	13 % MS	Protéines de soja	-	133,7 mM (a)	=	(100)
			16 % MS		-	135,3 mM (a)		

Tableau 4 : Effets de l'apport en protéines sur la concentration de butyrate. CO = schéma expérimental en cross over, % E : pourcentage d'énergie apportée par les protéines, % MS : grammes de protéines pour 100 grammes de matière sèche, g/j : grammes de protéines par jour, ↓ indique une diminution, ↑ indique une augmentation, = indique une absence d'effet, # valeur lue sur histogramme. Les valeurs associées à une lettre différente sont significativement différentes.

Espèce	Echantillon	Durée	Apport en protéines	Source de protéines	Apport en fibres	[Butyrate]	Effet d'une augmentation de l'apport en protéines	Référence
Humain n=20 (CO)	Fèces	2 semaines	12 % E 15 % E 27 % E	Mixte + protéines de lait	16,3 g/j 15,4 g/j 17,4 g/j	46,7 mg/L (a) 51,0 mg/L (a) 46,7 mg/L (a)	=	(13)
Humain n=5 (CO)	Fèces	1 semaine	15,4 % E 23,8 % E	Mixte + protéines de lait	18,9 g/j 17,2 g/j	10,8 mM (a) 8,7 mM (a)	=	(128)
Humain n=4(CO)	Fèces	2 semaines	62,7 g/j 136 g/j	Mixte	23,4 g/j 21,8 g/j	12,8 mM (a) 12,8 mM (a)	=	(129)
Humain n=17 (CO)	Fèces	28 jours	13 % E 28 % E 29 % E	Mixte	21,9 g/j 12,8 g/j 8,8 g/j	16,9 mM (a) 14,8 mM (a) 8,5 mM (b)	↓	(12)
Humain n=20	Fèces	28 jours	94,4 g/j 127,2 g/j 119,5 g/j	Mixte	27,9 g/j 11,7 g/j 6,1 g/j	17,67 mM (a) 8,90 mM (b) 4,36 mM (c)	↓	(97)
Humain n=91	Fèces	8 semaines	24 % MS 35 % MS	Mixte	31,5 g/j 13 g/j	20,6 mM (a) 14,4 mM (b)	↓	(98)
Rat n=4-7	Cæcum	2 semaines	14 % MS 53 % MS	Protéines totales de lait	5 % MS 5 % MS	1,88 µmol/g (a) 1,98 µmol/g (a)	=	(11)
Rat n=10	Côlon	6 semaines	20 % MS 45 % MS	Caséines	5 % MS 5 % MS	3 µmol/g (a)# 1 µmol/g (b)#	↓	(101)
Porc n=8	Côlon	20-23 jours	15 % MS 20 % MS	Protéines de soja	15 % MS 15 % MS	12,2 mM (a) 12,6 mM (a)	=	(99)
Porc n=10	Côlon	7 jours	15 % MS 22 % MS	Mixte	13 % MS 11 % MS	5,77 mM (a) 4,93 mM (a)	=	(131)
Porc n=6	Cæcum	100 jours	13 % MS 16 % MS	Protéines de soja	16 % MS 14 % MS	9,59 mM (a) 9,42 mM (a)	=	(100)
Porc n=6	Côlon	100 jours	13 % MS 16 % MS	Protéines de soja	16 % MS 14 % MS	11,16 mM (a) 9,16 mM (a)	=	(100)

Tableau 5 et 6 : Effets de l'apport en protéines sur la concentration d'isovalérate et d'isobutyrate. CO = schéma expérimental en cross over, % E : pourcentage d'énergie apportée par les protéines, % MS : grammes de protéines pour 100 grammes de matière sèche, g/j : grammes de protéines / jour, ↓ indique une diminution, ↑ indique une augmentation, = indique une absence d'effet. Les valeurs associées à une lettre différente sont significativement différentes. * : tendance ($P < 0.1$).

Espèce	Echantillon	Durée	Apport en protéines	Source de protéines	Apport en fibres	[Isovalérate]	Effet d'une augmentation de l'apport en protéines	Référence
Humain n=20 (CO)	Fèces	2 semaines	12 % E	Mixte + protéines de lait	16,3 g/j	10,2 mg/L (a)	=	(13)
			15 % E		15,4 g/j	9,2 mg/L (a)		
			27 % E		17,4 g/j	12,7 mg/L (a)		
Humain n=5 (CO)	Fèces	1 semaine	15 % E	Mixte + protéines de lait	18,9 g/j	2,6 mM (a)	↑	(128)
			23 % E		17,2 g/j	3,4 mM (b)*		
Humain n=17 (CO)	Fèces	28 jours	13 % E	Mixte	21,9 g/j	1,14 mM (a)	↑	(12)
			28 % E		12,8 g/j	1,85 mM (b)		
			29 % E		8,8 g/j	1,62 mM (b)		
Humain n=20	Fèces	28 jours	94,4 g/j	Mixte	27,9 g/j	2,13 mM (a)	↓	(97)
			127,2 g/j		11,7 g/j	1,88 mM (ab)		
Porc n=6	Cæcum	100 jours	13 % MS	Protéines de soja	16 % MS	0,56 mM (a)	↑	(100)
			16 % MS		14 % MS	0,82 mM (b)		
Porc n=6	Côlon	100 jours	13 % MS	Protéines de soja	16 % MS	1,35 mM (a)	=	(100)
			16 % MS		14 % MS	1,47 mM (a)		

Espèce	Echantillon	Durée	Apport en protéines	Source de protéines	Apport en fibres	[Isobutyrate]	Effet d'une augmentation de l'apport en protéines	Référence
Humain n=20 (CO)	Fèces	2 semaines	12 % E	Mixte + protéines de lait	16,3 g/j	10,4 mg/L (a)	↑	(13)
			15 % E		15,4 g/j	9,6 mg/L (ab)		
			27 % E		17,4 g/j	14,7 mg/L (b)		
Humain n=5 (CO)	Fèces	1 semaine	15,4 % E	Mixte + protéines de lait	18,9 g/j	1,4 mM (a)	↑	(128)
			23,8 % E		17,2 g/j	2,5 mM (b)		
Humain n=17 (CO)	Fèces	28 jours	13 % E	Mixte	21,9 g/j	1,60 mM (a)	↑	(12)
			28 % E		12,8 g/j	2,28 mM (b)		
			29 % E		8,8 g/j	2,01 mM (b)		
Humain n=20	Fèces	28 jours	94,4 g/j	Mixte	27,9 g/j	2,27 mM (a)	=	(97)
			127,2 g/j		11,7 g/j	2,45 mM (a)		
Porc n=6	Cæcum	100 jours	13 % MS	Protéines de soja	16 % MS	0,59 mM (a)	↑	(100)
			16 % MS		14 % MS	0,96 mM (b)		
Porc n=6	Côlon	100 jours	13 % MS	Protéines de soja	16 % MS	1,61 mM (a)	=	(100)
			16 % MS		14 % MS	1,70 mM (a)		

Tableau 7 : Effets de l'apport en protéines sur la concentration de valérate. CO = schéma expérimental en cross over, % E : pourcentage d'énergie apportée par les protéines, % MS : grammes de protéines pour 100 grammes de matière sèche, g/j : grammes de protéines / jour, ↓ indique une diminution, ↑ indique une augmentation, = indique une absence d'effet. Les valeurs associées à une lettre différente sont significativement différentes. * : tendance ($p < 0.1$).

Espèce	Echantillon	Durée	Apport en protéines	Source de protéines	Apport en fibres	[Valérate]	Effet d'une augmentation de l'apport en protéines	Référence
Humain n=5 (CO)	Fèces	1 semaine	15,4 % E 23,8 % E	Mixte + protéines de lait	18,9 g/j 17,2 g/j	1,3 mM (a) 2,4 mM (b)	↑	(128)
Humain n=17 (CO)	Fèces	28 jours	13 % E 28 % E 29 % E	Mixte + protéines de lait	21,9 g/j 12,8 g/j 8,8 g/j	2,07 mM (a) 2,49 mM (a) 1,90 mM (a)	=	(12)
Humain n=20	Fèces	28 jours	94,4 g/j 127,2 g/j 119,5 g/j	Mixte	27,9 g/j 11,7 g/j 6,1 g/j	3,14 mM (a) 2,04 mM (b) 1,38 mM (b)	↓	(97)
Rat n=4-7	Cæcum	2 semaines	14 % MS 55 % MS	Mixte	5 % MS 5 % MS	0,37 µmol/g (a) 0,39 µmol/g (a)	=	(11)
Porc n=6	Cæcum	100 jours	13 % MS 16 % MS	Protéines de soja	16 % MS 14 % MS	0,87 mM (a) 1,03 mM (a)	=	(100)
Porc n=6	Côlon	100 jours	13 % MS 16 % MS	Protéines de soja	16 % MS 14 % MS	1,13 mM (a) 1,19 mM (a)	=	(100)

3.2.2.2 Ammonium issu de la désamination des acides aminés

L'ammonium (NH_4^+) est produit par le microbiote principalement lors de la désamination des AA (figure 17 et 19) (109). Dans le contenu colique, compte tenu du pH luminal et du pKa du couple $\text{NH}_4^+/\text{NH}_3$ (pKa = 9,02), la grande majorité du couple $\text{NH}_4^+/\text{NH}_3$ est présente sous forme de NH_4^+ . Une partie du NH_4^+ est absorbée à travers la membrane des colonocytes via des transporteurs spécifiques alors que le NH_3 diffuse librement dans la cellule. Ces métabolites sont alors transportés dans la veine porte jusqu'au foie où ils sont convertis en urée. Le catabolisme des AA par le métabolisme humain entraîne également la production de NH_4^+ et d'urée. L'urée produite est excrétée en majorité dans les urines mais une partie diffuse également dans le gros intestin où sa dégradation par les uréases du microbiote entraîne à nouveau la production de NH_4^+ . Dans la lumière du côlon, le NH_4^+ non absorbé par la muqueuse peut être soit incorporé dans les bactéries (source importante d'azote pour ces dernières) soit excrété dans les fèces (minoritaire) (109). Chez l'homme, la concentration fécale en NH_4^+ est de l'ordre du millimolaire (10 - 50 mM). Elle augmente dans les parties distales du gros intestin, reflétant l'augmentation de l'activité protéolytique bactérienne (22,111,132). La concentration de NH_4^+ dans le cæcum est beaucoup plus faible chez les rats axéniques que chez les rats conventionnels, ce résultat illustre le rôle important du microbiote dans sa production (133).

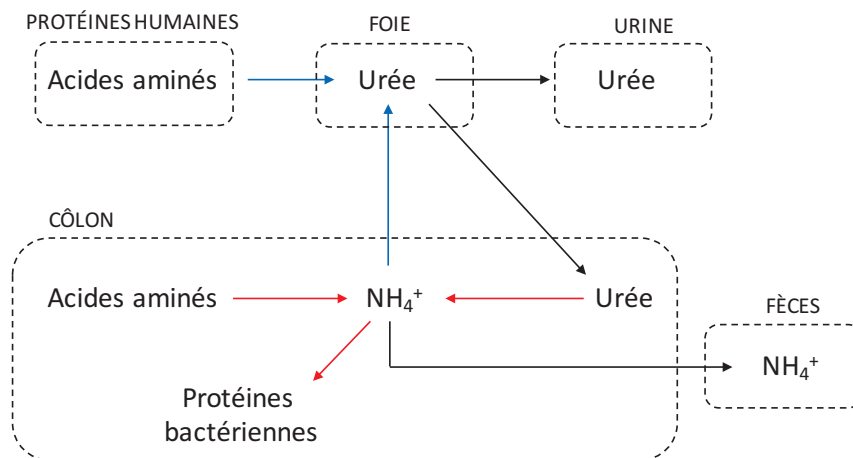

Figure 19 : Représentation schématique du métabolisme de l'ammonium (NH_4^+). Les flèches rouges indiquent des réactions du métabolisme bactérien, les flèches bleues indiquent des réactions du métabolisme humain. Les flèches noires indiquent des flux inter-compartiments.

Les effets de l'apport en protéines sur la concentration de NH_4^+ sont décrits dans le tableau 8. Toutes les études chez l'animal montrent une augmentation de la concentration de NH_4^+ dans les contenus du gros intestin lors d'un apport élevé en protéines, probablement en raison de l'augmentation de la désamination des AA par le microbiote. La concentration de NH_4^+ n'augmente pas lors d'un régime riche en protéines chez des rats axéniques contrairement aux rats conventionnels (133). Ces données confirment le rôle du microbiote dans cet effet des régimes HP sur les concentrations lumineales en NH_4^+ . De plus, une étude chez le rat a montré que la concentration de NH_4^+ dans le contenu du côlon est plus élevée lors d'un régime à base de protéines de pomme de terre que lors d'un régime à base de caséines (134). Ce résultat montre l'importance de la source de protéines dans la production de NH_4^+ par le microbiote. La différence de digestibilité entre les deux protéines testées (supérieure dans le cas des caséines) explique probablement cet effet. En conclusion, les données animales suggèrent que l'exposition de la muqueuse du côlon au NH_4^+ augmente lors d'un régime HP. Chez l'homme, il est plus difficile de conclure quant à l'effet du niveau d'apport en protéines sur la concentration de NH_4^+ . La concentration fécale en NH_4^+ ne reflète pas nécessairement la concentration lumineale, cela pourrait expliquer la variabilité des résultats obtenus lors des études cliniques.

Le NH_4^+ inhibe l'oxydation des AGCC et la consommation d' O_2 par les colonocytes de rats de manière dose-dépendante entre 10 et 50 mM (9,135). De plus, le NH_4^+ (20 mM) diminue l'expression du gène du transporteur du butyrate MCT1 *in vitro* dans des cellules Caco-2 (136). Cela pourrait contribuer au rôle de perturbateur métabolique du NH_4^+ pour l'épithélium intestinal. Par ailleurs, le NH_4^+ (20 mM) diminue la prolifération *in vitro* de cellules HT-29 provenant d'un adénocarcinome colique humain (137) alors que, au contraire, l'injection endoluminale de NH_4^+ (35 - 75 mM) dans le côlon de rat induit une augmentation de la prolifération dans l'épithélium (138,139). Cette disparité dans les résultats observées en fonction du modèle utilisé pourrait être expliquée en partie par les différences de capacités des cellules saines et cancéreuses à métaboliser le NH_4^+ . Ce métabolite n'affecte pas la viabilité de colonocytes de porc (50 mM) ni des cellules HT-29 (20 mM) (137). *Ex vivo*, le NH_4^+ (20 mM) induit l'expression du gène de la cytokine pro-inflammatoire *Tnf- α* dans le côlon de porcs (136). Enfin, *in vitro*, le NH_4^+ (10 à 100 mM) diminue la résistance transépithéliale de cellules Caco-2, indiquant une perturbation de la fonction barrière (140). En conclusion, lorsqu'il est présent en concentration élevée, le NH_4^+ est un métabolite bactérien toxique pour l'épithélium puisqu'il perturbe le métabolisme énergétique, joue un rôle pro-inflammatoire et affecte la fonction barrière. La détoxification du NH_4^+ par les colonocytes sains en glutamine et citrulline pourrait limiter ces effets délétères (137,141).

Tableau 8 : Effets de l'apport en protéines sur la concentration d'ammonium (NH₄⁺). CO = schéma expérimental en croisé, % E : pourcentage d'énergie apportée par les protéines, % MS : grammes de protéines sur 100 grammes de matière sèche, g/j : grammes de protéines par jour, ↓ indique une diminution, ↑ indique une augmentation, # : valeur lue sur un histogramme. Les valeurs associées à une lettre différente sont significativement différentes.

Espèce	Echantillon	Durée	Apport en protéines	Source de protéines	Apport en fibres	[NH ₄ ⁺]	Effet d'une augmentation de l'apport en protéines	Référence
Humain n=8 (CO)	Fèces	19 jours	68 g/j 192 g/j	Viande	12 g/j 11 g/j	12 mM (a) 24 mM (b)	↑	(142)
Humain n=5(CO)	Fèces	1 semaine	15,4 % E 23,8 % E	Mixte + protéines de lait	18,9 g/j 17,2 g/j	0,237 mM (a) 0,304 mM (b)	↑	(128)
Humain n=4 (CO)	Fèces	2 semaines	62,7 g/j 136 g/j	Mixte	23,4 g/j 21,8 g/j	14,8 mM (a) 30,4 mM (b)	↑	(129)
Humain n=17 (CO)	Fèces	28 jours	13 % E 28 % E 29 % E	Mixte	21,9 g/j 12,8 g/j 8,8 g/j	435 mg/mL (a) 456 mg/mL (a) 366 mg/mL (a)	=	(12)
Humain n=20	Fèces	28 jours	94,4 g/j 127,2 g/j 119,5 g/j	Mixte	27,9 g/j 11,7 g/j 6,1 g/j	51,67 mM (a) 42,98 mM (ab) 33,03 mM (b)	↓	(97)
Humain n=91	Fèces	8 semaines	24 % E 35 % E	Mixte	31,5 g/j 13 g/j	32,9 mM (a) 32,9 mM (a)	=	(98)
Porc n=8	Côlon	20-23 jours	15 % MS 20 % MS	Protéines de soja	15 % MS 15 % MS	7,3 mM (a) 14 mM (b)	↑	(99)
Porc n=10	Côlon	7 jours	15 % MS 22 % MS	Mixte	13 % MS 11 % MS	276 mg/L (a) 366 mg/L (b)	↑	(131)
Rat n=4-7	Cæcum	1 semaine	20 % MS 58 % MS	Caséines	2 % MS 7 % MS	10 mM (a)# 20 mM (b)#	↑	(137)
Rat n=12-13	Côlon	4 mois	8 % MS 16 % MS 32 % MS	Caséines	5 % MS 5 % MS 5 % MS	48 mM (a) 68 mM (b) 74 mM (c)	↑	(132)
Rat n=10	Cæcum	3 semaines	22 % MS 45 % MS	Protéines de poisson et de soja	5 % MS 5 % MS	3,27 µm ³ /g (a) 6,69 µm ³ /g (b)	↑	(133)

3.2.2.3 Métabolites issus de la dégradation des acides aminés aromatiques

La dégradation des AA aromatiques phénylalanine, tyrosine et tryptophane par le microbiote produit des molécules contenant un groupement benzène, phénol ou indole (respectivement) lors d'une série de désaminations, transaminations, décarboxylations et déshydrogénations (Figure 17) (35,123). Une grande diversité de bactéries est capable de dégrader les AA aromatiques, incluant les genres *Bacteroides*, *Clostridium*, *Lactobacillus*, *Bifidobacterium* et *Streptococcus* (123,143).

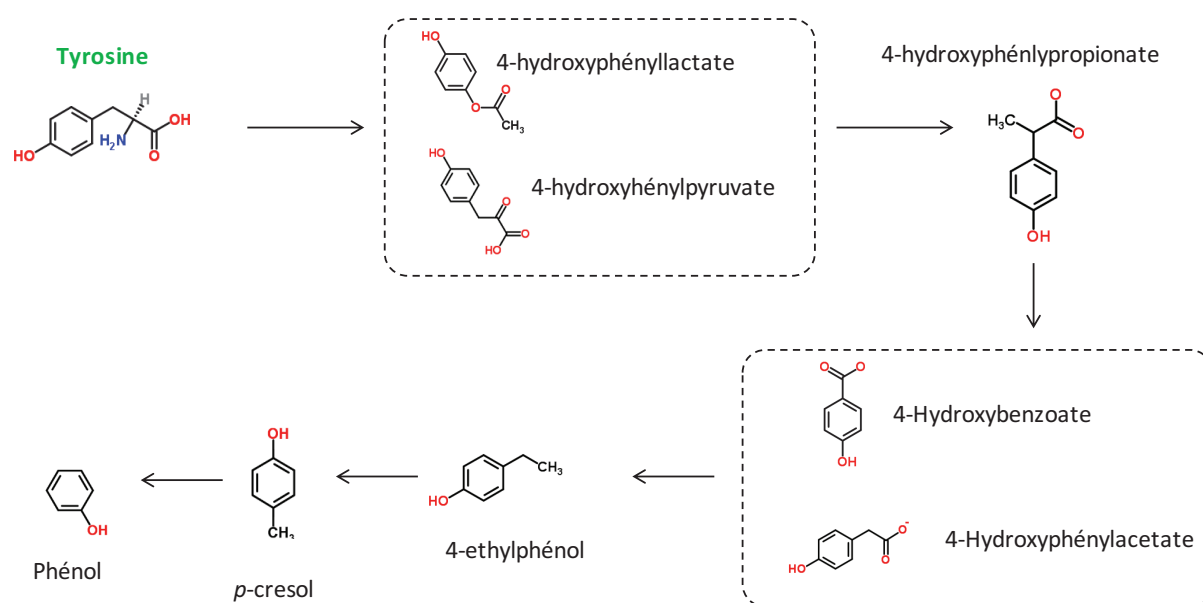

Figure 20 : Métabolites bactériens produits à partir de la tyrosine par le microbiote intestinal. D'après (122,123,143).

Métabolites bactériens produits à partir de la tyrosine

Les produits de dégradation de la tyrosine par le microbiote intestinal sont présentés sur la figure 20. Les métabolites majoritaires sont le *p*-cresol et le phénol. La production de composés phénoliques est favorisée par un temps de transit long et leur concentration augmente dans les parties distales du gros intestin où la dégradation des protéines par le microbiote est plus intense (123,129). Après absorption (90% des composés phénoliques produits), ces métabolites sont détoxiqués dans la muqueuse intestinale et dans le foie par conjugaison avec un groupement sulfate ou glucuronide (minoritaire) puis éliminés dans l'urine où les formes conjuguées du *p*-cresol représentent 90% des composés phénoliques excrétés (Figure 21) (35,144). Dans le contenu colique humain, la concentration totale en composés phénoliques est de 6,2 mM (123). La concentration fécale de *p*-cresol rapportée par différentes études chez l'homme

varie de 0,14 à 0,60 $\mu\text{mol/g}$ (soit environ de 140 à 600 μM) (116). En raison de l'importance de l'absorption, la concentration des formes conjuguées du *p*-cresol dans les urines est un meilleur reflet de sa production par le microbiote que sa concentration fécale (13). La concentration fécale en phénol mesurée dans plusieurs études chez l'homme est généralement plus faible que celle du *p*-cresol et varie de 0,037 à 0,58 $\mu\text{mol/g}$ (soit environ de 37 à 580 μM) (116). Ces composés phénoliques ne sont pas produits par le métabolisme humain mais seulement par le métabolisme bactérien, il s'agit donc de marqueurs spécifiques de la dégradation bactérienne des protéines par le microbiote (122). En effet, le phényl sulfate (forme conjuguée du phénol) et le *p*-cresyl sulfate ne sont pas détectés dans le sérum de souris axéniques (145). De plus, une étude utilisant des protéines d'œufs marquées avec des isotopes stables a démontré que la tyrosine provenant de l'alimentation est en partie convertie en *p*-cresol et en phénol (30). Cette conversion est d'autant plus importante que la digestibilité des protéines d'œufs est faible (œuf cru *versus* œuf cuit), probablement en raison de l'augmentation de la disponibilité en tyrosine pour le microbiote dans le gros intestin (30).

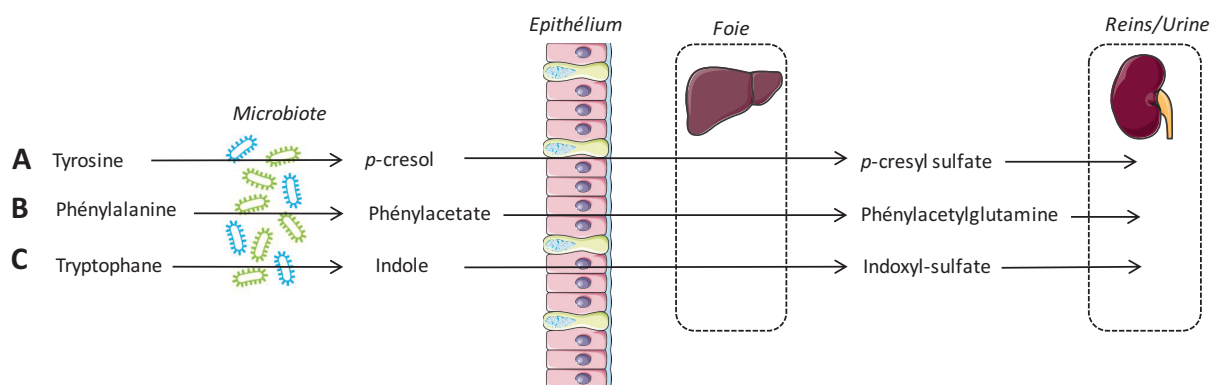

Figure 21 : Illustration du concept de co-métabolites bactérie-hôte. Les acides aminés aromatiques sont convertis en métabolites bactériens dans la lumière du côlon. Après absorption, ces métabolites sont métabolisés dans la muqueuse et/ou dans le foie puis excrétés dans les urines.

Tableau 9 : Effets de l'apport en protéines sur la concentration de *p*-cresol. CO = schéma expérimental en cross over, % E : pourcentage d'énergie apportée par les protéines, % MS : grammes de protéines pour 100 grammes de matière sèche, g/j : grammes de protéines par jour, ↓ indique une diminution, ↑ indique une augmentation, = indique une absence d'effet, # : valeur lue sur un histogramme. Les valeurs associées à une lettre différente sont significativement différentes. Dans les urines, les formes conjuguées du *p*-cresol ont été mesurées.

Espèce	Echantillon	Durée	Apport en protéines	Source de protéines	Apport en fibres	[<i>p</i> -cresol]	Effet d'une augmentation de l'apport en protéines	Référence
Humain n=16-17	Fèces	12 semaines	90,4 g/j	Mixte	33,8 g/j	Environ 55 µg/g #	=	(130)
			133,4 g/j		42,8 g/j	Idem		
Humain n=20 (CO)	Fèces	2 semaines	12 % E	Mixte + protéines de lait	16,3 g/j	1,9 mg/L (a)	=	(13)
			15 % E		15,4 g/j	1,9 mg/L (a)		
			27 % E		17,4 g/j	2,3 mg/L (a)		
Humain n=20 (CO)	Urines	2 semaines	12 % E	Mixte + protéines de lait	16,3 g/j	33,7 mg/24h (ab)	↑	(13)
			15 % E		15,4 g/j	32,1 mg/24h (a)		
			27 % E		17,4 g/j	45,8 mg/24h (b)		
Humain n=5 (CO)	Urine	1 semaine	15,4 % E	Mixte + protéines de lait	18,9 g/j	7,71 mg/g créatinine (a)	↑	(128)
			23,8 % E		17,2 g/j	17,59 mg/g créatinine (b)		
Rat n=8	Fèces	4 semaines	15 % MS	Caséines	5 % MS	25 µg/g# (a)	↑	(125)
			25 % MS		5 % MS	35 µg/g# (b)		

Le tableau 9 présente les concentrations en *p*-cresol en fonction de l'apport en protéines. A l'exception d'une étude chez le rat, la concentration de *p*-cresol fécal n'est pas affectée par le niveau d'apport en protéines. Au contraire, l'excrétion urinaire de *p*-cresol augmente lors d'un apport élevé en protéines. Ces résultats indiquent qu'un apport en protéines élevé augmente la production de *p*-cresol par le microbiote, mais en raison de son absorption rapide par la muqueuse, cette augmentation est difficilement détectable dans les fèces. Des résultats similaires ont été obtenus pour le phénol. Un apport élevé en protéines n'augmente pas la concentration de phénol dans le contenu caecal chez le rat et dans les fèces chez l'homme (125,130) alors qu'il induit une augmentation de la concentration plasmatique de la forme conjuguée phényl sulfate chez la souris (146). En conclusion, lors d'un apport élevé en protéines, la muqueuse du gros intestin est davantage exposée aux composés phénoliques produits par le microbiote à partir de la tyrosine.

Peu d'études ont décrit les effets sur l'épithélium du côlon des métabolites bactériens dérivés de la tyrosine. Le phénol (1 - 10 mM) diminue la résistance transépithéliale et augmente la perméabilité paracellulaire probablement en raison d'une déstabilisation des jonctions serrées (140,147). Ce métabolite (concentrations > 1,25 mM) réduit la viabilité de cultures primaires de colonocytes humains (148) mais ces résultats n'ont pas été confirmés *in vitro* sur des cellules épithéliales coliques SK-CO15 (concentrations > 3,2 mM) (147). Les différences de concentrations testées ainsi que les caractéristiques des cellules (saines ou issues de cancer) pourraient expliquer ces résultats divergents. Les effets du *p*-cresol sur l'épithélium intestinal n'ont jamais été testés. Néanmoins, chez le rat, la concentration fécale de *p*-cresol est corrélée positivement aux dommages à l'ADN dans les colonocytes (125) mais cette relation n'a pas été confirmée chez l'homme d'après le test des eaux fécales sur colonocytes *in vitro* (13). De plus, le *p*-cresol pourrait être toxique pour l'épithélium intestinal puisqu'il a été montré sur d'autres tissus (dans le cadre de l'étude des maladies rénales chroniques) qu'il perturbe le métabolisme mitochondrial et induit la production de ROS (149). Enfin, les composés phénoliques ont été impliqués dans les MICI en raison d'une altération de leur détoxification par la muqueuse lors de ces pathologies (144).

Métabolites bactériens produits à partir du tryptophane

Les composés indoliques produits lors de la dégradation du tryptophane par le microbiote sont présentés sur la figure 22. Parmi ces métabolites, les plus abondants sont l'indole (0,25 - 1,1 mM dans les fèces), l'indole propionate et l'indole acétate (150). L'indole produit dans la lumière de l'intestin est absorbé par l'épithélium et est conjugué en indoxyl sulfate (ou glucuronide) dans le foie avant d'être excrété dans les urines (Figure 21). Ces composés indoliques ne sont pas produits par le métabolisme humain mais seulement par le métabolisme bactérien. En effet, l'indole-3-propionate et l'indoxyl sulfate ne sont pas détectables chez les souris axéniques (145). Les composés indoliques sont plus concentrés

dans la partie distale du gros intestin où a la dégradation des protéines par le microbiote est la plus intense (151).

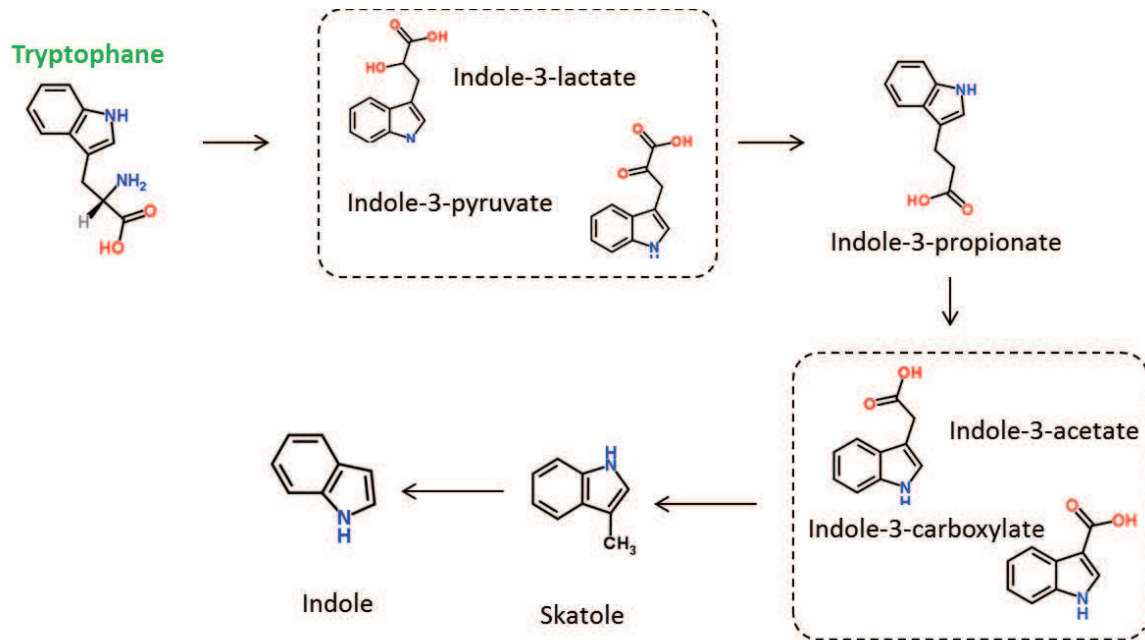

Figure 22 : Métabolites bactériens produits à partir du tryptophane par le microbiote intestinal. D’après (122,123,143).

Chez l’homme, il a été montré qu’un apport élevé en protéines augmente la concentration fécale en composés indoliques (128) mais ce résultat n’a pas été retrouvé dans une autre étude (12). Ici encore, les concentrations fécales pourraient ne pas être de bons reflets de l’exposition de la muqueuse en raison de l’absorption de ces composés. Lors d’un apport élevé en protéines, les concentrations d’indoxyl sulfate et d’indoxyl glucuronide sont augmentées dans les urines chez l’homme et la souris (146). Malgré le peu de données disponibles, il est vraisemblable que l’épithélium du côlon soit davantage exposé aux composés indoliques lors des régimes HP.

In vitro, l’indole (1 mM) a des effets immuno-modulateurs (diminution de l’expression de IL-8 et de l’activation de NF-κB, augmentation de l’expression de l’IL-10) et renforce la fonction barrière (augmentation de la résistance transépithéliale) dans des cellules épithéliales coliques HCT-8 (150). *In vivo*, l’indole-3-propionate est également anti-inflammatoire et contribue au maintien de la fonction barrière via le récepteur « pregnane X receptor » (152). Une autre étude a montré que l’indole-3-aldéhyde produit par des lactobacilles à partir du tryptophane joue un rôle immuno-modulateur *in vivo* via l’activation du récepteur « aryl hydrocarbon receptor » (153). Dans un modèle de MICI chez la souris, l’apport d’indole spécifiquement au niveau du côlon par des capsules améliore l’évolution de la

maladie (154). L'ensemble de ces données montre que les composés indoliques produits par le microbiote à partir du tryptophane jouent un rôle bénéfique pour l'épithélium intestinal.

Métabolites bactériens produits à partir de la phénylalanine

Les métabolites issus de la dégradation de la phénylalanine par le microbiote intestinal sont présentés sur la figure 23, le plus abondant étant le phénylacétate (143). Chez l'homme, le phénylacétate est absorbé puis métabolisé dans le foie en phénylacétylglutamine (phénylacétylglycine chez la souris) avant d'être excrété dans les urines (Figure 21). La phénylacétylglycine est nettement plus concentrée dans le plasma et dans les urines des souris conventionnelles que chez les souris axéniques qui en produisent tout de même de petites quantités, indiquant que les bactéries participent à la production de ce métabolite mais de manière non exclusive (145,155). Après absorption par la muqueuse, le benzoate est conjugué à la glycine dans le foie et dans les reins en hippurate (excrété dans les urines). Néanmoins, ce composé n'est pas considéré comme un marqueur de la dégradation des protéines puisqu'il peut également être produit à partir d'autres précurseurs que la phénylalanine (composés phénoliques des végétaux notamment) (156). Chez l'homme, la concentration fécale en phénylacétate est augmentée lors d'un régime HP alors que la concentration de phénylpropionate est diminuée (12). La concentration plasmatique en phénylacétate est également augmentée chez des souris nourries avec un régime HP (146). Les effets sur l'épithélium des métabolites bactériens dérivés de la phénylalanine ne sont pas connus.

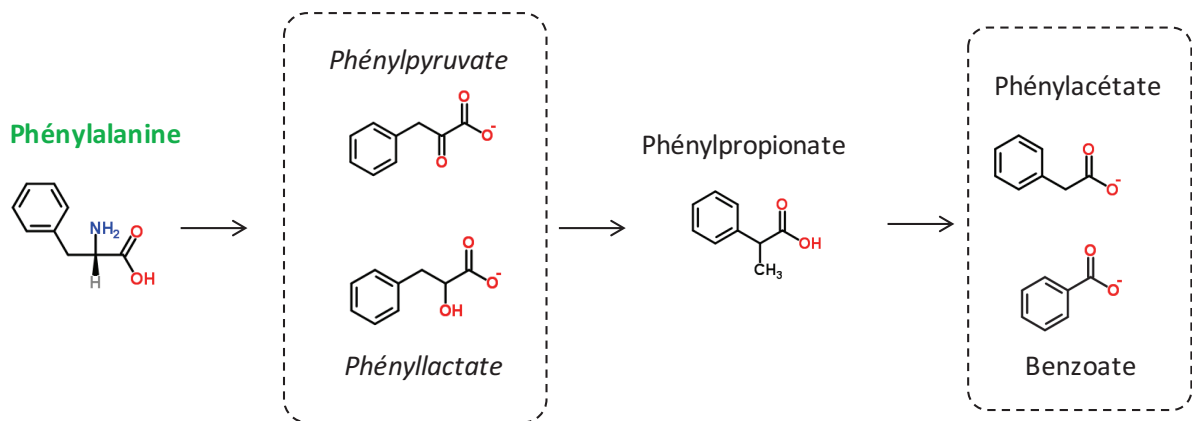

Figure 23 : Métabolites bactériens produits à partir de la phénylalanine par le microbiote intestinal. D'après (122,123,143).

3.2.2.4 Amines et polyamines issues de la décarboxylation des acides aminés

Les amines et les polyamines sont produites par les bactéries intestinales lors de la décarboxylation des AA (Figure 17) (35). Une grande diversité d'amines est produite par le microbiote en fonction de l'AA précurseur (Tableau 10). La production de polyamines a été observée chez plusieurs genres bactériens : *Bacteroides*, *Clostridium*, *Lactobacillus*, *Veillonella* et *Bifidobacterium* (157). L'excrétion de polyamines est réduite chez les rats axéniques ou chez les humains après un traitement antibiotique, indiquant un rôle des bactéries intestinales dans leur production (22). Néanmoins, la plupart de ces composés sont également produits par les mammifères. Chez le rat les concentrations coliques en putrescine, spermidine et spermine sont d'environ 700, 100 et 10 µM, respectivement (7). Chez le porc, la concentration dans le contenu colique en polyamines varie de 10 (histamine) à 200 µM (putrescine/cadavérine) (99). Ces amines sont détoxiquées dans la muqueuse intestinale et dans le foie par des monoamine et diamine oxydases (35).

Tableau 10 : Amines et polyamines produites lors de la décarboxylation des acides aminés par le microbiote. Les composés possédant des propriétés de neurotransmetteur sont indiqués en rouge. GABA : Acide γ-aminobutyrique.

Acide aminé précurseur	Amine ou Polyamine
Glycine	Méthylamine
Valine	2-méthylbutylamine
Ornithine	Agmatine, Putrescine, Spermidine, Spermine, GABA
Lysine	Cadavérine
Tyrosine	Tyramine, Dopamine
Tryptophane	Tryptamine, Sérotonine
Histidine	Histamine
Phénylalanine	Phényléthylamine
Arginine	Putrescine, Spermidine, Spermine, GABA
Alanine	Ethylamine

Chez le porc, la concentration colique de certaines polyamines (putrescine, histamine et spermidine mais pas cadavérine et spermine) augmente lors d'un régime riche en protéines (99). Chez le rat, une augmentation de la concentration des polyamines a également été observée lors d'un régime HP mais les polyamines affectées ne sont pas les mêmes (augmentation de la méthylamine, cadavérine, spermine mais pas de la tryptamine, phényléthylamine, putrescine, histamine, tyramine et spermidine) (101).

Les polyamines participent au renouvellement de l'épithélium, au maintien de la fonction barrière de l'intestin et au contrôle de l'inflammation (158) mais les effets varient en fonction de la nature des polyamines. Par exemple, la putrescine est indispensable à la prolifération des cellules épithéliales coliques *in vitro* alors qu'à l'inverse, l'agmatine l'inhibe (159). La plupart des études sur les polyamines n'ont pas distingué l'origine bactérienne ou eucaryote de ces molécules. Récemment, il a été montré que l'histamine et la spermine produites par le microbiote régulent l'inflammation dans l'épithélium intestinal (160). Enfin, le rôle de neurotransmetteur de certaines de ces amines (GABA, dopamine, sérotonine et histamine) (Tableau 10) produites par le microbiote pourrait avoir des effets sur le système nerveux entérique, mais cette hypothèse reste peu explorée.

En résumé

- Les principaux substrats (alimentaires et endogènes) disponibles pour le microbiote du côlon sont les glucides et les protéines.
- La dégradation des protéines par le microbiote a lieu principalement dans la partie distale du gros intestin et produit une grande diversité de métabolites.
- La fermentation des AA produit des AGCC communs avec la fermentation des glucides et considérés comme bénéfiques pour l'épithélium (acétate, propionate et butyrate) mais aussi des AGCC spécifiquement dérivés des AA (AGCB et valérate).
- Certains métabolites dérivés des AA produits par le microbiote sont considérés bénéfiques pour la muqueuse du côlon (composés indoliques) alors que d'autres sont délétères pour les colonocytes (NH_4^+ , phénol).
- La concentration fécale des métabolites bactériens dérivés des AA est généralement augmentée lors d'un régime HP.
- Certains métabolites bactériens dérivés des AA sont absorbés et métabolisés par la muqueuse et le foie, conduisant à la production de co-métabolites microbiote-hôte.

3.2.3 *Sulfure d'hydrogène bactérien et muqueuse digestive*

Le sulfure d'hydrogène est un gaz soluble dans l'eau et les lipides se dissociant en solution aqueuse sous trois formes : la forme hydrogénée (H_2S) et deux formes anioniques hemisulfide (HS^-) et sulfide (S^{2-}) (pKa 7,04 et 11,96) (161). Au pH physiologique, la forme HS^- est prédominante et la forme S^{2-} est présente en quantité négligeable (161). Bien que leurs propriétés soient probablement différentes, la distinction entre ces trois formes est rarement faite dans la littérature. H_2S diffuse librement à travers les membranes cellulaires et est considéré comme un gasotransmetteur comme le NO et le monoxyde de carbone. Ces trois gaz interagissent, régulent des fonctions communes (notamment au niveau cardiovasculaire et neuronal) et leurs effets sont « bi-modaux » : les faibles concentrations sont considérées bénéfiques (cytoprotecteur, anti-oxydant, anti-inflammatoire) alors que les concentrations élevées sont considérées délétères (inhibiteur du métabolisme mitochondrial, cytotoxique, pro-inflammatoire) (53). Le H_2S est produit en faibles concentrations (nM) par les cellules des mammifères principalement lors de la dégradation de la cystéine par trois enzymes (cystathionine- γ -lyase, CSE ; cystathionine- β -synthase, CBS ; 3-mercaptopyruvate sulfurtransferase, 3-MST) et agit via divers mécanismes tels que la régulation de canaux ioniques, des modifications post-traductionnelles des protéines (S-sulphydratation, formation de persulfides et de polysulfides) ou la réaction avec des ROS ainsi que via des effets sur la chaîne respiratoire (voir 3.2.3.3) (53,162). La principale difficulté dans le domaine de l'étude du H_2S est la mesure de sa concentration, puisqu'il s'agit d'un gaz très volatil. Enfin, le H_2S existe sous des formes libres ou liées dont la réactivité biologique est probablement différente mais la distinction est rarement faite dans la littérature en raison de la complexité des analyses requises (163).

3.2.3.1 Production de sulfure d'hydrogène par le microbiote intestinal

Le côlon est l'organe le plus exposé au H_2S en raison de son abondante production par les bactéries du microbiote (162). Dans la lumière de l'intestin, le soufre peut se trouver principalement sous forme d'AA soufrés (cystéine et méthionine), de sulfates (SO_4^{2-}) ou de sulfites (SO_3^{2-}), de sulfo-mucines ou encore de composés dérivés des sécrétions biliaires (acides biliaires sulfatés ou conjugués à la taurine) (Figure 24) (164). Il existe trois voies principales de production de H_2S par les bactéries intestinales : la dégradation de la cystéine, la sulfato-réduction et la dégradation de la taurine.

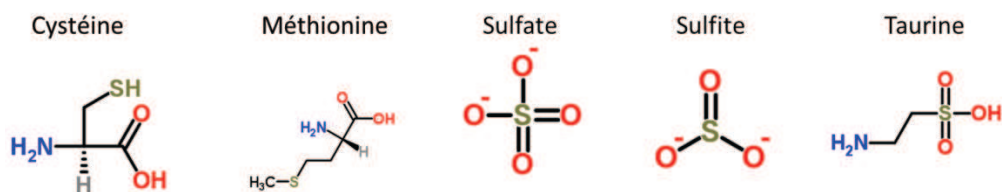

Figure 24 : Sources de soufre dans la lumière de l'intestin disponibles pour la production de H₂S par le microbiote.

➤ Le H₂S peut être produit à partir de la cystéine par les bactéries équipées de l'enzyme cystéine desulfhydrase (Figure 25 A1) (164). Une grande diversité de bactéries intestinales ont cette capacité : *Escherichia*, *Streptococcus*, *Prevotella*, *Fusobacterium*, *Clostridia*, *Enterobacteria*, *Enterococci* et *Salmonella* (164–166). La production de H₂S à partir de la cystéine implique également les enzymes bactériennes CBS, CSE et 3-MST (homologues des enzymes eucaryotes, voir 3.2.3) (Figure 25 A2) ainsi que d'autres enzymes (non décrites ici). Bien que ces voies métaboliques soient très répandues chez les bactéries, elles n'ont été que très partiellement décrites dans le cas du microbiote intestinal (164).

➤ La deuxième voie de production de H₂S par le microbiote est la sulfato-réduction (Figure 25 C). Les bactéries sulfato-réductrices (« sulfate-reducing bacteria », SRB) sont caractérisées par leur capacité à obtenir de l'énergie en utilisant les sulfates comme accepteurs finaux des électrons et en produisant du H₂S (164). La plupart des SRB font partie des Deltaproteobacteria et des Clostridia. Dans le microbiote intestinal humain, les genres prédominants sont *Desulfovibrio*, *Desulfobacter* et *Desulfobulbus* (167).

➤ La troisième voie de production de H₂S par le microbiote intestinal implique *Bilophila wadsworthia* qui est la seule espèce bactérienne de cet écosystème connue pour sa capacité à produire du H₂S à partir de la taurine via la libération de sulfites (Figure 25 B) (164). Lors d'un régime riche en lipides, l'augmentation de la sécrétion d'acides biliaires conjugués à la taurine entraîne la prolifération de *Bilophila wadsworthia* (168).

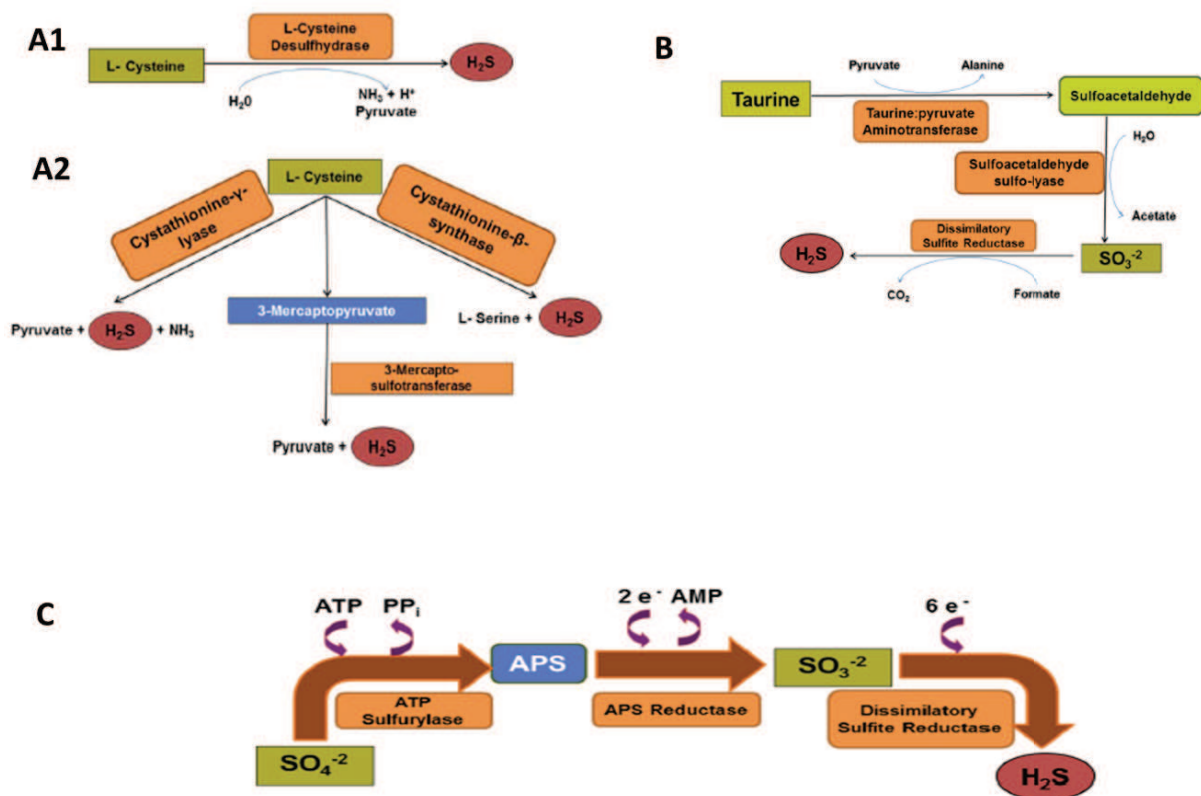

Figure 25 : Voies de production du H₂S par les bactéries du microbiote intestinal à partir de la cystéine (A1 et A2), de la taurine (B) et des sulfates (SO₄²⁻) (C). D'après (164).

Chez l'homme, la concentration de H₂S dans le contenu du gros intestin varie de 1 à 2,4 mM, la concentration la plus élevée étant mesurée au niveau distal (109). Dans les fèces d'hommes et de rats, la concentration de H₂S varie selon les études entre 0,17 et 3,38 mM (169). Néanmoins, une partie du H₂S est probablement liée aux contenus digestifs et moins de 8% du H₂S serait présent sous forme libre, soit environ 60 μM (163,170). Cependant, les composés liant le H₂S au niveau des contenus coliques ont été peu étudiés. La concentration fécale de H₂S est augmentée chez des personnes consommant un régime riche en viande, probablement en raison d'un apport en protéines plus important (171). Une autre étude chez l'homme a montré une augmentation de la concentration fécale des composés soufrés lors d'un régime riche en protéines, sans toutefois distinguer spécifiquement le H₂S (128). Chez le rat, une étude a décrit une augmentation considérable de la concentration de H₂S dans le contenu du côlon lors d'un régime HP par rapport à un régime NP (0,8 et 0,2 mg/g respectivement) (101) mais cette concentration semble anormalement élevée (30 mM environ) par rapport aux valeurs obtenues dans de nombreux autres laboratoires. Le dosage employé (bleu de méthylène) est connu pour être peu spécifique car détectant d'autres composés soufrés que le H₂S.

3.2.3.2 Détoxication du sulfure d'hydrogène par les colonocytes

A faible concentration (jusqu'à environ 20 μM), le H_2S peut être oxydé en thiosulfate ($\text{S}_2\text{O}_3^{2-}$) par les mitochondries des colonocytes (Figure 26) (172,173). Cette oxydation du H_2S est assurée par un complexe de trois enzymes mitochondriales (174). D'abord, la sulfide quinone reductase (SQR) oxyde le H_2S et transfère ses électrons dans la chaîne respiratoire au niveau du coenzyme Q. Le transport de ces électrons dans la chaîne mitochondriale aboutit à la réduction d' O_2 en H_2O et à la synthèse d'ATP. Le H_2S peut donc être un substrat énergétique inorganique pour les colonocytes lorsqu'il est présent à faible concentration. L'action séquentielle des deux autres enzymes du complexe de détoxication du H_2S , la « dioxygénase ethylmalonic encephalopathy » (ETHE1) et la « thiosulfur transferase » (TST) entraîne la production de thiosulfate associée à la consommation d'oxygène (Figure 26).

L'oxydation du H_2S par les colonocytes peut aussi être interprétée comme une voie métabolique de détoxication. Cette capacité est particulièrement élevée dans les colonocytes par rapport aux autres types cellulaires, résultant probablement d'une adaptation à l'exposition aux concentrations lumenales élevées de H_2S produit par le microbiote (172). La différenciation des colonocytes est associée à une augmentation de l'activité des enzymes de détoxication de H_2S probablement via une augmentation de la réserve respiratoire mitochondriale (174,175). Cela pourrait signifier que les cellules de la base des cryptes (non différenciées) sont plus sensibles aux effets toxiques du H_2S que les cellules de l'épithélium de plateau. Néanmoins, aucune étude n'a documenté la diffusion du H_2S jusqu'à la base des cryptes, ni les concentrations à proximité des cellules correspondantes.

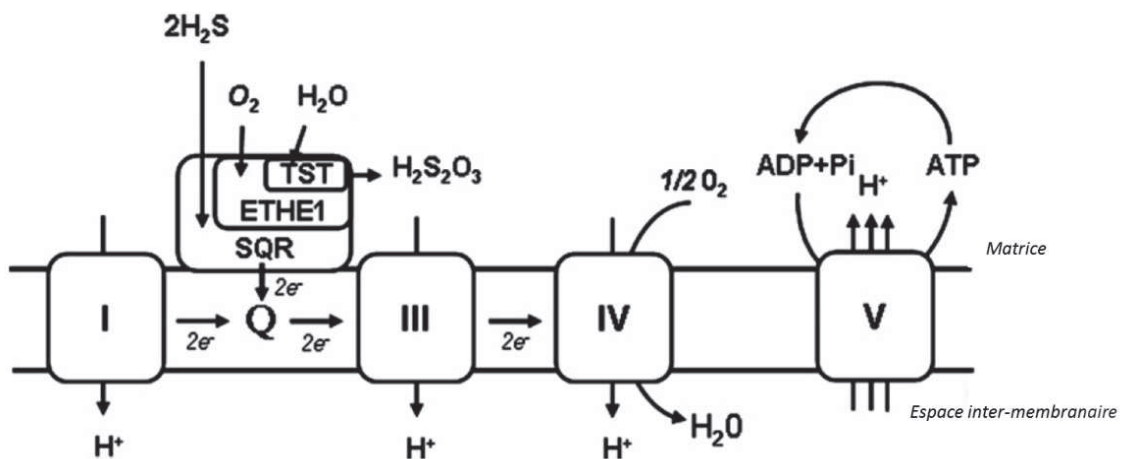

Figure 26 : Représentation schématique des complexes enzymatiques de la chaîne respiratoire mitochondriale (I, III, IV et V) et des enzymes de détoxication de H_2S (SQR, ETHE1 et TST). Complexe IV : cytochrome c oxydase, Complexe V : ATP synthase. D'après (174).

En adéquation avec les travaux menés dans ce travail de thèse, les études présentées dans les deux paragraphes suivants ne concernent que les effets du H₂S produit à une concentration proche de celle observée dans la lumière du gros intestin (µM - mM). Les études décrivant les effets de concentrations faibles de H₂S (nM) correspondant à sa synthèse endogène ne sont pas décrites.

3.2.3.3 Effets du sulfure d'hydrogène sur la muqueuse du gros intestin

In vitro, la consommation d'O₂ par des cellules HT-29 diminue en présence de NaHS (donneur de H₂S) à partir 65 µM (174) en raison de l'inhibition réversible du complexe IV (dernière enzyme de la chaîne respiratoire) (Figure 26) (176). Dans des colonocytes humains, l'oxydation de leurs principaux substrats énergétiques (AGCC et glutamine) est inhibée par le H₂S (NaHS 1 - 4 mM) (62,176). Lorsqu'il est présent à des concentrations élevées, le H₂S est donc un perturbateur métabolique. Des résultats contradictoires ont été obtenus concernant les effets du H₂S sur le renouvellement de l'épithélium. Trois études (l'une sur des biopsies rectales humaines, les autres sur des cellules en culture) ont montré que le H₂S (NaHS 0,2 - 5 mM) induit une augmentation de la prolifération des cellules épithéliales (177–179) alors que d'autres études *in vitro* ont montré que le H₂S (NaHS 0,3 - 1 mM) réduit la prolifération de cellules HT-29 (176,180). Ces résultats divergents pourraient être expliqués par la volatilité du H₂S et par son métabolisme cellulaire rendant le contrôle des conditions expérimentales délicat puisque les concentrations de H₂S sont susceptibles de diminuer rapidement dans les milieux d'incubation (176). Il a également été montré que le H₂S perturbe le cycle cellulaire des cellules épithéliales (180). Néanmoins, le H₂S n'induit pas l'apoptose de ces cellules excepté à des concentrations très élevées (à partir de 5 mM de NaHS) (176,178–180). De plus, le H₂S n'augmente pas la production de ROS *in vitro* dans des cellules HT-29 (176) alors que d'autres études montrent qu'il induit des cassures de l'ADN d'après le test de comètes effectué sur la lignée FHs 74 Int (Na₂S 250 – 2000 µM) probablement via un mécanisme impliquant le stress oxydant (181–183). Enfin, le H₂S (Na₂S 500 µM) induit *in vitro* une augmentation de l'expression des gènes pro-inflammatoires *Il-8* et « *Prostaglandin-endoperoxyde synthase 2* » (*Ptgs2*) dans les cellules FHs 74 Int (182). Récemment, il a été montré que le H₂S induit une rupture des ponts disulfures liants les mucines entre elles, entraînant ainsi une déstabilisation de la couche de mucus et favorisant l'accès de composés toxiques à l'épithélium (184). En conclusion, H₂S semble être un métabolite toxique pour l'épithélium mais la plupart de ces résultats obtenus *in vitro* n'ont pas été confirmés *in vivo*.

3.2.3.4 Sulfure d'hydrogène et maladies inflammatoires chroniques intestinales

Plusieurs études ont montré chez des patients atteints de MICI que les SRB sont plus abondantes ou que la concentration fécale de H₂S est plus élevée ou encore que la capacité du microbiote à produire du H₂S est plus importante que chez des sujets témoins (185). Néanmoins, ces différences n'ont pas été retrouvées dans toutes les études (185). Une étude prospective a montré qu'un apport élevé en composés alimentaires soufrés est associé à un risque élevé de rechute lors des MICI (186). Cette association pourrait impliquer une production plus importante de H₂S mais ce paramètre n'a pas été mesuré dans cette étude. Plusieurs études suggèrent également que la détoxification du H₂S pourrait être modifiée lors des MICI. En effet, l'activité de la TST est diminuée chez les malades et cette activité est négativement corrélée à l'expression génique de la cytokine pro-inflammatoire *Il-8* (187,188). Une diminution de l'expression de la TST a aussi été observée en cas de RCH (175). La plupart des études suggèrent donc un rôle du H₂S bactérien dans les MICI mais le lien de cause à effet n'a pas été démontré.

En résumé

- Le H₂S produit par le microbiote (principalement à partir des AA et des sulfates) est présent à des concentrations de l'ordre du millimolaire dans le contenu du gros intestin.
- Les colonocytes sont capables de détoxifier le H₂S présent en faibles concentrations grâce à un système enzymatique mitochondrial.
- Le H₂S est considéré comme un métabolite toxique pour l'épithélium car, *in vitro*, il inhibe la respiration des colonocytes, induit l'expression de gènes pro-inflammatoires et cause des cassures à l'ADN.
- Les concentrations fécales de H₂S sont généralement plus élevées lors des MICI alors que les capacités de détoxification de H₂S sont altérées chez les malades.

3.2.4 Toxicité de la dégradation des acides aminés par le microbiote

Les données présentées dans les paragraphes précédents montrent que si certains métabolites issus de la dégradation des protéines sont bénéfiques pour l'épithélium du côlon (butyrate, indole), d'autres sont toxiques (NH_4^+ , phénol) (Figure 27). Les effets d'autres composés bactériens dérivés des AA sont plus complexes car ils diffèrent en fonction de la concentration testée (H_2S , polyamines). Pour les métabolites produits à la fois par le microbiote et par l'hôte (H_2S , polyamines, NH_4^+), il est parfois difficile de distinguer leurs effets en fonction de l'origine du métabolite. Enfin, ces métabolites ont été testés individuellement alors qu'ils sont produits conjointement dans la lumière du côlon, notamment lors des régimes HP. Leurs effets combinés (additifs, antagonistes ou synergiques) ne sont donc pas connus. En conséquence, il est très difficile de conclure quant à l'effet global sur la muqueuse de la dégradation des protéines par le microbiote. Pourtant, dans la littérature, cette activité métabolique bactérienne est systématiquement qualifiée de délétère pour la santé digestive et cette théorie date de plus d'un siècle (189). Un des éléments en faveur de cette hypothèse est la fréquence élevée de pathologies digestives dans la partie distale du gros intestin où a principalement lieu la dégradation des protéines (107). Les données les plus convaincantes concernent le rôle délétère du H_2S dans les MICI mais restent à confirmer (voir 3.2.3.4).

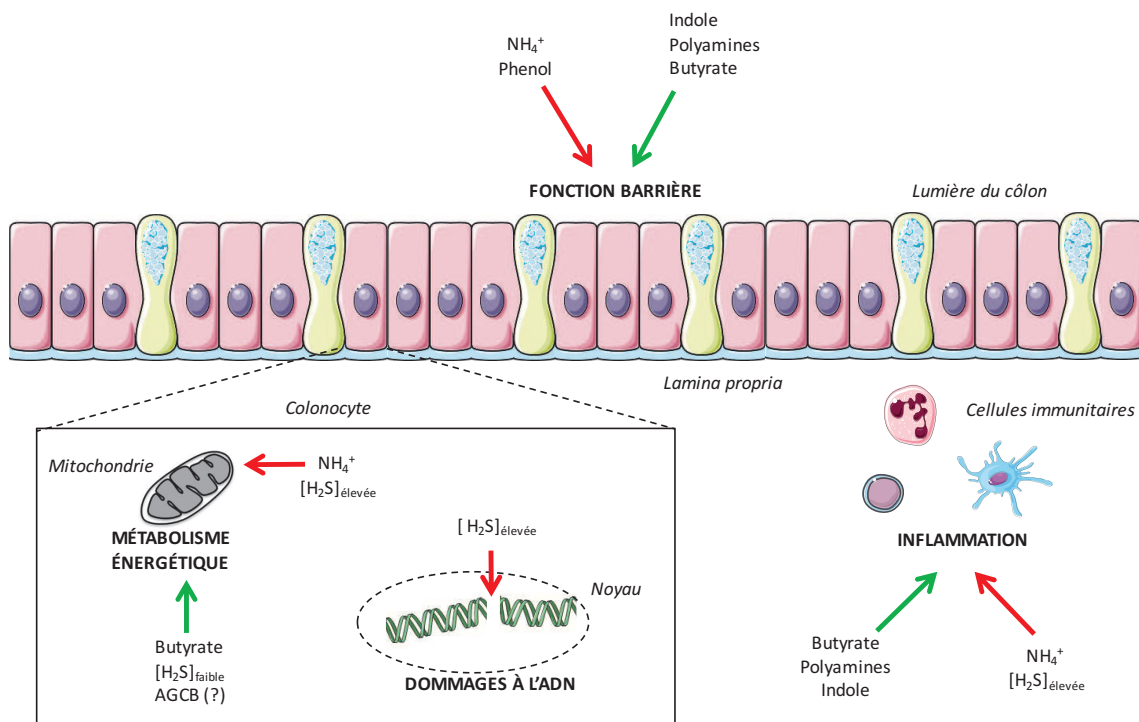

Figure 27 : Schéma récapitulatif des principaux effets des métabolites bactériens dérivés des acides aminés sur l'homéostasie de la muqueuse du côlon. Les effets considérés bénéfiques sont indiqués en vert, les effets considérés délétères sont indiqués en rouge.

Dans ce contexte, de nombreuses études ont mis en place des stratégies pour limiter la toxicité suspectée d'être associée à la dégradation des protéines par le microbiote. L'une de ces stratégies consiste à augmenter l'apport en glucides indigestibles pour orienter l'activité métabolique du microbiote vers l'utilisation des glucides et diminuer la dégradation des protéines (122). Il a été montré dans la plupart des études que la consommation de prébiotiques diminue la concentration des marqueurs de la dégradation des protéines (*p*-cresol, NH_4^+ et AGCB) (122). Deux mécanismes seraient impliqués dans ces effets d'une supplémentation en glucides indigestibles : les AA pourraient être utilisés principalement dans les voies anaboliques par les bactéries pour satisfaire leurs besoins en phase de croissance (35) et une accélération du transit limiterait le catabolisme des AA (85).

Il a été montré dans les parties précédentes que la quantité mais aussi la qualité de l'apport en protéines régulent la production par le microbiote de métabolites bactériens dérivés des AA. Une modification de l'apport en protéines pourrait donc avoir des effets bénéfiques ou délétères sur la muqueuse du gros intestin via une modulation de l'activité métabolique du microbiote intestinal. La dernière partie de l'introduction bibliographique détaille les effets d'une augmentation de l'apport en protéines au niveau du côlon.

4 Effets de l'apport en protéines sur la muqueuse du gros intestin

4.1 [Effets de l'apport en protéines sur les caractéristiques des contenus luminaux du gros intestin](#)

Deux études (l'une chez l'homme et l'autre chez le rat) ont montré une augmentation du pH fécal lors d'un apport élevé en protéines (12,132) mais ce résultat n'a pas été retrouvé dans la plupart des autres études chez l'homme (98,129,130,142), le rat (190,191) et le porc (99,131). Ces différences pourraient refléter les effets variables des régimes HP sur les concentrations en AGCC (voir 3.2.2.1). Chez le rat, un régime HP diminue le pH des contenus du cæcum par rapport à un régime NP dans le cas des protéines de soja mais pas dans le cas des caséines ou des protéines de lactosérum (192). Ainsi, la source de protéines semble déterminante et pourrait en partie expliquer les contradictions entre les résultats décrits dans la littérature quant aux effets des régimes HP sur le pH fécal. Il s'agit d'un paramètre important pour la physiologie de l'épithélium intestinal puisqu'une augmentation du pH est associée à des effets présumés délétères pour l'épithélium (augmentation de la prolifération par exemple) en lien avec certaines pathologies digestives (193).

Chez le rat, un régime HP entraîne une augmentation de la quantité de contenu dans le gros intestin, principalement en raison d'une augmentation de la quantité d'eau (9,11). Bien que la quantité totale de métabolites bactériens dérivés des AA soient plus importante chez les rats ayant consommé le régime HP, cette augmentation de la quantité de contenu entraîne le maintien de leurs concentrations à un niveau similaire aux rats nourris avec un régime NP. Ce mécanisme pourrait représenter une adaptation du côlon pour limiter les modifications des concentrations de composés potentiellement toxiques dérivés des AA (11). Néanmoins, cet effet des régimes HP semble spécifique à ce modèle puisque, au contraire, une diminution du contenu en eau dans les fèces a été observée chez l'homme (13). Enfin, chez le rat, les activités enzymatiques protéases dans le contenu du côlon sont fortement augmentées lors d'un régime HP, probablement en raison d'une adaptation du microbiote à un environnement riche en protéines (9). Cette augmentation pourrait être délétère pour l'épithélium puisque de telles augmentations des activités protéases ont été observées lors de diverses pathologies digestives, notamment inflammatoires (194).

4.2 [Effets de l'apport en protéines sur la muqueuse du côlon](#)

Les études portant sur les effets de l'apport en protéines sur la muqueuse du côlon ont employé des protocoles expérimentaux très divers. Trois paramètres sont particulièrement importants pour interpréter les résultats : le niveau d'apport en protéines, la source de protéines utilisée et la durée de l'étude. Le tableau 11 regroupe ces paramètres pour toutes les études citées ci-dessous afin de faciliter

leur comparaison. Les nombreuses études concernant les régimes riches en viande rouge ne sont pas présentées ici car d'autres facteurs que le niveau d'apport en protéines peuvent expliquer les effets observés sur la muqueuse (hème, composés produits lors de la cuisson, etc.) (195).

Tableau 11 : Description des régimes utilisés lors des études décrivant les effets de l'apport en protéines sur la muqueuse du côlon. % MS : grammes de protéines pour 100 grammes de matière sèche. % E : pourcentage d'énergie apportée par les protéines. g/j : grammes par jour. * : ces trois études ont utilisé le même protocole.

Référence	Espèce	Apport en protéines	Apport en fibres	Source de protéines	Durée (semaines)
(101)	Rat	21 % MS 45 % MS	5 % MS 5 % MS	Caséines	6
(134)	Rat	14 % MS 20 % MS 14 % MS 20 % MS	10 % MS 10 % MS 10 % MS 10 % MS	Caséines Protéines de pomme de terre	3
(9-11)*	Rat	14 % MS 53 % MS	5 % MS 5 % MS	Protéines totales de lait	2
(192)	Rat	15 % MS 25 % MS 15 % MS 25 % MS 15 % MS 25 % MS	5 % MS 5 % MS 5 % MS 5 % MS 5 % MS 5 % MS	Caséines Protéines de lactosérum Protéines de soja	4
(191)	Rat	15 % MS 25 % MS	5 % MS 5 % MS	Caséines	4
(190)	Rat	20 % MS 20 % MS	10 % MS 10 % MS	Caséines Protéines de soja	1
(136)	Porc	18 % MS 25 % MS	19 % MS 22 % MS	Mélange de protéines de soja, de poisson et de pomme de terre	3
(99)	Porc	15 % MS 20 % MS	15 % MS 15 % MS	Protéines de soja	3
(13)	Humain	12 % E 15 % E 27 % E	16,3 g/j 15,4 g/j 17,4 g/j	Mixte + protéines de lait	2
(130)	Humain	90 g/j 133 g/j	33,8 g/j 42,8 g/j	Mixte	12

4.2.1 Effets de l'apport en protéines sur le métabolisme énergétique des colonocytes

Chez le rat, un régime HP ne modifie pas la consommation basale d'O₂ (stade 3) par les colonocytes mais provoque une augmentation des fuites de protons dans les mitochondries, indiquant une réduction de l'efficacité énergétique (9). Dans une autre étude chez le rat, une diminution de l'expression de gènes impliqués dans les phosphorylations oxydatives a été observée lors d'un régime HP (101). Il est envisageable que l'exposition accrue des colonocytes à des perturbateurs métaboliques (NH₄⁺, H₂S) lors des régime HP soit impliquée dans ces observations. Etant donné l'importante consommation d'énergie par les colonocytes, ces effets des régimes HP pourraient être délétères pour l'épithélium (57). De plus, une étude chez le porc a montré une diminution de l'expression du

transporteur du butyrate MCT1 lors d'un régime HP mais cet effet n'a pas été observé chez le rat (11,136). Cette observation pourrait être spécifique du modèle porcin ou des sources protéiques utilisées (soja, poisson et pomme de terre *versus* protéines totales de lait) (Tableau 11). Une diminution du transport du butyrate pourrait compromettre le métabolisme énergétique des colonocytes et les effets bénéfiques de ce métabolite (57,117). Néanmoins, un régime HP ne modifie pas la capacité d'oxydation des principaux substrats (butyrate, glutamine et glucose) dans les colonocytes de rat (11). Enfin, l'activité de la glutamine synthase augmente dans les colonocytes de rats lors d'un régime HP (9) reflétant probablement une adaptation permettant une augmentation des capacités de détoxification du NH_4^+ , limitant ainsi ses effets délétères sur l'épithélium.

4.2.2 Effets de l'apport en protéines sur le stress oxydant et les dommages à l'ADN dans l'épithélium du côlon

Chez le porc, l'activité enzymatique glutathione-S-transferase et les concentrations en glutathion oxydé et réduit ne sont pas modifiées dans la muqueuse colique par un apport élevé en protéines (99). Ce résultat suggère qu'il n'y a pas d'augmentation du stress oxydant au niveau du côlon lors d'un régime HP. Cependant, des gènes impliqués dans le métabolisme du glutathion (« *Microsomal glutathione-S-transferase 1* » et « *Glutathione peroxidase 7* ») sont surexprimés dans la muqueuse du côlon de rats lors d'un régime HP (101). Cette contradiction entre les deux études pourrait être expliquée par les différences de niveau d'apport en protéines (20% *versus* 45%) et par un éventuel effet spécifique des sources de protéines utilisées (protéines de soja *versus* caséines) (Tableau 11). L'augmentation potentielle de l'expression des enzymes du métabolisme du glutathion lors des régimes HP pourrait refléter une adaptation à des expositions accrues à des composés susceptibles de favoriser le stress oxydant dont une des conséquences possibles est l'induction de dommages à l'ADN. Plusieurs études d'un même laboratoire ont montré chez le rat qu'un apport élevé en protéines (caséines ou protéines de soja) induit des cassures de l'ADN des colonocytes (191,192). Ces dommages à l'ADN sont positivement corrélés à la concentration fécale en *p*-cresol, suggérant un effet génotoxique de ce métabolite (192), mais les mécanismes impliqués dans cet effet génotoxique des régimes HP n'ont pas été élucidés. Néanmoins, les protéines de lactosérum n'ont pas eu d'effet sur l'intégrité de l'ADN dans le même modèle expérimental. Les auteurs ont proposé que ces différences pourraient être liées à des composés protecteurs contenus dans le lactosérum tels que la lactoferrine. Une autre étude chez le rat a montré qu'une augmentation modérée de l'apport en protéines induit une diminution des dommages à l'ADN dans les colonocytes (134). Il est difficile d'expliquer les contradictions entre ces études puisque les conditions expérimentales sont très proches notamment en ce qui concerne l'une des sources de protéines testées (caséines) (Tableau 11). Deux études cliniques ont montré que la génotoxicité des eaux fécales (contenant les métabolites potentiellement en contact avec l'épithélium) n'est pas modifiée par une augmentation du niveau d'apport en protéines alors que les marqueurs de dégradation des AA par

les bactéries sont augmentés (*p*-cresol par exemple) (13,130). En revanche, la diminution de la dégradation des protéines par le microbiote lors d'interventions nutritionnelles (utilisation de prébiotiques) est associée à une diminution de la génotoxicité des eaux fécales (122). Néanmoins, le lien causal entre ces deux paramètres n'est pas démontré. En raison des nombreuses contradictions, les données de la littérature ne permettent pas de conclure quant aux effets des régimes HP sur le stress oxydant et les dommages à l'ADN dans l'épithélium du côlon. Il apparaît cependant que la source de protéines semble jouer un rôle déterminant.

4.2.3 *Effets de l'apport en protéines sur le renouvellement de l'épithélium colique*

Les indicateurs histologiques d'apoptose dans l'épithélium ne sont pas modifiés lors d'un régime HP chez le rat et chez le porc (99,191) alors que des gènes liés à ce processus sont surexprimés dans la muqueuse du côlon de rats (101). Pourtant deux de ces études ont des protocoles expérimentaux très proches (Tableau 11). L'expression génique du marqueur de prolifération PCNA est augmentée dans la muqueuse du côlon chez des porcs lors d'un régime HP (99). Au contraire, la profondeur des cryptes du cæcum est plus faible chez des rats nourris avec un régime riche en protéines par rapport à des rats nourris avec un régime NP, suggérant une diminution de la prolifération (134). Cependant, cet effet n'est pas observé dans le côlon. Cette différence en fonction du segment du gros intestin pourrait s'expliquer par le fait que, chez le rat, la dégradation des protéines dans le cæcum est plus importante que dans le côlon. La source de protéines pourrait être également déterminante puisqu'un régime à base de protéines de soja entraîne une cytotoxicité des eaux fécales et une prolifération des cellules épithéliales du côlon de rats plus élevée que lors d'un régime à base de caséines (190). Le rôle des métabolites bactériens dérivés des AA dans l'augmentation de la prolifération des cellules épithéliales, bien que suspecté, n'a pas été démontré. Chez l'homme, la cytotoxicité des eaux fécales n'est pas modifiée par le niveau d'apport en protéines alors que leur dégradation par le microbiote est augmentée (13,130). Pourtant, la diminution de la dégradation des protéines par le microbiote induite par la consommation d'une quantité élevée de prébiotiques (30 grammes par jour) entraîne une diminution de la cytotoxicité des eaux fécales (196) bien que ce résultat n'ait pas été confirmé avec une dose inférieure (197). Enfin, l'excrétion urinaire de *p*-cresol est corrélée négativement à la cytotoxicité des eaux fécales ce qui ne suggère pas de rôle cytotoxique de la dégradation des protéines (13). En conclusion, les effets des régimes HP sur le renouvellement de l'épithélium du côlon sont mal compris, de nouvelles études sont donc nécessaires.

4.2.4 Effet de l'apport en protéines sur les réponses immunitaires dans la muqueuse du côlon

Chez le rat, un régime HP ne modifie pas la sécrétion d'IgA, ni l'expression de gènes de peptides anti-microbiens et de TLR dans la muqueuse colique (10). Parmi un grand nombre de cytokines dont l'expression a été mesurée, seule l'expression du gène de l'*Il-6* (pro-inflammatoire) est sous-exprimée chez ces animaux (10). De plus, l'activité myéloperoxidase (MPO, marqueur du recrutement des neutrophiles) dans le côlon n'a pas été pas modifiée (10). Dans une autre étude chez le rat, un régime HP n'a pas modifié l'expression des gènes *Tlr2* et *4*, *Ptgs2* et *Il-12* mais a régulé l'expression de gènes impliqués dans la signalisation des cytokines (surexpression de *Cx3cl1* et *Ccr12*, sous-expression de *Il2rg*) (101). Chez le porc, un régime riche en protéines induit une surexpression des gènes de cytokines pro-inflammatoires *Il-1 β* , *Il-8*, *Tnf- α* et *Ifn- γ* mais aussi des cytokines régulatrices *Tgf- β* et *Il-10* (99,136). Dans le même modèle, l'expression génique de certaines cytokines pro-inflammatoires est positivement corrélée à la concentration des métabolites bactériens dérivés des AA (136). En conclusion, les régimes HP semblent réguler l'expression de gènes liés à l'inflammation sans qu'il soit possible de conclure quant à un effet bénéfique ou délétère. Cette réponse complexe pourrait refléter les effets antagonistes de certains des métabolites bactériens dérivés des AA sur l'inflammation (indole et H₂S par exemple).

4.2.5 Effets de l'apport en protéines sur la fonction barrière du côlon

La consommation d'un régime HP ne modifie pas la morphologie de la muqueuse chez le rat (Figure 28 A) (9,10) ou chez le porc (99). Néanmoins, la taille des bordures en brosse des colonocytes est nettement réduite après un régime HP chez le rat alors que la structure des jonctions serrées n'est pas affectée (Figure 28 B) (9). La diminution de la taille des bordures en brosse pourrait correspondre à un défaut de différenciation des cellules, ou être liée au déficit en énergie associé à la perturbation du métabolisme mitochondrial dans ce modèle. Il est possible que cette perte de structure soit associée à une perturbation de la fonction de la membrane apicale des colonocytes (capacité d'absorption par exemple) (198). L'expression des gènes de protéines de jonctions serrées (*Claudine-2*, *Occludine*, et *Zo-1*) n'est pas modifiée lors d'un régime HP chez le rat (10,101) alors qu'elle est diminuée chez le porc, bien que la perméabilité paracellulaire ne soit pas modifiée dans ce modèle (199). Enfin, une autre étude chez le rat a montré une augmentation de l'expression du gène d'une intégrine (*Itgb6*) et d'un gène de collagène (*Coll2a1*) lors d'un apport élevé en protéines, suggérant un renforcement de l'adhésion des colonocytes à la lame basale (101). Par ailleurs, un régime HP chez le rat entraîne également une augmentation du nombre de cellules en gobelet dans les cryptes et diminue leur nombre dans l'épithélium de surface (Figure 28 C et D) (10). Au niveau de l'ARNm, un régime HP a entraîné une surexpression du gène de mucine *Muc3* chez le rat et de *Muc1*, *2* et *3* chez le porc (10,99) mais les mécanismes sous-jacents ne sont pas connus. Il est possible que ces observations reflètent une adaptation

à une augmentation de la toxicité de l'environnement luminal lors des régimes HP. Au contraire, une autre étude chez le rat a montré une diminution de l'épaisseur de la couche de mucus lors d'un régime HP à base de caséines mais pas avec d'autres sources de protéines (protéines de soja et de lactosérum) (192). Dans une autre étude chez le rat, la consommation d'un régime HP également à base de caséine a diminué l'expression de gènes impliqués dans la glycosylation des mucines (101). Ces résultats suggèrent, ici encore, que la source de protéines utilisée lors des régimes HP pourrait expliquer les différences de résultats obtenus entre les études (Tableau 11). En conclusion, les régimes HP ne semblent pas induire de rupture de la fonction barrière mais leurs effets sur la sécrétion de mucus sont incertains.

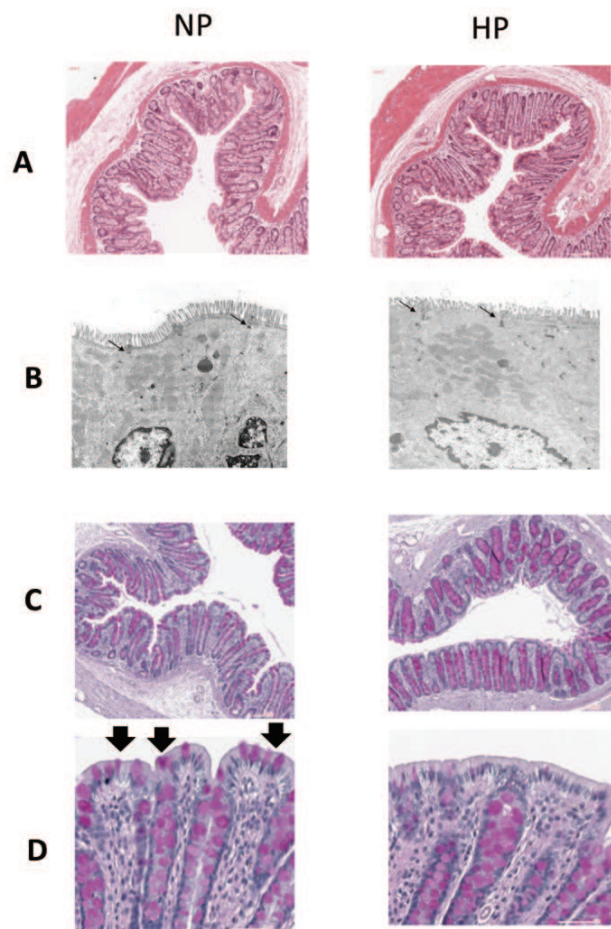

Figure 28 : Photographies d'observations au microscope de coupes histologiques de côlon de rats nourris avec un régime normoprotéique (NP) ou hyperprotéique (HP) pendant 15 jours. A - La morphologie de la muqueuse n'est pas modifiée par le niveau d'apport en protéines (coloration hématoxyline & éosine). B - La taille des bordures en brosse est réduite chez les rats nourris avec un régime HP alors que la structure des jonctions serrées (indiquées par les flèches) n'est pas modifiée (observations au microscope électronique). C - Le nombre de cellules en gobelet par crypte est plus élevée chez les rats nourris avec un régime HP (coloration à l'acide périodique de Schiff). D - Les cellules en gobelet sont absentes de l'épithélium de plateau (indiquées par les flèches) chez les rats nourris avec un régime HP (coloration acide périodique de Schiff). D'après (9,10).

4.2.6 Mécanismes potentiellement impliqués dans les effets des régimes hyperprotéiques sur la muqueuse du gros intestin

Les études présentées ci-dessus décrivent les effets de l'apport en protéines sur la muqueuse du côlon. Certaines de ces études ont rapporté une augmentation simultanée de la dégradation des protéines par le microbiote lors des régimes HP. Individuellement, les métabolites bactériens dérivés des AA sont actifs sur les cellules épithéliales. L'hypothèse d'un lien de cause à effet entre l'augmentation de la dégradation des protéines et les modifications observées dans la muqueuse du côlon est donc probable mais n'a pas été formellement démontrée. Si cette hypothèse est exacte, les différences observées en fonction du type de protéines testé pourraient s'expliquer par des différences de digestibilité et de profil en AA entraînant une modulation de la production de métabolites bactériens. Il est également envisageable que l'apport en AA plus important au niveau du pôle sanguin lors de la consommation des régimes HP puisse être impliqué dans certains des effets observés sur la muqueuse du côlon. Par exemple, il a été montré que le niveau d'apport en thréonine est un facteur déterminant pour la production de mucines (200). Ces deux hypothèses ne sont probablement pas exclusives et sont présentées sur la figure 29.

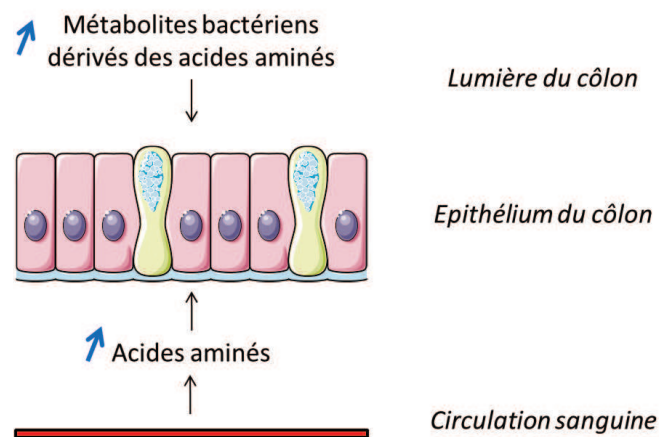

Figure 29 : Représentation schématique des deux mécanismes potentiellement impliqués dans les effets des régimes hyperprotéiques sur l'épithélium du côlon. Les flèches bleues indiquent les composés dont la concentration est augmentée lors d'un régime hyperprotéique.

4.3 Apport en protéines et maladies inflammatoires chroniques intestinales

Plusieurs études épidémiologiques ont décrit une association entre un apport important en protéines et une incidence élevée de MICI (RCH et/ou MC selon les études) (201–203). De plus, la source de protéines semble déterminante puisque les protéines végétales ne sont pas associées au risque de MICI contrairement aux protéines animales (201,203). Le risque de rechute lors de la RCH est également plus élevé chez les personnes ayant un apport élevé en protéines (186). Néanmoins, une revue systématique de la littérature a montré que davantage d'études n'ont pas observé d'effet significatif du niveau d'apport en protéines sur l'incidence des MICI (204).

En résumé

- Chez l'animal, un apport élevé en protéines modifie des paramètres clés de l'homéostasie de l'épithélium du côlon (métabolisme énergétique, renouvellement de l'épithélium, intégrité de l'ADN, fonction barrière, etc.).
- De nombreux résultats contradictoires ont été obtenus, il n'est donc pas possible d'affirmer que les régimes HP sont délétères pour l'épithélium du côlon.
- Les mécanismes des effets des régimes HP sur l'épithélium du côlon ne sont pas connus mais pourraient impliquer les métabolites bactériens dérivés des AA présent au pôle apical des colonocytes ou les AA apportés par la circulation.
- Peu d'études ont comparé les effets de la source de protéines alors que ce paramètre est probablement important en raison des différences de composition en AA et de digestibilité.

JUSTIFICATION DES TRAVAUX DE THESE

L'intérêt croissant de la communauté scientifique pour les effets de l'alimentation sur le microbiote intestinal et les conséquences pour la santé est illustré par l'augmentation exponentielle du nombre de publications à ce sujet. Ces travaux ont principalement concerné les apports en glucides indigestibles et leurs produits de fermentations (AGCC). En comparaison, les effets du niveau d'apport en protéines sur la composition et l'activité du microbiote ainsi que les conséquences pour la muqueuse n'ont été que peu étudiés. Pourtant, la consommation de protéines peut être très élevée chez certaines personnes, notamment lors de régimes HP amaigrissants.

Bien que quantitativement moins importante que la fermentation des glucides, la dégradation des protéines par le microbiote entraîne la production d'une diversité de composés bien plus importante. Certains de ces métabolites bactériens dérivés des AA sont délétères pour les cellules épithéliales coliques lorsqu'ils sont présents en concentration excessive (NH_4^+ , H_2S) alors que d'autres sont bénéfiques (composés indoliques). Néanmoins la description des effets de ces métabolites est encore très incomplète et repose essentiellement sur des expérimentations *in vitro*. Des études *in vivo* sont donc nécessaires pour confirmer et approfondir la description des effets de ces composés sur l'épithélium du côlon. Par ailleurs, d'autres métabolites bactériens dérivés des AA produits en quantité importante n'ont jamais été testés sur des colonocytes (*p*-cresol par exemple). Bien qu'il soit nécessaire de tester dans un premier temps les effets des métabolites dérivés des AA individuellement, il est également indispensable de les étudier simultanément sur l'épithélium du côlon puisque, en combinaison, ils pourraient avoir des effets additifs, synergiques ou antagonistes. En effet, une augmentation de l'apport en protéines entraîne une augmentation globale de l'exposition de l'épithélium du côlon à ces métabolites bactériens dérivés des AA.

Les études sur modèles animaux suggèrent qu'un apport élevé en protéines régule de nombreux processus essentiels au maintien de l'homéostasie de l'épithélium (métabolisme, adhésion et renouvellement cellulaire, intégrité de l'ADN, sécrétion de mucus, inflammation). Cependant, en raison des très nombreuses contradictions entre les études, il n'est pas possible de conclure quant à un potentiel effet délétère d'un apport élevé en protéines sur la muqueuse du côlon. Il est donc indispensable de mieux caractériser la réponse de l'épithélium lors de la consommation d'un régime HP. Certaines études épidémiologiques semblent indiquer qu'un apport élevé en protéines pourrait être un facteur de risque pour les MICI. Des études cliniques sont nécessaires car les effets de ce type de régimes sur la muqueuse du gros intestin n'ont jamais été étudiés chez l'homme de manière directe. De plus, les effets des régimes HP au niveau de l'écosystème du côlon ont été étudiés chez l'homme principalement en combinaison avec une diminution de l'apport en fibres ou avec une restriction calorique, il n'est donc pas possible de

conclure quant à des effets induits exclusivement par le changement de la composition en macronutriments.

La plupart des études ont décrit les effets du niveau d'apport en protéines au niveau du côlon mais très peu d'entre elles ont comparé différentes sources de protéines. Les quelques données disponibles suggèrent pourtant que ce paramètre pourrait moduler la composition du microbiote, son activité métabolique et la physiologie de la muqueuse du côlon probablement en raison des différences de digestibilités et de compositions en AA des diverses sources de protéines. D'un point de vue sociétal, le remplacement partiel des protéines animales par des protéines végétales est un des leviers identifiés pour rendre l'alimentation plus durable. Cette transition nécessite au préalable une comparaison des effets sur la santé des différentes sources de protéines en fonction de leurs niveaux d'apport, en particulier au niveau du côlon.

OBJECTIFS DE LA THESE ET DEMARCHE EXPERIMENTALE

En raison des arguments présentés ci-dessus, quatre objectifs ont été définis pour ce travail de thèse :

1. Déterminer *in vivo* les effets du H₂S sur les colonocytes
2. Déterminer *in vitro* l'effet du *p*-cresol sur l'intégrité de l'ADN dans les colonocytes
3. Caractériser les effets de la quantité et de la qualité de l'apport en protéines sur la composition du microbiote intestinal et sur les métabolites bactériens
4. Caractériser les effets de la quantité et de la qualité de l'apport en protéines sur l'épithélium et la muqueuse du gros intestin

Pour atteindre ces objectifs, différentes approches expérimentales complémentaires ont été utilisées :

- La culture *in vitro* de cellules HT-29 Glc ^{-/+} et LS-174T issues d'adénocarcinomes coliques humains a été utilisée pour tester les effets cytotoxiques et génotoxiques de métabolites bactériens seuls ou en combinaison (test des eaux fécales).
- Un modèle d'instillation intra-colique chez le rat anesthésié a été mis au point pour déterminer *in vivo* les effets du H₂S sur les colonocytes.
- Une étude nutritionnelle a été menée chez le rat pour déterminer les effets d'un apport élevé en protéines sur la production de H₂S par le microbiote intestinal ainsi que sur l'épithélium et la muqueuse du gros intestin.
- Une étude clinique d'intervention nutritionnelle randomisée et en double aveugle a été réalisée pour étudier chez l'homme les effets de la quantité et de la qualité de l'apport en protéines sur la composition et l'activité du microbiote intestinal ainsi que sur la muqueuse du gros intestin.

L'étude clinique a été réalisée au centre de recherche des volontaires du service de gastroentérologie de l'hôpital Avicenne à Bobigny. Une partie des expérimentations réalisées pendant la thèse ont été effectuées lors de séjours dans des laboratoires partenaires. Les expériences de cytotoxicité et génotoxicité ont été effectuées dans le laboratoire Toxalim (Centre de recherche en toxicologie alimentaire), UMR 1331, INRA, Toulouse, France, sous la supervision de Marc Audebert (deux séjours de 1 mois). Les expériences de métabolomique par résonance magnétique nucléaire (RMN) ont été effectuées à l'université de Reading au Royaume-Uni, « Department of Food and Nutritional Sciences », sous la supervision de Sandrine Claus (séjour de 1 mois). Les analyses transcriptomiques ont été réalisées en collaboration avec la plateforme de génomique de l'institut Cochin à Paris et avec le centre de ressources biologiques de l'INRA de Jouy-en-Josas. L'analyse de la composition du microbiote a été effectuée en collaboration avec le laboratoire Ecologie microbienne, nutrition et santé ; Institute of Agrochemistry and Food Technology, Spanish National Research Council, Valence, Espagne.

ETUDE 1 : EFFETS DU SULFURE D'HYDROGENE SUR LES COLONOCYTES DE RATS ET ADAPTATION A UN REGIME HYPERPROTEIQUE

Article publié dans la revue Free Radical Biology and Medicine, 2016.

Contexte

Le sulfure d'hydrogène (H₂S) est un métabolite bactérien produit dans le gros intestin à partir de composés alimentaires et endogènes soufrés (acides aminés et sulfates, principalement). *In vitro*, le H₂S est toxique pour les colonocytes (perturbateur du métabolisme énergétique, génotoxique et pro-inflammatoire) lorsqu'il est présent à des concentrations élevées. De plus, des données issues de plusieurs études cliniques suggèrent que le H₂S pourrait être impliqué dans les maladies inflammatoires chroniques de l'intestin. Le premier objectif de cette étude était de déterminer *in vivo* les effets d'une augmentation de l'exposition des colonocytes à H₂S. Le second objectif de l'étude était d'évaluer les effets d'un régime hyperprotéique (HP) sur la production de H₂S par le microbiote intestinal et sur sa détoxification par l'épithélium du côlon.

Méthodes

Dans la première partie de l'étude, un cathéter a été installé au niveau du côlon proximal de rats Wistar anesthésiés (Figure 30 A). Une solution contenant un donneur de H₂S (NaHS 0,5 ou 1,5 mM dissous dans du PBS) ou du PBS seul (groupe témoin) a été instillée pendant 1 heure par voie endoluminale dans le côlon. Le métabolisme mitochondrial et l'inflammation ont été évalués dans les colonocytes isolés par mesure de la consommation d'O₂ (polarographie) et de l'expression de gènes (qPCR). Le recrutement des neutrophiles dans le côlon distal a été analysé par la mesure de l'activité myéloperoxydase. Les dommages à l'ADN dans les colonocytes de rats ont été évalués par quantification de γ -H2AX par In-Cell Western et les résultats ont été confirmés *in vitro* sur la lignée cellulaire HT-29 Glc -/+. Des colonocytes de rats non traités ont également été utilisés pour déterminer l'effet combinés du H₂S et du monoxyde d'azote (NO) sur la consommation d'O₂.

Dans la seconde partie de l'étude (Figure 30 B), des rats Wistar ont été nourris pendant deux semaines avec un régime HP (55% d'énergie apportée par les protéines) ou avec un régime isocalorique normoprotéique (NP) (14% d'énergie apportée par les protéines). Le H₂S a été quantifié dans les contenus du gros intestin par GC-MS et les voies de production du H₂S par le microbiote ont été analysées par qPCR et par mesure de l'activité cystéine desulfhydrase. Les colonocytes des rats nourris avec les régimes HP et NP ont été isolés et l'expression des gènes des enzymes de détoxification du H₂S a été mesurée par qPCR.

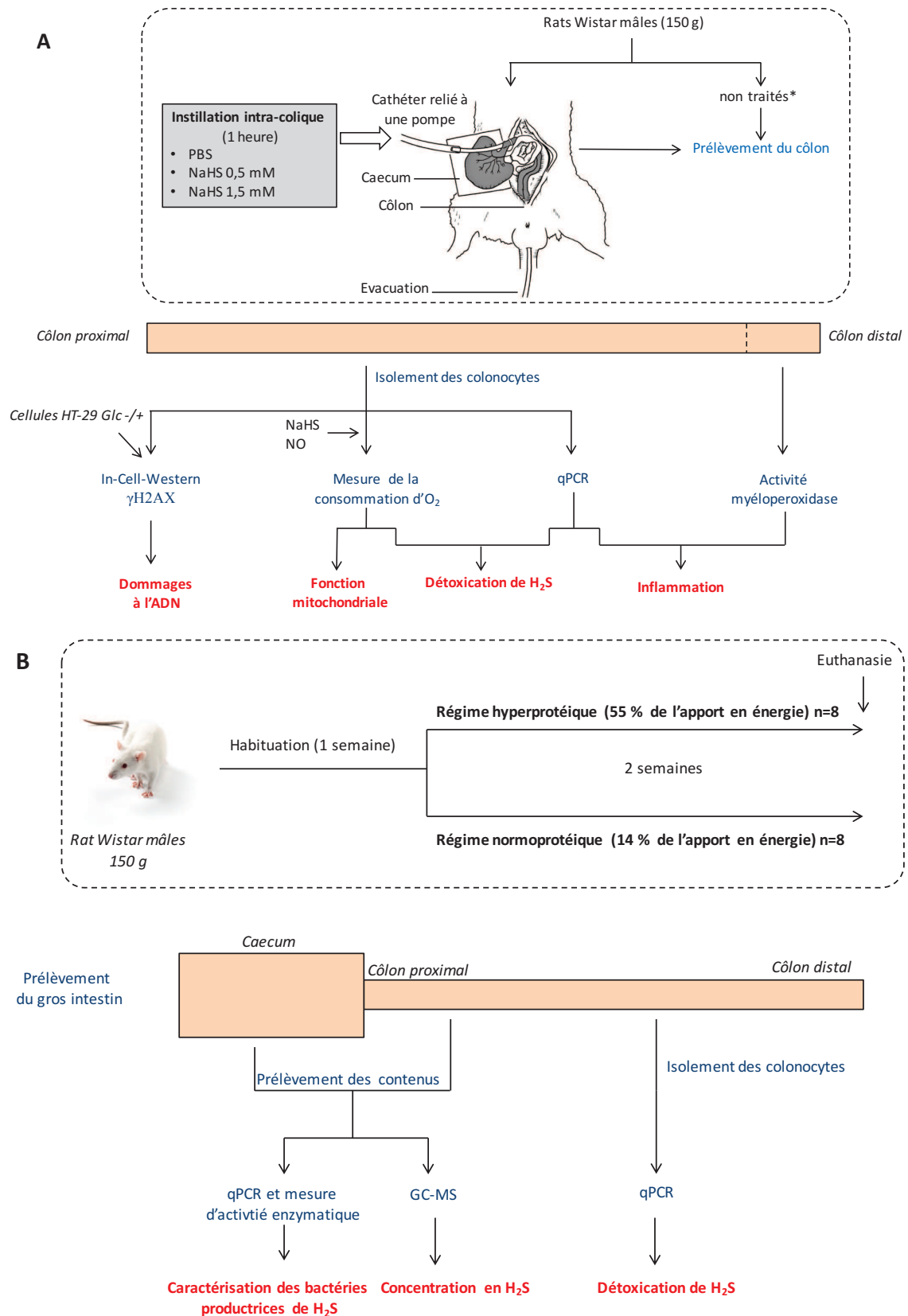

Figure 30 : Représentation schématique du protocole expérimental de l'étude 1. A - Etude d'instillation intra-colique. * Les rats non traités ont été utilisés pour certaines des mesures de consommation d'O₂. B - Etude nutritionnelle.

Résultats

L'instillation intra-colique de NaHS 1,5 mM a induit l'expression de gènes pro-inflammatoires (*iNos*, *Il-6*) dans les cellules épithéliales. La mesure de la consommation d'O₂ par les colonocytes de rats a montré que le H₂S est détoxiqué lorsqu'il est présent en faibles concentrations (20 et 40 μM NaHS) mais ce processus est inhibé en présence de NO. Les concentrations élevées de NaHS ont inhibé la respiration de manière réversible en association avec l'induction de l'expression du gène « *Hypoxia inducible factor 1 α* » (*Hif1α*). Les résultats obtenus *in vivo* et *in vitro* montrent que, dans nos conditions expérimentales, le H₂S n'est pas génotoxique pour les colonocytes, même à des concentrations élevées.

La quantité de H₂S était plus élevée dans le contenu du gros intestin des rats nourris avec le régime HP par rapport à ceux nourris avec le régime NP. Ce résultat est probablement dû à l'augmentation de la quantité d'acides aminés soufrés disponibles pour les bactéries puisque les voies de production de H₂S par le microbiote n'étaient pas modifiées par le niveau d'apport en protéines. Le régime HP a induit l'expression du gène de l'enzyme de détoxification de H₂S *sulfide quinone reductase* (*Sqr*), indiquant probablement une adaptation à une exposition accrue à ce métabolite. Enfin, le poids de contenu dans le gros intestin était plus important chez les rats nourris avec le régime HP que chez les rats ayant reçu le régime NP, résultant en des concentrations lumineales de H₂S similaires dans les deux groupes.

Conclusion

La capacité de détoxification du H₂S par les colonocytes de rats est limitée et est inhibée en présence d'une concentration élevée de NO, telle qu'observée en cas d'inflammation intestinale. *In vivo*, l'exposition des colonocytes à des concentrations élevées de H₂S perturbe de manière réversible la respiration, induit un état probable d'hypoxie, augmente l'expression de gènes pro-inflammatoires mais ne cause pas de dommages à l'ADN. Deux mécanismes adaptatifs pourraient limiter l'exposition de l'épithélium au H₂S lors d'un régime HP : l'augmentation de la quantité de contenu dans le gros intestin et de l'augmentation de la capacité de détoxification du H₂S dans les colonocytes.

Messages clés de l'étude 1

- *In vivo*, H₂S induit l'expression de gènes pro-inflammatoires dans les colonocytes.
- *In vivo*, H₂S perturbe de manière réversible le métabolisme mitochondrial des colonocytes.
- H₂S n'induit pas de cassures de l'ADN dans les colonocytes.
- Un régime HP entraîne une augmentation de la quantité de H₂S dans le gros intestin probablement via une augmentation de la quantité de cystéine.
- La surexpression de la *Sqr* dans les colonocytes et l'augmentation de la quantité de contenu dans le gros intestin pourraient être des processus adaptatifs permettant de limiter l'exposition de l'épithélium au H₂S lors des régimes HP.



Contents lists available at ScienceDirect

Free Radical Biology and Medicine

journal homepage: www.elsevier.com/locate/freeradbiomed

Original Contribution

Detrimental effects for colonocytes of an increased exposure to luminal hydrogen sulfide: The adaptive response



Martin Beaumont^a, Mireille Andriamihaja^a, Annaïg Lan^a, Nadezda Khodorova^a, Marc Audebert^b, Jean-Marc Blouin^a, Marta Grauso^a, Luciana Lancha^c, Pierre-Henri Benetti^a, Robert Benamouzig^{a,d}, Daniel Tomé^a, Frédéric Bouillaud^{e,f,g}, Anne-Marie Davila^a, François Blachier^{a,*}

^a UMR PNCA, AgroParisTech, INRA, Université Paris-Saclay, Paris, France

^b INRA, UMR 1331, Toxalim, Research Centre in Food Toxicology, Toulouse, France

^c Laboratory of Applied Nutrition and Metabolism, University of Sao Paulo, Brazil

^d Department of Gastroenterology, Hôpital Avicenne, Assistance Publique-Hôpitaux de Paris, Bobigny, France

^e INSERM U1016, Institut Cochin, Paris, France

^f CNRS UMR8104, Institut Cochin, Paris, France

^g Université Paris Descartes UMR51016, Institut Cochin, Paris, France

ARTICLE INFO

Article history:

Received 16 October 2015

Received in revised form

15 January 2016

Accepted 29 January 2016

Available online 2 February 2016

Keywords:

Hydrogen sulfide

Colonocyte

Inflammation

Mitochondria

Genotoxicity

Nitric oxide

Microbiota

High-protein diet

ABSTRACT

Protein fermentation by the gut microbiota releases in the large intestine lumen various amino-acid derived metabolites. Among them, hydrogen sulfide (H₂S) in excess has been suspected to be detrimental for colonic epithelium energy metabolism and DNA integrity. The first objective of this study was to evaluate in rats the epithelial response to an increased exposure to H₂S. Experiments from colonocyte incubation and intra-colonic instillation indicate that low millimolar concentrations of the sulfide donor NaHS reversibly inhibited colonocyte mitochondrial oxygen consumption and increased gene expression of hypoxia inducible factor 1 α (*Hif-1 α*) together with inflammation-related genes namely inducible nitric oxide synthase (*iNos*) and interleukin-6 (*Il-6*). Additionally, rat colonocyte H₂S detoxification capacity was severely impaired in the presence of nitric oxide. Based on the γ H2AX ICW technique, NaHS did not induce DNA damage in colonocytes. Since H₂S is notably produced by the gut microbiota from sulfur containing amino acids, the second objective of the study was to investigate the effects of a high protein diet (HPD) on large intestine luminal sulfide content and on the expression of genes involved in H₂S detoxification in colonocytes. We found that HPD markedly increased H₂S content in the large intestine but the concomitant increase of the content mass maintained the luminal sulfide concentration. HPD also provoked an increase of sulfide quinone reductase (*Sqr*) gene expression in colonocytes, indicating an adaptive response to increased H₂S bacterial production. In conclusion, low millimolar NaHS concentration severely affects colonocyte respiration in association with increased expression of genes associated with intestinal inflammation. Although HPD increases the sulfide content of the large intestine, the colonic adaptive responses to this modification limit the epithelial exposure to this deleterious bacterial metabolite.

© 2016 Elsevier Inc. All rights reserved.

Abbreviations: BAP, benzo(a)pyrene; COX, cytochrome c oxidase; dsrA, dissimilatory sulfite reductase; ETHE1, dioxygenase; ETO, etoposide; FCCP, carbonyl cyanide 4-(trifluoromethoxy) phenylhydrazone; H₂S, hydrogen sulfide; HS⁻, hemisulfide; HIF-1 α , hypoxia inducible factor 1 α ; HPD, high protein diet; IBD, inflammatory bowel disease; IL-6, interleukin 6; iNOS, inducible nitric oxide synthase; KCN, potassium cyanide; MPO, myeloperoxidase; NO, nitric oxide; NPD, normal protein diet; SAA, sulfur containing amino acid; SOU, sulfide oxidation unit; SQR, sulfide quinone reductase; SRB, sulfate reducing bacteria; TST, thiosulfate sulfur transferase

* Correspondence to: UMR914, 16 rue Claude Bernard, 75005 Paris, France.

E-mail address: francois.blachier@agroparistech.fr (F. Blachier).

1. Introduction

Gut microbiota is now established as a key player in various aspects of health and disease [35]. Commensal bacteria affect their host by various mechanisms including the production of metabolites [42]. While carbohydrate fermentation is mainly considered beneficial for the host through the production of short chain fatty acids, protein fermentation gives rise to a wide variety of compounds, some of them being suspected to be detrimental for gut health when present at excessive concentrations [2,6,17]. Among them, hydrogen sulfide (H₂S) is primarily produced

through fermentation of sulfur-containing amino acids (SAA) originating from undigested and partially-digested dietary and endogenous proteins or by reduction of inorganic sulfate by sulfate reducing bacteria (SRB) [7,33]. Sulfide concentrations in the luminal content in humans and rats have been reported to be in the millimolar range [32,37] with part of sulfide being present in bound form [26]. At the physiological colonic luminal pH, approximately one third of H_2S remains undissociated whereas the remaining two thirds is hydrosulfide anion (HS^-) [57]. In humans, colonic protein fermentation is increased in case of high protein diet (HPD) consumption and sulfide fecal excretion is increased after a meat-rich diet [20,38].

In the human colonic adenocarcinoma epithelial cell HT29 $Glc^{-/+}$ model, millimolar concentrations of NaHS (the sodium salt of H_2S which releases in aqueous medium HS^- and then H_2S) inhibit mitochondrial respiration through inhibition of the mitochondrial cytochrome c oxidase (COX) activity, and impair colonocyte butyrate and glutamine oxidation [31] these later substrates being preferred fuels for these cells [46]. At lower micromolar concentrations, H_2S is oxidized by the sulfide oxidation unit (SOU) with sulfide quinone reductase (SQR) representing the first and rate-limiting enzyme of this unit [9,40].

Both pro and anti-inflammatory properties of H_2S in intestinal mucosa have been reported, mostly depending on the concentration tested [33]. Indeed, low H_2S concentrations have been shown to participate in the resolution of colitis [19,55,56] while higher concentrations, likely originating from the luminal side, have been suspected to display pro-inflammatory effects on the large intestine mucosa [13,43]. At a given concentration of H_2S , the biological effects of this compound appear to depend on the cellular redox state and oxygen tension [53]. It has been shown by several studies (but not all) that fecal sulfide concentrations are higher and SRB more abundant in patients with ulcerative colitis than in control subjects (reviewed in [10]). Moreover, impaired H_2S detoxification in intestinal mucosa is associated with inflammatory bowel disease (IBD) [3,18]. In other studies, Attene-Ramos et al. [4,5], have shown *in vitro* that H_2S is able to damage DNA in intestinal epithelial cell lines. In addition, it has been demonstrated that H_2S produced endogenously is able to maintain colon cancer cellular bioenergetics supporting colonic tumor growth [23,52,54].

In this context, we first aimed to determine in rats, using an intra-colonic instillation model, the effects of an increased NaHS luminal concentration on colonocyte inflammatory parameters, DNA integrity and mitochondrial respiration. Regarding this latter parameter, we determined the impact of nitric oxide (NO) on the colonocyte capacity to detoxify H_2S . Then, we evaluated in rats the consequences of a HPD on sulfide content in large intestine and on the epithelial response in terms of detoxification metabolic pathway.

2. Material and methods

2.1. Animals and diets

The present protocols received written agreement from the local animal ethical committee (COMETHEA at Jouy-en-Josas, France, no. 12/143 and no. 12/090). Male Wistar rats (Harlan, Gannat, France) weighing 150 g (5–6 weeks) were fed for 1 week with a standard rodent diet containing 16% protein by weight.

2.1.1. Instillation study

Rats were starved for one night and then anesthetized with isoflurane and maintained on a heating plate (37 °C). A 1 mm catheter was introduced in the proximal colon. Colonic content was expelled manually and then colon was flushed twice with 10 mL PBS at 37 °C. The catheter was linked to a pump that delivered

drop-by-drop (1.5 mL/min) a phosphate-buffered saline (PBS) solution of NaHS (Sigma-Aldrich) used at 0.5 or 1.5 mM concentrations or PBS alone (control experiments) during 1 h at 37 °C (Fig. 1A). The whole colon was removed and the latest 1-cm segment was snap frozen in liquid nitrogen and stored at -80 °C up to myeloperoxidase (MPO) assay. Then, rats were sacrificed by the injection of a lethal dose of pentobarbital.

For colonocyte isolation, colon was flushed with a NaCl 9 g/L solution and then with a Ca^{2+} and Mg^{2+} -free Krebs Henseleit bicarbonate (pH7.4) buffer solution containing 10 mM HEPES, 5 mM DTT, and 2.5 g bovine serum albumin and equilibrated against a mixture of O_2 and CO_2 (19:1, vol/vol). Then, colon was perfused for 20 min at 37 °C with the same buffer containing 10 mM EDTA and then incubated in a buffer containing hyaluronidase (8 g/L) saturated with a mixture of O_2 and CO_2 containing (in mM) 120 NaCl, 4.7 KCl, 1.2 KH_2PO_4 , 1.2 Na_2SO_4 , 10 HEPES, and 25 $NaHCO_3$ and enriched with 2.5 g/L bovine serum albumine (incubation medium). Colonocytes were maintained in Dulbecco's

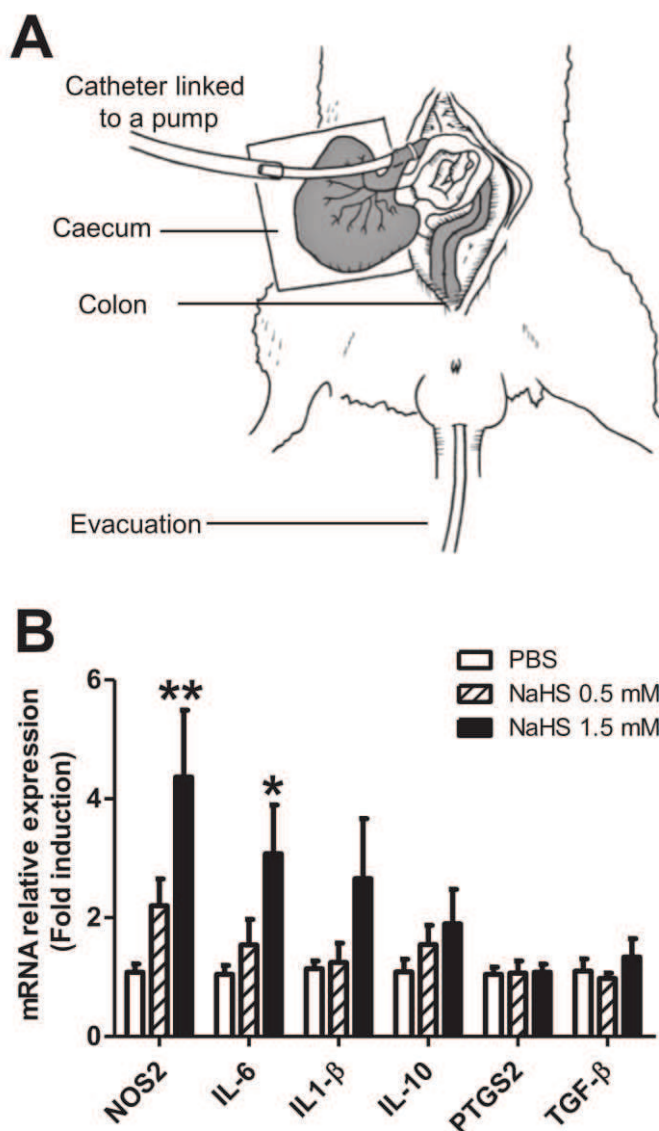

Fig. 1. Effects of intra-colonic instillation of NaHS on inflammation-related gene expression. (A) Experimental setting for 1 h colonic instillation in anesthetized rats. (B) Relative level of mRNA corresponding to inflammation-related genes in colonocytes of rats instilled with PBS without or with NaHS (0.5 or 1.5 mM) ($n=5-11$ rats/group). For each gene, mean relative mRNA expression in both NaHS-treated rat groups was compared to the mean value of control group (ANOVA, Bonferroni correction). Data are presented as mean values \pm SEM. * $p < 0.05$, ** $p < 0.01$.

Table 1
Composition of the experimental diets.

Ingredients (g/kg)	NPD ^a	HPD ^a
Whole milk proteins	140	530
Corn starch	622.7	287.0
Sucrose	100	45.7
Cellulose	50	50
Soybean oil	40	40
Choline	2.3	2.3
Vitamin mixture, AIN 93-V	10	10
Mineral mixture, AIN 93-M	35	35
Energy, kJ/g	14.6	14.6

^a NPD: Normal Protein Diet; HPD: High Protein Diet.

modified Eagle's medium. Colonocytes were counted with hemocytometer.

2.1.2. Nutritional study

After habituation, rats received for 15 days either a normoproteic diet (NPD) or a HPD isocaloric (Table 1) and water *ad libitum*. The animals were maintained in a 12:12-h light-dark cycle with the dark period beginning at 7:00 PM. The animals were then anesthetized with pentobarbital sodium (40 mg/kg body weight). The caecum and colon were isolated and the luminal contents removed by expulsion before being immediately frozen in liquid nitrogen and stored at -80°C until analysis. Colonocytes were isolated as described above.

2.2. Cell culture

The HT-29 Glc^{-/+} used in this study were selected by Zweibaum et al. from the parental line [59]. Cells between passages 44 and 48 (one passage every week) were grown in a Dulbecco's modified Eagle's medium (DMEM) containing 4 mM L-glutamine and supplemented with 10% (v/v) heat-inactivated fetal calf serum (Lonza). The culture medium was changed every day. Cells were seeded at a density of 2×10^4 cells/cm² and detached using PBS containing 0.5 g/L trypsin and 0.2 g/L EDTA.

2.3. Gene expression analysis in isolated rat colonocytes

Total RNA was extracted from isolated colonocytes using Trizol extraction derived from the method of Chomczynski and Sacchi [11]. A subsequent step of DNase and purification was done with the RNeasy Mini Kit and DNase I (Qiagen). Next, sample quality was controlled by the 260-to-280 nm absorption ratio measured with Nanodrop (between 1.8 and 2.0) and checked on 1% agarose gel. Quantitative real-time polymerase chain reaction (qRT-PCR) was performed with rat-specific primers (Eurogentec) designed based on published sequences of the target genes using Oligo Explorer 1.1.0 software (GeneLink) (Table 2). After cDNA synthesis

from mRNA using High Capacity cDNA Reverse Transcription Kit (Applied Biosystems), real-time PCR was performed subsequently on cDNA using the power SYBR Green PCR master mix and StepOne Real-Time PCR system (Applied Biosystems, Life Technologies). Gene expression levels for each sample were normalized relative to *HPRT* with $2^{-\Delta\Delta\text{Ct}}$ calculation.

2.4. Oxygen consumption by isolated colonocytes

Oxygen consumption was measured by polarography (oxygraph Hansatech Inst.) at 37°C using a Clark-type electrode. Isolated colonocytes (5×10^6 cells) were resuspended in 1.5 mL air-saturated incubation mixture (20 mM HEPES buffer containing 200 mM mannitol, 5 mM KH_2PO_4 , 2.5 mM MgCl_2 , and 0.5 mM EGTA; pH 7.4 enriched with 0.1% of serum albumin bovine). After stabilization of the basal respiratory rate (i.e. in the absence of any exogenous agent) tested compounds were added as a single bolus (FCCP, oligomycin, NaHS, MAMA NONOate or potassium cyanide (Sigma-Aldrich)).

2.5. Measurement of MPO activity

MPO activity was determined as an indicator of neutrophil infiltration using an o-dianisidine dihydrochloride assay. Distal colon samples were homogenized over ice using an Ultra-Turrax (3×10 s) in 0.5% hexadecyl-trimethylammonium bromide (Sigma-Aldrich) in potassium phosphate buffer (0.05 mM, pH 6.0). Then samples were centrifuged (10,000g, 30 min, 4°C) and the supernatant was kept on ice. The pellet was frozen, thawed and homogenized for 10 s before centrifugation (10,000g, 30 min, 4°C); this cycle being repeated two times. Final supernatants (50 μL) were mixed with 250 μL of potassium phosphate buffer containing 0.48 mg/mL of o-dianisidine dihydrochloride (Sigma-Aldrich) and 0.48 mM of hydrogen peroxide. Absorbance was read at 450 nm for 10 min. In parallel, protein assay on 5 μL of supernatant was performed using Bio-Rad DC Protein Assay (Bio-Rad). Activity was expressed as the difference after a 10-min reaction time between the absorbance and the baseline absorbance per milliliter of supernatant and per milligram of proteins.

2.6. In cell western (ICW) assay

The γH2AX ICW technique was performed as previously described [27]. Briefly, HT-29 Glc^{-/+} cells were distributed in a 96-well cell culture plate (36×10^3 cells, 200 μL /well). Sixteen hours later, the cells were treated in duplicate in serum free medium with NaHS (dissolved in DMEM). For each plate, DMSO (0.2% v/v final dose) or DMEM were used as negative controls and benzo(a)pyrene (BaP, 1 μM) or etoposide (Eto, 1 μM) from a stock solution in DMSO was used as positive control. After 24 h of treatment, the cells were washed in PBS and fixed in 4% paraformaldehyde (Electron Microscopy Science) in PBS at room temperature for

Table 2
Sequences (5'-3') of rat primers for qPCR experiments.

Gene name	Forward	Reverse
<i>Hprt</i>	CTCATGGACTGATTATGGACAGGAC	GCAGGTCAGCAAAGAACTTATAGCC
<i>Sqr</i>	ACAGACAATGGCAAGGAGA	GAGTGTITGGGAAGGTGAA
<i>Ethe1</i>	CTGTCACTCCGTCATCTCTC	GTCTCCAAAGCAAAGCGT
<i>Tst</i>	AAGGGAGTGTGAAGGAAGTGT	CGGCATTGAGGAGTAGAAC
<i>Nos 2</i>	AGGTATGCGGTATTITGGC	ATGTTGCGTITGGAAGTGTAG
<i>Il-6</i>	TCATCGCTGTTTACATAATCAGAA	AAGTCGGAGGCTTAATTACATATCTTC
<i>Il-1β</i>	GCACCTTCTTTTCCTTCATC	GCCGTCTTTCATCACACA
<i>Il-10</i>	CGGGGTGACAATAACTGC	CCTGGGGCATCACTTCTAC
<i>Tgf-β</i>	CTGACCCCACTGATACG	GTGTTGAGCCCTTTCAG
<i>Ptgs 2</i>	ACAGGAGAGAAAGAAATGGC	GGAGAACAGATGGGATTACC
<i>Hif-1α</i>	CAGACAGAGCAGGAAAGAGAG	CAAAGAAAGCGACATAGTAGG

10 min and then washed with PBS. Paraformaldehyde was neutralized with 20 mM NH_4Cl and the wells were then washed with PBS. Cells were permeabilized with 0.2% Triton X-100 in PBS and washed with PBS, 2% fetal calf serum, 0.2% Triton X-100 (PST buffer). Cells were blocked with MAXblock Blocking medium supplemented with phosphatase inhibitor PHOSTOP and RNase A, followed by 2 h incubation with rabbit monoclonal anti γH2AX (Clone 20E3, Cell Signaling) in PST buffer. After three washes with PST, secondary detection was carried out using an infrared fluorescent dye conjugated to goat antibody with an absorption peak at 770 nm (CF770, Biotium) in PST buffer. For DNA labeling, RedDot 2 (Biotium) in PST was used in conjugation with the secondary antibody. After 1 h of incubation and three washes with PST, DNA and γH2AX were simultaneously visualized using an Odyssey Infrared Imaging Scanner (Li-CorScienceTec). Raw absorbance data were averaged for the duplicate, corrected for background; the relative fluorescence units from the scanning enabled quantitative analysis. For the determination of genotoxicity, relative fluorescent units for γH2AX per cell (as determined by γH2AX divided by DNA content) were divided by the respective controls (vehicle only) to determine the change in phosphorylation of H2AX levels compared with control.

Isolated colonocytes from instilled rats were suspended in 10% DMSO, 40% SVF and 50% DMEM then, snaped frozen in liquid nitrogen and stored at -80°C . After thawing, colonocytes were distributed in a 96-well cell culture plate (36×10^3 cells, 200 μL /well) and fixed with 50 μL paraformaldehyde (20% final concentration) in PBS, for 15 min. Then cells were centrifuged for 10 min at 1500 rpm at 4°C and washed with PBS. Paraformaldehyde was neutralized with 20 mM NH_4Cl for 2 min. After centrifugation, cells were permeabilized with 0.1% Triton X-100 in PBS and blocked for 1 h with MAXblock Blocking medium supplemented with phosphatase inhibitor PHOSTOP and RNase A. From this step onwards, the ICW protocol was the same as the one described for HT29-Glc $^{-/+}$ cells.

2.7. Targeted GC-MS measurement of sulfide in large intestine contents

This assay was based on a previously described procedure [24,45] with some modifications. Briefly, 100 μL of 5 mM benzalkonium chloride (in deoxygenated water saturated with sodium tetraborate) were added to 100 mg frozen large intestine content in a vial. Then, 100 μL of 20 mM pentafluorobenzylbromide (in toluene) and 100 μL of ethylacetate containing internal standard (I.S.) naphthalene 100 μM were added before shaking the vial 4 h at 55°C . Then, 150 μL of saturated dihydrogenophosphate potassium in water solution was added before mixing by vortex and centrifugation (10,000g, 4°C , 10 min) for organic phase isolation. GC-MS system (GC 6890N coupled with 5973 N mass spectrometer, Agilent Technologies Inc.) was equipped with a HP-5HS capillary column (30 m length of 0.25 mm i.d. coated with a 0.25 μm film; Agilent Technologies). The gas chromatograph was operated with helium as carrier gas with the flow of 1 ml/min. A 1 μL organic phase was injected in a splitless mode. Injector and transfer line were held at 250°C . The ion source and the quadripole detector were set at 230 and 150°C , respectively. The GC conditions were as follows: 70°C held 1 min; 100 – 180°C , ramp $8^\circ\text{C}/\text{min}$, 180 – 300°C , ramp $50^\circ\text{C}/\text{min}$, held 2 min. Retention times of I.S. and bis(pentafluorobenzyl) sulfide were 8.01 and 15.21 min, respectively. The fragments m/z 128 (for I.S.) and 181 (for bis(pentafluorobenzyl)sulfide) were chosen for selected-ion monitoring (SIM).

2.8. Cysteine desulfhydrase activity measurement in large intestine contents

Large intestine content samples (100 mg) were homogenized in

0.05 mM phosphate buffer (9 $\mu\text{L}/\text{mg}$). Bacteria were isolated by centrifugation (200g, 5 min). Pellet was washed twice using the same procedure. Supernatants were pooled and centrifuged (9000g, 3 min) and bacteria were lysed in B-PER. Protein concentration in bacterial lysate was measured with Folin reagent. Bacterial lysate was incubated (15 min, 37°C) in a reaction buffer (Tris/HCl 100 mM, phosphate 5' pyridoxal 10 μM , cysteine 1 mM, pH 8, deoxygenated). Sulfide released was measured with the methylene blue method with reference to an external standard (Na_2S). Cysteine desulfhydrase specific activity was expressed as sulfide produced per minute per protein content.

2.9. Dissimilatory sulfite reductase gene quantification

Bacterial DNA extraction of fresh cecal and colonic luminal contents was performed with QIAamp DNA Stool Mini kit (Qiagen). The DNA concentration and purity were measured with Nanodrop. The DNA integrity was confirmed by electrophoresis on agarose gel with Gel red staining. Dissimilatory sulfite reductase (*dsrA*) gene copy number was quantified by q-PCR using specific primer (forward: ACSCACTGGAAGCACGCGG; reverse: GTGGMRCCGTGCAKRTTGG) [41]. Standard curve was generated from serial dilutions of a known copy number of the target gene cloned into a plasmid vector. Results are expressed as gene copy number per gram of content [30].

2.10. Statistical analysis

Statistical analyses were performed with R software with packages lme4, car and lsmeans. Student *t* test, ANOVA and Mixed-model ANOVA for repeated measures were used when appropriate. Multiple comparisons analysis was performed with Bonferonni post hoc tests for comparisons of means between groups as indicated in figure captions. Differences with *p*-values < 0.05 were considered as statistically significant.

3. Results

3.1. High NaHS luminal concentration induces pro-inflammatory gene expression in colonocytes

We first evaluated the epithelial inflammatory response to an increased luminal NaHS concentration. After one-hour intra-colonic instillation of a 1.5 mM NaHS solution (Fig. 1A), we observed a significant increase of iNOS (*Nos 2*) and interleukin-6 (*Il-6*) gene expression in colonocytes while 0.5 mM NaHS had no significant effect (Fig. 1B). Other measured mRNA levels of genes related to intestinal inflammation, including anti-inflammatory genes, were not significantly modified. To assess the effect of instillation on mucosal neutrophil recruitment, MPO activity was measured in the rat distal colon. In this short-term experiment, this parameter was similar in rats instilled with NaHS 1.5 mM or PBS (1.8 ± 0.3 and 2.1 ± 0.6 AU MPO/mg protein respectively; $n=5$ rats/group). Collectively, those results show that short term exposure to high NaHS concentration induce an early pro-inflammatory response in rat colonocytes.

3.2. NaHS is not genotoxic for colonocytes

Then, we evaluated the genotoxicity of NaHS on colonocytes *in vivo* using the instillation model (Fig. 1A). No induction of the phosphorylation of the H2AX histone was observed after 1 h of instillation with NaHS 1.5 mM when compared with PBS alone, indicating no genotoxicity of NaHS (Fig. 2A). Since rat colonocytes are viable for only 1 h after isolation, and in order to extend the duration of colonocyte exposure to NaHS, we treated human

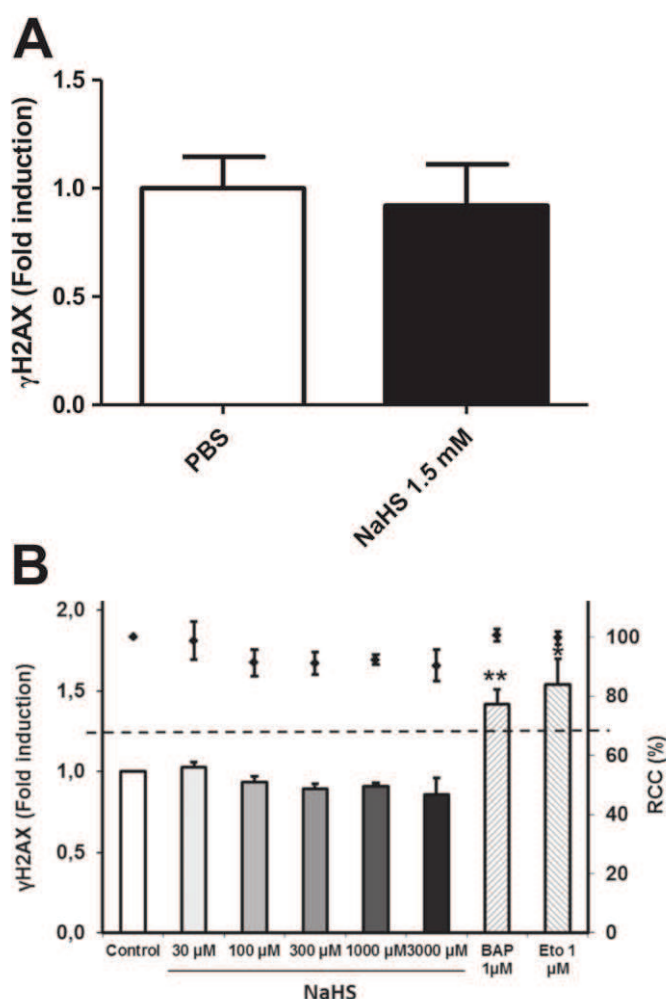

Fig. 2. Effects of NaHS on DNA integrity in colonocytes. (A) DNA damage in isolated colonocytes recovered from rats instilled with PBS alone or containing NaHS 1.5 mM. The results are expressed as fold induction for histone H2AX phosphorylation compared to control ($n=5$ rats/group). Mean values of both groups were compared using Student t test. (B) HT-29 Glc^{-/+} cells were cultured for 24 h with no added agent (control), or in the presence of benzo(a)pyrene or etoposide (BAP and Eto, positive controls) or with increasing concentrations of NaHS. The γ H2AX ICW assay was used to quantify DNA damage (left Y axis) and cytotoxicity (right Y axis). The results are expressed as fold induction for H2AX phosphorylation compared to negative control (histogram) and Relative Cell Count (RCC, individual points) expressed as percentages of control cell DNA content. γ H2AX fold induction above 1.3 (dotted line) indicates DNA damages ($n=3-4$ independent experiments). Means of treated group values were compared to control group (ANOVA, Bonferroni correction). Data are presented as mean values \pm SEM. * $p < 0.05$, ** $p < 0.01$.

colonocytes HT-29 Glc^{-/+} cells with increasing concentrations of NaHS (Fig. 2B). Consistent with *in vivo* data, we found that 24 h-NaHS treatment (30–3000 μ M) did not either induced H2AX phosphorylation. As expected, positive controls (benzo(a)pyrene and etoposide) induced H2AX phosphorylation. Incidentally, in the same assay, no cytotoxic effect of NaHS was observed (Fig. 2B). We conclude from those *in vivo* and *in vitro* experiments that NaHS does not induce DNA damages in colonocytes.

3.3. NaHS dose-dependently and reversibly affects mitochondrial oxygen consumption in colonocytes

We evaluated the effects of NaHS on oxygen consumption in rat colonocytes. We first isolated colonocytes from untreated rats and incubated them in the presence of increasing concentrations of NaHS. Using low concentrations of NaHS, we measured a rapid and

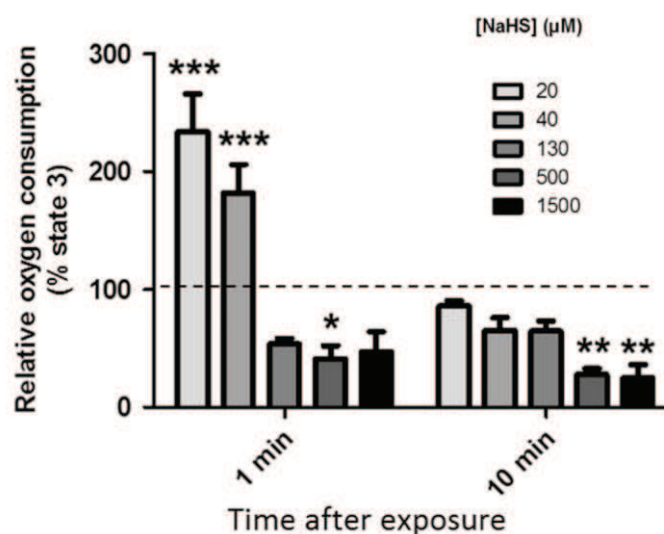

Fig. 3. Effects of NaHS on isolated rat colonocyte mitochondrial oxygen consumption. Basal oxygen consumption (state 3) by colonocytes from untreated rats was first measured in the absence of any added agent (considered as 100%, indicated by dotted line). Increasing NaHS concentrations were added as single shot and oxygen consumption rate was measured after 1 min and 10 min. Results are expressed as percentage of the basal value ($n=6$ independent experiments). The basal oxygen consumption represents 3.57 ± 0.15 nmol O_2 /min/ 10^6 cells. For each concentration and each time, mean values of oxygen consumption were compared to mean value of basal oxygen consumption (mixed-model ANOVA, Bonferroni correction). Data are presented as mean values \pm SEM. * $p < 0.05$, ** $p < 0.01$, *** $p < 0.001$.

transient increase of the O_2 consumption (Fig. 3), corresponding to the detoxification process of H_2S by oxidation. However, at higher concentrations ($> 130 \mu$ M NaHS), a marked inhibition of the oxygen consumption was recorded, corresponding to the known inhibitory effect of this compound on the mitochondrial COX activity. We found that the acute inhibition of respiration provoked by 1.5 mM NaHS could be entirely and instantaneously reversed by transferring colonocytes in an incubation buffer not containing NaHS (data not shown).

We then studied mitochondrial function in rat colonocytes isolated after intra-colonic instillation. The colonocyte basal oxygen consumption rate (state 3), the leak pathway measured in the presence of oligomycin (inhibitor of the F₀/F₁ ATPase), and the maximal oxygen consumption capacity measured in the presence of the uncoupling agent FCCP, were similar after 1.5 mM NaHS or PBS instillation (Fig. 4A). However, hypoxia inducible factor 1 α (Hif-1 α) mRNA level in colonocytes was increased by 23% in the NaHS instillation group when compared to PBS group (Fig. 4B), suggesting that exposure to 1.5 mM NaHS induced an hypoxia-like state.

Furthermore, the colonocyte capacity to oxidize 20 μ M NaHS was not modified after NaHS instillation (Fig. 4A) and the gene expression of the SOU enzymes was similar in colonocytes of rat after short-time instillation of NaHS or PBS (Fig. 4B)

3.4. Nitric oxide impairs H_2S detoxification in colonocytes

As we measured that NaHS instillation induced a large increase in the mRNA level of *nos 2* gene after 1 h of colonic infusion, and since the expression of iNOS is known to be mainly regulated at the transcriptional level [28], we decided to study the H_2S /NO interplay in colonocytes. Indeed, these two gasotransmitters are both known to target the COX activity [15]. In addition, NO inhibits other complexes in the mitochondrial respiratory chain including complex III [16,25]. As expected, micromolar concentration of the NO donor MAMA NONOate decreased markedly colonocyte

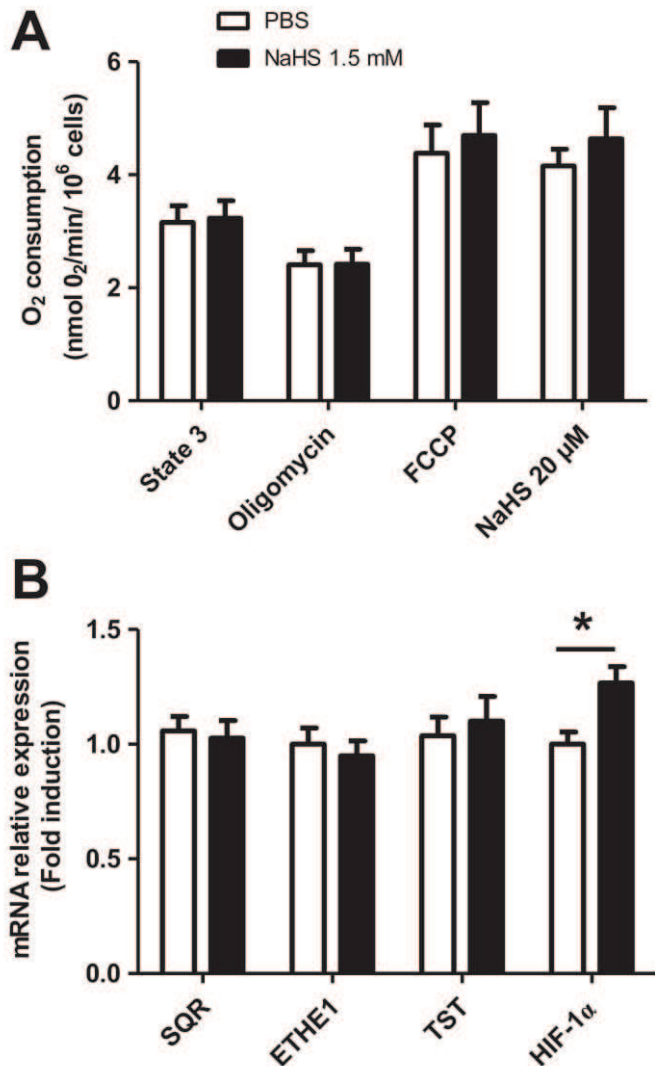

Fig. 4. Effects of intra-colonic instillation of NaHS on mitochondrial oxygen consumption and H₂S detoxification in colonocytes. (A) After colonic instillation with PBS without or with NaHS 1.5 mM, basal oxygen consumption rate (state 3) of isolated colonocytes was measured without any exogenous agent or after addition of the F₀/F₁ ATPase inhibitor oligomycin (0.5 μg/mL), or the uncoupler FCCP (1.5 μg/mL), or NaHS 20 μM ($n=4-6$ rats/group). Mean values in treated groups were compared to control group values by Student *t* test. (B) Relative level of mRNA corresponding to H₂S detoxification enzymes and hypoxia inducible factor 1α (*Hif-1α*) in colonocytes of rats recovered after instillation with PBS without or with NaHS 1.5 mM ($n=5-11$ rats/group). Mean values in treated groups were compared to mean values in control group by Student *t* test. Data are presented as mean values \pm SEM. * $p < 0.05$.

oxygen consumption (Fig. 5). When the colonocytes were first exposed to NO, and then to NaHS 20 μM, this latter compound failed to stimulate oxygen consumption (Fig. 5), demonstrating that NO impairs H₂S detoxification in colonocytes. When we inhibited the respiration of colonocytes with the COX inhibitor potassium cyanide (KCN), no stimulation of colonocyte oxygen consumption was observed in the presence of NaHS 20 μM (Fig. 5). Together, those data indicate that NO impairs H₂S detoxification by colonocytes through mitochondrial respiratory chain inhibition.

3.5. Large intestine sulfide content and expression of *Sqr* are modified after a high-protein diet consumption

Since H₂S is produced by the gut microbes notably from SAA, we decided to investigate the effects of a HPD on sulfide content in

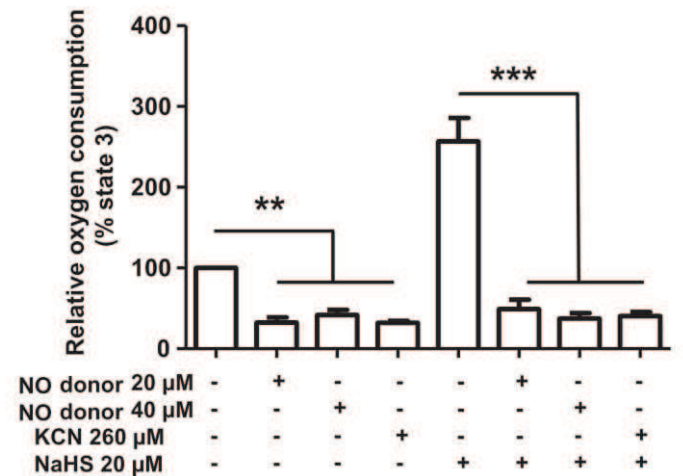

Fig. 5. Effects of NO on H₂S oxidation by colonocytes. Relative oxygen consumption by colonocytes was measured after a single shot of MAHMA NONOate (NO donor) or potassium cyanide (KCN) followed by a single shot of NaHS 20 μM ($n=6$ independent experiments). The basal oxygen consumption (state 3) measured without any added agent represents 4.16 ± 0.22 nmol O₂/min/10⁶ cells. Mean values of oxygen consumption in colonocytes exposed to NO or KCN were compared to mean basal oxygen consumption; and mean values of oxygen consumption in colonocyte exposed both to NO or KCN and then NaHS were compared to mean value of colonocyte treated in the sole presence of NaHS (ANOVA, Bonferroni correction). Data are presented as mean values \pm SEM. ** $p < 0.01$, *** $p < 0.001$.

rat large intestine. As shown in Fig. 6A, after 2 weeks of a HPD, a large increase of the sulfide content in both caecum and colon was measured when compared with control animals receiving a NPD. Microbiota cysteine desulfhydrase specific activity was similar in caecum and colon from both groups of rats (Fig. 7A) and the abundance of SRB in the large intestine contents was also not affected by the diet as measured by *dsrA* gene copy number (Fig. 7B). Those results indicate that the increased sulfide content is mainly related to increased substrate availability for sulfidogenesis during the HPD. Importantly, we observed an increase in large intestine luminal contents weight in HPD fed rats (Fig. 6B). Consequently, sulfide concentrations in the cecal and colonic content remained similar in the HPD and NPD group (Fig. 6C). Last, we measured an increased gene expression of the H₂S detoxification enzyme *Sqr* in colonocytes of HPD fed rats group when compared with the NPD group (Fig. 8), while the expression of the two other enzymes of the SOU were not affected by the diet. Together, this adaptive response of the SOU and the increase luminal bulk may reduce colonocyte exposure to H₂S during HPD.

4. Discussion

The results obtained in the present study indicate that excessive concentrations of H₂S in the colonic luminal content, in comparison with the capacity of colonocytes to detoxify this bacterial metabolite, may affect markedly the oxidative energy metabolism in the colonocytes. Since the colon epithelium is a dynamic structure with a renewal speed among the highest in the body, the anabolic processes associated with this renewal require a high rate of ATP production [58]. We thus reasoned that a marked increased concentration of sulfide in the colonic lumen might severely affect the energy metabolism in the colonic epithelium, triggering intestinal mucosal responses.

In the first part of this study, we decided to test in anaesthetized rats the effects of NaHS instilled for 1 h directly in the colon lumen. At 1.5 but not 0.5 mM concentration, NaHS markedly increased the expression of two pro-inflammatory genes (*Nos2* and *Il-6*) suggesting that under such experimental conditions, H₂S

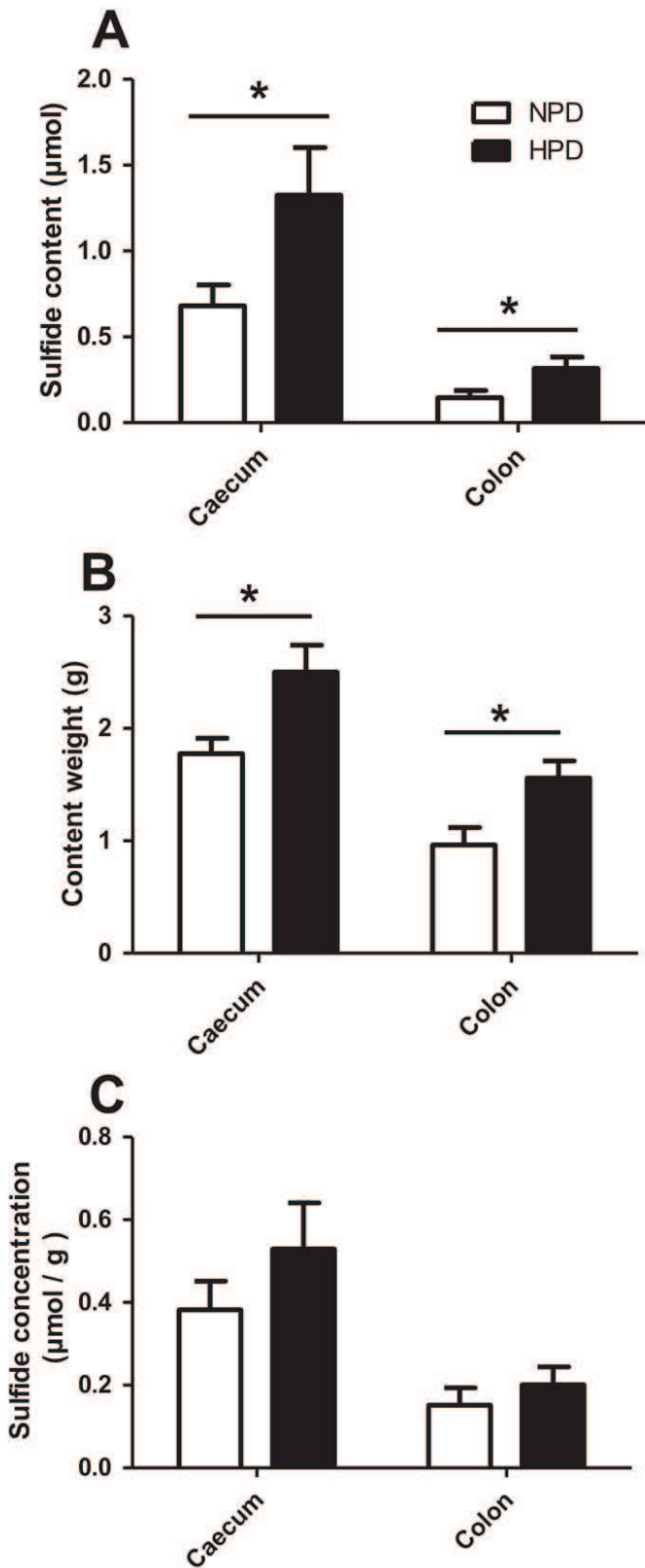

Fig. 6. Effects of high protein diet on large intestine luminal sulfide. (A) Sulfide quantity measured by GC-MS in large intestine contents of rats fed 15 days with a high protein diet (HPD) or a normal protein diet (NPD) ($n=10$ rats/group). (B) Weight of the large intestine luminal content of NPD and HPD rats ($n=10$ rats/group). (C) Sulfide concentration in large intestine contents of NPD and HPD rats ($n=10$ rats/group). Data are presented as mean values \pm SEM. Mean values in HPD group were compared to mean values in NPD group by Student t test. $^*p < 0.05$.

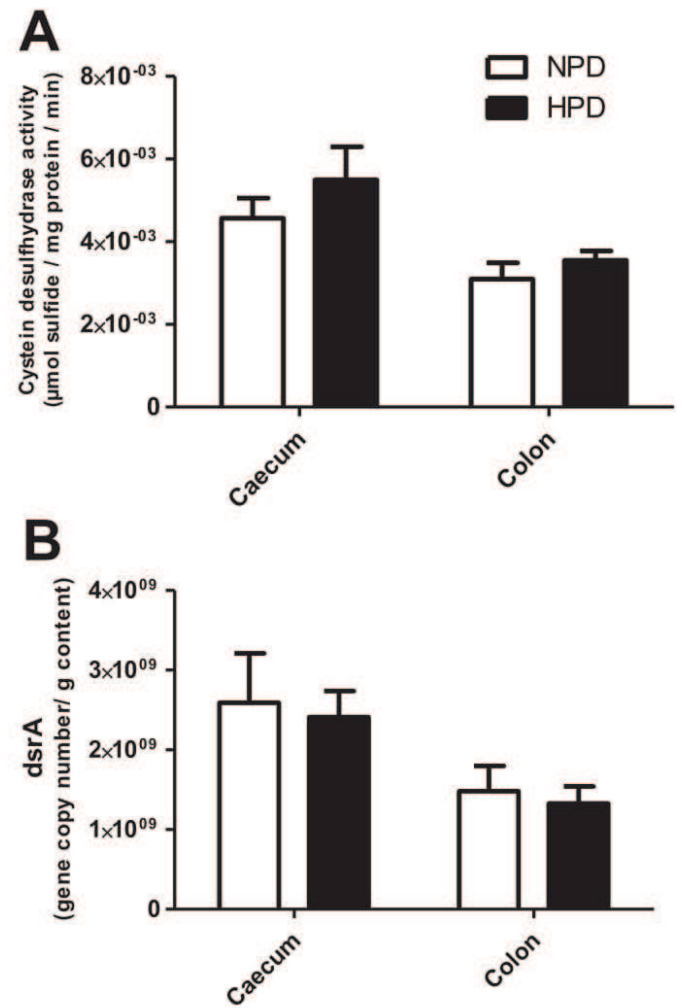

Fig. 7. Effects of high protein diet on gut bacterial sulfidogenic pathways. (A) Microbial cysteine desulfhydrase activity in large intestine contents of NPD and HPD rats ($n=9-10$ rats/group). (B) Dissimilatory sulfite reductase A (*dsrA*) gene abundance in large intestine contents of NPD and HPD rats ($n=10$ rats/group). Data are presented as mean values \pm SEM. Mean values in HPD group were compared to mean values in NPD group by Student t test.

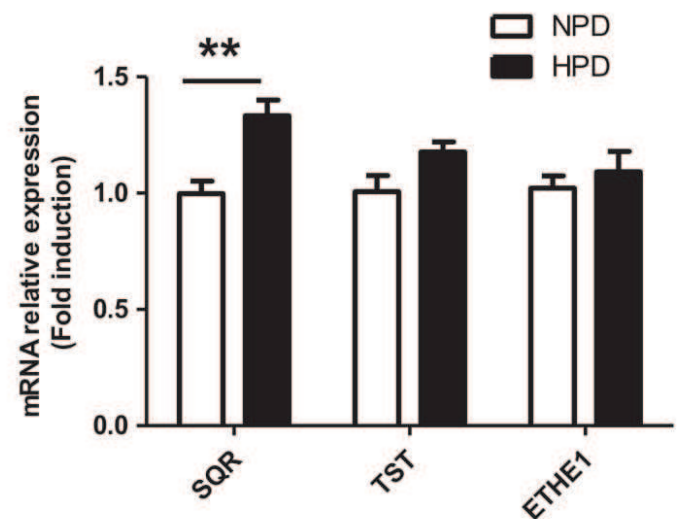

Fig. 8. Effects of high protein diet on the gene expression of H_2S detoxification enzymes in colonocytes. Relative level of mRNA corresponding to the H_2S detoxification enzymes SQR, ETHE1 and TST in colonocytes isolated from NPD and HPD rats ($n=6$ rats/group). Mean values in HPD group were compared to mean values in NPD group by Student t test. Data are presented as mean values \pm SEM. $^{**}p < 0.01$.

is able to induce the transcription of two genes well known to be implicated in the intestinal mucosal inflammation [28,49]. Both direct and indirect mechanisms of H₂S induction of gene expression are conceivable but their characterization is out of the scope of this study. After this short-term treatment of the colonic mucosa with NaHS, no difference in the gene expression of the SO₄ enzymes was recorded in isolated colonocytes indicating that the detoxification metabolic pathway towards H₂S is not rapidly induced.

When we used colonocytes recovered at the end of the instillation period with 1.5 mM NaHS, we found that the colonic cell oxygen consumption remained unaltered when compared with control experiments; raising the view that binding of H₂S to the mitochondrial complex IV of the respiratory chain is an easily and rapidly reversible phenomenon as previously described [15]. Although we did not measure the intracellular redox couples in our experiments, the fact that the state 3 oxygen consumption was similar between colonocytes recovered after NaHS instillation compared to PBS instillation is compatible with the view that the NADH/NAD couple was unaffected by NaHS treatment [12]. Regarding the experiments performed using isolated colonocytes obtained from untreated animals, our results indicate that although low NaHS concentrations (20, and to a lesser extent 40 μM) stimulate rapidly oxygen consumption, 500 and 1500 μM exerts strong inhibitory effects. In experiments performed with isolated colonocytes, it is worth noting that these cells are not protected by the mucous layer at difference with the *in vivo* situation. This may likely explain different sensitiveness towards H₂S of isolated colonocytes compared to *in situ* colonocytes as used in *in vivo* experiments.

The existence of a causal link between an effect of H₂S on colonocyte respiration and the induction of gene expression remains an open question. However, the increase of the mRNA level corresponding to *Hif-1α* in colonocytes following NaHS colonic instillation is indicative of a likely hypoxia-like status in these cells [14]; a situation that is observed in active IBD and which may

provoke an imbalance between ATP production and ATP utilization in colonocytes [9]. Anyway, as expected from our short time experiments, there was no overt sign of mucosal inflammation following NaHS instillation.

Another important aspect of our results is the absence of an effect of NaHS on colonocyte DNA damages using the sensitive quantitative γH2AX assay [27] at difference with previous results showing effect of H₂S on intestinal cell DNA integrity [4,5]. Differences between the results obtained may result from different experimental design and cell line used. The HT-29 Glc^{-/+} cells used in the present study cannot be considered as resistant to DNA damages as we found recently that another bacterial metabolite, namely *p*-cresol, is dose-dependently able to provoke such lesions on DNA in these cells [2].

In regard to the NO–H₂S interaction, our data show that the NO radical jeopardizes H₂S colonocyte detoxification through inhibition of cell respiration suggesting that NO may reinforce the deleterious effect of H₂S on colonocytes as previously suggested [47]. It has been convincingly demonstrated in clinical studies [8,22,28,39,44,51], that a marked increased expression of the inducible form of NOS is detected in the mucosa and colonocytes recovered from the large intestine during inflammation; and this is associated with a very marked increased concentration of the NO gas in the large intestine luminal content [36].

In the second and complementary part of our study, in order to increase the sulfide luminal content, we fed the animals with a high-protein diet (HPD), a nutritional intervention which has been shown to increase the transfer of undigested luminal proteins from the ileum to the large intestine [21,38,50] and accordingly to raise the large intestine content in several amino acid-derived bacterial metabolites [34,48]. The results obtained in our study indicate that the sulfide content was more than doubled in the large intestinal contents of rats fed with a HPD as compared to rats fed with a NPD. However, due to marked increase in the weight of the cecal and colonic luminal contents (mostly due to an increased water content [1]), the sulfide concentration in these intestinal

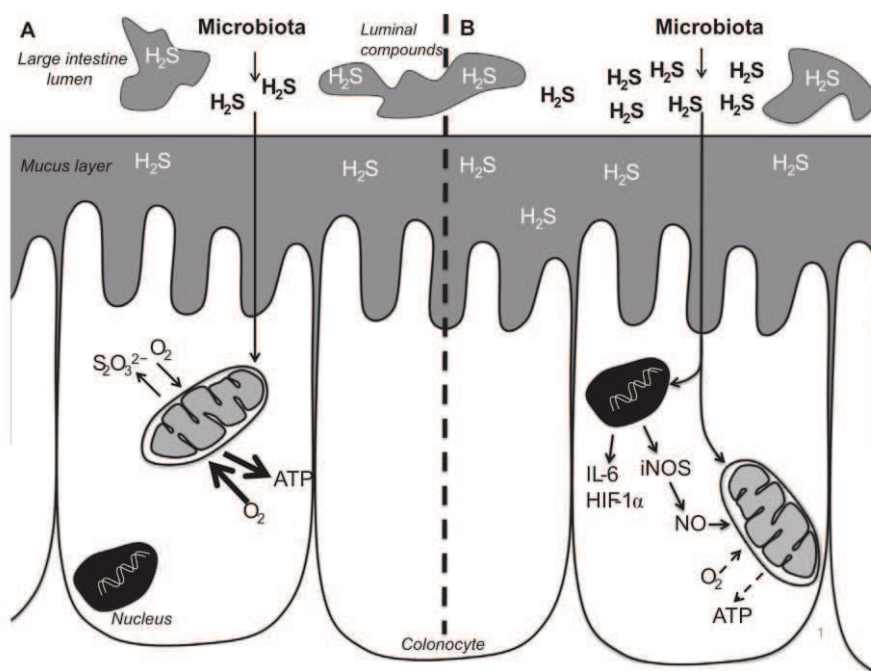

Fig. 9. Schematic view of the microbiota-derived H₂S effects on colonocytes. H₂S is produced by the gut microbiota partly from sulfur-containing amino acids and may bind to luminal compounds or diffuse through mucus layer and colonocyte apical membrane. (A) When H₂S concentration is low, mitochondria efficiently oxidize it into thiosulfate (S₂O₃²⁻), together with an increased oxygen consumption and ATP production. (B) When H₂S concentration is high, it exceeds H₂S detoxification capacity and cytochrome c oxidase is inhibited, leading to a decreased oxygen consumption and ATP production. Increased intra-cytoplasmic H₂S concentration induces the expression of genes related to inflammation. Nitric oxide (NO) impairs H₂S detoxification and may worsen its deleterious effects.

segments were not affected ranging approximately from 0.2 to 0.5 millimolar. In the meantime, increase of the *Sqr* gene expression (SQR being the first and rate-limiting enzyme for H₂S detoxification) was noticed. Since neither cysteine desulfhydrase specific activity nor the abundance of SRB were affected by the HPD, it is very likely that the increase in the sulfide luminal content was mainly due to increased substrate availability in the sulfidogenic metabolic pathway [17]. Although at first glance, the absence of modification of sulfide concentration in the large intestine following HPD ingestion fits with our previous results showing unmodified basal colonic mucosa inflammatory status in such situation [29], this nutritional intervention obviously affects numerous other parameters of the luminal environment [34].

Our results are compatible with the view that in healthy animals, moderate luminal concentration of H₂S can be handled by colonocytes which oxidize this bacterial metabolite (Fig. 9A). However, when the luminal H₂S concentration increases (for instance locally in the vicinity of the colonic epithelium), the concentration of this compound increases in colonocyte cytosol, allowing it to induce the transcription of genes involved in the mucosal inflammatory process (Fig. 9B). Meanwhile, H₂S accumulates in mitochondria and inhibits COX, decreasing the colonocyte respiration, and thus presumably challenging the ATP production rate and thus the epithelial anabolic metabolism (Fig. 9B). However, our study provides evidence that in our experimental model of HPD, increased luminal content mass and increased expression of *Sqr* in colonocytes represent adaptive processes limiting the potentially deleterious intracellular accumulation of H₂S.

Author disclosure statement

No competing financial interests exist.

Acknowledgments

The authors thank the European Commission (project My new gut, Grant agreement no. 613979), the Fondation ARC pour la Recherche sur le cancer (Grant no. 20131200283), PRES Sorbonne Paris Cité, INRA and AgroParisTech for their financial supports.

References

- [1] M. Andriamihaja, A.-M. Davila, M. Eklou-Lawson, N. Petit, S. Delpal, F. Allek, A. Blais, C. Deltiel, D. Tomé, F. Blachier, Colon luminal content and epithelial cell morphology are markedly modified in rats fed with a high-protein diet, *Am. J. Physiol. Gastrointest. Liver Physiol.* 299 (2010) G1030–G1037.
- [2] M. Andriamihaja, A. Lan, M. Beaumont, M. Audebert, X. Wong, K. Yamada, Y. Yin, D. Tomé, C. Carrasco-Pozo, M. Gotteland, et al., The deleterious metabolic and genotoxic effects of the bacterial metabolite p-cresol on colonic epithelial cells, *Free Radic. Biol. Med.* 85 (2015) 219–227.
- [3] I. Arijis, W. Vanhove, P. Rutgeerts, F. Schuit, K. Verbeke, V. De Preter, Decreased mucosal sulfide detoxification capacity in patients with Crohn's disease, *Inflamm. Bowel Dis.* 19 (2013) E70–E72.
- [4] M.S. Attene-Ramos, E.D. Wagner, M.J. Plewa, H.R. Gaskins, Evidence that hydrogen sulfide is a genotoxic agent, *Mol. Cancer Res.* 4 (2006) 9–14.
- [5] M.S. Attene-Ramos, G.M. Nava, M.G. Muellner, E.D. Wagner, M.J. Plewa, H. R. Gaskins, DNA damage and toxicogenomic analyses of hydrogen sulfide in human intestinal epithelial FHs 74 Int cells, *Environ. Mol. Mutagen.* 51 (2010) 304–314.
- [6] F. Blachier, F. Mariotti, J.F. Huneau, D. Tomé, Effects of amino acid-derived luminal metabolites on the colonic epithelium and physiopathological consequences, *Amino Acids* 33 (2007) 547–562.
- [7] F. Blachier, A.-M. Davila, S. Mimoun, P.-H. Benetti, C. Atanasiu, M. Andriamihaja, R. Benamouzig, F. Bouillaud, D. Tomé, Luminal sulfide and large intestine mucosa: friend or foe? *Amino Acids* 39 (2010) 335–347.
- [8] N.K. Boughton-Smith, S.M. Evans, C.J. Hawkey, A.T. Cole, M. Balsitis, B. J. Whittle, S. Moncada, Nitric oxide synthase activity in ulcerative colitis and Crohn's disease, *Lancet* 342 (1993) 338–340.
- [9] F. Bouillaud, F. Blachier, Mitochondria and sulfide: a very old story of poisoning, feeding, and signaling? *Antioxid. Redox Signal.* 15 (2011) 379–391.
- [10] F. Carbonero, A.C. Benefiel, H.R. Gaskins, Contributions of the microbial hydrogen economy to colonic homeostasis, *Nat. Rev. Gastroenterol. Hepatol.* 9 (2012) 504–518.
- [11] P. Chomczynski, N. Sacchi, Single-step method of RNA isolation by acid guanidinium thiocyanate-phenol-chloroform extraction, *Anal. Biochem.* 162 (1987) 156–159.
- [12] M.L. Circu, R.E. Maloney, T.Y. Aw, Disruption of pyridine nucleotide redox status during oxidative challenge at normal and low-glucose states: implications for cellular adenosine triphosphate, mitochondrial respiratory activity, and reducing capacity in colon epithelial cells, *Antioxid. Redox Signal.* 14 (2011) 2151–2162.
- [13] J.C. Coffey, F. Rowan, J. Burke, N.G. Dochery, N. Dochery, W.O. Kirwan, P. R. O'Connell, Pathogenesis of and unifying hypothesis for idiopathic pouchitis, *Am. J. Gastroenterol.* 104 (2009) 1013–1023.
- [14] S.P. Colgan, C.T. Taylor, Hypoxia: an alarm signal during intestinal inflammation, *Nat. Rev. Gastroenterol. Hepatol.* 7 (2010) 281–287.
- [15] C.E. Cooper, G.C. Brown, The inhibition of mitochondrial cytochrome oxidase by the gases carbon monoxide, nitric oxide, hydrogen cyanide and hydrogen sulfide: chemical mechanism and physiological significance, *J. Bioenerg. Biomembr.* 40 (2008) 533–539.
- [16] Z. Dai, Z. Wu, Y. Yang, J. Wang, M.C. Satterfield, C.J. Meininger, F.W. Bazer, G. Wu, Nitric oxide and energy metabolism in mammals, *Biofactors* 39 (2013) 383–391.
- [17] A.-M. Davila, F. Blachier, M. Gotteland, M. Andriamihaja, P.-H. Benetti, Y. Sanz, D. Tomé, Intestinal luminal nitrogen metabolism: role of the gut microbiota and consequences for the host, *Pharmacol. Res.* 68 (2013) 95–107.
- [18] V. De Preter, I. Arijis, K. Windey, W. Vanhove, S. Vermeire, F. Schuit, P. Rutgeerts, K. Verbeke, Decreased mucosal sulfide detoxification is related to an impaired butyrate oxidation in ulcerative colitis, *Inflamm. Bowel Dis.* 18 (2012) 2371–2380.
- [19] K.L. Flannigan, T.A. Agbor, J.-P. Motta, J.G.P. Ferraz, R. Wang, A.G. Buret, J. L. Wallace, Proresolution effects of hydrogen sulfide during colitis are mediated through hypoxia-inducible factor-1 α , *FASEB J.* 29 (2015) 1591–1602.
- [20] B. Geypens, D. Claus, P. Evenepoel, M. Hiele, B. Maes, M. Peeters, P. Rutgeerts, Y. Ghoo, Influence of dietary protein supplements on the formation of bacterial metabolites in the colon, *Gut* 41 (1997) 70–76.
- [21] J.A. Gibson, G.E. Sladen, A.M. Dawson, Protein absorption and ammonia production: the effects of dietary protein and removal of the colon, *Br. J. Nutr.* 35 (1976) 61–65.
- [22] G. Guihot, R. Guimbaud, V. Bertrand, B. Narcy-Lambare, D. Couturier, P. H. Duée, S. Chaussade, F. Blachier, Inducible nitric oxide synthase activity in colon biopsies from inflammatory areas: correlation with inflammation intensity in patients with ulcerative colitis but not with Crohn's disease, *Amino Acids* 18 (2000) 229–237.
- [23] M.R. Hellmich, C. Coletta, C. Chao, C. Szabo, The therapeutic potential of cystathionine β -synthetase/hydrogen sulfide inhibition in cancer, *Antioxid. Redox Signal.* 22 (2015) 424–448.
- [24] R. Hyspler, A. Tichá, M. Indrová, Z. Zádák, L. Hysplerová, J. Gasparic, J. Churáček, A simple, optimized method for the determination of sulphide in whole blood by GC-MS as a marker of bowel fermentation processes, *J. Chromatogr. B* 770 (2002) 255–259.
- [25] D.E. Iglesias, S.S. Bombicino, L.B. Valdez, A. Boveris, Nitric oxide interacts with mitochondrial complex III producing antimycin-like effects, *Free Radic. Biol. Med.* 89 (2015) 602–613.
- [26] J. Jørgensen, P.B. Mortensen, Hydrogen sulfide and colonic epithelial metabolism: implications for ulcerative colitis, *Dig. Dis. Sci.* 46 (2001) 1722–1732.
- [27] L. Khoury, D. Zalko, M. Audebert, Validation of high-throughput genotoxicity assay screening using γ H2AX in-cell western assay on HepG2 cells, *Environ. Mol. Mutagen.* 54 (2013) 737–746.
- [28] G. Kolios, V. Valatas, S.G. Ward, Nitric oxide in inflammatory bowel disease: a universal messenger in an unsolved puzzle, *Immunology* 113 (2004) 427–437.
- [29] A. Lan, M. Andriamihaja, J.-M. Blouin, X. Liu, V. Descatoire, C. Desclée de Maredsous, A.-M. Davila, F. Walker, D. Tomé, F. Blachier, High-protein diet differently modifies intestinal goblet cell characteristics and mucosal cytokine expression in ileum and colon, *J. Nutr. Biochem.* 26 (2015) 91–98.
- [30] C. Lee, J. Kim, S.G. Shin, S. Hwang, Absolute and relative qPCR quantification of plasmid copy number in *Escherichia coli*, *J. Biotechnol.* 123 (2006) 273–280.
- [31] X. Leschelle, M. Goubern, M. Andriamihaja, H.M. Blottié, E. Couplan, M.-D.-M. Gonzalez-Barroso, C. Petit, A. Pagniez, C. Chaumontet, B. Mignotte, et al., Adaptive metabolic response of human colonic epithelial cells to the adverse effects of the luminal compound sulfide, *Biochim. Biophys. Acta* 1725 (2005) 201–212.
- [32] M.D. Levitt, J. Springfield, J. Furne, T. Koenig, F.L. Suarez, Physiology of sulfide in the rat colon: use of bismuth to assess colonic sulfide production, *J. Appl. Physiol.* 1985 (92) (2002) 1655–1660.
- [33] D.R. Linden, Hydrogen sulfide signaling in the gastrointestinal tract, *Antioxid. Redox Signal.* 20 (2014) 818–830.
- [34] X. Liu, J.-M. Blouin, A. Santacruz, A. Lan, M. Andriamihaja, S. Wilkanowicz, P.-H. Benetti, D. Tomé, Y. Sanz, F. Blachier, et al., High-protein diet modifies colonic microbiota and luminal environment but not colonocyte metabolism in the rat model: the increased luminal bulk connection, *Am. J. Physiol. Gastrointest. Liver Physiol.* 307 (2014) G459–G470.
- [35] P. Louis, G.L. Hold, H.J. Flint, The gut microbiota, bacterial metabolites and colorectal cancer, *Nat. Rev. Microbiol.* 12 (2014) 661–672.
- [36] J.O. Lundberg, P.M. Hellström, J.M. Lundberg, K. Alving, Greatly increased luminal nitric oxide in ulcerative colitis, *Lancet* 344 (1994) 1673–1674.
- [37] G.T. Macfarlane, G.R. Gibson, J.H. Cummings, Comparison of fermentation reactions in different regions of the human colon, *J. Appl. Bacteriol.* 72 (1992) 57–64.

- [38] E.A. Magee, C.J. Richardson, R. Hughes, J.H. Cummings, Contribution of dietary protein to sulfide production in the large intestine: an in vitro and a controlled feeding study in humans, *Am. J. Clin. Nutr.* 72 (2000) 1488–1494.
- [39] S.J. Middleton, M. Shorhouse, J.O. Hunter, Increased nitric oxide synthesis in ulcerative colitis, *Lancet* 341 (1993) 465–466.
- [40] S. Mimoun, M. Andriamihaja, C. Chaumontet, C. Atanasiu, R. Benamouzig, J. M. Blouin, D. Tomé, F. Bouillaud, F. Blachier, Detoxification of H₂S by differentiated colonic epithelial cells: implication of the sulfide oxidizing unit and of the cell respiratory capacity, *Antioxid. Redox Signal.* 17 (2012) 1–10.
- [41] N. Nakamura, K.R. Amato, P. Garber, A. Estrada, R.I. Mackie, H.R. Gaskins, Analysis of the hydrogenotrophic microbiota of wild and captive black howler monkeys (*Alouatta pigra*) in palenque national park, Mexico, *Am. J. Primatol.* 73 (2011) 909–919.
- [42] E.P. Nyangale, D.S. Mottram, G.R. Gibson, Gut microbial activity, implications for health and disease: the potential role of metabolite analysis, *J. Proteome Res.* 11 (2012) 5573–5585.
- [43] M.C. Pitcher, J.H. Cummings, Hydrogen sulphide: a bacterial toxin in ulcerative colitis? *Gut* 39 (1996) 1–4.
- [44] D. Rachmilewitz, J.S. Stampler, D. Bachwich, F. Karmeli, Z. Ackerman, D. K. Podolsky, Enhanced colonic nitric oxide generation and nitric oxide synthase activity in ulcerative colitis and Crohn's disease, *Gut* 36 (1995) 718–723.
- [45] F.E. Rey, M.D. Gonzalez, J. Cheng, M. Wu, P.P. Ahern, J.I. Gordon, Metabolic niche of a prominent sulfate-reducing human gut bacterium, *Proc. Natl. Acad. Sci.* 110 (2013) 13582–13587.
- [46] W.E. Roediger, Utilization of nutrients by isolated epithelial cells of the rat colon, *Gastroenterology* 83 (1982) 424–429.
- [47] W.E. Roediger, W.J. Babidge, Nitric oxide effect on colonocyte metabolism: coaction of sulfides and peroxide, *Mol. Cell. Biochem.* 206 (2000) 159–167.
- [48] W.R. Russell, S.W. Gratz, S.H. Duncan, G. Holtrop, J. Ince, L. Scobbie, G. Duncan, A.M. Johnstone, G.E. Lobley, R.J. Wallace, et al., High-protein, reduced-carbohydrate weight-loss diets promote metabolite profiles likely to be detrimental to colonic health, *Am. J. Clin. Nutr.* 93 (2011) 1062–1072.
- [49] J. Scheller, C. Garbers, S. Rose-John, Interleukin-6: from basic biology to selective blockade of pro-inflammatory activities, *Semin. Immunol.* 26 (2014) 2–12.
- [50] K.R. Silvester, J.H. Cummings, Does digestibility of meat protein help explain large bowel cancer risk? *Nutr. Cancer* 24 (1995) 279–288.
- [51] I.I. Singer, D.W. Kawka, S. Scott, J.R. Weidner, R.A. Mumford, T.E. Riehl, W. F. Stenson, Expression of inducible nitric oxide synthase and nitrotyrosine in colonic epithelium in inflammatory bowel disease, *Gastroenterology* 111 (1996) 871–885.
- [52] M. Song, W.S. Garrett, A.T. Chan, Nutrients, foods, and colorectal cancer prevention, *Gastroenterology* 148 (2015) 1244.e16–1260.e16.
- [53] A. Stein, S.M. Bailey, Redox biology of hydrogen sulfide: implications for physiology, pathophysiology, and pharmacology, *Redox Biol.* 1 (2013) 32–39.
- [54] C. Szabo, C. Coletta, C. Chao, K. Módis, B. Szczesny, A. Papapetropoulos, M. R. Hellmich, Tumor-derived hydrogen sulfide, produced by cystathionine- β -synthase, stimulates bioenergetics, cell proliferation, and angiogenesis in colon cancer, *Proc. Natl. Acad. Sci.* 110 (2013) 12474–12479.
- [55] J.L. Wallace, L. Vong, W. McKnight, M. Dickey, G.R. Martin, Endogenous and exogenous hydrogen sulfide promotes resolution of colitis in rats, *Gastroenterology* 137 (2009) 569.e1–578.e1.
- [56] J.L. Wallace, J.G.P. Ferraz, M.N. Muscara, Hydrogen sulfide: an endogenous mediator of resolution of inflammation and injury, *Antioxid. Redox Signal.* 17 (2012) 58–67.
- [57] R. Wang, Two's company, three's a crowd: Can H₂S be the third endogenous gaseous transmitter? *FASEB J.* 16 (2002) 1792–1798.
- [58] M. Watford, P. Lund, H.A. Krebs, Isolation and metabolic characteristics of rat and chicken enterocytes, *Biochem. J.* 178 (1979) 589–596.
- [59] A. Zweibaum, M. Pinto, G. Chevalier, E. Dussaulx, N. Triadou, B. Lacroix, K. Haffen, J.L. Brun, M. Rousset, Enterocytic differentiation of a subpopulation of the human colon tumor cell line HT-29 selected for growth in sugar-free medium and its inhibition by glucose, *J. Cell. Physiol.* 122 (1985) 21–29.

ETUDE 2 : GENOTOXICITE DU *p*-CRESOL SUR LES COLONOCYTES *IN VITRO*

Résultats intégrés à un article publié dans la revue Free Radical Biology and Medicine, 2015.

Contexte

Le *p*-cresol est un métabolite produit par les bactéries intestinales à partir de la tyrosine. Bien qu'il s'agisse du principal composé phénolique produit par le microbiote, ses effets sur l'épithélium du côlon ne sont pas connus. Le but de cette étude était de déterminer *in vitro* les effets du *p*-cresol sur les colonocytes au niveau du métabolisme énergétique, de la prolifération, de la viabilité et de l'intégrité de l'ADN. *Seule l'évaluation de la génotoxicité du p-cresol a été réalisée dans le cadre de cette thèse et est décrite ici.*

Méthode (Décrit dans le paragraphe 2.8 de l'article)

Deux lignées cellulaires issues d'adénocarcinomes coliques humains (HT-29 Glc -/+ et LS-174T) ont été traitées pendant 24 heures avec du *p*-cresol. Les dommages à l'ADN ont été analysés par quantification de γ -H2AX par In-Cell Western. Au cours de la même expérience, la viabilité cellulaire a été estimée par la quantification de l'ADN.

Résultats (Décrit dans le paragraphe 3.7 et sur la figure 7 de l'article)

L'exposition au *p*-cresol a induit de manière dose dépendante des dommages à l'ADN des cellules HT-29 Glc -/+ (> 1.5 mM) et LS-174T (>1 mM). Cet effet n'était pas associé à une diminution de la viabilité des cellules.

Conclusion

Cette expérience montre pour la première fois que le *p*-cresol est un métabolite bactérien génotoxique pour les colonocytes. Une exposition à des concentrations élevées de *p*-cresol pourrait donc avoir des conséquences délétères pour l'homéostasie de l'épithélium.

Message clé de l'étude 2

- Le *p*-cresol est un métabolite génotoxique pour les colonocytes *in vitro*



Original Contribution

The deleterious metabolic and genotoxic effects of the bacterial metabolite *p*-cresol on colonic epithelial cells

Mireille Andriamihaja^a, Annaïg Lan^a, Martin Beaumont^a, Marc Audebert^b, Ximena Wong^c, Kana Yamada^a, Yulong Yin^d, Daniel Tomé^a, Catalina Carrasco-Pozo^c, Martin Gotteland^{c,e}, Xiangfeng Kong^d, François Blachier^{a,*}

^a UMR 914 INRA/AgroParisTech, Nutrition Physiology and Ingestive Behavior, Paris, France

^b INRA, UMR1331, Toxalim, Research Centre in Food Toxicology, F-31027 Toulouse, France

^c Department of Nutrition, Faculty of Medicine University of Chile, Santiago, Chile

^d Institute of Subtropical Agriculture, Chinese Academy of Sciences, Changsha, China

^e Institute of Nutrition and Food Technology (INTA), University of Chile, Santiago, Chile

ARTICLE INFO

Article history:

Received 30 January 2015

Received in revised form

20 March 2015

Accepted 6 April 2015

Available online 14 April 2015

Keywords:

Intestinal microbiota

Large intestine

Mitochondrial oxygen consumption

Cell proliferation

Anion superoxide production

Genotoxicity

ABSTRACT

p-Cresol that is produced by the intestinal microbiota from the amino acid tyrosine is found at millimolar concentrations in the human feces. The effects of this metabolite on colonic epithelial cells were tested in this study. Using the human colonic epithelial HT-29 Glc^{-/+} cell line, we found that 0.8 mM *p*-cresol inhibits cell proliferation, an effect concomitant with an accumulation of the cells in the S phase and with a slight increase of cell detachment without necrotic effect. At this concentration, *p*-cresol inhibited oxygen consumption in HT-29 Glc^{-/+} cells. In rat normal colonocytes, *p*-cresol also inhibited respiration. Pretreatment of HT-29 Glc^{-/+} cells with 0.8 mM *p*-cresol for 1 day resulted in an increase of the state 3 oxygen consumption and of the cell maximal respiratory capacity with concomitant increased anion superoxide production. At higher concentrations (1.6 and 3.2 mM), *p*-cresol showed similar effects but additionally increased after 1 day the proton leak through the inner mitochondrial membrane, decreasing the mitochondrial bioenergetic activity. At these concentrations, *p*-cresol was found to be genotoxic toward HT-29 Glc^{-/+} and also LS-174T intestinal cells. Lastly, a decreased ATP intracellular content was observed after 3 days treatment. *p*-Cresol at 0.8 mM concentration inhibits colonocyte respiration and proliferation. In response, cells can mobilize their "respiratory reserve." At higher concentrations, *p*-cresol pretreatment uncouples cell respiration and ATP synthesis, increases DNA damage, and finally decreases the ATP cell content. Thus, we have identified *p*-cresol as a metabolic troublemaker and as a genotoxic agent toward colonocytes.

© 2015 Elsevier Inc. All rights reserved.

1. Introduction

The degradation of aromatic amino acids (phenylalanine, tyrosine, and tryptophan) by the intestinal microbiota produces phenolic and indolic metabolic end products [12]. Among these bacterial metabolites, the phenolic compound *p*-cresol is produced from L-tyrosine in the large intestine lumen [46], notably by the anaerobic flora of the left colon [4]. Phenolic compound concentrations are high in the distal part of the large intestine where protein fermentation is intense [31]. Indeed, in humans, a 6.2 mM concentration of phenolic compounds has been measured in the distal colon while a 1.4 mM concentration

was found in the proximal colon [45]. Phenol and *p*-cresol account for 70% of all luminal products of dissimilatory aromatic amino acid metabolism in the distal gut. The *p*-cresol concentration in the human feces averages approximately 0.4 mM [19,27]. These compounds are absorbed from the intestinal luminal content to the bloodstream by colonocytes, metabolized in the liver, and finally excreted by the kidneys with more than 90% of urinary phenolic compounds being recovered as *p*-cresol [21,31,41]. An increase of the protein intake raises the urinary [18] and fecal [49] concentrations of *p*-cresol. This is related to the fact that undigested or partially digested alimentary, endogenous proteins and peptides are transferred from the small intestine to the large intestine where they are degraded by the microbiota proteases and peptidases which release free amino acids (including L-tyrosine) used for bacterial metabolism [3]. Conversely, the fecal excretion and concentration of *p*-cresol are diminished by a high resistant starch diet [2]. Thus, the amount and the nature of alimentary compounds can

* Correspondence to: INRA-AgroParisTech UMR 914 Nutrition Physiology and Ingestive Behavior, 16 rue Claude Bernard, F-75005 Paris, France
Fax: +33 1 44 08 18 58.

E-mail address: francois.blachier@agroparistech.fr (F. Blachier).

modify the luminal concentration of *p*-cresol. Interestingly, distinct urinary metabolic footprints were described in colorectal cancer (CRC) patients when compared with healthy counterparts with altered levels of metabolites derived from gut microbial-host co-metabolism. Among this panel of bacterial metabolites, *p*-cresol was selected as able to discriminate CRC subjects from their healthy counterparts [11].

Previous studies evaluating the genotoxicity of *p*-cresol reported divergent results depending on the cell types studied [10,17]. In addition, decreased cell proliferation together with increased reactive oxygen species production has been observed in endothelial and mononuclear cells treated with *p*-cresol [9].

p-Cresol is also well known to be a potential uremic toxin [23,39]. Indeed, in patients with chronic kidney disease (CKD), the accumulation of *p*-cresol and its metabolite *p*-cresyl-sulfate contributes to CKD-associated disorders [13,42]. Surprisingly there is a paucity of data on the effect of *p*-cresol on the colon epithelium even though this metabolite is present at high concentrations in the luminal content and is in vicinity to colonic epithelial cells [54].

In that context, the aim of the present study was to document the effects of *p*-cresol on colonic epithelial cells using the human colonic adenocarcinoma cells HT-29 Glc^{-/+} which have retained major metabolic characteristics of normal colonocytes [28]. We examined both the acute and longer-term effects of *p*-cresol on colonocytes, with emphasis on mitochondrial bioenergetics, cell proliferation, and genotoxic effects. In addition, we discussed the likely causal links between these different cellular parameters.

2. Materials and methods

2.1. Chemicals

All chemicals including *p*-cresol (99% pure) were obtained from Sigma (St. Louis, MO).

2.2. Cell culture and cell proliferation

The human adenocarcinoma cell line HT-29 Glc^{-/+} was established in permanent culture in 1975. HT29-Glc^{-/+} cells used in this study were selected by Zweibaum et al. from parental cells by growing them in a glucose-free medium for 36 passages, then leaving them to grow at 37 °C under 5% CO₂ atmosphere in Dulbecco's modified Eagle's medium (DMEM) supplemented with 10% (v/v) heat inactivated fetal bovine serum and containing 4 mM glutamine, 25 mM D-glucose. HT29-Glc^{-/+} cells were used between passages 37 and 65 (one passage every week) and were seeded at density of 2 × 10⁴ cells/cm² on day 0. The cells were cultured in six well plates or in T75 flasks without or with *p*-cresol freshly dissolved in the culture medium. The culture medium was changed every day.

For cell proliferation, cells were pretreated with or without *p*-cresol 0.2, 0.4, or 0.8 mM from day 3 to day 4 or from day 3 to day 7 after seeding. Then, the culture medium was recovered to count floating cells. Adherent cells were isolated using a phosphate-buffered saline (PBS) containing 1 g L⁻¹ EDTA and 0.25 g L⁻¹ trypsin and counted with a hemacytometer.

LS-174T human epithelial colorectal adenocarcinoma cells (ATCC No. CL-188) were grown in α MEM medium supplemented with 10% FBS.

2.3. Isolation of rat colonocytes

Colonic epithelial cells (colonocytes) were isolated as described [35] from Wistar Han 200–240 g rat colon (Harlan Laboratories Gannat, France). Briefly, the colon was removed and flushed

cleaned with NaCl 9 g L⁻¹ and then the colonocytes were isolated using the perfusion method with EDTA followed by hyaluronidase treatment. Colonocytes were maintained in DMEM medium up to oxygen consumption measurements.

2.4. Measurement of membrane integrity

The *in vitro* TOX7 toxicology assay kit (Sigma, St. Louis, MO) was used. After cell culture with or without *p*-cresol, the culture medium was recovered and centrifuged. Soluble LDH was measured in the supernatant (corresponding to LDH released from necrotic cells) and in the floating and adhering cells. Relative LDH activity was measured as percentages of total LDH activity.

2.5. Cell cycle distribution

Floating cells recovered in the culture medium and adherent cells recovered by trypsinization following treatment with *p*-cresol or butyrate (as positive control) were washed and incubated overnight with 70% ice-cold ethanol in PBS prior to staining with a propidium iodide solution (40 μ g mL⁻¹ PI) in PBS containing 50 μ g mL⁻¹ RNase A (30 min, 37 °C, in dark). The immunofluorescent staining of incorporated PI was measured on 20 × 10³ cells sorted with a FACSCalibur flow cytometer and analysis was performed using Cell Quest software [26]. FlowJo software was used to generate DNA content frequency histograms and to quantify the amount of cells in the individual cell cycle phases including sub-G0/G1 population.

2.6. Oxygen cell consumption

Oxygen consumption was measured by polarography (Oxygraph Hansatech Inst., Norfolk, UK) at 37 °C using a Clark-type electrode as described [1]. Control and cells pretreated with *p*-cresol were isolated and 5 × 10⁶ cells were resuspended in 1.5 mL air-saturated incubation mixture (20 mM Hepes buffer containing 200 mM mannitol, 5 mM KH₂PO₄, 2.5 mM MgCl₂, and 0.5 mM EGTA, pH 7.4, enriched with 0.1% bovine serum albumin) and placed in the oxygraph chamber for oxygen consumption measurement. Basal oxygen consumption (state 3) was measured in the absence of any exogenous agent. Uncoupled rate was determined after addition of the proton ionophore carbonyl cyanide 4-trifluoromethoxy phenyl hydrazone (FCCP 1.5 μ g mL⁻¹). The oxygen consumption due to the proton leak (state 4) was measured after the addition of the Fo/F1 ATPase inhibitor oligomycin (0.5 μ g mL⁻¹). For evaluating the acute effects of *p*-cresol on oxygen consumption, the compound was added as a single shot in the chamber of an oxygraph containing untreated cells.

2.7. Anion superoxide measurement

HT-29 Glc^{-/+} cells were seeded at a density of 2 × 10⁴ cells/cm² density on day 0. At day 3, cells were cultured without or with *p*-cresol. Then cells were isolated with trypsin, and floating and adhering cells were labeled using 5 μ M dihydroethidium (DHE, Molecular Probes, Eugene, OR) for 20 min at 37 °C in the dark to detect superoxide anion (O₂⁻) production. After washes with PBS, fluorescence emission of oxidized DHE was measured by flow cytometry [26]. Menadione (250 μ M, 20 min) was used as positive control. Superposition of control and menadione histograms allowed determination of the percentages of cells producing O₂⁻.

2.8. Genotoxicity measurement

For genotoxicity measurement, the γ H2AX (phosphorylated form of H2AX histone) In Cell Western (ICW) technique was performed as previously described [24]. Briefly, HT-29 Glc^{-/+} or

LS-174T colon epithelial cells were distributed in cell culture plate (36×10^3 cells, $200 \mu\text{L}/\text{well}$). Sixteen hours later, the cells were treated in serum-free medium containing *p*-cresol. For each plate, etoposide (Eto, $1 \mu\text{M}$) was used as a positive control. After 24 h of treatment, the cells were fixed in 4% paraformaldehyde. Paraformaldehyde was neutralized and cells were permeabilized with 0.2% Triton X-100 in PBS. Cells were blocked with MAXblock Blocking medium supplemented with phosphatase inhibitor PHOSTOP and RNase A, followed by 2 h incubation with rabbit monoclonal anti γH2AX (Clone 20E3, Cell Signaling) in PST buffer. Secondary detection was carried out using an infrared fluorescent dye conjugated to goat antibody with an absorption peak at 770 nm (CF770, Biotium). For DNA labeling, RedDot 2 (Biotium) was used in conjugation with the secondary antibody. After 1 h incubation, DNA and γH2AX were simultaneously visualized using an Odyssey infrared imaging scanner (LiCorScienceTec, Les Ulis, France). The relative fluorescence units from the scanning were used for quantitative analysis. For the determination of genotoxicity, relative fluorescent units for γH2AX per cell (as determined by γH2AX divided by DNA content) were divided by the respective controls (vehicle only) to determine the change in phosphorylation of H2AX levels compared with control. To determine relative cell count (RCC), the DNA content recorded in the different experiments was compared to the DNA content in control cells. Genotoxicity was considered positive when a compound produced a level of cytotoxicity below 50% and led to at least 1.3-fold γH2AX induction compared to the control.

2.9. Mitochondrial NADPH/NADH dehydrogenase activities

MTS is a MTT-like assay that is highly dependent on mitochondrial activity. The method is based on the reduction of MTS tetrazolium compound by viable cells to generate a colored formazan product that is soluble in cell culture media. This conversion is carried out by NAD(P)H-dependent dehydrogenase enzymes in metabolically active cells. MTS reduction is analyzed by a colorimetric assay to study mitochondrial dehydrogenase activity as a test of cytotoxicity. Cells were plated at density of 2×10^4 cells/cm² on day 0. At day 4, cells were cultured with *p*-cresol and then washed, and their ability to reduce MTS was evaluated by using the CellTiter 96 Aqueous assay according to the manufacturer's instructions (Promega, WI, USA). The absorbance at λ 490 nm was measured using a Multi-Mode microplate reader (Synergy HT, BioTek, and Sunrise, Tecan; respectively).

2.10. ATP cell content

The intracellular ATP content was measured using the CellTiter-Glo kit, which generates a luminescent signal proportional to the amount of ATP present in the assay [8]. Cells were plated at a density of 2×10^4

cells/cm² on day 0. At day 4, cells were incubated with *p*-cresol and ATP was assayed according to the manufacturer's instructions (Promega, WI, USA) with luminescence being measured using a Multi-Mode microplate reader. The ATP levels were normalized by the protein contents.

2.11. Data analysis

The results are expressed as mean value (\pm SEM). Statistical analysis was performed using the Student *t* test, ANOVA, and Tukey multiple-comparisons test when appropriate. Differences with *P* value < 0.05 were considered as statistically significant.

3. Results

3.1. Effect of *p*-cresol on HT-29 Glc^{-/+} cell proliferation

As indicated in Fig. 1A, when cells were cultured with increasing concentrations of *p*-cresol, the 0.8 mM concentration markedly and significantly decreased the number of adherent cells both after 1 and 4 days treatment when compared with the control experiment (without *p*-cresol). This *p*-cresol concentration was in addition able to modestly increase the amount of floating cells in the incubation medium after 4 days treatment but not after 1 day treatment (Fig. 1B). When comparing the respective number of adhering vs floating cells (Figs. 1A and B), it appears that the marked reduction of cell growth due to 0.8 mM *p*-cresol is only very partly due to cell detachment.

3.2. Effect of *p*-cresol on HT-29 Glc^{-/+} cell viability

As shown in Fig. 2, when the cells were cultured for 2 days in the presence of 0.8 mM *p*-cresol, and in good accordance with the results obtained in the experiments related to cell proliferation, this treatment slightly but significantly decreases the number of adherent cells and accordingly increased the number of floating cells in the incubation medium. However, the percentage of free LDH activity in the incubation medium, which is an indicator of cell necrosis, was not modified by *p*-cresol, whatever the concentration used (Fig. 2). When a higher *p*-cresol concentration (1.6 mM) was used, the results were superimposable with the results obtained using 0.8 mM *p*-cresol (Fig. 2). The highest concentration tested (3.2 mM) did not provoke cell necrosis even though it slightly increased the number of floating cells in the culture medium (Fig. 2).

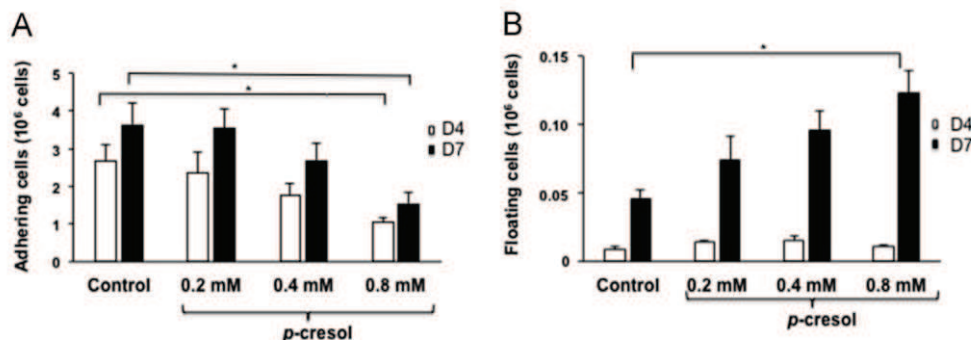

Fig. 1. Effects of *p*-cresol on HT-29 Glc^{-/+} cell proliferation and adhesion. Three days after cell seeding, the cells were cultured without (control) or with increasing concentrations of *p*-cresol for 1 and 4 days with the culture medium changed every day. Adhering (A) and floating cells (B) were measured at day 4 (1 day treatment) and at day 7 (4 days treatment). The results (mean \pm SEM) were obtained from 5 independent experiments. * Indicates significantly different values ($P < 0.05$).

3.3. Effect of *p*-cresol on HT-29 Glc^{-/+} cell cycle

As indicated in Fig. 3, when *p*-cresol was added at increasing doses in the incubation medium, the 0.8 mM concentration was able after 1 and 2 days of treatment to provoke a marked accumulation of the HT-29 Glc^{-/+} cells in the S-cell cycle phase and a decrease of the relative number of HT-29 Glc^{-/+} cells in the G0/G1 phase. The relative amount of cells in the subdiploid G1 peak, characteristic of cells undergoing nuclear fragmentation, was not modified by the treatment with 0.8 mM *p*-cresol (Fig. 3). When 10 mM butyrate was used as a positive control, the amount of cells in the S phase decreased, as expected, after 1 day treatment while after 2 days treatment, butyrate increased the number of apoptotic cells (Fig. 3).

3.4. Acute effect of *p*-cresol on HT-29 Glc^{-/+} cell oxygen consumption

As shown in Fig. 4A, when *p*-cresol was added at 0.8 mM concentration to the HT-29 Glc^{-/+} cells isolated 4 days after seeding, it decreased the state 3 basal cell oxygen consumption.

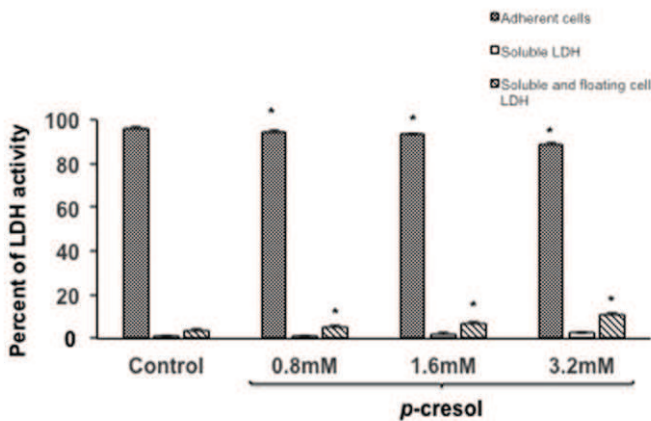

Fig. 2. Effects of *p*-cresol on HT-29 Glc^{-/+} cell viability. Three days after cell seeding, the cells were cultured without (control) or with increasing concentration of *p*-cresol for 2 days with the culture medium changed every day. The LDH activity was measured in adherent cells, in the culture medium, and in the floating cells. The results (mean \pm SEM) were obtained from 6 independent experiments. * indicates significantly different values between controls and matched groups ($P < 0.05$).

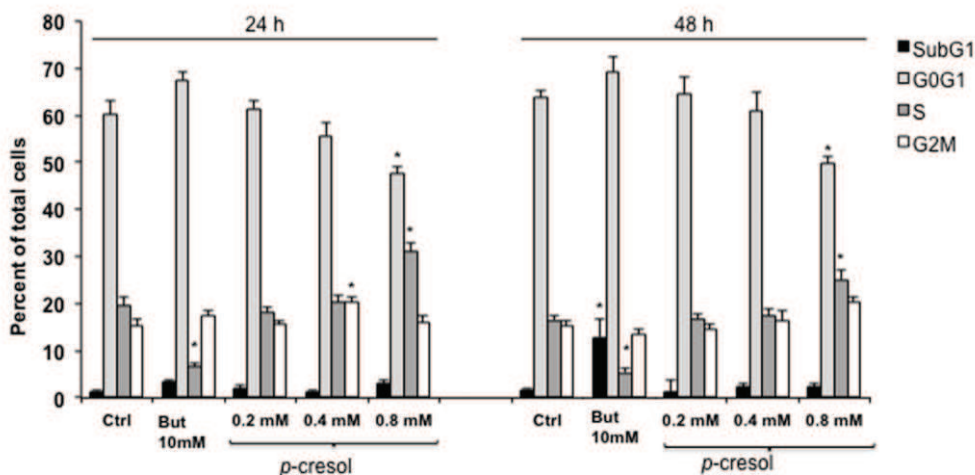

Fig. 3. Effects of *p*-cresol on HT-29 Glc^{-/+} cell distribution in the cell cycle phases. Three days after cell seeding, cells were cultured without (control) or with increasing concentrations of *p*-cresol added to the culture medium for 1 (24 h) or 2 (48 h) days, with the culture media changed every day. Adherent and floating cells were pooled together and stained with PI before cell cycle analysis by flow cytometry. A positive control was done in the presence of 10 mM butyrate. The results (mean \pm SEM) were obtained from 6 independent experiments. * indicates significantly different values compared to control group ($P < 0.05$).

No reversion of oxygen consumption back to the basal value was observed up to the longest time tested (10 min, data not shown). When *p*-cresol was used at 1.6 and 3.2 mM, the inhibition of oxygen consumption was not vastly different when compared with the effect recorded at 0.8 mM *p*-cresol (Fig. 4A). When the same experiments were performed using HT-29 Glc^{-/+} cells isolated 7 days after seeding, the inhibitory effect of *p*-cresol was similar to the effect recorded with cells isolated at day 4 (Fig. 4B), indicating that the acute *p*-cresol effect on HT-29 Glc^{-/+} cells is not dependent on the duration of the cell culture after seeding.

When the cells were isolated 7 days after seeding and cell oxygen consumption was measured either in the sole presence of the Fo/F1 ATPase inhibitor oligomycin or in the presence of 1.6 mM *p*-cresol and oligomycin, if the cell oxygen consumption is expressed in percentages of the basal state 3 oxygen consumption (no agent added), we found no significant difference between the percentage calculated in the sole presence of oligomycin (44.4% \pm 3.1 of the state 3, $n=10$) and the percentage calculated in the presence of *p*-cresol and oligomycin (56.6% \pm 7.3 of the state 3, $n=10$, data not shown) indicating that *p*-cresol had no immediate uncoupling effect in acute experiments. Likewise, when the cell oxygen consumption was measured either in the sole presence of the uncoupler FCCP or in the presence of 1.6 mM *p*-cresol and FCCP, and expressed in percentages of the basal state 3 oxygen consumption, we found no significant difference between the percentage calculated in the sole presence of FCCP (300.6% \pm 10.7 of the state 3, $n=10$) and the percentage calculated in the presence of *p*-cresol and FCCP (263.6% \pm 30.4 of the state 3, $n=10$, data not shown), indicating that *p*-cresol did not increase the maximal respiratory rate in acute experiments.

When *p*-cresol was added on isolated rat normal colonocytes at the intermediate concentration (1.6 mM), it also decreased cellular state 3 oxygen consumption (Fig. 4C), confirming the results obtained with the HT-29 Glc^{-/+} cell model.

3.5. Effect of *p*-cresol pretreatment on HT-29 Glc^{-/+} cell oxygen consumption

As indicated in Fig. 5A, when HT-29 Glc^{-/+} cells were pretreated for 1 day in the presence of 0.8 mM *p*-cresol, and then isolated for measurement of oxygen consumption under different experimental conditions, the state 3 basal oxygen consumption was significantly increased. When the same experiment was done in the presence of

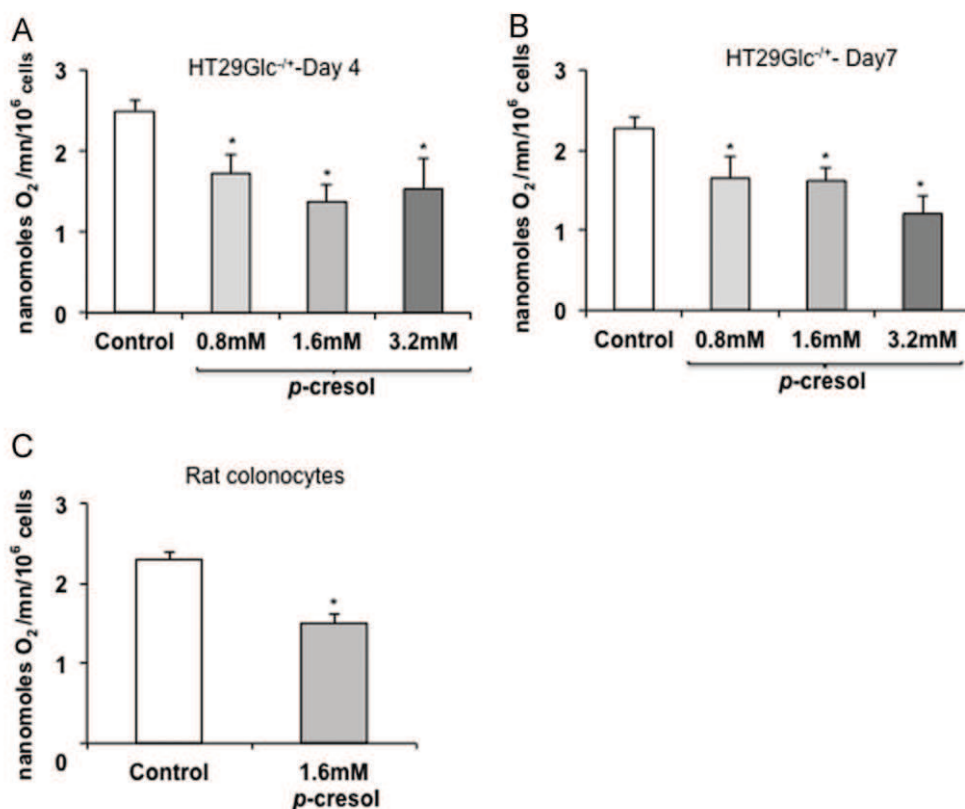

Fig. 4. Effects of acute treatment with *p*-cresol on HT-29 Glc^{+/+} cell oxygen consumption. Four days (A) or 7 days (B) after seeding, cells were isolated and used for O₂ consumption measurements. Rate of oxygen consumption was measured first without any exogenous compound (state 3) which corresponds to the basal oxygen consumption (control). Then a single shot of increasing concentration of *p*-cresol was added and oxygen consumption rate was measured after respiration stabilization. Rat colonocytes were isolated and incubated in the presence of the intermediate concentration of *p*-cresol 1.6 mM (C). The results (mean ± SEM) were obtained from at least 7 independent experiments. * indicates significantly different values between control and matched groups ($P < 0.05$).

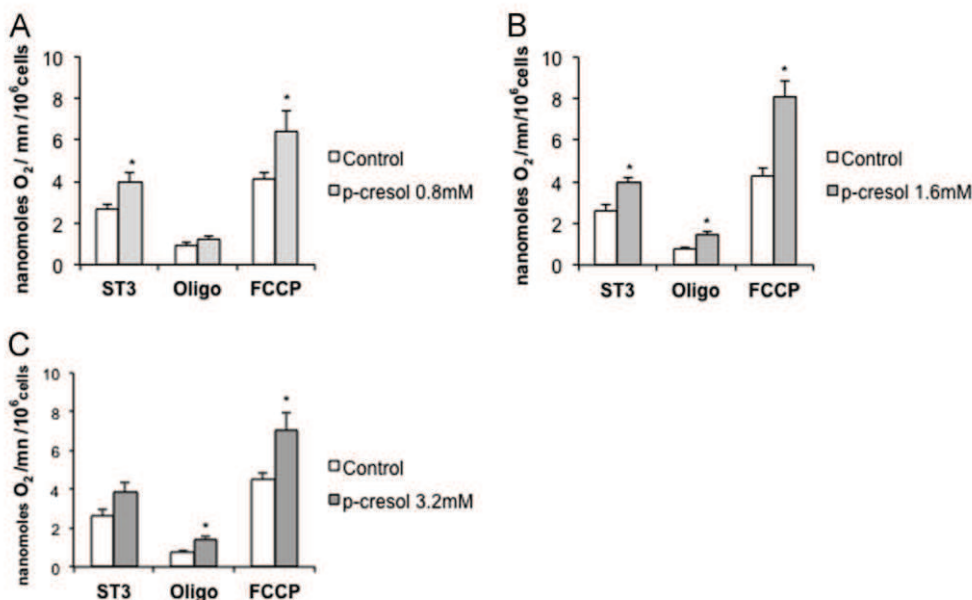

Fig. 5. Effects of *p*-cresol pretreatment on HT-29 Glc^{+/+} cell oxygen consumption. Three days after cell seeding, cells were cultured for 1 day without (control) or with 0.8 mM (A), 1.6 mM (B), and 3.2 mM *p*-cresol (C) and the cells were then isolated for oxygen consumption measurement first without any exogenous agent (state 3 (ST3)) and after addition of the Fo/F1 ATPase inhibitor oligomycin (Oligo) or the uncoupler FCCP. The results (mean ± SEM) were obtained from at least 7 independent experiments. * indicates significantly different values between control and matched groups ($P < 0.05$).

the uncoupling agent FCCP, a significant increase of the oxygen consumption was also observed, indicating an increase of the maximal oxygen consumption capacity in the mitochondrial respiratory chain. In the presence of the inhibitor of Fo/F1 ATPase oligomycin, the oxygen consumption was not different between the cells treated with

p-cresol and the control untreated cells, indicating a similar proton leak in both experimental situations.

When the HT-29 Glc^{+/+} cells were pretreated for 1 day with a higher *p*-cresol concentration (1.6 mM, see Fig. 5B), as for the 0.8 mM concentration, we observed an increase of oxygen

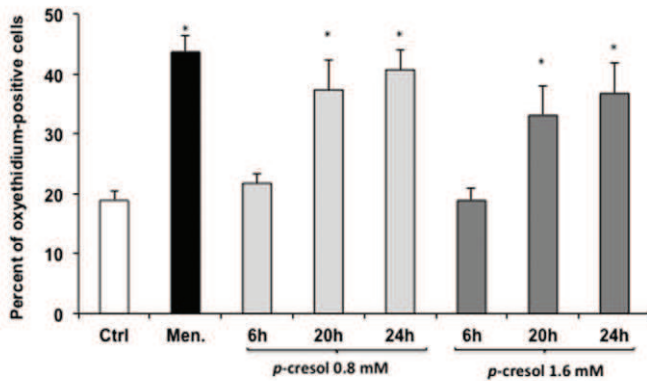

Fig. 6. Effects of *p*-cresol pretreatment on HT-29 $\text{Glc}^{-/+}$ cell anion superoxide production. Three days after cell seeding, cells were cultured for 6, 20, and 24 h without (control) or with *p*-cresol, and cells were then isolated and labeled with dihydroethidium for the measurement of oxyethidium fluorescence emission by flow cytometry. The prooxidant Menadione (Men., 250 μM , 20 min) was used as positive control. The results (mean \pm SEM) were obtained from 6 independent experiments. * indicates significantly different values ($P < 0.05$) compared to control group.

consumption both in the basal (state 3) condition and in the uncoupled situation. Moreover, we observed a significant increase of the oxygen consumption measured in the presence of oligomycin. This indicates that the mitochondria of the HT-29 $\text{Glc}^{-/+}$ cells pretreated with 1.6 mM *p*-cresol are markedly less coupled compared to mitochondria from untreated cells. When the cells were treated for 1 day with the 3.2 mM concentration, the results were almost identical to the results obtained using the 1.6 mM concentration (Fig. 5C).

3.6. Effects of *p*-cresol pretreatment on HT-29 $\text{Glc}^{-/+}$ cell anion superoxide production

When the cells were incubated with 0.8 mM *p*-cresol, the production of anion superoxide significantly increased after 20 and 24 h of treatment but not after 6 h (Fig. 6). Using a higher concentration of *p*-cresol (1.6 mM) did not further increase the anion superoxide production.

3.7. Genotoxic effects of *p*-cresol on colon epithelial cell lines

Because anion superoxide production may act as genotoxic compounds, we measured with the γH2AX ICW assay, the genotoxic potential of *p*-cresol on HT-29 $\text{Glc}^{-/+}$ cells. We found that 24 h *p*-cresol treatment dose dependently induced the phosphorylation of the H2AX histone, indicating that *p*-cresol induced DNA damage (Fig. 7A). This effect was statistically significant from 1.5 mM concentration of *p*-cresol and above on HT-29 $\text{Glc}^{-/+}$ cells (Fig. 7A). Similar results were obtained using another human colon epithelial cell line, that is, LS-174T cells (Fig. 7B). The genotoxic effect of *p*-cresol was not related to any cytotoxic effect of this compound (Figs. 7A and B).

3.8. Effects of *p*-cresol pretreatment on mitochondrial NADPH/NADH dehydrogenase activities

By using the MTS assay, we found that the treatment of cells for 1 and 2 days with 3.2 mM *p*-cresol decreased the mitochondrial NADPH/NADH dehydrogenase activities when compared with control experiments (no *p*-cresol, see Figs. 8A and B). A lower concentration of *p*-cresol (1.6 mM) has an effect on this parameter only after 2 days of treatment.

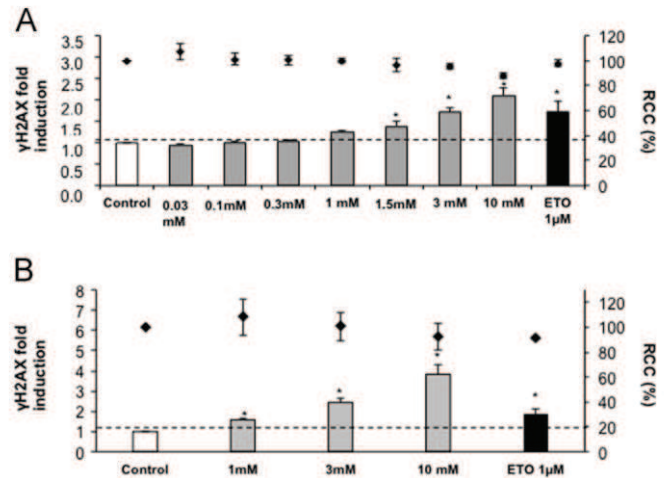

Fig. 7. Genotoxic effects of *p*-cresol on colon epithelial cell lines. HT-29 $\text{Glc}^{-/+}$ cells (A) or LS-174T (B) were cultured for 24 h with vehicle only (control), etoposide (Eto, positive control), or with increasing concentrations of *p*-cresol. The γH2AX ICW assay was used to quantify DNA damage (left Y axis) and cytotoxicity (right Y axis). The results are expressed as fold change for H2AX phosphorylation compared to negative control (histogram) and relative cell count (RCC, individual points) expressed as % of control cell DNA content. The results (mean \pm SEM) were obtained from at least 3 independent experiments in duplicate. * indicates values significantly different compared to negative control ($P < 0.05$).

3.9. Effects of *p*-cresol pretreatment on HT-29 $\text{Glc}^{-/+}$ cell ATP content

As indicated on Figs. 9A to C, although 0.8, 1.6, and 3.2 mM *p*-cresol had no effect on the intracellular concentration of ATP after 1 (A) and 2 day treatment (B), a decrease was clearly visible after 3 days of treatment (C).

4. Discussion

Our work with the human colonocytes HT-29 $\text{Glc}^{-/+}$ cell shows that a single shot of *p*-cresol at a moderate concentration (0.8 mM) decreased within minutes the cell oxygen consumption. Using rat isolated colonocytes which can be maintained viable for 1 h, we found that normal colonic epithelial cells are also sensitive to *p*-cresol for their respiration, thus validating the HT-29 $\text{Glc}^{-/+}$ cell model for such study.

In response to the pretreatment with 0.8 mM *p*-cresol, the HT-29 $\text{Glc}^{-/+}$ cells were found to increase their state 3 basal oxygen consumption and their maximal respiratory rate within 1 day. The maximal rate of electron transfer through the mitochondrial respiratory chain is revealed by the maximal oxygen consumption observed in the presence of the respiratory uncoupler FCCP. The increase of the basal and maximal respiratory rate likely corresponds to an attempt of the cells to counteract the effect of *p*-cresol on the cell respiration [33]. This most likely corresponds to a cell adaptation to the pretreatment with *p*-cresol since *p*-cresol did not increase the maximal respiratory rate in acute experiments.

However, despite this latter attempt, we measured in the meantime a decrease of HT-29 $\text{Glc}^{-/+}$ colonocyte proliferation, detectable within 1 day, which coincided with an accumulation of cells in the S-phase cell cycle and with some minor cell detachment. Reduced proliferation rate may be considered as an adaptive response to the impaired ATP synthesis in case of partial inhibition of respiration, allowing maintenance of cell integrity [29]. Indeed, a decrease in ATP cell content is associated and used as an indicator of cell necrosis [52]. Buttgerit and Brand documented that in mammalian cells, macromolecule biosynthesis is very sensitive to energy supply with a rate of protein and

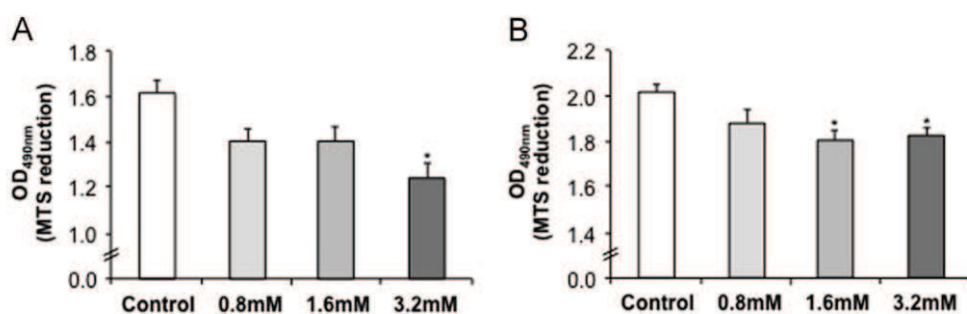

Fig. 8. Effects of *p*-cresol pretreatment on mitochondrial NADPH/NADH deshydrogenase activities. Three days after cell seeding, HT-29 Glc^{+/+} cells were cultured for 1 (A) and 2 days (B) without (control) or with increasing concentrations of *p*-cresol with the culture medium changed every day. Then the cells were tested for their mitochondrial NADPH/NADH deshydrogenase activities by using the MTS test. The results (mean ± SEM) were obtained from 3 independent experiments in quadruplicates. * indicates significantly different values ($P < 0.05$).

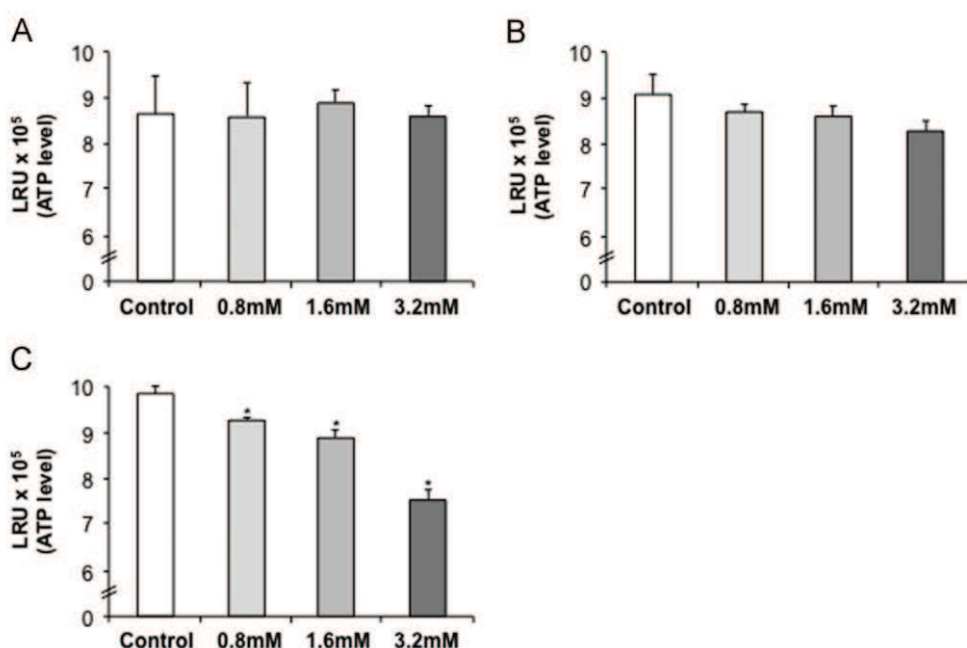

Fig. 9. Effects of *p*-cresol pretreatment on the ATP HT-29 Glc^{+/+} cell content. Three days after cell seeding, cells were cultured for 1 (A), 2 (B), and 3 days (C) without (control) or with increasing concentrations of *p*-cresol with the culture medium changed every day. Then the cells were tested for their intracellular ATP content. The results (mean ± SEM) were obtained from 3 independent experiments in quadruplicates. * indicates significantly different values ($P < 0.05$).

polynucleotide synthesis decreasing to 40% when the respiration is inhibited by 30% [6]. As a matter of fact, HT-29 Glc^{+/+} cells maintained up to 3 days of treatment with *p*-cresol a constant ATP intracellular content and showed no sign of cell necrosis nor apoptosis.

Following pretreatment with 0.8 mM *p*-cresol, an increased production of anion superoxide by the HT-29 Glc^{+/+} cells was measured after 20 h but not after 6 h treatment with *p*-cresol, indicating a lag period for cellular response to the treatment. In most eukaryotic cell types, anion superoxide are produced mainly (but not exclusively) at the mitochondrial complex I and III level in the course of oxidative phosphorylation, particularly in situations of mitochondrial complex activity inhibition [7,15,16,22,38,50,51]. The rate of mitochondrial anion superoxide production is dependent on the metabolic state of the mitochondria. Higher production can be explained by an increased proportion of the respiratory chain components in their reduced state and by a longer life duration of some intermediates involved in proton transfer like ubiquinone [16]. Then, we propose that the effect of *p*-cresol on the production of anion superoxide corresponds, at least partly, to an effect of this compound on the redox state and/or life duration of some intermediates of the mitochondrial respiratory chain. In other words, the acute effect of *p*-cresol toward

colonocytes is an inhibition of the respiration while the longer-term effect of this bacterial metabolite may involve the modified redox state of respiratory chain element(s). Interestingly, it has been shown [25,36] that *p*-cresol affects NAD- and succinate-linked respiration in liver mitochondria, and the inhibitory effect of *p*-cresol on the NAD-linked respiration was found to be stronger than those on the succinate-linked respiration, with little effect on the P/O ratio in liver mitochondria using glutamate or succinate as oxidative substrates. These results indicate that liver mitochondria are likely one of the targets for the hepatotoxic actions of *p*-cresol. Further experiments outside of the scope of this study are necessary to further decipher the mechanisms involved in the acute and longer-term effects of *p*-cresol, notably on the different mitochondrial complexes in colonic epithelial cells.

When higher concentrations of *p*-cresol were used (1.6 and 3.2 mM), interestingly we also observed after 1 day pretreatment, in addition to the effects documented with the 0.8 mM concentration, an increased cell oxygen consumption in the presence of the Fo/F1 ATPase inhibitor oligomycin. This result demonstrates that these *p*-cresol concentrations lead to an increase of the mitochondrial proton leak, an increase which favors mitochondrial uncoupling between oxygen consumption and ATP synthesis. Once again, this most likely corresponds to a cell adaptation to the

presence of *p*-cresol for 1 day since *p*-cresol did not increase the proton leak in acute experiments.

A mild uncoupling is considered as a way to speed up the respiratory chain and then to reduce the production of superoxide anion [34,43,47]. However, this mild uncoupling observed after pretreatment with 1.6 mM *p*-cresol did not coincide with any marked reduction of anion superoxide production when compared with the production measured with a lower concentration (0.8 mM) with no uncoupling effect, thus questioning the efficiency of uncoupling for such a purpose. In addition, decreased cellular bioenergetic performance is known to represent a price to be paid for uncoupling. Indeed, in that case, the protons are transferred from the mitochondrial intermembrane space to the matrix without ATP synthesis through the Fo/F1 ATPase.

Respiratory coupling in cells restricts the cellular respiration to a rate matching the ATP turnover. The consequence of the inhibition of cell respiration and of mitochondrial uncoupling, in terms of ATP intracellular content, was not immediate but was clearly visible after 3 days treatment at a time when presumably, despite decreased proliferation rate, the ATP synthesis does not meet anymore the ATP consumption by the colonic epithelial cells.

Regarding the important point of the genotoxic effect of *p*-cresol on colonocytes, our data show that after 1 day treatment, there was a dose-related induction of DNA damage by *p*-cresol in colonocytes as recorded by the γ H2AX ICW assay on HT-29 Glc^{-/+} cells and also on LS-174T human colonic epithelial cells. Increased reactive oxygen species production is often considered to be associated with genomic DNA damage [32,48,53]. However, our data showing that the dose-dependent genotoxic effect of *p*-cresol can be dissociated from the effect on anion superoxide production suggest that the damaging effect of *p*-cresol on the colonocyte DNA may involve other unknown pathways than oxidative stress, maybe, for instance, following *p*-cresol bioactivation in colonocytes. Importantly, our study is the first to evaluate the genotoxicity of this bacterial metabolite toward colonocytes. As those cells are directly facing the large intestine lumen where *p*-cresol is produced, they are probably the most exposed cells of the body to this bacterial metabolite. Importantly, positive correlation between DNA damage in colonocytes and *p*-cresol concentration in the large intestine content has been described in rats fed with varying levels of protein [49,54].

From our data, it appears that *p*-cresol can be considered both as a metabolic troublemaker and as a genotoxic luminal bacterial metabolite toward colonic epithelial cells. Limitations of this study are related to (i) the imprecision regarding the true luminal concentration of the unbound form of *p*-cresol in the immediate vicinity of the colonic epithelial cells (notably near the pluripotent stem cells located at the bottom of the crypt [37], a parameter difficult to assess for technical reasons; and (ii) to the unknown capacity of *p*-cresol to diffuse, according to its luminal concentration, across the mucous layer covering the epithelial cells [37]. Regarding this latter point, the fact that *p*-cresol is largely absorbed through the large intestine epithelium and excreted in the urine indicates that the passage of this compound across the mucous layer is efficient.

With these reservations in mind, the present study and previous ones indicate that the colon epithelial layer is facing a luminal content characterized by the presence of deleterious compounds, including *p*-cresol, when present in excess [20]. Indeed, we previously reported that other amino acid-derived bacterial metabolites, including hydrogen sulfide [5] and ammonia [1], act at excessive luminal concentrations as inhibitors of colonocyte respiration. In a context of a mean protein consumption largely above the recommended daily amount in industrialized countries [14,40,44] and taking into account that the increased protein consumption increases the *p*-cresol fecal concentration [49] our study showing that *p*-cresol is both a genotoxic agent and a metabolic troublemaker in human colonocytes calls for further studies regarding the potential impact of long-term increased luminal

concentration of *p*-cresol in the course of colorectal carcinogenesis [30]. Indeed, the identification of luminal compounds with deleterious effects on the process of colonic epithelium renewal associated with genotoxic effects, and finally loss of epithelial homeostasis, appears to represent an important step in the understanding of the relationship between the modifications of the colonocyte luminal environment and the preneoplastic and neoplastic processes.

In conclusion, our study represents a new contribution on the effects of bacterial metabolites on colonocytes. We show that *p*-cresol acts in acute exposure as a metabolic troublemaker inhibiting cell respiration. At 0.8 mM concentration, *p*-cresol pretreatment, despite a mobilization of the “respiratory reserve,” decreases cell proliferation but maintains the ATP intracellular content and the cell viability. At a higher concentration, *p*-cresol pretreatment increases proton leak through the mitochondrial inner membrane, resulting in decreased bioenergetics performance and finally decreased ATP intracellular content. At these concentrations, *p*-cresol is genotoxic for colonocytes reinforcing the view that *p*-cresol at excessive concentration is deleterious for these cells.

Author disclosure statement

No competing financial interest exists.

Acknowledgments

The authors thank the European Commission (project My New Gut, Grant Agreement No. 613979), ECOS-SUD (France/Chile project C12SO1), and Conicyt Chile (Grant Fondecyt 1120290), INRA, AgroParisTech, the Chinese Academy of Sciences (Grant 2013 T2 S0014), and the French Embassy in Japan for their financial supports.

References

- [1] Andriamihaja, M.; Davila, A. M.; Eklou-Lawson, M.; Petit, N.; Delpal, S.; Allek, F.; Blais, A.; Delteil, C.; Tome, D.; Blachier, F. Colon luminal content and epithelial cell morphology are markedly modified in rats fed with a high-protein diet. *Am. J. Physiol. Gastrointest. Liver Physiol.* **299**:G1030–G1037; 2010.
- [2] Birkett, A.; Muir, J.; Phillips, J.; Jones, G.; O’Dea, K. Resistant starch lowers fecal concentrations of ammonia and phenols in humans. *Am. J. Clin. Nutr.* **63**:766–772; 1996.
- [3] Blachier, F.; Mariotti, F.; Huneau, JF; Tome, D. Effects of amino acid-derived luminal metabolites on the colonic epithelium and physiopathological consequences. *Amino Acids* **33**:547–562; 2007.
- [4] Bone, E.; Tamm, A.; Hill, M. The production of urinary phenols by gut bacteria and their possible role in the causation of large bowel cancer. *Am. J. Clin. Nutr.* **29**:1448–1454; 1976.
- [5] Bouillaud, F.; Blachier, F. Mitochondria and sulfide: a very old story of poisoning, feeding, and signaling? *Antioxid. Redox Signal.* **15**:379–391; 2011.
- [6] Buttgerit, F.; Brand, MD. A hierarchy of ATP-consuming processes in mammalian cells. *Biochem. J.* **312**:163–167; 1995. Pt 1.
- [7] Cadenas E, DK. Mitochondrial free radical generation, oxidative stress, and aging. *Free Radic. Biol. Med.* **29**:222–230; 2000.
- [8] Carrasco-Pozo, C.; Mizgier, ML; Speisky, H; Gotteland, M. Differential protective effects of quercetin, resveratrol, rutin and epigallocatechin gallate against mitochondrial dysfunction induced by indomethacin in Caco-2 cells. *Chem. Biol. Interact.* **195**:199–205; 2012.
- [9] Chang, MC; Chang, HH; Chan, CP; Yeung, SY; Hsien, HC; Lin, BR; Yeh, CY; Tseng, WY; Tseng, SK; Jeng, JH. *p*-Cresol affects reactive oxygen species generation, cell cycle arrest, cytotoxicity and inflammation/atherosclerosis-related modulators production in endothelial cells and mononuclear cells. *PLoS One* **9**:e114446; 2014.
- [10] Cheng, M; Kligerman, AD. Evaluation of the genotoxicity of cresols using sister-chromatid exchange (SCE). *Mutat. Res.* **137**:51–55; 1984.
- [11] Cheng, Y; Xie, G; Chen, T; Qiu, Y; Zou, X; Zheng, M; Tan, B; Feng, B; Dong, T; He, P; Zhao, L; Zhao, A; Xu, LX; Zhang, Y; Jia, W. Distinct urinary metabolic profile of human colorectal cancer. *J. Proteome Res.* **11**:1354–1363; 2012.
- [12] Davila, AM; Blachier, F; Gotteland, M; Andriamihaja, M; Benetti, PH; Sanz, Y; Tome, D. Intestinal luminal nitrogen metabolism: role of the gut microbiota and consequences for the host. *Pharmacol. Res.* **68**:95–107; 2013.
- [13] Dou, L; Bertrand, E; Cerini, C; Faure, V; Sampol, J; Vanholder, R; Berland, Y; Brunet, P. The uremic solutes *p*-cresol and indoxyl sulfate inhibit endothelial proliferation and wound repair. *Kidney Int.* **65**:442–451; 2004.

- [14] Dubuisson, C; Lioret, S; Touvier, M; Dufour, A; Calamassi-Tran, G; Volatier, JL; Lafay, L. Trends in food and nutritional intakes of French adults from 1999 to 2007: results from the INCA surveys. *Br. J. Nutr.* **103**:1035–1048; 2010.
- [15] Dupre-Crochet, S; Erard, M; Nubetae, O. ROS production in phagocytes: why, when, and where? *J. Leukoc. Biol.* **94**:657–670; 2013.
- [16] Figueira, TR BM; Camargo, AA; Castilho, RF; Ferreira, JC; Kowaltowski, AJ; Sluse, FE; Souza-Pinto, NC; Vercesi, AE. Mitochondria as a source of reactive oxygen and nitrogen species: from molecular mechanisms to human health. *Antioxid. Redox Signal.* **16**:2029–2074; 2013.
- [17] Gaikwad, NW; Bodell, WJ. Formation of DNA adducts in HL-60 cells treated with the toluene metabolite *p*-cresol: a potential biomarker for toluene exposure. *Chem. Biol. Interact.* **145**:149–158; 2003.
- [18] Geypens, B; Claus, D; Evenepoel, P; Hiele, M; Maes, B; Peeters, M; Rutgeerts, P; Ghos, Y. Influence of dietary protein supplements on the formation of bacterial metabolites in the colon. *Gut* **41**:70–76; 1997.
- [19] Gostner, A; Blaut, M; Schaffer, V; Kozianski, G; Theis, S; Klingenberg, M; Dombrowski, Y; Martin, D; Ehrhardt, S; Taras, D; Schwierz, A; Kleessen, B; Luhrs, H; Schaubert, J; Dorbath, D; Menzel, T; Scheppach, W. Effect of isomalt consumption on faecal microflora and colonic metabolism in healthy volunteers. *Br. J. Nutr.* **95**:40–50; 2006.
- [20] Hamer, HM; De Preter, V; Windey, K; Verbeke, K. Functional analysis of colonic bacterial metabolism: relevant to health? *Am. J. Physiol. Gastrointest. Liver Physiol.* **302**:G1–G9; 2012.
- [21] Hughes, R; Magee, EA; Bingham, S. Protein degradation in the large intestine: relevance to colorectal cancer. *Curr. Issues Intest. Microbiol.* **1**:51–58; 2000.
- [22] Kamizato, M NK; Masuda, K; Takeo, K; Yamamoto, Y; Kawai, T; Teshima-Kondo, S; Tanahashi, T; Rokutan, K. Interleukin 10 inhibits interferon gamma-and tumor necrosis alpha-stimulated activation of NADPH oxidase 1 in human colonic epithelial cells and the mouse colon. *J. Gastroenterol.* **12**:1172–1184; 2009.
- [23] Ketteler, M. Kidney failure and the gut: *p*-cresol and the dangers from within. *Kidney Int.* **69**:952–953; 2006.
- [24] Khoury, L; Zalko, D; Audebert, M. Validation of high-throughput genotoxicity assay screening using gammaH2AX in-cell western assay on HepG2 cells. *Environ. Mol. Mutagen.* **54**:737–746; 2013.
- [25] Kitagawa, A. Effects of cresols (*o*-, *m*-, and *p*-isomers) on the bioenergetic system in isolated rat liver mitochondria. *Drug Chem. Toxicol.* **24**:39–47; 2001.
- [26] Lan, A; Lagadic-Gossmann, D; Lemaire, C; Brenner, C; Jan, G. Acidic extracellular pH shifts colorectal cancer cell death from apoptosis to necrosis upon exposure to propionate and acetate, major end-products of the human probiotic propionibacteria. *Apoptosis* **12**:573–591; 2007.
- [27] Lecerf, JM; Depeint, F; Clerc, E; Dugenet, Y; Niamba, CN; Rhazi, L; Cayzele, A; Abdelnour, G; Jaruga, A; Younes, H; Jacobs, H; Lambrey, G; Abdelnour, AM; Poullart, PR. Xylo-oligosaccharide (XOS) in combination with inulin modulates both the intestinal environment and immune status in healthy subjects, while XOS alone only shows prebiotic properties. *Br. J. Nutr.* **108**:1847–1858; 2012.
- [28] Leschelle, X; Delpal, S; Goubern, M; Blottiere, HM; Blachier, F. Butyrate metabolism upstream and downstream acetyl-CoA synthesis and growth control of human colon carcinoma cells. *Eur. J. Biochem.* **267**:6435–6442; 2000.
- [29] Leschelle, X; Goubern, M; Andriamihaja, M; Blottiere, HM; Couplan, E; Gonzalez-Barroso, MD; Petit, C; Pagniez, A; Chaumontet, C; Mignotte, B; Bouillaud, F; Blachier, F. Adaptive metabolic response of human colonic epithelial cells to the adverse effects of the luminal compound sulfide. *Biochim. Biophys. Acta* **1725**:201–212; 2005.
- [30] Louis, P; Hold, GL; Flint, HJ. The gut microbiota, bacterial metabolites and colorectal cancer. *Nat. Rev. Microbiol.* **12**:661–672; 2014.
- [31] Macfarlane, GT; Macfarlane, S. Human colonic microbiota: ecology, physiology and metabolic potential of intestinal bacteria. *Scand. J. Gastroenterol. Suppl.* **222**:3–9; 1997.
- [32] Meira, LB BJ; Green, SL; Lee, CW; Pang, B; Borenshtein, D; Rickman, BH; Rogers, AB; Moroski-Erkul, CA; MacFaline, JL; Schauer, DB; Dedon, PC; Fox, JG; Samson, LD. DNA damage induced by chronic inflammation contributes to colon carcinogenesis. *J. Clin. Invest.* **7**:2516–2525; 2008.
- [33] Mimoun, S; Andriamihaja, M; Chaumontet, C; Atanasiu, C; Benamouzig, R; Blouin, JM; Tome, D; Bouillaud, F; Blachier, F. Detoxification of H(2)S by differentiated colonic epithelial cells: implication of the sulfide oxidizing unit and of the cell respiratory capacity. *Antioxid. Redox Signal.* **17**:1–10; 2012.
- [34] Miwa, S; Brand, MD. Mitochondrial matrix reactive oxygen species production is very sensitive to mild uncoupling. *Biochem. Soc. Trans.* **31**:1300–1301; 2003.
- [35] Mouille, B; Robert, V; Blachier, F. Adaptive increase of ornithine production and decrease of ammonia metabolism in rat colonocytes after hyperproteic diet ingestion. *Am. J. Physiol. Gastrointest. Liver Physiol.* **287**:G344–G351; 2004.
- [36] Mutsaers, HA; Wilmer, MJ; Reijnders, D; Jansen, J; van den Broek, PH; Forkink, M; Schepers, E; Glorieux, G; Vanholder, R; van den Heuvel, LP; Hoenderop, JG; Masereeuw, R. Uremic toxins inhibit renal metabolic capacity through interference with glucuronidation and mitochondrial respiration. *Biochim. Biophys. Acta* **1832**:142–150; 2013.
- [37] Radtke, F; Clevers, H. Self-renewal and cancer of the gut: two sides of a coin. *Science* **307**:1904–1909; 2005.
- [38] Raha, S; Robinson, BH. Mitochondria, oxygen free radicals, disease and ageing. *Trends Biochem. Sci.* **25**:502–508; 2000.
- [39] Ramezani, A; Raj, DS. The gut microbiome, kidney disease, and targeted interventions. *J. Am. Soc. Nephrol.* **25**:657–670; 2014.
- [40] Rand, WM; Pellett, PL; Young, VR. Meta-analysis of nitrogen balance studies for estimating protein requirements in healthy adults. *Am. J. Clin. Nutr.* **77**:109–127; 2003.
- [41] Schmidt, EG. Urinary phenols: the simultaneous determination of phenol and *p*-cresol in urine. *J. Biol. Chem.* **179**:211–215; 1949.
- [42] Shiba, T; Kawakami, K; Sasaki, T; Makino, I; Kato, I; Kobayashi, T; Uchida, K; Kaneko, K. Effects of intestinal bacteria-derived *p*-cresyl sulfate on Th1-type immune response in vivo and in vitro. *Toxicol. Appl. Pharmacol.* **274**:191–199; 2014.
- [43] Skulachev, VP. Uncoupling: new approaches to an old problem of bioenergetics. *Biochim. Biophys. Acta* **1363**:100–124; 1998.
- [44] Smit, E; Nieto, FJ; Crespo, CJ; Mitchell, P. Estimates of animal and plant protein intake in US adults: results from the Third National Health and Nutrition Examination Survey, 1988–1991. *J. Am. Diet. Assoc.* **99**:813–820; 1999.
- [45] Smith, EA; Macfarlane, GT. Enumeration of human colonic bacteria producing phenolic and indolic compounds: effects of pH, carbohydrate availability and retention time on dissimilatory aromatic amino acid metabolism. *J. Appl. Bacteriol.* **81**:288–302; 1996.
- [46] Smith, EA; Macfarlane, GT. Formation of phenolic and indolic compounds by anaerobic bacteria in the human large intestine. *Microb. Ecol.* **33**:180–188; 1997.
- [47] Starkov, AA; Fiskum, G. Regulation of brain mitochondrial H₂O₂ production by membrane potential and NAD(P)H redox state. *J. Neurochem.* **86**:1101–1107; 2003.
- [48] Terzic, J; Grivennikov, S; Karin, E; Karin, M. Inflammation and colon cancer. *Gastroenterology* **138**:2101–2114; 2010.
- [49] Toden, S; Bird, AR; Topping, DL; Conlon, MA. Resistant starch attenuates colonic DNA damage induced by higher dietary protein in rats. *Nutr. Cancer* **51**:45–51; 2005.
- [50] Turrens, JF. Superoxide production by the mitochondrial respiratory chain. *Biosci. Rep.* **17**:3–8; 1997.
- [51] Venditti, P; Di Stefano, L; Di Meo, S. Mitochondrial metabolism of reactive oxygen species. *Mitochondrion* **13**:71–82; 2013.
- [52] Vidal, H; Comte, B; Beylot, M; Riou, JP. Inhibition of glucose oxidation by vasoactive intestinal peptide in isolated rat enterocytes. *J. Biol. Chem.* **263**:9206–9211; 1988.
- [53] Westbrook, AM; Wei, B; Braun, J; Schiestl, RH. Intestinal mucosal inflammation leads to systemic genotoxicity in mice. *Cancer Res.* **69**:4827–4834; 2009.
- [54] Winter, J; Nyskohus, L; Young, GP; Hu, Y; Conlon, MA; Bird, AR; Topping, DL; Le Leu, RK. Inhibition by resistant starch of red meat-induced promutagenic adducts in mouse colon. *Cancer Prev. Res. (Phila.)* **4**:1920–1928; 2011.

ETUDE 3 : EFFETS D'UN REGIME HYPERPROTEIQUE SUR L'EPITHELIUM DU COLON CHEZ LE RAT

Article soumis.

Contexte

La consommation d'un régime hyperprotéique (HP) entraîne une augmentation de la quantité de protéines alimentaires non digérées parvenant dans la lumière du côlon. Leur dégradation par les bactéries intestinales produit une grande diversité de composés, certains étant considérés bénéfiques pour la muqueuse alors que d'autres sont délétères. Il a été montré au laboratoire que, chez le rat, un régime HP modifie la composition du microbiote et la composition luminale en métabolites bactériens. Le but de cette étude était de caractériser, dans le même modèle, les effets d'un régime HP sur l'épithélium du côlon.

Méthodes

Des rats Wistar ont été nourris pendant deux semaines avec un régime HP (55% d'énergie apportée par les protéines) ou avec un régime normoprotéique (NP) isocalorique (14% d'énergie apportée par les protéines) (Figure 31). Le transcriptome dans les colonocytes a été analysé avec des puces à ADN. Les fonctions biologiques associées aux gènes dont l'expression était régulée par le niveau d'apport en protéines ont été identifiées. Des indicateurs du renouvellement de l'épithélium du côlon ont été étudiés par quantification de l'expression de marqueurs de la prolifération et de l'apoptose (immunohistochimie et western blot). L'expression de la protéine de jonction serrée claudine-1 a été quantifiée dans les colonocytes (western blot) et la fonction barrière dans le côlon distal a été évaluée par des expériences en chambre de Ussing. Les dommages à l'ADN ont été quantifiés dans les colonocytes par le test des comètes.

Résultats

Des signatures transcriptomiques distinctes ont été observées dans les colonocytes des rats nourris avec les régimes HP et NP. Le régime HP a induit une diminution de l'expression de gènes impliqués dans le métabolisme du glutathion et dans la réparation de l'ADN. Ces modifications étaient associées à une tendance à la diminution des dommages à l'ADN dans les colonocytes des rats nourris avec le régime HP. L'expression de nombreux gènes liés à la voie de signalisation NF- κ B et à la mort cellulaire était diminuée lors du régime HP. Néanmoins, l'expression protéique de la caspase 3 activée n'était pas significativement différente entre les deux groupes, suggérant que le régime HP n'a pas modulé l'apoptose dans l'épithélium. Au contraire, de nombreux gènes liés à la prolifération étaient surexprimés dans les colonocytes des rats nourris avec le régime HP et ces modifications étaient associées à une tendance à l'augmentation de l'expression protéique de marqueurs de la prolifération (Ki67, PCNA). Cinq gènes de mucines étaient significativement surexprimés dans les cellules épithéliales des

rats nourris avec le régime HP. Au contraire, de nombreux gènes liés à l'adhésion cellulaire étaient sous-exprimés après le régime HP mais l'expression de la protéine de jonction serrée claudine-1 n'était pas modifiée. Enfin, la fonction barrière dans le côlon distal n'était pas affectée par le régime HP.

Conclusion

Le régime HP a régulé l'expression génique dans l'épithélium du côlon, probablement via une modification de l'environnement luminal. Ces effets du régime HP au niveau transcriptionnel n'étaient pas associées à une rupture de l'homéostasie épithéliale, sur la base des paramètres mesurés. Il est possible que des mécanismes adaptatifs tels que la surexpression des mucines limitent les potentiels effets délétères des régimes HP. Les conséquences à long terme de ces régimes devront être caractérisées lors de futures études.

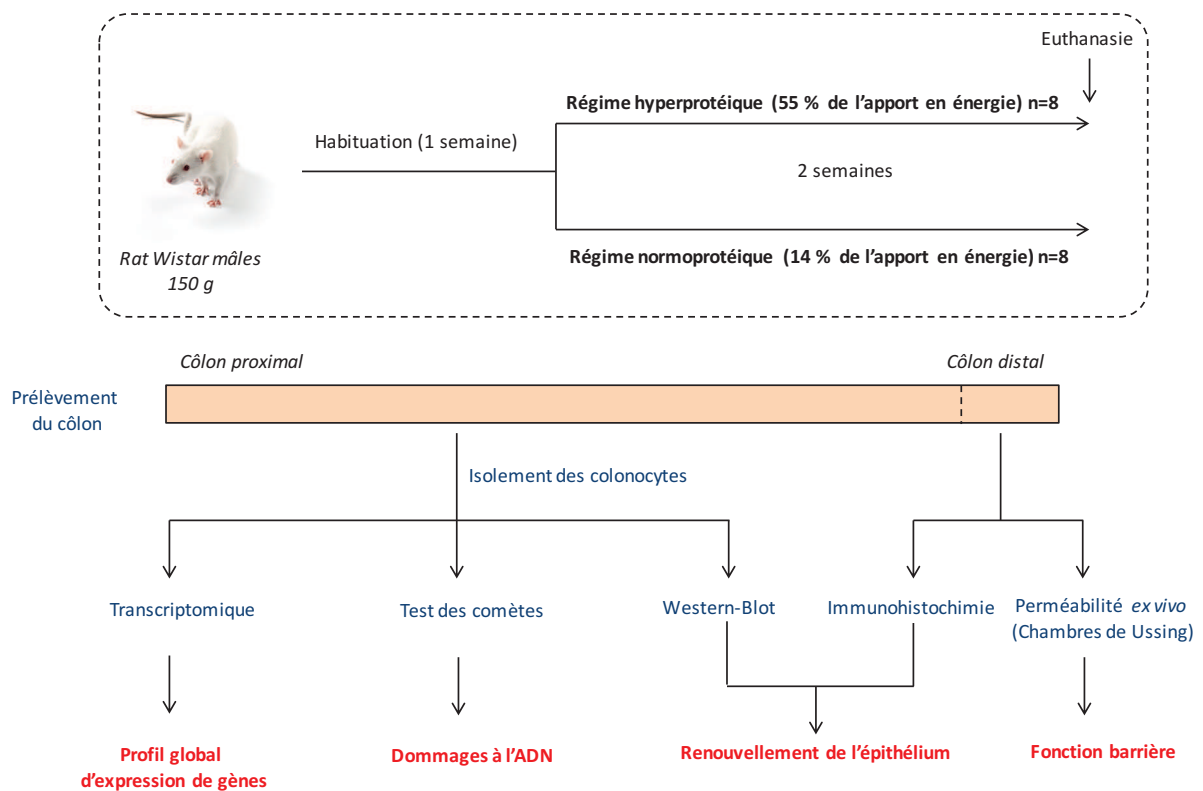

Figure 31 : Représentation schématique du protocole expérimental de l'étude 3.

Messages clés de l'étude 3

Chez le rat, la consommation d'un régime HP pendant deux semaines :

- Diminue l'expression de gènes liés à des mécanismes de protection cellulaire
- Régule l'expression de gènes liés au renouvellement de l'épithélium
- Augmente l'expression de plusieurs gènes de mucines
- N'a pas d'effet délétère en termes de dommage à l'ADN, de renouvellement de l'épithélium et de fonction barrière du côlon

Epithelial response to a high-protein diet in rat colon

Beaumont Martin¹, Andriamihaja Mireille¹, Armand Lucie¹, Grauso Marta¹, Jaffrézic Florence², Laloë Denis², Moroldo Marco³, Davila Anne-Marie¹, Tomé Daniel¹, Blachier François¹, Lan Annaïg¹

1- UMR Physiologie de la Nutrition et du Comportement Alimentaire, AgroParisTech, INRA, Université Paris-Saclay, 75005, Paris, France

2- UMR1313 Génétique Animale et Biologie Intégrative, INRA, 78350, Jouy-en-Josas France

3- CRB GADIE, INRA, 78350, Jouy-en-Josas France

Corresponding author:

Annaïg Lan

UMR Physiologie de la Nutrition et du Comportement Alimentaire,

AgroParisTech, INRA, Université Paris-Saclay,

16 rue Claude Bernard,

75005 Paris, France

Mail: annaig.lan@agroparistech.fr

Running Title: Dietary protein and colonocytes

Grants: This research was supported by the European Commission (project My New Gut, grant agreement no. 613979), INRA and AgroParisTech. Martin Beaumont is a recipient of a PhD grant from INRA-Université Paris-Saclay (ALIAS program).

Conflicts of interest: none

Keywords: epithelial cells, colon, DNA damage, high-protein diet, barrier function, transcriptome.

ABSTRACT

High-protein diets (HPD) alter the large intestine microbiota composition in association with a metabolic shift towards protein degradation. Some amino acid-derived metabolites produced by the colon bacteria are beneficial for the mucosa while others are deleterious when present at high concentrations. The aim of the present work was to define the colonic epithelial response to an HPD. Transcriptome profiling was performed on colonocytes of rats fed an HPD or an isocaloric normal-protein diet (NPD) for two weeks. The HPD downregulated the expression of genes notably implicated in pathways related to cellular metabolism, NF- κ B signaling, DNA repair, glutathione metabolism and integrin signaling in colonocytes. In contrast, the HPD upregulated the expressions of genes related to proliferation and mucus secretion. These changes at the mRNA level in colonocytes were not associated with detrimental effects of the HPD on DNA integrity (comet assay), epithelium renewal (quantification of proliferation and apoptosis markers by immunohistochemistry and western blot) and colonic barrier function (Ussing chamber experiments). In conclusion, the maintenance of the colonic homeostasis after an HPD might be owed to adaptive processes reflected by the epithelial transcriptome.

1. INTRODUCTION

Colonic epithelium faces a highly complex mixture of residual nutrients, resident bacteria and their metabolites. Modifications of the luminal environment are known to affect the colonic epithelium and may result in colonic homeostasis perturbation by alteration of the barrier function, modification of the epithelial renewal and impairment of the mucosal immune response [1]. Among several environmental factors, dietary changes have been shown to affect the colon luminal environment and mucosal homeostasis [2].

HPD have a significant effect on the large intestine luminal ecosystem. Indeed, HPD increase the amount of undigested peptides that reach the large intestine [3–5], modify the gut microbiota composition [6–8] and increase protein fermentation by the large intestine bacteria [8–10] resulting in the production of numerous amino acid-derived metabolites [11,12]. Among them, ammonia, *p*-cresol and hydrogen sulfide have been found to inhibit colonocyte respiration, when present at high concentrations [10,13,14]. In addition, *p*-cresol has been shown to induce DNA damage in colonocytes [13]. In contrast, other amino acid-derived metabolites such as indolic compounds contribute to the maintenance of epithelial homeostasis [15,16].

These HPD-induced changes in the colonic luminal environment have been associated with several effects on the large intestine mucosa. In rats fed an HPD, the height of colonocyte brush border (a key functional feature of absorptive cells) is markedly reduced probably in relation with the observed perturbation of mitochondrial metabolism [10]. An HPD also modifies goblet cell distribution in rat colonic epithelium together with an increased gene expression of mucin 3 (*Muc3*) [17] while colonic mucosal immune response is not changed by the HPD except for a decreased interleukin-6 (*Il-6*) mRNA expression [17]. In HPD-fed piglets, mucin gene expression as well as pro and anti-inflammatory cytokines are upregulated in the colonic mucosa without modification of the histological aspect [18,19]. In this latter animal model, there is no change in colonic barrier function after the HPD [20]. Conflicting results according to the model and/or the type of HPD used have been reported regarding the induction of DNA damage in colonocytes fed an HPD [21–24]. Recently, it was concluded from microarray

experiments in rat colonic mucosa that an HPD upregulates the expression of genes implicated in glutathione metabolism, chemotaxis, tumor necrosis factor- α signaling and apoptosis while it downregulates genes related to oxidative phosphorylation, glycosylation of mucins and innate immune responses [8]. Since the colonic mucosa contains a cell mixture from epithelium, lamina propia and muscularis mucosae layers, it is not possible to determine from that study what is the effect of HPD specifically on colonic epithelial cells that are directly exposed to luminal changes after HPD consumption.

In this context, the aim of the present study was to characterize the epithelial response to a whole milk protein-based HPD in rat colon compared to an NPD. The experimental settings were similar to our previous studies showing an HPD-induced modulation of the microbiota composition and luminal bacteria metabolite content in the rat large intestine [7,10,17]. Gene expression signature by transcriptome profiling in combination with cellular and functional analysis were measured to define the effects of an HPD consumption at the colonic epithelial level.

2. MATERIALS AND METHODS

2.1. Animals and diet

The present protocol received written agreement from the local animal ethical committee (COMETHEA at Jouy-en-Josas, France, N°12/090). Male Wistar rats (Harlan, Gannat, France) weighing 150 g (5-6 weeks) were fed for 1 week a standard rodent diet containing 16% protein by weight. Subsequently, 16 rats received for 15 days either an NPD (n=8) or an HPD isocaloric (n=8) adjusted on digestible carbohydrates (Table 1) and water *ad libitum*. The animals were maintained in a 12:12-h light-dark cycle with the dark period beginning at 7:00 PM. At the end of the experiments, rats were anesthetized with pentobarbital sodium (40 mg/kg body weight). The whole colon was isolated and the last 2 cm-segment was used for Ussing chamber experiments or for histology examination. The remaining part of the colon was used for colonocyte isolation.

2.2. Colonocyte isolation

Colon was flushed with a NaCl 9 g/l solution and then with a Ca²⁺ and Mg²⁺ -free Krebs Henseleit bicarbonate (pH 7.4) buffer solution containing 10 mM HEPES, 5 mM DTT, and 2.5 g bovine serum albumin and equilibrated against a mixture of O₂ and CO₂ (19:1, vol/vol). Then, colon was perfused for 20 min at 37°C with the same buffer containing 10 mM EDTA. Colonocytes were detached by gently tapping the colon.

2.3. RNA extraction from isolated colonocytes and microarray experiment

After three washes in PBS by centrifugation (200 g, 3 min), total RNA was extracted from isolated colonocytes using Trizol extraction [25]. A subsequent step of RNA purification was performed using the RNeasy Mini Kit and DNase I (Qiagen). RNA integrity was checked using a 2100 Bioanalyzer (Agilent Technologies). Sixteen colonocyte RNA samples (8 from NPD and 8 from HPD groups) were used for microarray experiment with SurePrint G3 Rat Gene Expression v2 8x60K Microarrays (AMADID: 028279) according to the manufacturer instructions (Agilent Technologies). Differential analysis of transcriptomic data was performed with the Bioconductor R package Limma [26]. Data were normalized with a log₂ transformation, centered by array and replicate spots were averaged. Correction

for multiple testing was done with the Benjamini-Hochberg procedure [27]. Principal component analysis revealed two outliers (one in each group) that were removed from further analysis. Differentially expressed (DE) genes selected with the adjusted p-value (q) cut-off $q < 0.1$ were used for pathway analysis using Ingenuity Pathway Analysis Software (Qiagen). A flow diagram of the transcriptome analysis is presented in Fig. S1. The data have been deposited in the Gene Expression Omnibus with the accession number GSE83953.

2.4. Real-time PCR

Quantitative real-time polymerase chain reaction (qRT-PCR) was performed to validate microarray experiment using a set of rat-specific primers (Eurogentec) which were designed using the Oligo Explorer 1.1.0 software (GeneLink), based on published sequences of the target genes (sequences available on request). After cDNA synthesis from mRNA using the High Capacity cDNA Reverse Transcription Kit (Life Technologies), qRT-PCR was performed using the power SYBR Green PCR master mix on a StepOne Real-Time PCR system platform (Life Technologies). Gene expression levels for each sample were normalized relative to the *Hprt* gene, using the $2^{-\Delta\Delta Ct}$ calculation.

2.5. Comet assay

DNA strand breaks and alkali-labile sites in isolated colonocytes were assessed using the alkaline version of the comet assay. Cells were rinsed with PBS and pelleted by centrifugation for 3 min at 200 g three times before re-suspension in sucrose 85.5 g/L, DMSO 50 mL/L prepared in citrate buffer (11.8 g/L), pH 7.6, and immediately frozen at -80°C . Three microscope slides per condition were coated with 1% normal melting point agarose (NMA) and allowed to dry. Ten thousand cells per slide were mixed with 0.6% low melting point agarose (LMPA) and deposited over the NMA layer. The cell/LMPA mix was then allowed to solidify on ice for 20 min. Slides were immersed in lysis solution (2.5 M NaCl, 100 mM EDTA, 10 mM Tris, 10% DMSO, 1% Triton X-100) overnight at 4°C , before being rinsed in 0.4 M Tris pH 7.4. DNA was then allowed to unwind for 1 h in alkaline electrophoresis solution (300 mM NaOH, 1 mM EDTA, pH > 13). Electrophoresis was performed in an electric field of 21 V and 300 mA for 20 min. Slides were then neutralized in 0.4 M Tris pH 7.4 and were stained with 20 μL of 10

000 X diluted Sybr Gold (Life Technologies). Fifty μM H_2O_2 (positive control) were directly deposited onto the agarose layer containing the cells and were incubated for 20 min at 37°C . At least 50 comets per slide were analyzed under a fluorescence microscope (Carl Zeiss) connected to a charge-coupled device camera with a 350-390 nm excitation and 456 nm emission filter at x 20 magnification. Comets were measured and analyzed using Comet IV software (Perceptive Instruments).

2.6. Histology

After an overnight fixation, 0.5 cm sections of distal colon were embedded in paraffin wax. Immunohistochemistry Ki67 labelling was carried out on 4 μm -transversal colon sections at the Cochin HistIM Facility. After antigen unmasking in sodium citrate buffer 10 mM pH 6.0, expression of Ki67 was detected using an anti-Ki67 antibody (ab15580, Abcam, dilution 1:500) and counterstained with hematoxylin and eosin.

2.7. Western blot

Isolated rat colonocytes were lysed in RIPA buffer containing a protease inhibitors cocktail (Roche). Total protein extracts (30 μg) were loaded into 4-12% Criterion XT gel (Bio-Rad) before electrophoresis in MOPS buffer (Bio-Rad). After transfer on nitrocellulose membrane and incubation in blocking solution (TBS pH 7.5, 0.05% Tween 20 and 5% (weight:volume) BSA, membranes were incubated overnight (4°C) with a primary antibody directed against activated-caspase 3 (Abcam 2303, rabbit, 1/1000) or proliferating cell nuclear antigen (PCNA, Abcam 29, mouse, 1/1000) or claudin-1 (Invitrogen, 717800, rabbit, 1/250) diluted in the blocking solution. After washes, blots were incubated for 2 h at room temperature with an anti-rabbit or anti-mouse HRP-linked secondary antibody (Jackson Immuno Research Laboratories, 1/5000) or a goat anti-actin-HRP (Santacruz Biotechnologies C-11, 1/1000) diluted in the blocking solution. After 3 washes, detection was performed by chemiluminescence using Clarity Western ECL substrate (Biorad) and the FluorChemFC2 device with AlphaView software (Cell Biosciences).

2.8. Ussing chambers experiments

Rat distal colon was mounted in the EasyMount (Physiologic Instrument Inc.) Ussing chambers with an exposed area of 0.5 cm^2 . Tissues were bathed in Krebs-Ringer bicarbonate buffer (KRB) with the following composition (in mM): 120 NaCl, 4.6 KCl, 0.5 MgCl_2 , 0.7 Na_2HPO_4 , 1.9 NaH_2PO_4 , 15 NaHCO_3 and 1.2 CaCl_2 . Serosal KRB contained 10 mM glucose (pH 7.35) and mucosal KRB, 10 mM mannitol (pH 7). Each chamber side was gassed with 95% O_2 – 5% CO_2 and kept at 37°C . After 15 min equilibration, the trans-mural potential (V_t , mV) was continuously recorded in open circuit configuration by the automated dual-channel epithelial voltage clamp EC825A (Warner Instruments LLC). Each 15 min, the tissues were successively voltage-clamped to zero to obtain the short-circuit current (I_{sc} , $\mu\text{A}/\text{cm}^2$) and a $\pm 5 \mu\text{A}$ current was pulsed to measure the trans-mural electrical resistance (R_t , $\text{ohm}\cdot\text{cm}^2$). Analogue signals were digitized using the PowerLab® 8/35 data acquisition system and analyzed with the LabChart® software (AD Instruments).

FITC dextran (FD4, Sigma) was used to evaluate the epithelial barrier integrity. After the 15 min tissue equilibration step, FD4 was added to the chamber mucosal side at the final concentration of 0.2 mM. 100 μL aliquots were collected from the serosal side every 15 min over two h and replaced with 100 μL of fresh KRB. Fluorescence was measured with the Infinite® 200 Pro spectrofluorimeter (Tecan) with an excitation and emission wavelengths of 490 nm and 520 nm respectively, and FD4 amounts were calculated against a FD4 standard curve. The FD4 apparent permeability coefficient (P_{app} , cm/s) was determined using the following equation: $P_{app} = (dQ/dt) \times (1/AC_0)$ where dQ/dt is the FD4 transport rate across the epithelium (mmol/s), A is the exposed surface area (cm^2), C_0 is the initial FD4 concentration in the mucosal compartment (mmol/mL).

2.9. Statistical analysis

Statistical analyses were performed with GraphPad Prim Software. Mean values of measured parameters in NPD and HPD-fed rat groups were compared with an unpaired t-test. Differences with p-values < 0.05 were considered as statistically significant.

3. RESULTS

As shown in Fig. 1A, the macroscopic aspect of colon from rats fed an HPD or an NPD were markedly different. Colons from rats fed an HPD were distended due to a very large increase in luminal content (Fig. 1B). This observation supports the hypothesis that the HPD deeply reshaped the luminal environment in contact with epithelial cells.

3.1. The high-protein diet regulates gene expression in colonocytes

Microarrays were used to compare the transcriptome profile in colonocytes from rats fed an HPD or an NPD. The analysis identified 1,910 differentially expressed (DE) genes between the HPD and the NPD groups at a q-value of 0.1. Among these genes, 646 were upregulated by the HPD while around twice more genes (1,264) were downregulated by the HPD. Fold changes in DE genes between HPD and NPD-fed rats ranged from 5.85 (*Mt2a*, metallothionein 2A) to -2.09 (*Slc39a4*, solute carrier family 39 zinc transporter, member 4). The 20 top DE genes between HPD and NPD-fed rats are listed in Table 2 while the complete list is shown in Table S1. In total, 315 genes were upregulated with a fold change > 1.2 while 1,103 were downregulated with a fold change < -1.2 , and 492 had limited changes in expression level ($-1.2 < \text{fold change} < 1.2$). To validate microarray data, the expression level of four genes of interest was assessed by qRT-PCR (Fig. S2). We confirmed that *Tfrc* (transferrin receptor) and *Mt1a* were upregulated in the HPD group while *Slc39a4* and *Sdc4* (syndecan 4) were downregulated ($p < 0.05$).

Functional analysis was performed to identify the biological pathways regulated at the mRNA level by the HPD in rat colonocytes. Seventy-seven biological functions were found to be significantly enriched in the set of genes DE between NPD- and HPD-fed rats ($p < 0.05$) (Table S2). Repartition of these functions into biological categories is shown in Fig. 2A. Eighteen canonical pathways significantly enriched ($p < 0.05$) were predicted to be downregulated in colonocyte of HPD-fed rats ($Z\text{-score} < -2$) and only 1 was predicted to be upregulated ($Z\text{-score} > 2$) (Fig. 2B). The complete list of significantly enriched canonical pathways is shown in Table S3. Functional analysis also identified two predicted

transcription regulators: MYC and E2F1, that are known to regulate, respectively, the expression of 29 and 13 genes DE between HPD and NPD-fed rats ($p < 0.05$).

3.2. Effects of the high-protein diet on the expression of genes related to metabolism in colonocytes

Many significantly enriched functions in the set of DE genes belonged to cell metabolism-related categories. Indeed, *Small Molecule Biochemistry*, *Protein Synthesis* and *Lipid Metabolism* were among the most represented biological categories (Fig. 2A). A full list of significantly enriched functions related to cell metabolism is presented in Table 3. The majority of the genes implicated in these pathways were downregulated in colonocytes of rats fed with an HPD. Interestingly, *Protein Synthesis* was the most affected metabolic pathway according to the number of enriched functions and to the number of genes implicated in each function.

3.3. Effects of the high-protein diet on glutathione metabolism, oxidative stress and DNA damages in colonocytes

Two canonical pathways related to glutathione metabolism were found to be significantly enriched in the set of genes regulated by the HPD (Table S3), namely *Glutathione Redox Reactions II* and *Glutathione-Mediated Detoxification*. The 8 DE genes participating to these pathways were all downregulated by the HPD as shown in Fig. 3A with selected DE genes as examples. The canonical pathway of *Nuclear factor (erythroid-derived 2)-like 2 (NRF2)-Mediated Oxidative Stress Response* was also predicted to be downregulated after the HPD (Fig. 2B). The functional analysis revealed that the function *Repair of DNA* was significantly enriched in the set of genes DE between NPD and HPD-fed rats (Table S2). Indeed, the HPD significantly decreased the gene expression of several DNA repair proteins in colonocytes (Fig. 3B). DNA damages in colonocytes were then evaluated by the comet assay. As shown in Fig. 3C, a trend towards lower DNA damage in colonocytes isolated from HPD-fed rats was observed when compared to NPD-fed rats ($p = 0.06$).

3.4. Effects of the high-protein diet on NF- κ B related pathways in colonocytes

An important finding of the present study was the predicted downregulation of *NF- κ B Signaling* canonical pathway in colonocytes of HPD-fed rats (Z-score: -3.13, Fig. 2B). Twenty-three genes DE in colonocytes of rats fed an HPD were implicated in this pathway, among which 19 were downregulated and only 4 were upregulated (Fig. 4A and Table S3). The relative expressions of several of these DE genes are shown in Fig. 4B. Other NF- κ B-related canonical pathways such as *IL-6* and *iNOS Signaling* were also predicted to be inhibited in colonocytes of rats fed an HPD (Fig. 2B).

3.5. Effects of the high-protein diet on epithelium renewal in colon

HPD regulated numerous functions implicated in biological processes related to *Cell Death and Survival, Development, Morphology, Growth and Proliferation* (Fig. 2A). A list of selected significantly enriched functions related to these biological categories is presented in Table 4. For all these functions, a majority of genes were downregulated by the HPD and some of them were highly relevant to epithelial renewal (*Cell Death, Anoikis, Neoplasia of Epithelial Tissue*) (Table 4). Strikingly, the function with the greatest number of genes regulated by the HPD was *Cell Death* (103 genes, 82.5% of which were downregulated) (Table 4 and S2). The relative expression of selected DE genes included in the function *Cell Death* are presented in Fig. 5A. However, the expression of the apoptosis marker activated caspase 3 measured by western blot in colonocytes was highly variable among rats and there was no significant effect of the diet (Fig. 5B). Numerous genes known to be highly expressed in proliferating cells (*Tfrc*, metallothioneins genes) were upregulated by the HPD while tumor suppressor genes (*Ppp2r2a*, *NdrG1* and *Prdx1*) were downregulated by the HPD (Fig. 6A) [28–32]. Proliferation in colonocytes was evaluated by immunodetection of Ki67 in distal colonic mucosa and by quantification of PCNA in colonocytes by western blot (Fig. 6 B and C). Although visually Ki67-labelling seemed generally more intense in the crypts of rats fed an HPD, there was no significant difference with NPD-fed rats (Fig. 6B). PCNA also tended to be more expressed in colonocytes of rats fed an HPD ($p = 0.06$) (Fig. 6C).

3.6. Effects of the high-protein diet on barrier function in colon

Based on the predefined hypothesis that HPD could regulate mucus secretion, mucins gene expression was specifically examined (Fig. 7A). The HPD significantly upregulated the expression of *Muc2*, *Muc5ac*, *Muc6*, *Muc16* and *Muc20*. Several canonical pathways related to cell adhesion were significantly enriched in the set of genes regulated by the HPD (Table S3). The *Integrin Signaling* canonical pathway was predicted to be inhibited in colonocytes of HPD-fed rats (Z-score: -3.16) (Fig. 2B and Figure S3). The HPD also regulated the expression of genes implicated in the following canonical pathways: *Tight Junction Signaling* (Fig. S4), *Actin-based Motility by Rho Family GTPases*, *ILK (Integrin Linked Kinase) Signaling*, *FAK (Focal Adhesion Kinase) Signaling* (Table S3), reinforcing the possibility of an HPD-induced modification of colonocyte adhesion and interaction with extracellular matrix. The relative expressions of selected DE genes participating to these pathways are presented in Fig. 7B, most of them being downregulated. However, the expression in colonocytes of the tight junction protein Claudin-1 was not significantly upregulated ($p = 0.10$) after the HPD as measured by western blot (Fig. 7C). To evaluate the effect of the level of protein intake on colonic barrier integrity, distal colon segments were mounted into Ussing chambers. After 15 min, distal colon transmural resistance tended ($p = 0.07$) to be higher in rats fed an HPD when compared to rats fed an NPD (Fig. 7D) while colon transmural resistance was similar between both groups after 60 min (data not shown). Moreover, FD4-apparent paracellular permeability across the colon wall was similar in NPD- and HPD-fed rats (Fig. 7E). In conclusion, these experiments showed that the HPD did not impair colonic barrier function in rat distal colon.

4. DISCUSSION

The results of the present study indicate that in the rat model, there is a marked colonic epithelial response to an HPD that is characterized by a specific transcriptional signature. The HPD downregulated, at the gene expression level, biological pathways related to cellular metabolism, glutathione metabolism, DNA repair, NF- κ B signaling, apoptosis and epithelial cell adhesion. In contrast, genes related to proliferation and mucus secretion were upregulated by the HPD. These transcriptional changes induced by a short-term HPD were not associated with detrimental effects on the colonic epithelium in terms of genotoxicity, epithelial renewal and barrier function.

Numerous genes downregulated in colonocytes by the HPD participate in cell anabolism and notably in protein synthesis. Interestingly, several bacterial metabolites derived from amino acids (*p*-cresol, hydrogen sulfide and ammonia) inhibit mitochondrial respiration when present in excess [10,13,14]. In addition, HPD increased proton leaks in rat colonocyte mitochondria leading to a lower energetic efficiency [10]. Therefore, it is tempting to propose that the downregulation of genes implicated in cell anabolism may represent an adaptation allowing ATP saving in colonocytes during HPD. Indeed, the colonic epithelium has a high energy need related to its constant renewal, water and electrolyte transports and barrier function maintenance [33].

Several genes related to glutathione metabolism were downregulated in rat colonocytes after the HPD. Notably, HPD induced a decrease in gene expression of several glutathione-S-transferases (GST) which are implicated in phase II metabolism of xenobiotics but also in the control of reactive oxygen species [34]. In agreement with the present study, GST gene expression appeared to be reduced in the colon of pigs fed an HPD [18]. HPD also induced a downregulation of genes encoding proteins involved in several DNA-repair pathways, namely base excision repair (*Ogg1*, *Ung*), non-homologous end joining (*Nhej1*) and nucleotide excision repair (*Ddb1*) [35] but this was not associated with significant changes in DNA damages in colonocytes of rats fed an HPD when compared to rats fed an NPD. However, the HPD induced a trend toward DNA damage decrease in colonocytes. This result is in agreement with a recent report showing lower DNA damages in rats fed with a moderate protein intake

(20 %) compared to an NPD (14 %) [24]. Moreover, two human studies found no increase in fecal water genotoxicity after a HPD [21,22]. In contrast, Toden *et al* found that a casein-based or soy protein-based HPD induce DNA damages in rat colonocytes while this effect was not found with whey protein-based HPD [23]. In the present study, the HPD contained whole milk protein. These protein source differences might contribute to the divergent effects of HPD consumption. Indeed, all the protein sources do not have the same digestibility, potentially modulating the quantity of dietary nitrogen entering in the large intestine [36]. However, all milk protein have very high digestibility in rats (around 96 %) [37], precluding a major role of this parameter to explain the divergent reported effects of milk protein-based HPD on DNA damage. Alternatively, differences between protein sources in amino acid composition, bioactive peptides or associated microconstituents might be implicated [38].

The proliferation markers Ki67 and PCNA tended to be both more expressed in colonocytes of rats fed an HPD. This was concordant with the transcriptional overexpression in colonocytes of markers of epithelial proliferation such as metallothioneins (up to 5.84 fold change) and *Tfrc* [28,30] while tumor suppressor genes such as *Ppp2r2a*, *Ndr1* and *Prdx1* were downregulated by the HPD [29,31,32]. In rats fed with the HPD, the expression of the apoptosis marker caspase 3 was unchanged in colonocytes, while there was a massive downregulation of cell death-related pathway at the mRNA level. Similar results were obtained in the colon of pigs fed an HPD: PCNA being upregulated at the gene expression level while caspase 3 remaining unchanged [18]. Collectively, these data suggest that HPD act on epithelium renewal by favoring colonocyte proliferation but not apoptosis.

The HPD-induced downregulation of pathways implicated in epithelial cell junction and adhesion of colonocytes to extracellular matrix might jeopardize barrier function. However, in Ussing chamber experiments, transmural resistance and apparent permeability to FD4 (that cross the epithelium by the paracellular route) were similar in rat fed an NPD or an HPD, indicating that colonic barrier integrity was not altered. These results are consistent with our previous electronic microscopy observation showing that there was no alteration of tight junction structure in colonic epithelium of rats

fed an HPD [10] and with another study showing that colonic barrier function is preserved in HPD-fed piglets [20].

A very striking result of the present study was the inhibition of the NF- κ B pathway in colonocytes of rats fed an HPD. In epithelial cells, NF- κ B plays a central role in immune homeostasis, epithelial renewal and maintenance of barrier function [39]. Since one of the pathways of NF- κ B activation is the stimulation of pattern recognition receptors by luminal bacteria, it can be hypothesized that the HPD decreased the contact between commensals and the epithelium. A potential mechanism for this process is the reinforcement of the mucus barrier [40]. Indeed, in the present study, five mucin genes, including *Muc2* (the predominant secreted mucin), were upregulated in epithelial cells of HPD-fed rats in agreement with previous studies in rats and pigs [17,18]. An increased mucus secretion is likely to result in an overall decreased exposure of the colonic epithelium to luminal compounds. This hypothesis provides a possible explanation for the observed decreased expression of genes related to glutathione metabolism and DNA repair after an HPD that may reflect a lower stimulation from the luminal side.

The results obtained in the present study are not in agreement with the transcriptome profile recently described in the colonic mucosa of rats fed an HPD [8]. Indeed, Mu et al. found that genes related to glutathione metabolism and apoptosis were upregulated by the HPD while the data of the present study indicated the opposite. For example, *Mgst1* (microsomal glutathione S-transferase 1) and *Ripk1* (receptor interacting serine/threonine kinase 1) were significantly regulated by the HPD in the two studies but with opposite direction. Three differences in the experimental designs of the two studies may explain these discrepancies. First, the present study used whole milk protein while Mu et al. used a protein isolate of casein [8]. As discussed above, the protein source might modulate the effects of HPD on gene expression in the colon. Secondly, gene expression was analyzed in the present study in isolated colonic epithelial cells while Mu et al. described the transcriptome in the whole colonic mucosa [8]. Since the gene expression patterns in the colonic epithelium and in the stroma are clearly distinct [41], the discrepancies between the two studies might be related to the heterogeneous cell types present in the

mucosa analyzed in the study of Mu et al. Thirdly, the different durations of the studies (2 *versus* 6 weeks) probably also explain part of the differences in the regulation of gene expression by the HPD. Indeed, time-course microarray experiments revealed early and late transcriptomic response to dietary intervention in mice [42]. In the present study, the dietary intervention with the HPD was performed during 2 weeks since previous results obtained using the same experimental model indicated that changes in gut microbiota composition and luminal bacteria metabolite content occurred within this duration [7,10,43].

In conclusion, a 2-week HPD in rat did not impair the colonic epithelium in term of DNA-damages, epithelial renewal and barrier function. However, the transcriptional signature in colonocytes of rats fed an HPD indicates a downregulation of pathways implicated in crucial physiological processes such as NF- κ B signaling, DNA repair and glutathione metabolism. These changes might be detrimental for the epithelium since a decreased expression and activity of GST is associated with colorectal cancer through a defect in carcinogen detoxification [44], unrepaired DNA damages can lead to genomic instability [35] and maintenance of an appropriate activation of NF- κ B is crucial for epithelial homeostasis [39]. Further experiments are obviously required to determine the long-term consequences of HPD on the colonic epithelium, taking into account that prolonged downregulation of the expression of genes associated with cell protection may be detrimental for colon mucosa health.

ACKNOWLEDGEMENTS

The authors are grateful to Dr M. Carrière (Nucleic Acid Lesions Laboratory, Grenoble) for the use of the Comet Assay IV software and to J. Lecardonnell from the CRB GADIE core facility (INRA, Jouy en Josas, France) for his technical assistance and expertise for microarray experiments.

REFERENCES

- [1] Peterson LW, Artis D. Intestinal epithelial cells: regulators of barrier function and immune homeostasis. *Nat Rev Immunol* 2014;14:141–53. doi:10.1038/nri3608.
- [2] Lee D, Albenberg L, Compher C, Baldassano R, Piccoli D, Lewis JD, et al. Diet in the pathogenesis and treatment of inflammatory bowel diseases. *Gastroenterology* 2015;148:1087–106. doi:10.1053/j.gastro.2015.01.007.
- [3] Gibson JA, Sladen GE, Dawson AM. Protein absorption and ammonia production: the effects of dietary protein and removal of the colon. *Br J Nutr* 1976;35:61–5.
- [4] Silvester KR, Cummings JH. Does digestibility of meat protein help explain large bowel cancer risk? *Nutr Cancer* 1995;24:279–88. doi:10.1080/01635589509514417.
- [5] Bax M-L, Buffière C, Hafnaoui N, Gaudichon C, Savary-Auzeloux I, Dardevet D, et al. Effects of meat cooking, and of ingested amount, on protein digestion speed and entry of residual proteins into the colon: a study in minipigs. *PloS One* 2013;8:e61252. doi:10.1371/journal.pone.0061252.
- [6] Russell WR, Gratz SW, Duncan SH, Holtrop G, Ince J, Scobbie L, et al. High-protein, reduced-carbohydrate weight-loss diets promote metabolite profiles likely to be detrimental to colonic health. *Am J Clin Nutr* 2011;93:1062–72. doi:10.3945/ajcn.110.002188.
- [7] Liu X, Blouin J-M, Santacruz A, Lan A, Andriamihaja M, Wilkanowicz S, et al. High-protein diet modifies colonic microbiota and luminal environment but not colonocyte metabolism in the rat model: the increased luminal bulk connection. *Am J Physiol Gastrointest Liver Physiol* 2014;307:G459–70. doi:10.1152/ajpgi.00400.2013.
- [8] Mu C, Yang Y, Luo Z, Guan L, Zhu W. The Colonic Microbiome and Epithelial Transcriptome Are Altered in Rats Fed a High-Protein Diet Compared with a Normal-Protein Diet. *J Nutr* 2016;146:474–83. doi:10.3945/jn.115.223990.
- [9] Geypens B, Claus D, Evenepoel P, Hiele M, Maes B, Peeters M, et al. Influence of dietary protein supplements on the formation of bacterial metabolites in the colon. *Gut* 1997;41:70–6. doi:10.1136/gut.41.1.70.
- [10] Andriamihaja M, Davila A-M, Eklou-Lawson M, Petit N, Delpal S, Allek F, et al. Colon luminal content and epithelial cell morphology are markedly modified in rats fed with a high-protein diet. *Am J Physiol Gastrointest Liver Physiol* 2010;299:G1030–7. doi:10.1152/ajpgi.00149.2010.
- [11] Davila A-M, Blachier F, Gotteland M, Andriamihaja M, Benetti P-H, Sanz Y, et al. Intestinal luminal nitrogen metabolism: role of the gut microbiota and consequences for the host. *Pharmacol Res Off J Ital Pharmacol Soc* 2013;68:95–107. doi:10.1016/j.phrs.2012.11.005.
- [12] Portune KJ, Beaumont M, Davila A-M, Tomé D, Blachier F, Sanz Y. Gut microbiota role in dietary protein metabolism and health-related outcomes: the two sides of the coin. *Trends Food Sci Technol* 2016. doi:10.1016/j.tifs.2016.08.011.
- [13] Andriamihaja M, Lan A, Beaumont M, Audebert M, Wong X, Yamada K, et al. The deleterious metabolic and genotoxic effects of the bacterial metabolite p-cresol on colonic epithelial cells. *Free Radic Biol Med* 2015;85:219–27. doi:10.1016/j.freeradbiomed.2015.04.004.
- [14] Beaumont M, Andriamihaja M, Lan A, Khodorova N, Audebert M, Blouin J-M, et al. Detrimental effects for colonocytes of an increased exposure to luminal hydrogen sulfide: The adaptive response. *Free Radic Biol Med* 2016;93:155–64. doi:10.1016/j.freeradbiomed.2016.01.028.
- [15] Bansal T, Alaniz RC, Wood TK, Jayaraman A. The bacterial signal indole increases epithelial-cell tight-

- junction resistance and attenuates indicators of inflammation. *Proc Natl Acad Sci* 2010;107:228–33. doi:10.1073/pnas.0906112107.
- [16] Shimada Y, Kinoshita M, Harada K, Mizutani M, Masahata K, Kayama H, et al. Commensal Bacteria-Dependent Indole Production Enhances Epithelial Barrier Function in the Colon. *PLoS ONE* 2013;8:e80604. doi:10.1371/journal.pone.0080604.
- [17] Lan A, Andriamihaja M, Blouin J-M, Liu X, Descatoire V, Desclée de Maredsous C, et al. High-protein diet differently modifies intestinal goblet cell characteristics and mucosal cytokine expression in ileum and colon. *J Nutr Biochem* 2015;26:91–8. doi:10.1016/j.jnutbio.2014.09.007.
- [18] Pieper R, Kröger S, Richter JF, Wang J, Martin L, Bindelle J, et al. Fermentable fiber ameliorates fermentable protein-induced changes in microbial ecology, but not the mucosal response, in the colon of piglets. *J Nutr* 2012;142:661–7. doi:10.3945/jn.111.156190.
- [19] Villodre Tudela C, Boudry C, Stumpff F, Aschenbach JR, Vahjen W, Zentek J, et al. Down-regulation of monocarboxylate transporter 1 (MCT1) gene expression in the colon of piglets is linked to bacterial protein fermentation and pro-inflammatory cytokine-mediated signalling. *Br J Nutr* 2015;113:610–7. doi:10.1017/S0007114514004231.
- [20] Richter JF, Pieper R, Zakrzewski SS, Günzel D, Schulzke JD, Van Kessel AG. Diets high in fermentable protein and fibre alter tight junction protein composition with minor effects on barrier function in piglet colon. *Br J Nutr* 2014;111:1040–9. doi:10.1017/S0007114513003498.
- [21] Windey K, De Preter V, Louat T, Schuit F, Herman J, Vansant G, et al. Modulation of protein fermentation does not affect fecal water toxicity: a randomized cross-over study in healthy subjects. *PloS One* 2012;7:e52387. doi:10.1371/journal.pone.0052387.
- [22] Benassi-Evans B, Clifton P, Noakes M, Fenech M. High-protein/high red meat and high-carbohydrate weight-loss diets do not differ in their effect on faecal water genotoxicity tested by use of the WIL2-NS cell line and with other biomarkers of bowel health. *Mutat Res* 2010;703:130–6. doi:10.1016/j.mrgentox.2010.08.009.
- [23] Toden S, Bird AR, Topping DL, Conlon MA. Differential effects of dietary whey, casein and soya on colonic DNA damage and large bowel SCFA in rats fed diets low and high in resistant starch. *Br J Nutr* 2007;97:535–43. doi:10.1017/S0007114507336817.
- [24] Taciak M, Barszcz M, Tuśnio A, Pastuszewska B. Interactive Effects of Indigestible Carbohydrates, Protein Type, and Protein Level on Biomarkers of Large Intestine Health in Rats. *PLOS ONE* 2015;10:e0142176. doi:10.1371/journal.pone.0142176.
- [25] Chomczynski P, Sacchi N. Single-step method of RNA isolation by acid guanidinium thiocyanate-phenol-chloroform extraction. *Anal Biochem* 1987;162:156–9. doi:10.1016/0003-2697(87)90021-2.
- [26] Ritchie ME, Phipson B, Wu D, Hu Y, Law CW, Shi W, et al. limma powers differential expression analyses for RNA-sequencing and microarray studies. *Nucleic Acids Res* 2015;43:e47. doi:10.1093/nar/gkv007.
- [27] Benjamini Y, Hochberg Y. Controlling the False Discovery Rate: A Practical and Powerful Approach to Multiple Testing. *J R Stat Soc Ser B Methodol* 1995;57:289–300.
- [28] Cherian M. Metallothioneins in human tumors and potential roles in carcinogenesis. *Mutat Res Mol Mech Mutagen* 2003;533:201–9. doi:10.1016/j.mrfmmm.2003.07.013.
- [29] Kovacevic Z, Sivagurunathan S, Mangs H, Chikhani S, Zhang D, Richardson DR. The metastasis suppressor, N-myc downstream regulated gene 1 (NDRG1), upregulates p21 via p53-independent mechanisms. *Carcinogenesis* 2011;32:732–40. doi:10.1093/carcin/bgr046.

- [30] Sutherland R, Delia D, Schneider C, Newman R, Kemshead J, Greaves M. Ubiquitous cell-surface glycoprotein on tumor cells is proliferation-associated receptor for transferrin. *Proc Natl Acad Sci U S A* 1981;78:4515–9.
- [31] Shen S, Yue H, Li Y, Qin J, Li K, Liu Y, et al. Upregulation of miR-136 in human non-small cell lung cancer cells promotes Erk1/2 activation by targeting PPP2R2A. *Tumour Biol J Int Soc Oncodevelopmental Biol Med* 2014;35:631–40. doi:10.1007/s13277-013-1087-2.
- [32] Cao J, Schulte J, Knight A, Leslie NR, Zagozdzon A, Bronson R, et al. Prdx1 inhibits tumorigenesis via regulating PTEN/AKT activity. *EMBO J* 2009;28:1505–17. doi:10.1038/emboj.2009.101.
- [33] Roediger WE. Utilization of nutrients by isolated epithelial cells of the rat colon. *Gastroenterology* 1982;83:424–9.
- [34] Beyerle J, Frei E, Stiborova M, Habermann N, Ulrich CM. Biotransformation of xenobiotics in the human colon and rectum and its association with colorectal cancer. *Drug Metab Rev* 2015;47:199–221. doi:10.3109/03602532.2014.996649.
- [35] Hakem R. DNA-damage repair; the good, the bad, and the ugly. *EMBO J* 2008;27:589–605. doi:10.1038/emboj.2008.15.
- [36] Gaudichon C, Bos C, Morens C, Petzke KJ, Mariotti F, Everwand J, et al. Ileal losses of nitrogen and amino acids in humans and their importance to the assessment of amino acid requirements. *Gastroenterology* 2002;123:50–9. doi:10.1053/gast.2002.34233.
- [37] Lacroix M, Léonil J, Bos C, Henry G, Airinei G, Fauquant J, et al. Heat markers and quality indexes of industrially heat-treated [15N] milk protein measured in rats. *J Agric Food Chem* 2006;54:1508–17. doi:10.1021/jf051304d.
- [38] Lönnnerdal B. Nutritional and physiologic significance of human milk proteins. *Am J Clin Nutr* 2003;77:1537S – 1543S.
- [39] Pasparakis M. Role of NF- κ B in epithelial biology. *Immunol Rev* 2012;246:346–58. doi:10.1111/j.1600-065X.2012.01109.x.
- [40] Johansson MEV, Sjövall H, Hansson GC. The gastrointestinal mucus system in health and disease. *Nat Rev Gastroenterol Hepatol* 2013;10:352–61. doi:10.1038/nrgastro.2013.35.
- [41] Thomas SS, Makar KW, Li L, Zheng Y, Yang P, Levy L, et al. Tissue-specific patterns of gene expression in the epithelium and stroma of normal colon in healthy individuals in an aspirin intervention trial. *BMC Med Genet* 2015;16. doi:10.1186/s12881-015-0161-6.
- [42] Kwon E-Y, Shin S-K, Cho Y-Y, Jung UJ, Kim E, Park T, et al. Time-course microarrays reveal early activation of the immune transcriptome and adipokine dysregulation leads to fibrosis in visceral adipose depots during diet-induced obesity. *BMC Genomics* 2012;13:1.
- [43] Mouille B. Adaptative increase of ornithine production and decrease of ammonia metabolism in rat colonocytes after hyperproteic diet ingestion. *AJP Gastrointest Liver Physiol* 2004;287:G344–51. doi:10.1152/ajpgi.00445.2003.
- [44] Traverso N, Ricciarelli R, Nitti M, Marengo B, Furfaro AL, Pronzato MA, et al. Role of Glutathione in Cancer Progression and Chemoresistance. *Oxid Med Cell Longev* 2013;2013:e972913. doi:10.1155/2013/972913.

TABLES

Table 1. Composition of the experimental diets

Ingredients (g/kg)	NPD*	HPD*
Whole milk proteins	140	530
Corn starch	622.7	287.0
Sucrose	100	45.7
Cellulose	50	50
Soybean oil	40	40
Choline	2.3	2.3
Vitamin mixture, AIN 93-V	10	10
Mineral mixture, AIN 93-M	35	35
Energy, kJ/g	14.6	14.6

*NPD: normal-protein diet; HPD: high-protein diet

Table 2: Most differentially expressed genes in colonocytes isolated from rats fed a high-protein diet compared to rats fed a normal-protein diet.

Gene Symbol	Gene name	Fold change	q-value
<i>Slc39a</i>	Solute Carrier Family 39 (Zinc Transporter), Member 4	- 2.09	0.001
<i>Cela1</i>	Chymotrypsin-Like Elastase Family, Member 1	-1.97	0.049
<i>Ppp2r2a</i>	Protein Phosphatase 2, Regulatory Subunit B, Alpha	-1.97	0.012
<i>Cpd</i>	Carboxypeptidase D	-1.92	0.034
<i>Hla-a</i>	Human Leucocyte Antigen-A	-1.80	0.013
<i>Ostc</i>	Oligosaccharyltransferase complex subunit (non-catalytic)	-1.76	0.035
<i>Ndrp1</i>	N-myc downstream regulated 1	-1.75	0.069
<i>Pnrc2</i>	Proline-rich nuclear receptor coactivator 2	-1.73	0.043
<i>Prdx1</i>	Peroxiredoxin 1	-1.72	0.078
<i>Rpl5</i>	Riposomal protein L5	-1.71	0.052
<i>Pdha2</i>	Pyruvate dehydrogenase E1 alpha 2	1.63	0.052
<i>Prap1</i>	Proline-rich acidic protein 1	1.66	0.078
<i>Tfrc</i>	Transferrin receptor	1.67	0.043
<i>Rab44</i>	Member RAS oncogene family	1.67	0.069
<i>Krtap13-2</i>	Keratin associated protein 13-2	1.67	0.035
<i>Znf780b</i>	Zinc finger protein 780B	1.68	0.013
<i>Mt4</i>	Metallothionein 4	1.84	0.034
<i>Mt1</i>	Metallothionein 1	2.90	0.012
<i>Spink4</i>	Serine peptidase inhibitor, Kazal type 4	3.06	0.049
<i>Mt1m/Mt2A</i>	Metallothionein 2A	5.85	0.001

Table 3: Significantly enriched functions related to cellular metabolism in the set of genes differentially expressed in colonocytes isolated from rats fed a high-protein diet compared to rats fed a normal-protein diet. ‘Genes’ indicates the number of genes differently expressed implicated in the function, ‘Up’ and ‘Down’ indicate the number of genes upregulated and downregulated, respectively.

<i>Biological category</i> Function annotation	p-value	Genes	Up	Down
<i>Protein synthesis</i>				
Polymerization of protein	1.08E-04	36	7	31
Metabolism of protein	3.52E-02	31	2	29
Oligomerization of protein	6.50E-05	30	6	24
Hetero-oligomerization of protein	1.69E-03	17	2	15
Homo-oligomerization of protein	2.12E-03	14	4	10
Hydrolysis of protein fragment	4.32E-02	12	2	9
Metabolism of peptide	1.39E-02	10	0	10
Translation	6.87E-03	9	0	9
Assembly of protein-protein complex	5.90E-03	8	0	8
Translation of protein	1.83E-02	8	0	8
Folding of protein	1.29E-03	7	1	6
Translation of mRNA	1.71E-02	7	0	7
Metabolism of neutral amino acid	3.38E-02	3	0	3
Transport of D-serine	9.13E-03	2	1	1
<i>Lipid metabolism</i>				
Synthesis of glycolipid	3.88E-02	6	1	5
Beta-oxidation of fatty acid	4.56E-02	6	1	5
Synthesis of long chain fatty acid	4.81E-02	2	0	2
Uptake of long chain fatty acid	4.81E-02	2	0	2
<i>Nucleic acid metabolism</i>				
Metabolism of purine nucleotide	3.31E-02	8	0	8
Metabolism of nucleoside triphosphate	3.88E-02	6	0	6
Transport of nucleoside	7.52E-03	3	0	3
<i>Metabolism of carbohydrate</i>	3.81E-02	28	3	25

Table 4: Significantly enriched functions in the set of genes differentially expressed in colonocytes isolated from rats fed a high-protein diet compared to rats fed a normal-protein diet. ‘Genes’ indicates the number of genes differentially expressed implicated in the function, ‘Up’ and ‘Down’ indicate the number of genes upregulated and downregulated, respectively.

Function annotation	p-value	Genes	Up	Down
Cell death	4.89E-02	103	18	85
Autophagy	2.96E-03	10	1	9
Neoplasia of epithelial tissue	1.83E-02	8	3	5
Senescence of cells	2.27E-02	3	0	3
Organization of mitochondria	2.27E-02	3	0	3
Anoikis of carcinoma cell lines	9.13E-03	2	0	2
Morphology of intestinal cell lines	9.13E-03	2	0	2
Polarity of cells	4.81E-02	2	0	2

FIGURES

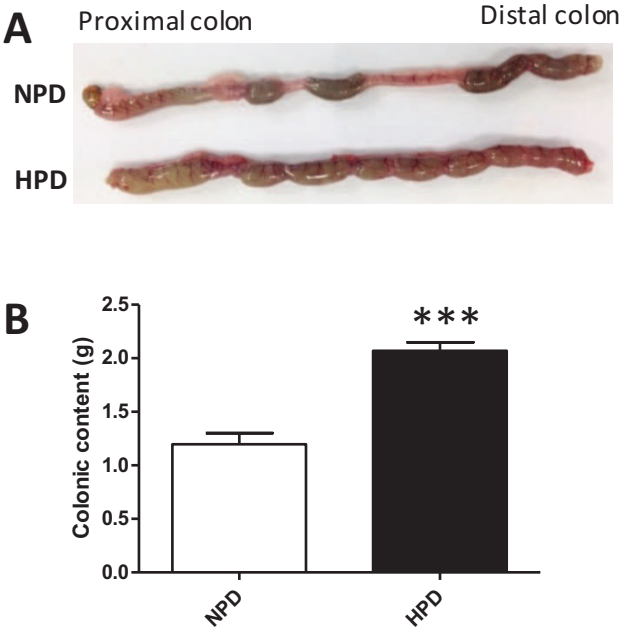

Fig. 1: A - Macroscopic aspects of colon from rats fed a normal-protein diet (NPD) or a high-protein diet (HPD). B - Colonic content weight. A - B: Data presented on histograms are means +/- S.E.M. Mean values were compared with a t test. ***: p<0.001.

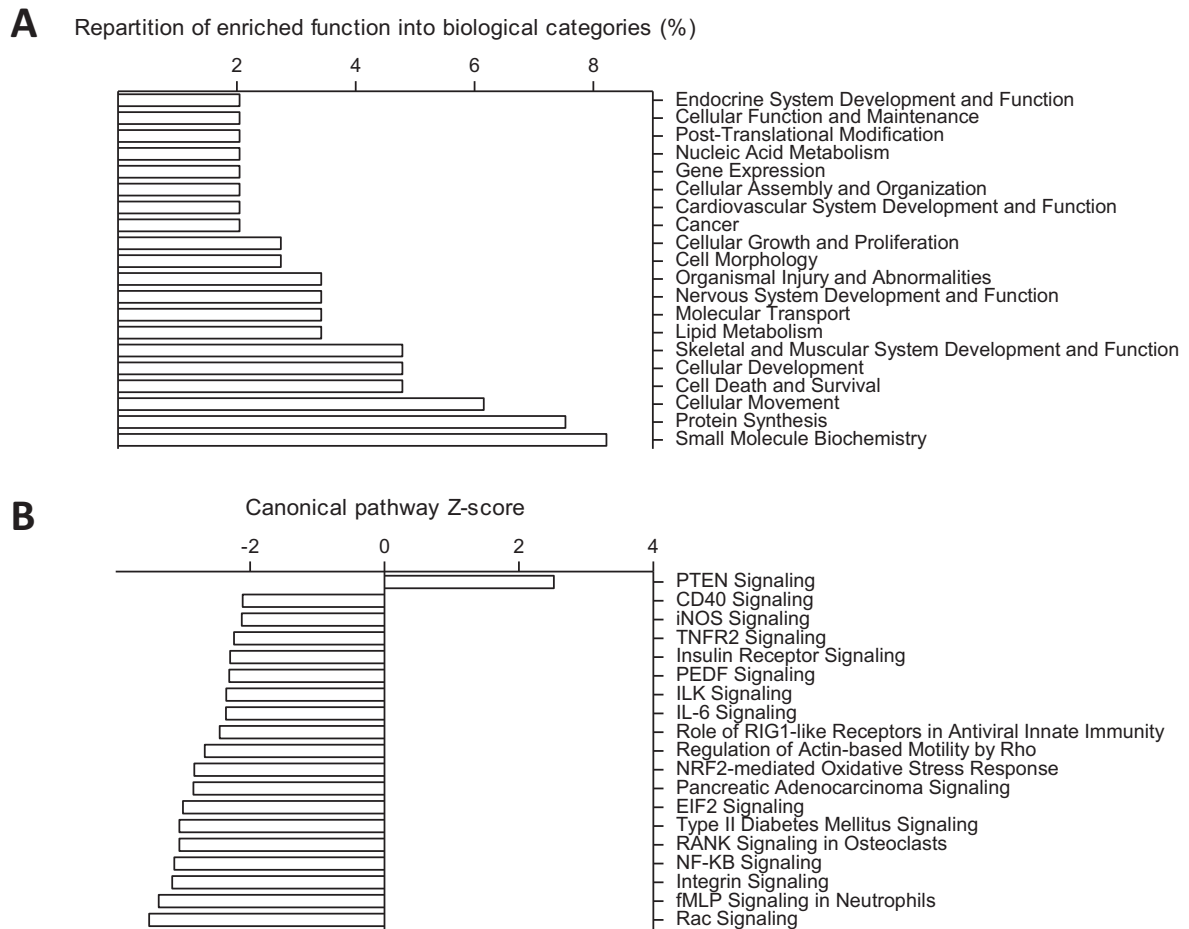

Fig. 2: Functional analysis of differentially expressed genes in colonocytes isolated from rats fed a high-protein diet (HPD) compared to a normal-protein diet was performed with Ingenuity Pathway Analysis software. A - Distribution of significantly enriched functions into biological categories is presented as a percentage of the total number of enriched functions (77). B - Canonical pathways significantly enriched. A pathway was considered downregulated in the colonocytes of HPD-fed rats when Z-score was < -2 and upregulated when Z-score was > 2 . Canonical pathways significantly enriched but not associated with a significant Z-score are not shown.

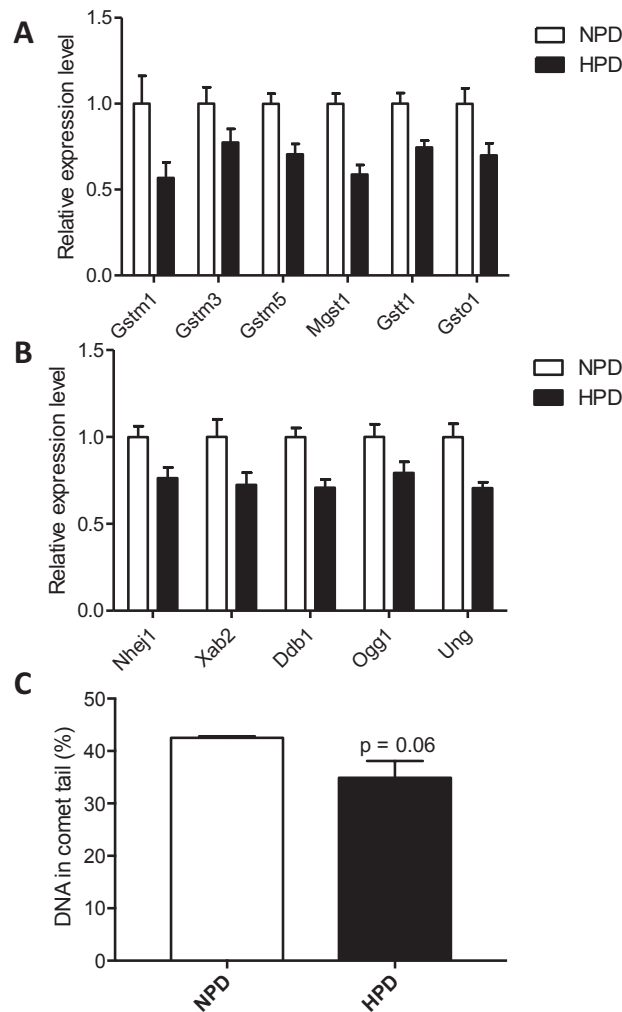

Fig. 3: A and B - Relative expression values of a selection of significantly differentially expressed genes participating to the enriched pathways *Glutathione-Mediated Detoxification* (A) and *DNA repair* (B) in the colonocytes of rats fed a high-protein diet (HPD) compared to a normal-protein diet (NPD). The expression values were obtained by microarray experiment and normalized to the mean value in the NPD group. *Gstm1*, 3 and 5 (glutathione S-transferase mu 1, 3 and 5), *Mgst1* (microsomal glutathione S-transferase 1), *Gstt1* (glutathione S-transferase theta 1), *Gsto1* (glutathione S-transferase omega 1), *Nhej1* (non-homologous end-joining factor 1), *Xab2* (XPA Binding Protein 2), *Ddb1* (damage-specific DNA binding protein 1), *Ogg1* (8-oxoguanine DNA glycosylase), *Ung* (uracil DNA glycosylase) gene expressions are presented. C - DNA damages in colonocytes of rats fed an HPD or an NPD were assessed with the comet assay. The percentage of DNA in the tail of the comet is proportional to the amount of DNA damages in the cells. Mean values were compared with a t test. A - C: Data presented are means +/- S.E.M.

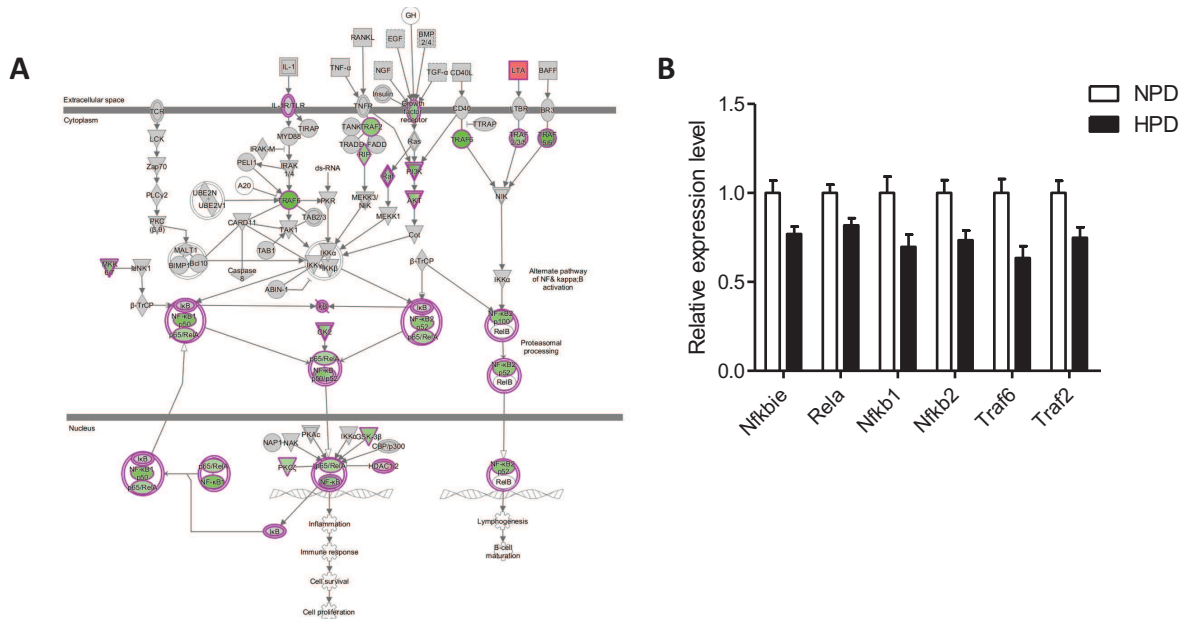

Fig. 4: A - *NF-κB* signaling canonical pathway diagram. This pathway was significantly enriched in the set of genes regulated by the high-protein diet (HPD). The diagram was obtained from Ingenuity Pathway Analysis software and depicts genes implicated in this pathway and their interactions. Expression of genes colored in green and red were respectively downregulated ($q < 0.1$) and upregulated ($q < 0.1$) in colonocytes of rats fed an HPD when compared to a normal-protein diet (NPD). B - Relative expression values of a selection of significantly differentially expressed genes participating to the *NF-κB* signaling pathway in the colonocytes of rats fed an HPD when compared to an NPD. The expression values were obtained by microarray experiment and normalized to the mean value in the NPD group. *Nfkbie* (NF-κB inhibitor epsilon), *Rela* (RELA proto-oncogene, NF-κB subunit), *Nfkb1* and 2 (NF-κB subunit 1 and 2), *Traf2* and 6 (TNF receptor associated factor 2 and 6) gene expressions are presented. Data presented on histograms are means \pm S.E.M.

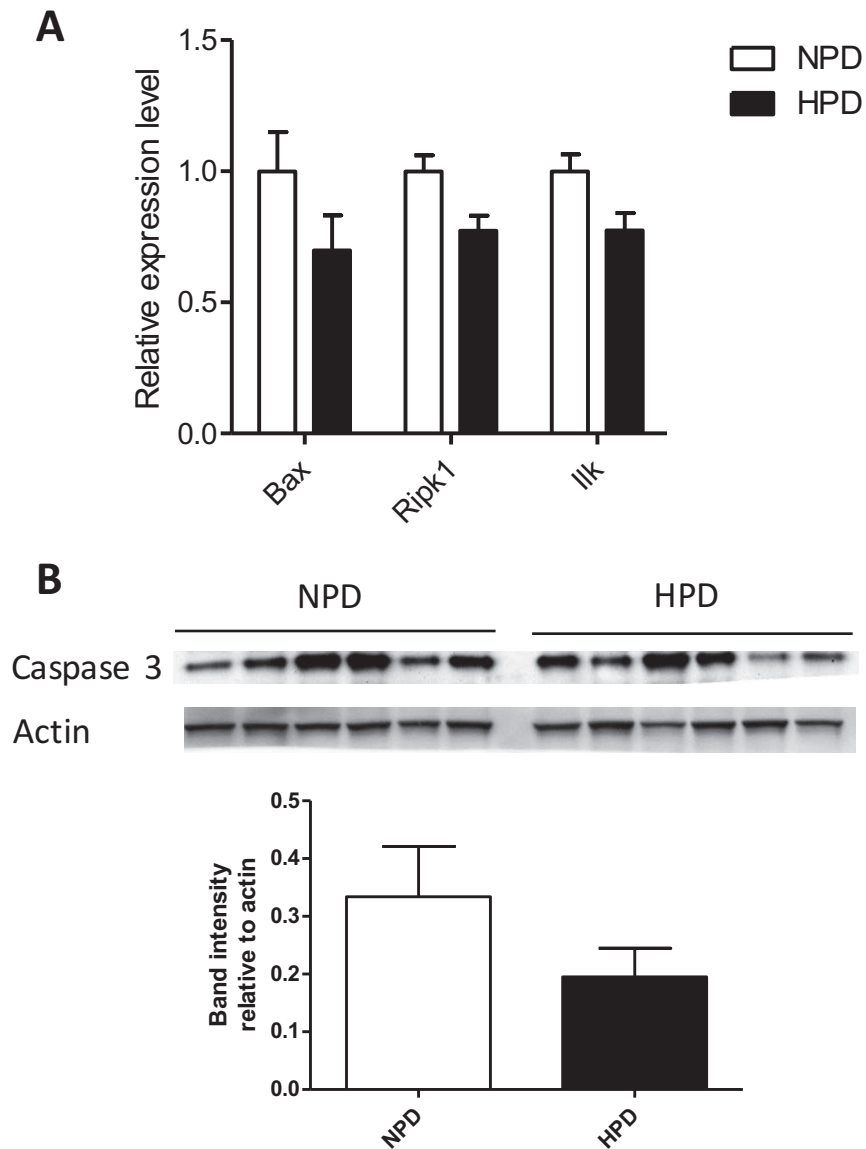

Fig. 5: A - Relative expression values of a selection of significantly differentially expressed genes participating to the enriched pathway *Cell death* in the colonocytes of rats fed a high-protein diet (HPD) when compared to a normal-protein diet (NPD). The expression values were obtained by microarray experiment and normalized to the mean value in the NPD group. *Bax* (BCL2 associated X, apoptosis regulator), *Ripk1* (receptor interacting serine/threonine kinase 1), *Ilk* (integrin linked kinase) gene expressions are presented. B - The expression of the apoptotic marker activated caspase 3 protein was quantified by western blot in colonocytes of rats fed an HPD or an NPD. Band intensity was quantified and normalized to the intensity of the band corresponding to actin. For each protein, mean values were compared with a t test. A - B: Data presented on histograms are means \pm S.E.M.

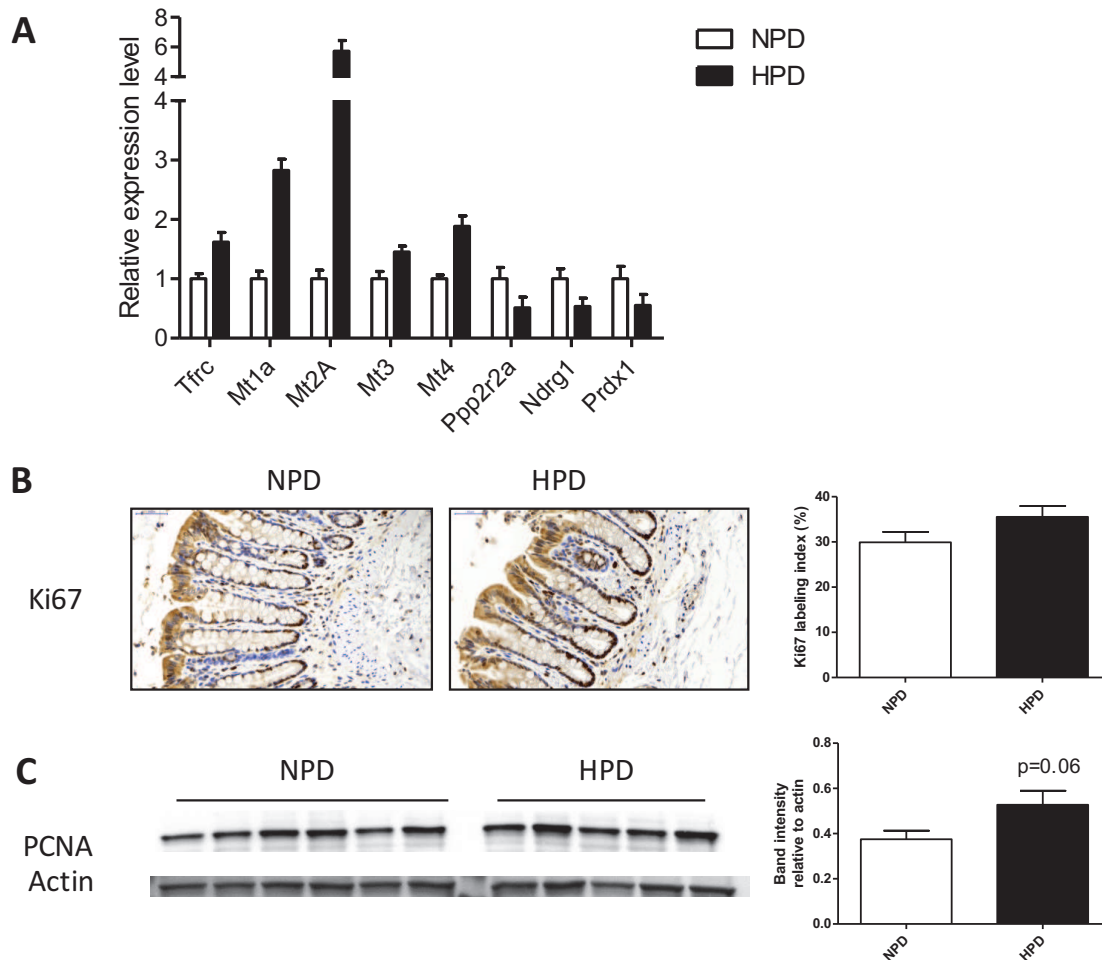

Fig. 6: A - Relative expression values of a selection of significantly differentially expressed genes related to proliferation in the colonocytes of rats fed a high-protein diet (HPD) when compared to a normal-protein diet (NPD). The expression values were obtained by microarray experiment and normalized to the mean value in the NPD group. *Tfrc* (transferrin receptor), *Mt1a*, *2a*, *3* and *4* (metallothionein 1A, 2A, 3 and 4), *Ppp2r2a* (protein phosphatase 2 regulatory subunit B alpha), *NdrG1* (N-myc downstream regulated 1), *Prdx1* (peroxiredoxin 1). B - Staining of Ki67 by immunohistochemistry on rat distal colon of rats fed an NPD or an HPD. Ki67 labelling index was calculated as the percentage of Ki67 positive cells relative to the total number of cells within the same crypts. C - Proliferating cell nuclear antigen (PCNA) protein expression was quantified by western blot in colonocytes of rats fed an HPD or an NPD. Band intensity was quantified and normalized to the intensity of the band corresponding to actin. B - C: Mean values were compared with a t test. A - C: Data presented on histograms are means +/- S.E.M.

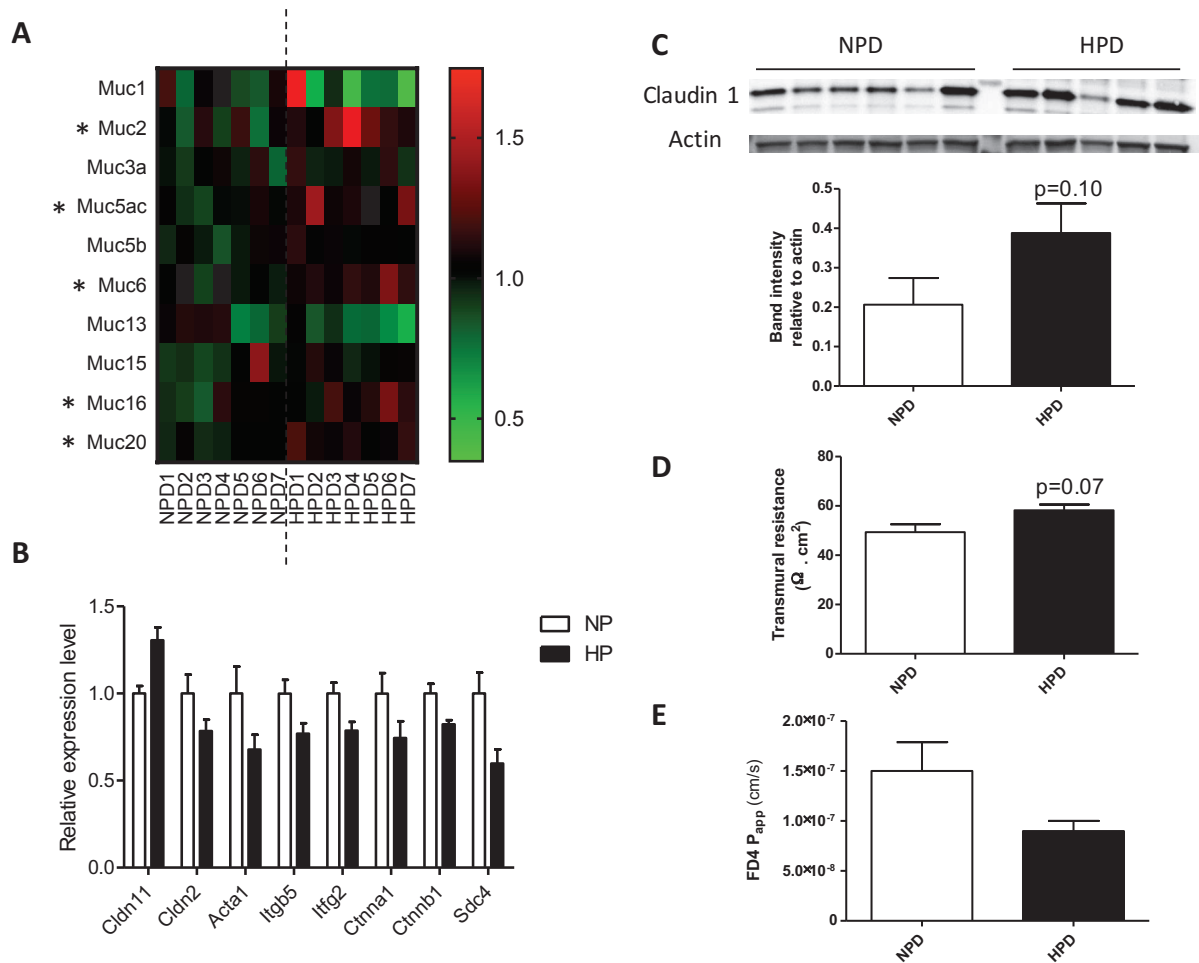

Fig. 7: A - Heatmap representing the expression values of mucin genes in colonocytes (*Muc*). Each row corresponds to one *Muc* gene. Each column corresponds to a single rat fed a normal-protein diet (NPD), or a high-protein diet (HPD). The color indicates the relative expression value (as indicated by the key) obtained from microarray experiment and normalized to the mean value in the NPD group. Mean expression values of the HPD and the NPD groups were compared with a t test. *: $p < 0.05$. B - Relative expression values of a selection of significantly differentially expressed genes participating to the enriched pathways *Integrin Signaling* and *Tight Junction Signaling* in the colonocytes of rats fed a HPD when compared to a NPD. The expression values were obtained by microarray experiment and normalized to the mean value in the NPD group. *Cldn11* and 2 (claudin 11 and 2), *Acta1* (actin, alpha 1, skeletal muscle), *Itgb5* (integrin subunit beta 5), *Ctnna1* (catenin alpha 1), *Ctnnb1* (catenin beta 1), *Itfg2* (integrin alpha FG-GAP repeat containing 2), *Scd4* (syndecan 4) gene expressions are presented. C - Claudin 1 protein expression was assessed by western blot in colonocytes of rats fed an HPD or an

NPD. Band intensity was quantified and normalized to the intensity of the band corresponding to actin. E - F: Barrier function was evaluated with Ussing-chambers in distal colon of rats fed an NPD or an HDP. E - Transmural resistance was measured for 15 minutes after mucosa mounting in the chamber. F - FITC-dextran (FD4) transport from mucosal to serosal side was recorded during two hours and FD4 apparent permeability (FD4 P_{app}) was calculated. C - E: For each parameter, mean values were compared with a t test. B - E: Data presented on histograms are means +/- S.E.M.

SUPPLEMENTARY FIGURES

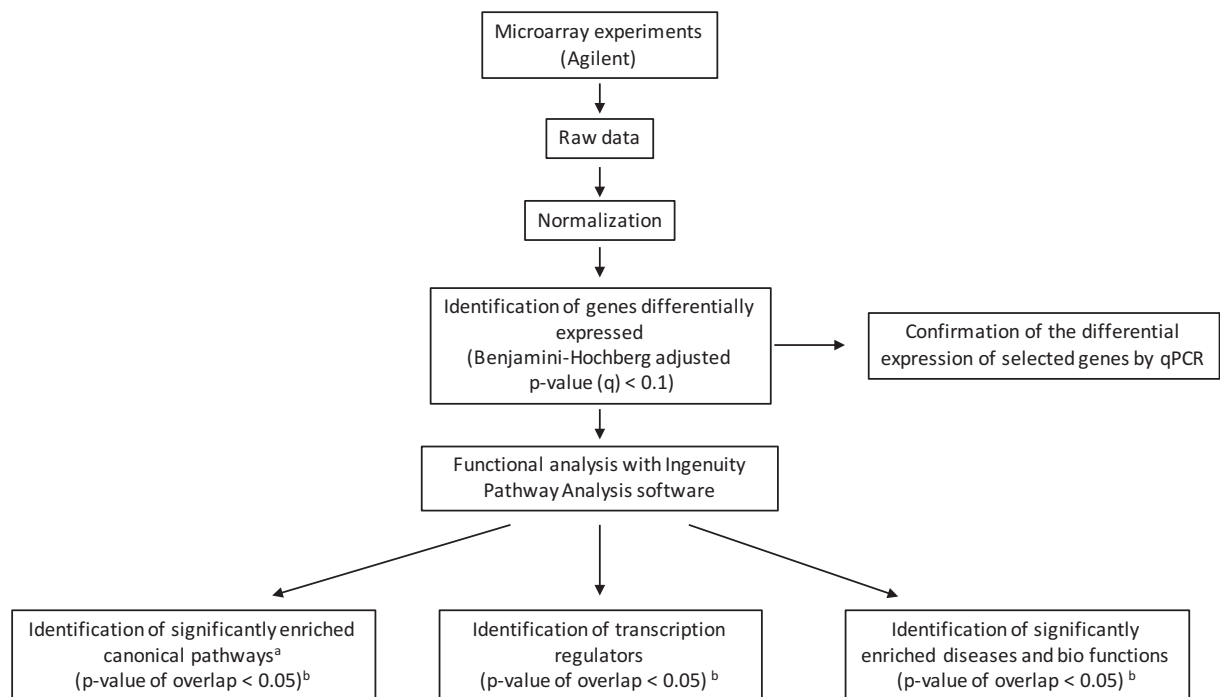

Fig. S1: Flow diagram of the transcriptome analysis in colonocytes of rats fed with a normal or a high-protein diet. a: for canonical pathways, Z-score statistics are calculated and indicate whether the canonical pathway is predicted to be activated (Z-score > 2) or inhibited (Z-score < 2). b: the p-value of overlap measures whether there is a statistical significant overlap between the set of genes differentially expressed between the two groups and the set of genes known to be associated with a given process or pathway. All the statistics were obtained with Ingenuity Pathways Software.

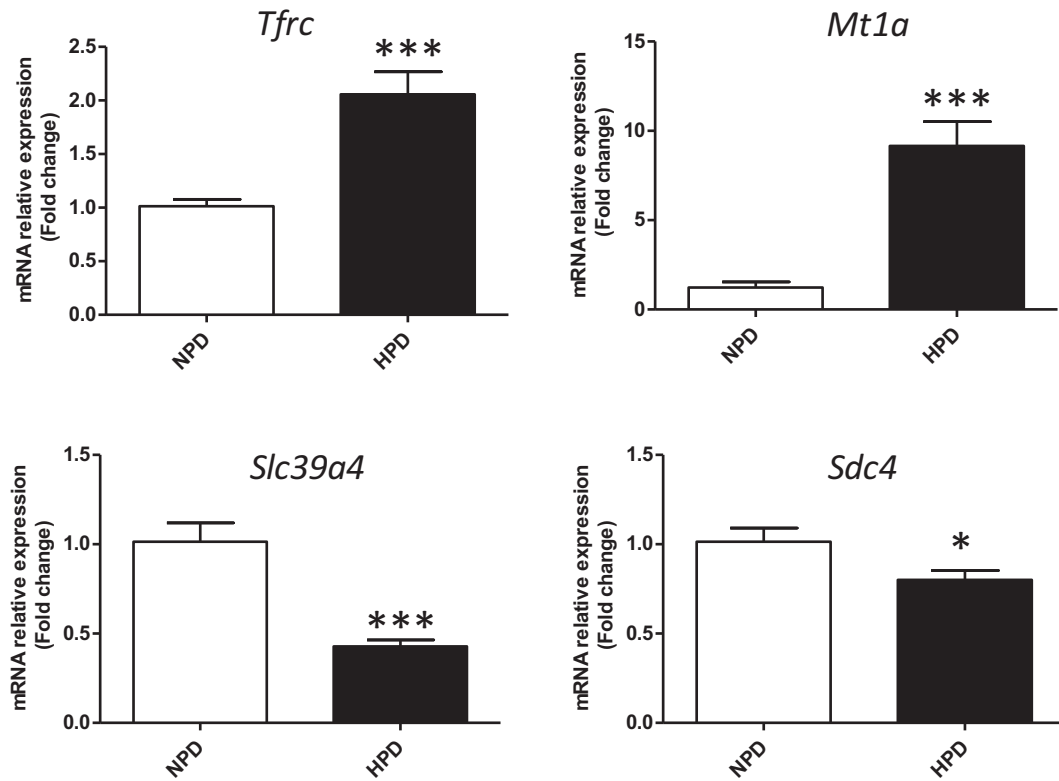
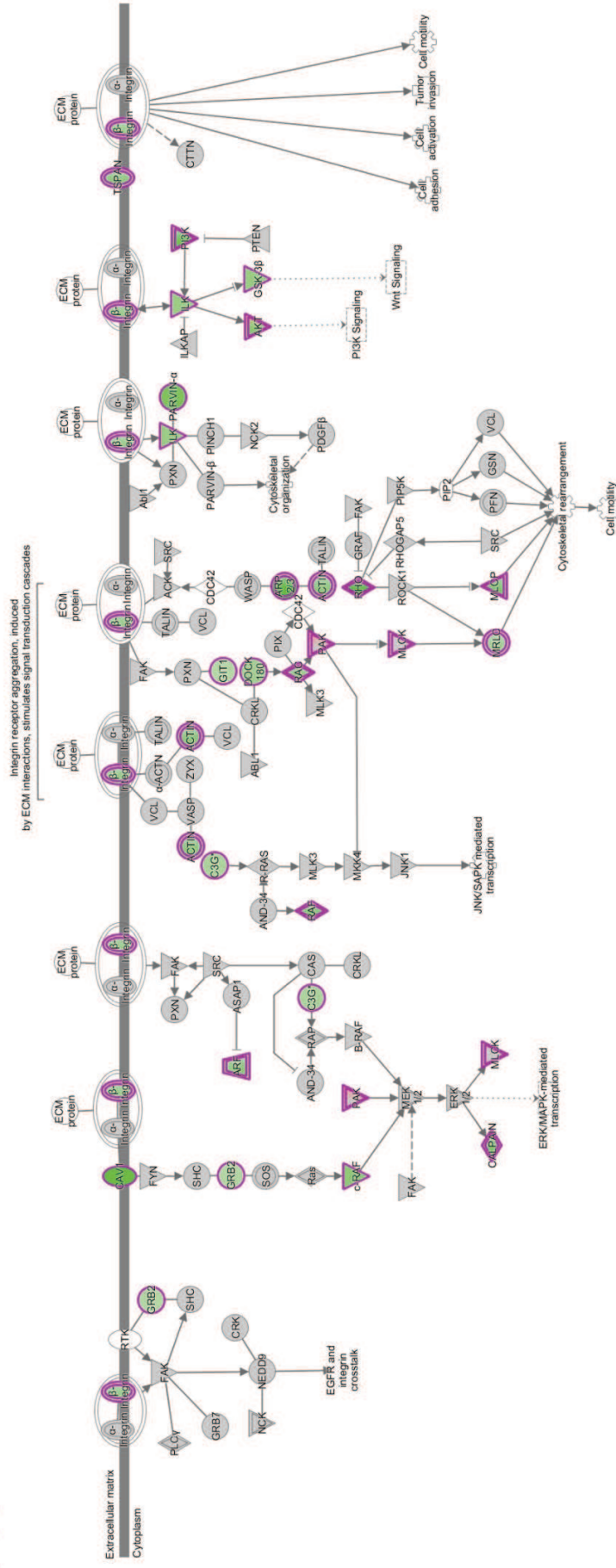

Fig. S2: Validation of microarray data on differentially expressed genes of interest. Relative mRNA levels were measured by qPCR in colonocytes isolated from rats fed a normal-protein diet (NPD) or a high-protein diet (HPD). *Mt1a* (metallothionein 1A), *Sdc4* (syndecan 4), *Tfr* (transferrin receptor), *Slc39a4* (solute carrier family 39 zinc transporter, member 4). Data presented are means +/- S.E.M. For each gene, mean values were compared with a t test. *: p<0.05, ***: p<0.001.



© 2000-2015 CALGENE. All rights reserved.

Fig. S3: *Integrin signaling* canonical pathway diagram. This pathway was significantly enriched in the set of genes regulated by the high-protein diet. The diagram was obtained from Ingenuity Pathway Analysis software and depicts genes implicated in this pathway and their interactions. Expression of genes colored in green were downregulated ($q < 0.1$) in colonocytes of rats fed a high-protein diet when compared to a normal-protein diet.

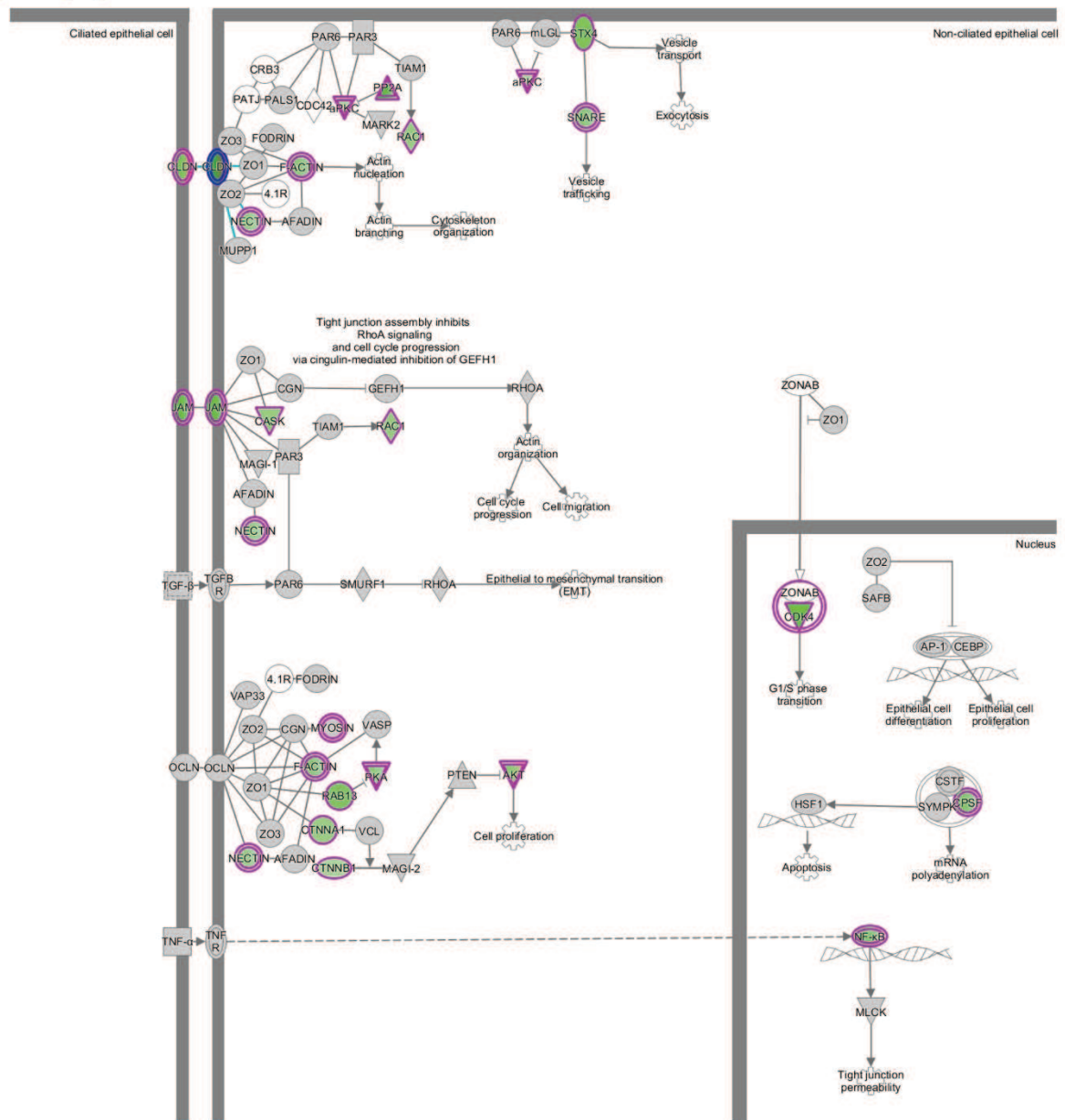

Fig. S4: *Tight-junction signaling* canonical pathway diagram. This pathway was significantly enriched in the set of genes regulated by the high-protein diet. The diagram was obtained from Ingenuity Pathway Analysis software and depicts genes implicated in this pathway and their interactions. Expression of genes colored in green were downregulated ($q < 0.1$) in colonocytes of rats fed a high-protein diet when compared to a normal-protein diet.

ETUDE 4 : EFFETS DE LA QUANTITE ET DE LA QUALITE DES PROTEINES ALIMENTAIRES SUR LA COMPOSITION DU MICROBIOTE INTESTINAL, SUR LES METABOLITES BACTERIENS ET SUR LA MUQUEUSE RECTALE CHEZ L'HOMME EN SURPOIDS

Article en préparation.

Contexte

L'alimentation est un des facteurs contrôlant la composition et l'activité métabolique du microbiote intestinal. Néanmoins, les effets des protéines alimentaires sur ces paramètres sont peu connus alors que la dégradation des acides aminés (AA) par les bactéries libère dans la lumière du côlon des métabolites actifs sur l'épithélium. Chez l'homme, les conséquences sur la muqueuse du gros intestin d'une modification de l'apport en protéines ne sont pas connues. Le but de cette étude était de déterminer, chez des volontaires en surpoids, les effets de la quantité et de la qualité de l'apport en protéines sur la composition du microbiote intestinal, sur les métabolites bactériens et sur la muqueuse rectale.

Méthodes

42 volontaires en surpoids ont participé à une étude d'intervention nutritionnelle randomisée et en double aveugle. Après deux semaines de normalisation de l'alimentation, les participants ont suivi pendant 3 semaines une supplémentation isocalorique en caséines (CAS), ou en protéines de soja (SOY) ou en maltodextrines (MD, groupe témoin) (Figure 32 A). Des échantillons de sang, d'urine, de fèces et des biopsies rectales ont été collectés au cours de l'étude. Les apports alimentaires ont été évalués à la fin de chaque période et l'urée a été dosée dans le plasma (marqueur de la consommation de protéines) (Figure 32 B). La composition du microbiote a été analysée par séquençage du gène de l'ARNr 16S dans les fèces. Les métabolites produits par les bactéries intestinales ont été étudiés par des méthodes ciblées et par métabolomique par RMN ¹H dans les fèces et les urines. La cytotoxicité des eaux fécales a été évaluée *in vitro* sur des cellules HT-29. Le transcriptome dans la muqueuse rectale a été analysé par des puces à ADN. Enfin, des indicateurs de l'immunité dans la muqueuse ont été évalués.

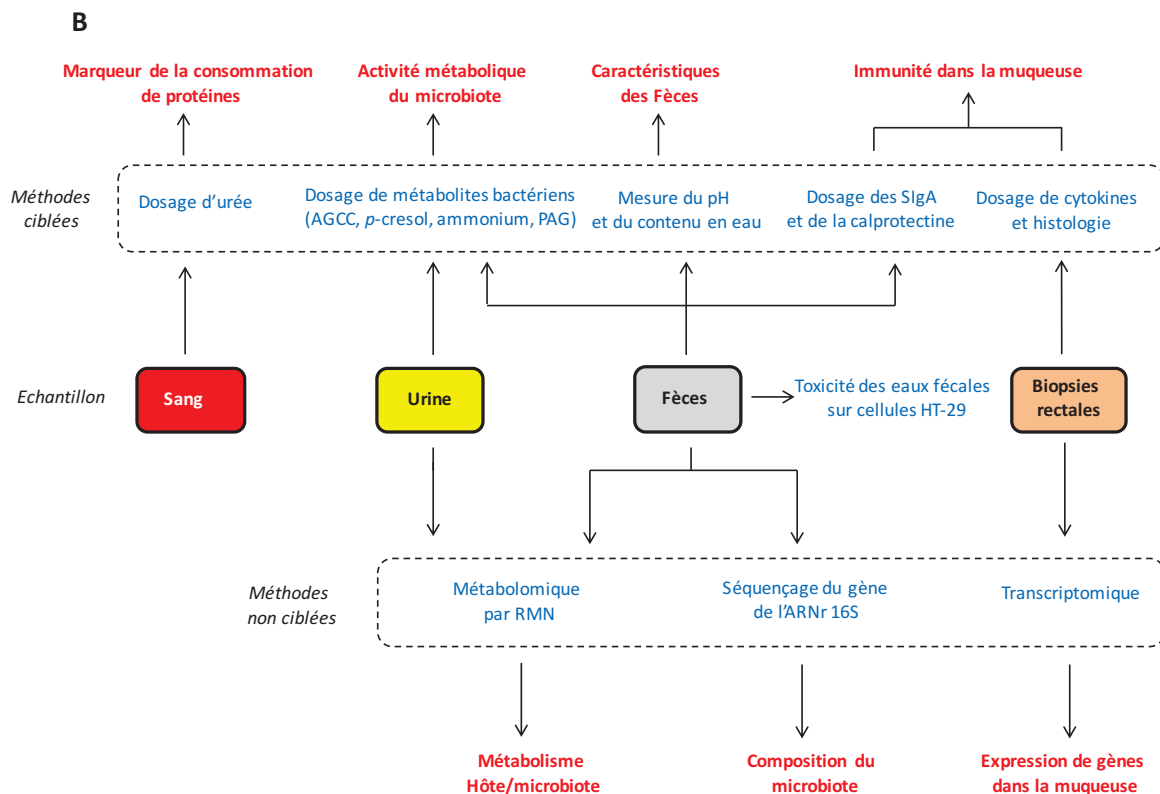
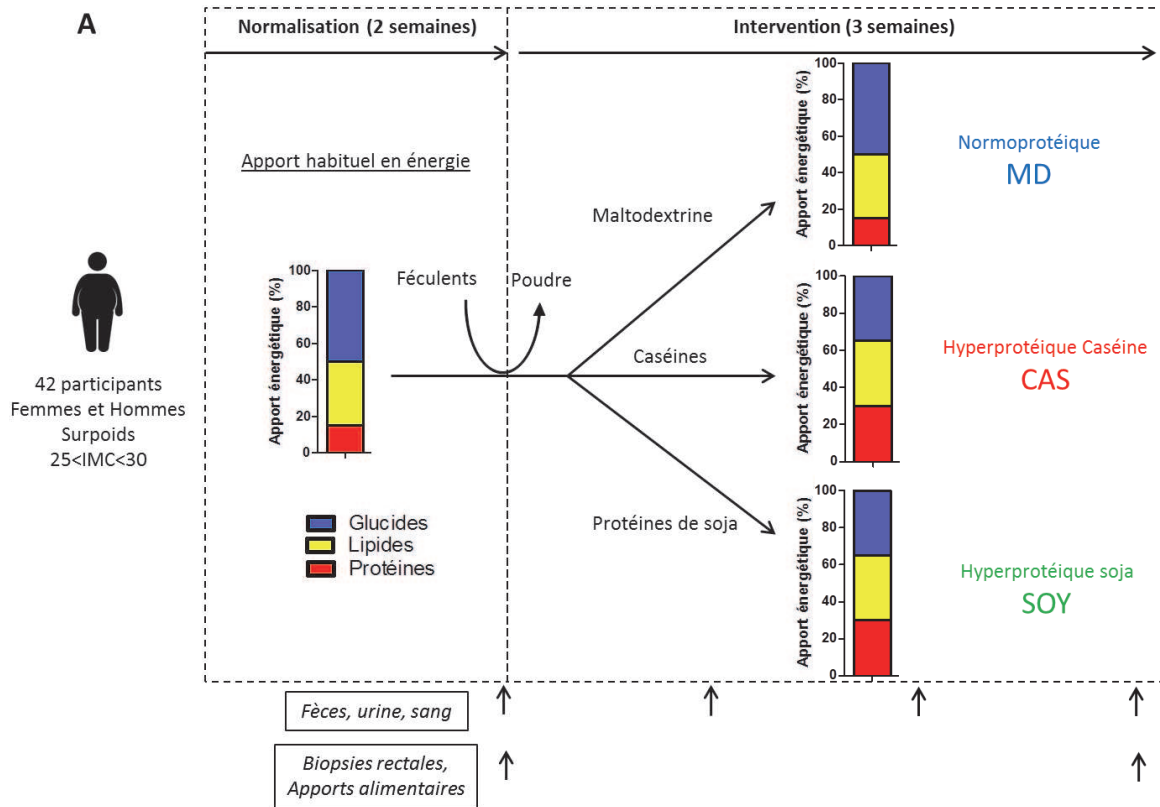

Figure 32 : A - Représentation schématique du protocole expérimental de l'étude 4. B - Représentation schématique des analyses effectuées. AGCC : acides gras à courtes chaînes, PAG : phénylacetylglutamine, SIgA : immunoglobulines A sécrétoires.

Résultats

L'intervention nutritionnelle a eu peu d'effets sur la composition du microbiote fécal. Les suppléments en protéines (CAS et SOY) ont induit une diminution de la concentration fécale en butyrate et une augmentation de la concentration fécale ou urinaire de plusieurs métabolites bactériens dérivés des AA par rapport au groupe témoin (MD). Des profils distincts de métabolites bactériens ont été observés en fonction de la source de protéines utilisée et le pH fécal a augmenté fortement dans le groupe CAS uniquement. Ces modifications n'étaient pas associées à une modification de la cytotoxicité des eaux fécales. Dans la muqueuse rectale, les régimes CAS et SOY ont régulé l'expression de gènes impliqués dans des fonctions cruciales pour le maintien de l'homéostasie et certaines de ces modifications étaient spécifiques de la source de protéines utilisée. Enfin, l'augmentation de l'apport en protéines n'a pas modifié les paramètres liés à l'inflammation intestinale.

Conclusion

La quantité et la qualité de l'apport en protéines influencent le profil de métabolites produits par le microbiote intestinal mais n'ont pas d'effets marqués sur sa composition. Le changement d'environnement luminal induit par un apport élevé en protéines est associé à une modification du transcriptome dans la muqueuse rectale. Les régimes HP pourraient donc avoir des conséquences sur l'homéostasie du gros intestin et ces effets pourraient être modulés par la source de protéines.

Messages clés de l'étude 4

- L'apport en protéine n'a pas d'effets marqués sur la composition du microbiote fécal.
- Un apport élevé en protéines augmente les concentrations fécales et urinaires de métabolites bactériens dérivés des AA et diminue la concentration fécale de butyrate.
- Le profil de métabolites bactériens est déterminé en partie par la source de protéines.
- Une augmentation de l'apport en protéines n'augmente pas la cytotoxicité des eaux fécales.
- La quantité et la qualité de l'apport en protéines modifient l'expression de gènes impliqués dans le maintien de l'homéostasie de la muqueuse rectale.
- Un apport élevé en protéines n'induit pas d'inflammation dans la muqueuse rectale.

**Quantity and quality of dietary protein alter the metabolites produced by the gut microbiota
and impact rectal mucosa gene expression in overweight humans**

Beaumont, M.¹, Portune, K.J.², Steuer, N.^{1,3}, Lan, A.¹, Audebert, M.⁴, Dumont., F.⁵, Mancano, G.⁶,
Khodorova, N.¹, Andriamihaja, M.¹, Airinei, G.^{1,3}, Tomé, D.¹, Benamouzig, R.^{1,3}, Davila, A.M.¹, Sanz,
Y.², Claus, S.P.⁶, Blachier, F.^{1*}.

¹UMR PNCA, AgroParisTech, INRA, Université Paris-Saclay, Paris, France

²Microbial Ecology, Nutrition & Health Research Unit. IATA-CSIC, Valencia, Spain

³Department of Gastroenterology, Hôpital Avicenne, Assistance Publique-Hôpitaux de Paris, Bobigny,
France

⁴Toxalim (Research Centre in Food Toxicology), Université de Toulouse, INRA, ENVT, INP-Purpan,
UPS, Toulouse, France

⁵Genomic platform, Institut Cochin, Paris, France

⁶Department of Food and Nutritional Sciences, The University of Reading, Reading, United Kingdom

*Corresponding Author:

Dr. François Blachier

UMR PNCA, INRA, AgroParisTech

16 rue Claude Bernard

75005 Paris, France

françois.blachier@agroparistech.fr

ABSTRACT

Objective

The intestinal microbiota has emerged as an important regulator of human health notably through the production of bacterial metabolites. Diet is a major factor controlling host-bacteria cross-talk but little is known about the effects of dietary protein. However, some bacterial amino acid-derived metabolites have been shown to be detrimental for the colonic epithelium. The objective of this study was to evaluate the effects of the quantity and quality of protein intake on the microbiota composition, on bacterial metabolites and on the consequences for the rectal mucosa in humans.

Design

This randomized, double-blind, parallel-design trial was conducted in 38 overweight individuals who received a 3 weeks isocaloric supplementation with casein (CAS), soy protein (SOY) or maltodextrin (MD) as control. Fecal microbiota composition was analyzed by 16S rRNA gene sequencing, fecal and urinary metabolome were assessed by ¹H-NMR and mucosal transcriptome in rectal biopsies was determined with microarrays. This high-throughput profiling was completed with targeted measurements of related parameters.

Results

The dietary intervention had very limited effects on fecal microbiota composition. In contrast, supplementation with dietary protein induced a shift in bacterial metabolism towards amino acid degradation. The CAS and SOY diets were associated with a specific metabolic signature characterized by a decrease in butyrate concentration in feces in both cases and an increase in amino acid-derived metabolite concentrations in feces and urine, with different profiles according to the protein source, indicating the importance of this parameter in the control of bacterial metabolism. Despite the changes in fecal bacteria metabolites concentrations, fecal water cytotoxicity was not modified by the dietary intervention. However, the CAS and SOY high-protein diets markedly regulated the expression of genes playing key roles in homeostatic processes such as epithelial renewal in rectal mucosa. Finally, no sign of intestinal inflammation was detectable after 3 weeks of protein supplementation.

Conclusion

This study reveals that quantity and quality of protein intake are two important factors for the control of the production of metabolites by the microbiota but not for its composition. These effects were associated with a regulation of crucial biological pathways in the rectal mucosa at the gene expression level. High-protein diets may therefore be considered with some caution as they might have consequences relevant to the health of the large intestine.

Key words: high-protein diet, amino acid, gut microbiota, protein fermentation, fecal water, cytotoxicity, transcriptomics, metabolomics, large intestine, inflammation.

Abbreviations:

AA: amino acid

BCFA: branched chain fatty acid

CAS: casein

DEG: differentially expressed gene

H₂S: hydrogen sulfide

HPD: high-protein diet

MD: maltodextrin

NH₄⁺: ammonia

O-PLS-DA: orthogonal projection to latent structure discriminant analyses

SCFA: short chain fatty acid

SOY: soy protein

INTRODUCTION

Recent studies have highlighted the pivotal role of the gut microbiota in human health and disease [1]. Among several environmental factors, long term diets and short-term dietary modifications have been shown to regulate the composition of the gut microbiota and its metabolic activity [2]. Most of the clinical studies focused on indigestible carbohydrates, while the effects of dietary protein on the gut microbiota have been much less studied. Yet, around 12 g of undigested protein and peptides reach the colon every day [3] and this quantity is increased during high-protein diet (HPD) that are frequently used for weight loss [4,5]. Some studies in humans have shown that HPD induce changes in the gut microbiota composition mainly characterized by a decrease in presumed beneficial bacterial groups [6–8] while another study did not confirm this result [9]. In addition, HPD induces a shift toward protein degradation by the gut microbiota [8–11]. While carbohydrate fermentation mainly produces the short chain fatty acids (SCFA) acetate, propionate and butyrate, which are believed to be beneficial for the colonic mucosa, the metabolic output of protein catabolism by the gut microbiota is far more diverse [12,13]. In addition to the aforementioned SCFA, amino acid (AA) fermentation specifically releases branched chain fatty acids (BCFA: 2-methylbutyrate, isobutyrate and isovalerate) and valerate [14]. AA degradation by the gut bacteria also produces ammonia (NH_4^+), hydrogen sulfide (H_2S), phenolic and indolic compounds, amines and polyamines. Some of these metabolites are detrimental for the colonic epithelium when they are present at excessive concentration (H_2S , *p*-cresol, NH_4^+) [15–17] while some others such as indolic compounds contribute to the maintenance of the epithelial barrier function [18–20].

Since microbial products of AA degradation are produced in combination during HPD, the effects of these diets on the large intestine mucosa are difficult to predict. As HPD are considered beneficial for metabolic health in overweight or obese individuals [21], there is a crucial need to evaluate the safety of these diets, notably at the level of the large intestine, for risk-benefit assessment. Indeed, there is no defined upper value of protein consumption with no adverse effect. In animal experiments, HPD impaired colonocyte morphology, mitochondrial metabolism, increased mucus secretion but did not

induced inflammation nor impaired colonic barrier function [22–24]. In humans, HPD did not increase fecal water toxicity and genotoxicity *in vitro* [9,25]. However, the effects of HPD on the large intestinal mucosa have never been evaluated directly in humans whereas some (but not all) epidemiological studies suggest that a high level of protein intake is associated with an increase inflammatory bowel disease incidence and relapse [26–28].

An important limit of most of the previous human studies on the effects of HPD on the large intestine ecosystem is the combination of the high level of protein intake with a low fiber intake or with a caloric restriction, precluding a direct interpretation of the effects of dietary protein *per se*. Moreover, the effect of protein source (from animals or plants) has never been investigated despite their different digestibility and AA composition [29,30] potentially leading to divergent effects on the colonic luminal environment. In this context, the aim of the present study was to evaluate in humans the effect of the quantity and quality of protein intake on the gut microbiota composition and bacterial metabolites together with the consequences for the large intestine mucosa. Protein isolates (from casein and soy) were used to minimize confusion with other factors present in protein-containing foods such as meat (e.g. heme) and to allow the use of an isocaloric control (maltodextrin, a digestible carbohydrate). The participants of this randomized and double-blind trial were overweight men and women since these people use HPD for weight-loss [31]. The effects of the dietary intervention were evaluated primarily by high-throughput methods for an unbiased approach.

METHODS

Subjects

Forty-two healthy male and female participants were recruited in Avicenne hospital, Bobigny, France. Inclusion criteria were: 18 to 45 years old, overweight ($25 < \text{BMI} < 30$), weight stable within the last 3-months and moderate physical activity. The main exclusion criteria were: gastrointestinal disease, antibiotics, prebiotics or probiotics use within the last 3 months, intolerance to the study dietary supplements and smoking. All subjects had normal range values for blood general health markers notably related to kidney and hepatic function. This study was approved by the Comité de Protection des Personnes Ile de France XI (CPP, ref. 14029) and authorized by the Agence Nationale de Sécurité du Médicament et des produits de santé (ANSM, ref. 140198B-21). All volunteers gave written informed consent. This trial was registered on clinicaltrial.gov (NCT02351297).

Dietary intervention

The study was conducted as a double-blind, randomized, 3-arms parallel trial consisting of 2-weeks run-in (dietary normalization) followed by a 3-weeks intervention period. Before the beginning of the study, individual habitual energy and macronutrients intakes of the participants were assessed by a dietician with 3-days food diaries. During the run-in period, the participants were instructed to eat according to individualized menus corresponding to a normal protein diet providing their own habitual energy intake with 15, 50 and 35% of the energy provided by proteins, carbohydrates and lipids, respectively. During the intervention period, the participants were instructed to decrease their energy intake by 15% with a decrease in starchy food intake according to provided menus. To maintain the diet isocaloric compared to the run-in period, participants consumed 3 times per day dietary supplements provided in opaque bags (double-blind study) by dissolving the contained powder in water (one at breakfast, one at lunch and one at dinner). Participants were randomly allocated into three groups who received either dietary supplements composed of plant protein (isolated soy protein, Supro670IP, Solae, France) for the SOY group or animal protein (milk protein isolate enriched in micellar casein (92%), Prodiet85B, Ingredia, France) for the CAS group or digestible carbohydrate as isocaloric control

(maltodextrin, Glucidex19, Roquette, France) for the MD group. All of the dietary supplements contained chocolate aroma (Colin, France) to allow good compliance. The amount of powder was calculated for each participant to provide 15% of his own usual energy intake. At the end of the run-in (baseline) and at the end of the intervention period, the dietary intakes of the participants were assessed by a dietician with 3-days food diaries that were entered in Nutrilog software to calculate energy and macronutrient intakes.

Sample collection and biochemical measurements

At baseline and every week during the intervention period, overnight-fasted participants visited the clinical center. At each visit, blood, urine (morning spot mixed with NaN₃ 1%) and stool samples (kept in a portable freezer) were obtained. Immediately after sample collection, blood urea was measured with an automated procedure in biochemistry department, Avicenne hospital, Bobigny, France. Stool water content was determined after evaporation (55°C, 24 h) and fecal pH was measured with a pH meter equipped with a penetration electrode. At baseline and at the end of the dietary intervention, rectal mucosal biopsies were collected through a colonoscope at the rectosigmoid junction (at about 15 cm from the anal verge), one biopsy was used for histological analysis (routinely hematoxylin & eosin stained in Avicenne hospital), one biopsy was kept over-night in RNA-later for RNA extraction and other biopsies were immediately frozen in liquid nitrogen. All samples were stored at -80°C until analyses.

Fecal microbiota composition

Frozen fecal samples (200 mg) were homogenized with glass beads in Inhibitex buffer (Qiagen) in a beadbeater for 1 min twice. Samples were then heated to 95°C for 10 minutes. DNA extraction was carried out using a Fast DNA Stool Mini Kit (Qiagen). Samples were amplified in triplicate via PCR using primers (S-D-Bact-0341-b-S-17 / S-D-Bact-0785-a-A-21) that target the V3-V4 variable regions of the 16S rRNA gene [32]. Each sample was tagged with a barcode to allow multiplexing during the sequencing process. Triplicate reactions consisted of final concentrations of Buffer HF (1X), dNTPs (0.11 µM) primers (0.29 µM each) and Taq Phusion High Fidelity (0.007 U/µl) in final volumes of 35

μL . Cycling conditions consisted of 98°C for 3 min, followed by 25 cycles of 95°C for 20 seconds, 55°C for 20 seconds, and 72°C for 20 seconds, followed by a final extension step of 72°C for 5 minutes. Triplicate sample amplicons were combined and purified using the Illustra GFX PCR DNA and Gel Band Purification Kit (GE Healthcare) according to the manufacturer's instructions and combined in equimolar concentrations before carrying out sequencing on a MiSeq instrument (Illumina). Bioinformatic processing of data was carried out using the software Qiime (Caporaso et al., 2010) and Mothur (Schloss et al., 2009). Paired-end forward and reverse Illumina reads were joined into contigs using the script `join_paired_ends.py`. Barcodes were extracted using `extract_barcodes.py` and reads were demultiplexed and quality filtered using `split_libraries_fastq.py`. Primers were then removed using the script `trim.seqs` from the software program Mothur. Using the Qiime script `pick_open_reference_otus.py`, reads were clustered at 97% identity using an open OTU-picking approach and then aligned, after which OTU tables and phylogenetic trees were constructed. Singletons were removed using `filter_otus_from_otu_table.py` and subsampling of the OTU table to the lowest number of sequences between all samples was performed using the script `single_rarefaction.py`.

Metabolic profiling by ^1H NMR

Urine samples (1 mL) were freeze-dried and resuspended in 650 μL NMR buffer (sodium phosphate 0.2 M, pH 7.4, TSP 1mM, 80% D_2O , 20% H_2O). Fecal samples (70 mg) were homogenized in 1.3 mL of NMR buffer for 5 min at 25 Hz in a tissue lyser (Qiagen). All homogenized samples were centrifuged (10 min, 4°C , 13 000 rpm) and transferred to 5 mm NMR tubes for analysis by NMR spectroscopy. The NMR experiments were carried out in the Chemical Analysis Facility of the University of Reading using a Bruker AV700 NMR instrument equipped with a 5 mm inverse CryoProbe[®] from the same manufacturer. All samples were analyzed at 300°K by ^1H -1D NOESY-PRESAT (noesypr). A representative sample of urine and fecal water were also characterized by 2D NMR using homonuclear ^1H - ^1H 2D COSY. In addition, the urine sample was also characterized by heteronuclear ^{13}C - ^1H HSQC experiments. All spectra were manually phased, baseline corrected and calibrated to the chemical shift of TSP using MestreNova (version 10.0m MestreLab Research). Urine spectra were manually aligned to correct shifting. Metabolites were assigned using 2D NMR experiments, STOCSY analysis [33],

online databases and data from literature. All processed spectra were digitalized and imported in Matlab (version 2014b). The residual water signal was removed and signal intensities were normalized to the total spectral area. Spectra relative to baseline were obtained by subtracting baseline signal intensities to signal intensities measured after 1, 2 or 3 weeks of dietary intervention. Relative spectra were mean centered and scaled to unit variance. Principal component analyses were used to observe the general variation in the datasets and to detect potential outliers. Orthogonal projection to latent structure discriminant analyses (O-PLS-DA) with 1 orthogonal component were used to compare the changes from baseline in metabolite concentration between groups. Relative NMR spectra were used as variable matrix (X) for modeling dietary groups as predictors (Y). Quality of statistical models was evaluated by the following parameters: R^2Y (goodness of fit, percentage of variation of Y explained by the model) and Q^2Y (goodness of prediction, percentage of Y predicted after a 7-fold cross-validation). This evaluation of the quality of the models was completed by visual observation of the plot of the scores (T) versus cross-validated scores (T-cv). Discriminant metabolites were identified based on visual examination of loadings plot color-coded according to correlation coefficient (r^2) of signal intensity with Y and based on comparison of individual spectra. In order to identify specific metabolic association with other measured parameters (bacterial relative abundances, pH, fecal water cytotoxicity) O-PLS models with 1 orthogonal component were used where NMR spectra were used as variable matrix (X) and linearly regressed to the variable of interest (Y).

Bacterial metabolites targeted measurements

Fecal SCFA and ammonia were extracted in ultrapure water by centrifugation (14 000 g, 15 min, 4°C) after vigorous homogenization. Supernatant was used for measurement of SCFA concentration in feces by gas chromatography after esterification as previously described [34]. For fecal ammonia assay, supernatant was deproteinized by filtration (30K Nanosep, Pall) and ammonia concentration was measured with an enzymatic colorimetric method according to the kit manufacturer instructions (Ammonia Kit, Megazyme). Fecal *p*-cresol was measured by HPLC with a method modified from a previously published method [35]. After homogenization of 180 mg of stool sample in 2.5 mL phosphate buffer (pH 5.8) and centrifugation (10 000 g, 5 min, 4°C), the supernatant was mixed in glass tubes with

25 μL internal standard (*p*-chlorophenol, 250 $\mu\text{g}/\text{mL}$) and 1 mL HCl before boiling 1 hour. After cooling, phenols were extracted in 2 mL diethylether by vortex. After centrifugation (500 g, 10 min, 4°C), the organic layer was mixed with 1.5 mL 0.05 NaOH in methanol before evaporation under a stream of nitrogen. Phenols were re-suspended in 125 μL ultrapure water before filtration (0.45 μM). The HPLC analysis was performed on Shimadzu Prominence system (Shimadzu Corp), consisting of LC-20AB solvent delivery system, SIL-20AC auto sampler and SPD-20 UV-detector. Phenols were separated on an Alltima C18 column (150 mm x 4.6 mm i.d., 5 μm particle size; Grace) in isocratic mode with the column temperature set at 35 °C. The mobile phase was a mixture of methanol and 0.02 M phosphate buffer pH 4.0 (48:52 v/v) delivered at a flow rate of 0.7 ml/min. Injection volume was 25 μL . The peak of *p*-cresol was detected at 270 nm and retention time was 6.3 min. The chromatograms were recorded and integrated using LC solutions (Shimadzu). *p*-cresol concentration was determined according to an external standard curve. For phenylacetylglutamine quantification, urine was diluted in ultrapure water (1:5 v/v) and filtered (0.2 μM) prior to injection. Samples were analyzed using the same HPLC system as described for *p*-cresol analysis. Chromatographic separation was achieved using Alltima C18 column (250 mm x 4.6 mm i.d., 5 μm particle size; Grace). Column temperature was set to 40°C and the eluents A and B were 0.1% acetic acid in water and acetonitrile, respectively. The gradient was run at 0.4 mL/min and consisted of an isocratic elution for 0.5 min of 5% B, and then B was increased at a linear rate to 30% at 14 min, followed by 2 min of isocratic elution, then increased linearly to 40% at 20 min and then re-equilibrated for 5 min with 5% B and held at 5% B until 40 min. Injection volume was 5 μL . The peak of phenylacetylglutamine was detected at 214 nm and the retention time was 26.8 min. The concentration was determined according to an external standard curve.

Fecal water toxicity

Fecal samples were homogenized in cell culture medium (DMEM, 1:5 w/v) with steel beads using a Tissue Lyzer (Quiagen) set to 25 Hz for 5 min. After centrifugation (20 000 g, 15 min, 4°C), supernatant (fecal water) were filtered (0.22 μM) and stored at -80°C. HT29 Glc^{+/+} cells (P44 - 47) were cultured in α -MEM supplemented with 10% fetal bovine serum and Penicillin / Streptomycin. For fecal water test, cells were distributed in 96-well plates (36 000 cells/well). Sixteen hours later, the cells were treated

with fecal water diluted 1:5 (v/v) in serum-free medium for 4 hours. From this step onward, toxicity was evaluated as previously described [16]. Fecal waters were considered cytotoxic when the cell viability was lower than 50% of the viability measured in control experiment (cells treated with culture media). Due to the high level of cytotoxicity in numerous fecal water samples, no reliable evaluation of genotoxicity was possible.

Mucosal transcriptome

After thawing on ice, rectal biopsies stored in RNA later were washed in cold PBS and homogenized in 1 mL Trizol (Invitrogen) with steel beads using a Tissue Lyzer (Quiagen) set to 25 Hz for 5 min twice. Total RNA was extracted based on the method of Chomczynski and Sacchi [36]. A subsequent step of DNase and purification was done with the RNeasy Mini Kit and DNase I (Quiagen). RNA concentration was measured with Nanodrop (Nanodrop technologies) and RNA quality was checked by determination of RNA Integrity Number (RIN) was with 2100 Bioanalyser (Agilent Technologies). Three samples did not yield enough RNA due to small biopsy size and one sample had poor RNA quality (RIN < 7), therefore the pairs of samples (baseline and after intervention) of these participants were not used for downstream experiments. Microarray experiments were performed with Affymetrix GeneChip® human Gene 2.0 ST according to the manufacturer instructions. Raw data were normalized using the Robust Multi-array Average (RMA) in R software. Raw data are available on the NCBI Gene Expression Omnibus (GEO) via the accession number GSE81970. Statistical analyses were carried out using Genomics Suit with ANOVA for repeated measures design (Partek). For each group (CAS, SOY and MD), we obtained a list of genes that were differentially expressed in the mucosa between baseline and after the dietary intervention ($P < 0.05$). For each of the 3 set of genes, we used Ingenuity Pathway Analysis software (Quiagen) to identify the biological functions regrouping differentially regulated genes. Significantly enriched biological functions were defined with enrichment P-value <0.05 and at least 3 differentially expressed genes implicated in the function. Quantitative real-time polymerase chain reaction (qRT-PCR) was performed to confirm microarray experiments with specific primers (Eurogentec) designed based on published sequences of the target genes using Oligo Explorer 1.1.0 software (GeneLink) (sequences available on request). After cDNA synthesis from mRNA using High

Capacity cDNA Reverse Transcription Kit (Applied Biosystems), real-time PCR was performed subsequently on cDNA using the power SYBR Green PCR master mix and StepOne Real-Time PCR system (Applied Biosystems). Gene expression levels for each sample were normalized relative to *Hprt* with $2^{-\Delta Ct}$ calculation.

Mucosal immunity

The concentration of fecal calprotectin was measured by an ELISA kit according to the manufacturer instructions (Calprest, Eurospital). Detection limit was 15 μg calprotectin / g stool. For determination of fecal SIgA concentration, stool samples were homogenized in PBS (1:10 w/v) with glass beads and centrifuged (15 000 g, 10 min, 4°C). Supernatant was diluted (1/250) and SIgA concentration was measured by an ELISA kit according to the manufacturer instructions (Bethyl Laboratories). For cytokines quantification, rectal biopsies were homogenized with steel beads using a Tissue Lyzer (Quiagen) in 100 μL lysis buffer (Life) containing proteases inhibitors (Roche) (25 Hz, 5 min, twice). After homogenization with a 25G needle, lysate was centrifuged (10 000 g, 10 min, 4°C) and protein concentration was measured with Bradford protein assay (Biorad). Cytokines concentration were measured with Bio-Plex ProTM Human Cytokine 8-plex Assay (Biorad). This assay included GC-CSF, IFN- γ , IL-2, IL-4, IL-6, IL-8, IL-10, TNF- α . Diluted biopsy lysates (1 μg protein/ μL) were diluted in Bioplex sample diluent (1:1 v/v) and experiment was performed according to manufacturer instructions using a Luminex-200 and Bioplex-manager software version 4.1 (Biorad). Among tested cytokines, only IFN- γ , IL-8 and TNF- α were sufficiently concentrated in biopsies lysates for appropriate quantification.

Statistical analysis

Statistical analyses were performed with R software with packages lme4, car, lsmeans and psych. Baseline values were compared between the 3 groups with an ANOVA with the group as a fixed effect (lm and Anova functions). Differential values were obtained by subtracting the value measured at baseline from the value measured after 1, 2 or 3 weeks of dietary intervention. For data measured every week during the intervention period, a mixed-model ANOVA (nlme and Anova functions) was used with participant as random effects while diet, time and diet x time were used as fixed effects. At each

time, the mean of differential values of the three groups were compared pairwise with Tukey correction for 9 comparisons (lsmeans function). For parameters measured only at baseline and at the end of the intervention, ANOVA with diet as a fixed effect was used (lm and Anova functions). In this case, the means of differential values of the three groups were compared pairwise with Tukey correction for 3 comparisons (lsmeans function). For correlation analysis, Spearman correlation coefficient (ρ) were calculated and P-values were adjusted with the Benjamini-Hodgberg method (corr.test function). For all statistical tests, the level of significance was set to $P < 0.05$.

RESULTS

Initially, 42 individuals participated in the study. Four of them were excluded for the following reasons: antibiotic use, influenza infection, non-respect of dietary advices as judged by the study dietician and undisclosed use of metformin as revealed by $^1\text{H-NMR}$ spectroscopy in fecal waters. Finally, the three experimental groups were composed as follow: MD (n=13), CAS (n=12) and SOY (n=13). The baseline characteristics of participants measured at the end of the dietary normalization period are presented in Supplementary Table 1. For all parameters measured, there were no significant differences between the 3 groups at baseline.

Dietary intakes

Changes from baseline dietary intakes after the 3-weeks intervention period are presented in Table 1. There was no significant difference for changes from baseline in energy, fat and fiber intake between the 3 groups. Of note, fiber intake was decreased similarly in the 3 groups due to the reduction in starchy food intake. There was a very marked increase in energy provided by protein in both CAS and SOY groups while it decreased marginally in the MD group (Table 1). After 1, 2 and 3 weeks of dietary intervention, blood urea concentration increased in both CAS and SOY groups while it decreased slightly in MD group (Figure 1 A). These results confirmed that, as expected, protein intake was higher in CAS and SOY groups than in the MD group during the intervention period [37]. Since diets were isocaloric, carbohydrate intake decreased in both CAS and SOY groups while there was a slight increase in the MD group (Table 1).

Fecal microbiota composition

At the phylum level, most of the OTUs were assigned to Bacteroidetes and Firmicutes corresponding to 47.6% and 42.5% of total reads, respectively, in all three treatment groups combined, followed by low percentages of Proteobacteria and Actinobacteria (3.9% and 1.2%). At the genus level, the top 20 most abundant classified taxonomic groups consisted of *Bacteroides*, *Prevotella*, *Dialister*, *Parabacteroides*, *Oscillospira*, *Lachnospira*, *Ruminococcus*, *Succinovibrio*, *Sutterella*, *Blautia*, *Roseburia*, *Bifidobacterium*, *Faecalibacterium*, *Coprococcus*, *Phascolarctobacterium*, *Paraprevotella*, *Megasphaera*, *Dorea*, *Odoribacter* and *Acidaminococcus*. Very high inter-individual differences in phylogenetic groups at all taxonomic levels were observed while the microbial profiles were relatively stable over time for each participant. There was no significant effect of the dietary intervention on changes in the relative abundance from baseline at phylum and genus levels (data not shown). However, the changes from baseline in blood urea concentration (used as a marker of protein intake) were significantly and positively correlated with the changes in abundance of Firmicutes and negatively with Bacteroidetes when using the whole data set (all time points and all groups) suggesting that the level of protein intake had small effects on the composition of fecal microbiota that requires high statistical power to be revealed (Table 2).

Fecal metabolome

There were no significant effects of the dietary intervention on water content in feces (data not shown) despite a negative correlation between variations in water content with the variations in uremia (Table 2). Fecal metabolome was assessed with untargeted ¹H-NMR metabolomics and targeted measurement of the main bacterial metabolites. Discriminant metabolites between dietary groups were identified by O-PLS-DA with all time points combined for identification of the global effect of the dietary intervention (Figure 2). Separate time point analyses showed that the dietary modulation of the fecal metabolome was mostly consistent across the intervention (Supplementary Table 3). The CAS diet induced an increased fecal concentration of the branched-chain AA leucine, valine and isoleucine when compared to the MD and SOY groups (Figure 2 A and C). Strikingly, the CAS and SOY diets decreased the butyrate concentration when compared to the MD group (Figure 2 A and B) and targeted

measurement confirmed that butyrate (expressed as a relative proportion of total SCFA) was decreased in the groups supplemented with dietary protein (Supplementary Table 2). Consistently, the variations in butyrate proportion of total SCFA were negatively correlated with the variations in blood urea concentration (Table 2). This effect was more pronounced for the CAS diet and might be related to the increased fecal pH specific to this group (Figure 1 B) since an O-PLS model indicates that butyrate concentration is one of the main driver of fecal pH (Supplementary Figure 1). Importantly, the decrease in butyrate proportion induced by dietary protein supplementation was specific since the proportions of the two other main SCFA (acetate and propionate) were virtually not affected by the dietary intervention and their variations were not correlated to uremia variations (Table 2 and Supplementary Table 2).

The isoleucine-derived bacterial metabolite 2-methylbutyrate was increased with both CAS and SOY diets when compared to the MD diet but this effect was more important with the CAS diet (Figure 2 A, B and C). When compared to the CAS and the MD diet, the SOY diet induced a specific increase in the concentration of the fermentation intermediate acetoin and of AA-derived bacterial metabolites (valerate, phenylacetate and tyramine derived from proline, phenylalanine and tyrosine, respectively) (Figure 2 B and C). Targeted measurements and correlation analyses confirmed that both protein supplementations induced a shift towards protein fermentation by the gut microbiota since the total concentration of AA-derived SCFA was increased with specific fermentation patterns according to protein source (Table 2 and Supplementary Table 2). In contrast, there were little effects of dietary protein intake on fecal *p*-cresol concentration (a bacterial metabolite produced from tyrosine) and no effects on ammonia concentration (a bacterial product of AA deamination) (Supplementary Table 2). Moreover, the changes in their fecal concentration were not correlated with uremia changes (Table 2).

In order to identify bacterial groups associated with fecal metabolite patterns, O-PLS models were used to correlate bacterial abundances determined by 16S rRNA gene sequencing with metabolome analyzed by ¹H-NMR (Supplementary Table 4). Firmicutes were associated with high levels of markers of AA degradation by the gut microbiota (isobutyrate, isovalerate, 2-methylbutyrate and phenylacetate) and low tyrosine levels (Figure 3). The subdominant phylum Verrucomicrobia was associated with a similar

metabolite pattern (Supplementary Table 4). In contrast, an opposed metabolic profile (low concentration of AA degradation markers) was found to be associated with Bacteroidetes that were also characterized by high levels of hydroxyphenylpropionate and glucose. Finally, Actinobacteria were associated with low levels of propionate.

Urinary metabolome

Urine metabolome was analyzed by ¹H-NMR and discriminant metabolites were identified by O-PLS-DA with all time points combined (Figure 4). The dietary interventions had consistent effects on urinary metabolome at various time points (Supplementary Table 5). As expected, urinary urea concentration increased with both protein diets when compared to the MD diet and this effect was more pronounced with the SOY diet (Figure 4 A, B and C). The CAS and SOY diets also induced a decrease in citrate concentration when compared to the MD diet (Figure 4 A and B). Both protein supplementations increased the urinary concentration of the bacterial metabolites isobutyrate, indoxylsulfate (derived from tryptophan) and phenylacetylglutamine (derived from phenylalanine) (Figure 4 A and B). Targeted quantification of urinary phenylacetylglutamine confirmed that its concentration increased with dietary protein supplementation despite some time dependent variations (Supplementary Table 2) and the changes in its concentration were positively correlated with the changes in blood urea concentration (Table 2), confirming the association with a high-protein intake. Some changes in urinary metabolites produced by the gut microbiota and/or by the host were specific to the protein source. Indeed, the CAS diet increased the concentration of *p*-cresyl sulfate (sulfate conjugated form of *p*-cresol), 3-hydroxyisovalerate and 3-hydroxybutyrate while the SOY diet increased the concentration of hydroxyphenylpropionate (derived from tyrosine) and of acetoin (Figure 5 A, B and C).

Fecal water cytotoxicity and associated metabolome

Fecal water cytotoxicity was not affected by the diet (Figure 1 C) and its variations were not correlated with the uremia changes from baseline (Table 2) confirming that the level of protein intake was not related to fecal water cytotoxicity. Since the main factor of variability of fecal water cytotoxicity was clearly the individual, we hypothesized that it could be related to specific profile of metabolites produced

by the gut microbiota. Indeed, O-PLS-DA analysis with fecal metabolome ¹H-NMR data revealed that cytotoxic fecal waters had high levels of bile acids, ethanol, amino-acids (leucine, valine, isoleucine, alanine, tyrosine) and microbial intermediate products of AA degradation (5-aminovalerate and hydroxyphenylacetate) (Figure 5 A). In urine, the AA-derived host-microbiota co-metabolites *p*-cresyl sulfate, phenylacetylglutamine and hippurate (a microbial co-metabolite derived from phenylalanine degradation into benzoate that is further conjugated with glycine in the liver) were less abundant in paired samples to cytotoxic fecal waters (Figure 5 B).

Mucosal response to the dietary intervention

Changes from baseline in gene expression in rectal mucosa after dietary intervention were assessed at whole-genome level using microarrays. Paired analysis revealed that there were more differentially expressed genes from baseline (DEG) after intervention with CAS (1324 DEG, 627 up, 697 down) and SOY (1515 DEG, 858 up, 657 down) than in the MD group (905 DEG, 517 up, 388 down) (Figure 6 A). Although there was little common DEG in each group (less than 10%), there was twice more gene in common between CAS and SOY groups than with MD and the two protein groups. We performed qPCR experiment for validation of microarray data on selected DEG and we observed significant correlation between the expression levels obtained by the two techniques as shown in Supplementary Table 6. As expected from a nutritional study [38,39], fold change in gene expression were relatively small (from -1.55 to 1.64). However, functional analysis revealed a clear clustering of DEG into biological functions in the CAS and SOY groups, which was not the case in the MD group. Indeed, there were only 72 functions significantly enriched in the MD group while there were 249 and 176 in CAS and SOY groups, respectively (Figure 6 B). Moreover, the mean number of DEG implicated in each enriched functions was strikingly higher in both CAS and SOY groups than in MD group (Figure 6 C). Collectively, these results clearly show that dietary intervention in SOY and CAS group regulated gene expression in rectal mucosa and this effect was not observed in the MD group.

To get insight into the biological relevance of these regulations of gene expression by the dietary intervention, we examined the pathways where DEG are involved. To avoid bias induced by the low

number of functions enriched in the MD group, we reasoned that the relative number of significantly enriched function in each group into biological categories would be more informative than the absolute number of functions in each category. Functions related to cancer were more represented in CAS and SOY groups when compared to the MD group (Figure 6 D). Importantly, the percentage of significantly enriched functions related to gastrointestinal diseases was higher in CAS (5.1%) and in SOY (2.4%) groups than in the MD (1.4%) group (Figure 6 D). Indeed, there was a significant enrichment of numerous functions highly relevant to colonic health in both protein supplemented groups such as *colon cancer*, *epithelial cancer* and *neoplasia of epithelial tissue* (the full list is presented in Supplementary Table 7). Of note, more of these functions were enriched in the CAS group when compared to SOY suggesting a more profound effect of the former protein source. Importantly, none of these functions were found to be enriched in the MD group, indicating a clear effect of dietary proteins on regulation of genes implicated in large intestine mucosal homeostasis. There were also more enriched functions related to infectious diseases in CAS (2.28%) and SOY (1.70%) groups than in the MD (0.47%) group. For instance, the function *infection of epithelial cell line* was significantly enriched in both CAS (27 DEG) and SOY (31 DEG) groups but not in the MD group.

At a cellular level, some biological categories relevant to mucosal homeostasis (including cell-death, cell cycle, cellular compromise and cell-to-cell interaction) were represented only in the CAS and SOY groups and not in the MD group (Figure 6 E). Indeed, both CAS and SOY diet regulated (mainly increased) the expression of genes related to apoptosis, cell cycle, proliferation and cytoskeleton (Table 3). Despite similar functions were affected by the supplementation with the two HPD, the genes regulated were mostly specific to one of the protein source (CAS or SOY) (Table 3, Figure 6 A). In addition, some functions were specifically regulated by only one of the protein source. The CAS diet up-regulated genes implicated in extracellular matrix and cellular adhesion and mucus production while the SOY diet regulated the expression of genes implicated in oxidative stress and detoxification processes.

Importantly, the relative abundance of functions related to inflammation was not higher in protein supplemented groups than in the control group (Figure 6 D), suggesting that high-protein intake does not regulate inflammatory processes in the rectal mucosa. In accordance with these results, the dietary intervention had no effects on the fecal concentrations of calprotectin (marker of neutrophil recruitment in the intestinal mucosa) and SIgA (Table 4). Moreover, the concentrations of the pro-inflammatory cytokines IL-8, IFN- γ and TNF- α in the rectal mucosa were not changed by the diet. Finally, an histological examination of the rectal biopsies revealed that the 3-weeks dietary intervention did not induce an overt perturbation of mucosal morphology, inflammation or epithelial proliferation (data not shown).

DISCUSSION

It is estimated that millions of people around the world consume HPD for body weight control [4]. However, its impact on the large intestinal ecosystem remains largely unknown. We show in the present dietary intervention study that a high intake of animal (casein from milk) or plant (soy) protein had no major effect on the composition of the fecal microbiota while it altered metabolites produced by the bacteria in association with a clear regulation of gene expression in the rectal mucosa. Importantly, some of these modifications were modulated by the source of the dietary protein

Quantity and quality of the protein intake had no any major effects on the gut microbiota composition evaluated by 16S rRNA gene sequencing. Importantly, the decrease from baseline of the fiber intake induced by the reduction in starchy food was similar in the 3 groups. This latter result is in accordance with a previous study showing that a HPD without fiber restriction did not change the microbiota profile obtained by DGGE-PCR [9]. In contrast, other studies found that a HPD combined with a low fiber intake reduced the abundance of *Bacteroides* and of the butyrate producers *Roseburia/Eubacterium rectale* detected by targeted qPCR [7,8]. These discrepancies suggest that the principal dietary factor influencing the gut microbiota composition is fiber content rather than protein. However, we observed a significant positive correlation between the variations of uremia (marker of protein intake) with the variations of Firmicutes abundance while this correlation was negative for Bacteroidetes. In accordance, Firmicutes and Bacteroidetes abundances were associated with high and low fecal concentration of AA fermentation products (2-methylbutyrate, isobutyrate and phenylacetate), respectively. This observation could be related to the important role of Clostridia (dominant members of the Firmicutes phylum) in AA degradation in the large intestine [40]. Of note, we also found that the Verrucomicrobia phylum was associated with AA fermentation products which might reflect mucin utilization by its only known member, *Akkermansia muciniphila* [41].

Recently, it has been suggested in humans (vegetarian or omnivorous) that the diet might influence the metabolic activity of the microbiota at a higher extent than its taxonomic composition [42]. In

accordance with this proposition, we found that, despite very modest effects on the microbiota composition, the increase in protein intake induced a marked shift in the concentration in feces and urine of metabolites produced by the gut microbiota (summarized in Figure 7). In feces, the concentrations of the branched chain amino acids were increased specifically with the casein supplementation. These AA were probably released by proteolytic bacteria from undigested peptides that escape digestion in the small intestine [3]. The high abundance of leucine and isoleucine in casein might explain partly that this effect was not observed with the soy protein supplementation (Supplementary Table 8).

Importantly, both casein and soy protein supplementation induced a decrease in butyrate fecal concentration and the variations in uremia were negatively correlated with the variations in butyrate concentration. This SCFA, mainly derived from carbohydrate fermentation, is considered beneficial since it represents a major fuel for colonocytes, regulates inflammation and the barrier function in the large intestine [43]. Therefore, the decreased butyrate concentration induced by a high-protein intake might be detrimental for colonic health. Conflicting results were previously reported on the effects of HPD on fecal butyrate concentration [6–11]. All studies that described a decrease in butyrate concentration with HPD were also low in indigestible carbohydrate [6–8]. In the present study, the decrease in starchy food intake induced a similar decrease in indigestible carbohydrate intake in all groups. Since the butyrate concentration did not decrease in the MD group, our results indicate that it is the combination of the HPD with a decrease in indigestible carbohydrate which is responsible for the decreased butyrate concentration observed with both casein and soy protein supplementations. Interestingly, HPD did not affect the other two main SCFA (acetate and propionate) suggesting that butyrate metabolism could be specifically impacted by dietary proteins.

For unknown reasons, casein induced a more important decrease in butyrate concentration than soy protein, and this is probably related to the important increase in fecal pH observed specifically with this HPD. This increase in fecal pH induced by a HPD has already been described in several [8,25] but not all studies [10,44], probably partly reflecting the divergent effects of HPD on fecal SCFA concentration.

A higher fecal pH has been considered to be detrimental for the intestinal mucosa [45] suggesting that a HPD with casein could induce a deleterious luminal environment in the colon.

The two HPD induced an increase in the concentration of AA-derived bacterial metabolites, indicating a metabolic shift towards protein degradation by the gut microbiota (Figure 7). Indeed, the casein and soy protein supplementation increased the fecal concentration of 2-methylbutyrate (fermentation product of isoleucine), the urinary concentration of isobutyrate (fermentation product of valine) and of the host-microbiota co-metabolites phenylacetylglutamine (human glutamine conjugate of phenylacetate derived from the bacterial metabolism of phenylalanine) and indoxyl sulfate (human sulfate conjugate of indole derived from the bacterial metabolism of tryptophan) [46]. While the effects of 2-methylbutyrate, isobutyrate and phenylacetate on the mucosa are little or not well characterized [12], indole has been shown to contribute to the maintenance of the colonic barrier function [18,19]. The increased exposure to this metabolite during HPD might therefore be beneficial for the mucosa.

Supplementation with casein specifically induced an increase in the urinary concentration of *p*-cresyl sulfate (human sulfate conjugate of *p*-cresol derived from the bacterial metabolism of tyrosine) [13]. Since tyrosine content is not higher in casein than in soy protein, it is not clear why this increase was specific to this protein source (Supplementary Table 8). This increase in *p*-cresol exposure with the casein supplementation might be deleterious for epithelial cells since this metabolite has recently been shown *in vitro* to alter mitochondrial metabolism, induce production of reactive oxygen species and DNA damage in colonocytes [15]. In contrast, the soy protein supplementation increased the concentrations of the tyrosine derived microbial metabolites tryamine and hydroxyphenylpropionate, suggesting that tyrosine degradation is less complete than with casein [47]. However, the effects of these metabolites on the mucosa are not known, asking for new studies in this area. Valerate (fermentation product of proline) and phenylacetate (microbial product of phenylalanine degradation) were also increased specifically with the soy protein supplementation [12,13]. The high phenylalanine content in soy protein might explain the increase in phenylacetate specific to the SOY group (Supplementary Table 8).

Since the CAS and SOY diets induce a shift toward protein fermentation and since several of the AA-derived bacterial metabolites are thought to be deleterious for the colonocytes [12], we hypothesized that the luminal environment could be detrimental for the epithelium with these diets. Contrary to our hypothesis, the dietary intervention had no effects on fecal water toxicity on human colonocytes *in vitro*. Our results are in agreement with two previous human studies that also showed that fecal water cytotoxicity was not related to protein intake [9,25]. However, interestingly, we found that the high inter-individual variability in fecal water toxicity was related to a specific metabolite signature (Figure 8). As previously described, fecal bile acids and ethanol were associated with cytotoxicity [48,49]. Interestingly, in cytotoxic samples, there were high fecal concentrations of two precursors of *p*-cresol (tyrosine and hydroxyphenylacetate) [46] while the concentration of its conjugate (*p*-cresyl sulfate) was decreased in urine, suggesting an incomplete degradation of tyrosine by the microbiota in cytotoxic samples. Interestingly, a previous study also found that urinary excretion of *p*-cresol was negatively correlated with fecal water cytotoxicity [9]. Cytotoxic samples were also characterized by high levels of free AA and of 5-aminovalerate that is an intermediate product of proline fermentation to valerate [50]. Last, urinary excretion of hippurate and phenylacetylglutamine, the conjugated forms of benzoate and phenylacetate (bacterial products of phenylalanine degradation) were decreased in samples paired to high fecal water cytotoxicity [46,51]. All together, these data suggest that an incomplete AA degradation by the gut microbiota is associated with high fecal water cytotoxicity. The mechanisms explaining this observation remain to be determined but it might be hypothesized that a high bile acid concentration inhibit bacterial AA catabolism. Importantly, these correlations allow the identification of a metabolic fingerprint associated with cytotoxicity that may not be the direct cause of cytotoxicity but may act as a proxy signature of a cytotoxic environment. For example, we tested that 5-aminovalerate is not cytotoxic for colonocytes *in vitro* (data not shown).

Transcriptome profiles in the rectal biopsies showed that the two HPD with casein and soy protein regulated the expression of genes associated with important biological functions while no consistent effects were observed for the control MD intervention. However, and as expected from a dietary intervention [38,39], fold change in gene expression were relatively limited. A high number of pathways

related to digestive diseases were significantly enriched with protein supplementation and not with MD. Indeed, key homeostatic cellular processes related to epithelial renewal were regulated at the gene expression level only in the CAS and SOY groups. A previous study in pigs had shown that a HPD regulated the expression of genes related to epithelial renewal [52]. Although the parameters involved in the modifications of gene expression in our study remain to be deciphered, the change in mucosal exposure to amino AA-derived bacterial metabolites known to regulate cell proliferation and/or apoptosis (e.g. butyrate, *p*-cresol) might be implicated in the effects of HPD [13,15,43]. Interestingly, casein and soy protein supplementation induced some distinct modifications of the mucosal transcriptome. This result emphasizes the importance of the protein source in the modulation of the effect of HPD. The CAS diet regulated more genes related to gastrointestinal diseases than the SOY diet. This difference might be related to the less-favorable bacterial metabolite profile induced by casein (lower butyrate and higher *p*-cresol exposure) than by soy protein. Moreover, the casein diet up-regulated the expression of several genes related to the mucus production that may be related to an adaptive response to an increase exposure to deleterious compounds [53]. In animal models, HPD also increased mucin expression in the colon [23,52]. The casein supplementation also increased the expression of genes implicated in the regulation of extracellular matrix, possibly reflecting modifications of epithelial cell adhesion. In accordance with our results, integrin and collagen genes were also increased in rat colonic mucosa after a HPD with casein [54]. Since the extracellular matrix is a major regulator of cell proliferation and differentiation [55], it is tempting to propose that remodeling of gene expression by a high-casein intake might lead to a loss of homeostasis in the mucosa. The regulation by the soy protein supplementation of the expression of genes related to oxidative stress and detoxification processes might reflect an adaptation to the modified exposure of the large intestinal epithelium to bacterial metabolites [56].

Importantly, the CAS and SOY diets did not regulate genes related to immunity in the rectal mucosa. Moreover, the protein intake did not alter mucosal pro-inflammatory cytokines, IgA secretion and fecal calprotectin. In agreement with our study, HPD in rats did not induce colonic inflammation [23] and HPD in pigs did not alter colonic barrier function [24]. These results suggest that the pro-inflammatory

effects of some AA-derived bacterial metabolite could be balanced by the anti-inflammatory effects of others, such as indole [16,18]. Last, the morphology of the rectal mucosa was not affected by the HPD, as previously described in rat colon [22].

The design of our study has several strengths and weaknesses. First, an increase in protein intake necessary induces a decrease in other macronutrients intake to maintain the diets isocaloric. The CAS and SOY diets should therefore be considered as high-protein/low carbohydrate diets. However, the reduction in starchy food was similar in the control group as in the two protein groups, then avoiding unwanted effects related to a reduction in indigestible carbohydrate induced by the decrease in carbohydrate intake. Secondly, although the use of protein isolates rather than protein containing food allows the identification of the effect of protein *per se*, it cannot be excluded that some of the observed effects might be related to minor compounds known to be associated with casein and soy protein isolates (calcium and phytoestrogens, respectively). Thirdly, although the longitudinal design allowed the comparison of variations from the baseline values, a cross-over design would have been more informative. However, this strategy was not chosen because of the subsequent multiple rectal biopsies necessary and decreased compliance reported with long-term dietary interventions. Lastly, although a limitation of our study is its short duration (3 weeks) that precludes identification of long-term effects of HPD on mucosal health, it is worth noting that HPD used for decreasing body weight in overweight individuals are generally used within few weeks.

In conclusion, HPD modified the luminal environment in the large intestine, mostly by decreasing butyrate concentration and by increasing AA-derived bacterial metabolites concentrations. These changes were associated with modifications of several key homeostatic processes at the gene expression levels in the rectal mucosa. Importantly, distinct effects were induced by animal and plant proteins, highlighting the importance of protein source for the impact fo HPD on rectal mucosa. HPD should be considered with some cautions given their potential effects on rectal mucosa homeostasis and careful selection of the protein source might be used to modulate these effects.

REFERENCES

- 1 Marchesi JR, Adams DH, Fava F, *et al.* The gut microbiota and host health: a new clinical frontier. *Gut* 2016;**65**:330–9. doi:10.1136/gutjnl-2015-309990
- 2 Portune KJ, Benítez-Páez A, Del Pulgar EMG, *et al.* Gut microbiota, diet and obesity-related disorders - the good, the bad and the future challenges. *Mol Nutr Food Res* Published Online First: June 2016. doi:10.1002/mnfr.201600252
- 3 Gibson JA, Sladen GE, Dawson AM. Protein absorption and ammonia production: the effects of dietary protein and removal of the colon. *Br J Nutr* 1976;**35**:61–5.
- 4 Pesta DH, Samuel VT. A high-protein diet for reducing body fat: mechanisms and possible caveats. *Nutr Metab* 2014;**11**:53. doi:10.1186/1743-7075-11-53
- 5 Silvester KR, Cummings JH. Does digestibility of meat protein help explain large bowel cancer risk? *Nutr Cancer* 1995;**24**:279–88. doi:10.1080/01635589509514417
- 6 Brinkworth GD, Noakes M, Clifton PM, *et al.* Comparative effects of very low-carbohydrate, high-fat and high-carbohydrate, low-fat weight-loss diets on bowel habit and faecal short-chain fatty acids and bacterial populations. *Br J Nutr* 2009;**101**:1493. doi:10.1017/S0007114508094658
- 7 Duncan SH, Belenguer A, Holtrop G, *et al.* Reduced Dietary Intake of Carbohydrates by Obese Subjects Results in Decreased Concentrations of Butyrate and Butyrate-Producing Bacteria in Feces. *Appl Environ Microbiol* 2007;**73**:1073–8. doi:10.1128/AEM.02340-06
- 8 Russell WR, Gratz SW, Duncan SH, *et al.* High-protein, reduced-carbohydrate weight-loss diets promote metabolite profiles likely to be detrimental to colonic health. *Am J Clin Nutr* 2011;**93**:1062–72. doi:10.3945/ajcn.110.002188
- 9 Windey K, De Preter V, Louat T, *et al.* Modulation of protein fermentation does not affect fecal water toxicity: a randomized cross-over study in healthy subjects. *PLoS One* 2012;**7**:e52387. doi:10.1371/journal.pone.0052387
- 10 Cummings JH, Hill MJ, Bone ES, *et al.* The effect of meat protein and dietary fiber on colonic function and metabolism. II. Bacterial metabolites in feces and urine. *Am J Clin Nutr* 1979;**32**:2094–101.
- 11 Geypens B, Claus D, Evenepoel P, *et al.* Influence of dietary protein supplements on the formation of bacterial metabolites in the colon. *Gut* 1997;**41**:70–6. doi:10.1136/gut.41.1.70
- 12 Davila A-M, Blachier F, Gotteland M, *et al.* Intestinal luminal nitrogen metabolism: role of the gut microbiota and consequences for the host. *Pharmacol Res Off J Ital Pharmacol Soc* 2013;**68**:95–107. doi:10.1016/j.phrs.2012.11.005
- 13 Portune KJ, Beaumont M, Davila A-M, *et al.* Gut microbiota role in dietary protein metabolism and health-related outcomes: the two sides of the coin. *Trends Food Sci Technol* Published Online First: August 2016. doi:10.1016/j.tifs.2016.08.011
- 14 Blachier F, Mariotti F, Huneau JF, *et al.* Effects of amino acid-derived luminal metabolites on the colonic epithelium and physiopathological consequences. *Amino Acids* 2007;**33**:547–62. doi:10.1007/s00726-006-0477-9

- 15 Andriamihaja M, Lan A, Beaumont M, *et al.* The deleterious metabolic and genotoxic effects of the bacterial metabolite p-cresol on colonic epithelial cells. *Free Radic Biol Med* 2015;**85**:219–27. doi:10.1016/j.freeradbiomed.2015.04.004
- 16 Beaumont M, Andriamihaja M, Lan A, *et al.* Detrimental effects for colonocytes of an increased exposure to luminal hydrogen sulfide: The adaptive response. *Free Radic Biol Med* 2016;**93**:155–64. doi:10.1016/j.freeradbiomed.2016.01.028
- 17 Lin HC, Visek WJ. Colon mucosal cell damage by ammonia in rats. *J Nutr* 1991;**121**:887–93.
- 18 Bansal T, Alaniz RC, Wood TK, *et al.* The bacterial signal indole increases epithelial-cell tight-junction resistance and attenuates indicators of inflammation. *Proc Natl Acad Sci* 2010;**107**:228–33. doi:10.1073/pnas.0906112107
- 19 Shimada Y, Kinoshita M, Harada K, *et al.* Commensal Bacteria-Dependent Indole Production Enhances Epithelial Barrier Function in the Colon. *PLoS ONE* 2013;**8**:e80604. doi:10.1371/journal.pone.0080604
- 20 Venkatesh M, Mukherjee S, Wang H, *et al.* Symbiotic Bacterial Metabolites Regulate Gastrointestinal Barrier Function via the Xenobiotic Sensor PXR and Toll-like Receptor 4. *Immunity* 2014;**41**:296–310. doi:10.1016/j.immuni.2014.06.014
- 21 Westerterp-Plantenga MS, Lemmens SG, Westerterp KR. Dietary protein – its role in satiety, energetics, weight loss and health. *Br J Nutr* 2012;**108**:S105–12. doi:10.1017/S0007114512002589
- 22 Andriamihaja M, Davila A-M, Eklou-Lawson M, *et al.* Colon luminal content and epithelial cell morphology are markedly modified in rats fed with a high-protein diet. *Am J Physiol Gastrointest Liver Physiol* 2010;**299**:G1030–7. doi:10.1152/ajpgi.00149.2010
- 23 Lan A, Andriamihaja M, Blouin J-M, *et al.* High-protein diet differently modifies intestinal goblet cell characteristics and mucosal cytokine expression in ileum and colon. *J Nutr Biochem* 2015;**26**:91–8. doi:10.1016/j.jnutbio.2014.09.007
- 24 Richter JF, Pieper R, Zakrzewski SS, *et al.* Diets high in fermentable protein and fibre alter tight junction protein composition with minor effects on barrier function in piglet colon. *Br J Nutr* 2014;**111**:1040–9. doi:10.1017/S0007114513003498
- 25 Benassi-Evans B, Clifton P, Noakes M, *et al.* High-protein/high red meat and high-carbohydrate weight-loss diets do not differ in their effect on faecal water genotoxicity tested by use of the WIL2-NS cell line and with other biomarkers of bowel health. *Mutat Res* 2010;**703**:130–6. doi:10.1016/j.mrgentox.2010.08.009
- 26 Jantchou P, Morois S, Clavel-Chapelon F, *et al.* Animal protein intake and risk of inflammatory bowel disease: The E3N prospective study. *Am J Gastroenterol* 2010;**105**:2195–201. doi:10.1038/ajg.2010.192
- 27 Jowett SL, Seal CJ, Pearce MS, *et al.* Influence of dietary factors on the clinical course of ulcerative colitis: a prospective cohort study. *Gut* 2004;**53**:1479–84. doi:10.1136/gut.2003.024828
- 28 Spooren CEGM, Pierik MJ, Zeegers MP, *et al.* Review article: the association of diet with onset and relapse in patients with inflammatory bowel disease. *Aliment Pharmacol Ther* 2013;**38**:1172–87. doi:10.1111/apt.12501

- 29 Gaudichon C, Mahé S, Benamouzig R, *et al.* Net postprandial utilization of [15N]-labeled milk protein nitrogen is influenced by diet composition in humans. *J Nutr* 1999;**129**:890–5.
- 30 Mariotti F, Mahé S, Benamouzig R, *et al.* Nutritional value of [15N]-soy protein isolate assessed from ileal digestibility and postprandial protein utilization in humans. *J Nutr* 1999;**129**:1992–7.
- 31 Leidy HJ, Clifton PM, Astrup A, *et al.* The role of protein in weight loss and maintenance. *Am J Clin Nutr* 2015;**101**:1320S – 1329S. doi:10.3945/ajcn.114.084038
- 32 Klindworth A, Pruesse E, Schweer T, *et al.* Evaluation of general 16S ribosomal RNA gene PCR primers for classical and next-generation sequencing-based diversity studies. *Nucleic Acids Res* 2013;**41**:e1. doi:10.1093/nar/gks808
- 33 Cloarec O, Dumas M-E, Craig A, *et al.* Statistical total correlation spectroscopy: an exploratory approach for latent biomarker identification from metabolic 1H NMR data sets. *Anal Chem* 2005;**77**:1282–9. doi:10.1021/ac048630x
- 34 Liu X, Blouin J-M, Santacruz A, *et al.* High-protein diet modifies colonic microbiota and luminal environment but not colonocyte metabolism in the rat model: the increased luminal bulk connection. *Am J Physiol Gastrointest Liver Physiol* 2014;**307**:G459–70. doi:10.1152/ajpgi.00400.2013
- 35 Birkett AM, Jones GP, Muir JG. Simple high-performance liquid chromatographic analysis of phenol and p-cresol in urine and feces. *J Chromatogr B Biomed Appl* 1995;**674**:187–91.
- 36 Chomczynski P, Sacchi N. Single-step method of RNA isolation by acid guanidinium thiocyanate-phenol-chloroform extraction. *Anal Biochem* 1987;**162**:156–9. doi:10.1016/0003-2697(87)90021-2
- 37 Young VR, El-Khoury AE, Raguso CA, *et al.* Rates of urea production and hydrolysis and leucine oxidation change linearly over widely varying protein intakes in healthy adults. *J Nutr* 2000;**130**:761–6.
- 38 Wittwer J, Rubio-Aliaga I, Hoefft B, *et al.* Nutrigenomics in human intervention studies: Current status, lessons learned and future perspectives. *Mol Nutr Food Res* 2011;**55**:341–58. doi:10.1002/mnfr.201000512
- 39 Keijer J, van Helden YGJ, Bunschoten A, *et al.* Transcriptome analysis in benefit-risk assessment of micronutrients and bioactive food components. *Mol Nutr Food Res* 2010;**54**:240–8. doi:10.1002/mnfr.200900304
- 40 Barker HA. Amino acid degradation by anaerobic bacteria. *Annu Rev Biochem* 1981;**50**:23–40.
- 41 Derrien M, Belzer C, de Vos WM. *Akkermansia muciniphila* and its role in regulating host functions. *Microb Pathog* Published Online First: 11 February 2016. doi:10.1016/j.micpath.2016.02.005
- 42 Wu GD, Compher C, Chen EZ, *et al.* Comparative metabolomics in vegans and omnivores reveal constraints on diet-dependent gut microbiota metabolite production. *Gut* 2016;**65**:63–72. doi:10.1136/gutjnl-2014-308209
- 43 Koh A, De Vadder F, Kovatcheva-Datchary P, *et al.* From Dietary Fiber to Host Physiology: Short-Chain Fatty Acids as Key Bacterial Metabolites. *Cell* 2016;**165**:1332–45. doi:10.1016/j.cell.2016.05.041

- 44 Silvester KR, Bingham SA, Pollock JRA, *et al.* Effect of meat and resistant starch on fecal excretion of apparent *N*-nitroso compounds and ammonia from the human large bowel. *Nutr Cancer* 1997;**29**:13–23. doi:10.1080/01635589709514596
- 45 Newmark HL, Lupton JR. Determinants and consequences of colonic luminal pH: Implications for colon cancer. *Nutr Cancer* 1990;**14**:161–73. doi:10.1080/01635589009514091
- 46 Windey K, De Preter V, Verbeke K. Relevance of protein fermentation to gut health. *Mol Nutr Food Res* 2012;**56**:184–96. doi:10.1002/mnfr.201100542
- 47 Smith EA, Macfarlane GT. Enumeration of human colonic bacteria producing phenolic and indolic compounds: effects of pH, carbohydrate availability and retention time on dissimilatory aromatic amino acid metabolism. *J Appl Bacteriol* 1996;**81**:288–302.
- 48 Elamin EE, Masclee AA, Dekker J, *et al.* Ethanol metabolism and its effects on the intestinal epithelial barrier. *Nutr Rev* 2013;**71**:483–99. doi:10.1111/nure.12027
- 49 Pearson JR, Gill CI, Rowland IR. Diet, fecal water, and colon cancer - development of a biomarker. *Nutr Rev* 2009;**67**:509–26. doi:10.1111/j.1753-4887.2009.00224.x
- 50 Barker HA, D'Ari L, Kahn J. Enzymatic reactions in the degradation of 5-aminovalerate by *Clostridium aminovalericum*. *J Biol Chem* 1987;**262**:8994–9003.
- 51 Lees HJ, Swann JR, Wilson ID, *et al.* Hippurate: the natural history of a mammalian-microbial cometabolite. *J Proteome Res* 2013;**12**:1527–46. doi:10.1021/pr300900b
- 52 Pieper R, Kröger S, Richter JF, *et al.* Fermentable fiber ameliorates fermentable protein-induced changes in microbial ecology, but not the mucosal response, in the colon of piglets. *J Nutr* 2012;**142**:661–7. doi:10.3945/jn.111.156190
- 53 Johansson MEV, Sjövall H, Hansson GC. The gastrointestinal mucus system in health and disease. *Nat Rev Gastroenterol Hepatol* 2013;**10**:352–61. doi:10.1038/nrgastro.2013.35
- 54 Mu C, Yang Y, Luo Z, *et al.* The Colonic Microbiome and Epithelial Transcriptome Are Altered in Rats Fed a High-Protein Diet Compared with a Normal-Protein Diet. *J Nutr* 2016;**146**:474–83. doi:10.3945/jn.115.223990
- 55 Bonnans C, Chou J, Werb Z. Remodelling the extracellular matrix in development and disease. *Nat Rev Mol Cell Biol* 2014;**15**:786–801. doi:10.1038/nrm3904
- 56 Circu ML, Aw TY. Redox biology of the intestine. *Free Radic Res* 2011;**45**:1245–66. doi:10.3109/10715762.2011.611509

TABLES

Table 1: Dietary intakes.

Dietary intakes were assessed at baseline and at the end of the intervention period (week 3). Data presented are mean changes from baseline \pm SEM. The effect of diet was tested with ANOVA. For pairwise comparison, P-values were adjusted with the Tukey method. NS: not significant ($P > 0.05$). MD: maltodextrin group, CAS: casein group, SOY: soy protein group. *: Change is different from the change in MD group. Differences were considered significant for $P < 0.05$.

	MD	CAS	SOY	P
Energy (Kcal/day)	36.92 \pm 123.46	-179.27 \pm 88.82	-175.92 \pm 74.46	NS
Protein (% energy)	-3.76 \pm 0.55	16.76 \pm 0.85*	14.72\pm0.92*	<0.001
Carbohydrate (% energy)	6.91 \pm 1.85	-16.41 \pm 1.75*	-13.61\pm1.41*	<0.001
Fat (% energy)	-2.54 \pm 1.69	0.13 \pm 1.76	-0.81 \pm 1.16	NS
Fiber (g/day)	-3.05 \pm 1.69	-7.93 \pm 1.71	-7.51 \pm 1.67	NS

Table 2: Correlation of uremia with fecal and urinary parameters.

For all variables, changes from baseline were correlated with the uremia changes from baseline (marker of protein intake). The correlations were made with the complete data set (all groups and all time points during intervention). ρ : Spearman coefficient of correlation with uremia changes from baseline, P: Benjamini-Hodgberg adjusted P-value. $P < 0.05$ was considered significant. AA-derived SCFA: amino acid derived short chain fatty acid (sum of isovalerate, isobutyrate and valerate), SIgA: secretory immunoglobulin A, PAG/creat: ratio of the urinary concentration of phenylacetylglutamine and creatinine.

	ρ	P
Bacteroidetes	-0.33	<0.001
Firmicutes	0.29	0.01
Proteobacteria	-	NS
Actinobacteria	-	NS
Acetate	-	NS
Propionate	-	NS
Butyrate	-0.35	<0.001
Isobutyrate	0.42	<0.001
Isovalerate	0.49	<0.001
Valerate	-	NS
AA-derived SCFA	0.50	<0.001
pH	0.28	0.01
Water	-0.33	<0.001
Ammonia	-	NS
<i>p</i> -cresol	-	NS
PAG/creat	0.42	<0.001
Cytotoxicity	-	NS
SIgA	-	NS
Calprotectin	-	NS

Table 3: Selected genes regulated in the large intestine mucosa by the dietary intervention.

Expression of selected genes measured by microarray experiments in the rectal mucosa before and after the dietary intervention. The fold change of gene expression is shown only for genes that are significantly regulated by the dietary intervention. $P < 0.05$ was considered as statistically significant.

MD: maltodextrin group, CAS: casein group, SOY: soy protein group.

Function	Symbol	Gene name	Fold change		
			MD	CAS	SOY
Apoptosis	IER3	immediate early response 3	-	1.32	-
	PRKD1	protein kinase D1	-	1.20	-
	PHLDA1	pleckstrin homology-like domain family A member 1	-	1.28	-
	PHLDA2	pleckstrin homology-like domain family A member 2	-	1.24	-
	NTRK2	neurotrophic tyrosine kinase receptor type 2	-	-1.27	-
	TLR3	toll like receptor 3	-	-	1.36
Cell cycle, Proliferation	TIPIN	TIMELESS interacting protein	-	1.21	-
	TAGLN	transgelin	-	1.39	-
	EDN1	endothelin 1	-	1.22	-
	IGFBP6	insulin-like growth factor binding protein 6	-	1.24	-
	PER2	period circadian clock 2	-	1.25	-
	SGK1	serum/glucocorticoid regulated kinase 1	-	1.28	-
	HBEGF	heparin-binding EGF-like growth factor	-	1.58	-
	CHRM3	cholinergic receptor, muscarinic 3	-	-1.40	-
	AURKA	aurora kinase A	-	-	1.25
	CRIP1	cysteine-rich protein 1	-	-	1.33
	MT1JP	metallothionein 1J pseudogene	-	-	1.40
	PCNA-AS1	PCNA antisense RNA 1	-	-	1.22
	NRG1	neuregulin 1	-	-	-1.25
Cytoskeleton	CAPN6	calpain 6	-	1.25	-
	MYL9	myosin, light chain 9, regulatory	-	1.27	-
	ACTG2	actin, gamma 2, smooth muscle, enteric	-	1.48	-
	KRT1	keratin 31, type I	-	1.21	-
	KRTAP10-5	keratin associated protein 10-5	-	1.32	1.29
	TPPP3	tubulin polymerization-promoting protein family member 3	-	1.34	1.27
Extracellular matrix, Adhesion	TNC	tenascin C	-	1.40	-
	COL12A1	collagen, type XII, alpha 1	-	1.21	-
	COL1A2	collagen, type I, alpha 2	-	1.23	-
	COL1A1	collagen, type I, alpha 1	-	1.25	-
	COL3A1	collagen, type III, alpha 1	-	1.29	-
	POSTN	periostin, osteoblast specific factor	-	1.21	-
	TNS1	tensin 1	-	1.21	-
	FBN1	fibronectin 1	-	1.22	-
	SMOC2	SPARC related modular calcium binding 2	-	1.22	-
	FBN1	fibrillin 1	-	1.24	-
	PGM5	phosphoglucomutase 5	-	1.28	-
	SPARC	secreted protein, acidic, cysteine-rich	-	1.30	-
MFAP5	microfibrillar associated protein 5	-	1.33	-	
Mucus production	ZG16	zymogen granule protein 16	-	1.22	-
	BEST2	bestrophin 2	-	1.32	-
	MUC17	mucin 17, cell surface associated	-	1.43	-
Oxidative stress, Detoxification	GSTZ1	glutathione S-transferase zeta 1	-	-	1.22
	NAGS	N-acetylglutamate synthase	-	-	1.21
	GSTM2	glutathione S-transferase mu 2	-	-	-1.41
	MPV17L	MPV17 mitochondrial membrane protein-like	-	-	-1.22
	CYP2D6	cytochrome P450, family 2, subfamily D, polypeptide 6	-	-	-1.23

Table 4: Effects of the dietary intervention on large intestine mucosal immunity.

Fecal calprotectin and secretory immunoglobulin A (SIgA) were quantified at baseline and every week during the intervention period. Cytokines were quantified in rectal biopsies at baseline and at the end of the intervention period (week 3). Data presented are mean changes from baseline \pm SEM. For cytokines, the effect of diet was tested with ANOVA. For fecal calprotectin and SIgA, mixed-model ANOVA was used with diet and time as fixed effects and participant as a random effect. NS: not significant ($P > 0.05$). MD: maltodextrin group, CAS: casein group, SOY: soy protein group. IL-8: interleukin-8, IFN- γ : interferon γ , TNF- α : tumor necrosis factor α .

	Week 1			Week 2			Week 3			P-value		
	MD	CAS	SOY	MD	CAS	SOY	MD	CAS	SOY	Diet	Time	D x T
Fecal calprotectin ($\mu\text{g/g}$)	9.46 \pm 6.98	-0.73 \pm 1.64	3.08 \pm 5.71	3.15 \pm 3.00	7.91 \pm 5.80	5.38 \pm 4.94	-2.38 \pm 2.94	2.09 \pm 2.25	3.54 \pm 4.60	NS	NS	NS
SIgA ($\mu\text{g/g}$)	-1.42 \pm 125.21	-136.99 \pm 102.33	92.92 \pm 89.90	-91.60 \pm 117.41	-96.53 \pm 113.47	10.85 \pm 52.00	-27.97 \pm 90.45	68.11 \pm 149.51	-65.90 \pm 53.92	NS	NS	NS
IFN- γ ($\mu\text{g/mg}$ protein)	-	-	-	-	-	-	6.69 \pm 10.31	2.64 \pm 12.44	5.10 \pm 8.25	NS	-	-
TNF- α ($\mu\text{g/mg}$ protein)	-	-	-	-	-	-	13.75 \pm 53.23	-54.29 \pm 64.99	31.15 \pm 52.94	NS	-	-
IL-8 ($\mu\text{g/mg}$ protein)	-	-	-	-	-	-	3.89 \pm 8.00	2.65 \pm 8.50	8.60 \pm 3.86	NS	-	-

FIGURES

Figure 1: Effects of the dietary intervention on uremia, fecal pH and fecal water cytotoxicity.

A - Uremia changes from baseline. B - Fecal pH changes from baseline. C - Fecal water cytotoxicity changes from baseline. Data presented are mean changes from baseline \pm SEM. Mixed model ANOVA was used to test differences in measured parameters changes with diet and time as fixed effects and participant as a random effect. For pairwise comparison, P-values were adjusted with the Tukey method. $P < 0.05$ was considered as statistically significant. MD: maltodextrin group, CAS: casein group, SOY: soy protein group. *: Change is different from the change in MD group at the same time.

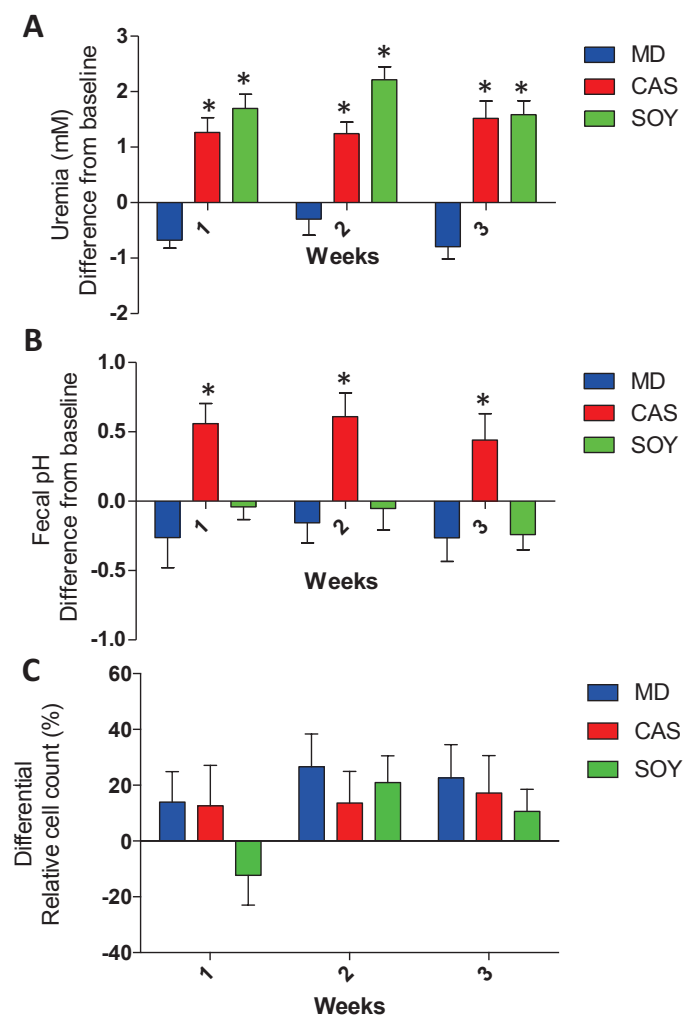

Figure 2: Effects of the dietary intervention on fecal metabolome.

Fecal metabolome was analyzed by $^1\text{H-NMR}$. CAS: casein group (red), SOY: soy protein group (green), MD: maltodextrin group (blue). O-PLS-DA models were used to compare the fecal metabolome at all time points of the following groups: CAS vs MD (A), SOY vs MD (B) and CAS vs SOY (C). For each pairwise comparison, the plot of the scores (T) versus cross-validated scores (Tcv) is shown on the left side and the loadings plot color-coded according to the correlation coefficient (r^2) with Y (predictor vector coding dietary group) is presented on the right side. Color triangles indicate relative metabolite concentration associated with indicated group (highest concentration in the widest part of the triangle). 2MB: 2-methylbutyrate (0.86 ppm), AC: acetoin (1.37), BUT: butyrate (0.89), PA: phenylacetate (3.54), TYRA: tyramine (7.22), U: unknown (1.16), V: valerate (1.30), VLI: valine, leucine, isoleucine (0.96, 0.99, 1.01). Numerical values in brackets indicate representative chemical shifts in ppm.

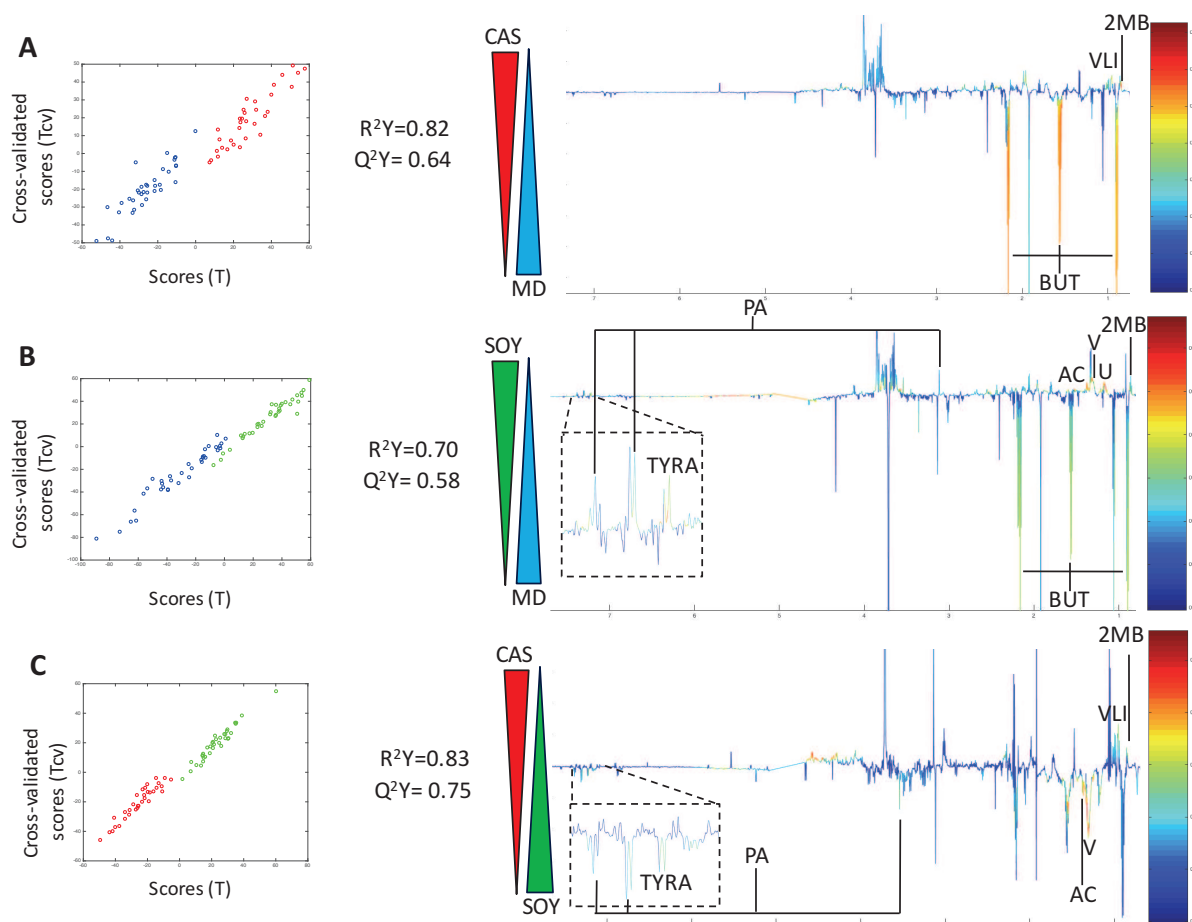

Figure 3: Fecal metabolome associated with Firmicutes abundance.

O-PLS model was used to correlate Firmicutes abundance (based on 16S rRNA gene sequencing) with fecal metabolome determined by ¹H-NMR. The plot of the scores (T) versus Firmicutes abundance is shown on the left side and the loadings plot color-coded according to the correlation coefficient (r^2) with Firmicutes abundance is presented on the right side. The vertical arrow indicates Firmicutes abundance (from low to high). 2MB: 2-methylbutyrate (0.86), IV: isovalerate (2.06), PA: phenylacetate (3.54), TYR: tyrosine (6.90). Numerical values in brackets indicate representative chemical shifts in ppm.

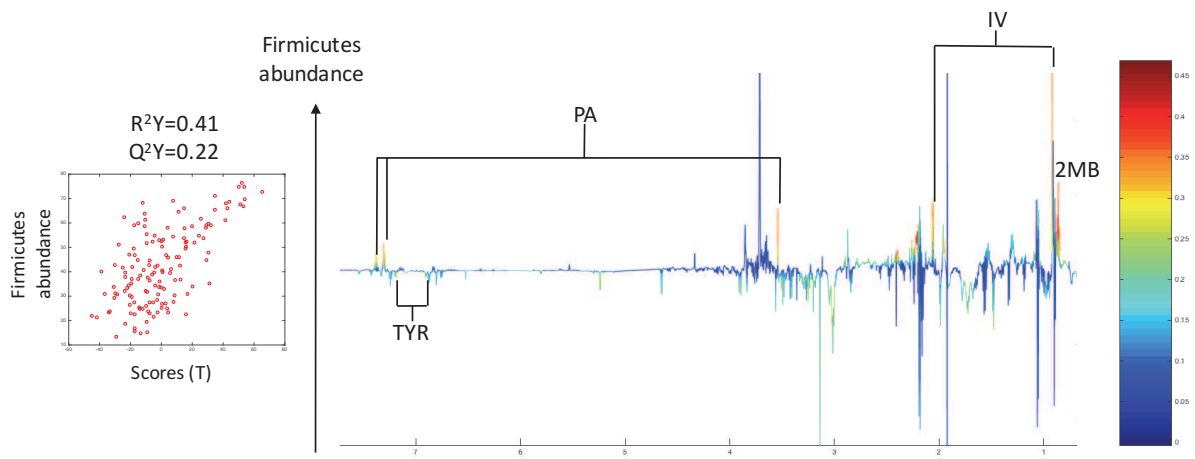

Figure 4: Effects of the dietary intervention on urinary metabolome.

Urinary metabolome was analyzed by $^1\text{H-NMR}$. CAS: casein group (red), SOY: soy protein group (green), MD: maltodextrin group (blue). O-PLS-DA models were used to compare the urinary metabolome at all time points of the following groups: CAS vs MD (A), SOY vs MD (B) and CAS vs SOY (C). For each pairwise comparison, the plot of the scores (T) versus cross-validated scores (Tcv) is shown on the left side and the loadings plot color-coded according to the correlation coefficient (r^2) with Y (predictor vector coding dietary group) is presented on the right side. Color triangles indicate relative metabolite concentration associated with the indicated group (highest concentration in the widest part of the triangle). 3HB: 3-hydroxybutyrate (1.20), 3HI: 3-hydroxyisovalerate (1.27), HPP: hydroxyphenylpropionate (2.48), AC: acetoin (1.37), CIT: citrate (2.55), IB: isobutyrate (1.08), IS: indoxyl sulfate (7.50), PAG: phenylacetylglutamine (2.28), PCS: *p*-cresyl sulfate (2.34), U: urea (5.80). Numerical values in brackets indicate representative chemical shifts in ppm.

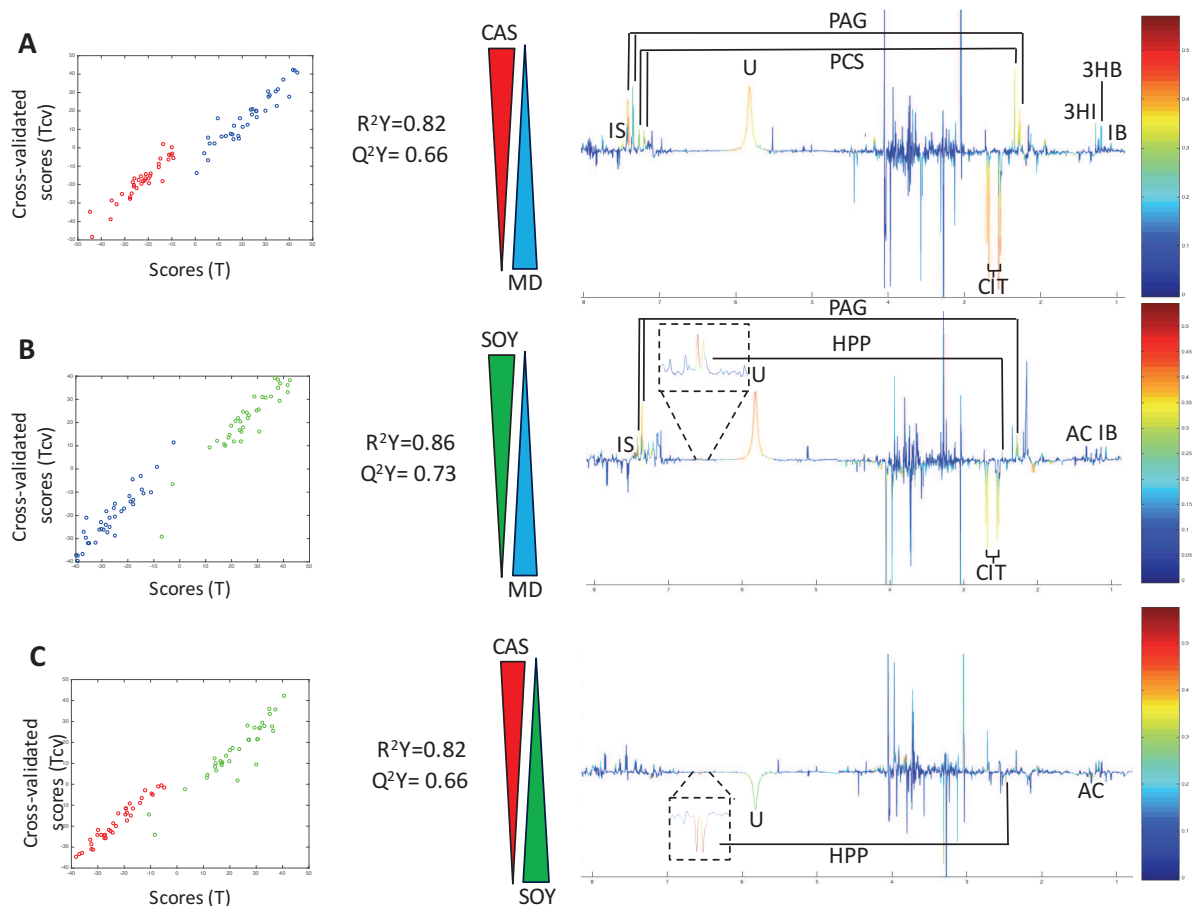

Figure 5: Fecal and urinary metabolome associated with fecal water cytotoxicity.

O-PLS-DA models were used to compare the fecal (A) and urinary (B) metabolome corresponding to cytotoxic (red) or non-cytotoxic (green) fecal waters. For each fluid (fecal water and urine), the plot of the scores (T) versus cross-validated scores (Tcv) is shown on the left side and the loadings plot color-coded according to the correlation coefficient (r^2) with Y (predictor vector coding fecal water cytotoxicity) is presented on the right side. The vertical arrow indicates the cytotoxicity of the fecal waters (from low to high cytotoxicity). 5AV: 5-aminovalerate (2.24), AL: alanine (1.48), BA: bile acids (0.69), ET: ethanol (1.18), H: hippurate (7.82), HPA: hydroxyphenylacetate (3.56), PAG: phenylacetylglutamine (2.28), PCS: *p*-cresyl sulfate (2.34), TYR: tyrosine (6.90), VLI: valine, leucine, isoleucine (0.96, 0.99, 1.01). Numerical values in brackets indicate representative chemical shifts in ppm.

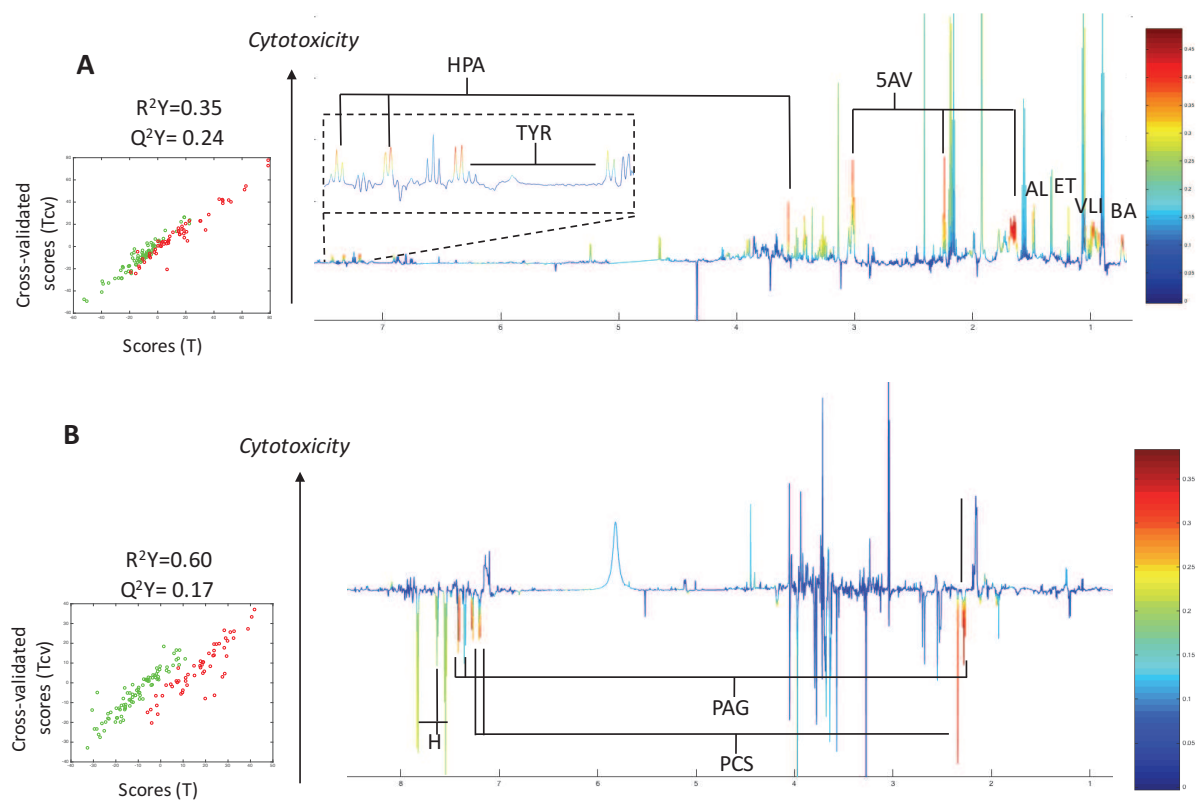

Figure 6: Effects of the dietary intervention on transcriptome profile in the rectal mucosa.

Gene expression in the rectal mucosa was analyzed by microarray experiments before and after the dietary intervention. CAS: casein group (red), SOY: soy protein group (green), MD: maltodextrin group (blue). A - Venn diagram showing the number of differentially expressed genes (DEG) in each group after the dietary intervention when compared to baseline (repeated measure analysis). B - Number of significantly enriched biological functions (P-value of enrichment < 0.05, more than 3 genes implicated in the function) identified by Ingenuity Pathway Analysis software. C - Number of DEG implicated in significantly enriched function. Data presented are mean \pm SEM. D and E -Repartition of significantly enriched function into biological categories expressed as a percentage of the total number of enriched function in each group (shown in panel B).

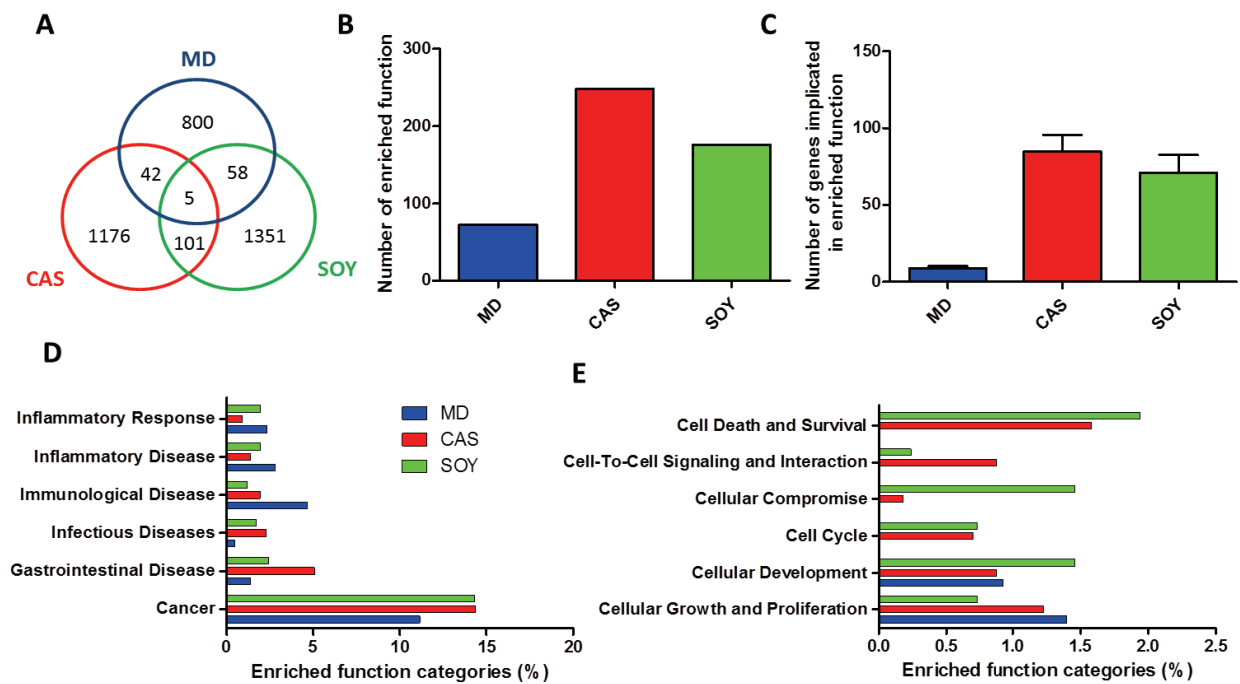

Figure 7: Schematic representation of the modulation of bacterial metabolism during the dietary intervention.

Red and green arrows indicate the change in metabolite concentration in the casein group and soy protein group (respectively) when compared to the maltodextrin group. When the arrow is up, it indicates that the metabolite concentration is higher than in the maltodextrin group, when it is down, it indicates that the metabolite concentration is lower than in the maltodextrin group

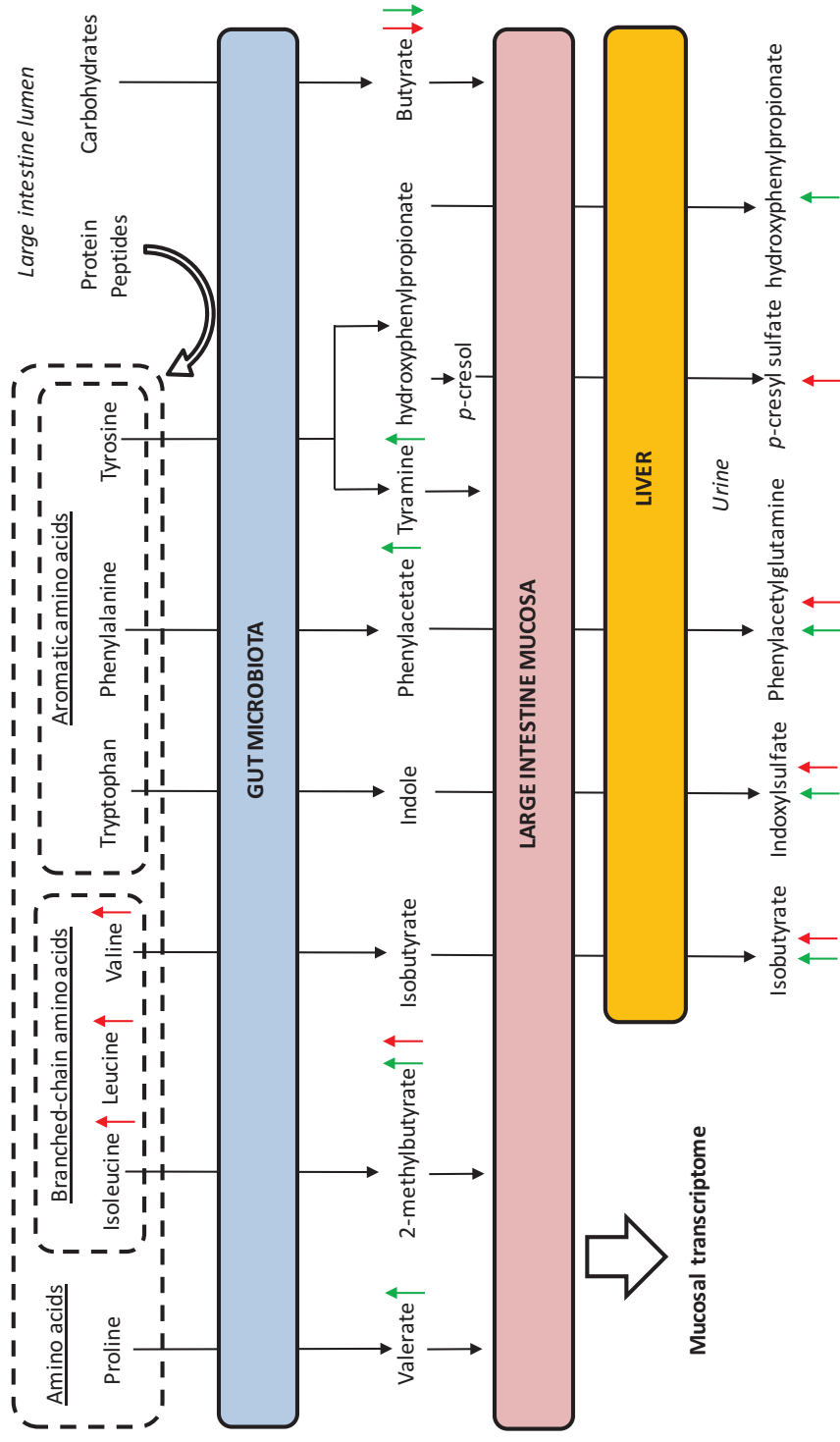
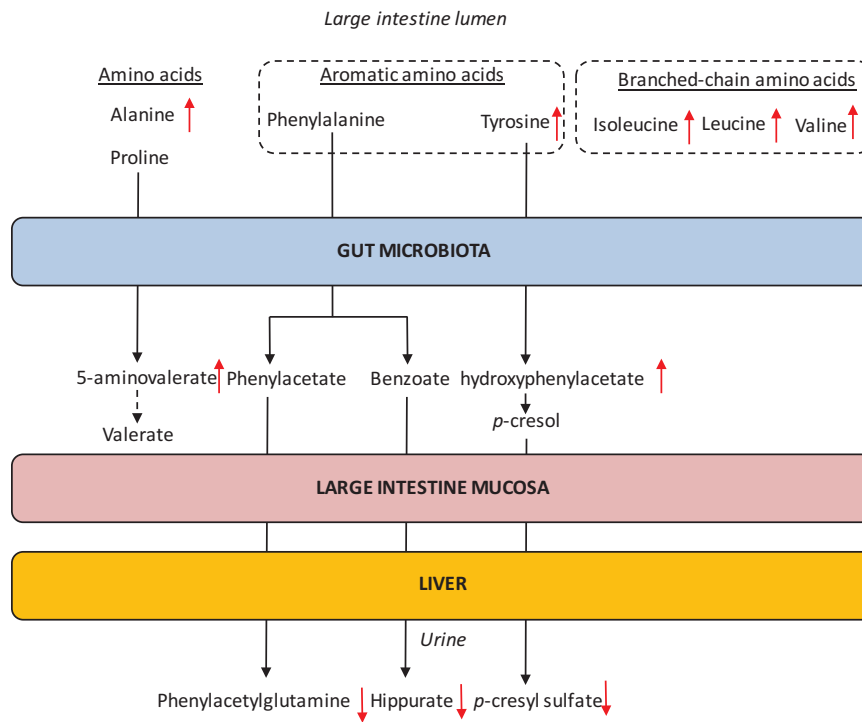

Figure 8: Schematic representation of the bacterial amino acid metabolism in cytotoxic samples.

When the red arrow is up, the corresponding metabolite is more abundant in cytotoxic samples than in non-cytotoxic samples. When the red arrow is down, the corresponding metabolite is less abundant in cytotoxic samples than in non-cytotoxic samples.



SUPPLEMENTARY FIGURES

Supplementary Figure 1: Fecal metabolome associated with fecal pH.

O-PLS model was used to correlate fecal pH with fecal metabolome determined by $^1\text{H-NMR}$. The plot of the scores (T) versus the fecal pH is shown on the left side and the loading plot colored according to the correlation coefficient (r^2) with fecal pH is presented on the right side. The vertical arrow indicates the pH value (from low to high pH). A: acetate (1.92), BUT: butyrate (0.89), ET: ethanol (1.18), G: glucose (5.24), LAC: lactate (1.33). Numerical values in brackets indicate representative chemical shifts in ppm. This plot shows that a low fecal pH is associated with high concentrations of butyrate, lactate, ethanol and glucose.

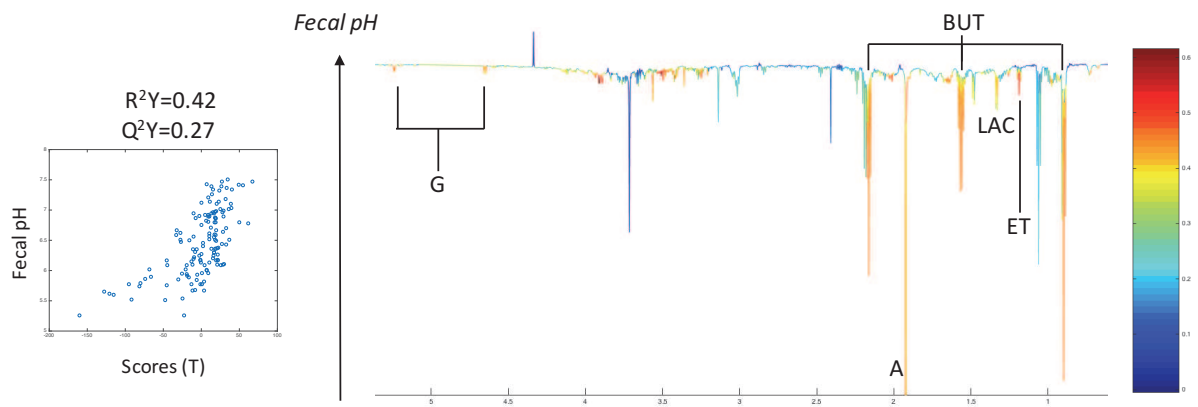

SUPPLEMENTARY TABLES

Supplementary Table 1: Subjects baseline characteristics.

Baseline corresponds to the end of the 2-weeks period of dietary normalization (run-in). Data presented are mean \pm SEM. The effect of group was tested with ANOVA. NS: not significant ($P > 0.05$). MD: maltodextrin group, CAS: casein group, SOY: soy protein group. SCFA: short chain fatty acids, AA-derived SCFA: amino acid derived SCFA (sum of isovalerate, isobutyrate and valerate), SIgA: secretory immunoglobulin A, PAG/creat: ratio of the urinary concentration of phenylacetylglutamine and creatinine, IL-8: interleukin-8, IFN- γ : interferon γ , TNF- α : tumor necrosis factor α .

	MD	CAS	SOY	P
Number of participants	13	12	13	-
Number of Males	4	3	6	-
Age (years)	31 \pm 2	28 \pm 1	31 \pm 2	NS
Body mass index (kg/m ²)	27.10 \pm 0.41	28.27 \pm 0.41	27.36 \pm 0.42	NS
<i>Dietary intakes</i>				
Energy (Kcal/day)	2035 \pm 163	1932 \pm 95	2332 \pm 127	NS
Protein (% energy)	18.2 \pm 0.4	16.9 \pm 0.7	16.4 \pm 0.6	NS
Uremia (mmol/L)	4.42 \pm 0.25	4.32 \pm 0.25	4.12 \pm 0.28	NS
Carbohydrate (% energy)	47.4 \pm 2.1	51.3 \pm 1.6	51.2 \pm 1.3	NS
Fat (% energy)	31.2 \pm 1.9	28.9 \pm 1.4	29.5 \pm 1.1	NS
Fiber (g/day)	20.0 \pm 1.5	22.3 \pm 1.8	25.4 \pm 1.7	NS
<i>Fecal parameters</i>				
Water content (%)	70.5 \pm 2.4	73.7 \pm 2.6	74.3 \pm 2.3	NS
pH	6.45 \pm 0.15	6.40 \pm 0.16	6.53 \pm 0.15	NS
Acetate (% total SCFA)	55.3 \pm 2.4	52.2 \pm 2.4	53.6 \pm 1.0	NS
Propionate (% total SCFA)	14.8 \pm 1.2	19.9 \pm 2.4	18.7 \pm 1.1	NS
Butyrate (% total SCFA)	14.8 \pm 2.0	17.6 \pm 2.5	17.2 \pm 1.8	NS
Isobutyrate (% total SCFA)	2.5 \pm 0.4	2.2 \pm 0.4	2.5 \pm 0.4	NS
Isovalerate (% total SCFA)	9.2 \pm 2.6	4.6 \pm 0.8	5.2 \pm 1.0	NS
Valerate (% total SCFA)	3.4 \pm 0.6	3.4 \pm 0.7	2.6 \pm 0.4	NS
AA-derived SCFA (% total)	15.1 \pm 2.6	10.3 \pm 1.4	10.3 \pm 1.4	NS
Ammonia (μ g/g)	177.08 \pm 20.12	247.05 \pm 39.58	268.63 \pm 51.76	NS
<i>p</i> -cresol (μ g/g)	58.18 \pm 11.33	37.85 \pm 10.03	43.28 \pm 10.44	NS
Fecal calprotectin (μ g/g)	26 \pm 4	18 \pm 2	26 \pm 7	NS
SIgA (μ g/g)	315.75 \pm 115.93	414.31 \pm 118.18	248.99 \pm 58.50	NS
Cytotoxicity (% viability)	54.4 \pm 10.9	31.2 \pm 12.7	59.9 \pm 12.6	NS
<i>Urinary parameter</i>				
PAG/creat (μ mol/mmol)	4.04 \pm 1.07	1.89 \pm 0.41	2.67 \pm 0.58	NS
<i>Mucosal cytokines</i>				
IFN- γ (μ g/g protein)	28.93 \pm 6.71	15.80 \pm 6.22	17.16 \pm 7.52	NS
IL-8 (μ g/g protein)	25.08 \pm 4.24	22.14 \pm 2.68	20.40 \pm 1.97	NS
TNF- α (μ g/g protein)	177.11 \pm 36.87	210.52 \pm 46.11	194.81 \pm 55.24	NS

Supplementary Table 2: Targeted measurements of fecal and urinary microbial metabolites.

Data presented are mean \pm SEM. Mixed model ANOVA was used to test differences in measured parameters changes with diet and time as fixed effects and participant as a random effect. For pairwise comparison, P-values were adjusted with the tukey method. Differences were considered significant for $P < 0.05$. NS: not significant ($P > 0.05$). MD: maltodextrin group, CAS: casein group, SOY: soy protein group, SCFA: short chain fatty acids, AA-derived SCFA: amino acid derived SCFA (sum of isovalerate, isobutyrate and valerate), SIgA: secretory immunoglobulin A, PAG/creat: ratio of the urinary concentration of phenylacetylglutamine and creatinine. *: Change is different from the change in MD group at the same time.

	Week 1			Week 2			Week 3			P-value		
	MD	CAS	SOY	MD	CAS	SOY	MD	CAS	SOY	Diet	Time	
											D x T	
Acetate (% total SCFA)	-2.41 \pm 2.00	4.38 \pm 1.63*	-0.40 \pm 1.46	-2.44 \pm 1.88	-2.44 \pm 2.09	-2.43 \pm 1.54	1.39 \pm 2.06	1.14 \pm 1.49	0.00 \pm 1.48	NS	< 0.001	0.032
Propionate (% total SCFA)	1.29 \pm 1.73	1.33 \pm 1.31	0.16 \pm 1.32	1.60 \pm 1.45	1.65 \pm 1.27	-0.90 \pm 0.87	0.42 \pm 1.18	1.97 \pm 1.20	-1.36 \pm 1.36	NS	NS	NS
Butyrate (% total SCFA)	5.82 \pm 1.78	-5.27 \pm 2.25*	-2.60 \pm 1.65*	3.84 \pm 1.57	-2.84 \pm 1.86*	-0.30 \pm 1.61	3.04 \pm 1.79	-3.44 \pm 1.81*	-0.97 \pm 1.43	0.001	NS	0.046
Isobutyrate (% total SCFA)	-0.43 \pm 0.41	0.19 \pm 0.42	0.34 \pm 0.41	-0.13 \pm 0.31	1.46 \pm 0.28*	0.69 \pm 0.26	-0.67 \pm 0.36	0.39 \pm 0.35	0.40 \pm 0.26	0.012	0.002	NS
Isovalerate (% total SCFA)	-4.01 \pm 1.31	-0.09 \pm 0.76	1.15 \pm 1.21*	-3.01 \pm 1.85	1.74 \pm 0.66*	2.31 \pm 0.97*	-4.30 \pm 2.30	0.42 \pm 0.94*	1.56 \pm 1.27*	0.004	0.024	NS
Valerate (% total SCFA)	-0.25 \pm 0.77	-0.55 \pm 0.80	1.35 \pm 0.68	0.13 \pm 0.47	0.43 \pm 0.67	0.63 \pm 0.19	-0.12 \pm 0.51	-0.48 \pm 0.81	0.37 \pm 0.31	NS	NS	NS
AA-derived SCFA (% total)	-4.70 \pm 1.41	-0.44 \pm 1.70	2.84 \pm 1.72	-3.00 \pm 2.09	3.63 \pm 1.36*	3.63 \pm 1.14*	-4.85 \pm 2.42	0.33 \pm 1.69	2.33 \pm 1.38*	0.017	0.011	NS
Ammonia (μ g/g)	18.44 \pm 17.20	-34.13 \pm 44.47	10.82 \pm 64.20	48.69 \pm 35.68	105.76 \pm 47.32	-2.89 \pm 39.30	22.63 \pm 31.70	0.01 \pm 41.10	-25.97 \pm 40.62	NS	NS	NS
<i>p</i> -cresol (μ g/g)	-6.00 \pm 15.69	7.89 \pm 18.20	15.02 \pm 14.57	-2.72 \pm 15.52	19.18 \pm 7.71	24.73 \pm 12.87	-25.19 \pm 10.91	19.97 \pm 5.81	24.63 \pm 5.27*	0.036	NS	NS
PAG/creat (μ mol/mmol)	-1.24 \pm 0.63	1.08 \pm 0.32*	1.16 \pm 0.62*	-0.91 \pm 0.75	1.71 \pm 0.50*	0.80 \pm 0.47	-1.06 \pm 0.65	2.28 \pm 1.19*	0.69 \pm 0.66	0.001	NS	NS

Supplementary Table 3: Effect of the dietary interventions on fecal metabolome.

Fecal metabolome was analyzed by ¹H-NMR. Discriminant fecal metabolites between dietary groups after 1, 2 or 3 weeks of dietary intervention were identified by O-PLS-DA. CAS: casein group, SOY: soy protein group, MD: maltodextrin group. ↓: decrease in relative concentration, ↑: increase in relative concentration.

For each metabolite, one representative chemical shift is indicated.

metabolites	Chemical shift (ppm)	Week 1		Week 2		Week 3	
		CAS vs MD	SOY vs MD	CAS vs MD	SOY vs MD	CAS vs MD	SOY vs MD
Butyrate	0.89	↓	↓	↓	↓	↓	↓
Leucine	0.96	↑	↑	↑	↑	↑	↑
Valine	0.99	↑	↑	↑	↑	↑	↑
Isoleucine	1.01	↑	↑	↑	↑	↑	↑
2-methylbutyrate	0.86	↑	↑	↑	↑	↑	↑
Valerate	1.30	↑	↑	↑	↑	↑	↑
Phenylacetate	3.54	↓	↓	↓	↓	↓	↓
Tyramine	7.22	↑	↑	↑	↑	↑	↑
Unknown 1 (multiple)	1.16	↑	↑	↑	↑	↑	↑
Acetoin	1.37	↑	↑	↑	↑	↑	↑

CAS vs MD R²Y=0.90 Q²Y=0.33
 SOY vs MD R²Y=0.71 Q²Y=0.12
 CAS vs SOY R²Y=0.86 Q²Y=0.48
 CAS vs MD R²Y=0.91 Q²Y=0.27
 SOY vs MD R²Y=0.82 Q²Y=0.65
 CAS vs SOY R²Y=0.91 Q²Y=0.65

Supplementary Table 4: Fecal metabolome associated with bacterial groups abundance.

O-PLS models were used to correlate bacterial groups abundance (based on 16S rRNA gene sequencing) with fecal metabolome determined by ¹H-NMR. 2MB: 2-methylbutyrate, BUT: butyrate, 5AV: 5-aminovalerate, CAD: cadaverine, GLU: glucose, HPP: hydroxyl-phenylpropionate, IB: isobutyrate, IV: isovalerate, PA: phenylacetate, PHE: phenylalanine, PRO: propionate, PUR: purines, TYR: tyrosine, VLI*: valine (0.99 ppm), leucine (0.96 ppm), isoleucine (1.01 ppm). Bacterial groups with no significant association with fecal metabolome are not shown.

Phylum	Genus	R ² Y	Q ² Y	Fecal metabolite														
				PRO	BUT	IB	IV	VAL	2MB	5AV	PA	VLI	HPP	GLU	TYR	CAD	PHE	PUR
Firmicutes		0.41	0.22			↑	↑	↑	↑	↑	↑	↓						
	<i>Oscillospira</i>	0.48	0.32		↓		↑	↑	↑									
	<i>Acidaminococcus</i>	0.50	0.14			↓	↓	↓	↓	↓								
	<i>Odoribacter</i>	0.50	0.15				↑	↑	↑	↑	↑	↑	↑	↑				
Bacteroidetes		0.36	0.12			↓	↓	↓	↓	↓	↓	↓	↓	↓	↓	↓	↓	↓
	<i>Bacteroides</i>	0.44	0.24			↓	↓	↓	↓	↓	↓	↓	↓	↓	↓	↓	↓	↓
	<i>Prevotella</i>	0.50	0.18															↑
Actinobacteria		0.54	0.21															
	<i>Bifidobacterium</i>	0.48	0.18															
Verrucomicrobia		0.29	0.11				↑	↑	↑	↑	↑	↑	↑	↑	↑	↑	↑	↑

Supplementary Table 5: Effects of the dietary interventions on urinary metabolome.

Urinary metabolome was analysed by ¹H-NMR. Discriminant urinary metabolites between dietary groups after 1, 2 or 3 weeks of dietary intervention were identified by O-PLS-DA. CAS: casein group, SOY: soy protein group, MD: maltodextrin group. ↓: decrease in relative concentration, ↑: increase in relative concentration. For each metabolite, one representative chemical shift is indicated.

Urine metabolites	Chemical shift (ppm)	Week 1			Week 2			Week 3		
		CAS vs MD	SOY vs MD	CAS vs SOY	CAS vs MD	SOY vs MD	CAS vs SOY	CAS vs MD	SOY vs MD	CAS vs SOY
Urea	5.80	↑	↑	↓	↑	↑	↓	↑	↑	↓
Isobutyrate	1.08	↑	↑		↑	↑				
3-hydroxybutyrate	1.20				↑			↑		
3-hydroxyisovalerate	1.27	↑	↑	↑						
Acetoin	1.38		↑	↓				↑	↑	↓
<i>p</i> -cresol	2.34	↑								
Citrate	2.55	↓	↓		↓	↓	↓	↓	↓	↓
Hydroxyphenylpropionate	2.48	↑	↑	↓	↑	↑	↓	↑	↑	↓
Phenylacetylglutamine	2.28	↑	↑		↑	↑		↑	↑	
Indoxylsulfate	7.50	↑	↑		↑	↑		↑	↑	

Supplementary table 6: Confirmation of microarray data by qPCR.

Expression levels of selected genes of interest measured by microarray were correlated to their expression levels assessed by qPCR (Log transformed). ρ : Spearman coefficient of correlation. $P < 0.05$ was considered significant. *Col3a1*: collagen type III alpha 1, *Tagln*: transgelin, *Gstm2*: glutathione S-transferase Mu 2, *Chrm3*: cholinergic receptor muscarinic 3, *Muc17*: mucin 17.

Gene name	ρ	P-value
<i>Col3a1</i>	0.58	<0.001
<i>Tagln</i>	0.58	<0.001
<i>Gstm2</i>	0.50	<0.001
<i>Chrm3</i>	0.30	0.014
<i>Muc17</i>	0.81	<0.001

Supplementary Table 7: Digestive diseases related functions significantly enriched in the set of differentially expressed genes in the rectal mucosa after the dietary intervention.

Significantly enriched functions in the sets of genes regulated by the dietary interventions were identified with Ingenuity Pathway Analysis software (P-value of enrichment < 0.05, more than 3 genes implicated in each function). CAS: casein group, SOY: soy protein group, MD: maltodextrin group. NS: not significant (P > 0.05).

Digestive diseases related functions	P-value of enrichment		
	CAS	SOY	MD
Cecum adenocarcinoma	0.010	0.008	NS
Colon adenocarcinoma	0.003	0.007	NS
Colon cancer	0.002	0.011	NS
Colon carcinoma	0.003	0.007	NS
Colorectal adenocarcinoma	0.004	0.008	NS
Colorectal carcinoma	0.004	0.010	NS
Epithelial cancer	0.006	<0.001	NS
Gastrointestinal adenocarcinoma	0.010	0.010	NS
Gastrointestinal carcinoma	0.004	0.015	NS
Infection of epithelial cell lines	0.015	0.002	NS
Neoplasia of epithelial tissue	0.004	<0.001	NS
Tumorigenesis of intestine	NS	0.011	NS
Proliferation of epithelial cell lines	NS	0.016	NS
Progression of digestive organ tumor	<0.001	NS	NS
Colon tumor	0.002	NS	NS
Colorectal adenoma	0.002	NS	NS
Breast or colorectal cancer	0.005	NS	NS
Colorectal neoplasia	0.005	NS	NS
Gastrointestinal tract cancer and tumors	0.006	NS	NS
Colorectal cancer	0.007	NS	NS
Gastrointestinal tract cancer	0.007	NS	NS
Senescence of colon cancer cell lines	0.029	NS	NS
Proliferation of colon cancer cell lines	0.036	NS	NS
Digestive system cancer	0.038	NS	NS
Invasion of epithelial cell lines	0.048	NS	NS

Supplementary Table 8: Amino acid composition of the protein isolates used for supplementation.

The amino acid compositions of the experimental protein isolates were provided by the suppliers. CAS: casein, SOY: soy protein isolate, EAA: essential amino acid, BCAA: branch-chain amino acid.

Amino acid	g/100 g protein	
	CAS	SOY
Alanine	4.8	4.3
Arginine	2.7	7.6
Aspartate + Asparagine	10.9	11.6
Cystein / Cystine	2.7	1.3
Glutamate + Glutamine	16.6	19.1
Glycine	1.8	4.2
Histidine (EAA)	2.0	2.6
Isoleucine (BCAA-EAA)	5.5	4.9
Leucine (BCAA-EAA)	12.1	8.2
Lysine (EAA)	9.6	6.3
Methionine (EAA)	2.2	1.3
Phenylalanine (EAA)	3.7	5.2
Proline	5.2	5.1
Serine	4.5	5.2
Threonine (EAA)	5.1	3.8
Tryptophan (EAA)	2.1	1.3
Tyrosine	3.5	3.8
Valine (BCAA-EAA)	5.0	5.1

ACKNOWLEDGMENTS

This work was supported by the European Union's Seventh Framework Program under the grant agreement n° 613979 (MyNewGut). Martin Beaumont is a recipient of a PhD grant from INRA-Université Paris-Saclay (ALIAS program). The authors thank Marie-Claude Amard for recruiting the subjects and collecting the samples, Aurélie Belvaux and Katia Spiczonek for dietetic work, Agnès Marsset-Baglieri for her supervision of dietary supplement formulation, Francine Walker and Antoine Martin for histological examinations, Nathalie Kapel for fecal calprotectin measurements, Olivier Cloarec for his supervision of NMR data statistical analyzes and the Genomic platform of Institut Cochin in Paris for microarray experiments.

DISCUSSION GENERALE ET PERSPECTIVES

Le but de ce travail de thèse était de caractériser les effets de l'apport en protéines sur l'écosystème du gros intestin. Chez l'homme, les régimes HP n'ont pas eu d'effets marqués sur la composition du microbiote fécal. Néanmoins, un apport élevé en protéines a augmenté les concentrations fécales et urinaires en métabolites bactériens dérivés des AA et a diminué la concentration fécale en butyrate. De plus, les effets des régimes HP sur les métabolites bactériens étaient différents selon la source de protéines utilisée. Parmi les métabolites bactériens dérivés des AA, les résultats obtenus dans des modèles pré-cliniques montrent que le H₂S et le *p*-cresol sont toxiques pour l'épithélium du côlon lorsqu'ils sont présents en concentration élevée. Enfin, chez le rat et chez l'homme, les régimes HP ont régulé l'expression de gènes participants à des fonctions importantes dans l'épithélium et dans la muqueuse du gros intestin, respectivement. Toutefois, sur la base des paramètres mesurés, ces modifications n'étaient pas associées à des effets délétères au niveau de la muqueuse.

Apport en protéines et composition du microbiote

En cas d'apport élevé en protéines, la quantité de composés azotés (protéines et peptides principalement) parvenant au niveau du gros intestin augmente (6). Pour un individu consommant 2500 Kcal par jour, un régime NP (15% de l'énergie apportée par les protéines) correspond à une consommation d'environ 94 grammes de protéines par jour. En cas de régime HP (30% de l'énergie apportée par les protéines), la consommation de protéines est d'environ 188 grammes par jour. Théoriquement, pour une source de protéines digestible à 95 % (protéines de lait par exemple), 4,7 et 9,4 grammes de protéines alimentaires arrivent dans le côlon chaque jour dans le cas du régime NP et HP, respectivement. En comparaison, il est estimé qu'entre 6 et 12 grammes de protéines endogènes arrivent chaque jour dans la lumière du côlon (5). Ainsi le régime HP entraîne une augmentation théorique modeste mais significative de la quantité de protéines disponibles pour le microbiote (entre +30 et + 40 % environ par rapport au régime NP, selon la quantité de protéines endogènes).

L'effet de l'alimentation sur la composition du microbiote serait principalement lié à la modification des substrats présents dans la lumière du gros intestin, les espèces bactériennes les plus adaptées à ce nouvel environnement étant favorisées (96). Pourtant, dans notre étude chez l'homme, les régimes HP n'ont pas eu d'effets majeurs sur la composition du microbiote fécal alors qu'ils ont probablement entraîné une augmentation de la quantité de protéines disponibles pour le microbiote. Néanmoins, cette augmentation est théoriquement de seulement quelques grammes de protéines. Lors des régimes HP, les glucides indigestibles (20 - 60 grammes par jour) (109) sont donc probablement présents dans la lumière du gros intestin en quantité largement supérieure aux protéines. La modification

des substrats présents induite par les régimes HP n'est donc peut-être pas suffisante pour induire des répercussions détectables sur la composition du microbiote. Cependant, le faible nombre de participants et la grande variabilité interindividuelle observée pourraient masquer d'éventuels effets discrets de l'apport en protéines sur la composition du microbiote. Ces résultats sont en contradiction avec plusieurs études sur des modèles animaux démontrant qu'un régime HP modifie la composition en bactéries (11,101,205). Ces différences pourraient être liées à la moindre variabilité interindividuelle de composition du microbiote et au meilleur contrôle des conditions expérimentales (95).

Lors de l'étude clinique, les sachets de protéines ou de maltodextrine étaient fournis aux participants et les apports en macronutriments, en fibres et en énergie étaient contrôlés. Néanmoins, il persistait une grande disparité quant aux aliments consommés par les participants. Il est possible que cela ait contribué à l'importante variabilité inter-individuelle observée au niveau de la composition du microbiote. Bien que difficile à mettre en place, l'idéal serait de faire une nouvelle étude clinique sur un plus grand nombre de sujets et dans laquelle l'alimentation serait plus strictement uniformisée. Enfin, l'analyse de la composition du microbiote adhérent à la muqueuse (associé aux biopsies rectales) est en cours et fournira des données plus représentatives de la situation à proximité de la muqueuse du côlon.

Apport en protéines et métabolites bactériens

Les régimes HP chez l'homme ont eu un effet marqué sur les concentrations fécales et urinaires des métabolites produits par les bactéries intestinales. Dans la mesure où la composition du microbiote n'est pas modifiée, il est très probable que les effets des suppléments en protéines sur les concentrations en métabolites bactériens soient principalement liés à une augmentation de la disponibilité en protéines et en peptides dans la lumière du gros intestin. Cette hypothèse est cohérente avec l'augmentation des concentrations en métabolites bactériens dérivés des AA lors des régimes HP observée lors de notre étude chez l'homme. La diminution de la concentration fécale de butyrate lors des régimes HP est plus difficile à expliquer. Des études *in vitro* d'incubation de bactéries intestinales avec différentes concentrations en protéines et en présence de glucides indigestibles (principaux précurseurs du butyrate) permettraient de mieux interpréter ce résultat. Pour approfondir, il serait intéressant d'étudier les effets de l'intervention nutritionnelle sur l'expression des gènes des bactéries intestinales (métatranscriptome) afin de mieux caractériser la réponse du microbiote au régime HP. Cette approche pourrait être combinée avec la mesure *in vitro* d'activités enzymatiques liées à la dégradation des AA par le microbiote.

Les deux sources de protéines utilisées lors des régimes HP chez l'homme ont été choisies en raison de leurs différences de digestibilité décrites dans la littérature (24,27). Notre hypothèse était que

la moindre digestibilité des protéines de soja par rapport aux caséines (90 et 95 %, respectivement) entraînerait un passage deux fois plus important de protéines alimentaires dans le côlon dans le cas des protéines de soja (10 et 5 %, respectivement) et donc une dégradation bactérienne des AA plus importante. Les données obtenues ne confirment pas cette hypothèse, les marqueurs de dégradation des AA par les bactéries étant augmentés à un niveau similaire quelle que soit la source de protéines consommée lors des régimes HP. Toutefois, les sources de caséines et de protéines de soja utilisées lors de l'étude clinique ne sont pas les mêmes que lors des études dans lesquelles la digestibilité de ces protéines a été étudiée (24,27). Il est donc envisageable que la différence de digestibilité entre les deux sources de protéines ne soit pas aussi importante que celle anticipée. Néanmoins, la source de protéines a clairement eu un effet sur la nature des métabolites bactériens affectés par les régimes HP. Ces différences sont probablement majoritairement dues à la composition distincte en AA des protéines de soja et des caséines. Pour vérifier cette hypothèse, il serait intéressant d'étudier la production de métabolites lors de l'incubation *in vitro* de bactéries intestinales avec un mélange d'AA mimant la composition des protéines de soja ou des caséines

Effets de l'apport en protéines sur la muqueuse du gros intestin

Les résultats obtenus montrent que la consommation d'un régime HP pendant quelques semaines n'induit pas d'effets délétères sur la muqueuse du gros intestin. En effet, chez l'homme, les paramètres inflammatoires et histologiques étaient normaux après la consommation des régimes HP. Chez le rat, aucun effet délétère significatif en termes de dommages à l'ADN, de renouvellement de l'épithélium et de fonction barrière n'était décelable. Pourtant, nos résultats obtenus chez l'homme suggèrent fortement que, lors des régimes HP, l'exposition de l'épithélium aux métabolites bactériens dérivés des AA était augmentée et certains de ces métabolites sont des composés délétères pour la muqueuse (*p*-cresol par exemple), lorsqu'ils sont testés individuellement. De plus, la diminution de la concentration fécale de butyrate observée lors des régimes HP pourrait s'accompagner d'effets délétères, compte tenu des effets bénéfiques généralement attribués à cet AGCC aux concentrations physiologiques (117).

Bien que le niveau d'apport en protéines n'ait pas affecté la cytotoxicité des eaux fécales dans notre étude chez l'homme, les changements d'environnement luminal mesurés semblent plutôt défavorables, du moins à première vue. Plusieurs hypothèses pourraient expliquer pourquoi, sur la base des paramètres mesurés, l'intégrité de la muqueuse est maintenue lors des régimes HP.

Premièrement, la toxicité des métabolites bactériens dérivés des AA est souvent observée seulement à une concentration élevée. Il est donc possible que l'augmentation de leur concentration lors des régimes HP ne soit pas suffisante pour dépasser le seuil de toxicité. Dans le cas du H₂S, la concentration luminale mesurée chez les rats nourris avec un régime HP était d'environ 0,4 mM alors que nous avons observé des effets pro-inflammatoires de ce métabolite seulement à partir de 1,5 mM dans le modèle d'instillation chez le rat.

Deuxièmement, tous les métabolites bactériens dérivés des AA ne sont pas délétères. Au contraire, certains métabolites tels que les composés indoliques ont des propriétés immuno-régulatrices et renforcent la fonction barrière (150,152). Il est donc possible que les effets délétères pour la muqueuse de certains métabolites bactériens soient contrebalancés par les effets bénéfiques d'autres métabolites, maintenant ainsi un état d'équilibre dans la muqueuse, par exemple entre les signaux pro et anti-inflammatoires. Cette hypothèse pourrait être vérifiée sur des colonocytes *in vitro* lors de co-incubations avec des métabolites aux effets divergents.

Troisièmement, il est possible que l'épithélium du côlon mette en place des adaptations permettant de limiter les effets toxiques de certains métabolites bactériens dérivés des AA lors des régimes HP. Par exemple, nous avons observé que le gène de la première enzyme du complexe de détoxification du H₂S (*Sqr*) était surexprimé lors d'un régime HP chez le rat. Cette adaptation pourrait entraîner une augmentation de la capacité de détoxification du H₂S par les colonocytes, limitant ainsi sa concentration intracellulaire. Cette hypothèse pourrait être vérifiée en déterminant si les effets du H₂S lors des régimes HP sont amplifiés chez des animaux déficients en *Sqr* spécifiquement dans les colonocytes. De la même manière, l'augmentation de l'activité de la glutamine synthétase dans les colonocytes de rats nourris avec un régime HP (9) pourrait refléter une augmentation de leur capacité à détoxifier le NH₄⁺ en glutamine. Les systèmes de détoxification des métabolites bactériens dérivés des AA pourraient donc être inductibles dans les colonocytes. Enfin, il est envisageable que l'augmentation de l'expression des gènes de mucines observée dans le côlon lors d'un régime HP chez le rat ou chez le porc (10,99) induise une augmentation de la sécrétion de mucus associée à une diminution de l'exposition de l'épithélium aux composés luminaux. Pour vérifier cette hypothèse du rôle protecteur d'une augmentation de la sécrétion de mucus lors des régimes HP, il serait intéressant de nourrir des souris déficientes en mucines (*Muc2* par exemple) avec un régime HP et d'observer les effets sur la muqueuse du côlon.

Chez le rat et chez l'homme, les régimes HP ont clairement régulé l'expression de nombreux gènes dans l'épithélium colique et dans la muqueuse rectale, respectivement. L'amplitude des changements d'expression de gènes induits par les régimes HP était limitée mais cette observation est

cohérente avec d'autres études cliniques d'intervention nutritionnelles montrant des régulations relativement subtiles au niveau transcriptomique (206). Cependant, collectivement, ces changements d'expressions modestes peuvent avoir un sens biologique, révélé par les analyses fonctionnelles (207). En effet, les gènes régulés par les régimes HP participent à des fonctions communes et jouent des rôles essentiels dans le renouvellement de l'épithélium et pour l'homéostasie de la muqueuse. Ces régulations d'expression de gènes dans la muqueuse du gros intestin induites par les régimes HP pourraient refléter la réponse aux changements d'environnement luminaux mais également les processus adaptatifs associés.

Il est probable que certains métabolites bactériens, dont les concentrations sont affectées par le niveau d'apport en protéines, soient impliqués dans cette régulation de l'expression génique. Par exemple, lors des régimes HP chez l'homme, la diminution de la concentration luminale de butyrate pourrait réguler l'expression de gènes dans les colonocytes via une diminution de l'inhibition des histones déacétylases par cet AGCC (117). Néanmoins, pour la majorité des métabolites bactériens dont la concentration est modifiée par le régime HP, les effets sur l'expression des gènes dans l'épithélium du gros intestin ne sont pas connus. De nouvelles études *in vitro* sont donc nécessaires pour caractériser les effets des nombreux métabolites bactériens dérivés des AA sur l'épithélium. Il serait également intéressant d'étudier les effets des régimes HP sur le transcriptome des colonocytes chez des animaux axéniques ou traités avec des antibiotiques de manière à mieux identifier le rôle du microbiote et des métabolites bactériens.

Enfin, il est également possible que la régulation de l'expression des gènes dans les colonocytes lors des régimes HP soit en partie liée à une augmentation de la concentration artérielle en AA. Pour tester cette hypothèse, l'expression de gènes pourrait être analysée dans des colonocytes polarisés cultivés *in vitro* en présence de concentrations élevées en AA à leur pôle basal. Par ailleurs, le profil transcriptomique observé dans la muqueuse du côlon lors des régimes HP pourrait également refléter les potentielles adaptations de la muqueuse du côlon au changement d'environnement luminal. Par exemple, le profil d'expression de gènes observé chez les rats nourris avec un régime HP semble refléter une diminution de l'exposition aux composés luminaux, peut-être en raison de l'augmentation de l'expression des gènes de mucines dans ce modèle. En effet, le régime HP a induit une diminution des gènes impliqués dans des mécanismes de protection contre les composés luminaux potentiellement toxiques dans les colonocytes (métabolisme du glutathion, réparation de l'ADN, voie de signalisation NF- κ B, fonction barrière).

En conclusion, nous proposons que la combinaison des effets des métabolites délétères, des métabolites bénéfiques et des possibles mécanismes adaptatifs se compensent et permettent le maintien

de l'homéostasie dans la muqueuse du gros intestin (Figure 33). La signature transcriptomique induite par les régimes HP pourrait dans ce contexte refléter un nouvel état d'équilibre dont la stabilité, en particulier à long terme, reste à explorer.

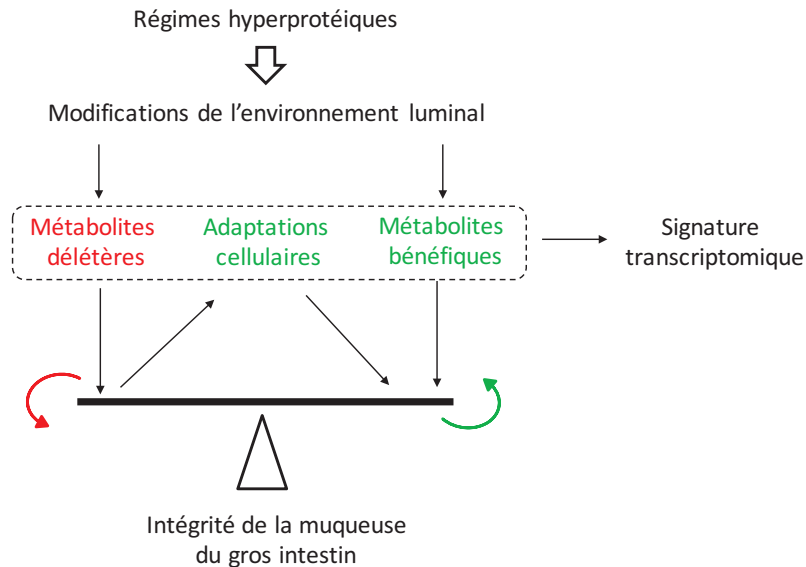

Figure 33 : Représentation schématique des mécanismes hypothétiques expliquant le maintien de l'intégrité de la muqueuse du gros intestin et la signature transcriptomique associée lors des régimes hyperprotéiques.

Apport en protéines et pathologies digestives

Comme décrit dans l'introduction, certaines études épidémiologiques ont montré une corrélation positive entre le niveau d'apport en protéines et l'incidence ou le risque de rechute des MICI (204). La principale hypothèse proposée pour expliquer cette association repose sur l'augmentation de la concentration fécale en H_2S observée chez l'homme lors d'un régime HP (171,186). En effet, nos données montrent que le H_2S est toxique pour les cellules épithéliales coliques lorsqu'il est présent en concentrations élevées. Néanmoins, nous n'avons pas observé d'augmentation de la concentration luminaire en H_2S lors d'un régime HP chez le rat, malgré une augmentation de l'expression du gène de la *Sqr* dans les colonocytes de ces animaux, suggérant que l'exposition de l'épithélium au H_2S était augmentée lors des régimes HP, au moins transitoirement. Il est possible que, chez le rat, l'augmentation de la quantité de contenu du gros intestin lors d'un régime HP limite l'augmentation de la concentration de H_2S . Ces données suggèrent, que dans ce modèle animal, des mécanismes adaptatifs permettent d'éviter de brusques modifications des concentrations lumineales des métabolites bactériens délétères. Au-delà des limites liées à la courte durée des études (2 semaines chez le rat, 3 semaines chez l'homme), il est possible qu'un apport élevé en protéines *per se* ne soit pas le facteur déclencheur de ces pathologies,

mais plutôt un facteur aggravant. Par exemple, en situation de perturbation de la fonction barrière de la muqueuse du côlon (comme souvent documenté dans les MICI), les potentiels effets délétères des régimes HP pourraient être amplifiés en raison d'une plus grande accessibilité des métabolites bactériens dérivés des AA à l'épithélium. En effet, une étude récente réalisée au laboratoire avec un modèle de RCH chimio-induite chez la souris montre que la consommation d'un régime HP augmente l'inflammation, la perte de poids et la mortalité lors de la phase de résolution de l'inflammation par rapport à un régime NP (208).

En raison de ses propriétés génotoxiques *in vitro*, le *p*-cresol pourrait causer des mutations dans l'ADN des colonocytes et ainsi perturber l'homéostasie du renouvellement de l'épithélium. Le type de mutations éventuellement lié à la présence excessive de ce métabolite bactérien reste à identifier, notamment en ce qui concerne les étapes d'initiation du cancer du colorectal (209). Néanmoins, les données épidémiologiques montrent qu'il n'existe pas de lien convaincant entre un apport en protéines élevé et le risque de cancer du côlon (210,211). De plus, les études expérimentales portant sur les effets de l'apport en protéines sur la cancérogénèse colique ont mené à des conclusions discordantes, peut-être en raison de la grande variété de quantité et de sources de protéines alimentaires testées (212). Au contraire, le lien entre consommation de viande rouge et incidence du cancer du côlon est avéré (213). Etant donné que la teneur en protéines est similaire dans la viande rouge et la viande blanche (1), ce facteur ne semble pas pouvoir expliquer l'effet spécifique de la viande rouge. D'autres composés de la viande rouge tels que l'hème, les composés produits lors de la cuisson et les nitrosamines ont été impliqués dans la cancérogénèse colique (195). Cependant, il est concevable que l'utilisation par le microbiote des protéines de la viande rouge génère des composés toxiques agissant en synergie avec l'hème (209). Récemment, il a été montré que le H₂S produit par le microbiote favoriserait l'accès de l'hème à l'épithélium en déstabilisant la couche de mucus (184). Ainsi, un apport élevé en protéines pourrait être un facteur non suffisant mais favorisant la cancérogénèse colique. Pour vérifier ces hypothèses, il serait intéressant de tester chez l'animal les éventuels effets synergiques d'un apport élevé en protéines avec un apport élevé en hème.

Limites liées aux conditions expérimentales

L'utilisation du modèle rat pour étudier les effets des régimes HP au niveau du gros intestin présente bien entendu plusieurs limites. Premièrement, les réactions de fermentation des glucides et des protéines sont très actives dans le cæcum chez le rat (11,137). Chez l'homme, la partie proximale du gros intestin (cæcum peu développé) est aussi un site de dégradation des glucides, mais la dégradation des protéines a principalement lieu dans la partie distale du gros intestin (151). Ces différences anatomiques entre l'homme et le rat ont probablement des conséquences en terme

d'exposition de l'épithélium du gros intestin aux métabolites bactériens. Deuxièmement, le régime HP induit chez le rat une augmentation de la quantité de contenu dans le gros intestin en raison d'une augmentation de la quantité d'eau, ce qui modifie les concentrations luminales en métabolites bactériens (9,11). Au contraire, chez l'homme nous avons observé une corrélation négative entre le niveau d'apport en protéines et la teneur en eau dans les fèces, comme précédemment observé dans une autre étude (13). Cette différence est une limite aux comparaisons des résultats obtenus chez les deux espèces. Troisièmement, les échantillons analysés chez le rat sont difficilement accessibles chez l'homme. Par exemple, les contenus du gros intestin et les colonocytes ont été étudiés chez le rat alors que les fèces et la muqueuse rectale ont été analysés chez l'homme. Les résultats obtenus ne sont donc pas directement comparables et cela pourrait expliquer certaines des différences observées.

De plus, les résultats obtenus doivent être interprétés en considérant la durée des régimes HP expérimentaux (2 semaines chez le rat et 3 semaines chez l'homme). Les effets observés sur la muqueuse du gros intestin sont donc des modifications induites par des régimes de relativement courte durée. Il est prévu de tester au laboratoire les effets des régimes HP pendant plusieurs mois chez le rat. En ce qui concerne les expériences sur volontaires, il est plus difficile d'envisager des expériences à long terme, sachant que le suivi des consignes nutritionnelles par les volontaires a tendance à diminuer avec la durée de l'intervention. Néanmoins, les niveaux d'apports en protéines testés sont très élevés (55 % et 30 % de l'énergie chez le rat et l'homme, respectivement) et correspondent aux niveaux de consommations atteints dans la population lors de régimes HP amaigrissants (2). La durée de ce type de régime varie généralement de quelques jours à un mois (2), les durées choisies pour les protocoles expérimentaux sont donc dans l'ordre de durée de ces pratiques alimentaires.

Les protocoles des études nutritionnelles chez l'animal et chez l'homme ont été conçus de manière à faire varier le minimum de paramètres simultanément. Pour cela, des régimes isocaloriques ont été choisis. En raison de cette contrainte, l'augmentation de l'apport en protéines a dû être compensé par la diminution de l'apport d'un des deux autres macronutriments. Les glucides ont été diminués puisqu'il s'agit de la situation la plus courante lors des régimes HP chez l'homme (2). Il est donc impossible d'exclure que certains des effets observés lors des régimes HP soient partiellement liés à la diminution de l'apport en glucides. Les conditions expérimentales choisies (régimes isocaloriques, riches en protéines, pauvres en glucides, apport en fibres identique entre les groupes) ont donc permis d'isoler le mieux possible l'effet de l'apport en protéines et de réduire les facteurs de confusions. Cependant, cette démarche de contrôle des conditions expérimentales entraîne une situation moins proche des pratiques dans la population. En effet, un apport élevé en protéines est généralement associé à une restriction en calorie et en fibres (2). Il est probable que les effets des régimes HP observés au niveau du côlon puissent être amplifiés lorsqu'ils sont liés à une réduction des apports en fibres (122).

Enfin, en cas de restriction calorique la quantité absolue de protéines ingérées lors d'un régime HP n'est pas nécessairement plus élevée comparativement à un régime normoprotéique (16).

Conclusion

Ce projet de thèse a été conçu dans le cadre de l'évaluation du rapport bénéfice-risque des régimes HP. Chez les personnes en surpoids ou obèses, la perte de poids permet une réduction des comorbidités associées. Parmi les stratégies nutritionnelles utilisées, les régimes HP entraînent une perte de poids et l'amélioration de divers paramètres métaboliques, au moins à court terme (16). De ce point de vue, les régimes HP peuvent donc être considérés comme bénéfiques. Néanmoins, les effets des régimes HP au niveau du gros intestin incitent globalement à la prudence. Bien que les régimes HP ne semblent pas induire d'effets délétères à court terme, il est certain que l'environnement luminal du côlon est modifié par les régimes HP et que de multiples modifications ont lieu dans la muqueuse, essentiellement au niveau de l'expression des gènes. Les conséquences des régimes HP consommés de manière prolongée ou répétée pourraient être plus marquées et de nouvelles études à ce sujet sont nécessaires. Les données obtenues au cours de cette thèse montrent aussi que les effets des régimes HP au niveau du côlon peuvent être modulés par la source de protéines utilisée. Bien que d'autres expériences soient nécessaires pour identifier les sources optimales de protéines pour la santé de la muqueuse du gros intestin, ce paramètre devrait être pris en compte dans l'élaboration des régimes HP afin d'en limiter les effets potentiels indésirables au niveau du gros intestin.

Les travaux présentés dans ce manuscrit se limitent aux effets de l'apport en protéines alimentaires sur la dégradation des AA par le microbiote, mais d'autres facteurs régulant le passage de protéines dans le côlon pourraient perturber cette activité métabolique. Par exemple, il a été montré que les marqueurs de dégradation des protéines par les bactéries (putrescine, *p*-cresol, indoxyl sulfate) sont augmentés chez des rats opérés de chirurgie bariatrique (214), probablement en raison d'une augmentation de la disponibilité en AA pour le microbiote dans ce modèle. D'autres situations telle qu'une insuffisance pancréatique pourrait également entraîner une augmentation de la dégradation des AA par les bactéries et potentiellement exacerber ses effets sur la santé, notamment au niveau du côlon (31). Dans cette thèse, les effets des métabolites bactériens dérivés des AA ont été étudiés uniquement au niveau du gros intestin. La présence de certains de ces métabolites dans les urines suggère néanmoins qu'ils pourraient également avoir des effets périphériques sur d'autres organes. En effet, il a été montré que les concentrations urinaires des dérivés du *p*-cresol et de l'indole sont plus élevées dans les urines des personnes atteintes de maladies rénales chroniques et que ces métabolites sont toxiques pour l'épithélium du rein (149). Par ailleurs, la concentration fécale en AGCB est élevée chez les femmes atteintes d'anorexie (215), l'excrétion urinaire de *p*-cresyl sulfate est élevée chez les enfants autistes

(216) et les centenaires excrètent davantage de phénylacetylglutamine et de *p*-cresyl sulfate dans les urines que les personnes plus jeunes (217). Ces observations sont intrigantes mais le rôle causal de l'augmentation de la dégradation des AA par le microbiote dans ces situations physio-pathologiques est inconnu et fait l'objet de nombreuses spéculations. Il est également possible que cette augmentation des concentrations de métabolites bactériens issus de la dégradation des AA soit simplement le reflet de modifications du niveau d'apport en protéines ou du temps de transit chez ces personnes (85) et ces aspects devraient être pris en compte. Cependant, dans toutes ces situations où la dégradation des protéines par le microbiote est perturbée, il est envisageable que l'exposition de l'épithélium du côlon aux métabolites bactériens dérivés des AA soit augmentée et donc que la physiologie et le métabolisme de la muqueuse se trouvent modifiés.

BIBLIOGRAPHIE

1. AFSSA (Agence Française de Sécurité Sanitaire des Aliments). « Apport en protéines : consommation, qualité, besoins et recommandations ». 2007.
2. ANSES (Agence nationale de sécurité sanitaire, de l'alimentation, de l'environnement et du travail). Evaluation des risques liés aux pratiques alimentaires d'amaigrissement. 2010.
3. Pesta DH, Samuel VT. A high-protein diet for reducing body fat: mechanisms and possible caveats. *Nutr Metab.* 2014;11(1):53.
4. Westerterp-Plantenga MS, Nieuwenhuizen A, Tomé D, Soenen S, Westerterp KR. Dietary Protein, Weight Loss, and Weight Maintenance. *Annu Rev Nutr.* 2009;29(1):21–41.
5. Gaudichon C, Bos C, Morens C, Petzke KJ, Mariotti F, Everwand J, et al. Ileal losses of nitrogen and amino acids in humans and their importance to the assessment of amino acid requirements. *Gastroenterology.* 2002 Jul;123(1):50–9.
6. Gibson JA, Sladen GE, Dawson AM. Protein absorption and ammonia production: the effects of dietary protein and removal of the colon. *Br J Nutr.* 1976 Jan;35(1):61–5.
7. Blachier F, Mariotti F, Huneau JF, Tomé D. Effects of amino acid-derived luminal metabolites on the colonic epithelium and physiopathological consequences. *Amino Acids.* 2007 Nov;33(4):547–62.
8. Silvester KR, Cummings JH. Does digestibility of meat protein help explain large bowel cancer risk? *Nutr Cancer.* 1995;24(3):279–88.
9. Andriamihaja M, Davila A-M, Eklou-Lawson M, Petit N, Delpal S, Allek F, et al. Colon luminal content and epithelial cell morphology are markedly modified in rats fed with a high-protein diet. *Am J Physiol Gastrointest Liver Physiol.* 2010 Nov;299(5):G1030–7.
10. Lan A, Andriamihaja M, Blouin J-M, Liu X, Descatoire V, Desclée de Maredsous C, et al. High-protein diet differently modifies intestinal goblet cell characteristics and mucosal cytokine expression in ileum and colon. *J Nutr Biochem.* 2015 Jan;26(1):91–8.
11. Liu X, Blouin J-M, Santacruz A, Lan A, Andriamihaja M, Wilkanowicz S, et al. High-protein diet modifies colonic microbiota and luminal environment but not colonocyte metabolism in the rat model: the increased luminal bulk connection. *Am J Physiol Gastrointest Liver Physiol.* 2014 Aug 15;307(4):G459–70.
12. Russell WR, Gratz SW, Duncan SH, Holtrop G, Ince J, Scobbie L, et al. High-protein, reduced-carbohydrate weight-loss diets promote metabolite profiles likely to be detrimental to colonic health. *Am J Clin Nutr.* 2011 May;93(5):1062–72.
13. Windey K, De Preter V, Louat T, Schuit F, Herman J, Vansant G, et al. Modulation of protein fermentation does not affect fecal water toxicity: a randomized cross-over study in healthy subjects. *PLoS One.* 2012;7(12):e52387.
14. Reeds PJ. Dispensable and indispensable amino acids for humans. *J Nutr.* 2000 Jul;130(7):1835S – 40S.

15. Wu G. Dietary protein intake and human health. *Food Funct.* 2016 Mar;7(3):1251–65.
16. Westerterp-Plantenga MS, Lemmens SG, Westerterp KR. Dietary protein – its role in satiety, energetics, weight loss and health. *Br J Nutr.* 2012 Aug;108(S2):S105–12.
17. Te Morenga L, Mann J. The role of high-protein diets in body weight management and health. *Br J Nutr.* 2012 Aug;108(S2):S130–8.
18. Leidy HJ, Clifton PM, Astrup A, Wycherley TP, Westerterp-Plantenga MS, Luscombe-Marsh ND, et al. The role of protein in weight loss and maintenance. *Am J Clin Nutr.* 2015 Jun 1;101(6):1320S – 1329S.
19. Hirst BH. Dietary regulation of intestinal nutrient carriers. *Proc Nutr Soc.* 1993 Aug;52(2):315–24.
20. Bergen WG, Wu G. Intestinal Nitrogen Recycling and Utilization in Health and Disease. *J Nutr.* 2009 Mar 25;139(5):821–5.
21. Fuller M. Determination of protein and amino acid digestibility in foods including implications of gut microbial amino acid synthesis. *Br J Nutr.* 2012 Aug;108(S2):S238–46.
22. Davila A-M, Blachier F, Gotteland M, Andriamihaja M, Benetti P-H, Sanz Y, et al. Intestinal luminal nitrogen metabolism: role of the gut microbiota and consequences for the host. *Pharmacol Res Off J Ital Pharmacol Soc.* 2013 Feb;68(1):95–107.
23. Chacko A, Cummings JH. Nitrogen losses from the human small bowel: obligatory losses and the effect of physical form of food. *Gut.* 1988 Jun;29(6):809–15.
24. Gaudichon C, Mahé S, Benamouzig R, Luengo C, Fouillet H, Daré S, et al. Net postprandial utilization of [15N]-labeled milk protein nitrogen is influenced by diet composition in humans. *J Nutr.* 1999 Apr;129(4):890–5.
25. Oberli M, Marsset-Baglieri A, Airinei G, Sante-Lhoutellier V, Khodorova N, Remond D, et al. High True Ileal Digestibility but Not Postprandial Utilization of Nitrogen from Bovine Meat Protein in Humans Is Moderately Decreased by High-Temperature, Long-Duration Cooking. *J Nutr.* 2015 Oct 1;145(10):2221–8.
26. Lacroix M, Léonil J, Bos C, Henry G, Airinei G, Fauquant J, et al. Heat markers and quality indexes of industrially heat-treated [15N] milk protein measured in rats. *J Agric Food Chem.* 2006 Feb 22;54(4):1508–17.
27. Mariotti F, Mahé S, Benamouzig R, Luengo C, Daré S, Gaudichon C, et al. Nutritional value of [15N]-soy protein isolate assessed from ileal digestibility and postprandial protein utilization in humans. *J Nutr.* 1999 Nov;129(11):1992–7.
28. Bos C, Airinei G, Mariotti F, Benamouzig R, Bérot S, Evrard J, et al. The poor digestibility of rapeseed protein is balanced by its very high metabolic utilization in humans. *J Nutr.* 2007 Mar;137(3):594–600.
29. Gausserès N, Mahé S, Benamouzig R, Luengo C, Drouet H, Rautureau J, et al. The gastro-ileal digestion of 15N-labelled pea nitrogen in adult humans. *Br J Nutr.* 1996 Jul;76(1):75–85.

30. Evenepoel P, Claus D, Geypens B, Hiele M, Geboes K, Rutgeerts P, et al. Amount and fate of egg protein escaping assimilation in the small intestine of humans. *Am J Physiol*. 1999 Nov;277(5 Pt 1):G935–43.
31. Dallas DC, Sanctuary MR, Qu Y, Khajavi SH, Van Zandt AE, Dyandra M, et al. Personalizing Protein Nourishment. *Crit Rev Food Sci Nutr*. 2015 Dec 29;00–00.
32. Bax M-L, Buffière C, Hafnaoui N, Gaudichon C, Savary-Auzeloux I, Dardevet D, et al. Effects of meat cooking, and of ingested amount, on protein digestion speed and entry of residual proteins into the colon: a study in minipigs. *PLoS One*. 2013;8(4):e61252.
33. Oberli M, Lan A, Khodorova N, Santé-Lhoutellier V, Walker F, Piedcoq J, et al. Compared with Raw Bovine Meat, Boiling but Not Grilling, Barbecuing, or Roasting Decreases Protein Digestibility without Any Major Consequences for Intestinal Mucosa in Rats, although the Daily Ingestion of Bovine Meat Induces Histologic Modifications in the Colon. *J Nutr*. 2016 Aug;146(8):1506–13.
34. Fallingborg J. Intraluminal pH of the human gastrointestinal tract. *Dan Med Bull*. 1999 Jun;46(3):183–96.
35. Macfarlane GT, Macfarlane S. Human Colonic Microbiota: Ecology, Physiology and Metabolic Potential of Intestinal Bacteria. *Scand J Gastroenterol*. 1997 Jan;32(sup222):3–9.
36. Albenberg L, Esipova TV, Judge CP, Bittinger K, Chen J, Laughlin A, et al. Correlation Between Intraluminal Oxygen Gradient and Radial Partitioning of Intestinal Microbiota. *Gastroenterology*. 2014 Nov;147(5):1055–63.e8.
37. Espey MG. Role of oxygen gradients in shaping redox relationships between the human intestine and its microbiota. *Free Radic Biol Med*. 2013 Feb;55:130–40.
38. Barker N. Adult intestinal stem cells: critical drivers of epithelial homeostasis and regeneration. *Nat Rev Mol Cell Biol*. 2013 Dec 11;15(1):19–33.
39. Paoli P, Giannoni E, Chiarugi P. Anoikis molecular pathways and its role in cancer progression. *Biochim Biophys Acta BBA - Mol Cell Res*. 2013 Dec;1833(12):3481–98.
40. van der Flier LG, Clevers H. Stem Cells, Self-Renewal, and Differentiation in the Intestinal Epithelium. *Annu Rev Physiol*. 2009 Mar;71(1):241–60.
41. Tomas J, Reygner J, Mayeur C, Ducroc R, Bouet S, Bridonneau C, et al. Early colonizing *Escherichia coli* elicits remodeling of rat colonic epithelium shifting toward a new homeostatic state. *ISME J*. 2015;9(1):46–58.
42. Martin-Belmonte F, Perez-Moreno M. Epithelial cell polarity, stem cells and cancer. *Nat Rev Cancer*. 2012 Jan;12(1):23–38.
43. Groschwitz KR, Hogan SP. Intestinal barrier function: molecular regulation and disease pathogenesis. *J Allergy Clin Immunol*. 2009 Jul;124(1):3–20; quiz 21–2.
44. Turner JR. Intestinal mucosal barrier function in health and disease. *Nat Rev Immunol*. 2009 Nov;9(11):799–809.

45. Camilleri M, Madsen K, Spiller R, Van Meerveld BG, Verne GN. Intestinal barrier function in health and gastrointestinal disease: Intestinal barrier function. *Neurogastroenterol Motil.* 2012 Jun;24(6):503–12.
46. Teller IC, Beaulieu JF. Interactions between laminin and epithelial cells in intestinal health and disease. *Expert Rev Mol Med.* 2001 Sep;3(24):1–18.
47. Heyman M, Abed J, Lebreton C, Cerf-Bensussan N. Intestinal permeability in coeliac disease: insight into mechanisms and relevance to pathogenesis. *Gut.* 2012 Sep;61(9):1355–64.
48. Johansson MEV, Sjövall H, Hansson GC. The gastrointestinal mucus system in health and disease. *Nat Rev Gastroenterol Hepatol.* 2013 Jun;10(6):352–61.
49. Johansson MEV, Hansson GC. Immunological aspects of intestinal mucus and mucins. *Nat Rev Immunol.* 2016 Aug 8;
50. Van der Sluis M, De Koning BAE, De Bruijn ACJM, Velcich A, Meijerink JPP, Van Goudoever JB, et al. Muc2-Deficient Mice Spontaneously Develop Colitis, Indicating That MUC2 Is Critical for Colonic Protection. *Gastroenterology.* 2006 Jul;131(1):117–29.
51. Peterson LW, Artis D. Intestinal epithelial cells: regulators of barrier function and immune homeostasis. *Nat Rev Immunol.* 2014 Mar;14(3):141–53.
52. Lundberg JO, Weitzberg E. Biology of nitrogen oxides in the gastrointestinal tract. *Gut.* 2013 Apr;62(4):616–29.
53. Szabo C. Gasotransmitters in cancer: from pathophysiology to experimental therapy. *Nat Rev Drug Discov.* 2015 Dec 18;15(3):185–203.
54. Pasparakis M. Role of NF- κ B in epithelial biology. *Immunol Rev.* 2012 Mar;246(1):346–58.
55. Pabst O, Cerovic V, Hornef M. Secretory IgA in the Coordination of Establishment and Maintenance of the Microbiota. *Trends Immunol.* 2016 May;37(5):287–96.
56. Blachier F, Boutry C, Bos C, Tomé D. Metabolism and functions of L-glutamate in the epithelial cells of the small and large intestines. *Am J Clin Nutr.* 2009 Sep;90(3):814S – 821S.
57. Roediger WE. Utilization of nutrients by isolated epithelial cells of the rat colon. *Gastroenterology.* 1982 Aug;83(2):424–9.
58. Brand MD, Nicholls DG. Assessing mitochondrial dysfunction in cells. *Biochem J.* 2011 Apr 15;435(2):297–312.
59. Divakaruni AS, Brand MD. The regulation and physiology of mitochondrial proton leak. *Physiol Bethesda Md.* 2011 Jun;26(3):192–205.
60. Donohoe DR, Garge N, Zhang X, Sun W, O’Connell TM, Bunker MK, et al. The microbiome and butyrate regulate energy metabolism and autophagy in the mammalian colon. *Cell Metab.* 2011 May 4;13(5):517–26.
61. Cooper CE, Brown GC. The inhibition of mitochondrial cytochrome oxidase by the gases carbon monoxide, nitric oxide, hydrogen cyanide and hydrogen sulfide: chemical mechanism and

physiological significance. *J Bioenerg Biomembr.* 2008 Oct;40(5):533–9.

62. Roediger WEW, Duncan A, Kapaniris O, Millard S. Sulphide impairment of substrate oxidation in rat colonocytes: a biochemical basis for ulcerative colitis? *Clin Sci.* 1993;85(5):623–7.

63. Colgan SP, Taylor CT. Hypoxia: an alarm signal during intestinal inflammation. *Nat Rev Gastroenterol Hepatol.* 2010 May;7(5):281–7.

64. Sena LA, Chandel NS. Physiological Roles of Mitochondrial Reactive Oxygen Species. *Mol Cell.* 2012 Oct;48(2):158–67.

65. Irrazábal T, Belcheva A, Girardin SE, Martin A, Philpott DJ. The multifaceted role of the intestinal microbiota in colon cancer. *Mol Cell.* 2014 Apr 24;54(2):309–20.

66. Schieber M, Chandel NS. ROS Function in Redox Signaling and Oxidative Stress. *Curr Biol.* 2014 May;24(10):R453–62.

67. Circu ML, Aw TY. Redox biology of the intestine. *Free Radic Res.* 2011 Nov;45(11-12):1245–66.

68. Beyerle J, Frei E, Stiborova M, Habermann N, Ulrich CM. Biotransformation of xenobiotics in the human colon and rectum and its association with colorectal cancer. *Drug Metab Rev.* 2015 May;47(2):199–221.

69. Sears CL, Garrett WS. Microbes, microbiota, and colon cancer. *Cell Host Microbe.* 2014 Mar 12;15(3):317–28.

70. Hakem R. DNA-damage repair; the good, the bad, and the ugly. *EMBO J.* 2008 Feb 20;27(4):589–605.

71. Khoury L, Zalko D, Audebert M. Validation of high-throughput genotoxicity assay screening using γ H2AX in-cell western assay on HepG2 cells. *Environ Mol Mutagen.* 2013 Dec;54(9):737–46.

72. Singh NP, McCoy MT, Tice RR, Schneider EL. A simple technique for quantitation of low levels of DNA damage in individual cells. *Exp Cell Res.* 1988 Mar 1;175(1):184–91.

73. Negroni A, Cucchiara S, Stronati L. Apoptosis, Necrosis, and Necroptosis in the Gut and Intestinal Homeostasis. *Mediators Inflamm.* 2015;2015:1–10.

74. Andersen V, Olsen A, Carbonnel F, Tjønneland A, Vogel U. Diet and risk of inflammatory bowel disease. *Dig Liver Dis Off J Ital Soc Gastroenterol Ital Assoc Study Liver.* 2012 Mar;44(3):185–94.

75. Maloy KJ, Powrie F. Intestinal homeostasis and its breakdown in inflammatory bowel disease. *Nature.* 2011 Jun 15;474(7351):298–306.

76. Singer II, Kawka DW, Scott S, Weidner JR, Mumford RA, Riehl TE, et al. Expression of inducible nitric oxide synthase and nitrotyrosine in colonic epithelium in inflammatory bowel disease. *Gastroenterology.* 1996 Oct;111(4):871–85.

77. Risques RA, Lai LA, Brentnall TA, Li L, Feng Z, Gallaher J, et al. Ulcerative colitis is a disease of accelerated colon aging: evidence from telomere attrition and DNA damage. *Gastroenterology.* 2008

Aug;135(2):410–8.

78. Donaldson GP, Lee SM, Mazmanian SK. Gut biogeography of the bacterial microbiota. *Nat Rev Microbiol*. 2015 Oct 26;14(1):20–32.
79. Sender R, Fuchs S, Milo R. Are We Really Vastly Outnumbered? Revisiting the Ratio of Bacterial to Host Cells in Humans. *Cell*. 2016 Jan;164(3):337–40.
80. Walker AW, Duncan SH, Louis P, Flint HJ. Phylogeny, culturing, and metagenomics of the human gut microbiota. *Trends Microbiol*. 2014 May;22(5):267–74.
81. Arumugam M, Raes J, Pelletier E, Le Paslier D, Yamada T, Mende DR, et al. Enterotypes of the human gut microbiome. *Nature*. 2011 May 12;473(7346):174–80.
82. Qin J, Li R, Raes J, Arumugam M, Burgdorf KS, Manichanh C, et al. A human gut microbial gene catalogue established by metagenomic sequencing. *Nature*. 2010 Mar 4;464(7285):59–65.
83. Eckburg PB, Bik EM, Bernstein CN, Purdom E, Dethlefsen L, Sargent M, et al. Diversity of the human intestinal microbial flora. *science*. 2005;308(5728):1635–8.
84. Tremaroli V, Bäckhed F. Functional interactions between the gut microbiota and host metabolism. *Nature*. 2012 Sep 12;489(7415):242–9.
85. Roager HM, Hansen LBS, Bahl MI, Frandsen HL, Carvalho V, Gøbel RJ, et al. Colonic transit time is related to bacterial metabolism and mucosal turnover in the gut. *Nat Microbiol*. 2016 Jun 27;1:16093.
86. Wu GD, Chen J, Hoffmann C, Bittinger K, Chen Y-Y, Keilbaugh SA, et al. Linking long-term dietary patterns with gut microbial enterotypes. *Science*. 2011 Oct 7;334(6052):105–8.
87. Faith JJ, Guruge JL, Charbonneau M, Subramanian S, Seedorf H, Goodman AL, et al. The Long-Term Stability of the Human Gut Microbiota. *Science*. 2013 Jul 5;341(6141):1237439–1237439.
88. Ley RE, Turnbaugh PJ, Klein S, Gordon JI. Microbial ecology: human gut microbes associated with obesity. *Nature*. 2006 Dec 21;444(7122):1022–3.
89. Tap J, Mondot S, Levenez F, Pelletier E, Caron C, Furet J-P, et al. Towards the human intestinal microbiota phylogenetic core. *Environ Microbiol*. 2009 Oct;11(10):2574–84.
90. Albenberg LG, Wu GD. Diet and the Intestinal Microbiome: Associations, Functions, and Implications for Health and Disease. *Gastroenterology*. 2014 May;146(6):1564–72.
91. Sokol H, Pigneur B, Watterlot L, Lakhdari O, Bermúdez-Humarán LG, Gratadoux J-J, et al. *Faecalibacterium prausnitzii* is an anti-inflammatory commensal bacterium identified by gut microbiota analysis of Crohn disease patients. *Proc Natl Acad Sci U S A*. 2008 Oct 28;105(43):16731–6.
92. David LA, Maurice CF, Carmody RN, Gootenberg DB, Button JE, Wolfe BE, et al. Diet rapidly and reproducibly alters the human gut microbiome. *Nature*. 2013 Dec 11;505(7484):559–63.
93. Portune KJ, Benítez-Páez A, Del Pulgar EMG, Cerrudo V, Sanz Y. Gut microbiota, diet and obesity-related disorders - the good, the bad and the future challenges. *Mol Nutr Food Res*. 2016 Jun 11;

94. Walker AW, Ince J, Duncan SH, Webster LM, Holtrop G, Ze X, et al. Dominant and diet-responsive groups of bacteria within the human colonic microbiota. *ISME J.* 2011 Feb;5(2):220–30.
95. Salonen A, Lahti L, Salojärvi J, Holtrop G, Korpela K, Duncan SH, et al. Impact of diet and individual variation on intestinal microbiota composition and fermentation products in obese men. *ISME J.* 2014;8(11):2218–30.
96. Flint HJ, Scott KP, Louis P, Duncan SH. The role of the gut microbiota in nutrition and health. *Nat Rev Gastroenterol Hepatol.* 2012 Sep 4;9(10):577–89.
97. Duncan SH, Belenguer A, Holtrop G, Johnstone AM, Flint HJ, Lobley GE. Reduced Dietary Intake of Carbohydrates by Obese Subjects Results in Decreased Concentrations of Butyrate and Butyrate-Producing Bacteria in Feces. *Appl Environ Microbiol.* 2007 Feb 15;73(4):1073–8.
98. Brinkworth GD, Noakes M, Clifton PM, Bird AR. Comparative effects of very low-carbohydrate, high-fat and high-carbohydrate, low-fat weight-loss diets on bowel habit and faecal short-chain fatty acids and bacterial populations. *Br J Nutr.* 2009 May;101(10):1493.
99. Pieper R, Kröger S, Richter JF, Wang J, Martin L, Bindelle J, et al. Fermentable fiber ameliorates fermentable protein-induced changes in microbial ecology, but not the mucosal response, in the colon of piglets. *J Nutr.* 2012 Apr;142(4):661–7.
100. Zhou L, Fang L, Sun Y, Su Y, Zhu W. Effects of the dietary protein level on the microbial composition and metabolomic profile in the hindgut of the pig. *Anaerobe.* 2016 Apr;38:61–9.
101. Mu C, Yang Y, Luo Z, Guan L, Zhu W. The Colonic Microbiome and Epithelial Transcriptome Are Altered in Rats Fed a High-Protein Diet Compared with a Normal-Protein Diet. *J Nutr.* 2016 Mar;146(3):474–83.
102. Miquel S, Martín R, Bridonneau C, Robert V, Sokol H, Bermúdez-Humarán LG, et al. Ecology and metabolism of the beneficial intestinal commensal bacterium *Faecalibacterium prausnitzii*. *Gut Microbes.* 2014 Apr;5(2):146–51.
103. Butteiger DN, Hibberd AA, McGraw NJ, Napawan N, Hall-Porter JM, Krul ES. Soy Protein Compared with Milk Protein in a Western Diet Increases Gut Microbial Diversity and Reduces Serum Lipids in Golden Syrian Hamsters. *J Nutr.* 2016 Apr 1;146(4):697–705.
104. Zhu Y, Lin X, Zhao F, Shi X, Li H, Li Y, et al. Meat, dairy and plant proteins alter bacterial composition of rat gut bacteria. *Sci Rep.* 2015 Oct 14;5:15220.
105. Gaboriau-Routhiau V, Rakotobe S, Lécuyer E, Mulder I, Lan A, Bridonneau C, et al. The Key Role of Segmented Filamentous Bacteria in the Coordinated Maturation of Gut Helper T Cell Responses. *Immunity.* 2009 Oct;31(4):677–89.
106. Li J, Jia H, Cai X, Zhong H, Feng Q, Sunagawa S, et al. An integrated catalog of reference genes in the human gut microbiome. *Nat Biotechnol.* 2014 Aug;32(8):834–41.
107. Hamer HM, De Preter V, Windey K, Verbeke K. Functional analysis of colonic bacterial metabolism: relevant to health? *AJP Gastrointest Liver Physiol.* 2012 Jan 1;302(1):G1–9.
108. Zheng X, Xie G, Zhao A, Zhao L, Yao C, Chiu NHL, et al. The footprints of gut microbial-

mammalian co-metabolism. *J Proteome Res.* 2011 Dec 2;10(12):5512–22.

109. Macfarlane, Cummings. The colonic flora, fermentation and large bowel digestive function. In: Philipps SF, Pemberton JH, Shorter RG (eds) *The large intestine: physiology, pathophysiology and disease* Raven Press NewYork. 1991;51–92.

110. Bernalier-Donadille A. [Fermentative metabolism by the human gut microbiota]. *Gastroentérologie Clin Biol.* 2010 Sep;34 Suppl 1:S16–22.

111. Scott KP, Gratz SW, Sheridan PO, Flint HJ, Duncan SH. The influence of diet on the gut microbiota. *Pharmacol Res.* 2013 Mar;69(1):52–60.

112. Wu GD, Compher C, Chen EZ, Smith SA, Shah RD, Bittinger K, et al. Comparative metabolomics in vegans and omnivores reveal constraints on diet-dependent gut microbiota metabolite production. *Gut.* 2016 Jan;65(1):63–72.

113. Vieira-Silva S, Falony G, Darzi Y, Lima-Mendez G, Garcia Yunta R, Okuda S, et al. Species–function relationships shape ecological properties of the human gut microbiome. *Nat Microbiol.* 2016 Jun 13;1(8):16088.

114. Ou J, Carbonero F, Zoetendal EG, DeLany JP, Wang M, Newton K, et al. Diet, microbiota, and microbial metabolites in colon cancer risk in rural Africans and African Americans. *Am J Clin Nutr.* 2013 Jul 1;98(1):111–20.

115. O’Keefe SJD, Li JV, Lahti L, Ou J, Carbonero F, Mohammed K, et al. Fat, fibre and cancer risk in African Americans and rural Africans. *Nat Commun.* 2015;6:6342.

116. Verbeke KA, Boobis AR, Chiodini A, Edwards CA, Franck A, Kleerebezem M, et al. Towards microbial fermentation metabolites as markers for health benefits of prebiotics. *Nutr Res Rev.* 2015 Jun;28(01):42–66.

117. Koh A, De Vadder F, Kovatcheva-Datchary P, Bäckhed F. From Dietary Fiber to Host Physiology: Short-Chain Fatty Acids as Key Bacterial Metabolites. *Cell.* 2016 Jun;165(6):1332–45.

118. Bergman EN. Energy contributions of volatile fatty acids from the gastrointestinal tract in various species. *Physiol Rev.* 1990 Apr;70(2):567–90.

119. Kelly CJ, Zheng L, Campbell EL, Saeedi B, Scholz CC, Bayless AJ, et al. Crosstalk between Microbiota-Derived Short-Chain Fatty Acids and Intestinal Epithelial HIF Augments Tissue Barrier Function. *Cell Host Microbe.* 2015 May;17(5):662–71.

120. Singh N, Gurav A, Sivaprakasam S, Brady E, Padia R, Shi H, et al. Activation of Gpr109a, receptor for niacin and the commensal metabolite butyrate, suppresses colonic inflammation and carcinogenesis. *Immunity.* 2014 Jan 16;40(1):128–39.

121. Sivaprakasam S, Prasad PD, Singh N. Benefits of short-chain fatty acids and their receptors in inflammation and carcinogenesis. *Pharmacol Ther.* 2016 Aug;164:144–51.

122. Windey K, De Preter V, Verbeke K. Relevance of protein fermentation to gut health. *Mol Nutr Food Res.* 2012 Jan;56(1):184–96.

123. Smith EA, Macfarlane GT. Enumeration of human colonic bacteria producing phenolic and indolic compounds: effects of pH, carbohydrate availability and retention time on dissimilatory aromatic amino acid metabolism. *J Appl Bacteriol.* 1996;81(3):288–302.
124. Amos HE, Little CO, Mitchell GE. Proline utilization during cellulose fermentation by rumen microorganisms. *J Agric Food Chem.* 1971 Feb;19(1):112–5.
125. Todén S, Bird AR, Topping DL, Conlon MA. Resistant starch attenuates colonic DNA damage induced by higher dietary protein in rats. *Nutr Cancer.* 2005;51(1):45–51.
126. Sakurazawa T, Ohkusa T. Cytotoxicity of organic acids produced by anaerobic intestinal bacteria on cultured epithelial cells. *J Gastroenterol.* 2005 Jun;40(6):600–9.
127. Boudry G, Jamin A, Chatelais L, Gras-Le Guen C, Michel C, Le Huerou-Luron I. Dietary Protein Excess during Neonatal Life Alters Colonic Microbiota and Mucosal Response to Inflammatory Mediators Later in Life in Female Pigs. *J Nutr.* 2013 Aug 1;143(8):1225–32.
128. Geypens B, Claus D, Evenepoel P, Hiele M, Maes B, Peeters M, et al. Influence of dietary protein supplements on the formation of bacterial metabolites in the colon. *Gut.* 1997 Jul 1;41(1):70–6.
129. Cummings JH, Hill MJ, Bone ES, Branch WJ, Jenkins DJ. The effect of meat protein and dietary fiber on colonic function and metabolism. II. Bacterial metabolites in feces and urine. *Am J Clin Nutr.* 1979;32(10):2094–101.
130. Benassi-Evans B, Clifton P, Noakes M, Fenech M. High-protein/high red meat and high-carbohydrate weight-loss diets do not differ in their effect on faecal water genotoxicity tested by use of the WIL2-NS cell line and with other biomarkers of bowel health. *Mutat Res.* 2010 Dec 21;703(2):130–6.
131. Bikker P, Dirkzwager A, Fledderus J, Trevisi P, le Huërou-Luron I, Lallès JP, et al. The effect of dietary protein and fermentable carbohydrates levels on growth performance and intestinal characteristics in newly weaned piglets. *J Anim Sci.* 2006;84(12):3337.
132. Lin HC, Visek WJ. Large intestinal pH and ammonia in rats: dietary fat and protein interactions. *J Nutr.* 1991 Jun;121(6):832–43.
133. Lhoste EF, Catala I, Fiszlewicz M, Gueugneau AM, Vaissade P, Corring T, et al. Influence of caecal microflora and of two dietary protein levels on the adaptation of the exocrine pancreas: comparative study in germ-free and conventional rats. *Br J Nutr.* 1996;75(03):433–44.
134. Taciak M, Barszcz M, Tuśnio A, Pastuszewska B. Interactive Effects of Indigestible Carbohydrates, Protein Type, and Protein Level on Biomarkers of Large Intestine Health in Rats. Covasa M, editor. *PLOS ONE.* 2015 Nov 4;10(11):e0142176.
135. Cremin JD, Fitch MD, Fleming SE. Glucose alleviates ammonia-induced inhibition of short-chain fatty acid metabolism in rat colonic epithelial cells. *Am J Physiol Gastrointest Liver Physiol.* 2003 Jul;285(1):G105–14.
136. Villodre Tudela C, Boudry C, Stumpff F, Aschenbach JR, Vahjen W, Zentek J, et al. Down-regulation of monocarboxylate transporter 1 (MCT1) gene expression in the colon of piglets is linked to bacterial protein fermentation and pro-inflammatory cytokine-mediated signalling. *Br J Nutr.* 2015 Feb

28;113(4):610–7.

137. Mouille B. Adaptative increase of ornithine production and decrease of ammonia metabolism in rat colonocytes after hyperproteic diet ingestion. *AJP Gastrointest Liver Physiol.* 2004 Aug 1;287(2):G344–51.
138. Ichikawa H, Sakata T. Stimulation of epithelial cell proliferation of isolated distal colon of rats by continuous colonic infusion of ammonia or short-chain fatty acids is nonadditive. *J Nutr.* 1998 May;128(5):843–7.
139. Lin HC, Visek WJ. Colon mucosal cell damage by ammonia in rats. *J Nutr.* 1991 Jun;121(6):887–93.
140. Hughes R, Kurth MJ, McGilligan V, McGlynn H, Rowland I. Effect of colonic bacterial metabolites on Caco-2 cell paracellular permeability in vitro. *Nutr Cancer.* 2008;60(2):259–66.
141. Eklou-Lawson M, Bernard F, Neveux N, Chaumontet C, Bos C, Davila-Gay A-M, et al. Colonic luminal ammonia and portal blood L-glutamine and L-arginine concentrations: a possible link between colon mucosa and liver ureagenesis. *Amino Acids.* 2009 Oct;37(4):751–60.
142. Silvester KR, Bingham SA, Pollock JRA, Cummings JH, O'Neill IK. Effect of meat and resistant starch on fecal excretion of apparent *N*-nitroso compounds and ammonia from the human large bowel. *Nutr Cancer.* 1997 Jan;29(1):13–23.
143. Russell WR, Duncan SH, Scobbie L, Duncan G, Cantlay L, Calder AG, et al. Major phenylpropanoid-derived metabolites in the human gut can arise from microbial fermentation of protein. *Mol Nutr Food Res.* 2013 Mar;57(3):523–35.
144. Ramakrishna BS, Roberts-Thomson IC, Pannall PR, Roediger WE. Impaired sulphation of phenol by the colonic mucosa in quiescent and active ulcerative colitis. *Gut.* 1991;32(1):46–9.
145. Wikoff WR, Anfora AT, Liu J, Schultz PG, Lesley SA, Peters EC, et al. Metabolomics analysis reveals large effects of gut microflora on mammalian blood metabolites. *Proc Natl Acad Sci.* 2009;106(10):3698–703.
146. Poesen R, Mutsaers HA, Windey K, van den Broek PH, Verweij V, Augustijns P, et al. The Influence of Dietary Protein Intake on Mammalian Tryptophan and Phenolic Metabolites. *PloS One.* 2015;10(10):e0140820.
147. McCall IC, Betanzos A, Weber DA, Nava P, Miller GW, Parkos CA. Effects of phenol on barrier function of a human intestinal epithelial cell line correlate with altered tight junction protein localization. *Toxicol Appl Pharmacol.* 2009 Nov;241(1):61–70.
148. Pedersen G, Brynskov J, Saermark T. Phenol toxicity and conjugation in human colonic epithelial cells. *Scand J Gastroenterol.* 2002 Jan;37(1):74–9.
149. Ramezani A, Massy ZA, Meijers B, Evenepoel P, Vanholder R, Raj DS. Role of the Gut Microbiome in Uremia: A Potential Therapeutic Target. *Am J Kidney Dis.* 2016 Mar;67(3):483–98.
150. Bansal T, Alaniz RC, Wood TK, Jayaraman A. The bacterial signal indole increases epithelial-cell tight-junction resistance and attenuates indicators of inflammation. *Proc Natl Acad Sci.* 2010 Jan

5;107(1):228–33.

151. Macfarlane GT, Gibson GR, Cummings JH. Comparison of fermentation reactions in different regions of the human colon. *J Appl Bacteriol.* 1992 Jan;72(1):57–64.
152. Venkatesh M, Mukherjee S, Wang H, Li H, Sun K, Benechet AP, et al. Symbiotic Bacterial Metabolites Regulate Gastrointestinal Barrier Function via the Xenobiotic Sensor PXR and Toll-like Receptor 4. *Immunity.* 2014 Aug;41(2):296–310.
153. Zelante T, Iannitti RG, Cunha C, De Luca A, Giovannini G, Pieraccini G, et al. Tryptophan Catabolites from Microbiota Engage Aryl Hydrocarbon Receptor and Balance Mucosal Reactivity via Interleukin-22. *Immunity.* 2013 Aug;39(2):372–85.
154. Shimada Y, Kinoshita M, Harada K, Mizutani M, Masahata K, Kayama H, et al. Commensal Bacteria-Dependent Indole Production Enhances Epithelial Barrier Function in the Colon. Heimesaat MM, editor. *PLoS ONE.* 2013 Nov 20;8(11):e80604.
155. Claus SP, Tsang TM, Wang Y, Cloarec O, Skordi E, Martin F-P, et al. Systemic multicompartmental effects of the gut microbiome on mouse metabolic phenotypes. *Mol Syst Biol.* 2008;4:219.
156. Lees HJ, Swann JR, Wilson ID, Nicholson JK, Holmes E. Hippurate: the natural history of a mammalian-microbial cometabolite. *J Proteome Res.* 2013 Apr 5;12(4):1527–46.
157. Allison C, Macfarlane GT. Influence of pH, nutrient availability, and growth rate on amine production by *Bacteroides fragilis* and *Clostridium perfringens*. *Appl Environ Microbiol.* 1989 Nov;55(11):2894–8.
158. Fan P, Li L, Rezaei A, Eslamfam S, Che D, Ma X. Metabolites of Dietary Protein and Peptides by Intestinal Microbes and their Impacts on Gut. *Curr Protein Pept Sci.* 2015;16(7):646–54.
159. Blachier F, Davila AM, Benamouzig R, Tome D. Channelling of arginine in NO and polyamine pathways in colonocytes and consequences. *Front Biosci Landmark Ed.* 2011;16:1331–43.
160. Levy M, Thaïss CA, Zeevi D, Dohnalová L, Zilberman-Schapira G, Mahdi JA, et al. Microbiota-Modulated Metabolites Shape the Intestinal Microenvironment by Regulating NLRP6 Inflammasome Signaling. *Cell.* 2015 Dec;163(6):1428–43.
161. Bouillaud F, Blachier F. Mitochondria and sulfide: a very old story of poisoning, feeding, and signaling? *Antioxid Redox Signal.* 2011 Jul 15;15(2):379–91.
162. Wallace JL, Wang R. Hydrogen sulfide-based therapeutics: exploiting a unique but ubiquitous gasotransmitter. *Nat Rev Drug Discov.* 2015 Apr 7;14(5):329–45.
163. Levitt MD, Springfield J, Furne J, Koenig T, Suarez FL. Physiology of sulfide in the rat colon: use of bismuth to assess colonic sulfide production. *J Appl Physiol Bethesda Md* 1985. 2002 Apr;92(4):1655–60.
164. Carbonero F, Benefiel AC, Alizadeh-Ghamsari AH, Gaskins HR. Microbial pathways in colonic sulfur metabolism and links with health and disease. *Front Physiol.* 2012;3:448.

165. Blachier F, Davila A-M, Mimoun S, Benetti P-H, Atanasiu C, Andriamihaja M, et al. Luminal sulfide and large intestine mucosa: friend or foe? *Amino Acids*. 2010 Jul;39(2):335–47.
166. Linden DR. Hydrogen sulfide signaling in the gastrointestinal tract. *Antioxid Redox Signal*. 2014 Feb 10;20(5):818–30.
167. Nava GM, Carbonero F, Ou J, Benefiel AC, O’Keefe SJ, Gaskins HR. Hydrogenotrophic microbiota distinguish native Africans from African and European Americans: Diet and colonic hydrogenotrophs. *Environ Microbiol Rep*. 2012 Jun;4(3):307–15.
168. Devkota S, Wang Y, Musch MW, Leone V, Fehlner-Peach H, Nadimpalli A, et al. Dietary-fat-induced taurocholic acid promotes pathobiont expansion and colitis in *Il10^{-/-}* mice. *Nature*. 2012 Jul 5;487(7405):104–8.
169. Medani M, Collins D, Docherty NG, Baird AW, O’Connell PR, Winter DC. Emerging role of hydrogen sulfide in colonic physiology and pathophysiology: *Inflamm Bowel Dis*. 2011 Jul;17(7):1620–5.
170. Jørgensen J, Mortensen PB. Hydrogen sulfide and colonic epithelial metabolism: implications for ulcerative colitis. *Dig Dis Sci*. 2001 Aug;46(8):1722–32.
171. Magee EA, Richardson CJ, Hughes R, Cummings JH. Contribution of dietary protein to sulfide production in the large intestine: an in vitro and a controlled feeding study in humans. *Am J Clin Nutr*. 2000 Dec;72(6):1488–94.
172. Goubern M, Andriamihaja M, Nübel T, Blachier F, Bouillaud F. Sulfide, the first inorganic substrate for human cells. *FASEB J Off Publ Fed Am Soc Exp Biol*. 2007 Jun;21(8):1699–706.
173. Lagoutte E, Mimoun S, Andriamihaja M, Chaumontet C, Blachier F, Bouillaud F. Oxidation of hydrogen sulfide remains a priority in mammalian cells and causes reverse electron transfer in colonocytes. *Biochim Biophys Acta*. 2010 Aug;1797(8):1500–11.
174. Mimoun S, Andriamihaja M, Chaumontet C, Atanasiu C, Benamouzig R, Blouin JM, et al. Detoxification of H₂S by differentiated colonic epithelial cells: implication of the sulfide oxidizing unit and of the cell respiratory capacity. *Antioxid Redox Signal*. 2012 Jul 1;17(1):1–10.
175. Ramasamy S, Singh S, Taniere P, Langman MJS, Eggo MC. Sulfide-detoxifying enzymes in the human colon are decreased in cancer and upregulated in differentiation. *Am J Physiol Gastrointest Liver Physiol*. 2006 Aug;291(2):G288–96.
176. Leschelle X, Goubern M, Andriamihaja M, Blottière HM, Couplan E, Gonzalez-Barroso M-D-M, et al. Adaptive metabolic response of human colonic epithelial cells to the adverse effects of the luminal compound sulfide. *Biochim Biophys Acta*. 2005 Sep 15;1725(2):201–12.
177. Christl SU, Eisner HD, Dusel G, Kasper H, Scheppach W. Antagonistic effects of sulfide and butyrate on proliferation of colonic mucosa: a potential role for these agents in the pathogenesis of ulcerative colitis. *Dig Dis Sci*. 1996 Dec;41(12):2477–81.
178. Deplancke B, Gaskins HR. Hydrogen sulfide induces serum-independent cell cycle entry in nontransformed rat intestinal epithelial cells. *FASEB J Off Publ Fed Am Soc Exp Biol*. 2003 Jul;17(10):1310–2.

179. Cai W, Wang M, Ju L, Wang C, Zhu Y. Hydrogen sulfide induces human colon cancer cell proliferation: role of Akt, ERK and p21. *Cell Biol Int*. 2010 Jun 1;34(6):565–72.
180. Wu YC, Wang XJ, Yu L, Chan FKL, Cheng ASL, Yu J, et al. Hydrogen Sulfide Lowers Proliferation and Induces Protective Autophagy in Colon Epithelial Cells. *Deb S*, editor. *PLoS ONE*. 2012 May 29;7(5):e37572.
181. Attene-Ramos MS, Wagner ED, Plewa MJ, Gaskins HR. Evidence that hydrogen sulfide is a genotoxic agent. *Mol Cancer Res MCR*. 2006 Jan;4(1):9–14.
182. Attene-Ramos MS, Nava GM, Muellner MG, Wagner ED, Plewa MJ, Gaskins HR. DNA damage and toxicogenomic analyses of hydrogen sulfide in human intestinal epithelial FHs 74 Int cells. *Environ Mol Mutagen*. 2010 May;51(4):304–14.
183. Attene-Ramos MS, Wagner ED, Gaskins HR, Plewa MJ. Hydrogen sulfide induces direct radical-associated DNA damage. *Mol Cancer Res MCR*. 2007 May;5(5):455–9.
184. Ijssennagger N, Belzer C, Hooiveld GJ, Dekker J, van Mil SWC, Müller M, et al. Gut microbiota facilitates dietary heme-induced epithelial hyperproliferation by opening the mucus barrier in colon. *Proc Natl Acad Sci*. 2015 Aug 11;112(32):10038–43.
185. Carbonero F, Benefiel AC, Gaskins HR. Contributions of the microbial hydrogen economy to colonic homeostasis. *Nat Rev Gastroenterol Hepatol*. 2012 Sep;9(9):504–18.
186. Jowett SL, Seal CJ, Pearce MS, Phillips E, Gregory W, Barton JR, et al. Influence of dietary factors on the clinical course of ulcerative colitis: a prospective cohort study. *Gut*. 2004 Oct;53(10):1479–84.
187. Arijs I, Vanhove W, Rutgeerts P, Schuit F, Verbeke K, De Preter V. Decreased mucosal sulfide detoxification capacity in patients with Crohn’s disease. *Inflamm Bowel Dis*. 2013 Apr;19(5):E70–2.
188. De Preter V, Arijs I, Windey K, Vanhove W, Vermeire S, Schuit F, et al. Decreased mucosal sulfide detoxification is related to an impaired butyrate oxidation in ulcerative colitis. *Inflamm Bowel Dis*. 2012 Dec;18(12):2371–80.
189. Mackowiak PA. Recycling metchnikoff: probiotics, the intestinal microbiome and the quest for long life. *Front Public Health*. 2013;1:52.
190. Govers MJ, Lapré JA, De Vries HT, Van der Meer R. Dietary soybean protein compared with casein damages colonic epithelium and stimulates colonic epithelial proliferation in rats. *J Nutr*. 1993 Oct;123(10):1709–13.
191. Bajka BH, Clarke JM, Cobiac L, Topping DL. Butyrylated starch protects colonocyte DNA against dietary protein-induced damage in rats. *Carcinogenesis*. 2008 Nov;29(11):2169–74.
192. Toden S, Bird AR, Topping DL, Conlon MA. Differential effects of dietary whey, casein and soya on colonic DNA damage and large bowel SCFA in rats fed diets low and high in resistant starch. *Br J Nutr*. 2007 Mar;97(3):535–43.
193. Newmark HL, Lupton JR. Determinants and consequences of colonic luminal pH: Implications for colon cancer. *Nutr Cancer*. 1990 Jan;14(3-4):161–73.

194. Steck N, Mueller K, Schemann M, Haller D. Bacterial proteases in IBD and IBS. *Gut*. 2012 Nov;61(11):1610–8.
195. Bastide NM, Pierre FHF, Corpet DE. Heme Iron from Meat and Risk of Colorectal Cancer: A Meta-analysis and a Review of the Mechanisms Involved. *Cancer Prev Res (Phila Pa)*. 2011 Feb 1;4(2):177–84.
196. Windey K, François I, Broekaert W, De Preter V, Delcour JA, Louat T, et al. High dose of prebiotics reduces fecal water cytotoxicity in healthy subjects. *Mol Nutr Food Res*. 2014 Nov;58(11):2206–18.
197. Windey K, De Preter V, Huys G, Broekaert WF, Delcour JA, Louat T, et al. Wheat bran extract alters colonic fermentation and microbial composition, but does not affect faecal water toxicity: a randomised controlled trial in healthy subjects. *Br J Nutr*. 2015 Jan 28;113(2):225–38.
198. Delacour D, Salomon J, Robine S, Louvard D. Plasticity of the brush border — the yin and yang of intestinal homeostasis. *Nat Rev Gastroenterol Hepatol*. 2016 Feb 3;13(3):161–74.
199. Richter JF, Pieper R, Zakrzewski SS, Günzel D, Schulzke JD, Van Kessel AG. Diets high in fermentable protein and fibre alter tight junction protein composition with minor effects on barrier function in piglet colon. *Br J Nutr*. 2014 Mar 28;111(6):1040–9.
200. Faure M, Moënnoz D, Montigon F, Mettraux C, Breuillé D, Ballèvre O. Dietary threonine restriction specifically reduces intestinal mucin synthesis in rats. *J Nutr*. 2005 Mar;135(3):486–91.
201. Jantchou P, Morois S, Clavel-Chapelon F, Boutron-Ruault M-C, Carbonnel F. Animal protein intake and risk of inflammatory bowel disease: The E3N prospective study. *Am J Gastroenterol*. 2010 Oct;105(10):2195–201.
202. Tragnone A, Valpiani D, Miglio F, Elmi G, Bazzocchi G, Pipitone E, et al. Dietary habits as risk factors for inflammatory bowel disease. *Eur J Gastroenterol Hepatol*. 1995 Jan;7(1):47–51.
203. Shoda R, Matsueda K, Yamato S, Umeda N. Epidemiologic analysis of Crohn disease in Japan: increased dietary intake of n-6 polyunsaturated fatty acids and animal protein relates to the increased incidence of Crohn disease in Japan. *Am J Clin Nutr*. 1996;63(5):741–5.
204. Spooren CEGM, Pierik MJ, Zeegers MP, Feskens EJM, Masclee A a. M, Jonkers DM a. E. Review article: the association of diet with onset and relapse in patients with inflammatory bowel disease. *Aliment Pharmacol Ther*. 2013 Nov;38(10):1172–87.
205. Rist VTS, Weiss E, Sauer N, Mosenthin R, Eklund M. Effect of dietary protein supply originating from soybean meal or casein on the intestinal microbiota of piglets. *Anaerobe*. 2014 Feb;25:72–9.
206. Wittwer J, Rubio-Aliaga I, Hoefl B, Bendik I, Weber P, Daniel H. Nutrigenomics in human intervention studies: Current status, lessons learned and future perspectives. *Mol Nutr Food Res*. 2011 Mar;55(3):341–58.
207. Keijer J, van Helden YGJ, Bunschoten A, van Schothorst EM. Transcriptome analysis in benefit-risk assessment of micronutrients and bioactive food components. *Mol Nutr Food Res*. 2010 Feb;54(2):240–8.

208. Lan A, Blais A, Coelho D, Capron J, Maarouf M, Benamouzig R, et al. Dual effects of a high-protein diet on DSS-treated mice during colitis resolution phase. *Am J Physiol Gastrointest Liver Physiol*. 2016 Aug 25;ajpgi.00433.2015.
209. Kim E, Coelho D, Blachier F. Review of the association between meat consumption and risk of colorectal cancer. *Nutr Res*. 2013 Dec;33(12):983–94.
210. Santarelli RL, Pierre F, Corpet DE. Processed meat and colorectal cancer: a review of epidemiologic and experimental evidence. *Nutr Cancer*. 2008;60(2):131–44.
211. Alexander DD, Cushing CA, Lowe KA, Scurman B, Roberts MA. Meta-analysis of animal fat or animal protein intake and colorectal cancer. *Am J Clin Nutr*. 2009 May 1;89(5):1402–9.
212. Le Leu RK, Brown IL, Hu Y, Morita T, Esterman A, Young GP. Effect of dietary resistant starch and protein on colonic fermentation and intestinal tumourigenesis in rats. *Carcinogenesis*. 2006 Jul 8;28(2):240–5.
213. American Institute for Cancer Research, World Cancer Research Fund, editors. *Food, nutrition, physical activity and the prevention of cancer: a global perspective: a project of World Cancer Research Fund International*. Washington, D.C: American Institute for Cancer Research; 2007. 517 p.
214. Li JV, Ashrafian H, Bueter M, Kinross J, Sands C, le Roux CW, et al. Metabolic surgery profoundly influences gut microbial-host metabolic cross-talk. *Gut*. 2011 Sep 1;60(9):1214–23.
215. Mack I, Cuntz U, Grämer C, Niedermaier S, Pohl C, Schwiertz A, et al. Weight gain in anorexia nervosa does not ameliorate the faecal microbiota, branched chain fatty acid profiles, and gastrointestinal complaints. *Sci Rep*. 2016 May 27;6:26752.
216. Altieri L, Neri C, Sacco R, Curatolo P, Benvenuto A, Muratori F, et al. Urinary p-cresol is elevated in small children with severe autism spectrum disorder. *Biomark Biochem Indic Expo Response Susceptibility Chem*. 2011 May;16(3):252–60.
217. Collino S, Montoliu I, Martin F-PJ, Scherer M, Mari D, Salvioli S, et al. Metabolic Signatures of Extreme Longevity in Northern Italian Centenarians Reveal a Complex Remodeling of Lipids, Amino Acids, and Gut Microbiota Metabolism. Wertheimer A, editor. *PLoS ONE*. 2013 Mar 6;8(3):e56564.

ANNEXE



Contents lists available at ScienceDirect

Trends in Food Science & Technology

journal homepage: <http://www.journals.elsevier.com/trends-in-food-science-and-technology>

Gut microbiota role in dietary protein metabolism and health-related outcomes: The two sides of the coin

Kevin J. Portune^{a,*}, Martin Beaumont^b, Anne-Marie Davila^b, Daniel Tomé^b, François Blachier^b, Yolanda Sanz^a^a Microbial Ecology, Nutrition & Health Research Unit, Institute of Agrochemistry and Food Technology, Spanish National Research Council, Valencia (IATA-CSIC), C/Catedratic Agustín Escardino Benloch, 7, 46980, Paterna, Valencia, Spain^b UMR Nutrition Physiology and Ingestive Behavior, AgroParisTech, INRA, Université Paris-Saclay, 75005, Paris, France

ARTICLE INFO

Article history:

Received 5 February 2016

Received in revised form

6 July 2016

Accepted 24 August 2016

Available online xxx

Keywords:

Microbiota

Microbiome

Protein metabolism

High-protein diet

ABSTRACT

Background: Human gut bacteria can synthesize proteinogenic amino acids and produce a range of metabolites via protein fermentation, some known to exert beneficial or harmful physiological effects on the host. However, the effects of the type and amount of dietary protein consumed on these metabolic processes, as well as the effects of the microbiota-derived amino acids and related metabolites on the host health are still predominantly unknown.

Scope and approach: This review provides an up-to-date description of the dominant pathways/genes involved in amino acid metabolism in gut bacteria, and provides an inventory of metabolic intermediates derived from bacterial protein fermentation that may affect human health. Advances in understanding bacterial protein fermentation pathways and metabolites generated at a global level via the implementation of 'omics' technologies are reviewed. Finally, the impact of dietary protein intake and high-protein diets on human health is discussed.

Key findings and conclusions: The intestinal microbiota is able to synthesize amino acids, but the net result of amino acid production and utilization, according to dietary patterns still needs to be determined. The amount of ingested dietary protein appears to modify both the diversity and composition of the intestinal microbiota as well as the luminal environment of the intestinal epithelium and peripheral tissues. The understanding of the consequences of such changes on the host physiology and pathophysiology is still in an early stage but major progress is expected in the near future with the investigation of host-microbe omics profiles from well-controlled human intervention studies.

© 2016 Elsevier Ltd. All rights reserved.

1. Introduction

The dietary protein consumption level in humans is vastly different according to food availability and cultural dietary habits (Wu et al., 2014). Although insufficient protein consumption remains a persistent problem in the developing world, the average daily protein intake in countries from Western Europe and the United States of America is generally higher than the recommended dietary intake of 0.83 g protein kg⁻¹ day⁻¹ for adults (EFSA Panel on Dietetic Products, 2012; Rand, Pellett, & Young, 2003). In individuals consuming a high-protein (HP) diet as a way to reduce their body weight, the protein consumption generally consists of

approximately two to three times the recommended dietary intake; and can even represent five times this latter value (Pesta & Samuel, 2014). Such diets have been shown to increase satiety, modify lipid metabolism, and facilitate short- and medium-term weight reduction (Westerterp-Plantenga, Nieuwenhuizen, Tome, Soenen, & Westerterp, 2009). Although a reduction of body weight in overweight and obese individuals is obviously associated with favorable outcomes in terms of health, such dietary modification are also associated with potentially deleterious effects in both healthy situations in the long-term and in some pathological situations, notably in kidney diseases (Juraschek, Appel, Anderson, & Miller, 2013) and in inflammatory bowel diseases (Jowett et al., 2004).

Besides host physiological factors, recent evidence demonstrates that human gut microbiota in the small and large intestine also plays a role in host dietary protein metabolism. The interplay

* Corresponding author.

E-mail address: kportune@iata.csic.es (K.J. Portune).

between host and gut microbial metabolism is complex, with microbes utilizing and even competing for dietary and endogenous proteins. Fermentation of amino acids by gut bacteria produces metabolites that can affect host protein/amino acid uptake (transport) and metabolism, as well as affect host cell physiology (Davila et al., 2013). Bacteria can also synthesize amino acids, which can be provided to the host (Metges, 2000). However, the net result of amino acid synthesis and degradation remains largely to be determined along with the role of the gut microbiota for the management of whole body nitrogen metabolism (Neis, Dejong, & Rensen, 2015). Such knowledge is important since it will yield information regarding the role of the microbiota in the utilization of amino acids from dietary origin in different physiological and pathological situations, as well as the role of the microbiota in the production of metabolites that could be available for the host and impact host metabolism and other physiological functions.

Despite the relatively rapid transit of the luminal content in the small intestine, part of the amino acid pool released from proteins through the action of pancreatic enzymes can be used by the host enterocytes (Davila et al., 2013) as well as by the small intestinal microbiota (Dai, Zhang, Wu, & Zhu, 2010). Protein digestion in the mammalian digestive tract is a very efficient process, being generally equal to or even higher than 90% (Bos et al., 2005). In the large intestine, where the microbiota concentration is much higher and the transit time is longer than in the small intestine, the remaining protein is broken down to peptides and amino acids via extracellular bacterial proteases and peptidases (Macfarlane, Cummings, & Allison, 1986). In contrast to the small intestine, however, the amino acids generated cannot be absorbed to any significant extent by the large intestine epithelium, except during the neonatal period in mammals (Darragh, Cranwell, & Moughan, 1994). Gut bacterial fermentation of amino acids thus results in an accumulation of various metabolic end-products in the luminal content, some of these metabolites being largely absorbed through the large intestinal epithelial cells, while others are released in feces in large amounts (Davila et al., 2013). Several bacterial metabolites have also been shown to be active on colonic epithelial cells, which, as detailed below, depending on their luminal concentrations, can exert beneficial or deleterious effects.

Bacterial metabolites which are not fully metabolized/detoxified by the colonic epithelial cells during their transcellular journey from the intestinal lumen to the bloodstream may reach the liver through the portal vein and then peripheral tissues where they can exert some biological effects, notably on kidney functions.

Investigations into the effects of microbially-derived metabolites on human health and the interaction of the microbiota with the human host have previously been limited due to the complexity of interactions between these two systems. The rapid advance of 'omics' technologies are beginning to expand our understanding of the relationships between the human host and gut microbiota by allowing a global analysis of the flow of host- and microbially-produced metabolites and genes involved in specific biochemical pathways (Qin et al., 2010; Sridharan et al., 2014). A thorough characterization and understanding of the bacterial pathways involved in amino acid metabolism and their derivatives is required for precise interpretation and prediction of dietary protein effects on the host health. Currently, a comprehensive review of those bacterial genes and metabolic routes is lacking.

This review merges up-to-date genomic information regarding amino acid-related metabolism in gut bacteria with their potential effects on human health. A description of the dominant pathways for bacterial amino acid biosynthesis as well as for amino acid degradation into metabolites that may play different roles in human health is provided. Moreover, information on the enzymes and homologous genes involved in these pathways as deduced from the

KEGG database (Kanehisa et al., 2014) is given. We then discuss the recent advances in understanding the effects of different dietary strategies (i.e. high-fat diet and HP diet) on the human gut microbiome and its role in protein/amino acid metabolism based on metagenomic and metabolomic studies. Finally, we analyzed how this metabolic activity, notably in terms of bacterial metabolite production, may be responsible for the effects of dietary protein intake levels on health-related outcomes in both physiological and pathological situations as well as underline research areas that need new developments.

2. Bacterial synthesis of amino acids

The effects of *de novo* production of amino acids by microbes on whole-body fluxes and human health are still not clearly understood. Bacterial production of amino acids that are accessible to the host may be useful to compensate indispensable amino acid deficiency in low quality protein diets. However, bacterially-produced amino acids could also have detrimental consequences in conditions such as insulin resistance in type 2 diabetes where systemic concentrations of amino acids such as aromatic and branched-chain amino acids are elevated (Neis et al., 2015). A deeper understanding of the effects of microbially-produced amino acids on host health is warranted, as well as a revision of the biosynthetic pathways of amino acids in bacteria which is provided here.

2.1. Pathways/genes involved in *de novo* biosynthesis of amino acids

Due to the high metabolic cost of synthesizing amino acids, the carbon backbone of all amino acids originates from common metabolic intermediates involved in processes such as the tricarboxylic acid cycle, the pentose phosphate pathway and glycolysis (Berg, Tymoczko, & Stryer, 2002). Among these intermediates, α -ketoglutarate plays a central role in amino acid biosynthesis through its conversion to glutamate, as well as its participation in the biosynthetic pathways of other amino acids. Amino acids can be grouped into families according to common starting products or use of common enzymes for synthesis. These consist of the following families: glutamate, serine, aspartate, pyruvate, and aromatic amino acid families, as well as several unique pathways for individual amino acids (Umbarger, 1978). It is important to note that an overwhelming amount of the literature on bacterial metabolism has historically been focused on a few bacterial taxa, namely *Escherichia coli* and *Salmonella typhimurium*, and to a lesser extent *Bacillus subtilis* and recently *Corynebacterium glutamicum*, thus creating a potential bias towards mechanisms found in these organisms. Although many of these pathways are conserved across bacterial lineages including those inhabiting the intestine, diversity is found among different bacterial species at both the species and strain level. For example, whole genome analysis has revealed that the common gut bacterium *Clostridium perfringens* lacks numerous amino acid biosynthetic genes for glutamate, arginine, histidine, lysine, methionine, serine, threonine, aromatic and branched-chain amino acids (Shimizu et al., 2002), while other *Clostridium* spp., such as *Clostridium acetobutylicum*, has a complete set of genes for amino acid biosynthesis (Nolling et al., 2001). The gut bacterium *Lactobacillus johnsonii* also appears incapable of carrying out *de novo* biosynthesis of almost all amino acids due to a lack of complete biosynthetic pathways, and exhibits an apparent dependence on exogenous host amino acids/peptides for protein synthesis (Pridmore et al., 2004). Other animal and human intestinal bacteria, including *Campylobacter jejuni*, *Helicobacter pylori*, *Enterococcus faecalis* and *Streptococcus agalactiae* have also lost certain amino acid biosynthetic pathways (Yu, Walker, Liu, & Zhang, 2009),

suggesting a dependence on availability of exogenous peptides/ amino acid sources. Furthermore, the sole presence of genes within a genome does not confirm their functionality. Genes for the biosynthesis of all 20 standard amino acids have been identified in the common gut bacterium *Lactococcus lactis*, although supplemented sources of certain amino acids (isoleucine, valine, leucine, histidine, methionine, and glutamic acid) are also required for growth since genes in these biosynthetic pathways have been demonstrated to be non-functional due to point mutations (Bolotin et al., 2001; Godon et al., 1993). This may also be the case with another gut bacterium *Staphylococcus aureus*, as two distinct strains exhibited auxotrophy for different amino acids, despite the presence of complete sets of genes for biosynthetic pathways of these essential amino acids in both strains (Kuroda et al., 2001). Given these different scenarios, it is likely that alternative intestinal

bacterial co-metabolic pathways and regulation strategies remain to be discovered.

2.1.1. Glutamate family (glutamate, glutamine, proline, arginine)

Glutamate and glutamine are both key nitrogen/amino group donors for amino acid synthesis and provide the major entry points of ammonia into bacterial metabolism (H. Shimizu & Hirasawa, 2007). These enzyme pathways are particularly important for some gut bacteria with a reliance on ammonia as a nitrogen source, such as many *Bacteroides* spp., which cannot replace ammonia with other nitrogen sources such as amino acids, peptides, urea or nitrate (reviewed in Fischbach & Sonnenburg, 2011). Glutamate is one of the most important central metabolites in all bacteria providing a link between carbon and nitrogen metabolism. Most enteric bacteria have two primary pathways for the synthesis of

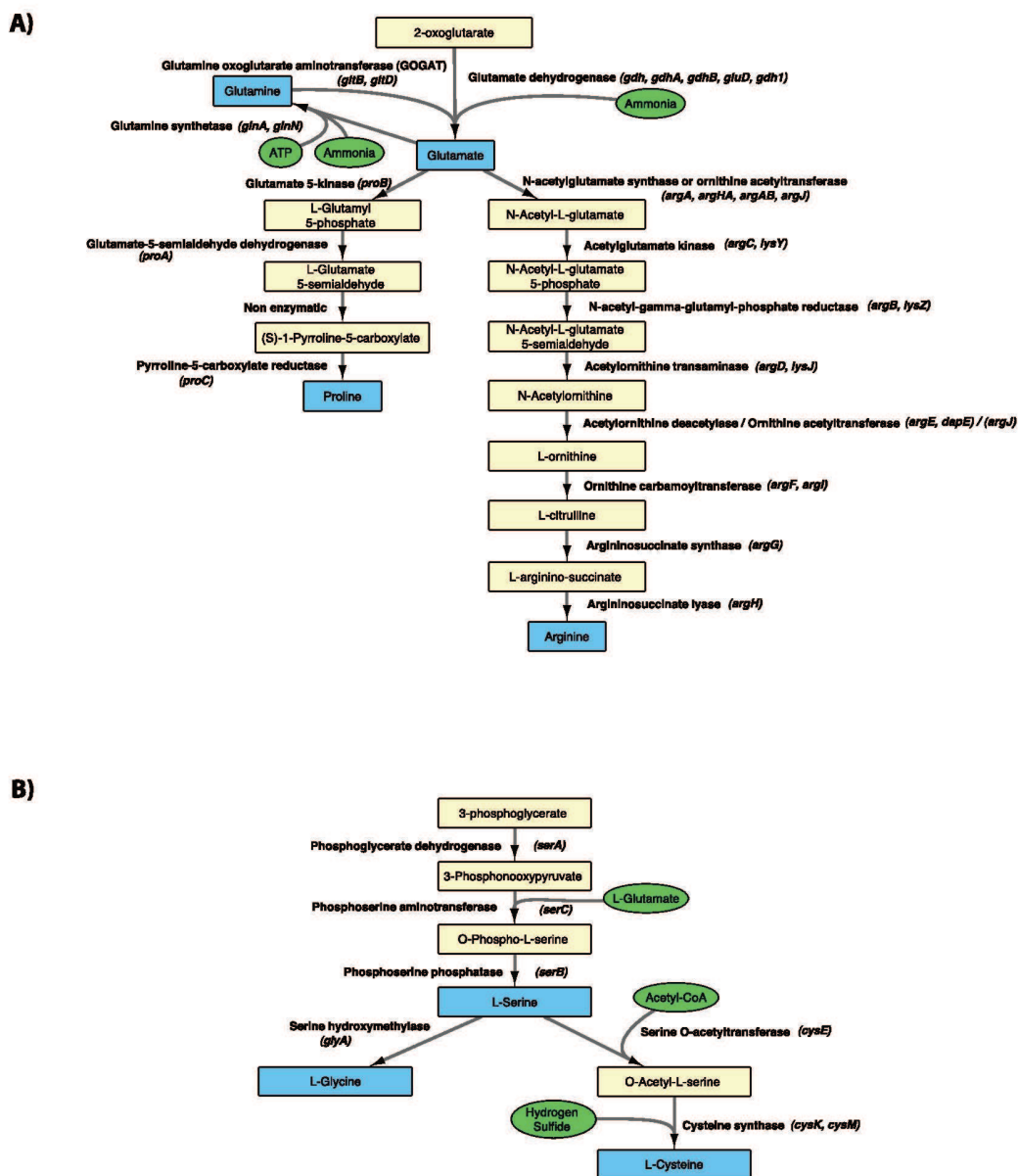

Fig. 1. Prokaryotic biosynthetic enzymatic pathways of (A) glutamate and (B) serine amino acid families. Enzymes with associated gene names compiled from the KEGG database are provided for each step in reaction pathways. Gene names include orthologous and paralogous gene groups among different bacterial taxa. Intermediate metabolites (yellow boxes) from the most common reaction pathways are provided for each end product amino acid (blue boxes) from each enzymatic family. (For interpretation of the references to colour in this figure legend, the reader is referred to the web version of this article.)

glutamate (Fig. 1a) involving either the enzyme glutamate dehydrogenase (GDH) or glutamine oxoglutarate aminotransferase (also called GOGAT or glutamate synthase) (Reitzer & Magasanik, 1987; H.; Shimizu & Hirasawa, 2007). Preferential use of either pathway depends on both the energy state and intracellular ammonium concentrations in the cells. GDH is preferentially utilized for glutamate synthesis when both energy and carbon sources are limited for the cell but ammonium and phosphate are present in excess, while the GOGAT pathway is preferred when the cell is not under energy limitation since this pathway requires the expenditure of ATP (Helling, 1994). However, exceptions to this strategy are seen in the common gut bacterium *Bacteroides fragilis* which contains 2 distinct glutamate dehydrogenase enzymes: a dual cofactor NAD(P)H-dependent (gene = *gdhB*) enzyme whose activity depends on high ammonia concentrations, and a NADH-specific enzyme whose activity depends on high peptide concentrations in which ammonia has no effect on activity (Abrahams & Abratt, 1998; Yamamoto, Saito, & Ishimoto, 1987). In the Gram-positive bacterium *Bacillus subtilis*, glutamate is exclusively synthesized by reductive amination of α -ketoglutarate by the enzyme glutamate synthase encoded by the *gltAB* operon (Belitsky, 2002).

Glutamine is synthesized by the single reaction of glutamine synthetase (GS; EC 6.3.1.2) in which ammonia is added to glutamate through ATP hydrolysis (Fig. 1a). Three distinct types of glutamine synthetases have been identified in bacteria: GSI is found in eubacteria and archaea including the ruminal *R. albus*, GSII is present only in eukaryotes and several soil bacteria: *Rhizobium*, *Frankia*, and *Streptomyces*, while GSIII has only been found in several unrelated bacteria *Bacteroides fragilis*, *Rhizobium leguminosarum*, and *Butyrivibrio fibrisolvens*, and *R. albus* (Brown, Masuchi, Robb, & Doolittle, 1994; Kim, Henriksen, Cann, & Mackie, 2014).

Several pathways exist for bacterial proline biosynthesis, however the most common pathway found in many groups involves a four-step process starting with the phosphorylation of glutamate (Fig. 1a) (reviewed in (Fichman et al., 2015)). Genomic analysis of proline biosynthesis has revealed that many eubacterial and archaeal species contain only one recognizable gene from this pathway (i.e. $\Delta 1$ -pyrroline-5-carboxylate reductase) while other species lack all genes from this pathway, suggesting that either these bacteria are dependent on exogenous proline sources for growth or that alternative pathways may exist that may not yet be elucidated (Fichman et al., 2015).

Biosynthesis of arginine involves an eight-step process starting with the acetylation of glutamate (Fig. 1a). This step occurs through the so-called "classical" pathway initially described for *E. coli* via the enzyme N-acetylglutamate synthase (NAGS) and encoded by the gene *argA* (reviewed in Xu, Labedan, & Glansdorff, 2007). In many bacterial species, this step can also be achieved by an ornithine N-acetyltransferase (OAT) with dual functional activities (E.C. 2.3.1.35/2.3.1.1) that can also synthesize acetylglutamate *de novo* from acetyl-CoA and glutamate (Marc, Weigel, Almeras, Glansdorff, & Sakanyan, 2000; Xu et al., 2007).

2.1.2. Serine family (serine, glycine, cysteine)

Serine is an important metabolite and precursor to multiple amino acids in bacteria (glycine, cysteine, tryptophan). It is also a precursor for the metabolism of sphingolipids, folate, methane, sulfur, cyanoamino acid, and pyruvate, and also participates in the biosynthesis of purines and pyrimidines (Stolz et al., 2007; Umbarger, 1978). Furthermore, L-serine plays a fundamental role in stabilizing blood sugar concentration in the liver (Remesy, Fafournoux, & Demigne, 1983). Synthesis of serine is a three-step process starting with the glycolytic intermediate 3-phosphoglycerate (Fig. 1b) (Peters-Wendisch et al., 2005). Glycine is generated from serine by the single enzyme serine

hydroxymethyltransferase (Fig. 1b) that catalyzes the reversible conversion of serine and tetrahydrofolate to glycine and 5,10-methylene tetrahydrofolate, which is a key intermediate in the biosynthesis of purines, thymidine, choline, glutathione and methionine (Trivedi et al., 2002). In enterobacteria and *Bacillus subtilis*, the synthesis of cysteine is a two-step reaction (Fig. 1b) that involves the substrates coenzyme A and hydrogen sulfide (H₂S) (Kredich, 1996). *Bifidobacterium longum* lacks the genes for the final step with cysteine synthase and may use alternative pathways with several enzymes such as succinylhomoserine and the sulfur-containing compounds H₂S or methanethiol produced by other colonic bacteria (Schell et al., 2002). Several strains of *Bifidobacterium bifidum* have further displayed cysteine auxotrophy (Ferrario et al., 2015), indicating a dependence of exogenous sources of this amino acid.

2.1.3. Aspartate family (aspartate, asparagine, lysine, threonine, methionine)

Aspartate is an important precursor for the biosynthesis of numerous amino acids. It is synthesized from the transfer of an amino group from glutamate to oxaloacetate via the enzyme aspartate transaminase (Fig. 2). Asparagine is commonly made by one of two distinct asparagine synthetases in bacteria in which one enzyme utilizes ammonia while the other synthetase carries out a transamination reaction from glutamine to aspartate (Fig. 2) (Min, Pelaschier, Graham, Tumbula-Hansen, & Soll, 2002). Alternate pathways exist in some gut bacteria, such as *B. longum*, which lack both types of asparagine synthetases and likely use an asparaginyl-tRNA-dependent route (Schell et al., 2002).

Two main pathways exist for lysine biosynthesis in bacteria, the diaminopimelic acid (DAP) and amino adipic acid (AAA) pathways. The DAP pathway is used by most bacteria and some archaea and utilizes aspartate and pyruvate as starting material with meso-2,6-diaminopimelic acid as an intermediate (Fig. 2) (Patte, 1996). Four variations of this pathway have been identified in bacteria: the succinylase (most common) (Fig. 2), acetylase, aminotransferase and dehydrogenase pathways (Liu, White, & Whitman, 2010). No organism is known to possess both DAP and AAA pathways (Liu et al., 2010). In *E. coli*, the first step in the DAP pathway employs three distinct aspartate kinase isozymes (ThrA, MetL, and LysC), each specific to one of three different biochemical pathways under regulation from lysine, methionine, and threonine (Vitreschak, Lyubetskaya, Shirshin, Gelfand, & Lyubetsky, 2004).

Synthesis of threonine shares the first two steps of the biosynthetic pathway of lysine (Fig. 2). In addition to the conversion of aspartate to 4-phospho-L-aspartate, ThrA and MetL isozymes also contain a homoserine dehydrogenase (Hom) domain that carries out the third step in the threonine biosynthetic pathway in which aspartate 4-semialdehyde is converted to homoserine (Fig. 2) (Vitreschak et al., 2004). Methionine shares the first three steps of the biosynthetic pathway of threonine (Fig. 2); after which several different pathways are utilized by different bacteria to attach a sulfur group to O-Succinyl-L-homoserine via either L-cysteine (Fig. 2) or incorporate inorganic sulfur with O-acetylhomoserine to form homocysteine (Rodionov, Vitreschak, Mironov, & Gelfand, 2004).

2.1.4. Pyruvate family (isoleucine, valine, leucine, alanine)

The branched-chain amino acids (BCAA), valine, leucine and isoleucine share common biosynthetic pathways all stemming from intermediates from pyruvate metabolism. These pathways are so similar that many of the same enzymes are shared for biosynthesis of all these amino acids (Fig. 3). In *E. coli* and *S. enterica* serovar *Typhimurium*, three different isoenzymes of the enzyme acetolactate synthase (AHAS; EC 2.2.1.6) are made up of a large and

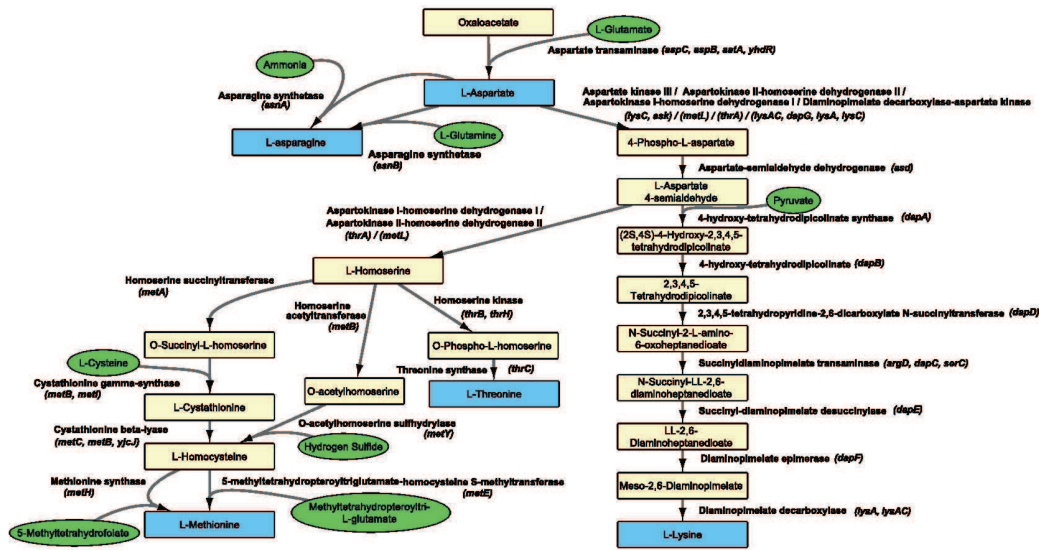

Fig. 2. Prokaryotic biosynthetic enzymatic pathways of the aspartic acid amino acid family. Enzymes with associated gene names compiled from the KEGG database are provided for each step in reaction pathways. Gene names include orthologous and paralogous gene groups among different bacterial taxa. Intermediate metabolites (yellow boxes) from the most common reaction pathways are provided for each end product amino acid (blue boxes) from each enzymatic family. (For interpretation of the references to colour in this figure legend, the reader is referred to the web version of this article.)

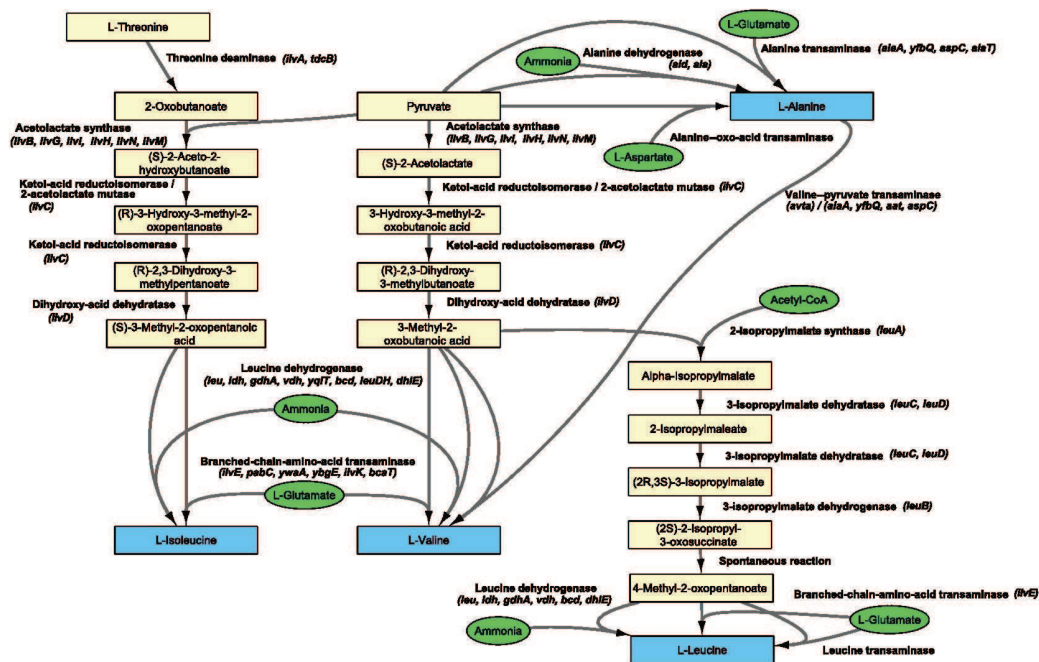

Fig. 3. Prokaryotic biosynthetic enzymatic pathways of the pyruvate amino acid family. Enzymes with associated gene names compiled from the KEGG database are provided for each step in reaction pathways. Gene names include orthologous and paralogous gene groups among different bacterial taxa. Intermediate metabolites (yellow boxes) from the most common reaction pathways are provided for each end product amino acid (blue boxes) from each enzymatic family. (For interpretation of the references to colour in this figure legend, the reader is referred to the web version of this article.)

small subunit encoded by the respective genes *ilvIH*, *ilvBN*, and *ilvGM* (Umbarger, 1996). Isoleucine biosynthesis starts with the conversion of threonine to 2-oxobutanoate via the enzyme threonine deaminase and then uses the same enzymes as those described for valine biosynthesis (Fig. 3). Leucine biosynthesis uses the last intermediate from the valine pathway, 2-oxoisovalerate (aka 3-methyl-2-oxobutanoic acid), to carry out the initial reaction (Fig. 3) (Patek, 2007). Leucine has also been demonstrated to be biosynthesized via the precursor SCFA isovalerate via

carboxylation in the gut bacteria *Bacteroides fragilis* and *Prevotella ruminicola* (previously *Bacteroides ruminicola*) (Allison, Baetz, & Wiegel, 1984). Both of these bacteria also preferentially utilize 2-methylbutyrate as a precursor for isoleucine biosynthesis instead of carrying out *de novo* synthesis starting from glucose (Allison et al., 1984). Several pathways exist for alanine biosynthesis, with starting precursors such as pyruvate and aspartate among the most common (Fig. 3). L-alanine is mainly synthesized from pyruvate and glutamate via an alanine transaminase (Oikawa, 2007).

2.1.5. Aromatic family (phenylalanine, tyrosine, tryptophan)

Biosynthesis of aromatic amino acids typically follows the shikimate pathway and starts with the condensation of the glycolytic intermediate phosphoenolpyruvate and the pentose phosphate pathway intermediate erythrose 4-phosphate, via the enzyme 3-Deoxy-d-arabinoheptulosonate 7-phosphate synthase (Fig. 4) (Sprenger, 2007). In *E. coli*, three distinct isoenzymes (called AroF, AroG and AroH) are involved in this step and each is specifically feed-back inhibited by the terminal end products tyrosine, phenylalanine and tryptophan, respectively (Sprenger, 2007). A single non-homologous DAHP synthase (AroA) is found in the Gram-positive *B. subtilis* (Panina, Vitreschak, Mironov, & Gelfand, 2003). The pathway proceeds for 6 steps to the common intermediate chorismate, which serves as a branchpoint to the individual pathways for phenylalanine, tryptophan and tyrosine (Fig. 4).

Alternative pathways exist for synthesis of each respective aromatic amino acid in different bacterial species, but commonalities within the pathways remain. The first reaction for both phenylalanine and tyrosine uses the enzyme chorismate mutase to convert chorismate to prephenate. In *E. coli*, chorismate mutases are bifunctional enzymes which can participate in the first two steps of both phenylalanine and tyrosine biosynthesis from chorismate (Fig. 4) (Sprenger, 2007). In *E. coli*, both pathways then use either the enzyme aromatic amino acid aminotransferase or aspartate aminotransferase (EC 2.6.1.1) to catalyze the transamination reaction into each respective α -keto acid using glutamate as the amino group donor (Pittard, 1996) (Fig. 4). Aromatic amino acid aminotransferase can also participate in an alternative pathway that catalyzes the conversion of prephenate to L-arogenate which can be

further converted to either phenylalanine or tyrosine using prephenate dehydratase or cyclohexadieny/prephenate dehydrogenase, respectively. Instead of *de novo* synthesis of phenylalanine, several gut bacteria (*B. fragilis* and *P. ruminicola*) preferentially use phenylacetate as a precursor for this amino acid (Allison et al., 1984).

Tryptophan biosynthesis uses a five-step pathway from chorismate (Fig. 4) in which glutamine or ammonia is used in the first step with anthranilate synthase (Nichols, 1996; Pittard, 1996). In the final step, serine is used as the amino group donor for tryptophan synthase (Sprenger, 2007). The tryptophan biosynthesis pathway is quite conserved in different bacteria, although differences in gene order and the enzymatic reactions carried out by separate or fused enzyme units exist in different bacteria (reviewed in Xie, Keyhani, Bonner, & Jensen, 2003). For example, all of the genes in the biosynthetic pathway for tryptophan have been identified in the gut bacterium *B. longum* except for TrpF (phosphoribosylanthranilate isomerase), indicating a possible replacement of this gene with an unidentified homolog (Schell et al., 2002).

2.1.6. Histidine

Histidine biosynthesis is a complex ten-step enzymatic pathway (Fig. 5) encoded by eight different genes, three of which (*hisD*, *hisB*, and *hisI*) encode bifunctional enzymes (reviewed in Alifano et al., 1996). Most of the work on the histidine biosynthetic pathway has mainly been studied in *E. coli* and *Salmonella typhimurium* and more recently in the industrially important *Corynebacterium glutamicum*, demonstrating large conservation along with some

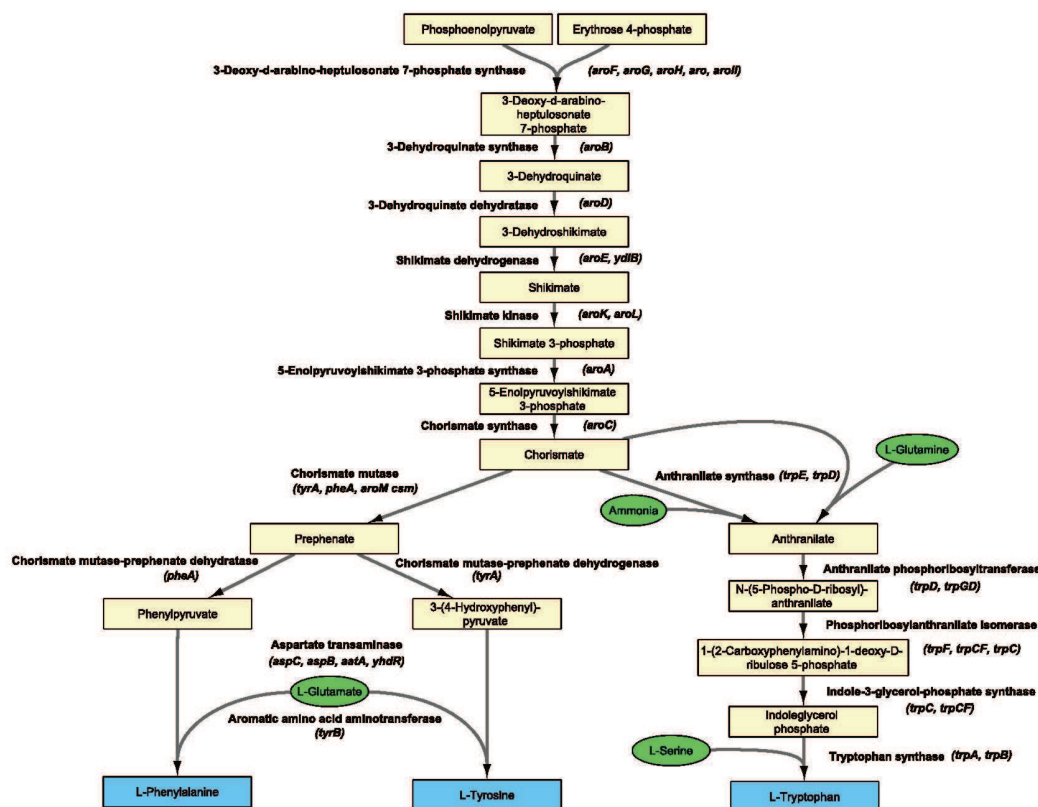

Fig. 4. Prokaryotic biosynthetic enzymatic pathways of the aromatic acid amino acid family. Enzymes with associated gene names compiled from the KEGG database are provided for each step in reaction pathways. Gene names include orthologous and paralogous gene groups among different bacterial taxa. Intermediate metabolites (yellow boxes) from the most common reaction pathways are provided for each end product amino acid (blue boxes) from each enzymatic family. (For interpretation of the references to colour in this figure legend, the reader is referred to the web version of this article.)

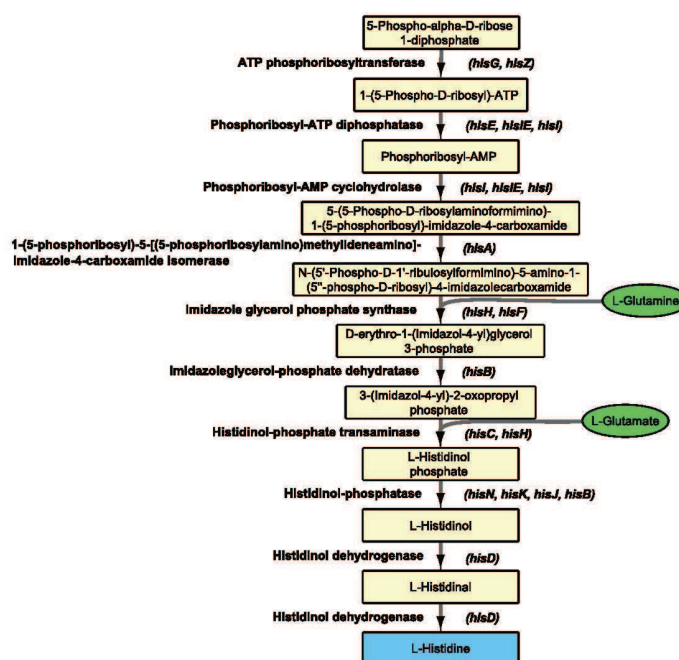

Fig. 5. Prokaryotic biosynthetic enzymatic pathway of histidine. Enzymes with associated gene names compiled from the KEGG database are provided for each step in reaction pathways. Gene names include orthologous and paralogous gene groups among different bacterial taxa. Intermediate metabolites (yellow boxes) from the most common reaction pathways are provided for each end product amino acid (blue boxes) from each enzymatic family. (For interpretation of the references to colour in this figure legend, the reader is referred to the web version of this article.)

differences in the biochemical pathways between the different species (Kulis-Horn, Persicke, & Kalinowski, 2014). Whole genome studies in bacteria identified in the gut such as *L. lactis* confirm the presence of all the genes of this pathway (Bolotin et al., 2001).

3. Overview of uptake systems and catabolism of proteins/ amino acids in gut bacteria

3.1. Protein hydrolysis and peptide/amino acid transporters

Initial steps of bacterial protein catabolism include the extracellular hydrolysis of proteins via different bacterial proteases. According to the MEROPS peptidase database (Rawlings, Waller, Barrett, & Bateman, 2014), bacteria contain a highly diverse number of different proteases, present in many common gut microbiota species such as *Clostridium* spp., *Bacteroides* spp., *Lactobacillus* spp., etc., containing up to hundreds of different identified proteases. Some bacteria, such as lactic acid bacteria, have developed sophisticated proteolytic systems to compensate for their reduced capabilities for amino acid biosynthesis (Pessione, 2012). Proteolytic systems in lactic acid bacteria consist of either extracellular or membrane-bound proteases (principally PrtP and CEP) that degrade proteins into oligopeptides, followed by their incorporation into the cell via peptide transporters (Opp, Dpp, Dtp, for oligopeptide, dipeptide, and di- and tripeptide, respectively) and finally numerous intracellular peptidases that degrade the peptides into short peptides and amino acids (reviewed in Liu, Bayjanov, Renckens, Nauta, & Siezen, 2010; Steiner, Naider, & Becker, 1995).

Amino acids and their derivatives are imported and exported from the bacterial cell via transmembrane proteins comprising ATP-dependent ABC transporters, several families of channel proteins, or secondary carriers relying on proton-motive force, sodium-ion motive force, solute-solute exchange, or uniport (Saier, 2000). Efflux systems for some amino acids such as lysine, arginine,

threonine, cysteine, leucine, isoleucine, and valine are well-known in the bacteria *E. coli* and *Clostridium glutamicum* (Eggeling & Sahm, 2003), whereas to date no export systems for histidine have been described in any organism (Kulis-Horn et al., 2014).

3.2. Transamination, deamination and decarboxylation

Bacteria may directly incorporate available amino acids as substrates for protein biosynthesis or may carry out catabolic reactions to use them as energy sources or to produce other metabolites. Under aerobic conditions, bacteria typically convert proteinogenic α -amino acids to α -oxo acids (aka. α -ketoacids) or saturated fatty acids via transamination or deamination, which are further oxidized as energy sources in the tricarboxylic acid (TCA) cycle. However, in the absence of oxygen or other suitable electron acceptors, only strict or facultative anaerobic bacteria in the gut, such as Clostridia and Fusobacteria, are capable of utilizing amino acids as energy sources, thus fermenting amino acids to short-chain fatty acids (SCFAs), molecular hydrogen (H_2), carbon dioxide (CO_2), and ammonia, with minor products of H_2S , methyl-mercaptane, phenols, alcohols and organic acids (Davila et al., 2013; Kim, Hetzel, Boiangiu, & Buckel, 2004). Several mechanisms for α -amino acid degradation exist for anaerobic bacteria, which includes the well-known Stickland reaction found in many proteolytic Clostridia which involves the coupled oxidation and reduction of two respective amino acids to organic acids. Other fermentation pathways found in various Clostridia as well as *Fusobacterium* spp. and *Acidaminococcus* spp. involve single amino acids that act as electron donors as well as acceptors (Fischbach & Sonnenburg, 2011; Kim et al., 2004). The genus *Clostridium* contains unique amino acid degradation pathways, such as B12-dependent aminomutases, selenium containing oxidoreductases and oxygen-sensitive 2-hydroxyacyl-CoA dehydratases (Fonknechten et al., 2010).

Amino acids can also be metabolized through decarboxylation reactions ultimately yielding amines and polyamines as products. Factors such as pH can influence the activity of deaminases and decarboxylases, ultimately affecting the accumulation of specific end products. Furthermore, many complex amino acids can undergo a series of metabolic reactions that produce a large variety of structurally-related metabolic end-products (Davila et al., 2013).

Amino acid utilization may be achieved in a preferential manner, as Fonknechten et al. (2010) demonstrated that *Clostridium sticklandii* preferentially used threonine, arginine and serine for carbon and energy sources, but hardly utilized glutamate, aspartate and aromatic amino acids, even though these catabolic pathways are found in this organism. Furthermore, lysine degradation, which is a process that provides a major energy source, was only observed in stationary growth phases (Fonknechten et al., 2010).

3.3. Factors influencing protein fermentation

Many different factors may influence protein fermentation in the gut, such as substrate availability, transit time, pH and osmolarity. The ratio of available carbohydrates:protein determines substrate utilization by the gut microbiota (Smith & Macfarlane, 1996), and in humans, it has been shown that availability of complex carbohydrates lowers protein fermentation (Birkett, Muir, Phillips, Jones, & O'Dea, 1996; De Preter et al., 2008; Geboes et al., 2006). When the main energy sources (i.e. fermentable carbohydrates) for microbiota are abundant, nitrogenous substrates can be used for biosynthetic (anabolic) process and bacterial growth. On the contrary, proteins are catabolized by bacteria when energy is scarce, leading to the production of amino acid-derived end products. Due to high carbohydrate fermentation in the proximal colon, there is a progressive decrease of carbohydrate availability in the distal colon, resulting in higher protein fermentation (Macfarlane, Gibson, & Cummings, 1992). Long transit time and elevated pH are also associated with high levels of protein fermentation (Cummings, Hill, Bone, Branch, & Jenkins, 1979; Macfarlane, Cummings, Macfarlane, & Gibson, 1989). Therefore, dietary carbohydrate and protein ratios may strongly influence the metabolic pathways activated in the large intestine and flow of metabolites generated.

4. Key intermediate products from bacterial protein/amino acid catabolism and effects on host physiology/health

Fermentation of amino acids derived from endogenous luminal and dietary protein by intestinal microbiota produces numerous metabolites with suspected or established effects on host intestinal physiology, liver and peripheral tissues. Relevant examples of such metabolites are described below.

4.1. Microbially-produced compounds with neuroactive properties

Recent evidence has shown that bacteria isolated from the mammalian gut have the capacity to synthesize neuroactive compounds including neurotransmitters, many of which result from the catabolism of amino acids. These compounds include GABA (produced by *Lactobacillus* spp., *Bifidobacterium* spp., and *Lactococcus lactis*); norepinephrine (produced by *Escherichia* spp. and *Bacillus* spp.); dopamine (produced by *Bacillus* spp.); histamine (produced by numerous bacterial genera); and serotonin (produced by *Streptococcus* spp., *Escherichia* spp. and *Enterococcus* spp.) (Sanders et al., 1998; Wall, Ross, & Stanton, 2014). In addition, bacteria have been demonstrated to produce other neuroactive compounds from amino acid degradation such as nitric oxide and the biogenic amines tryptamine and phenethylamine. It is worth noting that for

most of these bacterial metabolites, the understanding of their precise effects on the intestine and peripheral tissues remains in its infancy.

γ -aminobutyrate (GABA), known as an inhibitory neurotransmitter, is microbially-produced by the decarboxylation of glutamate via the enzyme glutamate decarboxylase (Table 1). This enzyme makes up part of the glutamate decarboxylase (GAD) system found in several bacterial genera, which is implicated in acid tolerance by maintaining intracellular pH homeostasis through proton consumption (Feehily & Karatzas, 2013). Other factors in addition to acidic stress have been demonstrated to activate the GAD system, including sodium, polyamines and hypoxia (Feehily & Karatzas, 2013). GABA is subsequently exported from the cell via antiporters that import glutamate, or it remains in the cells and is metabolized to succinate via the GABA shunt pathway (Feehily & Karatzas, 2013; Karatzas, Brennan, Heavin, Morrissey, & O'Byrne, 2010). Glutamate/GABA antiporters are found in numerous Gram-negative (*Escherichia*, *Shigella*, *Brucella*) and Gram-positive genera (*Listeria*, *Lactobacillus*, *Lactococcus*, *Clostridium*, *Bifidobacterium*) (Feehily & Karatzas, 2013). An *in vivo* study in mice also revealed that chronic administration of *Lactobacillus rhamnosus* (JB-1) induced changes in mRNA of GABA receptors B1b and A2, as well as reduced anxiety- and depression-related behavior (Bravo et al., 2011), although the direct production of GABA by gut bacteria was not investigated. *In vivo* studies are required to evaluate whether gut microbiota derived GABA is active on the host.

Serotonin, a neurotransmitter involved in numerous processes including behavior, learning, appetite and glucose homeostasis, is produced in the human brain but also notably in intestinal enteroendocrine cells (El-Merahbi, Loffler, Mayer, & Sumara, 2015). The key role of serotonin in the gut-brain axis has been extensively reviewed, indicating that peripherally it is involved in modulation of the gut immune system, gastrointestinal secretions, motility and visceral sensitivity and centrally in mood and cognition (O'Mahony, Clarke, Borre, Dinan, & Cryan, 2015). In humans, serotonin is produced from tryptophan degradation in a two-step process via the enzymes tryptophan 5-monoxygenase (tryptophan hydroxylase 1) and aromatic-L-amino-acid decarboxylase (Table 1). It has been experimentally demonstrated *in vitro* that serotonin can also be produced by several bacterial genera isolated from the human gut, including *Streptococcus*, *Escherichia*, *Enterococcus*, *Lactococcus* and *Lactobacillus* (Wall et al., 2014). However, the full mechanism of direct serotonin production by bacteria has not been clearly established. Analysis of the serotonin biosynthetic pathway in bacteria via the KEGG database reveals that several bacterial genera contain homologous genes for encoding aromatic-L-amino-acid decarboxylase (Table 1) used in the second step of this pathway (Kanehisa et al., 2014), but no homologous genes have presently been found for tryptophan 5-monoxygenase. Bacteria can also directly interact with the host to induce the production of serotonin by the host, with experimentally demonstrated effects on host physiology (Yano et al., 2015). A comparison between germ-free mice and colonized mice (with either mouse or human gut microbiota) has shown that the microbiota increased colonic expression of tryptophan hydroxylase 1, the rate limiting enzyme for mucosal serotonin synthesis, and thereby serotonin production, likely acting through SCFAs (Reigstad et al., 2015).

Histamine and its receptors were first described as part of the immune and gastrointestinal systems, but their presence in the central nervous system and implication in behavior and energy homeostasis is gaining increasing attention (Baronio et al., 2014). Production of histamine from the decarboxylation of the amino acid histidine has been well demonstrated in numerous Gram-positive and Gram-negative bacterial strains (Landete, De las Rivas, Marcolal, & Munoz, 2008). Gram-positive bacteria, such as

Table 1

Gut microbiota-produced metabolites from amino acid catabolism that have potential effects on host physiology and health. Genetic pathways for each metabolite are described along with enzymes and respective genes for each step in metabolic pathways. Gene names identified in the bacterium *E. coli* are highlighted in bold. Gene names include orthologous and paralogous gene groups among different bacterial taxa. All gene names are compiled from the KEGG database except where noted. Amino acid abbreviations refer to glutamate (Glu); tryptophan (Tryp); histidine (His); tyrosine (Tyr); arginine (Arg); phenylalanine (Phe); cysteine (Cys); methionine (Met); lysine (Lys).

Metabolite	Amino acid	Step	Substrate(s)	Product(s)	Enzyme (enzyme commission number)	Gene(s)
Neuroactive compounds						
GABA	Glut	1	L-Glutamate	γ -Aminobutanoate, CO ₂	Glutamate decarboxylase (4.1.1.15)	gadA, gadB
Serotonin (5-hydroxytryptamine)	Tryp	1	L-Tryptophan, Tetrahydrobiopterin, O ₂	5-Hydroxy-L-tryptophan, Dihydrobiopterin, H ₂ O	Tryptophan 5-monooxygenase (1.14.16.4)	No genes found in prokaryotes
		2	5-Hydroxy-L-tryptophan	Serotonin, CO ₂	Aromatic-L-amino-acid decarboxylase (4.1.1.28)	<i>ddc, dcd, dcd1</i>
Histamine (pathway 1)	His	1	L-Histidine	Histamine, CO ₂	Histidine decarboxylase (4.1.1.22)	<i>hdc, hdcA, angH, pmsA, basG, dchS, vlmD</i>
Histamine (pathway 2)	His	1	L-Histidine	Histamine, CO ₂	Aromatic-L-amino-acid decarboxylase (4.1.1.28)	<i>ddc, dcd1</i>
L-DOPA	Tyr	1	L-Tyrosine, O ₂	3,4-Dihydroxy-L-phenylalanine, (DOPA), H ₂ O	Tyrosinase (1.14.18.1)	<i>melO, melC1, melC2</i>
		2	2 N(ω)-Hydroxyarginine, NADH, H ⁺ , O ₂	2 Nitric oxide, 2 L-Citrulline, NAD ⁺ , 2 H ₂ O	Nitric-oxide synthase (1.14.13.165)	<i>nos, nosA, yfIM, rplB, sdaAB, txtD</i>
Tyramine (pathway 1)	Tyr	1	L-Tyrosine	Tyramine, CO ₂	Tyrosine decarboxylase (4.1.1.25)	<i>tyrDC, tdcA, mfmA, mfmA, gadD, gadB</i>
Tyramine (pathway 2)	Tyr	1	L-Tyrosine	Tyramine, CO ₂	Aromatic-L-amino-acid decarboxylase (4.1.1.28)	<i>ddc, dcd, dcd1</i>
Nitric Oxide	Arg	1	L-Arginine, NADH (or NADPH), H ⁺ , O ₂	N(ω)-Hydroxyarginine, NAD ⁺ (or NADP ⁺), H ₂ O	Nitric-oxide synthase (1.14.13.165)	<i>nos, nosA, yfIM, rplB, sdaAB, txtD</i>
Tryptamine	Tryp	1	L-Tryptophan	Tryptamine, CO ₂	Aromatic-L-amino-acid decarboxylase (4.1.1.28)	<i>dcd, dcd1, ddc</i>
Phenylethylamine	Phe	1	L-Phenylalanine	Phenethylamine, CO ₂	Aromatic-L-amino-acid decarboxylase (4.1.1.28)	<i>dcd, dcd1, ddc, tyrDC</i>
Sulfide-containing metabolites						
H ₂ S (pathway 1)	Cys	1	L-Cysteine, H ₂ O	H ₂ S, Pyruvate, Ammonia	Cysteine desulfhydrase (4.4.1.1)	<i>cysA, metB, metC, yrhB, mccb, metC, metB, malY, patB</i>
H ₂ S (pathway 2)	Cys	1	L-Cysteine, H ₂ O	H ₂ S, Pyruvate, Ammonia	Cystathionine beta-lyase (4.4.1.8)	<i>metC, metB, malY, patB</i>
Methanethiol	Met	1	L-Methionine, H ₂ O	Methanethiol, Ammonia, 2-Oxobutanoate	Methionine-gamma-lyase (4.4.1.11)	<i>mdeA, megL, metB, metZ</i>
Aromatic compounds						
Phenol	Tyr	1	L-Tyrosine, H ₂ O	Phenol, Pyruvate, Ammonia	Tyrosine phenol-lyase (4.1.99.2)	<i>tpl</i>
<i>p</i> -cresol	Tyr	1	L-Tyrosine	unknown	unknown	Pathway unknown (Dawson et al., 2011)
		2	unknown	unknown	unknown	
		3	4-hydroxyphenylacetate, H ⁺	4-methylphenol (<i>p</i> -cresol), CO ₂	4-hydroxyphenylacetate decarboxylase (4.1.1.83)	<i>hpdB, hpdC, hpdA</i> (Yu et al., 2006)
Indole	Tryp	1	L-Tryptophan, H ₂ O	Indole, Pyruvate, Ammonia	Tryptophanase (4.1.99.1)	tnaA
Polyamines						
Agmatine	Arg	1	L-Arginine	Agmatine, CO ₂	Arginine decarboxylase (4.1.1.19)	speA, adiA, cad, pdad, aaxB
Putrescine (pathway 1)	Arg	1	L-Arginine	Agmatine, CO ₂	Arginine decarboxylase (4.1.1.19)	speA, adiA, cad, pdad, aaxB
		2	Agmatine, H ₂ O	Putrescine, Urea	Agmatinase (3.5.3.11)	speB, speB1, speB2, pah, gbh
Putrescine (pathway 2)	Arg	1	L-Arginine	Agmatine, CO ₂	Arginine decarboxylase (4.1.1.19)	speA, adiA, cad, pdad, aaxB
		2	Agmatine, H ₂ O	N-Carbamoylputrescine, Ammonia	Agmatine deiminase (3.5.3.12)	<i>aguA, aguA1, aguA2</i>
		3	N-Carbamoylputrescine, H ₂ O	Putrescine, CO ₂ , Ammonia	N-carbamoylputrescine amidase (3.5.1.53)	<i>aguB</i>
Putrescine (pathway 3)	Arg	1	L-Arginine, H ₂ O	L-Ornithine, Urea	Arginase (3.5.3.1)	<i>rocF</i>
		2	L-Ornithine	Putrescine, CO ₂	Ornithine decarboxylase (4.1.1.17)	speC, speF
Spermidine (pathway 1)	Arg	1	S-Adenosylmethioninamine, putrescine	5'-Methylthioadenosine, Spermidine	Spermidine synthase (2.5.1.16)	speE
Spermidine (pathway 2)	Arg	1	L-aspartate 4-semialdehyde, putrescine, NADPH, H ⁺	Carboxyspermidine, H ₂ O, NADP ⁺	Carboxynorspermidine synthase (1.5.1.43)	<i>cansdh</i>
		2	Carboxyspermidine	Spermidine, CO ₂	Carboxynorspermidine decarboxylase (4.1.1.96)	<i>nspC, cansdc</i>
Spermine	Arg	1	S-Adenosylmethioninamine, Spermidine	5'-Methylthioadenosine, Spermine	Spermine synthase (2.5.1.22)	SMS (not found in prokaryotes)
Cadaverine	Lys	1	L-Lysine	Cadaverine, CO ₂	Lysine decarboxylase (4.1.1.18)	ldcC, cadA, speA, cad

lactic acid bacteria, use a pyruvoyl-dependent histidine decarboxylase (EC 4.1.1.22) (Table 1), whereas Gram-negative bacteria use a

pyridoxal phosphate-dependent histidine decarboxylase (Landete, De las Rivas, et al., 2008). In *Lactobacillus* spp. histamine is readily

exported from the cell using electrogenic histidine/histamine antiporters (Molenaar, Bosscher, ten Brink, Driessen, & Konings, 1993). Bacterial histamine production can exert both positive and negative effects on human health. Recently, Thomas et al. (2012) demonstrated that histamine derived from a human gut isolate of the species *Lactobacillus reuteri* suppresses pro-inflammatory TNF- α production in isolated Toll-like receptor 2-activated human monocytoïd cells, indicating a potential beneficial effect of microbially-derived compounds for inflammatory conditions. However, histamine production by bacteria has also been implicated in food poisoning related to the ingestion of fish fermented by histamine-producing bacteria (scombrototoxin) (Bjornsdottir-Butler, Green, Bolton, & McClellan-Green, 2015).

Tyrosine is a precursor for several hormones including the thyroid hormones thyroxine (3,5,3',5'-tetraiodothyronine) and triiodothyronine, as well as a precursor to L-dihydroxyphenylalanine (L-DOPA) which is in itself a precursor to the catecholamine neurotransmitters dopamine, norepinephrine and epinephrine. Bacterial tyrosinases (EC 1.14.18.1) (Table 1), which catalyze the conversion of tyrosine to L-DOPA, are widely found in many bacterial genera (Claus & Decker, 2006). Although *Escherichia* spp. and *Bacillus* spp. have been reported to produce norepinephrine (Wall et al., 2014), enzymes necessary for production of the catecholamines norepinephrine and epinephrine have only been identified to date in animals, suggesting some mode of cooperation between host and gut microbes in the catecholamine biosynthetic process. However, catecholamine stress hormones have been demonstrated to promote both bacterial growth and virulence (Freestone, 2013). Some opportunistic pathogens inhabiting the intestinal tract (*Escherichia coli*, *Staphylococcus aureus*, etc.) are equipped with catechol siderophore uptake systems that facilitate the import Fe(III)-catecholamine complexes and, thereby, their growth under iron-restricted conditions (Beasley, Marolda, Cheung, Buac, & Heinrichs, 2011).

Tyramine is a biogenic amine capable of causing food poisoning if consumed at high levels and is involved in hypertension and migraine syndromes (Marcobal, De las Rivas, Landete, Tabera, & Munoz, 2012; Millichap & Yee, 2003). Tyramine is produced by the decarboxylation of tyrosine by the bacterial enzyme tyrosine decarboxylase (Table 1), which has been identified in Gram-positive bacteria such as lactic acid bacteria, but putative tyrosine decarboxylases in Gram-negative bacteria remain to be characterized (Marcobal et al., 2012). Tyramine is exported from bacterial cells via a tyrosine-tyramine antiporter (Linares, Fernandez, Martin, & Alvarez, 2009). In Gram-positive bacteria, high concentrations of tyrosine and acidic pH conditions have been demonstrated to increase the transcription of tyrosine decarboxylase and the tyrosine-tyramine antiporter (Linares et al., 2009; Marcobal et al., 2012). Gut microbiota-derived tyramine has been shown to increase circulating serotonin levels by elevating its synthesis by enteroendocrine cells (Yano et al., 2015) although this mechanism has not been defined.

Nitric oxide (NO) is produced from the amino acid arginine by many bacterial species via the enzyme nitric oxide synthase (NOS) (Table 1), although only several bacterial homologs of mammalian NOSs have been identified to date (Sudhamsu & Crane, 2009). Little is known about the extent that microbially-produced NO impacts the human host, notably at the intestinal mucosa level, although it is known that NO is involved in immune defense mechanisms and exerts cytotoxic effects at high concentrations.

Tryptamine is a β -arylamine neurotransmitter that has numerous biological roles including a ligand for the sigma-2 receptor, a trace amine-associated receptor that increases the inhibitory responses of cells to serotonin, and an inducer of serotonin release from enteroendocrine cells which can modulate

gastrointestinal motility and may play a role in the pathology of inflammatory bowel diseases (Williams et al., 2014 and references therein). Recently it was demonstrated that tryptamine is produced by *Clostridium sporogenes* by the decarboxylation of tryptophan via a Trp decarboxylase (Table 1) (Williams et al., 2014). Williams et al. (2014) also used a phylogeny-informed screening of other decarboxylases from the gut microbiota to show that a second Trp decarboxylase appears in the Firmicute *Ruminococcus gnavus*, and similar enzymes were found in at least 10% of the human population.

Phenethylamine is a trace amine that acts as a neurotransmitter and, depending on the concentrations, is associated with specific psychological disorders (Irsfeld, Spadafore, & Pruss, 2013) and can affect satiety and mood (Pessione, 2012). Phenethylamine is produced in bacteria by the decarboxylation of phenylalanine (Diaz, Ferrandez, Prieto, & Garcia, 2001) via the enzyme aromatic-L-amino-acid decarboxylase (Table 1). Potential physiological effects of microbially-derived phenethylamine on host health have yet to be elucidated.

4.2. Short- and branched-chain fatty acids

The main short-chain fatty acids (SCFAs) produced in the large intestine by the mammalian gut microbiota are acetate, butyrate and propionate (Rechkemmer, Ronnau, & von Engelhardt, 1988). Although it is well known that dietary substrates for SCFA production are mainly fibers and resistant starches (Laparra & Sanz, 2010), isolated colonic bacteria growing *in vitro* on proteins as the only available carbon source have been demonstrated to produce SCFAs as well as branched-chain fatty acids (BCFAs) (Neis et al., 2015). Bacterial fermentation of glycine, alanine, threonine, glutamate, lysine and aspartate can produce acetate; threonine, glutamate and lysine can produce butyrate, and alanine and threonine can produce propionate (Davila et al., 2013). Nonetheless, the molecular pathways involved in production of these SCFAs from amino acids are not well-defined.

Branched-chain fatty acids (BCFAs), namely isobutyrate, 2-methylbutyrate and isovalerate, are derived from branched-chain amino acids and are present at much lower concentrations in the large intestine luminal content (Liu et al., 2014). Although a full description of bacterial synthesis of BCFA from amino acids is beyond the scope of this article, many Gram-positive bacteria use the primers isovaleryl-CoA, isobutyryl-CoA, and 2-methylbutyryl-CoA derived from valine, isoleucine, and leucine to produce BCFA using a specialized branched-chain-keto acid dehydrogenase complex (Cronan & Thomas, 2009). The relative proportions of SCFAs and BCFAs depend on numerous factors including the type of protein degraded as well as the available concentrations of carbohydrates (Macfarlane & Macfarlane, 2012).

The SCFAs acetate, propionate and butyrate produced via bacterial fermentation of carbohydrates and/or amino acids have been proposed to exert various physiological effects, which have been recently reviewed (Hamer et al., 2008). Briefly, for instance, butyrate provides energy to colonocytes and regulates cell proliferation and differentiation as well as the transcription of numerous genes involved in mucin production and hormone secretion (i.e. PYY, GLP-1, GLP-2) that influence gut integrity and transit, appetite and glucose metabolism (Daly, Cuff, Fung, & Shirazi-Beechey, 2005). Butyrate also plays an anti-inflammatory role via different mechanisms, including inhibition of LPS-mediated inflammatory cytokine secretion by intestinal epithelial cells and other immune cells and via induction of colonic regulatory T cells partly by an epigenetic modification of the forkhead box-P3 promoter (Furusawa et al., 2013). Propionate and acetate undergo partial oxidation in colonocytes or can travel to the liver via the portal vein where they

serve as substrates for gluconeogenesis and lipogenesis (Tremaroli & Backhed, 2012). Acetate is also a substrate for cholesterol synthesis, whereas propionate can decrease cholesterol synthesis (Demigne et al., 1995). In addition, SCFAs are ligands for G protein-coupled receptors, namely Gpr41 and Gpr43, which are expressed in enteroendocrine L-cells of the distal small intestine and colon (Reigstad et al., 2015). Gpr41 deficiency has been shown to be associated with reduced expression of peptide YY (PYY), a gut hormone involved in satiety and gut motility (Samuel et al., 2008). Direct administration of SCFAs in the colon increase PYY plasma level, and *in vitro* administration on primary colonic crypts also increase the release of PYY, suggesting a direct effect of SCFA on secretion (Chambers et al., 2015; Cherbut et al., 1998). Butyrate can also bind the GPR109a receptor expressed by intestinal macrophages and dendritic cells, thus activating production of the anti-inflammatory cytokine IL-10 (Pabst & Bernhardt, 2010). BCFAs have also been shown to regulate electrolyte absorption and secretion (Musch, Bookstein, Xie, Sellin, & Chang, 2001). It has been proposed that SCFAs could exert effects beyond the gut via their interactions with Gpr expressed in different tissues and cellular types (e.g. adipocytes, pancreatic cells, neuronal cells) and thereby regulate metabolism by inducing energy expenditure and mitochondrial function (Gao et al., 2009). Whether these effects could be mediated by the SCFAs generated by the gut microbiota requires further investigation.

4.3. Sulfur-containing bacterial metabolites

Fecal S-containing substances are a complex mixture of bacterial metabolites including methanethiol and the well-studied H₂S, which is found at millimolar concentrations in the human colonic luminal contents and in feces (Macfarlane et al., 1992). In addition to production of H₂S via reduction of inorganic sulfate by intestinal sulfate reducing bacteria or microbial catabolism of intestinal sulfomucins, sulfide is produced by intestinal microbiota activity through fermentation of several S-containing amino acids of both dietary and endogenous origins (Blachier et al., 2010). H₂S is notably produced as a byproduct by the bacterial fermentation of cysteine via cysteine desulfhydrases, cystathione-B-lyase and tryptophanase (Table 1) (Awano, Wada, Mori, Nakamori, & Takagi, 2005). Fermentation of methionine yields the sulfur-containing compound methanethiol (Davila et al., 2013). Due to its lipophilic activity, H₂S penetrates biological membranes (Reiffenstein, Hulbert, & Roth, 1992) and, when present in excess, inhibits mitochondrial cytochrome c oxidase activity reversibly with a binding constant similar to cyanide (Leschelle et al., 2005). At lower concentrations, H₂S is able to increase cellular respiration and ATP production by means of the mitochondrial sulfide-oxidizing unit (Bouillaud & Blachier, 2011). Although several lines of evidence suggest that excessive concentrations of sulfide in the intestinal luminal content may be implicated in the etiology of ulcerative colitis (Pitcher & Cummings, 1996) and in the risk of relapse after an inflammatory episode (Jowett et al., 2004), there is also evidence that endogenously-formed low levels of H₂S in intestinal mucosa may participate in the resolution of mucosal inflammation (Flannigan et al., 2015). Experiments from colonocyte incubation and intra-colonic instillation with millimolar concentrations of NaHS, used as a H₂S donor, indicate that H₂S reversibly inhibits colonocyte oxygen consumption and increases the expression of hypoxia-inducible factor 1 alpha (HIF-1alpha) together with several inflammation-related genes, namely inducible nitric oxide synthase (iNOS) and interleukin 6 (IL-6) (Beaumont et al., 2016). Importantly, it has been demonstrated that endogenously produced H₂S maintains colon cancer cellular bioenergetics supporting colonic tumor growth (Szabo et al., 2013).

4.4. Aromatic compounds

In addition to neuroactive compounds, the catabolism of aromatic amino acids (phenylalanine, tyrosine and tryptophan) by the microbiota also produces phenolic and indolic compounds (Nyangale, Mottram, & Gibson, 2012). Recent support for a role of gut microbiota in the production of various aromatic amino acid metabolites has recently been demonstrated by comparing metabolites between specific pathogen-free (SPF) mice and germ-free (GF) mice (Sridharan et al., 2014). However, bacterial metabolism of aromatic compounds largely depends on the type of carbon availability, as fermentable carbohydrates largely inhibit aromatic amino acid fermentation (Smith & Macfarlane, 1996).

Phenol is produced from the conversion of tyrosine via the enzyme tyrosine phenol-lyase (Table 1). Optimal conditions for production of phenol by anaerobic bacteria in the human large intestine include a near-neutral pH of 6.8 and availability of free amino acids as opposed to peptides (Smith & Macfarlane, 1997). The types of intestinal bacteria may also play a significant role in production of phenol as aerobic bacteria tended to produce phenol from tyrosine degradation *in vitro* while anaerobic bacteria produced *p*-cresol (Bone, Tamm, & Hill, 1976). Phenol has been shown to decrease the integrity of the barrier function of colonocytes *in vitro* (Hughes, Kurth, McGilligan, McGlynn, & Rowland, 2008) and impaired the viability of human colonic epithelial cells at concentrations higher than 1.25 mM (Pedersen, Brynskov, & Saermark, 2002).

Formation of *p*-cresol (or 4-methylphenol) by microbes begins with the two-step conversion of tyrosine to 4-hydroxyphenylacetate (Meyer & Hostetter, 2012), although the genes involved in this conversion are unknown (Table 1) (Dawson et al., 2011). In the final step, the bacterium *Clostridium difficile* uses the enzyme *p*-hydroxyphenylacetate decarboxylase (genes *hpdB*, *hpaC*, *hpdA*) to convert 4-hydroxyphenylacetate to *p*-cresol (Selmer & Andrei, 2001; Yu, Blaser, Andrei, Pierik, & Selmer, 2006). The *hpdBCA* operon is rarely found in gut microflora other than *Clostridium* spp. (Dawson et al., 2011), and therefore it is unknown to what extent, if any, other gut genera play a role in *p*-cresol formation. Production of *p*-cresol is stimulated by Fe(III) and competitive growth conditions in *Clostridium* spp. (Doerner, Mason, Kridelbaugh, & Loughrin, 2009; Selmer & Andrei, 2001). The *p*-cresol concentration in human feces averages approximately 0.4 mM (Gostner et al., 2006; Lecerf et al., 2012). These compounds are absorbed from the intestinal lumen to the portal bloodstream through colonocytes, metabolized in the liver and finally excreted by the kidneys with more than 90% of urinary phenolic compounds being recovered as *p*-cresol (Hughes, Magee, & Bingham, 2000). At millimolar concentrations, *p*-cresol inhibits human colonocyte proliferation and cell respiration and increases superoxide production (Andriamihaja et al., 2015). Most importantly, in this latter study, *p*-cresol was found to be genotoxic towards human colonocytes. *p*-cresol can be conjugated in the colonic epithelium and in the liver, generating *p*-glucuronide and cresyl sulfate (Evenepoel, Meijers, Bammens, & Verbeke, 2009). Phenolic compound sulphation has been shown to be impaired in the mucosa of ulcerative colitis patients (Ramakrishna, Roberts-Thomson, Pannall, & Røediger, 1991). Interestingly, *p*-cresyl sulfate promotes insulin resistance in chronic kidney disease (CKD) patients (Koppe et al., 2013) and is found at elevated concentrations in the urine of autism patients (Heinken & Thiele, 2015). It can also cause damage in renal tubular cells by induction of oxidative stress through activation of NADPH oxidase (Watanabe et al., 2013).

Indole is produced from tryptophan via the enzyme tryptophanase (Table 1), which is found only in microbes (Meyer & Hostetter, 2012). After absorption through the intestinal

epithelium, indole is transported to the liver where it undergoes hydroxylation by the host to 3-hydroxy-indole and finally sulfonated to indoxyl sulfate, a uremic toxin, via a sulfotransferase (Meijers & Evenepoel, 2011; Wikoff et al., 2009). In contrast, indole also has a potential beneficial effect on host intestinal epithelial cells, as treatment of human enterocytes with indole was found to result in increased expression of genes involved in the mucosal barrier functions and was associated with a reduction of inflammatory parameters (Bansal, Alaniz, Wood, & Jayaraman, 2010). Secretion of the incretin GLP-1 from enteroendocrine cells is increased during short exposures to indole via interference of voltage-gated K^+ channels, but reduced over long periods of exposure to indole via slowing ATP production by blocking NADH dehydrogenase (Chimerel et al., 2014). Besides its role in glucose metabolism through increasing insulin secretion, GLP-1 is involved in inhibiting gastric secretion and motility; these phenomena being associated with increased satiety (Steinert, Beglinger, & Langhans, 2016). The indole derivative indole-3-aldehyde was also shown to regulate gut mucosal immune response through aryl hydrocarbon receptor as well as intestinal barrier function and inflammation through its sensing by pregnane X receptor (Venkatesh et al., 2014; Zelante et al., 2013).

Serum levels of the amino acid tryptophan itself also have a demonstrated role in host health, as decreases in this amino acid have been associated with increased immune activation, inflammatory diseases such as Crohn's disease, as well as cognitive deficit (Gupta et al., 2012; Widner et al., 1999). This may be particularly detrimental in elderly populations, as increased proportions of genes from gut microbiota involved in aromatic amino acid metabolism (including tryptophan), as well as decreased levels of tryptophan have been reported in elderly patients (Collino et al., 2013; Rampelli et al., 2013).

4.5. Polyamines

Intestinal luminal polyamines (i.e. agmatine, putrescine, spermidine, cadaverine, etc.) can originate from dietary components, microbiota metabolism (Davila et al., 2013), and endogenous origin, notably released from desquamated intestinal epithelial cells. Gram-negative bacteria such as *E. coli* produce high concentrations of putrescine and spermidine in minimal media (Tabor & Tabor, 1985). Numerous amines (including polyamines) have been measured in the intestinal luminal contents at concentrations ranging from micro- to millimolar (Osborne & Seidel, 1990). Intestinal epithelial cells have the capacity to take up polyamines from the intestinal luminal contents (Blachier et al., 1992).

Agmatine is formed by the decarboxylation of the amino acid arginine via the enzyme arginine decarboxylase (Table 1). Agmatine, which is produced and released by colonic bacteria as well as by desquamated intestinal epithelial cells and ingested in food, exerts inhibitory effects on colonocyte proliferation (Mayeur et al., 2005). Putrescine can be synthesized by bacteria from the amino acid arginine either through the intermediate ornithine or through agmatine (Nakada & Itoh, 2003). Agmatine is either directly converted to putrescine via the enzyme arginine decarboxylase, or goes through a two-step process which uses the enzymes agmatine deiminase and N-carbamoylputrescine amidase (Table 1). The agmatine deiminase pathway has been found in several bacterial genera such as *Pseudomonas*, *Enterococcus*, *Bacillus* and *Lactobacillus* (Landete, Arena, Pardo, Manca de Nadra, & Ferrer, 2008). Agmatine-putrescine antiporters have been identified in bacterial genera and function by importing agmatine and exporting putrescine (Polo, Gil-Ortiz, Cantin, & Rubio, 2012). Putrescine synthesis has been shown to be strictly necessary for colonic epithelial cell proliferation (Gamet, Cazenave, Trocheris, Denis-Pouxviel, &

Murat, 1991; Mouillé, Delpal, Mayeur, & Blachier, 2003).

In many bacteria including *E. coli*, spermidine is synthesized from putrescine and decarboxylated S-adenosylmethionine (SAM) via spermidine synthase (Tabor & Tabor, 1985). Recently, bacteria lacking spermidine synthase orthologues were discovered to have an alternate pathway in which spermidine is formed by the enzymes carboxynorspermidine dehydrogenase (aka carboxynorspermidine synthase) and carboxynorspermidine decarboxylase via the intermediate carboxyspermidine (Lee et al., 2009). This alternative pathway of spermidine synthesis has been identified as the dominant pathway in the human gut microbiota as well as diverse human pathogens and is critical for growth in selected species (Hanfrey et al., 2011). In host cells, SAM can react with spermidine via another enzyme, spermine synthase, to produce spermine. Prokaryotic cells do not appear to contain spermine synthase, but they can produce a different tetra-amine compound, thermospermine, that has been detected in lower eukaryotes and plants (Minguet, Vera-Sirera, Marina, Carbonell, & Blazquez, 2008). Spermidine and spermine are polycationic amines that are involved in numerous processes such as mitigating oxidative stress, and induction of autophagy to stimulate cellular longevity (Eisenberg et al., 2009; Yamamoto et al., 2012).

The polyamine cadaverine is synthesized from lysine in a one-step reaction with lysine decarboxylase (Table 1) and has been shown to provide an acid resistance mechanism in *E. coli* (Le Gall et al., 2011). However, the effects of cadaverine on the colonic epithelial cells remain unknown.

4.6. Ammonia

Ammonia provides the source of nitrogen for all amino acids and is primarily assimilated through either glutamate dehydrogenase or the glutamine synthetase/GOGAT cycle. It is also used directly in the biosynthesis of various amino acids including glutamate, glutamine, asparagine, valine, isoleucine, leucine, phenylalanine, tyrosine and tryptophan (Figs. 1–4). Ammonia can be produced by the microbial degradation of numerous amino acids to specific metabolites (i.e. arginine to putrescine, tyrosine to phenol, tryptophan to indole, Table 1). Ammonia (taken as the sum of NH_3 and NH_4^+) is found at millimolar concentrations in the large intestine luminal content of mammals including humans (Mouillé, Robert, & Blachier, 2004). In humans, the luminal ammonia concentration progressively increases from the ascending to the descending colon (Macfarlane et al., 1992), in accordance with a higher rate of protein fermentation in the distal colon. The luminal ammonia concentration in the large intestine is primarily the net result of microbiota utilization and production through amino acid deamination, urea hydrolysis, and absorption from the luminal content to the portal blood, with the unabsorbed/unmetabolized ammonia being excreted in feces (Eklou-Lawson et al., 2009). Although relatively large amounts of ammonia can be transferred from the intestinal lumen to the bloodstream, a part of this ammonia can be metabolized by colonocytes into citrulline and glutamine (Eklou-Lawson et al., 2009; Mouillé et al., 2004), allowing control of the intracellular ammonia concentration in colonocytes during its transfer from the luminal content to the portal bloodstream. Ammonia inhibits mitochondrial oxygen consumption in a dose-dependent manner, leading to the concept that excessive luminal ammonia concentration behaves as a metabolic troublemaker towards colonocyte energy metabolism (Andriamihaja et al., 2010). Accordingly, high millimolar concentrations of ammonia have been shown to markedly inhibit short-chain fatty acid oxidation in isolated colonocytes (Cremin, Fitch, & Fleming, 2003).

5. Gut microbiome features related to amino acid metabolism as a function of the subject's metabolic phenotype and diet

Recent metagenomic studies have allowed a detailed examination of the metabolic capacity of the mammalian gut microbiome in metabolizing nitrogenous components, particularly amino acid-related compounds. An important insight from these studies revealed that the gut microbiome contains a large enrichment of genes involved in amino acid metabolism compared to the human genome (Gill et al., 2006), thus expanding the human metabolic capacity to form a more diverse number of metabolites. In particular, the human microbiome had large enrichments of genes involved in the biosynthesis of lysine, phenylalanine, tyrosine, tryptophan, valine, leucine and isoleucine as well as enrichment in genes associated with the metabolism of alanine, aspartate, glutamate, histidine, methionine, glycine, serine, threonine and the urea cycle, with only slight to moderate enrichments of genes for the metabolism of other amino acids and non-protein amino acids (Gill et al., 2006). Qin et al. (2010) also found an enrichment of genes involved in pathways such as the biosynthesis of lysine, phenylalanine, tyrosine, tryptophan, valine, leucine and isoleucine in the human gut microbiome compared to the host genome. Since biosynthetic pathways for essential amino acids do not exist in humans, it is not surprising that gut microbiota has developed a specialized set of genes and metabolic pathways for synthesizing these essential nutrients to ensure its survival.

Metagenomic sequencing analysis has shown that the metabolic phenotype (obese versus lean subjects) and the diet (e.g. high-fat diets, prebiotic intake, etc.) are associated with shifts in both specific microbiota taxonomic groups and functions of the mammalian gut microbiome, such as those involved in the metabolism of amino acids. Recent studies comparing the short-term effects of animal- and plant-based diets on the human gut microbiota and expression of metabolic-related genes using RNA-Seq revealed an increased expression of several catabolic amino acid genes for glutamine and glutamate in animal-based diets, while increased expression of biosynthetic pathways for these amino acids was observed for plant diets (David et al., 2014). David et al. (2014) also found that KEGG modules and pathways involved in methionine and leucine biosynthesis and cysteine metabolism were significantly associated with animal diets, while histidine biosynthesis and lysine and branched-chain amino acid degradation were significantly associated with plant diets.

In studies in rodents, Turnbaugh et al. (2006) found that KEGG pathways related to lysine biosynthesis and D-alanine metabolism were significantly enriched in the pooled cecal microbiome of *ob/ob* obese mice relative to the pooled lean cecal microbiome, while the KEGG pathways involved in the metabolism of glutamate, glycine, serine, threonine, cysteine, arginine and proline and the biosynthesis of phenylalanine, tyrosine and tryptophan were depleted in the *ob/ob* mouse microbiome relative to the lean one. Comparison of obese/lean sibling pairs of mice revealed that KEGG pathways involved in phenylalanine, tyrosine and tryptophan biosynthesis were also depleted in the cecal microbiomes of the obese mice (Turnbaugh et al., 2006). Furthermore, using fecal samples from obese and lean human twin pairs, Turnbaugh et al. (2009) revealed a depletion of the KEGG pathway involved in tryptophan metabolism in obese twins compared to their lean counterparts. Recent studies by Everard et al. (2014) revealed that the clusters of orthologous group (COG) for amino acid transport and metabolism was enriched in both high-fat diet-fed (HFD) mice and HFD-fed mice treated with the prebiotic oligofructose (HFD-Pre) compared to controls with and without prebiotic treatment, with the HFD-Pre mice yielding the highest enrichment of all groups.

Nevertheless, the physiological meaning of those changes in gut microbiome amino acid metabolic pathways associated with genetically (*ob/ob*) or diet-induced (HFD) obesity remains unknown. Furthermore, to our knowledge there have not been detailed metagenomic studies examining the effect of a high-protein (HP) diet in either murine models or humans.

Recent metabolomic studies have provided further evidence of the role of gut microbiota in amino acid metabolism. Zheng et al. (2011) compared metabolites produced by the host (rat) and microbiota during antibiotic administration and also after a 14-day recovery period and showed that the recovered mammalian gut microbiota alters the host's systemic metabolism in terms of production of short chain fatty acids, tryptophan and tyrosine and possibly indole-melatonin. Metabolomic analyses have also recently suggested that individual amino acids may play key roles in diet-related diseases. For example, high concentrations of branched-chain amino acids (BCAA) and their respective metabolites have been linked with obesity and type 2 diabetes, while aromatic amino acids and high ratios of glutamate/glutamine have also been associated with type 2 diabetes (reviewed in Heinken & Thiele, 2015). Although the association of BCAA and other amino acids with insulin resistance and type 2 diabetes has been well-known for decades, Newgard et al. (2009) recently performed metabolomic profiling of obese and lean humans to show that the addition of branched-chain amino acids (valine, leucine, isoleucine) and two aromatic acids (phenylalanine and tyrosine) to a high-fat diet contributes to the development of obesity-associated insulin resistance. Wang et al. (2011) also carried out metabolic profiling to investigate whether specific metabolites could predict diabetes development and discovered that the same five branched-chain and aromatic acids were strongly associated with the onset of diabetes, thus suggesting a potential role of amino acid metabolism in the pathogenesis of diet-related diabetes. Although the direct role of the gut microbiota in production of these amino acids has not yet been clearly defined *in vivo*, theoretically the gut bacteria have the capacity to synthesize all of these essential amino acids and, thereby, play a role in those conditions. However, more work is needed to elucidate this connection.

In the case of increased dietary protein intake, the amount of undigested protein that is transferred to the large intestine markedly increases (Chacko & Cummings, 1988). Consequently, more substrate is available for bacterial amino acid catabolism. However, the consequences of this increased availability is not well described at a metabolic level as only a few studies have only partially examined microbial-derived metabolite profiles in HP diets by a non-targeted analytical approach in which all potential metabolites are analyzed. Russell et al. (2011) demonstrated that HP diets with low and moderate carbohydrate intake in humans displayed increased branched-chain fatty acids, phenylacetic acid and N-nitroso compounds compared to a weight-maintenance diet with moderate protein levels at the beginning of the intervention study. Reduced proportions of butyrate and antioxidant phenolic acids were also detected in the HP low-carbohydrate diets (Russell et al., 2011) likely as a result of the low carbohydrate intake. Those changes in fecal metabolic profiles were associated with a decrease in proportions of the known butyrate-producing bacteria *Roseburia/Eubacterium rectale* (Russell et al., 2011). Other studies in humans found that H₂S fecal concentration was increased in humans fed a meat-rich diet (Magee, Richardson, Hughes, & Cummings, 2000), and increased levels of phenol, *p*-cresol and phenylacetate have been detected in urine and feces of individuals receiving HP diets (Cummings et al., 1979; Geypens et al., 1997; Russell et al., 2011). Increasing the amount of alimentary protein also results in an increase of the luminal and fecal ammonia concentration in humans (Geypens et al., 1997). HP diets in humans

also caused elevations in plasma levels and urinary excretion of indoxyl sulfate and urinary excretion of indoxyl glucuronide, kynurenic acid and quinolinic acid (Poesen et al., 2015). Although several of these compounds are strictly produced only by gut microbiota, no study has effectively examined the direct role of the gut microbiota in the production of these metabolites.

In murine models, HP diets have been shown to modify the composition and the diversity of the colonic microbiota in rats, with associated changes in the total amount of ammonia, SCFAs, H₂S, branched-chain fatty acids, ethanol and several organic acids (L- and D-lactate, succinate) in the colonic luminal content (Liu et al., 2014). Although this experiment did not determine the direct role of microbiota composition and increased substrate availability in the changes observed after HP diet ingestion, it appears that both parameters are likely to be involved in such changes. A metabolomic analysis comparing a HP, low-carbohydrate (HPLC) diet to a moderate protein/carbohydrate (MPMC) diet in a rat model revealed that the HPLC diet induced weight loss and reduced adipose weight, and the plasma metabolites glucose, insulin, triglyceride, linoleate, palmitate, α -glycerophosphate and pyroglutamic acid and caused a significant increase in several plasma metabolites (i.e. urea, pyruvate, α -tocopherol, 2-oxoisocaproate, and β -hydroxybutyrate) (Mu, Yang, Luo, & Zhu, 2015). In the plasma of mice, increases in tryptophan and other aromatic acid-derived metabolites such as indole-3-acetic acid, *p*-cresyl glucuronide, phenyl sulfate and phenylacetic acid were detected in HP diets (Poesen et al., 2015). In the urinary metabolite profile, the HPLC urinary metabolite profile showed an increase in the fatty acids palmitate and stearate and a reduction of pantothenate and the TCA cycle intermediates citrate, 2-ketoglutarate and malate (Mu et al., 2015). In addition to murine models, study designs in humans still need to be refined to integrate data from complementary functional omics-technologies to progress in the understanding of the flow of metabolites between the microbiota and the host derived from dietary protein and their physiological consequences on the metabolic phenotype.

6. Impact of protein intake levels on health-related outcomes: possible contribution of gut microbiota metabolic pathways

Some of the metabolites produced by the microbiota from amino acids have been shown to be active on numerous host functions as illustrated above. These results suggest that some of the effects of HP diets on host metabolism and physiology may involve some of these metabolites and, therefore, microbiota-mediated metabolic pathways. In the following sections, the effects of high dietary protein intake observed in human and animal studies are summarized and suggest mechanisms that might implicate the gut bacteria-derived metabolites (Fig. 6).

6.1. HP diet-induced satiety

Two recent meta-analyses of clinical trials concluded that, when compared to normoproteic (NP) diet, a HP diet modestly reduces body weight, blood pressure, fat mass and triglyceride levels while sparing fat-free mass (Santesso et al., 2012; Wycherley, Moran, Clifton, Noakes, & Brinkworth, 2012). Those effects are mainly attributed to dietary protein induced satiety (Westerterp-Plantenga et al., 2009). In humans, HP diet-induced satiety is associated with an increase of PYY plasma levels (Batterham et al., 2006). Implication of gut microbiota in those mechanisms, however, has not been investigated yet. Nevertheless, SCFAs, indole, tryptamine and tyramine are compounds produced by the gut microbiota from amino acid precursors and are candidates for mediating the effects

of HP diet on enteroendocrine cell hormone secretion with an impact on satiety (Fig. 6).

6.2. HP diet effects on the intestinal mucosa

In the rat model, HP diet consumption for 15 days resulted in a marked reduction in the height of the colonocyte brush-border when compared with control animals receiving a NP/hyperglucidic isocaloric diet (Andriamihaja et al., 2010). This morphological change could be related to lower energy efficiency in HP rat colonocytes due to proton leaks in the mitochondrial inner membrane (Andriamihaja et al., 2010). A reduction of the mucosal myeloperoxidase activity (representative of neutrophil infiltration) together with a down-regulation of mucosal T_{helper} cytokines was measured in the ileum of rats receiving a HP diet (Lan et al., 2015). This decreased inflammatory status was associated with a hyperplasia of mucus-producing cells concomitant with an increased expression of Muc2 at both the gene and protein levels (Lan et al., 2015). A HP diet also induced DNA damages in rat colonocytes, in association with an increase in the bacterially-derived genotoxic metabolite *p*-cresol (Toden, Bird, Topping, & Conlon, 2005).

In an intervention study comparing volunteers receiving either HP diets or low protein isocaloric diet for two weeks, no evidence was found for a role of protein fermentation in gut toxicity in healthy human subjects despite identification of several metabolites in fecal water with presumably cytotoxic and genotoxic effects towards colonic epithelial cells (Windey et al., 2012). SCFA, H₂S, *p*-cresol and ammonia are metabolites produced from amino acids that could interfere with colonocyte energy metabolism and mucin secretion and may mediate the effects of HP diet on the intestinal mucosa. These metabolites could partly result from the activity of gut microbiota (Fig. 6). However, the consequences of a HP intake on large intestine mucosal health have never been directly investigated in humans.

6.2.1. HP diet effects in inflammatory bowel diseases

SCFAs, H₂S, indolic compounds, serotonin and histamine are all amino acid-derived bacterial metabolites which are likely to interfere with the process of mucosal inflammation due to their effects on the mucosal immune response and on the maintaining of the epithelial barrier function (Fig. 6). As reviewed by Halmos and Gibson (2015), only a few studies have examined the impact of the level of protein consumption on the risk of inflammatory bowel disease or risk of relapse in diagnosed patients. Jowett et al. (2004) reported an increased risk of relapse over 1 year in ulcerative colitis patients with the highest meat and protein consumption. A HP diet was also associated with an increased risk of incident inflammatory bowel diseases (Jantchou, Morois, Clavel-Chapelon, Boutron-Ruault, & Carbonnel, 2010), while Shoda, Matsueda, Yamato, and Umeda (1996) demonstrated that increased consumption of animal protein was related to increased incidence of Crohn's disease. However, another study did not find any association between elevated protein intake and development of ulcerative colitis (Hart et al., 2008).

6.2.2. HP diet effects in colorectal cancer

Experimental studies with animal models of chemically-induced colonic preneoplastic and neoplastic lesions have shown that dietary protein can influence the colonic carcinogenesis process, depending on their quantity and quality (McIntosh & Le Leu, 2001). The production of amino-acid derived genotoxic metabolites produced by the microbiota (e.g. *p*-cresol) could be implicated in this process. However, the complexity of the Western diet makes the identification of alimentary compounds that impact the risk of colorectal cancer a difficult task. In this context, it has been

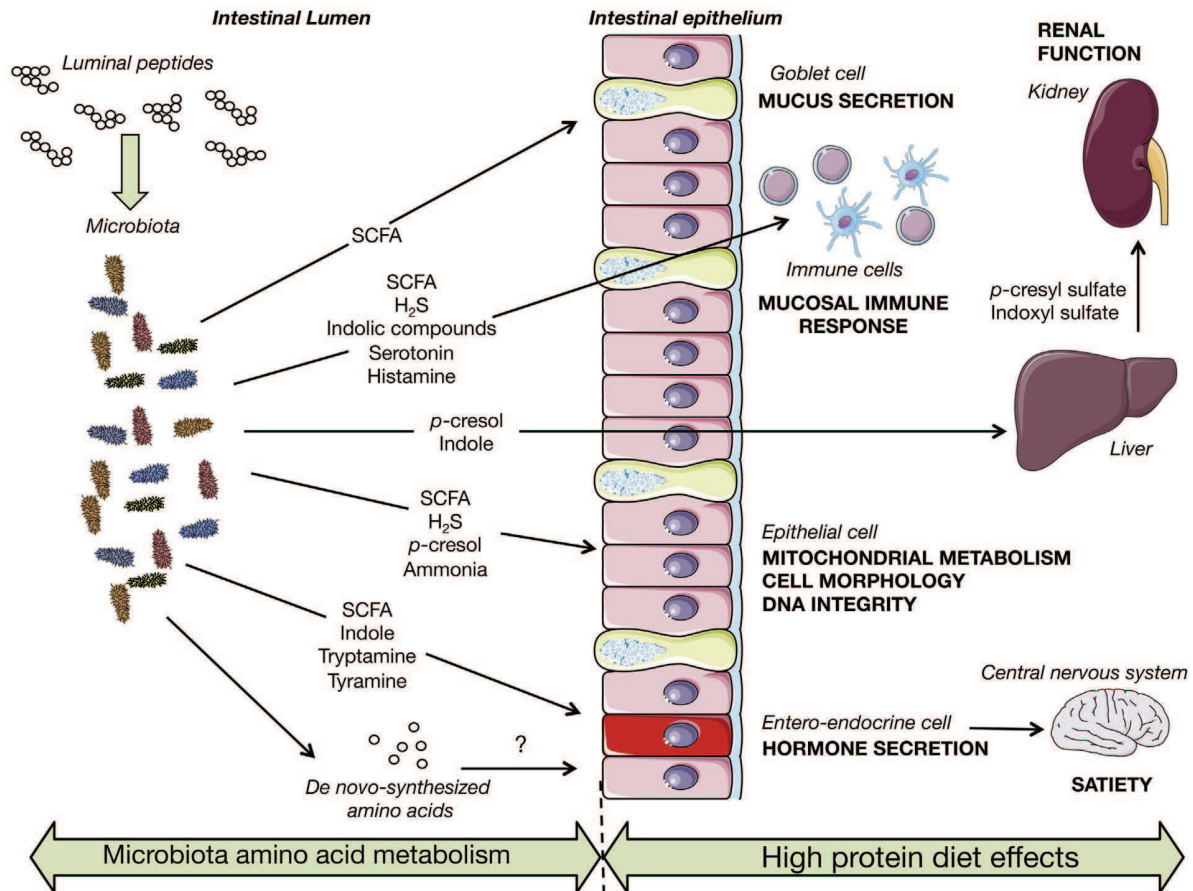

Fig. 6. High protein diet effects with potential involvement of gut microbiota metabolism. Left side: Peptides are degraded by the intestinal microbiota which release amino acid derived metabolites in the lumen. Gut bacteria can also produce amino acids. Right side: Host-functions affected by a high-protein diet demonstrated in human and animal studies (capital letters and bold). High protein diets increase the amount of protein available for fermentation by gut microbiota, which may mediate some of the effects of high protein diets on host physiology. Candidate bacterial amino acid derived metabolites for each effect of high protein diet are proposed. (Illustrations are from Servier Medical Art).

proposed that the positive association between high consumption of red and processed meat and colorectal cancer found in some epidemiological studies, may result from both the composition of meat (e.g. heme and protein) and from compounds generated by the cooking process (Kim, Coelho, & Blachier, 2013). In support of this hypothesis, a recent study has shown that hydrogen sulfide, which is produced by the gut microbiota from L-cysteine released from dietary and endogenous protein, can drive mucin denaturation and possibly increase the access of heme (a cytotoxic and genotoxic compound) to colonic epithelial cells (Ijssennagger et al., 2015).

6.3. HP diet effects on kidney function

It was concluded from a systematic review that indoxyl sulfate and *p*-cresyl sulfate are toxic for kidneys notably through reactive-oxygen species (ROS) generation (Vanholder, Schepers, Pletinck, Nagler, & Glorieux, 2014). Moreover, it has been proposed that *p*-cresol level in the blood is an indicator of CKD severity (Bammens, Evenepoel, Keuleers, Verbeke, & Vanrenterghem, 2006). Recently, it has been shown that CKD alters gut microbiota composition (Vaziri, Wong, et al., 2013) together with an increased bacterial metabolic capacity for nitrogen utilization, as evidenced by the increased abundance of urease, indole- and *p*-cresol-forming enzymes in CKD patients (Wong et al., 2014). Indeed, *p*-cresyl sulfate (or

glucuronide) and indoxyl sulfate are known conjugates of the gut microbiota-produced metabolites *p*-cresol and indole, respectively, and are elevated in the serum of chronic kidney diseases (CKD) patients (Vanholder & Glorieux, 2015). Furthermore, the elevated uremia in CKD induces an important diffusion of urea into the intestinal lumen, and it has been shown that elevated urea concentration impairs intestinal barrier function and induces inflammation in the digestive tract, most likely through excessive ammonia production by bacterial ureases (Vaziri, Yuan, & Norris, 2013), raising the view that CKD may impact gut health. Those events may play a causative role in the establishment of CKD-associated dysbiosis. Moreover, CKD patients generally have a lower fiber intake, prolonged transit time and protein malabsorption, all of which favor protein fermentation in the gut (Evenepoel et al., 2009).

Moderate protein intake (0.6–0.8 g protein/kg/day) has been demonstrated to be beneficial for CKD patients (Fouque, Pelletier, Mafra, & Chauveau, 2011). Reduced renal exposure to gut microbiota amino acid-derived metabolites through control of protein intake may contribute to better health outcomes. In healthy subjects, HP diets increase glomerular filtration rate, but the long-term consequences for kidney health remains unclear (Marckmann, Oster, Pedersen, & Jespersen, 2015). Thus, renal consequences of increased colonic protein fermentation should be further studied in healthy subjects.

6.4. Strategies to limit toxicity associated with the control of protein fermentation

Increased fermentable carbohydrate intake is one of the nutritional strategies that may help to limit adverse effects of protein fermentation, as demonstrated in an intervention study which has shown that dietary resistant starch lowers excretion of ammonia and phenols (Birkett et al., 1996). In healthy subjects, *p*-cresyl sulfate and indoxyl sulfate levels are markedly lower in vegetarians than in omnivores, likely because of a higher fiber intake and lower protein intake (Patel, Luo, Plummer, Hostetter, & Meyer, 2012). In rats, supplementation with resistant starch protects against HP diet-induced DNA damages in colonocytes in association with decreased excretion of *p*-cresol (Toden, Belobrajdic, Bird, Topping, & Conlon, 2010). Resistant carbohydrate supplementation also attenuates renal injury possibly through a decreased production of amino acid-derived metabolites by the microbiota (Vaziri et al., 2014). In CKD patients, improved disease markers (including lower *p*-cresyl sulfate) were observed after resistant starch supplementation (Vanholder & Glorieux, 2015). Unfortunately, CKD patients are advised to restrict their fruit and vegetable intake to avoid potassium overload, thus excluding one of the main fiber sources. In that context, the use of fibers may be an efficient tool to reduce protein fermentation (De Preter, Hamer, Windey, & Verbeke, 2011). This has been demonstrated in human studies with isotope-labeled biomarkers showing that fiber (lactulose) efficiently lowered ammonia and *p*-cresol production by the gut microbiota (De Preter et al., 2004).

Consumption of specific probiotic bacteria belonging to the genera *Lactobacillus* and *Bifidobacterium* has also been shown to decrease urinary *p*-cresol although to a lesser extent than with prebiotics, and with no effect on ammonia (De Preter et al., 2004; Wutzke, Lotz, & Zipprich, 2010). In CKD patients, some probiotic bacteria used to reduce the formation of gut-derived toxins have been investigated, but the level of evidence remains low (Rossi et al., 2014). Combining pre- and probiotics (known as “synbiotics”) has also been considered an attractive approach, but requires further clinical investigation (De Preter et al., 2007).

Other strategies such as elementary nutrition (free amino acid supplementation) or the use of substrates that bind deleterious compounds derived from amino-acid fermentation (e.g. zinc that binds H₂S) have been proposed to minimize their effects in medical conditions (e.g. CKD patients) (Mimoun et al., 2012), but are out of the scope of this review.

7. Conclusion and perspectives

Dietary protein metabolism is the result of the interplay between host and gut bacterial metabolic pathways but their respective roles and contributions to host physiology and metabolic health remain undefined. Several gut microbiota-derived amino acid metabolites may theoretically have both beneficial and deleterious physiological consequences on host cells and tissues, but so far their effects have only been tested individually (i.e. in unphysiological conditions). The use of global-scale omics technologies in tightly-controlled intervention studies will help to identify the specific gut microbial metabolic pathways activated in response to dietary protein and to disentangle the flow of metabolites between the host and the gut microbiota and their contribution to host physiology. Moreover, since human diets consist of a wide range of different protein sources (plant and animal) with different characteristics (digestibility, amino acid composition); these differences also need to be taken into consideration for interpretation of metadata obtained in the context of a varied diet. These future studies will represent an important and necessary step for a better

understanding of the complex interplay between diet, microbiota and host metabolism and physiology and will contribute to informing microbiome-based dietary recommendations.

Acknowledgements

This work is supported by the European Union's Seventh Framework Program under the grant agreement no 613979 (MyNewGut).

References

- Abrahams, G. L., & Abratt, V. R. (1998). The NADH-dependent glutamate dehydrogenase enzyme of *Bacteroides fragilis* Bf1 is induced by peptides in the growth medium. *Microbiology*, 144(Pt 6), 1659–1667.
- Alifano, P., Fani, R., Lio, P., Lazzano, A., Bazzicalupo, M., Carlomagno, M. S., et al. (1996). Histidine biosynthetic pathway and genes: Structure, regulation, and evolution. *Microbiological Reviews*, 60, 44–69.
- Allison, M. J., Baetz, A. L., & Wiegel, J. (1984). Alternative pathways for biosynthesis of leucine and other amino acids in *Bacteroides ruminicola* and *Bacteroides fragilis*. *Applied and Environmental Microbiology*, 48, 1111–1117.
- Andriamihaja, M., Davila, A. M., Eklou-Lawson, M., Petit, N., Delpal, S., Allek, F., et al. (2010). Colon luminal content and epithelial cell morphology are markedly modified in rats fed with a high-protein diet. *American Journal of Physiology-Gastrointestinal Liver Physiology*, 299, G1030–G1037.
- Andriamihaja, M., Lan, A., Beaumont, M., Audebert, M., Wong, X., Yamada, K., et al. (2015). The deleterious metabolic and genotoxic effects of the bacterial metabolite *p*-cresol on colonic epithelial cells. *Free Radical Biology and Medicine*, 85, 219–227.
- Awano, N., Wada, M., Mori, H., Nakamori, S., & Takagi, H. (2005). Identification and functional analysis of *Escherichia coli* cysteine desulfhydrases. *Applied and Environmental Microbiology*, 71, 4149–4152.
- Bammens, B., Evenepoel, P., Keuleers, H., Verbeke, K., & Vanrenterghem, Y. (2006). Free serum concentrations of the protein-bound retention solute *p*-cresol predict mortality in hemodialysis patients. *Kidney International*, 69, 1081–1087.
- Bansal, T., Alaniz, R. C., Wood, T. K., & Jayaraman, A. (2010). The bacterial signal indole increases epithelial-cell tight-junction resistance and attenuates indicators of inflammation. *Proceedings of the National Academy Sciences U S A*, 107, 228–233.
- Baronio, D., Gonchoroski, T., Castro, K., Zanatta, G., Gottfried, C., & Riesgo, R. (2014). Histaminergic system in brain disorders: Lessons from the translational approach and future perspectives. *Annals of General Psychiatry*, 13, 34.
- Batterham, R. L., Heffron, H., Kapoor, S., Chivers, J. E., Chandarana, K., Herzog, H., et al. (2006). Critical role for peptide YY in protein-mediated satiation and body-weight regulation. *Cell Metabolism*, 4, 223–233.
- Beasley, F. C., Marolda, C. L., Cheung, J., Buac, S., & Heinrichs, D. E. (2011). *Staphylococcus aureus* transporters Hts, Sir, and Sst capture iron liberated from human transferrin by staphyloferrin A, staphyloferrin B, and catecholamine stress hormones, respectively, and contribute to virulence. *Infection and Immunity*, 79, 2345–2355.
- Beaumont, M., Andriamihaja, M., Lan, A., Khodorova, N., Audebert, M., Blouin, J. M., et al. (2016). Detrimental effects for colonocytes of an increased exposure to luminal hydrogen sulfide: The adaptive response. *Free Radical Biology and Medicine*, 93, 155–164.
- Belitsky, B. R. (2002). Chapter 16: Biosynthesis of amino acids of the glutamate and aspartate families, alanine, and polyamines. In A. Sonenshein, R. Losick, & J. Hoch (Eds.), *Bacillus subtilis and its closest relatives*. Washington, D.C.: ASM Press.
- Berg, J. M., Tymoczko, J. L., & Stryer, L. (2002). *Biochemistry* (5th ed.). New York: W. H. Freeman.
- Birkett, A., Muir, J., Phillips, J., Jones, G., & O'Dea, K. (1996). Resistant starch lowers fecal concentrations of ammonia and phenols in humans. *The American Journal of Clinical Nutrition*, 63, 766–772.
- Bjornsdottir-Butler, K., Green, D. P., Bolton, G. E., & McClellan-Green, P. D. (2015). Control of histamine-producing bacteria and histamine formation in fish muscle by trisodium phosphate. *Journal of Food Science*, 80, M1253–M1258.
- Blachier, F., Davila, A. M., Mimoun, S., Benetti, P. H., Atanasiu, C., Andriamihaja, M., et al. (2010). Luminal sulfide and large intestine mucosa: Friend or foe? *Amino Acids*, 39, 335–347.
- Blachier, F., M'Rabet-Touil, H., Posho, L., Morel, M. T., Bernard, F., Darcy-Vrillon, B., et al. (1992). Polyamine metabolism in enterocytes isolated from newborn pigs. *Biochimica Biophysica Acta*, 1175, 21–26.
- Bolotin, A., Wincker, P., Mauger, S., Jaillon, O., Malarme, K., Weissenbach, J., et al. (2001). The complete genome sequence of the lactic acid bacterium *Lactococcus lactis* ssp. *lactis* IL1403. *Genome Research*, 11, 731–753.
- Bone, E., Tamm, A., & Hill, M. (1976). The production of urinary phenols by gut bacteria and their possible role in the causation of large bowel cancer. *The American Journal of Clinical Nutrition*, 29, 1448–1454.
- Bos, C., Juillet, B., Fouillet, H., Turlan, L., Dare, S., Luengo, C., et al. (2005). Postprandial metabolic utilization of wheat protein in humans. *The American Journal of Clinical Nutrition*, 81, 87–94.

- Bouillaud, F., & Blachier, F. (2011). Mitochondria and sulfide: A very old story of poisoning, feeding, and signaling? *Antioxidants and Redox Signaling*, *15*, 379–391.
- Bravo, J. A., Forsythe, P., Chew, M. V., Escaravage, E., Savignac, H. M., Dinan, T. G., et al. (2011). Ingestion of *Lactobacillus* strain regulates emotional behavior and central GABA receptor expression in a mouse via the vagus nerve. *Proceedings of the National Academy Sciences U S A*, *108*, 16050–16055.
- Brown, J. R., Masuchi, Y., Robb, F. T., & Doolittle, W. F. (1994). Evolutionary relationships of bacterial and archaeal glutamine synthetase genes. *Journal of Molecular Evolution*, *38*, 566–576.
- Chacko, A., & Cummings, J. H. (1988). Nitrogen losses from the human small bowel: Obligatory losses and the effect of physical form of food. *Gut*, *29*, 809–815.
- Chambers, E. S., Viardot, A., Psichas, A., Morrison, D. J., Murphy, K. G., Zaccaghese, S. E., et al. (2015). Effects of targeted delivery of propionate to the human colon on appetite regulation, body weight maintenance and adiposity in overweight adults. *Gut*, *64*, 1744–1754.
- Cherbut, C., Ferrier, L., Roze, C., Anini, Y., Blottiere, H., Lecannu, G., et al. (1998). Short-chain fatty acids modify colonic motility through nerves and polypeptide YY release in the rat. *American Journal of Physiology-Gastrointestinal and Liver Physiology*, *275*, G1415–G1422.
- Chimere, C., Emery, E., Summers, D. K., Keyser, U., Gribble, F. M., & Reimann, F. (2014). Bacterial metabolite indole modulates incretin secretion from intestinal enteroendocrine L cells. *Cell Reports*, *9*, 1202–1208.
- Claus, H., & Decker, H. (2006). Bacterial tyrosinases. *Systematic and Applied Microbiology*, *29*, 3–14.
- Collino, S., Montoliu, I., Martin, F. P., Scherer, M., Mari, D., Salvioli, S., et al. (2013). Metabolic signatures of extreme longevity in northern Italian centenarians reveal a complex remodeling of lipids, amino acids, and gut microbiota metabolism. *PLoS One*, *8*, e56564.
- Cremin, J. D., Jr., Fitch, M. D., & Fleming, S. E. (2003). Glucose alleviates ammonia-induced inhibition of short-chain fatty acid metabolism in rat colonic epithelial cells. *American Journal of Physiology-Gastrointestinal and Liver Physiology*, *285*, G105–G114.
- Cronan, J. E., & Thomas, J. (2009). Bacterial fatty acid synthesis and its relationships with polyketide synthetic pathways. *Methods in Enzymology*, *459*, 395–433.
- Cummings, J. H., Hill, M. J., Bone, E. S., Branch, W. J., & Jenkins, D. J. (1979). The effect of meat protein and dietary fiber on colonic function and metabolism. II. Bacterial metabolites in feces and urine. *American Journal of Clinical Nutrition*, *32*, 2094–2101.
- Dai, Z. L., Zhang, J., Wu, G., & Zhu, W. Y. (2010). Utilization of amino acids by bacteria from the pig small intestine. *Amino Acids*, *39*, 1201–1215.
- Daly, K., Cuff, M. A., Fung, F., & Shirazi-Beechey, S. P. (2005). The importance of colonic butyrate transport to the regulation of genes associated with colonic tissue homeostasis. *Biochemical Society Transactions*, *33*, 733–735.
- Darragh, A. J., Cranwell, P. D., & Moughan, P. J. (1994). Absorption of lysine and methionine from the proximal colon of the piglet. *British Journal of Nutrition*, *71*, 739–752.
- David, L. A., Maurice, C. F., Carmody, R. N., Gootenberg, D. B., Button, J. E., Wolfe, B. E., et al. (2014). Diet rapidly and reproducibly alters the human gut microbiome. *Nature*, *505*, 559–563.
- Davila, A. M., Blachier, F., Gotteland, M., Andriamihaja, M., Benetti, P. H., Sanz, Y., et al. (2013). Intestinal luminal nitrogen metabolism: Role of the gut microbiota and consequences for the host. *Pharmacological Research*, *68*, 95–107.
- Dawson, L. F., Donahue, E. H., Cartman, S. T., Barton, R. H., Bundy, J., McEnerney, R., et al. (2011). The analysis of para-cresol production and tolerance in *Clostridium difficile* 027 and 012 strains. *BMC Microbiology*, *11*, 86.
- De Preter, V., Geboes, K., Verbrugghe, K., De Vuyst, L., Vanhoutte, T., Huys, G., et al. (2004). The *in vivo* use of the stable isotope-labelled biomarkers lactose-[¹⁵N]ureide and [²H₄]tyrosine to assess the effects of pre- and probiotics on the intestinal flora of healthy human volunteers. *British Journal of Nutrition*, *92*, 439–446.
- De Preter, V., Hamer, H. M., Windey, K., & Verbeke, K. (2011). The impact of pre- and/or probiotics on human colonic metabolism: Does it affect human health? *Molecular Nutrition and Food Research*, *55*, 46–57.
- De Preter, V., Raemen, H., Cloetens, L., Houben, E., Rutgeerts, P., & Verbeke, K. (2008). Effect of dietary intervention with different pre- and probiotics on intestinal bacterial enzyme activities. *European Journal of Clinical Nutrition*, *62*, 225–231.
- De Preter, V., Vanhoutte, T., Huys, G., Swings, J., De Vuyst, L., Rutgeerts, P., et al. (2007). Effects of *Lactobacillus casei* Shirota, *Bifidobacterium breve*, and oligofructose-enriched inulin on colonic nitrogen-protein metabolism in healthy humans. *American Journal of Physiology-Gastrointestinal and Liver Physiology*, *292*, G358–G368.
- Demigne, C., Morand, C., Levrat, M. A., Besson, C., Moundras, C., & Remy, C. (1995). Effect of propionate on fatty acid and cholesterol synthesis and on acetate metabolism in isolated rat hepatocytes. *British Journal of Nutrition*, *74*, 209–219.
- Diaz, E., Ferrandez, A., Prieto, M. A., & Garcia, J. L. (2001). Biodegradation of aromatic compounds by *Escherichia coli*. *Microbiology and Molecular Biology Reviews*, *65*, 523–569.
- Doerner, K. C., Mason, B. P., Kridelbaugh, D., & Loughrin, J. (2009). Fe(III) stimulates 3-methylindole and 4-methylphenol production in swine lagoon enrichments and *Clostridium scatogenes* ATCC 25775. *Letters in Applied Microbiology*, *48*, 118–124.
- EFSA Panel on Dietetic Products, N. a. A. (2012). Scientific opinion on dietary reference values for protein. *EFSA Journal*, *10*, 1–66.
- Eggeling, L., & Sahn, H. (2003). New ubiquitous translocators: Amino acid export by *Corynebacterium glutamicum* and *Escherichia coli*. *Archives of Microbiology*, *180*, 155–160.
- Eisenberg, T., Knauer, H., Schauer, A., Buttner, S., Ruckstuhl, C., Carmona-Gutierrez, D., et al. (2009). Induction of autophagy by spermidine promotes longevity. *Nature Cell Biology*, *11*, 1305–1314.
- Eklou-Lawson, M., Bernard, F., Neveux, N., Chaumontet, C., Bos, C., Davila-Gay, A. M., et al. (2009). Colonic luminal ammonia and portal blood L-glutamine and L-arginine concentrations: A possible link between colon mucosa and liver ureagenesis. *Amino Acids*, *37*, 751–760.
- El-Merabhi, R., Loffler, M., Mayer, A., & Sumara, G. (2015). The roles of peripheral serotonin in metabolic homeostasis. *FEBS Letters*, *589*, 1728–1734.
- Evenepoel, P., Meijers, B. K., Bammens, B. R., & Verbeke, K. (2009). Uremic toxins originating from colonic microbial metabolism. *Kidney International Supplement*, *S12*–S19.
- Everard, A., Lazarevic, V., Gaia, N., Johansson, M., Stahlman, M., Backhed, F., et al. (2014). Microbiome of prebiotic-treated mice reveals novel targets involved in host response during obesity. *ISME Journal*, *8*, 2116–2130.
- Feehily, C., & Karatzas, K. A. (2013). Role of glutamate metabolism in bacterial responses towards acid and other stresses. *Journal of Applied Microbiology*, *114*, 11–24.
- Ferrario, C., Duranti, S., Milani, C., Mancabelli, L., Lugli, G. A., Turrone, F., et al. (2015). Exploring amino acid auxotrophy in *Bifidobacterium bifidum* PRL2010. *Frontiers in Microbiology*, *6*, 1331.
- Fichman, Y., Gerdes, S. Y., Kovacs, H., Szabados, L., Zilberstein, A., & Csonka, L. N. (2015). Evolution of proline biosynthesis: Enzymology, bioinformatics, genetics, and transcriptional regulation. *Biological Reviews of the Cambridge Philosophical Society*, *90*(4), 1065–1099.
- Fischbach, M. A., & Sonnenburg, J. L. (2011). Eating for two: How metabolism establishes interspecies interactions in the gut. *Cell Host Microbe*, *10*, 336–347.
- Flannigan, K. L., Agbor, T. A., Motta, J. P., Ferraz, J. G., Wang, R., Buret, A. G., et al. (2015). Proresolutive effects of hydrogen sulfide during colitis are mediated through hypoxia-inducible factor-1alpha. *FASEB Journal*, *29*, 1591–1602.
- Fonknechten, N., Chaussonnerie, S., Tricot, S., Lajus, A., Andreesen, J. R., Perchat, N., et al. (2010). *Clostridium sticklandii*, a specialist in amino acid degradation: revisiting its metabolism through its genome sequence. *BMC Genomics*, *11*, 555.
- Fouque, D., Pelletier, S., Mafra, D., & Chauveau, P. (2011). Nutrition and chronic kidney disease. *Kidney International*, *80*, 348–357.
- Freestone, P. (2013). Communication between bacteria and their hosts. *Scientifica (Cairo)*, *2013*, 361073.
- Furusawa, Y., Obata, Y., Fukuda, S., Endo, T. A., Nakato, G., Takahashi, D., et al. (2013). Commensal microbe-derived butyrate induces the differentiation of colonic regulatory T cells. *Nature*, *504*, 446–450.
- Gamet, L., Cazenave, Y., Trocheris, V., Denis-Pouxviel, C., & Murat, J. C. (1991). Involvement of ornithine decarboxylase in the control of proliferation of the HT29 human colon cancer cell line. Effect of vasoactive intestinal peptide on enzyme activity. *International Journal of Cancer*, *47*, 633–638.
- Gao, Z., Yin, J., Zhang, J., Ward, R. E., Martin, R. J., Lefevre, M., et al. (2009). Butyrate improves insulin sensitivity and increases energy expenditure in mice. *Diabetes*, *58*, 1509–1517.
- Geboes, K. P., De Hertogh, G., De Preter, V., Luybaerts, A., Bammens, B., Evenepoel, P., et al. (2006). The influence of inulin on the absorption of nitrogen and the production of metabolites of protein fermentation in the colon. *British Journal of Nutrition*, *96*, 1078–1086.
- Geyens, B., Claus, D., Evenepoel, P., Hiele, M., Maes, B., Peeters, M., et al. (1997). Influence of dietary protein supplements on the formation of bacterial metabolites in the colon. *Gut*, *41*, 70–76.
- Gill, S. R., Pop, M., Deboy, R. T., Eckburg, P. B., Turnbaugh, P. J., Samuel, B. S., et al. (2006). Metagenomic analysis of the human distal gut microbiome. *Science*, *312*, 1355–1359.
- Godon, J. J., Delorme, C., Bardowski, J., Chopin, M. C., Ehrlich, S. D., & Renault, P. (1993). Gene inactivation in *Lactococcus lactis*: Branched-chain amino acid biosynthesis. *Journal of Bacteriology*, *175*, 4383–4390.
- Gostner, A., Blaut, M., Schaffer, V., Kozianowski, G., Theis, S., Klingenberg, M., et al. (2006). Effect of isomalt consumption on faecal microflora and colonic metabolism in healthy volunteers. *British Journal of Nutrition*, *95*, 40–50.
- Gupta, N. K., Thaker, A. I., Kanuri, N., Riehl, T. E., Rowley, C. W., Stenson, W. F., et al. (2012). Serum analysis of tryptophan catabolism pathway: Correlation with Crohn's disease activity. *Inflammatory Bowel Diseases*, *18*, 1214–1220.
- Halmos, E. P., & Gibson, P. R. (2015). Dietary management of IBD—insights and advice. *Nature Reviews Gastroenterology & Hepatology*, *12*, 133–146.
- Hamer, H. M., Jonkers, D., Venema, K., Vanhoutte, S., Troost, F. J., & Brummer, R. J. (2008). Review article: The role of butyrate on colonic function. *Alimentary Pharmacology & Therapeutics*, *27*, 104–119.
- Hanfrey, C. C., Pearson, B. M., Hazeldine, S., Lee, J., Gaskin, D. J., Woster, P. M., et al. (2011). Alternative spermidine biosynthetic route is critical for growth of *Campylobacter jejuni* and is the dominant polyamine pathway in human gut microbiota. *Journal of Biological Chemistry*, *286*, 43301–43312.
- Hart, A. R., Luben, R., Olsen, A., Tjonneland, A., Linseisen, J., Nagel, G., et al. (2008). Diet in the aetiology of ulcerative colitis: A European prospective cohort study. *Digestion*, *77*, 57–64.
- Heinken, A., & Thiele, I. (2015). Systems biology of host-microbe metabolomics. *Wiley Interdisciplinary Reviews: Systems Biology and Medicine*, *7*, 195–219.
- Helling, R. B. (1994). Why does *Escherichia coli* have two primary pathways for synthesis of glutamate? *Journal of Bacteriology*, *166*, 4664–4668.

- Hughes, R., Kurth, M. J., McGilligan, V., McGlynn, H., & Rowland, I. (2008). Effect of colonic bacterial metabolites on Caco-2 cell paracellular permeability in vitro. *Nutrition and Cancer*, 60, 259–266.
- Hughes, R., Magee, E. A., & Bingham, S. (2000). Protein degradation in the large intestine: Relevance to colorectal cancer. *Current Issues in Intestinal Microbiology*, 1, 51–58.
- Ijssennagger, N., Belzer, C., Hooiveld, G. J., Dekker, J., van Mil, S. W., Muller, M., et al. (2015). Gut microbiota facilitates dietary heme-induced epithelial hyperproliferation by opening the mucus barrier in colon. *Proceedings of the National Academy of Sciences of the United States of America*, 112, 10038–10043.
- Irsfeld, M., Spadafore, M., & Pruss, B. M. (2013). beta-phenylethylamine, a small molecule with a large impact. *Webmedcentral*, 4(9).
- Jantchou, P., Morois, S., Clavel-Chapelon, F., Boutron-Ruault, M. C., & Carbonnel, F. (2010). Animal protein intake and risk of inflammatory bowel disease: The E3N prospective study. *American Journal of Gastroenterology*, 105, 2195–2201.
- Jowett, S. L., Seal, C. J., Pearce, M. S., Phillips, E., Gregory, W., Barton, J. R., et al. (2004). Influence of dietary factors on the clinical course of ulcerative colitis: A prospective cohort study. *Gut*, 53, 1479–1484.
- Juraschek, S. P., Appel, L. J., Anderson, C. A., & Miller, E. R., 3rd (2013). Effect of a high-protein diet on kidney function in healthy adults: Results from the omnihart trial. *American Journal of Kidney Diseases*, 61, 547–554.
- Kanehisa, M., Goto, S., Sato, Y., Kawashima, M., Furumichi, M., & Tanabe, M. (2014). Data, information, knowledge and principle: Back to metabolism in KEGG. *Nucleic Acids Research*, 42, D199–D205.
- Karatzas, K. A., Brennan, O., Heavin, S., Morrissey, J., & O'Byrne, C. P. (2010). Intracellular accumulation of high levels of gamma-aminobutyrate by *Listeria monocytogenes* 10403S in response to low pH: Uncoupling of gamma-aminobutyrate synthesis from efflux in a chemically defined medium. *Applied and Environmental Microbiology*, 76, 3529–3537.
- Kim, E., Coelho, D., & Blachier, F. (2013). Review of the association between meat consumption and risk of colorectal cancer. *Nutrition Research*, 33, 983–994.
- Kim, J. N., Henriksen, E. D., Cann, I. K., & Mackie, R. I. (2014). Nitrogen utilization and metabolism in *Ruminococcus albus* 8. *Applied and Environmental Microbiology*, 80, 3095–3102.
- Kim, J., Hetzel, M., Boiangiu, C. D., & Buckel, W. (2004). Dehydration of (R)-2-hydroxyacyl-CoA to enoyl-CoA in the fermentation of alpha-amino acids by anaerobic bacteria. *FEMS Microbiology Reviews*, 28, 455–468.
- Koppe, L., Pillon, N. J., Vella, R. E., Croze, M. L., Pelletier, C. C., Chambert, S., et al. (2013). p-Cresyl sulfate promotes insulin resistance associated with CKD. *Journal of the American Society of Nephrology*, 24, 88–99.
- Kredich, N. M. (1996). Biosynthesis of cysteine. In F. C. Neidhardt, Curtiss, II, J. L. Ingraham, E. C. C. Lin, B. L. Low, B. Magasanik, et al. (Eds.), *Escherichia coli and Salmonella: Cellular and molecular biology* (2nd ed., pp. 514–527). Washington, D. C.: ASM Press.
- Kulis-Horn, R. K., Persicke, M., & Kalinowski, J. (2014). Histidine biosynthesis, its regulation and biotechnological application in *Corynebacterium glutamicum*. *Microbial Biotechnology*, 7, 5–25.
- Kuroda, M., Ohta, T., Uchiyama, I., Baba, T., Yuzawa, H., Kobayashi, I., et al. (2001). Whole genome sequencing of methicillin-resistant *Staphylococcus aureus*. *Lancet*, 357, 1225–1240.
- Lan, A., Andriamihaja, M., Blouin, J. M., Liu, X., Descatoire, V., Desclee de Maredsous, C., et al. (2015). High-protein diet differently modifies intestinal goblet cell characteristics and mucosal cytokine expression in ileum and colon. *The Journal of Nutritional Biochemistry*, 26, 91–98.
- Landete, J. M., Arena, M. E., Pardo, I., Manca de Nadra, M. C., & Ferrer, S. (2008). Comparative survey of putrescine production from agmatine deamination in different bacteria. *Food Microbiology*, 25, 882–887.
- Landete, J. M., De las Rivas, B., Marcobal, A., & Munoz, R. (2008). Updated molecular knowledge about histamine biosynthesis by bacteria. *Critical Reviews In Food Science and Nutrition*, 48, 697–714.
- Laparra, J. M., & Sanz, Y. (2010). Interactions of gut microbiota with functional food components and nutraceuticals. *Pharmacological Research*, 61, 219–225.
- Le Gall, G., Noor, S. O., Ridgway, K., Scovell, L., Jamieson, C., Johnson, I. T., et al. (2011). Metabolomics of fecal extracts detects altered metabolic activity of gut microbiota in ulcerative colitis and irritable bowel syndrome. *Journal of Proteome Research*, 10, 4208–4218.
- Lecerf, J. M., Depeint, F., Clerc, E., Dugenet, Y., Niamba, C. N., Rhazi, L., et al. (2012). Xylo-oligosaccharide (XOS) in combination with inulin modulates both the intestinal environment and immune status in healthy subjects, while XOS alone only shows prebiotic properties. *British Journal of Nutrition*, 108, 1847–1858.
- Lee, J., Sperandio, V., Frantz, D. E., Longgood, J., Camilli, A., Phillips, M. A., et al. (2009). An alternative polyamine biosynthetic pathway is widespread in bacteria and essential for biofilm formation in *Vibrio cholerae*. *Journal of Biological Chemistry*, 284, 9899–9907.
- Leschelle, X., Goubern, M., Andriamihaja, M., Blottiere, H. M., Couplan, E., Gonzalez-Barroso, M. D., et al. (2005). Adaptive metabolic response of human colonic epithelial cells to the adverse effects of the luminal compound sulfide. *Biochimica et Biophysica Acta*, 1725, 201–212.
- Linares, D. M., Fernandez, M., Martin, M. C., & Alvarez, M. A. (2009). Tyramine biosynthesis in *Enterococcus durans* is transcriptionally regulated by the extracellular pH and tyrosine concentration. *Microbial Biotechnology*, 2, 625–633.
- Liu, M., Bayjanov, J. R., Renckens, B., Nauta, A., & Siezen, R. J. (2010). The proteolytic system of lactic acid bacteria revisited: A genomic comparison. *BMC Genomics*, 11, 36.
- Liu, X., Blouin, J. M., Santacruz, A., Lan, A., Andriamihaja, M., Wilkanowicz, S., et al. (2014). High-protein diet modifies colonic microbiota and luminal environment but not colonocyte metabolism in the rat model: The increased luminal bulk connection. *American Journal of Physiology-Gastrointestinal and Liver Physiology*, 307, G459–G470.
- Liu, Y., White, R. H., & Whitman, W. B. (2010). Methanococci use the diaminoethylamine aminotransferase (DapL) pathway for lysine biosynthesis. *Journal of Bacteriology*, 192, 3304–3310.
- Macfarlane, G. T., Cummings, J. H., & Allison, C. (1986). Protein degradation by human intestinal bacteria. *Journal of General and Applied Microbiology*, 132, 1647–1656.
- Macfarlane, G. T., Cummings, J. H., Macfarlane, S., & Gibson, G. R. (1989). Influence of retention time on degradation of pancreatic enzymes by human colonic bacteria grown in a 3-stage continuous culture system. *Journal of Applied Bacteriology*, 67, 520–527.
- Macfarlane, G. T., Gibson, G. R., & Cummings, J. H. (1992). Comparison of fermentation reactions in different regions of the human colon. *Journal of Applied Bacteriology*, 72, 57–64.
- Macfarlane, G. T., & Macfarlane, S. (2012). Bacteria, colonic fermentation, and gastrointestinal health. *Journal of AOAC International*, 95, 50–60.
- Magee, E. A., Richardson, C. J., Hughes, R., & Cummings, J. H. (2000). Contribution of dietary protein to sulfide production in the large intestine: An *in vitro* and a controlled feeding study in humans. *American Journal of Clinical Nutrition*, 72, 1488–1494.
- Marckmann, P., Osther, P., Pedersen, A. N., & Jespersen, B. (2015). High-protein diets and renal health. *Journal of Renal Nutrition*, 25, 1–5.
- Marcobal, A., De las Rivas, B., Landete, J. M., Tabera, L., & Munoz, R. (2012). Tyramine and phenylethylamine biosynthesis by food bacteria. *Critical Reviews In Food Science and Nutrition*, 52, 448–467.
- Marc, F., Weigel, P. C. L., Almeras, Y. M. S., Glandsdorff, N., & Sakanyan, V. (2000). Characterization and kinetic mechanism of mono- and bifunctional ornithine acetyltransferases from thermophilic microorganisms. *European Journal of Biochemistry*, 267, 5217–5226.
- Mayeur, C., Veuillet, G., Michaud, M., Raul, F., Blottiere, H. M., & Blachier, F. (2005). Effects of agmatine accumulation in human colon carcinoma cells on polyamine metabolism, DNA synthesis and the cell cycle. *Biochimica et Biophysica Acta*, 1745, 111–123.
- McIntosh, G. H., & Le Leu, R. K. (2001). The influence of dietary proteins on colon cancer risk. *Nutrition Research*, 21, 1053–1066.
- Meijers, B. K., & Evenepoel, P. (2011). The gut-kidney axis: Indoxyl sulfate, p-cresyl sulfate and CKD progression. *Nephrology Dialysis Transplantation*, 26, 759–761.
- Metges, C. C. (2000). Contribution of microbial amino acids to amino acid homeostasis of the host. *The Journal of Nutrition*, 130, 1857S–1864S.
- Meyer, T. W., & Hostetter, T. H. (2012). Uremic solutes from colon microbes. *Kidney International*, 81, 949–954.
- Millichap, J. G., & Yee, M. M. (2003). The diet factor in pediatric and adolescent migraine. *Pediatric Neurology*, 28, 9–15.
- Mimoun, S., Andriamihaja, M., Chaumontet, C., Atanasiu, C., Benamouzig, R., Blouin, J. M., et al. (2012). Detoxification of H₂S by differentiated colonic epithelial cells: Implication of the sulfide oxidizing unit and of the cell respiratory capacity. *Antioxid Redox Signal*, 17, 1–10.
- Minguet, E. G., Vera-Sirera, F., Marina, A., Carbonell, J., & Blazquez, M. A. (2008). Evolutionary diversification in polyamine biosynthesis. *Molecular Biology and Evolution*, 25, 2119–2128.
- Min, B., Pelaschier, J. T., Graham, D. E., Tumbula-Hansen, D., & Soll, D. (2002). Transfer RNA-dependent amino acid biosynthesis: An essential route to asparagine formation. *Proceedings of the National Academy of Sciences of the United States of America*, 99, 2678–2683.
- Molenaar, D., Bosscher, J. S., ten Brink, B., Driessen, A. J., & Konings, W. N. (1993). Generation of a proton motive force by histidine decarboxylation and electrogenic histidine/histamine antiport in *Lactobacillus buchneri*. *Journal of Bacteriology*, 175, 2864–2870.
- Mouillé, B., Delpal, S., Mayeur, C., & Blachier, F. (2003). Inhibition of human colon carcinoma cell growth by ammonia: A non-cytotoxic process associated with polyamine synthesis reduction. *Biochimica Biophysica Acta*, 1624, 88–97.
- Mouillé, B., Robert, V., & Blachier, F. (2004). Adaptive increase of ornithine production and decrease of ammonia metabolism in rat colonocytes after hyperproteic diet ingestion. *American Journal of Physiology-Gastrointestinal and Liver Physiology*, 287, G344–G351.
- Musch, M. W., Bookstein, C., Xie, Y., Sellin, J. H., & Chang, E. B. (2001). SCFA increase intestinal Na absorption by induction of NHE3 in rat colon and human intestinal C2/bbe cells. *American Journal of Physiology-Gastrointestinal and Liver Physiology*, 280, G687–G693.
- Mu, C., Yang, Y., Luo, Z., & Zhu, W. (2015). Metabolomic analysis reveals distinct profiles in the plasma and urine of rats fed a high-protein diet. *Amino Acids*, 47, 1225–1238.
- Nakada, Y., & Itoh, Y. (2003). Identification of the putrescine biosynthetic genes in *Pseudomonas aeruginosa* and characterization of agmatine deaminase and N-carbamoylputrescine amidohydrolase of the arginine decarboxylase pathway. *Microbiology*, 149, 707–714.
- Neis, E. P., Dejong, C. H., & Rensen, S. S. (2015). The role of microbial amino acid metabolism in host metabolism. *Nutrients*, 7, 2930–2946.
- Newgard, C. B., An, J., Bain, J. R., Muehlbauer, M. J., Stevens, R. D., Lien, L. F., et al. (2009). A branched-chain amino acid-related metabolic signature that differentiates obese and lean humans and contributes to insulin resistance. *Cell*

- Metabolism*, 9, 311–326.
- Nichols, B. P. (1996). Evolution of genes and enzymes of tryptophan biosynthesis. In F. C. Neidhardt (Ed.), *Escherichia coli and Salmonella: Cellular and molecular biology* (Vol. 2, pp. 2638–2648). Washington DC: ASM.
- Nolling, J., Breton, G., Omelchenko, M. V., Makarova, K. S., Zeng, Q., Gibson, R., et al. (2001). Genome sequence and comparative analysis of the solvent-producing bacterium *Clostridium acetobutylicum*. *Journal of Bacteriology*, 183, 4823–4838.
- Nyangale, E. P., Mottram, D. S., & Gibson, G. R. (2012). Gut microbial activity, implications for health and disease: The potential role of metabolite analysis. *Journal of Proteome Research*, 11, 5573–5585.
- O'Mahony, S. M., Clarke, G., Borre, Y. E., Dinan, T. G., & Cryan, J. F. (2015). Serotonin, tryptophan metabolism and the brain-gut-microbiome axis. *Behavioural Brain Research*, 277, 32–48.
- Oikawa, T. (2007). Alanine, aspartate, and asparagine metabolism in microorganisms. In V. F. Wendisch (Ed.), *Amino acid biosynthesis* (pp. 273–288). Berlin Heidelberg: Springer-Verlag.
- Osborne, D. L., & Seidel, E. R. (1990). Gastrointestinal luminal polyamines: Cellular accumulation and enterohepatic circulation. *American Journal of Physiology*, 258, G576–G584.
- Pabst, O., & Bernhardt, G. (2010). The puzzle of intestinal lamina propria dendritic cells and macrophages. *European Journal of Immunology*, 40, 2107–2111.
- Panina, E. M., Vitreschak, A. G., Mironov, A. A., & Gelfand, M. S. (2003). Regulation of biosynthesis and transport of aromatic amino acids in low-GC Gram-positive bacteria. *FEMS Microbiology Letters*, 222, 211–220.
- Patel, K. P., Luo, F. J., Plummer, N. S., Hostetter, T. H., & Meyer, T. W. (2012). The production of *p*-cresol sulfate and indoxyl sulfate in vegetarians versus omnivores. *Clinical Journal of the American Society of Nephrology*, 7, 982–988.
- Patte, J. C. (1996). Biosynthesis of threonine and lysine. In F. C. Neidhardt (Ed.), *Escherichia coli and Salmonella typhimurium: Cellular and molecular biology* (Vol. 1, pp. 528–541). Washington, DC: ASM Press.
- Patek, M. (2007). Branched-chain amino acids. In V. F. Wendisch (Ed.), *Amino acid biosynthesis* (pp. 129–162). Berlin Heidelberg: Springer-Verlag.
- Pedersen, G., Brynskov, J., & Saermark, T. (2002). Phenol toxicity and conjugation in human colonic epithelial cells. *Scandinavian Journal of Gastroenterology*, 37, 74–79.
- Pessione, E. (2012). Lactic acid bacteria contribution to gut microbiota complexity: Lights and shadows. *Front Cell Infect Microbiol*, 2, 86.
- Pesta, D. H., & Samuel, V. T. (2014). A high-protein diet for reducing body fat: Mechanisms and possible caveats. *Nutrition & Metabolism (Lond)*, 11, 53.
- Peters-Wendisch, P., Stolz, M., Etterich, H., Kennerknecht, N., Sahn, H., & Eggeling, L. (2005). Metabolic engineering of *Corynebacterium glutamicum* for L-serine production. *Applied and Environmental Microbiology*, 71, 7139–7144.
- Pitcher, M. C., & Cummings, J. H. (1996). Hydrogen sulphide: A bacterial toxin in ulcerative colitis? *Gut*, 39, 1–4.
- Pittard, J. (1996). Biosynthesis of the aromatic amino acids. In F. C. Neidhardt (Ed.), *Escherichia coli and Salmonella: Cellular and molecular biology* (Vol. 1, pp. 458–484). Washington DC: ASM.
- Poesen, R., Mutsaers, H. A., Windey, K., van den Broek, P. H., Verweij, V., Augustijns, P., et al. (2015). The influence of dietary protein intake on mammalian tryptophan and phenolic metabolites. *PLoS One*, 10, e0140820.
- Polo, L. M., Gil-Ortiz, F., Cantin, A., & Rubio, V. (2012). New insight into the transcarbamylase family: The structure of putrescine transcarbamylase, a key catalyst for fermentative utilization of agmatine. *PLoS One*, 7, e31528.
- Priddy, R. D., Berger, B., Desiere, F., Vilanova, D., Barretto, C., Pittet, A. C., et al. (2004). The genome sequence of the probiotic intestinal bacterium *Lactobacillus johnsonii* NCC 533. *Proceedings of the National Academy of Sciences of the United States of America*, 101, 2512–2517.
- Qin, J., Li, R., Raes, J., Arumugam, M., Burgdorf, K. S., Manichanh, C., et al. (2010). A human gut microbial gene catalogue established by metagenomic sequencing. *Nature*, 464, 59–65.
- Ramakrishna, B. S., Roberts-Thomson, I. C., Pannall, P. R., & Roediger, W. E. (1991). Impaired sulphation of phenol by the colonic mucosa in quiescent and active ulcerative colitis. *Gut*, 32, 46–49.
- Rampelli, S., Candela, M., Turroni, S., Biagi, E., Collino, S., Franceschi, C., et al. (2013). Functional metagenomic profiling of intestinal microbiome in extreme ageing. *Ageing (Albany NY)*, 5, 902–912.
- Rand, W. M., Pellett, P. L., & Young, V. R. (2003). Meta-analysis of nitrogen balance studies for estimating protein requirements in healthy adults. *American Journal of Clinical Nutrition*, 77, 109–127.
- Rawlings, N. D., Waller, M., Barrett, A. J., & Bateman, A. (2014). MEROPS: The database of proteolytic enzymes, their substrates and inhibitors. *Nucleic Acids Research*, 42, D503–D509.
- Reckemmer, G., Ronnau, K., & von Engelhardt, W. (1988). Fermentation of polysaccharides and absorption of short chain fatty acids in the mammalian hindgut. *Comparative Biochemistry and Physiology A Comparative Physiology*, 90, 563–568.
- Reiffenstein, R. J., Hulbert, W. C., & Roth, S. H. (1992). Toxicology of hydrogen sulfide. *Annual Review of Pharmacology and Toxicology*, 32, 109–134.
- Reigstad, C. S., Salmons, C. E., Rainey, J. F., 3rd, Szurszewski, J. H., Linden, D. R., Sonnenburg, J. L., et al. (2015). Gut microbes promote colonic serotonin production through an effect of short-chain fatty acids on enterochromaffin cells. *FASEB Journal*, 29, 1395–1403.
- Reitzer, L. J., & Magasanik, B. (1987). Ammonium assimilation and the biosynthesis of glutamate, glutamate, aspartate, asparagine, L-alanine, and D-alanine. In J. L. F. C. Neidhardt, K. B. Low, B. Magasanik, M. Schaechter, & H. E. Umbarger (Eds.), *Escherichia coli and Salmonella typhimurium: Cellular and molecular biology* (pp. 302–320). Washington, D.C.: American Society for Microbiology.
- Remesy, C., Fafournoux, P., & Demigne, C. (1983). Control of hepatic utilization of serine, glycine and threonine in fed and starved rats. *The Journal of Nutrition*, 113, 28–39.
- Rodionov, D. A., Vitreschak, A. G., Mironov, A. A., & Gelfand, M. S. (2004). Comparative genomics of the methionine metabolism in gram-positive bacteria: A variety of regulatory systems. *Nucleic Acids Research*, 32, 3340–3353.
- Rossi, M., Johnson, D. W., Morrison, M., Pascoe, E., Coombes, J. S., Forbes, J. M., et al. (2014). SYNbiotics easing renal failure by improving gut microbiology (synergy): A protocol of placebo-controlled randomised cross-over trial. *BMC Nephrology*, 15, 106.
- Russell, W. R., Gratz, S. W., Duncan, S. H., Holtrop, G., Ince, J., Scobbie, L., et al. (2011). High-protein, reduced-carbohydrate weight-loss diets promote metabolite profiles likely to be detrimental to colonic health. *American Journal of Clinical Nutrition*, 93, 1062–1072.
- Saier, M. H., Jr. (2000). Families of transmembrane transporters selective for amino acids and their derivatives. *Microbiology*, 146(Pt 8), 1775–1795.
- Samuel, B. S., Shaito, A., Motoike, T., Rey, F. E., Backhed, F., Manchester, J. K., et al. (2008). Effects of the gut microbiota on host adiposity are modulated by the short-chain fatty-acid binding G protein-coupled receptor, Gpr41. *Proceedings of the National Academy of Sciences of the United States of America*, 105, 16767–16772.
- Sanders, J. W., Leenhouts, K., Burghoorn, J., Brands, J. R., Venema, G., & Kok, J. (1998). A chloride-inducible acid resistance mechanism in *Lactococcus lactis* and its regulation. *Molecular Microbiology*, 27, 299–310.
- Santesso, N., Akl, E. A., Bianchi, M., Mente, A., Mustafa, R., Heels-Ansdell, D., et al. (2012). Effects of higher- versus lower-protein diets on health outcomes: A systematic review and meta-analysis. *European Journal of Clinical Nutrition*, 66, 780–788.
- Schell, M. A., Karmirantzou, M., Snel, B., Vilanova, D., Berger, B., Pessi, G., et al. (2002). The genome sequence of *Bifidobacterium longum* reflects its adaptation to the human gastrointestinal tract. *Proceedings of the National Academy of Sciences of the United States of America*, 99, 14422–14427.
- Selmer, T., & Andrei, P. I. (2001). *p*-Hydroxyphenylacetate decarboxylase from *Clostridium difficile*. A novel glycol radical enzyme catalysing the formation of *p*-cresol. *European Journal of Biochemistry*, 268, 1363–1372.
- Shimizu, H., & Hirasawa, T. (2007). Production of glutamate and glutamate-related amino acids: Molecular mechanism analysis and metabolic engineering. In V. F. Wendisch (Ed.), *Amino acid biosynthesis* (pp. 1–38). Berlin Heidelberg: Springer-Verlag.
- Shimizu, T., Ohtani, K., Hirakawa, H., Ohshima, K., Yamashita, A., Shiba, T., et al. (2002). Complete genome sequence of *Clostridium perfringens*, an anaerobic flesh-eater. *Proceedings of the National Academy of Sciences of the United States of America*, 99, 996–1001.
- Shoda, R., Matsueda, K., Yamato, S., & Umeda, N. (1996). Epidemiologic analysis of Crohn disease in Japan: Increased dietary intake of n-6 polyunsaturated fatty acids and animal protein relates to the increased incidence of Crohn disease in Japan. *American Journal of Clinical Nutrition*, 63, 741–745.
- Smith, E. A., & Macfarlane, G. T. (1996). Enumeration of human colonic bacteria producing phenolic and indolic compounds: Effects of pH, carbohydrate availability and retention time on dissimilatory aromatic amino acid metabolism. *Journal of Applied Bacteriology*, 81, 288–302.
- Smith, E. A., & Macfarlane, G. T. (1997). Formation of phenolic and indolic compounds by anaerobic bacteria in the human large intestine. *Microbial Ecology*, 33, 180–188.
- Sprenger, G. A. (2007). Aromatic amino acids. In V. F. Wendisch (Ed.), *Amino acid biosynthesis* (pp. 93–127). Berlin Heidelberg: Springer-Verlag.
- Sridharan, G. V., Choi, K., Klemashevich, C., Wu, C., Prabhakaran, D., Pan, L. B., et al. (2014). Prediction and quantification of bioactive microbiota metabolites in the mouse gut. *Nature Communications*, 5, 5492.
- Steiner, H. Y., Naider, F., & Becker, J. M. (1995). The PTR family: A new group of peptide transporters. *Molecular Microbiology*, 16, 825–834.
- Steinert, R. E., Beglinger, C., & Langhans, W. (2016). Intestinal GLP-1 and satiety: From man to rodents and back. *International Journal of Obesity (London)*, 40(2), 198–205.
- Stolz, M., Peters-Wendisch, P., Etterich, H., Gerharz, T., Faurie, R., Sahn, H., et al. (2007). Reduced folate supply as a key to enhanced L-serine production by *Corynebacterium glutamicum*. *Applied and Environmental Microbiology*, 73, 750–755.
- Sudhamsu, J., & Crane, B. R. (2009). Bacterial nitric oxide synthases: What are they good for? *Trends in Microbiology*, 17, 212–218.
- Szabo, C., Coletta, C., Chao, C., Modis, K., Szczesny, B., Papapetropoulos, A., et al. (2013). Tumor-derived hydrogen sulfide, produced by cystathionine-beta-synthase, stimulates bioenergetics, cell proliferation, and angiogenesis in colon cancer. *Proceedings of the National Academy of Sciences of the United States of America*, 110, 12474–12479.
- Tabor, C. W., & Tabor, H. (1985). Polyamines in microorganisms. *Microbiological Reviews*, 49, 81–99.
- Thomas, C. M., Hong, T., van Pijkeren, J. P., Hemarajata, P., Trinh, D. V., Hu, W., et al. (2012). Histamine derived from probiotic *Lactobacillus reuteri* suppresses TNF via modulation of PKA and ERK signaling. *PLoS One*, 7, e31951.
- Toden, S., Belobrajdic, D. P., Bird, A. R., Topping, D. L., & Conlon, M. A. (2010). Effects of dietary beef and chicken with and without high amylose maize starch on blood malondialdehyde, interleukins, IGF-1, insulin, leptin, MMP-2, and TIMP-2

- concentrations in rats. *Nutrition and Cancer*, 62, 454–465.
- Toden, S., Bird, A. R., Topping, D. L., & Conlon, M. A. (2005). Resistant starch attenuates colonic DNA damage induced by higher dietary protein in rats. *Nutrition and Cancer*, 51, 45–51.
- Tremaroli, V., & Backhed, F. (2012). Functional interactions between the gut microbiota and host metabolism. *Nature*, 489, 242–249.
- Trivedi, V., Gupta, A., Jala, V. R., Saravanan, P., Rao, G. S., Rao, N. A., et al. (2002). Crystal structure of binary and ternary complexes of serine hydroxymethyltransferase from *Bacillus stearothermophilus*: Insights into the catalytic mechanism. *Journal of Biological Chemistry*, 277, 17161–17169.
- Turnbaugh, P. J., Hamady, M., Yatsunenko, T., Cantarel, B. L., Duncan, A., Ley, R. E., et al. (2009). A core gut microbiome in obese and lean twins. *Nature*, 457, 480–484.
- Turnbaugh, P. J., Ley, R. E., Mahowald, M. A., Magrini, V., Mardis, E. R., & Gordon, J. I. (2006). An obesity-associated gut microbiome with increased capacity for energy harvest. *Nature*, 444, 1027–1031.
- Umbarger, H. E. (1978). Amino acid biosynthesis and its regulation. *Annual Review of Biochemistry*, 47, 532–606.
- Umbarger, H. E. (1996). Biosynthesis of the branched-chain amino acids. In F. C. Neidhardt, J. L. Ingraham, B. L. Low, B. Magasanik, M. Schaechter, & H. E. Umbarger (Eds.), *Escherichia coli and Salmonella typhimurium* (pp. 442–457). Washington, DC: ASM Press.
- Vanholder, R., & Glorieux, G. (2015). The intestine and the kidneys: A bad marriage can be hazardous. *Clinical Kidney Journal*, 8, 168–179.
- Vanholder, R., Schepers, E., Pletinck, A., Nagler, E. V., & Glorieux, G. (2014). The uremic toxicity of indoxyl sulfate and *p*-cresyl sulfate: A systematic review. *Journal of the American Society of Nephrology*, 25, 1897–1907.
- Vaziri, N. D., Liu, S. M., Lau, W. L., Khazaeli, M., Nazertehrani, S., Farzaneh, S. H., et al. (2014). High amylose resistant starch diet ameliorates oxidative stress, inflammation, and progression of chronic kidney disease. *PLoS One*, 9, e114881.
- Vaziri, N. D., Wong, J., Pahl, M., Piceno, Y. M., Yuan, J., DeSantis, T. Z., et al. (2013). Chronic kidney disease alters intestinal microbial flora. *Kidney International*, 83, 308–315.
- Vaziri, N. D., Yuan, J., & Norris, K. (2013). Role of urea in intestinal barrier dysfunction and disruption of epithelial tight junction in chronic kidney disease. *American Journal of Nephrology*, 37, 1–6.
- Venkatesh, M., Mukherjee, S., Wang, H., Li, H., Sun, K., Benechet, A. P., et al. (2014). Symbiotic bacterial metabolites regulate gastrointestinal barrier function via the xenobiotic sensor PXR and Toll-like receptor 4. *Immunity*, 41, 296–310.
- Vitreschak, A. G., Lyubetskaya, E. V., Shirshin, M. A., Gelfand, M. S., & Lyubetsky, V. A. (2004). Attenuation regulation of amino acid biosynthetic operons in proteobacteria: Comparative genomics analysis. *FEMS Microbiology Letters*, 234, 357–370.
- Wall, R., Ross, R. P., & Stanton, C. (2014). Bacterial neuroactive compounds produced by psychobiotics. In M. Lyte, & J. F. Cryan (Eds.), *Microbial Endocrinology: The Microbiota-Gut-Brain Axis in Health and Disease* (Vol. 817). New York: Springer.
- Wang, T. J., Larson, M. G., Vasani, R. S., Cheng, S., Rhee, E. P., McCabe, E., et al. (2011). Metabolite profiles and the risk of developing diabetes. *Nature Medicine*, 17, 448–453.
- Watanabe, H., Miyamoto, Y., Honda, D., Tanaka, H., Wu, Q., Endo, M., et al. (2013). *p*-Cresyl sulfate causes renal tubular cell damage by inducing oxidative stress by activation of NADPH oxidase. *Kidney International*, 83, 582–592.
- Westerterp-Plantenga, M. S., Nieuwenhuizen, A., Tome, D., Soenen, S., & Westerterp, K. R. (2009). Dietary protein, weight loss, and weight maintenance. *Annual Review of Nutrition*, 29, 21–41.
- Widner, B., Leblhuber, F., Walli, J., Titz, G. P., Demel, U., & Fuchs, D. (1999). Degradation of tryptophan in neurodegenerative disorders. *Advances In Experimental Medicine and Biology*, 467, 133–138.
- Wikoff, W. R., Anfora, A. T., Liu, J., Schultz, P. G., Lesley, S. A., Peters, E. C., et al. (2009). Metabolomics analysis reveals large effects of gut microflora on mammalian blood metabolites. *Proceedings of the National Academy of Sciences of the United States of America*, 106, 3698–3703.
- Williams, B. B., Van Benschoten, A. H., Cimermancic, P., Donia, M. S., Zimmermann, M., Taketani, M., et al. (2014). Discovery and characterization of gut microbiota decarboxylases that can produce the neurotransmitter tryptamine. *Cell Host Microbe*, 16, 495–503.
- Windey, K., De Preter, V., Louat, T., Schuit, F., Herman, J., Vansant, G., et al. (2012). Modulation of protein fermentation does not affect fecal water toxicity: A randomized cross-over study in healthy subjects. *PLoS One*, 7, e52387.
- Wong, J., Piceno, Y. M., DeSantis, T. Z., Pahl, M., Andersen, G. L., & Vaziri, N. D. (2014). Expansion of urease- and uricase-containing, indole- and *p*-cresol-forming and contraction of short-chain fatty acid-producing intestinal microbiota in ESRD. *American Journal of Nephrology*, 39, 230–237.
- Wu, G., Fanzo, J., Miller, D. D., Pingali, P., Post, M., Steiner, J. L., et al. (2014). Production and supply of high-quality food protein for human consumption: Sustainability, challenges, and innovations. *Annals of the New York Academy of Sciences*, 1321, 1–19.
- Wutzke, K. D., Lotz, M., & Zipprich, C. (2010). The effect of pre- and probiotics on the colonic ammonia metabolism in humans as measured by lactose-¹⁵N₂ ureide. *European Journal of Clinical Nutrition*, 64, 1215–1221.
- Wycherley, T. P., Moran, L. J., Clifton, P. M., Noakes, M., & Brinkworth, G. D. (2012). Effects of energy-restricted high-protein, low-fat compared with standard-protein, low-fat diets: A meta-analysis of randomized controlled trials. *American Journal of Clinical Nutrition*, 96, 1281–1298.
- Xie, G., Keyhani, N. O., Bonner, C. A., & Jensen, R. A. (2003). Ancient origin of the tryptophan operon and the dynamics of evolutionary change. *Microbiology and Molecular Biology Reviews*, 67, 303–342.
- Xu, Y., Labedan, B., & Glansdorff, N. (2007). Surprising arginine biosynthesis: A reappraisal of the enzymology and evolution of the pathway in microorganisms. *Microbiology and Molecular Biology Reviews*, 71, 36–47.
- Yamamoto, T., Hinoi, E., Fujita, H., Iezaki, T., Takahata, Y., Takamori, M., et al. (2012). The natural polyamines spermidine and spermine prevent bone loss through preferential disruption of osteoclastic activation in ovariectomized mice. *British Journal of Pharmacology*, 166, 1084–1096.
- Yamamoto, I., Saito, H., & Ishimoto, M. (1987). Regulation of synthesis and reversible inactivation *in vivo* of dual coenzyme-specific glutamate dehydrogenase in *Bacteroides fragilis*. *Journal of General and Applied Microbiology*, 133, 2773–2780.
- Yano, J. M., Yu, K., Donaldson, G. P., Shastri, G. G., Ann, P., Ma, L., et al. (2015). Indigenous bacteria from the gut microbiota regulate host serotonin biosynthesis. *Cell*, 161, 264–276.
- Yu, L., Blaser, M., Andrei, P. I., Pierik, A. J., & Selmer, T. (2006). 4-Hydroxyphenylacetate decarboxylases: Properties of a novel subclass of glycol radical enzyme systems. *Biochemistry*, 45, 9584–9592.
- Yu, X. J., Walker, D. H., Liu, Y., & Zhang, L. (2009). Amino acid biosynthesis deficiency in bacteria associated with human and animal hosts. *Infection, Genetics and Evolution*, 9, 514–517.
- Zelante, T., Iannitti, R. G., Cunha, C., De Luca, A., Giovannini, G., Pieraccini, G., et al. (2013). Tryptophan catabolites from microbiota engage aryl hydrocarbon receptor and balance mucosal reactivity via interleukin-22. *Immunity*, 39, 372–385.
- Zheng, X., Xie, G., Zhao, A., Zhao, L., Yao, C., Chiu, N. H., et al. (2011). The footprints of gut microbial-mammalian co-metabolism. *Journal of Proteome Research*, 10, 5512–5522.

Effets des régimes hyperprotéiques et des métabolites bactériens dérivés des acides aminés sur la muqueuse du gros intestin

Mots clés : protéines alimentaires, microbiote intestinal, métabolites bactériens, muqueuse du côlon

Résumé : Les régimes hyperprotéiques sont couramment consommés mais les conséquences au niveau du gros intestin sont peu connues. L'objectif de la thèse était d'étudier les effets des régimes hyperprotéiques et des métabolites bactériens dérivés des acides aminés sur la muqueuse du gros intestin.

Une série d'expérimentations animales et *in vitro* a permis de montrer que deux métabolites bactériens dérivés des acides aminés (le sulfure d'hydrogène et le *p*-cresol) sont toxiques pour l'épithélium lorsqu'ils sont présents en concentration élevée. Les résultats obtenus lors d'une étude clinique montrent que la quantité et la qualité des protéines alimentaires n'ont pas d'effets marqués sur la composition du microbiote fécal mais modifient les concentrations fécales et urinaires de métabolites bactériens.

Ces modifications de l'environnement luminal du gros intestin n'étaient pas associées à une augmentation de la cytotoxicité des eaux fécales *in vitro*. Néanmoins, dans la muqueuse rectale, l'augmentation de l'apport en protéines a régulé l'expression de gènes impliqués dans le maintien de l'homéostasie et ces effets étaient distincts de l'origine de protéines utilisées. Toutefois, le niveau d'apport en protéines n'a pas eu d'effet sur les paramètres inflammatoires et histologiques dans la muqueuse. Ces résultats ont été complétés par une étude chez le rat montrant qu'un régime hyperprotéique modifie le transcriptome dans les colonocytes mais n'a pas d'effets délétères en termes d'intégrité de l'ADN, de renouvellement de l'épithélium et de fonction barrière.

Effects of high-protein diets and of amino-acid derived bacterial metabolites on the large intestine mucosa

Keywords: dietary protein, gut microbiota, bacterial metabolites, colonic mucosa

Abstract: High-protein diets are frequently consumed but the consequences for the large intestine are not well described. The objective of this thesis was to evaluate the effects of high-protein diets and of amino acid derived bacterial metabolites on the large intestine mucosa. Animal and *in vitro* studies showed that two amino acid derived bacterial metabolites (hydrogen sulfide and *p*-cresol) are toxic for the epithelium when present at high concentration. The results obtained in a clinical trial indicate that quantity and quality of dietary protein do not have major effects on the fecal microbiota composition but modify the fecal and urinary concentrations of bacterial metabolites.

These changes in the luminal environment were not associated with an increase in fecal water cytotoxicity *in vitro*. Nevertheless, in the rectal mucosa, the increase in protein intake regulated the expression of genes implicated in homeostatic processes and these effects were modulated by the source of protein. However, the level of protein intake had no effect on immune and histological parameters in the mucosa. These results were completed with a study in rats showing a clear transcriptome profile in colonocytes induced by a high-protein diet but that was not associated with detrimental effects in terms of DNA integrity, epithelial renewal and barrier function.