



HAL
open science

Development and application of analytical methodologies for trace elements pollution assessment in different compartments of the marine environment

Anna Maria Orani

► **To cite this version:**

Anna Maria Orani. Development and application of analytical methodologies for trace elements pollution assessment in different compartments of the marine environment. Other. COMUE Université Côte d'Azur (2015 - 2019), 2017. English. NNT : 2017AZUR4112 . tel-02418618

HAL Id: tel-02418618

<https://theses.hal.science/tel-02418618>

Submitted on 19 Dec 2019

HAL is a multi-disciplinary open access archive for the deposit and dissemination of scientific research documents, whether they are published or not. The documents may come from teaching and research institutions in France or abroad, or from public or private research centers.

L'archive ouverte pluridisciplinaire **HAL**, est destinée au dépôt et à la diffusion de documents scientifiques de niveau recherche, publiés ou non, émanant des établissements d'enseignement et de recherche français ou étrangers, des laboratoires publics ou privés.

ÉCOLE DOCTORALE SCIENCE FONDAMENTALES APPLIQUÉES
Géoazur UMR 7329

Thèse de doctorat

Présentée en vue de l'obtention du
grade de docteur en **Chimie**

de **L'UNIVERSITÉ COTE D'AZUR**

par

Anna Maria ORANI

Développements analytiques pour la détermination des
concentrations et de l'origine des contaminants
inorganiques dans des environnements marins

Dirigée par Pr. Olivier THOMAS

et codirigée par Dr. Emilia VASSILEVA et Dr. Aurélie BARATS

Soutenue le **15 Décembre 2017**

Devant le jury composé de :

Dr. Aurélie BARATS, Maître de conférences, Géoazur, Université Côte d'Azur

co-directrice de thèse

Prof. Ewa BULSKA, Chemistry Department, University of Warsaw

rapporteur

Prof. Veselin J. KMETOV, Analytical Chemistry Department, University of Plovdiv

rapporteur

Prof. Christophe RENAC, Géoazur, Université Côte d'Azur

examinateur, président du jury

Prof. Olivier P. THOMAS, National University of Ireland Galway

directeur de thèse

Dr. Emilia VASSILEVA, Research scientist, Environment Laboratories, IAEA

co-directrice de thèse

Development and application of analytical methodologies for trace elements pollution assessment in different compartments of the marine environment

AKNOWLEDGMENTS

First of all I would like to express my gratitude to Prof. Ewa Bulska, Prof. Veselin Kmetov, and Prof. Christophe Renac for their interest in my PhD work and for taking the time to review my thesis. I am confident that their suggestions will be of great help for my future.

This PhD comes to an end after a tortuous path, full of challenges but most importantly full of interesting experiences. A real life-changing adventure during which I have learnt a lot!

Many people helped me in this period, fighting for and with me and for this reason I will be forever grateful to each of them, starting from my supervisors:

-My PhD director Olivier Thomas, who accepted this role and never gave up even in the middle of many administrative challenges!

-My PhD co-director Emilia Vassileva, who encouraged me to start a PhD in the first place and with her precious teaching always supported my work and believed in me.

-My second PhD co-director Aurélie Barats, who helped and encouraged me even during the most difficult periods, with many advices and positive attitude.

Special thanks go to Prof Petko Mandjukov and Dr Irena Wysocka, for sharing their knowledge with me and for their crucial contribution to this PhD work and to Ms Sabine Azemard for her constant help.

I would like to thank all the fellows and office mates I have been the pleasure to work with, in France and Ireland, which have contributed to accumulate many wonderful memories!

Je voudrais remercier toute la famille Calabro, pour m'avoir accueilli à bras ouverts ces dernières années et pour être toujours un gros point de référence, ma deuxième famille !

Ancora una volta vorrei ringraziare la mia meravigliosa famiglia e le mie fantastiche amiche che mi sono stati vicino (da lontano). Il loro sostegno è stato fondamentale in questi anni, e lo sarà per sempre.

Voglio dedicare questa tesi a Kevin, che mi ha supportato (e sopportato) in questi anni, garantendomi amore incondizionato, condividendo con me le tante soddisfazioni ma soprattutto insegnandomi a non mollare e perseverare sempre!

CONTENTS

PART I: GENERAL INTRODUCTION	11
1. Trace elements in the environment.....	13
1.1. Trace elements in the aquatic system	13
1.2. Trace elements speciation	16
1.2.1. Arsenic.....	17
1.2.2. Mercury.....	20
1.3. Trace elements isotopes	22
1.3.1. Pb Isotopic ratios.....	24
2. Trace elements monitoring programs	26
2.1. Trace elements in sediments	27
2.1.1. Sediment components and classification	27
2.1.2. Factors affecting TE accumulation in sediments	29
2.1.3. TE monitoring in sediments	32
2.2. Trace elements in marine organisms	33
2.2.1. Bivalves	33
2.2.2. Sponges.....	35
3. Trace elements analysis	38
3.1. Atomic Absorption Spectrometry	40
3.2. Inductively Coupled Plasma Mass Spectrometry.....	41
REFERENCES.....	44
PART II: SCIENTIFIC PUBLICATIONS.....	69
FIRST BLOCK	71
Paper 1	71
Paper 2	81
Paper 3	95
SECOND BLOCK	115
Paper 4	115
Paper 5	150
THIRD BLOCK.....	201
Paper 6	201
Paper 7	254
Conclusion and future perspectives	297

PART I: GENERAL INTRODUCTION

In this first part of the thesis, some general information is discussed. These concepts are useful for the understanding of the general picture presented in this PhD.

The origin and fate of TE in different compartments of the aquatic system are presented as well as a brief description of analytical techniques used during the present work.

1. TRACE ELEMENTS IN THE ENVIRONMENT

The IUPAC Compendium of Chemical Terminology defines trace element as “any element having an average concentration of less than about 100 parts per million atoms or less than $100 \mu\text{g g}^{-1}$ ” (McNaught and Wilkinson, 1997). Among TE, some are oligo elements and are thus considered essential for various biochemical and physiological functions within a certain range of concentrations. Metals/metalloids considered by World Health Organization to be essential for human health are: chromium, cobalt, copper, iron, molybdenum, selenium and zinc (WHO, 1996)(WHO, 1996). On the other hand, other TE are considered toxic at any concentration (Hg, Pb, Cd) (WHO/FAO/IAEA, 1996).

These elements are naturally present in the ecosystem because of natural processes such as weathering and erosion but also volcanic activity. Nevertheless, in the last decades, several anthropogenic activities have increased the loads of these elements in the environment (Bagul, 2015). Main anthropogenic sources of TE include metal mining, mineral processing, smelting, coal mining, power generation but also municipal waste incinerators, industrial waste of many types and petroleum utilization. Specifically, in coastal systems, the anthropogenic sources can be represented by building of infrastructure, land reclamation for port and industrial development, habitat modification, tourism and recreational activities (Rao et al., 2006). The levels of TE in the environment are thus dominated by several concomitant processes, related to the origin but also to the different fates of these components in through environmental compartments.

1.1. Trace elements in the aquatic system

Trace elements have been transported along the hydrological cycle since the first occurrence of water on the planet. Water provides the medium for weathering of the continents as well as the medium for transport them in other environmental compartments (Salomons and Förstner, 1984). Along the way to the oceans, trace elements undergo different processes, due to environmental changes that affect their distribution in dissolved and particulate phases. TE under the form of particulates may accumulate in rivers and lakes and from there reach the coast through estuarine systems. Several important processes take place in the interfaces river/ocean as well as in the continental shelf. In these areas (often hosting harbors and industrial centers), TE from natural and anthropogenic origins are accumulated. Once the riverine or atmospheric TE loads have entered the oceans, they take part in an intricate group of geochemical processes, ultimately ending their path as

accumulated substance by marine sediments. An illustration of these complex patterns is shown in figure 1. The residence time of TE in aquatic environment varies from a few days (rivers and atmosphere) to several thousands of years (oceans) (Salomons and Förstner, 1984).

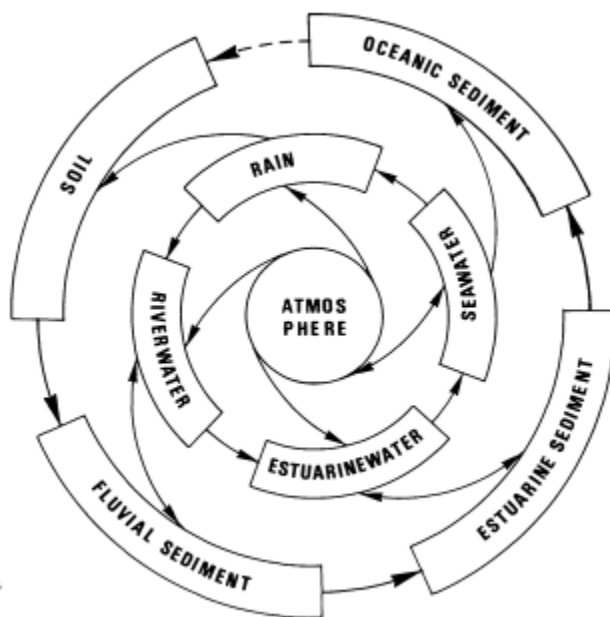

Figure 1. Movement of trace metals in the hydrological cycle. Copyright Springer

Intrinsic water characteristics such as physiochemical and biological properties have a great influence on the geochemical cycle of elements in the oceans (Elderfield, 2003). Trace elements can be found in the environment under the form of free cations (M^{n+}), which is the most bioavailable form especially for aquatic organisms such as phytoplankton (Bruland and Lohan, 2003). Others are more often under the form of oxyanions, such as MoO_4^{2-} and AsO_4^{2-} . In aquatic ecosystems, trace elements are very often bound to ligands. Most natural waters have a certain capacity to reduce the bioavailability, and thus the toxicity, of such elements, due to the presence of ligands complexing the free ions (Salomons and Förstner, 1984). Nevertheless, some of the complexes can, in turn, be bio-available, such as those accumulated by the marine biota (Vicente-Martorell et al., 2009; Strady et al., 2011). Water contamination can thus have a direct effect on the food chain as well as be biomagnified through it (Bocher et al., 2003; Majer et al., 2014). The understanding of TE cycle in the aquatic system is of prime

interest to address the right correction actions and help decision makers in the process of efficient restoration of natural conditions.

The behavior of trace elements in the water column is governed by several factors. Direct precipitation of dissolved elements is possible as a consequence of changes in physiochemical condition, such as pH, oxidation potential or concentrations of precipitating substances. These circumstances can occur as a consequence of water mixing processes, loss or addition of gasses as well as the mixing of water with solids (Rose and Hawkes, 1979). An example is the precipitation of U, V, Cu, Se, and Ag as metal or lower-valency oxide because of reduction usually caused by an encounter with organic matter or mixing with reducing waters or gasses. The redox potential E_h thus plays a crucial role in the behavior of trace elements in aquatic environments. In natural system, E_h is often a measure of total dissolved oxygen, although other dissolved species can act as oxidizing (NO_3^- , SO_4^{2-}) and reducing (Fe^{2+} , Mn^{2+}) agents (Plant and Raiswell, 1983). The pH also influences the mineral dissolution and precipitation reactions, additionally affecting the complexing process. The speciation of many elements in the surface environment may be represented in E_h vs pH diagrams (Plant and Raiswell, 1983). An example is shown in Figure 2.

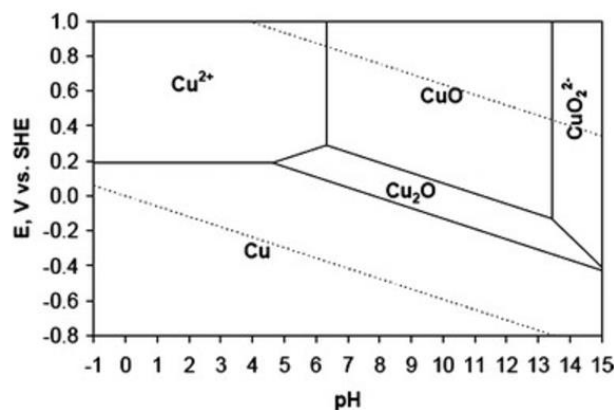

Figure 2. Potential-pH diagram for Cu in water. Full lines separate the stability fields for copper species. The y-axis is the potential in Volts with respect to hydrogen electrode (Nolan and Cadien, 2012)

TE occurrence of TE in the particulate or dissolved phase of water affects directly their assimilation by organisms and thus their involvement in marine biogeochemical cycles. Additionally, their solubility is influenced by their source, so the way through which they reach the water column. For example, trace

elements having an urban source are more soluble than those derived from crustal weathering (Chester et al., 1993). It is possible to distinguish three main groups on trace elements, depending on their behavior all along the water column, as shown in Figure 3 (Bruland and Lohan, 2003):

- Conservative (or bio-unlimited) elements: low affinity with particles and long residence time; their concentration does not change with depth (e.g., Cs, Rb, Mg)
- Nutrient elements: show lower concentration on the surface and higher in the bottom of water columns, as a result of plankton uptake and incorporation on the surface (e.g., Cd, Cr, Cu, Ag, As, Ba, etc.)
- Scavenged elements: have a high affinity for particles and they are rapidly sorbed onto particles and liberated to the sediments. Therefore, their concentration is lower in the bottom of water column

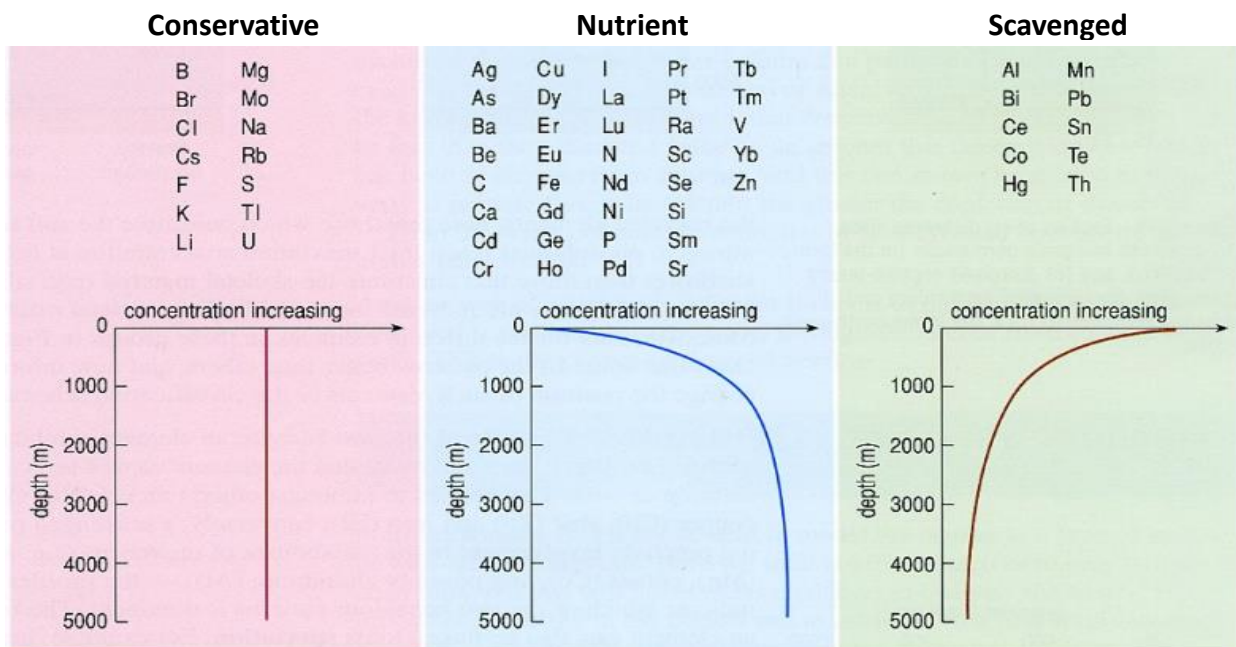

Figure.3. Classification of major and trace elements according to their behavior in the water column
(adapted from Nozaki, 2001)

1.2. Trace elements speciation

As already mentioned, trace elements can have variable toxicity which often depends on their chemical forms. As a consequence, the bulk concentration of the element is often not sufficient information for the assessment of its real toxicity (Chai et al., 2004). Consequently, in the last decades,

researches have been focusing on the analysis of chemical species of several TE to evaluate their impact on the environment (Sánchez Uría, 1998; Leermakers et al., 2005; Semeniuk et al., 2016). Among toxic elements, arsenic and mercury are two of the most studied elements regarding chemical speciation in environmental samples.

1.2.1. Arsenic

Arsenic (As) is classified as metalloid as it presents characteristics of both, metallic and non-metallic element (Phillips, 1990). It is associated with igneous and sedimentary rocks, particularly with sulfidic ores as it is strongly chalcophile. Several anthropogenic activities such as metals and alloys manufacturing, petroleum refining and burning of wastes and fossil fuels, have contributed to a strong legacy of As pollution throughout the world (Melamed, 2005). Several As-containing compounds are produced by industry and have been used to manufacture products for agricultural applications such as insecticides, herbicides, and fungicides. Numerous species of As can occur in the environment and the interconversion of species from toxic to less harmful and vice versa is possible as a consequence of some physical-chemical changes such as biological activity, changes in redox potential, or pH. To determine the actual risk represented by this element in the environment, a proper study should include identifying and quantifying both the total quantity of arsenic and the specific chemical forms present in the sample (Gong, 2002).

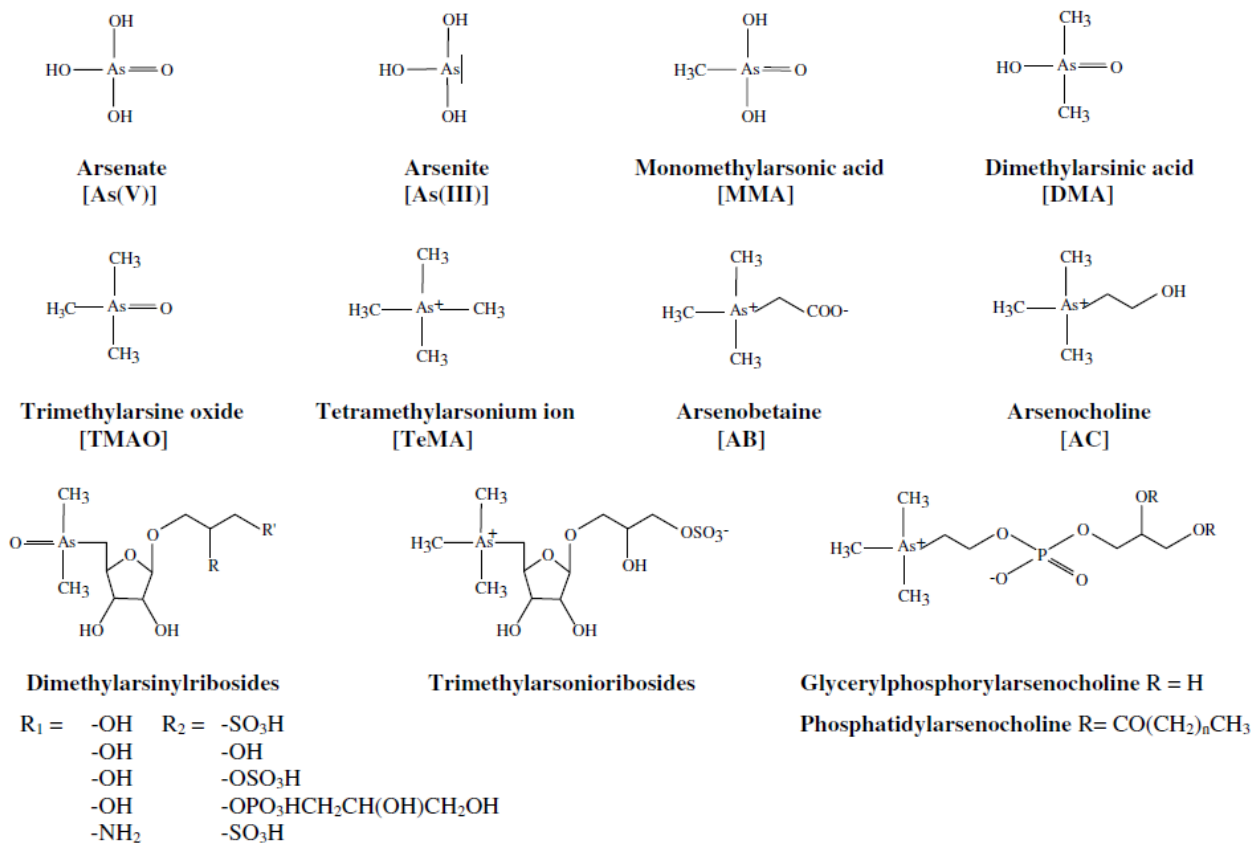

Figure 4. Structures of the principal As compounds in the marine environment (Leermakers et al., 2006)

In the environment, arsenic occurs usually under inorganic species, and rarely under organic ones (Figure 4). The main inorganic species are found under two oxidation states: arsenite As(+III) and arsenate As(+V), as the oxyacids (H_3AsO_3 and H_3AsO_4). In many environments (under neutral conditions), As(+V) is often deprotonated as an arsenate oxyanion (H_2AsO_4^- or HAsO_4^{2-}); in contrast, As(+III) remains predominantly in its neutral form as H_3AsO_3 . Arsenate oxyanions and the neutral arsenite constitute the main targets for field analytical assays (Melamed, 2005). Inorganic As species are found in water and soils and in small quantities in living organisms where rather organoarsenic species dominate. Some biological processes (mainly due to bacterial activities) can also promote the oxidation or the reduction of inorganic As (Anderson et al., 1992; Santini et al., 2004; Silver and Phung, 2005; van den Hoven and Santini, 2004). Usually freshwaters and ground waters scarcely contain organic As species such as methylarsonate (MMA, $\text{CH}_3\text{AsO}_3\text{H}_2$) and dimethylarsinate (DMA, $(\text{CH}_3)_2\text{AsO}_2\text{H}$) (Bednar et al., 2004; Bohari et al., 2001; Martinez-Bravo et al., 2001). Organic As species (methylated species and arsenosugars) usually occur in biological organisms (particularly in marine ecosystems). Arsenobetaine (AsB) is usually the dominant As species occurring in fishes and seafood, but other methylated

compounds are also found in marine biota (Nam et al., 2010; Grotti et al., 2010). Biological processes promoted by some microorganisms or bacteria enhance the methylation of inorganic species in organic ones, such as MMA, DMA, trimethylarsine [TMA, $(\text{CH}_3)_3\text{As}$] (Bentley and Chasteen, 2002; Cullen and Reimer, 1989; Irgolic and Stockton, 1987). Arsenic is essential for some organisms, e.g., 12 to 25 μg of total As per day is required by humans, but it is also toxic at low and high concentration (WHO, 2006). Chronic As exposure increases the risk of cancer and skin pigmentation. Arsenic has great notoriety as a poison, though there are great differences in the toxicity of different arsenic compounds. Arsenic occurs as organic and inorganic species, and it can have different oxidation states (-III, 0, +III and +V). Its toxicity also depends on its valence and speciation, inorganic species being by far the most toxic species (Table 1).

Table 1. Experimental LD_{50} (median lethal dose) for some As compounds (adapted from Leermakers et al., 2006 and Levy, 1946)

Arsenic species	LD_{50} (g/kg)
Arsine (AsH_3)	0.003
Arsenite As(+III)	0.014
Arsenate As(+V)	0.020
TeMA	0.89
DMA	1.2
MMA	1.8
Arsenocholine	>6.5
TMAO	10.6
Arsenobetaine	>10.0

Most cases of arsenic human toxicity have been associated with exposure to inorganic arsenic. Inorganic trivalent arsenite As(+III) is 2–10 times more toxic than inorganic pentavalent arsenate As(+V) (Goyer, 2001). By binding to thiol or sulfhydryl groups on proteins, As(+III) can inactivate over 200 enzymes. This mechanism is the likely mechanism responsible for arsenic's widespread effects on different organ systems (Tchounwou et al., 2012). The acute toxicity of As(+V) is related to its ability to replace phosphate, which is involved in many biochemical pathways (Goyer, 2001; Hughes, 2002). Arsenic toxicity is much higher in inorganic forms than organic species of arsenic (Table 1). The major metabolic pathway for inorganic arsenic in humans is methylation. Most of the mammalian species methylate inorganic arsenic (Vahter, 1994). Inorganic arsenic is metabolized by a sequential process involving a two-electron reduction of inorganic pentavalent arsenic to inorganic trivalent arsenic, followed by oxidative methylation to pentavalent organic arsenic (Thomas et al., 2001). The reduction can occur non-enzymatically in the presence of a thiol such as glutathione (GSH) (Delnomdedieu et al.,

1994; Scott et al., 1993). However in human livers, some specific enzymes have been isolated, suggesting that the reduction occurs using enzymatic reaction (Radabaugh and Aposhian, 2000; Zakharyan et al., 2001). The species produced as a result of these reactions are then expelled along with urine.

Biogeochemical processes regulating As speciation in the aquatic environment are summarized in Figure 5. Biological activities, weathering, and volcanic activities on one hand and anthropogenic activities on the other, are responsible for the emission of inorganic As into the atmosphere, from where it is redistributed on the earth's surface by rain and dry fallout (Cullen and Reimer, 1989).

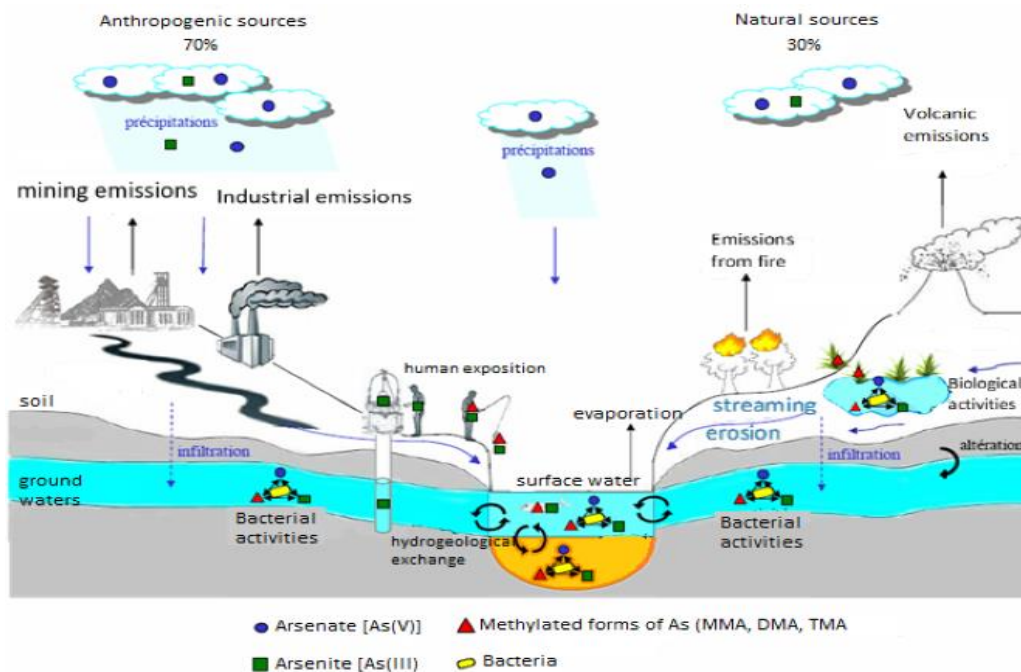

Figure 5. Global arsenic geo-cycle (Bossy, 2010). Black and blue arrows represent arsenic emissions in the atmosphere and its entrance back in surface/ground waters

1.2.2. Mercury

Mercury (Hg) is non-essential and highly toxic trace element. This metal has a very different chemistry from its group and period neighbors, and it is the only metal liquid at room temperature. Mercury naturally occurs in the environment although it is considered rather rare chalcophile element. The principal mineral is cinnabar (HgS), along with the metacinnabar group of minerals; other primary

Hg minerals include native mercury, corderoite $\text{Hg}_3\text{S}_2\text{Cl}_2$ and livingstonite HgSb_4S_8 . Most mercury is derived by natural sources but its biogeochemical cycles is disrupted by anthropic inputs as several human activities have contribute to increase its environmental input since the industrial revolution (Wu et al., 2006; Chen et al., 2013; Lamborg et al., 2014). Anthropogenic sources of mercury come from metal production, chlor-alkali, and pulp industries, waste handling and treatment, and coal, peat, and wood burning (Lindqvist et al., 1991).

Mercury occurs in the environment under three principal forms: $\text{Hg}(0)$, inorganic Hg and organic forms such as methyl mercury (MeHg). Hg coming from natural and anthropogenic sources is principally emitted in the atmosphere, where its global cycle (Figure 6) is largely controlled by oxidation–reduction reactions. For instance, it can easily oxidize into soluble (inorganic) Hg^{2+} which in turn can deposit on water and soil surfaces. A small fraction of mercury in natural waters is converted to organic forms such as methylmercury (CH_3Hg^+) and dimethylmercury [$(\text{CH}_3)_2\text{Hg}$], by bacterial action in anoxic environments.

Metallic Hg is relatively inert and not readily taken up by organisms, but it is volatile and its vapor is toxic. Inorganic forms such as HgCl_2 are also considered toxic especially for long-term exposure (Lohren et al., 2015). Fat-soluble organic forms (especially MeHg) accumulate in the biota via the food chain (up to several mg kg^{-1}), resulting in human exposure through consumption of fish (Morel et al., 1998). This compound is considered the most toxic form of mercury since it causes serious central nervous system dysfunctions (Harada, 1995). Additionally, contrary to other trace elements efficiently accumulated by organisms, Hg is bio-magnified through the food chain, meaning that the highest concentrations of this element are found in the highest levels of the food chain. $\text{Hg}(0)$ and Me_2Hg are not bioaccumulated by organisms because they are not reactive and thus not retained by plankton in the first place (Morel et al., 1998). On the other hand, Hg(II) is efficiently retained by microorganisms but not efficiently transferred to other organisms through food chain in comparison to MeHg (Mason et al., 1996) as it probably happens when considering other trace elements. In 2013, a multilateral environmental agreement known as Minamata convention, has been promoted by UNEP and it addresses the adverse effects of mercury through practical actions to protect human health and the environment from anthropogenic emissions and releases of mercury and its compounds (Briant et al., 2017).

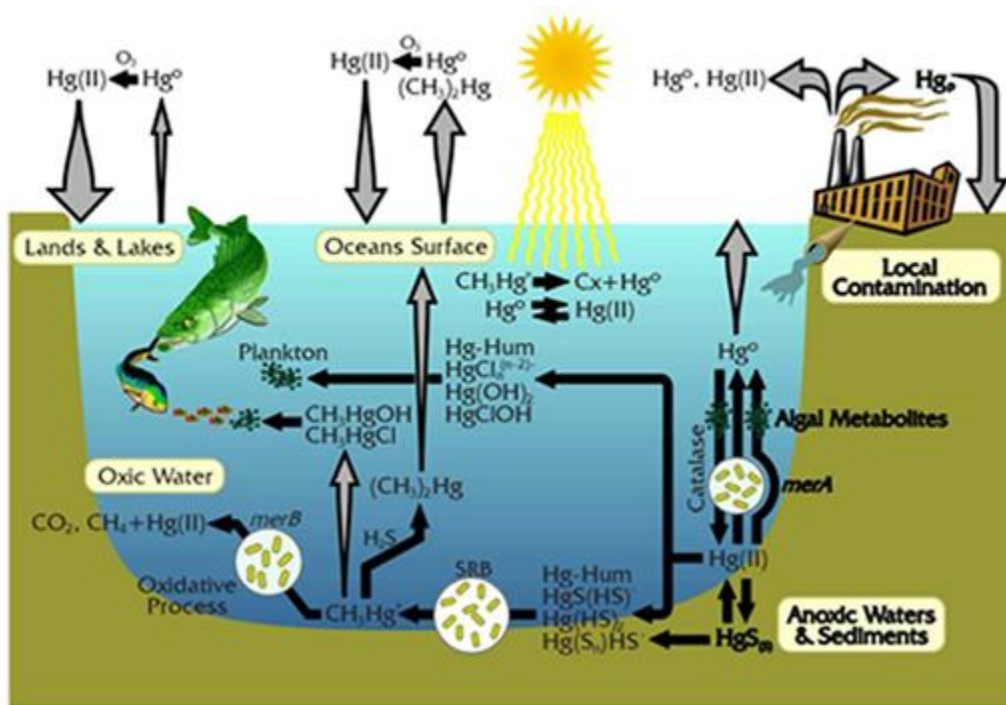

Figure 6. Mercury cycling and methylation in the aquatic environment. (Morel et al., 1998). SRB stands for Sulfate Reducing Bacteria. MerA and MerB are enzymes involved in the hydrolysis of MeHg and reduction of Hg(II) respectively (Morel et al., 1998)

1.3. Trace elements isotopes

Many elements exist in nature with different isotopes, i.e., atoms of the same element which differ from each other only in their number of neutrons. Generally speaking, it can be stated that all elements have an isotopic composition stable in nature. However, there are some reasons why this isotopic composition may show some variation. One of this reason is the presence, among the isotopes, of radiogenic nuclides. Such nuclides are produced as a result of radioactive decay. The additional production of this radiogenic isotope can have a pronounced effect on the final isotopic composition of a given element. Other phenomena responsible for a change in isotopic composition are interaction with cosmic rays, mass-dependent and mass-independent mass fractionation and the presence of extraterrestrial material (Vanhaecke and Degryse, 2012).

As already stated, some elements show natural variation in their isotopic composition as a consequence of the presence, among its isotopes, of radiogenic nuclides (Ault et al., 1970). A radiogenic nuclide is continuously produced as long as the parent radionuclide is available, leading to an increase of its relative abundance with respect to other isotopes of the same element. The presence of one radiogenic isotope within the same element affects the general isotopic composition and the relative abundance of other isotopes. Mass fractionation is related to the fact that different isotopes can participate with different efficiency to chemical and physical processes. These differences in efficiency are related to slight differences in equilibrium for each different isotopic molecule (thermodynamic effect) or in the rate with which the isotopes participate in a process or reaction (kinetic effect) (Vanhaecke and Degryse, 2012). As a result, the isotopic composition of such element will be different at the end of the process in comparison to the isotopic composition at the beginning of it. These effects need to be considered when measurements of isotopic ratios are performed. Most of the time the phenomenon of mass fractionation shows linear dependency with the mass of the isotope: but for some elements it constitutes a hot topic of research (Vanhaecke and Degryse, 2012).

When measuring isotope ratios by ICP-MS, the effect known as mass discrimination has to be taken into consideration. As a result of differences in the efficiency of ion extraction, transmission and detection as a function of analyte mass, an isotope ratio measured with ICP-MS may show significant bias with respect to the corresponding true value (Vanhaecke et al., 2009). This effect is constant and needs to be corrected during the measurement session. For this purpose, several correction models have been developed, often involving a mathematical correction based on the measurement of a certified external isotopic standard (e.g. NIST 981 or NIST 982). Another method involves the use of an internal standard, with similar mass to the analyte, directly added in the sample to be analyzed. For example, in Pb isotopic analysis, a Tl standard is added to the sample solution and the bias between the measured $^{203}\text{Tl}/^{205}\text{Tl}$ and the corresponding true value is used to determine the mass discrimination per mass unit, which is in turn used to correct the Pb ratio data (Vanhaecke et al., 2009).

The measurement of isotopic ratios finds application for numerous elements, especially in provenance studies. Sr, Pb, Nd and U are only few examples of elements used for this application, measurable by ICP-MS (Debord et al., 2017; Kingson et al., 2017; Vio et al., 2018).

1.3.1. Pb Isotopic ratios

Lead is perhaps the most popular among elements partly radiogenic accessible via ICP-MS. It has four stable isotopes, three of which are radiogenic. The decay chain of ^{238}U ($t_{1/2}=4.468 \times 10^9$ years), ^{235}U ($t_{1/2}=0.407 \times 10^9$ years) and ^{232}Th ($t_{1/2}=14.010 \times 10^9$ years) finally results in ^{206}Pb , ^{207}Pb and ^{208}Pb respectively. ^{204}Pb is the only natural isotope, and its abundance is constant since the formation of the solar system (Komárek et al., 2008). As a consequence, the final Pb isotopic composition depends on the original U/Pb and U/Th elemental ratios, becoming characteristic of a particular geographical location. For this reason, Pb isotope ratios find application in provenance studies in several fields (Sjåstad et al., 2011; Nakata et al., 2015; Dudás et al., 2016; Shepherd et al., 2016; Sjåstad et al., 2016). In environmental science, the use of Pb isotope ratios is a well-known tool, helping scientist to determine the actual presence of Pb pollution and to track the source of anthropogenic inputs. There is a substantial difference between isotopic composition of crustal Pb and that in ores. Pb isotope ratios analysis provides thus an excellent tool to distinguish between local Pb and Pb pollution derived from ores (e.g., anti-knock compounds added to petrol or for industrial use) (Monna et al., 1995; Bollhöfer and Rosman, 2000; Bollhöfer and Rosman, 2001). In environmental samples such as aerosol, sediments and snow, the final isotopic composition is the result of natural and one or more anthropogenic inputs. A way to verify such a possibility is to plot the results in the so called three isotope graph (Figure 7), which is a graphical representation of two different ratios with a common term e.g. $^{208}\text{Pb}/^{204}\text{Pb}$ vs $^{206}\text{Pb}/^{204}\text{Pb}$.

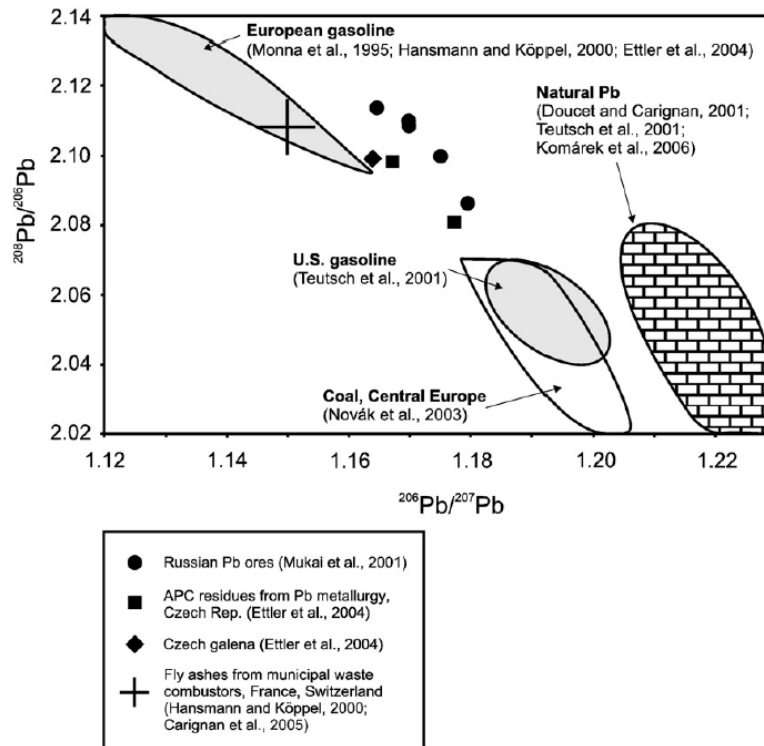

Figure 7. Example of three-isotope graph showing the isotopic composition of different sources of Pb, based on $^{206}\text{Pb}/^{207}\text{Pb}$ vs $^{208}\text{Pb}/^{206}\text{Pb}$ (Komárek et al., 2008)

If the results will fall in a mixing line (linear trend) in this diagram, it means that Pb originates from two sources, which are the two end members of the mentioned line. With this representation, the contribution of the 2 sources can be calculated (Komárek et al., 2008). If three end members contribute to the final isotopic composition, the results in the three isotopes graph will plot in a triangular field, delimited by lines connecting the ratios of the three end-members. In such and more complex case, the determination of the single contribution is rather complicated (Vanhaecke and Degryse, 2012). A popular plot in environmental studies is the $^{207}\text{Pb}/^{206}\text{Pb}$ versus $^{208}\text{Pb}/^{206}\text{Pb}$, which often shows a linear trend that can be interpreted as a simple mixture of two Pb sources. Ellam (2010) recently demonstrated that this type of representation could lead to the erroneous conclusion since the linear trend in such representation is inevitable and thus it is not suitable in the case of multiple source mixing. A more reliable test for multiple mixing models can be obtained by plots involving $^{206}\text{Pb}/^{204}\text{Pb}$, $^{207}\text{Pb}/^{204}\text{Pb}$, and $^{208}\text{Pb}/^{204}\text{Pb}$, which highlights the importance of ^{204}Pb isotope. The limitation of this

approach arises from the difficult determination of ^{204}Pb using ICP-MS, as it is the least abundant isotope (about 1.4% natural abundance) and it is affected by ^{204}Hg isobaric interference.

2. TRACE ELEMENTS MONITORING PROGRAMS

Environmental monitoring describes the processes and activities that are put in place in order to assess the quality of the environment. All monitoring strategies and programs have reasons and justifications which are often designed to establish the current status of an environment or to establish trends in environmental parameters. The ecological, economic and social importance of marine ecosystems being undeniable, a well-planned approach of managing the marine space is essential to achieve sustainability (Jonathan and Gobert, 2016). In parallel with growing concern for environmental conditions, several ocean monitoring programs have been introduced, at national and international levels (Kennish, 1994). Environmental assessment programs have a crucial role in the management of pollution sources and the preservation of marine habitats. The piece of coasts to be managed may be under actual pressure, such as eutrophication and pollution, or it may be under threat of pressure from some proposed development. Historically, most of the water quality investigations have attempted to assess trace elements in aquatic systems by direct analysis of water samples. Many studies have dealt with the determination of total and dissolved TE concentrations through the analysis of filtered and non-filtered water (Cidu and Frau, 2009; Bu et al., 2017). Concentration associated with suspended particulate matters (SPM) is usually indirectly determined as the difference between results obtained by non-filtered water and filtered one. In most of aquatic systems, TE concentrations in SPM are much higher (several order of magnitude) than those in the water samples. Some of the most toxic trace elements (e.g., Hg, As, Cd, Pb and Zn) are strongly associated with sediments and plankton which means that their distribution, mobility and bioavailability in the aquatic ecosystem cannot be solely evaluated by their determination in water (Horowitz, 1991). In Europe, the recent Environmental Quality Standard Directive 2008/105/EC (EQSD, 2008) marked an important step in the use of sediments and biota in environmental monitoring programs, in the frame of Water Framework Directive 2000/60/EC (WFD). Analysis of TE in sediments and biota is widely recognized as an effective approach in water-quality monitoring to provide baseline regional values for local monitoring, for describing the actual contamination levels as well as to identify areas of particular concern (Carere et al., 2012). Most of the toxic substances listed in the principal environmental ranking, accumulate in both sediments and biota.

Is therefore of crucial importance to include sediments, suspended or bed sediments, and biota in a proper environmental monitoring program.

2.1. Trace elements in sediments

Since sediments can act as reservoirs for many trace elements, they are often included in the planning and design of environmental monitoring (Carere et al., 2012; Quevauviller, 2016). One of the great application of sediment analysis in monitoring programs is related to the capability of this final sink to accumulate trace elements and thus providing an historical record of contamination; this property being often observed in sediment cores (Kljaković-Gašpić et al., 2008; Karbassi et al., 2005; Sun et al., 2012; Vallius, 2014). Additionally, under changing environmental and physiochemical conditions (e.g. pH, dissolved oxygen, bacterial actions), TE bound to sediments can be released in the water column, increasing their harmful effect in the environment and food chain (Le Pape et al., 2012; Tripti et al., 2013; Joung and Shiller, 2016).

2.1.1. Sediment components and classification

Marine sediments have very heterogeneous composition, depending on their origin and their geographical localization. The accumulation of TE in sediments depends directly on the nature of sediments. Three main types of sediments can be distinguished based on sources and components (Fütterer et al., 2006): (1) lithogenous (terrigenous or volcanogenic) sediments, transported and dissolved into the oceans as detrital particles; (2) biogenous sediments, formed directly by accumulation of skeletal parts of marine organisms; and (3) hydrogenous sediments, which precipitate directly out of solution as new formations.

Terrigenous material can be transported for several hundreds of kilometers in the form of weathered minerals, by wind. The latter only transport particles of fine grain size, such as silt and clay. Clay minerals constitute up to 50% of entire terrigenous sediments and they are of special importance because of their capability to absorb and release ions (Fütterer et al., 2006). Despite all regional variabilities, the clay mineral composition is rather constant, including only a few basic minerals (Table 2). Regarding the biogenic sediments, they can be considered as all solid hard materials formed in the biosphere. The amount of carbonate deposited in the oceans today is almost entirely derived from biogenic processes. Despite the great variability of marine organisms, only a small group produces hard parts which can contribute to sediment formation in substantial amount. Relevant for sediment formation are only carbonate minerals in the form of aragonite, Mg-calcite and calcite, as well as

biogenic opal in the form of amorphous $\text{SiO}_2 \cdot n\text{H}_2\text{O}$. Hydrogeneous sediments represent a negligible contribution to sediment classification, in comparison with previous types. They are mostly formed as direct inorganic precipitates from seawater, like sodium chloride.

Table 2. Mineralogy of main lithogeneous components (adapted from Fütterer et al., 2006)

Principal minerals	Idealized composition
Quartz	SiO_2
Calcite	CaCO_3
Dolomite	$(\text{Ca}, \text{Mg})\text{CO}_3$
Feldspars	$\text{KAlSi}_3\text{O}_8 - \text{NaAlSi}_3\text{O}_8 - \text{CaAl}_2\text{Si}_2\text{O}_8$ (repeating units)
Muscovite	$\text{KAl}_2[(\text{AlSi}_3)\text{O}_{10}](\text{OH})_2$
Clay minerals	
Kalonite	$\text{Al}_2\text{Si}_2\text{O}_5(\text{OH})_4$
Mica group	$\text{X}_2\text{Y}_{4-6}\text{Z}_8\text{O}_{20}(\text{OH}, \text{F})_4$ $\text{X}=\text{K}, \text{Na}, \text{Ca}; \text{Y}=\text{Al}, \text{Mg}, \text{Fe}; \text{Z}=\text{Si}, \text{Al}$
Chlorite	$(\text{Mg}_{3-y}\text{Al}_1\text{Fe}_y)\text{Mg}_3(\text{Si}_{4-x}\text{Al})\text{O}_{10}(\text{OH})_8$
Smectite group <i>e.g.</i> Montmorillonite	$\text{Na}_{0.33}(\text{Al}_{1.67}\text{Mg}_{0.33})\text{Si}_4\text{O}_{10}(\text{OH})_2 \cdot n\text{H}_2\text{O}$

Sediments are also classified according to: (1) the area of their deposition, distinguishing shallow-water deposits, terrigenous deposits in shallow and deep water close to land and pelagic deposits in deep waters (Fütterer et al., 2006); or (2) the distribution of the grain size. Sediments displays a great variety of grain sizes, from very coarse sand or gravel to very fine-grinded material. The Udden-Wentworth scale pinpoints four major categories, based on the grain size (Wentworth, 1922): gravel (>2 mm), sand (2 mm-63 μm), silt (63 μm – 3.9 μm), clay (<3.9 μm). Plotting the percentage of these categories in a three-plot diagram results in a graphic classification of terrigenous sediments based on grain size distribution, as shown in Figure 8.

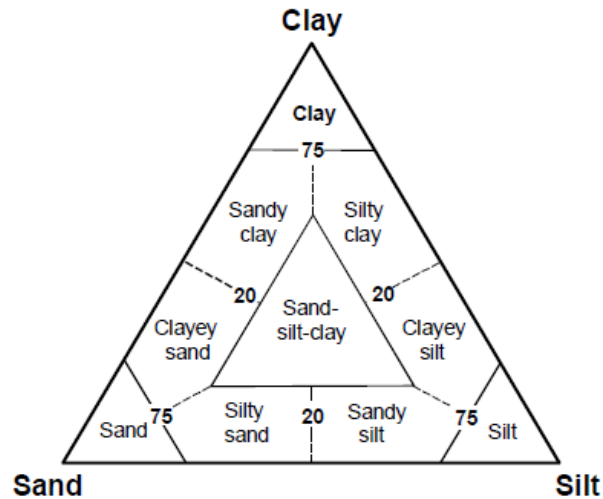

Figure 8. Ternary diagram of sand-silt-clay grain-size distribution showing principal names for terrigenous sediments (from Fütterer et al., 2006)

2.1.2. Factors affecting TE accumulation in sediments

A number of geochemical factors should be considered in the understanding of trace elements behavior in sediments. These factors help in the investigation of TE transport and environmental effects. The identification and quantification of these factors is often called partitioning, and divided into physical and chemical. Physical partitioning involves parameters such as grain size, surface area, magnetic properties etc. while chemical partitioning refers to the determination of chemical components such as carbonates, clay minerals, organic matter, silicates etc. These two types of partitioning are in fact strongly correlated to each other (Horowitz, 1991).

2.1.2.1. Physical factors

The principal physical parameter influencing TE chemistry in sediments is recognized to be the grain size (Thorne and Nickless, 1981; Horowitz and Elrick, 1987). There is a very strong correlation between decreasing grain size and increasing TE concentrations. Fine grained sediments, because of their large surface areas, are the main sites for collection and transport of TE. Nevertheless, TE accumulate on coarse material as well, including sand, but the highest concentrations are usually found in fine particles (Horowitz, 1991). In order to mitigate differences due to grain size, it is possible to perform a normalization with respect to this parameter. A recent study has examined the efficiency of normalization using the <math><63 \mu\text{m}</math> fraction as normalizing parameter, showing that the possibility to

misinterpretation is quite high. The reason is that this fraction is unlikely to accurately embody the clay content, which represents a major factor in TE adsorption in sediments (Szava-Kovats, 2008). The correlation between grain size and TE content was observed in a broad range of sizes such as <16, <70, <125 μm among others (Beeson, 1984; Horowitz and Elrick, 1987). Additionally different tendency can be observed for different elements, i.e. different slopes when the element concentration is plotted against percentage of fine grain-sized portion of the sediment. The element distribution in different granulometric fractions of the sediment can be very specific and characteristic, thus allowing the differentiation of samples from diverse origins.

The surface area, reported in area per mass, is another very important physical parameter to be considered. It is strongly correlated with grain-size (it increases with decreasing in grain size) but it also depends on chemical composition. This parameters is very important since the majority of processes through which TE are collected, concentrated and retained in sediment fall into the general category of “surface reactions”. It follows that materials with large surface areas are those mainly involved in TE chemistry (Horowitz, 1991). The main process involved in TE collection is the adsorption, which is the condensation of constituents on the surface of another material. Materials with high surface areas can be seen as mechanical substrates upon which the inorganic particles can concentrate without involving chemical reactions. The more the surface area increases the more the capacity of these materials to adsorb TE improves. The surface areas of some substances are shown in Table 3.

Table 3. Surface areas of some materials with diameters <2 μm (data from Forstner and Wittmann, 1981, table from Horowitz, 1991)

	Material	Surface area (m^2/g)
	Calcite	12.5
Clay minerals	Kaolinite	10-50
	Illite	30-80
	Montmorillonite	50-150
	Iron hydroxide	300
	Organic Matter	1900

2.1.2.2. Chemical factors

Several chemical processes govern the chemistry of TE in sediments. Adsorption, precipitation and co-precipitation, organometallic bonding, cation exchange are some of the main chemical processes affecting TE association with sediments or TE release from sediments.

Most of TE behave as cations and are readily sorbed and released on and from surfaces of materials with net negative charge, such as clay minerals, iron and manganese hydroxides and organic matter. This process is called cation exchange and it occurs thanks to the sorptive capacity of different anionic sites such as SiOH, Al(OH)₂, AlOH (clay minerals) and -COOH or -OH groups (from organic matter) among others (Forstner and Wittmann, 1981). The cation exchange capacity (CEC) determines the ability of a material to hold cations, and it has been proven to be correlated with grain size and surface area. Some of the materials with the highest CEC are manganese hydroxide, humic acids and iron hydroxide (Horowitz, 1991). Bearing in mind the strong relation between physical and chemical properties, a number of compounds and substances most important in TE behavior in sediments can be identified. These materials (or geochemical substrates) are characterized by large surface areas, high CEC and they are mostly concentrated in the finer size fractions.

- Fe and Mn oxides are well known for acting as excellent TE scavengers in solutions (Gadde and Laitinen, 1974), they are mostly found in sediments under the form of nodules, micro-nodules and coating. They have been proven to be important concentrators of TE in aquatic systems (Jones and Browser, 1987; Forstner, 1982; Horowitz and Elrick, 1987).
- Organic matters (OM), generally named humic substances (humic acids, fulvic acids, humins) are well known for concentrate TE in soils and sediments (Hirner et al., 1990; Rieuwerts et al., 1998). The capacity of organic matter to concentrate TE varies with the constituent and the type of OM but also to the stability of the TE-organic compound formed. The concentration of aquatic organic matter is indicated measuring the total organic carbon. Negative or no-correlation between OM and some TE were also reported in the literature (Wang and Qin, 2006) showing a very variable interaction which might depends on the source (natural or anthropogenic) of both, OM and TE (Wang, 2008).
- Clay minerals are the main components of fine-grained sediments, characterized by large surface areas per unit mass. They are considered to be the major reasons for enrichment of TE in sediments. The actual role of clays in TE transport and accumulation depends on a number of factors, such as valence of TE, ionic radius, type of mineral (Förstner et al., 1989). It has been proposed that clay minerals might simply provide a mechanical substrate for other materials, such as OM and second minerals, and the latter carry out the actual concentration of TE (Horowitz and Elrick, 1987; Horowitz, 1991).

2.1.3. TE monitoring in sediments

Several trace and major elements have been analyzed in sediment samples in many parts of the world as a mean to provide environmental assessment. Considering that TE natural occur in sediments as primary components of minerals, it is often needed to set a background local level in order to be able to determine whether a high concentration is due to natural or anthropogenic input. It is rather difficult to set a “normal” trace elements concentration, as the natural background play an important role and the concentration ranges can be very wide for the majority of elements, even in pristine areas. For instance concentrations between 1.4-4.9, 673-5075 and 55-389 mg kg⁻¹ for Cd, Cu and Co respectively in sediments from the Tigris River (Varol, 2011); Vallius et al. (2007) reported values between 7.3-19.1 and 46-83 mg kg⁻¹ for As and Cr respectively in surface sediment from the Finnish coast of the Baltic Sea while Parra et al. (2015) measured concentrations between 41-1476, 8-17, 6-15, 17-36, 9-20 mg kg⁻¹ for Cu, Ni, Co, Pb and As respectively in marine sediments from Chile.

The “quantification” of sediment pollution thus needs to be assessed after the evaluation of the extent of TE naturally present in the considered area. For this purpose a chemical normalization is often performed, with respect to reference elements such as Fe and Al (Abraham and Parker, 2008; Karbassi et al., 2007) but also Mn, Ti and Sc (Zahra et al., 2014; Salati and Moore, 2010) and Li (Aloupi and Angelidis, 2001). The background (BG) concentration can be taken from reported natural abundances in the earth crust or taking as a reference the TE concentration measured in a proved uncontaminated place form the same area of study. Geochemical normalization has extensively been used to calculate enrichment and to reduce heavy metal variability caused by grain size and mineralogy of sediments (Zahra et al., 2014). Using both, background concentrations and normalizing elements, some parameters such as Enrichment Factors, Geoaccumulation Indices, Metal Pollution Indices and Pollution Load indices can be calculated in order to evaluate the extent of metal contamination in the sediments. the results are then evaluated following specific criteria (Guan et al., 2016).

The application of such parameters is nowadays very often used in monitoring studies involving lake, river and marine sediments ad proved to be useful tool in TE pollution assessment. For instance Guan et al. (2016) found rather high Co concentrations in river sediments from the Yellow river (max 339 mg kg⁻¹) but being the BG level around 280 the final enrichment was not considered substantial. Opposite conclusions were drawn for Cu, with max sample and BG concentrations of about 44 and 1.9

mg kg⁻¹ respectively. As a result the calculated parameters revealed significant anthropogenic influence for Cu (and other elements) but not for Co.

This approach has also been used for the study of sediment core samples, in order to evaluate a possible TE enrichment during the history, evaluating the vertical variation. In this case the BG value is often taken from the deepest sediment layer collected in the studied area (Veerasingam et al., 2015).

Nevertheless even though a high concentration of TE might not reflect anthropogenic influence it can still represents a threat for other compartments of the environment, adversely affecting for example the aquatic organisms. In order to evaluate such a possibility, sediment quality assessment guidelines are very useful to screen sediment contamination by comparing sediment contaminant concentration with the corresponding quality guideline (Macdonald et al., 1996). Quality guidelines and threshold values for marine sediments (but also for water and some biota) are provided by national and international institution such as EPA (Environmental Protection Agency).

2.2. Trace elements in marine organisms

TE accumulation by living organisms is based on the fundamental characteristics of living cells to take up elements from a solution against a gradient of concentration. This is perhaps most obvious for marine (or generally aquatic) organisms which obtain their nutrients directly from water (mollusks, algae, sponges for instance) (Bowen, 1966). Several studies have been published on the use of different biota and marine organisms to monitor TE in the ecosystem. Aquatic biota represent an incredible source of diversity in their biochemical adaptations to the environment and they are of increasing interest to scientists for several applications (Carpenè et al., 2017). Generally the selected organisms need to have some characteristics, such as being representative of the water body, accumulating one or more priority substances, being sampled on a regular basis without endangering the population of the organism itself. Additionally an adequate amount of sample needs to be available for chemical analysis (AMPS Expert Group, 2005).

2.2.1. Bivalves

Among marine organisms, mollusks such as oysters, mussels, scallops, clams and snails have been often used in monitoring TE contamination in the marine environment. These organisms are known for accumulating toxic elements. Since some of them are consumed as seafood in many countries, they can present a tangible risk for human health (He and Wang, 2013). In terms of human consumption, oysters are often the most important farming species, followed by clams, mussels and scallops. Bivalves have

been also employed as biomonitors of TE pollution in coastal environments because of their widespread distribution (Wang and Lu, 2017). Wide surveys such as the US Mussel Watch Program were put in place, involving the measurement of TE and other contaminants in different species of mussels and oysters and providing a database with results from long term studies (Cantillo, 1998).

Oysters are known to especially accumulate great amounts of Zn and Cu, both essential elements for these organisms. The accumulation varies according to oyster species and elemental availability. Cu and Zn concentrations in oysters collected in relatively clean places were reported to be around 50-100 and 500-2000 $\mu\text{g g}^{-1}$ respectively (Baudrimont et al., 2005; Wang et al., 2011; Ochoa et al., 2013). However, very high concentrations of these two elements ($>10000 \mu\text{g g}^{-1}$) were found in China and Australia in ecosystems known contaminated by Zn and Cu due to industrial releases (Weng and Wang, 2014 ;Birch et al., 2014). An interesting study recently investigated the Cu and Zn speciation in oysters, finding out that the excess of these elements is “stored” in the organisms tissue in O- and N- complexes, as a way of detoxification (Tan et al., 2015). It has also been reported that Ni, Cr and Pb do not concentrate at such high extent in these organisms, never reaching values reported for Cu and Zn (Wang and Lu, 2017). Pb concentrations reported for oysters are generally lower than $4 \mu\text{g g}^{-1}$, but there were a few cases where Pb tissue concentrations were high (e.g., up to $58.2 \mu\text{g g}^{-1}$ in Persian Gulf, (Heidari et al., 2013), suggesting a potential Pb contamination in the region. Ni is not often reported but it is generally found in quite low concentration ($2-4 \mu\text{g g}^{-1}$), except for a study of Weng and Wang, 2014 in which concentrations up to $43 \mu\text{g g}^{-1}$ are reported for oysters from Jiuzhen, China.

Mussels have also been extensively used in TE monitoring studies but again, as for oysters, limited studies have been focused on the comparison of accumulation properties for different species of mussels (Wang and Lu, 2017). Mussels are often used as biomonitors of Cd contamination as they present a response in their accumulation proportional to the external concentration. Nevertheless, Cd is more efficiently removed from mussel’s tissue compared to oyster (Wang and Lu, 2017). Cd concentrations in mussels are usually lower than $2 \mu\text{g g}^{-1}$ but some high concentrations ($>60 \mu\text{g g}^{-1}$) were found in the Gulf of Maine (USA) by Chen et al. (2016). In contrast to oysters, mussels are known to regulate their Cu and Zn tissue concentrations. The values reported for mussels are thus generally lower than those reported for oysters for these two elements. In this regards, bivalves show different accumulation properties and such characteristics have to be taken into considerations when these organisms are used as biomonitors of TE pollution. Among bivalves, clams are generally less studied but

they are considered to have a behavior similar to mussels, with respect to TE accumulation (Wang and Lu, 2017).

Marine organisms have a crucial role in the conversion of TE chemical forms. As already seen in previous paragraphs, the mobility and toxicity of some TE and their bio-availability depends on their chemical forms. The conversion of a given species from a chemical form to another one, can happen as a result of biochemical process, e.g. within the organism's tissue. For example inorganic mercury is transformed into organic mercury compounds by aquatic micro-organisms and accumulates in the food chain (Hartwig and Jahnke, 2012). The organic mercury compounds, of which methyl-mercury is the most common, are of special concern because of their great toxicity (Coulibaly et al., 2016) since they accumulate in living organisms and damage their central nervous system (Lauwerys et al., 2007). Hg, especially mono methyl-Hg, is also recognized to be biomagnified through the food chain. In this context, it is not surprising that several studies have been focusing on Hg speciation analysis in marine organisms (Leermakers et al., 2005; Spada et al., 2012; Azemard and Vassileva, 2015; Krata et al., 2016; Lang et al., 2017). On the contrary, other elements such as arsenic are transformed in less toxic species by the action of living organisms, as illustrated in paragraph 1.2.1. This is probably the most evident characteristic that differentiates As and Hg, and highlights the important role of biological processes in the aquatic environment.

2.2.2. Sponges

Sponges (Phylum Porifera) are an aquatic filter-feeding group of animals. The group consists of about 15000 species distinguished in three classes (Hooper and van Soest, 2002): the glass sponges (Class Hexactinellida)

- the calcareous sponges (Class Calcarea)
- the demosponges (Class Demospongiae)

Adult sponges come in a variety of colors, sizes and shapes including arborescent (tree-like), flabellate (fan-shaped), caliculate (cup shaped), tubular (tube shaped), globular (ball shaped), and amorphous (shapeless) among others. Sponges occupy both freshwater and marine environments, from shallow to abysmal depths, and are common in coral reef, mangroves, and seagrass ecosystems. Some years ago a study proved the ancient origin of sponges, which were shown to be the most primitive metazoans (Clark, 1968). The ancient origin of sponges was also proved by the existence of a poriferan fossil record going back to the Early Vendian (~580 Mya) (Li et al., 1998), and by sponge biomarker

record going back to the Cryogenian period (~750 Mya) (Love et al., 2009). Sponges represent a very important component of the benthic community, and their role in the marine ecosystem is of crucial importance for other organisms such as corals (Wulff, 2001; Diaz and Rutzler, 2001). Sponges have shown to be able to enhance coral survival, to have an important role in carbon and nitrogen cycles in the ocean (Bell, 2008) and to provide habitat for other organisms.

In environmental chemistry, sponges can be used as bioindicators of marine pollution but, studies focusing on sponges are limited in comparison to other marine organisms, such as mussels, oysters, clams. Recently these organisms gained scientists attention as possible biomonitors of TE contamination since they are abundant and widespread, long-living, sessile, and easily sampled and they have shown high tolerance for several pollutants. Additionally sponge communities can remain stable for long time periods, making them suitable model organisms for long and short-term monitoring studies. Sponges are filter feeding organisms, capable to pump very high quantities of seawater ($100\text{-}1200\text{ mL h}^{-1}\text{ g}^{-1}$). These filtering capacity are larger than most of other marine organisms (Olesen and Weeks, 1994) such as bivalves (Negri et al., 2006; Gentric et al., 2016). Sponges have also shown a high capacity for TE accumulation in a large time scale (Patel et al., 1985; Padovan et al., 2012) and revealed high tolerance for several pollutants (de Mestre et al., 2012; Batista et al., 2014). They can be considered as “biological particle traps” as they are able to concentrate a wide range of pollutants from both the suspended and dissolved phases, often showing high bio-concentration factors (Berthet et al., 2005; Cebrian et al., 2003). The detection of large quantities of TE in sponges suggests the existence of detoxification systems (Aly et al., 2013). All these characteristics make them suitable as a model organisms for monitoring studies, and their use as TE biomonitors has been proposed in several areas (Negri et al., 2006; Venkateswara Rao et al., 2009; Illuminati et al., 2016). Sponges have also been reported as efficient environmental remediators of different toxic compounds such as the bacterium *Escherichia coli* (Milanese et al., 2003) and the lindane, an organochlorine pesticide (Aresta et al., 2015). These characteristics, combined with recent interests in sponges as a source of novel pharmaceuticals and bioactive compounds (Anjum et al., 2016; Laport et al., 2009), indicate the possibility for a self-financing remediation program (Gifford et al., 2007).

A common way to evaluate the organisms' capability to quantitatively accumulate TE is the calculation of bioaccumulation and bioconcentration factors (BAF and BCF). Specifically BAF and BCF are calculated as the ratios between contaminant's concentrations found in the organism and the corresponding concentration found in water and sediment, respectively (Gobas, 2001).

Most of TE have been shown to be highly accumulated in several sponges species, showing higher BCF >1. The differences in TE accumulation among sponges seem to be strictly dependent on both, the species and the considered element. Among TE, Cu and Zn are usually highly accumulated in sponges because of their essential role: required for sponges growth (Cebrian et al., 2007; Mayzel et al., 2014). The range of their concentrations can be very wide depending on sponge specie and element availability in the environment. For example, Cu and Zn were reported to range between 0.2 and 19 mg kg⁻¹ and 2 and 1397 mg kg⁻¹ respectively in sponges from Southeast Brazil (Batista et al., 2014). Arsenic was also shown to be highly accumulated in different species of sponges, proving its important role in sponge's biological processes. High As concentrations were reported in sponges: higher than 100 mg kg⁻¹ by Pan et al. (2011), but also higher than those usually reported for fishes and other marine organisms such as algae and shellfish (Llorente-Mirandes et al., 2010). Cd was also recognized to be accumulated in sponges: *e.g.* in all the 16 sponge species analyzed by Mayzel et al. (2014) (BCF up to 60), or in different species of Antarctic sponges analyzed by Negri et al. (2006) and Bargagli et al. (1996). Other elements such as Mo, Ag, Cr and Pb are also often included in studies involving sponges, showing very variable accumulation properties, depending on the species. For example, Gentric et al (2016) reported values up to 12, 1.2, 6.2 and 6.8 mg kg⁻¹ for Cr, Mo, Ni and Pb, consistently higher than a specie of oyster collected from the same place. Pan et al. (2011) measured TE in different sponges and sediments from Red Sea, showing bioconcentration factors up to 74, 22, 3, 56 and 5 for Cd, Zn, Ag, Cu and As respectively. A particular behavior was observed in the specie *Acanthella acuta* with regards to Ag, showing very high concentrations in sponge tissue as well as a longer detoxification process (Genta-Jouve et al., 2012).

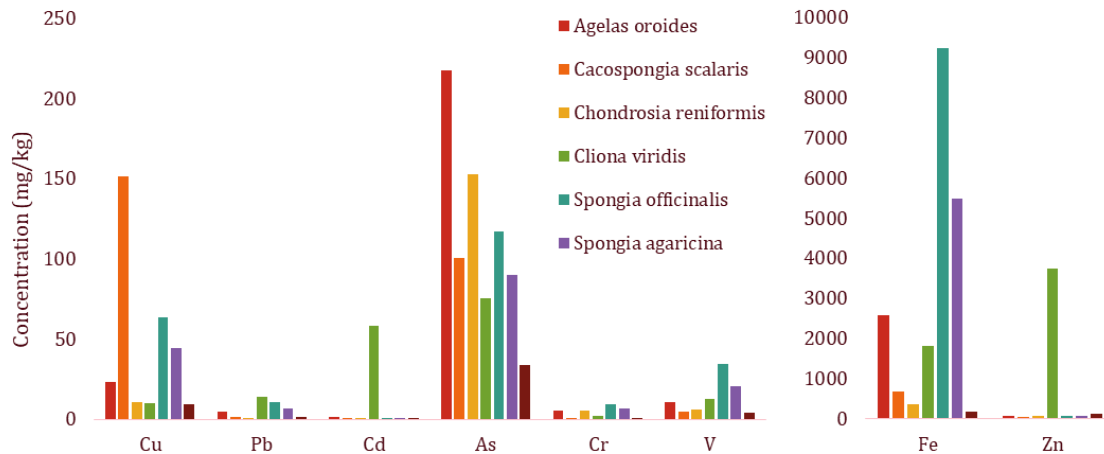

Figure 9. Comparison of TE measured in six sponges species (*Cacospongia scalaris*, *Spongia officinalis*, *Spongia agaricina*, *Agelas oroides*, *Chondrosia reniformis* Nardo and *Cliona viridis*) and a common mussel (*Mytilus galloprovincialis*). Adapted from Perez et al., 2003.

In conclusion, several properties make sponges good models for biomonitor TE pollution in coastal ecosystems. Among TE, Cu and Zn seem to be better accumulated in oysters and mussels. Sponges have shown to be better accumulators of other elements such as As, Ag and Ni.

3. TRACE ELEMENTS ANALYSIS

As a consequence of the increasing interest in TE analyses in different matrices, several techniques have been developed in the last decades. The main challenges are linked to the need for precise and accurate determination of these low-level analytes occurring usually in complex matrices with particular chemical and physical features. Accurate TE determination in environmental samples is of primary interest, as national, European and international legislations have reduced the maximum concentration of several analytes in different environmental samples. A variety of techniques based on different principles can be applied : electroanalytical methods, atomic spectrometry, X-ray and nuclear techniques (Brown and Milton, 2005).

Atomic spectrometry techniques, such as Atomic Absorption Spectrometry (AAS), Inductively Coupled Plasma Atomic Emission Spectrometry (ICP-AES) and Inductively Coupled Plasma Mass Spectrometry (ICP-MS) are very sensitive and capable of determining several elements within a limited amount of sample in a few minutes. These methodologies are extremely useful for the determination of

total amount of TE in environmental samples (Bermejo-Barrera et al., 1996; Damiano et al., 2011; Barats et al., 2014; Wysocka and Vassileva, 2016; Wang et al., 2017). The atomic spectrometric techniques used in this study (AAS and ICP-MS) imply the atomization and ionization of the samples, and their analysis according to their interaction with electromagnetic radiation or their mass (Brown and Milton, 2005). Very often the analysis of environmental samples by AAS and ICP-MS implies a sample preparation step: e.g., microwave digestion and solid-liquid extraction. This step might be responsible for systematic bias due to analyte loss, contamination, variability in analyte recovery. This preparation can represent a significant contribution to the total uncertainty (Barwick and Ellison, 1999). The increasing need for reliable data on TE concentration in a variety of environmental matrices has led to the production of several Certified Reference Materials (CRMs) used to assess the quality of the analytical method both in the development and in the application stages. The use of CRMs, when available, is especially needed when sample preparation is needed, to verify the correctness of the procedure and to identify the source of possible errors related to recovery and contaminations. The use of procedural blanks is also of crucial importance for the assessment of the method quality and to check possible contaminations occurring during the sample preparation.

Graphite furnace (GF) AAS is often directly compared with ICP-MS in the literature (Ndung'u et al., 2003). Table 4 shows a comparison between typical Limits of Detection (LOD) of these techniques. ICP-MS is a more sensitive analytical technique, with the great advantage to be multi elemental, while AAS is a mono-elemental technique.

Table 4. Comparison of approximate LOD between ICP-MS and GF-AAS (Adapted from Brown and Milton, 2005)

LOD (ng/g)	ICP-MS	GF-AAS
0.01-0.001	Al, Cr, Se, Mg	Mn, Al, Zn, Fe, Cu, Cr
0.001-0.0001	As, Ni, Cu, Zn, V, Sb Pt, Be, Au, Pb	Ni, Pb, Cd, Hg, Co, Ag
0.0001-0.00001	Cd, Mo, Ag, Ce	
<0.00001	U, Th	

3.1. Atomic Absorption Spectrometry

AAS is particularly indicated for the measurement of major elements. It can be used with Flame (F-AAS) or Graphite Furnace (GF-AAS or ET-AAS) atomizers. F-AAS typically works with liquid, and it is relatively inexpensive and simple to operate. It requires a large sample volume (around 10 mL). This analytical method is not indicated for some refractory elements such as Zr, As and Se, since the flame working temperature are not sufficiently high, but it is particularly indicated for the measurement of major elements in sediment and soil samples previously mineralised, e.g. in sediments such as Fe, Zn and Mn ($10\text{-}10000\text{ mg Kg}^{-1}$) (Loring and Rantala, 1992). GF-AAS exhibits LOD typically 10-100 times lower compared to F-AAS (Brown and Milton, 2005). The atomization takes place in a graphite furnace at higher temperature than atomization in the flame and the samples can be liquid or solid. Solid Sampling (SS) GF-AAS is very promising and finds already several applications (Belarra et al., 2002). Since the sample preparation step is not necessary, the risk of contamination and losses of analyte are removed. Relatively small quantities of solid (50-500 mg) may be analysed. Many of the interferences from which GF-AAS used to suffer (mostly associated with the sample matrix) can now be overcome with a combination of background correction and matrix modification (Brown and Milton, 2005). Another advantage of the use of (SS) GF-AAS is the possibility to work with fast programs, in which drying and pyrolysis steps are drastically shortened or even eliminated (Mandjukov et al., 2015). This aspect not only represents an advantage since it reduces the analysis time, but it also reduces the possibility of analyte losses, especially for volatile elements such as Hg and As. The recent introduction in the market of instruments equipped with High Resolution Continuous Source (HR-CS) and a charged coupled device (CCD) array detector has allowed several limitations due to classical line sources (LS) to be overcome (Figure 8). The continuous background covering the spectral range observed by the array detector is corrected automatically using correction pixels on both sides of the analytical line. In difference, the structured background can be corrected using reference spectra and a least-squares algorithm (Welz et al., 2007). In such configuration, it is possible to monitor not only the absorbance over time, as in classic LS AAS but a 3D information is also provided, about absorbance over time and over wavelength. This helps in avoiding interferences and generally in the method development stage.

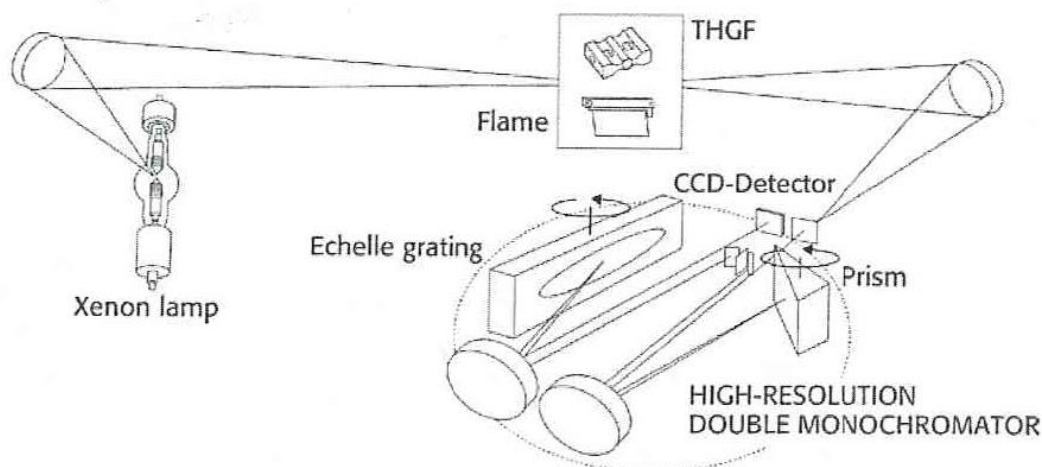

Figure 10. Representation of optical system in HR-CS-AAS (Analytic Jena, ContrAA 600)

3.2. Inductively Coupled Plasma Mass Spectrometry

Since its introduction in the market more than 30 years ago, ICP-MS has been gaining popularity among the techniques for TE determination for several reasons. First of all, in comparison with AAS, it can detect multiple elements in a few minutes single run. Additionally, its detection limits are close to or below the ng L^{-1} or the part per trillion (ppt) for most of the elements in the periodic table. Furthermore, ICP-MS gives the opportunity to perform isotopic analysis, opening to a larger application field in comparison to other techniques. Most of the elements in the periodic table are measurable by ICP-MS, with some exceptions (e.g. F, H, He, Ar). There are some different configuration commercially available which can differ in the design of specific parts such as the introduction system (nebulizer and spray chamber), the interface and the mass analyzer. The working principle of this technique includes the introduction of a liquid sample, usually through a peristaltic pump, into a nebulizer where it is converted in fine aerosols with an argon gas (Thomas, 2003). The fine aerosol is separated from the rest of the sample and carried through an injector to the plasma thanks to an Ar flux of 1 L min^{-1} . The Ar plasma is formed inside a quartz torch by the interaction of an intense magnetic field (produced by a radio frequency generator) on a tangential flow of Ar gas. In this condition, the Ar is ionized and when a spark act as a source of electrons, a very high-temperature (about 10000K) plasma discharge is formed. The plasma is responsible for atomization and further ionization of the analytes of interest. The energy available in an Ar plasma is about 15.8 eV which is sufficient to ionize most of the elements in the periodic table (Thomas, 2003).

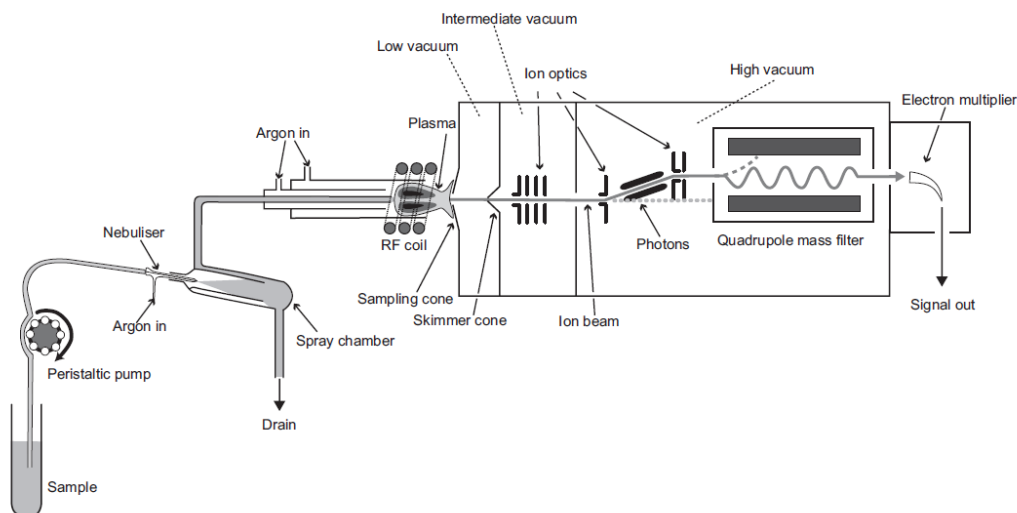

Figure 11. Basic instrumental components of an ICP mass spectrometer (Linge and Jarvis, 2009)

Once the ions are produced in the plasma, they are directed to an interface region (maintained under vacuum) consisting of two metallic cones (generally made of Ni or Pt), called sampler and skimmer cones. Ions emerging are then directed to the mass analyzer through the ion optic region. The mass separation device has the purpose to allow analytes of a particular mass to charge (m/z) to pass and reach the detector. There are different available mass analyzers, among which quadrupole and sector field (SF) are the most common. The final process is the conversion of ions into an electrical signal with an ions detector (usually an electron-multiplier).

The main advantage of SF mass analyzers is the possibility to increase the resolution, often solving the interference problems which represent the main limitation when working with quadrupole ICP-MS. Quadrupole-based instruments operate normally at resolving power of about 300 while SF instruments can reach 10000. Here resolving power is defined as $R=m/\Delta m$ where m is the nominal mass at which the peak occurs, and Δm is the difference between two resolved peaks (Adams et al., 1988). It has to be pointed out that an increasing of resolution is directly reflected in a decrease in sensitivity. Another attractive feature of SF instrument is a very high sensitivity combined with low background levels. When operating at low resolution, SF instruments provide LOD 5-10 times lower than quadrupole based instruments (Thomas, 2003). Another feature often important, especially in isotope ratios

measurements is the precision of the obtained result, normally expressed by RSD% (Relative Standard Deviation). Typical RSD obtained using Q-ICP-MS is in the range of 0.1-1% while it reaches 0.04% in SF based instruments (with single detector) and up to 0.01% when the instrument is equipped with multi-collector (Roehl et al., 1995; Quétel et al., 2000; Galy et al., 2003; Yang et al., 2003). (Q) ICPMS are rather used for quantification of trace elements whereas (SF) ICPMS and (MC) ICPMS are the best techniques for isotopic measurements of TE.

ICP-MS is often coupled with other techniques in order to perform trace element speciation analysis. For instance, High Performance Liquid Chromatography (HPLC) coupled with ICP-MS has been extensively used in the speciation analysis of arsenic and mercury in different matrices (Jagtap et al., 2011; Raber et al., 2012; Stiboller et al., 2015; Jagtap and Maher, 2015). HPLC-ICP-MS has become the main analytical technique of speciation analysis in the last 20 years. This hyphenated technique is robust and sensitive and it is capable to give a complete picture of the elemental species in solution (Francesconi and Sperling, 2005). When performing speciation analysis on sediments and biota samples, a solid-liquid extraction procedure is usually required before HPLC-ICP-MS analysis. This step is crucial and delicate as it has to preserve the chemical forms separating the analyte from the interfering matrix without loss, contamination, or change of speciation, and with the minimum of interferences (Leermakers et al., 2005).

REFERENCES

- Abraham, G.M.S., Parker, R.J., 2008. Assessment of heavy metal enrichment factors and the degree of contamination in marine sediments from Tamaki Estuary, Auckland, New Zealand. *Environ. Monit. Assess.* 136, 227–238. <https://doi.org/10.1007/s10661-007-9678-2>
- Adams, F., Gijbels, R., Van Grieken, R., 1988. *Inorganic Mass Spectrometry*. John Wiley & Sons.
- Aide, M.T., Aide, C., 2012. Rare Earth Elements: Their Importance in Understanding Soil Genesis. *ISRN Soil Sci.* 2012, 1–11. <https://doi.org/10.5402/2012/783876>
- Alleman, L.Y., Hamelin, B., Véron, A.J., Miquel, J.-C., Heussner, S., 2000. Lead sources and transfer in the coastal Mediterranean: evidence from stable lead isotopes in marine particles. *Deep Sea Res. Part II Top. Stud. Oceanogr.* 47, 2257–2279. [https://doi.org/10.1016/S0967-0645\(00\)00024-2](https://doi.org/10.1016/S0967-0645(00)00024-2)
- Aloupi, M., Angelidis, M., 2001. Geochemistry of natural and anthropogenic metals in the coastal sediments of the island of Lesbos, Aegean Sea. *Environ. Pollut.* 113, 211–219. [https://doi.org/10.1016/S0269-7491\(00\)00173-1](https://doi.org/10.1016/S0269-7491(00)00173-1)
- Aly, W., Williams, I.D., Hudson, M.D., 2013. Metal contamination in water, sediment and biota from a semi-enclosed coastal area. *Environ. Monit. Assess.* 185, 3879–3895. <https://doi.org/10.1007/s10661-012-2837-0>
- AMPS Expert Group, 2005. Contributions of the Expert Group on Analysis and Monitoring of Priority Substances to the Water Framework Directive. EU Report EUR 21587.
- Anderson, G.L., Williams, J., Hille, R., 1992. The purification and characterization of arsenite oxidase from *Alcaligenes faecalis*, a molybdenum-containing hydroxylase. *J. Biol. Chem.* 267, 23674–23682.
- Andrewes, P., Demarini, D.M., Funasaka, K., Wallace, K., Lai, V.W.M., Sun, H., Cullen, W.R., Kitchin, K.T., 2004. Do arsenosugars pose a risk to human health? The comparative toxicities of a trivalent and pentavalent arsenosugar. *Environ. Sci. Technol.* 38, 4140–4148. <https://doi.org/10.1021/es035440f>
- Angelidis, M.O., Radakovitch, O., Veron, A., Aloupi, M., Heussner, S., Price, B., 2011. Anthropogenic metal contamination and sapropel imprints in deep Mediterranean sediments. *Mar. Pollut. Bull.* 62, 1041–1052. <https://doi.org/10.1016/j.marpolbul.2011.02.030>
- Anjum, K., Abbas, S.Q., Shah, S.A., Akhter, N., Batool, S., Hassan, S.S., 2016. Marine Sponges as a Drug Treasure. *Biomol. Ther.* 24, 347–362.
- Araújo, M.F., Conceição, A., Barbosa, T., Lopes, M.T., Humanes, M., 2003. Elemental composition of marine sponges from the Berlengas Natural Park, western Portuguese coast. *X-Ray Spectrom.* 32, 428–433. <https://doi.org/10.1002/xrs.660>
- Aresta, A., Marzano, C.N., Lopane, C., Corriero, G., Longo, C., Zambonin, C., Stabili, L., 2015. Analytical investigations on the lindane bioremediation capability of the demosponge *Hymeniacidon perlevis*. *Mar. Pollut. Bull.* 90, 143–149. <https://doi.org/10.1016/j.marpolbul.2014.11.003>
- Armstrong-Altrin, J.S., Verma, S.P., Madhavaraju, J., Lee, Y. II, Ramasamy, S., 2003. Geochemistry of Upper Miocene Kudankulam Limestones, Southern India. *Int. Geol. Rev.* 45, 16–26. <https://doi.org/10.2747/0020-6814.45.1.16>

- Ashraf, A., Saion, E., Gharibshahi, E., Kamari, H.M., Yap, C.K., Hamzah, M.S., Elias, M.S., 2017. Distribution of Trace Elements in Core Marine Sediments of Coastal East Malaysia by Instrumental Neutron Activation Analysis. *Appl. Radiat. Isot.* 122, 96–105. <https://doi.org/10.1016/j.apradiso.2017.01.006>
- Ashraf, A., Saion, E., Gharibshahi, E., Mohamed Kamari, H., Chee Kong, Y., Suhaimi Hamzah, M., Suhaimi Elias, M., 2016. Rare earth elements in core marine sediments of coastal East Malaysia by instrumental neutron activation analysis. *Appl. Radiat. Isot.* 107, 17–23. <https://doi.org/10.1016/j.apradiso.2015.09.004>
- ATSDR, 2007. Toxicological Profile for Arsenic, U.S Public Health Service, Agency for Toxic Substances and Disease Registry. <https://doi.org/http://dx.doi.org/10.1155/2013/286524>
- Ault, W.U., Senechal, R.G., Erlebach, W.E., 1970. Isotopic Composition as a Natural Tracer of Lead in the Environment: Discussions Follow. *Environ. Sci. Technol.* 4, 305–313. <https://doi.org/10.1021/es60039a001>
- Azemard, S., Vassileva, E., 2015. Determination of methylmercury in marine biota samples with advanced mercury analyzer: Method validation. *Food Chem.* 176, 367–375. <https://doi.org/10.1016/j.foodchem.2014.12.085>
- Azizur Rahman, M., Hasegawa, H., Peter Lim, R., 2012. Bioaccumulation, biotransformation and trophic transfer of arsenic in the aquatic food chain. *Environ. Res.* 116, 118–135. <https://doi.org/10.1016/j.envres.2012.03.014>
- Bagul V. R., S.D.N., 2015. New perspective on heavy metal pollution of water. *J. Chem. Pharm. Res.* 7, 700–705.
- Barats, A., Féraud, G., Potot, C., Philippinini, V., Travi, Y., Durrieu, G., Dubar, M., Simler, R., 2014. Naturally dissolved arsenic concentrations in the Alpine/Mediterranean Var River watershed (France). *Sci. Total Environ.* 473–474, 422–436. <https://doi.org/10.1016/J.SCITOTENV.2013.12.007>
- Bargagli, R., Nelli, L., Ancora, S., Focardi, S., 1996. Elevated cadmium accumulation in marine organisms from Terra Nova Bay (Antarctica). *Polar Biol.* 16, 513–520. <https://doi.org/10.1007/BF02329071>
- Barwick, V.J., Ellison, S.L.R., 1999. Measurement uncertainty: Approaches to the evaluation of uncertainties associated with recovery†. *Analyst* 124, 981–990. <https://doi.org/10.1039/a901845j>
- Batista, D., Muricy, G., Rocha, R.C., Miekeley, N.F., 2014. Marine sponges with contrasting life histories can be complementary biomonitors of heavy metal pollution in coastal ecosystems. *Environ. Sci. Pollut. Res.* 21, 5785–5794. <https://doi.org/10.1007/s11356-014-2530-7>
- Baudrimont, M., Schäfer, J., Marie, V., Maury-Brachet, R., Bossy, C., Boudou, A., Blanc, G., 2005. Geochemical survey and metal bioaccumulation of three bivalve species (*Crassostrea gigas*, *Cerastoderma edule* and *Ruditapes philippinarum*) in the Nord Médoc salt marshes (Gironde estuary, France). *Sci. Total Environ.* <https://doi.org/10.1016/j.scitotenv.2004.07.009>
- Beauchemin, D., 2008. Inductively coupled plasma mass spectrometry. *Anal. Chem.* 80, 4455–4486.
- Bednar, A.J., Garbarino, J.R., Burkhardt, M.R., Ranville, J.F., Wildeman, T.R., 2004. Field and laboratory arsenic speciation methods and their application to natural-water analysis. *Water Res.* 38, 355–364. <https://doi.org/10.1016/j.watres.2003.09.034>

- Beeson, R., 1984. The use of the fine fractions of stream sediments in geochemical exploration in arid and semi-arid terrains. *J. Geochemical Explor.* 22, 119–132. [https://doi.org/10.1016/0375-6742\(84\)90009-8](https://doi.org/10.1016/0375-6742(84)90009-8)
- Belarra, M.A., Resano, M., Vanhaecke, F., Moens, L., 2002. Direct solid sampling with electrothermal vaporization/atomization: What for and how? *TrAC - Trends Anal. Chem.* 21, 828–839. [https://doi.org/10.1016/S0165-9936\(02\)01206-2](https://doi.org/10.1016/S0165-9936(02)01206-2)
- Bell, J.J., 2008. The functional roles of marine sponges. *Estuar. Coast. Shelf Sci.* 79, 341–353. <https://doi.org/10.1016/j.ecss.2008.05.002>
- Bennett, W.W., Teasdale, P.R., Panther, J.G., Welsh, D.T., Zhao, H., Jolley, D.F., 2012. Investigating arsenic speciation and mobilization in sediments with DGT and DET: A mesocosm evaluation of oxic-anoxic transitions. *Environ. Sci. Technol.* 46, 3981–3989. <https://doi.org/10.1021/es204484k>
- Bentley, R., Chasteen, T.G., 2002. Microbial Methylation of Metalloids: Arsenic, Antimony, and Bismuth. *Microbiol. Mol. Biol. Rev.* 66, 250–271.
- Bermejo-Barrera, P., Barciela-Alonso, M.C., Moreda-Piñeiro, J., González-Sixto, C., Bermejo-Barrera, a., 1996. Determination of trace metals (As, Cd, Hg, Pb and Sn) in marine sediment slurry samples by electrothermal atomic absorption spectrometry using palladium as a chemical modifier. *Spectrochim. Acta Part B At. Spectrosc.* 51, 1235–1244. [https://doi.org/10.1016/0584-8547\(96\)01487-5](https://doi.org/10.1016/0584-8547(96)01487-5)
- Bermudez-Lugo, O., 2014. 2012 Minerals Yearbook, Usgs- 2012 Minerals Yearbook.
- Berthet, B., Mouneyrac, C., Pérez, T., Amiard-Triquet, C., 2005. Metallothionein concentration in sponges (*Spongia officinalis*) as a biomarker of metal contamination. *Comp. Biochem. Physiol. - C Toxicol. Pharmacol.* 141, 306–313. <https://doi.org/10.1016/j.cca.2005.07.008>
- Bhuiyan, M.A.H., Parvez, L., Islam, M.A., Dampare, S.B., Suzuki, S., 2010. Heavy metal pollution of coal mine-affected agricultural soils in the northern part of Bangladesh. *J. Hazard. Mater.* 173, 384–392. <https://doi.org/10.1016/j.jhazmat.2009.08.085>
- Birch, G.F., Melwani, A., Lee, J.H., Apostolatos, C., 2014. The discrepancy in concentration of metals (Cu, Pb and Zn) in oyster tissue (*Saccostrea glomerata*) and ambient bottom sediment (Sydney estuary, Australia). *Mar. Pollut. Bull.* 80, 263–274. <https://doi.org/10.1016/j.marpolbul.2013.12.005>
- Bocher, P., Caurant, F., Miramand, P., Cherel, Y., Bustamante, P., 2003. Influence of the diet on the bioaccumulation of heavy metals in zooplankton-eating petrels at Kerguelen archipelago, Southern Indian Ocean. *Polar Biol.* 26, 759–767. <https://doi.org/10.1007/s00300-003-0552-6>
- Bohari, Y., Astruc, A., Astruc, M., Cloud, J., 2001. Improvements of hydride generation for the speciation of arsenic in natural freshwater samples by HPLC-HG-AFS. *J. Anal. At. Spectrom.* 16, 774–778. <https://doi.org/10.1039/B101591P>
- Bollhöfer, A., Rosman, K.J., 2000. Isotopic source signatures for atmospheric lead: the Southern Hemisphere. *Geochim. Cosmochim. Acta* 64, 3251–3262. [https://doi.org/10.1016/S0016-7037\(00\)00436-1](https://doi.org/10.1016/S0016-7037(00)00436-1)
- Bollhöfer, A., Rosman, K.J.R., 2001. Isotopic source signatures for atmospheric lead: The Northern Hemisphere. *Geochim. Cosmochim. Acta* 65, 1727–1740. [https://doi.org/10.1016/S0016-7037\(00\)00630-X](https://doi.org/10.1016/S0016-7037(00)00630-X)

- Bossy, A., 2010. Origines de l'arsenic dans les eaux, sols et sédiments du district aurifère de St-Yrieix-la-Perche (Limousin, France) : contribution du lessivage des phases porteuses d'arsenic. Université de Limoges.
- Bowen, H.J.M., 1966. The Uptake and Excretion of Elements by Organisms, in: Trace Elements in Biochemistry. Academic Press London, pp. 85–101.
- Bremner, J.M., Willis, J.P., 1993. Mineralogy and geochemistry of the clay fraction of sediments from the Namibian continental margin and the adjacent hinterland. *Mar. Geol.* 115, 85–116. [https://doi.org/10.1016/0025-3227\(93\)90076-8](https://doi.org/10.1016/0025-3227(93)90076-8)
- Briant, N., Chouvelon, T., Martinez, L., Brach-Papa, C., Chiffolleau, J.F., Savoye, N., Sonke, J., Knoery, J., 2017. Spatial and temporal distribution of mercury and methylmercury in bivalves from the French coastline. *Mar. Pollut. Bull.* 114, 1096–1102. <https://doi.org/10.1016/j.marpolbul.2016.10.018>
- Briefing, 1980. Namibia in the frontline: the political economy of decolonisation in South Africa's colony. *Rev. Afr. Polit. Econ.* <https://doi.org/10.1080/03056248008703415>
- Broadley, M.R., White, P.J., Hammond, J.P., Zelko, I., Lux, A., 2007. Zinc in plants. *New Phytol.* 173, 677–702. <https://doi.org/10.1111/j.1469-8137.2007.01996.x>
- Brongersma-Sanders, M., Stephan, K.M., Kwee, T., De Bruin, M., 1980. DISTRIBUTION OF MINOR ELEMENTS IN CORES FROM THE SOUTH- WEST AFRICA SHELF WITH NOTES ON PLANKTON AND FISH MORTALITY Along the coast of Southwest Africa a belt of olive-green diatomaceous muds is found between 19 ° S and 25 ° S , bordered on the wester. *Mar. Geol.* 37, 91–132.
- Brown, J.L., Kitchin, K.T., George, M., 1997. Dimethylarsinic acid treatment alters six different rat biochemical parameters: Relevance to arsenic carcinogenesis. *Teratog. Carcinog. Mutagen.* 17, 71–84. [https://doi.org/10.1002/\(SICI\)1520-6866\(1997\)17:2<71::AID-TCM3>3.0.CO;2-B](https://doi.org/10.1002/(SICI)1520-6866(1997)17:2<71::AID-TCM3>3.0.CO;2-B)
- Brown, J.S., 1962. Ore leads and isotopes. *Econ. Geol.* 57, 673–720. <https://doi.org/10.2113/gsecongeo.57.5.673>
- Brown, R.J.C., Milton, M.J.T., 2005. Analytical techniques for trace element analysis: An overview. *TrAC - Trends Anal. Chem.* 24, 266–274. <https://doi.org/10.1016/j.trac.2004.11.010>
- Bruland, K.W., Bertine, K., Koide, M., Goldberg, E.D., 1974. History of metal pollution in southern California coastal zone. *Environ. Sci. Technol.* 8, 425–432. <https://doi.org/10.1021/es60090a010>
- Bruland, K.W., Lohan, M.C., 2003. Controls of trace metals in seawater, in: *Treatise on Geochemistry*. Elsevier Ltd, pp. 23–47.
- Bryan, G.W., Langston, W.J., 1992. Bioavailability, accumulation and effects of heavy metals in sediments with special reference to United Kingdom estuaries: a review. *Environ. Pollut.* 76, 89–131. [https://doi.org/10.1016/0269-7491\(92\)90099-V](https://doi.org/10.1016/0269-7491(92)90099-V)
- Bu, H., Song, X., Guo, F., 2017. Dissolved trace elements in a nitrogen-polluted river near to the Liaodong Bay in Northeast China. *Mar. Pollut. Bull.* 114, 547–554. <https://doi.org/10.1016/j.marpolbul.2016.09.003>
- Cabon, J.Y., Cabon, N., 2000. Speciation of major arsenic species in seawater by flow injection hydride generation atomic absorption spectrometry. *Fresenius. J. Anal. Chem.* 368, 484–9. <https://doi.org/10.1007/s002160000526>

- Cabrita, M.T., Padeiro, A., Amaro, E., dos Santos, M.C., Leppe, M., Verkulich, S., Hughes, K.A., Peter, H.-U., Canário, J., 2017. Evaluating trace element bioavailability and potential transfer into marine food chains using immobilised diatom model species *Phaeodactylum tricornutum*, on King George Island, Antarctica. *Mar. Pollut. Bull.* 121, 192–200. <https://doi.org/10.1016/j.marpolbul.2017.05.059>
- Caccia, V.G., Millero, F.J., Palanques, A., 2003. The distribution of trace metals in Florida Bay sediments. *Mar. Pollut. Bull.* 46, 1420–1433. [https://doi.org/10.1016/S0025-326X\(03\)00288-1](https://doi.org/10.1016/S0025-326X(03)00288-1)
- Calvert, S.E., Price, N.B., 1970. Minor Metal Contents of Recent Organic-rich Sediments off South West Africa. *Nature* 227, 593–595.
- Cantillo, A.Y., 1998. Comparison of results of Mussel Watch Programs of the United States and France with Worldwide Mussel Watch Studies. *Mar. Pollut. Bull.* 36, 712–717. [https://doi.org/10.1016/S0025-326X\(98\)00049-6](https://doi.org/10.1016/S0025-326X(98)00049-6)
- Carere, M., Dulio, V., Hanke, G., Polesello, S., 2012. Guidance for sediment and biota monitoring under the Common Implementation Strategy for the Water Framework Directive. *TrAC - Trends Anal. Chem.* 36, 15–24. <https://doi.org/10.1016/j.trac.2012.03.005>
- Carpenè, E., Andreani, G., Isani, G., 2017. Trace elements in unconventional animals: A 40-year experience. *J. Trace Elem. Med. Biol.* 43, 169–179. <https://doi.org/10.1016/j.jtemb.2017.02.003>
- Caumette, G., Koch, I., Reimer, K.J., 2012. Arsenobetaine formation in plankton: a review of studies at the base of the aquatic food chain. *J. Environ. Monit.* 14, 2841. <https://doi.org/10.1039/c2em30572k>
- Cebrian, E., Martí, R., Uriz, J.M., Turon, X., 2003. Sublethal effects of contamination on the Mediterranean sponge *Crambe crambe*: Metal accumulation and biological responses. *Mar. Pollut. Bull.* 46, 1273–1284. [https://doi.org/10.1016/S0025-326X\(03\)00190-5](https://doi.org/10.1016/S0025-326X(03)00190-5)
- Cebrian, E., Uriz, M.-J., Turon, X., 2007. Sponges as biomonitors of heavy metals in spatial and temporal surveys in northwestern mediterranean: multispecies comparison. *Environ. Toxicol. Chem.* 26, 2430–2439. <https://doi.org/10.1897/07-292.1>
- Cebrian, E., Uriz, M.J., 2007. Contrasting effects of heavy metals on sponge cell behavior. *Arch. Environ. Contam. Toxicol.* 53, 552–558. <https://doi.org/10.1007/s00244-006-0257-2>
- Chai, Z.F., Zhang, Z.Y., Feng, W.Y., Chen, C.Y., Xu, D.D., Hou, X.L., 2004. Study of chemical speciation of trace elements by molecular activation analysis and other nuclear techniques. *J. Anal. At. Spectrom.* 19, 26–33. <https://doi.org/10.1039/B307337H>
- Charlesworth, M.E., Chenery, S., Mellor, A., Service, M., 2006. Isotopic composition and concentration of Pb in suspended particulate matter of the Irish Sea reveals distribution and sources. *Mar. Pollut. Bull.* 52, 81–88. <https://doi.org/10.1016/j.marpolbul.2005.08.009>
- Chen, C.Y., Darren, M., Williams, J.J., Fisher, N.S., 2016. Metal Bioaccumulation by Estuarine Food Webs in New England, USA. *J. Mar. Sci. Engineer* 4, 41. <https://doi.org/10.1016/j.cell.2016.05.007.Mapping>
- Chen, C.Y., Stemberger, R.S., Klaue, B., Blum, J.D., Pickhardt, P.C., Folt, C.L., 2000. Accumulation of heavy metals in food web components across a gradient of lakes. *Limnol. Oceanogr.* 45, 1525–1536. <https://doi.org/10.4319/lo.2000.45.7.1525>

- Chen, L., Liu, M., Fan, R., Ma, S., Xu, Z., Ren, M., He, Q., 2013. Mercury speciation and emission from municipal solid waste incinerators in the Pearl River Delta, South China. *Sci. Total Environ.* 447, 396–402. <https://doi.org/10.1016/j.scitotenv.2013.01.018>
- Chester, R., Murphy, K.J.T., Lin, F.J., Berry, A.S., Bradshaw, G.A., Corcoran, P.A., 1993. Factors controlling the solubilities of trace metals from non-remote aerosols deposited to the sea surface by the “dry” deposition mode. *Mar. Chem.* 42, 107–126. [https://doi.org/10.1016/0304-4203\(93\)90241-F](https://doi.org/10.1016/0304-4203(93)90241-F)
- Ciardullo, S., Aureli, F., Raggi, A., Cubadda, F., 2010. Arsenic speciation in freshwater fish: Focus on extraction and mass balance. *Talanta* 81, 213–221. <https://doi.org/10.1016/j.talanta.2009.11.060>
- Cidu, R., Frau, F., 2009. Distribution of trace elements in filtered and non filtered aqueous fractions: Insights from rivers and streams of Sardinia (Italy). *Appl. Geochemistry* 24, 611–623. <https://doi.org/10.1016/j.apgeochem.2008.12.013>
- Clark, H., 1968. On the Spongiae ciliatae as infusoria flagellata, or observations on the structure, animality and relationship of *Leucosolenia botryoides*, Bowerbank. *Ann. Mag. Nat. Hist.* 4, 133–142.
- Clowes, L.A., Francesconi, K.A., 2004. Uptake and elimination of arsenobetaine by the mussel *Mytilus edulis* is related to salinity. *Comp. Biochem. Physiol. - C Toxicol. Pharmacol.* 137, 35–42. <https://doi.org/10.1016/j.cca.2003.11.003>
- Coulibaly, M., Bamba, D., Yao, N.A., Zoro, E.G., El Rhazi, M., 2016. Some aspects of speciation and reactivity of mercury in various matrices. *Comptes Rendus Chim.* 19, 832–840. <https://doi.org/10.1016/j.crci.2016.02.005>
- Covelli, S., Fontolan, G., 1997. Application of a normalization procedure in determining regional geochemical baselines. *Environ. Geol.* 30, 34–45. <https://doi.org/10.1007/s002540050130>
- Crompton, T.R., Crompton, T.R., 1989. Chapter 8 – Organometallic compounds, in: *Analysis of Seawater*. pp. 336–359. <https://doi.org/10.1016/B978-0-407-01610-1.50011-4>
- Cullen, W.R., Reimer, K.J., 1989. Arsenic speciation in the environment. *Chem. Rev.* 89, 713–764. <https://doi.org/10.1021/cr00094a002>
- Dahms, S., van der Bank, F.H., Greenfield, R., 2014. A baseline study of metal contamination along the Namibian coastline for *Perna perna* and *Choromytilus meridionalis*. *Mar. Pollut. Bull.* 85, 297–305. <https://doi.org/10.1016/j.marpolbul.2014.05.037>
- Damiano, S., Papetti, P., Menesatti, P., 2011. Accumulation of heavy metals to assess the health status of swordfish in a comparative analysis of Mediterranean and Atlantic areas. *Mar. Pollut. Bull.* 62, 1920–1925. <https://doi.org/10.1016/j.marpolbul.2011.04.028>
- De Gregori H., I., Pinochet C., H., Arancibia J., M., Vidal B., A., 1996. Grain Size Effect on Trace Metals Distribution in Sediments from Two Coastal Areas of Chile. *Bull. Environ. Contam. Toxicol.* 57, 163–170. <https://doi.org/10.1007/s001289900170>
- de Mestre, C., Maher, W., Roberts, D., Broad, A., Krikowa, F., Davis, A.R., 2012. Sponges as sentinels: Patterns of spatial and intra-individual variation in trace metal concentration. *Mar. Pollut. Bull.* 64, 80–89. <https://doi.org/10.1016/j.marpolbul.2011.10.020>
- Debord, J., Pourmand, A., Jantzi, S., Panicker, S., Almirall, J., 2017. Profiling of Heroin and Assignment of

- Provenance by $^{87}\text{Sr}/^{86}\text{Sr}$ Isotope Ratio Analysis. *Inorganica Chim. Acta*.
<https://doi.org/10.1016/j.ica.2017.07.049>
- Delnomdedieu, M., Basti, M.M., Otvos, J.D., Thomas, D.J., 1994. Reduction and binding of arsenate and dimethylarsinate by glutathione: a magnetic resonance study. *Chem. Biol. Interact.* 90, 139–155.
[https://doi.org/10.1016/0009-2797\(94\)90099-X](https://doi.org/10.1016/0009-2797(94)90099-X)
- Denton, G.R.W., Concepcion, L.P., Wood, H.R., Morrison, R.J., 2006. Trace metals in marine organisms from four harbours in Guam. *Mar. Pollut. Bull.* 52, 1784–1804.
<https://doi.org/10.1016/j.marpolbul.2006.09.010>
- Diaz, M.C., Rutzler, K., 2001. Sponges: an essential component of Caribbean coral reefs. *Bull. Mar. Sci.* 69, 535–546.
- Drivelos, S.A., Georgiou, C.A., 2012. Multi-element and multi-isotope-ratio analysis to determine the geographical origin of foods in the European Union. *TrAC Trends Anal. Chem.* 40, 38–51.
<https://doi.org/10.1016/j.trac.2012.08.003>
- Dudás, F.Ö., LeBlanc, S.A., Carter, S.W., Bowring, S.A., 2016. Pb and Sr concentrations and isotopic compositions in prehistoric North American teeth: A methodological study. *Chem. Geol.* 429, 21–32. <https://doi.org/10.1016/j.chemgeo.2016.03.003>
- Duncan, E.G., Maher, W.A., Foster, S.D., 2015. Contribution of arsenic species in unicellular algae to the cycling of arsenic in marine ecosystems. *Environ. Sci. Technol.* 49, 33–50.
<https://doi.org/10.1021/es504074z>
- Edmonds, J.S., Francesconi, K.A., Stick, R. V., 1993. Arsenic compounds from marine organisms. *Nat. Prod. Rep.* 10, 421–428.
- Edmonds, J.S., Shibata, Y., Francesconi, K. a, Rippingale, R.J., Morita, M., 1997. Arsenic transformations in short marine food chains studied by HPLC-ICP MS. *Appl. Organomet. Chem.* 11, 281–287.
[https://doi.org/10.1002/\(sici\)1099-0739\(199704\)11:4<281::aid-aoc581>3.3.co;2-j](https://doi.org/10.1002/(sici)1099-0739(199704)11:4<281::aid-aoc581>3.3.co;2-j)
- Elbaz-Poulichet, F., Holliger, P., Martin, J.M., Petit, D., 1986. Stable lead isotopes ratios in major french rivers and estuaries. *Sci. Total Environ.* 54, 61–76. [https://doi.org/10.1016/0048-9697\(86\)90256-1](https://doi.org/10.1016/0048-9697(86)90256-1)
- Elderfield, H., 2003. Introduction to Volume 6, in: Turekian, K.K., Holland, H.D. (Eds.), *Treatise on Geochemistry*. Elsevier Ltd, pp. 15–27.
- Ellam, R.M., 2010. The graphical presentation of lead isotope data for environmental source apportionment. *Sci. Total Environ.* 408, 3490–3492.
<https://doi.org/10.1016/j.scitotenv.2010.03.037>
- Ellwood, M.J., Maher, W.A., 2003. Measurement of arsenic species in marine sediments by high-performance liquid chromatography-inductively coupled plasma mass spectrometry. *Anal. Chim. Acta* 477, 279–291. [https://doi.org/10.1016/s0003-2670\(02\)01414-9](https://doi.org/10.1016/s0003-2670(02)01414-9)
- Esslemont, G., 2000. Heavy metals in seawater, marine sediments and corals from the Townsville section, Great Barrier Reef Marine Park, Queensland. *Mar. Chem.* 71, 215–231.
[https://doi.org/10.1016/S0304-4203\(00\)00050-5](https://doi.org/10.1016/S0304-4203(00)00050-5)
- Fang, T.-H., Hsiao, S.-H., Nan, F.-H., 2014. Nineteen trace elements in marine copepods collected from the coastal waters off northeastern Taiwan. *Cont. Shelf Res.* 91, 70–81.

<https://doi.org/10.1016/j.csr.2014.09.003>

FAO, 2007. Fishery Country Profile- The Republic of Namibia [WWW Document]. URL <http://www.fao.org/fi/oldsite/FCP/en/NAM/profile.htm>

FLETCHER, C.J.N., SWAINBANK, I.G., COLMAN, T.B., 1993. Metallogenic evolution in Wales: constraints from lead isotope modelling. *J. Geol. Soc. London.* 150, 77–82. <https://doi.org/10.1144/gsjgs.150.1.0076>

Forstner, U., 1982. Chemical forms of metal enrichment in recent sediments, in: Amstutz, G. (Ed.), *Ore Genesis*. Springer-Verlag New York, pp. 269–284.

Förstner, U., Ahlf, W., Calmano, W., 1989. Studies on the transfer of heavy metals between sedimentary phases with a multi-chamber device: Combined effects of salinity and redox variation. *Mar. Chem.* 28, 145–158. [https://doi.org/10.1016/0304-4203\(89\)90192-8](https://doi.org/10.1016/0304-4203(89)90192-8)

Forstner, U., Wittmann, G., 1981. *Metal pollution in the aquatic environment*, 2nd revise. ed. Springer-Verlag New York.

Foster, S., Maher, W., 2016. Arsenobetaine and thio-arsenic species in marine macroalgae and herbivorous animals: Accumulated through trophic transfer or produced in situ? *J. Environ. Sci.* 49, 131–139. <https://doi.org/10.1016/j.jes.2016.06.003>

Francesconi, K.A., Sperling, M., 2005. Speciation analysis with HPLC-mass spectrometry: time to take stock. *Analyst* 130, 998. <https://doi.org/10.1039/b504485p>

Francesconi, K. a., 2010. Arsenic species in seafood: Origin and human health implications. *Pure Appl. Chem.* 82, 373–381. <https://doi.org/10.1351/PAC-CON-09-07-01>

Fütterer, D.K., Cojan, I., Renard, M., 2006. The solid phase of marine sediments, in: *Marine Geochemistry*. pp. 1–25.

Gadde, R.R., Laitinen, H.A., 1974. Studies of Heavy Metal Adsorption by Hydrous Iron and Manganese Oxides. *Anal. Chem.* 46, 2022–2026. <https://doi.org/10.1021/ac60349a004>

Galy, A., Pomies, C., Day, J.A., Pokrovsky, O.S., Schott, J., 2003. High precision measurement of germanium isotope ratio variations by multiple collector-inductively coupled plasma mass spectrometry. *J. Anal. At. Spectrom.* 18, 115–119. <https://doi.org/10.1039/B210233A>

Gazave, E., Carteron, S., Chenuil, A., Richelle-Maurer, E., Boury-Esnault, N., Borchiellini, C., 2010. Polyphyly of the genus *Axinella* and of the family *Axinellidae* (Porifera: Demospongiaep). *Mol. Phylogenet. Evol.* 57, 35–47. <https://doi.org/10.1016/j.ympev.2010.05.028>

Genta-Jouve, G., Cachet, N., Oberhänsli, F., Noyer, C., Teyssié, J.L., Thomas, O.P., Lacoue-Labarthe, T., 2012. Comparative bioaccumulation kinetics of trace elements in Mediterranean marine sponges. *Chemosphere* 89, 340–349. <https://doi.org/10.1016/j.chemosphere.2012.04.052>

Gentric, C., Rehel, K., Dufour, A., Sauleau, P., 2016. Bioaccumulation of metallic trace elements and organic pollutants in marine sponges from the South Brittany Coast, France. *J. Environ. Sci. Heal. Part A* 51, 213–219. <https://doi.org/10.1080/10934529.2015.1094327>

Gifford, S., Dunstan, R.H., O'Connor, W., Koller, C.E., MacFarlane, G.R., 2007. Aquatic zooremediation: deploying animals to remediate contaminated aquatic environments. *Trends Biotechnol.* 25, 60–65. <https://doi.org/10.1016/j.tibtech.2006.12.002>

- Giusti, L., Zhang, H., 2002. Heavy metals and arsenic in sediments, mussels and marine water from Murano (Venice, Italy). *Environ. Geochem. Health* 24, 47–65. <https://doi.org/10.1023/A:1013945117549>
- Gobas, F., 2001. Assessing Bioaccumulation Factors of Persistent Organic Pollutants in Aquatic Food-Chains, in: *Persistent Organic Pollutants: Environmental Behaviour and Pathways of Human Exposure*. pp. 145–165. https://doi.org/10.1007/978-1-4615-1571-5_6
- Gong, Z., 2002. Arsenic speciation analysis. *Talanta* 58, 77–96. [https://doi.org/10.1016/S0039-9140\(02\)00258-8](https://doi.org/10.1016/S0039-9140(02)00258-8)
- Goodenough, K.M., Schilling, J., Jonsson, E., Kalvig, P., Charles, N., Tuduri, J., Deady, E.A., Sadeghi, M., Schiellerup, H., Møller, A., Bertrand, G., Arvanitidis, N., Eliopoulos, D.G., Shaw, R.A., Thrane, K., Keulen, N., 2016. Europe's rare earth element resource potential: An overview of REE metallogenetic provinces and their geodynamic setting. *Ore Geol. Rev.* 72, 838–856. <https://doi.org/10.1016/j.oregeorev.2015.09.019>
- Goran, P., 1981. The Carcinogenicity of Arsenic. *Environ. Health Perspect.* 40, 93–100.
- Goyer, R.A., 2001. Toxic effects of metals, in: Klaassen, C.D. (Ed.), *Casarett and Doull's Toxicology: The Basic Science of Poisons*. McGraw-Hill Publisher, pp. 811–867.
- Grotti, M., Lagomarsino, C., Goessler, W., Francesconi, K.A., 2010. Arsenic speciation in marine organisms from Antarctic coastal environments. *Environ. Chem.* 7, 207–214. <https://doi.org/10.1071/EN09131>
- Grotti, M., Soggia, F., Lagomarsino, C., Riva, S.D., Goessler, W., Francesconi, K.A., 2008. Natural variability and distribution of trace elements in marine organisms from Antarctic coastal environments. *Antarct. Sci.* 20, 39–52. <https://doi.org/doi:10.1017/S0954102007000831>
- Grousset, F.E., Quétel, C.R., Thomas, B., Buat-Menard, P., Donard, O.F.X., Bucher, A., 1994. Transient Pb Isotopic Signatures in the Western European Atmosphere. *Environ. Sci. Technol.* 28, 1605–1608. <https://doi.org/10.1021/es00058a011>
- Guan, Q., Cai, A., Wang, F., Wang, L., Wu, T., Pan, B., Song, N., Li, F., Lu, M., 2016. Heavy metals in the riverbed surface sediment of the Yellow River, China. *Environ. Sci. Pollut. Res.* 23, 24768–24780. <https://doi.org/10.1007/s11356-016-7712-z>
- Guyonnet, D., Planchon, M., Rollat, A., Escalon, V., Tuduri, J., Charles, N., Vaxelaire, S., Dubois, D., Fargier, H., 2015. Material flow analysis applied to rare earth elements in Europe. *J. Clean. Prod.* 107, 215–228. <https://doi.org/10.1016/J.JCLEPRO.2015.04.123>
- Hansmann, W., Köppel, V., 2000. Lead-isotopes as tracers of pollutants in soils. *Chem. Geol.* 171, 123–144. [https://doi.org/10.1016/S0009-2541\(00\)00230-8](https://doi.org/10.1016/S0009-2541(00)00230-8)
- Harada, M., 1995. Minamata Disease: Methylmercury Poisoning in Japan Caused by Environmental Pollution. *Crit. Rev. Toxicol.* 25, 1–24. <https://doi.org/10.3109/10408449509089885>
- Hartwig, A., Jahnke, G., 2012. Toxic metals and metalloids in foods, in: *Chemical Contaminants and Residues in Food*. Elsevier, pp. 233–249. <https://doi.org/10.1533/9780857095794.2.233>
- Hatje, V., Bruland, K.W., Flegal, A.R., 2016. Increases in Anthropogenic Gadolinium Anomalies and Rare Earth Element Concentrations in San Francisco Bay over a 20 Year Record. *Environ. Sci. Technol.* 50,

4159–4168. <https://doi.org/10.1021/acs.est.5b04322>

He, M., Wang, W.X., 2013. Bioaccessibility of 12 trace elements in marine molluscs. *Food Chem. Toxicol.* 55, 627–636. <https://doi.org/10.1016/j.fct.2013.01.046>

Heidari, B., Bakhtiari, A.R., Shirneshan, G., 2013. Concentrations of Cd, Cu, Pb and Zn in soft tissue of oyster (*Saccostrea cucullata*) collected from the Lengeh Port coast, Persian Gulf, Iran: A comparison with the permissible limits for public health. *Food Chem.* 141, 3014–3019. <https://doi.org/10.1016/j.foodchem.2013.06.002>

Hinrichs, J., Dellwig, O., Brumsack, H.-J., 2002. Lead in sediments and suspended particulate matter of the German Bight: natural versus anthropogenic origin. *Appl. Geochemistry* 17, 621–632. [https://doi.org/10.1016/S0883-2927\(01\)00124-X](https://doi.org/10.1016/S0883-2927(01)00124-X)

Hirner, A.V., Kritsotakis, K., Tobschall, H.J., 1990. Metal-organic associations in sediments—I. Comparison of unpolluted recent and ancient sediments and sediments affected by anthropogenic pollution. *Appl. Geochemistry* 5, 491–505. [https://doi.org/10.1016/0883-2927\(90\)90023-X](https://doi.org/10.1016/0883-2927(90)90023-X)

Holser, W.T., 1997. Evaluation of the application of rare-earth elements to paleoceanography. *Palaeogeogr. Palaeoclimatol. Palaeoecol.* 132, 309–323. [https://doi.org/10.1016/S0031-0182\(97\)00069-2](https://doi.org/10.1016/S0031-0182(97)00069-2)

Hong, S., Khim, J.S., Park, J., Son, H.S., Choi, S.D., Choi, K., Ryu, J., Kim, C.Y., Chang, G.S., Giesy, J.P., 2014. Species- and tissue-specific bioaccumulation of arsenicals in various aquatic organisms from a highly industrialized area in the Pohang City, Korea. *Environ. Pollut.* 192, 27–35. <https://doi.org/10.1016/j.envpol.2014.05.004>

Hooper, J., van Soest, R., 2002. *Systema porifera. A guide to the Classification of Sponges.* Kluwer Academic/Plenum publishers, New York.

Hornung, H., Krom, M.D., Cohen, Y., 1989. Trace metal distribution in sediments and benthic fauna of Haifa Bay, Israel. *Estuar. Coast. Shelf Sci.* 29, 43–56. [https://doi.org/10.1016/0272-7714\(89\)90072-3](https://doi.org/10.1016/0272-7714(89)90072-3)

Horowitz, A.J., 1991. *A Primer on Sediment-Trace Element Chemistry.* U.S.G.S. Open-File Rep. 2nd Editio, 136 (2 fiche).

Horowitz, A.J., Elrick, K.A., 1987. The relation of stream sediment surface area, grain size and composition to trace element chemistry. *Appl. Geochemistry* 2, 437–451. [https://doi.org/10.1016/0883-2927\(87\)90027-8](https://doi.org/10.1016/0883-2927(87)90027-8)

Hsieh, M.W., Liu, C.L., Chen, J.H., Jiang, S.J., 2010. Speciation analysis of arsenic and selenium compounds by CE-dynamic reaction cell-ICP-MS. *Electrophoresis* 31, 2272–2278. <https://doi.org/10.1002/elps.200900632>

Hughes, M.F., 2002. Arsenic toxicity and potential mechanisms of action. *Toxicol. Lett.* 133, 1–16. [https://doi.org/10.1016/S0378-4274\(02\)00084-X](https://doi.org/10.1016/S0378-4274(02)00084-X)

Illuminati, S., Annibaldi, A., Truzzi, C., Scarponi, G., 2016a. Heavy metal distribution in organic and siliceous marine sponge tissues measured by square wave anodic stripping voltammetry. *Mar. Pollut. Bull.* 111, 476–482. <https://doi.org/10.1016/j.marpolbul.2016.06.098>

Illuminati, S., Annibaldi, A., Truzzi, C., Scarponi, G., 2016b. Heavy metal distribution in organic and

- siliceous marine sponge tissues measured by square wave anodic stripping voltammetry. *Mar. Pollut. Bull.* 111, 476–482. <https://doi.org/10.1016/j.marpolbul.2016.06.098>
- Irgolic, K.J., Stockton, R.A., 1987. Element-specific detectors for liquid chromatography: The determination of arsenic compounds. *Mar. Chem.* 22, 265–278.
- Jagtap, R., Krikowa, F., Maher, W., Foster, S., Ellwood, M., 2011. Measurement of methyl mercury (I) and mercury (II) in fish tissues and sediments by HPLC-ICPMS and HPLC-HGAAS. *Talanta* 85, 49–55. <https://doi.org/10.1016/j.talanta.2011.03.022>
- Jagtap, R., Maher, W., 2015. Measurement of mercury species in sediments and soils by HPLC-ICPMS. *Microchem. J.* <https://doi.org/10.1016/j.microc.2015.01.010>
- Jonathan, R., Gobert, S., 2016. Trace Elements in Marine Environments: Occurrence, Threats and Monitoring with Special Focus on the Coastal Mediterranean. *J. Environ. Anal. Toxicol.* in press.
- Jones, B., Browser, C., 1987. The mineralogy and related chemistry of lake sediments, in: Lerman, A. (Ed.), *Lakes: Chemistry, Geology, Physics*. Springer-Verlag New York, pp. 179–235.
- Joung, D.J., Shiller, A.M., 2016. Temporal and spatial variations of dissolved and colloidal trace elements in Louisiana Shelf waters. *Mar. Chem.* 181, 25–43. <https://doi.org/10.1016/j.marchem.2016.03.003>
- Jung, H.S., Lim, D., Choi, J.Y., Yoo, H.S., Rho, K.C., Lee, H.B., 2012. Rare earth element compositions of core sediments from the shelf of the South Sea, Korea: Their controls and origins. *Cont. Shelf Res.* 48, 75–86. <https://doi.org/10.1016/j.csr.2012.08.008>
- Jung, S., Mezger, K., 2003. Petrology of basement-dominated terranes: I. Regional metamorphic T-t path from U-Pb monazite and Sm-Nd garnet geochronology (Central Damara orogen, Namibia). *Chem. Geol.* 198, 223–247. [https://doi.org/10.1016/S0009-2541\(03\)00037-8](https://doi.org/10.1016/S0009-2541(03)00037-8)
- Karbassi, A.R., Monavari, S.M., Nabi Bidhendi, G.R., Nouri, J., Nematpour, K., 2007. Metal pollution assessment of sediment and water in the Shur River. *Environ. Monit. Assess.* 147, 107. <https://doi.org/10.1007/s10661-007-0102-8>
- Karbassi, A.R., Nabi-Bidhendi, G.R., Bayati, I., 2005. Environmental Geochemistry of Heavy Metals in Sediment Core Off Bushehr, Persian Gulf. *Iran J. Environ. Health. Sci. Eng.* 2, 255–260.
- Keren, R., Lavy, A., Ilan, M., 2016. Increasing the Richness of Culturable Arsenic-Tolerant Bacteria from *Theonella swinhoei* by Addition of Sponge Skeleton to the Growth Medium. *Microb. Ecol.* 71, 873–886. <https://doi.org/10.1007/s00248-015-0726-0>
- Keren, R., Lavy, A., Mayzel, B., Ilan, M., 2015. Culturable associated-bacteria of the sponge *Theonella swinhoei* show tolerance to high arsenic concentrations. *Front. Microbiol.* 6, 1–11. <https://doi.org/10.3389/fmicb.2015.00154>
- Keren, R., Mayzel, B., Lavy, A., Polishchuk, I., Levy, D., Fakra, S.C., Pokroy, B., Ilan, M., 2017. Sponge-associated bacteria mineralize arsenic and barium on intracellular vesicles. *Nat. Commun.* 8, 14393. <https://doi.org/10.1038/ncomms14393>
- KeyToNature, 2015. Marine Species Identification Portal [WWW Document]. URL <http://species-identification.org/index.php> (accessed 7.4.17).
- Kingson, O., Bhutani, R., Dash, J.K., Sebastian, S., Balakrishnan, S., 2017. Resolving the conundrum in origin of the Manipur Ophiolite Complex, Indo-Myanmar range: Constraints from Nd isotopic ratios

- and elemental concentrations in serpentinized peridotite. *Chem. Geol.* 460, 117–129. <https://doi.org/10.1016/j.chemgeo.2017.04.021>
- Kljaković-Gašpić, Z., Bogner, D., Ujević, I., 2008. Trace metals (Cd, Pb, Cu, Zn and Ni) in sediment of the submarine pit Dragon ear (Soline Bay, Rogoznica, Croatia). *Environ. Geol.* 58, 751. <https://doi.org/10.1007/s00254-008-1549-9>
- Komárek, M., Ettler, V., Chrastný, V., Mihaljevič, M., 2008. Lead isotopes in environmental sciences: A review. *Environ. Int.* 34, 562–577. <https://doi.org/10.1016/j.envint.2007.10.005>
- Krata, A., Vassileva, E., Bulska, E., 2016. Reference measurements for total mercury and methyl mercury content in marine biota samples using direct or species-specific isotope dilution inductively coupled plasma mass spectrometry. *Talanta* 160, 562–569. <https://doi.org/10.1016/j.talanta.2016.07.033>
- Kucuksezgin, F., Gonul, L.T., Tasel, D., 2014. Total and inorganic arsenic levels in some marine organisms from Izmir Bay (Eastern Aegean Sea): A risk assessment. *Chemosphere* 112, 311–316. <https://doi.org/10.1016/j.chemosphere.2014.04.071>
- Kulaksiz, S., Bau, M., 2011. Rare earth elements in the Rhine River, Germany: First case of anthropogenic lanthanum as a dissolved microcontaminant in the hydrosphere. *Environ. Int.* 37, 973–979. <https://doi.org/10.1016/j.envint.2011.02.018>
- Lai, V.W.M., Cullen, W.R., Ray, S., 1999. Arsenic speciation in scallops. *Mar. Chem.* 66, 81–89. [https://doi.org/10.1016/S0304-4203\(99\)00025-0](https://doi.org/10.1016/S0304-4203(99)00025-0)
- Lamborg, C.H., Hammerschmidt, C.R., Bowman, K.L., Swarr, G.J., Munson, K.M., Ohnemus, D.C., Lam, P.J., Heimbürger, L.-E., Rijkenberg, M., Saito, M.A., 2014. A global ocean inventory of anthropogenic mercury based on water column measurements. *Nature* 512, 65–68. <https://doi.org/10.1038/nature13563>
- Lang, T., Kruse, R., Haarich, M., Wosniok, W., 2017. Mercury species in dab (*Limanda limanda*) from the North Sea, Baltic Sea and Icelandic waters in relation to host-specific variables. *Mar. Environ. Res.* 124, 32–40. <https://doi.org/10.1016/j.marenvres.2016.03.001>
- Laport, M.S., Santos, O.C., Muricy, G., 2009. Marine sponges: potential sources of new antimicrobial drugs. *Curr. Pharm. Biotechnol.* 10, 86–105.
- Larsen, M.M., Blusztajn, J.S., Andersen, O., Dahllöf, I., 2012. Lead isotopes in marine surface sediments reveal historical use of leaded fuel. *J. Environ. Monit.* 14, 2893. <https://doi.org/10.1039/c2em30579h>
- Lauwerys, R.R., Haufroid, V., Hoet, P., Lison, D., 2007. *Toxicologie industrielle et intoxications professionnelles*, Fifth. ed. Masson, Paris, Paris.
- Le Pape, P., Ayrault, S., Quantin, C., 2012. Trace element behavior and partition versus urbanization gradient in an urban river (Orge River, France). *J. Hydrol.* 472–473, 99–110. <https://doi.org/10.1016/j.jhydrol.2012.09.042>
- Leermakers, M., Baeyens, W., De Gieter, M., Smedts, B., Meert, C., De Bisschop, H.C., Morabito, R., Quevauviller, P., 2006. Toxic arsenic compounds in environmental samples: Speciation and validation. *TrAC - Trends Anal. Chem.* 25, 1–10. <https://doi.org/10.1016/j.trac.2005.06.004>

- Leermakers, M., Baeyens, W., Quevauviller, P., Horvat, M., 2005. Mercury in environmental samples: Speciation, artifacts and validation. *TrAC Trends Anal. Chem.* 24, 383–393. <https://doi.org/10.1016/j.trac.2004.01.001>
- Levy, G.A., 1946. The toxicity of arsine administered by intraperitoneal injection. *Levy GA. Toxic. arsine Adm. by intraperitoneal Inject. Br. J. Pharmacol. Chemother.* 287–290.
- Li, C.-W., Chen, J.-Y., Hua, T.-E., 1998. Precambrian Sponges with Cellular Structures. *Science* (80-.). 279, 879–882. <https://doi.org/10.1126/science.279.5352.879>
- Li, X., Wai, O.W.H., Li, Y.S., Coles, B.J., Ramsey, M.H., Thornton, I., 2000. Heavy metal distribution in sediment profiles of the Pearl River estuary, South China. *Appl. Geochemistry* 15, 567–581. [https://doi.org/10.1016/S0883-2927\(99\)00072-4](https://doi.org/10.1016/S0883-2927(99)00072-4)
- Liang, T., Li, K., Wang, L., 2014. State of rare earth elements in different environmental components in mining areas of China. *Environ. Monit. Assess.* 186, 1499–1513. <https://doi.org/10.1007/s10661-013-3469-8>
- Lindqvist, O., Johansson, K., Bringmark, L., Timm, B., Aastrup, M., Andersson, A., Hovsenius, G., Håkanson, L., Iverfeldt, Å., Meili, M., 1991. Mercury in the Swedish environment --- Recent research on causes, consequences and corrective methods. *Water. Air. Soil Pollut.* 55, xi--261. <https://doi.org/10.1007/BF00542429>
- Linge, K.L., Jarvis, K.E., 2009. Quadrupole ICP-MS: Introduction to Instrumentation, Measurement Techniques and Analytical Capabilities. *Geostand. Geoanalytical Res.* 33, 445–467. <https://doi.org/10.1111/j.1751-908X.2009.00039.x>
- Liu, L., Wang, Z., Ju, F., Zhang, T., 2015. Co-occurrence correlations of heavy metals in sediments revealed using network analysis. *Chemosphere* 119, 1305–1313. <https://doi.org/10.1016/j.chemosphere.2014.01.068>
- Llorente-Mirandes, T., Ruiz-Chancho, M.J., Barbero, M., Rubio, R., López-Sánchez, J.F., 2010. Measurement of arsenic compounds in littoral zone algae from the Western Mediterranean Sea. Occurrence of arsenobetaine. *Chemosphere* 81, 867–875. <https://doi.org/10.1016/j.chemosphere.2010.08.007>
- Lohren, H., Blagojevic, L., Fitkau, R., Ebert, F., Schildknecht, S., Leist, M., Schwerdtle, T., 2015. Toxicity of organic and inorganic mercury species in differentiated human neurons and human astrocytes. *J. Trace Elem. Med. Biol.* 32, 200–208. <https://doi.org/10.1016/j.jtemb.2015.06.008>
- Longo, C., Corriero, G., Licciano, M., Stabili, L., 2010. Bacterial accumulation by the Demospongiae *Hymeniacidon perlevis*: A tool for the bioremediation of polluted seawater. *Mar. Pollut. Bull.* 60, 1182–1187. <https://doi.org/10.1016/j.marpolbul.2010.03.035>
- Loring, D.H., Rantala, R.T.T., 1992. Manual for the geochemical analyses of marine sediments and suspended particulate matter. *Earth Sci. Rev.* 32, 235–283. [https://doi.org/10.1016/0012-8252\(92\)90001-A](https://doi.org/10.1016/0012-8252(92)90001-A)
- Love, G.D., Grosjean, E., Stalvies, C., Fike, D.A., Grotzinger, J.P., Bradley, A.S., Kelly, A.E., Bhatia, M., Meredith, W., Snape, C.E., Bowring, S.A., Condon, D.J., Summons, R.E., 2009. Fossil steroids record the appearance of Demospongiae during the Cryogenian period. *Nature* 457, 718–721. <https://doi.org/10.1038/nature07673>

- Lu, X., Wang, L., Lei, K., Huang, J., Zhai, Y., 2009. Contamination assessment of copper, lead, zinc, manganese and nickel in street dust of Baoji, NW China. *J. Hazard. Mater.* 161, 1058–1062. <https://doi.org/10.1016/j.jhazmat.2008.04.052>
- Luoma, S.N., Rainbow, P.S., 2005. Why is metal bioaccumulation so variable? Biodynamics as a unifying concept. *Environ. Sci. Technol.* 39, 1921–1931. <https://doi.org/10.1021/es048947e>
- Macdonald, D.D., Carr, R.S., Calder, F.D., Long, E.R., Ingersoll, C.G., 1996. Development and evaluation of sediment quality guidelines for Florida coastal waters. *Ecotoxicology* 5, 253–78. <https://doi.org/10.1007/BF00118995>
- Magnusson, B., Ornemark, U., 2014. *Eurachem Guide: The Fitness for Purpose of Analytical Methods – a Laboratory Guide to Method Validation and Related Topics*. EURACHEM.
- Majer, A.P., Petti, M.A.V., Corbisier, T.N., Ribeiro, A.P., Theophilo, C.Y.S., Ferreira, P.A. de L., Figueira, R.C.L., 2014. Bioaccumulation of potentially toxic trace elements in benthic organisms of Admiralty Bay (King George Island, Antarctica). *Mar. Pollut. Bull.* 79, 321–325. <https://doi.org/10.1016/j.marpolbul.2013.12.015>
- Mandal, B.K., Suzuki, K.T., 2002. Arsenic round the world: A review. *Talanta* 58, 201–235. [https://doi.org/10.1016/S0039-9140\(02\)00268-0](https://doi.org/10.1016/S0039-9140(02)00268-0)
- Mandjukov, P., Orani, A.M., Han, E., Vassileva, E., 2015. Determination of total mercury for marine environmental monitoring studies by solid sampling continuum source high resolution atomic absorption spectrometry. *Spectrochim. Acta - Part B At. Spectrosc.* 103–104, 24–33. <https://doi.org/10.1016/j.sab.2014.11.006>
- Mapani, B., Ellmies, R., Kamona, F., Křibek, B., Majer, V., Knésl, I., Pašava, J., Mufenda, M., Mbingeneeko, F., 2009. Human health risks associated with historic ore processing at Berg Aukas, Grootfontein area, Namibia. *Communs geol. Surv. Namibia* 14, 25–40. <https://doi.org/10.1016/j.jafrearsci.2010.07.007>
- Martinez-Bravo, Y., Roig-Navarro, A.F., Lopez, F.J., Hernandez, F., 2001. Multielemental determination of arsenic, selenium and chromium(VI) species in water by high-performance liquid chromatography-inductively coupled plasma mass spectrometry. *J. Chromatogr. A* 926, 265–274.
- Mason, R.P., Reinfelder, J.R., Morel, F.M.M., 1996. Uptake, Toxicity, and Trophic Transfer of Mercury in a Coastal Diatom. *Environ. Sci. Technol.* 30, 1835–1845. <https://doi.org/10.1021/es950373d>
- Mayzel, B., Aizenberg, J., Ilan, M., 2014. The elemental composition of demospongiae from the Red Sea, Gulf of Aqaba. *PLoS One* 9. <https://doi.org/10.1371/journal.pone.0095775>
- McArthur, J.M., Walsh, J.N., 1984. Rare-earth geochemistry of phosphorites. *Chem. Geol.* 47, 191–220. [https://doi.org/10.1016/0009-2541\(84\)90126-8](https://doi.org/10.1016/0009-2541(84)90126-8)
- McLennan, S.M., 1989. Rare earth elements in sedimentary rocks; influence of provenance and sedimentary processes. *Rev. Mineral. Geochemistry* 21, 169–200.
- McNaught, A.D., Wilkinson, A., 1997. *Compendium of Chemical Terminology. The gold book*. Blackwell Science, London. <https://doi.org/10.1351/goldbook.i03352>
- Melamed, D., 2005. Monitoring arsenic in the environment: a review of science and technologies with the potential for field measurements. *Anal. Chim. Acta* 532, 1–13.

<https://doi.org/10.1016/j.aca.2004.10.047>

- Mil-Homens, M., Vale, C., Brito, P., Naughton, F., Drago, T., Raimundo, J., Anes, B., Schmidt, S., Caetano, M., 2017. Insights of Pb isotopic signature into the historical evolution and sources of Pb contamination in a sediment core of the southwestern Iberian Atlantic shelf. *Sci. Total Environ.* 586, 473–484. <https://doi.org/10.1016/j.scitotenv.2017.01.204>
- Milanese, M., Chelossi, E., Manconi, R., Sarà, A., Sidri, M., Pronzato, R., 2003. The marine sponge *Chondrilla nucula* Schmidt, 1862 as an elective candidate for bioremediation in integrated aquaculture. *Biomol. Eng.* 20, 363–368. [https://doi.org/10.1016/S1389-0344\(03\)00052-2](https://doi.org/10.1016/S1389-0344(03)00052-2)
- Mileusnić, M., Mapani, B.S., Kamona, A.F., Ružičić, S., Mapaure, I., Chimwamurombe, P.M., 2014. Assessment of agricultural soil contamination by potentially toxic metals dispersed from improperly disposed tailings, Kombat mine, Namibia. *J. Geochemical Explor.* 144, 409–420. <https://doi.org/10.1016/j.gexplo.2014.01.009>
- Ministry of Environment and Tourism, 2008. Strategic Environmental Assessment (SEA) of the coastal areas of the Erongo and Kunene regions.
- Mitra, N., Rezvan, Z., Seyed Ahmad, M., Gharraie Mohamad Hosein, M., 2012. Studies of Water Arsenic and Boron Pollutants and Algae Phytoremediation in Three Springs, Iran. *Int. J. Ecosyst.* 2, 32–37. <https://doi.org/10.5923/j.ije.20120203.01>
- Miyashita, S., Murota, D.C., Kondo, B.K., 2016. Arsenic metabolism in cyanobacteria. *Environ. Chem.* 13, 577–589.
- Miyashita, S., Shimoya, M., Kamidate, Y., Kuroiwa, T., Shikino, O., Fujiwara, S., Francesconi, K.A., Kaise, T., 2009. Rapid determination of arsenic species in freshwater organisms from the arsenic-rich Hayakawa River in Japan using HPLC-ICP-MS. *Chemosphere* 75, 1065–1073. <https://doi.org/10.1016/j.chemosphere.2009.01.029>
- Monna, F., Ben Othman, D., Luck, J.M., 1995. Pb isotopes and Pb, Zn and Cd concentrations in the rivers feeding a coastal pond (Thau, southern France): constraints on the origin(s) and flux(es) of metals. *Sci. Total Environ.* 166, 19–34. [https://doi.org/10.1016/0048-9697\(95\)04514-2](https://doi.org/10.1016/0048-9697(95)04514-2)
- MONNA, F., BENOETHMAN, D., LUCK, J., 1995. Pb isotopes and Pb, Zn and Cd concentrations in the rivers feeding a coastal pond (Thau, southern France): constraints on the origin(s) and flux(es) of metals. *Sci. Total Environ.* 166, 19–34. [https://doi.org/10.1016/0048-9697\(95\)04514-2](https://doi.org/10.1016/0048-9697(95)04514-2)
- Monna, F., Hamer, K., Lévêque, J., Sauer, M., 2000. Pb isotopes as a reliable marker of early mining and smelting in the Northern Harz province (Lower Saxony, Germany). *J. Geochemical Explor.* 68, 201–210. [https://doi.org/10.1016/S0375-6742\(00\)00005-4](https://doi.org/10.1016/S0375-6742(00)00005-4)
- Monna, F., Poujol, M., Losno, R., Dominik, J., Annegarn, H., Coetzee, H., 2006. Origin of atmospheric lead in Johannesburg, South Africa. *Atmos. Environ.* 40, 6554–6566. <https://doi.org/10.1016/j.atmosenv.2006.05.064>
- Morel, F.M.M., Kraepiel, A.M.L., Amyot, M., 1998. THE CHEMICAL CYCLE AND BIOACCUMULATION OF MERCURY. *Annu. Rev. Ecol. Syst.* 29, 543–566. <https://doi.org/10.1146/annurev.ecolsys.29.1.543>
- Müller, W.E.G., Batel, R., Lacorn, M., Steinhart, H., Simat, T., Lauenroth, S., Hassanein, H., Schröder, H.C., 1998. Accumulation of cadmium and zinc in the marine sponge *Suberites domuncula* and its potential consequences on single-strand breaks and on expression of heat-shock protein: A natural

- field study. *Mar. Ecol. Prog. Ser.* 167, 127–135. <https://doi.org/10.3354/meps167127>
- Nakata, H., Nakayama, S.M.M., Ikenaka, Y., Mizukawa, H., Ishii, C., Yohannes, Y.B., Konnai, S., Darwish, W.S., Ishizuka, M., 2015. Metal extent in blood of livestock from Dandora dumping site, Kenya: Source identification of Pb exposure by stable isotope analysis. *Environ. Pollut.* 205, 8–15. <https://doi.org/10.1016/j.envpol.2015.05.003>
- Nam, S.H., Oh, H.J., Min, H.S., Lee, J.H., 2010. A study on the extraction and quantitation of total arsenic and arsenic species in seafood by HPLC-ICP-MS. *Microchem. J.* 95, 20–24. <https://doi.org/10.1016/j.microc.2009.08.009>
- Ndung'u, K., Franks, R.P., Bruland, K.W., Flegal, A.R., 2003. Organic complexation and total dissolved trace metal analysis in estuarine waters: comparison of solvent-extraction graphite furnace atomic absorption spectrometric and chelating resin flow injection inductively coupled plasma-mass spectrometric analysis. *Anal. Chim. Acta* 481, 127–138. [https://doi.org/10.1016/S0003-2670\(03\)00063-1](https://doi.org/10.1016/S0003-2670(03)00063-1)
- Nearing, M.M., Koch, I., Reimer, K.J., 2014. Complementary arsenic speciation methods: A review. *Spectrochim. Acta - Part B At. Spectrosc.* 99, 150–162. <https://doi.org/10.1016/j.sab.2014.07.001>
- Negri, A., Burns, K., Boyle, S., Brinkman, D., Webster, N., 2006. Contamination in sediments, bivalves and sponges of McMurdo Sound, Antarctica. *Environ. Pollut.* 143, 456–467. <https://doi.org/10.1016/j.envpol.2005.12.005>
- Nieboer, E., Richardson, D.H.S., 1980. The replacement of the nondescript term “heavy metals” by a biologically and chemically significant classification of metal ions. *Environ. Pollut. Ser. B, Chem. Phys.* 1, 3–26. [https://doi.org/10.1016/0143-148X\(80\)90017-8](https://doi.org/10.1016/0143-148X(80)90017-8)
- Nolan, L., Cadien, K., 2012. *Chemical Mechanical Polish for Nanotechnology*. Nanofabrication Tech. Princ.
- Nozaki, Y., 2001. Elemental distribution: Overview, in: Steele, J.H., Thorpe, S.A., Turekian, K.K. (Eds.), *Encyclopedia of the Ocean Sciences*, Vol. 2. Academic Press London, pp. 840–845. <https://doi.org/http://dx.doi.org/10.1006/rwos.2001.0402>
- Ochoa, V., Barata, C., Riva, M.C., 2013. Heavy metal content in oysters (*Crassostrea gigas*) cultured in the Ebro Delta in Catalonia, Spain. *Environ. Monit. Assess.* 185, 6783–6792. <https://doi.org/10.1007/s10661-013-3064-z>
- Olesen, T.M.E., Weeks, J.M., 1994. Accumulation of Cd by the marine sponge *Halichondria panicea* pallas: effects upon filtration rate and its relevance for biomonitoring. *Bull. Environ. Contam. Toxicol.* 52, 722–728. <https://doi.org/10.1007/BF00195494>
- Olmedo, P., Pla, A., Hernández, A.F., Barbier, F., Ayouni, L., Gil, F., 2013. Determination of toxic elements (mercury, cadmium, lead, tin and arsenic) in fish and shellfish samples. Risk assessment for the consumers. *Environ. Int.* 59, 63–72. <https://doi.org/10.1016/j.envint.2013.05.005>
- Orris, G.J., Grauch, R.I., 2002. *Rare Earth Element Mines, Deposits, and Occurrences*.
- Ortega, G.S., Pécheyran, C., Bérail, S., Donard, O.F.X., 2012. A fit-for purpose procedure for lead isotopic ratio determination in crude oil, asphaltene and kerogen samples by MC-ICPMS. *J. Anal. At. Spectrom.* 27, 1447. <https://doi.org/10.1039/c2ja30143a>

- Ostrom, K.M., Simpson, T.L., 1978. Calcium and the release from dormancy of freshwater sponge gemmules. *Dev. Biol.* 64, 332–338. [https://doi.org/10.1016/0012-1606\(78\)90083-0](https://doi.org/10.1016/0012-1606(78)90083-0)
- Padovan, A., Munksgaard, N., Alvarez, B., McGuinness, K., Parry, D., Gibb, K., 2012. Trace metal concentrations in the tropical sponge *Spherospongia vagabunda* at a sewage outfall: Synchrotron X-ray imaging reveals the micron-scale distribution of accumulated metals. *Hydrobiologia* 687, 275–288. <https://doi.org/10.1007/s10750-011-0916-9>
- Pan, K., Lee, O.O., Qian, P.Y., Wang, W.X., 2011. Sponges and sediments as monitoring tools of metal contamination in the eastern coast of the Red Sea, Saudi Arabia. *Mar. Pollut. Bull.* 62, 1140–1146. <https://doi.org/10.1016/j.marpolbul.2011.02.043>
- Parra, S., Bravo, M.A., Quiroz, W., Querol, X., Paipa, C., 2015. Distribution and pollution assessment of trace elements in marine sediments in the Quintero Bay (Chile). *Mar. Pollut. Bull.* 99, 256–263. <https://doi.org/10.1016/j.marpolbul.2015.07.066>
- Parsons, J.G., Martinez-Martinez, A., Peralta-Video, J.R., Gardea-Torresdey, J.L., 2008. Speciation and uptake of arsenic accumulated by corn seedlings using XAS and DRC-ICP-MS. *Chemosphere* 70, 2076–2083. <https://doi.org/10.1016/j.chemosphere.2007.08.069>
- Patel, B., Balani, M., Patel, S., 1985. Sponge “sentinel” of heavy metals. *Sci. Total Environ.* 41, 143–152.
- Perez, T., Longet, D., Schembri, T., Rebouillon, P., Vacelet, J., 2005. Effects of 12 years’ operation of a sewage treatment plant on trace metal occurrence within a Mediterranean commercial sponge (*Spongia officinalis*, *Demospongiae*). *Mar. Pollut. Bull.* 50, 301–309. <https://doi.org/10.1016/j.marpolbul.2004.11.001>
- Perez, T., Vacelet, J., Rebouillon, P., 2004. In situ comparative study of several Mediterranean sponges as potential biomonitors for heavy metals. *Boll. Mus. Ist. Biol. Univ. Genova* 68, 517–525.
- Phillips, D.J.H., 1990. Arsenic in aquatic organisms: a review, emphasising chemical speciation. *Aquat. Toxicol.* 16, 151–186.
- Piper, D.Z., 1974. Rare earth elements in the sedimentary cycle: A summary. *Chem. Geol.* 14, 285–304. [https://doi.org/10.1016/0009-2541\(74\)90066-7](https://doi.org/10.1016/0009-2541(74)90066-7)
- Plant, J.A., Raiswell, R., 1983. Principles of environmental geochemistry, in: Thornton, I. (Ed.), *Applied Environmental Geochemistry*. Academic Press London.
- Pourret, O., Davranche, M., Gruau, G., Dia, A., 2007. Rare earth elements complexation with humic acid. *Chem. Geol.* 243, 128–141. <https://doi.org/10.1016/j.chemgeo.2007.05.018>
- Quetel, C.R., Prohaska, T., Hamester, M., Kerl, W., Taylor, P.D.P., 2000. Examination of the performance exhibited by a single detector double focusing magnetic sector ICP-MS instrument for uranium isotope abundance ratio measurements over almost three orders of magnitude and down to pg[space]g⁻¹ concentration levels. *J. Anal. At. Spectrom.* 15, 353–358. <https://doi.org/10.1039/A907084B>
- Quevauviller, P., 2016. *Marine Chemical Monitoring. Policies, techniques and metrological principles*. John Wiley & Sons.
- Raber, G., Stock, N., Hanel, P., Murko, M., Navratilova, J., Francesconi, K.A., 2012. An improved HPLC-ICPMS method for determining inorganic arsenic in food: Application to rice, wheat and tuna fish.

- Food Chem. 134, 524–532. <https://doi.org/10.1016/j.foodchem.2012.02.113>
- Radabaugh, T.R., Aposhian, H.V., 2000. Enzymatic Reduction of Arsenic Compounds in Mammalian Systems: Reduction of Arsenate to Arsenite by Human Liver Arsenate Reductase. *Chem. Res. Toxicol.* 13, 26–30. <https://doi.org/10.1021/tx990115k>
- Rainbow, P., 2002. Trace metal concentrations in aquatic invertebrates: why and so what? *Environ. Pollut.* 120, 497–507. [https://doi.org/10.1016/S0269-7491\(02\)00238-5](https://doi.org/10.1016/S0269-7491(02)00238-5)
- Rainbow, P.S., 1997. Trace Metal Accumulation in Marine Invertebrates: Marine Biology or Marine Chemistry? *J. Mar. Biol. Assoc. United Kingdom* 77, 195–210. <https://doi.org/doi:10.1017/S0025315400033877>
- Rand, G.M., Wells, P.G., McCarthy, L.S., 1995. Introduction to aquatic ecology, in: Rand, G.M. (Ed.), *Fundamentals of Aquatic Toxicology*. Taylor and Francis, London, pp. 3–53.
- Resongles, E., Casiot, C., Freydier, R., Dezileau, L., Viers, J., Elbaz-Poulichet, F., 2014. Persisting impact of historical mining activity to metal (Pb, Zn, Cd, Tl, Hg) and metalloid (As, Sb) enrichment in sediments of the Gardon River, Southern France. *Sci. Total Environ.* 481, 509–521. <https://doi.org/10.1016/j.scitotenv.2014.02.078>
- Rezaee, K., Saion, E.B., Wood, A.K., Abdi, M.R., 2010. Rare earth elements determination and distribution patterns in surface marine sediments of the South China Sea by INAA, Malaysia. *J. Radioanal. Nucl. Chem.* 283, 823–829. <https://doi.org/10.1007/s10967-009-0421-z>
- Rieuwerts, J.S., Thornton, I., Farago, M.E., Ashmore, M.R., 1998. Factors influencing metal bioavailability in soils: preliminary investigations for the development of a critical loads approach for metals. *Chem. Speciat. Bioavailab.* 10, 61–75. <https://doi.org/10.3184/095422998782775835>
- Roehl, R., Gomez, J., Woodhouse, L.R., 1995. Correction of mass bias drift in inductively coupled plasma mass spectrometry measurements of zinc isotope ratios using gallium as an isotope ratio internal standard. *J. Anal. At. Spectrom.* 10, 15–23. <https://doi.org/10.1039/JA9951000015>
- Roose, P., Albaigés, J., Bebianno, M.J., Camphuysen, C., Cronin, M., de Leeuw, J., Gabrielsen, G., Hutchinson, T., Hylland, K., Jansson, B., Jenssen, B.M., Schulz-Bull, D., Szefer, P., Webster, L., Bakke, T., Janssen, C., 2011. Monitoring Chemical Pollution in Europe's Seas: Programmes, practices and priorities for Research. *Mar. Board Position* 108.
- Rose, A.W., Hawkes, H.E., 1979. *Geochemistry in mineral exploration*. Academic Press.
- Roussiez, V., Ludwig, W., Probst, J.-L., Monaco, A., 2005. Background levels of heavy metals in surficial sediments of the Gulf of Lions (NW Mediterranean): An approach based on ¹³³Cs normalization and lead isotope measurements. *Environ. Pollut.* 138, 167–177. <https://doi.org/10.1016/j.envpol.2005.02.004>
- Sakko, A.L., 1998. The influence of the Benguela upwelling system on Namibia's marine biodiversity. *Biodivers. & Conserv.* 7, 419–433. <https://doi.org/10.1023/A:1008867310010>
- Salati, S., Moore, F., 2010. Assessment of heavy metal concentration in the Khoshk River water and sediment, Shiraz, Southwest Iran. *Environ. Monit. Assess.* 164, 677–689. <https://doi.org/10.1007/s10661-009-0920-y>
- Salaün, P., Planer-Friedrich, B., van den Berg, C.M.G., 2007. Inorganic arsenic speciation in water and

- seawater by anodic stripping voltammetry with a gold microelectrode. *Anal. Chim. Acta* 585, 312–322. <https://doi.org/10.1016/j.aca.2006.12.048>
- Salomons, W., Förstner, U., 1984. *Metals in the Hydrocycle*. Springer-Verlag Berlin Heidelberg. <https://doi.org/10.1007/978-3-642-69325-0>
- Sánchez Uría, J., 1998. Inorganic and methylmercury speciation in environmental samples. *Talanta* 47, 509–524. [https://doi.org/10.1016/S0039-9140\(98\)00116-7](https://doi.org/10.1016/S0039-9140(98)00116-7)
- Santini, J.M., Streimann, I.C.A., Hoven, R.N. vanden, 2004. *Bacillus macyae* sp. nov., an arsenate-respiring bacterium isolated from an Australian gold mine. *Int. J. Syst. Evol. Microbiol.* 54, 2241–2244.
- Santos-Gandelman, J.F., Giambiagi-Demarval, M., Muricy, G., Barkay, T., Laport, M.S., 2014. Mercury and methylmercury detoxification potential by sponge-associated bacteria. *Antonie van Leeuwenhoek, Int. J. Gen. Mol. Microbiol.* 106, 585–590. <https://doi.org/10.1007/s10482-014-0224-2>
- Schaeffer, R., Francesconi, K.A., Kienzl, N., Soeroes, C., Fodor, P., Váradi, L., Raml, R., Goessler, W., Kuehnelt, D., 2006. Arsenic speciation in freshwater organisms from the river Danube in Hungary. *Talanta* 69, 856–865. <https://doi.org/10.1016/j.talanta.2005.11.025>
- Scott, N., Hatlelid, K.M., MacKenzie, N.E., Carter, D.E., 1993. Reactions of arsenic(III) and arsenic(V) species with glutathione. *Chem. Res. Toxicol.* 6, 102–106. <https://doi.org/10.1021/tx00031a016>
- Semeniuk, D.M., Maldonado, M.T., Jaccard, S.L., 2016. Chromium uptake and adsorption in marine phytoplankton – Implications for the marine chromium cycle. *Geochim. Cosmochim. Acta* 184, 41–54. <https://doi.org/10.1016/j.gca.2016.04.021>
- Semlali, R.M., Dessogne, J.-B., Monna, F., Bolte, J., Azimi, S., Navarro, N., Denaix, L., Loubet, M., Chateau, C., van Oort, F., 2004. Modeling Lead Input and Output in Soils Using Lead Isotopic Geochemistry. *Environ. Sci. Technol.* 38, 1513–1521. <https://doi.org/10.1021/es0341384>
- Shepherd, T.J., Dirks, W., Roberts, N.M.W., Patel, J.G., Hodgson, S., Pless-Mulloli, T., Walton, P., Parrish, R.R., 2016. Tracing fetal and childhood exposure to lead using isotope analysis of deciduous teeth. *Environ. Res.* 146, 145–153. <https://doi.org/10.1016/j.envres.2015.12.017>
- Shiomi, K., Aoyama, M., Yamanaka, H., Kikuchi, T., 1988. Chemical Forms of Arsenic in Sponges, Sea-Anemones and Sea Hare. *Comp. Biochem. Physiol. C-Pharmacology Toxicol. Endocrinol.* 90, 361–365.
- Silver, S., Phung, L.T., 2005. Genes and Enzymes Involved in Bacterial Oxidation and Reduction of Inorganic Arsenic. *Appl. Environ. Microbiol.* 71.
- Sjåstad, K.-E., Lucy, D., Andersen, T., 2016. Lead isotope ratios for bullets, forensic evaluation in a Bayesian paradigm. *Talanta* 146, 62–70. <https://doi.org/10.1016/j.talanta.2015.07.070>
- Sjåstad, K.-E., Simonsen, S.L., Andersen, T., 2011. Use of lead isotopic ratios to discriminate glass samples in forensic science. *J. Anal. At. Spectrom.* 26, 325. <https://doi.org/10.1039/c0ja00054j>
- Søndergaard, J., Asmund, G., Larsen, M.M., 2015. Trace elements determination in seawater by ICP-MS with on-line pre-concentration on a Chelex-100 column using a “standard” instrument setup. *MethodsX* 2, 323–330. <https://doi.org/10.1016/j.mex.2015.06.003>
- Song, Y.H., Choi, M.S., 2009. REE geochemistry of fine-grained sediments from major rivers around the

- Yellow Sea. *Chem. Geol.* 266, 337–351. <https://doi.org/10.1016/j.chemgeo.2009.06.019>
- Spada, L., Annicchiarico, C., Cardellicchio, N., Giandomenico, S., Di Leo, A., 2012. Mercury and methylmercury concentrations in Mediterranean seafood and surface sediments, intake evaluation and risk for consumers. *Int. J. Hyg. Environ. Health* 215, 418–426. <https://doi.org/10.1016/j.ijheh.2011.09.003>
- Split, P.M., Delta, A., 2010. Sediment Quality Guidelines for the Protection of Aquatic Life, Canadian Council of Ministers of the Environment.
- Stiboller, M., Raber, G., Francesconi, K.A., 2015. Simultaneous determination of glycine betaine and arsenobetaine in biological samples by HPLC/ICPMS/ESMS and the application to some marine and freshwater fish samples. *Microchem. J.* 122, 172–175. <https://doi.org/10.1016/j.microc.2015.04.022>
- Strady, E., Schäfer, J., Baudrimont, M., Blanc, G., 2011. Tracing cadmium contamination kinetics and pathways in oysters (*Crassostrea gigas*) by multiple stable Cd isotope spike experiments. *Ecotoxicol. Environ. Saf.* 74, 600–606. <https://doi.org/10.1016/j.ecoenv.2010.10.020>
- Sulochanan, B., Krishnakumar, P.K., Prema, D., Kaladharan, P., Valsala, K.K., Bhat, G.S., Muniyandi, K., 2007. Trace metal contamination of the marine environment in Palk Bay and Gulf of Mannar. *J. Mar. Biol. Assoc. India* 49, 12–18.
- Sun, M., Liu, G., Wu, Q., Liu, W., 2013. Speciation analysis of inorganic arsenic in coal samples by microwave-assisted extraction and high performance liquid chromatography coupled to hydride generation atomic fluorescence spectrometry. *Talanta* 106, 8–13. <https://doi.org/10.1016/j.talanta.2012.12.012>
- Sun, Q., Liu, D., Liu, T., Di, B., Wu, F., 2012. Temporal and spatial distribution of trace metals in sediments from the northern Yellow Sea coast, China: Implications for regional anthropogenic processes. *Environ. Earth Sci.* 66, 697–705. <https://doi.org/10.1007/s12665-011-1277-4>
- Suner, M.A., Devesa, V., Munoz, O., Velez, D., Montoro, R., 2001. Application of column switching in high-performance liquid chromatography with on-line thermo-oxidation and detection by HG-AAS and HG-AFS for the analysis of organoarsenical species in seafood samples. *J. Anal. At. Spectrom.* 16, 390–397. <https://doi.org/10.1039/B007518N>
- Szava-Kovats, R.C., 2008. Grain-size normalization as a tool to assess contamination in marine sediments: Is the $63\mu\text{m}$ fraction fine enough? *Mar. Pollut. Bull.* 56, 629–632. <https://doi.org/10.1016/j.marpolbul.2008.01.017>
- Tan, Q.G., Wang, Y., Wang, W.X., 2015. Speciation of Cu and Zn in two colored oyster species determined by x-ray absorption spectroscopy. *Environ. Sci. Technol.* 49, 6919–6925. <https://doi.org/10.1021/es506330h>
- Tang, J., Johannesson, K.H., 2010. Ligand extraction of rare earth elements from aquifer sediments: Implications for rare earth element complexation with organic matter in natural waters. *Geochim. Cosmochim. Acta* 74, 6690–6705. <https://doi.org/10.1016/j.gca.2010.08.028>
- Taylor, S.R., 1964. Abundance of chemical elements in the continental crust: a new table. *Geochim. Cosmochim. Acta* 28, 1273–1285. [https://doi.org/10.1016/0016-7037\(64\)90129-2](https://doi.org/10.1016/0016-7037(64)90129-2)
- Taylor, V.F., Jackson, B.P., Siegfried, M.R., Navratilova, J., Francesconi, K.A., Kirshtein, J., Voytek, M.,

2012. Arsenic speciation in food chains from mid-Atlantic hydrothermal vents. *Environ. Chem.* 9, 130–138. <https://doi.org/10.1071/EN11134>
- Tchounwou, P.B., Yedjou, C.G., Patlolla, A.K., Sutton, D.J., 2012. Heavy Metals Toxicity and the Environment. *Mol. Clin. Environ. Toxicol.* 101, 1–30. <https://doi.org/10.1007/978-3-7643-8340-4>
- Thomas, D.J., Styblo, M., Lin, S., 2001. The Cellular Metabolism and Systemic Toxicity of Arsenic. *Toxicol. Appl. Pharmacol.* 176, 127–144. <https://doi.org/10.1006/taap.2001.9258>
- Thomas, R., 2003. Practical guide to ICP-MS: a tutorial for beginners. CRC Press.
- Thorne, L.T., Nickless, G., 1981. The relation between heavy metals and particle size fractions within the severn estuary (U.K.) inter-tidal sediments. *Sci. Total Environ.* 19, 207–213. [https://doi.org/10.1016/0048-9697\(81\)90017-6](https://doi.org/10.1016/0048-9697(81)90017-6)
- Tian, Y., Chen, M.-L., Chen, X.-W., Wang, J.-H., Hirano, Y., Sakamoto, H., Setsu, I., 2010. Arsenic speciation with gradient hydride generation interfacing liquid chromatography and atomic absorption spectrometry. *J. Anal. At. Spectrom.* 25, 48–54. <https://doi.org/10.1039/B913198A>
- Tomlinson, D.L., Wilson, J.G., Harris, C.R., Jeffrey, D.W., 1980. Problems in the assessment of heavy-metal levels in estuaries and the formation of a pollution index. *Helgoländer Meeresuntersuchungen* 33, 566–575. <https://doi.org/10.1007/BF02414780>
- Tompkins-MacDonald, G.J., Gallin, W.J., Sakarya, O., Degnan, B., Leys, S.P., Boland, L.M., 2009. Expression of a poriferan potassium channel: insights into the evolution of ion channels in metazoans. *J. Exp. Biol.* 212, 761–767. <https://doi.org/10.1242/jeb.026971>
- Tripti, M., Gurumurthy, G.P., Balakrishna, K., Chadaga, M.D., 2013. Dissolved trace element biogeochemistry of a tropical river, Southwestern India. *Environ. Sci. Pollut. Res.* 20, 4067–4077. <https://doi.org/10.1007/s11356-012-1341-y>
- Tsimplis, M.N., Baker, T.F., 2000. Sea level drop in the Mediterranean Sea: An indicator of deep water salinity and temperature changes? *Geophys. Res. Lett.* 27, 1731–1734. <https://doi.org/10.1029/1999GL007004>
- Turekian, K.K., Wedepohl, K.H., 1961. Distribution of the Elements in Some Major Units of the Earth's Crust. *Geol. Soc. Am. Bull.* 72, 175–192. [https://doi.org/10.1130/0016-7606\(1961\)72](https://doi.org/10.1130/0016-7606(1961)72)
- UN DOALOS (Division for Ocean Affairs and the Law of the Sea), 2016. First Global Integrated Marine Assessment (first World Ocean Assessment) [WWW Document]. URL http://www.un.org/depts/los/global_reporting/WOA_RegProcess.htm
- UNEP, 2011. Abidjan Convention. Convention for Co-operation in the Protection and Development of the Marine and Coastal environment of the West and Central African Region [WWW Document].
- UNEP regional seas, 2017 [WWW Document], n.d. URL <http://www.unep.org/regionalseas/> (accessed 7.13.17).
- US EPA, 2006. Marine Sediment Screening Benchmarks, Region III.
- V.E Vaskovsky, O.D. Korotchenko, L.P.K. and V.S.L., 1972. Arsenic in the lipid extracts of marine invertebrates. *Comp. Biochem. Physiol. C-Pharmacology Toxicol. Endocrinol.* 41, 777–784.
- Vahter, M., 1994. Species differences in the metabolism of arsenic compounds. *Appl. Organomet. Chem.*

- 8, 175–182. <https://doi.org/10.1002/aoc.590080304>
- Vallius, H., 2014. Heavy metal concentrations in sediment cores from the northern Baltic Sea: Declines over the last two decades. *Mar. Pollut. Bull.* 79, 359–364. <https://doi.org/10.1016/j.marpolbul.2013.11.017>
- Vallius, H., Ryabchuk, D., Kotilainen, A., Distribution, A., 2007. Distribution of heavy metals and arsenic in soft surface sediments of the coastal area off Kotka, North-eastern Gulf of Finland, Baltic Sea. *Geol. Surv. Finland, Spec. Pap.* 45, 33–48.
- van den Hoven, R.N., Santini, J.M., 2004. Arsenite oxidation by the heterotroph *Hydrogenophaga* sp. str. NT-14: the arsenite oxidase and its physiological electron acceptor. *Biochim. Biophys. Acta (BBA)-Bioenergetics* 1656, 148–155.
- Vanhaecke, F., Degryse, P., 2012. The Isotopic Composition of the Elements, in: *Isotopic Analysis: Fundamentals and Applications Using ICP-MS*. John Wiley and sons, pp. 1–29. <https://doi.org/10.1002/9783527650484>
- Varol, M., 2011. Assessment of heavy metal contamination in sediments of the Tigris River (Turkey) using pollution indices and multivariate statistical techniques. *J. Hazard. Mater.* 195, 355–364. <https://doi.org/10.1016/j.jhazmat.2011.08.051>
- Veerasingam, S., Vethamony, P., Mani Murali, R., Fernandes, B., 2015. Depositional record of trace metals and degree of contamination in core sediments from the Mandovi estuarine mangrove ecosystem, west coast of India. *Mar. Pollut. Bull.* 91, 362–367. <https://doi.org/10.1016/j.marpolbul.2014.11.045>
- Venkateswara Rao, J., Srikanth, K., Pallela, R., Gnaneshwar Rao, T., 2009. The use of marine sponge, *Haliclona tenuiramosa* as bioindicator to monitor heavy metal pollution in the coasts of Gulf of Mannar, India. *Environ. Monit. Assess.* 156, 451–459. <https://doi.org/10.1007/s10661-008-0497-x>
- Véron, A., Flament, P., Bertho, M.L., Alleman, L., Flegal, R., Hamelin, B., 1999. Isotopic evidence of pollutant lead sources in northwestern France. *Atmos. Environ.* 33, 3377–3388. [https://doi.org/10.1016/S1352-2310\(98\)00376-8](https://doi.org/10.1016/S1352-2310(98)00376-8)
- Vicente-Martorell, J.J., Galindo-Riaño, M.D., García-Vargas, M., Granado-Castro, M.D., 2009. Bioavailability of heavy metals monitoring water, sediments and fish species from a polluted estuary. *J. Hazard. Mater.* 162, 823–836. <https://doi.org/10.1016/j.jhazmat.2008.05.106>
- Vio, L., Martelat, B., Isnard, H., Nonell, A., Chartier, F., 2018. Multi-elemental Nd, Sm, Eu, Gd isotope ratio measurements by stop-flow isotachopheresis coupled to MC-ICPMS. *Talanta* 176, 582–588. <https://doi.org/10.1016/j.talanta.2017.08.013>
- Wahlen, R., McSheehy, S., Scriver, C., Mester, Z., 2004. Arsenic speciation in marine certified reference materials - Part 2. The quantification of water-soluble arsenic species by high-performance liquid chromatography-inductively coupled plasma mass spectrometry. *J. Anal. At. Spectrom.* 19, 876–882. <https://doi.org/10.1039/b402482f>
- Wall, F., Niku-Paavola, V.N., Storey, C., Müller, A., Jeffries, T., 2008. Xenotime-(Y) from carbonatite dykes at Lofdal, Namibia: Unusually low LREE:HREE ratio in carbonatite, and the first dating of xenotime overgrowths on zircon. *Can. Mineral.* 46, 861–877. <https://doi.org/10.3749/canmin.46.4.861>

- Wang, G., Zeng, C., Zhang, F., Zhang, Y., Scott, C.A., Yan, X., 2017. Traffic-related trace elements in soils along six highway segments on the Tibetan Plateau: Influence factors and spatial variation. *Sci. Total Environ.* 581–582, 811–821. <https://doi.org/10.1016/j.scitotenv.2017.01.018>
- Wang, W.-X., Lu, G., 2017. Heavy Metals in Bivalve Mollusks, in: *Chemical Contaminants and Residues in Food*. Elsevier, pp. 553–594. <https://doi.org/10.1016/B978-0-08-100674-0.00021-7>
- Wang, X., Qin, Y., 2006. Spatial distribution of metals in urban topsoils of Xuzhou (China): controlling factors and environmental implications. *Environ. Geol.* 49, 905–914. <https://doi.org/10.1007/s00254-005-0122-z>
- Wang, X.S., 2008. Correlations between heavy metals and organic carbon extracted by dry oxidation procedure in urban roadside soils. *Environ. Geol.* 54, 269–273. <https://doi.org/10.1007/s00254-007-0814-7>
- Wang, Y., Wang, S., Xu, P., Liu, C., Liu, M., Wang, Y., Wang, C., Zhang, C., Ge, Y., 2015. Review of arsenic speciation, toxicity and metabolism in microalgae. *Rev. Environ. Sci. Bio/Technology* 14, 427–451. <https://doi.org/10.1007/s11157-015-9371-9>
- Wang, Z.H., Lin, Q., Qang, X., Liu-Dong, L.I., 2011. The variation features of heavy metal contents in oyster samples from the coast of South China Sea and their safety assessment. *J. Fish. China* 35, 291–297.
- Watkins, R.T., Nathan, Y., Bremner, J.M., 1995. Rare earth elements in phosphorite and associated sediment from the Namibian and South African continental shelves. *Mar. Geol.* 129, 111–128. [https://doi.org/10.1016/0025-3227\(95\)00107-7](https://doi.org/10.1016/0025-3227(95)00107-7)
- Weis, P., Weis, J.S., 1999. Accumulation of metals in consumers associated with chromated copper arsenate-treated wood panels. *Mar. Environ. Res.* 48, 73–81. [https://doi.org/10.1016/S0141-1136\(99\)00028-8](https://doi.org/10.1016/S0141-1136(99)00028-8)
- Weisz, J.B., Lindquist, N., Martens, C.S., 2008. Do associated microbial abundances impact marine demosponge pumping rates and tissue densities? *Oecologia* 155, 367–376. <https://doi.org/10.1007/s00442-007-0910-0>
- Welz, B., Borges, D.L.G., Lepri, F.G., Vale, M.G.R., Heitmann, U., 2007. High-resolution continuum source electrothermal atomic absorption spectrometry — An analytical and diagnostic tool for trace analysis. *Spectrochim. Acta Part B At. Spectrosc.* 62, 873–883. <https://doi.org/10.1016/j.sab.2007.03.009>
- Weng, N., Wang, W.X., 2014. Variations of trace metals in two estuarine environments with contrasting pollution histories. *Sci. Total Environ.* 485–486, 604–614. <https://doi.org/10.1016/j.scitotenv.2014.03.110>
- Wentworth, C.K., 1922. A Scale of Grade and Class Terms for Clastic Sediments. *J. Geol.* 30, 377–392. <https://doi.org/10.1086/622910>
- WHO, 2006. *Arsenic in Drinking-water*.
- WHO, 1996. *Trace Elements in Human Nutrition and Health*. Geneva, Switzerland.
- WHO/FAO/IAEA, 1996. *Trace Elements in Human Nutrition and Health*. Geneva, Switzerland.
- Wu, X., Gao, M., Wang, L., Luo, Y., Bi, R., Li, L., Xie, L., 2014. The arsenic content in marketed seafood

- and associated health risks for the residents of Shandong, China. *Ecotoxicol. Environ. Saf.* 102, 168–173. <https://doi.org/10.1016/j.ecoenv.2014.01.028>
- Wu, Y., Wang, S., Streets, D.G., Hao, J., Chan, M., Jiang, J., 2006. Trends in Anthropogenic Mercury Emissions in China from 1995 to 2003. *Environ. Sci. Technol.* 40, 5312–5318. <https://doi.org/10.1021/es060406x>
- Wulff, J., 2001. Assessing and monitoring coral reef sponges: why and how? *Bull. Mar. Sci.* 69.
- Wysocka, I., Vassileva, E., 2016. Determination of cadmium, copper, mercury, lead and zinc mass fractions in marine sediment by isotope dilution inductively coupled plasma mass spectrometry applied as a reference method. *Microchem. J.* 128, 198–207. <https://doi.org/10.1016/j.microc.2016.05.002>
- Xu, Y., Sun, Q., Yi, L., Yin, X., Wang, A., Li, Y., Chen, J., 2014. The source of natural and anthropogenic heavy metals in the sediments of the Minjiang River Estuary (SE China): Implications for historical pollution. *Sci. Total Environ.* 493, 729–736. <https://doi.org/10.1016/j.scitotenv.2014.06.046>
- Xu, Z., Lim, D., Choi, J., Yang, S., Jung, H., 2009. Rare earth elements in bottom sediments of major rivers around the Yellow Sea: implications for sediment provenance. *Geo-Marine Lett.* 29, 291–300. <https://doi.org/10.1007/s00367-009-0142-x>
- Yamaoka, Y., Carmona, M.L., Oclarit, J.M., Jin, K., Shibata, Y., 2006. Characterization of water-soluble organoarsenic compounds in marine sponges. *Appl. Organomet. Chem.* 20, 545–548. <https://doi.org/10.1002/aoc>
- Yamaoka, Y., Carmona, M.L., Oclarit, J.M., Jin, K., Shibata, Y., 2001. Arsenic compounds in marine sponge (*Haliclona permolis*, *Halichondria japonica*, *Halichondria okadai* and *Haliclona* sp. white) from Seto Inland Sea, Japan. *Appl. Organomet. Chem.* 15, 261–265. <https://doi.org/10.1002/aoc.135>
- Yang, L., Mester, Z., Sturgeon, R.E., 2003. Comparison of sector field- and quadrupole-ICP-MS for the determination of DBT and TBT in sediment following GC separation. *J. Anal. At. Spectrom.* 18, 1365–1370. <https://doi.org/10.1039/b304705a>
- Zahra, A., Hashmi, M.Z., Malik, R.N., Ahmed, Z., 2014. Enrichment and geo-accumulation of heavy metals and risk assessment of sediments of the Kurang Nallah—Feeding tributary of the Rawal Lake Reservoir, Pakistan. *Sci. Total Environ.* 470–471, 925–933. <https://doi.org/10.1016/j.scitotenv.2013.10.017>
- Zakharyan, R.A., Sampayo-Reyes, A., Healy, S.M., Tsaprailis, G., Board, P.G., Liebler, D.C., Aposhian, H.V., 2001. Human Monomethylarsonic Acid (MMAV) Reductase Is a Member of the Glutathione-S-transferase Superfamily. *Chem. Res. Toxicol.* 14, 1051–1057. <https://doi.org/10.1021/tx010052h>
- Zhang, W., Chen, L., Zhou, Y., Wu, Y., Zhang, L., 2016a. Biotransformation of inorganic arsenic in a marine herbivorous fish *Siganus fuscescens* after dietborne exposure. *Chemosphere* 147, 297–304. <https://doi.org/10.1016/j.chemosphere.2015.12.121>
- Zhang, W., Feng, H., Chang, J., Qu, J., Xie, H., Yu, L., 2009. Heavy metal contamination in surface sediments of Yangtze River intertidal zone: An assessment from different indexes. *Environ. Pollut.* 157, 1533–1543. <https://doi.org/10.1016/j.envpol.2009.01.007>
- Zhang, W., Guo, Z., Zhou, Y., Chen, L., Zhang, L., 2016b. Comparative contribution of trophic transfer and biotransformation on arsenobetaine bioaccumulation in two marine fish. *Aquat. Toxicol.* 179, 65–

71. <https://doi.org/10.1016/j.aquatox.2016.08.017>

Zhang, W., Guo, Z., Zhou, Y., Liu, H., Zhang, L., 2015. Biotransformation and detoxification of inorganic arsenic in Bombay oyster *Saccostrea cucullata*. *Aquat. Toxicol.* 158, 33–40. <https://doi.org/10.1016/j.aquatox.2014.10.021>

PART II: SCIENTIFIC PUBLICATIONS

The second part of the thesis is focused on the presentation of the scientific publication originated from this PhD work. Some of the papers are already published in peer reviewed journals; some others are under revisions or ready to be submitted.

The part can be in turn divided in three main blocks:

1. The first block is represented by the first three publications. These are related to the development and validation of analytical methodologies for the determination of some TE in sediments and biota samples by SS-HR-CS-AAS. Special attention was given to very important metrological concepts applied in the validation part.
2. The second block includes two publications on the application of TE measurements in surface and core sediment samples, collected in the Namibian region. These studies represent a first baseline monitoring of TE distribution and historical variation in the Namibian coastal area.
3. The third block consists of two publications regarding the TE accumulation and As speciation in marine sponges, and the study of these marine organisms as possible bio-monitors of TE pollutions in different coastal environments.

FIRST BLOCK

Paper 1

Spectrochimica Acta Part B 103–104 (2015) 24–33



Contents lists available at ScienceDirect

Spectrochimica Acta Part B

journal homepage: www.elsevier.com/locate/sab

Determination of total mercury for marine environmental monitoring studies by solid sampling continuum source high resolution atomic absorption spectrometry[☆]



Petko Mandjukov, Anna Maria Orani, Eunmi Han, Emilia Vassileva^{*}

International Atomic Energy Agency, Environmental Laboratories, 4 Quai Antoine 1er, MC 98000 Monaco, Monaco

ARTICLE INFO

Article history:

Received 15 May 2014

Accepted 20 November 2014

Available online 27 November 2014

Keywords:

Mercury

High resolution continuum source atomic absorption spectroscopy

Solid sampling

Marine environmental sample

Method validation

ABSTRACT

The most critical step in almost all commonly used analytical procedures for Hg determination is the sample preparation due to its extreme volatility. One of the possible solutions of this problem is the application of methods for direct analysis of solid samples. The possibilities for solid sampling high resolution continuum source atomic absorption spectrometry (HR CS AAS) determination of total mercury in various marine environmental samples e.g. sediments and biota are object of the present study. The instrumental parameters were optimized in order to obtain reproducible and interference free analytical signal. A calibration technique based on the use of solid standard certified reference materials similar to the nature of the analyzed sample was developed and applied to various CRMs and real samples. This technique allows simple and reliable evaluation of the uncertainty of the result and the metrological characteristics of the method. A validation approach in line with the requirements of ISO 17025 standard and Eurachem guidelines was followed. With this in mind, selectivity, working range (0.06 to 25 ng for biota and 0.025 to 4 ng for sediment samples, expressed as total Hg) linearity (confirmed by Student's *t*-test), bias (1.6–4.3%), repeatability (4–9%), reproducibility (9–11%), and absolute limit of detection (0.025 ng for sediment, 0.096 ng for marine biota) were systematically assessed using solid CRMs. The relative expanded uncertainty was estimated at 15% for sediment sample and 8.5% for marine biota sample ($k = 2$). Demonstration of traceability of measurement results is also presented. The potential of the proposed analytical procedure, based on solid sampling HR CS AAS technique was demonstrated by direct analysis of sea sediments from the Caribbean region and various CRMs.

Overall, the use of solid sampling HR CS AAS permits obtaining significant advantages for the determination of this complex analyte in marine samples, such as straightforward calibration, a high sample throughput (15 min per sample), sufficient precision, a suitable limit of detection, and reduced risk of analyte loss and contamination.

Published by Elsevier B.V.

1. Introduction

The United States Comprehensive Environmental Response, Compensation, and Liability Act (CERCLA) lists mercury and its compounds in third place on the "Priority List of Hazardous Substances". The European Water Framework Directive (2000/60/EG) classifies mercury as one of 30 "precarious dangerous pollutants".

In 2003 United Nation Environment Programme (UNEP) declared mercury to be the pollutant of greatest global concern due to its persistence in the environment and its negative effect on human health and environment. The new Minamata Convention, finalized this year by UNEP, aims to reduce mercury from all sources globally. Although

simply banning or phasing out mercury use and emissions would be ideal, there are a multitude of practical challenges to be faced.

One of them is the development of monitoring database for mercury based on reliable measurement results. Good quality of data on mercury in the environment is of particular importance for monitoring studies. Development, validation and dissemination of reliable methods, based on the basic metrological principles foster the application of common methodologies and the generation of comparable data worldwide.

With the predicted rise in global atmospheric mercury emissions, mercury will continue to be a problematic contaminant for the foreseeable future, causing particular damage to mercury-sensitive ecosystems around the world. Key to the continued understanding and mitigation of the mercury problem is the fundamental science controlling its movement and bioaccumulation in ecosystems.

The direct production of an analytical signal from a solid sample offers a number of important advantages, resulting from the elimination of the dissolution step. The risk of contamination is considerably

[☆] Selected Paper from the European Symposium on Atomic Spectrometry ESAS 2014 & 15th Czech–Slovak Spectroscopic Conference, Prague, Czech Republic, 16–21 March 2014.

^{*} Corresponding author.

E-mail address: evassileva-veleva@iaea.org (E. Vassileva).

reduced, normally the sensitivity increases, since the samples are not diluted and the time of analysis might be reduced.

Numerous methods for total Hg determination in environmental samples have been described [1–4]. Because of the low concentration levels of mercury in many types of environmental samples and its potentially complicated matrix, the pre-concentration and separation of the analyte prior to measurement are frequently applied [5,6].

Among the different techniques permitting the determination of this element at trace level, the cold vapor technique, coupled either with atomic absorption spectrometry or atomic fluorescence spectrometry, can be considered as the most popular one [7,8]. ICP-MS is recognized to be excellent analytical tools for trace element analysis in environment samples, but in the case of mercury it suffers from severe memory effect. Mercury accumulates within the sample introduction system and it is slowly released over time, thus increasing the response signals for the same mercury concentration. This fact results in non-linear calibration curve, need for long washing time and poor sensitivity [9]. However one additional advantage of ICP-MS is the ease with which it can be used in conjunction with alternative sample introduction techniques and therefore direct solid sampling becomes possible if laser ablation or electrochemical vaporization is used for sample introduction [10–12].

Electrothermal vaporization combined with AAS has shown its value in a variety of applications, either using the solid sampling (SS) [13–15] or the slurry approach [16,17]. This technique has proven its suitability to deal with environmental and biological matrices offering a high sample throughput and very low sample mass requirements (usually a few milligrams).

Important aspect of direct solid sampling analysis of mercury with electrothermal atomizer combined with AAS is the possibility to operate with fast programs. With the application of these programs the drying and pyrolysis times are minimized or the pyrolysis step is eliminated and overall analytical time is significantly shortened, with an increase of analytical throughput [18]. In the particular case of mercury analysis, short program has an additional advantage: the elimination of thermal pre-treatment step decreases the possibility of mercury losses.

In many cases the direct determination of elements in solid samples with ET AAS has been carried out by using an electrothermal atomizer. The most important problem in this case is related with the achievement of a correct calibration. Using liquid standards, the processes of vaporization and atomization of the analyte may depend on the form in which the analyte is present in the solid sample, and may also be affected by the solid matrix [19]. Besides, the difference in physical form of standards and samples leads to a difficult evaluation of metrological parameters. Despite these aspects, most of solid sampling quantifications of different analytes by AAS are performed using a liquid-standard calibration [15,20,21].

The possibility for direct mercury determination in environmental samples, without any chemical pre-treatment, shows considerable advantages solving the analyte volatility problems. Several of the so-called “Hg analyzers” have been reported to be able to directly deal with direct analysis of solid samples. This kind of device is capable of sensitive Hg determination, although some drawbacks have also been pointed out, such as the lack of a background correction system that may result in problems with possible interferences, especially for analysis of samples with a high organic content [22–24].

The possibilities for solid sampling HR CS AAS determination of total mercury in various marine environmental samples e.g. sediments and biota, using fast temperature programs, are object of the present study. The applied calibration method based on the use of solid CRMs and statistics of linear regression allows evaluation of the typical validation parameters. Accordingly, selectivity, linearity and working range of the calibration curve, limit of detection, limit of quantification, repeatability and reproducibility, as well as recovery and trueness (using a certified reference material, CRM) were systematically assessed. In addition, estimations of the individual uncertainty contributions of

each parameter as well as the final expanded uncertainty have been performed. Traceability of the results was also demonstrated.

2. Experimental

2.1. Reagents, standards, samples and solutions

Stock standard solution of mercury in hydrochloric acid was obtained from Brooks Rand Instruments (Seattle WA, USA). Working standard solutions were prepared by gravimetric dilution of the stock standard solution with 2% (w/w) nitric acid in pre-cleaned Teflon vials. For comparison between inorganic and methyl mercury (MeHg) in terms of thermal stabilization and sensitivity, a MeHg standard solution with concentration 1 mg L^{-1} (Brooks Rand Instruments, Seattle WA, USA) was used for preparation of MeHg working solutions.

ICP Standard Iridium Solution containing 1000 mg L^{-1} Iridium Nitrate (Merck, Dortmund, Germany) was used for the treatment of graphite platforms.

Mixed chemical modifier containing 500 mg L^{-1} Pd and 300 mg L^{-1} Mg was prepared by diluting and mixing of 10 g L^{-1} solutions of Palladium and Magnesium Nitrates (Matrix modifiers for GF AAS, Analytica Ltd, Prague, Czech Republic).

For optimization, calibration and validation purposes the following certified reference materials were applied:

- Marine sediments: IAEA 405 and IAEA 356 from the International Atomic Energy Agency (IAEA), Monaco; PACS 2 from the National Research Council (NRC), Canada; and SRM 2703 from the National Institute for Standards and Technology (NIST), USA.
- Tuna fish: IAEA 436 from the IAEA, Monaco; ERM CC 464 and ERM CC 580 from the European Commission, Institute for Reference Materials and Measurements (IRMM), Geel, Belgium;
- Dogfish muscle and liver: DORM 2 from the NRC, Canada;
- Marine Biota Scallop Sample: IAEA 452 from the IAEA, Monaco.

The sediment samples analyzed in this study were collected in 2009 from the Cartagena Bay (Caribbean Coast Region, Colombia) and Puerto Príncipe Bay (Caribbean Coast, Haiti). Samples were freeze dried and frozen at $-20 \text{ }^{\circ}\text{C}$ until being thawed immediately before the analysis.

2.2. Instrumentation

Advanced Mercury Analyzer 254, Altech (AMA) with autosampler ASS-254 (Prague, Czech Republic) was used as an alternative technique for mercury determination in sea sediments from the Caribbean Region. Milli-Q water used in all experiments was produced using Millipore Milli-Q system (EMD Millipore Corporation, Billerica, MA, USA).

All measurements in this work were carried out using a High Resolution Continuum Source Atomic Absorption Spectrometer HR CS AAS (ContrAA 700), which is commercially available from Analytik Jena AG (Jena, Germany). This instrument is equipped with flame, graphite furnace atomizers and solid sampling part, in separate compartments, a Xenon short-arc lamp (GLE, Berlin, Germany) operating in “hot-spot” mode as the radiation source, a high-resolution double echelle monochromator (DEMON) and a linear CCD array detector with 588 pixels, 200 of which are used for monitoring the analytical signal and performing BG corrections. The HR CS AAS instrument operates with a transversely heated graphite tube atomizer and an automated solid sampling accessory (SSA 600). The solid sampling device incorporates a microbalance with a declared precision of 0.001 mg . The samples were introduced using solid sampling platforms.

In all cases, integrated absorbance (A_{int}) was selected as measurement mode. Due to the relatively complex fine structure of the analytical signal, the integration was carried out in “peak volume” mode and the sum of the signals obtained for 9 pixels (the central pixel corresponding to wavelength of 253.6519 nm plus eight side pixels

CP \pm 4, corresponding to bandwidth of approximately 18 pm) was considered as the analytical signal.

The only exceptions were made during some of the optimization experiments.

2.3. Temperature programs

Two different fast programs were developed for the determination of total Hg in marine sediments and marine biota samples respectively. The temperature programs used for the determination of mercury in marine sediment and biota samples were carefully optimized and are presented in Table 1. All experiments were carried out in preliminary treated with Ir graphite platforms. The Ir treatment of each platform included 8 cycles. During each cycle 30 μ L of 1000 mg L⁻¹ Ir solution was introduced and the furnace dried at 130 °C. Pyrolysis step was carried out at 400 °C followed by heating at 1000 °C for 10 s and at 2000 °C for 5 s. The ramp was 100 °C s⁻¹ for both pyrolysis steps. It should be noted that, in the case of direct solid sampling, the Ir treatment is practically not related to thermal stability of Hg due to the poor contact between platform surface and the sample. Thus, the main goal of the treatment is to enhance the platform life time and to support mechanical cleaning of the platform after the sample measurement cycle.

For cross validation purposes a conventional temperature program using mixed chemical modifier (5 μ g Pd + 3 μ g Mg) was also applied, as presented in Table 1.

All temperature programs involve a gas adaption step between pyrolysis and atomization, automatically included by the software, during which the Ar flow is adapted to atomization conditions. The required duration of this step is 5 s and the temperature is equal to the pyrolysis one.

3. Results and discussion

3.1. Optimization of the fast temperature programs

The obvious advantage of the fast programs compared with the conventional ones is the considerably shorter pretreatment time. In case of direct solid sampling, without the use of liquid chemical modifiers, the drying and pyrolysis steps can be reduced to the lowest allowed by the software values (1 s hold time). Thus the losses of Hg from the atomizer can be reduced significantly and an improvement of the analytical characteristics could be achieved. It should be noted that in some cases the refractory matrix might play the role of modifier, decreasing the partial vapor pressure of the volatile analyte. It holds true especially for sediments.

The thermal behavior of Hg and MeHg was also investigated. Despite the minor differences between both analytes observed, it was impossible neither with conventional nor with fast temperature programs to find conditions allowing their definite separation. The first losses for

both species were observed at approximately 200 °C. Therefore pyrolysis temperature of 150 °C was finally selected, providing high and comparable in terms of sensitivity signals for Hg and MeHg.

Moderate variations in the pyrolysis and atomization temperatures were not changing critically the analytical signal and the linearity of the calibration graph. Changing the atomization ramp in wide range was also tolerable in the case of sediment samples.

A specific problem related to biota samples was too high background signal, exceeding the level of applicability of the two-dimensional Fast Fourier Transformation (FFT) procedure, applied for background correction in the software of the instrument (Fig. 1a). The high background signal can be explained with the higher volatility of biota matrix causing release of large amount of interfering pyrolysis products in the gas phase during the atomization and making the quantification of the atomic absorbance impossible.

The solution of this problem was found in limited increase of the pyrolysis temperature and hold time combined with decrease of atomization temperature. The aim was to find conditions, in which Hg can be released from the sample before the interfering species. Atomization ramp was additionally decreased for better separation between the atomic absorption of Hg and the matrix background signal. Slower atomization provides complete registration of the Hg signal before increasing the background over the correctable level. In Fig. 1 3-D plots of the corrected analytical and background signals plotted vs. time and the spectral area close to the Hg resonance line are presented. All graphics are registered for comparable masses of the IAEA 436 biota sample. Within a wide ramp range (from 2000 °C s⁻¹ down to 500 °C s⁻¹) background signal is stable at level beyond the measurable limit (4 a.u.) which cannot be corrected and provides a typical "noisy" structure of the spectra as seen in Fig. 1. Ramp below 500 °C s⁻¹ provides a significant decrease of the background to correctable levels (Fig. 1S in Supplement 1) combined with optimal separation from the analyte signal at the level of 200 °C s⁻¹. As a result interference free analytical signals with slightly lower sensitivity in comparison with signals from sediments were obtained (Figs. 2S and 3S). This result is acceptable having in mind that the levels of total Hg in marine biota samples are typically higher than those in sediments, due to the effect of bioaccumulation.

3.2. Calibration and analyte quantification

In most of the studies reported in the literature liquid standards are used for calibration in solid sampling measurements. This is also the quantification procedure suggested as default by the producer of the analytical equipment used.

3.2.1. Calibration using solid CRMs

It is well known that the behavior of analyte during the thermal pretreatment and atomization in liquid solutions cannot be expected to be very similar to those in the solid samples. It holds true especially for the

Table 1

Comparison between fast temperature programs for direct solid sampling determination of mercury in sediment and biota samples, and conventional program using liquid calibration and chemical modifier. (Integration time was 7.7 s with delay of 2.0 s for sediments and 3.7 s with delay of 0.8 s for biota in fast programs). The volume of modifier used with the conventional program was 10 μ L at Pd and Mg concentration levels of 500 mg L⁻¹ and 300 mg L⁻¹ respectively.

Step	Name	Fast programs								Conventional program			
		Sediments				Biota				Sediments and biota			
		Temp (°C)	Ramp (°C s ⁻¹)	Hold (s)	Ar flow	Temp (°C)	Ramp (°C s ⁻¹)	Hold (s)	Ar flow	Temp (°C)	Ramp (°C s ⁻¹)	Hold (s)	Ar flow
1	Drying step 1	–	–	–	–	–	–	–	–	90	10	15	Max
2	Drying step 2	55	100	1	Max	55	100	1	Max	130	10	10	Max
3	Pyrolysis	200	100	1	Max	300	100	5	Max	150	10	10	Max
4	Gas adaption	200	0	5	Stop	300	0	5	Stop	150	0	5	Stop
5	Atomization	1200	2000	6	Stop	1000	200	1	Stop	1500	3000	6	Stop
6	Cleaning	2450	500	4	Max	2450	500	4	Max	2450	500	5	Max
	Duration (s)	21.7				25.1				65.2			

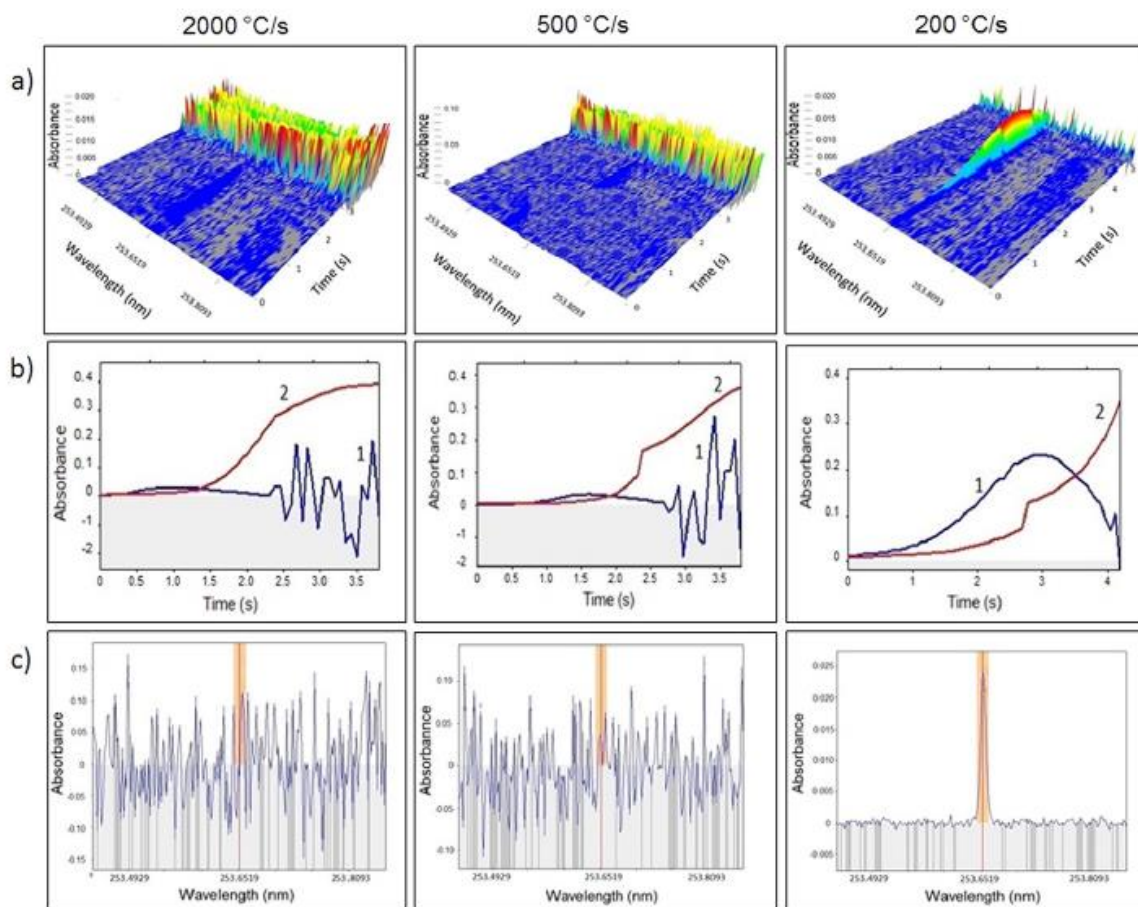

Fig. 1. Analytical signals obtained during the optimization of atomization ramp in the fast program for biota samples (IAEA 436). a) – 3-D high resolution presentation of corrected analytical signal; b) – corrected analytical signal (1) and background (2) vs. time; c) – high resolution spectra of the region around the Hg resonance line at 253.6519 nm.

case of extremely volatile analytes as mercury. Conventional temperature programs using liquid calibration standards were applied for total Hg determination in various CRMs in order to check the possible matrix effects. The results from those experiments were used as a reference and compared with the results obtained with the procedure proposed in the present study, based on fast programs and solid sampling calibration approach.

In the case of application of fast programs, without liquid chemical modifier, calibration using liquid standards becomes difficult. Introduction of comparatively long drying step in the temperature program, required for the liquid standards, would cause uncontrollable and significant Hg losses and would make the use of proposed fast temperature programs impossible. On the other hand, the addition of liquid modifier only to the calibration standards could make the analyte signal incomparable to those obtained from the solid sample.

To avoid this problem, a new calibration concept, based on analysis of different masses of solid CRM and subsequent statistical analysis, was applied. In addition to the determination of analyte concentration, proposed concept allows to evaluate some basic metrological characteristics of the analytical method.

Solid sampling analysis implies measurement of portions of the sample differing more or less in their masses. Practically repeated measurements of samples with the same masses measured with a precision within 1 μg cannot be achieved. It should be noted that the analytical signals cannot be corrected with corresponding blanks because procedural solid blank sample cannot be prepared. Thus, the

information, normally obtained by mean of statistics of multiple measurements, in the case of solid sampling analysis can be obtained by applying statistics related to the regression analysis (see Supplement 2).

Usually the analyte determination in solid sample implies measurements of several different masses of the sample and CRM used for calibration and subsequent regression analysis of both data sets.

Applying linear calibration function, the intercept can be assumed as evaluated blank absorbance. Thus, its standard deviation is an estimator for the blank's standard deviation and can be used for calculation of some metrological characteristics of the method even when the intercept is not significantly different from 0. In all studied cases the intercept was insignificant.

The standard deviations of both regression coefficients can be assumed as standard uncertainties of type "A".

An important question related to the applicability of the unweighted linear regression is homoscedasticity of the calibration data set. Since measuring of replicates at each calibration point is impossible in case of direct solid sampling, the most frequently used homoscedasticity tests (Hartley and Bartlett tests) are inapplicable. The homoscedasticity of the calibration data sets in the present study was confirmed using the Breusch–Pagan test [27]. Additionally the regression coefficients, calculated using two different mathematical procedures, were compared. The standard Gaussian regression procedure, implying normal distribution of the residual errors and homoscedasticity of the data sets, was compared with robust linear regression. Both, slopes

and intercepts were not significantly different. This proves applicability of the conventional Gaussian regression without weight coefficients.

3.2.2. Sensitivity

In case of solid sampling calibration, the slope of the calibration line cannot be related directly to sensitivity. Analyte mass fraction of the analyte in the CRM used should be also considered. Relation between analyte mass and corresponding CRM mass can be defined as:

$$m_a = x_a f m \quad (1)$$

where: m is the mass of the CRM containing analyte mass m_a introduced in the atomiser; x_a is the mass fraction of the analyte in the CRM used and f is a conversion factor depending on the units in which m_a , x_a and m are expressed. Typically x_a is expressed in mg kg^{-1} , m is always in mg and thus, to obtain m_a in ng^{-1} , a conversion factor $f = 1$ should be used.

Considering sensitivity definition and Eq. (1), the following expression describes the sensitivity in case of direct solid sampling:

$$S = \frac{a_1}{x_a f} \quad (2)$$

The dimension of the sensitivity calculated by Eq. (1) is usually ng^{-1} or pg^{-1} depending on the dimension of x_a and selection of the conversion factor f .

From Eq. (2) it is obvious that, in the case of direct solid sampling, it is impossible to make conclusion about the differences in sensitivity for two different samples (CRMs) by simply comparing the slopes of their calibration graphs (A vs. m). The slope depends on analyte mass fraction and the sensitivities should be calculated before the comparison.

A reasonable comparison between sensitivities for a certain analyte in different matrices implies evaluation of the uncertainties of these parameters. Taking into account the uncertainty propagation law and Eq. (2), the combined uncertainty (U_c) of the sensitivity can be estimated as:

$$U_c = S \sqrt{\left(\frac{U_{SL}}{a_1}\right)^2 + \left(\frac{U_{x_a}}{x_a}\right)^2} \quad (3)$$

where: U_{x_a} is the uncertainty of the analyte mass fraction in the CRM (x_a) according to the certificate; and U_{SL} is the uncertainty of the slope of the regression line for the CRM (a_1) (see the Supplement). It should be noted that the conversion factor f is a value without uncertainty.

The expanded uncertainty of S (half width of the confidence interval) can be obtained by multiplying U_c by the corresponding coverage factor k (typically $k = 2$).

3.2.3. Analyte quantification

From the two calculated regression parameters a_0 and a_1 , the slope (a_1) is the one directly related to the concentration of the sample. Quantification of analyte content in analyzed sample implies the absorbance measurement for several mass portions from the sample and the CRM used for calibration.

Considering close enough values for the sensitivity (S) both for the calibration CRM and the sample, for the slopes of the two regression lines ($a_1^{(S)}$ and $a_1^{(CRM)}$) and analyte mass fractions ($x_a^{(S)}$ and $x_a^{(CRM)}$) in the sample and CRM respectively, the unknown analyte mass fraction in the sample can be obtained by:

$$x_a^{(S)} = x_a^{(CRM)} \frac{a_1^{(S)}}{a_1^{(CRM)}} \quad (4)$$

The analyte mass fraction ($x_a^{(S)}$) calculated according to Eq. (4) is always expressed in the same units as those for the calibration CRM. Application of this approach for quantification includes selection of

the CRM with a matrix as close as possible to that of the sample. The influence of the matrix can be evaluated by cross-checking of different certified reference materials. This quantification approach allows also comparatively simple and reliable evaluation of the uncertainty of analyte mass fraction in the sample.

3.3. Validation of the method

A validation of the proposed analytical procedure followed the requirements of ISO 17025 standard and Eurachem guidelines [25,26]. Accordingly, selectivity, linearity and working range, limit of detection, characteristic mass, repeatability and reproducibility, as well as recovery and trueness (using a certified reference material, CRM) were systematically assessed. In addition, estimations of the individual uncertainty contributions of each parameter as well as the final expanded uncertainty have been performed. Demonstration of traceability of measurement results is also provided.

The proposed method allows comparatively simple and reasonable evaluation of the basic validation parameters. In most of the works dealing with direct solid sampling these parameters are not evaluated, or are transferred from data obtained from analysis of liquid standards.

3.3.1. Uncertainty of the analytical result

3.3.1.1. Main sources of uncertainty. Taking into account the specificity of the proposed analytical procedure the major contributors to the uncertainty of the result can be identified as follows:

- *Uncertainties on the weighted mass*

The microbalance of the instrument is operating in “noisy” working conditions, showing skewed distribution with negative bias from the expected readings 0 (robust mean – 0.002 mg) and increased uncertainty (robust standard deviation 0.004 mg) as shown in Fig. 4S. Airflow might also cause losses of sample particle during the platform transfer to the atomizer. Practically this means that masses below 0.040 mg are charged with relative uncertainty exceeding 10% only by the sample dosing.

- *Uncertainties of the measured absorbances*

Due to the optical stability of the instrument the absorbances are usually a minor contribution to combined uncertainty typically not exceeding 0.1% (0.001 a.u.).

- *Inhomogeneity*

In many cases, when the solid sampling is used, inhomogeneity of analyzed samples is the major uncertainty source. The homogeneity at sample masses between 20 and 500 μg could be significantly different from the certificated one. It should be noted that even some CRMs do not fulfill requirements of the solid sampling HR CS AAS for micro-homogeneity. In some cases additional homogenization of the sample material can be helpful.

According to our observations, micro-homogeneity of the sample material starts to play a substantial role on the uncertainty of the results when particle size is over 260 μm . The sample inhomogeneity results in higher regression standard deviation due to bigger residual errors. As seen from Fig. 2, the inhomogeneity generally does not affect dramatically the measurement bias; however, the effect on the uncertainty might be rather significant.

- *Uncertainty of the Hg mass fraction in the CRM, used for calibration*

For the CRMs used in the present study the uncertainty of the certified values was reported as expanded uncertainty or as confidence intervals. In order to provide compatibility with the other contributors,

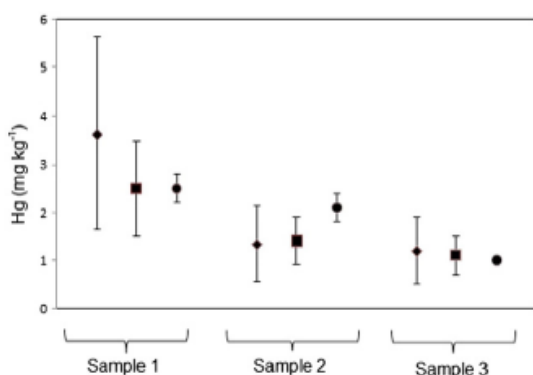

Fig. 2. Comparison between results for Hg mass fraction in sediments from the region of Haiti obtained by using SS CS HRAAS before (◆) and after (■) additional sample homogenization. With (●) are presented results for Hg mass fraction, obtained with AMA. Error bars represent expanded uncertainty ($k = 2$).

the half width of the confidence interval was transformed in standard uncertainty assuming rectangular distribution.

It should be noted that, especially in case of low Hg mass fraction in the calibration CRM, this uncertainty source might be quite substantial.

• Possible unidentified sources affecting the analytical procedure

The spread of data points around the regression line is the direct result of contributions of all possible uncertainty sources, and is evaluated by the residual (regression) standard deviation (see the Supplement). Thus, the uncertainties of the slopes $a_1^{(CRM)}$ and $a_1^{(S)}$, are measures of the effect of all contributors mentioned above on the calibration CRM and sample respectively. The value of $U_{INT}^{(CRM)}$ (see the Supplement) does not affect the analyte quantification, but might be used for evaluation of method validation parameters.

3.3.1.2. Evaluation of the combined standard uncertainty. Considering Eq. (4) and applying the uncertainty propagation law, the following estimation of combined uncertainty (U_c) of Hg mass fraction in the sample ($x_a^{(S)}$) can be proposed:

$$U_c = x_a^{(S)} \sqrt{\left(\frac{U_{xa}^{(CRM)}}{x_a^{(CRM)}}\right)^2 + \left(\frac{U_{SL}^{(CRM)}}{a_1^{(CRM)}}\right)^2 + \left(\frac{U_{SL}^{(S)}}{a_1^{(S)}}\right)^2} \quad (5)$$

where: $U_{xa}^{(CRM)}$ is the uncertainty of analyte mass fraction ($x_a^{(CRM)}$) in the CRM according to the certificate, $U_{SL}^{(CRM)}$ and $U_{SL}^{(S)}$ are the slope's uncertainties of the regression lines for CRM ($a_1^{(CRM)}$) and sample ($a_1^{(S)}$) respectively, calculated according to the equations presented in the Supplement.

The uncertainties included in Eq. (5) are covering practically all uncertainty sources, including the ones which are impossible to be

Table 2
Validation parameters for biota and sediment samples.

Parameter	Biota	Sediment
Test material	IAEA 436	PACS-2
Certified values (mg kg^{-1})	4.19 ± 0.36	3.04 ± 0.20
Determined value (mg kg^{-1})	4.01 ± 0.34	2.90 ± 0.40
Bias (mg kg^{-1})	-0.18	-0.05
Expanded uncertainty ($k = 2$)	8.5%	15%
Repeatability (RSD)	3.2%	5.4%
Reproducibility (RSD)	11%	9.2%
LOD (ng Hg)	0.096	0.025
LOQ (ng Hg)	0.32	0.06
Calibration CRM	BCR 464	ERM-CC 580
Calibration CRM certified value for Hg	BCR 464	ERM-CC 580
	$5.24 \pm 0.10 \text{ mg kg}^{-1}$	$132 \pm 3 \text{ mg kg}^{-1}$

evaluated directly. Expanded uncertainty (the half width of the confidence interval) of the result can be obtained by multiplying U_c by the corresponding coverage factor k (typically $k = 2$).

As shown in Table 2 the typical relative expanded uncertainties obtained for Hg mass fraction in sediment and biota samples after propagation of all input parameters, as described above, were 15% and 8.5% ($k = 2$) respectively. Higher relative expanded uncertainty for sediments is related to the lower Hg content in these CRMs.

The contribution of the uncertainty of slopes to the total combined uncertainty is dominant, followed by the uncertainty of analyte mass fraction in the CRM and the mass fraction level of Hg in the analyzed sample. When the Hg mass fractions in CRM are very small the uncertainty of the slope of calibration line increases dramatically and becomes the major contributor to the combined uncertainty. When the Hg mass fraction of analyzed sample is low the uncertainty on sample homogeneity starts to play a significant role.

3.3.1.3. Limits of detection and quantification. Traditional calibration with liquid standards does not allow reasonable evaluation of LOD and LOQ since the parallel measurements of blanks are practically impossible for direct solid sampling. In the proposed calibration method the estimators for blank absorbance and its standard deviation are the intercept of the calibration graph and its standard deviation respectively (see Supplement 2).

Thus the value of LOD (as absorbance) can be calculated according to:

$$A_{LOD} = a_0 + 3SD_{INT} \quad (6)$$

Transforming the analytical signal A_{LOD} in mass, two important characteristics of the analytical method can be revealed – the minimum masses of CRM and analyte, providing statistically significant signal. The minimum sample size (m_{LOD} in mg) can be derived from:

$$m_{LOD} = 3 \frac{SD_{INT}}{a_1} \quad (7)$$

The corresponding lowest detectable analyte mass (m_{aLOD}) will be in this case:

$$m_{aLOD} = 3 \frac{SD_{INT}}{a_1} f x_a = 3 \frac{SD_{INT}}{S} \quad (8)$$

where: SD_{INT} is the intercept's standard deviation of the regression line; a_1 is the slope; f is the unit conversion factor as explained above; x_a is the analyte mass fraction in the sample or calibration CRM and S is the sensitivity.

Similarly, the LOQ value can be evaluated as:

$$A_{LOQ} = a_0 + 10SD_{INT} \quad (9)$$

or expressed as a mass of the calibration CRM:

$$m_{LOQ} = 10 \frac{SD_{INT}}{a_1} \quad (10)$$

where: A_{LOQ} is the absorbance signal corresponding to LOQ; a_0 and SD_{INT} are the intercept of the CRM calibration line and its standard deviation; m_{LOQ} is the mass of the calibration CRM corresponding to the blank and a_1 is the slope of the calibration line.

Since the proposed approach is based on regression analysis instead of statistics of repeated measurements, the estimation of SD_{INT} is affected by the spread of the experimental points around the regression line in the entire calibration range. Thus the values for LOD and LOQ calculated according to Eqs. (7) and (10) respectively are affected by the uncertainties of data points measured at considerably higher masses. Due to this reason the LOD and LOQ values seem to be significantly

overestimated. This suggestion was confirmed by obtaining unbiased results for CRMs with rather low Hg content (even lower than LOD). The lowest sample mass which can be quantified by the regression line can be calculated as the half width of the confidence interval of the mass (m^*) corresponding to absorbance 0 according to the calibration function (see the Supplement).

$$A^* = a_1 m^* \quad (11)$$

Practically in all studied cases: $A_{LOD} < A^*$. Thus A^* can be used for more realistic evaluation of the LOQ instead of A_{LOQ} (Eq. (9)) [28,29].

The parameters A_{LOD} and A^* are of significant importance for the ecological monitoring. Samples showing absorbance signals $A < A_{LOD}$, calculated according to Eq. (19), could be reported as samples containing Hg below the limit of detection, although A_{LOD} seems to be also overestimated. In samples for which $A > A^*$, the analyte can be quantified with reasonable precision, considering all factors discussed above. For the samples from the absorbance region: $A_{LOD} \leq A \leq A^*$ Hg can be detected but for quantification a different analytical technique should be applied.

In the evaluation of LOD and LOQ calculated according to the described approach all data points from the calibration line are used. Thus these values are related to a CRM with specific analyte content and homogeneity, but not to a specific sample mass as in the case of calibration with standard solutions.

3.3.2. Linearity and working range

In the present study the linearity test was performed with 12 different masses of the calibration CRM. At the lower end of the concentration range, the limiting factors were the values of the limits of detection and/or quantification as well as the precision of the microbalance. For masses below 0.020 mg the uncertainty of the weighted masses contributes significantly (> 10%). From practical point of view, the upper limit of the working range is not so interesting when speaking about the environmental monitoring. It should be noted that increasing the sample mass above a certain limit (usually 0.3–0.5 mg depending on the matrix) results in higher levels of interferences due to the higher matrix amount in the atomizer, or in deviation from the linear response due to very high sample mass introduced.

The linearity of the calibration lines was confirmed using Student's *t*-test procedure proving that the squared correlation coefficient is not significantly different from 1.

Calibration graphics used for the determination of Hg mass fraction in marine sediment and biota samples are presented in Figs. 3 and 4. The summary of the obtained validation parameters for biota and sediment samples with those calibration lines is presented in Table 2.

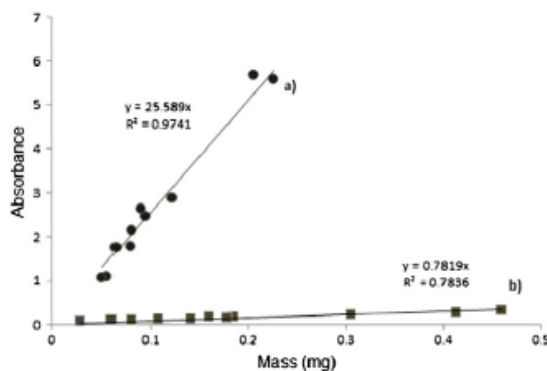

Fig. 3. Calibration graphics for SS CS HR AAS determination of Hg in sediment samples: a) IAEA 405 used as calibration CRM (●) and b) PACS 2 used as test CRM (■).

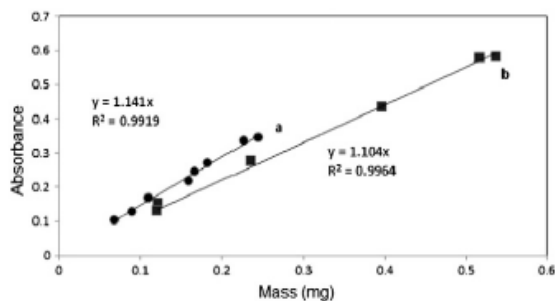

Fig. 4. Calibration graphics for SS CS HRAAS determination of Hg in biota samples: a) BCR 464 used as calibration CRM (●) and b) IAEA 436 used as test CRM (■).

The typical working ranges in this study, expressed as mass of the CRMs used for calibration, were from 0.020 to 0.500 mg for sediments and from 0.020 to 0.300 mg for biota samples.

3.3.3. Repeatability and reproducibility

The repeatability was evaluated by the application of the described measurement procedure on 6 subsamples, the same day; whereas the intermediate precision (within-laboratory reproducibility) was assessed by analyzing 3 subsamples on three different days. The relative standard deviations (RSDs) were calculated on the basis of normalized absorbance and found to be 3–5% and 9–11% for sediment and biota samples, respectively. It should be noted that RSD value is strongly influenced by the Hg content in the CRM used. When it is close to the LOQ (LOD) of the method the RSD might be significantly higher.

3.3.4. Trueness and bias of obtained results

The trueness of the results obtained for different samples was confirmed by analysis of different marine sediments and biota CRMs. In all cases the biases between results and the certified or reference values were insignificant and within the estimated uncertainty. It is important to note that for all CRMs the biases from the certified values obtained by solid phase calibration were lower than those obtained after calibration using liquid standards. The results from the experiments mentioned above are presented in Table 3.

3.3.5. Comparison with calibration using standard solutions

The default quantification approach of the Analytik – Jena instrument was applied as a reference calibration technique both to biota and sediment certified reference materials to validate the proposed calibration method. In all reference measurements 10 μ L of mixed modifier solution containing 5 μ g Pd and 3 μ g Mg was injected in the sample platform together with calibration solutions and solid samples.

Table 3

Comparison of results (value \pm U, $k = 2$) obtained after calibration with liquid standards and conventional program and results obtained after calibration with solid CRM and fast temperature program.

CRM	Matrix	Calibration		Certified value (mg kg^{-1})
		Liquid standards (mg kg^{-1})	Solid CRMs (mg kg^{-1})	
PACS-2	Sediment	4.1 ± 3.1	2.99 ± 0.8	3.04 ± 0.20
IAEA 405	Sediment	1.27 ± 0.44	0.85 ± 0.18	0.81 ± 0.09
SRM 2703	Sediment	0.82 ± 0.46	0.45 ± 0.16	0.474 ± 0.066
BCR 464	Tuna fish	4.8 ± 1.2	5.46 ± 0.71	5.24 ± 0.1
IAEA 436	Tuna fish	6.9 ± 3.3	4.01 ± 0.36	4.19 ± 0.36
DORM-2	Dogfish	1.42 ± 0.68	4.4 ± 1.2	4.64 ± 0.26
MA-RDPME-2/TM	Fish homogenate	2.98 ± 0.69	2.91 ± 0.82	2.18 ± 0.15

The results were compared with those obtained for the same CRMs using fast temperature programs, without the addition of liquid modifier and calibration with different CRMs of the same type.

The comparison was carried out for 4 biota and 3 sediment certified reference materials. The results are presented in Table 3 and Fig. 5S in Supplement 1. In all studied cases the biases from the certified values of the results obtained using liquid calibration standards were significantly higher than those from the presently described method. For one of the CRMs (Dogfish – DORM-2) the Hg content calculated on the base of standard solutions was not even in agreement with the certified value taking into account the corresponding confidence intervals. In most of the cases (5 from 7) the uncertainty provided by the calibration with solid CRMs is significantly lower. One of the two observed exceptions was DORM-2 for which, the result obtained by conventional calibration was not in agreement with the certified value. The higher uncertainty from the conventional programs can be explained with poor mixing between the solid sample and injected modifier solution. This holds true especially for hydrophobic biota samples with quite low density. The problem could be partly solved by the addition of Triton X-100 detergent, which decreases the surface tension of the modifier and standard solutions.

This suggestion was also confirmed by the agreement between the certified and obtained Hg mass fractions in sediment CRMs which are less hydrophobic and with higher density than biota samples.

The general conclusion of the comparison is that the conventional calibration with liquid standard solutions is less reliable than the calibration using solid CRMs. Assumption for completely “matrix independent analytical signal” is quite doubtful, especially in the case of biota samples. The results are showing significant differences in sensitivity even between matrices of different varieties of fish e.g. tuna fish (BCR 464) and Dogfish (DORM-2). The proposed calibration method provides simple and more reliable evaluation of uncertainty of the results as well as estimation of the basic validation parameters.

3.3.6. Comparison with an independent analytical method

Sea sediment samples from two cores located in Colombia and Haiti were measured by solid sampling CS HR AAS and the obtained results were compared with those obtained with AMA. For the measurements based on solid sampling CS HR AAS the mercury content was quantified applying CRM IAEA-405 for calibration, according to the approach described above. The comparison between solid sampling CS HR AAS and AMA technique is graphically represented in Fig. 5. As demonstrated, there is an excellent agreement within stated uncertainties between the above results, which contributes for further validation of the described analytical procedure for solid sampling CS HR AAS determination of Hg in biota and sediment samples based on fast program and calibration with solid CRM.

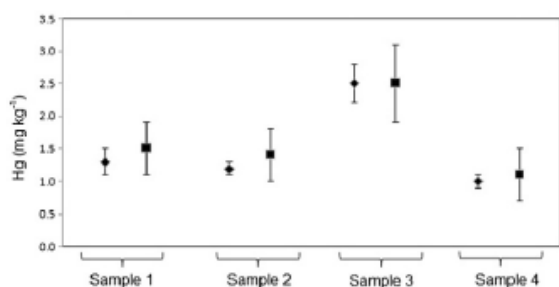

Fig. 5. Comparison between results for Hg content in sediments from the region of Cuba obtained using SS CS HRAAS (◆) and AMA (■) as a reference technique. Error bars represent expanded uncertainty ($k = 2$).

3.4. Traceability

The key steps to demonstrate traceability of measurement results obtained with the proposed method were as follows:

- I. The analytical method used was properly selected and validated, both in terms of matrix composition and analyte concentration.
- II. The use of CRM for calibration is the way to link Hg mass fraction to the common system of reference SI. The general concept for analyte quantification guarantees the SI traceability of the measurement results via direct comparison between analytical signal vs. sample mass for the studied sample and CRM used for calibration.
- III. The use of gravimetric operation in solid sampling is a way to link the final measurement result to the kilogram.

3.5. Selection of the certified reference material for calibration

Question of crucial importance for the proposed method for calibration and analyte quantification is the selection of proper CRM for calibration. Definitely the main requirement is for the best possible matrix matching i.e. the matrix of the CRM to be as close as possible to the matrix of measured samples.

Solid sampling technique sets additional requirements to the CRMs used for calibration. One of the most important requirements is the micro-homogeneity of the material. Homogeneity tests for the CRMs are usually performed using larger amount of the material (e.g. 0.2–0.3 g). The certified homogeneity can be considered for sample aliquots of the same or bigger size. Such aliquots are close to the sample size for AMA, but are approximately 3 orders of magnitude larger than the ones required for solid sampling CS HR AAS. Therefore not all CRMs are suitable for calibration in the discussed method. The homogeneity influence can be easily checked by change of the CRM used. Considering homogeneity data for the most of CRMs it should be noted that homogeneity tests are usually carried out using 10^3 or more times higher sample mass and wet decomposition of the studied CRM. Homogeneity at sample masses between 20 and 500 μg (the typical range for solid sampling CS HR AAS) could be significantly different from the one reported in the certificate. CRM with particle size dimension below or equal to 260 μm is usually suitable for solid sampling calibration, when the CRM subsamples used for calibration purposes are between 20 and 500 μg .

In Fig. 6 three calibration graphics prepared using different CRMs selected as representative cases are presented.

Appearance of significant residual errors (case of PACS 2 in Fig. 6b) is a clear indication of micro-inhomogeneity of the selected CRM. The use of such material for calibration is also possible and may provide relatively low bias, covered by the estimated expanded uncertainty. However, in order to obtain reliable results, the CRM chosen for calibration should be with the minimum possible uncertainty of the calibration graphic slope.

Another important parameter is the analyte mass fraction in the CRM. If the analyte mass fraction is too high, with respect to sensitivity, mass fraction would require very small aliquots for measurement and in such a case the influence of uncertainty of the microbalance might become a substantial contribution to the combined uncertainty of result. Too small mass fraction (case of IAEA 452 in Fig. 6a) is also not a suitable case. The increase of aliquot mass is limited since the solid sampling implies direct introduction of matrix in the furnace which should be kept as low as possible. Too low value of the slope of the regression line increases dramatically its relative uncertainty and it might become the major contributor to the combined uncertainty.

Generally, the uncertainty of the certified value is another source contributing directly to the combined uncertainty of results and should be also taken into consideration, especially when the selection of CRM for calibration is performed.

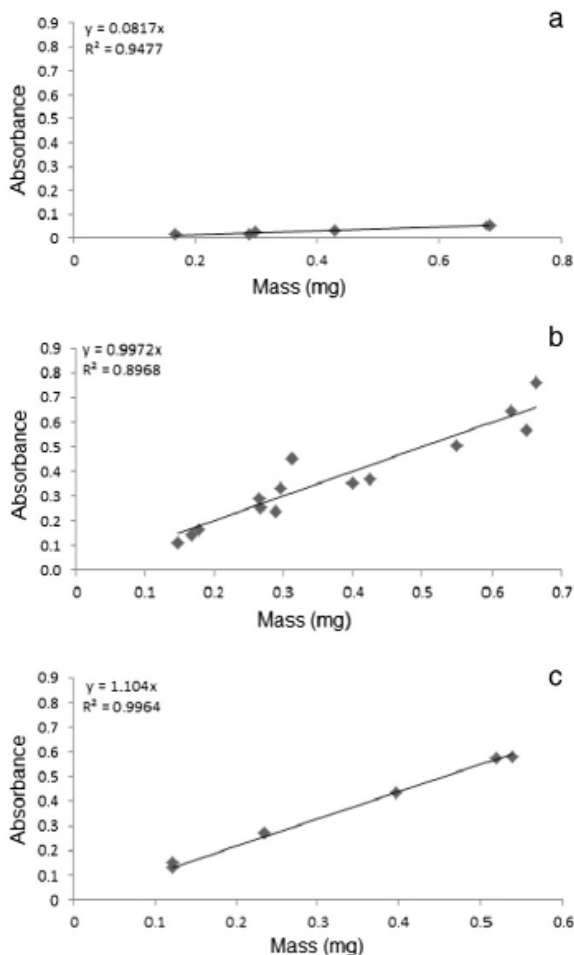

Fig. 6. Three typical cases of CRMs used for calibration: a) IAEA 452 (biota) – very low analyte content; b) PACS 2 (sediment) – poor micro-homogeneity; c) IAEA 436 (biota) – recommendable CRM for calibration.

In Fig. 6c the calibration line obtained using IAEA 436 tuna fish CRM, selected as recommendable choice is presented. The analyte content and homogeneity for this particular reference material are within the optimal range, providing reliable calibration with relatively low contribution to the uncertainty of the results.

3.6. Calibration line as an optimization criterion of the method

Analysis of the regression line absorbance vs. sample mass might be used also as a criterion in instrument parameter optimization. The most important parameter in this case is the linearity of the regression line. Usually a good linearity indicates interference-free analytical procedure and very high homogeneity of the studied sample. The most common reason for poor linearity is the sample inhomogeneity causing different analyte distributions and atomization efficiencies among different sample particles. Since there is no “reagent blank” in solid sampling techniques, the intercept (a_0) should be low enough. In all measurements of the present study a_0 was statistically insignificant. The possible contamination of the stored sample practically cannot be distinguished from the analyte content in the sample. However, such contamination might be an additional reason for poor linearity of the regression line. Improper compensation of background signal and/or improper settings for the “delay time” and “integration time” might be one of the possible

reasons for the significant intercept. It should be noted that, the algorithm for mathematical background compensation employed in the instrument used, is not reliable in case of background signals exceeding value of 0.8 a.u. absorbance. Other possible reasons for significant value of a_0 could be the poor homogeneity of the sample or CRM if combined with low number of data points.

3.7. Fast vs. conventional temperature programs

The advantages of the fast programs used for the determination of Hg mass fraction in marine samples can be summarized as follows:

- I. Considerably shorter temperature programs providing faster analysis and longer lifetime of the graphite tubes and sampling platforms.
- II. No additional liquid chemical modifiers and reagents are needed.
- III. Better possibility to separate the analytical signal for extremely volatile analytes as Hg from the background absorbance (Figs. 6S and 7S).
- IV. Better accuracy and repeatability due to the lower losses during the pretreatment steps are especially important for Hg analysis – in this case the analyte losses can take place even during the drying step below 100 °C.
- V. Possibility for calibration using solid CRMs providing better “matrix matching” calibration and proper evaluation of several validation parameters such as uncertainty, sensitivity, LOD and LOQ.
- VI. Guaranteed traceability of analytical results provided by the use of certified reference materials for calibration purposes and gravimetric dosing.

The major limitation of the fast programs in comparison with the conventional ones combined with liquid standard calibration is the necessity for greater number of matrix and concentration matching CRMs corresponding to the studied unknown samples, having high homogeneity.

4. Conclusions

A solid sampling method for the determination of Hg in marine samples based on fast programs is developed and validated. Two fast programs were optimized for analysis of sediment and biota samples. Calibration and analyte quantification procedure based on the use of solid CRMs is proposed. The method allows reasonable evaluation of uncertainty of the results as well as estimation of the basic metrological characteristics of the measurement procedure.

The method proposed allows the determination of Hg without sample treatment in challenging environmental samples such as marine sediments and biota, with combined uncertainty below 20% corresponding to the requirements for environmental monitoring. Proposed calibration concept is applicable also to other analytical techniques for direct solid sampling analysis and allows more reliable data treatment.

Acknowledgments

The Agency is grateful for the support provided to its Environment Laboratories by the Government of the Principality of Monaco.

Appendix A. Supplementary data

Supplementary data to this article can be found online at <http://dx.doi.org/10.1016/j.sab.2014.11.006>.

References

- [1] I. Geleuda, R. Dams, M. Resano, F. Vanhaecke, L. Moens, Direct determination of methylmercury and inorganic mercury in biological materials by solid sampling-

- electrothermal vaporization–inductively coupled plasma–isotope dilution–mass spectrometry, *Anal. Chem.* 74 (2002) 3833–3842.
- [2] R.G.O. Araujo, F. Vignola, I.N.B. Castilho, D.L.G. Borges, B. Welz, M.G.R. Vale, P. Smichowski, S.L.C. Ferreira, H. Becker-Ross, Determination of mercury in airborne particulate matter collected on glass fiber filters using high-resolution continuum source graphite furnace atomic absorption spectrometry and direct solid sampling, *Spectrochim. Acta B* 66 (2011) 378–382.
 - [3] M. Resano, E. Garcia-Ruiz, M. Aramendia, M.A. Belarra, Solid sampling-graphite furnace atomic absorption spectrometry for Hg monitoring in soils. Performance as a quantitative and as a screening method, *J. Anal. At. Spectrom.* 20 (2005) 1374–1390.
 - [4] Y. Gao, Z. Shi, Z. Long, P. Wu, C. Zheng, X. Hou, Determination and speciation of mercury in environmental and biological samples by analytical atomic spectrometry, *Microchem. J.* 103 (2012) 1–14.
 - [5] V.A. Lemos, L.O. dos Santos, A new method for preconcentration and determination of mercury in fish, shellfish and saliva by cold vapour atomic absorption spectrometry, *Food Chem.* 149 (2014) 203–207.
 - [6] K. Leopold, M. Foulkes, P. Worsfold, Methods for the determination and speciation of mercury in natural waters: a review, *Anal. Chim. Acta.* 663 (2010) 127–138.
 - [7] E. Kenduzler, M. Ates, Z. Arslan, M. McHenry, P.B. Tchounwou, Determination of mercury in fish otoliths by cold vapor generation inductively coupled plasma mass spectrometry (CVG-ICP-MS), *Talanta* 93 (2012) 404–410.
 - [8] N. Ferrúa, S. Cerutti, J.A. Salonia, R.A. Olsina, L.D. Martinez, On-line preconcentration and determination of mercury in biological and environmental samples by cold vapor-atomic absorption spectrometry, *J. Hazard. Mater.* 141 (2007) 693–699.
 - [9] K. Leopold, L. Harwardt, M. Schuster, G. Schlemmer, A new fully automated on-line digestion system for ultra trace analysis of mercury in natural waters by means of FI-CV-AFS, *Talanta* 76 (2008) 382–388.
 - [10] M.A. Belarra, M. Resano, F. Vanhaecke, L. Moens, Direct solid sampling with electrothermal atomization/vaporization. What for and how? *Trends Anal. Chem.* 21 (2002) 828–839.
 - [11] F. Vanhaecke, I. Gelaude, L. Moens, R. Dams, Solid sampling electrothermal vaporization inductively coupled plasma mass spectrometry for the direct determination of Hg in sludge samples, *Anal. Chim. Acta.* 383 (1999) 253–261.
 - [12] M. Resano, I. Gelaude, R. Dams, F. Vanhaecke, Solid sampling electrothermal vaporization inductively coupled plasma mass spectrometry for the direct determination of Hg in different materials using isotope dilution with gaseous phase for calibration, *Spectrochim. Acta B* 60 (2005) 319–326.
 - [13] P. Török, M. Žemberyová, Direct solid sampling electrothermal atomic absorption spectrometric determination of toxic and potentially toxic elements in certified reference materials of brown coal fly ash, *Spectrochim. Acta B* 71–72 (2012) 80–85.
 - [14] B. Welz, M.G.R. Vale, D.L.G. Borges, U. Heitmann, Progress in direct solid sampling analysis using line source and high-resolution continuum source electrothermal atomic absorption spectrometry, *Anal. Bioanal. Chem.* 389 (2007) 2085–2095.
 - [15] M.A. Belarra, C. Crespo, M.P. Martinez-Garbayo, M. Resano, Direct determination of cobalt and zinc in samples of different volatility by means of solid sampling-graphite furnace atomic absorption spectrometry, *Spectrochim. Acta B* 58 (2003) 1847–1858.
 - [16] P. Fernández Rodríguez, J.M. Marchante-Gayón, A. Sanz-Medel, Elemental analysis of silicon based minerals by ultrasonic slurry sampling electrothermal vaporisation ICP-MS, *Talanta* 68 (2006) 869–875.
 - [17] L.O.B. Silva, D.J. Leao, D.C. dos Santos, G.D. Matos, J.B. de Andrade, S.L.C. Ferreira, Determination of copper in airborne particulate matter using slurry sampling and chemical vapour generation atomic absorption spectrometry, *Talanta* 127 (2014) 140–145.
 - [18] M. Hoenig, A. Gilissen, Electrothermal atomic absorption spectrometry: fast or conventional programs? *Spectrochim. Acta B* 48 (1993) 1003–1012.
 - [19] A.F. da Silva, F.G. Lepri, D.L.G. Borges, B. Welz, A.J. Curtius, U. Heitmann, Determination of mercury in biological samples using solid sampling high resolution continuum source electrothermal atomization atomic absorption spectrometry with calibration against aqueous standards, *J. Anal. At. Spectrom.* 21 (2006) 1321–1326.
 - [20] A. Detcheva, K.H. Grobceker, Determination of Hg, Cd, Mn, Pb and Sn in seafood by solid sampling Zeeman atomic absorption spectrometry, *Spectrochim. Acta B* 61 (2006) 454–459.
 - [21] K.H. Grobceker, A. Detcheva, Validation of mercury determination by solid sampling Zeeman atomic absorption spectrometry and a specially designed furnace, *Talanta* 70 (2006) 962–965.
 - [22] C. Maggi, M.T. Berducci, Bianchi, M. Giani, L. Campanella, Methylmercury determination in marine sediment and organisms by direct mercury analyser, *Anal. Chim. Acta.* 641 (2009) 32–36.
 - [23] G.E.M. Hall, P. Pelchat, Evaluation of a direct solid sampling atomic absorption spectrometer for the trace determination of mercury in geological samples, *Analyst* 122 (1997) 921–924.
 - [24] T. Costley, K.F. Mossop, J.R. Dean, L.M. Garden, J. Marshall, J. Carroll, Determination of mercury in environmental and biological samples using pyrolysis atomic absorption spectrometry with gold amalgamation, *Anal. Chim. Acta.* 405 (2000) 179–183.
 - [25] International Organization for Standardization, ISO/IEC 17025, General Requirements for the Competence of Testing and Calibration Laboratories, Geneva 2005, (ISO 17025).
 - [26] EURACHEM, The Fitness for Purpose of Analytical Methods, 1998.
 - [27] T.S. Breusch, A.R. Pagan, Simple test for heteroscedasticity and random coefficient variation, *Econometrica* 47 (1979) 1287–1294.
 - [28] K. Danzer, L. Currie, Guidelines for calibration in analytical chemistry part 1. fundamentals and single component calibration (IUPAC Recommendations 1998), *Pure Appl. Chem.* 70 (1998) 993–1014.
 - [29] K. Danzer, M. Otto, L. Currie, Guidelines for calibration in analytical chemistry part 2. Multispecies calibration (IUPAC Technical Report), *Pure Appl. Chem.* 76 (2004) 1215–1225.

Paper 2

Spectrochimica Acta Part B 103–104 (2015) 131–143



Contents lists available at ScienceDirect

Spectrochimica Acta Part B

journal homepage: www.elsevier.com/locate/sab

Marine sediments monitoring studies for trace elements with the application of fast temperature programs and solid sampling high resolution continuum source atomic absorption spectrometry[☆]



Anna Maria Orani, Eunmi Han, Petko Mandjukov, Emilia Vassileva^{*}

International Atomic Energy Agency, Environment Laboratories, 4 Quai Antoine 1er, MC98000, Monaco

ARTICLE INFO

Article history:

Received 16 July 2014

Accepted 16 December 2014

Available online 26 December 2014

Keywords:

High resolution continuum source atomic

absorption spectrometry

Solid sampling

Marine sediment

Validation

Uncertainty

ABSTRACT

Analytical procedure for the determination of As, Cd, Cu, Ni, Co and Cr in marine sediment samples using high-resolution continuum source graphite furnace atomic absorption spectrometry (HR CS AAS) and direct solid sample analysis has been developed. The application of fast programs in combination with direct solid sampling allows to eliminate the drying and pretreatment steps, however makes impossible the use of liquid standards for calibration. Iridium treated platforms were applied throughout the present study. Calibration technique based on the use of solid certified reference materials (marine sediments) similar to the nature of the analyzed sample and statistics of regression analysis were applied to the real sediment samples. The instrumental parameters were optimized in order to obtain reproducible and interference free analytical signals. The ISO-17025 requirements and Eurachem guidelines were followed in the validation of the proposed analytical procedure. Accordingly, blanks, selectivity, calibration, linearity, working range, trueness, repeatability reproducibility, limits of detection and quantification and expanded uncertainty ($k = 2$) for all investigated elements were assessed. Two different approaches for the estimation of measurement uncertainty were applied and obtained results compared. The major contributors to the combined uncertainty of the analyte mass fraction were found to be the homogeneity of the samples and the microbalance precision. The influence of sample particle sizes on the total combined uncertainty was also evaluated.

Traceability to SI system of units of the obtained by the proposed analytical procedure results was demonstrated. Additionally, validation of the methodology developed was effectuated by the comparison of the obtained results with independent method e.g. ICP-MS with external calibration. The use of solid sampling HR CS AAS for the determination of trace elements in marine sediment matrix gives significant advantages, such as straightforward calibration, a high sample throughput, sufficient precision, suitable limits of detection, appropriate for monitoring studies concentration range and reduced risk of analyte loss and contamination. This approach allows comparatively simple and reliable evaluation of uncertainty of the results and the basic validation parameters and in a natural way provides traceability of the obtained results. A comparison between the proposed fast programs with solid standard calibration and the conventional ones with liquid standard calibration demonstrates advantages of the new methodology. It provides faster, accurate and unbiased results typically with significantly lower uncertainties.

The potential of the HR CS AAS technique is demonstrated by direct analysis of marine sediments from the Caribbean region and various sediment CRMs within the frame of monitoring program for this region.

© 2014 Elsevier B.V. All rights reserved.

1. Introduction

Trace elements naturally occur in the lithosphere and oceans. However human activities have introduced high loads of these elements in the environment, making the differentiation of natural

and anthropogenic contributions difficult. Sediment samples provide a temporally integrated indication of the aquatic environment condition and act as a major reservoir for metals. Furthermore, sediments have high physicochemical stability and their characteristics usually represent the average condition of the system, often being representative for the overall water quality. Due to the significant temporal stability of the trace element concentrations in the sediments the study of their in-depth distribution allows also to follow the history of the pollution. Therefore the level of metals in marine sediments is a problem of particular importance and the

[☆] Selected papers presented at European Symposium on Atomic Spectrometry ESAS 2014, Prague, Czech Republic, March 16–21, 2014.

^{*} Corresponding author.

E-mail address: e.vassileva-veleva@iaea.org (E. Vassileva).

determination of some toxic pollutants in such matrix is recently widely investigated [1–6].

Accurate measurement of elements at low levels in marine environmental matrices is important and is being driven by new national, European and international legislation, reducing the allowable concentration of pollutants in the environment to trace and ultra-trace levels. New techniques and analytical capabilities are being developed and validated to perform accurate measurements of these pollutants (particularly trace elements) in marine environmental matrices in order to assess compliance with legislative limits that equate to element mass fractions of 10^{-9} g·g⁻¹ and below. These requirements are often underpinned by primary standards and certified reference materials (CRMs) at low concentrations, developed for the purpose of accurate calibration, with a traceable uncertainty statement. In most of the frequently used analytical methods, the samples are pre-treated and the decomposition of the sample matrix by means of an acid digestion is performed [7–9]. The main risks during sample preparation and storage are the analyte losses, as well as contamination caused by reagents used.

Direct analytical techniques are obviously preferable over those that require significant sample preparation, particularly in the case of complex samples, such as marine sediments. It should be noted that each technique has its advantages and limitations. For example, inductively coupled plasma mass spectrometry (ICP-MS) is the most sensitive, multi-elemental technique, but it requires sample digestion, unless electrothermal vaporization (ETV) or laser ablation is used. The most important advantages of solid sampling ETV ICP-MS are the possibilities of carrying out multi-element and/or isotopic analysis and using it for some elements for which GF AAS is not appropriate. As for the drawbacks of solid sampling ETV ICP-MS, its cost is noticeably higher and the method is more complex, and that leads to a greater risk of spectral and non-spectral interferences [10,11].

In contrast, traditional graphite furnace atomic absorption spectrometry (GF AAS) is a one element-at-a-time technique, but it enables the direct analysis of solid samples without significant additional efforts.

The major arguments against direct solid sampling have been the difficulty to introduce a solid sample into the graphite tube and the relatively high RSD, due to the natural inhomogeneity of real samples. The first problem has been overcome with the commercial introduction of new systems for manual and automatic solid sampling [12]. Another important problem is related to the correct calibration. The processes of analyte vaporization and atomization may depend on its form in the sample, and also be affected by the matrix [13]. This problem can be partly solved in the process of sample dissolution combined with use of chemical modifiers. However, in the case of direct solid sampling the differences between sample and aqueous calibration standards might increase dramatically. On one hand it is practically impossible to expect similarity in the matrix content in sample and calibration standards. On the other, the chemical forms of the analyte in sample and standards also can be significantly different. Besides, the difference in physical form of standards and samples leads to serious difficulties in the evaluation of important metrological parameters. It should be noted that, in the case of calibration with liquid standards, containing usually simple inorganic salts in strongly diluted nitric acid, it is practically impossible to measure directly the procedural blank and to evaluate its standard deviation. Despite these aspects, most of solid sampling quantifications of different analytes by AAS are usually performed using a liquid-standard calibration [14–17]. This quantification method is suggested as default and implemented in the software of the Analytik Jena ContrAA 700 instrument used in the present study.

Another aspect of the direct analysis of solid samples by AAS is the possibility to operate with fast programs. In these procedures the drying and pyrolysis times are minimized or eliminated. Thus, the fast programs are attractive approaches due to their significantly shorter analytical time, increase analytical throughput [18] and

increase the furnace/platform lifetime. In the particular case of volatile analytes, such as As and Cd among others, fast program represents another advantage: the elimination of thermal pre-treatment step decreases the possibility of analyte losses due to the high volatility of these elements [19].

With the use of HR CS AAS, equipped with a charge coupled device array detector, several limitations of classical line sources could be overcome, particularly those associated with spectral interferences. The continuous background covering the spectral range observed by the array detector is corrected automatically using correction pixels on both sides of the analytical line. In difference, the structured background can be corrected using reference spectra and a least-squares algorithm [13,20].

Most of the highly toxic environmental pollutants (e.g. Hg, As, Se, Cd, Pb etc.) are elements with high or medium volatility. Critical question for their determination with AAS is on avoiding their losses during the sample digestion procedure and sample pretreatment steps in the temperature program for graphite furnace atomic absorption spectrometry (GF-AAS) determination. The most recent and revolutionary development in the AAS – the high resolution continuum source atomic absorption spectrometer (HR CS AAS) equipped with direct solid sampling device, in combination with fast temperature programs, are potentially powerful tools for solving such analytical problems.

Within this context, subject of the present study is the development and validation of analytical procedure for the determination of As, Cd, Co, Cr, Cu, and Ni in marine sediment samples based on solid sampling HR CS AAS, fast temperature programs and calibration with solid phase CRMs.

2. Experimental

2.1. Reagents, solutions and samples

Deionized water from Milli-Q system (Millipore, Bedford, MA, USA) was used throughout this work. Ultra-pure HNO₃ (Ultrex, T. T. Baker, Phillipsburg, NJ, USA), hydrogen peroxide (p.a. from Merck) and HF (p.a. from Merck, Darmstadt, Germany) were used for sample digestion.

Only new lab ware material (bottles, vessels, tips, syringes etc.) was employed and it was cleaned thoroughly following a procedure described elsewhere in detail [21]. In order to avoid risks of memory effects from previous experiments, digestion vessels were submitted to a supplementary hot cleaning procedure: first addition of approximately 10 g concentrated HNO₃ to each vessel; second microwave treatment at 350 W for 10 min; third the vessels were thoroughly rinsed with Milli-Q water.

All sample processing steps with liquid samples were performed in clean chemical laboratory (class < 100 clean room) to reduce the risks of airborne contamination. In all experiments involving liquid calibration, the standard solutions for each element were prepared by dilution of CertiPur Reference Material containing 1000 mg l⁻¹ of the corresponding analyte (Merck, Dortmund, Germany).

ICP Standard Iridium Solution containing 1000 mg l⁻¹ Iridium (Merck, Dortmund, Germany) was used for the treatment of graphite platforms.

Mixed chemical modifier, used for conventional programs, containing 500 mg l⁻¹ Pd and 300 mg l⁻¹ Mg, was prepared by diluting and mixing 10 mg l⁻¹ solution of Palladium Nitrate (Matrix modifier for GF AAS, Analytika Ltd., Prague, Czech Republic) and 10 mg l⁻¹ solution of Magnesium Nitrate (Matrix modifier for GF AAS, Analytika Ltd., Prague, Czech Republic).

For optimization, calibration and validation purposes the following certified reference materials from the IAEA (International Atomic Energy Agency, Monaco, Principality of Monaco) were used: IAEA 433 and IAEA 458 (marine sediments from the Algerian coast of the Mediterranean Sea and South Korea), IAEA 158 and IAEA 405 (estuarine sediments with origin of Scotland and Portugal respectively) as well as

MESS-2 (estuarine sediment from Canada) from the NRC (National Research Council, Canada).

The sediment samples analyzed in this study were collected in 2009 from the Cartagena Bay (Caribbean Coast Region, Colombia) and Puerto Príncipe Bay (Caribbean Coast, Haiti). These samples have been collected as a part of the environmental assessment program held by the IAEA, in the frame of one of its technical cooperation projects in the Caribbean region. The study area selected in Colombia was Cartagena Bay, an area of great interest because of the confluence of productive activities such as tourism, fishing, industry and port services. The samples collected were freeze-dried, grinded and measured for grain size. The sediment texture profile was predominantly (>90%) silt and clay, showing a diameter lower than 0.063 mm; further manual homogenization did not produce significant changes in results obtained by SS CS HR AAS.

2.2. Instrumentation

All AAS measurements in the present study were carried out using a HR CS AAS instrument ContrAA 700, Analytik Jena AG (Jena, Germany). This instrument is equipped with transversely heated graphite tube atomizer operating with pyrolytically coated solid sampling (SS) graphite tubes and SS graphite platforms. A Xenon short-arc lamp (GLE, Berlin, Germany) operating in "hot-spot" mode as the radiation source, a high-resolution double scale monochromator (DEMON) and a linear CCD array detector with 588 pixels, 200 of which are used for monitoring the analytical signal and performing BG corrections. Introduction of the solid samples was performed by an automated solid sampling accessory SSA 600 (Analytik Jena) with incorporated M2P micro-balance (Sartorius, Göttingen, Germany) with a declared precision of 0.001 mg. The samples were introduced using solid sampling platforms.

The resonance lines at 228.8018 nm, 240.7254 nm, and 193.6960 nm were used for the determination of Cd, Co and As respectively. The secondary lines at 341.4774 nm, 327.3960 nm and 359.3488 nm were used for the determination of Ni, Cu, and Cr due to their high content in the marine sediments. Decreasing sensitivity by use of secondary lines provides signals within the linear range for all analytes in the samples. Peak volume selected absorbance i.e., the integrated absorbance (A_{int}) summed over three pixels around the line core, was used for signal evaluation and quantification for all elements.

For all analytes, integrated absorbance (A_{int}) was selected as measurement mode.

The default calibration using liquid standards was based on the assumption that for each analyte the normalized absorbance is constant and matrix independent. The instrument provides output of both integrated and normalized absorbance for each sample/standard measured. The normalized absorbance is usually obtained as a ratio between two relatively small values having their own uncertainty. Thus, the uncertainty of the normalized absorbance increases significantly, especially for elements showing comparatively high sensitivity and low content in the studied solid material. Due to this reason in all experiments involving calibration with solid standards only the integrated absorbance was used. Argon with a purity of 99.996% (Alpha Gaz, France) was applied as purge and protective gas.

Quadrupole inductively coupled plasma mass spectrometer Q-ICP-MS (X SERIES, Thermo Fisher Scientific, USA) was used for comparative measurements of studied trace elements in sediment samples from the Caribbean region. The instrument was equipped with a Micromist nebulizer (0.2 ml min^{-1} , Glass Expansion) and a cyclonic spray chamber cooled by Peltier cooling system ESL. The concentration of elements in the sediment samples was determined via external calibration using appropriate working standards, prepared in 2% HNO_3 , derived from multi elemental standard (1000 mg l^{-1} Merck, Darmstadt, Germany). Working condition for the ICP-MS is presented in Table 1.

Table 1
ICP-MS parameters and working conditions.

Parameter	
Coolant gas flow	13.5 l min^{-1}
Auxiliary gas flow	0.8 l min^{-1}
Nebulizer gas flow	0.90 l min^{-1}
Plasma power	1300 W
Background on mass 220	<10 cps
Dead time	44 ± 2 (k = 2) ns
Accusation mode	Peak jumping
Number of sweeps	200
Number of cycles	3
Dwell time per amu per isotope	50 ms
Collision reaction gas	Helium 4.3 ml min^{-1}
Measured isotopes in standard mode	^{112}Cd , ^{65}Cu , ^{60}Ni , ^{53}Cr , ^{59}Co
Measured isotopes in collision reaction mode	^{75}As
Mass resolution	Low
Oxide formation CeO^+/Ce	<2%

2.3. Samples and sample preparation

2.3.1. Sample preparation for HR CS AAS solid sampling analysis

A number of marine samples from the Caribbean region have been analyzed in order to demonstrate the applicability of the developed method for real samples. The samples collected were freeze-dried and ground manually in an agate mortar until the material passed a sieve of 0.5 mm. Further grinding was done in a planetary ball mill (Fritsch, Rudolstadt, Germany) with agate cups, lids and balls for 20 min at 300 rpm. After that, samples were passed again through laboratory sieves of 0.1 mm and stored in polyethylene cups until they were analyzed.

2.3.2. Particle size analysis

An aliquot of approximately 0.5 g of sediment sample was placed in a 10 ml tube. Five ml of MilliQ water were added and the tube was shaken in order to separate the silt particles properly. An equilibration period of about half an hour was used to insure that the sample was uniformly wet before analysis.

The particle size distribution was determined using a Malvern Mastersizer Micro (Malvern Instruments, UK) device. The principle of this device is that small particles cause incident light to be diffracted through a large angle whereas large particles will diffract incident light through a small angle. Particle size information is derived by deconvolution of the diffraction data obtained by the instrument.

The analysis of the particles is performed by slurring a sediment sample into a beaker containing 500 ml of water. The mixture is pumped through a cell which is interrogated by the instrument's laser beam. The particle size distribution is determined from the resulting diffraction pattern.

2.3.3. Microwave digestion for samples analyzed by ICP-MS

Digestion of sediment samples was carried out by a microwave procedure using a Mars X-press Microwave System (CEM Mars X-press) equipped with a carousel holding 12 digestion vessels. A quantity of $250 \pm 50 \text{ mg}$ of sediment sample was weighed for digestion. Samples were digested in acid-cleaned Teflon microwave vessels with 5 ml of ultrapure nitric acid, and 2 ml of hydrogen peroxide, 2 ml ultrapure concentrated hydrofluoric acid was used in addition for complete silicate destruction. Each digestion batch included at least 2 reagent blanks and an appropriate natural matrix certified reference material.

The digestion procedure involves gradually increasing the temperature to 190°C for 15 min period, then isothermal treatment for additional 15 min. After the digestion obtained solutions were placed on a ceramic heating plate and evaporated to near dryness. The residues

were taken up in 0.14 mol l⁻¹ HNO₃, transferred to 50 ml PE bottles and stored at 4 °C.

2.4. Procedure for analysis by solid sampling with HR CS GFAAS

Two types of temperature programs – conventional and fast, were applied for the determination of investigated elements in marine sediments.

All experiments were carried out in graphite platforms, preliminary treated with Ir. The temperature program for the platform treatment with Ir is presented in Table 1S. The initial Ir treatment includes 8 cycles for each platform. During each cycle 30 µl of 1000 mg l⁻¹ were injected on the platform. The treatment was repeated periodically to provide permanent quality of the Ir coating.

External calibration was performed using solid marine sediment CRMs containing similar matrix and appropriate analyte concentrations. The calibration strategy is based on the assumption that the ratio between slopes of the regression lines absorbance vs. sample mass for two different samples from the same type (containing similar matrix) is equal to the ratio of the analyte fractions in both samples.

Thus, a regression function [22] calculated for solid CRM with certified analyte concentration makes possible quantification of the analyte mass fraction in a solid sample of the same type [23]. Initially the regression line based on 10–12 different masses of CRM used for calibration was calculated. The procedure was repeated for each of the samples with reduced number of points – 6 to 8 different masses. The analyte mass fraction was calculated according to Eq. (1) as described recently [23]:

$$x_a^{(S)} = x_a^{(CRM)} \frac{a_1^{(S)}}{a_1^{(CRM)}} \quad (1)$$

where $x_a^{(S)}$ and $x_a^{(CRM)}$ are the analyte mass fractions in the sample and CRM used for calibration respectively; $a_1^{(S)}$ and $a_1^{(CRM)}$ are the respective slopes of the regression lines.

A new calibration was done every day for the selected element, at the beginning of the sequence, followed by the sample analysis. The calibration is rather stable and therefore one calibration with solid CRM per day was found to be enough for obtaining reliable results.

For validation purposes a second CRM of similar type was used instead of sample.

3. Results and discussions

3.1. Temperature programs

The fast program for the determination of As, Cd, Co, Cr, Cu and Ni in sediment samples were developed and optimized in order to provide interference free analytical signals and background signal below 0.8 which can be compensated by the mathematical correction algorithm used in the Analytik – Jena software (Tables 2a and 2b). For cross validation purposes a conventional temperature programs and mixed

chemical modifier (5 µg Pd + 3 µg Mg) were also applied (Tables 3a and 3b).

The obvious advantage of the fast programs compared with the conventional one is the considerably shorter pre-treatment time. In the case of direct solid sampling, without using liquid chemical modifiers, the drying and pyrolysis steps can be reduced to the lowest allowed by the software values (1 s hold time). Thus the losses from the atomizer can be reduced significantly, due to kinetic reason, and higher sensitivity and stability of the analytical signals could be achieved. It should be noted, that in some cases the refractory matrix might play the role of modifier, decreasing the partial vapor pressure of the volatile analyte. Earlier studies [e.g. 24] provide experimental evidences that the analyte evaporation rate in the graphite atomizer in the presence of chemical modifier (refractory matrix) is controlled by its partial vapor pressure over non-ideal solid solution. This effect is substantial for the marine sediments consisting mainly of silicates. Due to the low volatility of the matrix the background remains low enough even at sample masses around 0.500 mg. Besides analytical advantages of the fast programs they are less harmful for the atomizers and sampling platforms used and allow an increase in their lifetime. On the other hand determination becomes less energy consuming.

Moderate changes of the pyrolysis and atomization temperatures were not changing critically the analytical signal and the linearity of the calibration graph. Changing the atomization ramp in wide range was also tolerable. This indicates significant robustness of the developed fast programs.

In Fig. 1 3-D high resolution plots of the corrected analytical signals, and the spectral area close to the respective spectral lines are presented. All graphics are registered by measuring different masses of selected sediment CRM.

The major limitation of the fast programs in comparison with the conventional ones combined with liquid standard calibration is the necessity from greater number of matrix and concentration matching CRMs corresponding to the studied unknown samples and having high homogeneity.

3.2. Validation of the analytical procedure

Validation of a “fit-for-purpose” analytical procedure for the determination of As, Cd, Co, Cu, Cr and Ni in marine sediment samples, based on solid sampling CS AAS determination followed the requirements of ISO 17025 standard and Eurachem guidelines [25,26]. Utmost care was placed on the full method validation. Accordingly, selectivity, linearity and working range of the calibration curve, limit of detection, characteristic mass, repeatability and reproducibility, as well as trueness and bias (using CRMs) were systematically assessed. In addition, estimations of the individual uncertainty contributions of each parameter as well as the final expanded uncertainty have been performed. Demonstration of traceability of measurement results is also provided.

The proposed method allows comparatively simple and reasonable evaluation of the basic validation parameters. In most of the works dealing with direct solid sampling these parameters are not evaluated, or

Table 2a
Fast temperature programs for HR CS AAS determination of As, Cd and Co in sediment samples.

Step	Name	As (193.696 nm)				Cd (228.725 nm)				Co (240.725 nm)			
		Temp (°C)	Ramp (°C s ⁻¹)	Hold (s)	Ar flow	Temp (°C)	Ramp (°C s ⁻¹)	Hold (s)	Ar flow	Temp (°C)	Ramp (°C s ⁻¹)	Hold (s)	Ar flow
1	Drying	400	100	1	Max	750	300	1	Max	500	100	2	Max
2	Pyrolysis	400	0	5	Max	750	0	1	Max	850	300	5	Max
3	Gas adaption	400	0	5	Stop	750	0	5	Stop	850	0	5	Stop
4	Atomization	2600	2000	2	Stop	2000	1200	3	Stop	2600	2000	7	Stop
5	Cleaning	2600	0	4	Max	2450	500	4	Max	2600	0	4	Max
Duration (s)		21.8				18.3				29.8			

Table 2b

Fast temperature programs for HR CS AAS determination of Cr, Cu and Ni in sediment samples.

Step	Name	Cr (359.349 nm)				Cu (327.396 nm)				Ni (341.477 nm)			
		Temp (°C)	Ramp (°C s ⁻¹)	Hold (s)	Ar flow	Temp (°C)	Ramp (°C s ⁻¹)	Hold (s)	Ar flow	Temp (°C)	Ramp (°C s ⁻¹)	Hold (s)	Ar flow
1	Drying	1000	500	2	Max	1000	500	2	Max	1150	200	6	Max
2	Pyrolysis	1000	0	2	Max	1000	0	2	Max	1150	0	5	Max
3	Gas adaption	1000	0	5	Stop	1000	0	5	Stop	1150	0	5	Stop
4	Atomization	2450	2000	10	Min	2400	1500	5	Stop	2600	500	4	Stop
5	Cleaning	2500	500	4	Max	2600	2000	4	Max	2600	0	4	Max
Duration (s)		25.7				19.0				30.0			

doubtfully transferred from data obtained from analysis of liquid standards.

3.2.1. Linearity and working range

Considering HR CS AAS, the atomic absorption signal is recorded and processed in a different way in comparison with the traditional line source AAS. In fact, the HR CS AAS technique provides a 3D signal, adding an extra dimension (wavelength) to traditional line source AAS signals. As a consequence, there is some additional flexibility to adjust the sensitivity and to expand the linear range. The exact resolution of the instrument depends on the wavelength monitored and the sensitivity ultimately obtained depends on the number of detector pixels used, a setting that can be freely selected by the operator. It is possible to expand the linear range simply by selecting the appropriate detector pixels on the wings of the absorption line. Indeed, as higher analyte amounts are introduced into the atomizer, at some mass the signal at the center of the absorption line will grow more slowly, losing the linear response and eventually become saturated or even self-absorbed. However, as the analyte mass increases, the absorption line profile also becomes broader, such that use of side pixels becomes advantageous by permitting an increase in the working range. This strategy is simple to apply, as the information from all the detector pixels is always available. Optimal sensitivity and best limits of detection are obtained when using the three central pixels, but linearity can be expanded up to three orders of magnitude using side pixels.

In the present study the test was performed with 12 different masses of the CRM used for calibration. At the lower end of the concentration range, the limiting factors are the values of the limits of detection and/or quantitation. Another limiting factor is the precision of the microbalance. For masses below 0.020 mg the uncertainty of the weighted masses contributes significantly (> 10%). From practical point of view, the upper limit of the working range is not so interesting speaking about the environmental monitoring. It should be noted that increasing the sample mass above certain limit (usually 0.400–0.600 mg depending on the matrix) will result in higher levels of interferences due to the higher matrix amount in the atomizer, or to deviation from the linear response due to very high analyte mass introduced. Within the working range the response is typically linear.

The extent of the linear range of the calibration curve was established during the evaluation of the working range. The regression calculations in principle are insufficient to establish linearity. The linearity of the calibration lines was confirmed using Student's t-test procedure proving that the squared correlation coefficient is not significantly different from 1 [23].

If the obtained calibration graphic shows good linearity the highest calibration point should not be exceeded.

Calibration graphics used for the determination of As, Cd, Co, Cu, Cr and Ni in marine sediment samples are presented in Fig. 3. Summary of the obtained validation parameters with those calibration lines, are presented in Table 4.

The typical working ranges for the determination of all elements in sediment samples in this study, expressed as mass of the CRMs used for calibration, was between 0.05 and 0.3 mg.

3.2.2. Selectivity and sensitivity

Critical for selectivity of the method factor is the selection of the appropriate spectral interval band width for monitoring the investigated analyte. While the use of a continuum source in AAS certainly opens possibilities for simultaneous multi-element determinations, the potential of the instrumentation currently available is rather limited in this regard. One of the main characteristics of this instrument is its excellent resolution, since each pixel monitors a range of only 1 to 2 pm (the exact value depends on wavelength: the lower the wavelength, the higher the resolution is).

The direct production of an analytical signal from a solid sample offers a number of important advantages, resulting from the elimination of the dissolution step. In addition, since samples are not diluted at all, usually the sensitivity increases.

The use of Ir as permanent modifier for the determination of different analytes (also volatile) in a large variety of matrices has been widely studied [27,28] and it was the choice applied during the present study.

It should be noted that in the case of direct solid sampling Ir treated surface acts in a completely different way than in the case of liquid samples. Due to the poor contact, significant Ir-analyte interactions cannot be expected. Thermal stabilization of the volatile analytes was not observed in the present study. The function of Ir is to provide higher

Table 3a

Conventional temperature programs for HR CS AAS determination of As, Cd and Co in sediment samples using liquid standards for calibration.

Step	Name	As (193.696 nm)				Cd (228.725 nm)				Co (240.725 nm)			
		Temp (°C)	Ramp (°C s ⁻¹)	Hold (s)	Ar flow	Temp (°C)	Ramp (°C s ⁻¹)	Hold (s)	Ar flow	Temp (°C)	Ramp (°C s ⁻¹)	Hold (s)	Ar flow
1	Drying	90	3	20	Max	90	10	10	Max	100	10	10	Max
2	Drying	130	5	10	Max	130	5	10	Max	300	20	10	Max
3	Pyrolysis	350	50	10	Max	350	50	20	Max	1000	50	15	Max
4	Pyrolysis	600	50	10	Max	750	300	10	Max	–	–	–	–
5	Gas adaption	600	0	5	Stop	750	0	5	Stop	1000	0	5	Stop
6	Atomization	2400	3000	4	Stop	2000	1200	5	Stop	2400	3000	6	Stop
7	Cleaning	2450	500	4	Max	2450	500	4	Max	2450	500	4	Max
Duration (s)		101.1				85.6				81.6			

Table 3b

Conventional temperature programs for HRCS AAS determination of Cr, Cu and Ni or As, Cd and Co in sediment samples using liquid standards for calibration.

Step	Name	Cr (359.349 nm)				Cu (327.396 nm)				Ni (341.477 nm)			
		Temp (°C)	Ramp (°C s ⁻¹)	Hold (s)	Ar flow	Temp (°C)	Ramp (°C s ⁻¹)	Hold (s)	Ar flow	Temp (°C)	Ramp (°C s ⁻¹)	Hold (s)	Ar flow
1	Drying	90	10	10	Max	150	10	20	Max	195	15	20	Max
2	Drying	130	5	10	Max	250	25	15	Max	–	–	–	–
3	Pyrolysis	350	50	10	Max	1000	250	10	Max	1100	200	20	Max
4	Pyrolysis	700	300	10	Max	–	–	–	–	–	–	–	–
5	Gas adaption	700	0	5	Stop	1000	0	5	Stop	1100	0	5	–
6	Atomization	2450	3000	8	Stop	2400	3000	6	Stop	2600	1000	5	Stop
7	Cleaning	2450	0	4	Max	2450	500	4	Max	2600	0	4	Max
Duration (s)		77.2				79.6				62.2			

stability of the sampling platform surface, to assist the mechanical cleaning after each measurement and to provide uniform conditions and increasing the lifetime of the platforms.

3.2.3. Trueness and bias of obtained results

The trueness of the results obtained for different samples was confirmed by analysis of marine sediment CRMs and comparison with the corresponding reference values. In all cases the bias between results obtained by the proposed method and the certified or reference values were insignificant and within the estimated uncertainty. It is important to note that for all CRMs the biases from the certified values obtained by solid phase calibration were lower than those obtained after calibration using liquid standards. The results for As, Cd, Co, Cu, Cr and Ni from the experiments mentioned above are presented in Table 4.

3.2.4. Limits of detection and quantification

The major challenge in the evaluation of these parameters is due to the fact that in direct solid sampling practically does not exist "Blank". A simple approach based on the linear regression data from the calibration line obtained using solid CRM was applied in the present work.

The blank is supposed to be a constant value with definite uncertainty within the whole working range of the analytical method. In the case of reagent free analysis with proper background correction the blank value should be equal to zero. It cannot be measured directly, but can be evaluated as an intercept value from the linear regression. Thus the standard deviation (standard uncertainty) of the intercept of the calibration line A vs. m [22,23] provides the value of SD_{BL} obtained on the data from all calibration points. This approach was described and discussed in details earlier [23]. In all present studies the intercept was statistically insignificant which corresponds to $A_{BL} = 0$.

3.2.5. Repeatability and reproducibility

Since multiple dosing of the sample with deviations within 0.001 mg is practically impossible in the case of direct solid sampling evaluation of these metrological characteristics is also a challenging task. Two different methods for repeatability evaluation were compared in the present study.

3.2.5.1. Repeatability evaluated by series of replicates. The repeatability was evaluated by the application of the described measurement procedure on three samples of the same CRM for each element in the same day. Repeatability was estimated as standard deviation of these three results. Each analysis was performed using 6 different masses of the CRM used as a test sample.

The number of points was optimized in an additional experiment. On the basis of the set of 16 points, corresponding to different masses of the test CRM, 16 sets containing subsequently from 1 to 6 points were randomly selected and used for evaluation of the mass fraction. Mean value, bias and relative standard deviation were calculated from the obtained 16 analyte mass fraction data points. The use of more than four masses for mass fraction evaluation leads to a decrease in bias and RSD to a stable level and obtaining results practically identical within the stated uncertainty. The critical point might be influenced by the sample homogeneity and various matrix effects. Thus 6 masses were selected as a proper and reliable number for evaluation of repeatability and reproducibility for all elements studied. For the case of As the results for repeatability evaluated by series of replicates are presented in Figure 4.

The major drawback of the described procedure is the necessity of additional time and energy consuming experiments.

3.2.5.2. Repeatability evaluated by statistical analysis of single calibration line. The specificity of the solid CRM calibration method implies at least 6–8 measurements at different sample masses and calculating regression line A vs. m for calibration.

The degree of random spread of the points around the regression line can be characterized by the regression (residual) standard deviation (SD_R), calculated according to the following equation:

$$SD_R = \sqrt{\frac{\sum_{i=1}^n (A_i - a_0 - a_1 m_i)^2}{n - c}} \quad (2)$$

where: A_i and m_i are the analytical signals and corresponding masses for calibration point indexed as i ; a_0 and a_1 are the regression coefficients; n is the number of data points. The variable c in the denominator corresponds to the number of statistically significant coefficients in the regression equation. In fact, each member of the sum under the square root is the squared deviation of the experimental data point i from the regression line. The denominator in this expression has a statistical meaning of degrees of freedom. It is obvious that in the case of insignificant slope (a_1) the expression in Eq. (2) becomes identical with the expression for standard deviation of the mean calculated from repeated measurements and the intercept (a_0) becomes identical with the mean value. The regression standard deviation can be assumed as "an extension" of the standard deviation of the mean for case when a trend exists in the data set. Thus, the SD_R value calculated from the regression data for sample or test CRM is standard deviation of the measured absorbance corresponding to the different masses introduced in the atomizer. The

Fig. 1. Clear analytical signals obtained for As and Cd, (Fig. 1a) Co and Cu (Fig. 1b) Cr and Ni (Fig. 1c) in marine sediment samples. First line graphs are 3D high resolution presentation of the corrected analytical signals; second line – high resolution spectra of the region around the analyte resonance line.

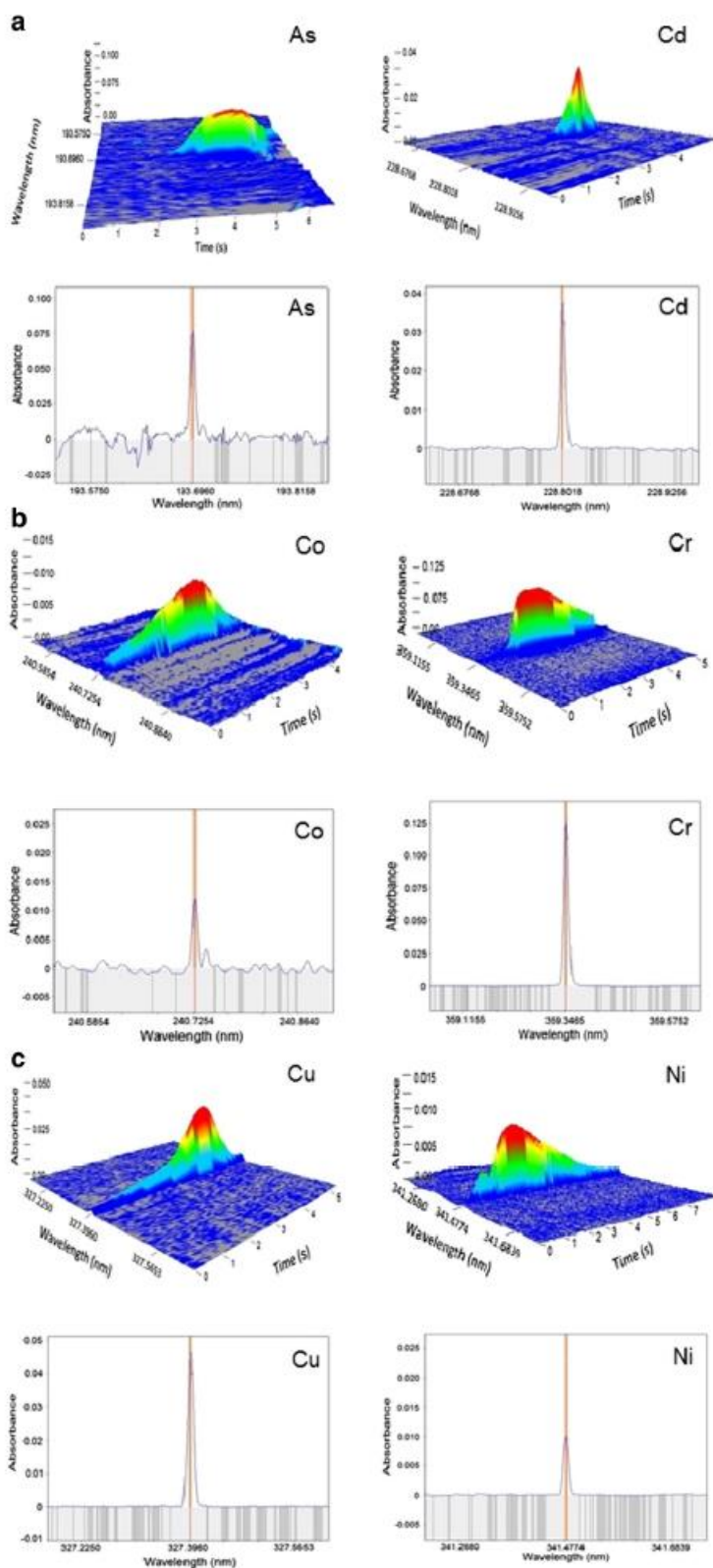

standard deviation related to analyte mass fraction (SD_a) can be revealed by the following equation:

$$SD_a = \frac{SD_R}{a_1} x_a \quad (3)$$

where SD_R is the regression standard deviation calculated by Eq. (2), a_1 is the slope of the regression line (Eq. (3)) and x_a is the analyte mass fraction in the sample or test CRM.

The results for repeatability for each element studied obtained by the described two different methods have been compared by Fisher's F-test and in all cases the differences in variations (squared standard deviations) were found to be statistically insignificant.

The robustness of the estimation of repeatability by the regression standard deviation was confirmed by the comparison between values calculated using different calibration lines measured in a

short period of time. In all cases no significant differences were observed.

The major advantages of the method described above are that it does not require additional experiment and the estimated standard deviation has higher statistical significance (bigger number of degrees of freedom). The repeatability results for all elements calculated according to the two approaches described are presented in Table 4.

3.2.5.3. Reproducibility. The intermediate precision (within-laboratory reproducibility) was evaluated by analyzing 3 samples on three different days in the same way as for repeatability. The relative standard deviations (RSDs) were found to be between 7% and 11% for sediment samples. It should be noted that RSD value is strongly influenced by the level of element content in the CRM used. When it is close to the LOQ (LOD) of the method the RSD might be significantly higher.

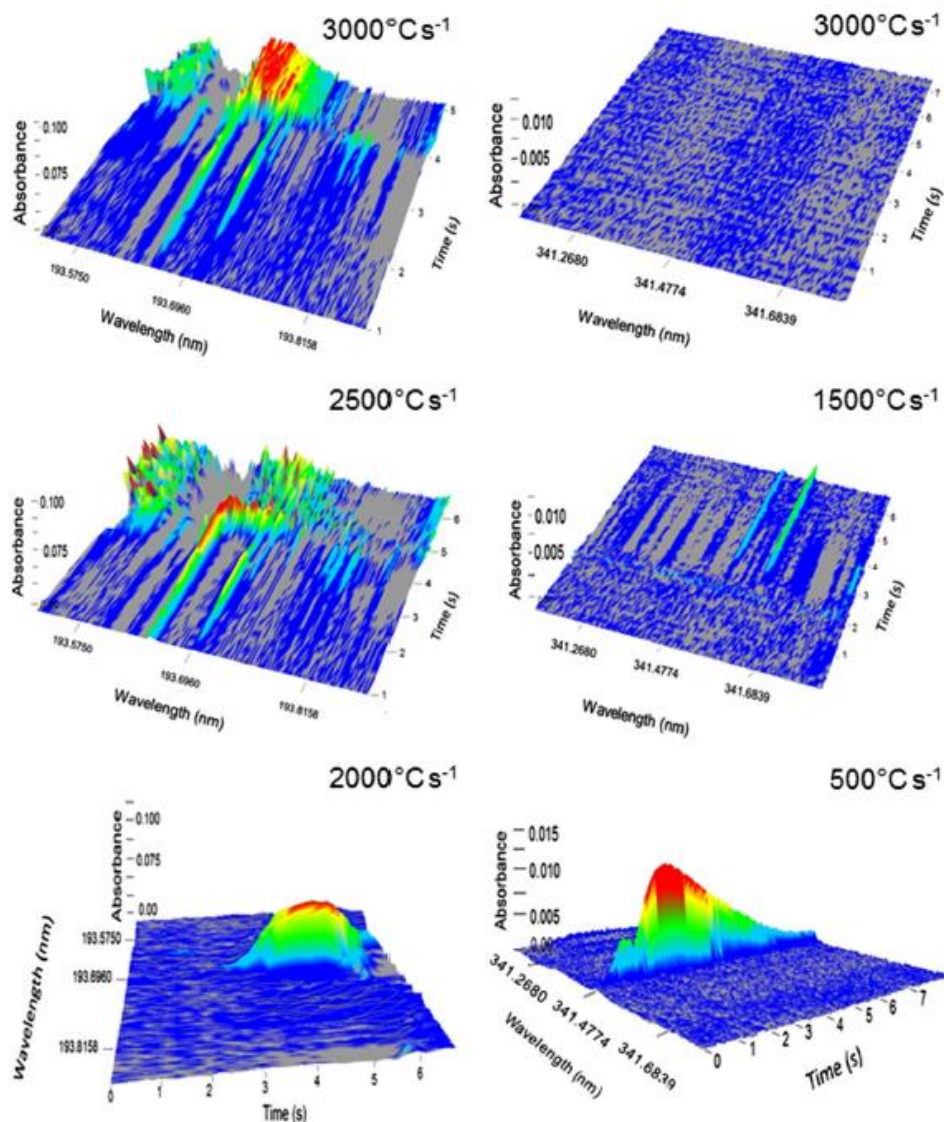

Fig. 2. 3D high resolution presentations of the decreasing background and general improvement of analytical signals, as a function of ramp optimization for As, Co and Ni in sediment CRMs.

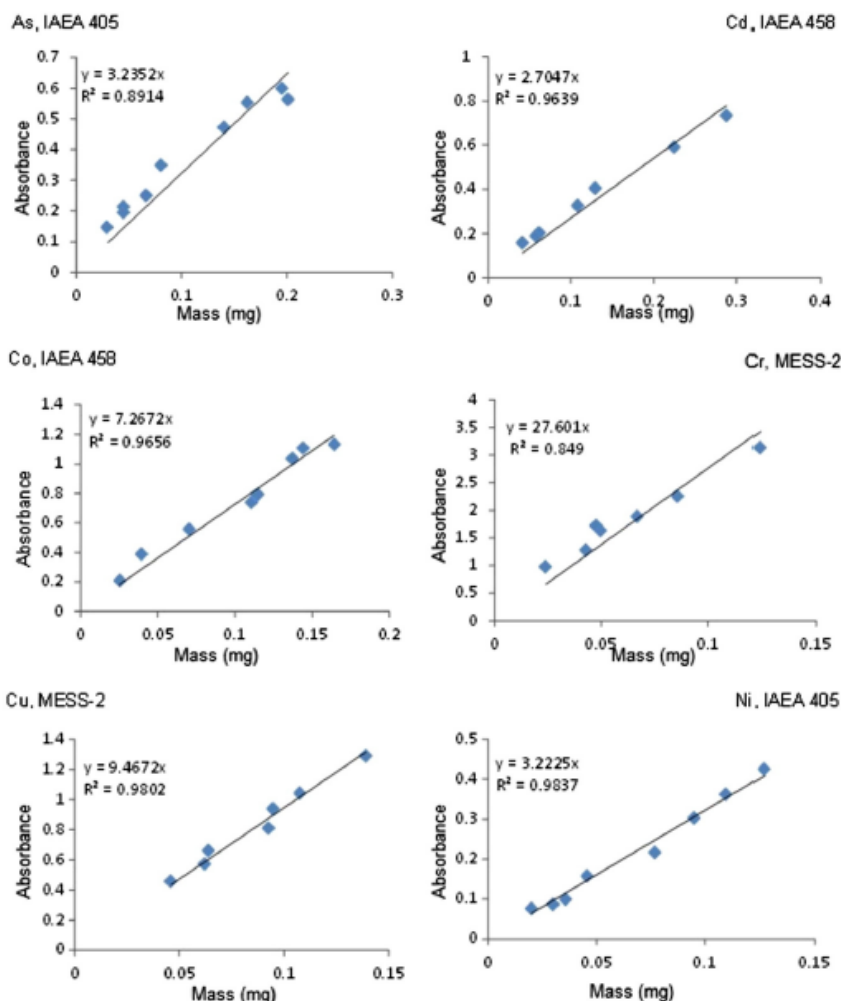

Fig. 3. Calibration curves for As, Cd, Co, Cr, Cu and Ni obtained from the absorbance values for different masses of the selected marine sediment CRM.

3.2.6. Evaluation of the combined standard uncertainty

Evaluation of the measurement uncertainty was performed according to the recommendations given in the Guide to the Expression of Uncertainty in Measurement [29] by using two

different approaches. The first one is the described earlier [23] approach based on uncertainty propagation error applied to the model equation and the second is so called top down approach or Nord test approach [30].

Table 4

Validation parameters for the determination of As, Cd, Co, Cr, Cu and Ni mass fractions (mg kg^{-1}) in marine sediment samples.

Parameter	As	Cd	Co	Cr	Cu	Ni
Test material	MESS-2	MESS-2	MESS-2	IAEA 158	IAEA 433	IAEA 158
CRM certified value	20.0 ± 0.8	0.24 ± 0.01	13.8 ± 1.4	74.4 ± 5.8	30.8 ± 2.6	30.3 ± 2.9
Determined value	19	0.22	12.8	73	31.3	29
Expanded uncertainty	2	0.01	1.1	7.5	2	1.9
Model equation approach ($k = 2$)						
Expanded uncertainty	3	0.03	2.2	8	2	2.5
Single laboratory validation approach ($k = 2$)						
Bias	-1.8	-0.02	-1.5	-1.4	-0.5	-1.3
Repeatability (SD, 3 replicates)	1.0	0.01	1.6	7.4	1.2	3.4
Repeatability (SD from regression line)	1.2	0.02	1.7	9.4	1.4	3.3
Reproducibility, %	9%	10%	10%	7%	8%	7%
LOD (ng)	0.02	0.01	0.021	0.015	0.016	0.011
LOQ (ng)	0.03	0.02	0.027	0.020	0.018	0.026
Calibration CRM	IAEA 405	IAEA 458	IAEA 458	IAEA 405	MESS-2	IAEA 405
CRM certified value	23.6 ± 0.7	0.043 ± 0.033	15.6 ± 1.2	84 ± 1.63	39.8 ± 2.0	32.5 ± 1.4

140

A.M. Orani et al. / Spectrochimica Acta Part B 103–104 (2015) 131–143

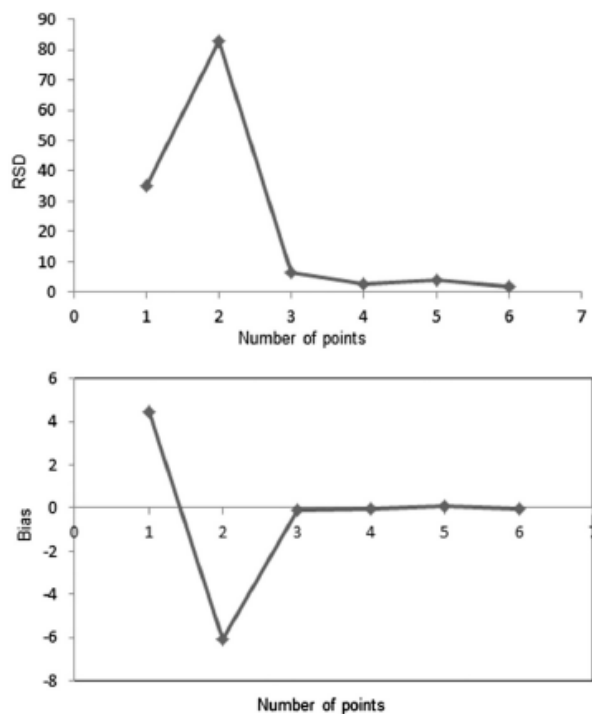

Fig. 4. Dependence of RSD and bias on the number of subsamples (replicates) from the test CRM measured in the quantification of the analyte mass fraction.

3.2.6.1. *Model equation approach.* Considering Eq. (1) and the uncertainty propagation law, the combined uncertainty (U_c) of the analyte

mass fraction in the sample ($x_a^{(S)}$) can be evaluated using the equation:

$$U_c = x_a^{(S)} \sqrt{\left(\frac{U_{x_a}^{(CRM)}}{x_a^{(CRM)}}\right)^2 + \left(\frac{U_{a_1}^{(CRM)}}{a_1^{(CRM)}}\right)^2 + \left(\frac{U_{a_1}^{(S)}}{a_1^{(S)}}\right)^2} \quad (4)$$

where: $U_{x_a}^{(CRM)}$ is the uncertainty of the analyte mass fraction ($x_a^{(CRM)}$) in the CRM according to the certificate, $U_{a_1}^{(CRM)}$ and $U_{a_1}^{(S)}$ are the uncertainties of the slopes of the regression lines for the CRM ($a_1^{(CRM)}$) and sample ($a_1^{(S)}$) respectively. This approach has been described and discussed in details earlier [23].

3.2.6.2. *Main sources of uncertainty.* Taking into account the specificity of the proposed analytical procedure the major contributors to the uncertainty of the result can be identified as follows:

- Uncertainties on the weighted mass

The microbalance of the instrument is operating in “noisy” working conditions. The readings are affected by the instrument vibrations, air flows caused by the ventilation, variations in the positioning of the platforms on the balance by the auto sampler and various external influences. It should be noted that airflow might cause also losses of sample particle during the platform transfer to the atomizer. Practically that means that masses below 0.040 mg are charged with relative uncertainty exceeding 10% only by the sample dosing.

- Uncertainties of the measured absorbance

Due to the optical stability of the instrument the absorbances are usually a minor contribution to the combined uncertainty. Possible test for evaluation of the uncertainty coming only from the repeatability of the absorption signals and the drift of the signal are the repeated measurements of “zero absorbance” (without sample and platform in the furnace). It shows uncertainty of c.a. 0.0002 or relative uncertainty below 0.1%. It should be noted that the normalized absorbance is not a suitable measure for the optical stability because it is dependent also on the measured masses and their uncertainties.

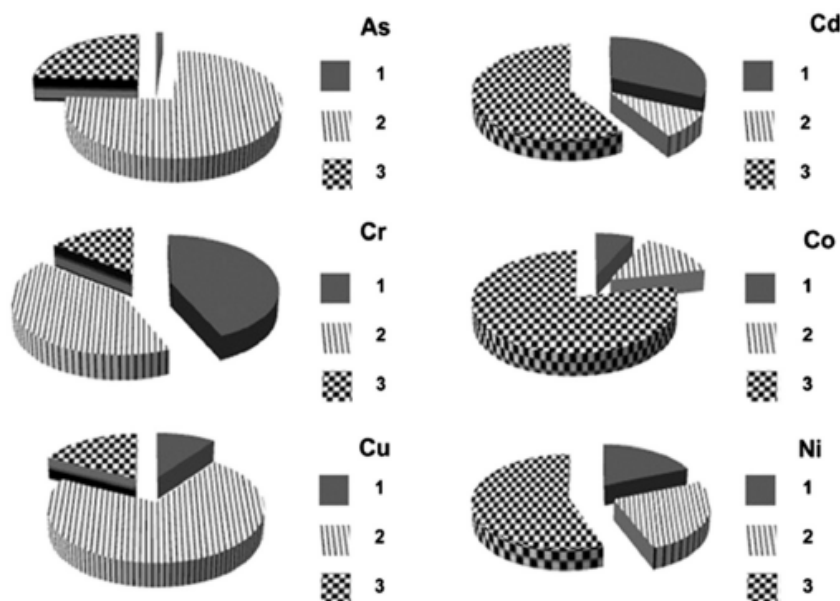

Fig. 5. Graphical representation of the contributions of all sources of uncertainty in the case of determination of As, Cd, Co, Cr, Cu and Ni mass fractions in marine sediment samples. 1 – uncertainty of the certified value of the analyte mass fraction in the CRM used for calibration; 2 – uncertainty of the slope of the regression line for calibration CRM; 3 – uncertainty of the slope of the regression line for the test material.

Table 5

Comparison between mass fractions obtained for As, Cd, Co, Cr, Cu and Ni with fast program/solid CRMs for calibration and conventional program/liquid calibration standards for different CRMs (mg kg^{-1}).

	Element	As	Cd	Co	Cr	Cu	Ni
	CRM	SRM 2976	MESS-2	MESS-2	IAEA 158	IAEA 433	IAEA 158
	Certified value	20.0 ± 0.8	0.24 ± 0.01	13.8 ± 1.4	74.4 ± 5.8	30.8 ± 2.6	30.3 ± 2.9
Fast program	Obtained value	19.8	0.22	12.8	69	32.6	26
	U % (k = 2)	18%	9%	20%	19%	13%	19%
Conventional program	Obtained value	19.7	0.31	11.8	77	27.9	26.5
	U % (k = 2)	40%	26%	62%	67%	32%	32%

- Uncertainty of the element mass fraction in the CRM, used for calibration

Generally, the uncertainty of the certified value $u(C_{ref})$ (see Eq. (3)) is an important source contributing directly to the combined uncertainty of the results and should be taken into consideration, always when the selection of CRM for calibration is performed. For the CRMs used in the present study the uncertainty of the certified values were reported as expanded uncertainty or as confidence intervals. In order to provide compatibility with the other contributors, the half width of the confidence interval was transformed in standard uncertainty assuming rectangular distribution [23] according to the following equation:

$$u(C_{ref}) = \Delta x a / 1.732 \quad (5)$$

where: $u(C_{ref})$ is the uncertainty to be associated to the certified analyte value, $\Delta x a$ is the half-width of the confidence interval of the certified value. It should be noted that, especially in the case of low element mass fraction in the calibration CRM, this uncertainty source might be quite substantial.

- Homogeneity of CRM used for calibration and sample

Solid sampling technique sets additional requirements to the CRMs used for calibration and samples. Such an important requirement is the micro-homogeneity of the material. Considering homogeneity data for most of the CRMs should be noted that homogeneity tests are usually carried out using 100 or more times higher sample mass and wet decomposition of the studied CRM. Homogeneity at sample masses between 0.020 and 0.500 mg (the typical range for SS CS HR AAS) could be significantly different from the reported in the certificate one determined in aliquots typically between 200 and 500 mg. CRM with particle size dimension below or equal to 260 μm are usually suitable for solid sampling calibration. The same requirement is relevant to the solid samples.

- Analyte mass fraction in the calibration CRM

Other important parameter is the analyte mass fraction in the CRM. If it is too high, with respect to sensitivity, mass fraction would require very small aliquots for measurement and in such a case the influence of the uncertainty of the microbalance might become a substantial contribution to the combined uncertainty of the result. Too small mass fraction is also not a suitable case. The increase of aliquot mass is limited since the solid sampling implies direct introduction of matrix in the furnace which should be kept as low as possible. Too low value of the slope of the regression line increases dramatically its relative uncertainty and it might become the major contributor to the combined uncertainty.

The calibration lines obtained using CRMs, selected as recommendable choice for the determination of As, Cd, Co, Cu, Cr and Ni in sediment samples are presented in Fig. 3. These CRMs were selected with respect to their homogeneity and analyte content for each element determined in this study, in order to provide reliable calibration with relatively low contribution to the uncertainty of the results.

The major contributors to the uncertainty in the cases of determination of all studied elements in marine sediment CRMs are presented in Fig. 5.

3.2.6.3. Single laboratory validation approach. The single-lab validation approach, contrary to the equation modeling approach, does not go deeply into the measurement procedure and does not attempt to quantify all uncertainty sources individually. Instead uncertainty sources are quantified in large "batches" via components that take a number of uncertainty sources into account. Most of the data that are used come from validation of the analytical procedure. This is the reason for the word "validation" in the name of the approach. This type of approach is called the "top-down" approach and also known as a Nordtest approach [30].

Applying single laboratory validation approach the estimation of the combined uncertainty (U_c) of the element mass fraction in the sediment sample can be done according to the following measurement equations:

$$u_c = \sqrt{u(R_w)^2 + u(bias)^2} \quad (6)$$

$$u(bias) = \sqrt{RMS_{bias}^2 + u(C_{ref})^2} \quad (7)$$

$$RMS_{bias} = \sqrt{\frac{\sum_{i=1}^n (bias)^2}{n}} \quad (8)$$

Eq. (7) includes the two main components of uncertainty budget: $u(R_w)$ which stands for the within laboratory reproducibility component of uncertainty and $u(bias)$ accounting the uncertainty component taking into account possible biases.

RMS_{bias} accounts for the uncertainty of the bias of the laboratory results from the reference value C_{ref} and $u(C_{ref})$ accounts for the uncertainty of the CRM reference values C_{ref} .

The laboratory reproducibility (intermediate precision) component R_w , takes into account all uncertainty sources that are random in a long term. The bias component takes into account the systematic effects that cause long-term bias. The long-term bias can be regarded as sum of procedure bias (bias inherent in the nature of the procedure) and laboratory bias (bias caused by the way of the implementation of given procedure in the laboratory).

The expanded uncertainty (the half width of the confidence interval) of the result can be obtained by multiplication of U_c by the corresponding coverage factor k (typically $k = 2$).

Combined uncertainty values calculated using both methods are consistent and in good agreement. They are presented in Table 4.

Table 6
Comparison of values and their expanded uncertainties ($k = 2$) for As, Cd, Co, Cr, Cu and Ni mass fractions ($\text{mg}\cdot\text{kg}^{-1}$) in sediment samples from Caribbean region obtained with HR CS AAS and ICP-MS.

Samples	Element	HR SS AAS	ICP-MS
Sample 1	As	13.34 \pm 2.2	14.6 \pm 1.2
Sample 2	Cd	0.54 \pm 0.05	0.53 \pm 0.04
Sample 3	Co	10.0 \pm 1.8	10.0 \pm 0.8
Sample 4	Cr	117 \pm 33	110 \pm 9
Sample 5	Cu	37.0 \pm 7.9	35.9 \pm 2.8
Sample 6	Ni	27 \pm 3	31.5 \pm 2.5

3.2.7. Traceability

Key steps in the demonstration of traceability of obtained with the proposed procedure measurement results in this study were as follows:

- I. The analytical method used was properly selected and validated, both in terms of matrix composition and analyte concentration.
- II. The use of CRM for calibration is the way to link analyte mass fraction to the common system of reference SI. The general concept for analyte quantification guarantees the SI traceability of the measurement results via direct comparison between analytical signal vs. sample mass for the studied sample and CRM used for calibration.
- III. The use of gravimetric operation in the dosing of all samples and calibration CRMs is a way to link the final measurement result to the kg.

4. Comparison with conventional AAS programs and calibration using liquid standards

Most commonly used approach in AAS is calibration with liquid standard solutions. Such quantification approach is accepted as a default calibration method in the software of Analytik – Jena instrument. The use of liquid standards and solutions of chemical modifiers implies significantly longer temperature programs including long drying and pyrolysis steps.

In order to compare both techniques CRMs were analyzed using conventional programs and liquid calibration standards and in parallel using fast programs and solid phase calibration with other CRM. Results are presented in Table 5.

Practically in all studied cases the bias and expanded uncertainties obtained with the conventional programs were considerably greater than those with fast programs and calibration using solid CRMs. The general conclusion of the comparison is that calibration with liquid standard solutions is less reliable than calibration using solid CRMs. Such effect was observed earlier for the case of determination of Hg in various CRMs [23]. Obviously, the assumption for complete “matrix independent analytical signal” cannot be confirmed. The proposed calibration approach provides simple and reliable evaluation of uncertainty of the results as well as estimation of the basic validation parameters.

The advantages of the fast programs used in this study can be summarized as follows:

- Better possibility to separate the analytical signal from the background absorbance (Fig. 2). This especially holds true for extremely very volatile analytes as As and Cd. Use of the fast temperature programs allows to volatilize the analyte before the matrix components which improves the method selectivity.
- Higher sensitivity due to the lower losses during the pre-treatment step
- Possibility for calibration using solid CRMs providing better “matrix matching”
- Shorter time analysis and minimum sample manipulation
- Possibility to work avoiding the use of chemical solvents.

5. Comparison with an independent analytical method

Comparison of obtained results with the results obtained with an independent method was applied as a part of our validation scheme. Sea sediment samples from a core collected in Colombia were measured by SS CS HR AAS and ICP-MS after microwave dissolution procedure. The obtained results were compared. For the measurements based on SS CS HR AAS the As content was quantified using IAEA 458 as CRM for calibration, for the determination of Cd MESS-2 was used for calibration while the CRM IAEA 405 was applied in the calibration for the determination of Co, Cu, Cr and Ni. In all cases, CRM particle sizes were below 0.125 mm diameter. The comparison between SS CS HR AAS and ICP-MS technique are represented in Table 6. As demonstrated, there is an excellent agreement within stated uncertainties between the above results, which is a substantial contribution to the validation of the described analytical procedures for SS CS HR AAS determination of As, Cd, Co, Cu and Ni sediment samples based on fast programs and calibration with solid CRM.

6. Conclusions

A modifier free method for the determination of As, Cd, Co, Cu, Cr and Ni mass fractions in marine sediment samples, based on fast programs is developed. The described method provides unbiased and precise results for the studied analytes in various sediments.

Fast programs were optimized for the analysis of sediment and biota samples. Calibration and analyte quantification procedure based on the use of solid CRMs is proposed. The method allows reasonable evaluation of uncertainty of the result according to GUM:1995 (JCGM 100:2008) [29] recommendations as well as estimation of the basic metrological characteristics of the measurement procedure.

The method proposed was validated according to the ISO 17025 and allows determination of described analytes without sample treatment in challenging environmental samples such as marine sediments, with precision and reproducibility, corresponding to the requirements for environmental monitoring.

The feasibility of using calibration against solid standards, fast programs, Ir modifier and the minimum sample manipulation makes this procedure appropriate for routine applications. The analysis of marine sediments by SS HR CS AAS has the clear advantage of providing fast results, as no sample preparation at all is involved, besides the homogenization of the samples, avoiding the use of other reagents, which might be considered a contribution to the green chemistry. It might be expected that this technique could be extended to the determination of other trace elements in marine samples: sediment and biota.

Supplementary data to this article can be found online at <http://dx.doi.org/10.1016/j.sab.2014.12.005>.

Acknowledgments

The agency is grateful for the support provided to its Environment Laboratories by the Government of the Principality of Monaco.

References

- [1] X. Jiang, A. Teng, W. Xu, X. Liu, Distribution and pollution assessment of heavy metals in surface sediments in the Yellow Sea, *Mar. Pollut. Bull.* 83 (2014) 366–375.
- [2] X. Gao, F. Zhou, C.-T.A. Chen, Pollution status of the Bohai Sea: an overview of the environmental quality assessment related trace metals, *Environ. Int.* 62 (2014) 12–30.
- [3] R. di Leonadro, G. Adelfio, A. Bellanca, M. Chiodi, S. Mazzola, Analysis and assessment of trace element contamination in offshore sediments of the Augusta Bay (SE Sicily): a multivariate statistical approach based on canonical correlation analysis and mixture density estimation approach, *J. Sea Res.* 85 (2014) 428–442.
- [4] N.S. Magesh, N. Chandrasekar, S. Krishna Kumar, M. Glory, Trace element contamination in the estuarine sediments along Tuticorin coast – Gulf of Mannar, southeast coast of India, *Mar. Pollut. Bull.* 73 (2010) 355–361.

- [5] B.M. Angel, S.L. Simpson, C.V. Jarolimek, R. Jung, J. Waworuntu, G. Batterham, Trace metals associated with deep-sea tailings placement at the Batu Hijau copper-gold mine, Sumbawa, Indonesia, *Mar. Pollut. Bull.* 73 (2013) 306–313.
- [6] K. Florian, J. Hassler, N. Plietsovskaya, W. Schron, Direct spectrochemical analysis of solids: a method for characterization of sediments, *Microchem. J.* 54 (1996) 375–383.
- [7] A. Landajo, G. Arana, A. de Diego, N. Etxebarria, O. Zuloaga, D. Amouroux, Analysis of heavy metal distribution in superficial estuarine sediments (estuary of Bilbao, Basque Country) by open-focused microwave-assisted extraction and ICP-OES, *Chemosphere* 56 (2004) 1033–1041.
- [8] V. Tomero, M. Ribera d'Alcalá, Contamination by hazardous substances in the Gulf of Naples and nearby coastal areas: a review of sources, environmental levels and potential impacts in the MSFD prospective, *Sci. Total Environ.* 466–467 (2014) 820–840.
- [9] X. Gao, C.-T.A. Chen, Heavy metal pollution status in surface sediments of the coastal Bohai Bay, *Water Res.* 46 (2012) 1901–1911.
- [10] M.A. Belarra, M. Resano, F. Vanhaecke, L. Moens, Direct solid sampling with electrothermal atomization/vaporization. What for and how? *Trends Anal. Chem.* 21 (2002) 828–839.
- [11] M. Aramendia, M. Resano, F. Vanhaecke, Electrothermal vaporization-inductively coupled plasma-mass spectrometry: a versatile tool for tracking challenging samples, *Anal. Chim. Acta* 648 (2009) 23–44.
- [12] B. Welz, M.G.R. Vale, D.L.G. Borges, U. Heitmann, Progress in direct solid sampling analysis using line source and high-resolution continuum source electrothermal atomic absorption spectrometry, *Anal. Bioanal. Chem.* 389 (2007) 2085–2095.
- [13] B. Welz, D. Borges, F. Lepri, M.G. Vale, U. Heitmann, High-resolution continuum source electrothermal atomic absorption spectrometry: an analytical and diagnostic tool for trace analysis, *Spectrochim. Acta B* 62 (2006) 873–883.
- [14] A.F. da Silva, F.G. Lepri, D.L.G. Borges, B. Welz, A.J. Curtius, U. Heitmann, Determination of mercury in biological samples using solid sampling high resolution continuum source electrothermal atomization atomic absorption spectrometry with calibration against aqueous standards, *J. Anal. At. Spectrom.* 21 (2006) 1321–1326.
- [15] A. Detcheva, K.-H. Grobbeck, Determination of Hg, Cd, Mn, Pb and Sn in seafood by solid sampling Zeeman atomic absorption spectrometry, *Spectrochim. Acta B* 61 (2006) 454–459.
- [16] A. Detcheva, K.-H. Grobbeck, Determination of trace elements in aquatic plants by solid sampling Zeeman atomic absorption spectrometry (SS-ZAAS), *Environ. Chem. Lett.* 6 (2008) 183–187.
- [17] M.A. Belarra, C. Crespo, M.P. Martinez-Garbayo, M. Resano, Direct determination of cobalt and zinc in samples of different volatility by means of solid sampling-graphite furnace atomic absorption spectrometry, *Spectrochim. Acta B* 58 (2003) 1847–1858.
- [18] M. Hoenig, A. Glissen, Electrothermal atomic absorption spectrometry: fast or conventional programs? *Spectrochim. Acta B* 48 (1993) 1003–1012.
- [19] E. Vassileva, H. Baeten, M. Hoenig, Advantages of the iridium permanent modifier in fast programs applied to trace element analysis of plant samples by electrothermal atomic absorption spectrometry, *Fresenius' Z. Anal. Chem.* 369 (2001) 491–495.
- [20] K. Danzer, K. Florian, J. Haßler, M. Matherny, W. Schron, Gy. Zaray, Comparison of solid sampling spectrochemical methods by means of multivariate statistics and information theory, *J. Anal. At. Spectrom.* 13 (1998) 371–375.
- [21] E. Vassileva, C.R. Quérel, I. Petrov, Certification of Cu and Cd amount contents in artificial food digest, *Spectrochim. Acta B* 58 (2003) 1553.
- [22] K. Danzer, I. Currie, Guidelines for calibration in analytical chemistry. Part 1. Fundamentals and single component calibration (IUPAC recommendations 1998), *Pure Appl. Chem.* 70 (1998) 993–1014.
- [23] P. Mandjukov, A.M. Orani, E. Han, E. Vassileva, Determination of total mercury for marine environmental monitoring studies by solid sampling continuous source high resolution atomic absorption spectroscopy, *Spectrochim. Acta B* 103–104 (2015) 24–33.
- [24] P. Mandjukov, E. Vassileva, V. Simeonov, Regular solution theory in model interpretation of the analyte losses during preatomization sample treatment in the presence of chemical modifiers in electrothermal atomization atomic absorption spectrometry, *Anal. Chem.* 64 (1992) 2596–2603.
- [25] ISO/IEC 17025, General Requirements for the Competence of Testing and Calibration Laboratories, International Organization for Standardization, Geneva, 2005.
- [26] EURACHEM Guide, The Fitness for Purpose of Analytical Methods, 2014.
- [27] L. Bianchin, D. Nadvorny, A. Furtado da Silva, M.G. Rodrigues Vale, M. Messias da Silva, W.N.L. dos Santos, S.L.C. Ferreira, B. Welz, U. Heitmann, Feasibility of employing permanent chemical modifiers for the determination of cadmium in coal using slurry sampling electrothermal atomic absorption spectrometry, *Microchem. J.* 82 (2006) 174–182.
- [28] B. Ambrozini, V.R.A. Filho, S.R. Oliveira, L.V.S. Sacramento, J.A. Gomes Neto, Evaluation of modifiers for determination of V in parsley by GF AAS, *Food Chem.* 116 (2009) 1024–1028.
- [29] JCGM 100: 2008, Evaluation of measurement data – guide to the expression of uncertainty in measurement, (GUM, 1995 with minor corrections) 103–104 (2015) 24–33 Available at <http://www.bipm.org/eng/publications/guides>.
- [30] B. Magnusson, T. Näykki, H. Hovind, M. Krysell, NORDTEST report TR 537, Handbook for Calculation of Measurement Uncertainty in Environmental Laboratories (NT TR 537 – Edition 3.1), Oslo 2012.

Paper 3

INTERNATIONAL JOURNAL OF ENVIRONMENTAL ANALYTICAL CHEMISTRY, 2017
<https://doi.org/10.1080/03067319.2017.1351961>



ORIGINAL PAPER

Determination of selected trace elements in marine biota samples with the application of fast temperature programs and solid sampling continuous source high resolution atomic absorption spectroscopy: method validation

Anna Maria Orani^{a,b}, Petko Mandjukov^c and Emilia Vassileva^a

^aDepartment of Nuclear Sciences and Applications, Environment Laboratories, International Atomic Energy Agency, Principality of Monaco, Monaco; ^bCNRS, IRD, Observatoire de la Côte d'Azur, Géoazur UMR 7329, Université de Nice Sophia Antipolis, Valbonne, France; ^cDepartment of Chemistry, South West University "Neofit Rilski", ul. "Ivan Mihaylov" 66, Blagoevgrad, Bulgaria

ABSTRACT

Analytical procedure for the determination of As, Cd, Cu, Ni, Co and Cr in marine biota samples using solid sampling high-resolution continuum source atomic absorption spectrometry (HR CS AAS) and accelerated fast temperature programmes has been developed. Calibration technique based on the use of solid certified reference materials similar to the nature of the analysed sample and statistics of regression analysis were applied. A validation approach in line with the requirements of ISO 17025 standard and Eurachem guidelines was followed. Accordingly, blanks, selectivity, calibration, linearity, working range, trueness, repeatability and reproducibility, limits of detection and quantification and expanded uncertainty for all investigated elements were assessed. The major contributors to the combined uncertainty of the analyte mass fractions were found to be the homogeneity of the samples and the microbalance precision. Traceability to the SI system of units of the obtained with the proposed analytical procedure results was also demonstrated. The potential of the proposed analytical procedure based on solid sampling HR CS AAS technique was demonstrated by direct analysis of marine reference biota samples. Overall, the use of solid sampling HR CS AAS permits obtaining significant advantages for the determination of selected trace elements in marine biota samples, such as straightforward calibration, a high sample throughput, sufficient precision, a suitable limit of detection and reduced risk of analyte loss and contamination.

ARTICLE HISTORY

Received 1 February 2017

Accepted 30 June 2017

KEYWORDS

Solid sampling; high resolution continuum source atomic absorption spectroscopy; fast programmes; trace elements; solid sampling; marine biota; calibration

1. Introduction

Trace elements' pollution in the oceans increased considerably in the recent decades and has become an important concern for the environment protection. The trace elements have a great impact on the natural resources and the quality of the environment justifies the increased interest in their monitoring. Human activities release trace

CONTACT Emilia Vassileva e.vassileva-veleva@iaea.org

© 2017 Informa UK Limited, trading as Taylor & Francis Group

elements into the environment in chemical forms that may increase their bioavailability. Arsenic, cadmium, cobalt, copper chromium and nickel are among the trace elements carrying the highest risk to human health. The monitoring and control of these elements in the environment and in food requires processing of large number of samples to accurately characterise their content and to take reliable decisions. Assessment of monitoring data helps to identify trends in environment quality and the effectiveness of management measures.

The use of biota samples for monitoring of trace elements in the marine environment has been widely investigated [1–3]. It confers several advantages as marine organisms can accumulate trace elements in their tissues thus providing time-integrated estimation of the bioavailable fraction of metals in the environment [4]. In addition to its use as an environmental monitoring tool, the determination of trace elements in marine biota samples could be of high importance since fish and seafood may represent risks for human health: aquatic organisms are often contaminated by toxic elements from the surrounding environment and the extent of this contamination is magnified through the food chain. The accumulation level of trace elements in fish organs and tissues depends on the fish species, age, patterns, physical-biochemical characteristics and the chemical status of the environment where the fish have been living [5].

Accurate determination of trace elements at low levels in marine biota samples is important and it is being driven by new regulations at national, regional and international levels, with the objective to ensure a higher level of human health and environmental protection [6]. New techniques and analytical capabilities are being developed and validated to perform accurate measurements of trace elements in marine biota samples in order to assess compliance with legislative limits. Direct analytical techniques are obviously preferable over those requiring complicated sample preparation, particularly in the case of complex samples such as biota matrices.

Electrothermal atomic absorption spectrometry (ETAAS) has long been used for trace element analyses and over the past few years, the main constraints of atomic absorption spectrometry (AAS) methods, namely matrix interferences leading to the high background absorption and interferences, have been reduced. The progress in control of atomisation temperatures, new designs of atomisers and advances in methods for background spectral interferences' correction have permitted an improvement in sensitivity, and the detection power, reduction in sample manipulation and increase in the reliability of obtained measurement results.

ETAAS greatly facilitates alternative sample introduction techniques, such as direct solid sample (SS) analysis. The use of solid sampling can be a very suitable analytical method for trace elements due to the possibility for direct analysis of biological samples with a minimal sample preparation [7], showing good sensitivity even for very low analytes concentrations, which is often the case in marine biota samples. This potential has been further enhanced by the introduction of equipment with a continuum source, high-resolution monochromator, and CCD (Charge Coupled Device) array detector, the most revolutionary development in the field of AAS at the moment [8]. The conventional method to analyse biota samples by AAS includes a microwave digestion using a mixture of concentrated acids, usually nitric and hydrochloric [9,10]. This procedure is not only time- and reagent-consuming, but also includes the risk of losses of volatile

trace elements during the high-temperature digestion and/or contamination during the sample digestion.

Moreover, the recent introduction of high resolution continuum source ETAAS (HR CS ETAAS) has facilitated direct solid sampling, reducing background noise and opening the possibility of achieving even more rapid quantitation of some elements. The introduction of the HR CS ETAAS, equipped with automate devices, also allows overcoming one of the main arguments against the use of solid sampling approach, which is the difficulty to introduce a solid sample into the graphite tube [11]. A crucial point to be faced when working with solid sampling AAS is related to the correct calibration and reliable validation. Most of solid sampling quantifications in AAS are usually performed using an aqueous standard calibration [12–15] and this is also the quantification method suggested as default method in the software of Analytik Yena instrument, used in the present work. However, in the case of solid sampling analysis, the difference in physical state between the sample and calibration solution can represent an obstade, because of the consequent difference in chemical behaviour and forms of the analyte. Besides, the difference in physical form of standards and samples leads to serious difficulties in the evaluation of important metrological parameters. It should be noted that, in the case of calibration with liquid standards, containing usually simple inorganic salts in strongly diluted nitric acid, it is practically impossible to measure directly the correct procedural blank and to evaluate its standard deviation [16].

The pretreatment step in conventional ETAAS temperature programmes is, generally, conducted at highest possible temperature in order to eliminate as large as possible part of the sample matrix. It has been proven to be a good approach for the analysis of several elements in a large variety of matrices [17]. Contrary, the concept of fast temperature programmes, developed later, is based on assumption that the effective enough background correction might allow to skip the matrix elimination step and to reduce in this way the duration of the temperature programme. Introducing the direct solid sampling allows further acceleration of the ETAAS temperature programmes by eliminating or decreasing to possible minimum time the drying step as well.

Fast temperature programmes and solid sampling were used for the HR CS AAS determination of trace elements in marine sediments in the frame of several monitoring studies [18,19]. One of the aims of the present work is to extend the application of this new concept to marine biota samples.

Method validation is an essential component of the measurement procedure that should be implemented to attain accurate, reliable and comparable over time and space results. Some of the guidelines that exist for the validation of the measurement procedure are the ISO 17025 standard on 'General requirements for the competence of testing and calibration laboratories' [20], the Eurachem Guide 'Fitness for purpose of analytical methods' [21], the International Union for Pure and Applied Chemistry guide on 'Single method validation' [22] and the European Commission Decision on 'Method validation for contaminants' [23]. The validation and dissemination of reliable and sensitive methods, based on the basic metrological principles, fosters the application of common methodologies and the generation of comparable monitoring data by laboratories.

Nowadays, the validation of the fit intended use of analytical procedure, including assessment of measurement uncertainty, is increasingly being recognised as an unavoidable practice, as it allows comparisons between/within laboratories and is a requirement

of the ISO 17025 standard [20]. Moreover, only results obtained with a validated measurement procedure and having stated uncertainty can be traceable to the common system of reference. Method validation, metrological traceability and measurement uncertainty are the three milestones to assess the quality of measurement results and the key concepts in the measurement science – metrology in chemistry. Thereupon, the formulation of an uncertainty budget is a substantial tool to identify which components of the analytical process provide the major contributions to the overall measurement uncertainty, allowing the analyst to focus on such components in order to improve the quality of the analytical result. Nonetheless, studies on measurement uncertainty associated to the determination of trace elements in marine biota samples have seldom been reported [24,25]. Particularly, to the best of our knowledge, no studies performing the validation, according to the accepted international guidelines, on a method for the determination of trace elements in biota samples based on HR CS AAS and solid sampling have been published until now.

Within this context, subject of the present study is the development and validation of a ‘fit-for-purpose’ analytical procedure for the determination of As, Cd, Co, Cr, Cu and Ni in marine biota samples based on solid sampling HR CS AAS, fast temperature programmes and calibration with solid phase certified reference materials (CRMs). Hence, selectivity, linearity and working range of the calibration curve, recovery, repeatability and reproducibility, limit of detection and quantification as well as trueness were systematically assessed, using matrix-matching CRMs. Additionally, estimations of the individual uncertainty contributions of each parameter to the final expanded uncertainty have been carried out. Demonstration of traceability of measurement results is also presented.

2. Experimental

2.1. Reagents, solutions and samples

Deionised water from Milli-Q system (Millipore, Bedford, MA, USA) was used throughout this work. CertiPur Reference Material containing 1000 mg L⁻¹ of As, Cd, Co, Cr, Cu and Ni (Merck, Dortmund, Germany) was used to prepare all standard solutions for liquid calibration. ICP Standard Iridium Solution containing 1000 mg L⁻¹ Iridium (Merck, Dortmund, Germany) was used for the treatment of graphite platforms. Mixed chemical modifier, used for conventional programmes, containing 500 mg L⁻¹ Pd, 300 mg L⁻¹ Mg and 1% (v/v) Triton X-100 (Merck, Dortmund, Germany) was prepared by diluting and mixing 1000 mg L⁻¹ solution of Palladium Nitrate (Matrix modifier for ETAAS, Analytika Ltd., Prague, Czech Republic) and 1000 mg L⁻¹ solution of Magnesium Nitrate (Matrix modifier for ETAAS, Analytika Ltd, Prague, Czech Republic).

For optimisation, calibration and validation purposes following CRMs were used: IAEA 407 (trace elements and methylmercury in North Sea fish homogenate) from International Atomic Energy Agency, Monaco; DORM-2 (trace elements in dogfish muscle), DOLT-2 (trace elements and methylmercury in dogfish liver) and TORT-2 (trace elements and methylmercury in lobster hepatopancreas) from National Research Council, Canada; SRM 2976 (trace elements and methylmercury in mussels tissue) from National Institute of Standards and Technology, Maryland, USA; BCR 278 (trace elements

in *mytilus edulis* mussels) from Institute for Reference Materials and Measurements, Belgium.

Two biota samples, IAEA 461 and IAEA 470 CRMs (clams and oysters, respectively) with varying content of trace elements, were also used in this study. The dry material was first ground by using a universal cutting mill Pulverisette 19 (Fritsch, Idar-Oberstein, Germany) made of tungsten-carbide, chromium-free steel, then sieved at 250 μm using a vibratory sieve shaker (Fritsch, Idar-Oberstein, Germany). Portions of about 5 kg were micronised to achieve a final powder size <100 μm . Particle size distribution was checked from the beginning to the end of the processing by using a particle analyser (Mastersizer, Malvern Instruments, Germany) on randomly selected subsamples. The resulting materials showed 100% particle size below 60 μm .

Extensive homogeneity tests were carried out on all samples used in this study in order to ensure its suitability as a representative biota sample and to estimate the uncertainty associated with homogeneity of the samples.

2.2. Instrumentation

All the experiments in the present work were carried out using a high-resolution continuum source AAS (HR CS AAS), ContrAA 700, commercially available from Analytik Jena AG (Jena, Germany), equipped with transversely heated graphite tube atomiser, operating with pyrolytically coated solid sampling graphite tubes and platforms. The optical system comprises a Xenon short-arc lamp (GLE, Berlin, Germany) operating in 'hot-spot' mode as the radiation source, a high-resolution double monochromator (DEMON) and a linear charge coupled array detector (CCD) with 588 pixels, 200 of which are used for monitoring the analytical signal and performing background corrections. Introducing the solid samples was performed by an automated solid sampling accessory SSA 600 (Analytik Jena) with incorporated M2P micro-balance (Sartorius, Gottingen, Germany) with a declared precision of 0.001 mg. The samples were introduced using solid sampling platforms. Argon with a purity of 99.996% (Alpha Gaz, France) was applied as purge and protective gas.

The resonance lines at 193.6960 nm, 228.8018 nm, 240.7254 nm, 357.8687 nm, 327.3960 nm and 232.0030 nm were used for the determination of As, Cd, Co, Cr, Cu and Ni, respectively. In all cases, integrated absorbance (A_{int}) was selected as measurement mode and the integration was carried out in a 'peak volume' mode. Each value A_{int} was normalised with the corresponding sample mass dispensed into the furnace, which was called normalised integrated absorbance.

2.3. Procedure for analysis by solid sampling using HR CS ETAAS and experimental set-up for the method validation

Fast temperature programmes were developed and optimised in several iterative steps. All experiments were carried out in graphite platforms preliminarily treated with permanent modifier Ir. External calibration was performed using solid marine sediment CRMs containing similar matrix and appropriate analyte concentrations. The use of solid CRMs as calibration standards was reported elsewhere [26,27]. The approach used in the present study is based on the concept that the ratio between slopes of two regression

lines (absorbance vs. sample mass) for samples of the same type is equal to the ratio of the analyte mass fractions in both samples.

This concept was developed previously and already tested and applied for determination of trace elements in sediment samples in the frame of several monitoring studies [18,19].

Initially the regression line based on 10–12 different masses of CRM used for calibration and validation purposes was calculated. The procedure was repeated for each of the samples with reduced number of points – 6–8 (not less than 4) different masses. Then, a regression function [28] calculated for solid CRM with certified analyte content makes possible quantification of the analyte mass fraction in a solid sample of the same type [18]. The analyte mass fraction was calculated according to the following equation:

$$x_a^{(S)} = x_a^{(CRM)} \frac{a_1^{(S)}}{a_1^{(CRM)}} \quad (1)$$

where $x_a^{(S)}$ and $x_a^{(CRM)}$ are the analyte mass fractions in the sample and CRM used for calibration, respectively; $a_1^{(S)}$ and $a_1^{(CRM)}$ are the respective slopes of the regression lines.

The calibration was performed every day for all investigated elements, at the beginning of the sequence, followed by the samples analysis. Second biota CRM of similar matrix type was analysed for every 10 measurements as a quality control sample.

Combined standard uncertainties were obtained by propagating together individual uncertainty components according to the ISO/GUM guide [20,29]. All uncertainties indicated in the final results are expanded uncertainties $U = k \cdot u_c$, where u_c is the combined standard uncertainty and k is a coverage factor equal to 2.

3. Results and discussion

3.1. Temperature programmes

All experiments were carried out in graphite platforms preliminary treated with Ir. The Ir treatment of each platform included 8 cycles. During each cycle, 30 μl of 1000 mg L^{-1} Ir solution was introduced and the furnace dried at 130°C. Pyrolysis step was carried out at 400°C followed by heating at 1000°C for 10 s and at 2000°C for 5 s. The ramp temperature was 100°C s^{-1} for each pyrolysis step.

Thermal stabilisation by permanent modifiers is a well-known concept since 1980s and was developed and widely applied in analysis of liquid samples and calibration standards, providing far better contact with the treated surface than solid state samples. Thus, the reported analyte thermal stabilisation by Ir coating cannot be automatically attributed to the case of solid sampling. In the developed fast temperature programmes for solid sampling, the drying and pyrolysis steps were reduced to several seconds and the temperature was selected to be low enough to prevent analyte losses even without any modifier. Considering also the delay in heating of solid sampling platforms, the thermal stabilisation of the analytes was certainly not an aim of Ir coating. This treatment provides smooth and hard surface of the platforms, supporting the mechanical

cleaning after each sample heating cycle and improving the life time up to over 1000 firing cycles.

Two types of temperature programmes, fast and conventional, have been developed for the determination of As, Cd, Co, Cr, Cu and Ni in marine biota samples. They are presented in Tables 1–4. All steps in both types of programmes have been optimised in order to obtain interference-free analytical signals and background signal below $A = 0.8$. Object of optimisation in the temperature programmes for SAs were the atomisation temperature, ramp and hold time. The entire concept for fast programmes without drying and pyrolysis makes these steps rather insignificant for the analytical signal quality.

Cleaning of the platforms before the subsequent use included: cleaning step at the end of every temperature programme; mechanical scratching of the sample residue with dedication for this operation tool; additional thermal platform cleaning, using a default programme (500°C/s ramp up to 2450°C, 5 s hold).

Table 1. HR CS AAS fast temperature programmes for As, Cd and Co determination in biota samples.

Step	Name	As (193.6960 nm)				Cd (228.8018 nm)				Co (240.7254 nm)			
		Temp (°C)	Ramp (°C s ⁻¹)	Hold (s)	Ar flow	Temp (°C)	Ramp (°C s ⁻¹)	Hold (s)	Ar flow	Temp (°C)	Ramp (°C s ⁻¹)	Hold (s)	Ar flow
1	Drying	400	100	1	Max	750	300	1	Max	500	100	2	Max
2	Pyrolysis	400	0	5	Max	750	0	1	Max	850	300	5	Max
3	Gas adaption	400	0	5	Stop	750	0	5	Stop	850	0	5	Stop
4	Atomisation	2500	2000	2	Stop	2000	1200	3	Stop	2600	2000	7	Stop
5	Cleaning	2600	0	4	Max	2450	500	4	Max	2600	0	4	Max
Duration (s)		21.8				18.3				29.8			

Table 2. HR CS AAS fast temperature programmes for Cr, Cu and Ni determination in biota samples.

Step	Name	Cr (357.8687 nm)				Cu (327.396 nm)				Ni (232.003 nm)			
		Temp (°C)	Ramp (°C s ⁻¹)	Hold (s)	Ar flow	Temp (°C)	Ramp (°C s ⁻¹)	Hold (s)	Ar flow	Temp (°C)	Ramp (°C s ⁻¹)	Hold (s)	Ar flow
1	Drying	1000	500	2	Max	1000	500	2	Max	1150	200	6	Max
2	Pyrolysis	1000	0	2	Max	1000	0	2	Max	1150	0	5	Max
3	Gas adaption	1000	0	5	Stop	1000	0	5	Stop	1150	0	5	Stop
4	Atomisation	2500	2000	10	Min	2400	1500	5	Stop	2600	500	4	Stop
5	Cleaning	2600	500	4	Max	2600	2000	4	Max	2600	0	4	Max
Duration (s)		25.7				19.0				30.0			

Table 3. HR CS AAS conventional temperature programmes using liquid standard calibration for As, Cd and Co determination in biota samples.

Step	Name	As (193.6960 nm)				Cd (228.8018 nm)				Co (240.7254 nm)			
		Temp (°C)	Ramp (°C s ⁻¹)	Hold (s)	Ar flow	Temp (°C)	Ramp (°C s ⁻¹)	Hold (s)	Ar flow	Temp (°C)	Ramp (°C s ⁻¹)	Hold (s)	Ar flow
1	Drying	90	10	10	Max	90	10	10	Max	90	10	10	Max
2	Drying	130	5	10	Max	130	5	10	Max	130	5	10	Max
3	Pyrolysis	200	50	5	Max	500	200	10	Max	500	200	10	Max
4	Pyrolysis	400	50	10	Max	1000	200	10	Max	1000	200	10	Max
5	Gas adaption	400	0	5	Stop	1000	0	5	Stop	1000	0	5	Stop
6	Atomisation	2500	600	3	Stop	2000	3000	5	Stop	2400	3000	6	Stop
7	Cleaning	2600	500	4	Max	2450	500	4	Max	2450	500	4	Max
Duration (s)		70.1				72.6				74			

Table 4. HR CS AAS conventional temperature programmes using liquid standard calibration for Cr, Cu and Ni determination in biota samples.

Step	Name	Cr (357.8687 nm)				Cu (327.396 nm)				Ni (232.003 nm)			
		Temp (°C)	Ramp (°C s ⁻¹)	Hold (s)	Ar flow	Temp (°C)	Ramp (°C s ⁻¹)	Hold (s)	Ar flow	Temp (°C)	Ramp (°C s ⁻¹)	Hold (s)	Ar flow
1	Drying	90	10	10	Max	90	10	10	Max	90	10	10	Max
2	Drying	130	5	10	Max	130	5	10	Max	130	5	10	Max
3	Pyrolysis	350	50	5	Max	500	200	10	Max	600	200	10	Max
4	Pyrolysis	700	100	10	Max	1000	200	10	Max	1100	200	10	Max
5	Gas adaption	700	0	5	Stop	1000	0	5	Stop	1100	0	5	Stop
6	Atomisation	2450	3000	8	Stop	2400	3000	6	Stop	2600	1000	5	Stop
7	Cleaning	2450	0	4	Max	2450	500	4	Max	2600	0	4	Max
Duration (s)		74.5				73.5				74.4			

The Analytik Jena software offers two distinctly different background correction systems: the first one uses correction pixels on both sides of the analytical line which corrects for 'continuous' background absorption, i.e. background that does not change significantly within the spectral range monitored by the detector. The second system is the least squares background correction (LSBC), which can correct any structured background caused by diatomic molecules. In this mode, correction spectra is measured and stored and finally subtracted from the sample spectrum. The automatic correction using correction pixels chosen by the software was used for all investigated elements in the present study.

In addition to the corrections pixels on both side of the analytical line, in the case of As, preliminary recorded reference spectrum of PO molecule was subtracted from the sample spectrum using a LSBC algorithm provided by the *contrAA* software.

The PO spectrum was registered with a solution of (NH₄)₂HPO₄ and applying the temperature programme developed for As determination, then stored and saved in the database as correction spectrum. After this step, the biota sample was analysed and reprocessed, by subtracting the registered PO spectrum. The software of the instrument allowed the automatic integration of the above described procedure directly into the measurement method. After comparison of results obtained with and without PO spectrum subtraction, it was found out that the PO interference do not influence significantly obtained for As amount content results as well as their uncertainties.

Conventional programmes, involving the use of liquid chemical modifier (5 µg Pd + 3 µg Mg) and liquid standard calibration, were applied for comparison purposes.

Since the fast programmes developed in this work do not involve the use of liquid modifier, the drying and pretreatment steps have been reduced, leading to a considerably shorter total analysis time.

One specific problem related to As determination in biota samples was the high background signal. The high background signal at 193.6960 nm can be explained with the higher volatility of biota matrix, causing a release of large amount of interfering pyrolysis products in the gas phase during the atomisation and making difficult the quantification of the atomic absorbance.

The solution of this problem was found in the limited increase of the pyrolysis temperature and hold time combined with an increase of the atomisation ramp. On [Figure 1](#) are shown 3D high resolution presentations of the background decrease and

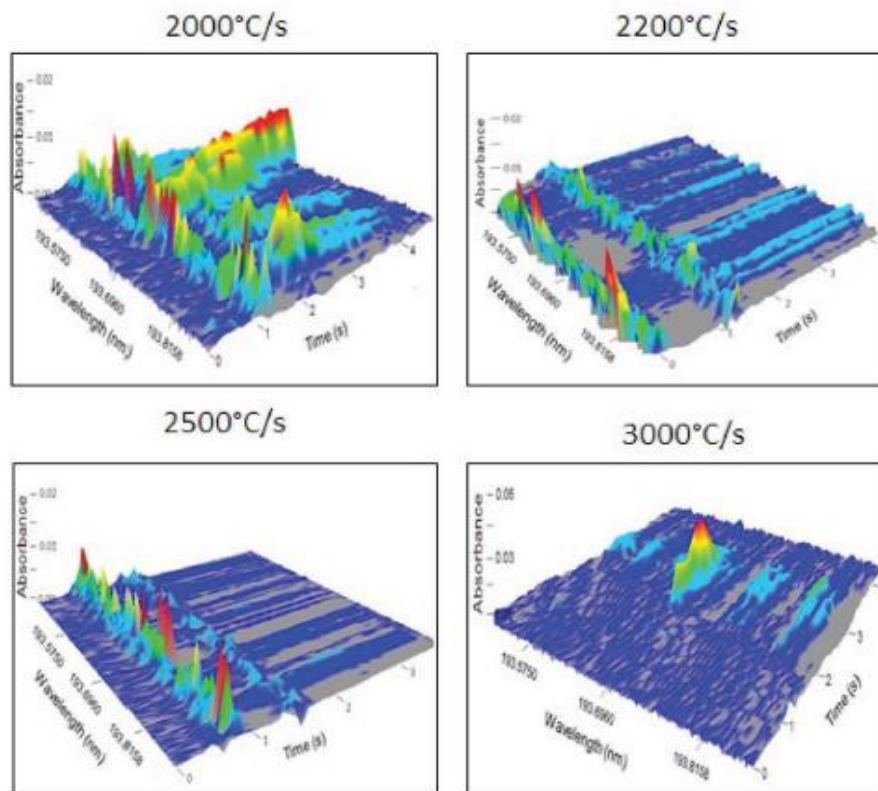

Figure 1. 3D high resolution presentations of background decrease and general improvement of analytical signal, as a function of atomisation ramp for As in biota SRM 2976.

the improvement of the analytical signal, as a function of the atomisation ramp for As in SRM 2976 biota sample. The obvious advantage of the fast programmes compared with the conventional one is the considerably shorter pretreatment time. In the case of direct solid sampling, without liquid chemical modifiers, the drying and pyrolysis steps were reduced to the lowest allowed by the software values (1 s hold time). Due to kinetic reason the losses from the atomiser were reduced significantly, and the achieved sensitivity and stability of the analytical signals increased.

The optimised fast temperature programmes were completely applicable to untreated platforms as well. They were less harmful for the atomisers and sampling platforms used and allowed significant increase of their life time. On the other hand, measurement step became faster and less energy consuming.

Moderate changes of the pyrolysis and atomisation temperatures were not changing critically the analytical signal and the linearity of the calibration graph. Variations of the atomisation ramps in wide range were also tolerable. This indicated significant robustness of the developed fast programmes for As, Cd, Co, Cr, Cu and Ni in marine biota samples.

On Figure 2 are presented the 3-D high resolution plots of the corrected analytical signals for As, Cd, Co, Cr, Cu and Ni in biota CRM and the spectral area close to the respective spectral lines.

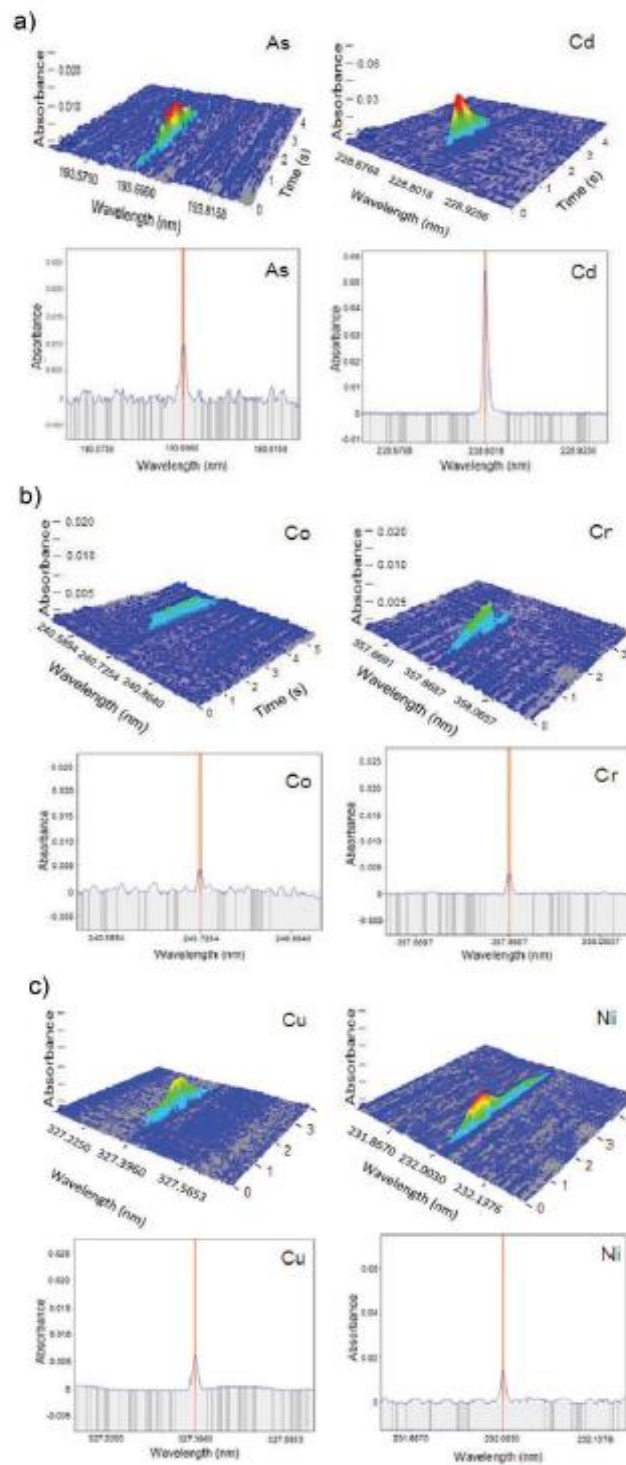

Figure 2. Analytical signals obtained for (a) As (SRM 2976) and Cd (Nies No 6); (b) Co (DOLT-2) and Cu (Nies No 6); (c) Cr (IAEA 407) and Ni (IAEA 407). First line shows 3D high-resolution presentation of the corrected analytical signals; second line shows high-resolution spectra of the region around the analyte resonance line.

3.2. Method validation

A full validation of the analytical procedure has been performed, following ISO 17025 standard and Eurachem guidelines [20,21]. Accordingly, selectivity, linearity and working range, limit of detection, characteristic mass, repeatability and reproducibility, as well as recovery and trueness (using a CRM) were systematically assessed. In addition, estimations of the individual uncertainty contributions of each parameter as well as the final expanded uncertainty have been performed. Demonstration of traceability of measurement results is also provided. The proposed calibration method allowed comparatively simple and reasonable evaluation of the basic validation parameters. In most of the publications dealing with direct solid sampling, these parameters are not evaluated, or are directly transferred from data obtained from analysis of liquid standard solutions. The proposed validation scheme was applied in our previous studies related with the application of fast temperature programmes and solid sampling HR CS ETAAS for monitoring trace elements in marine sediments [19].

3.2.1. Linearity and working range

The standard concept of linearity and working range is implemented to the avant-garde instrumentation available nowadays. The HR CS AAS technique provides a 3D signal, adding an extra dimension (wavelength) to traditional line source that includes time and absorbance. As a consequence, there is some additional flexibility to adjust the sensitivity and to expand the linear range. It is possible to expand the linearity by selecting the appropriate number of detector pixels integrated which basically provides better control of the sensitivity. This simple strategy is also helpful for the increasing of working range. Optimal sensitivity and good limits of detection were obtained using the three central pixels. Generally, the linearity can be expanded significantly by using additional side pixels. The linearity of the calibration lines obtained in the present study was confirmed using Student's *t*-test [30] proving that the squared value of the correlation coefficient is not significantly different from 1. The linearity test was performed using 12 different masses of the calibration CRM. The lower limit of the concentration range was typically determined by limits of detection (LOD)/limits of quantification (LOQ) values. Another important factor was the precision of the microbalance. For masses below 0.020 mg, the uncertainty of the weighted masses contributing significantly ($\approx 10\%$) to the total combined uncertainty should be noted that increasing the sample mass above a certain limit (usually 0.4–0.6 mg) results in higher levels of interferences due to the higher matrix amount in the atomiser [20]. The typical working ranges for the determination of all analytes, expressed as mass of the sample/calibration CRMs was between 0.05 and 0.5 mg. The linear regression equations and determination coefficients (R^2) for the calibration curves obtained with fast programmes/solid CRMs and used for the determination of As, Cd, Co, Cr, Cu and Ni in biota samples are presented in Table 5.

3.2.2. Trueness and bias

The trueness of the obtained results was evaluated by analysing several marine biota CRMs. The obtained analyte mass fractions results were compared with the certified values. As can be seen from the data shown in the Table 6, in all cases there was a good agreement between determined and certified mass fractions values within the stated

Table 5. Linear regression equations for the calibration curves obtained with fast programmes/solid CRMs and used for determination of As, Cd, Co, Cr, Cu and Ni mass fractions (mg kg^{-1}) in biota samples.

Element	CRM	Sample mass range (mg)	Linear regression equation	Coefficient of correlation, R^2
As	DORM-2	49–71	$Y = 2.7907x$	0.8615
Cd	SRM2976	45–100	$Y = 0.2762x$	0.9311
Co	TORT-2	45–550	$Y = 7.1611x$	0.9359
Cr	BCR 278	51–301	$Y = 2.2647x$	0.9952
Cu	BCR 278	50–126	$Y = 0.2243x$	0.9514
Ni	SRM 2976	51–191	$Y = 0.6608x$	0.9297

uncertainty. It is important to note that in all cases the uncertainties obtained by the application of conventional programmes using liquid calibration were systematically higher than those obtained with fast programmes and solid standards.

3.2.3. Repeatability and reproducibility

In the case of solid sampling analysis, the evaluation of some metrological parameters is particularly challenging. The major limitation factor in the evaluation of repeatability and reproducibility is the inability for multiple dosing of the solid sample with small deviations (within 0.001 mg). Two different methods for repeatability evaluation were compared in the present study: evaluation based on a series of replicates and an alternative evaluation based on statistical analysis of single calibration line.

3.2.3.1. Evaluation of repeatability by series of replicates. The subsamples from the same marine biota CRM have been measured three times in the same day. Each measurement included six different masses of the sample and the repeatability was evaluated as standard deviation of these three measurement sessions. The critical points for repeatability determination are the sample homogeneity and the influence of the sample matrix. Thus, six masses were selected as a proper and reliable number for evaluation of repeatability. The major drawback of the described procedure is the variation (within 1%), which can be observed for various biota sample matrices and the time- and energy-consuming experiments.

3.2.3.2. Repeatability evaluated by statistical analysis of single calibration line.

The second method for repeatability evaluation involves the evaluation of regression line of the calibration curve and it has been described in detail elsewhere [19]. The results for repeatability for each element studied obtained by the described two different methods have been compared by Fisher's F -test and in all cases the differences in variations (squared standard deviations) were found to be statistically insignificant. Obtained results from repeatability studies with both methods are presented in Table 6.

From practical point of view, the second method is preferable since it does not require additional measurements and specially designed experiment.

3.2.3.3. Reproducibility. Reproducibility was evaluated as intermediate precision (within-laboratory reproducibility) by analysing nine samples on three different days in the same way as for repeatability. The relative standard deviations (RSDs) were found to be between 7 and 11%. It should be noted that RSD value is strongly influenced by the

Table 6. Validation parameters for the determination of As, Cd, Co, Cr, Cu and Ni mass fractions (mg kg^{-1}) in marine biota samples.

Parameter	As	Cd	Co	Cr	Cu	Ni
Test material	SRM 2976 (n = 7)	Nies No 6 (n = 7)	DOLT-2 (n = 6)	IAEA 407 (n = 6)	Nies No 6 (n = 8)	IAEA 407 (n = 6)
CRM-certified value	13.3 ± 1.8	0.82 ± 0.16	0.24 ± 0.05	0.73 ± 0.22	4.9 ± 0.3	0.6 ± 0.18
Determined value	12.2	0.83	0.23	0.75	4.9	0.51
Bias	-1.1	0.1	-0.01	0.02	0.0	-0.09
Expanded uncertainty model equation approach (k = 2)	4.6	0.18	0.06	0.2	0.8	0.1
Expanded uncertainty single laboratory validation approach (k = 2)	4.1	0.18	0.1	0.2	1.2	0.2
Repeatability (sd, 3 replicates)	1.2	0.05	0.06	0.02	0.5	0.3
Repeatability (from regression line)	3.0	0.1	0.03	0.02	1.0	0.2
Reproducibility (RSD)	12%	5%	5%	10%	12%	12%
LOD (ng)	0.03	0.014	0.017	0.07	0.004	0.03
LOQ (ng)	0.04	0.016	0.03	0.1	0.01	0.1
Calibration CRM	DORM-2	SRM 2976	TORT-2	BCR 278	BCR 278	SRM 2976
CRM-certified value	18 ± 1.1 (n = 9)	0.82 ± 0.16 (n = 8)	0.51 ± 0.09 (n = 7)	0.78 ± 0.6 (n = 8)	9.45 ± 0.13 (n = 7)	0.93 ± 0.12 (n = 6)
Characteristic mass (pg)	40	10	77	66	77	12

level of element content in the CRM used. When it is close to the LOQ (LOD) of the method, the RSD might be significantly higher.

3.2.4. LOD and LOQ

Another challenging point of the validation was the evaluation of the limits of detection and quantification. The main difficulty is related to the fact that in direct solid sampling practically there does not exist 'Blank'. A simple approach based on the linear regression data from the calibration line obtained using solid CRM has been described recently [19] and applied in the present work as well. The obtained results for LOD and LOQ for HR CS AAS determination of As, Cd, Co, Cr, Cu and Ni in marine biota sample are presented in Table 6.

3.2.5. Combined uncertainty of the measurement results

Evaluation of the measurement uncertainty was performed according to the recommendations given in the ISO Guide for Expression of Measurement Uncertainty [29] by using two different approaches. The first one is the described earlier approach [18] based on uncertainty propagation error applied to the model equation and the second is so-called top-down approach or Nord test approach [31].

3.2.5.1. Model equation approach. The evaluation of combined uncertainty is based on application of the uncertainty propagation law to the model Equation (1). Thus, the following equation can be revealed:

$$U_c = x_a^{(S)} \sqrt{\left(\frac{U_{x_a}^{(CRM)}}{x_a^{(CRM)}}\right)^2 + \left(\frac{U_{SL}^{(CRM)}}{a_1^{(CRM)}}\right)^2 + \left(\frac{U_{SL}^{(S)}}{a_1^{(S)}}\right)^2} \quad (2)$$

where $U_{x_a}^{(CRM)}$ is the uncertainty of the analyte mass fraction ($x_a^{(CRM)}$) in the CRM according to the certificate, $U_{SL}^{(CRM)}$ and $U_{SL}^{(S)}$ are the uncertainties of the slopes of the regression lines for the CRM ($a_1^{(CRM)}$) and sample ($a_1^{(S)}$), respectively.

Principally, solid sampling technique sets additional requirements to the CRMs used for calibration and samples. One important requirement is the micro-homogeneity of the samples and CRMs used for calibration. Considering homogeneity data for most of the CRMs, it should be noted that homogeneity tests are usually carried out using 200 mg or higher sample mass and wet decomposition of the studied CRM. Homogeneity at sample masses between 0.020 and 0.500 mg (the typical range for solid sampling HR CS AAS) could be significantly different from those reported in the certificate which is determined in aliquots typically between 200 and 500 mg. CRM with particle size below or equal to 260 μm are usually suitable for solid sampling calibration. The same requirement is relevant to the SSs.

Taking into account the specificity of the proposed analytical procedure, the major contributors to the uncertainty of the result can be identified as follows:

- Homogeneity of the sample.
- Homogeneity of the CRM, used for calibration.
- Uncertainty of the element mass fraction in the CRM, used for calibration.
- Element mass fraction in the calibration CRM and its uncertainty.
- Uncertainties of the weighted masses.
- Uncertainties of the measured absorbance.

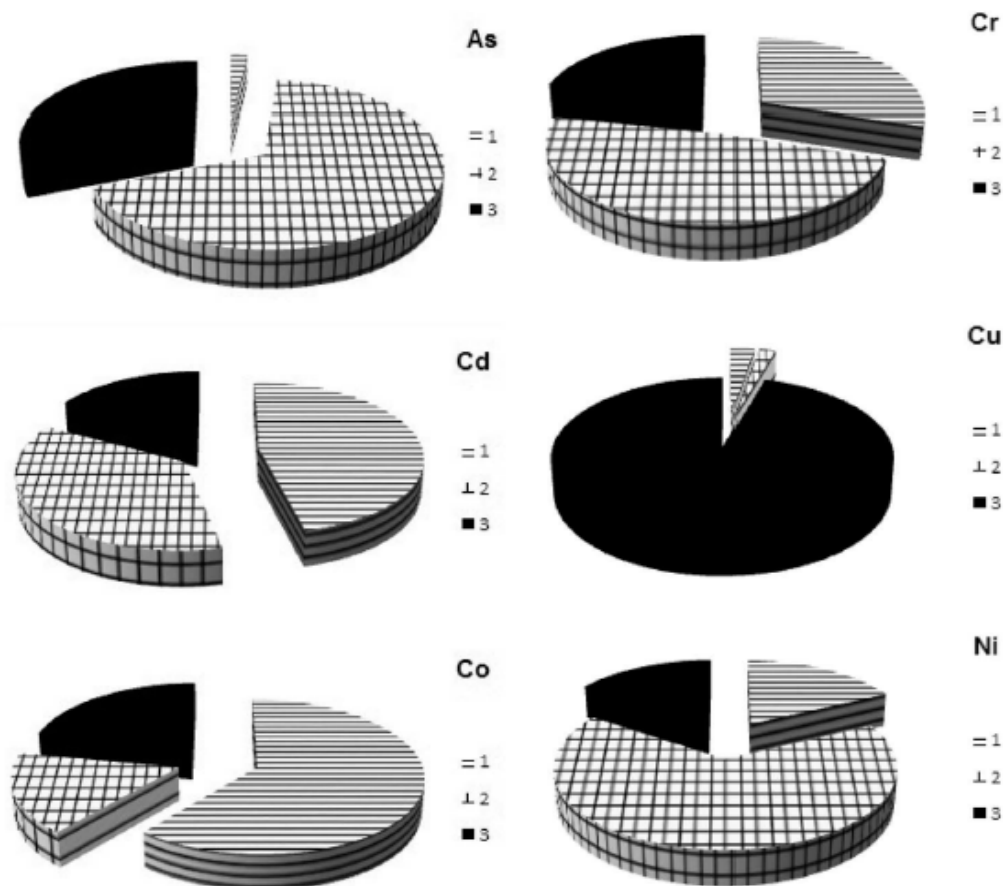

Figure 3. Graphical representation of the contributions of all sources of uncertainty, calculated using the model equation approach, for the determination of As, Cd, Co, Cr, Cu and Ni mass fractions in marine biota samples. 1. Uncertainty of the certified value in the CRM used for calibration; 2. Uncertainty of the slope of the regression line from the CRM used for calibration; 3. Uncertainty of the slope of the regression line from the test material.

More details on the quantification of measurement uncertainty have been already discussed in recently published studies [16,17]. Graphical presentation of the main contributors to the combined measurement uncertainty for several elements is given in Figure 3.

3.2.5.2. Single laboratory validation approach. The single-lab validation approach, contrary to the equation modelling approach, does not go deeply into the measurement procedure and most of the data that are used come from validation of the analytical procedure. By applying single laboratory validation approach, the estimation of the combined uncertainty (U_c) of the element mass fraction in the marine biota sample can be done according to the following measurement equations:

$$u_c = \sqrt{u(R_w)^2 + u(bias)^2} \quad (3)$$

$$u(bias) = \sqrt{RMS_{bias}^2 + u(C_{ref})^2} \quad (4)$$

$$RMS_{bias} = \sqrt{\frac{\sum_1^n (bias)^2}{n}} \quad (5)$$

Equation (3) includes the two main components of uncertainty budget: $u(R_w)$ which stands for within laboratory reproducibility component of uncertainty and $u(bias)$ accounting for the uncertainty component taking into account possible biases.

RMS_{bias} accounts for the uncertainty of the bias of the laboratory results from the reference value C_{ref} and $u(C_{ref})$ accounts for the uncertainty of the CRM reference values C_{ref} .

The laboratory reproducibility (intermediate precision) component R_w takes into account all long-term random uncertainty sources. The bias component takes into account the systematic effects that cause long-term bias. The long-term bias can be regarded as sum of procedural bias (inherent in the nature of the procedure) and laboratory bias (caused by the way of the implementation of given procedure in the laboratory).

The expanded uncertainty (the half width of the confidence interval) of the result can be obtained by multiplication of Uc by the corresponding coverage factor k (typically $k = 2$).

Combined uncertainty values calculated using both methods are consistent and in good agreement. They are presented in Table 6.

3.2.6. Metrological traceability

Key steps in the demonstration of metrological traceability of the results obtained with the developed and validated method were:

- The analytical method used was properly selected and validated, both in terms of matrix composition and analyte concentration.
- The use of CRM for calibration was the way to link analyte mass fraction to the common system of units.
- The use of gravimetric operation in the dosing of all samples and calibration CRMs is a way to link the final measurement result to the SI mass unit (kg).

Summary of obtained results from the described validation study are presented in Table 6.

4. Comparison with conventional temperature programs and liquid standards calibration

Conventional temperature programmes have been developed for comparison purposes. In all programmes, the calibration was performed using liquid standard solutions and liquid matrix modifier besides the permanent Ir coating. The determination of As, Cd, Co, Cr, Cu and Ni was performed using the same solid CRM biota samples and the results, compared to those obtained using fast temperature programmes, are shown in Table 7. Generally, it can be noted that both bias and expanded uncertainties obtained with the conventional programmes were considerably higher than those obtained with fast

Table 7. Comparison between mass fractions obtained for As, Cd, Co, Cr, Cu and Ni with fast programmes/solid CRMs for calibration and conventional programme/liquid calibration standards for different CRMs (mg kg^{-1}). In all cases, the number of measurements for conventional programmes was set to 6.

	Element	As	Cd	Co	Cr	Cu	Ni
	CRM	SRM 2976	Nies No 6	DOLT-2	IAEA 407	Nies No 6	IAEA 407
Fast programme	Certified value	13.3 ± 1.8	0.82 ± 0.16	0.24 ± 0.05	0.73 ± 0.22	4.9 ± 0.3	0.6 ± 0.18
	Obtained value	12.2 ± 4.6	0.83 ± 0.18	0.23 ± 0.06	0.75 ± 0.21	4.9 ± 0.8	0.51 ± 0.12
	U, % ($k = 2$)	34%	21%	24%	28%	17%	24%
Conventional programme	Obtained value	10.0 ± 6.8	0.91 ± 0.53	0.2 ± 0.11	0.67 ± 0.38	4.2 ± 2.0	0.46 ± 0.24
		($n = 6$)	($n = 6$)	($n = 6$)	($n = 6$)	($n = 6$)	($n = 6$)
	U, % ($k = 2$)	68%	58%	55%	57%	48%	51%

programmes and calibration using solid CRMs. Thus, it can be concluded that the calibration with liquid standard solutions is less reliable than calibration using solid CRMs. Such effect was observed earlier for the case of determination of Hg in various CRMs [18] and number of toxic elements in marine sediment samples [19].

5. Comparison with independent analytical method and reference values

A further step of the method validation performed in this study was the determination of As, Cd, Co, Cr, Cu and Ni in some biota samples already analysed using other analytical methods.

The results for As, Cd, Co and Cu obtained with the analytical procedure developed and validated in this study, based on solid sampling HR CS AAS and fast temperature programmes were used as IAEA contribution in the certification campaigns for clams and oyster samples (respectively, IAEA 461 and IAEA 470 CRMs) [32,33]. As, Cd, Co and Cu contents were quantified using DORM-2, SRM 2976, TORT-2 and DOLT-2 as CRMs for calibration, respectively, whereas Cr and Ni mass fractions were determined and quantified using BCR 278 and SRM 2976 CRMs as calibration standards.

As can be seen from the data presented in the Table 8, there is an excellent agreement within stated uncertainties between the results obtained in this study and reference values, which represents a substantial contribution to the validation of the described analytical procedures.

Table 8. Comparison of values and their expanded uncertainties ($k = 2$) for As, Cd, Co, Cr, Cu and Ni mass fractions (mg kg^{-1}) in biota CRMs IAEA 461 and IAEA 470 (clams and oysters) obtained with HR CS AAS and certified values. In all cases, the number of measurements for the test material was set to 6.

Samples	Element	HR SS AAS results	Certified values
IAEA 461	As	28 ± 6	30.2 ± 1.5
IAEA 461	Cd	0.6 ± 0.1	0.56 ± 0.04
IAEA 461	Co	4 ± 1	4.78 ± 0.64
IAEA 470	Cr	0.9 ± 0.2	0.96 ± 0.11
IAEA 461	Cu	26 ± 2	26.1 ± 2.0
IAEA 470	Ni	0.9 ± 0.1	$0.85^* \pm 0.29$

*information value.

6. Conclusions

A fit-for-purpose modifier-free method for the determination of As, Cd, Co, Cr, Cu and Ni in marine biota samples, based on fast temperature programmes and direct solid sampling is presented. Fast programmes were optimised for the analysis of biota samples. Calibration and analyte quantification procedure based on the use of solid CRMs was applied. The method allows reasonable evaluation of uncertainty of the result according to GUM: 1995 (JCGM 100:2008) [29] recommendations as well as the estimation of the basic metrological characteristics of the measurement procedure. The entire analytical concept, proposed already for monitoring studies with marine sediment samples [19], was optimised, applied and confirmed as effective for other type of complex and ecologically important environmental samples – marine biota.

The presented method has several advantages as compared with the conventional atomic absorption techniques involving liquid standard calibration and use of liquid chemical modifiers:

- Simple and reliable evaluation of the basic validation characteristics without the use of liquid calibration standards, usually different than the real sample matrix.
- Better possibility to separate the analytical signal from the background absorbance (Figure 2). This especially holds true for highly volatile analytes as As and Cd, which can be volatilised before the matrix components. Higher sensitivity due to reduced losses during the pretreatment steps.
- Possibility for calibration using solid CRMs providing better ‘matrix matching’ and guarantees the metrological traceability of the obtained results.
- Shorter duration of the analysis and minimum sample manipulation without use of chemical solvents and modifiers. This provides longer lifetime of graphite tubes and platforms on one hand, and better statistical reliability of the results on the other.

The major limitations of the proposed fast method are the following:

- Necessity to use CRMs for calibration. They are more expensive than calibration standard solutions and usually proper matrix matching can be achieved with application of larger number solid CRMs.
- Limited possibility for extension of the working range. Pre-concentration is practically impossible and dilution is very difficult. Work on solid phase dilution procedure using for example pure graphite powder is in progress.
- Strong requirements for homogeneity of samples and calibration CRMs.

The feasibility of using calibration against solid standards, fast programmes, Ir permanent modifier and the minimum sample manipulation makes the proposed procedure appropriate for monitoring applications.

Acknowledgement

The Agency is grateful for the support provided to its Environment Laboratories by the Government of the Principality of Monaco.

Disclosure statement

No potential conflict of interest was reported by the authors.

References

- [1] S. Damiano, P. Papetti and P. Menesatti, *Marine Poll. Bull.* **62**, 1920 (2011). doi:10.1016/j.marpolbul.2011.04.028.
- [2] S. Islam, K. Ahmed, H. Al-Mamun and S. Masunaga, *Environ. Toxicol. Pharmacol.* **39**, 347 (2015). doi:10.1016/j.etap.2014.12.009.
- [3] R. Merciai, H. Guasch, A. Kumar, S. Sabater and E. García-Berthou, *Ecotox. Environ. Safe* **107**, 154 (2014). doi:10.1016/j.ecoenv.2014.05.006.
- [4] M.Y. Kenneth Leung, R.W. Furness, J. Svavarsson, T.C. Lau and R.S.S. Wu, *Marine. Poll. Bull.* **57**, 790 (2008). doi:10.1016/j.marpolbul.2008.01.033.
- [5] A. Meche, M.C. Martins, B.E. Lofrano, C.J. Hardaway, M. Merchant and L. Verdade, *Microchem. J* **94**, 171 (2010). doi:10.1016/j.microc.2009.10.018.
- [6] Commission Regulation (EC) No. 629/2008 of 2 July 2008 amending Regulation (EC) No. 1881/2006 setting maximum levels for certain contaminants in foodstuffs, *Off. J. Eur. Union L* **173**, 6 (2008).
- [7] M. Resano, E. Mozas, C. Crespo, J. Briceño, J. Del Campo Menoyoa and M.A. Belarra, *J. Anal. Atom. Spectrom.* **25**, 1864 (2010). doi:10.1039/c0ja00086h.
- [8] B. Welz, H. Becker-Ross, S. Florek and U. Heitmann, *High-Resolution Continuum Source AAS—The Better Way to Do Atomic Absorption Spectrometry* (Wiley-VCH, Weinheim, NY, 2005).
- [9] A.K. Psoma, I.N. Pasiias, N.I. Rousis, K.A. Barkonikos and N.S. Thomaidis, *Food. Chem* **151**, 72 (2014). doi:10.1016/j.foodchem.2013.11.045.
- [10] European Commission, Guidance Document No. 33 on analytical methods for biota monitoring under the water framework directive, Technical Report, 2014-084.
- [11] B. Welz, M.G.R. Vale, D.L.G. Borges and U. Heitmann, *Anal. Bioanal. Chem.* **389**, 2085 (2007). doi:10.1007/s00216-007-1555-x.
- [12] A.F. Da Silva, F.G. Lepri, D.L.G. Borges, B. Welz, A.J. Curtius and U. Heitmann, *J. Anal. Atom. Spectrom.* **21**, 1321 (2006). doi:10.1039/b607256a.
- [13] A. Detcheva and K.-H. Grobecker, *Spectrochim. Acta. B* **61**, 454 (2006). doi:10.1016/j.sab.2006.03.016.
- [14] A. Detcheva and K.-H. Grobecker, *Environ. Chem. Lett.* **6**, 183 (2008). doi:10.1007/s10311-007-0124-z.
- [15] M.A. Belarra, C. Crespo, M.P. Martinez-Garbayo and M. Resano, *Spectrochim. Acta B* **58**, 1847 (2003). doi:10.1016/S0584-8547(03)00165-4.
- [16] M.G.R. Vale, M.M. Silva, B. Welz and E.C. Lima, *Spectrochim. Acta B* **56**, 1859 (2001). doi:10.1016/S0584-8547(01)00336-6.
- [17] M. Hoening and A. Clissen, *Spectrochim. Acta B* **48**, 1003 (1993). doi:10.1016/S0584-8547(05)80005-9.
- [18] P. Mandjukov, A.M. Orani, E. Han and E. Vassileva, *Spectrochim. Acta B* **103–104**, 24 (2015). doi:10.1016/j.sab.2014.11.006.
- [19] A.M. Orani, P. Mandjukov, E. Han and E. Vassileva, *Spectrochim. Acta B* **103–104**, 131 (2015). doi:10.1016/j.sab.2014.12.005.
- [20] ISO/IEC 17025, *General Requirements for the Competence of Testing and Calibration Laboratories* (International Organization for Standardization, Geneva, 2005).
- [21] B. Magnusson, and U. Örnemark, editors, *Eurachem Guide: The Fitness for Purpose of Analytical Methods – a Laboratory Guide to Method Validation and Related Topics*, 2nd ed (EURACHEM, 2014). ISBN 978-91-87461-59-0.
- [22] M. Thompson, S.L.R. Ellison and R. Wood, *Pure Appl. Chem* **74**, 835 (2002). doi:10.1351/pac200274050835.

20  A. M. ORANI ET AL.

- [23] European Union, Commission Decision 2002/657/EC of 12 August 2002 implementing council directive 96/23/EC concerning the performance of analytical methods and the interpretation of the results, Official Journal of the European Communities, Brussels (2002)
- [24] A.K. Psoma, I.N. Pasiás, N.I. Rousis, K.A. Barkonikos and N.S. Thomaidis, *Food. Chem* **151**, 72 (2014). doi:10.1016/j.foodchem.2013.11.045.
- [25] S.C. Hight and J. Cheng, *Anal. Chim. Acta* **567**, 160 (2006). doi:10.1016/j.aca.2006.03.048.
- [26] B. Gómez-Nieto, M. Gismera, M.T. Sevilla and J.R. Procopio, *Talanta* **116**, 860 (2013). doi:10.1016/j.talanta.2013.07.083.
- [27] J.F. Rego, A. Virgilio, J.A. Nobrega and J.A. Gomes Neto, *Talanta* **100**, 21 (2012). doi:10.1016/j.talanta.2012.08.038.
- [28] K. Danzer and L. Currie, *Pure. Appl. Chem.* **70**, 993 (1998). doi:10.1351/pac199870040993.
- [29] JCGM 100: 2008, Evaluation of measurement data — guide to the expression of uncertainty in measurement, (GUM, 1995 with minor corrections) **103–104**, 24 (2015). <http://www.bipm.org/eng/publications/guides>.
- [30] N. James, J. Millerand and C. Miller, *Statistics and Chemometrics for Analytical Chemistry*, 6th ed. (Pearson Education Limited, Harlow, 2010).
- [31] B. Magnusson, T. Näykki, H. Hovind and M. Krysell, NORDTEST report TR 537, Handbook for Calculation of Measurement Uncertainty in Environmental Laboratories (NT TR 537 — Edition 3.1), Oslo (2012)
- [32] E. Vassileva and S. Azemard, IAEA Certification of Trace Elements and Methyl Mercury Mass Fractions in the IAEA-461 Clam (*Gafrarium tumidum*) Sample. IAEA Analytical Quality in Nuclear Applications Series, Vienna, No. 44 (2016)
- [33] E. Vassileva and S. Azemard, IAEA Certification of Trace Elements and Methyl Mercury Mass Fractions in the IAEA-470 Oyster Sample. IAEA Analytical Quality in Nuclear Applications Series, Vienna, No. 47 (2016)

SECOND BLOCK

Paper 4

Submitted to peer reviewed journal Marine Pollution Bulletin (Elsevier) - accepted

Baseline study on trace and rare earth elements in marine sediments collected along the Namibian coast

Anna Maria Orani ^{a,b}, Emilia Vassileva ^{*a}, Irena Wysocka ^{a,c}, Michael O. Angelidis ^{a,d}, Martina Rozmaric ^a Deon Louw ^e

^a International Atomic Energy Agency, Environment Laboratories, 4 Quai Antoine 1er, Monaco, Principality of Monaco

^b Université de Nice Sophia Antipolis, CNRS, IRD, Observatoire de la Côte d'Azur, Géoazur UMR 7329, 250 rue Albert Einstein, Sophia Antipolis 06560 Valbonne, France

^c Polish Geological Institute National Research Institute, Rakowiecka 4, 00-975 Warsaw, Poland

^d University of the Aegean, Department of Environment Lofos Panepistimiou, 81100 Mytilini, Greece

^e Ministry of Fisheries and Marine Resources, National Marine Information Research Centre, Strand Street, Swakopmund, Namibia

Abstract

Namibia is a fast-growing country with extensive mineral extraction activities used in diamond, fluorspar, uranium, and metals production. In order to assess the impact of land based human activities on the Namibian coastal marine environment, 25 elements were analyzed in 22 surface sediment samples collected along the coast. By applying a variety of pollution assessment indices (Enrichment Factor, Igeo and Pollution Load Index), it was concluded that As, Cd and Sb were considerably enriched in the sediments from several sampling sites, while Cu, Pb and Zn showed very high enrichment at the vicinity of the Walvis Bay harbor. Pearson's correlation and Principal Component Analysis were used to investigate common metal sources. Additionally, the determination of Pb isotope ratios confirmed the contribution of land based human activities at Walvis Bay and Lüderitz as sources of Pb pollution. The analysis of REEs did not reveal any important enrichment due to anthropogenic activities in the region, but provides a needed baseline for further investigations, since previous mineralogical studies indicated that Namibia has substantial REEs resources.

Keywords: Benguela, surface sediments, trace elements, REEs, Pb isotope ratios

Studies show that sediment analysis is an appropriate approach for the assessment of trace element pollution in marine environments, since it can provide a temporally integrated indication of the environmental conditions of a given area (Caccia et al., 2003). Marine ecosystems can become contaminated by trace metals from numerous and diverse sources. However, anthropogenic activities such as mining and industrial processing of ores and metals, still remain a major source of increased amount of trace elements (De Gregori H. et al., 1996). These anthropogenic inputs can accumulate in local sediments at concentrations up to five orders of magnitude above that found in the the overlying water (Bryan and Langston, 1992), and then transferred to aquatic organisms, causing direct toxicity to aquatic life and indirect toxicity to the human population through consumption of contaminated seafood. Recognizing the importance of this kind of contamination, trace element determination in marine sediments has been included as a standard procedure in marine pollution monitoring programs at national and regional levels since the late 70's (Roose et al., 2011) ("UNEP regional seas, 2017," n.d.). However, although important information on the level and temporal trends of trace element concentrations in sediment has been collected for several coastal areas (UN DOALOS, 2016), there are still important geographical gaps around the world that need to be investigated. In the framework of the Convention for Co-operation in the Protection and Development of the Marine and Coastal environment of the West and Central African Region (Abidjan Convention), marine pollution monitoring, is an issue of priority (UNEP, 2011). Unfortunately, marine pollution monitoring programmes have not yet been implemented in most coastal areas of the West and Central African Region; therefore, it is of the utmost importance to establish baseline information for trace element concentrations in the larger marine environment off the coast of the Namibian marine coastal zone.

The Namibian marine environment is remarkable in several ways. It is part of one of the four major eastern boundary regions (Benguela, California, Northwest Africa and Peru) upwelling systems in the world and is exceptionally productive in supporting abundant marine life (Sakko, 1998). Namibia has an exceptionally low, and geographically very concentrated, coastal population compared to other countries, with five coastal towns on a coastline of 1500 km, including two harbour towns (Walvis Bay and Lüderitz). Potential human threats to Namibian biodiversity, and generally to its marine ecosystems, can be related to naval and fishing activities, diamond and other mining activities (Sakko, 1998). The exploitation of minerals and other natural resources has been the backbone of the Namibian economy for many years and the mining sector maintains its importance to the gross national product (Ministry of

Environment and Tourism, 2008). Diamond, fluorspar, and uranium continue to be the most significant mineral commodities to Namibia's economy. The country also produces metals such as arsenic, copper, gold, lead, manganese, silver, and zinc, as well as industrial minerals including cement, dolomite, granite, marble, salt, semiprecious stones, sulfur, and wollastonite. In addition to the physical impacts of open pit mining, the consumption, transportation and discharge of effluents are key issues from an environmental perspective. Mining and associated activities can have a negative impact on the environment, mainly because of the tailings, mine waste that is generally toxic. Tailings composition is very variable, prone to wind and water erosion; its physical and chemical characteristics favour metals dispersion and mobilization in the environment (Mileusnić et al., 2014). Some studies have dealt with the assessment of environmental consequences related to mining and industrial activities, especially soils (Mileusnić et al., 2014) around mining areas. Confirmation that a real threat to human health exists, came from a study of Mapani et al. (2009) whose results point to severe heavy metals contamination with immediate risk to the inhabitants of the Tsumeb area, with almost a century long mining and smelting activities. Namibia's economy heavily depends on fisheries, which exploit one of the most productive fishing grounds in the world, due to the Benguela upwelling current system (FAO, 2007). The catches from the fishery are landed at two major ports, at Walvis Bay and Lüderitz. These ports have in recent years, been expanded dramatically with Walvis Bay as the major Namibian port, connecting the landlocked countries such as Botswana, Zambia, Zimbabwe.

Several major rivers discharge along the central Namibian marine coastline including the Omaruru River in Henties Bay, Swakop River in Swakopmund and the Kuiseb River in Walvis Bay. Their catchment areas act as collector of sediments and transport particles to the coast during the rainy season. Nevertheless, Namibia has a rather dry and windy climate in the coastal region. The transport of particle is not perennial, but rather associated to flash flood events or eastward windstorm. Mining and agricultural activities taking place in the catchment areas of these rivers can contribute to the input of contaminants in the coastal area.

To the best of our knowledge, no published data are available on trace element concentrations in the nBUS (northern Benguela upwelling system) off Namibia. In consideration of these aspects, it is important that we establish new baseline data for future reference.

The group of Rare Earth Elements (REEs) was also included in the present study since some mineralogical investigations have confirmed that Namibia may have potential REEs resources (Orris and Grauch, 2002). Additionally, since REEs are naturally associated with U-containing minerals, their

determination in these areas with long history of U mining, is of great interest. The distribution patterns of REEs has often been applied to geological studies of river and marine ecosystems (Song and Choi, 2009; Rezaee et al., 2010) since they are a reliable tool for determining depositional processes and sediment provenance (Xu et al., 2009); Jung et al., 2012). In the last decade the use of REEs in the industry have increased as these elements find application in the production of several modern devices, such as superconductors, electronic components, luminescent materials and car components. As a consequence of their increased use, the potential anthropogenic influence on REEs natural distribution has extended their geochemistry into the field of environmental chemistry (Kulaksiz and Bau, 2011); Hatje et al., 2016), leading scientists to refer to these elements as “new emerging pollutants”.

The aim of this study was to assess the ecological risk associated with trace elements concentrations in sediments along the Namibian coast and thus provide a record for present and future evaluations of the state of the Namibian marine environment. For this purpose, the concentration of selected trace elements, including rare earth elements (REEs) and lead isotopic ratios was determined in 22 sediment samples collected along the Namibian coast.

All sample handling was carried out in class 10 laminar hoods. Ultrapure water with resistivity > 18 MΩ was obtained from Milli-Q Element system (Millipore, USA) and was used throughout this work to dilute concentrated acids. Trace grade HNO₃, HF, H₂O₂ and ultrapure HNO₃ were purchased from Fisher Scientific (Hampton, USA). TraceCert standard solutions for Al, Zn, Mn and Fe used for Flame AAS calibration, TraceCert Hg standard solution for AMA calibration and TraceCert multielemental standard for ICP-MS calibration, were purchased from Sigma Aldrich (Buchs, Switzerland) in concentrations of 1000 mg/L (mono-elemental standards) and 10 mg/L (multielemental standard). The Certified Reference Material MESS-2 (Estuarine sediment, National Research Council, Canada) was used for assessing data accuracy. The Standard Reference Material SRM 981 from the National Institute of Standards and Technology (NIST, USA) with the natural Pb isotopic composition was used for correction of the instrumental mass discrimination when measuring Pb isotope ratios. All Teflon and PE lab ware used in the sample preparation and analysis, was pre-cleaned with a procedure consisting of at least 24h bath in 10% HNO₃ and careful rinsing with MilliQ water.

Following a request for assistance from the Environmental Division of the Ministry of Fisheries and Marine Resources (MFMR), the IAEA Environment Laboratories participated in a scientific sampling expedition in May 2014, during a survey along the Namibian coast, together with the National Marine Information and Research Centre (NatMIRC). Furthermore, additional sediment samples were collected,

during the same period, in the frame of a technical cooperation (TC) project between the IAEA and Namibia. The sampling was carried out in various sites along the Namibian coast, between 20°S and 27°S latitude and 11°E and 15°E longitude (Table 1); to facilitate the comparison with existing radioactivity data, the original sampling coding is also included in the table.

Table 1. Sample list

Sample code	Original sampling code	Latitude °S	Longitude °E
N1	1876	20°20.86	12°7.3'
N2	20010	19°60.0	12°51.3'
N3	ZZ9	21°00.5	13°29.1'
N4	ZZ7	21°30.2	13°49.7'
N5	ZZ8	21°15.1	13°00.3'
N6	1862	22°59.97	14°19.83'
N7	ZZ3	22°20.5	14°21.0'
N8	1867	22°59.99	13°30.62'
N9	ZZ1	22° 40.0'	14°29.8'
N10	1864	23° 02.93'	14°04.19'
N11	1866	23° 00.71'	13°40.39'
N12	WBHC	22° 54.4'	14°30.3'
N13	LAG	26°38,0'	15°08,5'
N14	WBH	22° 56.5'	14°30.1'
N15	23002	23°00.0	14°22.1'
N16	23070	23°00.0	13°8.24'
N17	1917	24°15.98	14°3.02'
N18	26010	26°00,0'	14°77.12'
N19	26050	26°00,0'	14°18.0'
N20	LUDHC	26°37,4'	15°09,6'
N21	SWB	26°37,7'	15°06,5'
N22	LUDH	26°38,4'	15°09,2'

A total of 22 surface samples have been analyzed in this work and the sampling area was relatively broad (Fig.1), including sediments collected on the coastal zone, as well as sediments collected in deeper water at the open sea.

Figure 1. Sampling stations map along the Namibian coast

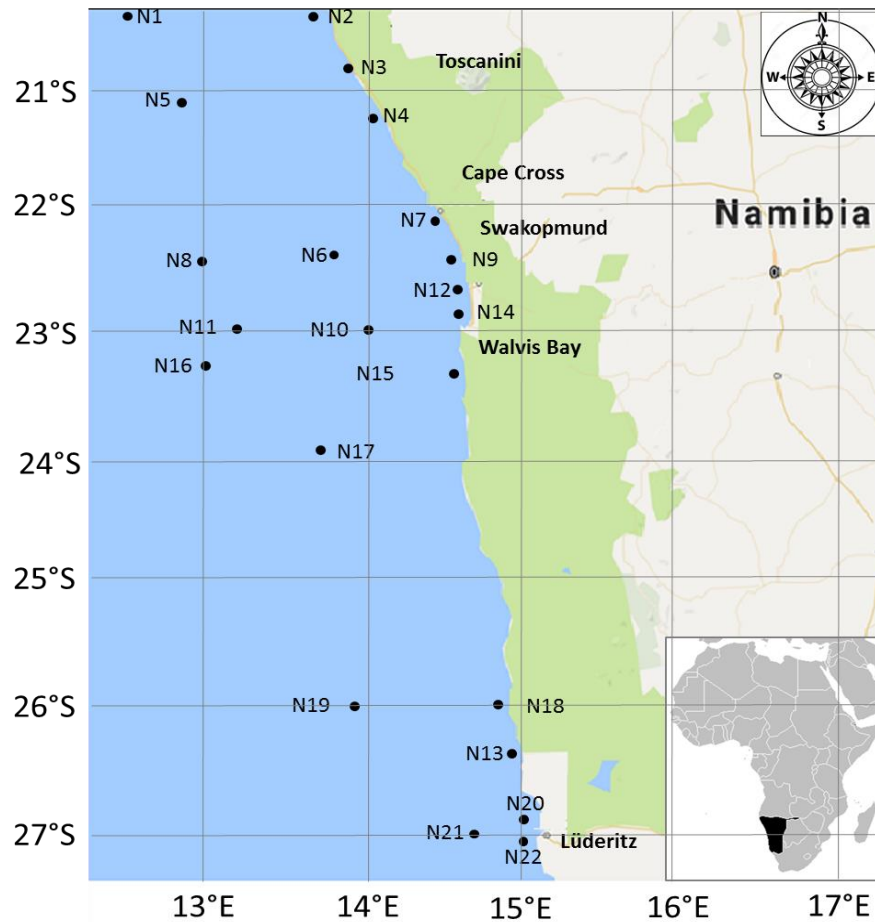

After collection, sediment samples have been kept frozen during transportation at the laboratory. Later, samples were freeze-dried, sieved at 1 mm and homogenized in agate mortar. Acid digestion was carried out in a microwave system using a Mars X-press Microwave (CEM Mars X-press) equipped with a carousel holding 12 digestion vessels. A quantity of 150 ± 50 mg of dried sample was weighed in Teflon microwave vessels, where 5 ml of ultrapure HNO_3 , 2 ml of H_2O_2 and 2 ml ultrapure concentrated HF were added. Each digestion batch included 2 reagent blanks and two replicates of a selected certified reference material. The digestion procedure involves gradual increasing of temperature to 190°C for 15 min, then additional isothermal treatment for 15 min. After the digestion, obtained solutions were placed on a ceramic heating plate and evaporated to near dryness. The residues were taken up in 2% HNO_3 , transferred to 50 ml PE tubes and stored at 4°C .

Inductively Coupled Plasma Mass Spectrometry (ICP-MS) was the method used for the determination of trace elements (TE: As, Ba, Be, Cd, Co, Cr, Cu, Li, Mo, Ni, P, Pb, Sb, Sn, Sr, Th, Ti, U, V and Y) and Rare Earth Elements (REE: La, Ce, Pr, Nd, Sm, Eu, Gd, Tb, Dy, Ho, Er, Tm, Yb, Lu) in sediment samples. Measurements were carried out using a quadrupole mass spectrometer, Q-ICP-MS (XSERIES, Thermo Fisher Scientific); instrumental parameters are presented in Table 2.

Table 2. Optimized parameters for the Q-ICP-MS in a) standard mode and b) CCT mode (XSERIES 2. Thermo Fisher Scientific)

Parameter	Standard mode	CCT
Plasma gas flow. L min ⁻¹	13.5	13.5
Nebuliser gas flow. L min ⁻¹	0.91	0.89
Auxiliary gas flow. L min ⁻¹	1.05	0.95
RF power. W	1200	1200
Sensitivity for 1 ppb In. cps	>100000	>20000
Background on mass 220. cps	0	0
Dead time. ns	39	39
Number of sweeps/ replicate	100	100
Number of replicates	3	3
Dwell time per amu. ms	50	50
Sample uptake. mL min ⁻¹	0.1	0.1
Oxide formation CeO ⁺ /Ce ⁺ . %	<3	<0.2
Measured isotopes	⁹ Be, ¹¹⁰ Cd, ⁵⁹ Co, ⁶⁵ Cu, ⁷ Li,, ⁹⁵ Mo, ⁶⁰ Ni, ²⁰⁸ Pb, ¹²¹ Sb, ¹¹⁸ Sn, ²³² Th, ²⁰⁵ Tl, ²³⁸ U, ⁸⁸ Y, ¹³⁹ La, ¹⁴⁰ Ce, ¹⁴¹ Pr, ¹⁴³ Nd ¹⁴⁶ Nd, ¹⁴⁷ Sm, ¹⁵¹ Eu, ¹⁵² Sm, ¹⁵³ Eu, ¹⁵⁷ Gd, ¹⁵⁸ Gd, ¹⁵⁹ Tb, ¹⁶¹ Dy, ¹⁶³ Dy, ¹⁶⁵ Ho, ¹⁶⁶ Er, ¹⁶⁷ Er, ⁶⁹ Tm, ¹⁷² Yb, ¹⁷⁴ Yb, ¹⁷⁵ Lu	⁷⁵ As, ⁵³ Cr, ⁵¹ V

Determination of Pb isotope ratios was performed on digested samples by means of High Resolution Sector Field ICP-MS (NuAtom, NuInstruments Ltd., Wrexham, UK); the instrument parameters are presented in Table 3.

Table 3. Optimized ICP-SFMS instrumental parameters for Pb isotopic ratio determinations (Atom, Nu Instruments)

Parameter	Value
Coolant gas flow	13.5 L min ⁻¹
Auxiliary gas flow	0.8 L min ⁻¹
Nebulizer gas flow	29.6 psi
Plasma power	1300 W
Sensitivity for 1 ng g ⁻¹ (²⁰⁸ Pb)	> 800000 cps
Background on mass 220	< 2 cps
Dead time	14 ± 2 (k=2) ns
Acquisition Mode	Peak Jumping
Number of sweeps	500
Number of cycles	25
Dwell time per isotope (ms)	1000
Measured isotopes	²⁰² Hg, ²⁰⁴ Pb, ²⁰⁶ Pb, ²⁰⁷ Pb, ²⁰⁸ Pb
Mass resolution	300
Oxide Formation CeO ⁺ /Ce ⁺	<1%

Determination of Al, Fe, Mn and Zn was carried out by Flame Atomic Absorption Spectroscopy (ContraAA 700, Analytik Jena, Germany) on the same digested solutions used for ICP-MS, using external calibration. Mercury was determined in sediment samples directly, using a solid AAS analyzer (AMA 254, Altech, USA), therefore no digestion was needed. Total Organic Carbon (TOC) and Total Inorganic Carbon (TIC) were determined by means of acidification and combustion in a one-unit carbon analysis system (Vario EL Cube, Elementar, Langensfeld, Germany). The analytical methods used in this study were properly selected and validated, both in terms of matrix composition and analyte concentration. All possible sources of uncertainty of obtained monitoring results were carefully identified. Afterwards, the uncertainty components were quantified and the combined uncertainty calculated. Combined standard uncertainties were obtained by propagating together individual uncertainty components according to the ISO/GUM guide (Magnusson and Örnemark eds, 2014). All uncertainties indicated in the final results are expanded uncertainties:

$$(1) \quad U = k \cdot uc$$

where uc is the combined standard uncertainty and k is a coverage factor equal to 2.

A principal requirement of the standard ISO 17025 (ISO/IEC 17025, 2017) is for laboratories to produce measurements that are traceable to a common system of reference, SI system, and ensure comparability of measurement results. The way to demonstrate traceability in the present study was the use of an uncertainty budget, where all the parameters influencing the final result were systematically assessed. In addition, the use of CRM throughout the whole analytical procedure and bias (recovery) estimation was the way to link obtained trace elements mass fraction to the common system of reference SI. CRM with similar matrix were used also in the validation of sample preparation step.

Different approaches are proposed to evaluate the anthropogenic influence on trace elements content in the sediments. In this work we are using three widely used approaches: Enrichment Factor (EF), Geo-accumulation Index (I_{geo}) and Pollution Load Index (PLI), as already described in details elsewhere (Zahra et al., 2014; Guan et al., 2016). Graphical representation of trace elements results is given in Fig. 2.

As it can be seen from this representation, As, Cd, Cr and Ni show high variability in terms of contents. The ranges of mass fractions were 2.4-42 mg kg⁻¹ for As, 0.2-12 mg kg⁻¹ for Cd, 45-270 mg kg⁻¹ for Cr, 31-580 mg kg⁻¹ for Mn and 12-61 mg kg⁻¹ for Ni. On the other hand, Pb, Zn and Cu show significantly higher levels only in sampling station N14, while Hg was consistently low along the coastline.

Figure 2. Graphical representation of trace elements results found in surface sediments

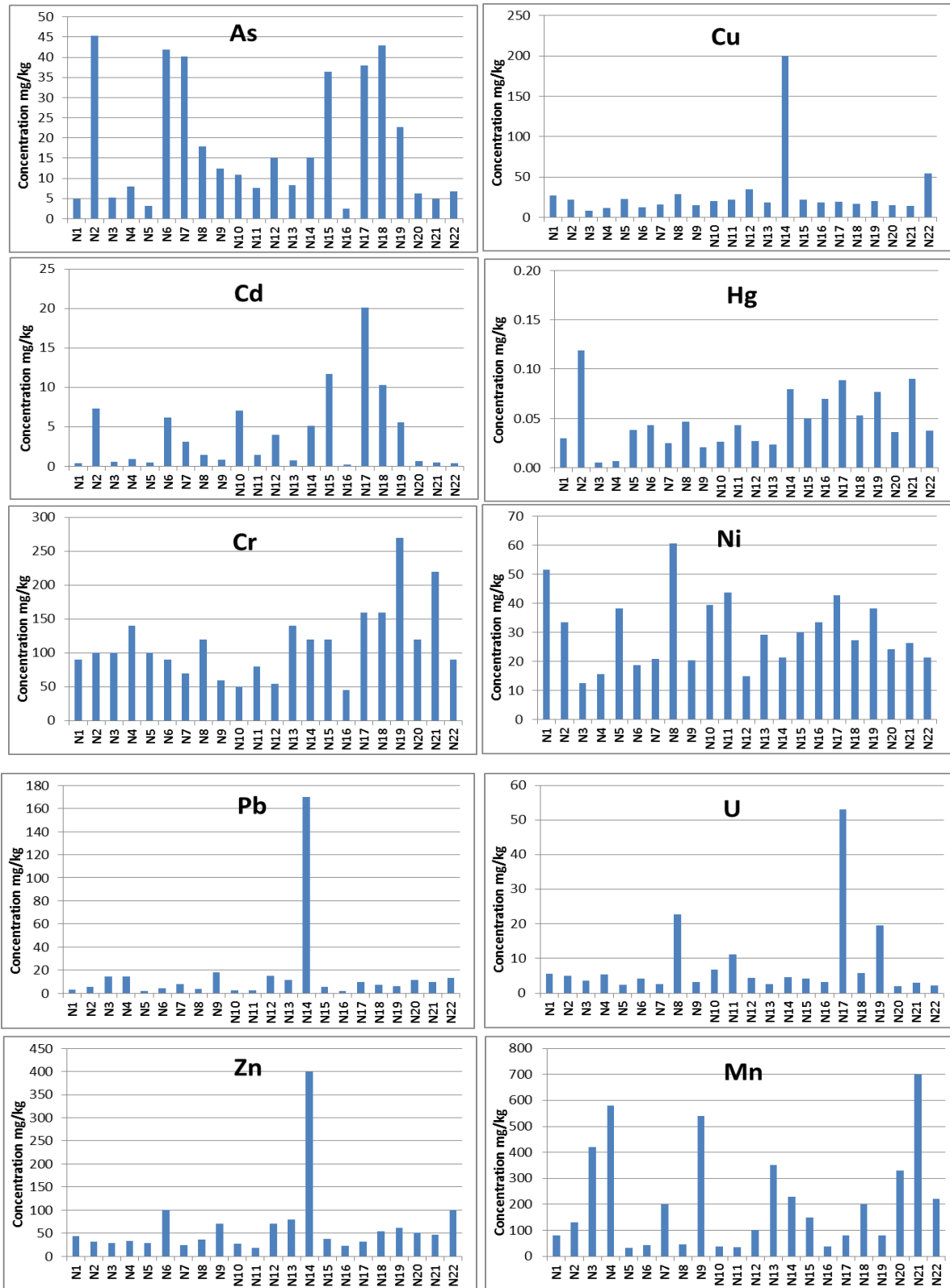

A summary of trace and major elements results is presented in Table 1S (supplementary file) and results of grain size distribution and organic carbon is presented in Table 2S. In order to facilitate the interpretation of such results and to highlight common patterns, a Person's correlation test has been performed. The correlation matrix is presented in Table 3S. High correlation coefficients between different metals, considered significantly different from zero at 95% confidence interval, mean common sources, mutual dependence, and identical behavior during transport (Guan et al., 2016).

Unexpectedly, no significant correlation between organic carbon (TOC) and analyzed trace and major elements was found. The property of organic matter to influence the content of some trace metals in environmental samples has been reported in several studies (Wang and Qin, 2006; Kljaković-Gašpić et al., 2008) but the relation between these two components is still considered complex and very variable (Wang, 2008). Among toxic elements, As and Cd showed a similar pattern, displaying the highest contents (up to 12 mg kg⁻¹Cd and 45 mgkg⁻¹As) at the Walvis Bay and Swakopmund regions (Fig. 2) and, Pearson's test confirmed a positive correlation between their patterns ($R^2 = 0.73$); Arsenic showed significant correlation only with Cd, while Cd presented significant correlation also with some other elements such as Mo, Th and U. Bremner and Willis, (1993) already highlighted an unusual Cd distribution in unconsolidated continental-margin sediments in the Namibian coast, reporting values up to 60 mg kg⁻¹precisely in the region between Walvis Bay and Swakopmund (Bremner and Willis, 1993). The authors suggested a possible source of Cd as impurity of Zn minerals coming from Ugab River but no correlation between Cd and Zn was found in this study ($R^2 = 0.02$). On the other hand, positive correlation with As patterns might suggest a possible enrichment caused by anthropogenic activities. Ni and Cr seem to have more homogeneous distributions along the coast, even with values comparable to those previously measured by Bremner and Willis; additionally, these elements did not show any significant correlation with other toxic elements.

N14 was the only sampling station where very high mass fractions of Pb, Zn and Cu were found. Maximum concentration of 87±9 mg kg⁻¹Cu and 49±16 mg kg⁻¹Pb were found by Bremner and Willis in surface sediment samples collected in the same area while samples analyzed in this study presented much higher concentrations: 200±20 and 170±20 mg kg⁻¹for Cu and Pb respectively. Very high positive correlation between Cu and Pb ($R^2 = 0.96$) can be observed, suggesting a common source of contamination. Interestingly also Zn correlates positively with both Pb and Cu, reaching values up to 400±40 mg kg⁻¹in sample N14. No significant correlation was found with carbonate content, meaning that the enrichment of Pb, Cu and Zn cannot be justified with the presence of carbonate minerals. It has

to be pointed out that upwelling systems are naturally characterized by metal enrichment as a consequence of high metal inputs from plankton but the metal content in Namibian coast was previously suggested to be intimately related to organic matter content (Calvert and Price, 1970). In consideration of the fact that no positive correlation was found between organic content and trace elements concentration in surface samples, it is reasonable to assume that metal enrichments found in coastal stations is mainly related to anthropogenic metals inputs from land based sources.

The analysis of EF, Igeo and PLI corroborate the hypothesis of anthropogenic contribution in some of the sampling stations. The background values considered for the calculation of EF and Igeo were those measured on the bottom of a small core sampled offshore, at station N16. Following the evaluation criteria of EF described elsewhere (Guan et al., 2016), it was possible to identify As significant enrichment in nine sampling stations: N2, N6, N7, N8, N10, N12, N15, N17 and N18 with EF between 6 and 9; the N11, N14 and N19 sites were found to be moderately enriched in As (EF = 3-4). Exactly the same sites were found to be moderately/ significantly enriched in Cd with EF between 3 and 24. Pb showed significant/very high enrichment in two locations around Walvis Bay (N12 and N14) with EF equal to 7 and 45 respectively; additionally, N14 was the only sampling site presenting Cu and Zn enrichment. Among toxic elements also Mo and Sb presented significant enrichment in some locations, reaching values up to 28 and 16 respectively. Some of the calculated EFs are presented in Fig. 3.

Figure 3. Graphical representation of some enrichment factors calculated for surface samples

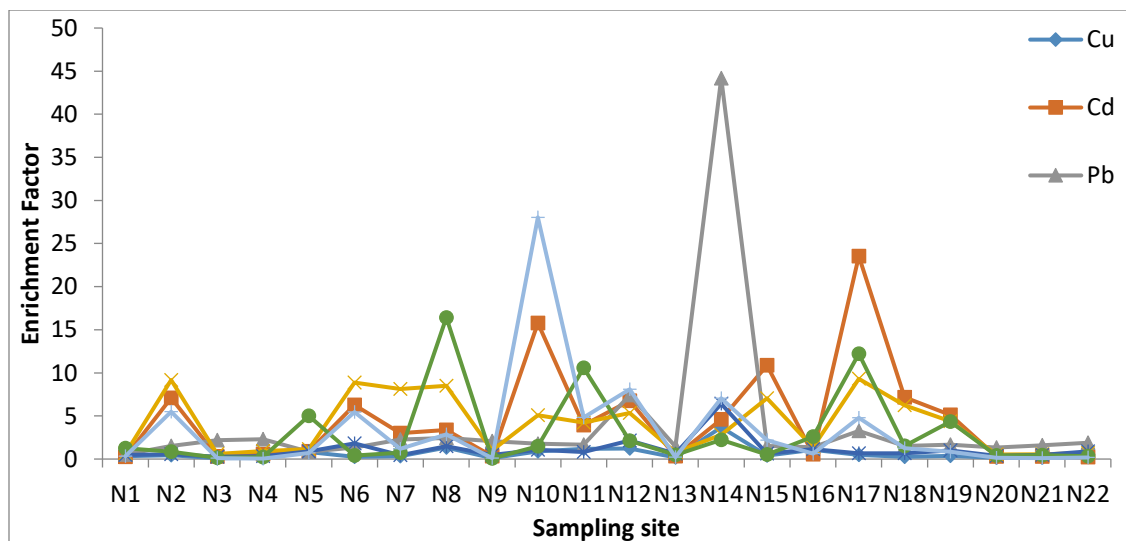
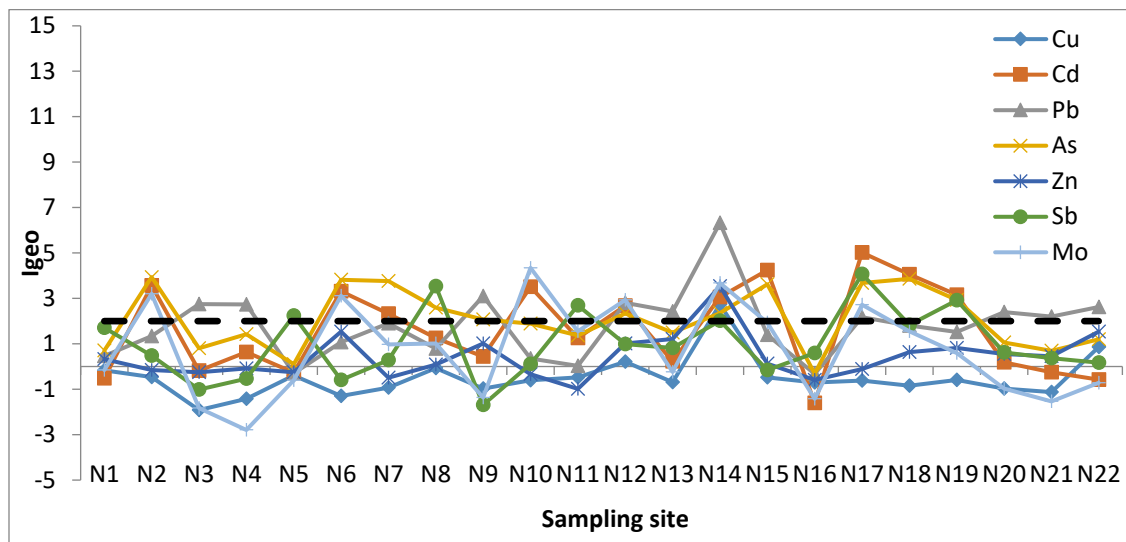

Figure 4. Cu, Cd, Pb As, Zn, Sb and Mo Igeo indices calculated for each sampling site. Dotted line represents the limit above which the sample can be considered moderately/strongly contaminated

Igeo indexes confirmed the already highlighted contamination in the above-mentioned locations, giving also additional information about other stations and elements. The percentages of Igeo indexes beyond the level 2, which reflects at least a moderate contamination in the analyzed area, were 41%, 18%, 27%, 27% and 36% for Cd, Sb, Pb, Mo and As respectively while only 5% of sites showed Igeo>2 Cu and Zn, since only the N14 site was found to be contaminated with these elements. A graphic representation of some Igeo indices results is shown in Fig. 4; the Igeo indexes of Be, Co Ni, U, V, Cr, Hg, Sn and Th were below 2, suggesting that contamination by these elements has not occurred in the studied area.



Finally the analysis of Pollution Load Indices (PLI) calculated on surface samples, gave an additional confirmation that an anthropogenic impact is present in the whole studied area, since only a few sites among the sampling stations appear not to be contaminated from any of the studied elements (Fig. 5). These sites are N5 and N16. PLI results, presented in Fig. 5, show that the N14 site is by far the most contaminated one, followed by sampling locations close to Swakopmund and Lüderitz.

Figure 5. Graphical representation of Pollution Load Indices calculated for each sampling site

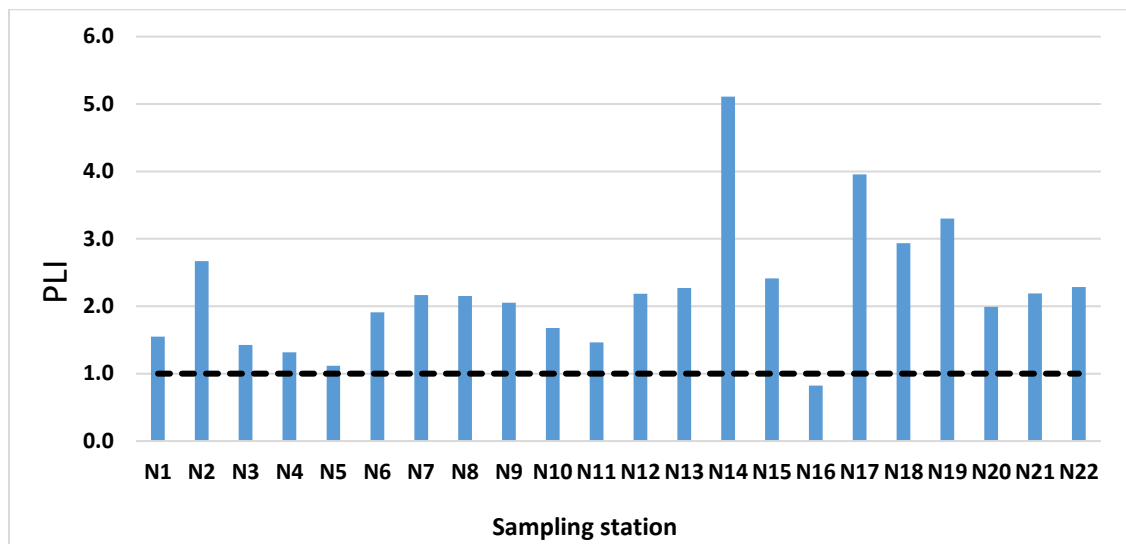

The spatial distribution of trace element concentrations therefore suggests that sediment contamination is more pronounced around Walvis Bay, Lüderitz and Swakopmund. These areas host important commercial businesses including fishing and mining activities while areas close to Toscanini and Cape Cross are less polluted judging by the indices calculated in this work. Specifically, pollution challenges in the Namibian coast are associated with industrial and urban activities, especially in and around the Walvis Bay harbor area. Minor oil spills, discharge of waste containing traces of antifouling paints, sewage from ships and heavy metals from the export of semi-processed mine ore also contribute to the pollution of the seawater in the harbor and bay area. In Walvis Bay harbor, several products extracted from the mining industry are exported and the synchrolift for ship repairing are also based in the area. In addition, solid waste, sewerage and small amounts of oil products coming from the ships are occasionally discharged into the sea resulting in wastes being washed ashore on the beaches of the Namibian coastline (Ministry of Environment and Tourism, 2008). It has been documented that there is a limited water exchange in bays, which can increase the metal residence time in the aquatic system (Sulochanan et al., 2007). Walvis Bay is an industrial town with relatively high resident population: 62400 inhabitants for both, rural and industrial areas (Namibia census, 2011). The Walvis Bay urban area has the highest population density of the Erongo region. Trace elements enrichment at stations near Swakopmund could be attributed to the vicinity of Walvis Bay.

To further examine the extent and origin of trace elements contamination in the Namibian coast, we performed a Principal Component Analysis (PCA) on some selected trace elements and C results (Cu, Cd, Pb, Cr, As, Zn, Mo, Sb, P, CaCO₃ and TOC) based on the results discussed in previous paragraphs. Data

were standardized using the biased standard deviation, in order to avoid misclassification due to differences in data dimensionality; results are shown in Fig. 6.

Figure 6. Biplot representation of PCA results obtained for selected trace elements determined in Namibian surface sediments

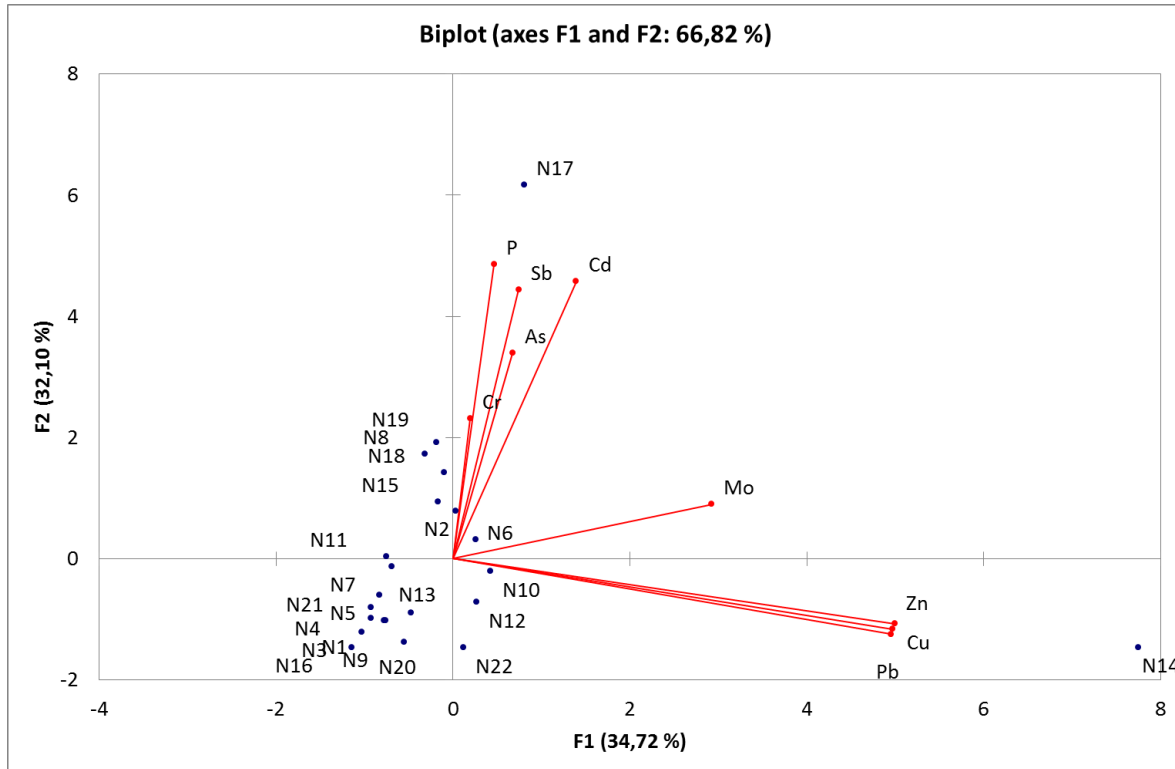

PCA was performed on the correlation matrix between different parameters and gave three principal components with eigenvalues higher than 1. The first two components (F1 and F2) explained 58.5% of the total variance (Table 4). F1 accounted for 29.9 % of total variance and it is mainly characterized by high positive loadings of Cu, Pb, and Zn. The second component F2 accounted for 28.6% of the total variance, with high positive loadings for As, Cd, Sb and P. On the basis of their loadings values (higher than 0.96 in F1) it can be assumed that Cu, Pb and Zn might come from the same source, and these elements are responsible for the evident separation of sample N14 in the biplot graph shown in Fig. 6. CaCO₃ and TOC have low loadings in both components, suggesting that they are not linked to the high concentration of these elements in some samples, as already hypothesized in the previous paragraph.

Table 4. Statistical parameters relative to Principal Component Analysis performed on selected trace elements

	F1	F2	F3	F4
Eigenvalues	6.383	3.11	2.257	1.357
Variability (%)	42.59	20.73	15.05	9.04

	Factor loadings				
	F1	F2		F1	F2
Li	0.613	0.4819	Mn	0.8873	-0.484
Co	0.8609	-0.4107	Fe	0.8738	0.2752
Ni	-0.3495	0.5535	V	0.9258	0.1086
Cu	0.0418	0.2597	Cr	0.5332	0.33
Cd	0.3004	0.7936	As	0.3951	0.6888
Ba	0.882	-0.2178	Zn	0.5132	0.1224
Pb	0.7121	-0.1247	Al	0.8449	-0.3586
U	0.181	0.7703			

As, Cd, Sb and P form a separated group as they all show loadings higher than 0.7 in F2 and lower than 0.1 in F1, which might be indication of a common source. This group of elements is responsible for the separation of sample N17 in the biplot representation; this sample also showed the highest Cd enrichment factor and one of the highest As EF found in this study. Sample N17 was collected relatively far from the coast and it is likely to be enriched in As and Cd because they are often associated to the same type of minerals. On the other hand As and Cd are also used in fertilizers under the form of phosphate, which may also explain the positive correlation with P found in this study (Tchounwou et al., 2012). Nevertheless, Namibia does not have any agricultural activities close to the coast and the enrichment in As and Cd as well as their correlation with P is most likely related to the presence of phosphate minerals.

Pb isotope ratios results are presented in Table 4S and three isotopes graphs are shown in Fig. 7. The linear trend in both graphs ($0.8 < R^2 < 0.9$) shown in Fig. 7 is ascribable to the presence of at least two mixing Pb sources. The deviation from linearity in the graph involving ^{204}Pb isotope, is indicative of more than two different sources (Ellam, 2010). Generally speaking, Pb originating from natural sources (i.e. from bedrocks weathering) is characterized by a higher radiogenic isotopic composition, when compared with anthropogenic sources of Pb. The explanation resides in the origin of Pb used for industrial application which is extracted by ores by age dependent isotopic composition, generally relatively un-radiogenic (Hansmann and Köppel, 2000). It is thus not surprising that sediment samples considered the most polluted in the present study (samples collected around the Walvis Bay and Lüderitz regions) are characterized by less radiogenic Pb isotopic composition while the ratios increase

in absolute $^{206}\text{Pb}/^{204}\text{Pb}$ and $^{208}\text{Pb}/^{204}\text{Pb}$ values for samples collected in less contaminated areas. Among the samples analyzed in this study the N14 showed by far the lowest values of Pb isotope ratios ($^{206}\text{Pb}/^{204}\text{Pb} = 17.68$ and $^{206}\text{Pb}/^{207}\text{Pb} = 1.125$); this was also the sample characterized by the highest measured Pb content. Samples N12, N13, N20 and N22 also can be grouped together on the basis of their isotopic composition ($18.1 < ^{206}\text{Pb}/^{204}\text{Pb} < 18.5$ and $1.155 < ^{206}\text{Pb}/^{207}\text{Pb} < 1.180$) while other samples presented higher ratio values ($^{206}\text{Pb}/^{204}\text{Pb} > 18.78$ and $^{206}\text{Pb}/^{207}\text{Pb} > 1.191$).

Because of the lack in the literature of Pb isotope ratios data in Namibia coastal area, the interpretation of these results is particularly challenging. The Pb isotopic composition of the most contaminated samples is similar to the one measured in aerosol coming from Namib Desert, which could be influenced by Pb emissions from the Tsumeb mine and smelter (Bollhöfer and Rosman, 2000). Pb isotopic composition of Tsumeb ores were reported from Brown (Brown, 1962) and it is characterized by a high radiogenic contribution, with $^{206}\text{Pb}/^{204}\text{Pb}$ and $^{206}\text{Pb}/^{207}\text{Pb}$ ratios of 18.29 and 1.15 respectively. Another probable source of Pb in the most contaminated area is related to gasoline. The average $^{206}\text{Pb}/^{207}\text{Pb}$ in the most contaminated samples was found to be closer to European gasoline signature (1.080-1.156) than to the South African one (1.055-1.083) as already reported in surface sediment sample from Cape Town (Larsen et al., 2012). The lack of published data on this subject makes difficult any further interpretation of these results.

Figure 7 Three isotope graph representation of Pb isotope ratios results in sediment surface samples: a) $^{206}\text{Pb}/^{204}\text{Pb}$ vs $^{208}\text{Pb}/^{204}\text{Pb}$, $R^2= 0.8049$ and b) $^{206}\text{Pb}/^{204}\text{Pb}$ vs $^{206}\text{Pb}/^{207}\text{Pb}$, $R^2= 0.9771$

a)

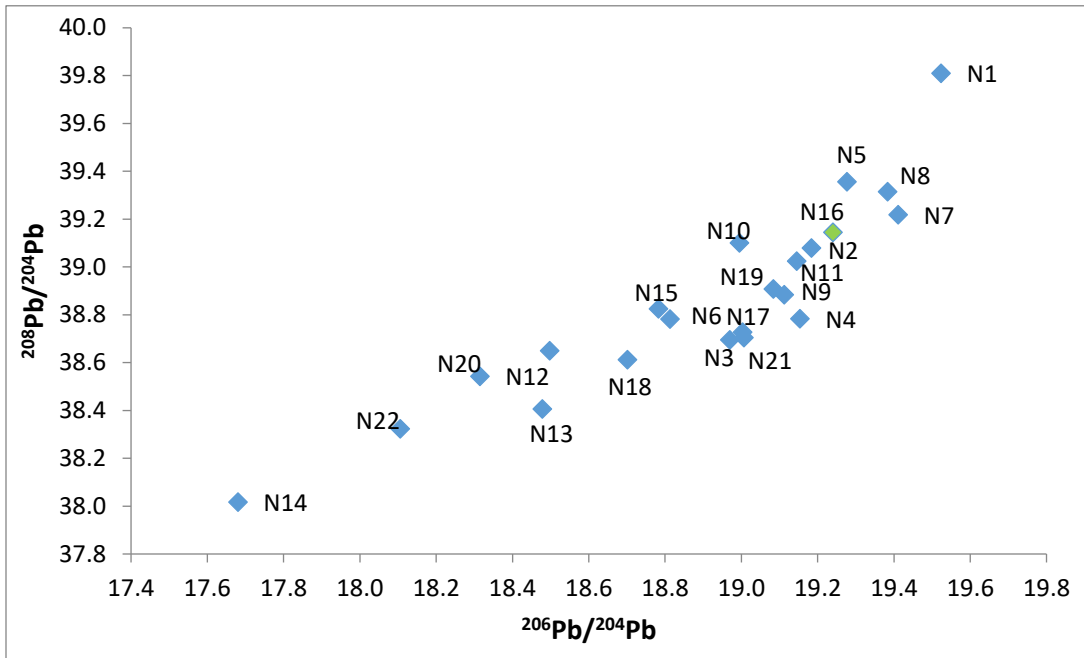

b)

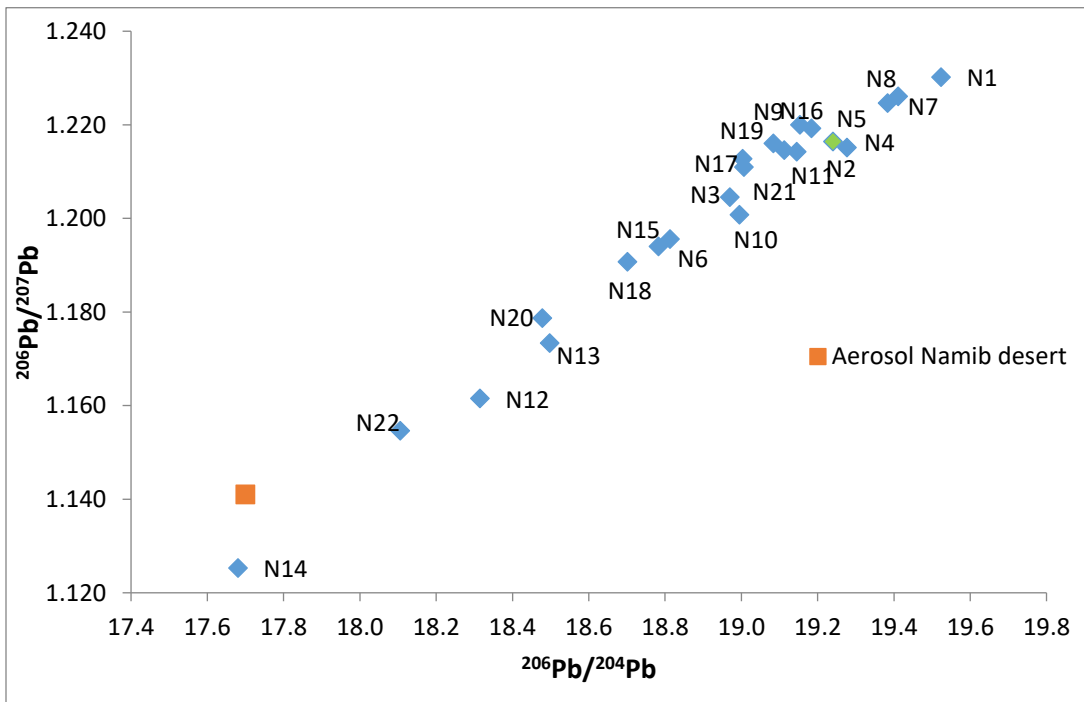

Rare Earth Elements results are shown in Table 5S. Their concentrations were normalized in order to allow easier comparison in different sediment samples (Um et al., 2013; Alibo and Nozaki, 1999). In this study the normalization was performed using the North American shale (NASC, Piper, 1974) and the Upper Continental Crust standards (UCC, McLennan, 1989). The ratio Ce/Ce^* (cerium anomaly) was also evaluated (Hatje et al., 2016). A representation of normalized results is shown in Fig. 8a and 8b.

Although the concentration of single REEs differed from site to site, the overall normalized patterns in the Namibian sediments showed common characteristics. Samples N8, N17 and N19 at off-shore stations are characterized by an increased concentration of basically all REEs and they are presented in a separated graph in Fig.8 for simplifying the data visualization. The calculated Ce/Ce^* in the analyzed samples did not exceed 1 in most of the sampling locations, showing a behavior similar to the shale standard. The only visible exception was observed for sample N17 and N19 which showed Ce/Ce^* of 1.5 and 1.6 respectively, as they are characterized by a much higher concentration of REEs: high contents simply highlight the characteristic pattern that can be considered, making it more visible in the graphical representation.

Normalization performed using UCC highlighted a slight enrichment of heavy REEs (HREEs) in three locations N3 N13 and N21 being the only sites showing normalized values above 1 for Lu, Yb, Tm, Er, Ho, Dy, Tb, Gd and Eu. Nevertheless, the REEs path in both normalized sets of data did not show elemental anomalies that could be related to anthropogenic activities. Another characteristic of this profile is a slight Tb depletion, which can be observed in both graphic representations.

$(La/Yb)_N$ ratios, calculated on both normalized data sets, showed a constant tendency to HREEs enrichment over light REEs (LREEs) in almost all sampling sites, with values below 1 in practically all analyzed samples. The ratios exceeded 1 only in two locations, N14 and N5; interestingly N12 showed also the highest amount of organic carbon. Some studies have investigated the influence of organic matter on REEs retention and fractionation (Pourret et al., 2007; Tang and Johannesson, 2010) and it seems reasonable to assume that the REEs behavior and fractionation was influenced by organic matter in the analyzed samples. Positive correlation was indeed found between the normalized La/Yb ratios and the organic carbon content ($R^2 = 0.731$), results are shown in Table 6S. Sediments collected in other sampling sites showed very stable La/Yb ratios, consistently lower than 1 which can be considered characteristic of the studied area and ascribable to the presence of primary minerals such as zircon (Aide and Aide, 2012). The enrichment in heavy REEs represents a unique and interesting characteristic since most rare earth deposits have a preponderance of light REEs. Some studies have shown that deposits in

Lofdal (carbonatite-dykes), located at about 450 km northeast of Windhoek and Okorusu (carbonatite-associated) display REEs enrichment (Wall et al., 2008). Especially, Xenotime present in Lofdal deposits seems to be precious source of heavy rare earths and could be the first sustainable supply of HREEs outside of China. Table 6S also shows a significant correlation between Y, Th, U, P and REEs as they naturally occur together in the same minerals, such as Xenotime and Monazite. The pattern found in sediment samples analyzed in the present study resembles the pattern found in Xenotime minerals collected in Lofdal (Wall et al., 2008), confirming that the input of REEs in the analyzed area is uniquely related to geochemical background.

In conclusion the present work provides a baseline study of metal contamination in the Namibian coast. The highest values of the Pollution Load Index (PLI) were found around Walvis Bay and Swakopmund, suggesting that trace element concentrations in those areas are influenced by human activities. Among toxic elements, the highest Enrichment Factor (EF) were determined for As, Cd and Sb in several sampling sites while Cu, Pb and Zn showed very high enrichment only in one site, located on the Walvis Bay harbor. Other elements such as Cr, Co and Ni, even when presenting high values compared to other studies, did not show substantial enrichment, suggesting non-anthropogenic sources. No significant correlation was found between any of the elements determined in this study and organic carbon, suggesting that the upwelling current, which is usually rich in both trace elements and organic matter, did not influence the metal content in sediment samples analyzed in this work. The determination of Pb isotope ratios, gave confirmation that the high enrichment of Pb at Walvis Bay and Lüderitz, derives from anthropogenic activities, and it is probably related to anthropogenic activities around the main harbor including spilling of products delivered to the main harbors. Pearson's correlation and Principal Component Analysis (PCA) applied to the results highlighted common sources for As, Cd and Sb and a common source for Zn, Pb and Cu. REEs concentrations in the sediment samples showed high variability, but they followed a common characteristic pattern, with no significant anomalies. These results suggest that this group of elements is not influenced by anthropogenic activities and it is characteristic of the geochemical background of the area.

Figure 8. Graphic representation of a) North American Shale Composite and b) Upper Continental Crust normalized REE concentrations measured along the Namibian coast

a)

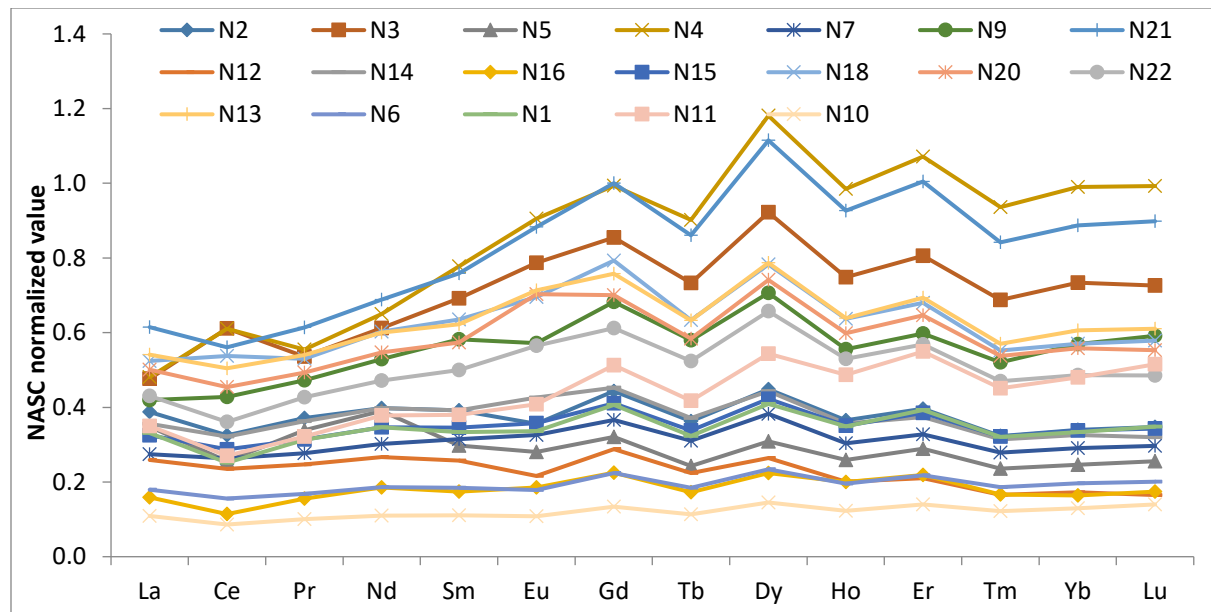
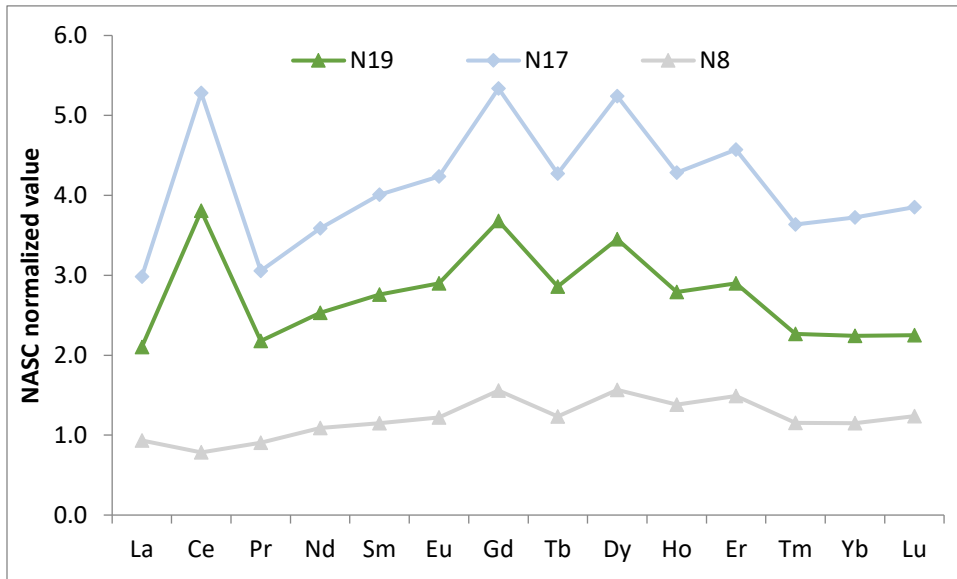

b)

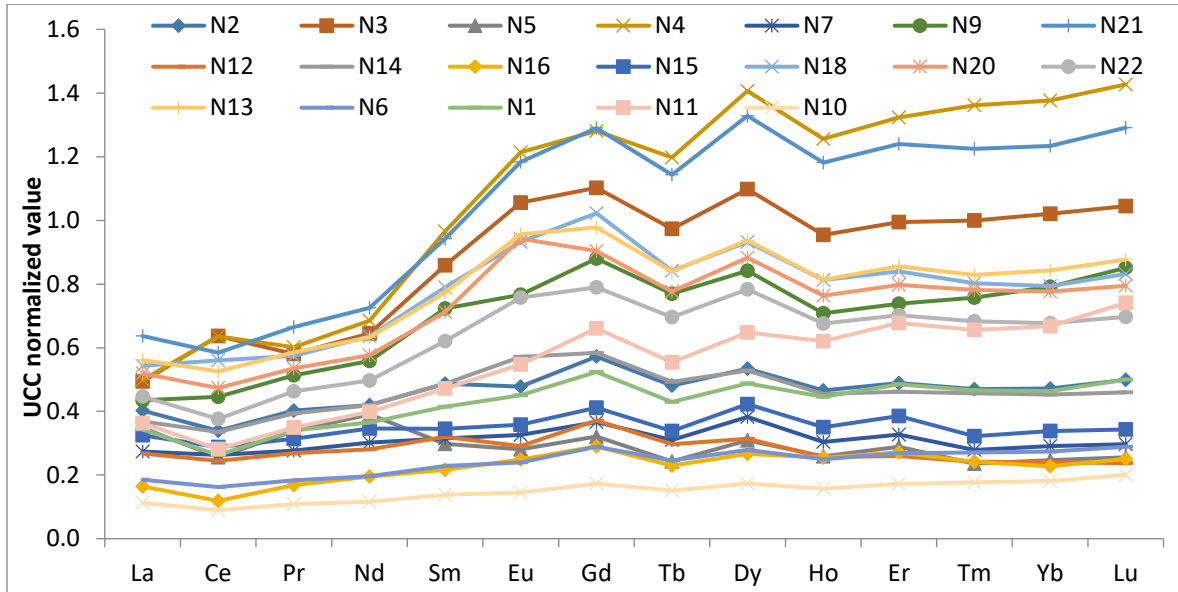
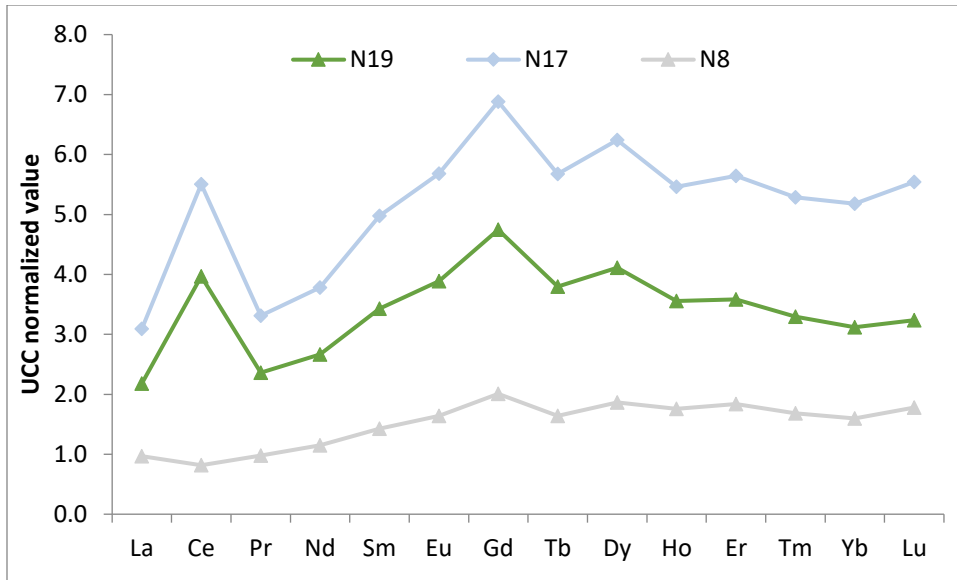

References (paper 4)

- Aide, M.T., Aide, C., 2012. Rare Earth Elements: Their Importance in Understanding Soil Genesis. *ISRN Soil Sci.* 2012, 1–11. doi:10.5402/2012/783876
- Alibo, D.S., Nozaki, Y., 1999. Rare earth elements in seawater: Particle association, shale-normalization, and Ce oxidation. *Geochim. Cosmochim. Acta* 63, 363–372. doi:10.1016/S0016-7037(98)00279-8
- Bollhöfer, A., Rosman, K.J., 2000. Isotopic source signatures for atmospheric lead: the Southern Hemisphere. *Geochim. Cosmochim. Acta* 64, 3251–3262. doi:10.1016/S0016-7037(00)00436-1
- Bremner, J.M., Willis, J.P., 1993. Mineralogy and geochemistry of the clay fraction of sediments from the Namibian continental margin and the adjacent hinterland. *Mar. Geol.* 115, 85–116. doi:10.1016/0025-3227(93)90076-8
- Brown, J.S., 1962. Ore leads and isotopes. *Econ. Geol.* 57, 673–720. doi:10.2113/gsecongeo.57.5.673
- Bryan, G.W., Langston, W.J., 1992. Bioavailability, accumulation and effects of heavy metals in sediments with special reference to United Kingdom estuaries: a review. *Environ. Pollut.* 76, 89–131. doi:10.1016/0269-7491(92)90099-V
- Caccia, V.G., Millero, F.J., Palanques, A., 2003. The distribution of trace metals in Florida Bay sediments. *Mar. Pollut. Bull.* 46, 1420–1433. doi:10.1016/S0025-326X(03)00288-1
- Calvert, S.E., Price, N.B., 1970. Minor Metal Contents of Recent Organic-rich Sediments off South West Africa. *Nature* 227, 593–595.
- De Gregori H., I., Pinochet C., H., Arancibia J., M., Vidal B., A., 1996. Grain Size Effect on Trace Metals Distribution in Sediments from Two Coastal Areas of Chile. *Bull. Environ. Contam. Toxicol.* 57, 163–170. doi:10.1007/s001289900170
- Ellam, R.M., 2010. The graphical presentation of lead isotope data for environmental source apportionment. *Sci. Total Environ.* 408, 3490–3492. doi:10.1016/j.scitotenv.2010.03.037
- FAO, 2007. Fishery Country Profile- The Republic of Namibia [WWW Document]. URL <http://www.fao.org/fi/oldsite/FCP/en/NAM/profile.htm>
- Guan, Q., Cai, A., Wang, F., Wang, L., Wu, T., Pan, B., Song, N., Li, F., Lu, M., 2016. Heavy metals in the riverbed surface sediment of the Yellow River, China. *Environ. Sci. Pollut. Res.* 23, 24768–24780. doi:10.1007/s11356-016-7712-z
- Hansmann, W., Köppel, V., 2000. Lead-isotopes as tracers of pollutants in soils. *Chem. Geol.* 171, 123–144. doi:10.1016/S0009-2541(00)00230-8
- Hatje, V., Bruland, K.W., Flegal, A.R., 2016. Increases in Anthropogenic Gadolinium Anomalies and Rare Earth Element Concentrations in San Francisco Bay over a 20 Year Record. *Environ. Sci. Technol.* 50, 4159–4168. doi:10.1021/acs.est.5b04322
- ISO/IEC 17025, 2017. General Requirements for the Competence of Testing and Calibration Laboratories. Geneva, Switzerland.
- Jung, H.S., Lim, D., Choi, J.Y., Yoo, H.S., Rho, K.C., Lee, H.B., 2012. Rare earth element compositions of core sediments from the shelf of the South Sea, Korea: Their controls and origins. *Cont. Shelf Res.* 48, 75–86. doi:10.1016/j.csr.2012.08.008

- Kljaković-Gašpić, Z., Bogner, D., Ujević, I., 2008. Trace metals (Cd, Pb, Cu, Zn and Ni) in sediment of the submarine pit Dragon ear (Soline Bay, Rogoznica, Croatia). *Environ. Geol.* 58, 751. doi:10.1007/s00254-008-1549-9
- Kulaksiz, S., Bau, M., 2011. Rare earth elements in the Rhine River, Germany: First case of anthropogenic lanthanum as a dissolved microcontaminant in the hydrosphere. *Environ. Int.* 37, 973–979. doi:10.1016/j.envint.2011.02.018
- Larsen, M.M., Blusztajn, J.S., Andersen, O., Dahllöf, I., 2012. Lead isotopes in marine surface sediments reveal historical use of leaded fuel. *J. Environ. Monit.* 14, 2893. doi:10.1039/c2em30579h
- Mapani, B., Ellmies, R., Kamona, F., Křibek, B., Majer, V., Knésl, I., Pašava, J., Mufenda, M., Mbingeneeko, F., 2009. Human health risks associated with historic ore processing at Berg Aukas, Grootfontein area, Namibia. *Communs geol. Surv. Namibia* 14, 25–40. doi:10.1016/j.jafrearsci.2010.07.007
- McLennan, S.M., 1989. Rare earth elements in sedimentary rocks; influence of provenance and sedimentary processes. *Rev. Mineral. Geochemistry* 21, 169–200.
- Mileusnić, M., Mapani, B.S., Kamona, A.F., Ružičić, S., Mapaure, I., Chimwamurombe, P.M., 2014. Assessment of agricultural soil contamination by potentially toxic metals dispersed from improperly disposed tailings, Kombat mine, Namibia. *J. Geochemical Explor.* 144, 409–420. doi:10.1016/j.gexplo.2014.01.009
- Ministry of Environment and Tourism, 2008. Strategic Environmental Assessment (SEA) of the coastal areas of the Erongo and Kunene regions.
- Orris, G.J., Grauch, R.I., 2002. Rare Earth Element Mines, Deposits, and Occurrences.
- Piper, D.Z., 1974. Rare earth elements in the sedimentary cycle: A summary. *Chem. Geol.* 14, 285–304. doi:10.1016/0009-2541(74)90066-7
- Pourret, O., Davranche, M., Gruau, G., Dia, A., 2007. Rare earth elements complexation with humic acid. *Chem. Geol.* 243, 128–141. doi:10.1016/j.chemgeo.2007.05.018
- Rezaee, K., Saion, E.B., Wood, A.K., Abdi, M.R., 2010. Rare earth elements determination and distribution patterns in surface marine sediments of the South China Sea by INAA, Malaysia. *J. Radioanal. Nucl. Chem.* 283, 823–829. doi:10.1007/s10967-009-0421-z
- Roose, P., Albaigés, J., Bebianno, M.J., Camphuysen, C., Cronin, M., de Leeuw, J., Gabrielsen, G., Hutchinson, T., Hylland, K., Jansson, B., Jenssen, B.M., Schulz-Bull, D., Szefer, P., Webster, L., Bakke, T., Janssen, C., 2011. Monitoring Chemical Pollution in Europe's Seas: Programmes, practices and priorities for Research. *Mar. Board Position* 108.
- Sakko, A.L., 1998. The influence of the Benguela upwelling system on Namibia's marine biodiversity. *Biodivers. {&} Conserv.* 7, 419–433. doi:10.1023/A:1008867310010
- Song, Y.H., Choi, M.S., 2009. REE geochemistry of fine-grained sediments from major rivers around the Yellow Sea. *Chem. Geol.* 266, 337–351. doi:10.1016/j.chemgeo.2009.06.019
- Sulochanan, B., Krishnakumar, P.K., Prema, D., Kaladharan, P., Valsala, K.K., Bhat, G.S., Muniyandi, K., 2007. Trace metal contamination of the marine environment in Palk Bay and Gulf of Mannar. *J. Mar. Biol. Assoc. India* 49, 12–18.
- Tang, J., Johannesson, K.H., 2010. Ligand extraction of rare earth elements from aquifer sediments:

- Implications for rare earth element complexation with organic matter in natural waters. *Geochim. Cosmochim. Acta* 74, 6690–6705. doi:10.1016/j.gca.2010.08.028
- Tchounwou, P.B., Yedjou, C.G., Patlolla, A.K., Sutton, D.J., 2012. Heavy Metals Toxicity and the Environment. *Mol. Clin. Environ. Toxicol.* 101, 1–30. doi:10.1007/978-3-7643-8340-4
- Um, I. kwon, Choi, M.S., Bahk, J.J., Song, Y.H., 2013. Discrimination of sediment provenance using rare earth elements in the ulleung basin, east/japan sea. *Mar. Geol.* 346, 208–219. doi:10.1016/j.margeo.2013.09.007
- UN DOALOS (Division for Ocean Affairs and the Law of the Sea), 2016. First Global Integrated Marine Assessment (first World Ocean Assessment) [WWW Document]. URL http://www.un.org/depts/los/global_reporting/WOA_RegProcess.htm
- UNEP, 2011. Abidjan Convention. Convention for Co-operation in the Protection and Development of the Marine and Coastal environment of the West and Central African Region [WWW Document].
- UNEP regional seas, 2017 [WWW Document], n.d. URL <http://www.unep.org/regionalseas/> (accessed 7.13.17).
- Wall, F., Niku-Paavola, V.N., Storey, C., Müller, A., Jeffries, T., 2008. Xenotime-(Y) from carbonatite dykes at Lofdal, Namibia: Unusually low LREE:HREE ratio in carbonatite, and the first dating of xenotime overgrowths on zircon. *Can. Mineral.* 46, 861–877. doi:10.3749/canmin.46.4.861
- Wang, X., Qin, Y., 2006. Spatial distribution of metals in urban topsoils of Xuzhou (China): controlling factors and environmental implications. *Environ. Geol.* 49, 905–914. doi:10.1007/s00254-005-0122-z
- Wang, X.S., 2008. Correlations between heavy metals and organic carbon extracted by dry oxidation procedure in urban roadside soils. *Environ. Geol.* 54, 269–273. doi:10.1007/s00254-007-0814-7
- Xu, Z., Lim, D., Choi, J., Yang, S., Jung, H., 2009. Rare earth elements in bottom sediments of major rivers around the Yellow Sea: implications for sediment provenance. *Geo-Marine Lett.* 29, 291–300. doi:10.1007/s00367-009-0142-x
- Zahra, A., Hashmi, M.Z., Malik, R.N., Ahmed, Z., 2014. Enrichment and geo-accumulation of heavy metals and risk assessment of sediments of the Kurang Nallah—Feeding tributary of the Rawal Lake Reservoir, Pakistan. *Sci. Total Environ.* 470–471, 925–933. doi:10.1016/j.scitotenv.2013.10.017

SUPPLEMENTARY INFORMATION (paper 4)

Table 15. Trace and major elements concentrations (mg/kg) with corresponding expanded uncertainties (k=2) in surface sediment samples

Sample	As	Be	Cd	Co	Cr	Cu	Hg	Li	Mo
N1	4.8 ± 0.7	0.7 ± 0.1	0.43 ± 0.07	3.0 ± 0.5	90 ± 10	27 ± 4	0.030 ± 0.004	21 ± 3	1.9 ± 0.3
N2	45 ± 7	0.8 ± 0.1	7.3 ± 1	3.7 ± 0.6	100 ± 20	22 ± 3	0.12 ± 0.02	18 ± 3	19 ± 3
N3	5.2 ± 0.8	1.5 ± 0.2	0.54 ± 0.08	5.3 ± 0.8	100 ± 20	8 ± 1	0.005 ± 0.001	13 ± 2	0.59 ± 0.09
N4	8 ± 1	0.14 ± 0.02	1.0 ± 0.1	6 ± 1	140 ± 20	11 ± 2	0.007 ± 0.001	12 ± 2	0.30 ± 0.05
N5	3.2 ± 0.5	0.41 ± 0.06	0.5 ± 0.1	1.9 ± 0.3	100 ± 20	23 ± 3	0.038 ± 0.006	10 ± 1	1.4 ± 0.2
N6	42 ± 6	0.51 ± 0.08	6 ± 1	1.7 ± 0.3	90 ± 10	12 ± 2	0.043 ± 0.006	10 ± 1	18 ± 3
N7	40 ± 6	1.2 ± 0.2	3.1 ± 0.5	4.8 ± 0.7	70 ± 11	16 ± 2	0.025 ± 0.004	23 ± 3	4.1 ± 0.6
N8	18 ± 3	0.7 ± 0.1	1.5 ± 0.2	2.7 ± 0.4	120 ± 20	29 ± 4	0.047 ± 0.007	7 ± 1	4.2 ± 0.6
N9	12 ± 2	2.3 ± 0.4	0.8 ± 0.1	8 ± 1	59 ± 9	15 ± 2	0.021 ± 0.003	27 ± 4	0.8 ± 0.1
N10	11 ± 2	0.35 ± 0.05	7 ± 1	1.6 ± 0.2	50 ± 8	20 ± 3	0.026 ± 0.004	6.2 ± 0.9	43 ± 6
N11	8 ± 1	0.41 ± 0.06	1.5 ± 0.2	1.7 ± 0.3	80 ± 10	22 ± 3	0.043 ± 0.006	5.1 ± 0.8	6.2 ± 0.9
N12	15 ± 2	0.63 ± 0.09	4.0 ± 0.6	3.2 ± 0.5	55 ± 8	35 ± 5	0.027 ± 0.004	14 ± 2	16 ± 2
N13	8 ± 1	1.4 ± 0.2	0.7 ± 0.1	10 ± 1	140 ± 20	19 ± 3	0.023 ± 0.003	27 ± 4	1.8 ± 0.3
N14	15 ± 2	0.8 ± 0.1	5.2 ± 0.8	7 ± 1	120 ± 20	200 ± 30	0.08 ± 0.01	16 ± 2	27 ± 4
N15	36 ± 5	0.8 ± 0.1	12 ± 2	4.7 ± 0.7	120 ± 20	22 ± 3	0.050 ± 0.008	15 ± 2	8 ± 1
N16	2.4 ± 0.4	0.34 ± 0.05	0.20 ± 0.03	1.7 ± 0.3	45 ± 7	18 ± 3	0.07 ± 0.01	9 ± 1	0.8 ± 0.1
N17	38 ± 6	1.5 ± 0.2	20 ± 3	3.1 ± 0.5	160 ± 20	19 ± 3	0.09 ± 0.01	8 ± 1	14 ± 2
N18	43 ± 6	1.0 ± 0.2	10 ± 2	5.0 ± 0.7	160 ± 20	17 ± 2	0.053 ± 0.008	20 ± 3	6.2 ± 0.9
N19	23 ± 3	3.0 ± 0.5	5.5 ± 0.8	3.0 ± 0.5	270 ± 40	20 ± 3	0.08 ± 0.01	36 ± 5	3.2 ± 0.5
N20	6.2 ± 0.9	1.1 ± 0.2	0.7 ± 0.1	9 ± 1	120 ± 20	15 ± 2	0.036 ± 0.005	18 ± 3	1.1 ± 0.2
N21	4.8 ± 0.7	0.8 ± 0.1	0.52 ± 0.08	13 ± 2	220 ± 30	14 ± 2	0.09 ± 0.01	12 ± 2	0.7 ± 0.1
N22	7 ± 1	0.9 ± 0.1	0.42 ± 0.06	5.8 ± 0.9	90 ± 10	54 ± 8	0.038 ± 0.006	15 ± 2	1.3 ± 0.2

Table 1S (continued)

Sample	Ni	Pb	Sb	Sn	Th	Tl	U	Y	V
N1	52 ± 8	2.9 ± 0.4	0.8 ± 0.1	0.9 ± 0.1	2.6 ± 0.4	0.21 ± 0.03	5.7 ± 0.9	10 ± 2	32 ± 5
N2	34 ± 5	5.4 ± 0.8	0.34 ± 0.05	1.2 ± 0.2	3.6 ± 0.5	0.7 ± 0.1	5.1 ± 0.8	11 ± 2	46 ± 7
N3	12 ± 2	14 ± 2	0.12 ± 0.02	2.0 ± 0.3	4.8 ± 0.7	0.7 ± 0.1	3.6 ± 0.5	24 ± 4	61 ± 9
N4	16 ± 2	14 ± 2	0.17 ± 0.03	0.15 ± 0.02	0.7 ± 0.1	0.07 ± 0.01	5.5 ± 0.8	6 ± 1	80 ± 10
N5	38 ± 6	1.7 ± 0.3	1.2 ± 0.2	0.47 ± 0.07	1.7 ± 0.3	0.15 ± 0.02	2.4 ± 0.4	10 ± 1	20 ± 3
N6	19 ± 3	4.5 ± 0.7	0.16 ± 0.02	0.7 ± 0.1	1.9 ± 0.3	3.1 ± 0.5	4.2 ± 0.6	7 ± 1	70 ± 11
N7	21 ± 3	7.9 ± 1	0.30 ± 0.04	2.5 ± 0.4	3.3 ± 0.5	0.9 ± 0.1	2.6 ± 0.4	10 ± 1	90 ± 10
N8	61 ± 9	3.7 ± 0.5	2.9 ± 0.4	0.52 ± 0.08	1.9 ± 0.3	9 ± 1	23 ± 3	34 ± 5	26 ± 4
N9	20 ± 3	18 ± 3	0.08 ± 0.01	3.4 ± 0.5	7 ± 1	0.8 ± 0.1	3.1 ± 0.5	19 ± 3	80 ± 10
N10	39 ± 6	2.7 ± 0.4	0.27 ± 0.04	0.7 ± 0.1	1.1 ± 0.2	1.4 ± 0.2	6.9 ± 1	2.5 ± 0.4	70 ± 11
N11	44 ± 7	2.2 ± 0.3	1.6 ± 0.2	0.33 ± 0.05	0.9 ± 0.1	2.0 ± 0.3	11 ± 2	11 ± 2	23 ± 3
N12	15 ± 2	15 ± 2	0.48 ± 0.07	1.2 ± 0.2	2.6 ± 0.4	0.9 ± 0.1	4.4 ± 0.7	6 ± 1	46 ± 7
N13	29 ± 4	11 ± 2	0.43 ± 0.06	2.1 ± 0.3	5.5 ± 0.8	0.55 ± 0.08	2.7 ± 0.4	20 ± 3	80 ± 10
N14	21 ± 3	170 ± 20	1.0 ± 0.1	10 ± 1	2.6 ± 0.4	1.0 ± 0.1	4.6 ± 0.7	11 ± 2	70 ± 11
N15	30 ± 4	5.6 ± 0.8	0.22 ± 0.03	1 ± 0.1	2.9 ± 0.4	1.8 ± 0.3	4.3 ± 0.6	12 ± 2	56 ± 8
N16	33 ± 5	1.7 ± 0.3	0.37 ± 0.06	0.45 ± 0.07	1.8 ± 0.3	0.15 ± 0.02	3.3 ± 0.5	16 ± 2	14 ± 2
N17	43 ± 6	10 ± 1	4.1 ± 0.6	0.54 ± 0.08	14 ± 2	17 ± 3	53 ± 8	148 ± 20	47 ± 7
N18	27 ± 4	7.4 ± 1	0.9 ± 0.1	1.2 ± 0.2	3.8 ± 0.6	1.2 ± 0.2	5.7 ± 0.9	19 ± 3	70 ± 10
N19	38 ± 6	6.1 ± 0.9	1.9 ± 0.3	0.7 ± 0.1	8 ± 1	2.6 ± 0.4	20 ± 3	94 ± 10	130 ± 20
N20	24 ± 4	11 ± 2	0.38 ± 0.06	2.2 ± 0.3	4.2 ± 0.6	0.49 ± 0.07	2.1 ± 0.3	16 ± 2	80 ± 10
N21	26 ± 4	10 ± 1	0.32 ± 0.05	1.4 ± 0.2	5.4 ± 0.8	0.49 ± 0.07	3.0 ± 0.5	29 ± 4	140 ± 20
N22	21 ± 3	13 ± 2	0.28 ± 0.04	27 ± 4	4.9 ± 0.7	0.38 ± 0.06	2.1 ± 0.3	16 ± 2	56 ± 8

Table 1S (continued)

Sample	Al	Ba	Fe	Mn	P	Sr	Ti	Zn
N1	36000 ± 5000	90 ± 10	13000 ± 2000	80 ± 10	1400 ± 200	1500 ± 200	1500 ± 200	43 ± 6
N2	23000 ± 3000	170 ± 30	17000 ± 2000	130 ± 20	3700 ± 600	230 ± 40	1800 ± 300	31 ± 5
N3	42000 ± 6000	290 ± 40	18000 ± 2700	420 ± 60	2600 ± 400	140 ± 20	5000 ± 700	29 ± 4
N4	40000 ± 6000	290 ± 40	22000 ± 3000	580 ± 90	700 ± 100	160 ± 20	330 ± 50	33 ± 5
N5	13000 ± 2000	40 ± 6	8300 ± 1200	31 ± 5	1300 ± 200	200 ± 30	600 ± 100	29 ± 4
N6	22000 ± 3000	140 ± 20	12000 ± 2000	42 ± 6	2600 ± 400	1100 ± 200	900 ± 100	100 ± 20
N7	23000 ± 3000	210 ± 30	20000 ± 3000	200 ± 30	1900 ± 300	160 ± 20	2500 ± 400	25 ± 4
N8	9800 ± 1000	55 ± 8	6900 ± 1000	44 ± 7	29000 ± 4000	190 ± 30	860 ± 100	37 ± 5
N9	57000 ± 9000	210 ± 30	32000 ± 5000	540 ± 80	1200 ± 200	500 ± 80	6800 ± 1000	70 ± 11
N10	10000 ± 2000	190 ± 30	3600 ± 500	37 ± 5	1500 ± 200	440 ± 70	530 ± 80	27 ± 4
N11	8400 ± 1000	40 ± 6	5700 ± 900	36 ± 5	12000 ± 2000	200 ± 30	600 ± 100	17 ± 3
N12	13000 ± 2000	170 ± 30	15000 ± 2000	100 ± 20	1400 ± 200	130 ± 20	1300 ± 200	70 ± 11
N13	51000 ± 8000	330 ± 50	44000 ± 6600	350 ± 50	2000 ± 300	190 ± 30	4600 ± 700	80 ± 10
N14	25000 ± 4000	220 ± 30	26000 ± 4000	230 ± 30	4100 ± 600	220 ± 30	2600 ± 400	400 ± 60
N15	24000 ± 4000	220 ± 30	20000 ± 3000	150 ± 20	3800 ± 600	220 ± 30	2200 ± 300	38 ± 6
N16	8000 ± 1000	70 ± 10	5000 ± 800	36 ± 5	1600 ± 200	190 ± 30	700 ± 100	23 ± 3
N17	19000 ± 3000	120 ± 20	17000 ± 2000	80 ± 10	56500 ± 8000	170 ± 30	1800 ± 300	32 ± 5
N18	32000 ± 5000	290 ± 40	31000 ± 4600	200 ± 30	3800 ± 600	1000 ± 100	3200 ± 500	54 ± 8
N19	24000 ± 4000	140 ± 20	86000 ± 13000	80 ± 10	16500 ± 2000	1000 ± 200	2300 ± 300	61 ± 9
N20	54000 ± 8000	240 ± 40	35000 ± 5000	330 ± 50	1800 ± 300	1100 ± 200	4200 ± 600	51 ± 8
N21	40000 ± 6000	310 ± 50	37000 ± 6000	700 ± 100	2300 ± 400	1200 ± 200	7400 ± 1100	47 ± 7
N22	45000 ± 7000	240 ± 40	25000 ± 4000	220 ± 30	1100 ± 200	200 ± 30	2700 ± 400	100 ± 20

Table 2S. Grain size distribution and organic carbon results in percentage (w/w)

Sample	Grain size distribution (%)				Organic C (%)
	>300 μm	1-4 μm	4-65 μm	65-300 μm	
N1	0.7	1.48	54.1	43.7	5.6
N2	1.4	0.12	18.6	79.9	7.6
N3	0.1	0.00	8.0	91.9	0.1
N4	0.05	0.00	8.0	92.0	0.2
N5	38	0.55	24.7	36.7	6.6
N6	0.06	0.73	51.6	47.6	6.3
N7	1.5	0.37	37.8	60.3	3.0
N8	13	0.30	16.4	70.3	5.7
N9	1.2	0.15	27.7	71.0	0.5
N10	1	0.92	60.6	37.5	5.8
N11	31	0.18	14.7	54.1	5.6
N12	0.2	0.54	48.2	51.0	38.2
N13	1.6	1.32	54.9	42.2	1.8
N14	6	0.71	42.6	50.7	2.8
N15	0.6	0.09	24.5	74.8	5.2
N16	2.6	0.73	38.5	58.1	3.6
N17	8.5	0.38	8.2	83.0	3.3
N18	1.1	0.59	34.2	64.1	3.1
N19	1	0.00	30.6	68.4	2.9
N20	0.2	0.15	36.5	75.1	1.6
N21	1	0.00	9.9	89.1	0.4
N22	22	0.41	34.8	42.8	2.2

Table 3S. Pearson's correlation matrix relative to trace and major elements determined in Namibian sediment samples. Values in bold are different from 0 with a significance level $\alpha=0.05$

Variables	Al	As	Ba	Be	Cd	Co	Cr	Cu	Fe	Hg	Li	Mn	Mo	Ni	P	Pb	Sb	Sn	Sr	Th	Ti	U	V	Y	Zn	OC
Al	1																									
As	-0.22	1																								
Ba	0.71	0.02	1																							
Be	0.41	0.15	0.19	1																						
Cd	-0.30	0.73	-0.04	0.13	1																					
Co	0.79	-0.24	0.77	0.25	-0.27	1																				
Cr	0.21	0.13	0.28	0.49	0.23	0.36	1																			
Cu	-0.07	-0.07	0.03	-0.08	0.03	0.13	-0.02	1																		
Fe	0.47	0.05	0.41	0.79	0.00	0.45	0.78	0.01	1																	
Hg	-0.30	0.40	-0.20	0.10	0.45	-0.01	0.42	0.25	0.18	1																
Li	0.54	0.13	0.36	0.77	-0.11	0.36	0.38	0.01	0.81	-0.03	1															
Mn	0.77	-0.29	0.76	0.20	-0.33	0.88	0.28	-0.06	0.33	-0.19	0.24	1														
Mo	-0.46	0.30	-0.08	-0.26	0.46	-0.32	-0.25	0.38	-0.29	0.22	-0.30	-0.39	1													
Ni	-0.47	-0.03	-0.68	-0.07	0.14	-0.44	0.11	-0.11	-0.17	0.29	-0.21	-0.55	0.05	1												
P	-0.31	0.30	-0.36	0.26	0.63	-0.25	0.33	-0.04	0.01	0.38	-0.22	-0.29	0.06	0.52	1											
Pb	0.06	-0.06	0.18	0.01	0.03	0.26	0.03	0.96	0.09	0.20	0.07	0.12	0.35	-0.25	-0.06	1										
Sb	-0.40	0.19	-0.50	0.20	0.51	-0.33	0.36	0.07	0.02	0.37	-0.20	-0.40	0.03	0.65	0.95	0.00	1									
Sn	0.31	-0.17	0.23	0.05	-0.17	0.20	-0.10	0.43	0.08	-0.03	0.07	0.09	-0.05	-0.27	-0.15	0.31	-0.16	1								
Sr	0.31	0.01	0.07	0.18	-0.07	0.20	0.39	-0.17	0.36	0.11	0.30	0.11	-0.11	0.12	-0.16	-0.15	-0.11	-0.16	1							
Th	0.34	0.18	0.25	0.58	0.46	0.29	0.64	-0.10	0.52	0.24	0.28	0.32	-0.21	0.00	0.67	-0.01	0.54	0.02	0.03	1						
Ti	0.75	-0.15	0.65	0.53	-0.20	0.85	0.30	-0.05	0.47	0.00	0.44	0.77	-0.35	-0.39	-0.18	0.10	-0.28	0.13	0.27	0.28	1					
U	-0.31	0.30	-0.35	0.27	0.67	-0.29	0.35	-0.06	0.04	0.36	-0.19	-0.30	0.11	0.50	0.99	-0.08	0.93	-0.18	-0.12	0.70	-0.21	1				
V	0.49	0.10	0.66	0.53	0.00	0.65	0.65	-0.03	0.76	0.08	0.54	0.61	-0.05	-0.40	-0.15	0.10	-0.23	0.02	0.42	0.40	0.61	-0.11	1			
Y	-0.07	0.25	-0.15	0.57	0.60	-0.08	0.58	-0.10	0.39	0.42	0.12	-0.11	-0.07	0.31	0.87	-0.08	0.80	-0.10	0.02	0.85	0.06	0.90	0.18	1		
Zn	0.10	-0.02	0.18	0.03	0.02	0.25	0.06	0.95	0.15	0.20	0.13	0.06	0.35	-0.26	-0.11	0.96	-0.04	0.41	-0.04	-0.04	0.10	-0.13	0.14	-0.10	1	
OC	-0.41	0.06	-0.24	-0.23	0.07	-0.33	-0.32	0.03	-0.23	-0.06	-0.13	-0.36	0.29	-0.09	-0.06	-0.06	-0.01	-0.12	-0.17	-0.26	-0.32	-0.04	-0.28	-0.15	-0.02	1

Table 4S. Lead isotope ratios for Namibian surface sediment samples with corresponding expanded uncertainties (k=2)

Sample	$^{206}\text{Pb}/^{204}\text{Pb}$	$^{207}\text{Pb}/^{204}\text{Pb}$	$^{208}\text{Pb}/^{204}\text{Pb}$	$^{208}\text{Pb}/^{206}\text{Pb}$	$^{206}\text{Pb}/^{207}\text{Pb}$
N1	19.52 ± 0.07	15.87 ± 0.06	39.8 ± 0.1	2.039 ± 0.004	1.230 ± 0.003
N2	19.18 ± 0.05	15.73 ± 0.04	39.1 ± 0.1	2.037 ± 0.002	1.219 ± 0.002
N3	18.97 ± 0.06	15.75 ± 0.05	38.7 ± 0.1	2.040 ± 0.004	1.205 ± 0.002
N4	19.15 ± 0.05	15.70 ± 0.04	38.8 ± 0.1	2.025 ± 0.003	1.220 ± 0.002
N5	19.28 ± 0.10	15.86 ± 0.08	39.4 ± 0.2	2.042 ± 0.009	1.215 ± 0.005
N6	18.81 ± 0.07	15.74 ± 0.06	38.8 ± 0.1	2.061 ± 0.003	1.196 ± 0.002
N7	19.41 ± 0.07	15.83 ± 0.06	39.2 ± 0.1	2.020 ± 0.004	1.226 ± 0.002
N8	19.38 ± 0.09	15.83 ± 0.07	39.3 ± 0.2	2.028 ± 0.008	1.225 ± 0.004
N9	19.11 ± 0.08	15.74 ± 0.06	38.9 ± 0.2	2.034 ± 0.004	1.215 ± 0.002
N10	19.00 ± 0.09	15.82 ± 0.07	39.1 ± 0.2	2.058 ± 0.007	1.201 ± 0.004
N11	19.15 ± 0.08	15.77 ± 0.06	39.0 ± 0.2	2.038 ± 0.006	1.214 ± 0.003
N12	18.31 ± 0.06	15.77 ± 0.05	38.5 ± 0.1	2.104 ± 0.004	1.162 ± 0.002
N13	18.48 ± 0.07	15.66 ± 0.06	38.4 ± 0.2	2.078 ± 0.003	1.180 ± 0.002
N14	17.68 ± 0.05	15.71 ± 0.06	38.0 ± 0.1	2.150 ± 0.004	1.125 ± 0.003
N15	18.78 ± 0.05	15.73 ± 0.04	38.8 ± 0.1	2.067 ± 0.003	1.194 ± 0.002
N16	19.24 ± 0.09	15.82 ± 0.07	39.1 ± 0.2	2.035 ± 0.006	1.216 ± 0.004
N17	19.00 ± 0.08	15.67 ± 0.07	38.7 ± 0.2	2.038 ± 0.008	1.213 ± 0.005
N18	18.70 ± 0.06	15.71 ± 0.05	38.6 ± 0.1	2.065 ± 0.004	1.191 ± 0.002
N19	19.08 ± 0.08	15.69 ± 0.06	38.9 ± 0.2	2.039 ± 0.005	1.216 ± 0.003
N20	18.50 ± 0.06	15.77 ± 0.05	38.6 ± 0.1	2.089 ± 0.003	1.173 ± 0.002
N21	19.01 ± 0.07	15.70 ± 0.05	38.7 ± 0.1	2.036 ± 0.004	1.211 ± 0.003
N22	18.11 ± 0.06	15.68 ± 0.05	38.3 ± 0.1	2.117 ± 0.004	1.155 ± 0.002

Table 55. Rare Earth Elements concentrations (mg/kg) with corresponding expanded uncertainties (k=2) in sediment samples collected along the Namibian coast

Sample	La	Ce	Pr	Nd	Sm	Eu	Gd
N1	10 ± 2	17 ± 3	2.4 ± 0.4	9.5 ± 1	1.9 ± 0.3	0.40 ± 0.06	2.0 ± 0.3
N2	12 ± 2	22 ± 3	2.9 ± 0.4	11 ± 2	2.2 ± 0.3	0.42 ± 0.06	2.2 ± 0.3
N3	15 ± 2	41 ± 6	4.1 ± 0.6	17 ± 3	3.9 ± 0.6	0.93 ± 0.14	4.2 ± 0.6
N4	15 ± 2	41 ± 6	4.3 ± 0.6	18 ± 3	4.3 ± 0.7	1.1 ± 0.16	4.9 ± 0.7
N5	11 ± 2	17 ± 3	2.6 ± 0.4	11 ± 2	1.7 ± 0.2	0.33 ± 0.05	1.6 ± 0.2
N6	6 ± 1	10 ± 2	1.3 ± 0.2	5.1 ± 1	1.0 ± 0.2	0.21 ± 0.03	1.1 ± 0.2
N7	8.5 ± 1	18 ± 3	2.1 ± 0.3	8.3 ± 1	1.8 ± 0.3	0.38 ± 0.06	1.8 ± 0.3
N8	29 ± 4	52 ± 8	7.0 ± 1.0	30 ± 4	6.4 ± 1.0	1.4 ± 0.22	7.6 ± 1.1
N9	13 ± 2	29 ± 4	3.6 ± 0.5	15 ± 2	3.3 ± 0.5	0.67 ± 0.10	3.3 ± 0.5
N10	3 ± 1	6 ± 1	0.8 ± 0.1	3.0 ± 0	0.6 ± 0.1	0.13 ± 0.02	0.7 ± 0.1
N11	11 ± 2	18 ± 3	2.5 ± 0.4	10 ± 2	2.1 ± 0.3	0.48 ± 0.07	2.5 ± 0.4
N12	8.0 ± 1	16 ± 2	1.9 ± 0.3	7.3 ± 1	1.4 ± 0.2	0.26 ± 0.04	1.4 ± 0.2
N13	17 ± 3	34 ± 5	4.2 ± 0.6	16 ± 2	3.5 ± 0.5	0.84 ± 0.13	3.7 ± 0.6
N14	11 ± 2	21 ± 3	2.8 ± 0.4	11 ± 2	2.2 ± 0.3	0.50 ± 0.08	2.2 ± 0.3
N15	10 ± 2	19 ± 3	2.4 ± 0.4	9.5 ± 1	1.9 ± 0.3	0.42 ± 0.06	2.0 ± 0.3
N16	4.9 ± 1	8 ± 1	1.2 ± 0.2	5 ± 1	1.0 ± 0.1	0.22 ± 0.03	1.1 ± 0.2
N17	93 ± 14	352 ± 53	23.5 ± 3.5	98 ± 15	22 ± 3.4	5.0 ± 0.75	26.2 ± 3.9
N18	16 ± 2	36 ± 5	4.1 ± 0.6	17 ± 2	3.6 ± 0.5	0.82 ± 0.12	3.9 ± 0.6
N19	65 ± 10	250 ± 38	17 ± 2.5	69 ± 10	15 ± 2.3	3.4 ± 0.51	18 ± 2.7
N20	16 ± 2	30 ± 5	3.8 ± 0.6	15 ± 2	3.2 ± 0.5	0.83 ± 0.12	3.4 ± 0.5
N21	19 ± 3	37 ± 6	4.7 ± 0.7	19 ± 3	4.2 ± 0.6	1.0 ± 0.16	4.9 ± 0.7
N22	13 ± 2	24 ± 4	3.3 ± 0.5	13 ± 2	2.8 ± 0.4	0.67 ± 0.10	3.0 ± 0.5
Mean	18	50	5	19	4	1	5
St dev	21	84	5	22	5	1	6
Min	3	6	1	3	1	0.1	0.7
Max	93	352	24	98	22	5	26

Table 5S (continued)

Sample	Tb	Dy	Ho	Er	Tm	Yb	Lu	Ce/Ce*	(La/Yb) _N
N1	0.275 ± 0.04	1.7 ± 0.3	0.4 ± 0.05	1.1 ± 0.2	0.2 ± 0.02	1.0 ± 0.2	0.2 ± 0.02	0.8	1.0
N2	0.31 ± 0.05	1.9 ± 0.3	0.37 ± 0.06	1.1 ± 0.2	0.16 ± 0.02	1.0 ± 0.2	0.16 ± 0.02	0.8	1.1
N3	0.62 ± 0.09	3.8 ± 0.6	0.76 ± 0.11	2.3 ± 0.3	0.33 ± 0.05	2.2 ± 0.3	0.33 ± 0.05	1.0	0.6
N4	0.77 ± 0.11	4.9 ± 0.7	1.0 ± 0.15	3.0 ± 0.5	0.45 ± 0.07	3.0 ± 0.5	0.46 ± 0.07	0.8	0.5
N5	0.21 ± 0.03	1.3 ± 0.2	0.26 ± 0.04	0.82 ± 0.1	0.11 ± 0.02	0.75 ± 0.1	0.12 ± 0.02	0.9	1.4
N6	0.157 ± 0.02	1.0 ± 0.1	0.2 ± 0.03	0.6 ± 0.1	0.1 ± 0.01	0.6 ± 0.1	0.1 ± 0.01	0.9	0.9
N7	0.26 ± 0.04	1.6 ± 0.2	0.31 ± 0.05	0.93 ± 0.1	0.13 ± 0.02	0.89 ± 0.1	0.14 ± 0.02	0.8	0.9
N8	1.048 ± 0.16	6.5 ± 1.0	1.4 ± 0.21	4.2 ± 0.6	0.6 ± 0.08	3.5 ± 0.5	0.6 ± 0.09	0.9	0.8
N9	0.49 ± 0.07	2.9 ± 0.4	0.57 ± 0.08	1.7 ± 0.3	0.25 ± 0.04	1.7 ± 0.3	0.27 ± 0.04	0.8	0.7
N10	0.097 ± 0.01	0.6 ± 0.1	0.1 ± 0.02	0.4 ± 0.1	0.1 ± 0.01	0.4 ± 0.1	0.1 ± 0.01	0.7	0.8
N11	0.355 ± 0.05	2.3 ± 0.3	0.5 ± 0.07	1.6 ± 0.2	0.2 ± 0.03	1.5 ± 0.2	0.2 ± 0.04	0.9	0.7
N12	0.19 ± 0.03	1.1 ± 0.2	0.21 ± 0.03	0.60 ± 0.1	0.08 ± 0.01	0.53 ± 0.1	0.08 ± 0.01	0.9	1.5
N13	0.54 ± 0.08	3.3 ± 0.5	0.65 ± 0.10	2.0 ± 0.3	0.27 ± 0.04	1.9 ± 0.3	0.28 ± 0.04	0.9	0.9
N14	0.32 ± 0.05	1.8 ± 0.3	0.36 ± 0.05	1.1 ± 0.2	0.15 ± 0.02	1.0 ± 0.1	0.15 ± 0.02	0.9	1.1
N15	0.29 ± 0.04	1.8 ± 0.3	0.36 ± 0.05	1.1 ± 0.2	0.15 ± 0.02	1.0 ± 0.2	0.16 ± 0.02	0.9	1.0
N16	0.15 ± 0.02	0.9 ± 0.1	0.20 ± 0.03	0.6 ± 0.1	0.08 ± 0.01	0.5 ± 0.1	0.08 ± 0.01	0.7	1.0
N17	3.632 ± 0.54	22 ± 3.3	4.4 ± 0.66	13.0 ± 1.9	1.7 ± 0.26	11.4 ± 1.7	1.8 ± 0.27	1.5	0.8
N18	0.54 ± 0.08	3.3 ± 0.5	0.65 ± 0.10	1.9 ± 0.3	0.26 ± 0.04	1.7 ± 0.3	0.27 ± 0.04	0.9	0.9
N19	2.4 ± 0.36	14 ± 2.2	2.8 ± 0.43	8.2 ± 1.2	1.1 ± 0.16	6.9 ± 1.0	1.0 ± 0.16	1.6	0.9
N20	0.50 ± 0.07	3.1 ± 0.5	0.61 ± 0.09	1.8 ± 0.3	0.26 ± 0.04	1.7 ± 0.3	0.25 ± 0.04	0.8	0.9
N21	0.73 ± 0.11	4.6 ± 0.7	0.95 ± 0.14	2.9 ± 0.4	0.40 ± 0.06	2.7 ± 0.4	0.41 ± 0.06	0.8	0.7
N22	0.45 ± 0.07	2.7 ± 0.4	0.54 ± 0.08	1.6 ± 0.2	0.23 ± 0.03	1.5 ± 0.2	0.22 ± 0.03	0.8	0.9
Mean	1	4	1	2	0.3	2	0.3	1	1
St dev	0.8	5	1	3	0.4	3	0.4	0.2	0.2
Min	0.1	0.6	0.1	0.4	0.1	0.4	0.1	0.7	0.5
Max	4	22	4	13	2	11	2	1.6	1.5

Table 6S. Pearson's correlation matrix for REE and related elements. Values in bold are different from 0 with a significance level $\alpha=0.05$

Variables	P	Y	Th	U	Σ LREE	Σ HREE	Σ LREE/ Σ HREE	Ce/Ce*	(La/Yb)N	OC
P	1									
Y	0.873	1								
Th	0.666	0.851	1							
U	0.987	0.900	0.704	1						
Σ LREE	0.854	0.989	0.875	0.893	1					
Σ HREE	0.879	0.982	0.896	0.909	0.991	1				
Σ LREE/ Σ HREE	0.117	0.252	0.098	0.154	0.282	0.176	1			
Ce/Ce*	0.620	0.868	0.835	0.686	0.911	0.878	0.389	1		
(La/Yb)N	-0.166	-0.169	-0.347	-0.169	-0.165	-0.257	0.841	-0.128	1	
OC	-0.059	-0.154	-0.258	-0.038	-0.135	-0.178	0.534	-0.070	0.692	1

Paper 5

Pollution history study for inorganic contaminant in Namibian coastal sediments

Anna Maria Orani ^{a,b}, Emilia Vassileva ^{*a}, Sabine Schmidt ^c, Michael O. Angelidis ^a

^a International Atomic Energy Agency, Environment laboratories, 4 Quai Antoine 1er, MC 9800, Monaco

^b Université de Nice Sophia Antipolis, CNRS, IRD, Observatoire de la Côte d'Azur, Géoazur UMR 7329, 250 rue Albert Einstein, Sophia Antipolis 06560 Valbonne, France

^c CNRS, OASU, EPOC, UMR 5805, 33615 Pessac, France

Abstract

Trace elements, Rare Earth Elements (REEs) and Pb isotope ratios were determined in six small cores sampled along the Namibian coast and pollution indices, such as Enrichment Factor, Geo-accumulation Index and Pollution load index, were calculated in order to evaluate possible metal contamination in the area. Concentrations of Pb, Cu, As and Cd were strongly enhanced at the upper 7 cm of core C5, which is located at Walvis Bay, at the vicinity of a major harbor and urban/industrial center, indicating impact from recent anthropogenic activities. Principal Component Analysis was applied to the data set indicating possible common sources of the contaminants Pb stable isotope ratios, combined with the dating of core C5 at Walvis Bay, further confirmed the anthropogenic provenance of Pb sources in the recent sediment deposits, which occurred after 1945, when the anthropogenic activities in the area began to increase. REEs profiles were also determined, showing interesting enrichment in REEs for some of the samples, typical of the minerals present in the area. Ce anomaly was detected in one of the cores but generally speaking the REEs profile did not reveal anomalies ascribable to anthropogenic influence.

Key words: Trace elements, Rare Earth Elements, Lead isotope ratios, sediment core, pollution history, Namibian coast.

1. Introduction

Runoff material from the continent plays a key role on the mineralogy of coastal marine sediments. At drainage basins and coastal zones with important urban, industrial and mining activities, runoff material is enriched in trace elements, which are transported to the sea and accumulate on the marine sediments following flocculation of the colloidal constituents and suspended particle sedimentation (Gibbs 1986). As a result marine sediments constitute an archive of trace element inputs to the marine coastal environment and may be used as tools for establishing the effects of anthropogenic and natural processes on depositional environments (Harikumar and Nasir, 2010), and often used to study the pollution history of aquatic ecosystems (Valette-Silver, 1993, A.R.Karbassi, 2005; Kljaković-Gašpić et al., 2008, Sun et al., 2012; Vallius, 2014; Veerasingam et al., 2015). Trace element pollution in the coastal marine environment is an issue of major concern because of the toxicity to marine organisms and the potential threat to the health of local population through the consumption of contaminated seafood ((Harikumar and Nasir, 2010; Maggi et al., 2012; Di Lena, et al 2017, Korkmaz et al 2017, Kuranchie-Mensah, 2016, Nkpaa, K.W. 2016).

The coastal marine environment of Namibia is part of one of four major upwelling systems in the world and is exceptionally productive, supporting abundant marine life (Sakko, 1998). Namibia has low, but geographically very concentrated coastal population compared to other countries. Growing economic development and human activities along the coast lead to unprecedented migration, resulting to uncontrolled urban development and generation of untreated domestic and industrial effluents, which are discharged to the sea, Furthermore, the exploitation of mineral resources has been the backbone of the Namibian economy for many years as it is reflected to its contribution to the gross national product of the country (Ministry of Environment and Tourism, 2008), diamond, fluorspar, and uranium being the most significant mineral commodities to Namibia's economy. In 2012 the country was ranked sixth in terms of the total value of diamond production and fifth ranked producer of uranium (Bermudez-Lugo, 2014). Over the recent years the increasing profitability in the uranium market has seen several new Namibian uranium projects emerge. Mining activities together with urban centers developed at the Namibian coastline, appear to have an impact on the geochemistry of trace elements in coastal surface sediments, indicating possible contaminations from land based pollution sources. (Orani et al, submitted) In view of further investigation of trace element accumulation in the area, as well as to study historic records of metal accumulation in the Namibian marine coastal environment, six sediment cores were taken and analyzed for key trace elements and Rare Earth Elements. Pb stable isotopes were also determined to provide additional information on the provenance of trace elements (natural vs

anthropogenic) (Díaz-Somoano et al., 2009; Larsen et al., 2012, Xu et al., 2014; Mil-Homens et al., 2017). Also, several contamination indices were calculated (Enrichment Factors, Geo-accumulation Index and Pollution Load Index) in order to evaluate the extent of pollution and identify potential land based pollution sources.

2. Experimental

2.1. Reagents and materials

All sample handling was carried out in class 10 laminar hoods. Ultrapure water with resistivity > 18 MΩ was obtained from Milli-Q Element system (Millipore, USA) and was used throughout this work to dilute concentrated acids.

Trace grade HNO₃, HF and ultrapure HNO₃ were purchased from Fisher Scientific (Hampton, USA). Standard solutions for Al, Zn, Mn and Fe used for Flame AAS calibration and multielemental standard TraceCert used for ICP-MS external calibration, were purchased from Sigma Aldrich (Buchs, Switzerland) in concentrations of 1000 and 10 mg/L respectively. The Certified Reference Material MESS-2 (Estuarine sediment, National Research Council, Canada) was used for assessing data accuracy. The Standard Reference Material SRM 981 from the National Institute of Standards and Technology (NIST, USA) with the natural Pb isotopic composition was used for correction of the instrumental mass discrimination when measuring Pb isotope ratios.

All Teflon and PE lab ware used in the sample preparation and analysis, was pre-cleaned with a procedure consisting of at least 24h bath in 10% HNO₃ and careful rinsing with MilliQ water.

2.2. Instrumentation

Trace elements (TE: As, Ba, Cd, Co, Cr, Cu, Li, Ni, Pb, Sb, Sn, Sr, Th, U, and V) were determined by Inductively Coupled Plasma Quadrupole Mass Spectrometry (Q-ICP-MS, XSERIES, Thermo Fisher Scientific). The instrument was equipped with a micromist nebulizer (0.2 ml/min, Glass Expansion) and a cyclonic spray chamber cooled by Peltier cooling system ESI. Instrument is also equipped with collision cell technology (CCT) for interference removal; high purity He was used as collision gas. Before measurements, the method parameters in normal and collision modes were optimized for maximum

intensity and precision of each single isotope. As, Cr and V were measured in CCT mode, whereas the rest of trace elements and REE determined in sediment samples were measured in normal mode. Determination of Pb isotope ratios has been performed on digested samples by means of High Resolution Sector Field ICP-MS (NuAttom, NuInstruments Ltd., Wrexham, UK). The Standard Reference Material SRM 981 from the National Institute of Standards and Technology (NIST, USA) with the natural Pb isotopic composition was used for correction of the instrumental mass discrimination and verification of the developed analytical procedure. Instrumental conditions for TE, REEs and Pb isotope ratios were described in detail in the previous paper (Orani et al., paper 4).

Determination of Al, Fe, Mn and Zn was carried out by Flame Atomic Absorption Spectroscopy (ContrAA 700, Analytik Jena, Germany) on the same digested solutions used for ICP-MS, using external calibration. Temperature programs were developed and optimized for each of the studied elements. Calibration curves were daily prepared using proper dilution of commercially available standard solutions. The method blanks and CRMs prepared with each batch of samples were measured at the beginning and at the end of each measurement sequence to validate samples measurements.

Mercury was determined in sediment samples directly, using a solid AAS analyzer (AMA 254, Altech, USA), therefore no digestion was needed. A portion of about 100 mg of sediment was measured. The internal calibration of the instrument was checked every day using an external standard solution and a CRM (MESS-2) sampled at different intake masses, in order to verify the linearity of the calibration. The instrument was recalibrated if any of the checks failed. Organic Carbon (TOC) was measured by means of acidification and combustion in a one-unit carbon analysis system (Vario EL Cube, Elementar, Langenselbold, Germany).

Results were analyzed using XLSTAT (version 2014.05.5, Addinsoft, Paris, France). Regression analysis (Pearson's Product-Moment Correlation) was used to examine relationships between trace metals content and other parameters such as organic matter in order to identify common sources of pollution; in all cases, the level of significance was set at $p < 0.05$. Principal component analysis (PCA) was used to further investigate results patterns.

2.1. Sample preparation

Sediment cores were collected during a sampling campaign carried out in May 2014 in the frame of collaboration between the IAEA Environment Laboratories and the Environmental Division of the Namibian Ministry of Fisheries and Marine Resources. Several cores were collected in various sites along the Namibian coast, between 20°S and 24°S latitude and 11°E and 15°E longitude. Six core samples of different size were analyzed in this study; the sampling map is shown in Fig 1. The core length sizes (6 to 20 cm) differ between the stations due to variations in nature of the substrate.

Figure 1. Sampling station map. Black stars represent the sampling locations for each sediment core analyzed in this study

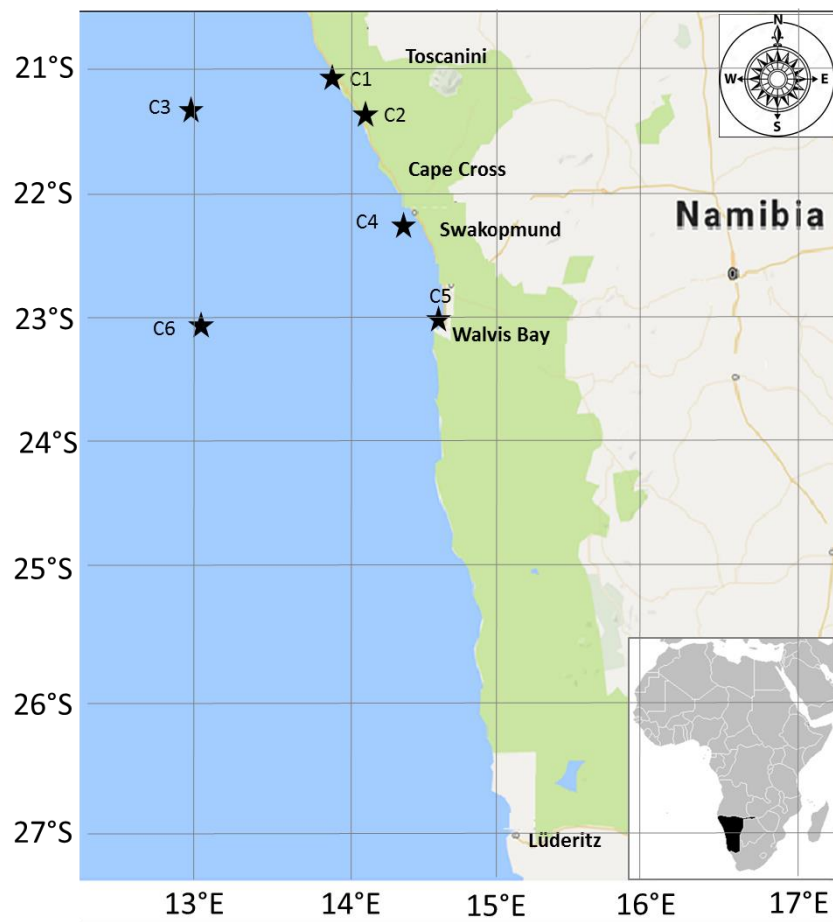

Sediments were collected using a MC-200-4 MiniMulti-Corer; samples were sliced per 1cm up to 10cm and per 2cm after 10cm length. After collection, sediments were packed in plastic bags, labelled and kept frozen during transportation at the laboratory. Later, samples were freeze-dried, sieved at 1 mm and crushed in agate mortar to homogenize. Acid digestion was carried out in a microwave system using a Mars X-press Microwave (CEM Mars X-press) equipped with a carousel holding 12 digestion vessels. A quantity of 150 ± 50 mg of dried sample was weighed in Teflon microwave vessels, where 5ml of ultrapure HNO_3 , 2 ml of H_2O_2 and 2 ml ultrapure concentrated HF were added. Each digestion batch included two reagent blanks and two replicates of certified reference material MESS-2 (estuarine sediment, National Research Council, Canada). The digestion procedure involves gradual increasing of temperature to 190 °C for 15 min period, then isothermal treatment for additional 15 min. After digestion, obtained solutions were placed on a ceramic heating plate and evaporated to near dryness. The residues were taken up in 2% HNO_3 , transferred to 50 ml PE tubes and stored at 4 °C.

2.4. Risk assessment methods of TE sediment contamination

To assess pollution state of an area, calculation is very often based on comparing data with background reference levels of the same element. The most accurate approach involves the use of background levels measured in uncontaminated sediments of the same area with mineralogical and textural characteristics similar to those shown by contaminated samples (Hornung et al., 1989; Abraham and Parker, 2008). Very often the uncontaminated samples used as background levels are taken from the bottom of sediment cores collected in uncontaminated areas. The background reference levels used for normalization purposes in this study were those measured in the bottom of sample C6, which shows stable values for most of the elements along the 7 cm of the core. Additionally the grain size distribution is also very similar to the one measured in the majority of core samples analyzed in our work (Varol, 2011).

Different parameters can be calculated to evaluate the anthropogenic influence on trace elements content in the sediments. In this work three parameters were evaluated: Enrichment Factors (EF), Geo-accumulation Index (I_{geo}) and Pollution Load Index (PLI). When the calculation of these parameters is applied to sediment cores, it is possible to evaluate potential historical differences

EF are used for studying heavy metal contamination and sources in sediments (Xu et al., 2014; Resongles et al., 2014) and their calculation implies the use of a normalizing element. Al is the normalizing

element more often chosen for this purpose (Guan et al., 2016; Zahra et al., 2014) since it is one of the most abundant elements on the Earth and usually has no contamination concerns (Zhang et al., 2009). EF are calculated using the following equation (1):

$$(1) \quad EF = \frac{[\frac{Metal}{Al}]_{sample}}{[\frac{Metal}{Al}]_{BG}}$$

where $[\frac{Metal}{Al}]_{Sample}$ is the metal to Al concentration ratio in the sample of interest, and $[\frac{Metal}{Al}]_{BG}$ is the natural background value of metal to Al ratio. EF results are interpreted following the guidelines previously shown (Orani et al., paper 4).

Similarly, the Geo-accumulation Index represents another parameter correlating metal concentrations in sediment samples with background levels, in order to evaluate additional metal inputs. It is calculated applying the following equation (2):

$$(2) \quad I_{geo} = \log_2 \frac{C_{metal}}{k \times C_{BG}}$$

where C_{metal} is the metal content measured in the sample, C_{BG} is the corresponding background content of the metal and k is the background matrix correction factor which accounts for possible differences in the background values due to lithospheric effects, ($k = 1.5$; Lu et al., 2009; Bhuiyan et al., 2010; Varol, 2011). I_{geo} provides a classification system for the degree of pollution (Table 3).

Pollution Load Index (PLI) evaluates the sediment's environmental quality and potential ecological risk caused by heavy metals (Bhuiyan et al., 2010). PLI has been determined as the n^{th} root of the product of the n CF (Contamination Factors) according to the equation (3):

$$(3) \quad PLI = (CF1 \times CF2 \times CF3 \dots \times CFn)^{1/n}$$

CF are calculated as the ratio between the concentration of each metal in the sediment sample and its concentration in the uncontaminated sediment, used as background, applying the equation (4):

$$(4) \quad CF = \frac{C_{metal}}{C_{background}}$$

This empirical index provides a simple, comparative means for assessing the level of heavy metal pollution. When $PLI > 1$, it means that a pollution exists; otherwise, if $PLI < 1$, the analyzed sample can be considered unpolluted (Tomlinson et al., 1980).

1.1. Dating

The age-depth model of core C5 was established based on ^{210}Pb excess ($^{210}\text{Pb}_{\text{xs}}$; $T_{1/2} = 22.3$ years), a naturally - occurring radionuclide which is incorporated rapidly into the sediment from atmospheric fallout and water column scavenging. The activities of ^{210}Pb and ^{226}Ra were measured using a well-type, low background germanium detector (CANBERRA) equipped of a Cryocycle (Schmidt and De Deckker, 2015). ^{210}Pb activity was determined by the direct measurement of its gamma decay energy at 46.5 keV, while ^{226}Ra was estimated as the weighted average of two ^{214}Pb peaks at 295.2 keV and 352 keV and a ^{214}Be peak at 609.3 keV. $^{210}\text{Pb}_{\text{xs}}$ was determined by subtracting the activity supported by its parent isotope, ^{226}Ra , from the total measured ^{210}Pb activity in sediment. Sediment accumulation rate (SAR, 0.07 cm yr^{-1}) was calculated from the sedimentary profiles of $^{10}\text{Pb}_{\text{xs}}$ plotted against depth. The deposition time, in years, was calculated by dividing the depth of each sediment layer by the SAR. The deposition year for each sediment layer was subsequently estimated based on the 2014 sampling date for the sediment-water interface.

2.6. Lead isotope ratios

The determination of lead isotope ratios has been proven to be a very helpful tool in the assessment of Pb source in the environment. Lead has a partially radiogenic isotopic composition as three of its stable isotopes (^{206}Pb , ^{207}Pb and ^{208}Pb) are the final results of radioactive decay of ^{235}U , ^{232}Th and ^{238}U respectively (Vanhaecke and Degryse, 2012). The fourth isotope ^{204}Pb is the only natural one, and its abundance has remained constant since the origin of solar system (Komárek et al., 2008).

Because of its partially radiogenic nature, Pb isotopic composition is characteristic of a given geographical origin or geochemical profile and it is often used for provenance studies in several fields (Sjåstad et al., 2011; Drivelos and Georgiou, 2012; Ortega et al., 2012). Since natural and anthropogenic Pb sources will show different Pb isotope composition in a given area, this analytical tool is often used in environmental science as efficient way to evaluate the actual occurrence of Pb pollution. Additionally the analysis of Pb isotope ratios can represent an efficient way to track the pollution source, as different Pb inputs show a different and specific Pb isotope composition (Hinrichs et al., 2002). A popular way to

present Pb isotope ratios results is the so-called three isotope graph (e.g., $^{206}\text{Pb}/^{207}\text{Pb}$ vs. $^{208}\text{Pb}/^{206}\text{Pb}$) which is used for distinguishing between separate Pb sources. Additionally, several models for assessing the relative contribution of separate Pb sources have been proposed (Monna et al., 2000; Semlali et al., 2004) and in all of them the knowledge of Pb isotopic composition of both natural background and pollution sources is needed.

2.7. Rare Earth Elements

The Rare Earth Elements (REEs) are a group of elements including the series of lanthanides, Sc and Y. They are often grouped together as they have similar behavior in most of environmental systems. The distribution patterns of REE has often been applied to geological studies of river and marine ecosystems (Song and Choi, 2009; Rezaee et al., 2010) since they can be used as reliable tool for determining depositional processes and sediment provenance (Xu et al., 2009; Jung et al., 2012). Some members of this group are used in various components of some modern devices, such as high-strength magnets, hard disk drives, smartphones screens and batteries, among others (Guyonnet et al., 2015). The demand of these components is constantly increasing due to their widespread applications. Recycling of post-consumer and components will increasingly contribute to the supply in the future but most probably it will not be sufficient and the mining of natural deposits will continue to represent the major source of REEs (Goodenough et al., 2016). Mining extraction from ores as well as the processes involved in the production of different materials, have contributed to the increased release of these elements in the environment, causing contamination in soils and waters (Liang et al., 2014). As a consequence of their increased widespread use, the potential anthropogenic influence on REE natural distribution has extended their application from geochemistry to environmental chemistry (Kulaksiz and Bau, 2011; Hatje et al., 2016), leading scientists to refer to these elements as “new emerging pollutants”. A recent paper has, for the first time, given baseline data for REEs in the Namibian coastal sediment (Orani et al., 2017, submitted) but, to the best of our knowledge, no data are available in the literature about REEs profiles in Namibian sediment samples. Some studies have been focusing on the determination of REEs in phosphorite, quite widespread around Namibia and generally South Africa (McArthur and Walsh, 1984; Watkins et al., 1995) and data published on surface sediments have shown a particular trend, with heavy REEs (HREEs) enrichment over the light ones.

REEs results are often presented after normalization to a standard material, in order to be able to easily recognize possible element anomalies in the pattern (Kulaksiz and Bau, 2011). The REEs results obtained in this study were normalized using the American Shale Composite (Piper, 1974); some indices can be calculated to better interpret the results, such as the La/Yb ratio which show possible enrichment in LREEs over the HREEs (Hatje et al., 2016).

2.8 Data Quality Assurance

The analytical methods used in this study were properly selected and validated, both in terms of matrix composition and analyte concentration. All possible sources of uncertainty of obtained results were carefully identified. Afterwards, the uncertainty components were quantified and the combined uncertainty calculated according to the ISO/GUM guide (Magnusson and Ornemark, 2014).

A principal requirement of the standard ISO 17025 (ISO/IEC, 2005) is for laboratories to produce measurements that are traceable to a common system of reference, SI system, and ensure comparability of measurement results. The way to demonstrate traceability in the present study was the use of an uncertainty budget, where all the parameters influencing the final result were systematically assessed. In addition the use of CRM throughout the whole analytical procedure and bias (recovery) estimation was the way to link obtained trace elements mass fraction to the common system of reference SI. CRM with similar matrix were also used in the validation of sample preparation step.

3. Results and discussion

In order to perform a complementary study on the historical variation in TE contamination in Namibia coastal area, analysis on 6 core samples, collected at different stations along the coast, were performed. A total of 54 samples were collected at different depths; sampling map is shown in Fig 1. Most of the sediments measured in this study were classified as silty sand, with about 30-50% of grain size distribution between 1-65 μm . Grain size of samples from cores C1 and C2 was mainly characterized by particles between 65 and 300 μm .

3.1. Distribution of trace elements in core samples

A summary of TE and Total Organic Carbon results is presented in Table 1S (supplementary information). The core samples C4 and C5 show the highest variability in TE contents along the depth (Fig.1S, supplementary information), suggesting different inputs of these elements during the period covered by the analyzed cores. Particularly in C5, Pb ranged between 47 and 220 mg/kg and Cu ranged between 43 and 240 mg/kg. Higher concentrations for both Cu and Pb were measured in the first 7 cm while the lower 7 cm exhibit a more stable content for both elements (Fig 2). Zn also had higher concentrations in the surface layers (up to 380 mg/kg in the upper 3 cm) in the same core. The core C4 is characterized by high variability in As, Zn and Cd contents; very interestingly some of these analytes showed higher concentrations in the bottom of the sediment core. Generally speaking the cores C3 and C6 were characterized by a very constant trend of almost all elements along their depth. Some analytes like Li, Co and Hg show very low variability in all the studied cores, suggesting a unique source, most probably natural.

Figure 2. Graphical representation of Pb and Cu content variation along the core C5

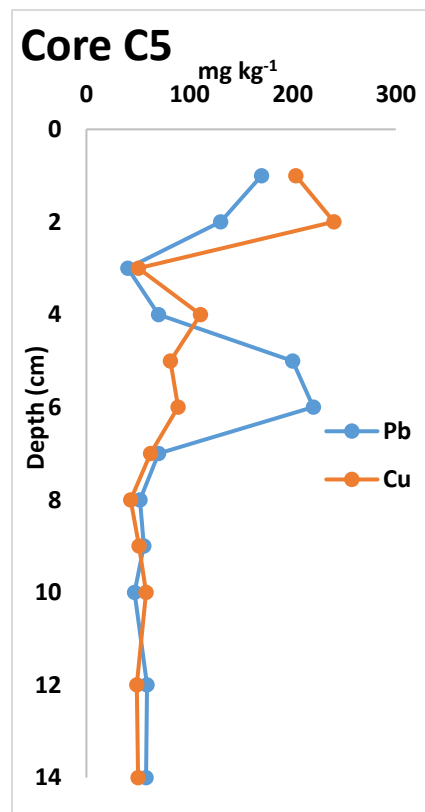

Higher metals concentrations at the upper layers of the core C5, which is located at the vicinity of the harbor of Walvis Bay, suggest recent accumulation of these metals as a result of anthropogenic activities. However, in order to strengthen the interpretation of these results and to highlight possible common patterns in the distribution of trace elements, a Pearson's correlation test was performed for each analyzed core: high correlation coefficients between different metals mean common sources, mutual dependence, and identical behavior during transport (Guan et al., 2016). As already mentioned, Cu, Zn, As and Cd appear to have similar patterns along the core C5 and the Pearson's correlations confirm a positive correlation between these elements ($p < 0.05$). Among toxic elements, Pb showed positive correlation with Cr, Co and Ni in samples C2, C4 and C5 while As and Cd exhibit positive correlation in samples C5, C2 and C3 and negative correlation in sample C1. Organic Carbon (OC) showed very variable correlations, in the different cores. Organic Carbon was found to be positively correlated with Ni, Cu, As, Cd, Zn and V in sample C4, where the percentage of OC ranged from 1.3 and 5.2; additionally a positive correlation with Cr, Co was found in sample C6. No correlation between TOC and any of the analyzed TE was found in sample C3 while in sample C5 the only analyte correlating with TOC was Cd. The property of organic matter to influence the concentration of some trace metals in environmental samples has been reported in several studies (Wang and Qin, 2006; Kljaković-Gašpić et al., 2008) but the relation between these two components is still considered complex and very variable (Wang, 2008).

It has to be pointed out that upwelling systems are naturally characterized by metal enrichment as a consequence of high metal inputs from plankton but the metal content in Namibian coast was previously suggested to be intimately related to organic matter content (Calvert and Price, 1970). From the simple observation of trace elements variation along the analyzed cores, it is already clear that at least samples C4 and C5 were subject to different element inputs, most probably of anthropogenic origin given the location of these sampling stations. It appears equally clear that samples C1, C3 and C6 did not show significant changes in most of the analytes concentrations. In order to be able to clearly state whether an anthropogenic input influenced the TE contents during the time in the analyzed region, different indices of sediment contamination were evaluated.

3.2. Indices of sediment contamination in core samples

The analysis of EF, I_{geo} and PLI corroborate the hypothesis of anthropogenic contribution in some of the sampling stations. Following the evaluation criteria of EF it was possible to identify the sample C5 as the most contaminated among the cores analyzed in this study. Significant enrichment was found for Cd, As, Cu and Zn especially in the surface area; Pb showed extremely high enrichment in the first 6 centimeters and its Enrichment Factors decreased towards deeper sediment layers. Sample C4 showed significant enrichment of As in surface area and moderate enrichment of Cd in surface and bottom samples, suggesting different inputs for this element. Pb also showed minimal enrichment in some samples from core C4 (mostly in the first 10 centimeters) as well as in all samples from cores C2 and C1. The same behavior was found for Mn. Core samples C3 and C6 did not show any enrichment for all elements analyzed in this study. Some of the calculated EFs are presented in Fig. 3.

Figure 3. Graphical representation of some of the Enrichment factors determined for core samples collected in this study. A threshold equal to 2 has been set, according to the evaluation criteria in use, in order to highlight samples above minimal enrichment

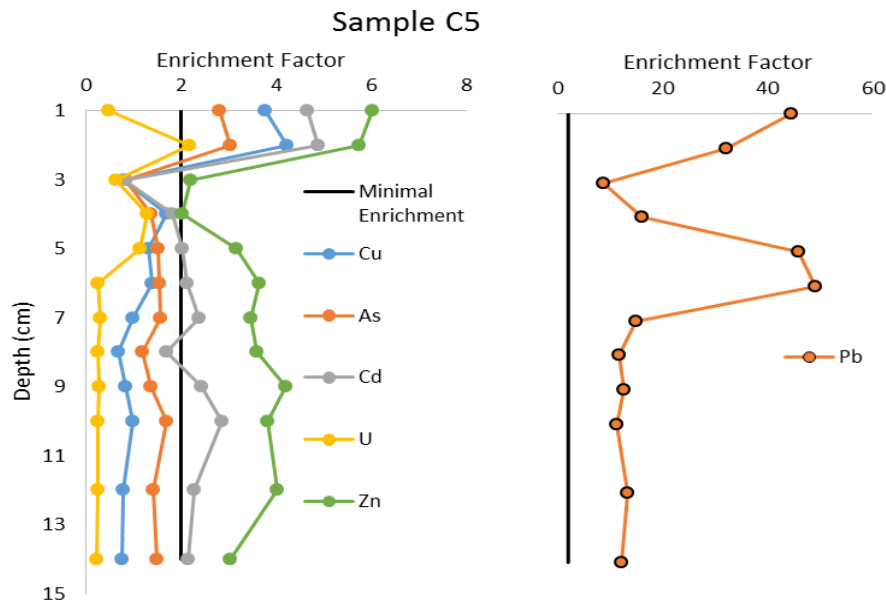

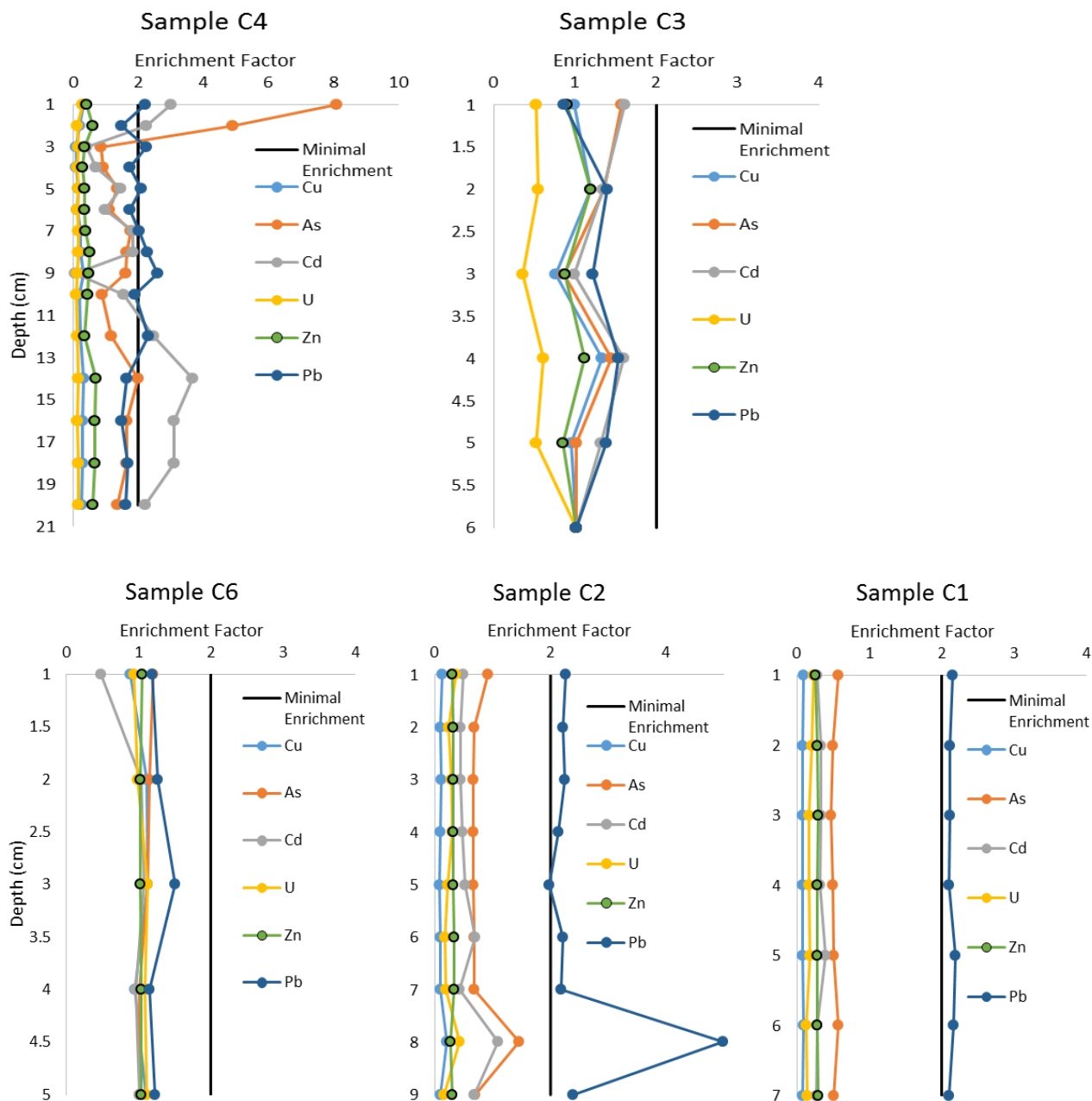

I_{geo} indexes confirmed the already highlighted contamination in the above mentioned locations. The analysis of these parameters confirmed the core C5 as very strongly contaminated for Pb and strongly contaminated for Zn (Fig 2S, supplementary information). This sample was also confirmed to be moderately contaminated for As, Cd and Cu in the first two centimeters. Additionally, the I_{geo} calculated for sample C4 revealed, in accordance with EFs, a moderate-strong contamination of As, Cd, Pb and Mn.

Finally the analysis of Pollution Load Indices (PLI) calculated on core samples, gave the ultimate confirmation that an anthropogenic contamination exists mostly on samples C5 and C4 (Fig 3S, supplementary information). The PLI values calculated for these samples were between 3 and 5 while values for remaining cores were found to be around 2 for samples C1 and C2.

In accordance with the analysis of surface sediments in the study area (Orani et al, submitted), the spatial distribution of trace elements in the cores suggests that only areas around Walvis Bay and Swakopmund could be considered as contaminated. Especially in the case of sample C5, collected in the Walvis Bay harbor, the contamination seems to be recent, in the upper 6 centimeters of the sediment core, which marks a period between 1945(\pm 7) and 2014. Walvis Bay has had a varied pollution history because of its strategic position and the access to different natural resources, which have been exploited during many years. It is located at the edge of the Namib Desert and is Namibia's principal harbor hosting the important fishing activities. The region receives less than 20 millimeters average precipitation per year, making it one of the driest cities on earth. The exploitation of Namibian natural resources, especially mining activities, have drastically increased after 1945 (Briefing, 1980). Since the Second World War the exploitation and industrialization of different areas has markedly increased, especially attracting transnational mining corporations. Bearing in mind this historical background, it is not surprising that in economically important areas, such as the Walvis Bay, trace element inputs have recently increased as a consequence of bigger anthropogenic activities.

3.3. Trace elements source analysis based on PCA

To further examine the extent and origin of trace elements contamination in the area, a PCA analysis was performed on core samples C5, which appear to be the most contaminated among the samples analyzed in this work. Data used for PCA were standardized using the biased standard deviation, in order to avoid misclassification due to differences in data dimensionality; biplot results are shown in Fig 4.

3.4. Pb isotope ratios results

In a three plot representation including all core samples (Fig. 5) it is clear that core C5 has a Pb isotopic composition very different from other samples. The C5 core shows less radiogenic Pb isotope ratios, which is generally indicative of anthropogenic influence (i.e. Pb from mining ores), (Hansmann and Köppel, 2000). The linear trend shown in Fig. 5 for the entire set of sample ($R^2=0.883$) is indicative of multiple source of Pb (Ellam, 2010) especially when the isotope ^{204}Pb is included in this representation. The three plot graphs representing the data for each single core also shown very linear trend ($R^2>0.8$) except for sample C1 where $R^2<0.1$ in $^{206}\text{Pb}/^{204}\text{Pb}$ vs $^{208}\text{Pb}/^{204}\text{Pb}$ plot. These results suggest multiple sources of Pb even if the variation along the depth, also in terms of Pb concentration and enrichment, was quite low.

Figure 5. Three isotopes graphic representations of Pb isotope ratios measured in sediment samples analyzed in this study. In both graphs the separation of sample C5 from the rest of cores is evident. Comparison values from Monna et al. (2006), Bollhöfer and Rosman (2000), Larsen et al. (2012), Jung and Mezger (2003).

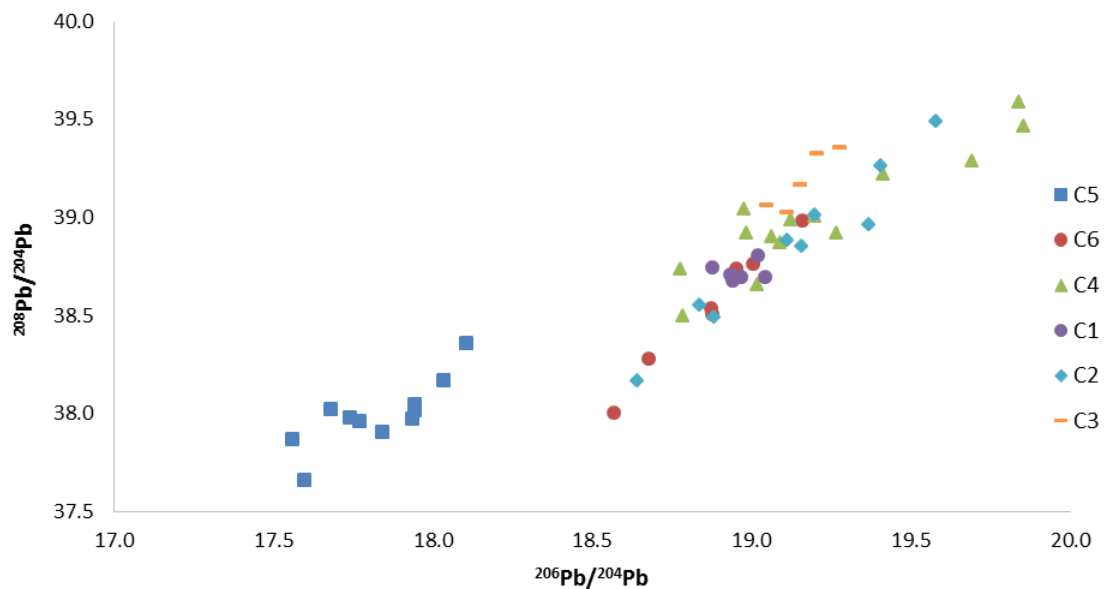

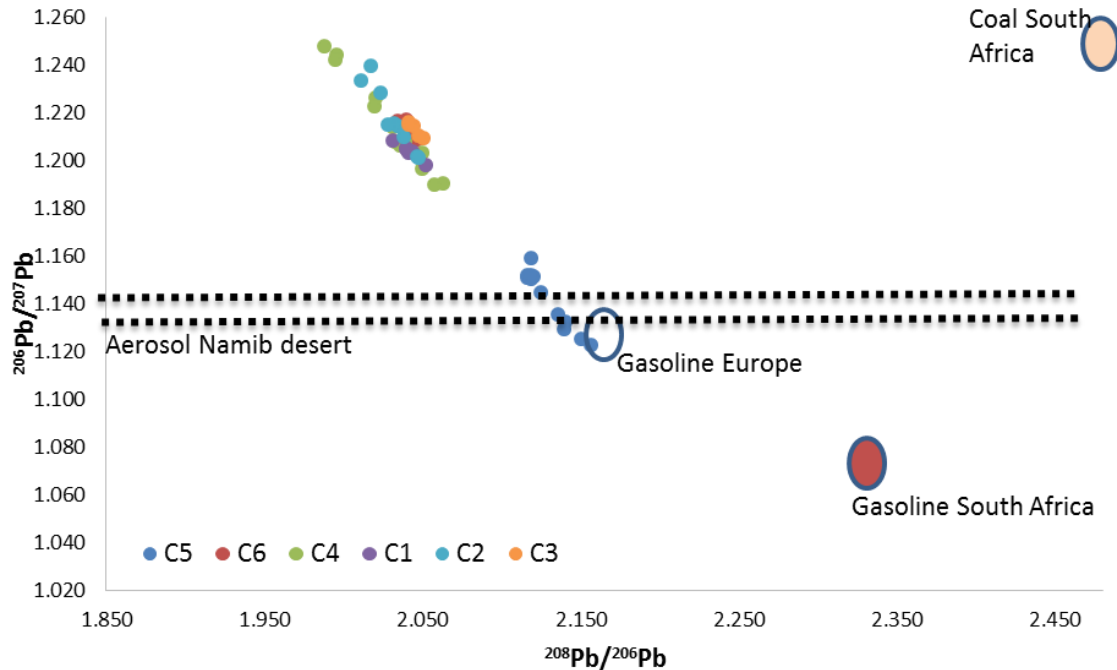

Regarding the vertical distribution, the core C5 was also the sample with the highest variability in terms of Pb isotopic composition along the depth in comparison with the other core samples. As shown in Fig. 6 the $^{206}\text{Pb}/^{204}\text{Pb}$ and the $^{206}\text{Pb}/^{207}\text{Pb}$ vertical profiles show a very similar pattern with high variability in the upper 7 centimeters of the core and then a more constant profile in deeper sediment layers. The isotopic composition of this sample starts to change in the period before 1940, specifically decreasing towards lower values showing then a pick around 1945 and then another decreasing trend up to the surface. Even if the general isotopic composition of this sample is quite different from the rest of the cores, it is worth noticing that samples at the bottom layers are closer to the other samples group in Fig.5, suggesting that they are most likely characterized by higher inputs of Pb from natural source.

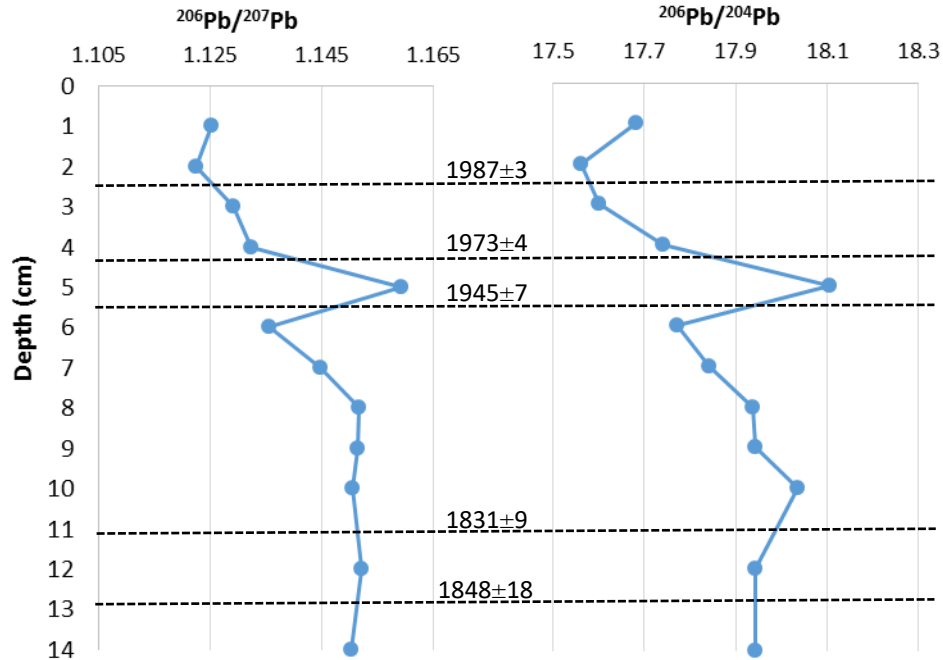
Figure 6. $^{206}\text{Pb}/^{207}\text{Pb}$ and $^{206}\text{Pb}/^{204}\text{Pb}$ vertical profile (and dating) of the core sample C5

The literature data available for comparison purposes in the area are certainly not abundant. Monna et al., (2006) reported Pb isotopic composition of several potential sources of Pb contamination in South Africa (around Johannesburg), showing $^{206}\text{Pb}/^{207}\text{Pb}$ of 1.057-1.072 and $^{208}\text{Pb}/^{206}\text{Pb}$ of 2.330-2.336 for leaded gasoline, very different from those found in the present study. The values reported for South African coal and mine dumps are also very far away in terms of isotopic composition (Fig 5). On the other hand C5 core shows, ratios close to those measured in aerosol samples from the Namib Desert, much probably influenced by Tsumeb ores (Bollhöfer and Rosman, 2000). Leaded gasoline is the most probable source of Pb in the period after the 1970's but the results obtained in sample C5 are much closer to the European isotopic signature for gasoline, behavior already observed by Larsen in surface samples from Cape Town (Larsen et al., 2012). The rest of core samples show signature closer to those reported by Jung and Mezger (2003) in granites from central Namibia and thus most likely associated to a natural Pb source.

3.5. REEs results

REEs profiles determined in the six cores analyzed in this study are presented in Figure 7. All results were normalized using the North American Shale Composite (NASC) standard and shown in a graphic

representation in which is easier to detect element anomalies. The study of REEs profiles is of particular interest for this area since some mineralogical investigations have confirmed that Namibia may have potential REEs resources (Orris and Grauch, 2002). Additionally, since REEs are naturally associated with U-containing minerals, their determination in these areas with long history of U mining, is of great interest.

Figure 7. Graphical representation of REEs pattern in each core sample. Results were normalized to NASC standard

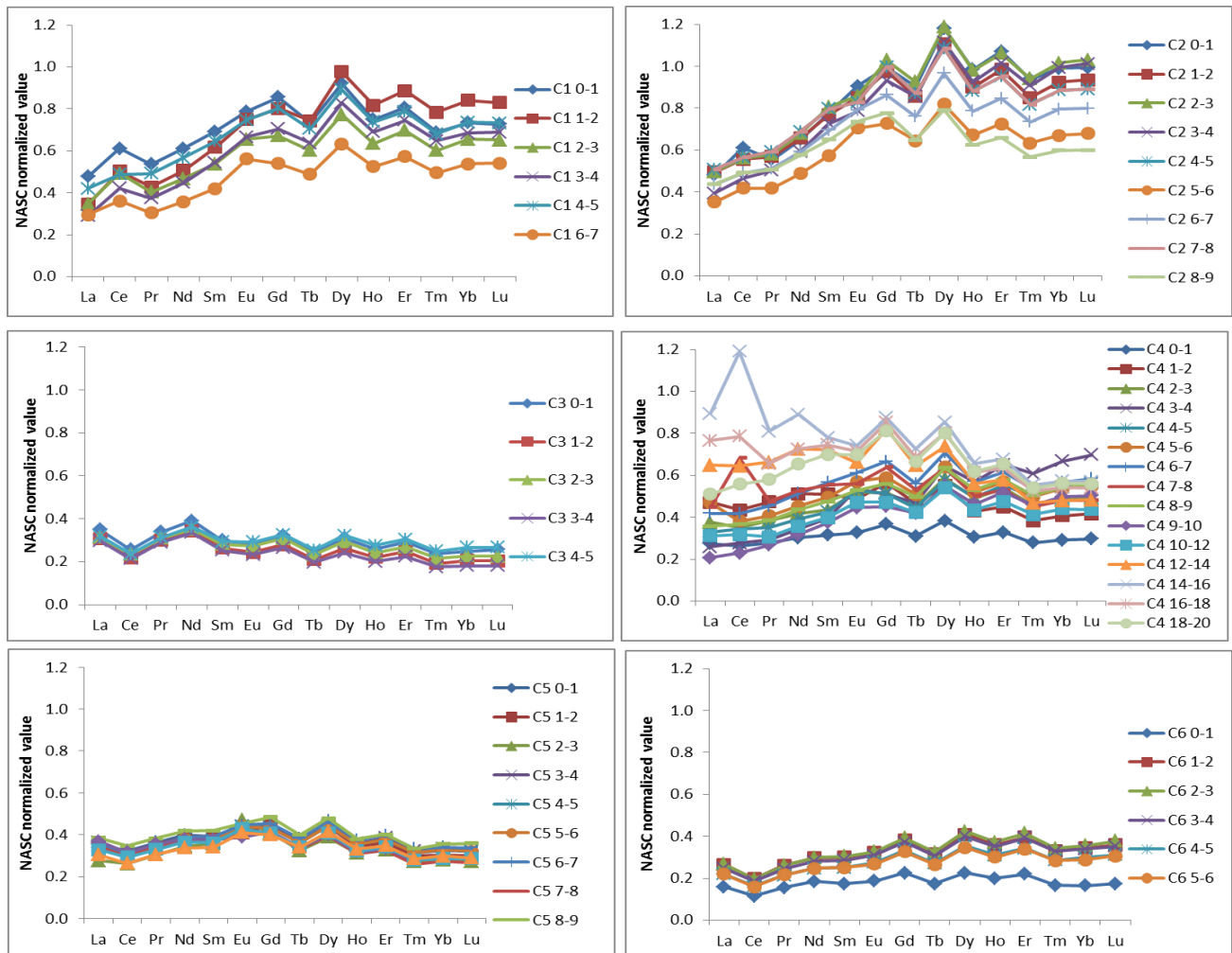

Although single element concentrations were quite different from site to site, the overall pattern of each core was generally quite consistent. The samples C3, C4 and C6 did not show enrichment with respect to NASC values, as all normalized results were consistently below 1 and no elemental anomalies were observed. Samples C1 and C2 showed a slight enrichment in HREEs (Dy, Ho, Er, Tm, Yb, Lu) over LREEs, behavior very characteristic of the area and already observed in Lofdal (carbonatite-dykes) deposits, located 450 km northeast of Windoek (Wall et al., 2008). The pattern shown by samples C1

and C2 resembles the one found for xenotime from Lofdal deposits and it is probable that these two samples are richer in xenotime minerals than other core samples collected along the coast.

The sample C4 was the only one, among analyzed cores, which show an non-homogeneous pattern. Looking at Figure 7 it is clear that, even if the normalized values rarely exceed 1, the biggest differences in REEs pattern was observed for the deepest samples (from 14 to 20 cm depth). To better appreciate this trend, an additional graphic representation is shown in Figure 8, where normalized REEs values are directly plotted against the core depth. Apart from a general increase of REEs concentrations in bottom samples, a positive Ce anomaly is also detectable at 16 cm depth. The Ce/Ce* ratio was then calculated (Armstrong-Altrin et al., 2003) according the following equation:

$$\frac{Ce}{Ce^*} = 2 \times \left[\frac{Ce}{Ce_{shale}} \right] \left[\frac{La}{La_{shale}} + \frac{Sm}{Sm_{shale}} \right]^{-1}$$

The calculated ratio exceeded 1 at 7-8 cm as well as in the last 4 cm of the C4 sample. Cerium anomaly is linked to the fact that unlike the other REEs, Ce also presents +4 oxidation state, additional to the more common +3. Changes in the redox condition in the water column can thus be the reason for positive or negative Ce anomalies. Ce(IV) is highly insoluble in seawater which means that in oxidizing condition a precipitation of this element is expected and thus an higher (positive anomaly) concentration in sediments (Hatje et al., 2016). This anomaly is thus related to changes in the water column condition; it can be finally stated that REEs analysis did not show anomalies ascribable to anthropogenic sources.

Figure 8. Representation of REEs normalized values pattern along the C4 core sample

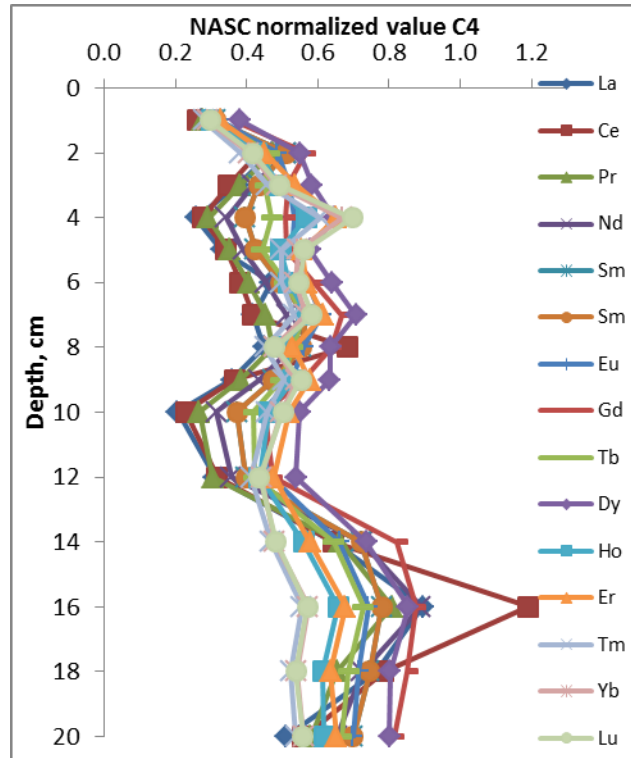

Conclusion

The present study represents the first investigation of trace element pollution history of sediments of the Namibian marine coastal environment. The analysis of six small core samples provided the means to analyze the changes in trace elements and REEs variations in sediments of the area since 1940. The enrichment in Pb, Cu, As, Cd and Zn almost entirely limited to the surface samples of the C5 core, collected in the vicinity of Walvis Bay, confirmed that the major increased inputs of these elements is related to the development of land-based activities. The evaluation of several risk assessment indices and the use of statistical tools such as Pearson's correlation and PCA, revealed some common features in the most contaminated areas. The Pb isotopic composition further confirmed the anthropogenic provenance of key trace elements accumulated on recent sediment layers at the vicinity of Walvis Bay and also provides a record of Pb isotope ratios for this coastal area. Finally REEs patterns determined in the cores did not reveal any anthropogenic influence but provided baseline information on the historic deposition of these elements in the Namibian coastal sediments.

References (paper 5)

- Abraham, G.M.S., Parker, R.J., 2008. Assessment of heavy metal enrichment factors and the degree of contamination in marine sediments from Tamaki Estuary, Auckland, New Zealand. *Environ. Monit. Assess.* 136, 227–238. <https://doi.org/10.1007/s10661-007-9678-2>
- Adams, F., Gijbels, R., Van Grieken, R., 1988. *Inorganic Mass Spectrometry*. John Wiley & Sons.
- Aide, M.T., Aide, C., 2012. Rare Earth Elements: Their Importance in Understanding Soil Genesis. *ISRN Soil Sci.* 2012, 1–11. <https://doi.org/10.5402/2012/783876>
- Alleman, L.Y., Hamelin, B., Véron, A.J., Miquel, J.-C., Heussner, S., 2000. Lead sources and transfer in the coastal Mediterranean: evidence from stable lead isotopes in marine particles. *Deep Sea Res. Part II Top. Stud. Oceanogr.* 47, 2257–2279. [https://doi.org/10.1016/S0967-0645\(00\)00024-2](https://doi.org/10.1016/S0967-0645(00)00024-2)
- Aloupi, M., Angelidis, M., 2001. Geochemistry of natural and anthropogenic metals in the coastal sediments of the island of Lesbos, Aegean Sea. *Environ. Pollut.* 113, 211–219. [https://doi.org/10.1016/S0269-7491\(00\)00173-1](https://doi.org/10.1016/S0269-7491(00)00173-1)
- Aly, W., Williams, I.D., Hudson, M.D., 2013. Metal contamination in water, sediment and biota from a semi-enclosed coastal area. *Environ. Monit. Assess.* 185, 3879–3895. <https://doi.org/10.1007/s10661-012-2837-0>
- AMPS Expert Group, 2005. Contributions of the Expert Group on Analysis and Monitoring of Priority Substances to the Water Framework Directive. EU Report EUR 21587.
- Anderson, G.L., Williams, J., Hille, R., 1992. The purification and characterization of arsenite oxidase from *Alcaligenes faecalis*, a molybdenum-containing hydroxylase. *J. Biol. Chem.* 267, 23674–23682.
- Andrewes, P., Demarini, D.M., Funasaka, K., Wallace, K., Lai, V.W.M., Sun, H., Cullen, W.R., Kitchin, K.T., 2004. Do arsenosugars pose a risk to human health? The comparative toxicities of a trivalent and pentavalent arsenosugar. *Environ. Sci. Technol.* 38, 4140–4148. <https://doi.org/10.1021/es035440f>
- Angelidis, M.O., Radakovitch, O., Veron, A., Aloupi, M., Heussner, S., Price, B., 2011. Anthropogenic metal contamination and sapropel imprints in deep Mediterranean sediments. *Mar. Pollut. Bull.* 62, 1041–1052. <https://doi.org/10.1016/j.marpolbul.2011.02.030>
- Anjum, K., Abbas, S.Q., Shah, S.A., Akhter, N., Batool, S., Hassan, S.S., 2016. Marine Sponges as a Drug Treasure. *Biomol. Ther.* 24, 347–362.
- Araújo, M.F., Conceição, A., Barbosa, T., Lopes, M.T., Humanes, M., 2003. Elemental composition of marine sponges from the Berlengas Natural Park, western Portuguese coast. *X-Ray Spectrom.* 32, 428–433. <https://doi.org/10.1002/xrs.660>
- Aresta, A., Marzano, C.N., Lopane, C., Corriero, G., Longo, C., Zambonin, C., Stabili, L., 2015. Analytical investigations on the lindane bioremediation capability of the demosponge *Hymeniacidon perlevis*. *Mar. Pollut. Bull.* 90, 143–149. <https://doi.org/10.1016/j.marpolbul.2014.11.003>
- Armstrong-Altrin, J.S., Verma, S.P., Madhavaraju, J., Lee, Y. II, Ramasamy, S., 2003. Geochemistry of Upper Miocene Kudankulam Limestones, Southern India. *Int. Geol. Rev.* 45, 16–26. <https://doi.org/10.2747/0020-6814.45.1.16>
- Ashraf, A., Saion, E., Gharibshahi, E., Kamari, H.M., Yap, C.K., Hamzah, M.S., Elias, M.S., 2017. Distribution of Trace Elements in Core Marine Sediments of Coastal East Malaysia by Instrumental

- Neutron Activation Analysis. *Appl. Radiat. Isot.* 122, 96–105. <https://doi.org/10.1016/j.apradiso.2017.01.006>
- Ashraf, A., Saion, E., Gharibshahi, E., Mohamed Kamari, H., Chee Kong, Y., Suhaimi Hamzah, M., Suhaimi Elias, M., 2016. Rare earth elements in core marine sediments of coastal East Malaysia by instrumental neutron activation analysis. *Appl. Radiat. Isot.* 107, 17–23. <https://doi.org/10.1016/j.apradiso.2015.09.004>
- ATSDR, 2007. Toxicological Profile for Arsenic, U.S Public Health Service, Agency for Toxic Substances and Disease Registry. <https://doi.org/http://dx.doi.org/10.1155/2013/286524>
- Ault, W.U., Senechal, R.G., Erlebach, W.E., 1970. Isotopic Composition as a Natural Tracer of Lead in the Environment: Discussions Follow. *Environ. Sci. Technol.* 4, 305–313. <https://doi.org/10.1021/es60039a001>
- Azemard, S., Vassileva, E., 2015. Determination of methylmercury in marine biota samples with advanced mercury analyzer: Method validation. *Food Chem.* 176, 367–375. <https://doi.org/10.1016/j.foodchem.2014.12.085>
- Azizur Rahman, M., Hasegawa, H., Peter Lim, R., 2012. Bioaccumulation, biotransformation and trophic transfer of arsenic in the aquatic food chain. *Environ. Res.* 116, 118–135. <https://doi.org/10.1016/j.envres.2012.03.014>
- Bagul V. R., S.D.N., 2015. New perspective on heavy metal pollution of water. *J. Chem. Pharm. Res.* 7, 700–705.
- Barats, A., Féraud, G., Potot, C., Philippinini, V., Travi, Y., Durrieu, G., Dubar, M., Simler, R., 2014. Naturally dissolved arsenic concentrations in the Alpine/Mediterranean Var River watershed (France). *Sci. Total Environ.* 473–474, 422–436. <https://doi.org/10.1016/J.SCITOTENV.2013.12.007>
- Bargagli, R., Nelli, L., Ancora, S., Focardi, S., 1996. Elevated cadmium accumulation in marine organisms from Terra Nova Bay (Antarctica). *Polar Biol.* 16, 513–520. <https://doi.org/10.1007/BF02329071>
- Barwick, V.J., Ellison, S.L.R., 1999. Measurement uncertainty: Approaches to the evaluation of uncertainties associated with recovery†. *Analyst* 124, 981–990. <https://doi.org/10.1039/a901845j>
- Batista, D., Muricy, G., Rocha, R.C., Miekeley, N.F., 2014. Marine sponges with contrasting life histories can be complementary biomonitors of heavy metal pollution in coastal ecosystems. *Environ. Sci. Pollut. Res.* 21, 5785–5794. <https://doi.org/10.1007/s11356-014-2530-7>
- Baudrimont, M., Schäfer, J., Marie, V., Maury-Brachet, R., Bossy, C., Boudou, A., Blanc, G., 2005. Geochemical survey and metal bioaccumulation of three bivalve species (*Crassostrea gigas*, *Cerastoderma edule* and *Ruditapes philippinarum*) in the Nord Médoc salt marshes (Gironde estuary, France). *Sci. Total Environ.* <https://doi.org/10.1016/j.scitotenv.2004.07.009>
- Beauchemin, D., 2008. Inductively coupled plasma mass spectrometry. *Anal. Chem.* 80, 4455–4486.
- Bednar, A.J., Garbarino, J.R., Burkhardt, M.R., Ranville, J.F., Wildeman, T.R., 2004. Field and laboratory arsenic speciation methods and their application to natural-water analysis. *Water Res.* 38, 355–364. <https://doi.org/10.1016/j.watres.2003.09.034>
- Beeson, R., 1984. The use of the fine fractions of stream sediments in geochemical exploration in arid and semi-arid terrains. *J. Geochemical Explor.* 22, 119–132. <https://doi.org/10.1016/0375->

6742(84)90009-8

- Belarra, M.A., Resano, M., Vanhaecke, F., Moens, L., 2002. Direct solid sampling with electrothermal vaporization/atomization: What for and how? *TrAC - Trends Anal. Chem.* 21, 828–839. [https://doi.org/10.1016/S0165-9936\(02\)01206-2](https://doi.org/10.1016/S0165-9936(02)01206-2)
- Bell, J.J., 2008. The functional roles of marine sponges. *Estuar. Coast. Shelf Sci.* 79, 341–353. <https://doi.org/10.1016/j.ecss.2008.05.002>
- Bennett, W.W., Teasdale, P.R., Panther, J.G., Welsh, D.T., Zhao, H., Jolley, D.F., 2012. Investigating arsenic speciation and mobilization in sediments with DGT and DET: A mesocosm evaluation of oxic-anoxic transitions. *Environ. Sci. Technol.* 46, 3981–3989. <https://doi.org/10.1021/es204484k>
- Bentley, R., Chasteen, T.G., 2002. Microbial Methylation of Metalloids: Arsenic, Antimony, and Bismuth. *Microbiol. Mol. Biol. Rev.* 66, 250–271.
- Bermejo-Barrera, P., Barciela-Alonso, M.C., Moreda-Piñeiro, J., González-Sixto, C., Bermejo-Barrera, a., 1996. Determination of trace metals (As, Cd, Hg, Pb and Sn) in marine sediment slurry samples by electrothermal atomic absorption spectrometry using palladium as a chemical modifier. *Spectrochim. Acta Part B At. Spectrosc.* 51, 1235–1244. [https://doi.org/10.1016/0584-8547\(96\)01487-5](https://doi.org/10.1016/0584-8547(96)01487-5)
- Bermudez-Lugo, O., 2014. 2012 Minerals Yearbook, Usgs- 2012 Minerals Yearbook.
- Berthet, B., Mouneyrac, C., Pérez, T., Amiard-Triquet, C., 2005. Metallothionein concentration in sponges (*Spongia officinalis*) as a biomarker of metal contamination. *Comp. Biochem. Physiol. - C Toxicol. Pharmacol.* 141, 306–313. <https://doi.org/10.1016/j.cca.2005.07.008>
- Bhuiyan, M.A.H., Parvez, L., Islam, M.A., Dampare, S.B., Suzuki, S., 2010. Heavy metal pollution of coal mine-affected agricultural soils in the northern part of Bangladesh. *J. Hazard. Mater.* 173, 384–392. <https://doi.org/10.1016/j.jhazmat.2009.08.085>
- Birch, G.F., Melwani, A., Lee, J.H., Apostolatos, C., 2014. The discrepancy in concentration of metals (Cu, Pb and Zn) in oyster tissue (*Saccostrea glomerata*) and ambient bottom sediment (Sydney estuary, Australia). *Mar. Pollut. Bull.* 80, 263–274. <https://doi.org/10.1016/j.marpolbul.2013.12.005>
- Bocher, P., Caurant, F., Miramand, P., Cherel, Y., Bustamante, P., 2003. Influence of the diet on the bioaccumulation of heavy metals in zooplankton-eating petrels at Kerguelen archipelago, Southern Indian Ocean. *Polar Biol.* 26, 759–767. <https://doi.org/10.1007/s00300-003-0552-6>
- Bohari, Y., Astruc, A., Astruc, M., Cloud, J., 2001. Improvements of hydride generation for the speciation of arsenic in natural freshwater samples by HPLC-HG-AFS. *J. Anal. At. Spectrom.* 16, 774–778. <https://doi.org/10.1039/B101591P>
- Bollhöfer, A., Rosman, K.J., 2000. Isotopic source signatures for atmospheric lead: the Southern Hemisphere. *Geochim. Cosmochim. Acta* 64, 3251–3262. [https://doi.org/10.1016/S0016-7037\(00\)00436-1](https://doi.org/10.1016/S0016-7037(00)00436-1)
- Bollhöfer, A., Rosman, K.J.R., 2001. Isotopic source signatures for atmospheric lead: The Northern Hemisphere. *Geochim. Cosmochim. Acta* 65, 1727–1740. [https://doi.org/10.1016/S0016-7037\(00\)00630-X](https://doi.org/10.1016/S0016-7037(00)00630-X)
- Bossy, A., 2010. Origines de l'arsenic dans les eaux, sols et sédiments du district aurifère de St-Yrieix-la-

- Perche (Limousin, France) : contribution du lessivage des phases porteuses d'arsenic. Université de Limoges.
- Bowen, H.J.M., 1966. The Uptake and Excretion of Elements by Organisms, in: Trace Elements in Biochemistry. Academic Press London, pp. 85–101.
- Bremner, J.M., Willis, J.P., 1993. Mineralogy and geochemistry of the clay fraction of sediments from the Namibian continental margin and the adjacent hinterland. *Mar. Geol.* 115, 85–116. [https://doi.org/10.1016/0025-3227\(93\)90076-8](https://doi.org/10.1016/0025-3227(93)90076-8)
- Briant, N., Chouvelon, T., Martinez, L., Brach-Papa, C., Chiffolleau, J.F., Savoye, N., Sonke, J., Knoery, J., 2017. Spatial and temporal distribution of mercury and methylmercury in bivalves from the French coastline. *Mar. Pollut. Bull.* 114, 1096–1102. <https://doi.org/10.1016/j.marpolbul.2016.10.018>
- Briefing, 1980. Namibia in the frontline: the political economy of decolonisation in South Africa's colony. *Rev. Afr. Polit. Econ.* <https://doi.org/10.1080/03056248008703415>
- Broadley, M.R., White, P.J., Hammond, J.P., Zelko, I., Lux, A., 2007. Zinc in plants. *New Phytol.* 173, 677–702. <https://doi.org/10.1111/j.1469-8137.2007.01996.x>
- Brongersma-Sanders, M., Stephan, K.M., Kwee, T., De Bruin, M., 1980. DISTRIBUTION OF MINOR ELEMENTS IN CORES FROM THE SOUTH- WEST AFRICA SHELF WITH NOTES ON PLANKTON AND FISH MORTALITY Along the coast of Southwest Africa a belt of olive-green diatomaceous muds is found between 19 ° S and 25 ° S , bordered on the wester. *Mar. Geol.* 37, 91–132.
- Brown, J.L., Kitchin, K.T., George, M., 1997. Dimethylarsinic acid treatment alters six different rat biochemical parameters: Relevance to arsenic carcinogenesis. *Teratog. Carcinog. Mutagen.* 17, 71–84. [https://doi.org/10.1002/\(SICI\)1520-6866\(1997\)17:2<71::AID-TCM3>3.0.CO;2-B](https://doi.org/10.1002/(SICI)1520-6866(1997)17:2<71::AID-TCM3>3.0.CO;2-B)
- Brown, J.S., 1962. Ore leads and isotopes. *Econ. Geol.* 57, 673–720. <https://doi.org/10.2113/gsecongeo.57.5.673>
- Brown, R.J.C., Milton, M.J.T., 2005. Analytical techniques for trace element analysis: An overview. *TrAC - Trends Anal. Chem.* 24, 266–274. <https://doi.org/10.1016/j.trac.2004.11.010>
- Bruland, K.W., Bertine, K., Koide, M., Goldberg, E.D., 1974. History of metal pollution in southern California coastal zone. *Environ. Sci. Technol.* 8, 425–432. <https://doi.org/10.1021/es60090a010>
- Bruland, K.W., Lohan, M.C., 2003. Controls of trace metals in seawater, in: *Treatise on Geochemistry*. Elsevier Ltd, pp. 23–47.
- Bryan, G.W., Langston, W.J., 1992. Bioavailability, accumulation and effects of heavy metals in sediments with special reference to United Kingdom estuaries: a review. *Environ. Pollut.* 76, 89–131. [https://doi.org/10.1016/0269-7491\(92\)90099-V](https://doi.org/10.1016/0269-7491(92)90099-V)
- Bu, H., Song, X., Guo, F., 2017. Dissolved trace elements in a nitrogen-polluted river near to the Liaodong Bay in Northeast China. *Mar. Pollut. Bull.* 114, 547–554. <https://doi.org/10.1016/j.marpolbul.2016.09.003>
- Cabon, J.Y., Cabon, N., 2000. Speciation of major arsenic species in seawater by flow injection hydride generation atomic absorption spectrometry. *Fresenius. J. Anal. Chem.* 368, 484–9. <https://doi.org/10.1007/s002160000526>
- Cabrita, M.T., Padeiro, A., Amaro, E., dos Santos, M.C., Leppe, M., Verkulich, S., Hughes, K.A., Peter, H.-

- U., Canário, J., 2017. Evaluating trace element bioavailability and potential transfer into marine food chains using immobilised diatom model species *Phaeodactylum tricornutum*, on King George Island, Antarctica. *Mar. Pollut. Bull.* 121, 192–200. <https://doi.org/10.1016/j.marpolbul.2017.05.059>
- Caccia, V.G., Millero, F.J., Palanques, A., 2003. The distribution of trace metals in Florida Bay sediments. *Mar. Pollut. Bull.* 46, 1420–1433. [https://doi.org/10.1016/S0025-326X\(03\)00288-1](https://doi.org/10.1016/S0025-326X(03)00288-1)
- Calvert, S.E., Price, N.B., 1970. Minor Metal Contents of Recent Organic-rich Sediments off South West Africa. *Nature* 227, 593–595.
- Cantillo, A.Y., 1998. Comparison of results of Mussel Watch Programs of the United States and France with Worldwide Mussel Watch Studies. *Mar. Pollut. Bull.* 36, 712–717. [https://doi.org/10.1016/S0025-326X\(98\)00049-6](https://doi.org/10.1016/S0025-326X(98)00049-6)
- Carere, M., Dulio, V., Hanke, G., Polesello, S., 2012. Guidance for sediment and biota monitoring under the Common Implementation Strategy for the Water Framework Directive. *TrAC - Trends Anal. Chem.* 36, 15–24. <https://doi.org/10.1016/j.trac.2012.03.005>
- Carpenè, E., Andreani, G., Isani, G., 2017. Trace elements in unconventional animals: A 40-year experience. *J. Trace Elem. Med. Biol.* 43, 169–179. <https://doi.org/10.1016/j.jtemb.2017.02.003>
- Caumette, G., Koch, I., Reimer, K.J., 2012. Arsenobetaine formation in plankton: a review of studies at the base of the aquatic food chain. *J. Environ. Monit.* 14, 2841. <https://doi.org/10.1039/c2em30572k>
- Cebrian, E., Martí, R., Uriz, J.M., Turon, X., 2003. Sublethal effects of contamination on the Mediterranean sponge *Crambe crambe*: Metal accumulation and biological responses. *Mar. Pollut. Bull.* 46, 1273–1284. [https://doi.org/10.1016/S0025-326X\(03\)00190-5](https://doi.org/10.1016/S0025-326X(03)00190-5)
- Cebrian, E., Uriz, M.-J., Turon, X., 2007. Sponges as biomonitors of heavy metals in spatial and temporal surveys in northwestern mediterranean: multispecies comparison. *Environ. Toxicol. Chem.* 26, 2430–2439. <https://doi.org/10.1897/07-292.1>
- Cebrian, E., Uriz, M.J., 2007. Contrasting effects of heavy metals on sponge cell behavior. *Arch. Environ. Contam. Toxicol.* 53, 552–558. <https://doi.org/10.1007/s00244-006-0257-2>
- Chai, Z.F., Zhang, Z.Y., Feng, W.Y., Chen, C.Y., Xu, D.D., Hou, X.L., 2004. Study of chemical speciation of trace elements by molecular activation analysis and other nuclear techniques. *J. Anal. At. Spectrom.* 19, 26–33. <https://doi.org/10.1039/B307337H>
- Charlesworth, M.E., Chenery, S., Mellor, A., Service, M., 2006. Isotopic composition and concentration of Pb in suspended particulate matter of the Irish Sea reveals distribution and sources. *Mar. Pollut. Bull.* 52, 81–88. <https://doi.org/10.1016/j.marpolbul.2005.08.009>
- Chen, C.Y., Darren, M., Williams, J.J., Fisher, N.S., 2016. Metal Bioaccumulation by Estuarine Food Webs in New England, USA. *J. Mar. Sci. Engineer* 4, 41. <https://doi.org/10.1016/j.cell.2016.05.007.Mapping>
- Chen, C.Y., Stemberger, R.S., Klaue, B., Blum, J.D., Pickhardt, P.C., Folt, C.L., 2000. Accumulation of heavy metals in food web components across a gradient of lakes. *Limnol. Oceanogr.* 45, 1525–1536. <https://doi.org/10.4319/lo.2000.45.7.1525>

- Chen, L., Liu, M., Fan, R., Ma, S., Xu, Z., Ren, M., He, Q., 2013. Mercury speciation and emission from municipal solid waste incinerators in the Pearl River Delta, South China. *Sci. Total Environ.* 447, 396–402. <https://doi.org/10.1016/j.scitotenv.2013.01.018>
- Chester, R., Murphy, K.J.T., Lin, F.J., Berry, A.S., Bradshaw, G.A., Corcoran, P.A., 1993. Factors controlling the solubilities of trace metals from non-remote aerosols deposited to the sea surface by the “dry” deposition mode. *Mar. Chem.* 42, 107–126. [https://doi.org/10.1016/0304-4203\(93\)90241-F](https://doi.org/10.1016/0304-4203(93)90241-F)
- Ciardullo, S., Aureli, F., Raggi, A., Cubadda, F., 2010. Arsenic speciation in freshwater fish: Focus on extraction and mass balance. *Talanta* 81, 213–221. <https://doi.org/10.1016/j.talanta.2009.11.060>
- Cidu, R., Frau, F., 2009. Distribution of trace elements in filtered and non filtered aqueous fractions: Insights from rivers and streams of Sardinia (Italy). *Appl. Geochemistry* 24, 611–623. <https://doi.org/10.1016/j.apgeochem.2008.12.013>
- Clark, H., 1968. On the Spongiae ciliatae as infusoria flagellata, or observations on the structure, animality and relationship of *Leucosolenia botryoides*, Bowerbank. *Ann. Mag. Nat. Hist.* 4, 133–142.
- Clowes, L.A., Francesconi, K.A., 2004. Uptake and elimination of arsenobetaine by the mussel *Mytilus edulis* is related to salinity. *Comp. Biochem. Physiol. - C Toxicol. Pharmacol.* 137, 35–42. <https://doi.org/10.1016/j.cca.2003.11.003>
- Coulibaly, M., Bamba, D., Yao, N.A., Zoro, E.G., El Rhazi, M., 2016. Some aspects of speciation and reactivity of mercury in various matrices. *Comptes Rendus Chim.* 19, 832–840. <https://doi.org/10.1016/j.crci.2016.02.005>
- Covelli, S., Fontolan, G., 1997. Application of a normalization procedure in determining regional geochemical baselines. *Environ. Geol.* 30, 34–45. <https://doi.org/10.1007/s002540050130>
- Crompton, T.R., Crompton, T.R., 1989. Chapter 8 – Organometallic compounds, in: *Analysis of Seawater*. pp. 336–359. <https://doi.org/10.1016/B978-0-407-01610-1.50011-4>
- Cullen, W.R., Reimer, K.J., 1989. Arsenic speciation in the environment. *Chem. Rev.* 89, 713–764. <https://doi.org/10.1021/cr00094a002>
- Dahms, S., van der Bank, F.H., Greenfield, R., 2014. A baseline study of metal contamination along the Namibian coastline for *Perna perna* and *Choromytilus meridionalis*. *Mar. Pollut. Bull.* 85, 297–305. <https://doi.org/10.1016/j.marpolbul.2014.05.037>
- Damiano, S., Papetti, P., Menesatti, P., 2011. Accumulation of heavy metals to assess the health status of swordfish in a comparative analysis of Mediterranean and Atlantic areas. *Mar. Pollut. Bull.* 62, 1920–1925. <https://doi.org/10.1016/j.marpolbul.2011.04.028>
- De Gregori H., I., Pinochet C., H., Arancibia J., M., Vidal B., A., 1996. Grain Size Effect on Trace Metals Distribution in Sediments from Two Coastal Areas of Chile. *Bull. Environ. Contam. Toxicol.* 57, 163–170. <https://doi.org/10.1007/s001289900170>
- de Mestre, C., Maher, W., Roberts, D., Broad, A., Krikowa, F., Davis, A.R., 2012. Sponges as sentinels: Patterns of spatial and intra-individual variation in trace metal concentration. *Mar. Pollut. Bull.* 64, 80–89. <https://doi.org/10.1016/j.marpolbul.2011.10.020>
- Debord, J., Pourmand, A., Jantzi, S., Panicker, S., Almirall, J., 2017. Profiling of Heroin and Assignment of

- Provenance by $^{87}\text{Sr}/^{86}\text{Sr}$ Isotope Ratio Analysis. *Inorganica Chim. Acta*.
<https://doi.org/10.1016/j.ica.2017.07.049>
- Delnomdedieu, M., Basti, M.M., Otvos, J.D., Thomas, D.J., 1994. Reduction and binding of arsenate and dimethylarsinate by glutathione: a magnetic resonance study. *Chem. Biol. Interact.* 90, 139–155.
[https://doi.org/10.1016/0009-2797\(94\)90099-X](https://doi.org/10.1016/0009-2797(94)90099-X)
- Denton, G.R.W., Concepcion, L.P., Wood, H.R., Morrison, R.J., 2006. Trace metals in marine organisms from four harbours in Guam. *Mar. Pollut. Bull.* 52, 1784–1804.
<https://doi.org/10.1016/j.marpolbul.2006.09.010>
- Diaz, M.C., Rutzler, K., 2001. Sponges: an essential component of Caribbean coral reefs. *Bull. Mar. Sci.* 69, 535–546.
- Drivelos, S.A., Georgiou, C.A., 2012. Multi-element and multi-isotope-ratio analysis to determine the geographical origin of foods in the European Union. *TrAC Trends Anal. Chem.* 40, 38–51.
<https://doi.org/10.1016/j.trac.2012.08.003>
- Dudás, F.Ö., LeBlanc, S.A., Carter, S.W., Bowring, S.A., 2016. Pb and Sr concentrations and isotopic compositions in prehistoric North American teeth: A methodological study. *Chem. Geol.* 429, 21–32. <https://doi.org/10.1016/j.chemgeo.2016.03.003>
- Duncan, E.G., Maher, W.A., Foster, S.D., 2015. Contribution of arsenic species in unicellular algae to the cycling of arsenic in marine ecosystems. *Environ. Sci. Technol.* 49, 33–50.
<https://doi.org/10.1021/es504074z>
- Edmonds, J.S., Francesconi, K.A., Stick, R. V., 1993. Arsenic compounds from marine organisms. *Nat. Prod. Rep.* 10, 421–428.
- Edmonds, J.S., Shibata, Y., Francesconi, K. a, Rippingale, R.J., Morita, M., 1997. Arsenic transformations in short marine food chains studied by HPLC-ICP MS. *Appl. Organomet. Chem.* 11, 281–287.
[https://doi.org/10.1002/\(sici\)1099-0739\(199704\)11:4<281::aid-aoc581>3.3.co;2-j](https://doi.org/10.1002/(sici)1099-0739(199704)11:4<281::aid-aoc581>3.3.co;2-j)
- Elbaz-Poulichet, F., Holliger, P., Martin, J.M., Petit, D., 1986. Stable lead isotopes ratios in major french rivers and estuaries. *Sci. Total Environ.* 54, 61–76. [https://doi.org/10.1016/0048-9697\(86\)90256-1](https://doi.org/10.1016/0048-9697(86)90256-1)
- Elderfield, H., 2003. Introduction to Volume 6, in: Turekian, K.K., Holland, H.D. (Eds.), *Treatise on Geochemistry*. Elsevier Ltd, pp. 15–27.
- Ellam, R.M., 2010. The graphical presentation of lead isotope data for environmental source apportionment. *Sci. Total Environ.* 408, 3490–3492.
<https://doi.org/10.1016/j.scitotenv.2010.03.037>
- Ellwood, M.J., Maher, W.A., 2003. Measurement of arsenic species in marine sediments by high-performance liquid chromatography-inductively coupled plasma mass spectrometry. *Anal. Chim. Acta* 477, 279–291. [https://doi.org/10.1016/s0003-2670\(02\)01414-9](https://doi.org/10.1016/s0003-2670(02)01414-9)
- Esslemont, G., 2000. Heavy metals in seawater, marine sediments and corals from the Townsville section, Great Barrier Reef Marine Park, Queensland. *Mar. Chem.* 71, 215–231.
[https://doi.org/10.1016/S0304-4203\(00\)00050-5](https://doi.org/10.1016/S0304-4203(00)00050-5)
- Fang, T.-H., Hsiao, S.-H., Nan, F.-H., 2014. Nineteen trace elements in marine copepods collected from the coastal waters off northeastern Taiwan. *Cont. Shelf Res.* 91, 70–81.

<https://doi.org/10.1016/j.csr.2014.09.003>

FAO, 2007. Fishery Country Profile- The Republic of Namibia [WWW Document]. URL <http://www.fao.org/fi/oldsite/FCP/en/NAM/profile.htm>

FLETCHER, C.J.N., SWAINBANK, I.G., COLMAN, T.B., 1993. Metallogenic evolution in Wales: constraints from lead isotope modelling. *J. Geol. Soc. London.* 150, 77–82. <https://doi.org/10.1144/gsjgs.150.1.0076>

Forstner, U., 1982. Chemical forms of metal enrichment in recent sediments, in: Amstutz, G. (Ed.), *Ore Genesis*. Springer-Verlag New York, pp. 269–284.

Förstner, U., Ahlf, W., Calmano, W., 1989. Studies on the transfer of heavy metals between sedimentary phases with a multi-chamber device: Combined effects of salinity and redox variation. *Mar. Chem.* 28, 145–158. [https://doi.org/10.1016/0304-4203\(89\)90192-8](https://doi.org/10.1016/0304-4203(89)90192-8)

Forstner, U., Wittmann, G., 1981. *Metal pollution in the aquatic environment*, 2nd revise. ed. Springer-Verlag New York.

Foster, S., Maher, W., 2016. Arsenobetaine and thio-arsenic species in marine macroalgae and herbivorous animals: Accumulated through trophic transfer or produced in situ? *J. Environ. Sci.* 49, 131–139. <https://doi.org/10.1016/j.jes.2016.06.003>

Francesconi, K.A., Sperling, M., 2005. Speciation analysis with HPLC-mass spectrometry: time to take stock. *Analyst* 130, 998. <https://doi.org/10.1039/b504485p>

Francesconi, K. a., 2010. Arsenic species in seafood: Origin and human health implications. *Pure Appl. Chem.* 82, 373–381. <https://doi.org/10.1351/PAC-CON-09-07-01>

Fütterer, D.K., Cojan, I., Renard, M., 2006. The solid phase of marine sediments, in: *Marine Geochemistry*. pp. 1–25.

Gadde, R.R., Laitinen, H.A., 1974. Studies of Heavy Metal Adsorption by Hydrous Iron and Manganese Oxides. *Anal. Chem.* 46, 2022–2026. <https://doi.org/10.1021/ac60349a004>

Galy, A., Pomies, C., Day, J.A., Pokrovsky, O.S., Schott, J., 2003. High precision measurement of germanium isotope ratio variations by multiple collector-inductively coupled plasma mass spectrometry. *J. Anal. At. Spectrom.* 18, 115–119. <https://doi.org/10.1039/B210233A>

Gazave, E., Carteron, S., Chenuil, A., Richelle-Maurer, E., Boury-Esnault, N., Borchiellini, C., 2010. Polyphyly of the genus *Axinella* and of the family Axinellidae (Porifera: Demospongiaep). *Mol. Phylogenet. Evol.* 57, 35–47. <https://doi.org/10.1016/j.ympev.2010.05.028>

Genta-Jouve, G., Cachet, N., Oberhänsli, F., Noyer, C., Teyssié, J.L., Thomas, O.P., Lacoue-Labarthe, T., 2012. Comparative bioaccumulation kinetics of trace elements in Mediterranean marine sponges. *Chemosphere* 89, 340–349. <https://doi.org/10.1016/j.chemosphere.2012.04.052>

Gentric, C., Rehel, K., Dufour, A., Sauleau, P., 2016. Bioaccumulation of metallic trace elements and organic pollutants in marine sponges from the South Brittany Coast, France. *J. Environ. Sci. Heal. Part A* 51, 213–219. <https://doi.org/10.1080/10934529.2015.1094327>

Gifford, S., Dunstan, R.H., O'Connor, W., Koller, C.E., MacFarlane, G.R., 2007. Aquatic zooremediation: deploying animals to remediate contaminated aquatic environments. *Trends Biotechnol.* 25, 60–65. <https://doi.org/10.1016/j.tibtech.2006.12.002>

- Giusti, L., Zhang, H., 2002. Heavy metals and arsenic in sediments, mussels and marine water from Murano (Venice, Italy). *Environ. Geochem. Health* 24, 47–65. <https://doi.org/10.1023/A:1013945117549>
- Gobas, F., 2001. Assessing Bioaccumulation Factors of Persistent Organic Pollutants in Aquatic Food-Chains, in: *Persistent Organic Pollutants: Environmental Behaviour and Pathways of Human Exposure*. pp. 145–165. https://doi.org/10.1007/978-1-4615-1571-5_6
- Gong, Z., 2002. Arsenic speciation analysis. *Talanta* 58, 77–96. [https://doi.org/10.1016/S0039-9140\(02\)00258-8](https://doi.org/10.1016/S0039-9140(02)00258-8)
- Goodenough, K.M., Schilling, J., Jonsson, E., Kalvig, P., Charles, N., Tuduri, J., Deady, E.A., Sadeghi, M., Schiellerup, H., Müller, A., Bertrand, G., Arvanitidis, N., Eliopoulos, D.G., Shaw, R.A., Thrane, K., Keulen, N., 2016. Europe's rare earth element resource potential: An overview of REE metallogenetic provinces and their geodynamic setting. *Ore Geol. Rev.* 72, 838–856. <https://doi.org/10.1016/j.oregeorev.2015.09.019>
- Goran, P., 1981. The Carcinogenicity of Arsenic. *Environ. Health Perspect.* 40, 93–100.
- Goyer, R.A., 2001. Toxic effects of metals, in: Klaassen, C.D. (Ed.), *Casarett and Doull's Toxicology: The Basic Science of Poisons*. McGraw-Hill Publisher, pp. 811–867.
- Grotti, M., Lagomarsino, C., Goessler, W., Francesconi, K.A., 2010. Arsenic speciation in marine organisms from Antarctic coastal environments. *Environ. Chem.* 7, 207–214. <https://doi.org/10.1071/EN09131>
- Grotti, M., Soggia, F., Lagomarsino, C., Riva, S.D., Goessler, W., Francesconi, K.A., 2008. Natural variability and distribution of trace elements in marine organisms from Antarctic coastal environments. *Antarct. Sci.* 20, 39–52. <https://doi.org/doi:10.1017/S0954102007000831>
- Grousset, F.E., Quétel, C.R., Thomas, B., Buat-Menard, P., Donard, O.F.X., Bucher, A., 1994. Transient Pb Isotopic Signatures in the Western European Atmosphere. *Environ. Sci. Technol.* 28, 1605–1608. <https://doi.org/10.1021/es00058a011>
- Guan, Q., Cai, A., Wang, F., Wang, L., Wu, T., Pan, B., Song, N., Li, F., Lu, M., 2016. Heavy metals in the riverbed surface sediment of the Yellow River, China. *Environ. Sci. Pollut. Res.* 23, 24768–24780. <https://doi.org/10.1007/s11356-016-7712-z>
- Guyonnet, D., Planchon, M., Rollat, A., Escalon, V., Tuduri, J., Charles, N., Vaxelaire, S., Dubois, D., Fargier, H., 2015. Material flow analysis applied to rare earth elements in Europe. *J. Clean. Prod.* 107, 215–228. <https://doi.org/10.1016/J.JCLEPRO.2015.04.123>
- Hansmann, W., Köppel, V., 2000. Lead-isotopes as tracers of pollutants in soils. *Chem. Geol.* 171, 123–144. [https://doi.org/10.1016/S0009-2541\(00\)00230-8](https://doi.org/10.1016/S0009-2541(00)00230-8)
- Harada, M., 1995. Minamata Disease: Methylmercury Poisoning in Japan Caused by Environmental Pollution. *Crit. Rev. Toxicol.* 25, 1–24. <https://doi.org/10.3109/10408449509089885>
- Hartwig, A., Jahnke, G., 2012. Toxic metals and metalloids in foods, in: *Chemical Contaminants and Residues in Food*. Elsevier, pp. 233–249. <https://doi.org/10.1533/9780857095794.2.233>
- Hatje, V., Bruland, K.W., Flegal, A.R., 2016. Increases in Anthropogenic Gadolinium Anomalies and Rare Earth Element Concentrations in San Francisco Bay over a 20 Year Record. *Environ. Sci. Technol.* 50,

4159–4168. <https://doi.org/10.1021/acs.est.5b04322>

He, M., Wang, W.X., 2013. Bioaccessibility of 12 trace elements in marine molluscs. *Food Chem. Toxicol.* 55, 627–636. <https://doi.org/10.1016/j.fct.2013.01.046>

Heidari, B., Bakhtiari, A.R., Shirneshan, G., 2013. Concentrations of Cd, Cu, Pb and Zn in soft tissue of oyster (*Saccostrea cucullata*) collected from the Lengeh Port coast, Persian Gulf, Iran: A comparison with the permissible limits for public health. *Food Chem.* 141, 3014–3019. <https://doi.org/10.1016/j.foodchem.2013.06.002>

Hinrichs, J., Dellwig, O., Brumsack, H.-J., 2002. Lead in sediments and suspended particulate matter of the German Bight: natural versus anthropogenic origin. *Appl. Geochemistry* 17, 621–632. [https://doi.org/10.1016/S0883-2927\(01\)00124-X](https://doi.org/10.1016/S0883-2927(01)00124-X)

Hirner, A.V., Kritsotakis, K., Tobschall, H.J., 1990. Metal-organic associations in sediments—I. Comparison of unpolluted recent and ancient sediments and sediments affected by anthropogenic pollution. *Appl. Geochemistry* 5, 491–505. [https://doi.org/10.1016/0883-2927\(90\)90023-X](https://doi.org/10.1016/0883-2927(90)90023-X)

Holser, W.T., 1997. Evaluation of the application of rare-earth elements to paleoceanography. *Palaeogeogr. Palaeoclimatol. Palaeoecol.* 132, 309–323. [https://doi.org/10.1016/S0031-0182\(97\)00069-2](https://doi.org/10.1016/S0031-0182(97)00069-2)

Hong, S., Khim, J.S., Park, J., Son, H.S., Choi, S.D., Choi, K., Ryu, J., Kim, C.Y., Chang, G.S., Giesy, J.P., 2014. Species- and tissue-specific bioaccumulation of arsenicals in various aquatic organisms from a highly industrialized area in the Pohang City, Korea. *Environ. Pollut.* 192, 27–35. <https://doi.org/10.1016/j.envpol.2014.05.004>

Hooper, J., van Soest, R., 2002. *Systema porifera. A guide to the Classification of Sponges.* Kluwer Academic/Plenum publishers, New York.

Hornung, H., Krom, M.D., Cohen, Y., 1989. Trace metal distribution in sediments and benthic fauna of Haifa Bay, Israel. *Estuar. Coast. Shelf Sci.* 29, 43–56. [https://doi.org/10.1016/0272-7714\(89\)90072-3](https://doi.org/10.1016/0272-7714(89)90072-3)

Horowitz, A.J., 1991. *A Primer on Sediment-Trace Element Chemistry.* U.S.G.S. Open-File Rep. 2nd Editio, 136 (2 fiche).

Horowitz, A.J., Elrick, K.A., 1987. The relation of stream sediment surface area, grain size and composition to trace element chemistry. *Appl. Geochemistry* 2, 437–451. [https://doi.org/10.1016/0883-2927\(87\)90027-8](https://doi.org/10.1016/0883-2927(87)90027-8)

Hsieh, M.W., Liu, C.L., Chen, J.H., Jiang, S.J., 2010. Speciation analysis of arsenic and selenium compounds by CE-dynamic reaction cell-ICP-MS. *Electrophoresis* 31, 2272–2278. <https://doi.org/10.1002/elps.200900632>

Hughes, M.F., 2002. Arsenic toxicity and potential mechanisms of action. *Toxicol. Lett.* 133, 1–16. [https://doi.org/10.1016/S0378-4274\(02\)00084-X](https://doi.org/10.1016/S0378-4274(02)00084-X)

Illuminati, S., Annibaldi, A., Truzzi, C., Scarponi, G., 2016a. Heavy metal distribution in organic and siliceous marine sponge tissues measured by square wave anodic stripping voltammetry. *Mar. Pollut. Bull.* 111, 476–482. <https://doi.org/10.1016/j.marpolbul.2016.06.098>

Illuminati, S., Annibaldi, A., Truzzi, C., Scarponi, G., 2016b. Heavy metal distribution in organic and

- siliceous marine sponge tissues measured by square wave anodic stripping voltammetry. *Mar. Pollut. Bull.* 111, 476–482. <https://doi.org/10.1016/j.marpolbul.2016.06.098>
- Irgolic, K.J., Stockton, R.A., 1987. Element-specific detectors for liquid chromatography: The determination of arsenic compounds. *Mar. Chem.* 22, 265–278.
- Jagtap, R., Krikowa, F., Maher, W., Foster, S., Ellwood, M., 2011. Measurement of methyl mercury (I) and mercury (II) in fish tissues and sediments by HPLC-ICPMS and HPLC-HGAAS. *Talanta* 85, 49–55. <https://doi.org/10.1016/j.talanta.2011.03.022>
- Jagtap, R., Maher, W., 2015. Measurement of mercury species in sediments and soils by HPLC-ICPMS. *Microchem. J.* <https://doi.org/10.1016/j.microc.2015.01.010>
- Jonathan, R., Gobert, S., 2016. Trace Elements in Marine Environments: Occurrence, Threats and Monitoring with Special Focus on the Coastal Mediterranean. *J. Environ. Anal. Toxicol.* in press.
- Jones, B., Browser, C., 1987. The mineralogy and related chemistry of lake sediments, in: Lerman, A. (Ed.), *Lakes: Chemistry, Geology, Physics*. Springer-Verlag New York, pp. 179–235.
- Joung, D.J., Shiller, A.M., 2016. Temporal and spatial variations of dissolved and colloidal trace elements in Louisiana Shelf waters. *Mar. Chem.* 181, 25–43. <https://doi.org/10.1016/j.marchem.2016.03.003>
- Jung, H.S., Lim, D., Choi, J.Y., Yoo, H.S., Rho, K.C., Lee, H.B., 2012. Rare earth element compositions of core sediments from the shelf of the South Sea, Korea: Their controls and origins. *Cont. Shelf Res.* 48, 75–86. <https://doi.org/10.1016/j.csr.2012.08.008>
- Jung, S., Mezger, K., 2003. Petrology of basement-dominated terranes: I. Regional metamorphic T-t path from U-Pb monazite and Sm-Nd garnet geochronology (Central Damara orogen, Namibia). *Chem. Geol.* 198, 223–247. [https://doi.org/10.1016/S0009-2541\(03\)00037-8](https://doi.org/10.1016/S0009-2541(03)00037-8)
- Karbassi, A.R., Monavari, S.M., Nabi Bidhendi, G.R., Nouri, J., Nematpour, K., 2007. Metal pollution assessment of sediment and water in the Shur River. *Environ. Monit. Assess.* 147, 107. <https://doi.org/10.1007/s10661-007-0102-8>
- Karbassi, A.R., Nabi-Bidhendi, G.R., Bayati, I., 2005. Environmental Geochemistry of Heavy Metals in Sediment Core Off Bushehr, Persian Gulf. *Iran J. Environ. Health. Sci. Eng.* 2, 255–260.
- Keren, R., Lavy, A., Ilan, M., 2016. Increasing the Richness of Culturable Arsenic-Tolerant Bacteria from *Theonella swinhoei* by Addition of Sponge Skeleton to the Growth Medium. *Microb. Ecol.* 71, 873–886. <https://doi.org/10.1007/s00248-015-0726-0>
- Keren, R., Lavy, A., Mayzel, B., Ilan, M., 2015. Culturable associated-bacteria of the sponge *Theonella swinhoei* show tolerance to high arsenic concentrations. *Front. Microbiol.* 6, 1–11. <https://doi.org/10.3389/fmicb.2015.00154>
- Keren, R., Mayzel, B., Lavy, A., Polishchuk, I., Levy, D., Fakra, S.C., Pokroy, B., Ilan, M., 2017. Sponge-associated bacteria mineralize arsenic and barium on intracellular vesicles. *Nat. Commun.* 8, 14393. <https://doi.org/10.1038/ncomms14393>
- KeyToNature, 2015. Marine Species Identification Portal [WWW Document]. URL <http://species-identification.org/index.php> (accessed 7.4.17).
- Kingson, O., Bhutani, R., Dash, J.K., Sebastian, S., Balakrishnan, S., 2017. Resolving the conundrum in origin of the Manipur Ophiolite Complex, Indo-Myanmar range: Constraints from Nd isotopic ratios

- and elemental concentrations in serpentinized peridotite. *Chem. Geol.* 460, 117–129. <https://doi.org/10.1016/j.chemgeo.2017.04.021>
- Kljaković-Gašpić, Z., Bogner, D., Ujević, I., 2008. Trace metals (Cd, Pb, Cu, Zn and Ni) in sediment of the submarine pit Dragon ear (Soline Bay, Rogoznica, Croatia). *Environ. Geol.* 58, 751. <https://doi.org/10.1007/s00254-008-1549-9>
- Komárek, M., Ettler, V., Chrastný, V., Mihaljevič, M., 2008. Lead isotopes in environmental sciences: A review. *Environ. Int.* 34, 562–577. <https://doi.org/10.1016/j.envint.2007.10.005>
- Krata, A., Vassileva, E., Bulska, E., 2016. Reference measurements for total mercury and methyl mercury content in marine biota samples using direct or species-specific isotope dilution inductively coupled plasma mass spectrometry. *Talanta* 160, 562–569. <https://doi.org/10.1016/j.talanta.2016.07.033>
- Kucuksezgin, F., Gonul, L.T., Tasel, D., 2014. Total and inorganic arsenic levels in some marine organisms from Izmir Bay (Eastern Aegean Sea): A risk assessment. *Chemosphere* 112, 311–316. <https://doi.org/10.1016/j.chemosphere.2014.04.071>
- Kulaksiz, S., Bau, M., 2011. Rare earth elements in the Rhine River, Germany: First case of anthropogenic lanthanum as a dissolved microcontaminant in the hydrosphere. *Environ. Int.* 37, 973–979. <https://doi.org/10.1016/j.envint.2011.02.018>
- Lai, V.W.M., Cullen, W.R., Ray, S., 1999. Arsenic speciation in scallops. *Mar. Chem.* 66, 81–89. [https://doi.org/10.1016/S0304-4203\(99\)00025-0](https://doi.org/10.1016/S0304-4203(99)00025-0)
- Lamborg, C.H., Hammerschmidt, C.R., Bowman, K.L., Swarr, G.J., Munson, K.M., Ohnemus, D.C., Lam, P.J., Heimbürger, L.-E., Rijkenberg, M., Saito, M.A., 2014. A global ocean inventory of anthropogenic mercury based on water column measurements. *Nature* 512, 65–68. <https://doi.org/10.1038/nature13563>
- Lang, T., Kruse, R., Haarich, M., Wosniok, W., 2017. Mercury species in dab (*Limanda limanda*) from the North Sea, Baltic Sea and Icelandic waters in relation to host-specific variables. *Mar. Environ. Res.* 124, 32–40. <https://doi.org/10.1016/j.marenvres.2016.03.001>
- Laport, M.S., Santos, O.C., Muricy, G., 2009. Marine sponges: potential sources of new antimicrobial drugs. *Curr. Pharm. Biotechnol.* 10, 86–105.
- Larsen, M.M., Blusztajn, J.S., Andersen, O., Dahllöf, I., 2012. Lead isotopes in marine surface sediments reveal historical use of leaded fuel. *J. Environ. Monit.* 14, 2893. <https://doi.org/10.1039/c2em30579h>
- Lauwerys, R.R., Haufroid, V., Hoet, P., Lison, D., 2007. *Toxicologie industrielle et intoxications professionnelles*, Fifth. ed. Masson, Paris, Paris.
- Le Pape, P., Ayrault, S., Quantin, C., 2012. Trace element behavior and partition versus urbanization gradient in an urban river (Orge River, France). *J. Hydrol.* 472–473, 99–110. <https://doi.org/10.1016/j.jhydrol.2012.09.042>
- Leermakers, M., Baeyens, W., De Gieter, M., Smedts, B., Meert, C., De Bisschop, H.C., Morabito, R., Quevauviller, P., 2006. Toxic arsenic compounds in environmental samples: Speciation and validation. *TrAC - Trends Anal. Chem.* 25, 1–10. <https://doi.org/10.1016/j.trac.2005.06.004>

- Leermakers, M., Baeyens, W., Quevauviller, P., Horvat, M., 2005. Mercury in environmental samples: Speciation, artifacts and validation. *TrAC Trends Anal. Chem.* 24, 383–393. <https://doi.org/10.1016/j.trac.2004.01.001>
- Levy, G.A., 1946. The toxicity of arsine administered by intraperitoneal injection. *Levy GA. Toxic. arsine Adm. by intraperitoneal Inject. Br. J. Pharmacol. Chemother.* 287–290.
- Li, C.-W., Chen, J.-Y., Hua, T.-E., 1998. Precambrian Sponges with Cellular Structures. *Science* (80-.). 279, 879–882. <https://doi.org/10.1126/science.279.5352.879>
- Li, X., Wai, O.W.H., Li, Y.S., Coles, B.J., Ramsey, M.H., Thornton, I., 2000. Heavy metal distribution in sediment profiles of the Pearl River estuary, South China. *Appl. Geochemistry* 15, 567–581. [https://doi.org/10.1016/S0883-2927\(99\)00072-4](https://doi.org/10.1016/S0883-2927(99)00072-4)
- Liang, T., Li, K., Wang, L., 2014. State of rare earth elements in different environmental components in mining areas of China. *Environ. Monit. Assess.* 186, 1499–1513. <https://doi.org/10.1007/s10661-013-3469-8>
- Lindqvist, O., Johansson, K., Bringmark, L., Timm, B., Aastrup, M., Andersson, A., Hovsenius, G., Håkanson, L., Iverfeldt, Å., Meili, M., 1991. Mercury in the Swedish environment --- Recent research on causes, consequences and corrective methods. *Water. Air. Soil Pollut.* 55, xi--261. <https://doi.org/10.1007/BF00542429>
- Linge, K.L., Jarvis, K.E., 2009. Quadrupole ICP-MS: Introduction to Instrumentation, Measurement Techniques and Analytical Capabilities. *Geostand. Geoanalytical Res.* 33, 445–467. <https://doi.org/10.1111/j.1751-908X.2009.00039.x>
- Liu, L., Wang, Z., Ju, F., Zhang, T., 2015. Co-occurrence correlations of heavy metals in sediments revealed using network analysis. *Chemosphere* 119, 1305–1313. <https://doi.org/10.1016/j.chemosphere.2014.01.068>
- Llorente-Mirandes, T., Ruiz-Chancho, M.J., Barbero, M., Rubio, R., López-Sánchez, J.F., 2010. Measurement of arsenic compounds in littoral zone algae from the Western Mediterranean Sea. Occurrence of arsenobetaine. *Chemosphere* 81, 867–875. <https://doi.org/10.1016/j.chemosphere.2010.08.007>
- Lohren, H., Blagojevic, L., Fitkau, R., Ebert, F., Schildknecht, S., Leist, M., Schwerdtle, T., 2015. Toxicity of organic and inorganic mercury species in differentiated human neurons and human astrocytes. *J. Trace Elem. Med. Biol.* 32, 200–208. <https://doi.org/10.1016/j.jtemb.2015.06.008>
- Longo, C., Corriero, G., Licciano, M., Stabili, L., 2010. Bacterial accumulation by the Demospongiae *Hymeniacidon perlevis*: A tool for the bioremediation of polluted seawater. *Mar. Pollut. Bull.* 60, 1182–1187. <https://doi.org/10.1016/j.marpolbul.2010.03.035>
- Loring, D.H., Rantala, R.T.T., 1992. Manual for the geochemical analyses of marine sediments and suspended particulate matter. *Earth Sci. Rev.* 32, 235–283. [https://doi.org/10.1016/0012-8252\(92\)90001-A](https://doi.org/10.1016/0012-8252(92)90001-A)
- Love, G.D., Grosjean, E., Stalvies, C., Fike, D.A., Grotzinger, J.P., Bradley, A.S., Kelly, A.E., Bhatia, M., Meredith, W., Snape, C.E., Bowring, S.A., Condon, D.J., Summons, R.E., 2009. Fossil steroids record the appearance of Demospongiae during the Cryogenian period. *Nature* 457, 718–721. <https://doi.org/10.1038/nature07673>

- Lu, X., Wang, L., Lei, K., Huang, J., Zhai, Y., 2009. Contamination assessment of copper, lead, zinc, manganese and nickel in street dust of Baoji, NW China. *J. Hazard. Mater.* 161, 1058–1062. <https://doi.org/10.1016/j.jhazmat.2008.04.052>
- Luoma, S.N., Rainbow, P.S., 2005. Why is metal bioaccumulation so variable? Biodynamics as a unifying concept. *Environ. Sci. Technol.* 39, 1921–1931. <https://doi.org/10.1021/es048947e>
- Macdonald, D.D., Carr, R.S., Calder, F.D., Long, E.R., Ingersoll, C.G., 1996. Development and evaluation of sediment quality guidelines for Florida coastal waters. *Ecotoxicology* 5, 253–78. <https://doi.org/10.1007/BF00118995>
- Magnusson, B., Ornemark, U., 2014. *Eurachem Guide: The Fitness for Purpose of Analytical Methods – a Laboratory Guide to Method Validation and Related Topics*. EURACHEM.
- Majer, A.P., Petti, M.A.V., Corbisier, T.N., Ribeiro, A.P., Theophilo, C.Y.S., Ferreira, P.A. de L., Figueira, R.C.L., 2014. Bioaccumulation of potentially toxic trace elements in benthic organisms of Admiralty Bay (King George Island, Antarctica). *Mar. Pollut. Bull.* 79, 321–325. <https://doi.org/10.1016/j.marpolbul.2013.12.015>
- Mandal, B.K., Suzuki, K.T., 2002. Arsenic round the world: A review. *Talanta* 58, 201–235. [https://doi.org/10.1016/S0039-9140\(02\)00268-0](https://doi.org/10.1016/S0039-9140(02)00268-0)
- Mandjukov, P., Orani, A.M., Han, E., Vassileva, E., 2015. Determination of total mercury for marine environmental monitoring studies by solid sampling continuum source high resolution atomic absorption spectrometry. *Spectrochim. Acta - Part B At. Spectrosc.* 103–104, 24–33. <https://doi.org/10.1016/j.sab.2014.11.006>
- Mapani, B., Ellmies, R., Kamona, F., Kříbek, B., Majer, V., Knésl, I., Pašava, J., Mufenda, M., Mbingeneeko, F., 2009. Human health risks associated with historic ore processing at Berg Aukas, Grootfontein area, Namibia. *Communs geol. Surv. Namibia* 14, 25–40. <https://doi.org/10.1016/j.jafrearsci.2010.07.007>
- Martinez-Bravo, Y., Roig-Navarro, A.F., Lopez, F.J., Hernandez, F., 2001. Multielemental determination of arsenic, selenium and chromium(VI) species in water by high-performance liquid chromatography-inductively coupled plasma mass spectrometry. *J. Chromatogr. A* 926, 265–274.
- Mason, R.P., Reinfelder, J.R., Morel, F.M.M., 1996. Uptake, Toxicity, and Trophic Transfer of Mercury in a Coastal Diatom. *Environ. Sci. Technol.* 30, 1835–1845. <https://doi.org/10.1021/es950373d>
- Mayzel, B., Aizenberg, J., Ilan, M., 2014. The elemental composition of demospongiae from the Red Sea, Gulf of Aqaba. *PLoS One* 9. <https://doi.org/10.1371/journal.pone.0095775>
- McArthur, J.M., Walsh, J.N., 1984. Rare-earth geochemistry of phosphorites. *Chem. Geol.* 47, 191–220. [https://doi.org/10.1016/0009-2541\(84\)90126-8](https://doi.org/10.1016/0009-2541(84)90126-8)
- McLennan, S.M., 1989. Rare earth elements in sedimentary rocks; influence of provenance and sedimentary processes. *Rev. Mineral. Geochemistry* 21, 169–200.
- McNaught, A.D., Wilkinson, A., 1997. *Compendium of Chemical Terminology. The gold book*. Blackwell Science, London. <https://doi.org/10.1351/goldbook.i03352>
- Melamed, D., 2005. Monitoring arsenic in the environment: a review of science and technologies with the potential for field measurements. *Anal. Chim. Acta* 532, 1–13.

<https://doi.org/10.1016/j.aca.2004.10.047>

- Mil-Homens, M., Vale, C., Brito, P., Naughton, F., Drago, T., Raimundo, J., Anes, B., Schmidt, S., Caetano, M., 2017. Insights of Pb isotopic signature into the historical evolution and sources of Pb contamination in a sediment core of the southwestern Iberian Atlantic shelf. *Sci. Total Environ.* 586, 473–484. <https://doi.org/10.1016/j.scitotenv.2017.01.204>
- Milanese, M., Chelossi, E., Manconi, R., Sarà, A., Sidri, M., Pronzato, R., 2003. The marine sponge *Chondrilla nucula* Schmidt, 1862 as an elective candidate for bioremediation in integrated aquaculture. *Biomol. Eng.* 20, 363–368. [https://doi.org/10.1016/S1389-0344\(03\)00052-2](https://doi.org/10.1016/S1389-0344(03)00052-2)
- Mileusnić, M., Mapani, B.S., Kamona, A.F., Ružičić, S., Mapaure, I., Chimwamurombe, P.M., 2014. Assessment of agricultural soil contamination by potentially toxic metals dispersed from improperly disposed tailings, Kombat mine, Namibia. *J. Geochemical Explor.* 144, 409–420. <https://doi.org/10.1016/j.gexplo.2014.01.009>
- Ministry of Environment and Tourism, 2008. Strategic Environmental Assessment (SEA) of the coastal areas of the Erongo and Kunene regions.
- Mitra, N., Rezvan, Z., Seyed Ahmad, M., Gharai Mohamad Hosein, M., 2012. Studies of Water Arsenic and Boron Pollutants and Algae Phytoremediation in Three Springs, Iran. *Int. J. Ecosyst.* 2, 32–37. <https://doi.org/10.5923/j.ije.20120203.01>
- Miyashita, S., Murota, D.C., Kondo, B.K., 2016. Arsenic metabolism in cyanobacteria. *Environ. Chem.* 13, 577–589.
- Miyashita, S., Shimoya, M., Kamidate, Y., Kuroiwa, T., Shikino, O., Fujiwara, S., Francesconi, K.A., Kaise, T., 2009. Rapid determination of arsenic species in freshwater organisms from the arsenic-rich Hayakawa River in Japan using HPLC-ICP-MS. *Chemosphere* 75, 1065–1073. <https://doi.org/10.1016/j.chemosphere.2009.01.029>
- Monna, F., Ben Othman, D., Luck, J.M., 1995. Pb isotopes and Pb, Zn and Cd concentrations in the rivers feeding a coastal pond (Thau, southern France): constraints on the origin(s) and flux(es) of metals. *Sci. Total Environ.* 166, 19–34. [https://doi.org/10.1016/0048-9697\(95\)04514-2](https://doi.org/10.1016/0048-9697(95)04514-2)
- MONNA, F., BENOETHMAN, D., LUCK, J., 1995. Pb isotopes and Pb, Zn and Cd concentrations in the rivers feeding a coastal pond (Thau, southern France): constraints on the origin(s) and flux(es) of metals. *Sci. Total Environ.* 166, 19–34. [https://doi.org/10.1016/0048-9697\(95\)04514-2](https://doi.org/10.1016/0048-9697(95)04514-2)
- Monna, F., Hamer, K., Lévêque, J., Sauer, M., 2000. Pb isotopes as a reliable marker of early mining and smelting in the Northern Harz province (Lower Saxony, Germany). *J. Geochemical Explor.* 68, 201–210. [https://doi.org/10.1016/S0375-6742\(00\)00005-4](https://doi.org/10.1016/S0375-6742(00)00005-4)
- Monna, F., Poujol, M., Losno, R., Dominik, J., Annegarn, H., Coetzee, H., 2006. Origin of atmospheric lead in Johannesburg, South Africa. *Atmos. Environ.* 40, 6554–6566. <https://doi.org/10.1016/j.atmosenv.2006.05.064>
- Morel, F.M.M., Kraepiel, A.M.L., Amyot, M., 1998. THE CHEMICAL CYCLE AND BIOACCUMULATION OF MERCURY. *Annu. Rev. Ecol. Syst.* 29, 543–566. <https://doi.org/10.1146/annurev.ecolsys.29.1.543>
- Müller, W.E.G., Batel, R., Lacorn, M., Steinhart, H., Simat, T., Lauenroth, S., Hassanein, H., Schröder, H.C., 1998. Accumulation of cadmium and zinc in the marine sponge *Suberites domuncula* and its potential consequences on single-strand breaks and on expression of heat-shock protein: A natural

- field study. *Mar. Ecol. Prog. Ser.* 167, 127–135. <https://doi.org/10.3354/meps167127>
- Nakata, H., Nakayama, S.M.M., Ikenaka, Y., Mizukawa, H., Ishii, C., Yohannes, Y.B., Konnai, S., Darwish, W.S., Ishizuka, M., 2015. Metal extent in blood of livestock from Dandora dumping site, Kenya: Source identification of Pb exposure by stable isotope analysis. *Environ. Pollut.* 205, 8–15. <https://doi.org/10.1016/j.envpol.2015.05.003>
- Nam, S.H., Oh, H.J., Min, H.S., Lee, J.H., 2010. A study on the extraction and quantitation of total arsenic and arsenic species in seafood by HPLC-ICP-MS. *Microchem. J.* 95, 20–24. <https://doi.org/10.1016/j.microc.2009.08.009>
- Ndung'u, K., Franks, R.P., Bruland, K.W., Flegal, A.R., 2003. Organic complexation and total dissolved trace metal analysis in estuarine waters: comparison of solvent-extraction graphite furnace atomic absorption spectrometric and chelating resin flow injection inductively coupled plasma-mass spectrometric analysis. *Anal. Chim. Acta* 481, 127–138. [https://doi.org/10.1016/S0003-2670\(03\)00063-1](https://doi.org/10.1016/S0003-2670(03)00063-1)
- Nearing, M.M., Koch, I., Reimer, K.J., 2014. Complementary arsenic speciation methods: A review. *Spectrochim. Acta - Part B At. Spectrosc.* 99, 150–162. <https://doi.org/10.1016/j.sab.2014.07.001>
- Negri, A., Burns, K., Boyle, S., Brinkman, D., Webster, N., 2006. Contamination in sediments, bivalves and sponges of McMurdo Sound, Antarctica. *Environ. Pollut.* 143, 456–467. <https://doi.org/10.1016/j.envpol.2005.12.005>
- Nieboer, E., Richardson, D.H.S., 1980. The replacement of the nondescript term “heavy metals” by a biologically and chemically significant classification of metal ions. *Environ. Pollut. Ser. B, Chem. Phys.* 1, 3–26. [https://doi.org/10.1016/0143-148X\(80\)90017-8](https://doi.org/10.1016/0143-148X(80)90017-8)
- Nolan, L., Cadien, K., 2012. *Chemical Mechanical Polish for Nanotechnology*. Nanofabrication Tech. Princ.
- Nozaki, Y., 2001. Elemental distribution: Overview, in: Steele, J.H., Thorpe, S.A., Turekian, K.K. (Eds.), *Encyclopedia of the Ocean Sciences*, Vol. 2. Academic Press London, pp. 840–845. <https://doi.org/http://dx.doi.org/10.1006/rwos.2001.0402>
- Ochoa, V., Barata, C., Riva, M.C., 2013. Heavy metal content in oysters (*Crassostrea gigas*) cultured in the Ebro Delta in Catalonia, Spain. *Environ. Monit. Assess.* 185, 6783–6792. <https://doi.org/10.1007/s10661-013-3064-z>
- Olesen, T.M.E., Weeks, J.M., 1994. Accumulation of Cd by the marine sponge *Halichondria panicea* pallas: effects upon filtration rate and its relevance for biomonitoring. *Bull. Environ. Contam. Toxicol.* 52, 722–728. <https://doi.org/10.1007/BF00195494>
- Olmedo, P., Pla, A., Hernández, A.F., Barbier, F., Ayouni, L., Gil, F., 2013. Determination of toxic elements (mercury, cadmium, lead, tin and arsenic) in fish and shellfish samples. Risk assessment for the consumers. *Environ. Int.* 59, 63–72. <https://doi.org/10.1016/j.envint.2013.05.005>
- Orris, G.J., Grauch, R.I., 2002. *Rare Earth Element Mines, Deposits, and Occurrences*.
- Ortega, G.S., Pécheyran, C., Bérail, S., Donard, O.F.X., 2012. A fit-for purpose procedure for lead isotopic ratio determination in crude oil, asphaltene and kerogen samples by MC-ICPMS. *J. Anal. At. Spectrom.* 27, 1447. <https://doi.org/10.1039/c2ja30143a>

- Ostrom, K.M., Simpson, T.L., 1978. Calcium and the release from dormancy of freshwater sponge gemmules. *Dev. Biol.* 64, 332–338. [https://doi.org/10.1016/0012-1606\(78\)90083-0](https://doi.org/10.1016/0012-1606(78)90083-0)
- Padovan, A., Munksgaard, N., Alvarez, B., McGuinness, K., Parry, D., Gibb, K., 2012. Trace metal concentrations in the tropical sponge *Spherospongia vagabunda* at a sewage outfall: Synchrotron X-ray imaging reveals the micron-scale distribution of accumulated metals. *Hydrobiologia* 687, 275–288. <https://doi.org/10.1007/s10750-011-0916-9>
- Pan, K., Lee, O.O., Qian, P.Y., Wang, W.X., 2011. Sponges and sediments as monitoring tools of metal contamination in the eastern coast of the Red Sea, Saudi Arabia. *Mar. Pollut. Bull.* 62, 1140–1146. <https://doi.org/10.1016/j.marpolbul.2011.02.043>
- Parra, S., Bravo, M.A., Quiroz, W., Querol, X., Paipa, C., 2015. Distribution and pollution assessment of trace elements in marine sediments in the Quintero Bay (Chile). *Mar. Pollut. Bull.* 99, 256–263. <https://doi.org/10.1016/j.marpolbul.2015.07.066>
- Parsons, J.G., Martinez-Martinez, A., Peralta-Video, J.R., Gardea-Torresdey, J.L., 2008. Speciation and uptake of arsenic accumulated by corn seedlings using XAS and DRC-ICP-MS. *Chemosphere* 70, 2076–2083. <https://doi.org/10.1016/j.chemosphere.2007.08.069>
- Patel, B., Balani, M., Patel, S., 1985. Sponge “sentinel” of heavy metals. *Sci. Total Environ.* 41, 143–152.
- Perez, T., Longet, D., Schembri, T., Rebouillon, P., Vacelet, J., 2005. Effects of 12 years’ operation of a sewage treatment plant on trace metal occurrence within a Mediterranean commercial sponge (*Spongia officinalis*, *Demospongiae*). *Mar. Pollut. Bull.* 50, 301–309. <https://doi.org/10.1016/j.marpolbul.2004.11.001>
- Perez, T., Vacelet, J., Rebouillon, P., 2004. In situ comparative study of several Mediterranean sponges as potential biomonitors for heavy metals. *Boll. Mus. Ist. Biol. Univ. Genova* 68, 517–525.
- Phillips, D.J.H., 1990. Arsenic in aquatic organisms: a review, emphasising chemical speciation. *Aquat. Toxicol.* 16, 151–186.
- Piper, D.Z., 1974. Rare earth elements in the sedimentary cycle: A summary. *Chem. Geol.* 14, 285–304. [https://doi.org/10.1016/0009-2541\(74\)90066-7](https://doi.org/10.1016/0009-2541(74)90066-7)
- Plant, J.A., Raiswell, R., 1983. Principles of environmental geochemistry, in: Thornton, I. (Ed.), *Applied Environmental Geochemistry*. Academic Press London.
- Pourret, O., Davranche, M., Gruau, G., Dia, A., 2007. Rare earth elements complexation with humic acid. *Chem. Geol.* 243, 128–141. <https://doi.org/10.1016/j.chemgeo.2007.05.018>
- Quetel, C.R., Prohaska, T., Hamester, M., Kerl, W., Taylor, P.D.P., 2000. Examination of the performance exhibited by a single detector double focusing magnetic sector ICP-MS instrument for uranium isotope abundance ratio measurements over almost three orders of magnitude and down to pg[space]g⁻¹ concentration levels. *J. Anal. At. Spectrom.* 15, 353–358. <https://doi.org/10.1039/A907084B>
- Quevauviller, P., 2016. *Marine Chemical Monitoring. Policies, techniques and metrological principles*. John Wiley & Sons.
- Raber, G., Stock, N., Hanel, P., Murko, M., Navratilova, J., Francesconi, K.A., 2012. An improved HPLC-ICPMS method for determining inorganic arsenic in food: Application to rice, wheat and tuna fish.

- Food Chem. 134, 524–532. <https://doi.org/10.1016/j.foodchem.2012.02.113>
- Radabaugh, T.R., Aposhian, H.V., 2000. Enzymatic Reduction of Arsenic Compounds in Mammalian Systems: Reduction of Arsenate to Arsenite by Human Liver Arsenate Reductase. *Chem. Res. Toxicol.* 13, 26–30. <https://doi.org/10.1021/tx990115k>
- Rainbow, P., 2002. Trace metal concentrations in aquatic invertebrates: why and so what? *Environ. Pollut.* 120, 497–507. [https://doi.org/10.1016/S0269-7491\(02\)00238-5](https://doi.org/10.1016/S0269-7491(02)00238-5)
- Rainbow, P.S., 1997. Trace Metal Accumulation in Marine Invertebrates: Marine Biology or Marine Chemistry? *J. Mar. Biol. Assoc. United Kingdom* 77, 195–210. <https://doi.org/doi:10.1017/S0025315400033877>
- Rand, G.M., Wells, P.G., McCarthy, L.S., 1995. Introduction to aquatic ecology, in: Rand, G.M. (Ed.), *Fundamentals of Aquatic Toxicology*. Taylor and Francis, London, pp. 3–53.
- Resongles, E., Casiot, C., Freydier, R., Dezileau, L., Viers, J., Elbaz-Poulichet, F., 2014. Persisting impact of historical mining activity to metal (Pb, Zn, Cd, Tl, Hg) and metalloid (As, Sb) enrichment in sediments of the Gardon River, Southern France. *Sci. Total Environ.* 481, 509–521. <https://doi.org/10.1016/j.scitotenv.2014.02.078>
- Rezaee, K., Saion, E.B., Wood, A.K., Abdi, M.R., 2010. Rare earth elements determination and distribution patterns in surface marine sediments of the South China Sea by INAA, Malaysia. *J. Radioanal. Nucl. Chem.* 283, 823–829. <https://doi.org/10.1007/s10967-009-0421-z>
- Rieuwerts, J.S., Thornton, I., Farago, M.E., Ashmore, M.R., 1998. Factors influencing metal bioavailability in soils: preliminary investigations for the development of a critical loads approach for metals. *Chem. Speciat. Bioavailab.* 10, 61–75. <https://doi.org/10.3184/095422998782775835>
- Roehl, R., Gomez, J., Woodhouse, L.R., 1995. Correction of mass bias drift in inductively coupled plasma mass spectrometry measurements of zinc isotope ratios using gallium as an isotope ratio internal standard. *J. Anal. At. Spectrom.* 10, 15–23. <https://doi.org/10.1039/JA9951000015>
- Roose, P., Albaigés, J., Bebianno, M.J., Camphuysen, C., Cronin, M., de Leeuw, J., Gabrielsen, G., Hutchinson, T., Hylland, K., Jansson, B., Jenssen, B.M., Schulz-Bull, D., Szefer, P., Webster, L., Bakke, T., Janssen, C., 2011. Monitoring Chemical Pollution in Europe's Seas: Programmes, practices and priorities for Research. *Mar. Board Position* 108.
- Rose, A.W., Hawkes, H.E., 1979. *Geochemistry in mineral exploration*. Academic Press.
- Roussiez, V., Ludwig, W., Probst, J.-L., Monaco, A., 2005. Background levels of heavy metals in surficial sediments of the Gulf of Lions (NW Mediterranean): An approach based on ¹³³Cs normalization and lead isotope measurements. *Environ. Pollut.* 138, 167–177. <https://doi.org/10.1016/j.envpol.2005.02.004>
- Sakko, A.L., 1998. The influence of the Benguela upwelling system on Namibia's marine biodiversity. *Biodivers. Conserv.* 7, 419–433. <https://doi.org/10.1023/A:1008867310010>
- Salati, S., Moore, F., 2010. Assessment of heavy metal concentration in the Khoshk River water and sediment, Shiraz, Southwest Iran. *Environ. Monit. Assess.* 164, 677–689. <https://doi.org/10.1007/s10661-009-0920-y>
- Salaün, P., Planer-Friedrich, B., van den Berg, C.M.G., 2007. Inorganic arsenic speciation in water and

- seawater by anodic stripping voltammetry with a gold microelectrode. *Anal. Chim. Acta* 585, 312–322. <https://doi.org/10.1016/j.aca.2006.12.048>
- Salomons, W., Förstner, U., 1984. *Metals in the Hydrocycle*. Springer-Verlag Berlin Heidelberg. <https://doi.org/10.1007/978-3-642-69325-0>
- Sánchez Uría, J., 1998. Inorganic and methylmercury speciation in environmental samples. *Talanta* 47, 509–524. [https://doi.org/10.1016/S0039-9140\(98\)00116-7](https://doi.org/10.1016/S0039-9140(98)00116-7)
- Santini, J.M., Streimann, I.C.A., Hoven, R.N. vanden, 2004. *Bacillus macyae* sp. nov., an arsenate-respiring bacterium isolated from an Australian gold mine. *Int. J. Syst. Evol. Microbiol.* 54, 2241–2244.
- Santos-Gandelman, J.F., Giambiagi-Demarval, M., Muricy, G., Barkay, T., Laport, M.S., 2014. Mercury and methylmercury detoxification potential by sponge-associated bacteria. *Antonie van Leeuwenhoek, Int. J. Gen. Mol. Microbiol.* 106, 585–590. <https://doi.org/10.1007/s10482-014-0224-2>
- Schaeffer, R., Francesconi, K.A., Kienzl, N., Soeroes, C., Fodor, P., Váradi, L., Raml, R., Goessler, W., Kuehnelt, D., 2006. Arsenic speciation in freshwater organisms from the river Danube in Hungary. *Talanta* 69, 856–865. <https://doi.org/10.1016/j.talanta.2005.11.025>
- Scott, N., Hatlelid, K.M., MacKenzie, N.E., Carter, D.E., 1993. Reactions of arsenic(III) and arsenic(V) species with glutathione. *Chem. Res. Toxicol.* 6, 102–106. <https://doi.org/10.1021/tx00031a016>
- Semeniuk, D.M., Maldonado, M.T., Jaccard, S.L., 2016. Chromium uptake and adsorption in marine phytoplankton – Implications for the marine chromium cycle. *Geochim. Cosmochim. Acta* 184, 41–54. <https://doi.org/10.1016/j.gca.2016.04.021>
- Semlali, R.M., Dessogne, J.-B., Monna, F., Bolte, J., Azimi, S., Navarro, N., Denaix, L., Loubet, M., Chateau, C., van Oort, F., 2004. Modeling Lead Input and Output in Soils Using Lead Isotopic Geochemistry. *Environ. Sci. Technol.* 38, 1513–1521. <https://doi.org/10.1021/es0341384>
- Shepherd, T.J., Dirks, W., Roberts, N.M.W., Patel, J.G., Hodgson, S., Pless-Mulloli, T., Walton, P., Parrish, R.R., 2016. Tracing fetal and childhood exposure to lead using isotope analysis of deciduous teeth. *Environ. Res.* 146, 145–153. <https://doi.org/10.1016/j.envres.2015.12.017>
- Shiomi, K., Aoyama, M., Yamanaka, H., Kikuchi, T., 1988. Chemical Forms of Arsenic in Sponges, Sea-Anemones and Sea Hare. *Comp. Biochem. Physiol. C-Pharmacology Toxicol. Endocrinol.* 90, 361–365.
- Silver, S., Phung, L.T., 2005. Genes and Enzymes Involved in Bacterial Oxidation and Reduction of Inorganic Arsenic. *Appl. Environ. Microbiol.* 71.
- Sjåstad, K.-E., Lucy, D., Andersen, T., 2016. Lead isotope ratios for bullets, forensic evaluation in a Bayesian paradigm. *Talanta* 146, 62–70. <https://doi.org/10.1016/j.talanta.2015.07.070>
- Sjåstad, K.-E., Simonsen, S.L., Andersen, T., 2011. Use of lead isotopic ratios to discriminate glass samples in forensic science. *J. Anal. At. Spectrom.* 26, 325. <https://doi.org/10.1039/c0ja00054j>
- Søndergaard, J., Asmund, G., Larsen, M.M., 2015. Trace elements determination in seawater by ICP-MS with on-line pre-concentration on a Chelex-100 column using a “standard” instrument setup. *MethodsX* 2, 323–330. <https://doi.org/10.1016/j.mex.2015.06.003>
- Song, Y.H., Choi, M.S., 2009. REE geochemistry of fine-grained sediments from major rivers around the

- Yellow Sea. *Chem. Geol.* 266, 337–351. <https://doi.org/10.1016/j.chemgeo.2009.06.019>
- Spada, L., Annicchiarico, C., Cardellicchio, N., Giandomenico, S., Di Leo, A., 2012. Mercury and methylmercury concentrations in Mediterranean seafood and surface sediments, intake evaluation and risk for consumers. *Int. J. Hyg. Environ. Health* 215, 418–426. <https://doi.org/10.1016/j.ijheh.2011.09.003>
- Split, P.M., Delta, A., 2010. Sediment Quality Guidelines for the Protection of Aquatic Life, Canadian Council of Ministers of the Environment.
- Stiboller, M., Raber, G., Francesconi, K.A., 2015. Simultaneous determination of glycine betaine and arsenobetaine in biological samples by HPLC/ICPMS/ESMS and the application to some marine and freshwater fish samples. *Microchem. J.* 122, 172–175. <https://doi.org/10.1016/j.microc.2015.04.022>
- Strady, E., Schäfer, J., Baudrimont, M., Blanc, G., 2011. Tracing cadmium contamination kinetics and pathways in oysters (*Crassostrea gigas*) by multiple stable Cd isotope spike experiments. *Ecotoxicol. Environ. Saf.* 74, 600–606. <https://doi.org/10.1016/j.ecoenv.2010.10.020>
- Sulochanan, B., Krishnakumar, P.K., Prema, D., Kaladharan, P., Valsala, K.K., Bhat, G.S., Muniyandi, K., 2007. Trace metal contamination of the marine environment in Palk Bay and Gulf of Mannar. *J. Mar. Biol. Assoc. India* 49, 12–18.
- Sun, M., Liu, G., Wu, Q., Liu, W., 2013. Speciation analysis of inorganic arsenic in coal samples by microwave-assisted extraction and high performance liquid chromatography coupled to hydride generation atomic fluorescence spectrometry. *Talanta* 106, 8–13. <https://doi.org/10.1016/j.talanta.2012.12.012>
- Sun, Q., Liu, D., Liu, T., Di, B., Wu, F., 2012. Temporal and spatial distribution of trace metals in sediments from the northern Yellow Sea coast, China: Implications for regional anthropogenic processes. *Environ. Earth Sci.* 66, 697–705. <https://doi.org/10.1007/s12665-011-1277-4>
- Suner, M.A., Devesa, V., Munoz, O., Velez, D., Montoro, R., 2001. Application of column switching in high-performance liquid chromatography with on-line thermo-oxidation and detection by HG-AAS and HG-AFS for the analysis of organoarsenical species in seafood samples. *J. Anal. At. Spectrom.* 16, 390–397. <https://doi.org/10.1039/B007518N>
- Szava-Kovats, R.C., 2008. Grain-size normalization as a tool to assess contamination in marine sediments: Is the $63\mu\text{m}$ fraction fine enough? *Mar. Pollut. Bull.* 56, 629–632. <https://doi.org/10.1016/j.marpolbul.2008.01.017>
- Tan, Q.G., Wang, Y., Wang, W.X., 2015. Speciation of Cu and Zn in two colored oyster species determined by x-ray absorption spectroscopy. *Environ. Sci. Technol.* 49, 6919–6925. <https://doi.org/10.1021/es506330h>
- Tang, J., Johannesson, K.H., 2010. Ligand extraction of rare earth elements from aquifer sediments: Implications for rare earth element complexation with organic matter in natural waters. *Geochim. Cosmochim. Acta* 74, 6690–6705. <https://doi.org/10.1016/j.gca.2010.08.028>
- Taylor, S.R., 1964. Abundance of chemical elements in the continental crust: a new table. *Geochim. Cosmochim. Acta* 28, 1273–1285. [https://doi.org/10.1016/0016-7037\(64\)90129-2](https://doi.org/10.1016/0016-7037(64)90129-2)
- Taylor, V.F., Jackson, B.P., Siegfried, M.R., Navratilova, J., Francesconi, K.A., Kirshtein, J., Voytek, M.,

2012. Arsenic speciation in food chains from mid-Atlantic hydrothermal vents. *Environ. Chem.* 9, 130–138. <https://doi.org/10.1071/EN11134>
- Tchounwou, P.B., Yedjou, C.G., Patlolla, A.K., Sutton, D.J., 2012. Heavy Metals Toxicity and the Environment. *Mol. Clin. Environ. Toxicol.* 101, 1–30. <https://doi.org/10.1007/978-3-7643-8340-4>
- Thomas, D.J., Styblo, M., Lin, S., 2001. The Cellular Metabolism and Systemic Toxicity of Arsenic. *Toxicol. Appl. Pharmacol.* 176, 127–144. <https://doi.org/10.1006/taap.2001.9258>
- Thomas, R., 2003. *Practical guide to ICP-MS: a tutorial for beginners*. CRC Press.
- Thorne, L.T., Nickless, G., 1981. The relation between heavy metals and particle size fractions within the severn estuary (U.K.) inter-tidal sediments. *Sci. Total Environ.* 19, 207–213. [https://doi.org/10.1016/0048-9697\(81\)90017-6](https://doi.org/10.1016/0048-9697(81)90017-6)
- Tian, Y., Chen, M.-L., Chen, X.-W., Wang, J.-H., Hirano, Y., Sakamoto, H., Setsu, I., 2010. Arsenic speciation with gradient hydride generation interfacing liquid chromatography and atomic absorption spectrometry. *J. Anal. At. Spectrom.* 25, 48–54. <https://doi.org/10.1039/B913198A>
- Tomlinson, D.L., Wilson, J.G., Harris, C.R., Jeffrey, D.W., 1980. Problems in the assessment of heavy-metal levels in estuaries and the formation of a pollution index. *Helgoländer Meeresuntersuchungen* 33, 566–575. <https://doi.org/10.1007/BF02414780>
- Tompkins-MacDonald, G.J., Gallin, W.J., Sakarya, O., Degnan, B., Leys, S.P., Boland, L.M., 2009. Expression of a poriferan potassium channel: insights into the evolution of ion channels in metazoans. *J. Exp. Biol.* 212, 761–767. <https://doi.org/10.1242/jeb.026971>
- Tripti, M., Gurumurthy, G.P., Balakrishna, K., Chadaga, M.D., 2013. Dissolved trace element biogeochemistry of a tropical river, Southwestern India. *Environ. Sci. Pollut. Res.* 20, 4067–4077. <https://doi.org/10.1007/s11356-012-1341-y>
- Tsimplis, M.N., Baker, T.F., 2000. Sea level drop in the Mediterranean Sea: An indicator of deep water salinity and temperature changes? *Geophys. Res. Lett.* 27, 1731–1734. <https://doi.org/10.1029/1999GL007004>
- Turekian, K.K., Wedepohl, K.H., 1961. Distribution of the Elements in Some Major Units of the Earth's Crust. *Geol. Soc. Am. Bull.* 72, 175–192. [https://doi.org/10.1130/0016-7606\(1961\)72](https://doi.org/10.1130/0016-7606(1961)72)
- UN DOALOS (Division for Ocean Affairs and the Law of the Sea), 2016. First Global Integrated Marine Assessment (first World Ocean Assessment) [WWW Document]. URL http://www.un.org/depts/los/global_reporting/WOA_RegProcess.htm
- UNEP, 2011. Abidjan Convention. Convention for Co-operation in the Protection and Development of the Marine and Coastal environment of the West and Central African Region [WWW Document].
- UNEP regional seas, 2017 [WWW Document], n.d. URL <http://www.unep.org/regionalseas/> (accessed 7.13.17).
- US EPA, 2006. *Marine Sediment Screening Benchmarks, Region III*.
- V.E Vaskovsky, O.D. Korotchenko, L.P.K. and V.S.L., 1972. Arsenic in the lipid extracts of marine invertebrates. *Comp. Biochem. Physiol. C-Pharmacology Toxicol. Endocrinol.* 41, 777–784.
- Vahter, M., 1994. Species differences in the metabolism of arsenic compounds. *Appl. Organomet. Chem.*

- 8, 175–182. <https://doi.org/10.1002/aoc.590080304>
- Vallius, H., 2014. Heavy metal concentrations in sediment cores from the northern Baltic Sea: Declines over the last two decades. *Mar. Pollut. Bull.* 79, 359–364. <https://doi.org/10.1016/j.marpolbul.2013.11.017>
- Vallius, H., Ryabchuk, D., Kotilainen, A., Distribution, A., 2007. Distribution of heavy metals and arsenic in soft surface sediments of the coastal area off Kotka, North-eastern Gulf of Finland, Baltic Sea. *Geol. Surv. Finland, Spec. Pap.* 45, 33–48.
- van den Hoven, R.N., Santini, J.M., 2004. Arsenite oxidation by the heterotroph *Hydrogenophaga* sp. str. NT-14: the arsenite oxidase and its physiological electron acceptor. *Biochim. Biophys. Acta (BBA)-Bioenergetics* 1656, 148–155.
- Vanhaecke, F., Degryse, P., 2012. The Isotopic Composition of the Elements, in: *Isotopic Analysis: Fundamentals and Applications Using ICP-MS*. John Wiley and sons, pp. 1–29. <https://doi.org/10.1002/9783527650484>
- Varol, M., 2011. Assessment of heavy metal contamination in sediments of the Tigris River (Turkey) using pollution indices and multivariate statistical techniques. *J. Hazard. Mater.* 195, 355–364. <https://doi.org/10.1016/j.jhazmat.2011.08.051>
- Veerasingam, S., Vethamony, P., Mani Murali, R., Fernandes, B., 2015. Depositional record of trace metals and degree of contamination in core sediments from the Mandovi estuarine mangrove ecosystem, west coast of India. *Mar. Pollut. Bull.* 91, 362–367. <https://doi.org/10.1016/j.marpolbul.2014.11.045>
- Venkateswara Rao, J., Srikanth, K., Pallela, R., Gnaneshwar Rao, T., 2009. The use of marine sponge, *Haliclona tenuiramosa* as bioindicator to monitor heavy metal pollution in the coasts of Gulf of Mannar, India. *Environ. Monit. Assess.* 156, 451–459. <https://doi.org/10.1007/s10661-008-0497-x>
- Véron, A., Flament, P., Bertho, M.L., Alleman, L., Flegal, R., Hamelin, B., 1999. Isotopic evidence of pollutant lead sources in northwestern France. *Atmos. Environ.* 33, 3377–3388. [https://doi.org/10.1016/S1352-2310\(98\)00376-8](https://doi.org/10.1016/S1352-2310(98)00376-8)
- Vicente-Martorell, J.J., Galindo-Riaño, M.D., García-Vargas, M., Granado-Castro, M.D., 2009. Bioavailability of heavy metals monitoring water, sediments and fish species from a polluted estuary. *J. Hazard. Mater.* 162, 823–836. <https://doi.org/10.1016/j.jhazmat.2008.05.106>
- Vio, L., Martelat, B., Isnard, H., Nonell, A., Chartier, F., 2018. Multi-elemental Nd, Sm, Eu, Gd isotope ratio measurements by stop-flow isotachopheresis coupled to MC-ICPMS. *Talanta* 176, 582–588. <https://doi.org/10.1016/j.talanta.2017.08.013>
- Wahlen, R., McSheehy, S., Scriver, C., Mester, Z., 2004. Arsenic speciation in marine certified reference materials - Part 2. The quantification of water-soluble arsenic species by high-performance liquid chromatography-inductively coupled plasma mass spectrometry. *J. Anal. At. Spectrom.* 19, 876–882. <https://doi.org/10.1039/b402482f>
- Wall, F., Niku-Paavola, V.N., Storey, C., Müller, A., Jeffries, T., 2008. Xenotime-(Y) from carbonatite dykes at Lofdal, Namibia: Unusually low LREE:HREE ratio in carbonatite, and the first dating of xenotime overgrowths on zircon. *Can. Mineral.* 46, 861–877. <https://doi.org/10.3749/canmin.46.4.861>

- Wang, G., Zeng, C., Zhang, F., Zhang, Y., Scott, C.A., Yan, X., 2017. Traffic-related trace elements in soils along six highway segments on the Tibetan Plateau: Influence factors and spatial variation. *Sci. Total Environ.* 581–582, 811–821. <https://doi.org/10.1016/j.scitotenv.2017.01.018>
- Wang, W.-X., Lu, G., 2017. Heavy Metals in Bivalve Mollusks, in: *Chemical Contaminants and Residues in Food*. Elsevier, pp. 553–594. <https://doi.org/10.1016/B978-0-08-100674-0.00021-7>
- Wang, X., Qin, Y., 2006. Spatial distribution of metals in urban topsoils of Xuzhou (China): controlling factors and environmental implications. *Environ. Geol.* 49, 905–914. <https://doi.org/10.1007/s00254-005-0122-z>
- Wang, X.S., 2008. Correlations between heavy metals and organic carbon extracted by dry oxidation procedure in urban roadside soils. *Environ. Geol.* 54, 269–273. <https://doi.org/10.1007/s00254-007-0814-7>
- Wang, Y., Wang, S., Xu, P., Liu, C., Liu, M., Wang, Y., Wang, C., Zhang, C., Ge, Y., 2015. Review of arsenic speciation, toxicity and metabolism in microalgae. *Rev. Environ. Sci. Bio/Technology* 14, 427–451. <https://doi.org/10.1007/s11157-015-9371-9>
- Wang, Z.H., Lin, Q., Qang, X., Liu-Dong, L.I., 2011. The variation features of heavy metal contents in oyster samples from the coast of South China Sea and their safety assessment. *J. Fish. China* 35, 291–297.
- Watkins, R.T., Nathan, Y., Bremner, J.M., 1995. Rare earth elements in phosphorite and associated sediment from the Namibian and South African continental shelves. *Mar. Geol.* 129, 111–128. [https://doi.org/10.1016/0025-3227\(95\)00107-7](https://doi.org/10.1016/0025-3227(95)00107-7)
- Weis, P., Weis, J.S., 1999. Accumulation of metals in consumers associated with chromated copper arsenate-treated wood panels. *Mar. Environ. Res.* 48, 73–81. [https://doi.org/10.1016/S0141-1136\(99\)00028-8](https://doi.org/10.1016/S0141-1136(99)00028-8)
- Weisz, J.B., Lindquist, N., Martens, C.S., 2008. Do associated microbial abundances impact marine demosponge pumping rates and tissue densities? *Oecologia* 155, 367–376. <https://doi.org/10.1007/s00442-007-0910-0>
- Welz, B., Borges, D.L.G., Lepri, F.G., Vale, M.G.R., Heitmann, U., 2007. High-resolution continuum source electrothermal atomic absorption spectrometry — An analytical and diagnostic tool for trace analysis. *Spectrochim. Acta Part B At. Spectrosc.* 62, 873–883. <https://doi.org/10.1016/j.sab.2007.03.009>
- Weng, N., Wang, W.X., 2014. Variations of trace metals in two estuarine environments with contrasting pollution histories. *Sci. Total Environ.* 485–486, 604–614. <https://doi.org/10.1016/j.scitotenv.2014.03.110>
- Wentworth, C.K., 1922. A Scale of Grade and Class Terms for Clastic Sediments. *J. Geol.* 30, 377–392. <https://doi.org/10.1086/622910>
- WHO, 2006. *Arsenic in Drinking-water*.
- WHO, 1996. *Trace Elements in Human Nutrition and Health*. Geneva, Switzerland.
- WHO/FAO/IAEA, 1996. *Trace Elements in Human Nutrition and Health*. Geneva, Switzerland.
- Wu, X., Gao, M., Wang, L., Luo, Y., Bi, R., Li, L., Xie, L., 2014. The arsenic content in marketed seafood

- and associated health risks for the residents of Shandong, China. *Ecotoxicol. Environ. Saf.* 102, 168–173. <https://doi.org/10.1016/j.ecoenv.2014.01.028>
- Wu, Y., Wang, S., Streets, D.G., Hao, J., Chan, M., Jiang, J., 2006. Trends in Anthropogenic Mercury Emissions in China from 1995 to 2003. *Environ. Sci. Technol.* 40, 5312–5318. <https://doi.org/10.1021/es060406x>
- Wulff, J., 2001. Assessing and monitoring coral reef sponges: why and how? *Bull. Mar. Sci.* 69.
- Wysocka, I., Vassileva, E., 2016. Determination of cadmium, copper, mercury, lead and zinc mass fractions in marine sediment by isotope dilution inductively coupled plasma mass spectrometry applied as a reference method. *Microchem. J.* 128, 198–207. <https://doi.org/10.1016/j.microc.2016.05.002>
- Xu, Y., Sun, Q., Yi, L., Yin, X., Wang, A., Li, Y., Chen, J., 2014. The source of natural and anthropogenic heavy metals in the sediments of the Minjiang River Estuary (SE China): Implications for historical pollution. *Sci. Total Environ.* 493, 729–736. <https://doi.org/10.1016/j.scitotenv.2014.06.046>
- Xu, Z., Lim, D., Choi, J., Yang, S., Jung, H., 2009. Rare earth elements in bottom sediments of major rivers around the Yellow Sea: implications for sediment provenance. *Geo-Marine Lett.* 29, 291–300. <https://doi.org/10.1007/s00367-009-0142-x>
- Yamaoka, Y., Carmona, M.L., Oclarit, J.M., Jin, K., Shibata, Y., 2006. Characterization of water-soluble organoarsenic compounds in marine sponges. *Appl. Organomet. Chem.* 20, 545–548. <https://doi.org/10.1002/aoc>
- Yamaoka, Y., Carmona, M.L., Oclarit, J.M., Jin, K., Shibata, Y., 2001. Arsenic compounds in marine sponge (*Haliciona permolis*, *Halichondria japonica*, *Halichondria okadai* and *Haliciona* sp. white) from Seto Inland Sea, Japan. *Appl. Organomet. Chem.* 15, 261–265. <https://doi.org/10.1002/aoc.135>
- Yang, L., Mester, Z., Sturgeon, R.E., 2003. Comparison of sector field- and quadrupole-ICP-MS for the determination of DBT and TBT in sediment following GC separation. *J. Anal. At. Spectrom.* 18, 1365–1370. <https://doi.org/10.1039/b304705a>
- Zahra, A., Hashmi, M.Z., Malik, R.N., Ahmed, Z., 2014. Enrichment and geo-accumulation of heavy metals and risk assessment of sediments of the Kurang Nallah—Feeding tributary of the Rawal Lake Reservoir, Pakistan. *Sci. Total Environ.* 470–471, 925–933. <https://doi.org/10.1016/j.scitotenv.2013.10.017>
- Zakharyan, R.A., Sampayo-Reyes, A., Healy, S.M., Tsaprailis, G., Board, P.G., Liebler, D.C., Aposhian, H.V., 2001. Human Monomethylarsonic Acid (MMAV) Reductase Is a Member of the Glutathione-S-transferase Superfamily. *Chem. Res. Toxicol.* 14, 1051–1057. <https://doi.org/10.1021/tx010052h>
- Zhang, W., Chen, L., Zhou, Y., Wu, Y., Zhang, L., 2016a. Biotransformation of inorganic arsenic in a marine herbivorous fish *Siganus fuscescens* after dietborne exposure. *Chemosphere* 147, 297–304. <https://doi.org/10.1016/j.chemosphere.2015.12.121>
- Zhang, W., Feng, H., Chang, J., Qu, J., Xie, H., Yu, L., 2009. Heavy metal contamination in surface sediments of Yangtze River intertidal zone: An assessment from different indexes. *Environ. Pollut.* 157, 1533–1543. <https://doi.org/10.1016/j.envpol.2009.01.007>
- Zhang, W., Guo, Z., Zhou, Y., Chen, L., Zhang, L., 2016b. Comparative contribution of trophic transfer and biotransformation on arsenobetaine bioaccumulation in two marine fish. *Aquat. Toxicol.* 179, 65–

71. <https://doi.org/10.1016/j.aquatox.2016.08.017>

Zhang, W., Guo, Z., Zhou, Y., Liu, H., Zhang, L., 2015. Biotransformation and detoxification of inorganic arsenic in Bombay oyster *Saccostrea cucullata*. *Aquat. Toxicol.* 158, 33–40. <https://doi.org/10.1016/j.aquatox.2014.10.021>

SUPPLEMENTARY INFORMATION (Paper 5)

Table 1S. Summary of major and trace elements presented in mg/kg \pm Ue (n=3, k=2) and Total Organic Carbon (% w/w) measured in sediment cores from Namibia.

	Al	As	Ba	Cd	Co	Cr	Cu	Fe
C10-1	42000 ± 6000	5.2 ± 0.8	290 ± 40	0.54 ± 0.08	5.3 ± 0.8	100 ± 20	8 ± 1	18000 ± 3000
C11-2	42000 ± 6000	4.4 ± 0.7	210 ± 30	0.62 ± 0.09	6.0 ± 0.9	99 ± 20	7 ± 1	17000 ± 3000
C12-3	42000 ± 6000	4.3 ± 0.6	200 ± 30	0.6 ± 0.1	5.6 ± 0.8	85 ± 10	7 ± 1	17000 ± 3000
C13-4	42000 ± 6000	4.4 ± 0.7	180 ± 30	0.61 ± 0.09	5.3 ± 0.8	84 ± 10	7 ± 1	16000 ± 2000
C14-5	41000 ± 6000	4.5 ± 0.7	200 ± 30	0.7 ± 0.1	5.8 ± 0.9	86 ± 10	7 ± 1	17000 ± 3000
C15-6	42000 ± 6000	5.1 ± 0.8	250 ± 40	0.53 ± 0.08	6.0 ± 0.9	110 ± 20	8 ± 1	16000 ± 2000
C16-7	44000 ± 7000	4.8 ± 0.7	220 ± 30	0.53 ± 0.08	5.3 ± 0.8	73 ± 10	7 ± 1	17000 ± 3000
C20-1	40000 ± 6000	8 ± 1	290 ± 40	0.9 ± 0.1	7 ± 1	140 ± 20	11 ± 2	22000 ± 3000
C21-2	40000 ± 6000	5.9 ± 0.9	240 ± 40	0.8 ± 0.1	6.3 ± 0.9	110 ± 20	9 ± 1	21000 ± 3000
C22-3	38000 ± 6000	5.6 ± 0.8	230 ± 30	0.8 ± 0.1	6 ± 1	120 ± 20	10 ± 1	21000 ± 3000
C23-4	42000 ± 6000	6.2 ± 0.9	220 ± 30	0.9 ± 0.1	6.2 ± 0.9	100 ± 20	9 ± 1	20000 ± 3000
C24-5	43000 ± 6000	6.1 ± 0.9	250 ± 40	1.0 ± 0.2	5.9 ± 0.9	110 ± 20	8 ± 1	19000 ± 3000
C25-6	41000 ± 6000	6.0 ± 0.9	270 ± 40	1.3 ± 0.2	5.8 ± 0.9	94 ± 10	8 ± 1	19000 ± 3000
C26-7	40000 ± 6000	5.9 ± 0.9	300 ± 50	0.8 ± 0.1	5.8 ± 0.9	95 ± 10	8 ± 1	18000 ± 3000
C27-8	48000 ± 7000	15 ± 2	740 ± 100	2.4 ± 0.4	15 ± 2	250 ± 40	22 ± 3	19000 ± 3000
C28-9	54000 ± 8000	8 ± 1	400 ± 60	1.7 ± 0.2	8 ± 1	100 ± 20	12 ± 2	20000 ± 3000
C30-1	12000 ± 2000	4.1 ± 0.6	40 ± 6	0.9 ± 0.1	2.1 ± 0.3	115 ± 20	26 ± 4	8300 ± 1000
C31-2	7000 ± 1000	2.1 ± 0.3	36 ± 5	0.43 ± 0.06	1.4 ± 0.2	68 ± 10	18 ± 3	7200 ± 1000
C32-3	14000 ± 2000	2.6 ± 0.4	61 ± 9	0.63 ± 0.09	2.2 ± 0.3	100 ± 20	23 ± 3	11000 ± 2000
C33-4	8000 ± 1000	2.5 ± 0.4	46 ± 7	0.58 ± 0.09	1.9 ± 0.3	89 ± 10	23 ± 4	9000 ± 1000
C34-5	14000 ± 2000	3.1 ± 0.5	80 ± 10	0.8 ± 0.1	2.7 ± 0.4	114 ± 20	29 ± 4	11000 ± 2000
C35-6	9000 ± 1000	2.0 ± 0.3	80 ± 10	0.41 ± 0.06	1.7 ± 0.3	40 ± 6	20 ± 3	5400 ± 800
C40-1	23000 ± 3000	40 ± 6	210 ± 30	3.1 ± 0.5	4.8 ± 0.7	66 ± 10	16 ± 2	20000 ± 3000
C41-2	42000 ± 6000	45 ± 7	240 ± 40	4.3 ± 0.6	5.5 ± 0.8	66 ± 10	18 ± 3	28000 ± 4000
C42-3	37000 ± 5000	7 ± 1	400 ± 60	0.7 ± 0.1	7 ± 1	130 ± 20	9 ± 1	22000 ± 3000
C43-4	38000 ± 6000	7 ± 1	250 ± 40	1.2 ± 0.2	4.4 ± 0.7	71 ± 10	9 ± 1	18000 ± 3000
C44-5	39000 ± 6000	12 ± 2	300 ± 40	2.6 ± 0.4	5.8 ± 0.9	71 ± 10	14 ± 2	23500 ± 3500
C45-6	42000 ± 6000	10 ± 2	280 ± 40	1.9 ± 0.3	5.6 ± 0.8	71 ± 10	13 ± 2	20500 ± 3000
C46-7	45000 ± 7000	17 ± 3	290 ± 40	3.8 ± 0.6	8 ± 1	83 ± 10	22 ± 3	21000 ± 3000
C47-8	47000 ± 7000	17 ± 3	380 ± 60	3.9 ± 0.6	9 ± 1	97 ± 20	23 ± 3	30000 ± 4000
C48-9	48000 ± 7000	17 ± 3	690 ± 100	0.2 ± 0.03	12 ± 2	85 ± 10	34 ± 5	30000 ± 4500
C49-10	51000 ± 8000	10 ± 2	350 ± 50	3.6 ± 0.5	10 ± 1	90 ± 10	21 ± 3	31000 ± 4500
C410-12	40000 ± 6000	10 ± 2	270 ± 40	4.5 ± 0.7	9 ± 1	84 ± 10	21 ± 3	22000 ± 3000
C412-14	45000 ± 7000	20 ± 3	240 ± 40	8 ± 1	9 ± 1	100 ± 20	32 ± 5	38000 ± 5500
C414-16	58000 ± 9000	21 ± 3	310 ± 50	8 ± 1	11 ± 2	120 ± 20	37 ± 5	45000 ± 7000
C416-18	54000 ± 8000	19 ± 3	310 ± 50	8 ± 1	11 ± 2	110 ± 20	35 ± 5	41000 ± 6000
C418-20	64000 ± 9000	19 ± 3	320 ± 50	6 ± 1	11 ± 2	87 ± 10	35 ± 5	44000 ± 7000
C50-1	25000 ± 4000	15 ± 2	220 ± 30	5.2 ± 0.8	7 ± 1	120 ± 20	203 ± 30	26000 ± 4000
C51-2	26000 ± 4000	17 ± 3	190 ± 30	5.8 ± 0.9	7 ± 1	80 ± 10	240 ± 40	19000 ± 3000
C52-3	29000 ± 4000	5 ± 0.8	280 ± 40	1.1 ± 0.2	5.4 ± 0.8	80 ± 10	50 ± 8	17000 ± 2500
C53-4	30000 ± 4000	9 ± 1	210 ± 30	2.4 ± 0.4	5.2 ± 0.8	70 ± 10	111 ± 20	17000 ± 2600
C54-5	28000 ± 4000	9 ± 1	220 ± 30	2.6 ± 0.4	5.6 ± 0.8	80 ± 10	81 ± 10	19000 ± 3000
C55-6	29000 ± 4000	10 ± 1	250 ± 40	2.8 ± 0.4	6.3 ± 0.9	90 ± 10	89 ± 10	20000 ± 3000
C56-7	29000 ± 4000	10 ± 1	250 ± 40	3.1 ± 0.5	5.7 ± 0.9	80 ± 10	62 ± 9	18000 ± 3000
C57-8	28000 ± 4000	7 ± 1	250 ± 40	2.2 ± 0.3	4.7 ± 0.7	61 ± 9	43 ± 6	16000 ± 2000
C58-9	28000 ± 4000	8 ± 1	280 ± 40	3.1 ± 0.5	4.9 ± 0.7	64 ± 10	51 ± 8	17000 ± 2500
C59-10	26000 ± 4000	10 ± 1	150 ± 20	3.4 ± 0.5	3.6 ± 0.5	48 ± 7	58 ± 9	14000 ± 2000
C510-12	28000 ± 4000	9 ± 1	240 ± 40	2.9 ± 0.4	4.8 ± 0.7	60 ± 9	49 ± 7	20000 ± 3000
C512-14	30000 ± 4000	10 ± 1	270 ± 40	3.0 ± 0.4	4.8 ± 0.7	59 ± 9	50 ± 7	17000 ± 2500
C60-1	9000 ± 1000	2.4 ± 0.4	70 ± 10	0.20 ± 0.03	2.0 ± 0.3	45 ± 7	18 ± 3	6000 ± 900
C61-2	9000 ± 1000	2.2 ± 0.3	80 ± 10	0.41 ± 0.06	1.7 ± 0.3	42 ± 6	21 ± 3	5600 ± 800
C62-3	8000 ± 1000	2.0 ± 0.3	70 ± 11	0.41 ± 0.06	1.8 ± 0.3	44 ± 7	20 ± 3	5600 ± 800
C63-4	9000 ± 1000	1.9 ± 0.3	60 ± 9	0.38 ± 0.06	1.6 ± 0.2	40 ± 6	18 ± 3	5600 ± 800
C64-5	8000 ± 1000	1.8 ± 0.3	55 ± 8	0.37 ± 0.06	1.6 ± 0.2	37 ± 6	19 ± 3	5000 ± 700
C65-6	8000 ± 1000	2.8 ± 0.4	56 ± 8	0.37 ± 0.06	2.6 ± 0.4	38 ± 6	20 ± 3	5000 ± 700

Table 1S (continued)

	Hg		Li		Mn		Ni		Pb		U		V		Zn		TOC %
C10-1	0.005	± 0.001	13	± 2	460	± 70	12	± 2	14	± 2	3.6	± 0.5	61	± 9	27	± 4	0.1%
C11-2	0.006	± 0.001	8	± 1	370	± 50	14	± 2	14	± 2	3.2	± 0.5	70	± 10	30	± 4	0.2%
C12-3	0.009	± 0.001	9	± 1	350	± 50	14	± 2	14	± 2	2.7	± 0.4	62	± 9	31	± 5	0.2%
C13-4	0.008	± 0.001	7	± 1	320	± 50	13	± 2	14	± 2	2.6	± 0.4	60	± 9	29	± 4	0.1%
C14-5	0.004	± 0.0006	8	± 1	360	± 60	13	± 2	14	± 2	2.8	± 0.4	63	± 9	29	± 4	0.1%
C15-6	0.010	± 0.002	11	± 2	320	± 50	13	± 2	14	± 2	2.0	± 0.3	57	± 9	29	± 4	0.2%
C16-7	0.005	± 0.001	9	± 1	320	± 50	13	± 2	14	± 2	2.5	± 0.4	70	± 11	33	± 5	0.2%
C20-1	0.007	± 0.001	12	± 2	630	± 90	16	± 2	14	± 2	5.5	± 0.8	80	± 10	31	± 5	0.2%
C21-2	0.007	± 0.001	10	± 2	530	± 80	14	± 2	14	± 2	3.5	± 0.5	70	± 10	31	± 5	0.1%
C22-3	0.007	± 0.001	10	± 2	510	± 80	15	± 2	14	± 2	4.3	± 0.6	70	± 10	32	± 5	0.2%
C23-4	0.004	± 0.001	11	± 2	470	± 71	14	± 2	14	± 2	5.0	± 0.7	70	± 10	34	± 5	0.2%
C24-5	0.011	± 0.002	11	± 2	450	± 70	13	± 2	13	± 2	3.7	± 0.6	70	± 10	34	± 5	0.2%
C25-6	0.008	± 0.001	12	± 2	420	± 60	14	± 2	14	± 2	2.7	± 0.4	70	± 10	35	± 5	0.2%
C26-7	0.008	± 0.001	11	± 2	400	± 60	13	± 2	14	± 2	3.0	± 0.4	70	± 10	34	± 5	0.2%
C27-8	0.007	± 0.001	31	± 5	400	± 60	37	± 5	37	± 6	8.0	± 1.2	180	± 30	33	± 5	0.2%
C28-9	0.009	± 0.001	20	± 3	350	± 50	19	± 3	20	± 3	3.2	± 0.5	80	± 10	40	± 6	0.2%
C30-1	0.04	± 0.006	9	± 1	35	± 5	42	± 6	1.6	± 0.2	2.4	± 0.4	20	± 3	27	± 4	6.6%
C31-2	0.03	± 0.004	6	± 1	23	± 3	27	± 4	1.5	± 0.2	1.5	± 0.2	16	± 2	21	± 3	4.1%
C32-3	0.03	± 0.004	9	± 1	53	± 8	38	± 6	2.6	± 0.4	1.9	± 0.3	23	± 4	31	± 5	2.5%
C33-4	0.04	± 0.006	8	± 1	23	± 3	38	± 6	1.9	± 0.3	1.9	± 0.3	20	± 3	23	± 3	2.9%
C34-5	0.05	± 0.007	11	± 2	51	± 8	47	± 7	3.0	± 0.4	2.8	± 0.4	28	± 4	30	± 5	1.7%
C35-6	0.022	± 0.003	8	± 1	35	± 5	34	± 5	1.4	± 0.2	3.5	± 0.5	15	± 2	23	± 3	3.0%
C40-1	0.025	± 0.004	23	± 3	200	± 30	21	± 3	8	± 1	2.6	± 0.4	90	± 10	23	± 3	5.2%
C41-2	0.053	± 0.008	21	± 3	230	± 30	23	± 4	10	± 1	2.3	± 0.3	90	± 10	64	± 10	1.2%
C42-3	0.016	± 0.002	12	± 2	350	± 50	17	± 3	13	± 2	2.1	± 0.3	61	± 9	34	± 5	0.3%
C43-4	0.006	± 0.001	12	± 2	450	± 70	13	± 2	10	± 2	1.7	± 0.3	60	± 9	29	± 4	1.7%
C44-5	0.013	± 0.002	19	± 3	460	± 70	18	± 3	13	± 2	2.3	± 0.3	59	± 9	35	± 5	2.7%
C45-6	0.013	± 0.002	18	± 3	360	± 50	18	± 3	11	± 2	2.1	± 0.3	70	± 10	38	± 6	1.6%
C46-7	0.018	± 0.003	29	± 4	300	± 40	26	± 4	14	± 2	2.9	± 0.4	80	± 10	42	± 6	2.8%
C47-8	0.023	± 0.003	31	± 5	340	± 50	28	± 4	17	± 2	2.9	± 0.4	80	± 10	60	± 9	3.6%
C48-9	0.025	± 0.004	57	± 9	330	± 50	42	± 6	19	± 3	2.2	± 0.3	90	± 10	60	± 9	2.2%
C49-10	0.014	± 0.002	26	± 4	430	± 60	30	± 4	15	± 2	2.3	± 0.3	100	± 10	58	± 9	2.8%
C410-12	0.009	± 0.001	25	± 4	340	± 50	28	± 4	14	± 2	2.1	± 0.3	95	± 10	36	± 5	4.3%
C412-14	0.023	± 0.003	31	± 5	270	± 40	35	± 5	12	± 2	2.9	± 0.4	90	± 10	80	± 10	4.7%
C414-16	0.024	± 0.004	37	± 6	330	± 50	40	± 6	14	± 2	3.3	± 0.5	110	± 20	100	± 10	4.4%
C416-18	0.022	± 0.003	39	± 6	320	± 50	39	± 6	14	± 2	3.1	± 0.5	110	± 20	90	± 10	3.9%
C418-20	0.022	± 0.003	13	± 2	350	± 50	41	± 6	16	± 2	4.2	± 0.6	120	± 20	100	± 10	4.1%
C50-1	0.079	± 0.012	16	± 2	220	± 30	21	± 3	170	± 30	4.6	± 0.7	70	± 11	370	± 60	5.2%
C51-2	0.059	± 0.009	15	± 2	160	± 20	21	± 3	130	± 20	22	± 3	61	± 9	380	± 60	2.1%
C52-3	0.034	± 0.005	11	± 2	170	± 30	13	± 2	40	± 6	7.3	± 1	54	± 8	160	± 30	3.2%
C53-4	0.062	± 0.009	13	± 2	190	± 30	16	± 2	70	± 10	15	± 2	55	± 8	150	± 20	2.9%
C54-5	0.052	± 0.008	14	± 2	170	± 30	16	± 2	200	± 30	12	± 2	63	± 9	220	± 30	2.6%
C55-6	0.075	± 0.011	16	± 2	180	± 30	18	± 3	220	± 30	2.8	± 0.4	66	± 10	270	± 41	4.2%
C56-7	0.071	± 0.011	15	± 2	180	± 30	17	± 3	70	± 11	3.3	± 0.5	65	± 10	250	± 40	2.4%
C57-8	0.069	± 0.010	14	± 2	150	± 20	14	± 2	52	± 8	2.7	± 0.4	54	± 8	260	± 40	4.1%
C58-9	0.076	± 0.011	15	± 2	150	± 20	16	± 2	56	± 8	3.0	± 0.4	57	± 9	300	± 40	4.3%
C59-10	0.076	± 0.011	13	± 2	130	± 20	13	± 2	47	± 7	2.6	± 0.4	54	± 8	260	± 40	2.2%
C510-12	0.078	± 0.012	14	± 2	180	± 30	15	± 2	59	± 9	2.6	± 0.4	55	± 8	290	± 40	3.4%
C512-14	0.082	± 0.012	14	± 2	150	± 20	15	± 2	58	± 9	2.7	± 0.4	56	± 8	230	± 40	3.6%
C60-1	0.073	± 0.011	9	± 1	36	± 5	33	± 5	1.7	± 0.3	3.3	± 0.5	14	± 2	24	± 4	1.6%
C61-2	0.045	± 0.007	9	± 1	39	± 6	33	± 5	1.7	± 0.3	3.3	± 0.5	16	± 2	22	± 3	2.0%
C62-3	0.025	± 0.004	9	± 1	41	± 6	33	± 5	1.9	± 0.3	3.6	± 0.5	16	± 2	22	± 3	1.3%
C63-4	0.022	± 0.003	8	± 1	37	± 6	30	± 4	1.6	± 0.2	3.7	± 0.5	15	± 2	23	± 3	1.3%
C64-5	0.026	± 0.004	8	± 1	34	± 5	32	± 5	1.5	± 0.2	3.4	± 0.5	15	± 2	21	± 3	1.3%
C65-6	0.026	± 0.004	9	± 1	35	± 5	33	± 5	1.5	± 0.2	3.6	± 0.5	16	± 2	22	± 3	1.0%

Figure 1S. Graphic representation of Cd and Zn concentrations along the core sample C5 and of Cd, As and Zn along the core sample C4

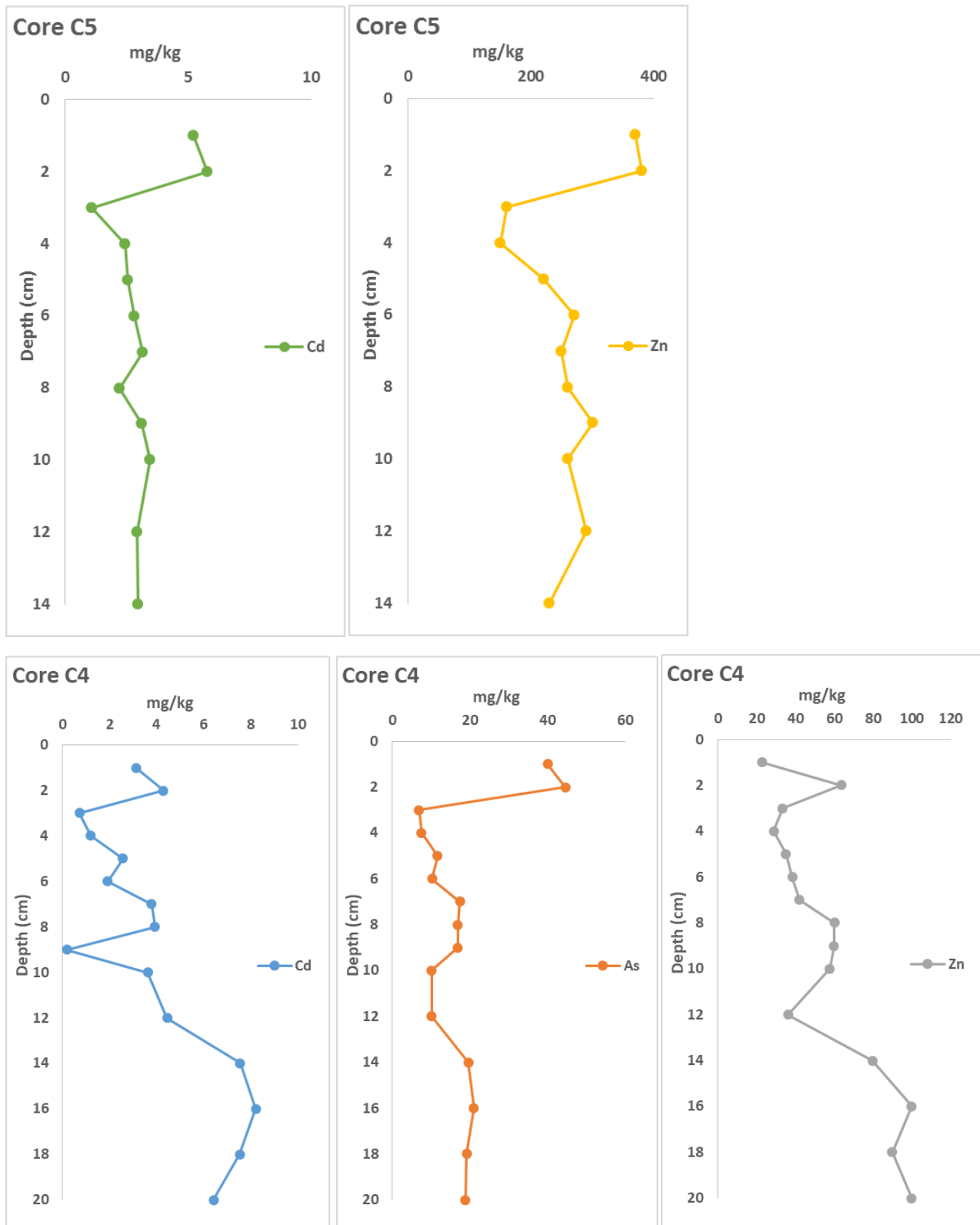

Figure 2S. Some of the Geochemical indices' (Igeo) variations along the core samples C4 and C5

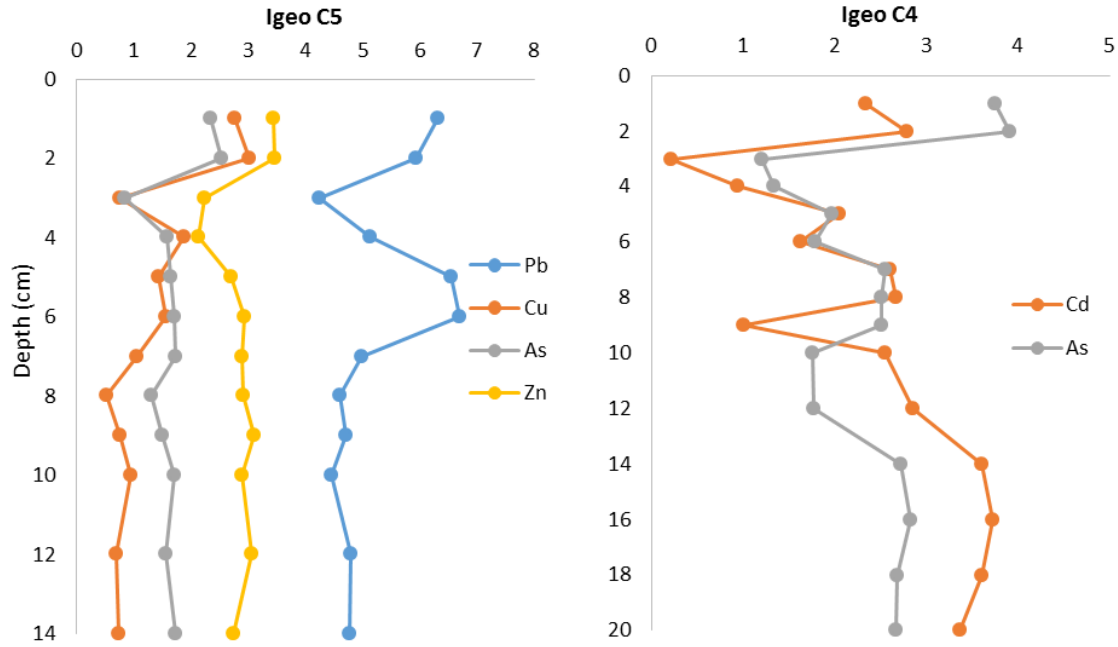
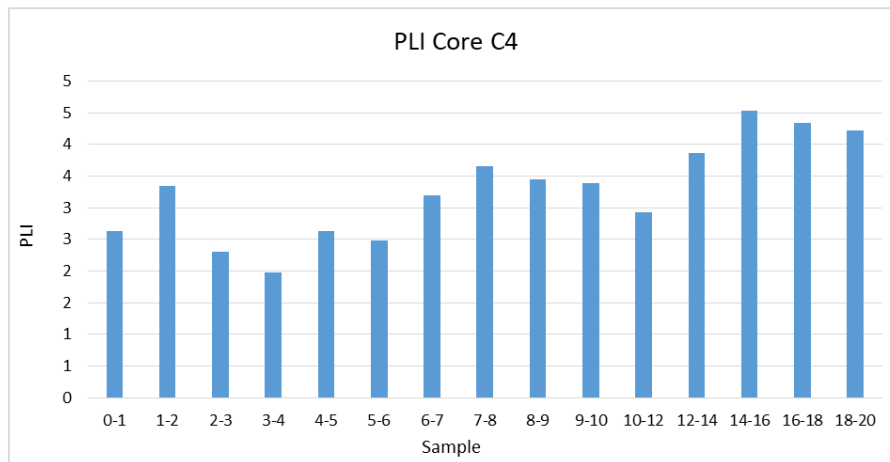
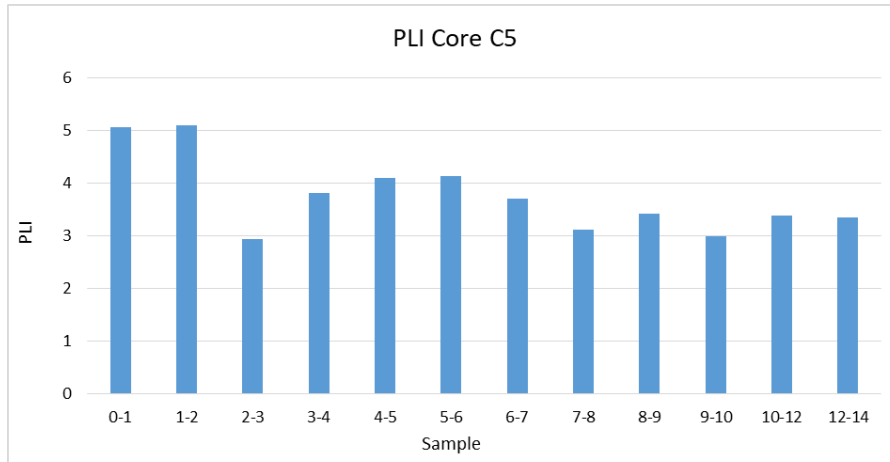

Figure 3A. Pollution Load Indices for each subsamples from sediment cores C4 and C5



THIRD BLOCK

Paper 6

Submitted to the peer reviewed journal Marine Pollution Bulletin (Elsevier)

Marine sponges as a powerful tool for trace elements biomonitoring studies in coastal environment

Anna Maria Orani *^{a,b}, Aurélie Barats^a, Emilia Vassileva^b, Olivier P. Thomas^c

^a Université Nice Sophia Antipolis, CNRS, IRD, Observatoire de la Côte d'Azur, Géoazur, UMR 7329, 250 rue Albert Einstein, Sophia Antipolis 06560 Valbonne, France

^b International Atomic Energy Agency, Environment Laboratories, 4 Quai Antoine 1er, MC 9800, Monaco

^c National University of Ireland Galway, Marine Biodiscovery, School of Chemistry, University Road, Galway, Ireland

Abstract

The use of marine sponges as trace elements (TE) biomonitors is evaluated in this study. Six sponge species from the French Mediterranean coast and in two locations in the Irish coast were analyzed for Ag, As, Ba, Cd, Cu, Mo, Ni, V, Pb and Zn contents. Intra and inter-species variability in TE accumulation were examined. Results show that *C. damicornis* accumulates significantly more As and Cu than others sponge species; *C. nucula* more Ni and Mo and *A. acuta* more Ag. Among Irish samples *H. perlevis* showed higher accumulation properties for most of TE (particularly for Zn) in comparison to *H. panicea*. Additionally, BCF, calculated using TE levels in sediment samples, were >1 in all species for most of TE. The determination of Pb isotope ratios revealed a natural Pb sources for Mediterranean and Kilkieran Bay's samples while it highlighted anthropogenic Pb inputs in sponges and sediment from Belfast

Keywords: marine sponges, trace elements, biomonitoring, lead isotope ratios, marine environment

1. Introduction

The occurrence of trace elements (TE) in aquatic environments is related to natural sources, but also to anthropogenic inputs due to industrial developments and other human activities. TE contaminations occur worldwide and the assessment of the pollution status is usually required, leading to the publication of several studies on this subject (Li et al., 2000; Caccia et al., 2003; Fang et al., 2014; Parra et al., 2015; Cabrita et al., 2017; Ashraf et al., 2017). An ideal biomonitor should be a natural accumulator of the element of interest and possibly with high concentration factor, in order to highlight possible difference between times or sites (Rainbow, 2002). Environmental surveys are often performed on water samples but, in marine ecosystems, the very low TE concentrations and the salinity of the seawater cause measurement limitations (Søndergaard et al., 2015). Monitoring studies on TE contamination are also focused on sediments and biota. Sediments act as sink and reservoirs of contaminants thus displaying higher TE contents and do not present problems related to short residence time such as for water (Varol, 2011; Liu et al., 2015). Marine organisms are also relevant tools for characterizing the state of a marine ecosystem because they are recognized to accumulate TE. They can be a good tool especially in rocky shores where sediments do not occur. Sessile and active filter feeding invertebrates are often used to determine temporal and spatial variation of TE in aquatic systems (Weis and Weis, 1999; Denton et al., 2006; Dahms et al., 2014). Historically, bivalves are considered as ideal biomonitor organisms as exemplified by the “mussel watch program” (Cantillo, 1998) which is also supported by the bivalve use as common seafood. More recently, sponges gained scientists attention as possible biomonitors of TE contamination because they are abundant and widespread, long-living, sessile, easily sampled and they have shown high tolerance for several pollutants (de Mestre et al., 2012; Batista et al., 2014). Additionally sponge communities can remain stable for long time periods, making them suitable model organisms for monitoring studies. Sponges are filter feeding organisms, pumping huge quantities of seawater ($100\text{-}1200\text{ mL h}^{-1}\text{ g}^{-1}$ larger than for most of other marine organisms (Olesen and Weeks, 1994). Sponges have a high capacity for TE accumulation for a long period of time (Patel et al., 1985; Padovan et al., 2012), exhibiting higher filtering capacity than bivalves (Negri et al., 2006; Gentric et al., 2016). They are considered as “biological particle traps” as they are able to concentrate a wide range of pollutants from both the suspended and dissolved phases, showing high bio-concentration factors (Perez et al., 2005; Cebrian et al., 2003). The detection of large quantities of TE in sponges suggests the existence of detoxification systems (Aly et al., 2013). These characteristics make them suitable as a model organisms for monitoring studies, and their use has been proposed in several fields of study (Negri et al., 2006; Venkateswara Rao et al., 2009; Illuminati et al., 2016). Sponges

have also been reported as efficient environmental remediators of different toxic compounds such as the bacterium *Escherichia coli* (Milanese et al., 2003) and the organochlorine pesticide lindane (Aresta et al., 2015). These characteristics, combined with recent interest in sponges as a source of novel pharmaceuticals and bioactive compounds (Anjum et al., 2016), indicate the possibility for a self-financing remediation program (Gifford et al., 2007).

The main objective of this work was the assessment of TE pollution in different sponge species collected in different areas. A comparative study on TE bioaccumulation have been performed on six sponge species collected in the Southern French Mediterranean coast and in Ireland. These areas have been selected because of their differences in terms of TE biogeochemical background and anthropogenic inputs. The bioaccumulation potential of these sponges was examined for a broad range of TE, comparing with values measured in sediment samples collected in the same area. Additionally, measurements of Pb isotope ratios were performed for the first time in sponges and allowed us to give insights on the principal sources of Pb contamination in the studied zones.

2. Materials and methods

2.1. Sampling

Sponge and sediment samples were collected in three sampling sites: the Mediterranean coast, in the Grotte du Lido at Villefranche sur Mer, France (N 43° 41' 59.0", E 07° 19' 31.5"), and two coastal sites in Ireland, Greenisland at the Belfast Lough (N54°41'24.383", O 5° 51' 36.633") and in Kilkieran Bay (N 53° 21' 22.625", O 9° 42' 17.153") (Fig. 1). Sediment samples were collected during each sampling session, using an acid pre-cleaned polyethylene tube. Sponges were collected using a plastic knife and placed in separate plastic bag. Sponge specimens of similar size were selected in order to reduce intra-species variations due to sponge age. At least, three specimens with similar size of each sponge species were randomly selected in each collection. Sediments and four species of Mediterranean sponges (*Acanthella acuta*, *Cymbaxinella damicornis*, *Chondrilla nucula* and *Haliclona fulva*) were collected by scuba diving at 20m for two different periods of the year (February and September 2016). During the first sampling, three specimens of *C. damicornis* were collected in the center of the cave while the remaining two specimens were from the entrance. During the second sampling, three specimens of *C. nucula* were collected at 5m depth while three other specimens were taken at 20m. In Ireland, sediments and two species of sponges (*Halichondria panicea* and *Hymeniacidon perlevis*) were hand-sampled in intertidal

zones. Samples from Kilkieran Bay and from Belfast were collected in September 2016 and in October 2016, respectively.

Figure 1. Maps showing the sampling sites (indicated with black stars) located a) in the French Mediterranean coast (http://d-maps.com/carte.php?num_car=110470&lang=en) and b) in two locations along the Irish coast (http://d-maps.com/carte.php?num_car=14642&lang=en). Copyright d-maps.com

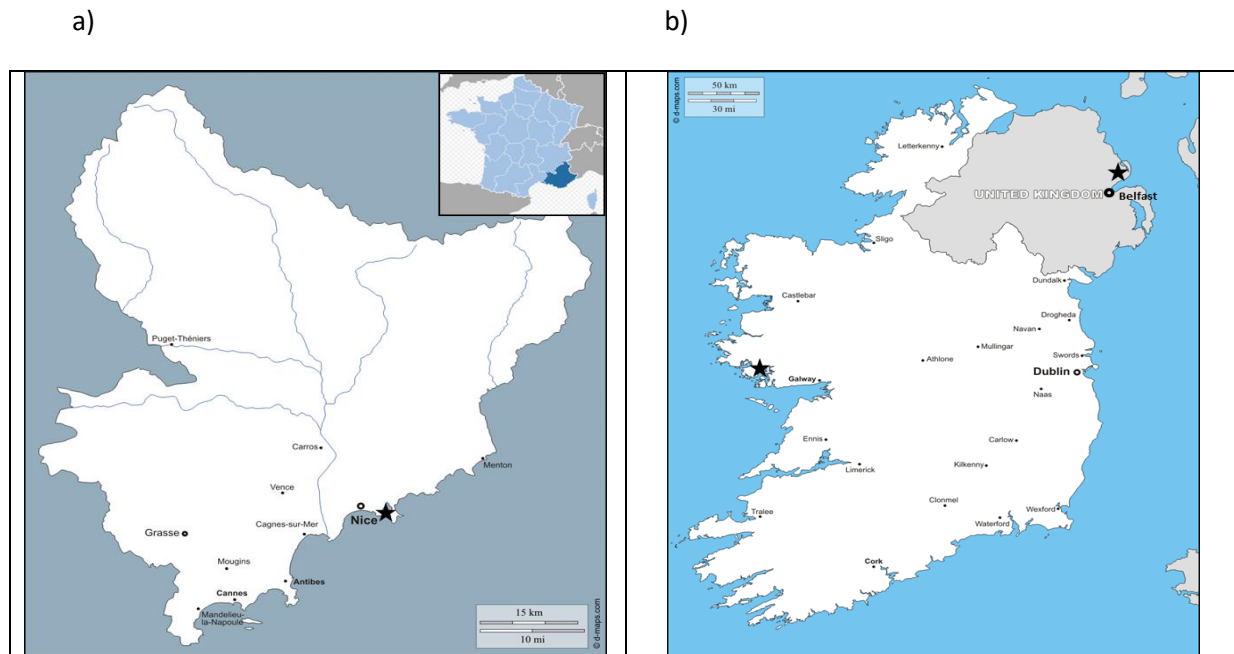

2.2. Target sponge species

This study focusses on different target sponge species: *Acanthella acuta*, *Cymbaxinella damicornis*, *Chondrilla nucula* and *Haliclona fulva* in the Mediterranean coast; and *Halichondria panicea* and *Hymeniacidon perlevis* in Ireland. A list of samples is presented in Table 1. These species were selected because of their widespread occurrence, but also for their different morphological characteristics (KeyToNature, 2015):

- a) *Acanthella acuta* (Class: Demospongiae, Order: Axinellida, Family: Dictyonellidae) is a small erected sponge with rather small oscules
- b) *Cymbaxinella damicornis* (Class: Demospongiae, Order: Axinellida, Family: Axinellidae) is a rather small, erectly branching sponge with short, compressed branches. Oscules are small and are located on the apices of the branches, oscules are surrounded by a small triangular ‘flap’ of tissue. The genus *Axinella* is difficult to define on the basis of morphological characteristic but

for the specie analyzed in this study the name *Cymbaxinella damicornis* was recently proposed by (Gazave et al., 2010), following the *phylocode*.

- c) *Chondrilla nucula* (Class: Demospongiae, Order: Chondrillida, Family: Chondrillidae) is amorphous, with globular lobes, or thickly incrusting, up to about 1 cm thick, spreading horizontally, with pronounced, deeply incised and lacunose, meandering lobes. The color is dark-brown to walnut-brown.
- d) *Haliclona fulva* (Class: Demospongiae, Order: Haplosclerida, Family: Chalinidae). The surface of the specimen is irregular and slightly hispid. The ectosomal and choanosomal skeletons have a regular, delicate, unispicular, and isotropic reticulation. Color is dark orange.
- e) *Halichondria panicea* (Class: Demospongiae, Order: Suberitida, Family: Halichondriidae). Intertidal or shallow-subtidal, thickly encrusting, massive or occasionally branching sponge, with typical volcano-shaped oscular chimneys. Surface smooth, consistency firm, texture crumb-of-bread. Basically light orange-yellow or pale yellowish green.
- f) *Hymeniacidon perlevis* (Class: Demospongiae, Order: Suberitida, Family: Halichondriidae). One of the most common species along the Atlantic coasts of Western Europe. It is orange and has an irregular surface, often with lower or higher irregular projections; oscules are inconspicuous.

Table 1. List of specimens collected and analyzed in the present study

Sampling site	Sponge specie	Number of specimens	Code
Villefranche-sur-mer	<i>Haliclona fulva</i>	6	HA.F
	<i>Axinella damicornis</i>	7	CY.D
	<i>Acanthella acuta</i>	6	AC.A
	<i>Chondrilla nucula</i>	9	CH.N
Kilkieran Bay	<i>Halichondria panicea</i>	4	HA.P
	<i>Hymeniacidon perlevis</i>	3	Hy.P
Belfast Lough	<i>Halichondria panicea</i>	6	HA.P Bel
	<i>Hymeniacidon perlevis</i>	7	Hy.P Bel

2.3. Sample preparation

All solutions were prepared with doubly deionized water obtained from Millipore water purification system (Elix & Synergy) (resistivity of 18.2 M Ω cm⁻¹, Total Organic Carbon < 5 μ g L⁻¹ and microorganisms < 0.1 UFC ml⁻¹). All PTFE and Teflon containers used for sample preparation and analysis were pre-

cleaned using a procedure consisting of 24 h bath in 10% HNO₃ (prepared from proper dilution of 65% analytical grade HNO₃, Fisher Chemicals) and careful rinsing three times with Milli-Q water. Sediment and sponge samples were freeze-dried, ground in agate mortar and kept in a desiccator in closed PTFE tubes.

Analysis for TE and Pb isotope ratios determination were performed using preliminary validated methods. For trace elements analysis by ICP-MS, a microwave digestion was carried out into a closed microwave system (Ethos One, Milestone). Teflon reactors were filled with an aliquot of about 0.05 g of sponge sample or 0.1 g of sediment sample (bulk samples), and with 5 mL of HNO₃ (Trace Metal Grade, 67 to 70% w/w, Fisher Chemical) and 2 mL of HF (Ultra Trace Elemental Analysis 47-51% w/w, Optima, Fisher Chemical). Temperature program used for acid digestion consisted of a 20 min ramp temperature up to 180 °C, followed by an isothermal phase of 30 min. The mineralized solutions were then transferred to PE pre-cleaned tubes and gravimetrically diluted with Milli-Q water, up to a final volume of 50 mL. These solutions were further diluted 15 times in Milli-Q water prior to ICP-MS analyses.

Similar digestions and analyses were performed on two Certified Reference Materials (CRMs) to assure a quality control of the entire analytical procedure: TORT-2 (Lobster hepatopancreas, NRC, Canada) and MESS-2 (Estuarine sediment, NRC, Canada), weighting systematically 50 and 100 mg respectively. At least one procedural blank and one CRM were included in each digestion run and analyzed with the rest of the samples. A summary of results obtained for CRMs analyzed in this study, is presented in Table 2; Cd and Ag in MESS-2 were below limits of quantification, therefore they are not listed in the table with other analytes.

One specimen of each sponge's specie and one sediment sample for each location were selected for Pb isotope ratios analysis. An aliquot of about 100 mg of sponge or sediment sample was decomposed in 5 mL ultrapure HNO₃ (Fisher scientific, Hampton, USA) and 2 mL of ultrapure HF (Fisher scientific, Hampton, USA) using the Mars X-press Microwave (CEM Mars X-press) equipped with a 12 vessels carousel. After the digestion, obtained solutions were placed on a ceramic heating plate, under laminar hood, and evaporated to near dryness. The residues were taken up in 2% HNO₃, transferred to 50 ml PE tubes and stored at 4 °C. Solutions for Pb isotope ratios determination were properly diluted with 2% HNO₃ in class 100 clean room.

Table 2. Comparison of measured concentrations and certified values in 2 CRMs: TORT-2 (lobster hepatopancreas) and MESS-2 (estuarine sediments).

		Measured value (mg kg ⁻¹)	Relative Standard Deviation (%)	Certified value (mg kg ⁻¹)
TORT-2 (n=10)	V	2.2±0.56	25	1.64±0.15
	Ni	2.7±0.7	25	2.5±0.19
	Cu	97±6	6	106±10
	Zn	205±36	17	180±6
	As	19.8±3.5	18	21.6±1.8
	Mo	0.94±0.21	22	0.95±0.1
	Ag	6.1±0.4	6	
	Cd	25.7±1.7	6	26.7±0.6
	Ba	2.6±0.8	30	
	Pb	0.35±0.20	57	0.35±0.13
MESS-2 (n=4)	V	234±15	6	252±10
	Ni	46±2	4	49.3±1.4
	Cu	37±3	8	39.3±2.0
	Zn	155±12	8	172±16
	As	19±1	8	20.7±0.8
	Mo	2.9±0.8	27	2.85±0.12
	Ba	794±183	23	
	Pb	20±4	23	21.9±1.2

2.4. Instrumentation

A quadrupole Inductively Coupled Plasma Mass Spectrometer ((Q) ICP-MS; Elan DRCII, Perkin Elmer) was used for the determination of Ag, As, Cd, Cu, Mo, Ni, Pb, Ba and Zn in sponge and sediment samples. ICP-MS operating parameters are summarized in Table 3. Analytes quantification was performed by means of external calibration, using daily prepared standards obtained by proper dilution of multi-elemental standard for ICP-MS (ICP-MS standard N°3 Perkin Elmer® and ICPMS standard N°2 from SCP SCIENCE®). An internal standard solution, containing 10 and 1 µg L⁻¹ of Ge and Tb respectively, was prepared by dilution of mono-elemental standards of Ge and Tb (PlasmaCal, SCP SCIENCE®) and used during the ICP-MS analysis to correct possible matrix effects. Daily analyses of the certified reference natural river water SLRS-5 or SLRS-6 (National Research Council, Canada) were carried out to check measurement accuracy (Barats et al., 2014). All results were corrected for instrumental blanks. The

ongoing instrument performance was monitored with the repeated analysis of standards. Detection limits for analytes are also reported in Table 3.

Table 3. (Q) ICP-MS settings used for the determination of trace metals in sediments and sponges and limits of detection

Parameter	Value			
RF power	1550 W			
Plasma gas flow	15 L min ⁻¹			
Auxiliary gas flow	1.1 mL min ⁻¹			
Carrier gas flow	0.9 L min ⁻¹			
Nebulizer	Quartz concentric			
Spray chamber	Cyclonic			
Interface	Pt sampling and skimmer cones			
Oxide formation ¹⁴⁰ Ce ¹⁶ O ⁺ / ¹⁴⁰ Ce ⁺	<3%			
Double charged species	<2%			
Measured isotopes	⁵¹ V, ⁶⁰ Ni, ⁶³ Cu, ⁶⁶ Zn, ⁷⁵ As, ⁹⁸ Mo ¹⁰⁷ Ag, ¹¹¹ Cd, ¹³⁸ Ba, ²⁰⁸ Pb			
Mass for interference assessment	⁴⁰ Ar ³⁷ Cl, ⁸² Se, ⁹⁵ Mo ¹⁶ O, ³⁷ Cl ¹⁶ O			
Limits of detection (µg L ⁻¹)				
V = 0.02	Zn = 0.3	As = 0.03	Ag = 0.002	Ba = 0.006
Ni = 0.03	Cu = 0.008	Mo = 0.002	Cd = 0.007	Pb = 0.002

Determination of Pb isotope ratios was carried out by means of High Resolution Sector Field (HR-SF) ICP-MS (NuAttom, NuInstruments Ltd., Wrexham, UK). The Standard Reference Material SRM 981 from the National Institute of Standards and Technology (NIST, USA) with certified Pb isotopic composition was used for correction of the instrumental mass discrimination. The bracketing approach based on linear law was used for correction (Vanhaecke et al., 2009). The instrument parameters for Pb isotopic ratios measurements with (HR-SF) ICP-MS are presented in Table 4. The ²⁰⁴Hg isobaric interference on ²⁰⁴Pb isotope was corrected by monitoring the mass ²⁰²Hg and applying a correction equation based on natural abundancy of isotopes ²⁰²Hg, ²⁰⁴Hg and ²⁰⁴Pb.

Statistical data treatments were performed using XLSTAT (version 2014.05.5, Addinsoft, Paris, France). Principal component analysis (PCA) was applied to TE concentrations measured in sponges in order to highlight common trends between different species. Data were standardized using the biased standard deviation, to avoid biases due to differences in data dimensionality. Lead was not included in the PCA due to its high intra-species variability and it will be treated in a separated paragraph.

Table 4. (HR-SF) ICP-MS parameters optimized for the determination of Pb isotope ratios in sponges and sediment samples.

Parameter	Value
Coolant gas flow	13.5 L min ⁻¹
Auxiliary gas flow	0.8 L min ⁻¹
Nebulizer gas flow	29.6 psi
Plasma power	1300 W
Sensitivity for 1 ng g ⁻¹ (²⁰⁸ Pb)	> 800000 cps
Background on mass 220	< 2 cps
Acquisition Mode	Peak Jumping
Number of sweeps	500
Number of cycles	25
Dwell time per isotope (ms)	1000
Measured isotopes	²⁰² Hg, ²⁰⁴ Pb, ²⁰⁶ Pb, ²⁰⁷ Pb, ²⁰⁸ Pb
Mass resolution	300
Oxide Formation ¹⁴⁰ Ce ¹⁶ O ⁺ / ¹⁴⁰ Ce ⁺	<1%

2.5. The use of lead isotope ratios

Lead isotope ratios measurement represents a very powerful analytical tool applied to several fields of study. Pb has a partially-radiogenic isotopic composition, since three of its stable isotopes (²⁰⁶Pb, ²⁰⁷Pb and ²⁰⁸Pb) are the final product of the radioactive decay of ²³⁵U, ²³²Th and ²³⁸U respectively (Vanhaecke and Degryse, 2012). ²⁰⁴Pb is the only natural isotope and its abundance has remained constant since the formation of the solar system (Komárek et al., 2008). Thanks to this characteristic, Pb isotope composition is governed by the original composition of the parent isotopes, and thus is typical and characteristic of a given area/sample. Pb isotope ratios are a powerful tool often used for provenance studies in several fields, such as forensic science and cultural heritage investigations (Sjåstad et al., 2011; Drivelos and Georgiou, 2012; Ortega et al., 2012). The application of Pb isotope ratios measurement in environmental science is of great interest since it allows to distinguish between different Pb sources, whether they are natural or anthropogenic (Hinrichs et al., 2002; Larsen et al., 2012).

3. Results and discussion

3.1. TE concentrations in sponges

In order to evaluate intra-species variability, at least three individuals of same sponge specie were analyzed. Numerical results are shown in Tables 1S and 2S (supplementary information). Accounting for

the intra-species variability, it was possible to evaluate the differences in TE accumulation for different sampling conditions (depth, light, and seasons) or between different species of the same sampling site (Fig.2). Additionally, the same two species (*H. panicea* and *H. perlevis*) were collected in two different sampling sites located in Ireland, making possible a direct comparison of these species bioaccumulation trends with respect to TE availability in the surrounding environment.

3.1.1. Intra-species variability

The variability within a same sponge species can be evaluated looking at the relative standard deviation (RSD%) calculated for results obtained from different specimens of the same sponge species. In Mediterranean sponges, the results reveal a variability of TE concentrations more or less significant depending on the target TE and sponge species, and averaging 30%. Among TE, Mo, As, Cd and Cu shows the lowest variability (averaging 21, 15, 16, 17 and 21%, respectively). The intra-species variability can be also very low for specific sponge species: *e.g.* for Ba in *C. damicornis* (1%) or for As in *C. nucula*. at 20 m depth (3%) during the second sampling. Generally, the intra-species variability averages 33% for V, Ni, Zn, Ag, Ba. For all species collected in the Mediterranean sites, Pb showed by far the highest intra-specie variability, showing an average RSD of 69% and reaching values up to 121% (*e.g.* for *H. fulva* second sampling).

In Irish sponges, the intra-species variability ranges from 2 to 55 % for all TE (even for Pb), and averages 33%, such as in Mediterranean samples. However, these results did not present RSD as high as those found in Mediterranean samples. The maximum RSD value found for Irish samples is 55% for Ba measured in *H. panicea* from Kilkieran Bay. Arsenic showed the lowest intra-species variability for *H. panicea* from Belfast (14%) and for *H. perlevis* from Kilkieran (8%). Mo and Zn presented the lowest RSD values in *H. panicea* from Kilkieran (2%) and *H. perlevis* from Belfast (7%), respectively. Pb did not show the same behavior as in the Mediterranean samples, since its intra-species variability for all studied species was similar to values obtained for other TE.

In this study, the natural variability within the same sponge species seems to be dependent both on the considered analyte and the sponge species itself. The factor most likely governing this intra-species variability can be related to possible differences in organism's age (what we intended to avoid collecting organisms of same sizes). Besides, it seems that some elements like Pb are more affected by this natural internal variability than other TE such as Cd, Mo and V. For the Irish and French sponge samples, the

natural intra-species variability observed in this study averages 30-33%, which agrees with literature data on TE in sponges. Müller et al. (1998) reported RSD up to 33% for Cd and Cu in *Suberites domuncula*. Perez et al. (2005) showed RSD up to 70% and 50 % for Mn and Pb in *Spongia officinalis*, respectively. These previous results agree with the high RSD found for Pb in Mediterranean sponges. A natural variability has thus to be expected, even for samples analyzed in pristine environment such as Antarctic (Grotti et al., 2008). This natural variability is not always taken into consideration in biomonitoring studies and should be considered when interpreting results in the future.

3.1.2. Influence of sampling site characteristics on the TE concentrations in Mediterranean sponges

For the same sampling date, some specimens of *C. damicornis* and *C. nucula* were collected at different depths and light conditions in order to evaluate the influence of sampling conditions. Results are shown in Fig. 2. Differences between TE contents were examined taking into consideration the intra-species variability.

- Influence of the light: During the sampling campaign carried out in February 2016, three specimens of *C. damicornis* were collected at the entrance of a cave and two others in its center. Taking into account the intra-species variability, TE concentrations were similar in the two cave sites. Slight differences were found on the mean Ni and As concentrations, but not so significant accounting RSD values. Ni content averaged $3 \pm 1 \text{ mg kg}^{-1}$ for sponges collected in the cave entrance, and $5 \pm 1 \text{ mg kg}^{-1}$ for those collected in the center of the cave. On the contrary, As was found in higher concentration in samples from the cave entrance: 85 ± 15 vs $67 \pm 4 \text{ mg kg}^{-1}$. But, RSD on the mean value being important, it is not easy to evaluate the real difference.
- Influence of the depth: During the second sampling campaign, three samples of *C. nucula* were collected from 5m depth and other three specimens from 20m depth. TE sponges concentrations were generally similar for the two sampling depth. Significant differences were shown for V, Mo and Cd. Differences in Mo were borderline (2.1 ± 0.3 and $1.52 \pm 0.08 \text{ mg kg}^{-1}$, for 5 and 20 m depth respectively). V and Cd did not show drastic differences and in both case their level were slightly higher in samples collected at a depth of 20m than at 5m. Slight differences occur on the mean Cu and As sponge contents, but not so significant accounting the intra-species variability.

In conclusion, it seems that small changes in the sampling location and/or depth do not have a significant impact on TE accumulation in sponges. These organisms can thus be considered representative of a rather spread “zone” of environment, showing consistent and homogeneous TE distribution within the same sampling period.

- Influence of the sampling season

Mediterranean sponges were collected at the same sampling site during two periods in order to estimate the influence of seasonal variations in TE sponge accumulation. The average values obtained for each species in each sampling period were compared, and differences were evaluated taking into consideration the intra-specie natural variability observed for each pool of specimens. Results are shown in Table 5.

Considering the intra-species variability, TE concentrations were similar for the two sampling seasons, especially for *C. nucula* and *A. acuta*. However for some of them, concentrations were slightly higher during the first sampling carried out in September 2016: for As in *A. acuta* sponges, for Mo and Pb in *C. nucula* sponges, for Ba, As, Mo and Ag in *C. damicornis*, and for V, Ni, Ag, Ba and Pb in *H. fulva* sponges. In conclusion, most of TE presented no significant seasonal fluctuations accounting RSD values, as differences of TE concentrations involved each time different TE or sponge species. If a common trend of TE enrichment in all sponge species was observed for a sampling period, this could signify an external increased input (e.g. from anthropogenic activities). But this behavior it was not observed in sediment samples either, as presented in one of the following paragraph. These fluctuations are most likely associated with natural processes: e.g. linked to changes in biological activities of associated bacteria, physio-chemical changes in the water column affecting the uptake and elimination of TE.

Figure 2. Graphic representation of inter-species variability of trace element mass fractions for sponges collected in Mediterranean coast during the two sampling campaigns. Comparisons for *C. damicornis* collected at the entrance (E) and center (C) of the cave as well as for *C. nucula* collected at two different depths (5 and 20 m), are also presented. Error bars stand for standard deviations on mean TE values obtained for different specimens of same sponge specie (n ≥3)

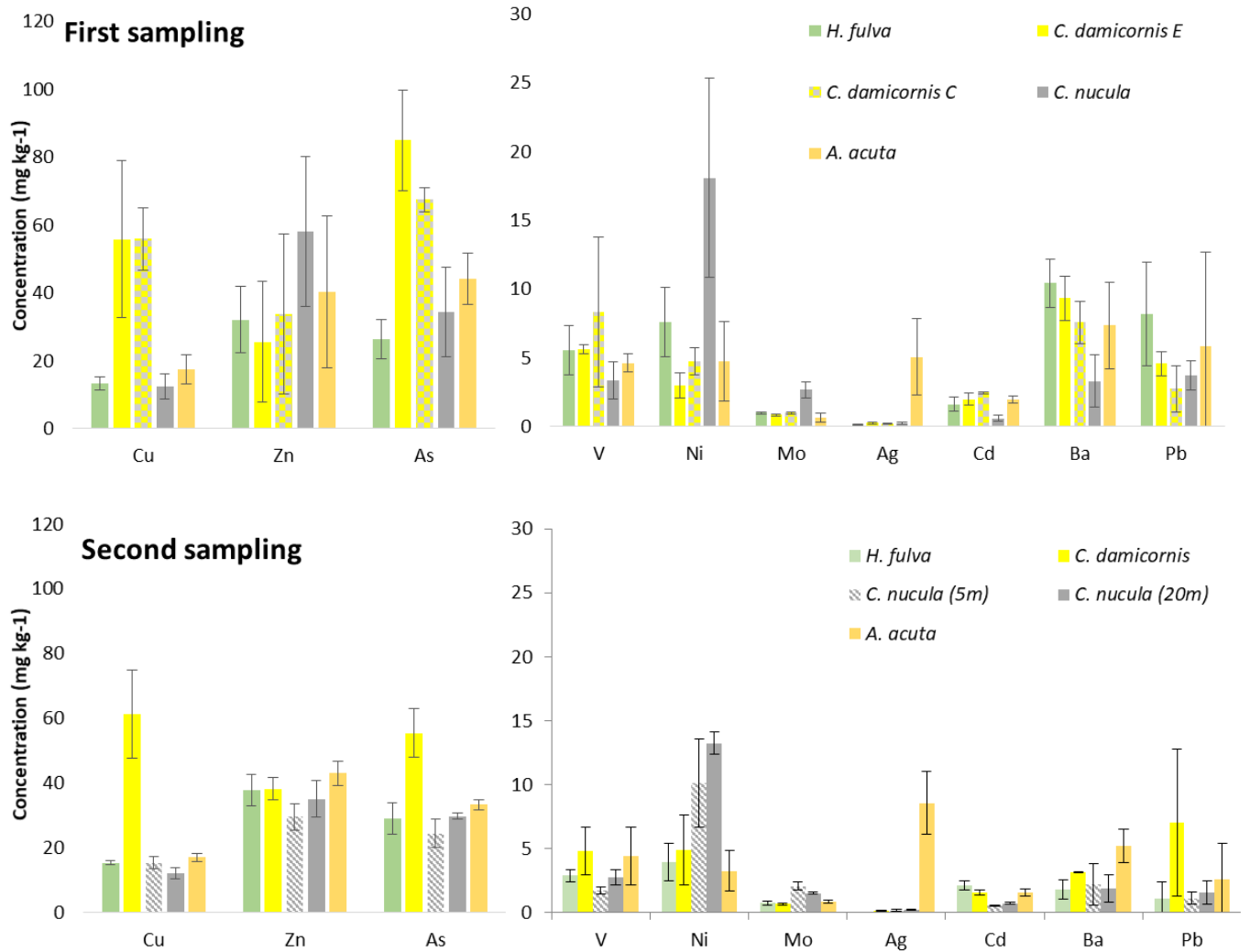

3.1.3. Inter-species variability

- Mediterranean sponges

The differences in TE contents between different species were first evaluated for Mediterranean sponges. Since four different species were collected in Villefranche-sur-mer for two different sampling campaigns, it was possible to carry out a comparative study on the different accumulation properties of these species; a graphic representation of obtained results is shown in Fig. 2.

The accumulation of TE within sponges depends directly on the target element: for instance among the analyzed elements, As, Cu and Zn presented the highest contents (some tens of mg kg⁻¹). Additionally, the accumulation of TE depends strongly on the sponge specie. *C. damicornis* showed about two times higher As and Cu contents than other species: between 56-61 and 55-85 mg kg⁻¹, respectively. The highest content of Ni and Mo were found in *C. nucula*, with values twice (or more) higher than other species. Zn showed also higher content in *C. nucula*, but only for the first sampling. The lowest Cd and V concentrations were revealed in *C. nucula* sponges. In this study, Ba and Pb accumulation in sponges could not be demonstrated specific to a sponge species contents. This result can be also due to high intra-species variations and great seasonal variations previously described. A particular behavior was observed for Ag in *A. acuta*, which showed content up to 100 times higher than those found in the other three species. It is forth noticing that *H. fulva* is the only sponge species which did not exhibit a specific ability for one TE comparing to the other sponge species.

A statistical data treatment was performed to better constrain this inter-species variations. The biplot obtained by Principal Component Analyses (PCA) is presented in Fig. 3. The first two components (F1 and F2) explained 59.6% of the total variance. F1 accounted for 42.2% of total variance and 17.49% for F2. High positive loadings of V, Cu, As, Cd and Ba and high negative loadings of Ni and Mo characterized the F1 axis. The F2 axis was mainly characterized by a Ag positive loading. These observations and the analysis of Fig. 3 led to the conclusions that a positive correlation ($p < 0.05$) was found for V, Cu, As, Cd, Ba and for Mo and Ni; these two groups of elements being negatively correlated between them. Ag was the only element that did not present any significant correlation with other analytes and thus it is the only one with high positive loadings on F2. The biplot graph shows four distinct groups, each of them including all specimens of the same species. These statistical results confirm the first observations on TE concentrations and that sponge species can be distinguished on the basis of their TE accumulation. As previously demonstrated with TE concentrations, this biplot highlights: (1) that *C. damicornis* accumulate preferentially As, Cu and V; (2) *C. nucula* rather Mo and Ni; (3) and an exceptional capacity of *A. acuta* to accumulate Ag; (4) no specificity for *H. fulva* to accumulate more one TE comparing to other sponge species. Since Mediterranean sponges were collected in the same site and at the same date, we can assume that they were exposed to the same amount of TE. The great differences in TE accumulation in these sponges it is thus related to particular characteristics of sponge specie.

Figure 3. Biplot representation of PCA performed on all mass fractions found in Mediterranean sponge specimens analyzed in this study

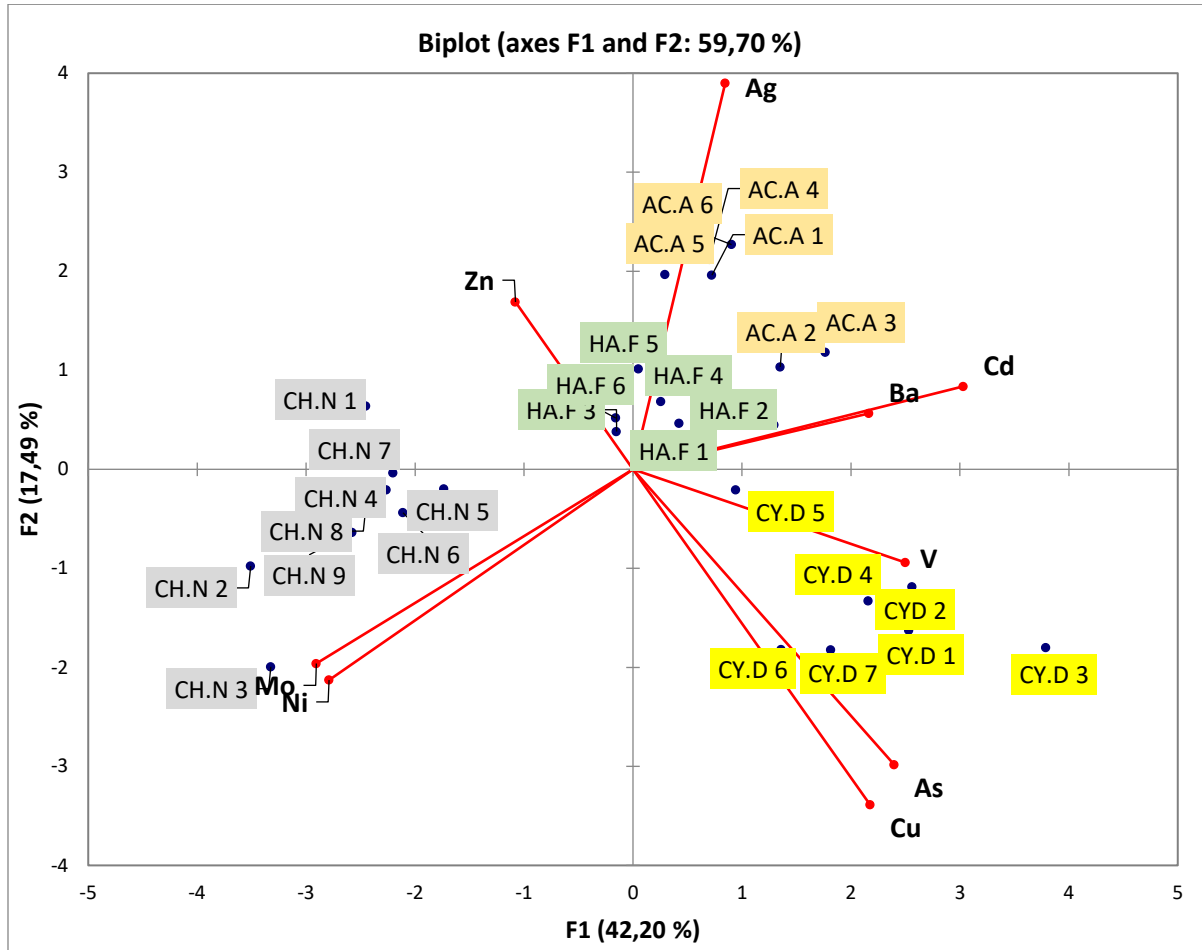

- Irish sponges

The inter-species variability of TE concentrations were then evaluated for two sponge species collected in 2 Irish sampling sites; the results are shown in Fig. 4. Principal Component Analysis was also performed separately for each sampling site in Ireland in order to highlight specific properties of the species, and not accounting for differences on element availability in the surrounding. Results are presented in two separated biplots (Fig 5). In Kilkieran bay, *H. perlevis* sponges revealed higher TE concentrations than those measured in *H. panicea*, except for As and Mo with similar contents.

Figure 4. Graphic comparison between TE concentrations on *H. panicea* and *H. perlevis* collected in two sampling locations in Ireland

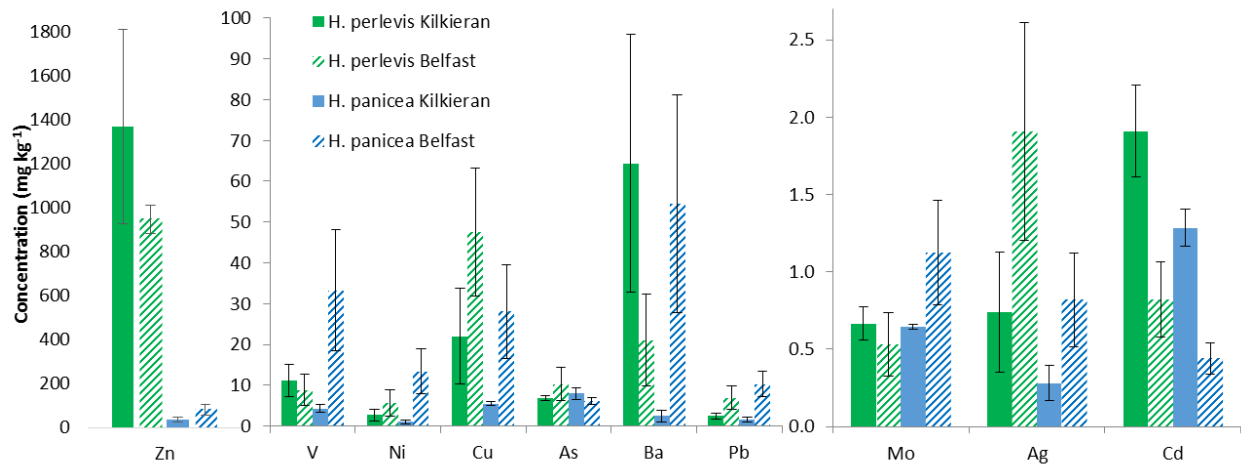

The PCA results gave two components (F1 and F2) with eigenvalues higher than one, which explained the 81.6% of variance (Fig. 5 a). The F1 was characterized by high positive loadings of all analytes except As, the only element presenting negative contribution to this component. The F2 presented the highest positive loading of Mo and the highest one of Cd, while others TE show low positive or negative contribution. The separation of sponges' species in the biplot is evident, as *H. panicea* specimens are grouped in the negative part of F1 while *H. perlevis* are grouped on the opposite side. Even if As revealed similar sponge contents, this metalloids seems to unequivocally distinguish the two sponge species in the PCA. Additionally, it can be noted that Cu, Ag, Zn and Cd form a first group whereas Pb, Ni, Ba and V another one. TE forming the first group close to the *H. perlevis* samples agree with the observation of higher Cu, Ag, Zn and Cd contents in *H. perlevis* sponges and thus specific affinity for this sponge species. At Belfast Lough, *H. perlevis* sponges revealed also significant higher concentrations for Cu, Cd, Ag and Zn, similar contents of As and Mo and lower concentrations for V, Ni and Ba (Fig. 4 and Table 6). The PCA results gave two components (F1 and F2) with eigenvalues higher than one, which accounted for 87.1% of the total variance. The F1 was characterized by high positive values of V, Ni, Mo, Ba and Pb and by high negative loadings of Cu, Zn, Ag and Cd. The second component F2 shows high positive contribution from As, Pb, Ag and Cu and while in this case none of the factors gave negative contribution. The biplot shows again a clear separation between the two-different species, even if the samples appear to be quite scattered in the graph (Fig. 5 b). Specifically, specimens belonging to *H. perlevis* are grouped in the negative part of F1, close to Zn/Cd or Cu/Ag loadings but additionally characterized by negative scores in both F1 and F2. Specimens of *H. panicea*, on the other hand, are distinguishable as they show factors always positive in F1 and almost always negative in F2 (except for

specimens HP Bel 3 and 4). While it is clear that *H. perlevis* is discernible according to its Cd and Zn accumulation, *H. panicea* separation is most likely related to Ba, Mo, Ni and V.

In conclusion, this survey on two sampling sites demonstrated that: (1) *H. perlevis* is characterized by higher affinity for Cu, Cd, Ag and Zn than *H. panicea* sponges; and (2) the remaining TE are not specifically accumulated by one of these two sponge species. The difference on Zn concentrations between the two sponge species is considerable (at least 10 times more). Similarly to Ag in *A. acuta*, *H. perlevis* present the exceptional characteristic to accumulate Zn. This difference is quite surprising since the two Irish sponge species belong to the same family (Halichondriidae).

3.1.4. Inter-site variability

For Irish sponges, the difference on TE bioaccumulation according to TE availability in the surrounding environment was investigated. Same species of Irish sponges were collected in two different sampling sites: a relatively uncontaminated area (Kilkieran Bay) and in a more contaminated environment (Belfast Lough). Within the stated intra-specie variability, the comparison of TE concentrations in sponges highlights significant differences according to the sampling site (Fig. 4).

Except for As and Cd, *H. panicea* from Belfast showed higher TE concentrations than those in Kilkieran: 2-3 times higher for Zn, Ag and Mo; 6-10 times higher for Ni, Zn, Cu and Pb; and more than 20 times higher for Ba. On the contrary, As and Cd presented higher concentrations in *H. panicea* from Kilkieran. For *H. perlevis* sponges, Ni, Cu, Pb and Ag revealed significant higher concentrations in Belfast than those in Kilkieran; whereas Zn, Ba and Cd revealed significant higher concentrations in Kilkieran. Taking into account the intra-species variability, these results allow a first suggestion to be proposed. With TE sponge contents, Belfast sampling site seems more contaminated than Kilkieran for Ni, Cu, Pb and Ag, whereas Kilkieran seems more contaminated for Cd only. The inter-site variability being opposite or similar within the sponge species for the other TE (Zn, V, As, Ba, Mo), nothing can be concluded on the other TE bioavailability in the surrounding environment.

The great differences in TE accumulation in sponges and other organisms can have different explanations: TE bioavailability and specific chemistry, geochemical influence on the TE availability in the environment as well species-specific physiological characteristics (Luoma and Rainbow, 2005). Differences can be related to specific binding sites and detoxification processes as the TE have often affinity for sulfur and nitrogen atoms present in proteins (Nieboer and Richardson, 1980) thus offering many possibility for binding sites within the cell (Rainbow, 1997).

Figure 5. Biplot representation of PCA performed on mass fractions found in Irish sponges collected in a) Killkieran bay and b) Belfast lough

a)

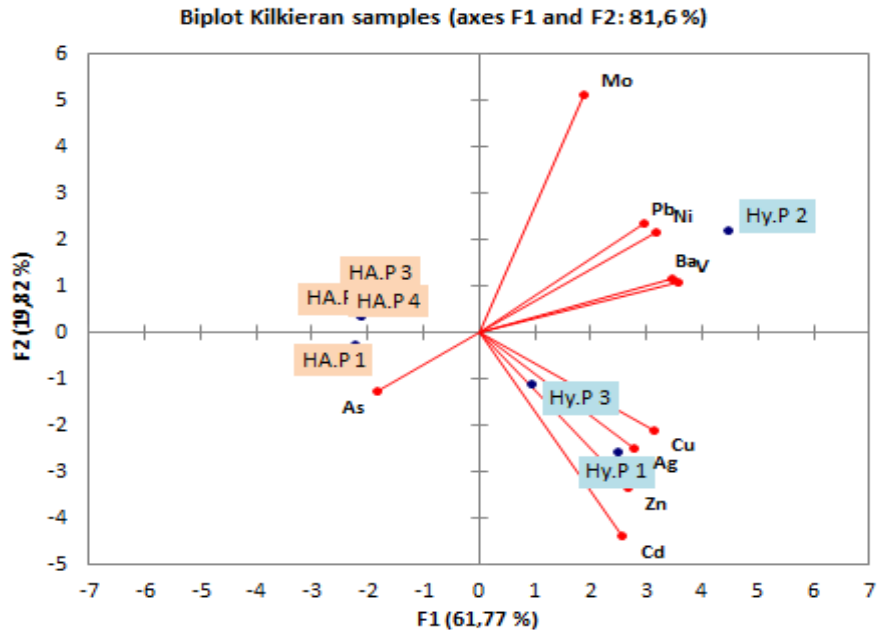

b)

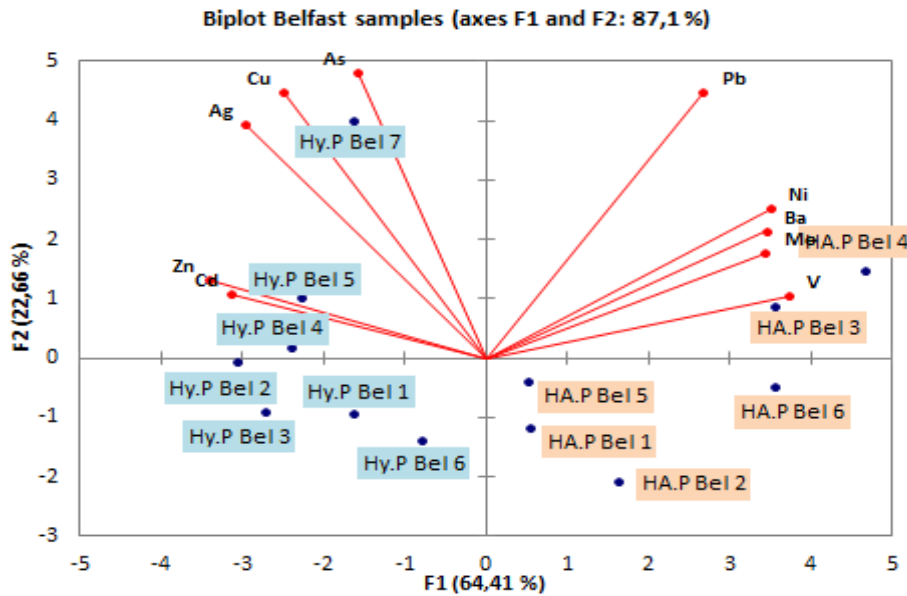

3.2. TE bioaccumulation in sponges

A common way to interpret the accumulation of TE in organisms' tissue is the calculation of Bio-Concentration Factors (BCF). These two parameters are useful in the evaluation of the sponge ability to accumulate the analyte with respect to its availability in the environment. According to the classic definition given by (Rand et al., 1995), the bioconcentration is defined as the uptake of a chemical by an organism from the abiotic environment (non-living chemical and physical components of the environment that affect the living organisms, for instance sunlight, soil, water and pollution). The bioaccumulation, on the other hand, is defined as the uptake from abiotic and/or biotic (food) environment, that is from all sources. Usually BCF for sponges are calculated as the ratio between the chemical concentration measured in the organism and the one measured in local sediment (Negri et al., 2006; Mayzel et al., 2014; Pan et al., 2011). A BCF value of 1 was set as threshold for all analytes, with results equal or above 1 being considered indicative of bioconcentration. When TE concentration in seawater is included in the study, the BAF are also calculated by dividing the TE sponge's content by the one found in seawater (Padovan et al., 2012; Venkateswara Rao et al., 2009; Batista et al., 2014).

3.2.1. Bio-Concentration Factors (BCF)

TEs concentration found in sediments from the three sampling sites are shown in Table 5. Overall, the values are typical of uncontaminated areas, based on the principal environmental regulations (US EPA, 2006; Split and Delta, 2010). It has to be pointed out that the grain size distribution appeared to be quite inhomogeneous, and the appearance was typical of sandy samples. These characteristics might explain the relatively low values and the high standard deviation for some elements among replicates collected in the same station (especially for Irish samples). Higher concentrations of V, Ni, Cu, Zn, and Ba were observed for sediments collected in Irish sites than in the French one. Similar Ag contents were measured in sediments regardless of the sampling site. Cd and Pb presented higher concentrations in the French site. Finally, the French site and Kilkieran sampling site presented similar Mo and As contents in sediments, higher than those from the Belfast site. Comparing the two Irish sites, sediments revealed similar concentrations for most TE, except Ni, Cd, As and Mo. As and Mo revealed higher concentrations in sediments from Kilkieran, whereas Ni and Cd exhibited higher concentrations in Belfast's samples.

Table 5. Summary of TE concentrations found in all sediments samples analyzed in this study. Standard deviations were calculated on the basis of different samples collected in the same sampling site. The n refers to the number of specimens analyzed for each sponge species.

Concentrations in sediments (mg kg ⁻¹)	Sampling stations								
	Villefranche (n=6)			Kilkieran (n=3)			Belfast (n=3)		
V	9.5	±	0.3	47	±	1	59	±	9
Ni	4.9	±	0.2	10.9	±	0.7	22	±	3
Cu	3	±	0.7	9	±	5	7	±	1
Zn	21	±	2	49	±	11	63	±	9
As	7	±	1	7	±	2	2.9	±	0.3
Mo	0.3	±	0.1	0.35	±	0.07	0.12	±	0.02
Ag	0.17	±	0.01	0.14	±	0.08	0.10	±	0.06
Cd	0.5	±	0.4	0.08	±	0.03	0.26	±	0.03
Ba	10	±	2	151	±	24	142	±	13
Pb	13	±	4	8.7	±	0.7	5.6	±	0.3

The BCF for Mediterranean and Irish sponges are presented in Table 6. BCF obtained for V, Pb, Ba and Ni were lower than 1 (or close) regardless of the sponge species, leading to the conclusion that these elements are more accumulated in sediments than in sponge' tissue. Ba was demonstrated to be toxic for some sponges (Ostrom and Simpson, 1978; Tompkins-MacDonald et al., 2009), and its BCF were already reported lower than 1 in several sponges species (Mayzel et al., 2014), thus implying its non-essential role in sponges' biological activities. Analogously the same assumption can be made for V, which showed the same behavior in other sponge species, as reported by Mayzel et al (2014). BCF for Pb were however close or higher than one only in sponges collected in Belfast. BCF for Ni were found to be higher than one only for *H. fulva* and *C. nucula*. For all the other TE (Cu, Zn, As, Mo, Ag, Cd), BCF were consistently higher than one, agreeing with the assumption of their essential role for these organisms as already observed in previous studies. Cd and Cu were found to be accumulated by several sponges species collected in the Red and Mediterranean seas ((Pan et al., 2011; Mayzel et al., 2014) (Cebrian et al., 2007), highlighting their essential role in sponges' metabolism. The high Zn bioaccumulation is likely to be associated not only to its geochemical availability, but also to its crucial role in multiple biological processes as well as to its higher uptake rate for species of this family (Rainbow, 2002). This element is also present in all six classes of enzymes (Broadley et al., 2007), it is thus not surprising that Zn is actively accumulated by sponges.

Table 6. Average bioconcentration factors calculated for the sponge species analyzed in this study

	Average BCF									
	V	Ni	Cu	Zn	As	Mo	Ag	Cd	Ba	Pb
<i>H. fulva</i>	0.4	1.2	4.8	1.5	3.8	2.6	0.3	3.9	0.6	0.3
<i>C. damicornis</i>	0.6	0.9	18.1	1.6	9.0	2.4	1.0	3.9	0.6	0.4
<i>A. acuta</i>	0.5	0.6	5.7	2.0	5.4	2.3	41.1	3.7	0.6	0.3
<i>C. nucula</i>	0.3	2.8	4.4	1.8	4.1	6.3	1.3	1.3	0.2	0.2
<i>H. panicea</i> Kilkieran	0.1	0.1	0.6	0.8	1.2	1.8	2.1	21.2	0.02	0.2
<i>H. panicea</i> Belfast	0.6	0.6	4.3	1.3	2.1	9.3	8.4	1.7	0.4	1.8
<i>H. perlevis</i> Kilkieran	0.2	0.2	2.5	27.8	1.0	1.9	5.4	31.5	0.4	0.3
<i>H. perlevis</i> Belfast	0.2	0.3	7.2	15.1	3.5	4.4	19.7	3.2	0.1	1.2

The inter-site and inter-species variations of BCF are shown in Fig. 6. Except for Cd and Zn, all the BCFs calculated for Belfast samples were higher than those determined in Kilkieran sponges, despite the similar (V, Cu, Ag, Ba) or lower (As, Mo, Pb) content in sediments. This is particularly evident for Cu, As, Mo, Ag and Pb. *C. damicornis* showed the highest BCF for Cu and As compared to other species (BCF = 18.1 and 9.0, respectively), agreeing with the previous observation of the highest Cu and As concentrations in this sponge specie (Fig. 3). Arsenic was previously shown to be highly accumulated by sponges, reaching concentration values above 100 mg kg⁻¹ (Pan et al., 2011; Yamaoka et al., 2006; Araújo et al., 2003). Arsenic accumulation was also demonstrated to be higher in demosponges than calcareous sponges (Yamaoka et al., 2001), and additionally quite variable among demosponges as demonstrated in the present study with a particular affinity in *C. damicornis*.

As already observed in Zn concentrations results, Zn BCF were the highest in *H. perlevis* sponges (BCF = 15-28) regardless of the sampling site, showing a clear affinity of the species for this element. The highest BCF was found in *A. acuta* sponges for Ag (BCF = 41.1), as expected from the higher concentrations measured in this sponge specie. Similarly to results found in this study, the propensity for Ag accumulation in *A. acuta* sponges was already observed, also revealing a much reduced Ag decontamination process, compared to other species (Genta-Jouve et al., 2012). The reason for this particular behavior resides, according to Genta-Jouve et al. (2012), in the role of Ag in the secondary metabolism of this sponge specie. High Ag BCF values were also observed for Irish sponges, reaching 19.7 for *H. perlevis* in Belfast. Concerning Mo, its BCF is significantly higher for *C. nucula* among the in Mediterranean sponges (BCF = 6.3), and in *H. panicea* and *H. perlevis* in Belfast (BCF = 9.3 and 4.4,

respectively). It is worth noticing that Mo bioaccumulation is higher in sponges from Belfast (BCF = 21.2-31.5) whereas Mo sediment content was significantly lower in Belfast than in Kilkieran. Mo was seldom included in TE accumulation studies performed on sponges. Gentric et al. (2016) reported Mo sponge concentrations between 0.2 and 1.2 mg kg⁻¹ (similar than those measured in this study), showing a special affinity of this element for the specie *H. perlevis* comparing to the specie *Raspailia ramosa*. Cd presented the same opposite behavior between sponge and sediment results. Cd BCF in both Irish sponge species were surprisingly high in Kilkieran Bay (21-31) whereas the Cd content in sediments was significantly lower in this sampling site comparing to Belfast. The disagreement between Cd contamination profiles and accumulation in organisms was already observed in barnacles and mussels (Phillips and Rainbow, 1988) indicating the existence of subtle differences in bioavailability of this element. In other words, Cd bioavailability and thus its uptake is not necessarily proportional to its concentration measurable in sediments or generally in the surrounding environment.

Figure 6. Graphical representation of some of the Bio-concentration factors calculated for all sponge species

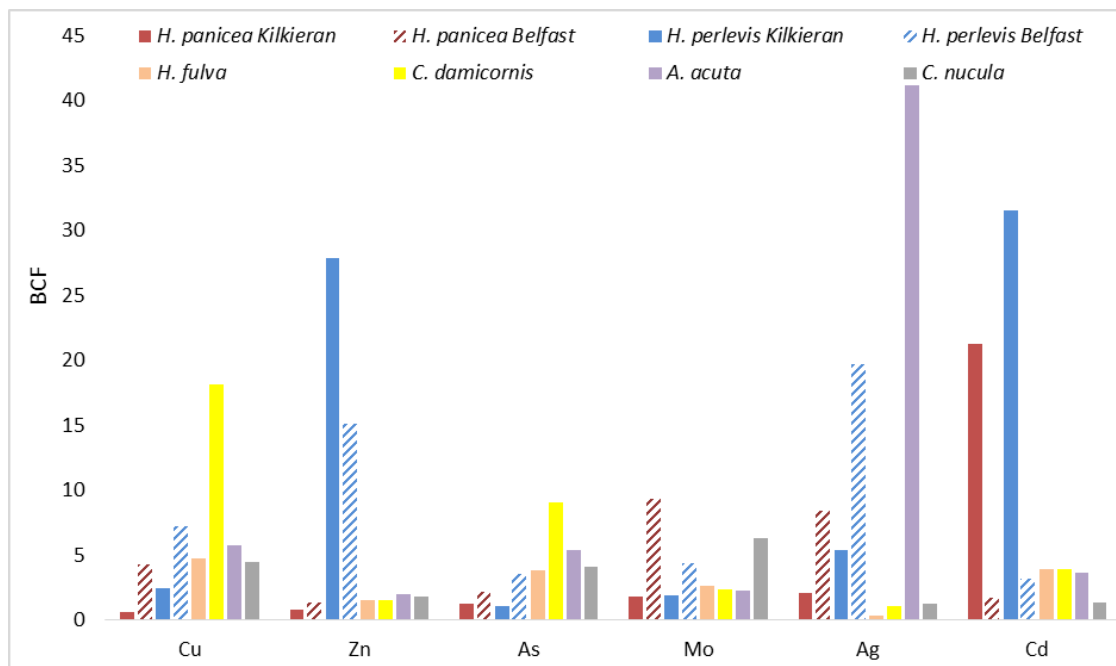

Padovan et al. (2012) reported BCF for the sponge *Spheciospongia vagabunda* up to 375, 48 and 1850 for Ni, Zn and Cd respectively, which is higher than BCF calculated in our study. However, sponges and sediments from this previous study were sampled close to a sewage outfall proving thus large anthropogenic TE inputs. Similar BCF values were reported by Cebrian et al. (2007) in Northwestern Mediterranean sponges for Cu and Pb: *i.e.* up to 17.5 and up to 0.23, respectively for *Dysidea avara* and

Chondrosia reniformis, values comparable with maximum BCF for Cu of 18 in *C. damicornis*, and similar than usual BCF for Pb (except in Belfast). Pan et al. (2011) measured TE in different sponges and sediments from Red Sea, showing maximum BCF of 74, 22, 3, 56 and 5 for Cd, Zn, Ag, Cu and As respectively. These results were higher than those reported in the present study for Cd and Cu, lower for Ag and overall comparable for Zn and As. Mayzel et al. (2014) analyzed 16 sponges species and reported BCF consistently lower than 1 for Ba (except for one specie) and V; additionally the study shows BCF>1 for As, Cd and Zn. A significant As BCF of 477 was previously measured in only one sponge specie, *Theonella swinhoei*, which was explained by the presence of a particular bacterium (Mayzel et al., 2014). It is worth noticing that *T. swinhoei* is a slow growing and long lived specie so As concentration could be linked to the age of the sponge and thus responsible for the elevated BCF. Negri et al. (2006) reported also BCF comparable with the present study for Cu, Pb and Zn (not considering *H. perlevis*), but much higher BCF were reported for As (up to 19) and Cd (up to 690). Results from our study as well as literature data thus support the evidence that the variability in TE accumulation (and bioconcentration) in sponges occurs at many scales including within and between species, within and between locations, and related to the targeted TE.

3.2.2. Sponges as tool for biomonitoring studies

In order to better appreciate the extent of TE bio-concentration in sponges, the results are compared with values determined in other organisms, potentially used as monitors of TE in coastal/marine environment. The great advantages of sponges comparing to other “common” biomonitors like bivalves is that they are simple organisms without complex organs and tissues. It is thus reasonable to think that sponge tissues show low intra-individual variation in TE concentrations (de Mestre et al., 2012).

In a baseline study lead in the Pacific Ocean in Guam harbors, sponges were shown to accumulate consistently higher amounts of Ag, As, Cd, Cu, Ni, Pb and Zn in comparison to seaweeds, but not in comparison to oysters or other bivalves (Denton et al., 2006). Aly et al., (2013) found out that most of TE in sponge specimens of *H. oculata* from Poole Harbour (UK) were accumulated much more efficiently than in species of bivalve *Cerastoderma edule*, a common cockle. The latter showed TE concentrations lower than sediment for almost all analytes while the sponge exhibited very high bioconcentration factors. A study published by Perez et al., (2004) also shows that sponges from Mediterranean coast concentrate more TE than mussels (*Mytilus galloprovincialis*), exception made for Zn. According to the target TE, concentrations measured in sponges were from 6 to 145 times higher than those measured in mussels. Gentric et al. (2016) reported also higher concentration values of Mo, Ni, and Pb in *H. perlevis*

and *R. ramosa* collected in Northern France, in comparison with *Crassostrea gigas* (oyster). On the other hand, this oyster specie showed much higher content of Cu and Zn in comparison with all the sponges species analyzed in the mentioned study. Cu and Zn concentrations in oysters were shown to reach more than $>10000 \text{ mg kg}^{-1}$ (Weng and Wang, 2014; Birch et al., 2014). Other benthic organisms such as macroalgae, gastropods and nemertean were shown to accumulate TE in extent more or less comparable to sponges. (Majer et al., 2014) reported BCF values up to 2, 8, 2, 0.4, 1.6 and 5.6 for As, Cd, Cu, Ni, Pb and Zn respectively, for different benthic organisms collected in Antarctica. Corals also shown interesting TE accumulation properties, with BCF reaching 22 for Cd, 7 for Pb, 24 for Cu and 66 for Zn (Esslemont, 2000).

In conclusion, elements such as Ag, As, Mo and Cd seem to have more affinity for sponges in comparison to other organisms. Even if Cu and Zn are often better accumulated by other organisms in comparison to sponges, these TE are also significantly bioconcentrated in sponges. This and previous studies demonstrate that sponges are a good tool to biomonitor the TE level, especially since they are widespread in coastal ecosystems.

3.3. Source of lead in sponges

In the Mediterranean site, as already mentioned, Pb showed an unusual high variability within the species. The initial hypothesis is that the sponge samples were exposed to different Pb sources in different extent, thus leading to very high differences even among specimens of the same species. In order to evaluate this possibility, the analysis of Pb isotope ratios was performed in sponge and sediment samples. Results are shown in Fig 7. Results clearly show that all samples have been exposed to the same Pb source, as the isotopic compositions are practically undistinguishable. The absence of multiple Pb sources is also confirmed by the lack of any linear trend in the presented graph ($R^2=0.2624$) (Ellam, 2010). Being the result of only one source, the isotopic composition found in our samples is likely to be associated to a natural source. Results are indeed more radiogenic than those reported for gasoline in France (Monna et al., 1995) or average French industrial Pb (Véron et al., 1999). Results are closer to Pb isotopic composition measured in pre-industrial sediments discharged by the major French rivers ($^{206}\text{Pb}/^{207}\text{Pb} = 1.197\text{-}1.206$, Elbazpoulichet et al., 1986) and to Miocene siltstone and Jurassic limestone analyzed by Monna et al., (1995).

Figure 7. Three isotopes graph of Pb isotope ratios results obtained for Mediterranean sample plotted together with some literature data of common anthropogenic sources and typical natural composition of the area. Data from Elbaz-Poulichet et al. (1986), Monna et al. (1995), Véron et al. (1999).

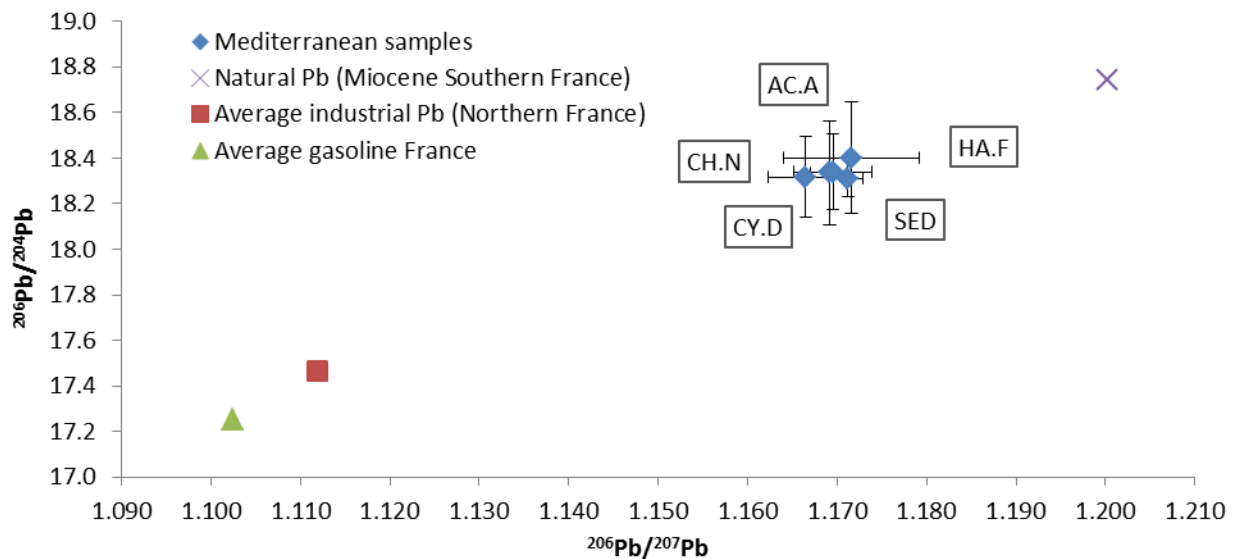

In Ireland, the Pb concentrations found in sediments were higher in Kilkieran than in Belfast (8.7 vs 5.6 mg kg^{-1}) whereas it is the reverse in sponges with higher Pb contents in Belfast. Three isotope graph presented in Fig. 8 show a clear linear trend for Irish samples ($R^2=0.9595$) suggesting that two different Pb sources influenced these samples' isotopic composition. Samples collected in Belfast show lower $^{206}\text{Pb}/^{207}\text{Pb}$ as well as lower $^{206}\text{Pb}/^{204}\text{Pb}$ values, close to $^{206}\text{Pb}/^{207}\text{Pb}$ values reported by Fletcher et al., (1993) for Welsh ore and by Charlesworth et al., (2006) for Dublin surface sediments, influenced by the industrial activities of the area. Charlesworth et al. (2006) also reported $^{206}\text{Pb}/^{207}\text{Pb}$ equal to 1.191 for bottom sediment cores collected in the Irish Sea (between Dublin and Belfast). This value is quite close to our results on sponges and sediment collected in Kilkieran Bay, confirming that the Pb found in both, sponges and sediment from Kilkieran, is most likely associated to a natural source. These results thus show how the mere determination of Pb concentration is often not sufficient for the assessment of contamination of a given place, especially when sediments of proper grain size are not available. Pb isotopic composition can give relevant additional information and the ultimate confirmation of the presence of Pb from anthropogenic source.

Figure 8. Three isotopes graphs showing Pb isotope ratios results for sponges and sediments collected in Ireland. Data from Fletcher et al. (1993) and Charleston et al. (2006).

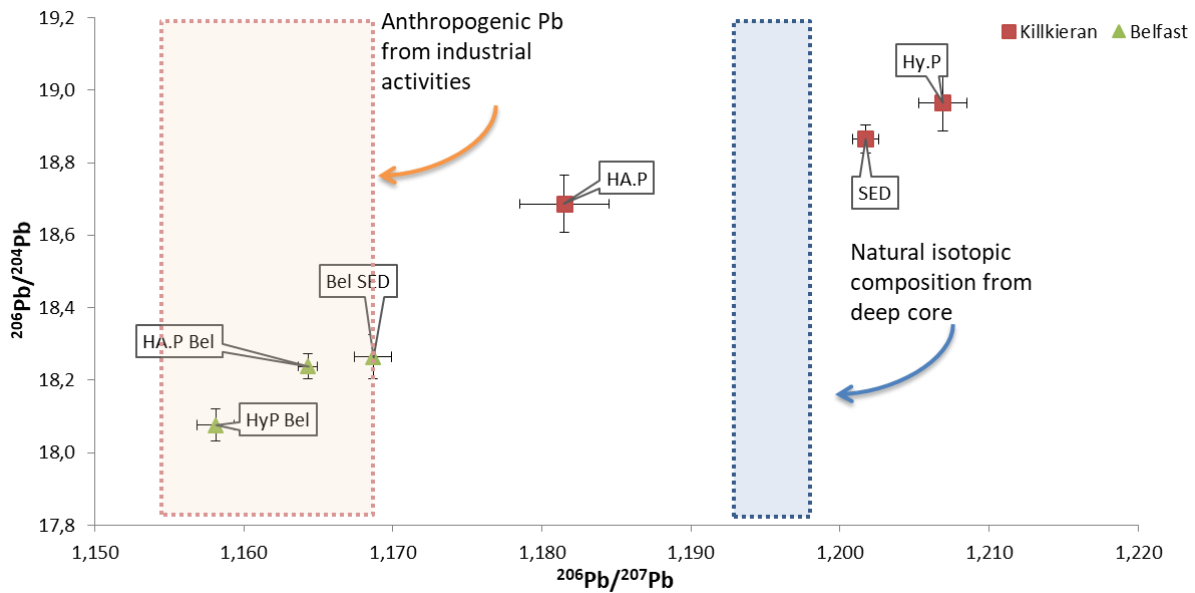

Conclusion

In conclusion, the present work shows the great capabilities of sponges as TE bioaccumulators and their suitability as environmental biomonitors. The six analyzed species show generally different accumulation properties depending on the considered element and the sampling station. Some elements such as Ba, V and in some cases Ni, were poorly accumulated by sponges, meaning that these elements are not involved in biological processes. Statistical data treatment by PCA and BCF calculations shows how it is possible to distinguish different species on the basis of their bioaccumulation properties. Specifically, Cu and As are demonstrated to be highly accumulated in *C. damicornis*, Zn in *H. perlevis* and, as already shown in previous studies, Ag, Mo and Ni in *A. acuta*. Except for Ba, V and Pb, BCF were higher than one, highlighting the bioaccumulation properties of these organisms. This study confirms that sponges are an efficient bio indicator of TE environmental state such as or better than other marine organisms. Finally, the determination of Pb isotope ratios, offered the opportunity to evaluate the source of Pb in the studied area, revealing mostly natural sources for samples collected in the Mediterranean area (even though the Pb concentrations were higher than both Irish sites) and Killkieran bay, while an anthropogenic signature was found in samples collected from Belfast Lough.

References (paper 6)

- Abraham, G.M.S., Parker, R.J., 2008. Assessment of heavy metal enrichment factors and the degree of contamination in marine sediments from Tamaki Estuary, Auckland, New Zealand. *Environ. Monit. Assess.* 136, 227–238. <https://doi.org/10.1007/s10661-007-9678-2>
- Adams, F., Gijbels, R., Van Grieken, R., 1988. *Inorganic Mass Spectrometry*. John Wiley & Sons.
- Aide, M.T., Aide, C., 2012. Rare Earth Elements: Their Importance in Understanding Soil Genesis. *ISRN Soil Sci.* 2012, 1–11. <https://doi.org/10.5402/2012/783876>
- Alleman, L.Y., Hamelin, B., Véron, A.J., Miquel, J.-C., Heussner, S., 2000. Lead sources and transfer in the coastal Mediterranean: evidence from stable lead isotopes in marine particles. *Deep Sea Res. Part II Top. Stud. Oceanogr.* 47, 2257–2279. [https://doi.org/10.1016/S0967-0645\(00\)00024-2](https://doi.org/10.1016/S0967-0645(00)00024-2)
- Aloupi, M., Angelidis, M., 2001. Geochemistry of natural and anthropogenic metals in the coastal sediments of the island of Lesbos, Aegean Sea. *Environ. Pollut.* 113, 211–219. [https://doi.org/10.1016/S0269-7491\(00\)00173-1](https://doi.org/10.1016/S0269-7491(00)00173-1)
- Aly, W., Williams, I.D., Hudson, M.D., 2013. Metal contamination in water, sediment and biota from a semi-enclosed coastal area. *Environ. Monit. Assess.* 185, 3879–3895. <https://doi.org/10.1007/s10661-012-2837-0>
- AMPS Expert Group, 2005. Contributions of the Expert Group on Analysis and Monitoring of Priority Substances to the Water Framework Directive. EU Report EUR 21587.
- Anderson, G.L., Williams, J., Hille, R., 1992. The purification and characterization of arsenite oxidase from *Alcaligenes faecalis*, a molybdenum-containing hydroxylase. *J. Biol. Chem.* 267, 23674–23682.
- Andrewes, P., Demarini, D.M., Funasaka, K., Wallace, K., Lai, V.W.M., Sun, H., Cullen, W.R., Kitchin, K.T., 2004. Do arsenosugars pose a risk to human health? The comparative toxicities of a trivalent and pentavalent arsenosugar. *Environ. Sci. Technol.* 38, 4140–4148. <https://doi.org/10.1021/es035440f>
- Angelidis, M.O., Radakovitch, O., Veron, A., Aloupi, M., Heussner, S., Price, B., 2011. Anthropogenic metal contamination and sapropel imprints in deep Mediterranean sediments. *Mar. Pollut. Bull.* 62, 1041–1052. <https://doi.org/10.1016/j.marpolbul.2011.02.030>
- Anjum, K., Abbas, S.Q., Shah, S.A., Akhter, N., Batool, S., Hassan, S.S., 2016. Marine Sponges as a Drug Treasure. *Biomol. Ther.* 24, 347–362.
- Araújo, M.F., Conceição, A., Barbosa, T., Lopes, M.T., Humanes, M., 2003. Elemental composition of marine sponges from the Berlengas Natural Park, western Portuguese coast. *X-Ray Spectrom.* 32, 428–433. <https://doi.org/10.1002/xrs.660>
- Aresta, A., Marzano, C.N., Lopane, C., Corriero, G., Longo, C., Zambonin, C., Stabili, L., 2015. Analytical investigations on the lindane bioremediation capability of the demosponge *Hymeniacidon perlevis*. *Mar. Pollut. Bull.* 90, 143–149. <https://doi.org/10.1016/j.marpolbul.2014.11.003>
- Armstrong-Altrin, J.S., Verma, S.P., Madhavaraju, J., Lee, Y. II, Ramasamy, S., 2003. Geochemistry of Upper Miocene Kudankulam Limestones, Southern India. *Int. Geol. Rev.* 45, 16–26. <https://doi.org/10.2747/0020-6814.45.1.16>
- Ashraf, A., Saion, E., Gharibshahi, E., Kamari, H.M., Yap, C.K., Hamzah, M.S., Elias, M.S., 2017.

- Distribution of Trace Elements in Core Marine Sediments of Coastal East Malaysia by Instrumental Neutron Activation Analysis. *Appl. Radiat. Isot.* 122, 96–105. <https://doi.org/10.1016/j.apradiso.2017.01.006>
- Ashraf, A., Saion, E., Gharibshahi, E., Mohamed Kamari, H., Chee Kong, Y., Suhaimi Hamzah, M., Suhaimi Elias, M., 2016. Rare earth elements in core marine sediments of coastal East Malaysia by instrumental neutron activation analysis. *Appl. Radiat. Isot.* 107, 17–23. <https://doi.org/10.1016/j.apradiso.2015.09.004>
- ATSDR, 2007. Toxicological Profile for Arsenic, U.S Public Health Service, Agency for Toxic Substances and Disease Registry. <https://doi.org/http://dx.doi.org/10.1155/2013/286524>
- Ault, W.U., Senechal, R.G., Erlebach, W.E., 1970. Isotopic Composition as a Natural Tracer of Lead in the Environment: Discussions Follow. *Environ. Sci. Technol.* 4, 305–313. <https://doi.org/10.1021/es60039a001>
- Azemard, S., Vassileva, E., 2015. Determination of methylmercury in marine biota samples with advanced mercury analyzer: Method validation. *Food Chem.* 176, 367–375. <https://doi.org/10.1016/j.foodchem.2014.12.085>
- Azizur Rahman, M., Hasegawa, H., Peter Lim, R., 2012. Bioaccumulation, biotransformation and trophic transfer of arsenic in the aquatic food chain. *Environ. Res.* 116, 118–135. <https://doi.org/10.1016/j.envres.2012.03.014>
- Bagul V. R., S.D.N., 2015. New perspective on heavy metal pollution of water. *J. Chem. Pharm. Res.* 7, 700–705.
- Barats, A., Féraud, G., Potot, C., Philippinini, V., Travi, Y., Durrieu, G., Dubar, M., Simler, R., 2014. Naturally dissolved arsenic concentrations in the Alpine/Mediterranean Var River watershed (France). *Sci. Total Environ.* 473–474, 422–436. <https://doi.org/10.1016/J.SCITOTENV.2013.12.007>
- Bargagli, R., Nelli, L., Ancora, S., Focardi, S., 1996. Elevated cadmium accumulation in marine organisms from Terra Nova Bay (Antarctica). *Polar Biol.* 16, 513–520. <https://doi.org/10.1007/BF02329071>
- Barwick, V.J., Ellison, S.L.R., 1999. Measurement uncertainty: Approaches to the evaluation of uncertainties associated with recovery†. *Analyst* 124, 981–990. <https://doi.org/10.1039/a901845j>
- Batista, D., Muricy, G., Rocha, R.C., Miekeley, N.F., 2014. Marine sponges with contrasting life histories can be complementary biomonitors of heavy metal pollution in coastal ecosystems. *Environ. Sci. Pollut. Res.* 21, 5785–5794. <https://doi.org/10.1007/s11356-014-2530-7>
- Baudrimont, M., Schäfer, J., Marie, V., Maury-Brachet, R., Bossy, C., Boudou, A., Blanc, G., 2005. Geochemical survey and metal bioaccumulation of three bivalve species (*Crassostrea gigas*, *Cerastoderma edule* and *Ruditapes philippinarum*) in the Nord Médoc salt marshes (Gironde estuary, France). *Sci. Total Environ.* <https://doi.org/10.1016/j.scitotenv.2004.07.009>
- Beauchemin, D., 2008. Inductively coupled plasma mass spectrometry. *Anal. Chem.* 80, 4455–4486.
- Bednar, A.J., Garbarino, J.R., Burkhardt, M.R., Ranville, J.F., Wildeman, T.R., 2004. Field and laboratory arsenic speciation methods and their application to natural-water analysis. *Water Res.* 38, 355–364. <https://doi.org/10.1016/j.watres.2003.09.034>
- Beeson, R., 1984. The use of the fine fractions of stream sediments in geochemical exploration in arid

- and semi-arid terrains. *J. Geochemical Explor.* 22, 119–132. [https://doi.org/10.1016/0375-6742\(84\)90009-8](https://doi.org/10.1016/0375-6742(84)90009-8)
- Belarra, M.A., Resano, M., Vanhaecke, F., Moens, L., 2002. Direct solid sampling with electrothermal vaporization/atomization: What for and how? *TrAC - Trends Anal. Chem.* 21, 828–839. [https://doi.org/10.1016/S0165-9936\(02\)01206-2](https://doi.org/10.1016/S0165-9936(02)01206-2)
- Bell, J.J., 2008. The functional roles of marine sponges. *Estuar. Coast. Shelf Sci.* 79, 341–353. <https://doi.org/10.1016/j.ecss.2008.05.002>
- Bennett, W.W., Teasdale, P.R., Panther, J.G., Welsh, D.T., Zhao, H., Jolley, D.F., 2012. Investigating arsenic speciation and mobilization in sediments with DGT and DET: A mesocosm evaluation of oxic-anoxic transitions. *Environ. Sci. Technol.* 46, 3981–3989. <https://doi.org/10.1021/es204484k>
- Bentley, R., Chasteen, T.G., 2002. Microbial Methylation of Metalloids: Arsenic, Antimony, and Bismuth. *Microbiol. Mol. Biol. Rev.* 66, 250–271.
- Bermejo-Barrera, P., Barciela-Alonso, M.C., Moreda-Piñeiro, J., González-Sixto, C., Bermejo-Barrera, a., 1996. Determination of trace metals (As, Cd, Hg, Pb and Sn) in marine sediment slurry samples by electrothermal atomic absorption spectrometry using palladium as a chemical modifier. *Spectrochim. Acta Part B At. Spectrosc.* 51, 1235–1244. [https://doi.org/10.1016/0584-8547\(96\)01487-5](https://doi.org/10.1016/0584-8547(96)01487-5)
- Bermudez-Lugo, O., 2014. 2012 Minerals Yearbook, Usgs- 2012 Minerals Yearbook.
- Berthet, B., Mouneyrac, C., Pérez, T., Amiard-Triquet, C., 2005. Metallothionein concentration in sponges (*Spongia officinalis*) as a biomarker of metal contamination. *Comp. Biochem. Physiol. - C Toxicol. Pharmacol.* 141, 306–313. <https://doi.org/10.1016/j.cca.2005.07.008>
- Bhuiyan, M.A.H., Parvez, L., Islam, M.A., Dampare, S.B., Suzuki, S., 2010. Heavy metal pollution of coal mine-affected agricultural soils in the northern part of Bangladesh. *J. Hazard. Mater.* 173, 384–392. <https://doi.org/10.1016/j.jhazmat.2009.08.085>
- Birch, G.F., Melwani, A., Lee, J.H., Apostolatos, C., 2014. The discrepancy in concentration of metals (Cu, Pb and Zn) in oyster tissue (*Saccostrea glomerata*) and ambient bottom sediment (Sydney estuary, Australia). *Mar. Pollut. Bull.* 80, 263–274. <https://doi.org/10.1016/j.marpolbul.2013.12.005>
- Bocher, P., Caurant, F., Miramand, P., Cherel, Y., Bustamante, P., 2003. Influence of the diet on the bioaccumulation of heavy metals in zooplankton-eating petrels at Kerguelen archipelago, Southern Indian Ocean. *Polar Biol.* 26, 759–767. <https://doi.org/10.1007/s00300-003-0552-6>
- Bohari, Y., Astruc, A., Astruc, M., Cloud, J., 2001. Improvements of hydride generation for the speciation of arsenic in natural freshwater samples by HPLC-HG-AFS. *J. Anal. At. Spectrom.* 16, 774–778. <https://doi.org/10.1039/B101591P>
- Bollhöfer, A., Rosman, K.J., 2000. Isotopic source signatures for atmospheric lead: the Southern Hemisphere. *Geochim. Cosmochim. Acta* 64, 3251–3262. [https://doi.org/10.1016/S0016-7037\(00\)00436-1](https://doi.org/10.1016/S0016-7037(00)00436-1)
- Bollhöfer, A., Rosman, K.J.R., 2001. Isotopic source signatures for atmospheric lead: The Northern Hemisphere. *Geochim. Cosmochim. Acta* 65, 1727–1740. [https://doi.org/10.1016/S0016-7037\(00\)00630-X](https://doi.org/10.1016/S0016-7037(00)00630-X)

- Bossy, A., 2010. Origines de l'arsenic dans les eaux, sols et sédiments du district aurifère de St-Yrieix-la-Perche (Limousin, France) : contribution du lessivage des phases porteuses d'arsenic. Université de Limoges.
- Bowen, H.J.M., 1966. The Uptake and Excretion of Elements by Organisms, in: Trace Elements in Biochemistry. Academic Press London, pp. 85–101.
- Bremner, J.M., Willis, J.P., 1993. Mineralogy and geochemistry of the clay fraction of sediments from the Namibian continental margin and the adjacent hinterland. *Mar. Geol.* 115, 85–116. [https://doi.org/10.1016/0025-3227\(93\)90076-8](https://doi.org/10.1016/0025-3227(93)90076-8)
- Briant, N., Chouvelon, T., Martinez, L., Brach-Papa, C., Chiffolleau, J.F., Savoye, N., Sonke, J., Knoery, J., 2017. Spatial and temporal distribution of mercury and methylmercury in bivalves from the French coastline. *Mar. Pollut. Bull.* 114, 1096–1102. <https://doi.org/10.1016/j.marpolbul.2016.10.018>
- Briefing, 1980. Namibia in the frontline: the political economy of decolonisation in South Africa's colony. *Rev. Afr. Polit. Econ.* <https://doi.org/10.1080/03056248008703415>
- Broadley, M.R., White, P.J., Hammond, J.P., Zelko, I., Lux, A., 2007. Zinc in plants. *New Phytol.* 173, 677–702. <https://doi.org/10.1111/j.1469-8137.2007.01996.x>
- Brongersma-Sanders, M., Stephan, K.M., Kwee, T., De Bruin, M., 1980. DISTRIBUTION OF MINOR ELEMENTS IN CORES FROM THE SOUTH- WEST AFRICA SHELF WITH NOTES ON PLANKTON AND FISH MORTALITY Along the coast of Southwest Africa a belt of olive-green diatomaceous muds is found between 19 ° S and 25 ° S , bordered on the wester. *Mar. Geol.* 37, 91–132.
- Brown, J.L., Kitchin, K.T., George, M., 1997. Dimethylarsinic acid treatment alters six different rat biochemical parameters: Relevance to arsenic carcinogenesis. *Teratog. Carcinog. Mutagen.* 17, 71–84. [https://doi.org/10.1002/\(SICI\)1520-6866\(1997\)17:2<71::AID-TCM3>3.0.CO;2-B](https://doi.org/10.1002/(SICI)1520-6866(1997)17:2<71::AID-TCM3>3.0.CO;2-B)
- Brown, J.S., 1962. Ore leads and isotopes. *Econ. Geol.* 57, 673–720. <https://doi.org/10.2113/gsecongeo.57.5.673>
- Brown, R.J.C., Milton, M.J.T., 2005. Analytical techniques for trace element analysis: An overview. *TrAC - Trends Anal. Chem.* 24, 266–274. <https://doi.org/10.1016/j.trac.2004.11.010>
- Bruland, K.W., Bertine, K., Koide, M., Goldberg, E.D., 1974. History of metal pollution in southern California coastal zone. *Environ. Sci. Technol.* 8, 425–432. <https://doi.org/10.1021/es60090a010>
- Bruland, K.W., Lohan, M.C., 2003. Controls of trace metals in seawater, in: *Treatise on Geochemistry*. Elsevier Ltd, pp. 23–47.
- Bryan, G.W., Langston, W.J., 1992. Bioavailability, accumulation and effects of heavy metals in sediments with special reference to United Kingdom estuaries: a review. *Environ. Pollut.* 76, 89–131. [https://doi.org/10.1016/0269-7491\(92\)90099-V](https://doi.org/10.1016/0269-7491(92)90099-V)
- Bu, H., Song, X., Guo, F., 2017. Dissolved trace elements in a nitrogen-polluted river near to the Liaodong Bay in Northeast China. *Mar. Pollut. Bull.* 114, 547–554. <https://doi.org/10.1016/j.marpolbul.2016.09.003>
- Cabon, J.Y., Cabon, N., 2000. Speciation of major arsenic species in seawater by flow injection hydride generation atomic absorption spectrometry. *Fresenius. J. Anal. Chem.* 368, 484–9. <https://doi.org/10.1007/s002160000526>

- Cabrera, M.T., Padeiro, A., Amaro, E., dos Santos, M.C., Leppe, M., Verkulich, S., Hughes, K.A., Peter, H.-U., Canário, J., 2017. Evaluating trace element bioavailability and potential transfer into marine food chains using immobilised diatom model species *Phaeodactylum tricornutum*, on King George Island, Antarctica. *Mar. Pollut. Bull.* 121, 192–200. <https://doi.org/10.1016/j.marpolbul.2017.05.059>
- Caccia, V.G., Millero, F.J., Palanques, A., 2003. The distribution of trace metals in Florida Bay sediments. *Mar. Pollut. Bull.* 46, 1420–1433. [https://doi.org/10.1016/S0025-326X\(03\)00288-1](https://doi.org/10.1016/S0025-326X(03)00288-1)
- Calvert, S.E., Price, N.B., 1970. Minor Metal Contents of Recent Organic-rich Sediments off South West Africa. *Nature* 227, 593–595.
- Cantillo, A.Y., 1998. Comparison of results of Mussel Watch Programs of the United States and France with Worldwide Mussel Watch Studies. *Mar. Pollut. Bull.* 36, 712–717. [https://doi.org/10.1016/S0025-326X\(98\)00049-6](https://doi.org/10.1016/S0025-326X(98)00049-6)
- Carere, M., Dulio, V., Hanke, G., Polesello, S., 2012. Guidance for sediment and biota monitoring under the Common Implementation Strategy for the Water Framework Directive. *TrAC - Trends Anal. Chem.* 36, 15–24. <https://doi.org/10.1016/j.trac.2012.03.005>
- Carpenè, E., Andreani, G., Isani, G., 2017. Trace elements in unconventional animals: A 40-year experience. *J. Trace Elem. Med. Biol.* 43, 169–179. <https://doi.org/10.1016/j.jtemb.2017.02.003>
- Caumette, G., Koch, I., Reimer, K.J., 2012. Arsenobetaine formation in plankton: a review of studies at the base of the aquatic food chain. *J. Environ. Monit.* 14, 2841. <https://doi.org/10.1039/c2em30572k>
- Cebrian, E., Martí, R., Uriz, J.M., Turon, X., 2003. Sublethal effects of contamination on the Mediterranean sponge *Crambe crambe*: Metal accumulation and biological responses. *Mar. Pollut. Bull.* 46, 1273–1284. [https://doi.org/10.1016/S0025-326X\(03\)00190-5](https://doi.org/10.1016/S0025-326X(03)00190-5)
- Cebrian, E., Uriz, M.-J., Turon, X., 2007. Sponges as biomonitors of heavy metals in spatial and temporal surveys in northwestern mediterranean: multispecies comparison. *Environ. Toxicol. Chem.* 26, 2430–2439. <https://doi.org/10.1897/07-292.1>
- Cebrian, E., Uriz, M.J., 2007. Contrasting effects of heavy metals on sponge cell behavior. *Arch. Environ. Contam. Toxicol.* 53, 552–558. <https://doi.org/10.1007/s00244-006-0257-2>
- Chai, Z.F., Zhang, Z.Y., Feng, W.Y., Chen, C.Y., Xu, D.D., Hou, X.L., 2004. Study of chemical speciation of trace elements by molecular activation analysis and other nuclear techniques. *J. Anal. At. Spectrom.* 19, 26–33. <https://doi.org/10.1039/B307337H>
- Charlesworth, M.E., Chenery, S., Mellor, A., Service, M., 2006. Isotopic composition and concentration of Pb in suspended particulate matter of the Irish Sea reveals distribution and sources. *Mar. Pollut. Bull.* 52, 81–88. <https://doi.org/10.1016/j.marpolbul.2005.08.009>
- Chen, C.Y., Darren, M., Williams, J.J., Fisher, N.S., 2016. Metal Bioaccumulation by Estuarine Food Webs in New England, USA. *J. Mar. Sci. Engineer* 4, 41. <https://doi.org/10.1016/j.cell.2016.05.007.Mapping>
- Chen, C.Y., Stemberger, R.S., Klaue, B., Blum, J.D., Pickhardt, P.C., Folt, C.L., 2000. Accumulation of heavy metals in food web components across a gradient of lakes. *Limnol. Oceanogr.* 45, 1525–1536. <https://doi.org/10.4319/lo.2000.45.7.1525>

- Chen, L., Liu, M., Fan, R., Ma, S., Xu, Z., Ren, M., He, Q., 2013. Mercury speciation and emission from municipal solid waste incinerators in the Pearl River Delta, South China. *Sci. Total Environ.* 447, 396–402. <https://doi.org/10.1016/j.scitotenv.2013.01.018>
- Chester, R., Murphy, K.J.T., Lin, F.J., Berry, A.S., Bradshaw, G.A., Corcoran, P.A., 1993. Factors controlling the solubilities of trace metals from non-remote aerosols deposited to the sea surface by the “dry” deposition mode. *Mar. Chem.* 42, 107–126. [https://doi.org/10.1016/0304-4203\(93\)90241-F](https://doi.org/10.1016/0304-4203(93)90241-F)
- Ciardullo, S., Aureli, F., Raggi, A., Cubadda, F., 2010. Arsenic speciation in freshwater fish: Focus on extraction and mass balance. *Talanta* 81, 213–221. <https://doi.org/10.1016/j.talanta.2009.11.060>
- Cidu, R., Frau, F., 2009. Distribution of trace elements in filtered and non filtered aqueous fractions: Insights from rivers and streams of Sardinia (Italy). *Appl. Geochemistry* 24, 611–623. <https://doi.org/10.1016/j.apgeochem.2008.12.013>
- Clark, H., 1968. On the Spongiae ciliatae as infusoria flagellata, or observations on the structure, animality and relationship of *Leucosolenia botryoides*, Bowerbank. *Ann. Mag. Nat. Hist.* 4, 133–142.
- Clowes, L.A., Francesconi, K.A., 2004. Uptake and elimination of arsenobetaine by the mussel *Mytilus edulis* is related to salinity. *Comp. Biochem. Physiol. - C Toxicol. Pharmacol.* 137, 35–42. <https://doi.org/10.1016/j.cca.2003.11.003>
- Coulibaly, M., Bamba, D., Yao, N.A., Zoro, E.G., El Rhazi, M., 2016. Some aspects of speciation and reactivity of mercury in various matrices. *Comptes Rendus Chim.* 19, 832–840. <https://doi.org/10.1016/j.crci.2016.02.005>
- Covelli, S., Fontolan, G., 1997. Application of a normalization procedure in determining regional geochemical baselines. *Environ. Geol.* 30, 34–45. <https://doi.org/10.1007/s002540050130>
- Crompton, T.R., Crompton, T.R., 1989. Chapter 8 – Organometallic compounds, in: *Analysis of Seawater*. pp. 336–359. <https://doi.org/10.1016/B978-0-407-01610-1.50011-4>
- Cullen, W.R., Reimer, K.J., 1989. Arsenic speciation in the environment. *Chem. Rev.* 89, 713–764. <https://doi.org/10.1021/cr00094a002>
- Dahms, S., van der Bank, F.H., Greenfield, R., 2014. A baseline study of metal contamination along the Namibian coastline for *Perna perna* and *Choromytilus meridionalis*. *Mar. Pollut. Bull.* 85, 297–305. <https://doi.org/10.1016/j.marpolbul.2014.05.037>
- Damiano, S., Papetti, P., Menesatti, P., 2011. Accumulation of heavy metals to assess the health status of swordfish in a comparative analysis of Mediterranean and Atlantic areas. *Mar. Pollut. Bull.* 62, 1920–1925. <https://doi.org/10.1016/j.marpolbul.2011.04.028>
- De Gregori H., I., Pinochet C., H., Arancibia J., M., Vidal B., A., 1996. Grain Size Effect on Trace Metals Distribution in Sediments from Two Coastal Areas of Chile. *Bull. Environ. Contam. Toxicol.* 57, 163–170. <https://doi.org/10.1007/s001289900170>
- de Mestre, C., Maher, W., Roberts, D., Broad, A., Krikowa, F., Davis, A.R., 2012. Sponges as sentinels: Patterns of spatial and intra-individual variation in trace metal concentration. *Mar. Pollut. Bull.* 64, 80–89. <https://doi.org/10.1016/j.marpolbul.2011.10.020>
- Debord, J., Pourmand, A., Jantzi, S., Panicker, S., Almirall, J., 2017. Profiling of Heroin and Assignment of

- Provenance by $^{87}\text{Sr}/^{86}\text{Sr}$ Isotope Ratio Analysis. *Inorganica Chim. Acta*.
<https://doi.org/10.1016/j.ica.2017.07.049>
- Delnomdedieu, M., Basti, M.M., Otvos, J.D., Thomas, D.J., 1994. Reduction and binding of arsenate and dimethylarsinate by glutathione: a magnetic resonance study. *Chem. Biol. Interact.* 90, 139–155.
[https://doi.org/10.1016/0009-2797\(94\)90099-X](https://doi.org/10.1016/0009-2797(94)90099-X)
- Denton, G.R.W., Concepcion, L.P., Wood, H.R., Morrison, R.J., 2006. Trace metals in marine organisms from four harbours in Guam. *Mar. Pollut. Bull.* 52, 1784–1804.
<https://doi.org/10.1016/j.marpolbul.2006.09.010>
- Diaz, M.C., Rutzler, K., 2001. Sponges: an essential component of Caribbean coral reefs. *Bull. Mar. Sci.* 69, 535–546.
- Drivelos, S.A., Georgiou, C.A., 2012. Multi-element and multi-isotope-ratio analysis to determine the geographical origin of foods in the European Union. *TrAC Trends Anal. Chem.* 40, 38–51.
<https://doi.org/10.1016/j.trac.2012.08.003>
- Dudás, F.Ö., LeBlanc, S.A., Carter, S.W., Bowring, S.A., 2016. Pb and Sr concentrations and isotopic compositions in prehistoric North American teeth: A methodological study. *Chem. Geol.* 429, 21–32. <https://doi.org/10.1016/j.chemgeo.2016.03.003>
- Duncan, E.G., Maher, W.A., Foster, S.D., 2015. Contribution of arsenic species in unicellular algae to the cycling of arsenic in marine ecosystems. *Environ. Sci. Technol.* 49, 33–50.
<https://doi.org/10.1021/es504074z>
- Edmonds, J.S., Francesconi, K.A., Stick, R. V., 1993. Arsenic compounds from marine organisms. *Nat. Prod. Rep.* 10, 421–428.
- Edmonds, J.S., Shibata, Y., Francesconi, K. a, Rippingale, R.J., Morita, M., 1997. Arsenic transformations in short marine food chains studied by HPLC-ICP MS. *Appl. Organomet. Chem.* 11, 281–287.
[https://doi.org/10.1002/\(sici\)1099-0739\(199704\)11:4<281::aid-aoc581>3.3.co;2-j](https://doi.org/10.1002/(sici)1099-0739(199704)11:4<281::aid-aoc581>3.3.co;2-j)
- Elbaz-Poulichet, F., Holliger, P., Martin, J.M., Petit, D., 1986. Stable lead isotopes ratios in major french rivers and estuaries. *Sci. Total Environ.* 54, 61–76. [https://doi.org/10.1016/0048-9697\(86\)90256-1](https://doi.org/10.1016/0048-9697(86)90256-1)
- Elderfield, H., 2003. Introduction to Volume 6, in: Turekian, K.K., Holland, H.D. (Eds.), *Treatise on Geochemistry*. Elsevier Ltd, pp. 15–27.
- Ellam, R.M., 2010. The graphical presentation of lead isotope data for environmental source apportionment. *Sci. Total Environ.* 408, 3490–3492.
<https://doi.org/10.1016/j.scitotenv.2010.03.037>
- Ellwood, M.J., Maher, W.A., 2003. Measurement of arsenic species in marine sediments by high-performance liquid chromatography-inductively coupled plasma mass spectrometry. *Anal. Chim. Acta* 477, 279–291. [https://doi.org/10.1016/s0003-2670\(02\)01414-9](https://doi.org/10.1016/s0003-2670(02)01414-9)
- Esslemont, G., 2000. Heavy metals in seawater, marine sediments and corals from the Townsville section, Great Barrier Reef Marine Park, Queensland. *Mar. Chem.* 71, 215–231.
[https://doi.org/10.1016/S0304-4203\(00\)00050-5](https://doi.org/10.1016/S0304-4203(00)00050-5)
- Fang, T.-H., Hsiao, S.-H., Nan, F.-H., 2014. Nineteen trace elements in marine copepods collected from the coastal waters off northeastern Taiwan. *Cont. Shelf Res.* 91, 70–81.

<https://doi.org/10.1016/j.csr.2014.09.003>

FAO, 2007. Fishery Country Profile- The Republic of Namibia [WWW Document]. URL <http://www.fao.org/fi/oldsite/FCP/en/NAM/profile.htm>

FLETCHER, C.J.N., SWAINBANK, I.G., COLMAN, T.B., 1993. Metallogenic evolution in Wales: constraints from lead isotope modelling. *J. Geol. Soc. London.* 150, 77–82. <https://doi.org/10.1144/gsjgs.150.1.0076>

Forstner, U., 1982. Chemical forms of metal enrichment in recent sediments, in: Amstutz, G. (Ed.), *Ore Genesis*. Springer-Verlag New York, pp. 269–284.

Förstner, U., Ahlf, W., Calmano, W., 1989. Studies on the transfer of heavy metals between sedimentary phases with a multi-chamber device: Combined effects of salinity and redox variation. *Mar. Chem.* 28, 145–158. [https://doi.org/10.1016/0304-4203\(89\)90192-8](https://doi.org/10.1016/0304-4203(89)90192-8)

Forstner, U., Wittmann, G., 1981. *Metal pollution in the aquatic environment*, 2nd revise. ed. Springer-Verlag New York.

Foster, S., Maher, W., 2016. Arsenobetaine and thio-arsenic species in marine macroalgae and herbivorous animals: Accumulated through trophic transfer or produced in situ? *J. Environ. Sci.* 49, 131–139. <https://doi.org/10.1016/j.jes.2016.06.003>

Francesconi, K.A., Sperling, M., 2005. Speciation analysis with HPLC-mass spectrometry: time to take stock. *Analyst* 130, 998. <https://doi.org/10.1039/b504485p>

Francesconi, K. a., 2010. Arsenic species in seafood: Origin and human health implications. *Pure Appl. Chem.* 82, 373–381. <https://doi.org/10.1351/PAC-CON-09-07-01>

Fütterer, D.K., Cojan, I., Renard, M., 2006. The solid phase of marine sediments, in: *Marine Geochemistry*. pp. 1–25.

Gadde, R.R., Laitinen, H.A., 1974. Studies of Heavy Metal Adsorption by Hydrous Iron and Manganese Oxides. *Anal. Chem.* 46, 2022–2026. <https://doi.org/10.1021/ac60349a004>

Galy, A., Pomies, C., Day, J.A., Pokrovsky, O.S., Schott, J., 2003. High precision measurement of germanium isotope ratio variations by multiple collector-inductively coupled plasma mass spectrometry. *J. Anal. At. Spectrom.* 18, 115–119. <https://doi.org/10.1039/B210233A>

Gazave, E., Carteron, S., Chenuil, A., Richelle-Maurer, E., Boury-Esnault, N., Borchiellini, C., 2010. Polyphyly of the genus *Axinella* and of the family Axinellidae (Porifera: Demospongiaep). *Mol. Phylogenet. Evol.* 57, 35–47. <https://doi.org/10.1016/j.ympev.2010.05.028>

Genta-Jouve, G., Cachet, N., Oberhänsli, F., Noyer, C., Teyssié, J.L., Thomas, O.P., Lacoue-Labarthe, T., 2012. Comparative bioaccumulation kinetics of trace elements in Mediterranean marine sponges. *Chemosphere* 89, 340–349. <https://doi.org/10.1016/j.chemosphere.2012.04.052>

Gentric, C., Rehel, K., Dufour, A., Sauleau, P., 2016. Bioaccumulation of metallic trace elements and organic pollutants in marine sponges from the South Brittany Coast, France. *J. Environ. Sci. Heal. Part A* 51, 213–219. <https://doi.org/10.1080/10934529.2015.1094327>

Gifford, S., Dunstan, R.H., O'Connor, W., Koller, C.E., MacFarlane, G.R., 2007. Aquatic zooremediation: deploying animals to remediate contaminated aquatic environments. *Trends Biotechnol.* 25, 60–65. <https://doi.org/10.1016/j.tibtech.2006.12.002>

- Giusti, L., Zhang, H., 2002. Heavy metals and arsenic in sediments, mussels and marine water from Murano (Venice, Italy). *Environ. Geochem. Health* 24, 47–65. <https://doi.org/10.1023/A:1013945117549>
- Gobas, F., 2001. Assessing Bioaccumulation Factors of Persistent Organic Pollutants in Aquatic Food-Chains, in: *Persistent Organic Pollutants: Environmental Behaviour and Pathways of Human Exposure*. pp. 145–165. https://doi.org/10.1007/978-1-4615-1571-5_6
- Gong, Z., 2002. Arsenic speciation analysis. *Talanta* 58, 77–96. [https://doi.org/10.1016/S0039-9140\(02\)00258-8](https://doi.org/10.1016/S0039-9140(02)00258-8)
- Goodenough, K.M., Schilling, J., Jonsson, E., Kalvig, P., Charles, N., Tuduri, J., Deady, E.A., Sadeghi, M., Schiellerup, H., Møller, A., Bertrand, G., Arvanitidis, N., Eliopoulos, D.G., Shaw, R.A., Thrane, K., Keulen, N., 2016. Europe's rare earth element resource potential: An overview of REE metallogenetic provinces and their geodynamic setting. *Ore Geol. Rev.* 72, 838–856. <https://doi.org/10.1016/j.oregeorev.2015.09.019>
- Goran, P., 1981. The Carcinogenicity of Arsenic. *Environ. Health Perspect.* 40, 93–100.
- Goyer, R.A., 2001. Toxic effects of metals, in: Klaassen, C.D. (Ed.), *Casarett and Doull's Toxicology: The Basic Science of Poisons*. McGraw-Hill Publisher, pp. 811–867.
- Grotti, M., Lagomarsino, C., Goessler, W., Francesconi, K.A., 2010. Arsenic speciation in marine organisms from Antarctic coastal environments. *Environ. Chem.* 7, 207–214. <https://doi.org/10.1071/EN09131>
- Grotti, M., Soggia, F., Lagomarsino, C., Riva, S.D., Goessler, W., Francesconi, K.A., 2008. Natural variability and distribution of trace elements in marine organisms from Antarctic coastal environments. *Antarct. Sci.* 20, 39–52. <https://doi.org/doi:10.1017/S0954102007000831>
- Grousset, F.E., Quétel, C.R., Thomas, B., Buat-Menard, P., Donard, O.F.X., Bucher, A., 1994. Transient Pb Isotopic Signatures in the Western European Atmosphere. *Environ. Sci. Technol.* 28, 1605–1608. <https://doi.org/10.1021/es00058a011>
- Guan, Q., Cai, A., Wang, F., Wang, L., Wu, T., Pan, B., Song, N., Li, F., Lu, M., 2016. Heavy metals in the riverbed surface sediment of the Yellow River, China. *Environ. Sci. Pollut. Res.* 23, 24768–24780. <https://doi.org/10.1007/s11356-016-7712-z>
- Guyonnet, D., Planchon, M., Rollat, A., Escalon, V., Tuduri, J., Charles, N., Vaxelaire, S., Dubois, D., Fargier, H., 2015. Material flow analysis applied to rare earth elements in Europe. *J. Clean. Prod.* 107, 215–228. <https://doi.org/10.1016/J.JCLEPRO.2015.04.123>
- Hansmann, W., Köppel, V., 2000. Lead-isotopes as tracers of pollutants in soils. *Chem. Geol.* 171, 123–144. [https://doi.org/10.1016/S0009-2541\(00\)00230-8](https://doi.org/10.1016/S0009-2541(00)00230-8)
- Harada, M., 1995. Minamata Disease: Methylmercury Poisoning in Japan Caused by Environmental Pollution. *Crit. Rev. Toxicol.* 25, 1–24. <https://doi.org/10.3109/10408449509089885>
- Hartwig, A., Jahnke, G., 2012. Toxic metals and metalloids in foods, in: *Chemical Contaminants and Residues in Food*. Elsevier, pp. 233–249. <https://doi.org/10.1533/9780857095794.2.233>
- Hatje, V., Bruland, K.W., Flegal, A.R., 2016. Increases in Anthropogenic Gadolinium Anomalies and Rare Earth Element Concentrations in San Francisco Bay over a 20 Year Record. *Environ. Sci. Technol.* 50,

4159–4168. <https://doi.org/10.1021/acs.est.5b04322>

He, M., Wang, W.X., 2013. Bioaccessibility of 12 trace elements in marine molluscs. *Food Chem. Toxicol.* 55, 627–636. <https://doi.org/10.1016/j.fct.2013.01.046>

Heidari, B., Bakhtiari, A.R., Shirneshan, G., 2013. Concentrations of Cd, Cu, Pb and Zn in soft tissue of oyster (*Saccostrea cucullata*) collected from the Lengeh Port coast, Persian Gulf, Iran: A comparison with the permissible limits for public health. *Food Chem.* 141, 3014–3019. <https://doi.org/10.1016/j.foodchem.2013.06.002>

Hinrichs, J., Dellwig, O., Brumsack, H.-J., 2002. Lead in sediments and suspended particulate matter of the German Bight: natural versus anthropogenic origin. *Appl. Geochemistry* 17, 621–632. [https://doi.org/10.1016/S0883-2927\(01\)00124-X](https://doi.org/10.1016/S0883-2927(01)00124-X)

Hirner, A.V., Kritsotakis, K., Tobschall, H.J., 1990. Metal-organic associations in sediments—I. Comparison of unpolluted recent and ancient sediments and sediments affected by anthropogenic pollution. *Appl. Geochemistry* 5, 491–505. [https://doi.org/10.1016/0883-2927\(90\)90023-X](https://doi.org/10.1016/0883-2927(90)90023-X)

Holser, W.T., 1997. Evaluation of the application of rare-earth elements to paleoceanography. *Palaeogeogr. Palaeoclimatol. Palaeoecol.* 132, 309–323. [https://doi.org/10.1016/S0031-0182\(97\)00069-2](https://doi.org/10.1016/S0031-0182(97)00069-2)

Hong, S., Khim, J.S., Park, J., Son, H.S., Choi, S.D., Choi, K., Ryu, J., Kim, C.Y., Chang, G.S., Giesy, J.P., 2014. Species- and tissue-specific bioaccumulation of arsenicals in various aquatic organisms from a highly industrialized area in the Pohang City, Korea. *Environ. Pollut.* 192, 27–35. <https://doi.org/10.1016/j.envpol.2014.05.004>

Hooper, J., van Soest, R., 2002. *Systema porifera. A guide to the Classification of Sponges.* Kluwer Academic/Plenum publishers, New York.

Hornung, H., Krom, M.D., Cohen, Y., 1989. Trace metal distribution in sediments and benthic fauna of Haifa Bay, Israel. *Estuar. Coast. Shelf Sci.* 29, 43–56. [https://doi.org/10.1016/0272-7714\(89\)90072-3](https://doi.org/10.1016/0272-7714(89)90072-3)

Horowitz, A.J., 1991. *A Primer on Sediment-Trace Element Chemistry.* U.S.G.S. Open-File Rep. 2nd Editio, 136 (2 fiche).

Horowitz, A.J., Elrick, K.A., 1987. The relation of stream sediment surface area, grain size and composition to trace element chemistry. *Appl. Geochemistry* 2, 437–451. [https://doi.org/10.1016/0883-2927\(87\)90027-8](https://doi.org/10.1016/0883-2927(87)90027-8)

Hsieh, M.W., Liu, C.L., Chen, J.H., Jiang, S.J., 2010. Speciation analysis of arsenic and selenium compounds by CE-dynamic reaction cell-ICP-MS. *Electrophoresis* 31, 2272–2278. <https://doi.org/10.1002/elps.200900632>

Hughes, M.F., 2002. Arsenic toxicity and potential mechanisms of action. *Toxicol. Lett.* 133, 1–16. [https://doi.org/10.1016/S0378-4274\(02\)00084-X](https://doi.org/10.1016/S0378-4274(02)00084-X)

Illuminati, S., Annibaldi, A., Truzzi, C., Scarponi, G., 2016a. Heavy metal distribution in organic and siliceous marine sponge tissues measured by square wave anodic stripping voltammetry. *Mar. Pollut. Bull.* 111, 476–482. <https://doi.org/10.1016/j.marpolbul.2016.06.098>

Illuminati, S., Annibaldi, A., Truzzi, C., Scarponi, G., 2016b. Heavy metal distribution in organic and

- siliceous marine sponge tissues measured by square wave anodic stripping voltammetry. *Mar. Pollut. Bull.* 111, 476–482. <https://doi.org/10.1016/j.marpolbul.2016.06.098>
- Irgolic, K.J., Stockton, R.A., 1987. Element-specific detectors for liquid chromatography: The determination of arsenic compounds. *Mar. Chem.* 22, 265–278.
- Jagtap, R., Krikowa, F., Maher, W., Foster, S., Ellwood, M., 2011. Measurement of methyl mercury (I) and mercury (II) in fish tissues and sediments by HPLC-ICPMS and HPLC-HGAAS. *Talanta* 85, 49–55. <https://doi.org/10.1016/j.talanta.2011.03.022>
- Jagtap, R., Maher, W., 2015. Measurement of mercury species in sediments and soils by HPLC-ICPMS. *Microchem. J.* <https://doi.org/10.1016/j.microc.2015.01.010>
- Jonathan, R., Gobert, S., 2016. Trace Elements in Marine Environments: Occurrence, Threats and Monitoring with Special Focus on the Coastal Mediterranean. *J. Environ. Anal. Toxicol.* in press.
- Jones, B., Browser, C., 1987. The mineralogy and related chemistry of lake sediments, in: Lerman, A. (Ed.), *Lakes: Chemistry, Geology, Physics*. Springer-Verlag New York, pp. 179–235.
- Joung, D.J., Shiller, A.M., 2016. Temporal and spatial variations of dissolved and colloidal trace elements in Louisiana Shelf waters. *Mar. Chem.* 181, 25–43. <https://doi.org/10.1016/j.marchem.2016.03.003>
- Jung, H.S., Lim, D., Choi, J.Y., Yoo, H.S., Rho, K.C., Lee, H.B., 2012. Rare earth element compositions of core sediments from the shelf of the South Sea, Korea: Their controls and origins. *Cont. Shelf Res.* 48, 75–86. <https://doi.org/10.1016/j.csr.2012.08.008>
- Jung, S., Mezger, K., 2003. Petrology of basement-dominated terranes: I. Regional metamorphic T-t path from U-Pb monazite and Sm-Nd garnet geochronology (Central Damara orogen, Namibia). *Chem. Geol.* 198, 223–247. [https://doi.org/10.1016/S0009-2541\(03\)00037-8](https://doi.org/10.1016/S0009-2541(03)00037-8)
- Karbassi, A.R., Monavari, S.M., Nabi Bidhendi, G.R., Nouri, J., Nematpour, K., 2007. Metal pollution assessment of sediment and water in the Shur River. *Environ. Monit. Assess.* 147, 107. <https://doi.org/10.1007/s10661-007-0102-8>
- Karbassi, A.R., Nabi-Bidhendi, G.R., Bayati, I., 2005. Environmental Geochemistry of Heavy Metals in Sediment Core Off Bushehr, Persian Gulf. *Iran J. Environ. Health. Sci. Eng.* 2, 255–260.
- Keren, R., Lavy, A., Ilan, M., 2016. Increasing the Richness of Culturable Arsenic-Tolerant Bacteria from *Theonella swinhoei* by Addition of Sponge Skeleton to the Growth Medium. *Microb. Ecol.* 71, 873–886. <https://doi.org/10.1007/s00248-015-0726-0>
- Keren, R., Lavy, A., Mayzel, B., Ilan, M., 2015. Culturable associated-bacteria of the sponge *Theonella swinhoei* show tolerance to high arsenic concentrations. *Front. Microbiol.* 6, 1–11. <https://doi.org/10.3389/fmicb.2015.00154>
- Keren, R., Mayzel, B., Lavy, A., Polishchuk, I., Levy, D., Fakra, S.C., Pokroy, B., Ilan, M., 2017. Sponge-associated bacteria mineralize arsenic and barium on intracellular vesicles. *Nat. Commun.* 8, 14393. <https://doi.org/10.1038/ncomms14393>
- KeyToNature, 2015. Marine Species Identification Portal [WWW Document]. URL <http://species-identification.org/index.php> (accessed 7.4.17).
- Kingson, O., Bhutani, R., Dash, J.K., Sebastian, S., Balakrishnan, S., 2017. Resolving the conundrum in origin of the Manipur Ophiolite Complex, Indo-Myanmar range: Constraints from Nd isotopic ratios

- and elemental concentrations in serpentinized peridotite. *Chem. Geol.* 460, 117–129. <https://doi.org/10.1016/j.chemgeo.2017.04.021>
- Kljaković-Gašpić, Z., Bogner, D., Ujević, I., 2008. Trace metals (Cd, Pb, Cu, Zn and Ni) in sediment of the submarine pit Dragon ear (Soline Bay, Rogoznica, Croatia). *Environ. Geol.* 58, 751. <https://doi.org/10.1007/s00254-008-1549-9>
- Komárek, M., Ettler, V., Chrastný, V., Mihaljevič, M., 2008. Lead isotopes in environmental sciences: A review. *Environ. Int.* 34, 562–577. <https://doi.org/10.1016/j.envint.2007.10.005>
- Krata, A., Vassileva, E., Bulska, E., 2016. Reference measurements for total mercury and methyl mercury content in marine biota samples using direct or species-specific isotope dilution inductively coupled plasma mass spectrometry. *Talanta* 160, 562–569. <https://doi.org/10.1016/j.talanta.2016.07.033>
- Kucuksezgin, F., Gonul, L.T., Tasel, D., 2014. Total and inorganic arsenic levels in some marine organisms from Izmir Bay (Eastern Aegean Sea): A risk assessment. *Chemosphere* 112, 311–316. <https://doi.org/10.1016/j.chemosphere.2014.04.071>
- Kulaksiz, S., Bau, M., 2011. Rare earth elements in the Rhine River, Germany: First case of anthropogenic lanthanum as a dissolved microcontaminant in the hydrosphere. *Environ. Int.* 37, 973–979. <https://doi.org/10.1016/j.envint.2011.02.018>
- Lai, V.W.M., Cullen, W.R., Ray, S., 1999. Arsenic speciation in scallops. *Mar. Chem.* 66, 81–89. [https://doi.org/10.1016/S0304-4203\(99\)00025-0](https://doi.org/10.1016/S0304-4203(99)00025-0)
- Lamborg, C.H., Hammerschmidt, C.R., Bowman, K.L., Swarr, G.J., Munson, K.M., Ohnemus, D.C., Lam, P.J., Heimbürger, L.-E., Rijkenberg, M., Saito, M.A., 2014. A global ocean inventory of anthropogenic mercury based on water column measurements. *Nature* 512, 65–68. <https://doi.org/10.1038/nature13563>
- Lang, T., Kruse, R., Haarich, M., Wosniok, W., 2017. Mercury species in dab (*Limanda limanda*) from the North Sea, Baltic Sea and Icelandic waters in relation to host-specific variables. *Mar. Environ. Res.* 124, 32–40. <https://doi.org/10.1016/j.marenvres.2016.03.001>
- Laport, M.S., Santos, O.C., Muricy, G., 2009. Marine sponges: potential sources of new antimicrobial drugs. *Curr. Pharm. Biotechnol.* 10, 86–105.
- Larsen, M.M., Blusztajn, J.S., Andersen, O., Dahllöf, I., 2012. Lead isotopes in marine surface sediments reveal historical use of leaded fuel. *J. Environ. Monit.* 14, 2893. <https://doi.org/10.1039/c2em30579h>
- Lauwerys, R.R., Haufroid, V., Hoet, P., Lison, D., 2007. *Toxicologie industrielle et intoxications professionnelles*, Fifth. ed. Masson, Paris, Paris.
- Le Pape, P., Ayrault, S., Quantin, C., 2012. Trace element behavior and partition versus urbanization gradient in an urban river (Orge River, France). *J. Hydrol.* 472–473, 99–110. <https://doi.org/10.1016/j.jhydrol.2012.09.042>
- Leermakers, M., Baeyens, W., De Gieter, M., Smedts, B., Meert, C., De Bisschop, H.C., Morabito, R., Quevauviller, P., 2006. Toxic arsenic compounds in environmental samples: Speciation and validation. *TrAC - Trends Anal. Chem.* 25, 1–10. <https://doi.org/10.1016/j.trac.2005.06.004>

- Leermakers, M., Baeyens, W., Quevauviller, P., Horvat, M., 2005. Mercury in environmental samples: Speciation, artifacts and validation. *TrAC Trends Anal. Chem.* 24, 383–393. <https://doi.org/10.1016/j.trac.2004.01.001>
- Levy, G.A., 1946. The toxicity of arsine administered by intraperitoneal injection. *Levy GA. Toxic. arsine Adm. by intraperitoneal Inject. Br. J. Pharmacol. Chemother.* 287–290.
- Li, C.-W., Chen, J.-Y., Hua, T.-E., 1998. Precambrian Sponges with Cellular Structures. *Science* (80-.). 279, 879–882. <https://doi.org/10.1126/science.279.5352.879>
- Li, X., Wai, O.W.H., Li, Y.S., Coles, B.J., Ramsey, M.H., Thornton, I., 2000. Heavy metal distribution in sediment profiles of the Pearl River estuary, South China. *Appl. Geochemistry* 15, 567–581. [https://doi.org/10.1016/S0883-2927\(99\)00072-4](https://doi.org/10.1016/S0883-2927(99)00072-4)
- Liang, T., Li, K., Wang, L., 2014. State of rare earth elements in different environmental components in mining areas of China. *Environ. Monit. Assess.* 186, 1499–1513. <https://doi.org/10.1007/s10661-013-3469-8>
- Lindqvist, O., Johansson, K., Bringmark, L., Timm, B., Aastrup, M., Andersson, A., Hovsenius, G., Håkanson, L., Iverfeldt, Å., Meili, M., 1991. Mercury in the Swedish environment --- Recent research on causes, consequences and corrective methods. *Water. Air. Soil Pollut.* 55, xi--261. <https://doi.org/10.1007/BF00542429>
- Linge, K.L., Jarvis, K.E., 2009. Quadrupole ICP-MS: Introduction to Instrumentation, Measurement Techniques and Analytical Capabilities. *Geostand. Geoanalytical Res.* 33, 445–467. <https://doi.org/10.1111/j.1751-908X.2009.00039.x>
- Liu, L., Wang, Z., Ju, F., Zhang, T., 2015. Co-occurrence correlations of heavy metals in sediments revealed using network analysis. *Chemosphere* 119, 1305–1313. <https://doi.org/10.1016/j.chemosphere.2014.01.068>
- Llorente-Mirandes, T., Ruiz-Chancho, M.J., Barbero, M., Rubio, R., López-Sánchez, J.F., 2010. Measurement of arsenic compounds in littoral zone algae from the Western Mediterranean Sea. Occurrence of arsenobetaine. *Chemosphere* 81, 867–875. <https://doi.org/10.1016/j.chemosphere.2010.08.007>
- Lohren, H., Blagojevic, L., Fitkau, R., Ebert, F., Schildknecht, S., Leist, M., Schwerdtle, T., 2015. Toxicity of organic and inorganic mercury species in differentiated human neurons and human astrocytes. *J. Trace Elem. Med. Biol.* 32, 200–208. <https://doi.org/10.1016/j.jtemb.2015.06.008>
- Longo, C., Corriero, G., Licciano, M., Stabili, L., 2010. Bacterial accumulation by the Demospongiae *Hymeniacidon perlevis*: A tool for the bioremediation of polluted seawater. *Mar. Pollut. Bull.* 60, 1182–1187. <https://doi.org/10.1016/j.marpolbul.2010.03.035>
- Loring, D.H., Rantala, R.T.T., 1992. Manual for the geochemical analyses of marine sediments and suspended particulate matter. *Earth Sci. Rev.* 32, 235–283. [https://doi.org/10.1016/0012-8252\(92\)90001-A](https://doi.org/10.1016/0012-8252(92)90001-A)
- Love, G.D., Grosjean, E., Stalvies, C., Fike, D.A., Grotzinger, J.P., Bradley, A.S., Kelly, A.E., Bhatia, M., Meredith, W., Snape, C.E., Bowring, S.A., Condon, D.J., Summons, R.E., 2009. Fossil steroids record the appearance of Demospongiae during the Cryogenian period. *Nature* 457, 718–721. <https://doi.org/10.1038/nature07673>

- Lu, X., Wang, L., Lei, K., Huang, J., Zhai, Y., 2009. Contamination assessment of copper, lead, zinc, manganese and nickel in street dust of Baoji, NW China. *J. Hazard. Mater.* 161, 1058–1062. <https://doi.org/10.1016/j.jhazmat.2008.04.052>
- Luoma, S.N., Rainbow, P.S., 2005. Why is metal bioaccumulation so variable? Biodynamics as a unifying concept. *Environ. Sci. Technol.* 39, 1921–1931. <https://doi.org/10.1021/es048947e>
- Macdonald, D.D., Carr, R.S., Calder, F.D., Long, E.R., Ingersoll, C.G., 1996. Development and evaluation of sediment quality guidelines for Florida coastal waters. *Ecotoxicology* 5, 253–78. <https://doi.org/10.1007/BF00118995>
- Magnusson, B., Ornemark, U., 2014. *Eurachem Guide: The Fitness for Purpose of Analytical Methods – a Laboratory Guide to Method Validation and Related Topics*. EURACHEM.
- Majer, A.P., Petti, M.A.V., Corbisier, T.N., Ribeiro, A.P., Theophilo, C.Y.S., Ferreira, P.A. de L., Figueira, R.C.L., 2014. Bioaccumulation of potentially toxic trace elements in benthic organisms of Admiralty Bay (King George Island, Antarctica). *Mar. Pollut. Bull.* 79, 321–325. <https://doi.org/10.1016/j.marpolbul.2013.12.015>
- Mandal, B.K., Suzuki, K.T., 2002. Arsenic round the world: A review. *Talanta* 58, 201–235. [https://doi.org/10.1016/S0039-9140\(02\)00268-0](https://doi.org/10.1016/S0039-9140(02)00268-0)
- Mandjukov, P., Orani, A.M., Han, E., Vassileva, E., 2015. Determination of total mercury for marine environmental monitoring studies by solid sampling continuum source high resolution atomic absorption spectrometry. *Spectrochim. Acta - Part B At. Spectrosc.* 103–104, 24–33. <https://doi.org/10.1016/j.sab.2014.11.006>
- Mapani, B., Ellmies, R., Kamona, F., Kříbek, B., Majer, V., Knésl, I., Pašava, J., Mufenda, M., Mbingeneeko, F., 2009. Human health risks associated with historic ore processing at Berg Aukas, Grootfontein area, Namibia. *Communs geol. Surv. Namibia* 14, 25–40. <https://doi.org/10.1016/j.jafrearsci.2010.07.007>
- Martinez-Bravo, Y., Roig-Navarro, A.F., Lopez, F.J., Hernandez, F., 2001. Multielemental determination of arsenic, selenium and chromium(VI) species in water by high-performance liquid chromatography-inductively coupled plasma mass spectrometry. *J. Chromatogr. A* 926, 265–274.
- Mason, R.P., Reinfelder, J.R., Morel, F.M.M., 1996. Uptake, Toxicity, and Trophic Transfer of Mercury in a Coastal Diatom. *Environ. Sci. Technol.* 30, 1835–1845. <https://doi.org/10.1021/es950373d>
- Mayzel, B., Aizenberg, J., Ilan, M., 2014. The elemental composition of demospongiae from the Red Sea, Gulf of Aqaba. *PLoS One* 9. <https://doi.org/10.1371/journal.pone.0095775>
- McArthur, J.M., Walsh, J.N., 1984. Rare-earth geochemistry of phosphorites. *Chem. Geol.* 47, 191–220. [https://doi.org/10.1016/0009-2541\(84\)90126-8](https://doi.org/10.1016/0009-2541(84)90126-8)
- McLennan, S.M., 1989. Rare earth elements in sedimentary rocks; influence of provenance and sedimentary processes. *Rev. Mineral. Geochemistry* 21, 169–200.
- McNaught, A.D., Wilkinson, A., 1997. *Compendium of Chemical Terminology. The gold book*. Blackwell Science, London. <https://doi.org/10.1351/goldbook.i03352>
- Melamed, D., 2005. Monitoring arsenic in the environment: a review of science and technologies with the potential for field measurements. *Anal. Chim. Acta* 532, 1–13.

<https://doi.org/10.1016/j.aca.2004.10.047>

- Mil-Homens, M., Vale, C., Brito, P., Naughton, F., Drago, T., Raimundo, J., Anes, B., Schmidt, S., Caetano, M., 2017. Insights of Pb isotopic signature into the historical evolution and sources of Pb contamination in a sediment core of the southwestern Iberian Atlantic shelf. *Sci. Total Environ.* 586, 473–484. <https://doi.org/10.1016/j.scitotenv.2017.01.204>
- Milanese, M., Chelossi, E., Manconi, R., Sarà, A., Sidri, M., Pronzato, R., 2003. The marine sponge *Chondrilla nucula* Schmidt, 1862 as an elective candidate for bioremediation in integrated aquaculture. *Biomol. Eng.* 20, 363–368. [https://doi.org/10.1016/S1389-0344\(03\)00052-2](https://doi.org/10.1016/S1389-0344(03)00052-2)
- Mileusnić, M., Mapani, B.S., Kamona, A.F., Ružičić, S., Mapaure, I., Chimwamurombe, P.M., 2014. Assessment of agricultural soil contamination by potentially toxic metals dispersed from improperly disposed tailings, Kombat mine, Namibia. *J. Geochemical Explor.* 144, 409–420. <https://doi.org/10.1016/j.gexplo.2014.01.009>
- Ministry of Environment and Tourism, 2008. Strategic Environmental Assessment (SEA) of the coastal areas of the Erongo and Kunene regions.
- Mitra, N., Rezvan, Z., Seyed Ahmad, M., Gharai Mohamad Hosein, M., 2012. Studies of Water Arsenic and Boron Pollutants and Algae Phytoremediation in Three Springs, Iran. *Int. J. Ecosyst.* 2, 32–37. <https://doi.org/10.5923/j.ije.20120203.01>
- Miyashita, S., Murota, D.C., Kondo, B.K., 2016. Arsenic metabolism in cyanobacteria. *Environ. Chem.* 13, 577–589.
- Miyashita, S., Shimoya, M., Kamidate, Y., Kuroiwa, T., Shikino, O., Fujiwara, S., Francesconi, K.A., Kaise, T., 2009. Rapid determination of arsenic species in freshwater organisms from the arsenic-rich Hayakawa River in Japan using HPLC-ICP-MS. *Chemosphere* 75, 1065–1073. <https://doi.org/10.1016/j.chemosphere.2009.01.029>
- Monna, F., Ben Othman, D., Luck, J.M., 1995. Pb isotopes and Pb, Zn and Cd concentrations in the rivers feeding a coastal pond (Thau, southern France): constraints on the origin(s) and flux(es) of metals. *Sci. Total Environ.* 166, 19–34. [https://doi.org/10.1016/0048-9697\(95\)04514-2](https://doi.org/10.1016/0048-9697(95)04514-2)
- MONNA, F., BENOETHMAN, D., LUCK, J., 1995. Pb isotopes and Pb, Zn and Cd concentrations in the rivers feeding a coastal pond (Thau, southern France): constraints on the origin(s) and flux(es) of metals. *Sci. Total Environ.* 166, 19–34. [https://doi.org/10.1016/0048-9697\(95\)04514-2](https://doi.org/10.1016/0048-9697(95)04514-2)
- Monna, F., Hamer, K., Lévêque, J., Sauer, M., 2000. Pb isotopes as a reliable marker of early mining and smelting in the Northern Harz province (Lower Saxony, Germany). *J. Geochemical Explor.* 68, 201–210. [https://doi.org/10.1016/S0375-6742\(00\)00005-4](https://doi.org/10.1016/S0375-6742(00)00005-4)
- Monna, F., Poujol, M., Losno, R., Dominik, J., Annegarn, H., Coetzee, H., 2006. Origin of atmospheric lead in Johannesburg, South Africa. *Atmos. Environ.* 40, 6554–6566. <https://doi.org/10.1016/j.atmosenv.2006.05.064>
- Morel, F.M.M., Kraepiel, A.M.L., Amyot, M., 1998. THE CHEMICAL CYCLE AND BIOACCUMULATION OF MERCURY. *Annu. Rev. Ecol. Syst.* 29, 543–566. <https://doi.org/10.1146/annurev.ecolsys.29.1.543>
- Müller, W.E.G., Batel, R., Lacorn, M., Steinhart, H., Simat, T., Lauenroth, S., Hassanein, H., Schröder, H.C., 1998. Accumulation of cadmium and zinc in the marine sponge *Suberites domuncula* and its potential consequences on single-strand breaks and on expression of heat-shock protein: A natural

- field study. *Mar. Ecol. Prog. Ser.* 167, 127–135. <https://doi.org/10.3354/meps167127>
- Nakata, H., Nakayama, S.M.M., Ikenaka, Y., Mizukawa, H., Ishii, C., Yohannes, Y.B., Konnai, S., Darwish, W.S., Ishizuka, M., 2015. Metal extent in blood of livestock from Dandora dumping site, Kenya: Source identification of Pb exposure by stable isotope analysis. *Environ. Pollut.* 205, 8–15. <https://doi.org/10.1016/j.envpol.2015.05.003>
- Nam, S.H., Oh, H.J., Min, H.S., Lee, J.H., 2010. A study on the extraction and quantitation of total arsenic and arsenic species in seafood by HPLC-ICP-MS. *Microchem. J.* 95, 20–24. <https://doi.org/10.1016/j.microc.2009.08.009>
- Ndung'u, K., Franks, R.P., Bruland, K.W., Flegal, A.R., 2003. Organic complexation and total dissolved trace metal analysis in estuarine waters: comparison of solvent-extraction graphite furnace atomic absorption spectrometric and chelating resin flow injection inductively coupled plasma-mass spectrometric analysis. *Anal. Chim. Acta* 481, 127–138. [https://doi.org/10.1016/S0003-2670\(03\)00063-1](https://doi.org/10.1016/S0003-2670(03)00063-1)
- Nearing, M.M., Koch, I., Reimer, K.J., 2014. Complementary arsenic speciation methods: A review. *Spectrochim. Acta - Part B At. Spectrosc.* 99, 150–162. <https://doi.org/10.1016/j.sab.2014.07.001>
- Negri, A., Burns, K., Boyle, S., Brinkman, D., Webster, N., 2006. Contamination in sediments, bivalves and sponges of McMurdo Sound, Antarctica. *Environ. Pollut.* 143, 456–467. <https://doi.org/10.1016/j.envpol.2005.12.005>
- Nieboer, E., Richardson, D.H.S., 1980. The replacement of the nondescript term “heavy metals” by a biologically and chemically significant classification of metal ions. *Environ. Pollut. Ser. B, Chem. Phys.* 1, 3–26. [https://doi.org/10.1016/0143-148X\(80\)90017-8](https://doi.org/10.1016/0143-148X(80)90017-8)
- Nolan, L., Cadien, K., 2012. *Chemical Mechanical Polish for Nanotechnology*. Nanofabrication Tech. Princ.
- Nozaki, Y., 2001. Elemental distribution: Overview, in: Steele, J.H., Thorpe, S.A., Turekian, K.K. (Eds.), *Encyclopedia of the Ocean Sciences*, Vol. 2. Academic Press London, pp. 840–845. <https://doi.org/http://dx.doi.org/10.1006/rwos.2001.0402>
- Ochoa, V., Barata, C., Riva, M.C., 2013. Heavy metal content in oysters (*Crassostrea gigas*) cultured in the Ebro Delta in Catalonia, Spain. *Environ. Monit. Assess.* 185, 6783–6792. <https://doi.org/10.1007/s10661-013-3064-z>
- Olesen, T.M.E., Weeks, J.M., 1994. Accumulation of Cd by the marine sponge *Halichondria panicea* pallas: effects upon filtration rate and its relevance for biomonitoring. *Bull. Environ. Contam. Toxicol.* 52, 722–728. <https://doi.org/10.1007/BF00195494>
- Olmedo, P., Pla, A., Hernández, A.F., Barbier, F., Ayouni, L., Gil, F., 2013. Determination of toxic elements (mercury, cadmium, lead, tin and arsenic) in fish and shellfish samples. Risk assessment for the consumers. *Environ. Int.* 59, 63–72. <https://doi.org/10.1016/j.envint.2013.05.005>
- Orris, G.J., Grauch, R.I., 2002. *Rare Earth Element Mines, Deposits, and Occurrences*.
- Ortega, G.S., Pécheyran, C., Bérail, S., Donard, O.F.X., 2012. A fit-for purpose procedure for lead isotopic ratio determination in crude oil, asphaltene and kerogen samples by MC-ICPMS. *J. Anal. At. Spectrom.* 27, 1447. <https://doi.org/10.1039/c2ja30143a>

- Ostrom, K.M., Simpson, T.L., 1978. Calcium and the release from dormancy of freshwater sponge gemmules. *Dev. Biol.* 64, 332–338. [https://doi.org/10.1016/0012-1606\(78\)90083-0](https://doi.org/10.1016/0012-1606(78)90083-0)
- Padovan, A., Munksgaard, N., Alvarez, B., McGuinness, K., Parry, D., Gibb, K., 2012. Trace metal concentrations in the tropical sponge *Spherospongia vagabunda* at a sewage outfall: Synchrotron X-ray imaging reveals the micron-scale distribution of accumulated metals. *Hydrobiologia* 687, 275–288. <https://doi.org/10.1007/s10750-011-0916-9>
- Pan, K., Lee, O.O., Qian, P.Y., Wang, W.X., 2011. Sponges and sediments as monitoring tools of metal contamination in the eastern coast of the Red Sea, Saudi Arabia. *Mar. Pollut. Bull.* 62, 1140–1146. <https://doi.org/10.1016/j.marpolbul.2011.02.043>
- Parra, S., Bravo, M.A., Quiroz, W., Querol, X., Paipa, C., 2015. Distribution and pollution assessment of trace elements in marine sediments in the Quintero Bay (Chile). *Mar. Pollut. Bull.* 99, 256–263. <https://doi.org/10.1016/j.marpolbul.2015.07.066>
- Parsons, J.G., Martinez-Martinez, A., Peralta-Video, J.R., Gardea-Torresdey, J.L., 2008. Speciation and uptake of arsenic accumulated by corn seedlings using XAS and DRC-ICP-MS. *Chemosphere* 70, 2076–2083. <https://doi.org/10.1016/j.chemosphere.2007.08.069>
- Patel, B., Balani, M., Patel, S., 1985. Sponge “sentinel” of heavy metals. *Sci. Total Environ.* 41, 143–152.
- Perez, T., Longet, D., Schembri, T., Rebouillon, P., Vacelet, J., 2005. Effects of 12 years’ operation of a sewage treatment plant on trace metal occurrence within a Mediterranean commercial sponge (*Spongia officinalis*, *Demospongiae*). *Mar. Pollut. Bull.* 50, 301–309. <https://doi.org/10.1016/j.marpolbul.2004.11.001>
- Perez, T., Vacelet, J., Rebouillon, P., 2004. In situ comparative study of several Mediterranean sponges as potential biomonitors for heavy metals. *Boll. Mus. Ist. Biol. Univ. Genova* 68, 517–525.
- Phillips, D.J.H., 1990. Arsenic in aquatic organisms: a review, emphasising chemical speciation. *Aquat. Toxicol.* 16, 151–186.
- Piper, D.Z., 1974. Rare earth elements in the sedimentary cycle: A summary. *Chem. Geol.* 14, 285–304. [https://doi.org/10.1016/0009-2541\(74\)90066-7](https://doi.org/10.1016/0009-2541(74)90066-7)
- Plant, J.A., Raiswell, R., 1983. Principles of environmental geochemistry, in: Thornton, I. (Ed.), *Applied Environmental Geochemistry*. Academic Press London.
- Pourret, O., Davranche, M., Gruau, G., Dia, A., 2007. Rare earth elements complexation with humic acid. *Chem. Geol.* 243, 128–141. <https://doi.org/10.1016/j.chemgeo.2007.05.018>
- Quetel, C.R., Prohaska, T., Hamester, M., Kerl, W., Taylor, P.D.P., 2000. Examination of the performance exhibited by a single detector double focusing magnetic sector ICP-MS instrument for uranium isotope abundance ratio measurements over almost three orders of magnitude and down to pg[space]g⁻¹ concentration levels. *J. Anal. At. Spectrom.* 15, 353–358. <https://doi.org/10.1039/A907084B>
- Quevauviller, P., 2016. *Marine Chemical Monitoring. Policies, techniques and metrological principles*. John Wiley & Sons.
- Raber, G., Stock, N., Hanel, P., Murko, M., Navratilova, J., Francesconi, K.A., 2012. An improved HPLC-ICPMS method for determining inorganic arsenic in food: Application to rice, wheat and tuna fish.

- Food Chem. 134, 524–532. <https://doi.org/10.1016/j.foodchem.2012.02.113>
- Radabaugh, T.R., Aposhian, H.V., 2000. Enzymatic Reduction of Arsenic Compounds in Mammalian Systems: Reduction of Arsenate to Arsenite by Human Liver Arsenate Reductase. *Chem. Res. Toxicol.* 13, 26–30. <https://doi.org/10.1021/tx990115k>
- Rainbow, P., 2002. Trace metal concentrations in aquatic invertebrates: why and so what? *Environ. Pollut.* 120, 497–507. [https://doi.org/10.1016/S0269-7491\(02\)00238-5](https://doi.org/10.1016/S0269-7491(02)00238-5)
- Rainbow, P.S., 1997. Trace Metal Accumulation in Marine Invertebrates: Marine Biology or Marine Chemistry? *J. Mar. Biol. Assoc. United Kingdom* 77, 195–210. <https://doi.org/doi:10.1017/S0025315400033877>
- Rand, G.M., Wells, P.G., McCarthy, L.S., 1995. Introduction to aquatic ecology, in: Rand, G.M. (Ed.), *Fundamentals of Aquatic Toxicology*. Taylor and Francis, London, pp. 3–53.
- Resongles, E., Casiot, C., Freydier, R., Dezileau, L., Viers, J., Elbaz-Poulichet, F., 2014. Persisting impact of historical mining activity to metal (Pb, Zn, Cd, Tl, Hg) and metalloid (As, Sb) enrichment in sediments of the Gardon River, Southern France. *Sci. Total Environ.* 481, 509–521. <https://doi.org/10.1016/j.scitotenv.2014.02.078>
- Rezaee, K., Saion, E.B., Wood, A.K., Abdi, M.R., 2010. Rare earth elements determination and distribution patterns in surface marine sediments of the South China Sea by INAA, Malaysia. *J. Radioanal. Nucl. Chem.* 283, 823–829. <https://doi.org/10.1007/s10967-009-0421-z>
- Rieuwerts, J.S., Thornton, I., Farago, M.E., Ashmore, M.R., 1998. Factors influencing metal bioavailability in soils: preliminary investigations for the development of a critical loads approach for metals. *Chem. Speciat. Bioavailab.* 10, 61–75. <https://doi.org/10.3184/095422998782775835>
- Roehl, R., Gomez, J., Woodhouse, L.R., 1995. Correction of mass bias drift in inductively coupled plasma mass spectrometry measurements of zinc isotope ratios using gallium as an isotope ratio internal standard. *J. Anal. At. Spectrom.* 10, 15–23. <https://doi.org/10.1039/JA9951000015>
- Roose, P., Albaigés, J., Bebianno, M.J., Camphuysen, C., Cronin, M., de Leeuw, J., Gabrielsen, G., Hutchinson, T., Hylland, K., Jansson, B., Jenssen, B.M., Schulz-Bull, D., Szefer, P., Webster, L., Bakke, T., Janssen, C., 2011. Monitoring Chemical Pollution in Europe's Seas: Programmes, practices and priorities for Research. *Mar. Board Position* 108.
- Rose, A.W., Hawkes, H.E., 1979. *Geochemistry in mineral exploration*. Academic Press.
- Roussiez, V., Ludwig, W., Probst, J.-L., Monaco, A., 2005. Background levels of heavy metals in surficial sediments of the Gulf of Lions (NW Mediterranean): An approach based on ¹³³Cs normalization and lead isotope measurements. *Environ. Pollut.* 138, 167–177. <https://doi.org/10.1016/j.envpol.2005.02.004>
- Sakko, A.L., 1998. The influence of the Benguela upwelling system on Namibia's marine biodiversity. *Biodivers. Conserv.* 7, 419–433. <https://doi.org/10.1023/A:1008867310010>
- Salati, S., Moore, F., 2010. Assessment of heavy metal concentration in the Khoshk River water and sediment, Shiraz, Southwest Iran. *Environ. Monit. Assess.* 164, 677–689. <https://doi.org/10.1007/s10661-009-0920-y>
- Salaün, P., Planer-Friedrich, B., van den Berg, C.M.G., 2007. Inorganic arsenic speciation in water and

- seawater by anodic stripping voltammetry with a gold microelectrode. *Anal. Chim. Acta* 585, 312–322. <https://doi.org/10.1016/j.aca.2006.12.048>
- Salomons, W., Förstner, U., 1984. *Metals in the Hydrocycle*. Springer-Verlag Berlin Heidelberg. <https://doi.org/10.1007/978-3-642-69325-0>
- Sánchez Uría, J., 1998. Inorganic and methylmercury speciation in environmental samples. *Talanta* 47, 509–524. [https://doi.org/10.1016/S0039-9140\(98\)00116-7](https://doi.org/10.1016/S0039-9140(98)00116-7)
- Santini, J.M., Streimann, I.C.A., Hoven, R.N. vanden, 2004. *Bacillus macyae* sp. nov., an arsenate-respiring bacterium isolated from an Australian gold mine. *Int. J. Syst. Evol. Microbiol.* 54, 2241–2244.
- Santos-Gandelman, J.F., Giambiagi-Demarval, M., Muricy, G., Barkay, T., Laport, M.S., 2014. Mercury and methylmercury detoxification potential by sponge-associated bacteria. *Antonie van Leeuwenhoek, Int. J. Gen. Mol. Microbiol.* 106, 585–590. <https://doi.org/10.1007/s10482-014-0224-2>
- Schaeffer, R., Francesconi, K.A., Kienzl, N., Soeroes, C., Fodor, P., Váradi, L., Raml, R., Goessler, W., Kuehnelt, D., 2006. Arsenic speciation in freshwater organisms from the river Danube in Hungary. *Talanta* 69, 856–865. <https://doi.org/10.1016/j.talanta.2005.11.025>
- Scott, N., Hatlelid, K.M., MacKenzie, N.E., Carter, D.E., 1993. Reactions of arsenic(III) and arsenic(V) species with glutathione. *Chem. Res. Toxicol.* 6, 102–106. <https://doi.org/10.1021/tx00031a016>
- Semeniuk, D.M., Maldonado, M.T., Jaccard, S.L., 2016. Chromium uptake and adsorption in marine phytoplankton – Implications for the marine chromium cycle. *Geochim. Cosmochim. Acta* 184, 41–54. <https://doi.org/10.1016/j.gca.2016.04.021>
- Semlali, R.M., Dessogne, J.-B., Monna, F., Bolte, J., Azimi, S., Navarro, N., Denaix, L., Loubet, M., Chateau, C., van Oort, F., 2004. Modeling Lead Input and Output in Soils Using Lead Isotopic Geochemistry. *Environ. Sci. Technol.* 38, 1513–1521. <https://doi.org/10.1021/es0341384>
- Shepherd, T.J., Dirks, W., Roberts, N.M.W., Patel, J.G., Hodgson, S., Pless-Mulloli, T., Walton, P., Parrish, R.R., 2016. Tracing fetal and childhood exposure to lead using isotope analysis of deciduous teeth. *Environ. Res.* 146, 145–153. <https://doi.org/10.1016/j.envres.2015.12.017>
- Shiomi, K., Aoyama, M., Yamanaka, H., Kikuchi, T., 1988. Chemical Forms of Arsenic in Sponges, Sea-Anemones and Sea Hare. *Comp. Biochem. Physiol. C-Pharmacology Toxicol. Endocrinol.* 90, 361–365.
- Silver, S., Phung, L.T., 2005. Genes and Enzymes Involved in Bacterial Oxidation and Reduction of Inorganic Arsenic. *Appl. Environ. Microbiol.* 71.
- Sjåstad, K.-E., Lucy, D., Andersen, T., 2016. Lead isotope ratios for bullets, forensic evaluation in a Bayesian paradigm. *Talanta* 146, 62–70. <https://doi.org/10.1016/j.talanta.2015.07.070>
- Sjåstad, K.-E., Simonsen, S.L., Andersen, T., 2011. Use of lead isotopic ratios to discriminate glass samples in forensic science. *J. Anal. At. Spectrom.* 26, 325. <https://doi.org/10.1039/c0ja00054j>
- Søndergaard, J., Asmund, G., Larsen, M.M., 2015. Trace elements determination in seawater by ICP-MS with on-line pre-concentration on a Chelex-100 column using a “standard” instrument setup. *MethodsX* 2, 323–330. <https://doi.org/10.1016/j.mex.2015.06.003>
- Song, Y.H., Choi, M.S., 2009. REE geochemistry of fine-grained sediments from major rivers around the

- Yellow Sea. *Chem. Geol.* 266, 337–351. <https://doi.org/10.1016/j.chemgeo.2009.06.019>
- Spada, L., Annicchiarico, C., Cardellicchio, N., Giandomenico, S., Di Leo, A., 2012. Mercury and methylmercury concentrations in Mediterranean seafood and surface sediments, intake evaluation and risk for consumers. *Int. J. Hyg. Environ. Health* 215, 418–426. <https://doi.org/10.1016/j.ijheh.2011.09.003>
- Split, P.M., Delta, A., 2010. Sediment Quality Guidelines for the Protection of Aquatic Life, Canadian Council of Ministers of the Environment.
- Stiboller, M., Raber, G., Francesconi, K.A., 2015. Simultaneous determination of glycine betaine and arsenobetaine in biological samples by HPLC/ICPMS/ESMS and the application to some marine and freshwater fish samples. *Microchem. J.* 122, 172–175. <https://doi.org/10.1016/j.microc.2015.04.022>
- Strady, E., Schäfer, J., Baudrimont, M., Blanc, G., 2011. Tracing cadmium contamination kinetics and pathways in oysters (*Crassostrea gigas*) by multiple stable Cd isotope spike experiments. *Ecotoxicol. Environ. Saf.* 74, 600–606. <https://doi.org/10.1016/j.ecoenv.2010.10.020>
- Sulochanan, B., Krishnakumar, P.K., Prema, D., Kaladharan, P., Valsala, K.K., Bhat, G.S., Muniyandi, K., 2007. Trace metal contamination of the marine environment in Palk Bay and Gulf of Mannar. *J. Mar. Biol. Assoc. India* 49, 12–18.
- Sun, M., Liu, G., Wu, Q., Liu, W., 2013. Speciation analysis of inorganic arsenic in coal samples by microwave-assisted extraction and high performance liquid chromatography coupled to hydride generation atomic fluorescence spectrometry. *Talanta* 106, 8–13. <https://doi.org/10.1016/j.talanta.2012.12.012>
- Sun, Q., Liu, D., Liu, T., Di, B., Wu, F., 2012. Temporal and spatial distribution of trace metals in sediments from the northern Yellow Sea coast, China: Implications for regional anthropogenic processes. *Environ. Earth Sci.* 66, 697–705. <https://doi.org/10.1007/s12665-011-1277-4>
- Suner, M.A., Devesa, V., Munoz, O., Velez, D., Montoro, R., 2001. Application of column switching in high-performance liquid chromatography with on-line thermo-oxidation and detection by HG-AAS and HG-AFS for the analysis of organoarsenical species in seafood samples. *J. Anal. At. Spectrom.* 16, 390–397. <https://doi.org/10.1039/B007518N>
- Szava-Kovats, R.C., 2008. Grain-size normalization as a tool to assess contamination in marine sediments: Is the $63\mu\text{m}$ fraction fine enough? *Mar. Pollut. Bull.* 56, 629–632. <https://doi.org/10.1016/j.marpolbul.2008.01.017>
- Tan, Q.G., Wang, Y., Wang, W.X., 2015. Speciation of Cu and Zn in two colored oyster species determined by x-ray absorption spectroscopy. *Environ. Sci. Technol.* 49, 6919–6925. <https://doi.org/10.1021/es506330h>
- Tang, J., Johannesson, K.H., 2010. Ligand extraction of rare earth elements from aquifer sediments: Implications for rare earth element complexation with organic matter in natural waters. *Geochim. Cosmochim. Acta* 74, 6690–6705. <https://doi.org/10.1016/j.gca.2010.08.028>
- Taylor, S.R., 1964. Abundance of chemical elements in the continental crust: a new table. *Geochim. Cosmochim. Acta* 28, 1273–1285. [https://doi.org/10.1016/0016-7037\(64\)90129-2](https://doi.org/10.1016/0016-7037(64)90129-2)
- Taylor, V.F., Jackson, B.P., Siegfried, M.R., Navratilova, J., Francesconi, K.A., Kirshtein, J., Voytek, M.,

2012. Arsenic speciation in food chains from mid-Atlantic hydrothermal vents. *Environ. Chem.* 9, 130–138. <https://doi.org/10.1071/EN11134>
- Tchounwou, P.B., Yedjou, C.G., Patlolla, A.K., Sutton, D.J., 2012. Heavy Metals Toxicity and the Environment. *Mol. Clin. Environ. Toxicol.* 101, 1–30. <https://doi.org/10.1007/978-3-7643-8340-4>
- Thomas, D.J., Styblo, M., Lin, S., 2001. The Cellular Metabolism and Systemic Toxicity of Arsenic. *Toxicol. Appl. Pharmacol.* 176, 127–144. <https://doi.org/10.1006/taap.2001.9258>
- Thomas, R., 2003. Practical guide to ICP-MS: a tutorial for beginners. CRC Press.
- Thorne, L.T., Nickless, G., 1981. The relation between heavy metals and particle size fractions within the severn estuary (U.K.) inter-tidal sediments. *Sci. Total Environ.* 19, 207–213. [https://doi.org/10.1016/0048-9697\(81\)90017-6](https://doi.org/10.1016/0048-9697(81)90017-6)
- Tian, Y., Chen, M.-L., Chen, X.-W., Wang, J.-H., Hirano, Y., Sakamoto, H., Setsu, I., 2010. Arsenic speciation with gradient hydride generation interfacing liquid chromatography and atomic absorption spectrometry. *J. Anal. At. Spectrom.* 25, 48–54. <https://doi.org/10.1039/B913198A>
- Tomlinson, D.L., Wilson, J.G., Harris, C.R., Jeffrey, D.W., 1980. Problems in the assessment of heavy-metal levels in estuaries and the formation of a pollution index. *Helgoländer Meeresuntersuchungen* 33, 566–575. <https://doi.org/10.1007/BF02414780>
- Tompkins-MacDonald, G.J., Gallin, W.J., Sakarya, O., Degnan, B., Leys, S.P., Boland, L.M., 2009. Expression of a poriferan potassium channel: insights into the evolution of ion channels in metazoans. *J. Exp. Biol.* 212, 761–767. <https://doi.org/10.1242/jeb.026971>
- Tripti, M., Gurumurthy, G.P., Balakrishna, K., Chadaga, M.D., 2013. Dissolved trace element biogeochemistry of a tropical river, Southwestern India. *Environ. Sci. Pollut. Res.* 20, 4067–4077. <https://doi.org/10.1007/s11356-012-1341-y>
- Tsimplis, M.N., Baker, T.F., 2000. Sea level drop in the Mediterranean Sea: An indicator of deep water salinity and temperature changes? *Geophys. Res. Lett.* 27, 1731–1734. <https://doi.org/10.1029/1999GL007004>
- Turekian, K.K., Wedepohl, K.H., 1961. Distribution of the Elements in Some Major Units of the Earth's Crust. *Geol. Soc. Am. Bull.* 72, 175–192. [https://doi.org/10.1130/0016-7606\(1961\)72](https://doi.org/10.1130/0016-7606(1961)72)
- UN DOALOS (Division for Ocean Affairs and the Law of the Sea), 2016. First Global Integrated Marine Assessment (first World Ocean Assessment) [WWW Document]. URL http://www.un.org/depts/los/global_reporting/WOA_RegProcess.htm
- UNEP, 2011. Abidjan Convention. Convention for Co-operation in the Protection and Development of the Marine and Coastal environment of the West and Central African Region [WWW Document].
- UNEP regional seas, 2017 [WWW Document], n.d. URL <http://www.unep.org/regionalseas/> (accessed 7.13.17).
- US EPA, 2006. Marine Sediment Screening Benchmarks, Region III.
- V.E Vaskovsky, O.D. Korotchenko, L.P.K. and V.S.L., 1972. Arsenic in the lipid extracts of marine invertebrates. *Comp. Biochem. Physiol. C-Pharmacology Toxicol. Endocrinol.* 41, 777–784.
- Vahter, M., 1994. Species differences in the metabolism of arsenic compounds. *Appl. Organomet. Chem.*

- 8, 175–182. <https://doi.org/10.1002/aoc.590080304>
- Vallius, H., 2014. Heavy metal concentrations in sediment cores from the northern Baltic Sea: Declines over the last two decades. *Mar. Pollut. Bull.* 79, 359–364. <https://doi.org/10.1016/j.marpolbul.2013.11.017>
- Vallius, H., Ryabchuk, D., Kotilainen, A., Distribution, A., 2007. Distribution of heavy metals and arsenic in soft surface sediments of the coastal area off Kotka, North-eastern Gulf of Finland, Baltic Sea. *Geol. Surv. Finland, Spec. Pap.* 45, 33–48.
- van den Hoven, R.N., Santini, J.M., 2004. Arsenite oxidation by the heterotroph *Hydrogenophaga* sp. str. NT-14: the arsenite oxidase and its physiological electron acceptor. *Biochim. Biophys. Acta (BBA)-Bioenergetics* 1656, 148–155.
- Vanhaecke, F., Degryse, P., 2012. The Isotopic Composition of the Elements, in: *Isotopic Analysis: Fundamentals and Applications Using ICP-MS*. John Wiley and sons, pp. 1–29. <https://doi.org/10.1002/9783527650484>
- Varol, M., 2011. Assessment of heavy metal contamination in sediments of the Tigris River (Turkey) using pollution indices and multivariate statistical techniques. *J. Hazard. Mater.* 195, 355–364. <https://doi.org/10.1016/j.jhazmat.2011.08.051>
- Veerasingam, S., Vethamony, P., Mani Murali, R., Fernandes, B., 2015. Depositional record of trace metals and degree of contamination in core sediments from the Mandovi estuarine mangrove ecosystem, west coast of India. *Mar. Pollut. Bull.* 91, 362–367. <https://doi.org/10.1016/j.marpolbul.2014.11.045>
- Venkateswara Rao, J., Srikanth, K., Pallela, R., Gnaneshwar Rao, T., 2009. The use of marine sponge, *Haliclona tenuiramosa* as bioindicator to monitor heavy metal pollution in the coasts of Gulf of Mannar, India. *Environ. Monit. Assess.* 156, 451–459. <https://doi.org/10.1007/s10661-008-0497-x>
- Véron, A., Flament, P., Bertho, M.L., Alleman, L., Flegal, R., Hamelin, B., 1999. Isotopic evidence of pollutant lead sources in northwestern France. *Atmos. Environ.* 33, 3377–3388. [https://doi.org/10.1016/S1352-2310\(98\)00376-8](https://doi.org/10.1016/S1352-2310(98)00376-8)
- Vicente-Martorell, J.J., Galindo-Riaño, M.D., García-Vargas, M., Granado-Castro, M.D., 2009. Bioavailability of heavy metals monitoring water, sediments and fish species from a polluted estuary. *J. Hazard. Mater.* 162, 823–836. <https://doi.org/10.1016/j.jhazmat.2008.05.106>
- Vio, L., Martelat, B., Isnard, H., Nonell, A., Chartier, F., 2018. Multi-elemental Nd, Sm, Eu, Gd isotope ratio measurements by stop-flow isotachopheresis coupled to MC-ICPMS. *Talanta* 176, 582–588. <https://doi.org/10.1016/j.talanta.2017.08.013>
- Wahlen, R., McSheehy, S., Scriver, C., Mester, Z., 2004. Arsenic speciation in marine certified reference materials - Part 2. The quantification of water-soluble arsenic species by high-performance liquid chromatography-inductively coupled plasma mass spectrometry. *J. Anal. At. Spectrom.* 19, 876–882. <https://doi.org/10.1039/b402482f>
- Wall, F., Niku-Paavola, V.N., Storey, C., Müller, A., Jeffries, T., 2008. Xenotime-(Y) from carbonatite dykes at Lofdal, Namibia: Unusually low LREE:HREE ratio in carbonatite, and the first dating of xenotime overgrowths on zircon. *Can. Mineral.* 46, 861–877. <https://doi.org/10.3749/canmin.46.4.861>

- Wang, G., Zeng, C., Zhang, F., Zhang, Y., Scott, C.A., Yan, X., 2017. Traffic-related trace elements in soils along six highway segments on the Tibetan Plateau: Influence factors and spatial variation. *Sci. Total Environ.* 581–582, 811–821. <https://doi.org/10.1016/j.scitotenv.2017.01.018>
- Wang, W.-X., Lu, G., 2017. Heavy Metals in Bivalve Mollusks, in: *Chemical Contaminants and Residues in Food*. Elsevier, pp. 553–594. <https://doi.org/10.1016/B978-0-08-100674-0.00021-7>
- Wang, X., Qin, Y., 2006. Spatial distribution of metals in urban topsoils of Xuzhou (China): controlling factors and environmental implications. *Environ. Geol.* 49, 905–914. <https://doi.org/10.1007/s00254-005-0122-z>
- Wang, X.S., 2008. Correlations between heavy metals and organic carbon extracted by dry oxidation procedure in urban roadside soils. *Environ. Geol.* 54, 269–273. <https://doi.org/10.1007/s00254-007-0814-7>
- Wang, Y., Wang, S., Xu, P., Liu, C., Liu, M., Wang, Y., Wang, C., Zhang, C., Ge, Y., 2015. Review of arsenic speciation, toxicity and metabolism in microalgae. *Rev. Environ. Sci. Bio/Technology* 14, 427–451. <https://doi.org/10.1007/s11157-015-9371-9>
- Wang, Z.H., Lin, Q., Qang, X., Liu-Dong, L.I., 2011. The variation features of heavy metal contents in oyster samples from the coast of South China Sea and their safety assessment. *J. Fish. China* 35, 291–297.
- Watkins, R.T., Nathan, Y., Bremner, J.M., 1995. Rare earth elements in phosphorite and associated sediment from the Namibian and South African continental shelves. *Mar. Geol.* 129, 111–128. [https://doi.org/10.1016/0025-3227\(95\)00107-7](https://doi.org/10.1016/0025-3227(95)00107-7)
- Weis, P., Weis, J.S., 1999. Accumulation of metals in consumers associated with chromated copper arsenate-treated wood panels. *Mar. Environ. Res.* 48, 73–81. [https://doi.org/10.1016/S0141-1136\(99\)00028-8](https://doi.org/10.1016/S0141-1136(99)00028-8)
- Weisz, J.B., Lindquist, N., Martens, C.S., 2008. Do associated microbial abundances impact marine demosponge pumping rates and tissue densities? *Oecologia* 155, 367–376. <https://doi.org/10.1007/s00442-007-0910-0>
- Welz, B., Borges, D.L.G., Lepri, F.G., Vale, M.G.R., Heitmann, U., 2007. High-resolution continuum source electrothermal atomic absorption spectrometry — An analytical and diagnostic tool for trace analysis. *Spectrochim. Acta Part B At. Spectrosc.* 62, 873–883. <https://doi.org/10.1016/j.sab.2007.03.009>
- Weng, N., Wang, W.X., 2014. Variations of trace metals in two estuarine environments with contrasting pollution histories. *Sci. Total Environ.* 485–486, 604–614. <https://doi.org/10.1016/j.scitotenv.2014.03.110>
- Wentworth, C.K., 1922. A Scale of Grade and Class Terms for Clastic Sediments. *J. Geol.* 30, 377–392. <https://doi.org/10.1086/622910>
- WHO, 2006. *Arsenic in Drinking-water*.
- WHO, 1996. *Trace Elements in Human Nutrition and Health*. Geneva, Switzerland.
- WHO/FAO/IAEA, 1996. *Trace Elements in Human Nutrition and Health*. Geneva, Switzerland.
- Wu, X., Gao, M., Wang, L., Luo, Y., Bi, R., Li, L., Xie, L., 2014. The arsenic content in marketed seafood

- and associated health risks for the residents of Shandong, China. *Ecotoxicol. Environ. Saf.* 102, 168–173. <https://doi.org/10.1016/j.ecoenv.2014.01.028>
- Wu, Y., Wang, S., Streets, D.G., Hao, J., Chan, M., Jiang, J., 2006. Trends in Anthropogenic Mercury Emissions in China from 1995 to 2003. *Environ. Sci. Technol.* 40, 5312–5318. <https://doi.org/10.1021/es060406x>
- Wulff, J., 2001. Assessing and monitoring coral reef sponges: why and how? *Bull. Mar. Sci.* 69.
- Wysocka, I., Vassileva, E., 2016. Determination of cadmium, copper, mercury, lead and zinc mass fractions in marine sediment by isotope dilution inductively coupled plasma mass spectrometry applied as a reference method. *Microchem. J.* 128, 198–207. <https://doi.org/10.1016/j.microc.2016.05.002>
- Xu, Y., Sun, Q., Yi, L., Yin, X., Wang, A., Li, Y., Chen, J., 2014. The source of natural and anthropogenic heavy metals in the sediments of the Minjiang River Estuary (SE China): Implications for historical pollution. *Sci. Total Environ.* 493, 729–736. <https://doi.org/10.1016/j.scitotenv.2014.06.046>
- Xu, Z., Lim, D., Choi, J., Yang, S., Jung, H., 2009. Rare earth elements in bottom sediments of major rivers around the Yellow Sea: implications for sediment provenance. *Geo-Marine Lett.* 29, 291–300. <https://doi.org/10.1007/s00367-009-0142-x>
- Yamaoka, Y., Carmona, M.L., Oclarit, J.M., Jin, K., Shibata, Y., 2006. Characterization of water-soluble organoarsenic compounds in marine sponges. *Appl. Organomet. Chem.* 20, 545–548. <https://doi.org/10.1002/aoc>
- Yamaoka, Y., Carmona, M.L., Oclarit, J.M., Jin, K., Shibata, Y., 2001. Arsenic compounds in marine sponge (*haliclona permolis*, *Halichondria japonica*, *Halichondria okadai* and *Haliclona* sp. white) from Seto Inland Sea, Japan. *Appl. Organomet. Chem.* 15, 261–265. <https://doi.org/10.1002/aoc.135>
- Yang, L., Mester, Z., Sturgeon, R.E., 2003. Comparison of sector field- and quadrupole-ICP-MS for the determination of DBT and TBT in sediment following GC separation. *J. Anal. At. Spectrom.* 18, 1365–1370. <https://doi.org/10.1039/b304705a>
- Zahra, A., Hashmi, M.Z., Malik, R.N., Ahmed, Z., 2014. Enrichment and geo-accumulation of heavy metals and risk assessment of sediments of the Kurang Nallah—Feeding tributary of the Rawal Lake Reservoir, Pakistan. *Sci. Total Environ.* 470–471, 925–933. <https://doi.org/10.1016/j.scitotenv.2013.10.017>
- Zakharyan, R.A., Sampayo-Reyes, A., Healy, S.M., Tsaprailis, G., Board, P.G., Liebler, D.C., Aposhian, H.V., 2001. Human Monomethylarsonic Acid (MMAV) Reductase Is a Member of the Glutathione-S-transferase Superfamily. *Chem. Res. Toxicol.* 14, 1051–1057. <https://doi.org/10.1021/tx010052h>
- Zhang, W., Chen, L., Zhou, Y., Wu, Y., Zhang, L., 2016a. Biotransformation of inorganic arsenic in a marine herbivorous fish *Siganus fuscescens* after dietborne exposure. *Chemosphere* 147, 297–304. <https://doi.org/10.1016/j.chemosphere.2015.12.121>
- Zhang, W., Feng, H., Chang, J., Qu, J., Xie, H., Yu, L., 2009. Heavy metal contamination in surface sediments of Yangtze River intertidal zone: An assessment from different indexes. *Environ. Pollut.* 157, 1533–1543. <https://doi.org/10.1016/j.envpol.2009.01.007>
- Zhang, W., Guo, Z., Zhou, Y., Chen, L., Zhang, L., 2016b. Comparative contribution of trophic transfer and biotransformation on arsenobetaine bioaccumulation in two marine fish. *Aquat. Toxicol.* 179, 65–

71. <https://doi.org/10.1016/j.aquatox.2016.08.017>

Zhang, W., Guo, Z., Zhou, Y., Liu, H., Zhang, L., 2015. Biotransformation and detoxification of inorganic arsenic in Bombay oyster *Saccostrea cucullata*. *Aquat. Toxicol.* 158, 33–40. <https://doi.org/10.1016/j.aquatox.2014.10.021>

SUPPLEMENTARY INFORMATION (paper 6)

Table 1S. TE concentrations expressed in mg kg⁻¹ and their variability (standard deviation SD and relative standard deviation in %) in Mediterranean sponges collected in February and September 2016.

	First sampling campaign (February 2016)										Second sampling campaign (September 2016)									
	V	Ni	Cu	Zn	As	Mo	Ag	Cd	Ba	Pb	V	Ni	Cu	Zn	As	Mo	Ag	Cd	Ba	Pb
	<i>Haliclona fulva</i> (n=3)										<i>Haliclona fulva</i> (n=3)									
Average	6	8	13	32	26	1	0.11	1.6	10	8	2.9	4	15.3	38	29	0.8	0.04	2.1	1.8	1.1
SD	2	3	2	10	6	0.1	0.04	0.5	2	4	0.5	1	0.6	5	5	0.1	0.01	0.4	0.8	1.3
%RSD	33	33	16	31	22	7	34	31	17	46	16	38	4	13	17	18	39	17	41	121
	<i>Cymbaxinella damicornis</i> (cave entrance, n=3)										<i>Cymbaxinella damicornis</i> (n=3)									
Average	5.6	3	56	26	85	0.82	0.25	2	9	4.6	5	5	61	38	55	0.68	0.14	1.6	3.17	7
SD	0.3	1	23	18	15	0.06	0.05	0.4	2	0.9	2	3	24	4	7	0.07	0.01	0.2	0.04	6
%RSD	6	31	42	70	17	7	22	22	17	19	38	55	38	9	13	10	7	12	1	81
	<i>Cymbaxinella damicornis</i> (cave center, n=2)																			
Average	8	5	56	34	67	0.98	0.2	2.5	8	3										
SD	5	1	9	24	4	0.07	0.03	0.1	2	2										
%RSD	66	21	16	70	5	7	13	3	21	61										
	<i>Chondrilla nucula</i> (n=3)										<i>Chondrilla nucula</i> (20m depth, n=3)									
Average	3	18	12	58	34	2.7	0.22	0.6	3	4	2.8	13.2	12	35	30	1.52	0.25	0.73	2	1.6
SD	1	7	4	22	13	0.6	0.08	0.2	2	1	0.6	0.9	2	6	0.9	0.08	0.05	0.07	1	0.9
%RSD	41	40	30	38	38	21	35	38	58	29	21	7	14	16	3	5	18	9	55	57
	<i>Chondrilla nucula</i> (5m depth, n=3)																			
Average											1.7	10	15	30	24	2.1	0.18	0.56	2	1.1
SD											0.3	3	2	4	4	0.3	0.07	0.05	2	0.5
%RSD											16	34	12	14	18	14	38	9	73	44
	<i>Acanthella acuta</i> (n=3)										<i>Acanthella acuta</i> (n=3)									
Average	4.6	5	17	40	44	0.7	5	1.9	7	6	4.4	3	17	43	33	0.9	9	1.6	5	3
SD	0.7	3	4	22	8	0.3	3	0.3	3	7	2.3	2	1	4	2	0.1	2	0.3	1	3
%RSD	14	61	25	56	17	48	55	14	43	116	51	49	8	9	5	16	29	17	25	111

Table 2S. TE concentrations and their variability (standard deviation, SD and relative standard deviation in %) in Irish sponges

<i>Halichondria panicea</i>											
Sampling sites	mg kg ⁻¹	V	Ni	Cu	Zn	As	Mo	Ag	Cd	Ba	Pb
Kilkieran	Average (n=4)	4.3	1.1	5.6	39	8	0.64	0.3	1.3	2	1.6
	SD	0.9	0.5	0.4	13	1	0.02	0.1	0.1	1	0.5
	RSD%	22	48	8	33	18	2	40	9	55	34
Belfast Lough	Average (n=6)	33	13	28	82	6.2	1.1	0.8	0.4	54	10
	SD	15	6	11	25	0.8	0.3	0.3	0.1	27	3
	RSD%	45	41	41	31	14	30	37	23	49	30
<i>Hymeniacidon perlevis</i>											
Kilkieran	Average (n=3)	11	3	22	1371	7	0.7	0.7	1.9	64	2.5
	St dev	4	1	12	442	0.5	0.1	0.4	0.3	32	0.6
	RSD%	35	53	53	32	8	16	52	15	49	26
Belfast Lough	Average (n=7)	10	5	48	950	10	1	1.9	0.8	21	7
	SD	4	3	16	64	4	0.2	0.7	0.2	11	3
	RSD%	41	55	33	7	40	39	37	30	53	42

Paper 7

Submitted to the peer reviewed journal Chemosphere (Elsevier) - accepted

Comparative study on the bioaccumulation and biotransformation of arsenic by some Northeastern Atlantic and Northwestern Mediterranean sponges

Anna Maria Orani * ^{a,c}, Aurélie Barats ^a, Wendy Zitte ^a, Christine Morrow ^b, Olivier P. Thomas ^b

^a Université Nice Sophia Antipolis, CNRS, IRD, Observatoire de la Côte d'Azur, Géoazur, UMR 7329, 250 rue Albert Einstein, Sophia Antipolis 06560 Valbonne, France

^b National University of Ireland Galway, Marine Biodiscovery, School of Chemistry, University Road, Galway, Ireland

^c International Atomic Energy Agency, Environment Laboratories, 4 Quai Antoine 1er, MC 9800, Monaco

Abstract

The bioaccumulation and biotransformation of arsenic (As) were studied in six representative marine sponges from the French Mediterranean and Irish Atlantic coasts. Methodologies were carefully optimized in one of the species on *Haliclona fulva* sponges for two critical steps: the sample mineralization for total As analysis by ICP-MS and the extraction of As species for HPLC-ICP-MS analysis. During the optimization, extractions performed with 0.6 mol L⁻¹ H₃PO₄ were shown to be the most efficient. Extraction recovery of 81 % was obtained which represents the best results obtained until now in sponge samples. Total As analyses and As speciation were performed on certified reference materials and allow confirming the measurement quality both during the the sample preparation and analysis. Additionally, this study represents an environmental survey demonstrating a high variability of total As concentrations among the different species, probably related to different physiological or microbial features. As speciation results showed the predominance of arsenobetaine (AsB) regardless of the sponge species, as well as the occurrence of low amounts of dimethylarsinic acid (DMA), arsenate (As(+V)), and unknown As species in some samples. The process responsible for As transformation in sponges is most likely related to sponges metabolism itself or the action of symbiont organisms. AsB is supposed to be implied in the protection against osmolytic stress. This study demonstrates the ability of sponges to accumulate and bio-transform As, proving that sponges are relevant bio-monitors for As contamination in the marine environment, and potential tools in environmental bio-remediation.

Keywords: marine sponges; biomonitor; arsenic bioaccumulation; arsenic speciation; bioremediation

1. Introduction

Arsenic (As) is a ubiquitous element that ranks 20th in abundance in the earth's crust (1.5–3 mg kg⁻¹). This metalloid occurs naturally in the environment, and it is also provided by some anthropogenic activities (Mandal and Suzuki, 2002). As is recognized to be toxic and one of the six most preoccupying pollutants on earth together with lead, mercury, chromium, some radionuclides and pesticides. The understanding of As cycle in marine ecosystem remains a challenging task since arsenic often occurs at very low concentrations (around 1 µg L⁻¹ in seawater) and under one of the most toxic inorganic species (As(+V)) (Cabon and Cabon, 2000). Within this context, there is a clear need to gain a better understanding of the As cycle in the marine environment.

The quantification of total As in marine organisms and especially in seafood has been performed in numerous studies (Phillips, 1990; Kucuksezgin et al., 2014; Wu et al., 2014; Olmedo et al., 2013), but rarely in marine invertebrates. Among marine invertebrates, sponges are sessile filter feeders, capable of filtering every day a volume of seawater up to 50 000 times that of their body (Weisz et al., 2008). They have been recognized as excellent bio-monitors for trace element pollution (Perez et al., 2005; Cebrian et al., 2007) as they are capable to accumulate trace elements at concentrations higher than bivalves (Patel et al., 1985; Negri et al., 2006; Padovan et al., 2012). On hard substrata, sponges are one of the top spatial competitors (Bell, 2008) and have recently been proposed as model organisms to monitor aquatic contamination, in addition to the already existing and well known "Mussel Watch Program" (Genta-Jouve et al., 2012). The bioaccumulation of trace elements in sponges was suggested to differ according to sponge species and the element of interest (Batista et al., 2014; Mayzel et al., 2014; Cebrian et al., 2007; Patel et al., 1985). Only few studies focused on As bioaccumulation in sponges (Aly et al., 2013; Araújo et al., 2003; Batista et al., 2014; Denton et al., 2006; Keren et al., 2015; Keren et al., 2016; Keren et al., 2017; Padovan et al., 2012; Pan et al., 2011; Perez et al., 2005; Schaeffer et al., 2006; Shiomi et al., 1988; Vaskovsky et al., 1972; Venkateswara Rao et al., 2009; Yamaoka et al., 2001; Yamaoka et al., 2006). These studies revealed how As concentrations in sponges is variable, exceeding 100 mg kg⁻¹ in some cases, and usually higher than in other marine organisms (generally < 10 mg kg⁻¹ in fish, algae and shellfish) (Llorente-Mirandes et al., 2010). Sponges seem to accumulate more As than other marine organisms, which makes them suitable models for biomonitoring studies, as already proposed by Genta-Jouve et al., 2012. As accumulation was previously demonstrated to be strongly related to sponge orders or species; for instance higher in demosponges than in calcareous sponges (Yamaoka et al., 2001).

The determination of total As concentration is however not sufficient as As toxicity and biological impact depend directly on its chemical form, *i.e.* its speciation (Cullen and Reimer, 1989; Hughes, 2002; Sakurai, 2002). Among arsenic species, inorganic arsenite As(+III) and arsenate As(+V) are the most toxic forms. These two inorganic forms are carcinogenic and cause damage to the respiratory, cardiovascular, nervous, and hematopoietic systems, as well as lesions to skin and liver (Pershagen, 1981). The methylated forms monomethylarsonic acid (MMA) and dimethylarsinic acid (DMA) are less toxic than the previously mentioned inorganic species, but they are recognized as cancer promoters (Brown et al., 1997) while arsenobetaine (AsB), the major species in marine animals, arsenocholine (AsC), trimethylarsine oxide (TMAO) and tetramethylarsonium ion (TMAs) are considered nontoxic (ATSDR, 2007). Other As species, like arsenosugars (AsS), often found in seafood and generally in marine organisms, have been recognized not to be acutely toxic; nevertheless a chronic toxicity is a possibility (Andrewes et al., 2004). The quantitation of the different As chemical forms, *i.e.* arsenic speciation, can be performed with different analytical techniques (Benramdane et al., 1999; Hsieh et al., 2010; Nearing et al., 2014; Tian et al., 2010). HPLC-ICP-MS represents the most used technique by far (Benramdane et al., 1999; Nearing et al., 2014) because this hyphenated technique combines a rapid, powerful and reproducible separation method with a very efficient detector due to its high sensitivity and large linear dynamic range (Beauchemin, 2008).

In most aquatic organisms, As speciation analysis has already revealed the occurrence of AsB, AsS, DMA and inorganic species. In freshwater organisms, the inorganic As(+III) species was reported as dominant for gastropods (Hong et al., 2014), two AsS species for microalgae, DMA for *Anguilla japonica* and more often AsB for other fish-species and crustaceans (Miyashita et al., 2009). AsB was suggested to contribute in a greater proportion of total As in marine organisms than in freshwater ones, which represents the major difference in As speciation between aquatic organisms (Schaeffer et al., 2006; Hong et al., 2014). AsB is reported as the most abundant As-species in several organisms, such as shrimps, bivalves, crabs and fishes (Lai et al., 1999; Schaeffer et al., 2006; Taylor et al., 2012; Caumette et al., 2012; Hong et al., 2014), whereas some AsS species can also be dominant in clams and mussels (Grotti et al., 2010; Taylor et al., 2012). The relative proportions of these two major As-compounds (AsB and AsS) would depend on the position of the organism in the food chain: the percentage of AsB normally increases through the food web, whereas the AsS fraction decreases (Grotti et al., 2010). Concerning sponges, the inorganic As(+V) specie was reported as dominant in freshwater sponges from the Danube River in Hungary (Schaeffer et al., 2006) whereas in Japanese and Philippine marine sponges, AsS and AsB were found to be dominant, showing interesting variability among the studied

species (Shiomi et al., 1988; Yamaoka et al., 2001; Yamaoka et al., 2006). Recently, the role of sponge-associated bacteria in As bioaccumulation was evaluated since bacteria are known as key contributors to important elemental cycling in sponges, specifically for carbon, nitrogen, sulfur as well as trace elements (Keren et al., 2015; Keren et al., 2016; Keren et al., 2017). The sponge symbiotic bacterium *Entotheonella* sp. was shown to constitute the As-accumulating entity within the holobiont.

Considering the lack of studies on As speciation in marine sponges a deeper knowledge of As speciation in marine sponges is needed. In this work, a methodology was first developed for total As analyses by ICP-MS and As speciation by HPLC-ICP-MS in sponges. This approach was then applied to different sponge species collected in distinct marine environments. This study focused on different sampling sites located in the French Mediterranean coast, but also in the Irish Atlantic coast. These sites were characterized by different natural and anthropogenic As inputs offering thus the opportunity to study possible differences in As bioaccumulation and biotransformation related to the element availability.

2. Materials and methods

2.1. Sampling and target species

The sponge samples analyzed in this study were collected either by SCUBA diving in the French Mediterranean coast in the Villefranche-sur-Mer Bay, or in the Irish Atlantic coast shore in Greenisland and in the Killkieran Bay. The French sampling area is densely populated and a well-known tourist destination, especially in summer time. Greenisland is a large inlet in the Belfast Lough, at the western end is the city and the port of Belfast, which sits at the mouth of the Lagan River. The lough opens into the North Channel and connects Belfast to the Irish Sea. Killkieran Bay is a large, complex inlet in southern Connemara, County Galway, on west coast of Ireland.

Initial sampling of specimens of the sponge *Haliclona fulva* was carried out in the Bay of Villefranche sur Mer (N 43° 41' 59.0", E 07° 19' 31.5") on January 2014, in order to optimize the mineralization and extraction procedures for As analyses. Subsequent sampling was conducted in the Bay of Villefranche sur Mer on February and September 2016, in Killkieran Bay (N 53° 21' 22.625", O 9° 42' 17.153") in October 2016, and in Greenisland, Carrickfergus (N54°41'24.383", O 5° 51' 36.633") in November 2016. Sampling locations are shown in Fig. 1A (supplementary information). At least, three specimens of each sponge species were collected from each sampling site and period. In order to minimize differences due

to sponge ages, organisms of a similar size were chosen. In the Mediterranean coast, samples were collected between 5 and 40 m depth, whereas in Ireland, they were collected from intertidal areas.

The following sponge species were collected for 2 sampling dates in the Mediterranean coast: *Acanthella acuta*; *Cymbaxinella*^p *damicornis*; *Chondrilla nucula* and *Haliclona fulva*. From Greenisland and Killkieran Bay, the following species were collected: *Halichondria panicea* and *Hymeniacidon perlevis* (Fig. 2A, supplementary information). These species were selected because of their widespread occurrence but also for their different morphological characteristics (KeyToNature, 2015):

- a) *Acanthella acuta* (Class: Demospongiae, Order: Axinellida, Family: Dictyonellidae) is a small erect sponge with rather small oscules.
- b) *Cymbaxinella*^p *damicornis* (Class: Demospongiae, Order: Axinellida, Family: Axinellidae, ^pphylocode name), is a rather small, erectly branching sponge with short, compressed branches. Oscules are small and are located on the apices of the branches, the oscules are surrounded by a small triangular ‘flap’ of tissue. The genus *Axinella* is difficult to define on the basis of morphological characteristic but for the specie analyzed in this study the name *Cymbaxinella damicornis* was recently proposed by Gazave et al. (2010) following the *phylocode*.
- c) *Chondrilla nucula* (Class: Demospongiae, Order: Chondrillida, Family: Chondrillidae) is amorphous, with globular lobes, or thickly incrusting, up to about 1 cm thick, spreading horizontally, with pronounced, deeply incised and lacunose, meandering lobes. The color is dark-brown to walnut-brown.
- d) *Haliclona fulva* (Class: Demospongiae, Order: Haplosclerida, Family: Chalinidae), is a specimen with irregular and slightly hispid surface. The ectosomal and choanosomal skeletons have a regular, delicate, unispicular, and isotropic reticulation. Color is dark orange.
- e) *Halichondria panicea* (Class: Demospongiae, Order: Suberitida, Family: Halichondriidae), is intertidal or shallow-subtidal, thickly encrusting, massive or occasionally branching, and presents typical volcano-shaped oscular chimneys. The surfaces of this sponge are smooth, consistency firm, texture crumb-of-bread. These sponges are basically light orange-yellow or pale yellowish green.
- f) *Hymeniacidon perlevis* (Class: Demospongiae, Order: Suberitida, Family: Halichondriidae), is one of the most common species along the Atlantic coasts of Western Europe. It is orange and has an irregular surface, often with lower or higher irregular projections. Oscules are inconspicuous.

Samples were kept frozen at -20°C . The sponge samples were then freeze-dried (Christ MartinTM AlphaTM 1-2 Ldplus) and ground in an agate mortar in order to obtain a homogeneous powder. Samples were transferred into PTFE pre-cleaned tubes and kept in a desiccator.

2.2. Sample preparation

All solutions were prepared with doubly deionized water obtained from Millipore water purification system (Elix & Synergy) (resistivity of $18.2\text{ M}\Omega\text{ cm}^{-1}$, Total Organic Carbon $<5\text{ }\mu\text{g L}^{-1}$ and microorganisms $<0.1\text{ UFC ml}^{-1}$). All PTFE and Teflon containers used for sample preparation and/or analysis were pre-cleaned using a procedure consisting of 24 h bath in 10% HNO_3 and careful rinsing with Milli-Q water. For total As quantification, samples were digested in a closed microwave system (Ethos One, Milestone) prior to ICP-MS analysis. The digestion program included a 20 min temperature ramp up to 180°C followed by 30 min isothermal step (power 2000 W). An aliquot of dried sponge sample was weighted in Teflon reactors. Chemical reagents were added and the microwave digestion was carried out. The sample mass and the use of different chemical reagents were optimized within this study. The following chemical reagents were used: HNO_3 (Trace Metal Grade, 67 to 70% w/w, Fisher Chemical), HF (Ultra Trace Elemental Analysis 47-51% w/w, Optima, Fisher Chemical), HCl ($\geq 30\%$, for trace analysis, Sigma-Aldrich) and H_2O_2 ($\geq 30\%$, for trace analysis, Sigma-Aldrich). The mineralized solution was then transferred to PE pre-cleaned tubes and gravimetrically diluted with Milli-Q water, up to a final volume of 50 mL. All samples were further diluted 15 times in Milli-Q water prior to ICP-MS analysis. At least one procedural blank and one quality control Certified Reference Materials (CRM) were included in each digestion run and analyzed with the rest of the samples. The following CRMs were used in this study: TORT-2 (lobster hepatopancreas, Institute for Environmental Chemistry, National Research Council Canada, Ottawa, Canada), BCR-627 (tuna fish powder, Institute for Reference Materials and Measurements, Geel, Belgium) and MESS-2 (estuarine sediment, Institute for Environmental Chemistry, National Research Council Canada, Ottawa, Canada). These CRM were prepared and analyzed along with the vent samples as an assessment of analytical accuracy.

For As speciation, the extraction method was optimized using different chemicals and/or proportion: Milli-Q water, methanol (MeOH, HPLC Plus, $\geq 99.9\%$, Sigma-Aldrich) and H_3PO_4 ($\geq 85\text{ wt. \%}$ in H_2O , trace metals basis, Sigma-Aldrich). Extractions were performed the day before analyses and extracts were kept frozen during the night. Since no sponge CRM is available on the market, the extraction

performances were evaluated using the certified reference material BCR-627 (certified for As speciation) and TORT-2. For sponge samples, extractions were performed at least 3 times for each species to account for intra-specie variability. 10 mL of the selected solvent were added to about 50 mg of dried sample. The mixture was sonicated for one h. The extracts were then filtered with a single-use syringe through single-use syringe filters (0.45 μm , Minisart® RC25, Sartorius) and gravimetrically diluted 10 times in Milli-Q water. The extracts were analyzed by HPLC-ICP-MS.

2.3. Sample analyses

A quadrupole ICP-MS (Elan DRCII, Perkin Elmer) was used as detection system for the determination of total As in sponge samples. ICP-MS operating parameters are summarized in Table 1. ^{75}As isotope may be interfered in saline matrices by Cl (by $^{40}\text{Ar}^{35}\text{Cl}^+$). The most common way to remove these spectral interferences is using the following correction equation: $I(\text{As}) = I(m/z=75) - 3.127 \times I(m/z=77) + 2.733 \times I(m/z=82)$ where I stands for intensity (Potot et al., 2012; Barats et al., 2014). This mathematical correction accounts for about possible polyatomic interferences ($^{40}\text{Ar}^{35}\text{Cl}^+$ or $^{40}\text{Ar}^{37}\text{Cl}^+$) as well as for the occurrence of selenium ($^{77,82}\text{Se}$) in samples. Preparation of standard solutions and dilution of samples for analysis were carried out in a class 100 clean laboratory. External calibrations were performed with daily prepared standards obtained by proper dilution of multi-elemental standard for ICP-MS (ICP-MS standard N°3 Perkin Elmer®, ICP-MS standard N°2 from SCP SCIENCE®) or a mono-elemental As standard (PlasmaCal, SCP SCIENCE®). An internal standard solution (containing 10 and 1 $\mu\text{g L}^{-1}$ of Ge and Tb respectively) was prepared by dilution of mono-elemental standards of Ge and Tb (PlasmaCal, SCP SCIENCE®). ^{74}Ge was chosen as an internal standard for As analyses to correct instrumental drifts. All sample analyses were preceded by a minimum of a five-point calibration curve spanning the entire concentration range of interest. All results were instrument blank corrected to account for any operational bias. The ongoing instrument performance was monitored by the analysis of continuing calibration verification standards. Daily analyses of the certified reference natural river water SLRS-5 or SLRS-6 (National Research Council, Canada) and analyses of the 3 solid CRM (MESS-2, TORT-2 and BCR-627) were carried out to check measurement accuracy and reproducibility of analytical calculations. Detection limits for ^{75}As averaged 30 ng L^{-1} .

As speciation analysis was performed by HPLC-ICP-MS. Instrumental settings and chromatographic conditions used throughout this work were described in Table 1. Ion intensities at $m/z = 75, 77$ and 82

were monitored using a ‘time-resolved’ method from Chromera software (version 2, Perkin Elmer). No mathematical correction equation was used, but signals at $m/z = 77$ and 82 were thoroughly monitored to insure the absence of the polyatomic interference with Cl.

Table 1. ICP-MS and HPLC-ICP-MS settings used for total As analysis and As speciation in marine sponge samples

ICP-MS Settings		
RF power		1550 W
Plasma gas flow		15 L min ⁻¹
Auxiliary gas flow		1.1 mL min ⁻¹
Carrier gas flow		0.9 L min ⁻¹
Nebulizer		quartz concentric
Spray chamber		Cyclonic
Interface		Pt sampling and skimmer cones
Analytical mass		⁷⁵ As
Mass for interference assessment		⁴⁰ Ar ³⁷ Cl, ⁸² Se
HPLC conditions		
Column (anion exchange)		Hamilton PRP-X100
Column temperature		20°C
Injection volume		250 µL
Mobile phase A		5 mM (NH ₄) ₂ CO ₃ pH=9
Mobile phase B		70 mM (NH ₄) ₂ CO ₃ pH=9
Flow rate		2 mL min ⁻¹
Gradient programme		0-2 min: 100% A 3-6 min: 100% B 7-10 min: 100% A

The HPLC used in this study (Serie 200 Pump, Perkin Elmer) was equipped with an anion exchange column (Hamilton PRP-X100, length 25 cm, particle size 10 µm, i.d. 4.1 mm). Mobile phases were prepared by dissolving (NH₄)₂CO₃ salt (Sigma Aldrich) in Milli-Q water. This salt is commonly used with this type of anion exchange column (Wahlen et al., 2004). The final pH of the solution was adjusted to 9, by adding small amounts of either nitric acid or ammonia. The HPLC injection loop was cleaned using a 10% MeOH solution. The outlet of the HPLC column was connected via PEEK capillary tubing (0.125 mm i.d.) to a Rheodyne switching valve (6 ports, 2 positions, purchased by Perkin), which was in turn connected to the ICP-MS cyclonic nebulizer. Chromatographic conditions were optimized (composition of mobile phase, gradient, flowrate) to reach a rapid and sensitive analysis of 5 As species in 5 min. For calibration, the procedural blank chromatogram was subtracted. External calibration curves were used to quantify AsB, As(+III), DMA, MMA, As(+V) with the corresponding standards. Limits of detection were estimated using peak maximum height, and averaged 0.13 µg L⁻¹ of As in diluted extracts, corresponding

to $0.25 \mu\text{g g}^{-1}$ in sponge samples. Arsenic speciation analyses were performed on diluted solutions obtained after a solid-liquid extraction, optimized in this study, lead on each dried sponge samples. For quantification in sponge samples and CRM, the chromatograms of the extraction blanks were systematically subtracted. In case of unknown As species, the calibration curves are similar for all As species analyzed in this work, as previously demonstrated (Francesconi and Sperling, 2005) and serves to quantify unknown As species when are detected. This approach was previously used for algae (Llorente-Mirandes et al., 2010) and in sponge samples (Taylor et al., 2012). Standards used for As speciation were prepared daily from dilution of As(+III) and As(+V) stocks (1000 mg L^{-1} , Absolute standard, Inc.) and organic As-mono-species solutions. The latter were prepared from salts of arsenobetaine (AsB), sodium dimethylarsenite (DMA), disodium methylarsenate (MMA) (Sigma-Aldrich). Species were identified by their retention times compared with standard compounds. Concentrations were determined by comparing peak heights to known standards. The CRM BCR-627, certified for AsB and DMA, was analyzed to check the accuracy of extraction and analytical methods. The TORT-2 was also analyzed for As speciation and compared with literature data.

Statistical data treatments were carried out using XLSTAT (version 2014.05.5, Addinsoft, Paris, France). One-way ANOVA tests were performed with a significance level of $p < 0.05$ to estimate the inter-species variability of As concentrations, between sites (Irish sponges), and between seasons (Mediterranean sponges).

3. Results and discussion

3.1. Optimization of analytical methodologies

3.1.1. Development of the mineralization method for total As analysis in sponges

Nitric acid is often used to digest different types of marine organisms for trace elements analyses (shrimps, mussels, gastropods, worm, oysters) (Taylor et al., 2012; Zhang et al., 2015), even for freshwater sponges (Schaeffer et al., 2006). A two-steps method using HNO_3 and then H_2O_2 was also reported in aquatic organisms such as algae, fishes, bivalves, crabs, and shrimps (Hong et al., 2014; Llorente-Mirandes et al., 2010), as well as in sponges and associated bacteria (Keren et al., 2017). In order to select the best digestion procedure for As determination in marine sponges, an optimization was carried out on a *Haliclona fulva* sample. Mineralization protocols were developed on about 100 mg of dried sponge sample. The different methods and their results are presented in Table 1A (supplementary information). Protocols without microwaves have been rapidly abandoned because they resulted in jelly solutions, low As recoveries or results with a poor reproducibility. Acid digestions

assisted by microwaves without HF usually resulted in slightly lower As recovery than those obtained with HF (around 20% less). Sample microscope observations revealed undigested spicules in the solution without HF (Fig. 3A, supplementary information). These protocols conducted to a partial mineralization of sponge samples. In Antarctic Demospongiae (*Sphaerotylus antarcticus*, *Kirkpatrickia coulmani* and *Haliclona sp.*) and in the Mediterranean species *Petrosia ficiformis*, the accumulation of pollutants (Cd, Pb and Cu) was demonstrated as being lower in the spicules than in the corresponding organic fraction even if spicules represent about 80% of the biomass (Illuminati et al., 2016). This observation is in full agreement with our results. Nevertheless, the As amount in *Haliconia fulva* spicules cannot be neglected because it represents around 20% of the total As. For sponges with siliceous skeletons, the use of HF is thus recommended. Higher As concentrations were obtained with the use of HNO₃/HF or HCl/HNO₃/HF mixtures. Nevertheless, the use of HNO₃/HF was preferred to prevent possible interferences onto the ⁷⁵As isotope coming from HCl. Finally, the chosen sample preparation procedure involving a microwave digestion has been performed using 5 ml of HNO₃ and 2 ml of HF.

The optimized mineralization protocol was then applied to BCR-627 and TORT-2 marine biota CRMs as well as to MESS-2 sediment CRM. The obtained results for total As were in all cases in good agreement with the certified values, as shown in Table 2. Further applications of the developed procedure were performed on about 50 mg of dried sponge.

Table 2. Total As and As speciation results for three CRMs: BCR-627, TORT-2 and MESS-2. Extracted As concentrations were determined by ICP-MS and AsB concentrations by HPLC-ICP-MS. * and ** represent Indicative values given by *Sunner et al., 2001 and **Wahlen et al., 2004.

Certified Reference Materials		TORT-2	BCR 627	MESS-2
Microwave digested solutions	Total As (mg kg ⁻¹)	22 ± 2 (n=6)	5.2 ± 0.5 (n=4)	19.2 ± 1.1 (n=4)
	Certified value	21.6 ± 1.8	4.8 ± 0.3	20.7 ± 0.8
	Recovery (%)	102	108	92
Extracted solutions	Extracted As (mg kg ⁻¹)	23 ± 4 (n=3)	4.6 ± 0.3 (n=6)	
	Extraction recovery (%)	106	97	
	As from AsB (mg kg ⁻¹)	13 ± 5 (n=4)	4.5 ± 0.5 (n=6)	
	Certified value	13.8 ± 0.2* 14.3 ± 1.1**	3.9 ± 0.2	
	As from DMA (mg kg ⁻¹)	1.2 ± 0.8 (n=4)	0.1 < c < 0.3	
	Certified value	0.97 ± 0.05* 0.84 ± 0.10**	0.15 ± 0.02	
	As from unknown peak	1.9 ± 0.6 (n=4)	-	
	Speciation recovery (%)	74	98	

3.1.2. Development of the extraction method for sponge samples

A very delicate step of the speciation analyses is the chemical extraction of As species as it has to guarantee the preservation of original chemical forms, avoiding oxidation, reduction or more generally any conversion in other chemical species. As reported by different authors (Lai et al., 1999; Schaeffer et al., 2006; Ciardullo et al., 2010; Llorente-Mirandes et al., 2010; Taylor et al., 2012; Zhang et al., 2015), the most common solid-liquid extraction for As species from biological materials include the use of H₂O, MeOH or a mixture of them, since AsB is the predominant specie in marine animals and it is soluble in both solvents (Leermakers et al., 2006). A solution made of 2% HNO₃ was also used in chemical extraction for various aquatic organisms (fishes, bivalves, crabs, shrimps) (Hong et al., 2014). H₃PO₄ was more often used for As extraction from soils and sediments as it preserves the two redox states of As in these samples (Ellwood and Maher, 2003). In sponges, extractions were performed either with H₂O in freshwater organisms (revealing low recovery of 30%) (Schaeffer et al., 2006), or with a mixture H₂O/MeOH (Shiomi et al., 1988; Yamaoka et al., 2001; Yamaoka et al., 2006; Keren et al., 2017).

Extraction recoveries were not estimated in these last studies using methanol. Due to lack of some data in these studies, an estimation of extraction recoveries obtained from sponges, can only be performed with the results from Shiomi et al., 1988, using the ratio of the total water-soluble As divided by the total As. These calculations gave extraction recoveries ranging from 19-56% for three sponge species. The aim of the present study was then to develop a more efficient extraction method using different extracting solutions.

The optimization of the extraction procedure was performed on three replicates of *H. fulva* sponge samples, using 10 mL of a given solution and 50 mg of dried sponge sample. Extraction recoveries were calculated considering the total average As content of 29 ± 5 mg kg⁻¹ previously measured by ICP-MS on digested samples. Regardless of the tested extracting solution, extraction recoveries obtained in the present study were higher than 72 % (Table 3) which are significantly higher than previous published results on sponges.

Table 3. Extracted As concentrations and As speciation results obtained using different extraction methods on a pool of *H. fulva* sponges. Extracted As concentrations were determined by ICP-MS and AsB concentrations by HPLC-ICPMS. Extraction recoveries were calculated on the average total As content of 29 ± 5 mg kg⁻¹.

	Extracted As (mg kg ⁻¹)	Extraction recovery (%)	As from AsB (mg kg ⁻¹)	As from AsB in extracts (%)
H₂O	21 ± 3	72	14 ± 3	67
MeOH 50%	21 ± 2	72	24 ± 3	114
MeOH 25%	25 ± 1	86	19 ± 3	76
H₃PO₄ 0.3 mol L⁻¹	20 ± 3	69	13.0 ± 0.8	65
H₃PO₄ 0.6 mol L⁻¹	23.5 ± 0.7	81	15.2 ± 0.8	64
H₃PO₄ 1 mol L⁻¹	24.2 ± 0.5	83	13.9 ± 0.8	57

The use of pure water as extracting solvent was not preferred because this method led to a lower extraction recovery (72%) than those obtained with the other methods. This result is in accordance with previous studies demonstrating that some As species are not soluble in water (Shiomi et al., 1988). The extraction procedures which gave the best recoveries of total As were those involving MeOH, reaching an extraction recovery of 86 %. Nevertheless, the use of MeOH can lead to severe matrix effects, as already described in a previous study (Nam et al., 2010). Extraction methods using methanol revealed also a high variability of the results, as shown by high standard deviations (Table 3). Accounting uncertainties, similar results were reached for extracted As with 25% MeOH or 0.6 mol L⁻¹ H₃PO₄ as extractants. Even if extractions performed with 25% MeOH revealed a highest extraction recovery (86%), this method was not retained due to possible analytical discrepancies and higher variabilities of

the results. The 0.6 mol L⁻¹ H₃PO₄ solution was selected because it appeared to be the best compromise: a good extraction recovery 81% (close to the 86% obtained with 25% of MeOH) and a good reproducibility of the results (RSD=3%). Considering that only a few studies have been published on As speciation in sponges, the choice of H₃PO₄ solution was also made in order not to lose the possible inorganic As species (the most toxic ones) possibly occurring in sponges samples, and to be able to preserve their chemical forms. The chosen extraction method was therefore applied to the selected CRMs. The extraction recoveries were found to be quite good, 106 and 97 %, for TORT-2 and BCR 627 respectively (Table 2). These results thus demonstrated the efficiency of the selected extraction solution.

3.1.3. As speciation analyses

Speciation analyses of the extracts allowed mainly AsB to be quantified whatever the extraction methods, AsB representing 57-114% of the extracted As (Table 3). The AsB concentration was overestimated using 50% MeOH as extractant, as shown by the anomalous high proportion of As from AsB in extracts (114%). As previously demonstrated, AsB concentrations can be overestimated using MeOH (Nam et al., 2010). Such as for extracted As, As from AsB concentrations revealed similar results with 25% MeOH or 0.6 mol L⁻¹ H₃PO₄ as extractants, accounting uncertainties. The difference on extraction recovery obtained for As from AsB were thus not significant due to the high variability of the results obtained with 25% MeOH. Finally, the extraction method with 25% MeOH was not retained due to possible analytical discrepancies and higher variabilities of the results. With the 0.6 mol L⁻¹ H₃PO₄ solutions, AsB represent 64% of the extracted As with a better precision.

Speciation analyses were performed then on CRMs and conducted to good speciation recoveries: 74% and 98% for TORT-2 and BCR 627 respectively (Table 2), highlighting the efficiency of speciation analyses. Measurements on the certified reference material BCR-627 gave a mean value of AsB equal to 4.5 ± 0.5 mg kg⁻¹ (n=6) and the occurrence of DMA just above the detection limit, in agreement with certified values. In TORT-2, the average AsB value was 13 ± 5 mg kg⁻¹ (n=4), in accordance with previously reported values (Suner et al., 2001; Wahlen et al., 2004). Two other As species occurred at low concentrations: DMA at 1.2 ± 0.8 mg kg⁻¹ and another unknown As specie, named A, at 1.9 ± 0.6 mg kg⁻¹, eluting between DMA and MMA (retention time: t_R = 2.5 min). The DMA result is in agreement with the indicative value. These results on the two CRMs confirm thus the efficiency of speciation analyses with accurate measurements of AsB.

3.2. As bioaccumulation in sponges

3.2.1. Variability of As concentrations in sponges

The variability of As content in sponges was estimated within the same specimen (intra-specimen variability), within the same sponge species (inter-specimen or intra-species variability), between different sampling sites or seasons, as well between different sponge species (inter-species variability).

The intra-specimen variability was evaluated analyzing at least 3 replicates of each sponge specimen (Table 2A, supplementary information). Each replicate underwent the whole sample preparation (i.e. microwave digestion and dilution). The total As content was highly variable within each specimen, with relative standard deviations (RSD) ranging from 8 to 36%. This result highlights a certain inhomogeneity which may be related to the low amount of sponge samples weighted for digestion (50 mg).

The inter-specimen (or intra-species) variability was evaluated by determination of total As in different specimens collected for each sponge species (Table 4). The variability, expressed with RSD, was usually around 10%, but it reached 38% for *C. nucula* in Feb. 2016. In Irish sponges inter-specimen variability was lower than in French samples (Table 4). Different authors reported RSD higher than 30% when evaluating intra-species variability in total As and other trace elements found in sponge samples (Batista et al., 2014; Cebrian and Uriz, 2007). A relevant natural variation shall further be considered for these marine invertebrates.

Table 4. Summary of As speciation results obtained for different sponges species sampled between February and November 2016 in three sites located in western Europe

Site	Date	Sponge species	Total As (mg kg ⁻¹)	Extracted As (mg kg ⁻¹)	Extraction recovery (%)	As from AsB (mg kg ⁻¹)	As from DMA (mg kg ⁻¹)	As(+V) (mg kg ⁻¹)	Unknown As specie A (mg kg ⁻¹)	Unknown As specie B (mg kg ⁻¹)	Speciation recovery (%)	Known As in sponge (%)
Villefranche sur Mer (France)	Feb. 2016	<i>H. fulva</i>	26± 6	16± 9	59	12± 8	1.7± 0.6	1.4± 0.2	<0.1	1.5± 0.5	106	66
		<i>A. acuta</i>	44± 8	28± 1	64	24± 6	3.1± 0.7	1.9± 0.3	<0.1	1.9± 0.4	109	69
		<i>C. nucula</i>	34± 13	26± 7	77	24± 9	3± 1.0	1.44± 0.02	<0.1	1.3± 0.1	116	88
		<i>C. damicornis</i>	74± 11	36± 8	49	23± 8	3± 1.0	1.6± 0.4	<0.1	1.7± 0.4	79	39
	Sep. 2016	<i>H. fulva</i>	29± 5	20± 5	69	16± 2	1.9± 0.1	0.1<c<0.4	<0.1	1.0± 0.1	95	66
		<i>A. acuta</i>	33± 2	17± 2	51	16± 4	2.1± 0.1	0.6± 0.2	<0.1	1.4± 0.4	119	61
		<i>C. nucula</i>	27± 4	24± 7	87	22± 7	2.3± 0.7	0.1<c<0.3	1.5± 0.4	0.1<c<0.3	104	92
		<i>C. damicornis</i>	55± 7	25± 3	46	27± 13	2.7± 1	0.1<c<0.3	<0.1	1.0± 0.2	120	56
Kilkieran Bay (Ireland)	Oct. 2016	<i>H. panicea</i>	7.3± 0.8	6.0± 0.1	83	2.5± 0.2	<0.1	0.1<c<0.3	<0.1	0.89± 0.08	57	47
		<i>H. perlevis</i>	6.9± 0.5	7.2± 0.4	105	2.4± 0.3	<0.1	0.1<c<0.3	<0.1	1.1± 0.2	47	49
Greenisland (Northern Ireland)	Nov. 2016	<i>H. panicea</i>	5.7± 0.5	4.7± 0.4	81	1.7± 0.3	<0.1	0.1<c<0.3	<0.1	0.8± 0.2	52	43
		<i>H. perlevis</i>	7.6± 0.3	7± 2	88	3.7± 1.1	<0.1	0.1<c<0.3	<0.1	0.91± 0.03	66	61

Variability of the total As content related to sampling site characteristics was also estimated. The variability of As content and its species were estimated according to light conditions and the depth of the sampling (Fig. 1). ANOVA tests revealed no significant difference between As content in *C. damicornis* specimens collected in the cave center and those collected at the cave entrance; analogously no significant differences were found between *C. nucula* specimens collected at different depths. For Irish sponges, ANOVA analyses revealed no significant differences in As contents for the same Irish specie collected in Belfast and Killkieran Bay. ANOVA analyses performed on Mediterranean sponges, showed no significant differences between As contents measured in samples collected in two different period, except for *C. damicornis* sponges which showed significant lower As content in September 2016. As-bioaccumulation is an integrative data over the sponge's life. This explains in part the low temporal variations of As content in Mediterranean sponges between the two sampling periods. Seasonal variations in As contents within the same species can be thus considered moderate taking into account the inter-specimen variability.

Results on total As in digested and extracted samples, and on As speciation for two sponge species (*C. nucula* and *C. damicornis*) collected under different environmental conditions (depth and light). The error bars represent the standard deviation calculated considering every replicate performed on each species (n=3).

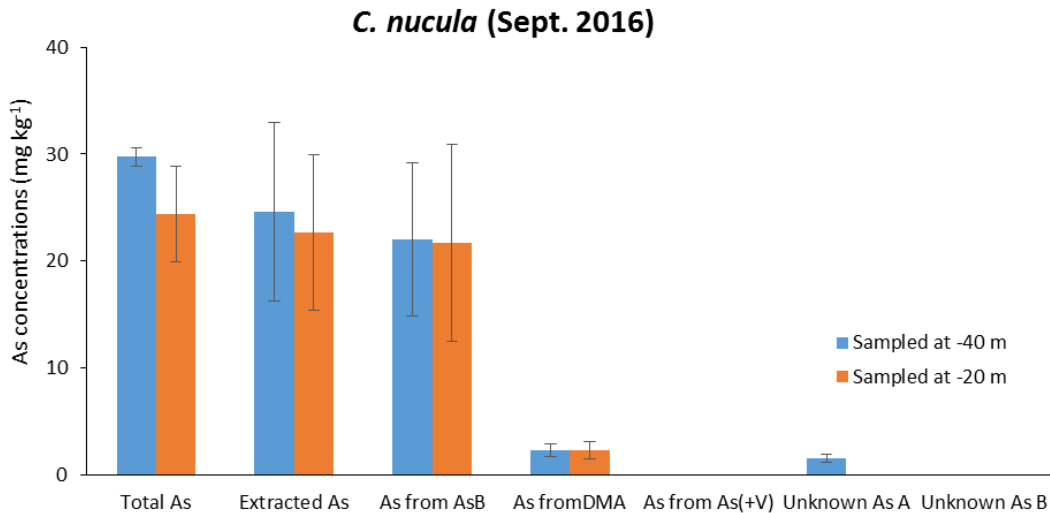

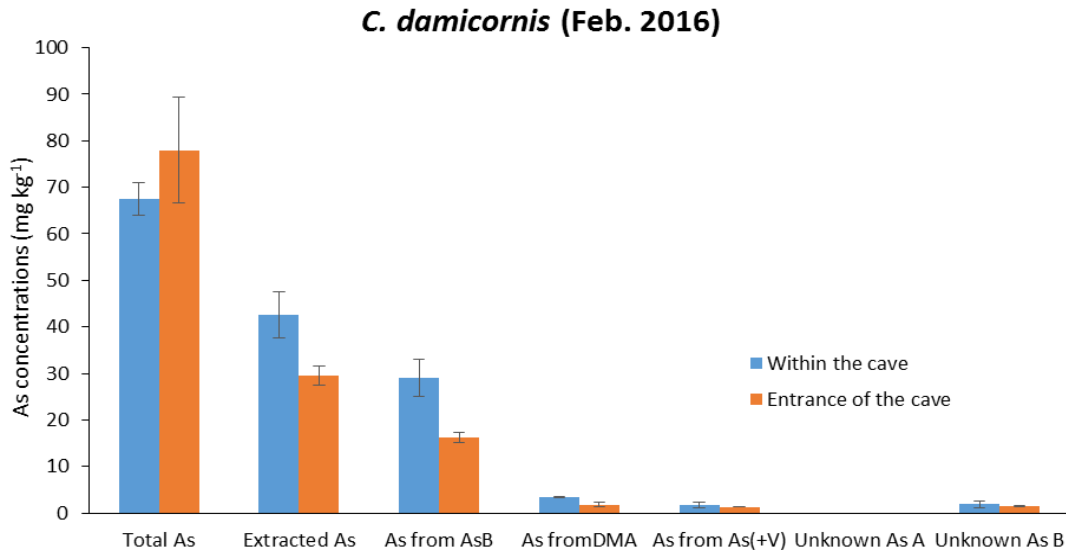

A significant inter-species variability of total As content was shown, regardless of the considered sampling period, and confirmed by ANOVA analysis. In France, *C. damicornis* sponges accumulate significantly higher As amounts compared to other Mediterranean species (up to two times more). In Irish samples, As concentrations were significantly lower than those measured in Mediterranean specimens (2 times lower). Differences in accumulation efficiency between sponge species can be related to differences in morphological characteristics but also to the age of the sponges. The different species have different growing rates. *H. panicea* and *H. perlevis* are very fast growing compared to *C. damicornis* and *C. nucula*. The samples collected in the Irish coasts belong to the same order (*Suberitida*), which could explain similar behavior in terms of As accumulation while the Mediterranean sponges belong to the different orders *Axinellida* (*C. damicornis*), *Chondrosida* (*C. nucula*), *Haplosclerida* (*H. fulva*), and *Bubarida* (*A. acuta*). This study confirms that As concentration is dependent on sponge species, as shown by the variable As contents found in the literature (Table 5). Sponges accumulate more As than other marine organisms, which makes them suitable models for biomonitoring studies, as already proposed by Genta-Jouve et al., 2012. As accumulation was previously demonstrated to be higher in demosponges than in calcareous sponges (Yamaoka et al., 2001) and highly variable among different species of demosponges, as shown in the present study. Yamaoka et al. (2006) measured an As content equal to 6.1 mg kg⁻¹ in *Acanthella* sp., which is slightly lower than values found in the present study. This difference is easily explained considering that the present study refers to As content in sponges measured after total digestion while Yamaoka et al. worked on water soluble fractions. Additionally, sponges may have very different morphological characteristics or microbiomes even when

belonging to the same genus. In *Haliclona sp.*, previous study revealed As concentrations of 0.81 mg kg⁻¹ in *Haliclona sp.* white, 13 mg kg⁻¹ in *Haliclona permolis* (Yamaoka et al., 2001), 1.03 mg kg⁻¹ in *Haliclona tenuiramosa* (Venkateswara Rao et al., 2009) and between 1.5 and 8.5 mg kg⁻¹ for *Haliclona oculata* (Aly et al., 2013). For these two species (*Acanthella sp.* and *Haliclona sp.*), the present study revealed higher As contents ranging from 29-44 mg kg⁻¹ (Table 4). Perez et al. (2005) measured also high As concentrations in another sponge species collected in the Mediterranean sea, *Spongia officinalis* (86.3-134.1 mg kg⁻¹). Regarding *Halichondria panicea*, Vaskovsky et al. (1972) reported similar As concentrations (6 mg kg⁻¹). But these results refer to As concentration measured in lipid extracts which is only a part of the total As content determined in this study. The present study confirms thus that As concentrations in sponges depends on the specific properties related to a particular sponge species.

Table 5. Summary of literature data available on total As and its speciation in sponges. Total As results refer to total content in dried sample, unless otherwise stated

Sponge specie	Sampling location	Total As (mg kg ⁻¹)	As concentration (mg kg ⁻¹)			Reference
			AsB	AsS	Others	
<i>Hymeniacidon heliophila</i>	Guanabara Bay, Brazil	4.6-8.1				Batista et al., 2014
<i>Paraleucilla magna</i>		1.2-2.6				
<i>Haliclona oculata</i>	Poole harbor, UK	1.5-8.5				Aly et al., 2013
<i>Sphaciospongia vagabunda</i>	Darwin Harbour, Australia	10.1-56.4				Padovan et al., 2012
<i>Hyrtios erectus</i>	Red Sea, Saudi Arabia	15-63.9				Pan et al., 2011
<i>Hyrtios sp.</i>		2.30				
<i>Stylissa carteri</i>		7.5-10.7				
<i>Chalinula sp.</i>		13.7-22.1				
<i>Xestospongia testudinaria</i>		20.7-42.2				
<i>Phyllospongia papyracea</i>		8.0				
<i>Amphimedon sp.</i>		11.2				
<i>Spongia arabica</i>		106.1				
<i>Sphaciospongia inconstans</i>		15.0				
<i>Haliclona tenuiramosa</i>	Gulf of Mannar, India	0.32-1.09				Rao et al., 2009
<i>Petrosia testudinaria</i>	Gulf of Mannar, India	2.30				Rao et al., 2006
<i>Thorecta sp.</i>	Bohol Sea, Philippines	6.2*	3.0	2	1.2	Yamaoka et al., 2006 *water fraction
<i>Dysidea sp.</i>		24.8*	15.2	1.4	8.1	
<i>Theonella sp.</i>		157.0*	136.6	2.21	18.2	
<i>Acanthella sp.</i>		6.1 *	1.7	2.0	2.4	
<i>Phyllospongia sp.</i>		4.4*	1.5	2.12	0.7	
<i>Aaptos sp.</i>		112.5*	98.1	0.25	14.2	
<i>Biemna fortis</i>		1.0*	0.13	0.15	0.8	
<i>Jaspis sp.</i>		6.1*	0.6	3.7	1.7	
<i>Subertes sp.</i>		10.3*	1.7	7.4	1.1	

<i>Haliclona permolis</i>		13*	3.3	9.9	0.5	
<i>Halichondria japonica</i>		3.4*	1.1	1.6	0.8	
<i>Haliclona sp. white</i>		0.8*	0.2	0.5	0.2	
<i>Halichondria okadai</i>		5.5*	0.5	4.5	0.5	
<i>Ephydatia fluviatilis</i>	Danube river, Hungary	8.07	<0.02	0.29	0.12 (DMA)	Schaeffer et al., 2006
<i>Spongia officinalis</i>	Marseille, France	86.3-134.1				Perez et al., 2005
<i>Callispongia diffusa</i>	Guam Island, Pacific Ocean	<0.01				Denton et al., 2006
<i>Cinachyra sp.</i>		<0.01				
<i>Clathria vulpina</i>		<0.01				
<i>Dysidea sp.</i>		0.01-10.5				
<i>Liosina cf. granularis</i>		39.7-47.7				
<i>Stylotella aurantium</i>		0.01-6.42				
Unidentified sponge 1		5.91-19.8				
Unidentified sponge 2		37.9				
Unidentified sponge 3		0.01-43.1				
<i>Cliona viridis</i>		Berlangas Islands, Portugal	25-32			
<i>Cliona celata</i>	12-47					
<i>Myriastrananoora</i>	73					
<i>Erylus discophorus</i>	60-99					
<i>Adocia sp.</i>	16-21					
<i>Spongia nitens</i>	33-65					
<i>Spongia agaricina</i>	47-83					
<i>Spongia officinalis</i>	47-64					
<i>Cacospongia scalaris</i>	64-119					
<i>Ircinia fasciculata</i>	31-65					
<i>Haliclona permolis</i>	Seto Inland Sea, Japan	13.00*	3.34	9.2	0.52	Yamaoka et al., 2001 *water fraction
<i>Halichondria japonica</i>		3.42*	1.10	1.54	0.78	
<i>Halichondria okadai</i>		5.50*	0.53	4.5	0.47	
<i>Haliclona sp. white</i>		0.81*	0.15	0.45	0.21	
<i>Halichondria okadai</i>	Chiba, Japan	6.80	n.q.			Shiomi et al., 1988 n.q. : not quantified
<i>Halichondria japonica</i>		6.40				
<i>Spirastrella insignis</i>		3.20	n.q.		n.q.	
<i>Halichondria panicea</i>	Posiet Bay Japan	6.4**				Vaskovsky et al., 1972 **lipid extract

3.2.2. As bioaccumulation in sponges

The Bio-Concentration Factor (BCF) and the Bio-Accumulation Factor (BAF) are useful and powerful tools in the interpretation of such results, since they give an idea of sponge behavior related to the surrounding environment and feeding habits. BCF represents the ratio between the As concentration found in biota and in the habitat, in this case the sediment. BAF represents the ratio between the As

concentration found in biota and in the organism's diet, in our case seawater, since sponges are filter feeders (Gobas, 2001).

In this work, sediment collected from the French coast showed a constant As content for both sampling period: $7 \pm 2 \text{ mg kg}^{-1}$ of As (measured on three sediment samples for each sampling period) while sediment samples collected from Kilkieran Bay and Greenisland show an As content of 7 ± 2 and $2.9 \pm 0.3 \text{ mg kg}^{-1}$ respectively. These values are below the limit imposed by the principal environmental authorities for As in marine sediments (7.24 mg kg^{-1} , US EPA, 2006). Regarding sponges collected in Ireland, specimens coming from Kilkieran bay showed BCF close to 1, while specimens of *H. panicea* and *H. perlevis* sponges collected in Belfast showed BCF of 2.1 and 3.5 respectively. BCF in Mediterranean sponges range from 3.6 to 12. Similar values were reported for bivalves (6-19) (Negri et al., 2006) and were found to be higher than in other sponges (close to 1) (Mayzel et al., 2014). Extremely high As BCF of 477 was also previously measured in only one sponge species, *Theonella swinhoei*, which was explained by the presence of a particular bacterium (Mayzel et al., 2014). It is worth noticing that *Theonella swinhoei* is a slow growing and long-lived sponge specie so As concentration may be also linked to the age of the sponge and thus responsible for the elevated BCF. The fact that most BCF were higher than 1 (except in Kilkieran Bay) proves that sponges are able to accumulate As at higher concentrations than their surrounding environment (sediment in our case), which means that there are additional biological processes involved in As accumulation.

As concentration in seawater used for the calculation of BAF in Mediterranean sponges was determined in a sample collected in Monaco and measured at the Environment Laboratories of the International Atomic Energy Agency. The average value found in seawater sample was $1.5 \pm 0.2 \mu\text{g L}^{-1}$ and it was used for BAF calculations because of the vicinity of the sampling site. This As content is in agreement with total As content of $1.3 \mu\text{g L}^{-1}$ previously measured in surface seawater from Mediterranean Sea (Cabon and Cabon, 2000). Mediterranean sponges BAF of As ranged between 15000 and 60000, i.e. in the order of 4.2 to 4.8 for log BAF. For the calculation of BAF in Irish sponges, the average reference value for As in seawater was $2.5 \mu\text{g L}^{-1}$, as reported by Crompton and Crompton (1989). The BAF obtained were between 274 and 318 for samples collected in Kilkieran Bay and between 250 and 412 for samples collected in Greenisland, namely values between 2.4 and 2.6 in logarithmic scale. BAF calculations revealed thus significant higher values for Mediterranean sponges than Irish ones, but both sufficiently high to indicate that these organisms are efficient bioaccumulators of As.

Other BAFs reported in the literature for freshwater or marine organisms are in the range of $3 < \log \text{BAF} < 4$ for fishes, bivalves, shrimps, gastropods and mussels (Hong et al., 2014; Giusti and Zhang, 2002) algae and plankton (Chen et al., 2000; Mitra et al., 2012). In uncontaminated environments, As concentrations were measured in freshwater sponges (*Ephydatia fluviatilis*), water and sediments by Schaeffer et al., (2006) showing values of about 8.07 mg kg^{-1} , $1.1 \mu\text{g L}^{-1}$ and 3.6 mg kg^{-1} respectively (which is lower As contents than our Mediterranean sampling site but comparable with the Irish one). With these previous measurements on freshwater sponges, BAF and BCF calculations performed for As revealed: a BCF of 2.24 and a BAF of 7336 ($\log \text{BAF}=3.9$). These results were slightly lower than those determined in our Mediterranean marine sponges but higher than results obtained for Irish samples. Nevertheless, it is quite difficult to compare these results due to different environmental conditions (freshwater or seawater). Concentrations of As in water, sediments and biota were previously suggested to increase with increasing salinity and BAF for As in other aquatic organisms might be slightly inversely proportional to salinity (Hong et al., 2014). In this study, BAF for As were higher in samples coming from the Mediterranean Sea (average salinity of about 38‰) than those collected in Ireland (average salinity 34‰) (Salaün et al., 2007; Tsimplis and Baker, 2000). However, the comparison is not easy due to the presence different sponge species, and the fact that TEs bioaccumulation in sponges was suggested to differ according to sponge species (Batista et al., 2014; Mayzel et al., 2014). Factors affecting the differences in the bioaccumulation are suggested to be mainly related to sponge species due to morphological characters like spicules, fibers but also the microbial content.

3.3. As biotransformation in sponges

3.3.1. Variability of extracted As according to sponge specie

For all sponge species collected in this study, extraction recoveries vary from 49% to 105% (Table 4), demonstrating the efficiency of the optimized extraction method for As. The variability of As extracted amounts within the same species was quite moderate (ranging from 10 to 30%). It can be easily noticed that the extraction recoveries differ according to sponge species. The best As extraction recoveries (> 77 %) were obtained for *C. nucula*, *H. panicea* and *H. perlevis*. Extraction recoveries ranged between 51 and 69% for *H. fulva* and *A. acuta* sponge species. Lowest extraction recoveries were obtained for *C. damicornis* (46-49 %). These low extraction recoveries may be explained by the occurrence of As organic species (for example, AsS), not extracted with our method and which would be better extracted with

methanol. For *C. damicornis* sponges, further development of the extraction procedure would be necessary to increase the extraction recovery.

3.3.2. As speciation in sponges

As speciation analyses were performed on extracts of sponge samples (Table 4). For each sponge species, speciation analyses were carried out on 3 sponge specimens. Significant differences on As speciation occur between the Irish and Mediterranean sponges (Fig. 2).

Figure 2. Distribution of different As species in a) different sponge species collected during two sampling periods in France and b) different sponge species collected in two sampling sites in Ireland.

a)

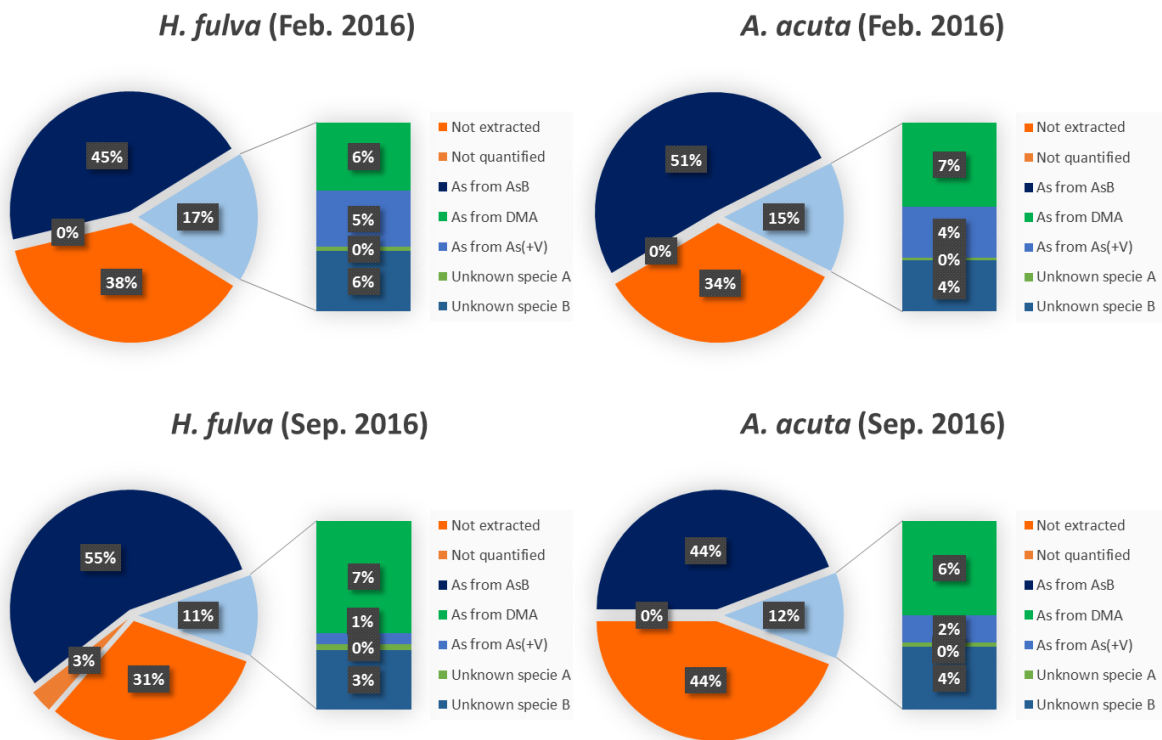

***C. nucula* (Feb. 2016)**

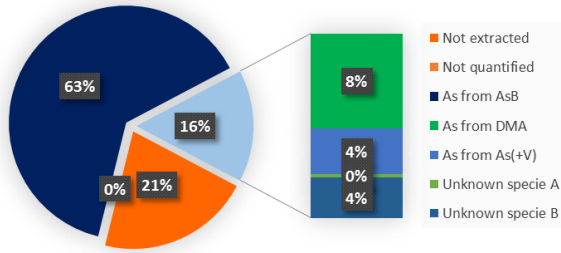

***C. damicornis* (Feb. 2016)**

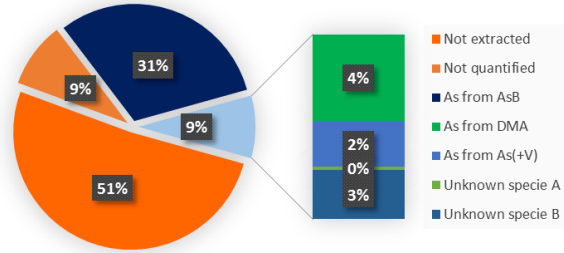

***C. nucula* (Sep. 2016)**

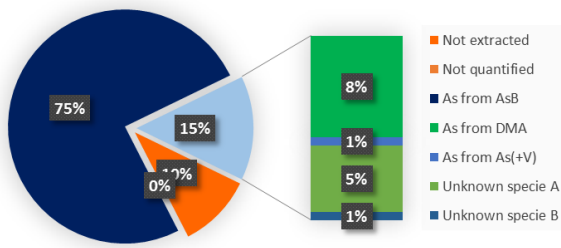

***C. damicornis* (Sep. 2016)**

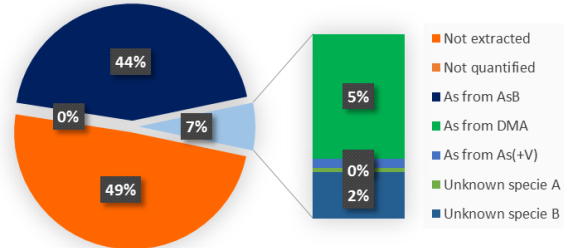

b)

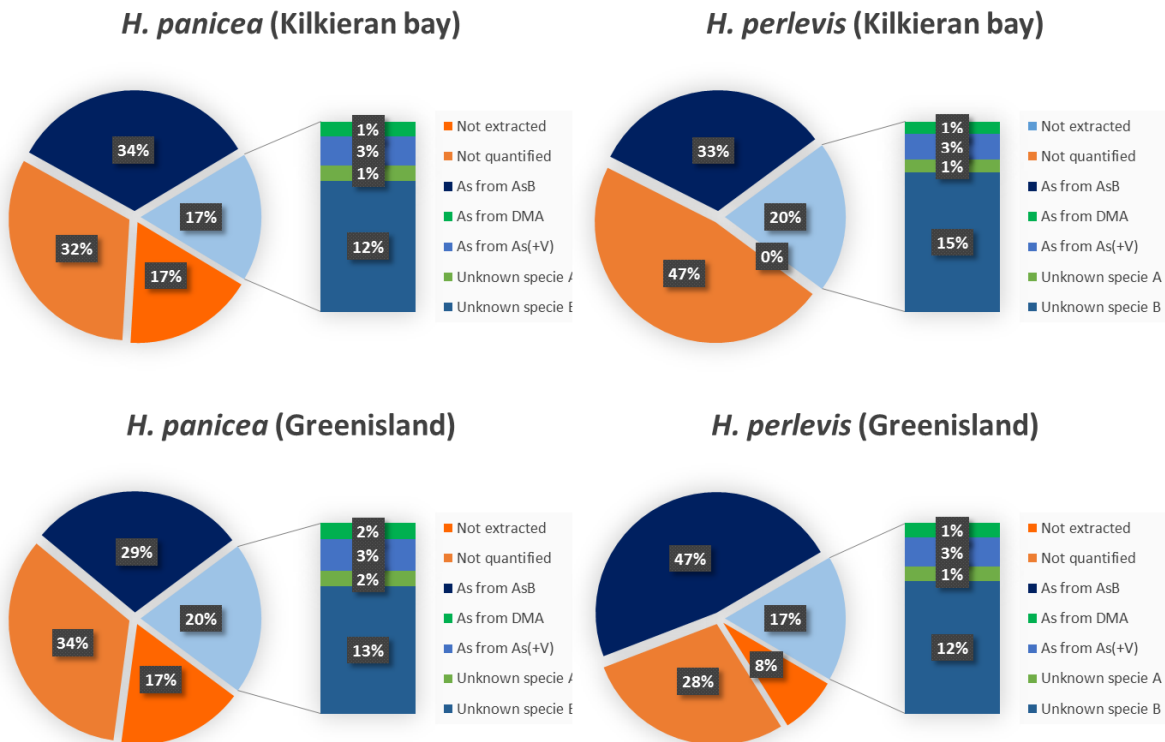

Despite the fact that most of the As was successfully extracted in Irish sponges (>81 %), a large proportion of the extracted species was not identified/quantified (speciation recoveries ranged from 52 to 66 %). Vaskovsky et al. (1972) reported a similar As concentrations in *Halichondria panicea* sponges, but measured in lipid extracts. This result may prove the occurrence of As rather under organic As species, probably those not identified in our study. For Mediterranean sponges, although the extraction recovery was generally lower than Irish samples (especially for *C. damicornis*), almost the totality of extracted species were identified and quantified, with a speciation recovery between 79 and 119%. Within the same sponge species and the same sampling date, the variability of extracted As content and As speciation related to sampling site characteristics was also estimated (Fig. 1). ANOVA analysis revealed no difference on extracted As and As speciation for *C. nucula* sponges sampled at different depth; analogously no significant difference in extracted As and As speciation was found for *C. damicornis* specimens collected at the center and entrance of the cave. Such as As bioaccumulation, As speciation in sponges is suggested to be mainly related to sponge species.

As speciation analysis in sponge extracts reveals the large occurrence of AsB (>29% of the total As) and the presence of different As species at low concentrations: DMA, As(+V) (Fig. 2). Additionally, two unknown species were found: a first one eluting between DMA and MMA (only for *C. nucula* in Sep. 2016) and a second one eluting after As(+V). These results on As speciation in marine sponges are different from those obtained in freshwater sponge *Ephydatia fluviatilis* in which inorganic species were found to be dominant: 57 % of As(+V), 20 % of As(+III), AsS (11%), DMA (4%) and undetected AsB (<1%) (Schaeffer et al., 2006). In the present study, among minor As species, DMA accounted for about 10% of extracted As in Mediterranean sponges, (i.e. 4-8% of the total As content) whereas this specie was not detected in Irish sponges at all. As(+V) was detected in all sponges' species, but it was possible to quantify it only for some of the Mediterranean specimens. This species represents about 5-9 % of the extracted As content (i.e. 1-5 % of the total As content). The unknown As species, named B and eluting after As(+V) (retention time, $t_R = 4.5$ min), presents a similar As concentration (close to 1 mg kg⁻¹) regardless of the sponge species, representing between 5% and 15 % of extracted As in Mediterranean and Irish sponges respectively (i.e. 2 and 15% of the total As). The unknown As specie A, eluting between DMA and MMA ($t_R=2.5$ min), occurs in *A. acuta* specimens but only in samples collected in September 2016, representing 6% of extracted As (i.e. 5% of the total As). Even if AsB is the main As species in *H. fulva*, *A. acuta* and *C. nucula* sponge species, it occurs in a lesser proportion in *C. damicornis* (31-44 %), *H. panicea* (29-34 %), and *H. perlevis* (33-47 %) (Fig. 2). Even though *C. damicornis* accumulates more As than the other sponge species, this sponge specie does not accumulate more AsB. This higher As content is thus related to other As species, probably other organic forms not extracted or not detected with the methodology used in the present study. The AsB predominance in *A. acuta* (86-94% of As extracted or 48-55% of total As) is in accordance with the previous results on a sponge of the same genus (28% of the water soluble extract) (Yamaoka et al., 2006). Two AsS were also reported to occur in large amounts (22% oxo-AsS-phosphate, 11% oxo-AsS-glycerol, and 39% of unknown As species). These other As species may coincide with the occurrence of unknown As species found in our study or other As species not extracted with our method, specifically the As specie B representing 7.5% of extracted As. In *H. fulva*, AsB was also the predominant As-species (75-80% of As extracted or 46-55% of total As), whereas in the same genus (*H. permolis*), the oxo-AsS-phosphate was identified (61% of the water soluble extract) (Yamaoka et al., 2001 and 2006). The same authors also reported AsS as predominant As species in *Halichondria sp.*, and a content of AsB between 9 and 32% whereas AsB were reported dominant in another study (Shiomi et al., 1988). In the present study, *H. panicea* sponges from the same genus contained an AsB which accounts for 34 and 29% of total As, for samples collected in

Kilkieran bay and Greenisland, respectively. All these results demonstrate that As speciation and the predominance of AsB or the AsS may not result only from sponge specie or genus characteristics. Yamaoka et al., (2001 and 2006) suggested that the different proportions of AsS may reflect the different symbionts living within sponges. This previous hypothesis would support: (1) the change of the predominant As-species within the same sponge species, and (2) the difference of As-bioaccumulation and biotransformation within a specific sponge species (*C. damicornis*, here) comparing to the others.

3.4. Pathways of As bioaccumulation and biotransformation

In surface seawater, As usually occurs under toxic inorganic species, mainly As(+V). Arsenic speciation analyses in seawater reported in the literature revealed a content of $1 \mu\text{g L}^{-1}$ of As(+V) and $0.2 \mu\text{g L}^{-1}$ of As(+III) in the Mediterranean sea (Cabon and Cabon, 2000) and from 1.9 to $3 \mu\text{g L}^{-1}$ of As(+V) and As(+III) <LOD in Irish seawater (Salaün et al., 2007). Sponges are efficient filter feeders, strongly accumulating As ($4 < \log \text{BAF} < 5$). Due to As bioaccumulation and biotransformation (converting toxic inorganic As species in less-toxic organic species) within the sponge tissue, sponges may be a relevant tool for bioremediation of As-contaminated site, producing possible secondary metabolites of great interests (pharmaceuticals and bioactive compounds) under stressful environmental conditions (due to pollution). For instance, a polyarsenic organic compound showing antibacterial and antifungal properties was recently isolated from sponges (Mancini et al., 2006). The possible application of sponges in the field of environmental bioremediation has been proposed in previous studies with different applications (Longo et al., 2010; Santos-Gandelman et al., 2014).

The main occurrence of AsB in osmoconformers such as sponges may be justified in waters characterized by high salinity because this molecule (as glycine-betaine) may serve to protect against osmolytic stress (Clowes and Francesconi, 2004; Caumette et al., 2012). Since AsB is also the least toxic form of arsenic, the production of such a molecule during a protecting process could be useful in the detoxification of As contaminated waters. Since no AsB occurs in seawater and low contents of inorganic As measured in sponges, biotransformation is responsible of these changes of As speciation. During their feeding process, sponges ingest water (where the dominant As-species is As(+V)), and microorganisms (potentially containing organic As species). Two different pathways may be responsible of the As bioaccumulation and biotransformation within sponges: (1) a dietary route, through the feeding of microorganisms (phytoplankton) enriched by organic species; (2) and/or a waterborne route, i.e. a direct uptake from seawater and biotransformation within sponges.

Phytoplankton is considered as a major food source for the organisms of higher trophic levels, such as sponges; this autotrophic organism plays an important role in the distribution and biotransformation of As species in the marine environment (Rahman et al., 2012). Microorganisms which constitute the sponge's food, are known as producers (the first link of the food chain), contain high concentrations of As. AsB retained first the attention because it is formed by organisms at low trophic levels and accumulated through the food chain (Edmonds et al., 1993; Edmonds et al., 1997; Cullen and Reimer, 1989; Francesconi, 2010). Phytoplankton, microalgae, bacteria or cyanobacteria are able to convert inorganic As into organic species through biological processes (Azizur Rahman et al., 2012; Wang et al., 2015; Miyashita et al., 2016). For example, in phytoplankton, inorganic arsenic is incorporated in cells where it is methylated and transformed into AsS via adenosylation steps, possibly as a detoxification process (Caumette et al., 2012). The direct uptake of AsB-enriched microorganisms by sponges seems thus to be unlikely because As speciation in producers (algae, phytoplankton) revealed the main occurrence of AsS and a low content of AsB (Grotti et al., 2010; Llorente-Mirandes et al., 2010). Another dietary route would be the ingestion of AsS enriched microorganisms and the further conversion of AsS into AsB with sponge metabolisms or their symbionts organism. The unknown or undetected As species found in this study may be related to the occurrence of these AsS species.

The occurrence of AsB in sponges may be also related to microorganisms enriched with another As species, the (arsenoriboside) and ingested by the sponges. . As proposed by Caumette et al. (2012) for zooplankton, once sponges ingest phytoplankton, AsS may be degraded by associated bacterial communities, leading to the formation of AsB. The latter was also suggested to be produced within marine organisms from the transformation of arsenoribosides accumulated from their diet (Foster and Maher, 2016). Arsonioribosides would be thus another precursor of AsB formation. If the occurrence of As(+V) in seawater is recognized to be constant along time, the occurrence of micro-organisms is not continuous and can vary with seasons (e.g. phytoplankton dynamics vs nutrients in seawater). Because of the main occurrence of AsB within our sponge samples and the seasonal phytoplankton dynamic, the As biotransformation pathway via a dietary route it is rather unlikely to be the main process.

A waterborne route is the second hypothetic pathway for As bioaccumulation and transformation in sponges. After direct uptake of As(+V) from seawater, sponges might biotransform this inorganic As into AsB. Biological processes including methylation steps and conversion into AsB have previously been proposed for marine fishes (Zhang et al., 2016a; Zhang et al., 2016b) as well as for marine sponges (Yamaoka et al., 2006). For marine sponges, DMA was also proposed to be converted into AsS and

further into AsB (Yamaoka et al., 2006). The unknown or undetected As species found in our sponge samples may account for the occurrence of AsS occurring in different proportions within sponges (34 - 60 %, orange parts in Fig. 2). The As biotransformation within sponges may be directly related to the sponge metabolism, but could also indirectly occur by the action of symbiotic micro-organisms (microalgae, bacteria). Symbiotic cyanobacteria can contain high As content and were already recognized as the source of the AsS in sponges (Yamaoka et al., 2001). Recently, As cycle in a *Theonella swinhoei* sponges was demonstrated to be largely driven by symbiotic bacteria (Keren et al., 2017). This last result suggested rather the main implication of symbiont bacteria for As biotransformation within sponges; but it is not obvious to confirm this pathway with our results.

4. Conclusions

For the first time, several sponge species from the northwestern Mediterranean, and the northeastern and western Irish coasts were investigated for their As bioaccumulation and biotransformation. Methodologies were optimized for As total determination and speciation in these marine organisms. The total As content was found to be very diverse according to sponge species and sampling sites, ranging between 6 and 77 mg kg⁻¹. Bioaccumulation and bioconcentration factors revealed the great capabilities of sponges to accumulate this element with respect to concentration found in surrounding environment. As speciation showed predominance of AsB in all analyzed samples, in accordance with previous studies on marine organisms. The pathway for the conversion of As(+V) from seawater into AsB in sponges is likely to be associated to the sponge metabolism or symbiont organisms. Finally, the outcomes of this study contribute to a better understanding of the distribution and metabolism of arsenic compounds in marine sponges.

References (paper 7)

- Aly, W., Williams, I.D., Hudson, M.D., 2013. Metal contamination in water, sediment and biota from a semi-enclosed coastal area. *Environ. Monit. Assess.* 185, 3879–3895. <https://doi.org/10.1007/s10661-012-2837-0>
- Andrewes, P., Demarini, D.M., Funasaka, K., Wallace, K., Lai, V.W.M., Sun, H., Cullen, W.R., Kitchin, K.T., 2004. Do arsenosugars pose a risk to human health? The comparative toxicities of a trivalent and pentavalent arsenosugar. *Environ. Sci. Technol.* 38, 4140–4148. <https://doi.org/10.1021/es035440f>
- Araújo, M.F., Conceição, A., Barbosa, T., Lopes, M.T., Humanes, M., 2003. Elemental composition of marine sponges from the Berlengas Natural Park, western Portuguese coast. *X-Ray Spectrom.* 32, 428–433. <https://doi.org/10.1002/xrs.660>
- ATSDR, 2007. Toxicological Profile for Arsenic, U.S. Public Health Service, Agency for Toxic Substances and Disease Registry. <https://doi.org/http://dx.doi.org/10.1155/2013/286524>
- Rahman, M., Hasegawa, H., Peter Lim, R., 2012. Bioaccumulation, biotransformation and trophic transfer of arsenic in the aquatic food chain. *Environ. Res.* 116, 118–135. <https://doi.org/10.1016/j.envres.2012.03.014>
- Barats, A., Féraud, G., Potot, C., Philippinini, V., Travi, Y., Durrieu, G., Dubar, M., Simler, R., 2014. Naturally dissolved arsenic concentrations in the Alpine/Mediterranean Var River watershed (France). *Sci. Total Environ.* 473–474, 422–436. <https://doi.org/10.1016/J.SCITOTENV.2013.12.007>
- Batista, D., Muricy, G., Rocha, R.C., Miekeley, N.F., 2014. Marine sponges with contrasting life histories can be complementary biomonitors of heavy metal pollution in coastal ecosystems. *Environ. Sci. Pollut. Res.* 21, 5785–5794. <https://doi.org/10.1007/s11356-014-2530-7>
- Beauchemin, D., 2008. Inductively coupled plasma mass spectrometry. *Anal. Chem.* 80, 4455–4486.
- Bell, J.J., 2008. The functional roles of marine sponges. *Estuar. Coast. Shelf Sci.* 79, 341–353. <https://doi.org/10.1016/j.ecss.2008.05.002>
- Benramdane, L., Bressolle, F., Vallon, J.-J., 1999. Arsenic speciation in humans and food products: a review. *J. Chromatogr. Sci.* 37, 330–44. <https://doi.org/10.1093/chromsci/37.9.330>
- Brown, J.L., Kitchin, K.T., George, M., 1997. Dimethylarsinic acid treatment alters six different rat biochemical parameters: Relevance to arsenic carcinogenesis. *Teratog. Carcinog. Mutagen.* 17, 71–84. [https://doi.org/10.1002/\(SICI\)1520-6866\(1997\)17:2<71::AID-TCM3>3.0.CO;2-B](https://doi.org/10.1002/(SICI)1520-6866(1997)17:2<71::AID-TCM3>3.0.CO;2-B)
- Cabon, J.Y., Cabon, N., 2000. Speciation of major arsenic species in seawater by flow injection hydride generation atomic absorption spectrometry. *Fresenius. J. Anal. Chem.* 368, 484–9. <https://doi.org/10.1007/s002160000526>
- Caumette, G., Koch, I., Reimer, K.J., 2012. Arsenobetaine formation in plankton: a review of studies at the base of the aquatic food chain. *J. Environ. Monit.* 14, 2841. <https://doi.org/10.1039/c2em30572k>

- Cebrian, E., Uriz, M.-J., Turon, X., 2007. Sponges as biomonitors of heavy metals in spatial and temporal surveys in northwestern mediterranean: multispecies comparison. *Environ. Toxicol. Chem.* 26, 2430–2439. <https://doi.org/10.1897/07-292.1>
- Cebrian, E., Uriz, M.J., 2007. Contrasting effects of heavy metals on sponge cell behavior. *Arch. Environ. Contam. Toxicol.* 53, 552–558. <https://doi.org/10.1007/s00244-006-0257-2>
- Chen, C.Y., Stemberger, R.S., Klaue, B., Blum, J.D., Pickhardt, P.C., Folt, C.L., 2000. Accumulation of heavy metals in food web components across a gradient of lakes. *Limnol. Oceanogr.* 45, 1525–1536. <https://doi.org/10.4319/lo.2000.45.7.1525>
- Ciardullo, S., Aureli, F., Raggi, A., Cubadda, F., 2010. Arsenic speciation in freshwater fish: Focus on extraction and mass balance. *Talanta* 81, 213–221. <https://doi.org/10.1016/j.talanta.2009.11.060>
- Clowes, L.A., Francesconi, K.A., 2004. Uptake and elimination of arsenobetaine by the mussel *Mytilus edulis* is related to salinity. *Comp. Biochem. Physiol. - C Toxicol. Pharmacol.* 137, 35–42. <https://doi.org/10.1016/j.cca.2003.11.003>
- Crompton, T.R., Crompton, T.R., 1989. Chapter 8 – Organometallic compounds, in: *Analysis of Seawater*. pp. 336–359. <https://doi.org/10.1016/B978-0-407-01610-1.50011-4>
- Cullen, W.R., Reimer, K.J., 1989. Arsenic speciation in the environment. *Chem. Rev.* 89, 713–764. <https://doi.org/10.1021/cr00094a002>
- Denton, G.R.W., Concepcion, L.P., Wood, H.R., Morrison, R.J., 2006. Trace metals in marine organisms from four harbours in Guam. *Mar. Pollut. Bull.* 52, 1784–1804. <https://doi.org/10.1016/j.marpolbul.2006.09.010>
- Edmonds, J.S., Francesconi, K.A., Stick, R. V, 1993. Arsenic compounds from marine organisms. *Nat. Prod. Rep.* 10, 421–428.
- Edmonds, J.S., Shibata, Y., Francesconi, K. a, Rippingale, R.J., Morita, M., 1997. Arsenic transformations in short marine food chains studied by HPLC-ICP MS. *Appl. Organomet. Chem.* 11, 281–287. [https://doi.org/10.1002/\(sici\)1099-0739\(199704\)11:4<281::aid-aoc581>3.3.co;2-j](https://doi.org/10.1002/(sici)1099-0739(199704)11:4<281::aid-aoc581>3.3.co;2-j)
- Ellwood, M.J., Maher, W.A., 2003. Measurement of arsenic species in marine sediments by high-performance liquid chromatography-inductively coupled plasma mass spectrometry. *Anal. Chim. Acta* 477, 279–291. [https://doi.org/10.1016/s0003-2670\(02\)01414-9](https://doi.org/10.1016/s0003-2670(02)01414-9)
- Foster, S., Maher, W., 2016. Arsenobetaine and thio-arsenic species in marine macroalgae and herbivorous animals: Accumulated through trophic transfer or produced in situ? *J. Environ. Sci.* 49, 131–139. <https://doi.org/10.1016/j.jes.2016.06.003>
- Francesconi, K.A., Sperling, M., 2005. Speciation analysis with HPLC-mass spectrometry: time to take stock. *Analyst* 130, 998. <https://doi.org/10.1039/b504485p>
- Francesconi, K. a., 2010. Arsenic species in seafood: Origin and human health implications. *Pure Appl. Chem.* 82, 373–381. <https://doi.org/10.1351/PAC-CON-09-07-01>

- Gazave, E., Carteron, S., Chenuil, A., Richelle-Maurer, E., Boury-Esnault, N., Borchiellini, C., 2010. Polyphyly of the genus *Axinella* and of the family *Axinellidae* (Porifera: Demospongiae). *Mol. Phylogenet. Evol.* 57, 35–47. <https://doi.org/10.1016/j.ympev.2010.05.028>
- Genta-Jouve, G., Cachet, N., Oberhänsli, F., Noyer, C., Teyssié, J.L., Thomas, O.P., Lacoue-Labarthe, T., 2012. Comparative bioaccumulation kinetics of trace elements in Mediterranean marine sponges. *Chemosphere* 89, 340–349. <https://doi.org/10.1016/j.chemosphere.2012.04.052>
- Giusti, L., Zhang, H., 2002. Heavy metals and arsenic in sediments, mussels and marine water from Murano (Venice, Italy). *Environ. Geochem. Health* 24, 47–65. <https://doi.org/10.1023/A:1013945117549>
- Gobas, F., 2001. Assessing Bioaccumulation Factors of Persistent Organic Pollutants in Aquatic Food-Chains, in: *Persistent Organic Pollutants: Environmental Behaviour and Pathways of Human Exposure*. pp. 145–165. https://doi.org/10.1007/978-1-4615-1571-5_6
- Grotti, M., Lagomarsino, C., Goessler, W., Francesconi, K.A., 2010. Arsenic speciation in marine organisms from Antarctic coastal environments. *Environ. Chem.* 7, 207–214. <https://doi.org/10.1071/EN09131>
- Hong, S., Khim, J.S., Park, J., Son, H.S., Choi, S.D., Choi, K., Ryu, J., Kim, C.Y., Chang, G.S., Giesy, J.P., 2014. Species- and tissue-specific bioaccumulation of arsenicals in various aquatic organisms from a highly industrialized area in the Pohang City, Korea. *Environ. Pollut.* 192, 27–35. <https://doi.org/10.1016/j.envpol.2014.05.004>
- Hsieh, M.W., Liu, C.L., Chen, J.H., Jiang, S.J., 2010. Speciation analysis of arsenic and selenium compounds by CE-dynamic reaction cell-ICP-MS. *Electrophoresis* 31, 2272–2278. <https://doi.org/10.1002/elps.200900632>
- Hughes, M.F., 2002. Arsenic toxicity and potential mechanisms of action. *Toxicol. Lett.* 133, 1–16. [https://doi.org/10.1016/S0378-4274\(02\)00084-X](https://doi.org/10.1016/S0378-4274(02)00084-X)
- Illuminati, S., Annibaldi, A., Truzzi, C., Scarponi, G., 2016. Heavy metal distribution in organic and siliceous marine sponge tissues measured by square wave anodic stripping voltammetry. *Mar. Pollut. Bull.* 111, 476–482. <https://doi.org/10.1016/j.marpolbul.2016.06.098>
- Keren, R., Lavy, A., Ilan, M., 2016. Increasing the Richness of Culturable Arsenic-Tolerant Bacteria from *Theonella swinhoei* by Addition of Sponge Skeleton to the Growth Medium. *Microb. Ecol.* 71, 873–886. <https://doi.org/10.1007/s00248-015-0726-0>
- Keren, R., Lavy, A., Mayzel, B., Ilan, M., 2015. Culturable associated-bacteria of the sponge *Theonella swinhoei* show tolerance to high arsenic concentrations. *Front. Microbiol.* 6, 1–11. <https://doi.org/10.3389/fmicb.2015.00154>
- Keren, R., Mayzel, B., Lavy, A., Polishchuk, I., Levy, D., Fakra, S.C., Pokroy, B., Ilan, M., 2017. Sponge-associated bacteria mineralize arsenic and barium on intracellular vesicles. *Nat. Commun.* 8, 14393. <https://doi.org/10.1038/ncomms14393>
- KeyToNature, 2015. Marine Species Identification Portal [WWW Document]. URL

identification.org/index.php (accessed 7.4.17).

- Kucuksezgin, F., Gonul, L.T., Tasel, D., 2014. Total and inorganic arsenic levels in some marine organisms from Izmir Bay (Eastern Aegean Sea): A risk assessment. *Chemosphere* 112, 311–316. <https://doi.org/10.1016/j.chemosphere.2014.04.071>
- Lai, V.W.M., Cullen, W.R., Ray, S., 1999. Arsenic speciation in scallops. *Mar. Chem.* 66, 81–89. [https://doi.org/10.1016/S0304-4203\(99\)00025-0](https://doi.org/10.1016/S0304-4203(99)00025-0)
- Leermakers, M., Baeyens, W., De Gieter, M., Smedts, B., Meert, C., De Bisschop, H.C., Morabito, R., Quevauviller, P., 2006. Toxic arsenic compounds in environmental samples: Speciation and validation. *TrAC - Trends Anal. Chem.* 25, 1–10. <https://doi.org/10.1016/j.trac.2005.06.004>
- Llorente-Mirandes, T., Ruiz-Chancho, M.J., Barbero, M., Rubio, R., López-Sánchez, J.F., 2010. Measurement of arsenic compounds in littoral zone algae from the Western Mediterranean Sea. Occurrence of arsenobetaine. *Chemosphere* 81, 867–875. <https://doi.org/10.1016/j.chemosphere.2010.08.007>
- Longo, C., Corriero, G., Licciano, M., Stabili, L., 2010. Bacterial accumulation by the Demospongiae *Hymeniacion perlevis*: A tool for the bioremediation of polluted seawater. *Mar. Pollut. Bull.* 60, 1182–1187. <https://doi.org/10.1016/j.marpolbul.2010.03.035>
- Mancini, I., Guella, G., Frostin, M., Hnawia, E., Laurent, D., Debitus, C., Pietra, F., 2006. On the first polyarsenic organic compound from nature: Arsenicin A from the new caledonian marine sponge *Echinochalina bargibanti*. *Chem. - A Eur. J.* 12, 8989–8994. <https://doi.org/10.1002/chem.200600783>
- Mandal, B.K., Suzuki, K.T., 2002. Arsenic round the world: A review. *Talanta* 58, 201–235. [https://doi.org/10.1016/S0039-9140\(02\)00268-0](https://doi.org/10.1016/S0039-9140(02)00268-0)
- Mayzel, B., Aizenberg, J., Ilan, M., 2014. The elemental composition of demospongiae from the Red Sea, Gulf of Aqaba. *PLoS One* 9. <https://doi.org/10.1371/journal.pone.0095775>
- Mitra, N., Rezvan, Z., Seyed Ahmad, M., Gharaie Mohamad Hosein, M., 2012. Studies of Water Arsenic and Boron Pollutants and Algae Phytoremediation in Three Springs, Iran. *Int. J. Ecosyst.* 2, 32–37. <https://doi.org/10.5923/j.ije.20120203.01>
- Miyashita, S., Murota, D.C., Kondo, B.K., 2016. Arsenic metabolism in cyanobacteria. *Environ. Chem.* 13, 577–589.
- Miyashita, S., Shimoya, M., Kamidate, Y., Kuroiwa, T., Shikino, O., Fujiwara, S., Francesconi, K.A., Kaise, T., 2009. Rapid determination of arsenic species in freshwater organisms from the arsenic-rich Hayakawa River in Japan using HPLC-ICP-MS. *Chemosphere* 75, 1065–1073. <https://doi.org/10.1016/j.chemosphere.2009.01.029>
- Nam, S.H., Oh, H.J., Min, H.S., Lee, J.H., 2010. A study on the extraction and quantitation of total arsenic and arsenic species in seafood by HPLC-ICP-MS. *Microchem. J.* 95, 20–24. <https://doi.org/10.1016/j.microc.2009.08.009>

- Nearing, M.M., Koch, I., Reimer, K.J., 2014. Complementary arsenic speciation methods: A review. *Spectrochim. Acta - Part B At. Spectrosc.* 99, 150–162. <https://doi.org/10.1016/j.sab.2014.07.001>
- Negri, A., Burns, K., Boyle, S., Brinkman, D., Webster, N., 2006. Contamination in sediments, bivalves and sponges of McMurdo Sound, Antarctica. *Environ. Pollut.* 143, 456–467. <https://doi.org/10.1016/j.envpol.2005.12.005>
- Olmedo, P., Pla, A., Hernandez, A.F., Barbier, F., Ayouni, L., Gil, F., 2013. Determination of toxic elements (mercury, cadmium, lead, tin and arsenic) in fish and shellfish samples. Risk assessment for the consumers. *Environ. Int.* 59, 63–72. <https://doi.org/10.1016/j.envint.2013.05.005>
- Padovan, A., Munksgaard, N., Alvarez, B., McGuinness, K., Parry, D., Gibb, K., 2012. Trace metal concentrations in the tropical sponge *Sphaciospongia vagabunda* at a sewage outfall: Synchrotron X-ray imaging reveals the micron-scale distribution of accumulated metals. *Hydrobiologia* 687, 275–288. <https://doi.org/10.1007/s10750-011-0916-9>
- Pan, K., Lee, O.O., Qian, P.Y., Wang, W.X., 2011. Sponges and sediments as monitoring tools of metal contamination in the eastern coast of the Red Sea, Saudi Arabia. *Mar. Pollut. Bull.* 62, 1140–1146. <https://doi.org/10.1016/j.marpolbul.2011.02.043>
- Patel, B., Balani, M., Patel, S., 1985. Sponge “sentinel” of heavy metals. *Sci. Total Environ.* 41, 143–152.
- Perez, T., Longet, D., Schembri, T., Rebouillon, P., Vacelet, J., 2005. Effects of 12 years’ operation of a sewage treatment plant on trace metal occurrence within a Mediterranean commercial sponge (*Spongia officinalis*, Demospongiae). *Mar. Pollut. Bull.* 50, 301–309. <https://doi.org/10.1016/j.marpolbul.2004.11.001>
- Phillips, D.J.H., 1990. Arsenic in aquatic organisms: a review, emphasising chemical speciation. *Aquat. Toxicol.* 16, 151–186.
- Potot, C., Féraud, G., Schärer, U., Barats, A., Durrieu, G., Le Poupon, C., Travi, Y., Simler, R., 2012. Groundwater and river baseline quality using major, trace elements, organic carbon and Sr-Pb-O isotopes in a Mediterranean catchment: The case of the Lower Var Valley (south-eastern France). *J. Hydrol.* 472–473, 126–147. <https://doi.org/10.1016/j.jhydrol.2012.09.023>
- Sakurai, T., 2002. Review: Biological effects of organic arsenic compounds in seafood. *Appl. Organomet. Chem.* 16, 401–405. <https://doi.org/10.1002/aoc.325>
- Salaün, P., Planer-Friedrich, B., van den Berg, C.M.G., 2007. Inorganic arsenic speciation in water and seawater by anodic stripping voltammetry with a gold microelectrode. *Anal. Chim. Acta* 585, 312–322. <https://doi.org/10.1016/j.aca.2006.12.048>
- Santos-Gandelman, J.F., Giambiagi-Demarval, M., Muricy, G., Barkay, T., Laport, M.S., 2014. Mercury and methylmercury detoxification potential by sponge-associated bacteria. *Antonie van Leeuwenhoek, Int. J. Gen. Mol. Microbiol.* 106, 585–590. <https://doi.org/10.1007/s10482-014-0224-2>
- Schaeffer, R., Francesconi, K.A., Kienzl, N., Soeroes, C., Fodor, P., Váradi, L., Raml, R., Goessler, W., Kuehnelt, D., 2006. Arsenic speciation in freshwater organisms from the river Danube in Hungary. *Talanta* 69, 856–865. <https://doi.org/10.1016/j.talanta.2005.11.025>

- Shiomi, K., Aoyama, M., Yamanaka, H., Kikuchi, T., 1988. Chemical Forms of Arsenic in Sponges, Sea-Anemones and Sea Hare. *Comp. Biochem. Physiol. C-Pharmacology Toxicol. Endocrinol.* 90, 361–365.
- Suner, M.A., Devesa, V., Munoz, O., Velez, D., Montoro, R., 2001. Application of column switching in high-performance liquid chromatography with on-line thermo-oxidation and detection by HG-AAS and HG-AFS for the analysis of organoarsenical species in seafood samples. *J. Anal. At. Spectrom.* 16, 390–397. <https://doi.org/10.1039/B007518N>
- Taylor, V.F., Jackson, B.P., Siegfried, M.R., Navratilova, J., Francesconi, K.A., Kirshtein, J., Voytek, M., 2012. Arsenic speciation in food chains from mid-Atlantic hydrothermal vents. *Environ. Chem.* 9, 130–138. <https://doi.org/10.1071/EN11134>
- Tian, Y., Chen, M.-L., Chen, X.-W., Wang, J.-H., Hirano, Y., Sakamoto, H., Setsu, I., 2010. Arsenic speciation with gradient hydride generation interfacing liquid chromatography and atomic absorption spectrometry. *J. Anal. At. Spectrom.* 25, 48–54. <https://doi.org/10.1039/B913198A>
- Tsimplis, M.N., Baker, T.F., 2000. Sea level drop in the Mediterranean Sea: An indicator of deep water salinity and temperature changes? *Geophys. Res. Lett.* 27, 1731–1734. <https://doi.org/10.1029/1999GL007004>
- US EPA, 2006. Marine Sediment Screening Benchmarks, Region III.
- Vaskovsky, V.E., Korotchenko, O.D., Kosheleva, L.P., Levin, V.S., 1972. Arsenic in the lipid extracts of marine invertebrates. *Comp. Biochem. Physiol. Part B Comp. Biochem.* 41, 777–784. [https://doi.org/10.1016/0305-0491\(72\)90090-9](https://doi.org/10.1016/0305-0491(72)90090-9)
- Venkateswara Rao, J., Srikanth, K., Pallela, R., Gnaneshwar Rao, T., 2009. The use of marine sponge, *Haliclona tenuiramosa* as bioindicator to monitor heavy metal pollution in the coasts of Gulf of Mannar, India. *Environ. Monit. Assess.* 156, 451–459. <https://doi.org/10.1007/s10661-008-0497-x>
- Wahlen, R., McSheehy, S., Scriver, C., Mester, Z., 2004. Arsenic speciation in marine certified reference materials - Part 2. The quantification of water-soluble arsenic species by high-performance liquid chromatography-inductively coupled plasma mass spectrometry. *J. Anal. At. Spectrom.* 19, 876–882. <https://doi.org/10.1039/b402482f>
- Wang, Y., Wang, S., Xu, P., Liu, C., Liu, M., Wang, Y., Wang, C., Zhang, C., Ge, Y., 2015. Review of arsenic speciation, toxicity and metabolism in microalgae. *Rev. Environ. Sci. Bio/Technology* 14, 427–451. <https://doi.org/10.1007/s11157-015-9371-9>
- Weisz, J.B., Lindquist, N., Martens, C.S., 2008. Do associated microbial abundances impact marine demosponge pumping rates and tissue densities? *Oecologia* 155, 367–376. <https://doi.org/10.1007/s00442-007-0910-0>
- Wu, X., Gao, M., Wang, L., Luo, Y., Bi, R., Li, L., Xie, L., 2014. The arsenic content in marketed seafood and associated health risks for the residents of Shandong, China. *Ecotoxicol. Environ. Saf.* 102, 168–173. <https://doi.org/10.1016/j.ecoenv.2014.01.028>
- Yamaoka, Y., Carmona, M.L., Oclarit, J.M., Jin, K., Shibata, Y., 2006. Characterization of water-soluble

organoarsenic compounds in marine sponges. *Appl. Organomet. Chem.* 20, 545–548. <https://doi.org/10.1002/aoc>

Yamaoka, Y., Carmona, M.L., Oclarit, J.M., Jin, K., Shibata, Y., 2001. Arsenic compounds in marine sponge (*haliclona permolis*, *Halichondria japonica*, *Halichondria okadai* and *Haliclona sp. white*) from Seto Inland Sea, Japan. *Appl. Organomet. Chem.* 15, 261–265. <https://doi.org/10.1002/aoc.135>

Zhang, W., Chen, L., Zhou, Y., Wu, Y., Zhang, L., 2016a. Biotransformation of inorganic arsenic in a marine herbivorous fish *Siganus fuscescens* after dietborne exposure. *Chemosphere* 147, 297–304. <https://doi.org/10.1016/j.chemosphere.2015.12.121>

Zhang, W., Guo, Z., Zhou, Y., Chen, L., Zhang, L., 2016b. Comparative contribution of trophic transfer and biotransformation on arsenobetaine bioaccumulation in two marine fish. *Aquat. Toxicol.* 179, 65–71. <https://doi.org/10.1016/j.aquatox.2016.08.017>

Zhang, W., Guo, Z., Zhou, Y., Liu, H., Zhang, L., 2015. Biotransformation and detoxification of inorganic arsenic in Bombay oyster *Saccostrea cucullata*. *Aquat. Toxicol.* 158, 33–40. <https://doi.org/10.1016/j.aquatox.2014.10.021>

SUPPLEMENTARY INFORMATION (paper 7)

Figure 1A. Maps showing the sampling sites (indicated with black stars) located in a) French Mediterranean coast (http://d-maps.com/carte.php?num_car=110470&lang=en) and b) in two locations along the Irish coast (http://d-maps.com/carte.php?num_car=14642&lang=en). Copyright d-maps.com

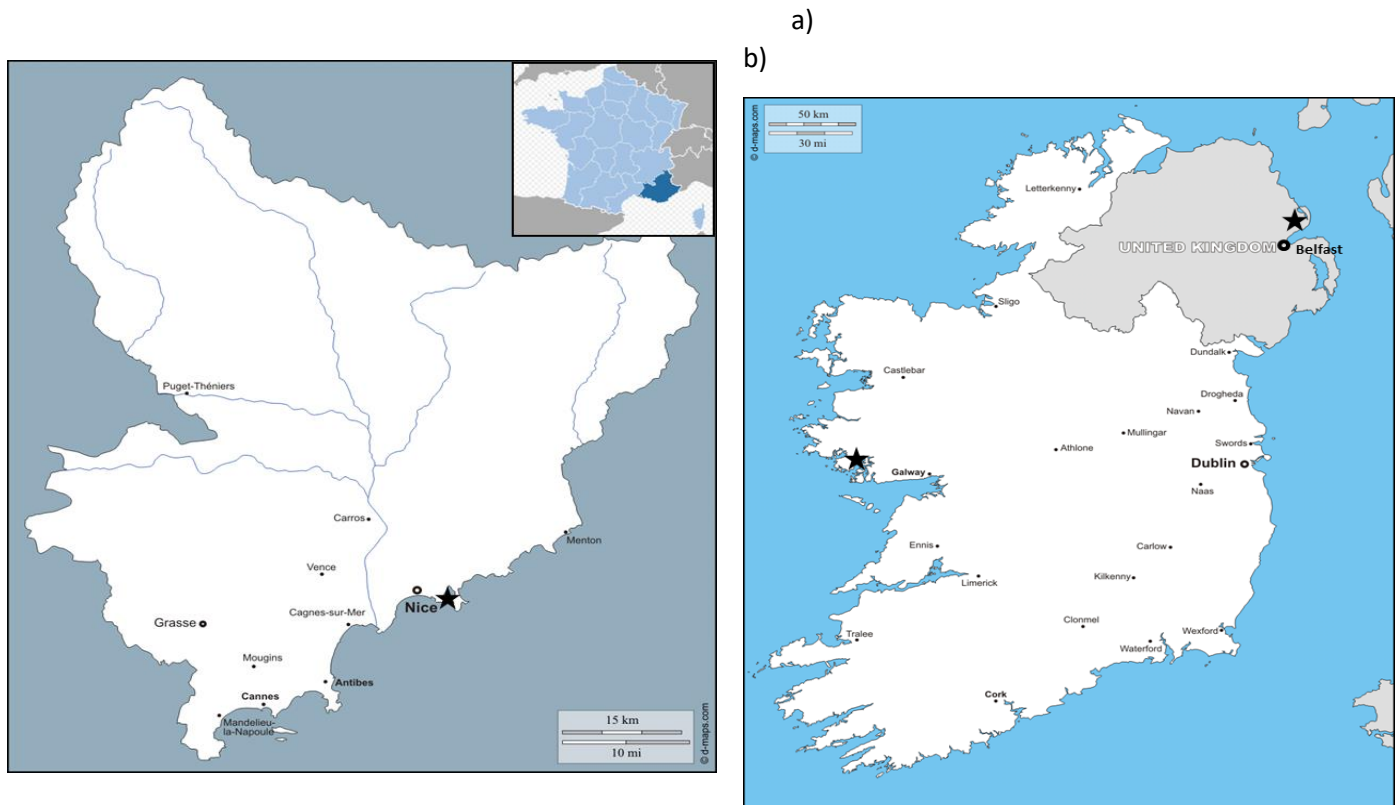

Figure 2A. Pictures of sponge species analyzed in this study. From left: *Acanthella acuta*, *Cymbaxinella damicornis*, *Chondrilla nucula*, *Haliclona fulva*, *Halichondria panacea* and *Hymeniacion perlevis*. (Pictures from O. P. Thomas)



Figure 3A. Microscopic observation (x100) of microwave digested samples using different solutions: a) HCl/HNO₃ (6/2 mL); b) HNO₃ (10 mL); c) HNO₃/HF (6/2 mL); d) HCl/HNO₃/HF (6/2/0.5 mL).

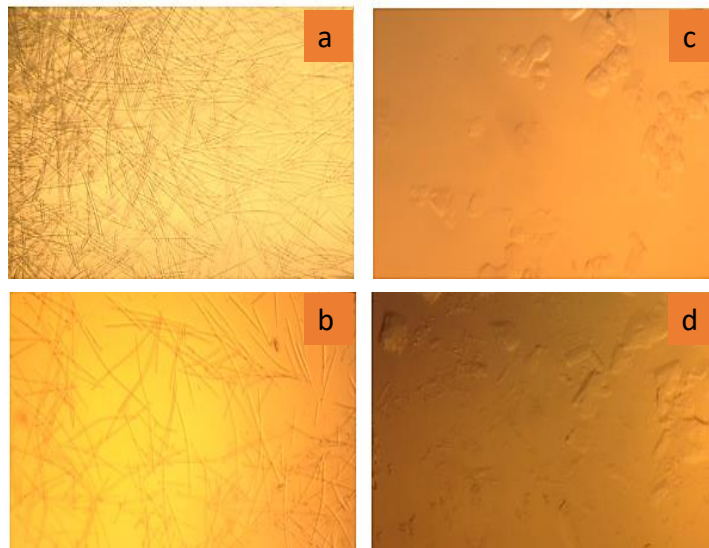

Figure 2S. Chromatograms obtained for the specimen A of each specie analyzed in this study. For *C. nucula* (CHO S), refers to a specimen collected at the surface (20 m). Chromatograms were corrected by subtraction of the background baseline (obtained by the chromatogram of the extracted blank sample).

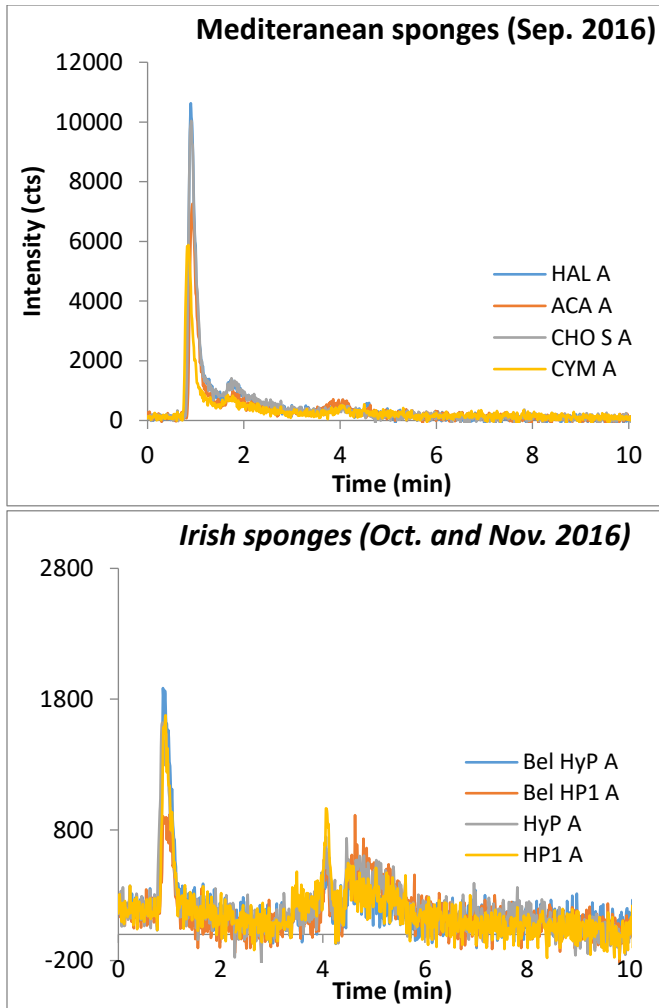

Table 1A. Total As results from *Haliclona fulva* sponge samples (m=100 mg) obtained by different mineralization methods

Methods	n	[As] (mg kg ⁻¹)		
2 mL HNO ₃ + 0.5 mL H ₂ O ₂	6	18	±	2
3 mL HNO ₃ + 1 mL H ₂ O ₂	6	52	±	32
15 min ultrasound extraction and volume completed up to 15 mL with Milli-Q water				
500 µL HNO ₃	3	18.7	±	0.5
1 mL HNO ₃	3	18.3	±	0.5
2 mL HNO ₃	3	18.7	±	0.5
Microwave digestion				
10 mL HNO ₃	7	24	±	4
6 mL HCl + 2 mL HNO ₃	7	24	±	2
6 mL HCl + 2 mL HNO ₃ + 0.5 mL HF	7	27	±	2
6 mL HCl + 2 mL HNO ₃ + 1 mL HF	7	30	±	3
6 mL HNO ₃ + 2 mL HF	11	29	±	5

Table 2A. Variability of total As concentrations measured in digested and extracted samples for Mediterranean sponges collected in February 2016. Digested samples results are presented together with standard deviation calculated on the basis of three digestions. For *C. damicornis*, there are 4 replicates because there are 2 samples collected within the cave (A and C) and 2 others collected at the entrance of the cave

Mediterranean sponges collected in February 2016													
		<i>H. fulva</i>			<i>A. acuta</i>			<i>C. nucula</i>			<i>C. damicornis</i>		
Total As (mg kg⁻¹)	Replicate A	22	±	8	37	±	7	20	±	5	70	±	9
	Replicate B	33	±	3	52	±	9	37	±	8	86	±	7
	Replicate C	24	±	5	44	±	4	46	±	9	65	±	5
	Replicate D										70	±	12
	Average	26	±	6	44	±	8	34	±	13	73	±	9
Extracted As (mg kg⁻¹)	Replicate A	11	±	1	29	±	3	18	±	2	39	±	5
	Replicate B	26	±	3	29	±	3	31	±	3	31	±	3
	Replicate C	10	±	1	27	±	3	30	±	3	46	±	4
	Replicate D										28	±	3
	Average	16	±	9	28	±	1	26	±	7	38	±	9
Extraction recovery (%)		62			64			76			52		

CONCLUSION AND FUTURE PERSPECTIVES

In conclusion, this PhD work has led to different final accomplishments. Three main parts of this work can be identified: a first part related to the development and validation of analytical methods for TE determination in environmental samples, then the second and third part were focused on the study of TE environmental monitoring, through the analysis of sediments and marine sponges respectively.

- ✚ The first part of this work was related to the development and validation of analytical methodologies for the determination of Hg, As, Cd, Co, Cu, Cr and Ni in sediment and biota samples. These methods were based on the use of Atomic Absorption Spectrometry equipped with a continuum source and high-resolution detection. The methods were developed for analysis directly on solid samples, avoiding the sample preparation step which can contribute to the blanks values and it is often very time consuming. The temperature programs were carefully optimized for each element separately for the two different matrices (sediment and marine biota) leading to the development of fast programs in which the drying and pyrolysis steps are minimized (or eliminated). The calibration used in these methods also included solid materials, specifically CRMs, using an original calibration approach based on the direct comparison of regression lines obtained when measuring different masses of CRMs and samples. For the validation of the methods, an approach in line with the requirements of ISO 17025 standard and Eurachem guidelines was followed. In this respect, several parameters were evaluated such as linearity and working range, trueness, repeatability and reproducibility, limits of detection and quantification and expanded uncertainty. The linearity of the calibration lines was assessed by Student's t-test, proving that the squared value of the correlation coefficient is not significantly different from 1. Additionally, this parameter can be significantly improved in the nowadays technology, since it is possible to increase the detector pixel, adding a certain flexibility to the sensitivity. Nevertheless, a limiting factor was represented by the microbalance stability and in the reality the working range was dominated by the minimum and maximum amount of sample measurable by the balance with a reasonable uncertainty (classically between 0.05 and 0.5 mg). Trueness and bias were evaluated through the analysis of different sediments and biota CRMs and the recovery obtained on the certified values were between 92-103% for biota and 92-102% for sediments. The reproducibility was between 5-12% for biota and 7-10% for sediments while the repeatability (evaluated with two different approaches) was found to be

generally around 10-20% for biota and 4-10% for sediments. The expanded uncertainties ($k=2$) were also determined with two different approach, giving consistent results, which were generally higher in biota than sediments. This result is not surprising considering that the TE contents in biota were in some cases up to 10 times lower than the respective values in sediments. The traceability of the results was assessed throughout the entire procedure using CRMs and gravimetric operations in dosing all samples.

To evaluate the practical advantage of solid sampling fast programs over the more conventional programs using liquid standard for calibration, a direct comparison was carried out. The results showed that the programs developed in the present study gave better uncertainties and overall better results in much shorter analytical time. As last step of the method validation, the developed methods were applied to some sediments and biota samples and results compared with those obtained by an independent analytical method. The sediment samples used for this step came from the Caribbean region while the biota samples (oyster and clam) were candidate CRMs.

In sediment samples, the Hg measurements for the comparison purpose were carried out by AMA directly on solid material while the remaining elements were measured by ICP-MS after microwave digestion. For biota candidate CRM, the obtained values were compared with reference values obtained from different analytical methods. In all cases, a good agreement, between stated uncertainties, was found between results, thus proving the effectiveness of the developed method.

Future perspectives regarding this subject would include the study on additional TE (such as Pb for instance) and the application on other environmental matrices (e.g. other marine organisms).

As the main objective of this thesis was the TE pollution assessment in different compartments of the marine environment, the second and third parts were related to the application of different analytical methods to different areas and different kind of samples.

- ✚ A part of this PhD focused on a baseline monitoring program conducted in Namibian coast. The main purpose of the study was to assess the baseline levels of TE in the sediments collected along the Namibian coast, and provide first data for present and future evaluation of the marine environmental status. Two separate studies were carried out in sediments: the first was focused

on a survey on surface sediments collected along the coast and offshore, to have an idea of TE levels in the area and to identify natural and anthropogenic inputs along the coast; the second concerned the study of historical trends of TE inputs and levels, by analyzing six core samples coming from the same area. In both studies, TE mass fractions determined in sediments were linked to other parameters such as grain size and organic carbon, to better understand the main features of the sediments of the area. Some parameters such as Enrichment Factors, Geoaccumulation Index and Pollution load index were used to evaluate possible enrichment in TE with regards to the natural background levels of the area. Additionally, the determination of Pb isotope ratios, used as tool to track the pollution source, was of great help and interest for the evaluation of natural and anthropogenic Pb sources in the Namibian coast. Additionally, to TE, also Rare Earth Elements were studied, since the area was recently discovered to be potentially rich in this specific class of elements. The interpretation of the obtained results was rather challenging as these studies (on surface and core sediments) represent the first literature record of TE concentrations in the Namibian coastline. The TE results in surface sediments revealed high enrichment of As, Cd and Sb in several sites while Pb, Cu and Zn inputs were found to be particularly high only around Walvis Bay, the most industrialized area among the studied sites. Additionally, the analysis of a sediment core collected in the Walvis Bay harbor revealed that the highest inputs of these elements occurred after the year 1945. In both studies the data were further analyzed using Pearson's correlation and Principal Component Analysis: the purpose was to identify possible correlations and common sources between metals. The positive correlation found in both studies for Cu, Pb and Zn (and specifically in Walvis Bay core) confirmed that these elements had common pattern and possibly common sources in some of the areas. The positive correlation found for Cd and As (together with P in surface samples) can be explained by the presence of phosphate mines in the vicinity: both Cd and As are often associated with phosphate minerals. Apart from the sampling sites around Walvis Bay, and a few close to Swakopmund, it can be stated that the area is rather not contaminated, as especially shown by many of the cores analyzed in one of our studies. Elements such as Ni, Cr and Co did not show enrichment neither in surface sediment nor in the vertical profiles, suggesting that no anthropogenic inputs influenced their contents. The analysis of TE historical variation in the cores revealed a significant enrichment of Pb, Zn and Cu almost entirely limited to the surface samples coming from Walvis Bay harbor. Rare Earth Elements results did not highlight anomalies ascribable to anthropogenic inputs but nevertheless provided a record of the typical patterns

found in the samples, with specific enrichment in Heavy REEs. These studies also represent the first record of Pb isotopic composition of Namibian sediment thus providing not only the possibility to verify a potential anthropogenic Pb input but also a record of the natural isotopic composition of the area. The analysis of results on surface sediments highlighted and confirmed the anthropogenic origin of Pb around the Walvis Bay area. Additionally, the measurement of Pb isotope ratios in sediment cores revealed the big variability of the ratios in the first half of the core collected in the Walvis Bay harbor and a more stable isotopic composition in the deep samples meaning that after 1945 new Pb sources of anthropogenic origin affected the area. The Pb isotope ratios trends in the other cores revealed a rather stable pattern with natural isotopic composition characterized by $^{208}\text{Pb}/^{206}\text{Pb}$ and $^{206}\text{Pb}/^{207}\text{Pb}$ between 1.988-2.063 and 1.190-1.248 respectively. These studies on TE distribution in surface and core samples from Namibia are of crucial importance as they provide a first record of natural and anthropogenic inputs in the area. The importance of this baseline resides on its usefulness in future monitoring programs in the Namibian coastal area.

Future applications and perspective should include long term monitoring programs to have better insight on TE availability and source in the region as well as the study of different matrices such as estuarine and coastal waters and biota.

The other compartment of the marine environment chosen for being studied in this PhD work, regarded marine organisms, specifically marine sponges. Marine sponges were chosen among marine organisms because of several characteristics that make them suitable bio-monitor of TE pollution.

✚ The studies performed in this PhD work concerned six sponges' species collected in different sites in the Mediterranean and Irish coasts. The main purpose was to evaluate the different abilities of these species to accumulate and/or transform TE according to sponge species, sample sites, and seasons. Four sponge's species were collected in the French Mediterranean coast (*Haliclona fulva*, *Cymbaxinella damicornis*, *Chondrilla nucula* and *Acanthella acuta*) and two species (*Halichondria panicea* and *Hymeniacidon perlevis*) were collected in two sites located in Ireland (Kilkieran Bay and Belfast). Two types of study were performed: the first one focusing on the TE accumulation in the different sponge species and second one on the specific accumulation and biotransformation of arsenic.

In the first study, the mass fraction of different TE were determined in at least three replicates of each sponges specie and the variability of the TE accumulation was determined within the

same species as well as between different species. TE accumulation in sponges was demonstrated significantly different according to sponge species and the target element. *C. damicornis* had specific affinity for As and Cu while Ag, Mo and Ni were found in higher concentrations in *A. acuta* and Zn in *H. perlevis* compared to other species. The influence of sampling sites characteristics (such as sampling depth and exposition to light) and seasons were evaluated in Mediterranean sponges. The results indicated that sponges can be considered representative of rather broad area without showing significant variations in TE accumulation; the same holds true for seasonal variations. Regarding the Irish species the objective was also to evaluate possible difference related to different TE inputs from different sites. As a matter of fact higher concentrations of TE were generally found in sponges from Belfast, considered more polluted area, with some exceptions (Cd and As). A common way to evaluate the extent of TE accumulation is the calculation of BCF, using the concentrations determined in sediments collected in the same area. The results found in this PhD work highlighted the great capabilities of sponges to quantitatively accumulate TE within their tissue since the great majority of BCF determined in this study were >1 , regardless of the sampling site. The highest BCF were calculated for Ag in *A. acuta*, (41), for Cu in *C. damicornis* (18), for Cd in *H. panicea* and *H. perlevis* collected in Kilkieran (21 and 31 respectively). Some elements such as Ba, Ni and V show rather low BCF in all species, leading to the conclusion that they are probably not involved in biological processes within the organism.

Lead isotopic ratios were also measured in selected sponges and sediments samples from each location, to determine whether a Pb pollution occurred and to possibly track the source of Pb. Even though the Pb concentrations in sediments from all locations were quite low and typical of non-contaminated areas, the isotopic data revealed a different scenario. Regarding the Mediterranean samples, the same Pb isotopic composition was found for all analyzed samples. The absence of linear trend in the three plot graphs and the comparison with literature data gave confirmation that the unique source is most likely ascribable to natural source. On the other hand, the analysis of results from Irish samples (sponges and sediments) and comparison with literature data, showed a Pb source mostly natural for Kilkieran Bay and influenced by anthropogenic activities in Belfast.

This part of the study on sponges highlights the tangible possibility of their use as biomonitors of TE pollution in coastal areas as well as their possible application in environmental remediation.

Further investigation could include long term temporal survey and the evaluation of bioaccumulation factors, calculated using the TE concentration in surrounding seawater.

The second study on sponges was specifically focused on the bioaccumulation and biotransformation of arsenic, one of the most TE accumulated in sponges. A very few studies have been published on this subject because analytical protocols need to be developed yet. In this PhD, the analytical method has been optimized including microwave digestion for total As determination, extraction for As speciation by HPLC-ICP-MS and HPLC chromatographic conditions. For this purpose, the use of CRM was of crucial importance in all the optimization steps. The study was carried out on the same sponges analyzed for TE contents and the As species investigated were: arsenobetaine (AsB), dimethylarsinic acid (DMA), monomethylarsonic acid (MMA) and the inorganic forms arsenate (As(+V)) and arsenite (As(+III)). The optimization of mineralization protocol gave as a result the choice of a mixture of HNO₃ and HF in microwave assisted digestion. Several extraction solvents were tested on some sponges' samples and the best results were obtained when using a solution of 0.6 M H₃PO₄. The selected mineralization and extraction procedures were applied to several specimens of the analyzed species and the speciation analysis was performed by HPLC-ICP-MS. As already discussed the arsenic accumulation (and the obtained BCF) was substantially different depending on the considered specie. *C. damicornis* was by far the specie which showed the highest affinity for this element. The speciation analysis results highlighted the predominance of AsB, as already found for several marine organisms since it is supposed to have a crucial role in protecting organisms from osmolytic stress in seawater. Lower amounts of DMA were also found in Mediterranean sponges, while the concentrations in Irish sponges were negligible. The same holds true for As(+V), equally found in small proportion. Additionally, the presence of two unknown species here called A and B was also detected in all analyzed species and again in higher content in Mediterranean sponges compared to Irish sponges. The As biotransformation within sponges may be related directly to the sponge metabolism, but also indirectly by symbiotic microorganisms (microalgae, bacteria). This study suggests that As originates from the transformation of the inorganic form taken up from seawater into the organic form (or forms) found in sponges' tissue, due likely to reduction-methylation processes carried out by symbiotic sponge-bacteria. This study highlights the possible use of sponges for bio-remediation studies, since the toxic inorganic As species taken up from seawater are transformed in organic species, much less toxic,

thanks to intrinsic sponges' biological processes (or involving symbiotic microorganisms). Perspectives on this subject should include analytical improvements: extraction procedure, decrease of detection limits, identification of unknown As species, as well as the study of other arsenic species such as arsenosugars.

Résumé

Les éléments traces (ET) se trouvent naturellement dans l'environnement. Ces dernières années, des apports croissants en ET sont induits par des activités anthropiques, causant des problèmes environnementaux surtout dans le milieu marin. Certains ET sont toxiques et le besoin de méthodes fiables pour leur analyse dans des échantillons environnementaux est indéniable. À travers cette thèse, des méthodes analytiques ont été développées et validées pour l'analyse des ET dans les sédiments et les organismes marins par spectrométrie d'absorption atomique à source continu, haute résolution et introduction solide directe (SS-HR-CS-AAS). Des études environnementales basées sur l'utilisation de cette méthode et d'autres ont été réalisées. Une première étude a été réalisée sur des sédiments (de surface et carottes) collectés en Namibie. Cette thèse présente une série inédite de concentrations de base sur la côte namibienne. Une contamination importante en Pb, Cu, Zn et Cd a été démontrée autour des zones les plus peuplées. Les pollutions au Pb et leurs sources ont été étudiées grâce aux rapports isotopiques du Pb. Une deuxième étude a été réalisée sur différentes espèces d'éponges marines et des sédiments collectés en France et en Irlande. Il est montré que les éponges accumulent plus les ET que les sédiments et de façon différente selon les espèces. Des analyses de spéciation de l'arsenic ont été réalisées sur les éponges par chromatographie liquide haute performance couplée à un ICP-MS. Les résultats ont montré une bioaccumulation très importante de ce métalloïde dans les éponges et sa biotransformation des formes inorganiques en formes organiques beaucoup moins toxiques

Mots-clés : validation de méthode, métaux traces, environnement marin, sédiments, bioaccumulation, biotransformation

Abstract

Trace elements (TE) naturally occur in the environment but their inputs have been increasing by anthropogenic activities in the last decades, causing environmental concerns, particularly in coastal ecosystems. TE are toxic and the need of reliable methods for their determination in environmental samples is undeniable. The first part of this PhD was focused on the development and full validation of methods for the analysis of TE in sediments and marine organisms by Solid Sampling High Resolution Continuum Source Atomic Absorption Spectrometry (SS-HR-CS-AAS). Second, environmental studies based on these and other methodologies were then performed. A first monitoring survey was performed on sediments (surface and core samples) collected along the Namibian coast. This thesis provides the first baseline of TE contents and historical record of pollution in the area. Significant Pb, Cu, Cd and Zn enrichments were highlighted around the most populated areas, providing a needed baseline for present and future evaluation of the Namibian marine environment. Pb pollutions and their sources were also tracked using Pb isotope ratios. A second monitoring survey was performed on different marine sponges and sediments collected in the French Mediterranean and in the Irish coasts. This work showed that sponges accumulate more TE than sediments in different extents according to species. Arsenic speciation analysis was performed in sponges by High Performance Liquid Chromatography (HPLC) coupled with ICP-MS. This special focus on arsenic highlighted the great bioaccumulation of this metalloid in sponges and its biotransformation from inorganic forms to less toxic organic forms

Key words: method validation, trace elements, marine environment, sediments, bioaccumulation, biotransformation

