



HAL
open science

Topics in Complex and CR geometry

The Anh Ta

► **To cite this version:**

The Anh Ta. Topics in Complex and CR geometry. Complex Variables [math.CV]. Université Paris-Saclay, 2020. English. NNT : 2020UPASM007 . tel-02971589

HAL Id: tel-02971589

<https://theses.hal.science/tel-02971589>

Submitted on 19 Oct 2020

HAL is a multi-disciplinary open access archive for the deposit and dissemination of scientific research documents, whether they are published or not. The documents may come from teaching and research institutions in France or abroad, or from public or private research centers.

L'archive ouverte pluridisciplinaire **HAL**, est destinée au dépôt et à la diffusion de documents scientifiques de niveau recherche, publiés ou non, émanant des établissements d'enseignement et de recherche français ou étrangers, des laboratoires publics ou privés.

Topics in Complex and CR geometry

Thèse de doctorat de l'université Paris-Saclay

École doctorale n° 574, École doctorale de Mathématiques
Hadamard (EDMH)
Spécialité de doctorat: Mathématiques fondamentales
Unité de recherche: Université Paris-Saclay, CNRS, Laboratoire de
mathématiques d'Orsay, 91405, Orsay, France
Réfèrent: Faculté des sciences d'Orsay

Thèse présentée et soutenue en visioconférence totale,
le 30 septembre 2020, par

The Anh TA

Composition du jury:

Xiaonan MA Professeur, Université de Paris	Président
Damian BROTBK Professeur, Université de Lorraine	Rapporteur & Examineur
Chin-Yu HSIAO Directeur de recherche (HDR), Academia Sinica	Rapporteur & Examineur
Julien DUVAL Professeur, Université Paris-Saclay	Examineur
Elisha FALBEL Professeur, Sorbonne Université	Examineur
Pawel NUROWSKI Professeur, Polish Academy of Sciences	Examineur
Joël MERKER Professeur, Université Paris-Saclay	Directeur de thèse

Acknowledgments

First and foremost, I would like to express my sincere gratitude and appreciation to my supervisor, Professor Joël Merker for his guidance, his kindness and his enormous generosity. I would like to thank him for providing continuous helps and supports at every step of my graduate study. I would like to thank him for always being patient and tolerant with my numerous issues, and for offering invaluable advices about research and about life. Everything I know about the subjects of this thesis, I learned from him, either from many lessons he gave in his office or through our joint works. I would like to thank him for sharing his knowledge and ideas, and for generously allowing me to join his research projects which constitute this thesis.

I would like to thank the rapporteurs, Professor Damian Brotbek and Professor Chin-Yu Hsiao, for sacrificing their time and their energy on reviewing and writing their reports for my thesis.

I would like to thank Professor Damian Brotbek, Professor Julien Duval, Professor Elisha Falbel, Professor Chin-Yu Hsiao, Professor Paweł Nurowski, Professor Xiaonan Ma and Professor Joël Merker for accepting the invitations to become members of the jury for my thesis defense.

I also would like to thank Wei-Guo Foo and Zhangchi Chen for their collaborations in our joint works and their helps during my graduate study.

During my stay in Orsay, Professor Paweł Nurowski started a close collaboration with my supervisor and I benefited greatly from his visits and his lectures. I would like to thank him for sharing his deep knowledge about Cartan's method of equivalence and his openness.

I would like to thank Université Paris-Saclay and the Fondation Mathématique Jacques Hadamard (FMJH) for their scholarship which gave me the opportunity to come and study in France for the last 4 years. I also would like to thank Professor Frédéric Paulin and Professor Stéphane Nonnenmacher for their helps with many administrative problems and their advices.

My special thanks go to Professor Stéphane Nonnenmacher and Professor Joël Merker for their helps which make it possible for me to organise my thesis defense on videoconference.

Finally, I thank my family, Tâm and An, for accompanying me on this journey.

Contents

Résumé	6
Introduction	17
Chapter 1. Degrees $d \geq (\sqrt{n} \log n)^n$ and $d \geq (n \log n)^n$ in the Conjectures of Green-Griffiths and of Kobayashi	27
1. Introduction	27
2. Preliminary: Link with Darondeau's Work	28
3. End of Proof of Theorem 1.3	31
4. From Coordinates (t_1, t_2, \dots, t_n) to Coordinates (w_2, \dots, w_n)	38
5. Approximations of multinomial quotients M_{k_2, \dots, k_n}^n	46
6. Majorant power series $\widehat{C}(w_2, \dots, w_n)$ and its diagonalization $\widehat{C}(x, \dots, x)$	50
7. Positivity of diagonal sums coefficients C_h^{n-1}	54
8. Cauchy inequalities	59
9. Estimations of $\widehat{C}(\frac{1}{r})$ and of $C(\frac{1}{r})$	60
10. Final minorations	64
11. Some inequalities on circles $\{ z = \rho\}$	70
Chapter 2. Rigid equivalences of 5-dimensional 2-nondegenerate rigid real hypersurfaces $M^5 \subset \mathbb{C}^3$ of constant Levi rank 1	79
1. Introduction	79
2. Recall on the geometry of CR real hypersurfaces	83
3. Initial G -structure for rigid equivalences of rigid real hypersurfaces	86
4. Cartan equivalence method for the model case	88
5. Representation by vector fields	96
6. The general case	100
7. Cartan process: first loop	101
8. Cartan process: second loop	102
9. Final loop	104
10. The $\{e\}$ -structure.	106
Chapter 3. Normal Forms for Rigid $\mathcal{C}_{2,1}$ Hypersurfaces $M^5 \subset \mathbb{C}^3$	110
1. Introduction	110
2. Rigid Equivalences of Rigid Hypersurfaces in \mathbb{C}^2 : A Toy Study	130
3. Two Invariant Determinants for Hypersurfaces $M^5 \subset \mathbb{C}^3$	137
4. Rigid Infinitesimal CR Automorphisms of the Gaussier-Merker Model	138
5. Prenormalization	138
6. Weighted Homogeneous Normalizing Biholomorphisms	144
7. Normal Form	146

8. Finalized Expression of Q_0	153
Chapter 4. On Convergent Poincaré-Moser Reduction for Levi Degenerate Embedded 5-Dimensional CR Manifolds	161
1. Introduction	161
2. $\mathfrak{C}_{2,1}$ Hypersurfaces $M^5 \subset \mathbb{C}^3$	166
3. Two Invariant Determinants	167
4. Infinitesimal CR Automorphisms	169
5. Fractional Representation of the Isotropy Group	170
6. Lie Jet Theory	171
7. Intrinsic Isotropy Automorphisms of the Gaussier-Merker Model	172
8. Prolongation to the Jet Space of Order 1	173
9. Prolongation to the Jet Space of Order 2	174
10. Road Map to Convergent Normal Form	177
11. Chain Straightening and Harmonic Killing	180
12. Prenormalization: Step I	182
13. Dependent and Independent Jets	184
14. Prenormalization: Step II	185
15. Expression of the Assumption of 2-Nondegeneracy at the Origin	187
16. Prenormalization: Step III	187
17. Normalization $F_{3,0,0,1}(v) = 0$	191
18. Repetition of Prenormalization	192
19. Normalization $F_{3,0,1,1}(v) = 0$	194
20. Normalizations at the Origin	196
21. Point Translations of \mathcal{C}^ω Hypersurfaces $M^5 \subset \mathbb{C}^3$	199
22. CR-Invariant 1-Jets 2-codimensional Submanifold $\Sigma^1 \subset J_M^1 \cong M^5 \times \mathbb{R}^4$	200
23. Order 1 Chains in $\mathfrak{C}_{2,1}$ Hypersurfaces $M^5 \subset \mathbb{C}^3$	202
24. End of Point Normalization of \mathcal{C}^ω Hypersurfaces $M^5 \subset \mathbb{C}^3$	206
25. Order 2 Chains in $\mathfrak{C}_{2,1}$ Hypersurfaces $M^5 \subset \mathbb{C}^3$	208
26. Moser-like Normal Form for $\mathfrak{C}_{2,1}$ Hypersurfaces $M^5 \subset \mathbb{C}^3$	211
27. Consequence of Prenormalization on Dependent Jets	212
28. Consequence of Prenormalization on Equivalences	215
29. Uniqueness of Normal Form	217
Chapter 5. Parametric CR-umbilical Locus of Ellipsoids in \mathbb{C}^2	231
1. Introduction	231
2. Explicit Expression of Cartan's CR-Invariant \mathfrak{J}	233
3. Pullback to an Exceptional Curve on an Ellipsoid	237
Chapter 6. Nonvanishing of Cartan CR curvature on boundaries of Grauert tubes around hyperbolic surfaces	241
1. Introduction	241
2. The Canonical Kähler Potential on Grauert Tubes	242
3. Two Examples: Round Sphere and Flat Torus	245
4. Semi-global Grauert Tube Around Poincaré's Upper Half-Plane	246
5. Calculation of the Complex Cartan Curvature of $\partial\Omega_\varepsilon \subset \mathbb{H}^c$	248
6. Transfer to Hyperbolic Genus $g \geq 2$ Compact Surfaces	252
7. Grauert Tubes with Respect to Extrinsic Metrics	255

Bibliography

261

Résumé

Ce mémoire contient des résultats de recherche en géométrie complexe et en géométrie CR. Les sujets incluent les bornes de degré pour les hypersurfaces dans les problèmes liés à l'hyperbolicité de Kobayashi (Chapitre 1), les problèmes d'équivalence et la construction de formes normales pour certaines classes d'hypersurfaces à 5-dimensions de Levi dégénérées dans des espaces complexes (Chapitre 2, Chapitre 3 et Chapitre 4), et des investigations sur le lieu de fuite des courbures CR de Cartan sur les frontières de certaines variétés CR 3-dimensionnelles (Chapitre 5 et Chapitre 6). Le thème commun ici est l'utilisation de jets supérieurs dans diverses situations géométriques pour étudier les invariants des objets géométriques, et l'utilisation intensive de programmes de calcul symbolique pour aider à des calculs complexes. Décrivons plus en détail les principaux résultats.

De nouvelles bornes de degré pour les hypersurfaces dans les conjectures de Green-Griffiths et de Kobayashi. Dans le Chapitre 1, nous étudions les degrés d'hypersurfaces algébriques génériques dans les espaces projectifs complexes pour lesquels les conjectures de Green-Griffiths et de Kobayashi sont vraies. La notion d'*hyperbolicité de Kobayashi* est définie pour les espaces complexes généraux par la non-dégénérescence de la métrique de Kobayashi (Voir [73]). Pour une variété complexe compacte lisse X , un théorème de Brody [6] déclare que X est une hyperbolique de Kobayashi si et seulement si toutes les courbes holomorphes entières $f : \mathbb{C} \rightarrow X$ sont constantes. Puisque dans ce Chapitre, nous ne considérerons que les hypersurfaces algébriques lisses, nous prenons pour définition qu'une hypersurface est hyperbolique de Kobayashi si toutes les courbes holomorphes entières sont constantes. La conjecture d'hyperbolicité de Kobayashi pour les hypersurfaces déclare que

CONJECTURE (Kobayashi). *Une hypersurface générique en $\mathbb{P}^n(\mathbb{C})$ de degré au moins $2n + 1$ est hyperbolique de Kobayashi.*

Une notion liée à l'hyperbolicité de Kobayashi est celle de *dégénérescence algébrique*. Une courbe holomorphe entière $f : \mathbb{C} \rightarrow X$ sur une variété algébrique complexe X est algébriquement dégénérée s'il existe une sous-variété algébrique propre Z de X telle que $f(\mathbb{C}) \subset Z$. La conjecture de Green-Griffiths stipule que

CONJECTURE (Green-Griffiths). *Pour toute variété algébrique complexe lisse X de type général, il existe une sous-variété algébrique propre Z de X telle que toutes les courbes holomorphes entières non constantes sur X doivent se trouver dans Z .*

Rappelons qu'une hypersurface dans l'espace projectif complexe n -dimensionnel est de type général si et seulement si son degré est au moins $n + 2$.

Après des activités de recherche intensives au cours des dernières décennies de Siu [115], Demailly [28, 31] et d'autres, la conjecture d'hyperbolicité de Kobayashi est maintenant connue pour être vraie pour les hypersurfaces génériques de degrés assez

grands. Une nouvelle preuve a été récemment donnée par Brotbek [8]. Du côté de la dégénérescence algébrique, le résultat saisissant de Diverio-Merker-Rousseau [34] démontre la conjecture de Green-Griffiths pour les hypersurfaces génériques en $\mathbb{P}^{n+1}(\mathbb{C})$ de degré au moins 2^{n^5} . Plus tard, Darondeau a grandement amélioré la borne à $(5n)^2 n^n$ dans son travail [25]. Il faut mentionner que nos résultats dans le Chapitre 1 sont largement obtenus en poussant plus loin les arguments de positivité clés de [25] basés sur les idées de Bérczi [3]. Le principal outil technique sous ces développements est la technique des différentiels de jets issue des travaux de Bloch [5] et développée en un outil puissant grâce aux travaux de Green-Griffiths, Siu, Demailly, Merker et autres. D'autres méthodes incluent l'utilisation des différentiels wronskiens par Brotbek [8] et des méthodes de géométrie équivariante par Bérczi [3].

Après les résolutions impressionnantes de la conjecture de Kobayashi et de la conjecture de Green-Griffiths pour les hypersurfaces génériques de degrés suffisamment élevés, un prochain objectif naturel dans ce domaine de recherche est d'améliorer les degrés d'hypersurfaces afin que les conjectures susmentionnées restent vraies. Pour le moment, les limites optimales prédites semblent hors de portée avec l'utilisation des techniques actuelles, néanmoins de nombreuses améliorations ont été obtenues pour le cas de la conjecture de Green-Griffiths dans la percée de Diverio-Merker-Rousseau [34], par Demailly [29], Bérczi [3], et Darondeau [27]; et pour le cas de la conjecture de Kobayashi par Deng [33] et Demailly [31] en rendant effective la méthode de Brotbek.

Nous renvoyons à l'article [31] de Demailly pour une enquête à jour et le récit le plus récent sur le sujet.

Récemment, dans un développement surprenant, Riedl-Yang [114] a trouvé un lien étroit entre les deux conjectures montrant que la validité d'une conjecture implique la validité de l'autre dans une gamme convenable de degrés. De plus, en supposant qu'une conjecture est vraie pour des limites de degrés optimales, alors une telle correspondance montre même la validité de la conjecture restante également avec des limites de degrés optimales. Inspiré par ce résultat intéressant, Merker expose un plan pour améliorer les limites des degrés dans la conjecture de Green-Griffiths, et ainsi obtenir des améliorations à la fois pour la conjecture de Kobayashi en poussant plus loin la technique connue dans les travaux antérieurs de Darondeau [27]. Dans sa pré-impression [91] de 2018, Merker a obtenu le degré lié n^{2n} pour la conjecture de Kobayashi. Plus tard, dans un travail conjoint [94] avec Merker, nous explorons plus avant cette ligne de pensée et obtenons les améliorations suivantes

THÉORÈME 0.1. (i) *Pour n assez grand, toutes les courbes holomorphes entières non constantes sur une hypersurface générique en $\mathbb{P}^n(\mathbb{C})$ de degré au moins $(\sqrt{n} \log n)^n$ sont algébriquement dégénérées.*

(ii) *Pour n assez grand, une hypersurface générique en $\mathbb{P}^n(\mathbb{C})$ de degré au moins $(n \log n)^n$ est hyperbolique de Kobayashi.*

Equivalences rigides d'hypersurfaces rigides 2-nondégénérées en 5 dimensions dans \mathbb{C}^3 de forme de Levi de rang constant 1. Dans le Chapitre 2, le Chapitre 3 et le Chapitre 4, nous considérons deux cas particuliers, d'hypersurfaces à 5 dimensions dans \mathbb{C}^3 , de la domaine de recherche générale sur problème d'équivalence et problème de classification de sous-variétés réelles dans des espaces complexes sous l'action de transformations biholomorphes.

Le problème d'équivalence déclare que pour une hypersurface analytique réelle donnée M dans \mathbb{C}^n et un point $P \in M$, et une autre hypersurface donnée M' dans \mathbb{C}^n et un autre

point $P' \in M'$, existe-t-il un biholomorphisme (local) de \mathbb{C}^n qui envoie M à M' et P à P' ? Ceci conduit immédiatement à des recherches sur les invariants biholomorphes locaux de (M, P) . Le problème de classification concerne alors la classification de toutes les hypersurfaces analytiques réelles jusqu'aux transformations biholomorphes, pour lesquelles on espère généralement déterminer des représentants, peut-être jusqu'à quelques ambiguïtés, pour chaque classe d'équivalence biholomorphique (i.e. formes normales).

Poincaré a été le premier à considérer le problème d'équivalence des hypersurfaces réelles sous l'action de biholomorphismes dans des espaces complexes de dimensions supérieures à 1. Dans un article [112] de 1907, il a discuté de la pertinence du problème d'équivalence pour les hypersurfaces réelles dans \mathbb{C}^2 en donnant des arguments heuristiques pour montrer que les hypersurfaces générales ne sont pas localement biholomorphes les unes par rapport aux autres. Il a ensuite proposé d'utiliser des méthodes issues des systèmes dynamiques et de la mécanique céleste pour construire des formes normales d'hypersurfaces dans des espaces complexes.

Puis en 1932, Élie Cartan [17] reprit le problème d'équivalence des hypersurfaces tridimensionnelles dans \mathbb{C}^2 et donna une solution complète en termes de structures géométriques sur les hypersurfaces, un cas particulier de ce que nous appelons maintenant les connexions Cartan. Notez que le problème d'équivalence n'est intéressant que pour les hypersurfaces non dégénérées de Levi, car le cas des hypersurfaces dégénérées de Levi est assez facile en dimension complexe 2.

L'approche de forme normale de Poincaré et l'approche géométrique de É. Cartan a été développée en une théorie à part entière dans l'article [23] de Chern et Moser, qui résout le problème d'équivalence et le problème de classification des hypersurfaces *Levi nondégénérées* dans toute dimension complexe $n \geq 2$. Après des études approfondies suite aux travaux de Chern-Moser, nous avons maintenant une bonne compréhension de la classe des hypersurfaces *Levi nondégénérées*.

Ce n'est qu'au début des années 2000 que les premières études sur les hypersurfaces *Levi dégénérées* ont commencé à apparaître. Le premier cas intéressant à considérer est la classe des hypersurfaces réelles à 5 dimensions dans \mathbb{C}^3 dont la *forme Levi a le rang constant 1*. La première tâche est de déterminer des modèles localement homogènes, qui jouent le rôle des sphères dans le cas de Levi nondégénéré. Le modèle homogène a été déterminé après les travaux d'Ebenfelt [36], Gaussier-Merker [56] et Fels-Kaup [44] pour être le modèle de Gaussier-Merker (voir ci-dessous).

Après avoir trouvé le modèle homogène, le problème d'équivalence pour les hypersurfaces dégénérées de Levi dans \mathbb{C}^3 a été poursuivi par de nombreux groupes de mathématiciens. La solution a été obtenue dans les travaux de Pocchiola [113, 93], Isaev-Zaitsev [68] et Medori-Spiro [82]. Nous renvoyons au travail de Foo-Merker [49] pour un traitement définitif avec tous les détails.

Dans le Chapitre 2 et le Chapitre 3, nous considérons une classe spéciale d'hypersurfaces analytiques réelles *2-nondégénérées, rigides* dans \mathbb{C}^3 ayant *forme de Levi de rang constant 1*.

Nous allons résoudre le problème d'équivalence pour cette classe d'hypersurfaces sous des transformations biholomorphiques *rigides* en appliquant la méthode d'équivalence de Cartan, qui se traduit par une réduction de type Cartan à $\{e\}$ -structure (Chapitre 2). Ensuite, nous résolvons le problème de classification en construisant dans ce cas une forme normale de type Poincaré-Moser (Chapitre 3).

La classe des hypersurfaces *rigides*, telle que popularisée par Isaev [63], est intermédiaire entre la classe des produits des hypersurfaces tridimensionnelles et \mathbb{R}^2 , pour laquelle la théorie est bien comprise, et la classe des hypersurfaces générales à 5 dimensions dans \mathbb{C}^3 . Cela permet beaucoup de simplifications par rapport au cas des hypersurfaces dégénérées générales de Levi, tout en donnant lieu à une théorie intéressante, assez compliquée et significative.

Plus tard, dans le Chapitre 4, nous développerons une théorie de la réduction de type Poincaré-Moser pour la classe des hypersurfaces analytiques réelles générales 2-*non-dégénérées* ayant *forme Levi de rang constant 1* en \mathbb{C}^3 , pas nécessaire *rigide*, sous l'action du groupe complet de toutes les transformations biholomorphes.

Nous donnons maintenant un bref résumé des résultats dans le Chapitre 2 et le Chapitre 3.

Une hypersurface analytique réelle M^5 dans \mathbb{C}^3 est appelée *rigide* s'il existe des coordonnées complexes appropriées (z_1, z_2, w) de \mathbb{C}^3 , avec $w = u + iv$, de sorte que M puisse être représenté sous forme de graphique

$$M : u = F(z_1, z_2, \bar{z}_1, \bar{z}_2),$$

où F est une fonction analytique à valeur réelle dans les variables $z_1, z_2, \bar{z}_1, \bar{z}_2$ et est indépendante de la variable réelle v . Les transformations biholomorphes *rigides* de la forme

$$(z_1, z_2, w) \mapsto (f_1(z_1, z_2), f_2(z_1, z_2), aw + g(z_1, z_2))$$

où $a \in \mathbb{R}^*$, préserve la propriété rigide des hypersurfaces dans \mathbb{C}^3 . Nous étudierons le problème d'équivalence pour la classe des hypersurfaces rigides, qui sont aussi 2-*non-dégénérées* et ont *forme Levi de rang constant 1*, sous l'action du groupe des transformations biholomorphes locaux *rigides*.

Le fibré de structure CR $T^{1,0}M = (\mathbb{C} \otimes TM) \cap T^{1,0}\mathbb{C}^3$ est de rang réel constant 2. De plus, $T^{1,0}M$ est généré partout sur M par deux champs vectoriels $\mathcal{L}_1, \mathcal{L}_2$ donnés par

$$\mathcal{L}_1 = \frac{\partial}{\partial z_1} - iF_{z_1} \frac{\partial}{\partial v} \quad \text{et} \quad \mathcal{L}_2 = \frac{\partial}{\partial z_2} - iF_{z_2} \frac{\partial}{\partial v}.$$

La forme de Levi LF de M en un point $p \in M$ est définie sur $T_p^{1,0}M$ par

$$\begin{aligned} LF_p : T_p^{1,0}M \times T_p^{1,0}M &\longrightarrow \mathbb{C} \otimes T_pM \bmod T_p^{1,0}M \oplus \overline{T_p^{1,0}M}, \\ (X_p, Y_p) &\longmapsto i[X, \bar{Y}]_p \bmod T_p^{1,0}M \oplus \overline{T_p^{1,0}M}, \end{aligned}$$

pour deux vecteurs tangents holomorphes quelconques $X_p, Y_p \in T_p^{1,0}M$ et leurs deux extensions arbitraires de champ de vecteurs holomorphes locaux X, Y près de p . La forme de Levi est un invariant CR de M .

Lors de l'évaluation par rapport au cadre $\{\mathcal{L}_1, \mathcal{L}_2\}$, la forme de Levi peut être représentée sous la forme d'un champ à valeur matricielle 2×2

$$LF_p = 2 \begin{pmatrix} F_{z_1 \bar{z}_1}(p) & F_{z_2 \bar{z}_1}(p) \\ F_{z_1 \bar{z}_2}(p) & F_{z_2 \bar{z}_2}(p) \end{pmatrix}.$$

On ne considère que l'hypersurface M dont la *forme de Levi est de rang constant 1*, c'est-à-dire la matrice $2 \times 2 \begin{pmatrix} F_{z_1 \bar{z}_1}(p) & F_{z_2 \bar{z}_1}(p) \\ F_{z_1 \bar{z}_2}(p) & F_{z_2 \bar{z}_2}(p) \end{pmatrix}$ a rang constant 1 en tout point $p \in M$. Sous cette hypothèse de *dégénérescence de Levi*, le noyau de la forme de Levi en chaque point donne naissance à un sous-fibré $K^{1,0}M$ de rang constant 1 du fibré de structure CR $T^{1,0}M$.

Le sous-fibré $K^{1,0}M$ est généré par le champ de vectors $\mathcal{K} = k\mathcal{L}_1 + \mathcal{L}_2$, avec la fonction oblique $k = -\frac{F_{z_2\bar{z}_1}}{F_{z_1\bar{z}_1}}$.

On rappelle maintenant le prochain invariant CR de M , la forme Freeman FF , qui est donnée en un point $p \in M$ par

$$FF_p : K_p^{1,0}M \times (T_p^{1,0}M \bmod K_p^{1,0}M) \rightarrow T_p^{1,0}M \oplus \overline{T_p^{1,0}M} \bmod K_p^{1,0}M \oplus \overline{T_p^{1,0}M},$$

$$(K_p, L_p) \longmapsto [K, \bar{L}]_p \bmod K_p^{1,0}M \oplus \overline{T_p^{1,0}M},$$

pour deux vecteurs tangents quelconques $K_p \in K_p^{1,0}M$ et $L_p \in T_p^{1,0}M$, et leurs extensions arbitraires des champs de vectors local: K comme section locale de $K^{1,0}M$ et L en tant que section locale de $T^{1,0}M$ près de p .

Nous faisons l'hypothèse que la forme Freeman de M est de rang constant 1 en tout point $p \in M$. Notre hypersurface M est alors appelée *2-nondégénérée*. La 2-nondégénérescence de M équivaut à la condition que $\overline{\mathcal{L}_1(k)}(p) \neq 0, \forall p \in M$.

Le modèle hypersurface de la classe des hypersurfaces rigides 2 nondégénérées de forme Levi de rang constant 1 est le modèle de Gaussier-Merker

$$u = \frac{z_1\bar{z}_1 + \frac{1}{2}z_1^2\bar{z}_2 + \frac{1}{2}\bar{z}_1^2z_2}{1 - z_2\bar{z}_2}$$

dont l'algèbre de Lie des automorphismes CR rigides infinitésimaux est à 7 dimensions.

Dans un travail conjoint [46] avec Foo et Merker, nous effectuons la méthode d'équivalence de Cartan pour obtenir la réduction à $\{e\}$ -structure pour le problème d'équivalence considéré comme suit

THÉORÈME 0.2. *Il existe une fibré invariante 7-dimensionnel $P^7 \rightarrow M^5$ équipé des coordonnées:*

$$(z_1, z_2, \bar{z}_1, \bar{z}_2, v, c, \bar{c}),$$

avec $c \in \mathbb{C}$, avec une collection de sept 1-forme complexe qui font un cadre pour TP^7 , noté:

$$\{\rho, \kappa, \zeta, \bar{\kappa}, \bar{\zeta}, \alpha, \bar{\alpha}\} \quad (\bar{\rho} = \rho),$$

qui satisfont 7 équations de structure invariante de la forme:

$$\begin{aligned} d\rho &= (\alpha + \bar{\alpha}) \wedge \rho + i \kappa \wedge \bar{\kappa}, \\ d\kappa &= \alpha \wedge \kappa + \zeta \wedge \bar{\kappa}, \\ d\zeta &= (\alpha - \bar{\alpha}) \wedge \zeta + \frac{1}{c} I_0 \kappa \wedge \zeta + \frac{1}{c\bar{c}} V_0 \kappa \wedge \bar{\kappa}, \\ d\alpha &= \zeta \wedge \bar{\zeta} - \frac{1}{c} I_0 \zeta \wedge \bar{\kappa} + \frac{1}{c\bar{c}} Q_0 \kappa \wedge \bar{\kappa} + \frac{1}{c} \bar{I}_0 \bar{\zeta} \wedge \kappa, \end{aligned}$$

avec les équations de structure conjuguée pour $d\bar{\kappa}, d\bar{\zeta}, d\bar{\alpha}$.

Les invariants primaires I_0, V_0 sont exprimés explicitement en termes des 5-jets de la fonction graphique F de M . L'invariant secondaire Q_0 peut être exprimé en termes de différentiels des deux invariants primaires et de la fonction F . La disparition de I_0 et V_0 implique la disparition de Q_0 . Une hypersurface rigide 2-nondégénérée M en \mathbb{C}^3 de forme Levi de rang constant 1 est localement équivalente au modèle de Gaussier-Merker sous une transformation biholomorphe rigide si et seulement si $I_0 \equiv 0$ et $V_0 \equiv 0$.

Formes normales d'hypersurfaces rigides 2-dimensionnelles 2-nondégénérées dans \mathbb{C}^3 de forme Levi de rang constant 1. La seconde approche du problème d'équivalence d'hypersurfaces dans des espaces complexes consiste à construire *formes normales*. Proposé par Poincaré [112] et réalisé avec succès pour le cas des hypersurfaces de Levi nondégénérées de toute dimension $n \geq 2$ par Chern et Moser [23]. Cette méthode trouve son origine dans les domaines des systèmes dynamiques et de la mécanique céleste. L'idée est d'appliquer successivement des changements biholomorphiques appropriés de variables afin de simplifier au maximum l'expansion de la série de puissance en un point choisi de la fonction graphique de l'hypersurface considérée. Le but est qu'après des séries de normalisations généralement longues et élaborées, on espère atteindre un représentant pour chaque classe d'équivalence d'hypersurfaces, pouvant aller jusqu'à certaines ambiguïtés.

Conformément à la réduction de type Cartan aux structures $\{e\}$ -dans l'approche géométrique de Cartan et de ses disciples, nous utilisons le terme de réduction *Poincaré-Moser* pour les formes normales obtenues en appliquant la méthode de Moser.

Dans un travail conjoint [22] avec Chen, Foo et Merker, très influencé par les travaux récents [21] de Chen et Merker sur les formes normales de surfaces affines, nous suivons la méthode de Moser de construire une réduction de type Poincaré-Moser pour des hypersurfaces rigides 2-nondégénérées en \mathbb{C}^3 de forme Levi de rang constant 1 sous l'action de transformations biholomorphes rigides locales (Chapitre 3). Décrivons plus précisément la procédure.

Tout d'abord, afin de réduire les complications lors de l'écriture de séries de puissance dans de nombreuses variables, nous allons passer de la coordonnée (z_1, z_2, w) aux nouvelles coordonnées (z, ζ, w) de \mathbb{C}^3 , dans lequel M admet l'expansion de la série de puissance près de l'origine comme

$$u = \sum_{a+b+c+d \geq 1} F_{a,b,c,d} z^a \zeta^b \bar{z}^c \bar{\zeta}^d.$$

Après avoir appliqué quelques transformations rigides préliminaires, M peut être amené à une forme plus simple

$$u = z\bar{z} + \frac{1}{2} z^2 \bar{\zeta} + \frac{1}{2} \bar{z}^2 \zeta + \sum_{\substack{a+b+c+d \geq 4 \\ a+b \geq 1 \\ c+d \geq 1}} F_{a,b,c,d} z^a \zeta^b \bar{z}^c \bar{\zeta}^d.$$

Après avoir appliqué d'autres transformations rigides, les premières simplifications significatives sont obtenues sous la forme *prénormalisée* de $F(z, \zeta, \bar{z}, \bar{\zeta}) = z\bar{z} + \frac{1}{2} \bar{z}^2 \zeta + O_{\bar{z}}(3) + O_{\bar{\zeta}}(1)$, plus précisément:

$$\begin{aligned} 0 &= F_{a,b,0,0} = F_{0,0,c,d}, \\ 0 &= F_{a,b,1,0} = F_{1,0,c,d}, \\ 0 &= F_{a,b,2,0} = F_{2,0,c,d}, \end{aligned}$$

sauf pour $F_{1,0,1,0} = 1$ et $F_{2,0,0,1} = \frac{1}{2} = F_{0,1,2,0}$.

Nous sommes maintenant en mesure de représenter M comme une perturbation du modèle de Gaussier-Merker:

$$u = F(z, \zeta, \bar{z}, \bar{\zeta}) = m(z, \zeta, \bar{z}, \bar{\zeta}) + G(z, \zeta, \bar{z}, \bar{\zeta}),$$

where $m(z, \zeta, \bar{z}, \bar{\zeta}) = \frac{z\bar{z} + \frac{1}{2}z^2\bar{\zeta} + \frac{1}{2}\bar{z}^2\zeta}{1 - \zeta\bar{\zeta}}$. Dans le cadre d'une extension de série de puissance de M , la série de puissance G doit satisfaire certaines contraintes, notamment $G = O_{z, \bar{z}}(3)$.

Ensuite, nous attribuons les poids suivants à la coordonnée variables:

$$[z] := 1 =: [\bar{z}], \quad [\zeta] := 0 =: [\bar{\zeta}], \quad [w] := 2 =: [\bar{w}].$$

Pour aller plus loin, nous recherchons des transformations rigides qui stabilisent la prénormalisation obtenue jusqu'à présent. L'idée est qu'après avoir composé avec un élément de groupe d'isotropie d'origine du modèle de Gaussier-Merker, on peut supposer que la carte de normalisation a une expansion pondérée de la forme:

$$f = z + f_2 + f_3 + \dots, \quad g = \zeta + g_1 + g_2 + \dots, \quad h = w + h_3 + h_4 + \dots,$$

où fonctions holomorphes $f_{\nu-1}, g_{\nu-2}, h_{\nu}$ sont pondérés homogènes des poids correspondants, pour $\nu = 3, 4, 5, \dots$. Nous effectuons des transformations rigides holomorphes successives:

$$z' := z + f_{\nu-1}, \quad \zeta' := \zeta + g_{\nu-2}, \quad w' := w + h_{\nu},$$

qui prennent l'hypersurface $u = F = \mathbf{m} + G$ sous une nouvelle forme $u' = F' = \mathbf{m}' + G'$, avec G, G' prénormalisé, afin de normaliser davantage G' .

Pour $\nu = 3$, il ne reste que deux monômes de degré pondéré 3 (jusqu'à la conjugaison) après la prénormalisation en G :

$$G_3 = 2 \operatorname{Re} \left\{ z^3 \bar{\zeta} G_{3,0,0,1} + z^3 \bar{\zeta}^2 G_{3,0,0,2} \right\} + O_{z, \zeta, \bar{z}, \bar{\zeta}}(6),$$

et nous pouvons annihiler $G'_{3,0,0,1} = 0$.

Pour $\nu = 4$, il ne reste plus que deux monômes:

$$G_4 = 2 \operatorname{Re} \left\{ z^4 \bar{\zeta} G_{4,0,0,1} + z^3 \bar{z} \bar{\zeta} G_{3,0,1,1} \right\} + O_{z, \zeta, \bar{z}, \bar{\zeta}}(6),$$

et nous pouvons annihiler $\operatorname{Im} G'_{3,0,1,1} = 0$.

Enfin, pour $\nu \geq 5$, seule la transformation d'identité stabilise la prénormalisation et les normalisations précédemment obtenues:

$$0 = G_{3,0,0,1} = G'_{3,0,0,1}, \quad 0 = \operatorname{Im} G_{3,0,1,1} = \operatorname{Im} G'_{3,0,1,1}.$$

La réduction de type Poincaré-Moser que nous avons obtenue dans notre travail conjoint [22] avec Chen, Foo et Merker, qui fait l'objet du Chapitre 3, peut maintenant être éat comme

THÉORÈME 0.3. *Toute hypersurface rigide 2-nondégénérée analytique 5 dimensions réelle $M^5 \subset \mathbb{C}^3$ ayant la forme de Levi de rang constant 1 est équivalente, à travers un biholomorphisme rigide local, à une hypersurface rigide analytique réelle ayant la fonction graphique comme un perturbation du modèle de Gaussier-Merker:*

$$u = \frac{z\bar{z} + \frac{1}{2}z^2\bar{\zeta} + \frac{1}{2}\bar{z}^2\zeta}{1 - \zeta\bar{\zeta}} + \sum_{\substack{a,b,c,d \geq 0 \\ a+c \geq 3}} G_{a,b,c,d} z^a \zeta^b \bar{z}^c \bar{\zeta}^d,$$

où le reste G :

(1) est normalisé pour être d'ordre $O_{z, \bar{z}}(3)$;

(2) satisfait aux conditions de prénormatisation $G = O_{\bar{z}}(3) + O_{\bar{z}}(1) = O_z(3) + O_{\zeta}(1)$:

$$G_{a,b,0,0} = 0 = G_{0,0,c,d},$$

$$G_{a,b,1,0} = 0 = G_{1,0,c,d},$$

$$G_{a,b,2,0} = 0 = G_{2,0,c,d};$$

(3) satisfait d'autres conditions de normalisation:

$$G_{3,0,0,1} = 0 = G_{0,1,3,0},$$

$$\operatorname{Im} G_{3,0,1,1} = 0 = \operatorname{Im} G_{1,1,3,0}.$$

De plus, deux de ces hypersurfaces $M^5 \subset \mathbb{C}^3$ et $M'^5 \subset \mathbb{C}'^3$, toutes deux ramenées à une telle forme normale, sont strictement biholomorphiquement équivalentes si et seulement s'il existe deux constantes $\rho \in \mathbb{R}_+^*$, $\varphi \in \mathbb{R}$, telles que pour tous les indices a, b, c, d :

$$G_{a,b,c,d} = G'_{a,b,c,d} \rho^{\frac{a+c-2}{2}} e^{i\varphi(a+2b-c-2d)}.$$

Sous forme normale $u = m + G$, les invariants différentiels que nous avons obtenus précédemment par la méthode d'équivalence de Cartan [46] prennent maintenant les valeurs suivantes à l'origine

$$I_0 = 4 \overline{F_{3,0,0,2}}, \quad V_0 = -8 \overline{F_{4,0,0,1}}, \quad Q_0 = 4 \operatorname{Re} F_{3,0,1,1}.$$

Réduction convergente de Poincaré-Moser pour les hypersurfaces 5-dimensionnelles Levi dégénérées en \mathbb{C}^3 . Dans le Chapitre 4, nous considérons le problème de la construction de la réduction de type Poincaré-Moser pour la classe des hypersurfaces 2-nondégénérées en 5 dimensions analytiques réelles générales $M^5 \subset \mathbb{C}^3$, non étant nécessaire *rigide*, sous l'action du groupe complet de toutes les transformations biholomorphes de \mathbb{C}^3 . L'approche est en général dans le même esprit avec le cas rigide, mais les détails sont beaucoup plus impliqués, notamment dans la preuve de l'unicité de la forme normale qui n'apparaît pas dans le cas rigide, et nécessite également de nouvelles idées, notamment le adaptation dans ce cas de la récente remarquable construction de Lie théorique des chaînes de Cartan-Moser par Merker [95].

La réduction de type Cartan à $\{e\}$ -structure pour la classe d'hypersurfaces considérée a été réalisée dans les travaux de Pocchiola [113, 93] et de Foo-Merker [49]. Notre construction peut être considérée comme l'équivalent théorique de la forme normale côté de Moser de leur résultat géométrique côté Cartan. À ce stade, nous voulons souligner qu'en général, la construction de formes normales pour des objets géométriques dans des espaces complexes est difficile à réaliser, et peut même conduire à des problèmes complexes tels que la divergence des formes normales formelles en raison de petits diviseurs comme dans le travail de Moser-Webster [104]. Ce n'est qu'avec les informations cruciales sur l'application réussie de la méthode d'équivalence de Cartan et l'existence des invariants différentiels avec des ordres précis fournis par la méthode géométrique de Pocchiola et Foo-Merker que l'on peut espérer produire des transformations biholomorphes correctes pour éliminer successivement les coefficients non invariants dans la série de puissance de M .

L'hypersurface M est représentée près de l'origine comme un graphe en coordonnées $(z, \zeta, w = u + iv)$ de \mathbb{C}^3 par

$$u = F(z, \zeta, \bar{z}, \bar{\zeta}, v)$$

où F est une série de puissance en variables $z, \zeta, \bar{z}, \bar{\zeta}, v$.

Tout d'abord, nous notons que le modèle hypersurface dans ce cas est à nouveau le modèle de Gaussier-Merker

$$u = \frac{z\bar{z} + \frac{1}{2}z^2\bar{\zeta} + \frac{1}{2}\bar{z}^2\zeta}{1 - \zeta\bar{\zeta}},$$

mais maintenant sous l'action du groupe de toutes les transformations biholomorphes de \mathbb{C}^3 , l'algèbre de Lie des automorphismes CR infinitésimaux du modèle de Gaussier-Merker est 10 dimensions, plus grande que dans le cas rigide.

Ensuite, nous adaptons la construction théorique de Lie des chaînes Cartan-Moser de Merker [95] du cas des hypersurfaces Levi non dégénérées dans \mathbb{C}^2 au cas considéré dans \mathbb{C}^3 . Il en résulte deux jets invariants d'ordre 1 et 2, que nous appelons également chaînes de Cartan-Moser.

En intégrant et en redressant n'importe quelle chaîne Cartan-Moser d'ordre 2, nous obtenons la forme normale suivante pour M dans un travail conjoint [48] avec Foo et Merker, qui est le résultat principal du Chapitre 4

THÉORÈME 0.4. *Il existe une transformation biholomorphique locale $\Phi : (z, \zeta, w) \mapsto (z', \zeta', w')$ fixant l'origine, ce qui ramène $(M, 0)$ à la forme normale*

$$\begin{aligned} u = & \frac{z\bar{z} + \frac{1}{2}z^2\bar{\zeta} + \frac{1}{2}\bar{z}^2\zeta}{1 - \zeta\bar{\zeta}} \\ & + 2 \operatorname{Re} \left\{ z^3\bar{\zeta}^2 F_{3,0,0,2}(v) + 3z^2\bar{z}\zeta\bar{\zeta}^2 F_{3,0,0,2}(v) \right\} \\ & + 2 \operatorname{Re} \left\{ z^5\bar{\zeta} F_{5,0,0,1}(v) + z^4\bar{\zeta}^2 F_{4,0,0,2}(v) \right. \\ & \quad \left. + z^3\bar{z}^2\bar{\zeta} F_{3,0,2,1}(v) + z^3\bar{z}\bar{\zeta}^2 F_{3,0,1,2}(v) + z^3\bar{\zeta}^3 F_{3,0,0,3}(v) \right\} \\ & + z^3\bar{z}^3 O_{z,\bar{z}}(1) + \bar{z}^3\zeta O_{z,\zeta,\bar{z}}(3) + z^3\bar{\zeta} O_{z,\bar{z},\bar{\zeta}}(3) + \zeta\bar{\zeta} O_{z,\bar{z}}(3) O_{z,\bar{z},\zeta,\bar{\zeta}}(2). \end{aligned}$$

De plus, la transformation Φ peut être choisie uniquement de la forme

$$(z, \zeta, w) \mapsto (z + f_{\geq 2}(z, \zeta, w), \zeta + g_{\geq 1}(z, \zeta, w), w + h_{\geq 3}(z, \zeta, w)),$$

avec $f_w(0) = 0$ et $\operatorname{Im} h_{ww}(0) = 0$.

Pour une hypersurface M en forme normale, les valeurs à l'origine des deux invariants différentiels primaires de Pocchiola [113, 93, 49] sont

$$W_0 = 4 \overline{F_{3,0,0,2}(0)} \quad \text{and} \quad J_0 = 20 F_{5,0,0,1}(0).$$

Calcul des courbures CR de Cartan des frontières des ellipsoïdes en \mathbb{C}^2 et des tubes de Grauert autour des surfaces hyperboliques. La solution de Élie Cartan [17] en 1932 du problème d'équivalence des hypersurfaces analytiques réelles dans \mathbb{C}^2 montre en particulier l'existence d'une fonction invariante CR à valeur complexe $I_{Cartan} : M \rightarrow \mathbb{C}$ avec la propriété que $I_{Cartan} \equiv 0$ si et seulement si M est biholomorphiquement équivalent à la sphère dans \mathbb{C}^2 . Un point $p \in M$ est appelé *CR-ombilical* si $I_{Cartan}(p) = 0$. Une vieille question de Chern et Moser dans [23] demande si le lieu des points CR-ombilicaux d'une hypersurface compacte de Levi nondégénérée dans \mathbb{C}^2 peut être vide. En dimension complexe 3 ou supérieure, Webster [118] a montré que pour les hypersurfaces ellipsoïdales

génériques, le lieu de fuite des invariants de Cartan-Hachtroudi-Chern, la contrepartie de dimension supérieure de I_{Cartan} , est en effet vide. Dans \mathbb{C}^2 de coordonnées $(z = x + iy, w = u + iv)$, Huang et Ji [60] ont montré que le locus CR-ombilical de l'ellipsoïde

$$\mathbf{E}_{a,b} : ax^2 + y^2 + bu^2 + v^2 = 1$$

n'est pas vide pour $a, b \geq 1, (a, b) \neq (1, 1)$. La principale difficulté dans l'étude des invariants de type CR de Cartan tient en grande partie à sa complexité écrasante. Par exemple, Merker et Sabzevari ont estimé dans [87] que la formule explicitement développée de I_{Cartan} de $\mathbf{E}_{a,b}$ en contient autant comme 40 000 termes.

Dans le Chapitre 5, nous étudions davantage le locus CR-ombilical de $\mathbf{E}_{a,b}$ à l'aide de l'approche informatique de Merker-Sabzevari [87]. Plus précisément, dans un travail conjoint [45] avec Foo et Merker, nous montrons que

THÉORÈME 0.5. *Le lieu CR-ombilical de l'ellipsoïde $\mathbf{E}_{a,b}$ contient une courbe lisse donnée par de simples équations explicites.*

Pour une surface analytique réelle compacte fermée S , c'est un théorème de Bruhat et Whitney [7] qu'il existe une variété complexe M^c de dimension complexe 2, avec une prolongement analytique totalement réelle de S dans M^c . De plus, le travail [59] de Guillemin et Stenzel fournit un Kähler potentiel plus élevé ρ défini dans un petit voisinage de S dans M^c . En particulier, pour chaque ε assez petit: $0 < \varepsilon \leq \varepsilon_0 \ll 1$, l'ensemble $\Omega_\varepsilon := \rho^{-1}([0, \varepsilon])$, appelé le *tube de Grauert* de rayon ε autour de S , a une frontière fortement pseudo-convexe $\mathcal{C}^\omega M_\varepsilon := \rho^{-1}(\varepsilon)$ contenu dans la surface complexe M^c .

Récemment, Ebenfelt-Duong-Zaitsev [37] a donné des exemples de variétés CR Levi nondégénérées en 3 dimensions, comme limites de tubes de Grauert minces autour du tore plat 2-dimensionnel, ayant un locus CR-ombilical vide.

Dans un travail conjoint [47] avec Foo et Merker, qui constitue le Chapitre 6, nous montrons que les frontières M_ε de nombreux autres tubes de Grauert minces Ω_ε autour des surfaces hyperboliques ont également un locus CR-ombilical vide

THÉORÈME 0.6. *Pour $\varepsilon > 0$ assez petit, les parties réelle et imaginaire de I_{Cartan} ne disparaissent nulle part à la frontière du tube de Grauert M_ε .*

Nous concluons cette introduction en mentionnant que les résultats de ce mémoire sont obtenus dans nos travaux conjoints avec Joël Merker, Wei-Guo Foo et Zhangchi Chen, qui ont tous paru sur arxiv.org sous forme de prépublication:

- Wei-Guo Foo, Joël Merker, The-Anh Ta, *Parametric CR-umbilical Locus of Ellipsoids in \mathbb{C}^2* , Comptes Rendus Mathématique 356 (2018): 214-221.
arXiv:1707.06787
- Joël Merker, The-Anh Ta, *Degrees $d \geq (\sqrt{n} \log n)^n$ and $d \geq (n \log n)^n$ in the Conjectures of Green-Griffiths and of Kobayashi*,
arXiv:1901.04042
- Wei-Guo Foo, Joël Merker, The-Anh Ta, *Rigid equivalences of 5-dimensional 2-nondegenerate rigid real hypersurfaces $M^5 \subset \mathbb{C}^3$ of constant Levi rank 1*,
arXiv:1904.02562
- Wei-Guo Foo, Joël Merker, The-Anh Ta, *Nonvanishing of Cartan CR curvature on boundaries of Grauert tubes around hyperbolic surfaces*,
arXiv:1904.10203

- Zhangchi Chen, Wei-Guo Foo, Joël Merker, The-Anh Ta, *Normal Forms for Rigid $\mathcal{C}_{2,1}$ Hypersurfaces $M^5 \subset \mathbb{C}^3$* ,
arXiv:1912.01655
- Wei-Guo Foo, Joël Merker, The-Anh Ta, *On Convergent Poincaré-Moser Reduction for Levi Degenerate Embedded 5-Dimensional CR Manifolds*,
arXiv:2003.01952

Introduction

This memoir contains research results in complex geometry and CR geometry. The topics include degree bounds for hypersurfaces in Kobayashi hyperbolicity related problems (Chapter 1), equivalence problems and construction of normal forms for certain classes of Levi degenerate 5-dimensional hypersurfaces in complex spaces (Chapter 2, Chapter 3 and Chapter 4), and investigations on the vanishing locus of Cartan CR curvatures on boundaries of some 3-dimensional CR manifolds (Chapter 5 and Chapter 6). The common theme here is the use of higher jets in diverse geometric situations to investigate invariants of geometric objects, and the extensive use of symbolic computational programs to help with complicated calculations. Let us describe in more details the main results.

New degree bounds for hypersurfaces in the conjectures of Green-Griffiths and of Kobayashi. In Chapter 1, we investigate degrees of generic algebraic hypersurfaces in the complex projective spaces for which the conjectures of Green-Griffiths and of Kobayashi holds true. The notion of *Kobayashi hyperbolicity* is defined for general complex spaces by the nondegeneracy of the Kobayashi metric (See [73]). For a smooth compact complex manifold X , a theorem of Brody [6] states that X is Kobayashi hyperbolic if and only if all entire holomorphic curves $f : \mathbb{C} \rightarrow X$ are constant. Since in this chapter, we will only consider smooth algebraic hypersurfaces, we take for definition that a hypersurface is Kobayashi hyperbolic if all entire holomorphic curves on it are constant. The Kobayashi hyperbolicity conjecture for hypersurfaces states that

CONJECTURE (Kobayashi). *A generic hypersurface in $\mathbb{P}^n(\mathbb{C})$ of degree at least $2n + 1$ is Kobayashi hyperbolic.*

A related notion to Kobayashi hyperbolicity is that of *algebraic degeneracy*. An entire holomorphic curve $f : \mathbb{C} \rightarrow X$ on a complex algebraic variety X is algebraically degenerate if there exists a proper algebraic subvariety Z of X such that $f(\mathbb{C}) \subset Z$. The Green-Griffiths conjecture states that

CONJECTURE (Green-Griffiths). *For any smooth complex algebraic variety X of general type, there exists a proper algebraic subvariety Z of X such that all nonconstant entire holomorphic curves on X must lie in Z .*

Recall that a hypersurface in the n -dimensional complex projective space is of general type if and only if its degree is at least $n + 2$.

After intensive activities of research during the last few decades of Siu [115], Demailly [28, 31] and others, the Kobayashi hyperbolicity conjecture is now known to hold true for generic hypersurfaces of large enough degrees. A new proof was recently given by Brotbek [8]. On the side of algebraic degeneracy, the striking result of Diverio-Merker-Rousseau [34] demonstrates the Green-Griffiths conjecture for generic hypersurfaces in $\mathbb{P}^{n+1}(\mathbb{C})$ of degree at least $2n^5$. Later, Darondeau greatly improved the bound to $(5n)^2n^n$

in his work [25]. It should be mentioned that our results in Chapter 1 are largely obtained by pushing further the key positivity arguments of [25] based on Bérczi's ideas [3]. The main technical tool under these developments is the technique of jet differentials originated from the work of Bloch [5] and developed into a powerful tool through the works of Green-Griffiths, Siu, Demailly, Merker and others. Other methods include the use of Wronskian differentials by Brotbek [8] and methods from equivariant geometry by Bérczi [3].

After the impressive resolutions of the Kobayashi conjecture and the Green-Griffiths conjecture for generic hypersurfaces of high enough degrees, one natural next goal in this research area is to improve on degrees of hypersurfaces so that the aforementioned conjectures still hold true. At the moment, the predicted optimal bounds seems to be out of reach with the use of current techniques, nevertheless many improvements have been obtained for the case of Green-Griffiths conjecture in the breakthrough of Diverio-Merker-Rousseau [34], by Demailly [29], Bérczi [3], and Darondeau [27]; and for the case of Kobayashi conjecture by Deng [33] and Demailly [31] by making effective the method of Brotbek.

We refer to the paper [31] of Demailly for an up to date survey and the most recent account of the subject.

Recently, in a surprising development, Riedl-Yang [114] found a close connection between the two conjectures showing that the validity of one conjecture implies the validity of the other in a suitable range of degrees. Moreover, assuming one conjecture holds true for optimal degree bounds, then such correspondence even shows the validity of the remaining conjecture also with optimal degree bounds. Inspired by this interesting result, Merker sets out a plan to improve the degree bounds in the Green-Griffiths conjecture, and so obtain improvements at once for the Kobayashi conjecture by pushing further the known technique in the earlier work of Darondeau [27]. In his preprint [91] of 2018, Merker obtained the degree bound n^{2n} for the Kobayashi conjecture. Later, in a joint work [94] with Merker, we explore further this line of thoughts of his and obtain the following improvements

THEOREM A. (i) *For n large enough, all nonconstant entire holomorphic curves on a generic hypersurface in $\mathbb{P}^n(\mathbb{C})$ of degree at least $(\sqrt{n} \log n)^n$ are algebraically degenerate.*
(ii) *For n large enough, a generic hypersurface in $\mathbb{P}^n(\mathbb{C})$ of degree at least $(n \log n)^n$ is Kobayashi hyperbolic.*

Rigid equivalences of 5-dimensional 2-nondegenerate rigid hypersurfaces in \mathbb{C}^3 having Levi form of constant rank 1. In Chapter 2, Chapter 3 and Chapter 4, we consider two particular cases, of 5-dimensional hypersurfaces in \mathbb{C}^3 , of the general research area on equivalence problem and classification problem of real submanifolds in complex spaces under the action of biholomorphic transformations.

The equivalence problem states that for a given real analytic hypersurface M in \mathbb{C}^n and a point $P \in M$, and another given hypersurface M' in \mathbb{C}^n and another point $P' \in M'$, is there a (local) biholomorphism of \mathbb{C}^n that sends M to M' and P to P' ? This immediately leads to investigations on local biholomorphic invariants of (M, P) . The classification problem then concerns with classifying all real analytic hypersurfaces up to biholomorphic transformations, for which one usually hopes to determine representatives, possibly up to some ambiguities, for each biholomorphic equivalence class (i.e. normal forms).

Poincaré was the first to consider the equivalence problem of real hypersurfaces under the action of biholomorphisms in complex spaces of dimensions greater than 1. In a paper [112] of 1907, he discussed the relevance of equivalence problem for real hypersurfaces

in \mathbb{C}^2 by giving heuristic arguments to show that general hypersurfaces are not locally biholomorphic to each other. He then proposed to use methods from Dynamical Systems and Celestial Mechanics to construct normal forms for hypersurfaces in complex spaces.

Then in 1932, Élie Cartan [17] took up the equivalence problem of 3-dimensional hypersurfaces in \mathbb{C}^2 and gave a complete solution in terms of geometric structures on the hypersurfaces, a particular case of what we now call Cartan connections. Note that the equivalence problem is only interesting for Levi nondegenerate hypersurfaces, as the case of Levi degenerate hypersurfaces is rather easy in complex dimension 2.

Both the normal form approach of Poincaré and the geometric approach of É. Cartan were developed into a full-fledged theory in the landmark paper [23] of Chern and Moser, which solves the equivalence problem and the classification problem of *Levi nondegenerate* hypersurfaces in any complex dimension $n \geq 2$. After extensive studies following the work of Chern-Moser, we now have a fair understanding of the class of *Levi nondegenerate* hypersurfaces.

It was only in early 2000's that the first studies on *Levi degenerate* hypersurfaces started to appear. The first interesting case to consider is the class of 5-dimensional real hypersurfaces in \mathbb{C}^3 whose *Levi form has constant rank 1*. The first task is to determine locally homogeneous models, which play the role of the spheres in Levi nondegenerate case. The homogeneous model was determined after the works of Ebenfelt [36], Gaussier-Merker [56] and Fels-Kaup [44] to be the Gaussier-Merker model (see below).

After the homogeneous model was found, equivalence problem for Levi degenerate hypersurfaces in \mathbb{C}^3 was pursued by many groups of mathematicians. The solution was obtained in the works of Pocchiola [113, 93], Isaev-Zaitsev [68] and Medori-Spiro [82]. We refer to the work of Foo-Merker [49] for a definite treatment with full details.

In Chapter 2 and Chapter 3, we consider a special class of real analytic *2-nondegenerate, rigid* hypersurfaces in \mathbb{C}^3 having *Levi form of constant rank 1*. We will solve the equivalence problem for this class of hypersurfaces under *rigid* biholomorphic transformations by applying Cartan's method of equivalence, which results in a Cartan type reduction to $\{e\}$ -structure (Chapter 2). Next, we solve the classification problem by constructing Poincaré-Moser type normal form in this case (Chapter 3).

The class of *rigid* hypersurfaces, as popularized by Isaev [63], is intermediate between the class of products of 3-dimensional hypersurfaces and \mathbb{R}^2 , for which the theory is well understood, and the class of general 5-dimensional hypersurfaces in \mathbb{C}^3 . This allows for a lot of simplifications in comparison with the case of general Levi degenerate hypersurfaces, while still gives rises to an interesting, complicated enough and meaningful theory.

Later on, in Chapter 4, we will develop a theory of Poincaré-Moser type reduction for the class of general real analytic *2-nondegenerate* hypersurfaces having *Levi form of constant rank 1* in \mathbb{C}^3 , not necessary *rigid*, under the action of the full group of all biholomorphic transformations.

We now give a brief summary of results in Chapter 2 and Chapter 3.

A real analytic hypersurface M^5 in \mathbb{C}^3 is called *rigid* if there exist suitable complex coordinates (z_1, z_2, w) of \mathbb{C}^3 , with $w = u + iv$, such that M can be represented as a graph

$$M : u = F(z_1, z_2, \bar{z}_1, \bar{z}_2),$$

where F is a real-valued analytic function in variables $z_1, z_2, \bar{z}_1, \bar{z}_2$ and is independent of the real variable v . The *rigid* biholomorphic transformations of the form

$$(z_1, z_2, w) \mapsto (f_1(z_1, z_2), f_2(z_1, z_2), aw + g(z_1, z_2))$$

where $a \in \mathbb{R}^*$, preserve the rigid property of hypersurfaces in \mathbb{C}^3 . We will study the equivalence problem for the class of rigid hypersurfaces, which are also *2-nondegenerate* and have *Levi form of constant rank 1*, under the action of the group of local *rigid* biholomorphic transformations.

The CR structure bundle $T^{1,0}M = (\mathbb{C} \otimes TM) \cap T^{1,0}\mathbb{C}^3$ is of constant real rank 2. Furthermore, $T^{1,0}M$ is generated everywhere on M by two vector fields $\mathcal{L}_1, \mathcal{L}_2$ given by

$$\mathcal{L}_1 = \frac{\partial}{\partial z_1} - iF_{z_1} \frac{\partial}{\partial v} \quad \text{and} \quad \mathcal{L}_2 = \frac{\partial}{\partial z_2} - iF_{z_2} \frac{\partial}{\partial v}.$$

The Levi form LF of M at a point $p \in M$ is defined on $T_p^{1,0}M$ by

$$\begin{aligned} LF_p : T_p^{1,0}M \times T_p^{1,0}M &\longrightarrow \mathbb{C} \otimes T_p M \text{mod} T_p^{1,0}M \oplus \overline{T_p^{1,0}M}, \\ (X_p, Y_p) &\longmapsto i[X, \bar{Y}]_p \text{mod} T_p^{1,0}M \oplus \overline{T_p^{1,0}M}, \end{aligned}$$

for any two holomorphic tangent vectors $X_p, Y_p \in T_p^{1,0}M$ and their arbitrary two local holomorphic vector field extensions X, Y near p . The Levi form is a CR invariant of M . When evaluating with respect to the frame $\{\mathcal{L}_1, \mathcal{L}_2\}$, the Levi form can be represented in the form of a 2×2 matrix-valued field

$$LF_p = 2 \begin{pmatrix} F_{z_1 \bar{z}_1}(p) & F_{z_2 \bar{z}_1}(p) \\ F_{z_1 \bar{z}_2}(p) & F_{z_2 \bar{z}_2}(p) \end{pmatrix}.$$

We only consider hypersurface M whose *Levi form is of constant rank 1*, that is the 2×2 matrix $\begin{pmatrix} F_{z_1 \bar{z}_1}(p) & F_{z_2 \bar{z}_1}(p) \\ F_{z_1 \bar{z}_2}(p) & F_{z_2 \bar{z}_2}(p) \end{pmatrix}$ has constant rank 1 at every point $p \in M$. Under this assumption of *Levi degeneracy*, the kernel of the Levi form at each point gives rise to a subbundle $K^{1,0}M$ of constant rank 1 of the CR structure bundle $T^{1,0}M$. The subbundle $K^{1,0}M$ is generated by the vector field $\mathcal{K} = k\mathcal{L}_1 + \mathcal{L}_2$, with the slant function $k = -\frac{F_{z_2 \bar{z}_1}}{F_{z_1 \bar{z}_1}}$.

We now recall the next CR invariant of M , the Freeman form FF , which is given at a point $p \in M$ by

$$\begin{aligned} FF_p : K_p^{1,0}M \times (T_p^{1,0}M \text{mod} K_p^{1,0}M) &\rightarrow T_p^{1,0}M \oplus \overline{T_p^{1,0}M} \text{mod} K_p^{1,0}M \oplus \overline{T_p^{1,0}M}, \\ (K_p, L_p) &\longmapsto [K, \bar{L}]_p \text{mod} K_p^{1,0}M \oplus \overline{T_p^{1,0}M}, \end{aligned}$$

for any two tangent vectors $K_p \in K_p^{1,0}M$ and $L_p \in T_p^{1,0}M$, and their arbitrary local vector field extensions: K as a local section of $K^{1,0}M$ and L as a local section of $T^{1,0}M$ near p .

We make the assumption that the Freeman form of M is of constant rank 1 at every point $p \in M$. Our hypersurface M is then called *2-nondegenerate*. The 2-nondegeneracy of M is equivalent to the condition that $\overline{\mathcal{L}_1}(k)(p) \neq 0, \forall p \in M$.

The model hypersurface in the class of 2-nondegenerate, rigid hypersurfaces having Levi form of constant rank 1 is the Gaussier-Merker model

$$u = \frac{z_1 \bar{z}_1 + \frac{1}{2} z_1^2 \bar{z}_2 + \frac{1}{2} \bar{z}_1^2 z_2}{1 - z_2 \bar{z}_2}$$

whose Lie algebra of infinitesimal rigid CR automorphisms is 7-dimensional.

In a joint work [46] with Foo and Merker, we perform the Cartan's method of equivalence to obtain reduction to $\{e\}$ -structure for the equivalence problem under consideration as follows

THEOREM B. *There exists an invariant 7-dimensional bundle $P^7 \rightarrow M^5$ equipped with coordinates:*

$$(z_1, z_2, \bar{z}_1, \bar{z}_2, v, c, \bar{c}),$$

with $c \in \mathbb{C}$, together with a collection of seven complex-valued 1-form which make a frame for TP^7 , denoted:

$$\{\rho, \kappa, \zeta, \bar{\kappa}, \bar{\zeta}, \alpha, \bar{\alpha}\} \quad (\bar{\rho} = \rho),$$

which satisfy 7 invariant structure equations of the form:

$$\begin{aligned} d\rho &= (\alpha + \bar{\alpha}) \wedge \rho + i \kappa \wedge \bar{\kappa}, \\ d\kappa &= \alpha \wedge \kappa + \zeta \wedge \bar{\kappa}, \\ d\zeta &= (\alpha - \bar{\alpha}) \wedge \zeta + \frac{1}{c} I_0 \kappa \wedge \zeta + \frac{1}{c\bar{c}} V_0 \kappa \wedge \bar{\kappa}, \\ d\alpha &= \zeta \wedge \bar{\zeta} - \frac{1}{c} I_0 \zeta \wedge \bar{\kappa} + \frac{1}{c\bar{c}} Q_0 \kappa \wedge \bar{\kappa} + \frac{1}{c} \bar{I}_0 \bar{\zeta} \wedge \kappa, \end{aligned}$$

together with the conjugate structure equations for $d\bar{\kappa}$, $d\bar{\zeta}$, $d\bar{\alpha}$.

The *primary* invariants I_0, V_0 are expressed explicitly in terms of the 5-jets of the graphing function F of M . The *secondary* invariant Q_0 can be expressed in terms of differentials of the two primary invariants and the function F . The vanishing of I_0 and V_0 implies the vanishing of Q_0 . A 2-nondegenerate, rigid hypersurface M in \mathbb{C}^3 having Levi form of constant rank 1 is locally equivalent to the Gaussier-Merker model under a rigid biholomorphic transformation if and only if $I_0 \equiv 0$ and $V_0 \equiv 0$.

Normal forms of 5-dimensional 2-nondegenerate rigid hypersurfaces in \mathbb{C}^3 having Levi form of constant rank 1. The second approach to the equivalence problem of hypersurfaces in complex spaces is by constructing *normal forms*. Proposed by Poincaré [112] and successfully carried out for the case of Levi nondegenerate hypersurfaces in any dimension $n \geq 2$ by Chern and Moser [23]. This method has its origin from the fields of Dynamical Systems and Celestial Mechanics. The idea is to apply successively suitable biholomorphic changes of variables in order to simplify as much as possible the power series expansion at a chosen point of the graphing function of the hypersurface under consideration. The goal is that after usually long and elaborated series of normalizations, one hopes to reach a representative for each equivalence class of hypersurfaces, possibly up to certain ambiguities.

In accordance with Cartan type reduction to $\{e\}$ -structures in the geometric approach of Cartan and his followers, we use the term *Poincaré-Moser* reduction for the normal forms obtained by applying Moser's method.

In a joint work [22] with Chen, Foo and Merker, much influenced by the recent work [21] of Chen and Merker on normal forms of affine surfaces, we follow Moser's method to construct a Poincaré-Moser type reduction for 2-nondegenerate, rigid hypersurfaces in \mathbb{C}^3 having Levi form of constant rank 1 under the action of local rigid biholomorphic transformations (Chapter 3). Let us describe the procedure more precisely.

First, in order to reduce the complications in writing power series in many variables, we will switch from the coordinate (z_1, z_2, w) to new coordinates (z, ζ, w) of \mathbb{C}^3 , in which M admits power series expansion near the origin as

$$u = \sum_{a+b+c+d \geq 1} F_{a,b,c,d} z^a \zeta^b \bar{z}^c \bar{\zeta}^d.$$

After applying some preliminary rigid transformations, M can be brought to a simpler form

$$u = z\bar{z} + \frac{1}{2} z^2 \bar{\zeta} + \frac{1}{2} \bar{z}^2 \zeta + \sum_{\substack{a+b+c+d \geq 4 \\ a+b \geq 1 \\ c+d \geq 1}} F_{a,b,c,d} z^a \zeta^b \bar{z}^c \bar{\zeta}^d.$$

After applying further rigid transformations, the first significant simplifications are obtained in the *prenormalized* form of $F(z, \zeta, \bar{z}, \bar{\zeta}) = z\bar{z} + \frac{1}{2} \bar{z}^2 \zeta + O_{\bar{z}}(3) + O_{\bar{\zeta}}(1)$, more precisely:

$$\begin{aligned} 0 &= F_{a,b,0,0} = F_{0,0,c,d}, \\ 0 &= F_{a,b,1,0} = F_{1,0,c,d}, \\ 0 &= F_{a,b,2,0} = F_{2,0,c,d}, \end{aligned}$$

except for $F_{1,0,1,0} = 1$ and $F_{2,0,0,1} = \frac{1}{2} = F_{0,1,2,0}$.

We are now in the position to represent M as a perturbation of the Gaussier-Merker model:

$$u = F(z, \zeta, \bar{z}, \bar{\zeta}) = m(z, \zeta, \bar{z}, \bar{\zeta}) + G(z, \zeta, \bar{z}, \bar{\zeta}),$$

where $m(z, \zeta, \bar{z}, \bar{\zeta}) = \frac{z\bar{z} + \frac{1}{2} z^2 \bar{\zeta} + \frac{1}{2} \bar{z}^2 \zeta}{1 - \zeta \bar{\zeta}}$. As part of a power series expansion of M , the power series G must satisfy certain constraints, in particular $G = O_{z, \bar{z}}(3)$.

Next, we assign the following weights to the coordinate variables:

$$[z] := 1 =: [\bar{z}], \quad [\zeta] := 0 =: [\bar{\zeta}], \quad [w] := 2 =: [\bar{w}].$$

To proceed further, we look for rigid transformations which stabilize the prenormalization obtained so far. The idea is that after composing with some element of the isotropy group of the origin of the Gaussier-Merker model, we can assume that the normalizing map has weighted expansion of the form:

$$f = z + f_2 + f_3 + \cdots, \quad g = \zeta + g_1 + g_2 + \cdots, \quad h = w + h_3 + h_4 + \cdots,$$

where holomorphic functions $f_{\nu-1}, g_{\nu-2}, h_{\nu}$ are weighted homogeneous of the corresponding weights, for $\nu = 3, 4, 5, \dots$. We perform successive holomorphic rigid transformations:

$$z' := z + f_{\nu-1}, \quad \zeta' := \zeta + g_{\nu-2}, \quad w' := w + h_{\nu},$$

which take the hypersurface $u = F = \mathbf{m} + G$ into new form $u' = F' = \mathbf{m}' + G'$, with G, G' prenormalized, in order to normalize further G' .

For $\nu = 3$, only two monomials of weighted degree 3 (up to conjugation) remain after prenormalization in G :

$$G_3 = 2 \operatorname{Re} \left\{ z^3 \bar{\zeta} G_{3,0,0,1} + z^3 \bar{\zeta}^2 G_{3,0,0,2} \right\} + O_{z, \zeta, \bar{z}, \bar{\zeta}}(6),$$

and we can annihilate $G'_{3,0,0,1} = 0$.

For $\nu = 4$, there are only two monomials remain:

$$G_4 = 2 \operatorname{Re} \left\{ z^4 \bar{\zeta} G_{4,0,0,1} + z^3 \bar{z} \bar{\zeta} G_{3,0,1,1} \right\} + O_{z,\zeta,\bar{z},\bar{\zeta}}(6),$$

and we can annihilate $\operatorname{Im} G'_{3,0,1,1} = 0$.

Finally, for $\nu \geq 5$, only the identity transformation stabilizes the prenormalization and the previously achieved normalizations:

$$0 = G_{3,0,0,1} = G'_{3,0,0,1}, \quad 0 = \operatorname{Im} G_{3,0,1,1} = \operatorname{Im} G'_{3,0,1,1}.$$

The Poincaré-Moser type reduction that we obtained in our joint work [22] with Chen, Foo and Merker, which is the subject of Chapter 3, can now be state as

THEOREM C. *Every real analytic 5-dimensional 2-nondegenerate rigid hypersurface $M^5 \subset \mathbb{C}^3$ having Levi form of constant rank 1 is equivalent, through a local rigid biholomorphism, to a real analytic rigid hypersurface having the graphing function as a perturbation of the Gaussier-Merker model:*

$$u = \frac{z\bar{z} + \frac{1}{2}z^2\bar{\zeta} + \frac{1}{2}\bar{z}^2\zeta}{1 - \zeta\bar{\zeta}} + \sum_{\substack{a,b,c,d \geq 0 \\ a+c \geq 3}} G_{a,b,c,d} z^a \zeta^b \bar{z}^c \bar{\zeta}^d,$$

where the remainder G :

(1) is normalized to be of order $O_{z,\bar{z}}(3)$;

(2) satisfies the prenormalization conditions $G = O_{\bar{z}}(3) + O_{\bar{\zeta}}(1) = O_z(3) + O_{\zeta}(1)$:

$$G_{a,b,0,0} = 0 = G_{0,0,c,d},$$

$$G_{a,b,1,0} = 0 = G_{1,0,c,d},$$

$$G_{a,b,2,0} = 0 = G_{2,0,c,d};$$

(3) satisfies further normalization conditions:

$$G_{3,0,0,1} = 0 = G_{0,1,3,0},$$

$$\operatorname{Im} G_{3,0,1,1} = 0 = \operatorname{Im} G_{1,1,3,0}.$$

Furthermore, two such hypersurfaces $M^5 \subset \mathbb{C}^3$ and $M'^5 \subset \mathbb{C}'^3$, both brought into such a normal form, are rigidly biholomorphically equivalent if and only if there exist two constants $\rho \in \mathbb{R}_+^*$, $\varphi \in \mathbb{R}$, such that for all indices a, b, c, d :

$$G_{a,b,c,d} = G'_{a,b,c,d} \rho^{\frac{a+c-2}{2}} e^{i\varphi(a+2b-c-2d)}.$$

In normal form $u = m + G$, the differential invariants that we obtained earlier by Cartan's method of equivalence [46] now take the following values at the origin

$$I_0 = 4 \overline{F_{3,0,0,2}}, \quad V_0 = -8 \overline{F_{4,0,0,1}}, \quad Q_0 = 4 \operatorname{Re} F_{3,0,1,1}.$$

Convergent Poincaré-Moser reduction for general Levi degenerate 5-dimensional hypersurfaces in \mathbb{C}^3 . In Chapter 4, we consider the problem of constructing Poincaré-Moser type reduction for the class of general real analytic 5-dimensional 2-nondegenerate hypersurfaces $M^5 \subset \mathbb{C}^3$, not necessary being *rigid*, under the action of the full group of all biholomorphic transformations of \mathbb{C}^3 . The approach is in general in the same spirit with the rigid case, but the details are much more involved, especially in the proof of the uniqueness of the normal form which does not appear in the rigid case, and also requires new ideas,

notably the adaption into this case of the recent remarkable Lie theoretic construction of Cartan-Moser chains by Merker [95].

The Cartan type reduction to $\{e\}$ -structure for the class of hypersurfaces under consideration was accomplished in the works of Pocchiola [113, 93] and of Foo-Merker [49]. Our construction can be regarded as the Moser-side normal form theoretic counterpart to their Cartan-side geometric result. At this point, we want to emphasize that in general, construction of normal forms for geometric objects in complex spaces are difficult to achieve, and can even lead to complicated issues such as divergence of formal normal forms due to small divisors as in the work of Moser-Webster [104]. Only with the crucial informations about successful application of Cartan's method of equivalence and the existence of the differential invariants with precise orders provided by the geometric method of Pocchiola and Foo-Merker that one can hope to produce correct biholomorphic transformations to successively eliminate the noninvariant coefficients in the power series of M .

The hypersurface M is represented near the origin as a graph in coordinates $(z, \zeta, w = u + iv)$ of \mathbb{C}^3 by

$$u = F(z, \zeta, \bar{z}, \bar{\zeta}, v)$$

where F is a power series in variables $z, \zeta, \bar{z}, \bar{\zeta}, v$.

First, we note that the model hypersurface in this case is again the Gaussier-Merker model

$$u = \frac{z\bar{z} + \frac{1}{2}z^2\bar{\zeta} + \frac{1}{2}\bar{z}^2\zeta}{1 - \zeta\bar{\zeta}},$$

but now under the action of the group of all biholomorphic transformations of \mathbb{C}^3 , the Lie algebra of infinitesimal CR automorphisms of the Gaussier-Merker model is 10-dimensional, larger than in the rigid case.

Next, we adapt the Lie theoretic construction of Cartan-Moser chains of Merker [95] from the case of Levi nondegenerate hypersurfaces in \mathbb{C}^2 to the case under consideration in \mathbb{C}^3 . This results in two invariant jets of order 1 and 2, which we also call Cartan-Moser chains.

By integrating and straightening any given Cartan-Moser chain of order 2, we obtain the following normal form for M in a joint work [48] with Foo and Merker, which is the main result of Chapter 4

THEOREM D. *There exists a local biholomorphic transformation $\Phi : (z, \zeta, w) \mapsto (z', \zeta', w')$ fixing the origin, which brings $(M, 0)$ to the normal form*

$$\begin{aligned} u = & \frac{z\bar{z} + \frac{1}{2}z^2\bar{\zeta} + \frac{1}{2}\bar{z}^2\zeta}{1 - \zeta\bar{\zeta}} \\ & + 2 \operatorname{Re} \left\{ z^3\bar{\zeta}^2 F_{3,0,0,2}(v) + 3z^2\bar{z}\zeta\bar{\zeta}^2 F_{3,0,0,2}(v) \right\} \\ & + 2 \operatorname{Re} \left\{ z^5\bar{\zeta} F_{5,0,0,1}(v) + z^4\bar{\zeta}^2 F_{4,0,0,2}(v) \right. \\ & \quad \left. + z^3\bar{z}^2\bar{\zeta} F_{3,0,2,1}(v) + z^3\bar{z}\bar{\zeta}^2 F_{3,0,1,2}(v) + z^3\bar{\zeta}^3 F_{3,0,0,3}(v) \right\} \\ & + z^3\bar{z}^3 O_{z,\bar{z}}(1) + \bar{z}^3\zeta O_{z,\zeta,\bar{z}}(3) + z^3\bar{\zeta} O_{z,\bar{z},\bar{\zeta}}(3) + \zeta\bar{\zeta} O_{z,\bar{z}}(3) O_{z,\bar{z},\zeta,\bar{\zeta}}(2). \end{aligned}$$

Furthermore, the transformation Φ can be chosen uniquely of the form

$$(z, \zeta, w) \mapsto (z + f_{\geq 2}(z, \zeta, w), \zeta + g_{\geq 1}(z, \zeta, w), w + h_{\geq 3}(z, \zeta, w)),$$

with $f_w(0) = 0$ and $\operatorname{Im} h_{ww}(0) = 0$.

For a hypersurface M in normal form, values at the origin of the two primary differential invariants of Pocchiola [113, 93, 49] are

$$W_0 = 4 \overline{F_{3,0,0,2}(0)} \quad \text{and} \quad J_0 = 20 F_{5,0,0,1}(0).$$

Calculations of Cartan CR curvatures of the boundaries of ellipsoids in \mathbb{C}^2 and of Grauert tubes around hyperbolic surfaces. The solution of Élie Cartan [17] in 1932 of the equivalence problem for real analytic hypersurfaces in \mathbb{C}^2 shows in particular the existence of a complex valued CR invariant function $I_{Cartan} : M \rightarrow \mathbb{C}$ with the property that $I_{Cartan} \equiv 0$ if and only if M is biholomorphically equivalent to the sphere in \mathbb{C}^2 . A point $p \in M$ is called *CR-umbilical* if $I_{Cartan}(p) = 0$. An old question of Chern and Moser in [23] asks whether the locus of CR-umbilical points of a compact Levi non-degenerate hypersurface in \mathbb{C}^2 can be empty. In complex dimension 3 or higher, it was showed by Webster [118] that for generic ellipsoidal hypersurfaces, the vanishing locus of the Cartan-Hachtroudi-Chern invariants, the higher dimensional counterpart of I_{Cartan} , is indeed empty. In \mathbb{C}^2 with coordinates $(z = x + iy, w = u + iv)$, Huang and Ji [60] showed that the CR-umbilical locus of the ellipsoid

$$\mathbf{E}_{a,b} : ax^2 + y^2 + bu^2 + v^2 = 1$$

is not empty for $a, b \geq 1, (a, b) \neq (1, 1)$. The main difficulty in the study of Cartan type CR invariants is largely due to its overwhelming complexity. For examples, it was estimated by Merker and Sabzevari in [87] that the explicitly expanded formula of I_{Cartan} of the $\mathbf{E}_{a,b}$ contains as many as 40 000 terms.

In Chapter 5, we investigate further CR-umbilical locus of $\mathbf{E}_{a,b}$ with the help of the computational approach of Merker-Sabzevari [87]. More precisely, in a joint work [45] with Foo and Merker, we show that

THEOREM E. *The CR-umbilical locus of the ellipsoid $\mathbf{E}_{a,b}$ contains a smooth curve given by simple explicit equations.*

For a closed compact real-analytic surface S , it is a theorem of Bruhat and Whitney [7] that there exists a complex manifold M^c of complex dimension 2, together with an analytic totally real embedding of S into M^c . Moreover, the work [59] of Guillemin and Stenzel provides a canonical Kähler potential ρ defined in a small neighborhood of S in M^c . In particular, for each ε small enough: $0 < \varepsilon \leq \varepsilon_0 \ll 1$, the set $\Omega_\varepsilon := \rho^{-1}([0, \varepsilon))$, called the *Grauert tube* of radius ε around S , has strongly pseudoconvex \mathcal{C}^ω boundary $M_\varepsilon := \rho^{-1}(\varepsilon)$ contained in the complex surface M^c .

Recently, Ebenfelt-Duong-Zaitsev [37] gave examples of 3-dimensional Levi nondegenerate CR manifolds, as boundaries of thin Grauert tubes around the flat 2-dimensional torus, having empty CR-umbilical locus.

In a joint work [47] with Foo and Merker, which constitutes Chapter 6, we show that the boundaries M_ε of many other thin Grauert tubes Ω_ε around hyperbolic surfaces also have empty CR-umbilical locus

THEOREM F. *For $\varepsilon > 0$ small enough, the real and imaginary parts of I_{Cartan} vanish nowhere on the boundary of the Grauert tube M_ε .*

We conclude this introduction by mentioning that results in this memoir are obtained in our joint works with Joël Merker, Wei-Guo Foo and Zhangchi Chen, all of which have appeared on arxiv.org in preprint form:

- Wei-Guo Foo, Joël Merker, The-Anh Ta, *Parametric CR-umbilical Locus of Ellipsoids in \mathbb{C}^2* , *Comptes Rendus Mathématique* 356 (2018): 214-221.
arXiv:1707.06787
- Joël Merker, The-Anh Ta, *Degrees $d \geq (\sqrt{n} \log n)^n$ and $d \geq (n \log n)^n$ in the Conjectures of Green-Griffiths and of Kobayashi*,
arXiv:1901.04042
- Wei-Guo Foo, Joël Merker, The-Anh Ta, *Rigid equivalences of 5-dimensional 2-nondegenerate rigid real hypersurfaces $M^5 \subset \mathbb{C}^3$ of constant Levi rank 1*,
arXiv:1904.02562
- Wei-Guo Foo, Joël Merker, The-Anh Ta, *Nonvanishing of Cartan CR curvature on boundaries of Grauert tubes around hyperbolic surfaces*,
arXiv:1904.10203
- Zhangchi Chen, Wei-Guo Foo, Joël Merker, The-Anh Ta, *Normal Forms for Rigid $\mathcal{C}_{2,1}$ Hypersurfaces $M^5 \subset \mathbb{C}^3$* ,
arXiv:1912.01655
- Wei-Guo Foo, Joël Merker, The-Anh Ta, *On Convergent Poincaré-Moser Reduction for Levi Degenerate Embedded 5-Dimensional CR Manifolds*,
arXiv:2003.01952

CHAPTER 1

Degrees $d \geq (\sqrt{n} \log n)^n$ and $d \geq (n \log n)^n$ in the Conjectures of Green-Griffiths and of Kobayashi

Once first answers in any dimension to the Green-Griffiths and Kobayashi conjectures for generic algebraic hypersurfaces $\mathbb{X}^{n-1} \subset \mathbb{P}^n(\mathbb{C})$ have been reached, the principal goal is to decrease (to improve) the degree bounds, knowing that the ‘celestial’ horizon lies near $d \geq 2n$.

For Green-Griffiths algebraic degeneracy of entire holomorphic curves, we obtain:

$$d \geq (\sqrt{n} \log n)^n,$$

and for Kobayashi-hyperbolicity (constancy of entire curves), we obtain:

$$d \geq (n \log n)^n.$$

The latter improves $d \geq n^{2n}$ obtained by Merker in [arxiv.org/1807/11309/](https://arxiv.org/abs/1807.11309).

Admitting a certain technical conjecture $I_0 \geq \tilde{I}_0$, the method employed (Diverio-Merker-Rousseau, Bérczi, Darondeau) conducts to constant power n , namely to:

$$d \geq 2^{5n} \quad \text{and, respectively, to} \quad d \geq 4^{5n}.$$

This Chapter is based on our jointwork with Joël Merker, which has appeared in preprint form:

Joël Merker, The-Anh Ta, *Degrees $d \geq (\sqrt{n} \log n)^n$ and $d \geq (n \log n)^n$ in the Conjectures of Green-Griffiths and of Kobayashi*, arXiv:1901.04042

1. Introduction

The goal is to establish that generic algebraic hypersurfaces of the projective space satisfy the Green-Griffiths conjecture, as well as their complements, with improvements on lower degree bounds.

THEOREM 1.1. *For a generic hypersurface $\mathbb{X}^{n-1} \subset \mathbb{P}^n(\mathbb{C})$ of degree:*

$$d \geq (\sqrt{n} \log n)^n \quad (\forall n \geq N_{GG}),$$

(1) *there exists a proper subvariety $\mathbb{Y} \subset \mathbb{P}^n$ of codimension ≥ 2 such that all nonconstant entire holomorphic curves $f: \mathbb{C} \rightarrow \mathbb{P}^n \setminus \mathbb{X}$ are in fact contained in $\mathbb{Y} \supset f(\mathbb{C})$;*

(2) *there exists a proper subvariety $\mathbb{W} \subset \mathbb{X}$ of codimension ≥ 2 such that all nonconstant entire holomorphic curves $f: \mathbb{C} \rightarrow \mathbb{X}$ are in fact contained in $\mathbb{W} \supset f(\mathbb{C})$.*

This lower degree bound:

$$d \geq d_{GG}(n) := (\sqrt{n} \log n)^n$$

improves $d \geq (5n)^2 n^n$ of [25] and improves $d \geq 2^{n^5}$ of [34]. In the demonstrations, we will treat mainly the details of the complement case **(1)**, since the computations in the compact case **(2)** are essentially similar, thanks to Darondeau’s works [26, 24, 25].

By [114], any solution to the Green-Griffiths conjecture in all dimensions n for hypersurfaces of degrees $d \geq d_{GG}(n)$ implies a solution to the Kobayashi conjecture in all dimensions n for hypersurfaces of degrees:

$$d \geq d_K(n) := d_{GG}(2n).$$

Rounding off a small technical improvement of Theorem 1.1 in order to present only an elegant degree bound, we obtain as a corollary the following

THEOREM 1.2. *For a generic hypersurface $\mathbb{X}^{n-1} \subset \mathbb{P}^n(\mathbb{C})$ of degree:*

$$d \geq (n \log n)^n \quad (\forall n \geq N_K)$$

- (1) $\mathbb{P}^n \setminus \mathbb{X}^{n-1}$ is Kobayashi-hyperbolically imbedded in \mathbb{P}^n ;
- (2) \mathbb{X}^{n-1} is Kobayashi-hyperbolic.

An inspection of the end of Section 10 shows that the dimensions N_{GG} and N_K at which these statements begin to hold true can be made effective.

Theorem 1.2 improves the degree bound $d \geq n^{2n}$ obtained in [91]. For standard presentations of the research field, and for up-to-date history, including degree bound comparisons, the reader is referred to the introductions of the articles [91, 114, 9, 30, 61, 32, 8, 25, 24, 26, 115, 3, 34], listed in chronological order of prepublication.

Under the technical assumption (or conjecture):

$$I_0 \geq \tilde{I}_0,$$

the explanation of which the reader will find in Section 2, and which is equivalent to Problem 4.2, we obtain better results.

THEOREM 1.3. *If $I_0 \geq \tilde{I}_0$ holds true, then for a generic hypersurface $\mathbb{X}^{n-1} \subset \mathbb{P}^n(\mathbb{C})$ of degree:*

$$d \geq 2^{5n} \quad (\forall n \geq 10),$$

the two conclusions (1) and (2) of Theorem 1.1 hold true.

Similarly, we also obtain as corollary the

THEOREM 1.4. *Under the same technical assumption $I_0 \geq \tilde{I}_0$, the conclusions (1) and (2) of Theorem 1.2 hold true in degree:*

$$d \geq 4^{5n} \quad (\forall n \geq 20).$$

Acknowledgments. In 2013, 2014, the first author exchanged with Lionel Darondeau.

2. Preliminary: Link with Darondeau's Work

This section continues [25], and goes slightly beyond. The jet order $\kappa = n$ will be chosen equal to the dimension n , because some reflections on the concerned estimates convince that any choice of $\kappa > n$ cannot improve the degree bound anyway.

Let $n \geq 1$ be an integer. Let t_1, \dots, t_n be formal variables. Introduce:

$$C(t_1, \dots, t_n) := \prod_{1 \leq i < j \leq n} \frac{t_j - t_i}{t_j - 2t_i} \prod_{2 \leq i < j \leq n} \frac{t_j - 2t_i}{t_j - 2t_i + t_{i+1}}.$$

As explained in [25], this rational expression possesses an iterated Laurent series at the origin as:

$$C(t) = \sum_{\substack{k_1, \dots, k_n \in \mathbb{Z} \\ k_1 + \dots + k_n = 0}} C_{k_1, \dots, k_n} t_1^{k_1} \dots t_n^{k_n},$$

for certain coefficients C_{k_1, \dots, k_n} ; soon, this object $C(t_1, t_2, \dots, t_n)$ will be re-interpreted as a standard converging power series $C(w_2, \dots, w_n)$ in terms of alternative new variables (w_2, \dots, w_n) , hence it is not necessary to recall what an iterated Laurent series is.

For certain integer weights $a_1, \dots, a_n \in \mathbb{N}^*$, introduce also an expression which comes from an application of the so-called *holomorphic Morse inequalities*:

$$f_0(t) := (a_1 t_1 + \dots + a_n t_n)^{n^2}.$$

It expands:

$$f_0(t) = \sum_{\substack{m_1, \dots, m_n \geq 0 \\ m_1 + \dots + m_n = n^2}} \frac{(n^2)!}{m_1! \dots m_n!} (a_1 t_1)^{m_1} \dots (a_n t_n)^{m_n},$$

by means of (integer) multinomial coefficients:

$$M_{m_1, \dots, m_n} := \frac{(n^2)!}{m_1! \dots m_n!}.$$

It is well known that the binomial $\binom{2n}{n}$ is the unique largest one among all the $\binom{2n}{i}$ with $0 \leq i \leq 2n$. In fact, an application of Stirling's asymptotic formula:

$$n! \underset{n \rightarrow \infty}{\sim} \sqrt{2\pi n} \left(\frac{n}{e}\right)^n \left[1 + \frac{1}{12n} + \frac{1}{288n^2} - \frac{139}{51\,840n^3} - \frac{571}{2\,488\,320n^4} + O\left(\frac{1}{n^5}\right)\right],$$

shows that asymptotically as $n \rightarrow \infty$:

$$\binom{2n}{n} \sim \frac{2^{2n}}{\sqrt{\pi n}} \left[1 - \frac{1}{8n} + \frac{1}{128n^2} + \frac{5}{1024n^3} - \frac{21}{32\,768n^4} + O\left(\frac{1}{n^5}\right)\right].$$

Similarly, the *central multinomial coefficient*:

$$M_{n, \dots, n} := \frac{(n^2)!}{n! \dots n!} = \frac{(n^2)!}{(n!)^n},$$

happens to be the unique largest one, as states the next observation (*see* also Lemma 5.1).

LEMMA 2.1. *For all integers $m_1, \dots, m_n \geq 0$ with $m_1 + \dots + m_n = n^2$ and $(m_1, \dots, m_n) \neq (n, \dots, n)$, the corresponding multinomial coefficients are smaller than the central one:*

$$M_{m_1, \dots, m_n} < M_{n, \dots, n}.$$

PROOF. This amounts to verify that:

$$\frac{n!}{m_1!} \dots \frac{n!}{m_i!} \dots \frac{n!}{m_n!} \stackrel{?}{<} 1.$$

The $m_i = n$ are neutral, for $\frac{n!}{n!} = 1$. By assumption, at least one $m_i \neq n$.

• When $m_i < n$, simplify:

$$\frac{n!}{m_i!} = n(n-1) \dots (m_i+1).$$

• When $m_i > n$, simplify:

$$\frac{n!}{m_i!} = \frac{1}{(n+2)(n+1) \dots m_i}.$$

After these simplifications:

$$\prod_{1 \leq i \leq n} \frac{n!}{m_i!} = \frac{\prod_{m_i < n} (n-0)(n-1) \cdots (m_i+1)}{\prod_{m_i > n} (n+1)(n+2) \cdots m_i}.$$

Since $m_1 + \cdots + m_n = n^2$, the number of factors in the numerator is the same as that in the denominator, and since *each* factor upstairs is $\leq n$, while *each* factor downstairs is $\geq n+1$, the result is indeed < 1 . \square

A further application of Stirling's formula shows that, asymptotically as $n \rightarrow \infty$:

$$\frac{(n^2)!}{n! \cdots n!} \sim n^{n^2 - \frac{n}{2} + 1} \frac{1}{(2\pi)^{\frac{n-1}{2}}} \frac{1}{e^{\frac{1}{12}}} \left[1 + \frac{31}{360n^2} + \frac{5287}{181440n^4} + O\left(\frac{1}{n^6}\right) \right].$$

TERMINOLOGY 2.2. Call the coefficient of $t_1^n \cdots t_n^n$ in $f_0(t)$:

$$\begin{aligned} \tilde{I}_0 &:= [t_1^n \cdots t_n^n] (f_0(t)) \\ &= \frac{(n^2)!}{n! \cdots n!} a_1^n \cdots a_n^n \end{aligned}$$

the *central monomial*.

Since $a_1, \dots, a_n \in \mathbb{N}^*$, this is a large integer. The notation \tilde{I}_0 is borrowed from [25].

In fact, Appendices 1 and 2 of [25] provided almost all the details to verify that the choice of weights:

$$a_i := r^{n-i} \quad (1 \leq i \leq n),$$

for some constant r independent of n , shall offer a degree bound in the Green-Griffiths conjecture of the form:

$$d \geq \text{constant}^n.$$

which would improve the current $d \gtrsim n^n$ obtained in [25, 91].

For a certain nefness condition required to apply the holomorphic Morse inequalities, it is necessary to have at least:

$$r \geq 3.$$

It is also allowed to take r larger, for instance:

$$r = 9 \quad \text{or} \quad r = 12 \quad \text{or} \quad r = 20,$$

but one should try *not* to choose r increasing with n , like for instance $r = \sqrt{n}$, since the final degree bound would otherwise be (explanations will appear later):

$$d \gtrsim (\sqrt{n})^n \gg \text{constant}^n.$$

In [25], the choice was $r := n$, and this conducted to $d \gtrsim n^n$.

With a fixed (bounded) constant $r \geq 3$, the final degree bound for Green-Griffiths will be close to:

$$d \gtrsim (r(1 + \varepsilon(r)))^n = \text{constant}^n,$$

as we will verify in details later. The only remaining substantial piece of work to be done is to solve the following

PROBLEM 2.3. *With the choice of weights:*

$$a_1 := r^{n-1}, \quad a_2 := r^{n-2}, \quad \dots, \quad a_{n-1} := r, \quad a_n := 1,$$

to show that the coefficient of the monomial $t_1^n \cdots t_n^n$ in the product $C(t) \cdot f_0(t)$, namely:

$$I_0 := [t_1^n \cdots t_n^n] \left(C(t_1, \dots, t_n) \cdot f_0(t_1, \dots, t_n) \right)$$

is at least equal to the central monomial:

$$\begin{aligned} I_0 &\stackrel{?}{\geq} \tilde{I}_0 \\ &= \frac{(n^2)!}{(n!)^n} r^{n \frac{n(n-1)}{2}}. \end{aligned}$$

In fact, several computer experiments convince that instead of $\frac{I_0}{\tilde{I}_0} \geq 1$, a better inequality seems to hold:

$$\frac{I_0}{\tilde{I}_0} \gtrsim (\text{constant}_r)^n,$$

for some constant $r > 1$ which depends on r , and is closer and closer to 1 when r increases. So experimentally, $I_0 \geq \tilde{I}_0$ is more than true. The goal is to set up a proof.

We start in Section 3 by verifying that a proof of $\frac{I_0}{\tilde{I}_0} \geq 1$ implies a degree bound for Green-Griffiths of the announced form $d \geq \text{constant}^n$; this task was already almost completely performed by Darondeau in [25].

Then in subsequent sections, we study the product $C(t_1, \dots, t_n)$ and we establish $I_0 \geq \tilde{I}_0$.

3. End of Proof of Theorem 1.3

It essentially suffices to read Appendices 1 and 2 of [25], with in mind that Darondeau's (simplifying) choice:

$$a_i := n^{n-i} \quad (1 \leq i \leq n),$$

should be replaced with the choice:

$$a_i := r^{n-i} \quad (1 \leq i \leq n),$$

where $r \geq 3$ is a fixed constant. Later, we will see that the choice $r = 3$ might expose to some computational difficulties, while as soon that $r \geq 9$, a serendipitous positivity property occurs. In any case, the estimates of the mentioned Appendix 2 were prepared in advance to work for any choice of $r = 3, 9, 12, 20, \log n, \sqrt{n}, n$, while they were applied in [25] to $r = n$ by lack of a solution to Problem 2.3. Before solving this problem in the next sections, let us admit temporarily that it has a positive answer for a certain fixed:

$$9 \leq r \leq 20 \quad (\text{hypothesis throughout}).$$

END OF PROOF OF THEOREM 1.3. In the notations of [25], the lower degree bound:

$$d \geq d_{\text{GG}}(n)$$

is determined by the largest root of a certain polynomial equation:

$$d^n I_0 + d^{n-1} I_1 + \cdots + d^{n-p} I_p + \cdots + I_n = 0,$$

with $I_0 > 0$. Of course, I_0 is the same as in Problem 2.3, hence we assume temporarily not only that it is positive, but also that it is quite large:

$$\frac{I_0}{\tilde{I}_0} \geq 1.$$

We refer to [25] for a presentation of the other coefficients I_p .

PROPOSITION 3.1. *The polynomial in the degree d of a hypersurface $\mathbb{X}^n \subset \mathbb{P}^{n-1}(\mathbb{C})$:*

$$d^n I_0 + d^{n-1} I_1 + \cdots + d^{n-p} I_p + \cdots + d I_{n-1} + I_n$$

takes positive values for all degrees:

$$\begin{aligned} d &\geq 25 n^2 \cdot (r+3)^n. \\ &=: d_{\text{GG}}(n, r) \end{aligned}$$

In fact, a glance at the end of the proof shows a slightly better, though more complicated:

$$d_{\text{GG}}(n, r) := (20 n^2 + 4 n) \cdot \frac{r^3}{(r-1)^3 (r+3)} \cdot (r+3)^n.$$

Theorem 1.3 terminates by checking on a computer that:

$$2^{5n} \geq (20 n^2 + 4 n) \cdot \frac{r^3}{(r-1)^3 (r+3)} \cdot (r+3)^n \quad (\forall n \geq 20),$$

for any choice of $9 \leq r \leq 20$. □

PROOF OF PROPOSITION 3.1. In [25], the pôle order of so-called *slanted vector fields* $c_n := n(n+2)$ is used. But the article [24] improves it to:

$$c_n := 5n - 2.$$

Then with $c := c_n + 1$, the quantity $\frac{c+2}{2}$ appears several times in [25], so we may read:

$$\frac{c+2}{2} = \frac{5n+1}{2}.$$

Next, with:

$$a_i := r^{n-i} \quad (1 \leq i \leq n),$$

set:

$$\mu(a) := 1 a_1 + 2 a_2 + \cdots + n a_n,$$

and for all $1 \leq p \leq n$, set:

$$\tilde{I}_p := \underbrace{\frac{(n^2)!}{(n!)^n} a_1^n \cdots a_n^n}_{\text{recognize } \tilde{I}_0} (2n\mu(a))^p \sum_{1 \leq i_1 < \cdots < i_p \leq n} \frac{1}{a_{i_1}} \cdots \frac{1}{a_{i_p}},$$

Importantly, Lemma A.6 on page 1919 of Appendix 2 shows that:

$$\frac{|I_p|}{\tilde{I}_p} \leq \frac{5n+1}{2} \cdot |B| \left(\frac{2n\mu(a)h}{a_1}, \dots, \frac{2n\mu(a)h}{a_n} \right) \cdot |C| \left(\frac{1}{a_1}, \dots, \frac{1}{a_n} \right) \quad (1 \leq p \leq n).$$

It is not necessary to dwell into details about the middle quantity $|B|$, since Lemma A.7 on page 1920 shows that for any choice of weights a_1, \dots, a_n :

$$\begin{aligned} |B|\left(\frac{2n\mu(a)h}{a_1}, \dots, \frac{2n\mu(a)h}{a_n}\right) &\leq \left(\frac{2n}{2n-1}\right)^{n+1} \\ &\leq 2 \end{aligned} \quad (\forall n \geq 4 - \text{exercise}).$$

Consequently, we get:

$$\frac{|I_p|}{\tilde{I}_p} \leq (5n+1) \cdot |C|\left(\frac{1}{a_1}, \dots, \frac{1}{a_n}\right) \quad (1 \leq p \leq n).$$

Next, page 1914 uses the control:

$$|C|\left(\frac{1}{a_1}, \dots, \frac{1}{a_n}\right) \leq \hat{C}\left(\frac{1}{a_1}, \dots, \frac{1}{a_n}\right),$$

by the ‘majorant’ series:

$$\hat{C}(t_1, \dots, t_n) := \prod_{1 \leq i < j \leq n} \frac{t_j - t_i}{t_j - 2t_i} \prod_{2 \leq i < j \leq n} \frac{t_j - 2t_i}{t_j - 2t_i - t_{i-1}}.$$

Replacing the formal variables by the inverses of the weights, we get:

$$\hat{C}\left(\frac{1}{a_1}, \dots, \frac{1}{a_{n-1}}, \frac{1}{a_n}\right) = \prod_{1 \leq i < j \leq n} \frac{a_i/a_j - 1}{a_i/a_j - 2} \prod_{2 \leq i < j \leq n} \frac{a_i/a_j - 2}{a_i/a_j - 2 - a_i/a_{i-1}}.$$

Since $a_i = r^{n-i}$ for $1 \leq i \leq n$, this rewrites as:

$$\begin{aligned} \hat{C}\left(\frac{1}{r^{n-1}}, \dots, \frac{1}{r}, \frac{1}{1}\right) &= \prod_{1 \leq i < j \leq n} \frac{r^{j-i} - 1}{r^{j-i} - 2} \prod_{2 \leq i < j \leq n} \frac{r^{j-i} - 2}{r^{j-i} - 2 - \frac{1}{r}} \\ \text{[Extract } i = 1] &= \prod_{2 \leq j \leq n} \frac{r^{j-1} - 1}{r^{j-1} - 2} \prod_{2 \leq i < j \leq n} \left[\frac{r^{j-i} - 1}{r^{j-i} - 2} \frac{r^{j-i} - 2}{r^{j-i} - 2 - \frac{1}{r}} \right] \\ \text{[Simplify]} &= \prod_{2 \leq j \leq n} \frac{r^{j-1} - 1}{r^{j-1} - 2} \prod_{2 \leq i < j \leq n} \left[\frac{r^{j-i+1} - r}{r^{j-i+1} - 2r - 1} \right] \\ \text{[Rename indices]} &= \prod_{1 \leq k \leq n-1} \frac{r^k - 1}{r^k - 2} \prod_{2 \leq \ell \leq n-1} \left(\frac{r^\ell - r}{r^\ell - 2r - 1} \right)^{n-\ell}. \end{aligned}$$

Using inequalities valid as soon as $r \geq 4$ hence for $r \geq 9$:

$$\frac{1}{r^k - 2} \leq \frac{2}{r^k} \quad (\forall k \geq 1),$$

the first product is bounded by a universal constant, and even by a constant which decreases as r increases:

$$\begin{aligned}
\prod_{1 \leq k \leq n-1} \left(1 + \frac{1}{r^k - 2}\right) &\leq \prod_{k=1}^{\infty} \left(1 + \frac{2}{r^k}\right) \\
&= \exp\left(\sum_{k=1}^{\infty} \log\left(1 + \frac{2}{r^k}\right)\right) \\
[\log(1 + \varepsilon) \leq 1 + \varepsilon] \quad &\leq \exp\left(\frac{2}{r} \sum_{k=0}^{\infty} \frac{1}{r^k}\right) \\
&= \exp\left(\frac{2}{r-1}\right) \\
[\text{Computer help}] \quad &\leq 1 + \frac{3}{r}.
\end{aligned}$$

The second product is bounded by a constant power $n - 2$:

$$\begin{aligned}
\prod_{2 \leq \ell \leq n-1} \left(\frac{r^\ell - r}{r^\ell - 2r - 1}\right)^{n-\ell} &= \prod_{2 \leq \ell \leq n-1} \left(1 + \frac{r+1}{r^\ell - 2r - 1}\right)^{n-\ell} \\
&\leq \left(\prod_{2 \leq \ell \leq n-1} \left(1 + \frac{r+1}{r^\ell - 2r - 1}\right)\right)^{n-2} \\
&\leq \left(\prod_{\ell=2}^{\infty} \left(1 + \frac{r+1}{r^\ell - 2r - 1}\right)\right)^{n-2}.
\end{aligned}$$

Let us estimate this constant, which depends on r :

$$\alpha(r) := \prod_{\ell=2}^{\infty} \left(1 + \frac{r+1}{r^\ell - 2r - 1}\right).$$

LEMMA 3.2. *For all $r \geq 6$, one has:*

$$1 + \frac{r+1}{r^\ell - 2r - 1} \leq 1 + \frac{2}{r^{\ell-1}} \quad (\forall \ell \geq 2).$$

PROOF. This is equivalent to:

$$4r + 2 \leq r^\ell - r^{\ell-1} \quad (\forall r \geq 6, \forall \ell \geq 2),$$

which is easily checked, on a computer, to be true. \square

Hence we can majorize still assuming $r \geq 9$ throughout:

$$\begin{aligned}
\alpha(r) &\leq \prod_{\ell=2}^{\infty} \left(1 + \frac{2}{r^{\ell-1}}\right) \\
&= \exp\left(\sum_{\ell=0}^{\infty} \log\left(1 + \frac{2}{r^{\ell+1}}\right)\right) \\
[\log(1 + \varepsilon) \leq 1 + \varepsilon] \quad &\leq \exp\left(\frac{2}{r} \sum_{\ell=0}^{\infty} \frac{1}{r^{\ell}}\right) \\
&= \exp\left(\frac{2}{r-1}\right) \\
[\text{Computer help}] \quad &\leq 1 + \frac{3}{r}.
\end{aligned}$$

In summary, we have shown that:

$$\frac{|I_p|}{\tilde{I}_p} \leq (5n+1) \cdot \left(1 + \frac{3}{r}\right) \cdot \left(1 + \frac{3}{r}\right)^{n-2} \quad (\forall n \geq 2).$$

Next, we estimate, still with $a_i = r^{n-i}$ for $i = 1, \dots, n$:

$$\begin{aligned}
\mu(a) &= 1 \cdot a_1 + 2 \cdot a_2 + \dots + (n-1) a_{n-1} + n a_n \\
&= 1 r^{n-1} + 2 r^{n-2} + \dots + (n-1) r^1 + n r^0 \\
&= (n+1) [r^{n-1} + r^{n-2} + \dots + r^1 + r^0] \\
&\quad - n r^{n-1} - (n-1) r^{n-2} - \dots - 2 r^1 - 1 r^0 \\
&= (n+1) \frac{r^n - 1}{r-1} \\
&\quad - \frac{n r^{n+1} - (n+1) r^n + 1}{(r-1)^2},
\end{aligned}$$

the result in this last line being obtained simply by differentiating with respect to r the classical:

$$r^n + r^{n-1} + \dots + r^2 + r + 1 = \frac{r^{n+1} - 1}{r - 1}.$$

A reduction to the same denominator contracts:

$$\begin{aligned}
\mu(a) &= \frac{r^{n+1} - (n+1)r + n}{(r-1)^2} \\
&\leq \frac{r^{n+1}}{(r-1)^2} \\
&= \frac{r}{(r-1)^2} r^n.
\end{aligned}$$

Next, consider generally a polynomial of degree $n \geq 1$ with complex coefficients $c_p \in \mathbb{C}$:

$$c_0 z^n + c_1 z^{n-1} + \dots + c_{n-1} z^1 + c_n \quad (c_0 \neq 0).$$

Abbreviate:

$$K_n := \text{unique positive zero of } z^n - z^{n-1} - \dots - z - 1,$$

which satisfies:

$$1 < \mathbf{K}_n < 2 \quad (\text{close to } 2).$$

THEOREM 3.3. [Fujiwara] *The moduli of all roots of $c_0 z^n + c_1 z^{n-1} + \dots + c_n$ are bounded by:*

$$\max |\text{roots}| \leq \underbrace{\mathbf{K}_n}_{< 2} \max_{1 \leq p \leq n} \sqrt[p]{\frac{|c_p|}{|c_0|}}. \quad \square$$

Now, come back to the polynomial $d^n I_0 + d^{n-1} I_1 + \dots + I_n$ of Proposition 3.1. Thanks to Fujiwara:

$$\begin{aligned} \max |\text{roots}| &\leq 2 \max_{1 \leq p \leq n} \sqrt[p]{\frac{|I_p|}{I_0}} \\ [I_0 \geq \tilde{I}_0] &\leq 2 \max_{1 \leq p \leq n} \sqrt[p]{\frac{|I_p|}{\tilde{I}_0}} \\ &= 2 \max_{1 \leq p \leq n} \sqrt[p]{\frac{|I_p|}{\tilde{I}_p} \cdot \frac{\tilde{I}_p}{\tilde{I}_0}} \\ [\text{Seen above}] &\leq 2 \max_{1 \leq p \leq n} \sqrt[p]{(5n+1) \left(1 + \frac{3}{r}\right)^{n-1} \cdot \frac{\tilde{I}_p}{\tilde{I}_0}} \\ &\leq 2 \max_{1 \leq p \leq n} \sqrt[p]{(5n+1) \left(1 + \frac{3}{r}\right)^{n-1}} \cdot \max_{1 \leq p \leq n} \sqrt[p]{\frac{\tilde{I}_p}{\tilde{I}_0}} \\ &= 2 (5n+1) \left(1 + \frac{3}{r}\right)^{n-1} \cdot \max_{1 \leq p \leq n} \sqrt[p]{\frac{\tilde{I}_p}{\tilde{I}_0}}. \end{aligned}$$

Next, coming back to the definition of \tilde{I}_p , it remains to estimate the p -th roots of the quotients:

$$\frac{\tilde{I}_p}{\tilde{I}_0} = (2n \mu(a))^p \underbrace{\sum_{1 \leq i_1 < \dots < i_p \leq n} \frac{1}{a_{i_1}} \dots \frac{1}{a_{i_p}}}_{=: \sigma_p\left(\frac{1}{a_1}, \dots, \frac{1}{a_n}\right)},$$

which incorporate the p -th symmetric functions σ_p of the weight inverses $\frac{1}{a_i}$. We start by extracting the p -th root of $(2n \mu(a))^p$ easily:

$$\begin{aligned} \max_{1 \leq p \leq n} \sqrt[p]{\frac{\tilde{I}_p}{\tilde{I}_0}} &= 2n \mu(a) \cdot \max_{1 \leq p \leq n} \sqrt[p]{\sigma_p\left(\frac{1}{a_1}, \dots, \frac{1}{a_n}\right)} \\ [\text{Seen above}] &\leq 2n \frac{r}{(r-1)^2} r^n \cdot \max_{1 \leq p \leq n} \sqrt[p]{\sigma_p\left(\frac{1}{a_1}, \dots, \frac{1}{a_n}\right)}. \end{aligned}$$

LEMMA 3.4. *One has:*

$$\max_{1 \leq p \leq n} \sqrt[p]{\sigma_p\left(\frac{1}{a_1}, \dots, \frac{1}{a_n}\right)} = \sigma_1\left(\frac{1}{a_1}, \dots, \frac{1}{a_n}\right).$$

PROOF. For positive real numbers $b_1, \dots, b_n > 0$, the renormalized symmetric functions:

$$\begin{aligned} s_p(b_1, \dots, b_n) &:= \frac{1}{\binom{n}{p}} \sum_{1 \leq i_1 < \dots < i_p \leq n} b_{i_1} \cdots b_{i_p} \\ &= \frac{1}{\binom{n}{p}} \sigma_p(b_1, \dots, b_n), \end{aligned}$$

satisfy the classical *Mac Laurin inequality*:

$$s_1 \geq \sqrt[2]{s_2} \geq \sqrt[3]{s_3} \geq \dots \geq \sqrt[n]{s_n}.$$

A modified version, useful to us, is:

ASSERTION 3.5. *A similar, less fine, inequality, holds before renormalization:*

$$\sigma_1 \geq \sqrt[2]{\sigma_2} \geq \dots \geq \sqrt[p]{\sigma_p} \geq \sqrt[p+1]{\sigma_{p+1}} \geq \dots \geq \sqrt[n]{\sigma_n}.$$

PROOF. For $1 \leq p \leq n-1$, we would deduce from Mac Laurin what we want:

$$\left(\sqrt[p]{\frac{\sigma_p}{\binom{n}{p}}} \stackrel{\text{known}}{\geq} \sqrt[p+1]{\frac{\sigma_{p+1}}{\binom{n}{p+1}}} \right) \implies \left(\sqrt[p]{\sigma_p} \stackrel{?}{\geq} \sqrt[p+1]{\sigma_{p+1}} \right),$$

provided it would be true that:

$$\frac{\sqrt[p]{\binom{n}{p}}}{\sqrt[p+1]{\binom{n}{p+1}}} \stackrel{?}{\geq} 1 \quad (\forall 1 \leq p \leq n-1).$$

We claim that such numerical inequalities hold true. Indeed, from the two visible minorations:

$$\begin{aligned} n(n-1) \cdots (n-p+1) &\geq (n-p)^p, \\ (p+1)^p &\geq 1 \cdot 2 \cdots p, \end{aligned}$$

comes:

$$\frac{n(n-1) \cdots (n-p+1)}{1 \cdot 2 \cdots p} \geq \frac{(n-p)^p}{(p+1)^p},$$

whence:

$$\left[\frac{n(n-1) \cdots (n-p+1)}{1 \cdot 2 \cdots p} \right]^{p+1} \geq \left[\frac{n(n-1) \cdots (n-p+1)}{1 \cdot 2 \cdots p} \cdot \frac{(n-p)}{(p+1)} \right]^p,$$

and this is exactly what we wanted:

$$\binom{n}{p}^{p+1} \geq \binom{n}{p+1}^p. \quad \square$$

Lastly, with $b_1 := \frac{1}{a_1}, \dots, b_n := \frac{1}{a_n}$, we get:

$$\sigma_1\left(\frac{1}{a_1}, \dots, \frac{1}{a_n}\right) \geq \sqrt[p]{\sigma_p\left(\frac{1}{a_1}, \dots, \frac{1}{a_n}\right)} \quad (\forall 1 \leq p \leq n),$$

which forces the maximum to be attained precisely when $p = 1$. □

So we obtain:

$$\max_{1 \leq p \leq n} \sqrt[p]{\frac{\tilde{I}_p}{\tilde{I}_0}} \leq 2n \frac{r}{(r-1)^2} r^n \cdot \sigma_1\left(\frac{1}{a_1}, \dots, \frac{1}{a_n}\right).$$

and it only remains to estimate:

$$\begin{aligned} \sigma_1\left(\frac{1}{a_1}, \dots, \frac{1}{a_{n-1}}, \frac{1}{a_n}\right) &\leq \frac{1}{r^{n-1}} + \dots + \frac{1}{r} + 1 \\ &\leq \frac{r}{r-1}, \end{aligned}$$

in order to finish the proof of Proposition 3.1:

$$\begin{aligned} \max |\text{roots}| &\leq (10n+2) \left(1 + \frac{3}{r}\right)^{n-1} \cdot \max_{1 \leq p \leq n} \sqrt[p]{\frac{\tilde{I}_p}{\tilde{I}_0}} \\ &\leq (10n+2) \left(1 + \frac{3}{r}\right)^{n-1} \cdot 2n \frac{r}{(r-1)^2} r^n \cdot \sigma_1\left(\frac{1}{a_1}, \dots, \frac{1}{a_n}\right) \\ &\leq (10n+2) \frac{(r+3)^{n-1}}{r^{n-1}} \cdot 2n \frac{r}{(r-1)^2} r^n \cdot \frac{r}{r-1} \\ &= (20n^2 + 4n) \cdot \frac{r^3}{(r-1)^3 (r+3)} \cdot (r+3)^n \\ &\leq 25n^2 \cdot (r+3)^n. \end{aligned} \quad \square$$

4. From Coordinates (t_1, t_2, \dots, t_n) to Coordinates (w_2, \dots, w_n)

The goal of this section is to transform both the product $C(t)$ and the n^2 -power $f_0(t)$ into more tractable expressions, by introducing the formal variables:

$$w_2 := \frac{t_1}{t_2}, \quad w_3 := \frac{t_2}{t_3}, \quad \dots, \quad w_n := \frac{t_{n-1}}{t_n}.$$

To enhance intuition, start by expanding the writing of the factors of two types in the considered double big product:

$$\begin{aligned} C(t_1, \dots, t_n) &= \frac{t_2 - t_1}{t_2 - 2t_1} \frac{t_3 - t_1}{t_3 - 2t_1} \dots \frac{t_n - t_1}{t_n - 2t_1} \\ &\quad \frac{t_3 - t_2}{t_3 - 2t_2} \dots \frac{t_n - t_2}{t_n - 2t_2} \\ &\quad \dots \quad \vdots \\ &\quad \frac{t_n - t_{n-1}}{t_n - 2t_{n-1}} \\ &\quad \frac{t_3 - 2t_2}{t_3 - 2t_2 + t_1} \dots \frac{t_n - 2t_2}{t_n - 2t_2 + t_1} \\ &\quad \dots \quad \vdots \\ &\quad \frac{t_n - 2t_{n-1}}{t_n - 2t_{n-1} + t_{n-2}}. \end{aligned}$$

To pass to the new variables, compute first for instance:

$$\begin{aligned} \frac{t_2 - t_1}{t_2 - 2t_1} &= \frac{1 - \frac{t_1}{t_2}}{1 - 2\frac{t_1}{t_2}} = \frac{1 - w_2}{1 - 2w_2}, \\ \frac{t_3 - t_1}{t_3 - 2t_1} &= \frac{1 - \frac{t_1}{t_3}}{1 - 2\frac{t_1}{t_3}} = \frac{1 - \frac{t_1}{t_2} \frac{t_2}{t_3}}{1 - 2\frac{t_1}{t_2} \frac{t_2}{t_3}} = \frac{1 - w_2 w_3}{1 - 2w_2 w_3}, \\ \frac{t_5 - 2t_2}{t_5 - 2t_2 + t_1} &= \frac{1 - 2\frac{t_2}{t_3} \frac{t_3}{t_4} \frac{t_4}{t_5}}{1 - 2\frac{t_2}{t_3} \frac{t_3}{t_4} \frac{t_4}{t_5} + \frac{t_1}{t_2} \frac{t_2}{t_3} \frac{t_3}{t_4} \frac{t_4}{t_5}} = \frac{1 - 2w_3 w_4 w_5}{1 - 2w_3 w_4 w_5 + w_2 w_3 w_4 w_5}. \end{aligned}$$

Generally, with as above:

$$w_i := \frac{t_{i-1}}{t_i} \quad (2 \leq i \leq n),$$

we can transform all the factors of first type, for indices $2 \leq i \leq j \leq n$ — mind the shift $i \mapsto i - 1$ from the original definition of $C(t)$:

$$\begin{aligned} E_{i,j}(t) &:= \frac{t_j - t_{i-1}}{t_j - 2t_{i-1}} = \frac{1 - \frac{t_{i-1}}{t_j}}{1 - 2\frac{t_{i-1}}{t_j}} = \frac{1 - \frac{t_{i-1}}{t_i} \dots \frac{t_{j-1}}{t_j}}{1 - 2\frac{t_{i-1}}{t_i} \dots \frac{t_{j-1}}{t_j}} \\ &= \frac{1 - w_i \dots w_j}{1 - 2w_i \dots w_j} \\ &=: E_{i,j}(w), \end{aligned}$$

Similarly, for $3 \leq i \leq j \leq n$, again with the shift $i \mapsto i - 1$:

$$\begin{aligned} F_{i,j}(t) &:= \frac{t_j - 2t_{i-1}}{t_j - 2t_{i-1} + t_{i-2}} = \frac{1 - 2\frac{t_{i-1}}{t_j}}{1 - 2\frac{t_{i-1}}{t_j} + \frac{t_{i-2}}{t_j}} = \frac{1 - 2\frac{t_{i-1}}{t_i} \dots \frac{t_{j-1}}{t_j}}{1 - 2\frac{t_{i-1}}{t_i} \dots \frac{t_{j-1}}{t_j} + \frac{t_{i-2}}{t_{i-1}} \frac{t_{i-1}}{t_i} \dots \frac{t_{j-1}}{t_j}} \\ &= \frac{1 - 2w_i \dots w_j}{1 - 2w_i \dots w_j + w_{i-1} w_i \dots w_j} \\ &=: F_{i,j}(w). \end{aligned}$$

Consequently:

$$\begin{aligned} C(t_1, t_2, \dots, t_n) = C(w_2, \dots, w_n) &:= \frac{1 - w_2}{1 - 2w_2} \frac{1 - w_2 w_3}{1 - 2w_2 w_3} \dots \frac{1 - w_2 w_3 \dots w_n}{1 - 2w_2 w_3 \dots w_n} \\ &\quad \frac{1 - w_3}{1 - 2w_3} \dots \frac{1 - w_3 \dots w_n}{1 - 2w_3 \dots w_n} \\ &\quad \dots \quad \vdots \\ &\quad \frac{1 - w_n}{1 - 2w_n} \\ &\quad \frac{1 - 2w_3}{1 - 2w_3 + w_2 w_3} \dots \frac{1 - 2w_3 \dots w_n}{1 - 2w_3 \dots w_n + w_2 w_3 \dots w_n} \\ &\quad \dots \quad \vdots \\ &\quad \frac{1 - 2w_n}{1 - 2w_n + w_{n-1} w_n}. \end{aligned}$$

This can be abbreviated as:

$$\begin{aligned} C(w) &= \prod_{2 \leq i \leq j \leq n} \frac{1 - w_i \cdots w_j}{1 - 2w_i \cdots w_j} \prod_{3 \leq i \leq j \leq n} \frac{1 - 2w_i \cdots w_j}{1 - 2w_i \cdots w_j + w_{i-1}w_i \cdots w_j} \\ &= \prod_{2 \leq i \leq j \leq n} E_{i,j} \prod_{3 \leq i \leq j \leq n} F_{i,j}. \end{aligned}$$

As is visible — and as was already visible before in variables (t_1, \dots, t_n) —, the terms $1 - 2w_i \cdots w_j$ that appear in the denominators of the $E_{i,j}$ cancel out with the same terms appearing in the numerators of the $F_{i,j}$, though only for $3 \leq i \leq j \leq n$. These simplifications conduct to the shorter representation:

$$\begin{aligned} C(w_2, \dots, w_n) &:= \frac{1 - w_2}{1 - 2w_2} \frac{1 - w_2w_3}{1 - 2w_2w_3} \cdots \frac{1 - w_2w_3 \cdots w_n}{1 - 2w_2w_3 \cdots w_n} \\ &\quad \frac{1 - w_3}{1 - 2w_3 + w_2w_3} \cdots \frac{1 - w_3 \cdots w_n}{1 - 2w_3 \cdots w_n + w_2w_3 \cdots w_n} \\ &\quad \quad \quad \ddots \quad \quad \quad \vdots \\ &\quad \quad \quad \quad \quad \quad \ddots \quad \quad \quad \vdots \\ &\quad \quad \quad \quad \quad \quad \quad \quad \quad \frac{1 - w_n}{1 - 2w_n + w_{n-1}w_n}, \end{aligned}$$

which can be abbreviated as:

$$\begin{aligned} C(w_2, \dots, w_n) &= E'_2(w_2) E'_3(w_2, w_3) \cdots E'_n(w_2, w_3, \dots, w_n) \\ &\quad F'_{3,3}(w_2, w_3) \cdots F'_{3,n}(w_2, w_3, \dots, w_n) \\ &\quad \quad \quad \ddots \quad \quad \quad \vdots \\ &\quad \quad \quad \quad \quad \quad F'_{n,n}(w_{n-1}, w_n), \end{aligned}$$

that is to say:

$$C(w_2, \dots, w_n) = \prod_{2 \leq j \leq n} \underbrace{\frac{1 - w_2 \cdots w_j}{1 - 2w_2 \cdots w_j}}_{=: E'_j} \prod_{3 \leq i \leq j \leq n} \underbrace{\frac{1 - w_i \cdots w_j}{1 - 2w_i \cdots w_j + w_{i-1}w_i \cdots w_j}}_{=: F'_{i,j}}.$$

Next, let us re-express in the w_i variables:

$$\begin{aligned} f_0(t) &= \left(a_1 t_1 + \cdots + a_{n-2} t_{n-2} + a_{n-1} t_{n-1} + a_n t_n \right)^{n^2} \\ &= \left(a_1 \frac{t_1}{t_n} + \cdots + a_{n-2} \frac{t_{n-2}}{t_n} + a_{n-1} \frac{t_{n-1}}{t_n} + a_n \frac{t_n}{t_n} \right)^{n^2} (t_n)^{n^2} \\ &= \left(r^{n-1} w_2 \cdots w_n + \cdots + r^2 w_{n-1} w_n + r w_n + 1 \right)^{n^2} (t_n)^{n^2}. \end{aligned}$$

To yet transform $t_n^{n^2}$ at the end, observe that:

$$\begin{aligned} \frac{1}{(w_2)^n (w_3)^{2n} \dots (w_{n-1})^{n^2-2n} (w_n)^{n^2-n}} &= \frac{1}{\left(\frac{t_1}{t_2}\right)^n \left(\frac{t_2}{t_3}\right)^{2n} \dots \left(\frac{t_{n-2}}{t_{n-1}}\right)^{n^2-2n} \left(\frac{t_{n-1}}{t_n}\right)^{n^2-n}} \\ &= \frac{1}{t_1^n t_2^{2n} \dots t_{n-2}^n t_{n-1}^n \frac{1}{t_n^{n^2-n}}} \\ &= \frac{t_n^{n^2}}{t_1^n t_2^{2n} \dots t_{n-2}^n t_{n-1}^n t_n^n}, \end{aligned}$$

whence:

$$f_0(t) = \frac{(r^{n-1} w_2 \dots w_n + \dots + r^2 w_{n-1} w_n + r w_n + 1)^{n^2}}{w_2^n w_3^{2n} \dots w_{n-1}^{n^2-2n} w_n^{n^2-n}} \frac{1}{t_1^n t_2^n \dots t_{n-1}^n t_n^n}.$$

Consequently, in Problem 2.3, the coefficient I_0 of the monomial $t_1^n \dots t_n^n$ in the product $C(t) \cdot f_0(t)$ identifies with the *constant* term, namely the coefficient of $w_2^0 \dots w_n^0 = 1$, in the product:

$$\frac{(r^{n-1} w_2 \dots w_n + \dots + r^2 w_{n-1} w_n + r w_n + 1)^{n^2}}{w_2^n w_3^{2n} \dots w_{n-1}^{n^2-2n} w_n^{n^2-n}} \cdot \frac{1-w_2}{1-2w_2} \quad \frac{1-w_2 w_3}{1-2w_2 w_3} \quad \dots \quad \frac{1-w_2 w_3 \dots w_n}{1-2w_2 w_3 \dots w_n}$$

$$\frac{1-w_3}{1-2w_3+w_2 w_3} \quad \dots \quad \frac{1-w_3 \dots w_n}{1-2w_3 \dots w_n + w_2 w_3 \dots w_n}$$

$$\vdots \quad \quad \quad \vdots$$

$$\dots \quad \quad \quad \vdots$$

$$\frac{1-w_n}{1-2w_n+w_{n-1}w_n}.$$

It is now appropriate to expand the n^2 power in the numerator above plainly as:

$$\frac{1}{(w_2)^n \dots (w_n)^{n^2-2n}} \sum_{\substack{i_1, \dots, i_n \geq 0 \\ i_1 + \dots + i_n = n^2}} (1)^{i_1} (r w_n)^{i_2} (r^2 w_{n-1} w_n)^{i_3} \dots (r^{n-1} w_2 \dots w_n)^{i_n} \frac{(n^2)!}{i_1! i_2! i_3! \dots i_n!}$$

Next, we would like to point out that $C(w_2, \dots, w_n)$ is a product of rational expressions which expand all in converging power series at the origin. More precisely, using the trivial expansion:

$$\begin{aligned} E(x) &:= \frac{1-x}{1-2x} = 1 + \frac{x}{1-2x} \\ &= 1 + \sum_{i=1}^{\infty} 2^{i-1} x^i, \end{aligned}$$

together with the expansion of Lemma 6.1 — with the convention that $\binom{\ell-1}{-1} = 0 = \binom{\ell-1}{\ell}$ — :

$$\begin{aligned} F(x, y) &:= \frac{1-y}{1-2y+xy} = 1 + \frac{y-xy}{1-2y+xy} \\ &= 1 + \sum_{\ell=1}^{\infty} y^\ell \sum_{0 \leq k \leq \ell} (-1)^k x^k \left[2^{\ell-1-k} \binom{\ell-1}{k} + 2^{\ell-k} \binom{\ell-1}{k-1} \right], \end{aligned}$$

and re-expressing:

$$C(w_2, \dots, w_n) = \prod_{2 \leq j \leq n} E(w_2 \cdots w_j) \prod_{3 \leq i \leq j \leq n} F(w_{i-1}, w_i \cdots w_j),$$

and lastly, multiplying all the obtained converging power series, one can in principle receive an expansion:

$$C(w_2, \dots, w_n) = \sum_{k_2=0}^{\infty} \cdots \sum_{k_n=0}^{\infty} C_{k_2, \dots, k_n} (w_2)^{k_2} \cdots (w_n)^{k_n},$$

which is holomorphic in a neighborhood of the origin. However, it is very delicate to reach closed explicit expressions for these integer Taylor coefficients C_{k_2, \dots, k_n} , a difficulty which lies at the very core of Problem 2.3.

In summary, the quantity I_0 we want to determine, in order to show that it satisfies $I_0 \geq \tilde{I}_0$, is the coefficient of the constant term $w_2^0 \cdots w_n^0$ in a product consisting of 2 rows:

$$\begin{aligned} & \sum_{k_2=0}^{\infty} \cdots \sum_{k_n=0}^{\infty} C_{k_2, \dots, k_n} (w_2)^{k_2} \cdots (w_n)^{k_n} \cdot \\ & \cdot \frac{1}{(w_2)^n \cdots (w_n)^{n^2-n}} \sum_{\substack{i_1, \dots, i_n \geq 0 \\ i_1 + \dots + i_n = n^2}} (1)^{i_1} (r w_n)^{i_2} (r^2 w_{n-1} w_n)^{i_3} \cdots (r^{n-1} w_2 \cdots w_n)^{i_n} \frac{(n^2)!}{i_1! i_2! i_3! \cdots i_n!}. \end{aligned}$$

Clearly, the second row becomes, after reorganization, a Laurent series of the form:

$$\sum_{-n \leq \ell_2} \cdots \sum_{-(n^2-n) \leq \ell_n} J_{\ell_2, \dots, \ell_n} (w_2)^{\ell_2} \cdots (w_n)^{\ell_n}.$$

But because in the first row one always has $k_2, \dots, k_n \geq 0$, all Laurent monomials $(w_2)^{\ell_2} \cdots (w_n)^{\ell_n}$ in the second row for which $\ell_i \geq 1$ for some $1 \leq i \leq n$ do *not* contribute to the determination of the desired constant term $w_2^0 \cdots w_n^0$. So the summation in the second row can be truncated to:

$$\sum_{-n \leq \ell_2 \leq 0} \cdots \sum_{-(n^2-n) \leq \ell_2 \leq 0} J_{\ell_2, \dots, \ell_n} (w_2)^{\ell_2} \cdots (w_n)^{\ell_n}.$$

A supplementary change of indices followed by a reorganization conducts to an appropriate reformulation of what is I_0 : the following statement will then constitute the very starting point of our further explorations.

PROPOSITION 4.1. *One has:*

$$I_0 = [w_2^0 \cdots w_n^0] \left(A(w_2, \dots, w_n) \cdot C(w_2, \dots, w_n) \right),$$

where:

$$\begin{aligned} A(w_2, \dots, w_n) := & \sum_{\substack{0 \leq k_2 \leq n \\ 0 \leq k_3 \leq n+k_2 \\ \dots \\ 0 \leq k_{n-1} \leq n+k_{n-2} \\ 0 \leq k_n \leq n+k_{n-1}}} \frac{(n^2)!}{(n-k_2)!(n+k_2-k_3)! \cdots (n+k_{n-2}-k_{n-1})!(n+k_{n-1}-k_n)!(n+k_n)!} \\ & \cdot \frac{r^{n \frac{n(n-1)}{2}}}{r^{k_2 + \dots + k_n}} \frac{1}{(w_2)^{k_2} \cdots (w_n)^{k_n}}, \end{aligned}$$

and where $C(w_2, \dots, w_n)$ is as before.

PROOF. We therefore rewrite:

$$\frac{1}{w_2^n w_3^{2n} \dots w_{n-1}^{(n-2)n} w_n^{(n-1)n}} \sum_{\substack{i_1, \dots, i_n \geq 0 \\ i_1 + \dots + i_n = n^2}} (1)^{i_1} (r w_n)^{i_2} (r^2 w_{n-1} w_n)^{i_3} \dots (r^{n-2} w_3 \dots w_{n-1} w_n)^{i_{n-1}} (r^{n-1} w_2 w_3 \dots w_{n-1} w_n)^{i_n} \\ \cdot \frac{(n^2)!}{i_1! i_2! i_3! \dots i_{n-1}! i_n!} = \\ =: \sum_{-n \leq \ell_2} \sum_{-2n \leq \ell_3} \dots \sum_{-(n-2)n \leq \ell_{n-1}} \sum_{-(n-1)n \leq \ell_n} J_{\ell_2, \ell_3, \dots, \ell_{n-1}, \ell_n} (w_2)^{\ell_2} (w_3)^{\ell_3} \dots (w_{n-1})^{\ell_{n-1}} (w_n)^{\ell_n},$$

so that the correspondence between exponents is:

$$\begin{aligned} -n &\leq \ell_2 = i_n - n, \\ -2n &\leq \ell_3 = i_n + i_{n-1} - 2n, \\ &\dots\dots\dots \\ -(n-2)n &\leq \ell_{n-1} = i_n + i_{n-1} + \dots + i_3 - (n-2)n, \\ -(n-1)n &\leq \ell_n = i_n + i_{n-1} + \dots + i_3 + i_2 - (n-1)n. \end{aligned}$$

Performing the harmless truncations $\ell_2 \leq 0, \dots, \ell_n \leq 0$ leads then to the inequalities:

$$\begin{aligned} 0 &\leq i_n \leq n, \\ 0 &\leq i_n + i_{n-1} \leq 2n, \\ &\dots\dots\dots \\ 0 &\leq i_n + i_{n-1} + \dots + i_3 \leq (n-2)n, \\ 0 &\leq i_n + i_{n-1} + \dots + i_3 + i_2 \leq (n-1)n, \end{aligned}$$

so that it suffices to consider, before multiplying by $C(w_2, \dots, w_n)$, the truncated series:

$$A := \sum_{\substack{i_1 + \dots + i_n = n^2 \\ i_1 \geq 0, \dots, i_n \geq 0 \\ 0 \leq i_n \leq n \\ 0 \leq i_n + i_{n-1} \leq 2n \\ \dots\dots\dots \\ 0 \leq i_n + i_{n-1} + \dots + i_3 \leq (n-2)n \\ 0 \leq i_n + i_{n-1} + \dots + i_3 + i_2 \leq (n-1)n}} \frac{1}{w_2^{n-i_n} w_3^{2n-i_{n-1}-i_n} \dots w_{n-1}^{(n-2)n-i_n-i_{n-1}-\dots-i_3} w_n^{(n-1)n-i_n-i_{n-1}-\dots-i_3-i_2}} \\ \cdot r^{i_2 + 2i_3 + \dots + (n-2)i_{n-1} + (n-1)i_n} \cdot \frac{(n^2)!}{i_1! i_2! i_3! \dots i_{n-1}! i_n!}.$$

To reach the expression shown by the proposition, introduce the new nonnegative integer indices:

$$\begin{aligned} k_2 &:= n - i_n && (k_2 \geq 0), \\ k_3 &:= 2n - i_{n-1} - i_n && (k_3 \geq 0), \\ &\dots\dots\dots && (\dots\dots\dots), \\ k_{n-1} &:= (n-2)n - i_3 - \dots - i_{n-1} - i_n && (k_{n-1} \geq 0), \\ k_n &:= (n-1)n - i_2 - i_3 - \dots - i_{n-1} - i_n && (k_n \geq 0). \end{aligned}$$

To finish, three explanations are needed.

Firstly, one has the inequalities:

$$\begin{aligned} 0 &\leq k_2 \leq n, \\ 0 &\leq k_3 \leq n + k_2, \end{aligned}$$

because $i_n \geq 0$ and because:

$$k_3 = n - i_{n-1} + n - i_n = \underbrace{n - i_{n-1}}_{i_{n-1} \geq 0} + k_2 \leq n + k_2.$$

Similarly:

$$0 \leq k_4 = 3n - i_{n-2} - i_{n-1} - i_n = n - i_{n-2} + k_3 \leq n + k_3,$$

and so on up to:

$$\begin{aligned} 0 &\leq k_{n-1} \leq n + k_{n-2}, \\ 0 &\leq k_n \leq n + k_{n-1}. \end{aligned}$$

Secondly, since:

$k_2 + k_3 + \dots + k_{n-1} + k_n = n(1 + 2 + \dots + (n-2) + (n-1)) - i_2 - 2i_3 - \dots - (n-2)i_{n-1} - (n-1)i_n$,
the exponent of r becomes:

$$i_2 + 2i_3 + \dots + (n-2)i_{n-1} + (n-1)i_n = n \frac{n(n-1)}{2} - k_2 - k_3 - \dots - k_{n-1} - k_n.$$

Thirdly and lastly, the factorials become:

$$\begin{aligned} i_n! &= (n - k_2)!, \\ i_{n-1}! &= (n + n - i_n - k_3)! = (n + k_2 - k_3)!, \\ &\dots \dots \dots \\ i_2! &= (-k_n + (n-1)n - i_3 - \dots - i_n)! = (n + k_{n-1} - k_n)!, \\ i_1! &= (nn - (n + k_{n-1} - k_n) - \dots - (n + k_2 - k_3) - (n - k_2)) = (n + k_n)!. \end{aligned}$$

These three explanations yield the expression of $A(w_2, \dots, w_n)$ stated by the proposition. □

Next, because only the quotient $\frac{I_0}{\tilde{I}_0}$ must be studied in order to reach the minoration $I_0 \geq \tilde{I}_0$, we can divide everything in advance by the central monomial:

$$\tilde{I}_0 = \frac{(n^2)!}{n! \dots n!} r^{n \frac{n(n-1)}{2}}.$$

Equivalently, we factor:

$$\begin{aligned} A &= \frac{(n^2)!}{n! \dots n!} r^{n \frac{n(n-1)}{2}} \cdot \\ &\cdot \sum_{\substack{0 \leq k_2 \leq n \\ 0 \leq k_3 \leq n+k_2 \\ \dots \dots \dots \\ 0 \leq k_{n-1} \leq n+k_{n-2} \\ 0 \leq k_n \leq n+k_{n-1}}} \frac{n!}{(n - k_2)!} \frac{n!}{(n + k_2 - k_3)!} \dots \frac{n!}{(n + k_{n-2} - k_{n-1})!} \frac{n!}{(n + k_{n-1} - k_n)!(n + k_n)!} \cdot \\ &\cdot \frac{1}{r^{k_2+k_3+\dots+k_{n-1}+k_n}} \frac{1}{w_2^{k_2} w_3^{k_3} \dots w_{n-1}^{k_{n-1}} w_n^{k_n}}, \end{aligned}$$

we keep the same name A after eliminating the factor \tilde{I}_0 on the first line, and we reformulate our goal as a more precise

PROBLEM 4.2. *For some specific choice of a fixed constant $r \geq 3$, to show that for any $n \geq 2$, the coefficient of the constant monomial $w_2^0 \cdots w_n^0$ in the product $C(w) \cdot A(w)$ is at least equal to 1, namely:*

$$1 \leq [w_2^0 \cdots w_n^0] \left(C(w_2, \dots, w_n) \cdot A(w_2, \dots, w_n) \right),$$

where:

$$C(w_2, \dots, w_n) := \frac{1-w_2}{1-2w_2} \frac{1-w_2w_3}{1-2w_2w_3} \cdots \frac{1-w_2w_3 \cdots w_n}{1-2w_2w_3 \cdots w_n} \\ \frac{1-w_3}{1-2w_3} \cdots \frac{1-w_3 \cdots w_n}{1-2w_3 \cdots w_n} \\ \cdots \quad \vdots \\ \frac{1-w_n}{1-2w_n} \\ \frac{1-2w_3}{1-2w_3+w_2w_3} \cdots \frac{1-2w_3 \cdots w_n}{1-2w_3 \cdots w_n + w_2w_3 \cdots w_n} \\ \cdots \quad \vdots \\ \frac{1-2w_n}{1-2w_n+w_{n-1}w_n},$$

and where:

$$A(w_2, \dots, w_n) := \sum_{\substack{0 \leq k_2 \leq n \\ 0 \leq k_3 \leq n+k_2 \\ \dots \\ 0 \leq k_{n-1} \leq n+k_{n-2} \\ 0 \leq k_n \leq n+k_{n-1}}} \frac{n!}{(n-k_2)!} \frac{n!}{(n+k_2-k_3)!} \cdots \frac{n!}{(n+k_{n-2}-k_{n-1})!} \frac{n!}{(n+k_{n-1}-k_n)!(n+k_n)!} \cdot \\ \cdot \frac{1}{r^{k_2+k_3+\dots+k_{n-1}+k_n}} \frac{1}{w_2^{k_2} w_3^{k_3} \cdots w_{n-1}^{k_{n-1}} w_n^{k_n}}.$$

Of course, under the hypothesis that the power series expansion of $C(w)$ is known:

$$C(w_2, \dots, w_n) = \sum_{k_2=0}^{\infty} \cdots \sum_{k_n=0}^{\infty} C_{k_2, \dots, k_n} (w_2)^{k_2} \cdots (w_n)^{k_n},$$

the coefficient in question writes up as the sum:

$$CA_{n-1}^n := \sum_{\substack{0 \leq k_2 \leq n \\ 0 \leq k_3 \leq n+k_2 \\ \dots \\ 0 \leq k_{n-1} \leq n+k_{n-2} \\ 0 \leq k_n \leq n+k_{n-1}}} \frac{n!}{(n-k_2)!} \frac{n!}{(n+k_2-k_3)!} \cdots \frac{n!}{(n+k_{n-2}-k_{n-1})!} \frac{n!}{(n+k_{n-1}-k_n)!(n+k_n)!} \cdot \\ \cdot \frac{1}{r^{k_2+k_3+\dots+k_{n-1}+k_n}} C_{k_2, k_3, \dots, k_{n-1}, k_n},$$

which should satisfy:

$$CA_{n-1}^n \stackrel{?}{\geq} 1 \quad (\forall n \geq 2).$$

5. Approximations of multinomial quotients M_{k_2, \dots, k_n}^n

Let us attribute a name to the quotients of multinomial coefficients which have appeared above:

$$M_{k_2, k_3, \dots, k_{n-1}, k_n}^n := \frac{n!}{(n - k_2)!} \frac{n!}{(n + k_2 - k_3)!} \cdots \frac{n!}{(n + k_{n-1} - k_n)!} \frac{n!}{(n + k_n)!}$$

$$= \frac{(n^2)!}{(n-k_2)!(n+k_2-k_3)! \cdots (n+k_{n-1}-k_n)!(n+k_n)!} \cdot \frac{(n^2)!}{n!n! \cdots n!n!}.$$

When $k_2 = k_3 = \cdots = k_{n-1} = k_n = 0$, this is just:

$$M_{0,0,\dots,0,0}^n = 1.$$

LEMMA 5.1. For all indices $(k_2, k_3, \dots, k_{n-1}, k_n) \neq (0, 0, \dots, 0, 0)$ in the domain:

$$0 \leq k_2 \leq n,$$

$$0 \leq k_3 \leq n + k_2,$$

.....

$$0 \leq k_{n-1} \leq n + k_{n-2},$$

$$0 \leq k_n \leq n + k_{n-1},$$

there are strict inequalities:

$$(0 \leq) \quad M_{k_2, k_3, \dots, k_{n-1}, k_n}^n < 1,$$

with equality = 1 only when $k_2 = k_3 = \cdots = k_{n-1} = k_n = 0$.

PROOF. Coming back to the old (nonnegative) indices:

$$i_n = n - k_2,$$

$$i_{n-1} = n + k_2 - k_3,$$

.....

$$i_2 = n + k_{n-1} - k_n,$$

$$i_1 = n + k_n,$$

which satisfy $i_1 + i_2 + \cdots + i_{n-1} + i_n = n^2$ and are not all equal to n — otherwise all $k_\lambda = 0$ —, we have to explain the inequalities:

$$\frac{n!}{i_1!} \frac{n!}{i_2!} \cdots \frac{n!}{i_{n-1}!} \frac{n!}{i_n!} \stackrel{?}{<} 1.$$

After a reordering, we can assume that:

$$i_1 \neq n, \dots, i_\kappa \neq n, i_{\kappa+1} = n, \dots, i_n = n,$$

for a certain integer $1 \leq \kappa \leq n$. Since the factors $\frac{n!}{n!} = 1$ have no effect, we are led to ask whether:

$$\frac{n!}{i_1!} \cdots \frac{n!}{i_\lambda!} \cdots \frac{n!}{i_\kappa!} \stackrel{?}{<} 1.$$

Observing that:

$$i_1 + \cdots + i_\lambda + \cdots + i_\kappa = \kappa n,$$

let us distinguish two cases about these i_λ for every $1 \leq \lambda \leq \kappa$:

$$i_\lambda < n \quad \text{or} \quad i_\lambda > n.$$

When $i_\lambda < n$, we simplify:

$$\frac{n!}{i_\lambda!} = n(n-1) \cdots (i_\lambda + 1),$$

and when $i_\lambda > n$, we simplify:

$$\frac{n!}{i_\lambda!} = \frac{1}{i_\lambda(i_\lambda - 1) \cdots (n + 1)},$$

so that:

$$\frac{n!}{i_1!} \cdots \frac{n!}{i_\lambda!} \cdots \frac{n!}{i_\kappa!} = \frac{\prod_{i_\lambda < n} n(n-1) \cdots (i_\lambda + 1)}{\prod_{i_\lambda > n} i_\lambda(i_\lambda - 1) \cdots (n + 1)}.$$

Now, we observe that in this fraction the number of integer factors at numerator place is equal to the number of integer factors at denominator place, because the equality above:

$$\kappa n = \sum_{1 \leq \lambda \leq \kappa} i_\lambda = \sum_{i_\lambda < n} i_\lambda + \sum_{i_\lambda > n} i_\lambda$$

can be rewritten as:

$$\sum_{i_\lambda < n} (n - i_\lambda) = \sum_{i_\lambda > n} (i_\lambda - n).$$

But *each* integer factor at denominator place is *larger* than *all* integer factors at numerator place, so the fraction must be < 1 . \square

Visibly, in the quantity under study:

$$M_{k_2, k_3, \dots, k_{n-1}, k_n}^n = \frac{n!}{(n - k_2)!} \frac{n!}{(n + k_2 - k_3)!} \cdots \frac{n!}{(n + k_{n-1} - k_n)!} \frac{n!}{(n + k_n)!},$$

there are two types of quotients:

$$\frac{n!}{(n - k)!} \quad \text{with } k \geq 0 \quad \text{and} \quad \frac{n!}{(n + \ell)!} \quad \text{with } \ell \geq 0.$$

We can simplify, factorize, and rewrite the first type quotients as:

$$\begin{aligned} \frac{n!}{(n - k)!} &= \frac{n(n-1) \cdots (n - k + 1)}{1} = n^k \left(1 - \frac{0}{n}\right) \left(1 - \frac{1}{n}\right) \cdots \left(1 - \frac{k-1}{n}\right) \\ &= n^k \prod_{0 \leq i \leq k-1} \left(1 - \frac{i}{n}\right), \end{aligned}$$

and the second type quotients as:

$$\begin{aligned} \frac{n!}{(n + \ell)!} &= \frac{1}{(n + \ell) \cdots (n + 1)} = \frac{1}{\left(1 + \frac{\ell}{n}\right) \cdots \left(1 + \frac{1}{n}\right) n^\ell} \\ &= n^{-\ell} \prod_{1 \leq j \leq \ell} \left(1 + \frac{j}{n}\right)^{-1}. \end{aligned}$$

In order to estimate the proximity to 1 of these products, let us take their logarithms:

$$\begin{aligned} \log \prod_{0 \leq i \leq k-1} \left(1 - \frac{i}{n}\right) &= \log \left(1 - \frac{0}{n}\right) + \log \left(1 - \frac{1}{n}\right) + \cdots + \log \left(1 - \frac{k-1}{n}\right) \\ &\leq 0, \end{aligned}$$

and:

$$\log \prod_{1 \leq j \leq \ell} \left(1 + \frac{j}{n}\right)^{-1} = -\log \left(1 + \frac{1}{n}\right) - \log \left(1 + \frac{2}{n}\right) - \cdots - \log \left(1 + \frac{\ell}{n}\right) \leq 0.$$

Certainly, we have already seen implicitly in the proof of the previous Lemma 5.1 that all the logarithms of these products are ≤ 0 . But we are now searching for a *minoration* of these coefficients:

$$M_{k_2, \dots, k_n}^n \geq \text{what?}$$

For a reason that will become transparent just after a preliminary lemma, we will soon restrict ourselves to suppose that:

$$k_2 + k_3 + \cdots + k_{n-1} + k_n \leq \sqrt{n}.$$

LEMMA 5.2. For all $0 \leq \delta \leq 3/5$:

$$\log(1 - \delta) \geq -\delta - \delta^2,$$

and for all $\varepsilon \geq 0$:

$$-\log(1 + \varepsilon) \geq -\varepsilon.$$

PROOF. The first inequality — which is in fact true for $0 \leq \delta \leq 0,683$ as can be seen with the help of a computer —:

$$-\delta - \frac{\delta^2}{2} - \frac{\delta^3}{3} - \frac{\delta^4}{4} - \frac{\delta^5}{5} - \cdots \stackrel{?}{\geq} -\delta - \delta^2,$$

is equivalent to:

$$\frac{\delta^2}{2} \stackrel{?}{\geq} \frac{\delta^3}{3} + \frac{\delta^4}{4} + \frac{\delta^5}{5} + \cdots.$$

In this inequality under questioning, let us insert a computable infinite sum:

$$1 \stackrel{?}{\geq} \frac{2}{3} \delta (1 + \delta + \delta^2 + \cdots) \geq \frac{2}{3} \delta + \frac{2}{4} \delta^2 + \frac{2}{5} \delta^3 + \cdots,$$

in order to come to an elementary minoration:

$$1 \stackrel{?}{\geq} \frac{2}{3} \delta \frac{1}{1 - \delta} \iff 3 - 3\delta \stackrel{\text{yes}}{\geq} 2\delta.$$

The second inequality $\log(1 + \varepsilon) \leq \varepsilon$ is well known. □

Now, let us suppose that:

$$k \leq \sqrt{n},$$

whence as soon as $n \geq 4$:

$$\frac{k-1}{n} < \frac{1}{\sqrt{n}} \leq \frac{1}{2} < \frac{3}{5}.$$

Then:

$$\begin{aligned} \sum_{i=0}^{k-1} \log\left(1 - \frac{i}{n}\right) &\geq -\sum_{i=0}^{k-1} \frac{i}{n} - \sum_{i=0}^{k-1} \frac{i^2}{n^2} \\ &= -\frac{(k-1)k}{2n} - \frac{(k-1)k(2k-1)}{6n^2} \\ &= -\frac{k^2}{2n} + \frac{k}{2n} - \frac{k^3}{3n^2} + \frac{k^2}{2n^2} - \frac{k}{6n^2}. \end{aligned}$$

The three terms here underlined have a positive contribution and we can even neglect the second of them:

$$\frac{k}{2n} + \frac{k^2}{2n^2} - \frac{k}{6n^2} \geq \frac{k}{2n} \left(1 - \frac{1}{3n}\right) > 0.$$

Therefore, we obtain a useful minoration:

$$\begin{aligned} \sum_{i=0}^{k-1} \log \left(1 - \frac{i}{n}\right) &\geq -\frac{k^2}{2n} - \frac{k^3}{3n^2} = -\frac{k^2}{2n} - \frac{k^2}{3n} \frac{k}{n} \\ [\frac{k}{n} \leq 1] &\geq -\frac{k^2}{2n} - \frac{k^2}{3n} \\ &\geq -\frac{k^2}{n}. \end{aligned}$$

Next, for the quotients of second type which are present in the various M_{k_2, \dots, k_n}^n , the minoration work is easier:

$$\begin{aligned} -\sum_{j=1}^{\ell} \log \left(1 + \frac{j}{n}\right) &\geq -\sum_{j=1}^{\ell} \frac{j}{n} \\ &= -\frac{\ell^2}{2n} - \frac{\ell}{2n} \\ [l \leq \ell^2] &\geq -\frac{\ell^2}{n}. \end{aligned}$$

Without forgetting the powers n^k and $n^{-\ell}$, these estimates can now be summarized as the following

LEMMA 5.3. For all $0 \leq k \leq \frac{3}{5}n$:

$$\frac{n!}{(n-k)!} \geq n^k e^{-\frac{k^2}{n}}$$

and for all $0 \leq \ell$:

$$\frac{n!}{(n+\ell)!} \geq n^{-\ell} e^{-\frac{\ell^2}{n}}. \quad \square$$

Importantly, we point out that there is a *uniform* minoration:

$$\frac{n!}{(n+m)!} \geq n^{-m} e^{-\frac{m^2}{n}},$$

valid for all integers $m \in \mathbb{Z}$, positive or negative, in the range:

$$-\frac{3}{5}n \leq m < \infty.$$

Notice that the exponential factor is always ≤ 1 .

Next, thanks to all this, we will assume from now on that the range of the integers k_2, \dots, k_n is restricted to:

$$0 \leq k_2 + k_3 + \dots + k_{n-1} + k_n \leq \frac{\sqrt{n}}{c(n)},$$

for some function $c(n) \xrightarrow{n \rightarrow \infty} \infty$ that will be chosen later — think for instance $c(n) := \log \log \log n$. In particular, this implies that:

$$0 \leq k_2 \leq \frac{3}{5} n, \quad |k_2 - k_3| \leq \frac{\sqrt{n}}{c(n)} \leq \frac{3}{5}, \dots, |k_{n-1} - k_n| \leq \frac{\sqrt{n}}{c(n)} \leq \frac{3}{5},$$

so that the lemma applies to minorize:

$$\begin{aligned} M_{k_2, k_3, \dots, k_{n-1}, k_n}^n &= \frac{n!}{(n - k_2)!} \frac{n!}{(n + k_2 - k_3)!} \dots \frac{n!}{(n + k_{n-1} - k_n)!} \frac{n!}{(n + k_n)!} \\ &\geq \underbrace{n^{k_2}}_o e^{-\frac{k_2^2}{n}} \underbrace{n^{-k_2+k_3}}_o e^{-\frac{(k_2-k_3)^2}{n}} \dots \underbrace{n^{-k_{n-1}+k_n}}_o e^{-\frac{(k_{n-1}-k_n)^2}{n}} \underbrace{n^{-k_n}}_o e^{-\frac{k_n^2}{n}} \\ &= e^{-\frac{1}{n} [k_2^2 + (k_2 - k_3)^2 + \dots + (k_{n-1} - k_n)^2 + k_n^2]} \\ &= e^{-\frac{1}{n} [2k_2^2 - 2k_2k_3 + k_3^2 + \dots + 2k_{n-1}^2 - 2k_{n-1}k_n + 2k_n^2]} \\ &\geq e^{-\frac{1}{n} [2(k_2 + k_3 + \dots + k_{n-1} + k_n)^2]} \\ &\geq e^{-\frac{1}{n} 2 \frac{n}{c(n)^2}} \\ &= e^{-\frac{2}{c(n)^2}} \xrightarrow{n \rightarrow \infty} 1. \end{aligned}$$

We thus have proved the key

PROPOSITION 5.4. For any choice of function $c(n) \xrightarrow{n \rightarrow \infty} \infty$, the quantities:

$$M_{k_2, k_3, \dots, k_{n-1}, k_n}^n = \frac{n!}{(n - k_2)!} \frac{n!}{(n + k_2 - k_3)!} \dots \frac{n!}{(n + k_{n-1} - k_n)!} \frac{n!}{(n + k_n)!}$$

enjoy the inequalities:

$$e^{-\frac{2}{c(n)^2}} \leq M_{k_2, k_3, \dots, k_{n-1}, k_n}^n \leq 1,$$

when their indices range in the set:

$$\left\{ \begin{aligned} (k_2, k_3, \dots, k_{n-1}, k_n) \in \mathbb{N}^n: & 0 \leq k_2 \leq n, \\ & 0 \leq k_3 \leq n + k_2, \\ & \dots \dots \dots \\ & 0 \leq k_{n-1} \leq n + k_{n-2}, \\ & 0 \leq k_n \leq n + k_{n-1}, \\ & k_2 + k_3 + \dots + k_{n-1} + k_n \leq \frac{\sqrt{n}}{c(n)}. \end{aligned} \right\}. \quad \square$$

6. Majorant power series $\widehat{C}(w_2, \dots, w_n)$ and its diagonalization $\widehat{C}(x, \dots, x)$

Now, come back to:

$$F(x, y) = \frac{1 - y}{1 - 2y + xy}$$

and observe that for all $3 \leq i \leq n - 1$:

$$\frac{1 - x^{i-1}}{1 - 2x^{i-1} + x^i} = F(x, x^{i-1}).$$

Its expansion:

$$\begin{aligned} F(x, y) &= 1 + \frac{y - xy}{1 - 2y + xy} \\ &= 1 + \sum_{\ell=1}^{\infty} y^{\ell} \sum_{k=0}^{\infty} x^k F_{k,\ell} \end{aligned}$$

will be (easily) computed soon. With $F(x, y)$, introduce also — notice the single sign change in the denominator:

$$\begin{aligned} \widehat{F}(x, y) &= \frac{1 - y}{1 - 2y - xy} = 1 + \frac{y + xy}{1 - 2y - xy} \\ &= 1 + \sum_{\ell=1}^{\infty} y^{\ell} \sum_{k=0}^{\infty} x^k \widehat{F}_{k,\ell}, \end{aligned}$$

a new function which will act as a *majorant series*, in the sense that:

$$|F_{k,\ell}| \leq \widehat{F}_{k,\ell} \quad (\forall k \geq 0, \forall \ell \geq 0).$$

Such inequalities are made transparent from the following clear explicit expressions, in which just a factor $(-1)^k$ drops.

LEMMA 6.1. *With the convention that $\binom{\ell-1}{-1} = 0 = \binom{\ell-1}{\ell}$, the power series expansions are:*

$$\begin{aligned} F(x, y) &= 1 + \sum_{\ell=1}^{\infty} y^{\ell} \sum_{0 \leq k \leq \ell} (-1)^k x^k \left[2^{\ell-1-k} \binom{\ell-1}{k} + 2^{\ell-k} \binom{\ell-1}{k-1} \right], \\ \widehat{F}(x, y) &= 1 + \sum_{\ell=1}^{\infty} y^{\ell} \sum_{0 \leq k \leq \ell} x^k \left[2^{\ell-1-k} \binom{\ell-1}{k} + 2^{\ell-k} \binom{\ell-1}{k-1} \right]. \end{aligned}$$

PROOF. Expand:

$$\begin{aligned} F(x, y) &= 1 + \frac{y - xy}{1 - y(2 - x)} \\ &= 1 + (y - xy) \sum_{h=0}^{\infty} y^h (2 - x)^h \\ &= 1 + (y - xy) \sum_{h=0}^{\infty} y^h \sum_{0 \leq m \leq h} (-1)^m x^m 2^{h-m} \binom{h}{m}. \end{aligned}$$

Two double sums must be reorganized. In the first one, replace $h = \ell - 1$ and $m = k$:

$$\sum_{h=0}^{\infty} y^{h+1} \sum_{0 \leq k \leq h} (-1)^m x^m 2^{h-m} \binom{h}{m} = \sum_{\ell=1}^{\infty} y^{\ell} \sum_{0 \leq k \leq \ell-1} (-1)^k x^k 2^{\ell-1-k} \binom{\ell-1}{k},$$

and observe that the last sum can be extended to the range $0 \leq k \leq \ell$, thanks to the convention. In the second one, replace $h = \ell - 1$ and $m = k - 1$:

$$- \sum_{h=0}^{\infty} y^{h+1} \sum_{0 \leq m \leq h} (-1)^m x^{m+1} 2^{h-m} \binom{h}{m} = - \sum_{\ell=1}^{\infty} \sum_{1 \leq k \leq \ell} (-1)^{k-1} x^k 2^{\ell-k} \binom{\ell-1}{k-1},$$

and observe that the term $k = 0$ in the sum can be included, thanks to the convention. Adding these two expressions yield the stated power expansion of $F(x, y)$.

Next, for what concerns:

$$\begin{aligned}\widehat{F}(x, y) &= 1 + \frac{y + xy}{1 - 2y - xy} \\ &= 1 + (y + xy) \sum_{h=0}^{\infty} y^h (2+x)^h \\ &= 1 + (y + xy) \sum_{h=0}^{\infty} y^h \sum_{0 \leq m \leq h} x^m 2^{h-m} \binom{h}{m},\end{aligned}$$

exactly the same transformations work, except that the $(-1)^m$ factor has disappeared. \square

Next, our goal is to introduce a majorant power series $\widehat{C}(w_2, \dots, w_n)$ for the power series $C(w_2, \dots, w_n)$. As anticipated above, it is now clear by means of the triangle inequality that:

$$(6.2) \quad |F_{k,\ell}| \leq \widehat{F}_{k,\ell},$$

for all $k \geq 0$ and all $\ell \geq 0$. In terms of $F(x, y)$ and of the already seen power series:

$$E(x) := \frac{1-x}{1-2x} = \sum_{k=0}^{\infty} E_k x^k,$$

having positive coefficients $E_0 = 1$ and $E_k = 2^{k-1}$ for $k \geq 1$, we can write:

$$\begin{aligned}C(w_2, \dots, w_n) &= \prod_{2 \leq i \leq n} \frac{1 - w_2 \cdots w_i}{1 - 2w_2 \cdots w_i} \\ &\quad \prod_{2 \leq i < j \leq n} \frac{1 - w_{i+1} \cdots w_j}{1 - 2w_{i+1} \cdots w_j + w_i w_{i+1} \cdots w_j} \\ &=: \prod_{2 \leq i \leq n} E(w_2 \cdots w_i) \\ &\quad \prod_{2 \leq i < j \leq n} F(w_i, w_{i+1} \cdots w_j).\end{aligned}$$

Hence we may introduce similarly:

$$\begin{aligned}\widehat{C}(w_2, \dots, w_n) &:= \prod_{2 \leq i \leq n} E(w_2 \cdots w_i) \\ &\quad \prod_{2 \leq i < j \leq n} \widehat{F}(w_i, w_{i+1} \cdots w_j).\end{aligned}$$

The expansions of the factors of the first product show as:

$$\begin{aligned}C(w_2, \dots, w_n) &= \prod_{2 \leq i \leq n} \left(\sum_{k=0}^{\infty} E_k (w_2 \cdots w_i)^k \right) \\ &\quad \prod_{2 \leq i < j \leq n} \left(\sum_{k=0}^{\infty} \sum_{\ell=0}^{\infty} F_{k,\ell} (w_i)^k (w_{i+1} \cdots w_j)^\ell \right) \\ &=: \sum_{k_2, \dots, k_n \geq 0} C_{k_2, \dots, k_n} (w_2)^{k_2} \cdots (w_n)^{k_n},\end{aligned}$$

and similarly:

$$\begin{aligned} \widehat{C}(w_2, \dots, w_n) &= \prod_{2 \leq i \leq n} \left(\sum_{k=0}^{\infty} E_k (w_2 \cdots w_i)^k \right) \\ &\quad \prod_{2 \leq i < j \leq n} \left(\sum_{k=0}^{\infty} \sum_{\ell=0}^{\infty} \widehat{F}_{k,\ell} (w_i)^k (w_{i+1} \cdots w_j)^\ell \right) \\ &=: \sum_{k_2, \dots, k_n \geq 0} \widehat{C}_{k_2, \dots, k_n} (w_2)^{k_2} \cdots (w_n)^{k_n}. \end{aligned}$$

Since all $E_k \geq 0$ and all $\widehat{F}_{k,\ell} \geq 0$, we have all $\widehat{C}_{k_2, \dots, k_n} \geq 0$ as well — however, many C_{k_2, \dots, k_n} are ≤ -1 .

Thanks to (6.2) and to the triangle inequality in expansions, we obtain:

$$(6.3) \quad |C_{k_2, \dots, k_n}| \leq \widehat{C}_{k_2, \dots, k_n},$$

for all $k_2, \dots, k_n \geq 0$, which means that \widehat{C} is a *majorant power series* for C . Notice that:

$$C_{k_2, \dots, k_n} \in \mathbb{Z} \quad \text{and} \quad \widehat{C}_{k_2, \dots, k_n} \in \mathbb{N}.$$

Now, passing to the diagonal:

$$\{w_2 = \cdots = w_n =: x\},$$

we deduce for every $k \in \mathbb{N}$, again by means of the triangle inequality:

$$\begin{aligned} |C_h| &= \left| \sum_{k_2 + \cdots + k_n = h} C_{k_2, \dots, k_n} \right| \\ &\leq \sum_{k_2 + \cdots + k_n = h} |C_{k_2, \dots, k_n}| \\ [(6.3)] \quad &\leq \sum_{k_2 + \cdots + k_n = h} \widehat{C}_{k_2, \dots, k_n} =: \widehat{C}_h. \end{aligned}$$

In fact, these integers $\widehat{C}_h \geq 0$ express as *coefficients* of the diagonal majorant series:

$$\begin{aligned} \widehat{C}^{n-1}(x) &:= \widehat{C}(x, \dots, x) \\ &= \prod_{2 \leq i \leq n} \frac{1 - x^{i-1}}{1 - 2x^{i-1}} \prod_{2 \leq i < j \leq n} \frac{1 - x^{j-i}}{1 - 2x^{j-i} - x^{j-i+1}} \\ &= \sum_{k_2, \dots, k_n \geq 0} \widehat{C}_{k_2, \dots, k_n} x^{k_2} \cdots x^{k_n} \\ &= \sum_{h=0}^{\infty} \left(\sum_{k_2 + \cdots + k_n = h} \widehat{C}_{k_2, \dots, k_n} \right) x^h =: \sum_{h=0}^{\infty} \widehat{C}_h x^h. \end{aligned}$$

Let us therefore state these observations as a

LEMMA 6.4. *The 1-variable products/series:*

$$C^{n-1}(x) := \prod_{i=1}^{n-1} \frac{1-x^i}{1-2x^i} \prod_{i=2}^{n-1} \left(\frac{1-x^{i-1}}{1-2x^{i-1}+x^i} \right)^{n-i} = \sum_{h=0}^{\infty} C_h^{n-1} x^h,$$

$$\widehat{C}^{n-1}(x) := \prod_{i=1}^{n-1} \frac{1-x^i}{1-2x^i} \prod_{i=2}^{n-1} \left(\frac{1-x^{i-1}}{1-2x^{i-1}-x^i} \right)^{n-1} = \sum_{h=0}^{\infty} \widehat{C}_h^{n-1} x^h,$$

have coefficients satisfying the inequalities:

$$|C_h^{n-1}| \leq \widehat{C}_h^{n-1} \quad (\forall h \geq 0). \quad \square$$

7. Positivity of diagonal sums coefficients C_h^{n-1}

Now, study the power series $C(w_2, \dots, w_n)$ along the diagonal:

$$\{w_2 = \dots = w_n =: x\},$$

that is to say, introduce:

$$\begin{aligned} C^{n-1}(x) &:= C(x, \dots, x) \\ &= \sum_{k_2=0}^{\infty} \dots \sum_{k_n=0}^{\infty} C_{k_2, \dots, k_n} x^{k_2} \dots x^{k_n} \\ &= \sum_{h=0}^{\infty} \left(\sum_{k_2 + \dots + k_n = h} C_{k_2, \dots, k_n} \right) x^h \\ &=: \sum_{h=0}^{\infty} C_h^{n-1} x^h, \end{aligned}$$

in terms of certain integer coefficients $C_h^{n-1} \in \mathbb{Z}$. In fact, coming back to the product expression of $C(w_2, \dots, w_n)$, we realize that in:

$$\begin{aligned} C^{n-1}(x) &= \frac{1-x}{1-2x} \frac{1-x^2}{1-2x^2} \dots \frac{1-x^{n-1}}{1-2x^{n-1}} \\ &\quad \frac{1-x}{1-2x} \dots \frac{1-x^{n-2}}{1-2x^{n-2}} \\ &\quad \vdots \\ &\quad \frac{1-x}{1-2x} \\ &\quad \frac{1-2x}{1-2x+x^2} \dots \frac{1-2x^{n-2}}{1-2x^{n-2}+x^{n-1}} \\ &\quad \vdots \\ &\quad \frac{1-2x}{1-2x+x^2}, \end{aligned}$$

some simplifications indicated by underlinings conduct us to:

$$C^{n-1}(x) = \frac{1-x}{1-2x} \frac{1-x^2}{1-2x^2} \frac{1-x^3}{1-2x^3} \cdots \frac{1-x^{n-1}}{1-2x^{n-1}} \\ \left(\frac{1-x}{1-2x+x^2} \right)^{n-2} \left(\frac{1-x^2}{1-2x^2+x^3} \right)^{n-3} \cdots \left(\frac{1-x^{n-2}}{1-2x^{n-2}+x^{n-1}} \right)^1.$$

Furthermore, on the second line, the first fraction to the power $(\cdot)^{n-2}$ trivially simplifies as:

$$\frac{1-x}{(1-x)^2} = \frac{1}{1-x},$$

whence:

$$C^{n-1}(x) = \frac{1-x}{1-2x} \frac{1-x^2}{1-2x^2} \frac{1-x^3}{1-2x^3} \cdots \frac{1-x^{n-1}}{1-2x^{n-1}} \\ \left(\frac{1}{1-x} \right)^{n-2} \left(\frac{1-x^2}{1-2x^2+x^3} \right)^{n-3} \cdots \left(\frac{1-x^{n-2}}{1-2x^{n-2}+x^{n-1}} \right)^1.$$

Let us focus on the second line, which we now call:

$$P^{n-1}(x) := \left(\frac{1}{1-x} \right)^{n-2} \left(\frac{1-x^2}{1-2x^2+x^3} \right)^{n-3} \cdots \left(\frac{1-x^{n-2}}{1-2x^{n-2}+x^{n-1}} \right)^1 \\ =: \sum_{h=0}^{\infty} P_h^{n-1} x^h.$$

We believe that all the coefficients of the full product $C^{n-1}(x)$ are positive, but a restricted statement will be enough for our purposes.

LEMMA 7.1. *For all indices h in the range:*

$$0 \leq h \leq \lfloor \sqrt{n} \rfloor$$

one has:

$$P_h^{n-1} \geq 1, \\ C_h^{n-1} \geq 2^h.$$

PROOF. First, we make the following transformation for each term in the product $P^{n-1}(x)$:

$$\left(\frac{1-x^k}{1-2x^k+x^{k+1}} \right)^{n-k-1} = \left(\frac{1-x^k}{1-x^k-(x^k-x^{k+1})} \right)^{n-k-1} \\ = \left(\frac{1}{1-\frac{x^k-x^{k+1}}{1-x^k}} \right)^{n-k-1} \\ = \left(\frac{1}{1-\frac{x^k}{1+x+\dots+x^{k-1}}} \right)^{n-k-1} \quad (1 \leq k \leq n-2).$$

Using the expansion and factorization:

$$\frac{1}{1-T} = (1+T) \sum_{i=0}^{\infty} T^{2i} = (1+T)(1+T^2+T^4+T^6+\dots)$$

and substituting $T = \frac{x^k}{1+x+\dots+x^{k-1}}$ gives us:

$$\begin{aligned} \left(\frac{1}{1 - \frac{x^k}{1+x+\dots+x^{k-1}}} \right)^1 &= \left(1 + \frac{x^k}{1+x+\dots+x^{k-1}} \right) \left(\sum_{i=0}^{\infty} \left(\frac{x^k}{1+x+\dots+x^{k-1}} \right)^{2i} \right) \\ &= \left(\frac{1+x+\dots+x^k}{1+x+\dots+x^{k-1}} \right) \left(\sum_{i=0}^{\infty} \left(\frac{x^k}{1+x+\dots+x^{k-1}} \right)^{2i} \right). \end{aligned}$$

We then put together these expansions of terms in the product $P^{n-1}(x)$ to obtain:

$$\begin{aligned} P^{n-1}(x) &= (1+x)^{n-2} (1+x^2+x^4+x^6+\dots)^{n-2} \\ &\quad \cdot \left(\frac{1+x+x^2}{1+x} \right)^{n-3} \left(1 + \left(\frac{x^2}{1+x} \right)^2 + \left(\frac{x^2}{1+x} \right)^4 + \dots \right)^{n-3} \\ &\quad \dots \dots \dots \\ &\quad \cdot \left(\frac{1+x+\dots+x^{k-1}+x^k}{1+x+\dots+x^{k-1}} \right)^{n-k-1} \left(\sum_{i=0}^{\infty} \left(\frac{x^k}{1+x+\dots+x^{k-1}} \right)^{2i} \right)^{n-k-1} \\ &\quad \dots \dots \dots \\ &\quad \cdot \left(\frac{1+x+\dots+x^{n-3}+x^{n-2}}{1+x+\dots+x^{n-3}} \right)^1 \left(1 + \left(\frac{x^{n-2}}{1+x+\dots+x^{n-3}} \right)^2 + \dots \right)^1. \end{aligned}$$

Notice that the product of the first terms in all lines admits simplification as follows:

$$\begin{aligned} (1+x)^{n-2} \left(\frac{1+x+x^2}{1+x} \right)^{n-3} \dots \left(\frac{1+\dots+x^{k-1}+x^k}{1+\dots+x^{k-1}} \right)^{n-k-1} \dots \left(\frac{1+\dots+x^{n-3}+x^{n-2}}{1+\dots+x^{n-3}} \right)^1 \\ = (1+x)(1+x+x^2) \dots (1+x+\dots+x^k) \dots (1+x+\dots+x^{n-2}), \end{aligned}$$

while the other terms can be expanded using

$$\begin{aligned} \left(\sum_{i=0}^{\infty} T^{2i} \right)^m &= \left(1 + T^2 + T^4 + \dots + T^{2j} + \dots \right)^m \\ &= \sum_{j=0}^{\infty} \binom{m+j-1}{j} T^{2j} \\ &= 1 + \binom{m}{1} T^2 + \binom{m+1}{2} T^4 + \dots + \binom{m+j-1}{j} T^{2j} + \dots \end{aligned}$$

The expansion of $P^{n-1}(x)$ now becomes

$$\begin{aligned}
P^{n-1}(x) &= (1+x)(1+x+x^2) \cdots (1+x+\cdots+x^k) \cdots (1+x+\cdots+x^{n-2}) \\
&\cdot \left(1 + \binom{n-2}{1}x^2 + \binom{n-1}{2}x^4 + \binom{n}{3}x^6 + \cdots\right) \\
&\cdot \left(1 + \binom{n-3}{1}\left(\frac{x^2}{1+x}\right)^2 + \binom{n-2}{2}\left(\frac{x^2}{1+x}\right)^4 + \cdots\right) \\
&\quad \dots\dots\dots \\
&\cdot \left(\sum_{i=0}^{\infty} \binom{n-k-1+i-1}{i} \left(\frac{x^k}{1+x+\cdots+x^{k-1}}\right)^{2i}\right) \\
&\quad \dots\dots\dots \\
&\cdot \left(1 + \left(\frac{x^{n-2}}{1+x+\cdots+x^{n-3}}\right)^2 + \left(\frac{x^{n-2}}{1+x+\cdots+x^{n-3}}\right)^4 + \cdots\right).
\end{aligned}$$

Since we are only interested in the coefficients P_h^{n-1} with $0 \leq h \leq \lfloor \sqrt{n} \rfloor$, we will ignore the terms $\left(\frac{x^k}{1+x+\cdots+x^{k-1}}\right)^{2i}$ with $k \cdot 2i > n$, i.e. with $i > \frac{n}{2k}$. The first $\lfloor \sqrt{n} \rfloor$ coefficients in the power series expansion of $P^{n-1}(x)$ are the same as those of

$$\begin{aligned}
&(1+x)(1+x+x^2) \cdots (1+x+\cdots+x^k) \cdots (1+x+\cdots+x^{n-2}) \\
&\cdot \left(1 + \binom{n-2}{1}x^2 + \binom{n-1}{2}x^4 + \cdots + \binom{n-2+\lfloor \frac{\sqrt{n}}{2} \rfloor - 1}{\lfloor \frac{\sqrt{n}}{2} \rfloor} x^{2\lfloor \frac{\sqrt{n}}{2} \rfloor}\right) \\
&\cdot \left(1 + \binom{n-3}{1}\left(\frac{x^2}{1+x}\right)^2 + \cdots + \binom{n-3+\lfloor \frac{\sqrt{n}}{4} \rfloor - 1}{\lfloor \frac{\sqrt{n}}{4} \rfloor} \left(\frac{x^2}{1+x}\right)^{2\lfloor \frac{\sqrt{n}}{4} \rfloor}\right) \\
&\quad \dots\dots\dots \\
&\cdot \left(1 + \cdots + \binom{n-k-1+\lfloor \frac{\sqrt{n}}{2k} \rfloor - 1}{\lfloor \frac{\sqrt{n}}{2k} \rfloor} \left(\frac{x^k}{1+x+\cdots+x^{k-1}}\right)^{2\lfloor \frac{\sqrt{n}}{2k} \rfloor}\right) \\
&\quad \dots\dots\dots \\
&\cdot \left(1 + \binom{n-\lfloor \frac{\sqrt{n}}{2} \rfloor - 1}{1} \left(\frac{x^{\lfloor \frac{\sqrt{n}}{2} \rfloor}}{1+x+\cdots+x^{\lfloor \frac{\sqrt{n}}{2} \rfloor - 1}}\right)^2\right).
\end{aligned}$$

Now it is clear that in order to show the positivity of P_h^{n-1} for all $0 \leq h \leq \lfloor \sqrt{n} \rfloor$, it suffices to prove that the product

$$(1+x)^{2\lfloor \frac{\sqrt{n}}{4} \rfloor} (1+x+x^2)^{2\lfloor \frac{\sqrt{n}}{6} \rfloor} \cdots (1+x+\cdots+x^{\lfloor \frac{\sqrt{n}}{2} \rfloor - 1})^2$$

is divisible by

$$(1+x)(1+x+x^2) \cdots (1+x+\cdots+x^k) \cdots (1+x+\cdots+x^{n-2}),$$

and at the same time that the quotient also has nonnegative coefficients.

Note that for any $j \geq 0$, one has

$$1 + x + \cdots + x^{kj+k-1} = \left(1 + x + \cdots + x^{k-1}\right) \left(1 + x^k + x^{2k} + \cdots + x^{kj}\right),$$

that is $1 + x + \cdots + x^{k-1}$ is divisible by $1 + x + \cdots + x^{kj+k-1}$ with quotient having nonnegative coefficients.

Now, we divide the set of indices $\{1, 2, \dots, (\lfloor \sqrt{n} \rfloor)^2 - 1\}$ into $\lfloor \sqrt{n} \rfloor$ disjoint sets:

$$\left\{ \lfloor \sqrt{n} \rfloor j + 1, \lfloor \sqrt{n} \rfloor j + 2, \dots, \lfloor \sqrt{n} \rfloor j + \lfloor \sqrt{n} \rfloor \right\}$$

for $j = 0, 1, \dots, \lfloor \sqrt{n} \rfloor - 1$. Then, for each index k , the number of integers of the form $kj + k - 1$ in the interval $\left\{ \lfloor \sqrt{n} \rfloor k + 1, \lfloor \sqrt{n} \rfloor k + 2, \dots, \lfloor \sqrt{n} \rfloor k + \lfloor \sqrt{n} \rfloor \right\}$ is at least $\frac{\lfloor \sqrt{n} \rfloor}{k}$.

Since $2 \lfloor \frac{\sqrt{n}}{2k} \rfloor \leq \frac{\lfloor \sqrt{n} \rfloor}{k}$, the polynomial $\left(1 + x + \cdots + x^{k-1}\right)^{2 \lfloor \frac{\sqrt{n}}{2k} \rfloor}$ is divisible by

$$\prod_{i=\lfloor \sqrt{n} \rfloor k + 1}^{\lfloor \sqrt{n} \rfloor (k+1)} \left(1 + x + \cdots + x^i\right),$$

with quotient having nonnegative coefficients. Taking in account all the values of $k = 1, 2, \dots, \lfloor \frac{\sqrt{n}}{2} \rfloor - 1$, and making the product of all the $\lfloor \frac{\sqrt{n}}{2} \rfloor - 1$ terms gives us the desired divisibility.

At this point, notice further that the set $\{1, 2, \dots, \lfloor \sqrt{n} \rfloor\}$, corresponding to $k = 0$, has not been used in obtaining the above divisibility. Thus, the first $\lfloor \sqrt{n} \rfloor$ coefficients of $P^{n-1}(x)$ are those of the product between

$$\left(1 + x\right) \left(1 + x + x^2\right) \cdots \left(1 + x + \cdots + x^{\lfloor \sqrt{n} \rfloor}\right)$$

and a power series having constant coefficient 1 and the first $\lfloor \sqrt{n} \rfloor$ coefficients nonnegative. This clearly implies the positivity of P_h^{n-1} for all $0 \leq h \leq \lfloor \sqrt{n} \rfloor$.

For the first $\lfloor \sqrt{n} \rfloor$ coefficients in the power series expansion of $C^{n-1}(x)$, it is enough to consider the product

$$\left(\frac{1-x}{1-2x}\right) P^{n-1}(x),$$

since all the remaining terms in the product $C^{n-1}(x)$ have power series expansions with nonnegative coefficients and constant coefficient 1. Now using the expansion

$$\frac{1-x}{1-2x} = 1 + \sum_{i=1}^{\infty} 2^{i-1} x^i,$$

we get

$$C_h^{n-1} = P_h^{n-1} + \sum_{i=1}^h 2^{i-1} P_{h-i}^{n-1}.$$

Since we have already showed that $P_h^{n-1} \geq 1$ for all $0 \leq h \leq \lfloor \sqrt{n} \rfloor$, it follows that

$$C_h^{n-1} \geq 1 + \sum_{i=1}^h 2^{i-1} = 2^h$$

for all $0 \leq h \leq \lfloor \sqrt{n} \rfloor$. This finishes our proof of the lemma. \square

8. Cauchy inequalities

Next, we will set up a useful (and trivial) version of the Cauchy inequalities for power series having nonnegative coefficients. We start by determining the radius of convergence $R > 0$ of $C^{n-1}(x)$ and the one $\widehat{R} > 0$ of $\widehat{C}^{n-1}(x)$, where, from Lemma 6.4:

$$C^{n-1}(x) := \prod_{i=1}^{n-1} \frac{1-x^i}{1-2x^i} \prod_{i=2}^{n-1} \left(\frac{1-x^{i-1}}{1-2x^{i-1}+x^i} \right)^{n-i},$$

$$\widehat{C}^{n-1}(x) := \prod_{i=1}^{n-1} \frac{1-x^i}{1-2x^i} \prod_{i=2}^{n-1} \left(\frac{1-x^{i-1}}{1-2x^{i-1}-x^i} \right)^{n-1},$$

LEMMA 8.1. *The smallest moduli of poles of the two rational functions $C^{n-1}(x)$ and $\widehat{C}^{n-1}(x)$ are:*

$$R := \frac{1}{2} = 0.5 \quad \text{and} \quad \widehat{R} := \sqrt{2} - 1 \approx 0.414 \dots$$

PROOF. The moduli of the roots of the denominator of the first product $\prod_{1 \leq i \leq n-1} \frac{*}{1-2x^i}$ appearing in $C^{n-1}(x)$ are $\frac{1}{2}, \frac{1}{\sqrt{2}}, \frac{1}{\sqrt[3]{2}}, \dots, \frac{1}{\sqrt[n-1]{2}}$, and the smallest among them is $\frac{1}{2}$. But then in the disc $\{x \in \mathbb{C} : |x| < \frac{1}{2}\}$, we assert that all denominators in the second product constituting $C^{n-1}(x)$ are nowhere vanishing. Indeed, as already observed above, taking account of the simplification for $i = 2$:

$$\frac{1-x^{2-1}}{1-2x^{2-1}+x^2} = \frac{1}{1-x},$$

this second product writes as:

$$\left(\frac{1}{1-x} \right)^{n-2} \prod_{i=3}^{n-1} \left(\frac{*}{1-2x^{i-1}+x^i} \right)^{n-i}.$$

Then the root 1 is certainly $> \frac{1}{2}$, while the subsequent denominators for $3 \leq i \leq n$ are nonvanishing when $|x| \leq \frac{1}{2}$, because:

$$\begin{aligned} |1-2x^{i-1}+x^i| &\geq 1-2|x|^{i-1}-|x|^i \\ &\geq 1-2\left(\frac{1}{2}\right)^{i-1}-\left(\frac{1}{2}\right)^i \\ &\geq 1-2\left(\frac{1}{2}\right)^2-\left(\frac{1}{2}\right)^3 = \frac{3}{8} > 0. \end{aligned}$$

On the other hand, while the first product constituting $\widehat{C}^{n-1}(x)$ is exactly the same, such a simplification in the second product does not occur, and in fact, in:

$$\left(\frac{*}{1-2x-x^2} \right)^{n-2} \prod_{i=3}^{n-1} \left(\frac{*}{1-2x^{i-1}-x^i} \right)^{n-i},$$

the same minoration for $3 \leq i \leq n-1$ applies:

$$|1-2x^{i-1}-x^i| \geq 1-2|x|^{i-1}-|x|^i \geq \frac{3}{8},$$

whereas the positive root $\sqrt{2}-1$ of $1-2x-x^2=0$ is smaller than $\frac{1}{2}$, and the other root $-1-\sqrt{2}$ has (much) larger modulus. \square

Let therefore $0 < \rho < \sqrt{2} - 1$ be any radius in these convergence discs. A trivial version of the Cauchy inequalities for power series having nonnegative coefficients is as follows. From:

$$\widehat{C}^{n-1}(\rho) = \sum_{h=0}^{\infty} \widehat{C}_h^{n-1} \rho^h,$$

it comes for any $h \in \mathbb{N}$ fixed, since all terms are ≥ 0 :

$$\widehat{C}^{n-1}(\rho) \geq \widehat{C}_h^{n-1} \rho^h.$$

Soon, we will take $\rho = \rho(n) \xrightarrow[n \rightarrow \infty]{} 0$, in fact:

$$\rho := \frac{1}{\sqrt{n}} \quad (\text{later}).$$

OBSERVATION 8.2. For any $0 < \rho < \sqrt{2} - 1$ and every $h \in \mathbb{N}$:

$$\widehat{C}_h \leq \frac{1}{\rho^h} \widehat{C}(\rho). \quad \square$$

Section 11 provides an exploration of the way moduli of the elementary constituents $\frac{1-x^k}{1-2x^k}$ and $\frac{1-x^\ell}{1-2x^\ell-x^{\ell+1}}$ vary with drastic oscillations on circles $\{|x| = \rho\}$.

Thanks to these basic Cauchy inequalities, we can now start to control the growth of $\widehat{C}^{n-1}(\rho)$.

9. Estimations of $\widehat{C}(\frac{1}{r})$ and of $C(\frac{1}{r})$

At first, we reorganize $\widehat{C}^{n-1}(x)$ from Lemma 6.4, writing its second product up to $i = n$ included instead of $i = n - 1$, using $(*)^{n-n} = 1$:

$$\begin{aligned} \widehat{C}^{n-1}(x) &= \prod_{i=1}^{n-1} \frac{1-x^i}{1-2x^i} \prod_{i=2}^n \left(\frac{1-x^{i-1}}{1-2x^{i-1}-x^i} \right)^{n-i} \\ &= \underbrace{\prod_{i=1}^{n-1} \frac{1}{1-2x^i}}_{i=:k} \underbrace{\prod_{i=1}^{n-1} (1-x^i)}_{i=:k} \underbrace{\prod_{i=2}^n (1-x^{i-1})^{n-i}}_{i=:k+1} \underbrace{\prod_{i=2}^n \frac{1}{(1-2x^{i-1}-x^i)^{n-i}}}_{i=:k+1} \\ &= \prod_{k=1}^{n-1} \frac{1}{1-2x^k} \prod_{k=1}^{n-1} (1-x^k)^1 \prod_{k=1}^{n-1} (1-x^k)^{n-k-1} \prod_{k=1}^{n-1} \frac{1}{(1-2x^k-x^{k+1})^{n-k-1}} \\ &= \prod_{k=1}^{n-1} \frac{1}{1-2x^k} \prod_{k=1}^{n-1} (1-x^k)^{n-k} \prod_{k=1}^{n-1} \frac{1}{(1-2x^k-x^{k+1})^{n-k-1}}. \end{aligned}$$

In order to set up a general statement, we will take:

$$x := \frac{1}{r},$$

with $r = r(n) \xrightarrow[n \rightarrow \infty]{} \infty$, always with $0 < \frac{1}{r} < \sqrt{2} - 1$. In fact, to fix ideas, we shall assume at least $r \geq 10$.

LEMMA 9.1. One has:

$$\widehat{C}\left(\frac{1}{r}\right) \leq e^{\frac{n}{r} + 12 \frac{n}{r^2}}.$$

PROOF. Take logarithm:

$$\begin{aligned} \log \widehat{C}(\frac{1}{r}) &= \sum_{k=1}^{n-1} \left(-\log \left(1 - \frac{2}{r^k} \right) + (n-k) \log \left(1 - \frac{1}{r^k} \right) - (n-k-1) \log \left(1 - \frac{2}{r^k} - \frac{1}{r^{k+1}} \right) \right) \\ &= -\log \left(1 - \frac{2}{r} \right) + (n-1) \log \left(1 - \frac{1}{r} \right) - (n-2) \log \left(1 - \frac{2}{r} - \frac{1}{r^2} \right) - \\ &\quad - \log \left(1 - \frac{2}{r^2} \right) + (n-2) \log \left(1 - \frac{1}{r^2} \right) - (n-3) \log \left(1 - \frac{2}{r^2} - \frac{1}{r^3} \right) + \\ &\quad + \sum_{k=3}^{n-1} \left\{ -\log \left(1 - \frac{2}{r^k} \right) + (n-k) \log \left(1 - \frac{1}{r^k} \right) - (n-k-1) \log \left(1 - \frac{2}{r^k} - \frac{1}{r^{k+1}} \right) \right\}. \end{aligned}$$

Now, employ the majorations valuable for $0 \leq \delta \leq 0.5$:

$$\begin{aligned} \log(1 - \delta) &\leq -\delta - \frac{1}{2} \delta^2, \\ -\log(1 - \varepsilon) &\leq \varepsilon + \varepsilon^2, \end{aligned}$$

to get using the assumption $r \geq 10$:

$$\begin{aligned} \log \widehat{C}(\frac{1}{r}) &\leq \frac{2}{r} + \frac{4}{r^2} + (n-1) \left[-\frac{1}{r} - \frac{1}{2} \frac{1}{r^2} \right] + (n-2) \left[\underbrace{\left(\frac{2}{r} + \frac{1}{r^2} \right) + \left(\frac{2}{r} + \frac{1}{r^2} \right)^2}_{\leq \frac{5}{r^2}} \right] + \\ &\quad + \underbrace{\frac{2}{r^2} + \frac{4}{r^4}}_{\leq \frac{3}{r^2}} + (n-2) \left[-\frac{1}{r^2} - \frac{1}{2} \frac{1}{r^4} \right] + (n-3) \left[\underbrace{\left(\frac{2}{r^2} + \frac{1}{r^3} \right) + \left(\frac{2}{r^2} + \frac{1}{r^3} \right)^2}_{\leq \frac{4}{r^2}} \right] + \\ &\quad + \sum_{k=3}^{n-1} \left\{ \underbrace{\frac{2}{r^k} + \frac{4}{r^{2k}}}_{\leq \frac{3}{r^k}} + \underbrace{(n-k) \log \left(1 - \frac{1}{r^k} \right)}_{< 0} + (n-k-1) \left[\underbrace{\left(\frac{2}{r^k} + \frac{1}{r^{k+1}} \right) + \left(\frac{2}{r^k} + \frac{1}{r^{k+1}} \right)^2}_{\leq \frac{3}{r^k}} \right] \right\} \\ &\leq \frac{1}{r} [2 - n + 1 + 2n - 4] + \frac{1}{r^2} [4 - \frac{n}{2} + \frac{1}{2} + n - 2 + 5n - 10 + 3 - n + 2 + 0 + 4n - 12] \\ &\quad + \sum_{k=3}^{n-1} \frac{3}{r^k} [1 + 0 + n - k - 1] \\ &\leq \frac{1}{r} [n - 1] + \frac{1}{r^2} [\frac{17}{2}n - \frac{29}{2}] + \\ &\quad + \frac{3}{r^3} \frac{1}{1 - \frac{1}{r}} [n] \\ &\leq \frac{n}{r} + 9 \frac{n}{r^2} + 3 \frac{n}{r^2}. \end{aligned} \quad \square$$

Similarly to the expression:

$$\widehat{C}(x) = \prod_{k=1}^{n-1} \frac{1}{1 - 2x^k} \prod_{k=1}^{n-1} (1 - x^k)^{n-k} \prod_{k=1}^{n-1} \frac{1}{(1 - 2x^k - x^{k+1})^{n-k-1}},$$

we obtain by simply changing the last sign $-$ to the sign $+$ in the denominator of the third product:

$$C(x) = \prod_{k=1}^{n-1} \frac{1}{1-2x^k} \prod_{k=1}^{n-1} (1-x^k)^{n-k} \prod_{k=1}^{n-1} \frac{1}{(1-2x^k+x^{k+1})^{n-k-1}}.$$

LEMMA 9.2. *One has:*

$$\frac{\widehat{C}\left(\frac{1}{r}\right)}{C\left(\frac{1}{r}\right)} \leq e^{17 \frac{n}{r^2}}.$$

PROOF. This quotient writes as:

$$\frac{\widehat{C}\left(\frac{1}{r}\right)}{C\left(\frac{1}{r}\right)} = \prod_{k=1}^{n-2} \left(\frac{1-2\frac{1}{r^k}+\frac{1}{r^{k+1}}}{1-2\frac{1}{r^k}-\frac{1}{r^{k+1}}} \right)^{n-k-1},$$

since the terms for $k = n-1$ drop. Take logarithm and use the above majorations:

$$\begin{aligned} \log \frac{\widehat{C}\left(\frac{1}{r}\right)}{C\left(\frac{1}{r}\right)} &= \sum_{k=1}^{n-2} (n-k-1) \left[\log \left(1 - \left(\frac{2}{r^k} - \frac{1}{r^{k+1}} \right) \right) - \log \left(1 - \left(\frac{2}{r^k} + \frac{1}{r^{k+1}} \right) \right) \right] \\ &= (n-2) \left[\log \left(1 - \left(\frac{2}{r} - \frac{1}{r^2} \right) \right) - \log \left(1 - \left(\frac{2}{r} + \frac{1}{r^2} \right) \right) \right] + \\ &\quad + (n-3) \left[\log \left(1 - \left(\frac{2}{r^2} - \frac{1}{r^3} \right) \right) - \log \left(1 - \left(\frac{2}{r^2} + \frac{1}{r^3} \right) \right) \right] + \\ &\quad + \sum_{k=3}^{n-2} (n-k-1) \left[\underbrace{\log \left(1 - \left(\frac{2}{r^k} - \frac{1}{r^{k+1}} \right) \right)}_{< 0} - \log \left(1 - \left(\frac{2}{r^k} + \frac{1}{r^{k+1}} \right) \right) \right] \\ &\leq (n-2) \left[\underbrace{-\left(\frac{2}{r} - \frac{1}{r^2} \right)}_{< 0} - \underbrace{\frac{1}{2} \left(\frac{2}{r} - \frac{1}{r^2} \right)^2}_{< 0} + \underbrace{\left(\frac{2}{r} + \frac{1}{r^2} \right)}_{< 0} + \underbrace{\left(\frac{2}{r} + \frac{1}{r^2} \right)^2}_{\leq \frac{5}{r^2}} \right] + \\ &\quad + (n-3) \left[\underbrace{-\left(\frac{2}{r^2} - \frac{1}{r^3} \right)}_{< 0} - \underbrace{\frac{1}{2} \left(\frac{2}{r^2} - \frac{1}{r^3} \right)^2}_{< 0} + \underbrace{\left(\frac{2}{r^2} + \frac{1}{r^3} \right)}_{< 0} + \underbrace{\left(\frac{2}{r^2} + \frac{1}{r^3} \right)^2}_{\leq \frac{4}{r^2}} \right] + \\ &\quad + \sum_{k=3}^{n-2} (n-k-1) \left[0 + 2 \underbrace{\left(\frac{2}{r^k} + \frac{1}{r^{k+1}} \right)}_{\leq \frac{3}{r^k}} \right], \end{aligned}$$

$[\varepsilon + \varepsilon^2 \leq 2\varepsilon]$

and notice, *importantly*, that the $\frac{1}{r}$ -terms disappear, so that at the end:

$$\begin{aligned} \log \frac{\widehat{C}\left(\frac{1}{r}\right)}{C\left(\frac{1}{r}\right)} &\leq (n-2) \left[\frac{7}{r^2} \right] + (n-3) \left[\frac{4}{r^2} \right] + 6n \sum_{k=3}^{\infty} \frac{1}{r^k} \\ &\leq 11n \frac{1}{r^2} + 6n \frac{1}{r^2} \frac{1}{r-1}. \end{aligned} \quad \square$$

Lastly, making the choice:

$$r := \sqrt{n} a(n),$$

with a function $a(n) \xrightarrow[n \rightarrow \infty]{} \infty$ tending *slowly* to infinity — think $a(n) := \log \log n$ — and satisfying at least $a(n) \ll n^\epsilon$ for any $\epsilon > 0$, we want to minorize:

$$\mathbf{CR}_\infty := C\left(\frac{1}{r}\right) = C\left(\frac{1}{\sqrt{na(n)}}\right).$$

LEMMA 9.3. *One has:*

$$C\left(\frac{1}{\sqrt{na(n)}}\right) \geq e^{\frac{1}{2} \frac{\sqrt{n}}{a(n)}} \xrightarrow[n \rightarrow \infty]{} \infty.$$

PROOF. Take logarithm:

$$\begin{aligned} \log C\left(\frac{1}{r}\right) &= \sum_{k=1}^{n-1} \left(-\log\left(1 - \frac{2}{r^k}\right) + (n-k) \log\left(1 - \frac{1}{r^k}\right) - (n-k-1) \log\left(1 - \left(\frac{2}{r^k} - \frac{1}{r^{k+1}}\right)\right) \right) \\ &= -\log\left(1 - \frac{2}{r}\right) + (n-1) \log\left(1 - \frac{1}{r}\right) - (n-2) \log\left(1 - \left(\frac{2}{r} - \frac{1}{r^2}\right)\right) - \\ &\quad - \log\left(1 - \frac{2}{r^2}\right) + (n-2) \log\left(1 - \frac{1}{r^2}\right) - (n-3) \log\left(1 - \left(\frac{2}{r^2} - \frac{1}{r^3}\right)\right) + \\ &\quad + \sum_{k=3}^{n-1} \left\{ -\log\left(1 - \frac{2}{r^k}\right) + (n-k) \log\left(1 - \frac{1}{r^k}\right) - (n-1-k) \log\left(1 - \left(\frac{2}{r^k} - \frac{1}{r^{k+1}}\right)\right) \right\}, \end{aligned}$$

use the minorations:

$$\begin{aligned} -\log(1 - \varepsilon) &\geq \varepsilon, \\ \log(1 - \delta) &\geq -\delta - \delta^2, \end{aligned}$$

to get:

$$\begin{aligned} \log C\left(\frac{1}{r}\right) &\geq \frac{2}{r} + (n-1) \left[-\frac{1}{r} - \frac{1}{r^2} \right] + (n-2) \left[\frac{2}{r} - \frac{1}{r^2} \right] + \\ &\quad + \frac{2}{r^2} + (n-2) \left[\underbrace{-\frac{1}{r^2} - \frac{1}{r^4}}_{\geq -\frac{2}{r^2}} \right] + (n-3) \left[\underbrace{\frac{2}{r^2} - \frac{1}{r^3}}_{\geq \frac{1}{r^2}} \right] + \\ &\quad + \sum_{k=3}^{n-1} \left\{ \frac{2}{r^k} + (n-k) \left[\underbrace{-\frac{1}{r^k} - \frac{1}{r^{2k}}}_{\geq -\frac{2}{r^k}} \right] + (n-k-1) \left[\underbrace{\frac{2}{r^k} - \frac{1}{r^{k+1}}}_{\geq \frac{1}{r^k}} \right] \right\} \\ &\geq \frac{1}{r} [2 - n + 1 + 2n - 4] + \frac{1}{r^2} [-n + 1 - n + 2 + 2 - 2n + 4 + n - 3] + \\ &\quad + \sum_{k=3}^{n-1} \frac{1}{r^k} [2 - 2n + 2k + n - k - 1] \\ &= \frac{1}{r} [n - 1] + \frac{1}{r^2} [-3n + 6] + \sum_{k=3}^{n-1} \frac{1}{r^k} \left[\underbrace{-n + k + 1}_{\geq -n+1} \right] \\ &\geq (n-1) \left[\frac{1}{r} - \frac{3}{r^2} - \sum_{k=3}^{\infty} \frac{1}{r^k} \right] \\ &\geq (n-1) \left[\frac{1}{r} - \frac{4}{r^2} \right]. \end{aligned}$$

Lastly, again with $a(n) \ll n^\epsilon$:

$$\begin{aligned} \log C\left(\frac{1}{\sqrt{n} a(n)}\right) &\geq \frac{n-1}{\sqrt{n} a(n)} - \underbrace{\frac{4n-4}{n a(n)^2}}_{\geq -4} \\ &\geq \frac{1}{2} \frac{\sqrt{n}}{a(n)}. \end{aligned} \quad \square$$

10. Final minorations

As explained at the end of Section 4, with a suitable choice of r , the goal is to show:

$$\begin{aligned} 1 &\stackrel{?}{\leq} \sum_{\substack{0 \leq k_2 \leq n \\ 0 \leq k_3 \leq n+k_2 \\ \dots \\ 0 \leq k_{n-1} \leq n+k_{n-2} \\ 0 \leq k_n \leq n+k_{n-1}}} C_{k_2, k_3, \dots, k_{n-1}, k_n} M_{k_2, k_3, \dots, k_{n-1}, k_n} \frac{1}{r^{k_2+k_3+\dots+k_{n-1}+k_n}} \\ &=: \text{CMR}. \end{aligned}$$

Abbreviate this domain range as:

$$\begin{aligned} \triangleleft \square := \left\{ (k_2, k_3, \dots, k_{n-1}, k_n) \in \mathbb{N}^n : \right. & 0 \leq k_2 \leq n, \\ & 0 \leq k_3 \leq n + k_2, \\ & \dots \dots \dots \\ & 0 \leq k_{n-1} \leq n + k_{n-2}, \\ & \left. 0 \leq k_n \leq n + k_{n-1} \right\}. \end{aligned}$$

Observe that:

$$\left\{ k_2 + k_3 + \dots + k_{n-1} + k_n \leq n \right\} \subset \triangleleft \square,$$

hence *a fortiori* with a function $c(n) \xrightarrow{n \rightarrow \infty} \infty$ tending slowly to infinity to be chosen later:

$$\left\{ k_2 + k_3 + \dots + k_{n-1} + k_n \leq \frac{\sqrt{n}}{c(n)} \right\} \subset \triangleleft \square.$$

Introduce:

$$\text{CMR}_T := \sum_{k_2+\dots+k_n \leq \frac{\sqrt{n}}{c(n)}} C_{k_2, \dots, k_n} M_{k_2, \dots, k_n} \frac{1}{r^{k_2+\dots+k_n}},$$

the letter ‘T’ standing for ‘Truncated’, with the Remainder:

$$\begin{aligned} \text{CMR} - \text{CMR}_T &= \sum_{\substack{(k_2, \dots, k_n) \in \triangleleft \square \\ k_2+\dots+k_n \geq 1 + \frac{\sqrt{n}}{c(n)}}} C_{k_2, \dots, k_n} M_{k_2, \dots, k_n} \frac{1}{r^{k_2+\dots+k_n}} \\ &=: \text{CMR}_R. \end{aligned}$$

Along with these quantities, introduce also:

$$CMR_T^+ := \sum_{\substack{k_2 + \dots + k_n \leq \frac{\sqrt{n}}{c(n)} \\ C_{k_2, \dots, k_n} \geq 0}} C_{k_2, \dots, k_n} M_{k_2, \dots, k_n} \frac{1}{r^{k_2 + \dots + k_n}} \quad (\geq 0),$$

$$CMR_T^- := \sum_{\substack{k_2 + \dots + k_n \leq \frac{\sqrt{n}}{c(n)} \\ C_{k_2, \dots, k_n} < 0}} (-C_{k_2, \dots, k_n}) M_{k_2, \dots, k_n} \frac{1}{r^{k_2 + \dots + k_n}} \quad (\geq 0),$$

two nonnegative quantities which decompose:

$$CMR_T = CMR_T^+ - CMR_T^-.$$

In addition, without the multinomial-quotient coefficients, introduce:

$$CR := \sum_{(k_2, \dots, k_n) \in \Delta} C_{k_2, \dots, k_n} \cdot 1 \cdot \frac{1}{r^{k_2 + \dots + k_n}},$$

$$CR_T := \sum_{k_2 + \dots + k_n \leq \frac{\sqrt{n}}{c(n)}} C_{k_2, \dots, k_n} \cdot 1 \cdot \frac{1}{r^{k_2 + \dots + k_n}},$$

$$CR_R := \sum_{\substack{(k_2, \dots, k_n) \in \Delta \\ k_2 + \dots + k_n \geq 1 + \frac{\sqrt{n}}{c(n)}}} C_{k_2, \dots, k_n} \cdot 1 \cdot \frac{1}{r^{k_2 + \dots + k_n}},$$

and similarly also:

$$CR_T^+ := \sum_{\substack{k_2 + \dots + k_n \leq \frac{\sqrt{n}}{c(n)} \\ C_{k_2, \dots, k_n} \geq 0}} C_{k_2, \dots, k_n} \cdot 1 \cdot \frac{1}{r^{k_2 + \dots + k_n}} \quad (\geq 0),$$

$$CR_T^- := \sum_{\substack{k_2 + \dots + k_n \leq \frac{\sqrt{n}}{c(n)} \\ C_{k_2, \dots, k_n} < 0}} (-C_{k_2, \dots, k_n}) \cdot 1 \cdot \frac{1}{r^{k_2 + \dots + k_n}} \quad (\geq 0).$$

Recall that we are choosing:

$$r(n) = \sqrt{n} a(n),$$

and we now endeavor to find a condition guaranteeing that the remainder $|CMR_R|$ be small in absolute value.

To this aim, choose in the Cauchy inequalities $\rho := \frac{1}{\sqrt{n}}$, apply Lemma 9.1:

$$\widehat{C}\left(\frac{1}{\sqrt{n}}\right) \leq e^{12} e^{\sqrt{n}},$$

so that Observation 8.2 gives:

$$\widehat{C}_h \leq \frac{1}{\left(\frac{1}{\sqrt{n}}\right)^h} e^{12} e^{\sqrt{n}} \quad (\forall h \geq 0).$$

Now, majorize the remainder:

$$\begin{aligned}
|CMR_R| &= \left| \sum_{\substack{(k_2, \dots, k_n) \in \Delta \\ k_2 + \dots + k_n \geq 1 + \frac{\sqrt{n}}{c(n)}}} C_{k_2, \dots, k_n} M_{k_2, \dots, k_n} \frac{1}{r^{k_2 + \dots + k_n}} \right| \\
&\leq \sum_{\substack{(k_2, \dots, k_n) \in \Delta \\ k_2 + \dots + k_n \geq 1 + \frac{\sqrt{n}}{c(n)}}} |C_{k_2, \dots, k_n}| \cdot 1 \cdot \frac{1}{r^{k_2 + \dots + k_n}} \\
&\leq \sum_{k_2 + \dots + k_n \geq 1 + \frac{\sqrt{n}}{c(n)}} |C_{k_2, \dots, k_n}| \frac{1}{r^{k_2 + \dots + k_n}} \\
&\leq \sum_{k_2 + \dots + k_n \geq 1 + \frac{\sqrt{n}}{c(n)}} \widehat{C}_{k_2, \dots, k_n} \frac{1}{r^{k_2 + \dots + k_n}} \\
&= \sum_{h=1 + \frac{\sqrt{n}}{c(n)}}^{\infty} \frac{1}{r^h} \sum_{k_2 + \dots + k_n = h} \widehat{C}_{k_2, \dots, k_n} \\
&= \sum_{h=1 + \frac{\sqrt{n}}{c(n)}}^{\infty} \frac{1}{r^h} \widehat{C}_h,
\end{aligned}$$

and hence, thanks to what precedes:

$$\begin{aligned}
|CMR_R| &\leq \sum_{h=1 + \frac{\sqrt{n}}{c(n)}}^{\infty} \frac{1}{r^h} \frac{1}{\left(\frac{1}{\sqrt{n}}\right)^h} e^{12} e^{\sqrt{n}} \\
&= e^{12} e^{\sqrt{n}} \sum_{h=1 + \frac{\sqrt{n}}{c(n)}}^{\infty} \frac{1}{\left(\sqrt{n} \cdot a(n) \cdot \frac{1}{\sqrt{n}}\right)^h} \\
&= e^{12} e^{\sqrt{n}} \frac{1}{(a(n))^{1 + \frac{\sqrt{n}}{c(n)}}} \sum_{h=0}^{\infty} \left(\frac{1}{a(n)}\right)^h \\
&= e^{12} e^{\sqrt{n}} e^{-\left(1 + \frac{\sqrt{n}}{c(n)}\right) \log a(n)} \underbrace{\frac{1}{1 - \frac{1}{a(n)}}}_{\leq 2} \\
&\leq 2 e^{12} e^{-\log a(n)} e^{\sqrt{n}} \left[1 - \frac{\log a(n)}{c(n)}\right].
\end{aligned}$$

In order to insure that the right-hand side is small, since $e^{-\log a(n)} \xrightarrow{n \rightarrow \infty} 0$, it suffices to choose:

$$c(n) := \log a(n) \xrightarrow{n \rightarrow \infty} \infty,$$

to obtain:

$$|CMR_R| \leq 2 e^{12} e^{-\log a(n)} \xrightarrow{n \rightarrow \infty} 0.$$

LEMMA 10.1. *With $c(n) = \log a(n)$, it holds:*

$$\begin{aligned} |\mathbf{CMR}_R| &\leq \sum_{k_2+\dots+k_n \geq 1 + \frac{\sqrt{n}}{c(n)}} \widehat{C}_{k_2, \dots, k_n} \frac{1}{r^{k_2+\dots+k_n}} \\ &\leq 2e^{12} e^{-\log a(n)}. \end{aligned} \quad \square$$

Further, it is now necessary to estimate the size of the first terms \mathbf{CMR}_T , and to show that they are large. It will be useful that:

$$\frac{\sqrt{n}}{\log a(n)} = o(\sqrt{n}) \quad (n \rightarrow \infty).$$

Introduce the quantities:

$$\begin{aligned} \mathbf{CR}_\infty &:= \sum_{k_2, \dots, k_n \geq 0} C_{k_2, \dots, k_n} \frac{1}{r^{k_2+\dots+k_n}} = C^{m-1}\left(\frac{1}{r}\right), \\ \mathbf{CR}_\infty^+ &:= \sum_{\substack{k_2, \dots, k_n \geq 0 \\ C_{k_2, \dots, k_n} \geq 0}} C_{k_2, \dots, k_n} \frac{1}{r^{k_2+\dots+k_n}}, \\ \mathbf{CR}_\infty^- &:= \sum_{\substack{k_2, \dots, k_n \geq 0 \\ C_{k_2, \dots, k_n} < 0}} (-C_{k_2, \dots, k_n}) \frac{1}{r^{k_2+\dots+k_n}}, \\ \widehat{\mathbf{CR}}_\infty &:= \sum_{k_2, \dots, k_n \geq 0} \widehat{C}_{k_2, \dots, k_n} \frac{1}{r^{k_2+\dots+k_n}} = \widehat{C}^{m-1}\left(\frac{1}{r}\right), \end{aligned}$$

for which it is clear that:

$$\mathbf{CR}_\infty^+ + \mathbf{CR}_\infty^- \leq \widehat{\mathbf{CR}}_\infty.$$

By Lemma 9.2:

$$\frac{\widehat{\mathbf{CR}}_\infty}{\mathbf{CR}_\infty} \leq e^{\frac{17}{a(n)^2}},$$

and next:

$$\mathbf{CR}_\infty^+ + \mathbf{CR}_\infty^- \leq \widehat{\mathbf{CR}}_\infty \leq e^{\frac{17}{a(n)^2}} \mathbf{CR}_\infty = e^{\frac{17}{a(n)^2}} (\mathbf{CR}_\infty^+ - \mathbf{CR}_\infty^-),$$

from which it comes:

$$\mathbf{CR}_\infty^- \left(\underbrace{1 + e^{\frac{17}{a(n)^2}}}_{\geq 2} \right) \leq \left(e^{\frac{17}{a(n)^2}} - 1 \right) \mathbf{CR}_\infty^+,$$

whence:

$$(10.2) \quad \mathbf{CR}_\infty^- \leq \frac{1}{2} \left(e^{\frac{17}{a(n)^2}} - 1 \right) \mathbf{CR}_\infty^+.$$

Next, we want to minorize CMR_T in order to show it is large:

$$\begin{aligned}
CMR_T &= CMR_T^+ - CMR_T^- \\
&= \sum_{\substack{k_2+\dots+k_n \leq \frac{\sqrt{n}}{c(n)} \\ C_{k_2,\dots,k_n} \geq 0}} C_{k_2,\dots,k_n} M_{k_2,\dots,k_n} \frac{1}{r^{k_2+\dots+k_n}} - \\
&\quad - \sum_{\substack{k_2+\dots+k_n \leq \frac{\sqrt{n}}{c(n)} \\ C_{k_2,\dots,k_n} < 0}} (-C_{k_2,\dots,k_n}) M_{k_2,\dots,k_n} \frac{1}{r^{k_2+\dots+k_n}} \\
\text{[Proposition 5.4]} \quad &\geq \sum_{\substack{k_2+\dots+k_n \leq \frac{\sqrt{n}}{c(n)} \\ C_{k_2,\dots,k_n} \geq 0}} C_{k_2,\dots,k_n} e^{-\frac{2}{c(n)^2}} \frac{1}{r^{k_2+\dots+k_n}} - \\
\text{[Lemma 5.1]} \quad &- \sum_{\substack{k_2+\dots+k_n \leq \frac{\sqrt{n}}{c(n)} \\ C_{k_2,\dots,k_n} < 0}} (-C_{k_2,\dots,k_n}) \cdot 1 \cdot \frac{1}{r^{k_2+\dots+k_n}} \\
&= e^{-\frac{2}{c(n)^2}} CR_T^+ - CR_T^-,
\end{aligned}$$

but we yet need to compare these to the quantities CR_∞^\pm . Hence we estimate:

$$\begin{aligned}
|CR_\infty^+ - CR_T^+| &= CR_\infty^+ - CR_T^+ = \sum_{\substack{k_2+\dots+k_n \geq 1 + \frac{\sqrt{n}}{c(n)} \\ C_{k_2,\dots,k_n} \geq 0}} C_{k_2,\dots,k_n} \frac{1}{r^{k_2+\dots+k_n}} \\
&\leq \sum_{k_2+\dots+k_n \geq 1 + \frac{\sqrt{n}}{c(n)}} \widehat{C}_{k_2,\dots,k_n} \frac{1}{r^{k_2+\dots+k_n}} \\
&\leq 2e^{12} e^{-\log a(n)}
\end{aligned}$$

and more simply:

$$-CR_T^- \geq -CR_\infty^-,$$

since:

$$0 \leq CR_\infty^- - CR_T^- = \sum_{\substack{k_2+\dots+k_n \geq 1 + \frac{\sqrt{n}}{c(n)} \\ C_{k_2,\dots,k_n} < 0}} (-C_{k_2,\dots,k_n}) \frac{1}{r^{k_2+\dots+k_n}}.$$

Thanks to all this:

$$\begin{aligned}
CMR_T &\geq e^{-\frac{2}{c(n)^2}} CR_T^+ - CR_T^- \\
&\geq e^{-\frac{2}{c(n)^2}} \left[CR_\infty^+ - 2e^{12} e^{-\log a(n)} \right] - CR_\infty^-
\end{aligned}$$

hence applying the minoration (10.2) for $-CR_\infty^-$:

$$\begin{aligned}
CMR_T &\geq e^{-\frac{2}{c(n)^2}} \left[CR_\infty^+ - 2e^{12} e^{-\log a(n)} \right] - \frac{1}{2} \left(e^{\frac{17}{a(n)^2}} - 1 \right) CR_\infty^+ \\
&= CR_\infty^+ \left[\underbrace{e^{-\frac{2}{(\log a(n))^2}}}_{\xrightarrow{n \rightarrow \infty} 1} - \frac{1}{2} \left(\underbrace{e^{\frac{17}{a(n)^2}}}_{\xrightarrow{n \rightarrow \infty} 0} - 1 \right) \right] - \underbrace{2e^{12} e^{-\log a(n)} e^{-\frac{2}{(\log a(n))^2}}}_{\xrightarrow{n \rightarrow \infty} 0}.
\end{aligned}$$

Since trivially:

$$\begin{aligned} CR_{\infty}^+ &= CR_{\infty} + CR_{\infty}^- \\ &\geq CR_{\infty}, \end{aligned}$$

it comes:

$$CMR_T \geq CR_{\infty} \left[e^{-\frac{2}{(\log a(n))^2}} - \frac{1}{2} \left(e^{\frac{17}{a(n)^2}} - 1 \right) \right] - 2 e^{12} e^{-\log a(n)} e^{-\frac{2}{(\log a(n))^2}},$$

whence using Lemma 9.3:

$$CMR_T \geq e^{\frac{1}{2} \frac{\sqrt{n}}{a(n)}} \left[e^{-\frac{2}{(\log a(n))^2}} - \frac{1}{2} \left(e^{\frac{17}{a(n)^2}} - 1 \right) \right] - 2 e^{12} e^{-\log a(n)} e^{-\frac{2}{(\log a(n))^2}}.$$

Coming back to:

$$\begin{aligned} CMR &\geq CMR_T - |CMR_R| \\ &\geq CMR_T - 2 e^{12} e^{-\log a(n)} e^{-\frac{2}{(\log a(n))^2}}, \end{aligned}$$

we obtain finally:

$$CMR \geq e^{\frac{1}{2} \frac{\sqrt{n}}{a(n)}} \left[e^{-\frac{2}{(\log a(n))^2}} - \frac{1}{2} \left(e^{\frac{17}{a(n)^2}} - 1 \right) \right] - 2 e^{12} e^{-\log a(n)} \left(1 + e^{-\frac{2}{(\log a(n))^2}} \right).$$

This minorant is ≥ 1 for all $n \gg N$ large enough.

PROOF OF THEOREM 1.1. Choose — think integer value —:

$$r := \sqrt{n} \frac{\log n}{2}.$$

Proposition 3.1 concludes for $\mathbb{X}^{n-1} \subset \mathbb{P}^n$ of degree at least:

$$\begin{aligned} d_{GG}(n) &:= \left(\sqrt{n} \frac{\log n}{2} + 3 \right)^n 25 n^2 \\ &= \left(\sqrt{n} \log n \right)^n \frac{1}{2^n} \left(1 + \frac{6}{\sqrt{n} \log n} \right)^n 25 n^2 \\ &= \left(\sqrt{n} \log n \right)^n e^{-n \log 2} e^{n \log \left(1 + \frac{6}{\sqrt{n} \log n} \right)} 25 n^2 \\ &\leq \left(\sqrt{n} \log n \right)^n \underbrace{e^{-n \log 2 + \frac{6 \sqrt{n}}{\log n}}}_{< 1 \text{ when } n \geq N_{GG}} 25 n^2. \end{aligned}$$

□

PROOF OF THEOREM 1.2. Thanks to [114], Proposition 3.1 concludes for $\mathbb{X}^{n-1} \subset \mathbb{P}^n$ of degree at least:

$$\begin{aligned}
d_k(n) &:= \left(\sqrt{2n} \frac{\log \log (2n)}{2} + 3 \right)^{2n} 25 (2n)^2 \\
&= \left(\frac{\sqrt{n}}{\sqrt{2}} \log \log (2n) \right)^{2n} \left(1 + \frac{3\sqrt{2}}{\sqrt{n} \log \log (2n)} \right)^{2n} 100 n^2 \\
&= \left(n \log n \right)^n \frac{(\log \log (2n))^{2n}}{(\log n)^n} \frac{1}{\sqrt{2}^{2n}} \left(1 + \frac{3\sqrt{2}}{\sqrt{n} \log \log (2n)} \right)^{2n} 100 n^2 \\
&= \left(n \log n \right)^n e^{2n \log \log \log (2n) - n \log \log n - n \log 2 + 2n \log \left(1 + \frac{3\sqrt{2}}{\sqrt{n} \log \log (2n)} \right)} 100 n^2 \\
&\leq \left(n \log n \right)^n \underbrace{e^{2n \log \log \log (2n) - n \log \log n - n \log 2 + \frac{2\sqrt{n} 3\sqrt{2}}{\log \log (2n)}}}_{< 1 \text{ when } n \geq N_k} 100 n^2. \quad \square
\end{aligned}$$

11. Some inequalities on circles $\{|z| = \rho\}$

PROPOSITION 11.1. For every radius $0 \leq \rho \leq \frac{1}{4}$, the functions:

$$G_k(z) := \frac{1 - z^k}{1 - 2z^k} \quad (k \geq 1),$$

$$H_\ell(z) := \frac{1 - z^\ell}{1 - 2z^\ell - z^{\ell+1}}, \quad (\ell \geq 1)$$

attain, on the circle $\{z \in \mathbb{C} : |z| = \rho\}$, their maximum modulus at the real point $z = \rho$:

$$\begin{aligned}
\max_{|z|=\rho} \left| \frac{1 - z^k}{1 - 2z^k} \right| &= \frac{1 - \rho^k}{1 - 2\rho^k} \quad (\forall k \geq 1), \\
\max_{|z|=\rho} \left| \frac{1 - z^\ell}{1 - 2z^\ell - z^{\ell+1}} \right| &= \frac{1 - \rho^\ell}{1 - 2\rho^\ell - \rho^{\ell+1}} \quad (\forall \ell \geq 1),
\end{aligned}$$

and with the choice $\rho := 0.25$, the graphs on the unit circle of the two quotient functions:

$$\theta \mapsto \frac{|G_k(\rho e^{i\theta})|}{G_k(\rho)} \quad \text{and} \quad \theta \mapsto \frac{|H_\ell(\rho e^{i\theta})|}{H_\ell(\rho)} \quad (-\pi \leq \theta \leq \pi)$$

show up, respectively, for the three choices $k = 2, 5, 10$ and the three choices $\ell = 2, 5, 10$, as:

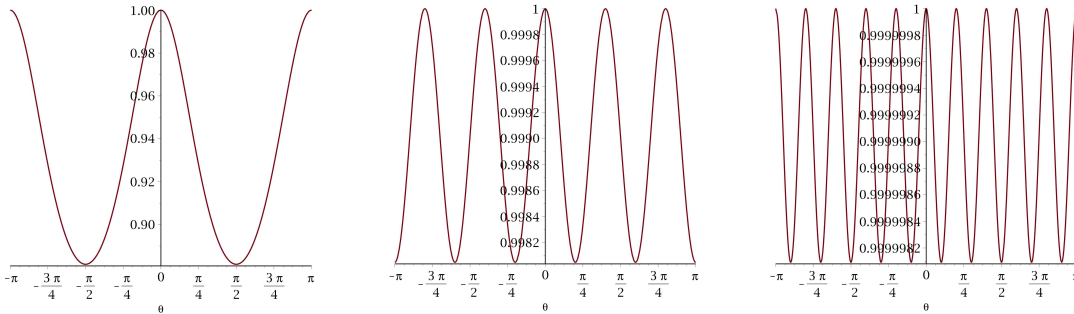

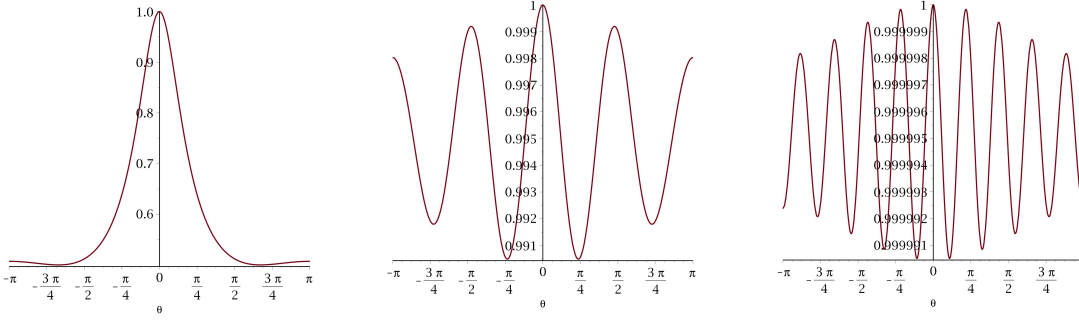

PROOF. Treat at first the $G_k(\rho e^{i\theta})$ with $\theta \in \mathbb{R}$, by squaring:

$$\frac{|1 - \rho^k e^{ik\theta}|^2}{|1 - 2\rho^k e^{ik\theta}|^2} \stackrel{?}{\leq} \frac{(1 - \rho^k)^2}{(1 - 2\rho^k)^2} \quad (\forall \theta \in \mathbb{R}),$$

that is to say:

$$\frac{(1 - \rho^k \cos k\theta)^2 + (-\rho^k \sin k\theta)^2}{(1 - 2\rho^k \cos k\theta)^2 + (-2\rho^k \sin k\theta)^2} \stackrel{?}{\leq} \frac{1 - 2\rho^k + \rho^{2k}}{1 - 4\rho^k + 4\rho^{2k}},$$

or equivalently, after crossing/clearing the fractions:

$$\begin{aligned} 0 &\stackrel{?}{\leq} (1 - 2\rho^k + \rho^{2k})(1 - 4\rho^k \cos k\theta + 4\rho^{2k}) - (1 - 4\rho^k + 4\rho^{2k})(1 - 2\rho^k \cos k\theta + \rho^{2k}) \\ &= \underline{1} - 4\rho^k \cos k\theta + \underline{4\rho^{2k}} \\ &\quad - 2\rho^k + \underline{8\rho^{2k} \cos k\theta} - 8\rho^{3k} \\ &\quad + \underline{\rho^{2k}} - 4\rho^{3k} \cos k\theta + \underline{4\rho^{4k}} \\ &- \underline{1} + 2\rho^k \cos k\theta - \underline{\rho^{2k}} \\ &\quad + 4\rho^k - \underline{8\rho^{2k} \cos k\theta} + 4\rho^{3k} \\ &\quad - \underline{4\rho^{2k}} + 8\rho^{3k} \cos k\theta - \underline{4\rho^{4k}}. \end{aligned}$$

Visibly, $5 \cdot 2 = 10$ underlined terms annihilate by pairs:

$$\begin{aligned} 0 &\stackrel{?}{\leq} 2\rho^k - 2\rho^k \cos k\theta - 4\rho^{3k} + 4\rho^{3k} \cos k\theta \\ &= 2\rho^k \left[1 - \cos k\theta - 2\rho^{2k} + 2\rho^{2k} \cos k\theta \right], \end{aligned}$$

and by luck, the obtained expression factorizes under a form which shows well that it takes only nonnegative values because $0 \leq \rho \leq 0.25$:

$$0 \stackrel{\text{yes}}{\leq} 2\rho^k (1 - 2\rho^{2k})(1 - \cos k\theta) \quad (\forall k \geq 1, \forall \theta \in \mathbb{R}).$$

Secondly, for the functions $(H_\ell(z))_{\ell \geq 1}$, no such pleasant factorization is available. One can then view these $H_\ell(z)$ as ‘perturbations’ of the $G_\ell(z)$, with the addition of $-z^{\ell+1}$ at the denominator. More precisely, starting from the desired inequality of which we take the squared modulus:

$$\frac{|1 - \rho^\ell e^{i\ell\theta}|^2}{|1 - 2\rho^\ell e^{i\ell\theta} - \rho^{\ell+1} e^{i(\ell+1)\theta}|^2} \stackrel{?}{\leq} \frac{(1 - \rho^\ell)^2}{(1 - 2\rho^\ell - \rho^{\ell+1})^2},$$

the ‘perturbing terms’ being underlined, after crossing/clearing the denominators, we are led to establish an inequality which is a ‘perturbation’ of the one just done above:

$$0 \stackrel{?}{\leq} (1 - 2\rho^\ell + \rho^{2\ell}) \left[(1 - 2\rho^\ell \cos \ell\theta - \underline{\rho^{\ell+1} \cos(\ell+1)\theta})^2 + (2\rho^\ell \sin \ell\theta + \underline{\rho^{\ell+1} \sin(\ell+1)\theta})^2 \right] \\ - (1 - 4\rho^\ell + 4\rho^{2\ell} - \underline{2\rho^{\ell+1} + 4\rho^{2\ell+1} + \rho^{2\ell+2}}) \left[(1 - \rho^\ell \cos \ell\theta)^2 + (\rho^\ell \sin \ell\theta)^2 \right],$$

the perturbing terms being still underlined, that is to say:

$$0 \stackrel{?}{\leq} (1 - 2\rho^\ell + \rho^{2\ell}) \left[1 - 4\rho^\ell \cos \ell\theta + 4\rho^{2\ell} \cos^2 \ell\theta + 4\rho^{2\ell} \sin^2 \ell\theta \right. \\ \left. - \underline{2\rho^{\ell+1} \cos(\ell+1)\theta + 4\rho^{2\ell+1} \cos \ell\theta \cos(\ell+1)\theta + \rho^{2\ell+2} \cos^2(\ell+1)\theta} \right. \\ \left. + \underline{4\rho^{2\ell+1} \sin \ell\theta \sin(\ell+1)\theta + \rho^{2\ell+2} \sin^2(\ell+1)\theta} \right] \\ - (1 - 4\rho^\ell + 4\rho^{2\ell} - \underline{2\rho^{\ell+1} + 4\rho^{2\ell+1} + \rho^{2\ell+2}}) \left[1 - 2\rho^\ell \cos \ell\theta + \rho^{2\ell} \cos^2 \ell\theta + \rho^{2\ell} \sin^2 \ell\theta \right].$$

Without redoing the calculation concerning the (principal, not underlined) terms, and using:

$$\cos(\ell+1)\theta \cos(-\ell\theta) - \sin(\ell+1)\theta \sin(-\ell\theta) = \cos((\ell+1-\ell)\theta),$$

we obtain:

$$0 \stackrel{?}{\leq} 2\rho^\ell (1 - 2\rho^{2\ell}) (1 - \cos \ell\theta) \\ + (1 - 2\rho^\ell + \rho^{2\ell}) \left[-2\rho^{\ell+1} \cos(\ell+1)\theta + 4\rho^{2\ell+1} \cos \theta + \rho^{2\ell+2} \right] \\ + (2\rho^{\ell+1} - 4\rho^{2\ell+1} - \rho^{2\ell+2}) \left[1 - 2\rho^\ell \cos \ell\theta + \rho^{2\ell} \right].$$

Now, organize the expansion of lines 2 and 3 in a convenient synoptic way:

$$\begin{array}{r} -2\rho^{\ell+1} \cos(\ell+1)\theta + 4\rho^{2\ell+1} \cos \theta \quad + \underline{\rho^{2\ell+2}} \\ \quad + 4\rho^{2\ell+1} \cos(\ell+1)\theta \quad - 8\rho^{3\ell+1} \cos \theta - 2\rho^{3\ell+2} \\ \quad \quad \quad - 2\rho^{3\ell+1} \cos(\ell+1)\theta + 4\rho^{4\ell+1} \cos \theta + \underline{\rho^{4\ell+2}} \\ + 2\rho^{\ell+1} \quad - 4\rho^{2\ell+1} \cos \ell\theta \quad + 2\rho^{3\ell+1} \\ \quad - 4\rho^{2\ell+1} \quad + 8\rho^{3\ell+1} \cos \ell\theta \quad - 4\rho^{4\ell+1} \\ \quad \quad \quad - \underline{\rho^{2\ell+2}} \quad + 2\rho^{3\ell+2} \cos \ell\theta \quad - \underline{\rho^{4\ell+2}}. \end{array}$$

Only $4 = 2 \cdot 2$ terms annihilate by pairs, and the question is reduced to determine whether there is nonnegativity:

$$0 \stackrel{?}{\leq} 2\rho^\ell (1 - 2\rho^{2\ell}) (1 - \cos \ell\theta) + 2\rho^{\ell+1} (1 - \cos(\ell+1)\theta) \\ + \rho^{2\ell+1} \left[4\cos \theta + 4\cos(\ell+1)\theta - 4\cos \ell\theta - 4 \right] \\ + \rho^{3\ell+1} \left[-8\cos \theta - 2\cos(\ell+1)\theta + 8\cos \ell\theta + 2 \right] \\ + \rho^{3\ell+2} \left[2\cos \ell\theta - 2 \right] + \rho^{4\ell+1} \left[4\cos \theta - 4 \right] \\ =: f_{\ell,\rho}(\theta),$$

for a certain family $(f_{\ell,\rho})_{1 \leq \ell}^{0 < \rho \leq 1/4}$ of 2π -periodic functions. Since this is trivially satisfied when $\rho = 0$, we shall from now on assume that:

$$0 < \rho \leq \frac{1}{4} = 0.25 \quad (\text{assumption}).$$

For the first term of $f_{\ell,\rho}$, since we have:

$$1 < 2(1 - 2 \cdot 0.25^2) \leq 2(1 - 2\rho^{2\ell}) \quad (\forall \ell \geq 1),$$

after division by ρ^ℓ , it would suffice to have, with certain new minorizing functions:

$$g_{\ell,\rho} \leq \frac{1}{\rho^\ell} f_{\ell,\rho},$$

the nonnegativity:

$$\begin{aligned} 0 &\stackrel{?}{\leq} g_{\ell,\rho}(\theta) \\ &:= 1 - \cos \ell\theta + 2\rho(1 - \cos(\ell+1)\theta) \\ &\quad + \rho^{\ell+1} [4 \cos \theta + 4 \cos(\ell+1)\theta - 4 \cos \ell\theta - 4] \\ &\quad + \rho^{2\ell+1} [-8 \cos \theta - 2 \cos(\ell+1)\theta + 8 \cos \ell\theta + 2] \\ &\quad + \rho^{2\ell+2} [2 \cos \ell\theta - 2] + \rho^{3\ell+1} [4 \cos \theta - 4]. \end{aligned}$$

For instance, again with the choice $\rho := 0.25$, the graphs on the unit circle of the functions

$$\theta \mapsto g_{\ell,\rho}(\theta) \quad (-\pi \leq \theta \leq \pi)$$

show up, respectively, for the three choices $\ell = 2, 5, 10$, as:

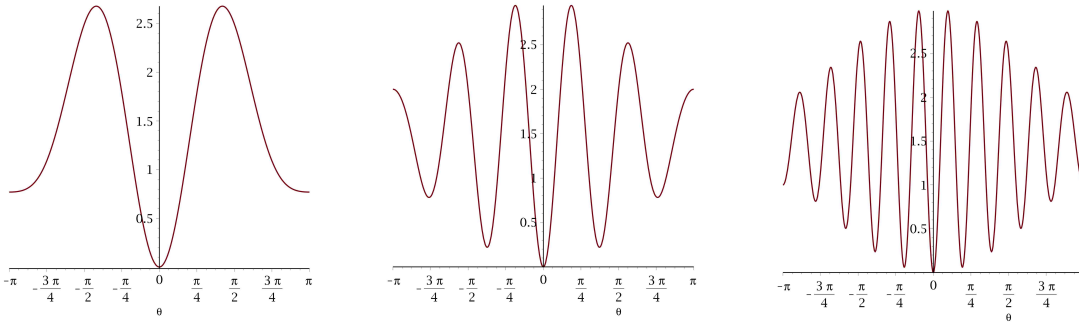

Since these functions $g_{\ell,\rho}$ are even, it suffices to establish their nonnegativity on $[0, \pi]$. Let us begin with examining their behavior in a right half-neighborhood of 0. Starting from:

$$0 = g_{\ell,\rho}(0),$$

a positivity of the first derivatives of the $g_{\ell,\rho}$ would be welcome, at least on a small interval like $]0, \frac{\pi}{4\ell}]$.

LEMMA 11.2. *For all real $0 < \rho \leq 0.25$ and for every integer $\ell \geq 1$, one has:*

$$g'_{\ell,\rho}(\theta) > 0 \quad (\forall 0 < \theta \leq \frac{\pi}{4\ell}).$$

PROOF. Observe that this is true even when $\rho = 0$, since the function $g_{\ell,0}(\theta) = 1 - \cos \ell\theta$ has derivative $\ell \sin \ell\theta > 0$ on $]0, \frac{\pi}{4\ell}]$. Anyway, we assume $0 < \rho \leq 0.25$.

Our aim is to minorize this derivative:

$$\begin{aligned}
g'_{\ell,\rho}(\theta) &= \ell \sin \ell \theta + 2\rho(\ell+1) \sin(\ell+1)\theta \\
&\quad + \rho^{\ell+1} \left[-4 \sin \theta - 4(\ell+1) \sin(\ell+1)\theta + 4\ell \sin \ell \theta \right] \\
&\quad + \rho^{2\ell+1} \left[8 \sin \theta + 2(\ell+1) \sin(\ell+1)\theta - 8\ell \sin \ell \theta \right] \\
&\quad + \rho^{2\ell+2} \left[-2\ell \sin \ell \theta \right] + \rho^{3\ell+1} \left[-4 \sin \theta \right],
\end{aligned}$$

by a quantity which can be seen to be positive. However, we have to treat the special case $\ell = 1$ separately, namely for all $0 < \rho \leq \frac{1}{4}$ and for all $0 < \theta \leq \frac{\pi}{4}$, we first check that:

$$\begin{aligned}
g'_{1,\rho}(\theta) &= \sin \theta + 4\rho \sin 2\theta + \rho^2 \left[-8 \sin 2\theta \right] + \rho^3 \left[4 \sin 2\theta \right] + \rho^4 \left[-6 \sin \theta \right] \\
&= \sin \theta \left\{ 1 + 8\rho \cos \theta - \rho^2 16 \cos \theta + \rho^3 8 \cos \theta - \rho^4 6 \right\} \\
&\geq \sin \theta \left\{ \underset{\circ}{1} + 8\rho \frac{1}{\sqrt{2}} - \frac{1}{4^2} 16 \underset{\circ}{} + \rho^3 \frac{8}{\sqrt{2}} - \rho^4 6 \right\} \\
&\geq \rho \sin \theta \cdot \left\{ \frac{8}{\sqrt{2}} + 0^2 \frac{8}{\sqrt{2}} - \frac{1}{4^3} 6 \right\} \\
&= \rho \sin \theta \cdot 5,563 \dots \\
&> 0.
\end{aligned}$$

So we may assume $\ell \geq 2$. If we use the classical inequalities valid for $\varphi \in [0, \pi]$:

$$\sin \varphi \geq \varphi - \frac{1}{6} \varphi^3 \quad \text{and} \quad -\sin \varphi \geq -\varphi,$$

we are conducted to ask ourselves whether:

$$\begin{aligned}
g'_{\ell,\rho}(\theta) &\geq \ell \left(\ell \theta - \frac{1}{6} (\ell \theta)^3 \right) + 2\rho(\ell+1) \left((\ell+1)\theta - \frac{1}{6} ((\ell+1)\theta)^3 \right) \\
&\quad + \rho^{\ell+1} \left[-4\theta - 4(\ell+1) (\ell+1)\theta + 4\ell \left(\ell \theta - \frac{1}{6} (\ell \theta)^3 \right) \right] \\
&\quad + \rho^{2\ell+1} \left[8 \left(\theta - \frac{1}{6} \theta^3 \right) + 2(\ell+1) \left((\ell+1)\theta - \frac{1}{6} ((\ell+1)\theta)^3 \right) - 8\ell \theta \right] \\
&\quad + \rho^{2\ell+2} \left[-2\ell \theta \right] + \rho^{3\ell+1} \left[-4\theta \right] \\
&\stackrel{?}{>} 0 \quad (\forall 0 < \theta \leq \frac{\pi}{4\ell}).
\end{aligned}$$

To have a better view, let us set:

$$t := \ell \theta, \quad \text{whence} \quad 0 < t \leq \frac{\pi}{4} < 1,$$

and let us simplify this minorant by writing $(\ell+1)\theta = \frac{\ell+1}{\ell} \ell \theta = \frac{\ell+1}{\ell} t$:

$$\begin{aligned}
g'_{\ell,\rho}(\theta) &\geq \ell t \left(1 - \frac{1}{6} t^2 \right) + 2\rho(\ell+1) \frac{\ell+1}{\ell} t \left(1 - \frac{1}{6} \left(\frac{\ell+1}{\ell} \right)^2 t^2 \right) \\
&\quad + \rho^{\ell+1} \left[-\frac{4}{\ell} t - 4(\ell+1) \frac{\ell+1}{\ell} t + 4\ell t \left(1 - \frac{1}{6} t^2 \right) \right] \\
&\quad + \rho^{2\ell+1} \left[8 \frac{t}{\ell} \left(1 - \frac{1}{6} \left(\frac{t}{\ell} \right)^2 \right) + 2(\ell+1) \frac{\ell+1}{\ell} t \left(1 - \frac{1}{6} \left(\frac{\ell+1}{\ell} \right)^2 t^2 \right) - 8\ell t \right] \\
&\quad + \rho^{2\ell+2} \left[-2\ell t \right] + \rho^{3\ell+1} \left[-\frac{4}{\ell} t \right] \\
&\stackrel{?}{>} 0 \quad (\forall 0 < \theta \leq \frac{\pi}{4\ell}).
\end{aligned}$$

In order to minorize this by an even simpler quantity, we can use, since $\ell \geq 2$:

$$-\left(\frac{\ell+1}{\ell}\right)^2 \geq -\left(\frac{3}{2}\right)^2 \quad \text{and also} \quad -t^2 \geq -1,$$

so that:

$$\begin{aligned} \text{preceding minorant} &\geq \ell t \frac{5}{6} + \underline{2\rho(\ell+1) \frac{\ell+1}{\ell} t \frac{5}{8}} \\ &\quad + \rho^{\ell+1} \left[-2t - 4(\ell+1) \frac{3}{2} t + 4\ell t \frac{5}{6} \right] \\ &\quad + \rho^{2\ell+1} \left[8 \cdot 0 + 2(\ell+1) 1 t \frac{5}{8} - 8\ell t \right] \\ &\quad + \rho^{2\ell+2} [-2\ell t] + \rho^{3\ell+1} [-2t] \quad \stackrel{?}{>} 0, \end{aligned}$$

and we even once more minorize this intermediate minorant by neglecting the term underlined and summing the expressions in brackets:

$$\begin{aligned} g'_{\ell,\rho}(\theta) &\geq \ell t \frac{5}{6} + 0 \\ &\quad + \rho^{\ell+1} \left[-8t + \frac{16}{6} \ell t \right] \\ &\quad + \rho^{2\ell+1} \left[\frac{5}{4} t - \frac{27}{4} \ell t \right] \\ &\quad + \rho^{2\ell+2} [-2\ell t] + \rho^{3\ell+1} [-2t] \quad \stackrel{?}{>} 0. \end{aligned}$$

We conclude by a factorization and by a final computer check, still for all $\ell \geq 2$:

$$\begin{aligned} g'_{\ell,\rho}(\theta) &\geq t \left\{ \frac{5}{6} \ell - \rho^{\ell+1} \left[8 + \frac{16}{6} \ell \right] - \rho^{2\ell+1} \left[\frac{5}{4} + \frac{27}{4} \ell \right] - \rho^{2\ell+2} [2\ell] - \rho^{3\ell+1} [2] \right\} \\ &\geq t \left\{ \frac{5}{6} \ell - 0.25^{\ell+1} \left[8 + \frac{16}{6} \ell \right] - 0.25^{2\ell+1} \left[\frac{5}{4} + \frac{27}{4} \ell \right] - 0.25^{2\ell+2} [2\ell] - 0.25^{3\ell+1} [2] \right\} \\ &\geq t \cdot 1,442 \dots \quad \square \end{aligned}$$

In summary, we have established for all $\ell \geq 1$ the positivity on a starting interval:

$$0 < g_{\ell,\rho}(\theta) \quad (\forall \theta \in]0, \frac{\pi}{4\ell}),$$

and our next goal is to establish the positivity of this minoring function $g_{\ell,\rho}$ on the remaining (large) subinterval of $[0, \pi]$:

$$0 \stackrel{?}{<} g_{\ell,\rho}(\theta) \quad (\forall \theta \in [\frac{\pi}{4\ell}, \pi]).$$

We first finish the case $\ell = 1$.

LEMMA 11.3. *For all $0 < \rho \leq 0.25$, the function $g_{1,\rho}(\theta)$ is positive on $[\frac{\pi}{4.1}, \pi]$.*

PROOF. Indeed:

$$\begin{aligned}
g_{1,\rho}(\theta) &= 1 - \cos \theta + 2\rho (1 - \cos 2\theta) \\
&\quad + \rho^2 [4 \cos 2\theta - 4] \\
&\quad + \rho^3 [-2 \cos 2\theta + 2] \\
&\quad + \rho^4 [6 \cos \theta - 6] \\
&= (1 - \cos \theta) [1 - 6\rho^4] + (1 - \cos 2\theta) [2\rho (1 - 2\rho + \rho^2)] \\
&\geq \left(1 - \frac{1}{\sqrt{2}}\right) [1 - 6 \cdot 0.25^4] + \text{nonnegative} \\
&= 0.286 \dots \\
&> 0.
\end{aligned}$$

□

From now on, when we work on $[\frac{\pi}{4\ell}, \pi]$, we can therefore assume that:

$$\ell \geq 2.$$

LEMMA 11.4. For all $0 < \rho < 0.25$ and every integer $\ell \geq 2$, there is on $[\frac{\pi}{4\ell}, \pi]$ a minoration:

$$0 < \overset{?}{h_{\ell,\rho}(\theta)} \leq g_{\ell,\rho}(\theta) \leq \frac{1}{\rho^\ell} f_{\ell,\rho}(\theta),$$

with the new:

$$h_{\ell,\rho}(\theta) := 1 - \cos \ell\theta + 2\rho (1 - \cos (\ell + 1)\theta) - 18\rho^{\ell+1}.$$

Again with the choice $\rho := 0.25$, the graphs on the unit circle of the functions

$$\theta \mapsto h_{\ell,\rho}(\theta) \quad (-\pi \leq \theta \leq \pi)$$

show up, respectively, for the three choices $\ell = 2, 5, 10$, as:

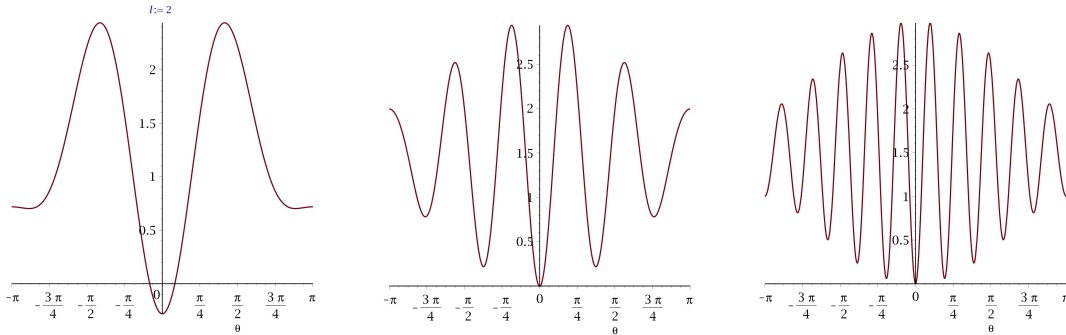

PROOF. Indeed, we minorize simply the reminders:

$$\begin{aligned}
g_{\ell,\rho}(\theta) &\geq 1 - \cos \ell\theta + 2\rho (1 - \cos (\ell + 1)\theta) \\
&\quad - \rho^{\ell+1} [4 + 4 + 4 + 4] - \rho^{2\ell+1} [8 + 2 + 8 + 2] - \rho^{2\ell+2} [2 + 2] - \rho^{3\ell+1} [4 + 4],
\end{aligned}$$

and to even simplify the second line by replacing it by $-18\rho^{\ell+1}$ as announced, we assert that:

$$-16\rho^{\ell+1} - 20\rho^{2\ell+1} - 4\rho^{2\ell+2} - 8\rho^{3\ell+1} \geq -18\rho^{\ell+1},$$

simply since:

$$\begin{aligned} \rho^{\ell+1} (1 - 10\rho^\ell - 2\rho^{\ell+1} - 4\rho^{2\ell}) &\geq \rho^{\ell+1} (1 - 10 \cdot 0.25^2 - 2 \cdot 0.25^3 - 4 \cdot 0.25^4) \\ &> \rho^{\ell+1} (0.328 \dots) \\ &> 0. \end{aligned} \quad \square$$

It therefore remains to treat all the cases $\ell \geq 2$. We start by looking at the subintervals $[\frac{\pi}{4\ell}, \frac{7\pi}{4\ell}] \subset [\frac{\pi}{4\ell}, \pi]$.

LEMMA 11.5. *For every real $0 < \rho \leq 0.25$ and every integer $\ell \geq 2$:*

$$0 < h_{\ell,\rho}(\theta) \quad (\forall \theta \in [\frac{\pi}{4\ell}, \frac{7\pi}{4\ell}]).$$

PROOF. Since:

$$\frac{\pi}{4} \leq \ell\theta \leq \frac{7\pi}{4}$$

it comes:

$$1 - \cos \ell\theta \geq 1 - \frac{1}{\sqrt{2}},$$

and since $1 - \cos(\ell+1)\theta \geq 0$ anyway, we can minorize:

$$\begin{aligned} h_{\ell,\rho}(\theta) &\geq 1 - \cos \ell\theta + 0 - 18\rho^{\ell+1} \\ &\geq 1 - \frac{1}{\sqrt{2}} - 18 \cdot 0.25^{2+1} \\ &= 0.01164 \dots \end{aligned} \quad \square$$

We can now finish the case $\ell = 2$. It remains to show positivity of $h_{2,\rho}(\theta)$ on $[\frac{7\pi}{8}, \pi]$. Since $\frac{21\pi}{8} \leq 3\theta \leq 3\pi$, or equivalently $\frac{5\pi}{8} \leq 3\theta - \pi \leq \pi$, we can minorize:

$$\begin{aligned} h_{2,\rho}(\theta) &= 1 - \cos 2\theta + 2\rho(1 - \cos 3\theta) - 18\rho^3 \\ &\geq 0 + 2\rho \left[(1 - \cos \frac{5\pi}{8}) - 9 \cdot 0.25^2 \right] \\ &= 2\rho \cdot 0.820 \dots \\ &> 0. \end{aligned}$$

It still remains to treat all the cases $\ell \geq 3$.

LEMMA 11.6. *For every real $0 \leq \rho \leq 0.25$ and every integer $\ell \geq 3$, the function:*

$$h_{\ell,\rho}(\theta) := 1 - \cos \ell\theta + 2\rho(1 - \cos(\ell+1)\theta) - 18\rho^{\ell+1}$$

takes only positive values in the interval $[\frac{7\pi}{4\ell}, \pi]$:

$$h_{\ell,\rho}(\theta) > 0 \quad (\forall \frac{7\pi}{4\ell} \leq \theta \leq \pi).$$

PROOF. Using $1 - \cos \varphi = 2 \sin^2 \frac{\varphi}{2}$, let us rewrite:

$$h_{\ell,\rho}(\theta) = 2 \sin^2 \frac{\ell\theta}{2} + 4\rho \sin^2 \frac{(\ell+1)\theta}{2} - 18\rho^{\ell+1}.$$

At a point $\theta \in [\frac{7\pi}{4\ell}, \pi]$, if we have either:

$$2 \sin^2 \frac{\ell\theta}{2} - 18\rho^{\ell+1} > 0 \quad \text{or} \quad 4\rho \sin^2 \frac{(\ell+1)\theta}{2} - 18\rho^{\ell+1} > 0,$$

then there is nothing to prove. We claim that the opposite inequalities cannot hold.

ASSERTION 11.7. *For every $\ell \geq 3$, there is no $\theta \in [\frac{7\pi}{4\ell}, \pi]$ at which:*

$$\sin^2 \frac{\ell\theta}{2} \leq 9\rho^{\ell+1} \quad \text{and} \quad \sin^2 \frac{(\ell+1)\theta}{2} \leq \frac{9}{2}\rho^\ell.$$

PROOF. Suppose nevertheless that such a $\theta \in [\frac{7\pi}{4\ell}, \pi]$ exists. Modulo π , there exist two unique representatives $-\frac{\pi}{2} < \alpha, \beta \leq \frac{\pi}{2}$ of:

$$\frac{\ell\theta}{2} - p\pi = \alpha \quad \text{and} \quad \frac{(\ell+1)\theta}{2} - q\pi = \beta,$$

with certain unique integers $p, q \in \mathbb{Z}$, whence:

$$\sin^2 \alpha = \sin^2 \frac{\ell\theta}{2} \leq 9\rho^{\ell+1} \quad \text{and} \quad \sin^2 \beta = \sin^2 \frac{(\ell+1)\theta}{2} \leq \frac{9}{2}\rho^\ell.$$

LEMMA 11.8. For all $0 \leq |\gamma| \leq \frac{\pi}{2}$, one has the classical inequality $\frac{|\gamma|}{2} \leq |\sin \gamma| \leq |\gamma|$. \square

Consequently, using $\rho^{1/2} \leq 0.25^{1/2} = \frac{1}{2}$, it comes:

$$\frac{|\alpha|}{2} \leq |\sin \alpha| \leq 3\rho^{\frac{\ell+1}{2}} \leq 3\frac{1}{2^{\ell+1}} \quad \text{and} \quad \frac{|\beta|}{2} \leq |\sin \beta| \leq \frac{3}{\sqrt{2}}\rho^{\frac{\ell}{2}} \leq \frac{3}{\sqrt{2}}\frac{1}{2^\ell},$$

that is to say:

$$|\alpha| \leq 3\frac{1}{2^\ell} \quad \text{and} \quad |\beta| \leq 3\sqrt{2}\frac{1}{2^\ell}.$$

From a chain of estimations:

$$\begin{aligned} 3\frac{1+\sqrt{2}}{2^\ell} &\geq |\beta - \alpha| = \left| \frac{\theta}{2} + (q-p)\pi \right| \\ &\geq \left| \frac{1}{2}\frac{7\pi}{4\ell} + (q-p)\pi \right| \\ &\geq \min_{r \in \mathbb{Z}} \left| \frac{7\pi}{8\ell} - r\pi \right| \\ &= \frac{7\pi}{8\ell} \end{aligned}$$

$[\frac{7\pi}{8\ell} \leq \frac{7\pi}{64}]$

we obtain the inequality:

$$3\frac{1+\sqrt{2}}{2^\ell} \geq \frac{7\pi}{8\ell},$$

which is visibly false for large ℓ , and which begins to be false when $\ell \geq 3$:

$$3\frac{1+\sqrt{2}}{2^3} = 0.905\dots \stackrel{\text{no!}}{\geq} 0.916\dots = \frac{7\pi}{8 \cdot 3},$$

This contradiction proves the assertion. \square

The proof of Lemma 11.6 is complete. \square

The proof of Proposition 11.1 is complete. \square

CHAPTER 2

Rigid equivalences of 5-dimensional 2-nondegenerate rigid real hypersurfaces $M^5 \subset \mathbb{C}^3$ of constant Levi rank 1

We study the local equivalence problem for real-analytic (\mathcal{C}^ω) hypersurfaces $M^5 \subset \mathbb{C}^3$ which, in some holomorphic coordinates $(z_1, z_2, w) \in \mathbb{C}^3$ with $w = u + \sqrt{-1}v$, are *rigid* in the sense that their graphing functions:

$$u = F(z_1, z_2, \bar{z}_1, \bar{z}_2)$$

are independent of v . Specifically, we study the group $\text{Hol}_{\text{rigid}}(M)$ of *rigid* local biholomorphic transformations of the form:

$$(z_1, z_2, w) \mapsto (f_1(z_1, z_2), f_2(z_1, z_2), aw + g(z_1, z_2)),$$

where $a \in \mathbb{R} \setminus \{0\}$ and $\frac{D(f_1, f_2)}{D(z_1, z_2)} \neq 0$, which preserve rigidity of hypersurfaces.

After performing a Cartan-type reduction to an appropriate $\{e\}$ -structure, we find exactly *two* primary invariants I_0 and V_0 , which we express explicitly in terms of the 5-jet of the graphing function F of M . The identical vanishing $0 \equiv I_0(J^5 F) \equiv V_0(J^5 F)$ then provides a necessary and sufficient condition for M to be locally *rigidly-biholomorphic* to the known model hypersurface:

$$M_{\text{LC}} : \quad u = \frac{z_1 \bar{z}_1 + \frac{1}{2} z_1^2 \bar{z}_2 + \frac{1}{2} \bar{z}_1^2 z_2}{1 - z_2 \bar{z}_2}.$$

We establish that $\dim \text{Hol}_{\text{rigid}}(M) \leq 7 = \dim \text{Hol}_{\text{rigid}}(M_{\text{LC}})$ always.

If one of these two primary invariants $I_0 \neq 0$ or $V_0 \neq 0$ does not vanish identically, then on either of the two Zariski-open sets $\{p \in M : I_0(p) \neq 0\}$ or $\{p \in M : V_0(p) \neq 0\}$, we show that this rigid equivalence problem between rigid hypersurfaces reduces to an equivalence problem for a certain 5-dimensional $\{e\}$ -structure on M , that is, we get an invariant absolute parallelism on M^5 . Hence $\dim \text{Hol}_{\text{rigid}}(M)$ drops from 7 to 5, illustrating the *gap phenomenon*.

This Chapter is based on our jointwork with Wei-Guo Foo and Joël Merker, which has appeared in preprint form:

Wei-Guo Foo, Joël Merker, The-Anh Ta, *Rigid equivalences of 5-dimensional 2-nondegenerate rigid real hypersurfaces $M^5 \subset \mathbb{C}^3$ of constant Levi rank 1*, arXiv:1904.02562

1. Introduction

In appropriate affine coordinates $(z_1, z_2, w) \in \mathbb{C}^3$ with $w = u + \sqrt{-1}v$, a real-analytic (\mathcal{C}^ω) real hypersurface $M^5 \subset \mathbb{C}^3$ may locally be represented as the graph of a \mathcal{C}^ω function F over the 5-dimensional real hyperplane $\mathbb{C}_{z_1} \times \mathbb{C}_{z_2} \times \mathbb{R}$. When F is independent of v :

$$M : \quad u = F(z_1, z_2, \bar{z}_1, \bar{z}_2),$$

the hypersurface is called *rigid*.

Its fundamental CR-bundle:

$$T^{1,0}M := (\mathbb{C} \otimes_{\mathbb{R}} TM) \cap T^{1,0}\mathbb{C}^3$$

is of complex rank 2 = $\text{CRdim} M$, as well as its conjugate $T^{0,1}M = \overline{T^{1,0}M}$.

Relevant foundational material for CR geometry focused on the local biholomorphic equivalence problem of \mathcal{C}^ω CR submanifolds $M \subset \mathbb{C}^N$ has been set up in the memoir [89], to which readers will be referred for details.

The *Levi forms* at various points $p \in M$ are maps measuring Lie bracket non-involutivity [89, p. 45]:

$$\begin{aligned} T_p^{1,0}M \times T_p^{1,0}M &\longrightarrow \mathbb{C} \otimes_{\mathbb{R}} T_pM \quad \text{mod}(T_p^{1,0}M \oplus T_p^{0,1}M), \\ (\mathcal{M}_p, \mathcal{N}_p) &\longmapsto \sqrt{-1}[\mathcal{M}, \overline{\mathcal{N}}]|_p \quad \text{mod}(T_p^{1,0}M \oplus T_p^{0,1}M), \end{aligned}$$

where \mathcal{M} and \mathcal{N} are any two local sections of $T^{1,0}M$ defined near p which extend $\mathcal{M}_p = \mathcal{M}|_p$ and $\mathcal{N}_p = \mathcal{N}|_p$, the result being independent of extensions.

Levi forms are known to be biholomorphically invariant. In terms of two natural intrinsic generators for $T^{1,0}M$:

$$\mathcal{L}_1 := \frac{\partial}{\partial z_1} - \sqrt{-1}F_{z_1} \frac{\partial}{\partial v} \quad \text{and} \quad \mathcal{L}_2 := \frac{\partial}{\partial z_2} - \sqrt{-1}F_{z_2} \frac{\partial}{\partial v},$$

the Levi forms at all points $p \in M$ identify with the matrix-valued map:

$$\text{LF}_M(p) := 2 \begin{pmatrix} F_{z_1 \bar{z}_1} & F_{z_2 \bar{z}_1} \\ F_{z_1 \bar{z}_2} & F_{z_2 \bar{z}_2} \end{pmatrix} (p).$$

Throughout this article, we will make two main (invariant) assumptions. The first one is that the rank of $\text{LF}_M(p)$ be constant equal to 1 at every point $p \in M$.

Since $2 = \text{rank } T^{1,0}M$, this implies that there is a rank 1 *Levi kernel subbundle*:

$$K^{1,0}M \subset T^{1,0}M,$$

which is generated by the vector field:

$$\mathcal{K} := k\mathcal{L}_1 + \mathcal{L}_2,$$

incorporating the *slant function*:

$$k := -\frac{F_{z_2 \bar{z}_1}}{F_{z_1 \bar{z}_1}}.$$

Indeed, a direct check convinces that both $[\mathcal{K}, \overline{\mathcal{L}}_1]$ and $[\mathcal{K}, \overline{\mathcal{L}}_2]$ vanish modulo $T^{1,0}M \oplus T^{0,1}M$. The known involutivity properties of the Levi kernel subbundle $K^{1,0}M \subset T^{1,0}M$ together with its conjugate $K^{0,1}M \subset T^{0,1}M$ then read as (see [89, pp. 72-73]):

$$\begin{aligned} [K^{1,0}M, K^{1,0}M] &\subset K^{1,0}M, \\ [K^{0,1}M, K^{0,1}M] &\subset K^{0,1}M, \\ [K^{1,0}M, K^{0,1}M] &\subset K^{1,0}M \oplus K^{0,1}M. \end{aligned}$$

Another fundamental function will also be needed in a while:

$$P := \frac{F_{z_1 z_1 \bar{z}_1}}{F_{z_1 \bar{z}_1}}.$$

All this justifies the introduction of the so-called *Freeman form* ([89, p. 89]):

$$\begin{aligned} K_p^{1,0}M \times (T_p^{1,0}M \text{ mod } K_p^{1,0}M) &\longrightarrow T_p^{1,0}M \oplus T_p^{0,1}M \quad \text{mod}(K_p^{1,0}M \oplus T_p^{0,1}M), \\ (\mathcal{K}_p, \mathcal{L}_p) &\longmapsto [\mathcal{K}, \overline{\mathcal{L}}]|_p \quad \text{mod}(K_p^{1,0}M \oplus T_p^{0,1}M), \end{aligned}$$

where \mathcal{K} and \mathcal{L} are any two local sections of $K^{1,0}M$ and of $T^{1,0}M$ defined near p which extend $\mathcal{K}_p = \mathcal{K}|_p$ and $\mathcal{L}_p = \mathcal{L}|_p$, the result being independent of extensions. In bases, these Freeman forms at various points $p \in M$ are simply maps $\mathbb{C} \times \mathbb{C} \longrightarrow \mathbb{C}$. They are known to be biholomorphically invariant.

Our second main (invariant) assumption will be that the rank of the Freeman form be maximal equal to 1 at every point $p \in M$. Such M are called *2-nondegenerate* at p .

A computation:

$$\begin{aligned} [\mathcal{H}, \overline{\mathcal{L}}_1] &= [k\mathcal{L}_1 + \mathcal{L}_2, \overline{\mathcal{L}}_1] = -\overline{\mathcal{L}}_1(k)\mathcal{L}_1 + \underline{k [\mathcal{L}_1, \overline{\mathcal{L}}_1] + [\mathcal{L}_2, \overline{\mathcal{L}}_1]} \\ &= -\overline{\mathcal{L}}_1(k)\mathcal{L}_1 \end{aligned}$$

shows that

$$M \text{ is 2-nondegenerate at } p \in M \iff \overline{\mathcal{L}}_1(k)(p) \neq 0.$$

Next, for a \mathcal{C}^ω hypersurface $M^5 \subset \mathbb{C}^3$, define the Lie pseudogroup:

$$\text{Hol}_{\text{rigid}}(M) := \left\{ h : M \longrightarrow M \text{ local rigid biholomorphism} \right\}.$$

Its Lie algebra, obtained by differentiating 1-parameter local groups of rigid biholomorphisms, is:

$$\begin{aligned} \text{Lie}(\text{Hol}_{\text{rigid}}(M)) &= \mathfrak{hol}_{\text{rigid}}(M) \\ &:= \left\{ X = A_1(z_1, z_2) \frac{\partial}{\partial z_1} + A_2(z_1, z_2) \frac{\partial}{\partial z_2} + (\alpha w + B(z_1, z_2)) \frac{\partial}{\partial w} : \right. \\ &\quad \left. (X + \overline{X})|_M \text{ is tangent to } M \right\}, \end{aligned}$$

where A_1, A_2, B are holomorphic functions of only (z_1, z_2) , and where $\alpha \in \mathbb{R}$.

Our first result is the elementary

PROPOSITION 1.1. *For the model hypersurface:*

$$M_{\text{LC}} : u = \frac{z_1 \overline{z}_1 + \frac{1}{2} z_1^2 \overline{z}_2 + \frac{1}{2} \overline{z}_1^2 z_2}{1 - z_2 \overline{z}_2},$$

the Lie algebra $\mathfrak{hol}_{\text{rigid}}(M_{\text{LC}})$ of infinitesimal biholomorphisms is 7-dimensional, generated by:

$$\begin{aligned} X^1 &= \sqrt{-1} \partial_w, \\ X^2 &= z_1 \partial_{z_1} + 2w \partial_w, \\ X^3 &= \sqrt{-1} z_1 \partial_{z_1} + 2\sqrt{-1} z_2 \partial_{z_2}, \\ X^4 &= (z_2 - 1) \partial_{z_1} - 2z_1 \partial_w, \\ X^5 &= (\sqrt{-1} + \sqrt{-1} z_2) \partial_{z_1} - 2\sqrt{-1} z_1 \partial_w, \\ X^6 &= z_1 z_2 \partial_{z_1} + (z_2^2 - 1) \partial_{z_2} - z_1^2 \partial_w, \\ X^7 &= \sqrt{-1} z_1 z_2 \partial_{z_1} + (\sqrt{-1} z_2^2 + \sqrt{-1}) \partial_{z_2} - \sqrt{-1} z_1^2 \partial_w. \end{aligned}$$

Next, we conduct the Cartan process for rigid biholomorphic equivalences to this model M_{LC} , reaching a representation of a Lie algebra isomorphic to the dual of the one generated by X^1, \dots, X^7 .

THEOREM 1.2. *A basis for the Maurer-Cartan forms on the local Lie group $\text{Hol}_{\text{rigid}}(M_{\text{LC}})$ is provided by 7-differential 1-forms:*

$$\{\rho, \kappa, \zeta, \overline{\kappa}, \overline{\zeta}, \alpha, \overline{\alpha}\},$$

where $\bar{\rho} = \rho$ is real, which enjoys the 7 structure equations with constant coefficients:

$$\begin{aligned} d\rho &= (\alpha + \bar{\alpha}) \wedge \rho + \sqrt{-1}\kappa \wedge \bar{\kappa}, \\ d\kappa &= \alpha \wedge \kappa + \zeta \wedge \bar{\kappa}, & d\bar{\kappa} &= \bar{\alpha} \wedge \bar{\kappa} + \bar{\zeta} \wedge \kappa, \\ d\zeta &= (\alpha - \bar{\alpha}) \wedge \zeta, & d\bar{\zeta} &= (\bar{\alpha} - \alpha) \wedge \bar{\zeta}, \\ d\alpha &= \zeta \wedge \bar{\zeta}, & d\bar{\alpha} &= \bar{\zeta} \wedge \zeta. \end{aligned}$$

This preliminary study of the model M_{LC} then constitutes our guiding map within the general problem. Recall that two fundamental functions expressed in terms of F are:

$$k := -\frac{F_{z_2\bar{z}_1}}{F_{z_1\bar{z}_1}} \quad \text{and} \quad P := \frac{F_{z_1z_1\bar{z}_1}}{F_{z_1\bar{z}_1}}.$$

THEOREM 1.3. *The equivalence problem under local rigid biholomorphisms of \mathcal{C}^ω rigid real hypersurfaces $\{u = F(z_1, z_2, \bar{z}_1, \bar{z}_2)\}$ in \mathbb{C}^3 whose Levi form has constant rank 1 and which are everywhere 2-nondegenerate reduces to classifying $\{e\}$ -structures on the 7-dimensional bundle $M^5 \times \mathbb{C}$ equipped with coordinates $(z_1, z_2, \bar{z}_1, \bar{z}_2, v, c, \bar{c})$ together with a coframe of 7 differential 1-forms:*

$$\{\rho, \kappa, \zeta, \bar{\kappa}, \bar{\zeta}, \alpha, \bar{\alpha}\},$$

which satisfy invariant structure equations of the shape:

$$\begin{aligned} d\rho &= (\alpha + \bar{\alpha}) \wedge \rho + \sqrt{-1}\kappa \wedge \bar{\kappa}, \\ d\kappa &= \alpha \wedge \kappa + \zeta \wedge \bar{\kappa}, \\ d\zeta &= (\alpha - \bar{\alpha}) \wedge \zeta + \frac{1}{c}\mathbf{I}_0 \kappa \wedge \zeta + \frac{1}{c\bar{c}}\mathbf{V}_0 \kappa \wedge \bar{\kappa}, \\ d\alpha &= \zeta \wedge \bar{\zeta} - \frac{1}{c}\mathbf{I}_0 \zeta \wedge \bar{\kappa} + \frac{1}{c\bar{c}}\mathbf{Q}_0 \kappa \wedge \bar{\kappa} + \frac{1}{c}\bar{\mathbf{I}}_0 \bar{\zeta} \wedge \kappa, \end{aligned}$$

conjugate equations for $d\bar{\kappa}$, $d\bar{\zeta}$, $d\bar{\alpha}$ being understood.

Exactly two invariants are primary:

$$\begin{aligned} \mathbf{I}_0 &:= -\frac{1}{3} \frac{\mathcal{H}(\overline{\mathcal{L}_1(\mathcal{L}_1(\mathbf{k}))})}{\overline{\mathcal{L}_1(\mathbf{k})}^2} + \frac{1}{3} \frac{\mathcal{H}(\overline{\mathcal{L}_1(\mathbf{k}))}\overline{\mathcal{L}_1(\mathcal{L}_1(\mathbf{k}))})}{\overline{\mathcal{L}_1(\mathbf{k})}^3} \\ &\quad + \frac{2}{3} \frac{\mathcal{L}_1(\overline{\mathcal{L}_1(\bar{\mathbf{k}})})}{\overline{\mathcal{L}_1(\bar{\mathbf{k}})}} + \frac{2}{3} \frac{\mathcal{L}_1(\overline{\mathcal{L}_1(\mathbf{k}))})}{\overline{\mathcal{L}_1(\mathbf{k})}}, \\ \mathbf{V}_0 &:= -\frac{1}{3} \frac{\overline{\mathcal{L}_1(\mathcal{L}_1(\overline{\mathcal{L}_1(\mathbf{k}))})}}{\overline{\mathcal{L}_1(\mathbf{k})}} + \frac{5}{9} \left(\frac{\overline{\mathcal{L}_1(\overline{\mathcal{L}_1(\mathbf{k}))})}{\overline{\mathcal{L}_1(\mathbf{k})}} \right)^2 - \\ &\quad - \frac{1}{9} \frac{\overline{\mathcal{L}_1(\overline{\mathcal{L}_1(\mathbf{k}))}\bar{\mathbf{P}}}}{\overline{\mathcal{L}_1(\mathbf{k})}} + \frac{1}{3} \overline{\mathcal{L}_1(\bar{\mathbf{P}})} - \frac{1}{9} \bar{\mathbf{P}}\bar{\mathbf{P}}, \end{aligned}$$

while one invariant, which is real valued (see equation 10.7), is secondary:

$$\mathbf{Q}_0 := \frac{1}{2} \overline{\mathcal{L}_1(\mathbf{I}_0)} - \frac{1}{3} \left(\bar{\mathbf{P}} - \frac{\mathcal{L}_1(\overline{\mathcal{L}_1(\bar{\mathbf{k}})})}{\overline{\mathcal{L}_1(\bar{\mathbf{k}})}} \right) \bar{\mathbf{I}}_0 - \frac{1}{6} \left(\bar{\mathbf{P}} - \frac{\overline{\mathcal{L}_1(\overline{\mathcal{L}_1(\mathbf{k}))})}{\overline{\mathcal{L}_1(\mathbf{k})}} \right) \mathbf{I}_0 - \frac{1}{2} \frac{\mathcal{H}(\mathbf{V}_0)}{\overline{\mathcal{L}_1(\mathbf{k})}}.$$

It is elementary to verify that both \mathbf{I}_0 and \mathbf{V}_0 vanish identically for M_{LC} . As is known in Cartan theory, the identical vanishing of all invariants provide constant coefficients Maurer-Cartan equations of a uniquely defined Lie group. Hence as a corollary, we obtain the

THEOREM 1.4. *A 2-nondegenerate \mathcal{C}^ω constant Levi rank 1 local rigid hypersurface $M^5 \subset \mathbb{C}^3$ is rigidly biholomorphic to the model M_{LC} if and only if*

$$0 \equiv I_0 \equiv V_0. \quad \square$$

Next, when either $I_0 \neq 0$ or $V_0 \neq 0$, we may restrict considerations to either of the Zariski-open subsets $\{p \in M : I_0(p) \neq 0\}$ or $\{p \in M : V_0(p) \neq 0\}$, we may pursue the Cartan process, and we obtain the

THEOREM 1.5. *Let $M^5 \subset \mathbb{C}^3$ be a local rigid 2-nondegenerate \mathcal{C}^ω constant Levi rank 1 hypersurface. If either $I_0 \neq 0$ or $V_0 \neq 0$ everywhere on M , the local rigid-biholomorphic equivalence problem reduces to an invariant 5-dimensional $\{e\}$ -structure on M .*

In fact, once the last remaining group parameter $c \in \mathbb{C}^*$ is seen to be normalizable from either:

$$\frac{1}{c}I_0 = 1 \quad \text{or} \quad \frac{1}{\bar{c}c}V_0 = 1,$$

the proof is completed if one does not require to make explicit the $\{e\}$ -structure on M . Because of the size of computations, we will not attempt to set up such an explicit $\{e\}$ -structure.

Lastly, from general Cartan theory, we deduce the

COROLLARY 1.6. *All such rigid $M^5 \subset \mathbb{C}^3$ that are not rigidly-biholomorphic to the model M_{LC} satisfy*

$$\dim \text{Hol}_{\text{rigid}}(M) \leq 5.$$

In continuation with these results, a further task appears: to classify up to rigid biholomorphisms the ‘*submaximal*’ hypersurfaces with $\dim \text{Hol}_{\text{rigid}}(M) = 5$ whose rigid biholomorphic group is locally transitive. Another question would be to classify under rigid biholomorphisms those rigid $M^5 \subset \mathbb{C}^3$ that have identically vanishing Pocchiola invariants $0 \equiv W_0 \equiv J_0$, hence which are equivalent to M_{LC} , but under a general biholomorphism, not necessarily rigid. Upcoming publications will be devoted to advances in these directions.

2. Recall on the geometry of CR real hypersurfaces

Let (z_1, z_2, w) be holomorphic coordinates in \mathbb{C}^3 with $w = u + \sqrt{-1}v$, and let $M^5 \subset \mathbb{C}^3$ be a real-analytic, real hypersurface passing through the origin. Assuming that the real hypersurface is smooth at the origin, and that the vector

$$\left. \frac{\partial}{\partial u} \right|_0 \notin T_0M$$

does not lie in the vector subspace $T_0M \subset T_0\mathbb{C}^3$. The implicit function theorem therefore implies the existence of a real analytic (denoted by \mathcal{C}^ω) graphing function such that M^5 is represented near the origin by

$$u = F(z_1, z_2, \bar{z}_1, \bar{z}_2, v).$$

DÉFINITION 2.1. The smooth real hypersurface $M^5 \subset \mathbb{C}^3$ is *rigid* at the origin if M^5 may be represented by a graphing function $u = F(z_1, z_2, \bar{z}_1, \bar{z}_2)$, where the function F is independent of v .

HYPOTHESIS 2.2. In the rest of the article, we will assume that M^5 is rigid.

The complexified tangent bundle $\mathbb{C}TM = TM \otimes_{\mathbb{R}} \mathbb{C}$ inherits from $\mathbb{C}TC^3 = TC^3 \otimes_{\mathbb{R}} \mathbb{C}$ two biholomorphically invariant complex vector bundles

$$T^{1,0}M := \mathbb{C}TM \cap T^{1,0}\mathbb{C}^3, \quad T^{0,1}M := \mathbb{C}TM \cap T^{0,1}\mathbb{C}^3 = \overline{T^{1,0}M}.$$

The two vector fields

$$\mathcal{L}_1 := \frac{\partial}{\partial z_1} + A^1 \frac{\partial}{\partial v} \quad \text{and} \quad \mathcal{L}_2 := \frac{\partial}{\partial z_2} + A^2 \frac{\partial}{\partial v},$$

with

$$A^1 := -\sqrt{-1}F_{z_1}, \quad \text{and} \quad A^2 := -\sqrt{-1}F_{z_2},$$

then form a $T^{1,0}M$ frame. The differential 1-form

$$\rho_0 = dv + \sqrt{-1}F_{z_1} dz^1 + \sqrt{-1}F_{z_2} dz^2 - \sqrt{-1}\overline{F}_{\bar{z}_1} d\bar{z}^1 - \sqrt{-1}\overline{F}_{\bar{z}_2} d\bar{z}^2$$

has the kernel

$$\ker \rho_0 = \{\rho_0 = 0\} = T^{1,0}M \oplus T^{0,1}M.$$

By a formula in Merker-Pocchiola-Sabzevari [89], page 82, the Levi matrix is shown to be

$$\begin{aligned} \text{Levi}(M) &= \begin{pmatrix} \rho_0(\sqrt{-1}[\mathcal{L}_1, \overline{\mathcal{L}}_1]) & \rho_0(\sqrt{-1}[\mathcal{L}_2, \overline{\mathcal{L}}_1]) \\ \rho_0(\sqrt{-1}[\mathcal{L}_1, \overline{\mathcal{L}}_2]) & \rho_0(\sqrt{-1}[\mathcal{L}_2, \overline{\mathcal{L}}_2]) \end{pmatrix} \\ 2.3 \quad &= 2 \begin{pmatrix} F_{z_1 \bar{z}_1} & F_{z_2 \bar{z}_1} \\ F_{z_1 \bar{z}_2} & F_{z_2 \bar{z}_2} \end{pmatrix}, \end{aligned}$$

which is not identically zero if M is further assumed to be not Levi-flat. After a change of coordinates in the (z_1, z_2) space, without loss of generality,

$$\rho_0(\sqrt{-1}[\mathcal{L}_1, \overline{\mathcal{L}}_2]) = 2F_{z_1 \bar{z}_1} \neq 0$$

everywhere on M , and hence the vector field

$$\mathcal{T} := \sqrt{-1}[\mathcal{L}_1, \overline{\mathcal{L}}_1] = 2F_{z_1, \bar{z}_1} \frac{\partial}{\partial v} := \ell \frac{\partial}{\partial v}$$

vanishes nowhere on M .

2.1. The rank 1 hypothesis.

HYPOTHESIS 2.4. The smooth real-analytic (rigid) real-hypersurface M^5 is of constant Levi rank 1.

With this hypothesis, the collection of 1-dimensional kernels $K_p^{1,0}M$ of the Levi form at all points $p \in M$ spans a real-analytic sub-distribution of the $T^{1,0}M$ bundle

$$K^{1,0}M \subset T^{1,0}M,$$

satisfying the following inclusions

$$\begin{aligned} [K^{1,0}M, K^{1,0}M] &\subset K^{1,0}M, \\ [K^{0,1}M, K^{0,1}M] &\subset K^{0,1}M, \\ [K^{1,0}M, K^{0,1}M] &\subset K^{1,0}M \oplus K^{0,1}M. \end{aligned}$$

To construct a generator \mathcal{K} of the Levi kernel, introduce a *slant function* k satisfying

$$\begin{pmatrix} F_{z_1, \bar{z}_1} & F_{z_2, \bar{z}_1} \\ F_{z_1, \bar{z}_2} & F_{z_2, \bar{z}_2} \end{pmatrix} \begin{pmatrix} k \\ 1 \end{pmatrix} = \begin{pmatrix} 0 \\ 0 \end{pmatrix}.$$

The first equation then implies that

$$k = -\frac{F_{z_2\bar{z}_1}}{F_{z_1\bar{z}_1}}$$

while the same k satisfies the second equation

$$kF_{z_1\bar{z}_2} + F_{z_2\bar{z}_2} = 0$$

trivially by using the vanishing determinant of the matrix. Then the Levi kernel sub-bundle $\mathcal{H}^{1,0}M \subset T^{1,0}M$ is of complex rank 1 and is generated by the vector field

$$\mathcal{H} = k\mathcal{L}_1 + \mathcal{L}_2.$$

The slant function enjoys the following property

PROPOSITION 2.5 (See Merker-Pocchiola-Sabzevari [89]). *The smooth real-analytic (rigid) real hypersurface M is 2-nondegenerate in the sense of Freeman if and only if*

$$\overline{\mathcal{L}}_1(k) \neq 0$$

everywhere on M .

In the rigid case, a direct calculation shows that

$$\begin{aligned} \mathcal{L}_1(k) &= -\frac{-F_{z_1,\bar{z}_1}F_{z_2\bar{z}_1z_1} + F_{z_2\bar{z}_1}F_{z_1\bar{z}_1z_1}}{(F_{z_1\bar{z}_1})^2}, \\ \overline{\mathcal{L}}_1(k) &= \frac{-F_{z_1\bar{z}_1}F_{z_2\bar{z}_1\bar{z}_1} + F_{z_2\bar{z}_1}F_{z_1\bar{z}_1\bar{z}_1}}{(F_{z_1\bar{z}_1})^2}, \\ \mathcal{T}(k) &= 0. \end{aligned} \tag{2.6}$$

Moreover, introduce the next fundamental function

$$P = \frac{\ell_{z_1}}{\ell} = \frac{F_{z_1\bar{z}_1z_1}}{F_{z_1\bar{z}_1}}.$$

LEMMA 2.7 (See Pocchiola [113] or Foo-Merker [49]). *The following 3 functional identities hold on M :*

$$\begin{aligned} \mathcal{H}(\bar{k}) &\equiv 0, \\ \mathcal{H}(P) &\equiv -P\mathcal{L}_1(k) - \mathcal{L}_1(\mathcal{L}_1(k)), \\ \mathcal{H}(\bar{P}) &\equiv -P\overline{\mathcal{L}}_1(k) - \overline{\mathcal{L}}_1(\mathcal{L}_1(k)). \end{aligned} \tag{2.8}$$

According to Pocchiola [113] page 37, there are 10 Lie bracket identities

$$\begin{aligned} [\mathcal{T}, \mathcal{L}_1] &\equiv -P\mathcal{T}, & [\mathcal{L}_1, \overline{\mathcal{L}}_1] &\equiv \sqrt{-1}\mathcal{T}, \\ [\mathcal{T}, \mathcal{H}] &\equiv \mathcal{L}_1(k)\mathcal{T} + 0, & [\mathcal{L}_1, \overline{\mathcal{H}}] &\equiv \mathcal{L}_1(\bar{k})\overline{\mathcal{L}}_1, \\ [\mathcal{T}, \overline{\mathcal{L}}_1] &\equiv -\bar{P}\mathcal{T}, & [\mathcal{H}, \overline{\mathcal{L}}_1] &\equiv -\overline{\mathcal{L}}_1(k)\mathcal{L}_1, \\ [\mathcal{T}, \overline{\mathcal{H}}] &\equiv \overline{\mathcal{L}}_1(\bar{k})\mathcal{T} + 0, & [\mathcal{H}, \overline{\mathcal{H}}] &\equiv 0, \\ [\mathcal{L}_1, \mathcal{H}] &\equiv \mathcal{L}_1(k)\mathcal{L}_1 & [\overline{\mathcal{L}}_1, \overline{\mathcal{H}}] &\equiv \overline{\mathcal{L}}_1(\bar{k})\overline{\mathcal{L}}_1. \end{aligned} \tag{2.9}$$

where the "+0" is deliberately added to show the difference from the general case. The following 1-forms

$$\begin{aligned}
\rho_0 &= \frac{1}{\ell} (dv - A^1 dz_1 - A^2 dz_2 - \bar{A}^1 d\bar{z}_1 - \bar{A}^2 d\bar{z}_2), \\
\kappa_0 &= dz_1 - \mathbf{k} dz_2, \\
\zeta_0 &= dz_2, \\
\bar{\kappa}_0 &= d\bar{z}_1 - \bar{\mathbf{k}} d\bar{z}_2, \\
\bar{\zeta}_0 &= d\bar{z}_2,
\end{aligned}
\tag{2.10}$$

are, by a simple computation, dual to the corresponding vector fields $\mathcal{I}, \mathcal{L}_1, \mathcal{K}, \bar{\mathcal{L}}_1, \bar{\mathcal{K}}$. Using the Cartan-Lie formula which states that for any smooth vector fields X, Y and any smooth 1-form ω , one has

$$d\omega(X, Y) = X\omega(Y) - Y\omega(X) - \omega([X, Y]),$$

the initial Darboux-Cartan structure is therefore obtained:

$$\begin{aligned}
d\rho_0 &= \mathbf{P} \rho_0 \wedge \kappa_0 - \mathcal{L}_1(\mathbf{k}) \rho_0 \wedge \zeta_0 + \bar{\mathbf{P}} \rho_0 \wedge \bar{\kappa}_0 - \bar{\mathcal{L}}_1(\bar{\mathbf{k}}) \rho_0 \wedge \bar{\zeta}_0 + \sqrt{-1} \kappa_0 \wedge \bar{\kappa}_0, \\
d\kappa_0 &= -\mathcal{L}_1(\mathbf{k}) \kappa_0 \wedge \zeta_0 + \bar{\mathcal{L}}_1(\mathbf{k}) \zeta_0 \wedge \bar{\kappa}_0, \\
d\zeta_0 &= 0.
\end{aligned}
\tag{2.11}$$

Here, conjugate equations for $d\bar{\kappa}_0$ and for $d\bar{\zeta}_0$ are not written, as they can be immediately deduced.

3. Initial G -structure for rigid equivalences of rigid real hypersurfaces

Our objective is to study absolute parallelism of rigid equivalences of rigid real hypersurfaces using Cartan method. We introduce the

DÉFINITION 3.1. Two local rigid real hypersurfaces at the origin are *rigidly equivalent* if there exists a biholomorphic map of the form

$$\varphi : (z_1, z_2, w) \mapsto (z'_1, z'_2, w') := (f(z_1, z_2), g(z_1, z_2), aw + h(z_1, z_2)),$$

for some $a \in \mathbb{R}^\times$, and local holomorphic functions f, g, h , transforming one hypersurface into the other.

To make sure that the definition makes sense, let M' be another rigid real hypersurface in the target space of the form

$$\frac{w' + \bar{w}'}{2} - F'(z'_1, z'_2, \bar{z}'_1, \bar{z}'_2) = 0.$$

Then the pullback by φ of the defining function is

$$0 = a \frac{w + \bar{w}}{2} + \left(\frac{1}{2} h(z_1, z_2) + \frac{1}{2} \bar{h}(\bar{z}_1, \bar{z}_2) - F'(f(z_1, z_2), g(z_1, z_2), \bar{f}(\bar{z}_1, \bar{z}_2), \bar{g}(\bar{z}_1, \bar{z}_2)) \right)$$

which is again a defining function of a rigid real hypersurface.

Since φ is holomorphic, its differential $\varphi_* : \mathbb{C}T\mathbb{C}^3 \rightarrow \mathbb{C}T\mathbb{C}^3$ stabilises the holomorphic $(1, 0)$ and the anti-holomorphic $(0, 1)$ vector fields:

$$\begin{aligned} \varphi_* T^{1,0} M &\subseteq T^{1,0} M, \\ \varphi_* T^{0,1} M &\subseteq T^{0,1} M. \end{aligned} \tag{3.2}$$

Furthermore, by the invariance of the Freeman forms, the pushforward maps φ_* also respects the Levi kernel distributions

$$\varphi_* K^{1,0} M \subset K^{1,0} M.$$

Consequently, there exist functions f' , c' and e' on M' such that

$$\begin{aligned} \varphi_*(\mathcal{K}) &= f' \mathcal{K}', \\ \varphi_*(\mathcal{L}_1) &= c' \mathcal{L}'_1 + e' \mathcal{K}'. \end{aligned} \tag{3.3}$$

The difference with the articles of Pocchiola [113], Merker-Pocchiola [92] and Foo-Merker [49] is that the rigid equivalence assumption made on the map $\varphi : M \rightarrow M'$ between two rigid real hypersurfaces greatly simplifies the initial G -structure, especially because $\varphi_* \mathcal{T}$ is a multiple of \mathcal{T}' by a function that vanishes nowhere on M' . In fact, if $R(z'_1, z'_2, \bar{z}'_1, \bar{z}'_2, v')$ is any \mathcal{C}^ω function on M' , then by definition of the pushforward of a vector field,

$$\begin{aligned} (\varphi_* \mathcal{T}) \left(R(z'_1, z'_2, \bar{z}'_1, \bar{z}'_2, v') \right) &= \mathcal{T}(R \circ \varphi) \\ &= \ell \frac{\partial}{\partial v} \left(R(f(z_1, z_2), g(z_1, z_2), \bar{f}(\bar{z}_1, \bar{z}_2), \bar{g}(\bar{z}_1, \bar{z}_2), av + \text{Im}(h(z_1, z_2))) \right) \\ &= a \ell \frac{\partial R}{\partial v'} \circ \varphi \\ &= a \frac{\ell}{\ell' \circ \varphi} \underbrace{\left(\ell' \circ \varphi \frac{\partial R}{\partial v'} \circ \varphi \right)}_{=(\mathcal{T}' R) \circ \varphi} \\ &= a \frac{\ell}{\ell' \circ \varphi} (\mathcal{T}' R) \circ \varphi, \end{aligned} \tag{3.4}$$

whence

$$\varphi_* \mathcal{T} = \frac{a\ell}{\ell'} \mathcal{T}'.$$

Hence, there exists a real-valued function a' nowhere vanishing on M' such that

$$\varphi_* \mathcal{T} = a' \mathcal{T}'.$$

In fact, this function is determined since

$$\begin{aligned} a' \mathcal{T}' &= \varphi_* \mathcal{T} = \varphi_* (\sqrt{-1}[\mathcal{L}_1, \overline{\mathcal{L}}_1]) \\ &= \sqrt{-1}[\varphi_* \mathcal{L}_1, \varphi_* \overline{\mathcal{L}}_1] \\ &= c' \bar{c}' \sqrt{-1}[\mathcal{L}'_1, \overline{\mathcal{L}}'_1]. \end{aligned} \tag{3.5}$$

This implies that

$$a' = c' \bar{c}'.$$

Summarising, we therefore have the following matrix

$$3.6 \quad \varphi_* \begin{pmatrix} \mathcal{I} \\ \mathcal{L}_1 \\ \mathcal{K} \\ \overline{\mathcal{L}}_1 \\ \overline{\mathcal{K}} \end{pmatrix} = \begin{pmatrix} c'\bar{c}' & 0 & 0 & 0 & 0 \\ 0 & c' & e' & 0 & 0 \\ 0 & 0 & f' & 0 & 0 \\ 0 & 0 & 0 & \bar{c}' & \bar{e}' \\ 0 & 0 & 0 & 0 & \bar{f}' \end{pmatrix} \begin{pmatrix} \mathcal{I}' \\ \mathcal{L}'_1 \\ \mathcal{K}' \\ \overline{\mathcal{L}}'_1 \\ \overline{\mathcal{K}}' \end{pmatrix}.$$

Taking transposition of the matrix, one obtains the pullback formula for the two coframes

$$3.7 \quad \varphi^* \begin{pmatrix} \rho'_0 \\ \kappa'_0 \\ \zeta'_0 \\ \bar{\kappa}'_0 \\ \bar{\zeta}'_0 \end{pmatrix} = \begin{pmatrix} c'\bar{c}' & 0 & 0 & 0 & 0 \\ 0 & c' & 0 & 0 & 0 \\ 0 & e' & f' & 0 & 0 \\ 0 & 0 & 0 & \bar{c}' & 0 \\ 0 & 0 & 0 & \bar{e}' & \bar{f}' \end{pmatrix} \begin{pmatrix} \rho_0 \\ \kappa_0 \\ \zeta_0 \\ \bar{\kappa}_0 \\ \bar{\zeta}_0 \end{pmatrix}$$

In conclusion, for the rigid CR transformation between rigid CR real hypersurfaces, the initial G -structure is constituted by the following 5 by 5 matrices

$$\begin{pmatrix} c\bar{c} & 0 & 0 & 0 & 0 \\ 0 & c & 0 & 0 & 0 \\ 0 & e & f & 0 & 0 \\ 0 & 0 & 0 & \bar{c} & 0 \\ 0 & 0 & 0 & \bar{e}' & \bar{f}' \end{pmatrix}$$

with the free complex variables

$$c, f \in \mathbb{C} - \{0\}, \quad \text{and} \quad e \in \mathbb{C}.$$

4. Cartan equivalence method for the model case

Before starting the Cartan equivalence method for rigid equivalences of \mathcal{C}^ω smooth rigid real hypersurfaces, a study of the equivalence method for the model case is necessary to obtain a model $\{e\}$ -structure, which will serve as a reference for the general case. Recall that the model case is the tube over the future light cone, denoted by Pocchiola's notation as MLC, is locally defined by the the following rigid equation

$$u = \frac{z_1\bar{z}_1 + \frac{1}{2}z_1^2\bar{z}_2 + \frac{1}{2}\bar{z}_1^2z_2}{1 - z_2\bar{z}_2}.$$

The vector fields $\mathcal{L}_1, \mathcal{K}, \overline{\mathcal{L}}_1, \overline{\mathcal{K}}, \mathcal{I}$, which constitute a frame for the complexified tangent bundle of M_{LC} , thus have the following expressions

$$4.1 \quad \begin{aligned} \mathcal{L}_1 &= \frac{\partial}{\partial z_1} - \sqrt{-1} \frac{\bar{z}_1 + z_1\bar{z}_2}{1 - z_2\bar{z}_2} \frac{\partial}{\partial v}, \\ \mathcal{K} &= -\frac{\bar{z}_1 + z_1\bar{z}_2}{1 - z_2\bar{z}_2} \frac{\partial}{\partial z_1} + \frac{\partial}{\partial z_2} + \frac{\sqrt{-1} \bar{z}_1^2 + 2z_1\bar{z}_1\bar{z}_2 + z_1^2\bar{z}_2^2}{(1 - z_2\bar{z}_2)^2} \frac{\partial}{\partial v}, \\ \mathcal{I} &= -\frac{2}{1 - z_2\bar{z}_2} \frac{\partial}{\partial v}, \end{aligned}$$

and the slant function is given by

$$k = -\frac{\bar{z}_1 + z_1\bar{z}_2}{1 - z_2\bar{z}_2}.$$

The initial coframe according to Pocchiola (model case) [113] has the form

$$\begin{aligned}
\rho_0 &= -\frac{\sqrt{-1}}{2}(\bar{z}_1 + z_1\bar{z}_2) dz_1 - \frac{\sqrt{-1}}{4} \frac{\bar{z}_1^2 + 2z_1\bar{z}_1\bar{z}_2 + z_1^2\bar{z}_2^2}{1 - z_2\bar{z}_2} dz_2 \\
&\quad + \frac{\sqrt{-1}}{2}(z_1 + \bar{z}_1z_2) d\bar{z}_2 + \frac{\sqrt{-1}}{4} \frac{z_1^2 + 2z_1\bar{z}_1z_2 + \bar{z}_1^2z_2^2}{1 - z_2\bar{z}_2} d\bar{z}_2 + \frac{1}{2}(-1 + z_2\bar{z}_2) dv, \\
\kappa_0 &= dz_1 + \frac{\bar{z}_1 + z_1\bar{z}_2}{1 - z_2\bar{z}_2} dz_2, \\
\zeta_0 &= dz_2,
\end{aligned}
\tag{4.2}$$

which then satisfy the following structure equations

$$\begin{aligned}
d\rho_0 &= \frac{\bar{z}_2}{1 - z_2\bar{z}_2} \rho_0 \wedge \zeta_0 + \frac{z_2}{1 - z_2\bar{z}_2} \rho_0 \wedge \bar{\zeta}_0 + \sqrt{-1}\kappa_0 \wedge \bar{\kappa}_0, \\
d\kappa_0 &= \frac{\bar{z}_2}{1 - z_2\bar{z}_2} \kappa_0 \wedge \zeta_0 - \frac{1}{1 - z_2\bar{z}_2} \zeta_0 \wedge \bar{\kappa}_0, \\
d\zeta_0 &= 0.
\end{aligned}
\tag{4.3}$$

In the case of rigid biholomorphisms as previously explained, the transformation group, denoted by g , acts on the coframe $(\rho_0, \kappa_0, \zeta_0)$ by the matrix

$$g = \begin{pmatrix} c\bar{c} & 0 & 0 \\ 0 & c & 0 \\ 0 & e & f \end{pmatrix}$$

while ignoring the $T^{0,1*}M$ counterpart. Its inverse

$$g^{-1} = \begin{pmatrix} \frac{1}{c\bar{c}} & 0 & 0 \\ 0 & \frac{1}{c} & 0 \\ 0 & -\frac{e}{cf} & \frac{1}{f} \end{pmatrix}$$

provides the following Maurer-Cartan matrix of 1-forms

$$dg \cdot g^{-1} = \begin{pmatrix} \alpha + \bar{\alpha} & 0 & 0 \\ 0 & \alpha & 0 \\ 0 & \delta & \varepsilon \end{pmatrix},$$

where the 1-forms α , δ , and ε take on the following expressions

$$\begin{aligned}
\alpha &= \frac{dc}{c}, \\
\delta &= \frac{de}{c} - \frac{e}{c} \frac{df}{f}, \\
\varepsilon &= \frac{df}{f}.
\end{aligned}
\tag{4.4}$$

Hence after some computation

$$\begin{aligned}
d\rho &= (\alpha + \bar{\alpha}) \wedge \rho - \frac{e\bar{z}_2}{\text{cf}(1 - z_2\bar{z}_2)} \rho \wedge \kappa + \frac{\bar{z}_2}{\text{f}(1 - z_2\bar{z}_2)} \rho \wedge \zeta \\
&\quad - \frac{\bar{e}z_2}{\bar{\text{cf}}(1 - z_2\bar{z}_2)} \rho \wedge \bar{\kappa} + \frac{z_2}{\bar{\text{f}}(1 - z_2\bar{z}_2)} \rho \wedge \bar{\zeta} + \sqrt{-1}\kappa \wedge \bar{\kappa}, \\
4.5 \quad d\kappa &= \alpha \wedge \kappa + \frac{\bar{z}_2}{\text{f}(1 - z_2\bar{z}_2)} \kappa \wedge \zeta + \frac{\text{ce}}{\text{c}\bar{\text{c}}\text{f}(1 - z_2\bar{z}_2)} \kappa \wedge \bar{\kappa} - \frac{\text{c}}{\bar{\text{c}}\text{f}(1 - z_2\bar{z}_2)} \zeta \wedge \bar{\kappa}, \\
d\zeta &= \delta \wedge \kappa + \varepsilon \wedge \zeta + \frac{e\bar{z}_2}{\text{cf}(1 - z_2\bar{z}_2)} \kappa \wedge \zeta + \frac{e^2}{\text{c}\bar{\text{c}}\text{f}(1 - z_2\bar{z}_2)} \kappa \wedge \bar{\kappa} \\
&\quad + \frac{e}{\text{e}\text{f}(1 - z_2\bar{z}_2)} \zeta \wedge \bar{\kappa}.
\end{aligned}$$

In the rest of the article, we will adopt the following order for the coefficients appearing in front of the 2-forms:

$$\begin{array}{cccc}
\rho_0 \wedge \kappa_0 & \rho_0 \wedge \zeta_0 & \rho_0 \wedge \bar{\kappa}_0 & \rho_0 \wedge \bar{\zeta}_0 \\
\mathbf{1} & \mathbf{2} & \mathbf{3} & \mathbf{4} \\
\kappa_0 \wedge \zeta_0 & \kappa_0 \wedge \bar{\kappa}_0 & \kappa_0 \wedge \bar{\zeta}_0 & \\
\mathbf{5} & \mathbf{6} & \mathbf{7} & \\
\zeta_0 \wedge \bar{\kappa}_0 & \zeta_0 \wedge \bar{\zeta}_0 & & \\
\mathbf{8} & \mathbf{9} & & \\
& \bar{\kappa}_0 \wedge \bar{\zeta}_0 & & \\
& \mathbf{10} & &
\end{array}$$

Therefore, the 2-forms may be abbreviated as

$$\begin{aligned}
d\rho &= (\alpha + \bar{\alpha}) \wedge \rho + R_1 \rho \wedge \kappa + R_2 \rho \wedge \zeta + R_3 \rho \wedge \bar{\kappa} + R_4 \rho \wedge \bar{\zeta} \\
&\quad + \sqrt{-1}\kappa \wedge \bar{\kappa}, \\
4.7 \quad d\kappa &= \alpha \wedge \kappa + K_5 \kappa \wedge \zeta + K_6 \kappa \wedge \bar{\kappa} + K_7 \zeta \wedge \bar{\kappa}, \\
d\zeta &= \delta \wedge \kappa + \varepsilon \wedge \zeta + Z_5 \kappa \wedge \zeta + Z_6 \kappa \wedge \bar{\kappa} + Z_8 \zeta \wedge \bar{\kappa}.
\end{aligned}$$

Observe that $R_3 = \bar{R}_1$ and $R_4 = \bar{R}_2$. We will then proceed with the absorption, which can be done by replacing α , δ and ε with the new Maurer-Cartan 1-forms

$$\begin{aligned}
4.8 \quad \alpha &= \hat{\alpha} - x_\rho \rho - x_\kappa \kappa - x_\zeta \zeta - x_{\bar{\kappa}} \bar{\kappa} - x_{\bar{\zeta}} \bar{\zeta}, \\
\delta &= \hat{\delta} - y_\rho \rho - y_\kappa \kappa - y_\zeta \zeta - y_{\bar{\kappa}} \bar{\kappa} - y_{\bar{\zeta}} \bar{\zeta}, \\
\varepsilon &= \hat{\varepsilon} - z_\rho \rho - z_\kappa \kappa - z_\zeta \zeta - z_{\bar{\kappa}} \bar{\kappa} - z_{\bar{\zeta}} \bar{\zeta}.
\end{aligned}$$

for certain unknowns x_\bullet , y_\bullet and z_\bullet . Therefore the 2-forms may be re-written as

$$\begin{aligned}
d\rho &= (\hat{\alpha} + \bar{\hat{\alpha}}) \wedge \rho + (R_1 + x_\kappa + \bar{x}_{\bar{\kappa}}) \rho \wedge \kappa + (R_2 + x_\zeta + \bar{x}_{\bar{\zeta}}) \rho \wedge \zeta \\
&\quad + (R_3 + x_{\bar{\kappa}} + \bar{x}_\kappa) \rho \wedge \bar{\kappa} + (R_4 + x_{\bar{\zeta}} + \bar{x}_\zeta) \rho \wedge \bar{\zeta} \\
&\quad + \sqrt{-1}\kappa \wedge \bar{\kappa}, \\
4.9 \quad d\kappa &= \hat{\alpha} \wedge \kappa + (K_5 + x_\zeta) \kappa \wedge \zeta + (K_6 + x_{\bar{\kappa}}) \kappa \wedge \bar{\kappa} - x_\rho \rho \wedge \kappa \\
&\quad + x_{\bar{\zeta}} \kappa \wedge \bar{\zeta} + K_7 \zeta \wedge \bar{\kappa}, \\
d\zeta &= \hat{\delta} \wedge \kappa + \hat{\varepsilon} \wedge \zeta - y_\rho \rho \wedge \kappa - z_\rho \rho \wedge \zeta + (Z_5 + y_\zeta - z_\kappa) \kappa \wedge \zeta \\
&\quad + (Z_6 + y_{\bar{\kappa}}) \kappa \wedge \bar{\kappa} + (Z_8 + z_{\bar{\kappa}}) \zeta \wedge \bar{\kappa} + y_{\bar{\zeta}} \kappa \wedge \bar{\zeta} + z_{\bar{\zeta}} \zeta \wedge \bar{\zeta}.
\end{aligned}$$

This therefore leads to the following set of equations

$$\begin{aligned}
4.10 \quad x_\kappa + \overline{x_{\bar{\kappa}}} &= -\frac{e\bar{z}_2}{\text{cf}(1 - z_2\bar{z}_2)}, & y_\zeta - z_\kappa &= -\frac{e\bar{z}_2}{\text{cf}(1 - z_2\bar{z}_2)}, \\
x_\zeta + \overline{x_{\bar{\zeta}}} &= \frac{\bar{z}_2}{\text{f}(1 - z_2\bar{z}_2)}, & x_{\bar{\kappa}} &= -\frac{ce}{\text{c}\bar{\text{c}}\text{f}(1 - z_2\bar{z}_2)}, & y_{\bar{\kappa}} &= -\frac{e^2}{\text{c}\bar{\text{c}}\text{f}(1 - z_2\bar{z}_2)}, \\
x_{\bar{\kappa}} + \overline{x_\kappa} &= -\frac{ez_2}{\text{cf}(1 - z_2\bar{z}_2)}, & x_\rho &= 0, & z_{\bar{\kappa}} &= -\frac{e}{\bar{\text{c}}\text{f}(1 - z_2\bar{z}_2)}, \\
x_{\bar{\zeta}} + \overline{x_\zeta} &= \frac{z_2}{\bar{\text{f}}(1 - z_2\bar{z}_2)}, & x_{\bar{\zeta}} &= 0, & y_{\bar{\zeta}} &= 0, \\
x_\zeta &= -\frac{\bar{z}_2}{\text{f}(1 - z_2\bar{z}_2)}, & y_\rho &= 0, & z_{\bar{\zeta}} &= 0, \\
& & z_\rho &= 0, & &
\end{aligned}$$

These equations have solutions which result in the absorption of all the torsions except K_7 , and hence

$$\begin{aligned}
4.11 \quad d\rho &= (\hat{\alpha} + \bar{\hat{\alpha}}) \wedge \rho + \sqrt{-1}\kappa \wedge \bar{\kappa}, \\
d\kappa &= \hat{\alpha} \wedge \kappa - \frac{c}{\text{cf}(1 - z_2\bar{z}_2)} \zeta \wedge \bar{\kappa}, \\
d\zeta &= \hat{\delta} \wedge \kappa + \hat{\varepsilon} \wedge \bar{\kappa}.
\end{aligned}$$

As in Pocchiola (model case) [113], the essential torsion

$$-\frac{c}{\text{cf}(1 - z_2\bar{z}_2)}$$

may be normalised to 1 by making the following choice

$$\text{f} = -\frac{c}{\bar{\text{c}}(1 - z_2\bar{z}_2)}.$$

With this normalisation being made, we proceed with the second loop of the Cartan's equivalence method. The new transformation group then becomes

$$\begin{aligned}
4.12 \quad \begin{pmatrix} \rho \\ \kappa \\ \zeta \end{pmatrix} &= \begin{pmatrix} \text{c}\bar{\text{c}} & 0 & 0 \\ 0 & c & 0 \\ 0 & e & \frac{c}{\bar{\text{c}}} \end{pmatrix} \begin{pmatrix} \rho_0 \\ \kappa_0 \\ -\frac{1}{1 - z_2\bar{z}_2} \zeta_0 \end{pmatrix} \\
&:= \begin{pmatrix} \text{c}\bar{\text{c}} & 0 & 0 \\ 0 & c & 0 \\ 0 & e & \frac{c}{\bar{\text{c}}} \end{pmatrix} \begin{pmatrix} \rho_0 \\ \kappa_0 \\ \hat{\zeta}_0 \end{pmatrix},
\end{aligned}$$

with a change of the base coframe $(\rho_0, \kappa_0, \zeta_0) \mapsto (\rho_0, \kappa_0, \hat{\zeta}_0)$ via

$$\hat{\zeta}_0 := -\frac{1}{1 - z_2\bar{z}_2} \zeta_0.$$

According to Pocchiola (model case) [113], the 2-forms become

$$\begin{aligned}
4.13 \quad d\rho_0 &= -\bar{z}_2 \rho_0 \wedge \hat{\zeta}_0 - z_2 \rho_0 \wedge \bar{\hat{\zeta}}_0 + \sqrt{-1}\kappa_0 \wedge \bar{\kappa}_0, \\
d\kappa_0 &= -\bar{z}_2 \kappa_0 \wedge \hat{\zeta}_0 + \hat{\zeta}_0 \wedge \bar{\kappa}_0, \\
d\hat{\zeta}_0 &= z_2 \hat{\zeta}_0 \wedge \bar{\hat{\zeta}}_0.
\end{aligned}$$

Moreover, one has the following Maurer-Cartan matrix of 1-forms

$$4.14 \quad \begin{pmatrix} \alpha + \bar{\alpha} & 0 & 0 \\ 0 & \alpha & 0 \\ 0 & \delta & \alpha - \bar{\alpha} \end{pmatrix},$$

where

$$\alpha = \frac{dc}{c}, \quad \text{and} \quad \delta = \frac{de}{c} - \frac{e}{c} \left(\frac{dc}{c} - \frac{d\bar{c}}{\bar{c}} \right).$$

A computation by hand gives

$$\begin{aligned} d\rho &= (\alpha + \bar{\alpha}) \wedge \rho + \bar{z}_2 \frac{e\bar{c}}{c^2} \rho \wedge \kappa - \bar{z}_2 \frac{\bar{c}}{c} \rho \wedge \zeta + z_2 \frac{\bar{e}c}{c^2} \rho \wedge \bar{\kappa} - z_2 \frac{c}{\bar{c}} \rho \wedge \bar{\zeta} + \sqrt{-1} \kappa \wedge \bar{\kappa}, \\ &= (\alpha + \bar{\alpha}) \wedge \rho + R_1 \rho \wedge \kappa + R_2 \rho \wedge \bar{\zeta} + \bar{R}_1 \rho \wedge \bar{\kappa} + \bar{R}_2 \rho \wedge \bar{\zeta} + \sqrt{-1} \kappa \wedge \bar{\kappa}, \\ d\kappa &= \alpha \wedge \kappa - \bar{z}_2 \frac{\bar{c}}{c} \kappa \wedge \zeta - \frac{e}{c} \kappa \wedge \bar{\kappa} + \zeta \wedge \bar{\kappa} \\ &= \alpha \wedge \kappa + K_5 \kappa \wedge \zeta + K_6 \kappa \wedge \bar{\kappa} + \zeta \wedge \bar{\kappa}, \\ d\zeta &= \delta \wedge \kappa + (\alpha - \bar{\alpha}) \wedge \zeta - \bar{z}_2 \frac{e\bar{c}}{c^2} \kappa \wedge \zeta + \left(-\frac{e^2}{c^2} + z_2 \frac{e\bar{e}}{c^2} \right) \kappa \wedge \bar{\kappa} \\ &\quad + \left(\frac{e}{c} - z_2 \frac{\bar{e}c}{c^2} \right) \zeta \wedge \bar{\kappa} - z_2 \frac{e}{\bar{c}} \kappa \wedge \bar{\zeta} + \frac{z_2 c}{\bar{c}} \zeta \wedge \bar{\zeta} \\ &= \delta \wedge \kappa + (\alpha - \bar{\alpha}) \wedge \zeta + Z_5 \kappa \wedge \zeta + Z_6 \kappa \wedge \bar{\kappa} + Z_8 \zeta \wedge \bar{\kappa} + Z_7 \kappa \wedge \bar{\zeta} + Z_9 \zeta \wedge \bar{\zeta}. \end{aligned}$$

Then we proceed with the absorption by setting

$$\begin{aligned} \alpha &= \hat{\alpha} - x_\rho \rho - x_\kappa \kappa - x_\zeta \zeta - x_{\bar{\kappa}} \bar{\kappa} - x_{\bar{\zeta}} \bar{\zeta}, \\ \delta &= \hat{\delta} - y_\rho \rho - y_\kappa \kappa - y_\zeta \zeta - y_{\bar{\kappa}} \bar{\kappa} - y_{\bar{\zeta}} \bar{\zeta}, \end{aligned}$$

and we obtain

$$\begin{aligned} d\rho &= (\hat{\alpha} + \bar{\alpha}) \wedge \rho + (R_1 + x_\kappa + \bar{x}_{\bar{\kappa}}) \rho \wedge \kappa + (R_2 + x_\zeta + \bar{x}_{\bar{\zeta}}) \rho \wedge \zeta \\ &\quad + (\bar{R}_1 + x_{\bar{\kappa}} + \bar{x}_{\bar{\kappa}}) \rho \wedge \bar{\kappa} + (\bar{R}_2 + x_{\bar{\zeta}} + \bar{x}_{\bar{\zeta}}) \rho \wedge \bar{\zeta} + \sqrt{-1} \kappa \wedge \bar{\kappa}, \\ d\kappa &= \hat{\alpha} \wedge \kappa - x_\rho \rho \wedge \kappa + (K_5 + x_\zeta) \kappa \wedge \zeta + (K_6 + x_{\bar{\kappa}}) \kappa \wedge \bar{\kappa} + x_{\bar{\zeta}} \kappa \wedge \bar{\zeta} + \zeta \wedge \bar{\kappa}, \\ d\zeta &= \hat{\delta} \wedge \kappa + (\hat{\alpha} - \bar{\alpha}) \wedge \zeta - y_\rho \rho \wedge \kappa + (\bar{x}_\rho - x_\rho) \rho \wedge \zeta + (Z_5 - x_\kappa + y_\zeta + \bar{x}_{\bar{\kappa}}) \kappa \wedge \zeta \\ &\quad + (Z_6 + y_{\bar{\kappa}}) \kappa \wedge \bar{\kappa} + Z_7 \kappa \wedge \bar{\zeta} + (Z_8 - \bar{x}_{\bar{\kappa}} + x_{\bar{\kappa}}) \zeta \wedge \bar{\kappa} + (Z_9 - \bar{x}_{\bar{\zeta}} + x_{\bar{\zeta}}) \zeta \wedge \bar{\zeta}. \end{aligned}$$

This leads to another set of absorption equations

$$\begin{aligned}
x_\kappa + \overline{x_{\bar{\kappa}}} &= -\bar{z}_2 \frac{e\bar{c}}{c^2}, & x_{\bar{\zeta}} &= 0, \\
x_\zeta + \overline{x_{\bar{\zeta}}} &= \bar{z}_2 \frac{\bar{c}}{c}, & y_\rho &= 0, \\
x_{\bar{\kappa}} + \overline{x_\kappa} &= -z_2 \frac{\bar{e}c}{c^2}, & \overline{x_\rho} - x_\rho &= 0, \\
x_{\bar{\zeta}} + \overline{x_\zeta} &= z_2 \frac{c}{\bar{c}}, & -x_\kappa + \overline{x_{\bar{\kappa}}} + y_\zeta &= -\bar{z}_2 \frac{e\bar{c}}{c^2}, \\
x_\rho &= 0, & y_{\bar{\kappa}} &= -\frac{e^2}{c^2} + z_2 + \frac{e\bar{e}}{c^2}, \\
x_\zeta &= \bar{z}_2 \frac{\bar{c}}{c}, & -\overline{x_\kappa} + x_{\bar{\kappa}} &= -\frac{e}{c} + z_2 \frac{\bar{e}c}{c^2}, \\
x_{\bar{\kappa}} &= -\frac{e}{c}, & -\overline{x_\zeta} + x_{\bar{\zeta}} &= -z_2 \frac{c}{\bar{c}}.
\end{aligned}
\tag{4.15}$$

The following equations

$$\begin{aligned}
x_{\bar{\kappa}} + \overline{x_\kappa} &= -z_2 \frac{\bar{e}c}{c^2}, \\
x_{\bar{\kappa}} &= -\frac{e}{c}, \\
x_{\bar{\kappa}} - \overline{x_\kappa} &= -\frac{e}{c} + z_2 \frac{\bar{e}c}{c^2}
\end{aligned}
\tag{4.16}$$

force us to conclude that $e = 0$, which is consistent with Pocchiola (model case) [113], page 146, where he sets

$$d = -\sqrt{-1} \frac{e^2 \bar{c}}{2c}.$$

In our case, $d = 0$ due to our rigidity assumption, and thus we are led to $e = 0$.

This new normalisation gives rise to the new transformation group,

$$\begin{pmatrix} \rho \\ \kappa \\ \zeta \end{pmatrix} = \begin{pmatrix} c\bar{c} & 0 & 0 \\ 0 & c & 0 \\ 0 & 0 & \frac{c}{\bar{c}} \end{pmatrix} \begin{pmatrix} \rho_0 \\ \kappa_0 \\ \hat{\zeta}_0 \end{pmatrix}$$

with the new Maurer-Cartan matrix

$$dg \cdot g^{-1} = \begin{pmatrix} \alpha + \bar{\alpha} & 0 & 0 \\ 0 & \alpha & 0 \\ 0 & 0 & \alpha - \bar{\alpha} \end{pmatrix}$$

and the following 2-forms

$$\begin{aligned}
d\rho &= (\alpha + \bar{\alpha}) \wedge \rho - \bar{z}_2 \frac{\bar{c}}{c} \rho \wedge \zeta - z_2 \frac{c}{\bar{c}} \rho \wedge \bar{\zeta} + \sqrt{-1} \kappa \wedge \bar{\kappa}, \\
d\kappa &= \alpha \wedge \kappa - \bar{z}_2 \frac{\bar{c}}{c} \kappa \wedge \zeta + \zeta \wedge \bar{\kappa}, \\
d\zeta &= (\alpha - \bar{\alpha}) \wedge \zeta + z_2 \frac{c}{\bar{c}} \zeta \wedge \bar{\zeta}.
\end{aligned}
\tag{4.17}$$

We will proceed with the absorption process by setting

$$\alpha = \hat{\alpha} - x_\rho \rho - x_\kappa \kappa - x_\zeta \zeta - x_{\bar{\kappa}} \bar{\kappa} - x_{\bar{\zeta}} \bar{\zeta},$$

which leads to

$$\begin{aligned}
d\rho &= (\hat{\alpha} + \bar{\alpha}) \wedge \rho + (x_\zeta + \bar{x}_\zeta - \bar{z}_2 \frac{\bar{c}}{c}) \rho \wedge \zeta + (x_{\bar{\zeta}} + \bar{x}_{\bar{\zeta}} - z_2 \frac{c}{\bar{c}}) \rho \wedge \bar{\zeta} \\
&\quad + (x_\kappa + \bar{x}_\kappa) \rho \wedge \kappa + (x_\kappa + \bar{x}_\kappa) \rho \wedge \bar{\kappa} + \sqrt{-1} \kappa \wedge \bar{\kappa}, \\
4.18 \quad d\kappa &= \hat{\alpha} \wedge \kappa - x_\rho \rho \wedge \kappa + (x_\zeta - \bar{z}_2 \frac{\bar{c}}{c}) \kappa \wedge \zeta + x_{\bar{\kappa}} \kappa \wedge \bar{\kappa} + x_{\bar{\zeta}} \kappa \wedge \bar{\zeta} + \zeta \wedge \bar{\kappa}, \\
d\zeta &= (\hat{\alpha} - \bar{\alpha}) \wedge \zeta + (-x_\rho + \bar{x}_\rho) \rho \wedge \zeta + (-x_\kappa + \bar{x}_\kappa) \kappa \wedge \zeta + (\bar{x}_\kappa - x_{\bar{\kappa}}) \zeta \wedge \bar{\kappa} \\
&\quad + (x_{\bar{\zeta}} - \bar{x}_{\bar{\zeta}} + z_2 \frac{c}{\bar{c}}) \zeta \wedge \bar{\zeta}.
\end{aligned}$$

To remove all the torsions, one has to solve for x_\bullet the following system of linear equations

$$\begin{aligned}
4.19 \quad x_\zeta + \bar{x}_\zeta &= \bar{z}_2 \frac{\bar{c}}{c}, \\
x_{\bar{\zeta}} + \bar{x}_{\bar{\zeta}} &= z_2 \frac{c}{\bar{c}}, \\
x_\kappa + \bar{x}_\kappa &= 0, \\
x_\rho &= 0, \\
x_{\bar{\kappa}} &= 0, \\
x_{\bar{\zeta}} &= 0, \\
x_\zeta &= \bar{z}_2 \frac{\bar{c}}{c}, \\
-x_\rho + \bar{x}_\rho &= 0, \\
-x_\kappa + \bar{x}_\kappa &= 0, \\
\bar{x}_\kappa - x_{\bar{\kappa}} &= 0, \\
x_{\bar{\zeta}} - \bar{x}_{\bar{\zeta}} + z_2 \frac{c}{\bar{c}} &= 0.
\end{aligned}$$

This time the solution set is unambiguous:

$$x_\rho = 0, \quad x_\kappa = 0, \quad x_\zeta = \bar{z}_2 \frac{\bar{c}}{c}, \quad x_{\bar{\kappa}} = 0, \quad x_{\bar{\zeta}} = 0,$$

and since the degree of indeterminacy is zero, Cartan's test tells us that there is no need for prolongation. The absorption takes place and we get

$$\begin{aligned}
4.20 \quad d\rho &= (\hat{\alpha} + \bar{\alpha}) \wedge \rho + \sqrt{-1} \kappa \wedge \bar{\kappa}, \\
d\kappa &= \hat{\alpha} \wedge \kappa + \zeta \wedge \bar{\kappa}, \\
d\zeta &= (\hat{\alpha} - \bar{\alpha}) \wedge \zeta.
\end{aligned}$$

The $\{e\}$ -structure is then completed by the following

PROPOSITION 4.21. *One has $d\hat{\alpha} = \zeta \wedge \bar{\zeta}$.*

PROOF. Applying the Poincaré derivative on both sides of the three equations above, we get

$$4.22 \quad (d\hat{\alpha} + d\bar{\alpha}) \wedge \rho = 0,$$

$$4.23 \quad (d\hat{\alpha} - \zeta \wedge \bar{\zeta}) \wedge \kappa = 0,$$

$$4.24 \quad (d\hat{\alpha} - d\bar{\alpha}) \wedge \zeta = 0.$$

By applying complex conjugation to both sides of the third equation, one has an additional relation

$$4.25 \quad (d\hat{\alpha} - d\bar{\hat{\alpha}}) \wedge \bar{\zeta} = 0.$$

In the second equation 4.23, Cartan's lemma provides a 1-form A so that

$$d\hat{\alpha} = \zeta \wedge \bar{\zeta} + A \wedge \kappa.$$

Hence in 4.22, 4.24 and 4.25,

$$\begin{aligned} (d\hat{\alpha} + d\bar{\hat{\alpha}}) \wedge \rho &= A \wedge \kappa \wedge \rho + \bar{A} \wedge \bar{\kappa} \wedge \rho = 0, \\ (d\hat{\alpha} - d\bar{\hat{\alpha}}) \wedge \zeta &= A \wedge \kappa \wedge \zeta - \bar{A} \wedge \bar{\kappa} \wedge \zeta = 0, \\ (d\hat{\alpha} - d\bar{\hat{\alpha}}) \wedge \bar{\zeta} &= A \wedge \kappa \wedge \bar{\zeta} - \bar{A} \wedge \bar{\kappa} \wedge \bar{\zeta} = 0. \end{aligned}$$

Wedging with ζ on both sides of the first equation, and by ρ on the second, we get

$$\begin{aligned} A \wedge \kappa \wedge \rho \wedge \zeta + \bar{A} \wedge \bar{\kappa} \wedge \rho \wedge \zeta &= 0, \\ A \wedge \kappa \wedge \rho \wedge \zeta - \bar{A} \wedge \bar{\kappa} \wedge \rho \wedge \zeta &= 0. \end{aligned}$$

Similarly, wedging with $\bar{\zeta}$ on both sides of the first equation, and by ρ on the third, it comes

$$\begin{aligned} A \wedge \kappa \wedge \rho \wedge \bar{\zeta} + \bar{A} \wedge \bar{\kappa} \wedge \rho \wedge \bar{\zeta} &= 0, \\ A \wedge \kappa \wedge \rho \wedge \bar{\zeta} - \bar{A} \wedge \bar{\kappa} \wedge \rho \wedge \bar{\zeta} &= 0. \end{aligned}$$

Therefore,

$$4.26 \quad \begin{aligned} A \wedge \kappa \wedge \rho \wedge \zeta &= 0, \\ A \wedge \kappa \wedge \rho \wedge \bar{\zeta} &= 0. \end{aligned}$$

This implies the existence of functions f and g with

$$A = f\rho + g\kappa.$$

Hence

$$d\hat{\alpha} = \zeta \wedge \bar{\zeta} + f\rho \wedge \kappa.$$

Substituting this into 4.24,

$$0 = (\zeta \wedge \bar{\zeta} + f\rho \wedge \kappa - \bar{\zeta} \wedge \zeta - \bar{f}\rho \wedge \bar{\kappa}) \wedge \zeta = f\rho \wedge \kappa \wedge \zeta - \bar{f}\rho \wedge \bar{\kappa} \wedge \zeta,$$

we conclude by linear independence of these 3-forms that $f = 0$. \square

4.1. Summary. For the model case, there exists a coframe $(\rho, \kappa, \zeta, \alpha, \bar{\kappa}, \bar{\zeta}, \bar{\alpha})$ satisfying the following structure equations

$$4.27 \quad \begin{aligned} d\rho &= (\alpha + \bar{\alpha}) \wedge \rho + \sqrt{-1}\kappa \wedge \bar{\kappa}, \\ d\kappa &= \alpha \wedge \kappa + \zeta \wedge \bar{\kappa}, \\ d\zeta &= (\alpha - \bar{\alpha}) \wedge \zeta, \\ d\alpha &= \zeta \wedge \bar{\zeta}, \end{aligned}$$

along with the conjugates $d\rho$, $d\bar{\kappa}$, $d\bar{\zeta}$ and $d\bar{\alpha}$. Observe that α cannot be purely imaginary as seen during the absorption of the final Cartan process. This therefore constitutes the Maurer-Cartan constant coefficients equations for the 7 dimensional complex Lie algebra of automorphisms of the model light cone M_{LC} . We will confirm that this is $\text{aut}_{CR}(M_{LC})$, arguing by means of vector fields.

5. Representation by vector fields

By a result of Gaussier-Merker [56, 57], it is known that the Lie algebra of infinitesimal CR automorphisms of the tube over future light cone M_{LC} is generated by the following 10 holomorphic vector fields

$$\begin{aligned}
X^1 &= \sqrt{-1}\partial_w, \\
X^2 &= z_1\partial_{z_1} + 2w\partial_w, \\
X^3 &= \sqrt{-1}z_1\partial_{z_1} + 2\sqrt{-1}z_2\partial_{z_2}, \\
X^4 &= (z_2 - 1)\partial_{z_1} - 2z_1\partial_w, \\
X^5 &= (\sqrt{-1} + \sqrt{-1}z_2)\partial_{z_1} - 2\sqrt{-1}z_1\partial_w, \\
5.1 \quad X^6 &= z_1z_2\partial_{z_1} + (z_2^2 - 1)\partial_{z_2} - z_1^2\partial_w, \\
X^7 &= \sqrt{-1}z_1z_2\partial_{z_1} + (\sqrt{-1}z_2^2 + \sqrt{-1})\partial_{z_2} - \sqrt{-1}z_1^2\partial_w, \\
X^8 &= \sqrt{-1}wz_1\partial_{z_1} - \sqrt{-1}z_1^2\partial_{z_2} + \sqrt{-1}w^2\partial_w, \\
X^9 &= (z_1^2 - wz_2 - w)\partial_{z_1} + (2z_1z_2 + 2z_1)\partial_{z_2} + 2wz_1\partial_w, \\
X^{10} &= (-\sqrt{-1}z_1^2 + \sqrt{-1}wz_2 - \sqrt{-1}w)\partial_{z_1} + (-2\sqrt{-1}z_1z_2 + 2\sqrt{-1}z_1)\partial_{z_2} - 2\sqrt{-1}wz_1\partial_w.
\end{aligned}$$

It can be shown that for each $1 \leq i \leq 10$, the vector field $X^i + \overline{X^i}$ is tangent to M_{LC} . The commutator table of these 10 vector fields is as follows.

	X^1	X^2	X^3	X^4	X^5	X^6	X^7	X^8	X^9	X^{10}
X^1	0	$2X^1$	0	0	0	0	0	$-X^2$	$-X^5$	$-X^4$
X^2		0	0	$-X^4$	$-X^5$	0	0	$2X^8$	X^9	X^{10}
X^3			0	X^5	$-X^4$	$2X^7$	$-2X^6$	0	$-X^{10}$	X^9
X^4				0	$4X^1$	$-X^4$	$-X^5$	X^{10}	$2X^6 - 2X^2$	$-2X^7 + 2X^3$
X^5					0	X^5	$-X^4$	X^9	$2X^7 + 2X^3$	$2X^6 + 2X^2$
X^6						0	$-2X^3$	0	$-X^9$	X^{10}
X^7							0	0	X^{10}	X^9
X^8								0	0	0
X^9									0	$4X^8$
X^{10}										0

It is therefore clear from the table above that the vector fields X^1, \dots, X^7 generate a Lie sub-algebra, which we will denote by \mathfrak{h} . Next, we are going to find out which among these 10 vector fields have integral curves that define local rigid automorphisms of \mathbb{C}^3 (in the sense of Definition 3.1).

Recall that an integral curve of a vector field X on \mathbb{C}^3 is the map

$$\gamma : \mathbb{R} \rightarrow \mathbb{C}^3$$

satisfying the following differential equation with initial condition:

$$\begin{aligned}
5.2 \quad \frac{d\gamma}{dt} \Big|_{\gamma(t)} &= X|_{\gamma(t)}, \\
\gamma(0) &= p.
\end{aligned}$$

Usually such an integral curve at p is denoted by

$$\exp(tX)(p) := \gamma(t) \quad (\gamma(0)=p).$$

Due to the following identity

$$\exp(-tX) \exp(tX)(p) = p,$$

an integral curve therefore defines an automorphism of \mathbb{C}^3 for each fixed t :

$$\begin{aligned} \exp(tX) : \mathbb{C}^3 &\longrightarrow \mathbb{C}^3 \\ 5.3 \quad p &\longmapsto \exp(tX)(p). \end{aligned}$$

For notational ease, we will let p_1, p_2 and p_3 denote the coordinates of

$$\gamma(0) = (\gamma_1(0), \gamma_2(0), \gamma_3(0)) = (p_1, p_2, p_3).$$

5.1. Vector field X^1 . Integral curve:

$$(\gamma_1(t), \gamma_2(t), \gamma_3(t)) = (p_1, p_2, p_3 + it).$$

Therefore for each fixed t , the holomorphic map

$$(z_1, z_2, w) \mapsto (z_1, z_2, w + it)$$

is rigid (we see it as a constant holomorphic function).

5.2. Vector field X^2 . Integral curve:

$$(\gamma_1(t), \gamma_2(t), \gamma_3(t)) = (e^t p_1, p_2, e^{2t} p_3).$$

Then for each fixed t , the holomorphic map

$$(z_1, z_2, w) \mapsto (e^t z_1, z_2, e^{2t} w)$$

is rigid.

5.3. Vector field X^3 . Integral curve:

$$(\gamma_1(t), \gamma_2(t), \gamma_3(t)) = (e^{\sqrt{-1}t} p_1, e^{2\sqrt{-1}t} p_2, p_3).$$

Therefore for each fixed t , the holomorphic map

$$(z_1, z_2, w) \mapsto (e^{\sqrt{-1}t} z_1, e^{2\sqrt{-1}t} z_2, w)$$

is rigid.

5.4. Vector field X^4 . Integral curve:

$$(\gamma_1(t), \gamma_2(t), \gamma_3(t)) = ((p_2 - 1)t + p_1, p_2, -(p_2 - 1)t^2 - 2p_1 t + p_3).$$

For each fixed t , the holomorphic map

$$(z_1, z_2, w) \mapsto ((z_2 - 1)t + z_1, z_2, w - ((z_2 - 1)t^2 + 2z_1 t))$$

is rigid.

5.5. Vector field X^5 . Integral curve:

$$(\gamma_1(t), \gamma_2(t), \gamma_3(t)) = (p_1 + \sqrt{-1}(p_2 + 1)t, p_2, p_3 - 2\sqrt{-1}p_1 t + (p_2 + 1)t^2).$$

For each fixed t , the holomorphic map

$$(z_1, z_2, w) \mapsto (z_1 + \sqrt{-1}(z_2 + 1)t, z_2, w - 2\sqrt{-1}z_1 t + (z_2 + 1)t^2)$$

is therefore rigid.

5.6. Vector field X^6 . The integral curve $(\gamma_1(t), \gamma_2(t), \gamma_3(t))$ is given by the following equations

$$5.4 \quad \begin{aligned} \gamma_1(t) &= \frac{2p_1(1+p_2)e^t}{(1+p_2)(1+p_2+e^{2t}(1-p_2))}, \\ \gamma_2(t) &= \frac{(1+p_2) - e^{2t}(1-p_2)}{(1+p_2) + e^{2t}(1-p_2)}, \\ \gamma_3(t) &= p_3 + \frac{p_1^2}{1-p_2} - \frac{2p_1^2}{1-p_2} \frac{1}{(1+p_2) + (1-p_2)e^{2t}}. \end{aligned}$$

For each fixed t , the holomorphic map

$$(z_1, z_2, w) \mapsto \left(\frac{2z_1(1+z_2)e^t}{(1+z_2)(1+z_2+e^{2t}(1-z_2))}, \frac{(1+z_2) - e^{2t}(1-z_2)}{(1+z_2) + e^{2t}(1-z_2)}, \right. \\ \left. w + \frac{z_1^2}{1-z_2} - \frac{2z_1^2}{1-z_2} \frac{1}{(1+z_2) + e^{2t}(1-z_2)} \right)$$

is therefore rigid.

5.7. Vector field X^7 . The integral curve $(\gamma_1(t), \gamma_2(t), \gamma_3(t))$ is given by

$$\begin{aligned} \gamma_1(t) &= \frac{\sqrt{-1}p_1}{p_2 \sinh(t) + \sqrt{-1} \cosh(t)}, \\ \gamma_2(t) &= \frac{-p_2 - \sqrt{-1} \tanh(t)}{\sqrt{-1} + p_2 \tanh(t)}, \\ \gamma_3(t) &= p_3 + \frac{p_1^2 \sinh(t)}{p_2 \sinh(t) + \sqrt{-1} \cosh(t)}. \end{aligned}$$

Hence for each fixed t , the holomorphic map

$$(z_1, z_2, w) \mapsto \left(\frac{iz_1}{z_2 \sinh(t) + \sqrt{-1} \cosh(t)}, \frac{-z_2 - \sqrt{-1} \tanh(t)}{\sqrt{-1} + z_2 \tanh(t)}, w + \frac{z_1^2 \sinh(t)}{z_2 \sinh(t) + \sqrt{-1} \cosh(t)} \right)$$

is rigid.

One can deduce directly from the table that the Lie algebra \mathfrak{h} is neither semi-simple nor reductive. Indeed, the Killing form applied to the first vector field vanishes

$$\text{trace}(\text{ad}(X^1)\text{ad}(X^j)) = 0, \quad (j=1, \dots, 7)$$

and hence \mathfrak{h} is not semi-simple by Cartan's criterion. Moreover, suppose by means of *reductio ad absurdum* that \mathfrak{h} is reductive, then it has a decomposition

$$\mathfrak{h} = \mathfrak{s} \oplus \mathfrak{z}(\mathfrak{h}),$$

where \mathfrak{s} is a semi-simple Lie sub-algebra and $\mathfrak{z}(\mathfrak{h})$ is the centre of \mathfrak{h} . But it is clear from the table that \mathfrak{h} has no element in the centre except the zero vector field, and hence

$$\mathfrak{h} = \mathfrak{s}$$

so that \mathfrak{h} is semi-simple, a contradiction.

We will now proceed to establish a link between the Maurer-Cartan coframe

$$5.5 \quad (\rho, \kappa, \zeta, \alpha, \bar{\kappa}, \bar{\zeta}, \bar{\alpha})$$

appearing in the structure equations in the previous sections, and the vector fields X^1, \dots, X^7 . In fact, let

$$\partial_\rho, \partial_\kappa, \partial_\zeta, \partial_\alpha, \partial_{\bar{\kappa}}, \partial_{\bar{\zeta}}, \partial_{\bar{\alpha}}$$

be the right-invariant vector fields that are respective duals to the 1-forms in equation 5.5, and let \mathfrak{h}' be the Lie algebra generated by these vector fields. In what follows, the link will be established by seeking a Lie algebra isomorphism

$$5.6 \quad \tau : \mathfrak{h} \longrightarrow \mathfrak{h}'$$

between \mathfrak{h} and \mathfrak{h}' .

We make the following recall which can be found in Olver [109], page 257. Consider a set of 1-forms $\theta = \{\theta^1, \dots, \theta^m\}$ on a manifold M producing the fundamental structure equations

$$d\theta^i = \sum_{1 \leq j < k \leq m} T_{jk}^i \theta^j \wedge \theta^k \quad (i=1, \dots, m).$$

If ∂_{θ^i} are the vector fields dual to θ^i , one has the following commutation relations

$$[\partial_{\theta^j}, \partial_{\theta^k}] = - \sum_{i=1}^m T_{jk}^i \partial_{\theta^i} \quad (1 \leq i < j \leq m).$$

Following this formula, and if we adopt the order of indices

$$\rho < \kappa < \zeta < \alpha < \bar{\kappa} < \bar{\zeta} < \bar{\alpha},$$

the Maurer-Cartan structure equations in equation 4.27 therefore provide the following commutator table of the vector fields:

	∂_ρ	∂_κ	∂_ζ	∂_α	$\partial_{\bar{\kappa}}$	$\partial_{\bar{\zeta}}$	$\partial_{\bar{\alpha}}$
∂_ρ	0	0	0	∂_ρ	0	0	$\partial_{\bar{\rho}}$
∂_κ	0	0	0	∂_κ	$-\sqrt{-1}\partial_\rho$	$\partial_{\bar{\kappa}}$	0
∂_ζ	0	0	0	∂_ζ	$-\partial_\kappa$	$-\partial_\alpha + \partial_{\bar{\alpha}}$	$-\partial_\zeta$
∂_α	$-\partial_\rho$	$-\partial_\kappa$	$-\partial_\zeta$	0	0	$\partial_{\bar{\zeta}}$	0
$\partial_{\bar{\kappa}}$	0	$\sqrt{-1}\partial_\rho$	∂_κ	0	0	0	$\partial_{\bar{\kappa}}$
$\partial_{\bar{\zeta}}$	0	$-\partial_{\bar{\kappa}}$	$-\partial_{\bar{\alpha}} + \partial_\alpha$	$-\partial_{\bar{\zeta}}$	0	0	$\partial_{\bar{\zeta}}$
$\partial_{\bar{\alpha}}$	$-\partial_\rho$	0	∂_ζ	0	$-\partial_{\bar{\kappa}}$	$-\partial_{\bar{\zeta}}$	0

Let W^1, \dots, W^7 be the vector fields defined by

$$5.7 \quad \begin{aligned} W^1 &:= -\frac{\sqrt{-1}}{2}\partial_\rho, & W^4 &:= \partial_\kappa - \partial_{\bar{\kappa}}, \\ W^2 &:= \partial_\alpha + \partial_{\bar{\alpha}}, & W^5 &:= \partial_\kappa + \partial_{\bar{\kappa}}, \\ W^3 &:= \partial_\zeta - \partial_{\bar{\zeta}}, & W^6 &:= \partial_\zeta + \partial_{\bar{\zeta}}, \\ & & W^7 &:= -\partial_\alpha + \partial_{\bar{\alpha}}. \end{aligned}$$

Using the commutator table above, one has the following table of Lie brackets of various vector fields W^i :

	W^1	W^2	W^3	W^4	W^5	W^6	W^7
W^1	0	$2W^1$	0	0	0	0	0
W^2		0	0	$-W^4$	$-W^5$	0	0
W^3			0	W^5	$-W^4$	$2W^7$	$-2W^6$
W^4				0	$4W^1$	$-W^4$	$-W^5$
W^5					0	W^5	$-W^4$
W^6						0	$-2W^3$
W^7							0

which is the same as the commutator table of the vector fields X^1, \dots, X^7 . Therefore the map which sends for each $i = 1, \dots, 7$:

$$5.8 \quad \begin{aligned} \tau : \mathfrak{h} &\longrightarrow \mathfrak{h}' \\ X^i &\longmapsto \tau(X^i) := W^i \end{aligned}$$

defines a Lie algebra isomorphism. The following theorem summarises what has been done so far for the rigid automorphisms of the model case:

THEOREM 5.9. *The set of infinitesimal rigid CR-automorphisms of the tube over the future light cone*

$$\text{MLC} : (\text{Re}z_1)^2 - (\text{Re}z_2)^2 - (\text{Re}z_3)^2 = 0 \quad \text{Re}z_1 > 0,$$

is a 7-dimensional Lie sub-algebra of the set of all of its infinitesimal CR-automorphisms. A basis for the Maurer-Cartan forms of the infinitesimal rigid CR-automorphisms is provided by the 7 differential 1-forms $\rho, \kappa, \zeta, \alpha, \bar{\kappa}, \bar{\zeta}, \bar{\alpha}$ on $\text{MLC} \times \mathbb{C}$ which satisfy the following Maurer-Cartan equations:

$$5.10 \quad \begin{aligned} d\rho &= (\alpha + \bar{\alpha}) \wedge \rho + \sqrt{-1}\kappa \wedge \bar{\kappa}, \\ d\kappa &= \alpha \wedge \kappa + \zeta \wedge \bar{\kappa}, \\ d\zeta &= (\alpha - \bar{\alpha}) \wedge \zeta, \\ d\alpha &= \zeta \wedge \bar{\zeta}, \\ d\bar{\kappa} &= \bar{\alpha} \wedge \bar{\kappa} + \bar{\zeta} \wedge \kappa, \\ d\bar{\zeta} &= -(\alpha - \bar{\alpha}) \wedge \bar{\zeta}, \\ d\bar{\alpha} &= -\zeta \wedge \bar{\zeta}. \end{aligned}$$

Moreover, if $\{\partial_\rho, \partial_\kappa, \partial_\zeta, \partial_\alpha, \partial_{\bar{\kappa}}, \partial_{\bar{\zeta}}, \partial_{\bar{\alpha}}\}$ is a set of right-invariant vector fields that are dual to the respective coframe 1-forms $\{\rho, \kappa, \zeta, \alpha, \bar{\kappa}, \bar{\zeta}, \bar{\alpha}\}$, then there is an isomorphism of Lie algebras between the Lie algebra \mathfrak{h}' generated by these vector fields, and the Lie algebra of infinitesimal rigid automorphisms of the tube over the future light cone. \square

6. The general case

The previous theorem shows that the Maurer-Cartan form that we have obtained, together with the structure equations, give a good setup for the equivalence problem. Recall from equations 2.10 and 2.11 that the Darboux-Cartan structure equations are given by the

1-forms $\{\rho_0, \kappa_0, \zeta_0\}$ with

$$\begin{aligned} d\rho_0 &= \mathbf{P} \rho_0 \wedge \kappa_0 - \mathcal{L}_1(\mathbf{k}) \rho_0 \wedge \zeta_0 + \bar{\mathbf{P}} \rho_0 \wedge \bar{\kappa}_0 - \bar{\mathcal{L}}_1(\bar{\mathbf{k}}) \rho_0 \wedge \bar{\zeta}_0 + \sqrt{-1}\kappa_0 \wedge \bar{\kappa}_0, \\ 6.1 \quad d\kappa_0 &= -\mathcal{L}_1(\mathbf{k}) \kappa_0 \wedge \zeta_0 + \bar{\mathcal{L}}_1(\bar{\mathbf{k}}) \zeta_0 \wedge \bar{\kappa}_0, \\ d\zeta_0 &= 0. \end{aligned}$$

In equation 3.7, the group transformation of the (1, 0) coframe is determined by the matrix

$$\omega = \begin{pmatrix} \rho \\ \kappa \\ \zeta \end{pmatrix} = \begin{pmatrix} c\bar{c} & 0 & 0 \\ 0 & c & 0 \\ 0 & e & f \end{pmatrix} \begin{pmatrix} \rho_0 \\ \kappa_0 \\ \zeta_0 \end{pmatrix} := \mathbf{g}\omega_0.$$

We will also continue to adopt the order of coefficients as stated in equation 4.6

7. Cartan process: first loop

Using the formula

$$d\omega = (d\mathbf{g})\mathbf{g}^{-1}\omega + \mathbf{g}d\omega_0,$$

the Maurer-Cartan form is

$$(d\mathbf{g})\mathbf{g}^{-1} = \begin{pmatrix} \alpha + \bar{\alpha} & 0 & 0 \\ 0 & \alpha & 0 \\ 0 & \delta & \varepsilon \end{pmatrix},$$

where α, δ and ε are given by those in equation 4.4. A direct computation shows that

$$\begin{aligned} d\rho &= \alpha \wedge \rho + \bar{\alpha} \wedge \rho + \left(\frac{\mathbf{P}}{c} + \frac{e\mathcal{L}_1(\mathbf{k})}{cf}\right) \rho \wedge \kappa + \left(\frac{\bar{\mathbf{P}}}{\bar{c}} + \frac{\bar{e}\bar{\mathcal{L}}_1(\bar{\mathbf{k}})}{\bar{c}\bar{f}}\right) \rho \wedge \bar{\kappa} \\ &\quad + \left(\frac{-\mathcal{L}_1(\mathbf{k})}{f}\right) \rho \wedge \zeta + \left(\frac{-\bar{\mathcal{L}}_1(\bar{\mathbf{k}})}{\bar{f}}\right) \rho \wedge \bar{\zeta} + \sqrt{-1}\kappa \wedge \bar{\kappa}, \\ 7.1 \quad d\kappa &= \alpha \wedge \kappa + \left(\frac{-\mathcal{L}_1(\kappa)}{f}\right) \kappa \wedge \zeta + \left(-\frac{e\bar{\mathcal{L}}_1(\bar{\mathbf{k}})}{\bar{c}\bar{f}}\right) \kappa \wedge \bar{\kappa} + \left(\frac{c\bar{\mathcal{L}}_1(\mathbf{k})}{\bar{c}\bar{f}}\right) \zeta \wedge \bar{\kappa}, \\ d\zeta &= \delta \wedge \kappa + \varepsilon \wedge \zeta + \left(\frac{-e\mathcal{L}_1(\mathbf{k})}{cf}\right) \kappa \wedge \zeta + \left(\frac{-e^2\bar{\mathcal{L}}_1(\bar{\mathbf{k}})}{c\bar{c}\bar{f}}\right) \kappa \wedge \bar{\kappa} \\ &\quad + \left(\frac{e\mathcal{L}_1(\mathbf{k})}{\bar{c}\bar{f}}\right) \zeta \wedge \bar{\kappa}. \end{aligned}$$

We proceed with the absorption by setting

$$\begin{aligned} \alpha &= \hat{\alpha} - x_\rho \rho - x_\kappa \kappa - x_\zeta \zeta - x_{\bar{\kappa}} \bar{\kappa} - x_{\bar{\zeta}} \bar{\zeta}, \\ \delta &= \hat{\delta} - y_\rho \rho - y_\kappa \kappa - y_\zeta \zeta - y_{\bar{\kappa}} \bar{\kappa} - y_{\bar{\zeta}} \bar{\zeta}, \\ \varepsilon &= \hat{\varepsilon} - z_\rho \rho - z_\kappa \kappa - z_\zeta \zeta - z_{\bar{\kappa}} \bar{\kappa} - z_{\bar{\zeta}} \bar{\zeta}. \end{aligned}$$

Solving a system of linear equations to eliminate as many torsions as possible, one obtains

$$\begin{aligned} 7.2 \quad d\rho &= (\hat{\alpha} + \bar{\alpha}) \wedge \rho + \sqrt{-1}\kappa \wedge \bar{\kappa}, \\ d\kappa &= \hat{\alpha} \wedge \kappa + \frac{c\bar{\mathcal{L}}_1(\bar{\mathbf{k}})}{\bar{c}\bar{f}} \zeta \wedge \bar{\kappa}, \\ d\zeta &= \hat{\delta} \wedge \kappa + \hat{\varepsilon} \wedge \zeta. \end{aligned}$$

Notice that the function

$$\frac{\overline{c\mathcal{L}_1(\mathbf{k})}}{\bar{c}}$$

is nowhere vanishing, and hence the torsion that appears in $d\kappa$ may be normalised to 1 by setting

$$f = \frac{\overline{c\mathcal{L}_1(\mathbf{k})}}{\bar{c}}.$$

8. Cartan process: second loop

With this normalisation, we proceed with a change of the base coframe

$$\hat{\zeta}_0 := \overline{\mathcal{L}_1(\kappa)}\zeta_0,$$

so that the new transformation group becomes

$$\begin{pmatrix} \rho \\ \kappa \\ \zeta \end{pmatrix} = \begin{pmatrix} c\bar{c} & 0 & 0 \\ 0 & c & 0 \\ 0 & e & \frac{e}{\bar{c}} \end{pmatrix} \begin{pmatrix} \rho_0 \\ \kappa_0 \\ \hat{\zeta}_0 \end{pmatrix}.$$

Observe that both functions vanish identically

$$\mathcal{F}(\mathbf{k}) \equiv 0, \quad \mathcal{F}(\mathcal{L}_1(\mathbf{k})) \equiv 0,$$

since both \mathbf{k} and $\mathcal{L}_1(\mathbf{k})$ are independent of v . Using equation (5.5) of Foo-Merker [49], the new Darboux-Cartan structure equations become

$$\begin{aligned} d\rho_0 &= \mathbf{P} \rho \wedge \kappa_0 - \frac{\mathcal{L}_1(\mathbf{k})}{\overline{\mathcal{L}_1(\mathbf{k})}} \rho \wedge \hat{\zeta}_0 + \bar{\mathbf{P}} \rho_0 \wedge \bar{\kappa}_0 - \frac{\overline{\mathcal{L}_1(\bar{\mathbf{k}})}}{\overline{\mathcal{L}_1(\bar{\mathbf{k}})}} \rho_0 \wedge \hat{\bar{\zeta}}_0 + \sqrt{-1}\kappa_0 \wedge \bar{\kappa}_0, \\ 8.1 \quad d\kappa_0 &= -\frac{\mathcal{L}_1(\mathbf{k})}{\overline{\mathcal{L}_1(\mathbf{k})}} \kappa_0 \wedge \hat{\zeta}_0 + \hat{\zeta}_0 \wedge \bar{\kappa}_0, \\ d\hat{\zeta}_0 &= \frac{\mathcal{L}_1(\overline{\mathcal{L}_1(\mathbf{k})})}{\overline{\mathcal{L}_1(\mathbf{k})}} \kappa_0 \wedge \hat{\zeta}_0 - \frac{\overline{\mathcal{L}_1(\overline{\mathcal{L}_1(\mathbf{k})})}}{\overline{\mathcal{L}_1(\mathbf{k})}} \hat{\zeta}_0 \wedge \bar{\kappa}_0 + \frac{\overline{\mathcal{L}_1(\bar{\mathbf{k}})}}{\overline{\mathcal{L}_1(\bar{\mathbf{k}})}} \hat{\zeta}_0 \wedge \hat{\bar{\zeta}}_0. \end{aligned}$$

Moreover, one has the following Maurer-Cartan matrix

$$(d\mathbf{g})\mathbf{g}^{-1} = \begin{pmatrix} \alpha + \bar{\alpha} & 0 & 0 \\ 0 & \alpha & 0 \\ 0 & \delta & \alpha - \bar{\alpha} \end{pmatrix},$$

with the 1-forms

$$\alpha = \frac{dc}{c}, \quad \delta = \frac{de}{c} - \frac{e}{c} \left(\frac{dc}{c} - \frac{d\bar{c}}{\bar{c}} \right).$$

One obtains therefore

$$\begin{aligned}
d\rho &= (\alpha + \bar{\alpha}) \wedge \rho + \left(\frac{\mathbf{P}}{\mathbf{c}} + \frac{\mathcal{L}_1(\mathbf{k}) \mathbf{e}\bar{\mathbf{c}}}{\mathcal{L}_1(\mathbf{k}) \mathbf{c}^2} \right) \rho \wedge \kappa + \left(-\frac{\mathcal{L}_1(\mathbf{k}) \bar{\mathbf{c}}}{\mathcal{L}_1(\mathbf{k}) \mathbf{c}} \right) \rho \wedge \zeta \\
&\quad + \left(\frac{\bar{\mathbf{P}}}{\bar{\mathbf{c}}} + \frac{\overline{\mathcal{L}_1(\bar{\mathbf{k}})} \bar{\mathbf{e}}\bar{\mathbf{c}}}{\overline{\mathcal{L}_1(\bar{\mathbf{k}})} \bar{\mathbf{c}}^2} \right) \rho \wedge \bar{\kappa} + \left(-\frac{\overline{\mathcal{L}_1(\bar{\mathbf{k}})} \bar{\mathbf{c}}}{\overline{\mathcal{L}_1(\bar{\mathbf{k}})} \bar{\mathbf{c}}} \right) \rho \wedge \bar{\zeta} + \sqrt{-1}\kappa \wedge \bar{\kappa}, \\
d\kappa &= \alpha \wedge \kappa + \left(-\frac{\mathcal{L}_1(\mathbf{k}) \bar{\mathbf{c}}}{\mathcal{L}_1(\mathbf{k}) \mathbf{c}} \right) \kappa \wedge \zeta - \frac{\mathbf{e}}{\mathbf{c}} \kappa \wedge \bar{\kappa} + \zeta \wedge \bar{\kappa}, \\
d\zeta &= \delta \wedge \kappa + (\alpha - \bar{\alpha}) \wedge \zeta + \left(-\frac{\mathcal{L}_1(\mathbf{k}) \mathbf{e}\bar{\mathbf{c}}}{\mathcal{L}_1(\mathbf{k}) \mathbf{c}^2} + \frac{\mathcal{L}_1(\overline{\mathcal{L}_1(\mathbf{k}))} 1}{\mathcal{L}_1(\mathbf{k}) \mathbf{c}} \right) \kappa \wedge \zeta \\
&\quad + \left(-\frac{\mathbf{e}^2}{\mathbf{c}^2} + \frac{\overline{\mathcal{L}_1(\bar{\mathbf{k}})} \mathbf{e}\bar{\mathbf{e}}}{\overline{\mathcal{L}_1(\bar{\mathbf{k}})} \bar{\mathbf{c}}^2} + \frac{\overline{\mathcal{L}_1(\overline{\mathcal{L}_1(\mathbf{k}))} \mathbf{e}}}{\overline{\mathcal{L}_1(\bar{\mathbf{k}})} \mathbf{c}\bar{\mathbf{c}}} \right) \kappa \wedge \bar{\kappa} + \left(\frac{\mathbf{e}}{\mathbf{c}} - \frac{\overline{\mathcal{L}_1(\bar{\mathbf{k}})} \bar{\mathbf{e}}\bar{\mathbf{c}}}{\overline{\mathcal{L}_1(\bar{\mathbf{k}})} \bar{\mathbf{c}}^2} - \frac{\overline{\mathcal{L}_1(\overline{\mathcal{L}_1(\mathbf{k}))} 1}{\overline{\mathcal{L}_1(\bar{\mathbf{k}})} \bar{\mathbf{c}}} \right) \zeta \wedge \bar{\kappa} \\
&\quad - \frac{\overline{\mathcal{L}_1(\bar{\mathbf{k}})} \mathbf{e}}{\overline{\mathcal{L}_1(\bar{\mathbf{k}})} \bar{\mathbf{c}}} \kappa \wedge \bar{\zeta} + \frac{\mathbf{c}\overline{\mathcal{L}_1(\bar{\mathbf{k}})}}{\bar{\mathbf{c}}\overline{\mathcal{L}_1(\bar{\mathbf{k}})}} \zeta \wedge \bar{\zeta}.
\end{aligned}$$

As before, we proceed with the absorption by setting

$$\begin{aligned}
\alpha &= \hat{\alpha} - x_\rho \rho - x_\kappa \kappa - x_\zeta \zeta - x_{\bar{\kappa}} \bar{\kappa} - x_{\bar{\zeta}} \bar{\zeta}, \\
\delta &= \hat{\delta} - y_\rho \rho - y_\kappa \kappa - y_\zeta \zeta - y_{\bar{\kappa}} \bar{\kappa} - y_{\bar{\zeta}} \bar{\zeta}.
\end{aligned}$$

The equations that need attention are

$$\begin{aligned}
x_{\bar{\kappa}} + \bar{x}_\kappa &= -\frac{\bar{\mathbf{P}}}{\bar{\mathbf{c}}} - \frac{\overline{\mathcal{L}_1(\bar{\mathbf{k}})} \bar{\mathbf{e}}\bar{\mathbf{c}}}{\overline{\mathcal{L}_1(\bar{\mathbf{k}})} \bar{\mathbf{c}}^2}, \\
x_{\bar{\kappa}} &= \frac{\mathbf{e}}{\mathbf{c}}, \\
x_{\bar{\kappa}} - \bar{x}_\kappa &= -\frac{\mathbf{e}}{\mathbf{c}} + \frac{\overline{\mathcal{L}_1(\bar{\mathbf{k}})} \bar{\mathbf{e}}\bar{\mathbf{c}}}{\overline{\mathcal{L}_1(\bar{\mathbf{k}})} \bar{\mathbf{c}}^2} + \frac{\overline{\mathcal{L}_1(\overline{\mathcal{L}_1(\mathbf{k}))} 1}{\overline{\mathcal{L}_1(\bar{\mathbf{k}})} \bar{\mathbf{c}}}.
\end{aligned}$$

For the linear equations to have solutions, one therefore has to make the following choice for e:

$$\mathbf{e} = \frac{\mathbf{c}}{\bar{\mathbf{c}}} \left(-\frac{1}{3} \bar{\mathbf{P}} + \frac{1}{3} \frac{\overline{\mathcal{L}_1(\overline{\mathcal{L}_1(\mathbf{k}))}}}{\overline{\mathcal{L}_1(\bar{\mathbf{k}})}} \right).$$

We remark as well that in [49], a similar normalisation is done during second loop of the Cartan process where the following choice for b is made:

$$\mathbf{b} = -\sqrt{-1}\bar{\mathbf{c}}\mathbf{e} + \frac{\sqrt{-1}}{3}\mathbf{c} \left(\frac{\overline{\mathcal{L}_1(\overline{\mathcal{L}_1(\mathbf{k}))}}}{\overline{\mathcal{L}_1(\bar{\mathbf{k}})}} - \bar{\mathbf{P}} \right),$$

so that when $\mathbf{b} = 0$ due to rigidity assumption, the same expression for e is also obtained. At this stage, we set

$$\mathbf{B} := -\frac{1}{3} \bar{\mathbf{P}} + \frac{1}{3} \frac{\overline{\mathcal{L}_1(\overline{\mathcal{L}_1(\mathbf{k}))}}}{\overline{\mathcal{L}_1(\bar{\mathbf{k}})}}.$$

9. Final loop

We make another change of base coframe by setting

$$\zeta'_0 = \hat{\zeta}_0 + \mathbf{B}\kappa_0.$$

The new transformation group becomes

$$\begin{pmatrix} \rho \\ \kappa \\ \zeta \end{pmatrix} = \begin{pmatrix} c\bar{c} & 0 & 0 \\ 0 & c & 0 \\ 0 & 0 & \bar{c} \end{pmatrix} \begin{pmatrix} \rho_0 \\ \kappa_0 \\ \zeta'_0 \end{pmatrix},$$

with the new Darboux-Cartan structure:

$$\begin{aligned} d\rho_0 &= \left(\mathbf{P} + \mathbf{B} \frac{\mathcal{L}_1(\mathbf{k})}{\mathcal{L}_1(\mathbf{k})} \right) \rho_0 \wedge \kappa_0 - \frac{\mathcal{L}_1(\mathbf{k})}{\mathcal{L}_1(\mathbf{k})} \rho_0 \wedge \zeta'_0 \\ &\quad + \left(\bar{\mathbf{P}} + \bar{\mathbf{B}} \frac{\overline{\mathcal{L}_1(\bar{\mathbf{k}})}}{\mathcal{L}_1(\bar{\mathbf{k}})} \right) \rho_0 \wedge \bar{\kappa}_0 - \frac{\overline{\mathcal{L}_1(\bar{\mathbf{k}})}}{\mathcal{L}_1(\bar{\mathbf{k}})} \rho_0 \wedge \bar{\zeta}'_0 \\ &\quad + \sqrt{-1}\kappa_0 \wedge \bar{\kappa}_0 \\ &= \left(\mathbf{P} - \frac{\bar{\mathbf{P}}\mathcal{L}_1(\mathbf{k})}{3\mathcal{L}_1(\mathbf{k})} + \frac{\overline{\mathcal{L}_1(\overline{\mathcal{L}_1(\mathbf{k}))}\mathcal{L}_1(\mathbf{k})}}{3\mathcal{L}_1(\mathbf{k})^2} \right) \rho_0 \wedge \kappa_0 - \frac{\mathcal{L}_1(\mathbf{k})}{\mathcal{L}_1(\mathbf{k})} \rho_0 \wedge \zeta'_0 \\ 9.1 \quad &\quad + \left(\bar{\mathbf{P}} - \frac{\mathbf{P}\overline{\mathcal{L}_1(\bar{\mathbf{k}})}}{3\mathcal{L}_1(\bar{\mathbf{k}})} + \frac{\mathcal{L}_1(\overline{\mathcal{L}_1(\bar{\mathbf{k}})}\overline{\mathcal{L}_1(\bar{\mathbf{k}})})}{3\mathcal{L}_1(\bar{\mathbf{k}})^2} \right) \rho_0 \wedge \bar{\kappa}_0 - \frac{\overline{\mathcal{L}_1(\bar{\mathbf{k}})}}{\mathcal{L}_1(\bar{\mathbf{k}})} \rho_0 \wedge \bar{\zeta}'_0 \\ &\quad + \sqrt{-1}\kappa_0 \wedge \bar{\kappa}_0 \\ &=: \mathbf{R}_1 \rho_0 \wedge \kappa + \mathbf{R}_2 \rho_0 \wedge \zeta'_0 + \bar{\mathbf{R}}_1 \rho_0 \wedge \bar{\kappa}_0 + \bar{\mathbf{R}}_2 \rho_0 \wedge \bar{\zeta}'_0 + \sqrt{-1}\kappa_0 \wedge \bar{\kappa}_0, \\ d\kappa_0 &= -\frac{\mathcal{L}_1(\mathbf{k})}{\mathcal{L}_1(\mathbf{k})} \kappa_0 \wedge \zeta'_0 - \mathbf{B} \kappa_0 \wedge \bar{\kappa}_0 + \zeta'_0 \wedge \bar{\kappa}_0 \\ &= -\frac{\mathcal{L}_1(\mathbf{k})}{\mathcal{L}_1(\mathbf{k})} \kappa_0 \wedge \zeta'_0 + \left(\frac{\bar{\mathbf{P}}}{3} - \frac{\overline{\mathcal{L}_1(\overline{\mathcal{L}_1(\mathbf{k}))}}}{3\mathcal{L}_1(\mathbf{k})} \right) \kappa_0 \wedge \bar{\kappa}_0 + \zeta'_0 \wedge \bar{\kappa}_0 \\ &=: \mathbf{K}_5 \kappa_0 \wedge \zeta'_0 + \mathbf{K}_6 \kappa_0 \wedge \bar{\kappa}_0 + \zeta'_0 \wedge \bar{\kappa}_0, \end{aligned}$$

The 2-form $d\zeta'_0$ requires a bit of computation, as will be seen in the proof of the following

PROPOSITION 9.2. *One has*

$$\begin{aligned} d\zeta'_0 &= \left(-\mathbf{B} \frac{\mathcal{L}_1(\mathbf{k})}{\mathcal{L}_1(\mathbf{k})} + \frac{\mathcal{L}_1(\overline{\mathcal{L}_1(\mathbf{k}))}}{\mathcal{L}_1(\mathbf{k})} - \frac{\mathcal{H}(\mathbf{B})}{\mathcal{L}_1(\mathbf{k})} \right) \kappa_0 \wedge \zeta'_0 + \left(-\mathbf{B}^2 + \mathbf{B} \frac{\overline{\mathcal{L}_1(\overline{\mathcal{L}_1(\mathbf{k}))}}}{\mathcal{L}_1(\mathbf{k})} - \overline{\mathcal{L}_1(\mathbf{B})} \right) \kappa_0 \wedge \bar{\kappa}_0 \\ &\quad + \left(\mathbf{B} - \frac{\overline{\mathcal{L}_1(\overline{\mathcal{L}_1(\mathbf{k}))}}}{\mathcal{L}_1(\mathbf{k})} - \bar{\mathbf{B}} \frac{\overline{\mathcal{L}_1(\bar{\mathbf{k}})}}{\mathcal{L}_1(\bar{\mathbf{k}})} \right) \zeta'_0 \wedge \bar{\kappa}_0 + \frac{\overline{\mathcal{L}_1(\bar{\mathbf{k}})}}{\mathcal{L}_1(\bar{\mathbf{k}})} \zeta'_0 \wedge \bar{\zeta}'_0 \\ &=: \mathbf{Z}_5 \kappa_0 \wedge \zeta'_0 + \mathbf{Z}_6 \kappa_0 \wedge \bar{\kappa}_0 + \mathbf{Z}_8 \zeta'_0 \wedge \bar{\kappa}_0 + \mathbf{Z}_9 \zeta'_0 \wedge \bar{\zeta}'_0. \end{aligned}$$

PROOF. Using the transformation $\zeta'_0 = \hat{\zeta}_0 + \mathbf{B}\kappa_0$, the 2-forms $d\hat{\zeta}_0$ and $d\kappa_0$ are expressed in terms of the new coframe $(\rho, \kappa_0, \zeta'_0)$ as

$$\begin{aligned} d\hat{\zeta}_0 &= \frac{\mathcal{L}_1(\overline{\mathcal{L}}_1(\mathbf{k}))}{\overline{\mathcal{L}}_1(\mathbf{k})} \kappa_0 \wedge \zeta'_0 - \mathbf{B} \frac{\overline{\mathcal{L}}_1(\overline{\mathbf{k}})}{\overline{\mathcal{L}}_1(\overline{\mathbf{k}})} \kappa_0 \wedge \overline{\zeta}'_0 - \left(\frac{\overline{\mathcal{L}}_1(\overline{\mathcal{L}}_1(\mathbf{k}))}{\overline{\mathcal{L}}_1(\mathbf{k})} + \overline{\mathbf{B}} \frac{\overline{\mathcal{L}}_1(\overline{\mathbf{k}})}{\overline{\mathcal{L}}_1(\overline{\mathbf{k}})} \right) \zeta'_0 \wedge \overline{\kappa}_0 \\ &+ \left(\mathbf{B} \frac{\overline{\mathcal{L}}_1(\overline{\mathcal{L}}_1(\mathbf{k}))}{\overline{\mathcal{L}}_1(\mathbf{k})} + \mathbf{B}\overline{\mathbf{B}} \frac{\overline{\mathcal{L}}_1(\overline{\mathbf{k}})}{\overline{\mathcal{L}}_1(\overline{\mathbf{k}})} \right) \kappa_0 \wedge \overline{\kappa}_0 + \frac{\overline{\mathcal{L}}_1(\overline{\mathbf{k}})}{\overline{\mathcal{L}}_1(\overline{\mathbf{k}})} \zeta'_0 \wedge \overline{\zeta}'_0, \end{aligned}$$

as well as

$$d\kappa_0 = -\frac{\mathcal{L}_1(\mathbf{k})}{\overline{\mathcal{L}}_1(\mathbf{k})} \kappa_0 \wedge \zeta'_0 - \mathbf{B} \kappa_0 \wedge \overline{\kappa}_0 + \zeta'_0 \wedge \overline{\kappa}_0.$$

Moreover one has for the 1-form $d\mathbf{B}$ the following expansion

$$d\mathbf{B} = \mathcal{T}(\mathbf{B}) \rho_0 + \mathcal{L}_1(\mathbf{B}) \kappa_0 + \mathcal{H}(\mathbf{B}) \zeta_0 + \overline{\mathcal{L}}_1(\mathbf{B}) \overline{\kappa}_0 + \overline{\mathcal{H}}(\mathbf{B}) \overline{\zeta}_0.$$

By rigidity assumption, $\mathcal{T}(\mathbf{B}) \equiv 0$; and by using the Assertion 7.4 on page 26 of Foo-Merker [49],

$$\overline{\mathcal{H}}(\mathbf{B}) = -\mathbf{B}\overline{\mathcal{L}}_1(\overline{\mathbf{k}}).$$

Using these two observations, the 1-form $d\mathbf{B}$ is therefore

$$d\mathbf{B} = \left(\mathcal{L}_1(\mathbf{B}) - \mathbf{B} \frac{\mathcal{H}(\mathbf{B})}{\overline{\mathcal{L}}_1(\mathbf{k})} \right) \kappa_0 + \frac{\mathcal{H}(\mathbf{B})}{\overline{\mathcal{L}}_1(\mathbf{k})} \zeta'_0 + \left(\overline{\mathcal{L}}_1(\mathbf{B}) + \mathbf{B}\overline{\mathbf{B}} \frac{\overline{\mathcal{L}}_1(\overline{\mathbf{k}})}{\overline{\mathcal{L}}_1(\overline{\mathbf{k}})} \right) \overline{\kappa}_0 - \mathbf{B} \frac{\overline{\mathcal{L}}_1(\overline{\mathbf{k}})}{\overline{\mathcal{L}}_1(\overline{\mathbf{k}})} \overline{\zeta}'_0.$$

Substituting $d\hat{\zeta}_0$, $d\kappa_0$ and $d\mathbf{B}$ in the following identity

$$d\zeta'_0 = d\hat{\zeta}_0 + d\mathbf{B} \wedge \kappa_0 + \mathbf{B} d\kappa_0$$

by the expressions computed above finishes the proof of the proposition. \square

Explicitly,

$$\begin{aligned} d\zeta'_0 &= \left(\frac{\overline{\mathbf{P}}\overline{\mathcal{L}}_1(\mathbf{k})}{3\overline{\mathcal{L}}_1(\mathbf{k})} - \frac{\overline{\mathcal{L}}_1(\overline{\mathcal{L}}_1(\mathbf{k}))\overline{\mathcal{L}}_1(\mathbf{k})}{3\overline{\mathcal{L}}_1(\mathbf{k})^2} + \frac{\overline{\mathcal{L}}_1(\overline{\mathcal{L}}_1(\mathbf{k}))}{\overline{\mathcal{L}}_1(\mathbf{k})} + \frac{\mathcal{H}(\overline{\mathbf{P}})}{3\overline{\mathcal{L}}_1(\mathbf{k})} \right. \\ &\quad \left. - \frac{\mathcal{H}(\overline{\mathcal{L}}_1(\overline{\mathcal{L}}_1(\mathbf{k})))}{3\overline{\mathcal{L}}_1(\mathbf{k})^2} + \frac{\mathcal{H}(\overline{\mathcal{L}}_1(\mathbf{k}))\overline{\mathcal{L}}_1(\overline{\mathcal{L}}_1(\mathbf{k})))}{3\overline{\mathcal{L}}_1(\mathbf{k})^3} \right) \kappa_0 \wedge \zeta'_0 \\ &+ \left(\frac{-\overline{\mathbf{P}}^2}{9} - \frac{\overline{\mathbf{P}}\overline{\mathcal{L}}_1(\overline{\mathcal{L}}_1(\mathbf{k}))}{9\overline{\mathcal{L}}_1(\mathbf{k})} + \frac{5\overline{\mathcal{L}}_1(\overline{\mathcal{L}}_1(\mathbf{k}))^2}{9\overline{\mathcal{L}}_1(\mathbf{k})^2} \right. \\ &\quad \left. - \frac{\overline{\mathcal{L}}_1(\overline{\mathcal{L}}_1(\overline{\mathcal{L}}_1(\mathbf{k})))}{3\overline{\mathcal{L}}_1(\mathbf{k})} + \frac{\overline{\mathcal{L}}_1(\overline{\mathbf{P}})}{3} \right) \kappa_0 \wedge \overline{\kappa}_0 \\ &+ \left(\frac{-\overline{\mathbf{P}}}{3} - \frac{2\overline{\mathcal{L}}_1(\overline{\mathcal{L}}_1(\mathbf{k}))}{3\overline{\mathcal{L}}_1(\mathbf{k})} + \frac{\overline{\mathbf{P}}\overline{\mathcal{L}}_1(\overline{\mathbf{k}})}{3\overline{\mathcal{L}}_1(\overline{\mathbf{k}})} - \frac{\overline{\mathcal{L}}_1(\overline{\mathcal{L}}_1(\overline{\mathbf{k}}))\overline{\mathcal{L}}_1(\overline{\mathbf{k}})}{3\overline{\mathcal{L}}_1(\overline{\mathbf{k}})^2} \right) \zeta'_0 \wedge \overline{\kappa}_0 \\ &+ \frac{\overline{\mathcal{L}}_1(\overline{\mathbf{k}})}{\overline{\mathcal{L}}_1(\overline{\mathbf{k}})} \zeta'_0 \wedge \overline{\zeta}'_0. \end{aligned}$$

9.3

After transformation, the new 2-forms $d\rho$, $d\kappa$ and $d\zeta$ become

$$d\rho = (\alpha + \bar{\alpha}) \wedge \rho + \frac{1}{c} \mathbf{R}_1 \rho \wedge \kappa + \frac{\bar{c}}{c} \mathbf{R}_2 \rho \wedge \zeta + \frac{1}{c} \bar{\mathbf{R}}_1 \rho \wedge \bar{\kappa} + \frac{c}{c} \bar{\mathbf{R}}_2 \rho \wedge \bar{\zeta} + \sqrt{-1} \kappa \wedge \bar{\kappa},$$

$$d\kappa = \alpha \wedge \kappa + \frac{\bar{c}}{c} \mathbf{K}_5 \kappa \wedge \zeta + \frac{1}{c} \mathbf{K}_6 \kappa \wedge \bar{\kappa} + \zeta \wedge \bar{\kappa},$$

$$d\zeta = (\alpha - \bar{\alpha}) \wedge \zeta + \frac{1}{c} \mathbf{Z}_5 \kappa \wedge \zeta + \frac{1}{c^2} \mathbf{Z}_6 \kappa \wedge \bar{\kappa} + \frac{1}{c} \mathbf{Z}_8 \zeta \wedge \bar{\kappa} + \frac{c}{c} \mathbf{Z}_9 \zeta \wedge \bar{\zeta}.$$

By setting the new Maurer-Cartan 1-form as

$$\alpha := \hat{\alpha} - x_\rho \rho - x_\kappa \kappa - x_\zeta \zeta - x_{\bar{\kappa}} \bar{\kappa} - x_{\bar{\zeta}} \bar{\zeta},$$

with

$$9.4 \quad x_\rho = 0, \quad x_\kappa = -\frac{1}{c} \mathbf{R}_1 + \frac{1}{c} \bar{\mathbf{K}}_6, \quad x_{\bar{\kappa}} = \frac{1}{c} \mathbf{B}, \quad x_\zeta = \frac{\bar{c} \mathcal{L}_1(\mathbf{k})}{c \mathcal{L}_1(\mathbf{k})}, \quad x_{\bar{\zeta}} = 0,$$

the final absorbed equations become:

$$9.5 \quad d\rho = (\hat{\alpha} + \bar{\alpha}) \wedge \rho + \sqrt{-1} \kappa \wedge \bar{\kappa},$$

$$9.6 \quad d\kappa = \hat{\alpha} \wedge \kappa + \zeta \wedge \bar{\kappa},$$

$$9.7 \quad d\zeta = (\hat{\alpha} - \bar{\alpha}) \wedge \zeta + \frac{1}{c} (\mathbf{Z}_5 - \bar{\mathbf{Z}}_8) \kappa \wedge \zeta + \frac{1}{c^2} \mathbf{Z}_6 \kappa \wedge \bar{\kappa}.$$

10. The $\{e\}$ -structure.

This time, for ease of notation, we write

$$\mathbf{S}_5 = \frac{1}{c} (\mathbf{Z}_5 - \bar{\mathbf{Z}}_8) := \frac{1}{c} \mathbf{I}_0, \quad \mathbf{S}_6 = \frac{1}{c^2} \mathbf{Z}_6 := \frac{1}{c^2} \mathbf{V}_0.$$

If we write

$$\psi := -\mathbf{S}_5 \zeta - \mathbf{S}_6 \bar{\kappa},$$

equation 9.7 may be written otherwise as

$$d\zeta = (\hat{\alpha} - \bar{\alpha}) \wedge \zeta + \psi \wedge \kappa.$$

Based on the model case in Section 4, one should obtain for $d\hat{\alpha}$ the following:

$$d\hat{\alpha} = \zeta \wedge \bar{\zeta} + \cdots,$$

where the remaining terms are 2-forms that vanish in the model case. Taking exterior derivatives of both sides of equations 9.5, 9.6 and 9.7:

$$0 = (d\hat{\alpha} + d\bar{\alpha}) \wedge \rho,$$

$$10.1 \quad 0 = (d\hat{\alpha} - \zeta \wedge \bar{\zeta} + \mathbf{S}_5 \zeta \wedge \bar{\kappa}) \wedge \kappa$$

$$0 = (d\hat{\alpha} - d\bar{\alpha}) \wedge \zeta - (\hat{\alpha} - \bar{\alpha}) \wedge d\zeta + d\psi \wedge \kappa - \psi \wedge \alpha \wedge \kappa.$$

In the second equation of 10.1, Cartan's lemma provides a 1-form A with

$$d\hat{\alpha} = \zeta \wedge \bar{\zeta} - \mathbf{S}_5 \zeta \wedge \bar{\kappa} + A \wedge \kappa.$$

To study A , write it as a formal linear combination of the 1-forms with unknown coefficients:

$$A = A_\rho \rho + A_\kappa \kappa + A_\zeta \zeta + A_{\hat{\alpha}} \hat{\alpha} + A_{\bar{\kappa}} \bar{\kappa} + A_{\bar{\zeta}} \bar{\zeta} + A_{\bar{\alpha}} \bar{\alpha}.$$

From the first equation of 10.1, one obtains

$$A_{\bar{\zeta}} = \bar{S}_5, \quad A_{\zeta} = 0, \quad A_{\bar{\kappa}} \text{ is real}, \quad A_{\hat{\alpha}} = A_{\bar{\alpha}} = 0,$$

and so

$$d\hat{\alpha} = \zeta \wedge \bar{\zeta} - S_5 \zeta \wedge \bar{\kappa} + A_{\rho} \rho \wedge \kappa + A_{\bar{\kappa}} \bar{\kappa} \wedge \kappa + \bar{S}_5 \bar{\zeta} \wedge \kappa.$$

Using this expression of $d\hat{\alpha}$ in the third equation of 10.1, the remaining coefficients of A are therefore obtained:

$$A_{\rho} = 0, \quad 0 = 2A_{\bar{\kappa}} \bar{\kappa} \wedge \kappa \wedge \zeta \wedge \bar{\zeta} + \bar{\alpha} \wedge \psi \wedge \kappa \wedge \bar{\zeta} + d\psi \wedge \kappa \wedge \bar{\zeta}.$$

We expand $d\psi$ so that

$$\begin{aligned} 10.2 \quad d\psi \wedge \kappa \wedge \bar{\zeta} &= (-dS_5 \wedge \zeta - S_5 d\zeta - dS_6 \wedge \bar{\kappa} - S_6 d\bar{\kappa}) \wedge \kappa \wedge \bar{\zeta} \\ &= -((S_5)_{\bar{\kappa}} - (S_6)_{\zeta}) \kappa \wedge \bar{\kappa} \wedge \zeta \wedge \bar{\zeta} + \dots, \end{aligned}$$

where $(\bullet)_{\bar{\kappa}}$ denotes the covariant derivative of the function \bullet with respect to $\bar{\kappa}$ (and same definition applies to $(\bullet)_{\zeta}$). We could have concluded the $\{e\}$ -structure by declaring

$$A_{\bar{\kappa}} = -\frac{1}{2}((S_5)_{\bar{\kappa}} - (S_6)_{\zeta}),$$

which is a secondary invariant.

To make sure that the equation does make sense, the term on the right needs to be verified that it is real-valued. This requires some computation. First we need a lemma:

LEMMA 10.3. *On the G -structure $M \times G^2$ with coordinates $(z_1, z_2, \bar{z}_1, \bar{z}_2, v, c, \bar{c})$, let $F : M \times G^2 \rightarrow \mathbb{C}$ be a function. Then*

$$\begin{aligned} 10.4 \quad dF &= c \partial_c F \hat{\alpha} + \bar{c} \partial_{\bar{c}} F \bar{\hat{\alpha}} + \left(\frac{1}{c\bar{c}} \mathcal{I}(F) - cx_{\rho} \partial_c F - \bar{c} x_{\bar{\rho}} \partial_{\bar{c}} F \right) \rho \\ &+ \left(\frac{1}{c} \left(\mathcal{L}_1(F) - \mathbf{B} \frac{\mathcal{K}(F)}{\mathcal{L}_1(\mathbf{k})} \right) - cx_{\kappa} \partial_c F - \bar{c} x_{\bar{\kappa}} \partial_{\bar{c}} F \right) \kappa \\ &+ \left(\frac{\bar{c}}{c} \frac{\mathcal{K}(F)}{\mathcal{L}_1(\mathbf{k})} - cx_{\zeta} \partial_c F - \bar{c} x_{\bar{\zeta}} \partial_{\bar{c}} F \right) \zeta \\ &+ \left(\frac{1}{\bar{c}} \left(\bar{\mathcal{L}}_1(F) - \bar{\mathbf{B}} \frac{\bar{\mathcal{K}}(F)}{\bar{\mathcal{L}}_1(\bar{\mathbf{k}})} \right) - cx_{\bar{\kappa}} \partial_c F - \bar{c} x_{\kappa} \partial_{\bar{c}} F \right) \bar{\kappa} \\ &+ \left(\frac{c}{\bar{c}} \frac{\mathcal{K}(F)}{\mathcal{L}_1(\bar{\mathbf{k}})} - cx_{\bar{\zeta}} \partial_c F - \bar{c} x_{\zeta} \partial_{\bar{c}} F \right) \bar{\zeta} \\ &:= \partial_{\alpha}(F) \alpha + \partial_{\bar{\alpha}}(F) \bar{\alpha} + \partial_{\rho}(F) \rho + \partial_{\kappa}(F) \kappa + \partial_{\zeta}(F) \zeta \\ &+ \partial_{\bar{\kappa}}(F) \bar{\kappa} + \partial_{\bar{\zeta}}(F) \bar{\zeta}. \end{aligned}$$

The proof of the lemma is done by straightforward computation which will be skipped. With the solution to the absorption equations 9.4, we therefore have the following vector fields:

$$\begin{aligned}
\partial_\alpha &:= c\partial_c, \\
\partial_\rho &:= \frac{1}{c\bar{c}}\mathcal{F}, \\
10.5 \quad \partial_{\bar{\kappa}} &:= \frac{1}{c}\left(\mathcal{L}_1 - B\frac{\mathcal{K}}{\mathcal{L}_1(\mathbf{k})}\right) - c\left(-\frac{1}{c}\mathbf{R}_1 + \frac{1}{c}\bar{\mathbf{K}}_6\right)\partial_c + \frac{\bar{c}}{c}\bar{B}\partial_{\bar{c}}, \\
\partial_\zeta &= \frac{\bar{c}}{c}\frac{\mathcal{K}}{\mathcal{L}_1(\mathbf{k})} - \bar{c}\frac{\mathcal{L}_1(\mathbf{k})}{\mathcal{L}_1(\bar{\mathbf{k}})}\partial_c,
\end{aligned}$$

while the vector fields $\partial_{\bar{\alpha}}$, $\partial_{\bar{\kappa}}$, $\partial_{\bar{\zeta}}$ are respective complex conjugates of ∂_α , ∂_κ , ∂_ζ . As a result:

$$\begin{aligned}
(\mathbf{S}_5)_{\bar{\kappa}} - (\mathbf{S}_6)_\zeta &= \frac{1}{c\bar{c}}\left(\overline{\mathcal{L}_1}(\mathbf{I}_0) - \bar{B}\frac{\overline{\mathcal{K}}(\mathbf{I}_0)}{\mathcal{L}_1(\bar{\mathbf{k}})} + B\mathbf{I}_0 - \frac{\mathcal{K}(\mathbf{V}_0)}{\mathcal{L}_1(\mathbf{k})}\right) := \frac{1}{c\bar{c}}\mathbf{Q}_0 \\
&= \frac{1}{c\bar{c}}\left(\overline{\mathcal{L}_1}(\mathbf{Z}_5) - \overline{\mathcal{L}_1}(\bar{\mathbf{Z}}_8) - \bar{B}\frac{\overline{\mathcal{K}}(\mathbf{Z}_5)}{\mathcal{L}_1(\bar{\mathbf{k}})} + \bar{B}\frac{\overline{\mathcal{K}}(\bar{\mathbf{Z}}_8)}{\mathcal{L}_1(\bar{\mathbf{k}})} + B\mathbf{Z}_5 - B\bar{\mathbf{Z}}_8 - \frac{\mathcal{K}(\mathbf{Z}_6)}{\mathcal{L}_1(\mathbf{k})}\right).
\end{aligned}$$

We will also need the following

LEMMA 10.6. *One has the following identity*

$$\overline{\mathcal{L}_1}(\mathbf{Z}_5) - \frac{\mathcal{K}(\mathbf{Z}_6)}{\mathcal{L}_1(\mathbf{k})} = \bar{B}\frac{\overline{\mathcal{K}}(\mathbf{Z}_5)}{\mathcal{L}_1(\bar{\mathbf{k}})} + \mathbf{Z}_5\mathbf{K}_6 - \mathbf{Z}_6\mathbf{K}_5 - \mathcal{L}_1(\mathbf{Z}_8) + B\frac{\mathcal{K}(\mathbf{Z}_8)}{\mathcal{L}_1(\mathbf{k})} + \mathbf{Z}_8\bar{\mathbf{K}}_6 + \mathbf{Z}_9\bar{\mathbf{Z}}_6.$$

PROOF. We will compute the terms on the left-hand side by applying $d^2 \equiv 0$ to the third equation of equation 9.1. Doing so, while wedging on both sides of $d^2\zeta'_0 = 0$ with $\rho \wedge \bar{\zeta}'_0$, one should get

$$0 = ((\mathbf{Z}_5)_{\bar{\kappa}_0} - \mathbf{Z}_5\mathbf{K}_6 - \mathbf{Z}_5\mathbf{Z}_8 - (\mathbf{Z}_6)_{\zeta'_0} + \mathbf{Z}_6\mathbf{K}_5 + (\mathbf{Z}_8)_{\kappa_0} + \mathbf{Z}_8\mathbf{Z}_5 - \mathbf{Z}_8\bar{\mathbf{K}}_6 - \mathbf{Z}_9\bar{\mathbf{Z}}_6)\rho_0 \wedge \kappa_0 \wedge \bar{\kappa}_0 \wedge \zeta'_0 \wedge \bar{\zeta}'_0.$$

Finally, for any function G independent of c , one uses the following formula

$$\begin{aligned}
dG &= \mathcal{F}(G)\rho + \left(\mathcal{L}_1(G) - B\frac{\mathcal{K}(G)}{\mathcal{L}_1(\mathbf{k})}\right)\kappa_0 + \frac{\mathcal{K}(G)}{\mathcal{L}_1(\mathbf{k})}\zeta'_0 \\
&\quad + \left(\overline{\mathcal{L}_1}(G) - \bar{B}\frac{\overline{\mathcal{K}}(G)}{\mathcal{L}_1(\bar{\mathbf{k}})}\right)\bar{\kappa}_0 + \frac{\overline{\mathcal{K}}(G)}{\mathcal{L}_1(\bar{\mathbf{k}})}\bar{\zeta}'_0.
\end{aligned}$$

The proof is therefore complete by applying this to $(\mathbf{Z}_5)_{\bar{\kappa}_0}$, $(\mathbf{Z}_6)_{\zeta'_0}$ and $(\mathbf{Z}_8)_{\kappa_0}$. \square

Substituting the identity into $A_{\bar{\kappa}}$, one has therefore

$$10.7 \quad -2A_{\bar{\kappa}} = \frac{1}{c\bar{c}}\left((- \mathbf{Z}_6\mathbf{K}_5 + \mathbf{Z}_9\bar{\mathbf{Z}}_6) - \mathcal{L}_1(\mathbf{Z}_8) - \overline{\mathcal{L}_1}(\bar{\mathbf{Z}}_8) + B\frac{\mathcal{K}(\mathbf{Z}_8)}{\mathcal{L}_1(\mathbf{k})} + \bar{B}\frac{\overline{\mathcal{K}}(\bar{\mathbf{Z}}_8)}{\mathcal{L}_1(\bar{\mathbf{k}})} - \mathbf{Z}_8\bar{B} - \bar{\mathbf{Z}}_8B\right),$$

and observing that $\mathbf{Z}_9 = -\bar{\mathbf{K}}_5$, the coefficient $A_{\bar{\kappa}}$ is thus real-valued, and the $\{e\}$ -structure is finally complete.

We have therefore proved Theorem 1.3.

In the interest of computations, the secondary invariant

$$\mathbf{Q}_0 := \frac{1}{2}\left(\overline{\mathcal{L}_1}(\mathbf{I}_0) - \bar{B}\frac{\overline{\mathcal{K}}(\mathbf{I}_0)}{\mathcal{L}_1(\bar{\mathbf{k}})} + B\mathbf{I}_0 - \frac{\mathcal{K}(\mathbf{V}_0)}{\mathcal{L}_1(\mathbf{k})}\right)$$

may further be simplified using the following:

PROPOSITION 10.8. *Under the Levi degeneracy assumption, one has:*

$$\frac{\overline{\mathcal{H}}(I_0)}{\mathcal{L}_1(\overline{k})} = -2\overline{I}_0.$$

PROOF. We remark here that the Levi-degeneracy condition is necessary to normalise the expression and thus it cannot be dropped. It is implicitly used in $d\rho$ the first equation of the following $\{e\}$ -structure:

$$\begin{aligned} d\rho &= (\alpha + \overline{\alpha}) \wedge \rho + \sqrt{-1}\kappa \wedge \overline{\kappa}, \\ d\kappa &= \alpha \wedge \kappa + \zeta \wedge \overline{\kappa}, \\ d\zeta &= (\alpha - \overline{\alpha}) \wedge \zeta + \frac{1}{c}I_0 \kappa \wedge \zeta + \frac{1}{c\overline{c}}V_0 \kappa \wedge \overline{\kappa}, \\ d\alpha &= \zeta \wedge \overline{\zeta} - \frac{1}{c}I_0 \zeta \wedge \overline{\kappa} + \frac{1}{c\overline{c}}Q_0 \kappa \wedge \overline{\kappa} + \frac{1}{c}\overline{I}_0 \overline{\zeta} \wedge \kappa. \end{aligned}$$

Applying Poincaré derivative to the third equation $d\zeta$ and using $d^2 \equiv 0$, while wedging on both sides with $\alpha \wedge \overline{\alpha} \wedge \rho \wedge \overline{\kappa}$, we obtain

$$\begin{aligned} 0 &= d\alpha \wedge \zeta \wedge \alpha \wedge \overline{\alpha} \wedge \rho \wedge \overline{\kappa} - d\overline{\alpha} \wedge \zeta \wedge \alpha \wedge \overline{\alpha} \wedge \rho \wedge \overline{\kappa} \\ &\quad + \partial_{\overline{\zeta}} \left(\frac{1}{c}I_0 \right) \overline{\zeta} \wedge \kappa \wedge \zeta \wedge \alpha \wedge \overline{\alpha} \wedge \rho \wedge \overline{\kappa}, \end{aligned}$$

where $\partial_{\overline{\zeta}}$ is the following vector field coming from equation 10.5:

$$\partial_{\overline{\zeta}} = \frac{c}{\overline{c}} \frac{\overline{\mathcal{H}}}{\mathcal{L}_1(\overline{k})} - c \frac{\overline{\mathcal{L}}_1(\overline{k})}{\mathcal{L}_1(\overline{k})} \partial_{\overline{c}}.$$

Then using $d\alpha$ and $d\overline{\alpha}$ from the $\{e\}$ -structure, we obtain the desired identity. \square

Thus we recover the expression of Q_0 as appeared in the introduction.

CHAPTER 3

Normal Forms for Rigid $\mathfrak{C}_{2,1}$ Hypersurfaces $M^5 \subset \mathbb{C}^3$

Consider a 2-nondegenerate constant Levi rank 1 rigid \mathcal{C}^ω hypersurface $M^5 \subset \mathbb{C}^3$ in coordinates $(z, \zeta, w = u + iv)$:

$$u = F(z, \zeta, \bar{z}, \bar{\zeta}).$$

The Gaussier-Merker model $u = \frac{z\bar{z} + \frac{1}{2}z^2\bar{\zeta} + \frac{1}{2}\bar{z}^2\zeta}{1 - \zeta\bar{\zeta}}$ was shown by Fels-Kaup 2007 to be locally CR-equivalent to the light cone $\{x_1^2 + x_2^2 - x_3^2 = 0\}$. Another representation is the tube $u = \frac{x^2}{1-y}$.

Inspired by Alexander Isaev, we study *rigid* biholomorphisms:

$$(z, \zeta, w) \longmapsto (f(z, \zeta), g(z, \zeta), \rho w + h(z, \zeta)) =: (z', \zeta', w').$$

The G-M model has 7-dimensional rigid automorphisms group.

A Cartan-type reduction to an $\{e\}$ -structure was done by Foo-Merker-Ta in [arxiv.org/abs/1904.02562/](https://arxiv.org/abs/1904.02562). Three relative invariants appeared: V_0, I_0 (primary) and Q_0 (derived). In Pocchiola's formalism, Section 8 provides a finalized expression for Q_0 .

The goal is to establish the Poincaré-Moser complete normal form:

$$u = \frac{z\bar{z} + \frac{1}{2}z^2\bar{\zeta} + \frac{1}{2}\bar{z}^2\zeta}{1 - \zeta\bar{\zeta}} + \sum_{\substack{a,b,c,d \in \mathbb{N} \\ a+c \geq 3}} G_{a,b,c,d} z^a \zeta^b \bar{z}^c \bar{\zeta}^d,$$

with $0 = G_{a,b,0,0} = G_{a,b,1,0} = G_{a,b,2,0}$ and $0 = G_{3,0,0,1} = \text{Im } G_{3,0,1,1}$.

In terms of F , the numerators of V_0, I_0, Q_0 incorporate 11, 52, 824 differential monomials.

This Chapter is based on our jointwork with Zhangchi Chen, Wei-Guo Foo and Joël Merker, which has appeared in preprint form:

Zhangchi Chen, Wei-Guo Foo, Joël Merker, The-Anh Ta, *Normal Forms for Rigid $\mathfrak{C}_{2,1}$ Hypersurfaces $M^5 \subset \mathbb{C}^3$* , arXiv:1912.01655

1. Introduction

The problem of equivalence for CR manifolds was begun by Poincaré in 1907, who, by a plain counting argument, pointed out that real hypersurfaces $M^3 \subset \mathbb{C}^2$ must *a priori* possess infinitely many *invariants* under biholomorphic transformations.

Nous pourrions [...] supposer que F est de la forme

$$F = X - \Phi(Y, X, X'),$$

et il y a alors

$$N' = \frac{(n+1)(n+2)(n+3)}{6} - 1$$

coefficients arbitraires réels [...]. Enfin, les équations de la transformation peuvent s'écrire

$$Z = \psi(z, z'), \quad Z' = \psi_1(z, z'),$$

ψ et ψ_1 étant deux fonctions analytiques complexes développables suivant les puissances de z et de z' : nous avons besoin des termes jusqu'au n^e ordre, ce qui fait

$$2 \left[\frac{(n+1)(n+2)}{2} - 1 \right]$$

coefficients arbitraires complexes, ou, ce qui revient au même,

$$N'' = 2n^2 + 6n$$

coefficients arbitraires réels que nous appellerons les coefficients C .

[112, pp. 194–195]

Thus in \mathbb{C}^2 , there are more hypersurfaces, namely $\sim \frac{n^3}{6}$, than there are biholomorphisms, namely $\sim 2n^2$, did argue Poincaré.

As in the theory that Lie erected in the end of the XIXth Century with his students Engel, Scheffers, Kowalevski and others, the existence of (local) invariants creates a (local) classification problem, not even terminated nowadays for hypersurfaces in \mathbb{C}^3 .

Analogously, given the action of a finite-dimensional Lie group on a manifold M which induces an action on (local) graphs embedded in M , Lie discovered that prolongations of the G -action to jet bundles of sufficiently high order automatically create infinitely many differential invariants [78, 109], hence various classification problems can be undertaken.

Throughout all of this memoir, concentrated on CR geometry, all CR manifolds will be assumed real analytic (\mathcal{C}^ω). An elementary complex Frobenius theorem proved *e.g.* by Paulette Libermann in [77], guarantees embeddability in some \mathbb{C}^N . We will restrict ourselves to the definite class of *hypersurfaces* $M^{2n+1} \subset \mathbb{C}^{n+1}$, which are automatically CR. Results for *embedded* hypersurfaces $M^{2n+1} \subset \mathbb{C}^{n+1}$ of class \mathcal{C}^∞ or \mathcal{C}^k with $k \gg 1$ sufficiently high can be formulated, and proofs easily adapted. In fact, only \mathcal{C}^ω hypersurfaces $M^3 \subset \mathbb{C}^2$ and $M^5 \subset \mathbb{C}^3$ will be studied here.

The interest of studying *rigidly equivalent* — in Alexander Isaev's terminology — *rigid* hypersurfaces was pointed out to us during his February 2019 stay in Orsay. In recent publications [64, 65, 66, 67], Alexander tackled to *integrate* Pocchiola's zero CR curvature equations $\bar{W} = 0 = \bar{J}$ of tube and rigid 2-nondegenerate constant Levi rank 1 hypersurfaces $M^5 \subset \mathbb{C}^3$ (more will be said later).

A local hypersurface $M^{2n+1} \subset \mathbb{C}^{n+1}$ with coordinates $Z = (z_1, \dots, z_{n+1})$ is said to be *rigid* if there exists an infinitesimal CR automorphism, namely a vector field T tangent to M of the form $T = X + \bar{X}$ with a nonzero holomorphic vector field $X = \sum_{i=1}^{n+1} a_i(z) \partial_{z_i}$, which is *transversal* to the complex tangent space $T^c M$ in the sense that $TM = T^c M \oplus \mathbb{R}T$. After a local biholomorphic straightening, one makes $X = i \frac{\partial}{\partial w}$ with $w = z_{n+1}$, and tangency of $X + \bar{X} = 2 \frac{\partial}{\partial w}$ to M shows that, restricting considerations to dimensions $n+1 = 2, 3$, writing coordinates $\mathbb{C}^2 \ni (z, w)$ and $\mathbb{C}^3 \ni (z, \zeta, w)$, the right-hand side \mathcal{C}^ω graphing functions:

$$M^3: \quad u = F(z, \bar{z}), \quad M^5: \quad u = F(z, \zeta, \bar{z}, \bar{\zeta}),$$

are independent of v , where $w = u + iv$:

Alexander Isaev's concept of *rigid biholomorphic transformation* is less popular or widespread. In \mathbb{C}^2 and in \mathbb{C}^3 , such are biholomorphisms of the form:

$$(z, w) \longmapsto (f(z), \rho w + g(z)), \quad (z, \zeta, w) \longmapsto (f(z, \zeta), g(z, \zeta), \rho w + h(z, \zeta)),$$

where f, g, h are holomorphic of their arguments, *independently of w* , and where $\rho \in \mathbb{R}^*$. The interest is that rigid biholomorphisms trivially send rigid hypersurfaces to rigid hypersurfaces: they respect the pre-given CR symmetry, and much more will be explained later.

As Poincaré did, but without assuming that the origin is left fixed, for any integer $d \geq 1$, writing $f(z) = \sum_{0 \leq k \leq d} f_k z^k$ with $f_k \in \mathbb{C}$ and similarly $g(z) = \sum g_k z^k$, the (rough) “number” of rigid biholomorphisms of degree $\leq d$ is the number of incoming *real* parameters, namely $2(d+1) + 1 + 2(d+1) = 4d + 5 \sim 4d$, while the (rough) “number” of rigid hypersurfaces $\{u = \sum_{j+k \leq d} F_{j,k} x^j y^k\}$ of degree $\leq d$ too, with $F_{j,k} \in \mathbb{R}$, is equal to $\binom{d+2}{2} \sim \frac{1}{2} d^2$, hence much larger as $d \rightarrow \infty$.

Similarly in \mathbb{C}^3 , the (rough) “space” of rigid biholomorphisms of degree $\leq d$ is of real dimension:

$$2 \binom{d+2}{2} + 2 \binom{d+2}{2} + 1 + 2 \binom{d+2}{2} = 3(d+2)(d+1) + 1 \sim 3d^2,$$

much smaller than the dimension of the “space” of hypersurfaces of degree $\leq d$ too:

$$\binom{d+4}{4} \sim \frac{1}{24} d^4.$$

To classify CR manifolds, two methods exist in the supermarket: that of Cartan, and that of Moser.

Cartan devised a quite sophisticated and proteiform *method of equivalence*. Given a manifold M equipped with a certain class of geometric, say CR here, structures, Cartan's *method of equivalence* consists in constructing a bundle $\pi: P \rightarrow M$ together with an *absolute (co)parallelism* on P , namely a coframe of everywhere linearly independent 1-forms $\theta^1, \dots, \theta^{\dim P}$ on P such that:

$$\begin{array}{ccc} P & \xrightarrow{\quad \Pi \quad} & P' \\ \pi \downarrow & & \downarrow \pi' \\ M & \xrightarrow[\quad \Phi \quad]{} & M' \end{array}$$

- every local CR diffeomorphism $\Phi: M \rightarrow M'$ between two CR manifolds lifts uniquely as a diffeomorphism $\Pi: P \rightarrow P'$ satisfying $\Pi^* \theta'^i = \theta^i$ for $1 \leq i \leq \dim P$, with P' and the θ'^i similarly constructed;
- conversely, every diffeomorphism $\Pi: P \rightarrow P'$ commuting with projections π, π' whose horizontal part is a diffeomorphism $M \rightarrow M'$ and which satisfies $\Pi^* \theta'^i = \theta^i$ for $1 \leq i \leq \dim P$, has a horizontal part which is *Cauchy-Riemann* diffeomorphism (or, more generally, a diffeomorphism respecting the considered geometric structure).

[Beyond, there can exist *Cartan connections* associated to (modifications of) $P \rightarrow M$, but we will not need this concept.]

Reexpressing the exterior differentials $d\theta^i$ and $d\theta'^i$ from both sides in terms of the basic 2-forms provided by the two ambient coframes:

$$d\theta^i = \sum_{j < k} T_{j,k}^i(p) \theta^j \wedge \theta^k \quad \text{and} \quad d\theta'^i = \sum_{j < k} T_{j,k}'(p') \theta'^j \wedge \theta'^k,$$

certain *structure functions* appear, defined for $p \in P$ and for $p' \in P'$, and the exact pullback relations $\Pi^*\theta'^i = \theta^i$ force *individual invariance* of all them:

$$T_{j,k}'(\Phi(p)) = T_{j,k}^i(p) \quad (\forall p \in P).$$

As is known, Cartan's method is computationally *extremely intensive*, especially in CR geometry, where several normalizations and prolongations are required. Explicit expressions of intermediate torsion coefficients which conduct to the final $T_{j,k}^i(p)$ grow dramatically in complexity.

One reason for such a complexity is the presence of large isotropy groups for the CR automorphisms groups of (standard) models, which imposes a great number of steps. Another reason is the *nonlinear* character of differential algebraic polynomial expressions that must be handled progressively. The last reason is that Cartan's method studies geometric structures *at every point* of the base manifold, and there is a price to pay for this generality.

In most existing references (*cf.* the bibliography), the trick that Cartan himself devised to avoid nonlinear complications while retaining anyway some essential information, is the so-called *Cartan Lemma*. It is explicit only at the level of linear algebra. Even admitting to only deal with linear algebra computations, as Chern always did, Cartan's method is often long and demanding.

In his works, Moser usually searched for wisdom rather than simply knowledge, and thus he strongly emphasized developments of methods and insights over pushing a specific result to the limit. Accordingly, he sometimes described the outcome of his own work as methods rather than theorems. [74, p. 1348]

Moser's method is more 'down to Earth', computationally speaking, since it usually proceeds at only *one* point, often the origin, of a manifold, manipulating power series expanded at that point. Hence it needs geometric objects of class \mathcal{C}^ω , while adaptations to the \mathcal{C}^∞ or $\mathcal{C}^{k \gg 1}$ classes can concern only formal Taylor expansions at the point.

Coming from problems and techniques in Dynamical Systems and Celestial Mechanics, Moser's method consists in constructing certain *normal forms* for the objects studied, in order to simplify them and hence to enable one to rapidly determine whether two given objects are *the same*, up to equivalence.

For instance, for our rigid toy hypersurfaces $\{u = F(z, \bar{z})\}$ in \mathbb{C}^2 , assuming that they are Levi nondegenerate at the origin:

$$u = z\bar{z} + O_{z,\bar{z}}(3) = z\bar{z} + \sum_{j+k \geq 3} F_{j,k} z^j \bar{z}^k,$$

Moser's game consists in applying several local rigid biholomorphisms in order to obtain a simpler graphing function $F(z, \bar{z})$, *e.g.* with as many as possible coefficients $F_{j,k} = 0$ disappearing, so that the equation becomes closest as possible to the model Heisenberg sphere $\{u = z\bar{z}\}$.

It is not difficult to realize that the isotropy subgroup of the origin, namely the group of *rigid* biholomorphisms fixing $(0, 0) \in \mathbb{C}^2$, is 2-dimensional, and consists of weighted scalings coupled with 'horizontal rotations':

$$(1.2) \quad z' = \rho^{1/2} e^{i\varphi} z, \quad w' = \rho w,$$

with $\rho \in \mathbb{R}^*$ and $\varphi \in \mathbb{R}$. Then Section 2 will elementarily show that one can annihilate all $F_{j,0} = 0 = F_{0,k}$ and all $F_{j,1} = 0 = F_{1,k}$ as well, except of course $F_{1,1} = 1$, bringing any two rigid hypersurfaces in $M \subset \mathbb{C}^2$ and $M' \subset \mathbb{C}^2$ to the *normalized* forms:

$$u = z\bar{z} + \sum_{j,k \geq 2} F_{j,k} z^j \bar{z}^k \quad \text{and} \quad u' = z'\bar{z}' + \sum_{j,k \geq 2} F'_{j,k} z'^j \bar{z}'^k,$$

and then an analysis of what freedom remains in the group of rigid biholomorphisms will (easily) show that only *two* real parameters remain free to send M in normal form to M' also in normal form, namely (ρ, φ) above. Moreover, it will follow that M and M' are rigidly biholomorphically equivalent if and only if they exchange through such a trivial scaling-rotation transformation, hence if and only if there exist $\rho \in \mathbb{R}_+^*$ and $\varphi \in \mathbb{R}$ such that:

$$F_{j,k} = \rho^{\frac{j+k-2}{2}} e^{i\varphi(j-k)} F'_{j,k} \quad (j \geq 2, k \geq 2).$$

Thus, once two normal forms are constructed, whether $M \sim M'$ or not can be straightforwardly seen.

What is true of the toy will be true of higher dimensional CR objects. In particular, crude normal forms cannot be made unique, they are defined only up to the action of a certain finite-dimensional Lie group, namely the isotropy subgroup of the (always transitive) model.

Beyond, in most circumstances, *e.g.* when $F_{2,2} \neq 0$ above, one can push further Moser's method, and obtain normal forms for which *all* remaining coefficients $F_{j,k}$ are uniquely defined, so that $F_{j,k} = F'_{j,k}$ exactly, with no isotropy ambiguity. This is analog to what one can do in Cartan's method when some curvature torsion coefficients are nonvanishing: one can indeed normalize some group parameters present in some $T_{j,k}^i$ further and further, and thereby decrease the dimension of the bundle $P \rightarrow M$, reducing it to smaller subbundles $P \supsetneq P_1 \subsetneq P_2 \supsetneq \dots$.

In comparison to Cartan's method, we repeat that one drawback of Moser's method is that it seems to capture invariants only at one point. Fortunately, Moser's method can be applied simultaneously to all nearby points, especially to determine all homogeneous models of a given class of geometries, and in a CR context, this was done *e.g.* in Loboda's works [79, 80, 81].

Recently, Chen-Merker [21] found an alternative (probably known) method to capture differential invariants at *all points* while working *only at one point*. This method avoids then to move the origin everywhere nearby by translations, and it works most of the times, namely when the group of transformations is only assumed transitive, either finite or infinite dimensional, *see* especially [21, Sec. 12]. Hence this method clearly applies to the group of rigid biholomorphisms. Chen-Merker studied mainly parabolic (real) surfaces $S^2 \subset \mathbb{R}^3$ under the group of special affine transformations of \mathbb{R}^3 , and developed an analog of Moser's method in this context.

Links between Affine Geometry and CR geometry have been studied in depth by Alexander Isaev in his monograph [63]. Here, to a given a parabolic surface $\{u = F(x, y)\}$, namely a surface whose graphing function F satisfies everywhere:

$$F_{xx} \neq 0 \equiv \begin{vmatrix} F_{xx} & F_{xy} \\ F_{yx} & F_{yy} \end{vmatrix},$$

one can associate the *tube* hypersurface $M^5 \subset \mathbb{C}^3$ defined as $M^5 := S^2 \times (i\mathbb{R})^3$. The paper [100] shows that Pocchiola's invariant \mathcal{W} associated to M^5 produces a seemingly

new affine invariant W_{aff} for parabolic $S^2 \subset \mathbb{R}^3$. During Alexander Isaev's stay in Orsay, and after fruitful exchanges with Peter Olver, it became clear that an independent study of affine differential invariants of parabolic surfaces $S^2 \subset \mathbb{R}^3$ should be endeavoured, and this was pushed to an end in [21].

There, by keeping memory of all terms in the power series that lie above those coefficients that are progressively normalized, Chen-Merker obtained certain (complicated) differential-algebraic expressions made from Taylor coefficients at the origin, from which one can straightforwardly recover differential invariants *at every point*. But traditionally instead, people only look at lowest order currently normalized coefficients in each step, so that computations remain simple.

Since the technique of [21] seems not to have been well developed or understood by CR geometers up to now, we decided to write up the present memoir. Its main goal is to construct a *bridge*:

Cartan's method

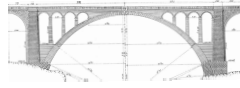

Moser's method,

and exhibit how differential invariants pass from one side of the river to the other side, *computationally*. Reading the toy Section 2 below is enough to understand the key arch-ideas of such a bridge. We indeed first focus on the toy case of rigid equivalences of rigid hypersurfaces in \mathbb{C}^2 (easily reached results), before passing to the not so simple case of rigid equivalences in the rigid class denoted $\mathfrak{C}_{2,1}$ by Alexander Isaev which consists, as written above, of 2-nondegenerate constant Levi rank 1 hypersurfaces $M^5 \subset \mathbb{C}^3$ with $0 \in M$.

In \mathbb{C}^2 , on the Cartan side of the bridge, we construct in Section 2 an absolute parallelism on $P^5 := M^3 \times \mathbb{C}$ equipped with coordinates $(z, \bar{z}, v, c, \bar{c})$ consisting of 5 differential 1-forms:

$$\{\rho, \zeta, \bar{\zeta}, \pi, \bar{\pi}\} \quad (\bar{\rho} = \rho),$$

which satisfy invariant structure equations of the shape:

$$\begin{aligned} d\rho &= (\pi + \bar{\pi}) \wedge \rho + i \zeta \wedge \bar{\zeta}, \\ d\zeta &= \pi \wedge \zeta, & d\bar{\zeta} &= \bar{\pi} \wedge \bar{\zeta}, \\ d\pi &= \frac{1}{c\bar{c}} R \zeta \wedge \bar{\zeta}, & d\bar{\pi} &= -\frac{1}{c\bar{c}} \bar{R} \zeta \wedge \bar{\zeta}, \end{aligned}$$

where there is only invariant function:

$$R := \frac{F_{zz\bar{z}\bar{z}} F_{z\bar{z}} - F_{z\bar{z}\bar{z}} F_{z\bar{z}z}}{(F_{z\bar{z}})^2}.$$

We show that M is rigidly equivalent to $\{u = z\bar{z}\}$ if and only if $R(F) \equiv 0$.

On the Moser side of the bridge, starting from a given $u = \sum_{j+k \geq 1} F_{j,k} z^j \bar{z}^k$ passing by the origin, we perform as said above a few normalizing biholomorphisms in order to reach:

$$\begin{aligned} 0 &= F_{j,0} = F_{0,k} & (j \geq 1, k \geq 1), \\ 1 &= F_{1,1}, \\ 0 &= F_{j,1} = F_{1,k} & (j \geq 2, k \geq 2), \end{aligned}$$

and the key feature of the method is to *keep track* of all performed rigid biholomorphic transformations, which will give us at the end:

$$u = z\bar{z} + \left[\frac{F_{2,2} F_{1,1} - F_{2,1} F_{1,2}}{F_{1,1}^3} \right] z^2 \bar{z}^2 + z^2 \bar{z}^3 (\dots) + z^3 \bar{z}^2 (\dots),$$

and from this rational expression of the final $F'_{2,2}$ coefficient at the origin, it is easy to recognize/reconstitute/translate Cartan's invariant $R(F)$ at every point (up to a nowhere vanishing factor $\text{const} \cdot F_{z\bar{z}}$). Why this is so has already been explained in [21, Sec. 12] and will not be repeated here.

PRINCIPLE 1.3. *In all CR equivalence problems (and outside CR geometry too), there exists a way of computing with power series at only one point which generates all Cartan-like invariants together with their syzygies.*

Because such a 'bridge-principle' has neither been constructed nor really noticed in CR geometry, a joint forthcoming publication will tackle to build it also for *nonrigid* $M^5 \subset \mathbb{C}^3$ that are 2-nondegenerate and have constant rank 1 Levi form, thereby recovering the full explicit expressions of Pocchiola's invariants W and J at every point, not only as number-coefficients at one given point as in [75, Thm. 2].

The first question is: *what is the appropriate local graphed model for 2-nondegenerate constant Levi rank 1 hypersurfaces $M^5 \subset \mathbb{C}^3$?* Of course, it is known from the recent Cartan-theoretic achievements in [68, 82, 92] that the local model is any neighborhood of any smooth point of the tube in \mathbb{C}^3 over the light cone in \mathbb{R}^3 having equation $x_2^2 - x_3^2 = x_1^2$. But it is not graphed! We claim that in different notations, this cone has local graphed equation:

$$u = \frac{x^2}{1-y},$$

with x, y, u being the real parts of three complex coordinates on $\mathbb{C}^3 \ni (z, \zeta, w)$. As we agreed orally with Alexander Isaev, this is the best, most compact existing graphed equation. It happens to also be the central model of parabolic surface $S^2 \subset \mathbb{R}^3$ occurring in [21].

The claim is easy. By CR-homogeneity, one can recenter at any smooth point, *e.g.* at $(0, 1, 1)$, write $(1 + x_2)^2 - (1 + x_3)^2 = x_1^2$, factor, divide, get $x_2 - x_3 = \frac{x_1^2}{2+x_2+x_3}$, and linearly change coordinates.

However, this tube graphed equation contains many pluriharmonic terms:

$$\frac{w + \bar{w}}{2} = \frac{(z + \bar{z})^2}{4 - 2\zeta - 2\bar{\zeta}} = \frac{1}{8} z^2 \zeta + \frac{1}{8} \bar{z}^2 \bar{\zeta} + \dots,$$

that Moser's method would compulsorily kill at the very beginning. Thus, $u = \frac{x^2}{1-y}$ is not the right start. Similarly, $u = x^2 = \frac{1}{2} z^2 + \frac{1}{2} \bar{z}^2 + \dots$ in \mathbb{C}^2 is not the right start from Moser's point of view.

The right graphed equation for the model light cone $M_{\text{LC}} \subset \mathbb{C}^3$ in $\mathfrak{E}_{2,1}$ was discovered by Gaussier-Merker in [56]:

$$M_{\text{LC}}: \quad u = \frac{z\bar{z} + \frac{1}{2} z^2 \bar{\zeta} + \frac{1}{2} \bar{z}^2 \zeta}{1 - \zeta \bar{\zeta}} =: m(z, \zeta, \bar{z}, \bar{\zeta}),$$

and before commenting about very funny zig-zag errors made in the field at that time, we review the naive reasoning. Here, the letter m is from *model*. By luck, M_{LC} is rigid!

Start with $M^5 \subset \mathbb{C}^3$, with $0 \in M$, rigid, graphed as:

$$u = F(z, \zeta, \bar{z}, \bar{\zeta}).$$

Constant Levi rank 1 means, possibly after a linear transformation in $\mathbb{C}_{z, \zeta}^2$, that:

$$(1.4) \quad F_{z\bar{z}} \neq 0 \equiv \begin{vmatrix} F_{z\bar{z}} & F_{z\bar{\zeta}} \\ F_{\zeta\bar{z}} & F_{\zeta\bar{\zeta}} \end{vmatrix} =: \text{Levi}(F),$$

while 2-nondegeneracy means that:

$$(1.5) \quad 0 \neq \begin{vmatrix} F_{z\bar{z}} & F_{z\bar{\zeta}} \\ F_{zz\bar{z}} & F_{zz\bar{\zeta}} \end{vmatrix}.$$

By direct symbolic computations, Propositions 3.1 and 3.2 will establish *invariancy* of these vanishing/nonvanishing properties under rigid changes of holomorphic coordinates.

At the origin, M_{LC} of equation:

$$u = z\bar{z} + \frac{1}{2}z^2\bar{\zeta} + \frac{1}{2}\bar{z}^2\zeta + O_{z, \zeta, \bar{z}, \bar{\zeta}}(4),$$

is obviously 2-nondegenerate, thanks to the cubic monomial $\frac{1}{2}z^2\bar{\zeta}$ which gives that (1.5) at $(z, \zeta) = (0, 0)$ becomes $|\begin{smallmatrix} 1 & 0 \\ * & 1 \end{smallmatrix}| = 1$. As for constant Levi rank 1, order two terms $u = z\bar{z} + \dots$ show that this condition is true at the origin, and simple computations show that (1.4) is identically zero:

$$\begin{vmatrix} \frac{1}{1-\zeta\bar{\zeta}} & \frac{\bar{z}+z\bar{\zeta}}{(1-\zeta\bar{\zeta})^2} \\ \frac{z+z\bar{\zeta}}{(1-\zeta\bar{\zeta})^2} & \frac{(\bar{z}+z\bar{\zeta})(z+z\bar{\zeta})}{(1-\zeta\bar{\zeta})^3} \end{vmatrix} \equiv 0 \quad (- \text{ indeed!}).$$

So how to easily produce one simple example? How M_{LC} was born?

Normalizing the Levi form at the origin, one can assume $F = z\bar{z} + \dots$. Hence the 2-nondegeneracy determinant (1.5) becomes at the origin $|\begin{smallmatrix} 1 & 0 \\ * & F_{zz\bar{\zeta}}(0) \end{smallmatrix}| = 1$. Thus, a monomial like $\frac{1}{2}z^2\bar{\zeta}$ must be present. Since F is real, its conjugate $\frac{1}{2}\bar{z}^2\zeta$ also comes:

$$u = F = z\bar{z} + \frac{1}{2}z^2\bar{\zeta} + \frac{1}{2}\bar{z}^2\zeta + \sum_{k \geq 4} F^k(z, \zeta, \bar{z}, \bar{\zeta});$$

here of course, the F^k are homogeneous polynomials of degree k . Without remainders, *i.e.* with all $F^k = 0$, the cubic equation is *not* of constant Levi rank 1 (exercise).

The idea of Gaussier-Merker was to take the simplest possible successive F^4, F^5, F^6, \dots in order to guarantee $\text{Levi}(F) \equiv 0$. Thus, plug all this in:

$$0 \stackrel{?}{\equiv} \begin{vmatrix} 1 + F_{z\bar{z}}^4 + F_{z\bar{z}}^5 + F_{z\bar{z}}^6 + \dots & \bar{z} + F_{\zeta\bar{z}}^4 + F_{\zeta\bar{z}}^5 + F_{\zeta\bar{z}}^6 + \dots \\ z + F_{z\bar{\zeta}}^4 + F_{z\bar{\zeta}}^5 + F_{z\bar{\zeta}}^6 + \dots & F_{\zeta\bar{\zeta}}^4 + F_{\zeta\bar{\zeta}}^5 + F_{\zeta\bar{\zeta}}^6 + \dots \end{vmatrix}.$$

At first, look at terms of order 2, get $0 = F_{\zeta\bar{\zeta}}^4 - z\bar{z}$, integrate as the simplest possible $F^4 := z\bar{z}\zeta\bar{\zeta}$. Next, plug this F^4 in, chase only homogeneous terms of degree 3, get $F_{\zeta\bar{\zeta}}^5 = z^2\bar{\zeta} + \bar{z}^2\zeta$, and integrate most simply as $F^5 := \frac{1}{2}z^2\bar{\zeta}(\zeta\bar{\zeta}) + \frac{1}{2}\bar{z}^2\zeta(\zeta\bar{\zeta})$. Next, plug this F^5 in, get $F_{\zeta\bar{\zeta}}^6 = 4z\bar{z}\zeta\bar{\zeta}$, integrate $F^6 := z\bar{z}(\zeta\bar{\zeta})^2$, and so on.

An easy induction then shows that powers $(\zeta\bar{\zeta})^k$ appear, and a geometric summation reconstitutes the denominator $\frac{1}{1-\zeta\bar{\zeta}}$ in the Gaussier-Merker model. \triangle

Gaussier-Merker made an error when computing (by hand) the Lie algebra of infinitesimal CR automorphisms of M_{LC} , and found a 7-dimensional Lie algebra. This looked ‘coherent’ with a paper published by Ebenfelt in the Duke Mathematical Journal (year 2000), which pretended to bound by 7 the dimension of the CR automorphism group of any $\mathfrak{C}_{2,1}$ hypersurface $M^5 \subset \mathbb{C}^3$ — but due to an incorrect expression of the initial G -structure, Ebenfelt’s paper appeared later to be wrong. Experts of Cartan theory know how sensitive can be any little error in normalizations/reductions of G -structures.

Then the masters Fels-Kaup of Lie transformation groups cleaned up the subject, showing in [43], *inter alia*, that the Gaussier-Merker model is locally biholomorphically equivalent to the tube over the light cone, so that everybody was wrong before. They proceeded as follows.

Let $S_{2 \times 2} \equiv \mathbb{R}^3 \subset \mathbb{R}^{2 \times 2}$ be the space of all real symmetric 2×2 matrices. The open set $\Omega\mathbb{C}^+ \subset S_{2 \times 2}$ consisting of positive definite matrices has boundary the future light cone, which may be represented as:

$$\text{LC}^+ = \left\{ \begin{pmatrix} t + x_1 & x_2 \\ x_2 & t - x_1 \end{pmatrix} \in S_{2 \times 2} : t^2 = x_1^2 + x_2^2, t > 0 \right\}.$$

The objects of study are the following tube domain — Siegel’s upper half plane up to the factor i — and its boundary hypersurface:

$$\text{H} := \Omega\mathbb{C}^+ \times iS_{2 \times 2} \quad \text{and} \quad \text{T} := \text{LC}^+ \times iS_{2 \times 2}.$$

The global CR automorphism group of T consists of just affine transformations, while the global biholomorphic transformation group $\text{Aut}(\text{H})$ of the domain H is known for a long time to consist of the 10-dimensional group of all biholomorphic transformations $z \mapsto (az + ib)(icz + d)^{-1}$, where $z = \begin{pmatrix} w & z_1 \\ z_1 & z_2 \end{pmatrix}$ with $(z_1, z_2, w) \in \mathbb{C}^3$, and where $\begin{pmatrix} a & b \\ c & d \end{pmatrix}$ belongs to the real symplectic subgroup $\text{SP}_2(\mathbb{R}) \subset \text{SL}_4(\mathbb{R})$.

Differentiating this action yields that the algebra of infinitesimal automorphisms $\text{aut}(\text{H})$ of the *domain* is equal to $\mathfrak{sp}(2, \mathbb{R}) \cong \mathfrak{so}_{2,3}(\mathbb{R})$, also 10-dimensional.

Fels-Kaup then asked how such automorphisms could be inherited by (transmitted to) the boundary $\text{T} = \partial\text{H}$.

They chose a Cartan subalgebra of $\mathfrak{so}_{2,3}(\mathbb{R})$ represented by $\mathbb{R}\zeta_1 \oplus \mathbb{R}\zeta_2$, where:

$$\zeta_1 := 2w \partial_w \quad \text{and} \quad \zeta_2 := z_1 \partial_{z_1} + 2z_2 \partial_{z_2},$$

and they showed that any hypersurface $M^5 \subset \mathbb{C}^3$ whose graphing function starts as $w + \bar{w} = 2z_1 \bar{z}_1 + z_1^2 \bar{z}_2 + \bar{z}_1^2 z_2 + O(4)$ such that $\mathfrak{hol}(M, 0)$ includes ζ_1 and $i\zeta_2$ is locally homogeneous if and only if $\mathfrak{hol}(M, 0)$ also contains the two further infinitesimal transformations:

$$(1 - z_2) \partial_{z_1} + 2z_1 \partial_w \quad \text{and} \quad -z_1 z_2 \partial_{z_1} + (1 - z_2^2) \partial_w.$$

Analyzing further structure-theoretic features of the simple Lie algebra $\mathfrak{so}_{2,3}(\mathbb{R})$, they showed that this holds if and only if the graphed equation reads as the Gaussier-Merker model (up to a factor 2):

$$(1.6) \quad w + \bar{w} = \frac{2z_1 \bar{z}_1 + z_1^2 \bar{z}_2 + \bar{z}_1^2 z_2}{1 - z_2 \bar{z}_2},$$

thus giving another natural way to produce this model. The main thing was that aut_{CR} is 10-dimensional, not 7!

Fels-Kaup also deduced an explicit rational biholomorphism from this model (1.6) onto a subdomain of \mathbb{T} :

$$(z_1, z_2, w) \longmapsto \frac{1}{1+z_2} \begin{pmatrix} w + wz_2 + z_1^2 & \sqrt{2} z_1 \\ \sqrt{2} z_1 & 1 - z_2 \end{pmatrix}.$$

At about the same time, Fels-Kaup in *Acta Mathematica* made the breakthrough of classifying all homogeneous models $M \in \mathfrak{C}_{2,1}$. They showed that, excepting the light cone, all such M are in fact *simply homogeneous* — isotropy Lie subgroup reduced to identity — and necessarily *tube*, namely biholomorphically equivalent to $S^2 + (i\mathbb{R})^3$, for some surface $S^2 \subset \mathbb{R}^3$ which is simply homogeneous with respect to the affine group $A_3(\mathbb{R})$. Fels-Kaup's complete classification is:

- (1) $S = \{x_1^2 + x_2^2 = x_3^2, x_3 > 0\}$ the future light cone;
- (2a) $S = \{r(\text{cost}, \text{sint}, e^{\omega t}) \in \mathbb{R}^3 : r \in \mathbb{R}^+ \text{ and } t \in \mathbb{R}\}$ with $\omega > 0$ arbitrary;
- (2b) $S = \{r(1, t, e^t) \in \mathbb{R}^3 : r \in \mathbb{R}^+ \text{ and } t \in \mathbb{R}\}$;
- (2c) $S = \{r(1, e^t, e^{\theta t}) \in \mathbb{R}^3 : r \in \mathbb{R}^+ \text{ and } t \in \mathbb{R}\}$ with $\theta > 2$ arbitrary;
- (3) $S = \{c(t) + rc'(t) \in \mathbb{R}^3 : r \in \mathbb{R}^+ \text{ and } t \in \mathbb{R}\}$, where $c(t) := (t, t^2, t^3)$ parametrizes the *twisted cubic* $\{(t, t^2, t^3) : t \in \mathbb{R}\}$ in \mathbb{R}^3 and $c'(t) = (1, 2t, 3t^2)$.

The limit case $\omega = 0$ in (2a) regives the future light cone (1), while the limit case $\theta = 2$ in (2c) gives $\{x \in \mathbb{R}^3 : x_1 x_3 = x_2^2 \text{ and } x_1, x_2 > 0\}$ which is locally linearly (but not globally) equivalent to (1). These five (families of) surfaces are known to be pairwise locally inequivalent under affine transformations ([35, 40]).

As spectacular as they were, the Fels-Kaup articles did not treat the equivalence problem for *all* hypersurfaces $M^5 \subset \mathbb{C}^3$ in the class $\mathfrak{C}_{2,1}$. Indeed, like in Riemannian geometry, it is well known that homogeneous CR manifolds are rather rare in the set of all CR manifolds. Although Lie-theoretic methods seem to be undoubtedly the best to determine homogeneous structures, they lose their power when dealing with *generic*, non-homogeneous, structures. Only Cartan's and Moser's methods of equivalence are able to handle *all* geometric objects of a given kind.

Thus, it was only in the years 2010's that the three papers [68, 82, 92] achieved the construction of 10-dimensional $\{e\}$ -structure bundles (or Cartan connections) $P^{10} \rightarrow M^5$.

Among these, only Pocchiola's Ph.D. [113], published as [92], really performed sufficiently advanced computations to determine what are the primary curvature invariants, he called W and I . Let us review Pocchiola's results. We also follow the article [49], written because Alexander Isaev insisted that *all* details be made public, while Pocchiola intensively used his computer.

Recall that we denote the class of (local) hypersurfaces $M^5 \subset \mathbb{C}^3$ passing by the origin $0 \in M$ that are 2-nondegenerate and whose Levi form has constant rank 1 as:

$$\mathfrak{C}_{2,1}.$$

Consider therefore a not necessarily rigid hypersurface $M^5 \subset \mathbb{C}^3$ which belongs to this class $\mathfrak{C}_{2,1}$, and which is graphed as:

$$u = F(z_1, z_2, \bar{z}_1, \bar{z}_2, v).$$

The two natural generators of $T^{1,0}M$ and $T^{0,1}M$ are:

$$\mathcal{L}_1 := \frac{\partial}{\partial z_1} - i \frac{F_{z_1}}{1 + iF_v} \frac{\partial}{\partial v} \quad \text{and} \quad \mathcal{L}_2 := \frac{\partial}{\partial z_2} - i \frac{F_{z_2}}{1 + iF_v} \frac{\partial}{\partial v},$$

in the intrinsic coordinates $(z_1, z_2, \bar{z}_1, \bar{z}_2, v)$ on M . We will use the abbreviations:

$$A^1 := -i \frac{F_{z_1}}{1 + iF_v} \quad \text{and} \quad A^2 := -i \frac{F_{z_2}}{1 + iF_v}.$$

Clearly, the real differential 1-form:

$$\varrho_0 := dv - A^1 dz_1 - A^2 dz_2 - \bar{A}^1 d\bar{z}_1 - \bar{A}^2 d\bar{z}_2$$

has kernel:

$$\{\varrho_0 = 0\} = T^{1,0}M \oplus T^{0,1}M.$$

At various points:

$$p = (z_1, z_2, \bar{z}_1, \bar{z}_2, v) \in M,$$

and in terms of ϱ_0 , the hypothesis that M has everywhere degenerate Levi form writes as:

$$0 \equiv = \begin{vmatrix} \varrho_0(i[\mathcal{L}_1, \bar{\mathcal{L}}_1]) & \varrho_0(i[\mathcal{L}_2, \bar{\mathcal{L}}_1]) \\ \varrho_0(i[\mathcal{L}_1, \bar{\mathcal{L}}_2]) & \varrho_0(i[\mathcal{L}_2, \bar{\mathcal{L}}_2]) \end{vmatrix} (p).$$

The hypothesis that the Levi form has constant rank equal to 1 — not to 0! — expresses as the fact that the real CR-transversal vector field:

$$\mathcal{T} := i[\mathcal{L}_1, \bar{\mathcal{L}}_1] = i\left(\mathcal{L}_1(\bar{A}^1) - \bar{\mathcal{L}}_1(A^1)\right) \frac{\partial}{\partial v} =: \ell \frac{\partial}{\partial v},$$

has nowhere vanishing real coefficient:

$$\ell := i\left(\bar{A}_{z_1}^1 + A^1 \bar{A}_v^1 - A_{z_1}^1 - \bar{A}^1 A_v^1\right) \neq 0.$$

The Levi kernel bundle $K^{1,0}M \subset T^{1,0}M$ is then generated by:

$$\mathcal{K} := k \mathcal{L}_1 + \mathcal{L}_2,$$

where:

$$k := - \frac{\mathcal{L}_2(\bar{A}^1) - \bar{\mathcal{L}}_1(A^2)}{\mathcal{L}_1(\bar{A}^1) - \bar{\mathcal{L}}_1(A^1)}$$

is the fundamental *slant function*. As is known from [89, 113, 92], the hypothesis of 2-nondegeneracy is then equivalent to the nonvanishing:

$$0 \neq \bar{\mathcal{L}}_1(k).$$

Also, the conjugate field $\bar{\mathcal{K}}$ generates the conjugate Levi kernel bundle $K^{0,1}M \subset T^{0,1}M$. There also is a second fundamental function:

$$P := \frac{\ell_{z_1} + A^1 \ell_v - \ell A_v^1}{\ell}.$$

Pocchiola conducted in [113] the Cartan equivalence method for such $M^5 \in \mathfrak{C}_{2,1}$ under general (local) biholomorphic transformations. Reduction to an explicit $\{e\}$ -structure was later done in [49], after Alexander Isaev insisted through e-mail exchanges to do this as was done in [68], though in a non-explicit way. However, such a task is not essential from the point of view of Cartan's theory, as was well understood by Pocchiola, and as we will explain in a while.

For now, introducing the five 1-forms:

$$\begin{aligned}\rho_0 &= \frac{dv - \mathbf{A}^1 dz_1 - \mathbf{A}^2 dz_2 - \bar{\mathbf{A}}^1 d\bar{z}_1 - \bar{\mathbf{A}}^2 d\bar{z}_2}{\ell}, \\ \kappa_0 &= dz_1 - \mathbf{k} dz_2, \\ \zeta_0 &= dz_2, \\ \bar{\kappa}_0 &= d\bar{z}_1 - \bar{\mathbf{k}} d\bar{z}_2, \\ \bar{\zeta}_0 &= d\bar{z}_2,\end{aligned}$$

after very, very intensive computations, redone manually by Foo-Merker in [49] all along ~ 50 pages, Pocchiola obtained modifications $\{\rho, \kappa, \zeta, \bar{\kappa}, \bar{\zeta}\}$ of these 1-forms $\{\rho_0, \kappa_0, \zeta_0, \bar{\kappa}_0, \bar{\zeta}_0\}$, together with four complicated 1-forms $\pi^1, \pi^2, \bar{\pi}^1, \bar{\pi}^2$ which satisfy structure equations of the specific concise shape:

$$(1.7) \quad \begin{aligned}d\rho &= (\pi^1 + \bar{\pi}^1) \wedge \rho + i \kappa \wedge \bar{\kappa}, \\ d\kappa &= \pi^2 \wedge \rho + \pi^1 \wedge \kappa + \zeta \wedge \bar{\kappa}, \\ d\zeta &= (\pi^1 - \bar{\pi}^1) \wedge \zeta + i \pi^2 \wedge \kappa + \\ &\quad + \mathbf{R} \rho \wedge \zeta + i \frac{1}{\mathbf{c}^3} \bar{\mathbf{J}}_0 \rho \wedge \bar{\kappa} + \frac{1}{\mathbf{c}} \mathbf{W}_0 \kappa \wedge \zeta,\end{aligned}$$

in which \mathbf{R} is a secondary invariant:

$$\mathbf{R} := \operatorname{Re} \left[i \frac{\mathbf{e}}{\mathbf{c}\mathbf{c}} \mathbf{W}_0 + \frac{1}{\mathbf{c}\bar{\mathbf{c}}} \left(-\frac{i}{2} \bar{\mathcal{L}}_1(\mathbf{W}_0) + \frac{i}{2} \left(-\frac{1}{3} \frac{\bar{\mathcal{L}}_1(\bar{\mathcal{L}}_1(\mathbf{k}))}{\bar{\mathcal{L}}_1(\mathbf{k})} + \frac{1}{3} \bar{\mathbf{P}} \right) \mathbf{W}_0 \right) \right],$$

expressed in terms of Pocchiola's two primary invariants whose explicit expressions have been confirmed in [49] (and also after [113] by Alexander Isaev in [64] assuming M is rigid):

$$\begin{aligned}\mathbf{W}_0 &:= -\frac{1}{3} \frac{\mathcal{H}(\bar{\mathcal{L}}_1(\bar{\mathcal{L}}_1(\mathbf{k})))}{\bar{\mathcal{L}}_1(\mathbf{k})^2} + \frac{1}{3} \frac{\mathcal{H}(\bar{\mathcal{L}}_1(\mathbf{k})) \bar{\mathcal{L}}_1(\bar{\mathcal{L}}_1(\mathbf{k}))}{\bar{\mathcal{L}}_1(\mathbf{k})^3} + \\ &\quad + \frac{2}{3} \frac{\mathcal{L}_1(\mathcal{L}_1(\bar{\mathbf{k}}))}{\mathcal{L}_1(\bar{\mathbf{k}})} + \frac{2}{3} \frac{\mathcal{L}_1(\bar{\mathcal{L}}_1(\mathbf{k}))}{\bar{\mathcal{L}}_1(\mathbf{k})} + \frac{i}{3} \frac{\mathcal{I}(\mathbf{k})}{\mathcal{L}_1(\mathbf{k})}, \\ \bar{\mathbf{J}}_0 &:= \frac{1}{6} \frac{\bar{\mathcal{L}}_1(\bar{\mathcal{L}}_1(\bar{\mathcal{L}}_1(\bar{\mathcal{L}}_1(\mathbf{k}))))}{\bar{\mathcal{L}}_1(\mathbf{k})} - \frac{5}{6} \frac{\bar{\mathcal{L}}_1(\bar{\mathcal{L}}_1(\bar{\mathcal{L}}_1(\mathbf{k}))) \bar{\mathcal{L}}_1(\bar{\mathcal{L}}_1(\mathbf{k}))}{\bar{\mathcal{L}}_1(\mathbf{k})^2} - \frac{1}{6} \frac{\bar{\mathcal{L}}_1(\bar{\mathcal{L}}_1(\bar{\mathcal{L}}_1(\mathbf{k})))}{\bar{\mathcal{L}}_1(\mathbf{k})} \bar{\mathbf{P}} + \\ &\quad + \frac{20}{27} \frac{\bar{\mathcal{L}}_1(\bar{\mathcal{L}}_1(\mathbf{k}))^3}{\bar{\mathcal{L}}_1(\mathbf{k})^3} + \frac{5}{18} \frac{\bar{\mathcal{L}}_1(\bar{\mathcal{L}}_1(\mathbf{k}))^2}{\bar{\mathcal{L}}_1(\mathbf{k})^2} \bar{\mathbf{P}} + \frac{1}{6} \frac{\bar{\mathcal{L}}_1(\bar{\mathcal{L}}_1(\mathbf{k})) \bar{\mathcal{L}}_1(\bar{\mathbf{P}})}{\bar{\mathcal{L}}_1(\mathbf{k})} - \frac{1}{9} \frac{\bar{\mathcal{L}}_1(\bar{\mathcal{L}}_1(\mathbf{k}))}{\bar{\mathcal{L}}_1(\mathbf{k})} \bar{\mathbf{P}} \bar{\mathbf{P}} - \\ &\quad - \frac{1}{6} \bar{\mathcal{L}}_1(\bar{\mathcal{L}}_1(\bar{\mathbf{P}})) + \frac{1}{3} \bar{\mathcal{L}}_1(\bar{\mathbf{P}}) \bar{\mathbf{P}} - \frac{2}{27} \bar{\mathbf{P}} \bar{\mathbf{P}} \bar{\mathbf{P}}.\end{aligned}$$

When M is assumed to be rigid for simplicity, the numerator of \mathbf{W}_0 contains 52 differential monomials. When M is not assumed rigid, it contains hundreds of thousands of differential monomials instead! Furthermore, the numerator of $\bar{\mathbf{J}}_0$ is even huger!

Thus, as is known, the complexity increases spectacularly from rigid to nonrigid CR manifolds. This justifies, in a way, to devote some mathematical works to *rigid* CR manifolds, as Alexander Isaev did, and as we do in the present memoir.

The full $\{e\}$ -structure obtained by Foo-Merker in [49] for nonrigid $M^5 \subset \mathbb{C}^3$ shows that a unique prolongation of G -structure is needed, introducing one further parameter $t \in \mathbb{R}$, together with a (very complicated) real modified Maurer-Cartan form $\Lambda = dt + \dots$ and that all appearing torsion coefficients are *secondary invariants*. The constructed bundle $P^{10} \rightarrow M^5$ is equipped with ten coordinates:

$$(z_1, z_2, \bar{z}_1, \bar{z}_2, v, c, \bar{c}, e, \bar{e}, t),$$

with $c \in \mathbb{C}^*$, $e \in \mathbb{C}$, $t \in \mathbb{R}$, together with a collection of ten complex-valued 1-form which make a frame for T^*P^{10} , denoted:

$$\{\rho, \kappa, \zeta, \bar{\kappa}, \bar{\zeta}, \pi^1, \bar{\pi}^1, \pi^2, \bar{\pi}^2, \Lambda\} \quad (\bar{\rho} = \rho, \bar{\Lambda} = \Lambda),$$

and which satisfy 10 invariant structure equations; however, we will not write the structure equations for $d\pi^1, d\bar{\pi}^1, d\pi^2, d\bar{\pi}^2, d\Lambda$, because they are not simple, and anyway, they incorporate only secondary invariants.

Thus quite unexpectedly, Pocchiola discovered that all primary invariants appear *before* prolongation of the equivalence problem, that is to say, they already appear at the beginning of the story, in the structure equations (1.7).

This phenomenon is in some sense ‘counter-intuitive’ to CR geometers, since for Levi nondegenerate CR structures $M^{2n+1} \subset \mathbb{C}^{n+1}$, and for the corresponding second order PDE systems, *no* curvatures appear after absorption before prolongation (summation convention holds):

$$\begin{aligned} d\omega &= \omega^\alpha \wedge \omega_\alpha + \omega \wedge \varphi, \\ d\omega^\alpha &= \omega^\beta \wedge \varphi_\beta^\alpha + \omega \wedge \varphi^\alpha, \\ d\omega_\alpha &= \varphi_\alpha^\beta \wedge \omega_\beta + \omega_\alpha \wedge \varphi + \omega \wedge \varphi_\alpha, \end{aligned}$$

while primary and secondary invariants appear afterwards, *e.g.* like $S_{\beta\rho}^{\alpha\sigma}$ and $R_{\beta\gamma}^\alpha, T_\beta^{\alpha\gamma}$ in:

$$\begin{aligned} d\varphi_\beta^\alpha &= \frac{1}{2} \delta_\beta^\alpha \psi \wedge \omega - \varphi_\beta^\gamma \wedge \varphi_\gamma^\alpha - \varphi_\beta \wedge \omega^\alpha - \varphi^\alpha \wedge \omega_\beta + \delta_\beta^\alpha \omega^\gamma \wedge \varphi_\gamma + \\ &+ S_{\beta\rho}^{\alpha\sigma} \omega^\rho \wedge \omega_\sigma + R_{\beta\gamma}^\alpha \omega^\gamma \wedge \omega + T_\beta^{\alpha\gamma} \omega_\gamma \wedge \omega. \end{aligned}$$

Next, in the ‘flat case’ where both $J_0 \equiv 0 \equiv W_0$ vanish identically, which implies $R \equiv 0$ too, Pocchiola’s structure equations reduce to constant coefficients:

$$(1.8) \quad \begin{aligned} d\rho &= (\pi^1 + \bar{\pi}^1) \wedge \rho + i \kappa \wedge \bar{\kappa}, \\ d\kappa &= \pi^2 \wedge \rho + \pi^1 \wedge \kappa + \zeta \wedge \bar{\kappa}, \\ d\zeta &= (\pi^1 - \bar{\pi}^1) \wedge \zeta + i \pi^2 \wedge \kappa. \end{aligned}$$

Then a key point is to show that after prolongation, precisely the structure equations of the Gaussier-Merker model pop up, namely (conjugate equations are unwritten):

$$\begin{aligned} d\rho &= \pi^1 \wedge \rho + \bar{\pi}^1 \wedge \rho + i \kappa \wedge \bar{\kappa}, \\ d\kappa &= \pi^1 \wedge \kappa + \pi^2 \wedge \rho + \zeta \wedge \bar{\kappa}, \\ d\zeta &= i \pi^2 \wedge \kappa + \pi^1 \wedge \zeta - \bar{\pi}^1 \wedge \zeta, \\ d\pi^1 &= i \kappa \wedge \bar{\pi}^2 + \zeta \wedge \bar{\zeta} + \Lambda \wedge \rho, \\ d\pi^2 &= \pi^2 \wedge \bar{\pi}^1 + \zeta \wedge \bar{\pi}^2 + \Lambda \wedge \kappa, \\ d\Lambda &= i \pi^2 \wedge \bar{\pi}^2 + \Lambda \wedge \pi^1 + \Lambda \wedge \bar{\pi}^1, \end{aligned}$$

and not the structure equations of any other kind of hypersurface $M^5 \subset \mathbb{C}^3$. This was done by Pocchiola at the very end of [113], not published in [92] for reasons of space.

In the meanwhile, Wei Guo Foo found that Pocchiola missed the presence of a purely imaginary function $h = iH$ with $\bar{H} = H$ in computations starting from (1.8), *which could have destroyed Pocchiola's main result (!)*, because some (phantom) primary invariants could have then existed in the structure equations for $d\pi^1, d\bar{\pi}^1, d\pi^2, d\bar{\pi}^2, d\Lambda$, exactly as in Cartan-Chern-Moser's computations!

Fortunately, this function $h = iH$ could be shown to vanish, hence phantoms remained phantoms, and the correction to the (unpublished) end of [113] will appear as [102], pre-published at the end of [49]. Maybe Pocchiola just did not type a proper presentation, and was anyway right in his manuscripts.

Lastly, we recall that Cartan adopted Lie's principle of thought ([78, Chap. 1]), as we do too, which admits that either a given differential invariant, call it P , is identically zero, or is assumed to be nowhere zero, after restriction to an appropriate open subset:

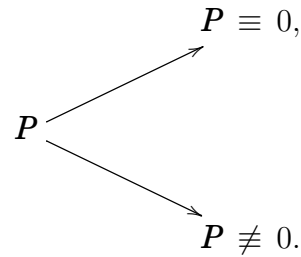

Mixed cases where some invariant is nonzero on some nonempty open subset and vanishes on a nonempty closed subset are excluded from exploration.

Therefore there is essentially no necessity to set up an $\{e\}$ -structure when $W_0 \equiv 0 \equiv J_0$, because when either $W_0 \not\equiv 0$, hence $W_0 \neq 0$ after restriction, or $J_0 \not\equiv 0$, hence $J_0 \neq 0$ after restriction, Cartan's method commands to continue the group parameter normalizations!

Pocchiola indeed listened to captain Cartan, and was able to prove the

THEOREM 1.9. [113, 92, 49, 102] *Only two primary invariants, W_0 and J_0 , occur for biholomorphic equivalences of $\mathfrak{C}_{2,1}$ real analytic hypersurfaces $M^5 \subset \mathbb{C}^3$, and:*

$$0 \equiv W_0 \equiv J_0 \iff M \text{ is equivalent to the Gaussier-Merker model.}$$

Furthermore, when either $W_0 \neq 0$ or $J_0 \neq 0$, the equivalence problem reduces to a 5-dimensional $\{e\}$ -structure on M^5 .

As a corollary known from general Cartan theory, every non-flat $M^5 \in \mathfrak{C}_{2,1}$ has CR automorphisms group of dimension ≤ 5 . This confirmed the same dimensional gap estimate $10 \downarrow 5$ obtained by Fels-Kaup in [44], who assumed M to be homogeneous from the beginning.

Now, as said, we will work with *rigid* hypersurfaces, which is easier. Only in a future publication will we complete the views of [75] by comparing them with Pocchiola's results in a deeper way, inspired by the present article.

We start by presenting the Moser side of the river. But before we really treat $\mathfrak{C}_{2,1}$ hypersurfaces $M^5 \subset \mathbb{C}^3$, let us explain first how we can get rid of *infinity* in the local Lie group of rigid biholomorphisms by performing what we will call as in [75] a *prenormalization*,

which is here, as we already saw, to reach:

$$(1.10) \quad u = z\bar{z} + \sum_{j,k \geq 2} F_{j,k} z^j \bar{z}^k,$$

with $\overline{F_{k,j}} = F_{j,k}$.

How can we do this? Simple! First, starting from a general $u = \sum_{j+k \geq 1} F_{j,k} z^j \bar{z}^k$, we get rid of all harmonic terms $F_{j,0} z^j, F_{0,k} \bar{z}^k$ in the graphing function by setting:

$$z' := z, \quad w' := w - 2 \sum_{j \geq 1} F_{j,0} z^j,$$

and we get a new graphed equation of the form (dropping primes):

$$u = \sum_{\substack{j \geq 1 \\ k \geq 1}} F_{j,k} z^j \bar{z}^k.$$

By this, we have erased an *infinite* number of coefficients $F_{j,0}, F_{0,k}$, which was possible thanks to the infinite dimensionality of the group of rigid biholomorphisms. More precisely, we have consumed 1 function of 1 complex variable.

Next, assuming Levi nondegeneracy at the origin, making an elementary linear transformation (exercise), we can assume:

$$\begin{aligned} u &= z\bar{z} + \sum_{\substack{j+k \geq 3 \\ j, k \geq 1}} F_{j,k} z^j \bar{z}^k \\ &= z\bar{z} + \bar{z} \left(\sum_{j \geq 2} F_{j,0} z^j \right) + z \left(\sum_{k \geq 2} F_{0,k} \bar{z}^k \right) + \sum_{\substack{j \geq 2 \\ k \geq 2}} F_{j,k} z^j \bar{z}^k. \end{aligned}$$

Here, the presence of the monomial $z\bar{z}$ is very advantageous in that it enables to *capture* all monomials $\bar{z} z^j$ and their conjugates $z \bar{z}^k$ in a tricky but simple *factorization*, in which we abbreviate $\Lambda(z) := \sum_{j \geq 2} F_{j,0} z^j$:

$$u = \left(z + \Lambda(z) \right) \left(\bar{z} + \overline{\Lambda(\bar{z})} \right) - \Lambda(z) \overline{\Lambda(\bar{z})} + \sum_{\substack{j \geq 2 \\ k \geq 2}} F_{j,k} z^j \bar{z}^k.$$

The same factorization idea will work soon for $M^5 \in \mathfrak{C}_{2,1}$. Then by making the biholomorphism:

$$z' := z + \Lambda(z) = z + O_z(2), \quad w' := w,$$

it is not difficult to see (details in Section 2) that we come to the prenormalized form (1.10). Observe that we have consumed a second infinity, again 1 function of 1 complex variable.

Why do we call this *prenormal* form? Firstly, because it is in a sense easily and almost freely got from the assumptions. Secondly, because one key aspect of power series normal forms is the progressive reduction of *stability groups*, not well emphasized in [71, 75]. The reader is referred to Sections 13 and 16 of Chen-Merker [21] to see examples of curves $C^1 \subset \mathbb{R}^2$ and surfaces $S^2 \subset \mathbb{R}^3$ modulo the group of special affine transformations for which successive stability groups are explicitly described.

The presence of group structure reduction *also* in Moser's theory of normal forms is in surprising *homology*, not to say *harmony*, with Cartan's method of equivalence, whose main gist *is* group structure reduction.

Plato's Philosophy states that Mathematical objects are one and the same in their World. Various theories elaborate different concept to grasp these Ideas. The more adequate the concepts are, the more unitary they are. What we are claiming is again a good sign of *Unity* in Mathematics.

Indeed, once a prenormalization is obtained, in order to normalize $F(z, \bar{z})$ further, it is natural to assume that the next rigid biholomorphic transformations $(z, w) \mapsto (z', w')$ to be used should keep unchanged the 'shape' of the prenormalization, namely send:

$$u = z\bar{z} + \sum_{j,k \geq 2} F_{j,k} z^j \bar{z}^k \quad \text{to} \quad u' = z'\bar{z}' + \sum_{j,k \geq 2} F'_{j,k} z'^j \bar{z}'^k.$$

This of course imposes many constraints on the map $(z, w) \mapsto (z', w')$. And in the rigid context, it is easy to see (in Section 2), that only a *finite-dimensional* Lie group remains. Thus, after prenormalization is performed, one is led back to Lie's original theory [78, 109] in jet spaces for finite-dimensional continuous groups, which can be safely and naturally applied, to finish.

Next, what about $\mathfrak{C}_{2,1}$ rigid hypersurface $M^5 \subset \mathbb{C}^3$? Quite the same!

In coordinates $(z, \zeta, \bar{z}, \bar{\zeta}) \in \mathbb{C}^3$, we start at the origin with:

$$u = \sum_{a+b+c+d \geq 1} F_{a,b,c,d} z^a \zeta^b \bar{z}^c \bar{\zeta}^d.$$

Abbreviating $\chi(z, \zeta) := \sum_{a+b \geq 1} F_{a,b,0,0} z^a \zeta^b$, we similarly get rid of *pluriharmonic* terms thanks to $z' := z$, $\zeta' := \zeta$, $w' := w - 2\chi(z, \zeta)$, receiving, after dropping primes, a right-hand side graphing function F which satisfies:

$$0 = F_{a,b,0,0} = F_{0,0,c,d}.$$

Next, since M is 2-nondegenerate and has Levi form of rank 1 at the origin, it is not difficult (*see* Section 5) to bring its cubic approximation to:

$$u = z\bar{z} + \frac{1}{2} z^2 \bar{\zeta} + \frac{1}{2} \bar{z}^2 \zeta + \sum_{\substack{a+b+c+d \geq 4 \\ a+b \geq 1 \\ c+d \geq 1}} F_{a,b,c,d} z^a \zeta^b \bar{z}^c \bar{\zeta}^d.$$

And now, the same idea of *absorption* by factorization pops up. But compared to $M^3 \subset \mathbb{C}^2$, there is a difference: *two* nontrivial monomials $z\bar{z}$ (self-conjugate) and $\frac{1}{2} \bar{z}^2 \zeta$ (with its equivalent conjugate) can be used to absorb infinities. Writing them as $\bar{z}(z)$ and $\bar{z}^2(\frac{1}{2} \zeta)$, we may therefore *capture* all holomorphic monomials behind $\bar{z}(\dots)$ and behind $\bar{z}^2(\dots)$, by making the rigid biholomorphism:

$$\begin{aligned} z + \sum_{a+b \geq 1} F_{a,b,1,0} z^a \zeta^b &=: z', \\ \frac{1}{2} \zeta + \sum_{a+b \geq 2} F_{a,b,2,0} z^a \zeta^b &=: \zeta', \end{aligned}$$

with unchanged $w' := w$. The true story is a little more subtle, requires more care, and will be told with rigorous details in Section 5.

Therefore, after having consumed *three* holomorphic functions of the two complex variables (z, ζ) , we end up with a graph $u = F(z, \zeta, \bar{z}, \bar{\zeta})$ which is *prenormalized* in the sense

that:

$$\begin{aligned} 0 &= F_{a,b,0,0} = F_{0,0,c,d}, \\ 0 &= F_{a,b,1,0} = F_{1,0,c,d}, \\ 0 &= F_{a,b,2,0} = F_{2,0,c,d}, \end{aligned}$$

except of course $F_{1,0,1,0} = 1$ and $F_{2,0,0,1} = \frac{1}{2} = F_{0,1,2,0}$. An equivalent way to express prenormalization is to write that (exercise):

$$u = F = z\bar{z} + \frac{1}{2}\bar{z}^2\zeta + O_{\bar{z}}(3) + O_{\bar{\zeta}}(1).$$

The next task is to normalize F beyond prenormalization.

Because in \mathbb{C}^2 a general rigid hypersurface $u = F = z\bar{z} + O_{z,\bar{z}}(3)$ is naturally represented as a perturbation of the (flat) model $u = z\bar{z}$, we represent a general rigid $M \in \mathfrak{C}_{2,1}$ as a perturbation of the Gaussier-Merker model:

$$u = F(z, \zeta, \bar{z}, \bar{\zeta}) = m(z, \zeta, \bar{z}, \bar{\zeta}) + G(z, \zeta, \bar{z}, \bar{\zeta}),$$

but — warning! —, the remainder function G here cannot be arbitrary, it must be so that $\text{Levi}(m + G) \equiv 0$.

Next, inspired by [75], we show in the key Proposition 5.7 that in prenormalized coordinates, one necessarily has:

$$G = O_{z,\bar{z}}(3).$$

Since the Gaussier-Merker function:

$$m(z, \zeta, \bar{z}, \bar{\zeta}) = \frac{z\bar{z} + \frac{1}{2}z^2\bar{\zeta} + \bar{z}^2\zeta}{1 - \zeta\bar{\zeta}}$$

is homogeneous of degree 2 in (z, \bar{z}) , this conducts us, as in [75], to assign the following weights to the coordinate variables:

$$[z] := 1 =: [\bar{z}], \quad [\zeta] := 0 =: [\bar{\zeta}], \quad [w] := 2 =: [\bar{w}].$$

Similarly as for rigid $M^3 \subset \mathbb{C}^2$, we next ask: *which rigid transformations stabilize prenormalization?*, and we will again realize that only a *finite-dimensional* Lie group remains.

Thus we take M in $\mathbb{C}^3 \ni (z_1, z_2, w)$ graphed as $u = F = m + G$ and M' in $\mathbb{C}^3 \ni (z'_1, z'_2, w')$ graphed as $u' = F' = m' + G'$, with G prenormalized:

$$(1.11) \quad G = O_{\bar{z}}(3) + O_{\bar{\zeta}}(1) = O_{z,\bar{z}}(3),$$

(none condition implies the other), and the same about G' . The goal is to *normalize further* G' .

Without waiting, we expand G in weighted homogeneous parts:

$$G = \sum_{\nu \geq 3} G_\nu, \quad G_\nu = \sum_{a+c=\nu} z^a \bar{z}^c G_{a,c}(\zeta, \bar{\zeta}),$$

and the same for G' , with, unlike in Moser's theory for Levi nondegenerate hypersurfaces in \mathbb{C}^{n+1} , coefficient-functions $G_{a,c}$ which are *analytic*, not polynomial.

The elementary Proposition 5.11 shows that, composing in advance with some element of the 2-dimensional isotropy group (1.2) of the origin for the Gaussier-Merker model, we can assume that the normalizing map has weighted expansion of the form:

$$(1.12) \quad f = z + f_2 + f_3 + \cdots, \quad g = \zeta + g_1 + g_2 + \cdots, \quad h = w + h_3 + h_4 + \cdots,$$

where, for $\nu = 3, 4, 5, \dots$, the appearing holomorphic functions $f_{\nu-1}$, $g_{\nu-2}$, h_ν are weighted homogeneous. Keeping good memory of this pre-composition, there will remain at the end a 2-dimensional ambiguity in the obtained normal form.

As in Jacobowitz's [71, Ch. 3] presentation of Moser's method, with increasing weights $\nu = 3, 4, 5, \dots$, we shall perform successive holomorphic rigid transformations of the shape:

$$z' := z + f_{\nu-1}, \quad \zeta' := \zeta + g_{\nu-2}, \quad w' := w + h_\nu.$$

Then in the main Proposition 6.2, we will show that through any such biholomorphism (1.12) which transforms:

$$u = m + G_3 + \dots + G_{\nu-1} + G_\nu + O(\nu+1) \quad \text{into} \quad u' = m + G'_3 + \dots + G'_{\nu-1} + G'_\nu + O'(\nu+1),$$

homogeneous terms are kept untouched up to order $\leq \nu - 1$:

$$G'_\mu(z, \zeta, \bar{z}, \bar{\zeta}) = G_\mu(z, \zeta, \bar{z}, \bar{\zeta}) \quad (3 \leq \mu \leq \nu-1),$$

while:

$$G'_\nu(z, \zeta, \bar{z}, \bar{\zeta}) = G_\nu(z, \zeta, \bar{z}, \bar{\zeta}) - 2 \operatorname{Re} \left\{ \frac{\bar{z} + z\bar{\zeta}}{1 - \zeta\bar{\zeta}} f_{\nu-1}(z, \zeta) + \frac{(\bar{z} + z\bar{\zeta})^2}{2(1 - \zeta\bar{\zeta})^2} g_{\nu-2}(z, \zeta) - \frac{1}{2} h_\nu(z, \zeta) \right\}.$$

Here, the *freedom*, which consists of a triple $\{f_{\nu-1}, g_{\nu-2}, h_\nu\}$ of holomorphic functions of the two complex variables (z, ζ) , can be used to simplify/normalize G'_ν in comparison with G_ν .

It is important to point out that in this paper, we dispense ourselves completely of making a *formal* theory of normal form *before* conducting a *geometric* reduction to normal form, we come directly to (geometric) heart.

Then we study the initial weights $\nu = 3, 4, 5$, even restricting our attention firstly to total degree $a + b + c + d \leq 5$. In Section 7, we show that only two monomials (up to conjugation) remain after prenormalization in:

$$G_3 = 2 \operatorname{Re} \left\{ z^3 \bar{\zeta} G_{3,0,0,1} + z^3 \bar{\zeta}^2 G_{3,0,0,2} \right\} + O_{z,\zeta,\bar{z},\bar{\zeta}}(6).$$

Using the freedom (1.12) and taking account of preservation of prenormalization, similarly as in [21], we show that we can annihilate $G'_{3,0,0,1} := 0$. And then, we show that no other Taylor coefficient of G_3 can be normalized, if one requires preservation of $G_{3,0,0,1} = 0 = G'_{3,0,0,1}$.

In particular, this implies that there is no invariant of (differential) order 4, and this confirms the results of [51], to be reviewed and compared in a while.

Next, we study $\nu = 4$, still with $a + b + c + d \leq 5$, and there are again only two monomials:

$$G_4 = 2 \operatorname{Re} \left\{ z^4 \bar{\zeta} G_{4,0,0,1} + z^3 \bar{z} \bar{\zeta} G_{3,0,1,1} \right\} + O_{z,\zeta,\bar{z},\bar{\zeta}}(6).$$

Using the freedom (1.12) and taking account of preservation of all preceding normalizations, we show that we can annihilate $\operatorname{Im} G'_{3,0,1,1} := 0$. And then, we show that no other Taylor coefficient of G_4 can be normalized.

Lastly, for every remaining $\nu \geq 5$, we verify that only the identity transformation $z' = z$, $\zeta' = \zeta$, $w' = w$, stabilizes prenormalization *and*:

$$0 = G_{3,0,0,1} = G'_{3,0,0,1}, \quad 0 = \operatorname{Im} G_{3,0,1,1} = \operatorname{Im} G'_{3,0,1,1}.$$

namely we show that $0 = f_{\nu-1} = g_{\nu-2} = h_\nu$, necessarily.

Moser's algorithm therefore terminates, and we may at last state our main

THEOREM 1.13. *Every hypersurface $M^5 \in \mathfrak{C}_{2,1}$ is equivalent, through a local rigid biholomorphism, to a rigid \mathcal{C}^ω hypersurface $M^5 \subset \mathbb{C}^3$ which, dropping primes for target coordinates, is a perturbation of the Gaussier-Merker model:*

$$u = \frac{z\bar{z} + \frac{1}{2}z^2\bar{\zeta} + \frac{1}{2}\bar{z}^2\zeta}{1 - \zeta\bar{\zeta}} + \sum_{\substack{a,b,c,d \in \mathbb{N} \\ a+c \geq 3}} G_{a,b,c,d} z^a \zeta^b \bar{z}^c \bar{\zeta}^d,$$

with a simplified remainder G which:

- (1) is normalized to be an $O_{z,\bar{z}}(3)$;
 (2) satisfies the prenormalization conditions $G = O_{\bar{z}}(3) + O_{\bar{\zeta}}(1) = O_z(3) + O_{\zeta}(1)$:

$$G_{a,b,0,0} = 0 = G_{0,0,c,d},$$

$$G_{a,b,1,0} = 0 = G_{1,0,c,d},$$

$$G_{a,b,2,0} = 0 = G_{2,0,c,d};$$

- (3) satisfies in addition the sporadic normalization conditions:

$$G_{3,0,0,1} = 0 = G_{0,1,3,0},$$

$$\operatorname{Im} G_{3,0,1,1} = 0 = \operatorname{Im} G_{1,1,3,0}.$$

Furthermore, two such rigid \mathcal{C}^ω hypersurfaces $M^5 \subset \mathbb{C}^3$ and $M'^5 \subset \mathbb{C}^3$, both brought into such a normal form, are rigidly biholomorphically equivalent if and only if there exist two constants $\rho \in \mathbb{R}_+^*$, $\varphi \in \mathbb{R}$, such that for all a, b, c, d :

$$G_{a,b,c,d} = G'_{a,b,c,d} \rho^{\frac{a+c-2}{2}} e^{i\varphi(a+2b-c-2d)}.$$

Now, before talking about any bridge, we must survey the results of the article [51], from Cartan's side of the river. These results were finalized after the stay in Orsay of Alexander Isaev, who raised the problem. The reader is referred to the introduction of [51] for more extensive information.

Consider as before a rigid $M^5 \subset \mathbb{C}^3$ with $0 \in M$, which is 2-nondegenerate and has Levi form of constant rank 1, *i.e.* belongs to the class $\mathfrak{C}_{2,1}$, and which is graphed as:

$$u = F(z_1, z_2, \bar{z}_1, \bar{z}_2).$$

The letter ζ is protected, hence not used instead of z_2 , since ζ will denote a 1-form. The two natural generators of $T^{1,0}M$ and $T^{0,1}M$ are:

$$\mathcal{L}_1 := \partial_{z_1} - i F_{z_1} \partial_v \quad \text{and} \quad \mathcal{L}_2 := \partial_{z_2} - i F_{z_2} \partial_v,$$

in the intrinsic coordinates $(z_1, z_2, \bar{z}_1, \bar{z}_2, v)$ on M . The Levi kernel bundle $K^{1,0}M \subset T^{1,0}M$ is generated by:

$$\mathcal{K} := k \mathcal{L}_1 + \mathcal{L}_2, \quad \text{where} \quad k := -\frac{F_{z_2 \bar{z}_1}}{F_{z_1 \bar{z}_1}},$$

is the slant function. The hypothesis of 2-nondegeneracy is equivalent to the nonvanishing:

$$0 \neq \overline{\mathcal{L}_1}(k).$$

Also, the conjugate $\overline{\mathcal{K}}$ generates the conjugate Levi kernel bundle $K^{0,1} \subset T^{0,1}M$.

There is a second fundamental function, and no more:

$$P := \frac{F_{z_1 z_1 \bar{z}_1}}{F_{z_1 \bar{z}_1}}.$$

In the rigid case, it looks so simple! But in the nonrigid case, P has a numerator involving 69 differential monomials!

Foo-Merker-Ta produced in [51] reduction to an $\{e\}$ -structure for the equivalence problem, under *rigid* (local) biholomorphic transformations, of such rigid $M^5 \in \mathfrak{C}_{2,1}$. They constructed an invariant 7-dimensional bundle $P^7 \rightarrow M^5$ equipped with coordinates:

$$(z_1, z_2, \bar{z}_1, \bar{z}_2, v, c, \bar{c}),$$

with $c \in \mathbb{C}$, together with a collection of seven complex-valued 1-form which make a frame for T^*P^7 , denoted:

$$\{\rho, \kappa, \zeta, \bar{\kappa}, \bar{\zeta}, \alpha, \bar{\alpha}\} \quad (\bar{\rho} = \rho),$$

which satisfy 7 invariant structure equations of the form:

$$\begin{aligned} d\rho &= (\alpha + \bar{\alpha}) \wedge \rho + i\kappa \wedge \bar{\kappa}, \\ d\kappa &= \alpha \wedge \kappa + \zeta \wedge \bar{\kappa}, \\ d\zeta &= (\alpha - \bar{\alpha}) \wedge \zeta + \frac{1}{c} I_0 \kappa \wedge \zeta + \frac{1}{c\bar{c}} V_0 \kappa \wedge \bar{\kappa}, \\ d\alpha &= \zeta \wedge \bar{\zeta} - \frac{1}{c} I_0 \zeta \wedge \bar{\kappa} + \frac{1}{c\bar{c}} Q_0 \kappa \wedge \bar{\kappa} + \frac{1}{c} \bar{I}_0 \bar{\zeta} \wedge \kappa, \end{aligned}$$

conjugate structure equations for $d\bar{\kappa}$, $d\bar{\zeta}$, $d\bar{\alpha}$ being easily deduced.

Here, as in Pocchiola's Ph.D., there are exactly *two* primary Cartan-curvature invariants:

$$\begin{aligned} I_0 &:= -\frac{1}{3} \frac{\mathcal{H}(\overline{\mathcal{L}}_1(\overline{\mathcal{L}}_1(k)))}{\overline{\mathcal{L}}_1(k)^2} + \frac{1}{3} \frac{\mathcal{H}(\overline{\mathcal{L}}_1(k)) \overline{\mathcal{L}}_1(\overline{\mathcal{L}}_1(k))}{\overline{\mathcal{L}}_1(k)^3} + \\ &\quad + \frac{2}{3} \frac{\mathcal{L}_1(\overline{\mathcal{L}}_1(\bar{k}))}{\mathcal{L}_1(\bar{k})} + \frac{2}{3} \frac{\mathcal{L}_1(\overline{\mathcal{L}}_1(k))}{\mathcal{L}_1(k)}, \\ V_0 &:= -\frac{1}{3} \frac{\overline{\mathcal{L}}_1(\overline{\mathcal{L}}_1(\overline{\mathcal{L}}_1(k)))}{\overline{\mathcal{L}}_1(k)} + \frac{5}{9} \left(\frac{\overline{\mathcal{L}}_1(\overline{\mathcal{L}}_1(k))}{\overline{\mathcal{L}}_1(k)} \right)^2 - \\ &\quad - \frac{1}{9} \frac{\overline{\mathcal{L}}_1(\overline{\mathcal{L}}_1(k)) \bar{P}}{\overline{\mathcal{L}}_1(k)} + \frac{1}{3} \overline{\mathcal{L}}_1(\bar{P}) - \frac{1}{9} \bar{P} \bar{P}. \end{aligned}$$

One can check that Pocchiola's W_0 which occurs under *general* biholomorphic transformations of \mathbb{C}^3 (not necessarily rigid!), when written for a *rigid* $M^5 \subset \mathbb{C}^3$, identifies with:

$$I_0(F(z_1, z_2, \bar{z}_1, \bar{z}_2)) \equiv W_0(F(z_1, z_2, \bar{z}_1, \bar{z}_2)).$$

Furthermore, there is *one* secondary invariant whose unpolished expression is:

$$Q_0 := \frac{1}{2} \overline{\mathcal{L}}_1(I_0) - \frac{1}{3} \left(\bar{P} - \frac{\mathcal{L}_1(\overline{\mathcal{L}}_1(\bar{k}))}{\mathcal{L}_1(\bar{k})} \right) \bar{I}_0 - \frac{1}{6} \left(\bar{P} - \frac{\overline{\mathcal{L}}_1(\overline{\mathcal{L}}_1(k))}{\overline{\mathcal{L}}_1(k)} \right) I_0 - \frac{1}{2} \frac{\mathcal{H}(V_0)}{\overline{\mathcal{L}}_1(k)}.$$

Visibly indeed, the vanishing of I_0 and V_0 implies the vanishing of Q_0 . In fact, a consequence of Cartan's general theory is:

$$0 \equiv I_0 \equiv V_0 \quad \iff \quad M \text{ is rigidly equivalent to the Gaussier-Merker model.}$$

In [51], by deducing new relations from the structure equations above, it was proved that Q_0 is real-valued, but a finalized expression was missing there. A clean finalized expression

of \mathcal{Q}_0 , in terms of only the two fundamental functions k, P (and their conjugates), from which one immediately sees real-valuedness, is:

$$\begin{aligned} \mathcal{Q}_0 := 2 \operatorname{Re} \left\{ \frac{1}{9} \frac{\mathcal{H}(\overline{\mathcal{L}}_1(k)) \overline{\mathcal{L}}_1(\overline{\mathcal{L}}_1(k))^2}{\overline{\mathcal{L}}_1(k)^4} - \right. \\ - \frac{1}{9} \frac{\mathcal{H}(\overline{\mathcal{L}}_1(\overline{\mathcal{L}}_1(k))) \overline{\mathcal{L}}_1(\overline{\mathcal{L}}_1(k))}{\overline{\mathcal{L}}_1(k)^3} - \frac{1}{9} \frac{\mathcal{H}(\overline{\mathcal{L}}_1(k)) \overline{\mathcal{L}}_1(\overline{\mathcal{L}}_1(k)) \overline{P}}{\overline{\mathcal{L}}_1(k)^3} - \\ - \frac{1}{9} \frac{\mathcal{L}_1(\overline{\mathcal{L}}_1(k)) \overline{\mathcal{L}}_1(\overline{\mathcal{L}}_1(k))}{\overline{\mathcal{L}}_1(k)^2} + \frac{1}{9} \frac{\mathcal{H}(\overline{\mathcal{L}}_1(\overline{\mathcal{L}}_1(k))) \overline{P}}{\overline{\mathcal{L}}_1(k)^2} - \\ - \frac{2}{9} \frac{\mathcal{L}_1(\overline{\mathcal{L}}_1(k)) \overline{P}}{\overline{\mathcal{L}}_1(k)} - \frac{1}{9} \frac{\overline{\mathcal{L}}_1(\overline{\mathcal{L}}_1(k)) P}{\overline{\mathcal{L}}_1(k)} + \frac{1}{3} \frac{\mathcal{L}_1(\overline{\mathcal{L}}_1(\overline{\mathcal{L}}_1(k)))}{\overline{\mathcal{L}}_1(k)} + \frac{1}{6} \overline{\mathcal{L}}_1(P) \left. \right\} \\ - \frac{1}{9} |\overline{P}|^2 + \frac{1}{3} \left| \frac{\overline{\mathcal{L}}_1(\overline{\mathcal{L}}_1(k))}{\overline{\mathcal{L}}_1(k)} \right|^2. \end{aligned}$$

Section 8 is devoted to provide the details of the necessary, nontrivial computations.

Acknowledgments. The realization of this research work in Cauchy-Riemann (CR) geometry has received generous financial support from the scientific grant 2018/29/B/ST1/02583 originating from the Polish National Science Center (NCN).

During fall 2019, in October in Warsaw, then in November and December in Paris, the authors benefited from countless oral exchanges with Paweł Nurowski (Center For Theoretical Physics), who explained, developed, and even *taught in the latest details* his deep knowledge of *Cartan's method of equivalence* (production of homogeneous models), whose tenuous relationships with the theory of normal forms *à la Poincaré* and *à la Moser* will continue to be explored and unveiled in several upcoming mathematical memoirs.

2. Rigid Equivalences of Rigid Hypersurfaces in \mathbb{C}^2 : A Toy Study

We first consider the equivalence problem of rigid hypersurfaces in \mathbb{C}^2 under the action of rigid biholomorphic transformations. We will solve this problem with both Cartan's method of equivalence and Moser's method of normal forms. The calculations here are simple, and they will serve as a toy model for our more substantial problem in \mathbb{C}^3 later. Throughout this section, we use the complex coordinates (z, w) on \mathbb{C}^2 with $w = u + iv$, where $u, v \in \mathbb{R}$.

We recall that a real analytic hypersurface in \mathbb{C}^2 is called *rigid* if it can be written $\{u = F(z, \bar{z})\}$, where F is a converging power series in z, \bar{z} . A local biholomorphic map of \mathbb{C}^2 of the form:

$$(2.1) \quad (z, w) \longmapsto (f(z), aw + g(z)),$$

with $a \in \mathbb{R}^*$, $c \in \mathbb{R}$, will be called *rigid*. Most of the times, we will assume that the origin is fixed, whence $0 = f(0) = g(0)$.

Since rigid transformations send rigid hypersurfaces to hypersurfaces which are again rigid, it then makes sense to consider rigid equivalences of rigid hypersurfaces in \mathbb{C}^2 , as we do here. The homogeneous model here is (still) the Heisenberg sphere $\{u = z\bar{z}\}$, whose rigid automorphisms fixing the origin can be extracted from the set of general automorphisms of the sphere (exercise).

As a starter, consider a rigid biholomorphic map $(z, w) \mapsto (f(z), aw + g(z)) =: (z', w')$ between two hypersurfaces $\{u = F(z, \bar{z})\}$ in \mathbb{C}^2 and $\{u' = F'(z', \bar{z}')\}$ in \mathbb{C}^2 too. From:

$$F'(f(z), \bar{f}(\bar{z})) = F'(z', \bar{z}') = u' = au + \operatorname{Re} g(z) = aF(z, \bar{z}) + \frac{1}{2}g(z) + \frac{1}{2}\bar{g}(\bar{z}),$$

it comes the *fundamental equation*, identically satisfied:

$$(2.2) \quad F'(f(z), \bar{f}(\bar{z})) \equiv aF(z, \bar{z}) + \frac{1}{2}g(z) + \frac{1}{2}\bar{g}(\bar{z}).$$

LEMMA 2.3. *Through a rigid biholomorphism between two rigid hypersurfaces $\{u = F\}$ and $\{u' = F'\}$ in \mathbb{C}^2 , it holds:*

$$F_{z\bar{z}} = \frac{1}{a} |f_z|^2 F'_{z'\bar{z}'}$$

PROOF. Applying $\partial_z \partial_{\bar{z}}$ eliminates g and \bar{g} above and yields the result. \square

Thus, $F_{z\bar{z}}$ is a *relative invariant*: it is nonvanishing in one system of coordinates if and only if it is nonvanishing in any other system of coordinates. Of course, M is *Levi nondegenerate* in the classical sense if and only if $F_{z\bar{z}} \neq 0$. We will constantly assume that this holds at *every point*.

2.4. Cartan's method of equivalence. Consider a real analytic graphed hypersurface $M^3 = \{u = F(z, \bar{z})\}$ passing through the origin in \mathbb{C}^2 . Its holomorphic tangent space $T^{1,0}M := (\mathbb{C} \otimes TM) \cap T^{1,0}\mathbb{C}$ is a 1-dimensional complex vector bundle on M . One can check directly that the vector field $\mathcal{L} := \frac{\partial}{\partial z} - iF_z \frac{\partial}{\partial v}$ generates $T^{1,0}M$, in the intrinsic coordinates (z, \bar{z}, v) on M . We abbreviate $A := -iF_z$ so that $\mathcal{L} = \frac{\partial}{\partial z} + A \frac{\partial}{\partial v}$ and $\overline{\mathcal{L}} = \frac{\partial}{\partial \bar{z}} + \bar{A} \frac{\partial}{\partial v}$.

Assume that M is everywhere Levi nondegenerate, namely $F_{z\bar{z}} \neq 0$. Next, define the real vector field \mathcal{T} on M by $\mathcal{T} := -i[\mathcal{L}, \overline{\mathcal{L}}] = \ell \frac{\partial}{\partial v}$, where $\ell := -2F_{z\bar{z}}$. As in [51], introduce also the auxiliary function on M :

$$\mathbf{P} := \frac{\ell_z}{\ell} = \frac{F_{zz\bar{z}}}{F_{z\bar{z}}}.$$

LEMMA 2.5. *The vector fields $\mathcal{T}, \mathcal{L}, \overline{\mathcal{L}}$ constitute a frame on $\mathbb{C} \otimes TM$, with Lie brackets:*

$$[\mathcal{T}, \mathcal{L}] = -\mathbf{P} \mathcal{T}, \quad [\mathcal{T}, \overline{\mathcal{L}}] = -\bar{\mathbf{P}} \mathcal{T}, \quad [\mathcal{L}, \overline{\mathcal{L}}] = -i \mathcal{T}. \quad \square$$

Next, denote by $\rho_0, \zeta_0, \bar{\zeta}_0$ the (complex) 1-forms on M which are dual to the (complex) vector fields $\mathcal{T}, \mathcal{L}, \overline{\mathcal{L}}$, respectively. More precisely, the expressions of $\rho_0, \zeta_0, \bar{\zeta}_0$ in terms of $dv, dz, d\bar{z}$ are:

$$\rho_0 := \frac{1}{\ell} (dv - A dz - \bar{A} d\bar{z}), \quad \zeta_0 := dz, \quad \bar{\zeta}_0 = d\bar{z}.$$

This gives us an initial coframe for $\mathbb{C} \otimes TM$ having structure equations:

$$\begin{aligned} d\rho_0 &= \mathbf{P} \rho_0 \wedge \zeta_0 + \bar{\mathbf{P}} \rho_0 \wedge \bar{\zeta}_0 + i \zeta_0 \wedge \bar{\zeta}_0, \\ d\zeta_0 &= d\bar{\zeta}_0 = 0. \end{aligned}$$

We now look at the action of rigid transformations on M in order to setup an initial G -structure. Observe that if a rigid biholomorphism $h: (z, w) \mapsto (f(z), aw + g(z)) =: (z', w')$ fixing the origin maps a rigid hypersurface $M \subset \mathbb{C}^2$ to another rigid hypersurface $M' \subset \mathbb{C}^2$, then h sends $T^{1,0}M$ to $T^{1,0}M'$, i.e. $h_*(T^{1,0}M) = T^{1,0}M'$. Without loss of

generality, it can be assumed that the target $M' = \{u' = F'(z', \bar{z}')\}$ is also graphed, and is equipped with a similar frame $\{\mathcal{F}', \mathcal{L}', \overline{\mathcal{L}}'\}$. It follows that there exists a uniquely defined nowhere vanishing function $c' : M' \rightarrow \mathbb{C}^*$ so that $h_*(\mathcal{L}) = c' \mathcal{L}'$.

Similarly, $h_*(\mathcal{F}) = a' \mathcal{F} + b' \mathcal{L} + \bar{b}' \overline{\mathcal{L}}'$. From Definition 2.1, it is clear that $h_*(\partial_v) = a \partial_{v'}$. Since $\mathcal{F} = \ell \partial_v$ and $\mathcal{F}' = \ell' \partial_{v'}$, it comes $h_*(\mathcal{F}) = a \frac{\ell}{\ell'} \mathcal{F}'$. Hence $b' = 0$. Furthermore:

$$h_*(\mathcal{F}) = h_*(-i[\mathcal{L}, \overline{\mathcal{L}}]) = -i[h_*(\mathcal{L}), h_*(\overline{\mathcal{L}})] = -i[c' \mathcal{L}', \bar{c}' \overline{\mathcal{L}}'] = c' \bar{c}' \mathcal{F}',$$

with necessarily $0 \equiv \mathcal{L}'(\bar{c}')$ while expanding the bracket thanks to $b' = 0$, and we conclude that the function $a' = c' \bar{c}'$ is determined.

Consequently, under the action of h , the frame $\{\mathcal{F}, \mathcal{L}, \overline{\mathcal{L}}\}$ changes as:

$$h_* \begin{pmatrix} \mathcal{F} \\ \mathcal{L} \\ \overline{\mathcal{L}} \end{pmatrix} = \begin{pmatrix} c' \bar{c}' & 0 & 0 \\ 0 & c' & 0 \\ 0 & 0 & \bar{c}' \end{pmatrix} \begin{pmatrix} \mathcal{F}' \\ \mathcal{L}' \\ \overline{\mathcal{L}}' \end{pmatrix} \quad (c' \neq 0).$$

This gives us the transfer relation between the two *dual* coframes, in terms of a nowhere vanishing function $c : M \rightarrow \mathbb{C}^*$:

$$h^* \begin{pmatrix} \rho'_0 \\ \zeta'_0 \\ \bar{\zeta}'_0 \end{pmatrix} = \begin{pmatrix} c \bar{c} & 0 & 0 \\ 0 & c & 0 \\ 0 & 0 & \bar{c} \end{pmatrix} \begin{pmatrix} \rho_0 \\ \zeta_0 \\ \bar{\zeta}_0 \end{pmatrix}.$$

The initial G -structure is now obtained as follows. Such a function c is replaced by a free variable $c \in \mathbb{C}^*$, an unknown of the problem. The structure group is the 2-dimensional Lie group of matrices of the form:

$$g = \begin{pmatrix} c \bar{c} & 0 & 0 \\ 0 & c & 0 \\ 0 & 0 & \bar{c} \end{pmatrix} \quad (c \neq 0),$$

and we introduce the *lifted coframe*:

$$\begin{pmatrix} \rho \\ \zeta \\ \bar{\zeta} \end{pmatrix} := g \cdot \begin{pmatrix} \rho_0 \\ \zeta_0 \\ \bar{\zeta}_0 \end{pmatrix}.$$

We are now in the position to apply Cartan's method of equivalence to the G -structure just obtained. First, we compute the Maurer-Cartan matrix as:

$$dg \cdot g^{-1} = \begin{pmatrix} \frac{dc}{c} + \frac{d\bar{c}}{\bar{c}} & 0 & 0 \\ 0 & \frac{dc}{c} & 0 \\ 0 & 0 & \frac{d\bar{c}}{\bar{c}} \end{pmatrix},$$

and there is only one (complex-valued) Maurer-Cartan form $\alpha := \frac{dc}{c}$. The structure equations are the following:

$$\begin{aligned} d\rho &= (\alpha + \bar{\alpha}) \wedge \rho + \frac{1}{c} \mathbf{P} \rho \wedge \zeta + \frac{1}{\bar{c}} \bar{\mathbf{P}} \rho \wedge \bar{\zeta} + i \zeta \wedge \bar{\zeta}, \\ d\zeta &= \alpha \wedge \zeta, \\ d\bar{\zeta} &= \bar{\alpha} \wedge \bar{\zeta}. \end{aligned}$$

We proceed to absorption of torsion by introducing the *modified Maurer-Cartan form*:

$$\pi := \alpha - \frac{1}{c} \mathbf{P} \zeta,$$

in terms of which the structure equations contract as:

$$\begin{aligned} d\rho &= (\pi + \bar{\pi}) \wedge \rho + i \zeta \wedge \bar{\zeta}, \\ d\zeta &= \pi \wedge \zeta, & d\bar{\zeta} &= \bar{\pi} \wedge \bar{\zeta}. \end{aligned}$$

At this point, no more absorption can be performed, because if one modifies the 1-form π as $\tilde{\pi} := \pi - A\rho - B\zeta - C\bar{\zeta}$, which transforms the structure equations into:

$$\begin{aligned} d\rho &= (\tilde{\pi} + \bar{\tilde{\pi}}) \wedge \rho - (B + \bar{C})\rho \wedge \zeta - (\bar{B} + C)\rho \wedge \bar{\zeta} + i \zeta \wedge \bar{\zeta}, \\ d\zeta &= \tilde{\pi} \wedge \zeta + A\rho \wedge \zeta - C\zeta \wedge \bar{\zeta}, \end{aligned}$$

all the functions A, B, C must be zero to conserve the same shape. In other words, the prolongation reduces to identity, and π is uniquely defined.

Therefore, Cartan's process stops, and to finish, it remains to finalize the expression of:

$$\begin{aligned} d\pi &= \frac{d\alpha_o}{c} + \frac{1}{c} \frac{dc}{c} \mathbf{P} \wedge \zeta - \frac{1}{c} d\mathbf{P} \wedge \zeta - \frac{1}{c} \mathbf{P} d\zeta \\ &= 0 + \frac{1}{c} \left(\pi + \frac{1}{c} \mathbf{P} \zeta \right) \mathbf{P} \wedge \zeta - \frac{1}{c} \left(P_z dz + P_{\bar{z}} d\bar{z} \right) \wedge \zeta - \frac{1}{c} \mathbf{P} \pi \wedge \zeta \\ &= -\frac{1}{c} \left(P_z \frac{1}{c} \zeta + P_{\bar{z}} \frac{1}{c} \bar{\zeta} \right) \wedge \zeta, \end{aligned}$$

where we need to know/abbreviate just:

$$\mathbf{P}_{\bar{z}} = \frac{F_{z\bar{z}\bar{z}\bar{z}} F_{z\bar{z}} - F_{z\bar{z}z\bar{z}} F_{z\bar{z}\bar{z}}}{(F_{z\bar{z}})^2} =: \mathbf{R},$$

whence:

$$d\pi = \frac{1}{c\bar{c}} \mathbf{R} \zeta \wedge \bar{\zeta}.$$

Visibly, $\bar{\mathbf{R}} = \mathbf{R}$ is real, because $\bar{F} = F$ is, whence $\overline{F_{z\bar{z}z\bar{z}}} = F_{\bar{z}z\bar{z}z}$.

THEOREM 2.6. *The equivalence problem under local rigid biholomorphisms of \mathcal{C}^ω rigid real hypersurfaces $\{u = F(z, \bar{z})\}$ in \mathbb{C}^2 whose Levi form is everywhere nondegenerate reduces to classifying $\{e\}$ -structures on the 5-dimensional bundle $M^3 \times \mathbb{C}$ equipped with coordinates $(z, \bar{z}, v, c, \bar{c})$ together with a coframe of 5 differential 1-forms:*

$$\{\rho, \zeta, \bar{\zeta}, \pi, \bar{\pi}\} \quad (\bar{\rho} = \rho),$$

which satisfy invariant structure equations of the shape:

$$\begin{aligned} d\rho &= (\pi + \bar{\pi}) \wedge \rho + i \zeta \wedge \bar{\zeta}, \\ d\zeta &= \pi \wedge \zeta, & d\bar{\zeta} &= \bar{\pi} \wedge \bar{\zeta}, \\ d\pi &= \frac{1}{c\bar{c}} \mathbf{R} \zeta \wedge \bar{\zeta}, & d\bar{\pi} &= -\frac{1}{c\bar{c}} \bar{\mathbf{R}} \zeta \wedge \bar{\zeta}. \end{aligned}$$

Another way to see that $\bar{\mathbf{R}} = \mathbf{R}$ is real from the structure equations is as follows, using Poincaré's relation:

$$\begin{aligned} 0 &= d \circ d\rho = (d\pi + d\bar{\pi}) \wedge \rho - (\pi + \bar{\pi}) \wedge d\rho + i d\zeta \wedge \bar{\zeta} - i \zeta \wedge d\bar{\zeta} \\ &= \frac{1}{c\bar{c}} \mathbf{R} \zeta \wedge \bar{\zeta} \wedge \rho + \frac{1}{c\bar{c}} \bar{\mathbf{R}} \bar{\zeta} \wedge \zeta \wedge \rho - (\pi + \bar{\pi}) \left[(\pi + \bar{\pi}) \wedge \rho + i \zeta \wedge \bar{\zeta} \right] + i \pi \wedge \zeta \wedge \bar{\zeta} - i \zeta \wedge \bar{\pi} \wedge \bar{\zeta} \\ &= \frac{1}{c\bar{c}} (\mathbf{R} - \bar{\mathbf{R}}) \rho \wedge \zeta \wedge \bar{\zeta}. \end{aligned}$$

Thus, the only invariant here is:

$$(2.7) \quad R := \frac{F_{zz\bar{z}\bar{z}} F_{z\bar{z}} - F_{z\bar{z}\bar{z}} F_{z\bar{z}\bar{z}}}{(F_{z\bar{z}})^2}.$$

When $R \equiv 0$, the structure equations have constants coefficients, which shows, by Cartan's theory, that all rigid hypersurfaces with $R \equiv 0$ are rigidly equivalent to each other, and equivalent to the model $\{u = z\bar{z}\}$. There also are straightforward arguments to get this.

PROPOSITION 2.8. *A rigid $M = \{u = F(z, \bar{z})\}$ in \mathbb{C}^2 is rigidly biholomorphically equivalent to the Heisenberg sphere $\{u' = z'\bar{z}'\}$ if and only if:*

$$0 \equiv R(F) \equiv F_{zz\bar{z}\bar{z}} F_{z\bar{z}} - F_{z\bar{z}\bar{z}} F_{z\bar{z}\bar{z}}.$$

PROOF. Recall that the condition $R(F) \equiv 0$ is invariant under rigid biholomorphisms. Trivially, $F := z\bar{z}$ implies $R(F) \equiv 0$.

For the converse, Lemma 2.3 guarantees that M is of course Levi-nondegenerate too, and by invariancy of $R = 0$, we can assume that $F = z\bar{z} + O_{z,\bar{z}}(3)$.

Set $G := F_{z\bar{z}}$, a function which is also real-valued, with $G(0) = 1$. Thus:

$$0 \equiv G_{z\bar{z}} G - G_z G_{\bar{z}} \iff (\log G)_{z\bar{z}} \equiv 0.$$

Consequently $\log G(z, \bar{z}) = \varphi(z) + \bar{\varphi}(\bar{z})$ for some holomorphic function with $\varphi(0) = 0$, whence $G(z, \bar{z}) = \psi(z) \cdot \bar{\psi}(\bar{z})$ with $\psi(0) = 1$, and

$$F(z, \bar{z}) = \int_0^z \psi(\zeta) d\zeta \cdot \int_0^{\bar{z}} \bar{\psi}(\bar{\zeta}) d\bar{\zeta} =: f(z) \cdot \bar{f}(\bar{z}),$$

with $f(z) = z + O_z(2)$. Thus $u = f(z) \bar{f}(\bar{z})$, and the rigid biholomorphism $z' := f(z)$ terminates. \square

We know from Lemma 2.3 that $F_{z\bar{z}}$ is a relative invariant. What about R ? It suffices to examine how the numerator of R behaves under transformations.

LEMMA 2.9. *Through a rigid biholomorphism $(z, w) \mapsto (f(z), aw + g(z)) =: (z', w')$ between two rigid hypersurfaces $\{u = F\}$ and $\{u' = F'\}$ in \mathbb{C}^2 , it holds:*

$$F_{zz\bar{z}\bar{z}} F_{z\bar{z}} - F_{z\bar{z}\bar{z}} F_{z\bar{z}\bar{z}} \equiv \frac{1}{a^2} (f_z \bar{f}_{\bar{z}})^3 \left[F'_{z'z'\bar{z}'\bar{z}'} F'_{z'\bar{z}'} - F'_{z'\bar{z}'\bar{z}'} F'_{z'z'\bar{z}'} \right].$$

PROOF. Differentiate the fundamental identity (2.2) four appropriate times:

$$\begin{aligned} a F_{z\bar{z}} &\equiv f_z \bar{f}_{\bar{z}} F'_{z'\bar{z}'}, \\ a F_{zz\bar{z}} &\equiv f_{zz} \bar{f}_{\bar{z}} F'_{z'\bar{z}'} + f_z \bar{f}_{\bar{z}} f_z F'_{z'z'\bar{z}'}, \\ a F_{z\bar{z}\bar{z}} &\equiv f_z \bar{f}_{\bar{z}\bar{z}} F'_{z'\bar{z}'} + f_z \bar{f}_{\bar{z}} \bar{f}_{\bar{z}} F'_{z'\bar{z}'\bar{z}'}, \\ a F_{zz\bar{z}\bar{z}} &\equiv f_{zz} \bar{f}_{\bar{z}\bar{z}} F'_{z'\bar{z}'} + f_{zz} \bar{f}_{\bar{z}} \bar{f}_{\bar{z}} F'_{z'z'\bar{z}'} + f_z \bar{f}_{\bar{z}\bar{z}} f_z F'_{z'z'\bar{z}'} + f_z \bar{f}_{\bar{z}} f_z \bar{f}_{\bar{z}} F'_{z'z'\bar{z}'\bar{z}'}, \end{aligned}$$

perform the necessary products, subtract, and get the result. \square

2.10. Method of normal forms of Moser. In this subsection, following the method of Moser, we will approach the equivalence problem for rigid hypersurfaces in \mathbb{C}^2 under rigid biholomorphisms by constructing a normal form. Notice that although the problem is (much) simpler than that considered by Moser for general hypersurfaces in \mathbb{C}^2 , our problem here is not a special case of what is already known.

The goal is to simplify the defining function $u = F(z, \bar{z})$ of a given hypersurface $M^3 \subset \mathbb{C}^2$ as much as possible by applying rigid holomorphic changes of variables $(z, w) \mapsto (f(z), \rho w + g(z)) =: (z', w')$, with $\rho \in \mathbb{R}^*$. We will find step by step changes, so that the transformed graphing functions F' for successive $M' = \{u' = F'(z', \bar{z}')\}$ will contain more and more zero coefficients.

Take a real analytic hypersurface $M = \{u = F(z, \bar{z})\}$ passing through the origin in \mathbb{C}^2 , and expand:

$$u = \frac{1}{2} (w + \bar{w}) = \sum_{j+k \geq 1} F_{j,k} z^j \bar{z}^k,$$

with $F_{j,k} = \overline{F_{k,j}}$. At first, set $z' := z$ and:

$$w' := w - 2 \sum_{j \geq 1} F_{j,0} z^j,$$

in order to subtract all harmonic monomials $F_{j,0} z^j$ and $F_{0,k} \bar{z}^k$ to obtain:

$$u' = \sum_{\substack{j \geq 1 \\ k \geq 1}} F_{j,k} z^j \bar{z}^k = F_{1,1} z \bar{z} + \sum_{\substack{j+k \geq 3 \\ j \geq 1 \text{ and } k \geq 1}} F_{j,k} z^j \bar{z}^k.$$

The invariant property $F_{1,1} \neq 0$ characterizes Levi nondegeneracy of M at the origin (hence in a neighborhood). Switching $u \mapsto -u$ if necessary, we may assume $F_{1,1} > 0$.

Next, make the rigid biholomorphism $z' := \sqrt{F_{1,1}} z$ with $w' := w$, drop the prime, single out monomials of degree 1 in either z or \bar{z} , factorize, and point out remainders:

$$\begin{aligned} u &= z \bar{z} + \sum_{\substack{j+k \geq 3 \\ j \geq 1 \text{ and } k \geq 1}} \frac{F_{j,k}}{\sqrt{F_{1,1}}^{j+k}} z^j \bar{z}^k \\ &= z \bar{z} + \bar{z} \left(\frac{F_{2,1}}{F_{1,1}^{3/2}} z^2 + \sum_{j \geq 3} \frac{F_{j,1}}{F_{1,1}^{(j+1)/2}} z^j \right) + z \left(\frac{F_{1,2}}{F_{1,1}^{3/2}} \bar{z}^2 + \sum_{k \geq 3} \frac{F_{1,k}}{F_{1,1}^{(1+k)/2}} \bar{z}^k \right) + \frac{F_{2,2}}{F_{1,1}^2} z^2 \bar{z}^2 + \sum_{\substack{j+k \geq 5 \\ j \geq 2 \text{ and } k \geq 2}} \frac{F_{j,k}}{F_{1,1}^{(j+k)/2}} z^j \bar{z}^k \\ &= \left(z + \frac{F_{2,1}}{F_{1,1}^{3/2}} z^2 + \sum_{j \geq 3} \frac{F_{j,1}}{F_{1,1}^{(j+1)/2}} z^j \right) \left(\bar{z} + \frac{F_{1,2}}{F_{1,1}^{3/2}} \bar{z}^2 + \sum_{k \geq 3} \frac{F_{1,k}}{F_{1,1}^{(1+k)/2}} \bar{z}^k \right) - \frac{F_{2,1} F_{1,2}}{F_{1,1}^3} z^2 \bar{z}^2 - z^2 \bar{z}^3 (\dots) - z^3 \bar{z}^2 (\dots) + \\ &+ \frac{F_{2,2}}{F_{1,1}^2} z^2 \bar{z}^2 + z^2 \bar{z}^3 (\dots) + z^3 \bar{z}^2 (\dots). \end{aligned}$$

Such a factorization suggests to perform the rigid biholomorphism:

$$z' := z + \frac{F_{2,1}}{F_{1,1}^{3/2}} z^2 + \sum_{j \geq 3} \frac{F_{j,1}}{F_{1,1}^{(j+1)/2}} z^j,$$

again with untouched $w' := w$. Its inverse is of the form $z = z'(1 + z'^2(\dots))$, so $O(z^l \bar{z}^m) = O(z'^l \bar{z}'^m)$, and finally, dropping primes, we have proved the

PROPOSITION 2.11. *Any rigid $M = \{u = \sum F_{j,k} z^j \bar{z}^k\}$ can be brought, by a rigid biholomorphic transformation fixing the origin, to:*

$$u = z \bar{z} + \left[\frac{F_{2,2} F_{1,1} - F_{2,1} F_{1,2}}{F_{1,1}^3} \right] z^2 \bar{z}^2 + z^2 \bar{z}^3 (\dots) + z^3 \bar{z}^2 (\dots). \quad \square$$

In other words:

$$0 = F_{j,0} = F_{0,k} \quad (j \geq 1, k \geq 1),$$

$$1 = F_{1,1},$$

$$0 = F_{j,1} = F_{1,k} \quad (j \geq 2, k \geq 2).$$

Can one normalize the graphing function F further? For instance, can one annihilate some other $F_{j,k}$? Not much freedom is left, as states the next

LEMMA 2.12. *If two rigid hypersurfaces in \mathbb{C}^2 having the form:*

$$u = z\bar{z} + \sum_{j,k \geq 2} F_{j,k} z^j \bar{z}^k \quad \text{and} \quad u' = z'\bar{z}' + \sum_{j,k \geq 2} F'_{j,k} z'^j \bar{z}'^k,$$

are equivalent through a rigid biholomorphism fixing the origin, then there exist $\rho \in \mathbb{R}_+^*$ and $\varphi \in \mathbb{R}$ such that:

$$z' = \rho^{1/2} e^{i\varphi} z, \quad w' = \rho w.$$

In particular, this shows that the group of rigid transformations fixing the origin of the Heisenberg sphere $\{u = z\bar{z}\}$ is 2-dimensional, generated by these obvious rotation/dilation commuting transformations (solution of the exercise).

PROOF. Write as above $(z', w') = (f(z), \rho w + g(z))$, with $f(0) = 0 = g(0)$. The fundamental equation (5.10) reads:

$$\rho F(z, \bar{z}) + \frac{1}{2} g(z) + \frac{1}{2} \bar{g}(\bar{z}) \equiv F'(f(z), \bar{f}(\bar{z})).$$

Put $\bar{z} := 0$, get $\bar{g}(\bar{z}) \equiv 0$. Thus:

$$\rho (z\bar{z} + z^2 \bar{z}^2(\dots)) \equiv f(z) \bar{f}(\bar{z}) + f(z)^2 \bar{f}(\bar{z})^2(\dots),$$

and using $f(z) = O(z)$:

$$\rho z\bar{z} \equiv f(z) \bar{f}(\bar{z}) + z^2 \bar{z}^2(\dots).$$

Invertibility of the Jacobian yields $f_z(0) \neq 0$. Apply $\partial_{\bar{z}}|_0$ and get:

$$\rho z \equiv f(z) \bar{f}'(0),$$

so $f(z) = \lambda z$ for some $\lambda \in \mathbb{C}^*$. Lastly, $\rho = \lambda \bar{\lambda}$, which concludes. \square

COROLLARY 2.13. *Two rigid hypersurfaces in \mathbb{C}^2 :*

$$u = z\bar{z} + \sum_{j,k \geq 2} F_{j,k} z^j \bar{z}^k \quad \text{and} \quad u' = z'\bar{z}' + \sum_{j,k \geq 2} F'_{j,k} z'^j \bar{z}'^k,$$

are rigidly biholomorphically equivalent if and only if there exist $\rho \in \mathbb{R}_+^*$ and $\varphi \in \mathbb{R}$ such that:

$$F_{j,k} = \rho^{\frac{j+k-2}{2}} e^{i\varphi(j-k)} F'_{j,k} \quad (j \geq 2, k \geq 2). \quad \square$$

At any point $(z_0, w_0) \in M$ close to the origin, all these results are also valid, and using the recentered holomorphic coordinates $z - z_0$ and $w - w_0$, one obtains:

$$u - u_0 = (z - z_0)(\bar{z} - \bar{z}_0) + \frac{4F_{zz\bar{z}\bar{z}}(z_0)F_{z\bar{z}}(z_0) - 2F_{zz\bar{z}}(z_0)2F_{z\bar{z}\bar{z}}(z_0)}{F_{z\bar{z}}(z_0)^3} (z - z_0)^2 (\bar{z} - \bar{z}_0)^2 + \dots$$

The $(2, 2)$ -coefficient at various points z_0 is, up to a power of $F_{z\bar{z}}$ in the denominator, exactly equal to the relative invariant function R found in (2.7) by applying Cartan's method.

According to Lie's principle of thought ([78, Chap. 1]), a relative invariant is assumed to be either identically zero, or nowhere zero, after restriction to an appropriate open subset. Since Proposition 2.8 already understood the branch $R \equiv 0$, it remains only to treat the branch $R \neq 0$. This is left as an exercise.

3. Two Invariant Determinants for Hypersurfaces $M^5 \subset \mathbb{C}^3$

Consider a rigid biholomorphism:

$$H: (z, \zeta, w) \mapsto (f(z, \zeta), g(z, \zeta), \rho w + h(z, \zeta)) =: (z', \zeta', w') \quad (\rho \in \mathbb{R}^*),$$

hence with Jacobian $f_z g_\zeta - f_\zeta g_z \neq 0$, between two rigid \mathcal{C}^ω hypersurfaces:

$$w = -\bar{w} + 2F(z, \zeta, \bar{z}, \bar{\zeta}) =: Q \quad \text{and} \quad w' = -\bar{w}' + 2F'(z', \zeta', \bar{z}', \bar{\zeta}') =: Q'.$$

Plugging the three components of H in the target equation:

$$\rho w + h(z, \zeta) + \rho \bar{w} + \bar{h}(\bar{z}, \bar{\zeta}) = 2F'(f(z, \zeta), g(z, \zeta), \bar{f}(\bar{z}, \bar{\zeta}), \bar{g}(\bar{z}, \bar{\zeta})),$$

and replacing $w + \bar{w} = 2F$, one receives the *fundamental equation* expressing $H(M) \subset M'$:

$$2\rho F(z, \zeta, \bar{z}, \bar{\zeta}) + h(z, \zeta) + \bar{h}(\bar{z}, \bar{\zeta}) \equiv 2F'(f(z, \zeta), g(z, \zeta), \bar{f}(\bar{z}, \bar{\zeta}), \bar{g}(\bar{z}, \bar{\zeta})).$$

By differentiating it (exercise! use a computer!), one expresses as follows the invariancy of the Levi determinant defined for general biholomorphisms [101] as:

$$\begin{vmatrix} Q_{\bar{z}} & Q_{\bar{\zeta}} & Q_{\bar{w}} \\ Q_{z\bar{z}} & Q_{z\bar{\zeta}} & Q_{z\bar{w}} \\ Q_{\zeta\bar{z}} & Q_{\zeta\bar{\zeta}} & Q_{\zeta\bar{w}} \end{vmatrix} = 2^2 \begin{vmatrix} F_{\bar{z}} & F_{\bar{\zeta}} & -1 \\ F_{z\bar{z}} & F_{z\bar{\zeta}} & 0 \\ F_{\zeta\bar{z}} & F_{\zeta\bar{\zeta}} & 0 \end{vmatrix}.$$

PROPOSITION 3.1. *Through any rigid biholomorphism:*

$$\begin{vmatrix} F'_{z'\bar{z}'} & F'_{z'\bar{\zeta}'} \\ F'_{\zeta'\bar{z}'} & F'_{\zeta'\bar{\zeta}'} \end{vmatrix} = \frac{\rho^2}{\begin{vmatrix} f_z & f_\zeta \\ g_z & g_\zeta \end{vmatrix} \begin{vmatrix} \bar{f}_{\bar{z}} & \bar{f}_{\bar{\zeta}} \\ \bar{g}_{\bar{z}} & \bar{g}_{\bar{\zeta}} \end{vmatrix}} \begin{vmatrix} F_{z\bar{z}} & F_{z\bar{\zeta}} \\ F_{\zeta\bar{z}} & F_{\zeta\bar{\zeta}} \end{vmatrix}. \quad \square$$

Consequently, the property that the Levi form is of constant rank 1 is biholomorphically invariant. The 2-nondegeneracy property [101] then expresses as the nonvanishing of:

$$\begin{vmatrix} Q_{\bar{z}} & Q_{\bar{\zeta}} & Q_{\bar{w}} \\ Q_{z\bar{z}} & Q_{z\bar{\zeta}} & Q_{z\bar{w}} \\ Q_{z\bar{z}\bar{z}} & Q_{z\bar{z}\bar{\zeta}} & Q_{z\bar{z}\bar{w}} \end{vmatrix} = 2^2 \begin{vmatrix} F_{\bar{z}} & F_{\bar{\zeta}} & -1 \\ F_{z\bar{z}} & F_{z\bar{\zeta}} & 0 \\ F_{z\bar{z}\bar{z}} & F_{z\bar{z}\bar{\zeta}} & 0 \end{vmatrix}.$$

PROPOSITION 3.2. *When the Levi form is of constant rank 1, through any rigid biholomorphism:*

$$\begin{vmatrix} F'_{z'\bar{z}'} & F'_{z'\bar{\zeta}'} \\ F'_{z'\bar{z}'\bar{z}'} & F'_{z'\bar{z}'\bar{\zeta}'} \end{vmatrix} = \frac{\rho^2 (g_\zeta F_{z\bar{z}\bar{z}} - g_z F_{\zeta\bar{z}\bar{z}})^3}{\begin{vmatrix} f_z & f_\zeta \\ g_z & g_\zeta \end{vmatrix}^3 \begin{vmatrix} \bar{f}_{\bar{z}} & \bar{f}_{\bar{\zeta}} \\ \bar{g}_{\bar{z}} & \bar{g}_{\bar{\zeta}} \end{vmatrix}} \begin{vmatrix} F_{z\bar{z}} & F_{z\bar{\zeta}} \\ F_{z\bar{z}\bar{z}} & F_{z\bar{z}\bar{\zeta}} \end{vmatrix}. \quad \square$$

Recall that we denote the class of (local) hypersurfaces $M^5 \subset \mathbb{C}^3$ passing by the origin $0 \in M$ that are 2-nondegenerate and whose Levi form has constant rank 1 as:

$$\mathfrak{C}_{2,1}.$$

4. Rigid Infinitesimal CR Automorphisms of the Gaussier-Merker Model

The appropriate model M_{LC} is rigid and was set up by Gaussier-Merker in [56] and Fels-Kaup in [43]:

$$M_{LC}: \quad u = \frac{z\bar{z} + \frac{1}{2}z^2\bar{\zeta} + \frac{1}{2}\bar{z}^2\zeta}{1 - \zeta\bar{\zeta}} =: m(z, \zeta, \bar{z}, \bar{\zeta}).$$

It is a locally graphed representation of the tube in \mathbb{C}^3 over the future light cone in \mathbb{R}^3 . The 10-dimensional simple Lie algebra of its infinitesimal CR automorphisms:

$$\mathfrak{g} := \text{aut}_{CR}(M_{LC}) \cong \mathfrak{so}_{2,3}(\mathbb{R}),$$

has 10 natural generators X_1, \dots, X_{10} , which are $(1, 0)$ vector fields having holomorphic coefficients with $X_\sigma + \bar{X}_\sigma$ tangent to M_{LC} . Assigning weights to variables, to vector fields, and the same weights to their conjugates:

(4.1)

$$[z] := 1 \quad [\zeta] := 0, \quad [w] := 2 \quad [\partial_z] := -1 \quad [\partial_\zeta] := 0 \quad [\partial_w] := -2,$$

this Lie algebra of vector fields isomorphic to $\mathfrak{so}_{2,3}(\mathbb{R})$ can be graded as:

$$\mathfrak{g} = \mathfrak{g}_{-2} \oplus \mathfrak{g}_{-1} \oplus \mathfrak{g}_0 \oplus \mathfrak{g}_1 \oplus \mathfrak{g}_2,$$

where, as shown in [56, 51]:

$$\begin{aligned} \mathfrak{g}_{-2} &:= \text{Span} \{i \partial_w\}, \\ \mathfrak{g}_{-1} &:= \text{Span} \{(\zeta - 1) \partial_z - 2z \partial_w, (i + i\zeta) \partial_z - 2iz \partial_w\}, \end{aligned}$$

where $\mathfrak{g}_0 = \mathfrak{g}_0^{\text{trans}} \oplus \mathfrak{g}_0^{\text{iso}}$:

$$\begin{aligned} \mathfrak{g}_0^{\text{trans}} &:= \text{Span} \left\{ z\zeta \partial_z + (\zeta^2 - 1) \partial_\zeta - z^2 \partial_w, iz\zeta \partial_z + (i + i\zeta^2) \partial_\zeta - iz^2 \partial_w \right\}, \\ \mathfrak{g}_0^{\text{iso}} &:= \text{Span} \left\{ z \partial_z + 2w \partial_w, iz \partial_z + 2i\zeta \partial_\zeta \right\}, \end{aligned}$$

while:

$$\begin{aligned} \mathfrak{g}_1 &:= \text{Span} \left\{ (z^2 - \zeta w - w) \partial_z + (2z\zeta + 2z) \partial_\zeta + 2zw \partial_w, \right. \\ &\quad \left. (-iz^2 + i\zeta w - iw) \partial_z + (-2iz\zeta + 2iz) \partial_\zeta - 2izw \partial_w \right\}, \\ \mathfrak{g}_2 &:= \text{Span} \{izw \partial_z - iz^2 \partial_\zeta + iw^2 \partial_w\}. \end{aligned}$$

Calling these X_1, \dots, X_{10} in order of appearance, the five $X_\sigma + \bar{X}_\sigma$ for $\sigma = 1, 2, 3, 4, 5$ span TM^5 while those for $\sigma = 6, 7, 8, 9, 10$ generate the isotropy subgroup of the origin.

5. Prenormalization

In coordinates $(z, \zeta, w) \in \mathbb{C}^3$ with $w = u + iv$, consider a local \mathcal{C}^ω rigid hypersurface $M^5 \subset \mathbb{C}^3$ graphed as $u = F(z, \zeta, \bar{z}, \bar{\zeta})$ passing through the origin. Expand $\sum_{a+b+c+d \geq 1} F_{a,b,c,d} z^a \zeta^b \bar{z}^c \bar{\zeta}^d$, and define by conjugating only coefficients:

$$\bar{F}(z, \zeta, \bar{z}, \bar{\zeta}) := \sum_{a+b+c+d \geq 1} \bar{F}_{a,b,c,d} z^a \zeta^b \bar{z}^c \bar{\zeta}^d.$$

The reality $\bar{u} = u$ forces $\overline{F(z, \zeta, \bar{z}, \bar{\zeta})} = F(z, \zeta, \bar{z}, \bar{\zeta})$ which becomes:

$$\bar{F}(\bar{z}, \bar{\zeta}, z, \zeta) \equiv F(z, \zeta, \bar{z}, \bar{\zeta}).$$

The 4 independent derivations $\partial_z, \partial_\zeta, \partial_{\bar{z}}, \partial_{\bar{\zeta}}$ commute. Applying $\frac{1}{a!}\partial_z^a \frac{1}{b!}\partial_\zeta^b \frac{1}{c!}\partial_{\bar{z}}^c \frac{1}{d!}\partial_{\bar{\zeta}}^d$ at the origin $(0, 0, 0, 0)$, it comes:

$$\bar{F}_{c,d,a,b} = F_{a,b,c,d}.$$

With $\chi(z, \zeta) := F(z, \zeta, 0, 0)$ which is holomorphic, setting $w' := w - 2\chi(z, \zeta)$, we get:

$$\frac{w'+\bar{w}'}{2} = u' = F(z, \zeta, \bar{z}, \bar{\zeta}) - \chi(z, \zeta) - \bar{\chi}(\bar{z}, \bar{\zeta}) =: F'(z, \zeta, \bar{z}, \bar{\zeta}),$$

with now $0 \equiv F'(z, \zeta, 0, 0) \equiv F'(0, 0, \bar{z}, \bar{\zeta})$.

By $O_x(3)$, we mean a (remainder) function equal to $x^3(\dots)$, where (\dots) is any function of one or several variables. By $O_{x,y}(2)$, we mean $x^2(\dots) + xy(\dots) + y^2(\dots)$, and so on.

PROPOSITION 5.1. *After a rigid biholomorphism, an $M \in \mathfrak{C}_{2,1}$ satisfies:*

$$F(z, \zeta, \bar{z}, 0) = z\bar{z} + \frac{1}{2}\zeta\bar{\zeta}^2 + O_{\bar{z}}(3).$$

Employing the letter \mathcal{R} for unspecified functions, this amounts to:

$$(5.2) \quad F(z, \zeta, \bar{z}, \bar{\zeta}) = z\bar{z} + \frac{1}{2}\zeta\bar{\zeta}^2 + \bar{z}^3\mathcal{R}(z, \zeta, \bar{z}) + \bar{\zeta}\mathcal{R}(z, \zeta, \bar{z}, \bar{\zeta}).$$

We will use without mention:

$$\mathcal{R}(z, \zeta, \bar{z}, \bar{\zeta}) = \mathcal{R}(z, \zeta, \bar{z}) + \bar{\zeta}\mathcal{R}(z, \zeta, \bar{z}, \bar{\zeta}).$$

PROOF. We will perform rigid biholomorphisms of the form $z' = z'(z, \zeta)$, $\zeta' = \zeta'(z, \zeta)$, $w' = w$ fixing 0. They transform $u = F(z, \zeta, \bar{z}, \bar{\zeta})$ into $u' = F'(z', \zeta', \bar{z}', \bar{\zeta}')$ with:

$$F'(z', \zeta', \bar{z}', \bar{\zeta}') := F(z(z', \zeta'), \zeta(z', \zeta'), \bar{z}(\bar{z}', \bar{\zeta}'), \bar{\zeta}(\bar{z}', \bar{\zeta}')),$$

hence they conserves $F'(z', \zeta', 0, 0) \equiv 0$.

The Levi form being of rank 1 at 0, we may assume:

$$u = z\bar{z} + O_3(z, \zeta, \bar{z}, \bar{\zeta}).$$

ASSERTION 5.3. *After a rigid biholomorphism fixing 0:*

$$F = z\bar{z} + \bar{z}^2\mathcal{R} + \bar{\zeta}\mathcal{R}.$$

PROOF. We can decompose:

$$F(z, \zeta, \bar{z}, \bar{\zeta}) = F(z, \zeta, \bar{z}, 0) + \bar{\zeta}\mathcal{R} = \bar{z}(z + \chi(z, \zeta)) + \bar{z}^2\mathcal{R} + \bar{\zeta}\mathcal{R},$$

with $\chi = O(2)$. Then:

$$F = (z + \chi)(\bar{z} + \bar{\chi}) - z\bar{\chi} - \chi\bar{\chi} + \bar{z}^2\mathcal{R} + \bar{\zeta}\mathcal{R}.$$

But $\bar{\chi} = \bar{z}^2\mathcal{R}(\bar{z}) + \bar{\zeta}\mathcal{R}(\bar{z}, \bar{\zeta})$ is absorbable, hence:

$$F = (z + \chi)(\bar{z} + \bar{\chi}) + \bar{z}^2\mathcal{R} + \bar{\zeta}\mathcal{R}.$$

Thus, we perform the rigid biholomorphism $z' := z + \chi(z, \zeta)$, $\zeta' := \zeta$, with inverse:

$$z = z' + O_{z',\zeta'}(2) = z' + z'^2\mathcal{R}' + \zeta'\mathcal{R}'.$$

Hence $\bar{z}^2 = \bar{z}'^2\mathcal{R}' + \bar{\zeta}'\mathcal{R}'$, and lastly:

$$F'(z', \zeta', \bar{z}', \bar{\zeta}') = z'\bar{z}' + \bar{z}'^2\mathcal{R}' + \bar{\zeta}'\mathcal{R}'. \quad \square$$

Next, dropping primes, specifying 3rd order (real) terms $P = P_3$ in $F = z\bar{z} + P_3 + O_{z,\zeta,\bar{z},\bar{\zeta}}(4)$, let us inspect the Levi determinant:

$$0 \equiv \begin{vmatrix} 1 + P_{z\bar{z}} + O_2 & P_{\zeta\bar{z}} + O_2 \\ P_{z\bar{\zeta}} + O_2 & P_{\zeta\bar{\zeta}} + O_2 \end{vmatrix}, \quad \text{whence} \quad 0 \equiv P_{\zeta\bar{\zeta}},$$

i.e. P is harmonic with respect to ζ when z, \bar{z} are seen as constants. Thus taking account of $0 \equiv P(z, \zeta, 0, 0)$:

$$P = a z^2 \bar{z} + \bar{a} z \bar{z}^2 + \zeta (b z \bar{z} + c \bar{z}^2) + \bar{\zeta} (\bar{b} z \bar{z} + \bar{c} z^2) + \zeta^2 (d \bar{z}) + \bar{\zeta}^2 (\bar{d} z).$$

But Assertion 5.3 forces $a = 0, b = 0, d = 0$, whence:

$$u = z\bar{z} + c\zeta\bar{z}^2 + \bar{c}\bar{\zeta}z^2 + O_{z,\zeta,\bar{z},\bar{\zeta}}(4).$$

From Proposition 3.2, we know that $c \neq 0$, hence $c\zeta =: \frac{1}{2}\zeta'$ conducts to:

$$(5.4) \quad u = z\bar{z} + \frac{1}{2}z^2\bar{\zeta} + \frac{1}{2}\bar{z}^2\zeta + O_{z,\zeta,\bar{z},\bar{\zeta}}(4) = z\bar{z} + \bar{z}^2\mathcal{R} + \bar{\zeta}\mathcal{R}.$$

Next, let us look at 4th order terms which depend only on (z, \bar{z}) , especially at the monomial $e z^2 \bar{z}^2$ with $e := F_{2,0,2,0} \in \mathbb{R}$. We can make $e = 0$ thanks to $\zeta' := \zeta + e z^2$:

$$u = z\bar{z} + \frac{1}{2}(\zeta + e z^2)\bar{z}^2 + \frac{1}{2}(\bar{\zeta} + e \bar{z}^2)z^2 + \bar{z}^2\mathcal{R} + \bar{\zeta}\mathcal{R}.$$

So we can assume $F_{2,0,2,0} = 0$. We then write:

$$u = z\bar{z} + \frac{1}{2}\bar{z}^2 S(z, \zeta, \bar{z}) + \bar{\zeta}\mathcal{R}(z, \zeta, \bar{z}, \bar{\zeta}),$$

with $S = \zeta + O_{z,\zeta,\bar{z}}(2)$ and with *no* z^2 monomial in the remainder. Hence with some function $\tau(z)$ which is an $O_z(3)$, and with some function $\omega(z, \zeta) = O_{z,\zeta}(1)$, we devise which biholomorphism to perform:

$$\begin{aligned} u &= z\bar{z} + \frac{1}{2}\bar{z}^2 (\zeta + \tau(z) + \zeta\omega(z, \zeta) + \bar{z}\theta(z, \zeta, \bar{z})) + \bar{\zeta}\mathcal{R} \\ &= z\bar{z} + \frac{1}{2}\bar{z}^2 \underbrace{(\zeta + \tau(z) + \zeta\omega(z, \zeta))}_{=: \zeta', \text{ while } z =: z'} + \bar{z}^3\mathcal{R} + \bar{\zeta}\mathcal{R}. \end{aligned}$$

ASSERTION 5.5. *The inverse $\zeta = \zeta' + O(2) = \tau'(z') + \zeta'[1 + \omega'(z', \zeta')]$ also satisfies $\tau'(z') = O_{z'}(3)$.*

PROOF. Indeed, by definition:

$$\zeta \equiv \tau'(z) + [\tau(z) + \zeta(1 + \omega(z, \zeta))] [1 + \omega'(z, \tau(z) + \zeta(1 + \omega(z, \zeta)))],$$

and it suffices to put $\zeta := 0$ to get a concluding relation which even shows that $\text{ord}_0\tau = \text{ord}_0\tau'$:

$$0 \equiv \tau'(z) + \tau(z) [1 + \omega'(z, \tau(z))]. \quad \square$$

All this enables to reach the goal (5.2) since $\bar{\tau}'(\bar{z}')$ is absorbable in $\bar{z}'^3\mathcal{R}'$:

$$u = z'\bar{z}' + \frac{1}{2}\bar{z}'^2\zeta' + \bar{z}'^3\mathcal{R}' + \left(\bar{\zeta}' + \bar{\tau}'(\bar{z}') + \bar{\zeta}'\bar{\omega}'(\bar{z}', \bar{\zeta}')\right)\mathcal{R}'. \quad \square$$

Coordinates like in Proposition 16.7 will be called *prenormalized*. Equivalently (exercise):

$$0 = F_{a,b,0,0} = F_{0,0,c,d},$$

$$0 = F_{a,b,1,0} = F_{1,0,c,d},$$

$$0 = F_{a,b,2,0} = F_{2,0,c,d},$$

with only three exceptions $F_{1,0,1,0} = 1$ and $F_{2,0,0,1} = \frac{1}{2} = F_{0,1,2,0}$. During the proof, in (5.4), we obtained simultaneously:

$$(5.6) \quad \boxed{u = F = z\bar{z} + \frac{1}{2}z^2\bar{z}\zeta + O_{\bar{z}}(3) + O_{\bar{\zeta}}(1) = z\bar{z} + \frac{1}{2}z^2\bar{\zeta} + \frac{1}{2}\bar{z}^2\zeta + O_{z,\zeta,\bar{z},\bar{\zeta}}(4).}$$

Now, recall that the Gaussier-Merker model is homogeneous of degree 2 in z, \bar{z} , when $\zeta, \bar{\zeta}$ are treated as constants:

$$u = \frac{z\bar{z} + \frac{1}{2}z^2\bar{\zeta} + \frac{1}{2}\bar{z}^2\zeta}{1 - \zeta\bar{\zeta}} =: m(z, \zeta, \bar{z}, \bar{\zeta}).$$

A general $M \in \mathfrak{C}_{2,1}$ is just a perturbation of it:

$$u = F = m + G, \quad \text{with } G := F - m = O_{z,\zeta,\bar{z},\bar{\zeta}}(4).$$

PROPOSITION 5.7. *In prenormalized coordinates, one has $G = O_{z,\bar{z}}(3)$.*

PROOF. Expand:

$$m = z\bar{z} \sum_{i \geq 0} \zeta^i \bar{\zeta}^i + \frac{1}{2}z^2 \sum_{i \geq 0} \zeta^i \bar{\zeta}^{i+1} + \frac{1}{2}\bar{z}^2 \sum_{i \geq 0} \zeta^{i+1} \bar{\zeta}^i = z\bar{z} + \frac{1}{2}z^2\bar{\zeta} + \frac{1}{2}\bar{z}^2\zeta + O_{z,\zeta,\bar{z},\bar{\zeta}}(4),$$

$$G = \sum_{k \geq 4} \sum_{a+b+c+d=k} G_{a,b,c,d} z^a \zeta^b \bar{z}^c \bar{\zeta}^d =: \sum_{k \geq 4} G^k.$$

Of course, $F^k = m^k + G^k$, with $G^2 = G^3 = 0$.

ASSERTION 5.8. *For every $k \geq 2$, one has $G^k = O_{z,\bar{z}}(3)$.*

PROOF. For some $k \geq 4$, assume by induction that G^2, G^3, \dots, G^{k-1} are $O_{z,\bar{z}}(3)$, whence:

$$G_{z\bar{z}}^\ell = O_{z,\bar{z}}(1), \quad G_{z\bar{\zeta}}^\ell = O_{z,\bar{z}}(2) = G_{z\bar{\zeta}}^\ell, \quad G_{\zeta\bar{\zeta}}^\ell = O_{z,\bar{z}}(3) \quad (1 \leq \ell \leq k-1).$$

Next, insert $F = \sum_{i \geq 2} F^i$ in the Levi determinant:

$$0 \equiv \begin{vmatrix} \sum_i F_{z\bar{z}}^i & \sum_j F_{\zeta\bar{\zeta}}^j \\ \sum_i F_{z\bar{\zeta}}^i & \sum_j F_{\zeta\bar{\zeta}}^j \end{vmatrix} = \sum_{\ell \geq 4} \left(\sum_{\substack{i+j=\ell \\ i,j \geq 2}} (F_{z\bar{z}}^i F_{\zeta\bar{\zeta}}^j - F_{z\bar{\zeta}}^i F_{\zeta\bar{\zeta}}^j) \right).$$

Behind \sum_ℓ , all terms are of constant homogeneous order $i - 2 + j - 2 = \ell - 4$, hence $0 \equiv \sum_{i+j=\ell}$ for each $\ell \geq 4$. Take $\ell := k + 2$ and expand:

$$\begin{aligned} 0 \equiv & F_{z\bar{z}}^2 \boxed{F_{\zeta\bar{\zeta}}^k} + \sum_{3 \leq i \leq k-1} F_{z\bar{z}}^i F_{\zeta\bar{\zeta}}^{k+2-i} + F_{z\bar{z}}^k \underline{F_{\zeta\bar{\zeta}}^2} - \\ & \underline{F_{z\bar{\zeta}}^2} F_{\zeta\bar{\zeta}}^k - \sum_{3 \leq i \leq k-1} F_{z\bar{\zeta}}^i F_{\zeta\bar{\zeta}}^{k+2-i} - F_{z\bar{\zeta}}^k \underline{F_{\zeta\bar{\zeta}}^2}. \end{aligned}$$

Observe from (5.6) that $1 \equiv F_{z\bar{z}}^2$ while $0 \equiv F_{\zeta\bar{\zeta}}^2 \equiv F_{z\bar{\zeta}}^2 \equiv F_{\zeta\bar{\zeta}}^2$. Of course, Levi determinant vanishing holds for $F := m$:

$$\begin{aligned} 0 \equiv & m_{z\bar{z}}^2 m_{\zeta\bar{\zeta}}^k + \sum_{3 \leq i \leq k-1} m_{z\bar{z}}^i m_{\zeta\bar{\zeta}}^{k+2-i} + m_{z\bar{z}}^k \underline{m_{\zeta\bar{\zeta}}^2} - \\ & \underline{m_{z\bar{\zeta}}^2} m_{\zeta\bar{\zeta}}^k - \sum_{3 \leq i \leq k-1} m_{z\bar{\zeta}}^i m_{\zeta\bar{\zeta}}^{k+2-i} - m_{z\bar{\zeta}}^k \underline{m_{\zeta\bar{\zeta}}^2}. \end{aligned}$$

Substituting the boxed term $F_{\zeta\bar{\zeta}}^k$ with $m_{\zeta\bar{\zeta}}^k + G_{\zeta\bar{\zeta}}^k$, solving for $G_{\zeta\bar{\zeta}}^k$, substituting as well the other $F_{\cdot\cdot}^\ell = m_{\cdot\cdot}^\ell + G_{\cdot\cdot}^\ell$, and subtracting, we obtain:

$$\begin{aligned} -G_{\zeta\bar{\zeta}}^k &\equiv \sum_{3 \leq i \leq k-1} \left(m_{z\bar{z}}^i G_{\zeta\bar{\zeta}}^{k+2-i} + G_{z\bar{z}}^i m_{\zeta\bar{\zeta}}^{k+2-i} + G_{z\bar{z}}^i G_{\zeta\bar{\zeta}}^{k+2-i} \right) - \\ &\quad - \sum_{3 \leq i \leq k-1} \left(m_{z\bar{z}}^i G_{\zeta\bar{\zeta}}^{k+2-i} + G_{z\bar{z}}^i m_{\zeta\bar{\zeta}}^{k+2-i} + G_{z\bar{z}}^i G_{\zeta\bar{\zeta}}^{k+2-i} \right). \end{aligned}$$

Since we also have $3 \leq k+2-i \leq k-1$, induction applies to all six products to get $G_{\zeta\bar{\zeta}}^k = O_{z,\bar{z}}(3)$.

By integration, $G^k = \lambda^k(z, \zeta, \bar{z}) + \bar{\lambda}^k(\bar{z}, \bar{\zeta}, z) + O_{z,\bar{z}}(3)$. After absorption in $O_{z,\bar{z}}(3)$, we can assume that λ^k is of degree ≤ 2 in (z, \bar{z}) , hence contains only monomials $z^a \zeta^b \bar{z}^c$ with $a+c \leq 2$ and $a+b+c = k$. So $b \geq k-2$.

Further, $G^k(z, \zeta, 0, 0) \equiv 0$ imposes $\lambda^k(z, \zeta, 0) \equiv 0$. So $1 \leq c \leq 2$. Consequently, λ^k can contain only three monomials:

$$\lambda^k(z, \zeta, \bar{z}) = a \bar{z} \zeta^{k-1} + b z \bar{z} \zeta^{k-2} + c \bar{z}^2 \zeta^{k-2}.$$

Since $k \geq 4$, we see that the conjugate $\bar{\lambda}^k(\bar{z}, \bar{\zeta}, z)$ is multiple of $\bar{\zeta}^{-k-2 \geq 2}$, hence:

$$G^k(z, \zeta, \bar{z}, 0) = \lambda^k(z, \zeta, \bar{z}) + \bar{\lambda}^k(\bar{z}, 0, z) + O_{z,\bar{z}}(3).$$

Finally, because the prenormalized coordinates of Proposition 16.7 require $G^k(z, \zeta, \bar{z}, 0) = O_{\bar{z}}(3)$, we reach $\lambda^k(z, \zeta, \bar{z}) = O_{z,\bar{z}}(3)$, which forces $a = b = c = 0 = \lambda^k$, so as asserted $G^k = O_{z,\bar{z}}(3)$. \square

In conclusion, $G = \sum G^k = O_{z,\bar{z}}(3)$. \square

According to [51], the Lie group G of rigid CR automorphisms of the Gaussier-Merker model $\{u = m\}$ has Lie algebra $\mathfrak{g}_{-2} \oplus \mathfrak{g}_{-1} \oplus \mathfrak{g}_0$ of dimension 7, generated by X_1, \dots, X_7 . The 2-dimensional isotropy subgroup $G_0 \subset G$ of the origin $0 \in \mathbb{C}^3$ has Lie algebra $\mathfrak{g}_0^{\text{iso}}$ generated by:

$$X_6 := z \partial_z + 2w \partial_w, \quad X_7 := iz \partial_z + 2i\zeta \partial_\zeta.$$

By computing the flows $\exp(tX_\sigma)(z, \zeta, w)$ for $t \in \mathbb{R}$ and $\sigma = 6, 7$, one verifies that G_0 consists of scalings coupled with ‘rotations’:

$$z' = \rho^{1/2} e^{i\varphi} z, \quad \zeta' = e^{2i\varphi} \zeta, \quad w' = \rho w \quad (\rho \in \mathbb{R}_+^*, \varphi \in \mathbb{R}).$$

Next, any holomorphic function $e = e(z, w)$ decomposes in weighted homogeneous terms as:

$$e(z, w) = \sum_{a,b} e_{a,b} z^a \zeta^b = \sum_{k \geq 0} \left(\sum_b e_{k,b} \zeta^b \right) z^k =: \sum_{k \geq 0} e_k.$$

Mind notation: for weights, indices e_k are lower case, while for orders, as *e.g.* in G^k before, they were upper case. Similarly:

$$E(z, \zeta, \bar{z}, \bar{\zeta}) = \sum_{k \geq 0} \left(\sum_{a+c=k} \left(\sum_{b,d} E_{a,b,c,d} \zeta^b \bar{\zeta}^d \right) z^a \bar{z}^c \right) =: \sum_{k \geq 0} E_k.$$

According to what precedes, we can assume that both the source M and the target M' rigid hypersurfaces are prenormalized. Assume therefore that a rigid biholomorphism:

$$H: (z, \zeta, w) \mapsto \left(f(z, \zeta), g(z, \zeta), \rho w + h(z, \zeta) \right) =: (z', \zeta', w'),$$

fixing the origin is given between:

$$\begin{aligned} u = F &= z\bar{z} + \frac{1}{2}\bar{z}^2\zeta + O_{\bar{z}}(3) = \mathbf{m} + G = \frac{z\bar{z} + \frac{1}{2}z^2\bar{\zeta} + \frac{1}{2}\bar{z}^2\zeta}{1 - \zeta\bar{\zeta}} + O_{z, \bar{z}}(3), \\ u' = F' &= z'\bar{z}' + \frac{1}{2}\bar{z}'^2\zeta' + O_{\bar{z}'}(3) = \mathbf{m}' + G' = \frac{z'\bar{z}' + \frac{1}{2}z'^2\bar{\zeta}' + \frac{1}{2}\bar{z}'^2\zeta'}{1 - \zeta'\bar{\zeta}'} + O_{z', \bar{z}'}(3). \end{aligned}$$

OBSERVATION 5.9. *Scalings and rotations* $(z', \zeta', w') \mapsto (\rho^{1/2}e^{i\varphi}z', e^{2i\varphi}\zeta', \rho w')$ *preserve prenormalizations.* \square

Since $T_0^c M = \{w = 0\}$ and $T_0^c M' = \{w' = 0\}$, and since $H_* T_0^c M = T_0^c M'$, we necessarily have $h = O_{z, \zeta}(2)$. After the scaling $w' \mapsto \frac{1}{\rho} w'$, we may therefore assume that the last component of H is $w + O_{z, \zeta}(2)$.

Let us decompose the components of H in weighted homogeneous parts:

$$f = f_0 + f_1 + f_2 + f_3 + \dots, \quad g = g_0 + g_1 + g_2 + \dots, \quad h = h_0 + h_1 + h_2 + h_3 + h_4 + \dots.$$

Plug in the components of H in the target rigid equation $\frac{w + \bar{w}}{2} = F'(z', \zeta', \bar{z}', \bar{\zeta}')$:

$$w + h(z, \zeta) + \bar{w} + \bar{h}(\bar{z}, \bar{\zeta}) = 2F'(f(z, \zeta), g(z, \zeta), \bar{f}(\bar{z}, \bar{\zeta}), \bar{g}(\bar{z}, \bar{\zeta})),$$

and then, substitute $w + \bar{w} = 2F$ to get a *fundamental equation*, holding identically:

$$(5.10) \quad 2F(z, \zeta, \bar{z}, \bar{\zeta}) + h(z, \zeta) + \bar{h}(\bar{z}, \bar{\zeta}) \equiv 2F'(f(z, \zeta), g(z, \zeta), \bar{f}(\bar{z}, \bar{\zeta}), \bar{g}(\bar{z}, \bar{\zeta})).$$

PROPOSITION 5.11. *Possibly after a rotation* $(z', \zeta', w') \mapsto (e^{i\varphi}z', e^{2i\varphi}\zeta', w')$, *one has:*

$$f = z + f_2 + f_3 + \dots, \quad g = \zeta + g_1 + g_2 + \dots, \quad h = w + h_3 + h_4 + \dots.$$

or equivalently: $f_0 = 0, f_1 = z; g_0 = \zeta; h_0 = 0, h_1 = 0, h_2 = w$.

PROOF. Recall that $F = \mathbf{m} + G$, that $\mathbf{m} = \mathbf{m}_2$ and that $G = G_3 + G_4 + \dots$, with the same about $F' = \mathbf{m}' + G'$. So F and F' have no terms of weights 0 or 1. Of course $f_0 = f_0(\zeta), g_0 = g_0(\zeta), h_0 = h_0(\zeta)$ depend on ζ only.

In (5.10), pick terms of weight zero:

$$0 + h_0(\zeta) + \bar{h}_0(\bar{\zeta}) \equiv 2F'(f_0(\zeta), g_0(\zeta), \bar{f}_0(\bar{\zeta}), \bar{g}_0(\bar{\zeta})),$$

put $\bar{\zeta} := 0$, use $F'(z', \zeta', 0, 0) \equiv 0$, and get $h_0 = 0$.

Once again, pick in (5.10) terms of weight zero using $F' = \mathbf{m}' + O_{z', \bar{z}'}(3)$:

$$0 \equiv \frac{f_0(\zeta)\bar{f}_0(\bar{\zeta}) + \frac{1}{2}f_0(\zeta)^2\bar{g}_0(\bar{\zeta}) + \frac{1}{2}\bar{f}_0(\bar{\zeta})g_0(\zeta)}{1 - g_0(\zeta)\bar{g}_0(\bar{\zeta})} + O_{f_0(\zeta), \bar{f}_0(\bar{\zeta})}(3).$$

We claim that $f_0(\zeta) \equiv 0$. Otherwise, $f_0 = c\zeta^\nu + O_\zeta(\nu + 1)$ with $c \neq 0$, but on the right, the monomial $c\bar{c}\zeta^\nu\bar{\zeta}^\nu$ cannot be killed — contradiction. This finishes examination of weight zero, for it remains only $0 \equiv 0$.

Hence, pass to weight 1. We claim that $h_1 = 0$. Of course, $f_1 = zf_1(\zeta)$ and $h_1 = zh_1(\zeta)$. Since m' is weighted homogeneous of degree 2, we have $F' = O_{z',\bar{z}'}(2)$, and we get from (5.10) what forces $h_1 = 0$:

$$O_{z,\bar{z}}(2) + zh_1(\zeta) + \bar{z}\bar{h}_1(\bar{\zeta}) \equiv O_{zf_1(\zeta),\bar{z}\bar{f}_1(\bar{\zeta})}(2) \equiv O_{z,\bar{z}}(2).$$

Before passing to weight 2, since $f = zf_1(\zeta) + O_z(2)$ and $g = g_0(\zeta) + zg_1(\zeta) + O_z(2)$, the nonzero Jacobian $\begin{vmatrix} f_z & f_\zeta \\ g_z & g_\zeta \end{vmatrix}$ has value at the origin $\begin{vmatrix} f_1(0) & 0 \\ g_1(0) & g'_0(0) \end{vmatrix}$, hence $f_1(0) \neq 0 \neq g'_0(0)$.

Lastly, picking weighted degree 2 terms in (5.10), we get:

$$2m(z, \zeta, \bar{z}, \bar{\zeta}) + z^2h_2(\zeta) + \bar{z}^2\bar{h}_2(\bar{\zeta}) \equiv 2m\left(zf_1(\zeta), g_0(\zeta), \bar{z}\bar{f}_1(\bar{\zeta}), \bar{g}_0(\bar{\zeta})\right).$$

This identity means that the map $(z, \zeta, w) \mapsto (zf_1(\zeta), g_0(\zeta), w + z^2h_2(\zeta))$ is an automorphism of the Gaussier-Merker model fixing the origin, hence is a rotation, so that $f_1(\zeta) = e^{i\varphi}$, $g_0(\zeta) = e^{2i\varphi}\zeta$, $h_2(z, \zeta) \equiv 0$. Post-composing with the inverse rotation, we attain the conclusion. \square

QUESTION 5.12. *Suppose given two rigid hypersurfaces prenormalized as before:*

$$u = F = z\bar{z} + \frac{1}{2}\bar{z}^2\zeta + O_{\bar{z}}(3) + O_{\bar{\zeta}}(1) = m + G = \frac{z\bar{z} + \frac{1}{2}z^2\bar{\zeta} + \frac{1}{2}\bar{z}^2\zeta}{1 - \zeta\bar{\zeta}} + O_{z,\bar{z}}(3),$$

$$u' = F' = z'\bar{z}' + \frac{1}{2}\bar{z}'^2\zeta' + O_{\bar{z}'}(3) + O_{\bar{\zeta}'}(1) = m' + G' = \frac{z'\bar{z}' + \frac{1}{2}z'^2\bar{\zeta}' + \frac{1}{2}\bar{z}'^2\zeta'}{1 - \zeta'\bar{\zeta}'} + O_{z',\bar{z}'}(3).$$

Is it true that the group of rigid biholomorphisms at the origin between them:

$$(z, \zeta, w) \mapsto \left(z + f(z, \zeta), \zeta + g(z, \zeta), w + h(z, \zeta)\right) =: (z', \zeta', w'),$$

where $f = f_2 + f_3 + \dots$, $g = g_1 + g_2 + \dots$, $h = h_3 + h_4 + \dots$, *is finite-dimensional?*

Here, the two appearing remainders $O_{z,\bar{z}}(3)$ and $O_{\bar{z}}(3) + O_{\bar{\zeta}}(1)$ are different. By expanding $1/(1 - \zeta\bar{\zeta})$ we see that:

$$m = z\bar{z} + \frac{1}{2}\bar{z}^2\zeta + \frac{1}{2}z^2\bar{\zeta} + \zeta\bar{\zeta}(\dots) = z\bar{z} + \frac{1}{2}\bar{z}^2\zeta + O_{\bar{\zeta}}(1),$$

hence by subtraction, we get that G is more than just an $O_{z,\bar{z}}(3)$.

OBSERVATION 5.13. *The remainder function satisfies $G = O_{z,\bar{z}}(3) = O_{\bar{z}}(3) + O_{\bar{\zeta}}(1)$.* \square

The synthesis between these two conditions will be made in Section 7.

6. Weighted Homogeneous Normalizing Biholomorphisms

Now, inspired by Jacobowitz's presentation [71] of Moser's normal form in \mathbb{C}^2 , Propositions 5.7 and 5.11 justify to introduce the spaces:

$$\mathcal{G} := \left\{ G = G(z, \zeta, \bar{z}, \bar{\zeta}) : G = G_3 + G_4 + \dots \right\},$$

$$\mathcal{D} := \left\{ (z + f(z, \zeta), \zeta + g(z, \zeta), w + h(z, \zeta)) : f = f_2 + f_3 + \dots, g = g_1 + g_2 + \dots, h = h_3 + h_4 + \dots \right\},$$

where lower indices denote homogeneous components with respect to the weighting (4.1) defined by:

$$[z^a \zeta^b \bar{z}^c \bar{\zeta}^d] = a + c.$$

The goal is to use the ‘freedom’ space \mathcal{D} of rigid biholomorphisms in order to ‘normalize’ as much as possible the remainder G in the graphed equation $\{u = m + G\}$ of any given hypersurface. Here, $m = \frac{z\bar{z} + \frac{1}{2}z^2\bar{\zeta} + \frac{1}{2}\bar{z}^2\zeta}{1 - \zeta\bar{\zeta}}$ is homogeneous of weight 2.

Both \mathcal{G} and \mathcal{D} decompose as direct sums graded by increasing weights:

$$\begin{aligned}\mathcal{G} &= \bigcup_{\nu \geq 3} \mathcal{G}_\nu, & \mathcal{G}_\nu &:= \{G_\nu\}, \\ \mathcal{D} &= \bigcup_{\nu \geq 3} \mathcal{D}_\nu, & \mathcal{D}_\nu &:= \{(f_{\nu-1}, g_{\nu-2}, h_\nu)\},\end{aligned}$$

and the (upcoming) justification for the shifts in \mathcal{D}_ν will be due to two multipliers:

$$m_z = \frac{\bar{z} + z\bar{\zeta}}{1 - \zeta\bar{\zeta}} \quad \text{of weight 1} \quad \text{and} \quad m_\zeta = \frac{(\bar{z} + z\bar{\zeta})^2}{2(1 - \zeta\bar{\zeta})^2} \quad \text{of weight 2.}$$

One can figure out that $G_2 := m$ and $G'_2 := m'$ are already finalized/normalized. With increasing weights $\nu = 3, 4, 5, \dots$, we shall perform successive holomorphic rigid transformations of the shape:

$$(6.1) \quad z' := z + f_{\nu-1}, \quad \zeta' := \zeta + g_{\nu-2}, \quad w' := w + h_\nu.$$

When $\nu \gg 1$ is high, it is intuitively clear that such transformations close to the identity will preserve previously achieved low order normalizations; to make this claim precise, let us follow and adapt [71, Chap. 3].

For $\mu \geq 0$, denote by $O(\mu)$ power series whose monomials $z^a \zeta^b \bar{z}^c \bar{\zeta}^d$ are all of weight $a + c \geq \mu$, and introduce the projection operators:

$$\pi_\mu \left(\sum_{a,b,c,d \geq 0} T_{a,b,c,d} z^a \zeta^b \bar{z}^c \bar{\zeta}^d \right) := \sum_{a+c \leq \mu} \sum_{b,d \geq 0} T_{a,b,c,d} z^a \zeta^b \bar{z}^c \bar{\zeta}^d.$$

PROPOSITION 6.2. *Through any biholomorphism (6.1) which transforms:*

$$u = m + G_3 + \dots + G_{\nu-1} + G_\nu + O(\nu+1) \quad \text{into} \quad u' = m + G'_3 + \dots + G'_{\nu-1} + G'_\nu + O'(\nu+1),$$

homogeneous terms are kept untouched up to order $\leq \nu - 1$:

$$G'_\mu(z, \zeta, \bar{z}, \bar{\zeta}) = G_\mu(z, \zeta, \bar{z}, \bar{\zeta}) \quad (3 \leq \mu \leq \nu-1),$$

while:

$$G'_\nu(z, \zeta, \bar{z}, \bar{\zeta}) = G_\nu(z, \zeta, \bar{z}, \bar{\zeta}) - 2 \operatorname{Re} \left\{ \frac{\bar{z} + z\bar{\zeta}}{1 - \zeta\bar{\zeta}} f_{\nu-1}(z, \zeta) + \frac{(\bar{z} + z\bar{\zeta})^2}{2(1 - \zeta\bar{\zeta})^2} g_{\nu-2}(z, \zeta) - \frac{1}{2} h_\nu(z, \zeta) \right\}.$$

Thus, by appropriately choosing $(f_{\nu-1}, g_{\nu-2}, h_\nu)$, we will be able to ‘kill’ many monomials in G_ν , hence make G'_ν simpler, or *normalized*. Exercise: verify that in fact $h_\nu \equiv 0$ necessarily, when F and F' are assumed to be prenormalized.

PROOF. As already seen, the fundamental equation, holding identically, is:

$$\operatorname{Re}(w + h_\nu) = F(z, \zeta, \bar{z}, \bar{\zeta}) + \operatorname{Re} h_\nu \equiv F'(z + f_{\nu-1}(z, \zeta), \zeta + g_{\nu-2}(z, \zeta), w + h_\nu(z, \zeta)).$$

Decomposing $F = m + G$, $F' = m' + G'$ and reorganizing, it becomes:

$$\frac{(z + f_{\nu-1})(\bar{z} + \bar{f}_{\nu-1}) + \frac{1}{2}(z + f_{\nu-1})^2(\bar{\zeta} + \bar{g}_{\nu-2}) + \frac{1}{2}(\bar{z} + \bar{f}_{\nu-1})^2(\zeta + g_{\nu-2})}{1 - (\zeta + g_{\nu-2})(\bar{\zeta} + \bar{g}_{\nu-2})} - \frac{z\bar{z} + \frac{1}{2}z^2\bar{\zeta} + \frac{1}{2}\bar{z}^2\zeta}{1 - \zeta\bar{\zeta}} - \operatorname{Re} h_\nu = G - G'.$$

A reduction of the left hand side to the same denominator shows after algebraic simplifications:

$$\frac{(1 - \zeta\bar{\zeta})[z\bar{f}_{\nu-1} + \bar{z}f_{\nu-1} + \frac{1}{2}(2zf_{\nu-1}\bar{\zeta} + z^2\bar{g}_{\nu-2}) + \frac{1}{2}(2\bar{z}\bar{f}_{\nu-1}\zeta + \bar{z}^2g_{\nu-2})] + (\zeta\bar{g}_{\nu-2} + \bar{\zeta}g_{\nu-2})(z\bar{z} + \frac{1}{2}z^2\bar{\zeta} + \frac{1}{2}\bar{z}^2\zeta)}{(1 - \zeta\bar{\zeta})(1 - \zeta\bar{\zeta} - \zeta\bar{g}_{\nu-2} - \bar{\zeta}g_{\nu-2} - g_{\nu-2}\bar{g}_{\nu-2})} - \operatorname{Re} h_\nu.$$

that this left-hand side is $O(\nu)$, hence has zero $\pi_{\nu-1}(\bullet) = 0$. Moreover, its homogeneous degree ν part is obtained by taking only weighted degree zero terms in the denominator, namely $\frac{\text{numerator}}{(1-\zeta\bar{\zeta})^2} - \text{Re } h_\nu$, and one recognizes/reconstitutes m_z, m_ζ as homogeneous multipliers of weights 1, 2:

$$\pi_\nu\left(m' - m - \text{Re } h_\nu\right) = 2 \text{Re} \left\{ \frac{\bar{z}+z\bar{\zeta}}{1-\zeta\bar{\zeta}} f_{\nu-1}(z, \zeta) + \frac{(\bar{z}+z\bar{\zeta})^2}{2(1-\zeta\bar{\zeta})^2} g_{\nu-2}(z, \zeta) - \frac{1}{2} h_\nu(z, \zeta) \right\}.$$

It remains to treat $\pi_\nu(\bullet)$ of the right-hand side:

$$\sum_{3 \leq \mu \leq \nu} G_\mu(z, \zeta, \bar{z}, \bar{\zeta}) - \pi_\nu\left(\sum_{3 \leq \mu \leq \nu} G'_\mu(z + f_{\nu-1}, \zeta + g_{\nu-2}, \bar{z} + \bar{f}_{\nu-1}, \bar{\zeta} + \bar{g}_{\nu-2})\right).$$

ASSERTION 6.3. For each $3 \leq \mu \leq \nu$:

$$\pi_\nu\left(G'_\mu(z + f_{\nu-1}, \zeta + g_{\nu-2}, \bar{z} + \bar{f}_{\nu-1}, \bar{\zeta} + \bar{g}_{\nu-2})\right) = G'_\mu(z, \zeta, \bar{z}, \bar{\zeta}).$$

PROOF. All possible monomials in G'_μ with $a + c = \mu \geq 3$ after binomial expansion:

$$\begin{aligned} (z + f_{\nu-1})^a (\zeta + g_{\nu-2})^b (\bar{z} + \bar{f}_{\nu-1})^c (\bar{\zeta} + \bar{g}_{\nu-2})^d &= (z^a + O(a-1+\nu-1))(\zeta^b + O(\nu-2))(\bar{z}^c + O(c-1+\nu-1))(\bar{\zeta}^d + O(\nu-2)) \\ &= z^a \zeta^b \bar{z}^c \bar{\zeta}^d + O(a+c-2+\nu), \end{aligned}$$

have the simple projection $\pi_\nu(\bullet) = z^a \zeta^b \bar{z}^c \bar{\zeta}^d$ since $a + c - 2 + \nu \geq 1 + \nu$. □

We therefore obtain an identity in which all arguments are $(z, \zeta, \bar{z}, \bar{\zeta})$:

$$2 \text{Re} \left\{ \frac{\bar{z}+z\bar{\zeta}}{1-\zeta\bar{\zeta}} f_{\nu-1} + \frac{(\bar{z}+z\bar{\zeta})^2}{2(1-\zeta\bar{\zeta})^2} g_{\nu-2} - \frac{1}{2} h_\nu \right\} \equiv \sum_{3 \leq \mu \leq \nu-1} (G_\mu - G'_{\mu o}) + G_\nu - G'_\nu.$$

Applying $\pi_{\nu-1}$ annihilates both the left-hand side and $G_\nu - G'_\nu$, whence $G_\mu = G'_\mu$ for $3 \leq \mu \leq \nu - 1$, which concludes. □

7. Normal Form

The assumption that the Levi form is of constant rank 1:

$$F_{z\bar{z}} \neq 0 \equiv F_{z\bar{z}} F_{\zeta\bar{\zeta}} - F_{\zeta\bar{z}} F_{z\bar{\zeta}},$$

enables to solve identically as functions of $(z, \zeta, \bar{z}, \bar{\zeta})$:

$$F_{\zeta\bar{\zeta}} \equiv \frac{F_{\zeta\bar{z}} F_{z\bar{\zeta}}}{F_{z\bar{z}}}.$$

By successively differentiating this identity and performing replacements, we get formulas.

LEMMA 7.1. For every jet multiindex $(a, b, c, d) \in \mathbb{N}^4$ with $b \geq 1$ and $d \geq 1$, abbreviating $n := a + b + c + d$, there exists a polynomial $P_{a,b,c,d}$ in its arguments and an integer $N_{a,b,c,d} \geq 1$ such that:

$$F_{z^a \zeta^b \bar{z}^c \bar{\zeta}^d} \equiv \frac{1}{(F_{z\bar{z}})^{N_{a,b,c,d}}} P_{a,b,c,d} \left(\{F_{z^{a'} \bar{z}^{c'}}\}_{a'+c' \leq n}, \{F_{z^{a'} \zeta^{b'} \bar{z}^{c'}}\}_{a'+b'+c' \leq n}^{b' \geq 1}, \{F_{z^{a'} \bar{z}^{c'} \bar{\zeta}^{d'}}\}_{a'+c'+d' \leq n}^{d' \geq 1} \right).$$
□

In other words, the Levi rank 1 assumption implies that all Taylor coefficients at the origin of $\sum_{a,b,c,d} F_{a,b,c,d} z^a \zeta^b \bar{z}^c \bar{\zeta}^d$ for which $b \geq 1$ and $d \geq 1$ are determined by the free Taylor coefficients:

$$\{F_{a,0,c,0}\}_{a \geq 0, c \geq 0} \cup \{F_{a,b,c,0}\}_{a \geq 0, b \geq 1, c \geq 0} \cup \{F_{a,0,c,d}\}_{a \geq 0, c \geq 0, d \geq 1}.$$

In subsequent computations, we will therefore normalize only these free (independent) Taylor coefficients at the origin, while those (dependent) attached to monomials that are multiple of $\zeta\bar{\zeta}$ will then be automatically determined by the formulas of Lemma 7.1.

As promised, we can now explore Observation 5.13 further. What precedes shows that it is best appropriate to expand G with respect to $(\zeta, \bar{\zeta})$:

$$G = \sum_{a,c \geq 0} G_{a,0,c,0} z^a \bar{z}^c + \sum_{b \geq 1} \zeta^b \left(\sum_{a,c \geq 0} G_{a,b,c,0} z^a \bar{z}^c \right) + \sum_{d \geq 1} \bar{\zeta}^d \left(\sum_{a,c \geq 0} G_{a,0,c,d} z^a \bar{z}^c \right) + \sum_{b,d \geq 1} \sum_{a,c \geq 0} G_{a,b,c,d} z^a \zeta^b \bar{z}^c \bar{\zeta}^d.$$

The last quadruple sum gathers all dependent jets. We will abbreviate this remainder as $\zeta\bar{\zeta}(\dots)$. With different notations, we can therefore write:

$$G = a(z, \bar{z}) + \sum_{k \geq 0} \zeta^{k+1} \Pi_k(z, \bar{z}) + \sum_{k \geq 0} \bar{\zeta}^{k+1} \bar{\Pi}_k(\bar{z}, z) + \zeta\bar{\zeta}(\dots),$$

with $a(z, \bar{z}) \equiv \bar{a}(\bar{z}, z)$ real, but no reality constraint on the $\Pi_k(z, \bar{z})$.

Recall that $G = O_{z,\bar{z}}(3)$. In view of Proposition 6.2, we must, for every weight $\nu \geq 3$, extract G_ν , while writing $\zeta^{k+1} = \zeta \zeta^k$:

$$\begin{aligned} G_\nu &= a_{\nu,0} z^\nu + a_{\nu-1,1} z^{\nu-1} \bar{z} + \dots + a_{1,\nu-1} z \bar{z}^{\nu-1} + a_{0,\nu} \bar{z}^\nu + \\ &+ \sum_{k \geq 0} \zeta \zeta^k \left(z^\nu \Pi_{k,\nu,0} + z^{\nu-1} \bar{z} \Pi_{k,\nu-1,1} + \dots + z \bar{z}^{\nu-1} \Pi_{k,1,\nu-1} + \bar{z}^\nu \Pi_{k,0,\nu} \right) + \\ &+ \sum_{k \geq 0} \bar{\zeta} \bar{\zeta}^k \left(\bar{z}^\nu \bar{\Pi}_{k,\nu,0} + \bar{z}^{\nu-1} z \bar{\Pi}_{k,\nu-1,1} + \dots + \bar{z} z^{\nu-1} \bar{\Pi}_{k,1,\nu-1} + z^\nu \bar{\Pi}_{k,0,\nu} \right) + \\ &+ \zeta\bar{\zeta}(\dots). \end{aligned}$$

To reorganize all this in powers of (z, \bar{z}) , let us introduce the two collections for all $0 \leq \mu \leq \nu$ of (anti)holomorphic functions (mind the inversion $\nu - \mu \longleftrightarrow \mu$ at the end):

$$B_{\nu-\mu,\mu}(\zeta) := \sum_{k \geq 0} \zeta^k \Pi_{k,\nu-\mu,\mu} \quad \text{and} \quad \bar{C}_{\nu-\mu,\mu}(\bar{\zeta}) := \sum_{k \geq 0} \bar{\zeta}^k \bar{\Pi}_{k,\mu,\nu-\mu}.$$

The definition of these $B_{\bullet,\bullet}$ and $\bar{C}_{\bullet,\bullet}$ enables us to emphasize that the obtained functions $\zeta B_{\bullet,\bullet}(\zeta)$ and $\bar{\zeta} \bar{C}_{\bullet,\bullet}(\bar{\zeta})$ vanish when either $\zeta := 0$ or $\bar{\zeta} := 0$, and we therefore obtain, taking also account of the fact that G_ν is real:

$$\begin{aligned} G_\nu &= z^\nu \left(a_{\nu,0} + \zeta B_{\nu,0}(\zeta) + \bar{\zeta} \bar{C}_{\nu,0}(\bar{\zeta}) \right) + z^{\nu-1} \bar{z} \left(a_{\nu-1,1} + \zeta B_{\nu-1,1}(\zeta) + \bar{\zeta} \bar{C}_{\nu-1,1}(\bar{\zeta}) \right) + \\ &+ \dots + \\ &+ z \bar{z}^{\nu-1} \left(\bar{a}_{\nu-1,1} + \bar{\zeta} \bar{B}_{\nu-1,1}(\bar{\zeta}) + \zeta C_{\nu-1,1}(\zeta) \right) + \bar{z}^\nu \left(\bar{a}_{\nu,0} + \bar{\zeta} \bar{B}_{\nu,0}(\bar{\zeta}) + \zeta C_{\nu,0}(\zeta) \right) + \zeta\bar{\zeta}(\dots). \end{aligned}$$

Of course, all these weighted homogeneous functions G_ν automatically satisfy $G_\nu = O_{z,\bar{z}}(3)$, since $\nu \geq 3$ thanks to Proposition 5.7. Now, Observation 5.13 also requires that they satisfy, since they are real:

$$(7.2) \quad G_\nu = O_{\bar{z}}(3) + O_{\bar{\zeta}}(1) = O_z(3) + O_\zeta(1).$$

LEMMA 7.3. For each weight $\nu \geq 5$, the function G_ν satisfies (7.2) if and only if it is of the form:

$$\begin{aligned}
 G_\nu = & z^\nu \left(0 + 0 + \bar{\zeta} \bar{C}_{\nu,0}(\bar{\zeta}) \right) \\
 & + z^{\nu-1} \bar{z} \left(0 + 0 + \bar{\zeta} \bar{C}_{\nu-1,1}(\bar{\zeta}) \right) \\
 & + z^{\nu-2} \bar{z}^2 \left(0 + 0 + \bar{\zeta} \bar{C}_{\nu-2,2}(\bar{\zeta}) \right) \\
 & + z^{\nu-3} \bar{z}^3 \left(a_{\nu-3,3} + \zeta B_{\nu-3,3}(\zeta) + \bar{\zeta} \bar{C}_{\nu-3,3}(\bar{\zeta}) \right) \\
 & + \dots + \\
 & + z^3 \bar{z}^{\nu-3} \left(\bar{a}_{\nu-3,3} + \zeta C_{\nu-3,3}(\zeta) + \bar{\zeta} \bar{B}_{\nu-3,3}(\bar{\zeta}) \right) \\
 & + z^2 \bar{z}^{\nu-2} \left(0 + \zeta C_{\nu-2,2}(\zeta) + 0 \right) \\
 & + z^1 \bar{z}^{\nu-1} \left(0 + \zeta C_{\nu-1,1}(\zeta) + 0 \right) \\
 & + \bar{z}^\nu \left(0 + \zeta C_{\nu,0}(\zeta) + 0 \right) + \zeta \bar{\zeta} (\dots).
 \end{aligned}$$

Just after, we will treat the two weights $\nu = 3, 4$ separately.

PROOF. Putting $\bar{\zeta} := 0$ above, it must hold that:

$$\begin{aligned}
 O_{\bar{z}}(3) + 0 = G_\nu|_{\bar{\zeta}=0} = & z^\nu \left(a_{\nu,0} + \zeta B_{\nu,0}(\zeta) + 0 \right) \\
 & + z^{\nu-1} \bar{z} \left(a_{\nu-1,1} + \zeta B_{\nu-1,1}(\zeta) + 0 \right) + \\
 & + z^{\nu-2} \bar{z}^2 \left(a_{\nu-2,2} + \zeta B_{\nu-2,2}(\zeta) + 0 \right) \\
 & + O_{\bar{z}}(3) + 0.
 \end{aligned}$$

Thus, all the appearing $a_{\bullet,\bullet}$ and $B_{\bullet,\bullet}$ should vanish, as stated, and the converse is clear. \square

Proceeding similarly, the reader will find for $\nu = 3$ that G_3 satisfies (7.2) if and only if:

$$\begin{aligned}
 G_3 = & z^3 \left(0 + 0 + \bar{\zeta} \bar{C}_{3,0}(\bar{\zeta}) \right) \\
 & + z^2 \bar{z} \left(0 + 0 + 0 \right) \\
 & + z \bar{z}^2 \left(0 + 0 + 0 \right) \\
 & + \bar{z}^3 \left(0 + \zeta C_{3,0}(\zeta) + 0 \right) + \zeta \bar{\zeta} (\dots),
 \end{aligned}$$

as well as:

$$\begin{aligned}
 G_4 = & z^4 \left(0 + 0 + \bar{\zeta} \bar{C}_{4,0}(\bar{\zeta}) \right) \\
 & + z^3 \bar{z} \left(0 + 0 + \bar{\zeta} \bar{C}_{3,1}(\bar{\zeta}) \right) \\
 & + z^2 \bar{z}^2 \left(0 + 0 + 0 \right) \\
 & + z \bar{z}^3 \left(0 + \zeta C_{1,3}(\zeta) + 0 \right) \\
 & + \bar{z}^4 \left(0 + \zeta C_{4,0}(\zeta) + 0 \right) + \zeta \bar{\zeta} (\dots).
 \end{aligned}$$

Now, consider a rigid biholomorphism $z' = f(z, \zeta)$, $\zeta' = g(z, \zeta)$, $w' = \rho w + h(z, \zeta)$ between two rigid hypersurfaces M and M' . Of course, as in Question 5.12, we may assume that both M and M' have already been prenormalized, and thanks to Proposition 5.11 also that $f = f_2 + f_3 + \dots$, $g = g_1 + g_2 + \dots$, $\rho = 1$, $h = h_3 + h_4 + \dots$.

The goal is to *normalize* M' even further, by means of appropriate choices of f , g , h .

We saw that it is natural to decompose $G = G_3 + G_4 + G_5 + \dots$ and $G' = G'_3 + G'_4 + G'_5 + \dots$ in weighted homogeneous parts, and we just finished to express what prenormalization means about these G_ν and G'_ν . Proceeding with increasing weights $\nu = 3, 4, 5, \dots$, we therefore consider biholomorphisms of the shape $z' = z + f_{\nu-1}$, $\zeta' = \zeta + g_{\nu-2}$, $w' = w + h_\nu$, and we recall that Proposition 6.2 showed that:

$$G'_\nu(z, \zeta, \bar{z}, \bar{\zeta}) = G_\nu(z, \zeta, \bar{z}, \bar{\zeta}) - 2 \operatorname{Re} \left\{ \frac{\bar{z} + z\bar{\zeta}}{1 - \zeta\bar{\zeta}} f_{\nu-1}(z, \zeta) + \frac{(\bar{z} + z\bar{\zeta})^2}{2(1 - \zeta\bar{\zeta})^2} g_{\nu-2}(z, \zeta) - \frac{1}{2} h_\nu(z, \zeta) \right\}.$$

The freedom to ‘normalize’ G'_ν even more than G_ν , namely the term $-2 \operatorname{Re} \{\dots\}$, is parametrized by the completely free choice for the triple of holomorphic functions $(f_{\nu-1}, g_{\nu-2}, h_\nu)$. However, prenormalizations should be left untouched.

LEMMA 7.4. *At every weight level $\nu \geq 5$, only the identity biholomorphic transformation $z' = z$, $\zeta' = \zeta$, $w' = w$ stabilizes prenormalization in source and target spaces:*

$$G_\nu(z, \zeta, \bar{z}, \bar{\zeta}) = O_{\bar{z}}(3) + O_{\bar{\zeta}}(1) = G'_\nu(z, \zeta, \bar{z}, \bar{\zeta}),$$

or equivalently, the ‘freedom function’ respects prenormalization:

$$O_{\bar{z}}(3) + O_{\bar{\zeta}}(1) = 2 \operatorname{Re} \left\{ \frac{\bar{z} + z\bar{\zeta}}{1 - \zeta\bar{\zeta}} f_{\nu-1}(z, \zeta) + \frac{(\bar{z} + z\bar{\zeta})^2}{2(1 - \zeta\bar{\zeta})^2} g_{\nu-2}(z, \zeta) - \frac{1}{2} h_\nu(z, \zeta) \right\} =: \Phi(z, \zeta, \bar{z}, \bar{\zeta}),$$

if and only if $0 = f_{\nu-1} = g_{\nu-2} = h_\nu$.

PROOF. It is easy to verify that the vanishings $G_\nu(z, \zeta, 0, 0) \equiv 0 \equiv G'_\nu(z, \zeta, 0, 0)$, which hold from the very beginning (of Proposition 16.7) already suffice to force $h_\nu(z, \zeta) \equiv 0$.

Next, write:

$$\begin{aligned} f_{\nu-1}(z, \zeta) &= z^{\nu-1} f(\zeta) = z^{\nu-1} (f_0 + f_1 \zeta + f_2 \zeta^2 + \dots), \\ g_{\nu-2}(z, \zeta) &= z^{\nu-2} g(\zeta) = z^{\nu-2} (g_0 + g_1 \zeta + g_2 \zeta^2 + \dots). \end{aligned}$$

The goal is to show that $f(\zeta) \equiv 0$ and $g(\zeta) \equiv 0$.

Prenormalization being expressed modulo $\zeta\bar{\zeta}(\dots)$, when we expand the two denominators of Φ , we have by luck $\frac{1}{1 - \zeta\bar{\zeta}} \equiv 1$ and $\frac{1}{2(1 - \zeta\bar{\zeta})^2} \equiv \frac{1}{2}$, and hence it suffices to require that:

$$O_{\bar{z}}(3) + O_{\bar{\zeta}}(1) \stackrel{?}{=} 2 \operatorname{Re} \left\{ (\bar{z} + z\bar{\zeta}) z^{\nu-1} \sum_{k \geq 0} f_k \zeta^k + \frac{1}{2} (\bar{z} + z\bar{\zeta})^2 z^{\nu-2} \sum_{k \geq 0} g_k \zeta^k \right\}.$$

Using $\nu \geq 5$ to guarantee that there is no interference when extracting the first three powers $z^\nu, z^{\nu-1}\bar{z}, z^{\nu-2}\bar{z}^2$, let us compute the three relevant terms of the freedom function:

$$\begin{aligned}\Phi(z, \zeta, \bar{z}, \bar{\zeta}) &= (\bar{z} + z\bar{\zeta}) z^{\nu-1} (f_0 + f_1 \zeta + f_2 \zeta^2 + \cdots) + \left(\frac{1}{2} \bar{z}^2 + z\bar{z}\bar{\zeta} + \frac{1}{2} z^2 \bar{\zeta}^2\right) z^{\nu-2} (g_0 + g_1 \zeta + g_2 \zeta^2 + \cdots) \\ &\quad + (z + \bar{z}\zeta) \bar{z}^{\nu-1} (\bar{f}_0 + \bar{f}_1 \bar{\zeta} + \bar{f}_2 \bar{\zeta}^2 + \cdots) + \left(\frac{1}{2} z^2 + \bar{z}z\zeta + \frac{1}{2} \bar{z}^2 \zeta^2\right) \bar{z}^{\nu-2} (\bar{g}_0 + \bar{g}_1 \bar{\zeta} + \bar{g}_2 \bar{\zeta}^2 + \cdots) \\ &= z^\nu \left(\underbrace{f_0 \bar{\zeta} + f_1 \zeta \bar{\zeta} + f_2 \zeta^2 \bar{\zeta} + \cdots}_{\circ} + \frac{1}{2} g_0 \bar{\zeta}^2 + \frac{1}{2} g_1 \zeta \bar{\zeta}^2 + \frac{1}{2} g_2 \zeta^2 \bar{\zeta}^2 + \cdots \right) \\ &\quad + z^{\nu-1} \bar{z} \left(f_0 + f_1 \zeta + f_2 \zeta^2 + \cdots + \underbrace{g_0 \bar{\zeta} + g_1 \zeta \bar{\zeta} + g_2 \zeta^2 \bar{\zeta} + \cdots}_{\circ} \right) \\ &\quad + z^{\nu-2} \bar{z}^2 \left(\frac{1}{2} g_0 + \frac{1}{2} g_1 \zeta + \frac{1}{2} g_2 \zeta^2 + \cdots \right) \\ &\quad + \bar{z}^3 (\cdots) + \zeta \bar{\zeta} (\cdots).\end{aligned}$$

Since the underlined terms can be absorbed into the remainder $\zeta \bar{\zeta}(\cdots)$, it remains only:

$$\begin{aligned}\Phi(z, \zeta, \bar{z}, \bar{\zeta}) &= \frac{1}{2} z^\nu (2f_0 \bar{\zeta} + g_0 \bar{\zeta}^2) \\ &\quad + z^{\nu-1} \bar{z} (f_0 + f_1 \zeta + f_2 \zeta^2 + \cdots + g_0 \bar{\zeta}) \\ &\quad + \frac{1}{2} z^{\nu-2} \bar{z}^2 (g_0 + g_1 \zeta + g_2 \zeta^2 + \cdots) \\ &\quad + \bar{z}^3 (\cdots) + \zeta \bar{\zeta} (\cdots).\end{aligned}$$

Putting $\bar{\zeta} := 0$, the result should be an $O_{\bar{z}}(3)$, hence the first three lines should vanish, and lines 2 and 3 conclude that $f(\zeta) \equiv 0 \equiv g(\zeta)$, as aimed at. \square

Next, inspect the two remaining weights $\nu = 3, 4$. For $\nu = 3$, again modulo $\zeta \bar{\zeta}(\cdots)$, the freedom function is:

$$\Phi_3 \equiv 2 \operatorname{Re} \left\{ (\bar{z} + z\bar{\zeta}) z^2 (f_0 + f_1 \zeta + f_2 \zeta^2 + \cdots) + \left(\frac{1}{2} \bar{z}^2 + z\bar{z}\bar{\zeta} + \frac{1}{2} z^2 \bar{\zeta}^2\right) z^1 (g_0 + g_1 \zeta + g_2 \zeta^2 + \cdots) \right\}.$$

ASSERTION 7.5. *Prenormalization $\Phi_3 = O_{\bar{z}}(3) + O_{\bar{\zeta}}(1)$ is preserved if and only if:*

$$0 = f_0 + \frac{1}{2} \bar{g}_0, \quad 0 = f_1, \quad 0 = f_2, \quad 0 = \bar{g}_0 + \frac{1}{2} g_1, \quad 0 = g_2, \quad \dots \quad \square$$

Consequently, only 1 complex constant is free, f_0 , in terms of which:

$$g_0 = -2 \bar{f}_0, \quad g_1 = -4 f_0.$$

With this, how can one normalize $G'_3 = G_3 - \Phi_3$ further? Still modulo $\zeta \bar{\zeta}(\cdots)$:

$$\Phi_3 \equiv z^3 (f_0 \bar{\zeta} - \bar{f}_0 \bar{\zeta}^2) + z^2 \bar{z} (0) + z \bar{z}^2 (0) + \bar{z}^3 (\bar{f}_0 \zeta - f_0 \zeta^2),$$

hence:

$$\begin{aligned}G'_{3,0,0,1} &= G_{3,0,0,1} - f_0, \\ G'_{3,0,0,2} &= G_{3,0,0,2} + \bar{f}_0.\end{aligned}$$

It is natural to normalize the lowest jet order $4 = 3 + 0 + 0 + 1$ coefficient here.

ASSERTION 7.6. *One can normalize $G'_{3,0,0,1} := 0$ by choosing $f_0 := G_{3,0,0,1}$.* \square

Once this is done, it is easy to see that preserving/maintaining the normalization:

$$G'_{3,0,0,1} = G_{3,0,0,1} = 0,$$

forces $f_0 = 0$ above.

ASSERTION 7.7. *In prenormalized coordinates which satisfy in addition $G_{3,0,0,1} = 0$, the coefficient:*

$$G'_{3,0,0,2} = G_{3,0,0,2}$$

is an invariant (at the origin). □

After such a normalization, we get:

$$u = z\bar{z} + \frac{1}{2} \bar{z}^2 \zeta + \frac{1}{2} z^2 \bar{\zeta} + z\bar{z}\zeta\bar{\zeta} + a z^2 \bar{z}^2 + O_{z,\zeta,\bar{z},\bar{\zeta}}(5),$$

with, possible, a nonzero real constant a , and possibly, a remainder that is *not* prenormalized.

Fortunately, we can apply the process of Proposition 16.7 to prenormalize again the coordinates, making in particular $a = 0$, without perturbing the normalizations obtained up to order 4 included.

Lastly, treat weight $\nu = 4$. The freedom function modulo $\zeta\bar{\zeta}(\dots)$, is:

$$\Phi_4 \equiv 2 \operatorname{Re} \left\{ (\bar{z} + z\bar{\zeta}) z^3 (f_0 + f_1 \zeta + f_2 \zeta^2 + \dots) + \left(\frac{1}{2} \bar{z}^2 + z\bar{z}\bar{\zeta} + \frac{1}{2} z^2 \bar{\zeta}^2 \right) z^2 (g_0 + g_1 \zeta + g_2 \zeta^2 + \dots) \right\}.$$

ASSERTION 7.8. *Prenormalization $\Phi_4 = O_{\bar{z}}(3) + O_{\bar{\zeta}}(1)$ is preserved if and only if:*

$$0 = f_0 = f_1 = f_2 = \dots, \quad 0 = g_0 + \bar{g}_0 = g_1 = g_2 = \dots. \quad \square$$

Thus now, only 1 *real* degree of freedom is left:

$$g_0 = i\tau \quad (\tau \in \mathbb{R}).$$

With this, how can one normalize $G'_4 = G_4 - \Phi_4$ further? Still modulo $\zeta\bar{\zeta}(\dots)$:

$$\Phi_4 \equiv z^4 \left(\frac{i}{2} \tau \bar{\zeta}^2 \right) + z^3 \bar{z} (i\tau \bar{\zeta}) + z^2 \bar{z}^2 (0) + z\bar{z}^3 (-i\tau \zeta) + z^4 \left(-\frac{i}{2} \tau \zeta^2 \right),$$

hence:

$$\begin{aligned} G'_{4,0,0,2} &= G_{4,0,0,2} - \frac{i}{2} \tau, \\ G'_{3,0,1,1} &= G_{3,0,1,1} - i\tau, \\ G'_{2,0,2,0} &= G_{2,0,2,0}. \end{aligned}$$

The third line shows an invariant. Notice also that $G'_{4,0,0,1} = G_{4,0,0,1}$ is an invariant. We choose to normalize the lowest jet order $3 + 0 + 1 + 1 = 5$ coefficient here.

ASSERTION 7.9. *One can normalize $\operatorname{Im} G'_{3,0,1,1} := 0$ by choosing $\tau := \operatorname{Im} G_{3,0,1,1}$.* □

Once this is done, $G'_{3,0,1,1} = G_{3,0,1,1} \in \mathbb{R}$ is an invariant.

Again, we can re-apply the process of Proposition 16.7 to prenormalize the coordinates without touching the lower order normalizations.

We already saw in Lemma 7.4 that for any weight $\nu \geq 5$, no degree of freedom exists. Since only $2 + 1 = 3$ real degrees of freedom have been encountered, namely $f_0 \in \mathbb{C}$ in weight $\nu = 3$ and $\operatorname{Im} g_0 \in \mathbb{R}$ in weight $\nu = 4$, we conclude that the answer to Question 5.12 is positive.

All this enables us to conclude the present section by stating results which come from our analysis.

THEOREM 7.10. *Every local rigid \mathcal{C}^ω graphed hypersurface $M^5 \subset \mathbb{C}^3 \ni (z, \zeta, w = u + iv)$ passing through the origin of equation:*

$$u = \sum_{a+b+c+d \geq 1} F_{a,b,c,d} z^a \zeta^b \bar{z}^c \bar{\zeta}^d,$$

whose Levi form is of constant rank 1 and which is 2-nondegenerate:

$$F_{z\bar{z}} \neq 0 \equiv \begin{vmatrix} F_{z\bar{z}} & F_{z\bar{\zeta}} \\ F_{\zeta\bar{z}} & F_{\zeta\bar{\zeta}} \end{vmatrix} \quad \text{and} \quad 0 \neq \begin{vmatrix} F_{z\bar{z}} & F_{z\bar{\zeta}} \\ F_{zz\bar{z}} & F_{zz\bar{\zeta}} \end{vmatrix},$$

is equivalent, through a local rigid biholomorphism:

$$(z, \zeta, w) \longmapsto \left(f(z, \zeta), g(z, \zeta), \rho w + h(z, \zeta) \right) =: (z', \zeta', w') \quad (\rho \in \mathbb{R}^*),$$

to a rigid \mathcal{C}^ω hypersurface $M'^5 \subset \mathbb{C}^3$ which, dropping primes for target coordinates, is a perturbation of the Gaussier-Merker model — homogeneous of order 2 in (z, \bar{z}) —:

$$u = \frac{z\bar{z} + \frac{1}{2} z^2 \bar{\zeta} + \frac{1}{2} \bar{z}^2 \zeta}{1 - \zeta \bar{\zeta}} + \sum_{\substack{a,b,c,d \in \mathbb{N} \\ a+c \geq 3}} G_{a,b,c,d} z^a \zeta^b \bar{z}^c \bar{\zeta}^d,$$

with a simplified remainder G which:

- (1) is normalized to be an $O_{z,\bar{z}}(3)$;
- (2) satisfies the prenormalization conditions $G = O_{\bar{z}}(3) + O_{\bar{\zeta}}(1) = O_z(3) + O_\zeta(1)$, or equivalently:

$$\begin{aligned} G_{a,b,0,0} &= 0 = G_{0,0,c,d}, \\ G_{a,b,1,0} &= 0 = G_{1,0,c,d}, \\ G_{a,b,2,0} &= 0 = G_{2,0,c,d}; \end{aligned}$$

- (3) satisfies in addition the sporadic normalization conditions:

$$\begin{aligned} G_{3,0,0,1} &= 0 = G_{0,1,3,0}, \\ \operatorname{Im} G_{3,0,1,1} &= 0 = \operatorname{Im} G_{1,1,3,0}. \quad \square \end{aligned}$$

There is of course *no* uniqueness of a rigid biholomorphic map which transfers M to an M' satisfying all these normalization conditions (1), (2), (3), just because any post-composition with a dilation-rotation map:

$$(z', \zeta', w') \longmapsto (\rho^{1/2} e^{i\varphi} z', e^{2i\varphi} \zeta', \rho w') = (z'', \zeta'', w'') \quad (\rho \in \mathbb{R}_+^*, \varphi \in \mathbb{R}),$$

will transfer M' into an $M'' = \{u'' = m'' + G''\}$ which enjoys again the normalization conditions (1), (2), (3), since one obviously has:

$$G''_{a,b,c,d} \rho^{\frac{a+c-2}{2}} e^{i\varphi(a+2b-c-2d)} = G'_{a,b,c,d}.$$

Remind that such dilation-rotation maps parametrize the 2-dimensional isotropy group of the origin for the Gaussier-Merker model $\{u' = m(z', \zeta', \bar{z}', \bar{\zeta}')\}$. Fortunately, an examination of our analysis above can show that these two parameters ρ, φ are the only ambiguity, since once one assumes that $f = z + f_2 + f_3 + \dots$, with no $\rho^{1/2} e^{i\varphi}$ in front of z , that $g = \zeta + g_1 + g_2 + \dots$, and that $h = w + h_3 + h_4 + \dots$, with no $\rho^{1/2} e^{i\varphi}$, our reasonings showed *uniqueness* (exercise) of the map to normal form.

To finish, let us abbreviate the space of power series $G = G(z, \zeta, \bar{z}, \bar{\zeta})$ satisfying the normalization conditions (1), (2), (3) as:

$$\mathfrak{N}_{2,1}.$$

COROLLARY 7.11. *Two rigid \mathcal{C}^ω hypersurfaces $M^5 \subset \mathbb{C}^3$ and $M'^5 \subset \mathbb{C}'^3$ belonging to $\mathfrak{C}_{2,1}$, both brought into normal form:*

$$\begin{aligned} u &= m + G, & G &\in \mathfrak{N}_{2,1}, \\ u' &= m' + G', & G' &\in \mathfrak{N}'_{2,1}, \end{aligned}$$

are rigidly biholomorphically equivalent if and only if there exist two constants $\rho \in \mathbb{R}_+^*$, $\varphi \in \mathbb{R}$, such that for all a, b, c, d :

$$G_{a,b,c,d} = G'_{a,b,c,d} \rho^{\frac{a+c-2}{2}} e^{i\varphi(a+2b-c-2d)}. \quad \square$$

Granted that hypersurfaces can be put into such a normal form, this criterion is quite effective to determine whether two $M, M' \in \mathfrak{C}_{2,1}$ are rigidly equivalent.

8. Finalized Expression of \mathcal{Q}_0

In this section, we revisit the secondary invariant \mathcal{Q}_0 . Our goal is to transform \mathcal{Q}_0 into a new expression which makes transparent two interesting features of \mathcal{Q}_0 : that it is real-valued and of order 5 (not 6 as it was first obtained by Cartan's method in [51]). The calculations in the following are laborious, and for readers who are only interested in the finalized expression of \mathcal{Q}_0 , we suggest to use a mathematical software for symbolic computations to have a quick and easy check to confirm that the finalized expression (8.2) of \mathcal{Q}_0 indeed agrees with the expression of \mathcal{Q}_0 obtained previously in [51], which will be recalled later in this section as the formula (8.5).

PROPOSITION 8.1. *The secondary invariant \mathcal{Q}_0 can be brought into the following form*

$$(8.2) \quad \mathcal{Q}_0 = BI_0 + \bar{B}\bar{I}_0 - B\bar{B} + \frac{2}{3} \operatorname{Re} \left\{ \mathcal{L}_1 \left[\frac{\overline{\mathcal{L}_1} \overline{\mathcal{L}_1(k)}}{\mathcal{L}_1(k)} \right] \right\} + \frac{1}{3} \operatorname{Re} \left(\overline{\mathcal{L}_1(P)} \right).$$

The rest of this section is devoted to the proof of Proposition 8.1. Let us first recall the formulas of I_0, V_0, \mathcal{Q}_0 from [51].

$$(8.3) \quad I_0 = -\frac{1}{3} \frac{\mathcal{K} \overline{\mathcal{L}_1} \overline{\mathcal{L}_1(k)}}{(\overline{\mathcal{L}_1(k)})^2} + \frac{1}{3} \frac{\mathcal{K} \overline{\mathcal{L}_1(k)} \overline{\mathcal{L}_1} \overline{\mathcal{L}_1(k)}}{(\overline{\mathcal{L}_1(k)})^3} + \frac{2}{3} \frac{\mathcal{L}_1 \mathcal{L}_1(\bar{k})}{\mathcal{L}_1(\bar{k})} + \frac{2}{3} \frac{\overline{\mathcal{L}_1} \overline{\mathcal{L}_1(k)}}{\overline{\mathcal{L}_1(k)}},$$

$$(8.4) \quad V_0 = -\frac{1}{3} \frac{\overline{\mathcal{L}_1} \overline{\mathcal{L}_1} \overline{\mathcal{L}_1(k)}}{\overline{\mathcal{L}_1(k)}} + \frac{5}{9} \frac{(\overline{\mathcal{L}_1} \overline{\mathcal{L}_1(k)})^2}{(\overline{\mathcal{L}_1(k)})^2} - \frac{1}{9} \frac{\overline{\mathcal{L}_1} \overline{\mathcal{L}_1(k)} \bar{P}}{\overline{\mathcal{L}_1(k)}} + \frac{1}{3} \overline{\mathcal{L}_1(P)} - \frac{1}{9} \bar{P} \bar{P},$$

and

$$(8.5) \quad \mathcal{Q}_0 = \frac{1}{2} \left\{ BI_0 + \overline{\mathcal{L}_1}(I_0) - \frac{\bar{B} \overline{\mathcal{K}}(I_0)}{\overline{\mathcal{L}_1(\bar{k})}} - \frac{\mathcal{K}(V_0)}{\overline{\mathcal{L}_1(k)}} \right\},$$

where

$$B = \frac{1}{3} \left(\frac{\overline{\mathcal{L}_1} \overline{\mathcal{L}_1(k)}}{\overline{\mathcal{L}_1(k)}} - \bar{P} \right) \quad \text{and} \quad \bar{B} = \frac{1}{3} \left(\frac{\mathcal{L}_1 \mathcal{L}_1(\bar{k})}{\mathcal{L}_1(\bar{k})} - P \right).$$

For convenience, we will do calculations with $3I_0$, $9V_0$, $18|\overline{\mathcal{L}_1(k)}|^2\mathbf{Q}_0$ and $3B, 3\overline{B}$.

$$(8.6) \quad 3I_0 = \frac{\mathcal{H} \overline{\mathcal{L}_1(k)} \overline{\mathcal{L}_1} \overline{\mathcal{L}_1(k)}}{(\overline{\mathcal{L}_1(k)})^3} - \frac{\mathcal{H} \overline{\mathcal{L}_1} \overline{\mathcal{L}_1(k)}}{(\overline{\mathcal{L}_1(k)})^2} + 2 \frac{\mathcal{L}_1 \overline{\mathcal{L}_1(k)}}{\mathcal{L}_1(\overline{k})} + 2 \frac{\mathcal{L}_1 \overline{\mathcal{L}_1(k)}}{\overline{\mathcal{L}_1(k)}},$$

$$(8.7) \quad 9V_0 = 5 \frac{(\overline{\mathcal{L}_1} \overline{\mathcal{L}_1(k)})^2}{(\overline{\mathcal{L}_1(k)})^2} - \frac{3\overline{\mathcal{L}_1} \overline{\mathcal{L}_1} \overline{\mathcal{L}_1(k)} + \overline{\mathcal{L}_1} \overline{\mathcal{L}_1(k)} \overline{P}}{\overline{\mathcal{L}_1(k)}} + 3\overline{\mathcal{L}_1}(\overline{P}) - \overline{P} \overline{P},$$

$$(8.8) \quad 18|\overline{\mathcal{L}_1(k)}|^2\mathbf{Q}_0 = [3B 3I_0 + 3\overline{\mathcal{L}_1}(3I_0)] \overline{\mathcal{L}_1}(\overline{k}) \overline{\mathcal{L}_1(k)} \\ - 3\overline{B} \mathcal{H}(3I_0) \overline{\mathcal{L}_1(k)} - \mathcal{H}(9V_0) \overline{\mathcal{L}_1}(\overline{k}),$$

with

$$3B = \frac{\overline{\mathcal{L}_1} \overline{\mathcal{L}_1(k)}}{\overline{\mathcal{L}_1(k)}} - \overline{P} \quad \text{and} \quad 3\overline{B} = \frac{\mathcal{L}_1 \overline{\mathcal{L}_1(k)}}{\mathcal{L}_1(\overline{k})} - P.$$

In order to transform the expression (8.8) of $18|\overline{\mathcal{L}_1(k)}|^2\mathbf{Q}_0$, we will make use of the following identities.

LEMMA 8.9. *We have the following identities:*

- (1) $\mathcal{H}(\overline{P}) = -P \overline{\mathcal{L}_1(k)} - \overline{\mathcal{L}_1} \mathcal{L}_1(k)$,
- (2) $\mathcal{H} \overline{\mathcal{L}_1}(\overline{P}) = -\overline{\mathcal{L}_1(k)} \cdot 2\text{Re}(\overline{\mathcal{L}_1(P)}) - P \overline{\mathcal{L}_1} \overline{\mathcal{L}_1(k)} - \overline{\mathcal{L}_1} \overline{\mathcal{L}_1} \mathcal{L}_1(k)$,
- (3) $\overline{\mathcal{H}}(I_0) = (-2) \overline{I_0} \cdot \mathcal{L}_1(\overline{k})$.

PROOF. The identities (1) and (3) are obtained in Lemma 2.7 and Lemma 10.6 of [51], respectively.

For the identity (2), we use the relation $[\mathcal{H}, \overline{\mathcal{L}_1}] = \mathcal{H} \overline{\mathcal{L}_1} - \overline{\mathcal{L}_1} \mathcal{H} = -\overline{\mathcal{L}_1(k)} \mathcal{L}_1$ from (2.9) of [51] to deduce that

$$\begin{aligned} \mathcal{H} \overline{\mathcal{L}_1}(\overline{P}) &= \overline{\mathcal{L}_1} \mathcal{H}(\overline{P}) - \overline{\mathcal{L}_1(k)} \mathcal{L}_1(\overline{P}) \\ &= \overline{\mathcal{L}_1} \left[-P \overline{\mathcal{L}_1(k)} - \overline{\mathcal{L}_1} \mathcal{L}_1(k) \right] - \overline{\mathcal{L}_1(k)} \mathcal{L}_1(\overline{P}) \quad (\text{using (1)}) \\ &= -\overline{\mathcal{L}_1(P)} \overline{\mathcal{L}_1(k)} - P \overline{\mathcal{L}_1} \overline{\mathcal{L}_1(k)} - \overline{\mathcal{L}_1} \overline{\mathcal{L}_1} \mathcal{L}_1(k) - \overline{\mathcal{L}_1(k)} \mathcal{L}_1(\overline{P}) \\ &= -\overline{\mathcal{L}_1(k)} \left[\overline{\mathcal{L}_1(P)} + \mathcal{L}_1(\overline{P}) \right] - P \overline{\mathcal{L}_1} \overline{\mathcal{L}_1(k)} - \overline{\mathcal{L}_1} \overline{\mathcal{L}_1} \mathcal{L}_1(k) \\ &= -\overline{\mathcal{L}_1(k)} \cdot 2\text{Re}(\overline{\mathcal{L}_1(P)}) - P \overline{\mathcal{L}_1} \overline{\mathcal{L}_1(k)} - \overline{\mathcal{L}_1} \overline{\mathcal{L}_1} \mathcal{L}_1(k). \end{aligned}$$

□

PROOF OF PROPOSITION 8.1. We first substitute the identity (3) of Lemma (8.9) into the term $-3\overline{B} \mathcal{H}(3I_0) \overline{\mathcal{L}_1(k)}$ of $18|\overline{\mathcal{L}_1(k)}|^2\mathbf{Q}_0$ to obtain

$$-3\overline{B} \mathcal{H}(3I_0) \overline{\mathcal{L}_1(k)} = -3\overline{B}(-6\overline{I_0} \mathcal{L}_1(\overline{k})) \overline{\mathcal{L}_1(k)} = 2 \cdot 3\overline{B} \cdot 3\overline{I_0} \overline{\mathcal{L}_1(k)} \mathcal{L}_1(\overline{k}),$$

with which the sum on the right hand side of (8.8) can be rewritten as

$$(8.10) \quad 18|\overline{\mathcal{L}_1(k)}|^2\mathbf{Q}_0 = [3B \cdot 3I_0 + 3\overline{B} \cdot 3\overline{I_0}] \overline{\mathcal{L}_1}(\overline{k}) \overline{\mathcal{L}_1(k)} + 3\overline{\mathcal{L}_1}(3I_0) \overline{\mathcal{L}_1}(\overline{k}) \overline{\mathcal{L}_1(k)} \\ + 3\overline{B} \cdot 3\overline{I_0} \mathcal{L}_1(\overline{k}) \overline{\mathcal{L}_1(k)} - \mathcal{H}(9V_0) \overline{\mathcal{L}_1}(\overline{k}).$$

Observe that on the right hand side of (8.10), the first term is already real-valued, which hints that we should keep it untouched until the very end of the proof. We proceed by transforming the other terms so that the real-valuedness of the sum in (8.10) will be transparent.

Our strategy is to look for terms that involve in P and \bar{P} first. From the expression (8.6) of $3\bar{I}_0$, one sees that the second term of the right hand side of (8.10) doesnot contain P and \bar{P} . Thus, we only need to extract parts involved in P and \bar{P} from the last two terms of the right hand side of (8.10).

Note that in the expression $3\bar{B} \cdot 3\bar{I}_0 = \left(\frac{\mathcal{L}_1 \mathcal{L}_1(\bar{k})}{\mathcal{L}_1(\bar{k})} - P \right) \cdot 3\bar{I}_0 = \frac{\mathcal{L}_1 \mathcal{L}_1(\bar{k})}{\mathcal{L}_1(\bar{k})} 3\bar{I}_0 - P \cdot 3\bar{I}_0$, the only part involved in P and \bar{P} is $-P \cdot 3\bar{I}_0$. We will see that by extracting terms involved in P and \bar{P} in $-\mathcal{H}(9V_0)\mathcal{L}_1(\bar{k})$, which is

$$(8.11) \quad -\mathcal{H} \left\{ -\frac{\overline{\mathcal{L}_1} \overline{\mathcal{L}_1(k)} \bar{P}}{\overline{\mathcal{L}_1(k)}} + 3\overline{\mathcal{L}_1(P)} - \bar{P}\bar{P} \right\} \mathcal{L}_1(\bar{k}),$$

we will obtain a conjugate of $-P \cdot 3\bar{I}_0 \cdot \mathcal{L}_1(\bar{k}) \overline{\mathcal{L}_1(k)}$. Indeed, let us expand

$$\begin{aligned} & -\mathcal{H} \left\{ -\frac{\overline{\mathcal{L}_1} \overline{\mathcal{L}_1(k)} \bar{P}}{\overline{\mathcal{L}_1(k)}} + 3\overline{\mathcal{L}_1(P)} - \bar{P}\bar{P} \right\} \mathcal{L}_1(\bar{k}) \\ &= \left\{ \mathcal{H} \left[\frac{\overline{\mathcal{L}_1} \overline{\mathcal{L}_1(k)} \bar{P}}{\overline{\mathcal{L}_1(k)}} \right] - 3 \mathcal{H} \overline{\mathcal{L}_1(P)} + 2\bar{P} \mathcal{H}(\bar{P}) \right\} \mathcal{L}_1(\bar{k}) \\ &= \left\{ \mathcal{H} \left[\frac{\overline{\mathcal{L}_1} \overline{\mathcal{L}_1(k)}}{\overline{\mathcal{L}_1(k)}} \right] \bar{P} + \frac{\overline{\mathcal{L}_1} \overline{\mathcal{L}_1(k)}}{\overline{\mathcal{L}_1(k)}} \mathcal{H}(\bar{P}) - 3 \mathcal{H} \overline{\mathcal{L}_1(P)} + 2\bar{P} \mathcal{H}(\bar{P}) \right\} \mathcal{L}_1(\bar{k}) \\ &= \left\{ \left[\frac{\mathcal{H} \overline{\mathcal{L}_1} \overline{\mathcal{L}_1(k)}}{\overline{\mathcal{L}_1(k)}} - \frac{\overline{\mathcal{L}_1} \overline{\mathcal{L}_1(k)} \mathcal{H} \overline{\mathcal{L}_1(k)}}{(\overline{\mathcal{L}_1(k)})^2} \right] \bar{P} + \frac{\overline{\mathcal{L}_1} \overline{\mathcal{L}_1(k)}}{\overline{\mathcal{L}_1(k)}} \left[-P \overline{\mathcal{L}_1(k)} - \overline{\mathcal{L}_1} \mathcal{L}_1(k) \right] \right. \\ &\quad \left. - 3 \left[-\overline{\mathcal{L}_1(k)} \cdot 2\text{Re}(\overline{\mathcal{L}_1(P)}) - P \overline{\mathcal{L}_1} \overline{\mathcal{L}_1(k)} - \overline{\mathcal{L}_1} \overline{\mathcal{L}_1} \mathcal{L}_1(k) \right] \right. \\ &\quad \left. + 2\bar{P} \left[-P \overline{\mathcal{L}_1(k)} - \overline{\mathcal{L}_1} \mathcal{L}_1(k) \right] \right\} \mathcal{L}_1(\bar{k}) \quad (\text{using (1) and (2) of Lemma 8.9}) \\ &= \left\{ \bar{P} \left[-\frac{\mathcal{H} \overline{\mathcal{L}_1(k)} \overline{\mathcal{L}_1} \overline{\mathcal{L}_1(k)}}{(\overline{\mathcal{L}_1(k)})^2} + \frac{\mathcal{H} \overline{\mathcal{L}_1} \overline{\mathcal{L}_1(k)}}{\overline{\mathcal{L}_1(k)}} \right] - P \overline{\mathcal{L}_1} \overline{\mathcal{L}_1(k)} \right. \\ &\quad \left. - \frac{\overline{\mathcal{L}_1} \overline{\mathcal{L}_1(k)} \overline{\mathcal{L}_1} \overline{\mathcal{L}_1(k)}}{\overline{\mathcal{L}_1(k)}} + 6 \overline{\mathcal{L}_1(k)} \cdot \text{Re}(\overline{\mathcal{L}_1(P)}) + 3P \overline{\mathcal{L}_1} \overline{\mathcal{L}_1(k)} \right. \\ &\quad \left. + 3 \overline{\mathcal{L}_1} \overline{\mathcal{L}_1} \mathcal{L}_1(k) - 2\bar{P} P \overline{\mathcal{L}_1(k)} - 2\bar{P} \overline{\mathcal{L}_1} \mathcal{L}_1(k) \right\} \mathcal{L}_1(\bar{k}). \end{aligned}$$

At this point, we extract $-\bar{P} \overline{\mathcal{L}_1(k)} \mathcal{L}_1(\bar{k}) \cdot 3\bar{I}_0$ to obtain

$$\begin{aligned} & -\mathcal{H} \left\{ -\frac{\overline{\mathcal{L}_1} \overline{\mathcal{L}_1(k)} \bar{P}}{\overline{\mathcal{L}_1(k)}} + 3\overline{\mathcal{L}_1(P)} - \bar{P}\bar{P} \right\} \mathcal{L}_1(\bar{k}) \\ &= -\bar{P} \overline{\mathcal{L}_1(k)} \mathcal{L}_1(\bar{k}) \left\{ \frac{\mathcal{H} \overline{\mathcal{L}_1(k)} \overline{\mathcal{L}_1} \overline{\mathcal{L}_1(k)}}{(\overline{\mathcal{L}_1(k)})^3} - \frac{\mathcal{H} \overline{\mathcal{L}_1} \overline{\mathcal{L}_1(k)}}{(\overline{\mathcal{L}_1(k)})^2} + 2 \frac{\overline{\mathcal{L}_1} \overline{\mathcal{L}_1(k)}}{\overline{\mathcal{L}_1(k)}} + 2 \frac{\overline{\mathcal{L}_1} \overline{\mathcal{L}_1(k)}}{\overline{\mathcal{L}_1(k)}} \right\} \\ &\quad + 2\bar{P} \overline{\mathcal{L}_1} \overline{\mathcal{L}_1(k)} \mathcal{L}_1(\bar{k}) + 2\bar{P} \overline{\mathcal{L}_1} \mathcal{L}_1(\bar{k}) \overline{\mathcal{L}_1(k)} - P \overline{\mathcal{L}_1} \overline{\mathcal{L}_1(k)} \mathcal{L}_1(\bar{k}) \\ &\quad + \frac{\overline{\mathcal{L}_1} \overline{\mathcal{L}_1(k)} \overline{\mathcal{L}_1} \overline{\mathcal{L}_1(k)} \mathcal{L}_1(\bar{k})}{\overline{\mathcal{L}_1(k)}} + 6 \overline{\mathcal{L}_1(k)} \mathcal{L}_1(\bar{k}) \cdot \text{Re}(\overline{\mathcal{L}_1(P)}) + 3P \overline{\mathcal{L}_1} \overline{\mathcal{L}_1(k)} \mathcal{L}_1(\bar{k}) \\ &\quad + 3 \overline{\mathcal{L}_1} \overline{\mathcal{L}_1} \mathcal{L}_1(k) \mathcal{L}_1(\bar{k}) - 2\bar{P} P \overline{\mathcal{L}_1(k)} \mathcal{L}_1(\bar{k}) - 2\bar{P} \overline{\mathcal{L}_1} \mathcal{L}_1(k) \mathcal{L}_1(\bar{k}) \end{aligned}$$

$$\begin{aligned}
&= -\bar{P} \overline{\mathcal{L}_1(k)} \mathcal{L}_1(\bar{k}) \cdot 3I_0 - \frac{\overline{\mathcal{L}_1(k)} \overline{\mathcal{L}_1(k)} \overline{\mathcal{L}_1(k)} \mathcal{L}_1(\bar{k})}{\mathcal{L}_1(k)} + 3\overline{\mathcal{L}_1} \overline{\mathcal{L}_1} \mathcal{L}_1(k) \mathcal{L}_1(\bar{k}) \\
&\quad + 2\operatorname{Re}\left(\frac{\overline{\mathcal{L}_1(k)} \overline{\mathcal{L}_1(k)} P}{\mathcal{L}_1(k)}\right) \overline{\mathcal{L}_1(k)} \mathcal{L}_1(\bar{k}) + 6\overline{\mathcal{L}_1(k)} \mathcal{L}_1(\bar{k}) \operatorname{Re}\left(\overline{\mathcal{L}_1(P)}\right) - 2\bar{P} P \overline{\mathcal{L}_1(k)} \mathcal{L}_1(\bar{k}) \\
&= -\bar{P} \overline{\mathcal{L}_1(k)} \mathcal{L}_1(\bar{k}) \cdot 3I_0 - \frac{\overline{\mathcal{L}_1(k)} \overline{\mathcal{L}_1(k)} \overline{\mathcal{L}_1(k)} \mathcal{L}_1(\bar{k})}{\mathcal{L}_1(k)} + 3\overline{\mathcal{L}_1} \overline{\mathcal{L}_1} \mathcal{L}_1(k) \mathcal{L}_1(\bar{k}) \\
&\quad + 2\operatorname{Re}\left(\frac{\overline{\mathcal{L}_1(k)} \overline{\mathcal{L}_1(k)} P}{\mathcal{L}_1(k)}\right) |\overline{\mathcal{L}_1(k)}|^2 + 6|\overline{\mathcal{L}_1(k)}|^2 \operatorname{Re}\left(\overline{\mathcal{L}_1(P)}\right) - 2|P|^2 |\overline{\mathcal{L}_1(k)}|^2,
\end{aligned}$$

whose last 3 terms are real-valued.

Now, we substitute the just obtained expansion

$$\begin{aligned}
&(-1)\mathcal{K} \left\{ (-1) \frac{\overline{\mathcal{L}_1(k)} \overline{\mathcal{L}_1(k)} \bar{P}}{\mathcal{L}_1(k)} + 3\overline{\mathcal{L}_1}(\bar{P}) - \bar{P}\bar{P} \right\} \cdot \mathcal{L}_1(\bar{k}) \\
&= (-1) \bar{P} \overline{\mathcal{L}_1(k)} \mathcal{L}_1(\bar{k}) \cdot 3I_0 + (-1) \frac{\overline{\mathcal{L}_1(k)} \overline{\mathcal{L}_1(k)} \overline{\mathcal{L}_1(k)} \mathcal{L}_1(\bar{k})}{\mathcal{L}_1(k)} + 3\overline{\mathcal{L}_1} \overline{\mathcal{L}_1} \mathcal{L}_1(k) \mathcal{L}_1(\bar{k}) \\
&\quad + 2\operatorname{Re}\left(\frac{\overline{\mathcal{L}_1(k)} \overline{\mathcal{L}_1(k)} P}{\mathcal{L}_1(k)}\right) \cdot |\overline{\mathcal{L}_1(k)}|^2 + 6|\overline{\mathcal{L}_1(k)}|^2 \cdot \operatorname{Re}(\overline{\mathcal{L}_1(P)}) + (-2) |P|^2 \cdot |\overline{\mathcal{L}_1(k)}|^2
\end{aligned}$$

back into the expression (8.10) of $18|\overline{\mathcal{L}_1(k)}|^2 \mathbf{Q}_0$ to obtain

$$\begin{aligned}
18|\overline{\mathcal{L}_1(k)}|^2 \mathbf{Q}_0 &= [3B 3I_0 + 3\bar{B} 3\bar{I}_0] \mathcal{L}_1(\bar{k}) \overline{\mathcal{L}_1(k)} + 3\overline{\mathcal{L}_1}(3I_0) \mathcal{L}_1(\bar{k}) \overline{\mathcal{L}_1(k)} \\
&\quad - P 3\bar{I}_0 \mathcal{L}_1(\bar{k}) \overline{\mathcal{L}_1(k)} + \frac{\mathcal{L}_1 \mathcal{L}_1(\bar{k})}{\mathcal{L}_1(\bar{k})} 3\bar{I}_0 \mathcal{L}_1(\bar{k}) \overline{\mathcal{L}_1(k)} \\
&\quad - \mathcal{K} \left\{ 5 \frac{(\overline{\mathcal{L}_1(k)} \overline{\mathcal{L}_1(k)})^2}{(\mathcal{L}_1(k))^2} - 3 \frac{\overline{\mathcal{L}_1} \overline{\mathcal{L}_1} \overline{\mathcal{L}_1(k)}}{\mathcal{L}_1(k)} \right\} \mathcal{L}_1(\bar{k}) \\
&\quad - \mathcal{K} \left\{ - \frac{\overline{\mathcal{L}_1(k)} \overline{\mathcal{L}_1(k)} \bar{P}}{\mathcal{L}_1(k)} + 3\overline{\mathcal{L}_1}(\bar{P}) - \bar{P}\bar{P} \right\} \mathcal{L}_1(\bar{k}) \\
&= [3B 3I_0 + 3\bar{B} 3\bar{I}_0] \mathcal{L}_1(\bar{k}) \overline{\mathcal{L}_1(k)} + 3\overline{\mathcal{L}_1}(3I_0) \mathcal{L}_1(\bar{k}) \overline{\mathcal{L}_1(k)} \\
&\quad - P 3\bar{I}_0 \mathcal{L}_1(\bar{k}) \overline{\mathcal{L}_1(k)} + \frac{\mathcal{L}_1 \mathcal{L}_1(\bar{k})}{\mathcal{L}_1(\bar{k})} 3\bar{I}_0 \mathcal{L}_1(\bar{k}) \overline{\mathcal{L}_1(k)} \\
&\quad - \mathcal{K} \left\{ 5 \frac{(\overline{\mathcal{L}_1(k)} \overline{\mathcal{L}_1(k)})^2}{(\mathcal{L}_1(k))^2} - 3 \frac{\overline{\mathcal{L}_1} \overline{\mathcal{L}_1} \overline{\mathcal{L}_1(k)}}{\mathcal{L}_1(k)} \right\} \mathcal{L}_1(\bar{k}) \\
&\quad - \bar{P} \overline{\mathcal{L}_1(k)} \mathcal{L}_1(\bar{k}) 3I_0 - \frac{\overline{\mathcal{L}_1(k)} \overline{\mathcal{L}_1(k)} \overline{\mathcal{L}_1(k)} \mathcal{L}_1(\bar{k})}{\mathcal{L}_1(k)} \\
&\quad + 3\overline{\mathcal{L}_1} \overline{\mathcal{L}_1} \mathcal{L}_1(k) \mathcal{L}_1(\bar{k}) - 2\operatorname{Re}\left(\frac{\overline{\mathcal{L}_1(k)} \overline{\mathcal{L}_1(k)} P}{\mathcal{L}_1(k)}\right) |\overline{\mathcal{L}_1(k)}|^2 \\
&\quad + 6|\overline{\mathcal{L}_1(k)}|^2 \operatorname{Re}\left(\overline{\mathcal{L}_1(P)}\right) - 2|P|^2 |\overline{\mathcal{L}_1(k)}|^2,
\end{aligned}$$

which after rearranging gives

$$\begin{aligned}
(8.12) \quad 18|\overline{\mathcal{L}_1(k)}|^2 \mathbf{Q}_0 &= [3\mathbf{B} 3\mathbf{I}_0 + 3\overline{\mathbf{B}} 3\overline{\mathbf{I}}_0] \mathcal{L}_1(\overline{k}) \overline{\mathcal{L}_1(k)} \\
&\quad - [3\overline{\mathbf{I}}_0 \mathbf{P} + 3\mathbf{I}_0 \overline{\mathbf{P}}] \mathcal{L}_1(\overline{k}) \overline{\mathcal{L}_1(k)} \\
&\quad + 3\overline{\mathcal{L}_1}(3\mathbf{I}_0) \mathcal{L}_1(\overline{k}) \overline{\mathcal{L}_1(k)} + \frac{\mathcal{L}_1 \mathcal{L}_1(\overline{k})}{\mathcal{L}_1(\overline{k})} 3\overline{\mathbf{I}}_0 \mathcal{L}_1(\overline{k}) \overline{\mathcal{L}_1(k)} \\
&\quad - \mathcal{H} \left\{ 5 \frac{(\overline{\mathcal{L}_1} \overline{\mathcal{L}_1(k)})^2}{(\mathcal{L}_1(k))^2} - 3 \frac{\overline{\mathcal{L}_1} \overline{\mathcal{L}_1} \overline{\mathcal{L}_1(k)}}{\mathcal{L}_1(k)} \right\} \mathcal{L}_1(\overline{k}) \\
&\quad - \frac{\overline{\mathcal{L}_1} \overline{\mathcal{L}_1(k)} \overline{\mathcal{L}_1} \mathcal{L}_1(k) \mathcal{L}_1(\overline{k})}{\mathcal{L}_1(k)} + 3 \overline{\mathcal{L}_1} \overline{\mathcal{L}_1} \mathcal{L}_1(k) \mathcal{L}_1(\overline{k}) \\
&\quad - 2 \operatorname{Re} \left(\frac{\overline{\mathcal{L}_1} \overline{\mathcal{L}_1(k)}}{\mathcal{L}_1(k)} \mathbf{P} \right) |\overline{\mathcal{L}_1(k)}|^2 + 6 |\overline{\mathcal{L}_1(k)}|^2 \operatorname{Re} \left(\overline{\mathcal{L}_1}(\mathbf{P}) \right) \\
&\quad - 2 |\mathbf{P}|^2 |\overline{\mathcal{L}_1(k)}|^2.
\end{aligned}$$

Next, we want to extract a conjugate of $\frac{\mathcal{L}_1 \mathcal{L}_1(\overline{k})}{\mathcal{L}_1(\overline{k})} 3\overline{\mathbf{I}}_0 \mathcal{L}_1(\overline{k}) \overline{\mathcal{L}_1(k)}$ and a copy of $-3\overline{\mathcal{L}_1}(3\mathbf{I}_0) \overline{\mathcal{L}_1(k)} \mathcal{L}_1(\overline{k})$ from $-\mathcal{H} \left\{ 5 \frac{(\overline{\mathcal{L}_1} \overline{\mathcal{L}_1(k)})^2}{(\mathcal{L}_1(k))^2} - 3 \frac{\overline{\mathcal{L}_1} \overline{\mathcal{L}_1} \overline{\mathcal{L}_1(k)}}{\mathcal{L}_1(k)} \right\} \mathcal{L}_1(\overline{k})$.

We first expand

$$\begin{aligned}
(8.13) \quad &\frac{\mathcal{L}_1 \mathcal{L}_1(\overline{k})}{\mathcal{L}_1(\overline{k})} 3\overline{\mathbf{I}}_0 \mathcal{L}_1(\overline{k}) \overline{\mathcal{L}_1(k)} = 3\overline{\mathbf{I}}_0 \mathcal{L}_1 \mathcal{L}_1(\overline{k}) \overline{\mathcal{L}_1(k)} \\
&= \frac{\mathcal{H} \mathcal{L}_1(\overline{k}) (\mathcal{L}_1 \mathcal{L}_1(\overline{k}))^2 \overline{\mathcal{L}_1(k)}}{(\mathcal{L}_1(\overline{k}))^3} - \frac{\mathcal{H} \mathcal{L}_1 \mathcal{L}_1(\overline{k}) \mathcal{L}_1 \mathcal{L}_1(\overline{k}) \overline{\mathcal{L}_1(k)}}{(\mathcal{L}_1(\overline{k}))^2} \\
&\quad + 2 \frac{\overline{\mathcal{L}_1} \mathcal{L}_1(\overline{k}) \mathcal{L}_1 \mathcal{L}_1(\overline{k}) \overline{\mathcal{L}_1(k)}}{\mathcal{L}_1(\overline{k})} + 2 \overline{\mathcal{L}_1} \overline{\mathcal{L}_1(k)} \mathcal{L}_1 \mathcal{L}_1(\overline{k}),
\end{aligned}$$

and

$$\begin{aligned}
(8.14) \quad &-3 \overline{\mathcal{L}_1}(3\mathbf{I}_0) \overline{\mathcal{L}_1(k)} \mathcal{L}_1(\overline{k}) \\
&= 9 \frac{\mathcal{H} \overline{\mathcal{L}_1(k)} (\overline{\mathcal{L}_1} \overline{\mathcal{L}_1(k)})^2 \mathcal{L}_1(\overline{k})}{(\overline{\mathcal{L}_1(k)})^3} - 9 \frac{\mathcal{H} \overline{\mathcal{L}_1} \overline{\mathcal{L}_1(k)} \overline{\mathcal{L}_1} \overline{\mathcal{L}_1(k)} \mathcal{L}_1(\overline{k})}{(\overline{\mathcal{L}_1(k)})^2} \\
&\quad - 3 \frac{\mathcal{H} \overline{\mathcal{L}_1(k)} \overline{\mathcal{L}_1} \overline{\mathcal{L}_1} \overline{\mathcal{L}_1(k)} \mathcal{L}_1(\overline{k})}{(\overline{\mathcal{L}_1(k)})^2} + 3 \frac{\mathcal{H} \overline{\mathcal{L}_1} \overline{\mathcal{L}_1} \overline{\mathcal{L}_1(k)} \mathcal{L}_1(\overline{k})}{\overline{\mathcal{L}_1(k)}} \\
&\quad - 3 \frac{\mathcal{L}_1 \overline{\mathcal{L}_1(k)} \overline{\mathcal{L}_1} \overline{\mathcal{L}_1(k)} \mathcal{L}_1(\overline{k})}{\overline{\mathcal{L}_1(k)}} + 3 \mathcal{L}_1 \overline{\mathcal{L}_1} \overline{\mathcal{L}_1(k)} \mathcal{L}_1(\overline{k}) \\
&\quad + 12 |\overline{\mathcal{L}_1(k)}|^2 \operatorname{Re} \left(\frac{\mathcal{L}_1 \overline{\mathcal{L}_1(k)} \overline{\mathcal{L}_1} \overline{\mathcal{L}_1(k)}}{(\overline{\mathcal{L}_1(k)})^2} \right) - 12 |\overline{\mathcal{L}_1(k)}|^2 \operatorname{Re} \left(\frac{\mathcal{L}_1 \overline{\mathcal{L}_1} \overline{\mathcal{L}_1(k)}}{\overline{\mathcal{L}_1(k)}} \right).
\end{aligned}$$

We now use the expansions (8.13) and (8.14) to expand $-\mathcal{H} \left\{ 5 \frac{(\overline{\mathcal{L}}_1 \overline{\mathcal{L}}_1(k))^2}{(\overline{\mathcal{L}}_1(k))^2} - 3 \frac{\overline{\mathcal{L}}_1 \overline{\mathcal{L}}_1 \overline{\mathcal{L}}_1(k)}{\overline{\mathcal{L}}_1(k)} \right\} \mathcal{L}_1(\bar{k})$ as follows.

$$\begin{aligned}
(8.15) \quad & -\mathcal{H} \left\{ 5 \frac{(\overline{\mathcal{L}}_1 \overline{\mathcal{L}}_1(k))^2}{(\overline{\mathcal{L}}_1(k))^2} - 3 \frac{\overline{\mathcal{L}}_1 \overline{\mathcal{L}}_1 \overline{\mathcal{L}}_1(k)}{\overline{\mathcal{L}}_1(k)} \right\} \mathcal{L}_1(\bar{k}) \\
&= \left\{ \left[-10 \frac{\overline{\mathcal{L}}_1 \overline{\mathcal{L}}_1(k) \mathcal{H} \overline{\mathcal{L}}_1 \overline{\mathcal{L}}_1(k)}{(\overline{\mathcal{L}}_1(k))^2} + 10 \frac{(\overline{\mathcal{L}}_1 \overline{\mathcal{L}}_1(k))^2 \mathcal{H} \overline{\mathcal{L}}_1(k)}{(\overline{\mathcal{L}}_1(k))^3} \right] \right. \\
&\quad \left. + \left[3 \frac{\mathcal{H} \overline{\mathcal{L}}_1 \overline{\mathcal{L}}_1 \overline{\mathcal{L}}_1(k)}{\overline{\mathcal{L}}_1(k)} - 3 \frac{\overline{\mathcal{L}}_1 \overline{\mathcal{L}}_1 \overline{\mathcal{L}}_1(k) \mathcal{H} \overline{\mathcal{L}}_1(k)}{(\overline{\mathcal{L}}_1(k))^2} \right] \right\} \mathcal{L}_1(\bar{k}) \\
&= 10 \frac{\mathcal{H} \overline{\mathcal{L}}_1(k) (\overline{\mathcal{L}}_1 \overline{\mathcal{L}}_1(k))^2 \mathcal{L}_1(\bar{k})}{(\overline{\mathcal{L}}_1(k))^3} - 10 \frac{\overline{\mathcal{L}}_1 \overline{\mathcal{L}}_1(k) \mathcal{H} \overline{\mathcal{L}}_1 \overline{\mathcal{L}}_1(k) \mathcal{L}_1(\bar{k})}{(\overline{\mathcal{L}}_1(k))^2} \\
&\quad - 3 \frac{\overline{\mathcal{L}}_1 \overline{\mathcal{L}}_1 \overline{\mathcal{L}}_1(k) \mathcal{H} \overline{\mathcal{L}}_1(k) \mathcal{L}_1(\bar{k})}{(\overline{\mathcal{L}}_1(k))^2} + 3 \frac{\mathcal{H} \overline{\mathcal{L}}_1 \overline{\mathcal{L}}_1 \overline{\mathcal{L}}_1(k)}{\overline{\mathcal{L}}_1(k)} \\
&= \overline{3I_0} \overline{\mathcal{L}}_1 \overline{\mathcal{L}}_1(\bar{k}) \overline{\mathcal{L}}_1(k) + 9 \frac{\mathcal{H} \overline{\mathcal{L}}_1(k) (\overline{\mathcal{L}}_1 \overline{\mathcal{L}}_1(k))^2 \mathcal{L}_1(\bar{k})}{(\overline{\mathcal{L}}_1(k))^3} - 9 \frac{\mathcal{H} \overline{\mathcal{L}}_1 \overline{\mathcal{L}}_1(k) \overline{\mathcal{L}}_1 \overline{\mathcal{L}}_1(k) \mathcal{L}_1(\bar{k})}{(\overline{\mathcal{L}}_1(k))^2} \\
&\quad - 3 \frac{\mathcal{H} \overline{\mathcal{L}}_1(k) \overline{\mathcal{L}}_1 \overline{\mathcal{L}}_1 \overline{\mathcal{L}}_1(k) \mathcal{L}_1(\bar{k})}{(\overline{\mathcal{L}}_1(k))^2} + 3 \frac{\mathcal{H} \overline{\mathcal{L}}_1 \overline{\mathcal{L}}_1 \overline{\mathcal{L}}_1(k) \mathcal{L}_1(\bar{k}) - 2 \overline{\mathcal{L}}_1 \overline{\mathcal{L}}_1(k) \overline{\mathcal{L}}_1 \overline{\mathcal{L}}_1(k) \mathcal{L}_1(\bar{k})}{\overline{\mathcal{L}}_1(k)} \\
&\quad - 2 \overline{\mathcal{L}}_1 \overline{\mathcal{L}}_1(k) \overline{\mathcal{L}}_1 \overline{\mathcal{L}}_1(\bar{k}) \\
&= \overline{3I_0} \overline{\mathcal{L}}_1 \overline{\mathcal{L}}_1(\bar{k}) \overline{\mathcal{L}}_1(k) - 3 \overline{\mathcal{L}}_1(3I_0) \overline{\mathcal{L}}_1(k) \mathcal{L}_1(\bar{k}) + \frac{\overline{\mathcal{L}}_1 \overline{\mathcal{L}}_1(k) \overline{\mathcal{L}}_1 \overline{\mathcal{L}}_1(k) \mathcal{L}_1(\bar{k})}{\overline{\mathcal{L}}_1(k)} \\
&\quad - 3 \overline{\mathcal{L}}_1 \overline{\mathcal{L}}_1 \overline{\mathcal{L}}_1(k) \mathcal{L}_1(\bar{k}) - 12 |\overline{\mathcal{L}}_1(k)|^2 \operatorname{Re} \left(\frac{\overline{\mathcal{L}}_1 \overline{\mathcal{L}}_1(k) \overline{\mathcal{L}}_1 \overline{\mathcal{L}}_1(k)}{(\overline{\mathcal{L}}_1(k))^2} \right) \\
&\quad + 12 |\overline{\mathcal{L}}_1(k)|^2 \operatorname{Re} \left(\frac{\overline{\mathcal{L}}_1 \overline{\mathcal{L}}_1 \overline{\mathcal{L}}_1(k)}{\overline{\mathcal{L}}_1(k)} \right) - 2 |\overline{\mathcal{L}}_1 \overline{\mathcal{L}}_1(k)|^2.
\end{aligned}$$

Substituting the expansion (8.15) into the right hand side of (8.12) leads to

$$\begin{aligned}
(8.16) \quad & 18 |\overline{\mathcal{L}}_1(k)|^2 \mathbf{Q}_0 = \left[3B \ 3I_0 + 3\overline{B} \ 3\overline{I_0} \right] \overline{\mathcal{L}}_1(k) \mathcal{L}_1(\bar{k}) \\
&\quad - \left[3\overline{I_0} \ P + 3I_0 \ \overline{P} \right] \overline{\mathcal{L}}_1(k) \mathcal{L}_1(\bar{k}) \\
&\quad + 3\overline{I_0} \overline{\mathcal{L}}_1 \overline{\mathcal{L}}_1(\bar{k}) \overline{\mathcal{L}}_1(k) + 3\overline{I_0} \overline{\mathcal{L}}_1 \overline{\mathcal{L}}_1(\bar{k}) \overline{\mathcal{L}}_1(k) \\
&\quad - 12 |\overline{\mathcal{L}}_1(k)|^2 \operatorname{Re} \left(\frac{\overline{\mathcal{L}}_1 \overline{\mathcal{L}}_1(k) \overline{\mathcal{L}}_1 \overline{\mathcal{L}}_1(k)}{(\overline{\mathcal{L}}_1(k))^2} \right) \\
&\quad + 12 |\overline{\mathcal{L}}_1(k)|^2 \operatorname{Re} \left(\frac{\overline{\mathcal{L}}_1 \overline{\mathcal{L}}_1 \overline{\mathcal{L}}_1(k)}{\overline{\mathcal{L}}_1(k)} \right) \\
&\quad + 2 |\overline{\mathcal{L}}_1(k)|^2 \operatorname{Re} \left(- \frac{P \ \overline{\mathcal{L}}_1 \overline{\mathcal{L}}_1(k)}{\overline{\mathcal{L}}_1(k)} + 3\overline{\mathcal{L}}_1(P) \right) \\
&\quad - 2 |\overline{\mathcal{L}}_1(k)|^2 |P|^2 - 2 |\overline{\mathcal{L}}_1 \overline{\mathcal{L}}_1(k)|^2.
\end{aligned}$$

At this point, we can see from the right hand side of (8.16) that \mathbf{Q}_0 is real valued and of order 5, but observe that we can contract more terms into $|\overline{\mathcal{L}}_1(k)|^2 3\overline{B} \ 3B$.

Let us expand

$$(8.17) \quad |\overline{\mathcal{L}}_1(k)|^2 3\overline{\mathbf{B}} 3\mathbf{B} = |\overline{\mathcal{L}}_1(k)|^2 |\mathbf{P}|^2 - 2 |\overline{\mathcal{L}}_1(k)|^2 \operatorname{Re}\left(\frac{\overline{\mathbf{P}} \overline{\mathcal{L}}_1 \mathcal{L}_1(k)}{\overline{\mathcal{L}}_1(k)}\right) + |\overline{\mathcal{L}}_1 \mathcal{L}_1(k)|^2.$$

By using the identity (8.17), we now substitute $-2 |\overline{\mathcal{L}}_1(k)|^2 3\overline{\mathbf{B}} 3\mathbf{B}$ into the expansion (8.16) of $18 |\overline{\mathcal{L}}_1(k)|^2 \mathbf{Q}_0$ in order to obtain

$$(8.18) \quad \begin{aligned} & 18 |\overline{\mathcal{L}}_1(k)|^2 \mathbf{Q}_0 = \\ & = \left[3\mathbf{B} 3\mathbf{I}_0 + 3\overline{\mathbf{B}} 3\overline{\mathbf{I}}_0 \right] \overline{\mathcal{L}}_1(k) \mathcal{L}_1(\overline{k}) - \left[3\overline{\mathbf{I}}_0 \mathbf{P} + 3\mathbf{I}_0 \overline{\mathbf{P}} \right] \overline{\mathcal{L}}_1(k) \mathcal{L}_1(\overline{k}) \\ & \quad + 3\overline{\mathbf{I}}_0 \mathcal{L}_1 \mathcal{L}_1(\overline{k}) \overline{\mathcal{L}}_1(k) + \overline{3\overline{\mathbf{I}}_0 \mathcal{L}_1 \mathcal{L}_1(\overline{k}) \overline{\mathcal{L}}_1(k)} - 2 |\overline{\mathcal{L}}_1(k)|^2 3\overline{\mathbf{B}} 3\mathbf{B} \\ & \quad - 12 |\overline{\mathcal{L}}_1(k)|^2 \operatorname{Re}\left(\frac{\mathcal{L}_1 \overline{\mathcal{L}}_1(k) \overline{\mathcal{L}}_1 \mathcal{L}_1(k)}{(\overline{\mathcal{L}}_1(k))^2}\right) + 12 |\overline{\mathcal{L}}_1(k)|^2 \operatorname{Re}\left(\frac{\mathcal{L}_1 \overline{\mathcal{L}}_1 \overline{\mathcal{L}}_1(k)}{\overline{\mathcal{L}}_1(k)}\right) \\ & \quad + 6 |\overline{\mathcal{L}}_1(k)|^2 \operatorname{Re}\left(-\frac{\mathbf{P} \overline{\mathcal{L}}_1 \mathcal{L}_1(k)}{\overline{\mathcal{L}}_1(k)} + \overline{\mathcal{L}}_1(\mathbf{P})\right) \\ & = \left[3\mathbf{B} 3\mathbf{I}_0 + 3\overline{\mathbf{B}} 3\overline{\mathbf{I}}_0 \right] \overline{\mathcal{L}}_1(k) \mathcal{L}_1(\overline{k}) + \left[3\overline{\mathbf{I}}_0 \mathbf{P} + 3\mathbf{I}_0 \overline{\mathbf{P}} \right] \overline{\mathcal{L}}_1(k) \mathcal{L}_1(\overline{k}) \\ & \quad + 3\overline{\mathbf{I}}_0 \mathcal{L}_1 \mathcal{L}_1(\overline{k}) \overline{\mathcal{L}}_1(k) + \overline{3\overline{\mathbf{I}}_0 \mathcal{L}_1 \mathcal{L}_1(\overline{k}) \overline{\mathcal{L}}_1(k)} - 2 |\overline{\mathcal{L}}_1(k)|^2 3\overline{\mathbf{B}} 3\mathbf{B} \\ & \quad + 12 |\overline{\mathcal{L}}_1(k)|^2 \operatorname{Re}\left\{\mathcal{L}_1\left[\frac{\overline{\mathcal{L}}_1 \mathcal{L}_1(k)}{\overline{\mathcal{L}}_1(k)}\right]\right\} + 6 |\overline{\mathcal{L}}_1(k)|^2 \operatorname{Re}\left(\overline{\mathcal{L}}_1(\mathbf{P})\right). \end{aligned}$$

At this point, a quick look at the first 4 terms on the right hand side of the expansion (8.18) suggests that we should contract them as follows.

$$(8.19) \quad \begin{aligned} & \left[3\mathbf{B} 3\mathbf{I}_0 + 3\overline{\mathbf{B}} 3\overline{\mathbf{I}}_0 \right] \overline{\mathcal{L}}_1(k) \mathcal{L}_1(\overline{k}) + \left[3\overline{\mathbf{I}}_0 \mathbf{P} + 3\mathbf{I}_0 \overline{\mathbf{P}} \right] \overline{\mathcal{L}}_1(k) \mathcal{L}_1(\overline{k}) \\ & \quad + 3\overline{\mathbf{I}}_0 \mathcal{L}_1 \mathcal{L}_1(\overline{k}) \overline{\mathcal{L}}_1(k) + \overline{3\overline{\mathbf{I}}_0 \mathcal{L}_1 \mathcal{L}_1(\overline{k}) \overline{\mathcal{L}}_1(k)} - 2 |\overline{\mathcal{L}}_1(k)|^2 3\overline{\mathbf{B}} 3\mathbf{B} \\ & = \overline{\mathcal{L}}_1(k) \mathcal{L}_1(\overline{k}) \left\{ \left[3\mathbf{B} 3\mathbf{I}_0 + 3\overline{\mathbf{B}} 3\overline{\mathbf{I}}_0 \right] + \left[3\overline{\mathbf{I}}_0 \mathbf{P} + 3\mathbf{I}_0 \overline{\mathbf{P}} \right] \right. \\ & \quad \left. + \frac{\mathcal{L}_1 \mathcal{L}_1(\overline{k})}{\overline{\mathcal{L}}_1(k)} 3\overline{\mathbf{I}}_0 + \frac{\overline{\mathcal{L}}_1 \overline{\mathcal{L}}_1(k)}{\overline{\mathcal{L}}_1(k)} 3\mathbf{I}_0 - 2 \cdot 3\overline{\mathbf{B}} 3\mathbf{B} \right\} \\ & = \overline{\mathcal{L}}_1(k) \mathcal{L}_1(\overline{k}) \left\{ \left[3\mathbf{B} 3\mathbf{I}_0 + 3\overline{\mathbf{B}} 3\overline{\mathbf{I}}_0 \right] + \left[3\overline{\mathbf{B}} 3\overline{\mathbf{I}}_0 + 3\mathbf{B} 3\mathbf{I}_0 \right] - 2 \cdot 3\overline{\mathbf{B}} 3\mathbf{B} \right\} \\ & = 2 |\overline{\mathcal{L}}_1(k)|^2 \left\{ \left[3\mathbf{B} 3\mathbf{I}_0 + 3\overline{\mathbf{B}} 3\overline{\mathbf{I}}_0 \right] - 3\overline{\mathbf{B}} 3\mathbf{B} \right\}. \end{aligned}$$

Substituting the contraction (8.19) into the right hand side of the expression (8.18) gives

$$(8.20) \quad \begin{aligned} & 18 |\overline{\mathcal{L}}_1(k)|^2 \mathbf{Q}_0 = 2 |\overline{\mathcal{L}}_1(k)|^2 \left(3\mathbf{B} 3\mathbf{I}_0 + 3\overline{\mathbf{B}} 3\overline{\mathbf{I}}_0 - 3\overline{\mathbf{B}} 3\mathbf{B} \right) \\ & \quad + 12 |\overline{\mathcal{L}}_1(k)|^2 \operatorname{Re}\left\{\mathcal{L}_1\left[\frac{\overline{\mathcal{L}}_1 \overline{\mathcal{L}}_1(k)}{\overline{\mathcal{L}}_1(k)}\right]\right\} \\ & \quad + 6 |\overline{\mathcal{L}}_1(k)|^2 \operatorname{Re}\left(\overline{\mathcal{L}}_1(\mathbf{P})\right). \end{aligned}$$

Finally, simplifying the factor $18|\overline{\mathcal{L}_1(\mathbf{k})}|^2$ on both side of (8.20) gives us the desired expression (8.2) of \mathbf{Q}_0 . \square

When we fully expand \mathbf{Q}_0 from the expression (8.2) using the formulas of I_0 and B , we arrive at the following long expression of \mathbf{Q}_0 , which only involves in the fundamental functions \mathbf{k} and P , and their derivatives:

$$\begin{aligned}
(8.21) \quad \mathbf{Q}_0 = & \frac{2}{9} \operatorname{Re} \left\{ \frac{\mathcal{H} \overline{\mathcal{L}_1(\mathbf{k})} (\overline{\mathcal{L}_1 \mathcal{L}_1(\mathbf{k})})^2}{(\overline{\mathcal{L}_1(\mathbf{k})})^4} \right\} \\
& - \frac{2}{9} \operatorname{Re} \left\{ \frac{\mathcal{H} \overline{\mathcal{L}_1 \mathcal{L}_1(\mathbf{k})} \overline{\mathcal{L}_1 \mathcal{L}_1(\mathbf{k})} + \mathcal{H} \overline{\mathcal{L}_1(\mathbf{k})} \overline{\mathcal{L}_1 \mathcal{L}_1(\mathbf{k})} \overline{P}}{(\overline{\mathcal{L}_1(\mathbf{k})})^3} \right\} \\
& + \frac{2}{9} \operatorname{Re} \left\{ \frac{2 \overline{\mathcal{L}_1 \mathcal{L}_1(\mathbf{k})} \overline{\mathcal{L}_1 \mathcal{L}_1(\mathbf{k})} + \mathcal{H} \overline{\mathcal{L}_1 \mathcal{L}_1(\mathbf{k})} \overline{P}}{(\overline{\mathcal{L}_1(\mathbf{k})})^2} \right\} \\
& - \frac{2}{9} \operatorname{Re} \left\{ \frac{2 \overline{\mathcal{L}_1 \mathcal{L}_1(\mathbf{k})} \overline{P} + \overline{\mathcal{L}_1 \mathcal{L}_1(\mathbf{k})} P}{\overline{\mathcal{L}_1(\mathbf{k})}} \right\} \\
& - \frac{1}{9} |P|^2 + \frac{1}{3} \left| \frac{\overline{\mathcal{L}_1 \mathcal{L}_1(\mathbf{k})}}{\overline{\mathcal{L}_1(\mathbf{k})}} \right|^2 \\
& + \frac{2}{3} \operatorname{Re} \left\{ \mathcal{L}_1 \left[\frac{\overline{\mathcal{L}_1 \mathcal{L}_1(\mathbf{k})}}{\overline{\mathcal{L}_1(\mathbf{k})}} \right] \right\} + \frac{1}{3} \operatorname{Re} (\overline{\mathcal{L}_1(P)}).
\end{aligned}$$

On Convergent Poincaré-Moser Reduction for Levi Degenerate Embedded 5-Dimensional CR Manifolds

Firstly, applying Lie's elementary theory for appropriate prolongations to jet spaces of orders 1 and 2, we show that any \mathcal{C}^ω hypersurface $M^5 \subset \mathbb{C}^3$ in the class $\mathfrak{C}_{2,1}$ carries *two* sorts of Cartan-Moser chains, that are of orders 1 and 2.

Secondly, integrating and straightening any given order 2 chain passing through any point $p \in M$ to be the v -axis in coordinates $(z, \zeta, w = u + iv)$ centered at p , without setting up the formal theory in advance, we show that there exists a *convergent* change of complex coordinates $(z, \zeta, w) \mapsto (z', \zeta', w')$ fixing the origin in which γ is the v -axis and in which M has *Poincaré-Moser reduced equation* (suppressing primes):

$$\begin{aligned} u = & z\bar{z} + \frac{1}{2}\bar{z}^2\zeta + \frac{1}{2}z^2\bar{\zeta} + z\bar{z}\zeta\bar{\zeta} + \frac{1}{2}\bar{z}^2\zeta\zeta\bar{\zeta} + \frac{1}{2}z^2\bar{\zeta}\bar{\zeta}\zeta + z\bar{z}\zeta\bar{\zeta}\zeta\bar{\zeta} \\ & + 2 \operatorname{Re} \left\{ z^3\bar{\zeta}^2 F_{3,0,0,2}(v) + \zeta\bar{\zeta} (3z^2\bar{z}\bar{\zeta} F_{3,0,0,2}(v)) \right\} \\ & + 2 \operatorname{Re} \left\{ z^5\bar{\zeta} F_{5,0,0,1}(v) + z^4\bar{\zeta}^2 F_{4,0,0,2}(v) + z^3\bar{z}^2\bar{\zeta} F_{3,0,2,1}(v) \right. \\ & \quad \left. + z^3\bar{z}\bar{\zeta}^2 F_{3,0,1,2}(v) + z^3\bar{\zeta}^3 F_{3,0,0,3}(v) \right\} \\ & + z^3\bar{z}^3 O_{z,\bar{z}}(1) + \bar{z}^3\zeta O_{z,\zeta,\bar{z}}(3) + z^3\bar{\zeta} O_{z,\bar{z},\bar{\zeta}}(3) + \zeta\bar{\zeta} O_{z,\zeta,\bar{z},\bar{\zeta}}(5), \end{aligned}$$

where all monomials in $\zeta\bar{\zeta}(\dots)$ gather *dependent* derivatives on which normalizations act automatically.

Thirdly, starting from an M having preliminary normalized equation:

$$u = z\bar{z} + \frac{1}{2}\bar{z}^2\zeta + \frac{1}{2}z^2\bar{\zeta} + z\bar{z}\zeta\bar{\zeta} + O_{z,\zeta,\bar{z},\bar{\zeta},v}(5),$$

assigning weights $[z] := 1$, $[\zeta] := 0$, $[w] := 2$, we show that a normalizing biholomorphism exists and is *unique* when it is assumed to be of the form:

$$\begin{aligned} z' &:= z + f_{\geq 2}(z, \zeta, w) & \zeta' &:= \zeta + g_{\geq 1}(z, \zeta, w), & w' &:= w + h_{\geq 3}(z, \zeta, w), \\ 0 &= f_w(0), & & & 0 &= \operatorname{Im} h_{ww}(0). \end{aligned}$$

The values at the origin of Pocchiola's two primary Cartan-type relative differential invariants are:

$$W_0 = 4 \overline{F_{3,0,0,2}(0)} \quad \text{and} \quad J_0 = 20 F_{5,0,0,1}(0).$$

The proofs are detailed, accessible to non-experts. The computer-generated aspects (forthcoming) have been reduced to a minimum here.

This Chapter is based on our jointwork with Wei-Guo Foo and Joël Merker, which has appeared in preprint form:

Wei-Guo Foo, Joël Merker, The-Anh Ta, *On Convergent Poincaré-Moser Reduction for Levi Degenerate Embedded 5-Dimensional CR Manifolds*, arXiv:2003.01952

1. Introduction

As explained in the survey introduction of [22], the appropriate local graphed model for 2-nondegenerate constant Levi rank 1 real analytic (\mathcal{C}^ω) hypersurfaces $M^5 \subset \mathbb{C}^3$, generally

graphed, in coordinates $(z, \zeta, w = u + iv)$ as:

$$u = F(z, \zeta, \bar{z}, \bar{\zeta}, v),$$

is the so-called *Gaussier-Merker model*:

$$u = \frac{z\bar{z} + \frac{1}{2}\bar{z}^2\zeta + \frac{1}{2}z^2\bar{\zeta}}{1 - \zeta\bar{\zeta}} =: m(z, \zeta, \bar{z}, \bar{\zeta}).$$

Fels-Kaup [43] showed that its (connected) intersection with $\{|\zeta| < 1\}$ is biholomorphic to a Zariski-open subset of the complex tube $S_{\mathbb{L}\mathbb{C}}^2 \times i\mathbb{R}^3$ over the real light cone $(\operatorname{Re} z_2)^2 - (\operatorname{Re} z_3)^2 = (\operatorname{Re} z_1)^2$. The light cone $S_{\mathbb{L}\mathbb{C}}^2 \subset \mathbb{R}^3$ is *the* maximally symmetric non-flat parabolic surface, characterized, according to [21], by the vanishing of certain two differential invariants.

By applying either Cartan's method of equivalence, or Tanaka's approach, several recent works ([68, 82, 83, 113, 92, 49]) have been devoted to construct absolute parallelisms, namely 10-dimensional $\{e\}$ -structure bundles $P^{10} \rightarrow M^5$ for such $M^5 \subset \mathbb{C}^3$, invariantly related to biholomorphic equivalences of such hypersurfaces.

By performing advanced electronic computations, Merker-Pocchiola [113, 92] found that only two primary curvature invariants exist, denoted W and I . These intensive computations have been redone manually by Foo-Merker in [49] all along ~ 50 pages. One obtains certain 'horizontal' (semi-basic) 1-forms $\{\rho, \kappa, \zeta, \bar{\kappa}, \bar{\zeta}\}$ with $\bar{\rho} = \rho$ together with four 'vertical' 1-forms $\pi^1, \pi^2, \bar{\pi}^1, \bar{\pi}^2$ which satisfy 'compact' structure equations of the form:

$$\begin{aligned} d\rho &= (\pi^1 + \bar{\pi}^1) \wedge \rho + i\kappa \wedge \bar{\kappa}, \\ d\kappa &= \pi^2 \wedge \rho + \pi^1 \wedge \kappa + \zeta \wedge \bar{\kappa}, \\ d\zeta &= (\pi^1 - \bar{\pi}^1) \wedge \zeta + i\pi^2 \wedge \kappa + \\ &\quad + R\rho \wedge \zeta + i\frac{1}{\mathbb{C}^3}\bar{J}_0\rho \wedge \bar{\kappa} + \frac{1}{\mathbb{C}}W_0\kappa \wedge \zeta, \end{aligned}$$

conjugate structure equations for $d\bar{\kappa}, d\bar{\zeta}$ being easily deduced.

In Sections 20 and 24, we copy the expressions of the two primary relative differential invariants $W_0: M \rightarrow \mathbb{C}$ and $\bar{J}_0: M \rightarrow \mathbb{C}$, while R is a certain (useless) secondary invariant.

THEOREM 1.1. [113, 92, 49] *Only two primary invariants, W_0 and J_0 , occur for biholomorphic equivalences of 2-nondegenerate constant Levi rank 1 real analytic hypersurfaces $M^5 \subset \mathbb{C}^3$, and:*

$$0 \equiv W_0 \equiv J_0 \iff M \text{ is equivalent to the Gaussier-Merker model.}$$

Furthermore, when either $W_0 \neq 0$ or $J_0 \neq 0$, the equivalence problem reduces to a 5-dimensional $\{e\}$ -structure on M^5 , and every non-flat M^5 has CR automorphisms group of dimension ≤ 5 . \square

In this article, our motivation is to view again these relative CR differential invariants by putting the equation of such $M^5 \subset \mathbb{C}^3$ into normal form, like Chern-Moser did in [23]. Generally, the Poincaré-Moser normal form [23] provides a distinguished choice of local holomorphic coordinates for a hypersurface, in which its defining equation is approximated

as far as possible by that of the local model, for instance in $\mathbb{C}^{n+1} \ni (z_1, \dots, z_n, w = u + i v)$, a real hyperquadric:

$$u = |z_1|^2 + \dots + |z_p|^2 - |z_{p+1}|^2 - \dots - |z_n|^2.$$

Usually, a biholomorphic transformation bringing a hypersurface to a normal form at the origin is defined up to composition with the automorphisms group of the model.

Two months ago, in [22], joint with Chen, we studied *rigid* \mathcal{C}^ω hypersurfaces $M^5 \subset \mathbb{C}^3$:

$$u = F(z, \zeta, \bar{z}, \bar{\zeta}) = \sum_{a,b,c,d \geq 0} z^a \zeta^b \bar{z}^c \bar{\zeta}^d F_{a,b,c,d} \quad (F_{a,b,c,d} \in \mathbb{C}, \overline{F_{c,d,a,b}} = F_{a,b,c,d}),$$

with graphing function F independent of v , which are everywhere 2-nondegenerate and of constant Levi rank 1, under the *rigid biholomorphisms group*, a group which consists of transformations of the form:

$$(z, \zeta, w) \longmapsto \left(f(z, \zeta), g(z, \zeta), \rho w + h(z, \zeta) \right) =: (z', \zeta', w'),$$

having nonzero holomorphic Jacobian $f_z g_\zeta - f_\zeta g_z \neq 0$, with $\rho \in \mathbb{R}^*$. We established that every such rigid $M^5 \subset \mathbb{C}^3$ is *rigidly equivalent* to a ‘perturbation’ of the Gaussier-Merker model:

$$u = \frac{z\bar{z} + \frac{1}{2}\bar{z}^2\zeta + \frac{1}{2}z^2\bar{\zeta}}{1 - \zeta\bar{\zeta}} + 2 \operatorname{Re} \left\{ F_{4,0,0,1} z^4 \bar{\zeta} + \operatorname{Re} F_{3,0,1,1} z^3 \bar{z} \bar{\zeta} + F_{3,0,0,2} z^3 \bar{\zeta}^2 \right\} \\ + z^3 \bar{z}^3 O_{z,\bar{z}}(0) + 2 \operatorname{Re} z^3 \bar{\zeta} O_{z,\bar{z},\bar{\zeta}}(2) + \zeta \bar{\zeta} O_{z,\bar{z}}(3) O_{z,\zeta,\bar{z},\bar{\zeta}}(1).$$

Here, by writing $\operatorname{Re} F_{3,0,1,1}$, we mean that the (complex) coefficient $F_{3,0,1,1} \in \mathbb{C}$ has been normalized to be real.

Furthermore, writing:

$$u = F(z, \zeta, \bar{z}, \bar{\zeta}) = m(z, \zeta, \bar{z}, \bar{\zeta}) + G(z, \zeta, \bar{z}, \bar{\zeta}) \\ = m(z, \zeta, \bar{z}, \bar{\zeta}) + \sum_{\substack{a,b,c,d \in \mathbb{N} \\ a+c \geq 3}} G_{a,b,c,d} z^a \zeta^b \bar{z}^c \bar{\zeta}^d,$$

two such rigid \mathcal{C}^ω hypersurfaces $M^5 \subset \mathbb{C}^3$ and $M'^5 \subset \mathbb{C}^3$, both brought into such a normal form, are rigidly biholomorphically equivalent if and only if there exist two constants $\rho \in \mathbb{R}_+^*$, $\varphi \in \mathbb{R}$, such that for all a, b, c, d :

$$G_{a,b,c,d} = G'_{a,b,c,d} \rho^{\frac{a+c-2}{2}} e^{i\varphi(a+2b-c-2d)}.$$

This means that the normal form is defined only up to the 2-dimensional action of the *rigid* isotropy group of the origin:

$$(z, \zeta, w) \longmapsto (\rho^{1/2} e^{i\varphi} z, e^{2i\varphi} \zeta, \rho w) \quad (\rho \in \mathbb{R}_+^*, \varphi \in \mathbb{R}),$$

Before making public this normal form, in [51], we produced Cartan-type reduction to an $\{e\}$ -structure for the equivalence problem, under *rigid* (local) biholomorphic transformations, of such rigid M^5 that are 2-nondegenerate of constant Levi rank 1. We constructed an invariant 7-dimensional bundle $P^7 \rightarrow M^5$ equipped with coordinates:

$$(z_1, z_2, \bar{z}_1, \bar{z}_2, v, c, \bar{c}),$$

with $c \in \mathbb{C}$, together with of seven 1-forms generating T^*P^7 , denoted:

$$\{\rho, \kappa, \zeta, \bar{\kappa}, \bar{\zeta}, \alpha, \bar{\alpha}\} \quad (\bar{\rho} = \rho),$$

which satisfy invariant structure equations of the form:

$$\begin{aligned} d\rho &= (\alpha + \bar{\alpha}) \wedge \rho + i \kappa \wedge \bar{\kappa}, \\ d\kappa &= \alpha \wedge \kappa + \zeta \wedge \bar{\kappa}, \\ d\zeta &= (\alpha - \bar{\alpha}) \wedge \zeta + \frac{1}{c} I_0 \kappa \wedge \zeta + \frac{1}{c\bar{c}} V_0 \kappa \wedge \bar{\kappa}, \\ d\alpha &= \zeta \wedge \bar{\zeta} - \frac{1}{c} I_0 \zeta \wedge \bar{\kappa} + \frac{1}{c\bar{c}} Q_0 \kappa \wedge \bar{\kappa} + \frac{1}{c} \bar{I}_0 \bar{\zeta} \wedge \kappa. \end{aligned}$$

We refer to [22] for explicit expressions of the two primary invariants $I_0, V_0: M \rightarrow \mathbb{C}$, and of the secondary invariant $Q_0: M \rightarrow \mathbb{R}$, which is real. Once M is put into normal form as above, their values at the origin are:

$$I_0 = 4 \overline{F_{3,0,0,2}} \quad V_0 = -8 \overline{F_{4,0,0,1}} \quad Q_0 = 4 \operatorname{Re} F_{3,0,1,1}.$$

The goal of this article is to set up a rigorous *convergent* Poincaré-Moser normal form for any everywhere 2-nondegenerate constant Levi rank 1 general (nonrigid) \mathcal{C}^ω hypersurface $M^5 \subset \mathbb{C}^3$ under the *full* (not necessarily rigid) biholomorphisms group:

$$(z, \zeta, w) \mapsto \left(f(z, \zeta, w), g(z, \zeta, w), h(z, \zeta, w) \right).$$

Given such an $M^5 \subset \mathbb{C}^3$ with $0 \in M$, by examining terms of F up to order 4, it is elementary to find a holomorphic system of coordinates in which it is:

$$u = F = z\bar{z} + \frac{1}{2} \bar{z}^2 \zeta + \frac{1}{2} z^2 \bar{\zeta} + z\bar{z}\zeta\bar{\zeta} + O_{z,\zeta,\bar{z},\bar{\zeta},v}(5).$$

Since the Gaussier-Merker model is invariant under the complex scalings:

$$(z, \zeta, w) \mapsto \left(\lambda z, \frac{\lambda}{\bar{\lambda}} \zeta, \lambda \bar{\lambda} w \right) \quad (\lambda \in \mathbb{C}^*),$$

it is natural to assign the weights:

$$[z] := 1 =: [\bar{z}], \quad [\zeta] := 0 =: [\bar{\zeta}], \quad [w] := 2 =: [\bar{w}].$$

Then by $e_{\geq \nu}(z, \zeta, w)$, we will mean a holomorphic function near the origin all of whose monomials $z^a \zeta^b w^e$ are of weight $a + 2e \geq \nu$.

THEOREM 1.2. [Main] *There exists a biholomorphism $(z, \zeta, w) \mapsto (z', \zeta', w')$ fixing 0 which maps $(M, 0)$ into $(M', 0)$ of normalized equation (suppressing primes):*

$$\begin{aligned} u &= \frac{z\bar{z} + \frac{1}{2} \bar{z}^2 \zeta + \frac{1}{2} z^2 \bar{\zeta}}{1 - \zeta\bar{\zeta}} \\ &\quad + 2 \operatorname{Re} \left\{ z^3 \bar{\zeta}^2 F_{3,0,0,2}(v) + \zeta\bar{\zeta} \left(3 z^2 \bar{z} \bar{\zeta} F_{3,0,0,2}(v) \right) \right\} \\ &\quad + 2 \operatorname{Re} \left\{ z^5 \bar{\zeta} F_{5,0,0,1}(v) + z^4 \bar{\zeta}^2 F_{4,0,0,2}(v) + z^3 \bar{z}^2 \bar{\zeta} F_{3,0,2,1}(v) \right. \\ &\quad \quad \left. + z^3 \bar{z} \bar{\zeta}^2 F_{3,0,1,2}(v) + z^3 \bar{\zeta}^3 F_{3,0,0,3}(v) \right\} \\ &\quad + z^3 \bar{z}^3 O_{z,\bar{z}}(1) + \bar{z}^3 \zeta O_{z,\zeta,\bar{z}}(3) + z^3 \bar{\zeta} O_{z,\bar{z},\bar{\zeta}}(3) + \zeta\bar{\zeta} O_{z,\bar{z}}(3) O_{z,\zeta,\bar{z},\bar{\zeta}}(2). \end{aligned}$$

Furthermore, the map exists and is unique if it is assumed to be of the form:

$$\begin{aligned} z' &:= z + f_{\geq 2}(z, \zeta, w) & \zeta' &:= \zeta + g_{\geq 1}(z, \zeta, w), & w' &:= w + h_{\geq 3}(z, \zeta, w), \\ 0 &= f_w(0), & & & 0 &= \operatorname{Im} h_{ww}(0). \end{aligned}$$

Equivalently, writing:

$$u = F = \sum_{a,b,c,d \geq 0} z^a \zeta^b \bar{z}^c \bar{\zeta}^d F_{a,b,c,d}(v),$$

the normal form is defined by the general *prenormalization conditions*:

$$\begin{aligned} 0 &\equiv F_{a,b,0,0}(v) \equiv F_{0,0,c,d}(v), \\ 0 &\equiv F_{a,b,1,0}(v) \equiv F_{1,0,c,d}(v), \\ 0 &\equiv F_{a,b,2,0}(v) \equiv F_{2,0,c,d}(v), \end{aligned}$$

with the obvious two exceptions $F_{1,0,1,0}(v) \equiv 1$ and $F_{0,1,2,0}(v) \equiv \frac{1}{2} \equiv F_{2,0,0,1}(v)$, together with the *sporadic normalization conditions*, listed by increasing order 4, 5, 6:

$$\begin{aligned} 0 &\equiv F_{3,0,0,1}(v) \equiv F_{0,1,3,0}(v), \\ 0 &\equiv F_{4,0,0,1}(v) \equiv F_{0,1,4,0}(v), & 0 &\equiv F_{3,0,1,1}(v) \equiv F_{1,1,3,0}(v), \\ 0 &\equiv F_{4,0,1,1}(v) \equiv F_{1,1,4,0}(v), & 0 &\equiv F_{3,0,3,0}(v). \end{aligned}$$

Without the above conditions $z' = z + f_{\geq 2}$, $\zeta' = \zeta + g_{\geq 1}$, $w' = w + h_{\geq 3}$ guaranteeing uniqueness, one can verify that a normalizing transformation is unique up to the right action of the 5-dimensional stability group of the Gaussier-Merker model having the finite equations:

$$\begin{aligned} z' &:= \lambda \frac{z + i\alpha z^2 + (i\alpha\zeta - i\bar{\alpha})w}{1 + 2i\alpha z - \alpha^2 z^2 - (\alpha^2\zeta - \alpha\bar{\alpha} + ir)w}, \\ \zeta' &:= \frac{\lambda}{\bar{\lambda}} \frac{\zeta + 2i\bar{\alpha}z - (\alpha\bar{\alpha} + ir)z^2 + (\bar{\alpha}^2 - ir\zeta - \alpha\bar{\alpha}\zeta)w}{1 + 2i\alpha z - \alpha^2 z^2 - (\alpha^2\zeta - \alpha\bar{\alpha} + ir)w}, \\ w' &:= \lambda\bar{\lambda} \frac{w}{1 + 2i\alpha z - \alpha^2 z^2 - (\alpha^2\zeta - \alpha\bar{\alpha} + ir)w}, \end{aligned}$$

where $\lambda \in \mathbb{C}^*$, $\alpha \in \mathbb{C}$, $r \in \mathbb{R}$ are arbitrary.

Lastly, the values at the origin of Pocchiola's two primary Cartan-type relative differential invariants are:

$$W_0 = 4 \overline{F_{3,0,0,2}(0)} \quad \text{and} \quad J_0 = 20 F_{5,0,0,1}(0).$$

However, Poincaré-Moser normal forms or Cartan-Tanaka reductions to $\{e\}$ -structures are only a *preliminary* towards the understanding of the biholomorphic equivalence problem for embedded \mathcal{C}^ω CR submanifolds $M \subset \mathbb{C}^N$, quite far from any resolution, not even to be termed 'complete resolution'.

Indeed, focusing on CR geometry, we would like to indicate two 'defects' of Poincaré-Moser normal forms in comparison to Cartan-Tanaka principal bundles.

- Moser-type CR normal forms are in fact *incomplete* in the sense that their invariants are only *relative*, yet defined up to the action of a certain ambiguity (isotropy) group.
- Moser-type CR normal forms hold only at one point, hence are incapable to fully characterize flatness as Cartan's method *does*.

The main reason why Cartan's method is more powerful is that it embraces computations *at every point* of a given manifold. Objects manipulated by Cartan's thought are (often very complicated) rational differential expressions in partial derivatives of fundamental

(graphing) functions. In comparison, objects manipulated by Moser's method are only plain Taylor coefficients, hence computations are *much more elementary*.

Fortunately, it is known that symmetries of a hypersurface can be read off from subsequently constructed *deeper* normal forms, not touched in the present paper, but forthcoming.

These comments conduct us to at least formulate and raise a certain number of questions showing that several mysteries remain.

Q^① How to get rid of ambiguity in Moser CR-normal forms? What are the true (absolute) differential invariants? Can one retrieve Pocchiola's dimension drop $10 \downarrow 5$? Can one link Moser's punctual invariants with Cartan's invariants at every point?

Q^② In all possibly existing branches, how to find a minimal set of generators for the differential algebra of absolute differential invariants? Using either Moser's or Cartan's method?

Q^③ In each branch, what are the differential relations (syzygies) between differential invariants?

Q^④ How to implement the determination of CR-homogeneous models beyond naive Taylor series manipulations at only one point? How to employ the theory of Lie? How to view Cartan's invariants in a Taylor series?

Q^⑤ How to implement, from Moser's side of the bridge, any sub-branch assumption that requires that an ideal of differential invariants, or a collection of Taylor coefficients, vanish (identically)?

To close this brief introduction, three aspects of the article should be emphasized.

A^① Analogs of Cartan-Moser chains will be 'discovered from scratch' by applying a method due to Lie, as in [95].

A^② Detailed proofs for the existence of a *convergent* normal form, missing on arxiv.org, will be offered to the reader.

A^③ The '*formal theory*' will be developed *after* the '*convergent theory*'.

Acknowledgments. Zhangchi Chen provided the Maple figures of Sections 8 and 9.

2. $\mathfrak{C}_{2,1}$ Hypersurfaces $M^5 \subset \mathbb{C}^3$

Our object of study is the collection of real \mathcal{C}^ω hypersurfaces $M^5 \subset \mathbb{C}^3$ whose Levi form is of constant rank 1 at every point and that are everywhere 2-nondegenerate (*see* below), a *class* that we will denote as:

$$\mathfrak{C}_{2,1}.$$

Pick any point $p \in M$ and adapt affine holomorphic coordinates $(z, \zeta, w = u + iv) \in \mathbb{C}^3$ in which p is the origin, so that $T_0M \oplus \mathbb{R}_u = \mathbb{C}^3$. From any \mathcal{C}^ω real defining equation for M near p , the analytic implicit function theorem enables to solve for u as:

$$u = F(z, \zeta, \bar{z}, \bar{\zeta}, v),$$

for some \mathcal{C}^ω graphing function F , the *core object* of our study. This F is expandable in converging power series as:

$$F(z, \zeta, \bar{z}, \bar{\zeta}, v) = \sum_{a+b+c+d+e \geq 1} F_{a,b,c,d,e} z^a \zeta^b \bar{z}^c \bar{\zeta}^d v^e,$$

for some infinite collection of complex coefficients $F_{a,b,c,d,e} \in \mathbb{C}$. Then by conjugating only complex coefficients, *define*:

$$\overline{F}(z, \zeta, \bar{z}, \bar{\zeta}, v) := \sum_{a+b+c+d+e \geq 1} \overline{F}_{a,b,c,d,e} z^a \zeta^b \bar{z}^c \bar{\zeta}^d v^e.$$

The reality $\bar{u} = u$ forces $\overline{F(z, \zeta, \bar{z}, \bar{\zeta}, v)} = F(z, \zeta, \bar{z}, \bar{\zeta}, v)$, that is:

$$(2.1) \quad \overline{F}(\bar{z}, \bar{\zeta}, z, \zeta, v) \equiv F(z, \zeta, \bar{z}, \bar{\zeta}, v).$$

Applying $\frac{1}{a!} \partial_z^a \frac{1}{b!} \partial_\zeta^b \frac{1}{c!} \partial_{\bar{z}}^c \frac{1}{d!} \partial_{\bar{\zeta}}^d \frac{1}{e!} \partial_v^e$ at the origin $(0, 0, 0, 0, 0)$, we obtain the (known) condition on the $F_{a,b,c,d,e} \in \mathbb{C}$ which guarantees reality of the graphing function:

$$\overline{F_{c,d,a,b,e}} = F_{a,b,c,d,e}.$$

Later, we will expand F in powers of $(z, \zeta, \bar{z}, \bar{\zeta})$ only, by introducing:

$$F(z, \zeta, \bar{z}, \bar{\zeta}, v) = \sum_{a,b,c,d} z^a \zeta^b \bar{z}^c \bar{\zeta}^d \sum_e F_{a,b,c,d,e} v^e =: \sum_{a,b,c,d} z^a \zeta^b \bar{z}^c \bar{\zeta}^d F_{a,b,c,d}(v).$$

The reality of F is then equivalent to:

$$(2.2) \quad \overline{F_{c,d,a,b}(v)} = F_{a,b,c,d}(v).$$

In the literature [55, 56, 85, 44, 89, 68, 82, 83, 96, 49, 51], several equivalent definitions of the class $\mathfrak{C}_{2,1}$ exist. We propose a computational formulation of the two concepts of constant Levi rank 1 and of 2-nondegeneracy, already shown in [22] when M is *rigid*, namely when F is independent of v .

For this, we need the *complex graphed representation* of any \mathcal{C}^ω hypersurface $M^5 \subset \mathbb{C}^3$:

$$w = Q(z, \zeta, \bar{z}, \bar{\zeta}, \bar{w}),$$

with a \mathbb{C} -valued analytic function Q which is obtained by solving for w in $\frac{w+\bar{w}}{2} = F(z, \zeta, \bar{z}, \bar{\zeta}, \frac{w-\bar{w}}{2i})$, so that:

$$\frac{1}{2} Q(z, \zeta, \bar{z}, \bar{\zeta}, \bar{w}) + \frac{1}{2} \bar{w} \equiv F\left(z, \zeta, \bar{z}, \bar{\zeta}, \frac{1}{2i} Q(z, \zeta, \bar{z}, \bar{\zeta}, \bar{w}) - \frac{1}{2i} \bar{w}\right).$$

Such an analytic function Q cannot be arbitrary, it must satisfy a compatibility condition obtained by replacing $\bar{w} := \overline{Q}$ in its last argument:

$$w \equiv Q\left(z, \zeta, \bar{z}, \bar{\zeta}, \overline{Q}(\bar{z}, \bar{\zeta}, z, \zeta, w)\right).$$

3. Two Invariant Determinants

A local biholomorphism:

$$(z, \zeta, w) \longmapsto \left(f(z, \zeta, w), g(z, \zeta, w), h(z, \zeta, w)\right) =: (z', \zeta', w'),$$

has nowhere vanishing holomorphic Jacobian determinant:

$$0 \neq \begin{vmatrix} f_z & g_z & h_z \\ f_\zeta & g_\zeta & h_\zeta \\ f_w & g_w & h_w \end{vmatrix}.$$

Suppose that it makes a biholomorphism between two \mathcal{C}^ω hypersurfaces both represented by complex graphing functions:

$$w = Q(z, \zeta, \bar{z}, \bar{\zeta}, \bar{w}) \quad \text{and} \quad w' = Q'(z', \zeta', \bar{z}', \bar{\zeta}', \bar{w}').$$

Plugging the three components of the biholomorphism in the target equation, we get the so-called *fundamental identity*:

$$h(z, \zeta, w) = Q' \left(f(z, \zeta, w), g(z, \zeta, w), \bar{f}(\bar{z}, \bar{\zeta}, \bar{w}), \bar{g}(\bar{z}, \bar{\zeta}, \bar{w}), \bar{h}(\bar{z}, \bar{\zeta}, \bar{w}) \right) \Big|_{w=Q(z, \zeta, \bar{z}, \bar{\zeta}, \bar{w})},$$

which holds identically in the ring of converging power series $\mathbb{C}\{z, \zeta, \bar{z}, \bar{\zeta}, \bar{w}\}$.

By differentiating this identity (exercise!), one may express the invariancy of the Levi form as a relation between the two Levi determinants defined as:

$$\begin{vmatrix} Q_{\bar{z}} & Q_{\bar{\zeta}} & Q_{\bar{w}} \\ Q_{z\bar{z}} & Q_{z\bar{\zeta}} & Q_{z\bar{w}} \\ Q_{\zeta\bar{z}} & Q_{\zeta\bar{\zeta}} & Q_{\zeta\bar{w}} \end{vmatrix} \quad \text{and} \quad \begin{vmatrix} Q'_{\bar{z}'} & Q'_{\bar{\zeta}'} & Q'_{\bar{w}'} \\ Q'_{z'\bar{z}'} & Q'_{z'\bar{\zeta}'} & Q'_{z'\bar{w}'} \\ Q'_{\zeta'\bar{z}'} & Q'_{\zeta'\bar{\zeta}'} & Q'_{\zeta'\bar{w}'} \end{vmatrix}.$$

Indeed, abbreviate:

$$\mathcal{L}_z := \frac{\partial}{\partial z} + Q_z(z, \zeta, \bar{z}, \bar{\zeta}, \bar{w}) \frac{\partial}{\partial w} \quad \text{and} \quad \mathcal{L}_\zeta := \frac{\partial}{\partial \zeta} + Q_\zeta(z, \zeta, \bar{z}, \bar{\zeta}, \bar{w}) \frac{\partial}{\partial w}.$$

PROPOSITION 3.1. *Through any biholomorphism between real hypersurfaces $\{w = Q\} \subset \mathbb{C}^3$ and $\{w' = Q'\} \subset \mathbb{C}'^3$, one has:*

$$\begin{vmatrix} Q'_{\bar{z}'} & Q'_{\bar{\zeta}'} & Q'_{\bar{w}'} \\ Q'_{z'\bar{z}'} & Q'_{z'\bar{\zeta}'} & Q'_{z'\bar{w}'} \\ Q'_{\zeta'\bar{z}'} & Q'_{\zeta'\bar{\zeta}'} & Q'_{\zeta'\bar{w}'} \end{vmatrix} = \frac{\begin{vmatrix} f_z & f_\zeta & f_w \\ g_z & g_\zeta & g_w \\ h_z & h_\zeta & h_w \end{vmatrix}^3}{\begin{vmatrix} \bar{f}_{\bar{z}} & \bar{f}_{\bar{\zeta}} & \bar{f}_{\bar{w}} \\ \bar{g}_{\bar{z}} & \bar{g}_{\bar{\zeta}} & \bar{g}_{\bar{w}} \\ \bar{h}_{\bar{z}} & \bar{h}_{\bar{\zeta}} & \bar{h}_{\bar{w}} \end{vmatrix}^1} \frac{1}{\begin{vmatrix} \mathcal{L}_z(f) & \mathcal{L}_\zeta(f) \\ \mathcal{L}_z(g) & \mathcal{L}_\zeta(g) \end{vmatrix}^4} \begin{vmatrix} Q_{\bar{z}} & Q_{\bar{\zeta}} & Q_{\bar{w}} \\ Q_{z\bar{z}} & Q_{z\bar{\zeta}} & Q_{z\bar{w}} \\ Q_{\zeta\bar{z}} & Q_{\zeta\bar{\zeta}} & Q_{\zeta\bar{w}} \end{vmatrix}.$$

□

Consequently, the property that the Levi form is of constant rank 1 is biholomorphically invariant. The 2-nondegeneracy property [96] then expresses as the nonvanishing of:

$$\begin{vmatrix} Q_{\bar{z}} & Q_{\bar{\zeta}} & Q_{\bar{w}} \\ Q_{z\bar{z}} & Q_{z\bar{\zeta}} & Q_{z\bar{w}} \\ Q_{zz\bar{z}} & Q_{zz\bar{\zeta}} & Q_{zz\bar{w}} \end{vmatrix} \quad \text{and} \quad \begin{vmatrix} Q'_{\bar{z}'} & Q'_{\bar{\zeta}'} & Q'_{\bar{w}'} \\ Q'_{z'\bar{z}'} & Q'_{z'\bar{\zeta}'} & Q'_{z'\bar{w}'} \\ Q'_{z'z'\bar{z}'} & Q'_{z'z'\bar{\zeta}'} & Q'_{z'z'\bar{w}'} \end{vmatrix}.$$

PROPOSITION 3.2. *When the Levi form is of constant rank 1, through any biholomorphism between real hypersurfaces $\{w = Q\} \subset \mathbb{C}^3$ and $\{w' = Q'\} \subset \mathbb{C}'^3$, one has:*

$$\frac{\begin{vmatrix} Q'_{\bar{z}'} & Q'_{\bar{\zeta}'} & Q'_{\bar{w}'} \\ Q'_{z'\bar{z}'} & Q'_{z'\bar{\zeta}'} & Q'_{z'\bar{w}'} \\ Q'_{z'z'\bar{z}'} & Q'_{z'z'\bar{\zeta}'} & Q'_{z'z'\bar{w}'} \end{vmatrix}}{\begin{vmatrix} Q_{\bar{z}} & Q_{\bar{\zeta}} & Q_{\bar{w}} \\ Q_{z\bar{z}} & Q_{z\bar{\zeta}} & Q_{z\bar{w}} \\ Q_{zz\bar{z}} & Q_{zz\bar{\zeta}} & Q_{zz\bar{w}} \end{vmatrix}} = \frac{\begin{vmatrix} f_z & f_\zeta & f_w \\ g_z & g_\zeta & g_w \\ h_z & h_\zeta & h_w \end{vmatrix}^3}{\begin{vmatrix} \bar{f}_{\bar{z}} & \bar{f}_{\bar{\zeta}} & \bar{f}_{\bar{w}} \\ \bar{g}_{\bar{z}} & \bar{g}_{\bar{\zeta}} & \bar{g}_{\bar{w}} \\ \bar{h}_{\bar{z}} & \bar{h}_{\bar{\zeta}} & \bar{h}_{\bar{w}} \end{vmatrix}^1} \frac{\left(\mathcal{L}_\zeta(g) \begin{vmatrix} Q_{\bar{z}} & Q_{\bar{w}} \\ Q_{z\bar{z}} & Q_{z\bar{w}} \end{vmatrix} - \mathcal{L}_z(g) \begin{vmatrix} Q_{\bar{z}} & Q_{\bar{w}} \\ Q_{\zeta\bar{z}} & Q_{\zeta\bar{w}} \end{vmatrix} \right)^3}{\begin{vmatrix} \mathcal{L}_z(f) & \mathcal{L}_\zeta(f) \\ \mathcal{L}_z(g) & \mathcal{L}_\zeta(g) \end{vmatrix}^6 \begin{vmatrix} Q_{\bar{z}} & Q_{\bar{w}} \\ Q_{z\bar{z}} & Q_{z\bar{w}} \end{vmatrix}^3}.$$

□

Recall that we denote the class of (local) hypersurfaces $M^5 \subset \mathbb{C}^3$ passing through the origin $0 \in M$ that are 2-nondegenerate and whose Levi form has constant rank 1 as:

$$\mathcal{C}_{2,1}.$$

Repeatedly, we shall use the real expression of the *Levi determinant*:

$$(3.3) \quad \text{Levi}(F) := \begin{vmatrix} 0 & F_z & F_\zeta & -\frac{1}{2} + \frac{1}{2i}F_v \\ F_{\bar{z}} & F_{z\bar{z}} & F_{\zeta\bar{z}} & \frac{1}{2i}F_{\bar{z}v} \\ F_{\bar{\zeta}} & F_{z\bar{\zeta}} & F_{\zeta\bar{\zeta}} & \frac{1}{2i}F_{\bar{\zeta}v} \\ -\frac{1}{2} - \frac{1}{2i}F_v & -\frac{1}{2i}F_{zv} & -\frac{1}{2i}F_{\zeta v} & \frac{1}{4}F_{vv} \end{vmatrix}.$$

The next (known) statement applies to $\rho := -u + F$.

LEMMA 3.4. [50] *If $M^5 \subset \mathbb{C}^3$ is implicitly defined by $\rho(z, \zeta, w, \bar{z}, \bar{\zeta}, \bar{w}) = 0$ with a \mathcal{C}^ω real function $\rho = \bar{\rho}$ satisfying $\rho_w \neq 0$, and if $w = Q(z, \zeta, \bar{z}, \bar{\zeta}, \bar{w})$ is its associated complex graphing function, then:*

$$\begin{vmatrix} 0 & \rho_z & \rho_\zeta & \rho_w \\ \rho_{\bar{z}} & \rho_{z\bar{z}} & \rho_{\zeta\bar{z}} & \rho_{w\bar{z}} \\ \rho_{\bar{\zeta}} & \rho_{z\bar{\zeta}} & \rho_{\zeta\bar{\zeta}} & \rho_{w\bar{\zeta}} \\ \rho_{\bar{w}} & \rho_{z\bar{w}} & \rho_{\zeta\bar{w}} & \rho_{w\bar{w}} \end{vmatrix} = \rho_w^4 \begin{vmatrix} Q_{\bar{z}} & Q_{\bar{\zeta}} & Q_{\bar{w}} \\ Q_{z\bar{z}} & Q_{z\bar{\zeta}} & Q_{z\bar{w}} \\ Q_{\zeta\bar{z}} & Q_{\zeta\bar{\zeta}} & Q_{\zeta\bar{w}} \end{vmatrix}. \quad \square$$

We leave as an exercise to find some invariant determinant expressed in terms of F which corresponds to the 2-nondegeneracy determinant of Proposition 3.2 in terms of Q .

4. Infinitesimal CR Automorphisms

In the class $\mathcal{C}_{2,1}$, the appropriate homogeneous model, named M_{LC} , was set up by Gaussier-Merker in [56] and Fels-Kaup in [43], see also [22]:

$$M_{LC}: \quad u = \frac{z\bar{z} + \frac{1}{2}z^2\bar{\zeta} + \frac{1}{2}\bar{z}^2\zeta}{1 - \zeta\bar{\zeta}} =: m(z, \zeta, \bar{z}, \bar{\zeta}).$$

The letter m here stands for *model*.

The 10-dimensional simple Lie algebra of its infinitesimal CR automorphisms:

$$\mathfrak{g} := \text{aut}_{CR}(M_{LC}) \cong \mathfrak{so}_{2,3}(\mathbb{R}),$$

has 10 natural generators X_1, \dots, X_{10} , which are $(1, 0)$ vector fields in \mathbb{C}^3 having holomorphic coefficients with $X_\sigma + \bar{X}_\sigma$ tangent to M_{LC} .

It is natural to assign the following weights to variables and to vector fields:

$$(4.1) \quad [z] := 1 \quad [\zeta] := 0, \quad [w] := 2 \quad [\partial_z] := -1 \quad [\partial_\zeta] := 0 \quad [\partial_w] := -2.$$

The Lie algebra $\mathfrak{g} = \text{aut}_{CR}(M_{LC})$ can be graded as:

$$\mathfrak{g} = \mathfrak{g}_{-2} \oplus \mathfrak{g}_{-1} \oplus \mathfrak{g}_0 \oplus \mathfrak{g}_1 \oplus \mathfrak{g}_2,$$

where, as shown in [56, 51]:

$$\begin{aligned} \mathfrak{g}_{-2} &:= \text{Span} \{i \partial_w\}, \\ \mathfrak{g}_{-1} &:= \text{Span} \{(\zeta - 1) \partial_z - 2z \partial_w, (i + i\zeta) \partial_z - 2iz \partial_w\}, \end{aligned}$$

where $\mathfrak{g}_0 = \mathfrak{g}_0^{\text{trans}} \oplus \mathfrak{g}_0^{\text{iso}}$:

$$\begin{aligned}\mathfrak{g}_0^{\text{trans}} &:= \text{Span} \left\{ z\zeta \partial_z + (\zeta^2 - 1) \partial_\zeta - z^2 \partial_w, \quad iz\zeta \partial_z + (i + i\zeta^2) \partial_\zeta - iz^2 \partial_w \right\}, \\ \mathfrak{g}_0^{\text{iso}} &:= \text{Span} \left\{ z \partial_z + 2w \partial_w, \quad iz \partial_z + 2i\zeta \partial_\zeta \right\},\end{aligned}$$

while:

$$\begin{aligned}\mathfrak{g}_1 &:= \text{Span} \left\{ (z^2 - \zeta w - w) \partial_z + (2z\zeta + 2z) \partial_\zeta + 2zw \partial_w, \right. \\ &\quad \left. (-iz^2 + i\zeta w - iw) \partial_z + (-2iz\zeta + 2iz) \partial_\zeta - 2izw \partial_w \right\}, \\ \mathfrak{g}_2 &:= \text{Span} \left\{ izw \partial_z - iz^2 \partial_\zeta + iw^2 \partial_w \right\}.\end{aligned}$$

Calling these X_1, \dots, X_{10} in order of appearance, the five $X_\sigma + \overline{X}_\sigma$ for $\sigma = 1, 2, 3, 4, 5$ span TM^5 while those for $\sigma = 6, 7, 8, 9, 10$ generate the isotropy subgroup of the origin.

In fact, we will use the alternative names for the 5 generators of the isotropy subgroup:

$$\begin{aligned}D &:= z \partial_z + 2w \partial_w, \\ R &:= iz \partial_z + 2i\zeta \partial_\zeta, \\ l_1 &:= (z^2 - \zeta w - w) \partial_z + (2z\zeta + 2z) \partial_\zeta + 2zw \partial_w, \\ l_2 &:= (-iz^2 + i\zeta w - iw) \partial_z + (-2iz\zeta + 2iz) \partial_\zeta - 2izw \partial_w, \\ J &:= izw \partial_z - iz^2 \partial_\zeta + iw^2 \partial_w,\end{aligned}$$

having commutator table:

	D	R	l_1	l_2	J
D	0	0	l_1	l_2	$2J$
R	*	0	$-l_2$	l_1	0
l_1	*	*	0	$4J$	0
l_2	*	*	*	0	0
J	*	*	*	*	0

5. Fractional Representation of the Isotropy Group

By integrating iterated flows of D, R, l_1, l_2, J , it can be shown (exercise) that the isotropy subgroup of the origin $0 \in M_{LC}$ in the Gaussier-Merker model has the finite equations:

$$\begin{aligned}z' &:= \lambda \frac{z + i\alpha z^2 + (i\alpha\zeta - i\bar{\alpha})w}{1 + 2i\alpha z - \alpha^2 z^2 - (\alpha^2\zeta - \alpha\bar{\alpha} + ir)w}, \\ \zeta' &:= \frac{\lambda}{\bar{\lambda}} \frac{\zeta + 2i\bar{\alpha}z - (\alpha\bar{\alpha} + ir)z^2 + (\bar{\alpha}^2 - ir\zeta - \alpha\bar{\alpha}\zeta)w}{1 + 2i\alpha z - \alpha^2 z^2 - (\alpha^2\zeta - \alpha\bar{\alpha} + ir)w}, \\ w' &:= \lambda\bar{\lambda} \frac{w}{1 + 2i\alpha z - \alpha^2 z^2 - (\alpha^2\zeta - \alpha\bar{\alpha} + ir)w},\end{aligned}$$

where $\lambda \in \mathbb{C}^*$, $\alpha \in \mathbb{C}$, $r \in \mathbb{R}$ are arbitrary.

The Taylor expansions up to respective weighted orders 5, 4, 6, will soon be useful:

$$\begin{aligned}
z' &= \lambda z \\
&- i \lambda \alpha z^2 - i \lambda \bar{\alpha} w \\
&- \lambda \alpha^2 z^3 + (-3 \lambda \alpha \bar{\alpha} + i \lambda r) z w + i \lambda \alpha \zeta w \\
&+ i \lambda \alpha^3 z^4 + (6i \lambda \alpha^2 \bar{\alpha} + 3 \lambda \alpha r) z^2 w + (\lambda \bar{\alpha} r + i \lambda \bar{\alpha}^2 \alpha) w^2 + 3 \lambda \alpha^2 z \zeta w \\
&+ \lambda \alpha^4 z^5 + (-6i \alpha^2 \lambda r + 10 \lambda \alpha^3 \bar{\alpha}) z^3 w - 6i \lambda \alpha^3 z^2 \zeta w + (5 \lambda \alpha^2 \bar{\alpha}^2 - 6i \lambda \alpha \bar{\alpha} r - \lambda r^2) z w^2 + (-2i \lambda \alpha^2 \bar{\alpha} - \lambda \alpha r) \zeta w^2, \\
\zeta' &= 2i \frac{\lambda}{\lambda} \bar{\alpha} z + \frac{\lambda}{\lambda} \zeta \\
&+ \left(-i \frac{\lambda}{\lambda} r + 3 \frac{\lambda}{\lambda} \alpha \bar{\alpha} \right) z^2 - 2i \frac{\lambda}{\lambda} \alpha z \zeta + \frac{\lambda}{\lambda} \bar{\alpha}^2 w \\
&+ \left(-4i \frac{\lambda}{\lambda} \alpha^2 \bar{\alpha} - 2 \frac{\lambda}{\lambda} \alpha r \right) z^3 - 3 \frac{\lambda}{\lambda} \alpha^2 z^2 \zeta + \left(-4i \frac{\lambda}{\lambda} \alpha \bar{\alpha}^2 - 2 \frac{\lambda}{\lambda} \bar{\alpha} r \right) z w - 2 \frac{\lambda}{\lambda} \alpha \bar{\alpha} \zeta w \\
&+ \left(-5 \frac{\lambda}{\lambda} \alpha^3 \bar{\alpha} + 3i \frac{\lambda}{\lambda} \alpha^2 r \right) z^4 + 4i \frac{\lambda}{\lambda} \alpha^3 z^3 \zeta + \left(-10 \frac{\lambda}{\lambda} \alpha^2 \bar{\alpha}^2 + 8i \frac{\lambda}{\lambda} \alpha \bar{\alpha} r + \frac{\lambda}{\lambda} r^2 \right) z^2 w \\
&\quad + \left(8i \frac{\lambda}{\lambda} \alpha^2 \bar{\alpha} + 2 \frac{\lambda}{\lambda} \alpha r \right) z \zeta w + \frac{\lambda}{\lambda} \alpha^2 \zeta^2 w + \left(i \frac{\lambda}{\lambda} \bar{\alpha}^2 r - \frac{\lambda}{\lambda} \alpha \bar{\alpha}^3 \right) w^2, \\
w' &= 0 \\
&+ \lambda \bar{\lambda} w \\
&- 2i \lambda \bar{\lambda} \alpha z w \\
&- 3 \lambda \bar{\lambda} \alpha^2 z^2 w + (i \lambda \bar{\lambda} r - \lambda \bar{\lambda} \alpha \bar{\alpha}) w^2 \\
&+ 4i \lambda \bar{\lambda} \alpha^3 z^3 + (4i \lambda \bar{\lambda} \alpha^2 \bar{\alpha} + 4 \lambda \bar{\lambda} \alpha r) z w^2 + \lambda \bar{\lambda} \alpha^2 \zeta w^2 \\
&+ 5 \lambda \bar{\lambda} \alpha^4 z^4 w + (10 \lambda \bar{\lambda} \alpha^3 \bar{\alpha} - 10i \lambda \bar{\lambda} \alpha^2 r) z^2 w^2 - 4i \lambda \bar{\lambda} \alpha^3 z \zeta w^2 + (-\lambda \bar{\lambda} r^2 - 2i \lambda \bar{\lambda} \alpha \bar{\alpha} r + \lambda \bar{\lambda} \alpha^2 \bar{\alpha}^2) w^3.
\end{aligned}$$

6. Lie Jet Theory

To apply Lie's theory similarly as in [95], we must work with the five *intrinsic, real*, coordinates (x, y, s, t, v) on M^5 , where:

$$z = x + i y, \quad \zeta = s + i t, \quad w = u + i v.$$

As in [95], we consider parametrized local real \mathcal{C}^ω curves passing by the origin

$$\tau \longmapsto (x(\tau), y(\tau), s(\tau), t(\tau), \tau).$$

with $v(\tau) \equiv \tau$ guaranteeing that the curve is *not* CR-tangential. We then use the parameter-letter v instead of τ .

The eight independent coordinates corresponding to $\dot{x}(v), \dot{y}(v), \dot{s}(v), \dot{t}(v), \ddot{x}(v), \ddot{y}(v), \ddot{s}(v), \ddot{t}(v)$ will be denoted:

$$(v, x, y, s, t, x_1, y_1, s_1, t_1, x_2, y_2, s_2, t_2).$$

The first jet space is $J_{1,4}^1 \equiv \mathbb{R}^{1+4+4}$, and the second jet space is $J_{1,4}^2 \equiv \mathbb{R}^{1+4+4+4}$.

Any diffeomorphism $(v, x, y, s, t) \longmapsto (v', x', y', s', t')$ lifts to jet spaces of any order. Because the formulas rapidly become complicated [109, 85, 21], Lie linearized the action of diffeomorphisms.

As in [95], we will *apply* Lie's formulas. Start from a general vector field:

$$\vec{v} := \xi(v, x, y, s, t) \frac{\partial}{\partial v} + \varphi(v, x, y, s, t) \frac{\partial}{\partial x} + \psi(v, x, y, s, t) \frac{\partial}{\partial y} + \lambda(v, x, y, s, t) \frac{\partial}{\partial s} + \mu(v, x, y, s, t) \frac{\partial}{\partial t}.$$

Introduce the *total differentiation operator*:

$$D_v := \frac{\partial}{\partial v} + x_1 \frac{\partial}{\partial x} + y_1 \frac{\partial}{\partial y} + s_1 \frac{\partial}{\partial s} + t_1 \frac{\partial}{\partial t} + x_2 \frac{\partial}{\partial x_1} + y_2 \frac{\partial}{\partial y_1} + s_2 \frac{\partial}{\partial s_1} + t_2 \frac{\partial}{\partial t_1} + x_3 \frac{\partial}{\partial x_2} + y_3 \frac{\partial}{\partial y_2} + s_3 \frac{\partial}{\partial s_2} + t_3 \frac{\partial}{\partial t_2}.$$

Then the second prolongation of \vec{v} :

$$\begin{aligned} \vec{v}^{(2)} = \vec{v} &+ \varphi_1 \frac{\partial}{\partial x_1} + \psi_1 \frac{\partial}{\partial y_1} + \lambda_1 \frac{\partial}{\partial s_1} + \mu_1 \frac{\partial}{\partial t_1} \\ &+ \varphi_2 \frac{\partial}{\partial x_2} + \psi_2 \frac{\partial}{\partial y_2} + \lambda_2 \frac{\partial}{\partial s_2} + \mu_2 \frac{\partial}{\partial t_2}, \end{aligned}$$

has coefficients ([78, 109, 85, 21]):

$$\begin{aligned} \varphi_1 &:= D_v(\varphi - \xi x_1) + \xi x_2, & \psi_1 &:= D_v(\psi - \xi y_1) + \xi y_2, & \lambda_1 &:= D_v(\lambda - \xi s_1) + \xi s_2, & \mu_1 &:= D_v(\mu - \xi t_1) + \xi t_2, \\ \varphi_2 &:= D_v D_v(\varphi - \xi x_1) + \xi x_3, & \psi_2 &:= D_v D_v(\psi - \xi y_1) + \xi y_3, & \lambda_2 &:= D_v D_v(\lambda - \xi s_1) + \xi s_3, & \mu_2 &:= D_v D_v(\mu - \xi t_1) + \xi t_3. \end{aligned}$$

7. Intrinsic Isotropy Automorphisms of the Gaussier-Merker Model

We want to apply Lie's prolongation formulas within the *first* jet space to our 5 vector fields $X = D, R, l_1, l_2, J$. But these *holomorphic* $(1, 0)$ fields were *extrinsic*, defined in \mathbb{C}^3 . We must therefore write up the five fields $X + \bar{X}$ in the *intrinsic* coordinates $(x, y, s, t, v) \in M_{\mathbb{C}}^5$. By slight abuse, we keep the notation X instead of $X + \bar{X}$:

$$D = x \partial_x + y \partial_y + 2v \partial_v,$$

$$R = -y \partial_x + x \partial_y - 2t \partial_s + 2s \partial_t,$$

$$\begin{aligned} l_1 = & \left[\frac{2x^2s^2 - 2y^2s^2 + 2y^2 + 2xyt + x^2t^2 - y^2t^2 + 2xyst - tv + s^2tv + t^3v + 2x^2s}{-1 + s^2 + t^2} \right] \frac{\partial}{\partial x} \\ & + \left[\frac{-y^2t - x^2st - v + s^2v + t^2v - sv + s^3v + st^2v - x^2t - 4xyt^2 + y^2st + 2xy - 2xys^2}{1 - s^2 + t^2} \right] \frac{\partial}{\partial y} \\ & + [2x - 2yt + 2xs] \frac{\partial}{\partial s} + [2y + 2ys + 2xt] \frac{\partial}{\partial t} \\ & + \left[\frac{-4xy^2t - 2x^2ys - 2x^2y + 2y^3s - 2xv + 2xs^2v + 2xt^2v - 2y^3}{-1 + s^2 + t^2} \right] \frac{\partial}{\partial v}, \end{aligned}$$

$$\begin{aligned} l_2 = & \left[\frac{-y^2t - x^2st - 4xyt^2 + y^2st - sv + s^3v + st^2v + 2xy - 2xys^2 + v - s^2v - t^2v - x^2t}{-1 + s^2 + t^2} \right] \frac{\partial}{\partial x} \\ & + \left[\frac{-2x^2 + 2x^2s^2 + x^2t^2 - 2xyt - 2y^2s^2 - y^2t^2 + 2xyst - tv + s^2tv + t^3v + 2y^2s}{1 - s^2 + t^2} \right] \frac{\partial}{\partial y} \\ & + [2xt - 2y + 2ys] \frac{\partial}{\partial s} + [-2xs + 2x + 2yt] \frac{\partial}{\partial t} \\ & + \left[\frac{-2xy^2s + 2xy^2 + 4x^2yt + 2x^3s + 2x^3 - 2yv + 2ys^2v + 2yt^2v}{-1 + s^2 + t^2} \right] \frac{\partial}{\partial v}, \end{aligned}$$

$$\begin{aligned} J = & \left[\frac{-2xy^2t - x^2ys - x^2y + y^3s - xv + xs^2v + xt^2v - y^3}{-1 + s^2 + t^2} \right] \frac{\partial}{\partial x} \\ & + \left[\frac{-xy^2s + xy^2 + 2x^2yt + x^3s + x^3 - yv + ys^2v + yt^2v}{1 - s^2 + t^2} \right] \frac{\partial}{\partial y} \\ & + [2xy] \frac{\partial}{\partial s} + [-x^2 + y^2] \frac{\partial}{\partial t} \\ & + \left[\frac{(v - s^2v - t^2v - x^2s - x^2 - 2xyt + y^2s - y^2)(-v + s^2v + t^2v - x^2 - x^2s - 2xyt + y^2s - y^2)}{(1 - s^2 - t^2)^2} \right] \frac{\partial}{\partial v}. \end{aligned}$$

8. Prolongation to the Jet Space of Order 1

As said, we work above the origin $0 \in M_{LC}$.

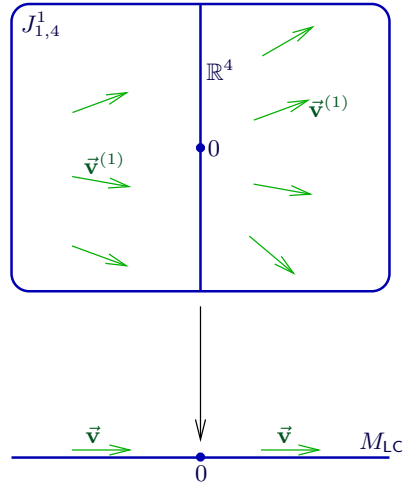

By Lie’s theory, any vector field \vec{v} on the base M lifts as a vector field $\vec{v}^{(1)}$ on the first jet space $J_{1,4}^1 = \mathbb{R}^{1+4+4}$.

Because our five intrinsic vector fields D, R, l_1, l_2, J vanish at $v = x = y = s = t = 0$, their prolongations will automatically be tangent to the fiber $\{(0, 0, 0, 0, 0, x_1, y_1, s_1, t_1)\}$ above $(0, 0, 0, 0, 0)$ in the first jet space.

Lie’s formulas yield the very simple values of these first prolongations above the origin $v = x = y = s = t = 0$:

	∂_{x_1}	∂_{y_1}	∂_{s_1}	∂_{t_1}
$D^{(1)}$	$-x_1$	$-y_1$	$-2s_1$	$-2t_1$
$R^{(1)}$	$-y_1$	x_1	$-2t_1$	$2s_1$
$l_1^{(1)}$	0	-1	$2x_1$	$2y_1$
$l_2^{(1)}$	1	0	$-2y_1$	$2y_1$
$J^{(1)}$	0	0	0	0

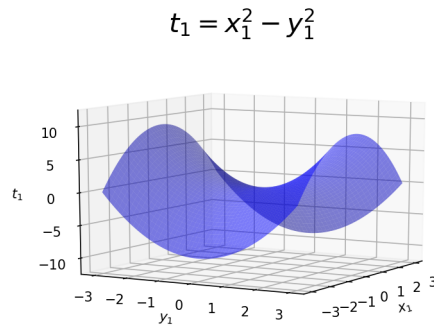
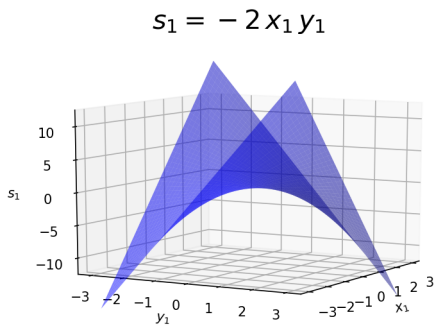

OBSERVATION 8.1. *On $\mathbb{R}^4 = \mathbb{R}^4_{x_1, y_1, s_1, t_1}$, there exists a unique $\{D^{(1)}, R^{(1)}, I_1^{(1)}, I_2^{(1)}, J^{(1)}\}$ -invariant 2-dimensional submanifold $\Sigma_0^1 \subset \mathbb{R}^4$, algebraic, graphed as:*

$$\begin{cases} s_1 = -2x_1y_1, \\ t_1 = x_1^2 - y_1^2, \end{cases}$$

Moreover, the complement $\mathbb{R}^4 \setminus \Sigma_0^1$ is a unique (transitive) orbit under $D^{(1)}, R^{(1)}, I_1^{(1)}, I_2^{(1)}, J^{(1)}$.

PROOF. We can drop the fifth line of $J^{(1)}$ containing only zeros. With a_1 and b_1 being parameters, any point of \mathbb{R}^4 can be written as (x_1, y_1, s_1, t_1) with:

$$s_1 := -2x_1y_1 + a_1, \quad t_1 := x_1^2 - y_1^2 + b_1.$$

Then replacing s_1 and t_1 :

$$\begin{pmatrix} -x_1 & -y_1 & -2s_1 & -2t_1 \\ -y_1 & x_1 & -2t_1 & 2s_1 \\ 0 & -1 & 2x_1 & 2y_1 \\ 1 & 0 & -2y_1 & 2x_1 \end{pmatrix} \xrightarrow{\text{Gauss-pivot}} \begin{pmatrix} 0 & 0 & -2a_1 & -2b_1 \\ 0 & 0 & -2b_1 & 2a_1 \\ 0 & -1 & 2x_1 & 2y_1 \\ 1 & 0 & -2y_1 & 2x_1 \end{pmatrix}.$$

This matrix has determinant $-4a_1^2 - 4b_1^2$, hence is of rank 4 when $(a_1, b_1) \neq (0, 0)$. In the corresponding locus, namely in $\mathbb{R}^4 \setminus \Sigma_0^1$, the five prolonged vector fields $D^{(1)}, R^{(1)}, I_1^{(1)}, I_2^{(1)}, J^{(1)}$ have everywhere rank 4, hence generate locally open orbits, so that $\mathbb{R}^4 \setminus \Sigma_0^1$ is a single orbit under their action.

When $a_1 = b_1 = 0$, the above matrix has rank 2. In this 2-dimensional graphed locus, the rank of $D^{(1)}, R^{(1)}, I_1^{(1)}, I_2^{(1)}, J^{(1)}$ is everywhere equal to 2, whence Σ_0^1 is a single orbit under their action. \square

Thus, the model M_{LC} has an invariant cone:

$$s_1 + it_1 = i(x_1 + iy_1)^2,$$

namely a cone invariant under the action of $D^{(1)}, R^{(1)}, I_1^{(1)}, I_2^{(1)}, J^{(1)}$. Soon, we will see that every $M^5 \subset \mathbb{C}^3$ in the class $\mathfrak{C}_{2,1}$ also possesses an invariant cone at any of its points $p \in M^5$.

9. Prolongation to the Jet Space of Order 2

Next, we increment the jet order by one unit. The second order Lie prolongations $D^{(2)}, R^{(2)}, I_1^{(2)}, I_2^{(2)}, J^{(2)}$ have the following coefficients above the origin, $v = x = y = s = t = 0$:

	∂_{x_1}	∂_{y_1}	∂_{s_1}	∂_{t_1}	∂_{x_2}	∂_{y_2}	∂_{s_2}	∂_{t_2}
$D^{(2)}$	$-x_1$	$-y_1$	$-2s_1$	$-2t_1$	$-3x_2$	$-3y_2$	$-4s_2$	$-4t_2$
$R^{(2)}$	$-y_1$	x_1	$-2t_1$	$2s_1$	$-y_2$	x_2	$-2t_2$	$2s_2$
$I_1^{(2)}$	0	-1	$2x_1$	$2y_1$	$2t_1 - 4x_1^2 - 4y_1^2$	$-2s_1$	$2x_2 - 4y_1t_1$	$2y_2 + 4x_1s_1$
$I_2^{(2)}$	1	0	$-2y_1$	$2y_1$	$-2s_1$	$-2t_1 - 4x_1^2 - 4y_1^2$	$-2y_2 + 4x_1t_1$	$2x_2 - 4x_1s_1$
$J^{(2)}$	0	0	0	0	0	0	$2s_1 + 4x_1y_1$	$2t_1 - 2x_1^2 + 2y_1^2$

Of course, we pull this matrix back to Σ_0^1 , hence the last line becomes null. Keeping only the first 4 lines, and performing a Gauss pivot, we get:

$$\begin{pmatrix} 0 & 0 & 0 & 0 & 6x_1^2y_1 + 6y_1^3 - 3x_2 & -6x_1y_1^2 - 6x_1^3 - 3y_2 & -2x_2y_1 - 4y_1^4 & -2y_1y_2 + 8x_1y_1^3 \\ 0 & 0 & 0 & 0 & -2x_1^3 - 2x_1y_1^2 - y_2 & -2x_1^2y_1 - 2y_1^3 + x_2 & -2x_1y_2 + 4x_1^4 - 4s_2 & +2x_1x_2 + 8x_1^3y_1 - 4t_2 \\ 0 & -1 & 2x_1 & 2y_1 & -2x_1^2 - 6y_1^2 & 4x_1y_1 & 2x_2 - 4x_1^2y_1 + 4y_1^3 & 2y_2 - 8x_1y_1^2 \\ 1 & 0 & -2y_1 & 2x_1 & 4x_1y_1 & -6x_1^2 - 2y_1^2 & -2y_2 + 4x_1^3 - 4x_1y_1^2 & 2x_2 + 8x_1^2y_1 \end{pmatrix}.$$

The upper 2×4 block, having 8 entries, then shows that x_2, y_2, s_2, t_2 can be uniquely and consistently defined in terms of x_1, y_1 , so that they define an invariant surface under the action of $D^{(2)}, R^{(2)}, I_1^{(2)}, I_2^{(2)}, J^{(2)}$.

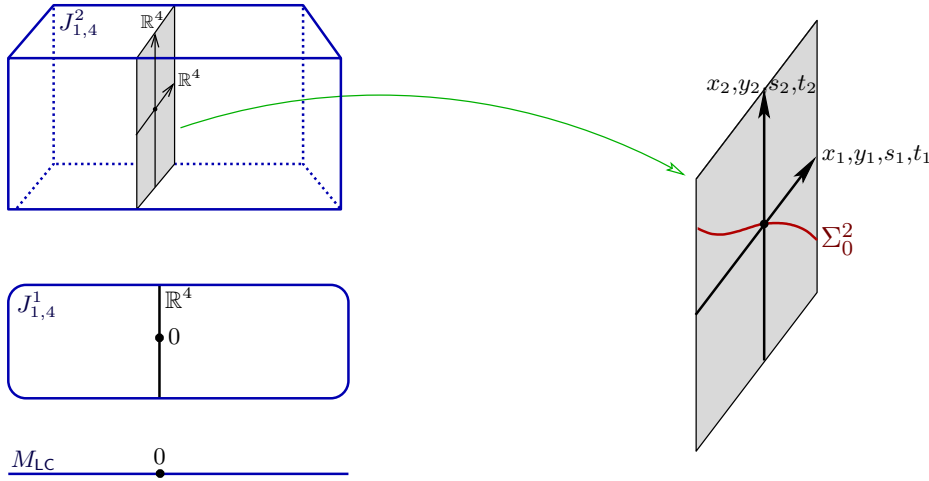

OBSERVATION 9.1. *On $\mathbb{R}^8 = \mathbb{R}_{x_1, y_1, s_1, t_1}^4 \times \mathbb{R}_{x_2, y_2, s_2, t_2}^4$, there exists a unique $\{D^{(2)}, R^{(2)}, I_1^{(2)}, I_2^{(2)}, J^{(2)}\}$ -invariant 2-dimensional submanifold $\Sigma_0^2 \subset \mathbb{R}^8$, algebraic, graphed as:*

$$\begin{cases} s_1 = -2x_1y_1, \\ t_1 = x_1^2 - y_1^2, \end{cases} \quad \begin{cases} x_2 = 2x_1^2y_1 + 2y_1^3, \\ y_2 = -2x_1^3 - 2x_1y_1^2, \\ s_2 = -2y_1^4 + 2x_1^4, \\ t_2 = 4x_1^3y_1 + 4x_1y_1^3. \end{cases}$$

Moreover, the complement $\mathbb{R}^8 \setminus \Sigma_0^2$ is a unique orbit under the transitive action of $D^{(2)}, R^{(2)}, I_1^{(2)}, I_2^{(2)}, J^{(2)}$.

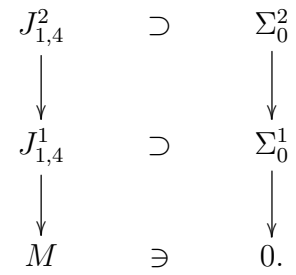

PROOF. As said, we pull everything back to Σ_0^1 having equations $s_1 = -2x_1y_1$, $t_1 = x_1^2 - y_1^2$. With a_2, b_2, c_2, d_2 being parameters, any point of $\mathbb{R}_{x_2, y_2, s_2, t_2}^4$ can be written as:

$$\begin{cases} x_2 = 2x_1^2y_1 + 2y_1^3 + a_2, \\ y_2 = -2x_1^3 - 2x_1y_1^2 + b_2, \end{cases} \quad \begin{cases} s_2 = -2y_1^4 + 2x_1^4 + c_2, \\ t_2 = 4x_1^3y_1 + 4x_1y_1^3 + d_2. \end{cases}$$

Replacing x_2, y_2 without replacing s_2, t_2 , the upper right 2×4 block becomes:

$$\begin{pmatrix} -3a_2 & -3b_2 & -8y_1^4 + 8x_1^4 - 4s_2 - 2y_1a_2 - 2x_1b_2 & 16x_1^3y_1 + 16x_1y_1^3 - 4t_2 - 2y_1b_2 + 2x_1a_2 \\ -b_2 & a_2 & 8x_1^3y_1 + 8x_1y_1^3 - 2t_2 + 2x_1a_2 - 2y_1b_2 & -4x_1^4 + 4y_1^4 + 2s_2 + 2x_1b_2 + 2y_1a_2 \end{pmatrix}.$$

Visibly, it is of rank 2 whenever $(a_2, b_2) \neq (0, 0)$.

Thus, put in it $a_2 := 0$ and $b_2 := 0$:

$$\begin{pmatrix} 0 & 0 & -8y_1^4 + 8x_1^4 - 4s_2 & 16x_1^3y_1 + 16x_1y_1^3 - 4t_2 \\ 0 & 0 & 8x_1^3y_1 + 8x_1y_1^3 - 2t_2 & -4x_1^4 + 4y_1^4 + 2s_2 \end{pmatrix},$$

and now replace s_2, t_2 , to get:

$$\begin{pmatrix} 0 & 0 & -4c_2 & -4d_2 \\ 0 & 0 & -2c_2 & 2d_2 \end{pmatrix},$$

a submatrix which has maximal rank 2 if and only if $(c_2, d_2) \neq (0, 0)$. This concludes. \square

We have therefore shown that, to every (fixed) 1-jet at the origin $0 \in M_{LC}$ of the form:

$$j_0^1 = (x_1, y_1, -2x_1y_1, x_1^2 - y_1^2)$$

is associated a unique second order jet at the origin:

$$j_0^2 = (x_1, y_1, -2x_1y_1, x_1^2 - y_1^2, 2x_1^2y_1 + 2y_1^3, -2x_1^3 - 2x_1y_1^2, -2y_1^4 + 2x_1^4, 4x_1^3y_1 + 4x_1y_1^3),$$

and since Σ_0^2 is invariant under the action of the stability group of the Gaussier-Merker model, this association is invariant.

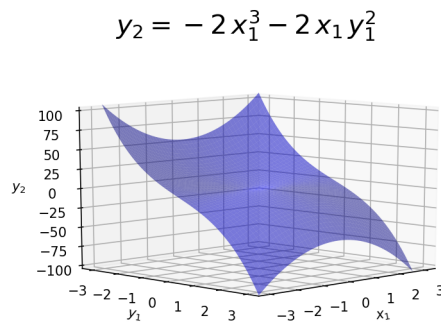
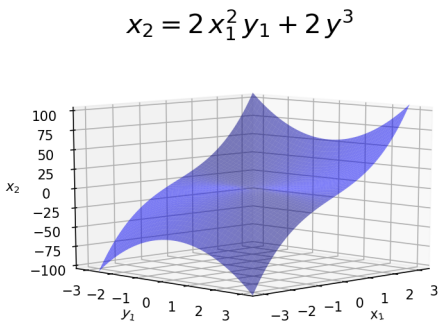

$$s_2 = -2y_1^4 + 2x_1^4$$

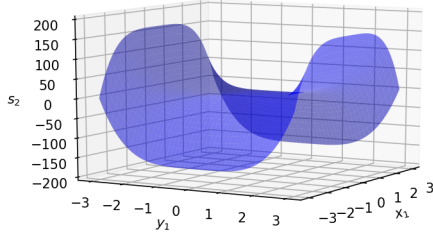

$$t_2 = 4x_1^3y_1 + 4x_1y_1^3$$

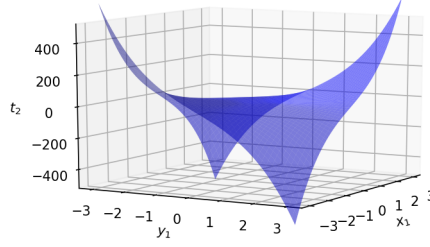

Our next goal will be to transfer this invariancy property to *any* $M^5 \in \mathfrak{C}_{2,1}$. But subtleties will spice up our job.

10. Road Map to Convergent Normal Form

A certain *Lie-theoretic* construction of Cartan-Moser chains for Levi nondegenerate hypersurfaces $M^3 \subset \mathbb{C}^2$ was set up in [95] in order to be imitated when studying hypersurfaces $M^5 \subset \mathbb{C}^3$ in the class $\mathfrak{C}_{2,1}$, in the present memoir. However, we will encounter not only analogies, but also differences.

Recall that any Levi nondegenerate $M^3 \subset \mathbb{C}^2$, taken at any point $p \in M$, can be brought, in local coordinates $(z, w = u + iv)$ vanishing at p , to the preliminary normal form [95, Prp. 2.2]:

$$v = z\bar{z} + O(6),$$

where the remainder is *weighted* according to $[z] := 1$, $[w] := 2$. Furthermore, the *ambiguity* of such a punctual preliminary normalization, namely *any* map:

$$z' = f_1 + f_2 + f_3 + f_4 + O(5), \quad w' = g_1 + g_2 + g_3 + g_4 + g_5 + O(6),$$

which preserves this normalization, *i.e.* which sends $v = z\bar{z} + O(6)$ to $v' = z'\bar{z}' + O(6)$, can be shown to be necessarily of the form [95, Prp. 2.4]:

$$\begin{aligned} z' := & \lambda z + 2i\lambda\bar{\alpha}z^2 + (-4\lambda\bar{\alpha}^2)z^3 + (-8i\lambda\bar{\alpha}^3)z^4 \\ & + \lambda\alpha w + (3i\lambda\alpha\bar{\alpha} + \lambda r)zw + (-8\lambda\alpha\bar{\alpha}^2 + 4i\bar{\alpha}\lambda r)z^2w \\ & + (\lambda\alpha r + i\lambda\alpha^2\bar{\alpha})w^2 + O(5), \end{aligned}$$

$$\begin{aligned} w' = & \lambda\bar{\lambda}w + 2i\lambda\bar{\lambda}\bar{\alpha}zw + (-4\lambda\bar{\lambda}\bar{\alpha}^2)z^2w + (-8i\lambda\bar{\lambda}\bar{\alpha}^3)z^3w \\ & + (i\lambda\bar{\lambda}\alpha\bar{\alpha} + \lambda\bar{\lambda}r)w^2 + (4i\lambda\bar{\lambda}\bar{\alpha}r - 4\lambda\bar{\lambda}\bar{\alpha}^2\alpha)zw^2 + O(6), \end{aligned}$$

and this form coincides exactly with the Taylor expansion, up to weighted orders 4, 5, of the general stability group of the *model* $\{v = z\bar{z}\} \rightarrow \{v' = z'\bar{z}'\}$, which is well known to be:

$$z' = \frac{\lambda(z + \alpha w)}{1 - 2i\bar{\alpha}z - (r + i\alpha\bar{\alpha})w}, \quad w' = \frac{\lambda\bar{\lambda}w}{1 - 2i\bar{\alpha}z - (r + i\alpha\bar{\alpha})w},$$

with arbitrary $\lambda \in \mathbb{C}^*$, $\alpha \in \mathbb{C}$, $r \in \mathbb{R}$.

One could then figure out that precisely similar statements hold for $M^5 \in \mathfrak{C}_{2,1}$. However, some ‘*discrepancies*’, which we will overcome, will occur. Indeed, let us briefly

describe some differences, as a preliminary view on the technical road we will drive into the forest.

Taking the weights $[z] := 1$, $[\zeta] := 1$, $[w] := 2$, starting with $u = F(z, \zeta, \bar{z}, \bar{\zeta}, v)$ passing through the origin, by progressively normalizing the power series expansion of F , it is not difficult to show that any $M^5 \in \mathfrak{C}_{2,1}$ can be brought to the form:

$$u = z\bar{z} + \frac{1}{2}\bar{z}^2\zeta + \frac{1}{2}z^2\bar{\zeta} + O_{z,\zeta,\bar{z},\bar{\zeta},v}(4).$$

As we know from Section 5, the isotropy group of the Gaussier-Merker model is also parametrized by 5 real constants $\lambda \in \mathbb{C}^*$, $\alpha \in \mathbb{C}$, $r \in \mathbb{R}$, and an expansion of the concerned fractional formulas was provided there.

However, one can verify (exercise) that the stability group of the above punctual normalization up to order 3 happens to be:

$$\begin{aligned} z' &:= \lambda z + \left(\frac{\delta}{\lambda} - \frac{1}{2} \frac{\lambda^2}{\lambda} \bar{\beta} \right) z^2 - \frac{1}{2} \frac{\bar{\delta}}{\lambda} w, \\ \zeta' &:= \frac{\lambda}{\lambda} \zeta + \beta z, \\ w' &:= \lambda \bar{\lambda} w + \delta z w, \end{aligned}$$

with arbitrary $\lambda \in \mathbb{C}^*$, $\beta \in \mathbb{C}$, $\delta \in \mathbb{C}$. This looks different from the stability group of the model, shown in Section 5 and truncated to orders 2, 1, 3.

Next, it can be shown (and we will do it) that that any $M^5 \in \mathfrak{C}_{2,1}$ can be brought to the form:

$$u = z\bar{z} + \frac{1}{2}\bar{z}^2\zeta + \frac{1}{2}z^2\bar{\zeta} + z\bar{z}\zeta\bar{\zeta} + O_{z,\zeta,\bar{z},\bar{\zeta},v}(5).$$

Lemma 20.1 will show that the stability of this equation reads as:

$$\begin{aligned} z' &:= \lambda z - i\lambda\alpha z^2 - i\lambda\bar{\alpha}w - \frac{\lambda^2}{\lambda}\bar{\beta}z^3 + \left(i\lambda r - \frac{3}{2}\lambda\alpha\bar{\alpha} - \frac{1}{4}\frac{\lambda^2}{\lambda}\bar{\varepsilon} - \frac{1}{4}\bar{\lambda}\varepsilon \right) zw + i\lambda\alpha\zeta w, \\ \zeta' &:= \frac{\lambda}{\lambda}\zeta + 2i\frac{\lambda}{\lambda}\bar{\alpha}z + \varepsilon z^2 - 2i\frac{\lambda}{\lambda}\alpha z\zeta + \beta w, \\ w' &:= \lambda\bar{\lambda}w - 2i\lambda\bar{\lambda}\alpha zw - (2\lambda\bar{\lambda}\alpha^2 + \lambda^2\bar{\beta})z^2w + (-\lambda\bar{\lambda}\alpha\bar{\alpha} + i\lambda\bar{\lambda}r)w^2, \end{aligned}$$

where $\lambda \in \mathbb{C}^*$, $\alpha \in \mathbb{C}$, $r \in \mathbb{R}$, $\beta \in \mathbb{C}$, $\varepsilon \in \mathbb{C}$ are arbitrary parameters. Thus, in comparison with the isotropy of the GM-model, shown in Section 5 and truncated to orders 3, 2, 4, there are two ‘extra’ complex parameters, namely β , ε .

Also, in Proposition 20.3 we will normalize, still at the origin only:

$$\begin{aligned} u &= z\bar{z} + \frac{1}{2}\bar{z}^2\zeta + \frac{1}{2}z^2\bar{\zeta} + z\bar{z}\zeta\bar{\zeta} + \frac{1}{2}\bar{z}^2\zeta\zeta\bar{\zeta} + \frac{1}{2}z^2\bar{\zeta}\zeta\bar{\zeta} \\ &\quad + z^3\bar{\zeta}^2 F_{3,0,0,2,0} + \bar{z}^3\zeta^2 \overline{F_{3,0,0,2,0}} + O_{z,\zeta,\bar{z},\bar{\zeta},v}(6), \end{aligned}$$

and in Lemma 20.4, we will see that the stability group of this normal form is:

$$\begin{aligned}
z' &:= \lambda z - i \lambda \alpha z^2 - i \lambda \bar{\alpha} w - \lambda \alpha^2 z^3 + \left(i \lambda r - 3 \lambda \alpha \bar{\alpha} + 2i \lambda \alpha F_{3,0,0,2,0} - 2i \lambda \bar{\alpha} \overline{F_{3,0,0,2,0}} \right) z w + i \lambda \alpha \zeta w \\
&\quad + i \lambda \alpha^3 z^4 + \left(8i \lambda \alpha^2 \bar{\alpha} + \frac{1}{2} \frac{\lambda^2}{\lambda} \bar{\gamma} + 4 \frac{\lambda}{\lambda} \bar{\tau} + 4 \lambda \alpha^2 F_{3,0,0,2,0} - 8 \lambda \alpha \bar{\alpha} \overline{F_{3,0,0,2,0}} \right) z^2 w + 3 \lambda \alpha^2 z \zeta w + \tau w^2, \\
\zeta' &:= \frac{\lambda}{\lambda} \zeta + 2i \frac{\lambda}{\lambda} \bar{\alpha} z + \left(3 \frac{\lambda}{\lambda} \alpha \bar{\alpha} - i \frac{\lambda}{\lambda} r - 2i \frac{\lambda}{\lambda} \alpha F_{3,0,0,2,0} + 6i \frac{\lambda}{\lambda} \bar{\alpha} \overline{F_{3,0,0,2,0}} \right) z^2 - 2i \frac{\lambda}{\lambda} \alpha z \zeta + \frac{\lambda}{\lambda} \bar{\alpha}^2 w \\
&\quad + \left(2 \frac{\lambda}{\lambda} \alpha r - 4i \frac{\lambda}{\lambda} \alpha^2 \bar{\alpha} - 2 \frac{\lambda^2}{\lambda^2} \bar{\gamma} - 8 \frac{\lambda}{\lambda^2} \bar{\tau} + 12 \frac{\lambda}{\lambda} \alpha^2 F_{3,0,0,2,0} + 4 \frac{\lambda}{\lambda} \alpha \bar{\alpha} \overline{F_{3,0,0,2,0}} \right) z^3 - 3 \frac{\lambda}{\lambda} \alpha^2 z^2 \zeta + \gamma z w \\
&\quad + \left(-2 \frac{\lambda}{\lambda} \alpha \bar{\alpha} + 4i \frac{\lambda}{\lambda} \alpha F_{3,0,0,2,0} - 4i \frac{\lambda}{\lambda} \bar{\alpha} \overline{F_{3,0,0,2,0}} \right) \zeta w, \\
w' &:= \lambda \bar{\lambda} w - 2i \lambda \bar{\lambda} \alpha z w - 3 \lambda \bar{\lambda} \alpha^2 z^2 w + \left(-\lambda \bar{\lambda} \alpha \bar{\alpha} + i \lambda \bar{\lambda} r \right) w^2 + 4i \lambda \bar{\lambda} \alpha^3 z^3 w \\
&\quad + \left(6i \lambda \bar{\lambda} \alpha^2 \bar{\alpha} + 2 \lambda \bar{\lambda} \alpha r + 2 \lambda \bar{\tau} + 4 \lambda \bar{\lambda} \alpha^2 F_{3,0,0,2,0} - 4 \lambda \bar{\lambda} \alpha \bar{\alpha} \overline{F_{3,0,0,2,0}} \right) z w^2 + \lambda \bar{\lambda} \alpha^2 \zeta w^2.
\end{aligned}$$

where $\lambda \in \mathbb{C}^*$, $\alpha \in \mathbb{C}$, $r \in \mathbb{R}$, $\gamma \in \mathbb{C}$, $\tau \in \mathbb{C}$ are arbitrary. Thus, there are again two ‘extra’ complex parameters, namely γ, τ .

To realize a Moser-like normal form for hypersurfaces $M^5 \in \mathfrak{C}_{2,1}$ and to define analogs of Cartan-Moser chains, we will therefore have to adapt a bit our ideas. Let us give a quick summary.

To start with, we will pick any curve $0 \in \gamma \subset M$ which is *CR-transversal* in the sense that $\dot{\gamma} \notin T^c M$. It is well known that one can always straighten it to be $\gamma = \{(0, 0, iv)\} \subset M$, the v -axis. It is also well known that, after an appropriate biholomorphism, one can make the graphing function $F(z, \zeta, \bar{z}, \bar{\zeta}, v)$ to have *no* pluriharmonic terms, in the sense that $F(z, \zeta, 0, 0, v) \equiv 0$.

In Section 11 to 19, we will continue to *prenormalize* and even start to *normalize* F further, *without touching* γ , namely by always stabilizing $\{(0, 0, iv)\} \subset M$.

However, at some moment of the normalization process, exactly as what occurs [23, 71] for Levi nondegenerate $M^3 \subset \mathbb{C}^2$, one is ‘forced’ to perform additional normalizations which *bend* the v -axis, hence destroy what was preserved up to this point. This fact confirms that it was inappropriate to choose at the beginning any CR-transversal curve $0 \in \gamma \subset M$, ‘at random’.

It is at this crucial moment that the Cartan-Moser chains start to appear to eyes. By appropriately interpreting the algebraic or geometric normalization conditions that force to change the v -axis, one realizes that certain CR-transversal curves are *invariant* under biholomorphisms of \mathbb{C}^2 . Our goal is to view something similar and new about $M^5 \in \mathfrak{C}_{2,1}$. We will do it.

The Lie-theoretical path taken in [95] consisted in normalizing the equation of M at only one point, only up to order 5, which is quite elementary, can be done by hand or on a computer, and does not employ (at all) the implicit function theorem. In this memoir, we will conduct essentially the same method as in [95] but with two differences. Firstly, we will prenormalize the equation of M not only at 0 but all along the v -axis $\gamma \subset M$ (chosen at random) and reach Proposition 19.4, until we come to the point where chains start to appear to eyes. Then we will work only at 0, with power series expansions of orders 5, 6, 7, and ‘discover’ that the chains are the same as stated by Observations 8.1 and 9.1 for the Gaussier-Merker model, notwithstanding the presence of extra complex parameters.

Once chains are known, we will go back to the starting point, and choose the CR-transversal $\gamma \subset M$ to be a chain, then we will plainly apply all what was done for a random

γ , and we will deduce that two normalizations of certain coefficients $F_{a,b,c,d}(v)$ realize themselves gratuitously thanks to chains, and lastly, we will obtain a complete Moser-like normal form.

To terminate our mathematical work and get some uniqueness property, we will work out the formal theory of the normal form only at the end of the paper.

11. Chain Straightening and Harmonic Killing

Start with any $\mathfrak{C}_{2,1}$ hypersurface $M \subset \mathbb{C}^3$, passing by the origin $0 \in M$. Since $T_0^c M \cong \mathbb{C}^2$, we can assume after a \mathbb{C} -linear transformation that $T_0^c M = \mathbb{C}_z \times \mathbb{C}_\zeta \times \{0\}$, in coordinates $(z, \zeta, w) \in \mathbb{C}^3$.

The ‘game’ is to transform M progressively into more and more *normalized* hypersurfaces. Each (partial) normalization step can be represented by means of a biholomorphism fixing the origin as:

$$\begin{array}{ccc} \mathbb{C}^3 \supset (M^5, 0) & \xrightarrow{\text{normalize}} & (M'^5, 0) \subset \mathbb{C}'^3, \\ (z, \zeta, w) & \longrightarrow & (f(z, \zeta, w), g(z, \zeta, w), h(z, \zeta, w)) \\ & & =: (z', \zeta', w'). \end{array}$$

Without loss of generality, both hypersurfaces will be assumed, with $w = u + iv$ and $w' = u' + iv'$, to be \mathcal{C}^ω -graphed as:

$$u = F(z, \zeta, \bar{z}, \bar{\zeta}, v) \quad \text{and} \quad u' = F'(z', \zeta', \bar{z}', \bar{\zeta}', v').$$

We may assume that $T_0^c M = \{w = 0\}$ is left untouched, so that $T_0^c M' = \{w' = 0\}$ too.

In fact, step by step, all previously achieved normalizations will be conserved while performing any further normalization. Once M has been partly normalized to some new M' , we will erase primes to the obtained $M' =: M$, normalize once more, and so on.

Now, the hypothesis that the biholomorphism establishes a CR-diffeomorphism $M \xrightarrow{\sim} M'$, expresses as saying that $u' = F'$ when $u = F$, namely:

$$0 = -\operatorname{Re} h(z, \zeta, w) + F' \left(f(z, \zeta, w), g(z, \zeta, w), \bar{f}(\bar{z}, \bar{\zeta}, \bar{w}), \bar{g}(\bar{z}, \bar{\zeta}, \bar{w}), \operatorname{Im} h(z, \zeta, w) \right) \Big|_{w=F(z, \zeta, \bar{z}, \bar{\zeta}, v) + iv}.$$

Performing the indicated replacement $w = F + iv$ yields

LEMMA 11.1. [Fundamental identity] *The map $(z', \zeta', w') = (f, g, h)$ sends $M = \{u = F\}$ to $M' = \{u' = F'\}$ if and only if:*

$$\begin{aligned} 0 \equiv & -\frac{1}{2} h(z, \zeta, F(z, \zeta, \bar{z}, \bar{\zeta}, v) + iv) - \frac{1}{2} \bar{h}(\bar{z}, \bar{\zeta}, F(z, \zeta, \bar{z}, \bar{\zeta}, v) - iv) + \\ & + F' \left(f(z, \zeta, F(z, \zeta, \bar{z}, \bar{\zeta}, v) + iv), g(z, \zeta, F(z, \zeta, \bar{z}, \bar{\zeta}, v) + iv), \bar{f}(\bar{z}, \bar{\zeta}, F(z, \zeta, \bar{z}, \bar{\zeta}, v) - iv), \right. \\ & \left. \bar{g}(\bar{z}, \bar{\zeta}, F(z, \zeta, \bar{z}, \bar{\zeta}, v) - iv), \frac{1}{2i} h(z, \zeta, F(z, \zeta, \bar{z}, \bar{\zeta}, v) + iv) - \frac{1}{2i} \bar{h}(\bar{z}, \bar{\zeta}, F(z, \zeta, \bar{z}, \bar{\zeta}, v) - iv) \right), \end{aligned}$$

holds identically in $\mathbb{C}\{z, \zeta, \bar{z}, \bar{\zeta}, v\}$. □

Although this equation looks complicated, it must be dealt with. Progressive normalizations will make it more tractable.

One of the first tasks is to annihilate all pluriharmonic monomials $F_{a,b,0,0,e} z^a \zeta^b v^e$ in (z, ζ) , and their conjugates as well. For completeness, we explain in details how to do this known normalization. We proceed in two steps.

As already explained in Section 10, a CR-transversal curve with $0 \in \gamma \subset M$ is now at first chosen ‘at random’, while a better choice will be made later, when the normalization process will reach a certain deeper point.

LEMMA 11.2. *Let $\gamma: \mathbb{R} \rightarrow M$ be any local \mathcal{C}^ω curve with $\gamma(0) = 0 \in M$ and $\dot{\gamma}(0) \notin T_0^c M = \{w = 0\}$. Then there exists a biholomorphism $(z, \zeta, w) \mapsto (z', w', \zeta')$ sending (stabilizing) $T_0^c M = \{w = 0\}$ to $T_0^c M' = \{w' = 0\}$ which sends γ to the curve $\gamma'(t) = (0, 0, it)$ straightened along the v -axis.*

Notice that the CR-transversal direction $\dot{\gamma}'(0) \in T_0 M' \setminus T_0^c M'$ together with $T_0^c M' = \{w' = 0\}$ implies $T_0 M' = \{u' = 0\}$.

PROOF. Write the curve as:

$$\gamma(t) = (\varphi(t), \psi(t), \chi(t)),$$

with some complex-valued analytic functions φ, ψ, χ . By assumption, $\dot{\chi}(0) \neq 0$. This guarantees invertibility of the *inverse* holomorphic change of coordinates:

$$z := z' + \varphi(-iw'), \quad \zeta := \zeta' + \psi(-iw'), \quad w := \chi(-iw').$$

Similarly, the target (transformed) curve can be written $\gamma'(t) = (\varphi'(t), \psi'(t), i\chi'(t))$ — note the i factor —, and the pointwise correspondence between curves writes as:

$$\varphi(t) \equiv \varphi'(t) + \varphi(-i(i\chi'(t))), \quad \psi(t) \equiv \psi'(t) + \psi(-i(i\chi'(t))), \quad \chi(t) \equiv \chi(-i(i\chi'(t))).$$

This last identity yields $t \equiv \chi'(t)$ thanks to $0 \neq \dot{\chi}(0)$. Replacing then $\chi'(t) := t$ inside the first two identities concludes that $0 \equiv \varphi'(t) \equiv \psi'(t)$. \square

Consequently, the graphing function of the transformed hypersurface writes, after erasing primes:

$$M: \quad u = F(z, \zeta, \bar{z}, \bar{\zeta}, v)$$

with $F = O(2)$ and also $F(0, 0, 0, 0, v) \equiv 0$. This last condition is technically needed for the next second elementary normalization.

LEMMA 11.3. *Starting from $F = O(2)$ with $F(0, 0, 0, 0, v) \equiv 0$, there exists a biholomorphism of the form:*

$$z' := z, \quad \zeta' := \zeta, \quad w' := w + h(z, \zeta, w),$$

with $h = O(2)$ and $h(0, 0, w) \equiv 0$ which transforms $\{u = F\}$ to $\{u' = F'\}$ satisfying:

$$0 \equiv F'(z', \zeta', 0, 0, v') \equiv F'(0, 0, \bar{z}', \bar{\zeta}', v').$$

The second vanishing identity is a consequence of the first by conjugation, thanks to (2.1). Equivalently, $F'_{a,b,0,0,e} = 0 = F'_{0,0,c,d,e}$ for all integer indices. Notice that $F'(0, 0, 0, 0, v') \equiv 0$ still holds.

PROOF. If such a biholomorphism exists, the fundamental identity of Lemma 11.1 shows that:

$$(11.4) \quad \begin{aligned} 0 \equiv & -F(z, \zeta, \bar{z}, \bar{\zeta}, v) - \frac{1}{2} h(z, \zeta, F(z, \zeta, \bar{z}, \bar{\zeta}, v) + iv) - \frac{1}{2} \bar{h}(\bar{z}, \bar{\zeta}, F(z, \zeta, \bar{z}, \bar{\zeta}, v) - iv) + \\ & + F'(z, \zeta, \bar{z}, \bar{\zeta}, v + \frac{1}{2i} h(z, \zeta, F(z, \zeta, \bar{z}, \bar{\zeta}, v) + iv) - \frac{1}{2i} \bar{h}(\bar{z}, \bar{\zeta}, F(z, \zeta, \bar{z}, \bar{\zeta}, v) - iv)). \end{aligned}$$

Our goal is to make $F'(z', \zeta', 0, 0, v) \equiv 0$.

If this vanishing identity would hold, putting $\bar{z} := 0 =: \bar{\zeta}$ in (11.4) we would deduce:

(11.5)

$$0 \equiv -F(z, \zeta, 0, 0, v) - \frac{1}{2} h(z, \zeta, F(z, \zeta, 0, 0, v) + iv) - \frac{1}{2} \bar{h}(0, 0, F(z, \zeta, 0, 0, v) - iv) + 0.$$

We claim that such an identity can be employed in order to define $h(z, \zeta, w)$ uniquely, with the supplementary condition that the last term $-\frac{1}{2} \bar{h}$ of (11.5) is zero.

Indeed, thanks to $F = O(2)$, we may apply the implicit function theorem to invert:

$$F(z, \zeta, 0, 0, v) + iv =: \omega \quad \iff \quad v = T(z, \zeta, \omega) = -i\omega + O(2).$$

Define therefore $h(z, \zeta, w)$ accordingly:

$$0 \equiv -F(z, \zeta, T(z, \zeta, \omega)) - \frac{1}{2} h(z, \zeta, \omega) - \frac{1}{2} \cdot 0.$$

Now, because $F(0, 0, 0, 0, v) \equiv 0$ by hypothesis, it comes $0 \equiv h(0, 0, \omega)$, just by putting $z := 0 =: \zeta$ in (11.5).

Consequently, the identity (11.5) is indeed realized with $-\frac{1}{2} \bar{h} = 0$. Finally, coming back to (11.4) $\big|_{\bar{z}=\bar{\zeta}=0}$, we get in conclusion what we want:

$$0 \equiv 0 + F'(z, \zeta, 0, 0, v + \frac{1}{2i} h(z, \zeta, F(z, \zeta, 0, 0, v) + iv) - 0). \quad \square$$

Thus, erasing primes, we have obtained the preliminary normalization:

$$u = F = \sum_{\substack{a+b \geq 1 \\ c+d \geq 1}} z^a \zeta^b \bar{z}^c \bar{\zeta}^d F_{a,b,c,d}(v) \quad \text{with} \quad F_{a,b,c,d}(v) := \sum_{e \geq 1} F_{a,b,c,d,e} v^e.$$

In the sequel, we shall perform normalizing biholomorphisms which stabilize this form.

12. Prenormalization: Step I

To start with, let us expand:

$$u = z\bar{z} F_{1,0,1,0}(v) + z\bar{\zeta} F_{1,0,0,1}(v) + \bar{z}\zeta F_{0,1,1,0}(v) + \zeta\bar{\zeta} F_{0,1,0,1}(v) + O_{z,\zeta,\bar{z},\bar{\zeta}}(3).$$

By assumption, the Levi matrix of F has rank 1 everywhere, hence in particular at the origin. We compute this matrix:

$$\text{Levi}(F) = \begin{pmatrix} 0 & O(1) & O(1) & -\frac{1}{2} + O(2) \\ O(1) & F_{1,0,1,0}(0) + O(1) & F_{0,1,1,0}(0) + O(1) & O(1) \\ O(1) & F_{1,0,0,1}(0) + O(1) & F_{0,1,0,1}(0) + O(1) & O(1) \\ -\frac{1}{2} + O(2) & O(1) & O(1) & O(1) \end{pmatrix},$$

where $O(N) = O_{z,\zeta,\bar{z},\bar{\zeta},v}(N)$ for any integer $N \in \mathbb{N}$. Hence at the origin $(z, \zeta, \bar{z}, \bar{\zeta}, v) = (0, 0, 0, 0, 0)$:

$$1 = \text{rank} \begin{pmatrix} F_{1,0,1,0}(0) & F_{0,1,1,0}(0) \\ F_{1,0,0,1}(0) & F_{0,1,0,1}(0) \end{pmatrix}.$$

After a \mathbb{C} -linear invertible transformation in the (z, ζ) -space, we can assume:

$$(12.1) \quad 1 = F_{1,0,1,0}(0) \quad \text{and} \quad 0 = F_{1,0,0,1}(0) = F_{0,1,1,0}(0) = F_{0,1,0,1}(0),$$

so that:

$$u = z\bar{z} + O_{z,\zeta,\bar{z},\bar{\zeta},v}(3).$$

LEMMA 12.2. *There exists a biholomorphism of the form:*

$$z' := z\varphi(w), \quad \zeta' := \zeta, \quad w' := w,$$

which transforms $M = \{u = F\}$ into M' of equation:

$$u' = z'\bar{z}' + \sum_{\substack{(a,b,c,d) \neq (1,0,1,0) \\ a+b \geq 1, c+d \geq 1}} z'^a \zeta'^b \bar{z}'^c \bar{w}'^d F'_{a,b,c,d}(v').$$

PROOF. We write the source hypersurface as:

$$u = F = z\bar{z} F_{1,0,1,0}(v) + \zeta(\cdots) + \bar{\zeta}(\cdots) + O_{z,\zeta,\bar{z},\bar{\zeta}}(3),$$

and similarly for the target:

$$u' = F' = z'\bar{z}' F'_{1,0,1,0}(v') + \zeta'(\cdots) + \bar{\zeta}'(\cdots) + O_{z',\zeta',\bar{z}',\bar{\zeta}'}(3).$$

Through any map of the form being considered, since $z' = z(\cdots)$ and $\zeta' = \zeta$, it is clear that the remainders correspond to one another:

$$\zeta'(\cdots) = \zeta(\cdots), \quad O_{z',\zeta',\bar{z}',\bar{\zeta}'}(3) = O_{z,\zeta,\bar{z},\bar{\zeta}}(3).$$

Since $u = u'$, the fundamental identity (11.1) writes:

$$0 \equiv -F(z, \zeta, \bar{z}, \bar{\zeta}) + F'(z\varphi(F+iv), \zeta, \bar{z}\bar{\varphi}(F-iv), \bar{\zeta}, v),$$

which implies, after taking account of the fact that remainders are the same and that $v = v'$:

$$0 \equiv -z\bar{z} F_{1,0,1,0}(v) + z\bar{z}\varphi(F+iv)\bar{\varphi}(F-iv) F'_{1,0,1,0}(v) + \zeta(\cdots) + \bar{\zeta}(\cdots) + O_{z,\zeta,\bar{z},\bar{\zeta}}(3).$$

Next, by Taylor expanding at iv , we get:

$$\varphi(iv + F) = \varphi(iv) + F(\cdots) = \varphi(iv) + O_{z,\zeta,\bar{z},\bar{\zeta}}(2),$$

and by inserting this above, we obtain:

$$0 \equiv -z\bar{z} F_{1,0,1,0}(v) + z\bar{z}\varphi(iv)\bar{\varphi}(-iv) F'_{1,0,1,0}(v) + O_{z,\zeta,\bar{z},\bar{\zeta}}(4) + \zeta(\cdots) + \bar{\zeta}(\cdots) + O_{z,\zeta,\bar{z},\bar{\zeta}}(3).$$

Identifying the coefficients of $z\bar{z}$ yields:

$$0 \equiv -F_{1,0,1,0}(v) + \varphi(iv)\bar{\varphi}(iv) F'_{1,0,1,0}(v).$$

We can normalize $F'_{1,0,1,0}(v) \equiv 1$ provided φ satisfies:

$$\varphi(iv)\bar{\varphi}(-iv) \equiv F_{1,0,1,0}(v).$$

Observing that $\overline{F_{1,0,1,0}(v)} = F_{1,0,1,0}(v)$ by the reality condition (2.2), it suffices to set:

$$\varphi(w) := \sqrt{F_{1,0,1,0}(-iw)},$$

a function which is holomorphic thanks to $F_{1,0,1,0}(0) = 1$. □

So, erasing primes, we have obtained:

$$(12.3) \quad u = z\bar{z} + \sum_{\substack{(a,b,c,d) \neq (1,0,1,0) \\ a+b \geq 1, c+d \geq 1}} z^a \zeta^b \bar{z}^c \bar{\zeta}^d F_{a,b,c,d}(v).$$

13. Dependent and Independent Jets

Now, the assumption of Levi degeneracy states as the vanishing identity:

$$0 \equiv \text{Levi}(F) := \begin{vmatrix} 0 & F_z & F_\zeta & -\frac{1}{2} + \frac{1}{2i}F_v \\ F_{\bar{z}} & F_{z\bar{z}} & F_{\zeta\bar{z}} & \frac{1}{2i}F_{\bar{z}v} \\ F_{\bar{\zeta}} & F_{z\bar{\zeta}} & F_{\zeta\bar{\zeta}} & \frac{1}{2i}F_{\bar{\zeta}v} \\ -\frac{1}{2} - \frac{1}{2i}F_v & -\frac{1}{2i}F_{zv} & -\frac{1}{2i}F_{\zeta v} & \frac{1}{4}F_{vv} \end{vmatrix}.$$

But the Levi form is *not* assumed to be identically zero, it is assumed to be constantly of rank 1. With $F = z\bar{z} + O(3)$ in (12.3), this assumption expresses as the nonvanishing of the minor:

$$0 \neq \text{Levi}_1(F) := \begin{vmatrix} 0 & F_z & -\frac{1}{2} + \frac{1}{2i}F_v \\ F_{\bar{z}} & F_{z\bar{z}} & \frac{1}{2i}F_{\bar{z}v} \\ -\frac{1}{2} - \frac{1}{2i}F_v & -\frac{1}{2i}F_{zv} & \frac{1}{4}F_{vv} \end{vmatrix}.$$

Expanding $\text{Levi}_2(F)$ along its third column gives:

$$\begin{aligned} F_{\zeta\bar{\zeta}} \cdot \text{Levi}_1(F) &\equiv -F_\zeta \begin{vmatrix} F_{\bar{z}} & F_{z\bar{z}} & \frac{1}{2i}F_{\bar{z}v} \\ F_{\bar{\zeta}} & F_{z\bar{\zeta}} & \frac{1}{2i}F_{\bar{\zeta}v} \\ -\frac{1}{2} - \frac{1}{2i}F_v & -\frac{1}{2i}F_{zv} & \frac{1}{4}F_{vv} \end{vmatrix} \\ &+ F_{\zeta\bar{z}} \begin{vmatrix} 0 & F_z & -\frac{1}{2} + \frac{1}{2i}F_v \\ F_{\bar{\zeta}} & F_{z\bar{\zeta}} & \frac{1}{2i}F_{\bar{\zeta}v} \\ -\frac{1}{2} - \frac{1}{2i}F_v & -\frac{1}{2i}F_{zv} & \frac{1}{4}F_{vv} \end{vmatrix} - \frac{1}{2i}F_{\zeta v} \begin{vmatrix} 0 & F_z & -\frac{1}{2} + \frac{1}{2i}F_v \\ F_{\bar{z}} & F_{z\bar{z}} & \frac{1}{2i}F_{\bar{z}v} \\ F_{\bar{\zeta}} & F_{z\bar{\zeta}} & \frac{1}{2i}F_{\bar{\zeta}v} \end{vmatrix}. \end{aligned}$$

Expanding $\text{Levi}_1(F)$ and dividing, we get a rational expression:

$$F_{\zeta\bar{\zeta}} \equiv \frac{\mathcal{P}(F_z, F_\zeta, F_{\bar{z}}, F_{\bar{\zeta}}, F_v, F_{z\bar{z}}, F_{z\bar{\zeta}}, F_{\zeta\bar{z}}, F_{zv}, F_{\zeta v}, F_{\bar{z}v}, F_{\bar{\zeta}v}, F_{vv})}{F_{z\bar{z}} + F_v F_v F_{z\bar{z}} + i F_{\bar{z}} F_{zv} - i F_z F_{\bar{z}v} + F_z F_{\bar{z}} F_{vv} - F_v F_{\bar{z}} F_{zv} - F_z F_v F_{\bar{z}v}},$$

whose numerator \mathcal{P} is a certain universal polynomial, not depending on F . By assumption, the denominator is nonvanishing (locally).

Differentiating this identity and successively performing appropriate replacements (exercise), we obtain

PROPOSITION 13.1. *For all integers $a, b, c, d, e \in \mathbb{N}$ with $b \geq 1$ and $d \geq 1$, there exist a polynomial $\mathcal{P}_{a,b,c,d,e}$ and an exponent $N_{a,b,c,d,e} \in \mathbb{N}_{\geq 1}$ such that:*

$$F_{z^a \zeta^b \bar{z}^c \bar{\zeta}^d v^e} \equiv \frac{\mathcal{P}_{a,b,c,d,e} \left(\{F_{z^{a'} \bar{z}^{c'} v^{e'}}\}_{a'+c'+e' \leq a+b+c+d+e}, \{F_{z^{a'} \zeta^{b'} \bar{z}^{c'} v^{e'}}\}_{a'+b'+c'+e' \leq a+b+c+d+e}, \{F_{z^{a'} \bar{z}^{c'} \bar{\zeta}^{d'} v^{e'}}\}_{a'+c'+d'+e' \leq a+b+c+d+e} \right)}{(F_{z\bar{z}} + F_v F_v F_{z\bar{z}} + i F_{\bar{z}} F_{zv} - i F_z F_{\bar{z}v} + F_z F_{\bar{z}} F_{vv} - F_v F_{\bar{z}} F_{zv} - F_z F_v F_{\bar{z}v})^{N_{a,b,c,d,e}}}$$

Accordingly, as in [21], we will term:

$$\text{Dependent derivatives} := \left\{ F_{z^a \zeta^b \bar{z}^c \bar{\zeta}^d v^e} \right\}_{a,b,c,d,e \geq 0}^{b \geq 1, d \geq 1},$$

$$\text{Independent derivatives} := \left\{ F_{z^a \bar{z}^c v^e} \right\}_{a,c,e \geq 0} \cup \left\{ F_{z^a \zeta^b \bar{z}^c v^e} \right\}_{a,c,e \geq 0}^{b \geq 1} \cup \left\{ F_{z^a \bar{z}^c \bar{\zeta}^d v^e} \right\}_{a,c,e \geq 0}^{d \geq 1}.$$

At the origin when we will progressively normalize the power series F , any modification of the values of the *independent* derivatives of F at 0 will automatically transfer to the

dependent derivatives of F at 0 via the formulas of Proposition 13.1. Thus, freedom of normalization concerns only *independent* derivatives:

$$\frac{1}{a!} \frac{1}{b!} \frac{1}{c!} \frac{1}{d!} \frac{1}{e!} \partial_z^a \partial_{\bar{z}}^b \partial_{\zeta}^c \partial_{\bar{\zeta}}^d \partial_v^e F(0, 0, 0, 0, 0) = F_{a,b,c,d,e} \quad (b+d \leq 1).$$

For this reason, we will often write:

$$u = F = z\bar{z} + \sum_{\substack{a+c \geq 3 \\ a \geq 1, c \geq 1}} z^a \bar{z}^c F_{a,0,c,0}(v) + \sum_{b \geq 1} z^a \zeta^b \bar{z}^c F_{a,b,c,0}(v) + \sum_{d \geq 1} z^a \bar{z}^c \bar{\zeta}^d F_{a,0,c,d}(v) \\ + \zeta \bar{\zeta}(\dots),$$

pointing out that all terms behind $\zeta \bar{\zeta}(\dots)$ are sorts of ‘*remainder terms*’. However, some information will be needed about these remainders anyway while normalizing the main independent derivatives. Indeed, regularly, we will come back to the Levi determinant (3.3).

14. Prenormalization: Step II

Now, we come back to (12.3), which we rewrite by selecting monomials having \bar{z}^1 as single antiholomorphic component:

$$u = z\bar{z} + \sum_{\substack{a+b \geq 1 \\ (a,b) \neq (1,0)}} z^a \zeta^b \bar{z}^1 F_{a,b,1,0}(v) + \sum_{\substack{a+b \geq 1 \\ c \geq 2}} z^a \zeta^b \bar{z}^c F_{a,b,c,0}(v) + \sum_{\substack{a+b \geq 1 \\ d \geq 1}} z^a \zeta^b \bar{z}^c \bar{\zeta}^d F_{a,b,c,d}(v) \\ = \bar{z} \left(z + \sum_{\substack{a+b \geq 1 \\ (a,b) \neq (1,0)}} z^a \zeta^b F_{a,b,1,0}(v) \right) + \bar{z}^2(\dots) + \bar{\zeta}(\dots).$$

LEMMA 14.1. *There exists a biholomorphism of the form:*

$$z' := z + \Lambda(z, \zeta, w) = z + O_{z,\zeta,w}(2), \quad \zeta' := \zeta, \quad w' := w,$$

which transforms $M = \{u = F\}$ into M' of equation:

$$u' = z' \bar{z}' + \bar{z}'^2(\dots) + \bar{\zeta}'(\dots).$$

PROOF. Set:

$$\Lambda(z, \zeta, w) := \sum_{\substack{a+b \geq 1 \\ (a,b) \neq (1,0)}} z^a \zeta^b F_{a,b,1,0}(-iw) = z^2(\dots) + \zeta(\dots).$$

Since $F_{0,1,1,0}(0) = 0$ by (12.1), we indeed have $\Lambda = O_{z,\zeta,w}(2)$. Thus the equation of M writes:

$$u = \bar{z} \left(z + \Lambda(z, \zeta, v) \right) + \bar{z}^2(\dots) + \bar{\zeta}(\dots).$$

Restricting $z' = z + \Lambda(z, \zeta, -iw)$ to M , Taylor expanding at (z, ζ, v) , and using $0 \equiv F(z, \zeta, 0, 0, v)$ we obtain:

$$z' = z + \Lambda(z, \zeta, v - iF) = z + \Lambda(z, \zeta, v) + F(\dots) \\ = z + \Lambda(z, \zeta, v) + \bar{z}(\dots) + \bar{\zeta}(\dots),$$

hence replacing $z + \Lambda(z, \zeta, v) = z' - \bar{z}(\dots) - \bar{\zeta}(\dots)$ and replacing $\zeta := \zeta'$:

$$u' = u = \bar{z} \left(z' - \bar{z}(\dots) - \bar{\zeta}(\dots) \right) + \bar{z}^2(\dots) + \bar{\zeta}(\dots) \\ = \bar{z} z' + \bar{z}^2(\dots) + \bar{\zeta}'(\dots).$$

Now, an inversion gives:

$$\begin{aligned} z + \Lambda = z + z^2(\cdots) + \zeta(\cdots) = z' & \iff z = z' + z'^2(\cdots) + \zeta'(\cdots) \\ & \implies \bar{z}^2 = \bar{z}'^2(\cdots) + \bar{\zeta}'(\cdots), \end{aligned}$$

which concludes:

$$u' = z' \bar{z}' + \bar{z}'^2(\cdots) + \bar{\zeta}'(\cdots). \quad \square$$

Erasing primes, and using the fact that the graphing function is real, we obtain

COROLLARY 14.2. *Any \mathcal{C}^ω hypersurface $0 \in M^5 \subset \mathbb{C}^3$ whose Levi form is of rank 1 at the origin can be brought to the form:*

$$u = z\bar{z} + z^2\bar{z}^2(\cdots) + \bar{z}^2\zeta(\cdots) + z^2\bar{\zeta}(\cdots) + \zeta\bar{\zeta}(\cdots). \quad \square$$

Next, as said, we need more information about the appearing dependent derivatives in the remainder $\zeta\bar{\zeta}(\cdots)$. We start to really use the assumption that the Levi form of $M \in \mathfrak{E}_{2,1}$ has constant rank 1.

LEMMA 14.3. *Any \mathcal{C}^ω hypersurface $0 \in M^5 \subset \mathbb{C}^3$ whose Levi form is of constant rank 1 around the origin can be brought to the form:*

$$u = z\bar{z} + z^2\bar{z}^2 O_{z,\bar{z}}(0) + \bar{z}^2\zeta O_{z,\zeta,\bar{z}}(0) + z^2\bar{\zeta} O_{z,\bar{z},\bar{\zeta}}(0) + \zeta\bar{\zeta} O_{z,\zeta,\bar{z},\bar{\zeta}}(2).$$

PROOF. Indeed, from the equation of Corollary 14.2, rewritten by emphasizing the remainder R , which is *real*, as:

$$u = z\bar{z} + z^2\bar{z}^2(\cdots) + \bar{z}^2\zeta(\cdots) + z^2\bar{\zeta}(\cdots) + \zeta\bar{\zeta}R,$$

the Levi determinant (3.3) writes:

$$0 \equiv \begin{vmatrix} 0 & \bar{z} + O(2) & O(1) & -\frac{1}{2} + O(2) \\ z + O(2) & 1 + O(2) & O(1) & O(2) \\ O(1) & O(1) & [\zeta\bar{\zeta}R]_{\zeta\bar{\zeta}} & O(1) \\ -\frac{1}{2} + O(2) & O(2) & O(1) & O(2) \end{vmatrix},$$

where, for abbreviation, we denote shortly $O(N)$ in the places of $O_{z,\zeta,\bar{z},\bar{\zeta}}(N)$, with $N \in \mathbb{N}$.

Expanding the determinant along its first column and computing modulo $O(2)$, we get:

$$\begin{aligned} 0 \equiv & -(z + O(2)) \begin{vmatrix} \bar{z} + O(2) & O(1) & -\frac{1}{2} + O(2) \\ O(1) & [\zeta\bar{\zeta}R]_{\zeta\bar{\zeta}} & O(1) \\ O(2) & O(1) & O(2) \end{vmatrix} + O(1) \begin{vmatrix} \bar{z} + O(2) & O(1) & -\frac{1}{2} + O(2) \\ 1 + O(2) & O(1) & O(2) \\ O(2) & O(1) & O(2) \end{vmatrix} \\ & - \left(-\frac{1}{2} + O(2)\right) \begin{vmatrix} \bar{z} + O(2) & O(1) & -\frac{1}{2} + O(2) \\ 1 + O(2) & O(1) & O(2) \\ O(1) & [\zeta\bar{\zeta}R]_{\zeta\bar{\zeta}} & O(1) \end{vmatrix} \\ = & O(2) + O(2) - \frac{1}{4} [\zeta\bar{\zeta}R]_{\zeta\bar{\zeta}} + O(2), \end{aligned}$$

whence:

$$R + \zeta R_\zeta + \bar{\zeta} R_{\bar{\zeta}} = O(2).$$

Then certainly $R = O_{z,\zeta,\bar{z},\bar{\zeta}}(1)$. Since $\bar{R} = R$ is real:

$$R = zA(v) + \zeta B(v) + \bar{z}\bar{A}(v) + \bar{\zeta}\bar{B}(v) + O_{z,\zeta,\bar{z},\bar{\zeta}}(2),$$

and replacing $R, R_\zeta, R_{\bar{\zeta}}$ above yields $0 \equiv A(v) \equiv 2B(v)$, so $R = O_{z,\zeta,\bar{z},\bar{\zeta}}(2)$. \square

15. Expression of the Assumption of 2-Nondegeneracy at the Origin

Consequently, abbreviating $\alpha := F_{2,0,0,1,0} \in \mathbb{C}$, we may show cubic terms:

$$u = z\bar{z} + \alpha z^2\bar{\zeta} + \bar{\alpha} \bar{z}^2\zeta + O_{z,\zeta,\bar{z},\bar{\zeta},v}(4).$$

Writing $u = \frac{1}{2}w + \frac{1}{2}\bar{w}$, and solving for w , we get:

$$w = Q(z, \zeta, \bar{z}, \bar{\zeta}, \bar{w}) = -\bar{w} + 2z\bar{z} + 2\alpha z^2\bar{\zeta} + 2\bar{\alpha} \bar{z}^2\zeta + O_{z,\zeta,\bar{z},\bar{\zeta},\bar{w}}(4).$$

Inserting this in the 3×3 invariant determinant of Proposition 3.2, we get, with $O(N)$ abbreviating $O_{z,\zeta,\bar{z},\bar{\zeta},\bar{w}}(N)$:

$$0 \neq \begin{vmatrix} Q_{\bar{z}} & Q_{\bar{\zeta}} & Q_{\bar{w}} \\ Q_{z\bar{z}} & Q_{z\bar{\zeta}} & Q_{z\bar{w}} \\ Q_{zz\bar{z}} & Q_{zz\bar{\zeta}} & Q_{zz\bar{w}} \end{vmatrix} = \begin{vmatrix} 2z + O(2) & 2\alpha z^2 + O(3) & -1 + O(3) \\ 2 + O(2) & 4\alpha z + O(2) & O(2) \\ O(1) & 4\alpha + O(1) & O(1) \end{vmatrix}.$$

Expanding along the last column and computing modulo $O(1)$:

$$0 \neq -8\alpha + O(1).$$

So the assumption of 2-nondegeneracy at the origin means that $\alpha \neq 0$. After the dilation $\zeta \mapsto \frac{1}{2\alpha} \zeta$, we obtain:

$$u = z\bar{z} + \frac{1}{2}z^2\bar{\zeta} + \frac{1}{2}\bar{z}^2\zeta + O_{z,\zeta,\bar{z},\bar{\zeta},v}(4).$$

16. Prenormalization: Step III

Thus, we have obtained the partial normalization:

$$u = z\bar{z} + \bar{z}^2\zeta F_{0,1,2,0}(v) + z^2\bar{\zeta} F_{2,0,0,1}(v) + z^2\bar{z}^2 O_{z,\bar{z}}(0) + \bar{z}^2\zeta O_{z,\zeta,\bar{z}}(1) + z^2\bar{\zeta} O_{z,\bar{z},\bar{\zeta}}(1) + \zeta\bar{\zeta} O_{z,\zeta,\bar{z},\bar{\zeta}}(2),$$

with $F_{0,1,2,0}(0) = \frac{1}{2} = F_{2,0,0,1}(0)$.

LEMMA 16.1. *There exists a biholomorphism of the form:*

$$z' := z, \quad \zeta' := \zeta \psi(w), \quad w' := w,$$

with $\psi(0) \neq 0$, which normalizes $F'_{0,1,2,0}(v') \equiv \frac{1}{2} \equiv F'_{2,0,0,1}(v')$:

$$u' = z'\bar{z}' + \frac{1}{2}\bar{z}'^2\zeta' + \frac{1}{2}z'^2\bar{\zeta}' + z'^2\bar{z}'^2 O_{z',\bar{z}'}(0) + \bar{z}'^2\zeta' O_{z',\zeta',\bar{z}'}(1) + z'^2\bar{\zeta}' O_{z',\bar{z}',\bar{\zeta}'}(1) + \zeta'\bar{\zeta}' O_{z',\zeta',\bar{z}',\bar{\zeta}'}(2).$$

PROOF. It is obvious that $O_{z',\zeta',\bar{z}',\bar{\zeta}'}(N) = O_{z,\zeta,\bar{z},\bar{\zeta}}(N)$.

From the source equation:

$$u = z\bar{z} + \bar{z}^2\zeta F_{0,1,2,0}(v) + z^2\bar{\zeta} F_{2,0,0,1}(v) + O_{z,\zeta,\bar{z},\bar{\zeta}}(4),$$

with $F_{0,1,2,0}(0) = \frac{1}{2} = F_{2,0,0,1}(0)$, the target equation will be of a similar form:

$$u' = z'\bar{z}' + \bar{z}'^2\zeta' F'_{0,1,2,0}(v') + z'^2\bar{\zeta}' F'_{2,0,0,1}(v') + O_{z',\zeta',\bar{z}',\bar{\zeta}'}(4).$$

Since $u = F$ and $u = u' = F'$, the fundamental equation writes:

$$0 \equiv -F(z, \zeta, \bar{z}, \bar{\zeta}, v) + F'(z, \zeta \psi(F + iv), \bar{z}, \zeta \bar{\psi}(F - iv), v),$$

that is:

$$0 \equiv -z\bar{z} - \bar{z}^2\zeta F_{0,1,2,0}(v) - z^2\bar{\zeta} F_{2,0,0,1}(v) - O_{z,\zeta,\bar{z},\bar{\zeta}}(4) + z\bar{z} + \bar{z}^2\zeta \psi(F + iv) F'_{0,1,2,0}(v) + z^2\bar{\zeta} \bar{\psi}(F - iv) F'_{2,0,0,1}(v) + O_{z,\zeta,\bar{z},\bar{\zeta}}(4).$$

Next, by Taylor expanding at iv :

$$\psi(F + iv) = \psi(iv) + F(\dots) = \psi(iv) + O_{z,\zeta,\bar{z},\bar{\zeta}}(2),$$

we get:

$$0 \equiv -\bar{z}^2 \zeta \left(F_{0,1,2,0}(v) - \psi(iv) F'_{0,1,2,0}(v) \right) - z^2 \bar{\zeta} \left(F_{2,0,0,1}(v) - \bar{\psi}(-iv) F'_{2,0,0,1}(v) \right) + O_{z,\zeta,\bar{z},\bar{\zeta}}(4).$$

Thus, to normalize $F'_{0,1,2,0}(v) \equiv \frac{1}{2} \equiv F'_{2,0,0,1}(v)$, it suffices to set:

$$\psi(w) := 2 F_{0,1,2,0}(-iw). \quad \square$$

So erasing primes, we have normalized:

$$(16.2) \quad \begin{aligned} u &= z\bar{z} + \frac{1}{2} \bar{z}^2 \zeta + \frac{1}{2} z^2 \bar{\zeta} + z^2 \bar{z}^2 F_{2,0,2,0}(v) + z^2 \bar{z}^2 O_{z,\bar{z}}(1) \\ &\quad + \bar{z}^2 \zeta O_{z,\zeta,\bar{\zeta}}(1) + z^2 \bar{\zeta} O_{z,\bar{z},\bar{\zeta}}(1) + \zeta \bar{\zeta} O_{z,\zeta,\bar{z},\bar{\zeta}}(2). \end{aligned}$$

Our next goal is to eliminate $F_{2,0,2,0}(v)$.

LEMMA 16.3. *There exists a biholomorphism of the form:*

$$z' := z, \quad \zeta' := \zeta + z^2 \psi(w), \quad w' := w,$$

which normalizes $F'_{2,0,2,0}(v') \equiv 0$:

$$\begin{aligned} u' &= z' \bar{z}' + \frac{1}{2} \bar{z}'^2 \zeta' + \frac{1}{2} z'^2 \bar{\zeta}' + z'^2 \bar{z}'^2 O_{z',\bar{z}'}(1) \\ &\quad + \bar{z}'^2 \zeta' O_{z',\zeta',\bar{z}'}(1) + z'^2 \bar{\zeta}' O_{z',\bar{z}',\bar{\zeta}'}(1) + \zeta' \bar{\zeta}' O_{z',\zeta',\bar{z}',\bar{\zeta}'}(2). \end{aligned}$$

PROOF. In (16.2), extract the real term $F_{2,0,2,0}(v)$ and split it:

$$(16.4) \quad \begin{aligned} u &= z\bar{z} + \frac{1}{2} \bar{z}^2 (\zeta + z^2 F_{2,0,2,0}(v)) + \frac{1}{2} z^2 (\bar{\zeta} + \bar{z}^2 F_{2,0,2,0}(v)) + z^2 \bar{z}^2 O_{z,\bar{z}}(1) \\ &\quad + \bar{z}^2 \zeta O_{z,\zeta,\bar{\zeta}}(1) + z^2 \bar{\zeta} O_{z,\bar{z},\bar{\zeta}}(1) + \zeta \bar{\zeta} O_{z,\zeta,\bar{z},\bar{\zeta}}(2). \end{aligned}$$

We claim that the biholomorphism which works is:

$$z' := z, \quad \zeta' := \zeta + z^2 F_{2,0,2,0}(-iw), \quad w' := w.$$

The inverse is:

$$\zeta = \zeta' - z'^2 F_{2,0,2,0}(-iw') = \zeta' + z'^2(\dots).$$

We verify first that all remainders correspond to one another:

$$\begin{aligned} z^2 \bar{z}^2 O_{z,\bar{z}}(1) &= z'^2 \bar{z}'^2 O_{z',\bar{z}'}(1), \\ \bar{z}^2 \zeta O_{z,\zeta,\bar{\zeta}}(1) &= \bar{z}'^2 (\zeta' + z'^2(\dots)) O_{z',\zeta',\bar{z}'}(1) \\ &= \bar{z}'^2 \zeta' O_{z',\zeta',\bar{z}'}(1) + z'^2 \bar{z}'^2 [O_{z',\bar{z}'}(1) + \zeta' O_{z',\zeta',\bar{z}'}(0)] \\ &= \bar{z}'^2 \zeta' O_{z',\zeta',\bar{z}'}(1) + z'^2 \bar{z}'^2 O_{z',\bar{z}'}(1), \\ \zeta \bar{\zeta} O_{z,\zeta,\bar{z},\bar{\zeta}}(2) &= (\zeta' + z'^2(\dots)) (\bar{\zeta}' + \bar{z}'^2(\dots)) O_{z',\zeta',\bar{z}',\bar{\zeta}'}(2) \\ &= \zeta' \bar{\zeta}' O_{z',\zeta',\bar{z}',\bar{\zeta}'}(2) + \zeta' \bar{z}'^2 [O_{z',\zeta',\bar{z}'}(2) + \bar{\zeta}' O_{z',\zeta',\bar{z}',\bar{\zeta}'}(1)] \\ &\quad + \bar{\zeta}' z'^2 [O_{z',\bar{z}',\bar{\zeta}'}(2) + \zeta' O_{z',\zeta',\bar{z}',\bar{\zeta}'}(1)] \\ &\quad + z'^2 \bar{z}'^2 [O_{z',\bar{z}'}(2) + \zeta' O_{z',\zeta',\bar{z}'}(1) + \bar{\zeta}' O_{z',\bar{z}',\bar{\zeta}'}(1) + \zeta' \bar{\zeta}' O_{z',\zeta',\bar{z}',\bar{\zeta}'}(0)] \\ &= z'^2 \bar{z}'^2 O_{z',\bar{z}'}(1) + \bar{z}'^2 \zeta' O_{z',\zeta',\bar{z}'}(1) + z'^2 \bar{\zeta}' O_{z',\bar{z}',\bar{\zeta}'}(1) + \zeta' \bar{\zeta}' O_{z',\zeta',\bar{z}',\bar{\zeta}'}(2). \end{aligned}$$

Next, using $0 \equiv F(0, 0, \bar{z}, \bar{\zeta}, v)$, and Taylor expanding at v' , we can write:

$$\begin{aligned}\zeta &= \zeta' - z'^2 F_{2,0,2,0}(v' - iF) \\ &= \zeta' - z'^2 F_{2,0,2,0}(v') - z'^2 F(\dots) \\ &= \zeta' - z'^2 F_{2,0,2,0}(v') - z'^2 [z(\dots) + \zeta(\dots)] \\ &= \zeta' - z'^2 F_{2,0,2,0}(v') - z'^2 [z'(\dots) + \zeta'(\dots)].\end{aligned}$$

Lastly, replacing $z, \zeta, \bar{z}, \bar{\zeta}, u, v$ in terms of $z', \zeta', \bar{z}', \bar{\zeta}', u', v'$ in (16.4), we obtain what was asserted:

$$\begin{aligned}u' &= z'\bar{z}' + \frac{1}{2}\bar{z}'^2 \left(\zeta' - \underline{z'^2 F_{2,0,2,0}(v')}_o - z'^3(\dots) - z'^2 \zeta'(\dots) + \underline{z'^2 F_{2,0,2,0}(v')}_o \right) \\ &\quad + \frac{1}{2}z'^2 \left(\bar{\zeta}' - \underline{\bar{z}'^2 F_{2,0,2,0}(v')}_o - \bar{z}'^3(\dots) - \bar{z}'^2 \bar{\zeta}'(\dots) + \underline{\bar{z}'^2 F_{2,0,2,0}(v')}_o \right) \\ &\quad + z'^2 \bar{z}'^2 O_{z', \bar{z}'}(1) + \bar{z}'^2 \zeta' O_{z', \zeta', \bar{z}'}(1) + z'^2 \bar{\zeta}' O_{z', \bar{z}', \bar{\zeta}'}(1) + \zeta' \bar{\zeta}' O_{z', \zeta', \bar{z}', \bar{\zeta}'}(2) \\ &= z'\bar{z}' + \frac{1}{2}\bar{z}'^2 \zeta' + \frac{1}{2}z'^2 \bar{\zeta}' \\ &\quad + z'^2 \bar{z}'^2 O_{z', \bar{z}'}(1) + \bar{z}'^2 \zeta' O_{z', \zeta', \bar{z}'}(1) + z'^2 \bar{\zeta}' O_{z', \bar{z}', \bar{\zeta}'}(1) + \zeta' \bar{\zeta}' O_{z', \zeta', \bar{z}', \bar{\zeta}'}(2). \quad \square\end{aligned}$$

Thus, dropping primes, we have reached the following normalization, where we show all monomials in F which have \bar{z}^2 as only antiholomorphic part:

$$\begin{aligned}u &= z\bar{z} + \frac{1}{2}\bar{z}^2 \zeta + \frac{1}{2}z^2 \bar{\zeta} + \sum_{\substack{a+c \geq 5 \\ a \geq 2, c \geq 2}} z^a \bar{z}^c F_{a,0,c,0}(v) + \sum_{\substack{a+b+c \geq 4 \\ b \geq 1, c \geq 2}} z^a \zeta^b \bar{z}^c F_{a,b,c,0}(v) \\ &\quad + \sum_{\substack{a+c+d \geq 4 \\ a \geq 2, d \geq 1}} z^a \bar{z}^c \bar{\zeta}^d F_{a,0,c,d}(v) + \sum_{\substack{a+b+c+d \geq 4 \\ b \geq 1, d \geq 1}} z^a \zeta^b \bar{z}^c \bar{\zeta}^d F_{a,b,c,d}(v).\end{aligned}$$

Now, we will work modulo $\bar{z}^3(\dots) + \bar{\zeta}(\dots)$, so the last two sums above disappear and many terms in the first two sums as well, so that it remains:

$$(16.5) \quad u = z\bar{z} + \frac{1}{2}\bar{z}^2 \left[\zeta + 2 \sum_{a \geq 3} z^a F_{a,0,2,0}(v) + 2 \sum_{\substack{a+b \geq 2 \\ b \geq 1}} z^a \zeta^b F_{a,b,2,0}(v) \right] + \bar{z}^3(\dots) + \bar{\zeta}(\dots).$$

LEMMA 16.6. *The biholomorphism:*

$$\begin{aligned}z' &:= z, & \zeta' &:= \zeta + 2 \sum_{a \geq 3} z^a F_{a,0,2,0}(-iw) + 2 \sum_{\substack{a+b \geq 2 \\ b \geq 1}} z^a \zeta^b F_{a,b,2,0}(-iw), \\ w' &:= w,\end{aligned}$$

transforms M into M' of equation:

$$u' = z'\bar{z}' + \frac{1}{2}\bar{z}'^2 \zeta' + \frac{1}{2}z'^2 \bar{\zeta}' + \bar{z}'^3(\dots) + \bar{\zeta}'(\dots).$$

PROOF. As in [51], we write:

$$\zeta' := \zeta + \tau(z, w) + \zeta \omega(z, \zeta, w),$$

where:

$$\tau = z^3(\dots) \quad \text{and} \quad \omega = O_{z, \zeta, w}(1).$$

The inverse is certainly of the form $\zeta = \zeta' + O_{z',\zeta',w'}(2)$, hence:

$$\zeta = \zeta' + \tau'(z', w') + \zeta' \omega'(z', \zeta', w'),$$

with $\tau' = O_{z',w'}(2)$ and $\omega' = O_{z',\zeta',w'}(1)$. We claim that $\tau' = z'^3(\dots)$.

Indeed, replacing $\zeta' = \tau(z, w) + \zeta [1 + \omega(z, \zeta, w)]$ into $\zeta = \tau'(z', w') + \zeta' [1 + \omega'(z', \zeta', w')]$, the following identity must hold in $\mathbb{C}\{z, \zeta, w\}$:

$$\zeta \equiv \tau'(z, w) + (\tau(z, w) + \zeta [1 + \omega(z, \zeta, w)]) \left[1 + \omega'(z, \tau(z, w) + \zeta [1 + \omega(z, \zeta, w)], w) \right].$$

Putting $\zeta := 0$, it comes:

$$0 \equiv \tau'(z, w) + \tau(z, w) [1 + O_{z,w}(1)] \equiv \tau'(z, w) + z^3(\dots) [1 + O_{z,w}(1)].$$

Thus $\zeta = \zeta'(\dots) + z^3(\dots)$, which enables us to verify that remainders correspond as follows:

$$\begin{aligned} \bar{\zeta}(\dots) &= \bar{\zeta}'(\dots) + \bar{z}^3(\dots), \\ \bar{z}^3(\dots) &= \bar{z}^3(\dots). \end{aligned}$$

Next, using $0 \equiv F(z, \zeta, 0, 0, 0)$, so that $F = \bar{z}(\dots) + \bar{\zeta}(\dots) = \bar{z}'(\dots) + \bar{\zeta}'(\dots)$, we have:

$$\begin{aligned} \zeta' &= \zeta + 2 \sum_{a \geq 3} z^a F_{a,0,2,0}(v - iF) + 2 \sum_{\substack{a+b \geq 2 \\ b \geq 1}} z^a \zeta^b F_{a,b,2,0}(v - iF) \\ &= \zeta + 2 \sum_{a \geq 3} z^a F_{a,0,2,0}(v) + F(\dots) + 2 \sum_{\substack{a+b \geq 2 \\ b \geq 1}} z^a \zeta^b F_{a,b,2,0}(v) + F(\dots). \end{aligned}$$

Lastly, coming back to (16.5), we conclude:

$$\begin{aligned} u' = u &= z' \bar{z}' + \frac{1}{2} \bar{z}'^2 [\zeta' - \bar{\zeta}(\dots) - \bar{z}(\dots)] + \bar{z}'^3(\dots) + \bar{\zeta}'(\dots) \\ &= z' \bar{z}' + \frac{1}{2} \bar{z}'^2 \zeta' + \bar{z}'^3(\dots) + \bar{\zeta}'(\dots). \end{aligned} \quad \square$$

Erasing primes, and using the fact that the graphing function is real, we obtain:

$$u = z \bar{z} + \frac{1}{2} \bar{z}^2 \zeta + \frac{1}{2} z^2 \bar{\zeta} + z^3 \bar{z}^3(\dots) + \bar{z}^3 \zeta(\dots) + z^3 \bar{\zeta}(\dots) + \zeta \bar{\zeta}(\dots).$$

It remains only to analyze the dependent-derivatives remainder $\zeta \bar{\zeta}(\dots)$. For this, we must extract the single 4th order monomial $z \bar{z} \zeta \bar{\zeta}$ in the GM-model $m(z, \zeta, \bar{z}, \bar{\zeta})$. Then we realize that behind $\zeta \bar{\zeta}(\dots)$, there must be order 3 terms only.

PROPOSITION 16.7. [Prenormalization] *Any hypersurface $M^5 \in \mathfrak{C}_{2,1}$ can be brought to the prenormal form:*

$$\begin{aligned} u &= z \bar{z} + \frac{1}{2} \bar{z}^2 \zeta + \frac{1}{2} z^2 \bar{\zeta} + z \bar{z} \zeta \bar{\zeta} \\ &\quad + z^3 \bar{z}^3 O_{z,\bar{z}}(0) + \bar{z}^3 \zeta O_{z,\zeta,\bar{z}}(0) + z^3 \bar{\zeta} O_{z,\bar{z},\bar{\zeta}}(0) + \zeta \bar{\zeta} O_{z,\zeta,\bar{z},\bar{\zeta}}(3). \end{aligned}$$

PROOF. We write:

$$u = \bar{z} z + \frac{1}{2} \bar{z}^2 \zeta + \frac{1}{2} z^2 \bar{\zeta} + z \bar{z} \zeta \bar{\zeta} + z^3 \bar{z}^3(\dots) + \bar{z}^3 \zeta(\dots) + z^3 \bar{\zeta}(\dots) + \zeta \bar{\zeta} R.$$

From Lemma 14.3, we already know that $R = O_{z,\zeta,\bar{z},\bar{\zeta}}(2)$.

To get more, we look at the Levi determinant:

$$0 \equiv \begin{vmatrix} 0 & \bar{z} + z\bar{\zeta} + O(3) & \frac{1}{2}\bar{z}^2 + O(3) & -\frac{1}{2} + O(4) \\ z + \bar{z}\zeta + O(3) & 1 + O(2) & \bar{z} + O(2) & O(3) \\ \frac{1}{2}z^2 + O(3) & z + O(2) & z\bar{z} + [\zeta\bar{\zeta}R]_{\zeta\bar{\zeta}} & O(3) \\ -\frac{1}{2} + O(4) & O(3) & O(3) & O(4) \end{vmatrix}.$$

Computing modulo $O(3)$, so that the entries $(2, 4)$, $(3, 4)$, $(4, 2)$, $(4, 3)$, $(4, 4)$ are ‘zero’, we get:

$$0 \equiv -\left(-\frac{1}{2}\right)\left(-\frac{1}{2}\right) \begin{vmatrix} 1 + O(2) & \bar{z} + O(2) \\ z + O(2) & z\bar{z} + [\zeta\bar{\zeta}R]_{\zeta\bar{\zeta}} \end{vmatrix} + O(3).$$

that is:

$$[\zeta\bar{\zeta}R]_{\zeta\bar{\zeta}} \equiv O(3).$$

Thanks to the already known $R = O(2)$:

$$R = Azz + Bz\zeta + Cz\bar{z} + Dz\bar{\zeta} + E\zeta\zeta + \bar{D}\zeta\bar{z} + G\zeta\bar{\zeta} + \bar{A}\bar{z}z + \bar{B}\bar{z}\bar{\zeta} + \bar{E}\bar{\zeta}\bar{\zeta} + O_{z,\zeta,\bar{z},\bar{\zeta}}(3),$$

with both $\bar{C} = C$ and $\bar{G} = G$ real, hence:

$$\begin{aligned} O(3) &\equiv R + \zeta R_{\zeta} + \bar{\zeta} R_{\bar{\zeta}} + \zeta\bar{\zeta} R_{\zeta\bar{\zeta}} \\ &\equiv Azz + 2Bz\zeta + (\bar{A} + C)z\bar{z} + 2Dz\bar{\zeta} + 3E\zeta\zeta + 2\bar{D}\zeta\bar{z} + 4G\zeta\bar{\zeta} + 2\bar{B}\bar{z}\bar{\zeta} + 3\bar{E}\bar{\zeta}\bar{\zeta}, \end{aligned}$$

and this forces $A = B = C = D = E = G = 0$, whence $R = O_{z,\zeta,\bar{z},\bar{\zeta}}(3)$. \square

17. Normalization $F_{3,0,0,1}(v) = 0$

Now, we specify the unique term of order 4 in $(z, \zeta, \bar{z}, \bar{\zeta})$:

$$u = z\bar{z} + \frac{1}{2}\bar{z}^2\zeta + \frac{1}{2}z^2\bar{\zeta} + z\bar{z}\zeta\bar{\zeta} + z^3\bar{\zeta}F_{3,0,0,1}(v) + \bar{z}^3\zeta\overline{F_{3,0,0,1}(v)} + O_{z,\zeta,\bar{z},\bar{\zeta}}(5).$$

Abbreviate:

$$\varphi(v) := F_{3,0,0,1}(v).$$

LEMMA 17.1. *The biholomorphism:*

$$\begin{aligned} z' &:= z + z^2\varphi(-iw) + 2z^3\varphi(-iw)\varphi(-iw), \\ \zeta' &:= \zeta - 2z\bar{\varphi}(-iw) + 4z\zeta\varphi(-iw) - 5z^2\varphi(-iw)\bar{\varphi}(-iw), \\ w' &:= w, \end{aligned}$$

transforms M into M' of equation:

$$u' = z'\bar{z}' + \frac{1}{2}\bar{z}'^2\zeta' + \frac{1}{2}z'^2\bar{\zeta}' + z'\bar{z}'\zeta'\bar{\zeta}' + O_{z',\zeta',\bar{z}',\bar{\zeta}'}(5).$$

PROOF. On restriction to M where $-iw = v - iF$:

$$\begin{aligned} z' &:= z + z^2\varphi(v - iF) + 2z^3\varphi(v - iF)\varphi(v - iF), \\ \zeta' &:= \zeta - 2z\bar{\varphi}(v - iF) + 4z\zeta\varphi(v - iF) - 5z^2\varphi(v - iF)\bar{\varphi}(v - iF), \end{aligned}$$

hence Taylor expanding at v and using $F = O(2)$:

$$\begin{aligned} z' &= z + z^2\varphi(v) + 2z^3\varphi(v)\varphi(v) + O_{z,\zeta,\bar{z},\bar{\zeta}}(4), \\ \zeta' &= \zeta - 2z\bar{\varphi}(v) + 4z\zeta\varphi(v) - 5z^2\varphi(v)\bar{\varphi}(v) + O_{z,\zeta,\bar{z},\bar{\zeta}}(3). \end{aligned}$$

An expansion concludes:

$$\begin{aligned}
& z'\bar{z}' + \frac{1}{2}\bar{z}'^2\zeta' + \frac{1}{2}z'^2\bar{\zeta}' + z'\bar{z}'\zeta'\bar{\zeta}' + O_{z',\zeta',\bar{z}',\bar{\zeta}'}(5) = \\
& = \left(z + z^2\varphi(v) + 2z^3\varphi(v)\varphi(v) \right) \left(\bar{z} + \bar{z}^2\bar{\varphi}(v) + 2\bar{z}^3\bar{\varphi}(v)\bar{\varphi}(v) \right) + O_{z,\zeta,\bar{z},\bar{\zeta}}(5) \\
& + \frac{1}{2} \left(\bar{z} + \bar{z}^2\bar{\varphi}(v) \right)^2 \left(\zeta - 2z\bar{\varphi}(v) + 4z\zeta\varphi(v) - 5z^2\varphi(v)\bar{\varphi}(v) \right) + O_{z,\zeta,\bar{z},\bar{\zeta}}(5) \\
& + \frac{1}{2} \left(z + z^2\varphi(v) \right)^2 \left(\bar{\zeta} - 2\bar{z}\varphi(v) + 4\bar{z}\bar{\zeta}\bar{\varphi}(v) - 5\bar{z}^2\bar{\varphi}(v)\varphi(v) \right) + O_{z,\zeta,\bar{z},\bar{\zeta}}(5) \\
& + z\bar{z} \left(\zeta - 2z\bar{\varphi}(v) \right) \left(\bar{\zeta} - 2\bar{z}\varphi(v) \right) + O_{z,\zeta,\bar{z},\bar{\zeta}}(5) \\
& = z\bar{z} + \frac{1}{2}\bar{z}^2\zeta + \frac{1}{2}z^2\bar{\zeta} + z\bar{z}\zeta\bar{\zeta} + z^3\bar{\zeta}\varphi(v) + \bar{z}^3\zeta\bar{\varphi}(v) + O_{z,\zeta,\bar{z},\bar{\zeta}}(5). \quad \square
\end{aligned}$$

After this, although $F_{a,b,0,0}(v) \equiv 0$ for all (a,b) , it is not necessarily still true that prenormalization holds:

$$\begin{aligned}
0 & \stackrel{?}{=} F_{a,b,1,0}(v) & (\forall (a,b) \neq (1,0)), \\
0 & \stackrel{?}{=} F_{a,b,2,0}(v) & (\forall (a,b) \neq (0,1)).
\end{aligned}$$

18. Repetition of Prenormalization

Fortunately, we can repeat the prenormalization. Indeed, let us write:

$$u = z\bar{z} + \frac{1}{2}\bar{z}^2\zeta + \frac{1}{2}z^2\bar{\zeta} + z\bar{z}\zeta\bar{\zeta} + \sum_{\substack{a+b+c+d \geq 5 \\ a+b \geq 1, c+d \geq 1}} z^a \zeta^b \bar{z}^c \bar{\zeta}^d F_{a,b,c,d}(v).$$

We will perform two biholomorphisms of the form:

$$z' := z + O_{z,\zeta}(4), \quad \zeta' := \zeta + O_{z,\zeta}(3), \quad w' = w,$$

so that normalizations of terms up to order 4 included will be stabilized and preserved.

Starting from:

$$u = \bar{z} \left(z + \sum_{a+b \geq 4} z^a \zeta^b F_{a,b,1,0}(v) \right) + \bar{z}^2(\dots) + \bar{\zeta}(\dots),$$

we perform the following first biholomorphism, with $z' := z + O_{z,\zeta}(4)$, $\zeta' := \zeta$, $w' := w$, which we restrict to M , using $F = \bar{z}(\dots) + \bar{\zeta}(\dots)$:

$$\begin{aligned}
z' & := z + \sum_{a+b \geq 4} z^a \zeta^b F_{a,b,1,0}(-iw) \\
& = z + \sum_{a+b \geq 4} z^a \zeta^b \left[F_{a,b,1,0}(v) + F(\dots) \right] \\
& = z + \sum_{a+b \geq 4} z^a \zeta^b F_{a,b,1,0}(v) + \bar{z}(\dots) + \bar{\zeta}(\dots),
\end{aligned}$$

hence:

$$z' - \bar{z}'(\dots) - \bar{\zeta}'(\dots) = z + \sum_{a+b \geq 4} z^a \zeta^b F_{a,b,1,0}(v),$$

so we can replace, using $z' = z + z^4(\dots) + \zeta(\dots)$ which gives by inversion $z = z' + z'^4(\dots) + \zeta'(\dots)$:

$$\begin{aligned} u' = u &= (\bar{z}' + \bar{z}'^4(\dots) + \bar{\zeta}'(\dots)) (z' - \bar{z}'(\dots) - \bar{\zeta}(\dots)) + \bar{z}'^2(\dots) + \bar{\zeta}'(\dots) \\ &= \bar{z}'z' + \bar{z}'^2(\dots) + \bar{\zeta}'(\dots). \end{aligned}$$

Next, erase primes, specify terms having \bar{z}^2 as only antiholomorphic part:

$$u = z\bar{z} + \frac{1}{2} \left(\zeta + 2 \sum_{a+b \geq 3} z^a \zeta^b F_{a,b,2,0}(v) \right) \bar{z}^2 + \bar{z}^3(\dots) + \bar{\zeta}(\dots),$$

and perform the second biholomorphism:

$$z' := z, \quad \zeta' := \zeta + 2 \sum_{a+b \geq 3} z^a \zeta^b F_{a,b,2,0}(-iw), \quad w' := w.$$

Since $-iw = v - iF$ on M , using $F = \bar{z}(\dots) + \bar{\zeta}(\dots)$, we have:

$$\begin{aligned} \zeta' &= \zeta + 2 \sum_{a+b \geq 3} z^a \zeta^b F_{a,b,2,0}(v - iF) \\ &= \zeta + 2 \sum_{a+b \geq 3} z^a \zeta^b F_{a,b,2,0}(v) + \bar{z}(\dots) + \bar{\zeta}(\dots), \end{aligned}$$

hence after an inversion:

$$\zeta' - \bar{z}'(\dots) - \bar{\zeta}'(\dots) = \zeta + 2 \sum_{a+b \geq 3} z^a \zeta^b F_{a,b,2,0}(v).$$

So using $\zeta' = \zeta + z^3(\dots) + \zeta O_{z,\zeta}(2)$ which gives after inversion $\zeta = \zeta' + z'^3(\dots) + \zeta' O_{z',\zeta'}(2)$, and observing that remainders correspond to one another, we can replace:

$$\begin{aligned} u' = u &= z'\bar{z}' + \frac{1}{2} \bar{z}'^2 (\zeta' - \bar{z}'(\dots) - \bar{\zeta}'(\dots)) + \bar{z}'^3(\dots) + \bar{\zeta}'(\dots) \\ &= z'\bar{z}' + \frac{1}{2} \bar{z}'^2 \zeta' + \bar{z}'^3(\dots) + \bar{\zeta}'(\dots). \end{aligned}$$

Since terms are unchanged up to order 5, and since the right-hand side is real, we have reached:

$$u' = z'\bar{z}' + \frac{1}{2} \bar{z}'^2 \zeta' + \frac{1}{2} z'^2 \bar{\zeta}' + z'\bar{z}' \zeta' \bar{\zeta}' + z'^3 \bar{z}'^3 O_{z',\bar{z}'}(0) + \bar{z}'^3 \zeta' O_{z',\zeta',\bar{z}'}(1) + z'^3 \bar{\zeta}' O_{z',\bar{z}',\zeta'}(1) + \zeta' \bar{\zeta}' O_{z',\zeta',\bar{z}',\bar{\zeta}'}(3).$$

LEMMA 18.1. *Starting from:*

$$u = z\bar{z} + \frac{1}{2} \bar{z}^2 \zeta + \frac{1}{2} z^2 \bar{\zeta} + z\bar{z} \zeta \bar{\zeta} + \sum_{\substack{a+b+c+d \geq 5 \\ a+b \geq 1, c+d \geq 1}} z^a \zeta^b \bar{z}^c \bar{\zeta}^d F_{a,b,c,d}(v),$$

there exists a biholomorphism of the form:

$$z' = z + O_{z,\zeta}(4), \quad \zeta' = \zeta + O_{z,\zeta}(3), \quad w' := w,$$

which transforms M into M' of equation:

$$u' = z'\bar{z}' + \frac{1}{2} \bar{z}'^2 \zeta' + \frac{1}{2} z'^2 \bar{\zeta}' + z'\bar{z}' \zeta' \bar{\zeta}' + z'^3 \bar{z}'^3 O_{z',\bar{z}'}(0) + \bar{z}'^3 \zeta' O_{z',\zeta',\bar{z}'}(1) + z'^3 \bar{\zeta}' O_{z',\bar{z}',\zeta'}(1) + \zeta' \bar{\zeta}' O_{z',\zeta',\bar{z}',\bar{\zeta}'}(4).$$

PROOF. The only modification is the information about the dependent jets remainder being an $O(4)$ after $\zeta' \bar{\zeta}'$, which improves the previous $O(3)$. The proof consists in examining the Levi determinant, and proceeds similarly as at the end of the proof of Proposition 16.7. \square

19. Normalization $F_{3,0,1,1}(v) = 0$

Including order 5 terms from $z^3 \bar{\zeta} O_{z, \bar{z}, \bar{\zeta}}(1)$, three new terms appear:

$$(19.1) \quad u = z\bar{z} + \frac{1}{2} \bar{z}^2 \zeta + \frac{1}{2} z^2 \bar{\zeta} + z\bar{z}\zeta\bar{\zeta} + \frac{1}{2} \bar{z}^2 \zeta \zeta \bar{\zeta} + \frac{1}{2} z^2 \bar{\zeta} \bar{\zeta} \zeta \\ + 2 \operatorname{Re} \left\{ z^3 \bar{z} \bar{\zeta} F_{3,0,1,1}(v) + z^4 \bar{\zeta} F_{4,0,0,1}(v) + z^3 \bar{\zeta}^2 F_{3,0,0,2}(v) \right\} + O_{z, \zeta, \bar{z}, \bar{\zeta}}(6),$$

and we gather all remainder terms as an $O(6)$.

LEMMA 19.2. *There exists a biholomorphism of the form:*

$$z' := z, \quad \zeta' := \zeta + i\varphi(-iw) z^2, \quad w' := w,$$

with $\varphi(v) \in \mathbb{R}$ for $v \in \mathbb{R}$, which normalizes:

$$\operatorname{Im} F'_{3,0,1,1}(v') \equiv 0.$$

PROOF. On restriction to M , the inverse writes:

$$\begin{aligned} \zeta &= \zeta' - i\varphi(-iw) z'^2 \\ &= \zeta' - i\varphi(v - iF) z'^2 \\ &= \zeta' - i\varphi(v) z'^2 + z'^2 F(\dots) \\ &= \zeta' - i\varphi(v') z'^2 + O_{z', \zeta', \bar{z}', \bar{\zeta}'}(4). \end{aligned}$$

So we insert in (19.1) and we conclude:

$$\begin{aligned} u' = u &= z' \bar{z}' + \frac{1}{2} \bar{z}'^2 (\zeta' - i\varphi(v') z'^2 + O(4)) + \frac{1}{2} z'^2 (\bar{\zeta}' + i\bar{\varphi}(v') \bar{z}'^2 + O(4)) \\ &\quad + z' \bar{z}' (\zeta' - i\varphi(v') z'^2) (\bar{\zeta}' + i\bar{\varphi}(v') \bar{z}'^2) + \frac{1}{2} \bar{z}'^2 \zeta' \zeta' \bar{\zeta}' + \frac{1}{2} z'^2 \bar{\zeta}' \bar{\zeta}' \zeta' \\ &\quad + 2 \operatorname{Re} \left\{ z'^3 \bar{z}' \bar{\zeta}' F_{3,0,1,1}(v') + z'^4 \bar{\zeta}' F_{4,0,0,1}(v') + z'^3 \bar{\zeta}'^2 F_{3,0,0,2}(v') \right\} + O_{z', \zeta', \bar{z}', \bar{\zeta}'}(6) \\ &= z' \bar{z}' + \frac{1}{2} \bar{z}'^2 \zeta' + \frac{1}{2} z'^2 \bar{\zeta}' + z' \bar{z}' \zeta' \bar{\zeta}' + \frac{1}{2} \bar{z}'^2 \zeta' \zeta' \bar{\zeta}' + \frac{1}{2} z'^2 \bar{\zeta}' \bar{\zeta}' \zeta' \\ &\quad + z'^2 \bar{z}'^2 \left[-\frac{i}{2} \varphi(v') + \frac{i}{2} \bar{\varphi}(v') \right] \\ &\quad + 2 \operatorname{Re} \left\{ z'^3 \bar{z}' \bar{\zeta}' [F_{3,0,1,1}(v') - i\varphi(v')] + z'^4 \bar{\zeta}' F_{4,0,0,1}(v') + z'^3 \bar{\zeta}'^2 F_{3,0,0,2}(v') \right\} \\ &\quad + O_{z', \zeta', \bar{z}', \bar{\zeta}'}(6). \end{aligned} \quad \square$$

Breaking routine, we do not erase primes.

LEMMA 19.3. *There exists a biholomorphism whose inverse is of the form:*

$$z' := z e^{i\varphi(-iw)}, \quad \zeta' := \zeta e^{2i\varphi(-iw)} + \psi(-iw) z^2, \quad w' := w,$$

with $\varphi(v) \in \mathbb{R}$ for $v \in \mathbb{R}$, which normalizes $u' = F'$ above to $u = F$ of the same shape, but with:

$$\operatorname{Re} F'_{3,0,1,1}(v) \equiv 0.$$

PROOF. Start with:

$$\begin{aligned} z' \bar{z}' &= z \bar{z} e^{i[\varphi(v-iF) - \bar{\varphi}(v+iF)]} \\ &= z \bar{z} e^{i[\varphi(v) + \varphi_v(v)(-iF) + F^2(\dots) - \bar{\varphi}(v) - \bar{\varphi}_v(v)(iF) - F^2(\dots)]} \\ &= z \bar{z} e^{2\varphi_v(v) F + F^2(\dots)} \\ &= z \bar{z} (1 + 2\varphi_v(v) F + O(4)) \\ &= z \bar{z} + 2\varphi_v(v) z^2 \bar{z}^2 + \varphi_v(v) z \zeta \bar{z}^3 + \varphi_v(v) z^3 \bar{z} \bar{\zeta} + O(6). \end{aligned}$$

Next:

$$\begin{aligned}
\operatorname{Re}(\bar{z}'^2 \zeta') &= \operatorname{Re}\left(\bar{z}^2 e^{-2i\bar{\varphi}(i\bar{w})} \left[\zeta e^{2i\varphi(-iw)} + \psi(-iw) z^2\right]\right) \\
&= \operatorname{Re}\left(\bar{z}^2 \zeta e^{2i[-\bar{\varphi}(v+iF)+\varphi(v-iF)]} + z^2 \bar{z}^2 e^{-2i\bar{\varphi}(v+iF)} \psi(v-iF)\right) \\
&= \operatorname{Re}\left(\bar{z}^2 \zeta e^{2i[-\bar{\varphi}(v)-\bar{\varphi}_v(v)(iF)-F^2(\dots)+\varphi(v)+\varphi_v(v)(-iF)+F^2(\dots)]}\right) + z^2 \bar{z}^2 \psi(v) + O(6) \\
&= \operatorname{Re}\left(\bar{z}^2 \zeta e^{2i[\bar{\varphi}_v(v)+\varphi_v(v)]F+F^2(\dots)}\right) + z^2 \bar{z}^2 \psi(v) + O(6) \\
&= \operatorname{Re}\left(\bar{z}^2 \zeta \left[1 + 4\varphi_v(v)(z\bar{z} + O(3)) + O(4)\right]\right) + z^2 \bar{z}^2 \psi(v) + O(6) \\
&= \frac{1}{2} \bar{z}^2 \zeta + \frac{1}{2} z^2 \bar{\zeta} + z^2 \bar{z}^2 \psi(v) + 2\varphi_v(v) \bar{z}^3 z \zeta + 2\varphi_v(v) z^3 \bar{z} \bar{\zeta} + O(6).
\end{aligned}$$

Lastly:

$$\begin{aligned}
z' \bar{z}' \zeta' \bar{\zeta}' &= (z\bar{z} + O(4)) \left(\zeta e^{2i\varphi(v)+F(\dots)} + (\psi(v) + F(\dots)) z^2\right) \left(\bar{\zeta} e^{-2i\bar{\varphi}(v)+F(\dots)} + (\bar{\psi}(v) + F(\dots)) \bar{z}^2\right) \\
&= z\bar{z} (\zeta + \psi(v) z^2) (\bar{\zeta} + \bar{\psi}(v) \bar{z}^2) + O(6) \\
&= z\bar{z} \zeta \bar{\zeta} + z\bar{z} \zeta \bar{z}^2 \bar{\psi}(v) + z\bar{z} \psi(v) z^2 \bar{\zeta} + O(6).
\end{aligned}$$

Summing, we conclude by taking $\psi(v) := -2\varphi_v(v)$ and $\varphi_v(v) := -F'_{3,0,1,1}(v)$:

$$\begin{aligned}
u' &= z' \bar{z}' + \frac{1}{2} \bar{z}'^2 \zeta' + \frac{1}{2} z'^2 \bar{\zeta}' + z' \bar{z}' \zeta' \bar{\zeta}' + \frac{1}{2} \bar{z}'^2 \zeta' \zeta' \bar{\zeta}' + \frac{1}{2} z'^2 \bar{\zeta}' \bar{\zeta}' \bar{\zeta}' \\
&\quad + 2 \operatorname{Re} \left\{ F'_{4,0,0,1}(v) z'^3 \bar{z}' \bar{\zeta}' + F'_{3,0,0,1} z'^3 \bar{z}' \bar{\zeta}' + F'_{3,0,0,2}(v) z'^3 \bar{\zeta}'^2 \right\} + O_{z', \zeta', \bar{z}', \bar{\zeta}'}(6) \\
&= z\bar{z} + \frac{1}{2} \bar{z}^2 \zeta + \frac{1}{2} z^2 \bar{\zeta} + z\bar{z} \zeta \bar{\zeta} + \frac{1}{2} \bar{z}^2 \zeta \zeta \bar{\zeta} + \frac{1}{2} z^2 \bar{\zeta} \bar{\zeta} \bar{\zeta} \\
&\quad + z^2 \bar{z}^2 [2\varphi_v(v) + \psi(v)] \\
&\quad + 2 \operatorname{Re} \left\{ 2\varphi_v(v) + \psi(v) + \varphi_v(v) + F'_{3,0,1,1}(v) \right\} \\
&\quad + 2 \operatorname{Re} \left\{ F'_{4,0,0,1}(v) z^4 \bar{\zeta} + F'_{3,0,0,2}(v) z^3 \bar{\zeta}^2 \right\} + O_{z, \zeta, \bar{z}, \bar{\zeta}}(6). \quad \square
\end{aligned}$$

PROPOSITION 19.4. *For every hypersurface $M^5 \in \mathfrak{C}_{2,1}$, at any point $p \in M$, given any CR-transversal curve $p \in \gamma \subset M$, there exist holomorphic coordinates $(z, \zeta, w) \in \mathbb{C}^3$ vanishing at p in which γ is the v -axis and in which M has equation:*

$$\begin{aligned}
u &= z\bar{z} + \frac{1}{2} \bar{z}^2 \zeta + \frac{1}{2} z^2 \bar{\zeta} + z\bar{z} \zeta \bar{\zeta} + \frac{1}{2} \bar{z}^2 \zeta \zeta \bar{\zeta} + \frac{1}{2} z^2 \bar{\zeta} \bar{\zeta} \bar{\zeta} \\
&\quad + z^3 \bar{z}^3 O_{z, \bar{z}}(0) \\
&\quad + 2 \operatorname{Re} \left\{ 0 + z^4 \bar{\zeta} F_{4,0,0,1}(v) + z^3 \bar{\zeta}^2 F_{3,0,0,2}(v) \right\} \\
&\quad + \bar{z}^3 \zeta O_{z, \zeta, \bar{\zeta}}(2) + z^3 \bar{\zeta} O_{z, \bar{z}, \bar{\zeta}}(2) + \zeta \bar{\zeta} O_{z, \zeta, \bar{z}, \bar{\zeta}}(4).
\end{aligned}$$

PROOF. The annihilation of $F_{3,0,1,1}(v) \equiv 0$ has been performed above. After that, it is necessary to repeat prenormalization, as was done in Section 18, and this does not perturb the normalizations done up to order 5 in $(z, \zeta, \bar{z}, \bar{\zeta})$.

Lastly, it remains to justify the vanishing order 4 of the dependent-derivatives remainder $\zeta \bar{\zeta}(\dots)$. This can be done by examining the Levi determinant (3.3), similarly as was done in e.g. the proof of Proposition 16.7. \square

20. Normalizations at the Origin

Now, we work at the origin. Expanding now in terms of all five variables $(z, \zeta, \bar{z}, \bar{\zeta}, v)$, and working modulo *weighted* order 6 terms, for the weights $[z] = 1$, $[\zeta] = 1$, $[w] = 2$, we have obtained:

$$u = z\bar{z} + \frac{1}{2}\bar{z}^2\zeta + \frac{1}{2}z^2\bar{\zeta} + z\bar{z}\zeta\bar{\zeta} + \frac{1}{2}\bar{z}^2\zeta\zeta\bar{\zeta} + \frac{1}{2}z^2\bar{\zeta}\bar{\zeta}\zeta \\ + z^4\bar{\zeta}F_{4,0,0,1,0} + \bar{z}^4\zeta\overline{F_{4,0,0,1,0}} + z^3\bar{\zeta}^2F_{3,0,0,2,0} + \bar{z}^3\zeta^2\overline{F_{3,0,0,2,0}} + O_{z,\zeta,\bar{z},\bar{\zeta},v}(6).$$

To normalize further, we can assume that the target hypersurface has already been normalized in the same way:

$$u' = z'\bar{z}' + \frac{1}{2}\bar{z}'^2\zeta' + \frac{1}{2}z'^2\bar{\zeta}' + z'\bar{z}'\zeta'\bar{\zeta}' + \frac{1}{2}\bar{z}'^2\zeta'\zeta'\bar{\zeta}' + \frac{1}{2}z'^2\bar{\zeta}'\bar{\zeta}'\zeta' \\ + z'^4\bar{\zeta}'F'_{4,0,0,1,0} + \bar{z}'^4\zeta'\overline{F'_{4,0,0,1,0}} + z'^3\bar{\zeta}'^2F'_{3,0,0,2,0} + \bar{z}'^3\zeta'^2\overline{F'_{3,0,0,2,0}} + O_{z',\zeta',\bar{z}',\bar{\zeta}',v'}(6).$$

But then, it is necessary to stabilize the normalization obtained up to order 4. With the help of a computer, one can prove the following:

LEMMA 20.1. *Any biholomorphic map of the form:*

$$z' := f_1 + f_2 + f_3, \quad \zeta' := g_1 + g_2, \quad w' := h_1 + h_2 + h_3 + h_4,$$

where $f_1, f_2, f_3, g_1, g_2, h_1, h_2, h_3, h_4$ are weighted homogeneous polynomials in (z, ζ, w) of degrees equal to their indices, which stabilizes the normalization up to order 4:

$$z\bar{z} + \frac{1}{2}\bar{z}^2\zeta + \frac{1}{2}z^2\bar{\zeta} + z\bar{z}\zeta\bar{\zeta} + O_{z,\zeta,\bar{z},\bar{\zeta},v}(5) \quad \longrightarrow \quad z'\bar{z}' + \frac{1}{2}\bar{z}'^2\zeta' + \frac{1}{2}z'^2\bar{\zeta}' + z'\bar{z}'\zeta'\bar{\zeta}' + O_{z',\zeta',\bar{z}',\bar{\zeta}',v'}(5)$$

is of the form:

$$z' := \lambda z - i\lambda\alpha z^2 - i\lambda\bar{\alpha}w - \frac{\lambda^2}{\lambda}\bar{\beta}z^3 + \left(i\lambda r - \frac{3}{2}\lambda\alpha\bar{\alpha} - \frac{1}{4}\frac{\lambda^2}{\lambda}\bar{\varepsilon} - \frac{1}{4}\bar{\lambda}\varepsilon\right)zw + i\lambda\alpha\zeta w, \\ \zeta' := \frac{\lambda}{\lambda}\zeta + 2i\frac{\lambda}{\lambda}\bar{\alpha}z + \varepsilon z^2 - 2i\frac{\lambda}{\lambda}\alpha z\zeta + \beta w, \\ w' := \lambda\bar{\lambda}w - 2i\lambda\bar{\lambda}\alpha zw - (2\lambda\bar{\lambda}\alpha^2 + \lambda^2\bar{\beta})z^2w + (-\lambda\bar{\lambda}\alpha\bar{\alpha} + i\lambda\bar{\lambda}r)w^2,$$

where $\lambda \in \mathbb{C}^*$, $\alpha \in \mathbb{C}$, $r \in \mathbb{R}$, $\beta \in \mathbb{C}$, $\varepsilon \in \mathbb{C}$ are arbitrary parameters. \square

Compared to the expansions to orders 3, 2, 4 of the components of the isotropy group of the Gaussier-Merker model shown in Section 5, *two new parameters appear*, namely β and ε . This causes little trouble to define *chains* for $M^5 \in \mathfrak{C}_{2,1}$, analogous to the Cartan-Moser chains for Levi nondegenerate $M^3 \subset \mathbb{C}^2$ redefined in [95], because the linearization of the above collection of maps (in fact a group) is:

$$z' := \lambda z - i\lambda\bar{\alpha}w, \\ \zeta' := \frac{\lambda}{\lambda}\zeta + 2i\frac{\lambda}{\lambda}\bar{\alpha}z + \beta w, \\ w' := \lambda\bar{\lambda}w,$$

and this action, parametrized by 6 variables $\lambda, \bar{\lambda}, \alpha, \bar{\alpha}, \beta, \bar{\beta}$, is *transitive* on 1-jets at the origin (exercise), contrary to the linearization of the action of the isotropy group of the

Gaussier-Merker model:

$$\begin{aligned} z' &:= \lambda z - i \lambda \bar{\alpha} w, \\ \zeta' &:= \frac{\lambda}{\lambda} \zeta + 2i \frac{\lambda}{\lambda} \bar{\alpha} z + \frac{\lambda}{\lambda} \bar{\alpha}^2 w, \\ w' &:= \lambda \bar{\lambda} w, \end{aligned}$$

in which $\beta = \frac{\lambda}{\lambda} \bar{\alpha}^2$ is a *dependent* parameter. This is why we obtained an invariant submanifold Σ_0^1 in Observation 8.1.

To resolve this little discrepancy, we must normalize to higher order at the origin.

So to normalize further, we will employ maps of the form:

$$\begin{aligned} z' &:= \lambda z - i \lambda \alpha z^2 - i \lambda \bar{\alpha} w - \frac{\lambda^2}{\lambda} \bar{\beta} z^3 + \left(i \lambda r - \frac{3}{2} \lambda \alpha \bar{\alpha} - \frac{1}{4} \frac{\lambda^2}{\lambda} \bar{\varepsilon} - \frac{1}{4} \bar{\lambda} \varepsilon \right) z w + i \lambda \alpha \zeta w \\ &\quad + \sum_{a+b+2e=4} f_{a,b,e} z^a \zeta^b w^e, \\ \zeta' &:= \frac{\lambda}{\lambda} \zeta + 2i \frac{\lambda}{\lambda} \bar{\alpha} z + \varepsilon z^2 - 2i \frac{\lambda}{\lambda} \alpha z \zeta + \beta w \\ &\quad + \sum_{a+b+2e=3} g_{a,b,e} z^a \zeta^b w^e, \\ w' &:= \lambda \bar{\lambda} w - 2i \lambda \bar{\lambda} \alpha z w - (2 \lambda \bar{\lambda} \alpha^2 + \lambda^2 \bar{\beta}) z^2 w + (-\lambda \bar{\lambda} \alpha \bar{\alpha} + i \lambda \bar{\lambda} r) w^2 \\ &\quad + \sum_{a+b+2e=5} h_{a,b,e} z^a \zeta^b w^e. \end{aligned}$$

Still on a computer, we verify

ASSERTION 20.2. *Whatever map is chosen, one has:*

$$F'_{3,0,0,2,0} = \frac{1}{\lambda} F_{3,0,0,2,0}. \quad \square$$

Furthermore, the map:

$$\begin{aligned} z' &:= z + 2 F_{4,0,0,1,0} z^3 - 2 F_{4,0,0,1,0} z \zeta w, \\ \zeta' &:= \zeta - 2 \overline{F_{4,0,0,1,0}} w + 10 z^2 \zeta F_{4,0,0,1,0}, \\ w' &:= w + 2 z^2 w F_{4,0,0,1,0}, \end{aligned}$$

normalizes $F'_{4,0,0,1,0} := 0$ (exercise). What we have proved so far deserved to be stated as a

PROPOSITION 20.3. *At every point $p \in M^5$ of a hypersurface $M^5 \subset \mathbb{C}^3$ in the class $\mathfrak{C}_{2,1}$, there exist holomorphic coordinates $(z, \zeta, w) \in \mathbb{C}^3$ centered at $p = (z_p, \zeta_p, w_p) = (0, 0, 0)$ in which M has equation:*

$$\begin{aligned} u &= z \bar{z} + \frac{1}{2} \bar{z}^2 \zeta + \frac{1}{2} z^2 \bar{\zeta} + z \bar{z} \zeta \bar{\zeta} + \frac{1}{2} \bar{z}^2 \zeta \zeta \bar{\zeta} + \frac{1}{2} z^2 \bar{\zeta} \zeta \bar{\zeta} \\ &\quad + z^3 \bar{\zeta}^2 F_{3,0,0,2,0} + \bar{z}^3 \zeta^2 \overline{F_{3,0,0,2,0}} + O_{z,\zeta,\bar{z},\bar{\zeta},v}(6). \quad \square \end{aligned}$$

By applying the technique of Chen-Foo-Merker-Ta [22, Sections 9, 10], one can realize, after rather hard computations, that there corresponds to this Taylor coefficient $F_{3,0,0,2,0}$,

the relative invariant W_0 of Pocchiola, presented in [113, 92, 49]:

$$\begin{aligned} W_0 := & -\frac{1}{3} \frac{\mathcal{H}(\overline{\mathcal{L}_1(\mathcal{L}_1(\mathbf{k}))})}{\overline{\mathcal{L}_1(\mathbf{k})}^2} + \frac{1}{3} \frac{\mathcal{H}(\overline{\mathcal{L}_1(\mathbf{k})}) \overline{\mathcal{L}_1(\mathcal{L}_1(\mathbf{k}))}}{\overline{\mathcal{L}_1(\mathbf{k})}^3} + \\ & + \frac{2}{3} \frac{\mathcal{L}_1(\overline{\mathcal{L}_1(\mathbf{k})})}{\overline{\mathcal{L}_1(\mathbf{k})}} + \frac{2}{3} \frac{\mathcal{L}_1(\overline{\mathcal{L}_1(\mathbf{k})})}{\overline{\mathcal{L}_1(\mathbf{k})}} + \frac{i}{3} \frac{\mathcal{I}(\mathbf{k})}{\overline{\mathcal{L}_1(\mathbf{k})}}, \end{aligned}$$

Much more simply, by plugging this normalized F into this formula, we obtain its value *only at one point*, namely at the origin:

$$W_0 = 4 \overline{F_{3,0,0,2,0}}.$$

Next, we determine the isotropy of this normalization.

LEMMA 20.4. *Any biholomorphic map of the form:*

$$z' := f_1 + f_2 + f_3 + f_4, \quad \zeta' := g_1 + g_2 + g_3, \quad w' := h_1 + h_2 + h_3 + h_4 + h_5,$$

where $f_1, f_2, f_3, f_4, g_1, g_2, g_3, h_1, h_2, h_3, h_4, h_5$, are weighted homogeneous polynomials in (z, ζ, w) of degrees equal to their indices, which stabilizes the normalization up to order 5 included:

$$\begin{aligned} & z\bar{z} + \frac{1}{2} \bar{z}^2 \zeta + \frac{1}{2} z^2 \bar{\zeta} + z\bar{z}\zeta\bar{\zeta} + \frac{1}{2} \bar{z}^2 \zeta\bar{\zeta} + \frac{1}{2} z^2 \bar{\zeta}\zeta\bar{\zeta} + F_{3,0,0,2,0} z^3 \bar{\zeta}^2 + \overline{F_{3,0,0,2,0}} \bar{z}^3 \zeta^2 + \mathcal{O}_{z,\zeta,\bar{z},\bar{\zeta},v}(6) \\ \rightarrow & z'z' + \frac{1}{2} \bar{z}'^2 \zeta' + \frac{1}{2} z'^2 \bar{\zeta}' + z'\bar{z}'\zeta'\bar{\zeta}' + \frac{1}{2} \bar{z}'^2 \zeta'\bar{\zeta}' + \frac{1}{2} z'^2 \bar{\zeta}'\zeta'\bar{\zeta}' + F'_{3,0,0,2,0} z'^3 \bar{\zeta}'^2 + \overline{F'_{3,0,0,2,0}} \bar{z}'^3 \zeta'^2 + \mathcal{O}_{z',\zeta',\bar{z}',\bar{\zeta}',v'}(6), \end{aligned}$$

is of the form:

$$\begin{aligned} z' := & \lambda z - i\lambda\alpha z^2 - i\lambda\bar{\alpha} w - \lambda\alpha^2 z^3 + \left(i\lambda r - 3\lambda\alpha\bar{\alpha} + 2i\lambda\alpha F_{3,0,0,2,0} - 2i\lambda\bar{\alpha} \overline{F_{3,0,0,2,0}} \right) zw + i\lambda\alpha \zeta w \\ & + i\lambda\alpha^3 z^4 + \left(8i\lambda\alpha^2\bar{\alpha} + \frac{1}{2} \frac{\lambda^2}{\lambda} \bar{\gamma} + 4 \frac{\lambda}{\lambda} \bar{\tau} + 4\lambda\alpha^2 F_{3,0,0,2,0} - 8\lambda\alpha\bar{\alpha} \overline{F_{3,0,0,2,0}} \right) z^2 w + 3\lambda\alpha^2 z\zeta w + \tau w^2, \\ \zeta' := & \frac{\lambda}{\lambda} \zeta + 2i \frac{\lambda}{\lambda} \bar{\alpha} z + \left(3 \frac{\lambda}{\lambda} \alpha\bar{\alpha} - i \frac{\lambda}{\lambda} r - 2i \frac{\lambda}{\lambda} \alpha F_{3,0,0,2,0} + 6i \frac{\lambda}{\lambda} \bar{\alpha} \overline{F_{3,0,0,2,0}} \right) z^2 - 2i \frac{\lambda}{\lambda} \alpha z\zeta + \frac{\lambda}{\lambda} \bar{\alpha}^2 w \\ & + \left(2 \frac{\lambda}{\lambda} \alpha r - 4i \frac{\lambda}{\lambda} \alpha^2 \bar{\alpha} - 2 \frac{\lambda^2}{\lambda^2} \bar{\gamma} - 8 \frac{\lambda}{\lambda^2} \bar{\tau} + 12 \frac{\lambda}{\lambda} \alpha^2 F_{3,0,0,2,0} + 4 \frac{\lambda}{\lambda} \alpha\bar{\alpha} \overline{F_{3,0,0,2,0}} \right) z^3 - 3 \frac{\lambda}{\lambda} \alpha^2 z^2 \zeta + \gamma zw \\ & + \left(-2 \frac{\lambda}{\lambda} \alpha\bar{\alpha} + 4i \frac{\lambda}{\lambda} \alpha F_{3,0,0,2,0} - 4i \frac{\lambda}{\lambda} \bar{\alpha} \overline{F_{3,0,0,2,0}} \right) \zeta w, \\ w' := & \lambda\bar{\lambda} w - 2i\lambda\bar{\lambda}\alpha zw - 3\lambda\bar{\lambda}\alpha^2 z^2 w + \left(-\lambda\bar{\lambda}\alpha\bar{\alpha} + i\lambda\bar{\lambda}r \right) w^2 + 4i\lambda\bar{\lambda}\alpha^3 z^3 w \\ & + \left(6i\lambda\bar{\lambda}\alpha^2\bar{\alpha} + 2\lambda\bar{\lambda}\alpha r + 2\lambda\bar{\lambda}\tau + 4\lambda\bar{\lambda}\alpha^2 F_{3,0,0,2,0} - 4\lambda\bar{\lambda}\alpha\bar{\alpha} \overline{F_{3,0,0,2,0}} \right) zw^2 + \lambda\bar{\lambda}\alpha^2 \zeta w^2. \end{aligned}$$

where $\lambda \in \mathbb{C}^*$, $\alpha \in \mathbb{C}$, $r \in \mathbb{R}$, $\gamma \in \mathbb{C}$, $\tau \in \mathbb{C}$ are arbitrary parameters. \square

In comparison to the normalization up to order 4, observe that the previous two supplementary parameters *have now been normalized*:

$$\begin{aligned} \beta := & \frac{\lambda}{\lambda} \bar{\alpha}^2, \\ \varepsilon := & -2i \frac{\lambda}{\lambda} \alpha F_{3,0,0,2,0} + 6i \frac{\lambda}{\lambda} \bar{\alpha} \overline{F_{3,0,0,2,0}} + 3 \frac{\lambda}{\lambda} \alpha\bar{\alpha} - i \frac{\lambda}{\lambda} r. \end{aligned}$$

With this, the *linearized* isotropy has become the *same* as the one of the GM-model written above:

$$(20.5) \quad \begin{aligned} z' &:= \lambda z - i \lambda \bar{\alpha} w, \\ \zeta' &:= \frac{\lambda}{\lambda} \zeta + 2i \frac{\lambda}{\lambda} \bar{\alpha} z + \frac{\lambda}{\lambda} \bar{\alpha}^2 w, \\ w' &:= \lambda \bar{\lambda} w. \end{aligned}$$

This key fact will enable us to define, at *every* point of *any* $\mathfrak{C}_{2,1}$ hypersurface $M^5 \subset \mathbb{C}^3$, a CR-invariant 1-jet locus $\Sigma_p^1 \subset J_{M,p}^1$ in the bundle of CR-transversal 1-jets of \mathcal{C}^ω curves $\gamma \subset M$.

We will follow the guide [95], which was prepared in advance on this purpose.

21. Point Translations of \mathcal{C}^ω Hypersurfaces $M^5 \subset \mathbb{C}^3$

Consider as before a local \mathcal{C}^ω hypersurface $M^5 \subset \mathbb{C}^3$ which is 2-nondegenerate and of constant Levi rank 1, namely belongs to the class $\mathfrak{C}_{2,1}$.

In coordinates $(z, \zeta, w) = (x + iy, s + it, u + iv)$, assume that M is locally graphed as $u = F(z, \zeta, \bar{z}, \bar{\zeta}, v)$. At all points $p = (z_p, \zeta_p, w_p) \in M$ with $u_p = F(z_p, \zeta_p, \bar{z}_p, \bar{\zeta}_p, v_p)$, let us expand up to weighted order 5:

$$u = F(z, \zeta, \bar{z}, \bar{\zeta}, v) = \sum_{a+b+c+d+2e \leq 5} \frac{(z-z_p)^a}{a!} \frac{(\zeta-\zeta_p)^b}{b!} \frac{(\bar{z}-\bar{z}_p)^c}{c!} \frac{(\bar{\zeta}-\bar{\zeta}_p)^d}{d!} \frac{(v-v_p)^e}{e!} F_{z^a \zeta^b \bar{z}^c \bar{\zeta}^d v^e}(z_p, \zeta_p, \bar{z}_p, \bar{\zeta}_p, v_p) + O(6),$$

subtract $u - u_p$, translate coordinates $z := z - z_p$, $\zeta := \zeta - \zeta_p$, $w := w - w_p$, and get a family of hypersurfaces $M^p \subset \mathbb{C}^3$, parametrized by $p \in M$ and passing through the origin:

$$u = F^p(z, \zeta, \bar{z}, \bar{\zeta}, v) = \sum_{1 \leq a+b+c+d+2e \leq 5} z^a \zeta^b \bar{z}^c \bar{\zeta}^d v^e F_{a,b,c,d,e}^p + O_{z,\zeta,\bar{z},\bar{\zeta},v}(6),$$

namely with $F^p(0, 0, 0, 0, 0) = 0$, whose graphing function has coefficients:

$$F_{a,b,c,d,e}^p := \frac{1}{a!} \frac{1}{b!} \frac{1}{c!} \frac{1}{d!} \frac{1}{e!} F_{z^a \zeta^b \bar{z}^c \bar{\zeta}^d v^e}(z_p, \zeta_p, \bar{z}_p, \bar{\zeta}_p, v_p),$$

analytically parametrized by $p \in M$. Thanks to this, working at *only one* point, namely at the origin, we will treat *all* points $p \in M$.

QUESTION 21.1. *Are there analogs, on hypersurfaces $M^5 \in \mathfrak{C}_{2,1}$, of Cartan-Moser chains [13, 13, 71, 95] for Levi nondegenerate hypersurfaces $M^3 \subset \mathbb{C}^2$?*

Thanks to Lemma 20.4, we will construct, at each point $p \in M$, an invariant surface in the bundle of 1-jets of CR-transversal curves in M . So there will be an important difference with Cartan-Moser chains for Levi nondegenerate $M^3 \subset \mathbb{C}^2$: the phenomenon that there exists a CR-transversal invariant object which is of *order 1*.

To view this object, similarly as in [95], we need to introduce bundles J_M^1 and J_M^2 of 1-jets and 2-jets of CR-transversal curves $\gamma: \mathbb{R} \rightarrow M$ with $\dot{\gamma} \notin T_\gamma^c M$ nowhere complex-tangential.

22. CR-Invariant 1-Jets 2-codimensional Submanifold $\Sigma^1 \subset J_M^1 \cong M^5 \times \mathbb{R}^4$

In local coordinates for which M is locally graphed as $u = F(z, \zeta, \bar{z}, \bar{\zeta}, v)$, at any point $p \in M$, the CR-transversal curves can be parametrized as:

$$v \longmapsto (x(v), y(v), s(v), t(v), v) \in \mathbb{R}_{x,y,z,t,v}^5$$

with $\gamma(0) = p = (x_p, y_p, s_p, t_p, v_p)$.

The $4 + 4 = 8$ independent coordinates corresponding to the first derivatives $(\dot{x}(v), \dot{y}(v), \dot{s}(v), \dot{t}(v))$ and to the second derivatives $(\ddot{x}(v), \ddot{y}(v), \ddot{s}(v), \ddot{t}(v))$ will be denoted as follows:

$$J_M^1 := \{(x_p, y_p, s_p, t_p, v_p, x_p^1, y_p^1, s_p^1, t_p^1, v_p^1)\} = \mathbb{R}^{5+4},$$

$$J_M^2 := \{(x_p, y_p, s_p, t_p, v_p, x_p^1, y_p^1, s_p^1, t_p^1, v_p^1, x_p^2, y_p^2, s_p^2, t_p^2, v_p^2)\} = \mathbb{R}^{5+4+4}.$$

Now, denote the translation map as:

$$\tau_p: (z, \zeta, w) \longrightarrow (z - z_p, \zeta - \zeta_p, w - w_p) =: (z, \zeta, w),$$

so that:

$$\tau_p(M, p) =: (M^p, 0).$$

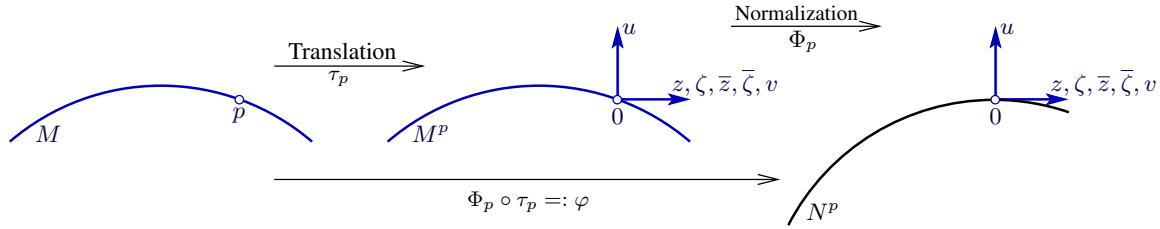

Also, let the punctual (at the origin) normalization map constructed up to now, by Proposition 20.3, be denoted by:

$$\begin{aligned} \Phi_p: (M^p, 0) &= \left\{ u = \sum_{1 \leq a+b+c+d+2e \leq 5} F_{a,b,c,d,e}^p z^a \zeta^b \bar{z}^c \bar{\zeta}^d v^e + O(6) \right\} \\ &\longrightarrow (N^p, 0) = \left\{ u = z\bar{z} + \frac{1}{2} \bar{z}^2 \zeta + \frac{1}{2} z^2 \bar{\zeta} + z\bar{z}\zeta\bar{\zeta} + \frac{1}{2} \bar{z}^2 \zeta \zeta \bar{\zeta} + \frac{1}{2} z^2 \bar{\zeta} \zeta \bar{\zeta} \right. \\ &\quad \left. + z^3 \bar{\zeta}^2 F_{3,0,0,2,0}^p + \bar{z}^3 \zeta^2 \overline{F_{3,0,0,2,0}^p} + O(6) \right\}. \end{aligned}$$

According to the constructions done in Sections 11 to 19 and according to Proposition 20.3, we know that Φ_p depends analytically on p .

Abbreviate:

$$\varphi := \Phi_p \circ \tau_p,$$

and consider the diagram:

$$\begin{array}{ccc} J_{M,p}^1 & \xrightarrow{\varphi^{(1)}} & J_{N^p,0}^1 \\ \downarrow & & \downarrow \\ (M, p) & \xrightarrow{\varphi} & (N^p, 0). \end{array}$$

As in Observation 8.1, in the 1-jet fiber above $0 \in N^p$, introduce the surface:

$$\Sigma_0^1 := \{(x_1, y_1, s_1, t_1) \in J_{N^p,0}^1: s_1 = -2x_1y_1, t_1 = x_1^2 - y_1^2\}.$$

Using the first prolongation $\varphi^{(1)}$, define the 2-dimensional submanifold of $J_{M,p}^1$:

$$\Sigma_p^1 := \varphi^{(1)-1}(\Sigma_0^1).$$

Since $\varphi^{(1)}$ is a diffeomorphism $J_{M,p}^1 \xrightarrow{\sim} J_{N^p,0}^1$, this Σ_p^1 is also graphed, say of the form:

$$s_p^1 = A(x_p^1, y_p^1), \quad t_p^1 = B(x_p^1, y_p^1),$$

with two \mathcal{C}^ω functions A, B which depend on p , and depend *also* a priori on the normalizing map φ .

$$\begin{array}{ccccc} & & \varphi^{(1)-1} & & \\ & \swarrow & \text{---} & \searrow & \\ \Sigma^1 & \xrightarrow{\quad} & J_{M,p}^1 & \xrightarrow{\quad \varphi^{(1)} \quad} & J_{N^p,0}^1 & \xleftarrow{\quad f \quad} & \Sigma^1 \\ & & \downarrow & & \downarrow & & \\ & & (M, p) & \xrightarrow{\quad \varphi \quad} & (N^p, 0) & & \end{array}$$

The union:

$$\bigcup_{p \in M} \Sigma_p^1 =: \Sigma^1 \subset J_M^1$$

is a \mathcal{C}^ω submanifold of dimension $5 + 2$ within J_M^1 which has dimension $5 + 4$.

ASSERTION 22.1. *This graphed surface $\Sigma_p^1 \subset J_{M,p}^1 \cong \mathbb{R}^4$ is independent of the map $\varphi = \Phi_p \circ \tau_p$ normalizing the initial hypersurface M of equation $u = F(z, \zeta, \bar{z}, \bar{\zeta}, v)$ near any of its points $p \in M$, to:*

$$\begin{aligned} u = & z\bar{z} + \frac{1}{2} \bar{z}^2 \zeta + \frac{1}{2} z^2 \bar{\zeta} + z\bar{z}\zeta\bar{\zeta} + \frac{1}{2} \bar{z}^2 \zeta\zeta\bar{\zeta} + \frac{1}{2} z^2 \bar{\zeta}\bar{\zeta}\zeta \\ & + z^3 \bar{\zeta}^2 F_{3,0,0,2,0}^p + \bar{z}^3 \zeta^2 \overline{F_{3,0,0,2,0}^p} + O_{z,\zeta,\bar{z},\bar{\zeta},v}(6). \end{aligned}$$

PROOF. Suppose another such normalizing map is given:

$$\begin{array}{ccc} & (N^p, 0) & \\ \varphi \nearrow & & \searrow \psi := \varphi_i \circ \varphi^{-1} \\ (M, p) & & \\ \varphi_i \searrow & & \downarrow \\ & (N_i^p, 0) & \end{array}$$

By Lemma 20.4 which holds for maps stabilizing the origin, ψ has linear terms exactly equal to the linear terms of the isotropy group of the GM-model, for which we already know, thanks to Observation 8.1, that:

$$\psi^{(1)}(\Sigma_0^1) = \Sigma_0^1.$$

Hence in conclusion:

$$\begin{aligned} \Sigma_p^1 &= \varphi_i^{(1)-1}(\Sigma_0^1) = \varphi_i^{(1)-1}(\psi^{(1)}(\Sigma_0^1)) = \varphi_i^{(1)-1}((\varphi_i \circ \varphi^{-1})^{(1)}(\Sigma_0^1)) \\ &= \varphi^{(1)-1}(\Sigma_0^1) = \Sigma_p^1. \quad \square \end{aligned}$$

So at each point $p \in M$, there exists a CR-invariant, or biholomorphically invariant, surface $\Sigma_p^1 \subset J_{M,p}^1$. Therefore, it is natural to select only CR-transversal curves $\gamma: \mathbb{R} \rightarrow M$, $\gamma(0) = p$, such that $\dot{\gamma}(\tau) \in \Sigma_{\gamma(\tau)}^1$ for every $\tau \in \mathbb{R}$.

But the ‘discovery’ of this CR-invariant submanifold $\Sigma_M^1 \subset J_M^1$ does not suffice, because the linear action:

$$\begin{aligned} z' &:= \lambda z - i \lambda \bar{\alpha} w, \\ \zeta' &:= \frac{\lambda}{\lambda} \zeta + 2i \frac{\lambda}{\lambda} \bar{\alpha} z + \frac{\lambda}{\lambda} \bar{\alpha}^2 w, \\ w' &:= \lambda \bar{\lambda} w, \end{aligned}$$

happens to be *transitive* on the invariant surface $\Sigma_0^1 \subset \mathbb{R}^4$ of 1-jets, according to the fact that the prolonged symmetry vector fields $D^{(1)}, R^{(1)}, l_1^{(1)}, l_2^{(1)}, J^{(1)}$, shown in Section 8, are of rank $2 = \dim \Sigma_0^1$ everywhere.

Remind from [13, 15, 71, 95] that Cartan-Moser chains were strictly of *second order*. Hence, we need to explore deeper, and to normalize further, still at $0 \in M^p$. We will realize that to each 1-jet $j_p^1 \in \Sigma_p^1$, there is associated a unique invariant 2-jet $j_p^2 = j_p^2(j_p^1)$, as we already saw when studying the GM-model in Section 9.

23. Order 1 Chains in $\mathcal{C}_{2,1}$ Hypersurfaces $M^5 \subset \mathbb{C}^3$

So far, at the origin, we have constructed a normalizing map Φ_p , composed with a translation map τ_p :

$$\varphi: (M, p) \xrightarrow{\tau_p} (M^p, 0) \xrightarrow{\Phi_p} (N^p, 0),$$

which brings (M, p) to $(N^p, 0)$ at the origin of equation fully normalized up to order 5 included:

$$\begin{aligned} u &= z\bar{z} + \frac{1}{2} \bar{z}^2 \zeta + \frac{1}{2} z^2 \bar{\zeta} + z\bar{z}\zeta\bar{\zeta} + \frac{1}{2} \bar{z}^2 \zeta\zeta\bar{\zeta} + \frac{1}{2} z^2 \bar{\zeta}\bar{\zeta}\zeta \\ &\quad + 2 \operatorname{Re} \left\{ 0 + 0 + z^3 \bar{\zeta}^2 F_{3,0,0,2,0}^p \right\} + O_{z,\zeta,\bar{z},\bar{\zeta},v}(6), \end{aligned}$$

namely with $0 = F_{3,0,1,1,0}^p = F_{4,0,0,1,0}^p$, knowing that $F_{3,0,0,2,0}^p$ is a relative invariant.

The differential φ_* establishes isomorphisms:

$$\begin{aligned} T_p M &\xrightarrow{\sim} T_0 N^p, \\ T_p^c M &\xrightarrow{\sim} T_0^c N^p, \\ K_p^c M &\xrightarrow{\sim} K_0^c N^p, \end{aligned}$$

where $K^c M \subset T^c M$ is the Levi-kernel subbundle [89]. It follows that φ_* establishes an isomorphism between the 3-dimensional real quotient bundles:

$$T_p M / (T_p^c M / K_p^c M) \xrightarrow{\sim} T_0 N^p / (T_0^c N^p / K_0^c N^p).$$

By definition, on these bundles T^c/K^c , the Levi form of M is nondegenerate, of maximal possible rank 1.

In a neighborhood of some reference point $p_0 \in M$, we can take coordinates (z, w, ζ) with $z = x + iy, \zeta = s + it, w = u + iv$, so that M is locally graphed as $u = F(z, \zeta, \bar{z}, \bar{\zeta}, v)$,

with $(v, x, y, s, t) \in M^5$ being intrinsic coordinates, so that the Levi form of M is *nonzero* near p_0 along the intrinsic $(1, 0)$ vector field:

$$\mathcal{L} := \frac{\partial}{\partial z} - i \frac{F_z}{1 + i F_v} \frac{\partial}{\partial v}.$$

We will let $p \sim p_0$ vary in a neighborhood of p_0 .

Taking jet coordinates (x_1, y_1, s_1, t_1) near p_0 so that:

$$J_M^1 = \{(v, x, y, s, t, x_1, y_1, s_1, t_1)\},$$

it follows from the above isomorphisms and from the definition of $\Sigma_0^1 \subset J_{M^p, 0}^1$ that $\Sigma^1 \subset J_M^1$ is locally defined near p_0 as a graph:

$$s_1 = A(v, x, y, s, t, x_1, y_1), \quad t_1 = B(v, x, y, s, t, x_1, y_1),$$

in terms of certain two \mathcal{C}^ω functions A, B , which vanish for $x_1 = y_1 = 0$. In this respect, the first two coordinates (x_p^1, y_p^1) of a 1-jet j_p^1 at some point $p = (v_p, x_p, y_p, s_p, t_p) \in M$ near p_0 should be thought of as being *horizontal*, and the last two coordinates (s_p^1, t_p^1) as being *vertical*.

An alternative presentation of CR-invariant CR-transversal 1-jets on hypersurfaces $M^5 \subset \mathbb{C}^3$ will be useful in a moment.

DÉFINITION 23.1. A 1-jet $j_p^1 \in J_{M, p}^1$ is said to be the jet of an *order 1 chain* at a point $p \in M$, or to *belong* to the invariant surface $\Sigma_p^1 \subset J_{M, p}^1$, if, given any punctual normalizing map from (M, p) to $(N^p, 0)$ up to order 5 as in Proposition 20.3:

$$u = z\bar{z} + \frac{1}{2} \bar{z}^2 \zeta + \frac{1}{2} z^2 \bar{\zeta} + z\bar{z} \zeta \bar{\zeta} + \frac{1}{2} \bar{z}^2 \zeta \zeta \bar{\zeta} + \frac{1}{2} z^2 \bar{\zeta} \bar{\zeta} \bar{\zeta} \\ + 2 \operatorname{Re} \left\{ 0 + 0 + z^3 \bar{\zeta}^2 F_{3,0,0,2,0}^p \right\} + O_{z, \zeta, \bar{z}, \bar{\zeta}, v}(6),$$

which sends j_p^1 to a 1-jet at $0 \in N^p$ having *vanishing* horizontal part:

$$\varphi^{(1)}(j_p^1) = (0, 0, s_0^1, t_0^1),$$

then in fact j_p^1 is the inverse image of the *flat* 1-jet at the origin:

$$j_p^1 = \varphi^{(1)^{-1}}(0, 0, 0, 0),$$

or equivalently $s_0^1 = t_0^1 = 0$.

This definition does not depend on the normalizing map Φ_p in $\varphi = \tau_p \circ \Phi_p$, because if another Φ'_p is chosen, which leads to the diagram:

$$\begin{array}{ccc} & (N^p, 0) & \\ \varphi \nearrow & & \searrow \psi := \varphi' \circ \varphi \\ (M, p) & & (N_r^p, 0) \\ & \searrow \varphi' & \end{array}$$

with $(N_r^p, 0)$ having an equation similar to the one of $(N^p, 0)$ above, then the ambiguity map $\psi := \varphi' \circ \varphi$ should stabilize the flat 1-jet, and for this to hold, we already know from the formulas (20.5) that this forces $\alpha = 0$.

We will now employ this definition in two ways. It is clear that the graphed equations of $\Sigma^1 \subset J_M^1$ lead to a system of two first-order ordinary differential equations:

$$\dot{s} = A(v, x, y, s, t, \dot{x}, \dot{y}), \quad \dot{t} = B(v, x, y, s, t, \dot{x}, \dot{y}),$$

the time parameter being v . For any choice of any two functions $(x(v), y(v))$ with $(x(0), y(0)) = (x_p, y_p)$, with $(\dot{x}(0), \dot{y}(0)) \neq (0, 0)$, and with $(s(0), t(0)) = (s_p, t_p)$, there exists a unique local \mathcal{C}^ω solution to this system passing through p at ‘time’ $v = 0$, which is a CR-transversal curve having tangents in Σ_M^1 .

TERMINOLOGY 23.2. Such a curve will be called an *order 1 chain*.

Later, when passing to *order 2 chains*, we will see that the large freedom in the choice of arbitrary functions $(x(v), y(v))$ will drop.

Once order 1 chains are known, it is natural to restart the whole process of prenormalization and of partial normalization which begun in Section 11, by assuming that the CR-transversal curve $p \in \gamma \subset M$ (not anymore chosen at random) is an order 1 chain.

Then, coming back to Proposition 19.4, but viewed at the origin up to order 6 in *all* variables $(z, \zeta, \bar{z}, \bar{\zeta}, v)$, we remember that we have constructed a normalizing map Φ_p , composed with a translation map τ_p :

$$\varphi: (M, p) \xrightarrow{\tau_p} (M^p, 0) \xrightarrow{\Phi_p} (N^p, 0),$$

which brings (M, p) to $(N^p, 0)$ at the origin of equation:

$$\begin{aligned} u = z\bar{z} + \frac{1}{2}\bar{z}^2\zeta + \frac{1}{2}z^2\bar{\zeta} + z\bar{z}\zeta\bar{\zeta} + \frac{1}{2}\bar{z}^2\zeta\zeta\bar{\zeta} + \frac{1}{2}z^2\bar{\zeta}\zeta\bar{\zeta} \\ + 2 \operatorname{Re} \left\{ 0 + z^4\bar{\zeta} F_{4,0,0,1,0}^p + z^3\bar{\zeta}^2 F_{3,0,0,2,0}^p \right\} + O_{z,\zeta,\bar{z},\bar{\zeta},v}(6), \end{aligned}$$

without changing the CR-transversal curve $0 \in \gamma \subset M$ being the v -axis, hence having *flat* 1-jet at the origin.

ASSERTION 23.3. Then $F_{4,0,0,1,0}^p = 0$ holds automatically, without having the needs to perform any further biholomorphism.

PROOF. Indeed, we already know that one can continue to normalize and make $F_{4,0,0,1,0}^p = 0$ by means of the map:

$$\begin{aligned} z' &:= z + 2 F_{4,0,0,1,0}^p z^3 - 2 F_{4,0,0,1,0}^p z\zeta w, \\ \zeta' &:= \zeta - 2 \overline{F_{4,0,0,1,0}^p} w + 10 z^2\zeta F_{4,0,0,1,0}^p, \\ w' &:= w + 2 z^2 w F_{4,0,0,1,0}^p, \end{aligned}$$

which we may call $\Psi: (N^p, 0) \rightarrow (N'_p, 0)$. We then reason as in [95, 9.5].

If $F_{4,0,0,1,0}^p \neq 0$ would be nonzero, due to the presence in ζ' of the linear term $2 \overline{F_{4,0,0,1,0}^p} w$, this map Ψ would *not* stabilize the flat order 1 jet $j_0^1 = (0, 0, 0, 0)$, and so, this would contradict Definition 23.1 applied to $(M, p) := (N^p, 0)$, to $\varphi := \Psi$, and to $(N^p, 0) := (N'_p, 0)$. \square

Lastly, coming again back to Proposition 19.4, we remember that we have constructed a normalizing map which brings M near $0 \in M$ to the equation:

$$\begin{aligned} u &= z\bar{z} + \frac{1}{2}\bar{z}^2\zeta + \frac{1}{2}z^2\bar{\zeta} + z\bar{z}\zeta\bar{\zeta} + \frac{1}{2}\bar{z}^2\zeta\zeta\bar{\zeta} + \frac{1}{2}z^2\bar{\zeta}\bar{\zeta}\zeta \\ &\quad + z^3\bar{z}^3 O_{z,\bar{z}}(0) \\ &\quad + 2 \operatorname{Re} \left\{ 0 + z^4\bar{\zeta} F_{4,0,0,1}(v) + z^3\bar{\zeta}^2 F_{3,0,0,2}(v) \right\} \\ &\quad + \bar{z}^3\zeta O_{z,\zeta,\bar{z}}(2) + z^3\bar{\zeta} O_{z,\bar{z},\bar{\zeta}}(2) + \zeta\bar{\zeta} O_{z,\zeta,\bar{z},\bar{\zeta}}(4). \end{aligned}$$

without changing any starting CR-transversal curve $0 \in \gamma \subset M$. We now realize that $F_{4,0,0,1}(v) \equiv 0$ vanishes for free.

PROPOSITION 23.4. *For every hypersurface $M^5 \in \mathfrak{C}_{2,1}$, at any point $p \in M$, given any CR-transversal curve $p \in \gamma \subset M$ which is an order 1 chain, there exist holomorphic coordinates $(z, \zeta, w) \in \mathbb{C}^3$ vanishing at p in which γ is the v -axis and in which M has equation:*

$$\begin{aligned} u &= z\bar{z} + \frac{1}{2}\bar{z}^2\zeta + \frac{1}{2}z^2\bar{\zeta} + z\bar{z}\zeta\bar{\zeta} + \frac{1}{2}\bar{z}^2\zeta\zeta\bar{\zeta} + \frac{1}{2}z^2\bar{\zeta}\bar{\zeta}\zeta \\ &\quad + z^3\bar{z}^3 O_{z,\bar{z}}(0) \\ &\quad + 2 \operatorname{Re} \left\{ 0 + 0 + z^3\bar{\zeta}^2 F_{3,0,0,2}(v) \right\} \\ &\quad + \bar{z}^3\zeta O_{z,\zeta,\bar{z}}(2) + z^3\bar{\zeta} O_{z,\bar{z},\bar{\zeta}}(2) + \zeta\bar{\zeta} O_{z,\zeta,\bar{z},\bar{\zeta}}(4). \end{aligned}$$

PROOF. What was done an instant ago by Assertion 23.3 at the origin $(z, \zeta, w) = (0, 0, 0)$ applies in fact at *every* point $(0, 0, iv)$ along the v -axis, thanks to the fact that the (pre)normalizations of Propositions 16.7 and 19.4 were achieved *all along* the v -axis. \square

Because we know the existence of a CR-invariant surface $\Sigma_p^1 \subset J_{M,p}^1$ on which the isotropy is transitive, we will assume that, starting with any fixed 1-jet $j_p^1 \in \Sigma_p^1$, the partial normalization map performed up to now sends j_p^1 to the *flat* 1-jet at $0 \in M^p$, namely to $j_0^1 = (0, 0, 0, 0)$. We will assume that subsequent normalizations *stabilize* this invariant flat 1-jet. For this, at the very beginning, we have to assume that the CR-transversal curve used in Section 11, whose choice was left free, has 1-jet at the origin 0 equal to the flat 1-jet. By surveying all normalizations done up to now, one realizes that the v -axis was always stabilized, contained in M , hence the flat 1-jet was always preserved (implicitly).

Preserving the flat 1-jet at 0 corresponds to making $\alpha := 0$ in the formulas of Section 9 and of Lemma 20.4. We state this explicitly as a

COROLLARY 23.5. *The biholomorphic maps of Lemma 20.4 which stabilize punctual normalizations of $(M^p, 0)$ at the origin up to order 5 and which stabilize also the flat 1-jet $j_0^1 = (0, 0, 0, 0) \in \Sigma_0^1$ read, with $\alpha := 0$ and $\theta := \gamma$, as:*

$$\begin{aligned} z' &:= \lambda z + i\lambda r zw + \left(\frac{1}{2} \frac{\lambda^2}{\lambda} \bar{\theta} + 4 \frac{\lambda}{\lambda} \bar{\tau} \right) z^2 w + \tau w^2, \\ \zeta' &:= \frac{\lambda}{\lambda} \zeta - i \frac{\lambda}{\lambda} r z^2 + \left(-2 \frac{\lambda^2}{\lambda} \bar{\theta} - 8 \frac{\lambda}{\lambda} \bar{\tau} \right) z^3 + \theta zw, \\ w' &:= \lambda \bar{\lambda} w + i \lambda \bar{\lambda} r w^2 + 2 \lambda \bar{\tau} z w^2. \end{aligned}$$

\square

24. End of Point Normalization of \mathcal{C}^ω Hypersurfaces $M^5 \subset \mathbb{C}^3$

Thus, we have to look at 6th order terms in the currently normalized equation of $(M^p, 0)$, which, taking account of the vanishing of the Levi determinant, are of the form (exercise):

$$\begin{aligned}
u = & z\bar{z} + \frac{1}{2}\bar{z}^2\zeta + \frac{1}{2}z^2\bar{\zeta} + z\bar{z}\zeta\bar{\zeta} + \frac{1}{2}\bar{z}^2\zeta\zeta\bar{\zeta} + \frac{1}{2}z^2\bar{\zeta}\bar{\zeta}\zeta + z\bar{z}\zeta\bar{\zeta}\zeta\bar{\zeta} \\
& + F_{3,0,0,2,0}^p z^3\bar{\zeta}^2 + \overline{F_{3,0,0,2,0}^p} \bar{z}^3\zeta^2 + \zeta\bar{\zeta} \left(3 F_{3,0,0,2,0}^p z^2\bar{z}\bar{\zeta} + 3 \overline{F_{3,0,0,2,0}^p} z\zeta\bar{z}^2 \right) \\
& + z^3\bar{z}^3 F_{3,0,3,0,0}^p \\
& + 2 \operatorname{Re} \left\{ z^5\bar{\zeta} F_{5,0,0,1,0}^p + z^4\bar{z}\bar{\zeta} F_{4,0,1,1,0}^p + z^4\bar{\zeta}^2 F_{4,0,0,2,0}^p \right. \\
& \quad \left. + z^3\bar{z}^2\bar{\zeta} F_{3,0,2,1,0}^p + z^3\bar{z}\bar{\zeta}^2 F_{3,0,1,2,0}^p \right. \\
& \quad \left. + z^3\bar{\zeta}^3 F_{3,0,0,3,0}^p \right\} + O_{z,\zeta,\bar{z},\bar{\zeta},v}(7).
\end{aligned}$$

To normalize further order 6 terms, it is natural to assume that the normalizations up to order 5 included are stabilized, *and also* that the flat 1-jet at the origin is stabilized as well. Thus we will employ maps of the form:

$$\begin{aligned}
z' & := \lambda z + i\lambda r zw + \left(\frac{1}{2} \frac{\lambda^2}{\lambda} \bar{\theta} + 4 \frac{\lambda}{\lambda} \bar{\tau} \right) z^2 w + \tau w^2 + \sum_{a+b+2e=5} f_{a,b,e} z^a \zeta^b w^e, \\
\zeta' & := \frac{\lambda}{\lambda} \zeta - i \frac{\lambda}{\lambda} r z^2 + \left(-2 \frac{\lambda^2}{\lambda^2} \bar{\theta} - 8 \frac{\lambda}{\lambda^2} \bar{\tau} \right) z^3 + \theta zw + \sum_{a+b+2e=4} g_{a,b,e} z^a \zeta^b w^e, \\
w' & := \lambda \bar{\lambda} w + i \lambda \bar{\lambda} r w^2 + 2 \lambda \bar{\tau} z w^2 + \sum_{a+b+2e=6} h_{a,b,e} z^a \zeta^b w^e.
\end{aligned}$$

LEMMA 24.1. *One can annihilate:*

$$F_{3,0,3,0,0}^p = 0 \quad \text{and} \quad \left(\text{either } F_{4,0,1,1,0}^p = 0 \quad \text{or} \quad F_{3,0,2,1,0}^p = 0 \right).$$

PROOF. By hand or on a computer, one verifies that the map:

$$\begin{aligned}
z' & := z + \frac{3}{4} F_{3,0,3,0,0}^p z w^2, \\
\zeta' & := \zeta, \\
w' & := w + \left(\frac{1}{4} F_{3,0,3,0,0}^p + \overline{F_{3,0,3,0,0}^p} \right) w^3,
\end{aligned}$$

makes $F_{3,0,3,0,0}^{p'} = 0$. It is visible (eyes exercise) that this map stabilizes the flat 1-jet $j_0^1 = (0, 0, 0, 0)$.

Next, assuming that $F_{3,0,3,0,0}^p = 0 = F_{3,0,3,0,0}^{p'}$, the map parametrized by $\tau \in \mathbb{C}$:

$$\begin{aligned}
z' & := z + 2\bar{\tau} z^2 w + \tau w^2 - \bar{\tau} \zeta w^2, \\
\zeta' & := \zeta - 4\tau zw + 4\bar{\tau} z\zeta w, \\
w' & := w + 2\bar{\tau} z w^2,
\end{aligned}$$

also stabilizes the flat 1-jet $j_0^1 = (0, 0, 0, 0)$, and it transforms as follows the six remaining coefficients:

$$\begin{aligned} F_{5,0,0,1,0}^{p'} &= F_{5,0,0,1,0}^p & F_{4,0,1,1,0}^{p'} &= F_{4,0,1,1,0}^p - 2\bar{\tau}, & F_{4,0,0,2,0}^{p'} &= F_{4,0,0,2,0}^p, \\ F_{3,0,2,1,0}^{p'} &= F_{3,0,2,1,0}^p + 2\tau, & F_{3,0,1,2,0}^{p'} &= F_{3,0,1,2,0}^p, & F_{3,0,0,3,0}^{p'} &= F_{3,0,0,3,0}^p. \end{aligned}$$

So one of the two mentioned coefficients can be normalized. \square

A choice must be made. We then determine the stability group for both choices of normalizations, again with the constraint of stabilizing the flat 1-jet j_0^1 . Both choices lead to the same stability group (exercise on a computer).

LEMMA 24.2. *Any biholomorphic map of the form:*

$$z' := f_1 + f_2 + f_3 + f_4 + f_5, \quad \zeta' := g_1 + g_2 + g_3 + g_4, \quad w' := h_1 + h_2 + h_3 + h_4 + h_5 + h_6,$$

where $f_1, f_2, f_3, f_4, f_5, g_1, g_2, g_3, g_4, h_1, h_2, h_3, h_4, h_5, h_6$, are weighted homogeneous, which stabilizes the normalization up to order 6 included:

$$\begin{aligned} u &= z\bar{z} + \frac{1}{2}\bar{z}^2\zeta + \frac{1}{2}z^2\bar{\zeta} + z\bar{z}\zeta\bar{\zeta} + \frac{1}{2}\bar{z}^2\zeta\bar{\zeta} + \frac{1}{2}z^2\bar{\zeta}\zeta\bar{\zeta} + z\bar{z}\zeta\bar{\zeta}\zeta\bar{\zeta} \\ &+ F_{3,0,0,2,0}^p z^3\bar{\zeta}^2 + \overline{F_{3,0,0,2,0}^p} \bar{z}^3\zeta^2 + \zeta\bar{\zeta} \left(3F_{3,0,0,2,0}^p z^2\bar{z}\bar{\zeta} + 3\overline{F_{3,0,0,2,0}^p} z\zeta\bar{z}^2 \right) \\ &+ 0 + 2\operatorname{Re} \left\{ z^5\bar{\zeta} F_{5,0,0,1,0}^p + 0 + z^4\bar{\zeta}^2 F_{4,0,0,2,0}^p \right. \\ &\quad \left. + z^3\bar{z}^2\bar{\zeta} F_{3,0,2,1,0}^p + z^3\bar{z}\bar{\zeta}^2 F_{3,0,1,2,0}^p \right. \\ &\quad \left. + z^3\bar{\zeta}^3 F_{3,0,0,3,0}^p \right\} + O_{z,\zeta,\bar{z},\bar{\zeta},v}(7), \end{aligned}$$

and which stabilizes the flat 1-jet at the origin, is of the form:

$$\begin{aligned} z' &:= \lambda z + i\lambda r zw + 2\frac{\lambda^2}{\lambda}\bar{\chi}z^3w + \psi zw^2, \\ \zeta' &:= \frac{\lambda}{\lambda}\zeta - i\frac{\lambda}{\lambda}r z^2 - 4\frac{\lambda^2}{\lambda^2}\bar{\chi}z^4 + \left(-\frac{8}{3}\frac{\psi}{\lambda} + \frac{4}{3}\frac{\lambda}{\lambda^2}\bar{\psi} - \frac{1}{3}\frac{\lambda}{\lambda}r^2 \right) z^2w + \chi w^2, \\ w' &:= \lambda\bar{\lambda}w + i\lambda\bar{\lambda}r w^2 + \lambda^2\bar{\chi}z^2w^2 + \left(-\frac{1}{3}\lambda\bar{\lambda}r^2 + \frac{1}{3}\lambda\bar{\lambda}\psi + \frac{1}{3}\lambda\bar{\lambda}\bar{\psi} \right) w^3. \end{aligned}$$

where $\lambda \in \mathbb{C}^*$, $r \in \mathbb{R}$, $\psi \in \mathbb{C}$, $\chi \in \mathbb{C}$ are arbitrary parameters. \square

Furthermore, with this map, if one stabilizes the normalization $F_{4,0,1,1,0} = 0 = F_{4,0,1,1,0}^{p'}$, the other coefficients transform as:

$$\begin{aligned} F_{5,0,0,1,0}^{p'} &= \frac{1}{\lambda^3} F_{5,0,0,1,0}^p & 0 &= 0, & F_{4,0,0,2,0}^{p'} &= \frac{1}{\lambda\lambda} F_{4,0,0,2,0}^p, \\ F_{3,0,2,1,0}^{p'} &= \frac{1}{\lambda\lambda^2} F_{3,0,2,1,0}^p - 2i\frac{1}{\lambda\lambda^2} F_{3,0,0,2,0}^p, & F_{3,0,1,2,0}^{p'} &= \frac{1}{\lambda^2} F_{3,0,1,2,0}^p, & F_{3,0,0,3,0}^{p'} &= \frac{\lambda}{\lambda^2} F_{3,0,0,3,0}^p, \end{aligned}$$

while if one stabilizes the normalization $F_{3,0,2,1,0} = 0 = F_{3,0,2,1,0}^{p'}$, the other coefficients transform as:

$$\begin{aligned} F_{5,0,0,1,0}^{p'} &= \frac{1}{\lambda^3} F_{5,0,0,1,0}^p & F_{4,0,1,1,0}^{p'} &= \frac{1}{\lambda^2\lambda^2} F_{4,0,1,1,0}^p - 2\bar{\tau}, & F_{4,0,0,2,0}^{p'} &= \frac{1}{\lambda\lambda} F_{4,0,0,2,0}^p, \\ & & 0 &= 2i\lambda\bar{\lambda}r F_{3,0,0,2,0}^p, & F_{3,0,1,2,0}^{p'} &= \frac{1}{\lambda^2} F_{3,0,1,2,0}^p, \\ & & & & F_{3,0,0,3,0}^{p'} &= \frac{\lambda}{\lambda^2} F_{3,0,0,3,0}^p. \end{aligned}$$

This second choice happens to be less natural than the first one, because it forces to discuss the dichotomy branching:

$$\begin{array}{c}
 F_{3,0,0,2,0}^p \\
 \swarrow \quad \searrow \\
 F_{3,0,0,2,0}^p = 0, \quad F_{3,0,0,2,0}^p \neq 0,
 \end{array}$$

and when $F_{3,0,0,2,0}^p \neq 0$, it leads to normalize the parameter r , which belongs to the isotropy of the GM-model, and such a normalization is too early to be done.

Therefore, we choose the normalization $F_{4,0,1,1,0}^{p'} = 0$.

By applying the technique of Chen-Foo-Merker-Ta [22, Sections 9, 10], one can realize, after rather hard computations, that there corresponds to the Taylor coefficient $F_{5,0,0,1,0}$, the relative invariant \mathcal{J}_0 of Pocchiola, presented in [113, 92, 49]:

$$\begin{aligned}
 \bar{\mathcal{J}}_0 := & \frac{1}{6} \frac{\overline{\mathcal{L}_1(\mathcal{L}_1(\overline{\mathcal{L}_1(\mathcal{L}_1(k))))}}{\overline{\mathcal{L}_1(k)}} - \frac{5}{6} \frac{\overline{\mathcal{L}_1(\mathcal{L}_1(\overline{\mathcal{L}_1(k)))}}{\overline{\mathcal{L}_1(k)^2}} \frac{\overline{\mathcal{L}_1(\overline{\mathcal{L}_1(k)})}}{\overline{\mathcal{L}_1(k)}} - \frac{1}{6} \frac{\overline{\mathcal{L}_1(\mathcal{L}_1(\overline{\mathcal{L}_1(k)))}}{\overline{\mathcal{L}_1(k)}} \bar{P} + \\
 & + \frac{20}{27} \frac{\overline{\mathcal{L}_1(\overline{\mathcal{L}_1(k)})^3}}{\overline{\mathcal{L}_1(k)^3}} + \frac{5}{18} \frac{\overline{\mathcal{L}_1(\overline{\mathcal{L}_1(k)})^2}}{\overline{\mathcal{L}_1(k)^2}} \bar{P} + \frac{1}{6} \frac{\overline{\mathcal{L}_1(\overline{\mathcal{L}_1(k)})}}{\overline{\mathcal{L}_1(k)}} \frac{\overline{\mathcal{L}_1(\bar{P})}}{\overline{\mathcal{L}_1(k)}} - \frac{1}{9} \frac{\overline{\mathcal{L}_1(\overline{\mathcal{L}_1(k)})}}{\overline{\mathcal{L}_1(k)}} \bar{P} \bar{P} - \\
 & - \frac{1}{6} \overline{\mathcal{L}_1(\overline{\mathcal{L}_1(\bar{P}))}} + \frac{1}{3} \overline{\mathcal{L}_1(\bar{P})} \bar{P} - \frac{2}{27} \bar{P} \bar{P} \bar{P}.
 \end{aligned}$$

Much more simply, by plugging this normalized F into this formula, we obtain its value *only at one point*, namely at the origin:

$$\bar{\mathcal{J}}_0 = 20 \overline{F_{5,0,0,1,0}}.$$

25. Order 2 Chains in $\mathfrak{C}_{2,1}$ Hypersurfaces $M^5 \subset \mathbb{C}^3$

In Lemma 24.2, the presence of the free parameter $\chi \in \mathbb{C}$ in the last term χw^2 , of order 4, of $\zeta' = \frac{\lambda}{\chi} \zeta + \dots + \chi w^2$, shows that the flat second jet $j_0^2 = (0, 0, 0, 0, 0, 0, 0, 0)$ is *not* invariant by transformations which stabilize the normalizations achieved up to now at order 6.

To define chains as in Definition 8.4 of [95], we need then to explore a bit further the normalizations.

As we already know thanks to Proposition 16.7, it is possible, by some punctual normalization, to also make, at order 7:

$$\begin{aligned}
 0 &= F_{a,b,0,0,e}^p && (a+b+2e=7), \\
 0 &= F_{a,b,1,0,e}^p && (a+b+2e=6), \\
 0 &= F_{a,b,2,0,e}^p && (a+b+2e=5).
 \end{aligned}$$

Once these normalizations are done, the condition that they are preserved forces $\chi = 0$ (exercise).

We therefore come to maps which express the ‘ambiguity’ of punctual normalizations being of the form:

$$\begin{aligned} z' &:= \lambda z + i \lambda r z w + \psi z w^2, \\ \zeta' &:= \frac{\lambda}{\lambda} \zeta - i \frac{\lambda}{\lambda} r z^2 + \left(-\frac{8}{3} \frac{\psi}{\lambda} + \frac{4}{3} \frac{\lambda}{\lambda^2} \bar{\psi} - \frac{1}{3} \frac{\lambda}{\lambda} r^2 \right) z^2 w, \\ w' &:= \lambda \bar{\lambda} w + i \lambda \bar{\lambda} r w^2 + \left(-\frac{1}{3} \lambda \bar{\lambda} r^2 + \frac{1}{3} \bar{\lambda} \psi + \frac{1}{3} \lambda \bar{\psi} \right) w^3. \end{aligned}$$

Then such maps have the property that they send curves $\mathbb{R}_v^1 \longrightarrow \mathbb{R}_{x,y,s,t}^4$ of the form:

$$x = O_v(2), \quad y = O_v(2), \quad s = O_v(2), \quad t = O_v(2),$$

to curves of the similar form:

$$x' = O_{v'}(2), \quad y = O_{v'}(2), \quad s = O_{v'}(2), \quad t = O_{v'}(2),$$

hence they stabilize the flat 2-jet $j_0^2 = (0, 0, 0, 0, 0, 0, 0, 0)$.

In conclusion, we have reached a point at which we can state an analog of Definition 8.4 in [95].

DÉFINITION 25.1. Given a hypersurface $M^5 \subset \mathbb{C}^3$ in the class $\mathfrak{C}_{2,1}$, a point $p \in M$, a 1-jet $j_p^1 \in \Sigma_p^1$ at p , given the translation map $\tau_p: (M, p) \longrightarrow (M^p, 0)$, and using any normalizing map $\Phi_p: M^p \longrightarrow N^p$ which sends $(M^p, 0)$ to a hypersurface $(N^p, 0)$ of equation:

$$\begin{aligned} & z \bar{z} + \frac{1}{2} \bar{z}^2 \zeta + \frac{1}{2} z^2 \bar{\zeta} + z \bar{z} \zeta \bar{\zeta} + \frac{1}{2} \bar{z}^2 \zeta \zeta \bar{\zeta} + \frac{1}{2} z^2 \bar{\zeta} \bar{\zeta} \zeta \\ & + 2 \operatorname{Re} \left\{ 0 + 0 + F_{3,0,0,2,0}^p z^3 \bar{\zeta}^2 + \zeta \bar{\zeta} (3 z^2 \bar{z} \zeta F_{3,0,0,2,0}^p) \right\} \\ & + 0 + 2 \operatorname{Re} \left\{ z^5 \bar{\zeta} F_{5,0,0,1,0}^p + 0 + z^4 \bar{\zeta}^2 F_{4,0,0,2,0}^p \right. \\ & \quad \left. + z^3 \bar{z}^2 \bar{\zeta} F_{3,0,2,1,0}^p + z^3 \bar{z} \bar{\zeta}^2 F_{3,0,1,2,0}^p \right. \\ & \quad \left. + z^3 \bar{\zeta}^3 F_{3,0,0,3,0}^p \right\} + O_{z,\zeta,\bar{z},\bar{\zeta},v}(7), \end{aligned}$$

with in addition:

$$\begin{aligned} 0 &= F_{a,b,0,0,e}^p & (a+b+2e=7), \\ 0 &= F_{a,b,1,0,e}^p & (a+b+2e=6), \\ 0 &= F_{a,b,2,0,e}^p & (a+b+2e=5), \end{aligned}$$

and which also sends j_p^1 to the flat 1-jet $j_0^1 = (0, 0, 0, 0)$ at $0 \in N^p$, assign the 2-jet j_p^2 of the chain at $p \in M$ associated with j_p^1 to be the inverse image of the flat 2-jet at $0 \in N^p$:

$$j_p^2 := (\Phi_p \circ \tau_p)^{(2)^{-1}}(0, 0, 0, 0, 0, 0, 0, 0).$$

Thanks to the preceding reasonings, the result j_p^2 is independent of the normalizing map $\Phi_p \circ \tau_p$ satisfying $(\Phi_p \circ \tau_p)^{(1)}(j_p^1) = (0, 0, 0, 0)$, the flat 1-jet at $0 \in N^p$.

Furthermore, there are \mathcal{C}^ω functions A, B, C, D, E, F , which can be made explicit in terms of $\{F_{a,b,c,d,e}^p\}_{1 \leq a+b+c+d+2e \leq 6}$, such that equations of chains are, with time parameter

v :

$$\begin{aligned} \dot{x} &= C(v, x, y, s, t, \dot{x}, \dot{y}), \\ \dot{s} &= A(v, x, y, s, t, \dot{x}, \dot{y}), & \ddot{y} &= D(v, x, y, s, t, \dot{x}, \dot{y}), \\ \dot{t} &= B(v, x, y, s, t, \dot{x}, \dot{y}), & \ddot{s} &= E(v, x, y, s, t, \dot{x}, \dot{y}), \\ & & \ddot{t} &= F(v, x, y, s, t, \dot{x}, \dot{y}). \end{aligned}$$

Integrability follows from the fact that Σ_0^2 is a surface.

After that order 2 chains are known, it is natural to restart once more the whole process of prenormalization and of partial normalization which begun in Section 11, by assuming that the CR-transversal curve $p \in \gamma \subset M$ (not anymore chosen at random) is an order 2 chain. In fact, to have a second order chain at a point $p \in M$, it suffices to prescribe two real constants, the initial values $\dot{x}(0), \dot{y}(0)$.

Then, coming back to Proposition 23.4, but viewed at the origin up to order 6 in *all* variables $(z, \zeta, \bar{z}, \bar{\zeta}, v)$, we remember that we have constructed a normalizing map Φ_p , composed with a translation map τ_p :

$$\varphi: (M, p) \xrightarrow{\tau_p} (M^p, 0) \xrightarrow{\Phi_p} (N^p, 0),$$

which brings (M, p) to $(N^p, 0)$ at the origin of equation:

$$\begin{aligned} u &= z\bar{z} + \frac{1}{2}\bar{z}^2\zeta + \frac{1}{2}z^2\bar{\zeta} + z\bar{z}\zeta\bar{\zeta} + \frac{1}{2}\bar{z}^2\zeta\zeta\bar{\zeta} + \frac{1}{2}z^2\bar{\zeta}\bar{\zeta}\zeta + z\bar{z}\zeta\bar{\zeta}\zeta\bar{\zeta} \\ &+ z^3\bar{z}^3 F_{3,0,3,0,0}^p + z^3\bar{z}^3 O_{z,\bar{z},v}(1) \\ &+ 2 \operatorname{Re} \left\{ 0 + 0 + z^3\bar{\zeta}^2 F_{3,0,0,2,0}^p + \zeta\bar{\zeta} (3z^2\bar{z}\bar{\zeta} F_{3,0,0,2,0}^p) \right\} \\ &+ 2 \operatorname{Re} \left\{ z^5\bar{\zeta} F_{5,0,0,1,0}^p + z^4\bar{z}\bar{\zeta} F_{4,0,1,1,0}^p + z^4\bar{\zeta}^2 F_{4,0,0,2,0}^p \right. \\ &\quad \left. + z^3\bar{z}^2\bar{\zeta} F_{3,0,2,1,0}^p + z^3\bar{z}\bar{\zeta}^2 F_{3,0,1,2,0}^p \right. \\ &\quad \left. + z^3\bar{\zeta}^3 F_{3,0,0,3,0}^p \right\} + O_{z,\zeta,\bar{z},\bar{\zeta},v}(7), \end{aligned}$$

without changing the CR-transversal curve $0 \in \gamma \subset M$ being the v -axis, hence having flat 1-jet at the origin.

ASSERTION 25.2. *Then $F_{4,0,1,1,0}^p = 0$ holds automatically, without having the needs to perform any further biholomorphism.*

PROOF. Indeed, from the proof of Lemma 24.1 we already know that with the choice:

$$\tau := \frac{1}{2} \overline{F_{4,0,1,1,0}^p},$$

one can continue to normalize and make $F_{4,0,1,1,0}^{p'} = 0$ by means of the map:

$$\begin{aligned} z' &:= z + F_{4,0,1,1,0}^p z^2 w - \frac{1}{2} F_{4,0,1,1,0}^p \zeta w^2 + \frac{1}{2} \overline{F_{4,0,1,1,0}^p} w^2, \\ \zeta' &:= \zeta - 2 \overline{F_{4,0,1,1,0}^p} z w + 2 F_{4,0,1,1,0}^p \zeta w^2, \\ w' &:= w + F_{4,0,1,1,0}^p z w^2, \end{aligned}$$

which we may call $\Psi: (N^p, 0) \longrightarrow (N_t^p, 0)$. We then reason as in [95, 9.5]

If $F_{4,0,1,1,0}^p \neq 0$ would be nonzero, due to the presence in z' of the quadratic term $\frac{1}{2} \overline{F_{4,0,1,1,0}^p} w^2$, this map Ψ would not stabilize the flat order 2 jet $j_0^2 = (0, 0, 0, 0, 0, 0, 0, 0)$,

and so, this would contradict Definition 25.1 applied to $(M, p) := (N^p, 0)$, to $\varphi := \Psi$, and to $(N^p, 0) := (N_r^p, 0)$. \square

26. Moser-like Normal Form for $\mathfrak{C}_{2,1}$ Hypersurfaces $M^5 \subset \mathbb{C}^3$

Lastly, coming again back to Proposition 19.4, all what precedes showed that, *without changing* any starting order 2 chain $0 \in \gamma \subset M$ to be straightened to be the v -axis, we have constructed a normalizing map $(M, 0) \rightarrow (N, 0)$ so that, in the equation of N , we may (at last!) let appear all the terms of order 6 in $(z, \zeta, \bar{z}, \bar{\zeta})$:

$$\begin{aligned} u = & z\bar{z} + \frac{1}{2}\bar{z}^2\zeta + \frac{1}{2}z^2\bar{\zeta} + z\bar{z}\zeta\bar{\zeta} + \frac{1}{2}\bar{z}^2\zeta\zeta\bar{\zeta} + \frac{1}{2}z^2\bar{\zeta}\bar{\zeta}\zeta + z\bar{z}\zeta\bar{\zeta}\zeta\bar{\zeta} \\ & + z^3\bar{z}^3 F_{3,0,3,0}(v) + z^3\bar{z}^3 O_{z,\bar{z}}(1) \\ & + 2 \operatorname{Re} \left\{ 0 + 0 + z^3\bar{\zeta}^2 F_{3,0,0,2}(v) + \zeta\bar{\zeta} (3 z^2\bar{z}\bar{\zeta} F_{3,0,0,2}(v)) \right\} \\ & + 2 \operatorname{Re} \left\{ z^5\bar{\zeta} F_{5,0,0,1}(v) + z^4\bar{z}\bar{\zeta} F_{4,0,1,1}(v) + z^4\bar{\zeta}^2 F_{4,0,0,2}(v) \right. \\ & \quad \left. + z^3\bar{z}^2\bar{\zeta} F_{3,0,2,1}(v) + z^3\bar{z}\bar{\zeta}^2 F_{3,0,1,2}(v) \right. \\ & \quad \left. + z^3\bar{\zeta}^3 F_{3,0,0,3}(v) \right\} \\ & + \bar{z}^3\zeta O_{z,\zeta,\bar{z}}(3) + z^3\bar{\zeta} O_{z,\bar{z},\bar{\zeta}}(3) + \zeta\bar{\zeta} O_{z,\zeta,\bar{z},\bar{\zeta}}(5). \end{aligned}$$

ASSERTION 26.1. *The function $F_{4,0,1,1}(v) \equiv 0$ vanishes for free.*

PROOF. What was done an instant ago by Assertion 25.2 at the origin $(z, \zeta, w) = (0, 0, 0)$ applies in fact at *every* point $(0, 0, iv)$ along the v -axis, thanks to the fact that the above graphed equation is the same *all along* the v -axis. \square

PROPOSITION 26.2. *There exists a biholomorphism of the form:*

$$z' := z\varphi(-iw), \quad \zeta' := \zeta + \chi(-iw)z^2, \quad w' := i\psi(-iw),$$

with $\psi(v) \in \mathbb{R}$ for $v \in \mathbb{R}$, which normalizes in addition $F'_{3,0,3,0}(v') \equiv 0$.

PROOF. Left to the reader. Hint: imitate [95, Lm. 12.4]. \square

In summary, we can state

THEOREM 26.3. **[Existence of normal form]** *For every 2-nondegenerate hypersurface $M^5 \in \mathfrak{C}_{2,1}$ whose Levi form has constant rank 1, at any point $p \in M$, given any order 2 CR-transversal chain $p \in \gamma \subset M$, there exist holomorphic coordinates $(z, \zeta, w) \in \mathbb{C}^3$ vanishing at p in which γ is the v -axis and in which M has normalized equation:*

$$\begin{aligned} u = & \frac{z\bar{z} + \frac{1}{2}\bar{z}^2\zeta + z^2\bar{\zeta}}{1 - \zeta\bar{\zeta}} \\ & + z^3\bar{z}^3 O_{z,\bar{z}}(1) + 2 \operatorname{Re} \left\{ z^3\bar{\zeta}^2 F_{3,0,0,2}(v) + \zeta\bar{\zeta} (3 z^2\bar{z}\bar{\zeta} F_{3,0,0,2}(v)) \right\} \\ & + 2 \operatorname{Re} \left\{ z^5\bar{\zeta} F_{5,0,0,1}(v) + z^4\bar{\zeta}^2 F_{4,0,0,2}(v) + z^3\bar{z}^2\bar{\zeta} F_{3,0,2,1}(v) + z^3\bar{z}\bar{\zeta}^2 F_{3,0,1,2}(v) + z^3\bar{\zeta}^3 F_{3,0,0,3}(v) \right\} \\ & + \bar{z}^3\zeta O_{z,\zeta,\bar{z}}(3) + z^3\bar{\zeta} O_{z,\bar{z},\bar{\zeta}}(3) + \zeta\bar{\zeta} O_{z,\zeta,\bar{z},\bar{\zeta}}(5). \end{aligned}$$

\square

27. Consequence of Prenormalization on Dependent Jets

After the prenormalization Proposition 16.7, we know that we have:

$$u = F = m + G = m + z^3 \bar{z}^3 O_{z, \bar{z}}(0) + z^3 \bar{\zeta} O_{z, \zeta, \bar{z}}(0) + \bar{z}^3 \zeta O_{z, \bar{z}, \bar{\zeta}}(0) + \zeta \bar{\zeta} O_{z, \zeta, \bar{z}, \bar{\zeta}}(3).$$

The next statement shows that the dependent-jets remainder is *in addition* an $O_{z, \bar{z}}(3)$.

PROPOSITION 27.1. *In prenormalized coordinates, $G = O_{z, \bar{z}}(3)$.*

This writing means here that G is of order 3 in (z, \bar{z}) , with coefficients being arbitrary functions of $(z, \zeta, \bar{z}, \bar{\zeta}, v)$, namely that:

$$G = z^3 (\dots) + z^2 \bar{z} (\dots) + z \bar{z}^2 (\dots) + \bar{z}^3 (\dots).$$

PROOF. Since the coordinates are prenormalized, we have at least:

$$u = z \bar{z} + \frac{1}{2} \bar{z}^2 \zeta + \frac{1}{2} z^2 \bar{\zeta} + O_{z, \zeta, \bar{z}, \bar{\zeta}}(4) = m + G.$$

Thus if we write:

$$G = \sum_{\kappa \geq 2} \sum_{a+b+c+d=\kappa} G_{a,b,c,d}(v) z^a \zeta^b \bar{z}^c \bar{\zeta}^d =: \sum_{\kappa \geq 2} G^\kappa(v).$$

we have $0 = G^2 = G^3$, which are certainly both $O_{z, \bar{z}}(3)$.

The proof will consist in examining, order by order, the Levi determinant for $F = m + G$:

$$\begin{vmatrix} 0 & F_z & F_\zeta & -\frac{1}{2} + \frac{1}{2i} F_v \\ F_{\bar{z}} & F_{z\bar{z}} & F_{\zeta\bar{z}} & \frac{1}{2i} F_{\bar{z}v} \\ F_{\bar{\zeta}} & F_{z\bar{\zeta}} & F_{\zeta\bar{\zeta}} & \frac{1}{2i} F_{\bar{\zeta}v} \\ -\frac{1}{2} - \frac{1}{2i} F_v & -\frac{1}{2i} F_{zv} & -\frac{1}{2i} F_{\zeta v} & \frac{1}{4} F_{vv} \end{vmatrix}.$$

Reasoning by induction, assume, for some $\kappa \geq 4$, that $G^2, G^3, \dots, G^{\kappa-1}$ are all $O_{z, \bar{z}}(3)$. For all $2 \leq \ell \leq \kappa - 1$, it then follows that:

$$\begin{array}{llll} G_z^\ell = O_{z, \bar{z}}(2), & G_\zeta^\ell = O_{z, \bar{z}}(3), & G_v^\ell = O_{z, \bar{z}}(3), \\ G_{\bar{z}}^\ell = O_{z, \bar{z}}(2), & G_{z\bar{z}}^\ell = O_{z, \bar{z}}(1), & G_{\zeta\bar{z}}^\ell = O_{z, \bar{z}}(2), & G_{\bar{z}v}^\ell = O_{z, \bar{z}}(2), \\ G_{\bar{\zeta}}^\ell = O_{z, \bar{z}}(3), & G_{z\bar{\zeta}}^\ell = O_{z, \bar{z}}(2), & G_{\zeta\bar{\zeta}}^\ell = O_{z, \bar{z}}(3), & G_{\bar{\zeta}v}^\ell = O_{z, \bar{z}}(3), \\ G_v^\ell = O_{z, \bar{z}}(3), & G_{zv}^\ell = O_{z, \bar{z}}(2), & G_{\zeta v}^\ell = O_{z, \bar{z}}(3), & G_{vv}^\ell = O_{z, \bar{z}}(3). \end{array}$$

To capture information about G^κ , we may truncate modulo $O_{z, \zeta, \bar{z}, \bar{\zeta}}(\kappa + 1)$:

$$\begin{aligned} m &\equiv m^2 + m^3 + \dots + m^{\kappa-2} + m^{\kappa-1} + m^\kappa, \\ G &\equiv G^2 + G^3 + \dots + G^{\kappa-2} + G^{\kappa-1} + G^\kappa, \end{aligned}$$

where, for any formal:

$$H = \sum_{a,b,c,d \geq 0} z^a \zeta^b \bar{z}^c \bar{\zeta}^d H_{a,b,c,d}(v),$$

and any $\mu \geq 0$, we set:

$$H^\mu := \sum_{a+b+c+d=\mu} z^a \zeta^b \bar{z}^c \bar{\zeta}^d H_{a,b,c,d}(v),$$

$$\pi^\mu(H) := \sum_{a+b+c+d \leq \mu} z^a \zeta^b \bar{z}^c \bar{\zeta}^d H_{a,b,c,d}(v).$$

We will insert $F = m + G$ in the Levi determinant and apply the projection $\pi^{\kappa-2}(\bullet)$ in order to capture $G_{\zeta\bar{\zeta}}^\kappa$.

ASSERTION 27.2. *Under the induction assumption, $G_{\zeta\bar{\zeta}}^\kappa = O_{z,\bar{z}}(3)$.*

PROOF. Some further preliminaries are necessary. At first, for any formal function $L = L(z, \zeta, \bar{z}, \bar{\zeta}, v)$ which is an $O_{z,\zeta,\bar{z},\bar{\zeta}}(\lambda)$ for some $\lambda \geq 0$, it holds, *with a shift*, that:

$$(27.3) \quad \pi^{\kappa-2}(L \cdot H) = \pi^{\kappa-2}\left(\pi^{\kappa-2}(L) \cdot \pi^{\kappa-2-\lambda}(H)\right).$$

Next, with \bullet and $\bullet\bullet$ denoting partial derivatives with respect to any of the variables $z, \zeta, \bar{z}, \bar{\zeta}$, we have:

$$\begin{aligned} \pi^{\kappa-2}(m) &= m^2 + \dots + m^{\kappa-2}, & \pi^{\kappa-2}(G) &= G^2 + \dots + G^{\kappa-2}, \\ \pi^{\kappa-2}(m_\bullet) &= m_\bullet^2 + \dots + m_\bullet^{\kappa-2} + m_\bullet^{\kappa-1}, & \pi^{\kappa-2}(G_\bullet) &= G_\bullet^2 + \dots + G_\bullet^{\kappa-2} + G_\bullet^{\kappa-1}, \\ \pi^{\kappa-2}(m_{\bullet\bullet}) &= m_{\bullet\bullet}^2 + \dots + m_{\bullet\bullet}^{\kappa-2} + m_{\bullet\bullet}^{\kappa-1} + m_{\bullet\bullet}^\kappa, & \pi^{\kappa-2}(G_{\bullet\bullet}) &= G_{\bullet\bullet}^2 + \dots + G_{\bullet\bullet}^{\kappa-2} + G_{\bullet\bullet}^{\kappa-1} + G_{\bullet\bullet}^\kappa. \end{aligned}$$

Also, we will be using various values $\lambda = 0, 1, 2$ of the integer $\lambda \geq 0$ above:

$$\begin{aligned} m_z &= \frac{\bar{z} + z\bar{\zeta}}{1 - \zeta\bar{\zeta}} = O_{z,\bar{z}}(1), & m_{\bar{z}} &= \frac{z + \bar{z}\zeta}{1 - \zeta\bar{\zeta}} = O_{z,\bar{z}}(1), \\ m_\zeta &= \frac{1}{2} \frac{(\bar{z} + z\bar{\zeta})^2}{(1 - \zeta\bar{\zeta})^2} = O_{z,\bar{z}}(2), & m_{\bar{\zeta}} &= \frac{1}{2} \frac{(z + \bar{z}\zeta)^2}{(1 - \zeta\bar{\zeta})^2} = O_{z,\bar{z}}(2), \\ m_{z\bar{z}} &= \frac{1}{1 - \zeta\bar{\zeta}} = O_{z,\bar{z}}(0), & m_{\zeta\bar{z}} &= \frac{\bar{z} + z\bar{\zeta}}{(1 - \zeta\bar{\zeta})^2} = O_{z,\bar{z}}(1), \\ m_{z\bar{\zeta}} &= \frac{z + \bar{z}\zeta}{(1 - \zeta\bar{\zeta})^2} = O_{z\bar{z}}(1), & m_{\zeta\bar{\zeta}} &= \frac{(z + \bar{z}\zeta)^2}{(1 - \zeta\bar{\zeta})^3} = O_{z,\bar{z}}(2). \end{aligned}$$

Indeed, we start from:

$$0 \equiv \pi^{\kappa-2} \begin{pmatrix} 0 & m_z + \sum_{4 \leq j \leq \kappa-1} G_z^j & m_\zeta + \sum_{4 \leq k \leq \kappa-1} G_\zeta^k & -\frac{1}{2} - \frac{i}{2} \sum_{4 \leq l \leq \kappa-2} G_v^l \\ m_{\bar{z}} + \sum_{4 \leq i \leq \kappa-1} G_{\bar{z}}^i & m_{z\bar{z}} + \sum_{4 \leq j \leq \kappa} G_{z\bar{z}}^j & m_{\zeta\bar{z}} + \sum_{4 \leq k \leq \kappa} G_{\zeta\bar{z}}^k & -\frac{i}{2} \sum_{4 \leq l \leq \kappa-1} G_{\bar{z}v}^l \\ m_{\bar{\zeta}} + \sum_{4 \leq i \leq \kappa-1} G_{\bar{\zeta}}^i & m_{z\bar{\zeta}} + \sum_{4 \leq j \leq \kappa} G_{z\bar{\zeta}}^j & m_{\zeta\bar{\zeta}} + \sum_{4 \leq k \leq \kappa} G_{\zeta\bar{\zeta}}^k & -\frac{i}{2} \sum_{4 \leq l \leq \kappa-1} G_{\bar{\zeta}v}^l \\ -\frac{1}{2} + \frac{i}{2} \sum_{4 \leq i \leq \kappa-2} G_v^i & \frac{i}{2} \sum_{4 \leq j \leq \kappa-1} G_{zv}^j & \frac{i}{2} \sum_{4 \leq k \leq \kappa-1} G_{\zeta v}^k & \frac{1}{4} \sum_{4 \leq l \leq \kappa-2} G_{vv}^l \end{pmatrix}.$$

Let us expand this determinant along its first row, using (27.3) in order to take account of various useful *negative shifts* for the summations in the entries of the obtained 3×3

determinants:

$$\begin{aligned}
0 \equiv \pi^{\kappa-2} & \left(- \left(m_z + \sum_{4 \leq j \leq \kappa-1} G_z^j \right) \begin{vmatrix} m_{\bar{z}} + \sum_{4 \leq i \leq \kappa-2} G_{\bar{z}}^i & m_{\zeta\bar{z}} + \sum_{4 \leq k \leq \kappa-1} G_{\zeta\bar{z}}^k & -\frac{i}{2} \sum_{4 \leq l \leq \kappa-2} G_{\bar{z}v}^l \\ m_{\bar{\zeta}} + \sum_{4 \leq i \leq \kappa-2} G_{\bar{\zeta}}^i & m_{\zeta\bar{\zeta}} + \sum_{4 \leq k \leq \kappa-1} G_{\zeta\bar{\zeta}}^k & -\frac{i}{2} \sum_{4 \leq l \leq \kappa-2} G_{\bar{\zeta}v}^l \\ -\frac{1}{2} + \frac{i}{2} \sum_{4 \leq i \leq \kappa-3} G_v^i & \frac{i}{2} \sum_{4 \leq k \leq \kappa-2} G_{\zeta v}^k & \frac{1}{4} \sum_{4 \leq l \leq \kappa-3} G_{vv}^l \end{vmatrix} \right. \\
& + \left(m_\zeta + \sum_{4 \leq k \leq \kappa-1} G_\zeta^k \right) \begin{vmatrix} m_{\bar{z}} + \sum_{4 \leq i \leq \kappa-3} G_{\bar{z}}^i & m_{z\bar{z}} + \sum_{4 \leq j \leq \kappa-2} G_{z\bar{z}}^j & -\frac{i}{2} \sum_{4 \leq l \leq \kappa-3} G_{\bar{z}v}^l \\ m_{\bar{\zeta}} + \sum_{4 \leq i \leq \kappa-3} G_{\bar{\zeta}}^i & m_{z\bar{\zeta}} + \sum_{4 \leq j \leq \kappa-2} G_{z\bar{\zeta}}^j & -\frac{i}{2} \sum_{4 \leq l \leq \kappa-3} G_{\bar{\zeta}v}^l \\ -\frac{1}{2} + \frac{i}{2} \sum_{4 \leq i \leq \kappa-4} G_v^i & \frac{i}{2} \sum_{4 \leq j \leq \kappa-3} G_{zv}^j & \frac{1}{4} \sum_{4 \leq l \leq \kappa-4} G_{vv}^l \end{vmatrix} \\
& - \left(-\frac{1}{2} + O_{z,\bar{z}}(3) \right) \begin{vmatrix} m_{\bar{z}} + \sum_{4 \leq i \leq \kappa-1} G_{\bar{z}}^i & m_{z\bar{z}} + \sum_{4 \leq j \leq \kappa} G_{z\bar{z}}^j & m_{\zeta\bar{z}} + \sum_{4 \leq k \leq \kappa} G_{\zeta\bar{z}}^k \\ m_{\bar{\zeta}} + \sum_{4 \leq i \leq \kappa-1} G_{\bar{\zeta}}^i & m_{z\bar{\zeta}} + \sum_{4 \leq j \leq \kappa} G_{z\bar{\zeta}}^j & m_{\zeta\bar{\zeta}} + \sum_{4 \leq k \leq \kappa} G_{\zeta\bar{\zeta}}^k \\ -\frac{1}{2} + \frac{i}{2} \sum_{4 \leq i \leq \kappa-2} G_v^i & \frac{i}{2} \sum_{4 \leq j \leq \kappa-1} G_{zv}^j & \frac{i}{2} \sum_{4 \leq k \leq \kappa-1} G_{\zeta v}^k \end{vmatrix} \Bigg).
\end{aligned}$$

Now, apply the induction assumption, and simultaneously also, expand the last determinant along its first column:

$$\begin{aligned}
0 \equiv \pi^{\kappa-2} & \left(- O_{z,\bar{z}}(1) \begin{vmatrix} O_{z,\bar{z}}(1) & O_{z,\bar{z}}(1) & O_{z,\bar{z}}(2) \\ O_{z,\bar{z}}(2) & O_{z,\bar{z}}(2) & O_{z,\bar{z}}(3) \\ O_{z,\bar{z}}(0) & O_{z,\bar{z}}(3) & O_{z,\bar{z}}(3) \end{vmatrix} + O_{z,\bar{z}}(2) \begin{vmatrix} O_{z,\bar{z}}(1) & O_{z,\bar{z}}(0) & O_{z,\bar{z}}(2) \\ O_{z,\bar{z}}(2) & O_{z,\bar{z}}(1) & O_{z,\bar{z}}(3) \\ O_{z,\bar{z}}(0) & O_{z,\bar{z}}(2) & O_{z,\bar{z}}(3) \end{vmatrix} \right. \\
& + \left(\frac{1}{2} + O_{z,\bar{z}}(3) \right) \left\{ \left(m_{\bar{z}} + \sum_{4 \leq i \leq \kappa-1} G_{\bar{z}}^i \right) \begin{vmatrix} m_{z\bar{\zeta}} + \sum_{4 \leq j \leq \kappa-1} G_{z\bar{\zeta}}^j & m_{\zeta\bar{\zeta}} + \sum_{4 \leq k \leq \kappa-1} G_{\zeta\bar{\zeta}}^k \\ \frac{i}{2} \sum_{4 \leq j \leq \kappa-2} G_{zv}^j & \frac{i}{2} \sum_{4 \leq k \leq \kappa-2} G_{\zeta v}^k \end{vmatrix} \right. \\
& - \left(m_{\bar{\zeta}} + \sum_{4 \leq i \leq \kappa-1} G_{\bar{\zeta}}^i \right) \begin{vmatrix} m_{z\bar{z}} + \sum_{4 \leq j \leq \kappa-2} G_{z\bar{z}}^j & m_{\zeta\bar{z}} + \sum_{4 \leq k \leq \kappa-2} G_{\zeta\bar{z}}^k \\ \frac{i}{2} \sum_{4 \leq j \leq \kappa-3} G_{zv}^j & \frac{i}{2} \sum_{4 \leq k \leq \kappa-3} G_{\zeta v}^k \end{vmatrix} \\
& \left. + \left(-\frac{1}{2} + O_{z,\bar{z}}(3) \right) \begin{vmatrix} m_{z\bar{z}} + \sum_{4 \leq j \leq \kappa} G_{z\bar{z}}^j & m_{\zeta\bar{z}} + \sum_{4 \leq k \leq \kappa} G_{\zeta\bar{z}}^k \\ m_{z\bar{\zeta}} + \sum_{4 \leq j \leq \kappa} G_{z\bar{\zeta}}^j & m_{\zeta\bar{\zeta}} + \sum_{4 \leq k \leq \kappa} G_{\zeta\bar{\zeta}}^k \end{vmatrix} \right\} \Bigg).
\end{aligned}$$

Taking account of $0 \equiv \begin{vmatrix} m_{z\bar{z}} & m_{\zeta\bar{\zeta}} \\ m_{z\bar{\zeta}} & m_{\zeta\bar{z}} \end{vmatrix}$ in the last 2×2 determinant, we may continue to expand:

$$0 \equiv O_{z,\bar{z}}(3) + O_{z,\bar{z}}(1) \begin{vmatrix} O_{z,\bar{z}}(1) & O_{z,\bar{z}}(2) \\ O_{z,\bar{z}}(2) & O_{z,\bar{z}}(3) \end{vmatrix} - O_{z,\bar{z}}(2) \begin{vmatrix} O_{z,\bar{z}}(0) & O_{z,\bar{z}}(1) \\ O_{z,\bar{z}}(2) & O_{z,\bar{z}}(3) \end{vmatrix} \\ + \left(-\frac{1}{4} + O_{z,\bar{z}}(3) \right) \left\{ m_{z\bar{z}} \sum_{4 \leq k \leq \kappa} G_{\zeta\bar{\zeta}}^k + m_{\zeta\bar{\zeta}} \sum_{4 \leq j \leq \kappa-2} G_{z\bar{z}}^j + \left(\sum_{4 \leq j \leq \kappa-2} G_{z\bar{z}}^j \right) \left(\sum_{4 \leq k \leq \kappa-2} G_{\zeta\bar{\zeta}}^k \right) \right. \\ \left. - m_{\zeta\bar{z}} \sum_{4 \leq j \leq \kappa-1} G_{z\bar{\zeta}}^j - m_{z\bar{\zeta}} \sum_{4 \leq k \leq \kappa-1} G_{\zeta\bar{z}}^k - \left(\sum_{4 \leq k \leq \kappa-2} G_{\zeta\bar{z}}^k \right) \left(\sum_{4 \leq j \leq \kappa-2} G_{z\bar{\zeta}}^j \right) \right\},$$

that is:

$$O_{z,\bar{z}}(3) \equiv m_{z\bar{z}} \left(\sum_{4 \leq k \leq \kappa-1} G_{\zeta\bar{\zeta}}^k + G_{\zeta\bar{\zeta}}^\kappa \right) + O_{z,\bar{z}}(2) O_{z,\bar{z}}(1) + O_{z,\bar{z}}(1) O_{z,\bar{z}}(3) \\ - O_{z,\bar{z}}(1) O_{z,\bar{z}}(2) - O_{z,\bar{z}}(1) O_{z,\bar{z}}(2) - O_{z,\bar{z}}(2) O_{z,\bar{z}}(2),$$

and reminding $m_{z\bar{z}} = \frac{1}{1-\zeta\bar{\zeta}}$, this gives the concluding identity:

$$O_{z,\bar{z}}(3) = \frac{1}{1-\zeta\bar{\zeta}} G_{\zeta\bar{\zeta}}^\kappa. \quad \square$$

By integration, $G^\kappa = \lambda^\kappa(z, \zeta, \bar{z}, v) + \bar{\lambda}^\kappa(\bar{z}, \bar{\zeta}, z, v) + O_{z,\bar{z}}(3)$. After absorption in $O_{z,\bar{z}}(3)$, we can assume that λ^κ is of degree ≤ 2 in (z, \bar{z}) , hence contains only monomials $z^a \zeta^b \bar{z}^c v^e$ with $a + c \leq 2$ and $a + b + c = \kappa$. So $b \geq \kappa - 2$.

Further, $G^\kappa(z, \zeta, 0, 0, v) \equiv 0$ imposes $\lambda^\kappa(z, \zeta, 0, v) \equiv 0$. So $1 \leq c \leq 2$. Consequently, λ^κ can contain only three monomials:

$$\lambda^\kappa(z, \zeta, \bar{z}, v) = a(v) \bar{z} \zeta^{\kappa-1} + b(v) z \bar{z} \zeta^{\kappa-2} + c(v) \bar{z}^2 \zeta^{\kappa-2}.$$

Since $\kappa \geq 4$, we see that the conjugate $\bar{\lambda}^\kappa(\bar{z}, \bar{\zeta}, z, v)$ is multiple of $\bar{\zeta}^{\kappa-2 \geq 2}$, hence:

$$G^\kappa(z, \zeta, \bar{z}, 0, v) = \lambda^\kappa(z, \zeta, \bar{z}, v) + \bar{\lambda}^\kappa(\bar{z}, 0, z, v) + O_{z,\bar{z}}(3).$$

Finally, because the prenormalized coordinates of Proposition 16.7 require $G^\kappa(z, \zeta, \bar{z}, 0, v) = O_{z,\bar{z}}(3)$, we reach $\lambda^\kappa(z, \zeta, \bar{z}, v) = O_{z,\bar{z}}(3)$, which forces $a = b = c = 0 = \lambda^\kappa$, so as asserted $G^\kappa = O_{z,\bar{z}}(3)$. \square

28. Consequence of Prenormalization on Equivalences

Thanks to Proposition 16.7, if we are given a holomorphic map $H: (z, \zeta, w) \mapsto (z', \zeta', w')$ between two $\mathcal{C}_{2,1}$ hypersurfaces $M^5 \subset \mathbb{C}^3$ and $M'^5 \subset \mathbb{C}'^3$, we can assume that both hypersurfaces are prenormalized. In particular, Proposition 27.1 tells us that the *whole* remainders after the GM-model part of their graphing functions is of order 3 in (z, \bar{z}) :

$$u = m + G = m + O_{z,\bar{z}}(3) \quad \text{and} \quad u' = m' + G' = m + O_{z',\bar{z}'}(3).$$

OBSERVATION 28.1. *Complex scalings* $(z, \zeta, w) \mapsto (\lambda z, \frac{\lambda}{\bar{\lambda}} \zeta, \lambda \bar{\lambda} w)$ with $\lambda \in \mathbb{C}^*$ preserve prenormalizations as in Proposition 16.7. \square

With $\lambda := \rho \in \mathbb{R}^*$, this is $(\rho^1 z, \rho^0 \zeta, \rho^2 w)$. Hence this observation suggests naturally to assign the following weights to the three complex variables and their real and imaginary parts:

$$[z] := 1 =: [\bar{z}], \quad [\zeta] := 0 =: [\bar{\zeta}], \quad [w] := 2 =: [\bar{w}].$$

Accordingly, let us decompose the components (f, g, h) of H in weighted homogeneous parts:

$$f = f_0 + f_1 + f_2 + f_3 + \cdots, \quad g = g_0 + g_1 + g_2 + \cdots, \quad h = h_0 + h_1 + h_2 + h_3 + h_4 + \cdots.$$

PROPOSITION 28.2. *If both M and M' are prenormalized, possibly after composing with a complex dilation $(z', \zeta', w') \mapsto (\lambda z', \frac{\lambda}{\bar{\lambda}} \zeta', \lambda \bar{\lambda} w')$, one has $f_0 = 0$, $f_1 = z$, $g_0 = \zeta$, $h_0 = 0$, $h_1 = 0$, $h_2 = w$, and the weighted homogeneous components of f, g, h are:*

$$f = z + f_2 + f_3 + \cdots, \quad g = \zeta + g_1 + g_2 + \cdots, \quad h = w + h_3 + h_4 + \cdots.$$

Mind the fact that this does not mean that the map is $\text{Id} + O_{z,w,\zeta}(2)$, since in f_2 , there can still be the linear term $f_{0,0,2} w$, and in $g_1 + g_2$, there can still be the linear terms $g_{1,0,0} z + g_{0,0,1} w$.

PROOF. The fundamental identity expressing that we have a map $M \rightarrow M'$ reads:

$$(28.3) \quad h_0 + h_1 + \cdots + \bar{h}_0 + \bar{h}_1 + \cdots = 2F'(f_0 + f_1 + \cdots, g_0 + g_1 + \cdots, \bar{f}_0 + \bar{f}_1 + \cdots, \bar{g}_0 + \bar{g}_1 + \cdots, \frac{1}{2i}(h_0 + h_1 + \cdots - \bar{h}_0 - \bar{h}_1 - \cdots)).$$

Observe that $f_0 = f_0(\zeta)$, $g_0 = g_0(\zeta)$, $h_0 = h_0(\zeta)$ depend only on ζ . This identity projected to weight 0 becomes:

$$h_0(\zeta) + \bar{h}_0(\bar{\zeta}) \equiv 2F'(f_0(\zeta), g_0(\zeta), \bar{f}_0(\bar{\zeta}), \bar{g}_0(\bar{\zeta}), \frac{1}{2i}h_0(\zeta) - \frac{1}{2i}\bar{h}_0(\bar{\zeta})).$$

Put $\bar{\zeta} := 0$, use the assumption that there are no pluriharmonic terms (coordinates are prenormalized), namely that $0 \equiv F'(z', \zeta', 0, 0, v')$, and get $h_0(\zeta) \equiv 0$.

Once again, look at (28.3), and get from $F' = m' + G' = m' + O_{z', \bar{z}'}(3)$:

$$0 \equiv \frac{2f_0(\zeta)\bar{f}_0(\bar{\zeta}) + f_0(\zeta)^2\bar{g}_0(\bar{\zeta}) + \bar{f}_0(\bar{\zeta})^2g_0(\zeta)}{1 - g_0(\zeta)\bar{g}_0(\bar{\zeta})} + O_{f_0(\zeta), \bar{f}_0(\bar{\zeta})}(3).$$

We claim that $f_0(\zeta) \equiv 0$. Otherwise, $f_0 = e\zeta^\tau + O_\zeta(\tau + 1)$ with $e \neq 0$ and $\tau \in \mathbb{N}_{\geq 1}$. Hence:

$$0 \equiv 2e\bar{e}\zeta^\tau\bar{\zeta}^{-\tau}(1 + O_{\zeta, \bar{\zeta}}(1)) + \zeta^{2\tau}(\cdots) + \bar{\zeta}^{-2\tau}(\cdots) + O_{\zeta, \bar{\zeta}}(3\tau),$$

and this forces $e\bar{e} = 0$. So $f_0(\zeta) \equiv 0$, and (28.3) at weight 0, namely the identity above, reduces to $0 = 0$.

Next, examine weight 1. Certainly, $f_1 = zf_1(\zeta)$ and $h_1 = zh_1(\zeta)$, while g will not participate here. Since m' is weighted 2-homogeneous, as it contains $z\bar{z}$, \bar{z}^2 , z^2 times functions of $(\zeta, \bar{\zeta})$, we have $F' = O_{z', \bar{z}'}(2)$, so the identity:

$$zh_1(\zeta) + \bar{z}\bar{h}_1(\bar{\zeta}) \equiv O_{zf_1(\zeta), \bar{z}\bar{f}_1(\bar{\zeta})}(2) = O_{z, \bar{z}}(2),$$

forces $h_1(\zeta) \equiv 0$.

Next, expand in powers of z, w :

$$f = zf_1(\zeta) + z^2(\cdots) + w(\cdots), \quad g = g_0(\zeta) + zg_1(\zeta) + z^2(\cdots) + w(\cdots), \quad h = h_2 + h_3 + \cdots, \\ h_2 = z^2\varphi(\zeta) + w\psi(\zeta).$$

The holomorphic Jacobian at the origin is assumed to be invertible:

$$0 \neq \begin{vmatrix} f_z(0) & f_\zeta(0) & f_w(0) \\ g_z(0) & g_\zeta(0) & g_w(0) \\ h_z(0) & h_\zeta(0) & h_w(0) \end{vmatrix} = \begin{vmatrix} f_1(0) & 0 & f_w(0) \\ g_1(0) & g'_0(0) & g_w(0) \\ 0 & 0 & h_w(0) \end{vmatrix},$$

whence $h_w(0) \neq 0$ and $g'_0(0) \neq 0$ and also $f_1(0) \neq 0$. Then the fundamental identity (28.3) becomes in weight 2:

$$h_2(\zeta) + \bar{h}_2(\bar{\zeta}) \equiv 2m'(zf_1(\zeta), g_0(\zeta), \bar{z}\bar{f}_1(\bar{\zeta}), \bar{g}_0(\bar{\zeta})),$$

that is, after replacing $w = m + iv$ in h_2 :

$$\begin{aligned} z^2 \varphi(\zeta) + \bar{z}^2 \bar{\varphi}(\bar{\zeta}) + m(z, \zeta, \bar{z}, \bar{\zeta}) [\psi(\zeta) + \bar{\psi}(\bar{\zeta})] + iv [\psi(\zeta) - \bar{\psi}(\bar{\zeta})] &\equiv \\ &\equiv \frac{2zf_1(\zeta)\bar{z}\bar{f}_1(\bar{\zeta}) + \bar{z}^2\bar{f}_1(\bar{\zeta})g_0(\zeta) + z^2f_1(\zeta)^2\bar{g}_0(\bar{\zeta})}{1 - g_0(\zeta)\bar{g}_0(\bar{\zeta})}, \end{aligned}$$

this holding identically in $\mathbb{C}\{z, \zeta, \bar{z}, \bar{\zeta}, v\}$. This forces $\psi(\zeta) \equiv \rho$ to be constant, with $\rho \in \mathbb{R}^*$, and then $\varphi(\zeta) \equiv 0$ necessarily.

It remains an identity:

$$m(z, \zeta, \bar{z}, \bar{\zeta}) 2\rho \equiv 2m'(zf_1(\zeta), g_0(\zeta), \bar{z}\bar{f}_1(\bar{\zeta}), \bar{g}_0(\bar{\zeta})),$$

which expresses that the map $(z, \zeta, w) \mapsto (zf_1(\zeta), g_0(\zeta), \rho w)$ is an *automorphism* — in fact a *rigid* automorphism, cf. [22] — of the Gaussier-Merker model. But we know from Section 5, see the fractional expression of w' there, that this requires $\alpha = 0$ and $r = 0$, while only $\lambda \in \mathbb{C}^*$ is free. Consequently, the map is of the form $(f_1, g_0, h_2) = (\lambda z, \frac{\lambda}{\lambda} \zeta, \lambda \bar{\lambda} w)$. Post-composing by the inverse map yields the conclusion. \square

29. Uniqueness of Normal Form

Starting with a \mathcal{C}^ω hypersurface $M^5 \subset \mathbb{C}^3$ which is 2-nondegenerate and of constant Levi rank 1, at any point $p \in M$, it is elementary to find holomorphic coordinates (z, ζ, w) vanishing at p in which M has equation:

$$(29.1) \quad u = F = z\bar{z} + \frac{1}{2}\bar{z}^2\zeta + \frac{1}{2}z^2\bar{\zeta} + z\bar{z}\zeta\bar{\zeta} + O_{z, \zeta, \bar{z}, \bar{\zeta}, v}(5).$$

Such an equation can hence freely be taken as the starting point towards a complete normalization of $F(z, \zeta, \bar{z}, \bar{\zeta}, v)$.

In the preceding sections, we have in fact established the *existence* of a *normal form* for M . We can now present a final *uniqueness* statement which will terminate our article.

THEOREM 29.2. *Given $M^5 \subset \mathbb{C}^3$ in the class $\mathfrak{E}_{2,1}$ with $0 \in M$ of the form:*

$$u = z\bar{z} + \frac{1}{2}\bar{z}^2\zeta + \frac{1}{2}z^2\bar{\zeta} + z\bar{z}\zeta\bar{\zeta} + O_{z, \zeta, \bar{z}, \bar{\zeta}, v}(5),$$

there exists a biholomorphism $(z, \zeta, w) \mapsto (z', \zeta', w')$ fixing 0 which maps $(M, 0)$ into $(M', 0)$ of normalized equation:

$$\begin{aligned}
u' = & z' \bar{z}' + \frac{1}{2} \bar{z}'^2 \zeta' + \frac{1}{2} z'^2 \bar{\zeta}' + z' \bar{z}' \zeta' \bar{\zeta}' + \frac{1}{2} \bar{z}'^2 \zeta' \bar{\zeta}' + \frac{1}{2} z'^2 \bar{\zeta}' \zeta' \bar{\zeta}' + z' \bar{z}' \zeta' \bar{\zeta}' \zeta' \bar{\zeta}' \\
& + 0 + z'^3 \bar{z}'^3 O_{z', \bar{z}'}(1) \\
& + 2 \operatorname{Re} \left\{ 0 + 0 + z'^3 \bar{\zeta}'^2 F'_{3,0,0,2}(v') + \zeta' \bar{\zeta}' (3 z'^2 \bar{z}' \bar{\zeta}' F'_{3,0,0,2}(v')) \right\} \\
& + 2 \operatorname{Re} \left\{ z'^5 \bar{\zeta}' F'_{5,0,0,1}(v') + 0 + z'^4 \bar{\zeta}'^2 F'_{4,0,0,2}(v') \right. \\
& \quad \left. + z'^3 \bar{z}'^2 \bar{\zeta}' F'_{3,0,2,1}(v') + z'^3 \bar{z}' \bar{\zeta}'^2 F'_{3,0,1,2}(v') \right. \\
& \quad \left. + z'^3 \bar{\zeta}'^3 F'_{3,0,0,3}(v') \right\} \\
& + \bar{z}'^3 \zeta' O_{z', \zeta', \bar{z}'}(3) + z'^3 \bar{\zeta}' O_{z', \bar{z}', \bar{\zeta}'}(3) + \zeta' \bar{\zeta}' O_{z', \zeta', \bar{z}'}(3) O_{z', \zeta', \bar{z}', \bar{\zeta}'}(2).
\end{aligned}$$

Furthermore, the map exists and is unique if it is assumed to be of the form:

$$\begin{aligned}
z' &:= z + f_{\geq 2}(z, \zeta, w) & \zeta' &:= \zeta + g_{\geq 1}(z, \zeta, w), & w' &:= w + h_{\geq 3}(z, \zeta, w), \\
0 &= f_w(0), & & & 0 &= \operatorname{Im} h_{ww}(0).
\end{aligned}$$

Here of course, $f_{\geq 2}$ is of weight ≥ 2 , while $g_{\geq 1}$ is of weight ≥ 1 , and $h_{\geq 3}$ is of weight ≥ 3 for the currently useful weighting $[z] := 1, [\zeta] := 0, [w] := 2$.

PROOF. By choosing a chain at $0 \in M$ whose first jet is flat, directed along the v -axis, one can verify (exercise) that all the constructions done in the preceding sections do indeed give a biholomorphism of this specific form. So our job is to establish uniqueness.

Suppose therefore that two such normalizations $H_\iota: (z, \zeta, w) \mapsto (z + f_\iota, \zeta + g_\iota, w + h_\iota)$, $\iota = 1, 2$, are given:

$$\begin{array}{ccc}
& & M'_1 \\
& \nearrow^{H_1} & \downarrow^{H_2 \circ H_1^{-1}} \\
M & & M'_2 \\
& \searrow_{H_2} &
\end{array}$$

with $0 = f_{\iota,w}(0)$ and $0 = \operatorname{Re} h_{\iota,ww}(0)$ for $\iota = 1, 2$. We leave to the reader to verify that, then, $H := H_2 \circ H_1^{-1}$ is also of the form $(z, \zeta, w) \mapsto (z + f_{\geq 2}, \zeta + g_{\geq 1}, w + h_{\geq 3})$ also with $0 = f_w(0)$ and $0 = \operatorname{Im} h_{ww}(0)$. For this, one has to take account of (29.1).

The theorem asserts that $H_1 = H_2$. Equivalently, $H_2 \circ H_1^{-1} = \operatorname{Id}$. This will be offered by the next independent key uniqueness statement. \square

THEOREM 29.3. *For a given $M^5 \subset \mathbb{C}^3$ in the class $\mathfrak{C}_{2,1}$, if two normal forms N and N_1 at some point $p \in M$ are constructed, with N having normalized equation:*

$$\begin{aligned} u = & z\bar{z} + \frac{1}{2} \bar{z}^2 \zeta + \frac{1}{2} z^2 \bar{\zeta} + z\bar{z}\zeta\bar{\zeta} + \frac{1}{2} \bar{z}^2 \zeta\zeta\bar{\zeta} + \frac{1}{2} z^2 \bar{\zeta}\bar{\zeta}\zeta + z\bar{z}\zeta\bar{\zeta}\zeta\bar{\zeta} \\ & + 0 + z^3 \bar{z}^3 O_{z,\bar{z}}(1) \\ & + 2 \operatorname{Re} \left\{ 0 + 0 + z^3 \bar{\zeta}^2 F_{3,0,0,2}(v) + \zeta\bar{\zeta} (3 z^2 \bar{z}\bar{\zeta} F_{3,0,0,2}(v)) \right\} \\ & + 2 \operatorname{Re} \left\{ z^5 \bar{\zeta} F_{5,0,0,1}(v) + 0 + z^4 \bar{\zeta}^2 F_{4,0,0,2}(v) \right. \\ & \quad \left. + z^3 \bar{z}^2 \bar{\zeta} F_{3,0,2,1}(v) + z^3 \bar{z}\bar{\zeta}^2 F_{3,0,1,2}(v) \right. \\ & \quad \left. + z^3 \bar{\zeta}^3 F_{3,0,0,3}(v) \right\} \\ & + \bar{z}^3 \zeta O_{z,\zeta,\bar{z}}(3) + z^3 \bar{\zeta} O_{z,\bar{z},\bar{\zeta}}(3) + \zeta\bar{\zeta} O_{z,\zeta,\bar{z}}(3) O_{z,\zeta,\bar{z},\bar{\zeta}}(2), \end{aligned}$$

and with N_1 having similarly normalized equation, and if the map $(z, \zeta, w) \mapsto (z', \zeta', w')$ between them is of the form:

$$\begin{aligned} z' &:= z + f_{\geq 2}(z, \zeta, w) & \zeta' &:= \zeta + g_{\geq 1}(z, \zeta, w), & w' &:= w + h_{\geq 3}(z, \zeta, w), \\ 0 &= f_w(0), & & & 0 &= \operatorname{Im} h_{ww}(0), \end{aligned}$$

then the map $(z', \zeta', w') = (z, \zeta, w)$ is the identity, and the two normal forms $N = N_1$ coincide.

PROOF. Equivalently, the graphing function $F = \sum_{a,b,c,d} z^a \zeta^b \bar{z}^c \bar{\zeta}^d F_{a,b,c,d}(v)$ of N satisfies the general prenormalization conditions:

$$\begin{aligned} 0 &\equiv F_{a,b,0,0}(v) \equiv F_{0,0,c,d}(v), \\ 0 &\equiv F_{a,b,1,0}(v) \equiv F_{1,0,c,d}(v), \\ 0 &\equiv F_{a,b,2,0}(v) \equiv F_{2,0,c,d}(v), \end{aligned}$$

with the obvious two exceptions $F_{1,0,1,0}(v) \equiv 1$ and $F_{0,1,2,0}(v) \equiv \frac{1}{2} \equiv F_{2,0,0,1}(v)$, together with the sporadic normalization conditions, listed by increasing order 4, 5, 6:

$$\begin{aligned} 0 &\equiv F_{3,0,0,1}(v) \equiv F_{0,1,3,0}(v), \\ 0 &\equiv F_{4,0,0,1}(v) \equiv F_{0,1,4,0}(v), & 0 &\equiv F_{3,0,1,1}(v) \equiv F_{1,1,3,0}(v), \\ 0 &\equiv F_{4,0,1,1}(v) \equiv F_{1,1,4,0}(v), & 0 &\equiv F_{3,0,3,0}(v), \end{aligned}$$

and the same holds about F' .

Accordingly, let us introduce:

$$\begin{aligned} S := & \left\{ (a, b, 0, 0), (0, 0, c, d), (a, b, 1, 0), (1, 0, c, d), (a, b, 2, 0), (2, 0, c, d) \right\} \\ & \cup \left\{ (3, 0, 0, 1), (0, 1, 3, 0), (4, 0, 0, 1), (0, 1, 4, 0), (3, 0, 1, 1), (1, 1, 3, 0), (4, 0, 1, 1), (1, 1, 4, 0), (3, 0, 3, 0) \right\}. \end{aligned}$$

Notice that S takes no dependent derivatives $\zeta\bar{\zeta}(\dots)$, namely one always has $b + d \leq 1$ for any $(a, b, c, d) \in S$.

For a general real converging power series vanishing at $(z, \zeta, \bar{z}, \bar{\zeta}, v) = (0, 0, 0, 0, 0)$:

$$H = \sum_{a,b,c,d,e} H_{a,b,c,d,e} z^a \zeta^b \bar{z}^c \bar{\zeta}^d v^e \quad (\overline{H_{c,d,a,b,e}} = H_{a,b,c,d,e}),$$

i.e. with $H_{0,0,0,0} = 0$, introduce the projection:

$$\Pi_S(H) := \sum_{(a,b,c,d) \in S} \sum_{e=0}^{\infty} H_{a,b,c,d,e} z^a \zeta^b \bar{z}^c \bar{\zeta}^d v^e,$$

so that:

$$\Pi_S(F) = z\bar{z} + \frac{1}{2} \bar{z}^2 \zeta + \frac{1}{2} z^2 \bar{\zeta} \quad \text{and} \quad \Pi_S(F') = z' \bar{z}' + \frac{1}{2} \bar{z}'^2 \zeta' + \frac{1}{2} z'^2 \bar{\zeta}'.$$

By assumption (or because of Proposition 28.2), the map is of the form:

$$z' = z + f_2 + f_3 + \dots, \quad \zeta' = \zeta + g_1 + g_2 + \dots, \quad w' = w + h_3 + h_4 + \dots,$$

that is, more precisely:

$$\begin{aligned} f &= \sum_{\nu \geq 3} f_{\nu-1} = \sum_{\nu \geq 3} \left(\sum_{a+b+2e=\nu-1} f_{a,b,e} z^a \zeta^b w^e \right), \\ g &= \sum_{\nu \geq 3} g_{\nu-2} = \sum_{\nu \geq 3} \left(\sum_{a+b+2e=\nu-2} g_{a,b,e} z^a \zeta^b w^e \right), \\ h &= \sum_{\nu \geq 3} h_{\nu} = \sum_{\nu \geq 3} \left(\sum_{a+b+2e=\nu} h_{a,b,e} z^a \zeta^b w^e \right). \end{aligned}$$

Let us introduce the projections:

$$\pi_{\nu-1}(f) := f_{\nu-1}, \quad \pi_{\nu-2}(g) := g_{\nu-2}, \quad \pi_{\nu}(h) := h_{\nu},$$

and also:

$$\pi_{\nu}(H) := \sum_{a+b+c+d+2e=\nu} H_{a,b,c,d,e} z^a \zeta^b \bar{z}^c \bar{\zeta}^d v^e,$$

so that:

$$\Pi_S(\pi_{\nu}(F)) = 0 = \Pi_S(\pi_{\nu}(F')) \quad (\forall \nu \geq 3).$$

Also, let us introduce:

$$\pi^{\nu} := \pi_2 + \dots + \pi_{\nu}.$$

Now, remind that $m = \frac{z\bar{z} + \frac{1}{2} \bar{z}^2 \zeta + z^2 \bar{\zeta}}{1 - \zeta \bar{\zeta}}$ is homogeneous of weight 2. Thanks to Proposition 27.1, we may write:

$$u = F = m + \sum_{\nu \geq 3} G_{\nu}.$$

Then for a holomorphic function $e_{\mu} = e_{\mu}(z, \zeta, w)$ which is weighed μ -homogeneous, it holds (exercise):

$$(29.4) \quad \pi^{\mu} \left(e_{\mu} \left(z, \zeta, i v + m(z, \zeta, \bar{z}, \bar{\zeta}) + \sum_{\nu \geq 3} G_{\nu}(z, \zeta, \bar{z}, \bar{\zeta}, v) \right) \right) = e_{\mu}(z, \zeta, i v + m).$$

Now, the fundamental identity expressing that $(z + f, \zeta + g, w + h)$ is a map $N \rightarrow N$, writes:

$$(29.5) \quad \begin{aligned} 0 &\equiv -\operatorname{Re} (w + h_3 + h_4 + \dots) \\ &\quad + F' \left(z + f_2 + f_3 + \dots, \zeta + g_1 + g_2 + \dots, \right. \\ &\quad \left. \bar{z} + \bar{f}_2 + \bar{f}_3 + \dots, \bar{\zeta} + \bar{g}_1 + \bar{g}_2 + \dots, \operatorname{Im} (w + h_3 + h_4 + \dots) \right). \end{aligned}$$

In order to prove that $(f, g, h) = (0, 0, 0)$, we may proceed progressively, by induction on $\nu \geq 3$:

$$(\bullet_3) (f_2, g_1, h_3) = (0, 0, 0);$$

$$(\bullet_{\nu-1}) (f_{\mu-1}, g_{\mu-2}, h_\mu) = (0, 0, 0) \text{ for } \mu = 3, \dots, \nu - 1 \text{ and some } \nu \geq 4 \text{ implies that } (f_{\nu-1}, g_{\nu-2}, h_\nu) = (0, 0, 0).$$

Therefore, let us examine first the fundamental identity in weight $\nu = 3$, remembering that this identity already holds true in weights 0, 1, 2 — according to (the proof of) Proposition 28.2, or according to our hypothesis —:

$$\begin{aligned} 0 &\equiv \pi^3 \left(-\operatorname{Re}(w + h_3) + m'(z + f_2, \zeta + g_1, \bar{z} + \bar{f}_2, \bar{\zeta} + \bar{g}_1) + F'_3(z + f_2, \zeta + g_1, \bar{z} + \bar{f}_2, \bar{\zeta} + \bar{g}_1) \right) \\ &\equiv \pi^3 \left(-m - F_3 - \operatorname{Re} h_3 + m'(z + f_2, \zeta + g_1, \bar{z} + \bar{f}_2, \bar{\zeta} + \bar{g}_1) \right) + F'_3(z, \zeta, \bar{z}, \bar{\zeta}), \end{aligned}$$

since m' is weighted homogeneous of degree 2, since we use here (29.4). Equivalently:

$$F_3(z, \zeta, \bar{z}, \bar{\zeta}) - F'_3(z, \zeta, \bar{z}, \bar{\zeta}) \equiv \pi^3 \left(m'(z + f_2, \zeta + g_1, \bar{z} + \bar{f}_2, \bar{\zeta} + \bar{g}_1) - m(z, \zeta, \bar{z}, \bar{\zeta}) \right) - \operatorname{Re} h_3(z, \zeta, m + iv).$$

Generally, for any $\nu \geq 3$, starting from the induction assumption expressed by $(\bullet_{\nu-1})$ above, the same reasoning (exercise) conducts to the identity:

$$F_\nu(z, \zeta, \bar{z}, \bar{\zeta}) - F'_\nu(z, \zeta, \bar{z}, \bar{\zeta}) \equiv \pi^\nu \left(m'(z + f_{\nu-1}, \zeta + g_{\nu-2}, \bar{z} + \bar{f}_{\nu-1}, \bar{\zeta} + \bar{g}_{\nu-2}) - m(z, \zeta, \bar{z}, \bar{\zeta}) \right) - \operatorname{Re} h_\nu(z, \zeta, m + iv).$$

Observe that:

$$m_z = \frac{\bar{z} + z\bar{\zeta}}{1 - \zeta\bar{\zeta}} \quad \text{and} \quad m_\zeta = \frac{1}{2} \frac{(\bar{z} + z\bar{\zeta})^2}{(1 - \zeta\bar{\zeta})^2}.$$

LEMMA 29.6. *One has:*

$$\begin{aligned} &\pi^\nu \left(m'(z + f_{\nu-1}, \zeta + g_{\nu-2}, \bar{z} + \bar{f}_{\nu-1}, \bar{\zeta} + \bar{g}_{\nu-2}) - m(z, \zeta, \bar{z}, \bar{\zeta}) \right) \\ &= 2 \operatorname{Re} \left\{ \frac{\bar{z} + z\bar{\zeta}}{1 - \zeta\bar{\zeta}} f_{\nu-1}(z, \zeta, m + iv) + \frac{1}{2} \frac{(\bar{z} + z\bar{\zeta})^2}{(1 - \zeta\bar{\zeta})^2} g_{\nu-2}(z, \zeta, m + iv) \right\}. \end{aligned}$$

PROOF. The reader is referred to [22, Prp. 6.2] which provides all arguments. \square

Next, let us apply $\Pi_S(\bullet)$ to the above identity, multiplied by 2, namely to:

$$2 F_\nu - 2 F'_\nu \equiv \pi^\nu (2 m' - 2 m) - 2 \operatorname{Re} h_\nu,$$

so that all monomials in the left-hand side disappear due to our assumption that both N and N' are in normal form:

$$\begin{aligned} 0 &\equiv \Pi_S \left(\pi^\nu (2 m' - 2 m) - 2 \operatorname{Re} h_\nu \right) \\ &\equiv \Pi_S \left(2 \operatorname{Re} \left\{ \frac{\bar{z} + z\bar{\zeta}}{1 - \zeta\bar{\zeta}} f_{\nu-1}(z, \zeta, m + iv) + \frac{(\bar{z} + z\bar{\zeta})^2}{(1 - \zeta\bar{\zeta})^2} g_{\nu-2}(z, \zeta, m + iv) - h_\nu(z, \zeta, m + iv) \right\} \right). \end{aligned}$$

Then for all monomials $z^a \zeta^b \bar{z}^c \bar{\zeta}^d v^e$ with $(a, b, c, d) \in S$ and $a + b + c + d + 2e = \nu$, we obtain a system of linear equations:

$$(E_\nu): \quad 0 = L_{a,b,c,d,e} \left(\{f_{a',b',e'}\}_{a'+b'+2e'=\nu-1}, \{g_{a',b',e'}\}_{a'+b'+2e'=\nu-2}, \{h_{a',b',e'}\}_{a'+b'+2e'=\nu} \right).$$

On the other hand, by considering the complete $f = f_2 + f_3 + \dots$, the complete $g = g_1 + g_2 + \dots$, and the complete $h = h_3 + h_4 + \dots$ — not to be confused with the previous $(z', \zeta', w') = (z, \zeta, w) + (f, g, h)$ —, we can introduce the analog ‘complete’ linear system:

$$0 \equiv \Pi_S \left(2 \operatorname{Re} \left\{ 2 \frac{\bar{z}+z\bar{\zeta}}{1-\zeta\bar{\zeta}} f(z, \zeta, \mathbf{m} + iv) + \frac{(\bar{z}+z\bar{\zeta})^2}{(1-\zeta\bar{\zeta})^2} g(z, \zeta, \mathbf{m} + iv) - h(z, \zeta, \mathbf{m} + iv) \right\} \right),$$

which, similarly, after extracting the coefficients of all monomials $z^a \zeta^b \bar{z}^c \bar{\zeta}^d v^e$ with $(a, b, c, d) \in S$ and any $e \in \mathbb{N}$, can be abbreviated as:

$$(E): \quad 0 = L_{a,b,c,d,e}(f_{\bullet,\bullet,\bullet}, g_{\bullet,\bullet,\bullet}, h_{\bullet,\bullet,\bullet}) \quad ((a,b,c,d) \in S, e \in \mathbb{N}).$$

The key and elementary observation is that, because $\mathbf{m} + iv$ is (weighted) 2-homogeneous, the full system (E) splits into the linear subsystems (E_ν) having separate unknowns $(f_{\nu-1}, g_{\nu-2}, h_\nu)$:

$$(E) = (E_3) \cup (E_4) \cup \dots \cup (E_\nu) \cup \dots .$$

Therefore:

$$\left((E) \implies (f, g, h) = (0, 0, 0) \right) \iff \left((E_\nu) \implies (f_{\nu-1}, g_{\nu-2}, h_\nu) = (0, 0) \text{ for all } \nu \geq 3 \right).$$

The interest of this equivalence is that one will be able to gather all powers v^e for $e \in \mathbb{N}$ in order to deal with functions of the real variable $v \in \mathbb{R}$, and hence, extract only coefficients of powers $z^a \zeta^b \bar{z}^c \bar{\zeta}^d$, as we will see in a while.

Thus, we are left with establishing the following main technical statement, which will close the proof of Theorem 29.3. □

THEOREM 29.7. *In weighted expansions, assume that $f = f_2 + f_3 + \dots$, that $g = g_1 + g_2 + \dots$, and that $h = h_3 + h_4 + \dots$ vanish at the origin and satisfy in addition:*

$$0 = f_w(0) \quad \text{and} \quad 0 = \operatorname{Im} h_{ww}(0).$$

If, for all $(a, b, c, d) \in S$ and all $e \in \mathbb{N}$:

$$0 = [z^a \zeta^b \bar{z}^c \bar{\zeta}^d v^e] \left(2 \operatorname{Re} \left\{ 2 \frac{\bar{z}+z\bar{\zeta}}{1-\zeta\bar{\zeta}} f(z, \zeta, \mathbf{m} + iv) + \frac{(\bar{z}+z\bar{\zeta})^2}{(1-\zeta\bar{\zeta})^2} g(z, \zeta, \mathbf{m} + iv) - h(z, \zeta, \mathbf{m} + iv) \right\} \right),$$

then $(f, g, h) = (0, 0, 0)$.

PROOF. For some reason of technical simplification, to be explained in a little interlude below, we now decide to ‘shift’ to the representation $v = F(z, \zeta, \bar{z}, \bar{\zeta}, u)$ instead of $u = F(z, \zeta, \bar{z}, \bar{\zeta}, v)$, where $u = \operatorname{Re} w$ and $v = \operatorname{Im} w$ as always.

The hypotheses become (exercise), instead:

$$0 = f_w(0) \quad \text{and} \quad 0 = \operatorname{Re} h_{ww}(0),$$

and also, for all $(a, b, c, d) \in S$ and all $e \in \mathbb{N}$:

$$0 = [z^a \zeta^b \bar{z}^c \bar{\zeta}^d u^e] \left(2 \operatorname{Re} \left\{ 2 \frac{\bar{z}+z\bar{\zeta}}{1-\zeta\bar{\zeta}} f(z, \zeta, u + i\mathbf{m}) + \frac{(\bar{z}+z\bar{\zeta})^2}{(1-\zeta\bar{\zeta})^2} f(z, \zeta, u + i\mathbf{m}) + i h(z, \zeta, u + i\mathbf{m}) \right\} \right).$$

Because S does not contain any dependent-jet monomial $\zeta\bar{\zeta}(\dots)$ by its very definition given above, we may compute everything modulo $\zeta\bar{\zeta}(\dots)$, and this will simplify our task.

Thus, by expanding:

$$\begin{aligned} m &= \frac{z\bar{z} + \frac{1}{2}\bar{z}^2\zeta + \frac{1}{2}z^2\bar{\zeta}}{1 - \zeta\bar{\zeta}} \\ &= z\bar{z} + \frac{1}{2}\bar{z}^2\zeta + \frac{1}{2}z^2\bar{\zeta} + z\bar{z}\zeta\bar{\zeta} + \frac{1}{2}\bar{z}^2\zeta\zeta\bar{\zeta} + \frac{1}{2}z^2\bar{\zeta}\zeta\bar{\zeta} + z\bar{z}\zeta\zeta\bar{\zeta}\bar{\zeta} + \dots, \end{aligned}$$

we visibly have:

$$\begin{aligned} m &\equiv z\bar{z} + \frac{1}{2}\bar{z}^2\zeta + \frac{1}{2}z^2\bar{\zeta}, \\ m_z &\equiv \bar{z} + z\bar{\zeta}, \\ m_\zeta &\equiv \frac{1}{2}\bar{z}^2 + z\bar{z}\bar{\zeta} + \frac{1}{2}z^2\bar{\zeta}^2, \\ m_{\bar{z}} &\equiv z + \bar{z}\zeta, \\ m_{\bar{\zeta}} &\equiv \frac{1}{2}z^2 + z\zeta\bar{z} + \frac{1}{2}\bar{z}^2\zeta^2. \end{aligned}$$

We will also need (little exercise), still modulo $\zeta\bar{\zeta}(\dots)$:

$$\begin{aligned} m^2 &\equiv z^2\bar{z}^2 + z\zeta\bar{z}^3 + z^3\bar{z}\bar{\zeta} + \frac{1}{4}z^4\bar{\zeta}^2 + \frac{1}{4}\zeta^2\bar{z}^4, \\ m^3 &\equiv z^3\bar{z}^3 + \frac{3}{2}z^2\zeta\bar{z}^4 + \frac{3}{2}z^4\bar{z}^2\bar{\zeta}^2 + \frac{3}{4}z^5\bar{z}\bar{\zeta}^2 + \frac{3}{4}z\bar{z}^5\zeta^2 + \frac{1}{8}z^6\bar{\zeta}^3 + \frac{1}{8}\zeta^3\bar{z}^6, \\ m m_\zeta &\equiv \frac{1}{2}z\bar{z}^3 + \frac{1}{4}\zeta\bar{z}^4 + \frac{5}{4}z^2\bar{z}\bar{\zeta} + z^3\bar{z}\bar{\zeta}^2 + \frac{1}{4}z^4\bar{\zeta}^3, \\ m m_z &\equiv z\bar{z}^2 + \frac{1}{2}\zeta\bar{z}^3 + \frac{3}{2}z^2\bar{z}\bar{\zeta} + \frac{1}{2}z^3\bar{\zeta}^2, \\ m^2 m_z &\equiv z^2\bar{z}^3 + z\zeta\bar{z}^4 + 2z^3\bar{z}^2\bar{\zeta} + \frac{1}{4}\zeta^2\bar{z}^5 + \frac{5}{4}z^4\bar{z}\bar{\zeta}^2 + \frac{1}{4}z^5\bar{\zeta}^3. \end{aligned}$$

Assuming therefore that the graphing equation $v = F = m + G$ is solved with respect to v , not to u , with arguments $(z, \zeta, w) = (z, \zeta, u + im)$, the Moser (linear) operator is defined as:

$$L(f, g, h) := 2m_z f + 2m_{\bar{z}}\bar{f} + 2m_\zeta g + 2m_{\bar{\zeta}}\bar{g} + i h - i\bar{h}.$$

Given a holomorphic function $e = e(w)$, we may Taylor expand at u :

$$\begin{aligned} e(u + im) &= e(u) + e_w(u) [im] + e_{ww}(u) \left[-\frac{m^2}{2}\right] + e_{www}(u) \left[-i\frac{m^3}{6}\right] + \dots \\ &=: e + e' [im] + e'' \left[-\frac{m^2}{2}\right] + e''' \left[-i\frac{m^3}{6}\right] + \dots, \end{aligned}$$

and we can abbreviate derivatives using primes, even without writing the argument u . Let us now make the promised little interlude.

The other choice of graphing $u = F = m + G$ leads to $e(w) = e(iv + m)$ which expands as:

$$e(iv + m) = e(iv) + e_w(iv) [m] + e_{ww}(iv) \left[\frac{m^2}{2}\right] + e_{www}(iv) \left[\frac{m^3}{6}\right] + \dots.$$

It is then convenient to consider the *composed* function of one real variable:

$$v \mapsto e(iv) =: E(v),$$

which satisfies:

$$\begin{aligned} \frac{d}{dv} E(v) &= i e_w(iv) && \iff && -i E'(v) &= e_w(iv), \\ \frac{d^2}{dv^2} E(v) &= -e_{ww}(iv) && \iff && -E''(v) &= e_{ww}(iv), \\ \frac{d^3}{dv^3} E(v) &= -i e_{www}(iv) && \iff && i E'''(v) &= e_{www}(iv). \end{aligned}$$

Thus:

$$e(iv + m) = E(v) - i E'(v) [m] - E''(v) \left[\frac{m^2}{2}\right] + i E'''(v) \left[\frac{m^3}{6}\right] + \dots,$$

$$\bar{e}(-iv + m) = \bar{E}(v) + i \bar{E}'(v) [m] - \bar{E}''(v) \left[\frac{m^2}{2}\right] - i \bar{E}'''(v) \left[\frac{m^3}{6}\right] + \dots,$$

and similarly for the conjugate. If by convention, we then make the abuse of notation to denote e instead of E , that is $e(v)$ instead of $E(v) = e(iv)$, we can abbreviate, without writing the arguments iv or $-iv$:

$$e(iv + m) = e + e' [-im] + e'' \left[-\frac{m^2}{2}\right] + e''' \left[i\frac{m^3}{6}\right] + \dots,$$

$$\bar{e}(-iv + m) = \bar{e} + \bar{e}' [im] + \bar{e}'' \left[-\frac{m^2}{2}\right] + \bar{e}''' \left[-i\frac{m^3}{6}\right] + \dots.$$

This can be applied to functions $e = f_{j,k}$ or $e = g_{j,k}$ or $e = h_{j,k}$ in the useful expansions:

$$f = \sum_j \sum_k z^j \zeta^k f_{j,k}(w), \quad g = \sum_j \sum_k z^j \zeta^k g_{j,k}(w), \quad h = \sum_j \sum_k z^j \zeta^k h_{j,k}(w).$$

But in these last paragraphs of our paper, we decided to choose $v = F$ in order to simplify a bit the presentation, so that $e = e(u) = E(u)$ and there will be no abuse of notation.

We can write the Moser operator as:

$$L(f, g, h) = T_1 + \bar{T}_1 + T_2 + \bar{T}_2 + T_3 + \bar{T}_3.$$

Computing modulo $\zeta\bar{\zeta}(\dots)$, start with:

$$\begin{aligned} T_3 &\equiv \sum_j \sum_k z^j \zeta^k i h_{j,k}(u + im) \\ &\equiv \sum_j \sum_k z^j \zeta^k \left\{ i h_{j,k} + h'_{j,k} [-m] + h''_{j,k} \left[-\frac{i}{2} m^2\right] + h'''_{j,k} \left[\frac{1}{6} m^3\right] + \dots \right\} \\ &\equiv \sum_j \sum_k z^j \zeta^k \left\{ h_{j,k} [i] + h'_{j,k} \left[-z\bar{z} - \frac{1}{2} z^2 \zeta - \frac{1}{2} z^2 \bar{\zeta}\right] + h''_{j,k} \left[-\frac{i}{2} z^2 \bar{z}^2 - \frac{i}{2} z \zeta \bar{z}^3 - \frac{i}{2} z^3 \bar{z} \bar{\zeta} - \frac{i}{8} z^4 \bar{\zeta}^2 - \frac{i}{8} \zeta^2 \bar{z}^4\right] \right. \\ &\quad \left. + h'''_{j,k} \left[\frac{1}{6} z^3 \bar{z}^3 + \frac{1}{4} z^2 \zeta \bar{z}^4 + \frac{1}{4} z^4 \bar{z}^2 \bar{\zeta}^2 + \frac{1}{8} z^5 \bar{z} \bar{\zeta}^2 + \frac{1}{8} z \bar{z}^5 \zeta^2 + \frac{1}{48} z^6 \bar{\zeta}^3 + \frac{1}{48} \zeta^3 \bar{z}^6\right] + \dots \right\} \\ &\equiv \sum_j \sum_k \left\{ h_{j,k} [iz^j \zeta^k] + h'_{j,k} \left[-z^{j+1} \zeta^k \bar{z} - \frac{1}{2} z^j \zeta^{k+1} \bar{z}^2 - \frac{1}{2} z^{j+2} \zeta^k \bar{\zeta}^3\right] \right. \\ &\quad \left. + h''_{j,k} \left[-\frac{i}{2} z^{j+2} \zeta^k \bar{z}^2 - \frac{i}{2} z^{j+1} \zeta^{k+1} \bar{z}^3 - \frac{i}{2} z^{j+3} \zeta^k \bar{z} \bar{\zeta} - \frac{i}{8} z^{j+4} \zeta^k \bar{\zeta}^2 - \frac{i}{8} z^j \zeta^{k+2} \bar{z}^4\right] \right. \\ &\quad \left. + h'''_{j,k} \left[\frac{1}{6} z^{j+3} \zeta^k \bar{z}^3 + \frac{1}{4} z^{j+2} \zeta^{k+1} \bar{z}^4 + \frac{1}{4} z^{j+4} \zeta^k \bar{z}^2 \bar{\zeta}^2 + \frac{1}{8} z^{j+5} \zeta^k \bar{z} \bar{\zeta}^2 + \frac{1}{8} z^{j+1} \zeta^k \bar{z}^5 \bar{\zeta}^2 + \frac{1}{48} z^{j+6} \zeta^k \bar{\zeta}^3 + \frac{1}{48} z^j \zeta^{k+3} \bar{z}^6\right] + \dots \right\}. \end{aligned}$$

The useful expression of \bar{T}_3 is obtained by plain complex conjugation.

Next, going only to derivatives of $g_{j,k}$ up to order 1, which will be enough, we obtain, without intermediate explanations:

$$\begin{aligned} T_2 &\equiv \sum_j \sum_k \left\{ g_{j,k} [z^j \zeta^k \bar{z}^2 + 2z^{j+1} \zeta^k \bar{z} \bar{\zeta} + z^{j+2} \zeta^k \bar{\zeta}^2] \right. \\ &\quad \left. + g'_{j,k} \left[iz^{j+1} \zeta^k \bar{z}^3 + \frac{i}{2} z^j \zeta^{k+1} \bar{z}^4 + \frac{5i}{2} z^{j+2} \zeta^k \bar{z}^2 \bar{\zeta} + 2iz^{j+3} \zeta^k \bar{z} \bar{\zeta}^2 + \frac{i}{2} z^{j+4} \zeta^k \bar{\zeta}^3\right] + \dots \right\}. \end{aligned}$$

Lastly, going to derivatives of order 2 of the $f_{j,k}$:

$$\begin{aligned} T_1 &\equiv \sum_j \sum_k \left\{ f_{j,k} [2z^j \zeta^k \bar{z} + 2z^{j+1} \zeta^k \bar{\zeta}] + f'_{j,k} [2iz^{j+1} \zeta^k \bar{z}^2 + iz^j \zeta^{k+1} \bar{z}^3 + 3iz^{j+2} \zeta^k \bar{z} \bar{\zeta} + iz^{j+3} \zeta^k \bar{z}^2] \right. \\ &\quad \left. + f''_{j,k} \left[-\frac{1}{2} z^{j+2} \zeta^k \bar{z}^3 - \frac{1}{2} z^{j+1} \zeta^{k+1} \bar{z}^4 - z^{j+3} \zeta^k \bar{z}^2 \bar{\zeta} - \frac{1}{8} z^j \zeta^{k+2} \bar{z}^5 - \frac{5}{8} z^{j+4} \zeta^k \bar{z} \bar{\zeta}^2 - \frac{1}{8} z^{j+5} \zeta^k \bar{\zeta}^3\right] + \dots \right\}. \end{aligned}$$

Now, patiently, in $0 = T_1 + T_2 + T_3 + \bar{T}_1 + \bar{T}_2 + \bar{T}_3$, we chase coefficients $z^a \zeta^b \bar{z}^c \bar{\zeta}^d$ for all $(a, b, c, d) \in S$, and each time, we obtain linear combinations of (differentiated) functions of u . Using a computer helps to avoid mistakes.

We hence obtain several groups of linear differential equations in the functions $f_{j,k}(u)$, $g_{j,k}(u)$, $h_{j,k}(u)$. We begin with three major groups coming from (part of) the prenormalization assumption and which imply a certain agreeable ‘nilpotency phenomenon’, well known to also hold for Levi nondegenerate hypersurfaces ([23, 71, 95]). Figures help to grasp the inequalities we are stating below, which show certain regions \mathbf{R}_h^* , \mathbf{R}_f^* , \mathbf{R}_g^* .

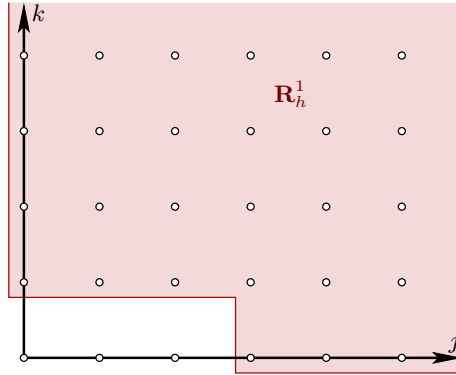

(\mathbf{R}_h^1) $0 = i h_{j,k}(u)$ for $(j, k, 0, 0) \in S$ with $j \geq 3$ or with $k \geq 1$. This yields, without writing the argument u of the $h_{j,k}(u)$, that h is a relative polynomial in (z, ζ) :

$$h = h_{0,0} + h_{1,0} z + h_{2,0} z^2.$$

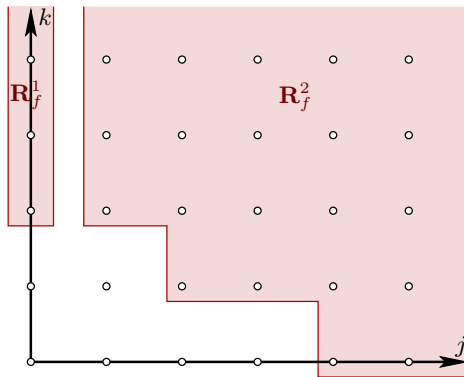

(\mathbf{R}_f^1) $0 = 2 f_{0,k}(u)$ for $(j, k, 1, 0) \in S$ with $j = 0$ and $k \geq 2$.

(\mathbf{R}_f^2) $0 = 2 f_{j,k}(u) - h'_{j-1,k}(u)$ for $(j, k, 1, 0) \in S$ with $j \geq 1$ and: with $k \geq 2$ when $j = 1$; with $k \geq 1$ when $j = 2, 3$; with $k \geq 0$ when $j \geq 4$. This yields relative polynomialness of:

$$f = f_{0,1} \zeta + f_{1,1} z \zeta + f_{0,0} + f_{1,0} z + f_{2,0} z^2 + f_{3,0} z^3.$$

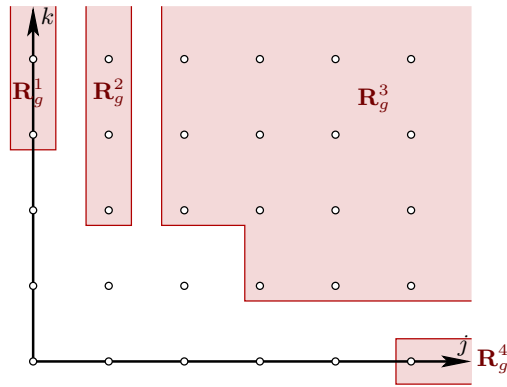

$$(\mathbf{R}_g^1) \quad 0 = g_{0,k} - \frac{1}{2}h'_{0,k-1} \quad \text{for } (j, k, 2, 0) \in S \text{ with } j = 0 \text{ and } k \geq 3.$$

$$(\mathbf{R}_g^2) \quad 0 = g_{1,k} - \frac{1}{2}h'_{1,k-1} + 2i f'_{0,k} \quad \text{for } (j, k, 2, 0) \in S \text{ with } j = 1 \text{ and } k \geq 2.$$

$$(\mathbf{R}_g^3) \quad 0 = g_{j,k} - \frac{1}{2}h'_{j,k-1} + 2i f'_{j-1,k} - \frac{i}{2}h''_{j-2,k} \quad \text{for } (j, k, 2, 0) \in S \text{ with } j \geq 2 \text{ and } k \geq 1$$

excepting $(j, k) = (2, 1)$.

$$(\mathbf{R}_g^4) \quad 0 = g_{j,0} + 2i f'_{j-1,0} - \frac{i}{2}h''_{j-2,0}, \quad \text{for } (j, k, 0, 0) \in S \text{ with } j \geq 5 \text{ and } k = 0.$$

All this also yields relative polynomialness of:

$$g = g_{0,2} \zeta^2 + g_{0,1} \zeta + g_{1,1} z \zeta + g_{2,1} z^2 \zeta + g_{0,0} + g_{1,0} z + g_{2,0} z^2 + g_{3,0} z^3 + g_{4,0} z^4.$$

To prove that $(f, g, h) = (0, 0, 0)$, it suffices to prove that the 3 + 6 + 9 remaining functions of u , namely $h_{0,0}, h_{1,0}, h_{2,0}$ and $f_{0,1}, f_{1,1}, f_{0,0}, f_{1,0}, f_{2,0}, f_{3,0}$, and $g_{0,2}, g_{0,1}, g_{1,1}, g_{2,1}, g_{0,0}, g_{1,0}, g_{2,0}, g_{3,0}, g_{4,0}$ are identically zero.

For this, we have to examine the remaining groups of linear ordinary differential equations with $(a, b, c, d) \in S$.

Firstly (first group), the equations for $(j, k, 0, 0) \in S$ outside the region \mathbf{R}_h^1 are:

$$\begin{aligned} (0, 0, 0, 0) \quad & 0 = i h_{0,0} - i \bar{h}_{0,0}, \\ (1, 0, 0, 0) \quad & 0 = 2 \bar{f}_{0,0} + i h_{1,0}, \\ (2, 0, 0, 0) \quad & 0 = \bar{g}_{0,0} + i h_{2,0}. \end{aligned}$$

The conjugate equations are not written, should be understood, and will in fact be considered later.

Secondly (second group), the equations for $(j, k, 1, 0) \in S$ outside $\mathbf{R}_f^1 \cup \mathbf{R}_f^2$ are:

$$\begin{aligned}
(0, 0, 1, 0) & \quad 0 = 2 f_{0,0} - i \bar{h}_{1,0} \quad [\text{Already seen}], \\
(1, 0, 1, 0) & \quad 0 = 2 f_{1,0} - h'_{0,0} - \bar{h}'_{0,0} + 2 \bar{f}_{1,0}, \\
(2, 0, 1, 0) & \quad 0 = 2 f_{2,0} + \bar{g}_{1,0} - h'_{1,0} - 2i \bar{f}'_{0,0}, \\
(3, 0, 1, 0) & \quad 0 = 2 f_{3,0} - h'_{2,0} - i \bar{g}'_{0,0}, \\
(0, 1, 1, 0) & \quad 0 = 2 f_{0,1} + 2 \bar{f}_{0,0}, \\
(1, 1, 1, 0) & \quad 0 = 2 f_{1,1} - \underline{h'_{0,1}} + 2 \bar{g}_{0,0}.
\end{aligned}$$

Notice that the last equation let appear $h_{0,1}(u)$, which we already know is identically zero. Again, the conjugate equations are understood.

Thirdly (third group), the equations for $(j, k, 2, 0)$ outside $\mathbf{R}_g^1 \cup \mathbf{R}_g^2 \cup \mathbf{R}_g^3 \cup \mathbf{R}_g^4$ are:

$$\begin{aligned}
(0, 0, 2, 0) & \quad 0 = g_{0,0} - i \bar{h}_{2,0} \quad [\text{Already seen}], \\
(1, 0, 2, 0) & \quad 0 = g_{1,0} + 2 \bar{f}_{2,0} - \bar{h}'_{1,0} + 2i f'_{0,0} \quad [\text{Already seen}], \\
(2, 0, 2, 0) & \quad 0 = g_{2,0} + \bar{g}_{2,0} - 2i \bar{f}'_{1,0} + 2i f'_{1,0} - \frac{i}{2} h''_{0,0} + \frac{i}{2} \bar{h}''_{0,0}, \\
(3, 0, 2, 0) & \quad 0 = g_{3,0} - i \bar{g}'_{1,0} + 2i f'_{2,0} - \frac{i}{2} h''_{1,0} - \bar{f}''_{0,0}, \\
(4, 0, 2, 0) & \quad 0 = g_{4,0} + 2i f'_{3,0} - \frac{i}{2} h''_{2,0} - \frac{1}{2} \bar{g}''_{0,0}, \\
(0, 1, 2, 0) & \quad 0 = g_{0,1} + 2 \bar{f}_{1,0} - \frac{1}{2} \bar{h}'_{0,0} - \frac{1}{2} h'_{0,0}, \\
(1, 1, 2, 0) & \quad 0 = g_{1,1} + 2 \bar{g}_{1,0} - \frac{1}{2} h'_{1,0} - 3i \bar{f}'_{0,0} + 2i f'_{0,1}, \\
(2, 1, 2, 0) & \quad 0 = g_{2,1} - \frac{1}{2} h'_{2,0} - \frac{5i}{2} \bar{g}'_{0,0} + 2i f'_{1,1} - \frac{i}{2} \underline{h''_{0,1}}, \\
(0, 2, 2, 0) & \quad 0 = g_{0,2} + \bar{g}_{0,0} - \frac{1}{2} \underline{h'_{0,1}}.
\end{aligned}$$

Notice that the last two equations let appear $h_{0,1}(u)$, which we already know is identically zero.

Fourthly (fourth group) and lastly, we list the sporadic equations:

$$\begin{aligned}
(3, 0, 0, 1) & \quad 0 \equiv 2 f_{2,0} - \frac{1}{2} h'_{1,0} - i \bar{f}'_{0,0}, \\
(3, 0, 3, 0) & \quad 0 \equiv \frac{1}{6} h'''_{0,0} + \frac{1}{6} \bar{h}'''_{0,0} - f''_{1,0} - \bar{f}''_{1,0} + i g'_{2,0} - i \bar{g}'_{2,0}, \\
(4, 0, 0, 1) & \quad 0 \equiv 2 f_{3,0} - \frac{1}{2} h'_{2,0} - \frac{i}{2} \bar{g}'_{0,0}, \\
(3, 0, 1, 1) & \quad 0 \equiv 2 g_{2,0} - i \bar{g}'_{0,1} - i \bar{f}'_{1,0} + 3i f'_{1,0} + \frac{i}{2} \bar{h}''_{0,0} - \frac{i}{2} h''_{0,0}, \\
(4, 0, 1, 1) & \quad 0 \equiv 2 g_{3,0} - \frac{i}{2} \bar{g}'_{1,0} + 3i f'_{2,0} - \frac{i}{2} h''_{1,0} - \bar{f}''_{0,0}.
\end{aligned}$$

Now, the assumptions of Theorem 29.7 can be reformulated by comparing the two representations:

$$f_{\geq 2} = \sum_j \sum_k z^j \zeta^k f_{j,k}(u), \quad g_{\geq 1} = \sum_j \sum_k z^j \zeta^k g_{j,k}(u), \quad h_{\geq 3} = \sum_j \sum_k z^j \zeta^k h_{j,k}(u),$$

and one realizes that:

$$\begin{aligned}
0 = f(0, 0, 0) = g(0, 0, 0) = h(0, 0, 0) &\iff 0 = f_{0,0}(0) = g_{0,0}(0) = h_{0,0}(0), \\
f = f_2 + f_3 + \dots &\implies f_{1,0}(0) = 0, \\
h = h_3 + h_4 + \dots &\implies h'_{0,0}(0) = 0, \\
f_w(0) = 0 &\iff f'_{0,0}(0) = 0, \\
\operatorname{Re} h_{ww}(0) = 0 &\iff \operatorname{Re} h''_{0,0}(0) = 0.
\end{aligned}$$

The proof of Theorem 29.7 will hence be finished with the next statement. \square

PROPOSITION 29.8. *If 3 + 6 + 9 analytic functions $h_{0,0}$, $h_{1,0}$, $h_{2,0}$ and $f_{0,1}$, $f_{1,1}$, $f_{0,0}$, $f_{1,0}$, $f_{2,0}$, $f_{3,0}$, and $g_{0,2}$, $g_{0,1}$, $g_{1,1}$, $g_{2,1}$, $g_{0,0}$, $g_{1,0}$, $g_{2,0}$, $g_{3,0}$, $g_{4,0}$ of the real variable $u \in \mathbb{R}$ with:*

$$\begin{aligned}
0 = f_{0,0}(0) = f_{1,0}(0), & & 0 = g_{0,0}(0), & & 0 = h_{0,0}(0), \\
0 = f'_{0,0}(0), & & & & 0 = h'_{0,0}(0) = \operatorname{Re} h''_{0,0}(0),
\end{aligned}$$

satisfy the above system of four groups of linear ordinary differential equations, then they all vanish identically.

PROOF. From the first two groups of equations and conjugate equations, we may solve:

$$\begin{aligned}
\bar{h}_{0,0} &:= h_{0,0}, & \bar{h}_{1,0} &:= -2i f_{0,0}, \\
h_{1,0} &:= 2i \bar{f}_{0,0}, & \bar{h}_{2,0} &:= -i g_{0,0}, \\
h_{2,0} &:= i \bar{g}_{0,0}, & \bar{f}_{1,0} &:= -f_{1,0} + h'_{0,0}, \\
\bar{f}_{1,0} &:= -f_{1,0} + h'_{0,0}, & \bar{f}_{2,0} &:= -\frac{1}{2} g_{1,0} - 2i f'_{0,0}, \\
f_{2,0} &:= -\frac{1}{2} \bar{g}_{1,0} + 2i \bar{f}'_{0,0}, & \bar{f}_{3,0} &:= -i g'_{0,0}, \\
f_{3,0} &:= i \bar{g}'_{0,0}, & \bar{f}_{0,1} &:= -f_{0,0}, \\
f_{0,1} &:= -\bar{f}_{0,0}, & \bar{f}_{1,1} &:= -g_{0,0}, \\
f_{1,1} &:= -\bar{g}_{0,0}, & & &
\end{aligned}$$

Once this is done, these first two groups of equations become just $0 = 0$, while the third group becomes¹:

$$\begin{aligned}
0 &\stackrel{2020}{=} g_{2,0} + \bar{g}_{2,0} - 2i h''_{0,0} + 4i f'_{1,0}, & 0 &\stackrel{2030}{=} \bar{g}_{3,0} + 2i g'_{1,0} - 4 f''_{0,0}, \\
0 &\stackrel{3020}{=} g_{3,0} - 2i \bar{g}'_{1,0} - 4 \bar{f}''_{0,0}, & 0 &\stackrel{2040}{=} \bar{g}_{4,0} - 2 g''_{0,0}, \\
0 &\stackrel{4020}{=} g_{4,0} - 2 \bar{g}''_{0,0}, & 0 &\stackrel{2001}{=} \bar{g}_{0,1} + 2 f_{1,0} - h'_{0,0}, \\
0 &\stackrel{0120}{=} g_{0,1} - 2 f_{1,0} + h'_{0,0}, & 0 &\stackrel{2011}{=} \bar{g}_{1,1} + 2 g_{1,0} + 6i f'_{0,0}, \\
0 &\stackrel{1120}{=} g_{1,1} + 2 \bar{g}_{1,0} - 6i \bar{f}'_{0,0}, & 0 &\stackrel{2021}{=} \bar{g}_{2,1} + 5i g'_{0,0}, \\
0 &\stackrel{2120}{=} g_{2,1} - 5i \bar{g}'_{0,0}, & 0 &\stackrel{2002}{=} \bar{g}_{0,2} + g_{0,0}, \\
0 &\stackrel{0220}{=} g_{0,2} + \bar{g}_{0,0}, & & &
\end{aligned}$$

¹ — mind the fact that because we have sometimes solved \bar{e} in terms of e for certain functions $e = e(u)$, the obtained equations are *not* all pairwise conjugates on certain lines, and this is normal —

and the fourth, last, sporadic group becomes:

$$\begin{aligned}
0 &\stackrel{3001}{=} 2i \bar{f}'_{0,0} - \bar{g}_{1,0}, & 0 &\stackrel{0130}{=} -2i f'_{0,0} - g_{1,0}, \\
0 &\stackrel{3030}{=} -\frac{2}{3} h'''_{0,0} + i g'_{2,0} - i \bar{g}'_{2,0}, & & \\
0 &\stackrel{4001}{=} i \bar{g}'_{0,0}, & 0 &\stackrel{0140}{=} -i g'_{0,0}, \\
0 &\stackrel{3011}{=} 2g_{2,0} - i \bar{g}'_{0,1} - i h''_{0,0} + 4i f'_{1,0}, & 0 &\stackrel{1130}{=} 2\bar{g}_{2,0} + i g'_{0,1} - 3i h''_{0,0} + 4i f'_{1,0}, \\
0 &\stackrel{4011}{=} 2g_{3,0} - 6\bar{f}''_{0,0} - 2i \bar{g}'_{1,0}, & 0 &\stackrel{1140}{=} 2\bar{g}_{3,0} - 6f''_{0,0} + 2i g'_{1,0}.
\end{aligned}$$

Hence, from the third group, we can solve:

$$\begin{aligned}
\bar{g}_{2,0} &:= -g_{2,0} - 4i f'_{1,0} + 2i h''_{0,0}, & \bar{g}_{3,0} &:= -2i g'_{1,0} + 4f''_{0,0}, \\
g_{3,0} &:= 2i \bar{g}'_{1,0} + 4\bar{f}''_{0,0}, & \bar{g}_{4,0} &:= 2g''_{0,0}, \\
g_{4,0} &:= 2\bar{g}''_{0,0}, & \bar{g}_{0,1} &:= -2f_{1,0} + h'_{0,0}, \\
g_{0,1} &:= 2f_{1,0} - h'_{0,0}, & \bar{g}_{1,1} &:= -6i f'_{0,0} - 2g_{1,0}, \\
g_{1,1} &:= 6i \bar{f}'_{0,0} - 2\bar{g}_{1,0}, & \bar{g}_{2,1} &:= -5i g'_{0,0}, \\
g_{2,1} &:= 5i \bar{g}'_{0,0}, & \bar{g}_{0,2} &:= -g_{0,0}, \\
g_{0,2} &:= -\bar{g}_{0,0}, & &
\end{aligned}$$

and after that, all equations of the third group reduce to $0 = 0$. Then the equations of the fourth group become:

$$\begin{aligned}
0 &\stackrel{3001}{=} 2i \bar{f}'_{0,0} - \bar{g}_{1,0}, & 0 &\stackrel{0130}{=} -2i f'_{0,0} - g_{1,0}, \\
0 &\stackrel{3030}{=} \frac{4}{3} h'''_{0,0} + 2i g'_{2,0} - 4f''_{1,0}, & & \\
0 &\stackrel{4001}{=} i \bar{g}'_{0,0}, & 0 &\stackrel{0140}{=} -i g'_{0,0}, \\
0 &\stackrel{3011}{=} 2g_{2,0} - 2i h''_{0,0} + 6i f'_{1,0}, & 0 &\stackrel{1130}{=} -2g_{2,0} - 2i f'_{1,0}, \\
0 &\stackrel{4011}{=} 2\bar{f}''_{0,0} + 2i \bar{g}'_{1,0}, & 0 &\stackrel{1140}{=} 2f''_{0,0} - 2i g'_{1,0}.
\end{aligned}$$

From this, we can solve, thanks to the assumption $g_{0,0}(0) = 0$:

$$\begin{aligned}
g_{0,0} &= 0, & \bar{g}_{0,0} &= 0, \\
g_{1,0} &= -2i f'_{0,0}, & \bar{g}_{1,0} &= 2i \bar{f}'_{0,0}, \\
g_{2,0} &:= -2i f'_{1,0}.
\end{aligned}$$

The remaining equations become:

$$\begin{aligned}
0 &\stackrel{3030}{=} \frac{4}{3} h'''_{0,0} - 2f''_{1,0}, & & \\
0 &\stackrel{3011}{=} -2i h''_{0,0} + 4i f'_{1,0}, & & \\
0 &\stackrel{4011}{=} -2\bar{f}''_{0,0} & 0 &\stackrel{1140}{=} -2f''_{0,0}.
\end{aligned}$$

Differentiating once the second equation, using $0 \neq \begin{vmatrix} \frac{4}{3} & -2 \\ -2i & 4i \end{vmatrix}$, we get:

$$h'''_{0,0} = 0, \quad f''_{1,0} = 0.$$

But we have assumed $0 = h_{0,0}(0) = h'_{0,0}(0) = \operatorname{Re} h''_{0,0}(0)$, and we know from the beginning that $\bar{h}_{0,0} = h_{0,0}$ is real. So $h_{0,0} = 0$.

Back to ³⁰¹¹ above, we get $f'_{1,0} = 0$. Also, we have assumed that $f_{1,0}(0) = 0$. So $f_{1,0} = 0$.

Lastly, $f''_{0,0} = 0$ together with $f'_{0,0}(0) = 0$ gives $f_{0,0} = 0$. This concludes everything. \square

CHAPTER 5

Parametric CR-umbilical Locus of Ellipsoids in \mathbb{C}^2

For every real numbers $a \geq 1, b \geq 1$ with $(a, b) \neq (1, 1)$, the curve parametrized by $\theta \in \mathbb{R}$ valued in $\mathbb{C}^2 \cong \mathbb{R}^4$

$$\gamma: \theta \longmapsto (x(\theta) + \sqrt{-1}y(\theta), u(\theta) + \sqrt{-1}v(\theta))$$

with components:

$$x(\theta) := \sqrt{\frac{a-1}{a(ab-1)}} \cos \theta, \quad y(\theta) := \sqrt{\frac{b(a-1)}{ab-1}} \sin \theta, \quad u(\theta) := \sqrt{\frac{b-1}{b(ab-1)}} \sin \theta, \quad v(\theta) := -\sqrt{\frac{a(b-1)}{ab-1}} \cos \theta,$$

has image contained in the CR-umbilical locus:

$$\gamma(\mathbb{R}) \subset \text{UmbCR}(E_{a,b}) \subset E_{a,b}$$

of the ellipsoid $E_{a,b} \subset \mathbb{C}^2$ of equation $ax^2 + y^2 + bu^2 + v^2 = 1$.

This Chapter is based on our jointwork with Wei-Guo Foo and Joël Merker, which has appeared in the publication:

Wei-Guo Foo, Joël Merker, The-Anh Ta, *Parametric CR-umbilical Locus of Ellipsoids in \mathbb{C}^2* , *Comptes Rendus Mathematique* 356 (2018): 214-221. arXiv:1707.06787

1. Introduction

In 1932, Élie Cartan [13, 15, 16] showed that a local real-analytic (\mathcal{C}^ω) hypersurface $M^3 \subset \mathbb{C}^2$ is determined up to local biholomorphic equivalence by a single invariant function:

$$I_{Cartan}^M: M \longrightarrow \mathbb{C},$$

together with its (covariant) derivatives with respect to a certain coframe of differential 1-forms on an 8-dimensional principal bundle $P^8 \longrightarrow M$. In coordinates $(z, w) = (x + \sqrt{-1}y, u + \sqrt{-1}v)$ on \mathbb{C}^2 , whenever M is:

- either a *complex graph*:

$$\{(z, w) \in \mathbb{C}^2: w = \Theta(z, \bar{z}, \bar{w})\},$$

- or a *real graph*:

$$\{(z, w) \in \mathbb{C}^2: v = \varphi(x, y, u)\},$$

- or represented in *implicit form*:

$$\{(z, w) \in \mathbb{C}^2: \rho(z, w, \bar{z}, \bar{w}) = 0\},$$

it is known that I_{Cartan}^M depends on the respective 6-jets:

$$J_{z, \bar{z}, \bar{w}}^6 \Theta, \quad J_{x, y, u}^6 \varphi, \quad J_{z, w, \bar{z}, \bar{w}}^6 \rho.$$

The *invariancy* of I_{Cartan}^M means that, for any local biholomorphism $h: \mathbb{C}^2 \longrightarrow \mathbb{C}^2$, setting $M' := h(M)$, it holds at every point $p \in M$ that:

$$I_{Cartan}^{M'}(h(p)) = \nu(p) I_{Cartan}^M(p) \quad (\forall p \in M),$$

for some nowhere vanishing (local) function $\nu: M \rightarrow \mathbb{C} \setminus \{0\}$. This guarantees that the locus of *CR-umbilical* points:

$$\text{UmbCR}(M) := \{p \in M: I_{Cartan}^M(p) = 0\}$$

is intrinsic. Furthermore, when M is connected, it is well known that $\text{UmbCR}(M)$ contains an open set $\emptyset \neq V \subset M$ if and only if M is *spherical*, in the sense of being locally biholomorphic to the unit sphere $S^3 \subset \mathbb{C}^2$.

In 1974, Chern-Moser [23] raised the problem whether $\emptyset \neq \text{UmbCR}(M)$ for compact Levi nondegenerate \mathcal{C}^ω hypersurfaces $M^{2N-1} \subset \mathbb{C}^N$ when $N \geq 2$. This (simple!) paper attacks the more specific:

QUESTION 1.1. *Can $\text{UmbCR}(M)$ be described explicitly?*

But because I_{Cartan}^M is ‘too complicated’ as confirmed in [88, 90], the question is nontrivial even in simplest nonspherical examples like e.g. real ellipsoids introduced and studied by Webster in [117, 118].

In $\mathbb{C}^{N \geq 2} \cong \mathbb{R}^{2N \geq 4}$ equipped with coordinates $z_i = x_i + \sqrt{-1}y_i$, an *ellipsoid* is the image of the unit sphere:

$$S^{2N-1} := \{z \in \mathbb{C}^N: |z_1|^2 + \dots + |z_N|^2 = 1\},$$

through a real affine transformation of \mathbb{R}^{2N} , hence has equation the form:

$$(E_{\alpha,\beta}) \quad \sum_{1 \leq i \leq N} (\alpha_i x_i^2 + \beta_i y_i^2) = 1,$$

with real constants $\alpha_i \geq \beta_i > 0$ — replace $z_i \mapsto \sqrt{-1}z_i$ if necessary.

The complex geometry of ellipsoids (Segre varieties, dynamics) began in Webster’s seminal article [117], in which it was verified that two ellipsoids $E_{\alpha,\beta} \cong E_{\alpha',\beta'}$ are biholomorphically equivalent if and only if up to permutation:

$$\frac{\alpha_i - \beta_i}{\alpha_i + \beta_i} = \frac{\alpha'_i - \beta'_i}{\alpha'_i + \beta'_i} \quad (1 \leq i \leq N).$$

Replacing $z_i \mapsto \frac{1}{\sqrt{\beta_i}}z_i$ and setting $a_i := \frac{\alpha_i}{\beta_i}$, whence $1 \leq a_i$, leads to a convenient representation:

$$(E_{a_1, \dots, a_N}) \quad \sum_{1 \leq i \leq N} (a_i x_i^2 + y_i^2) = 1.$$

Yet an alternative view, due to Webster in [118], is:

$$(E_{A_1, \dots, A_N}) \quad \sum_{1 \leq i \leq N} (z_i \bar{z}_i + A_i (z_i^2 + \bar{z}_i^2)) = 1,$$

obtained by setting $A_i := \frac{a_i - 1}{2a_i + 2}$, whence $0 \leq A_i < \frac{1}{2}$, so that $a_i = \frac{1 + 2A_i}{1 - 2A_i}$, then by changing coordinates $z_i := \sqrt{1 - 2A_i}z'_i$, and then by dropping primes.

In \mathbb{C}^N when $N \geq 3$, what corresponds to the invariant I_{Cartan}^M is the Hachtroudi-Chern tensor $S_{\rho\sigma}^{\alpha\beta}$ with indices $1 \leq \alpha, \beta, \rho, \sigma \leq N$, and the concerned *CR-umbilical* locus:

$$\text{UmbCR}(M) := \{p \in M: S_{\alpha\rho}^{\beta\sigma}(p) = 0, \forall \alpha, \rho, \beta, \sigma\},$$

is known, through local biholomorphisms $h: \mathbb{C}^N \rightarrow \mathbb{C}^N$ as above, to enjoy

$$h(\text{UmbCR}(M)) = \text{UmbCR}(h(M)).$$

THEOREM 1.2. ([118]) *In $\mathbb{C}^{N \geq 3}$, if $0 < A_1 < \dots < A_N < \frac{1}{2}$, then:*

$$\emptyset = \text{UmbCR}(E_{A_1, \dots, A_N}). \quad \square$$

This motivated Huang-Ji in [60] to study the question for compact \mathcal{C}^ω hypersurfaces $M \subset \mathbb{C}^2$. If $M = \{\rho = 0\}$, the expected dimension of:

$$\text{UmbCR}(M) = \{0 = \rho = \text{Re } I_{\text{Cartan}} = \text{Im } I_{\text{Cartan}}\}$$

should be $4 - 3 = 1$, although this is not rigorous, for \mathbb{R} is not algebraically closed!

THEOREM 1.3. (Implicitly proved in [60]) *Every real ellipsoid $E_{a,b} \subset \mathbb{C}^2$ of equation:*

$$a x^2 + y^2 + b u^2 + v^2 = 1 \quad (a \geq 1, b \geq 1, (a,b) \neq (1,1))$$

enjoys:

$$\dim_{\mathbb{R}} \text{UmbCR}(M) \geq 1. \quad \square$$

In other words, it contains at least some (real algebraic!) curve.

What curve? Simple? Complicated?

Can what follows be considered as a satisfactory answer?

THEOREM 1.4. *For every real numbers $a \geq 1, b \geq 1$ with $(a,b) \neq (1,1)$, the curve parametrized by $\theta \in \mathbb{R}$ valued in $\mathbb{C}^2 \cong \mathbb{R}^4$:*

$$\gamma: \theta \mapsto (x(\theta) + \sqrt{-1}y(\theta), u(\theta) + \sqrt{-1}v(\theta))$$

with components:

$$\begin{aligned} x(\theta) &:= \sqrt{\frac{a-1}{a(ab-1)}} \cos \theta, & y(\theta) &:= \sqrt{\frac{b(a-1)}{ab-1}} \sin \theta, \\ u(\theta) &:= \sqrt{\frac{b-1}{b(ab-1)}} \sin \theta, & v(\theta) &:= -\sqrt{\frac{a(b-1)}{ab-1}} \cos \theta, \end{aligned}$$

has image contained in the CR-umbilical locus:

$$\gamma(\mathbb{R}) \subset \text{UmbCR}(E_{a,b}) \subset E_{a,b}$$

of the ellipsoid $E_{a,b} \subset \mathbb{C}^2$ of equation $a x^2 + y^2 + b u^2 + v^2 = 1$.

In other words:

$$I_{\text{Cartan}}^{E_{a,b}}(\gamma(\theta)) = 0 \quad (\forall \theta \in \mathbb{R}).$$

As is known for ellipsoids, Cartan's invariant $I_{\text{Cartan}}^{E_{a,b}}$ exhibits a high complexity, e.g. $\sim 40\,000$ terms in [88]. So this theorem might be interpreted as a somewhat unexpectedly nice and simple description of $\text{UmbCR}(E_{a,b})$!

All computations of this paper were done by hand.

2. Explicit Expression of Cartan's CR-Invariant \mathfrak{J}

In \mathbb{C}^2 equipped with coordinates $(z, w) = (x + \sqrt{-1}y, u + \sqrt{-1}v)$, consider a connected real-analytic (\mathcal{C}^ω) 3-dimensional hypersurface:

$$M^3 := \{(z, w) \in \mathbb{C}^2: \rho(z, w, \bar{z}, \bar{w}) = 0\},$$

with $\bar{\rho} = \rho$, and with $d\rho|_M$ never zero. Local or global M , compact or open, bounded or unbounded, can be equally treated.

The two vector fields:

$$L := -\rho_w \frac{\partial}{\partial z} + \rho_z \frac{\partial}{\partial w} \quad \text{and} \quad \bar{L} := -\rho_{\bar{w}} \frac{\partial}{\partial \bar{z}} + \rho_{\bar{z}} \frac{\partial}{\partial \bar{w}}$$

generate $T^{1,0}M$ and $T^{0,1}M$.

If $h: \mathbb{C}^2 \rightarrow \mathbb{C}^2$ is a local biholomorphism:

$$(z, w) \mapsto (f(z, w), g(z, w)) =: (z', w'),$$

if $M = \{\rho = 0\}$ and $M' = \{\rho' = 0\}$ are two \mathcal{C}^ω hypersurfaces, if $h(M) \subset M'$, there is a nowhere vanishing function $\mu: M \rightarrow \mathbb{C} \setminus \{0\}$ such that:

$$\mu(z, w, \bar{z}, \bar{w}) \rho(z, w, \bar{z}, \bar{w}) \equiv \rho'(f(z, w), g(z, w), \bar{f}(\bar{z}, \bar{w}), \bar{g}(\bar{z}, \bar{w})),$$

whence in $\mathbb{C}\{z, w, \bar{z}, \bar{w}\}$ (exercise):

$$\mu \left(-\rho_w \frac{\partial}{\partial z} + \rho_z \frac{\partial}{\partial w} \right) = (f_z g_w - f_w g_z) \left(-\rho'_{w'} \frac{\partial}{\partial z'} + \rho'_{z'} \frac{\partial}{\partial w'} \right).$$

Furthermore, the *Levi determinant*:

$$\begin{aligned} \text{Levi}(\rho) &:= - \begin{vmatrix} 0 & \rho_z & \rho_w \\ \rho_{\bar{z}} & \rho_{z\bar{z}} & \rho_{w\bar{z}} \\ \rho_{\bar{w}} & \rho_{z\bar{w}} & \rho_{w\bar{w}} \end{vmatrix} \\ &= \rho_{\bar{z}} \rho_z \rho_{w\bar{w}} - \rho_{\bar{z}} \rho_w \rho_{z\bar{w}} - \rho_{\bar{w}} \rho_z \rho_{\bar{z}w} + \rho_{\bar{w}} \rho_w \rho_{z\bar{z}}, \end{aligned}$$

enjoys (exercise):

$$\mu^3 \text{L}(\rho) = (f_z g_w - f_w g_z) (\bar{f}_{\bar{z}} \bar{g}_{\bar{w}} - \bar{f}_{\bar{w}} \bar{g}_{\bar{z}}) \text{L}(\rho') \quad (\text{on } M).$$

DÉFINITION 2.1. A smooth hypersurface $M^3 \subset \mathbb{C}^2$ is called *Levi nondegenerate* at a point $p \in M$ if:

$$0 \neq \text{L}(p).$$

From now on, all M will be assumed smooth and Levi nondegenerate at every point, without further mention.

When $0 \neq \rho_w(p) = \rho_{\bar{w}}(p)$ at a point $p = (z_p, w_p) \in M$, the implicit function theorem represents M as a complex graph:

$$w = \Theta(z, \bar{z}, \bar{w}) \quad \text{or equivalently:} \quad \bar{w} = \bar{\Theta}(\bar{z}, z, w),$$

in terms of a \mathcal{C}^ω defining function Θ . A similar graphed representation exists at points $q = (z_q, w_q) \in M$ at which $0 \neq \rho_z(q) = \rho_{\bar{z}}(q)$.

Differentiating the identity:

$$0 \equiv \rho(z, \Theta(z, \bar{z}, \bar{w}), \bar{z}, \bar{w}) \quad (\text{in } \mathbb{C}\{z, \bar{z}, \bar{w}\}),$$

once with respect to z, \bar{z}, \bar{w} yields:

$$\begin{aligned} 0 &\equiv \rho_z + \Theta_z \rho_w, \\ 0 &\equiv \rho_{\bar{z}} + \Theta_{\bar{z}} \rho_w, \\ 0 &\equiv \rho_{\bar{w}} + \Theta_{\bar{w}} \rho_w, \end{aligned}$$

and next twice with respect to $zz, z\bar{z}, z\bar{w}, \bar{z}\bar{z}, \bar{z}\bar{w}, \bar{w}\bar{w}$ gives:

$$(2.2) \quad \begin{aligned} 0 &\equiv \rho_{zz} + 2\Theta_z \rho_{zw} + \Theta_z \Theta_z \rho_{ww} + \Theta_{zz} \rho_w, \\ 0 &\equiv \rho_{z\bar{z}} + \Theta_z \rho_{z\bar{w}} + \Theta_{\bar{z}} \rho_{zw} + \Theta_z \Theta_{\bar{z}} \rho_{ww} + \Theta_{z\bar{z}} \rho_w, \\ 0 &\equiv \rho_{z\bar{w}} + \Theta_z \rho_{w\bar{w}} + \Theta_{\bar{w}} \rho_{zw} + \Theta_z \Theta_{\bar{w}} \rho_{ww} + \Theta_{z\bar{w}} \rho_w, \\ 0 &\equiv \rho_{\bar{z}\bar{z}} + 2\Theta_{\bar{z}} \rho_{\bar{z}w} + \Theta_{\bar{z}} \Theta_{\bar{z}} \rho_{ww} + \Theta_{\bar{z}\bar{z}} \rho_w, \\ 0 &\equiv \rho_{\bar{z}\bar{w}} + \Theta_{\bar{z}} \rho_{w\bar{w}} + \Theta_{\bar{w}} \rho_{\bar{z}w} + \Theta_{\bar{z}} \Theta_{\bar{w}} \rho_{ww} + \Theta_{\bar{z}\bar{w}} \rho_w, \\ 0 &\equiv \rho_{\bar{w}\bar{w}} + 2\Theta_{\bar{w}} \rho_{w\bar{w}} + \Theta_{\bar{w}} \Theta_{\bar{w}} \rho_{ww} + \Theta_{\bar{w}\bar{w}} \rho_w. \end{aligned}$$

It holds that:

$$\{\rho_w \neq 0\} = \{\Theta_{\bar{w}} \neq 0\} \quad (\text{in } M).$$

DÉFINITION 2.3. Call M *spherical* if it is locally biholomorphic to:

$$S^3 := \{(z, w) \in \mathbb{C}^2 : z\bar{z} + w\bar{w} = 1\}.$$

When M is connected, the principle of analytic continuation guarantees propagation of this property. Next, set:

$$\Delta := -\Theta_{\bar{w}} \Theta_{z\bar{z}} + \Theta_{\bar{z}} \Theta_{z\bar{w}}.$$

LEMMA 2.4. At a point $p \in \{\Theta_{\bar{w}} \neq 0\}$:

$$M \text{ is Levi nondegenerate at } p \iff \Delta(p) \neq 0. \quad \square$$

Levi nondegeneracy being a biholomorphically invariant feature, spherical M are so since S^3 is.

Without restricting assumptions like *e.g.* *rigidity* or *tubity* ([63]), an explicit, complete characterization of sphericity in terms of some defining function for a hypersurface $M^3 \subset \mathbb{C}^2$ appeared in October 2009 as arxiv.org/abs/0910.1694/, *cf.* also [108, 60]. To recall it, set:

$$\square := \frac{\Delta}{-\Theta_{\bar{w}}},$$

and use instead:

$$\begin{aligned} \overline{\mathcal{L}} &:= -\frac{1}{\rho_{\bar{w}}} \overline{L} \\ &= \frac{\partial}{\partial \bar{z}} - \frac{\Theta_{\bar{z}}}{\Theta_{\bar{w}}} \frac{\partial}{\partial \bar{w}}. \end{aligned}$$

THEOREM 2.5. ([86]) At a point $p \in \{\Theta_{\bar{w}} \neq 0\}$, the hypersurface M is spherical if and only if, near p :

$$0 \equiv \frac{1}{\square} \overline{\mathcal{L}} \left(\frac{1}{\square} \overline{\mathcal{L}} \left(\frac{1}{\square} \overline{\mathcal{L}} \left(\frac{1}{\square} \overline{\mathcal{L}} (\Theta_{zz}) \right) \right) \right). \quad \square$$

Exchanging $z \longleftrightarrow w$ yields a similar formula at points $q \in \{\rho_z \neq 0\}$.

COROLLARY 2.6. In $\{\rho_w \neq 0\} = \{\Theta_{\bar{w}} \neq 0\}$, a partly expanded characterization of sphericity is:

$$\begin{aligned}
0 \equiv & \frac{\overline{\mathcal{L}}^4(\Theta_{zz})}{\square^4} - \\
& - 6 \frac{\overline{\mathcal{L}}(\square) \overline{\mathcal{L}}^3(\Theta_{zz})}{\square^5} - 4 \frac{\overline{\mathcal{L}}^2(\square) \overline{\mathcal{L}}^2(\Theta_{zz})}{\square^5} - \frac{\overline{\mathcal{L}}^3(\square) \overline{\mathcal{L}}(\Theta_{zz})}{\square^5} + \\
& + 15 \frac{[\overline{\mathcal{L}}(\square)]^2 \overline{\mathcal{L}}^2(\Theta_{zz})}{\square^6} + 10 \frac{\overline{\mathcal{L}}(\square) \overline{\mathcal{L}}^2(\square) \overline{\mathcal{L}}(\Theta_{zz})}{\square^6} - \\
& - 15 \frac{[\overline{\mathcal{L}}(\square)]^3 \overline{\mathcal{L}}(\Theta_{zz})}{\square^7}. \quad \square
\end{aligned}$$

Without presenting details, it is known that Cartan's treatment of the concerned biholomorphic equivalence problem brings a single invariant function:

$$I_{Cartan}^M: M \longrightarrow \mathbb{C},$$

other invariants being (covariant) derivations of it, and that:

$$M \text{ is spherical} \iff 0 \equiv I_{Cartan}^M.$$

NOTATION 2.7. For two functions $I_1: M \longrightarrow \mathbb{C}$ and $I_2: M \longrightarrow \mathbb{C}$, write:

$$I_2 \doteq I_1,$$

when there is a nowhere vanishing function $\mu: M \longrightarrow \mathbb{C} \setminus \{0\}$ such that:

$$I_2 = \mu I_1.$$

For instance:

$$I_{Cartan}^M \doteq \left(\frac{1}{\square} \overline{\mathcal{L}}\right)^4 (\Theta_{zz}).$$

Now, translate the formula of Corollary 2.6 to the case where M is given in implicit representation:

$$0 = \rho(z, w, \bar{z}, \bar{w}).$$

Set:

$$\text{Hessian}(\rho) := \rho_z \rho_z \rho_{w\bar{w}} - 2 \rho_z \rho_w \rho_{z\bar{w}} + \rho_w \rho_w \rho_{z\bar{z}},$$

with (exercise) on $\{\rho_w \neq 0\}$:

$$\Theta_{zz} = - \frac{\text{Hessian}(\rho)}{\rho_w \rho_w \rho_w}.$$

Remind the *Levi determinant*:

$$\text{Levi}(\rho) := \rho_{\bar{z}} \rho_z \rho_{w\bar{w}} - \rho_{\bar{z}} \rho_w \rho_{z\bar{w}} - \rho_{\bar{w}} \rho_z \rho_{z\bar{w}} + \rho_{\bar{w}} \rho_w \rho_{z\bar{z}},$$

that satisfies on $\{\rho_w \neq 0\}$:

$$\text{Levi}(\rho) \doteq \Delta,$$

i.e. more precisely (exercise) thanks to (2.2):

$$\text{Levi}(\rho) = - \rho_w \rho_w \rho_w \Delta.$$

COROLLARY 2.8. *On $\{\rho_w \neq 0\}$, up to a nowhere vanishing function:*

$$I_{Cartan}^M \doteq I_{[w]},$$

where:

$$\begin{aligned} I_{[w]} := & 12 (\rho_w)^9 \left\{ \left[\frac{\text{Levi}(\rho)}{\rho_w^2} \right]^3 \bar{L}^4 \left(\frac{\text{Hessian}(\rho)}{\rho_w^3} \right) - \right. \\ & - 6 \left[\frac{\text{Levi}(\rho)}{\rho_w^2} \right]^2 \bar{L} \left(\frac{\text{Levi}(\rho)}{\rho_w^2} \right) \bar{L}^3 \left(\frac{\text{Hessian}(\rho)}{\rho_w^3} \right) - 4 \left[\frac{\text{Levi}(\rho)}{\rho_w^2} \right]^2 \bar{L}^2 \left(\frac{\text{Levi}(\rho)}{\rho_w^2} \right) \bar{L}^2 \left(\frac{\text{Hessian}(\rho)}{\rho_w^3} \right) - \left[\frac{\text{Levi}(\rho)}{\rho_w^2} \right]^2 \bar{L}^3 \left(\frac{\text{Levi}(\rho)}{\rho_w^2} \right) \bar{L} \left(\frac{\text{Hessian}(\rho)}{\rho_w^3} \right) \\ & + 15 \frac{\text{Levi}(\rho)}{\rho_w^2} \left[\bar{L} \left(\frac{\text{Levi}(\rho)}{\rho_w^2} \right) \right]^2 \bar{L}^2 \left(\frac{\text{Hessian}(\rho)}{\rho_w^3} \right) + 10 \frac{\text{Levi}(\rho)}{\rho_w^2} \bar{L} \left(\frac{\text{Levi}(\rho)}{\rho_w^2} \right) \bar{L}^2 \left(\frac{\text{Levi}(\rho)}{\rho_w^2} \right) \bar{L} \left(\frac{\text{Hessian}(\rho)}{\rho_w^3} \right) - \\ & \left. - 15 \left[\bar{L} \left(\frac{\text{Levi}(\rho)}{\rho_w^2} \right) \right]^3 \bar{L} \left(\frac{\text{Hessian}(\rho)}{\rho_w^3} \right) \right\}. \end{aligned}$$

□

Furthermore, exchanging $z \longleftrightarrow w$, there is an *exact* formal coincidence (exercise!):

$$I_{[z]} = I_{[w]}.$$

In [99], an alternative formula for an equivalent invariant $M \doteq I_{[w]}$ is discussed, but it incorporates $5! = 120$ terms instead of 7 above, and is less cleaned up or finalized to really compute exciting things (by hand!).

3. Pullback to an Exceptional Curve on an Ellipsoid

To prove Theorem 1.4, it suffices to verify that:

$$0 \stackrel{?}{=} \gamma^*(I_{[w]})(\theta) \quad (\forall \theta \in \mathbb{R}).$$

Drop the factor $12 (\rho_w)^9 \doteq 1$, and call $T_1, T_2, T_3, T_4, T_5, T_6, T_7$ the seven concerned terms, so that the goal becomes:

$$0 \stackrel{?}{=} \gamma^*(T_1) + \gamma^*(T_2) + \gamma^*(T_3) + \gamma^*(T_4) + \gamma^*(T_5) + \gamma^*(T_6) + \gamma^*(T_7).$$

Hand computations provide formulas of the shape:

$$\begin{aligned} T_1 &= \frac{1}{8} \sqrt{-1} (a-1) \frac{N_1}{D}, \\ T_2 &= \frac{3}{4} \sqrt{-1} (a-1) \frac{N_2}{D}, \\ T_3 &= \frac{1}{2} \sqrt{-1} (a-1) \frac{N_3}{D}, \\ T_4 &= \frac{1}{8} \sqrt{-1} (a-1) \frac{N_4}{D}, \\ T_5 &= \frac{15}{8} \sqrt{-1} (a-1) \frac{N_5}{D}, \\ T_6 &= \frac{5}{4} \sqrt{-1} (a-1) \frac{N_6}{D}, \\ T_7 &= \frac{15}{8} \sqrt{-1} (a-1) \frac{N_7}{D}, \end{aligned}$$

with, in denominator place:

$$D := \left(\sqrt{a} \cos \theta - \sqrt{-1} \sqrt{b} \sin \theta \right)^8 (ab - 1) \left(\frac{b-1}{ab-1} \right)^{\frac{11}{2}},$$

with numerator 1:

$$\begin{aligned} N_1 := & \cos^7 \theta \left[499 a^{9/2} b^3 + 625 a^{9/2} b^2 - 233 a^{7/2} b^3 + 205 a^{9/2} b - 631 a^{7/2} b^2 + 15 a^{9/2} - 415 a^{7/2} b - 65 a^{7/2} \right] \\ & + \sqrt{-1} \cos^6 \theta \sin \theta \left[2887 a^4 b^{7/2} + 4401 a^4 b^{5/2} - 1297 a^3 b^{7/2} + 1905 a^4 b^{3/2} - 4059 a^3 b^{5/2} + 215 a^4 b^{1/2} - 3327 a^3 b^{3/2} - 725 a^3 b^{1/2} \right] \\ & + \cos^5 \theta \sin^2 \theta \left[-7023 a^{7/2} b^4 - 13021 a^{7/2} b^3 + 3013 a^{5/2} b^4 - 7105 a^{7/2} b^2 + 11011 a^{5/2} b^3 - 1075 a^{7/2} b + 11059 a^{5/2} b^2 + 3141 a^{5/2} b \right] \\ & + \sqrt{-1} \cos^4 \theta \sin^3 \theta \left[-9267 a^3 b^{9/2} - 20989 a^3 b^{7/2} + 3757 a^2 b^{9/2} - 14101 a^3 b^{5/2} + 16279 a^2 b^{7/2} - 2683 a^3 b^{3/2} + 19891 a^2 b^{5/2} + 7113 a^2 b^{3/2} \right] \\ & + \cos^3 \theta \sin^4 \theta \left[7113 a^{5/2} b^5 + 19891 a^{5/2} b^4 - 2683 a^{3/2} b^5 + 16279 a^{5/2} b^3 - 14101 a^{3/2} b^4 + 3757 a^{5/2} b^2 - 20989 a^{3/2} b^3 - 9267 a^{3/2} b^2 \right] \\ & + \sqrt{-1} \cos^2 \theta \sin^5 \theta \left[3141 a^2 b^{11/2} + 11059 a^2 b^{9/2} - 1075 a b^{11/2} + 11011 a^2 b^{7/2} - 7105 a b^{9/2} + 3013 a^2 b^{5/2} - 13021 a b^{7/2} - 7023 a b^{5/2} \right] \\ & + \cos^1 \theta \sin^6 \theta \left[-725 a^{3/2} b^6 - 3327 a^{3/2} b^5 + 215 a^{1/2} b^6 - 4059 a^{3/2} b^4 + 1905 a^{1/2} b^5 - 1297 a^{3/2} b^3 + 4401 a^{1/2} b^4 + 2287 a^{1/2} b^3 \right] \\ & + \sqrt{-1} \sin^7 \theta \left[-65 a b^{13/2} - 415 a b^{11/2} + 15 b^{13/2} - 631 a b^{9/2} + 205 b^{11/2} - 233 a b^{7/2} + 625 b^{9/2} + 499 b^{7/2} \right], \end{aligned}$$

with numerator 2:

$$\begin{aligned} N_2 := & \cos^7 \theta \left[-165 a^{9/2} b^3 - 193 a^{9/2} b^2 + 93 a^{7/2} b^3 - 67 a^{9/2} b + 205 a^{7/2} b^2 - 7 a^{9/2} + 115 a^{7/2} b + 19 a^{7/2} \right] \\ & + \sqrt{-1} \cos^6 \theta \sin \theta \left[-925 a^4 b^{7/2} - 1389 a^4 b^{5/2} + 505 a^3 b^{7/2} - 627 a^4 b^{3/2} + 1341 a^3 b^{5/2} - 83 a^4 b^{1/2} + 975 a^3 b^{3/2} + 203 a^3 b^{1/2} \right] \\ & + \cos^5 \theta \sin^2 \theta \left[2177 a^{7/2} b^4 + 4141 a^{7/2} b^3 - 1145 a^{5/2} b^4 + 2359 a^{7/2} b^2 - 3673 a^{5/2} b^3 + 395 a^{7/2} b - 3367 a^{5/2} b^2 - 887 a^{5/2} b \right] \\ & + \sqrt{-1} \cos^4 \theta \sin^3 \theta \left[2777 a^3 b^{9/2} + 6649 a^3 b^{7/2} - 1397 a^2 b^{9/2} + 4711 a^3 b^{5/2} - 5449 a^2 b^{7/2} + 983 a^3 b^{3/2} - 6211 a^2 b^{5/2} - 2063 a^2 b^{3/2} \right] \\ & + \cos^3 \theta \sin^4 \theta \left[-2063 a^{5/2} b^5 - 6211 a^{5/2} b^4 + 983 a^{3/2} b^5 - 5449 a^{5/2} b^3 + 4711 a^{3/2} b^4 - 1397 a^{5/2} b^2 + 6649 a^{3/2} b^3 + 2777 a^{3/2} b^2 \right] \\ & + \sqrt{-1} \cos^2 \theta \sin^5 \theta \left[-887 a^2 b^{11/2} - 3367 a^2 b^{9/2} + 395 a b^{11/2} - 3673 a^2 b^{7/2} + 2359 a b^{9/2} - 1145 a^2 b^{5/2} + 4141 a b^{7/2} + 2177 a b^{5/2} \right] \\ & + \cos^1 \theta \sin^6 \theta \left[203 a^{3/2} b^6 + 975 a^{3/2} b^5 - 83 a^{1/2} b^6 + 1341 a^{3/2} b^4 - 627 a^{1/2} b^5 + 505 a^{3/2} b^3 - 1389 a^{1/2} b^4 - 925 a^{1/2} b^3 \right] \\ & + \sqrt{-1} \sin^7 \theta \left[19 a b^{13/2} + 115 a b^{11/2} - 7 b^{13/2} + 205 a b^{9/2} - 67 b^{11/2} + 93 a b^{7/2} - 193 b^{9/2} - 165 b^{7/2} \right], \end{aligned}$$

with numerator 3:

$$\begin{aligned} N_3 := & \cos^7 \theta \left[-91 a^{9/2} b^3 - 109 a^{9/2} b^2 + 65 a^{7/2} b^3 - 37 a^{9/2} b + 115 a^{7/2} b^2 - 3 a^{9/2} + 55 a^{7/2} b + 5 a^{7/2} \right] \\ & + \sqrt{-1} \cos^6 \theta \sin \theta \left[-499 a^4 b^{7/2} - 777 a^4 b^{5/2} + 349 a^3 b^{7/2} - 357 a^4 b^{3/2} + 771 a^3 b^{5/2} - 47 a^4 b^{1/2} + 483 a^3 b^{3/2} + 77 a^3 b^{1/2} \right] \\ & + \cos^5 \theta \sin^2 \theta \left[1143 a^{7/2} b^4 + 2281 a^{7/2} b^3 - 781 a^{5/2} b^4 + 1369 a^{7/2} b^2 - 2143 a^{5/2} b^3 + 247 a^{7/2} b - 1723 a^{5/2} b^2 - 393 a^{5/2} b \right] \\ & + \sqrt{-1} \cos^4 \theta \sin^3 \theta \left[1407 a^3 b^{9/2} + 3589 a^3 b^{7/2} - 937 a^2 b^{9/2} + 2761 a^3 b^{5/2} - 3199 a^2 b^{7/2} + 643 a^3 b^{3/2} - 3271 a^2 b^{5/2} - 993 a^2 b^{3/2} \right] \\ & + \cos^3 \theta \sin^4 \theta \left[-993 a^{5/2} b^5 - 3271 a^{5/2} b^4 + 643 a^{3/2} b^5 - 3199 a^{5/2} b^3 + 2761 a^{3/2} b^4 - 937 a^{5/2} b^2 + 3589 a^{3/2} b^3 + 1407 a^{3/2} b^2 \right] \\ & + \sqrt{-1} \cos^2 \theta \sin^5 \theta \left[-393 a^2 b^{11/2} - 1723 a^2 b^{9/2} + 247 a b^{11/2} - 2143 a^2 b^{7/2} + 1369 a b^{9/2} - 781 a^2 b^{5/2} + 2281 a b^{7/2} + 1143 a b^{5/2} \right] \\ & + \cos^1 \theta \sin^6 \theta \left[77 a^{3/2} b^6 + 483 a^{3/2} b^5 - 47 a^{1/2} b^6 + 771 a^{3/2} b^4 - 357 a^{1/2} b^5 + 349 a^{3/2} b^3 - 777 a^{1/2} b^4 - 499 a^{1/2} b^3 \right] \\ & + \sqrt{-1} \sin^7 \theta \left[5 a b^{13/2} + 55 a b^{11/2} - 3 b^{13/2} + 115 a b^{9/2} - 37 b^{11/2} + 65 a b^{7/2} - 109 b^{9/2} - 91 b^{7/2} \right], \end{aligned}$$

with numerator 4:

$$\begin{aligned}
N_4 := & \cos^7 \theta \left[-75 a^{9/2} b^3 - 91 a^{9/2} b^2 + 75 a^{7/2} b^3 - 25 a^{9/2} b + 91 a^{7/2} b^2 - a^{9/2} + 25 a^{7/2} b + a^{7/2} \right] \\
& + \sqrt{-1} \cos^6 \theta \sin \theta \left[-391 a^4 b^{7/2} - 639 a^4 b^{5/2} + 391 a^3 b^{7/2} - 285 a^4 b^{3/2} + 639 a^3 b^{5/2} - 29 a^4 b^{1/2} + 285 a^3 b^{3/2} + 29 a^3 b^{1/2} \right] \\
& + \cos^5 \theta \sin^2 \theta \left[839 a^{7/2} b^4 + 1831 a^{7/2} b^3 - 839 a^{5/2} b^4 + 1165 a^{7/2} b^2 - 1831 a^{5/2} b^3 + 197 a^{7/2} b - 1165 a^{5/2} b^2 - 197 a^{5/2} b \right] \\
& + \sqrt{-1} \cos^4 \theta \sin^3 \theta \left[947 a^3 b^{9/2} + 2779 a^3 b^{7/2} - 947 a^2 b^{9/2} + 2401 a^3 b^{5/2} - 2779 a^2 b^{7/2} + 593 a^3 b^{3/2} - 2401 a^2 b^{5/2} - 593 a^2 b^{3/2} \right] \\
& + \cos^3 \theta \sin^4 \theta \left[-593 a^{5/2} b^5 - 2401 a^{5/2} b^4 + 593 a^{3/2} b^5 - 2779 a^{5/2} b^3 + 2401 a^{3/2} b^4 - 947 a^{5/2} b^2 + 2779 a^{3/2} b^3 + 947 a^{3/2} b^2 \right] \\
& + \sqrt{-1} \cos^2 \theta \sin^5 \theta \left[-197 a^2 b^{11/2} - 1165 a^2 b^{9/2} + 197 a b^{11/2} - 1831 a^2 b^{7/2} + 1165 a b^{9/2} - 839 a^2 b^{5/2} + 1831 a b^{7/2} + 839 a b^{5/2} \right] \\
& + \cos^1 \theta \sin^6 \theta \left[29 a^{3/2} b^6 + 285 a^{3/2} b^5 - 29 a^{1/2} b^6 + 639 a^{3/2} b^4 - 285 a^{1/2} b^5 + 391 a^{3/2} b^3 - 639 a^{1/2} b^4 - 391 a^{1/2} b^3 \right] \\
& + \sqrt{-1} \sin^7 \theta \left[a b^{13/2} + 25 a b^{11/2} - b^{13/2} + 91 a b^{9/2} - 25 b^{11/2} + 75 a b^{7/2} - 91 b^{9/2} - 75 b^{7/2} \right],
\end{aligned}$$

with numerator 5:

$$\begin{aligned}
N_5 := & \cos^7 \theta \left[63 a^{9/2} b^3 + 69 a^{9/2} b^2 - 45 a^{7/2} b^3 + 25 a^{9/2} b - 75 a^{7/2} b^2 + 3 a^{9/2} - 35 a^{7/2} b - 5 a^{7/2} \right] \\
& + \sqrt{-1} \cos^6 \theta \sin \theta \left[339 a^4 b^{7/2} + 509 a^4 b^{5/2} - 237 a^3 b^{7/2} + 237 a^4 b^{3/2} - 511 a^3 b^{5/2} + 35 a^4 b^{1/2} - 315 a^3 b^{3/2} - 57 a^3 b^{1/2} \right] \\
& + \cos^5 \theta \sin^2 \theta \left[-763 a^{7/2} b^4 - 1521 a^{7/2} b^3 + 521 a^{5/2} b^4 - 909 a^{7/2} b^2 + 1431 a^{5/2} b^3 - 167 a^{7/2} b + 1143 a^{5/2} b^2 + 265 a^{5/2} b \right] \\
& + \sqrt{-1} \cos^4 \theta \sin^3 \theta \left[-927 a^3 b^{9/2} - 2409 a^3 b^{7/2} + 617 a^2 b^{9/2} - 1841 a^3 b^{5/2} + 2139 a^2 b^{7/2} - 423 a^3 b^{3/2} + 2191 a^2 b^{5/2} + 653 a^2 b^{3/2} \right] \\
& + \cos^3 \theta \sin^4 \theta \left[653 a^{5/2} b^5 + 2191 a^{5/2} b^4 - 423 a^{3/2} b^5 + 2139 a^{5/2} b^3 - 1841 a^{3/2} b^4 + 617 a^{5/2} b^2 - 2409 a^{3/2} b^3 - 927 a^{3/2} b^2 \right] \\
& + \sqrt{-1} \cos^2 \theta \sin^5 \theta \left[265 a^2 b^{11/2} + 1143 a^2 b^{9/2} - 167 a b^{11/2} + 1431 a^2 b^{7/2} - 909 a b^{9/2} + 521 a^2 b^{5/2} - 1521 a b^{7/2} - 763 a b^{5/2} \right] \\
& + \cos^1 \theta \sin^6 \theta \left[-57 a^{3/2} b^6 - 315 a^{3/2} b^5 + 35 a^{1/2} b^6 - 511 a^{3/2} b^4 + 237 a^{1/2} b^5 - 237 a^{3/2} b^3 + 509 a^{1/2} b^4 + 339 a^{1/2} b^3 \right] \\
& + \sqrt{-1} \sin^7 \theta \left[-5 a b^{13/2} - 35 a b^{11/2} + 3 b^{13/2} - 75 a b^{9/2} + 25 b^{11/2} - 45 a b^{7/2} + 69 b^{9/2} + 63 b^{7/2} \right],
\end{aligned}$$

with numerator 6:

$$\begin{aligned}
N_6 := & \cos^7 \theta \left[39 a^{9/2} b^3 + 43 a^{9/2} b^2 - 39 a^{7/2} b^3 + 13 a^{9/2} b - 43 a^{7/2} b^2 + a^{9/2} - 13 a^{7/2} b - a^{7/2} \right] \\
& + \sqrt{-1} \cos^6 \theta \sin \theta \left[199 a^4 b^{7/2} + 315 a^4 b^{5/2} - 199 a^3 b^{7/2} + 141 a^4 b^{3/2} - 315 a^3 b^{5/2} + 17 a^4 b^{1/2} - 141 a^3 b^{3/2} - 17 a^3 b^{1/2} \right] \\
& + \cos^5 \theta \sin^2 \theta \left[-419 a^{7/2} b^4 - 919 a^{7/2} b^3 + 419 a^{5/2} b^4 - 577 a^{7/2} b^2 + 919 a^{5/2} b^3 - 101 a^{7/2} b + 577 a^{5/2} b^2 + 101 a^{5/2} b \right] \\
& + \sqrt{-1} \cos^4 \theta \sin^3 \theta \left[-467 a^3 b^{9/2} - 1399 a^3 b^{7/2} + 467 a^2 b^{9/2} - 1201 a^3 b^{5/2} + 1399 a^2 b^{7/2} - 293 a^3 b^{3/2} + 1201 a^2 b^{5/2} + 293 a^2 b^{3/2} \right] \\
& + \cos^3 \theta \sin^4 \theta \left[293 a^{5/2} b^5 + 1201 a^{5/2} b^4 - 293 a^{3/2} b^5 + 1399 a^{5/2} b^3 - 1201 a^{3/2} b^4 + 467 a^{5/2} b^2 - 1399 a^{3/2} b^3 - 467 a^{3/2} b^2 \right] \\
& + \sqrt{-1} \cos^2 \theta \sin^5 \theta \left[101 a^2 b^{11/2} + 577 a^2 b^{9/2} - 101 a b^{11/2} + 919 a^2 b^{7/2} - 577 a b^{9/2} + 419 a^2 b^{5/2} - 919 a b^{7/2} - 419 a b^{5/2} \right] \\
& + \cos^1 \theta \sin^6 \theta \left[-17 a^{3/2} b^6 - 141 a^{3/2} b^5 + 17 a^{1/2} b^6 - 315 a^{3/2} b^4 + 141 a^{1/2} b^5 - 199 a^{3/2} b^3 + 315 a^{1/2} b^4 + 199 a^{1/2} b^3 \right] \\
& + \sqrt{-1} \sin^7 \theta \left[-a b^{13/2} - 13 a b^{11/2} + b^{13/2} - 43 a b^{9/2} + 13 b^{11/2} - 39 a b^{7/2} + 43 b^{9/2} + 39 b^{7/2} \right],
\end{aligned}$$

with numerator 7:

$$\begin{aligned}
N_7 := & \cos^7 \theta \left[-27 a^{9/2} b^3 - 27 a^{9/2} b^2 + 27 a^{7/2} b^3 - 9 a^{9/2} b + 27 a^{7/2} b^2 - a^{9/2} + 9 a^{7/2} b + a^{7/2} \right] \\
& + \sqrt{-1} \cos^6 \theta \sin \theta \left[-135 a^4 b^{7/2} - 207 a^4 b^{5/2} + 135 a^3 b^{7/2} - 93 a^4 b^{3/2} + 207 a^3 b^{5/2} - 13 a^4 b^{1/2} + 93 a^3 b^{3/2} + 13 a^3 b^{1/2} \right] \\
& + \cos^5 \theta \sin^2 \theta \left[279 a^{7/2} b^4 + 615 a^{7/2} b^3 - 279 a^{5/2} b^4 + 381 a^{7/2} b^2 - 615 a^{5/2} b^3 + 69 a^{7/2} b - 381 a^{5/2} b^2 - 69 a^{5/2} b \right] \\
& + \sqrt{-1} \cos^4 \theta \sin^3 \theta \left[307 a^3 b^{9/2} + 939 a^3 b^{7/2} - 307 a^2 b^{9/2} + 801 a^3 b^{5/2} - 939 a^2 b^{7/2} + 193 a^3 b^{3/2} - 801 a^2 b^{5/2} - 193 a^2 b^{3/2} \right] \\
& + \cos^3 \theta \sin^4 \theta \left[-193 a^{5/2} b^5 - 801 a^{5/2} b^4 + 193 a^{3/2} b^5 - 939 a^{5/2} b^3 + 801 a^{3/2} b^4 - 307 a^{5/2} b^2 + 939 a^{3/2} b^3 + 307 a^{3/2} b^2 \right] \\
& + \sqrt{-1} \cos^2 \theta \sin^5 \theta \left[-69 a^2 b^{11/2} - 381 a^2 b^{9/2} + 69 a b^{11/2} - 615 a^2 b^{7/2} + 381 a b^{9/2} - 279 a^2 b^{5/2} + 615 a b^{7/2} + 279 a b^{5/2} \right] \\
& + \cos^1 \theta \sin^6 \theta \left[13 a^{3/2} b^6 + 93 a^{3/2} b^5 - 13 a^{1/2} b^6 + 207 a^{3/2} b^4 - 93 a^{1/2} b^5 + 135 a^{3/2} b^3 - 207 a^{1/2} b^4 - 135 a^{1/2} b^3 \right] \\
& + \sqrt{-1} \sin^7 \theta \left[a b^{13/2} + 9 a b^{11/2} - b^{13/2} + 27 a b^{9/2} - 9 b^{11/2} + 27 a b^{7/2} - 27 b^{9/2} - 27 b^{7/2} \right].
\end{aligned}$$

END OF PROOF OF THEOREM 1.4. The sum:

$$\frac{1}{8} N_1(\theta) + \frac{3}{4} N_2(\theta) + \frac{1}{2} N_3(\theta) + \frac{1}{8} N_4(\theta) + \frac{15}{8} N_5(\theta) + \frac{5}{4} N_6(\theta) + \frac{15}{8} N_7(\theta) = 0,$$

is indeed (visually!) identically null. \square

CHAPTER 6

Nonvanishing of Cartan CR curvature on boundaries of Grauert tubes around hyperbolic surfaces

We show that the boundaries of thin strongly pseudoconvex Grauert tubes, with respect to the Guillemin-Stenzel Kähler metric canonically associated with the Poincaré metric on closed hyperbolic real-analytic surfaces, has nowhere vanishing Cartan CR-curvature. This result provides a wealth of examples of compact 3-dimensional Levi nondegenerate CR manifolds having no CR-umbilical point.

We provide two proofs utilizing two recent formulas for determining the Cartan CR-curvature of any local \mathcal{C}^6 -smooth hypersurfaces in \mathbb{C}^2 . One was obtained in 2012 by the second named author joint with Sabzevari, and it is an *expanded* explicit formula, valid for locally graphed hypersurfaces, containing millions of terms. The other formula, which we published in 2018 when studying Webster’s ellipsoidal hypersurfaces, is not expanded, but more suitable for calculations with a hypersurface in \mathbb{C}^2 that is represented as the zero locus of some *implicit* — but ‘simple’ in some sense, *e.g.* quadratic — defining function.

We also discuss Grauert tubes constructed with respect to extrinsic metrics depending on embeddings in complex surfaces, together with a certain combinatorics of product metrics.

This Chapter is based on our jointwork with Wei-Guo Foo and Joël Merker, which has appeared in preprint form:

Wei-Guo Foo, Joël Merker, The-Anh Ta, *Nonvanishing of Cartan CR curvature on boundaries of Grauert tubes around hyperbolic surfaces*, arXiv:1904.10203

1. Introduction

The equivalence problem for local real-analytic hypersurfaces with respect to local bi-holomorphisms in \mathbb{C}^2 was first studied by Poincaré [112], and was later solved by Cartan [17] with the introduction of the so-called method of equivalence. The theory was later developed in \mathbb{C}^{n+1} by Chern and Moser [23], and resulted in the set up of invariant CR-curvatures, called Cartan curvatures in complex dimension 2, and Hachtroudi-Chern curvatures when $n \geq 3$.

For a long time, little was known about these curvatures due to their high computational complexity. Nonetheless, Webster [118], and later Huang and Ji [60] were able to investigate the case of real ellipsoidal hypersurfaces. In recent years, new variants and explicit formulas (*see* [37, 88, 90, 45]) made it possible to determine the vanishing locus of the Cartan curvatures for new classes of 3-dimensional CR manifolds. For instance, we were able to find a whole explicit curve of points of vanishing Cartan curvature on general ellipsoids in \mathbb{C}^2 in [45].

In their landmark paper [23, p. 247], Chern and Moser raised the following

PROBLEM 1.1. *Are there compact strictly pseudoconvex hypersurfaces $M^3 \subset \mathbb{C}^2$ without CR-umbilical points? Are there such manifolds diffeomorphic to the sphere $S^3 \subset \mathbb{C}^2$.*

It is well known that a standard 2-torus in \mathbb{R}^3 has no Riemannian-umbilic point. Similarly, it is not difficult to verify ([37]) that the boundaries of thin Grauert tubes around the

flat 2-dimensional torus $\mathbb{T}^2 = S^1 \times S^1 \subset \mathbb{C}^2$ have empty CR-umbilical locus. Thus, a topological restriction like $M^3 \cong S^3$ must be assumed.

In this paper, we are interested in the question of whether a similar phenomenon holds for higher genus surfaces. Let therefore S be a closed compact real-analytic (\mathcal{C}^ω) surface of genus ≥ 2 which is hyperbolic in the sense that its universal cover is the unit disc $\mathbb{D} \subset \mathbb{C}$. As a special case of a theorem of Bruhat and Whitney [7] in dimension 2, S admits an extrinsic complexification, namely there exists a complex manifold M^c of complex dimension 2, together with an analytic totally real embedding of S into M^c . Moreover, the work [59] of Guillemin and Stenzel provides a canonical Kähler potential ρ defined in a small neighborhood of S in M^c (see Section 2 below). In particular, for each ε with $0 < \varepsilon \leq \varepsilon_0 \ll 1$, the set $\Omega_\varepsilon := \rho^{-1}([0, \varepsilon])$, called the Grauert tube of radius ε around S , has strongly pseudoconvex \mathcal{C}^ω boundary $M_\varepsilon := \rho^{-1}(\varepsilon)$ contained in the complex surface M^c , to which Cartan's method of equivalence applies. Our main result is the following.

THEOREM 1.2. *There exists $0 < \varepsilon_0 \ll 1$ such that for every ε with $0 < \varepsilon \leq \varepsilon_0$, the real and imaginary parts of the primary complex Cartan curvature vanish nowhere on the boundary of M_ε .*

Equivalently:

COROLLARY 1.3. *The boundaries of these M_ε have no CR-umbilical point.* □

So far, our construction of the Grauert tubes Ω_ε take a complete intrinsic point of view, since the Guillemin-Stenzel potential is obtained only from a given intrinsic metric on the surface S . It is then natural to look at the Grauert tubes from an extrinsic point of view, that is we consider the surface S as being totally really embedded in a given (local) complex surface equipped with a given metric. Already in the case of a torus embedded in the standard \mathbb{C}^2 , the extrinsic construction will provide several new examples of compact hypersurfaces without CR-umbilical points (see Example 7.4). Further constructions in this vein are provided in Section 7.

This paper is organized as follows. In Section 2, we recall the construction of the canonical Kähler potential of Guillemin and Stenzel in [59], and we find an explicit formula for the potential in the case of hyperbolic surfaces. Section 3 discusses two standard examples of complexification of the round sphere and the flat torus. In Section 4, we work out the defining function for the Grauert tube around the Poincaré upper half-plane. The formula then will be used in Section 5 to calculate the Cartan curvatures on the boundaries of Grauert tubes of hyperbolic surfaces by explicit expressions given in [88] and [45], and to show that the Cartan curvatures do not vanish for small enough radii. Section 6 explains in details how nonvanishing of the Cartan curvature on the boundary of Grauert tubes around hyperbolic surfaces can be deduced from the calculations in Section 5. Finally, in Section 7, we discuss some extrinsic constructions of Grauert tubes based on product metrics.

2. The Canonical Kähler Potential on Grauert Tubes

For any compact real-analytic (\mathcal{C}^ω) manifold M of dimension $n \geq 1$, Bruhat and Whitney showed in [7] that there exists an n -dimensional complex manifold M^c , and a real-analytic embedding $M \hookrightarrow M^c$ which is totally real, *i.e.* such that the real tangent spaces to M contain no complex lines in the complex tangent spaces to M^c . The \mathcal{C}^ω changes of charts $\mathbb{R}^n \ni x \mapsto x' = \varphi(x) \in \mathbb{R}^n$ for M , where $x = (x_1, \dots, x_n)$, become

$\mathbb{C}^n \ni z \mapsto z' = \varphi(z) \in \mathbb{C}^n$, where $z = x + \sqrt{-1}y \in \mathbb{C}^n$, and where $\varphi(z)$ means substituting z for x in the punctual convergent power series of φ , giving the complex manifold structure of M^c . The Taylor coefficients of such \mathcal{C}^ω diffeomorphisms $\varphi = \bar{\varphi}$ are real, the complex conjugation $z \mapsto \bar{z}$ transfers coherently as $\bar{z}' = \varphi(\bar{z})$, which shows that $M = \text{Fix}(\sigma)$ is the set of fixed points of the antiholomorphic involution $\sigma: M^c \rightarrow M^c$ obtained from $z \mapsto \bar{z}$ in any chart.

Also by substituting z for x in power series, every \mathcal{C}^ω function $f: M \rightarrow \mathbb{R}$ extends uniquely as a holomorphic function $f^c: U^c \rightarrow \mathbb{C}$ with $f^c|_M = f$, in some open neighborhood U^c of M in $M^c: M \subset U^c \subset M^c$, and $f^c|_M \equiv 0$ if and only if $f^c \equiv 0$ in some subneighborhood $V^c: M \subset V^c \subset U^c$.

According to Grauert [58], there exists a \mathcal{C}^∞ strictly plurisubharmonic function $\rho: U^c \rightarrow [0, 1)$ defined in some open neighborhood U^c of M in M^c , with $\rho \circ \sigma = \rho$, $M = \rho^{-1}(0)$, $d\rho|_M \equiv 0$, and such that ρ has no critical point in $V^c \setminus M$, for some subneighborhood $V^c: M \subset V^c \subset U^c$. Hence for all small enough $\varepsilon: 0 < \varepsilon \leq \varepsilon_0 \ll 1$, the domain $\Omega_\varepsilon = \{\rho < \varepsilon\}$, a tubular neighborhood of M in M^c , has \mathcal{C}^∞ strictly pseudoconvex boundary $M_\varepsilon = \{\rho = \varepsilon\}$, and is called the *Grauert tube* of radius ε around M .

When the manifold M is equipped with some \mathcal{C}^ω Riemannian metric g , Guillemin and Stenzel gave in [59] a very elegant construction of such a strictly plurisubharmonic function

$$\rho = \rho_g: M^c \rightarrow [0, 1)$$

uniquely associated to g that will be called the *canonical Kähler potential* on M^c . Their construction can be summarized as follows.

Embed $M \hookrightarrow M \times M$ by $x \mapsto (x, x)$ and let W be an open neighborhood of M in $M \times M$. If W is thin enough, for any pair $(x, u) \in W$, the local uniqueness and distance minimizing properties of geodesics with respect to g guarantees that $\text{dist}_g(x, u)$ is the g -length of the geodesic from x to u , and an inspection of the g -length formula convinces that the (symmetric) *squared* distance function:

$$f(x, u) := (\text{dist}_g(x, u))^2 \quad (x, u \in W)$$

is \mathcal{C}^ω , hence can be complexified.

Since in local coordinates, we will denote $x = (x_1, \dots, x_n)$ and $u = (u_1, \dots, u_n)$ in \mathbb{R}^n and introduce $z := x + \sqrt{-1}y$ with $w := u + \sqrt{-1}v$ in \mathbb{C}^n , let us denote a pair of points in the global abstract product similarly as $(z, w) \in M^c \times M^c$, and let us abbreviate $\sigma: M^c \rightarrow M^c$ as $z \mapsto \bar{z}$. Also, let us use the embedding:

$$M^c \ni z \mapsto (z, \bar{z}) \in M^c \times M^c,$$

compatible with $x \mapsto (x, x)$ which makes M^c totally real in $M^c \times M^c$, and let W^c be a thin open neighborhood of M^c in $M^c \times M^c$ invariant under the conjugation $(z, w) \mapsto (\bar{w}, \bar{z})$ and satisfying $W = W^c \cap (M \times M)$.

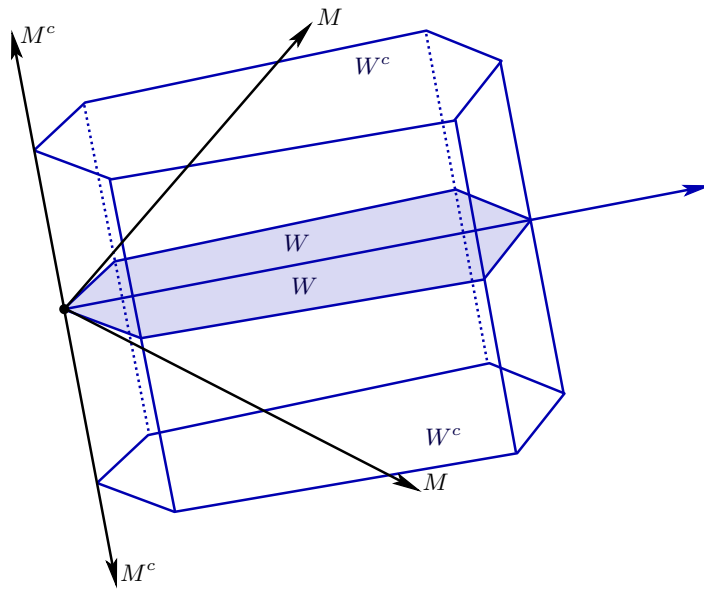

Then $f(x, u)$ complexifies as $f^c(z, w)$ defined and holomorphic for $(z, w) \in W^c$, with $f^c|_M \equiv f$ and enjoys the symmetry $f^c(w, z) = f^c(z, w)$. Furthermore, the reality condition $\overline{f(x, u)} = f(x, u)$ of f yields via complexification:

$$\overline{f^c(z, w)} \equiv f^c(\bar{z}, \bar{w}),$$

hence putting $w := \bar{z}$, and using the symmetry, we see the reality:

$$\overline{f^c(z, \bar{z})} \equiv f^c(\bar{z}, z) \equiv f^c(z, \bar{z}).$$

PROPOSITION 2.1. ([59], p. 565) *The real-valued function $f^c(z, \bar{z})$ is equal to 0 on $M \hookrightarrow M^c \times M^c$ and takes values < 0 outside M .*

So in $W^c \setminus \{f^c = 0\}$, the square root $\sqrt{f^c}$ is 2 : 1-valued, and the canonical Kähler potential $\rho = \rho_g$ is defined to be:

$$(2.2) \quad \rho := -f^c,$$

so that $\sqrt{\rho}$ is well defined in \mathbb{R}_+ .

Finally, a consequence of Gauss' orthogonality lemma ([59], p. 564) which provides the annihilation:

$$0 \equiv \det \left(\frac{\partial^2 \sqrt{f}}{\partial x_i \partial y_j} (x, y) \right) \quad (\forall (x, y) \in W \setminus M),$$

yields via complexification the Monge-Ampère equation:

$$0 \equiv \det \left(\frac{\partial^2 \sqrt{\rho}}{\partial z_i \partial w_j} (z, w) \right) \quad (\forall (z, w) \in W^c \setminus M^c).$$

In [59], Guillemin and Stenzel established the *uniqueness* of the Kähler metric $\omega := \sqrt{-1} \partial \bar{\partial} \rho_g$ on M^c satisfying this and restricting to $g = \omega|_M$ on M .

Of particular interest to us is the computational fact that $\rho = \rho_g$ has explicit, workable expressions once g is given, especially in the case of surfaces.

3. Two Examples: Round Sphere and Flat Torus

EXAMPLE 3.1. [59, Section 4] Consider $M := \mathbb{S}^2$ to be the 2-dimensional sphere:

$$\mathbb{S}^2 := \{(x_1, x_2, x_3) \in \mathbb{R}^3 : x_1^2 + x_2^2 + x_3^2 = 1\},$$

equipped with the standard round metric, whence the squared geodesic distance between two points $x, y \in \mathbb{S}^2$ is:

$$f(x, y) = \left(2 \arcsin \left(\frac{1}{2} \sqrt{(x_1 - y_1)^2 + (x_2 - y_2)^2 + (x_3 - y_3)^2}\right)\right)^2.$$

The Bruhat-Whitney complexification of \mathbb{S}^2 can be represented extrinsically as:

$$(\mathbb{S}^2)^c := \{(z_1, z_2, z_3) \in \mathbb{C}^3 : z_1^2 + z_2^2 + z_3^2 = 1\},$$

and on it, we have the useful relation:

$$(\operatorname{Im} z_1)^2 + (\operatorname{Im} z_2)^2 + (\operatorname{Im} z_3)^2 = (z_1 \bar{z}_1 + z_2 \bar{z}_2 + z_3 \bar{z}_3 - 1)/2.$$

The complexification of f is:

$$f^c(z, w) = \left(2 \arcsin \left(\frac{1}{2} \sqrt{(z_1 - w_1)^2 + (z_2 - w_2)^2 + (z_3 - w_3)^2}\right)\right)^2,$$

hence letting $w := \bar{z}$ and using the two identities:

$$\arcsin(\sqrt{-1}t) = \sqrt{-1} \operatorname{arcsinh}(t), \quad 2 \operatorname{arcsinh} t = \operatorname{arccosh}(1 + 2t^2),$$

we get:

$$\begin{aligned} f^c(z, \bar{z}) &= \left(2 \arcsin \left(\pm \sqrt{-1} \sqrt{(\operatorname{Im} z_1)^2 + (\operatorname{Im} z_2)^2 + (\operatorname{Im} z_3)^2}\right)\right)^2 \\ &= \left(\pm 2 \sqrt{-1} \operatorname{arcsinh} \left(\sqrt{(z_1 \bar{z}_1 + z_2 \bar{z}_2 + z_3 \bar{z}_3 - 1)/2}\right)\right)^2 \\ &= - \left(\operatorname{arccosh}(z_1 \bar{z}_1 + z_2 \bar{z}_2 + z_3 \bar{z}_3)\right)^2, \end{aligned}$$

whence, coming back to the definition (2.2) of $\rho := -f^c$, we obtain:

$$(3.2) \quad \rho(z, \bar{z}) = \left(\operatorname{arccosh}(z_1 \bar{z}_1 + z_2 \bar{z}_2 + z_3 \bar{z}_3)\right)^2.$$

EXAMPLE 3.3. [37, Section 3] Consider $M := \mathbb{T}^2 = \mathbb{R}^2/(2\pi\mathbb{Z}^2)$ to be the flat torus. Its complexification is $M^c := \mathbb{C}^2/(2\pi\mathbb{Z}^2)$. The geodesic distance between two close points on \mathbb{T}^2 is computed along straight lines within the flat universal cover $(\mathbb{R}^2, d_{\text{Eucl}})$. So, in a fundamental domain for \mathbb{T}^2 on \mathbb{R}^2 , the squared distance and its complexification are

$$\begin{aligned} f((x_1, x_2), (y_1, y_2)) &= (x_1 - y_1)^2 + (x_2 - y_2)^2, \\ f^c((z_1, z_2), (w_1, w_2)) &= (z_1 - w_1)^2 + (z_2 - w_2)^2, \end{aligned}$$

hence letting $(w_1, w_2) = (\bar{z}_1, \bar{z}_2)^c$, we get by the definition (2.2) of $\rho := -f^c$:

$$(3.4) \quad \rho(z, \bar{z}) = 4(\operatorname{Im} z_1)^2 + 4(\operatorname{Im} z_2)^2.$$

4. Semi-global Grauert Tube Around Poincaré’s Upper Half-Plane

For our purpose, we need to find the Kähler potential ρ locally on the Bruhat-Whitney complexification of any compact \mathcal{C}^ω surface S of genus ≥ 2 . When S is viewed as a Riemann surface, the uniformization theorem ([52, Chap. 27]) states that its universal cover is the upper half-plane $\mathbb{H} = \{z \in \mathbb{C} : \text{Im}(z) > 0\}$, and that:

$$S \cong \mathbb{H}/\pi_1(S).$$

We will then transfer geometric objects from \mathbb{H} to S .

But in this section, our calculations will be done entirely in $\mathbb{H} = \{(x_1, x_2) \in \mathbb{R} : x_2 > 0\}$, viewed as a *real* \mathcal{C}^ω surface equipped with the Poincaré metric $ds^2 = \frac{dx_1^2 + dx_2^2}{x_2^2}$. Since the squared Poincaré distance between two points (x_1, x_2) and (y_1, y_2) of \mathbb{H} , with $x_2, y_2 > 0$, is:

$$f((x_1, x_2), (y_1, y_2)) = \left(\text{arccosh} \left(1 + \frac{(x_1 - y_1)^2 + (x_2 - y_2)^2}{2x_2y_2} \right) \right)^2,$$

it comes by complexification

$$(4.1) \quad f^c((z_1, z_2), (\bar{z}_1, \bar{z}_2)) = \left(\text{arccosh} \left(1 - 2 \frac{(\text{Im } z_1)^2 + (\text{Im } z_2)^2}{(\text{Re } z_2)^2 + (\text{Im } z_2)^2} \right) \right)^2,$$

with $z_1 = \text{Re } z_1 + \sqrt{-1} \text{Im } z_1$ and $z_2 = \text{Re } z_2 + \sqrt{-1} \text{Im } z_2$, provided that certain inequalities are satisfied by $\text{Im } z_1$ and $\text{Im } z_2$ for this formula to be meaningful. Here, the complexification of \mathbb{H} reads as:

$$\mathbb{H}^c := \{(z_1, z_2) \in \mathbb{C}^2 : \text{Re } z_2 > 0\}.$$

LEMMA 4.2. *The domain of definition of f^c in \mathbb{H}^c contains:*

$$\{(\text{Im } z_1)^2 < (\text{Re } z_2)^2\}.$$

PROOF. Indeed, the argument $1 - 2Q$ of arccosh in (4.1) is real and ≤ 1 . But with $s = \sigma + \sqrt{-1}t$, for $\cosh s$ to be real ≤ 1 , since its imaginary part:

$$2 \text{Im} (\cosh s) = 2 \text{Im} (e^{\sigma+it} + e^{-\sigma-it}) = (e^\sigma - e^{-\sigma}) \sin t,$$

vanishes if and only if $t \equiv 0 \pmod{\pi}$, and since $\cosh \sigma > 1$ whenever $\sigma \in \mathbb{R} \setminus \{0\}$, necessarily $s = \sqrt{-1}t \in \sqrt{-1}\mathbb{R}$, hence:

$$\text{arccosh}(1 - 2Q) =: \sqrt{-1}T \in \sqrt{-1}\mathbb{R}$$

for some $T \in \mathbb{R}$, whence:

$$1 - 2Q = \cosh(\sqrt{-1}T) = \cos T \tag{4.2} \quad (T \in \mathbb{R}).$$

Then $-1 \leq \cos T \leq 1$ forces:

$$-1 \leq 1 - 2 \frac{(\text{Im } z_1)^2 + (\text{Im } z_2)^2}{(\text{Re } z_2)^2 + (\text{Im } z_2)^2} \leq 1,$$

the first inequality being equivalent to $(\text{Im } z_1)^2 \leq (\text{Re } z_2)^2$, while the second holds trivially. \square

For later convenience, let us rewrite the local complex coordinates as $z_1 = u + \sqrt{-1}v$ and $z_2 = x + \sqrt{-1}y$. Furthermore, let us restrict our considerations to the subdomain of the above domain $\{v^2 \leq x^2\}$ defined by:

$$0 \leq 1 - 2 \frac{y^2 + v^2}{x^2 + y^2} \leq 1 \iff 2y^2 + v^2 \leq x^2,$$

which guarantees that $\text{arccosh} \left(1 - 2 \frac{y^2 + v^2}{x^2 + y^2} \right)$ is single valued in $[0, \frac{\pi}{2}]$.

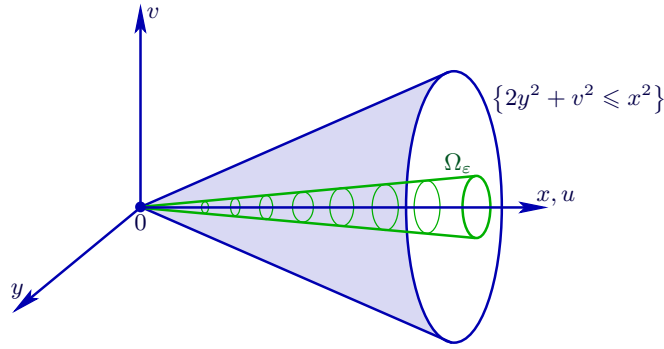

Drawing $\mathbb{H} = \{x > 0\}$ as a single right half-axis in order to keep two directions for the y - and v -axes, this domain $\{2y^2 + v^2 < x^2\}$ looks like a "security cone" which will contain all subsequent Grauert tubes Ω_ε .

Then by the relation:

$$\operatorname{arccosh}(t) = \sqrt{-1} \operatorname{arccos} t \quad (0 \leq t \leq 1),$$

we get from (4.1) in this subdomain $\{2y^2 + v^2 \leq x^2\}$ of \mathbb{H}^c :

$$f^c = - \left(\operatorname{arccos} \left(1 - 2 \frac{y^2 + v^2}{x^2 + y^2} \right) \right)^2,$$

hence coming back to (2.2):

$$(4.3) \quad \rho = \left(\operatorname{arccos} \left(1 - 2 \frac{y^2 + v^2}{x^2 + y^2} \right) \right)^2.$$

LEMMA 4.4. For every $0 < \varepsilon < (\frac{\pi}{2})^2$, the Grauert tube around \mathbb{H} in \mathbb{H}^c for the canonical Kähler potential associated with the Poincaré metric on \mathbb{H} :

$$\Omega_\varepsilon := \left\{ (u + \sqrt{-1}v, x + \sqrt{-1}y) \in \mathbb{H}^c : \sqrt{\rho}(u, v, x, y) < \sqrt{\varepsilon} \right\},$$

has \mathcal{C}^ω strongly pseudoconvex boundary $\partial\Omega_\varepsilon = \{\rho = \varepsilon\}$ of equation:

$$2v^2 - (1 - \cos \sqrt{\varepsilon}) x^2 + (1 + \cos \sqrt{\varepsilon}) y^2 = 0.$$

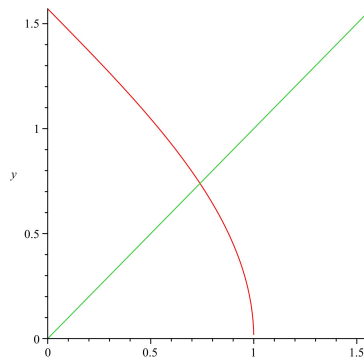
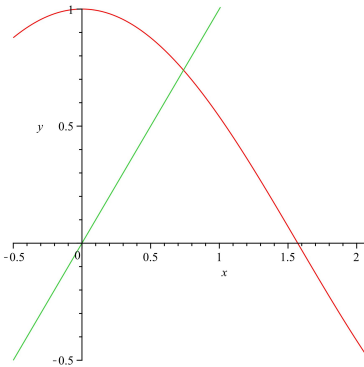

PROOF. Since the function arccos is a decreasing \mathcal{C}^ω diffeomorphism $[0, 1) \rightarrow (0, \frac{\pi}{2}]$, we have:

$$\begin{aligned} \operatorname{arccos} \left(1 - 2 \frac{y^2 + v^2}{x^2 + y^2} \right) < \sqrt{\varepsilon} &\iff 1 - 2 \frac{y^2 + v^2}{x^2 + y^2} > \cos \sqrt{\varepsilon} \\ &\iff \underbrace{2v^2 - (1 - \cos \sqrt{\varepsilon}) x^2 + (1 + \cos \sqrt{\varepsilon}) y^2}_{=: r_\varepsilon(u, v, x, y)} < 0. \end{aligned}$$

Since $x > 0$, the term $2x dx$ in the differential dr_ε guarantees that $\partial\Omega_\varepsilon = \{r_\varepsilon = 0\}$ is geometrically smooth at every point.

Furthermore, with $w := u + \sqrt{-1}v$ and $z := x + \sqrt{-1}y$, dropping pluriharmonic terms:

$$r_\varepsilon \equiv w\bar{w} - (1 - \cos \sqrt{\varepsilon}) \frac{z\bar{z}}{2} + (1 + \cos \sqrt{\varepsilon}) \frac{z\bar{z}}{2},$$

we see that r_ε is strictly plurisubharmonic, whence $\Omega_\varepsilon = \{r_\varepsilon < 0\}$ is strongly pseudoconvex. □

In particular, the result holds for thin tubes corresponding to $0 < \varepsilon \ll (\frac{\pi}{2})^2$.

5. Calculation of the Complex Cartan Curvature of $\partial\Omega_\varepsilon \subset \mathbb{H}^c$

In [37], the authors proved the non-existence of CR-umbilical points on the boundaries of Grauert tubes around flat tori by showing the nonvanishing of a certain invariant determinant introduced in [38], which vanishes exactly when the Cartan curvatures vanish. In this paper, we shall use an explicit expression of Cartan curvatures obtained before by the second named author and Sabzevari in [88, 90] for locally graphed hypersurfaces, and alternatively a formula in [45] for hypersurfaces given as zero locus of implicit functions.

For a \mathcal{C}^6 -smooth Levi-nondegenerate real 3-dimensional hypersurface $M \subset \mathbb{C}^2$ represented in complex coordinates $z = x + \sqrt{-1}y$, $w = u + \sqrt{-1}v$ by a local graphing function:

$$v = \varphi(x, y, u),$$

the Cartan essential curvatures of M are two real invariants Δ_1, Δ_4 expressed in [88, Theorem 1.1] by following a Tanaka approach, explicitly in terms of $J_{x,y,u}^6\varphi$, both containing more than 1,500,000 terms when expanded.

An equivalent approach [90] closer to Cartan’s [17] can be summarized as follows. Local generators of $T^{1,0}M$ and $T^{0,1}M$ are:

$$\mathcal{L} := \frac{\partial}{\partial z} - \frac{\varphi_z}{\sqrt{-1} + \varphi_u} \frac{\partial}{\partial u} \quad \text{and} \quad \overline{\mathcal{L}} := \frac{\partial}{\partial \bar{z}} - \frac{\varphi_{\bar{z}}}{-\sqrt{-1} + \varphi_u} \frac{\partial}{\partial u},$$

and their commutator:

$$\mathcal{T} := \sqrt{-1} [\mathcal{L}, \overline{\mathcal{L}}] = \ell \frac{\partial}{\partial u}$$

incorporates the *real* coefficient, so-called *Levi factor*:

$$\ell := 2 \frac{\varphi_{z\bar{z}}(1 + \varphi_u^2) - \sqrt{-1}\varphi_{\bar{z}}\varphi_{zu} + \sqrt{-1}\varphi_z\varphi_{\bar{z}u} - \varphi_{\bar{z}}\varphi_{zu}\varphi_u - \varphi_z\varphi_{\bar{z}u}\varphi_u + \varphi_z\varphi_{\bar{z}}\varphi_{uu}}{(1 + \varphi_u^2)^2},$$

which is nowhere vanishing if and only if M is Levi nondegenerate.

Abbreviating the coefficients of \mathcal{L} and $\overline{\mathcal{L}}$ as:

$$A := -\frac{\varphi_z}{\sqrt{-1} + \varphi_u} \quad \text{and} \quad \overline{A} := -\frac{\varphi_{\bar{z}}}{-\sqrt{-1} + \varphi_u},$$

then in terms of the following key function (the expansion of which is 1 page long):

$$\overline{P} := \frac{\ell_{\bar{z}} - \bar{\ell} \overline{A}_u + \overline{A} \ell_u}{\ell},$$

the (single) essential Cartan complex invariant expresses in non-expanded form as:

$$(5.1) \quad \mathfrak{J} := \frac{1}{6} \frac{1}{c\bar{c}^3} \left(-2 \overline{\mathcal{L}}(\mathcal{L}(\overline{\mathcal{L}}(\overline{P}))) + \right. \\ \left. + 3 \overline{\mathcal{L}}(\overline{\mathcal{L}}(\mathcal{L}(\overline{P}))) - 7 \overline{P} \overline{\mathcal{L}}(\mathcal{L}(\overline{P})) + \right. \\ \left. + 4 \overline{P} \mathcal{L}(\overline{\mathcal{L}}(\overline{P})) - \mathcal{L}(\overline{P}) \overline{\mathcal{L}}(\overline{P}) + 2 \overline{P} \overline{P} \mathcal{L}(\overline{P}) \right),$$

and a comparison with [88] done at the end of [90] shows that it also expresses as:

$$\mathfrak{J} = \frac{4}{c\bar{c}^3} (\Delta_1 + \sqrt{-1} \Delta_4),$$

where the quantity $c \in \mathbb{C} \setminus \{0\}$ is a group parameter of a certain initial G -structure, and it has the following signification.

Suppose there really is a local biholomorphic equivalence $h: \mathbb{C}^2 \rightarrow \mathbb{C}^2$ which transfers M into $M' := h(M)$, so that in some appropriate target coordinates $z' = x' + \sqrt{-1}y'$, $w' = u' + \sqrt{-1}v'$, the (localized) image is also graphed as:

$$v' = \varphi'(x', y', u').$$

Compute similarly \mathcal{L}' , $\overline{\mathcal{L}}'$, ℓ' , \overline{P}' , \mathfrak{J}' , but extract parts independent of group parameters:

$$\mathfrak{J} = \frac{1}{c\bar{c}^3} \mathfrak{J}_\bullet \quad \text{and} \quad \mathfrak{J}' = \frac{1}{c'\bar{c}'^3} \mathfrak{J}'_\bullet.$$

Because the differential $h_*: T\mathbb{C}^2 \rightarrow T\mathbb{C}^2$ leaves invariant complex tangents, whence $h_*(T^{1,0}M) = T^{1,0}M'$, there is a nowhere vanishing function $c': M' \rightarrow \mathbb{C} \setminus \{0\}$ such that:

$$h_*(\mathcal{L}) = c' \mathcal{L}'.$$

At a basic level, it is an easy exercise ([98, p. 44]) to express the invariance of the Levi factors ℓ and ℓ' through the biholomorphism h as:

$$\ell = c' \bar{c}' \ell',$$

and at a higher level, a standard feature of Cartan's method of equivalence then shows that:

$$\mathfrak{J}_\bullet = c' c'^3 \mathfrak{J}'_\bullet,$$

which justifies, since $c' \neq 0$ vanishes nowhere, the invariance, under changes of holomorphic coordinates, of the following

DÉFINITION 5.2. A point $p \in M$ at which $\mathfrak{J}(p) = 0$ is called a *CR-umbilical point*.

In continuation with Lemma 4.4 above, we are now ready to state and to establish the main proposition. Inside the complexification of Poincaré's upper half-plane:

$$\mathbb{H}^c = \left\{ (u + \sqrt{-1}v, x + \sqrt{-1}y) \in \mathbb{C}^2 : x > 0 \right\},$$

consider for every $0 < \varepsilon < \left(\frac{\pi}{2}\right)^2$ the hypersurface:

$$M_\varepsilon := \partial\Omega_\varepsilon = \left\{ (u + \sqrt{-1}v, x + \sqrt{-1}y) \in \mathbb{H}^c : v^2 - \left(\frac{1-\cos\sqrt{\varepsilon}}{2}\right) x^2 + \left(\frac{1+\cos\sqrt{\varepsilon}}{2}\right) y^2 = 0 \right\}.$$

PROPOSITION 5.3. All hypersurfaces $M_\varepsilon \subset \mathbb{H}^c$ with $0 < \varepsilon < \left(\frac{\pi}{2}\right)^2$ have no *CR-umbilical point*.

PROOF. The plain global linear biholomorphism of \mathbb{H}^c :

$$w' := w, \quad z' := z \sqrt{\frac{1+\cos\sqrt{\varepsilon}}{2}},$$

transforms M_ε into:

$$M'_\varepsilon := \left\{ (u' + \sqrt{-1}v', x' + \sqrt{-1}y') \in \mathbb{H}^c : v'^2 - \frac{1-\cos\sqrt{\varepsilon}}{1+\cos\sqrt{\varepsilon}} x'^2 + y'^2 = 0 \right\},$$

and it is appropriate to set — mind the change varepsilon \mapsto epsilon —:

$$\epsilon := \sqrt{\frac{1-\cos\sqrt{\varepsilon}}{1+\cos\sqrt{\varepsilon}}},$$

so that the equation of $M'_\varepsilon := M'_\epsilon$ becomes a bit simpler (dropping the primes):

$$v^2 - \epsilon^2 x^2 + y^2 = 0.$$

Since this fractional map $\varepsilon \mapsto \epsilon(\varepsilon)$ has derivative:

$$\frac{d}{d\varepsilon} \sqrt{\frac{1-\cos\sqrt{\varepsilon}}{1+\cos\sqrt{\varepsilon}}} = \frac{1}{2\sqrt{\varepsilon}} \frac{\sin(\sqrt{\varepsilon})}{\sqrt{\frac{1-\cos\sqrt{\varepsilon}}{1+\cos\sqrt{\varepsilon}}} (1 + \cos\sqrt{\varepsilon})^2}$$

everywhere positive, it is a \mathcal{C}^ω diffeomorphism $(0, \frac{\pi^2}{4}) \rightarrow (0, 1)$, so that the new ϵ varies plainly in the open unit real segment:

$$0 < \epsilon < 1.$$

Reminding that $x > 0$, this new equation:

$$y^2 + v^2 = \epsilon^2 x^2,$$

shows that, a bit similarly as for the flat torus in Example 3.3, either $v \neq 0$ or $y \neq 0$ at any point.

Suppose therefore firstly that $v \neq 0$. For the \mathcal{C}^ω graph:

$$v = \sqrt{\epsilon^2 x^2 - y^2},$$

a direct calculation of \mathfrak{J} from the formula (5.1), by hand or with help of a computer, provides a compact, serendipitous expression:

$$\mathfrak{J}_\bullet = -\frac{9}{16} \frac{1 - \epsilon^4}{(\epsilon^2 x^2 - y^2)^2} \frac{(x + \sqrt{-1}y)^2}{(x - \sqrt{-1}y)^2},$$

which visibly vanishes nowhere since $x > 0$ whence $(x + \sqrt{-1}y)^4 \neq 0$.

Suppose secondly that $y \neq 0$. Since only points with $v = 0$ are not already examined, assume $v = 0$. For the \mathcal{C}^ω graph:

$$y = \sqrt{\epsilon^2 x^2 - v^2},$$

at points with $v = 0$, another direct calculation of the invariant \mathfrak{J} from (5.1) also provides a compact, nowhere vanishing expression:

$$\mathfrak{J}_\bullet = \frac{9}{16} \frac{(1 - \epsilon^2)}{(\epsilon + \sqrt{-1})^2 \epsilon^4 x^4},$$

and this completes the proof of inexistence of CR-umbilical points on M_ε . \square

SECOND PROOF OF PROPOSITION 5.3. The formula (5.1), explicit as it is, usually gives long and complicated expression for the combined complex-valued Cartan invariant \mathfrak{J} . This reality is due to the iterated process of taking roots, derivatives, quotients, *etc.* when the graphing function of the hypersurfaces under consideration is not simple, including taking roots for example (see, for example, the formulas given in [90] and [41]). There are instances where the hypersurfaces actually have much simpler representation by mean of implicit functions. An example is the case of general ellipsoidal hypersurfaces in \mathbb{C}^2 considered in [45], where a direct calculation from the formula (5.1) for a graphing function of the ellipsoids gives a very complicated expression for \mathfrak{J} , while an alternative formula (cf. [45, Corollary 12]) applied to simple implicit defining functions of the ellipsoids allows one to see a whole curve of CR-umbilical points. As the implicit defining function of M_ε is also very simple, we shall use the formulation in [45] to verify the nonvanishing of the Cartan curvature of M_ε once again.

Let us recall the necessary formulas from [45]. For a Levi nondegenerate analytic hypersurface M in \mathbb{C}^2 given by an implicit defining function:

$$0 = F(z, w, \bar{z}, \bar{w}),$$

we set

$$\begin{aligned} L &:= -F_w \frac{\partial}{\partial z} + F_z \frac{\partial}{\partial w}, \\ \bar{L} &:= -F_{\bar{w}} \frac{\partial}{\partial \bar{z}} + F_{\bar{z}} \frac{\partial}{\partial \bar{w}}, \\ h(F) &:= F_z F_z F_{w\bar{w}} - 2F_z F_w F_{z\bar{w}} + F_w F_w F_{z\bar{z}}, \\ l(F) &:= F_{\bar{z}} F_z F_{w\bar{w}} - F_{\bar{z}} F_w F_{z\bar{w}} - F_{\bar{w}} F_z F_{z\bar{w}} + F_{\bar{w}} F_w F_{z\bar{z}}. \end{aligned}$$

THEOREM 5.4. ([45]) *On the domain $\{F_w \neq 0\}$, the Cartan invariant \mathfrak{J} of M vanishes exactly on the zero locus of*

$$(5.5) \quad \mathbf{I}_{[w]} := 12 (F_w)^9 \left(\sum_{i=1}^7 I_i \right),$$

where

$$\begin{aligned} I_1 &= \left(\frac{l(F)}{F_w^2} \right)^3 \cdot \bar{L}^4 \left(\frac{h(F)}{F_w^3} \right), \\ I_2 &= -6 \left(\frac{l(F)}{F_w^2} \right)^2 \cdot \bar{L} \left(\frac{l(F)}{F_w^2} \right) \cdot \bar{L}^3 \left(\frac{h(F)}{F_w^3} \right), \\ I_3 &= -4 \left(\frac{l(F)}{F_w^2} \right)^2 \cdot \bar{L}^2 \left(\frac{l(F)}{F_w^2} \right) \cdot \bar{L}^2 \left(\frac{h(F)}{F_w^3} \right), \\ I_4 &= - \left(\frac{l(F)}{F_w^2} \right)^2 \cdot \bar{L}^3 \left(\frac{l(F)}{F_w^2} \right) \cdot \bar{L} \left(\frac{h(F)}{F_w^3} \right), \\ I_5 &= 15 \frac{l(F)}{F_w^2} \cdot \left[\bar{L} \left(\frac{l(F)}{F_w^2} \right) \right]^2 \cdot \bar{L}^2 \left(\frac{h(F)}{F_w^3} \right), \\ I_6 &= 10 \frac{l(F)}{F_w^2} \cdot \bar{L} \left(\frac{l(F)}{F_w^2} \right) \cdot \bar{L}^2 \left(\frac{l(F)}{F_w^2} \right) \cdot \bar{L} \left(\frac{h(F)}{F_w^3} \right), \\ I_7 &= -15 \left[\bar{L} \left(\frac{l(F)}{F_w^2} \right) \right]^3 \cdot \bar{L} \left(\frac{h(F)}{F_w^3} \right). \end{aligned}$$

With this formula (5.5) for checking the nonvanishing of the Cartan curvature at hand, we now return to our hypersurface M_ε . We again take advantage of the elementary biholomorphic transformation as above, and consider the equivalent model M'_ε whose defining

function writes $v^2 - \epsilon^2 x^2 + y^2 = 0$, with $0 < \epsilon < 1$. Switching the notation for coordinates in order to reach $F_w \neq 0$, namely using instead:

$$z = u + \sqrt{-1}v \quad \text{and} \quad w = x + \sqrt{-1}y,$$

we can then rewrite:

$$\begin{aligned} v^2 - \epsilon^2 x^2 + y^2 &= \left(\frac{z-\bar{z}}{2\sqrt{-1}}\right)^2 - \epsilon^2 \left(\frac{w+\bar{w}}{2}\right)^2 + \left(\frac{w-\bar{w}}{2\sqrt{-1}}\right)^2 \\ &= -\frac{1}{4} [(z-\bar{z})^2 + (1+\epsilon^2)(w^2 + \bar{w}^2) - 2(1-\epsilon^2)w\bar{w}] \\ &=: -\frac{1}{4} F(z, w, \bar{z}, \bar{w}), \end{aligned}$$

so that $M'_\epsilon = \{F = 0\}$, and then as wanted we have the nowhere vanishing:

$$F_w = (1 + \epsilon^2)2w - 2(1 - \epsilon^2)\bar{w} = 4(\epsilon^2 x + \sqrt{-1}y) \neq 0$$

on M'_ϵ thanks to our constant assumption $x > 0$. Thus, the vanishing locus of $\mathbf{I}_{[w]}$ is exactly the set of CR-umbilical points of M'_ϵ in this case.

Now, direct calculation from the formula (5.5), by hand or preferably on a computer, and keeping in mind that on M'_ϵ we always have $v^2 = \epsilon^2 x^2 - y^2$, gives us:

$$\begin{aligned} \mathbf{I}_{[w]} &= \frac{27}{64} \epsilon^8 (1 - \epsilon^4) \bar{w}^2 w^6 \\ &= \frac{27}{64} \epsilon^8 (1 - \epsilon^4) (x - \sqrt{-1}y)^2 (x + \sqrt{-1}y)^6. \end{aligned}$$

It is then evident that $\mathbf{I}_{[w]}$ is everywhere nonzero on M'_ϵ because $x > 0$. This completes our second justification of the inexistence of CR-umbilical points on $M_\epsilon \cong M'_\epsilon$.

PROOF. 6. Transfer to Hyperbolic Genus $g \geq 2$ Compact Surfaces

Now, let S be a closed compact oriented \mathcal{C}^ω surface of genus $g \geq 2$, considered as a Riemann surface. The Poincaré-Köbe uniformization theorem provides a holomorphic covering:

$$\tau: \mathbb{H} \longrightarrow S \cong \mathbb{H}/\pi_1(S).$$

The Poincaré metric $ds_{\mathbb{H}}^2 = \lambda(dx_1^2 + dx_2^2)$ with $\lambda := \frac{1}{x_2^2}$ on \mathbb{H} has constant Gaussian curvature:

$$-\frac{1}{2\lambda} \left(\frac{\partial^2}{\partial x_1^2} + \frac{\partial^2}{\partial x_2^2} \right) (\log \lambda) = -1,$$

and is furthermore kept invariant by all elements of the group $\text{Aut } \mathbb{H} \cong PSL(2, \mathbb{R})$ of holomorphic automorphisms of \mathbb{H} :

$$(\text{Aut } \mathbb{H})^* (ds_{\mathbb{H}}^2) = ds_{\mathbb{H}}^2,$$

which acts transitively (and isometrically) on the homogeneous space \mathbb{H} .

Furthermore, the group of all covering automorphisms of $\mathbb{H} \xrightarrow{\tau} S$ happens to be a discrete *subgroup*:

$$\text{Aut} \left(\mathbb{H} \xrightarrow{\tau} S \right) \subset PSL(2, \mathbb{R}) = \text{Aut } \mathbb{H}.$$

Consequently (and as is well known), $ds_{\mathbb{H}}^2$ descends by push-forward, independently of preimage points, as a metric on S :

$$ds_S^2 := \tau_*(ds_{\mathbb{H}}^2),$$

having the same curvature -1 .

Next, forget the holomorphic structure on S , consider now S as a \mathcal{C}^ω real surface equipped with this \mathcal{C}^ω metric ds_S^2 , and denote the Bruhat-Whitney complexification of S by S^c . Then Section 2 gives by complexification a unique strictly plurisubharmonic \mathcal{C}^ω Kähler potential $\rho: S^c \rightarrow \mathbb{R}_+$ whose sublevel sets:

$$\Delta_\varepsilon := \{\rho < \varepsilon\} \subset S^c,$$

for all small enough $0 < \varepsilon \leq \varepsilon_0 \ll 1$, are strongly pseudoconvex domains bounded by the \mathcal{C}^ω hypersurfaces:

$$\partial\Delta_\varepsilon = \{\rho = \varepsilon\}.$$

Here, ε_0 might well be quite small, depending on the convergence radii of the real-analytic objects that are complexified.

LEMMA 6.1. *Shrinking $\varepsilon_0 > 0$ if necessary, M_ε has no CR-umbilical point for all $0 < \varepsilon \leq \varepsilon_0$.*

PROOF. The uniformizing map, viewed as a \mathcal{C}^ω map $\tau: \mathbb{H} \rightarrow S$, also complexifies to become a holomorphic map:

$$\mathbb{H}^c \supset V^c \xrightarrow{\tau^c} U^c \subset S^c,$$

where V^c is some open neighborhood of \mathbb{H} in \mathbb{H}^c : $\mathbb{H} \subset V^c \subset \mathbb{H}^c$, possibly narrowing much as one reaches $\partial\mathbb{H} = \{x_2 = 0\}$, and where U^c is also an open neighborhood of S in S^c : $S \subset U^c \subset S^c$.

Since $\tau: \mathbb{H} \rightarrow S$ is a covering map, hence a local \mathcal{C}^ω diffeomorphism, each point $p \in S$ has a small open neighborhood $p \in U_p \subset S$ on which there exist \mathcal{C}^ω -diffeomorphic inverses of τ , namely maps:

$$\chi_p: U_p \xrightarrow{\sim} \chi_p(U_p) =: V_{\chi_p(p)} \subset \mathbb{H},$$

that are uniquely defined as soon as a central point $\chi_p(p) \in \tau^{-1}(p) \subset \mathbb{H}$ has been chosen in the fiber to fix a level. Shrinking U_p if necessary, the complexification χ_p^c of $\chi_p(p)$ is also locally biholomorphic at p .

By compactness of $S \subset S^c$, there exists a finite open cover $U_1^c, \dots, U_\kappa^c \subset S^c$ of S :

$$S \subset U_1^c \cup \dots \cup U_\kappa^c \subset U^c \quad (\kappa \geq 1),$$

together with *biholomorphic* inverses of the complexification $\tau^c: V^c \rightarrow U^c$:

$$\chi_k^c: U_k^c \xrightarrow{\sim} \chi_k^c(U_k^c) =: V_k^c \subset \mathbb{H}^c \quad (1 \leq k \leq \kappa).$$

If necessary, shrink $\varepsilon_0 > 0$ so that, for all $0 < \varepsilon \leq \varepsilon_0$:

$$\Delta_\varepsilon \subset \Delta_{\varepsilon_0} \Subset U_1^c \cup \dots \cup U_\kappa^c.$$

Now, take any point $q \in \partial\Delta_\varepsilon$. How to convince oneself that the Cartan CR-curvatures of the strongly pseudoconvex hypersurface $\partial\Delta_\varepsilon$ is *nonzero* at q ?

This is very simple. For sure, $q \in U_k^c$ for some $1 \leq k \leq \kappa$. Remind also the tube $\Omega_\varepsilon \subset \mathbb{H}^c$. Then because the metric on S is the push-forward of Poincaré's metric on \mathbb{H} , the tubes Ω_ε and Δ_ε correspond to each other, namely χ_k^c sends $\Delta_\varepsilon \cap U_k^c$ biholomorphically onto $\Omega_\varepsilon \cap V_k^c$ with:

$$\chi_k^c(q) \in \partial\Omega_\varepsilon,$$

and since the nonvanishing of Cartan CR-curvatures is a biholomorphically invariant property, Proposition 5.3 offers what was wanted. \square

With some basic knowledge on Fuchsian groups, we can also provide a

VARIATION ON THE PROOF OF LEMMA 6.1. As already seen, the quotient map:

$$\tau: \mathbb{H} \longrightarrow S \cong \mathbb{H}/\pi_1(S)$$

is locally isometric. Abbreviate:

$$G := \text{Aut}\left(\mathbb{H} \xrightarrow{\tau} S\right) \cong \pi_1(S).$$

DÉFINITION 6.2. A *fundamental domain* for S is an open subset $D \subset \mathbb{H}$ whose G -translates cover:

$$\mathbb{H} = \bigcup_{g \in G} g(D),$$

being mutually disjoint:

$$\emptyset = D \cap g(D) \quad (\forall g \in G \setminus \{\text{Id}\}),$$

and which has the further property of being *locally finite* in the sense that each compact subset $K \Subset \mathbb{H}$ meets only finitely many G -images of D .

THEOREM 6.3. ([2, Chap. 9]) *Relatively compact fundamental domains $D \Subset \mathbb{H}$ having piecewise \mathcal{C}^ω boundary consisting of $4g$ geodesic segments always exist on the universal cover $\tau: \mathbb{H} \longrightarrow S$ of any genus $g \geq 2$ compact Riemann surface.* \square

Then in place of a (rough) finite Borel-Lebesgue covering $S \subset U_1 \cup \dots \cup U_K$ as used in the first proof, we can employ a geometrically more meaningful covering. For such a fundamental domain $D \subset \mathbb{H}$ of S , there is an atlas of S consisting of $4g + 1$ open charts:

- $V_0 := D$ itself;
- slightly thickened thin neighborhoods V_1, \dots, V_{4g} of the $4g$ sides of D .

Further, one can arrange that the restrictions:

$$\tau: V_i \longrightarrow \tau(V_i) =: U_i \subset S \quad (i=0, 1, \dots, 4g)$$

are \mathcal{C}^ω diffeomorphisms. Complexifying their inverses $\chi_i: U_i \xrightarrow{\sim} V_i$ as:

$$\chi_i^c: U_i^c \xrightarrow{\sim} V_i^c$$

we can now reason similarly as in the first proof, and this concludes. \square

REMARK 6.4. We observe the following interesting facts about the (non)vanishing of the essential curvatures Δ_1 and Δ_4 on the boundaries of Grauert tubes of small radii around closed surfaces S .

- (1) If S is the 2-sphere with the standard round metric, both Δ_1 and Δ_4 vanish identically.
- (2) If S is a 2-dimensional flat torus, we leave as an exercise to the reader to verify that Δ_1 never vanishes, while Δ_4 vanishes identically.
- (3) If S is a closed genus $g \geq 2$ hyperbolic surface, then both Δ_1 and Δ_4 vanish nowhere.

7. Grauert Tubes with Respect to Extrinsic Metrics

In Section 2, Grauert tubes are constructed with respect to metrics obtained from given *intrinsic* Riemannian metrics on surfaces. In this section, we look at constructions of Grauert tubes around surfaces from an *extrinsic* point of view. More precisely, let us consider a totally real embedding of a surface S into a complex manifold X of complex dimension 2. We will identify the surface S with its image under the embedding, so that S is viewed as a submanifold of X . A given Riemannian metric d_X on X always induces an *extrinsic* metric on S and the Grauert tubes Ω_ε around S also can be defined with respect to d_X as $\Omega_\varepsilon := \{x \in X : d_X(x, S) < \varepsilon\}$ for small enough positive ε .

Recall that for a real n -dimensional submanifold M of a complex n -dimensional manifold X , a point p of M is called a *complex point* if the tangent vector space of M at p contains at least one complex line with respect to the complex structure $J \in \text{End}(TX)$ on the tangent bundle of X , that is $T_p M \cap J(T_p M) \neq \{0\}$. An embedding of M into X is called a *totally real embedding* if M does not contain any complex point.

It is known that every affine n -dimensional totally real vector subspace $V \subset \mathbb{C}^n$ is affinely holomorphically equivalent to $\mathbb{R}^n \subset \mathbb{C}^n$. It is also known that every \mathcal{C}^ω real n -dimensional submanifold $M \subset \mathbb{C}^n$ is locally holomorphically equivalent to $\mathbb{R}^n \subset \mathbb{C}^n$, namely at any point $p \in M$, there is an open neighborhood $p \in U \subset \mathbb{C}^n$ and a biholomorphism $h: U \xrightarrow{\sim} h(U) =: V$ with $h(p) = 0$ such that $h(M \cap U) = \mathbb{R}^n \cap V$. Hence an alternative description of maximally real \mathcal{C}^ω submanifolds $M \subset \mathbb{C}^n$ is as follows.

DÉFINITION 7.1. A real n -dimensional \mathcal{C}^ω submanifold M of a complex n -dimensional manifold X is *totally real* if there exists a family indexed by $\alpha \in A$ of biholomorphisms:

$$\varphi_\alpha: U_\alpha \xrightarrow{\sim} \varphi_\alpha(U_\alpha) =: V_\alpha \subset X$$

with $U_\alpha \subset \mathbb{C}^n$ open, with $V_\alpha \subset X$ open, with $X = \bigcup_\alpha V_\alpha$, such that:

- if $\varphi_\alpha(0) \notin M$, then $\varphi_\alpha(U_\alpha) \cap M = \emptyset$;
- if $\varphi_\alpha(0) \in M$, then the restriction:

$$\varphi_\alpha|_{\mathbb{R}^n \cap U_\alpha}: \mathbb{R}^n \cap U_\alpha \xrightarrow{\sim} M \cap V_\alpha,$$

is a \mathcal{C}^ω real diffeomorphism.

EXAMPLE 7.2. By looking at the standard complex atlas of the complex projective space $\mathbb{C}\mathbb{P}^n$, it is clear that $\mathbb{R}\mathbb{P}^n$ is totally real in $\mathbb{C}\mathbb{P}^n$. On $\mathbb{R}\mathbb{P}^n$, there is a canonical round metric induced from the round metric on its double cover \mathbb{S}^n . The Guillemin-Stenzel metric associated to this round metric on $\mathbb{C}\mathbb{P}^n$ is nothing but the Fubini-Study metric on $\mathbb{C}\mathbb{P}^n$. The complexified manifold $(\mathbb{S}^n)^c$ is a double cover of $\mathbb{C}\mathbb{P}^n$, which is a real $2n$ -dimensional submanifold in the \mathbb{S}^1 -fibration \mathbb{S}^{2n+1} of $\mathbb{C}\mathbb{P}^n$.

EXAMPLE 7.3. Of particular interest for us here is the fact that a product of two totally real submanifolds is also totally real, which is evident from either definition.

EXAMPLE 7.4. Let us look at Example 3.3 once again, this time from an extrinsic point of view. Consider a 2-dimensional real vector subspace V of \mathbb{C}^2 which passes through the origin, with coordinates $(z, w) \in \mathbb{C}^2$. The intersections of V with the z -axis and w -axis are two real line. Therefore V can be written in exactly one of the following three forms.

Case 1: $V = \{y = \alpha x, v = \beta u\}$, where α, β are real. The Grauert tube $\Omega_\varepsilon(V)$ of radius ε around V with respect to the standard distance in \mathbb{C}^2 is given by:

$$\left\{ (x + \sqrt{-1}y, u + \sqrt{-1}v) \in \mathbb{C}^2 : \frac{(\alpha x - y)^2}{(\alpha^2 + 1)^2} + \frac{(\beta u - v)^2}{(\beta^2 + 1)^2} < \varepsilon^2 \right\}.$$

In order to obtain a compact hypersurface, we take the quotient $\tilde{\Omega}_\varepsilon(V)$ of $\Omega_\varepsilon(V)$ by the translations by 2π on each real coordinates of V . Then $\tilde{\Omega}_\varepsilon(V)$ can be embedded into \mathbb{C}^2 as:

$$\left\{ (z, w) \in \mathbb{C}^2 : \left(\log \left| e^{\frac{\sqrt{-1}z}{1+\sqrt{-1}\alpha}} \right| \right)^2 + \left(\log \left| e^{\frac{\sqrt{-1}w}{1+\sqrt{-1}\beta}} \right| \right)^2 < \varepsilon^2 \right\}.$$

Any point on the boundary of $\tilde{\Omega}_\varepsilon(V)$ admits the same local defining function as its preimage on the boundary of $\Omega_\varepsilon(V)$. Solving the local defining function for the variable v gives the graph:

$$v = \beta u - (\beta^2 + 1) \sqrt{\varepsilon^2 - \frac{(\alpha x - y)^2}{(\alpha^2 + 1)^2}}.$$

A direct calculation of the Cartan invariant using the formula (5.1) provides:

$$\mathfrak{J}_\bullet = \frac{-9(\alpha + \sqrt{-1})^9 (-\alpha + \sqrt{-1})^{11} (\beta + \sqrt{-1})^{16} (-\beta + \sqrt{-1})^{16} \varepsilon^8}{(-\alpha x + y + \varepsilon + a^2 \varepsilon)^8 (\alpha x - y + \varepsilon + a^2 \varepsilon)^8},$$

and this result is nowhere vanishing. So the boundary of $\tilde{\Omega}_\varepsilon(V)$ also does not contain any CR-umbilical point.

Case 2: $V = \{x = 0, v = \beta u\}$, where β is again real. The Grauert tube of radius ε around V with respect to the standard distance in \mathbb{C}^2 is now given by:

$$\Omega_\varepsilon(V) = \left\{ (x + \sqrt{-1}y, u + \sqrt{-1}v) \in \mathbb{C}^2 : x^2 + \frac{(\beta u - v)^2}{(\beta^2 + 1)^2} < \varepsilon^2 \right\}.$$

A point on the boundary of $\tilde{\Omega}_\varepsilon(V)$ or of $\Omega_\varepsilon(V)$ admits the local graphing function:

$$v = \beta u - (\beta^2 + 1) \sqrt{\varepsilon^2 - x^2},$$

of which the (relative) Cartan curvature can be computed from the formula (5.1) to be:

$$\mathfrak{J}_\bullet = \frac{9(\beta^2 + 1)^{16} \varepsilon^8}{(x^2 - \varepsilon^2)^8}.$$

Thus, the (relative) invariant \mathfrak{J}_\bullet is also nowhere vanishing on the boundary.

Note that $\tilde{\Omega}_\varepsilon(V)$ can be embedded into \mathbb{C}^2 as:

$$\left\{ (z, w) \in \mathbb{C}^2 : \left(\log |e^z| \right)^2 + \left(\log \left| e^{\frac{\sqrt{-1}w}{1+\sqrt{-1}\beta}} \right| \right)^2 < \varepsilon^2 \right\}.$$

Case 3: $V = \{x = 0 = u\}$. A point on $\tilde{\Omega}_\varepsilon(V)$ which can be embedded into \mathbb{C}^2 as:

$$\left\{ (z, w) \in \mathbb{C}^2 : \left(\log |e^z| \right)^2 + \left(\log |e^w| \right)^2 < \varepsilon^2 \right\},$$

now admits the local defining function

$$x^2 + u^2 = \varepsilon^2.$$

In this case, we do not obtain a local graphing function of the form $v = \phi(x, y, u)$, but a simple calculation using the alternative formula (5.5) for the implicit defining function

$F(z, w, \bar{z}, \bar{w}) = \left(\frac{z+\bar{z}}{2}\right)^2 + \left(\frac{w+\bar{w}}{2}\right)^2 - \varepsilon^2$ shows that the relative invariant \mathfrak{J}_\bullet is proportional to:

$$\frac{27(x^2 + u^2)^4}{64} = \frac{27\varepsilon^8}{64}.$$

So it is evident that the boundary of $\tilde{\Omega}_\varepsilon(V)$ also does not contain any CR-umbilical point.

For two given Riemannian manifolds $(X, d_X), (Y, d_Y)$, the distance $d_{X \times Y}$ with respect to the product metric on $X \times Y$ is:

$$(7.5) \quad d_{X \times Y}^2((x_1, y_1), (x_2, y_2)) = d_X^2(x_1, x_2) + d_Y^2(y_1, y_2),$$

assuming that X, Y are uniquely geodesic, *i.e.* there exists a unique geodesic between any two points.

Our next examples of Grauert tubes in $\mathbb{C} \times \mathbb{C}$ will be constructed with respect to products of two extrinsic metrics on $\mathbb{C} \supset \mathbb{R}$. For the two possible component metrics on \mathbb{C} , we will consider the three standard ones: flat, elliptic and hyperbolic.

- Flat metric on \mathbb{C} . Denote by d_{Flat} the flat Pythagorean metric on $\mathbb{C} \ni x + \sqrt{-1}y$. Consider the totally real line $V_{\text{Flat}} = \{y = 0\}$ in $U_{\text{Flat}} = \mathbb{C}$. The flat distance from any point $z \in U_{\text{Flat}}$ to V_{Flat} is:

$$(7.6) \quad d_{\text{Flat}}(z, V_{\text{Flat}}) = |\text{Im}(z)| = |y|.$$

- Elliptic metric on \mathbb{CP}^1 . For the elliptic metric d_{Ell} , we look at the local chart $U_0 = \{[1 : z] : z \in \mathbb{C}\}$ of \mathbb{CP}^1 . Since $(\mathbb{CP}^1, d_{\text{Ell}})$ is not uniquely geodesic, we consider a small neighborhood $U_{\text{Ell}} = \{[1 : z] : |z| < \delta\}$ of $[1 : 0]$ in U_0 , which is uniquely geodesic for small positive δ thanks to the fact that the injective radius of $(\mathbb{CP}^1, d_{\text{Ell}})$ is positive. Then $V_{\text{Ell}} = \{[1 : \text{Re}(z)] : \text{Re}(z) < \delta\}$ is totally real in U_{Ell} .

LEMMA 7.7. *The elliptic distance from any point $(x, y) \approx [1 : (x + \sqrt{-1}y)]$ of U_{Ell} to V_{Ell} is given by:*

$$(7.8) \quad d_{\text{Ell}}((x, y), V_{\text{Ell}}) = \arccos\left(\frac{\sqrt{1+x^2}}{\sqrt{1+x^2+y^2}}\right).$$

PROOF. A point $[1 : (x + \sqrt{-1}y)]$ of \mathbb{CP}^1 corresponds to the point $\left(\frac{1}{\sqrt{1+x^2+y^2}}, \frac{x}{\sqrt{1+x^2+y^2}}, \frac{y}{\sqrt{1+x^2+y^2}}\right)$ of \mathbb{S}^2 embedded in \mathbb{R}^3 , and a point $[1 : \alpha]$ of V_{Ell} corresponds to $\left(\frac{1}{\sqrt{1+\alpha^2}}, \frac{\alpha}{\sqrt{1+\alpha^2}}, 0\right)$.

Now $d_{\text{Ell}}((x, y), V_{\text{Ell}})$ is exactly the spherical distance between $P = \left(\frac{1}{\sqrt{1+x^2+y^2}}, \frac{x}{\sqrt{1+x^2+y^2}}, \frac{y}{\sqrt{1+x^2+y^2}}\right)$ and the arc $\{Q_\alpha = \left(\frac{1}{\sqrt{1+\alpha^2}}, \frac{\alpha}{\sqrt{1+\alpha^2}}, 0\right) : \alpha > 0\}$, that is:

$$\cos d_{\text{Ell}}((x, y), V_{\text{Ell}}) = \max_{\alpha > 0} \frac{\langle P, Q_\alpha \rangle}{|P| |Q_\alpha|}.$$

Using the Cauchy-Schwartz inequality, we have:

$$\begin{aligned} \frac{\langle P, Q_\alpha \rangle}{|P| |Q_\alpha|} &= \frac{1 + \alpha x}{\sqrt{1 + \alpha^2} \sqrt{1 + x^2 + y^2}} \\ &\leq \frac{\sqrt{1 + \alpha^2} \sqrt{1 + x^2}}{\sqrt{1 + \alpha^2} \sqrt{1 + x^2 + y^2}} \\ &= \frac{\sqrt{1 + x^2}}{\sqrt{1 + x^2 + y^2}}, \end{aligned}$$

where the maximum is attained at $\alpha = x$. \square

• Hyperbolic metric on \mathbb{H} . For the hyperbolic metric d_{Hyp} , we may consider a small open neighborhood U of 0 in the Poincaré disc, and the totally real interval $U \cap \{\text{Im}(z) = 0\}$ in U , but it is more convenient to work with the corresponding domain $U_{\text{Hyp}} = \{z = x + \sqrt{-1}y\}$ of U on the upper-half plane model, which is an open neighborhood of $\sqrt{-1}$. The corresponding totally real interval in U_{Hyp} is $V_{\text{Hyp}} = U_{\text{Hyp}} \cap \{\text{Re}(z) = 0\}$.

LEMMA 7.9. *The hyperbolic distance from any point $(x, y) \approx z = x + \sqrt{-1}y$ in U_{Hyp} to V_{Hyp} is given by:*

$$(7.10) \quad d_{\text{Hyp}}((x, y), V_{\text{Hyp}}) = \text{arccosh} \left(\frac{\sqrt{x^2 + y^2}}{y} \right).$$

PROOF. Recall that for a hyperbolic triangle on the upper-half plane with angles A, B, C and opposite sides of lengths a, b, c , the rule of sine reads:

$$\frac{\sin A}{\sinh a} = \frac{\sin B}{\sinh b} = \frac{\sin C}{\sinh c}.$$

Thus, given the angle A and the side a , the side b is of maximal length when $B = \frac{\pi}{2}$ because the function \sinh is monotone and because:

$$\sinh b = \sin B \frac{\sinh a}{\sin A} \leq \frac{\sinh a}{\sin A}.$$

It follows that to find the hyperbolic distance from a given point $z = x + \sqrt{-1}y$ to the line V_{Hyp} , we look at the geodesic line passing through z and orthogonal to V_{Hyp} , which is the half-circle on the upper-half plane model with centre at 0 and of radius $|z| = \sqrt{x^2 + y^2}$. This geodesic line intersects V_{Hyp} at the point $(0, \sqrt{x^2 + y^2}) \approx 0 + \sqrt{-1}\sqrt{x^2 + y^2}$. Thus, we have:

$$\begin{aligned} d_{\text{Hyp}}((x, y), V_{\text{Hyp}}) &= d_{\text{Hyp}}((x, y), (0, \sqrt{x^2 + y^2})) \\ &= \text{arccosh} \left(1 + \frac{(x - 0)^2 + (y - \sqrt{x^2 + y^2})^2}{2y\sqrt{x^2 + y^2}} \right) \\ &= \text{arccosh} \left(\frac{\sqrt{x^2 + y^2}}{y} \right). \end{aligned} \quad \square$$

We are now in position to give some non-trivial examples of Grauert tubes with respect to extrinsic metrics.

PROPOSITION 7.11. *The Grauert tubes of radius ε with respect to the product metric $d_1 \times d_2$ around the totally real submanifold $V_1 \times V_2$ in $U_1 \times U_2$ admit local defining functions:*

$$\begin{aligned} \rho(x, y, u, v) &:= [d_1((x, y), V_1)]^2 + [d_2((u, v), V_2)]^2 \\ &< \varepsilon^2, \end{aligned}$$

where (U_i, V_i, d_i) for $i = 1, 2$ is one of the three models:

$$(U_{\text{Flat}}, V_{\text{Flat}}, d_{\text{Flat}}), \quad (U_{\text{Ell}}, V_{\text{Ell}}, d_{\text{Ell}}), \quad (U_{\text{Hyp}}, V_{\text{Hyp}}, d_{\text{Hyp}}). \quad \square$$

In particular, we obtain six examples of Grauert tubes with respect to the corresponding extrinsic product metrics.

REMARK 7.12. Notice here that our examples are of local nature, and not compact. When both d_1 and d_2 are flat metrics, one recovers the local graphing function of the flat torus as in Example 3.3, since:

$$[d_{\text{Flat}}((x, y), V_{\text{Flat}})]^2 + [d_{\text{Flat}}((u, v), V_{\text{Flat}})]^2 = y^2 + v^2.$$

However, the remaining five examples are very different from those obtained from intrinsic metrics in Example 3.1, Example 3.3 and Lemma 4.4. Thus, the Grauert tubes around the same totally real manifolds with respect to intrinsic and extrinsic metrics look very different.

LEMMA 7.13. *In terms of:*

$$H := \sqrt{\varepsilon^2 - \left[\operatorname{arccosh} \frac{\sqrt{x^2 + y^2}}{y} \right]^2}$$

and of:

$$E := \sqrt{\varepsilon^2 - \left[\arccos \frac{\sqrt{1 + x^2}}{\sqrt{1 + x^2 + y^2}} \right]^2},$$

the local defining functions for the boundaries of the Grauert tubes of radius ε with respect to the product metrics are given by Table 1.

PROOF. We only treat the case of the product between the hyperbolic and flat metrics, in which the local graphing function is given by:

$$(7.14) \quad \rho(x, y, u, v) = \left[\operatorname{arccosh} \left(\frac{\sqrt{x^2 + y^2}}{y} \right) \right]^2 + v^2 < \varepsilon^2,$$

while the calculations for the other cases can be done in a similar way.

TABLE 1

Product metrics	Defining functions
$d_{\text{Flat}} \oplus d_{\text{Flat}}$	$v = \sqrt{\varepsilon^2 - y^2}$
$d_{\text{EII}} \oplus d_{\text{Flat}}$	$v = (\varepsilon^2 - \arcsin \frac{y}{\sqrt{1+x^2+y^2}})^{1/2}$
$d_{\text{Hyp}} \oplus d_{\text{Flat}}$	$v = (\varepsilon^2 - \operatorname{arcsinh} \frac{x}{y})^{1/2}$
$d_{\text{Hyp}} \oplus d_{\text{Hyp}}$	$v = \frac{u}{\sinh H}$
$d_{\text{EII}} \oplus d_{\text{Hyp}}$	$v = \frac{u}{\sinh E}$
$d_{\text{EII}} \oplus d_{\text{EII}}$	$v = \frac{1 + \sqrt{1 - 4(1+u^2)(\sin E)^2}}{2 \sin E}$

The defining function for the boundary of the Grauert tube is obtained by solving the equation $\rho = \varepsilon^2$ for the variable v as follows:

$$\begin{aligned}
 \rho = \varepsilon^2 &\implies \operatorname{arccosh}\left(\frac{\sqrt{x^2 + y^2}}{y}\right) = \sqrt{\varepsilon^2 - v^2} \\
 &\implies \frac{\sqrt{x^2 + y^2}}{y} = \cosh(\sqrt{\varepsilon^2 - v^2}) \\
 &\implies 1 + \frac{x^2}{y^2} = [\cosh(\sqrt{\varepsilon^2 - v^2})]^2 = [\sinh(\sqrt{\varepsilon^2 - v^2})]^2 + 1 \\
 &\implies \frac{x}{y} = \sinh(\sqrt{\varepsilon^2 - v^2}).
 \end{aligned}$$

So, the defining function belongs to the rigid case with the graph:

$$v = \sqrt{\varepsilon^2 - \operatorname{arcsinh}\left(\frac{x}{y}\right)}. \quad \square$$

Unfortunately, except for the case of $d_{\text{Flat}} \oplus d_{\text{Flat}}$, the expressions of the Cartan invariant obtained by calculations with either formula (5.1) or (5.5), though explicit, are overwhelmingly complicated, and so do not allow us to see the CR-umbilical locii.

Bibliography

- [1] Aghasi, M.; Merker, J.; Sabzevari, M.: *Effective Cartan-Tanaka connections on \mathcal{C}^6 strongly pseudoconvex hypersurfaces $M^3 \subset \mathbb{C}^2$* , arxiv.org/abs/1104.1509/, 113 pages.
- [2] E. Beardon, *The geometry of discrete groups*, Graduate Texts in Mathematics, 91, Springer Verlag, Berlin, 1995, xii+337 pp.
- [3] Bérczi G., *Thom polynomials and the Green-Griffiths-Lang conjecture for hypersurfaces with polynomial degree*. Intern. Math. Res. Not. **332** (2018), 1—56.
- [4] E. Bishop, *Differentiable manifolds in complex Euclidean space*, Duke Mathematical Journal **32** (1965), 1–21.
- [5] Bloch A., *Sur les systèmes de fonctions uniformes satisfaisant à l'équation d'une variété algébrique dont l'irrégularité dépasse la dimension*. J. Math. Pures Appl. **5** (1926), 19—66.
- [6] Brody R., *Compact manifolds and hyperbolicity*. Trans. Amer. Math. Soc. **235** (1978), 213–219.
- [7] F. Bruhat and H. Whitney, *Quelques propriétés fondamentales des ensembles analytiques-réels*, Commentarii Mathematici Helvetici **33** (1959), 132–160.
- [8] Brotbek D., *On the hyperbolicity of general hypersurfaces*. Publications Mathématiques de l'IHÉS, **126** (2017), 1–34.
- [9] Brotbek, D., Deng, Y., *Hyperbolicity of the complements of general hypersurfaces of high degree*, arxiv.org/abs/1804.01719/
- [10] Cap, A.; Slovak, I.; Zadnik, V.: *On distinguished curves in parabolic geometries*, Transform. Groups **9** (2004), no. 2, 143–166.
- [11] Cap, A.; Slovak, I.: *Parabolic geometries. I. Background and general theory*, Mathematical Surveys and Monographs, 154, American Mathematical Society, Providence, RI, 2009, x+628 pp.
- [12] Cap, A.; Zadnik, V.: *On the geometry of chains*, J. Differential Geom. **82** (2009), no. 1, 1–33
- [13] Cartan, É.: *Sur la géométrie pseudo-conforme des hypersurfaces de deux variables complexes I*, Annali di Matematica, **11** (1932), 17–90; Œuvres Complètes, Partie II, Vol. 2, 1231–1304.
- [14] Cartan, É.: *Sur le groupe de la géométrie hypersphérique*, Comment. Math. Helvetici, **4** (1932), 158–171. Œuvres Complètes, Partie III, Vol. 2, 1203–1216.
- [15] Cartan, É.: *Sur la géométrie pseudo-conforme des hypersurfaces de deux variables complexes II*, Annali Sc. Norm. Sup. Pisa, **1** (1932), 333–354. Œuvres Complètes, Partie III, Vol. 2, 1217–1238.
- [16] CARTAN, É.: *Sur l'équivalence pseudo-conforme de deux hypersurfaces de l'espace de deux variables complexes*, Verh. int. Math. Kongresses Zürich, II, pp. 54–56.
- [17] Cartan É., *Sur la géométrie pseudo-conforme des hypersurfaces de deux variables complexes*, part I. Ann. Math. Pura Appl., (4) **11** (1932), 17–90; part II, Ann. Scuola Norm. Sup. Pisa, (2) **1** (1932), 333–354.
- [18] Castro, A.L.; Montgomery, R.: *The chains of left-invariant Cauchy-Riemann structures on $SU(2)$* , Pacific J. Math. **238** (2008), no. 1, 41–71.
- [19] Cheng, J.H.: *Chain-preserving diffeomorphisms and CR equivalence*, Proc. Amer. Math. Soc. **103** (1988), no. 1, 75–80.
- [20] Cheng, J.H.; Marugame, T.; Matveev, V.; Montgomery, R.: *Chains in CR geometry as geodesics of a Kropina metric*, arxiv.org/abs/1806.01877/
- [21] Chen Z., Merker J., *On differential invariants of parabolic surfaces*. arXiv:1908.07867, math.DG
- [22] Chen Z., Foo W.-G., Merker J., Ta T.-A., *Normal Forms for Rigid $\mathcal{C}_{2,1}$ Hypersurfaces $M^5 \subset \mathbb{C}^3$* . arXiv:1912.01655, math.CV
- [23] Chern, S.-S.; Moser, J.: *Real hypersurfaces in complex manifolds*, Acta Math. **133** (1974), 219–271.
- [24] Darondeau, L., *Slanted vector fields for jet spaces*, Math. Z. **282** (2016), 547–575.
- [25] Darondeau, L., *On the logarithmic Green-Griffiths conjecture*, Int. Math. Res. Not. IMRN **2016**, no. 6, 1871–1923.
- [26] Darondeau, L., *Fiber integration on the Demailly tower*, Ann. Inst. Fourier (Grenoble) **66** (2016), no. 1, 29–54.
- [27] Darondeau L., *On the logarithmic Green-Griffiths conjecture*. Int. Math. Res. Not. (2016), no. 6, 1871–1923.

- [28] Demailly J.-P., *Algebraic criteria for Kobayashi hyperbolic projective varieties and jet differentials*. AMS Summer School on Algebraic Geometry, Santa Cruz 1995, Proc. Symposia in Pure Math., vol. **062.2**, ed. by J. Kollár and R. Lazarsfeld, Amer. Math. Soc., Providence, RI(1997), 285–360.
- [29] Demailly J.-P., *Holomorphic Morse Inequalities and the Green-Griffiths-Lang Conjecture*. Pure and Applied Math. Quarterly **7** (2011), 1165–1208.
- [30] Demailly, J.P., *Kobayashi and Green-Griffiths-Lang conjectures*, arxiv.org/abs/1801.04765/
- [31] Demailly J.-P., *Recent results on the Kobayashi and Green-Griffiths-Lang conjectures*. Japan. J. Math. **15** (2020), 1–120.
- [32] Deng, Y., *Effectivity in the hyperbolicity-related problems*, arxiv.org/abs/1606.03831/
- [33] Deng Y., *On the Diverio-Trapani Conjecture*. arXiv:1703.07560, math.CV.
- [34] Diverio S., Merker J., Rousseau E., *Effective algebraic degeneracy*. Invent. Math. **180** (2010), no. 1, 161—223.
- [35] Doubrov, B.; Komrakov, B.; Rabinovich, M.: *Homogeneous surfaces in the three-dimensional affine geometry*. Geometry and topology of submanifolds, VIII (Brussels, 1995/Nordfjordeid, 1995), 168–178, World Sci. Publ., River Edge, NJ, 1996.
- [36] Ebenfelt P., *Uniformly Levi degenerate CR manifolds: the 5-dimensional case*. Duke Math. **110** (2001), 37–80.
- [37] Ebenfelt P., Duong N.S., Zaitsev D., *A family of compact strictly pseudoconvex hypersurfaces in \mathbb{C}^2 without umbilical points*. Math. Res. Lett. **25** (2018), no. 1, 75–84.
- [38] P. Ebenfelt and D. Zaitsev, *Invariants and umbilical points on three dimensional CR manifolds embedded in \mathbb{C}^2* , arxiv.org/abs/1605.08709/
- [39] Y. Eliashberg and V. Kharlamov, *Some remarks on the number of complex points of a real surface in a complex one*, Proceeding of the Leningrad Institute Topology Conference 1982, pp. 143–148, Nauka Leningrad Otdel., Leningrad, 1983.
- [40] Eastwood, M.; Ezhov, V.: *On affine normal forms and a classification of homogeneous surfaces in affine three-space*, Geom. Dedicata **77** (1999), no. 1, 11–69.
- [41] V. Ezhov, B. McLaughlin and G. Schmalz, *From Cartan to Tanaka: getting real in the complex world*, Notices of the American Mathematical Society **58** (2011), no. 1, 20–27.
- [42] Ezhov, V.; Schmalz, G.: *Gerd Normal form and two-dimensional chains of an elliptic CR manifold in \mathbb{C}^4* , J. Geom. Anal. **6** (1996), no. 4, 495–529.
- [43] Fels, M.; Kaup, W.: *CR manifolds of dimension 5: a Lie algebra approach*, J. Reine Angew. Math. **604** (2007), 47–71.
- [44] Fels, M.; Kaup, W.: *Classification of Levi degenerate homogeneous CR-manifolds in dimension 5*, Acta Math. **201** (2008), 1–82.
- [45] Foo W.-G., Merker J., Ta T.-A., *Parametric CR-umbilical Locus of Ellipsoids in \mathbb{C}^2* , C.R. Math. **356** (2018), 214–221.
- [46] Foo W.-G., Merker J., Ta T.-A., *Rigid equivalences of 5-dimensional 2-nondegenerate rigid real hypersurfaces $M^5 \subset \mathbb{C}^3$ of constant Levi rank 1*. arXiv:1904.02562, math.DG
- [47] Foo W.-G., Merker J., Ta T.-A., *Nonvanishing of Cartan CR curvature on boundaries of Grauert tubes around hyperbolic surfaces*. arXiv:1904.10203, math.CV
- [48] Foo W.-G., Merker J., Ta T.-A., *On Convergent Poincaré-Moser Reduction for Levi Degenerate Embedded 5-Dimensional CR Manifolds*. arXiv:2003.01952, math.CV
- [49] Foo, W.G.; Merker, J.: *Differential $\{e\}$ -structures for equivalences of 2-nondegenerate Levi rank 1 hypersurfaces $M^5 \subset \mathbb{C}^3$* , arxiv.org/abs/1901.02028/, 72 pages.
- [50] Foo, W.G.; Merker, J.; Ta, T.A.: *Parametric CR-umbilical locus of ellipsoids in \mathbb{C}^2* , C. R. Math. Acad. Sci. Paris **356** (2018), no. 2, 214–221.
- [51] Foo, W.G.; Merker, J.; Ta, T.-A.: *Rigid equivalences of 5-dimensional 2-nondegenerate rigid real hypersurfaces $M^5 \subset \mathbb{C}^3$ of constant Levi rank 1*, arxiv.org/abs/1904.02562/, 31 pages.
- [52] O. Forster, *Lectures on Riemann surfaces*, Graduate Texts in Mathematics, 81, Springer Verlag, Berlin, 1991, viii+254 pp.
- [53] F. Forstnerič, *Complex tangents of real surfaces in complex surfaces*, Duke Mathematical Journal **67** (1992), no. 2, 353–376.
- [54] F. Forstnerič, *Stein manifolds and holomorphic mappings. The homotopy principle in complex analysis*. Ergebnisse der Mathematik und ihrer Grenzgebiete. 3. Folge. 56. Springer-Verlag, Heidelberg, 2011, xii+489 pp.
- [55] Freeman, M.: *Real submanifolds with degenerate Levi form*, Several complex variables, Proc. Sympos. Pure Math., Vol. XXX, Williams Coll., Williamstown, Mass., 1975, Part 1, Amer. Math. Soc., Providence, R.I., 1977, pp. 141–147.
- [56] Gaussier, H.; Merker, J.: *A new example of uniformly Levi degenerate hypersurface in \mathbb{C}^3* , Ark. Mat. **41** (2003), no. 1, 85–94. Erratum: **45** (2007), no. 2, 269–271.

- [57] Gaussier, H.; Merker, J.: *Erratum to “A new example of a uniformly Levi degenerate hypersurface in \mathbb{C}^3 ”*. Ark. Mat. **45** (2007), 269–271.
- [58] H. Grauert, *On Levi’s problem and the imbedding of real-analytic manifolds*, Annals of Mathematics **68** (1958), no. 2, 460–472.
- [59] V. Guillemin and M. Stenzel, *Grauert tubes and the homogeneous Monge-Ampère equation*, Journal of Differential Geometry **34** (1991), no. 2, 561–570.
- [60] Huang X., Ji S., *Every real ellipsoid in \mathbb{C}^2 admits CR umbilical points*, Transactions of the American Mathematical Society **359** (2007), no. 3, 1191–1204.
- [61] Huynh, D.T.: *Construction of hyperbolic hypersurfaces of low degree in $\mathbb{P}^n(\mathbb{C})$* , Internat. J. Math. **27** (2016), no. 8, 1650059, 9 pages.
- [62] Isaev, A.: *Analogues of Rossi’s map and E. Cartan’s classification of homogeneous strongly pseudoconvex 3-dimensional hypersurfaces*, J. Lie Theory **16** (2006), no. 3, 407–426.
- [63] Isaev, A.: *Spherical tube hypersurfaces*, Lecture Notes in Mathematics, 2020, Springer, Heidelberg, 2011, xii+220 pp.
- [64] Isaev, A.: *Affine rigidity of Levi degenerate tube hypersurfaces*, J. Differential Geom. **104** (2016), no. 1, 111–141.
- [65] Isaev, A.: *On the CR-curvature of Levi degenerate tube hypersurfaces*, arxiv.org/abs/1608.02919/, 11 pages.
- [66] Isaev, A.: *Zero CR-curvature equations for Levi degenerate hypersurfaces via Pocchiola’s invariants*, arxiv.org/abs/1809.03029/, Ann. Fac. Sci. Toulouse, to appear.
- [67] Isaev, A.: *Rigid Levi degenerate hypersurfaces with vanishing CR-curvature*, arxiv.org/abs/1901.03044/, 10 pages.
- [68] Isaev, A.; Zaitsev, D.: *Reduction of five-dimensional uniformly degenerate Levi CR structures to absolute parallelisms*, J. Anal. **23** (2013), no. 3, 1571–1605.
- [69] IVEY, Thomas A.; LANDSBERG, Joseph M. *Cartan for beginners.: Differential geometry via moving frames and exterior differential systems*. Second edition [of MR2003610]. Graduate Studies in Mathematics, 175. American Mathematical Society, Providence, RI, 2016. xviii + 453 pp. ISBN: 978-1-4704-0986-9
- [70] Jacobowitz, H.: *Chains in CR geometry*, J. Diff. Geom., **21** (1985), 163–194.
- [71] Jacobowitz, H.: *An introduction to CR structures*, Math. Surveys and Monographs, 32, Amer. Math. Soc., Providence, 1990, x+237 pp.
- [72] Koch, L.: *Chains, null-chains, and CR geometry*, Trans. Amer. Math. Soc. **338** (1993), no. 1, 245–261.
- [73] Kobayashi S., *Hyperbolic complex spaces*. Grundlehren der Mathematischen Wissenschaften, 318. Springer-Verlag, Berlin, 1998. xiv+471 pp.
- [74] Katok, B.; Hasselblatt, A.: *The development of dynamics in the 20th century and the contribution of Jürgen Moser*, Ergodic Theory Dynam. Systems **22** (2002), no. 5, 1343–1364.
- [75] Kolar, M.; Kossovskiy, I.: *A complete normal form for everywhere Levi-degenerate hypersurfaces in \mathbb{C}^3* , arxiv.org/abs/1905.05629/, 24 pages.
- [76] Lai H.F., *Characteristic classes of real manifolds immersed in complex manifolds*, Transactions of the American Mathematical Society **172** (1972), 1–33.
- [77] Libermann, P.: *Sur les structures presque complexes et autres structures infinitésimales régulières*, Bull. Soc. Math. France **83** (1955), 195–224.
- [78] Lie, S. (Author); Merker, J. (Editor): *Theory of Transformation Groups I. General Properties of Continuous Transformation Groups. A Contemporary Approach and Translation*, Springer-Verlag, Berlin, Heidelberg, 2015, xv+643 pp. arxiv.org/abs/1003.3202/
- [79] Loboda, A.V.: *Homogeneous strictly pseudoconvex hypersurfaces in C^3 with two-dimensional isotropy groups*, Sb. Math. **192** (2001), no. 11-12, 1741–1761.
- [80] Loboda, A.V.: *On the determination of a homogeneous strictly pseudoconvex hypersurface from the coefficients of its normal equation*, Math. Notes **73** (2003), no. 3-4, 419–423.
- [81] Loboda, A.V.: *Affinely homogeneous real hypersurfaces in \mathbb{C}^2* , Funct. Anal. Appl. **47** (2013), no. 2, 113–126.
- [82] Medori, C.; Spiro, A.: *The equivalence problem for 5-dimensional Levi degenerate CR manifolds*, Int. Math. Res. Not. IMRN **2014**, no. 20, 5602–5647.
- [83] Medori, C.; Spiro, A.: *Structure equations of Levi degenerate CR hypersurfaces of uniform type*. Rend. Semin. Mat. Univ. Politec. Torino **73** (2015), no. 1-2, 127–150.
- [84] Merker, J.: *The local geometry of generating submanifolds of \mathbb{C}^n and the analytic reflection principle*. I. (Russian) Sovrem. Mat. Prilozh. **6**, Kompleks. Anal. (2003), 3–79; translation in J. Math. Sci. (N.Y.) **125** (2005), no. 6, 751–824.
- [85] Merker, J.: *Lie symmetries of partial differential equations and CR geometry*, Journal of Mathematical Sciences (N.Y.), **154** (2008), 817–922.

- [86] MERKER, J.: *Nonrigid spherical real analytic hypersurfaces in \mathbb{C}^2* , Complex Variables and Elliptic Equations **55** (2010), no. 12, 1155–1182.
- [87] Merker J., Sabzevari M., *Explicit expression of Cartan's connections for Levi-nondegenerate 3-manifolds in complex surfaces, and identification of the Heisenberg sphere*. Cent. Eur. J. Math. **10** (2012), no. 5, 1801–1835.
- [88] J. Merker and M. Sabzevari, *Explicit expression of Cartan's connection for Levi-nondegenerate 3-manifolds in complex surfaces, and identification of the Heisenberg sphere*, Central European Journal of Mathematics **10** (2012), 1801–1835.
- [89] Merker, J.; Pocchiola, S.; Sabzevari, M.: *Equivalences of 5-dimensional CR manifolds, II: General classes I, II, III₁, III₂, IV₁, IV₂*, 5 figures, 95 pages, arxiv.org/abs/1311.5669/
- [90] Merker, J.; Sabzevari, M.: *The Cartan equivalence problem for Levi-non-degenerate real hypersurfaces $M^3 \subset \mathbb{C}^2$* (Russian), Izv. Ross. Akad. Nauk Ser. Mat. **78** (2014), no. 6, 103–140; translation in Izvestiya Math. **78** (2014), no. 6, 1158–1194. arxiv.org/abs/1401.2963/
- [91] Merker J., *Kobayashi hyperbolicity in degree $\geq n^{2n}$* . arXiv:1807.11309, math.AG
- [92] Merker, J.; Pocchiola, S.: *Explicit absolute parallelism for 2-nondegenerate real hypersurfaces $M^5 \subset \mathbb{C}^3$ of constant Levi rank 1*, Journal of Geometric Analysis, 10.1007/s12220-018-9988-3, 42 pages. Addendum: 10.1007/s12220-019-00195-2, 10 pages.
- [93] Merker J., Pocchiola S., *Explicit Absolute Parallelism for 2-Nondegenerate Real Hypersurfaces $M^5 \subset \mathbb{C}^3$ of Constant Levi Rank 1*. J. Geom. Anal. **30** (2020), 2689–2730.
- [94] Merker J., Ta T.-A., *Degrees $d \geq (\sqrt{n} \log n)^n$ and $d \geq (n \log n)^n$ in the Conjectures of Green-Griffiths and of Kobayashi*, arXiv:1901.04042, math.AG
- [95] Merker, J.: *A Lie-theoretic construction of Cartan-Moser chains*, 25 pages, arxiv.org/abs/2001.11276/
- [96] Merker, J.; Nurowski, P.: *On degenerate para-CR structures: Cartan reduction and homogeneous models*, upcoming.
- [97] J. Merker, *Rationality in differential algebraic geometry*, Complex Geometry and Dynamics, The Abel Symposium 2013, Abel Symposia, Vol. **10**, Fornæss, John Erik, Irgens, Marius, Wold, Erlend Fornæss (Eds.), pp. 157–209, Springer-Verlag, Berlin, 2015. arxiv.org/abs/1405.7625/
- [98] J. Merker, S. Pocchiola and M. Sabzevari, *Equivalences of 5-dimensional CR-manifolds, II: General classes I, II, III-1, III-2, IV-1, IV-2*, arxiv.org/abs/1311.5669.
- [99] MERKER, J.: *Lectures on CR-sphericity and CR-umbilicity*, www.math.u-psud.fr/~merker/, 53 pages.
- [100] Merker, J.: *Affine rigidity without integration*, arxiv.org/abs/1903.00889/, 28 pages.
- [101] Merker, J.; Nurowski, P.: *Equivalences of PDE systems associated to para-CR structures*, June 2019, 47 pages.
- [102] Merker, J.; Pocchiola, S.: *Addendum to 'Explicit absolute parallelism for 2-nondegenerate real hypersurfaces $M^5 \subset \mathbb{C}^3$ of constant Levi rank 1'*, Journal of Geometric Analysis, to appear, 8 pages.
- [103] MERKER, J. (Editor); LIE, S. (Author): *Theory of Transformation Groups I. General Properties of Continuous Transformation Groups. A Contemporary Approach and Translation*, Springer-Verlag, Berlin, Heidelberg, 2015, xv+643 pp.
- [104] Moser J.K., Webster S.M., *Normal forms for real surfaces in \mathbb{C}^2 near complex tangents and hyperbolic surface transformations*. Acta Math. **150** (1983), 255–296.
- [105] S.Yu. Nemirovski, *Complex analysis and differential topology on complex surfaces*, Uspekhi Mat. Nauk **54** (1999), no. 4(328), 47–74.
- [106] Noguchi, J., Winkelmann, J., *Nevanlinna theory in several complex variables and Diophantine approximation*. Grundlehren der Mathematischen Wissenschaften, 350. Springer, Tokyo, 2014. xiv+416 pp.
- [107] Nurowski, P.; Tafel, J.: *Symmetries of Cauchy-Riemann spaces*, Lett. Math. Phys. **15** (1988), no. 1, 31–38.
- [108] Nurowski P.; Sparling, G.: *Three-dimensional Cauchy-Riemann structures and second order ordinary differential equations*, Classical Quantum Gravity **20** (2003), no. 23, 4995–5016.
- [109] Olver, P.J.: *Equivalence, Invariance and Symmetries*. Cambridge, Cambridge University Press, 1995, xvi+525 pp.
- [110] Olver, P.J.: *Normal forms for submanifolds under group actions*, Symmetries, differential equations and applications, 1–25. Springer Proc. Math. Stat. **266**, Springer, Cham, 2018.
- [111] Olver, P.J.; Pohjanpelto, J.: *Differential invariant algebras of Lie pseudo-groups*, Adv. Math. **222** (2009), no. 5, 1746–1792.
- [112] Poincaré H., *Les fonctions analytiques de deux variables complexes et la représentation conforme*. Rend. Circ. Mat. Palermo **23** (1907), 185–220.
- [113] Pocchiola S., *Explicit Absolute Parallelism for 2-Nondegenerate Real Hypersurfaces $M^5 \subset \mathbb{C}^3$ of Constant Levi Rank 1*. arXiv:1312.6400, math.CV
- [114] Riedl E., Yang D., *Applications of a grassmannian technique in hypersurfaces*. arXiv:1806.02364, math.AG

- [115] Siu, Y.-T., *Hyperbolicity of generic high-degree hypersurfaces in complex projective space*, Invent. Math. **202** (2015), no. 3, 1069–1166.
- [116] Slapar, M., *Real surfaces in elliptic surfaces*, International Journal of Mathematics **16** (2005), no. 4, 357–363.
- [117] Webster, S.M.: *On the mapping problem for algebraic real hypersurfaces*, Invent. Math. **43** (1977), 53–68.
- [118] Webster, S.M., *Holomorphic differential invariants for an ellipsoidal real hypersurface*, Duke Mathematical Journal **104** (2000), no. 3, 463–475.

The-Anh Ta,

Université Paris-Saclay, Institut de Mathématique d'Orsay - Bâtiment 307,
91405 Orsay, France.

the-anh.ta@universite-paris-saclay.fr

Titre: Sujets en géométrie complexe et CR

Mots clés: Géométrie complexe, Hyperbolicité complexe, Géométrie CR, Forme normale, La méthode d'équivalences de Cartan

Résumé: Ce mémoire contient des résultats de recherche en géométrie complexe et en géométrie CR. Les sujets comprennent les bornes de degré pour les hypersurfaces dans les problèmes liés à l'hyperbolicité de Kobayashi, problèmes d'équivalence et construction de formes normales pour certaines classes d'hypersurfaces 5-dimensionnelles dégénérées de

Levi dans des espaces complexes et des enquêtes sur le lieu de disparition des courbures de Cartan aux frontières de certains domaines 3-dimensionnels. Le thème commun est l'utilisation de jets plus hauts dans diverses situations géométriques pour étudier les invariants des objets géométriques, et l'utilisation extensive de programmes de calcul symbolique pour aider aux calculs compliqués.

Title: Topics in Complex and CR geometry

Keywords: Complex geometry, Complex hyperbolicity, CR geometry, Normal form, Cartan's equivalence method

Abstract: This memoir contains research results in complex geometry and CR geometry. The topics include degree bounds for hypersurfaces in Kobayashi hyperbolicity related problems, equivalence problems and construction of normal forms for certain classes of Levi degenerate 5-dimensional hypersurfaces in complex

spaces and investigations on the vanishing locus of Cartan CR curvatures on boundaries of some 3-dimensional domains. The common theme is the use of higher jets in diverse geometric situations to investigate invariants of geometric objects, and the extensive use of symbolic computation programs to help with complicated calculations.