



HAL
open science

Study and optimisation of IEEE 802.11 PHY and MAC protocols towards a new generation integrated in 5G

Kaoutar Abdelalim

► **To cite this version:**

Kaoutar Abdelalim. Study and optimisation of IEEE 802.11 PHY and MAC protocols towards a new generation integrated in 5G. Networking and Internet Architecture [cs.NI]. Ecole nationale supérieure Mines-Télécom Atlantique, 2019. English. NNT : 2019IMTA0163 . tel-02986448

HAL Id: tel-02986448

<https://theses.hal.science/tel-02986448v1>

Submitted on 3 Nov 2020

HAL is a multi-disciplinary open access archive for the deposit and dissemination of scientific research documents, whether they are published or not. The documents may come from teaching and research institutions in France or abroad, or from public or private research centers.

L'archive ouverte pluridisciplinaire **HAL**, est destinée au dépôt et à la diffusion de documents scientifiques de niveau recherche, publiés ou non, émanant des établissements d'enseignement et de recherche français ou étrangers, des laboratoires publics ou privés.

THESE DE DOCTORAT DE

L'ÉCOLE NATIONALE SUPERIEURE MINES-TELECOM ATLANTIQUE
BRETAGNE PAYS DE LA LOIRE - IMT ATLANTIQUE
COMUE UNIVERSITE BRETAGNE LOIRE

ECOLE DOCTORALE N° 601
*Mathématiques et Sciences et Technologies
de l'Information et de la Communication*

Spécialité : Télécommunications

Par

Kaoutar ABDELALIM

Study and optimisation of IEEE 802.11 PHY and MAC protocols towards a new generation integrated in 5G

Thèse présentée et soutenue à Rennes le 09 décembre 2019
Unité de recherche : Département SC, laboratoire Lab-STICC
Thèse N° : 2019IMTA0163

Rapporteurs avant soutenance :

Jean-Marie GORCE Professeur, INSA de Lyon.
Didier LE RUYET Professeur, CNAM.

Composition du Jury :

Président :	Jean-François HELARD	Professeur, INSA de Rennes.
Examineurs :	Jean-Marie GORCE	Professeur, INSA de Lyon.
	Didier LE RUYET	Professeur, CNAM.
	Stefano AVALLONE	Maître de Conférences, Università di Napoli "Federico II".
	Getachew REDIETEAB	Ingénieur de recherche, Orange Labs. (Co-encadrant)
Directrice de thèse :	Sandrine DESTOUET ROBLOT	Ingénieure de recherche, Orange Labs. (Co-encadrante)
	Karine AMIS	Professeure, IMT Atlantique.

In Partial Fulfillment of the Requirements for the Degree of Doctor
of Philosophy from IMT Atlantique Bretagne-Pays de la Loire

Study and Optimisation of IEEE 802.11 PHY and MAC protocols towards a new generation integrated in 5G

Mention: Telecommunications

Presented by: Kaoutar ABDELALIM
Departement: Signal and Communications
Laboratory: LabSTICC

Thesis director: Karine AMIS

Defended on Decembre 09th, 2019

Jury :

<i>President</i>	Jean-François HELARD	INSA Rennes
<i>Reporters</i>	Didier LE RUYET	CNAM Paris
	Jean-Marie GORCE	INSA Lyon
<i>Examiner</i>	Stefano AVALLONE	University of Naples
<i>Ph.D director:</i>	Karine AMIS	IMT Atlantique, Brest
<i>Supervisors</i>	Getachew REDIETEAB	Orange Labs, Cesson-Sevigné
	Sandrine DESTOUET ROBLOT	Orange Labs, Cesson-Sevigné



This thesis took place at Orange Labs, team CTE, Rennes.

*To my beloved parents Malika and Ahmed,
To my husband Yassine...*

Acknowledgements

I would like to express my sincere thanks to my supervisors Karine AMIS, Sandrine DESTOUET ROBLOT and Getachew REDIETEAB, for giving me the opportunity to make this PhD thesis. Thanks a lot for all your insightful advises and guidance. I cannot thank you enough for all your support throughout these three years. It was a really big pleasure to work with you.

I would like to address my thanks to all the members of my thesis committee, Jean-François HELARD, Jean-Marie GORCE, Didier LE RUYET and Stefano AVALLONE for reviewing, evaluating and discussing this work.

I also express my sincere thanks to my Orange team leader Philippe Blusseau, and to his predecessor Jean-Christophe Rault, for welcoming me at the CTE team in Orange. Thank you for your continuous availability. I would like to warmly thank all my colleagues, the whole CTE team, PhD students and interns. Thank you for your kindness, your help and your support.

Last but not least, I am deeply grateful to my parents Malika and Ahmed who have always supported and encouraged me. I cannot thank you enough. Without you, this thesis would not have been possible. I address a special thank to my beloved husband Yassine for his unconditional love, patience and for always believing in me and encouraging me. I also express my thanks to my parents in law Khadija and Youssef for their continuous support. My thanks goes also to my brothers Walid and Youness, my sister in law Meryem and my little nephew Achraf for being always here for me.

Kaoutar ABDELALIM

Résumé

La perpétuelle croissance des applications sans fil pose de plus en plus de défis aux technologies sans fil nécessitant plus d'améliorations. L'une des technologies radio les plus utilisées est le Wi-Fi qui fait l'objet de ce travail. Elle devient l'une des principales technologies utilisées connectant toutes sortes d'appareils. Depuis son lancement en 1999 dans le cadre de la norme IEEE 802.11, son évolution cherche continuellement à relever tous les défis résultant d'une utilisation excessive. L'amélioration de la qualité des scénarios d'environnement dense (par exemple les aéroports, les stades, les centres commerciaux, etc.) a été l'un des principaux objectifs du dernier amendement Wi-Fi, qui est l'IEEE 802.11ax. Il vise à améliorer les transmissions des réseaux sans fil en faisant évoluer ou/et en ajoutant de nouvelles technologies soit pour améliorer la diversité des utilisateurs, soit pour augmenter le débit par utilisateur, entre autres. Les travaux de cette thèse rejoignent les mêmes objectifs qui se concentrent sur l'amélioration de l'expérience d'un utilisateur dans un environnement dense. En plus d'une analyse approfondie de la norme, nous avons développé deux axes principaux (exposés dans les paragraphes suivants) à savoir, l'allocation des ressources pour l'OFDMA (pour *orthogonal frequency multiple access*) en mode accès aléatoire pour la norme IEEE 802.11ax et la négociation adaptative de la session d'acquittement par bloc (AN-BA).

Le premier axe propose de nouvelles configurations concernant l'allocation des ressources pour l'OFDMA. Nous proposons d'allouer jusqu'à deux utilisateurs dans la même ressource afin de limiter les collisions entre les stations et permettre également une meilleure exploitation du spectre, notamment pour le mode d'accès aléatoire. Deux approches sont utilisées pour traiter l'allocation de plusieurs utilisateurs. La première est la technique SIC (pour *successive interference cancellation*), utilisée pour annuler l'interférence entre utilisateurs. La deuxième approche consiste à procéder par une détection conjointe au cas où les utilisateurs présenteraient un niveau de puissance équivalent.

Le deuxième axe concerne l'AN-BA, qui est basé sur une méthode modifiée du mécanisme d'acquittement par bloc (BA), permettant une plus grande flexibilité pour changer la taille du *buffer*. Pour le mécanisme d'origine, le changement de la taille du *buffer* doit être renégocié via une nouvelle négociation d'établissement de session incluant toutes les trames de contrôle initiales. Cette méthode permet de modifier la taille du *buffer* pendant la session, soit en l'augmentant, soit en le diminuant. L'analyse des performances a été établie à l'aide du simulateur de réseau ns-3 où plusieurs modifications ont été apportées pour supporter l'AN-BA. De plus, un modèle analytique de la méthode a été établi et validé.

mots clé: IEEE 802.11ax, OFDMA, accès aléatoire, allocation des ressources, block d'acquittement, QoS, WLANs, ns-3.

Abstract

The high growth of wireless applications brings greater challenges to wireless technologies and calls for more improvements and better efficiency. One of the most commonly used radio technologies is Wi-Fi which is the topic of this work. It becomes one of main used technologies connecting all sort of devices either for indoor or outdoor utilisation. Since its release in 1999 within the framework of the IEEE 802.11 norm, its evolution continuously tries to keep up with all the challenges resulting from an excessive use. Improving the quality of dense environment scenarios (e.g. airports, stadiums, malls, etc.) has been one of the main objectives of the last Wi-Fi amendment, the IEEE 802.11ax. It aims to improve wireless network transmissions by evolving or/and adding new technologies either to improve the user diversity or to increase the per user throughput, to mention a few. Meanwhile, the work of this thesis joins the same purposes which focus on the improvement of the user experience within a dense environment. In addition to a deep analysis of the norm, we developed two main directions (exposed in following paragraphs) namely, the resource allocation in orthogonal frequency division multiple access (OFDMA) in random access mode for the IEEE 802.11ax standard and the adaptive negotiation of the block acknowledgement session (AN-BA).

The first axis proposes new configurations regarding OFDMA resource allocations. We propose to allocate up to two users in the same resource in order to limit the collisions between the stations and also allow a better exploitation of the spectrum, in particular for the random access mode. Two approaches are used to treat the allocation of multiple users. The first one is the SIC (successive interference cancellation) technique, employed to cancel the interference between users. The second approach is to proceed by a joint detection in case users present same power levels.

The second axis includes the AN-BA, which is based on a modified method of the block acknowledgement (BA) mechanism, allowing greater flexibility in the size of the data *buffer*. For the original mechanism, the change of the *buffer* size must be renegotiated through a new session setup handshake including all initial control frames. This method allows to change the size of the *buffer* during the session, either by increasing it or decreasing it. The analysis of the performances have been established with the aid of the ns-3 network simulator where several modifications have been made to support AN-BA. In addition, an analytical model of the method has been established and validated.

Keywords: IEEE 802.11ax, OFDMA, random access, resource allocation, block acknowledgement, QoS, WLANs, ns-3.

List of Figures

1	Configurations proposées des allocations des RUs pour le IEEE 802.11ax	4
2	Mécanisme d’acquittement par bloc	6
3	Exemple d’établissement de la session d’acquittement par bloc sous l’AN-BA	7
1.1	IEEE 802.11 architectures	23
1.2	Different IEEE 802.11 PHY frame formats	26
1.3	IEEE 802.11 OFDM symbol	27
1.4	Basic channel access	31
1.5	AC-based queue management in EDCA	33
1.6	EDCA basic mechanism (PIFS stands for point coordination function IFS)	33
1.7	IEEE 802.11 protocol layering	34
1.8	MAC and PHY encapsulation of aggregated IEEE 802.11 frames	35
1.9	IEEE 802.11 MAC frame format	35
1.10	IEEE 802.11 control field	35
1.11	Example of Ack mechanism within the IEEE 802.11 amendment	39
1.12	Example of BA mechanism as proposed in the IEEE 802.11n	40
1.13	Immediate Block ACK	40
1.14	Delayed Block ACK	40
1.15	Orthogonal frequency multiple access	45
1.16	Different OFDMA allocation schemes	45
1.17	OFDMA configurations in 802.11ax for 20 MHz	47
1.18	Example of stations accessing to available RUs under the random access mode	49
1.19	IEEE 802.11ax HE PPDU frame format	50
1.20	IEEE 802.11ax MAC frame modified fields	52
1.21	Format of the HE variant HT Control field	52
1.22	A-Control subfields of the HE variant HT Control field	53
1.23	Example of MU transmission within the IEEE 802.11ax standard	54
2.1	Two stations in random access mode collide after choosing the same OBO value.	59
2.2	Proposed resource allocation configurations for the IEEE 802.11ax	60
3.1	Overview of ns-3 node involved objects	77
3.2	Architecture of ns-3 Wi-Fi module	78
3.3	File transfer protocol: server to client	81

3.4	Scenario (a) - Low-density scenario	83
3.5	Scenario (c) - Medium-density scenario	83
4.1	Example of a BA session	87
4.2	Example of the adaptive negotiation for BA session management	91
4.3	Example of a BA session under the basic BA mechanism (left) and the AN-BA method (right)	94
4.4	Channel access mechanism	99
4.5	Switch case example: Updating the buffer size from 2^{a-1} to 2^a	99
4.6	Increase case example: Periodic buffer size increase to reach the targeted value of 64	100
4.7	Different potential TXOP structures for AN-BA method . . .	103
4.8	Comparison of the per user saturation throughput with AN-BA obtained by the analytical model to ns-3 simulation measures for the buffer size switch case	108
4.9	Comparison of the per user saturation throughput with AN-BA obtained by the analytical model to ns-3 simulation measures for the buffer size increase case	109
4.10	Packet outage rate of the BA and AN-BA methods, low density environment, full-buffer, buffer size switch case	111
4.11	Per user average delay of the BA and AN-BA methods, low density environment, full-buffer, buffer size switch case	111
4.12	Per user average throughput of the BA and AN-BA methods, low density environment, full-buffer, buffer size switch case . .	111
4.13	Packet outage rate of the BA and AN-BA methods, medium density environment, full-buffer, buffer size switch	112
4.14	Per user average delay of the BA and AN-BA methods, medium density environment, full-buffer, buffer size switch case	112
4.15	Per user average throughput of the BA and AN-BA methods, medium density environment, full-buffer, switch case scheme .	113
4.16	Packet outage rate of the BA and AN-BA methods, low density environment, full-buffer, buffer size increase case	114
4.17	Per user average delay of the BA and AN-BA methods, low density environment, full-buffer, buffer size increase case . . .	114
4.18	Per user average throughput of the BA and AN-BA methods, low density environment, full-buffer, buffer size increase case .	115
4.19	Packet outage rate of the BA and AN-BA methods, medium density environment, full-buffer, buffer size increase case . . .	116
4.20	Per user average delay of the BA and AN-BA methods, medium density environment, full-buffer, buffer size increase case . . .	116
4.21	Per user average throughput of the BA and AN-BA methods, medium density environment, full-buffer, buffer size increase case	116

4.22	FTP packet outage rate of the BA and AN-BA methods, low density environment, FTP, buffer size switch case	117
4.23	Per user average delay of the BA and AN-BA methods, low density environment, FTP, buffer size switch case	118
4.24	Per user average throughput of the BA and AN-BA methods, low density environment, FTP, buffer size switch case	118
4.25	FTP packet outage rate of the BA and AN-BA methods, medium density environment, FTP, buffer size switch case	119
4.26	Per user average delay of the BA and AN-BA methods, medium density environment, FTP, buffer switch case	119
4.27	Per user average throughput of the BA and AN-BA methods, medium density environment, FTP, buffer size switch case	119
4.28	FTP packet outage rate of the BA and AN-BA methods, low density environment, FTP, buffer size increase case	120
4.29	Per user average delay of the BA and AN-BA methods, low density environment, FTP, buffer size increase case	120
4.30	Per user average throughput of the BA and AN-BA methods, low density environment, FTP, buffer size increase case	121
4.31	FTP packet outage rate of the BA and AN-BA methods, medium density environment, FTP, buffer size increase case	122
4.32	Per user average delay of the BA and AN-BA methods, medium density environment, FTP, buffer size increase case	122
4.33	Per user average throughput of the BA and AN-BA methods, medium density environment, FTP, buffer size increase case	122

List of Tables

1	Les différents états des bits de contrôle	7
1.1	IEEE 802.11 PHY layer evolution	21
1.2	IEEE 802.11 OFDM parameter values in 20 MHz bandwidth .	27
1.3	Modulation schemes of the IEEE 802.11a/g amendment	29
1.4	MCS table of the IEEE 802.11n/ac amendment for 1 spatial stream	29
1.5	Different access categories and corresponding priorities	33
1.6	Maximum number of RUs for each channel width	46
1.7	IEEE 802.11ax OFDM parameter values	47
1.8	Data rate of MCSs added by the IEEE 802.11ax for 1 SS and GI = 0.8 μ s	48
3.1	Common simulation parameters (Scenarios (a), (b) and (c)) .	82
4.1	Control bits states during setup session	91
4.2	Control bits states during established session	92
4.3	Simulation parameters for Matlab implementation of the ana- lytical model of AN-BA (Scenario (a))	107
4.4	Comparison of the packet outage rate of BA and AN-BA using the maximum buffer size value (i.e. 64)	124
4.5	Comparison of the per user average delay of BA and AN-BA under the maximum buffer size value (i.e. 64)	124
4.6	Comparison of the per user average throughput of BA and AN- BA under the maximum buffer size value (i.e. 64)	124

Acronyms

AC	Access Category
Ack	Acknowledgement mechanism
ACK	ACKnowledgement frame
ADDBA	ADD Block Acknowledgement
AIFS	Arbitration Inter Frame Space
AIFSN	AIFS Number
A-MPDU	Aggregate MAC Protocol Data Unit
A-MSDU	Aggregate MAC Service Data Unit
AN-BA	Adaptive Negotiation of the Block Acknowledgement session
AP	Access Point
ARF	Auto Rate Fallback
AWGN	Additive White Gaussian Noise
BA	Block Acknowledgement
BCC	Binary Convolutional Code
BE	Best Effort
BEB	Binary Exponential Back-off
BK	BacKground
BPSK	Binary Phase Shift Keying
BSA	Basic Service Area
BSR	<i>buffer</i> Status Report
BSS	Basic Service Set
BSSID	Basic Service Set IDentifier
CRC	Cyclic Redundancy Check
CSI	Channel State Information
CSMA/CA	Carrier Sense Multiple Access with Collision Avoidance
CST	Carrier Sense Threshold

CTS	Clear To Send
CW	Contention Window
DAB	Digital Audio Broadcasting
DCF	Distributed Coordination Function
DELBA	DELeTe Block Acknowledgement
DELI	DELImiter
DIFS	DCF Inter Frame Space
DL	DownLink
DS	Distribution System
DSC	Dynamic Sensitivity Control
DSSS	Direct Sequence Spread Spectrum
DVB	Digital Video Broadcasting
EDCA	Enhanced Distributed Channel Access
EIFS	Extended Inter Frame Space
ESS	Extended Service Set
FCS	Frame Check Sequence
FDM	Frequency Division Multiplexing
FFT	Fast Fourier Transform
FHSS	Frequency Hopping Spread Spectrum
Gbps	Giga bits per second
GI	Guard Interval
GNU GPLv2	GNU General Public License version 2
GO	Group Owner
HE	High Efficiency
HE ER SU	HE Extended-Range Single User
HE MU	HE Multiple User
HE SU	HE Single User

HE TB	HE Trigger-Based
HT	High Throughput
HT-LTF	HT Long Training Field
HT-STF	HT Short Training Field
ICI	Inter Carrier Interference
IEEE	Institute of Electrical and Electronics Engineers
IFFT	Inverse Fast Fourier Transform
IFS	Inter Frame Space
IP	Internet Protocol
IR	Infrared
ISI	Inter Symbol Interference
LDPC	Low-Density Parity-check Code
LLC	Logical Link Control
L-LTF	Legacy Long Training Field
L-SIG	Legacy Signal Field
L-STF	Legacy Short Training Field
LTE	Long Term Evolution
LTF	Long Training Field
MAC	Medium Access Control
Mbps	Mega bits per second
MCS	Modulation and Coding Scheme
MIMO	Multiple Input Multiple Output
MPDU	MAC Protocol Data Unit
MSDU	MAC Service Data Unit
MU	Multiple User
MU-MIMO	Multiple User MIMO
NAV	Network Allocation Vector

NDP	Null Data Packet
ns-3	network simulator 3
OBO	OFDMA Back-Off
OBSS	Overlapping Basic Service Set
OCW	OFDMA Contention Window
OFDM	Orthogonal Frequency Division Multiplexing
OFDMA	Orthogonal Frequency Division Multiple Access
PHY	PHYSical layer
PHY-CCA	Physical Clear Channel Assessment
PPDU	PHY Protocol Data Unit
PS	Power Save
PSDU	PHY Service Data Unit
QAM	Quadrature Amplitude Modulation
QoS	Quality of Service
QPSK	Quadrature Phase Shift Keying
RA	Random Access
RAA	Rate Adaptation Algorithm
RBAR	Receiver Based Auto Rate
RTS	Request To Send
RU	Resource Unit
SIC	Successive Interference Cancellation
SIFS	Short Inter Frame Space
SISO	Single Input Single Output
SNR	Signal to Noise Ratio
SS	Spatial Stream
SSID	Service Set IDentifier
SSN	Starting Sequence Number

ST	Saturation Throughput
STA	STAtion
STF	Short Training Field
SU	Single User
SU-MIMO	Single User MIMO
TCP	Transmission Control Protocol
TF	Trigger Frame
TF-R	Trigger Frame Random access
TGax	Task Group IEEE 802.11ax
TID	Traffic IDentifier
TPC	Transmit Power Control
TXOP	Transmission Opportunity
UDP	User Datagram Protocol
UL	UpLink
UORA	Uplink OFDMA Random Access
VHT	Very High Throughput
VHT-LTF	VHT Long Training Field
VHT-SIG	VHT Signal Field
VHT-STF	VHT Short Training Field
VI	VIdeo
VO	VOIce
Wi-Fi	Wireless Fidelity
WLAN	Wireless Local Area Network
YANS	Yet Another Network Simulator

Notations

OFDMA with random access mode

N	Number of resource units
K	Number of primary users
K'	Number of secondary users
L	Number of subcarriers
I	Number of available resource units for the secondary user
U_n	n -th resource unit
$\nu_{n,\ell}$	Frequency of the the n -th resource unit and ℓ -th subcarrier
$g_{n,\ell}^{(k)}$	Channel gain for the k -th primary user over the n -th resource unit and the ℓ -th subcarrier
$h_{i,\ell}^{(k')}$	Channel gain for the k' -th secondary user over the i -th resource unit and the ℓ -th subcarrier
σ^2	Noise variance
R	Total throughput
$\delta_{i,n}$	Kronecker symbol, equals to 1 if $i = n$ and 0 otherwise
P_M	Maximum power for primary user
Q_M	Maximum power for secondary user
$y_{i,\ell}$	Received signal over i -th resource unit and ℓ -th subcarrier
d_p	Symbol sent by the primary user
d_s	Symbol sent by the secondary user
P_{es}	Probability of symbol error
\hat{d}_p	Estimated symbol for primary user
d_{min}	Minimum distance between the transmitted and the received symbols
i^*	Index of the resource unit allocated to the secondary user
$p_{n,\ell}^{(k)}$	Effective power of the k -th primary user over the n -th resource unit and the ℓ -th subcarrier
$q_{i,\ell}^{(k')}$	Effective power of the k' -th secondary user over the i -th resource unit and the ℓ -th subcarrier
$\boldsymbol{\pi}_n^{(k)}$	Intermediate optimum power vector of the primary user
$\mathbf{s}_n^{(k)}$	Allocation indicator vector
$\mathbf{p}_n^{(k)}$	Effective power vector of the k -th primary user over the n -th resource unit
$\mathbf{b}_n^{(k)}$	Number of bits vector for the k -th primary user over the n -th resource unit
\mathbf{q}_i	Effective power vector of the secondary user over the i -th resource unit
\mathbf{b}'_i	Number of bits vector for the secondary user over

	the i -th resource unit
G	Matrix of channel gains for primary users
H	Matrix of channel gains for secondary users

Adaptive negotiation of the BA session

P_I	Probability that all stations are idle
P_S	Probability that a transmission is successful
P_C	Probability of collision
τ	Probability that a station accesses the medium
K	Number of stations aiming to access to the medium
$CW_{i,min}$	Minimum contention window value for the i -th access category
$CW_{i,max}$	Maximum contention window value for the i -th access category
CW_i^l	Contention window value for the i -th access category and the l -th retransmission
$b(t)$	Back-off counter at t -th time slot
$b_l(t)$	Back-off counter at t -th time slot and the l -th retransmission
$s(t)$	Stochastic process representing the number of retransmissions at t -th time slot
T	Total transmission time
$T_{(.)}$	Frame duration
$ST(i)$	Saturation throughput for the i -th access category
$(.)^{sw}$	Variables associated with the switch case
$(.)^{in}$	Variables associated with the increase case
L_f	Size of QoS Data packets
$N_f^{(.)}(i)$	Total number of aggregated MAC protocol data units for the i -th access category
$N_f^{(.)}(i, j)$	Number of transmitted aggregated MAC protocol data units for the i -th access category and the j -th aggregation level
$N_p^{(.)}(i, j)$	Number of transmitted PHY protocol data units for the i -th access category and the j -th aggregation level
$T_{(1,2)S}$	Block of frame durations in case of success
$T_{(1,2)C}$	Block of frame durations in case of collision
a	Aggregation level
T_{update}	Update period
γ	Number of T_{update} to reach the j -th aggregation level

Contents

Acknowledgement	iii
Résumé	v
Abstract	vii
List of Figures	xi
List of Tables	xiii
Acronyms	xv
Notations	xxi
Contents	xxv
Résumé étendu en français	1
Introduction	13
1 Survey on the IEEE 802.11 norm	19
1.1 Introduction	19
1.2 IEEE 802.11 basics and evolution toward the IEEE 802.11ac amendment	20
1.2.1 Overview of the IEEE 802.11 amendments' evolution	20
1.2.2 IEEE 802.11 architecture	22
1.2.3 PHY basics and evolution	24
1.2.4 MAC basics and evolution	30
1.3 IEEE 802.11ax	42
1.3.1 IEEE 802.11ax challenges and objectives	42
1.3.2 PHY layer improvements	43
1.3.3 MAC layer improvements	50
1.3.4 Multiple user enhancements	53
1.4 Summary	55
2 OFDMA with random access mode	57
2.1 Introduction	57
2.2 State-of-the-art and motivations	58
2.3 Resource allocation configurations	59
2.3.1 Configuration (1): Standard configuration	60

2.3.2	Configuration (2): Scheduled station and RA station	60
2.3.3	Configuration (3): Two RA stations	60
2.4	Analytical representation	61
2.4.1	Considered assumptions	61
2.4.2	Allocation of primary STAs	62
2.4.3	Allocation of secondary STAs	66
2.5	Analysis and conclusions	73
2.6	Perspectives	74
3	Network simulation environment and selected scenarios	75
3.1	Introduction	75
3.2	Network simulation tool: ns-3	75
3.2.1	Generalities	75
3.2.2	Organisation and key principles	76
3.2.3	Architecture of ns-3 Wi-Fi module	77
3.2.4	ns-3 modules affected by the block acknowledgement policy	79
3.3	Metrics of interest	80
3.4	Selected applications	80
3.4.1	File transfer protocol	80
3.4.2	Full-buffer application	81
3.5	Considered IEEE 802.11 scenarios	82
3.5.1	Common simulation parameters	82
3.5.2	Scenario (a): Low-density scenario under IEEE 802.11ac	83
3.5.3	Scenario (b): Low-density scenario under IEEE 802.11ax	83
3.5.4	Scenario (c): Medium-density scenario under IEEE 802.11ax	83
3.6	Conclusion	84
4	Adaptive negotiation of the BA session	85
4.1	Introduction	85
4.2	IEEE 802.11e block acknowledgement mechanism	86
4.2.1	Description	86
4.2.2	Discussion: BA performance analysis	88
4.3	Proposed adaptive negotiation of the block acknowledgement session	90
4.3.1	Description of the AN-BA mechanism	90
4.3.2	AN-BA potential benefits compared to BA	93
4.3.3	AN-BA backward compatibility	94
4.4	Analytical model for AN-BA	94
4.4.1	State-of-the-art	95
4.4.2	Generic model for IEEE 802.11 standard	96
4.4.3	Selected buffer size adaptation schemes	99

4.4.4	Saturation throughput: General expression	100
4.4.5	Analytical saturation throughput expression for AN-BA mechanism	102
4.5	Simulation setup	106
4.5.1	Matlab implementation of the analytical model	106
4.5.2	Implementation of the AN-BA in ns-3	107
4.6	Comparison of analytical model numerical results with ns-3 measured throughput	108
4.6.1	Results	108
4.6.2	Discussion	109
4.7	Comparison of AN-BA with BA reference	109
4.7.1	Full buffer application	110
4.7.2	File transfer protocol application	117
4.7.3	Analysis	123
4.8	Conclusion	125
	Conclusions and Perspectives	127
	Bibliography	131

Résumé étendu en français

Introduction

Avec l'émergence massive du trafic sans fil, les technologies sans fils, telles que le cellulaire ou le Wi-Fi (pour *Wireless Fidelity*), continuent d'améliorer la qualité globale de la connectivité. Il est prévu que pour l'an 2022 les utilisateurs du réseau internet dépasseront 4,8 milliards [1] (3,4 milliards utilisateurs d'internet ont enregistré en 2017). Exploitant toutes les applications existantes (tel que la vidéo, le streaming, les jeux vidéos, etc.) ou émergentes (Internet des objets pour n'en citer qu'une), d'ici 2022, le trafic total du protocole IP (pour *internet protocol*) devrait être distribué comme suit: 51 % Wi-Fi, 29 % filaire et 20 % cellulaire. Le Wi-Fi restera la technologie la plus utilisée pour l'accès à Internet. Une telle utilisation massive, combinée à l'étendue des applications sans fil, se traduit par des attentes plus élevées des utilisateurs Wi-Fi (débit, efficacité ...), en particulier avec l'amélioration parallèle des réseaux cellulaires. Il est presque impératif de continuer à améliorer le Wi-Fi tout en considérant toutes les améliorations prometteuses des réseaux cellulaires. En promettant des améliorations, nous pouvons citer la toute dernière technologie cellulaire qui est la cinquième génération 5G (pour *5th generation*) offrant l'une des performances les plus élevées à ce jour. Lorsque la 5G offre la meilleure couverture, spécialement pour les grands environnements extérieurs, le Wi-Fi reste le meilleur choix pour une utilisation en intérieur (entreprise, maison ...). Même si la 5G vise à devenir l'avenir des réseaux sans fil, cette approche est évidemment compliquée que ça économiquement ou pratiquement. La coexistence de ces deux technologies est donc complémentaire, même obligatoire, pour assurer un déploiement précis. Le contexte principal de cette thèse s'inscrit dans le domaine du Wi-Fi qui n'a cessé d'évoluer au fil de ces dernières années. La communauté scientifique continue de modifier les techniques et les protocoles de base pour ainsi améliorer la norme IEEE (pour *institute of electrical and electronics engineers* 802.11 [2] définissant les spécifications du Wi-Fi. Chaque version de la norme, définie en tant que standard, modifie les techniques existantes ou propose des nouvelles [3][4][5][6][7]. Chaque modification a pour but d'améliorer la qualité globale du réseau, pour le rendre plus robuste aux contraintes existantes. Ces améliorations concernent principalement les protocoles des couches PHY (PHY pour *physical*) et MAC (pour *medium access channel*) dans le but d'assurer de meilleures performances au sein du réseau. La norme a proposé d'importantes améliorations sur plusieurs techniques permettant d'assurer une meilleure qualité du réseau tout en assurant des débits de données plus élevés. A titre d'exemple,

le débit de données maximal de la couche PHY est passé de 54 Mbps (pour *mega bits per second*) dans l'IEEE 802.11a [4] à 6,93 Gbps (pour *giga bits par seconde*) dans IEEE 802.11ac [7]. Cette augmentation est assurée grâce à la modification de différentes technologies existantes (ordres de modulations plus élevés, plus grand nombre de flux spatiaux ...) ou l'introduction de nouvelles techniques. Entre autres l'OFDM (pour *orthogonal frequency division multiplexing*) [8][9][10], a été publié pour la première fois dans l'IEEE 802.11a [4] en 1999 et a permis de considérables améliorations [11]. La technique du MIMO (pour *multiple input multiple output*), dont l'histoire remonte aux années 1920, en fait également partie. Elle a été introduite pour la première fois dans l'IEEE 802.11n [6] et a beaucoup contribué à l'amélioration de la qualité des réseaux sans fils, en particulier en termes de débit de données [12]. Le standard IEEE 802.11ac [7] se basant sur ces différentes techniques (i.e. OFDM et MIMO) a pu aussi introduire des améliorations supplémentaires. Toutes ces améliorations se traduisent par de meilleures performances des réseaux sans fil, en termes de débit, de latence ou d'efficacité de transmission.

Grâce à toutes ces améliorations, l'utilisation de la technologie Wi-Fi connaît un énorme progrès en parallèle de l'utilisation massive du trafic IP. Telles contraintes entraînent d'importantes dégradations de performances, surtout quand il s'agit d'environnements denses (par exemple les aéroports ou les stades). Même si les deux standards IEEE 802.11n et IEEE 802.11ac incorporent plusieurs avancées technologiques importantes à la norme de base, elles se sont révélées assez inefficaces dans des environnements denses; on observe en effet une baisse importante du débit en présence d'un grand nombre d'utilisateurs. L'augmentation de l'ordre de modulation, de la bande passante ou du nombre de flux spatiaux ne semble pas d'une grande avancée pour les déploiements denses.

Pour toutes ces raisons, le groupe IEEE 802.11a constitué le groupe de travail TGax (pour *task group ax*) en 2013, afin de prendre en main tous les défis liés aux environnements denses. Le TGax fonctionne dans le cadre du dernier amendement connu sous le nom de l'IEEE 802.11ax. Ce standard introduit un certain nombre d'améliorations requises pour résoudre les problèmes de scénarios encombrés, tels que la réduction des interférences, l'augmentation du débit minimal par utilisateur ou l'amélioration de la réutilisation spectrale. Que ce soit en améliorant les techniques existantes ou en introduisant des nouvelles, son objectif ultime est d'améliorer la qualité du réseau dans les environnements denses en garantissant un débit plus élevé par utilisateur tout en améliorant la gestion des interférences. Cela est assuré grâce à plusieurs améliorations telles que l'introduction de l'OFDMA (pour *orthogonal frequency multiple access*) ou la réutilisation spatiale entre autres. Les principales améliorations IEEE 802.11ax sont soulignées dans ce travail de thèse. Ce dernier standard, dont la publication est prévue en 2020, est

donc très prometteur devrait permettre à l'IEEE 802.11 d'offrir un service équivalent à la 5G.

Allocation des ressources pour le mode d'accès aléatoire de l'OFDMA

Comme mentionné précédemment, le déploiement des équipements sans fils est en perpétuelle évolution, son utilisation est ainsi de plus en plus intense oeuvrant à des scénarios de grande capacité exposés aux dégradations. En effet, parmi les principaux objectifs du dernier standards, l'amélioration du débit par utilisateur dans un environnement dense sous une grande utilisation (aéroport, stade, gare...).

Dans cette perspective, le dernier standard IEEE 802.11ax apporte plusieurs améliorations pour le réseau sans fil en modifiant certaines techniques des standards antérieurs ou en y introduisant de nouvelles afin d'augmenter les performances. L'OFDMA fait partie des nouveaux mécanismes introduits au standard IEEE 802.11ax, qui en ayant la même spécificité de l'OFDM, assure l'accès multiple au réseau en exploitant la dimension fréquentielle, i.e. plusieurs utilisateurs peuvent occuper le canal et transmettre simultanément. Plus précisément, la bande totale disponible est subdivisée en RU (pour *resource unit*) de largeur variable afin de répartir, si besoin, les ressources fréquentielles entre les différents utilisateurs concernés par la trame à transmettre. Il est à noter que l'OFDMA s'applique autant en voie descendante (à savoir du point d'accès vers les stations) qu'en voie montante (des stations vers le point d'accès) mais que, dans les deux cas, l'allocation se fait par l'AP (pour *access point*). Par ailleurs, une nouvelle notion fait son apparition dans le dernier amendement qui est l'accès aléatoire aux ressources en voie montante pour l'OFDMA, où l'AP réserve des RU à des STA (pour *STA*), associé ou non à l'AP, où elles prennent le relais pour choisir aléatoirement une des RU disponibles. L'allocation est effectuée en tenant en compte de plusieurs paramètres (par exemple: rapport signal à bruit SNR (pour *Signal to Noise Ratio*), la puissance, le taux d'erreurs binaires BER (pour *bit error rate*)...). Par ailleurs, le mode d'accès aléatoire autorise la STA à choisir aléatoirement une des ressources disponibles communiquées à priori par l'AP dans la trame appelée TF-R (pour *trigger frame random access*) annonçant aux STAs le nombre de sous canaux disponibles pour accéder en mode d'accès aléatoire. L'accès au canal en mode d'accès aléatoire est fait de la même manière qu'en CSMA/CA (pour *carrier sense multiple access/collision avoidance*) qui est une technique permettant aux stations d'occuper le canal d'une manière équitable faisant appel à l'algorithme de backoff pour éviter les collisions. Pour choisir une RU en mode d'accès aléatoire, il faut que le nombre choisi de l'OBO (pour *OFDMA backoff*) de l'algorithme de backoff de la station

atteigne 0. Les présents travaux de thèse exploitent les techniques évoquées ci-dessous (OFDMA, le mode d'accès aléatoire) pour une amélioration des performances (maximisation du débit, réduction des dégradations dues aux collisions,...) en générale, et la réutilisation spectrale en particulier (entre autres, problème des ressources réservées pour le mode d'accès aléatoire mais restant non utilisées). La méthode fera appel à des techniques de détection et de suppression d'interférence à savoir l'utilisation de la technique SIC (pour *successive interference cancellation*). si les utilisateurs impliqués ont un niveau de puissance différent, ou la détection conjoint le cas échéant. Cette nouvelle technique permettra l'allocation de deux STA dans le même sous canal, sous des contraintes de puissance, tout en exploitant les techniques de SIC ou de la détection conjointe (qu'on suppose supportée par les équipements à l'émission) afin de supprimer les interférences générées par l'émission simultanée de deux STA sur le même RU. En plus de l'allocation par défaut (configuration (1) de la figure 1), nous distinguons deux nouvelles configurations (configuration (2) et (3) de la figure 1).

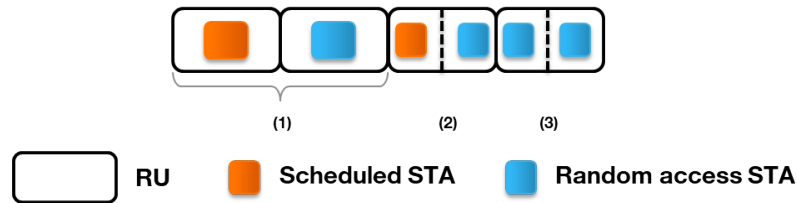

Figure 1: Configurations proposées des allocations des RUs pour le IEEE 802.11ax

Différentes configurations d'allocation, non supportées par le dernier standard, sont proposées. Ces configurations reposent principalement sur le niveau de puissance des utilisateurs impliqués.

La première configuration propose d'allouer une STA à accès aléatoire avec une STA programmée dans la même RU. Cette configuration pourrait être plus avantageuse pour les STA à accès aléatoire à faible bande passante qui ont peu de données à transmettre et ont une puissance limitée. Ces STA peuvent ainsi être attribués dans une RU déjà occupée où, par exemple, la STA programmée n'a pas besoin d'exploiter le spectre à son maximum d'efficacité. Cela peut être possible grâce à la technique SIC qui permet le décodage successif de plusieurs utilisateurs en annulant leurs interférences une fois qu'un utilisateur est détecté. Cette configuration devrait se traduire par une plus grande efficacité du spectre en permettant à plus d'une STA d'accéder au canal tout en assurant un débit approprié grâce à la technique adoptée. La procédure numérique est présentée dans l'algorithme 2.

La deuxième configuration considère l'allocation de deux stations en mode d'accès aléatoire. Dans le cas où deux STA à accès aléatoire, ayant des niveaux de puissance similaires, seraient normalement confrontés à une collision (ce qui se produit lorsque leurs valeurs OBO atteignent 0 en même temps et

qu'ils sélectionnent la même RU pour le mode d'accès aléatoire), l'allocation conjointe dans le cadre du processus de détection conjointe permet leur allocation simultanée (Algorithme 3). Sinon, si ces deux STA transmettent en utilisant des niveaux de puissance différents, le SIC est effectué (Algorithme 2). Cela réduit considérablement la latence globale qui est assez impactée par les collisions (où les STA doivent différer la suite de l'algorithme de back-off pour regagner l'accès, ou même, lutter pour l'accès aux canaux en mode mono-utilisateur classique). De même, comme pour l'allocation sous SIC, cette méthode devrait augmenter la capacité du réseau en permettant à plus d'utilisateurs de transmettre.

Enfin, nous proposons également un schéma hybride qui décode les STA dépendamment de leur niveau de puissance. Cela conduit à un processus optimisé précis considèrent deux cas différents de niveaux de puissance (c'est-à-dire des niveaux de puissance identiques ou différents). Cela peut représenter un gain intéressant de complexité d'implémentation par rapport aux algorithmes 2 ou 3.

La suites de ces travaux envisagera l'implémentation numérique des algorithmes proposés afin d'établir une analyse pratique des différentes configurations. La comparaison serait basée sur l'analyse du débit effectif offert par chaque configuration pour différents scénarios, qui différerait dans le nombre d'utilisateurs, les schémas de modulation, le type de RU, etc. Pour une implémentation numérique pertinente des algorithmes, plusieurs paramètres doivent être soigneusement choisis. Cela devrait être basé sur une analyse approfondie des implémentations propriétaires d'OFDMA dans les nouveaux enjeux du dernier standard IEEE 802.11ax, donnant un aperçu pratique des performances des modèles proposés.

La négociation adaptative de la session du bloc d'acquittement: AN-BA

Le deuxième axe de recherche concerne le mécanisme d'acquittement par bloc (BA pour *block acknowledgment*). Il a été introduit dans le standard 802.11e afin d'améliorer la qualité de service (QoS pour *quality of service*). Il permet d'acquitter la réception d'un groupe de trames de données à la fois, selon une procédure plus efficace comparée à l'acquittement normal ACK (pour *acknowledgment*) unitaire.

Toutefois, cette procédure inclut un nombre non négligeable de trames de contrôle surtout en présence d'un grand nombre d'utilisateurs. Pour un tel scénario, la négociation de la session d'acquittement par bloc avec chaque utilisateur induit une plus grande latence ainsi qu'une surcharge plus importante. Nous avons proposé une méthode optimisée pour pallier ces inconvénients et améliorer l'efficacité lors de l'établissement de la session. Cette méthode inclut

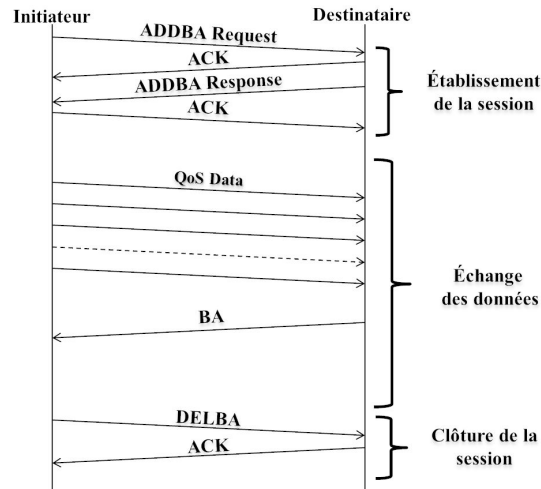

Figure 2: Mécanisme d'acquittement par bloc

dans les trames QoS Data des bits de contrôle qui permettent une négociation implicite de la session BA, à la fois pour l'établissement et la clôture de la session. L'établissement de la session se négociera à travers les bits de contrôle (à un état donné) remplaçant toute l'étape d'échange de trames ADDBA (pour *Add BA*) Request/Response. De même pour la clôture de la session, les bits de contrôle indiqueront au récepteur la requête de fermeture de la session. La méthode autorise une meilleure flexibilité quant à la taille du buffer de données. Pour le mécanisme d'origine, le changement de la taille du buffer doit être renégocié à travers une nouvelle session comprenant toutes les trames de contrôle. Cette méthode permet le changement de la taille du buffer au cours de la session, soit en l'augmentant soit en la diminuant. L'information de changement est également portée par les bits de contrôle inclus dans la trame de données. La demande de changement de taille du buffer peut être faite par l'émetteur comme par le récepteur.

Principe de fonctionnement

L'AN-BA optimise le mécanisme d'acquittement par bloc en négociant la session BA par le biais de deux bits de contrôle, notés b_1 et b_0 du côté de l'initiateur et b'_1 et b'_0 du côté du destinataire.

Inserés dans les trames QoS Data (pour les premiers), BA ou ACK (pour les seconds), ces deux bits transportent les informations relatives aux demandes de l'initiateur et du destinataire. L'AN-BA repose également sur trois phases explicitées ci-après et illustrées sur la figure 3.

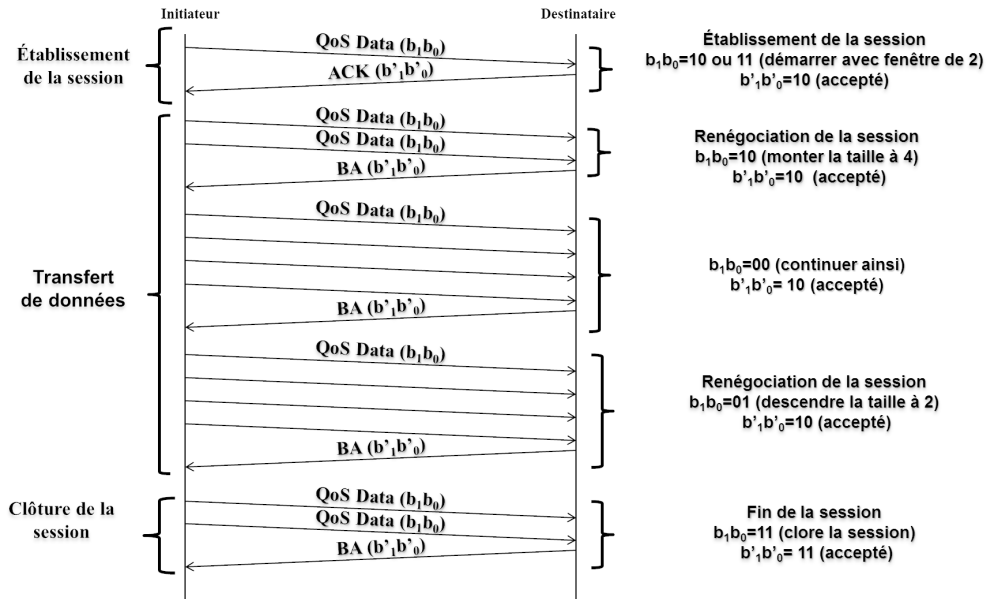

Figure 3: Exemple d'établissement de la session d'acquiescement par bloc sous l'AN-BA

Établissement de la session

Afin de créer la session BA, une première trame QoS Data comportant les deux bits de contrôle est envoyée, remplaçant les trames de contrôle ADDBA Request/Response. Cette demande peut être acceptée ou refusée par le destinataire à travers les deux bits de contrôle (i.e. b'_1 et b'_0) insérés dans la trame ACK consécutive au QoS Data. L'initiateur entame l'envoi des trames QoS Data dès que la session BA est acceptée. La Table 1 liste les différents états possibles des bits de contrôle pour l'initiateur et le destinataire.

Table 1: Les différents états des bits de contrôle

Phase	Initiateur		Destinataire	
	b_1	b_0	Interprétation	b'_1 b'_0 / Interprétation
Établissement de la session	0	0	Ne rien faire	0 0 / Ne rien faire / Temporiser la réponse
	0	1	Réservé	0 1 / Refuser la demande actuelle
	1	0	Initier sans A-MSDU	1 0 / Accepter la demande
	1	1	Initier avec A-MSDU	1 1 / Refuser car configuration non compatible
Régime établi	0	0	Continuer ainsi	0 0 / Demande de réduction
	0	1	Réduire la fenêtre (diviser par 2)	0 1 / Refuser la modification si augmentation / Temporiser si réduction
	1	0	Augmenter la fenêtre (doubler)	1 0 / Accepter la modification
	1	1	Clore la session	1 1 / Demande de clôture session

La négociation de la taille maximale du *buffer* est assurée par l'AN-BA à partir de l'état des deux bits de contrôle. Au cours de la session, l'initiateur peut réclamer une augmentation ou une diminution du nombre maximum de QoS Data envoyés par bloc. Le destinataire accepte ou refuse la requête reçue.

La figure 3 illustre un exemple de la procédure AN-BA:

- L'expéditeur initie la demande d'établissement de la session BA à travers une première trame QoS Data portant les bits b_1 et b_0 .
- Selon l'état des deux bits, le destinataire identifie la configuration à adopter pour la session : $b_1b_0 = 11$ pour des données agrégées, ou $b_1b_0 = 10$ le cas échéant.
- Ce dernier renvoie un ACK avec $b'_1b'_0 = 10$ pour accepter la session, ou avec $b'_1b'_0 = 01$ ou 11 pour la refuser. En cas d'acceptation, les données sont envoyées selon la configuration et la taille maximale négociée.
- L'initiateur peut à tout moment réclamer un changement de la taille maximale des QoS Data envoyées.

Régime établi

En régime établi, les bits de contrôle sont positionnés à $b_1b_0 = 10$ pour doubler la taille maximale du *buffer* ou à $b_1b_0 = 01$ pour la réduire de moitié. Le destinataire envoie sa décision d'acceptation ou de refus à travers les deux bits insérés dans le BA servant également à acquitter les QoS Data reçus. Si le destinataire accepte, l'initiateur renvoie un bloc de QoS data selon la nouvelle taille négociée. Dans le cas contraire, le *buffer* garde la même taille. Etant donné que la taille maximale du *buffer* est limitée, le récepteur peut aussi réclamer la réduction de sa taille en fixant les deux bits de contrôle à $b_1b_0 = 00$. L'initiateur pourra ainsi diminuer la taille maximale des QoS Data envoyées.

Clôture de la session

Le destinataire peut réclamer la fermeture de la session à travers le dernier BA envoyé. L'initiateur prend en compte sa requête et ferme la session lors de la transmission suivante.

Avantages de l'AN-BA

L'utilisation du mécanisme de bloc d'acquiescement classique peut induire une latence conséquente au sein des réseaux denses en raison du nombre élevé de trames de contrôle qu'il engendre. Nous montrons ici que l'AN-BA optimise le mécanisme du BA tout en offrant une meilleure flexibilité de gestion de la taille maximale du *buffer* de données. Dans le mécanisme d'origine, le changement de la taille du *buffer* doit être renégocié à travers une nouvelle session comprenant toutes les trames de contrôle; l'AN-BA quant à lui permet cette modification au cours de la session sans surcharge significative, améliorant ainsi le débit et le délai de transmission. La Section 4.7 du chapitre 4 illustre les performances des deux mécanismes dans un environnement moyennement

dense en prenant comme référence le standard IEEE 802.11ax. Cette évaluation est analysé à travers deux applications, à savoir FTP (pour File Transfert Protocol)

Analyse des resultats

Ce volet de recherche se concentre sur le mécanisme BA proposé dans IEEE 802.11e [13] et son amélioration dans la perspective de l'IEEE 802.11ax [14]. Comme mentionné précédemment, le BA est l'une des principales améliorations de l'amendement IEEE 802.11e, permettant une meilleure efficacité de transmission. L'activation de l'acquittement groupé de plusieurs trames de données a considérablement amélioré que ça soit le débit ou le délai de transmission. Il améliore en effet les performances du réseau sans fil par rapport au mécanisme d'acquittement de base (acquittement trame par trame). Néanmoins il comprend plusieurs trames de contrôle lorsqu'il s'agit d'établir une session BA. Cela peut représenter une limitation importante pour les environnements denses. En proposant le mécanisme de l'AN-BA, notre objectif est d'améliorer le mécanisme du BA afin qu'il soit bien adapté à la fois aux environnements à faible et haute densité.

Les mécanismes de l'AN-BA et du BA sont comparé en termes de débit moyen par utilisateur en utilisant le simulateur réseau ns-3 dans le cas de deux applications, full-buffer (transfert continu de données) et FTP (transfert de données pour une durée limitée) dans des environnements denses et pour deux schémas d'adaptation de taille de buffer (cas de commutation et d'augmentation).

Dans la plupart des configurations, l'AN-BA surpasse le BA. Dans certains cas, elle permet une augmentation du débit de 10 Mbps par utilisateur. Les délais de transmission sont également réduits, avec jusqu'à 40 % de retard moyen en moins pour le trafic de données continu. De plus, un modèle analytique du débit de saturation est établi et validé. Dans tous les scénarios considérés, la comparaison du débit calculé grâce au modèle analytique et celui mesuré via ns-3 a donné des performances similaires, avec un écart de 10 % seulement. Le modèle analytique pourrait être utilisé pour avoir une première estimation du comportement de performance AN-BA dans une configuration donnée et ainsi avoir une première sélection de paramètres, tandis que l'implémentation ns-3 permet d'affiner l'analyse et de prédire la performance dans des scénarios plus complexes. Il convient également de noter que l'une des limites de l'AN-BA est que la modification de la taille de la mémoire tampon est limitée au double ou à la moitié de la valeur négociée car elle ne repose que sur 2 bits de signalisation. L'extension du nombre de bits est possible dans la limite des bits vides disponibles pour conserver la compatibilité descendante. Nous soulignons également que la consommation d'énergie pourrait augmenter avec le changement instantané et potentiellement fréquent de la taille du tampon.

La suite des travaux étudieront l'extension de la méthode pour prendre en charge des valeurs de taille de tampon supplémentaires afin d'améliorer encore les performances. Le modèle analytique sera développé pour des hypothèses plus réalistes. Une perspective supplémentaire serait d'établir un modèle BA plus complet qui comprend non seulement la phase de transfert de données QoS mais aussi les phases de configuration et de démontage. En d'autres termes, nous visons à fournir un modèle qui inclut ADDBA Request / ADDBA Response et DELBA pour le comparer avec le modèle établi par AN-BA. Une autre étude intéressante pourrait être l'analyse des deux mécanismes dans un scénario d'application hétérogène, c'est-à-dire avec un réseau composé de stations utilisant différents types d'applications.

Conclusions et perspectives

Les technologies sans fil ont connu une énorme évolution en termes d'utilisation et d'applications. En particulier, l'augmentation du nombre d'utilisateurs appelle à plus de performances (efficacité plus élevée, débit élevé, efficacité énergétique améliorée, etc.), en particulier dans les environnements dense. Les modifications actuelles du Wi-Fi ont démontré certaines limites pour ce type de scénarios en particulier. Pour toutes ces raisons, le groupe de travail IEEE 802.11ax lancé le projet TGax pour travailler sur l'amélioration du réseau, dans le cas d'un environnement dense, pour offrir des performances plus élevées et assurer un débit optimal pour chaque utilisateur.

Le travail de cette thèse rejoint ces mêmes objectifs, à savoir l'amélioration des performances des environnements denses.

En plus d'analyser la norme IEEE 802.11 (voir le chapitre 1), deux autres contributions ont été adressées pour améliorer la couche PHY et la MAC. Des techniques avancées de couche PHY ont ainsi été développées (voir chapitre 2), offrant de nouveaux degrés de liberté pour l'allocation des ressources de l'accès aléatoire pour l'OFDMA. Une nouvelle méthode pour l'amélioration du mécanisme d'accusé de réception de bloc du côté de la couche MAC a également été proposée (voir le chapitre 4). L'IEEE 802.11ax supporte, en plus de l'OFDMA ordinaire, un mode d'accès basé sur l'OFDMA selon un mode d'accès aléatoire. L'AP réserve périodiquement certaines RU pour permettre l'accès aux STA non allouées. Les utilisateurs en mode d'accès aléatoire exécutent l'algorithme de back-off pour accéder au canal. Une fois que leur compteur de back-off atteint zéro, les STA choisissent elles-mêmes une RU parmi celles dédiées à l'accès aléatoire. La première limite soulevée de ce processus est que plusieurs STA pouvaient sélectionner le même RU lorsque leur OBO atteignait zéro en même temps. Une telle situation induirait plusieurs collisions et affecterait les performances globales.

Afin de minimiser ces dégradations, nous proposons d'autoriser l'allocation

d'au plus deux utilisateurs dans la même ressource. Dans ce but, nous proposons d'exploiter soit SIC soit des techniques de détection conjointe en fonction du niveau de puissance. Deux configurations pourraient être adoptées.

Dans la première configuration, nous considérons qu'une STA programmée et une STA en mode d'accès aléatoire, supposés avoir des niveaux de puissance différents, pourraient être alloués à la même RU. Une STA à accès aléatoire pourrait accéder à une RU déjà affectée et transmettre simultanément avec la STA programmée grâce à l'utilisation de la technique SIC au niveau du récepteur. Cette configuration pourrait être très intéressante lorsqu'une STA programmée n'occupe pas tout le spectre et qu'une STA à accès aléatoire à faible bande passante doit transmettre. Non seulement les collisions pourraient être réduites, mais la capacité du réseau devrait également être améliorée, en accueillant davantage d'utilisateurs. Un modèle mathématique d'un tel algorithme et sa résolution ont également été proposés.

Dans le cas où deux STA ont les mêmes niveaux de puissance, nous proposons une deuxième configuration. Elle considère l'allocation des deux STA en supposant une technique de détection conjointe au niveau du récepteur pour décoder leur signal respectif. Par exemple, en cas de collision de deux STA à accès aléatoire, cette configuration rend leur allocation possible grâce à la technique adoptée. Cela devrait considérablement réduire la latence globale et permettre à davantage de stations non allouées de transmettre.

Un schéma hybride a également été proposé pour combiner les deux configurations proposées en tenant compte à la fois des cas de niveau de puissance ainsi que des deux techniques de décodage associées.

La deuxième proposition concerne l'amélioration du mécanisme BA dans la perspective de l'amendement IEEE 802.11ax. Comme indiqué précédemment, le mécanisme de gestion de session BA classique comprend plusieurs trames de contrôle pour établir une session. Cela induit plus de latence dans un environnement dense et consomme de la bande passante.

Dans le but d'optimiser ce mécanisme pour mieux l'adapter aux environnements denses, nous avons proposé le mécanisme AN-BA. Cette méthode améliore l'efficacité des réseaux en permettant la négociation dynamique des paramètres de session BA, à savoir la taille du buffer, via deux bits de contrôle au lieu de trames de contrôle dédiées.

ns-3 a été appliqué pour mettre en oeuvre la méthode proposée et établir une analyse approfondie des performances.

Dans le premier, un modèle analytique a été dérivé. Sa validation s'est appuyée sur la comparaison du débit calculé grâce au modèle analytique et celui mesuré via ns-3. Les résultats numériques ont montré un écart de seulement 10 % entre le modèle établi et le modèle implémenté, démontrant ainsi sa précision. Nous pensons que le modèle analytique AN-BA pourrait être exploité pour estimer le comportement du réseau en donnant une première

vue générale d'un scénario non complexe tandis que la mise en oeuvre de ns-3 pourrait être réservée à des scénarios plus complexes.

Dans la deuxième partie, une comparaison des mécanismes AN-BA et BA a été effectuée en utilisant trois mesures principales: le débit moyen par utilisateur, le retard moyen et le taux d'interruption de paquets. À l'aide de ns-3, des applications à tampon complet et FTP ont été exploitées pour simuler des scénarios sélectionnés. Nous avons considéré deux schémas d'adaptation de la taille de buffer pour faire ressortir les gains du mécanisme AN-BA sur BA. Ce travail a montré que AN-BA surpasse BA dans la plupart des configurations. Pour certains d'entre eux, une augmentation de 10 Mbps du débit de données par utilisateur est assurée par l'AN-BA. Quant au délai de transmission, il a également été réduit, avec jusqu'à 40 % de retard moyen en moins (par rapport à BA) pour le trafic de données continu.

Introduction

General context

With the massive growth of wireless traffic, radio networks technologies, such as cellular or wireless-fidelity (Wi-Fi) among others, keep on improving the overall connectivity quality.

It is also predicted that Internet users will exceed 4.8 billion by 2022 [1] (3.4 billion in 2017). Exploiting all existing applications (e.g. video, streaming, gaming, etc.) or emerging ones (Internet of things to name one), by 2022, the total Internet protocol (IP) traffic should be distributed as: 51% Wi-Fi, 29% wired and 20% cellular. Wi-Fi should remain the most used technology for Internet access.

Such massive utilisation, combined with the expanse of wireless applications, ultimately results in higher expectations from Wi-Fi users (throughput, efficiency ...), especially with the parallel improvement of cellular networks. It is almost imperative to keep on enhancing Wi-Fi while considering all promising cellular networks improvements. By promising enhancements, we can cite the latest, fifth, generation (5G) cellular technology providing one of the highest performances so far. When 5G provides the best coverage, specially for wide outdoor environments, Wi-Fi remains the best choice for indoor use (enterprise, homes...). Even if 5G targets to become the de facto future of wireless networks, this approach is obviously complicated either economically or practically. The co-existence of both technologies is thus complementary, if not mandatory, to ensure an accurate deployment.

Wi-Fi, which is the main topic of this work, has considerably evolved over the years. The scientific community works at improving the underpinning techniques, thus enriching the IEEE 802.11 [2] standard, which defines Wi-Fi capabilities. Network performance is gradually enhanced over each amendment of the standard. Each standard comes with new technological advances or work on prior generations to improve existent techniques of the physical (PHY) and the medium access control (MAC) layers [3][4][5][6][7]. Nevertheless, the underlying motivations remain: improving the quality of the network, increasing the offered data rates and overcoming existing constraints. As increasing the data rate is among the significant targets, the standard made valuable progress on several techniques that ensured higher data rates across the IEEE 802.11 generations. For instance, the peak PHY layer data rate was increased from 54 mega bits per second (Mbps) in IEEE 802.11a [4] to 6.93 giga bits per second (Gbps) in IEEE 802.11ac [7]. This augmentation was obtained through key modifications (higher modulation orders, more spatial

streams...) but also through the introduction of new techniques. For example, OFDM (orthogonal frequency division multiplexing) [8][9][10], was published first in IEEE 802.11a [4] in 1999 and served as a basis for quite a few other enhancements [11]. Multiple input multiple output (MIMO), whose history starts back in the 1920s, is one of these. MIMO was introduced first in IEEE 802.11n [6] and contributed a lot to the later systems' quality improvement, especially in terms of data rate [12]. IEEE 802.11ac [7] built upon these two key technologies and introduced additional ones as well. All these improvements result in the amelioration of wireless networks performances, in terms of throughput, latency or general efficiency. Details about the evolution of IEEE 802.11 amendments are given in this dissertation.

Thanks to all these improvements the usage of this radio network technology knows a tremendous peak which comes with a massive increase of IP traffic. Such loads lead to significant performance impairments, particularly in dense environments (for instance airports or stadiums). Even if IEEE 802.11n and IEEE 802.11ac incorporate several important technological advances to the baseline standard, they have proven to be quite inefficient in dense environments; a significant decrease in terms of user throughput is indeed observed. Increasing the modulation order, the bandwidth or the number of spatial streams did not seem to be of any help when it comes to large deployments.

For these reasons, the IEEE 802.11 group constituted the task group ax (TGax) in 2013, in order to consider all issues related to dense environments, be they indoor or outdoor. The TGax works within the framework of last amendment known as the IEEE 802.11ax. This amendment introduces a number of required enhancements tackling crowded scenarios issues, such as reducing interference, increasing minimal per-user throughput and improving spectral reuse. Be it by improving existing techniques or introducing new ones, its ultimate goal is to improve network quality in dense environments by ensuring higher throughput per user while improving interference management. This is ensured thanks to several improvements such as the introduction of orthogonal frequency division multiple access (OFDMA), spatial reuse or a number of multiple users enhancements to mention a few. Major IEEE 802.11ax enhancements are pointed out within this work. This last amendment, that is planned for a publication in 2020, is thus very promising and should enable IEEE 802.11 to offer 5G-equivalent service.

Thesis objectives

This thesis' work follows the same objectives as IEEE 802.11ax, namely ameliorating performance in dense environments. It adopts the same logic: include new mechanisms and improve existing ones. To this end we set specific objectives which highly influence the overall network performance. We thus target to improve the network capacity and to enhance the per-user throughput while reducing the overall latency. To do so, we decide to address both IEEE 802.11 main layers, which are PHY and MAC layers. The enhancement of IEEE 802.11 networks is definitely more convenient when jointly considering MAC and PHY improvements.

We first analyse PHY layer techniques to select a potential mechanism considering aforementioned objectives. One of the major IEEE 802.11ax PHY enhancements is the introduction of the OFDMA multiplexing technique enabling, among others, an increase in capacity. In addition to that, the standard allows an optional mode for uplink referred to as random access mode for OFDMA. It allows non-scheduled users to transmit by occupying resource units periodically reserved for random access mode. The access to these resource units is subject to a set of rules. Nevertheless, this particular access may cause several issues due to its arbitrary access. For instance, two or more users may gain access at the same time and choose the same resource unit. These collisions induce latency which definitely affects the overall performance. Furthermore, resource units dedicated to random access mode may end up unused. This leads to a waste of spectrum. For these reasons the choice has been made to ameliorate this particular mode and propose some enhancement that should contribute to decrease induced collisions and thus ameliorate IEEE 802.11ax capacity.

When it comes to the MAC layer, several enhancements targeting dense environments have been proposed. Similarly, this thesis work also focuses on ameliorating the MAC layer of IEEE 802.11ax particularly in the presence of a high number of users. MAC mechanisms that may affect performance in case of dense scenarios have been examined. We thus targeted the block acknowledgement mechanism, which is one of IEEE 802.11 techniques that improves WLAN efficiency. We believe that in the presence of a high number of users, the negotiation of the block acknowledgement mechanism may induce supplementary latency. This is due to the several control frames needed to negotiate the block acknowledgement mechanism with each user. This lead us to propose an amelioration of this mechanism especially for dense environments.

By means of these two enhancements, the principal objective is indeed to improve performance in dense environments by ameliorating either per-user throughput or latency.

Thesis contributions

The following three main contributions of this thesis have addressed the objectives presented in the previous section.

The **first contribution** is a deep survey of the IEEE 802.11 standard. The related chapter outlines the evolution of this technology from the first Wi-Fi generations (1999) up to the bleeding-edge IEEE 802.11ax (2020). Most IEEE 802.11 PHY and MAC layer techniques are exposed while presenting their evolution over the years. The Wi-Fi standard is thus analysed while emphasising the techniques related to the other two contributions of this thesis.

The **second contribution** is an improvement of resource allocation for the OFDMA random access, which is, as mentioned earlier, a new feature of IEEE 802.11ax. In order to reduce collisions and unused resources, this work proposes to add new configurations to the OFDMA random access mode. The main idea is to allow at most two IEEE 802.11ax users to occupy a vacant resource unit. We thus propose two configurations. The first one concerns the allocation of two users where the first one is a scheduled user (i.e. allocated by the access point) and the second one is under random access (i.e. having selected a resource unit reserved for random access). The resource allocation scheme relies on the use of interference cancellation at the receiver to decode both users signals. Concerning the second configuration, it allocates two random access users having potentially same power level. To simultaneously allocate them, we assume joint detection at the receiver. An analysis is made for each configuration with a resolution framework for each one.

The **third contribution** is related to an already existent mechanism which is the block acknowledgement mechanism. As highlighted in the previous section (i.e. Thesis objectives section), the usage of the block acknowledgement mechanism in dense environments may induce some latency to network transmissions. This is due to its mandatory control frames used for establishing or updating the corresponding session. In order to optimise that, we propose a modified version of the block acknowledgement mechanism that we named the "adaptive negotiation of the block acknowledgement". It consists in an optimisation of the basic mechanism (i.e. block acknowledgement) particularly suited for dense environments. The proposed method is not only an optimisation of the mechanism but also offers the possibility of renegotiating, with virtually no overhead frames, some key parameters. This is obviously not the case of the block acknowledgement mechanism which requires a sup-

plementary exchange of dedicated control frames.

In addition, the implementation of the method is done in the network simulator 3 (ns-3)[15]. A detailed analysis is thus established to compare the proposed method to the basic mechanism by means of several metrics: average throughput per user, average delay and packet outage rate. This analysis relies on the usage of two applications: the full-buffer and the file transfer protocol applications. To complete the study, we develop an analytical model of the proposed method by deriving its saturation throughput expression. A validation of the model is also performed.

Thesis outline

This dissertation details aforementioned contributions through four main chapters while ending with some conclusions and perspectives.

In Chapter 1 a survey on the IEEE 802.11 standard is given where a thorough presentation of the latter and its continuous evolution is described. We expose MAC and PHY layer techniques starting from the first IEEE 802.11 release up to the last amendment, which is the IEEE 802.11ax. We exhibit the main issues faced by existent amendments and the improvements introduced by IEEE 802.11ax to overcome them. A special focus has been laid on the techniques related to our work. This concise yet historically based overview is our first contribution.

Chapter 2 treats the resource allocation for OFDMA in random access mode. It brings out the motivation of our second contribution and lists different resource allocation configurations. Their corresponding analytical models and their respective resolutions are also exposed.

Chapter 3 is dedicated to present the network simulation environment and selected scenarios. It introduces the ns-3 simulator by giving a general view and describing some of its main modules. In this chapter we expose all metrics of interest used to compare the third contribution to the reference scheme. A presentation of used applications and all considered scenarios is also provided.

Chapter 4 exposes the third contribution which is the adaptive negotiation of the block acknowledgement session. It first presents the basic mechanism of the block acknowledgement and its functionalities. The proposed solution and its analytical model are established and validated. This chapter thus gives two simulation analyses. The first analysis concerns the comparison of the established analytical model with its ns-3 implementation. The second one exposes the performance gains of the proposed method with regards to

the block acknowledgement mechanism. A detailed analysis of the results is given to complete the study.

The final chapter draws some conclusions and perspectives to conclude this thesis work.

List of Publications

Journal Paper

- K. Abdelalim, G. Redieteb, S. Destouet Roblot and K. Amis, "Analytical framework of the adaptive negotiation of the block acknowledgement session in latest IEEE 802.11 amendments", submitted in IEEE Transactions on Wireless Communications.

Conference Papers

- K. Abdelalim, G. Redieteb, S. Destouet Roblot and K. Amis, "Adaptive Negotiation for Block Acknowledgement Session Management", IEEE 89th Vehicular Technology Conference (VTC2019-Spring), April 2019.
- K. Abdelalim, G. Redieteb, S. Destouet Roblot and K. Amis, "Analyse des performances de la méthode de négociation adaptative de la session Block Acknowledgement pour le standard IEEE 802.11ax", Colloque GRETSI, August 2019.

Patent

- G. Redieteb, K. Abdelalim and S. Destouet Roblot, "Négociation adaptative de la session Block Acknowledgement", Patent number: WO/2019/077247. Submitted: October 19th 2017. Published: April 25th 2019.

Survey on the IEEE 802.11 norm

1.1 Introduction

Wireless networks are evolving at great pace due to both their important use and the diversity of supported applications, which require greater performances (in terms of throughput, efficiency ...) and fewer bottlenecks. As a side effect, the use of such networks has induced drastic changes especially on users' mobility and network flexibility. One of the most popular ones is the IEEE 802.11 [2], also known as Wi-Fi. The scientific community still works at improving its technical recommendations in order to expand the whole wireless network coverage, and especially that of WLAN. Different enhancement techniques were gradually introduced with each new amendment of the standard to develop network performance (in terms of both quality and data rate) and overcome constraints either by improving existent techniques of the PHY and the MAC layers [16][17] or by adding new ones. In other words, each amendment addressed new points with regards to previous generations, in an effort to develop and revise some aspects manifesting drawbacks. As increasing the data rate is among the significant targets, the standards made valuable progress on several techniques that ensured higher data rates across IEEE 802.11 generations [4][3][5][6][7][14]. This chapter presents the evolution of the IEEE 802.11 amendments, from the original norm published in 1997 to the ongoing IEEE 802.11ax, while highlighting some of the main improvements brought to PHY and MAC layers. The first part of this chapter (Section 1.2) presents the IEEE 802.11 basics as well as the enhancement made generation after generation up to IEEE 802.11ac. Section 1.2.1 is a synthesis of the Wi-Fi norm evolution. The IEEE 802.11 architecture is presented within Section 1.2.2. Section 1.2.3 brings a description of some PHY technique, mainly those related to this thesis while Section 1.2.4 focuses on MAC features. The second part of the chapter (Section 1.3) is an analysis of the IEEE 802.11ax standard, still in standardisation process and that will be published in 2020. Section 1.3.1 exposes the challenges and objectives of this new amendment. Section 1.3.2 is an analysis of the PHY enhancements developed in IEEE 802.11ax. Section 1.3.3 develops the MAC techniques improved or newly introduced. IEEE 802.11ax multiple users enhancement are presented in Section 1.3.4. The last part of the chapter (Section 1.4) summarises the chapter content and

opens on some axes of study carried out in this thesis.

1.2 IEEE 802.11 basics and evolution toward the IEEE 802.11ac amendment

1.2.1 Overview of the IEEE 802.11 amendments' evolution

The first IEEE 802.11 [2] standard was launched in 1997, specifying a lot of notions related to wireless transmissions. It defines three PHY layer technologies, namely infrared [18], direct sequence spread spectrum (DSSS) [19] and frequency hopping spread spectrum (FHSS) [20]. These specifications permit to reach data rate ranging from 1 Mbps up to 2 Mbps within a bandwidth of 22 MHz. This release supports mainly both DSSS and FHSS, in contrast to the IF mode that remains a contribution of the standard but has not been implemented. IEEE 802.11-1997 devices operate within the 2.4 GHz frequency band. The original IEEE 802.11 norm can be considered as a beta-specification. The multiple PHY layer options made it challenging for products to be inter-operable indeed. In addition, throughput became quickly a limiting factor as well.

To overcome IEEE 802.11-1997 limitations, new amendments were established to fix and enhance the network, starting with the IEEE 802.11b [3] amendment that was released in 1999. It maintains all IEEE 802.11-1997 specifications (except for the Frequency Hopping Spread Spectrum (FHSS) PHY layer) while enabling a data rate of 11 Mbps. Nevertheless this standard presented several limitations due to the interference generated by other 2.4 GHz equipments (microwaves, ovens, etc.) which became a real issue for Wi-Fi users.

IEEE 802.11a [4] was thus launched, switched to the 5 GHz frequency band that was a key step to minimise interference issues. It also introduces OFDM that offers a higher user diversity in addition to higher performances compared to IEEE 802.11b [11][10]. Combined with the usage of the 5 GHz channel, it results in a data rate increase from 11 Mbps to 54 Mbps within a 20 MHz bandwidth.

A bit later, IEEE 802.11g [5] followed IEEE 802.11a by introducing OFDM in the 2.4 GHz band (like IEEE 802.11b) while maintaining a peak data rate of 54 Mbps.

These standards were followed by IEEE 802.11n [6], also referred to as high throughput (HT) standard, which provides many new techniques that made a substantial change on network performance. IEEE 802.11n's major improvements are: MIMO, frame aggregation, beamforming and higher spatial diversity [21][22][23][24][25]. It also expands the bandwidth from 20 MHz

to 40 MHz. All these enhancements enable a ten-fold increase in data rates with regard to 802.11b/a/g, reaching then 600 Mbps. The most significant objectives were to deploy MIMO, as an enhancement of single input single output (SISO), for the same setting as IEEE 802.11a/g and double the bandwidth to increase the throughput [12]. Likewise, the aggregation mechanism offers a higher transmission efficiency thanks to the reduced overhead. The additional advantage of IEEE 802.11n is its backward compatibility with all previous standards since it works either at 2.4 GHz or 5 GHz.

After that, the working group defined IEEE 802.11ac [7][26][27][28], also referred to as very high throughput (VHT) standard, that keeps the specifications of 802.11n while introducing some notable improvements. It allows a larger bandwidth, i.e. up to 160 MHz. It also offers higher constellation orders (up to 256-quadrature amplitude modulation (QAM)) to increase the amount of transferred data. One will also note that, for greater efficiency, IEEE 802.11ac sets the frame aggregation mechanism as mandatory and introduces the multiple users (MU) transmission scheme, namely the MU-MIMO technique. With these improvements, IEEE 802.11ac shows substantial progress, be it in the quality of the network or its throughput [29][30]. Table 1.1 presents some of the enhancements offered by each successive amendment.

Table 1.1: IEEE 802.11 PHY layer evolution

IEEE standard	802.11b (1999)	802.11a (1999)	802.11g (2003)	802.11n (2009)	802.11ac (2013)
Maximum theoretical data rate (Mbps)	11	54	54	>100	>800 (160 MHz channels)
Frequency band (GHz)	2.4	2.4	5	2.4 and 5	5
Channel width (MHz)	22	20	20	20, 40 (optional)	20, 40, 80, 160 (optional), 80+80 (optional)
Antenna technology	SISO	SISO	SISO	MIMO	MIMO/MU-MIMO
Transmission technique	DSSS	OFDM	OFDM	OFDM	OFDM
Maximum number of spatial streams	1	1	1	4	8

It is worth noting that the network is effectively improved when both PHY and MAC layers are enhanced. The MAC layer, as originally proposed, is based on the carrier sense multiple access with collision avoidance (CSMA/CA) mechanism that relies on the "listen before talk" principle (like Ethernet technology). The rules of channel access are defined by several functions. The basic one is the distributed channel function (DCF) that

was mainly used up to the IEEE 802.11g [5]. More details can be found in Section 1.2.4.1 and Chapter 4. The MAC layer requires more improvements to meet with PHY layer enhancements and maximise PHY/MAC efficiency. This was the role of IEEE 802.11e [13] which focuses on the quality of service (QoS) of the network by adding several techniques. The enhanced distributed channel access (EDCA) and the block acknowledgement (BA) mechanisms are the most significant ones. EDCA is an enhancement of DCF where traffic is queued depending on its priority (a distinction made by EDCA mechanism). This proved to be efficient by means of the prioritisation of data [31][32][33][34]. Concerning BA mechanism, it highly reduces MAC overhead through the acknowledgement of a number of frames at once [35][36][37][38][39][40]. These mechanisms are exposed in this chapter and thoroughly detailed in Chapter 4.

1.2.2 IEEE 802.11 architecture

The conception of a wireless network under IEEE 802.11 specifications relies on a specific architecture that is composed of several physical components. Different IEEE 802.11 architectures with their different components are defined in what follows [16][17][28].

1.2.2.1 Components

1.2.2.1.1 Station

Stations (STAs) are all devices constituting a network and operating under IEEE 802.11 specification. STAs are the clients of the wireless/wired network such as laptops, smartphones, tablets, etc. They can be either mobile or fixed. Within this thesis, STA, node, user, originator, transmitter, receiver, or client could be used interchangeably and refer to the same term of station.

1.2.2.1.2 Access point

An access point (AP) is a specific type of Wi-Fi node. Its most important function is to bridge the wireless network to the wired one. It also performs the management of transmissions between stations belonging to the same network.

1.2.2.1.3 Wireless medium

A wireless medium is used to transport all transmissions within a network under Wi-Fi specifications. Several physical layers (i.e. wireless mediums) have been specified in the IEEE 802.11 norm to support the IEEE 802.11 MAC layer.

1.2.2.1.4 Distribution system

The AP is linked to a distribution system (DS) to ensure the connection to the network. The liaison can be established either by cable, digital subscriber line, Ethernet or optical fibre. The Ethernet technology is commonly used.

1.2.2.2 Architectures

The design of any wireless network relies on the basic service set (BSS) principle. The BSS presents the grouping of a number of stations in a specific manner in order to communicate together. Belonging to a BSS is generally mandatory to all stations so as to establish a connection while operating under same IEEE 802.11 specifications. There exist two fundamental types of BSS: independent BSS (IBSS) and infrastructure BSS. Several infrastructure BSSs can form an extended BSS (ESS). These different architectures are presented in Figure 1.1.

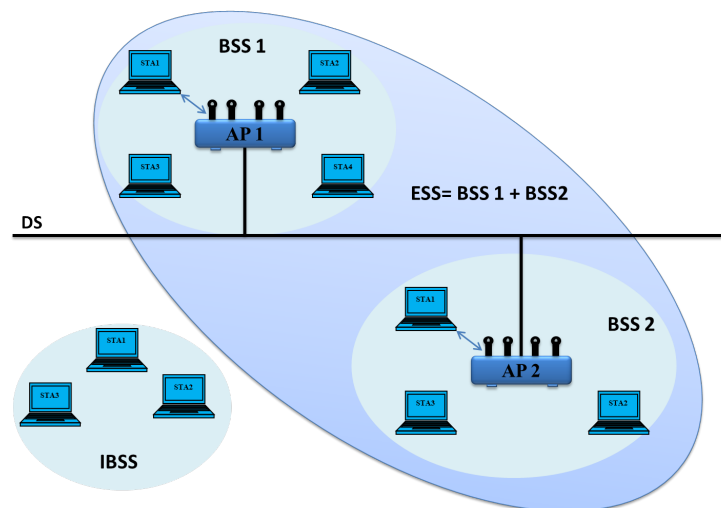

Figure 1.1: IEEE 802.11 architectures

Each BSS owns a unique 48-bit identifier referred to as BSS identifier (BSSID). This BSSID is used as a network address that must be used to establish connection between different BSSs. Most of the time, the AP MAC address is used as the BSSID of the BSS. Likewise, a BSS has a service set identifier (SSID) which designates the name of the BSS.

Let us now detail different BSS architectures.

- **Infrastructure BSS:** In infrastructure mode, all stations are associated to an AP that manages all BSS exchanges. The IEEE 802.11 thus specifies that each station is associated to only one AP. The latter is directly connected to the DS and insures network services for stations which are in its basic service area (BSA). Operating network parameters are fixed

by the AP and all frame exchanges must go through it. Namely, each station wanting to communicate with another station belonging to the same BSS must first send its data to the AP and then the AP sends it to its destination.

- **Independent BSS:** Stations under IBSS architecture operate autonomously and do not need an AP to manage transmissions. Stations establish a direct connection with one another without any relay point. One station from the IBSS, designated as the group owner (GO), takes charge of defining the parameters of the network. This type of architecture is generally conceived for a small number of users wanting to communicate during a short period. IBSS is sometimes referred to as *ad hoc* BSS.
- **Extended BSS:** A group of BSSs can constitute an ESS, permitting stations in the BSSs to communicate together and easily move between different BSAs. The APs act as bridges not only to their associated STAs but also to other APs belonging to the same ESS. It is one of the most used architectures (specially in companies) since it offers the possibility of establishing communications between station whatever their location in the ESS.

1.2.3 PHY basics and evolution

1.2.3.1 PHY frame structure

The framing of IEEE 802.11 [2] packets consists in ensuring a common language between communicating users. Thus, a frame includes, in its header, several fields containing information pertaining to operating protocols, frame types or communication policies to mention a few.

Concerning the IEEE 802.11 PHY frame, a packet received from the MAC layer is encapsulated, i.e. several PHY layer specific fields are added to the packet. This frame is referred to as PHY protocol data unit (PPDU) dedicated to be delivered to its destination. An illustration of layer encapsulation will be given later in 1.2.4.2.

Starting from the IEEE 802.11a/g, the PHY frame, also named OFDM frame, includes a number of fields such as the short training field (STF), the long training field (LTF), the signal field (SIG) and the data field. The IEEE 802.11a/g is exposed in Figure 1.2: (a).

- **STF/LTF fields:** placed at the beginning of a packet and decoded by all devices supporting OFDM techniques. They permit several operations including detection, synchronisation and channel estimation.

- **SIG field:** follows **STF** and **LTF** fields in the frame and indicates both the data rate and the length of the packet.

With the release of the IEEE 802.11n, a new frame format has been defined for IEEE 802.11n devices. Backward compatibility with IEEE 802.11a/g devices, referred to as legacy, is ensured by prepending the **STF**, **LTF** and **SIG** fields to the frame. These fields are thus termed as **L-STF**, **L-LTF** and **L-SIG**, with **L** for legacy, for IEEE 802.11n and following amendments. As presented in Figure 1.2: (b), several HT-specific fields are added just before the data field.

- **HT-STF/HT-LTF fields:** extend the synchronisation and channel estimation operations, started by **L-STF** and **L-LTF**.
- **HT-SIG field:** indicates the HT data rate and the length just like the **L-SIG** field for legacy devices. The **HT-SIG** also includes supplementary information about guard interval and aggregation, to mention a few.

With IEEE 802.11ac, another frame structure has been introduced to support this standard while keeping backward compatibility. The IEEE 802.11ac frame is presented in Figure 1.2: (c). In addition to legacy fields, the VHT frame includes:

- **VHT-SIG-A/VHT-SIG-B fields:** convey signalling information relative to the VHT standard, thus recognised only by IEEE 802.11ac devices. Several information are carried within **VHT-SIG-A** and **VHT-SIG-B** fields such as modulation and channel bandwidth.
- **VHT-STF/VHT-LTF fields:** are analogous to **L-STF/L-LTF** and **HT-STF/HT-LTF** for IEEE 802.11a/g and IEEE 802.11n respectively. They convey information about channel estimation for beamforming and also contribute for demodulation of the frame (depending on how many spatial streams are used).

Furthermore, as presented in 1.2, the **Data** field is common to all aforementioned modes. Inserted after the preamble (i.e all fields preceding the Data field) it contains the PHY payload.

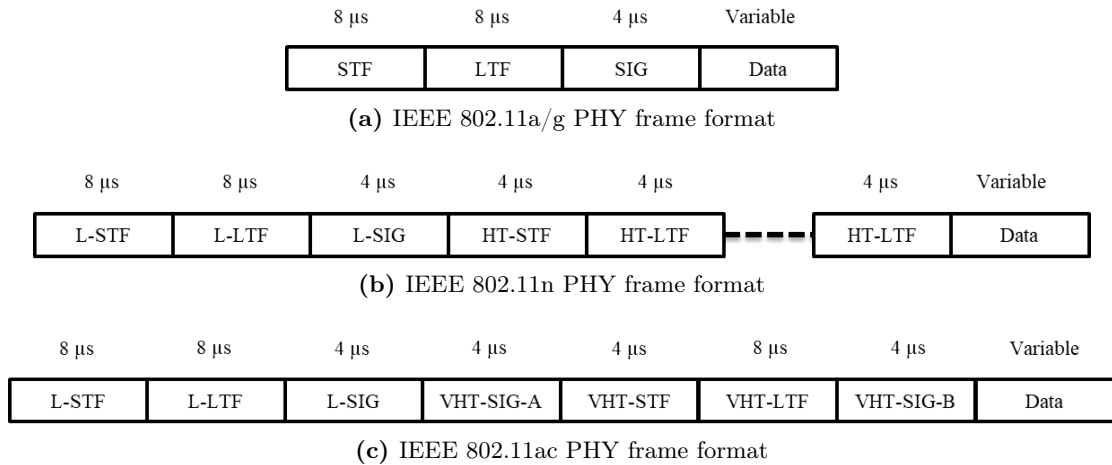

Figure 1.2: Different IEEE 802.11 PHY frame formats

This Data field could be empty, it is then referred to as null data packet (NDP), which can be used for measurement, beamforming and configuration. We note that, whatever the mode/standard, aforementioned fields constitute the PPDU frame.

1.2.3.2 Orthogonal frequency division multiplexing (OFDM)

The multicarrier concept has been proposed by Chang in the 1960s [41]. Later in 1971, a time-limited multi-carrier technique has been proposed in [8] by Weinstein and Ebert: it was the birth of OFDM. Because of its high efficiency, this technique has been heavily used with the expense of applications. For instance, the European digital audio broadcasting (DAB) and digital video broadcasting (DVB) are among the first technologies using OFDM.

OFDM is one of the multiplexing techniques that permits a high data rate transmission while ensuring a better exploitation of the channel compared to the conventional frequency division multiplexing (FDM)[9]. It overcomes the multipath problem by dividing the channel bandwidth into a number of orthogonal sub-bands that carry one modulation symbol each. It was presented as a new way to transmit signals without inter carrier interference (ICI) or inter symbol interference (ISI). Because of its high efficiency which results in improved data rates, OFDM has been considered as a key improvement when introduced within IEEE 802.11 specifications with IEEE 802.11a. Several works expose the use of OFDM while showing its performances within wireless networks [11][10].

OFDM splits a large amount of data over available subcarriers, that are then multiplexed to be simultaneously transmitted over the channel. Each sub-

band is orthogonal to all other sub-bands so as to null out ICI. Users can occupy the channel during an OFDM symbol duration and transmit within the corresponding frequency bandwidth. Combined with error correction coding, it allows time and frequency diversity. The subcarriers are spaced by a frequency interval denoted by Δf . In order to prevent ISI, a guard interval (GI) is added between two successive OFDM symbols. Practical implementation of OFDM uses inverse fast Fourier transform (IFFT) and FFT at transmitter and receiver respectively. The IFFT/FFT size equals the number of subcarriers. Table 1.2 presents different parameters involved in the OFDM technique for the Wi-Fi norm up to IEEE 802.11ac.

Table 1.2: IEEE 802.11 OFDM parameter values in 20 MHz bandwidth

FFT size	64 points
Subcarrier Frequency spacing (Δf)	312.5 kHz (20 MHz/64)
OFDM symbol time	3.2 μ s
Guard Interval (GI)	0.8/0.4 μ s
Inactive/unused subcarriers	12
Total number of subcarriers	52 (IEEE 802.11a/g) 56 (IEEE 802.11n/ac)
Number of data subcarriers	48 (IEEE 802.11a/g) 52 (IEEE 802.11n/ac)
Number of pilot subcarriers	4

Under IEEE 802.11 specifications (up to IEEE 802.11ac), an OFDM symbol is transmitted within a 20 MHz band, divided into 64 sub-bands of 312.5 kHz each. Each OFDM symbol corresponds to a duration of 3.2 μ s involving three types of subcarriers: pilot, data and inactive (that includes centre and guard subcarriers). An illustration of an IEEE 802.11 OFDM symbol is presented in Figure 1.3.



Figure 1.3: IEEE 802.11 OFDM symbol

Otherwise, depending on standard specifications, particularly PHY layer features, the coding of OFDM symbols could include different modulation and coding schemes (MCS). Different supported MCSs are exposed in Section 1.2.3.4.

1.2.3.3 Single and multiple user multiple input multiple output (MIMO)

For the purpose of improving the overall network performance through spatial diversity, the IEEE 802.11n [6] included the technique of MIMO.

Using multiple antennas at both the transmit and receiver sides enables to improve the spectral efficiency and/or transmission quality without additional bandwidth nor power increment. Thanks to full or partial channel state information (CSI) at the transmitter, optimised precoding of several spatial streams enables to increase the data rate while ensuring transmission quality. IEEE 802.11n supports a deployment of a maximum of 4 exchanged spatial streams (SS) for each single user. This is denoted by single user MIMO (SU-MIMO). Its successor, IEEE 802.11ac [7] extends the SS number from 4 to 8 for each user and also introduces the multiple user (MU) diversity to the Wi-Fi standard. Multiple user MIMO (MU-MIMO) [42] provides a transmission scheme using multiple antennas to simultaneously transmit to multiple users thus increasing the transmission gain and efficiency. However this is done at the expense of an interference increase induced by the multiplicity of either spatial streams or communicating stations. To overcome this issue, beamforming, which exploits available CSI at the transmitter, can be applied as a solution to limit the interference to the narrow neighbourhood of the target user. It has been normalised in the IEEE 802.11n and revised in the IEEE 802.11ac.

1.2.3.4 Modulation and coding scheme

The notion of MCS has been introduced by the IEEE 802.11n to have an index identifying modulation and coding rate couples. Many MCSs have been defined to encode transmitted frames. Each MCS index corresponds to a modulation scheme, a coding rate and a number of SS. These parameters induce a certain data rate depending either on the channel bandwidth or the GI (for amendments under OFDM technique). Either IEEE 802.11a or IEEE 802.11g recommend several modulations (e.g. binary phase shift keying (BPSK), quadrature phase shift keying (QPSK), 16-QAM and 64-QAM) under different coding rates (e.g. 1/2, 2/3 or 3/4). It thus allows both amendments (i.e. IEEE 802.11a/g) to achieve higher data rates compared to IEEE 802.11b. For IEEE 802.11a/g devices, a data rate of up to 54 Mbps can be reached using 64-QAM modulation and a coding rate of 3/4. A summary of modulation and coding parameters is given in Table 1.3.

Table 1.3 presents different supported OFDM-based modulation schemes for amendments IEEE 802.11a/g. With the introduction of additional MCS in IEEE 802.11n, higher data rates (e.g. 65 Mbps versus 54 Mbps for 20 MHz bandwidth and 1 SS) are provided. A bandwidth extension up to 40 MHz is also introduced. The VHT amendment (i.e. IEEE 802.11ac) not only extends

the bandwidth compared to the HT amendment (namely including 80 MHz and 160 MHz) but also adds two higher MCSs: 256-QAM with 3/4 and 5/6 coding rates. The highest one (i.e. 256-QAM, coding rate: 5/6) reaches data rate up to 780 Mbps per SS. IEEE 802.11n/ac MCS parameters are reported in Table 1.4.

Table 1.3: Modulation schemes of the IEEE 802.11a/g amendment

Modulation	Coding rate	Data rate (Mbps)
BPSK	1/2	6
BPSK	3/4	9
QPSK	1/2	12
QPSK	3/4	18
16-QAM	1/2	24
16-QAM	3/4	36
64-QAM	2/3	48
64-QAM	3/4	54

Table 1.4: MCS table of the IEEE 802.11n/ac amendment for 1 spatial stream

MCS index	Modulation	Coding rate	Data rate (Mbps)			
			20 MHz	40 MHz	80 ¹ MHz	160 ¹ MHz
0	BPSK	1/2	6.5	13.5	29.3	58.5
1	QPSK	1/2	13	27	58.5	117
2	QPSK	3/4	19.5	40.5	87.8	175.5
3	16-QAM	1/2	26	54	117.0	234
4	16-QAM	3/4	39	81	175.5	351
5	64-QAM	2/3	52	108	234	468
6	64-QAM	3/4	58.5	121.5	263.3	526.5
7	64-QAM	5/6	65	135	292.5	588
8 ¹	256-QAM	3/4	78	180.0	351	702
9 ¹	256-QAM	5/6	N/A ²	200.0	390	780

¹ Supported only by IEEE 802.11ac

² Not applicable

1.2.3.5 IEEE 802.11 rate adaptation algorithms

In order to optimise performance and obtain the best data rate given the conditions of the wireless network, IEEE 802.11 allows different rate adaptation algorithms (RAA). Their main purpose is to optimise the overall throughput or other metric of interest depending on channel conditions. RAAs mainly use

the physical layer to sense the channel by using either the signal-to-noise-ratio (SNR) or the frame loss ratio. The frame loss ratio is determined by the success (or not) of a transmission through the utilisation of several IEEE 802.11 mechanisms (acknowledgement (Section 1.11), ready to send (RTS) / clear to send (CTS) mechanism (Section 1.2.4.1, to name a few). Several algorithms have been defined in the literature to operate within IEEE 802.11 wireless networks. A survey of different WLANs RAA and their comparison can be found in [43]. One should note that RAAs are mainly specific to implementations. Main RAA are briefly defined in what follows.

The auto rate fallback (ARF) [44] is one of first proposed RAA algorithms. It adapts the data throughput depending on the efficiency of transmission, namely based on successfully/unsuccessfully received frames, i.e. based on successful/failed acknowledgements. The algorithm uses the acknowledgement frames as an implicit feedback to sense the frame loss ratio. The more successful transmissions there are the higher the data throughput. Otherwise, if acknowledgement is not received, the ARF assumes the data throughput is too high and reduces it.

Another RAA algorithm, referred to as receiver based auto rate (RBAR), uses the RTS/CTS mechanism to determine the SNR so as to determine the best rate for the transmission.

A RAA named sample rate (SampleRate) has been first defined in [45] and applies a statistical approach to adapt the throughput. The algorithm memorises several transmission parameters (e.g. number of transmitted frames, number of successfully received frames, number of failed frames, transmission times ...) so as to choose the maximum throughput. The choice is made by averaging all previous cases based on tracked parameters.

We mention that all simulations reported in this Ph.D work are based on a constant rate and no RAA is used.

1.2.4 MAC basics and evolution

This section gives an overview of MAC techniques and their evolution up to IEEE 802.11ac amendment.

Basics and evolution of the Wi-Fi norm channel access are presented in Section 1.2.4.1. The MAC framing is presented in Section 1.2.4.2. A description of IEEE 802.11 management operations, from accessing to the network up to leaving it, is presented in Section 1.2.4.3. IEEE 802.11 acknowledgement mechanisms are finally highlighted within Section 1.2.4.4.

1.2.4.1 Channel access

As mentioned before, IEEE 802.11 channel access techniques adopt the CSMA/CA that relies on the "listen before talk" mechanism. The basic prin-

principle behind CSMA/CA is to monitor if the channel is idle or busy so as to schedule stations' transmissions and avoid collisions by using random slots for actual access. The monitoring is based on two main carrier sense functions which are the physical and the virtual one. The physical carrier sense relies on the PHY layer by energy and frame length detection. The virtual one, called the network allocation vector (NAV), concerns MAC layer information included in the MAC header. Both mechanisms (i.e. virtual and physical carrier sense mechanisms) must state that the channel is free for it to be deemed accessible. When it comes to collisions reduction, it uses the binary exponential back-off (BEB) algorithm. Each station picks a number from a defined interval referred to as contention window (CW) interval, $[0, CW]$ that conditions its access time to the channel. The back-off algorithm is commonly used to access to a channel, switching from busy to idle and to reschedule transmissions after errors or collisions. It significantly contributes to reducing collisions. More details about this mechanism are exposed in Section 4.4.2.2. As stated in Section 1.2.1, the IEEE 802.11 MAC sub-layer provides two main channel access mechanisms. The first one is contention-based DCF mechanism which is the most basic one. The second one is the EDCA introduced within the IEEE 802.11e [13].

1.2.4.1.1 DCF

IEEE 802.11 devices perform the basic mechanism of DCF (also named legacy relative to EDCA) to gain access to the channel. Relying on an arbitrary access, it enables a fair share of the medium. Several timers are employed to manage the channel access under the DCF mechanism called inter-frame space (IFS). An example of basic DCF transmission is illustrated in Figure 1.4 [2].

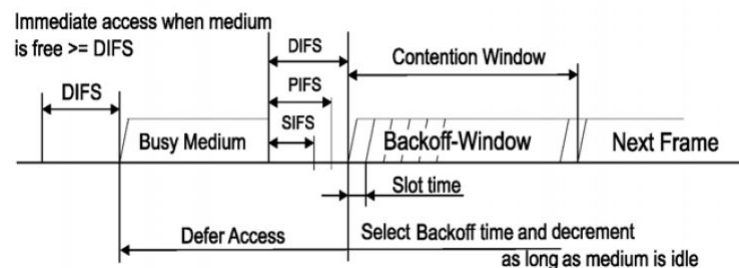

Figure 1.4: Basic channel access

Each station wanting to gain access to the channel checks if it is idle. Once it is true, the station waits for a DCF inter-frame space (DIFS) to either transmit directly if the medium was previously idle or launch its back-off counter if the medium was previously busy. The back-off counter selects its value within the current contention window. The channel can transmit once

the back-off counter reaches zero. For some types of frames, such as control frames (e.g. acknowledgement frame) a short IFS (SIFS) frame is used before transmitting. Otherwise, in case of non-received frames, DCF stations wait for an extended IFS period designated as EIFS^{leg}. More details about these IFS durations are given in Sections 4.4.2.2 and 4.4.2.3.

Additionally, for the purpose of enhancing transmission efficiency, an optional use of RTS/CTS is included to the DCF, especially for the hidden node problem (i.e. some nodes may detect one another during the carrier sensing, thus resulting in a high number of collisions). The station that initiates the transmission first sends an RTS frame to inquire about the availability for exchanging data. If the receiver accepts the communication, it sends a CTS frame. For simplicity reasons, this work does not suppose the use of the RTS/CTS mechanism.

Several works consider DCF mechanism within the IEEE 802.11 norm [46][47][48]. In [46] for instance, Bianchi analyses the saturation throughput of the DCF mechanism assuming an ideal channel. It came out that DCF performance mostly depends on parameters, such as back-off contention window value and the number of devices. Bianchi also shows the impact of using the RTS/CTS mechanism for large networks compared to small ones and how it enhances performances in the former. The same subject is treated in [47], where P.P Pham develops an analysis of the DCF mechanism by deriving several metrics (throughput, delay, packet loss, packet processing). An analysis of the DCF is also established in [48].

1.2.4.1.2 EDCA

To enhance the QoS of IEEE 802.11 networks, the TGe introduced several improvements in the IEEE 802.11e [13], and the enhanced distributed channel access (EDCA) is one of the major ones. It is an extension of the DCF mechanism that includes QoS traffic prioritisation for data packets. The corresponding data packets are referred to as QoS Data packets. QoS Data packets are queued depending on their access category (AC) while maintaining backward compatibility. It specifies four ACs from the highest to the lowest priority: voice (AC_VO), video (AC_VI), best effort (AC_BE), and background (AC_BK) (Figure 1.5). Concerning control and management frames, they operate under DCF mechanism. Table 1.5 lists the different ACs and their corresponding priorities.

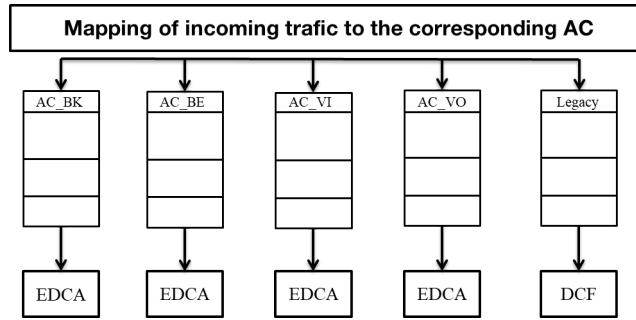

Figure 1.5: AC-based queue management in EDCA

Table 1.5: Different access categories and corresponding priorities

Priority	AC	Description	User priority
Lowest	AC_BK	Background	1
	AC_BE	Best effort	0
	AC_VI	Video	4
Highest	AC_VO	Audio	6

Similar to DCF, EDCA stations sense the channel and only transmit if it is idle. A packet with high priority will have to wait less than the one with the low priority. Once the channel is idle, station defer an arbitration inter-frame space (AIFS(*i*), *i* corresponding to AC type) depending on the elected AC just before launching the back-off algorithm. As stated before, the back-off counter is selected from contention window intervals which, under EDCA mechanism, depends on the selected AC (Figure 1.6).

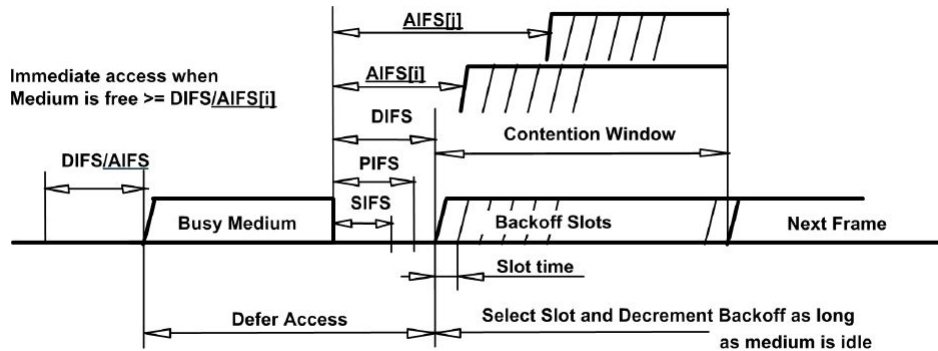

Figure 1.6: EDCA basic mechanism (PIFS stands for point coordination function IFS)

The station gains access to the channel once its back-off counter reaches zero. It can then transmit for a duration referred to as transmit opportunity (TXOP). This concept has been also introduced within IEEE 802.11e [13] to ensure channel access fairness. Under the EDCA mechanism, a station that gains access to the channel has the opportunity to transmit up to a maxi-

imum TXOP. In case a collision occurs, the packet with the highest priority is transmitted first and the one with the lowest priority has to double its contention window and waits for the next TXOP. A revisited EIFS, referred to as EIFS(i), is launched after a collision or errors. Its duration depends on the AC type. Different involved parameters are illustrated in Figure 1.6 [13].

Under same AC traffic, EDCA operates under the same parameters as the DCF. More details can be found in Sections 4.4.2.2 and 4.4.2.3.

Compared to DCF, EDCA achieves better MAC efficiency thanks to QoS-based prioritisation [31][32][33][34]. It is shown in [31] that the QoS prioritisation improves real-time application performances by providing higher throughput and lower delays. In addition, with EDCA, low priority traffic (e.g. best effort, background) does not hinder higher priority traffic (e.g. voice, video) thanks to the prioritisation mechanism. Furthermore Banchs et al. studied the coexistence of DCF and EDCA. [32] shows that EDCA indeed improves the overall network performance and points out how DCF users could suffer if coexisting with EDCA users. R.Biswel and D.Seth also compared DCF and EDCA and proved in [33] how both mechanisms achieve the same performances when the traffic category is similar. In addition, O.Leontyeva et al. analysed aforementioned mechanisms through simulation and analytical models. They proved in [34] that channel access mechanism performances strongly depends on the number of users, the size of data packets and the number of categories.

1.2.4.2 MAC frame format

Before exposing the IEEE MAC frame format, let us first explain some protocols related to the MAC layer with regards to higher or lower layers. Figure 1.7 [28] gives a global view of the protocol layering.

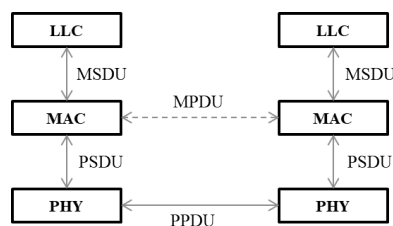

Figure 1.7: IEEE 802.11 protocol layering

Logical link control (LLC) layer sends MAC service data units (MSDUs) to the underlying MAC layer. The MAC layer can group some MSDU to form an aggregated MSDU (A-MSDU). The MSDU or A-MSDU is encapsulated just before being sent to the PHY layer as a PHY service data unit (PSDU). It is the encapsulation of a single MPDU or an aggregated one (A-MPDU).

Figure 1.8 [28] presents the two layers (PHY and MAC) encapsulation of an IEEE 802.11 frame using aggregation.

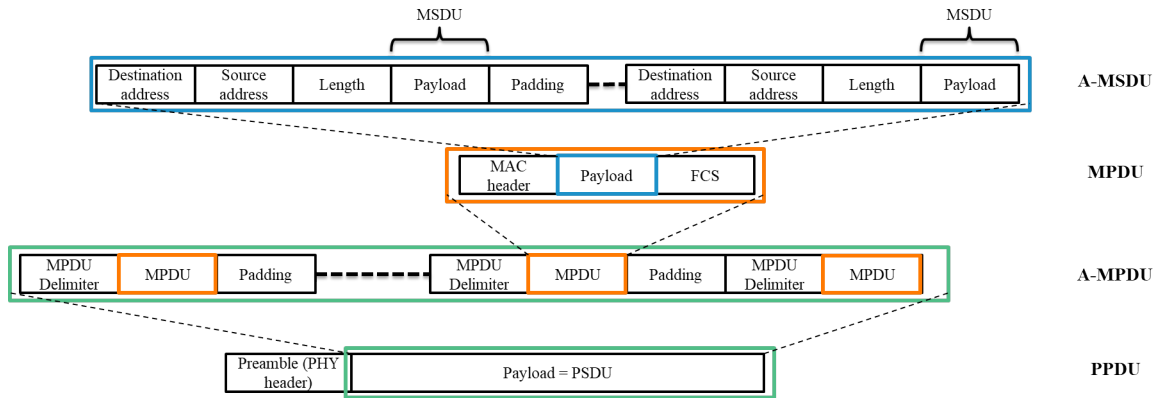

Figure 1.8: MAC and PHY encapsulation of aggregated IEEE 802.11 frames

The PSDU is thus experiencing PHY protocols to become a PPDU. The MAC layer (respectively the PHY layer) exchanges MAC protocol data units (MPDUs) (respectively PPDUs) with its peers.

Let us now give an overview of the MAC frame format for MPDUs (i.e. the product of the MAC encapsulation) within the IEEE 802.11 norm. Figure 1.9 presents different fields included in the IEEE MAC frame which are: the MAC header, the frame body (referred to here as the payload) and the frame check sequence (FCS).

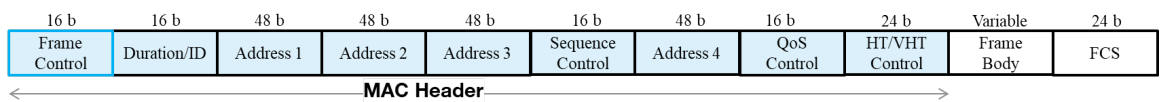

Figure 1.9: IEEE 802.11 MAC frame format

One should note that depending on the frame type (i.e. data, management or control), some sub-fields are not included.

1. **MAC header:** is the first field of the MAC frame and includes:

- **Frame Control field:** includes the following sub-fields also presented in Figure 1.10.

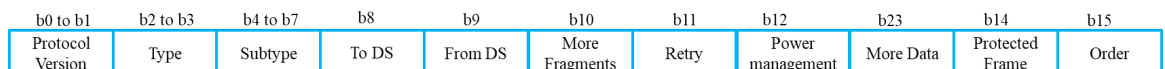

Figure 1.10: IEEE 802.11 control field

- **Protocol version sub-field:** is coded using 2 bits (b) which are always set to zero unless a non-backward compatibility is present.
 - **Type and sub-type sub-fields:** specify the type and the sub-type of the frame. We mention that there are three types of frames: control, data and management frames. Furthermore, the Wi-Fi standard also distinguishes several sub-type frames. For instance for data frame type there is plain data frame, QoS Data frame or Null frame to name a few. We can also cite some control frame sub-types such as RTS/CTS acknowledgement and block acknowledgement frames, and management frames such as beacon, association and action frames.
 - **To/From DS sub-fields:** take many combinations to specify the frame direction within the network.
 - **More Fragments sub-field:** is set to 1 if there are more fragments to transmit and 0 if the data frame transmission is complete.
 - **Retry sub-field:** indicates if the current data or management frame is a retransmission of an earlier frame. In that case, it is set to 1.
 - **Power management sub-field:** reports whether the station is in active mode (set to 0) or in power save (PS) mode (set to 1). For the AP, it is always set to 0.
 - **More Data sub-field** informs the station in PS mode if the AP still has more frames in the queue.
 - **Protected Frame sub-field:** indicates, when set to 1, that the frame is encrypted. This field is only present for data frames and authentication management frames.
 - **Order sub-field:** is used in case the AP has changed the delivery order of transmitted frames in broadcast or multi-cast mode. This field has never been widely exploited.
- **Duration/ID field:** acts as the NAV duration in microseconds if its value is less than 32 768. Otherwise it is the association identifier.
 - **Address 1, 2, 3, and 4 fields:** indicates the different addresses involved within a wireless transmission (i.e destination, source, etc.). Addresses 3 and 4 may be absent in some configurations.
 - **Sequence Control field:** is composed of **Fragment Number** and **Sequence Number** sub-fields which are coded using 4 and 12 bits respectively. They indicate the fragment and the sequence numbers assigned to the transmitted frame.

- **QoS Control field** includes information related to QoS. It includes 16 b representing several QoS parameters:
 - B0-B3: refer to the traffic identifier (TID) which identifies the type of the traffic of the QoS Data frame.
 - B4: carries the information of the end of service period.
 - B5-B6: indicate which acknowledgement policy is employed to notify the correct reception of the QoS Data. The IEEE 802.11 norm specifies 4 of them: normal acknowledgement, no acknowledgement, no explicit acknowledgement, or scheduled acknowledgement, and block acknowledgement. More details about the acknowledgement principles are given afterwards.
 - B7: indicates the presence or not of aggregated frames i.e. whether frame body contains an A-MSDU.
 - B8-B15: may carry many parameters depending on the frame sub-type. There are four options: TXOP limit, AP PS buffer state, TXOP duration request and queue size.
 - **HT/VHT Control field or HT variant Control field:** is present for IEEE 802.11n/ac within QoS Data frame and includes several sub-fields corresponding to specifications related to HT or VHT respectively. It is also named HT variant (being either HT or VHT) Control field.
2. **Frame body field:** carries information on the frame depending on its type or sub-type. For data frames, it is composed of frames received from LLC layer, namely a simple MSDU or A-MSDUs. The composition of an MSDU is presented in Figure 1.8.
 3. **FCS field:** it used to check whether the frame is correct. It includes a cyclic redundancy check code (CRC) of 32 bits.

Aforementioned fields constitute the MPDU frame which can be aggregated into an A-MPDU as presented in Figure 1.8. The latter includes:

1. **MPDU Delimiter or MAC Delimiter (DELI):** is placed before the MPDU and includes several information such as the signature and the length of the MPDU, an 8-bit CRC and the information about the end of the frame.
2. **Payload field:** which constitutes the MSDU or the A-MSDU.
3. **Padding field:** used to round the MPDU length to 4 octet frontier.

This frame (i.e. MPDU or A-MPDU) is thus forwarded to the PHY layer (becoming a PSDU from the latter's perspective) which generates a PPDU by prepending a PHY header (also named preamble).

1.2.4.3 IEEE 802.11 management operations

IEEE 802.11 supports several architectures as thoroughly exposed in Section 1.2.2. Either under BSS, IBSS or ESS mode, managing the communication is mandatory to ensure the coordination of present devices. This relies on several procedures specified by the Wi-Fi norm [2][16][17] for each node of the wireless networks. These proceedings enable to manage communications from accessing to a WLAN, until leaving it. For instance, each station, mobile or not, could join or leave a network at any moment. Its association or disassociation from the BSS or the IBSS must be handled. The basic management operations within an IEEE 802.11 network are listed below.

- (a) **Beaconing:** It has the function of periodically broadcasting a frame that includes several information such as supported capabilities, operating specifications or management information. It is handled by the AP and the GO for the BSS mode and the IBSS mode respectively.
- (b) **Scanning:** As its name indicates, this function enables to detect existing BSSs. A station can perform two types of scans. The first type is the active scanning where the station actively searches for an appropriate BSS by sending out Probe Request frames. APs (or GOs) can respond using a Probe Response if the station accepts the request. The second scanning type is the passive one. The station waits until it detects a Beacon frame sent by an AP (for infrastructure BSS mode) or an GO (for IBSS mode). An exchange of Probe Request / Response could be used if the station needs some information not available in the Beacon frame.
- (c) **Authentication:** To join a network, stations have to be authenticated under IEEE 802.11 specifications. Two methods are supported to perform this process: open system and shared key authentication. The first one does not require any log-in code to join a BSS in contrast to the second one where stations must have the shared encryption key. Authentication provides a secure network so that the BSS would not be accessed by any user and to prevent ones dropping.
- (d) **Association/Re-association:** Each station wanting to communicate with the BSS must be associated to the AP. To establish this association, a STA first sends an Association Request. If the request is accepted, the AP responds with a positive Association Response frame and thus finalises the association procedure. Information about the network configuration is transmitted during Association Request / Response exchange. Otherwise, in case the station is moving within an ESS, it has to be re-associated to the new BSS so that network mapping is maintained by concerned APs. In addition, a re-association could be performed in case network capabilities were changed.

- (e) **Disassociation:** The disassociation step is implicitly effective once an associated device wants to leave or its communication is lost after a defined amount of time. Explicitly, a disassociation frame is sent either by the STA or the AP to inform the disassociation request.

1.2.4.4 Acknowledgement

Transmissions within a wireless network are prone to collisions or errors. Among others, the knowledge of data paths is highly essential to provide an efficient transmission. The acknowledgement mechanism (Ack) is used for that purpose. IEEE 802.11 [2] specifications require most transmissions to be acknowledged so as to inform the transmitter of their correct (or not) reception. Reception status can be obtained by comparing the locally computed FCS with the received one. If the Ack frame is not received, the data frame is deemed lost and a retransmission is scheduled. Prior to QoS integration, legacy frames are acknowledged one by one by via the basic acknowledgement frame denoted as ACK. We mention that Ack refers to the acknowledgement mechanism while ACK is for the acknowledgement frame. It indeed provides a means of tracking sent data and thus improves transmission efficiency. Nevertheless this induces overhead for transmitting high amounts of data. To overcome this issue and improve QoS, the IEEE 802.11e [13] introduced the block BA mechanism. The difference with the Ack lies in the fact that a burst of data intended to the same destination is acknowledged at once. Both are briefly introduced in the two following paragraphs and thoroughly detailed in Chapter 4.

1.2.4.4.1 Normal acknowledgement

For IEEE 802.11 transmissions, receivers send an ACK frame for each correctly received frame. An example of data/ACK exchange is illustrated in Figure 1.11.



Figure 1.11: Example of Ack mechanism within the IEEE 802.11 amendment

Once the STA gains access to the channel, it begins to transmit its data just after deferring DIFS (if legacy channel access) or AIFS(i) (if EDCA channel access). For a burst of data, an ACK frame is sent by the receiver for each correctly received data frame. Likewise, for non broadcast management frames, an ACK frame is expected to inform their successful reception. A retransmission is scheduled either if the data frame or the ACK is lost.

1.2.4.4.2 Block acknowledgement

As stated earlier, BA enables to acknowledge a number of data frames at once (as illustrated in Figure 1.12) thus reducing overhead and enhancing the overall efficiency.

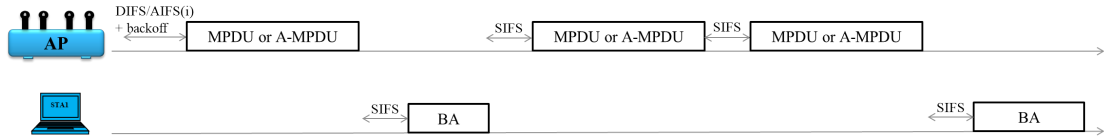

Figure 1.12: Example of BA mechanism as proposed in the IEEE 802.11n

In contrast to the Ack which is automatically expected after a received frame, the BA has to be negotiated through a BA session.

IEEE 802.11n amendment [6][21][22][23][28] introduced HT-immediate BA and HT-delayed BA while exploiting aggregation and higher data rates benefits to improve MAC efficiency. HT-immediate BA and HT-delayed BA (denoted afterwards as immediate BA and delayed BA respectively) are presented in Figure 1.13 and Figure 1.14 respectively. No special change was introduced with IEEE 802.11ac [7][26][27][28]; VHT stations support immediate BA and delayed BA. Indeed, the original mechanisms have been maintained in all amendments following 802.11n to support inter-operability with legacy stations. The immediate BA (where the BA is implicitly requested within the QoS Data frame) was initially intended for applications with strong latency constraints while delayed BA rather applied to applications without strong latency requirements. Either for immediate or delayed BA, the session is composed of three main steps as presented in either Figure 1.13 or Figure 1.14.

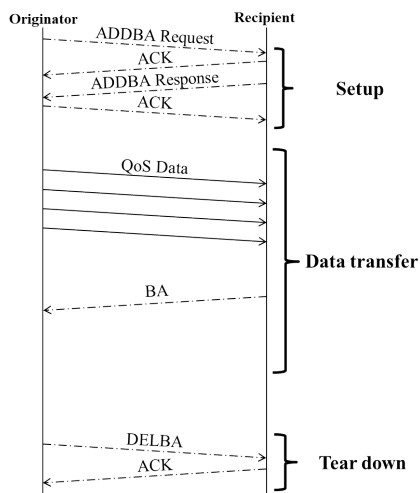

Figure 1.13: Immediate Block ACK

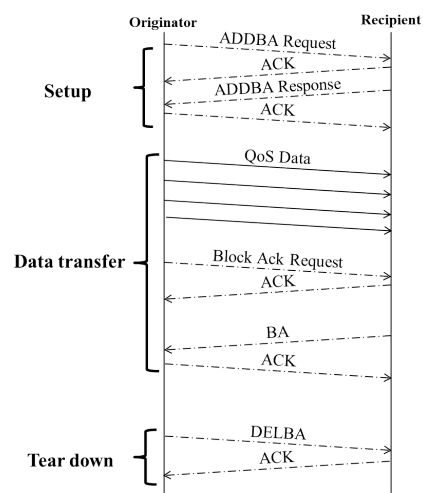

Figure 1.14: Delayed Block ACK

The first step relies on a four-way handshake of add BA (ADDBA) Request and ADDBA Response. By sending an ADDBA Request, the originator requests for the establishment of a one-way data transfer session using the BA mechanism. If this frame is correctly received (note that an ACK is sent to notify the originator of the correct reception of the ADDBA Request) the recipient may accept (or decline) the establishment of the BA session and send an ADDBA Response which is also acknowledged by an ACK.

The second step starts with the beginning of data transfer between the two parts. QoS Data frames are sent as a burst or aggregated. For the immediate BA, the data is acknowledged after a SIFS of sending all QoS Data frames, contrarily to the delayed one where the BA frame may be sent later in a separate channel access. Through the BA frame, the originator is informed about which QoS Data frames to reschedule for retransmission.

Once all data frames are correctly received/acknowledged and the originator has no more data to send, it can close the session by transmitting a delete BA (DELBA): this is the last step. The recipient sends an ACK for the DELBA frame and thus the BA session is closed on both sides. Furthermore, the BA session is considered closed in case one of the involved frames were not received (e.g. BA, QoS Data) for a long time.

1.3 IEEE 802.11ax

1.3.1 IEEE 802.11ax challenges and objectives

From legacy (i.e. IEEE 802.11a/b/g) to latest amendments (i.e. IEEE 802.11n/ac), significant improvements have been done. Thanks to them, network performances have been considerably improved. Either the aggregation or the MIMO mechanism with the IEEE 802.11n or the multiple user scheme introduced in IEEE 802.11ac, to name a few, are indeed key principles highly contributing to the enhancement of the overall data rate.

Such improvements are necessary, given the great technological evolution and high wireless equipment's usage. Nevertheless, WLANs are not protected from impairments/limitations. Indeed the main focus has been put on enhancing data rates regardless of either the spectrum use or the overall latency.

Nowadays, wireless networks are facing important challenges with the massive deployment of wireless devices combined with the ever rising amount of data. In such scenarios, the BSSs are prone to overlap with each other, thus becoming overlapping BSSs (OBSS) to one another. Obviously, a vast deployment with a large number of APs and STAs is always exposed to a lot of impairments which reduce the efficiency of the network. Performance is highly impacted due to the important number of induced collisions. Z. Zhong et al. highlight in [49] how high interference, due to OBSSs, induce a highly affected throughput.

Previous standards were not designed to deal with such a dense deployment of APs and STAs and the resulting consequences, if not taken into account, will affect the network functioning and service quality. In some deployments, e.g. shop malls, airports, or train stations, there is such a high density of users that a satisfactory minimum level of service cannot be offered because of degradation of performance. This saturated data rate is also caused by the limited spectrum specified within current amendment. Particularly, some users do need neither to transmit a huge size of data, nor occupy the channel for a long time. They may access the network and leave it after a while. Their short occupancy is not taken in consideration in the sense that available spectrum is not adapted to user requirements so as to reduce either overhead or transmitted payloads. This lack of adaptability highly influences data rates especially in the presence of high number of users. Main challenges are well exposed in [50] [51] and [52].

The aforementioned challenges definitely gain in momentum with the expanse either of wireless applications or data traffics. This directly affects the end-user experience and reduces global and individual throughput. To deal with these challenges, the IEEE 802.11 launched the TGax within the framework of the IEEE 802.11ax amendment [14], also referred to as high effi-

ciency (HE) standard. Its main objective is to improve network performance especially for dense scenarios. Contrary to earlier amendments which focus mainly on improving maximum throughput, the IEEE 802.11ax targets the improvement of the spectral efficiency of dense scenarios while insuring higher maximum throughput per user.

The IEEE 802.11ax thus promises a number of enhancements to address interference-related issues, in order to provide high efficiency not only in indoor environments but also outdoor environments (which are currently a great challenge for deployment teams). Principal improvements are thoroughly exposed in [53], [54] and [55]. Main objectives target improving the spatial usage, reducing interference, improving power efficiency, and increasing the efficiency of the network, so that end-user experience and global performance could be improved. A four-fold increase in the throughput of the user with the minimum average throughput, in comparison to 802.11ac, is targeted. In all cases, one condition is required, though: every integrated enhancement must maintain backward compatibility with all previous generations; 802.11ax will ensure backward compatibility with 802.11a/g/n/ac as it will work on both 2.4 GHz and 5 GHz bands. Furthermore The IEEE 802.11ax recently added the 6 GHz frequency band (this addition is out of scope of this work).

1.3.2 PHY layer improvements

To deal with dense environments, IEEE 802.11ax includes many technical solutions. Concerning the backward compatibility, 802.11ax reuses, in the PPDU, a legacy preamble duplicated over each 20 MHz sub-channel to ensure coexistence with other amendments. Moreover, TGax defines a number of PPDU types that will be presented in Section 1.3.2.4.

IEEE 802.11ax aims to enhance capacity and efficiency by making the OFDM symbol larger and by adding the 1024-QAM, for optional use (with the corresponding new MCSs being HE-MCS10 and HE-MCS11).

In addition, IEEE 802.11ax makes the LDPC (low density parity-check) code mandatory for large bands while binary convolutional code (BCC) code is reserved for narrower bands. When transmitting using a relatively narrow band, i.e. less than 40 MHz, BCC is used if less than 4 spatial streams are sent. For more than four spatial streams LDPC, which was optional in previous standards is now mandatory. Regarding larger bands, i.e. larger than 40 MHz, LDPC is mandatory regardless of the number of antennas. LDPC and BCC performances within the framework of the IEEE 802.11ax have been evaluated by R.P.F Hoefel in [56], where it is shown that the LDPC offers power gain of 2 (decibel) dB up to 4 dB.

Concerning MU diversity, IEEE 802.11ax follows the LTE (long term evolution) and uses orthogonal frequency multiple access (OFDMA) for both downlink and uplink transmissions. In the same direction, IEEE 802.11ax

allows - in addition to downlink (DL) MU-MIMO already allowed in IEEE 802.11ac- the use of uplink (UL) MU-MIMO (that relies on sending multiple spatial streams to multiple stations).

IEEE 802.11ax introduces, for optional support, a new multiple access technique which is UL OFDMA random access (UORA). It also provides multiuser diversity especially for unallocated stations. Stations can choose randomly a resource unit (RU) within the available ones announced by the AP through the trigger frame. This mode is ideal for non-greedy applications which do not require too much resource or sporadic channel access.

The next sections focus on some of the aforementioned IEEE 802.11ax features (while obviously focusing on the ones related to this PhD work). The technique of OFDMA as defined in the IEEE 802.11ax is presented in Section 1.3.2.1. IEEE 802.11ax added MCSs are presented in Section 1.3.2.2. The newly introduced OFDMA random access mode is presented in Section 1.3.2.3. Section 1.3.2.4 finally exposes the changes made by the last amendment within the PHY IEEE 802.11 frame.

1.3.2.1 Orthogonal frequency division multiple access (OFDMA)

To meet either increased capacity or improved network efficiency objective, the IEEE 802.11ax has introduced the OFDMA technique. It was first proposed in [57] by H. Sari and G. Karam, and adopted later in either digital terrestrial television [58] or the IEEE 802.16³ [59]. The multiple access offered by the OFDMA insures improved data rates and capacity.

Figure 1.15 represents generalised configurations of the OFDMA. It relies on the same concept as OFDM but offers more flexibility and improvements for multiuser diversity. Namely, OFDMA allows a number of IEEE 802.11ax users to share simultaneously the available spectrum by assigning a RU for each one of them. Contrary to earlier standards, OFDMA enables to allocate a channel to different users in the same slot. This improves the overall network efficiency and reduces latency. The last standard chose to adopt it either for UL or DL transmissions. As OFDM, OFDMA is a powerful way to minimise fading, ISI and ICI.

³IEEE 802.16, also named WiMAX, includes specifications related to accessing to Internet in wide geographical areas.

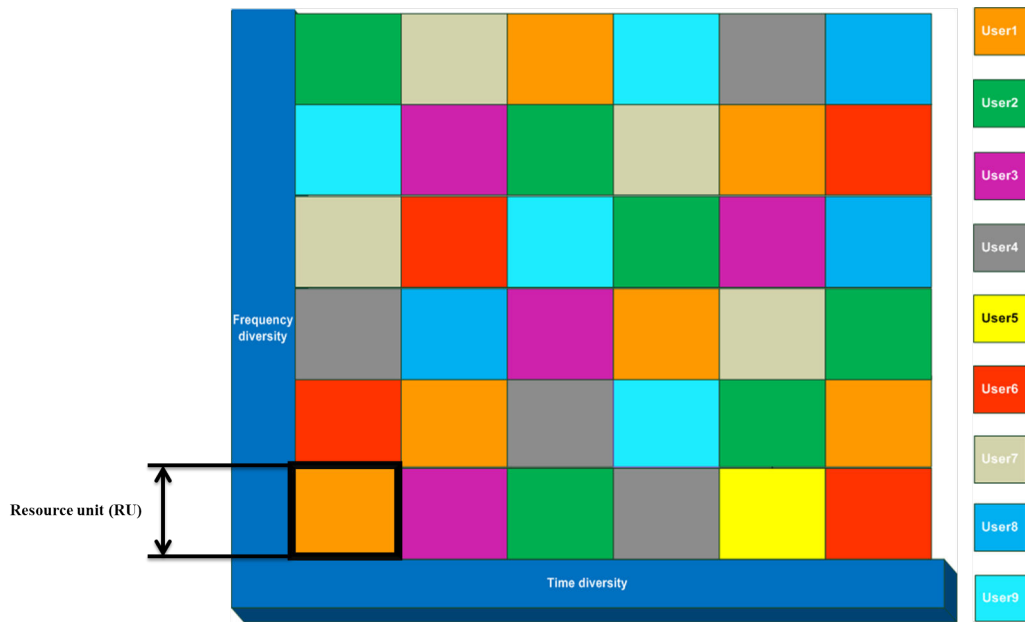

Figure 1.15: Orthogonal frequency multiple access

1.3.2.1.1 General aspect of OFDMA

OFDMA works the same way as OFDM except for the subcarrier allocations. In OFDM, all the available subcarriers are occupied by the same user for the whole allocated time slot. On the contrary, in the case of OFDMA, each user is allocated to only a subset of subcarriers for an amount of time. In a different way, a number of users will exploit available subcarriers which are divided into sub-channels (also named RU). Each sub-channel consists of a number of subcarriers. This configuration will provide a simultaneous transmission and spatial diversity. OFDMA will not provide higher throughput but a better efficiency, since a number of users can be allocated in the same slot of time, thus reducing latency. There are three different RU allocation schemes [60][61], presented in Figure 1.16.

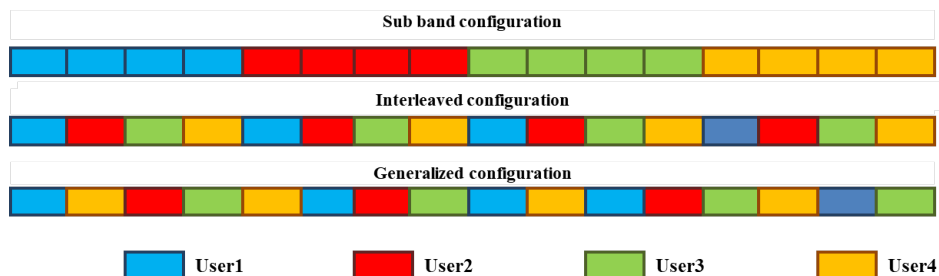

Figure 1.16: Different OFDMA allocation schemes

In the first scheme, called sub-band, each user is allocated to contiguous blocks while avoiding that a block is shared by different users. One of its

drawbacks is that it does not take advantage of the diversity provided by the multipath channel, since a deep fade will affect a number of adjacent subcarriers of a given user.

The second allocation scheme better exploits the diversity of the channel by allocating non-contiguous sub-channels to the same user. The RUs are uniformly allocated to the active users; each user can occupy several RUs among the interleaved RUs. This configuration is called the interleaved allocation scheme.

The third scheme allows a general configuration where a block or more are selected even if they are non-contiguous or not uniformly distributed. This scheme is the generalised one: the user selects the best available ones, which complicate the configuration task.

We mention that IEEE 802.11ax only supports the first allocation (due to its low complexity) scheme (i.e. sub-band scheme) allowing only contiguous RUs to be allocated to the same user.

1.3.2.1.2 Resource allocation within the IEEE 802.11ax

The allocation of IEEE 802.11ax users to available RUs is the task of the AP [62][63]. For UL, all information that concern resource allocation are included, by the AP, in a frame called trigger frame (TF) and sent to all concerned STAs. The AP can assign the spectrum to a single user or subdivide it to multiple RUs to serve multiple users. Each user occupies the RU that has been assigned to it according to the received TF. The bandwidth is divided into a number of RUs that include a given number of subcarriers, also named tones. In particular, 802.11ax has fixed for each channel bandwidth (i.e. 20 MHz, 40 MHz, 80 MHz, 80+80 MHz and 160 MHz) a maximum number of RU, and for every RU a maximum number of tones. Table 1.6 presents the different configurations supported in 802.11ax.

Table 1.6: Maximum number of RUs for each channel width

RU type	20 MHz	40 MHz	80 MHz	80 + 80 MHz /160 MHz
26-tone RU	9	18	37	74
52-tone RU	4	8	16	32
106-tone RU	2	4	8	16
242-tone RU	1	2	4	8
484-tone RU	N/A ²	1	2	4
996-tone RU	N/A ²	N/A ²	1	2
2 × 996-tone RU	N/A ²	N/A ²	N/A ²	1

³ Not applicable

For example, in a 20 MHz band, a user can transmit its PPDU in a RU composed of a number of 26-tones. The maximum of RUs that could be allocated in the same time slot is 74 26-tones RUs for the 80+80 MHz /

160 MHz channel bandwidth. The IEEE 802.11ax allocation allows the sub-band configuration only (as presented in Figure 1.16), namely a user can only occupy contiguous RUs. Figure 1.17 exposes an example of possible OFDMA configurations for 20 MHz band, knowing that RUs of different sizes could be used in the same PPDU.



Figure 1.17: OFDMA configurations in 802.11ax for 20 MHz

1.3.2.1.3 IEEE 802.11ax OFDM symbol

Several modifications are made within the Wi-Fi OFDM symbol in order to enhance data rates and ensure a better channel robustness adapted to all IEEE 802.11ax enhancements. The IEEE 802.11ax OFDM symbol is spread lasts 12.8 μ s, which is much larger than the IEEE 802.11a/g/n/ac OFDM symbol (3.2 μ s). The subcarrier spacing is thus decreased to 78.125 kHz leading, for a 20 MHz band, to 256 subcarriers. In addition, the TGax abandoned the usage of the 0.4 μ s and chose to add 1.6 μ s and 3.2 μ s while keeping 0.8 μ s. The different IEEE 802.11ax OFDMA symbol parameters are presented in Table 1.7.

Table 1.7: IEEE 802.11ax OFDM parameter values

Subcarrier frequency spacing (Δf)	78.125 kHz (20 MHz/256)
OFDM symbol time	12.8 μ s
Guard interval (GI)	0.8/1.6/3.2 μ s
Total number of subcarriers	256
Number of data subcarriers	234

1.3.2.2 Modulation and coding schemes

IEEE 802.11ax aims to enhance the per user peak data rates. For that purpose, it introduces a higher modulation scheme to existing ones (up to the IEEE 802.11ac) which is the 1024-QAM. In comparison with the current highest modulation scheme (256-QAM, 8 bits per symbol), it offers a data rate improvement of almost 20% (1024-QAM, 10 bits per symbol). The added modulation scheme is available, for optional usage, under two MCSs: HE-MCS10 and HE-MCS11. The HE-MCS10 corresponds to a coding rate of $3/4$ and permits to reach a data rate of 129 Mbps and 1080.9 Mbps for 20 MHz and 160 MHz respectively under 1 spatial stream [55]. Likewise, for the HE-MCS11, transmitting with 1 stream within the 20 MHz and 160 MHz enables 143.4 Mbps and 1201 Mbps of data rates respectively. Table 1.8 presents the data rates achieved by these IEEE 802.11ax specific MCSs for different bandwidths, with 1 spatial stream and a GI of $0.8 \mu\text{s}$.

Table 1.8: Data rate of MCSs added by the IEEE 802.11ax for 1 SS and $\text{GI} = 0.8 \mu\text{s}$

IEEE 802.11ax added HE-MCS index	Modulation	Coding rate	Data rate (Mbps)			
			20 MHz	40 MHz	80 MHz	160 MHz
10	1024-QAM	$3/4$	129	258.1	540.4	1,080.9
11	1024-QAM	$5/6$	149.4	286.8	600.5	1,201

1.3.2.3 Orthogonal frequency division multiple access with random access (ORA)

As a part of increasing the throughput in dense environments and improving overall network efficiency, IEEE 802.11ax introduces the uplink OFDMA in random access (RA) mode [14][62][63][64]. As its name suggests, the access to channel is handled by STAs whom chose themselves a RU from RA dedicated RUs. The main idea is to enable the access for users with unknown buffer status (e.g. which wake up from sleep or are unassociated to the AP) or non-greedy ones (i.e. which do not require too much resource).

Based on IEEE 802.11 specification, APs distribute the available RU to scheduled stations according to the received buffer status report (BSR). In addition, the IEEE 802.11ax proposes, for optional use, to allocate associated STAs to available RUs while providing some of them for RA. The AP sends a TF for random access (TF-R) in which it announces at least one RU dedicated for RA. When stations receive the TF-R and have a frame to send, they can choose randomly one RU from the available ones by launching the OFDMA

back-off (OBO) procedure. Figure 1.18 illustrates allocation stations under RA assuming that all stations do not choose the same OBO value.

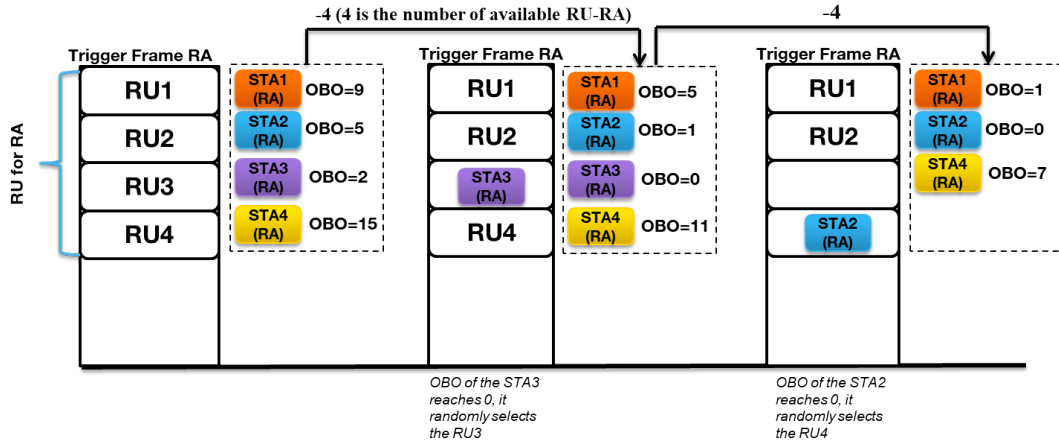

Figure 1.18: Example of stations accessing to available RUs under the random access mode

Each concerned station selects (depending on its traffic priorities) a value within a range of $[0, \text{OFDMA contention window (OCW)}]$ and decrements it by the number of RUs specified for RA in the TF-R. If the number of RUs for RA is greater than the chosen OBO value, the station resets its value to zero. When the OBO reaches zero, the station chooses randomly one RU among the available ones.

1.3.2.4 IEEE 802.11ax PHY frame formats

The IEEE 802.11ax defines four different transmission modes with each using a different PPDU frame format. Thus, four PHY headers are differentiated for each mode so as to support HE transmissions.

The TGax defines the four following formats: high efficiency single user (HE SU), high efficiency multiple user (HE MU), high efficiency extended-range single-user (HE ER SU) and high efficiency trigger-based (HE TB). Each PPDU frame format is presented in Figure 1.19.

The HE SU PPDU is used for single user transmission while the HE MU PPDU is for downlink multiple user mode (i.e. DL MU-MIMO and DL OFDMA).

The HE ER SU PPDU is tailored for outdoor scenarios, with a 3 dB gain compared to HE SU PPDU.

The fourth mode addresses UL MU transmission and uses HE TB PPDUs in response to a TFs. Concerning HE PPDU fields, an analogy could be established with the already defined HT and VHT PPDU concerning functions of HE-STF, HE-LTF, HE-SIG-A and HE-SIG-B (see Section 1.2.3.1).

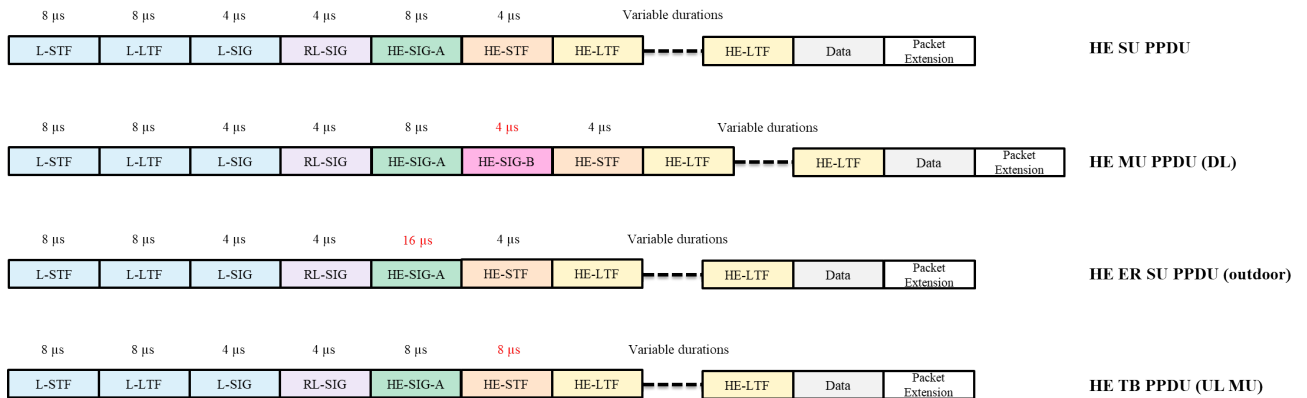

Figure 1.19: IEEE 802.11ax HE PPDU frame format

A supplementary field is involved within the IEEE 802.11ax PHY frames, the repeated legacy signal field (RL-SIG). It is used to differentiate an HE PPDU from a non-HT PPDU, HT PPDU and VHT PPDU.

1.3.3 MAC layer improvements

So as to reach optimal performances, several techniques have also been introduced within the MAC layer [53][54][55]. Most of these improvements concentrate on enhancing user experiences against interference within dense environments. They are mainly related to spectrum and power management. In addition to this, the IEEE 802.11 MAC has been modified in order to support the different introduced principles.

One of the most promising key techniques of the IEEE 802.11ax is spatial reuse. The last standard revises a number of MAC techniques in order to optimise the use of the spectrum such as improving: the physical clear channel assessment (PHY-CCA), the transmit power control (TPC) or the NAV. A new parameter, referred to as BSS colour, has also been introduced in order to improve the spatial reuse.

Furthermore, the last standard makes some modifications of existing techniques pertaining to interference management so as to improve the power efficiency. Aforementioned techniques are exposed in following sections. Section 1.3.3.1 is dedicated to an overview of the spatial reuse principle. The power efficiency point is raised in Section 1.3.3.2. Some IEEE 802.11 MAC frame modifications are briefly exposed in 1.3.3.3.

1.3.3.1 Spatial reuse

Improving the spatial reuse [65] is one of the main MAC improvements within the IEEE 802.11ax, especially since it meets one of its principal objectives which is to improve dense environment in case of high interference. Spatial

reuse enables better management of available resources in the framework of high usage of the spectrum.

- **Improving the PHY clear channel assessment (PHY-CCA):**

Due to this high envisioned usage, accessing the channel is more challenging. Current IEEE 802.11 devices sense the channel relying on a fixed carrier sense threshold (CST). Namely, multiple users aiming to access the channel, may access it if, and only if, the CST is higher than their measured power. In dense environments, some users may never access the channel and always consider the channel as occupied. For these reasons, the dynamic sensitivity control (DSC) algorithm was introduced to improve the access to the channel. The principle is to tune the value of the CST depending on channel conditions. The introduction of the DSC mechanism permits throughput gains of more than 20% compared to fixed CST [66]. It enables a tuning of the CST depending on the perceived environment. It has been shown that the combination of the DSC and RTS/CTS mechanism offers significant advance [67]. This is among the key technologies to improve the PHYCCA, which in turn improves spatial reuse in multiple concurrent transmissions and enhances global throughput.

- **BSS colouring:**

In order to reduce interference, and especially manage OBSSs, the BSS colouring is supported in IEEE 802.11ax. It was originally introduced in IEEE 802.11ah [68]. It relies on assigning an arbitrary number (1 to 63) to each BSS labelled as the 'colour'. The colour of the BSS is randomly chosen by the AP and signaled in PHY header. Once the PPDU is received, the destination verifies if it belongs to its BSS. The payload is decoded if the same colour as the receiver is detected and interpreted as an intra-BSS transmission. Otherwise, the frame is ignored and interpreted as an inter-BSS transmission. Thus, two NAVs are involved: intra-BSS and inter-BSS. A STA will decide to start or abort the transmission depending on these parameters. This mechanism anticipates interference and improves throughput. Only IEEE 802.11ax devices are able to understand this particular specificity since earlier devices (i.e. IEEE 802.11a/g/n/ac) do not support it.

- **Interference management:**

Among interference-related enhancements, the IEEE 802.11ax improves the RTS/CTS mechanism. For optional use, it proposes to activate/deactivate the mechanism depending on the conditions of the channel. This offers an adaptability with regards to network conditions and also a reduction of overhead that automatically decreases latency.

1.3.3.2 Power efficiency

Improving the power efficiency is also one of the points of the last standard. Among power-related enhancements, the TPC was revised in order to adapt the transmit energy with channel conditions. Namely the lowest power is dynamically assigned to the sub-channel with the highest path loss. This avoids excessive interference and increases spatial reuse.

Furthermore the introduction of different NAVs (as mentioned in Section 1.3.3.1) also contributes to improve the power efficiency. The receivers do not need to decode frames that do not belong to the BSS in question. This obviously reduces the power consumption

1.3.3.3 IEEE 802.11ax MAC frame

In this part we highlight two main modifications of the MAC frames. Taking the original IEEE 802.11 MAC frame, two of its fields are revised to support HE enhancements. Figure 1.20 highlights the involved fields.

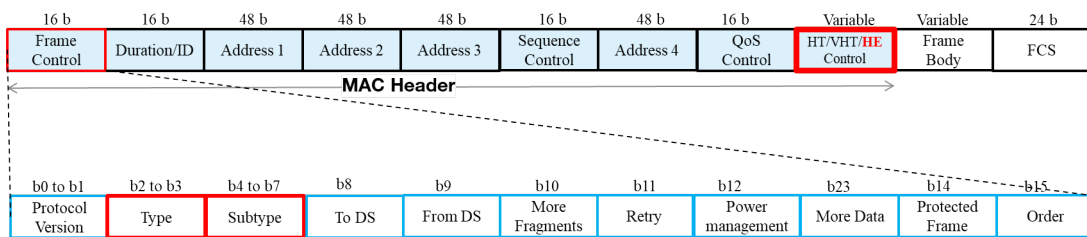

Figure 1.20: IEEE 802.11ax MAC frame modified fields

- For **Type** and **Subtype** fields, additional binary indicator values are supported in order to distinguish either TF (B4 B5 B6 B7 = 0010) or HE NDP (B4 B5 B6 B7 = 0101) frames.
- Concerning **HT/VHT Control** field an **HE** variant HT control field is now supported. It includes an **Aggregated Control** field, referred to as **A-Control** field or **HE A-Control** field, that follows two bits (B0 and B1 of the HT variant field) that are always set to 1. The format of the HE variant HT Control field is given in Figure 1.21 [14].

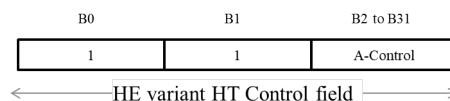

Figure 1.21: Format of the HE variant HT Control field

As defined by the IEEE 802.11ax standard, the A-Control subfield sizes 30 bits that form a sequence of one or more Control subfields. A-Control

subfield format is presented in Figure 1.22 [14].

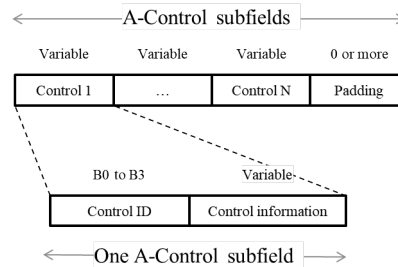

Figure 1.22: A-Control subfields of the HE variant HT Control field

Each Control subfield indicates the identifier and information related to different cases (e.g. triggered response scheduling (ID=0), operating mode (ID=1), buffer status report (ID=3) to name a few). Note that, so far, Control ID value from 7 to 14 are reserved.

1.3.4 Multiple user enhancements

The MU concept was first introduced in 802.11ac [7][42] combined with MIMO, in order to serve multiple STAs simultaneously. It contributes considerably in increasing the throughput. IEEE 802.11ax also adopts MU mechanism and to improve different MU techniques in order to enhance the spectral efficiency, touching upon, among others, simultaneous downlink and uplink transmissions. It benefits from frequency selective scheduling and diversity that will enhance not only the spectral efficiency but also the average throughput per user. As stated earlier, the last standard considers two techniques for the multi-user mode, namely MU-MIMO and OFDMA. For UL, the initiation of these MU techniques takes place after the transmission of the trigger frame that includes information about either resource allocation and adopted MCS.

IEEE 802.11ax adds UL MU-MIMO to the existing downlink MU-MIMO which improves capacity and allows stations to send simultaneously their traffic through several antennas. As in the IEEE 802.11ac, the technique of the beamforming is used to transmit packets. STAs use MU transmissions to send their beamforming-related frames simultaneously. A significant overhead could be induced by MU-MIMO, especially UL MU-MIMO, which makes it more ideal for bandwidth greedy application. UL MU-MIMO transmission relies on the exchange of HE trigger-based PPDU which are adapted to simultaneous UL traffics.

On the other hand, the multiuser diversity of OFDMA offers a better quality of service of the network since each data stream can be processed individually. OFDMA thus offers more flexibility with this multiuser diversity since users have their own resources and can communicate with the AP at the

same slots. Likewise, for UL MU-MIMO, OFDMA communications are based on the exchange of HE trigger-based PPDU.

Both techniques (i.e. MU-MIMO and OFDMA) proved significant improvement specially in the presence of a high number of users [55][69][70][71][72]. Meanwhile the MAC layer supports several specificities, for optional use, related to MU transmissions. Among them, we name the MU transmission for RTS/CTS and BA mechanisms and also MU aggregation. For the RTS/CTS mechanism, once the MU transmissions are activated, the AP is allowed to send a MU-RTS frame to all STAs which in turn simultaneously reply with CTS frames. An illustration of MU transmission MU-RTS/CTS is given in Figure 1.23.

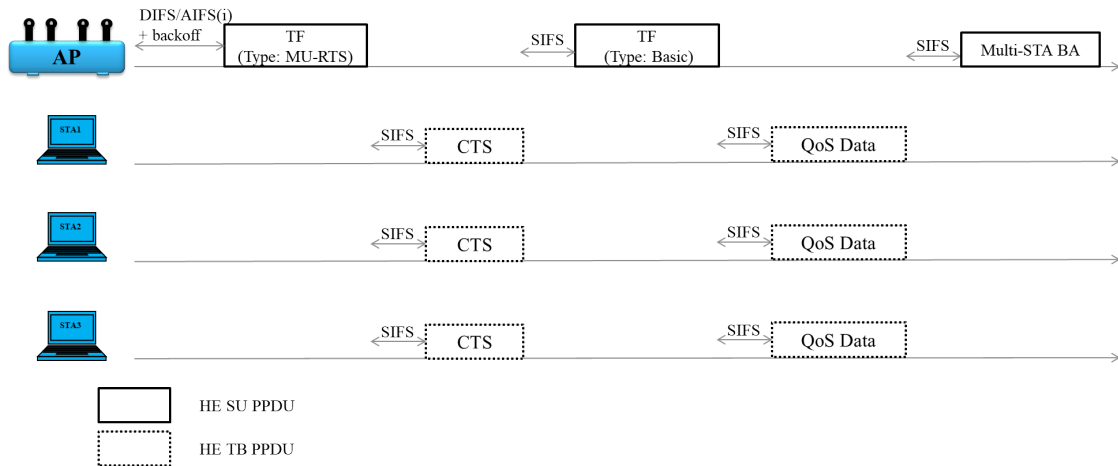

Figure 1.23: Example of MU transmission within the IEEE 802.11ax standard

Concerning the MU version of the BA, as supported by IEEE 802.11ax, APs have the capability of acknowledging frames of different stations at once by only one frame referred to as Multi-STA BA. Multi-STA BA is also presented in Figure 1.23. The introduction of these MU transmissions options clearly provide better performances, particularly lower latency, especially for dense environments.

1.4 Summary

This chapter presents the evolution of the IEEE 802.11 norm, from the original norm (1997) up to the last standard (i.e. IEEE 802.11ax) which is the future of WLANs technologies for indoor and outdoor environments requiring high capacity. Some challenges were mentioned to point out the relevance of 802.11ax when it comes to capacity issues in dense environments and throughput. The first part (Section 1.2) was dedicated to PHY and MAC basics and evolution up to the IEEE 802.11ac while the second one (Section 1.3) exposed main IEEE 802.11ax improvements.

Since first amendments, IEEE 802.11 norm has improved performance from standard to standard. This evolution was induced by either the evolution of technologies or usage. Each amendment proposes to enhance the standard either by improving existent techniques or introducing new ones. This has also been the case of the last standard that inherits most of previous IEEE 802.11ac techniques while introducing new ones to improve current wireless networks impairments. It is true that the IEEE 802.11ax focuses more on reducing interference, particularly for dense scenarios, but it also benefits from higher performances of supported IEEE 802.11 techniques in parallel with newly introduced ones.

This thesis work takes the same approach. Its goal is to improve some existing mechanisms by proposing a new ones while considering the same objective as the IEEE 802.11ax (i.e. performance improvement in dense environment). We first propose new allocation configurations to the OFDMA for the random access mode. Secondly we focus on enhancing the block acknowledgement mechanism in the presence of a high number of users. Both these PhD thesis axes are described in the following chapters.

Orthogonal frequency division multiple access random access mode

2.1 Introduction

This chapter deals with the resource allocation in IEEE 802.11ax, which recommends OFDMA as multiple access technique. In this chapter, we focus on the random access mode. As mentioned in Chapter 1, one of the main IEEE 802.11ax objectives is to enhance performance in dense environments by improving either maximum throughput or spectral efficiency. OFDMA, in its IEEE 802.11ax flavour, was introduced to that aim. In particular, the random access mode (referred to as OFDMA RA in the document) allows unallocated STAs to transmit in sub-channels which have been already reserved by the AP for this particular mode (see Section 1.3.2.3 in Chapter 1 for more details). This results in improved spectrum efficiency and enhanced network capacity.

Nevertheless, its main drawbacks are additional latency and waste of spectrum which will be studied later in this document. The evaluation of the performance of OFDMA RA as well as improvement mechanisms can be found in [73] and [74].

Our main contribution in this chapter is the proposition of resource allocation procedures that could limit the waste of spectrum and improve transmission efficiency of the random access mode. The key principle is to allow the allocation of a resource unit to more than one user (up to two in our scheme) to improve the capacity of the network. At least one of the two users is in RA mode. To ensure minimum quality of service, we assume advanced interference management techniques at the receiver, i.e. AP, side. Among state-of-the-art techniques, we have selected successive interference cancellation (SIC) and joint detection, which apply depending on the relative powers of users. The considered allocation is supposed for UL traffics, i.e. STAs are transmitters while APs are receivers.

This chapter is organised as follows. Section 2.2 presents a brief state-of-the-art and brings out the motivation of the propositions. Different resource

allocation configurations are described in Section 2.3 while their corresponding analytical models are given in Section 2.4. Some analyses and conclusions are drawn in 2.5. Major perspectives are exposed in Section 2.6.

2.2 State-of-the-art and motivations

As stated in Chapter 1, the IEEE 802.11ax allows random access mode with OFDMA technique. As a reminder, this standard amendment recommends that, for OFDMA, STAs are allocated either in a standard scheduling way (i.e. the AP assigns available RUs to STAs) or using a random access mode (cf. Section 1.3.2.3). In practice, the AP assigns a number of available RUs to scheduled stations while periodically reserving some of them for RA mode. The random access mode is particularly well adapted to allocate STAs: (i) that are not associated and want to send an Association Request, or (ii) that wake up from power save mode and have frames to transmit, or (iii) that do not need to heavily transmit or occupy the channel for a long time. Once RA STAs receive the TF-R which signals the available RUs for RA, each of them launches its back-off algorithm and accesses to the channel when the corresponding counter reaches zero.

Several works focused on OFDMA resource allocation and particularly in random access mode. Lanante et al., for example, analysed in [73] OFDMA RA performance applied to IEEE 802.11ax wireless networks. According to them, OFDMA RA allows a maximum efficiency of 37%. This work brings out how random access parameters (OBO, OCW...) highly affect the network efficiency. In [74], Yang et al. studied OFDMA-RA performance in terms of overall system efficiency while evaluating delay performances. They established an analytical model which enabled to identify the optimal set of random access parameters leading to maximum performance. In [75], an analytical model is derived to determine the number of random access dedicated RUs that could ensure optimal performance. Naik et al. evaluated the impact of the number of RUs for RA in [76]. Simulation results conclude that the greater the number of RA RUs, the lower the throughput. Additionally, OFDMA RA may face some impairments due to its channel access procedure. As stated in [73], the UL OFDMA RA proves a maximum of efficiency of only about 37% for a high number of stations. This is definitely due to collided and unused RUs. In other words, since stations randomly choose a sub-channel without information about peers, some resources can be selected by multiple stations while others can go about unused. Indeed, a number of stations can choose the same OBO value and experience collision. Figure 2.1 illustrates an example of collision in RA mode. STA2 and STA4 choose the OBO value of 5. The back-off counter decrements its value by the number of RUs for RA. The counters of both stations reach zero at the same time and the latter end

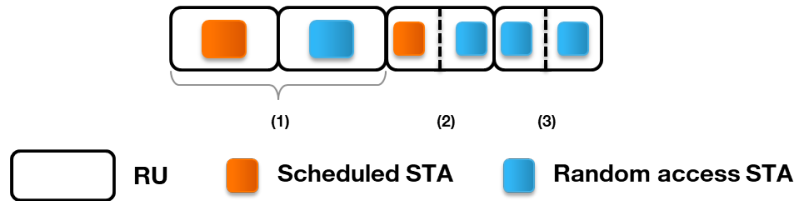

Figure 2.2: Proposed resource allocation configurations for the IEEE 802.11ax

2.3.1 Configuration (1): Standard configuration

This is the basic configuration for IEEE 802.11ax where one RU is allocated to be used by at most one STA. This can be the case of either a scheduled STA, using the RU explicitly assigned to it by the AP, or a STA that chose an RU dedicated to RA (called RA station in what follows).

2.3.2 Configuration (2): Scheduled station and RA station

This configuration allows two stations to transmit over the same RU, while being able to recover both frames. The first STA has explicitly been scheduled by the AP to transmit over the given RU. A second station, which is in RA mode, will have the right to randomly access this RU. SIC will be applied at the receiver to decode frames from both stations. We assume that both users differ by their transmitted power levels and are affected by similar channel gains. The scheduled station is supposed to have a transmitted power higher than the transmitted power of the RA station. In this case the signal with the higher power (i.e. scheduled station's signal) will be decoded first. And then its interference will be subtracted to decode the lower transmitted power signal (i.e. RA station's signal). For our analysis we rename the scheduled STA as the primary user while the RA one as the secondary user. Let us mention that we consider that both users are affected by same channel attenuation order.

This configuration should result in a higher capacity since it (potentially) allocates more than one STA per RU. Furthermore it allows a better exploitation of the spectrum, since there are no unused RUs.

2.3.3 Configuration (3): Two RA stations

In the current amendment, two STAs in RA are said in collision when their OBO counter reaches 0 at the same time and they select the same RU for RA. In this configuration, we allow two STAs to share such RUs. This contributes to reducing the number of collisions as well as the number of unused RUs. Depending on their received power level, either similar or highly different, the receiver applies either joint detection or SIC. Under this configuration, one of the two RA STAs is named primary (i.e. having the highest power) and the other one as secondary (i.e. having the lowest power).

2.4 Analytical representation

The allocation mechanism relies on some information provided either by the AP or the STA. According to these known parameters, the AP can solve an optimisation problem based on some chosen constraints adapted to each use case. The purpose is thus to allocate the STA whose characteristics (e.g. signal to noise ratio (SNR), bit error rate, transmit power...) are adapted to the RU, in order to optimise performance and increase efficiency. Such optimisation problems generally require the definition of a set of constraints depending on the goal behind the optimisation.

For example, the throughput can be maximised subject to a maximum interference level (often related to the average power, both total and per user). The interference can also be minimised (through power constraint) subject to a target throughput. The allocation can be made under different forms.

The first idea is to make allocation decisions on a per subcarrier basis. Such a way seems convenient for serving a high number of STAs at once. Nevertheless, the implementation is complex. This form of allocation, called single-subcarrier-based allocation, ensures a large utilisation but involves much overhead. It has been proven that under some constraint, BER threshold in particular, the multi-STA diversity is effective when the number of STAs is very small [60]. In case of a large number of STAs, the gain is saturated due to the induced overhead and the correlation between subcarriers.

The second scheme relies on the fact that adjacent subcarriers correspond to sub-channels whose transfer functions are similar. This inter-correlation can be considered to group adjacent subcarriers according to channel conditions. Such a group is called a resource unit or a chunk. Dividing the channel bandwidth into subcarrier subsets can make the allocation simpler and mitigate both overhead and complexity. In [60], chunk allocation showed much better performance for a large number of STAs compared to previously mentioned allocation scheme.

2.4.1 Considered assumptions

In this section we describe the system models for allocating scheduled and random access STAs under configuration (2) and configuration (3). For the recall, configuration (2) allocates one scheduled and one random access STAs, while configuration (3) considers the allocation of two random access STAs. The considered scenario assumes communications between a single AP and a number of STAs within the framework of IEEE 802.11ax (though slightly modified to consider such resource allocation configurations).

As stated before, the AP has the role of assigning available RUs to scheduled STAs and, periodically, reserve some of them for random access. The AP inserts information relative to resource allocation in the TF (when allocating

scheduled STAs only) or in the TF-R (when reserving some of RUs for random access).

In our analysis, we distinguish two types of STAs: primary STAs (i.e. scheduled STAs for configuration (2) or one random access STA for configuration (3)) and secondary STAs (i.e. random access STAs). Upon receipt the trigger frame, primary STAs access to the RU assigned/chosen by the AP while random access STAs determine themselves an RU from those reserved for random access mode. Several assumptions are taken into account to establish this study:

1. In order to increase the overall data rate, while reducing interference, we choose to maximise the throughput subject to power constraints.
2. The allocation is handled in two steps, first the allocation of the primary STA and then the secondary.
3. Information related to the primary STA (such as effective power, modulation scheme or allocated RU) is supposed to be included in the trigger frame. This information is collected so as to proceed to the allocation of the second user under SIC or joint detection technique assumption.
4. Since IEEE 802.11ax allows only one STA per RU, techniques that decode multi-users are not supported. However, we consider that SIC or joint detection are available at the AP. This assumption is quite reasonable since APs have generally much higher processing capabilities than simple stations.

2.4.2 Allocation of primary STAs

2.4.2.1 General notation

We consider here the allocation of a primary IEEE 802.11ax user. In configuration (2), the primary corresponds to a scheduled STA while for configuration (3) it is a RA one.

We suppose N OFDMA RUs are allocated to K primary STAs. We assume that each RU, denoted by U_n , is composed of L subcarriers. To meet with IEEE 802.11ax specifications, L is fixed depending on the chosen configuration (see Table 1.6). $\nu_{n,\ell}$ refers to the frequency that corresponds to the ℓ -th subcarrier and the n -th RU.

We assume that the channel state information is perfectly known by the AP. We denote by $g_{n,\ell}^{(k)}$ the channel gain of the k -th STA over the n -th RU and the ℓ -th subcarrier. The set of all $g_{n,\ell}^{(k)}$ form the matrix \mathbf{G} . We suppose the presence of an additive white Gaussian noise (AWGN) of variance σ^2 .

The k -th STA occupies the n -th RU and transmits over ℓ -th subcarrier with an average power of $p_{n,\ell}^{(k)}$. We thus form the vector of powers for the k -th

primary STA over L subcarriers:

$$\mathbf{p}_n^{(k)} = [p_{n,1}^{(k)} \dots p_{n,\ell}^{(k)} \dots p_{n,L}^{(k)}]^T. \quad (2.1)$$

Note that $\mathbf{p}_n^{(k)}$ is null when the n -th RU is already allocated. Its total average power equals $P^{(k)}$.

2.4.2.2 Resource allocation model

As previously mentioned, the allocation is carried out either by maximising or minimising a utility function subject to desired constraints. In our case, we chose the maximisation of the overall throughput subject to power constraints. Namely the utility function to maximise is the total throughput R expressed as:

$$R = \sum_{k=1}^K \sum_{n=1}^N s_n^{(k)} \sum_{\ell=1}^L \log_2 \left(1 + \frac{|g_{n,\ell}^{(k)}|^2 p_{n,\ell}^{(k)}}{\sigma^2} \right). \quad (2.2)$$

To derive the allocation model, we introduce an allocation indicator vector, denoted by $\mathbf{s}^{(k)}$, whose components except one are null. The non-zero value is equal to 1 and points to the index of the RU allocated to the k -th STA.

$$\mathbf{s}^{(k)} = [0 \dots 0 \ 1 \ 0 \dots 0]^T, \quad s_i^{(k)} = \delta_{i,n} \quad (2.3)$$

Namely, the position of the value 1 corresponds to the assigned RU. $\delta_{i,n}$ is the Kronecker delta function and n is the index of the assigned RU.

The main objective is to maximise the utility function in (2.2) to obtain both vectors $\mathbf{s}^{(k)}$ and $\mathbf{p}_n^{(k)}$ subject to following constraints.

$$\|\mathbf{s}^{(k)}\|_1 = 1, \quad s_n^{(k)} \in \{0, 1\}, \quad \|\mathbf{s}^{(k)}\|_0 = 1 \quad (2.4)$$

$$\langle \mathbf{s}^{(k)}, \mathbf{s}^{(k')} \rangle = 0, \quad k \neq k' \quad (2.5)$$

$$\|\mathbf{p}_n^{(k)}\|_1 \leq P_M, \quad k = 1, \dots, K \quad (2.6)$$

The condition (2.4) is fulfilled if the vector $\mathbf{s}^{(k)}$ includes one and only one non-null component, which reflects that each primary STA occupies only one RU. The condition (2.5) imposes that an RU is assigned to only one STA. The allocated power of each STA must not exceed a maximal power of P_M which leads to constraint (2.6).

2.4.2.3 Matrix representation of the allocation model

Let us now give a general representation of the optimisation problem through a matrix representation. We first define the matrix $\mathbf{\Lambda}^{(k)}(n)$ such as the ℓ -th component is expressed as $\lambda_{n,\ell}^{(k)} = \frac{|g_{n,\ell}^{(k)}|^2}{\sigma^2}$ (which is proportional to the SNR) :

$$\mathbf{\Lambda}^{(k)}(n) = \text{diag}[\lambda_{n,1}^{(k)} \dots \lambda_{n,L}^{(k)}]. \quad (2.7)$$

We then introduce the matrix $\mathbf{\Gamma}^{(k)}$ as the vertical concatenation of N matrices $\mathbf{\Lambda}^{(k)}(n)$:

$$\mathbf{\Gamma}^{(k)} = \begin{bmatrix} \mathbf{\Lambda}^{(k)}(1) \\ \mathbf{\Lambda}^{(k)}(2) \\ \vdots \\ \mathbf{\Lambda}^{(k)}(N) \end{bmatrix}. \quad (2.8)$$

We define a unitary column vector $\mathbf{1}_L$ of length L , such as

$$\mathbf{s}^{(k)} \otimes \mathbf{1}_L = (0 \ 0 \ \dots \ 0 \ 0 \ 0 \ 1 \ \dots \ 1 \ 1 \ 0 \ \dots \ 0)^T, \quad (2.9)$$

with \otimes the Kronecker product.

The product in (2.9) results in a vector of size NL which designates (by a value of 1) the indices of occupied subcarriers.

The allocation problem is thus formulated as:

$$\underset{\mathbf{s}^{(k)}, \mathbf{p}_n^{(k)}}{\text{maximise}} \quad (\mathbf{s}^{(k)} \otimes \mathbf{1}_L)^T \log_2 (\mathbf{1}_{NL} + \mathbf{\Gamma}^{(k)} \mathbf{p}_n^{(k)}) \quad (2.10a)$$

$$\text{subject to} \quad \|\mathbf{s}^{(k)}\|_1 = 1, s_n^{(k)} \in \{0, 1\}, \|\mathbf{s}^{(k)}\|_0 = 1 \quad (2.10b)$$

$$\langle \mathbf{s}^{(k)}, \mathbf{s}^{(k')} \rangle = 0, k \neq k' \quad (2.10c)$$

$$\|\mathbf{p}_n^{(k)}\|_1 \leq P_M, k = 1, \dots, K \quad (2.10d)$$

We assume that the maximum power per RU P_M is a known parameter.

2.4.2.4 Resolution method

Several methods/algorithms are used to solve this type of optimisation problem, for instance Lagrangian multipliers or Hungarian algorithms to name a few. [78] presents different approaches to solve resource allocation optimisation problems. These approaches rely on three main mechanisms: subcarrier assignment, bit loading or power loading. In our analysis, we choose to solve the optimisation problem using the bit loading algorithm for simplicity reasons.

The convergence of the problem (2.10) mainly relies on the convexity of the utility function (2.10a). Nevertheless the latter is non convex due to the discrete vector $\mathbf{s}^{(k)}$.

Our purpose is not the design of the best algorithm able to solve the optimisation problem but to see whether it is possible to improve the overall throughput, as well as to reduce collisions, by allocating up to two STAs to one RU. To solve the problem, we propose to proceed in two steps.

The first step consists in momentarily getting rid of the vector $\mathbf{s}^{(k)}$ and to search, for each STA k and for each RU n , independently, the intermediate optimum power vector $\boldsymbol{\pi}_n^{(k)}$ solution of the following problem:

$$\underset{\boldsymbol{\pi}_n^{(k)}}{\text{maximise}} \quad \sum_{\ell=1}^L \log_2 \left(1 + \frac{|g_{n,\ell}^{(k)}|^2 \pi_{n,\ell}^{(k)}}{\sigma^2} \right) \quad (2.11a)$$

$$\text{subject to} \quad \|\boldsymbol{\pi}_n^{(k)}\|_1 \leq P_M. \quad (2.11b)$$

This problem is a classical water-filling problem as usually used in point to point OFDM transmissions, with perfect channel knowledge at the transmitter. We apply the greedy bit loading algorithm described in [79]. We then compute the bit vector $\mathbf{b}_n^{(k)}$, such that $\mathbf{b}_n^{(k)} = [b_{n,1}^{(k)} \dots b_{n,\ell}^{(k)} \dots b_{n,L}^{(k)}]$, with $b_{n,\ell}^{(k)}$ being the number of bits over the n -th RU and the ℓ -th subcarrier. Let us mention that in practice, the number of bits $b_{n,\ell}^{(k)}$ is specified according to modulation and coding schemes supported by the standard (see Tables 1.4 and 1.8 for modulation schemes supported by the IEEE 802.11ax). In our analysis we compute $\mathbf{b}_n^{(k)}$ obtained by the bit loading algorithm using

$$b_{n,\ell}^{(k)} = \left\lfloor \log_2 \left(1 + \lambda_{n,\ell}^{(k)} \pi_{n,\ell}^{(k)} \right) \right\rfloor, \quad (2.12)$$

which enables to compute the power vector $\mathbf{p}_n^{(k)}$

$$p_{n,\ell}^{(k)} = \frac{2^{b_{n,\ell}^{(k)}} - 1}{\lambda_{n,\ell}^{(k)}}. \quad (2.13)$$

The second step consists in the allocation of the RUs among the STAs. We define $\boldsymbol{\beta}$, whose $((k-1)N+n)$ -th component equals $\beta_{(k-1)N+n} = \sum_{\ell=1}^L b_{n,\ell}^{(k)}$. The term $\beta_{(k-1)N+n}$, corresponds to the maximum number of bits that can be allocated to the n -th RU for the k -th STA. We thus have to determine the vector \mathbf{s} whose size equals KN and $s_{(k-1)N+n} = \delta_{n,k}$. For that purpose, we propose to solve the following problem:

$$\underset{\mathbf{s}}{\text{max}} \quad \boldsymbol{\beta}^T \mathbf{s} \quad (2.14a)$$

$$\text{subject to} \quad s_m \geq 0, \text{ with } m = 1, \dots, KN \quad (2.14b)$$

$$\sum_{k=1}^K s_{(k-1)N+n} = 1, \forall n, \quad (2.14c)$$

$$\sum_{n=1}^N s_{(k-1)N+n} = 1, \forall k, \quad (2.14d)$$

We mention that this allocation of scheduled STAs assumes that one RU is assigned to only one scheduled STA (as specified by IEEE 802.11ax).

The algorithm of the primary allocation is given by algorithm 1.

Algorithm 1 Allocation of the primary STA**Inputs:** $N, L, K, \mathbf{G}, \sigma, P_M$ **Outputs:** $\mathbf{b}_n^{(k)}, \mathbf{p}_n^{(k)}, \mathbf{s}$

- 1: Bit loading: proceed to the bit loading algorithm according to [79] to solve the optimisation problem given by (2.11).
- 2: Obtain $\mathbf{p}_n^{(k)}$: compute the bit loading vector $\mathbf{b}_n^{(k)}$ and the effective power $\mathbf{p}_n^{(k)}$ using (2.12) and (2.13) respectively.
- 3: Obtain \mathbf{s} : Define β such that $\beta_{(k-1)N+n} = \sum_{\ell=1}^L b_{n,\ell}^{(k)}$. Compute \mathbf{s} from the optimisation problem given by (2.14) that ends the allocation of primary STAs.

2.4.3 Allocation of secondary STAs

Once primary STAs are allocated, we propose to allow secondary STAs to occupy available RUs according to information received in the trigger frame. The purpose of this section is to establish the process of both configurations (2) and (3), as presented in Section 2.3.

As a reminder, configuration (2) simultaneously allocates a scheduled STA (primary) and an eventual RA STA (secondary), while configuration (3) simultaneously allocates at most two RA STAs (one as primary and the other as secondary).

We consider two scenarios: (i) primary STA's transmitted power is much higher than secondary STA's, or (ii) primary and secondary STAs transmit using similar power levels.

For case (i) we propose to use SIC to manage interference between multiple STAs on the same sub-channel. When primary and secondary STAs have approximately the same power levels (i.e. case (ii)), we propose to perform a joint detection, namely the simultaneous decoding of the two STAs allocated to the same RU. In addition to allocation under SIC or joint detection, we propose a hybrid scheme that takes into account both cases.

2.4.3.1 Notations

Let us first introduce some notations relative to secondary STAs. We denote by K' the number secondary STAs. I is the number of available RUs that the secondary user may occupy with $i = 1, \dots, I$.

As in Section 2.4.2.1, we suppose that the AP perfectly knows the channel for simplicity reasons. Let $h_{i,\ell}^{(k')}$ stand for the channel gain of the k' -th STA over the i -th RU and the ℓ -th subcarrier, with \mathbf{H} being the channel matrix grouping all gains. As earlier, we suppose the presence of an AWGN of variance σ^2 . We introduce the vector $\mathbf{q}_i^{(k')}$ as the power of the k' -th secondary STA over

the i -th RU. $\mathbf{q}_i^{(k')}$ is null when the i -th RU is already allocated.

$$\mathbf{q}_i^{(k')} = [q_{i,1}^{(k')} \dots q_{i,\ell}^{(k')} \dots q_{i,L}^{(k')}]^T \quad (2.15)$$

For simplicity reasons, we consider the allocation of secondary STAs on a one-by-one basis. Without loss of generality, we consider $K' = 1$.

2.4.3.2 Allocation under successive interference cancellation (SIC) assumption

In this section, the SIC technique and its application are briefly presented just before the formulation of the secondary STA allocation problem.

2.4.3.2.1 Overview of successive interference cancellation

SIC is a physical layer technique that allows to cancel interference between two or more received packets. The most common way is to decode the strongest signal first. Once detected, its contribution is subtracted from the received signal. The weakest ones are then constructed from the residue of this subtraction by applying the same process until all STAs are decoded. Since its introduction in some standards, this advanced technique has contributed to significantly increase the system capacity since it allows multiple STAs to share the same sub-channel. The work of Mollanoori and Ghaderi [80] is an evaluation of SIC performance used in wireless networks. It assessed the enhancement in throughput obtained by using this technique. There is also [81] where the use of SIC demonstrated significant improvement. They have duly observed the benefit of this method on wireless networks by taking the MAC efficiency as the comparison metric.

In our secondary STA allocation method, we assume that the SIC technique is supported by the receiver (i.e. the AP) and we allow up to two stations to transmit simultaneously within the same RU.

2.4.3.2.2 Interference cancellation process

We give here a brief analysis of interference cancellation performance.

We suppose that a secondary STA chooses an RU already allocated to a primary STA such that the power level of the secondary STA is well below the power level of the primary STA (so as to perform SIC in favourable conditions).

Since two STAs occupy the same RU of index i , the received signal on the ℓ -th subcarrier is expressed as:

$$y_{i,\ell} = g_{i,\ell} \sqrt{p_{i,\ell} d_p} + h_{i,\ell} \sqrt{q_{i,\ell} d_s} + \eta_{i,\ell}, \quad (2.16)$$

with :

- $y_{i,\ell}$ being the signal at the AP.

- $g_{i,\ell}\sqrt{p_{i,\ell}}d_p$ being the signal received from the primary STA, with $g_{i,\ell}$ its channel gain over the i -th RU and the l -th subcarrier, $p_{i,\ell}$ its power over the i -th RU and the l -th subcarrier. Finally, d_p is the symbol sent by the primary STA. We define element $\xi_{i,\ell}$, constituting the matrix $\boldsymbol{\xi}$, by

$$\xi_{i,\ell} = g_{i,\ell}\sqrt{p_{i,\ell}}. \quad (2.17)$$

- $h_{i,\ell}\sqrt{q_{i,\ell}}d_s$ being the signal received from the secondary STA, with $h_{i,\ell}$ its channel gain over the i -th RU and the l -th subcarrier, $q_{i,\ell}$ its power over the i -th RU and the l -th subcarrier. d_s is the symbol sent by the secondary STA.
- $\eta_{i,\ell}$ being the AWGN of zero mean and variance σ^2 .

Since SIC decodes the STA with highest power first, it considers $h_{i,\ell}\sqrt{q_{i,\ell}}d_s + \eta_{i,\ell}$ as Gaussian noise. The noise variance is then defined as: $\sigma^2 + |h_{i,\ell}|^2q_{i,\ell}$. The SNR can thus be expressed as: $\frac{\xi_{i,\ell}^2}{\sigma^2 + |h_{i,\ell}|^2q_{i,\ell}}$.

The probability of symbol error P_{es} can be approximated using the complementary error function erfc and depends on the chosen modulation scheme. For instance, under QAM modulation, P_{es} is approximated by:

$$P_{es} \approx \frac{(\sqrt{M} - 1)}{\sqrt{M}} \text{erfc} \left(\sqrt{\frac{3}{2(M-1)} \text{SNR}} \right), \quad (2.18)$$

with M being the order of the modulation.

Once the primary user detected, the receiver cancels its contribution to the received signal yielding to

$$z_{i,\ell} = y_{i,\ell} - \xi_{i,\ell}\hat{d}_p = h_{i,\ell}\sqrt{q_{i,\ell}}d_s + \eta_{i,\ell} + \xi_{i,\ell} \left(d_p - \hat{d}_p \right). \quad (2.19)$$

We then assume that the estimated symbol \hat{d}_p pertaining to the primary STA is at a certain distance from the actually sent symbol. We thus define $\left| d_p - \hat{d}_p \right|$ as the minimum distance between the transmitted and the received symbols. We suppose that $\left| d_p - \hat{d}_p \right|$ equals d_{min} with a probability of P_{es} and equals 0 with a probability of $(1 - P_{es})$. d_{min} is a defined minimum distance that depends on the chosen modulation. For instance $d_{min} = 2\sqrt{\frac{3}{M(M-1)}}$ for M -QAM modulation.

Once the primary STA is decoded, we decode the secondary STA using $z_{i,\ell}$. Thus the residual primary signal is considered as a Gaussian noise whose variance is

$$\kappa_{i,\ell}^2 = P_{es}\xi_{i,\ell}^2d_{min}^2. \quad (2.20)$$

The corresponding noise variance matrix is denoted by $\boldsymbol{\chi}$ and its component at i -th row and ℓ -th column equals to:

$$\chi_{i,\ell}^2 = \sigma^2 + \kappa_{i,\ell}^2. \quad (2.21)$$

2.4.3.2.3 Formulation and resolution of the resource allocation problem

To allocate the secondary STA for SIC decoding in an already occupied RU, we suppose that the information relative to the primary STA is known. The aim of the resource allocation problem is to obtain the vector \mathbf{q}_i and the RU index i that maximise the throughput. The optimisation problem for one random access STA is thus expressed as:

$$\underset{i, \mathbf{q}_i}{\text{maximise}} \quad \sum_{\ell=1}^L \log_2 \left(1 + \frac{|h_{i,\ell}|^2 q_{i,\ell}}{\chi_{i,\ell}^2} \right) \quad (2.22a)$$

$$\text{subject to} \quad \|\mathbf{q}_i\|_1 \leq Q_M. \quad (2.22b)$$

Q_M is the maximal power allowed for the secondary STA. $\chi_{i,\ell}^2 = \sigma^2 + \kappa_{i,\ell}^2$ if the i -th RU is already occupied by a primary STA or $\chi_{i,\ell}^2 = \sigma^2$ otherwise.

The numerical resolution of the optimisation problem below can proceed in two steps as in Section 2.4.2.4.

For the first step (as for the primary STA), we define the vector \mathbf{b}'_i as the result of the bit loading algorithm for the i -th RU, such that $\mathbf{b}'_i = [b'_{i,1} \dots b'_{i,\ell} \dots b'_{i,L}]$, with $b'_{i,\ell}$ being the number of bits over the i -th RU and the ℓ -th subcarrier. We define the vector $\boldsymbol{\beta}'$ such as $\beta'_i = \sum_{\ell=1}^L b'_{i,\ell}$, with i the index of the RU. The vector \mathbf{b}'_i is thus used to calculate effective power elements of the secondary STA, denoted by $q_{i,\ell}$, as follows (see (2.24)).

$$b'_{i,\ell} = \left\lfloor \log_2 \left(1 + \frac{|h_{i,\ell}|^2 q_{i,\ell}}{\chi_{i,\ell}^2} \right) \right\rfloor \quad (2.23)$$

$$q_{i,\ell} = \left(\frac{2^{b'_{i,\ell} - b_{i,\ell}} - 1}{|h_{i,\ell}|^2} \right) \chi_{i,\ell}^2 \quad (2.24)$$

In a second step, we search for the index of the RU with the highest number of bits:

$$i^* = \arg \max \beta'_i. \quad (2.25)$$

The i^* -th RU is then allocated to the secondary STA.

Algorithm 2 presents the numerical resolution for the allocation of the secondary STA under SIC technique.

Algorithm 2 Allocation of the secondary STA under SIC technique

Inputs: $I, L, \mathbf{H}, \chi, Q_M$

Outputs: $\mathbf{b}'_i, \mathbf{q}_i, i^*$

- 1: Bit loading: proceed to the bit loading algorithm according for the following optimisation problem:

$$\underset{\mathbf{q}_i}{\text{maximise}} \quad \sum_{\ell=1}^L \log_2 \left(1 + \frac{|h_{i,\ell}|^2 q_{i,\ell}}{\chi_{i,\ell}^2} \right) \quad (2.26a)$$

$$\text{subject to} \quad \|\mathbf{q}_i\|_1 \leq Q_M \quad (2.26b)$$

- 2: Obtain \mathbf{q}_i : compute the bit loading vector \mathbf{b}'_i and the effective power \mathbf{q}_i using (2.23) and (2.24) respectively.
 - 3: Obtain i^* : Obtain i^* from the optimisation problem (2.25) that indicates the RU index to allocate to the secondary STA.
-

2.4.3.3 Allocation under joint detection assumption

The principle of the joint detection is to simultaneously decode two signals received over the same RU. Like SIC, the joint detection has proven its efficiency either for improving spectrum efficiency or network capacity. It has been used in numerous wireless communication technologies such as the non orthogonal multiple access. In this section we propose to allocate two STAs of similar power levels in the same RU. We consider a joint decoding of the received signals. A formulation of the resource allocation problem and its numerical resolution are given hereinafter.

2.4.3.3.1 Formulation of the resource allocation problem under joint detection

The purpose of the allocation problem is the same as in the previously established study. We propose to allocate a secondary STA in the same RU as a primary STA under the constraint that the two STAs have the same power levels. Analogically to resource allocation under SIC, we establish the following optimisation problem:

$$\underset{i, \mathbf{q}_i}{\text{maximise}} \quad \sum_{\ell=1}^L \log_2 \left(1 + \frac{\xi_{i,\ell}^2 + |h_{i,\ell}|^2 q_{i,\ell}}{\sigma^2} \right) \quad (2.27a)$$

$$\text{subject to} \quad \|\mathbf{q}_i\|_1 \leq Q_M. \quad (2.27b)$$

The purpose is to obtain the RU index i and the vector of power \mathbf{q}_i that maximise the throughput (i.e. (2.27a)). We note that we reused the same parameters and notations as the ones described in resource allocation under

SIC with a few differences.

Accordingly the utility function \mathbf{b}'_i and the components of \mathbf{q}_i are expressed as:

$$b'_{i,\ell} = \left\lfloor \log_2 \left(1 + \frac{\xi_{i,\ell}^2 + |h_{i,\ell}|^2 q_{i,\ell}}{\sigma^2} \right) \right\rfloor \quad (2.28)$$

$$q_{i,\ell} = \left(\frac{(2^{b'_{i,\ell}} - 1)\sigma^2 - \xi_{i,\ell}^2}{|h_{i,\ell}|^2} \right). \quad (2.29)$$

As noticeable, the utility function of the joint allocation problem has the same expression as the allocation of a primary STA. Therefore, same reasoning as in Algorithms 1 and 2 can be applied to perform the joint detection.

Algorithm 3 Allocation of the secondary STA under joint detection technique

Inputs: $I, L, \boldsymbol{\xi}, \mathbf{H}, \sigma, Q_M$

Outputs: $\mathbf{b}'_i, \mathbf{q}_i, i^*$

- 1: Bit loading: proceed to the bit loading algorithm for the optimisation problem given by:

$$\underset{\mathbf{q}_i}{\text{maximise}} \quad \sum_{\ell=1}^L \log_2 \left(1 + \frac{\xi_{i,\ell}^2 + |h_{i,\ell}|^2 q_{i,\ell}}{\sigma^2} \right) \quad (2.30a)$$

$$\text{subject to} \quad \|\mathbf{q}_i\|_1 \leq Q_M \quad (2.30b)$$

- 2: Obtain \mathbf{q}_i : compute the bit loading vector \mathbf{b}'_i and the effective power \mathbf{q}_i using (2.28) and (2.29) respectively.
 - 3: Obtain i^* : Obtain i^* from the optimisation problem (2.25) that indicates the RU index to allocate to the secondary STA.
-

2.4.3.4 Hybrid formulation

In this section we propose a formulation of a hybrid process that takes into account the power level of the already allocated STA (whatever its power level, either higher or similar to that of the secondary STA). The optimisation problem is expressed as:

$$\underset{i, \mathbf{q}_i}{\text{maximise}} \quad \sum_{\ell=1}^L \log_2 \left(1 + \frac{\xi_{i,\ell}^2 + |h_{i,\ell}|^2 q_{i,\ell}}{\sigma^2 + \kappa_{i,\ell}^2} \right) \quad (2.31a)$$

$$\text{subject to} \quad \|\mathbf{q}_i\|_1 \leq Q_M \quad (2.31b)$$

with

- $\xi_{i,\ell} \neq 0$ if the i -th RU is already allocated to a STA of equivalent power level,
- $\kappa_{i,\ell} \neq 0$ if the i -th RU is already allocated to a higher power level STA. $\kappa_{i,\ell}$ is defined as in (2.20)
- $\xi_{i,\ell}$ and $\kappa_{i,\ell}$ coefficients are equal to 0 if the resource is not allocated.

This representation is the combination of resource allocations under the SIC technique and the joint detection one. Since we consider an allocation of at most 2 STAs, only one of the components $\xi_{i,\ell}$ or $\kappa_{i,\ell}$ is non-null. Accordingly the utility function \mathbf{b}'_i and the components of \mathbf{q}_i are expressed as:

$$b'_{i,\ell} = \left\lfloor \log_2 \left(1 + \frac{\xi_{i,\ell}^2 + |h_{i,\ell}|^2 q_{i,\ell}}{\sigma^2 + \kappa_{i,\ell}^2} \right) \right\rfloor \quad (2.32)$$

$$q_{i,\ell} = \left(\frac{((2^{b'_{i,\ell}} - 1)(\sigma^2 + \kappa_{i,\ell}^2)) - \xi_{i,\ell}^2}{|h_{i,\ell}|^2} \right). \quad (2.33)$$

Algorithm 4 presents the numerical resolution for the hybrid allocation of the secondary STA .

Algorithm 4 Hybrid allocation of the secondary STA**Inputs:** $I, L, \xi, \kappa, \sigma, \mathbf{H}, Q_M$ **Outputs:** $\mathbf{b}'_i, \mathbf{q}_i, i^*$

- 1: Bit loading: proceed to the bit loading algorithm for the optimisation problem given by

$$\underset{\mathbf{q}_i}{\text{maximise}} \quad \sum_{\ell=1}^L \log_2 \left(1 + \frac{\xi_{i,\ell}^2 + |h_{i,\ell}|^2 q_{i,\ell}}{\underbrace{\sigma^2 + \kappa_{i,\ell}^2}_{\chi_{i,\ell}^2}} \right) \quad (2.34a)$$

$$\text{subject to} \quad \|\mathbf{q}_i\|_1 \leq Q_M \quad (2.34b)$$

- 2: Obtain \mathbf{q}_i : compute the bit loading vector \mathbf{b}'_i and the effective power \mathbf{q}_i using (2.32) and (2.33) respectively.
- 3: Obtain i^* : Obtain i^* from the optimisation problem (2.25) that indicates the RU index to allocate to the secondary STA.

2.5 Analysis and conclusions

Our purpose was to propose a new resource allocation technique for STAs in random access mode in the framework of IEEE 802.11ax. To that aim, we first described an allocation method for the scheduled STA. Then we presented different allocation configurations, unsupported in the IEEE 802.11ax, designed to enhance the UL OFDMA allocation process. Depending on the power level of involved users, different configurations for allocating at the most two users in the same RU, have been presented.

The first configuration proposes to allocate a random access STA with a scheduled one in the same RU. This configuration could be more beneficial for low-bandwidth random access STAs that have little data to transmit and have limited power. These STAs can thus be allocated in an already occupied RU where, for instance, the scheduled STA does not need to exploit the spectrum at maximum efficiency. This can be feasible thanks to SIC technique that allows successive decoding of frames from multiple users by cancelling interference once a user is detected. This configuration should result in higher spectrum efficiency by allowing more STAs to access to the channel while ensuring an appropriate throughput thanks to the adopted technique. The numerical procedure is presented in Algorithm 2.

The second configuration considers the allocation of two random access mode. In the case where two random access STAs, having similar power levels, would normally face collision (which happens when their OBO values

reach 0 at the same time and they select the same RU for RA) the joint allocation under the joint detection process allows their simultaneous allocation (Algorithm 3). Otherwise, if these two STAs transmit using different power levels, SIC is performed (Algorithm 2). This considerably reduces the overall latency which is quite impacted by collisions (where STAs have to defer following the back-off algorithm to regain access, or, worse, contend for channel access in classical single user mode). Also, as for the allocation under SIC, this method should increase the capacity of the network by allowing more users to transmit.

Last but not least, we also proposed a hybrid scheme that includes the consideration of the power level of already allocated STAs and thus both reception techniques. This leads to an accurate optimised process since it considers two different cases of power levels (i.e same or different power levels). This may represent an interesting gain in implementation complexity compared to Algorithms 2 or 3.

2.6 Perspectives

A next step would consist in studying the feasibility of such new resource allocations in order to evaluate the gain we could obtain. These future works would consider the numerical implementation of proposed algorithms in order to establish a convenient analysis of different configurations. The comparison would be based on analysing the effective throughput offered by each configuration for different scenarios, that would differ in the number of users, the modulation schemes, the type of RUs, etc. For a relevant numerical implementation of the algorithms, multiple parameters would need to be carefully chosen. This should be based on a close analysis of the proprietary implementations of OFDMA in new IEEE 802.11ax chip-sets, giving a convenient overview of proposed models' performances. Additional thoughts would be dedicated as well to the relevance of considering this new resource allocation as OFDMA in the strict sense of the term. Finally, let us remind that OFDMA has just been introduced for the first time in Wi-Fi. Even if the proposed flavour of OFDMA is not compliant with IEEE 802.11ax, it could be considered in a next amendment of the IEEE 802.11 standard.

Network simulation environment and selected scenarios

3.1 Introduction

Due to the high cost of test equipment, simulation tools become a convenient substitution for test verification or research studies. Whatever the domain, they offer an accurate approximation of the system behaviour for any given phenomenon. Either to validate performances or to anticipate limitations, they proved to be very convenient. In particular, wireless network technologies are facing a continuous growth that calls for highly-efficient test tools. Their simulation remains a challenge when it comes to analysing the performance of complex scenarios performances. Several simulation tools, free or not, have been thoroughly developed so as to mimic and to predict, as much as possible, the behaviour of any configuration and to simulate modern networking systems. This kind of tool is practical in the sense that the user can design any wireless network scenario while freely acting on all involved parameters. It thus provides a controllable environment while offering a scenario model close to real-life scenarios. Numerous simulation tools have been designed for that purpose. We have chosen the latest version of network-simulator 3, referred to as ns-3 [15], which is one of the most popular communication network simulation systems.

This chapter is organised as follows. Section 3.2 gives an overview of the network simulator ns-3 and describes some of its modules. Section 3.3 defines all metrics of interest used to compare the contributions to the reference schemes. Applications that will be used in the performance analyses are presented in Section 3.4. Section 3.5 introduces all scenarios considered in the PhD. Section 3.6 concludes the chapter.

3.2 Network simulation tool: ns-3

3.2.1 Generalities

ns-3 is a wireless network simulation tool based on the description of successive discrete events. It includes many features permitting to reproduce

simulations as close as possible to real-life scenarios. Compared to its predecessor ns-2 [82], it includes several additional features which enable to model additional existing wireless technologies. Since its first release in June 2008, ns-3 kept on developing and is now one of the leading network simulators. It is an open source platform under the GNU general public license version 2 (GNU GPLv2)⁴ licence. At the time of writing, the latest version is ns-3.29. It was released on September 4, 2018 and provides additional features related to latest standards. The simulation of any network relies on a number of existing elementary modules implemented in C++. Users can reproduce wireless network configurations either by directly using these modules or by extending them so as to cover a non-supported functionality if needed. Users can simulate different wireless technologies with different scenarios. Its elementary modules enable to design a network simulation model for a wide range of wireless technologies such as Wi-Fi [2], WiMAX [59], LTE, etc. It includes models for devices, channels, applications, links, etc., that are mandatory to establish a simulation close to the truth. ns-3 is one of the most complex network simulation tools but it allows a step by step configuration of any network and thus an accurate prediction of its behaviour. In the remainder of this chapter, we will focus on the Wi-Fi module.

3.2.2 Organisation and key principles

As mentioned earlier, ns-3 includes elementary modules to enable the design of wireless networks. It works on the basis of discrete events, such as the creation of a wireless device, the expiration of a timer or the transmission of a packet. ns-3 modules rely on accurate mathematical models which enable to approximate as much as possible realistic scenarios. The creation of a network relies on a fundamental component which is the node, standing for any wireless/wired equipment. Each node includes several parts whose parameters must be correctly configured.

⁴GNU GPL is a widely-used free software license, guarantying to end users to freely run, study, share and modify the software.

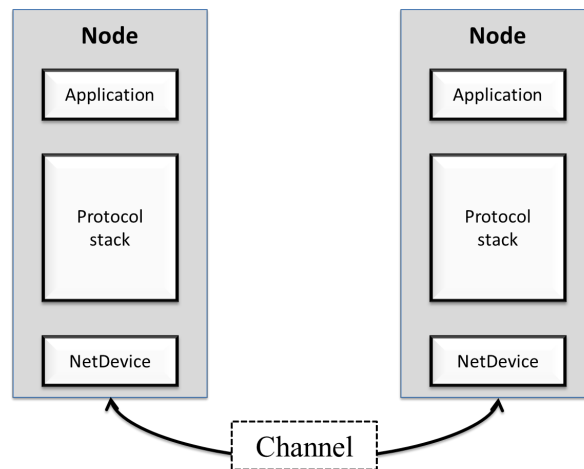

Figure 3.1: Overview of ns-3 node involved objects

As illustrated in Figure 3.1, representing an overview of node involved objects, in addition to the channel, nodes' transmissions rely essentially on three main components, which are NetDevice, Protocol stack and Application. The channel is inserted between nodes. It is designed such that NetDevices can interact with each other by receiving and sending packets. Each node can run different applications and can communicate through several channels using the corresponding NetDevices. Applications use the socket class to exchange packets according to the protocol that corresponds to the modelled node.

3.2.3 Architecture of ns-3 Wi-Fi module

One of the main elementary ns-3 modules is the Wi-Fi module which consists of several elementary classes. ns-3.29 release includes a thorough revision of this package compared to previous versions, so as to offer additional features. Both PHY and MAC layers are modelled which enables to accurately represent any WLAN. The *WifiPhy* class takes into account all features of the PHY layer of Wi-Fi. MAC classes are grouped into two parts: one addresses MAC high sublayer and the other one the MAC low sublayer. The latter includes MAC low models that deal with medium access functions as for instance DCF and EDCA functions, RTS/CTS and ACK. It is further subdivided into MAC low and MAC middle where the MAC middle mainly deals with channel access and queue management. The MAC high sublayer performs all priori MAC processes such as beacon generation, probing, association and rate control algorithms. An overview of the Wi-Fi package is given in Figure 3.2 [15].

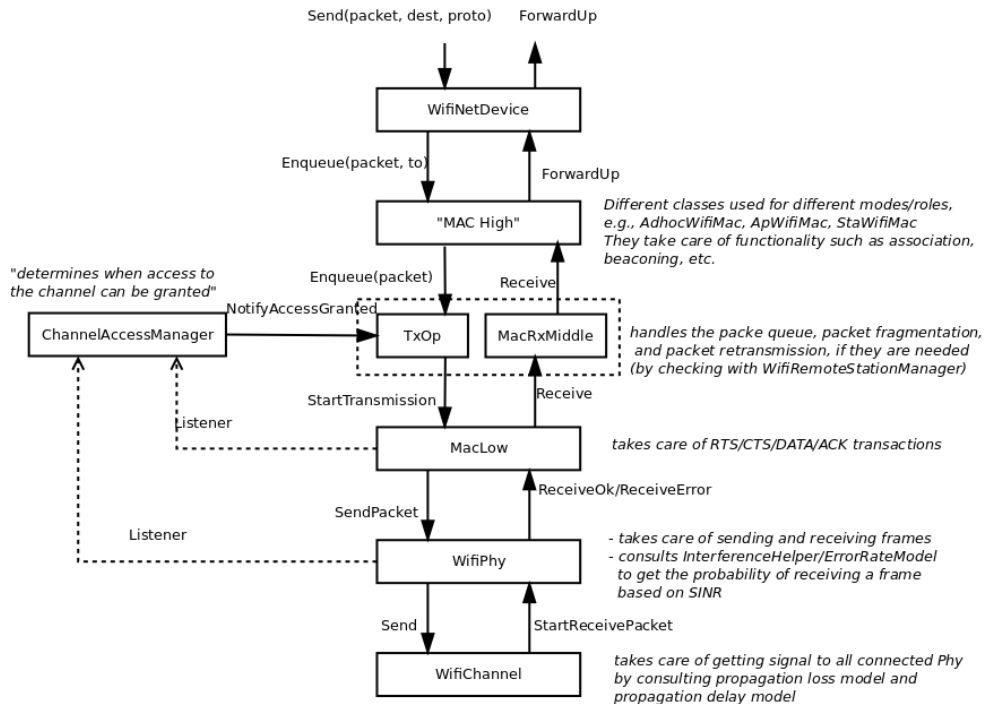

Figure 3.2: Architecture of ns-3 Wi-Fi module

MAC high: Depending on the Wi-Fi topology, the higher MAC sublayer includes three main classes: *ApWifiMac*, *StaWifiMac* and *AdhocWifiMac*. The *ApWifiMac* handles all AP-specific functions, namely periodic beacon generation and handling of association or re-association requests. The *StaWifiMac* class is in charge of probe request generation, establishing associations or re-association in case of failure. The *AdhocWifiMac* class takes charge of connected stations in an independent BSS (i.e. the network includes only non-AP stations) and does not carry out any frame generation (beacon, probe...). Besides, this class inherits from a common parent named *RegularWifiMac* that includes several features. Among them we can cite the most important ones which are: *QosSupported* attribute that enables configuration of 802.11e Wi-Fi Multimedia style QoS support, *HtSupported* attribute that allows configuration of 802.11n HT style support *VhtSupported* attribute that permits configuration of 802.11ac VHT style support and *HeSupported* attribute that allows configuration of 802.11ax HE style support.

MAC low: Four main classes are included in the MAC low sublayer: *MacLow*, *ChannelAccessManager*, *Txop*, and *QosTxop*. *MacLow* essentially deals with RTS, CTS, QoS Data/Data, and BA/ACK exchanges. It also implements MPDU aggregation. The classes *ChannelAccessManager* and *DcfState* carry out the access to the channel by organizing parallel transmission opportunities so as to prevent internal collisions.

The packet queue, packet fragmentation, and packet retransmissions are handled by *Txop* (for non QoS-enabled high MACs and DCF transmissions) and *QosTxop* (QoS-enabled high MACs and EDCA transmissions as well as MSDU aggregation).

PHY layer: In addition to the basic interface *WifiPhy* class, ns-3 includes two specialised PHY model classes. The first one is *YansWifiPhy* (YANS stands for yet another network simulator) which is an implementation of IEEE 802.11 PHY layer. It is the most basic one. The second model is the *SpectrumWifiPhy*, which is a more enhanced IEEE 802.11 PHY layer model including more functions (e.g. frequency depend fading) compared to *YansWifiPhy*. *SpectrumWifiPhy* has the advantage of being able to model any non-Wi-Fi interference (e.g. for coexistence studies).

Note that ns-3.29 does not include all Wi-Fi features, among which some proposed within the latest IEEE 802.11ax amendment. For instance, ns-3.29 supports neither MU-OFDMA nor MU-MIMO diversity techniques; only single-user format is available for IEEE 802.11ax PPDU frames. Transmissions are performed only with constant rate control algorithms when it comes to this amendment. Furthermore, neither 802.11 hybrid coordination function nor hybrid coordination function controlled channel access is implemented.

3.2.4 ns-3 modules affected by the block acknowledgement policy

Improving the block acknowledgement mechanism is one major goal of this PhD work. We describe in this section the classes which are involved in its execution. Block acknowledgement is essentially handled by the lower MAC layer. As a reminder, the block acknowledgement mechanism permits to notify a group of transmitted data at once. It is taken into account in aforementioned classes such as *MacLow*, *Txop* and *QosTxop*.

It is mainly carried out through the use of the following classes:

- *OriginatorBlockAck* deals with all information concerning transmitted MPDUs under the block acknowledgement policy for the originator station.
- *BlockAckManager* stores and manages all the block acknowledgement session agreements for the originator side.
- *BlockAckAgreement* contains agreement information related to MPDU transmission for the block acknowledgement.

Meanwhile, some of recipient information/agreements are also handled by *MacLow* class. In addition, most of the block acknowledgement mechanism configurations can be performed with the *WifiMacHelper* class. The main

tuning parameters are the block acknowledgement threshold and the block acknowledgement inactivity timeout. The block acknowledgement threshold attribute, referred to as *BlockAckThreshold*, is used to determine when to switch to BA. The acknowledgement policy is applied when the packet number to be sent is lower than this value and the block acknowledgement policy applies otherwise. The second attribute (i.e. the block ack inactivity timeout), referred to as *BlockAckInactivityTimeout*, is the inactivity duration after which the session is dismissed.

3.3 Metrics of interest

Our purpose is to investigate techniques that enable to enhance the user experience within the network which is one of last amendment's objectives. Three metrics have been chosen to evaluate the performance of the proposed mechanisms.

- **Average saturation throughput per user:** is the ratio between the total number of transmitted MAC payload bits per user and the total transmission duration.
- **Average delay per user:** presents the effective delay within a transmission. It is obtained by averaging the overall delay per user over the total transmission duration.
- **Packet outage rate per user:** considers the total number of dropped application-level packets over the total number of transmitted packets per user.

In our simulations, each metric is averaged over 50 independent runs.

3.4 Selected applications

3.4.1 File transfer protocol

3.4.1.1 Application description

File transfer protocol (FTP) had been defined by Avhay Bhushan in 1971 [83]. It is one of the earliest data transfer protocols which is still in use today. Its transfer is defined as the exchange of one or more packets between two nodes: a client and a server. It consists in an efficient and reliable exchange of already saved data transferred as a sequence of numbered packets. It is commonly used as a means of uploading or downloading files through Internet from a server to a client. Its main purposes were to: (i) enable sharing data files or computer programs, (ii) stimulate indirect exchanges via programs, (iii) protect user

from stored files variations, (iv) transfer data reliably and efficiently. The FTP application is illustrated in Figures 3.3.

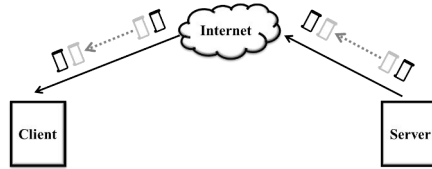

Figure 3.3: File transfer protocol: server to client

Each FTP client, aiming to download/upload data from an FTP server, must be authenticated to establish a connection. The access to the server requires a connection to a specific port number. Once the connection is established, the size of transmitted packets is fixed over a dedicated transmission duration.

3.4.1.2 Simulation of the FTP application in ns-3

A Poisson-distributed random process [84] can be used to model the packet exchange involved in the FTP application. The arrival rate is denoted by λ . It specifies the intensity of packet arrivals. FTP relies on user datagram protocol (UDP) which is in charge of exchanging short packets (datagrams) and is ideal for applications that cannot afford latency or packet loss (cf. video streaming, video games...). The transmissions are tuned such that arrivals are conditioned by λ . FTP simulation enables to evaluate the performance with a practical use case.

We use an already established file transfer class available in [85].

3.4.2 Full-buffer application

3.4.2.1 Description of the full-buffer application

The full-buffer application is one of the IEEE 802.11ax test applications [86]. It is mostly used to analyse the performance of the network through the computation of the average saturation throughput for example. Its transmissions are characterised by a limitless transfer of data between two nodes over the whole transmission duration.

3.4.2.2 Simulation of the full-buffer application in ns-3

ns-3 natively includes the *OnOffApplication* which is a class that allows to implement a full buffer traffic within any simulated network. It mainly relies on an *OnTime* and *OffTime* duration attributes that correspond respectively to the duration of the continuous data exchange and the duration during which the transfer is switched off. To model a full buffer exchange, one could use

the *OnOffHelper* and tune the number of packets to unlimited so that traffic cannot be interrupted.

3.5 Considered IEEE 802.11 scenarios

3.5.1 Common simulation parameters

Several wireless network scenarios have been defined within the latest standard amendment as reference configurations for tests and simulation. The TGax mainly define four configurations: residential, enterprise, indoor and outdoor scenarios [86]. It proposes several test recommendations for each configuration depending on the tested enhancement. These scenarios provide a real insight of real-life scenarios and definitely give a convenient behaviour preview.

For our study, we considered these IEEE 802.11ax proposed scenarios [86] to get meaningful results. We restrict ourselves to the residential configuration with different number of users either in a basic apartment or a building. The scenarios are described in Sections 3.5.2, 3.5.3 and 3.5.4. All scenarios support same PHY and MAC layer configurations. Each one will be exploited with both aforementioned applications (i.e. FTP and full-buffer applications) and with two different buffer size increase schemes (defined in Section 4.4.3). For simplicity reasons, we assume for all scenarios that all nodes have a random but fixed position during the whole simulation duration. Common parameters are listed in Table 3.1.

Table 3.1: Common simulation parameters (Scenarios (a), (b) and (c))

	Parameter	Value
PHY layer parameters	Radio band	5 GHz
	Number of antennas	2 (FTP), 1 (Full-buffer)
	OFDM guard interval	800 μ s
MAC layer parameters	Maximum number of retransmissions	7
	Data rate selection algorithm	Constant
	Access category	Best effort (AC_BE)
	EDCA parameters	Default
	Packet size	1024 Bytes
	Block ACK inactivity timeout	1 second
General parameters	AP location	Centre of each apartment ⁴
	Stations' location	Random without mobility
	Number of simulation runs	50
	Simulation duration	10 seconds
	Buffer size value	[2 4 8 16 32 64]
Application traffic parameters	Transport protocol	UDP
	Application	Full-buffer, FTP
	FTP packet size	512 kBytes
	FTP packet arrival rate (λ)	0.8

⁴ For simplicity reasons, we made a choice of placing the AP at the centre of each apartment

3.5.2 Scenario (a): Low-density scenario under IEEE 802.11ac

Scenario (a) is a basic low density scenario which considers single apartments with 5, 10 and 20 stations (Figure 3.4). Each apartment is 3 meters height with an area of 10x5 square meters. All stations are connected to a single AP and satisfy IEEE 802.11ac specifications [7]. The channel is assumed error-free and all stations operate with a same physical layer data rate corresponding to the VHT-MCS 7 (see Table.1.4).

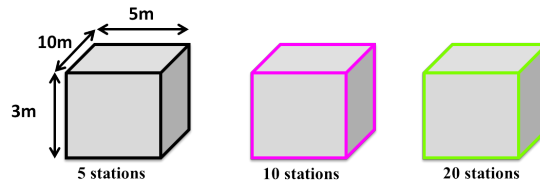

Figure 3.4: Scenario (a) - Low-density scenario

3.5.3 Scenario (b): Low-density scenario under IEEE 802.11ax

Here we only mention the differences between Scenario (b) and Scenario (a). In this scenario, stations satisfy last IEEE 802.11ax amendment specifications and the channel is no longer error-free. The HE-MCS11 (see Table 1.8), is exploited so as to evaluate performances with the highest data-rate available in latest standard amendment.

3.5.4 Scenario (c): Medium-density scenario under IEEE 802.11ax

Scenario (c) corresponds to a medium density environment. Two architectures are chosen. The first one is a ground floor including 5 apartments with 5 stations in each one. The second one is a building with 3 floors and 3 apartments per floor. Each apartment includes 4 stations. As in Scenario (b), stations satisfy last IEEE 802.11ax amendment specifications and the channel can introduce transmission errors. HE-MCS11 is used as modulation and coding scheme.

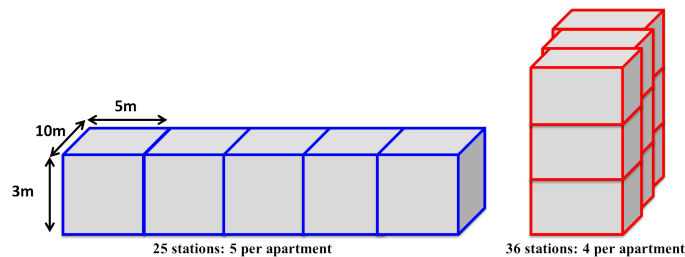

Figure 3.5: Scenario (c) - Medium-density scenario

3.6 Conclusion

This chapter has dealt with the network simulation environment. We have defined the scenarios that will be considered to assess the performance of the second contribution (i.e comparison of the BA and the proposed method) investigated during the PhD. We have briefly introduced the network simulation tool ns-3 with an overview on the module dedicated to the Wi-Fi standard. We have also described the classes that in which the block acknowledgement policy is implemented. The metrics of interest have been defined and we have quickly introduced the FTP and full-buffer applications that we will consider in our simulations.

In brief, this chapter sets our IEEE 802.11 network simulation environment. The next chapter investigates the block acknowledgement mechanism which should be enhanced so as to support both data-rate and user density increase.

Adaptive negotiation of the block acknowledgement session

4.1 Introduction

High throughput wireless applications have known a massive growth in the recent few years, jointly with the emergence of new usages. Wi-Fi has thus faced the need for developing new mechanisms to improve both its performances and efficiency. As stated in Section 1.2.4.4, the Ack is one of those introduced from the beginning, among other enhancements, to boost communications' efficiency. It enables each transmission to be notified as sent. The transmission between two devices includes an ACK frame after each sent data. It has actually improved transmissions, but it also induces much overhead. For this main reason, the IEEE 802.11e amendment [13] wanted to improve the QoS and introduced the BA mechanism that acknowledges a block of data frames instead of notifying them one by one. Even with such improvements, the BA still experiences high overhead and induces more latency due to its control frames and limited/fixed buffer size. These issues are even more detrimental when it comes to a high number of users.

The latest 802.11ax [14] standard focuses on increasing efficiency for dense environments. All the enhanced/included techniques, which were newly introduced in this amendment, aim to improve the user experience whatever the configuration or condition. As stated before, one of IEEE 802.11ax's main objectives, if not the most important one, is to increase the throughput per user. The purpose of this work joins the ones of the IEEE 802.11ax amendment namely to improve the overall wireless network performances. To achieve that, we have chosen to improve an existing technology that is the BA mechanism. Our objective is to enhance the average throughput per user within a crowded environment while insuring lower latency. We thus propose a modified BA mechanism that also enables the negotiation of block sizes of data in a more optimised way than the BA. The main objective of this chapter is to expose the proposed solution and compare it to the original one (i.e. the BA). Furthermore an analytical model of the proposed method is elaborated and validated. An analysis of performances is established to strengthen the

study.

This chapter is organised as follows. The elementary BA mechanism and its functionalities are presented in 4.2. Section 4.3 details the proposed solution. An analytical model of the proposed solution is established in Section 4.4. Simulation setup for model validation is presented in Section 4.5. Section 4.6 contains the comparison of analytical model numerical results with ns-3 measured throughput. The performance analysis is exposed in Section 4.7. Some conclusions are given in Section 4.8.

4.2 IEEE 802.11e block acknowledgement mechanism

In this section, we first describe the BA mechanism used in the IEEE 802.11e amendment. We then analyse its limitations. The latter encouraged us to propose the mechanism detailed in Section 4.3.

4.2.1 Description

The role of an acknowledgement frame is to notify the successful reception of a data frame. It improves the transmission efficiency between stations. The simple acknowledgement mechanism enables an individual feedback for each frame, i.e. for each sent frame an acknowledgement frame is expected to notify the successful transmission. This kind of structure induces more frames in communication which increases the latency of transmissions. This negatively affects real-time applications. The release of 802.11e [13] introduced quality of service in Wi-Fi networks to provide efficient transmissions. Its purpose was thus to improve the MAC layer efficiency and to include an advanced acknowledgement mechanism which is the BA mechanism. Instead of acknowledging each frame one by one, this BA can be used to acknowledge them once as a block. The maximum number of sent frames within a block is called block size and is limited.

As mentioned in the first chapter, there are two types of BA: immediate and delayed. Our study will focus on the most used one, the immediate BA. Figure 4.1 presents an overview of a typical BA session. It relies on three main steps detailed in the following paragraphs: session setup, data transfer and session tear-down.

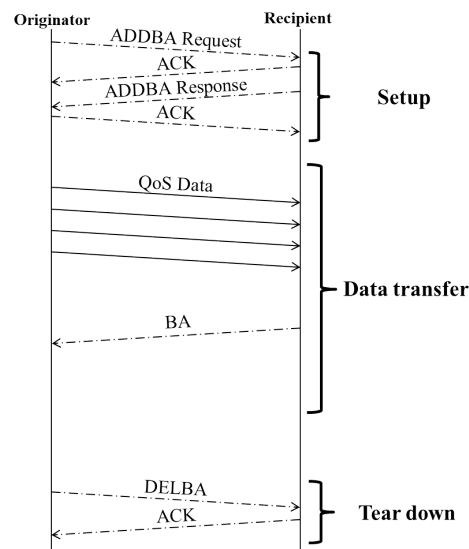

Figure 4.1: Example of a BA session

4.2.1.1 Session setup

The originator first sends an ADDBA Request frame to establish the BA session. Once the ADDBA Request is correctly received, the recipient sends an ACK followed by an ADDBA Response, whose correct reception is, in turn, acknowledged with an ACK.

Both ADDBA Request and ADDBA Response include a number of fields: Block Ack Policy, TID, Buffer Size, A-MSDU Supported, Block Ack Timeout Value and start sequence number (SSN).

The Block Ack Policy field specifies which BA type will be used (i.e. immediate or delayed BA). The Block Ack Policy required by the originator must be accepted or refused if both parts are HT stations. Otherwise, the non-HT station Block Ack policy should be considered within the exchange.

The TID field signals the access category of the session under negotiation to the recipient. The maximum number of MPDUs recommended by either the originator or selected by the recipient is included in the Buffer Size field. It is ultimately configured to the recipient desired value and it is up to the latter to set the buffer size that shall be used. Furthermore, the two parts concur to use A-MSDUs or not, through A-MSDU Supported field. Once there is no frame to transmit, the session is ended after the inactivity duration value of Block Ack Timeout Value. The SSN field provides the sequence number of the next MPDU to acknowledge.

The session is established once the originator acknowledges the positive ADDBA Response sent by the the recipient.

4.2.1.2 Data transfer

The second step begins once the BA session is accepted/set up. The originator sends a block of QoS Data frames separated by SIFS or as part of an A-MPDU. The BA frame can simultaneously acknowledge up to 64 consecutive MPDUs which are not fragments. The recipient has to prepare a BA according to the scoreboard saved before (a bitmap of 64 bits which forms an array of indices starting from the SSN). Then its MAC layer reassembles any complete MPDUs from buffered preceding MPDUs and transfers them up to higher layers. If an MPDU was indicated as not received in the BA map, the originator should retransmit the corresponding QoS Data frame until its lifetime inactivity limit is reached. The successful reception of at least one QoS Data is enough to send a BA frame with the appropriate bitmap.

4.2.1.3 Tear down

Once there is no more data to send, the last step begins with the originator sending a DELBA to end the session. The recipient can also send such a frame. If it is successfully received, an ACK is sent by the recipient and the BA session is closed. Otherwise, the session is closed after a duration defined by a timeout value.

4.2.2 Discussion: BA performance analysis

The main purpose of introducing an enhanced acknowledgement mechanism was to improve the general transmission efficiency. The BA actually demonstrates higher performances compared to the original acknowledgement. The latter enables an individual acceptance on a per-frame basis. With the BA mechanism, instead of acknowledging each frame one by one, a summary of the reception status of a block of frames is sent through a single frame called BA frame. Acknowledging frame per frame, as supported by generations preceding the 802.11e, leads to transmission latency and overhead augmentation with the increase of users. Grouping acknowledgement of several frames at once has significantly helped in reducing either latency or overhead. Several works [35][36][37][38][39][40] thoroughly studied the performance of the Block Acknowledgement compared to the frame-by-frame acknowledgement. All analyses lead to the same conclusion: BA performs better than the normal frame-by-frame acknowledgement mechanism.

In [35], E.Varthis et al. have shown that the BA offers an efficiency gain of 10% compared to the basic mechanism. They extended the study in [36] to treat it under saturation burst for various metrics such as the number of contending terminal units, frame error rate and window size. An improvement of up to 25% is shown for some configurations. One notable, yet logical,

behaviour is that the BA presents better performances for high buffer sizes than for small ones.

In [37], Tinnirello et al. also pointed out that the performance depends on the TXOP limit, the access mode and the acknowledgement policy. They confirmed that the BA is even more useful for high data rates and high TXOP values. The simulations reported in [38] show higher throughputs and lower delays for BA compared to legacy mechanism. More severe channel conditions were considered in [39] (noisy channel, dense environments) and in [40] (varying channel conditions); the superiority of BA mechanism was still observed.

The BA has indeed proven its high efficiency. Nevertheless, as it can be noticed from 4.2.1, it stills relies on several control frames. For the first step for instance, the exchange of ADDBA Request and ADDBA Response is mandatory to establish the BA session. Likewise for tearing down the session, the recipient needs to send a DELBA frame, and wait for an ACK, to close the session. The BA thus includes several control frames and ADDBA exchanges to set the session up. In addition, a session is set per AC and in only one direction (from the originator to the recipient). It thus results in significant control overhead and transmission latency in case of a high number of stations, as a session has to be established for each station.

Furthermore the buffer size is fixed by the recipient and maintained during all the session. This can cause bandwidth loss particularly for a high usage. Some researchers have analysed the limitations incurring from fixing this value [87][88][89][90]. They pointed out that a fixed buffer size could reduce throughput efficiency and increase the average delay. For instance, in [87], D. Malone et al. focused on the relation between buffering delays and loss for voice traffic. They proved that the choice of the buffer size had a great impact on the throughput of an AP/client conversation. In [88][89][90] there has been a stress on the effect of fixed buffer sizes for transmission control protocol (TCP) traffic and 802.11 WLANs. All of them showed how a static configuration of the buffer size can induce channel under-utilisation or higher delays, affirming the non existence of a fixed buffer size value that could insure a trade-off between buffering delays and throughput. In the three aforementioned works, T. Li et al. proposed dynamic approaches that enable to adapt the buffer size according to channel conditions. Their buffer sizing algorithms are based on the bandwidth delay product (namely the product of the bandwidth and the average delay of transmitting flows). As we can see, very few works have pointed out the limitations of fixed buffer sizes. Even fewer mentioned the high number of control frames within the BA session.

V. Pitschiah designed an improved BA setup mechanism in [91]. Instead of negotiating and establishing one or more BA sessions between stations by the ADDBA Request/ADDDBA Response exchanges, he proposed to do it during the association procedure and also during the access category negotiation.

Despite the fact that it improves the session establishment efficiency, it has the disadvantage of reserving unjustified resources, which could lead to a failed negotiation and hence increase the transmission delay.

As for us, one of our motivations in this PhD work is to overcome the aforementioned drawbacks of BA in order to reduce not only latency but also overhead. We thus propose an adaptive negotiation of BA session (AN-BA). Our solution not only enables a dynamic configuration of the buffer size according to the originator/recipient requirements but also an optimisation of the BA session, and thus the reduction of the transmission overhead. It does not rely on ADDBA Request/ADDDBA Response and DELBA. Instead, it uses two control bits in the MAC headers containing the desired agreement between the originator and the recipient instead. The negotiation of the buffer size at the originator side is also done via these bits. It can be re-adapted during the session and, contrary to [91], it is based on available resources only. The proposed AN-BA is detailed in Section 4.3.

4.3 Proposed adaptive negotiation of the block acknowledgement session

4.3.1 Description of the AN-BA mechanism

The adaptive negotiation of the BA session management has the same role as the basic mechanism of the BA. It is a modified manner of establishing the BA session while reducing the latency and improving the transmission efficiency. This is insured by minimising the number of control frames involved in the establishment of the BA session and the update of the buffer size.

This optimisation is made by replacing the ADDBA Request and the ADDDBA Response by one QoS Data frame tagged with 2 control bits. Namely, instead of exchanging ADDBA Request/Response for every step of the BA negotiation, the method is based on the use of two control bits (b_1 , b_0) by the originator and (b'_1 , b'_0) by the recipient. Each transmission is conditioned by the binary couple state communicated by either the originator or the recipient. The bits b_1 and b_0 are tagged within the QoS Data frame to transfer the originator's requirements to the recipient. ACK and BA frames carry b'_1 and b'_0 to notify the successful QoS Data reception while responding to originator's requirements.

Note that, in order to establish any connection between two stations, these ones must belong to the same network. An association phase is thus a prerequisite for any data exchange, be it through BA mechanism or the proposed AN-BA mechanism (association phase details are presented in Section 1.2.4.3).

Like BA, AN-BA consists of three phases: session setup, data exchange, and session tearing-down orchestrated by the control bits instead of control frames. An example of the establishment of a BA session under the AN-BA method is presented in Figure 4.2.

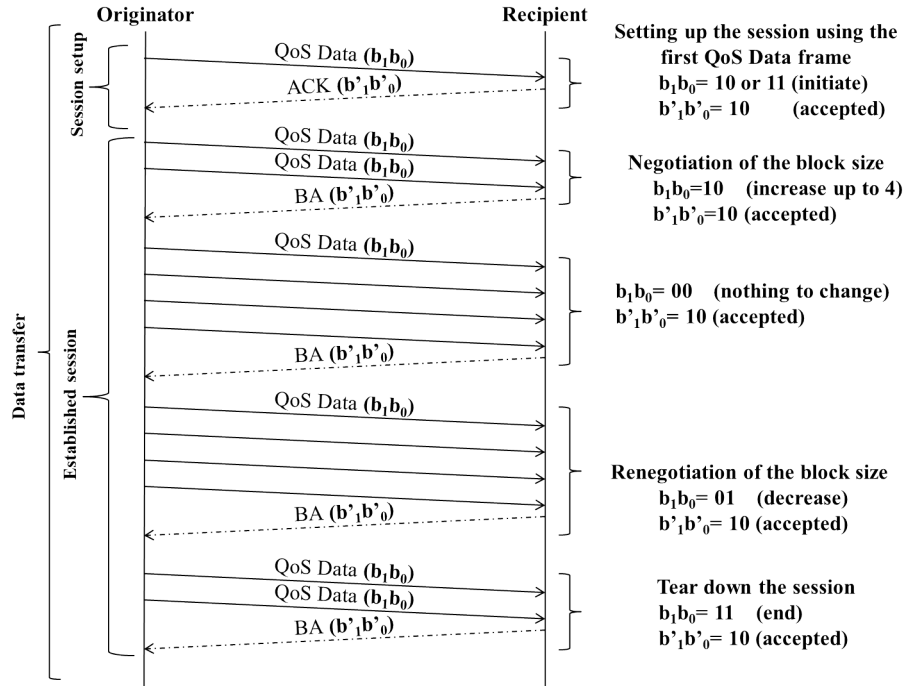

Figure 4.2: Example of the adaptive negotiation for BA session management

4.3.1.1 Session setup

To set the session up, the AN-BA replaces the ADDBA Request/ ADDBA Response handshake by one QoS Data frame. The latter includes two control bits (i.e. b_1 and b_0). Table 4.1 defines the meaning of the control bits states during this phase depending on the requirements of the two communicating nodes/stations.

Table 4.1: Control bits states during setup session

Session step	Originator		Case	Recipient		Case
	b_1	b_0		b'_1	b'_0	
Session setup	0	0	Nothing to do	0	0	Nothing to do/ Timeout
	0	1	Reserved	0	1	Reject the request
	1	0	Initiate without A-MSDU	1	0	Accept the request
	1	1	Initiate with A-MSDU	1	1	Reject for incompatibility

The originator could propose to establish a session using A-MSDUs (with $b_1b_0 = 11$) or without it (with $b_1b_0 = 10$). The recipient can then accept

the request by including the two control bits in the ACK frame ($b'_1b'_0 = 10$) or refuse it ($b'_1b'_0 = 11$, if the request option is not supported, or $b'_1b'_0 = 01$ otherwise). The acceptance or the rejection depends either on recipient's resource availability or on its policies. Figure 4.2 illustrates the case where both parts (i.e. originator and recipient) are under compatible policies. Otherwise, if either $b_1b_0 = 00$ or $b'_1b'_0 = 00$ nothing changes within the transmission, namely no session is to be established.

4.3.1.2 Established session

If the recipient accepts the session, the originator begins to send a bulk of QoS Data frames tagged with the control bits. The different states of the bits along with the corresponding meanings for this phase are listed in Table 4.2.

Table 4.2: Control bits states during established session

Session step	Originator			Recipient		
	b_1	b_0	Case	b'_1	b'_0	Case
Established session	0	0	Nothing to change	0	0	Reduction request
	0	1	Halve the buffer size	0	1	Reject buffer increase / Timeout if reduction
	1	0	Double the buffer size	1	0	Accept the modification
	1	1	Close the session	1	1	Tear down request

Depending on the control bits states, our solution includes an implicit negotiation involving the originator and the recipient. This negotiation concerns the adaptation of the number of sent frames from the originator to the recipient. The mechanism allows the originator to call for increasing or reducing the maximum number of QoS Data MPDUs to acknowledge at once using different control bits states. The recipient can accept or refuse the requested modification. The procedure is illustrated in Figure 4.2 for the case where the two STAs have compatible configurations and exchange QoS Data frames. The buffer size adaptation procedure is also illustrated in Figure 4.2. The originator sends a QoS Data frame including control bits to invite the recipient to establish the session. Using a specific state (i.e. $b_1b_0 = 10$ or $b_1b_0 = 11$) the originator announces to the recipient which configuration will be used for the data transmission: whether it is on non-aggregated frames or aggregated frames. The recipient should accept or refuse the request depending on its capacity of handling A-MSDUs. The recipient receives the QoS Data frame tagged with control bits and responds by an also tagged ACK, informing its acceptance ($b'_1b'_0 = 10$) or refusal ($b'_1b'_0 = 01$). When the recipient accepts to establish the session, the data transfer session begins. The originator sends a block of QoS Data frames with control bits indicating the type of request. The originator can for example ask to double the number of transmitted frames ($b_1b_0 = 10$). At recipient side, the increase request could be accepted or re-

fused. If it is accepted, a BA is sent to acknowledge the reception of previous frames with the control bits announcing the acceptance ($b'_1b'_0 = 10$). A similar procedure applies for the refusal ($b'_1b'_0 = 01$ or $b'_1b'_0 = 11$). Since the recipient's buffer size is limited, it can call for a reduction ($b'_1b'_0 = 00$) so that the originator would halve the number of transmitted QoS Data frames. If the recipient accepts the increase, the originator sends a block of QoS Data frames up to the new size. If not, it continues with the same size. The control bits are tuned depending on the state of the transmission.

4.3.1.3 Tearing down the BA session

The recipient can ask to stop the session by sending suited control bits in the last BA ($b'_1b'_0 = 11$ as in Table 4.2). The originator takes the last tagged BA and closes the session within the next transmission. The decision to close the session can also stem from the originator. In both cases, the originator closes the session just after sending the last QoS Data frame tagged with $b_1b_0 = 11$. The session is closed after the reception of last BA frame.

4.3.2 AN-BA potential benefits compared to BA

As stated earlier, the classical BA session management mechanism includes several control frames for establishing a session and updating some of its parameters. This induces more latency in crowded environment and consumes bandwidth. For instance, to update the buffer size value, both parts (originator and recipient) must exchange ADDBA Request/Response one more time. The proposed method improves the efficiency of networks by enabling dynamic negotiation of BA session parameters, namely buffer size, through two control bits instead of dedicated control frames. Such a mechanism permits an efficient means of tuning the channel resources according to the corresponding traffic.

The potential delay benefit in using AN-BA instead of BA is illustrated in Figure 4.3.

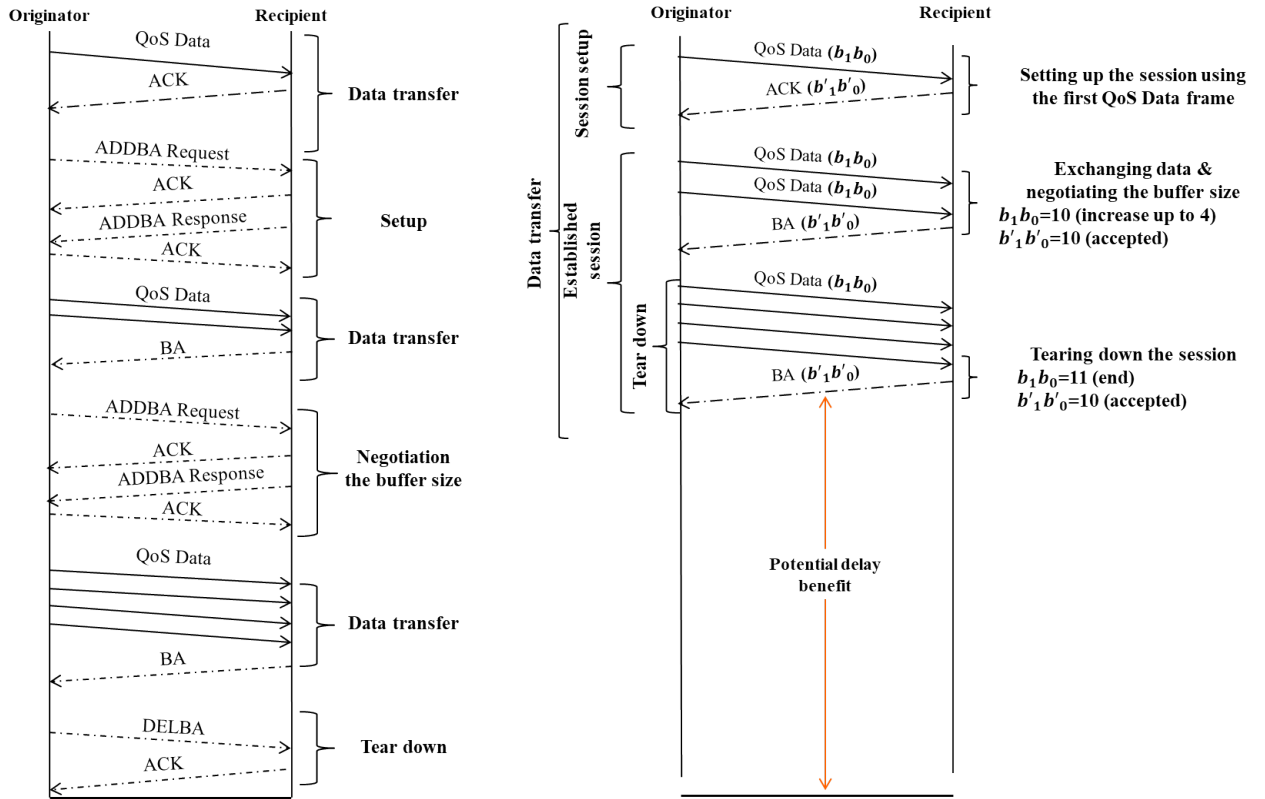

Figure 4.3: Example of a BA session under the basic BA mechanism (left) and the AN-BA method (right)

4.3.3 AN-BA backward compatibility

The support of the AN-BA either for legacy or last amendments should be guaranteed. From the originator side, one proposition is to insert the control bits within one of the **HE A-Control** (see Section 1.3.3.3) fields where 4 Control ID values from 7 to 14 are so far reserved [14]. At the reception side, the recipient could include them instead of two null bits within the Control field for the BA (from bit 0 to bit 11 [2]), and ACK [2].

Likewise, one should note that if either the originator or the recipient does not support the AN-BA methods (information exchanged during the association step) the session will rely on the BA mechanism.

4.4 Analytical model for AN-BA

An analytical model of the AN-BA is proposed in this section. It permits a first validation of the theoretical approach and provides at the same time a preliminary review of the results on some simple configurations. The validation is

made by means of ns-3 which is considered as the most accurate simulator for implementing simulator models of techniques. This section will thoroughly establish the AN-BA analytical model inspired by several literature studies exposed in Section 4.4.1. A generic model for IEEE 802.11 standard will be exposed in 4.4.2. Different buffer-size adaptation schemes are presented in Section 4.4.3. Section 4.4.4 will present the saturation throughput general expression. The saturation analytical model for the AN-BA will be established in Section 4.4.5.

4.4.1 State-of-the-art

Many models of the BA mechanism exist in the literature [46][39][92][93]. In [46], Bianchi introduced the reference analytical models of BA to propose a simple and accurate representation of the saturation throughput in the case of an error-free channel. To that end, he used a Markov chain to model the back-off algorithm. This model cannot be applied to the EDCA due to two limitations. First, it assumes that a packet can be infinitely retransmitted and thus it doesn't take into account the actual limitation in the number of retransmissions. Second, it doesn't consider each AC-specific parameters; indeed it addresses DCF. Later on, the Bianchi model was improved [39][92][93]. The impact of errors and collisions, along with the limitations on the number of retransmissions, were taken into account. These enhancements made the resulting model consistent with the DCF access mechanism [39][92]. Let us mention that none of these models is suited to analyse the EDCA mechanism. A. Banchs and L. Vollero extended these models in order to cover transmission under EDCA mechanism by establishing the model in [93]. This model is accurate and considers different access categories while assuming a limited number of retransmissions.

In our work, we establish an analytical model of the AN-BA and compare it to the AN-BA implemented in a local version of the network simulator ns-3 [15]. Compared to previously mentioned models, the proposed one applies to EDCA mechanism: it considers collisions with a limited number of retransmissions and it takes into account the different ACs as in [93], keeping the error-free channel assumption. To the best of our knowledge, the adaptation of the buffer size according to network requirements has not been thoroughly studied in the literature. The flexible buffer size update is one key advantage of AN-BA compared to the original BA in a dense environment and is also taken into account in the proposed mathematical model of the saturation throughput. This property is stressed in this section through AN-BA and BA performance comparison using ns-3.

4.4.2 Generic model for IEEE 802.11 standard

4.4.2.1 Probability system

Bianchi's model and its extension is based on a Markov chain requiring the consideration of three main events that occur in the network: idle station, successful transmission and collision. We assume that the channel is error-free. It is thus necessary to calculate the associated probabilities, which is the main task of this section.

Let K be the number of stations aiming to access to the medium. We denote by P_I the probability that all stations are idle (the medium is thus free), by P_T the probability that at least one station is active and transmits, by P_S the probability that a transmission is successful (that is to say reaches the receiver without collision with another transmission) and by P_C the probability of collision.

Let τ be the probability that a station accesses the medium. Then P_I is the probability that no station is active, that is to say

$$P_I = (1 - \tau)^K. \quad (4.1)$$

and

$$P_T = 1 - P_I = 1 - (1 - \tau)^K. \quad (4.2)$$

Assuming that at least one station is active, a transmission is successful if the station is the only active one, which gives the expression of P_S :

$$P_S = \frac{\binom{K}{1} \tau (1 - \tau)^{K-1}}{P_T} = \frac{K \tau (1 - \tau)^{K-1}}{1 - (1 - \tau)^K}. \quad (4.3)$$

A collision occurs when at least one station is active and at least one transmission does not succeed that is to say

$$P_C = P_T (1 - P_S). \quad (4.4)$$

The computation of parameter τ will be described in Section 4.4.2.2.

Control frames and QoS Data frames do not have the same parameters. Control frame configurations are defined using legacy DCF mode. EDCA introduced four access categories and as a consequence the parameters of QoS Data frames depend on the associated AC. For the i -th AC, they will be denoted by $P_{\bullet}(i)$ and $\tau(i)$.

4.4.2.2 Markov chain

As defined in IEEE 802.11 specifications, the exponential back-off algorithm is used to manage the access to the channel and to reschedule transmissions after errors or collisions.

Let $CW_{i,min}$ (respectively $CW_{i,max}$) denote the minimum (respectively maximum) contention window value for the i -th AC. If m stands for the maximum number of retransmissions, the contention window value for the i -th AC and the l -th retransmission ($l \in \{0, \dots, m\}$) is denoted by CW_i^l and equals $CW_i^l = 2^{\min(l,\mu)} CW_{i,min}$ (with $CW_{i,max} = 2^\mu CW_{i,min}$ such as μ corresponds to the maximum contention window level of each access category).

Given a station whose AC is identified by the index i and for l retransmissions, we introduce $b(t)$ the back-off counter at time slot index t . It is initialised with a random value within the range of $[0, CW_i^l]$. $b(t)$ is decremented before each time slot and the corresponding station can access the medium once it reaches zero. In case the transmission experiences collisions or errors, the contention window value is doubled up to the maximum size. The maximum number of retransmissions equals m .

In [46], the back-off counter $b(t)$ is described as a stochastic process. As the system evolution only depends on the current state, $b(t)$ satisfies the Markov property and can be modelled as a Markov chain. The back-off mechanism is described as a bi-dimensional Markov chain $\{s(t), b(t)\}$ where $s(t)$ is the stochastic process representing the number of retransmissions at time slot t ($s(t) \in \{0, \dots, m\}$). As in [46][92][93] we consider an error-free channel. Each station randomly picks an initial back-off level following $s(t)$ and initialises the back-off counter $b(t)$ with it. We suppose that every station has a frame to transmit. A transmitted frame can be corrupted with a collision probability p . The computation of τ and p can be found in [92][93]. Interpreting τ as the sum of the probabilities that the back-off counter reaches zero at level l , we obtain

$$\tau = \sum_{l=0}^m b_{l,0}, \quad (4.5)$$

with $b_{l,0} = \lim_{t \rightarrow \infty} \Pr(s(t) = l, b(t) = 0)$. To find τ and p , we adopt the non-linear system described in [93].

Let us denote by $b_l(t)$ the back-off counter at t -th time slot and contention window level l for the i -th AC. At first time slot, $b_l(0)$ is uniformly chosen in the interval $[0, CW_i^l]$. The back-off counter is decremented before each time slot and the corresponding station can access the medium as soon as it reaches zero.

4.4.2.3 Time division of IEEE 802.11 frames

As exposed in Chapter 1, DCF and EDCA are coordination functions that manage channel access for legacy and QoS transmissions respectively. With DCF, each station aiming to transmit must wait during a delay equal to the DIFS. For QoS transmissions, the station waits during an AIFS(i) for the i -th

AC whose duration equals

$$T_{AIFS(i)} = \sigma \cdot AIFSN(i) + T_{SIFS}, \quad (4.6)$$

where $AIFSN(i)$ is the AIFS Number which depends on the i -th AC and σ is the time slot duration. σ depends on the physical layer. SIFS is generally the amount of time the sender has to wait before replying with an ACK or BA.

By the end of the waiting delay (DIFS or AIFS), the station tries to access the channel using the binary exponential back-off (BEB) algorithm. The back-off counter is decremented before each time slot and the corresponding station can access the medium as soon as it reaches zero. In case of successful transmission, the station receives an ACK or a BA before deferring a DIFS (legacy transmissions) or an AIFS (QoS transmissions). If a collision occurs, the station has to wait during an EIFS and the contention window is doubled in anticipation of the next transmission opportunity. We distinguish EIFS^{leg} for legacy frames from EIFS(i) for i -th AC of QoS Data. The duration of EIFS^{leg} is defined as

$$T_{EIFS^{leg}} = T_{SIFS} + T_{H_{PHY-leg}} + T_{ACK} + T_{DIFS}, \quad (4.7)$$

where $T_{H_{PHY-leg}}$ and T_{ACK} are the duration of the legacy physical layer (PHY-leg) header and the duration of an ACK frame (i.e. MPDU) respectively. The duration of EIFS(i) equals

$$T_{EIFS(i)} = T_{EIFS^{leg}} - T_{DIFS} + T_{AIFS(i)}. \quad (4.8)$$

4.4.2.4 General transmission duration expression

Let us now derive the total transmission duration. The channel access mechanism is summarised in Figure 4.4.

In our analysis, we assume that in case the contention window level moves up to the maximum number of retransmissions (that is to say m consecutive collisions occur), a success should definitely be granted. As a consequence, the total transmission duration, denoted by T , can be computed as

$$T = \sum_{l=0}^{m-1} \left[(P_C)^l (P_I T_I b_l(t) + P_C T_C + P_S T_S) \right] + (P_C)^m (P_I T_I b_m(t) + T_S) \quad (4.9)$$

where T_S , T_C , and T_I correspond to the average success, collision and idleness state duration respectively. The first term of (4.9) represents the average duration of all retransmissions that could occur (experiencing a collision, an idleness or a success), while the second term corresponds to last retransmission supposed to succeed after m previous consecutive collisions occurred.

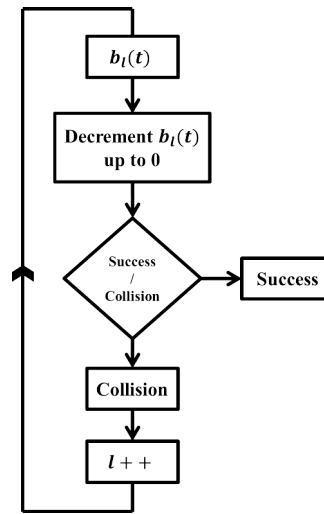

Figure 4.4: Channel access mechanism

4.4.3 Selected buffer size adaptation schemes

In order to evaluate the proposed method, two buffer size adaptation schemes have been chosen. One should note that in practice, algorithm controlling the buffer size is specific to the equipment used. Each chip-set constructor defines its own scheme and we never know precisely how it actually works. For these reasons we have chosen to analyse the method according to two extreme cases in order to give a general analysis of the method's performances. The first scheme is referred to as "switch case" and the second one as "increase case". They are exposed in Section 4.4.3.1 and Section 4.4.3.2 respectively.

4.4.3.1 Buffer size switch case

We first consider a quite favourable case, referred to as the switch case, presented in Figure 4.5.

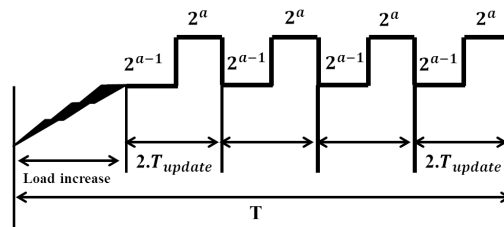
Figure 4.5: Switch case example: Updating the buffer size from 2^{a-1} to 2^a

It makes the buffer size switch from a maximum value of 2^{a-1} to a maximum value of 2^a with $a \in \{1, 2, 3, 4, 5, 6\}$. It is supposed to be close to a practical scenario such that it allows high flexibility in changing buffer size

values. It offers a convenient adaptability in terms of data exchange requirements.

4.4.3.2 Buffer size increase case

For the second case we suppose that at every update request, the buffer size is reset to 1 and increases up to the desired value, thus we call it the increase case, as presented in Figure 4.6. Compared to the switch case, it requires that the buffer size browses all the values that precede the targeted one every update period. We estimate that this configuration enables to evaluate the system performance in adverse conditions.

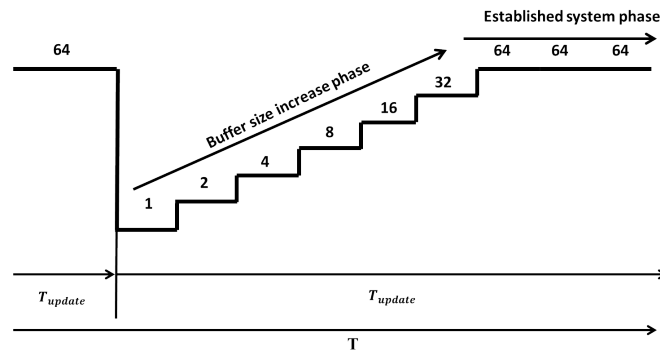

Figure 4.6: Increase case example: Periodic buffer size increase to reach the targeted value of 64

4.4.4 Saturation throughput: General expression

To establish a theoretical analysis, we choose the saturation throughput as a performance metric like most papers in the literature that deal with such analyses [39][46][92][93]. We thus derive a mathematical model for the saturation throughput. Among aforementioned works, we use the model of Banchs and Vollero [93] in order to take into account the IEEE 802.11ax recommendations [14] (EDCA for instance) as accurately as possible. We derive a generic expression that depends on many system parameters and thus enables an accurate performance evaluation. This section is dedicated to its theoretical expression in the case of an error-free channel and assuming that each station has a frame to transmit. The analysis focuses on the case of A-MPDUs for the bulk sending of QoS Data without an aggregation of the MSDUs. We also consider a finite maximum number of retransmissions m . For the sake of simplicity, we take into account a basic access to the channel. The extension to RTS/CTS access is quite straightforward. Furthermore, to bring out the impact of the AN-BA and to highlight performance in

case of frequent buffer size change depending on originator and recipient requirements, we consider that the maximum buffer size can be updated every T_{update} (as in Sections 4.4.3.1 and 4.4.3.2 for the switch and increase case respectively).

The saturation throughput (ST) is defined as in Section 3.3 of Chapter 2. Let us recall that, it is the ratio between the total number of transmitted MAC payload bits per user and the transmission duration. It can firstly be expressed as follows.

$$ST(i) = \frac{\text{Size of MSDU} \times \text{Total number of MPDUs for a given access category}}{\text{Transmission duration}} \quad (4.10)$$

Section 4.4.4.1 and Section 4.4.4.2 expose general expressions of ST in both configurations: switching the buffer size between 2^{a-1} and 2^a (Section 4.4.3.1), and increasing continuously the buffer size up to maximum and resetting it upon update (Section 4.4.3.2).

$(.)^{sw}$ and $(.)^{in}$ denote respectively the variables associated with switch and increase cases.

4.4.4.1 Buffer size switch case

In this section, we assume that the buffer size commutes between two maximum buffer size values: 2^{a-1} and 2^a in a cyclic manner as illustrated in Figure 4.5.

We focus the analysis on an interval of $2.T_{update}$. $ST^{sw}(i)$ denotes the saturation throughput corresponding to the i -th AC. According to (4.10) we obtain:

$$ST^{sw}(i) = \frac{L_f \cdot N_f^{sw}(i)}{2.T_{update}} = \frac{L_f \cdot (N_f^{sw}(i, a) + N_f^{sw}(i, a-1))}{2.T_{update}}, \quad (4.11)$$

where L_f is the size of QoS Data packets and $N_f^{sw}(i)$ denotes the total number of A-MPDUs over 2 update periods. $N_f^{sw}(i)$ corresponds to the sum of $N_f^{sw}(i, j)$ defined as the number of transmitted A-MPDUs for the j -th data aggregation level. In the considered case, j can be equal to $a-1$ or a . $N_f^{sw}(i, j)$ is expressed as:

$$N_f^{sw}(i, j) = 2^j \cdot N_p^{sw}(i, j), \quad (4.12)$$

where $N_p^{sw}(i, j)$ is the number of transmitted PSDUs for the i -th AC and the j -th aggregation level. In our analysis, we express $N_p^{sw}(i, j)$ in function of the event probabilities and durations of the adopted system. Section 4.4.5.1 thoroughly exposes the $ST^{sw}(i)$ expression assuming K stations.

4.4.4.2 Buffer size increase case

In this configuration, we assume an initial buffer size of 1 and a continuous size doubling until it reaches the targeted value. Figure 4.6 illustrates the periodic buffer size increase till the targeted value of 64 (i.e. $a = 6$). We follow the same reasoning as in Section 4.4.4.1 to obtain the general saturation throughput expression. We denote it by $ST^{in}(i)$. In this configuration the saturation throughput is computed for a period of T_{update} .

Therefore the basic expression of $ST^{in}(i)$ corresponding to the i -th AC is given by:

$$ST^{in}(i) = \frac{L_f \cdot N_f^{in}(i)}{T_{update}}. \quad (4.13)$$

Let us assume that a is the targeted aggregation level. We denote by $N_f^{in}(i)$ the total number of A-MPDUs to be transmitted for the i -th AC and $N_p^{in}(i, j)$ the number of PSDUs transmitted at the j -th aggregation level for the same AC. Due to the data load increase, the value of $N_f^{in}(i)$ depends on all crossed aggregation levels j :

$$N_f^{in}(i) = \sum_{j=0}^a 2^j N_p^{in}(i, j). \quad (4.14)$$

As the buffer size increases gradually to reach a maximal value maintained till the end of the session or till a potential buffer size update, $N_p^{in}(i, j)$ is defined as follows:

$$N_p^{in}(i, j) = \begin{cases} 1 & \text{if } j \in (0, a - 1) \\ N_p^{in}(i, a) - a & \text{otherwise} \end{cases} \quad (4.15)$$

The total number of MPDUs $N_f^{in}(i)$ is thus computed as:

$$N_f^{in}(i) = \sum_{j=0}^{a-1} 2^j + 2^a (N_p^{in}(i, a) - a). \quad (4.16)$$

The first term of equation (4.16) corresponds to the number of MPDUs during the data load increase and the second one is the number of MPDUs when the targeted buffer size value is reached. $N_p^{in}(i, a)$ can be expressed in function of the event probabilities and durations of the system. Section 4.4.5.2 thoroughly exposes the $ST^{in}(i)$ expression for K stations.

4.4.5 Analytical saturation throughput expression for AN-BA mechanism

In this section, we derive a mathematical model for AN-BA to theoretically analyse its performance. As mentioned before, we chose the saturation

throughput as the main performance metric like most papers in the literature that deal with such analyses. We derive a generic expression that depends on many system parameters (exposed earlier) and thus enables an accurate performance evaluation.

With the AN-BA method, the BA session requires to send a first QoS Data frame carrying the establishment request (this frame will be labelled with index 1 hereinafter). Once the receiver accepts the request, the session is established and the data exchange can begin, using aggregated QoS Data frames (labelled with index 2 hereinafter). The TXOP content depends on transmission experiences. In our analysis the channel is supposed to be error free, and frames can only experience collision or success.

Figure 4.7 illustrates the TXOP content depending on the session phase (establishment (index 1) or data exchange (index 2)) and on the state (success (index S) or collision (index C)).

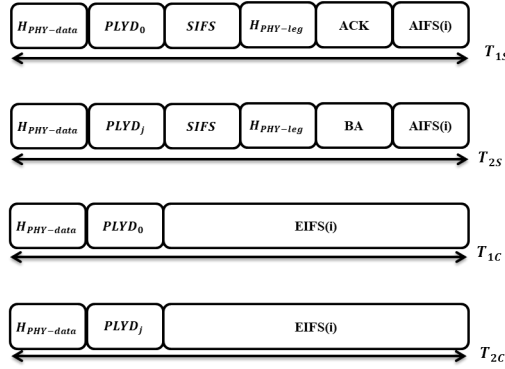

Figure 4.7: Different potential TXOP structures for AN-BA method

In case of a success, a QoS Data frame of the first type is followed by an ACK and an AIFS(i), while aggregated QoS Data frames (of second type) precede a BA and an AIFS(i) for the corresponding AC.

In case of collision, an EIFS(i) follows, instead, the QoS Data frame. Two block durations can be defined for each frame: $T_{(1,2)S}$ in case of success and $T_{(1,2)C}$ in case of collision. They are computed as follows:

$$T_{1S}(i) = T_{H_{PHY-data}} + T_{Plyd_0} + T_{SIFS} + T_{H_{PHY-leg}} + T_{ACK} + T_{AIFS(i)} \quad (4.17)$$

$$T_{2S}(i, j) = T_{H_{PHY-data}} + T_{Plyd_j} + T_{SIFS} + T_{H_{PHY-leg}} + T_{BA} + T_{AIFS(i)} \quad (4.18)$$

$$T_{1C}(i) = T_{H_{PHY-data}} + T_{Plyd_0} + T_{EIFS(i)} \quad (4.19)$$

$$T_{2C}(i, j) = T_{H_{PHY-data}} + T_{Plyd_j} + T_{EIFS(i)} \quad (4.20)$$

Given the aggregation level $j \in \{0, 1, 2, 3, 4, 5, 6\}$ with the corresponding

buffer size 2^j , the payload duration T_{Plyd_j} is defined as

$$T_{Plyd_j} = \begin{cases} \frac{H_{MAC}+MSDU}{C_{data}} & \text{if } j = 0 \\ \frac{(DELI+H_{MAC}+MSDU)2^j}{C_{data}} & \text{otherwise} \end{cases} \quad (4.21)$$

The first QoS Data includes only one frame, which corresponds to determining T_{Plyd_j} for $j = 0$.

DELI is the delimiter length and H_{MAC} is the MAC header length. We assume that our saturation throughput is calculated at the IP layer level, so the MSDU also includes the length of the IP payload (L_f), the IP header (H_{IP}) and LLC header (H_{LLC}) such that $MSDU = L_f + H_{IP} + H_{LLC}$. Note that we do not consider MSDU aggregation.

The modulation and coding scheme is supposed fixed: stations operate with the same physical data rate. We note C_{leg} the legacy PHY data rate used by control frames and C_{data} the PHY data rate used by QoS Data frames.

$T_{H_{PHY-data}}$ and $T_{H_{PHY-leg}}$ are the durations of the data physical layer (PHY-data) header and the legacy physical layer (PHY-leg) header respectively.

T_{ACK} and T_{BA} are for the durations of the ACK and BA frames.

Considering different ACs, $T_{1S}(i)$ and $T_{2S}(i, j)$ both involve $T_{AIFS(i)}$ which depends on the AC index i . The same applies to $T_{1C}(i)$ and $T_{2C}(i, j)$ which include $T_{EIFS(i)}$.

According to the general duration expression in (4.9), durations included within the AN-BA mechanism are thus expressed as:

$$T_1(i) = \sum_{l=0}^{m-1} \left[(P_C(i))^l (P_I(i)T_{Ib_l}(t) + P_C(i)T_{1C}(i) + P_S(i)T_{1S}(i)) \right] + (P_C(i))^m [P_I(i)T_{Ib_m}(t) + T_{1S}(i)] \quad (4.22)$$

$$T_2(i, j) = \sum_{l=0}^{m-1} \left[(P_C(i))^l (P_I(i)T_{Ib_l}(t) + P_C(i)T_{2C}(i, j) + P_S(i)T_{2S}(i, j)) \right] + (P_C(i))^m [P_I(i)T_{Ib_m}(t) + T_{2S}(i, j)] \quad (4.23)$$

Let us now establish the saturation throughput based on all previous defined parameters. Section 4.4.5.1 and Section 4.4.5.2 thoroughly expose expressions of ST in both configurations (i.e. switch case and increase case respectively).

$(.)^{sw}$ and $(.)^{in}$ denote respectively the variables associated with switch and increase cases.

4.4.5.1 Saturation throughput for the buffer size switch case

The parameter $N_p^{sw}(i, j)$ is expressed as:

$$N_p^{sw}(i, j) = \begin{cases} \frac{\gamma T_{update}/K}{T_1(i) + \sum_{k=0}^{j-1} T_2(i, k) + T_2(i, j)} & \text{for update period } j = 0, k \in (0, \dots, j-1) \\ \frac{T_{update}/K}{T_2(i, j)} & \text{otherwise} \end{cases} \quad (4.24)$$

To obtain the average throughput per user, we divide T_{update} by K since all stations have the same probability to access the channel. γ is the number of T_{update} to reach the j -th aggregation level.

The term $\left[T_1(i) + \sum_{k=0}^{j-1} T_2(i, k) \right]$ represents the duration of the load increase phase (as illustrated in Figure 4.6).

For simplicity reasons, we assume that the number of updating occurrences in established mode is significantly greater than the load phase (to reach $a-1$). Namely $\gamma \ll \frac{T}{T_{update}}$, with T the total transmission duration.

Under this assumption, we can express $N_p^{sw}(i, j)$ as:

$$N_p^{sw}(i, j) = \frac{T_{update}/K}{T_2(i, j)}. \quad (4.25)$$

Using (4.11), (4.12) and (4.25) the saturation throughput for the proposed AN-BA method for switch case is then expressed as:

$$\begin{aligned} ST^{sw}(i) &= \frac{L_f}{2.T_{update}} \cdot [N_f^{sw}(i, a) + N_f^{sw}(i, a-1)] \\ &= \frac{L_f}{2.T_{update}} \cdot \left[2^a \cdot \left(\frac{T_{update}/K}{T_2(i, a)} \right) + 2^{a-1} \cdot \left(\frac{T_{update}/K}{T_2(i, a-1)} \right) \right] \\ &= \frac{2^{a-1} \cdot L_f}{K} \cdot \left[\frac{1}{T_2(i, a)} + \frac{1}{2.T_2(i, a-1)} \right]. \end{aligned} \quad (4.26)$$

4.4.5.2 Saturation throughput for the buffer size increase case

To establish the final expression of $ST^{in}(i)$, we use the the general saturation expression established in (4.10). As previously mentioned, this case corresponds to a periodic data load doubling which is carried out during the AN-BA. We note that T_{update} depends on the parameter K to consider all present users. Consequently it is written as:

$$T_{update} = K \cdot \left[T_1(i) \cdot N_p^{in}(i, j=0) + \sum_{j=1}^a \left(T_2(i, j) \cdot N_p^{in}(i, j) \right) \right] \quad (4.27)$$

The first term of (4.27) refers to the duration of transmitting the first normal MPDU. The second one is the period of transmitting A-MPDU, namely from the first aggregation level of 1 to the maximum one of a . According to (4.15), T_{update} becomes

$$T_{update} = K \cdot \left[T_1(i) + \sum_{j=1}^{a-1} T_2(i, j) + (N_p^{in}(i, a) - a) \cdot T_2(i, a) \right]. \quad (4.28)$$

with $T_1(i)$ and $T_2(i, j)$ defined in (4.22) and (4.23) respectively. Equation (4.28) includes a first term that corresponds to the period of the data load increase phase (the buffer size increase phase illustrated in Figure 4.6) and a second one for the period of transmitting MPDUs using desired buffer size value (established system phase as illustrated in Figure 4.6). Therefore $N_p^{in}(i, a)$ can be expressed as:

$$N_p^{in}(i, a) = \frac{T_{update}/K - T_1(i) - \sum_{j=1}^{a-1} T_2(i, j)}{T_2(i, a)} + a. \quad (4.29)$$

Then using (4.13), (4.16) and (4.29), $ST^{in}(i)$ can be expressed as:

$$ST^{in}(i) = \frac{L_f}{T_{update}} \cdot \left[2^a \left(\frac{T_{update}/K - T_1(i) - \sum_{j=1}^{a-1} T_2(i, j)}{T_2(i, a)} \right) + \sum_{j=0}^{a-1} 2^j \right] \quad (4.30)$$

4.5 Simulation setup

The simulation setup mainly relies on the environment defined in Chapter 3. In this section, we introduce the AN-BA specificities that had to be taken into account. The Matlab implementation of the AN-BA analytical model is detailed in Section 4.5.1 while its ns-3 implementation is described in Section 4.5.2.

4.5.1 Matlab implementation of the analytical model

The numerical computing environment of Matlab has been used to implement the analytical model introduced in Section 4.4.

This model operates under Scenario (a) (low-density scenario under IEEE 802.11 ac) defined in Section 3.5.2. It includes a network of 5, 10 or 20 STAs that use the full buffer application over an error-free channel.

Table 4.3 lists values of the parameters used in the Matlab simulation.

Table 4.3: Simulation parameters for Matlab implementation of the analytical model of AN-BA (Scenario (a))

Parameter	Value
Number of spatial streams (SS)	1
C_{leg}	24 Mbps
C_{data}	64 Mbps per SS
CW_{max}	[1023 (AC_BK), 1023 (AC_BE), 31 (AC_VI), 15 (AC_VO), 1023 (Legacy)]
CW_{min}	[31 (AC_BK), 31 (AC_BE), 15 (AC_VI), 7 (AC_VO), 15 (Legacy)]
DELI	4 Bytes
H_{IP}	20 Bytes
H_{LLC}	8 Bytes
HMAC	34 Bytes
L_f	1472 Bytes
MSDU	$L_f + H_{IP} + H_{LLC}$
$T_{HPHY-leg}$	20 μs
$T_{HPHY-data}$	36 μs
T_{ACK}	8 μs (using C_{leg})
$AIFSN$	[7 (AC_BK), 3 (AC_BE), 2 (AC_VI), 2 (AC_VO), 2 (Legacy)]
T_{BA}	12 μs (using C_{leg})
T_{SIFS}	16 μs
σ	9 μs
T_{DIFS}	34 μs
$T_{EIFS^{leg}}$	$T_{SIFS} + T_{HPHY-leg} + T_{ACK} + T_{DIFS}$
$T_{AIFS(i)}$	$T_{SIFS} + AIFSN \cdot \sigma$
$T_{EIFS(i)}$	$T_{EIFS^{leg}} - T_{DIFS} + T_{AIFS(i)}$
m	7
T_I	σ
T_{update}	100 ms

4.5.2 Implementation of the AN-BA in ns-3

Contrary to the Matlab implementation of the analytical model of AN-BA, ns-3 implementation takes into account Wi-Fi norm policies (already considered in ns-3 as described in Chapter 3).

To implement the AN-BA mechanism, several ns-3 modules had to be modified (taking ns-3.29 as a basis). Specifically, a new class has been introduced to represent the control bits tag. *MacLow*, *QosTxop*, and *BlockAckManager* modules have also been modified. We shall recall that the new control bits tag class is used to manage the session either to establish it (thus replacing AD-DBA Request/Response exchanges) or to delete it (substituting the DELBA transmission). We also added the buffer size change update depending on originator and recipient requirements to take into account all specificities of AN-BA (compared to BA). Every T_{update} of the duration transmission, the buffer size can thus be updated. The three scenarios, (a), (b) and (c) defined in Sections 3.5.2, 3.5.3 and 3.5.4 respectively are considered with FTP (see

Section 3.4.1.2) and full-buffer (see Section 3.4.2.2) applications.

4.6 Comparison of analytical model numerical results with ns-3 measured throughput

In this section, our goal is to check that the previously established model of the AN-BA mechanism and its implementation using the network simulator ns-3 produce similar performances, which would assess their accuracy and match with the truth. For this purpose, we compute the saturation throughput as derived in Section 4.4.5 using Matlab model and we compare it to the saturation throughput obtained from ns-3 simulation results.

The simulation setup is defined in Section 4.5.1.

4.6.1 Results

As mentioned earlier we compare the saturation throughput obtained with the analytical model to the one measured with ns-3. Figure 4.8 and Figure 4.9 depict the per user saturation throughput behaviour for the buffer size switch case and the buffer size increase case respectively.

We observe that the analytical model and ns-3 achieve similar performance all the closer as K is high. For instance in the switch case, with $K = 20$ stations at 64 maximum buffer value, a throughput of 2.86 Mbps is reached in ns-3 simulations compared to 3.15 Mbps for the analytical model, which makes a difference of almost 10%. The difference comes from the fact that contrary to ns-3, the analytical model does not take into account several management frames (beacons, block ack request, etc.) that can contribute to reducing the average throughput.

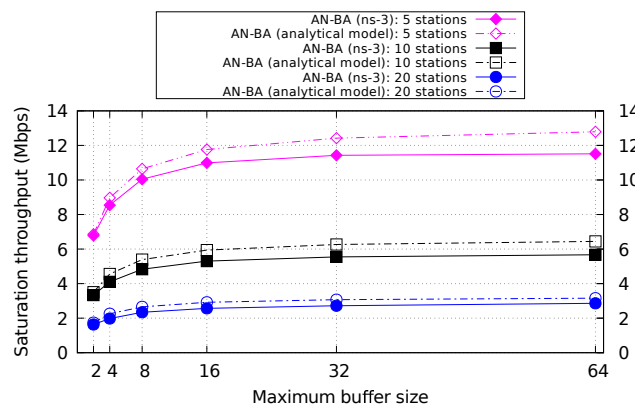

Figure 4.8: Comparison of the per user saturation throughput with AN-BA obtained by the analytical model to ns-3 simulation measures for the buffer size switch case

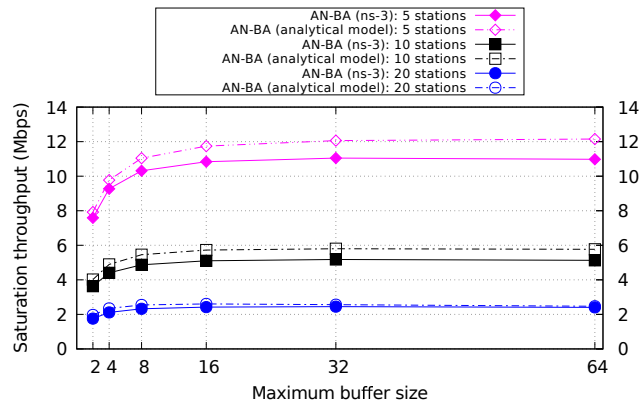

Figure 4.9: Comparison of the per user saturation throughput with AN-BA obtained by the analytical model to ns-3 simulation measures for the buffer size increase case

4.6.2 Discussion

The analytical model of the AN-BA mechanism that we developed and integrated in Matlab first and its implementation in a more complex network simulator such as ns-3 produce similar numerical results in terms of saturation throughput (almost 90%) which assess their accuracy and match with the truth. This was verified with different options of buffer size evolution as well as various numbers of stations. Based on this, we consider the analytical model to be a good tool for presaging the performance of the AN-BA method in a basic network configuration to compare different system parameters and potentially make a first approximate selection. As for the ns-3 implemented model, it can be used to investigate more complex scenarios (residential scenarios, enterprise scenario, etc.) and to refine the AN-BA performance analysis.

4.7 Comparison of AN-BA with BA reference

This section presents the comparison of AN-BA to the basic mechanism of the BA using ns-3. It relies on the implemented model of the AN-BA (as presented in Section 4.5.2) and the already available ns-3 model of the BA. As mentioned earlier, analysis of performances considers two applications for different scenarios, namely full-buffer and FTP applications (exposed in Chapter 3). They are applied for two buffer size increasing scheme (Sections 4.4.3.1 and 4.4.3.2) for different scenarios (presented in Chapter 3). Section 4.7.1 presents the comparison of both mechanisms under the full buffer application, while Section 4.7.2 considers FTP. A global analysis is presented in Section 4.7.3.

The analysis of performance relies on scenarios (b) and (c) (presented

in Sections 3.5.3 and 3.5.4 respectively). Furthermore we will use the same colour codes as in Figures 3.4 and 3.5 in Section 3.5.

4.7.1 Full buffer application

This section exposes the comparison of the AN-BA and the BA under a full-buffer exchange within scenarios (b) and (c). Simulations results are presented for both increasing schemes, i.e. the switch case and the increase case. As a reminder, we choose two types of buffer size changing schemes since the exact scheme cannot be known so far. The switch case is regarded as the closest case to reality (it considers a frequent change of the buffer size) while the increase one is considered as a case under unfavourable conditions (the buffer is reset to 1 every buffer size change).

4.7.1.1 Buffer size switch case

4.7.1.1.1 Low density scenario

This section compares AN-BA and BA under full-buffer application for the switch case and low density scenario. The low density scenario, presented as Scenario (b) (in Section 3.5.3), considers 3 configurations: 5, 10 and 20 stations. Figure 4.10 shows the packet outage rate obtained when BA or AN-BA is applied in a low density environment under full-buffer application and an evolution of the buffer size following the switch case scheme (expected to be the most favourable one, as explained in 4.4.3.1).

It is noticeable from Figure 4.10 that both mechanisms achieve similar performances except for the 20 stations case where BA presents a non-zero packet outage rate starting from 32 buffer size value. It reaches up to 15% of dropped packets for 64 buffer size value.

The same configurations and simulated environments are kept in Figures 4.11 and 4.12 that show respectively the per user average delay and the per user average throughput behaviours of BA and AN-BA. Regarding the average delay depicted in Figure 4.11, it is noticeable that stations using AN-BA experience lower delays compared to the ones using BA. One should note that the gap between both methods grows with the increase of the buffer size. Starting from 16 buffer size value, BA presents much more delay than AN-BA. For instance, 20 stations present an average delay of almost 2.70 seconds compared to 1.75 seconds for the AN-BA. This definitely impacts the overall throughput. Lower delays obviously increase the average throughput per user as presented in Figure 4.12.

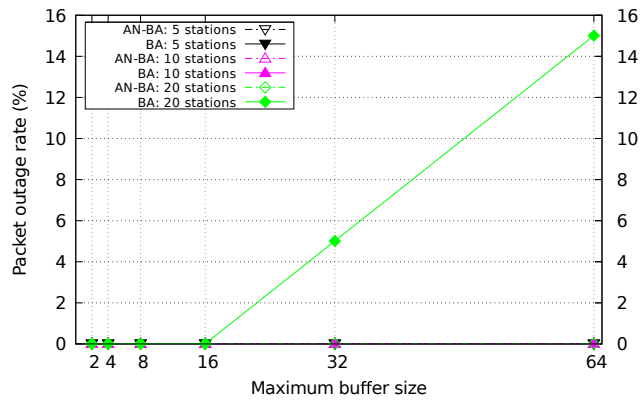

Figure 4.10: Packet outage rate of the BA and AN-BA methods, low density environment, full-buffer, buffer size switch case

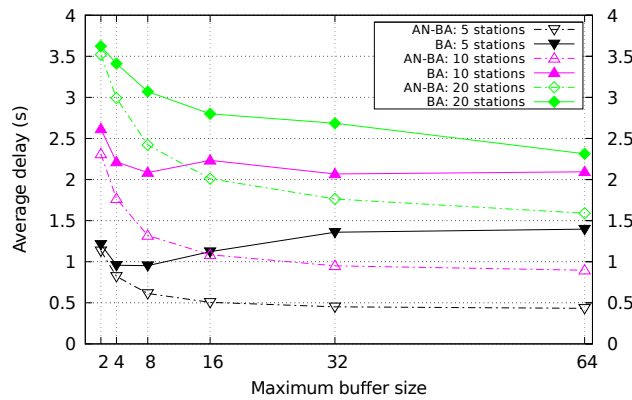

Figure 4.11: Per user average delay of the BA and AN-BA methods, low density environment, full-buffer, buffer size switch case

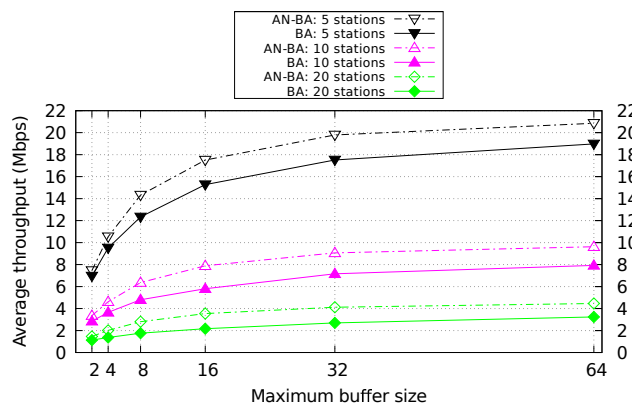

Figure 4.12: Per user average throughput of the BA and AN-BA methods, low density environment, full-buffer, buffer size switch case

4.7.1.1.2 Medium density scenario

We now consider the case where we increase the number of stations to 25 and 36. This is what we call medium density (or scenario (c)), as defined precisely in Section 3.5.4. Figures 4.13, 4.14 and 4.15 depict the results obtained for BA and AN-BA in terms of packet outage, per user average delay and per user average throughput in the case of medium density.

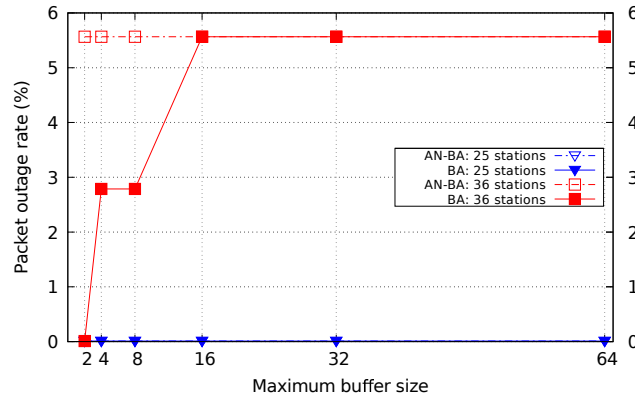

Figure 4.13: Packet outage rate of the BA and AN-BA methods, medium density environment, full-buffer, buffer size switch

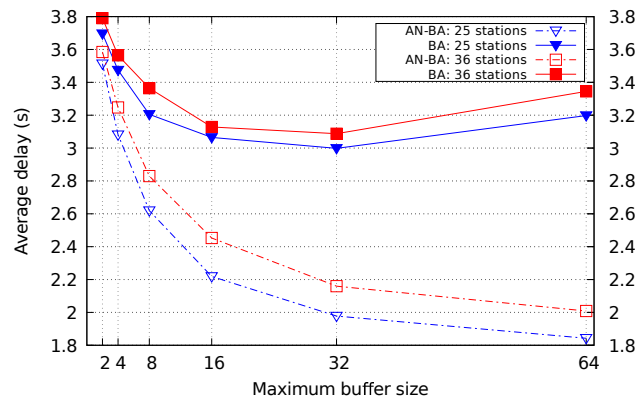

Figure 4.14: Per user average delay of the BA and AN-BA methods, medium density environment, full-buffer, buffer size switch case

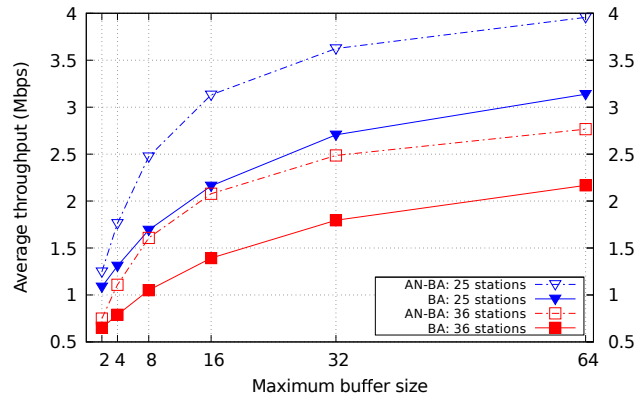

Figure 4.15: Per user average throughput of the BA and AN-BA methods, medium density environment, full-buffer, switch case scheme

Comparing the low density results of Figures 4.10, 4.11, 4.12 to the medium density ones of Figures 4.13, 4.14 and 4.15, we can globally observe that the usage of the AN-BA method in denser environments is even more beneficial. It is true that for this specific configuration both mechanisms have close packet outage rates. Still, AN-BA shows higher performances since it achieves much more lower average delays. The average throughput per user is thus increased from 2.25 Mbps to 2.75 Mbps for the 64 maximum buffer size value in the switch case with 36 stations. Similarly, with 36 stations, the average throughput is reduced under the BA mechanism and is almost 20% lower than the one with the AN-BA method.

4.7.1.2 Buffer size increase case

We now consider an evolution of the buffer size following the increase case developed in Section 4.4.3.2 which can be considered as adverse conditions compared to real life schemes.

4.7.1.2.1 Low density scenario

Figures 4.16, 4.17 and 4.18 show respectively the packet outage rate, the per user average delay and the per user average throughput behaviours of the BA and AN-BA methods in a low density environment, under full-buffer application and an evolution of the buffer size following the increase case scheme. The packet outage (Figure 4.16) is almost null for both mechanisms. For the average delay, we notice in Figure 4.17 that whatever the number of stations (5, 10 or 20), AN-BA transmissions consume less time than BA transmissions.

Figure 4.18 shows that AN-BA allows a better average throughput than BA mechanism. Comparing those results with the switch case in Figure 4.12,

we observe a similar behaviour but with a lower average throughput. Such throughput difference between switch and increase case comes from the fact that in the increase case, at every update, the buffer size is reset to 1 and increases up to the desired value. This is not the case with the switch scheme that instantly switches the buffer size to its lower or upper value.

Globally speaking, when we compare the curves obtained for both schemes of buffer size evolution (Figures 4.10, 4.11 and 4.12 for switch case and Figures 4.16, 4.17 and 4.18 for increase case), we observe that their results are pretty close. We can thus consider that in practice, the real life behaviour of the buffer size evolution should not be far from the one observed with the models we developed for this evaluation.

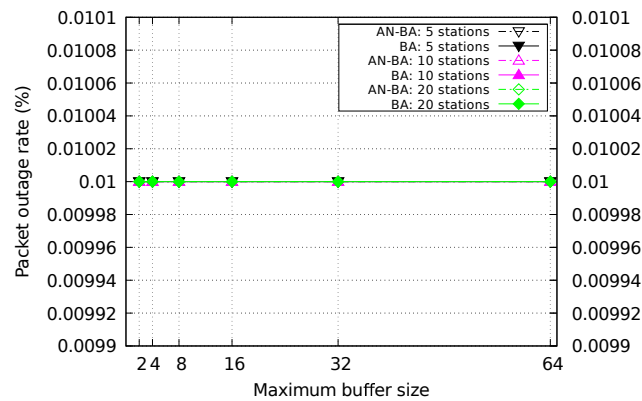

Figure 4.16: Packet outage rate of the BA and AN-BA methods, low density environment, full-buffer, buffer size increase case

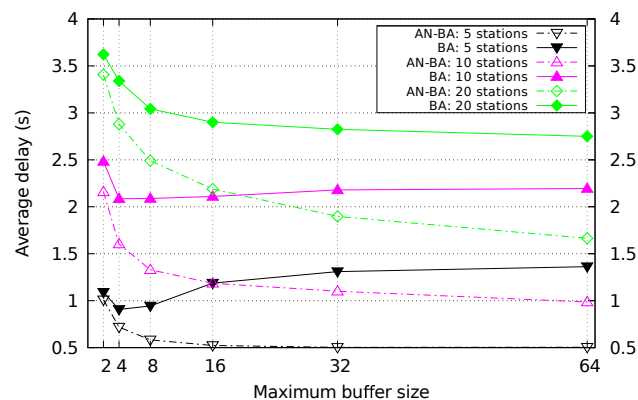

Figure 4.17: Per user average delay of the BA and AN-BA methods, low density environment, full-buffer, buffer size increase case

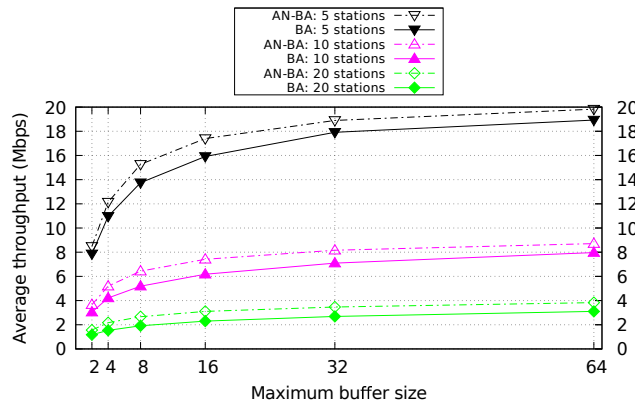

Figure 4.18: Per user average throughput of the BA and AN-BA methods, low density environment, full-buffer, buffer size increase case

4.7.1.2.2 Medium density scenario

Let us now consider the case where we increase the number of stations to 25 and 36 (as Scenario (c) in 3.5.4).

Similarly to the low density case, Figures 4.19, 4.20 and 4.21 depict the results obtained for BA and AN-BA in terms of packet outage, per user average delay and per user average throughput but this time in the case of medium density. BA and AN-BA achieve same packet outage rates while having a significant gap for the per user average delay. It is noticeable from Figure 4.20 that the gap between 25 and 36 under BA mechanism is very small, which is not the case of AN-BA that achieves higher efficiency for a lower number of stations. The average per user throughput obtained with the increase case, as depicted in Figure 4.21, presents the same behaviour as with the switch case (See Figure 4.15), while achieving lower average throughput. As mentioned before, this is most probably due to the buffer size reset to 1 in the increasing scheme.

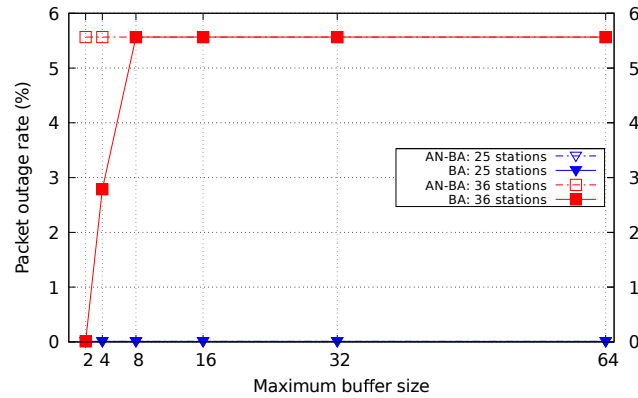

Figure 4.19: Packet outage rate of the BA and AN-BA methods, medium density environment, full-buffer, buffer size increase case

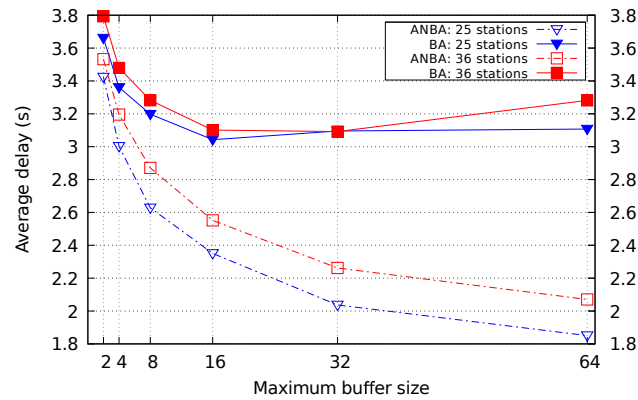

Figure 4.20: Per user average delay of the BA and AN-BA methods, medium density environment, full-buffer, buffer size increase case

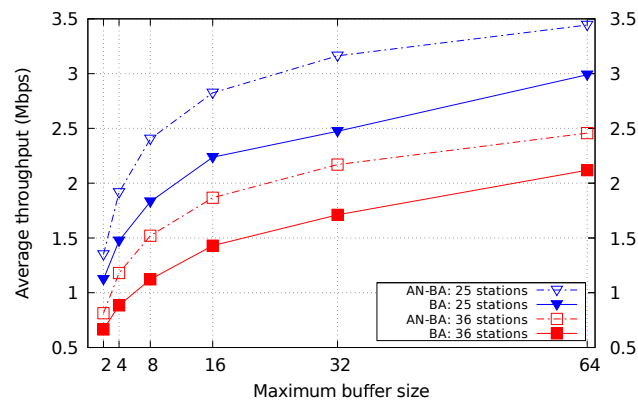

Figure 4.21: Per user average throughput of the BA and AN-BA methods, medium density environment, full-buffer, buffer size increase case

4.7.2 File transfer protocol application

In this section, the exchanged traffic relies on the FTP application. For each scenario and buffer size adaptation scheme, the packet outage rate, the per user average delay and the per user average throughput are measured. We note that the FTP per user average throughput is calculated during the data transmission. Namely the throughput is computed only when FTP packets are being transferred. Since FTP relies on Poisson law, the data transfer occurs only during dedicated periods.

4.7.2.1 Buffer size switch case

4.7.2.1.1 Low density scenario

Figures 4.22, 4.23 and 4.24, present performance in terms of FTP packet outage rate, per user average delay and per user average throughput, respectively for the low density scenario and switch case.

We can first observe that given a configuration, the average throughput obtained with the FTP application is significantly higher than with the full-buffer one. This is mainly due to the difference in the number of spatial streams (2 for FTP against 1 for full-buffer). As it can be observed from the three metrics, BA and AN-BA performances are approximately the same for 5 and 10 stations, either for the FTP packet outage rate or the per user average delay. The difference between BA and AN-BA is more significant for 20 stations, where AN-BA contributes to improve both the FTP packet outage rate and the per user average delay, which directly increases the overall throughput per user. Additionally, we can notice that the throughput in all cases is almost the same between 32 and 64 buffer size values. This is due to the ns-3 constraint of sending PPDU's of at most 5 milliseconds (as specified in the 802.11 OFDM-based standards).

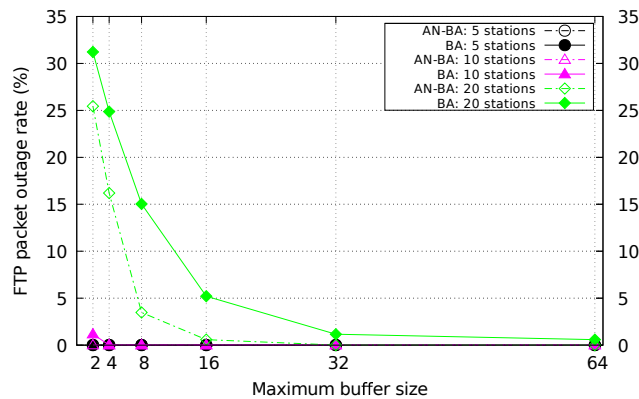

Figure 4.22: FTP packet outage rate of the BA and AN-BA methods, low density environment, FTP, buffer size switch case

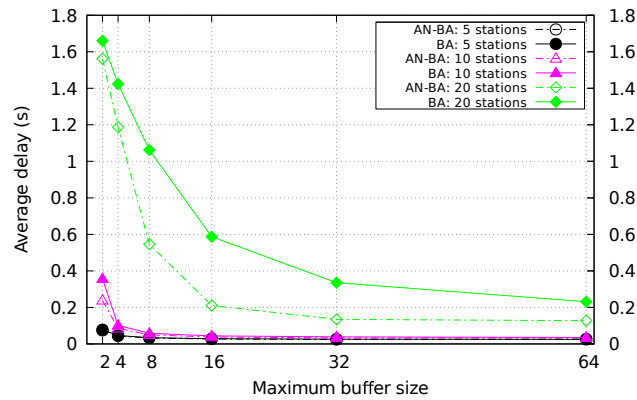

Figure 4.23: Per user average delay of the BA and AN-BA methods, low density environment, FTP, buffer size switch case

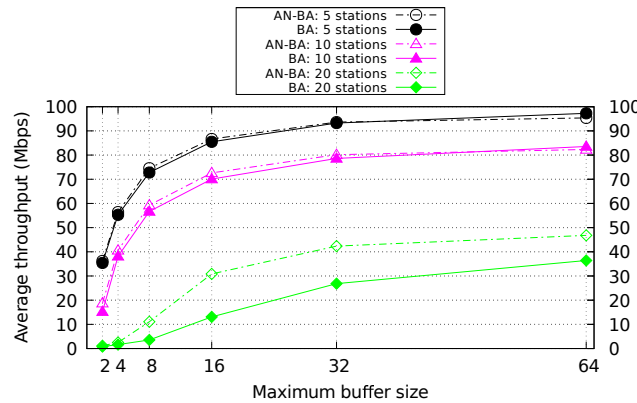

Figure 4.24: Per user average throughput of the BA and AN-BA methods, low density environment, FTP, buffer size switch case

4.7.2.1.2 Medium density scenario

FTP Packet outage rate, per user average delay and per user average throughput behaviours for medium density are presented in Figures 4.25, 4.26 and 4.27 respectively.

According to the simulated results obtained in this context, the AN-BA still outperforms BA. The FTP packet outage rate is higher under the BA mechanism. For 36 stations and 64 buffer size value, we can notice an outage rate of 21% versus 16% for AN-BA. In addition, AN-BA still achieves lower delays compared to BA. Except when the buffer size value is 64 with 36 stations for which BA seems to achieve same delay as AN-BA. This is an implication of exploiting the opportunity to send all remaining packets while a packet dropping event occurs. This reduces the overall delay and thus increases the throughput.

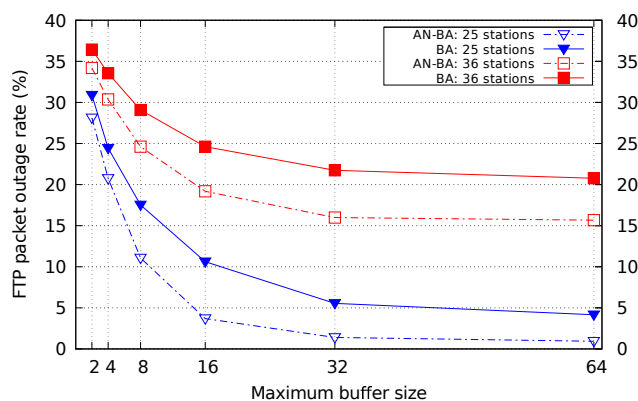

Figure 4.25: FTP packet outage rate of the BA and AN-BA methods, medium density environment, FTP, buffer size switch case

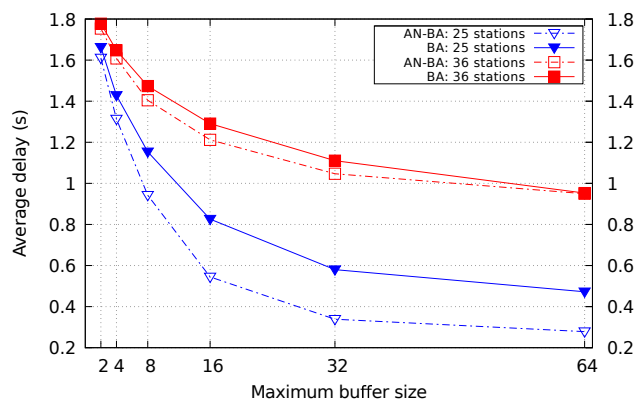

Figure 4.26: Per user average delay of the BA and AN-BA methods, medium density environment, FTP, buffer switch case

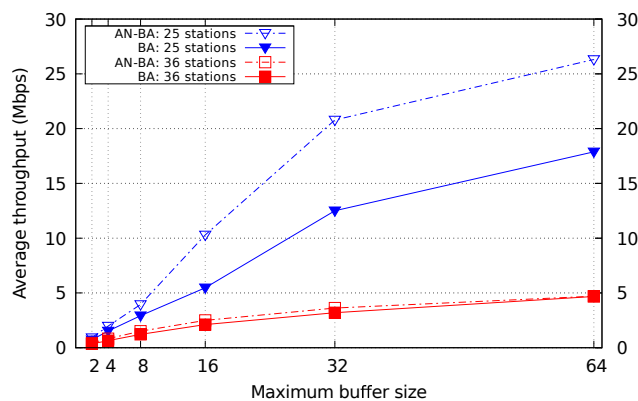

Figure 4.27: Per user average throughput of the BA and AN-BA methods, medium density environment, FTP, buffer size switch case

4.7.2.2 Buffer size increase case

4.7.2.2.1 Low density scenario

Figures 4.28, 4.29 and 4.30 show similar behaviour as with the full-buffer case under the switch case while presenting lower values whatever the metric. As mentioned earlier, this is due to the buffer size increasing scheme.

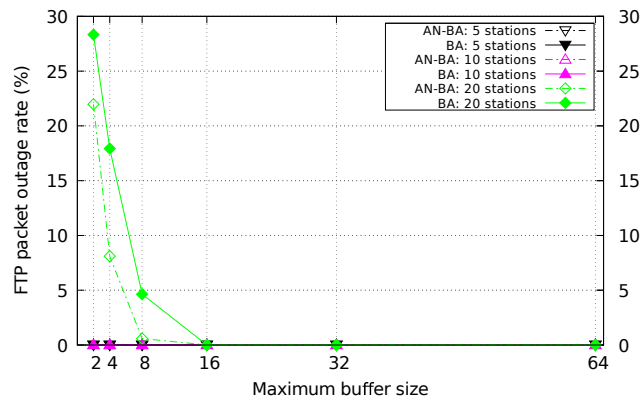

Figure 4.28: FTP packet outage rate of the BA and AN-BA methods, low density environment, FTP, buffer size increase case

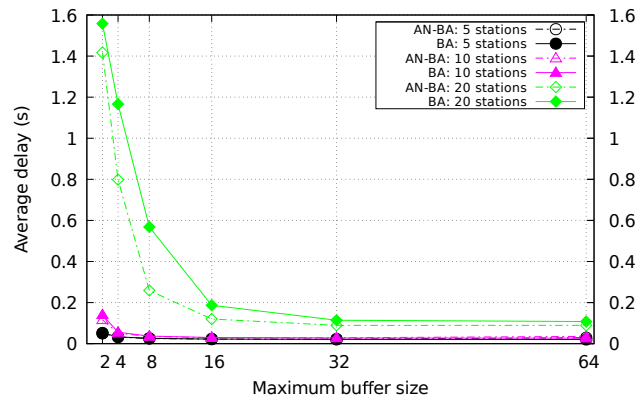

Figure 4.29: Per user average delay of the BA and AN-BA methods, low density environment, FTP, buffer size increase case

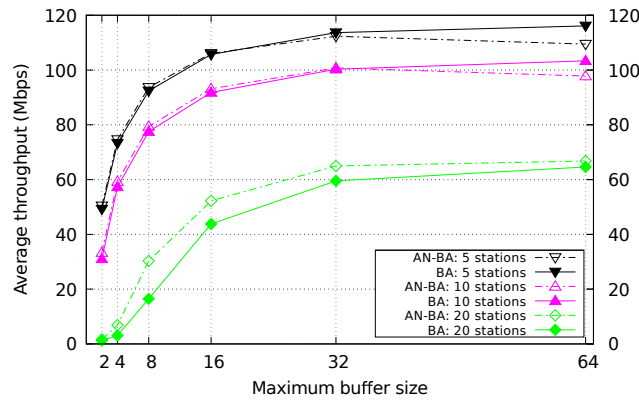

Figure 4.30: Per user average throughput of the BA and AN-BA methods, low density environment, FTP, buffer size increase case

4.7.2.2.2 Medium density scenario

The medium density case is shown in Figures 4.31, 4.32 and 4.33. FTP packet outage is more frequent with the BA mechanism than with the AN-BA method. We can also notice from Figure 4.31 that for 36 stations, there is 9% of packet loss with the BA mechanism compared to 11% for the AN-BA method for a buffer size of 64. In this case, the AN-BA method presents higher performances compared to the BA mechanism. We notice from Figure 4.33 that the per user average throughput for an AN-BA session is above the average throughput for BA mechanism in the presence of 25 stations. Nevertheless BA achieves higher throughput in the case of 36 stations. This is because when some packets are not transmitted, transmitting stations exploit the opportunity to send all the remaining FTP packets which consequently increases the throughput to 9 Mbps at maximum buffer size value (Figure 4.33). On the other hand, stations under AN-BA method managed to transmit more packets while maintaining a throughput of almost 7 Mbps. This explains the crossover points in case of 36 stations starting from 16 buffer size value (see Figures 4.32 and 4.33).

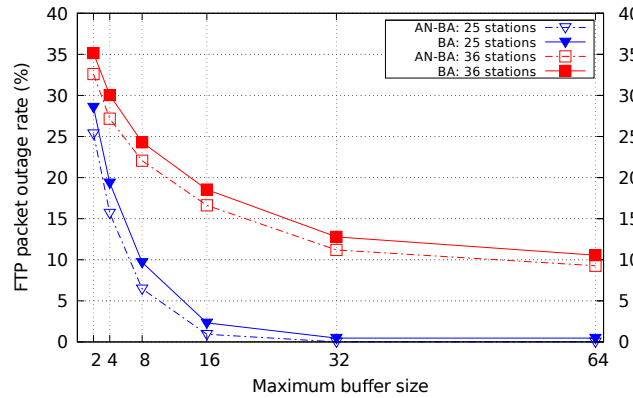

Figure 4.31: FTP packet outage rate of the BA and AN-BA methods, medium density environment, FTP, buffer size increase case

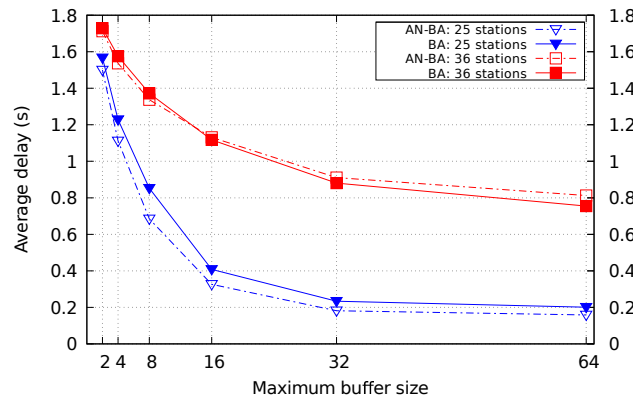

Figure 4.32: Per user average delay of the BA and AN-BA methods, medium density environment, FTP, buffer size increase case

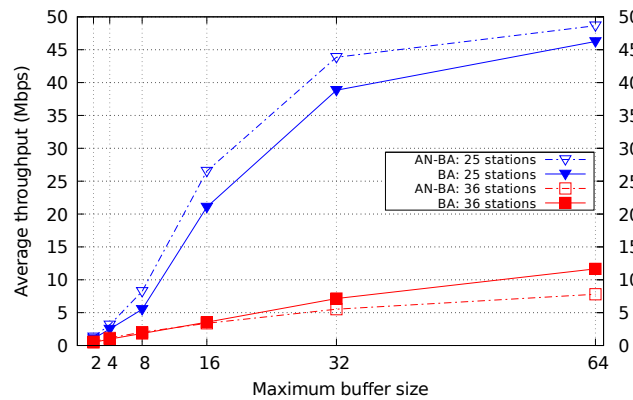

Figure 4.33: Per user average throughput of the BA and AN-BA methods, medium density environment, FTP, buffer size increase case

4.7.3 Analysis

In this section, we provide an analysis of the performance.

From a general viewpoint and for almost all tested configuration, the AN-BA clearly improves network performances compared to the original BA mechanism. The optimisation on the number of control frames and the dynamic adaptability of the buffer size have been proven effective. The performance gain compared to BA varies from one configuration to another and may not be noticeable on all metrics. It depends on several parameters such as the application, the environment density and the buffer size adaptation method. However in most cases, the improvement is even more significant in the presence of a high number of users.

For instance, taking full-buffer and FTP applications that differ from each other by the arrival packet rate, AN-BA gains are not the same for these applications. Simulation results show that they are higher for full-buffer application than for FTP. The reader can also notice that, for the FTP application, the increase case presents higher throughput compared to the switch case. This surprising behaviour is a direct consequence of the observed metric, i.e. the download throughput and thus the duration of the file transfer. In the switch case, transmitted packets can contain up to 2^a or 2^{a-1} MSDUs during the transfer, while in the increase case the buffer size gradually increases up to 2^a . Combined with the fact that data exchange relies on Poisson law (i.e. number of packet arrivals per second), longer packets under the switch case consume more time than the ones in the increase case. As a consequence the delay is slightly higher in the former; more FTP packets are dropped and thus it induces lower throughput. This behaviour is not observed with the full-buffer application due to the fact that the related traffic is not bursty and that the throughput is evaluated over the whole simulation period. Meanwhile the performance strongly depends on the density of the network. For most low-density configurations, specially for 5 and 10 stations, both methods behave the same whatever the application. Their behaviour tends to strongly diverge with the increase in the number of devices. To obtain an immediate overview of the comparison between AN-BA and BA, simulation results are summarised in numerical tables. Tables 4.4, 4.5 and 4.6 present results using the maximum buffer size value (i.e. 64) for packet outage rate, per user average delay and per user average throughput respectively. It is a synthesis of simulation results showing which method is better in which configuration. We considered results for 20 and 36 stations from scenarios (b) and (c) respectively.

These three tables enable to quickly observe that AN-BA outperforms BA in all configurations except one. In the case of FTP application with increase scheme and scenario (c) average delay and throughput per user are slightly lower for AN-BA as detailed previously.

Table 4.4: Comparison of the packet outage rate of BA and AN-BA using the maximum buffer size value (i.e. 64)

Packet outage rate (%)	Scenario (b) (20 stations)				Scenario (c) (36 stations)			
	FTP		Full-buffer		FTP		Full-buffer	
	BA	AN-BA	BA	AN-BA	BA	AN-BA	BA	AN-BA
Switch case	1	0	15	0	21	16	5.5	5.5
Increase case	0	0	0	0	10	9	6	6

Table 4.5: Comparison of the per user average delay of BA and AN-BA under the maximum buffer size value (i.e. 64)

Average delay (Seconds)	Scenario (b) (20 stations)				Scenario (c) (36 stations)			
	FTP		Full-buffer		FTP		Full-buffer	
	BA	AN-BA	BA	AN-BA	BA	AN-BA	BA	AN-BA
Switch case	0.23	0.13	2.3	1.5	0.95	0.95	3.3	2
Increase case	0.107	0.09	2.7	1.6	0.75	0.81	3.2	2

Table 4.6: Comparison of the per user average throughput of BA and AN-BA under the maximum buffer size value (i.e. 64)

Average throughput (Mbps)	Scenario (b) (20 stations)				Scenario (c) (36 stations)			
	FTP		Full-buffer		FTP		Full-buffer	
	BA	AN-BA	BA	AN-BA	BA	AN-BA	BA	AN-BA
Switch case	36.41	46.78	3.23	4.45	4.67	4.7	2.16	2.7
Increase case	64.59	66.79	3.1	3.8	11.65	7.79	2.1	2.4

4.8 Conclusion

This chapter focused on the BA mechanism applied in IEEE 802.11e [13] and its improvement in the perspective of IEEE 802.11ax [14]. BA is one of the main improvements of the IEEE 802.11e amendment, enabling higher transmission efficiency. Enabling the grouped acknowledgement of multiple data frames has drastically improved either throughput or transmission delay, as studied in several works cited in this section. It indeed enhances wireless network performances compared to previous frame-by-frame acknowledgement mechanism, but it includes several control frames when it comes to establishing a BA session. This is definitely an important limitation for dense environments. By proposing the AN-BA mechanism, our objective is to improve the acknowledgement mechanism so that it may be well suited both for low and high density environments.

We compared the AN-BA and BA mechanisms in terms of average per user throughput using ns-3 in the case of full-buffer and FTP applications in dense environments and for two buffer size adaptation schemes (switch and increase cases). In most configuration AN-BA outperforms BA. In some cases, it allows a rate increase of 10 Mbps per user. Transmission delays are also reduced, with up to 40% less average delay for continuous data traffic. Furthermore an analytical model of the saturation throughput has been established and validated. In all considered scenarios, the comparison of the throughput computed thanks to the analytical model and the one measured through ns-3 yielded similar performance, with a gap of 10% only. This proves their accuracy and match with the truth. The analytical model could be used to have a first estimation of the AN-BA performance behaviour in a given configuration and thus have a first parameter selection, while the ns-3 implementation enables to refine the analysis and predict the performance in more complex scenarios. We should also note that one of the limitations of the AN-BA is that changing buffer size is limited to double or halve the negotiated value due to the fact that it relies on only 2 signalling bits. The extension of the number of bits is feasible within the limit of available empty bits to conserve backward compatibility. We also point out that energy consumption could increase with the instantaneous and potentially frequent change in the buffer size.

Future work will investigate the extension of the method to support additional buffer size values so as to further improve the performance. The analytical model will be developed for more realistic assumptions, for instance under an erroneous and/or collided channel. An additional perspective would be to establish a more complete BA model that includes not only QoS Data transfer phase but also set up and tear down phases. In other words, we aim to provide a model that includes ADDBA Request/ADDBA Response and

DELBA to compare it with the AN-BA established model. Another interesting study could be the analysis of both mechanisms under an heterogeneous application scenario, i.e. with a network composed of stations using different types of applications.

Conclusions and Perspectives

Conclusions

Wireless technologies have experienced a tremendous evolution when it comes to usage and applications. In particular, the increase in the number of users calls for more performance (higher efficiency, increased throughput, improved energy efficiency, etc.), especially in wide environments. Current Wi-Fi amendments showed some limitations for these particular scenarios. Because of that, the IEEE 802.11 working group launched the TGax project to work on improving the network, in the case of a dense environment, to offer higher performance and insure an optimal throughput for each user.

This thesis' work considers similar objectives, namely improving performance in dense environments.

In addition to analysing the IEEE 802.11 norm (see Chapter 1), two other contributions have been addressed to improve either PHY or MAC layer. Advanced PHY layer techniques have thus been developed (see Chapter 2), offering new degrees of freedom for the resource allocation of OFDMA random access. A new method for the amelioration of the block acknowledgement mechanism at the MAC layer side has been proposed as well (see Chapter 4).

Resource allocation for OFDMA with random access mode

IEEE 802.11ax introduces, in addition to plain OFDMA, a special OFDMA-based access mode named random access mode. The AP periodically reserves some RUs to enable ad hoc access of unallocated STAs. Users under random access mode execute the back-off algorithm to gain the access to the channel. Once their back-off counter reaches zero, STAs choose themselves a RU from the ones dedicated for random access. The first raised limitation of this process is that several STAs could select the same RU when their OBO reach zero at the same time. Such a situation would induce several collisions and affect overall performances.

To minimise these impairments we propose to allow the allocation of at most two users in the same resource. To that purpose, we propose to exploit either SIC or joint detection techniques depending on the power level. Two configurations could be adopted.

In the first configuration, we consider that a scheduled and a random access STA, supposed to have different power levels, could be allocated to the same RU. A random access STA could access an already assigned RU and simultaneously transmits with the scheduled STA thanks to the use of the SIC

technique at the receiver. This configuration could be quite interesting when a scheduled STA does not occupy the whole spectrum and a low-bandwidth random access STA needs to transmit. Not only could collisions be reduced, the network capacity should also be improved, by hosting more users in the spectrum. A mathematical model of such an algorithm and its resolution has also been proposed.

In case two STAs have same power levels, we propose a second configuration. It considers the allocation of both STAs by assuming a joint detection technique at the receiver to decode their respective signal. For instance, in case two random access STAs end up collided, this configuration makes their allocation possible thanks to the adopted technique. This should considerably reduce the overall latency and allows more unallocated stations to transmit.

A hybrid scheme has also been proposed to combine both aforementioned configurations considering both power level cases as well as both associated decoding techniques.

Adaptive negotiation of the block acknowledgement session

The second innovation concerns the improvement of the BA mechanism in the perspective of IEEE 802.11ax amendment. As stated in this work, the classical BA session management mechanism includes several control frames for establishing a session. This induces more latency in crowded environment and consumes bandwidth. This can definitely affect performance in dense environments.

With the objective of optimising this mechanism to better suit dense environments, we proposed the AN-BA mechanism. This method improves the efficiency of networks by enabling dynamic negotiation of BA session parameters, namely buffer size, through two control bits instead of dedicated control frames.

ns-3 has been applied to implement the proposed method and establish an accurate performance analysis. It has been used in two ways.

In the first one, an analytical model has been derived. Its validation relied on the comparison of the throughput computed thanks to the analytical model and the one measured through ns-3. Numerical results showed a gap of only 10% between the established model and the implemented one, thus demonstrating its accuracy. We believe that AN-BA analytical model could be exploited to estimate the network behaviour by giving a first general view of a non complex scenario while ns-3 implementation could be reserved for more complex ones.

In the second part, a comparison of the AN-BA and BA mechanisms has been conducted using three main metrics: average per-user throughput, average delay and packet outage rate. Using ns-3, full-buffer and FTP applications have been exploited to simulate selected scenarios. We considered two buffer

size adaptation schemes to bring out the gains of AN-BA over BA mechanism. This work has showed that AN-BA outperforms BA in most configurations. For some of them, an increase of 10 Mbps of data rate per user is ensured by the AN-BA. As for the transmission delay, it has also been reduced, with up to 40% less average delay (compared to BA) for continuous data traffic.

Perspectives

Resource allocation for OFDMA with random access mode

Concerning this contribution, we would aim to extend the study by considering the numerical implementation of the proposed algorithms. This would build an accurate analysis of each configuration. The analysis would be based on the comparison of the effective throughput ensured by each configuration for different scenarios.

Adaptive negotiation of the block acknowledgement session

Regarding the AN-BA, future works would consider additional buffer size values so as to extend the AN-BA adaptability. Furthermore, more realistic assumptions would be considered to extend the AN-BA analytical model (e.g. erroneous and/or collided channel).

We would also aim to provide a model that includes ADDBA Request/ADDDBA Response and DELBA to establish an accurate comparison of the reference BA scheme with the proposed AN-BA model.

Moreover, simulation analysis could be addressed by considering heterogeneous application scenarios, where users transmit data from different applications.

Bibliography

- [1] Cisco, “Cisco Visual Networking Index: Global Mobile Data Traffic Forecast Update, 2017-2022,” *White Paper*, Feb. 2019. (Cited on pages 1 and 13.)
- [2] IEEE Std 802.11, “Part 11: Wireless LAN Medium Access Control (MAC) and Physical Layer (PHY) Specifications,” Mar. 2012. (Cited on pages 1, 13, 19, 20, 24, 31, 38, 39, 76 and 94.)
- [3] IEEE Std 802.11b, “Part 11: Wireless LAN Medium Access Control (MAC) and Physical Layer (PHY) Specifications: Higher Speed Physical Layer (PHY) Extension in the 2.4 GHz Band - Corrigendum 1,” Sep. 1999. (Cited on pages 1, 13, 19 and 20.)
- [4] IEEE Std 802.11a, “Part 11: Wireless LAN Medium Access Control (MAC) and Physical Layer (PHY) Specifications: High Speed Physical Layer in the 5 GHz band,” Sep. 1999. (Cited on pages 1, 2, 13, 14, 19 and 20.)
- [5] IEEE Std 802.11g, “Part 11: Wireless LAN Medium Access Control (MAC) and Physical Layer (PHY) Specifications: Further Higher Data Rate Extension in the 2.4 GHz Band,” 2003. (Cited on pages 1, 13, 19, 20 and 22.)
- [6] IEEE Std 802.11n, “Part 11: Wireless LAN Medium Access Control (MAC) and Physical Layer (PHY) Specifications: Enhancements for Higher Throughput,” Oct. 2009. (Cited on pages 1, 2, 13, 14, 19, 20, 28 and 40.)
- [7] IEEE Std 802.11ac, “Part 11: Wireless LAN Medium Access Control (MAC) and Physical Layer (PHY) Specifications - Amendment 4: Enhancements for Very High Throughput for Operation in Bands below 6 GHz,” Dec. 2013. (Cited on pages 1, 2, 13, 14, 19, 21, 28, 40, 53 and 83.)
- [8] S. Weinstein and P. Ebert, “Data Transmission by Frequency-Division Multiplexing Using the Discrete Fourier Transform,” *IEEE Transactions on Communication Technology*, vol. 19, pp. 628–634, Oct. 1971. (Cited on pages 2, 14 and 26.)
- [9] S. B. Weinstein, “The history of orthogonal frequency-division multiplexing [History of Communications],” *IEEE Communications Magazine*, vol. 47, no. 11, Nov. 2009. (Cited on pages 2, 14 and 26.)

- [10] P. Mittal, D. Somwanshi, and R. L. Dua, "A Survey on OFDM and IEEE WLAN Standard," *International Journal of Computer Applications (0975-8887)*, vol. 66, no. 22, Mar. 2013. (Cited on pages 2, 14, 20 and 26.)
- [11] M. Maadani and M. Baseri, "Performance evaluation of the OFDM modulation in IEEE 802.11-based wireless industrial networks," in *2nd International Conference on Knowledge-Based Engineering and Innovation (KBEI)*, Nov. 2015. (Cited on pages 2, 14, 20 and 26.)
- [12] Y. Dama, R. A. Abd-Alhameed, F. Salazar-Quinonez, S. Jones, K. N. Ramli, and M. S. A. A. Khambashi, "Experimental throughput analysis and MIMO indoor propagation prediction for 802.11n system," in *10th International Symposium on Electromagnetic Compatibility*, Nov. 2011. (Cited on pages 2, 14 and 21.)
- [13] IEEE Std 802.11e, "Part 11: Wireless LAN Medium Access Control (MAC) and Physical Layer (PHY) Specifications: Medium Access Control (MAC) Quality of Service Enhancements," Nov. 2005. (Cited on pages 9, 22, 31, 32, 33, 34, 39, 85, 86 and 125.)
- [14] IEEE Proposed TGax draft specification, "IEEE P802.11ax/D4.0," Feb. 2019. (Cited on pages 9, 19, 42, 48, 52, 53, 85, 94, 100 and 125.)
- [15] The network simulator ns-3. (2019). [Online]. Available: <https://www.nsnam.org/> (Cited on pages 17, 75, 77 and 95.)
- [16] D. Tse and P. Viswanath, *Fundamentals of wireless communications*. UK: Cambridge University Press, Jul. 2005. (Cited on pages 19, 22 and 38.)
- [17] M. Gast, *802.11 Wireless Networks the definitive guide*. O'Reilly Media, May 2005. (Cited on pages 19, 22 and 38.)
- [18] D. Sliney, R. Wangemann, J. Franks, and M. Wolbarsht, "Visual sensitivity of the eye to infrared laser radiation," *Journal of the Optical Society of America (1917-1983)*, vol. 66, p. 339, Apr. 1976. (Cited on page 20.)
- [19] S. Haykin, *Communication systems (4 ed.)*. John Wiley and Sons, Apr. 2015. (Cited on page 20.)
- [20] N. Tesla, "System of signaling," Patent US725 605A, 1901. (Cited on page 20.)
- [21] M. Gast, *802.11n: A survival Guide*. O'Reilly Media, Apr. 2012. (Cited on pages 20 and 40.)

- [22] E. Perahia, "IEEE 802.11n Development: History, Process, and Technology," *IEEE Communications Magazine*, vol. 46, no. 7, Jul. 2008. (Cited on pages 20 and 40.)
- [23] T. Paul and T. Ogunfrunmiri, "Wireless LAN comes of Age: Understanding the IEEE 802.11n Amendment," *IEEE Communications Magazine*, vol. 8, no. 1, Mar. 2008. (Cited on pages 20 and 40.)
- [24] D. Skordoulis, Q. Ni, H.-H. Chen, A. P. Stephens, C. Liu, and A. Jamalipour, "IEEE 802.11n MAC Frame Aggregation Mechanisms For Next-Generation High-Throughput WLANs," *IEEE Wireless Communications*, vol. 15, no. 1, Feb. 2008. (Cited on page 20.)
- [25] Y. Xiao, "IEEE 802.11n: Enhancements for Higher Throughput in Wireless LANs," *IEEE Wireless Communications*, vol. 12, no. 6, Dec. 2005. (Cited on page 20.)
- [26] M. Gast, *802.11ac: A survival Guide*. O'Reilly Media, Aug. 2013. (Cited on pages 21 and 40.)
- [27] E. H. Ong, J. Kneckt, O. Alanen, Z. Chang, T. Huovinen, and T. Nihtila, "IEEE 802.11ac: Enhancements for very high throughput WLANs," in *IEEE 22nd International Symposium on Personal, Indoor and Mobile Radio Communications*, Sep. 2011. (Cited on pages 21 and 40.)
- [28] E. Perahia and R. Stacey, *Next Generation wireless LANs: 802.11ac and 802.11n*. Cambridge University Press, May 2013. (Cited on pages 21, 22, 34, 35 and 40.)
- [29] Z. Shah, S. Rau, and A. Baig, "Throughput comparison of IEEE 802.11ac and IEEE 802.11n in an indoor environment with interference," in *International Telecommunication Networks and Applications Conference (ITNAC)*, Nov. 2015. (Cited on page 21.)
- [30] A. F. Rochim and R. F. Sari, "Performance comparison of IEEE 802.11n and IEEE 802.11ac," in *International Conference on Computer, Control, Informatics and its Applications (IC3INA)*, Oct. 2016. (Cited on page 21.)
- [31] A. A. Alahmadi and M. A. Madkour, "Performance Evaluation of the IEEE 802.11e EDCA Access Method," in *International Conference on Innovations in Information Technology*, Dec. 2008. (Cited on pages 22 and 34.)
- [32] A. Banchs, P. Serrano, and L. Vollero, "Providing Service Guarantees in 802.11e EDCA WLANs with Legacy Stations," *IEEE Transactions on Mobile Computing*, vol. 10, no. 8, Aug. 2010. (Cited on pages 22 and 34.)

-
- [33] R. Biswal and D. Seth, "Performance Analysis of IEEE 802.11 DCF and IEEE 802.11e EDCF Under Same Type of Traffic," *Springer*, vol. 309, 2015. (Cited on pages 22 and 34.)
- [34] O. Leontyeva and K. Obelovska, "Performance Analysis of IEEE 802.11 EDCA for a Different Number of Access Categories and Comparison with DCF," *Springer*, vol. 306, 2013. (Cited on pages 22 and 34.)
- [35] E. Varthis, P. Theodorou, and A. C. Boucouvalas, "Analysis of Burst Acknowledgment Mechanism of IEEE 802.11e MAC Protocol over Infrared Wireless LANs," in *IEEE International Conference on Network Softwarization*, Oct. 2003. (Cited on pages 22 and 88.)
- [36] E. Varthis and G. Karamitsos, "Saturation Analysis of IEEE 802.11e Burst Acknowledgment Mechanism over Infrared Wireless LANs," *WSEAS Transactions on Communications*, vol. 2, no. 2, Apr. 2003. (Cited on pages 22 and 88.)
- [37] I. Timmiello and S. Choi, "Efficiency analysis of burst transmissions with block ACK in contention-based 802.11e WLANs," *IEEE ICC*, vol. 5, pp. 3455–3460, Jun. 2005. (Cited on pages 22, 88 and 89.)
- [38] G. R. Hiertz, L. Stibor, J. Habetha, E. Weiss, and S. Mangold, "Throughput and Delay Performance of IEEE 802.11e Wireless LAN with Block Acknowledgments," in *11th European Wireless Conference - Next Generation wireless and Mobile Communications and Services*, Apr. 2005. (Cited on pages 22, 88 and 89.)
- [39] T. Li, S. Ni, T. Turletti, and Y. Xiao, "Performance analysis of the IEEE 802.11e block ACK scheme in a noisy channel," in *2nd International Conference on Broadband Networks*, Oct. 2005. (Cited on pages 22, 88, 89, 95 and 100.)
- [40] R. Faruqui and S. Ghani, "A simulation study of Block Acknowledgments and TXOPs under varying channel conditions," in *IEEE International Multitopic Conference*, Dec. 2008. (Cited on pages 22, 88 and 89.)
- [41] R. Chang, "High-speed multichannel data transmission with bandlimited orthogonal signals," *Bell System Technical Journal*, vol. 45, pp. 1775–1796, Dec. 1966. (Cited on page 26.)
- [42] O. Bejarano, E. W. Knightly, and M. Park, "IEEE 802.11ac: From Channelization to Multi-User MIMO," *IEEE Communications Magazine*, vol. 51, no. 10, Oct. 2013. (Cited on pages 28 and 53.)

- [43] S. Biaz and S. Wu, "Rate adaptation algorithms for IEEE 802.11 networks: A survey and comparison," in *IEEE Symposium on Computers and Communications*, Jul. 2008. (Cited on page 30.)
- [44] A. Kamerman and L. Monteban, "WaveLAN(C)-II: a highperformance wireless LAN for the unlicensed band," *Bell Labs Technical Journal*, vol. 14, no. 2, Apr. 1997. (Cited on page 30.)
- [45] R. T. Morris and J. C. Bicket, "Bit-rate selection in wireless networks," Master's Thesis, MIT, 2005. (Cited on page 30.)
- [46] G. Bianchi, "Performance analysis of the IEEE 802.11 distributed coordination function," *IEEE Journal on Selected Areas in Communications*, vol. 18, no. 3, Mar. 2000. (Cited on pages 32, 95, 97 and 100.)
- [47] P. Pham, S. Perreau, and A. Jayasuriya, "Performance Analysis of the IEEE 802.11 DCF," in *Asia-Pacific Conference on Communications*, Oct. 2005. (Cited on page 32.)
- [48] L. Dai and X. Sun, "A Unified Analysis of IEEE 802.11 DCF Networks: Stability, Throughput, and Delay," *IEEE Transactions on Mobile Computing*, vol. 12, no. 8, Aug. 2013. (Cited on page 32.)
- [49] Z. Zhong, P. Kulkarni, F. Cao, Z. Fan, and S. Armour, "Issues and challenges in dense WiFi networks," in *International Wireless Communications and Mobile Computing Conference (IWCMC)*, Aug. 2015. (Cited on page 42.)
- [50] M. Afaqui, E. Garcia-Villegas, and E. Lopez-Aguilera, "IEEE 802.11ax: Challenges and Requirements for Future High Efficiency WiFi," *IEEE Wireless Communications*, vol. 24, no. 3, Jun. 2017. (Cited on page 42.)
- [51] E. Khorov, A. Kiryanov, and A. Lyakhov, "IEEE 802.11ax: How to Build High Efficiency WLANs," in *International Conference on Engineering and Telecommunication (EnT)*, Nov. 2015. (Cited on page 42.)
- [52] D.-J. Deng, K.-C. Chen, and R.-S. Cheng, "IEEE 802.11ax: Next generation wireless local area networks," in *10th International Conference on Heterogeneous Networking for Quality, Reliability, Security and Robustness*, Aug. 2014. (Cited on page 42.)
- [53] B. Bellalta, "IEEE 802.11ax: High-efficiency WLANs," *IEEE Wireless Communications*, vol. 23, no. 1, Feb. 2016. (Cited on pages 43 and 50.)
- [54] E. Khorov, A. Kiryanov, A. Lyakhov, and G. Bianchi, "A Tutorial on IEEE 802.11ax High Efficiency WLANs," *IEEE Communications Surveys and Tutorials*, vol. 21, no. 1, Sep. 2018. (Cited on pages 43 and 50.)

- [55] Q. Qu, B. Li, M. Yang, Z. Yan, A. Yang, D.-J. Deng, and K.-C. Chen, "Survey and Performance Evaluation of the Upcoming Next Generation WLANs Standard - IEEE 802.11ax," *Mobile Networks and Applications*, May 2019. [Online]. Available: <https://doi.org/10.1007/s11036-019-01277-9> (Cited on pages 43, 48, 50 and 54.)
- [56] R. P. F. Hoefel, "IEEE 802.11ax: On Performance of Multi-Antenna Technologies with LDPC Codes," in *IEEE Seventh International Conference on Communications and Electronics (ICCE)*, Jul. 2018. (Cited on page 43.)
- [57] H. Sari and G. Karam, "Orthogonal frequency-division multiple access and its application to CATV networks," *European Transactions on Telecommunications*, vol. 9, no. 6, pp. 507–516, 1998. [Online]. Available: <https://onlinelibrary.wiley.com/doi/abs/10.1002/ett.4460090605> (Cited on page 44.)
- [58] "Interaction Channel for Digital Terrestrial Television (RCT) Incorporating Multiple Access OFDM," in *ETSI DVB RCT*, Mar. 2001. (Cited on page 44.)
- [59] IEEE Std 802.16, "IEEE Standard for WirelessMAN-Advanced Air Interface for Broadband Wireless Access Systems—Amendment 2: Higher Reliability Networks," Jun. 2013. (Cited on pages 44 and 76.)
- [60] H. Zhu and J. Wang, "Chunk-based resource allocation in OFDMA systems - Part I: chunk allocation," *IEEE Transactions on Communications*, vol. 57, no. 9, Sep. 2009. (Cited on pages 45 and 61.)
- [61] —, "Chunk-Based Resource Allocation in OFDMA Systems-Part II: Joint Chunk, Power and Bit Allocation," *IEEE Transactions on Communications*, vol. 60, no. 2, Feb. 2012. (Cited on page 45.)
- [62] Q. Qu, B. Li, M. Yang, and Z. Yan, "An OFDMA based concurrent Multiuser MAC for Upcoming IEEE 802.11ax," in *Wireless Communications and Networking Conference Workshops (WCNCW)*, Jun. 2015. (Cited on pages 46 and 48.)
- [63] B. Li, Q. Qu, Z. Yan, and M. Yang, "Survey on OFDMA bases MAC protocols for the Next Generation WLAN," in *Wireless Communications and Networking Conference Workshops (WCNCW)*, Jun. 2015. (Cited on pages 46 and 48.)
- [64] G. Chittabrata, IEEE Proposed TGax document, doc.: IEEE 802.11-15/1105r0, "UL OFDMA-based Random Access Procedure," Sep. 2015. (Cited on page 48.)

- [65] A. Valkanis, A. Iossifides, P. Chatzimisios, M. Angelopoulos, and V. Katos, "IEEE 802.11ax Spatial Reuse Improvement: An Interference-Based Channel-Access Algorithm," *IEEE Vehicular Technology Magazine*, vol. 14, no. 2, Apr. 2019. (Cited on page 50.)
- [66] M. S. Afaqui, E. Garcia-Villegas, E. Lopez-Aguilera, G. Smith, and D. Camps, "Evaluation of dynamic sensitivity control algorithm for IEEE 802.11ax," in *IEEE Wireless Communications and Networking Conference (WCNC)*, Mar. 2015. (Cited on page 51.)
- [67] M. S. Afaqui, E. Garcia-Villegas, and E. Lopez-Aguilera, "Dynamic Sensitivity Control Algorithm leveraging adaptive RTS/CTS for IEEE 802.11ax," in *Wireless Communications and Networking Conference (WCNC)*, Apr. 2016. (Cited on page 51.)
- [68] IEEE Std 802.11ah, "Part 11: Wireless LAN Medium Access Control (MAC) and Physical Layer (PHY) Specifications: Sub 1 GHz License Exempt Operation," May 2017. (Cited on page 51.)
- [69] B. Bellalta and K. K. Szott, "AP-initiated Multi-User Transmissions in IEEE 802.11ax WLANs," *Elsevier Ad Hoc Networks*, vol. 85, pp. 145 – 159, Feb. 2019. (Cited on page 54.)
- [70] G. Naik, S. Bhattarai, and J.-M. Park, "Performance Analysis of Uplink Multi-User OFDMA in IEEE 802.11ax," in *IEEE International Conference on Communications (ICC)*, May 2018. (Cited on page 54.)
- [71] S. Bhattarai, G. Naik, and J.-M. J. Park, "Uplink Resource Allocation in IEEE 802.11ax," in *2019 IEEE International Conference on Communications (ICC)*, May 2019. (Cited on page 54.)
- [72] G. Naik, S. Bhattarai, and J. Park, "Performance Analysis of Uplink Multi-User OFDMA in IEEE 802.11ax," in *IEEE International Conference on Communications (ICC)*, May 2018. (Cited on page 54.)
- [73] L. Lanante, H. O. T. Uwai, Y. Nagao, M. Kurosaki, and C. Ghosh, "Performance analysis of the 802.11ax UL OFDMA random access protocol in dense networks," in *IEEE 2017 IEEE International Conference on Communications (ICC)*, May 2017. (Cited on pages 57 and 58.)
- [74] H. Yang, D.-J. Deng, and K.-C. Chen, "Performance Analysis of IEEE 802.11ax UL OFDMA-Based Random Access Mechanism," in *IEEE Global Communications Conference*, Dec. 2017. (Cited on pages 57 and 58.)
- [75] T. Uwai, T. Miyamoto, Y. Nagao, L. Lanante, M. Kurosaki, and H. Ochi, "Performance evaluation of OFDMA random access in IEEE 802.11ax,"

- in *International Symposium on Intelligent Signal Processing and Communication Systems (ISPACS)*, Oct. 2016, pp. 1–6. (Cited on page 58.)
- [76] G. Naik, S. Bhattarai, and J. Park, “Performance Analysis of Uplink Multi-User OFDMA in IEEE 802.11ax,” in *IEEE International Conference on Communications (ICC)*, May 2018. (Cited on page 58.)
- [77] S. Baron, P. Nezou, R. Guignard and P. Viger, IEEE Proposed TGax document, Doc: IEEE 802.11-16/0333r0, “Issue related to unused UL OFDMA RUs,” Mar. 2016. (Cited on page 59.)
- [78] S. Chiochan and E. Hossain, “Adaptive radio resource allocation in OFDMA systems: a survey of the state-of-the-art approaches,” *Wireless Communications and Mobile Computing*, vol. 9, no. 4, pp. 513–527, 2009. [Online]. Available: <https://onlinelibrary.wiley.com/doi/abs/10.1002/wcm.696> (Cited on page 64.)
- [79] E. Baccarelli and M. Biagi, “Optimal integer bit-loading for multicarrier ADSL systems subject to spectral-compatibility limits,” *Signal Processing*, vol. 84, pp. 729–741, 2004. (Cited on pages 65 and 66.)
- [80] M. Mollanoori and M. Ghaderi, “On the Performance of Successive Interference Cancellation in Random Access Networks,” in *9th Annual IEEE Communications Society Conference on Sensor, Mesh and Ad Hoc Communications and Networks (SECON)*, Aug. 2012. (Cited on page 67.)
- [81] M. S. Mahmud and M. F. Uddin, “Improvement of throughput fairness in IEEE 802.11 based WLANs using successive interference cancellation,” in *Telecommunications and Photonics (ICTP)*, Dec. 2015. (Cited on page 67.)
- [82] The network simulator ns-2. [Online]. Available: <https://www.isi.edu/nsnam/ns/> (Cited on page 76.)
- [83] A. Bhushan, “A File Transfer Protocol,” Ph.D. dissertation, MIT, Apr. 1973. (Cited on page 80.)
- [84] F. A. Haight, *Handbook of the Poisson Distribution*. New York: John Wiley and Sons, 1967. (Cited on page 81.)
- [85] Geoge Riley. File transfer helper. [Online]. Available: <http://code.nsnam.org/laa/ns-3-lbt/file/fb0495e70736/src/applications/helper> (Cited on page 81.)
- [86] Simone Merlin et al., IEEE Proposed TGax document, doc.: IEEE 802.11-14/0980r16, “TGax Simulation scenarios,” Jul. 2015. (Cited on pages 81 and 82.)

-
- [87] D. Malone, P. Clifford, and D. Leith, “On Buffer Sizing for voice in 802.11,” vol. 10, no. 10, Oct. 2006. (Cited on page 89.)
- [88] T. Li and D. J. Leith, “Buffer Sizing for TCP Flows in 802.11e WLANs,” vol. 12, no. 3, Mar. 2008. (Cited on page 89.)
- [89] —, “Adaptive buffer sizing for TCP flows in 802.11e WLANs,” vol. 12, no. 3, pp. 216–218, Mar. 2008. (Cited on page 89.)
- [90] T. Li, D. Leith, and D. Malone, “Buffer Sizing for 802.11-Based Networks,” vol. 19, no. 1, Feb. 2011. (Cited on page 89.)
- [91] V. Pitchaiah, “Improved Block Acknowledgment Setup Mechanism,” Patent U.S. Patent WO2017030723, Oct., 2017. (Cited on pages 89 and 90.)
- [92] H. Wu, Y. Peng, K. Long, S. Cheng, and J. Ma, “Performance of Reliable Transport Protocol over IEEE 802.11 Wireless LAN: Analysis and Enhancement,” in *21st Annual Joint Conference of the IEEE Computer and Communications Societies*, Jun. 2002. (Cited on pages 95, 97 and 100.)
- [93] A. Banchs and L. Vulliamy, “Throughput analysis and optimal configuration of 802.11e EDCA,” *Computer Networks*, vol. 50, no. 11, pp. 1749–1768, Aug. 2006. (Cited on pages 95, 97 and 100.)

Titre: Etude et optimisation des protocoles PHY et MAC de l'IEEE 802.11 vers une nouvelle génération intégrée à la future 5G

Mots clés: IEEE 802.11ax, OFDMA, accès aléatoire, allocation de ressources, acquittement par bloc, QoS, WLAN, ns-3

Résumé: L'évolution des réseaux sans fil et leur utilisation massive soulève de plus en plus de défis. Cela est particulièrement vrai pour les environnements denses pour lesquels la performance par utilisateur est un problème clé. Le standard IEEE 802.11ax a été lancé dans ce contexte, afin d'améliorer les protocoles des couches PHY (Physical) et MAC (Medium Access Control) en maintenant la rétrocompatibilité avec les standards précédents.

Les travaux de cette thèse rejoignent les mêmes perspectives que le IEEE 802.11ax, à savoir l'amélioration des protocoles existants ou l'introduction de nouvelles techniques. Dans cette perspective, trois contributions principales sont proposées: premièrement, une analyse approfondie de la norme IEEE 802.11 a été élaborée, depuis sa première version en 1999 jusqu'au dernier amendement, le IEEE 802.11ax, en cours de finalisation. Deuxièmement, nous exposons une amélioration de la couche PHY à travers une nouvelle méthode d'allocation de ressources pour l'OFDMA (OFDMA pour Orthogonal Frequency Division Multiple Access) en mode accès aléatoire. Troisièmement, nous avons développé une évolution de la couche MAC avec un mode de négociation adaptatif pour la session d'acquiescement par bloc (AN-BA).

Title: Study and optimisation of IEEE 802.11 PHY and MAC protocols towards a new generation integrated in 5G

Keywords: IEEE 802.11ax, OFDMA, random access, resource allocation, block acknowledgment, QoS, WLANs, ns-3

Abstract: The high growth of wireless applications brings greater challenges to wireless technologies and calls for more improvements and better efficiency. This is particularly true for dense environments for which per user performance is a key issue. IEEE 802.11ax amendment was launched in that context, to improve the physical (PHY) and medium access control (MAC) layer protocols of Wi-Fi networks in dense environments while maintaining backward compatibility with previous standards.

The works of this thesis join the same perspectives as the IEEE 802.11ax, namely the improvement of existing protocols or the proposal of new ones. To that aim, three main contributions are proposed: first, we provide a deep analysis of the IEEE 802.11 norm, from its first version in 1999 to the ongoing IEEE 802.11ax amendment. Second, we expose a PHY layer improvement with a new method for the resource allocation in orthogonal frequency division multiple access (OFDMA) in random access mode. Third, we develop a MAC layer evolution with an adaptive negotiation mode for the block acknowledgement session (AN-BA).