



**HAL**  
open science

# Design tools for enriching the ceramics forms aesthetically by experimental treatments during and post firing

Mohammed El Abd El-Raouf El-Gohari Gohari

► **To cite this version:**

Mohammed El Abd El-Raouf El-Gohari Gohari. Design tools for enriching the ceramics forms aesthetically by experimental treatments during and post firing. History. Conservatoire national des arts et metiers - CNAM, 2012. English. NNT : 2012CNAM0824 . tel-02997195

**HAL Id: tel-02997195**

**<https://theses.hal.science/tel-02997195>**

Submitted on 10 Nov 2020

**HAL** is a multi-disciplinary open access archive for the deposit and dissemination of scientific research documents, whether they are published or not. The documents may come from teaching and research institutions in France or abroad, or from public or private research centers.

L'archive ouverte pluridisciplinaire **HAL**, est destinée au dépôt et à la diffusion de documents scientifiques de niveau recherche, publiés ou non, émanant des établissements d'enseignement et de recherche français ou étrangers, des laboratoires publics ou privés.

Ecole doctorale Abbé Grégoire

N° d'ordre :

**THÈSE DE DOCTORAT**

Histoire des Techniques

*présentée par :*

**Mohammed Mortada Abd El-Raouf El-Gohari**

**Design Tools for Enriching the Ceramics Forms  
Aesthetically by Experimental Treatments During and Post Firing**

**Analyse rétrospective et comparatiste du traitement  
des surfaces céramiques anciennes pendant et après cuisson.  
Modélisation des glacures**

*soutenue le :*

**24 September 2012 à Paris**

**devant les membres du jury :**

**THÈSE DIRIGÉE PAR**

M. André GUILLERME

*Professeur, Cnam, Directeur de Thèse*

**RAPPORTEURS**

Mm. Amina EBEID

*Professeur, Université de Helwan, Rapporteur*

Mm. Laurence LESTEL

*Professeur, Université Pierre et Marie Curie, Rapporteur*

**EXAMINATEURS**

M. Jean-Pierre CHEVALIER

*Professeur, Cnam, Examineur*

M. Renaud CAPLAIN

*Maître de Conférences, Cnam, Examineur*



## Dedication

I dedicate this dissertation to who was interested in my scientific future my late father, Mortada, who was always a source of pride and privilege, and my late mother who was a missing grace in my life since she died when I was a child, who have helped so much and have given me their fullest support. Particularly to my loving sister, Amany, and her small family and to my brother, Hany, and his small family. I thank my pretty daughter, Mariam, and my precious son, Mortada, who I missed very much during writing this work, and who have put up with these many years of research. Finally, I dedicate this work to everyone teach me something in my life, everyone help me for anything in my life or give me his nice smile, and my great family, my uncles and my aunts, all of whom believed in diligence, science, arts and the pursuit of academic excellence.





## Acknowledgements

This dissertation contains the results attained during my PhD at CNAM de Paris during the years 2008-2012. Four years at CNAM have been the time of my life. In addition to the wonderful environment for pursuing advancement in history of ceramics, technology of glazes and design ceramics kilns, the professors and students are extraordinary. I am grateful for graduating from CNAM. There are of course a group of people who made this possible and I would like to express my thanks to them.

At the outset, I would like to express my deep gratitude and thanks to my supervisor. Prof. André Guillerme. for his support throughout my time at Conservatoire national des arts et métiers . His excellent guidance has extensively contributed to successful finish of my Ph. D. thesis. His talent, dedication, and enthusiasm have been my source of inspiration.

I'm so glad to have the beneficial opportunity to work under supervision of prof. Jean-Pierre Chevallier in department of matériaux industriels métalliques et céramiques du CNAM and I'm very grateful to him for his valuable advices, continuous help and fruitful discussions.

I am very thankful to my co-advisor Prof. Renaud CAPLAIN, for his helpful suggestions, critical comments. I really appreciate the theoretical background that was given to me by him. Indeed, I'm grateful to him for the great experimental experience and support that was offered to me by him.

I sincerely thank to all of group in department of matériaux industriels métalliques et céramiques du CNAM , Jean-Pierre C., Sébastien Dubent, Zehoua Hamouche, Patrice L., Outsaphone Soumpholchareune, Aomar Ikhlef Gerard Ferrière Gerard Lallevé Fabrice M. Jacques Bechet, Mickaël PAYET, C. Nicolas, Henri Paqueton. I would like to acknowledge Doc. Ing. Gerard Ferrière for his help with the image analysis software. For their support, guidance, and friendship over the past four years, I'm also indebted to.

I sincerely thanks Prof. Amina Ebaid and Prof. Laurence Lestel for agreeing to be reporters for this thesis.

This research would not be possible without the generous scholarship from the Egyptian Government which offers me four years grant to accomplish my PhD research.

Last but not least, I want to take this opportunity to express my gratitude to my , brother, sister, and my lovely babies. I dedicate this thesis to them.

## Résumé

Dans les arts plastiques, le concept de la beauté doit être associé aux techniques sous-jacentes. L'artiste doit choisir et maîtriser ces techniques afin de les appliquer à l'art en vue d'atteindre les résultats esthétiques visés. Une approche scientifique de ces techniques a un rôle important dans l'amélioration de leur application dans les arts plastiques. Les céramiques et poteries sont un domaine complexe où les réactions chimiques et les propriétés physiques des argiles et des glaçures doivent être prises en compte. Dans ce domaine l'histoire de la science était un guide utile dans une telle recherche. Pour les céramiques, les réactions chimiques se produisant à la phase haute température du processus de cuisson déterminent essentiellement l'aspect final de la surface du produit. En conséquence, changer les conditions de ces réactions (profils de température, la nature de l'atmosphère du four) était une bonne méthode pour obtenir de nouveaux aspects de surface. L'atmosphère du four pendant et après la cuisson permettait de contrôler, dans une large mesure, l'aspect final des produits céramiques, et cela dépend à la fois de la conception et de la mise en place du four. L'étude de l'histoire des techniques céramiques, dans différentes civilisations, a conduit à un aperçu des techniques de cuisson. La compréhension scientifique de ces techniques a mené à des stratégies en vue de modifier la conception du four et la pratique de la cuisson.



# Abstract

In Plastic arts ; with the concept of beauty there are also techniques, artists choose between these techniques for apply art works matching with aesthetic viewpoint. As well as science have important role in improved applied arts and fine arts techniques. In ceramics and pottery we are confronted with the chemicals reactions and physical properties of clay and glaze which have deep roots in human history, so history techniques will guide us in this research. In ceramic, chemical reactions need high temperature as condition to exist (Firing process), and that have main role in determined final appearance of surface treatments for ceramics forms. When the chemical reactions and physical properties which happen in firing process are responsible of final appearance and aesthetics treatments of ceramics forms, the changing of reactions conditions was used for achieving new treatments for ceramic surface beauty. The atmosphere of kiln during and after firing process whom decide the final appearance for ceramics forms, presented as technique for modifying kiln structure as a factor of enriching aesthetics treatments for ceramic surface. The history and science of ceramics techniques in some civilizations was studied to understand some firing techniques and its roles in ceramic surface esthetics. These provided evidence with experimental study to design a new kiln which can be used as a tool to enrich ceramics forms aesthetically.



# Résumé

## Introduction

DANS les arts plastiques, la beauté est associée aux techniques. L'artiste doit choisir et maîtriser les techniques pour les appliquer en vue d'atteindre les objectifs esthétiques. Une approche historique de ces techniques doit permettre à l'artiste d'en accumuler les savoirs, d'en saisir l'épistémologie et l'heuristique tandis qu'une approche mécanique et thermique permet d'améliorer la qualité, de diversifier la production, bref de définir la phénoménologie.

Céramiques et poteries appartiennent à un domaine complexe où les réactions chimiques et les propriétés physiques des argiles et des glaçures doivent être prises en compte. Cette histoire des méthodes et des rationalités est précisée dès le traité de *l'Art de terre, de son utilité, des émaux et du feu* que Bernard Palissy publie vers 1585, à Paris : «je te mettrai ici par ordre tous les secrets que e j'ai trouvé en l'art de la terre, ensemble les compositions et divers effets des émaux : aussi te dirai les diversités des terres argileuses qui sera un point lequel il te faudra bien noter [1]». Pour Palissy comme pour Brongniard, deux siècles plus tard, la raison permet d'échapper aux secrets ; la technique, mot nouveau du XVIIIe siècle, applique concrètement cette rationalité. L'histoire des techniques céramiques, dans différentes civilisations, nous mène à un panorama des techniques de cuisson.



## RESUME

---

La compréhension scientifique de ces techniques nous conduit à saisir les intelligences qui ont conçu les fours que l'archéologie découvre et à définir des stratégies en vue de modifier la conception du four et la pratique de la cuisson. Ainsi pour les céramiques, les réactions chimiques se produisant à la phase haute température du processus de cuisson déterminent essentiellement l'aspect final de la surface du produit. En conséquence, changer les conditions de ces réactions (profils de température, la nature de l'atmosphère du four) est un bon moyen d'obtenir de nouveaux aspects de surface. L'atmosphère du four pendant et après la cuisson permet de contrôler, dans une large mesure, l'aspect final des produits céramiques, et cela dépend à la fois de la conception et de la mise en place du four.

## Contexte

La création dans le domaine de la porcelaine est liée à divers facteurs dont le céramiste doit être à même de se servir. La multiplicité des facteurs revient à la grande diversité des étapes par lesquelles passe la production céramique ; lesquelles étapes requièrent des outils nombreux et divers qui évoluent en raison du façonnage et de la production. Les principales étapes d'élaboration sont :

- 1- L'apprêt des pâtes.
- 2- Le moulage.
- 3- Les opérations précédant le séchage.
- 4- Le séchage.
- 5- La première cuisson (cuisson stricto sensu).
- 6- Les applications de la couverture vitrifiée.
- 7- La deuxième cuisson.
- 8- Les opérations d'après la cuisson (post-cuisson).

L'outil est lié à la fonction qu'il exécute et la fonction est liée à l'une des étapes de la production, et de cette relation naît une relation étroite entre l'outil

et l'étape à laquelle il est employé, ainsi que la diversité et la multiplicité des outils dans le domaine de la céramique. L'évolution dans le domaine de la céramique exige une évolution du projet, de la production et de ses outils.

L'évolution est rattachée à l'ensemble des étapes et apparaît dans la forme et la fonction du produit céramique final, lequel rappelle que toutes les étapes sont reliées et ne sont séparées que par la spécification, l'étude et la cuisson à l'étape où s'opèrent toutes les réactions chimiques ayant un certain impact sur l'esthétique de la forme céramique.

L'évolution du projet et de la production des fours de céramique favorise l'évolution dans le domaine de la céramique, et de l'enrichissement du côté esthétique, soit à l'étape du premier feu comme il apparaît en cas de production de formes céramiques à partir de pâtes spéciales modifiées par l'ajout de pâte à papier[2]; il résulte de l'ajout de certaines matières aux pâtes une modification de certaines de leurs caractéristiques spécifiques. Mais ceci requiert un abaissement de la température intérieure du four pour ne pas détruire les formes; Lors de la seconde cuisson, la production de la couverture vitrifiée cristallisée exige de contrôler la température [3] ou de modifier la construction du four pour l'adapter aux opérations après cuisson d'une manière sûre -céramique Racco ou vernis vitrifiés salins.

La cuisson des formes céramiques est un patrimoine de l'*anthropocène*. Elle témoigne l'une des plus anciennes professions et par la divulgation des connaissances et la succession des découvertes, elle démontre toute l'intelligence de *l'homo sapiens sapiens* qui accroît la connaissance de la céramique en fonction des secrets de la nature et de l'environnement; c'est ainsi que les techniques de la cuisson se sont diversifiées à travers les temps. La cuisson a évolué depuis la fosse jusqu'aux fours très élaborés, à deux étages ou à plusieurs chambres de cuisson. L'évolution s'est poursuivie jusqu'à l'emploi du four à gaz ou à l'électricité (moufle).

La construction des fours passe par deux étapes liées à la forme du four et à la nature des matériaux (combustibles) employés au feu selon que l'on veut obtenir une atmosphère oxydante ou réductrice.

## RESUME

---

Les techniques et les matières employées pour la production des formes céramiques résultent de la différence de nature de la cuisson ; c'est ainsi que nous avons trouvé la forme du four convenable au genre du produit, car les fours employés pour la production des formes céramiques enveloppées de vernis vitrifié salin, nécessite une structure permettant le passage du chlorure de sodium ( $\text{NaCl}$ ) à l'état vapeur pendant la cuisson et qui s'unit à une portion du silicate ajouté au corps de la pâte pour constituer la couche de vernis vitrifié à la surface. De même que les fours employés pour la production des formes céramiques à reflets métalliques doivent avoir une structure permettant d'employer des techniques de cuisson rendant réductrice l'atmosphère du four. Le carbone s'unit avec l'oxygène se trouvant à l'intérieur du four et des oxydes métalliques enduits sur la surface des formes pour former l'enduit vitrifié à brillant métallique.

D'après les fouilles archéologiques effectuées dans différentes civilisations nous avons remarqué une diversité de modèles dans la construction et le plan des fours céramiques : au Japon on trouve le four (anagama) que est représenté sur la figure (1), composé d'une seule chambre voûtée enterrée au versant d'un plateau[4].

Le four(anagama) a influencé le traitement esthétique de la surface céramique. Les fours grecs, qui sont représentés sur la figure (2), permettant à la chaleur de passer verticalement depuis la chambre inférieure jusqu'à la chambre supérieure par des ouvertures pratiquées dans la sole entre les deux chambres et vers une ouverture dans sa partie supérieure, le plan de construction du four devait être vertical[5].

En Chine, il y a un autre type de fours, dits fours horizontaux, où le sens de la chaleur intérieure est horizontal, étant donné qu'elle passe à travers la chambre de cuisson pour sortir par une cheminée élevée au fond de cette chambre, et de l'autre côté se trouve le foyer[5] et ce en dépit d'autres fours divers dans beaucoup de civilisations, ce qui a abouti à produire des formes céramiques de types esthétiques divers.

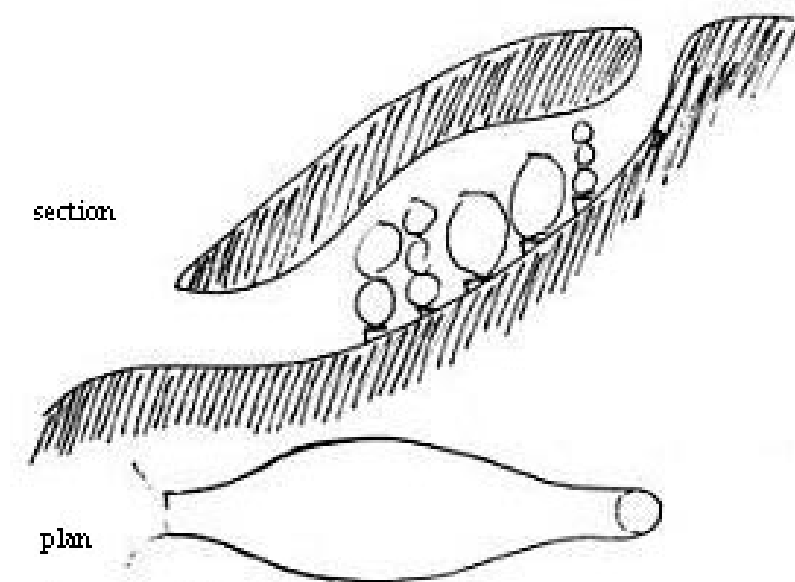


Figure 1: Anagma de base ou une grotte four [6].

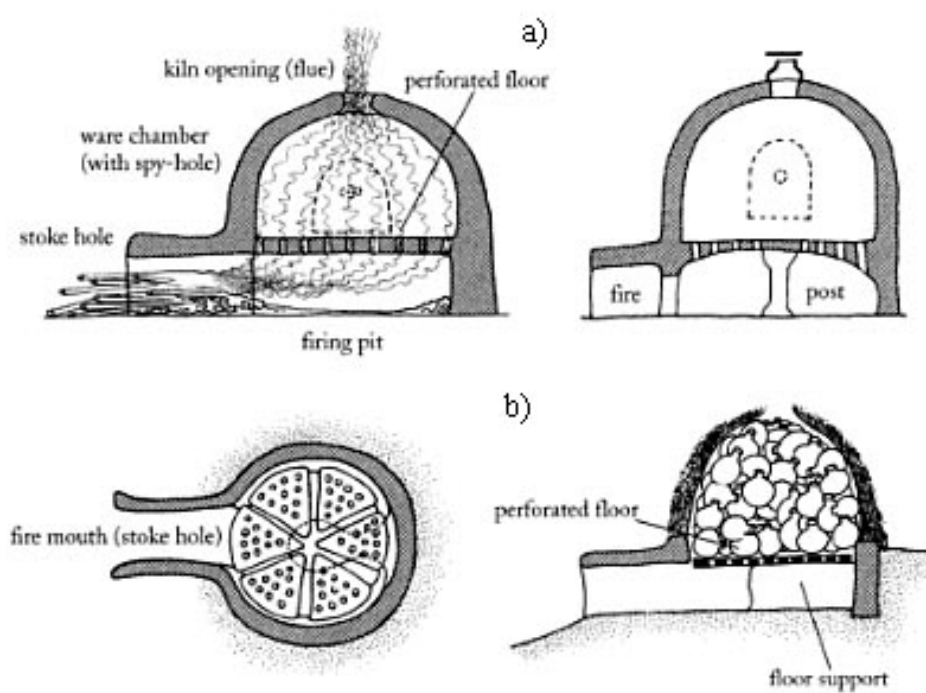


Figure 2: a) Reconstructions de fours grec b) Plan et en coupe du four romain [7].

C'est ainsi que la cuisson a une relation étroite avec l'esthétique de la forme céramique, et les fours dont les plans constituent le fondement de l'évolution dans le domaine de la céramique et de sa technique.

Cette recherche porte sur la structure et le mode de cuisson internes de certains fours dans les différentes civilisations; elle s'applique aussi aux matières, aux impressions esthétiques produites par les formes céramique. De cette page d'histoire technique on tentera d'en déduire de quoi construire (ou recréer) un four permettant d'effectuer certaines opérations expérimentales concernant la cuisson ou la post-cuisson pour obtenir des traitements esthétiques sur les surfaces. Etant donné ce que les outils (fours) peuvent réaliser comme évolution dans le domaine de l'industrie céramique, et le traitement esthétique des surfaces, ainsi que ce que peut réaliser la recherche et l'union des différentes techniques que le céramiste employait dans les civilisations passées, pour l'enrichissement des procédés et des techniques des traitements esthétiques des surfaces céramiques.

Etant données l'importance et les circonstances de la cuisson et vu que cette opération pendant laquelle s'effectuent les réactions chimiques qui influencent beaucoup la qualité des produits céramiques et la diversité des facteurs qui influent sur ces réactions pendant ou après la cuisson\*, le problème du chercheur se résume en une tentative d'étude et de re-création de plans de fours céramiques en accord avec des opérations effectuées pendant la cuisson, et les opérations de traitement après cuisson pour contribuer à l'enrichissement des procédés et des techniques des traitements esthétiques des surfaces.

---

\*Ce qui veut dire les procédures réalisées pendant la cuisson et affectant l'esthétique de la forme, la construction du four ayant un rôle dans sa réalisation sans lequel elle ne peut être effectuée :

1- La possibilité d'effectuer des opérations pendant et après la cuisson influant positivement sur l'esthétique de la forme des pièces.

2- La possibilité de modifier le plan et la construction des fours céramiques de façon à per-

### Contributions de la Thèse

La séparation de l'art et de la science ont été dans le début de la Renaissance, et la spécialisation dans divers domaines a commencé. Malgré les progrès qui réalisés grâce à cette séparation, il y a des points communs entre les sciences appliqués et l'art, et la recherche sur ces points peut enrichir chacune des deux. En raison de la relation entre l'art, la technologie et la science qui apparaissent dans l'évolution et l'histoire des techniques de la céramique, cette recherche vise à mettre en évidence ces points et de profiter d'eux dans la technologie du four et la cuisson de conduction avec les effets relatifs sur les traitements esthétiques de la forme de la céramique. L'étude historique de ces techniques avec l'étude scientifique a permis de découvrir que le progrès scientifique a conduit à disparaître ou à modifier certaines technologies. Revive ces technologies a conduit à la création de la technologie moderne d'utiliser le four comme un outil pour enrichir l'esthétique de surfaces céramique.

Notre étude historique porte sur deux types de céramiques historiques.

1-la décoration de réflexion métallique, est apparu en Irak pendant le califat abbasside (750-1258) : le milieu réducteur du four étant le procédé principal pour produire cet oxyde. Cette technique passe en Egypte puis vers le nord de l'Afrique ; de là en Espagne et en Italie. Mais tandis qu'opère l'acculturation mécanique, les conditions de cuisson ont glissé de réduction à oxydation.

2-la décoration de fissure (craquelé) qui ont été produites première fois en XI siècle ou Chine pendant la dynastie Sung (960-1279). Cette technique a été utilisée pour décorer les cinq porcelaines célèbres en cette dynastie . Considérant que, l'atmosphère réduction et la structure du four c'est l'effet principale de la production de ces styles de la céramique.

Pour reconnaître les procédés et les conditions de cuisson dans l'histoire de la céramique, nous nous sommes référés au maître, Brongniart, qui a su classer différents types d'art céramique et de poterie. L'atmosphère de cuisson a été mettre d'effectuer certaines opérations pouvant influencer sur l'esthétique de la forme des pièces.



**Figure 3:** Poterie Jomon, Bêcher et le couvercle. British Museum OA+.20, AN401059

réalisée dans la cuisson primitive et dans les fours à combustible. La structure de la cuisson primitive affecte au degré près la réduction ainsi que le type de four et le carburant. Dans le classe des poteries à pate tendre et terres cuites, il y a styles qui traité par condition de mise à feu comme Jomon poteries, qui a été fabriqué au Japon (10.000 BC), que est représenté sur la figure(3), poteries noires et rouges polies ou "black topped" (avec le haut coloré en noir), qui a été fabriqué en Egypte et au Soudan (3500 BC) que est représenté sur la figure(4), rouge-noir poteries (3500 - 3300 avant JC), et de l'antracite noir poterie, que est représenté sur la figure(5).

On montre que le style des céramiques vernissées décorées en fonction des conditions de cuisson sont

- Raku : vaisselle en pierre avec lime glaçure, Japonaise raku est une poterie créée par les descendants de la famille Raku pour la cérémonie du thé



## RESUME

---



**Figure 4:** Poteries noires et rouges polies ou "black topped" (avec le haut coloré en noir), Egyptian Museum and papyrus collection -Berlin 12Sj<sup>43</sup>

traditionnelle japonaise. Les Japonais raku a été tentée seulement pour les cérémonies et rituels traditionnels. Par conséquent, la traditionnelle japonaise raku n'a pas été soumis à des matériaux combustibles comme des traitements de réduction post-cuisson la figure (6) illustre le Raku traditionnelle, et le la figure (7) illustre le Occidental Raku.

- Shino : vaisselle en pierre avec glaçure feldspathique et reflets métalliques, Shino grés, ce type de céramique est également traditionnel en grés japonais et ses productions locales sont importantes. L'émail contient entre 60 et 80% de feldspathet de 20 à 40% d'argile. Il a tendance à varier en couleur du blanc laiteux à un orange clair, et il a un tache ou halo de rouge ou gris. Le premier Shino a été développé au Japon au cours de la période Momoyama (1573-1615)[9]. Aussi, le four de (Ogama) a été utilisé pour produire ce type de céramique [10].
- Reflets métalliques traitement, La première appliqtion d'émaux aux reflets métalliques a été produit en Irak, au IX siècle. Il était connu en Egypte à la fin du IXe siècle sous la dynastie toulounide (868-905) et il s'est poursuivi sous les Fatimide (909-1171). En outre, il a été produit à Kairouan



**Figure 5:** Tasse de coquille mince de la culture de Longshan découvert dans le Shandong, Chin, Peking University

## RESUME

---



**Figure 6:** La traditionnel raku thé bol- Rouge, en grès rouge avec la permission glaçure transparente, Musee Duxbury.MA.[8]

(Tunisie) en IX siècle [11, 12, 13]. Il y avait ALORS deux types de reflets métalliques décorations qui sont utilisés dans IX siècle utilisés : le lustre polychrome qui était rare et monochrome.

- Vase en terre cuite avec un éclat émaillé ;
- les porcelaines chinois : four de Ru, four de Jun, four de Guan, et four de Ge. Le four Ru est l'un des fours impériaux de la dynastie Song du Nord [14]. Il a été produit pour à peu près 20 ans seulement. Aujourd'hui, ce style est très rare. Il n'y a que 70 pièces de Ru qui ont été recueillies dans le monde [15].

Porcelaine de Jun trouvée dans le Juntai, Yuzhou ville, province du Henan. La couche d'émail est épaisse là où il a été émaillée deux fois. La gamme de couleur du vernis s'étend du vert au bleu ciel, bleu pâle, rose pourpre, rouge au violet.

Porcelaine de Guan produite pour l'usage à la cour impériale après la destruction du four Ru. L'empereur Huizong avait ordonné la construction de



**Figure 7:** « Occidental Raku » avec traitement métallique de glaçure par effet de  $\text{SnCl}_2$  fumant, créée par James C. Watkins

## RESUME

---



**Figure 8:** Bol de thé, shino type, Mino avec Shino émaux couvrir par peints en oxyde de fer, Musée national de Tokyo.



**Figure 9:** Bol, nezumi-shino type, Mino , Azuchi-Momoyama Période 16e au 17e siècle, Musée national de Tokyo.





**Figure 10:** (*Plat au porte-étendard*), Irak ,X siècle, décorée par un lustre métallique monochrome sur glaçure opacifier, musée du Louvre, département des arts islamiques, MAO 23



**Figure 11:** Ru coupe de Qingliangsi, Région de Baofeng, province du Henan, nord de la Chine, dynastie Song, fin du XIe ou début du XIIe siècle, British Museum OA 1971.9-21.1



## RESUME

---



**Figure 12:** Imperial Jun vaisselle ; Song du Nord

ce style dans le nord. Il y avait aussi le four Guan au sud où ont été produit pour les nouveaux chapitres Linan.

Les couleurs des glaçures de cette porcelaine sont bleu-vert, blanches, brillantes, grises et jaunes vertes. On devine des fissures qui couvrent la surface ; elles peuvent varier en épaisseur et en surface.

L'histoire technologique de la cuisson met clairement en évidence la relation entre traitement esthétique des styles et modes de cuisson-structure du four. Où les modes des cuissons en feu ouvert peuvent être classés en cuisson

- par pile sans canal de foyer ,
- pile avec canal de foyer vertical
- pile avec canal de foyer horizontal



**Figure 13:** Guan porcelaine de Nord

## RESUME

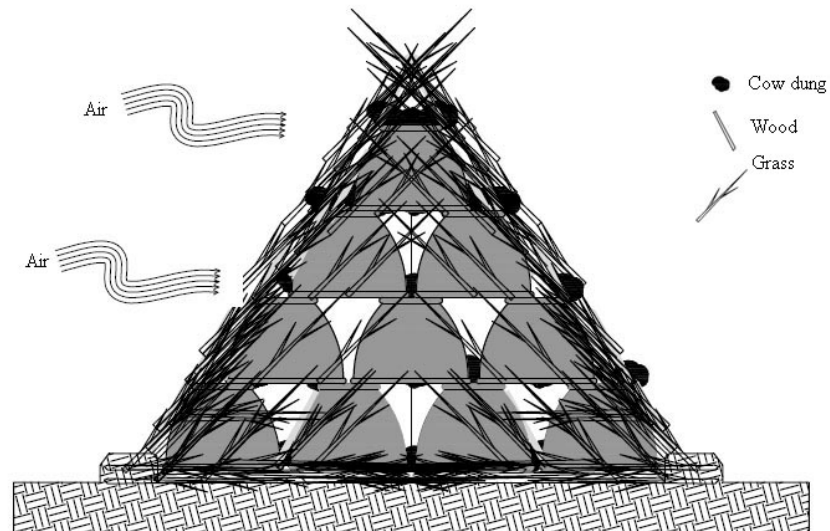
---



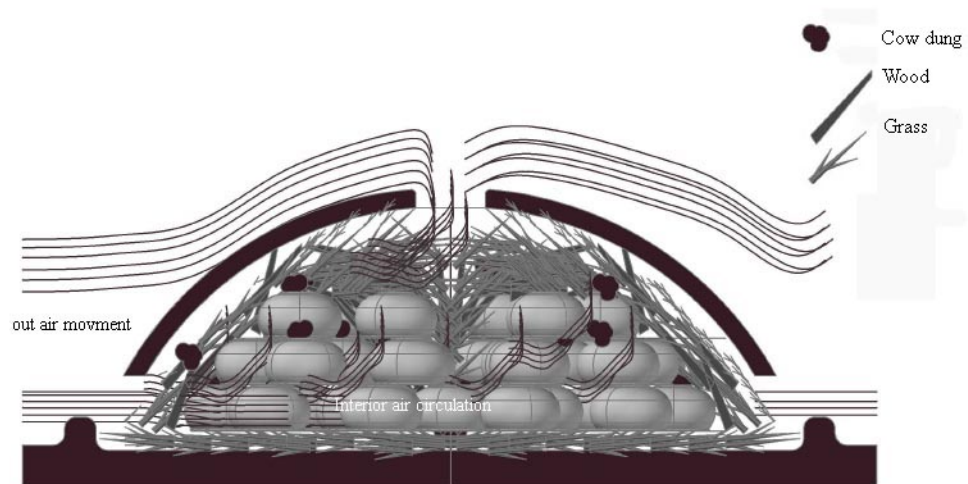
**Figure 14:** Ge cruche d'eau, dynastie Song

La figure(15) illustre l'influence de la méthode de cuisson des poteries en feu ouvert quand les poteries sont rangées sans canal de foyer , la figure(16) illustre l'influencer de la méthode de cuisson de poteries en feu ouvert tant que les poteries être organisée pour former un canal de foyer vertical, et la figure(17) illustre l'influencer de la méthode de cuisson de poteries en feu ouvert tant que les poteries sont rangées pour former un canal de foyer horizontal.

Les modes de cuissons en fosse légère, en fosse profonde ou en enceinte circulaire permettent de faire des traitements, mais la cuisson dans le four, ne permet pas de faire ce traitement et l'évolution du four prend une forme architecturale. Par conséquent, les traitements esthétiques des les poteries, à travers l'histoire de la céramique sont en relation avec modes de cuisson, la structure du four, et les sources de chaleur. La figure (18) illustre conception de la place des cuissons en fosse légère, et le figure (19) illustre conception de la place des cuissons en fosse profonde.



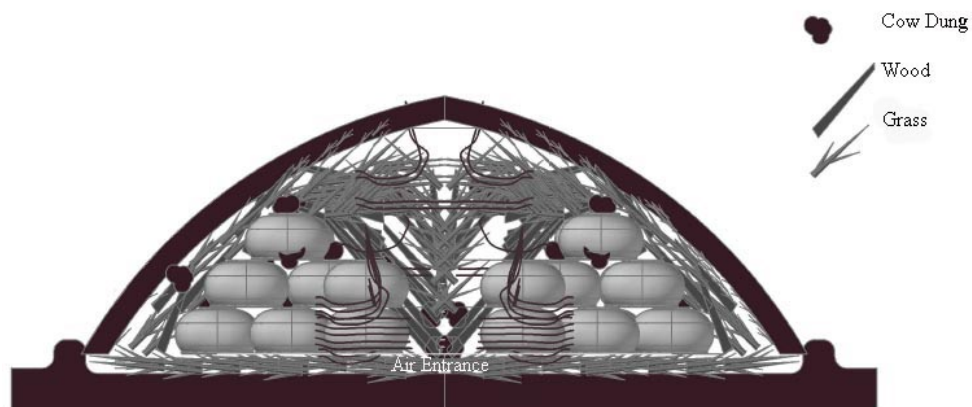
**Figure 15:** Diagramme illustrant l'influence de la méthode de cuisson de poteries en feu ouvert tant que les poteries sont organisées sans canal de foyer.



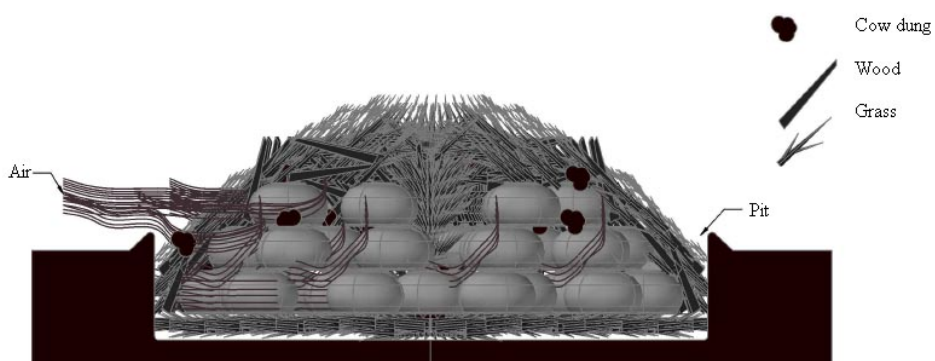
**Figure 16:** Diagramme illustre l'influence de la méthode de cuisson de poteries à feu ouvert tant que les poteries être organisée pour former un canal de foyer vertical

## RESUME

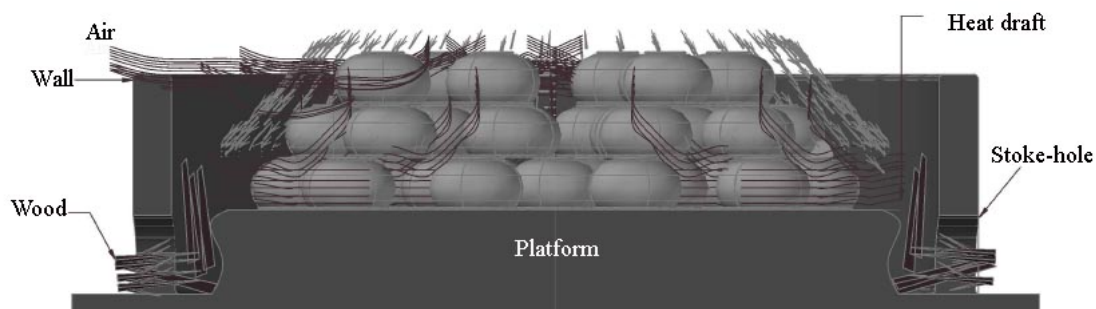
---



**Figure 17:** Diagramme illustrant l'influence de la méthode de cuisson de poteries en feu ouvert tant que les poteries être organisée pour former un canal de foyer horizontal

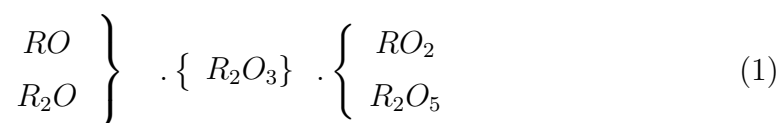


**Figure 18:** Schéma démontrant la structure de la cuisson en fosse



**Figure 19:** Schéma de démontrer la structure de la cuisson en fosse profonde

Les glaçures sont des traces matérielles qui sont traitées au cours de cuisson. Le traitement des aspects qui affectent la glaçure peut être déterminé à travers des réactions chimiques de ses composants et de ses propriétés physiques, c'est pourquoi la nature et la formation d'émail sont présentés pour concevoir la glaçure qui représente une entrée pour des réactions chimiques. La composition des glaçures répond à la formule de Seger - ou unitaire-, comme le montre l'équation (1). On a présenté plusieurs façons des conversions de Formules / Pondérales / Molaires / Seger, ce qui nous a permis de traiter la glaçure comme un composé chimique.



La importance de Sager formula est de déterminer la formule chimique des glaçures qui sont nécessaires pour la conception de réactions chimiques. Donc Maple<sup>TM</sup> logiciel est utilisé pour faire conversion de formules de seger à forme d'une liste de % molaires, et pour faire conversion de forme d'une liste de % molaires à formules de seger. Les figures (20) et (21) illustrent les fenêtre du logiciel Maple<sup>TM</sup> et les calculs pour conversions.

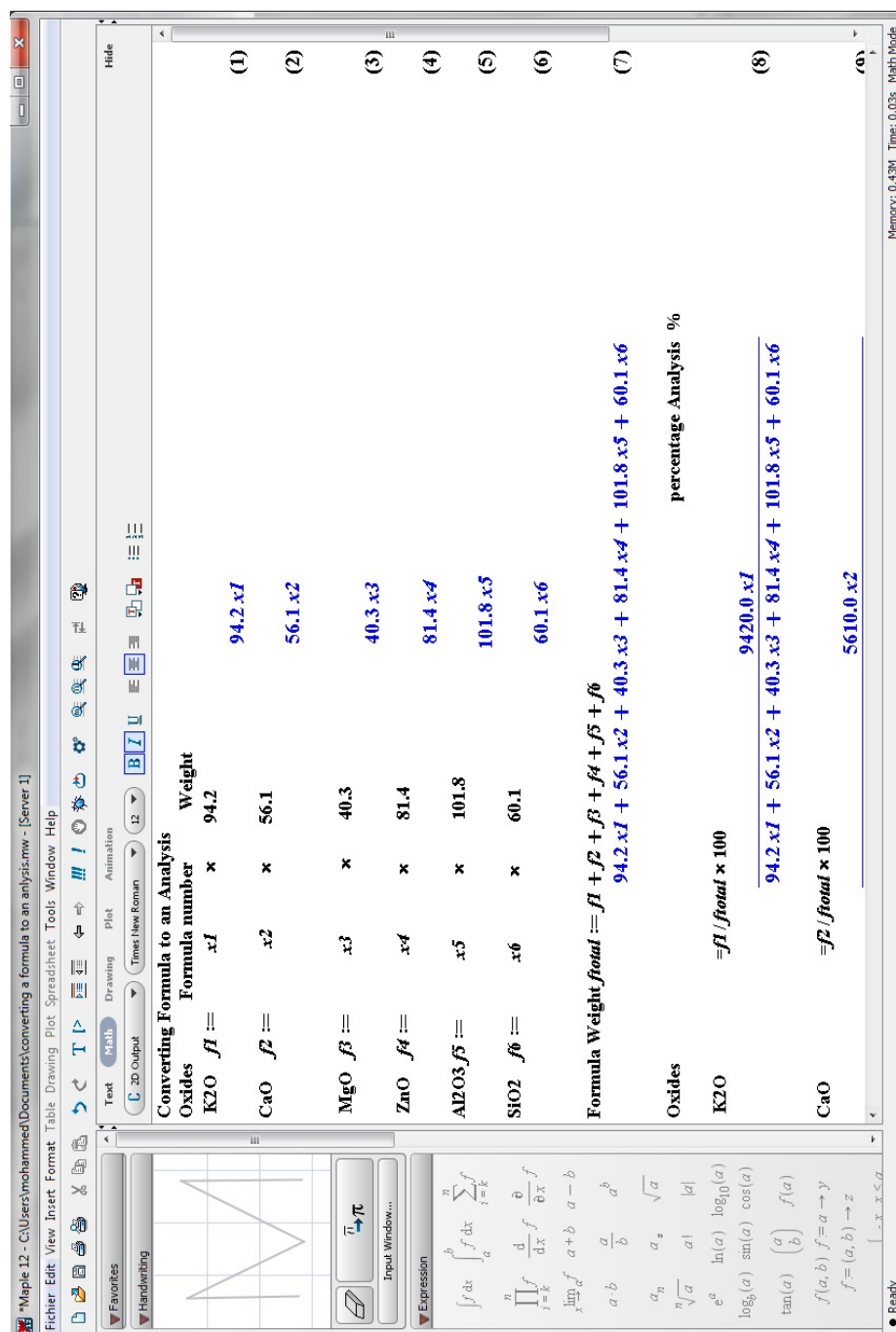


Figure 20: Fenêtre de Maple <sup>TM</sup> qui est utilisé pour faire conversion de formules de seger à forme d'une liste de % molaires



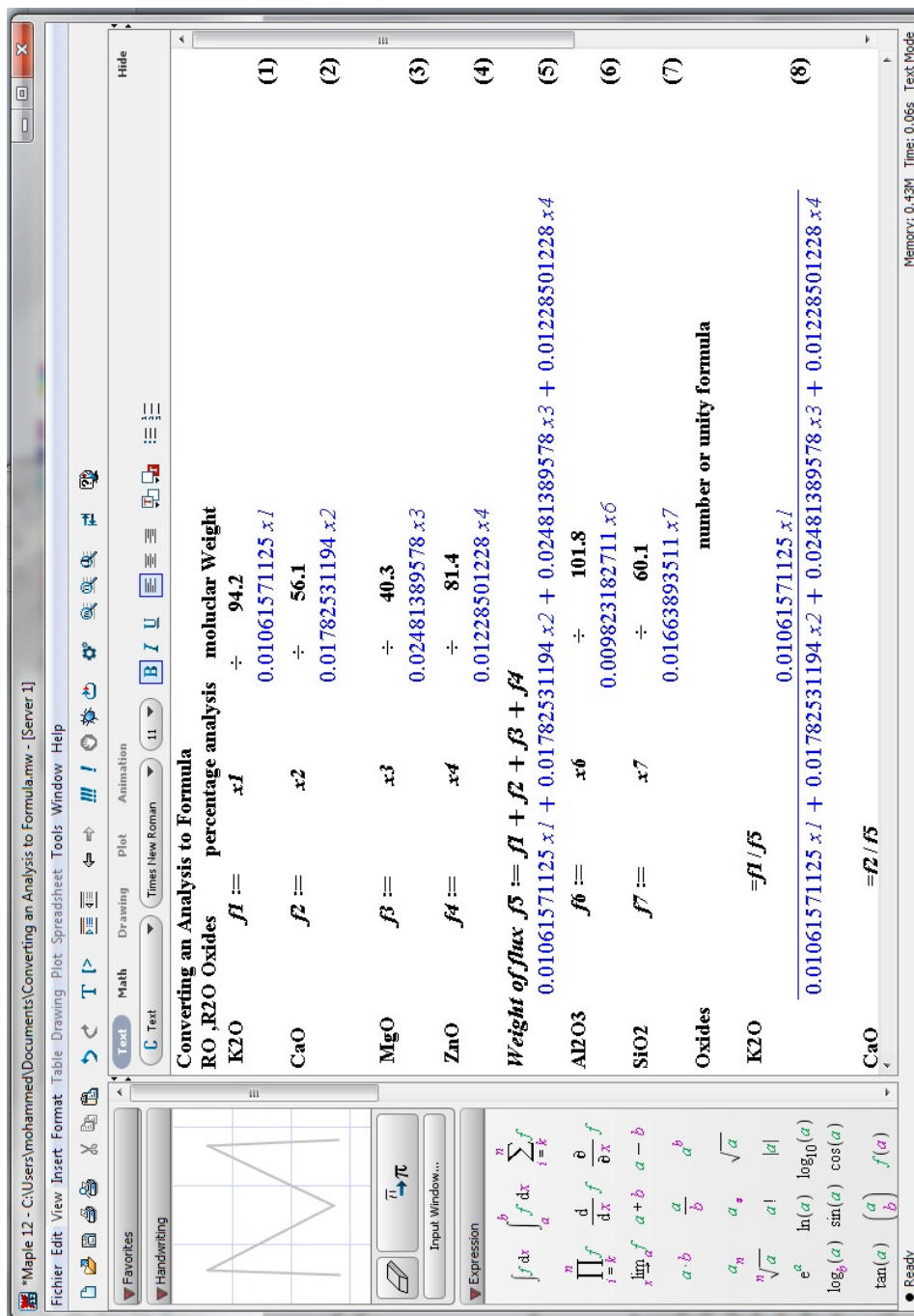


Figure 21: Fenêtre de Maple <sup>TM</sup> qui est utilisé pour faire conversion de forme d'une liste de % molaires à formules de seger.



## RESUME

---

En utilisant la formule de Seger, il peut identifier quelques-unes des caractéristiques des glaçures. On a discuté ses caractéristiques dans cet thèse. Déterminer le nombre relatif de molécule oxydes est un processus complexe dans la modélisation des glaçures , où il ya beaucoup d'usines doivent être pris en compte pour déterminer le nombre par rapport à une formule de glaçure. La ratio de de l'oxygène est calculé par l'équation suivante :

$$O_{ratio} = \frac{Mol_{oxygen}}{Mol_{Si} + Mol_B} \quad (2)$$

Cette ratio est de 2 à 3 pour toutes les émaux [16], et il est avec la molaire de l'alumine  $Al_2O_3$  peut donner idée de la température de cuisson Qui, théoriquement, pourrait déterminer par Lengersdorf facteurs de flux(**F**).

(**F** est le facteur de flux qui est calculée d'après l'équation suivante [17] :

$$F = \frac{\sum S_i f_i}{\sum S_j f_j} \times 100 \quad (3)$$

**FT** est la température de traitement thermique qui est calculée à partir de

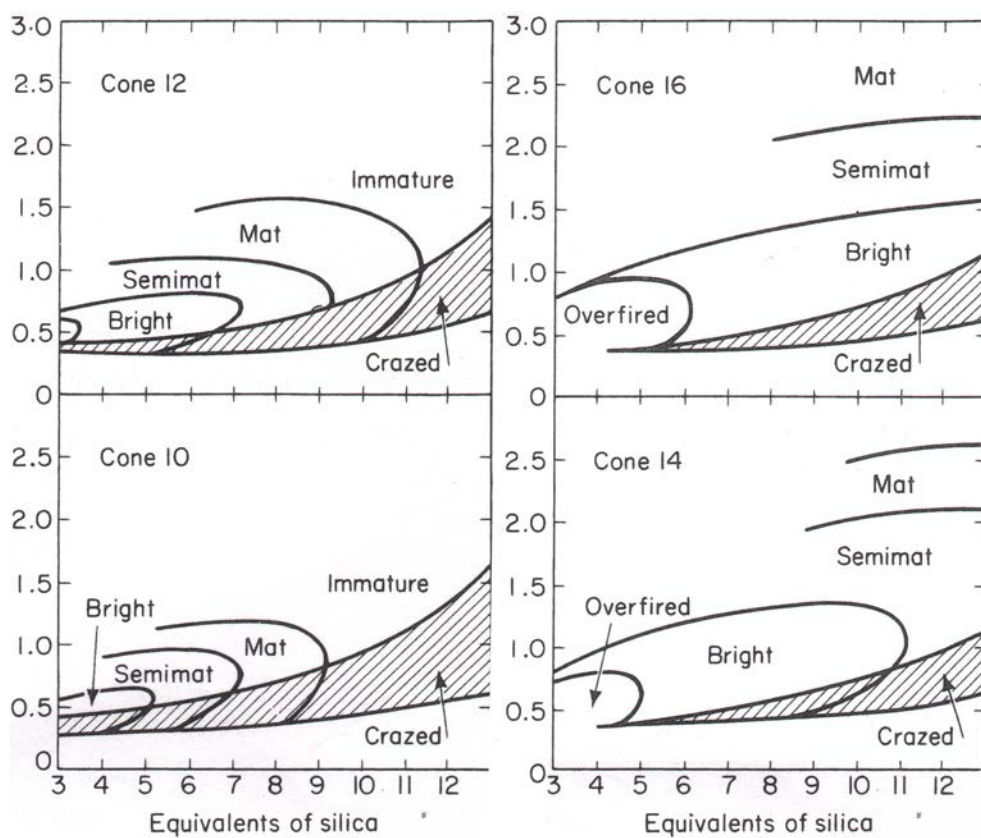
l'équation suivante [17] :

$$FT = \frac{161.21789 - F}{0.10252} \quad (4)$$

les Lengersdorff facteurs de flux est présenté dans le tableau (1) :

Ratio du Thorpe est utilisé pour contrôler la solubilité du plomb dans la structure glaçure qui est calculée à partir de l'équation suivante :

$$\frac{Moles\ de\ basiques\ +\ Moles\ de\ Alumine}{Moles\ de\ Oxydes\ acides} \times \frac{223}{60}, \quad (5)$$



**Figure 22:** Diagrammes illustre la relation entre la ratio de  $\text{SiO}_2$ ,  $\text{Al}_2\text{O}_3$  à coins 10,12,14 et 16.

## RESUME

---

**Table 1:** Caractéristiques et coefficients spécifiques utilisés pour la préparation des glaçures [18]

| Oxyde                          | Masse molaire | Winkelmannd Scott partial coefficients | Dietzel partial coefficients | Lengersdorff flux factors | Appen coefficients |
|--------------------------------|---------------|--|------------------------------|---------------------------|--------------------|
| Na <sub>2</sub> O              | 62            | 333.3                                  | 0.7                          | 0.88                      | 1.590              |
| K <sub>2</sub> O               | 94.2          | 283.3                                  | 0.7                          | 0.88                      | 1.575              |
| MgO                            | 40.3          | 003.3                                  | 6.6                          | 0.54                      | 1.610              |
| CaO                            | 56.1          | 166.7                                  | 4.8                          | 0.58                      | 1.730              |
| ZnO                            | 81.4          | 060.0                                  | 4.7                          | 0.60                      | 1.710              |
| BaO                            | 153.3         | 100.0                                  | 3.7                          | 0.60                      | 1.880              |
| Al <sub>2</sub> O <sub>3</sub> | 102           | 166.7                                  | 6.2                          | 0.32                      | 1.520              |
| Fe <sub>2</sub> O <sub>3</sub> | 159.7         | 133.3                                  | -                            | 0.7                       | -                  |
| B <sub>2</sub> O <sub>3</sub>  | 69.6          | 003.3                                  | 0.8                          | 1                         | 1.470              |
| SiO <sub>2</sub>               | 60.1          | 026.7                                  | 3.4                          | 0.38                      | 1.459              |
| TiO <sub>2</sub>               | 79.9          | 136.7                                  | 4.1                          | 0.38                      | 2.080              |
| P <sub>2</sub> O <sub>5</sub>  | 141.5         | 066.7                                  | -                            | -                         | -                  |
| MnO                            | 70.94         | -                                      | -                            | 0.6                       | -                  |

cette équation a été énoncé comme suit :

$$\frac{Ro + Al_2O_3}{RO_2} = 0.5(\text{comme maximale}), \quad (6)$$

Le module d'allongement (ou module de Young) d'une glaçure est calculé à

partir de l'équation suivante :

$$E = \sum a_i E_i, \quad (7)$$

**Table 2:** Facteurs pour le calcul de module de Young à partir de compositions chimiques [19]

| Oxydes                         | Facteurs des Winkelmann et schott (94) |                |                |
|--------------------------------|--|----------------|----------------|
|                                | A*                                     | B <sup>§</sup> | C <sup>¶</sup> |
| Na <sub>2</sub> O              | 6.0                                    | 9.8            | 6.9            |
| K <sub>2</sub> O               | 3.9                                    | 6.9            | 2.9            |
| MgO                            | -                                      | 3.9            | 2.9            |
| CaO                            | 6.9                                    | 6.9            | -              |
| ZnO                            | 5.1                                    | 9.8            | -              |
| BaO                            | -                                      | 6.9            | 2.9            |
| Al <sub>2</sub> O <sub>3</sub> | 17.6                                   | 14.7           | 12.7           |
| Fe <sub>2</sub> O <sub>3</sub> |  |                |                |
| B <sub>2</sub> O <sub>3</sub>  | -                                      | 5.9            | 2.5            |
| SiO <sub>2</sub>               | 6.9                                    | 6.9            | 6.9            |
| TiO <sub>2</sub>               |  |                |                |
| P <sub>2</sub> O <sub>5</sub>  | -                                      | -              | 6.9            |
| PbO                            | 4.5                                    | -              | 5.4            |
| As <sub>2</sub> O <sub>5</sub> | 3.9                                    | 3.9            | 3.9            |

\*Facteurs sous A sont pour glaçure ou verre libres de B<sub>2</sub>O<sub>3</sub>,P<sub>2</sub>O<sub>5</sub>,BaO,MgO.

§Facteurs sous B sont pour glaçure ou verre libres de PbO,P<sub>2</sub>O<sub>5</sub>.

¶Facteurs sous C sont pour glaçure ou verre libres de borosilicates, borosilicates de plomb,et

## RESUME

---

$E$  module de Young ,  $a_i$  % pondéral des oxydes et  $E_i$  les Winkelmann et Schott coefficients tel que présenté dans le tableau(2)

L'aspect de la glaçure pas déterminé par ses compositions seulement, mais aussi par les conditions de ces réactions qui existe pendant la cuisson et propriété physique qui peuvent être identifiés par les compositions. En outre, une partie de ce qui détermine les caractéristiques physiques de la glaçure est La relation entre les différentes phases : du verre, des cristaux et des liquides. On a discutés cette relation pour démontrer l'effet du taux de chauffage et le refroidissement ainsi que le calendrier de cuisson comme une opération pour produire Les glaçures cristallines.

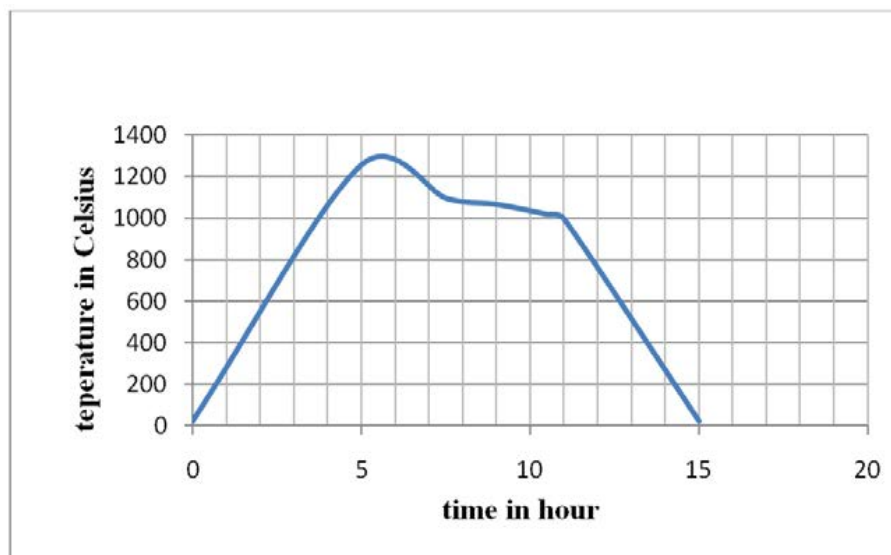
**Table 3:** Composition en unités de masse qui Doat Taxile utilisé pour produire la glaçure cristalline à Sèvres

| Composition                            | Frit No.1 | Frit No.2 |
|--|-----------|-----------|
| Dry carbonate of potash, ( $K_2CO_3$ ) | 138       | 069, 0    |
| Zink Oxide,(ZnO)                       | 162       | 202, 5    |
| Quartz, ( $SiO_2$ )                    | 360       | 350, 0    |

L'expression de la structure glaçure en formule de Seger est présentée pour organiser les oxydes métalliques présents dans les produits constitutifs de glaçure. Le traitement chimique des anciennes glaçures des reflets métalliques et céladon ont été présentés pour reconnaître les compositions d'émail qui découvert par des études antérieures, ainsi que son colorant. Or, la composition de la glaçure ancienne peut être conclue pour proposer une matière première à partir de leur analyse d'oxyde. le tableau (4)représente le  $Fe^{2+} / Fe^{3+}$  ratio, longueur d'onde et couleur de glaçure pour quelque échantillons de ancienne Ru porcelaine.

---

phosphates.



**Figure 23:** Calendrier pour vernis cristallin comme fait par George Juliano

Le traitement physique des glaçures qui peut produire un faïençage à la surface est présenté pour aider à concevoir un type de glaçure original. Nous avons ainsi reconsidéré la théorie chimique des propriétés de la glaçure et précisé sa formulation chimique pour affiner le glaçage dans un sens esthétique, à la manière de Brongniart.

En outre, le calcul de la structure chimique et l'analyse des oxydes d'émail sont expérimentés pour simuler l'échantillonnage du four Ru. La conclusion est que l'échantillon contient un corps de porcelaine qui a résisté à un choc thermique et qu'il a un faible coefficient de dilatation thermique. Par conséquent, l'étude incrémentielle qui permet de simuler et de concevoir le corps de porcelaine et émail est important pour produire le corps d'argile et de glaçure qui sont aptes à être traités par un choc thermique comme un traitement mécanique. Cette méthode amène aussi à concevoir celle qui établit un choc thermique lors de la période refroidissement.

## RESUME

---

**Table 4:** la Ratio de  $\text{Fe}^{2+} / \text{Fe}^{3+}$  ,longueur d'onde ( $\lambda_D$ ) et couleur de glaçure pour quelque échantillons de ancienne Ru porcelaine.

| NO       | $\text{Fe}^{2+}$ | $\text{Fe}^{3+}$ | $\text{Fe}^{2+} / \text{Fe}^{3+}$ | $(\lambda_D)(\text{nm})$ | couleur de glaçure |
|----------|------------------|------------------|-----------------------------------|--------------------------|--------------------|
|          | $I(\%)$          | $I(\%)$          |                                   |                          |                    |
| $R_{16}$ | 79.2             | 20.8             | 3.81                              | 420                      | vert               |
| $R_{18}$ | 78.4             | 21.6             | 3.63                              | 430                      | vert               |
| $R_1$    | 76.1             | 23.9             | 3.18                              | 520                      | vert               |
| $R_{14}$ | 68.1             | 31.9             | 2.13                              | 570                      | vert               |
| $R_{26}$ | 66.8             | 33.2             | 2.01                              | 570                      | vert pomme         |
| $R_{15}$ | 65.8             | 34.2             | 1.92                              | 600                      | vert pomme         |
| $R_{27}$ | 64.1             | 35.9             | 1.79                              | 600                      | vert pomme         |

Table 5: Calcul du pourcentage de matières premières pour la recette de R47b

| matières   | oxydes           |                                |      |                  |      |                  |                                | parties en |                                 | gaz                       |        |            |
|--|------------------|--------------------------------|------|------------------|------|------------------|--------------------------------|------------|---------------------------------|---------------------------|--------|------------|
|  | SiO <sub>2</sub> | Al <sub>2</sub> O <sub>3</sub> | CaO  | K <sub>2</sub> O | MnO  | TiO <sub>2</sub> | Fe <sub>2</sub> O <sub>3</sub> | poids      | poids                           | poids                     | volume | % matières |
| dioxyde de silicium  | 24.46            |                                |      |                  |      |                  |                                | 24.46      |                                 |                           |        | 21.75%     |
| SiO <sub>2</sub>   |                  |                                |      |                  |      |                  |                                |            |                                 |                           |        |            |
| Kaolin   | 38.33            | 30.57                          | 0.08 | 0.77             | 0.01 | 0.07             | 0.71                           | 81.30      | 10.45 <sup>H<sub>2</sub>O</sup> | 13.9L <sup>#20 °C</sup>   |        | 72.30%     |
| Al <sub>2</sub> O <sub>3</sub> · 2SiO <sub>2</sub> · 2H <sub>2</sub> O |                  |                                |      |                  |      |                  |                                |            |                                 |                           |        |            |
| K <sub>2</sub> CO <sub>3</sub>   |                  |                                |      | 1.43             |      |                  |                                | 2.12       | 0.67 <sup>CO<sub>2</sub></sup>  | 1.32L <sup>#1200 °C</sup> |        | 1.88%      |
| CaCO <sub>3</sub>  |                  |                                | 1.29 |                  |      |                  |                                | 2.33       | 1.01 <sup>CO<sub>2</sub></sup>  | 2.03L <sup>#800 °C</sup>  |        | 2.07%      |
| TiO <sub>2</sub>   |                  |                                |      |                  |      | 1.08             |                                | 1.09       |                                 |                           |        | 0.97%      |
| Fe <sub>3</sub> O <sub>4</sub>   |                  |                                |      |                  |      |                  | 1.20                           | 1.20       |                                 |                           |        | 1.03%      |
| % oxyde  | 62.79            | 30.57                          | 1.37 | 2.2              | 0.01 | 1.15             | 1.91                           |            |                                 |                           |        | 100%       |



**Table 6:** Les valeurs calculées des propriétés mécaniques en émail de porcelaine et le corps de Ru porcelaine

| Code<br>échantillon<br>No. | $\alpha_{glaze} - \alpha_{body}$<br>$10^{-7}K^{-1}$ | $\sigma_{glaze}$<br>MPs | $\sigma_{body}$<br>MPs | $\sigma_{glaze} - \sigma_{body}$<br>MPs | Note                    |
|----------------------------|---|-------------------------|------------------------|---|-------------------------|
| R40                        | 37.32   | -184.84                 | 7.39                   | -192.23                                 | tenseur des contrainte* |
| R41                        | 36.78   | -182.09                 | 7.28                   | -189.37                                 | tenseur des contrainte  |
| R42                        | 38.82   | -192.37                 | 7.69                   | -200.07                                 | tenseur des contrainte  |
| R43                        | 43.22   | -220.58                 | 8.82                   | -229.41                                 | tenseur des contrainte  |
| R44                        | 40.83   | -201.17                 | 8.04                   | -209.22                                 | tenseur des contrainte  |
| R47                        | 37.10   | -183.57                 | 7.34                   | -190.91                                 | tenseur des contrainte  |
| R271                       | 35.34   | -174.39                 | 6.97                   | -181.36                                 | tenseur des contrainte  |
| R275                       | 37.51   | -186.84                 | 7.47                   | -194.32                                 | tenseur des contrainte  |
| R330                       | 34.35   | -195.03                 | 7.80                   | -202.83                                 | tenseur des contrainte  |
| R333                       | 36.79   | -185.03                 | 7.40                   | -192.43                                 | tenseur des contrainte  |
| R339                       | 24.21   | -122.77                 | 4.91                   | -127.68                                 | tenseur des contrainte  |
| R382                       | 35.61   | -179.75                 | 7.19                   | -186.93                                 | tenseur des contrainte  |



**Figure 24:** Traitement des Fissures esthétique , créé par un choc thermique à 900 ° C.

Comme pour les traitements chimiques, la méthode de conception de la glaçure permet à préparer des glaçures qui sont appropriés pour réagir avec l'atmosphère du four pour produire des phases métalliques de fer et de cuivre comme une technique traditionnelle. Cette phase métallique a été conçu pour réagir sous atmosphère de sulfuration pour produire des oxydes sulfurés de fer ou cuivre qui donnent des glaçures de différentes couleurs. Le diagramme d'Ellingham et Cu : Fe : système de S sont utilisés pour réguler la relation entre la structure de la glaçure et la température de traitement de sulfuration. Par conséquent, en utilisant le four pour contrôler les réactions chimiques et en s'appuyant sur étude scientifique en laboratoire, on montre que les potiers avaient une excellente connaissance de la thermomécanique des fours pour concevoir les émaux, les craquelures et le faïençage. Ces arts de la céramiques qui Brongniart a pour

---

\*Fissure est créé lorsque le tenseur des contrainte au-dessus de 160 MPa, la résistance à la traction de glaçure commun



**Figure 25:** Traitement des Fissures esthétique , créé par un choc thermique à 1100°C.

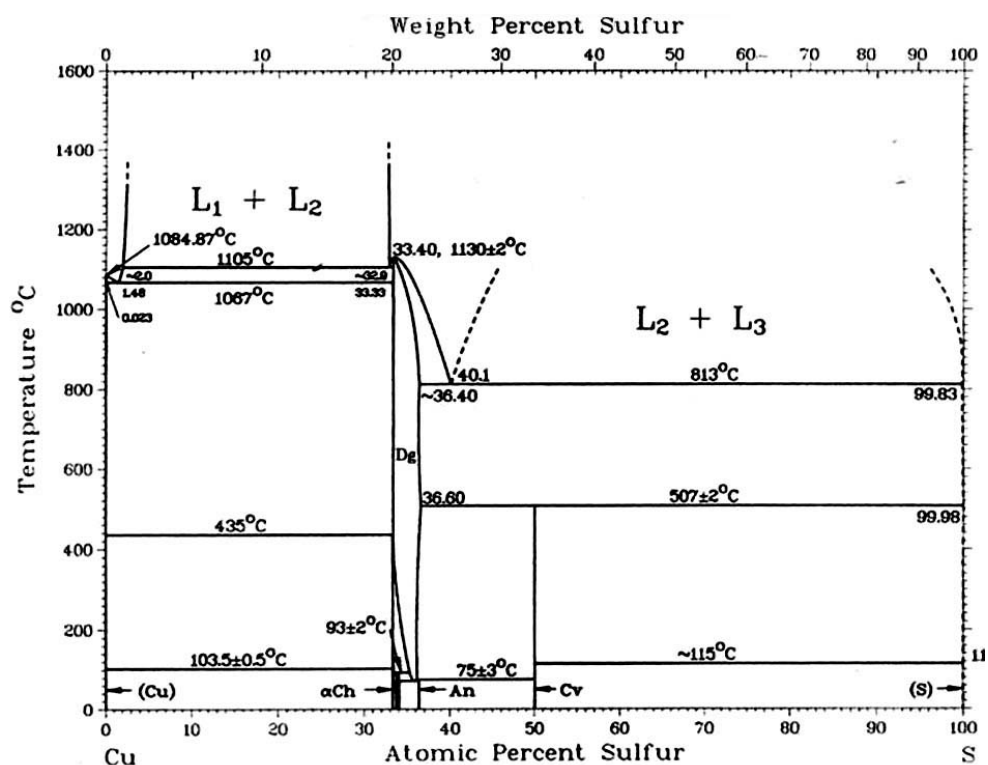


Figure 26: système de Cu-S [20].

la première fois rationalisé sont devenus des technologies dont on peut tirer de nouvelles méthodes de surfaçage notamment pour la dorure et l'argenture des glaçures céramiques. On peut obtenir en plus quelques autres couleurs comme le noir avec un éclat métallique, bleu indigo et le bleu de paon. On se réfère aux dix mille couleurs ou teintes que Chevreul a établi à la Manufacture de tapisserie des Gobelins au milieu du XIXe siècle.

On illustre l'analyse fonctionnelle et la conception d'un nouveau four qui est tenté d'appliquer les traitements historiques pendant la cuisson et de ses évolutions. En général, plutôt que, en particulier, l'architecture d'un four intermittent reformulé dans le cas d'un additif soit des fonctions pour produire des fissure et des couleurs en reflet métallique sur la surface de céramique vernissée. Dans le cadre du fonctionnel, les résultats des études historiques et expérimentales

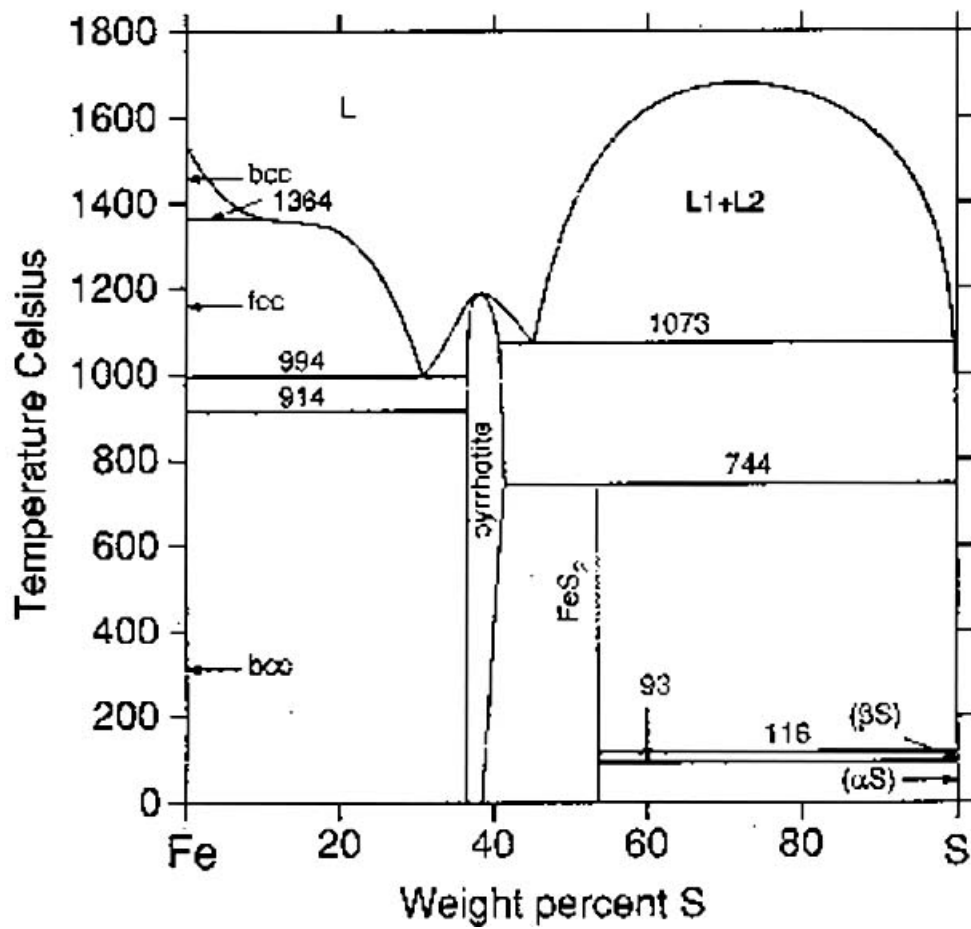
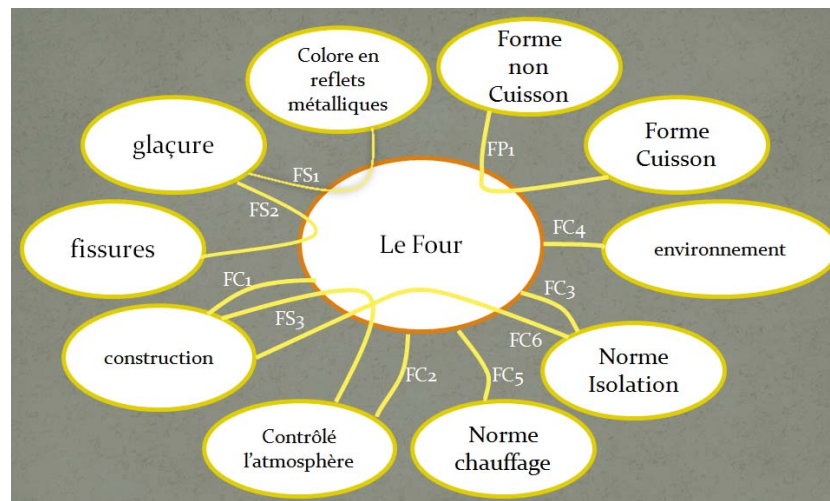


Figure 27: système de Fe-S[20].



**Figure 28:** Digramme pieuvre illustre les fonction contrainte, fonction principale et caractérisation des éléments du milieu extérieur(EME) pour nouveau four

sont représentées dans le cadre des exigences, des services et des solutions attendues.

La méthode APTE \*est utilisé pour expliquer le plan de nouveau four. Etude mathématique est utilisée pour estimer l'énergie qui est nécessaire pour faire fonctionner le four, et le choix des matériaux réfractaires pour la construction du four. Un programme d'éléments finis (ANSYS) est utilisé pour évaluer la déformation de la structure du four. La figure (28) illustre le digramme pieuvre pour nouveau four.

Un four spécial qui est utilisé comme un outil pour les traitements esthétiques, et tenant compte le traitement chimique des gaz et la fumée de sortir du four. Il peut être utilisé pour régler la température de l'cuisson de formes céramique en 1300°C. L'architecture de ce four permet d'avoir des procédures suivantes :

\*APTE est l'application des techniques d'Entreprises, une méthode d'analyse fonctionnelle et analyse de la valeur pour la gestion de projets d'innovation et d'optimisation.

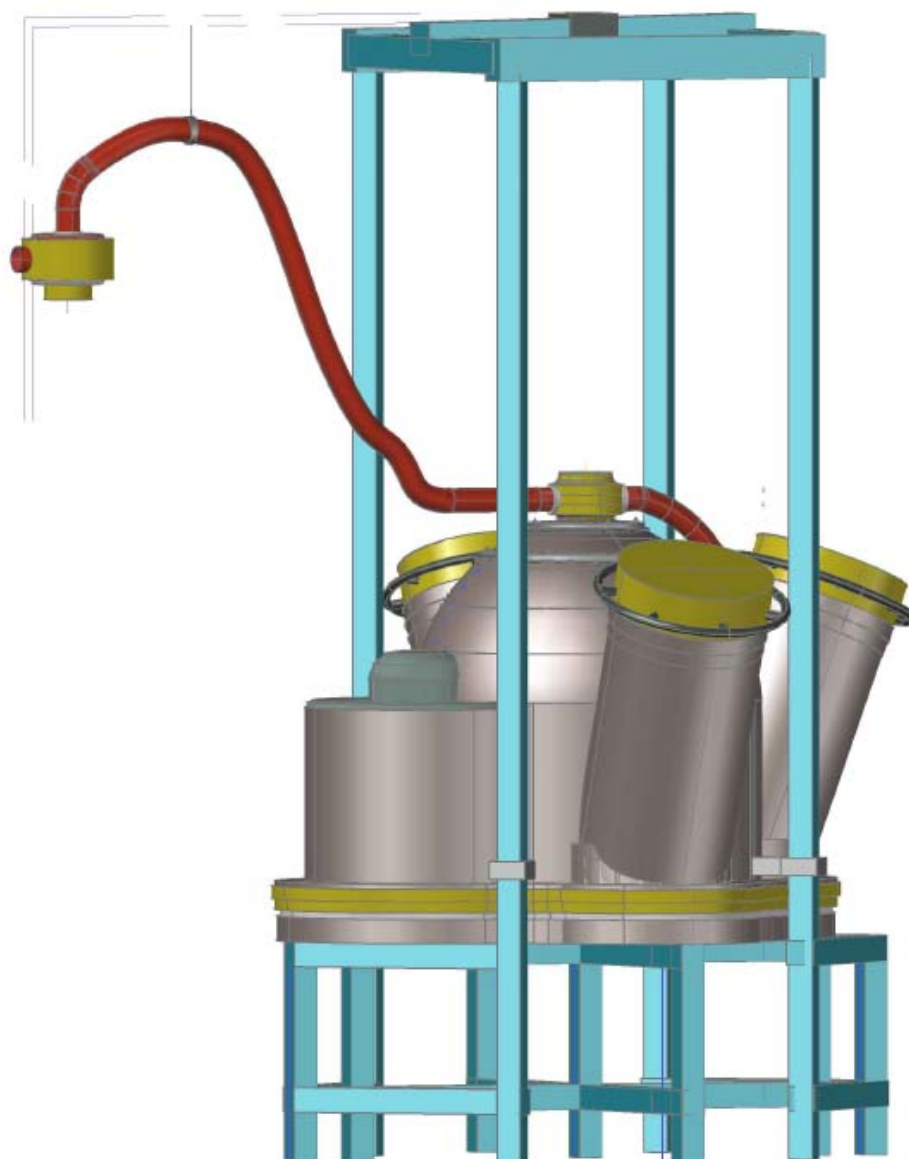
## RESUME

---

- Faire la cuisson dans l'atmosphère normale à partir du début jusqu'à la glaçure bien cuit (de 20° à 1300°C).
- Autorisés à passer quelques matériaux qui changent l'atmosphère du four à la température appropriée.
- Distribution de gaz et de fumée, qui traitent les surfaces des céramiques à l'intérieur du four.
- Serrée fermées du four afin de ne pas fuir de gaz dans l'air en place.

Les figures (29) et (30) illustrent le nouveau four de choc thermique et de traitement chimique quand il est fermé et quand il est ouvert.

La structure du four est composée de trois parties : la première est la base, une paroi en forme de cercle, d'autre part est sous forme de cylindre et la troisième partie est pointé dôme. Le figure (29) illustre certains coupes de nouveau four.

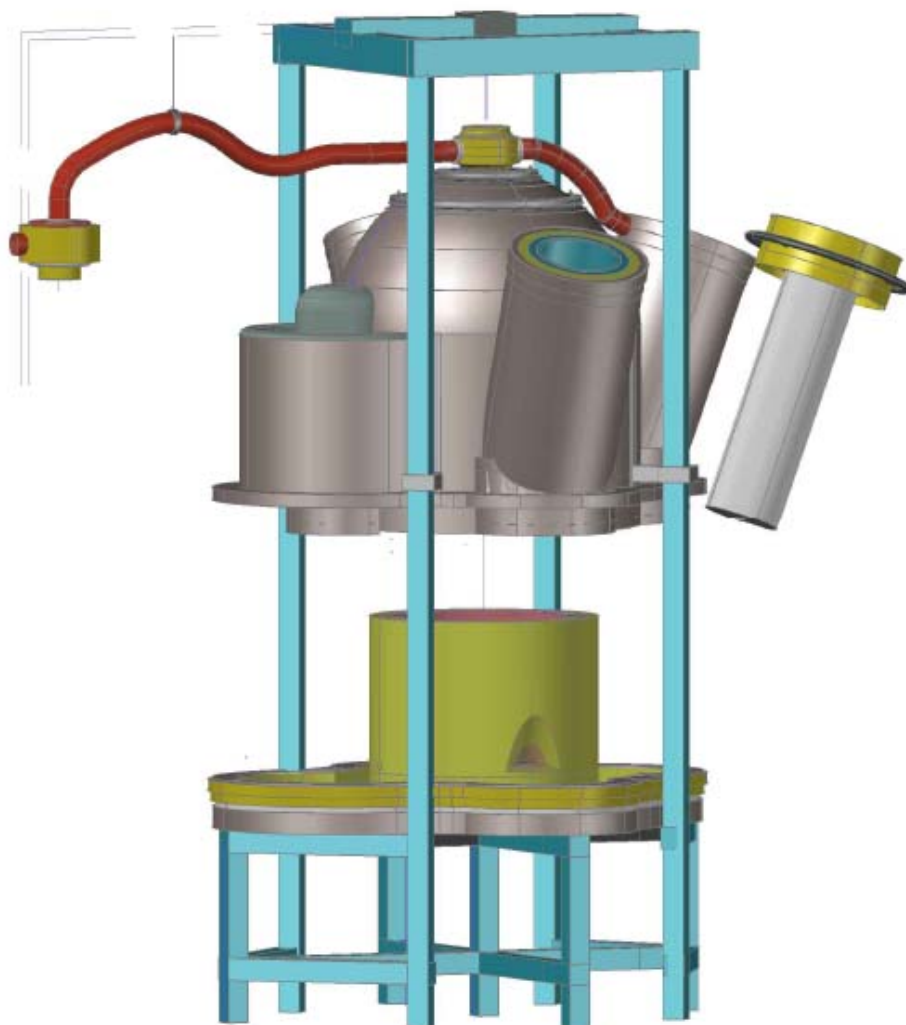


**Figure 29:** Le nouveau four de choc thermique et de traitement chimique quand il est fermé



## RESUME

---



**Figure 30:** Le nouveau four de choc thermique et de traitement chimique quand il est ouvert

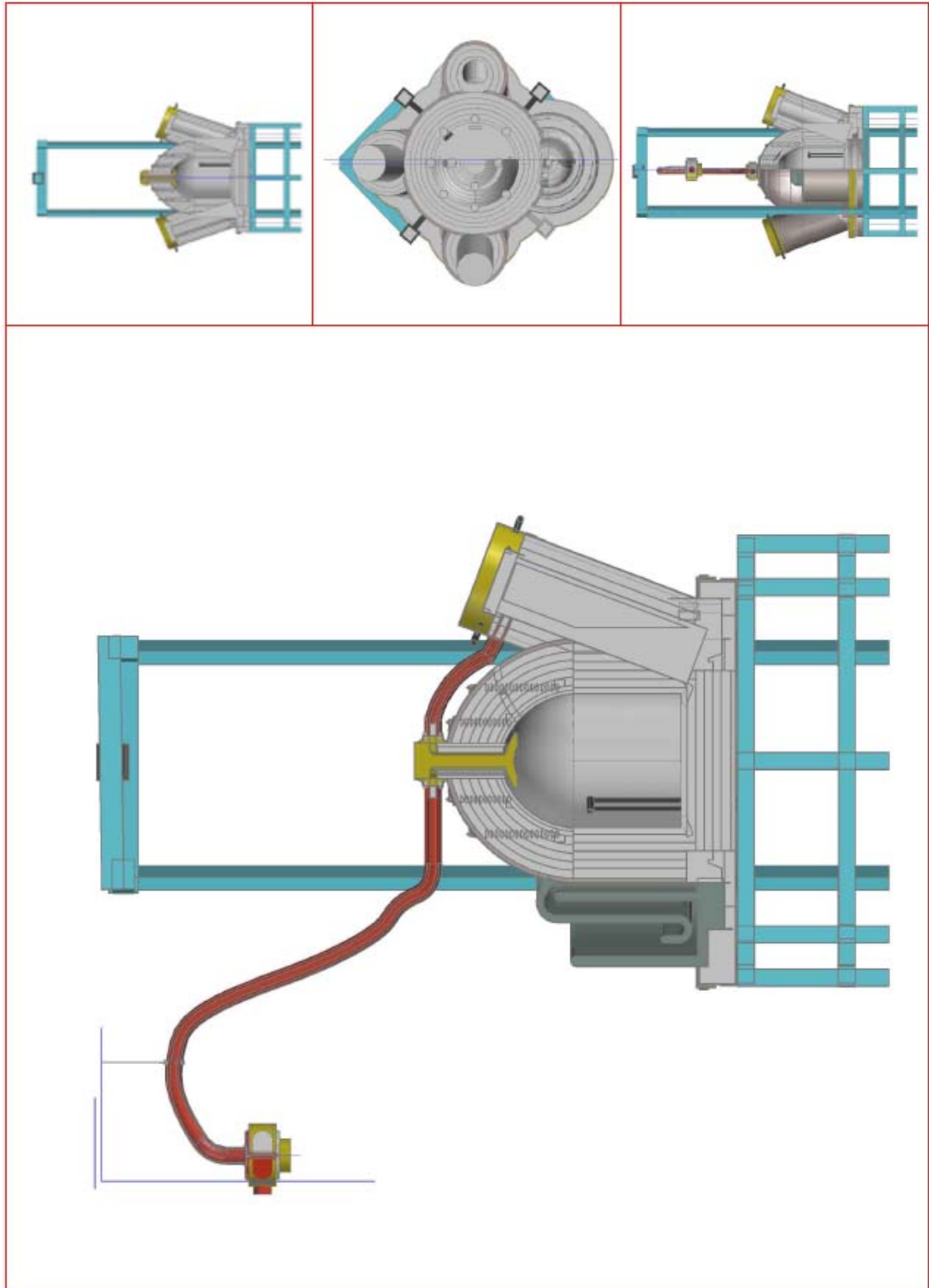


Figure 31: Coupe vertical de nouveau four

### Futurs travaux

Les futurs travaux devraient explorer d'autres possibilités et voies dans lesquelles cette thèse pourrait conduire à enrichir, dans la céramique, le point de vue historique et esthétique. Les principales perspectives devraient inclure :

#### 1. La mise en œuvre du four :

En raison de la possibilité de produire des reflets métalliques, des dorures, et des craquements de décorations, un tel four est nécessaire pour la pédagogie, la recherche et l'expérimentation, pour l'enseignement par la recherche et pour la recherche. Les technologies très précises de choc thermique et de choc chimique ont besoin de ce type de four, c'est pourquoi l'étude expérimentale de ces technologies doit continuer pour appliquer ces techniques et spécifier les palettes actuelles et la gamme des couleurs comme une fonction de traitement pendant la cuisson et la composition de glaçure. Cette recherche devrait conduire à découvrir d'autres paramètres d'incertitudes et à les rectifier en conséquence.

En outre, la recherche d'autres minerais métalliques pourrait amener à de nouveaux traitements esthétiques particuliers par la méthode de conception de glaçures et à l'aide de diagrammes de phase et des formules d'Ellingham. Or cette recherche peut conduire à adapter la technologie de la couleur de la glaçure, ou de créer de nouveaux traitements dont les conditions de cuisson sont contrôlées par la mise en œuvre du nouveau four.

#### 2. La vérification et l'évaluation de l'utilisation de la technique de Craquelés par choc thermique en présence des techniques et des traitements chimiques :

L'utilisation du choc thermique pourrait être vérifié des craquelées sur les surface de glaçures aux mêmes tempes de la possibilité de faire un traitement chimique pour avoir une craquelés colorées. La recherche sur la compatibilité

entre la résistance au choc thermique et le coefficient de dilatation thermique du corps de l'argile et la glaçure peut être amené à produire motifs des craquelés sur la glaçure.

**3. Recommandation pour plus de recherches scientifiques et expérimentales en histoire des techniques de céramiques :**

Le temps fait défaut à l'histoire. Notre investissement dans cette recherche nous a campé devant le four théorique et pratique. Palissy, Brongniard, Chevreul, sont les hérauts de la rationalité technologique auxquels nous devons constamment nous référer et que nous n'avons pas pu consacrer tout le temps nécessaire à leur puissance intellectuelle et heuristique. La recherche scientifique et expérimentale en histoire des techniques céramiques est fondamentale aux pratiques artistiques et céramiques, elle mène à découvrir et mettre en valeur les techniques anciennes, à les redécouvrir, à les retravailler pour en faire des technologies.



# Contents

|  |               |
|--|---------------|
| <b>Abstract</b>  | <b>vii</b>    |
| <b>Résumé</b>  | <b>ix</b>     |
| <b>List of Figures</b>   | <b>lxiii</b>  |
| <b>List of Tables</b>  | <b>lxxvii</b> |
| <b>Introduction</b>  | <b>1</b>      |
| <b>1 literature review</b>                                       | <b>9</b>      |
| 1.1 Relationship between some disciplines and ceramics . . . . . | 10            |
| 1.1.1 History . . . . .  | 10            |
| 1.1.2 Archeology . . . . .                                       | 11            |
| 1.1.3 art . . . . .  | 12            |
| 1.1.4 Science . . . . .  | 15            |
| 1.1.4.1 Relationship between science and technology. . .         | 16            |
| 1.1.4.2 Relationship between science research and art. . .       | 18            |
| 1.2 Alexandre BRONGNIART (1770-1847) . . . . .                   | 19            |
| 1.3 Manufacture nationale de Sèvres . . . . .                    | 27            |

## CONTENTS

---

|          |  |           |
|----------|--|-----------|
| 1.4      | General Factors Which Affecting the Productions of Promotional Ceramics . . . . .              | 32        |
| 1.4.1    | available materials . . . . .  | 32        |
| 1.4.2    | Production Technologies . . . . .  | 38        |
| 1.4.3    | Philosophy and Concept of Art . . . . .  | 39        |
| 1.5      | Important Role of Science in Ceramics Art . . . . .  | 40        |
| 1.6      | Important Role of History in Ceramics Art . . . . .  | 40        |
| 1.7      | Correlation Between Kiln Technology and Finale Appearance of Ceramic Forms . . . . .           | 43        |
| 1.7.1    | Atmosphere of kiln as referring to amount of oxygen: . . .                                     | 46        |
| 1.7.1.1  | Reduction Atmosphere . . . . .   | 46        |
| 1.7.1.2  | Oxidation Atmosphere . . . . .   | 48        |
| 1.7.1.3  | Neutral Atmosphere . . . . .   | 48        |
| 1.7.2    | Condition of firing as referring to heating rate and inserting vapor of substances : . . . . . | 50        |
| 1.7.2.1  | salt firing . . . . .  | 50        |
| 1.7.2.2  | Crystalline Glaze . . . . .  | 50        |
| 1.8      | Electric kiln . . . . .  | 55        |
| 1.9      | Electric Kiln with ventilation system and oxidation atmosphere .                               | 56        |
| 1.10     | Kiln as condition to reactions . . . . .   | 57        |
| <b>2</b> | <b>Ceramics history and firing process</b>   | <b>61</b> |
| 2.1      | Introduction . . . . .   | 61        |
| 2.2      | Classification of ceramics wares . . . . .   | 62        |
| 2.3      | History of ceramics that had treated during or after firing process.                           | 66        |
| 2.3.1    | Pottery or fired (baked) clay. . . . .   | 67        |
| 2.3.1.1  | Jomon pottery . . . . .  | 67        |
| 2.3.1.2  | Black-topped pottery . . . . .   | 68        |
| 2.3.1.3  | Red-black ware . . . . .   | 69        |
| 2.3.1.4  | anthracite Black pottery . . . . .   | 71        |

|         |   |     |
|---------|---|-----|
| 2.3.2   | Ceramics with glazes . . . . .                                | 74  |
| 2.3.2.1 | Stone ware with lead glaze (Raku ware) . . . . .              | 76  |
| 2.3.2.2 | Stone ware with feldspathic glaze (Shino ware) . . . . .      | 80  |
| 2.3.2.3 | Earthenware with luster glaze (metallic reflection) . . . . . | 84  |
| 2.3.2.4 | Porcelain in reduction atmosphere and crackle . . . . .       | 93  |
| 2.4     | History of ceramics firing process . . . . .                  | 103 |
| 2.4.1   | History of firing process atmosphere. . . . .                 | 103 |
| 2.4.2   | Primitive firing . . . . .                                    | 105 |
| 2.4.2.1 | Overground firing . . . . .                                   | 105 |
| 2.4.2.2 | pit firing . . . . .  | 107 |
| 2.4.2.3 | Oven (pit with walls) . . . . .                               | 108 |
| 2.4.3   | Firing in kilns . . . . .                                     | 109 |
| 2.4.3.1 | Up-draft kilns . . . . .                                      | 110 |
| 2.4.3.2 | Down-draft kilns . . . . .                                    | 117 |
| 2.5     | Structure analysis for historical kilns types . . . . .       | 122 |
| 2.5.1   | Developments of kilns structures . . . . .                    | 123 |
| 2.5.2   | The Architect of kilns . . . . .                              | 127 |
| 2.5.3   | Refractory materials . . . . .                                | 152 |
| 2.5.4   | Heating sources . . . . .                                     | 155 |
| 2.5.4.1 | Wood (Table (A.5)) . . . . .                                  | 155 |
| 2.5.4.2 | Lignite (Table(A.6)) . . . . .                                | 156 |
| 2.5.4.3 | Coal (Table(A.7)) . . . . .                                   | 156 |
| 2.5.4.4 | Fuel gases . . . . .  | 156 |
| 2.6     | Conclusion . . . . .  | 157 |

**3 Science of Glazes and preparation for treatment during or post**

|                                   |            |
|-----------------------------------|------------|
| <b>firing</b>                     | <b>161</b> |
| 3.1 Introduction . . . . .        | 162        |
| 3.2 Nature of the glaze . . . . . | 163        |



## CONTENTS

---

|          |  |            |
|----------|--|------------|
| 3.3      | Glass formation . . . . .  | 164        |
| 3.4      | The Volume-Temperature Diagram . . . . .   | 168        |
| 3.5      | Glaze calcification . . . . .  | 169        |
| 3.6      | Design the glaze structure . . . . .   | 172        |
| 3.6.1    | Expression of glaze structure . . . . .  | 172        |
| 3.6.2    | Calculation glaze structure from other structure . . . . .                         | 174        |
| 3.6.3    | Glaze structure designed by unity formula . . . . .                                | 175        |
| 3.7      | Scientific researching on technology of ancient ceramics . . . . .                 | 186        |
| 3.7.1    | Chemical treatment . . . . .   | 186        |
| 3.7.1.1  | Firing process of some famous Chinese porcelain . . . . .                          | 186        |
| 3.7.1.2  | Firing process of metallic reflation decoration . . . . .                          | 194        |
| 3.7.2    | Mechanical treatment . . . . .   | 199        |
| <b>4</b> | <b>Scientific and Excremental Basics for Treatments During Firing</b>              | <b>205</b> |
| 4.1      | Introduction . . . . .   | 206        |
| 4.2      | Simulation study for some ancient ceramics . . . . .                               | 207        |
| 4.2.1    | porcelain body . . . . .   | 207        |
| 4.2.2    | Glaze coating . . . . .  | 212        |
| 4.2.3    | Raw material for glaze and porcelain body . . . . .                                | 219        |
| 4.2.4    | Calculating the raw materials for batch recipe of porcelain<br>body . . . . .      | 221        |
| 4.2.5    | Calculating the raw recipe of glaze . . . . .                                      | 223        |
| 4.3      | Thermal shock as new technique to make cracking . . . . .                          | 232        |
| 4.4      | Crack pattern on ceramics surfaces by modification of kiln structure.              | 244        |
| 4.5      | Chemical treatment for producing copper ores as glaze colorant . . . . .           | 253        |
| 4.5.1    | Sulfide, copper ores . . . . .   | 254        |
| 4.5.2    | Phase diagram of copper-iron-sulfur system . . . . .                               | 255        |
| 4.5.3    | Design glaze formula for chemical treatment by sulfur vapor                        | 261        |
| 4.5.4    | Thermodynamic driving force for chemical reaction in these<br>treatments . . . . . | 262        |

|          |  |            |
|----------|--|------------|
| 4.6      | Conclusion . . . . .   | 267        |
| <b>5</b> | <b>Design kiln for thermal shock and chemical treatments</b>                               | <b>271</b> |
| 5.1      | Introduction . . . . .   | 272        |
| 5.2      | presentation of new kiln . . . . .   | 275        |
| 5.3      | Functional analysis for new kiln . . . . .   | 278        |
| 5.3.1    | Study boundaries . . . . .   | 278        |
| 5.3.2    | Articulate the requirements . . . . .  | 278        |
| 5.3.3    | Utilization phase of new kiln . . . . .  | 278        |
| 5.3.4    | Octopus diagram of new kiln . . . . .  | 279        |
| 5.3.5    | Characterization of elements of external milieu(EME) . .                                   | 281        |
| 5.3.5.1  | Unfired forms . . . . .  | 281        |
| 5.3.5.2  | Fired Forms . . . . .  | 281        |
| 5.3.5.3  | Glaze . . . . .  | 281        |
| 5.3.5.4  | Control atmosphere . . . . .   | 282        |
| 5.3.5.5  | Crackle . . . . .  | 282        |
| 5.3.5.6  | Metallic reflections colore . . . . .  | 282        |
| 5.3.5.7  | construction . . . . .   | 283        |
| 5.3.5.8  | Others elements of external milieu . . . . .   | 283        |
| 5.3.6    | Characterization of functions of serves . . . . .  | 283        |
| 5.3.6.1  | Permission to fair biscuit and glazed forms (FP1)  | 283        |
| 5.3.6.2  | permission to produce glaze which is decorated by<br>metallic luster colors (FS1). . . . . | 283        |
| 5.3.6.3  | permission to produce glaze which is decorated by<br>crackle (FS2). . . . .                | 285        |
| 5.3.6.4  | permission to change the conditione of firing pro-<br>cess (FS3). . . . .                  | 289        |
| 5.3.6.5  | Respect the chemical reactions conditions and phys-<br>ical properties (FC1). . . . .      | 293        |
| 5.3.6.6  | Adapt to the environment (FC2). . . . .  | 294        |

## CONTENTS

---

|                                     |   |            |
|-------------------------------------|---|------------|
| 5.3.6.7                             | Design appropriate construction of kiln (FC3). . .  | 294        |
| 5.3.6.8                             | Respect of the standards of thermal insulation<br>(FC4). . . . .  | 298        |
| 5.3.6.9                             | Respect of properties of refractory materials which<br>are selected for building the construction of kiln<br>(FC5). . . . . | 305        |
| 5.3.6.10                            | Respect of heating standards (FC6). . . . .   | 325        |
| 5.4                                 | conception of kiln . . . . .  | 326        |
| 5.5                                 | Conclusions . . . . .   | 332        |
| <b>Conclusions and Perspectives</b> |   | <b>333</b> |
|                                     | Concluding Remarks . . . . .  | 333        |
|                                     | Future Work . . . . .   | 339        |
| <b>A</b>                            |   | <b>343</b> |
| A.0.1                               | Calculating partes by of kaolin d'Arvor to give parts by<br>weight of composition oxides for porcelain body . . . . .       | 356        |
| A.0.2                               | Calculating partes by weight of potassium carbonate to give<br>parts by weight of potassium oxide for porcelain body . . .  | 357        |
| A.0.3                               | Calculating partes by weight of calcium carbonate to give<br>parts by weight of calcium oxide for porcelain body . . . .    | 358        |
| A.0.4                               | Calculating partes by of kaolin d'Arvor to give parts by<br>weight of composition oxides for glaze . . . . .                | 360        |
| A.0.5                               | Calculating partes by weight of calcium carbonate to give<br>parts by weight of calcium oxide for glaze . . . . .           | 360        |
| A.0.6                               | Calculating partes by weight of potassium carbonate to give<br>parts by weight of potassium oxide for glaze . . . . .       | 361        |
| A.0.7                               | Calculating partes by weight of manganese nitrate hydrate<br>to give parts by weight of oxide for glaze . . . . .           | 361        |

**CONTENTS**

---

A.0.8 Calculating the percentage of raw materials for batch recipe  
of Pemco Frit P-54 . . . . . 364

**References** . . . . . **377**

## CONTENTS

---

# List of Figures

|    |   |       |
|----|---|-------|
| 1  | Anagma de base ou une grotte four [6]. . . . .  | xiii  |
| 2  | a) Reconstructions de fours grec b)Plan et en coupe du four romain [7]. . . . .   | xiv   |
| 3  | Poterie Jomon, Bécher et le couvercle. British Museum OA+.20, AN401059 . . . . .  | xvii  |
| 4  | Poteries noires et rouges polies ou "black topped" (avec le haut coloré en noir), Egyptian Museum and papyrus collection -Berlin 12Sj <sup>43</sup> . . . . .                           | xviii |
| 5  | Tasse de coquille mince de la culture de Longshan découvert dans le Shandong, Chin, Peking University . . . . .   | xix   |
| 6  | La traditionnel raku thé bol- Rouge, en grès rouge avec la permission glaçure transparente, Musee Duxbury.MA.[8] . . . . .  | xx    |
| 7  | « Occidental Raku » avec traitement métallique de glaçure par effet de SnCl <sub>2</sub> fumant, créée par James C. Watkins . . . . .   | xxi   |
| 8  | Bol de thé, shino type, Mino avec Shino émaux couvrir par peints en oxyde de fer, Musée national de Tokyo. . . . .  | xxii  |
| 9  | Bol, nezumi-shino type, Mino , Azuchi-Momoyama Période 16e au 17e siècle, Musée national de Tokyo. . . . .  | xxiii |
| 10 | ( <i>Plat au porte-étendard</i> ),Irak ,X siècle, décorée par un lustre métallique monochrome sur glaçure opacifier, musée du Louvre, département des arts islamiques, MAO 23 . . . . . | xxiv  |

## LIST OF FIGURES

---

|    |   |        |
|----|---|--------|
| 11 | Ru coupe de Qingliangsi, Région de Baofeng, province du Henan, nord de la Chine, dynastie Song, fin du XIe ou début du XIIe siècle, British Museum OA 1971.9-21.1 . . . . . | xxv    |
| 12 | Imperial Jun vaisselle ; Song du Nord . . . . .   | xxvi   |
| 13 | Guan porcelaine de Nord . . . . .   | xxvii  |
| 14 | Ge cruche d'eau, dynastie Song . . . . .  | xxviii |
| 15 | Diagramme illustrant l'influence de la méthode de cuisson de poteries en feu ouvert tant que les poteries sont organisées sans canal de foyer. . . . .                      | xxix   |
| 16 | Diagramme illustre l'influence de la méthode de cuisson de poteries à feu ouvert tant que les poteries être organisée pour former un canal de foyer vertical . . . . .      | xxix   |
| 17 | Diagramme illustrant l'influence de la méthode de cuisson de poteries en feu ouvert tant que les poteries être organisée pour former un canal de foyer horizontal . . . . . | xxx    |
| 18 | Schéma démontrant la structure de la cuisson en fosse . . . . .   | xxx    |
| 19 | Schéma de démontrer la structure de la cuisson en fosse profonde . . . . .  | xxxi   |
| 20 | Fenêtre de Maple <sup>TM</sup> qui est utilisé pour faire conversion de formules de seger à forme d'une liste de % molaires . . . . .                                       | xxxii  |
| 21 | Fenêtre de Maple <sup>TM</sup> qui est utilisé pour faire conversion de forme d'une liste de % molaires à formules de seger. . . . .  | xxxiii |
| 22 | Diagrammes illustre la relation entre la ratio de SiO <sub>2</sub> , Al <sub>2</sub> O <sub>3</sub> à coins 10,12,14 et 16. . . . .   | xxxv   |
| 23 | Calendrier pour vernis cristallin comme fait par George Juliano . . . . .   | xxxix  |
| 24 | Traitement des Fissures esthétique , créé par un choc thermique à 900 ° C. . . . .  | xliii  |
| 25 | Traitement des Fissures esthétique , créé par un choc thermique à 1100°C. . . . .   | xliv   |
| 26 | système de Cu—S [20]. . . . .   | xlvi   |
| 27 | système deFe—S[20]. . . . .   | xlvi   |

## LIST OF FIGURES

---

|     |  |       |
|-----|--|-------|
| 28  | Digramme pieuvre illustre les fonction contrainte, fonction principale et caractérisation des éléments du milieu extérieur(EME) pour nouveau four . . . . .                    | xlvii |
| 29  | Le nouveau four de choc thermique et de traitement chimique quand il est fermé . . . . .   | xlix  |
| 30  | Le nouveau four de choc thermique et de traitement chimique quand il est ouvert . . . . .  | 1     |
| 31  | Coupe vertical de nouveau four . . . . .   | li    |
| 1.1 | Design and decoration for a vase called " <i>Jasmin</i> " which was designed by Alexandre-Théodore Brongniart, Paris 1801, at Sèvres factory[21]. . . . .                      | 24    |
| 1.2 | Design and decoration for a coffeepot called " <i>Theière 'Turqué</i> " which was designed by Alexandre Evariste Fragnored, Paris 1815, at Sèvres factory[21]. . . . .         | 25    |
| 1.3 | Design and decoration for vas called " <i>Jasmin Cornet</i> " which was designed by Jean-Charles François Leloy, Paris 1835, at Sèvres factory[21]. . . . .                    | 26    |
| 1.4 | vaisseau à mâts is used as potpourri of Madame de Pompadour, made of soft-porcelain , Sèvres Manufactory, Paris museum Louver (inv. OA 10965) . . . . .                        | 29    |
| 1.5 | Vase Ly 1850 , Sèvres Manufactory, Paris museum Louver MNC(inv. 4178-2) . . . . .  | 31    |
| 1.6 | Biscuit,soft-paste porcelain (porcelaine pâte tendre), Height : 168 mm,designed by E. M. Falconet, Paris 1760,at Sèvres factory . . . . .                                      | 33    |
| 1.7 | Biscuit, hard-paste porcelain ( porcelaine pâte dur), Height : 220 mm,designed by P. L. Cyfflé, France, 1775,at Niderviller factory,A&V museum,London Nbr: C367-1983 . . . . . | 34    |
| 1.8 | Vase " avec des cygnes " Soft-paste porcelain. In 1766, at Sèvres factory, louvre museum, purchased 1985 OA11024 . . . . .   | 36    |



## LIST OF FIGURES

---

|      |   |    |
|------|---|----|
| 1.9  | A Flow chart show relationship among Science, art, and history . . . . .  | 41 |
| 1.10 | Ceramic artwork (Orb, 2003) created by Linda Keleigh . . . . .  | 42 |
| 1.11 | ”Teapot” with black body was produced by reduction conditions,<br>reduction cooled, and glaze would be redundant, created by John<br>Neely, . . . . . | 47 |
| 1.12 | Kiln atmospheres[22] . . . . .  | 49 |
| 1.13 | Walter Keeler, Bowls on plinths, salt glaze, 15 cm high[23] . . . . .   | 51 |
| 1.14 | schedule for crystalline glaze as George Juliano firing . . . . .   | 52 |
| 1.15 | 10 in/25 cm, uranium oxide yellow vase . . . . .  | 53 |
| 1.16 | 18in /45cm diameter Ruby -yellow platter . . . . .  | 54 |
| 1.17 | Electric kiln with ventilation system that is produced by SKUTT<br>company . . . . .  | 57 |
| 1.18 | Chart shows how the kiln considers as conditions to chemical re-<br>actions . . . . .   | 58 |
| 2.1  | chart shows the Classification of types of ceramics ware as referring<br>to Jennie J. Young classification [24] . . . . .                             | 64 |
| 2.2  | Jomon ware, Beaker and lid. Low-fired red pottery. British Mu-<br>seum OA+.20, AN401059 . . . . .   | 68 |
| 2.3  | Flame Ware, Jomon Period Ceramics, Japan Tokyo National Mu-<br>seum . . . . .   | 69 |
| 2.4  | Black-Topped Pottery Jar, ca. 3500-3300 B.C.E. Pottery, 7 7/16<br>x Greatest Diam. 5 1/8 in. (18.9 x 13 cm). Brooklyn Museum . . . . .                | 70 |
| 2.5  | Tulip-shaped Cups, Classical Kerma, black-topped ceramics 1755-<br>1550 BC, Egyptian Museum and papyrus collection -Berlin . . . . .                  | 71 |
| 2.6  | Eggshell thin cup from Longshan Culture discovered in Shandong,<br>China, Peking University . . . . .   | 73 |
| 2.7  | A jar-shaped olla with completely black luster, from Indian civi-<br>lization. . . . .  | 74 |

## LIST OF FIGURES

---

|      |   |    |
|------|---|----|
| 2.8  | Smoking form of ceramic in sawdust to obtain luster black ware.<br>Produced by Pierre-Alain Capt. . . . . .   | 75 |
| 2.9  | luster black aspect appeared, when the form became cold. . . . .  | 75 |
| 2.10 | traditional red raku tea bowl, red earthenware; clear glaze courtesy<br>of art complex, Museum Duxbury.MA.[8] . . . . .   | 77 |
| 2.11 | traditional black raku, tea bowl, courtesy of art complex, Museum<br>Duxbury.MA.[8] . . . . .   | 78 |
| 2.12 | western raku ware with treatment metallic glaze from SnCl <sub>2</sub> fum-<br>ing, created by James C. Watkins . . . . .   | 79 |
| 2.13 | western raku bowl with crackle patterns exist as post firing treat-<br>ment, created by Michael Sheba. . . . .  | 80 |
| 2.14 | Tea bowl, shino type, Mino Ware with Shino glazes cover drawings<br>painted in iron oxide, Tokyo national Museum. . . . .   | 81 |
| 2.15 | Bowl, nezumi-shino type, Mino Ware, Azuchi-Momoyama Period<br>16th-17th century, Tokyo national Museum. . . . .   | 82 |
| 2.16 | carbon trap Shino tea bowl created by Malcolm Davis. . . . .  | 83 |
| 2.17 | luster polychrome and luster monochrome glazes used in Mahrab<br>of Sidi Oqba mosque in Kairouan IX century. . . . .  | 85 |
| 2.18 | dish of flag-bearer ( <i>plat au porte-étendard</i> ),Iraq ,X century. earth-<br>enware, decorated by monochrome metallic luster on opacify glaze,louvre<br>museum,department of Islamic arts ,MAO 23 . . . . . | 86 |
| 2.19 | fragments of glazed ceramics which was decorated by metallic lus-<br>ter, polychrome type, IX century, Sues, Iran. . . . .  | 88 |
| 2.20 | high quality metallic reflection decoration on opaque glaze and the<br>body was hard and high silica. . . . .   | 89 |
| 2.21 | A Hispano-Moresque dish , approx 32cm diameter, with Christian<br>monogram "IHS" , decorated in cobalt blue and gold luster. Valen-<br>cia 1430-1500. Burrell Collection. . . . .                               | 90 |

## LIST OF FIGURES

---

|      |   |     |
|------|---|-----|
| 2.22 | two-handled pot on a pedestal foot 22cm high probably from Valencia ,second half of 17th century, Instituto de valencia de Don Juan. Madrid . . . . .   | 92  |
| 2.23 | Ru ware cup-stand From Qingliangsi, Baofeng county, Henan province, northern China Song dynasty, late 11th- early 12th century, British Museum OA 1971.9-21.1 . . . . .   | 95  |
| 2.24 | Three-legged wine vessel Ru ware of Northern Song Dynasty, 11th Century . . . . .   | 95  |
| 2.25 | Jun wine jar Moon-white glazed with vertical flanges northern Sung dynasty . . . . .  | 97  |
| 2.26 | Imperial Jun ware;Northern Song . . . . .   | 97  |
| 2.27 | Northern Guan ware . . . . .  | 98  |
| 2.28 | Ge five-stud water jar, sung dynasty . . . . .  | 99  |
| 2.29 | Ge-type vase which has thick,Zhejiang province (1279-1368), Yuan dynasty.G95/case2/sh4 British Museum . . . . .   | 100 |
| 2.30 | Ge five-stud water jar, sung dynasty . . . . .  | 101 |
| 2.31 | open firing with preheating technique in the start of firing process[25].   | 106 |
| 2.32 | Pit firing before firing[25]. . . . .   | 108 |
| 2.33 | Engraved was plotted on the walls of hypogeum of Bin-Hassan in Luxor[26]. . . . .   | 111 |
| 2.34 | kiln for firing ceramics,Banpo site,Yangshao culture [27]. . . . .  | 112 |
| 2.35 | Kiln discovered in Normanton Field-Castor en England , <i>c.</i> Fire mouth , <b>D.</b> Perforated floor , <i>o.</i> Spy-holes in the floor, <b>G.</b> Medial of the floor of firing chamber which supported by stand [26]. . . . . | 113 |
| 2.36 | Corinthian pinakes from penteskouphia , Paris museum of louvre MNB 2856 [7]. . . . .  | 114 |
| 2.37 | a) reconstructions of typical Greek kiln b)plan and section of typical Roman kiln [7]. . . . .  | 115 |
| 2.38 | Basic anagma or cave kiln [6]. . . . .  | 118 |
| 2.39 | Anagama kiln with added with flame dividing pillar [6]. . . . .   | 119 |

## LIST OF FIGURES

---

|      |  |     |
|------|--|-----|
| 2.40 | ogama kiln (great kiln) [6]. . . . .   | 120 |
| 2.41 | Multi-chambered' climbing kiln (Noborigama) [6]. . . . .   | 122 |
| 2.42 | diagram demonstrate the structure of over-ground and open firing<br>without any fire-channel . . . . .   | 124 |
| 2.43 | diagram demonstrate the structure of over-ground and open firing<br>with vertical fire-channel . . . . .   | 125 |
| 2.44 | diagram demonstrate the structure of over-ground and open firing<br>with horizontal fire-channel . . . . .   | 125 |
| 2.45 | Diagram demonstrate the structure of pit firing . . . . .  | 126 |
| 2.46 | Diagram demonstrate the structure of oven with surrounding wall  | 127 |
| 2.47 | Plan for roman kiln which discovered in Heiligenberg. . . . .  | 128 |
| 2.48 | vertical section in line E-F. . . . .  | 129 |
| 2.49 | vertical section in line G-H. . . . .  | 130 |
| 2.50 | schematic present a vertical section of top dome closed kiln and its<br>major parts[5] . . . . .   | 132 |
| 2.51 | schematic present a vertical section of horizontal kiln [5] . . . . .  | 133 |
| 2.52 | schematic present a vertical section of Complex Updraft/Downdraft<br>Kiln from Iran . . . . .  | 133 |
| 2.53 | Schematic present a) front view b) right view of kiln kiln at Klirou<br>on Cyprus and demonstrate heat transfer in tow draft vertical and<br>horizontal [5]. . . . . | 134 |
| 2.54 | a) Chinese kiln for firing color and painting glazes b) small Chinese<br>kiln kiln . . . . .   | 135 |
| 2.55 | Chinese kiln for firing tile and brick with glazes, the glaze layer<br>was produced by treatment during firing . . . . .   | 136 |
| 2.56 | horizontal Chinese kiln constructs of two firing chamber . . . . .   | 137 |
| 2.57 | kiln for firing pottery from end of Bronze Age, it is constructed of<br>two parts [28] . . . . .   | 138 |
| 2.58 | principle of Sérvrier kiln [29] . . . . .  | 139 |
| 2.59 | Egyptian pottery kiln at Maylaouy and Manfalout in Upper Egypt   | 141 |

## LIST OF FIGURES

---

|      |  |     |
|------|--|-----|
| 2.60 | structure of stoneware kiln at Saveignies in France . . . . .  | 142 |
| 2.61 | structure of stoneware kiln that was used for producing salt glazes<br>, at Voissinlieu near Beauvais in France . . . . .  | 144 |
| 2.62 | snake kiln that designed by Naoki Kawabuchi , view of the kiln<br>from side . . . . .  | 145 |
| 2.63 | Hard-soft porcelain kiln that used coal at Laill in france . . . . .   | 147 |
| 2.64 | front view and vertical section of porcelain kiln in Sèvres . . . . .  | 149 |
| 2.65 | cross section in some levels as seen in vertical section of porcelain<br>kiln in Sèvres . . . . .  | 150 |
| 2.66 | details of iron box which is at terminal of iron bar <b>M</b> . . . . .  | 151 |
| 2.67 | details of iron box which is at terminal of iron bar <b>M</b> . . . . .  | 151 |
| 2.68 | flow chart shows the relationship among aesthetics treatments, ce-<br>ramics science and history of firing technologies .as a result of his-<br>torical study. . . . .   | 158 |
| 3.1  | constructive interference explains the Bragg's law . . . . .   | 165 |
| 3.2  | schematic demonstrate atomic structure of (a) composition in crys-<br>tal form (b) composition in glass random network . . . . .   | 166 |
| 3.3  | A two-dimensional representation of a sodium silicate glass. . . . .   | 167 |
| 3.4  | The volume-temperature diagram. . . . .  | 170 |
| 3.5  | window of Maple <sup>TM</sup> program that used for converting unity for-<br>mula to an analysis. . . . .  | 176 |
| 3.6  | window of Maple <sup>TM</sup> program that used for converting an analysis<br>to unity formula . . . . .   | 177 |
| 3.7  | diagrams domestrate the relation between SiO <sub>2</sub> , Al <sub>2</sub> O <sub>3</sub> ratio and<br>brightness of porcelain glazes at coins 10,12,14 and 16. . . . . | 183 |
| 3.8  | The mössbauer spectra of the sky-green glaze raw material at dif-<br>ferent firing temperatures . . . . .  | 188 |

## LIST OF FIGURES

---

|      |  |     |
|------|--|-----|
| 3.9  | Changing of $Fe^{2+}/(Fe^{2+}+Fe^{3+})$ of the paramagnetic peak and magnetic ratio ( $M_1+ M_2$ ) with firing temperature in sky-green glaze<br>(a) $Fe^{2+}/(Fe^{2+}+Fe^{3+})$ (b)( $M_1+ M_2$ ) . . . . .                                   | 189 |
| 3.10 | the relative contents of coloring elements in Ru glaze . . . . .   | 190 |
| 3.11 | Mössbauer spectrum for a sample of Ru glaze at room temperature  | 191 |
| 3.12 | The relation diagram between $Fe^{2+} / Fe^{3+}$ ratio and wavelength ( $\lambda_D$ ) of glaze color of ancient Ru kiln . . . . .  | 191 |
| 3.13 | Binary diagram demonstrates the relative concentration of $Cu / (Cu+Ag)$ and $Ag / (Cu+Ag)$ ratio in luster decoration from Kairouan Iraq and Sicily, and it demonstrates the relation between this relative concentration and color . . . . . | 196 |
| 4.1  | Small shape formed from simulated Ru porcelain body before firing  | 224 |
| 4.2  | Two microscopical photos to sample of simulated Ru porcelain body, before thermal shock and after thermal shock . . . . .  | 226 |
| 4.3  | The simulated Ru glaze recipe R47G fired at 1230 °C a) normal atmosphere b) reduction atmosphere . . . . .   | 227 |
| 4.4  | Apply the simulated glaze of R47G on the surface of simulated R47b porcelain body . . . . .  | 228 |
| 4.5  | The firing schedule to avoid bubbles appearing . . . . .   | 229 |
| 4.6  | Sample of Simulated Ru Guan porcelain that fired according to the firing schedule (4.5) . . . . .  | 230 |
| 4.7  | Successful simulated sample (R47) of Ru Guan porcelain with crackle treatment, according to calcined glaze recipe and firing schedule (4.5) . . . . .  | 230 |
| 4.8  | Successful simulated sample (R47) of Ru Guan porcelain with crackle treatment, according to calcined glaze recipe and firing schedule (4.5), with thermal shock at 100°C . . . . .   | 231 |
| 4.9  | Esthetic treatment of crackle, created by thermal shock at 900°C.  | 236 |
| 4.10 | Esthetic treatment of crackle, created by thermal shock at 900°C.  | 237 |

## LIST OF FIGURES

---

|      |  |     |
|------|--|-----|
| 4.11 | Esthetic treatment of crackle, created by thermal shock at 1000°C.   | 238 |
| 4.12 | Esthetic treatment of crackle, created by thermal shock at 1100°C.   | 238 |
| 4.13 | Esthetic treatment of crackle, created without thermal shock . . .   | 239 |
| 4.14 | The net crackle density , image analysis and column chart for sam-<br>ples treated by thermal shock at 900°C ,at 900°C two times with<br>applying two layer of glaze and at 1000°C . . . . . | 241 |
| 4.15 | The net crackle density , image analysis and column chart for sam-<br>ples treated by thermal shock at 1100°C , sample not treated by<br>thermal shock and sample simulated to R74 . . . . . | 242 |
| 4.16 | Typical optical surface morphology of surface crackle glaze is cre-<br>ated by thermal at 900°C, shows the filling of the deep of crack . .  | 243 |
| 4.17 | Thermal expansion of the principal forms of silica . . . . .   | 245 |
| 4.18 | Illustration for compressing cold air interior kiln . . . . .  | 246 |
| 4.19 | The design of jet . . . . .  | 247 |
| 4.20 | Illustration of staying of fluid attached to convex surface according<br>to Coandă phenomena . . . . .   | 249 |
| 4.21 | Illustration for cold front, the contact between cold mass of air and<br>warm mass of air . . . . .  | 250 |
| 4.22 | Illustration of thermal chock treatment interior kiln . . . . .  | 252 |
| 4.23 | Cu–Fe–S system under constant sulfur vapor pressure of 455 mm<br>Hg (60661.51 Pa)[20]. . . . .   | 256 |
| 4.24 | System Cu–S [20]. . . . .  | 257 |
| 4.25 | System Fe–S[20]. . . . .   | 258 |
| 4.26 | Ellingham diagram for the free energy change of formation of<br>metallic oxides [30]. . . . .  | 265 |
| 5.1  | The new kiln for thermal shock and chemical treatments when it<br>is closed . . . . .  | 276 |
| 5.2  | The new kiln for thermal shock and chemical treatments when it<br>is open . . . . .  | 277 |

## LIST OF FIGURES

---

|      |  |     |
|------|--|-----|
| 5.3  | Octopus diagram defining the serves function, principal functions and constraints in the environment of new kiln . . . . .   | 280 |
| 5.4  | relative temperature profile of cold air a) in circular tube b) in jet [31]. . . . .   | 287 |
| 5.5  | Section plan of developed design of jet with details of heat transfer, temperature and vicinity profile during air injection, and design of convex surface of jet and the outlet hole. . . . . | 288 |
| 5.6  | Section plan of tool which is designed to change condition of firing by solid materials . . . . .  | 290 |
| 5.7  | Section plan of tool which is designed to change condition of firing liquid materials . . . . .  | 292 |
| 5.8  | section plan of new kiln a) the position when the kiln closed and b) the position when kiln open . . . . .   | 296 |
| 5.9  | The masonry illustration of pointed arch which is used to design h thatched of kiln . . . . .  | 297 |
| 5.10 | Schematic demonstrate down draft and distribution of smoke and gasses in new kiln . . . . .  | 298 |
| 5.11 | Illustration to determine the equation of arc from relation between the arc and mean circle . . . . .  | 304 |
| 5.12 | Impermanent curve of $\Delta L$ % of Firelite 2500 <sup>TM</sup> as function of temperature K . . . . .  | 308 |
| 5.13 | permanent curve of $\Delta L$ % of Firelite 2500 <sup>TM</sup> as function of temperature K . . . . .  | 309 |
| 5.14 | Impermanent curve of $\Delta L$ % of Able cast 3000 as function of temperature K . . . . .   | 310 |
| 5.15 | Permanent curve of $\Delta L$ % of Able cast 3000 as function of temperature (K). . . . .  | 311 |
| 5.16 | Section plan of pointed dome with anchors which hold the dome part of kiln . . . . .   | 313 |



## LIST OF FIGURES

---

|      |  |     |
|------|--|-----|
| 5.17 | Static Young's modulus as function in temperature for monolithics refractories [32] . . . . .  | 314 |
| 5.18 | Result of total deformations in first two layers of cylinder and circle base which are designed to cast from 17 mm of "Able cast 3000" and 26mm "Firelite 2500 <sup>TM</sup> " . . . . . | 318 |
| 5.19 | Result of equivalent stress in first two layers of cylinder and circle base of kiln structure . . . . .  | 319 |
| 5.20 | Result of stress intensity in first two layers of cylinder and circle base of kiln structure . . . . .   | 320 |
| 5.21 | Result of total deformations in first two layers of pointed dome which are designed to cast from 10 mm of "Able cast 3000" and 14 mm "Firelite 2500 <sup>TM</sup> " . . . . .            | 321 |
| 5.22 | Result of equivalent stress in first two layers of pointed dome of kiln structure . . . . .  | 322 |
| 5.23 | Result of stress intensity in first two layers of pointed dome of kiln structure . . . . .   | 323 |
| 5.24 | The temperature profile in wall of cylinder and base parts of kiln, and the order of refractory materials . . . . .  | 325 |
| 5.25 | Silicone carbide elements in form CU with two leg which is recommended to new kiln . . . . .   | 327 |
| 5.26 | Chart of surface loading in function of kiln temperature and element temperature(recommended for Kanthal GLOBAR SD operated in air) [33]. . . . .  | 328 |
| 5.27 | Conception of new kiln . . . . .   | 330 |
| 5.28 | Plan of new kiln . . . . .   | 331 |
| A.1  | Ellingham diagram for the free energy change of formation of Fe oxides with carbon oxides. . . . .   | 366 |
| A.2  | Ellingham diagram for the free energy change of formation of Cu oxides with carbon oxides. . . . .   | 367 |

## LIST OF FIGURES

---

|      |  |     |
|------|--|-----|
| A.3  | Ellingham diagram for the free energy change of formation of K and Na oxides with carbon oxides. . . . . | 368 |
| A.4  | Ellingham diagram for the free energy change of formation of K and Na oxides with carbon oxides. . . . . | 369 |
| A.5  | Ellingham diagram for the free energy change of $B_2O_3$ and $SiO_2$ with carbon oxides. . . . .         | 370 |
| A.6  | . . . . .  | 371 |
| A.7  | . . . . .  | 372 |
| A.8  | . . . . .  | 373 |
| A.9  | . . . . .  | 374 |
| A.10 | . . . . .  | 375 |

## LIST OF FIGURES

---

# List of Tables

|     |   |         |
|-----|---|---------|
| 1   | Caractéristiques et coefficients spécifiques utilisés pour la préparation des glaçures [18] . . . . .   | xxxvi   |
| 2   | Facteurs pour le calcul de module de Young à partir de compositions chimiques [19] . . . . .  | xxxvii  |
| 3   | Composition en unités de masse qui Doat Taxile utilisé pour produire la glaçure cristalline à Sèvres . . . . .                                      | xxxviii |
| 4   | la Ratio de $Fe^{2+} / Fe^{3+}$ ,longueur d'onde ( $\lambda_D$ ) et couleur de glaçure pour quelque échantillons de ancienne Ru porcelaine. . . . . | xl      |
| 5   | Calcul du pourcentage de matières premières pour la recette de R47b . . . . .   | xli     |
| 6   | Les valeurs calculées des propriétés mécaniques en émail de porcelaine et le corps de Ru porcelaine . . . . .                                       | xlii    |
| 1.1 | composition% en masse of soft-paste porcelain at Saint Amans and Aikin . . . . .  | 35      |
| 1.2 | Composition % en masse of glaze to soft-paste porcelain at Saint Amans . . . . .  | 35      |
| 1.3 | Composition en unite of masse which Taxile Doat used for producing the crystalline glaze at Sèvres . . . . .  | 51      |
| 3.1 | Characteristics and specific coefficients used for glaze preparation[18]  | 182     |

## LIST OF TABLES

---

|     |   |     |
|-----|---|-----|
| 3.2 | Factors for calculating Young's modulus from chemical compositions [19] . . . . .   | 185 |
| 3.3 | The $Fe^{2+} / Fe^{3+}$ ,wavelength ( $\lambda_D$ ) and glaze color for some samples of Ru kiln . . . . .   | 192 |
| 3.4 | The $Fe^{2+} / Fe^{3+}$ ,wavelength ( $\lambda_D$ ) and glaze color for some samples of Guan glaze . . . . .  | 193 |
| 4.1 | Main chemical oxides of Ru Guan porcelain body (RGPD) . . . .   | 208 |
| 4.2 | Calculated values of different properties for Ru porcelain bodies samples . . . . .   | 211 |
| 4.3 | Main chemical oxides of Ru Guan glaze . . . . .   | 213 |
| 4.4 | Calculated values of different properties for Ru glaze samples) . .   | 216 |
| 4.5 | Calculated values of mechanical properties in glaze and porcelain body of Ru Guan kiln . . . . .  | 218 |
| 4.6 | The chemical composition of kaolin d'Arvor . . . . .  | 220 |
| 4.7 | Calculating the percentage of raw materials for batch recipe of Pemco Frit P-54, see appendix (A.0.8). . . . .  | 234 |
| 4.8 | Calculating the percentage of raw materials for batch recipe of glaze that is used for thermal shock treatment . . . . .  | 235 |
| 5.1 | The required data to simulate the total deformations,equivalent stress and stress intensity in two parts cylinder and base . . . . .  | 316 |
| 5.2 | The required data to simulate the total deformations,equivalent stress and stress intensity in dome part of kiln . . . . .  | 317 |
| A.1 | chemical analysis for some clay bodies from Iraq which are covered by luster metallic expressed in oxide percent and normalized to 100%. . . . .  | 343 |
| A.2 | chemical analysis for some clay bodies from Kairouan which are covered by luster metallic expressed in oxide percent and normalized to 100%( $\Delta$ is the standard deviation ) . . . . . | 344 |

## LIST OF TABLES

---

|      |   |     |
|------|---|-----|
| A.3  | chemical analysis of glazes with metallic reflection from Kairouan expressed in oxide percent and normalized to 100% ( $\Delta$ is the standard deviation ) . . . . . | 345 |
| A.4  | chemical analysis of Iraq luster metallic glaze expressed in oxide percent and normalized to 100%. . . . .  | 346 |
| A.5  | chemical analysis of some kinds of wood ,normalized to 100%. . .  | 346 |
| A.6  | chemical analysis of some kinds of lignite ,normalized to 100% . .  | 347 |
| A.7  | chemical analysis of some kinds of coal ,normalized to 100% . . .   | 347 |
| A.8  | classification for oxide glasses based on single bond strength . . .  | 348 |
| A.9  | Temperature equivalents for Orton standard large cones. Source: American Ceramic Society. . . . .   | 349 |
| A.10 | temperature equivalent for Seger standard cones ,source: Staatliche prozellan-manufaktur, Berlin . . . . .  | 350 |
| A.11 | A Cross Reference List Of Comparable Frits . . . . .  | 351 |
| A.12 | Standard glaze frits in order of Fusion temperature from Ferro Company ,Composition in Equivalent . . . . .   | 352 |
| A.13 | weight fraction of each oxides components of Ru Guan porcelain body (RGPD) . . . . .  | 354 |
| A.14 | weight fraction of each oxides components of Ru Guan glaze . . .  | 355 |
| A.15 | Calculating the percentage of raw materials for batch recipe of R47b . . . . .  | 359 |
| A.16 | Calculating the percentage of raw materials for batch recipe of R47G . . . . .  | 363 |
| A.17 | Product Information of dense Concretes <i>Firecrete<sup>TM</sup></i> 95 . . . . .   | 376 |

## LIST OF TABLES

---

# Introduction

CERAMIC, as an art, has interactive relationship between some domains such as arts, history, and science. Therefore reflecting on the nature of the interactive relationship between these domains can be a rational intention, in order to create new prospects for creativity in art and applied ceramics. Normally that creativity aims at the beauty in art, and this can be occurred basing on the information which discovered from the history of ceramics, and this depends on the ability of science represented in the modern technology.

Throughout history, there are many experiences about methods and techniques production of ceramics which have been accumulated, and these experiences are very interesting for everyone who is involved in ceramics especially ceramists artists. And there are many historical and archeological studies which try to discover ancient ceramics techniques that are used in art to produce expressive ceramics art. Therefore Ceramics technology is a multifaceted study involving the technique of manufacturing pottery and organization of the ceramics industry [34].

Simply the ceramics and pottery are considered as one of the oldest activities in the history of human societies, and they are related to human civilization, therefore the developments in the features of human civilization have resulted to developments in the ceramics productions and its embellishment. All civilizations were taking care of them everywhere in east or west. However, the quality and promoted ceramics productions depend on some general factors: *the available*



## INTRODUCTION

---

*materials, the known technologies of production, and the Philosophy and concept of art established*, and these factors were developed from place to place and from one era to another until the modern era in Europe.

Therefore, its aesthetic treatments and qualities were varied from place to place and from one era to another, And despite the great diversity of aesthetic treatments applied on the surfaces of ceramics production, but its stages production are similar to a large extent. Where the principles stages are:

1. Stage of preparing the clay.
2. Stage of forming the clay.
3. Stage of treatments before the drying.
4. Stage of drying.
5. Stage of primary firing.
6. Stage of applied glazes.
7. Stage of second firing.
8. The stage of treatments after the firing.

The implementation methods of each one of these stages are varied from one culture to another, also one or more stage can be added or delete to/of them, this bases on the exitance progress in life, the accumulations of notion in science of ceramics and experiences in technology of ceramics, and the philosophy of art and the spirit of beauty. Consequently, the technology has an effective role on evolving the production of ceramics, and the tools have roles in quality of technology, and due to the relationship between science and technology where technology is seen as "Knowing how" while science is seen as "Knowing why" [35] ,so the advancements of science have an important role in the development of tools which used in producing ceramics. Furthermore, each stage of the producing ceramics stages has specials tools.

There is a strong correlation between the tool and the stage which required this tool. This correlation comes from correlation between the tool and its function, and the correlation between the function and the stage of production. This led to the diversity of plentiful tools in ceramics field. However, the developments in ceramic require developing in design and production the ceramics' tools. And development process colligates with overall stages, and at the end, the developments appear in forms' beauty and function of ceramics products. The finale appearance of ceramics determined during the stage of firing where the clay body converts from Greenware to Stoneware, glazes recipes convert from fine powder to shiny glass phase and color oxides change from primary color to final color. All of these modifications in ceramics production resulted from high temperature which ceramic materials supposed to, so that some chemical reactions occurred and some physical properties changed. And this firing stage required kiln technology.

This firing stage required kiln technology. As kiln technology improved, more beauty treatments for ceramics and pottery surface increased[22], and also the construction of glaze was adapted with this kiln technology. . So one may look kiln as a tool for giving aesthetics treatment to ceramics forms; from importance of firing process, we can understand how ceramists, over long history, take care of the firing process and kiln technology. Where the prehistoric pottery was open-fired .open firing was in surface bonfires or in pits, by this early firing technology the quality of ceramics forms was imperfect, as a result of low temperature, contacting between the vessel and materials that used as sources of burning and difficulties during open-firing where it required added sufficiently coarse or the vessel will explode[36].

When this kiln technology was only available to potters, the vessels decoration was limited to black color which could be exist by smoking during and after the firing, or limited to some texture treatments by stamping or engraving. And

## INTRODUCTION

---

these imperfect quality and limitation decoration urged early potters to originate the oven-firing where pots fired in temporary or permanent oven made of bricks, clay or stone[37],and also these reasons with requiring high temperatures urged early potters to originate firing kiln where it conserve heat better than in case of open-firing and oven-firing, and decorating by colors need drafting the smoke and separating the ceramics objects from the flame[37].

After kiln technology had known in the history of ceramics production, there are a lot of styles of decorating ceramics surface depending on some procedures during or after firing process like wood-fire glaze, ash glaze, salt and soda glaze, and oriental glazes all of this glazes need especial atmosphere during the firing stage and the results of surface beauty are very interesting to many ceramists even in twenty-one century this adjacent to raku-firing and reduction saggar-firing.

In otherwise there are some of glazes, particularly earthenware (faïence) glazes containing lead or tin ,are require protection inside saggars, when fired in fuel-burning kilns. Highly decorated ceramics from Europe like Maiolica, Faïence, and slipware -Terra sigillata- be in the right place in this category[38]. These requirements led to improving kiln designs and use muffle section to separate the combustion gases from the main chamber or main tunnel, also may the development of the electric kiln was useful for these oxidation glazes, where heating is generate from passage electric current in heat coils so there is no fuel burning.

Therefore, searching in history of ceramics and in history of firing technology we can know more about the effect design of kiln on aesthetic treatment to ceramics surfaces.Also these aesthetic treatments from colors and textures of glazes are chemical reactions and physical properties occur during the firing. So the scientific studies to ceramic raw materials and condition of reactions for these raw materials can be useful for producing some aesthetic treatments by modifying the kiln design. Due to correlation between kiln and firing process, the kiln design and technology with organizing raw materials are the confrontation to use

kiln as a tool for making special aesthetics treatments. Considering kiln as tool to create aesthetics treatments requires two main things: the first thing is how we can modify it to control the atmosphere of firing process, the second one is possibility to modify kiln structure, so we can do experimental treatments during or after firing.\* By that modification we can do that:

-Isolate all the factors which have an effect in final appearance to ceramic during the firing process.

-We can change in one or some of these factors which could be modified in final appearance to ceramic.

So I ask:

-Does the firing process affect in the aesthetic of ceramic forms surfaces?

-Are we able to control that process to produce a new aesthetic treatment?

A history of techniques of ceramic in some civilization can give us evidence about some firing techniques that had affected ceramic surface treatments; it could help us to understand how we can start modifying kiln structure. Good studies of chemical reactions in kiln give monitoring, and modifications of the (new) kiln.

### **Problem of research**

The problem of research comes from: Ceramists required modifying their firing tools, especially it could be play an active role in aesthetic treatments of ceramic surfaces. As it is a tool which provides conditions to chemical reactions and physical characteristics that are affected in aesthetic treatments of ceramic forms. So, the problem is determined in design and produce ceramic kiln, which allow for some experimental treatments during and after firing process to enrich

---

\*After firing or post firing: that period of time when the temperature of the form came slowdown to low degree which we can do kind of procedure effect in aesthetics treatments of ceramics surfaces.

## INTRODUCTION

---

the aesthetics treatments for ceramics forms, this kiln provide an influence in reactions and properties conditions to clay and glaze raw materials.

### **Aim of research**

This research aim to modify firing process to influence the aesthetic of ceramic forms surfaces by:

- studying designs and structures to some last civilization kilns which there are affect in the aesthetic treatments to ceramic forms surfaces.

-Studying chemical reactions and physical properties which happened during firing process or post firing to know what we need in new kiln structure.

### **Research hypotheses**

To exist the aims of research the researcher suppose :

1. The historical study to firing techniques and kilns will indicate the potential for modify kilns to affect positively in aesthetics of ceramic form.

2. The possibility of doing operations during and after firing to affect positively in aesthetics of ceramic form.

3. The possibility of modification in designing and building ceramic kiln could do some processes during or after firing which affect in aesthetics of ceramic form.

### **Methodology and research procedures**

For verify assumptions of research; the researcher will use the historical curriculum, analytical curriculum, and experimental curriculum.

### **I-Theoretical study:**

1. Historical study to ceramic kilns and fundamentals designs to these kilns in some different civilizations
2. Scientific study for chemical reactions and physical properties which happen during or post firing, and factors are affecting it.
3. Analytical study to different applications which influence aesthetic of ceramics surfaces during firing or post firing.
4. Analytical study to kiln structure and its parts.

### **II-Experimental study:**

This depend on the historical, scientific and analysis studies:

1. Do experimental examples to test the theatrical and history study.
2. Design ceramic kiln could use to firing ceramics forms and could use to do some experimental treatments during or post firing

## INTRODUCTION

---

# Chapter 1

## literature review

THIS chapter briefly introduces a literature review of correlations between art, science, history and history of ceramic technology in referring to kiln technology and firing process. It focuses on the relationships between some discipline and ceramics, general factors which effect in promotional ceramics productions, important role of history in ceramics art, and the important role of science to improve ceramics technologies. Moreover the dynamical relationship between firing technologies in history and the aesthetic treatments on ceramics surfaces are mentioned. Conclusions concerning the kiln as a tool deserves attention to enrich the beauty of ceramics forms.



# 1.1 Relationship between some disciplines and ceramics

## 1.1.1 History

The historical studies are related to several domains as result of concerning events and human activities where history seek to understanding the events and put it over timeline. For this aims the history use all evidences, the pottery and ceramic as an oldest applied activity is related to aspects of life from prehistoric, and ceramics forms are used for a functions and decorations. So ceramics have important role in history as follows:

a. Where ceramic is evidence which can be used to knowing some information about trading between civilization and the other where ceramics products have distinctive features varies from culture to another.

b. Where ceramics are used to indicate about the development societies, where the improving in ceramics techniques require scientific discovering to prepare raw materials and achieving high temperatures.

c. Where decoration pattern and style of art which are used to decorate ceramics forms are important to understand the concept of art in some civilizations.

And also history gives very important information to ceramists about:

a. Past technology of ceramics and their tools which are used during history for producing the ceramics forms. Where historical studies about ceramics tools and technologies describe the deferent methods of producing ceramic and record the development in the ceramics technologies and their chronologies.

b. Description of all types and styles of ceramics, also history refer to some factories and famous trademarks, classification of the bodies and glazes of ceramics, and study of colors and decorations patterns.

Due to this study is concerning to some procedures which occurred during or after firing which enrich the aesthetics of ceramics shapes; so history of ceramics

technology is important to describe some of these procedures, and in otherwise it helps to understand the methods of producing these style of ceramics and understand the sequence of improving of firing ceramics and put these improvement on timeline to compare between technical of firing and finale appearance to ceramics shapes which is the remarkable to every ceramists.

### **1.1.2 Archeology**

Archaeologists studies search in investigation history of groups of people and understand development of entire culture based on their material and physical remains to describe and classify artifacts, known the relationships among sites, and build cultural chronologies [39]. Ceramics and pottery are oldest artifacts; they have deep roots from prehistory, wherefores they are very important for archaeologists as a material that can be found in all sites. At the same time the archeology give notion about:

- a. The ceramics materials like: clay, slip and glaze and what is deferent among these materials from culture to another.
- b. The kilns sites and their structure and how and why it was changed from culture to another.
- c. The factories places and their systems of production in addition to discuss why and how it was improved from culture to another.

Due to this study is concerning to understanding how and why development of kiln and firing technology changed, and due to we are interested in this study to knowing evolution of the role of culture, technology and raw materials in determination the beauty of ceramic products and their promotion; so archaeology studies that pertain to ceramics raw materials, ceramics firing technology, and kilns sites are important in order to provide us by necessary information to design the kiln which be used as tool for enrich the beauty of ceramics forms. Additionally, archeology reconstructs the history of cultures and it relies on methods of

## LITERATURE REVIEW

---

excavation, survey, sampling, collection, and relative and chronometric dating[39]. So the relationship between history and archeology is considered.

### 1.1.3 art

Art in contemporary philosophy is a matter of controversy; because there are many views about what is the art. And for answer this question, and discuss the concept scientifically, we have to involve in the philosophy of aesthetic and beauty of art but this is a huge work to do here. this controversy comes from the natural of beauty of art where is not as external perceptible, it is an inner object , and it is present to sensation depending on human intuition, so beauty has often been regarded as purely subjective pleasure, or a merely accidental sense [40]. and with the modification of human cultures and knowledge also the perception and awareness are changed , thus the views about what is art are developed. Despite of this, there was a familiar idea of the work of art, and it determines what is work of art. These common ideas of art take the three following heads[40]:

- a. the work of art is no natural product; it is brought by human activity
- b. the work of art is produced for apprehension by men's senses
- c. the work of art has an end and aim in itself

From the beginning, that a work of art is a product of human activity, there are some points of views are revealed over history to discuss issue of art, and they considered it as one of human activities, and they discuss how these views affect the styles of art works. It is important to mention these points of views. Despite every one of these views have some false aspect but they had effect and still effect in ceramists' beliefs about art works of ceramics.

According to these points of views, the relation between ceramics and art will be known, since ceramics are a human activity and we will discuss these philosophy views as following:

- a. This point of view considered this activity as conscious production of an external object, it can be known and expounded, and learnt .That in addition

## RELATIONSHIP BETWEEN SOME DISCIPLINES AND CERAMICS

---

to the rules of artistic production, and it would only be a matter of everyone's pleasure. In this view the ceramics forms and its surface beauty treatments could be imitate, it could be formally regular and mechanical. However, this mechanical aspect is an external kind that only purely empty exercise of well. Additionally this view gives value to the dexterity and the precision. Thus, production process conducts in accordance with prescriptions calculated for practical application[40]. From these procedures, mass production of ceramic and also ceramics crafts were claimed as an art. Consequently, all stages of ceramics production were learned as skills lead to special aspects for ceramics objects. In the stage of firing, ceramists aim at controlling the conditions and heat temperatures to do them every time by same manner.

b. In this point of view, the natural activity has been modified from a product of general human activity to a work of an entirely specially gifted spirit, nevertheless a conscious reflection interfering with its own instinctive-like productive activity. So the work of art has been claimed as product of talent and genius. Since talent is specific and genius universal capability. This view reverse role of technology in producing art, whereas it considers the work of art is a work of an entirely specially gifted spirit[40].

Thus the ceramic art, in this point of view, has been correlated to ceramist talent and his especial capability. So every ceramist, when they design, model, or decorate a form of ceramic, seek showing himself and his sense individually by producing a especial ceramic form style, and a surface treatment such as texture, colors, and sculpture. The competition between each other ceramists and each other manufactories has led to improve art of ceramics and make variety in applied method of each stages of ceramics production. They looked for uniqueness in production. From this, ceramist chose firing technology and kiln structure that help him to achieved aesthetics which are desired to show his talent and genius.

c. This point of view illustrates the place of a work of art in relation to external phenomena of nature, since a look at things comes from the notion that the human art-product ranked below the product of nature. The work of art

## LITERATURE REVIEW

---

has no feeling in itself and is not completely enlivened. Whereas the alive is an organism elaborated into all its tiniest parts, a work of art attains the appearance of life only in its surface. so art is more than aggregate of fundamentals elements which constitute a work of art ; Here a work of art is originate from the spirit, belongs to the territory of the spirit, and what has been formed in harmony with the spirit. Thus work of art is higher than any natural product which has not made a journey through the spirit. Also living thing in nature is transient, vanishing, changeable in outward appearance ,while the work of art persists and its having made spiritual inspiration conspicuous[40].

From this point of view, ceramists aim at decorating ceramics forms and their surface by natural appearance with spiritual inspiration. In ceramics art, the ceramist has using some elements to make a journey through the spirit: form, sculptor, colors and painting, and aspect of metallic. Ceramists have expressed themselves by these elements on surface of ceramic, and these expressions have to be permanence. Outward permanence appearance of ceramics forms usually came after firing. Therefore conditions of firing process effect in outward appearance of ceramics, so firing technology is important for completing work of ceramic art.

d. According to this point of view, an art work is made by man as creation of his spirit. Human activity which is a mode of self-production in external things which is present in work of art and it is not only with external thing, but no less with himself, and with his own natural figure. Therefore beauty is doing deliberately alterations in things, in artist himself, and his own natural figure.

Art is required as man's rational need to lift the inner and outer world into his spiritual consciousness as an object in which he recognizes again his own self[40]. Thus, beauty of ceramics forms is a highest aim, and it seems to bring what is inner ceramist into sight and knowledge for himself and others, which is in distinction from others actions, since this aim is present in form of ceramic. However, here the ceramist has started to get spiritual freedom, but that related to technology of producing ceramics projects where all of ideas will present in form of ceramics. Recently, ceramists are interesting to create new designs depending

## RELATIONSHIP BETWEEN SOME DISCIPLINES AND CERAMICS

---

on improved technologies of produced ceramics. They improve ceramic body materials for getting a higher ability for formation and whit color for body, if it is required in final appearance for design. They improve the glazes structure for achieving new color and texture could be used in new designs for ceramics surfaces in way of presenting the creation in work of ceramic art. However, if we are looking to the technology of firing as process that gives the ceramics form a final outward appearance, and if we imagine the variety in outward appearances that might exist by changing the condition of firing process, then the improving of kiln technology will be considered as tool for enriching ceramics surface artistically, since kiln technology will be method for creation. In all of these points of views about that idea which consider the art is a human activity; the technology it was important for producing art. Therefore where the concept of art was, the technology of producing ceramics was considered particularly the firing technology.

### 1.1.4 Science

Science attempt to understand how and why phenomena occur, focus on the "natural" world, belief in empirical information, value placed upon objectivity, codify into laws or principles, and test and refine the hypotheses[35]. Ceramics is an art reliance on working with clays and glazes, since clays are a natural composed of fine-grained minerals and the main mineral is a "kaolinite" and its chemical composition is  $\text{Al}_2\text{Si}_2\text{O}_5(\text{OH})_4$ , also glazes in raw state are composed of fine-grained and its chemical compositions are written in molecular unity formula which is called Seger formula . In addition, ceramists need to understand physical properties of clays and glazes through all stages of producing ceramics particularly during firing process.

From the considered relationship between science and ceramics, science explains nature of clay and glaze, understand how and why clays were decomposed sedimentary from rocks, explain ceramic color, and explain empirical information about clays and glazes, and influence of heat on clays and other minerals. Design

## LITERATURE REVIEW

---

and producing ceramics tools are considered, since it needs to understand the phenomena that are used for design and to produce this tool. Actually, these information and methods which are required to improve discipline of ceramic art related to science, in other word, development in ceramics productions depends on scientific discovers which are related to ceramic materials, ceramic applications, or ceramic tools.

So there are divisions of science that look at notion which helps in improving ceramics technology. Therefore, it is useful to mention the relationship between science and technology[35].

### 1.1.4.1 Relationship between science and technology.

Relationship between science and technology prove the direct relevance between art and science, whereby technology is a process that includes all terms of "knowing how" while science concerned with understanding phenomena and "knowing why", therefore, the information which exist as result of "knowing why" will bring achievements in "knowing how" so as to provide original possibility, easy performance, rapid performed, and quality of making. Technology is a creation system beyond the basic of ceramic work, wherefore relationship between science and technology is important for designing and producing new tools.

Scientist is seen as interested in understanding the principles, while technologists are seen as interested in making things and invention objects, tools, and machines. M. Kranzberg and C. Ppuursell define technology as:

"Man's effort to cope with his physical environment and his attempt to subdue or control that environment by means of his imagination and ingenuity in the use of available resources"[35]

From this definition, technology has existed before science and human used it to shape the physical world, and history of technology had little relation to science, for men could make tools without understanding why they worked, but the developers of technology in history refined their methods by learning from

## RELATIONSHIP BETWEEN SOME DISCIPLINES AND CERAMICS

---

other practitioners , observing all aspects of their environment ,and experimenting . With improvement of science in eighteenth century, technology began to use more scientific understanding to solve its problems, therefore scientific research became more important source of new technologies.

”Historically, technological research is considered somehow less ”pure”, and less lofty than science. The origins of these attitude lie deep in history of western culture. Among the Egyptians and the Greek, fabrication was done by slaves or low artisans.”[35]

With the 18th century in Europe, when many people began to emphasize the importance of science and reason, the attitude toward technology became positive and the interplay relationship between science and technology had established. As Francis Bacon considered that science has to be useful in developing technological innovation, and he mentioned to attempting to manipulate the nature technologically, for understanding it clearly[35]. and he suggested that the re-organization of knowledge and science is important to produce ”a line and race of inventions that may in some degree subdue and overcome the necessities and mysteries of humanity”[41].

In the 19th century, this relation became completely grown with the establishment of ”Ecole Polytechnique” in France, Germany, and technical school later in United State. These universities aimed to apply science into technology, and they played a most important role in expansion of technology at the end of century , and that was existed by using science to solve technological problems rather than to advance knowledge [42] In Europe, pottery making transformed from peasant craft to sophisticated industry ever since the relation between ceramic technology and science was established, and with experimentation to reproduce Chinese hard-paste porcelain. By this imitations there are many soft paste were given as well as the beautiful delft ware which produced for first time by German chemist J.F.B?ttger, it was in 1710 , at royal factory was set up at Meissen (near Dresden) in Saxony.



## LITERATURE REVIEW

---

At the French Nat. manufactory Sèvres second hard porcelain was produced in 1768 by P.-J. Macqre chief chemist in Sèvres [43] in this era which is considered a period of emerging transformation pottery to fine ceramic relation between technology and science was achieved at all famous factories in Europe by role of chemists to imitate hard-past porcelain. From relation between ceramic technology and science, new aesthetical applications for fine ceramics were appeared, and it has included new past for clay body, new glazes, and new method for firing and kilns.

### 1.1.4.2 Relationship between science research and art.

The relationship between science and art is modified over history as a result of exchanging between philosophies, where science and art were united before Renaissance, when artist was likely to be the person who had wisdom and a good observation. But with beginning of Renaissance a specialization was established in the West. Science was arranged as a segregated set of processes and world-views while art moved in its own direction, ignoring the agendas of science. From the beginning of industrial revolution, science has inspired technology more than art[35]. Despite the divergence between science and art since the Renaissance, nevertheless there are some relations between them that could explain the important role of materials and technology in arts, especially ceramics.

As designer's ideas are embodied in physical entity which is raw materials. The artist's ability to present the concept of work with aesthetical appearance comes from his ability to control and subdue materials. So science helps artists to accomplish these requirements. Due to a concept of artworks stem from the vision of artist, and the artist is the most one who realizes his requirements, and due to part of these requirements related to understanding properties of materials. Therefore the relationship between science and artist's necessities led to enriching the artistic vision and aesthetic treatment. Where, it enhances artists' ability for embodying the artistic vision.

With more reflection on relationship between art and science, we find that it includes a direct relationship that is to develop tools, technologies, and materials which are required for artistic production. Where artists search into new capabilities, and we find also that it includes an indirect relationship, which is illustrated by science influence on life, thought artist, and human culture.

## **1.2 Alexandre BRONGNIART (1770-1847)**

M.BRONGNIART has revitalized the porcelain manufactory at Sèvres, after he became the director in 14 may 1800 and remained so until his death in 1847. This revolution in the factory was due to the ability of Brongniart to achieve the correlation between art ceramics and other disciplines. Where, he was chemist and mineralogist, and he was cultivated to understand the neoclassical esthetic. So, he wrote many treatises on mineralogy and the ceramic arts. Brongniart study many ceramics samples of different culture which was necessary for creating ceramics museum , and he presented more of historical technologies, and he developed the technology of firing as well as color preparation after his traveling in Europe for this reason[44, 45]. The birth and upbringing of Brongniart in artistic home are affected in his attentions to art and science. He was born in 2 February 1770, and he grown up with wearing course to art and chemistry where his father was the fumes architect Alexandre-Théodore Brongniart (1739-1813), and his uncle was the fumes chemist Antoine Brongniart [46]. Brongniart's father was architect and decorator. He became member of France's Académie des Beaux-Arts in 1781[47],and he designed and drew numerous famous sites in Paris such as palais de la Bourse[48],and Boulevard des Invalides [49].

So, Alexandre Brongniart has owned a variety of experience about art according to career of his father, and his experience about science was promote by means of his first chance of success in natural history in 1779 to instruct the course of natural history at the Central School (l'École centrale), in France, also

## LITERATURE REVIEW

---

after working as a mining engineer in 1794 [50]. When he was 30 years, he was appointed by the First Consul to be director the Manufacture de Sèvres , due to surely through his treatise on (L'Art de l'émailleur) the art of enameling (1791) and its relationship with Claude Berthollet, who recommended him because he saw Brongniart as a man combining interest in art and chemistry expertise.

In order to understand how Brongniar was chosen to position of director of the Sèvres Porcelain Factory, the great change in political of France coincided with emergence of Brongniar in scientific activities. Where, the political changes were linked to scientific adventures and technological evolution. Thus the progress through science and its relation with politic necessitated to find new administrator and to provide instruction. Chemistry played an important role in applied fields at this period, so the scientists was sat on the Comité de salut public (Public Health Commission), and the École centrale des travaux publics was established, and later it become the École polytechnique which aimed to qualified the students in general scientific training and refining their qualification in specialized schools such as École de Mines. In this period, the École polytechnique was assigned to train the military for short time and civil engineering for long time.

Alexandre Brongniar participated in this mission and he wrote " I was part of the corps des Mines before the existence of École polytechnique" [21]. Alexandre Brongniar was the person who has a background that combines between science and art, therefore, appointed him to revitalize the porcelain manufactory at Sèvres was logical, especially he was close to political circles. In 1807 he published his work " Traité élémentaire de minéralogie, avec des applications aux arts" (Elementary treatise of mineralogy with application to arts). The breadth of Brongniar views between art and science was clearly presented in this work. He illustrated the correlation between theoretical information of science which involve in " Knowing why" and applied technologies which involve in " Knowing How", where the investigate new processes and mechanical inventions interested him and he traveled to numerous country to gather suitable objects for collocations of museum, as well as he attended scientific congresses. During this travels,

## ALEXANDRE BRONGNIART (1770-1847)

---

he succeeded to make others mineralogists tended to objects that give him advantage, and he succeeded to make them more cooperative with his requests for access, information and samples. Brongniart, during his trips, made extensive records of all things that he thought they are important for improving manufactory, where he was interested to past-making materials, technologies and capacity of kilns, and he drawn sketches of tools and kilns, and he given particular attention to new ideas in fabrication methods and history of ceramics[21].

He visited London from 23 September to 26 October 1802, and after his return to Paris, the Wedgwood's famous and fashionable "black basalt" ware was successfully simulated [51], this mentions that Alexandre Brongniart's experiences in mining, art and science helped him in transfer technologies and find alternative local raw materials to imitate and improve styles of ceramics which interested him in his travels. In 1812, Napolion sent him to visit manufactory of porcelain and workshops and kilns in German, where he aimed to learn about firing technologies in Berlin which was different from those at Sèvres and also about kilns that used less fuel in Bohemia[52]. In 1820, he traveled to Italy, from there he brought plat of porcelain and fine earthenware from Vicenza and le Nove . In Venice, he was attended to the soft-past porcelain which was produced by Cozzi factory. In 1824, the secretary of the academy of Sciences in Stockholm invited Brongniart to Sweden. During this travel, he visited the royal manufactory in Copenhagen and he brought, from there, fourteen pieces of hard-paste porcelain decorated by blue underglaze color. In Denmark, he selected some black pottery which was given a high luster by burnishing. In Sweden, he visited the Rörstrand factory and he obtained fourteen pieces of fine earthenware which used there and they have a typical range of ground colors. Between 1835 and 1836, he planned to visit Rhine in Belgium and Holland where the ancient production of faïence, and to visit Strasbourg, Mayence and Stuttgart. He selected glassware which were rich colors, and plate with ridged color from Frankfurt and Bonn, and he obtained teacup produced at Gotha factory which is decorated with a view of Bonn [21, 53].

## LITERATURE REVIEW

---

He had made numerous travels, varied between London, Staffordshire, Berlin, Dresden, Bohemia and Bavaria. The members of Royal Society helped him to visit the Staffordshire ceramics factories, and in London, he attempted to get an idea of the character of porcelain, earthenware, and stoneware products. He examined the Worcester porcelain at the request of Reverend W. Buckland a professor of mineralogy and geology who combined him during this travel in London. Also, he was interested to some samples of raw materials which he taken them from Thomase Grainger, where they confirmed that the English use of crushed bone in their past. He continued in his trip plan to visit Stonebridge in Birmingham to get idea about its stoneware factory. In Wood factory in Burslem, he admired the large quantities of production, and he visited Fürstenborg factory to review the recent advances there. Then he traveled to Berlin, and the director of Royal Porcelain Manufactory, Christoph Georg Frick, received him warmly. In Meissen, Brongniart got the chance to examine the new machine for shaping plats [21].

Brongniart during these travels discovered many technologies and necessary information to create the new direction to the porcelain manufactory at Sèvres under transferring scientific and historical information to applicable technology to produce art of ceramics. He focused in to important things the kiln and available materials. He decided to improve Sèvres porcelain paste to became the superior to that of Paris, and to be less expensive, easier to work, less subject to damage in firing, receptivity to colors and gliding, allowed for better glazing, whiter, more resistant to changes in temperature, and producing edges and relief details that were finer. Brongniart emphasized that the physical properties of materials were important in improving quality of paste as there compositions [21].

He reproduced painted and background colors such as ultramarine blue which was imitated of that from Vienna, and green of chrome. while the gliding was applied by using gold with sulphate of iron or mercury and after firing it polishing by agate to make difference effects of polish and mate surfaces of gold color [54].

Also, modifications of kiln technologies were taken in account, where Brongniart recognized from his trips the importance of firing process in improving sophisticated ceramics. He attended in measuring the accurate temperature of firing as possible, thus several test pieces were placed inside the kiln each firing [7]. In 1842, he organized new construction of kiln. He preferred wood as fuel instead of coal and peat.

The produced works, while Alexander Brongniart was director of the manufactory, were divided to a decorative works such as elaborate vases and centerpieces, and to functional works including different types of table services pieces. New forms were added to works productions such as zarf, a kind of cup holder variety of drawings of ornamental patterns were explored in this period. Many artistes, architectures and designers were included in the manufactory team to enhance the esthetics values of produced works. Brongniart's father designed the particular vase called "*Jasmin*", the figure (1.1) show the sketch of this vase. The form of this vase was among the first created in this period. Alexander Brongniart sent to Alexandre Evariste Fragnored, in 1815 the details of memo which was received from duke of Saxony-Gotha to request design and produce a small coffeepot with Turkish form, impressed earthen russet ground, dark brown, to contain only two cups and he request it with bronze handles gilded. Figure (1.2) shows the sketch of this coffeepot.

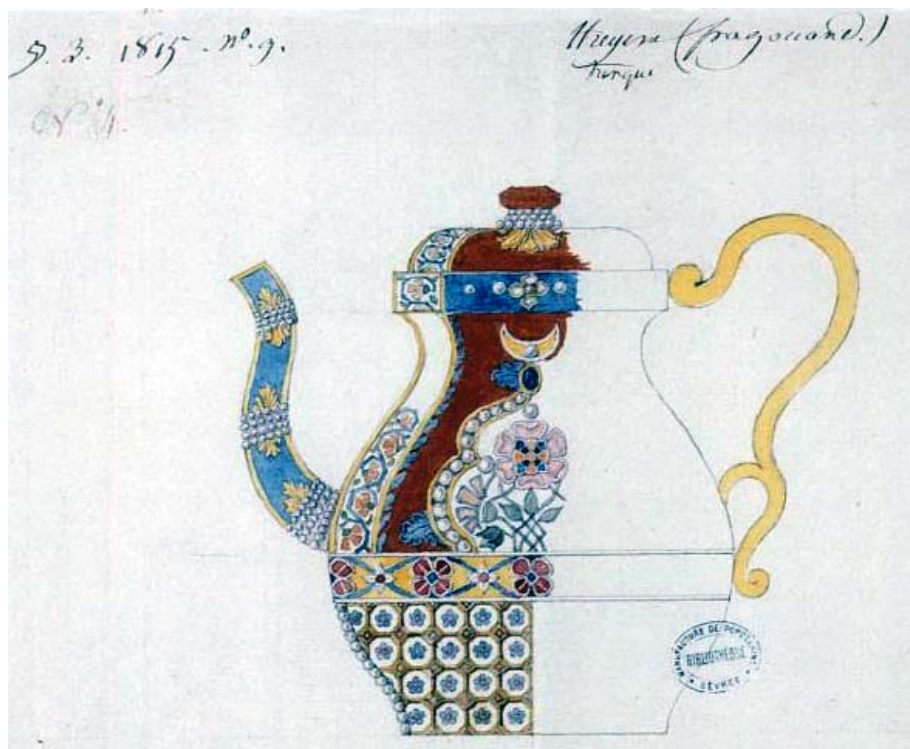
After Fragnored design the coffeepot, Brongniart sent the proposed pieces to the duke, who resent the drawing with some comments. The formes of coffeepot have done immediately by Charles-Antoine. Three Theière 'Turqué' teapots were presented for sales in 18818, one of them was sent to the duke. He was invented to produce some decorative vases withe some others smaller and sampler for the curt of kiln Louis-Philippe, research about sophistication of historical ceramics suggested several programmes of decoration, in this programmes Jean-Charles François Leloy designed the "*Jasmin Cornet*". Figure (1.3) show the sketch of this famous vase [21]. From Brongniart history with the porcelain manufactory at Sèvres, it was notable that his experiences in science, history, mineralogy and

## LITERATURE REVIEW

---



**Figure 1.1:** Design and decoration for a vase called "*Jasmin*" which was designed by Alexandre-Théodore Brongniart, Paris 1801, at Sèvres factory[21].



**Figure 1.2:** Design and decoration for a coffeepot called "*Theière 'Turqué'*" which was designed by Alexandre Evariste Fragnored, Paris 1815, at Sèvres factory[21].



## LITERATURE REVIEW

---



**Figure 1.3:** Design and decoration for vase called "*Jasmin Cornet*" which was designed by Jean-Charles François Leloy, Paris 1835, at Sèvres factory[21].

art played important role to develop the production process, where he applies his scientific knowledge to discover more sophisticated clay and porcelain body, glazes, colors, kiln technologies and gliding. His father helped him to develop appropriate designs, and he asked new designs from many architects, artists. In addition to the role of political that helped him to get information about historical and modern technologies from different countries that he visited to collect pieces for national museum of ceramics at Sèvres. The accomplishments of Sèvres Porcelain Manufactory under Brongniart's meticulous direction were evidence of correlation between some disciplines and ceramics production.

### 1.3 Manufacture nationale de Sèvres

As for the Manufacture nationale de Sèvres is of great importance in the history of the evolution of porcelain, especially in Europe, could indicate the relationship between science and art of ceramics from history of this factory. It is located in Sevres, France and the manufacture was successively over the political in France, where it was a royal factory, imperial and then national. It was also distinguished in the adornment by gilding. Since 1740, it was still in activity, manufacturing continues to editing objects created. Its production is largely geared towards the contemporary today, and it became in 2010 the city of ceramics, with the National Museum of Ceramics.

In 1740, the Manufacture de Vincennes was established with the support of Louis XV and Madame de Pompadour, to compete with productions of Meissen and Chantilly. In this year, the ancient carpenter who is called Claude-Humbert Gérin discovered that by adding calcined alum in the frit to obtain perfect porcelain. This discovering was used for expansion in the construction of factory. In 1746, the kiln of clay body and glaze was improved, as well as the tunnel kiln for firing decorations colors. In 1748, some recipes of porcelain body, glazes and gilding preparation were bought for improving the quality of productions[55].

## LITERATURE REVIEW

---

In August 1756 the factory was transferred to Sèvres in a building built at the initiative of Madame de Pompadour, near his castle of Bellevue. In 1759, Louis XV had given his permission to operate the factory at his own expense, under the supervision of Minister of State Léonard-Jean-Henri Bertin, the Commissioner Courteille, the director Jacques-René Boileau and chemist Jean Hellot who was assisted by his colleague Pierre-Joseph Macquer. Therefore the production process had grown steadily. In this period the factory Interested in Saxon and oriental decorations as shown in figure (1.4) , the Vaisseau à mât which created in 1757 with remaining the style of baroque[55].

The most important event which shows the relationship between ceramics and scientific experimentation in history of Manufacture nationale de Sèvres is the development of hard porcelain, since the factory has looked to improve properties of porcelain body. The identification of components was the main challenge. The kaolin which was the main component in producing this kind of porcelain was discovered at Saxe regain in Germany, in 1709 . Gérin and his assistant Gravant had used kaolin from Belgium; the factory had sought to acquire some secrets for modifying the properties of porcelain body by buying them from foreign. Macquer had made numerous experiments on French clays. In 1764, a polemic arose between Comte de Brancas-Lauraguais and the chemist Guettard for discovering the kaolin in France and producing the hard porcelain. The results which reached by Guettard was send to research about kaolin in all regions in France by Bertin , and the chemists and geologists including the Archbishop of Bordeaux in 1767 were involving in this research. This interest has led to discovery of a mine of raw kaolin which led to improvement in the qualities of products but also it required modification in production processes. It was required the modification of kiln to achieve the high temperature as well as the glaze and colors recipes[55].

The factory was passed by difficult period during the French Revolution. Despite all difficulties, the increasing shortage of raw materials, timber and gold, the factory never ceased to produce or to innovate. This period was followed by



**Figure 1.4:** vaisseau à mât is used as potpourri of Madame de Pompadour, made of soft-porcelain , Sèvres Manufactory, Paris museum Louver (inv. OA 10965)

## LITERATURE REVIEW

---

the direction of Alexander Brongniart from 1800 to 1847, and in this period the factory was flourished as mentioned in section (1.2).

During the period of the Second Republic, the chemist Alphonse-Louis Salvétat with Ebelmen analyzed the Chinese glazes, and the results of this research were reflected in the aesthetic aspects of sample forms (vases Ly, Bertin). Figure (1.5) show Ly vase. The name of this very simple form of inspired original Chinese is a tribute to R.P. Joseph Ly, who sent to Sèvres en 1844 a report on manufacturing processes and decoration of Chinese porcelain. This style was depended on translucency properties of porcelain body with transparent glaze, where in high temperature firing degrees of translucency of porcelain body differed as a function of its thickness.

Victore Regnault was the director of factory during the period of Second Empire after Brongniart and who was also an engineer in Mines. In this period the steam engine was used for preparing the powder and moving the wheel of forming. Also, the fuels of firing and pyrometric measurements were improved. The chromolithograph was used as method to apply the decorations. The factory under the direction of Théodore Deck improved the ability of forming porcelain clay and permitting to direct work in engraving or relief[55].

Manufacture nationale de Sèvres produced four types of different porcelain. The first is the hard-porcelain (pâte dure) ,it is riche of kaolin and relatively refractory and it used to produce pieces of table service. It is fired at 1400 °C. The second is the Pâte Nouvelle , it used for biscuits and to produce objects that are to be decorated with bright colors . It was fired at 1280 °C. The third soft-porcelain (Pâte tender) is used to reproduce the ancient objects and also it can be exploited in contemporary objects. The fourth is (Pâte Antoine d'albis), it is characterized by white color and it is fired at 1400°C[55].

The relationship between science and art pottery, which was exploited in the factory also helped in improvement of glaze and colors palette which is used to decorate the objects of ceramics. The gilding is one of most important decoration technologies that the Manufacture nationale de Sèvres used it brilliantly and in



**Figure 1.5:** Vase Ly 1850 , Sèvres Manufactory, Paris museum Louver MNC(inv. 4178-2)

## LITERATURE REVIEW

---

a distinctive. The technique of gilding to soft porcelain depends on mechanical preparation by gridding for long time, but for the hard porcelain it is depends on chemical dissolution of gold by aqua regia and then the iron sulfate ( $\text{FeSO}_4$ ) which isolates gold from its solvent[55].

From the history of Manufacture nationale de Sèvres, it was demonstrated that the science of ceramics and its history are important in identification the point which should be followed to enrich their esthetic treatments.

### 1.4 General Factors Which Affecting the Productions of Promotional Ceramics

Quality and promotion of ceramics, throughout history, differed from country to country and from one century to another, due to a level of progress of civilization and cultural in a country during such century play important role in these differences.

There are general factors that can be considered as influential in the advancement of product of Ceramic. We will discuss these factors as following:

#### 1.4.1 available materials

Information Purity of raw material as well other materials that are partially treated by some chemical or physical methods and further materials that are fully prepared in the laboratory used naturally and its availability effect in the quality. Therefore potters have given their attention to scientific research about materials since 1710 AD for production of soft-paste porcelain, bone-china, and hard-paste porcelain in Germany, England, and France and they used the alabaster or marble as fluxing agent, and bone-ash as ingredient. Where quality of clay body became finest in color, hardness, and translucency, as illustrated in Figure (1.6) and Figure(1.7),

## GENERAL FACTORS WHICH AFFECTING THE PRODUCTIONS OF PROMOTIONAL CERAMICS

---



**Figure 1.6:** Biscuit,soft-paste porcelain (porcelaine pâte tendre), Height : 168 mm,designed by E. M. Falconet, Paris 1760,at Sèvres factory

[57].

these ceramic bodies were required for improving surface decorations more than

common pottery, and their composition as Brongniart mention in table n°(1.1)

[56].



## LITERATURE REVIEW

---



**Figure 1.7:** Biscuit, hard-paste porcelain ( porcelaine pâte dur), Height : 220 mm,designed by P. L. Cyfflé, France, 1775,at Niderviller factory,A&V museum,London Nbr: C367-1983

## GENERAL FACTORS WHICH AFFECTING THE PRODUCTIONS OF PROMOTIONAL CERAMICS

---

**Table 1.1:** composition% en masse of soft-paste porcelain at Saint Amans and Aikin

| Saint Amans                      | N° 1. | N° 2. | Aikin                            | N° 3. |
|----------------------------------|-------|-------|----------------------------------|-------|
| Cornish clay                     | 11    | 41    | Cornish clay                     | 31    |
| <i>Kaolin argileux</i>           |       |       | <i>Kaolin argileux</i>           |       |
| Ball clay                        | 19    | 00    | Cornish stone                    | 26    |
| <i>Argile plastique</i>          |       |       | <i>Kaolin caillouteux</i>        |       |
| Flint                            | 21    | 16    | Flint,                           | 2,5   |
| <i>Silex</i>                     |       |       | <i>Silex</i>                     |       |
| calcium phosphate or "bone ash"  | 49    | 43    | calcium phosphate or "bone ash"  | 40,5  |
| <i>Phosphate de chaux des os</i> |       |       | <i>Phosphate de chaux des os</i> |       |

The composition of glaze which used for covering Saint-Amans biscuit soft-paste porcelain is in table n°(1.2)[58]

**Table 1.2:** Composition % en masse of glaze to soft-paste porcelain at Saint Amans

| Composition  | N° 1. |
|--|-------|
| Feldspar <i>Feldspath</i>                            | 48    |
| Flint or Sand Quartz <i>Silex ou sable quartzeux</i> | 09    |
| Uncalcined Crude Borax <i>Borax brut non calciné</i> | 21    |
| Frit-glass <i>Verre cristallin</i>                   | 49    |

So materials have a role that considered as a fundamental in development of aesthetics of ceramic shapes. Raw materials, synthesizing special recipes which

## LITERATURE REVIEW

---



**Figure 1.8:** Vase " avec des cygnes " Soft-paste porcelain. In 1766, at Sèvres factory, louvre museum, purchased 1985 OA11024

compose from these materials, and knowing properties of these materials are used to applying specific aesthetics. Thus these aesthetics are useful for design and produce ceramic shapes. Due to the practical actions of ceramics production process, green-ware shapes should be treated by heating or firing condition which led to change in chemical and physical properties, and these changes determine a final appearance of ceramic forms.

Therefore choosing materials and firing condition are an aesthetical treatment for ceramics surface. There are many aesthetic treatments that have been enriched by attention to make many experiments and researching on materials available, and Figure (1.8) shows aesthetic treatments that resulted from these experiments in the eighteenth century in 1766 at French state manufactory at Sèvres. Where this vas had been decorated by two mains background colors which are whit and navy blue (bleu foncé)with two another colors for decoration

## GENERAL FACTORS WHICH AFFECTING THE PRODUCTIONS OF PROMOTIONAL CERAMICS

---

and painting, which are gild and gray.

- Whit color (N° 2\*. Blanc fixe) was produced in the eighteenth century at Sèvres with this composition:

53% of white silica sand *Sable blanc d'Étampes*, 26% of calcined mixture that compose of 15 unit of Tin for 100 unit of lead *calcine à 15 d'étain pour 100 de plomb*, and 21% of Potassium carbonate *carbonate de potasse*. [58]

- Composition of navy blue color is:

61% of frit *Fondant gris n°2\**.which compose of (66.66% of Minium †, 22.22% of white silica sand *sable d'Étampes*, 11.11% of melted borax *borax fondu*), 13% of Cobalt Carbonate *carbonate de cobalt*, and 26% of zinc carbonate hydroxide *carbonate de zinc hydraté*. [58]

- Composition of gray color is:

20% of Gris n° 12\*.which compose of(68% of frit *Fondant gris n°2\**.which compose of (66.66% of Minium †, 22.22% of white silica sand *sable d'Étampes*, 11.11% of melted borax *borax fondu*), 25% of blue n° 28 T\* which compose of(79% of frit *Fondant gris n°2\**.which compose of (66.66% of Minium †, 22.22% of white silica sand *sable d'Étampes*, 11.11% of melted borax *borax fondu*),7% of Cobalt Carbonate *carbonate de cobalt*, and 14% of zinc carbonate hydroxide *carbonate de zinc hydraté*),25% of frit june n° 41.B\* which compose of(81% of frit *Fondant gris n°2\**.which compose of (66.66% of Minium †, 22.22% of white silica sand *sable d'Étampes*, 11.11% of melted borax *borax fondu*), 12% of potassium antimonate *antimoniate de potasse*,6%

---

\*this code refre to codes that are used in Sèver

†Lead tetroxide, also called minium, red lead or triplumbic tetroxide, is a bright red or orange crystalline or amorphous pigment. Chemically, red lead is lead tetroxide,  $Pb_3O_4$ , or  $2PbO.PbO_2$

## LITERATURE REVIEW

---

of zinc carbonate hydroxide *carbonate de zinc hydraté*, 1% of ferric oxide *oxyde de fer par l'eau* ),and 30% of zinc carbonate hydroxide *carbonate de zinc hydraté* .[58]

The process of gilding require some materials like gold chloride, aqua regia for dissolving gold ,sulphate of the protoxide of iron ,bismuth oxide , borax, and spirits of turpentine[59].

Therefore materials were an issue important for creating many colors and surface treatments to decorate ceramics forms, and some of glazes recipes require special circumstances in firing process.

### 1.4.2 Production Technologies

For producing ceramics forms, materials should be influenced by some circumstances that led to change in physical or chemical properties, and this change is responsible about final appearance of ceramics products. Physical and chemical change related to stages of production, and perfection of producing process depends on technology that used to prepare or form ceramic materials over stages of production.

The final appearances to ceramic forms reflect a point of view of one of ceramists, and we can imagine how the technique which be done to produce ceramics forms is important to get shape and color exactly. We can describe the technique used in the final appearance.

---

\*this code refre to codes that are used in *manufacture nationale de Sèvres*

†Lead tetroxide, also called minium, red lead or triplumbic tetroxide, is a bright red or orange crystalline or amorphous pigment. Chemically, red lead is lead tetroxide, $\text{Pb}_3\text{O}_4$ , or  $2\text{PbO}\cdot\text{PbO}_2$

## **GENERAL FACTORS WHICH AFFECTING THE PRODUCTIONS OF PROMOTIONAL CERAMICS**

---

So, creation of new technique is important to give ceramists more ability to express their viewpoints, especially if they couldn't produce by traditional technique. It is also taken in account for artist's viewpoint. That technical importance is identical in applied arts, and in fine arts, where changing technique will give us variety in aesthetic treatments as fine artists need it. Also controlling elements of technique could give us same treatments for mass production.

So tools and machines which are used in production process are very important to perfect the performance of ceramists for producing ceramic forms with high quality and with especial aesthetical decoration. Tools are varied from stage to another in ceramics productions. There are tools for preparing materials, for forming shapes, for firing, and for applying some treatment after firing.

Tool is linked to the function of performs, and it is linked to one of the stages of production, and this relationship becomes a close relationship between the tool and the stage at which it is used and that diversity and multiplicity of tools in the field of ceramics. Developments in the field of ceramics require a development of production tools. The evolution is linked to all stages and it appears in form and function of ceramic products. Here it is brought to mind that all steps are linked and they are separated only for specification study. In firing stage, all the chemical reactions taking place with some impact on the aesthetics of ceramic form. Therefore it could be a stage qualified to doing some procedures that could be used for enriching ceramics forms aesthetically in this research.

### **1.4.3 Philosophy and Concept of Art**

The concept of art is controversial issue in philosophy. Every artist especially ceramist tends to believe in one of philosophies of art and he is convinced of one concepts of art, so he translates this concept in his artworks, and ceramic forms, and chooses between techniques and also chooses suitable materials for applied art works matching with his viewpoint about aesthetic.

### 1.5 Important Role of Science in Ceramics Art

Science have important role in improving our techniques of applied arts and fine arts, and this is the base that this research stroke and discuss. It appears clearly in ceramics and pottery, ceramists grapple with chemicals reactions and physical properties of clay and glaze. Where science help in classification raw materials, discuss their chemical composition, and discuss their physical properties.

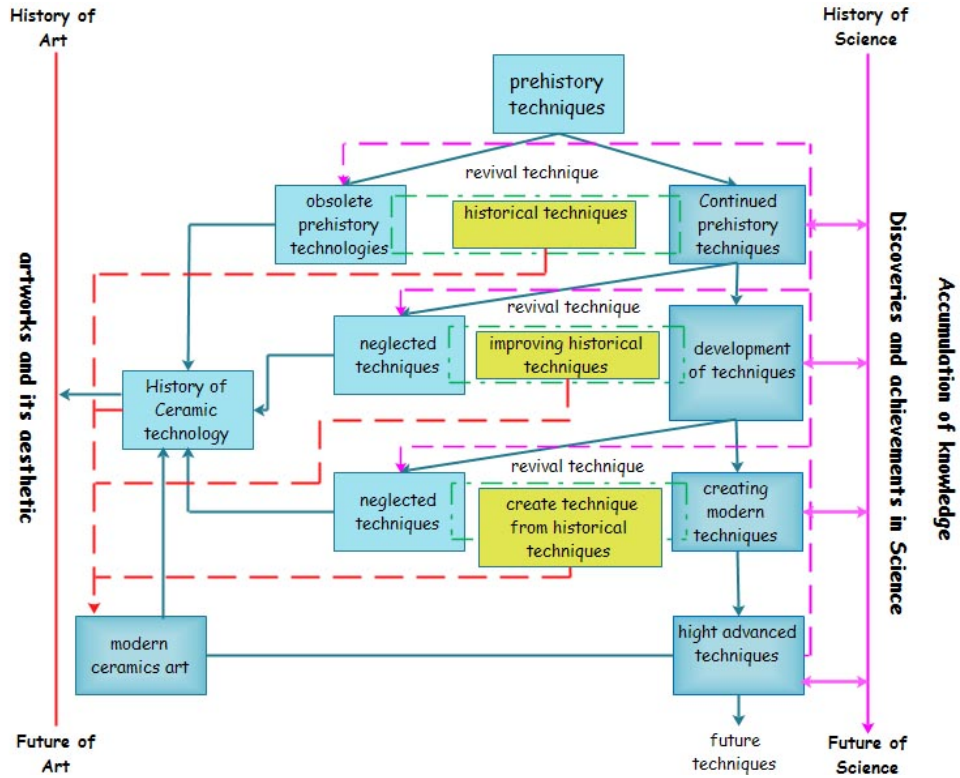
These chemical reactions and physical properties are inherent to high temperature (Firing process), and they have main role in determined final appearance and surface treatment to ceramic form. If the chemical reactions and physical properties, which happen in firing process, are responsible of final appearance and aesthetic treatment to ceramics forms, ceramist can imagine that changing conditions of these reactions and properties are a good way to achieve new treatments for ceramic surface beauty.

Where science provides us by expectations about reactions that could happen during firing process, also it could guide us to prepare a certain circumstance that make an especial reaction to take place on surface of ceramics, and these especial reactions lead to especial aesthetical treatments. As well as science has functional role in calculating the glaze recipes from converting a formula to an analysis and vice versa. In addition, science has a useful role in modifying quality of forming clay, quality of glaze and color painting over or under glazes , and condition of firing.

### 1.6 Important Role of History in Ceramics Art

Pottery has deep roots in human history, so history of technique guide us in this research, where it provide the details about types and styles of ceramics forms which required any treatments during or after firing process , and these treatments obligated to make a special aesthetic appearance . These historical

## IMPORTANT ROLE OF HISTORY IN CERAMICS ART



**Figure 1.9:** A Flow chart show relationship among Science, art, and history

techniques are desirable treatment especially with creative as a concept of art. Contemporary ceramists interest the traditional firing methods, as a result of its ability to make variables and individuals aesthetical treatments. Figure (1.9) shows the role of history in ceramics art.

Where it show how history reserve information about prehistoric and traditional pottery and ceramics techniques. History of ceramics technologies is used by artist for producing modern ceramics art. Additionally, history involve in discovering obsolete prehistory technologies and neglected techniques, so reproducing these techniques are useful to creating modern ceramics art as Figure (1.10) show a ceramic artwork was created by Linda Keleigh in 2003, it is a bur-nished terra sigillata; that is fired by barrel-fired reduction with wood, sawdust, pond grasses, and copper carbonate [60].



## LITERATURE REVIEW

---



**Figure 1.10:** Ceramic artwork (Orb, 2003) created by Linda Keleigh

The technique used to produce this artwork depended on prehistoric firing techniques which called pit-fire, the ceramist improve this technique by reviving the traditional technique, but this exists with modifying some materials, application and tools. These modifications come from accumulation of knowledge and discoveries in science and it aim at enriching modern ceramics art aesthetic and art.

Therefore, history of techniques of ceramic in some civilization can give us evidences about some firing techniques, which had affected ceramic surface treatments; it could help to understand how ceramics aesthetic can be enriched by certain treatments during or after firing process, and by modifying kiln structure. When these evidences are studied within a framework of new science and new technologies, it led to new prospects of creativity.

## 1.7 Correlation Between Kiln Technology and Finale Appearance of Ceramic Forms

Kiln technology is centered on heating ceramic forms, in order to give them hardness and to achieve finale colors. Kiln is a tool that is used for providing this heating process under control. From this common function of ceramic kilns, kiln designers design it as a thermally insulated chamber, in which a controlled temperature regime is produced. Over the history, kilns' structures are different according to a firing process technology, where kilns devolved from open-pit fire or close-pit fire to the kiln structure which copes of two floors, or of several chambers. Development of kiln structure continued till use gas or electric kiln. During these developments, a very high temperature was the first thing required from design to build kilns. According to archaeological excavations in different cultures, there is a variety of models in terms of construction and ceramic kilns: in Japan at thirteenth century, there is the (*Anagama*) kiln that is consisting of a single chamber and single flame dividing pillar. It form like a tunnel which dug into a mountain side.[4] These kilns ware among the earliest to reach stoneware temperatures, but it has no separation between fuel substances in the firebox and ceramic ware .Therefore, the burning wood ash comes into direct contact with ware.[61]With using firing technology of *Anagma* kiln, the outputs of ceramic have quite distinct aesthetic treatments.

In *Anagma* kiln, the heat was reached by controlling, as follows, the heat transferring. Heat was controlled inside tunnel the way of heat loss and by conductivity. While in Greece the historical kilns were expressed as an upward direction of the heat along an imaginary vertical axis. The draft that allows the heat to move upward is caused by an opening at the bottom (the stoking channel) and an opening at the top (the chimney)[5]. The fuel substances were separated from ceramic wares. Therefore a high temperature could be achieved by heat transferring in vertical axe inside kiln structure. In China, there was "additional

## LITERATURE REVIEW

---

types of kilns, the most common being the horizontal kiln (also known as cross-draft or downdraft). There the heat follows an imaginary horizontal axis across the firing chamber and it moves downward before it exits through a tall chimney at the end of the firing chamber, opposite the stoking area” [5]

Vertical kilns could reach a temperature range from 1100 C° to 1150 C° while the horizontal kilns reach temperatures of 1300C° or more, so it is very suitable for firing chinese porcelain.

Therefore, the relationship between kiln technologies and production sophisticated wares is clear, where this technology is necessary to reach temperatures necessary to fire sophisticated ceramics. The sophisticated ceramic wares are necessary for applying most decoration treatments, so the kiln technologies have indirect relationship with aesthetic treatments. Where J.F.B?ttger improved a type of kiln specially for producing delft ware that permitted firing at a temperature of 1300 C° -1400 C°[43].

In aim at reaching high temperatures, the source of heating and the kind of fuel substances were taken into account, where these sources and conditions of fringe have important function in output ceramic wares; therefore there were some kilns structures that were improved to permit special firing technology. Mainly, these technologies produce special conditions necessary for chemical reactions which are designed to do special aesthetics treatments on surface of ceramic wares.

According to the kiln technologies available, ceramists design chemicals properties of input ceramics wares and glazes recipes. In ease of oriental glazes valued for their beauty, the reduction or oxygen-poor atmosphere is required, while the earthenware glazes containing lead or tin are dulled by reduction , requires protection in saggars[38]. Additionally, the raku kiln technology and salt glaze firing are applications to direct responsibility of firing process in ceramic wares for aesthetic treatments.

Therefore the period of firing process is not only a period of heating wares, but more; it is a period of achieving chemicals reactions, and physical properties of clay and glaze. These chemical reactions and physical properties are inherent

## **CORRELATION BETWEEN KILN TECHNOLOGY AND FINALE APPEARANCE OF CERAMIC FORMS**

---

to high temperature (firing process), and they have main role in determined final appearance and surface treatment to ceramic form.

If the chemical reactions and physical properties, which happen during firing process, are responsible of final appearance and aesthetic treatment to ceramics forms, we can imagine that changing conditions of these reactions and properties are a good way to achieve new treatments for ceramic surface beauty.

Therefore in this research, the concept of firing process is more than just heating process; it is chemical reactions that exist during heating and physical properties that change after heating. According to the nature of exothermic or endothermic reactions, it is imperative to subdue firing process to control as precise as possible both mechanical and aesthetic finished of products.

With this new concept of firing process, designers of kilns have possibility to consider the kiln as a thermally insulated chamber, in which a controlled temperature regime and chemical condition are produced.

Based on the correlation between kiln technology and finale appearance of ceramic forms, design and production ceramics kiln have to take into account this correlation and its role in improved kiln as tool to enrich the aesthetics of ceramic shapes. In order to attain this new function of kiln, atmosphere of kiln and heat profile are new taken in account to enrich kiln role in ceramics beauty.

The description of kiln atmosphere is used to express condition which surrounds ceramics forms during firing process, since the firing process is divided to main processes: the first one is preheating and heating process, and second one is cooling process, so the relation between temperature and time of firing process is expressed by heat profile or firing schedule.

### 1.7.1 Atmosphere of kiln as referring to amount of oxygen:

Kiln's atmosphere refers to amount of oxygen relative to the amount of fuel during firing process. Combustible is burned to make heat and amount of oxygen is required for complete combustion of fuel. There are three basic descriptions of kiln's atmosphere: oxidation, neutral, and reduction[22].

#### 1.7.1.1 Reduction Atmosphere

Fuel kilns permit to control the balance of fuel VS oxygen and in reduction atmosphere oxygen is no more wanted to completely burn the fuel. However a light surplus of oxygen is necessary in reduction atmosphere: when amount of oxygen is slightly less than wanted, the reduction state is described as light reduction, if the amount of oxygen is very rare, the reduction state is called heavy reduction, and medium reduction is between that two states of reductions[22].

Reductions states leave their mark on both clay bodies and glazes. Reduction atmosphere modifies color and visual texture. Clay body colors are deepened, sometimes changing to rich orange and red and sometimes to gray colors. Some visual texture is produced by random dark spots when particles of iron oxide have been changed to black iron oxide in residual oxygen of reduction atmosphere. Glazes colors can be strongly modified by reduction atmosphere: for example, copper became a blood red, white glazes begin to have a cream color with a texture of dark spots, iron greens and other colors become burnt oranges and brick reds; sky blues become slate blues. Figure(1.11) show a teapot which is created by John Neely, and he maintained that black body was produced by reduction conditions in his kiln during the cooling period[62].

CORRELATION BETWEEN KILN TECHNOLOGY AND FINALE  
APPEARANCE OF CERAMIC FORMS

---



**Figure 1.11:** "Teapot" with black body was produced by reduction conditions, reduction cooled, and glaze would be redundant, created by John Neely,

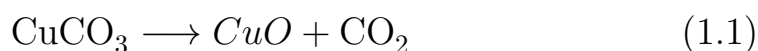
## LITERATURE REVIEW

---

### 1.7.1.2 Oxidation Atmosphere

In oxidation atmosphere the amount of oxygen is more than right amount needed for completed combustion of fuel[22]. In the past this was not easy to do, but with advent of modern kilns it became possible. The fan driven burners which are used in fuel-burning kilns, lent to oxidation firing. Forced induction of oxygen, related to the mandatory presence of fan that used to pass the air inside the kiln with the combustion of fuel, and promote the oxidation firing. Also electric kilns led to the oxidation fire[62]. Figure(1.12) show oxidation firing based on the relation between temperature and oxygen probe atmosphere reading.

In oxidation firing, colorants materials normally convert to their oxide forms. For example, when copper carbonate is fired in oxidation atmosphere or neutral, it will decompose thermally as in this chemical equation(1.1):



Therefore, glaze color more likely to be green and greenish blue, instead of red and oxblood if glaze recipe which contain copper carbonate fired in reduction atmosphere[62].

### 1.7.1.3 Neutral Atmosphere

In case of neutral atmosphere, the amount of oxygen is exactly the right amount that needed for complete combustion of the fuel no more, no less and the fuel is being used efficiently[22]. Figure(1.12) show the neutral firing based on the relation between temperature and oxygen probe atmosphere reading. If the firing process happened in electric kiln and their ports are left closed during the firing, the atmosphere will be neutral or favor a neutral atmosphere[63].

## CORRELATION BETWEEN KILN TECHNOLOGY AND FINALE APPEARANCE OF CERAMIC FORMS

---

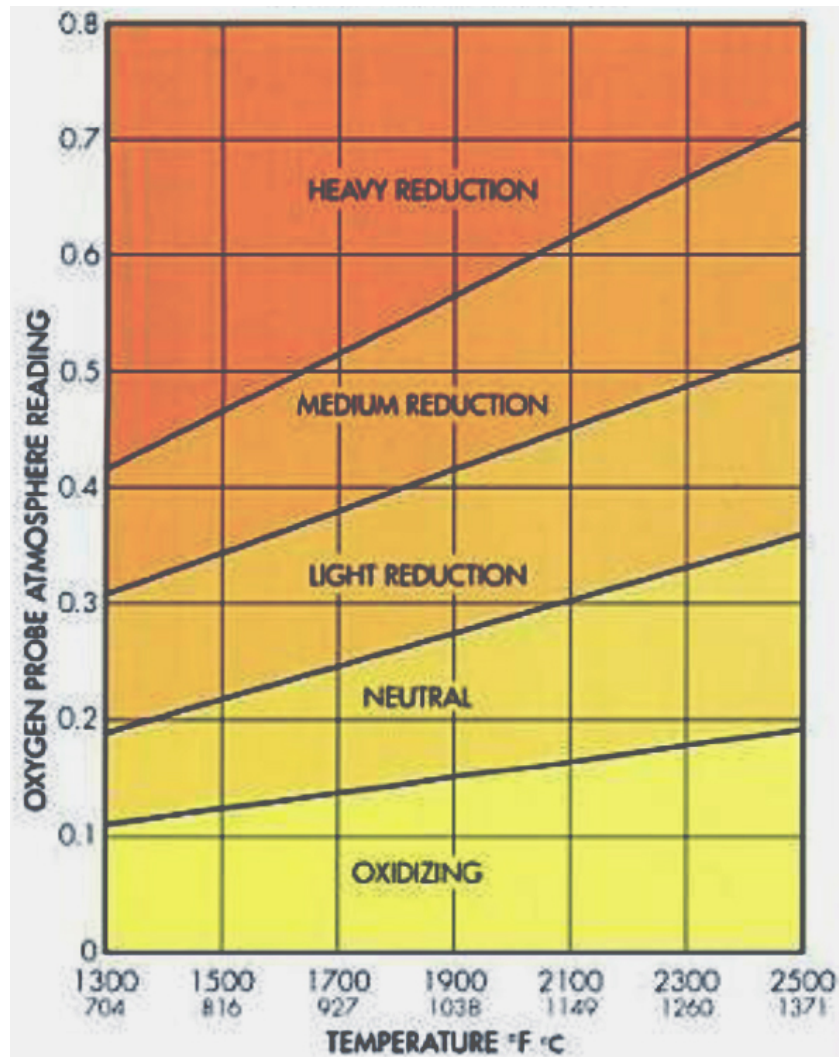


Figure 1.12: Kiln atmospheres[22]



### 1.7.2 Condition of firing as referring to heating rate and inserting vapor of substances :

Condition of firing also refers to a state of inserting vapor of substances into atmosphere of kiln such as soda ash or salt [22]. In this case heat profile is important to mention the effective time to change kiln's atmosphere, also the information about ideal temperature for the desired reactions is important.

#### 1.7.2.1 salt firing

Therefore, difference in the nature of firing process are used for producing different types of treatments on ceramic forms, there is a technique was used for producing ceramic forms covered with salt glaze, which requires a special structure for kiln to allowing passage of vapor of sodium chloride ( $\text{NaCl}$ ) during firing at ( $1232\text{ C}^\circ$  - $1260\text{ C}^\circ$ )[22].and this vapor combines with a portion of silica ( $\text{SiO}_2$ ) which added to clay body to form a layer of varnish salt glaze on surface forms.

A typical salt glaze piece has a glassine finish, usually with a glossy and slightly peels texture, enhancing the natural color of the body beneath as it is shown in Figure (1.13)

#### 1.7.2.2 Crystalline Glaze

It is another technique which depends on firing process strategies with special recipes. The feature of this glaze is characterized by metallic crystals that float on the surface. The spontaneous crystals are formed and grown when glazes are in molten state, while the pieces are cooling in the kiln. Therefore, an especial heat profile is required to produce this special glazes by control the kiln temperature between grow up and slow down in accurate time of firing process. Also for producing this glazes, the low alumina recipe that contained titanium or zinc are required[62]. In 1905, Taxile Doat, the French ceramist, maintained

## CORRELATION BETWEEN KILN TECHNOLOGY AND FINALE APPEARANCE OF CERAMIC FORMS

---



**Figure 1.13:** Walter Keeler, Bowls on plinths, salt glaze, 15 cm high[23]

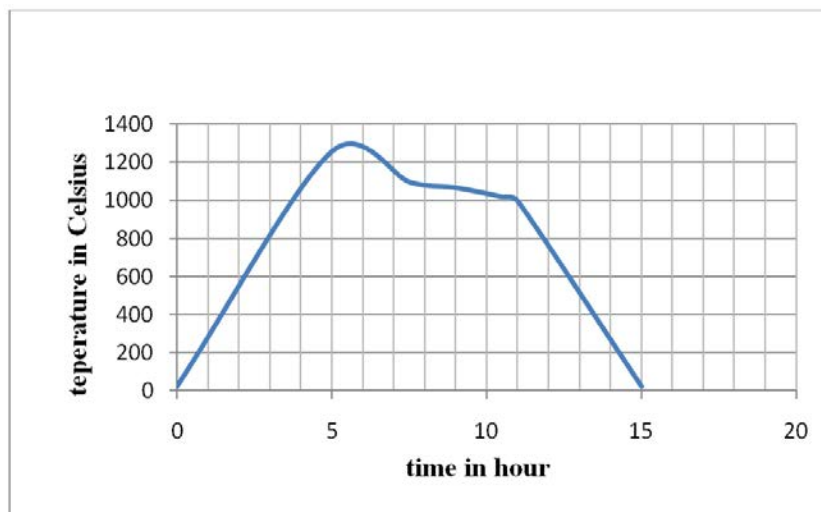
a rustle of researches made at Sèvres about crystalline glazes, and he confirmed that it can be obtained on stoneware as well as on porcelain. He invoked these two compositions which were used for producing the crystalline glaze [64] as in table (1.3). Frit No.1 and Frit No.2 are melted in oxidizing fire, and then various percentages of two frits were being triad. Taxile Doat noted that 85% of Frit No.1 with 15 % of Frit No.2 given him the best rustled, especially for porcelain.

**Table 1.3:** Composition en unite of masse which Taxile Doat used for producing the crystalline glaze at Sèvres

| Composition                            | Frit No.1 | Frit No.2 |
|--|-----------|-----------|
| Dry carbonate of potash, ( $K_2CO_3$ ) | 138       | 069, 0    |
| Zink Oxide,(ZnO)                       | 162       | 202, 5    |
| Quartz, ( $SiO_2$ )                    | 360       | 350, 0    |

## LITERATURE REVIEW

---



**Figure 1.14:** schedule for crystalline glaze as George Juliano firing

Gorge Juliano and Elizabeth Hudgins demonstrate a firing technology of crystalline glazes. Where there firing time /temperatures profile is described as in Figure (1.14), for a cone 9 (1260C°) porcelain firing, they set controller to raise the temperature quickly as possible to 2300°F(1260C°), then drop to 2012°F/1100°C in 2.5hours .Next, they lower the temperature by steps to 1958°F (1070C°) ,1872°F(1022C°) ,and 1832°F(1000C°), time between the step and other step is 1,5 hours[65].

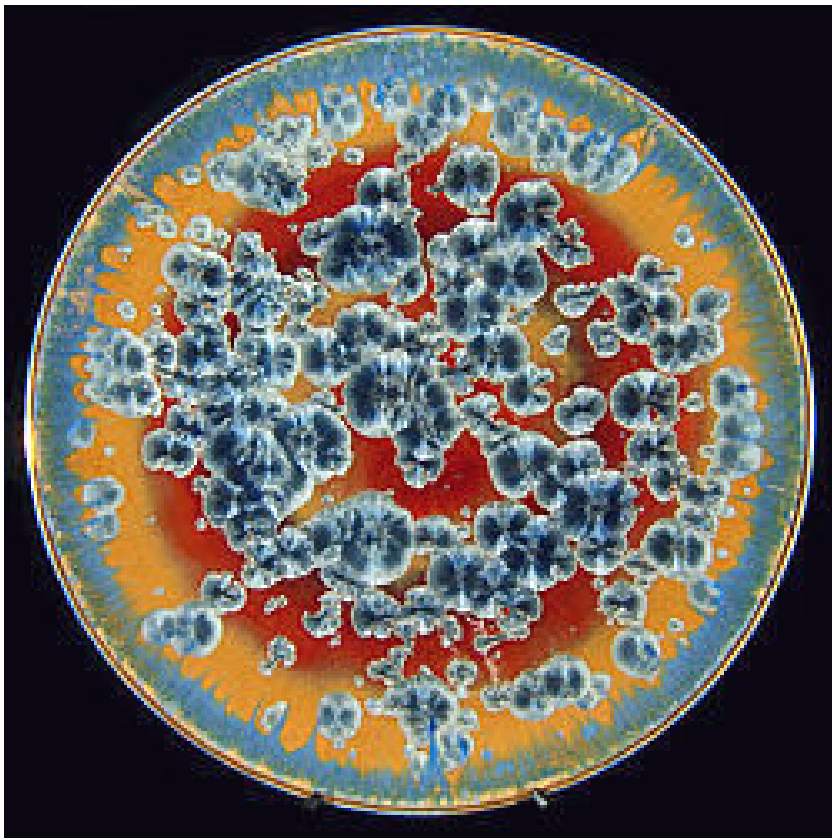
William Melstrom is a contemporary ceramist using crystalline glaze with special reward beauty, and he maintained in his website the role of condition within the kiln in his results. The Figure (1.15) and Figure (1.16) show the special beauty to crystalline glazes which are produced by William Melstrom. Therefore, this correlation, between firing technologies and finale appearance of ceramic forms, is worth attention from ceramists and kiln designers. Also it is worth attention to consider kiln as a tool that permits the conditions for all reactions along the heat profile, not only as a place for heating. Therefore, this correlation, between firing technologies and finale appearance of ceramic forms, is attractive for ceramists and kiln designers.

CORRELATION BETWEEN KILN TECHNOLOGY AND FINALE  
APPEARANCE OF CERAMIC FORMS

---



Figure 1.15: 10 in/25 cm, uranium oxide yellow vase



**Figure 1.16:** 18in /45cm diameter Ruby -yellow platter

Also it is worth attention to consider kiln as a tool that permits the conditions for all reactions along the heat profile, not only as a place for heating. In fuel kilns and in traditional kilns, this correlation is appeared from the influence of combustion gases, smock, vapors, and flame of fire, on chemical reactions; so firing in these kilns connected with particular aesthetics treatments, while it is considered as harmful for other aesthetics treatments. The muffle kiln is created to prevent these harmful influences, while electric kilns prevent the ability to use these influences. The atmosphere of electric kiln usually is natural atmosphere, and it can be oxidation atmosphere by using a ventilator.

### 1.8 Electric kiln

Architectural design of electric kiln differed according to its heating source. Heat is produced by Joule heating: an electric current through a resistor converts electrical energy into heat energy, that instead of heat of combustion which is the energy released as heat when a compound undergoes complete combustion with oxygen under standard conditions. Therefore, the atmosphere of electric kiln in normal conditions is natural atmosphere, where its source of heat not depends on chemical reaction which is a hydrocarbon reacting with oxygen to form carbon dioxide, water and heat. So there is no chemical reactions occurred during firing in electric kiln except the reactions that happen in clay and glaze materials. Some aesthetic treatment is required that and others aesthetic treatment is not required that. Additionally, due to physical properties of electric power and energy, the structure of electric kiln became very simple. It is just a thermal isolation chamber; heat elements and power supply. So it is small and portable, easy to control heating rate and profile, and easy to install and operate.

Suimi von Dassow mentions that studio potters preferred the reduction glazes and the oriental aesthetic, and that required the advantages of firing with electricity worked on methods of imitating reduction glazes in oxidation atmosphere,

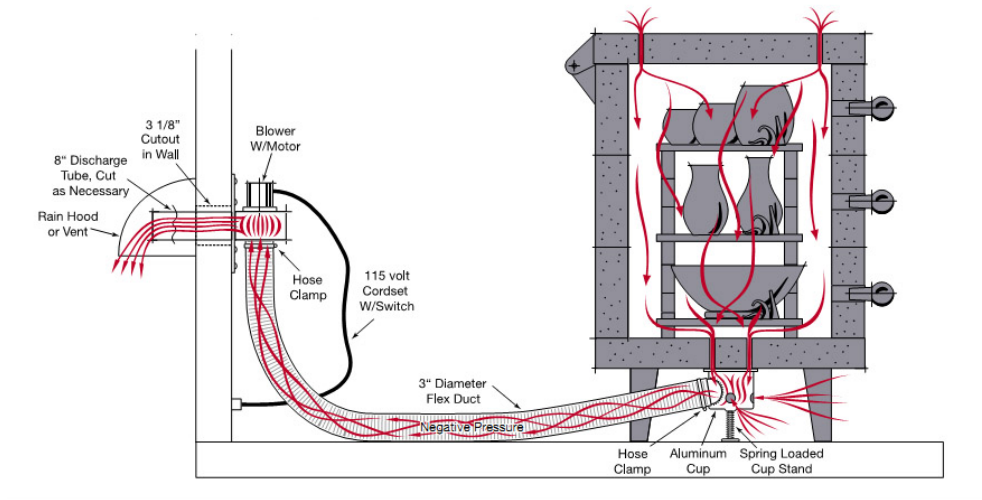
and there some potters discovered special glazes that require oxidation[38]. With increasing the experimental studies on glazes, the glazes which required oxidation are improved, and firing with eclectic kilns have a role to give a special aesthetical treatments. For that, the electric kiln designers invent a ventilator for permitting oxidation atmosphere in the interior of electric kiln[66].

### **1.9 Electric Kiln with ventilation system and oxidation atmosphere**

Until aesthetic of glazes which required oxidation atmosphere are developed successfully, all degrees of reduction atmospheres became undesirable especially during pre-heating and heating periods at heating profile, where  $\text{CO}_2$ ,  $\text{H}_2\text{O}$  and other gases that are released from many materials during these periods. Therefore, providing enough ventilation of interior the kiln is necessary for creating the right conditions (oxidation), which is a considerable parameter in aesthetical results for glazes. Figure(1.17) refer to the kiln with ventilation system that is produced by SKUTT company.

This kiln with ventilation tool changes the conduction of electric kiln from neutral atmosphere to oxidation atmosphere. The US pat. N 4,978,295 refer to this tool which was designed in 1990, and its aim is removing gases and oxidizing organic material normally present in glazes, bodies, and decorations.

Therefore, the atmospheres of kiln and condition of firing process are noted as very sensitive parameter in the process of design aesthetic treatments and decorations. Sometimes it is significantly used for doing special effects in aesthetic treatments, and sometimes it is completely avoids to achieving other aesthetic treatments.



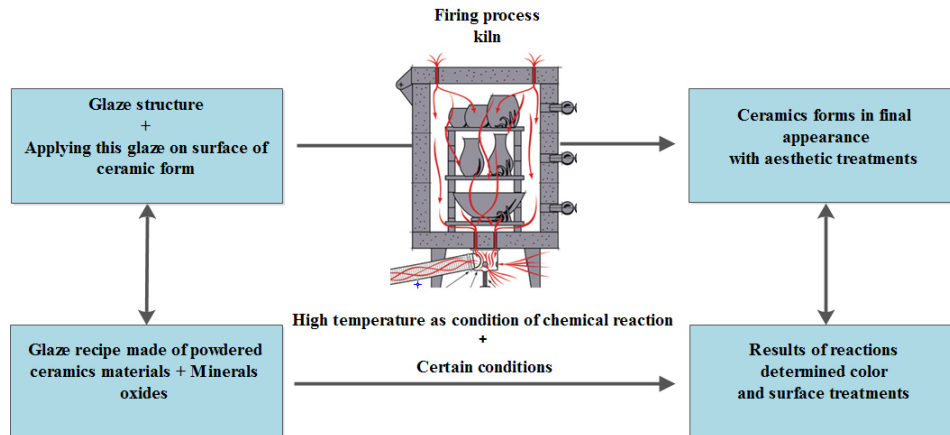
**Figure 1.17:** Electric kiln with ventilation system that is produced by SKUTT company

### 1.10 Kiln as condition to reactions

In Plastic Arts, ceramists are cared by aesthetic and final appearance of products, and consequently by techniques which help them to get their final appearance. Aesthetic treatments determined by the ceramist when he choose the shape , design , colors , and all elements which have any effect in final appearance of products . Artist chooses between techniques for applied art works matching with his viewpoint about aesthetic. It appears clearly in ceramics and potteries that ceramists aim at achieve some chemicals reactions and physical properties, which have main role in determined final appearance and surface treatment to ceramic form. These chemical reactions and physical properties are inherent to high temperature (firing process). Design some change in conditions of these reactions and properties, is a vision to achieve new treatments for ceramic surface beauty.

High temperature considers a main condition that is required for chemical





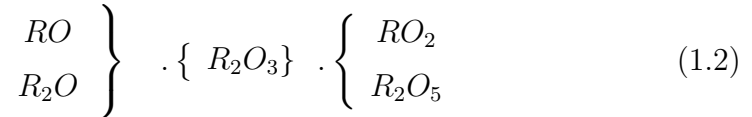
**Figure 1.18:** Chart shows how the kiln considers as conditions to chemical reactions

reactions, so any other desired conditions should be done with particle high temperatures. Kiln is the tool for heating ceramics, so kiln can be considered as a tool to permit the conduction that is necessary for producing ceramics. Figure (1.18) shows a Chart the demonstrate how the kiln considers as conditions to chemical reactions during the heat profile of ceramics forms. Where in facts, glazes structures is chemical materials calculated from chemicals formula, that need kiln (high temperature) for obtaining results of reactions that determined color and surface treatments, and also there is certain conditions which are exploited well in oriental firing technologies, and which can be considered a static coefficient in new firing technologies especially in European ceramics .

Therefore, modify structure of kiln to control conduction with prepare a special structure of glazes to react with particular condition will give a special aesthetic.

- **Glazes structure as in put of reaction** Glaze structure is a component of raw materials which are made from powder ceramics minerals, and it is mixture of insoluble and ground products which melt at a temperature

below the fusion temperature of its components. Herman Seger in 1902 created his formula to find the proportions for  $K_2O$ :  $CaO$  and  $(Al_2O_3)$ :  $(SiO_2)$ [67]. Structure of glazes is given in the formula in three major categories of oxides. The base or fluxing oxides ( $RO$ ,  $R_2O$ ) is the first group written in the left column, neutrals oxides ( $R_2O_3$ ) in the medial column help to control the viscosity of the glaze. Acid oxide or the glass former ( $RO_2$ ) is written in right column as shown in equation (1.2).



Normally glaze consists of a thin layer of glasses[16], and color in glasses is usually given by transition metal ions held in the network as modifiers[68]. So, structures of glazes clearly are chemical materials in a state of waiting the conditions for reacting, and most of recent aesthetic treatments on ceramics forms are designed by changing the chemical structures and color metal ions. Therefore, glaze structures can be considered as in-pup to chemical equations.

- **During firing process:**

During the firing process, raw glaze which is applied on surfaces of ceramics forms with slurry coats; change from powder particle to vitreous or partially vitreous, in sintering process[69]. There are batch reactions which are completed during firing process, and these reactions are of utmost importance to determine the final glaze phase[70] Therefore the final glaze phase is designed before firing process, and it is created during firing, conditions of firing process have an important role to achieve a phase that is designed. Two factors are responsible about conditions of firing process, one factor is

## LITERATURE REVIEW

---

heat profile, and other factor is atmosphere of kiln, where kiln can be considered as a tool to change the final glaze phase by permitting such reactions, or by permitting such reaction kinetics. In addition, changing in physical properties of glaze is existed during sintering process and re-cooling process, where success of firing depends on control of melting behavior[71]. So designing the firing process is useful as well as designing the glaze structure in ceramics production. Considering that the raw glaze is molecular formula that consists of network formers /acid oxides ( $\text{RO}_2$ ;  $\text{R}_2\text{O}_5$ ), network modifiers/ basic oxides ( $\text{R}_2\text{O}$ ;  $\text{RO}$ ) and network stabilizers/ amphoteric oxides ( $\text{R}_2\text{O}_3$ ),[18] whole these oxides' reactions during firing can be known from phase diagrams and chemistry of ceramics ,and the time of reactions on the heat profile can be known from DTA-TG analysis. This reaction can be modified by changing in its conditions. Usually the conditions to ceramics oxides happened in the kiln, therefore the changing in the conditions will be related to design and produce the ceramics kiln.

- **Aesthetic treatment to ceramics surfaces as out-put**

Aesthetic of ceramics surfaces, whether it is coating by glaze or not, depends on color, texture and vitrified coat. Color ions in the network of glasses are produced as results of chemical reactions that occur in firing process. The colors in glazes are classified to: solution colors which are produced in glassy phase by solution and colloidal colors which are "quite different from solution colors, where the absorption of light is caused by numerous particles of colloidal size suspended in the glassy phase[16]." The states of ions, which are the responsible about color, are created during firing. Also the ratio between  $(\text{RO}; \text{R}_2\text{O}):\text{Al}_2\text{O}_3:\text{SiO}_2$  determine the texture and vitrified surface of glaze, and heat schedule effect these properties of glazes.

## Chapter 2

# Ceramics history and firing process

### 2.1 Introduction

**H**ISTORICAL study refers to artistic styles of ceramics decorations and their production technologies. From prehistoric age, pottery has decoration and usefulness functions, and these two functions have impact of each in the other, as well as the impact of technology in both. Therefore history of ceramics art and their technologies have intrinsic worth to explain the artistic value of ceramics that had treated during or after firing process and to describe their production and materials.

### 2.2 Classification of ceramics wares

The classification of ceramics art and pottery demonstrates the different types of ceramics categories. M. Brongniart classified ceramics branches to three classes as following[56]:

1. **First class, soft-paste:**

- 1st Order. Terracotta (baked clay) without glaze.
- 2d Order. Lustred wares with silico-alkaline (ALKALI-SILICA) glaze.
- 3d Order. Glazed pottery with plumbiferous glaze.
- 4th Order. Enameled pottery (stanniferous faience), tin is used in enamel.

2. **Second class, hared-paste (opaque):**

- 5th Order. Fine faience, uncolored paste plumbiferous glaze.
- 6th Order. Stone-ware without glaze, or with salt or plumbiferous glaze.

3. **Third class, Hard-paste (translucent)**

- 7th Order Hard porcelain, paste and glaze both are feldspathic.
- 8th English artificial soft-past porcelain. Paste composes from argillaceous kaolin, pegmatite, phosphate of lime, etc; while glaze contains boraic.
- 9th Order. France artificial soft-past porcelain, paste composes from frit, marly alkaline, while glaze contains alkaline with lead, alkali, and silica.

## CLASSIFICATION OF CERAMICS WARES

---

In this classification, Brongniart made a gradual importance from humble ware terracotta, to artificial finest compounds. Under the topic of translucent hard-paste, he classed soft-past porcelain to one from England which is natural porcelain and other from France which is artificial. The paste of England porcelain is naturally soft, while that of France is made by chemical actions for preparing its constituents. He classed baked clay terracotta under the topic of soft-past also the lustered ware, and these two types are considered from types of ceramics that decorated in some civilizations by treatments that done during firing. This addition to salt glaze which covered stoneware and Brongniart classed it under topic of hard opaque paste.

Young studied the classifications of Brongniart carefully and made other classification which is shown in Figure (2.1)

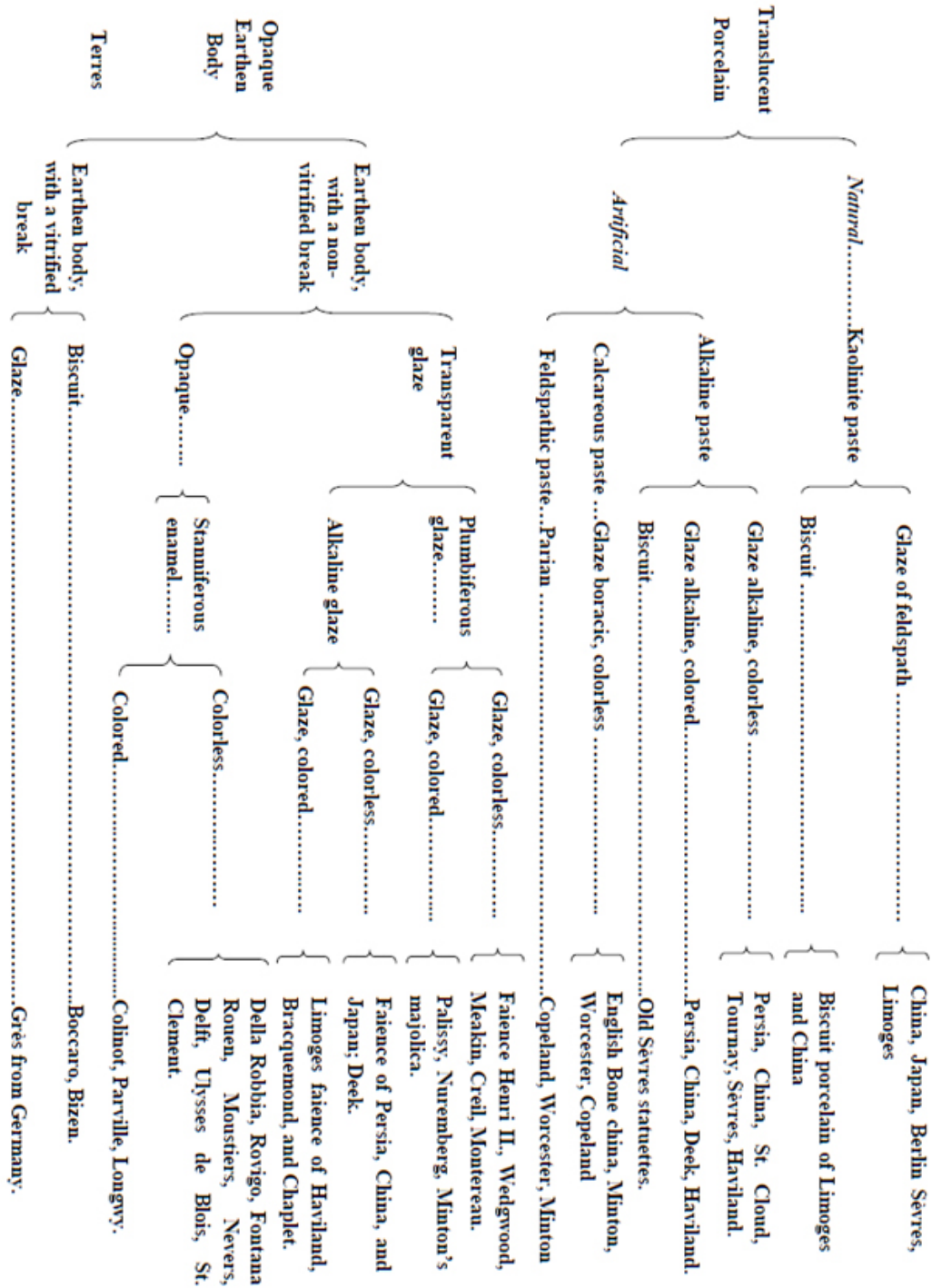
In Young classification, the Chinese porcelain is natural an artificial. The natural one is made from Kaolinie paste, and when it was covered, its glaze was pure feldspath. The artificial one is made from alkaline paste, and it was covered by alkaline glaze colored or colorless.

In this research, aesthete treatments and ornamentations are intended, so these classifications were given by Brongniart and Young. They have special importance in identifying some ceramics wares that were produced in history by making some procedures during or after firing process. Where available historical information about production technologies of ceramics wares refer to conceder some technologies of firing terracotta are used to change its aesthetic aspects, as that done for producing black-topped pottery in ancient Egypt.

In this research, aesthete treatments and ornamentations are intended, so these classifications that were given by Brongniart and Young have special importance in identifying some ceramics wares that were produced in history by making some procedures during or after firing process. Where available historical information about production technologies of ceramics wares refer to consider some technologies of firing terracotta are used to change its aesthetic aspects, as that done for producing black-topped pottery .

## CERAMICS HISTORY AND FIRING PROCESS

---



**Figure 2.1:** chart shows the Classification of types of ceramics ware as referring to Jennie J. Young classification [24]

## CLASSIFICATION OF CERAMICS WARES

---

This type of ceramic is one of the most proficient and complicated wares in ancient Egypt. It was manufactured during the Amratian (Naqada I) and Gerzean (Naqada II) Periods (4000-3000 BC). The black color in the top of pottery is due to a carbon adsorption caused by the organic materials and the firing under reducing conditions. The firing method of the black-topped pottery is considered to be one of two probably methods. One is the firing in which the red color of the body and the black one of the rim are produced simultaneously. The other is the two-step process in which the red-hot vessel is removed from the hearth and placed immediately rim down into organic materials [25].

In the same class the soft past in classifications of Brongniart, the Lusted wares with silico-alkaline (ALKALI-SILICA) glaze is a style of ceramics that produced by reduction atmosphere during firing process, it was produced in the 9th century In Mesopotamia (Iraq), and its technology was transported to Persia (Iran) and Syria[72]. In the 10th-12th centuries it was produced in Egypt during the Fatimid caliphate.[73]

Salt glaze is classified by Brongniart in Second class - hard paste (opaque) -, it applied on Stone-ware. The earliest production of salt glaze supposed to be made in Germany, the first known pieces being made by throwing salt into a kiln in the 15th century at Siegburg in the Rhine Valley. [24, 74, 75].

In third class - hard past translucent wares - in Brongniart classification and in Yang classification- the natural translucent porcelain-, Chinese porcelain in Song density in twelveth century supposed to be made by making testaments during firing process. This types of Chinese porcelain that called Ru kiln\*, Ge Kiln, Jun kiln, and Guan kiln have a net of cracks on glazes surface. Technology of firing is responsible as thinking about this surface treatment. In addition to the role of atmosphere of kiln is important for creating the colors of these styles of Chinese ceramics wares.

---

\*kiln is known as a creating highly prized Chinese stoneware.



## **CERAMICS HISTORY AND FIRING PROCESS**

---

Therefore the treatment during or past firing process is often known over the history and it is nearly done in three class the soft-paste wares, hard-paste (opaque) wares, and Hard-paste (translucent) wares. So these treatments are effective in most class of ceramics wares. That is historical evidence to consider treatments during firing are technique for enriching ceramics beauty, where it used for changing color of clay and glaze and changing texture of glaze . The information about these firing technologies is interested by ceramics artists, and some of these technologies are used by some ceramists to produce their ceramics arts. Rather they give the historical information an additional value to recreate this traditional ceramics, as well as redesign those techniques by using new facilities and technologies, such as figure (1.9) in section (1.6) demonstrates the role of history and science in ceramics.

### **2.3 History of ceramics that had treated during or after firing process.**

Final appearance of ceramics has been center attention for ceramists over the history, and for getting the beauty of final appearance to ceramics they used many methods. Some of these methods related to materials as natural of clay and adding materials, some related to design as forming, impressions, burnishing, glazes, under-glazes or over-glaze and adding relief sculpture, and some related to firing process. The firing process is obligated process to produce pottery and ceramics, so their applications and methods are permanent coefficient in the beauty of ceramics forms. Due to the historical firing technologies depend on Cultural heritage and the nature of societal progress, firing process technologies are different from civilization to another. However, the exchange of knowledge and experience among civilizations has led to development or enhancement of firing

## HISTORY OF CERAMICS THAT HAD TREATED DURING OR AFTER FIRING PROCESS.

---

technology, and usually that development reflected on the final appearance and the beauty of ceramics wares.

There are ceramics wares that were treated during firing process by particle treatment for getting special color or texture on surface of ceramics forms. That is discussed below.

### 2.3.1 Pottery or fired (baked) clay.

Pottery are divided to terracotta (terres cuites), soft-pottery matte (Poteries Tendres mattes), and fine pottery. This ceramics products almost characterized by they are without glazes expiate the exceptional cases. Brongniart demonstrated the Similarities and differences between terracotta and pottery, when he described the terracotta as it is similar with pottery; they are ceramic products which their clays have rough textures, low hardness and porous. Terracotta is used to produce sculpture figures, bricks, tiles, enceinte refractory bricks and tubes for transferring water or heat and smoke, while pottery is a product of ceramic which has a hollow form surrounding by outline curves of clay and it is used as container for liquids and grains[56].

The ornamentations of terracotta or backed clay which is naked clay without glaze, is limited than others ceramics wares, where its colors are determined by the chemical component of its clay and fill materials that are used to modify its properties. Also the historical pottery shows anther black terracotta or pottery. The colors of these potteries are changed by smoke fired when carbon trapped in the wall of forms.

#### 2.3.1.1 Jomon pottery

Jomon ware was made 10,000 BC in Japan and according to present information it is the earliest pottery. It was constructed by hand building techniques as coiling and paddling. This type of pottery was decorated by applying simple designs



**Figure 2.2:** Jomon ware, Beaker and lid. Low-fired red pottery. British Museum  
OA+.20, AN401059

with colored clays, or by scratching and impressing the clay surface to create a decoration of relief. Also the surface of this pottery was widely burnished or polished to give a smooth shiny appearance. All of these aesthetic treatments were made before firing process, while this pottery fired sometimes in carbonized or black fired to achieve color contrast[76]as shown in figure (2.2) and figure (2.3).

### 2.3.1.2 Black-topped pottery

The early method to make a treatment during firing can be seen in the work of the Predynastic Egyptian and Sudanese Pottery 3500 BC. The style of pottery called black-topped pottery or red and black pottery where its top have black-rimmed and its bottom have red color. Figure (2.4) illustrates a style of black-topped pottery which is produced in Naqada period and figure (2.5) illustrates black-topped pottery which produced in Kerma in Soudan 1750-1550 BC. Red and

## HISTORY OF CERAMICS THAT HAD TREATED DURING OR AFTER FIRING PROCESS.

---



**Figure 2.3:** Flame Ware, Jomon Period Ceramics, Japan Tokyo National Museum

black pottery, as it is known, is made of Nile silt clay. It is was a popular ceramic type in Badarian and early Naqada Period and disappeared after the beginning of the Naqada III period, except very few examples. In Nubia his pottery was produced until the end of Kerma period[25, 76].

The importance of this style comes from the existence of two colors the black and the red. In addition to, it have shiny feature which refers to applying polish technique, and the black top refers to a treatment during firing or after firing as acceptable theories explain the technique of produce this type of ceramic.

### 2.3.1.3 Red-black ware

In the Early Bronze age in ancient Cyprus in 2500 BC, there was a type of pottery that its surfaces show a combination of oxidized and reduced coloring. Therefore its surfaces have black and red areas of different proportions. Sometimes the

## CERAMICS HISTORY AND FIRING PROCESS

---



**Figure 2.4:** Black-Topped Pottery Jar, ca. 3500-3300 B.C.E. Pottery, 7 7/16 x  
Greatest Diam. 5 1/8 in. (18.9 x 13 cm). Brooklyn Museum

## HISTORY OF CERAMICS THAT HAD TREATED DURING OR AFTER FIRING PROCESS.

---



**Figure 2.5:** Tulip-shaped Cups, Classical Kerma, black-topped ceramics 1755-1550 BC, Egyptian Museum and papyrus collection -Berlin

colors changed from red to black in the upper part of vessel, or inside a bowl; sometimes the whole forms were blackened. This type of pottery was covered by red slip then polished by a smooth and hard object for producing a high burnish surface; sometimes abstract patterns of incised lines were cut into the clay and filled with a lime to give contrast. The final appearance with black color of this type of pottery achieved by smoke firing where vessel removes from the firing immediately and put it in grass.[76]

### 2.3.1.4 anthracite Black pottery

Smoke firing given different color depending on the degree of carbonization during heating and cooling processes in firing technology. The heating in reduction atmosphere then cooling in oxidized atmosphere make yellowish-buff color, heating in reduction atmosphere and cooling also in reduction atmosphere make gray color and black color is made by fired with an excess of black smoke which make pottery wale absorb the particulate carbon.[77]M. Brongniart mentioned to four groups of soft-pottery and each group of them has different color. The fourth group is a pottery with black color which is a matte or shiny and he mentioned

## CERAMICS HISTORY AND FIRING PROCESS

---

that shiny appearance made either by polishing or by luster anthracite which is depended on the firing process.[56]

The traditional technologies of smoke firing transform raw clay into durable ceramics while carbon from burning materials embeds itself in the clay. It covered with areas of different colors which do not form a regular pattern with blues and grays, leaving cloudy forms around resist materials, or blackening the surface completely. Each smoke-fired piece is a unique record of collaboration between heat, chemistry, and creativity.[76]

This type of pottery which has black luster aspect as known is produced in the Neolithic age[78] in many places in prehistoric world. M. Wu Jinding discovered in the remains of Longshan culture in traditional china type of pottery with a thin wall and it have a luster black color [79] as shown in figure(2.6).Also in roman in the Neoliteic age, this type of pottery was found and it was a common pottery[80] ,as same as it found in karma classic culture in Egypt and Soudan [81]. Moreover, it was produced in India, in medial of France, and in Holland black brick was produced by same technique. The color aspect of this pottery is like coke. Brongniart presented that this black color exists by smoking or may by introduced coal in the clay body [56]. This type of pottery has black color similar to the color of anthracite or it has similar color of black diamond when it dyed by brown color. Its layer of luster is very hard and thin[56]. Figure (2.7) present A jar-shaped olla from Indians Mexico civilization, it is completely black ware which is known in Indian culture [82].

Despite this method has its roots in traditional pottery, but its technological simplicity lends itself to today's artistic improvisation and experimentation[76]. There are some communities that still produce this type of pottery in Africa, and there some experimental studies had made to discover the technique and determine the treatment that is made during firing process to obtain the black luster aspect. Where Pierre-Alain Capt, is an Archeoceramiste working on the restoration of ancient ceramic techniques. He reproduced this type of ceramics and figure (2.8) show one of forms that were produced by him and how he smoke

HISTORY OF CERAMICS THAT HAD TREATED DURING OR  
AFTER FIRING PROCESS.

---



**Figure 2.6:** Eggshell thin cup from Longshan Culture discovered in Shandong, China, Peking University





**Figure 2.7:** A jar-shaped olla with completely black luster, from Indian civilization.

it after firing. The piece was buried in sawdust when it is hot. In the extraction, it is still smoking. The figure(2.9) show the aspect of luster black treatment when the piece became cold.

### 2.3.2 Ceramics with glazes .

The earliest only glaze was known for ancients that mainly made up of silica ( $\text{SiO}_2$ ) which can be able to fuse by introducing an alkaline such as potash \* or caustic soda<sup>§</sup> , and it is always colored by mineral oxide which is added to compositions or which is diffused from surface of clay-body. In ancient Egyptian pottery this type of glaze was thick , but it was thin in Roman pottery [56].

---

\*Potash is the ordinary name for different manufactured salts that contain potassium in water-soluble forme[83].

<sup>§</sup>Sodium hydroxide(NaOH).

HISTORY OF CERAMICS THAT HAD TREATED DURING OR  
AFTER FIRING PROCESS.

---



**Figure 2.8:** Smoking form of ceramic in sawdust to obtain luster black ware.

Produced by Pierre-Alain Capt.



**Figure 2.9:** luster black aspect appeared, when the form became cold.

## **CERAMICS HISTORY AND FIRING PROCESS**

---

The plumbiferous glaze was common in Greek culture from Antiquity to the Renaissance. The plumb-stanniferous opaque glaze which is considered as the enamel is used to cover the enameled pottery which is called common faience, majolica, and faience with stanniferous enamel. This type of glazes was used for pottery fine and pottery matte, the glaze of stoneware is plumbiferous, while other glazes which used for translucent ceramics, porcelain, are feldspar or alkaline glaze[84]

With this information about the glazes modification over the history, the firing process and treatment during or post-firing are important in changing the finale appearance of the ceramics wares with glazes. Over the history, not only there were some styles of ceramics which glazes is influenced by treatment during firing process, but also there was some glazes created on the surface of ceramics by one or more treatments during firing ,as well as, there some aspects was created by the same way. Despite of the effects of doing treatment during firing or post-firing are varied, but there are two main different treatments depending on the time of treatment on schedule of firing. The first one is existed after heating period complete outside the kiln or firing place as raku ceramics technique. The second one treatment happens during the heating or cooling period inside the kiln or firing place.

### **2.3.2.1 Stone were with led glaze (Raku ware )**

Raku ware can be considered a modification of fringe method for anthracite black pottery. The modifications are in chemical composts of glazes which applied on surface of Raku ware, where in raku the treatment happened for glazes composts while in anthracite black pottery the treatment happened for iron oxide in clay. This style of Japanese pottery originated in Kyoto area of Japan during the Momoyama period (1573-1615) that is usually used in the Japanese tea ceremony, most often in the form of tea bowls. Its glaze is low fire lead glazed technique that is transported from Fujian, China. Raku pots were placed in a small indoor

## HISTORY OF CERAMICS THAT HAD TREATED DURING OR AFTER FIRING PROCESS.

---



**Figure 2.10:** traditional red raku tea bowl, red earthenware; clear glaze courtesy of art complex, Museum Duxbury.MA.[8]

kiln, quickly brought up to firing temperature then they were removed from the kiln to cool in open air. In Japan, there were two traditional types of raku back raku which fired more slowly than the other type red raku. Figure (2.10) shows a red raku tea bowl,(8.4×9.4 cm), created by Chojiro (1516-1592) and figure (2.11) show black raku tea bowl,(9.5×10.2 cm), created by Donyu (1599-1656).[8] The Ogama kiln is used for firing the traditional Japanese Raku-yaki or raku ware, this kiln was built at the end of the sixteenth century.[10]

This style of Japanese pottery originated in Kyoto area of Japan during the Momoyama period (1573-1615) that is usually used in the Japanese tea ceremony, most often in the form of tea bowls. Its glaze is low fire lead glazed technique that is transported from Fujian, China. Raku pots were placed in a small indoor kiln, quickly brought up to firing temperature then they were removed from the kiln to cool in open air. This technique transfer from Japan into western world in 1911 and it became popular popularized in America in the late 1950s. Raku technique in Australia refers to a firing method, which is existed quickly heating and quickly cooling and red hot piece is immediately subjected to some procedures which usually is thrust the piece in organic materials. Therefore, the molten glaze treated by reduction and thermal chock and sometimes the effect

## CERAMICS HISTORY AND FIRING PROCESS

---



**Figure 2.11:** traditional black raku, tea bowl, courtesy of art complex, Museum Duxbury.MA.[8]

of thermal shock increased by water rather than air[85].The aesthetics of western raku ware is varied where the colorants mineral oxides and the glaze structure were diverse, as well as, the combustible materials effected on the aesthetic treatment of surface.

### **The differences between Japanese and western raku.**

The differences are integrally contained in method and philosophy, where Japanese raku is a pottery created by descendants of Raku family for the traditional Japanese tea ceremony. The Japanese raku was attempted just for traditional ceremonies and rituals. Therefore, the traditional Japanese raku ware was not subjected to combustible materials as reduction treatments post- firing.[60]

In western culture, the raku ware was known by Bernard Leach, where he was admired by the fast firing to bowls without break during the rapid cooling .therefore, the raku in western culture it is not tea ceremony. Warren Gilbertson is the first American potter who studies raku seriously.[8] Also the western raku wares are put in contact with some sort of combustible material after removing it from the kin when they are hot , that is means its atmosphere converted

## HISTORY OF CERAMICS THAT HAD TREATED DURING OR AFTER FIRING PROCESS.

---



**Figure 2.12:** western raku ware with treatment metallic glaze from  $\text{SnCl}_2$  fuming, created by James C. Watkins

to carbonized and this treatment was created in unites states of America ,in 1960 by Paul Soldner and others. Therefore the western raku is free from the traditional and culture, it is a form of art and its surface beauty combined between spontaneous and induced effects of colors and textures. Figure (2.12) shows the bird basket its dimensions (10.1×25.4 cm) ,its glaze was Duncan Antique brass glaze, masking-tape stencils was used to decorate the form ; it fired to A 04 and cooled to 800° F (427°C); stannous chloride fuming as the treatment post firing from western raku, created by James C. Watkins [60]Figure (2.13) shows bowl with crackle glaze as a treatment from western raku where most glazes craze from cooling stress when raku fired ,and the carbon inters the craze lines creating crackle patterns , its dimensions (20×5.6 cm) created by Michael Sheba [62]



**Figure 2.13:** western raku bowl with crackle patterns exist as post firing treatment, created by Michael Sheba.

### 2.3.2.2 Stone ware with feldspathic glaze (Shino ware)

This type of ceramics also is traditional Japanese stoneware and its productions required reduction atmosphere. Its glaze contains from 60 to 80 percent feldspar and from 20 to 40 percent clay. It tends to range in color from milky white to a light orange, and it has a spotting, haloing or lining of red or gray. The first Shino was developed in Japan during the Momoyama period (1573-1615)[9]. Also Ogama kiln was used to produce this type of ceramic [10]. There are styles of the traditional Shinos when Shino glaze covers drawings painted in iron oxide, they appear and disappear under the varying thickness of the glaze, creating a magnetic effect. This style is known as e-Shino glaze where (e) means picture, as seen in figure (2.14), a bowl tea from Azuchi-Momoyama - Edo Period 16th-17th century, its dimensions are: high 8.2 cm, mouth diameter 13.1cm, and bottom diameter 6.6 cm. When the drawings are etched into a layer of iron oxide which is then covered in Shino glaze, the result is a grey field with light drawings. This is known as nezumi Shino. Figure (2.15) shows a bowl decorated by nezumi-shino



## HISTORY OF CERAMICS THAT HAD TREATED DURING OR AFTER FIRING PROCESS.

---



**Figure 2.14:** Tea bowl, shino type, Mino Ware with Shino glazes cover drawings painted in iron oxide, Tokyo national Museum.

style from Mino ware 16th-17th centuries, its dimension are: high 11 cm, mouth diameter 28.5 cm.

Like raku ware ,the Shino ware technique has been transferred from Japan to America and it have especial feature[61], where it is often known as carbon trap which is trapping of carbon in the glaze during firing process[86]. This class of Shino glaze called carbon trap Shino, Virginia Wirt improved carbon trap Shino in the early 1970 and it is called the American Shino. Chris Gustin developed her works to improve the aesthetes of American Shino. These glazes are modified from the traditional Japan glaze where addition of 3 to 17 percent soda ash is added to structure of traditional glaze. During the firing process the soda ash emigrate to the surface of glaze, and this situation creates the possibility for carbon trapping because soda ash is soluble. Therefore in heavy reduction atmosphere, carbon will be deposited on the surface of ceramics forms. Melting soda ash will trap





**Figure 2.15:** Bowl, nezumi-shino type, Mino Ware, Azuchi-Momoyama Period  
16th-17th century, Tokyo national Museum.

## HISTORY OF CERAMICS THAT HAD TREATED DURING OR AFTER FIRING PROCESS.

---



**Figure 2.16:** carbon trap Shino tea bowl created by Malcolm Davis.

the carbon and create a solid, spotted black or gray glaze [22]. Figure (2.16) show carbon trap Shino tea bowl created by Malcolm Davis in 2003, its dimension (8.3×7.6cm)[87]

The firing techniques of Raku and Shino wares and Jomon pottery in Japan suggest confirming the hypothesis that considered the firing process technology is an important factor which determines the aesthetic treatments, the structure of glaze has the same importance. Where there were differences in aesthetic appearance between American Shino and western Raku due to differences in the compositions of glazes. Raku glaze is a lead glaze but Shino glaze is feldspathic glaze therefore the effect of reduction atmosphere and smoking firing process was different in its aesthetic treatments. Where in case of lead glaze carbon reacts with mineral oxide, while in feldspathic glaze carbon trapped in the glaze layer.

### 2.3.2.3 Earthenware with luster glaze (metallic reflection)

The first application for glazes with metallic reflections was produced in Iraq during Abbasid Caliphate period (750-1258), in IX century. This technique of decoration was experimented on glass before it was used to decorate the ceramics forms[12]. This type of ceramics was an important development in the history of ceramics, and its technique was improved to be the important decorative style in the Islamic world and it has been transferred also to Europe[88]. Consequently the luster techniques diffused right through the Mediterranean basin, where it was known in Egypt in the end of IX century during the Tulunid dynasty (868-905) and it was continued during the Fatimid period (909-1171). Also it was produced in Kairouan (Tunisia) in IX century[11, 12, 13]. Whatever the Iraq luster glazes were related to the Abbasid dynasty and it has special forms and motifs. M. Mason mentioned that Basra luster wares have motifs and forms that are no other wares like them, excluding the Egyptians Fustat luster wares which may be dated to the last quarter of IX century[88].

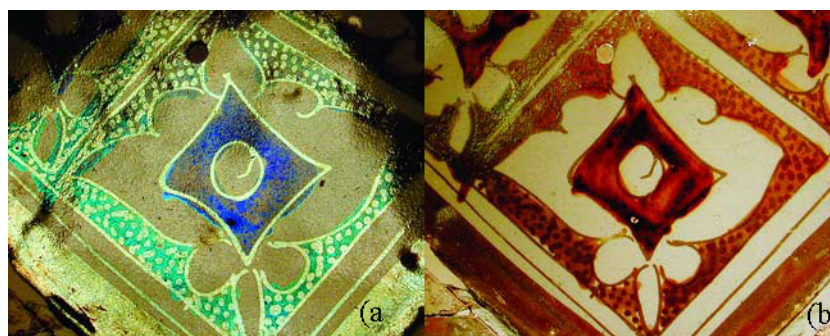
There were two types of decorations used in IX century: the polychrome luster that was rare and monochrome or one metallic reflection color and the figure (2.17) shows the difference between the two types. Where tile (a) is decorated with polychrome luster which is an example of 161 tiles used in the Mihrab\* of the Sidi Oqba mosque in Kairouan (Tunis IX century), and tile (b) is decorated with monochrome luster[89]. It was revealed recently that these types are produced in Mesopotamia and brought in Kairouan in IX century[90]. There are three groups of metallic luster decorations: polychrome with two tones; polychrome with three tones which their motifs are geometrics and floral and they are dated to the second half of the IX century; and the third group is monochrome which its motifs are animal and human, it is dated to the first of X century[89].

---

\*Mihrab is the small space in one wall of the mosque, formed by one part of a wall being further back than the parts on each side and it indicates the direction of Mecca.

## HISTORY OF CERAMICS THAT HAD TREATED DURING OR AFTER FIRING PROCESS.

---



**Figure 2.17:** luster polychrome and luster monochrome glazes used in Mahrab of Sidi Oqba mosque in Kairouan IX century.

There were some colors which are used in type monochrome, only the metallic reflection, gold, red, or silver. This reflection metallic colors technique was used to covered earthenware body in different qualities that may be quality of faience, quality clay normal and sometimes quality of very low temperature terracotta[12].

R. B. Mason presented the chemical analysis for some clay bodies which are covered by luster metallic treatments , from Iraq in , see table (A.1)[88], and O. Bobin present the chemical analysis for some clay bodies which are covered by luster metallic ,from Kairouan , see table (A.2)[90]. These analyses indicate that the clay bodies materials have percents of iron oxides in range from 6.58 % to 9.00% for samples from Kairouan, and range from 5.9% to 6.4% for samples from Iraq. Also these analyses refer to high percents of calcium oxide in range from 20.31% to 22.53% for samples from Kairouan, and range from 19.8% to 22.5% for samples from Iraq. The percents of magnesium oxide are in range from 6.05% to 7.88% for samples from Kairouan and in range from 5.9% to 6.4% for samples from Iraq .That indicate to the quality of clay bodies which was a quality of earthenware and it should be firing in temperature not more than 1000 C°.

The glazes which were used in Mesopotamia in the IX century were diverse and R. B. Mason dived them to three main glazes: alkali turquoise glazes (Turquoise-



**Figure 2.18:** dish of flag-bearer (*plat au porte-étendard*),Iraq ,X century. earthenware, decorated by monochrome metallic luster on opacify glaze,louvre museum,department of Islamic arts ,MAO 23

## HISTORY OF CERAMICS THAT HAD TREATED DURING OR AFTER FIRING PROCESS.

---

glazed class), lead-alkali opacified glazes (Opaque-glazed class), and simple lead glazes (Lead-glazed class). Where Islamic potters known about the alkali glazes of Mesopotamia and the high-lead glazes of the Romano-Byzantine Mediterranean, they developed the two traditional glazes to these three basics glazes[88].

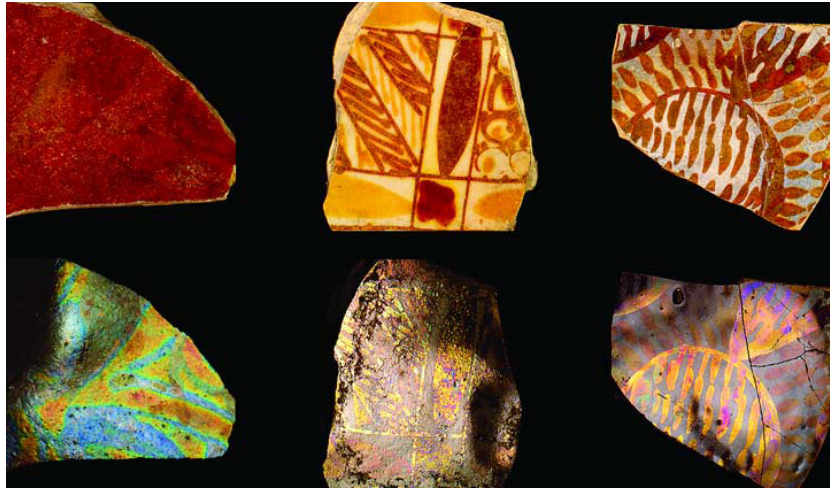
The chemical analyses which were presented by O. Bobin and Mason inform that types of metallic reflections glaze in Iraq and in Kairouan are lead-alkali opacified glazes, and table (A.3)[90] shows the oxides percents which compost metallic reflection glazes from Kairouan and table(A.4)[88] shows the oxides percents which compost metallic reflection glazes from Iraq .The tin oxide was used to give the opacity.

The glaze that is used for this style in Kairouan include from 1.69 % to 4.31 % of tin oxide, from 6.87 % to 9.27 % of lead oxide, from 5.73 % to 7.79 % of sodium, from 4.43% to 5.63 % of calcium oxide, from 2.95 % to 3.84 % of magnesium oxide and from 2.88 % to 3.85 % of potassium oxide. The glaze that is used for this style in Iraq include from 6.5% to 13.1 % of tin oxide, from 5.8 % to 14.4 % of lead oxide, from 5.8 % to 8.7 % of sodium, from 3.6% to 7.3 % of calcium oxide, from 2.2 % to 3.5 % of magnesium oxide and from 3.4 % to 4.7 % of potassium oxide.

These styles of aesthetic treatments for ceramics were modified in IX-X century when this technique was transferred to Sues in Iran. The figure(2.19) shows some fragments which are decorated by metallic reflection polychrome from Sues in IX century and the color view is different depending on the angle of observation and light impact [88]. this decoration was applied on background of white glaze, and it was applied on high silica clay and stanniferous glaze.

In Anatolia .from 1077 to 1307, this technique was used to produce some luster tile and it was decorated by human and animals motifs. In Iran under domination of Seljukds (1038-1194) and in Anatolia under domination of Ayyubids (1077 1307), the paste was used to produce the forms was highly silica and white paste .the glaze which used to cover this paste was sometimes transparent and sometimes lightly opacity[12].





**Figure 2.19:** fragments of glazed ceramics which was decorated by metallic luster, polychrome type, IX century, Sues, Iran.

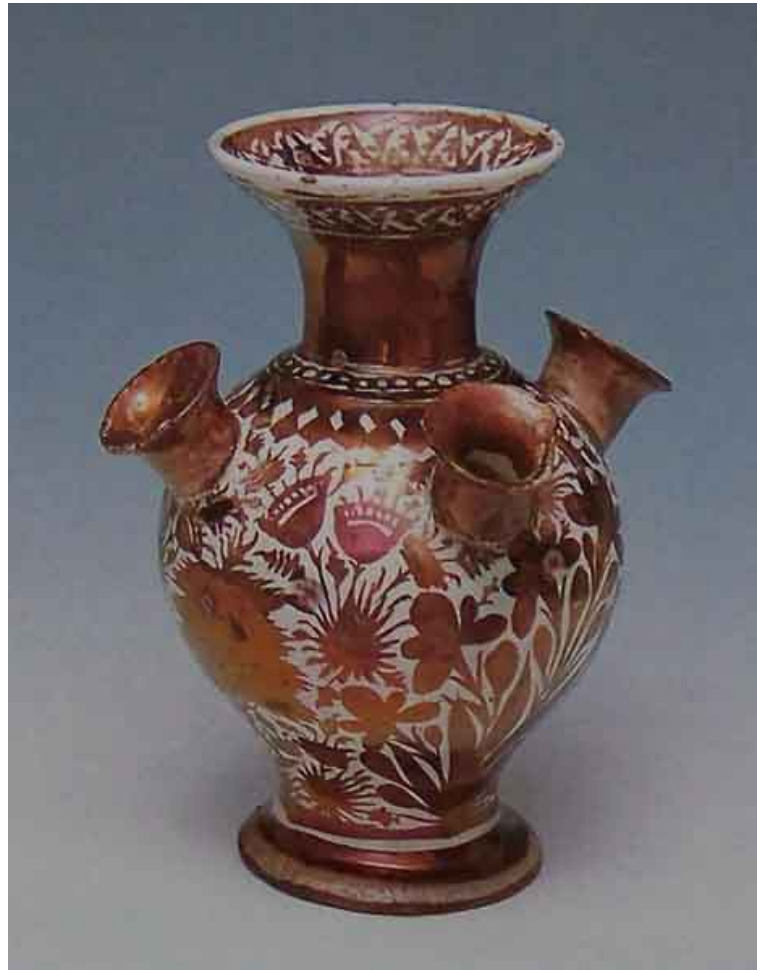
The metallic reflection continued produce in Iran en period of Timurid dynasty XV century in tile form and in (1588-1629).Its glazes was high quality and it was applied on hard-high silica and forms have thin wall and figure(2.20) show one of this ware that are in museum of ceramics Sèvres[89].

Also there were some fragments from Fustat Egypt which indicate that this style was produced in Egypt on highly silica and white paste that was good mixed past. The glazes which were used to cover this paste were transparent sometimes iridescent[91].

The metallic luster decoration and glaze flourished in the second half of XIV century in western region of the Mediterranean[12].The metallic luster technique was produced in Spain and the first examples for this technique in this region were found in Murcia and dated to twelfth century[92]. Then it was produced in large mass at Manises near Valencia where there are many similarities between the luster of Christian Spain and the earlier luster of the south.The ceramics which were produced in this period are called Hispano-Moresque. The Moorish

HISTORY OF CERAMICS THAT HAD TREATED DURING OR  
AFTER FIRING PROCESS.

---



**Figure 2.20:** high quality metallic reflection decoration on opaque glaze and the body was hard and high silica.





**Figure 2.21:** A Hispano-Moresque dish , approx 32cm diameter, with Christian monogram "IHS", decorated in cobalt blue and gold luster. Valencia 1430-1500. Burrell Collection.

craftsmen who had moved from Andalucía actually made the luster ware in Manises during Christian kingdoms[93]. The Moorish potters in Spain developed the ornamentation style to adapt with the requirements of their new societies, the figure (2.21) show the adapted ornamentation with continued use of arabesque tracteries, stanniferous enamel and metallic luster. Some of Hispano-Moresque plaques are superimposed luster and identical. It is of brownish yellow tone, but when the angle of view is changed, the brownish yellow tone is seen a bluish violet[94].

In the early sixteenth century, the Hispano-Moresque luster had some different

## HISTORY OF CERAMICS THAT HAD TREATED DURING OR AFTER FIRING PROCESS.

---

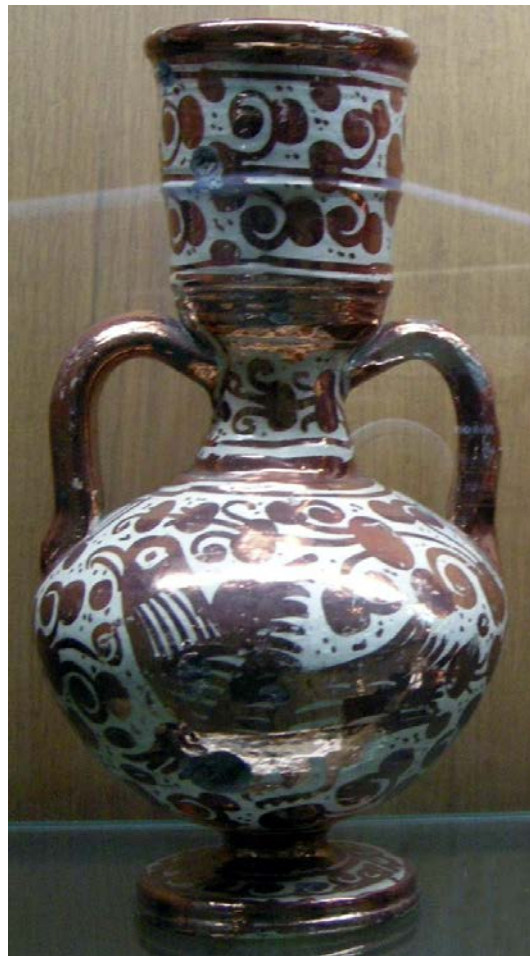
and beautiful luster. It was produced in Muel and Catatayud beyond Zaragoza also in beginning of sixteenth century. In the end of fifteenth century the Moulded cuenca tiles with lustred surfaces were produced by different techniques. Where the tiles appear to have been flooded with luster pigment, and this Seville technique is related to method which is known as cuerda seca . Its clay was covered by glazes of different colors, without any brushwork[93].

During the thirteenth to fifteenth centuries the metallic luster decorated Hispano-Moresque which was tin-glazed was widely exported through the Mediterranean Sea. The transparent lead glaze was also produced in considerable large amount. The copper-like color of metallic luster was produced in fourteenth century instead of the gold-like color which was known in thirteenth century[95] The figure(2.22) shows two-handled pot was decorated by copper-like color on tin-glaze.

The metallic luster technique was introduced into Italy by Moors. During the XIV and XV centuries, it was produced in the center of Italy, where the well known polychrome luster Renaissance ceramics was exploited to produce in Deruta and Gbbio, and it take new name which is majolica, [11, 12, 93, 94].

Metallic luster glaze has this deep root in history, and it was developed from era to era depending on the general factors that were mentioned in second chapter in section(1.4) .but the main common denominator in its technology over the history is that it was produced by treatment during firing process. This treatment is reduction, where the carbon reacts with mineral oxide to create Nano-particales of mineral[96]. The commons mineral oxides that were used as colored in glaze to obtain the metallic luster were silver and cooper colored materials and oxides. The aspect metallic of copper and silver are obtained by redaction atmosphere, in temperature at or below 650 -700 °C.[97] the redaction atmosphere is a treatment during firing where the results are very sensitive temperature and amount of redaction gases.

Where the reduction treatment during the firing process is a chemical process; it was created by limiting the combustion air in the interior of fuel kilns which were the developed in this time. Therefore the carbon monoxide (CO) will appear in



**Figure 2.22:** two-handled pot on a pedestal foot 22cm high probably from Valencia ,second half of 17th century, Instituto de valencia de Don Juan. Madrid

## HISTORY OF CERAMICS THAT HAD TREATED DURING OR AFTER FIRING PROCESS.

---

the combustion gases. It is unstable compound which still needs some oxygen that was taken from metallic oxide susceptible to this treatment. Monoxide converts itself to dioxide, the more stable state. Metallic oxides loss oxygen and its status also were changed as well as its color[98].

### 2.3.2.4 Porcelain in redaction atmosphere and crackle

In china during the Sung dynasty (690- 1279), there were five important classics wares that were produced in this dynasty, and the treatments during firing were the responsible about their especial aesthetics. The aesthetic treatments of " five great wares " in song dynasty were depended on the colors like white-color, sky-blue, green and blue-green, in addition to other treatment which is texture of crackling surface. The technique of crackle appeared in twelfth century. There were some styles which are interplays in crackled treatment, but they are different in colors and forms. These styles are: Ru kiln, Ge Kiln, Guan kiln, and Jun kiln. In Sung dynasty ,The art of porcelain entered era of unmatched success[99],and the imperial kilns classified to northern Sung kilns and southern Sung kilns[100].The song dynasty was the most important period in imperial Chinese history[15].

#### **-Ru Kiln**

The Ru kiln is one of imperial kilns from northern Sung dynasty[14].The Ru Guan kiln site is located in Qingliangsi, Baofeng County, Henan Province in China. It was produced for the royalty in the late Northern Sung dynasty (1086-1125)[101]. this glaze was thin , and the color of glaze ranges from white-blue, sky-blue, blue-gray, sky green, light green , pea green to pale blue [99, 101]. The white-blue porcelain from Ru kiln was famous[100]. This style of porcelain was only used in the imperial palace, due to there is agate in its glaze. only just some pieces which are rejected from the supplies to imperial palace can be sold and used outside the palace .The body of this kind of porcelain was light gray in color as the incense ash or gray-brown color, and it was thin body [14, 15, 98].

## CERAMICS HISTORY AND FIRING PROCESS

---

This firing process existed while the body was put on the nail-support in reason to glaze the body completely. Thus there were very tiny "sesame-seed" which marks were left on glaze surface[15, 101]. These supports have from three to five studs[14]

Ru kiln wares were produced for just about 20 years only. Nowadays, this style is very rare, where there were only 70 intact pieces of Ru wares which have been collected all over the world[15]. Ru ware has glazed surfaces which are usually crazed. Its glaze is a celadon-glazed with a relatively thick iron-blue glaze of especial beauty [98].

This style was imitated at Jingdezhen in the Xuande period (1426-1435). But the bodies of copies are less hardness than original of Ru kiln from Sung Dynasty, the glaze slightly more transparent and the crackles more dense. Also during the Qing period (1644-1911) there was the best imitation of Ru kiln wares, and it was created during the Yongzheng era but the glaze of the imitation which called imitation bronze vessels of Ru glaze was too transparent. A few imitations were decorated with embossed or impressed designs, and the shape was also different from that of Ru ware of Sung Dynasty[14]. Figure (2.23) shows a cup-stand of Ru wares, its diameter is 16,2 cm, its height is 7.6 cm, and its form is similar to forms that occur in Chinese lacquer and silver in Sung Dynasty[102].

### **-Jun Kiln**

Jun porcelain is located in Juntai, Yuzhou city, Henan province. Its glaze layer was thick, where it was glazed twice, the glaze colors range from sky green, sky blue, pale blue, rose purple, crabapple red to grape purple[101].

The pale blue was a celebrated glaze color which was used to cover this ware style. It was invented during the northern Sung Dynasty. In addition to its glaze is thick, also it is opalescence (its color reflects light and changes when the position of the person looking at it changes) and translucent. It was considered that these glazes are celadon even though their color often termed robin's egg blue. This distinctive color was created as result of that the glaze separate naturally into silica-rich and lime-rich glasses during firing process. The iron oxide is the

HISTORY OF CERAMICS THAT HAD TREATED DURING OR  
AFTER FIRING PROCESS.

---



**Figure 2.23:** Ru ware cup-stand From Qingliangsi, Baofeng county, Henan province, northern China Song dynasty, late 11th- early 12th century, British Museum OA 1971.9-21.1



**Figure 2.24:** Three-legged wine vessel Ru ware of Northern Song Dynasty, 11th Century

## CERAMICS HISTORY AND FIRING PROCESS

---

coloring agent in the glaze of Jun ware, and the color of glaze determined on the states of iron oxide which are arose after firing in reduction atmosphere. Its opalescence also happened from the phase separation where during at last stage of firing, while its degree was about 1200 C° or little below, the transformation of melted glaze into an emulsion of tow phase or liquid as silica-rich and lime-rich glasses causes the phase separation especially when the kiln was cooled slowly [103].

The glaze color of Jun porcelain also gives the feeling of color clouds, and it is very sensitive to the firing conditions. Where different colors can produce from firing with the same material in the same kiln[104]. This style of porcelain has been high reputation[101].

In the early of twelfth century and continued to thirteenth century, Jun ware pieces was decorated by splash of lavender ,purple or royal blue. As thinking, the potter used the filings of copper oxide to glaze before firing to produce this color, where at first they used the sprinkle filings, and then they mixed the filings with water may be with some of glaze to apply the solution by brush.[103].

### **-Guan Kiln**

Guan kiln as Jun kiln and Ru kiln are from the five great kilns of Sung Dynasty, it takes its name from the meaning of Guan, and it means official or government, where this style was produced for using in the imperial court that was after sting up the Ru kiln. Emperor Huizong who had ordered the construction of this style in Northern sung Dynasty. There was also Guan kiln of the south which was produced in new capital Linan. Where the sung court fled to south of the Changjian (Yangtest) river[14, 105].

the clay body of Guan kiln is dark due to it is iron-rich clays ,and its glaze is thick that created multiple crackle systems in cooling. This thick glaze was achieved by multiple glaze application on wafer-thin bodies. The benefit of the dark iron-rich clay is enhancement the apparent depth of crackled glazes[102]. The thick glaze layer trickled at the brim to leave the rim glaze layer thinner there than on other parts of the body. The iron oxide which fond in the clay

HISTORY OF CERAMICS THAT HAD TREATED DURING OR  
AFTER FIRING PROCESS.

---



**Figure 2.25:** Jun wine jar Moon-white glazed with vertical flanges northern Sung dynasty



**Figure 2.26:** Imperial Jun ware;Northern Song





**Figure 2.27:** Northern Guan ware

in form ferric oxide ( $\text{Fe}_3\text{O}_4$ ) comes from firing in reduction atmosphere. If the bottom rim is black, it called iron-foot , this artistic style known as famous purple rims and iron-feet [105].Figure (2.27) show the guan ware that was made in Northern sung[106].

### **-Ge kiln**

Ge kiln glazes colors were light greenish-blue, Moon-white, glossy-gray and yellow green. This crackle is different than others styles, where there was a net of crackle coats the surface of glaze which is similar to ice-crackles, fine crackles, or fish egg crackles. The areas enclosed within cracks can vary from the widely spaced to narrow as small as fish egg[99].

The large crackles are dark brown, and the smaller crackles are yellow brown. This style of crackles was known as "golden wire and iron thread". Figure (2.28) shows a five stud jar from Ge kiln and the distinguish crackles appear on glaze

## HISTORY OF CERAMICS THAT HAD TREATED DURING OR AFTER FIRING PROCESS.

---



**Figure 2.28:** Ge five-stud water jar, sung dynasty

surface. The bodies of Ge wares are purplish black, iron black or yellowish brown in color. The glazes are non-transparent[14].Figure(2.29 show Ge-type vase which has thick, opaque grey glaze with two layers of crackle, the wide crackle stained grey and the fine crackle brown. It was made in Zhejiang province (1279-1368), Yuan dynasty.

Ge Kiln porcelain belongs to the celadon family. The both of Ge like wares and Guan like wares could have considered from the same kilns, and dragon kiln provided the natural variation of atmosphere, temperature and cooling that was required for their aesthetics treatments[102].This style was imitated in Jingdezhen in the Yongle (1403-1424) and Xuand periods of the Ming Dynasty[14]. Figure (2.30)show one form from this imitation Ge style.

From this Chinese ceramics styles, the role of firing process in the aesthetics treatments is demonstrated. Where atmosphere of kiln, temperature and cooling kiln is important in produce these styles and produce theirs glazes' color. The



**Figure 2.29:** Ge-type vase which has thick,Zhejiang province (1279-1368), Yuan dynasty.G95/case2/sh4 British Museum

HISTORY OF CERAMICS THAT HAD TREATED DURING OR  
AFTER FIRING PROCESS.

---



**Figure 2.30:** Ge five-stud water jar, sung dynasty

## CERAMICS HISTORY AND FIRING PROCESS

---

reduction treatment during the firing process is a chemical process; it was created by limiting the supply of combustion air. Therefore the carbon monoxide(CO) will appear in the combustion gases. It is unstable compound which still needs some oxygen that was taken from ( $\text{Fe}_2\text{O}_3$ ) (red iron oxide) which is susceptible to this treatment. Monoxide converts itself to dioxide, the more stable state. The ( $\text{Fe}_2\text{O}_3$ ) loss oxygen and its status also were changed as well as its color. Thus the may became( $\text{Fe}_3\text{O}_4$ )(magnetic iron oxide) and then ( $\text{FeO}$ ) (black iron oxide) as redaction process strongly augments[98].

The treatments of crackle could have existed by many causes which create a compression stress or a tensile stress in glaze layer. These causes refer to physiquies treatments as well as reduction atmosphere refer to chemical treatments what happened during firing. The both treatments were existed to produced these Chinese porcelain as one of them was used to produce others styles that mentioned in this chapter. Most types in classification of wares have one or more of style which firing condition or treatments during firing were the responsible about their feature. this conclude to importance of firing process and led to consider kiln design as a tool for creating some aesthetic treatment on ceramics surface.

### 2.4 History of ceramics firing process

The important thing of firing process comes from that it is a deliberate process which prepares the heat treatment for ceramics bodies and their glazes. The technology of this heat treatment has deep root in history, and it was varied from culture to another and from place to other. The essential aim of firing process is sufficient solidity that was given to ceramics forms by heat treatment. Natural properties of clay determine the degree of heat that required for giving forms sufficient solidity. The technology of firing and its method were adapted over history to permit the temperature which is required. In spite of solidity is the essential aim of firing process, but this method and this technology shows more over influences on aesthetics treatments. Therefore, these influences were taken in consideration which imposed to develop firing and kiln technology.

Atmosphere of firing could be a main factor which influenced the final appearance of pottery during firing. History of firing demonstrates the relation between the firing technology and the atmosphere of firing. When firing process happened in place of firing that can be an open place, then the firing called open firing or can be a closed place, then firing is called firing in kiln. The structure of kiln and the heat resources are conception factors that could be used to control the atmosphere of firing.

#### 2.4.1 History of firing process atmosphere.

Development of firing process over the history made change of the atmosphere in pottery surroundings .when in primitive firing the objects are fired in atmosphere surround by flam, gases of combustion, vapors and ashes of fuel materials due to the heat resource was a result of chemical reaction during burning and the firing process was in open air, the oxygen which is necessary for continuing the reaction is sufficient or little less. Therefore the atmosphere of primitive firing is near to reduction atmosphere and ceramics surfaces contact with gases, vapor and ashes

## CERAMICS HISTORY AND FIRING PROCESS

---

which they affect in aesthetic treatment. Firing in open place means that there was no heat isolation. Therefore, the heat which could be achieved by open firing is low temperatures\*.

Firing in kiln was made separation between pottery objects and ashes; even the kiln structure was simple. However, the gases of combustion and vapors which were produced from fuel materials are still in contact with surface of objects. Design of kiln structure and architecture affect in air circulation and the amount of air normally was less than that was required to complete combustion reactions. Therefore, the almost fuel kiln is reduction atmosphere if there is non air supply or muffle to protect the objects from gases and vapor of combustion. With appearance of kiln in firing technology, the heat isolation and heat transfer was applied to achieve midrange temperatures or even very high temperatures. Construction of kiln was used to collapse the loss of heat and it used to store the heat inside the kiln until achieving required temperatures.

After discovering the electricity, electric energy was used as resource of heat. The structure of kiln changed to one chamber contacted with electric power supply or it changed to deep tunnel in case of continuous firing. Therefore some mechanical parts was added to the structure of kiln . Atmosphere of kiln became normal and it could be oxidized atmosphere by air supply unit. Also gas was used as fuel materials. This discover made and changing in the traditional structure of kiln. In gas fuel kilns the oxygen which supply from air circulation is important and atmosphere of firing is determined by amount of air.

The ceramists adapted their firing technology in order to create aesthetic treatment. They used the saggar to protect ceramics forms from surfing gasses inside the kiln. There are some aesthetic treatments which were created as re-

---

\*Very high temperatures" usually mean >2300 F (>1260 °C), "high temperatures" = 1900-2300 F (1038-1260 °C), "midrange temperatures" = 1100-1900 F (593-1038 °C), and "low temperatures" = < 1100 F (<593 °C).

sults of especial firing technology. Also the modification of technology and heat resources over the history affected the firing technology and its atmosphere.

### 2.4.2 Primitive firing

The first thermal treatment for clay in history was in open air and in pit. So it was developed to bonfire and bonfire with mud-covered bonfire. Primitive firing technologies were widespread in ancient cultures. Its methods and techniques are diverse into many broad types as following:

#### 2.4.2.1 Overground firing

In this method of firing, pots and objects were arranged into a pile on flat part of ground, on an elevated platform, or in a shallow hole. The fuel was put in below, among, and /or above the pots and objects. The pile of pots and objects could be arranged in many shapes that give three distinguish open firing techniques and methods. Open firing without any fire-channel and open firing carved by mud or shells, this technique distinguish to open firing with apical fire-channel and open firing with horizontal fire-channel[37].These distinctions of open firing be likely to achieve low temperatures 800-900 °C [107].

- **Open firing without any fire-channel**

It is simplest form of firing technology, where the pots placed in the flat ground. Wood, dray cattle-dung and /or straw were fuel materials[37].Thus rate of firing in this method was fast. Where the burning exists in air without any covering therefore the time of firing is short. In 1998, an experimental study to simulate the firing technique to explore the way of manufacturing black-topped Egyptian pottery. Maximum temperature could be reached by this method at between 700 to 800 °C [25].The potters could use two ways to avoid the effect of thermal chock with heating in short time in





**Figure 2.31:** open firing with preheating technique in the start of firing process[25].

this method. The first one is increase resistant of clay to thermal chock by adding the chamotte, grog, sand, and other materials. Second one is procedure during firing. Where fuel wood was spread out at some distances, after preheating slowly the firewood was gradually moved closer to pots in order to complete firing process. Figure (2.31) shows a simulation of this technique of preheating. This type of firing is still used in Africa .

- **Open firing with apical fire-channel**

In this method of open firing, pots were arranged in circular form in number layers ,so, in final state, the pile of pots became in form of dam. During the arrangement of pots, a free space is left in center which make vertical channel that opens in the top of dam. The fuel was put among and in-between pots and its layers. The fuel is connected with channel which created from a pile of pots. This makes a form of entire pile which is then covered by grass or husk to be covered with mud. The top of channel is left open through to cause a fire to start burning[37]. This type of firing

is still used in East Asia, and it is called Yunnan style. In this method, the fuel takes time to completely burn because of a small amount of air supply. The air supply is not direct as in the open firing without any fire-channel. Therefore also, the temperature that could be achieved is near 1000°C [25]. In this method, due to indirect air supply the atmosphere of firing is from reduction to heavy reduction. Refer figure(1.12).

- **Open firing with horizontal fire-channel**

The arrangement of pots in this method of firing takes different form; they are arranged in radial rows at bottom layer to form circular base permitting a contracted passage in between every two rows which works as a fire-channel. This passage down the pile of pots runs straight across diametrically opposite. The passage makes stoke-holes on both sides of fire-channel, the old pot used to prepare the stoke-holes which used to kindle the fire. The fuel is placed in this method as well as in open firing with apical fire-channel. The firing begins slowly then gradually gets much worse when it is stocked with a poker [37]. With this technique of firing, the potters avoided the surfing effect of thermal shock on the pots and objects.

### 2.4.2.2 pit firing

In this style of firing, there is a deep pit which is dug in ground to make the firing inside. This method is a clearly noticeable improvement over open-firing that are made aboveground or on pit not deep. The firing in the pit makes advantage to contain the fire in pit and the wall of pit help to hold the heat in. Usually around the pit there is a rime which made of dirt. The bottom and sides of pit are covered with fuel layer such as kindling. Tree branches and dry dung were used as fuel in this method [108].



**Figure 2.32:** Pit firing before firing[25].

The figure (2.32) show the a simulation to pit firing [25]. The pots placed on layer of fuel in the pit, gaps between the pots are filled by fuel and then the pile is covered by the fuel also.

### 2.4.2.3 Oven (pit with walls)

A permanent structure of oven appears in the method of firing and it is made of clay, stone or bricks. Inside this structure of oven, pots arranged inside surrounding walls. Elevated platform is fixed at equal distance near the stoke-hole .pots are placed upon this platform which made of clay props. The interior of posts is filled by fuel, and also it is put in gaps left in between pots. This exists during the process of instillation the pile of pots, and then it is covered by potshards. The firing start burning slowly at stokes holes. Bit by bit, it is gradually increased. The heat in this method is more conserved than in open-firing[37]. Due to there was a structure that built with a pit in this method ; so the oven firing is considered to be the beginning for creating kilns.

### 2.4.3 Firing in kilns

With development of firing technology, the fixed place for firing was known with pit firing, and a simple structure was known with oven firing. In kiln firing, the separation between fuel and pots begins to appear. Therefore, transfer the heat from fire box to firing chamber where pots are stocked to treat by greater retention of heat. This process of separation between the pots and burning fuel was existed in two methods: first, the pots were above the place of burning; second, fuel burning is beside pots in cave digging in mountainside[61].

Kiln which is designed as first method called up-draft kiln where the axe of transfer of heating across the pots is vertical, which the kiln which is designed as second method called down-draft kiln where the axe of transfer of heat across the pots is horizontal. Some of up-draft kilns are open from the top so it is called open kilns. With this structure of kilns the temperatures which could be realized were increased because heat become better isolated and conserved inside the kiln, and the structure of kiln permitted to feed the firing and increase the duration of firing.

The ancient kilns generally are composed from four principals parties. These parties are the hearth or fire-box, the holes of air vents, the firing or kiln chamber and the chimney. The fire-box is the place of combustion; holes of air vents are very important part in structure of all fuel kilns. They feed reaction of combustion by air which is very important to this reaction, and also their importance comes from their position determined by the direction of air and heat transferring, firing chamber is place or part of kiln where the objects and pots are put to treat by heat as required and the chimney in case of open kiln the chimney is the door of charging and discharging the kiln and it is in top to kiln as in ancient Egyptian kiln and Greek kilns but in other type of kilns it take cylinder form in closed kilns and its position in the kiln structure determine the direction of heat across the firing chamber [5, 56].

## CERAMICS HISTORY AND FIRING PROCESS

---

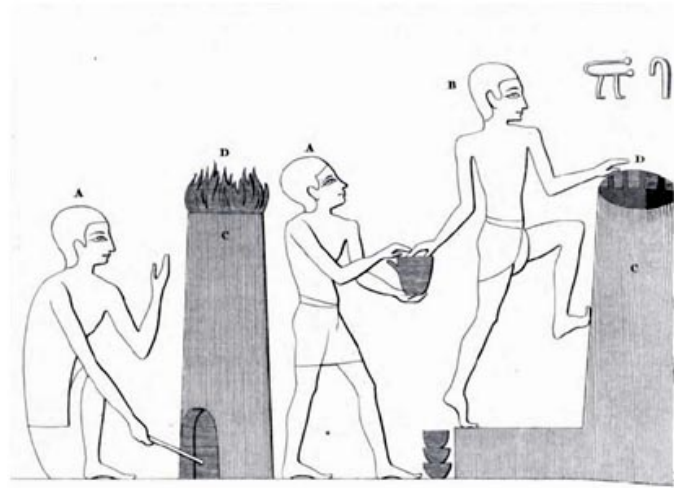
Ancient designer of kilns aimed to achieve higher temperatures especially to produce stoneware and porcelain therefore they created the downdraft kiln which it could achieve temperature of 1300 °C. The direction of transfer of heat inside the kiln was attractive to improvement structures of kilns from culture to another; the choice between the firing technologies in specific culture is decided by environmental, social, economical and requirements [5].

### 2.4.3.1 Up-draft kilns

This kind of kiln have very deep history where available information about an engraved depict ancient kilns in Egyptian history, the engraved show simple kiln in cylindrical form and refer to vertical heat transfer .see figure (2.33). From engraved, the structure of kiln seems to be a building not a digging. So from this information the updraft kiln was known in ancient Egypt. This engraved was plotted on the walls of hypogeum of Bin-Hassan in Luxor. (XVIII century BC - XIX century BC)[56]. The figure show the recharge the kiln where the pots are placed inside the kiln from the tope D. In other figure the firing process is started and the flame appear in the top D . This type of kiln called open-top kiln and it is sample kiln.

In China, Yangshao culture was discovered in 1921 developed which was Neolithic culture (VII century BC-IV century BC). Up-draft kiln with open top was found in Banpo site that was used to produce black and gray potteries. The figure (2.34) demonstrate that it was dug in hill[27]. Two designs of up-draft kilns appear in this figure: first one is composed from two chambers over each other; the upper one is firing chamber and the other chamber is fire-box and there is a hole between them, the flame passes through this hole from fire box to the firing chamber; second one is a tunnel in hill and it take slope form from the box fire to the top of hill where the chamber of firing.

There was a roman kiln which was an open updraft kiln. It was discovered in nineteen century in Normanton Field-Castor in England. Its fire mouth is



**Figure 2.33:** Engraved was plotted on the walls of hypogeum of Bin-Hassan in Luxor[26].

in lateral position, there was a pit fire under the firing chamber which is open from the top to load the kiln. So the axis of heat circulation is vertical. Heat transfer from fire mouth and firing pit to firing chamber through spy-holes which distributed over the surface of floor between the fire pit and firing chamber[26, 56]. See figure (2.35)

This kiln was built in a grand pit and brick and stones were used to complete the structure and architecture of the kiln. This refers to the beginning of the modification of the structure of the kiln from natural pits or two pits to building a structure which required artificial materials to complete the design of the kiln.

Most of the known Greek kilns are of the simple updraft type[5, 7]. The shapes of small kilns in ancient Greece were circular or elliptical but there were exceptions of some rectangular kilns which were considered as larger kilns. The temporary domed superstructure appeared in ancient Greek kilns, where they were stone-constructed and it was suggested that the temporary dome would have been made of clay mixed with turf, straw, and even wastes from previous firing[7]. Updraft heat

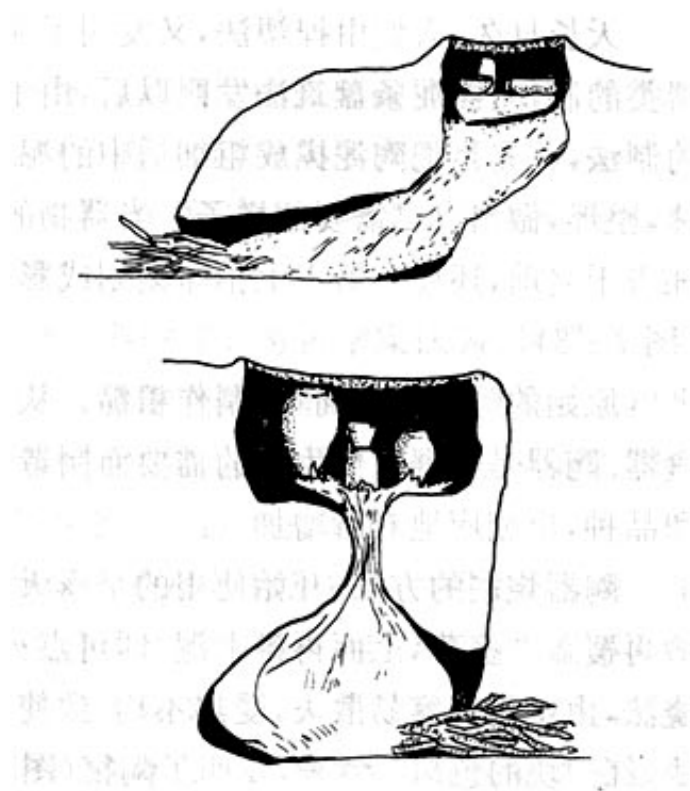
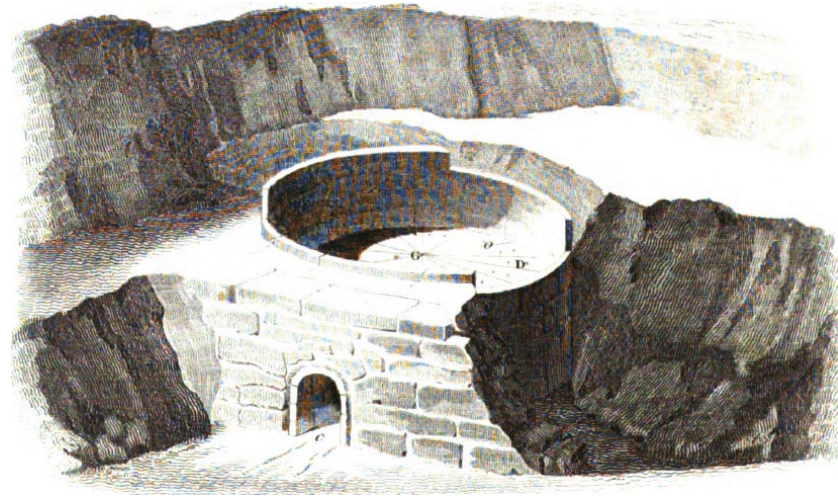


图 7—4 陶窑复原图(陕西半坡,仰韶文化)

Figure 2.34: kiln for firing ceramics,Banpo site,Yangshao culture [27].



**Figure 2.35:** Kiln discovered in Normanton Field-Castor en England , *c.* Fire mouth ,**D**. Perforated floor ,*o*. Spy-holes in the floor,**G**. Medial of the floor of firing chamber which supported by stand [26].

inside Greek kilns would have been existed by a small opening at the top of the temporary dome, as is illustrated in figure (2.36).

Greek kiln have stock channel that was used to reach high temperature interior the kiln without any harm to potter, where it was channel stoking out from the general circular or rectangular outline of the kiln[5].

M.Robert Cook described the normal way of making small ancient Greek kilns, as it was usually to dig two pits, one of them for stoking objects and the other for kiln proper and the two being contacted by a tunnel. Second pit which have been used for stacking and for facilitating the circulation of hot air was clay lined. As well as clay and arched were used to build the tunnel. This updraft system have advantages of easily controlling the fire and better heat preservation [7].

The structure of kilns improved to differ between the parts of kiln, where the combustion hole was separated from firing pit and also firing chamber separated



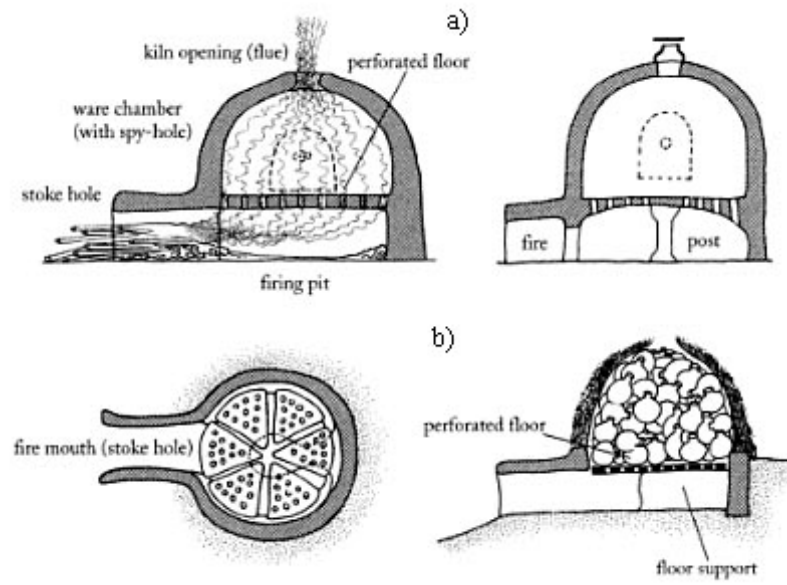


**Figure 2.36:** Corinthian pinakes from penteskouphia , Paris museum of louvre  
MNB 2856 [7].

from the firing pit by floor with spy-holes. The technique of build this floor was without supported firing floor in Bronze Age but supported firing floor was known in the late Bronze Age[7]. The figure ( 2.37 , a ) shows the reconstructions of typical Greek kiln where the heat transfer up from pit fire to firing chamber. Section in the right side show the floor without supported stands and the lift section show the floor with supported stand ,figure ( 2.37 , b ) shows plan and section of typical Roman kiln with temporary dome and floor support appear in plan and section.

The design form of updraft or vertical kiln was improved in early Bronze Age. The design form of updraft kiln has remained more or less unchanged where this design was used to achieve high temperatures than open firing. The temperature could be controlled by the intensity of fire and amount of draft. the intensity of fire is determined by amount of fuel and heat of combustion, but the draft could be controlling by adjusting the size of air inlet opening ,size of flue holes in floor and size of exit flue [109].

En Europe, the vertical kiln or updraft kiln was improved to multiple floors.



**Figure 2.37:** a) reconstructions of typical Greek kiln b) plan and section of typical Roman kiln [7].

## CERAMICS HISTORY AND FIRING PROCESS

---

Some kinds of kilns are simple were just multiplied firing chambers and the other kinds are complex because they composed of many floor in check floor there are firing chamber and fire mouth. Brongniart mentioned to these kilns. The rectangle kiln was first put into practice as multiple level kilns, but the temperatures were in general very unevenly distributed. Therefore, the different products which are required different temperatures for firing were put in different parts or firing chambers in these kilns. In this kilns the thick walls and envelopes are required and the floor which is separate between each chamber of kiln is vault arch. This structure of kiln cause to increase the quantity of heat loss during firing process and the process take very long time and more amount of fuel to complete the heating [56].

The idea of a high vertical kiln drawn attention to science and construction of kilns. It was subtle and complex in the early nineteenth century. High vertical building was preserved by designing iron bands and frames around the kiln and by using materials which could withstand many firing[7]. Practical ideas in architect were used to construct building of kiln.

The vertical cylinder kiln with laterals mouths firing help to solve most disadvantages in rectangle kiln. When the design of kiln was improved to have many fireboxes. This kiln called in France Alandiers kiln and it used for firing hard-paste porcelain. In England this kiln was used for producing the fine faience and this kiln are used also to produce different type of ceramics in Europe. From the name of this kiln it has cylinder form in base and firing chamber but its top closed by segment of a sphere. This type of kiln has variation number of mouth firing and combustion chamber, these variations are from three to eight and ten. In general there are two forms of Alandiers kiln, one type is simple and other one is complex. Brongniart mentioned that the complex form of alandier kiln was produced after thirty years of produce the simple form [56].

### 2.4.3.2 Down-draft kilns

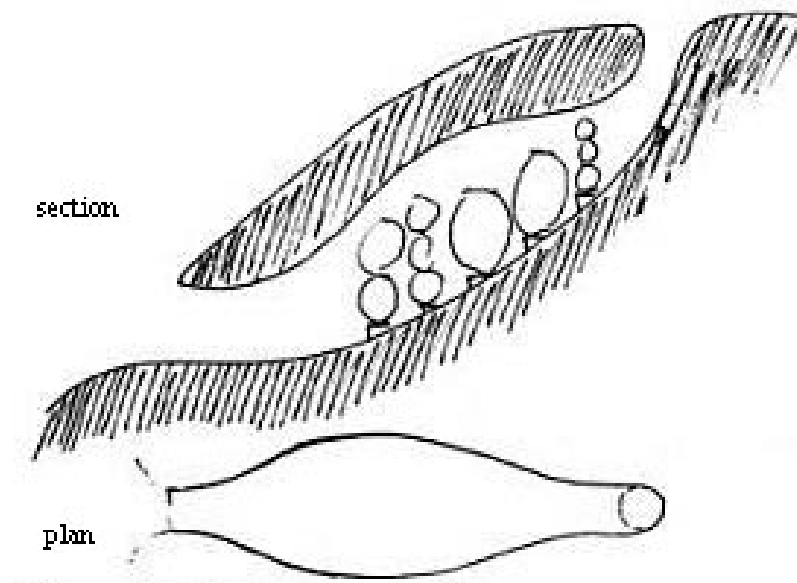
The design form of this kind kiln was improved from digging a tunnel as modification to pit firing in Japan Korea and China. The primary design of this kiln was called Anagama kiln where this name translate to "hole kiln". The first design of down-draft kiln was a single-chamber without separation between the wood burning in the fire-box and ceramics wares. This style of kiln was produced to achieve the temperature that required for firing the stoneware[61].

The down draft kiln form is a domesticated idea to achieve high-fired technology ,where its design depends on the arrangement of elements along horizontal axe rather than vertical axe. Fire box is located in the front and the flue exit from back side, between the fire box and exit flue ,the objects were placed from the end of fire box to treat by heating in the chamber firing. When the hot gases take direction toward the flue exit[109].

The sample or basic form of horizontal kiln called in Korea Tonggama where in Korean Tong means a hole or a space this style of kiln introduced to Korea from Han density China (206 BC - AD202). The elements of kiln structure are dug in hill side with slope from 25° to 32°[6]. There was an example of cross-draft or down-draft kiln that was popular in Crete during the Neopalatial period [7].

Therefore the floor is not required at early style of down-draft kiln where the firing chamber is beside the fire box not over it as in vertical kiln. The form of horizontal kiln is designed to be gradual radiation in cross section in going from fire box in the front of kiln to chimney in back of kiln. This down-draft of heat transformation is achieved successfully by making the design form of firing chamber increasingly smaller in height, width or both. The draft in horizontal kiln can be controlled by adjusting the size of air inlet opening and exit flue[109].

The figure (2.38) shows the plan and section of primary down-draft kiln. The idea of heat transfer gradually in horizontal slope axe is used in this kiln. The section shows that slope where the fire box is in lower end and the chimney in upper end. The plan shows the middle part between the fire box and chimney is

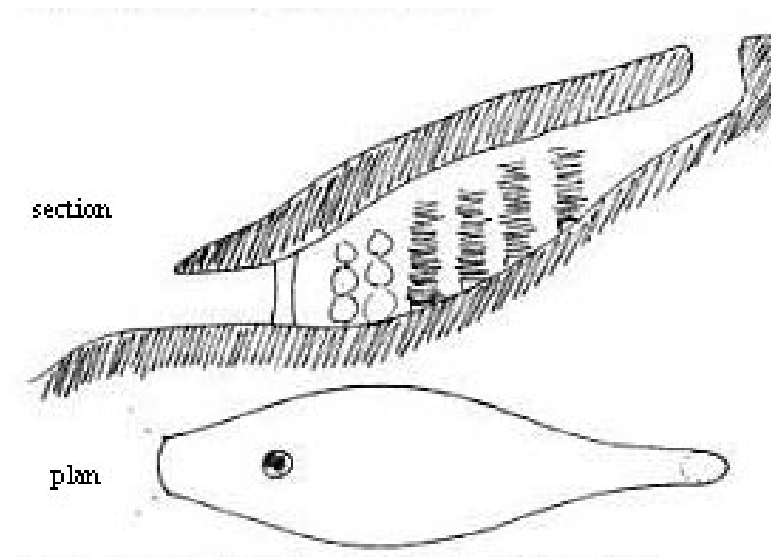


**Figure 2.38:** Basic anagama or cave kiln [6].

extended gradually from the end of fire box to the middle of firing chamber and from this part width reduced gradually to end by the chimney. In this cave kiln there is no dividing wall between firing chamber and fire box.

The structure of basic cave kiln was improved to divide between the flame and the wares in the firing chamber by flame divider wall. This wall was designed to prevent the most part of flame from affecting the surface of ceramics forms. This modification was made in Korean kiln in 10th century. Spoilt of Anagama kiln dating from 12th to 14th centuries shows the flame divider. It was in grounds of Aichi Prefectural ceramics Museum in Japan. Its length is 7.5m, its width is 2.6m and the degree of slope angle is  $32^\circ$  [6].

Figure (2.39) shows plan and section of cave kiln with flame dividing biller modification. there is still a tunnel in hill and it has the same slope axe but it is modified by that wall that divide the mane firing chamber than fire box .The flame dividing wall is temporarily and it was rebuilt each time of firing.



**Figure 2.39:** Anagama kiln with added with flame dividing pillar [6].

With modification the tunnel form of kiln was made by the bricks to complete the structure arch instead of digging in the hillside. With using the brick in building the horizontal climbing kiln, a next main advancement in kiln technology was existed in Japan. In 16th century a complete modification kiln - Ogama kiln (great kiln) - established in Seto and Mino. The design of kiln was improved like in the section of kiln, the floor of kiln was set a little way into the hillside and there are three or four internal pillars that support the wide arch of kiln and the floor of kiln is built over these supporting pillars. The air circulation was no longer from the fire box to chimney but from side entrance. The flame dividing pillar was dived into group of row or smaller pillars in the top that were made of clay-filled saggars. This pillar was arranged where the floor of principal chamber began. The plan of the kiln shows that the principal chamber extend from flame divided pillar to can placed more wares near the front of kiln and the design form of floor of kiln is domed form therefore it combined with rows of pillars to create downdraft [6]. See figure(2.40)

## CERAMICS HISTORY AND FIRING PROCESS

---

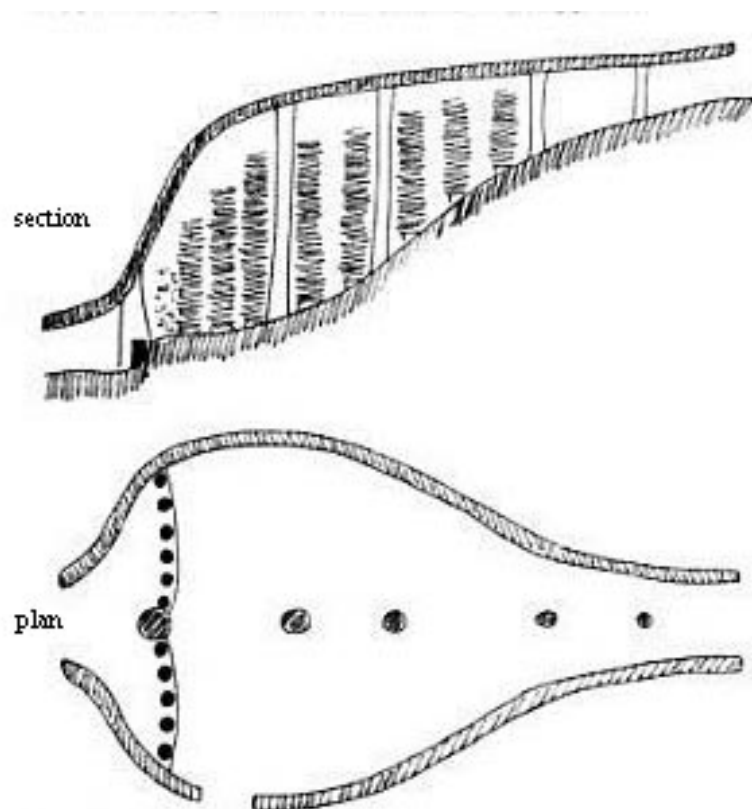


Figure 2.40: ogama kiln (great kiln) [6].

## HISTORY OF CERAMICS FIRING PROCESS

---

At the end of Ming dynasty (1368-1644)[110], in China the design of horizontal cross-draft kiln was improved to one longer chamber, so it is named the snake kiln or Jagama where its form is long narrow and its appearance is snake-like. It was built on the ground like long tunnel without any dividing walls but there are many stoking holes on sides of the kiln. The heat was transferred successfully from the front to back by stoking holes which they are used to heat up sections between these stoking holes [111].

M. Brongniart[58] presented an example for horizontal kiln which are used for produce stoneware in Saveignies in France. In its plan, it is oblate ellipsoid that cut out from the front and the back. In the front there is the mouth of firing that was built temporary during the firing and in the back there is the chimney. The main part of kiln is divided by pillar to two firing chambers.

In the 16th century or early in the 17th century, there was a down-draft kiln that its design was improved to be group of firing chambers by some dividing walls. This modification in the down-draft kiln takes two features first one is called split bamboo kiln. Its structure form like a barrel-vaulted floor which stretch from the fire box along to the top chamber. Kiln interior was divided by some walls to a series of separate chambers. There are some opening holes at the base of each dividing wall which permitted the flames pass into the next chamber. The second feature of this kiln was the multi-chambers kiln (norigama). It is considered as a next development of split bamboo kiln. Its structure design was composed of numerous interconnected stepped chambers, and each of which had its own arched roof, see the figure (2.41) .After reaching the temperature in first chamber the following chambers were stoked from side-holes to reach the right temperature[6].



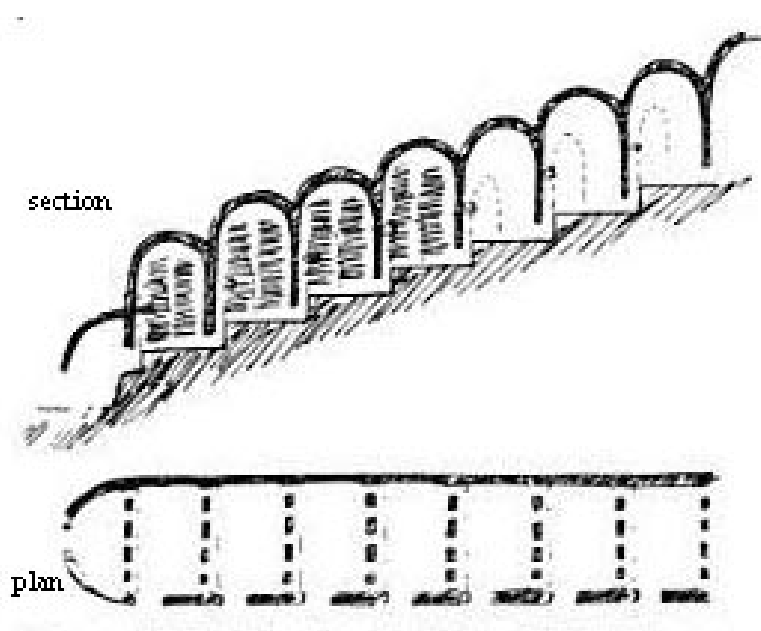


Figure 2.41: Multi-chambered' climbing kiln (Noborigama) [6].

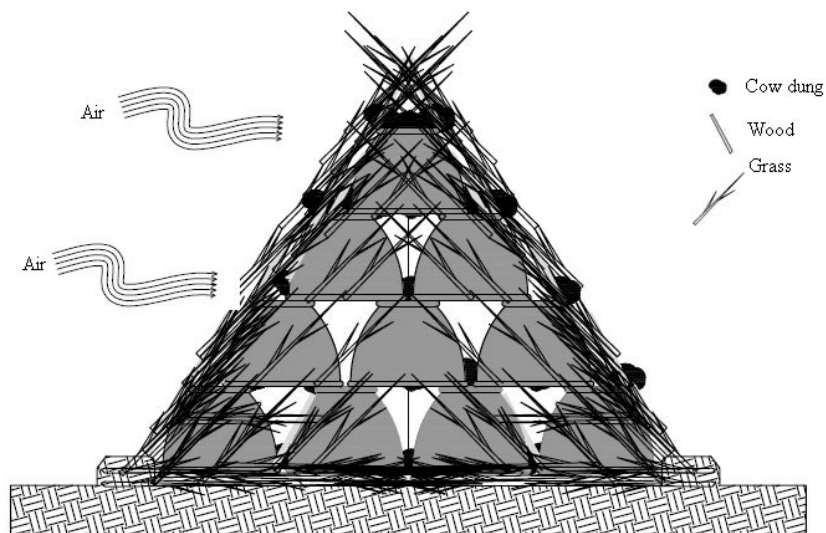
## 2.5 Structure analysis for historical kilns types

The relationship between the kiln as tool and aesthetic treatments appeared in two main historical firing technologies. The first one is atmosphere of kiln and the second one is a procedure that made interior or outside the kiln to change the aesthetic appearance. Any one of these treatments is correlated to the structure of kiln and used fuel. Therefore the analysis of kiln structure is important to imagine the potentials that were permitted by the structure of kiln. Despite the relation between the firing process and aesthetic treatments but it is not only aim from firing process. The essential aim of firing process is ceramics solidity; therefore the functional analysis of the kiln is important to demonstrate the role of kiln as a tool to enriching the aesthetic treatments of ceramics.

### 2.5.1 Developments of kilns structures

Developments of firing technology are dependant on the functional analysis of the kiln where the practical using led to new requirements as well as new discovers. Consequently these requirements led to improve the structure of kiln. Therefore in this analysis the sequence of improvements, architect of kilns, fuel or heat sours, and refractory, and isolating materials are useful to aware in the technology what is required for enriching ceramics aesthetic during or after firing.

Structure of open firing or on-ground firing, as the description in section (2.4.2.1 ), the pots are the all structure where they are arranged in pile and the fuel was arranged with pots. So the structure is a temporary structure. The experience is required for determining the amount of fuel and its distribution between the pots where during firing the structure does not allow to feed the fire. There no control in air circulation where it is existed in open air on flat ground. The requirement of this fire technology is the heating and the reduction atmosphere is mandatory atmosphere. The intensity of wind effected the degree of reduction atmosphere and it determine the heating rate. In this firing technology, the heat recourses are fuel burning which are chemicals reactions. The outputs of these reactions are in direct contacts with pots - as shown in the figure (2.42) - therefore the finale appearance of pots depending on the reactions that occur between the components on the surface of pots and gases that produced as result of burning wood, grass and cow dung. The lack of structure allows doing any procedures after firing as the procedure of smoking pots which is mentioned in section (2.3.1.4),figure (2.43)shows the apical fire-channel and figure(2.44) shows the horizontal fire-channel . In these three methods, the idea of heat isolation does not appear but it appears after using shells or mud to cover the pile of pots and fuel. This technology of firing called the bone firing, where the control of air circulation begin in this structure, where there were holes that designed in the layer of mud. The structure studies in figure (2.42), (2.43) and (2.44)shows the air circulation which effected by air direction, form of pots, layer of mud on surface

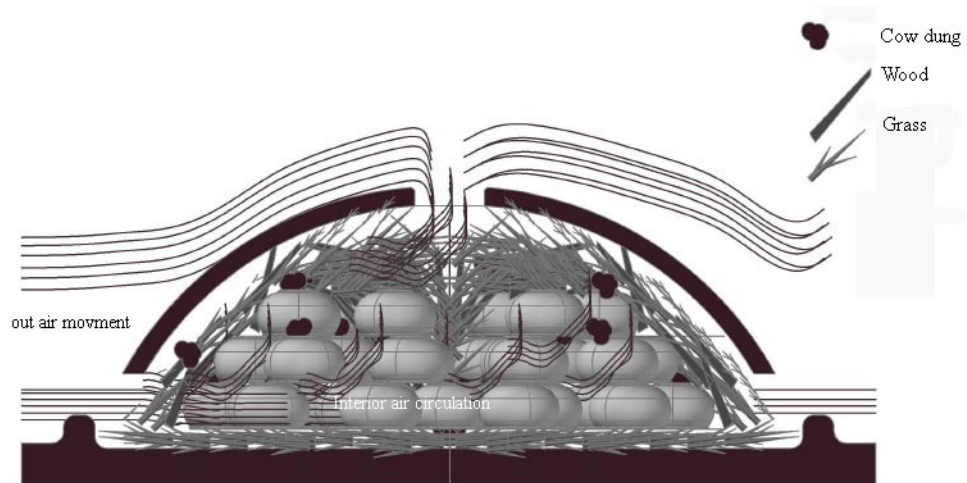


**Figure 2.42:** diagram demonstrate the structure of over-ground and open firing without any fire-channel

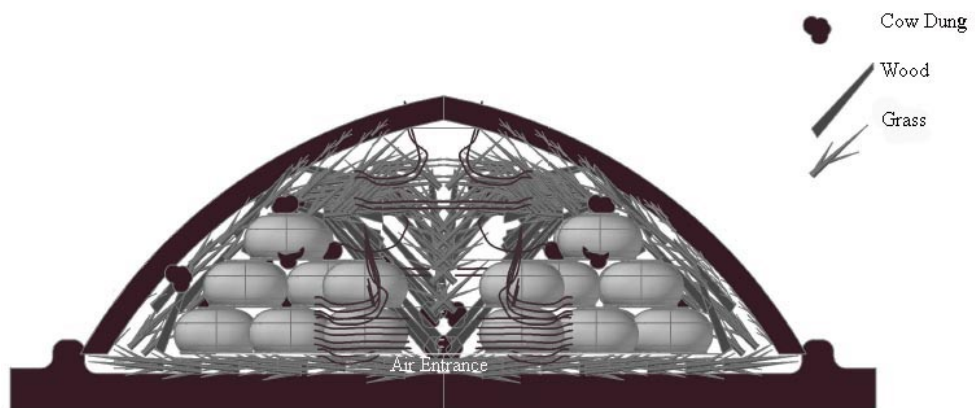
of structure and heat transfer. The structure in this technology is temporary and it depends on the arrangement of pots with fuel and the layer of shells, mud or both of them.

The functional roles of shells or mud layers are considered to be a reservation of heat. The advanced function from this modification is reaching temperature from 100 °C to 200 °C more than firing in air without shells or mud layers. Heat isolation by this way produced heavy reduction atmosphere which gives a spots cloudy gray or black colors in the surface of pots. So, the pit firing can be considered as an idea to reserve heat with open air to avoid heavy reduction effects. In pit firing, air circulation is free in the top of pile while the form of pit was like a part of heat container open from the top, where the pots are arranged. Figure (2.45) shows the structure of pit firing, the pots are still in contact with fuel. With this modification in fire technology, the idea of heat isolation was used and the refractory materials were pit walls which are part of earth where the pit was dug.

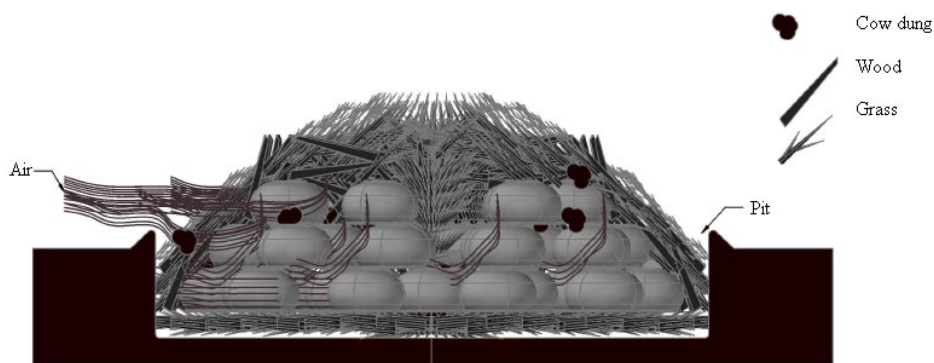
## STRUCTURE ANALYSIS FOR HISTORICAL KILNS TYPES



**Figure 2.43:** diagram demonstrate the structure of over-ground and open firing with vertical fire-channel



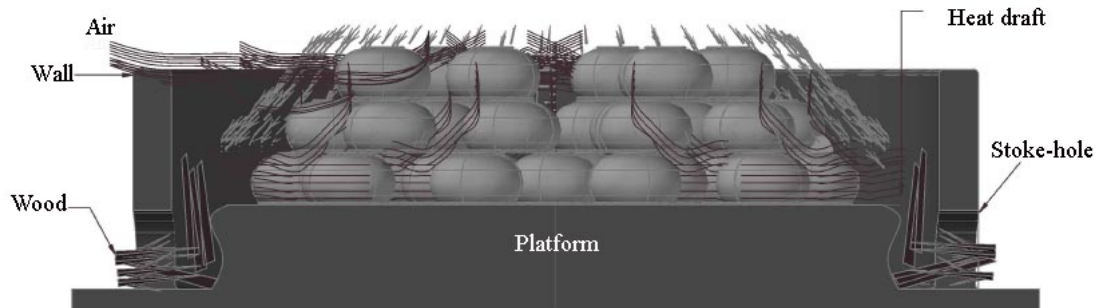
**Figure 2.44:** diagram demonstrate the structure of over-ground and open firing with horizontal fire-channel



**Figure 2.45:** Diagram demonstrate the structure of pit firing

The idea of heat isolation in a place of firing was improved from just dug a pit to built surrounding walls from stones, brick or clay. Figure (2.46) shows this wall that was developed functionally to make stoke-hole in this wall with improvement in the structure by platform inside the wall to arrange the pots upon it. The structure like that permitted to separate the fuel from pots arrangement and to use stoke-holes to feed the fire by fuel during firing.

The idea of separation between the pots and fuel led to develop the stoke hole in oven with surrounding wall to fire box in up-draft kiln structure and improve platform in oven with surrounding wall to floor in up-draft kiln structure. The kiln structure became more complex and its design became as architectural industrial.

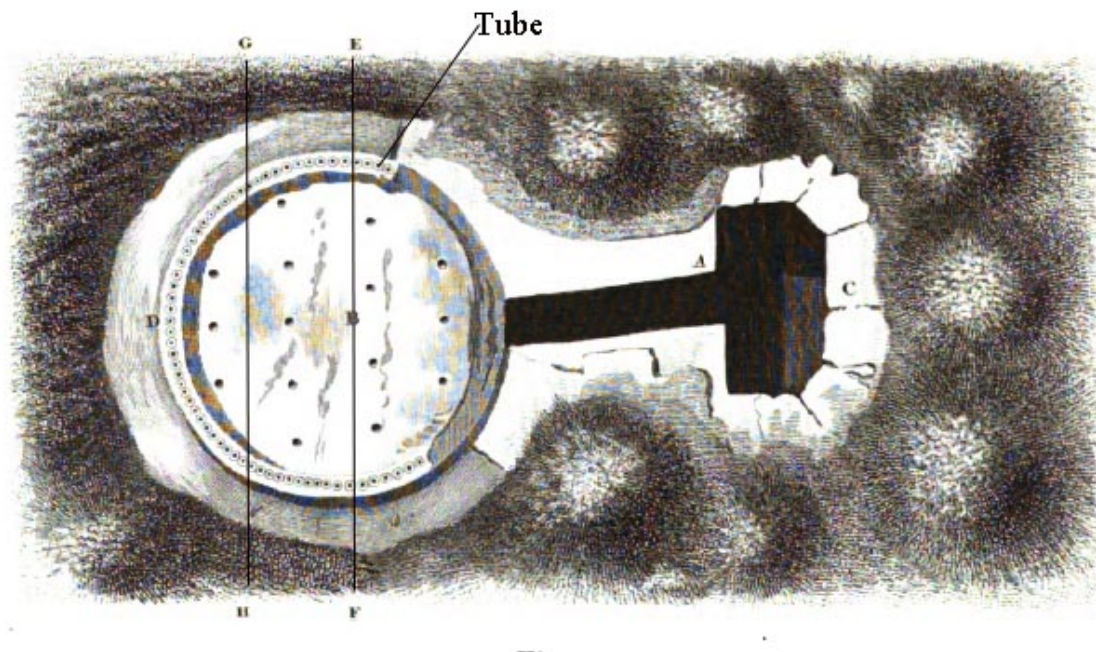


**Figure 2.46:** Diagram demonstrate the structure of oven with surrounding wall

## 2.5.2 The Architect of kilns

M. Brongniart[56] presented structure of open top kiln from up-draft roman kiln which was discovered in Heiligenberg not far from Strasbourg. The structure of this kiln was deferred to three parts. Mouth of fire box is long channel that its roof arch was ogival vault which have suitable curve to transfer the flame. The long of channel of mouth is upwards to 2.5 m. This channel transfers the flame and heat to under firing chamber. The figure (2.47) shows the plan view of this kiln and figure (2.48) and figure (2.49) shows the section on line E-F and on line G-H where in these sections the carve of ogival vault is appeared and also there are two sizes of tubes, largest size tubes are distributed on the surface of floor and extend from upper floor to the fire box to transfer the heat and flame from the box fire to firing chamber. The little size tubes (D) are surrounded inside the wall around firing chamber .From the two vertical sections on line E-F and on line G-H, the architecture of kiln was built on the big pit that was prepared by stones to complete the structure of kiln over it.

The idea of separation between the fuel and objects led to aim to get rid of the effects that happened because of heavy reduction atmosphere and connections between fuel and pots during firing. Therefore, this kiln was used to produce red



**Figure 2.47:** Plan for roman kiln which discovered in Heiligenberg.

pots. The architecture design of fire mouth taken the form ogival vault. This form helps to transfer the flame and heat to the fire box and tubes were used to distribute the heat and the flame in the fire chamber which was surrounded by wall. The construction of this wall is two layers of bricks between them layer of tubes that used to reserve the heat and equally distribute the heat in the firing chamber.

(A) refer to the fire box and its canal, (C) refer to the mouth of fire box , (B) refer to the floor and the channels which are used to transfer the heat and flame, and (D) refer to the tube in the wall that surround the firing chamber to equalize the temperature[26].

In this kiln there are cylinders of terracotta that used as tampons in the tubes to limit the transfer of combustion gases to the objects during firing[56].

The architecture of kiln was improved from an open kiln to closed kiln, where



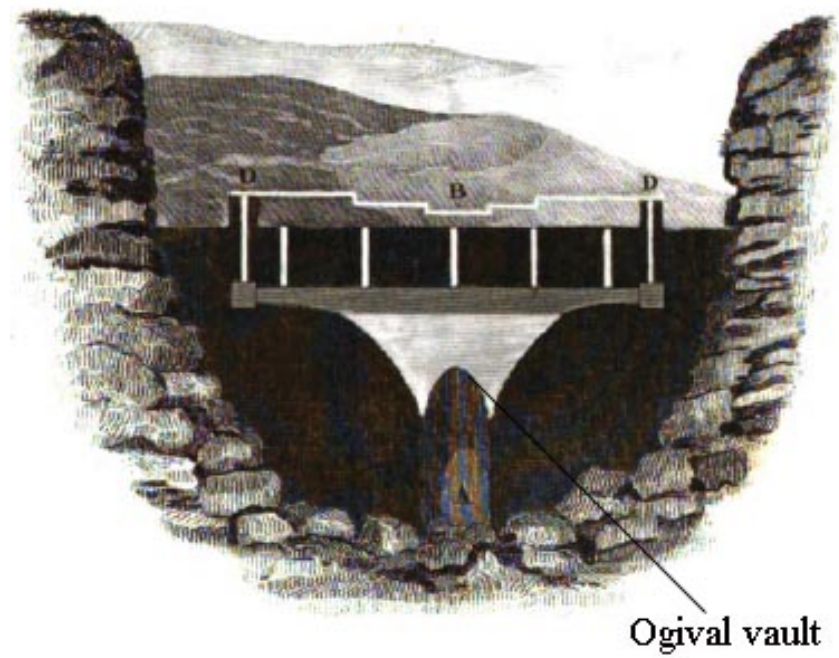


Figure 2.48: vertical section in line E-F.



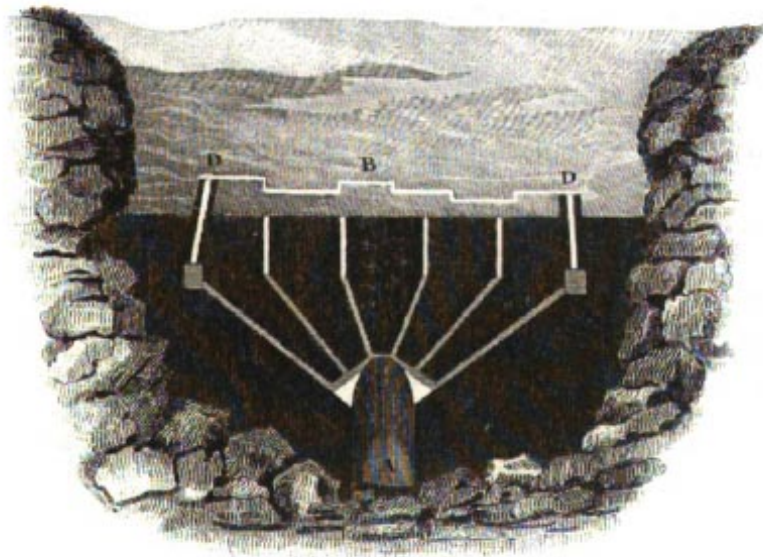


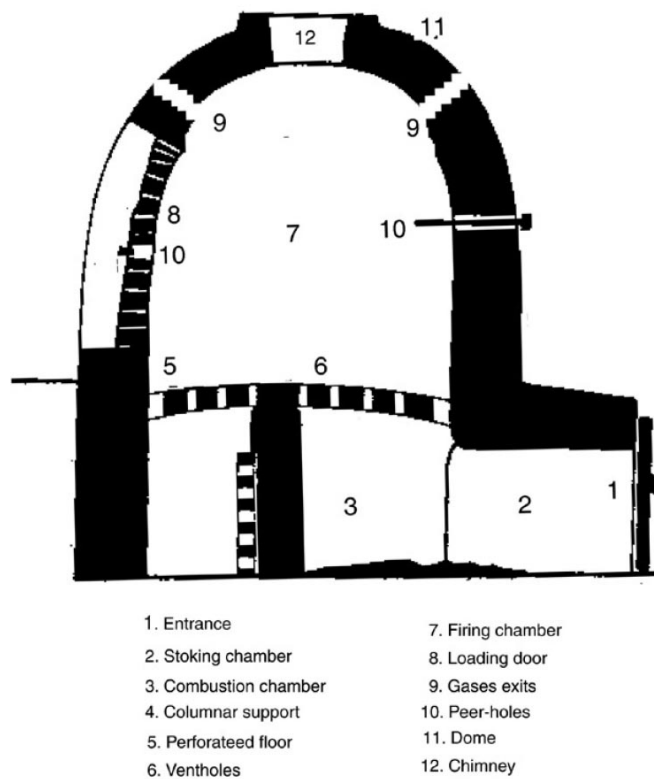
Figure 2.49: vertical section in line G-H.

## STRUCTURE ANALYSIS FOR HISTORICAL KILNS TYPES

its top became a dam and the loading door, was designed in the structure of firing chamber. Loading door in the firing chamber was closed after loading by temporary structure which is opened after firing. Figure (2.50) show the major parts of closed kiln at Pella in Greece during Hellenistic period[5]. Architecture of these parts was improved to reserve heat, separate between the combustion materials and ceramics forms and make up-draft circulation for the heat and air. Organization of kiln parts in its architecture design determined the kind of draft and air circulation in this kiln. In the figure (2.51) the architecture of firing chamber is similar to the up-draft kiln, but its position is different: the fire box (A) is in adjacent position to firing chamber (C), not beneath it like it is in the up-kiln. The wall (B) is for protecting the ceramics forms from combustion gases and the chimney (D) also take adjacent position in other side of firing chamber.

The architectural design of firing chamber can change the kind of draft of kiln by closing the top chimney and close the control damper. therefore, the exit way of gasses are changed from top chimney to two holes in the bottom of firing chamber. Even the fire box still in its position under the firing chamber as in the up-draft kiln, but this draft change to down-draft by modification of exit way of combustion gasses. design and architecture of kiln was adapted by two holes in the bottom part of wall of firing chamber and control dampers which are added to structure[112]. Figure (2.52) shows the heat transfer and air circulation where this architecture allows changing up-draft to down-draft in the same kiln. This permits to reach high temperature and heavy reduction atmosphere.

The closed kiln required for loading or unloading the objects into or from the kiln to design a suitable mean for this function. Design door in the firing chamber functionally can be used to combine between the up-draft and cross-draft as shown in the figure (2.53). This figure demonstrate front vertical view (a) and right vertical view (b) of kiln at Klirou on Cyprus[5], where there are gaps between the bricks or stones that are used to construct the temporary wall for closing loading door. This technology help in distributing the heat and smock in reduction firing.



**Figure 2.50:** schematic present a vertical section of top dome closed kiln and its major parts[5]

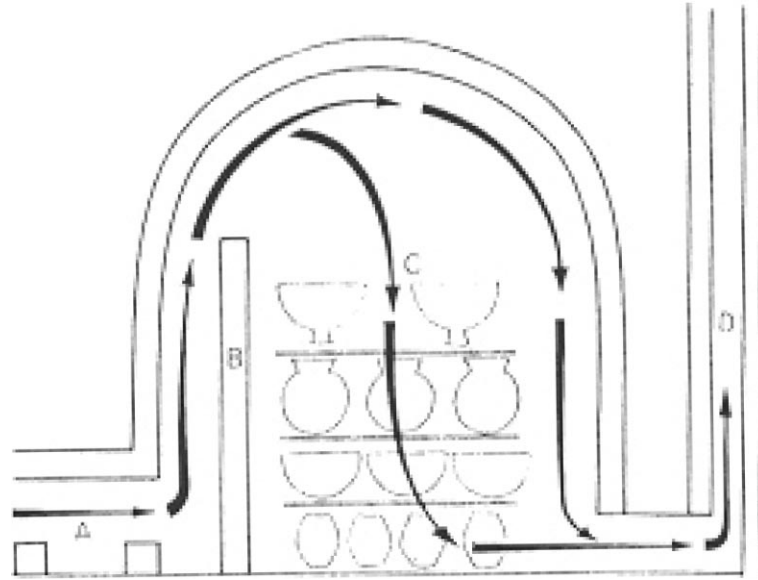


Figure 2.51: schematic present a vertical section of horizontal kiln [5]

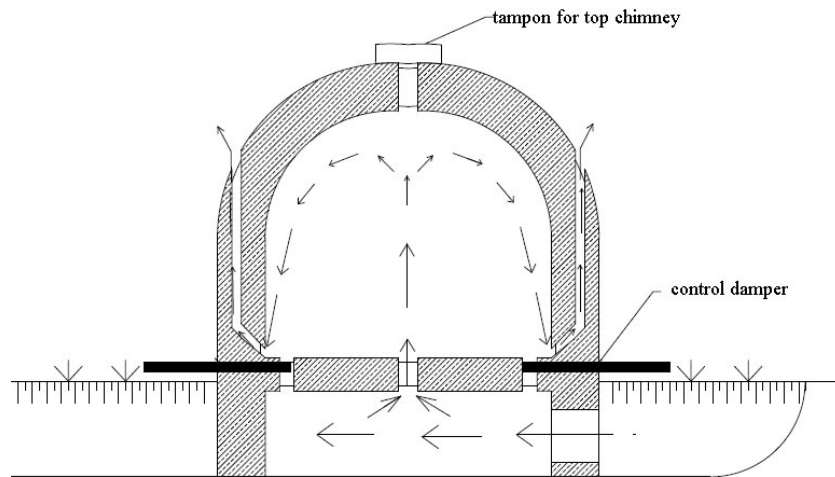
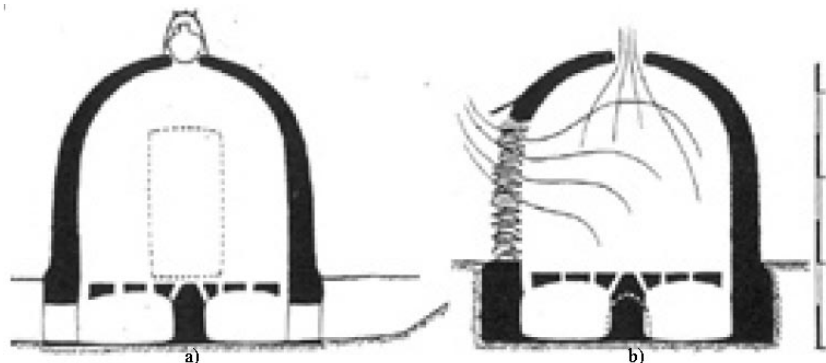
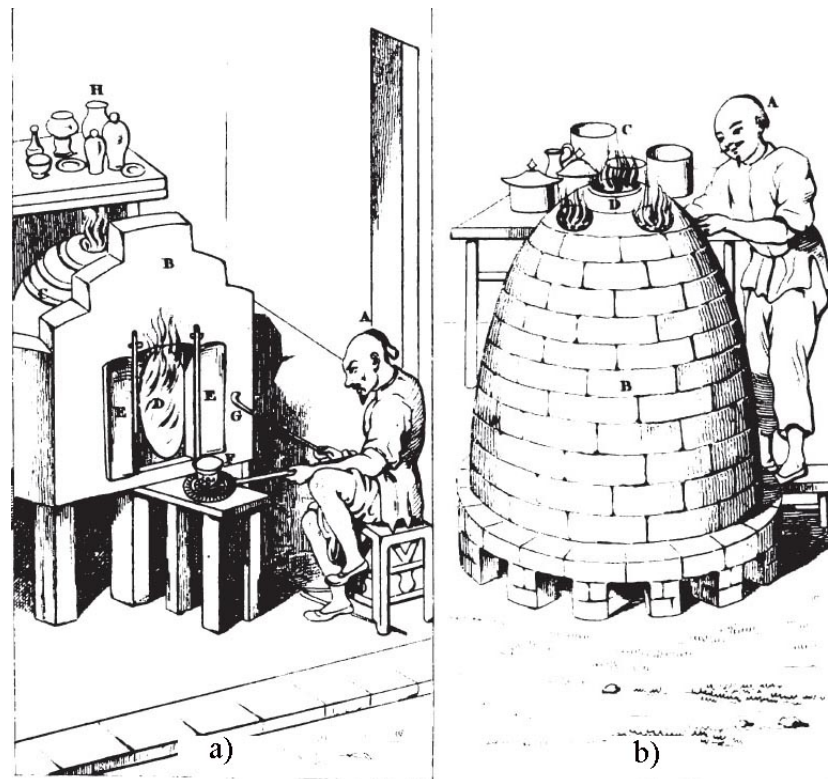


Figure 2.52: schematic present a vertical section of Complex Updraft/Downdraft Kiln from Iran



**Figure 2.53:** Schematic present a) front view b) right view of kiln kiln at Klirou on Cyprus and demonstrate heat transfer in tow draft vertical and horizontal [5].

The treatment during firing or after firing with using kiln technology it became only on the atmosphere of kiln and effects of combustion gasses on chemical reactions that happened during firing over firing schedule. The limitation of treatment that can be made after firing comes from the difficulties of high temperature interior the kiln and thermal conductivity of materials that used to construct the architecture of kiln. These difficulties increase in case of larger kilns. Therefore, the smaller kiln was used to do treatments after firing process. Raku kiln is an example of that small kiln that allows making treatment during firing or after firing where it could be opened, as shown in Chinese kiln in figure (2.54 a) , it is a muffle kiln which is used for firing the decoration paints over Chinese porcelain [58]. In China, there is other design of kiln which permits to insert wood inside during firing, as shown in figure (2.54b), the architecture of this kiln is part of Elliptical form made from bricks. It has holes in the top that can be used to lead the firing. The figure (2.55) shows other very important treatment where it is considered a chemical and physical treatment in same time, in this figure, there is someone slops water or something which is liquid (*s*). M. Brongniart [56] mentioned that this liquid was sloped after reaching high temperature. This



**Figure 2.54:** a) Chinese kiln for firing color and painting glazes b) small Chinese kiln kiln

treatment as translated from Chinese text was made to create a glassier layer in the surface of tiles which are produced by this kiln (*f*).

Also the architecture of down-draft Chinese kiln was designed with stock holes (*o*) to allow throwing pieces of wood during firing process to reach very high temperature which required for firing porcelain and the figure (2.56) show this treatment.

Other example of using architecture of kiln in doing treatment during the firing is the kiln was discovered in 1975 at Lake of Annecy in Sévrier in France. This kiln is dated to the end of Bronze Age[29].It is updraft kiln but its firing chamber dived to two parts as shown in the figure (2.57). The superior part is



**Figure 2.55:** Chinese kiln for firing tile and brick with glazes, the glaze layer was produced by treatment during firing



Figure 2.56: horizontal Chinese kiln constructs of two firing chamber





**Figure 2.57:** kiln for firing pottery from end of Bronze Age, it is constructed of two parts [28]

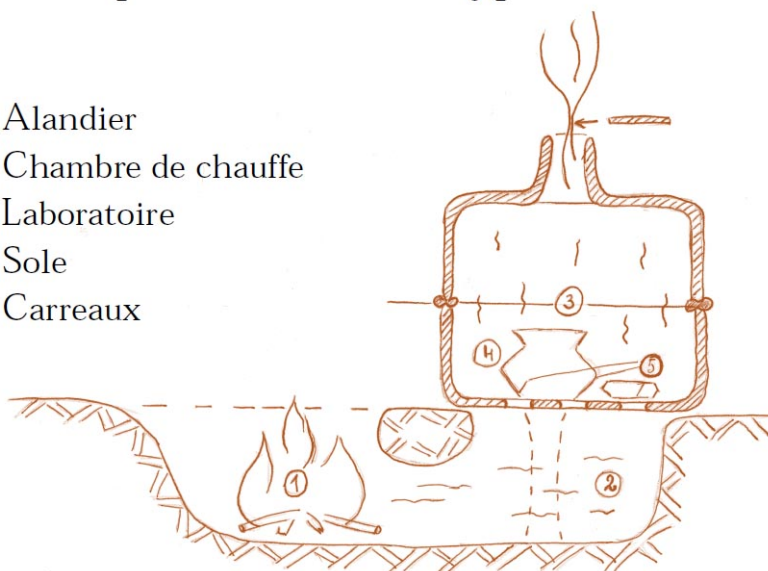
designed to close the firing chamber after loading the kiln and it has the dome form with chimney in its top. The inferior part is a fixed part. This kiln was small where the diameter of firing chamber is 0.70 m and the long of mouth of firing box is approximately 0.25m [113].

The architecture of his kiln permits to produce potteries with black and grey color, where it is a small kiln and its form distribute smoke and combustion gases in firing chamber which is closed by superior part. The idea of dividing the firing chamber in two parts, one of them movable, is a remarkable improvement in opening fire. The figure (2.58) shows a schematic for this especial design kiln.

Since the arches applications were used in architecture of kilns, the height building and multi-floor kiln were designed and built. The improvements in architecture and building technology effected in development of kiln design and architecture. Where the large horizontal kiln was built in the ellipse form and

## Principe d'un four de type "Sévrier"

- 1) Alandier
- 2) Chambre de chauffe
- 3) Laboratoire
- 4) Sole
- 5) Carreaux



**Figure 2.58:** principle of Sévrier kiln [29]

## CERAMICS HISTORY AND FIRING PROCESS

---

its improvement depends on art and design of architecture. The main structures that were used in the kiln building were arch, vault and dome, and they were very important in developing the kiln technology.

The figure shows the architecture of Egyptian kiln that is used to produce pottery at Maylaouy and Manfalout in Upper Egypt. Figure (2.59) shows (A) the plan, (B) the front view from outside the kiln and (C) the vertical section long the line XX of the plan. In general the kiln was built on plan that has the elliptic form, (F) refer to large stoking chamber that was direct open to the firing chamber (L) in first floor where the form of two nested domes appear in the vertical section where the architecture of mouth of stoking chamber (b) emerge, as well as the reservation holes ( $\nu$ ). The dome architecture was used also to construct the floor between first level and second one. the holes ( $l$ ) in dome roof transfer the heat from firing chamber (L) to firing chambers  $L'$  and  $L''$  in second level. Also there was channel ( $o$ ) that was designed to transfers the heat from stoking chamber to second level during the wall (M) . Top roof of the kiln was constructed from three domes that have the holes ( $c'$ ) in circle form and they work as chimneys. In the figure the pottery objects ( $e$ ) was charged for biscuit firing. The wall of kiln was thicker than Top roof domes [56].

The application of architecture was used to develop horizontal kiln, where it is form usually take elliptic form and the dividing walls have holes that it constructed of arches. The figure (2.60) shows the structure of Saveignies stoneware kiln. (A) is vertical section at long of axe, ( $l$ ) first firing chamber where its temperature is suitable for firing stoneware with  $l'$  the second firing chamber its temperature is fit for firing the commune pottery. (B) is a cross section for the kiln at the dividing wall ( $f$ ) between firing chamber and fire box. (C) is a front view to the firing box [26].

The architecture in this kiln guided by the idea of transfer of heat and the role of cross-draft in reaching high temperature which is required for stoneware. This idea of transfer of heat in horizontal axe of kiln was used to increase the heat gradually. The horizontal kiln that used for firing stoneware with slat glaze

STRUCTURE ANALYSIS FOR HISTORICAL KILNS TYPES

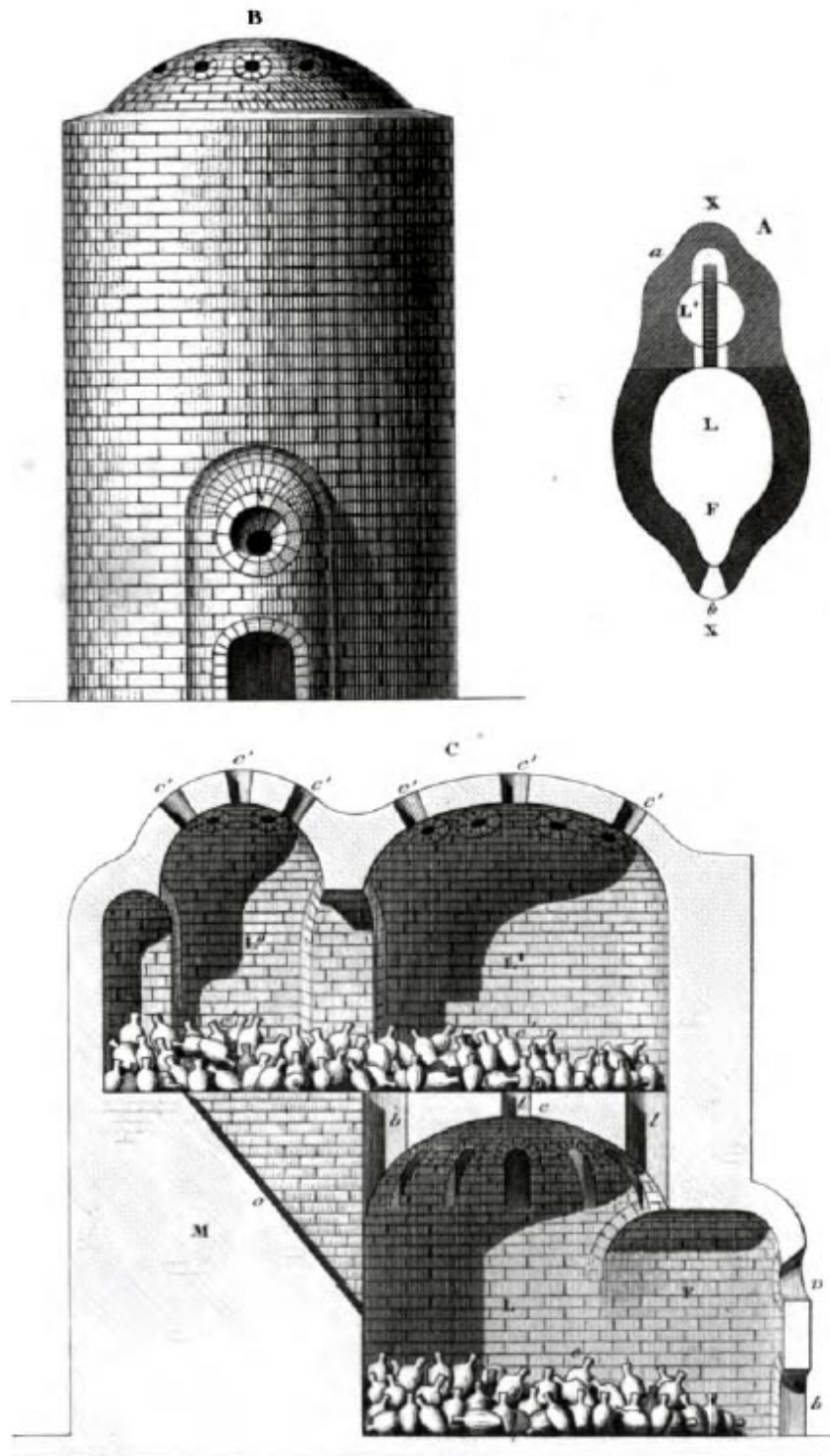


Figure 2.59: Egyptian pottery kiln at Maylaouy and Manfalout in Upper Egypt

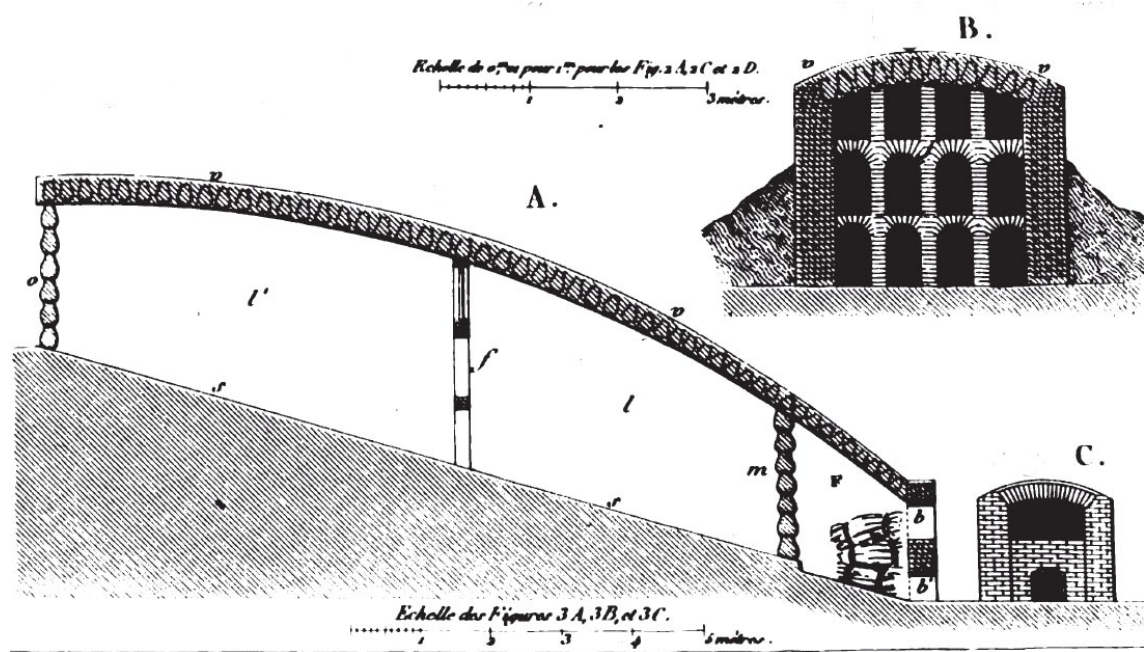


Figure 2.60: structure of stoneware kiln at Saveignies in France

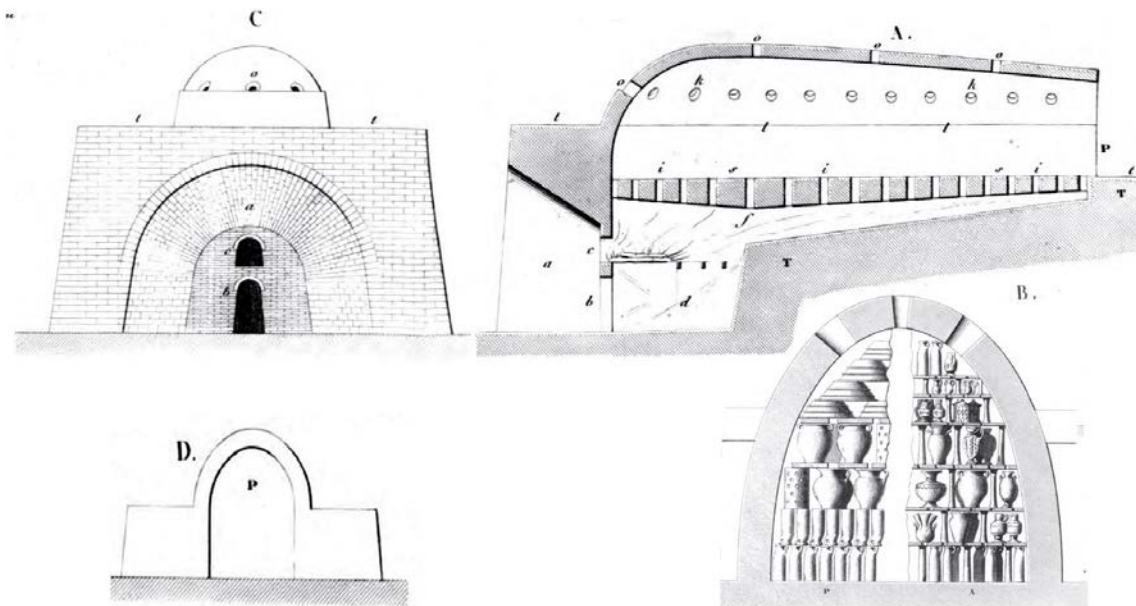
## STRUCTURE ANALYSIS FOR HISTORICAL KILNS TYPES

---

required architecture design that allows inserting the salt during firing. Figure (2.61) shows front and back views and vertical sections of stoneware kiln at Voissinlieu near Beauvais in France. (A) vertical section at long axe (B) cross section shows two deferent methods of loading this kiln A and P. (C) front view of the kiln and show the fire mouth and it take a form of arch. (D) is a back view of the kiln and (P) door of the firing chamber was appeared in this view. The form of firing chamber takes the parabolic carve and there are holes (*o*) in the tope that work as chimneys and used to insert salt for salting atmosphere of kiln. The stack chamber (*f*) is over the long of the firing chamber (*l*) and there is floor divide between them and it has holes (*i*) for transferring heat to firing chamber. (T) is a ground that surrounding the base of kiln. (*t*) is a flat roof surrounding firing chamber. Design of this kiln and its architecture were made to doing treatment during firing that is salting, this idea appear from position of holes (*o*) and flat roof (*t*) in kiln design.

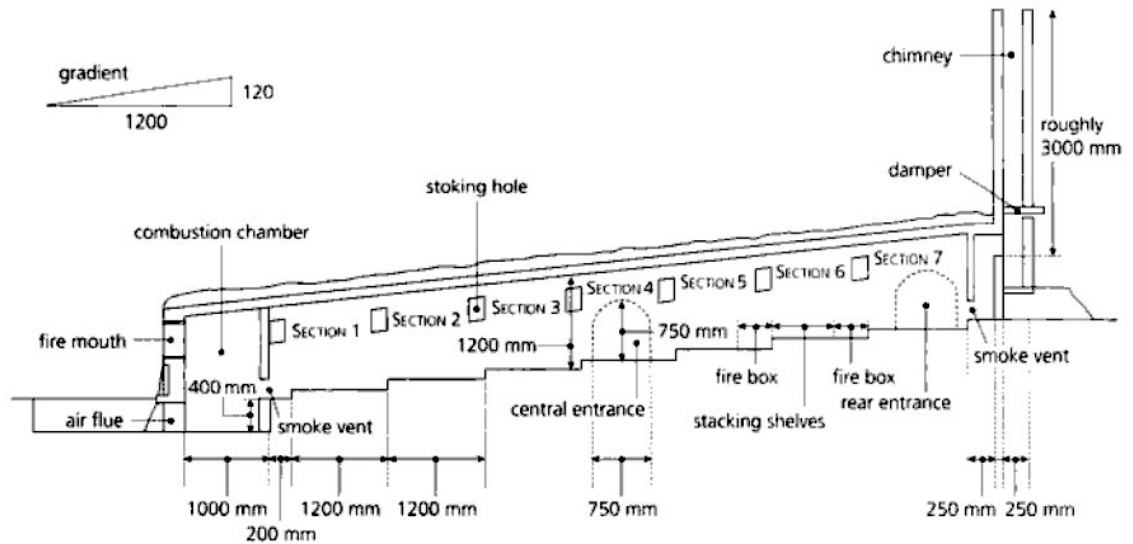
The architecture of climbing kiln in China was improved to multi-chamber or section for firing. It has a stacking chamber in the front of kiln with fire boxes in side. This fire boxes with side stoking were designed to reach right temperature 1280 °C. due to the fact that wood burn in very high temperature over 1000 °C gives amount of gases , which increase by four times than the same amount when it burn in temperature less than 400 °C [77]. The example of this kiln design was presented by Naoki Kawabuchi, which called the snake kiln in china. The figure (2.62) show the view side of this kiln. It is designed to go up over slope its angle was 6° . The gradient appears in the figure. The interior of the kiln was shaped seven levels that have a gradient of slope. Each level has shelves for stacking ware, fire box, and stoking hole. There is a chimney in the rear of the kiln[111]

The architecture was used to design very high building of kiln that is important to reach very high temperature for firing hard past porcelain. The updraft kiln was modified to very high building with multi fire box. With appearance of this kiln design and architecture, the idea of relation between energy of heat which lose and energy of heat which is generated by combustion was used; therefore the



**Figure 2.61:** structure of stoneware kiln that was used for producing salt glazes  
, at Voissinlieu near Beauvais in France

## STRUCTURE ANALYSIS FOR HISTORICAL KILNS TYPES



**Figure 2.62:** snake kiln that designed by Naoki Kawabuchi , view of the kiln from side

number of fire box was increased to reach the right temperature. This technology was used in Europe, the figure (2.63) shows structure design for kiln that was used to produce porcelain at Lille in France and it is two floors kiln. This kiln used coal as heat resource. Using coal as heat resource makes change in architecture and design of fire box. (A) is view from outside of the kiln with cut to show interior of the kiln, (L) is firing chamber in first floor used for firing glazed forms, (L') is the second firing chamber in second floor used for firing clay-body, (m) a structure made of iron bars which is used to place the porcelain for firing. This grating structure composed of horizontal bar supported in the wall and supported from other side by vertical bar (i), (G) is exterior wall of the kiln, (T) is a chimney, (n) is holes which used to transfer the heat to second floor, (s) is a chimney in the center of kiln to transfer the vault to the second firing chamber (L'), (S) the ground of the first chamber which is placed on vault I to avoid the dampness, (g) gate for receiving the coal, (c) ashtray, (b) mouth of fire boxes, (k) flanges of



## CERAMICS HISTORY AND FIRING PROCESS

---

iron which support circles ( $a$ ), ( $\mathbf{P}$ ) door of first firing chamber and ( $P'$ ) door of second firing chamber. ( $r$ ) is a louver that contacted by part of circle ( $q$ ) that turn on point ( $o$ ). Other margin of this circle part was connected by wire which rolls on a pulley ( $p$ ), other side of wire contacted by jack to open or close the chimney. In the cross section ( $\mathbf{B}$ ) the plan of kiln is presented at axe which passes by the gate ( $g$ ). and the four fire boxes and its position appear[26].

In factory of Sèvres, there was kiln constructed of double floor and wood was used as source of heat in this kiln. Architecture of this kiln was developed as shown in front view ( $\mathbf{A}$ ) in figure (2.64). This kiln was used to fire porcelain at very high temperature. The vertical section ( $\mathbf{B}$ ) at line VV which appear in cross section ( $\mathbf{D}$ ) that shown in figure (2.65) where ( $\mathbf{C}$ ) shows two half cross section of the kiln one half at line ZZ and other at line YY in line that appear in vertical section, and ( $\mathbf{D}$ ) shows two half cross section of the kiln, one half at line XX and other at line UU that appear in vertical section. There are three firing chamber  $L'$ ,  $L^2$ ,  $L^3$ , each chamber  $L'$  and  $L^2$  have four fire boxes ( $a'$ ) in first floor and ( $a^2$ ) in second floor. First firing chamber is closed by vault which has 25 holes ( $c'$ ) to transfer heat to second chamber and second firing chamber also is closed by vault which has the same number of holes ( $c^2$ )[58], ( $f'$ ) are stack chamber in inferior fire boxes ( $a'$ ), the flame divided by the gates ( $g'$ ) which formed by refractory bricks in first firing chamber  $L'$ . ( $C'$ ) is the ashtray, ( $e'$ ) is the place where wood put in for reaching high temperature in first floor, ( $o'$ ) is an open holes which is closed by tampon of fired clay. ( $b'$ ) mouth of inferior fire box ( $a'$ ) that were opened in starting firing at low temperature. Same parts repeat in superior floor are marked by same latter with proponent 2. Firing chamber ( $L^2$ ) is second chamber that used to very high temperature. ( $r'$ ) pillar of bricks which to used to load wood to fed fire boxes ( $a^2$ ) in second floor, this pillar was pierced by vault ( $d'$ ). T is floor of second level, ( $s$ ) entrance of the door ( $P^2$ ) for second firing chamber ( $L^2$ ), ( $t$ ) is iron shutter. ( $\mathbf{H}$ ) is a conical space above firing chamber in third floor ( $L^3$ ) that used for firing biscuit of porcelain.  $H'$  is chimney. The  $h$  is box of iron which is at terminal of iron bar  $\mathbf{M}$  and its details shown in figure (2.66). The architecture

STRUCTURE ANALYSIS FOR HISTORICAL KILNS TYPES

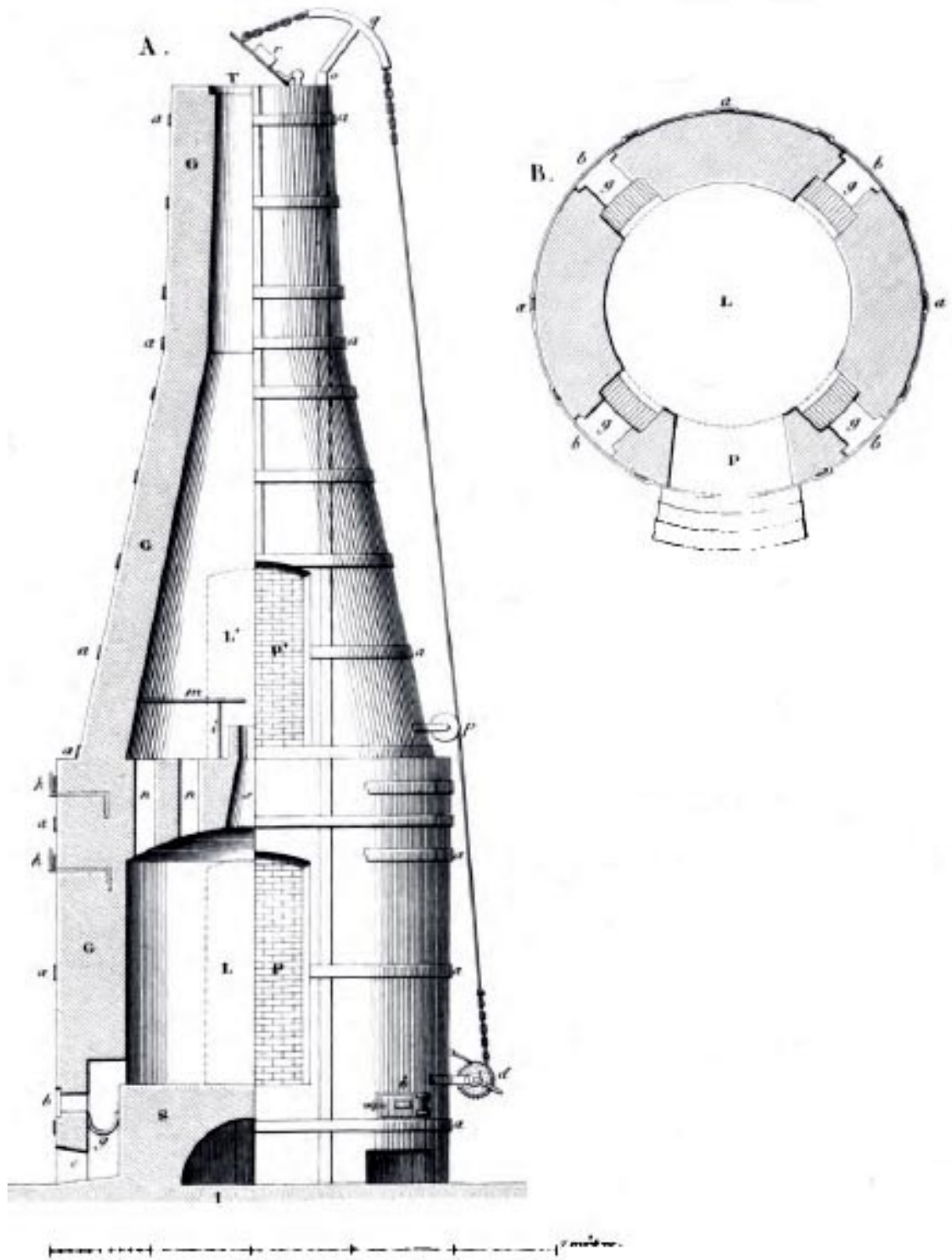


Figure 2.63: Hard-soft porcelain kiln that used coal at Lailly in France

## CERAMICS HISTORY AND FIRING PROCESS

---

of this kiln was supported by iron carcass which composed of **M** is vertical bar and **N** is circle . (*i*) is elastic key which squeeze these circle and it is shown in figure (2.67). **V** vide space over ground of kiln ,this space for giving or stopping the humidity and it appears in cross section (**C**)[26].

The design of kilns and its architecture were very important in improvement of ceramics products where these designs are responsible about some of important factors which effect in three parameters such as :

1. Temperature of firing process where the design of kiln has important role in temperature that can be achieved by the kiln.
2. Atmosphere of kiln where the air circulation has important role in this parameter.
3. Treatments that can be done during or after firing where kiln's design has important role in this parameter.

## STRUCTURE ANALYSIS FOR HISTORICAL KILNS TYPES

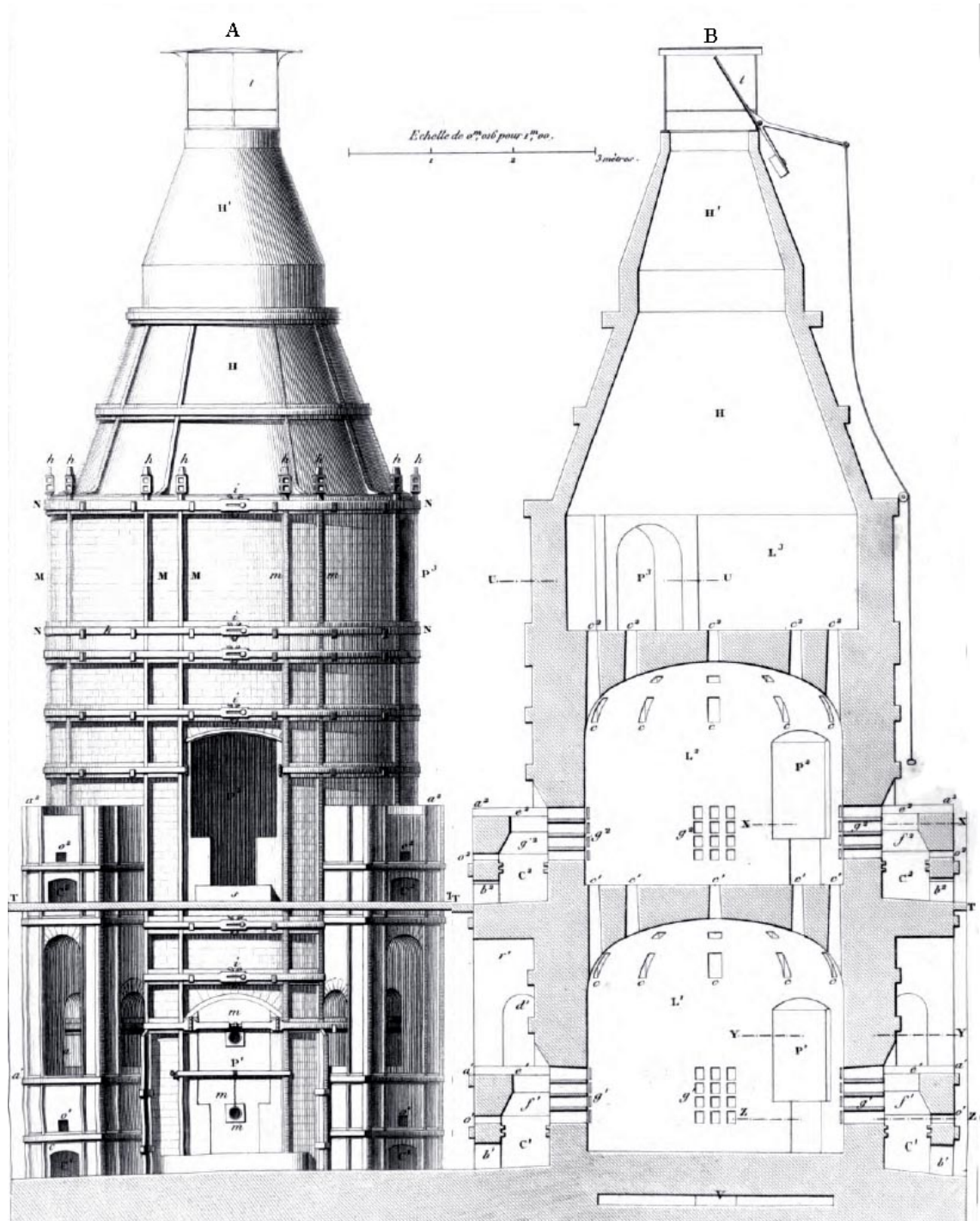
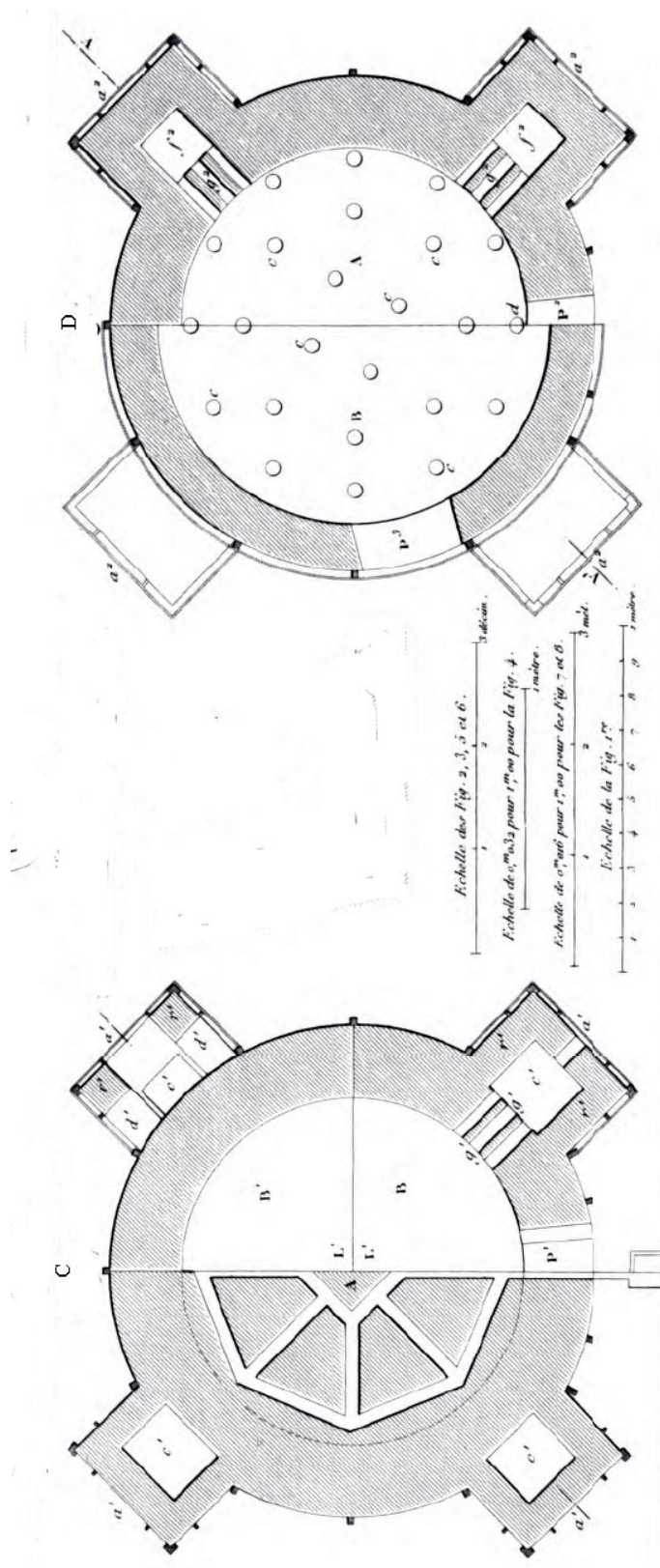


Figure 2.64: front view and vertical section of porcelain kiln in Sèvres



**Figure 2.65:** cross section in some levels as seen in vertical section of porcelain kiln in Sèvres

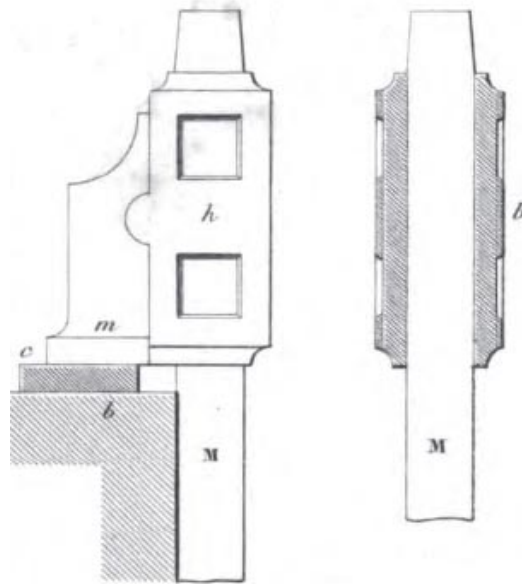


Figure 2.66: details of iron box which is at terminal of iron bar M

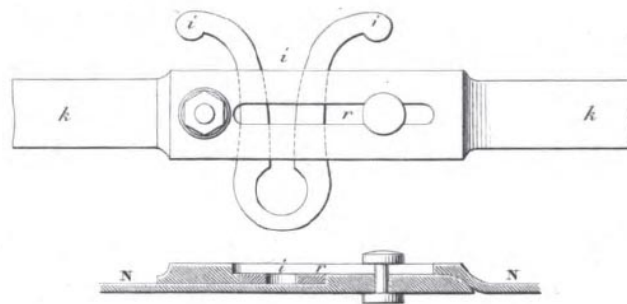


Figure 2.67: details of iron box which is at terminal of iron bar M



### 2.5.3 Refractory materials

The pursuance of kilns required materials, since kilns are realistic actually in these refractory materials. Therefore, improvement in technology of refractory is related to development of design and producing kilns. This relation comes from relation between design and materials.

In developments of ceramics firing, inside the earth was used as refractory materials. This is demonstrated in pit firing. Bricks which were made of clay also were used as refractory materials to build kilns. The chemical composition of clay that is used to produce these refractory bricks determined the efficiency of heat isolation.

The earliest kiln was found in China and it was dated about 30000 B.C. kilns were common in Egypt and in the Middle East by 10000 B.C. in this era the natural rocks and clay were suitable to be refractories materials for thousands of years from earliest kilns, while they were wood-fired. The introduction of coal and up-draft and down -draft kiln designs increased maximum temperature to 1100 °C in 4000 B.C, but stone, clay and fired clay refractories still served. After about 5000 year in China, porcelain was being made by 600 A.D, this required about 1300°C. The firebricks and stone are still used as refractories. In Europe by 1400 A.D, with using the water-powered bellows and design the vertical kiln ,maximum temperature increased to 1500 and the firebrick and stone still to be the refractory materials. In middle of 1830 A.D, the technology of pre-heated air was used to bring the maximum temperature up to close 1700 °C. Blocks or stone of natural steatite (soapstone) was used to build kilns after this date but fireclay was used for lower-temperature[32]. The technology of refractory was improved in twenty century. The refractory materials were classed according to **AFNOR** [114] - *Association Francaise de Normalisation* - classification as following:

1. Silica refractories that contain percentage of silica over 91% and percentage of alumina under 3%.

## STRUCTURE ANALYSIS FOR HISTORICAL KILNS TYPES

2. Silica refractories that contain percentage of silica enter 85% and 93% and percentage of alumina under 5%.
3. Clay-based refractories subdivided into:
  - a) Aluminosilicate products that contain percentages of alumina from 15% to 32%.
  - b) Alumina products that contain percentages of alumina from 23% to 40%.
  - c) Alumina products that contain percentages of alumina over 40%.
4. Especial refractrise , these are products based on high refractoris materials which constitute the main or total of following elements:
  - Bauxite,
  - Magnesia and dolomite,
  - Kyanite and Sillimanite-Mullite,
  - Corundum ,
  - Chromite ,
  - Magnesite-Chrome,
  - Silicon carbide,
  - Zircon and Zirconia,
  - Fused-castor refractrise,
  - Sintered refractoris.

There was other classification which classed according to (P.R.E) -*Produits Réfractaires Européens*- European refractories products, as flowing:

1. High alumina refractories are subdivided to:
  - a) Group I contains percentage of alumina more than or equal 56 %.



## CERAMICS HISTORY AND FIRING PROCESS

---

- b) Group II contains percentage of alumina more than or equal 45% and less than 56%.
- 2. Clay refractories contains percentage of alumina more than or equal 30% and less than 45%.
- 3. Siliceous-clay refractory contains percentage of alumina more than or equal 10% and less than 30%,and it contains percentage of silica less than 85%.
- 4. Semi-silica refractories contains percentage of silica more than or equal 85% and less than 93%.
- 5. Silica refractories contains percentage of silica more than or equal 93%.
- 6. Basic refractoris is classed as flowing:
  - a) Magnisa contains percentage of MgO more than or equal 80%.
  - b) Magnesite-Chrome contains percentage of MgO more than or equal 55% and less than 80%.
  - c) Chrome-Magnesite contains percentage of MgO more than or equal 25% and less than 55%.
  - d) Chromite contains percentage of MgO less than or equal 25% or contains percentage of  $\text{Cr}_2\text{O}_3$  more than or equal 25%.
  - e) Forsterite is the refractories that its principal constituent is forsterite.
  - f) Dolomite is the refractories that its principal constituent is dolomite.
- 7. Especial refractrise, these are products based on carbon, Graphite , Zirconia , Silicon carbide , Carbide , nitrides.

## **2.5.4 Heating sources**

Resources of heat in firing process take its importance in producing ceramics object from supplied kiln by efficient temperature and create especial atmosphere inside kiln. Right temperature for firing type of ceramics has a mean role in the aesthetics of this type of ceramics as well as the atmosphere of kiln. The ceramicists refer to the type of heat resources or the atmosphere of firing under their works. Also there were some styles of oriental ceramics that its aesthetics are created by using especial kind of fuel such as ash glaze firing and Anagama kiln. The natural of fuel and its chemical constants are affected in atmosphere of kiln and nature of burning flame.

### **2.5.4.1 Wood (Table (A.5))**

Choosing kind of wood is important where there are different in calories, ashes, and combustion gases from kind to another. The quantity of water as one of principal compositions of wood is different from green stat to high dry stat. carbon, hydrogen, nitrogen ,oxygen are combustion gases are produced when wood used as fuel,in addition to some quantities of ashes are produced from firing wood [56]. The flame reaction is an oxidation reaction, therefore atmosphere of kiln when wood used as a fuel redaction atmosphere by carbon, carbon monoxide, nitrogen, and vapor of water. The quantity of water in wood has effected by heat in two manners. These two manners are determined by the temperature of kiln when wood is thrown inside. Carbon reacts with water vapor superior than 1000°C to give heat and create Hydrogen reduction atmosphere, while fewer than 1000 °C the quantity of water in wood evaporate without chemical reaction. The kiln technology in China used this reaction to reach the high temperature and create reduction atmosphere to reduce iron (III). Chinese ceramists used treatments of throwing wood inside the kiln from stock holes and inserting water or vapor of water to inside the kiln after achieving 1000°C temperatures [77].Figures (2.55) and (2.56) show this treatments.

### 2.5.4.2 Lignite (Table(A.6))

Lignite, referred to as brown coal. It has low energy density and typically high moisture content and it has carbon content. Lignite was used for firing hard soft porcelain at Elbogen in the Czech Republic. It produces a long flame during firing. are presented in table .From the compositions of three type of lignite, the kiln which used lignite as fuel, has a reduction atmosphere [56].

### 2.5.4.3 Coal (Table(A.7))

Coal give calories more than wood and it was used to firing different types of ceramics in England also was used in Germany and France to fire some ceramics types . Referring to the time of coal the long flame was required to firing ceramics, so the larger pieces were preferred in ceramics kilns. Coal fuel required a strong circulation of air that usually need air supply system , therefore the structure of kiln that its heat resources is coal, required some modification in fire box architecture and design. See figure (2.63) . Coal contains high percentage of carbon, so the atmosphere of kiln is reduction[56].

### 2.5.4.4 Fuel gases

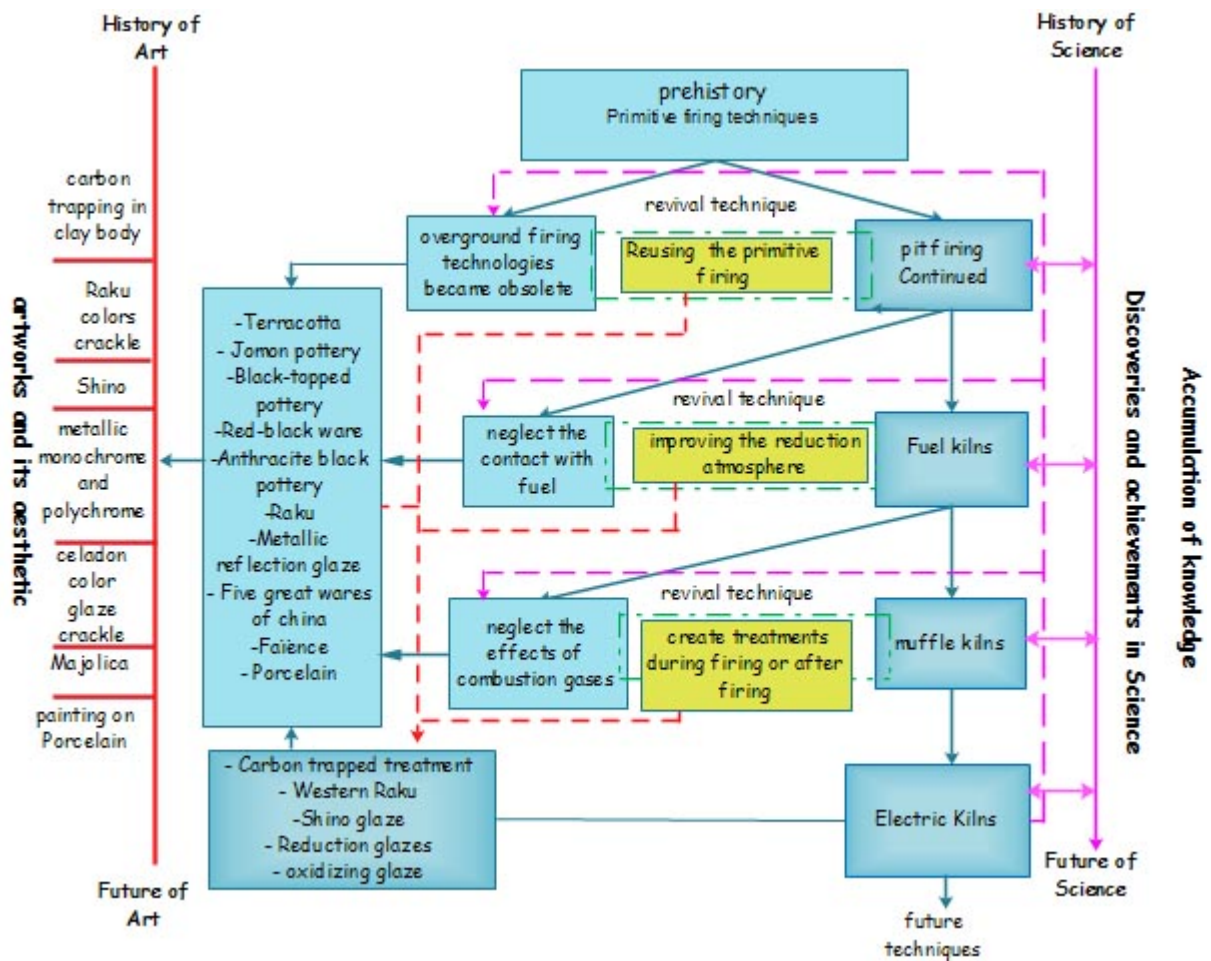
Fuel gases were used first time to fire hard-soft porcelain 1854. The entrance of fuel gases to kiln technology affected the efficient temperature, cost of firing, atmosphere of kiln and structure and lining of kiln. The first experimental of firing ceramics by fuel gases was depended on creating machines that are used to transfer the solid fuel to combustion gases and compress them inside the kiln[56]. Using natural gases in kiln technology was important change in the kiln structure and in its atmosphere. The major composition in natural gas is methane ( $\text{CH}_4$ ). The atmosphere of kiln is light reduction and there is no ashes produced.

## 2.6 Conclusion

Atmosphere of kiln can be considered a fixed parameter in most historical firing technology, where most kilns allow using only one of heat resources. Whatever this parameter was used to make positive influence. Kind of fuel and its combustion gases made reactive atmosphere, so using same atmosphere in every firing is related to kiln design and no kiln designed to make changing in atmosphere by intended manner. From the historical study, the idea of using the atmosphere of kiln as an effective parameter in treatments on ceramics surfaces is seen to be indispensable. This study refers to successful aesthetic treatments that were produced by chemical reactions between combustion gases and raw materials and mineral oxides in glaze structure. Also there is other aesthetic treatment that was made by physical properties which can be controlled during or after firing.

Over timeline in historical study, the atmosphere of kiln passes by two main technologies, first one is using the atmosphere of kiln; second one is avoiding the effect of atmosphere of kiln. In the second technology, the structure of glaze and colored oxides are the changeable parameter which used to create the aesthetic treatments on ceramic surfaces. In the two technologies, the relationship among science, art and history is released as shown in figure (2.68) where using the atmosphere of kiln is improved with improving of ceramics science and also some technologies of firing ceramics are neglected. This negligence resulted in disappearance of some aesthetic treatments. Therefore, the contemporary ceramists reused historical method of firing when they want producing some of special aesthetic treatments. Science of ceramics was useful in improving historical firing technology, where some ideas are improved to create special aesthetics, as applying glazes on the ceramic forms then fired them by pit firing technique for making reaction between glaze structure, fuel materials and other vapor. Also mixing some chemical powders as copper sulfate with fuel materials is an idea for creating special colors when pit firing used nowadays. Reflection metallic colors were produced from nine century by using the carbon atmosphere during

## CERAMICS HISTORY AND FIRING PROCESS



**Figure 2.68:** flow chart shows the relationship among aesthetics treatments, ceramics science and history of firing technologies .as a result of historical study.

firing process, but in nineteenth century, M. Théodore Deck [115] propose chemical formula to make reflection metallic especially red and gold colors by muffle kiln technology. This formula was suitable to decorate porcelain, where muffle kiln was created to fire painting of porcelain without effects of combustion gasses. Therefore, producing golden metallic color in oxidizing atmosphere was required. With improvements in science of ceramics and its technology, thermal analysis, chemical structure and physical properties led to inform about the expected reaction and its time during firing schedule, as they led to design structure of glaze for reacting with the atmosphere of kiln at right time on firing schedule. The reaction in right time on firing schedule gives an ability to do reflection metallic without surfing. Therefore, electric kiln which permit a normal atmosphere is suitable to modify its design to control the reactions during firing schedule.

The part of historical study guides the scientific part in this research by some concludes points as following:

1. Firing condition usually was correlated by fuel that used in kiln technology.
2. Available kiln technology determines the possible method of decoration.
3. Carbon, carbon monoxide and carbon dioxide were most gases that effect in final appearance to ceramics objects.
4. The correlation between the chemical compositions for clay or glazes and atmosphere of firing process is remarkable in many historical ceramics styles.
5. Structure and architecture of kiln are considered as a mean which enable or avoid on or more of parameters during firing process.
6. Ceramics kilns were designed to be an oxidizing atmosphere kiln or a reduction atmosphere kiln .



## Chapter 3

# Science of Glazes and preparation for treatment during or post firing

**H**IS chapter deals with scientific information about glaze materials, chemical reactions, physical properties and design structure of glaze to put in order with reactive gases or vapor during firing process or to put in order to create stress in surface of glaze. These scientific information exhibit chemical or physical performance which required such procedures in specific temperature, and therefore, different chemical reaction and physical properties control glazes states and their final appearance. Design such chemical reactions or physical properties for producing such appearance or colors required a theoretical about ceramics glazes. For this purpose, the chemistry state is comprehensively described and deduced for glaze and its structure with understood coloring mechanism of historical metallic reflection glazes (luster glaze) and ancient Chinese glazes ( five



grate wares). The mechanic properties of glaze and its body clay are described and proposed to control crackle on surface ceramics during firing or after firing.

### 3.1 Introduction

In ceramic production, firing process is used to give objects solidity and durable appearance, and during this process there are many chemical reactions occurred. These reactions exist in substrates forms, glazes layers and decoration enamels. The final appearance of ceramics is determined, based on these reactions. Since ceramists look for such design as final appearance, they can use chemical reactions of glazes to reach their purpose. Most of aesthetic treatments are presented in glaze applications, so chemical reactions and physical properties of glazes are attended to determine particular procedure which is done during firing process. Glaze is a continuous adherent smooth layer applied to surface of ceramics forms. These layers varied in transparent or opaque onse. There are variegated transparent glazes: colorless transparent glaze; and colored transparent glazes, also there are motley opaque glazes: white opaque glaze and colored opaque glazes. Therefore, glaze and its compositions are in center attention where they are in-input materials of chemical reactions.

Accordingly, nature of glaze is important to identify the nature of chemical reactions which exist during firing process. Nature of glaze differs from before firing, during firing to after firing. Where before firing, it is a mixture powder of raw materials, fritted glass or both of them, then it became sediment liquid when it added to water, and then it became a sediment layer over clay-body. During firing, at  $T_g$  temperature, it transit to glass, then at  $T_s$  temperature , it became a softening glossy layer on hot surface of clay-body, then at  $T_m$  temperature ,it became a melting phase. After firing the nature of normal glaze is a thin layer of glass( $T_g < T_s < T_m$ ) .

There is an important issue in this research that it must be taken in account to represent the relation between ceramics art and science ceramics. This issue based on transformation from final appearance of glaze as glassy state to chemical formula of this glaze which expresses in different degrees of saturation of normal silicates[116], from this formula, glaze and some reactions can be designed to occur during firing process. These reactions added to others factors that effect in the final appearance and aesthetic of glaze. Therefore, designing proper glazes, method of applied this glazes and conditions of firing are parameters which effect in colors and texture of glazes, and in this research the correlation between condition of firing and glaze structure leads to defined glazes and understand the relation between the chemical formula and know how it will look when it's fired and cooled.

### 3.2 Nature of the glaze

Glazes, before firing, are relatively thin dried layer commonly  $< 1$  mm in thickness which contains series of inorganic raw materials that is usually applied in suspension form in water . During firing, glazes compositions react to form glassy phase, glass particles called frit, ground crystalline ceramics colors and opacifiers, and processing additive. Also in maturing range, glaze reacts with surface of raw or biscuited ware in contact zone. After cooling, glazes are thin virtuous smooth layer of glassy state which consists of a thin layer glass, or glasses and crystals [16, 69, 117].

Glazes are applied to substrates to provide a shiny, normally smooth surface that protects the body. The feature of surface may be either matt or bright. The range of maturing temperature that glazes can be from  $600\text{ }^{\circ}\text{C}$  to  $1500\text{ }^{\circ}\text{C}$  [118], depending on the purpose of applied glaze and the ceramics bodies to which glazes are applied. Therefore, glazes are similar to glass, where the main component is silica with other inorganic oxides which are matured in the action of

heat at temperatures sufficient to cause sintering, solid-state reactions, bonding or conversion partially or wholly to the glassy state [119].

According to the nature of glazes, ceramists dealt with properties and structure of glass which may be defined as super-cooled of very high viscosity[16].Determining glasses combinations is major step to produce the glasses phase, and understanding structural theories of glass formation is required to design glasses and glazes structure and to improve the their aesthetic.

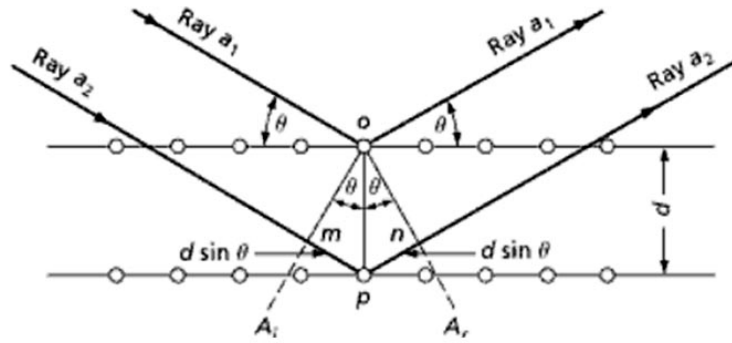
### 3.3 Glass formation

Despite the main component of glazes and glasses is silica ( $\text{SiO}_2$ ) , this is a common notion for most ceramists and artist, but definition of elements and oxides that are capable to form a glass, is necessary to design chemical conception for glass or glaze with an expected aspect and behavior. According to Bragg's law, glass is distinct from crystal by intense diffraction peaks which are produced by angle of incident x-ray, where the angle is related to the wavelength of incident x-ray ( $\lambda$ ) and the lattice spacing [120], so Bragg's law describes the conditions for constructive interference by this equation:

$$n\lambda = 2d\sin\theta \quad (3.1)$$

Where  $n = 1, 2, 3, \dots$  ,  $\lambda$  = wavelength in nm,  $d$ = interplaner distance in nm, and  $\theta$ = angle of incidence or reflection of x-ray beam. Figure (3.1) demonstrates the constructive interference which is resulted when reflection rays  $a_1, a_2$  be in phase, and the angles at constructive interference are very sharply if the reflections originate on many thousands of parallel lattice planes which exist in an undistorted crystal[121], so the X-ray diffraction patterns used to recognize the glass structure .

M.Zachariasen[122] mentioned that "mechanical properties of glasses are similar to those of the corresponding crystals", and glasses have higher internal energy



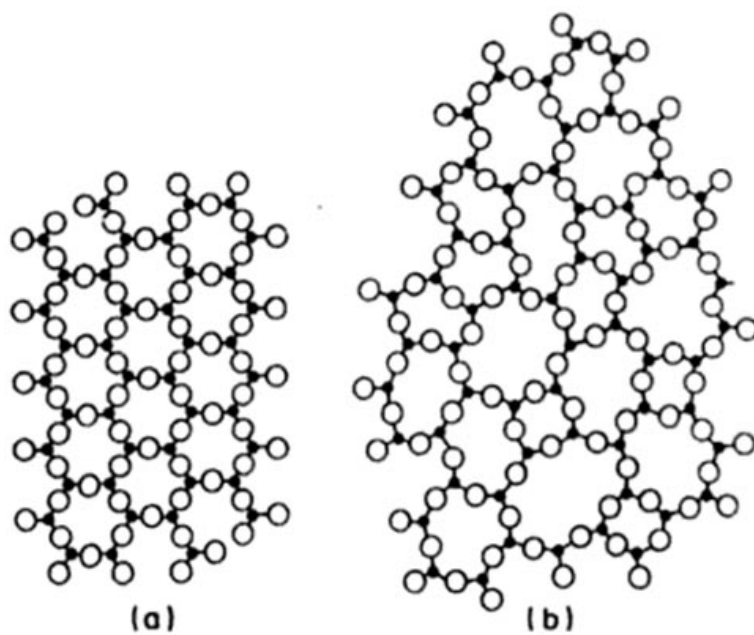
**Figure 3.1:** constructive interference explains the Bragg's law

than crystals, and therefore glasses consist of three-dimensional random network. So the glasses and crystals have the same building block, cation polyhedra, but have different configurations, where the polyhedra, in glasses, are arranged in different patterns not like crystals patterns as shown in figure(3.2), where (a) demonstrate the atomic structure of composition in crystal form, and (b) demonstrate the atomic structure of same composition in glass network .

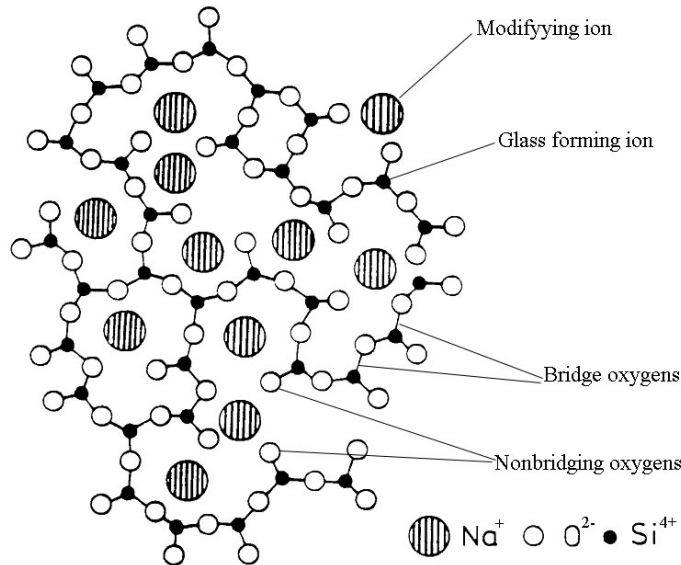
According to atomic arrangement, the oxides which form glasses by themselves must have four flowing rules which set up by Zachariasen [16, 122]:

1. Each oxygen atom should never be linked to more than two cations.
2. The number of oxygen atoms around the cation must be small 3 or 4.
3. Oxygen polyhedra should share corners, not edges or faces.
4. Three corners at least of each polyhedron must be shared.

Sun[122] suggested that the oxides which have higher single bond strengths are better to form glasses and they are glasses formers. He calculated the strength of the M-O single bond in oxide  $MO_{x/y}$  by obtained the values for energy  $E_d$  which is required to separate the molecule. table (A.8) presented glasses oxides with



**Figure 3.2:** schematic demonstrate atomic structure of (a) composition in crystal form (b) composition in glass random network



**Figure 3.3:** A two-dimensional representation of a sodium silicate glass.

classification to network formers, network modifiers, and intermediate glasses formers[118].

Therefore, it was found that the  $\text{SiO}_2$ ,  $\text{B}_2\text{O}_3$ , and  $\text{P}_2\text{O}_5$  often form glass network formers ( $NWF_s$ ), as well as  $\text{GeO}_2$  form glass but it is expensive to use in glaze. The networks which form from glasses oxides have holes that are filled by some oxides like  $\text{Na}_2\text{O}$ ,  $\text{K}_2\text{O}$ ,  $\text{CaO}$ ,  $\text{MgO}$  and  $\text{PbO}$ . These oxides called glass network modifiers ( $NWM_s$ ), they are not glasses former according to Zachariasen rules and to single bond strength. When (NWM) added to (NWF) , it will be modified to continuous random network (CRN) ,and the new network was modified to bridging oxygen link glass forming tetrahedral and non-bridging oxygen form ionic bonds with the modifiers [16, 123], as demonstrated in Figure (3.3),this network present example to structure of common glasses.

There are some oxides which not quit form glasses by themselves but when they are put in glasses network by small amount, they will take place the  $\text{Si}^{+4}$  or  $\text{B}^{+3}$ . This oxides called intermediate glass formers, they can rarely form

## SCIENCE OF GLAZES AND PREPARATION FOR TREATMENT DURING OR POST FIRING

---

network itself with some modifiers as in the system ( $\text{MgO} \cdot \text{CaO} \cdot \text{Al}_2\text{O}_3$ ) or ( $\text{K}_2\text{O} \cdot \text{CaO} \cdot \text{Al}_2\text{O}_3$ ). According the single bond strength, the common intermediate glasses formers are  $\text{Al}_2\text{O}_3$ ,  $\text{PbO}$ ,  $\text{ZnO}$ ,  $\text{ZrO}_2$  and  $\text{CdO}$ [16].

Therefore, glaze is glass network which was formed by  $\text{SiO}_2$ ,  $\text{B}_2\text{O}_3$  or  $\text{P}_2\text{O}_5$  formers, this network is modified by limited percentage of  $\text{CaO}$ ,  $\text{Na}_2\text{O}$  or substitutions for both of them, and some glasses forming ions in glaze continuous random network is replaced by  $\text{Al}_2\text{O}_3$ . Practically, this continuous random network is prepared from raw materials to treat by heating after it is applied on surface of ceramics body.

The position and the ratio of such oxide inside network affect the properties of glaze and its aspects. Therefore, design reactions to occur during firing process have to be that reaction with oxides which fill in the holes of network because it has the low bond strengths in the network. Cycle of heating treatment has an affects in network arrangement, the reaction that can be done after forming the network is interesting in this research. The network of glaze capable to has one or more crystalline phases that compressed with glossy phase, so the relation between different phases: glass, crystals, and liquid is required to expect the changed in phases when some treatments were done during the firing process.

### 3.4 The Volume-Temperature Diagram

The network of glaze capable to has one or more crystalline phases that compressed with glossy phase, so the relation between different phases: glass, crystals, and liquid is required to expect the changed in phases when some treatments were done during the firing process.

Specific volume is competing against temperature to describe the relation between different phases in volume-temperature diagram figure (3.4), where a melt is cooled from point  $a$  which is a temperature higher than melting temperature  $T_m$ , at point  $b$ , the volume  $V$  shrinks along the line  $ab$ . Although point  $b$  is

the thermodynamic freezing point in case of melt or the thermodynamic melting point  $T_m$  of a crystal of the same composition. The crystal occur only if there is sufficient nucleation rate  $\mathbf{I}$  which is followed by a significant crystal growth rate  $\mathbf{u}$ . these two rates are zero at  $T_m$  so there is no crystallizing at  $T_m$ , but the two rates increase in the shades region in figure (3.4) with increasing the super-cooling, so in this region there is highest probability of crystallization. In case of crystal at some point in shaded region, the mass shrinks in volume infrequently without changing in its temperature, this the first-order thermodynamic transition, the shrinking continues along the line (*de*) with cooling. If one of two rates  $\mathbf{I}$  or  $\mathbf{u}$  disappear at point b, the liquid passes the monotonically into a super-cooled liquid state without the appearance of crystals. [123]

According to this diagram ,and to the nature of glazes that have glassy phase and one or more of crystals phases, the treatments which can be made during firing to react with crystal phase consider to exist in temperature rang at some points in shaded region. Also any reaction was targeted to affect in aesthetic of glaze; its structure should have one or more of reactions components. Most of reactions that can be done in surface of glazes are with metal oxide. The aspects of crystalline glaze required a sufficient nucleation rate; this condition is provided in this case by added ZnO or TiO<sub>2</sub> to glaze structure, and a significant crystal growth rate condition is provided by slowly rate cooling. Without these two conditions the aesthetic treatment that is shown in figure (??) cannot exist.

### **3.5 Glaze calcification**

The glazes wither they are used in industrial or in artistic field, have been classified into some groups. These classifications are important to design glaze, where they varied into translucent layer and opaque layer. There are variegated translucent glazes: colorless translucent glaze; and colored translucent glazes, also there are motley opaque glazes: white opaque glaze and colored opaque glazes.



# SCIENCE OF GLAZES AND PREPARATION FOR TREATMENT DURING OR POST FIRING

---

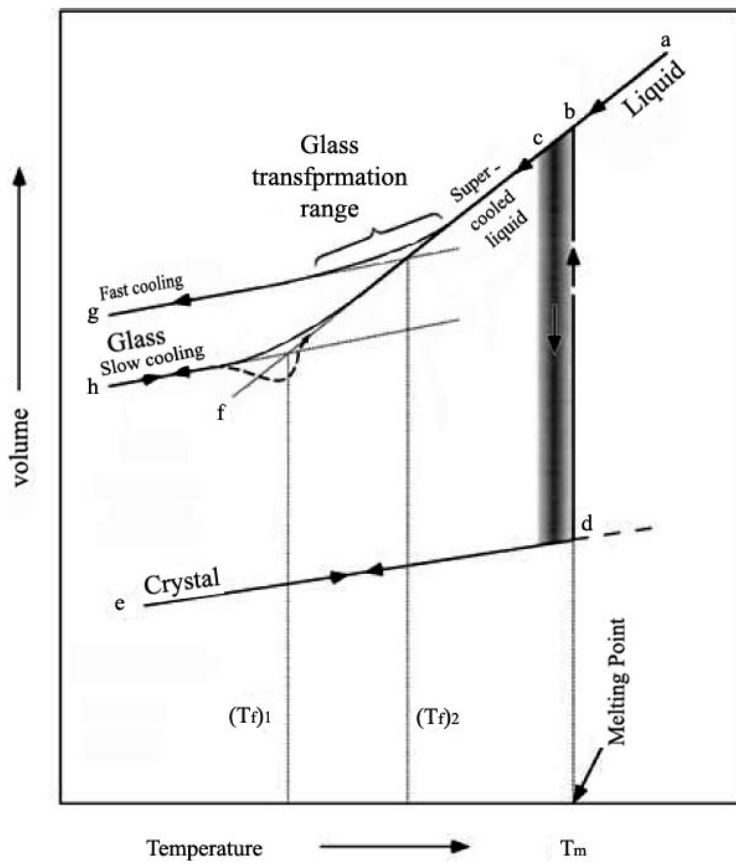


Figure 3.4: The volume-temperature diagram.

The application of glazes, in order to decorate ceramic bodies, makes another variation in glaze types. When pattern of colored glazes applied under layer of transparent glaze, this type of glaze called under-glaze, and if this pattern applied over layer of opaque glaze, this kind of glaze called over-glaze. In applied ceramic arts, the term of glaze is not limited to its nature: transparent, opacity, colored or colorless, but also glazes are classified according to types of ceramic bodies which are decorated by these glazes. Clay bodies classified into some groups based on the temperature, and therefore, glazes are divided up according at which temperature they are matured. In this way, glazes divided to three main groups: low temperature ( $1050^{\circ}\text{C}$ - $1150^{\circ}\text{C}$ ) for earthenware objects, medium temperature ( $1200^{\circ}\text{C}$  -  $1220^{\circ}\text{C}$ ) for stoneware bodies and high temperatures ( $1250^{\circ}\text{C}$ - $1280^{\circ}\text{C}$ ) for stoneware and porcelain forms[124]. It is worth to mention that the temperature of firing is mustered by standard parametric cones. Table (A.9) provide temperature equivalent for Orten standard large cones. American ceramic society, and table (A.10) provide temperature equivalent for Seger standard cones. Staatliche prozellan-manufaktur, Berlin[67]. These tables refer cone number which indicates to equivalent maturing temperature. Glazes are classified also by cone numbers which demonstrate the wide firing range.

The composition of glaze was used to classify glazes, where they are divided into lead glazes and leadless glazes; this may be a classification according to nature of the flux. Based on the composition of glazes, they are varied from alumina to silica ratio or the acid to base ratio, and the acidity number or acid equivalent. Therefore, there are lead-silicate glazes, lead-boro-silicate glazes, alkali-boro-silicate glazes and alkali-lime-silicate glazes[125]. The feature bright or mat of glaze is related to alumina to silica ratio. Glazes also can deviates, based on composition, to frit glazes and raw glazes.

In this research, aesthetic aspects is desired, and therefore, the appearance of glazes and their decorations will take in account as first selection from glaze classification, the chosen glaze will applied on various ceramics substrates, hence, in which temperature ceramic bodies are fired is important decision to select right

glaze. Also the classification by temperature is useful to put glazes layers in order especially in case of multi glazes decoration (over-glaze or under-glaze).

Glaze calcification, its applications, chemical structure and relation between them are required for designing a glaze structure, as they are a pressing desired. Especially in this thesis, design glaze is necessary to prepare chemical reactions and physical properties at final phases of glazes from first step of design these glazes. A structure of glaze which can react with atmosphere of kiln or can be reactive to such procedure during firing is the main target in this scientific study.

## **3.6 Design the glaze structure**

In this research, aesthetic aspects is desired, and therefore, the appearance of glazes and their decorations will take in account as first selection from glaze classification, the chosen glaze will applied on various ceramics substrates, hence in which temperature ceramic bodies are fired is important to select right glaze. Therefore, wide firing range of glaze is taken an account when ceramist designs the glaze. In case of multi glazes decoration (over-glaze or under-glaze), order of glazes layer on surface of ceramic body is related to order of wide firing range for each layer. Then most feature aspects of glaze are designed by added one or more oxide to structure of glaze.

### **3.6.1 Expression of glaze structure**

There are three ways that are used to write structure of glaze recipe, percentage analysis and unity formula. The recipe of glaze presents a list of raw materials quantities which compose the glaze, sometimes there are glasses forms which called frits are used in components of glazes recipes. The technique of fritted glaze is used with materials which are soluble in water such as boric oxide. Also for reasons of health , the lead is used in commerce glazes as frit[16]. Usually

fritted glazes are used in whitewares, but nowadays frit technologies are used in many types of ware. Some of most available glaze frits corporation are: Ferro, O-Hommel, Pemco, Fusion, and General. Substations among frits brands from this corporation are shown in table (A.11), and Ferro standard glaze frits are shown in table(A.12).

Batch recipes of glazes are measured quantities percentages of raw materials which mixed together by weight. They are prepared to be ready for application. For some considerations as location, availability, costs, and mineral impurities raw materials are selected for manufacturing of glaze. The form of batch recipe is written in two columns one refers to raw materials or fritted glass and the other refer to the weight of these materials in gram for small scales or kilogram in large scales. Therefore, this expression of glaze structure is the practical applicable form which especial experience and notion about the raw materials and frits. Percentages analysis which is one of three methods to write glazes structure are used to showing percentage of each individual oxide in recipe batch, where there total are 100 %. These percentages write in two columns one for the oxides and other one for percentage of oxide. These percentages analysis can be obtained by two ways; first is chemical analysis for traditional or ancient's glazes that is made by one of different methods; the second is a converting from unity formula. The important of this method comes from that it is required to convert from chemical formula to batches recipes[126].

The third way of writing glaze structure is Seger formula, where it is method to describe a glaze by its various chemical components, where Seger formula is a description for relations between component oxides, and molar equivalent is used to describe quantities of molecules which compose the glaze. Seger formula classifies the oxides to three groups: network former / acid oxides molecules ( $\text{RO}_2$ ;  $\text{R}_2\text{O}_5$ ), network modifiers/ basic oxides ( $\text{R}_2\text{O}$ ;  $\text{RO}$ ) and network stabilizers /amphoteric oxides ( $\text{R}_2\text{O}_3$ ). There are some rules regulate composition in equivalents. The sum of the bases  $\text{R}_2\text{O}$  and  $\text{RO}$  in the glaze is equal to 1 and is contrasted with the number of acid oxide molecules and amphoteric oxides molecules[18, 116]. Some

## SCIENCE OF GLAZES AND PREPARATION FOR TREATMENT DURING OR POST FIRING

---

actual used glazes are described by Seger formula with limited compositions, these were: RO = 1.0, SiO<sub>2</sub> = 1.5-3.0 for earthenware and fin French faience, RO = 1.0, AL<sub>2</sub>O<sub>3</sub> =0.1-0.4 SiO<sub>2</sub> = 1.5-3.0 for German and English white-wares and RO = 1.0, AL<sub>2</sub>O<sub>3</sub> =0.5-1.25 SiO<sub>2</sub> = 5.0-12.5 for porcelain[127].

These three methods of writing glaze structure are important to transfer the glazes structures from a collection of raw materials to a collection of molecules that react during firing with other element, molecules or complex molecules under control conditions that was constructive in design and expected such reaction to enrich aesthetes of glazes. This transformation from raw materials to unity formula is required to design these chemical reactions with retaining of glasses network and glazes properties, where these designs are made in Seger formula and then it can be transfer to batch recipes which are practical and applicable.

### 3.6.2 Calculation glaze structure from other structure

Percentage analysis of oxides can be converted to proposal batch recipe when the chemical analysis of raw materials is known. Percentage analysis of oxides for such glaze with the molecular weight for each raw materials which will used to give this oxide, and with knowing the chemical reactions to this raw materials ; the quantities of one or more oxides can be calculate by molecular weight . The sum of molecular weight for each molecule that are given by one raw material is equal to molecular weight that required of this raw materials, by comparison between molecular weight of each raw material and total molecular weight of all raw materials in batch recipe the percentage of batch recipe will be defined.

The converting unity formula to percentage analysis is calculated from numbers of molecules in unity formula, where multiplying the number by its molecular weight gives the weight of each oxides. So weight of formula is equal sum of weights for all oxides in glaze, then dividing weight of each oxide by weight formula to define the percentage analysis. Mathematical program - Mapel<sup>TM</sup> -

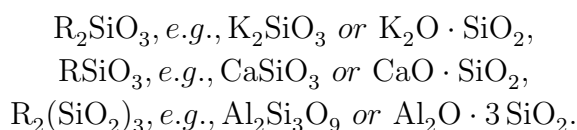
was used to do this calculation just by put the number of oxides instead of x1 ,x2.....xn in program windows that showing in the figure (3.5).

The converting from percentage analysis unity formula is calculated by dividing the percentage analysis value for the oxides by the molecular weight of oxides and then the results well are divided by the weight of flux group (RO, R<sub>2</sub>O) the results are number of unity formula. Figure (3.6) shows Maple<sup>TM</sup> program window that are used for converting an analysis to Seger formula.

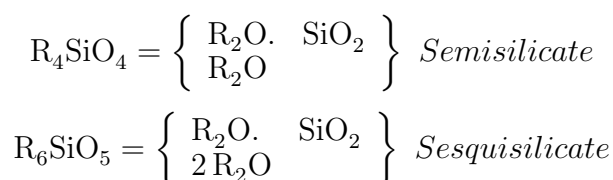
These calculations permit to transfer chemical analysis of ancient glazes to Seger formula which permits to understanding physical properties and chemicals reactions and allow reproducing these glazes and improving its structure to enrich its surfaces aesthetically. Also unity formula is used to design glaze structures by calculating the ratios between acid group, stabilizer and fluxes group.

### 3.6.3 Glaze structure designed by unity formula

The main ingredient in glaze is silicate and it takes salts form of dibasic silicic acid H<sub>2</sub>SiO<sub>3</sub>, actually the two hydrogen atoms are replaced by univalent metal oxide R<sub>2</sub>O ,bivalent metal oxide RO or trivalent metal oxide R<sub>2</sub>O<sub>3</sub>.The normal silicates have different degrees of saturation which can be expressed as following[116]:



But the second degree of saturation of silicates are expressed in following formula:



# SCIENCE OF GLAZES AND PREPARATION FOR TREATMENT DURING OR POST FIRING

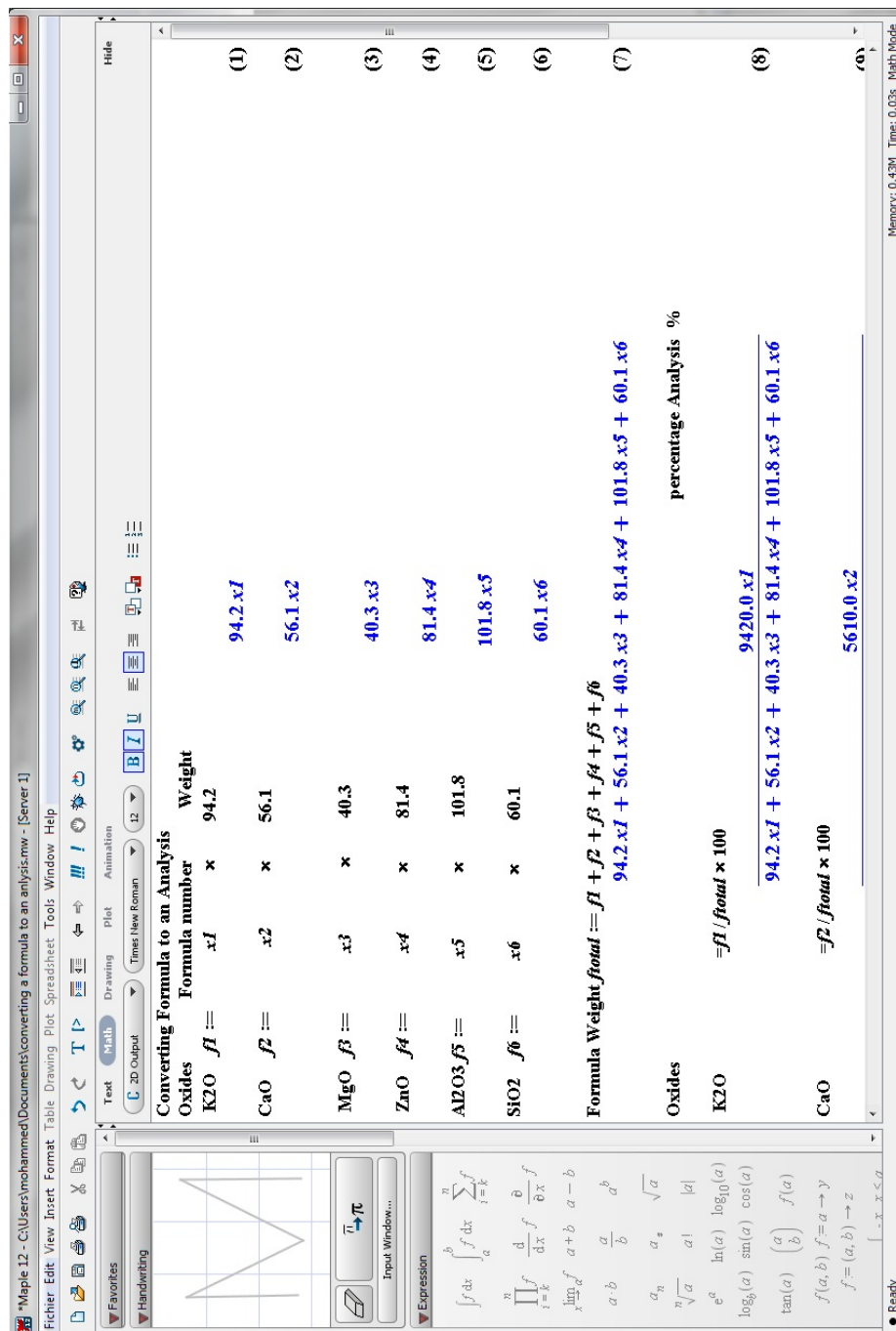


Figure 3.5: window of Maple™ program that used for converting unity formula to an analysis.

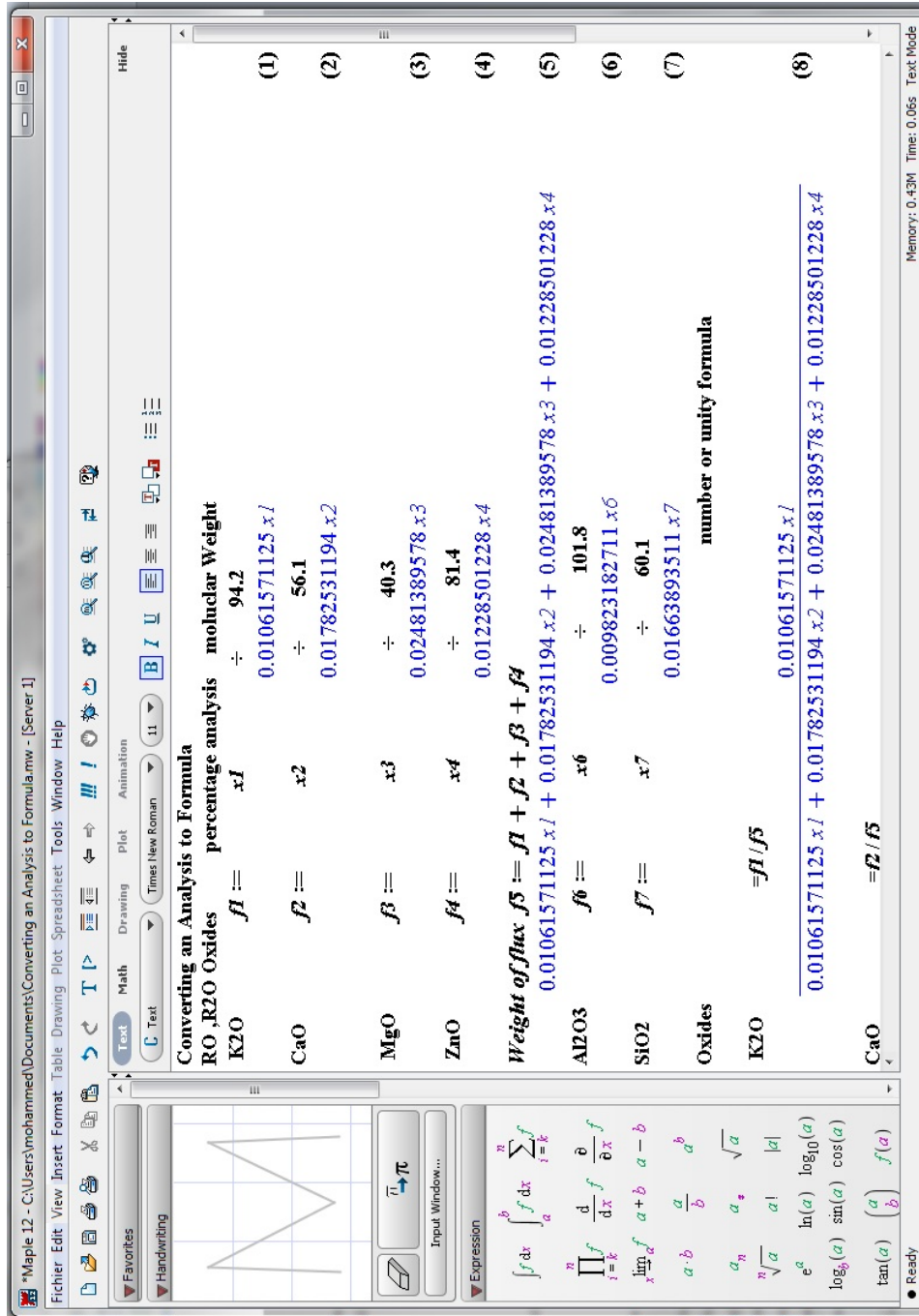
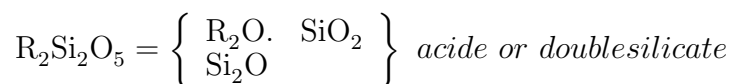


Figure 3.6: window of Maple™ program that used for converting an analysis to unity formula .

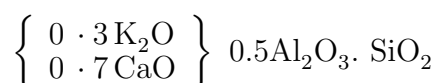


## SCIENCE OF GLAZES AND PREPARATION FOR TREATMENT DURING OR POST FIRING

---



Above formula expressed just a second degree of saturation of silicates, while glazes have extremely complex compositions of silicate. Glaze can be designed as natural minerals by represented its compositions in formula. The main considerations in design formula of glaze structures are the ratio between valence of acids and bases, sum of bases = 1 and is contrasted with the number of acid oxides and stabilizer oxides[116]. Therefore, designing glaze structure based on understanding the relation between these ratios and its features. Glaze with the composition  $K_6Ca_7Al_{10}Si_{40}O_{105}$  can be described by following formula:



The process of design the glaze by unity formula based on two procedures, first one is a determining which oxide molecule will be in the formula of glaze and determining in which group it will be : a glasses former, an intermediate former or a modifier, second procedure is determining valence of each group and of each oxide molecule.

The glazes classification by their composition is used to determine some oxides in glaze formula, where there are lead-silicate glazes, lead-boro-silicate glazes, alkali-boro-silicate glazes and alkali-lime-silicate glazes.  $SiO_2$  oxide is an essential component in glazes; sometimes  $B_2O_3$  and  $P_2O_5$  are used with  $SiO_2$  as network formers, however, the  $B_2O_3$  acts as powerful flux and it is used to decrease the viscosity of molten glaze. Therefore boric oxide in the glaze formula means a good smooth and brilliant carving to this glaze[22, 128, 129]. Also boric oxide used in formula to avoid crazing and to transfer the glaze from transparent glaze to opaque glaze especially when it is added in certain ratio with silica[130]. In small amount  $P_2O_5$  forms colloidal particles which lead to create a type of light-reflective quality called colloidal opacity, and thus, phosphorus oxide is usually used in slight amount in glaze. It is likely to give them a bluish flush[22]. Also

$P_2O_5$  is present in designed glaze formula to influence the rate of nucleation and/or crystallization in  $Li_2O$  and  $MgO$  low expansion glaze systems[131] and to combines with certain oxides of iron forms colorless compounds [132].

Therefore silica is the main glass former that is usually used in glaze structure, but boron oxide and phosphorus oxide are required for other reasons beside they are glass formers and their effects in glaze must taken in account for designing a glaze structure. The chemical formula of silica take form  $RO_2$ , therefore titanium oxide ( $TiO_2$ ), tin oxide ( $SnO_2$ ) and zirconium oxide ( $ZrO_2$ ) also belong to this group[133].

Second group is an intermediate oxide,  $Al_2O_3$  used as an intermediate between the glass former and modifiers so it used to control the flow of the glaze melt[22]. The high melting point of aluminum oxide leads to increase the melting point of the glaze[133]. It prevents devitrification and crystallization and gives chemical stability to a glaze. Therefore slight amount of  $Al_2O_3$  is important to create crystalline glaze.

Third group is the modifier oxides in formula of glaze which is designed according to some considerations, first of them, lowering the fusing. This consideration is the function of combined fluxes oxides group which are varied from lead, alkaline or alkaline-earth oxides. Other considerations based on the effect of oxides to determine which oxides are chosen and their amounts. Lead oxide is poison; therefore it must be first melted with silicate to reduce its ability to dissolve in saliva and gastric juice. Frit technology is used to transfer soluble state of lead components to less soluble states as:  $3PbO \cdot SiO_2$ ,  $2PbO \cdot SiO_2$  and  $3PbO \cdot 2SiO_2$ [116]. The safe lead glaze required that design glaze structure with high ratio between silica and flux group[134]. The importance of inserting lead oxide in glaze structure and formula comes from it helps to mature glaze in low melting range, reduces viscosity of glaze so the wide firing range is increased, impart low surface tension, give high index of refraction and gloss to glaze, reduce any tendencies towards surface crystallization or devitrification of the glaze and make glaze spread easily on surface of clay-body. In addition to the presence of

## SCIENCE OF GLAZES AND PREPARATION FOR TREATMENT DURING OR POST FIRING

---

PbO in the glaze lead to reduce the chemical stability[116, 134], therefore it is powerful in structure of reduction glazes to enhance effect of reduction firing.

The alkaline oxides, Na<sub>2</sub>O, K<sub>2</sub>O and Li<sub>2</sub>O also used to reduce the fusion point and they support the solution of other oxide in glazes. Potassium nitrate KNO<sub>3</sub> as source of K<sub>2</sub>O in finale formula of glaze is used to eliminate small bubbles on account of the generation of oxygen. The alkaline-earth oxide used in design glaze formula for different causes, where CaO is used to make glaze strong and shiny, but if it is added in large amount it lead to devitrification and crystallization of glaze. Barium oxide BaO can be used in formula of glaze instead of lead and calcium oxide, where it give the glaze an appearance like lead glaze with strength, hardness and low cost ,but it must use in frit for avoiding the toxicity of barium compounds [116]. For producing leadless glaze or lead free glaze the bismuth oxide, zinc oxide, or strontium oxide are used as an alternative of lead oxide in the formula of glaze structure[134]. The color elements and oxides are usually oxides of transition metals elements, also the rare-earth elements can be used as glaze colored[16].

The oxides that compose the glaze structure formula are ordered in Seger formula as following:

$$\left\{ \begin{array}{l} R_2O/RO \\ Base \\ Flux \end{array} \right\} \cdot \left\{ \begin{array}{l} R_2O_3 \\ Amphoteric \\ Stabilizer \end{array} \right\} \cdot \left\{ \begin{array}{l} RO_2 \\ Acid \\ Glass former \end{array} \right\}$$

Determining the relative numbers of oxides molecule is complex process in design glaze structure, where there are many factories must be taken in account for determining relative number to one glaze formula. According the temperature or cone of firing there some limitation for relatives numbers in formula are supposed, where the oxygen ratio (this the ratio between the total moles of oxygen and the total moles of glass former, as present in equation (3.2), it is from 2 to 3 for all glazes)[16] and mole ratio for alumina Al<sub>2</sub>O<sub>3</sub> in formula can give idea about firing

temperature.

$$O_{ratio} = \frac{Mol_{oxygen}}{Mol_{Si} + Mol_B} \quad (3.2)$$

The approximate temperature of heat treatment for glaze structure can be estimated from Seger formula depending on Lengersdorff flux factors. The F is flux factor which is calculated from equation (3.3)[17].

$$F = \frac{\sum S_i f_i}{\sum S_j f_j} \times 100 \quad (3.3)$$

Where  $S_i$  refers to the molar fraction of the oxides having the value of Lengersdorff factors  $f_i > 0.4$  and  $S_j$  is the molar fraction of the oxides having the value of Lengersdorff factors  $f_j < 0.4$  which are presented in table(3.1) with other specific coefficients used for glaze preparation. The FT temperature of heat treatment is calculated from equation (3.4)[17]:

$$FT = \frac{161.21789 - F}{0.10252} \quad (3.4)$$

F calculated with equation (3.3) FT is heat treatment (°C).

The equation (3.3) and Lengersdorff flux factors indicate that PbO(2.00) is the first oxide which decrease the temperature of heat treatments for glaze and it is immediately followed by B<sub>2</sub>O<sub>3</sub> and Sb<sub>2</sub>O<sub>3</sub> , SiO<sub>2</sub>,TiO<sub>2</sub> and Al<sub>2</sub>O<sub>3</sub> are the oxides which increase temperature of heat treatments , and Na<sub>2</sub>O and K<sub>2</sub>O have the equal effect in decrease the temperature of heat treatments and ZnO and BaO have equal effect also. Therefore, Lengersdorff flux factors are specific determinants of relative numbers for each oxide form oxides that be chosen to create the glaze structure. There is other important specific determinant which depends on the ratio between Al<sub>2</sub>O<sub>3</sub> and SiO<sub>2</sub> or glass former. This ratio determine the gloss and shiny aspect for glaze and this ratio varied according to a temperature of heat treatment to glazes.

Figure (3.7) show the relation between Al<sub>2</sub>O and SiO<sub>2</sub> ratio in cone 10 ~1305°C, cone 12 ~ 1326°C, cone 14 ~ 1366°C and cone 16 ~ 1450°C, the ratios between

## SCIENCE OF GLAZES AND PREPARATION FOR TREATMENT DURING OR POST FIRING

---

**Table 3.1:** Characteristics and specific coefficients used for glaze preparation[18]

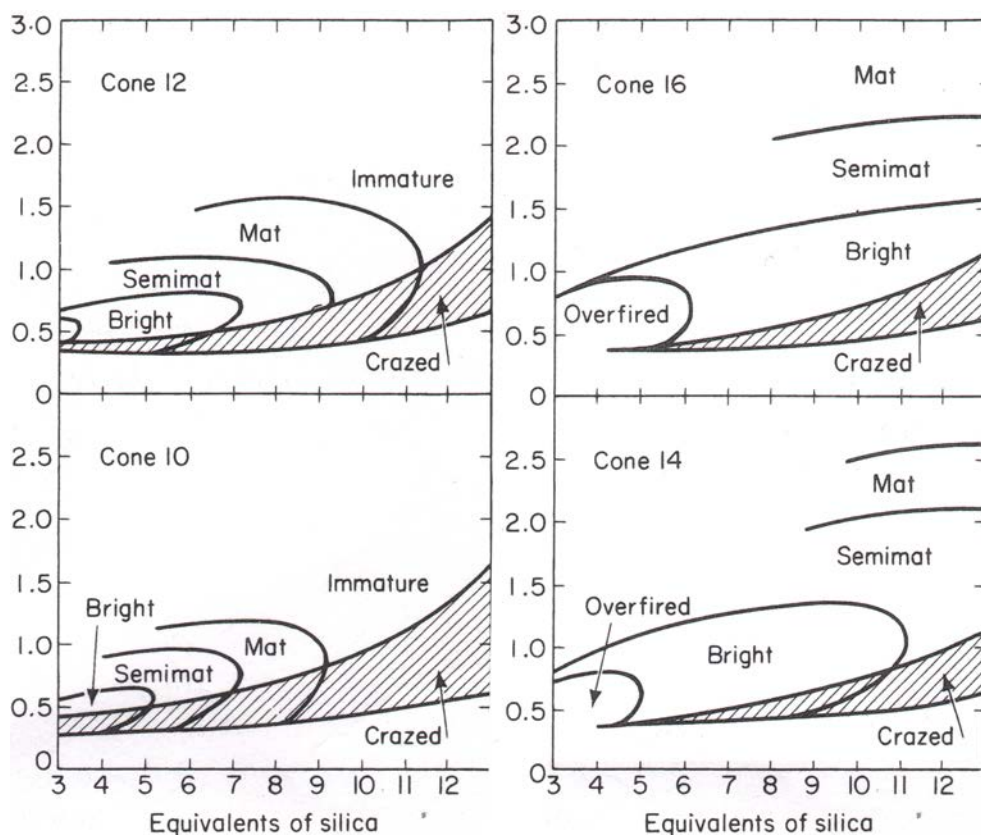
| Oxide                          | Molar Weight | Winkelmannand Scott partial coefficients | Dietzel partial coefficients | Lengersdorff flux factors | Appen coefficients |
|--------------------------------|--------------|--|------------------------------|---------------------------|--------------------|
| Na <sub>2</sub> O              | 62           | 333.3                                    | 0.7                          | 0.88                      | 1.590              |
| K <sub>2</sub> O               | 94.2         | 283.3                                    | 0.7                          | 0.88                      | 1.575              |
| MgO                            | 40.3         | 003.3                                    | 6.6                          | 0.54                      | 1.610              |
| CaO                            | 56.1         | 166.7                                    | 4.8                          | 0.58                      | 1.730              |
| ZnO                            | 81.4         | 060.0                                    | 4.7                          | 0.60                      | 1.710              |
| BaO                            | 153.3        | 100.0                                    | 3.7                          | 0.60                      | 1.880              |
| Al <sub>2</sub> O <sub>3</sub> | 102          | 166.7                                    | 6.2                          | 0.32                      | 1.520              |
| Fe <sub>2</sub> O <sub>3</sub> | 159.7        | 133.3                                    | -                            | 0.7                       | -                  |
| B <sub>2</sub> O <sub>3</sub>  | 69.6         | 003.3                                    | 0.8                          | 1                         | 1.470              |
| SiO <sub>2</sub>               | 60.1         | 026.7                                    | 3.4                          | 0.38                      | 1.459              |
| TiO <sub>2</sub>               | 79.9         | 136.7                                    | 4.1                          | 0.38                      | 2.080              |
| P <sub>2</sub> O <sub>5</sub>  | 141.5        | 066.7                                    | -                            | -                         | -                  |
| MnO                            | 70.94        | -  | -                            | 0.6                       | -                  |

silica and alumina are chosen to be in the areas of brightness, mat or semi-mat and not be in the areas of over-fired, immature, and crazed [16]. Sometimes in ceramic art studio those avoided ratios are recommended for producing especial features on surface of ceramics forms. To design the formula of glaze also a specific coefficient which was determined by Appen for oxides can be used for calculating the refraction coefficient ( $n$ ) from this equation :

$$n = \sum a_i n_i \quad (3.5)$$

where  $n_i$  are Appen coefficients see table(3.1) and  $a_i$  represents the weight fraction of oxide. The values of refraction index show that the PbO and TiO<sub>2</sub> are highest oxides which affect in refraction coefficient, where  $n(\text{PbO})$  is 2.42[18, 135]. This

## DESIGN THE GLAZE STRUCTURE



**Figure 3.7:** diagrams demonstrate the relation between  $\text{SiO}_2$ ,  $\text{Al}_2\text{O}_3$  ratio and brightness of porcelain glazes at cones 10,12,14 and 16.

values are considered in designing glaze structure. According to the rule of lead oxide in the refraction property of glaze, its effect in creating metallic reflection, and to toxic effect, the Thorpe's Ratio is used to control lead solubility. Thorpe recommended the empirical equation (3.6) to predict the solubility of lead frit, where the value of equation(3.6) should not exceed 2 [134].

$$\frac{\text{Mols of Basic} + \text{Mols Alumina}}{\text{Mols of Acidic Oxides}} \times \frac{223}{60}, \quad (3.6)$$

this equation was stated as following :

$$\frac{\text{Ro} + \text{Al}_2\text{O}_3}{\text{RO}_2} = 0.5(\text{As Maximum}), \quad (3.7)$$

## SCIENCE OF GLAZES AND PREPARATION FOR TREATMENT DURING OR POST FIRING

---

This ratio is used to calculate the additive of lead oxide in the frit or glaze, and it should be equal 0.5 or less for recommending this glaze for table-ware[134].

The mechanical properties of glazes can be controlled also by limiting and designing the formula of glaze, where the coefficient of thermal expansion and Young's modulus of glaze are effected by chemical composition of glaze. Mechanical properties are considered properties to affect the aspects of glaze especially crazing and cracking treatments on surface of ceramics objects.

Young's modulus ( $E$ ) of glaze is approximately calculated according to following equation(3.8):

$$E = \sum a_i E_i, \quad (3.8)$$

where  $E$  the elasticity modulus;  $a_i$  the weight fraction of each oxide component and  $E_i$  the Winkelmann and Schott coefficients for each oxide component as presented in table (3.2 [18].

(TEC) the coefficient of thermal expansion for such glaze can be closed to calculate according equation(3.9):

$$\alpha = \sum a_i \alpha_i \quad (3.9)$$

where  $a_i$  represents the % molar for different oxide component and  $\alpha_i$  represents coefficient of thermal expansion for different oxide component[18].

Glaze formula should be designed to has a thermal expansion coefficient(TEC) that is adequate with a thermal expansion coefficient(TEC) of the body-clay. The surface treatments of glaze after firing are taken in account where crackle treatment is required some different between glaze and clay-body thermal expansion coefficient, while the smooth no cracking treatment is required the equality or at least the value of the difference (TEC) between body and glaze is not more about  $5 \times 10^{-7} K^{-1}$  [136].

Design Seger formula for glaze structure is relative to expect the aspects of ceramics objects, where aspects of glaze related to its chemical components. Also, this formula is relative to explain aspects of historical ceramics types according to

## DESIGN THE GLAZE STRUCTURE

their chemical analysis. A visualization about technologies of these types can be created from this explanation and it is benefit for reproducing or improving these types. The formula of glaze organizes components oxides which are considered as in-put of chemical reactions which is treated by heat inside the kiln. During this heating process the out-put of chemical reactions can be created or controlled to affect on the aesthetics of glaze as demonstrate in figure (1.18).

**Table 3.2:** Factors for calculating Young's modulus from chemical compositions [19]

| Oxide                          | Winkelmann and schott (94) |                |                |
|--------------------------------|----------------------------|----------------|----------------|
|                                | A*                         | B <sup>§</sup> | C <sup>¶</sup> |
| Na <sub>2</sub> O              | 6.0                        | 9.8            | 6.9            |
| K <sub>2</sub> O               | 3.9                        | 6.9            | 2.9            |
| MgO                            | -                          | 3.9            | 2.9            |
| CaO                            | 6.9                        | 6.9            | -              |
| ZnO                            | 5.1                        | 9.8            | -              |
| BaO                            | -                          | 6.9            | 2.9            |
| Al <sub>2</sub> O <sub>3</sub> | 17.6                       | 14.7           | 12.7           |
| Fe <sub>2</sub> O <sub>3</sub> |                            |                |                |
| B <sub>2</sub> O <sub>3</sub>  | -                          | 5.9            | 2.5            |
| SiO <sub>2</sub>               | 6.9                        | 6.9            | 6.9            |
| TiO <sub>2</sub>               |                            |                |                |
| P <sub>2</sub> O <sub>5</sub>  | -                          | -              | 6.9            |
| PbO                            | 4.5                        | -              | 5.4            |
| As <sub>2</sub> O <sub>5</sub> | 3.9                        | 3.9            | 3.9            |

\*Factors under A are fore glaze or glasses free from B<sub>2</sub>O<sub>3</sub>,P<sub>2</sub>O<sub>5</sub>,BaO,MgO.

<sup>§</sup>Factors under B are for glaze or glasses free from PbO,P<sub>2</sub>O<sub>5</sub>.

<sup>¶</sup>Factors under C are for borosilicates, lead borosilicates,and phosphates.



## **3.7 Scientific researching on technology of ancient ceramics**

According to historical styles of ceramic art which are mentioned in chapter three, study on the glaze structure of these styles and their chemicals elements assists in designing the suitable glaze formula which is fundamental for establishing treatments during firing for enriching aesthetic of glaze. These treatments can be chemical or physical, therefore in this thesis, metallic reflection from Islamic ceramics and Ru kiln from Chinese ceramics are ideal styles that helps in establishing kiln as a tool for enriching the aesthetics of ceramics forms during or post firing.

### **3.7.1 Chemical treatment**

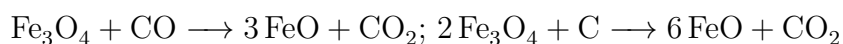
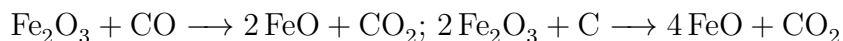
After maturing the glaze, the network of glass is modified by network modifiers and colored oxides which reacted with atmosphere of kiln to influence in the final appearance. The most effects which happened during the firing process are produced in carbonized atmosphere. Both of metallic reflection and colors of five grate kilns in song dynasty are treated by carbon during firing as chemical treatment.

#### **3.7.1.1 Firing process of some famous Chinese porcelain**

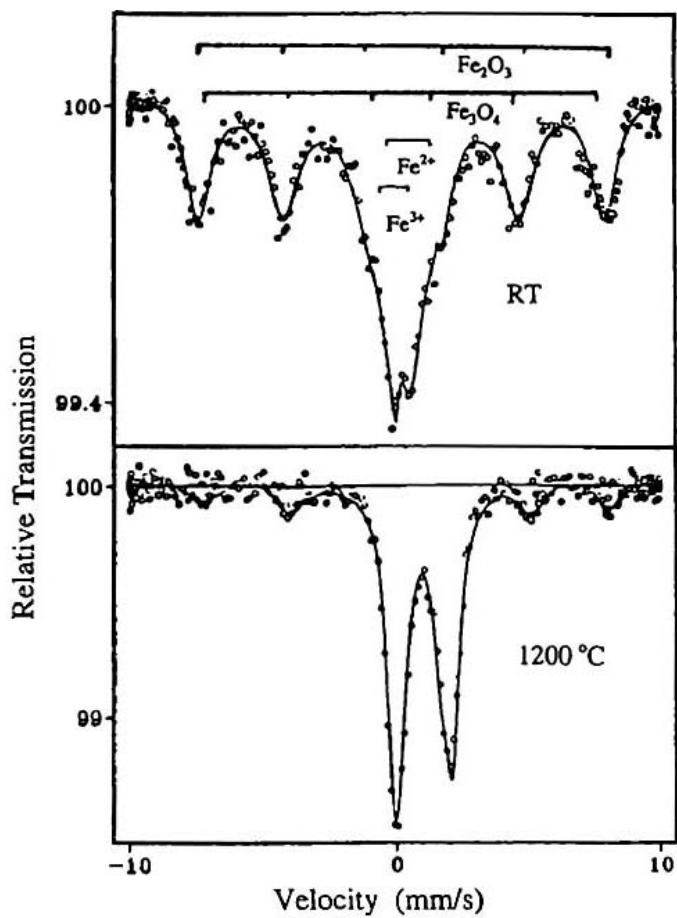
The glaze colors of the superior Ru porcelain are sky green and sky blue, the inferior are spawn white, powder green, pea green, shrimp green and verdant. The variation of all these colors are produced depend on firing technology, where there are some scientific studies which used to discover the scientific and technological aspects of Ru kiln and the other famous porcelain from the Chinese Song dynasty. Chen Songhua [137] studied the specimen of raw material of sky-green glaze

from city of Ruzhou, in the Henan province. This study demonstrated that the Structural iron( $\text{Fe}^{2+}$  and  $\text{Fe}^{3+}$ );  $\text{Fe}_2\text{O}_3$  and  $\text{Fe}_3\text{O}_4$  ( $\text{FeO}$ ,  $\text{Fe}_2\text{O}_3$ ) are contained in the sky-green glaze as the Mössbauer spectra of this glaze at different firing temperatures are shown in figure(3.8). The different firing temperatures affect the relative intensities of various iron minerals as shown in figure (3.9). The line (a) shows that with the temperature increases, the relative intensity of paramagnetic peak of  $\text{Fe}^{2+}$ ,  $\text{Fe}^{2+}/(\text{Fe}^{2+}+\text{Fe}^{3+})$  increases slowly from starting temperature to  $700^\circ\text{C}$  then rapidly to  $1200^\circ\text{C}$  where relative intensity is changed from 40% to 80% . The  $(M_1 + M_2)$  indicates the sum of magnetic ratio of  $\text{Fe}_2\text{O}_3$  ( $M_1$ ) and  $\text{Fe}_3\text{O}_4$  ( $M_2$ ). The line (b) shows relation of  $M_1 + M_2$  with firing temperature where the  $M_1 + M_2$  begins to increase at first to reach its maximum near  $400^\circ\text{C}$ , and then the magnetic ratio decreases rapidly and after  $900^\circ\text{C}$  it decreases to 20%.

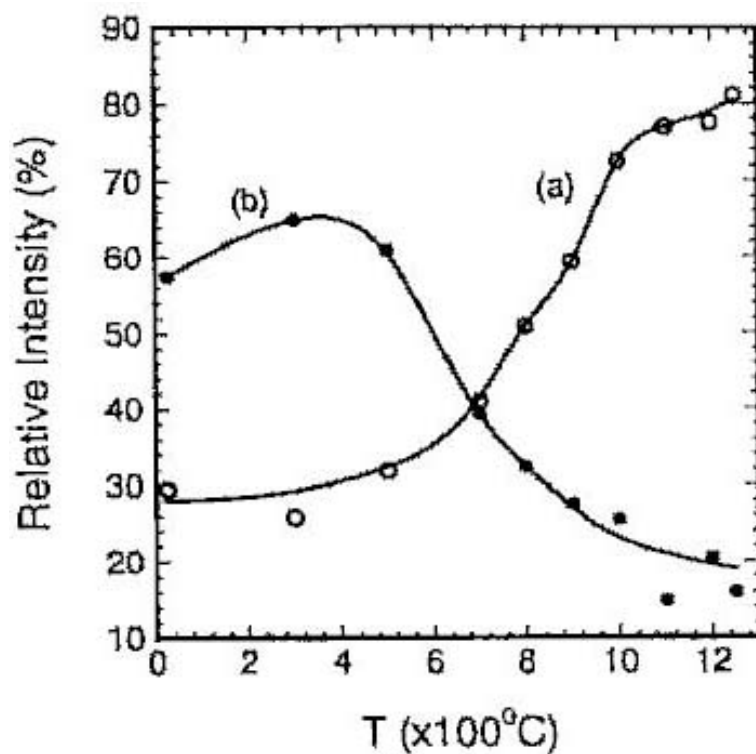
Chen Songhua [137] discussed the coloring mechanism of feature of sky-green glaze and he explained that color of glaze is near related to chemical state of iron, where high temperature range and reductive atmosphere,  $\text{Fe}_2\text{O}_3$  and  $\text{Fe}_3\text{O}_4$  reduced into  $\text{FeO}$ :



Chen Songhua [138] presented also an explanation for coloring mechanism Moon-white Jun ancient porcelain with sky-blue Jun imitative ancient porcelain. He studied also the relation between the  $\text{Fe}^{2+}/(\text{Fe}^{2+}+\text{Fe}^{3+})$ ,  $(M_1 + M_2)$  of moon-white glaze of Yuan Dynaasty and re-firing temperature, and the same thing he do for sky-blue glaze of imitative ancient Jun porcelain. The relative intensity of  $\text{Fe}^{2+}/(\text{Fe}^{2+}+\text{Fe}^{3+})$  in moon-white Jun glaze equals 0.68, while in ordinary unfired clay it equals 0.3. This means that the firing atmosphere of moon-white Jun porcelain is reductive. Also the study demonstrate that at the  $1250^\circ\text{C}$ , the  $\text{Fe}^{2+}/(\text{Fe}^{2+}+\text{Fe}^{3+})$  of sky-blue imitative Jun glaze is 0.76, and therefore, it can be seen that the reductive firing for ancient moon-white Jun porcelain is weaker than that of sky-blue imitative Jun porcelain, and is modestly reductive (review degree of reduction in figure 1.12). Chen Songhua mentioned in this study that



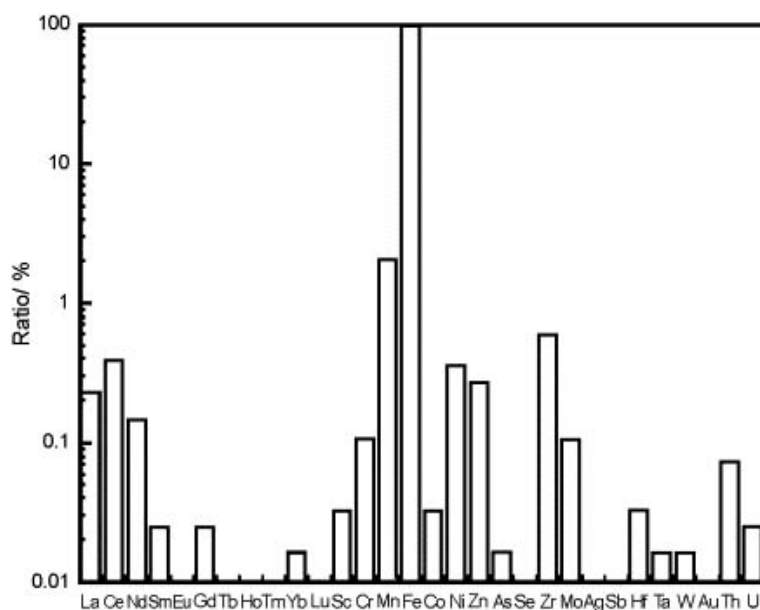
**Figure 3.8:** The mössbauer spectra of the sky-green glaze raw material at different firing temperatures



**Figure 3.9:** Changing of  $Fe^{2+}/(Fe^{2+}+Fe^{3+})$  of the paramagnetic peak and magnetic ratio  $(M_1+ M_2)$  with firing temperature in sky-green glaze  
 (a)  $Fe^{2+}/(Fe^{2+}+Fe^{3+})$  (b)  $(M_1+ M_2)$

## SCIENCE OF GLAZES AND PREPARATION FOR TREATMENT DURING OR POST FIRING

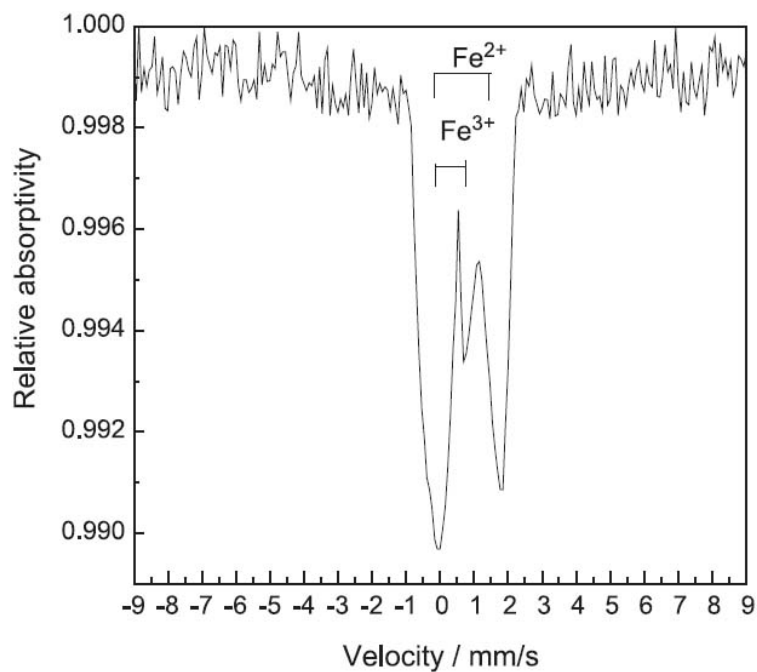
---



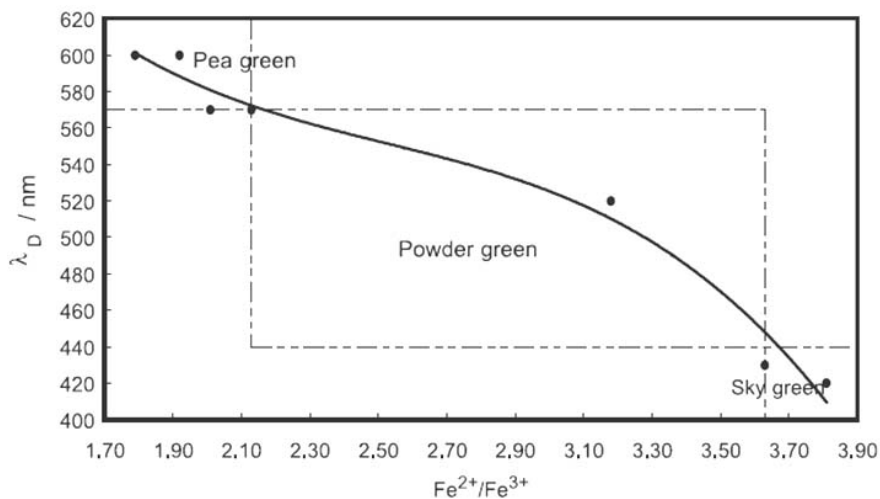
**Figure 3.10:** the relative contents of coloring elements in Ru glaze

the coordination number (CNs) of  $\text{Fe}^{2+}$  and  $\text{Fe}^{3+}$  in moon-whit Jun glaze are determined to be both 4. Iron is the colorant in Jun glaze and its chemical state is one of factors that affect the glaze color.

Zhang Bin [139] studied the relation between glaze color and its wavelength ( $\lambda_D$ ), where the concentrations of 30 coloring elements in glaze of ancient Ru porcelain are determined by neutron activation analysis (NAA). Figure(3.10) shows the relative contents of coloring elements in glaze, the relative content of iron accounts for about 96% of the total contents of all coloring elements. The Mössbauer spectrum of glaze at room temperature are shown in figure(3.11) and it demonstrate that the magnetic components are little enough to be ignored but the paramagnetic components ,that is  $\text{Fe}^{2+}$  or  $\text{Fe}^{3+}$  ions presented in the glaze structure and the ratio of  $\text{Fe}^{2+} / \text{Fe}^{3+}$  determines the glaze color. The table (3.3) represents the  $\text{Fe}^{2+} / \text{Fe}^{3+}$  ratio ,wavelength ( $\lambda_D$ ) and glaze color for some several samples ancient Ru porcelain,and the relation between wavelength and the  $\text{Fe}^{2+} / \text{Fe}^{3+}$  ratio is shown in figure (3.12).  $\text{Fe}^{2+} / \text{Fe}^{3+}$  determines the glaze color.



**Figure 3.11:** Mössbauer spectrum for a sample of Ru glaze at room temperature



**Figure 3.12:** The relation diagram between  $Fe^{2+} / Fe^{3+}$  ratio and wavelength ( $\lambda_D$ ) of glaze color of ancient Ru kiln

## SCIENCE OF GLAZES AND PREPARATION FOR TREATMENT DURING OR POST FIRING

---

**Table 3.3:** The  $\text{Fe}^{2+} / \text{Fe}^{3+}$  ,wavelength ( $\lambda_D$ ) and glaze color for some samples of Ru kiln

| NO       | $\text{Fe}^{2+}$<br>$I(\%)$ | $\text{Fe}^{3+}$<br>$I(\%)$ | $\text{Fe}^{2+} / \text{Fe}^{3+}$ | $(\lambda_D)(\text{nm})$ | Glaze color  |
|----------|-----------------------------|-----------------------------|-----------------------------------|--------------------------|--------------|
| $R_{16}$ | 79.2                        | 20.8                        | 3.81                              | 420                      | sky green    |
| $R_{18}$ | 78.4                        | 21.6                        | 3.63                              | 430                      | sky green    |
| $R_1$    | 76.1                        | 23.9                        | 3.18                              | 520                      | Powder green |
| $R_{14}$ | 68.1                        | 31.9                        | 2.13                              | 570                      | Pea green    |
| $R_{26}$ | 66.8                        | 33.2                        | 2.01                              | 570                      | Pea green    |
| $R_{15}$ | 65.8                        | 34.2                        | 1.92                              | 600                      | Pea green    |
| $R_{27}$ | 64.1                        | 35.9                        | 1.79                              | 600                      | Pea green    |

It is observed that with increasing  $\text{Fe}^{2+} / \text{Fe}^{3+}$  ratio the glaze colore of Ru porcelain gradually change from pea green to sky green, this ratio, as Songhua explained, depones firing condition. The larger ratio of  $\text{Fe}^{2+} / \text{Fe}^{3+}$  existed in more reducing atmosphere and higher temperature as a required treatment for producing the sky green color, the powder green required more reducing atmosphere at lower temperature and pea green produced by lightly reducing atmosphere at lowest temperature.the ratio of  $\text{Fe}^{2+} / \text{Fe}^{3+}$  in all colors of Ru glazes is  $> 1$ [139]. Also the content of iron is the highest in the relative content of coloring elements in Guan glaze ,and its amount is 85% of total content , Mn is lower than 5% and (samarium) is lower 10% therefore iron is the main coloring element in Guan porcelain. The Mössbauer spectrum at room temperature indicate that the content of  $(\text{Fe}_2\text{O}_3)$  and  $\text{Fe}_3\text{O}_4$  is lower[140]. The paramagnetic component is formed by iron ions  $\text{Fe}^{2+}$  ,  $\text{Fe}^{3+}$ . The table (3.4) represent the values of  $\text{Fe}^{2+}$  ,  $\text{Fe}^{3+}$  and  $\text{Fe}^{2+} / \text{Fe}^{3+}$  of Guan glaze[140].

The glaze color is determined by iron concentration and the content of ratio  $\text{Fe}^{2+} / \text{Fe}^{3+}$  which is changed according to the temperature of firing and reducing

## SCIENTIFIC RESEARCHING ON TECHNOLOGY OF ANCIENT CERAMICS

---

**Table 3.4:** The  $Fe^{2+} / Fe^{3+}$  ,wavelength ( $\lambda_D$ ) and glaze color for some samples of Guan glaze

| NO       | $Fe^{2+}$<br>$I(\%)$ | $Fe^{3+}$<br>$I(\%)$ | $Fe^{2+} / Fe^{3+}$ | $(\lambda_D)(nm)$ | Glaze color  |
|----------|----------------------|----------------------|---------------------|-------------------|--------------|
| $G_{27}$ | 75.8                 | 24.2                 | 3.13                | 540               | Powder-green |
| $G_{25}$ | 75.2                 | 24.8                 | 3.03                | 540               | Powder-green |
| $G_{26}$ | 75.1                 | 24.9                 | 3.01                | 560               | Powder-green |
| $G_4$    | 74.0                 | 26.0                 | 2.85                | 560               | Powder-green |
| $G_3$    | 73.0                 | 27.0                 | 2.70                | 560               | Powder-green |
| $G_6$    | 70.8                 | 29.2                 | 2.43                | 570               | Grey-green   |
| $G_5$    | 55.2                 | 44.8                 | 1.23                | 620               | Grey-green   |
| $G_{15}$ | 52.6                 | 47.4                 | 1.11                | 700               | cream        |

atmospheres of the kiln , where the firing under changeable reducing condition at specific temperature.there fore the colore of glaze Guan was produced as result of using the firing condition to control the aesthetic treatment.

These discovering about historical firing technology, that affect the colors of glazes even the glaze structure was the same, indicate to the possibility of using the the kiln as a tool to enrich the aesthetic treatment of ceramics glaze during the firing when the chemical reaction of iron oxides with carbon is possible to occur and to leave iron ions  $Fe^{2+}$  ,  $Fe^{3+}$  in the network of glass or glaze. The ratio of this ions in the glaze determines the color of glaze according color phenomena for glaze. Also this discovering is considered as as important for reproducing these styles of ancient ceramics that have hight artistic value.



### 3.7.1.2 Firing process of metallic reflection decoration

Historical study demonstrate the importance of kiln atmosphere, thermal paths and glaze composition for producing luster glaze and metallic reflection since the early 9th century AD and their technologies are transferred to Egypt, Syria and through the Mediterranean basin. Due to the artistic value of ceramics forms that are decorated by luster and metallic reflection colors, this technique continued to be produced in Europe until the sixteenth century depending on kiln technology of reduction atmosphere.

In this technology chemicals reactions between  $\text{CuO}(\text{CuII})$ ,  $\text{Cu}_2\text{O}(\text{CuI})$  and  $\text{Ag}_2\text{O}$  with reducing gases which almost in traditional technology are carbon oxides. These reaction create metallic film in network of glass and produce especial optical properties. This copper and/or silver deposition was applied in historical tradition luster technology by putting a mixture salts and oxides of copper and silver, together with vinegar ochre, and clay on glazed surface and then heated to about  $600\text{ }^\circ\text{C}$  in carbon reductive atmosphere as sudan reactions during re-cool path of firing schedule [11, 96].

There are some scientific studies which tried to explain this technique and to divined the parameters that affected in colors or metallic aspects of luster decoration. In this technique the collided ions of cooper  $\text{Cu}^+$ ,  $\text{Cu}^{2+}$  and silver  $\text{Ag}^+$  are embodied in glass matrix, and with sufficient reduction atmosphere they are changed to metallic state which remained trapped inside the glaze within first layer. The metal particle size is between 5nm and 50nm, and therefore, the luster seems to be a nanosized metal-glass, this metal particles forme a layer in varying thickness from 100 nm to  $1\text{ }\mu\text{m}$ . The average between pure copper to pure silver was observed in luster layer. Cu/Ag ratio indicated to different color[11, 96, 141].

The concentration of copper and silver in the glaze show the significant affects in color of luster glaze, where yellow and green is related to silver rich and orange, brown and red is related to copper rich. Bobin [13], in his study about the role of copper and silver in coloration of metallic luster, refers to the decoration with

## SCIENTIFIC RESEARCHING ON TECHNOLOGY OF ANCIENT CERAMICS

---

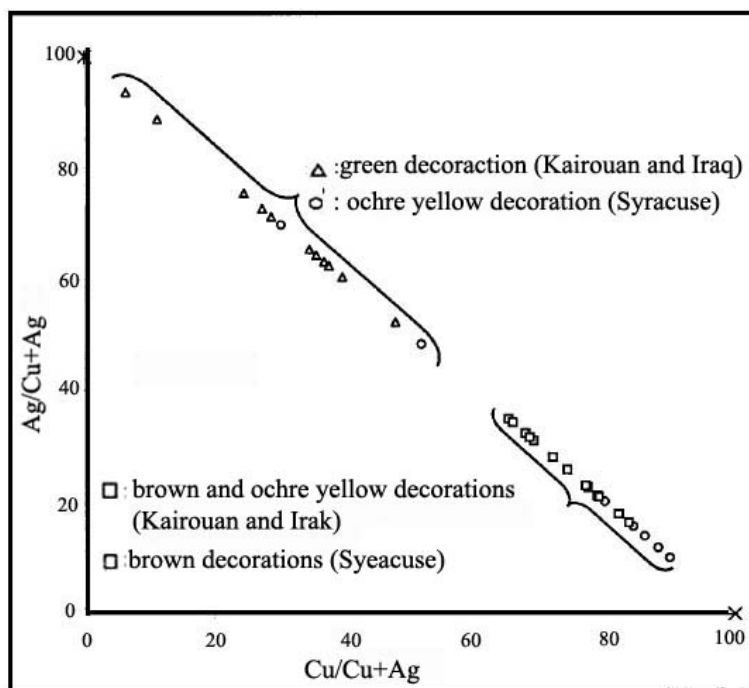
green color and ocher-yellow have more silver than copper and the  $\text{Ag}/(\text{Cu}+\text{Ag})$  ratio between 52-92%. While the ratio of  $\text{Cu}/(\text{Cu}+\text{Ag})$  in range between 65-90% led to produce brown and ocher-yellow color, but also the  $\text{Ag}/(\text{Cu}+\text{Ag})$  ratio lead to ocher-yellow as exit in samples from Kairouan , Mesopotamia and Sicily. Figure (3.13) shows a binary diagram which demonstrates the normal situation of atomic percent  $\text{Cu}/(\text{Cu}+\text{Ag})$  and  $\text{Ag}/(\text{Cu}+\text{Ag})$ ratio in green, brown, and ocher-yellow metallic luster decoration. These ratio is important when Seger formula of glaze or decoration are designed to limit the relative number of  $\text{CuO}$ ,  $\text{Cu}_2\text{O}$  and/or  $\text{Ag}_2\text{O}$ . The tables (A.3and A.4) shows chemical composition of Kairouan , Mesopotamia glazes. Padovani [11] discovers that the glaze with gold luster decoration ,on samples of XVI century pottery from Deruta, contains silver in average approximately 20 wt.% . This percentage appears to be diffused within glaze which also include a small amount of copper 1-3 wt.%. The red luster contains average of copper which is estimated about 8 wt.%. The state of copper in glass matrix are  $\text{Cu}^+$ ,  $\text{Cu}^{2+}$  and no metallic state in gold luster and the relative concentration of tow states are estimated that 40% of copper is in the oxidation state  $\text{Cu}^+$  ,and 60% is in state  $\text{Cu}^{2+}$ . The 20% of copper in red luster was metallic phase and 80 % is in the  $\text{Cu}^+$  state. The Seger formula of renaissance glaze, which its composition analysis was presented by Padovani, is:

$$\left\{ \begin{array}{l} 0,49 - 0,61\text{K}_2\text{O} \\ 0,39 - 0,51\text{PbO} \end{array} \right\} \cdot 0,11 - 0,16\text{Al}_2\text{O}_3 \cdot \left\{ \begin{array}{l} 2,45 - 6,24\text{SiO}_2 \\ 0,11 - 0,15\text{SnO}_2 \end{array} \right\}$$

The glaze structure influences in the the state of copper, where the  $\text{Cu}^+$  is mainly exchange with  $\text{Na}^+$ , and also copper-alkali ion exchange existed in glass that contains both  $\text{Na}^+$  and  $\text{K}^+$ . The luster reflection form as a frits step from copper- and silver-alkali ion-exchange and then followed by nucleation and growth of metal nanoparticles,the crystal size is related functionally to the depth inside the glaze that is result of exchanging the  $\text{Cu}^+$  and  $\text{Ag}^+$  ions from raw paint applied on glaze with  $\text{Na}^+$ and  $\text{K}^+$ from the glaze ant that flowed by the crystal formation of copper nanocreystals in glaze matrix [11, 142].

SCIENCE OF GLAZES AND PREPARATION FOR TREATMENT DURING OR POST FIRING

---



**Figure 3.13:** Binary diagram demonstrates the relative concentration of Cu / (Cu+Ag) and Ag / (Cu+Ag) ratio in luster decoration from Kairouan Iraq and Sicily, and it demonstrates the relation between this relative concentration and color

Mechanism of ionic exchange in glaze and glass was concerned the driving force responsible for diffusion of silver and copper ions into glaze layer. Therefore the contents of  $\text{Na}^+$  and  $\text{K}^+$  in glaze structure is method to control the diffusion of  $\text{Cu}^+$  and  $\text{Ag}^+$  that play role in determining the color of metallic luster, as it is discovered from the analysis of early Islamic luster from Iraq, and of later Hispano Moresque luster from Paterna. The molten salt of copper and silver as sulfates or nitrates help atomic exchange and replacement of alkalis of glaze by copper and silver ions. This explain the use of sulfur containing compound in luster recipes, where cinnabar ( $\text{HgS}$ ) was added to luster metallic recipes in XIII century AD with silver sulfide that to create a sulfo reducing atmosphere which is necessary to reduce the silver and copper. The cinnabar ( $\text{HgS}$ ) at temperature above  $400^\circ\text{C}$  to provide sulfur ( $\text{S}$ ) which make sulfo reducing atmosphere of firing. Using cinnabar instead of sulfur to produce sulfo atmosphere transforms  $\text{CuO}$  into  $\text{Cu}_2\text{O}$  and forms silver or copper sulfates and sulfides, but the two later decomposes in high temperature to leave the final phase metallic copper and silver in the glaze. Therefore the role of cinnabar is producing the sulfo reducing condition between  $500^\circ\text{C}$  and  $600^\circ\text{C}$  that helps in reducing the copper to  $\text{Cu}^+$ , and to avoid the reduction of silver to its metallic state before it has impeded inside the glaze [96]. Therefore the duration and time of reaction during firing and kiln technology are important to achieve intentional chemicals reaction in finale phase inside glaze to determine the aesthetic treatment of glaze.

The diffusion of coloring elements inside the glaze layer depends on the exchange ion mechanism between colors and glaze, therefore the contents of alkali oxides in glaze structure is related to affect of colored. The content of potassium in gold-like luster decreases from 1.7% to 0.5%  $\text{K}_2\text{O}$ , and from 2.8% to 1.5%  $\text{K}_2\text{O}$  in copper-like luster [143].

Bobin [13] demonstrated an important factor in the diffuse coloration of metallic luster decoration beside the relative concentration of  $\text{Cu}^+$  and  $\text{Ag}^+$  which is the refractive index of glaze. in addition to the role of radius of the colloids in the glaze. Therefore the structure of glaze and process of design glaze are important in

## SCIENCE OF GLAZES AND PREPARATION FOR TREATMENT DURING OR POST FIRING

---

enriching the aesthetic of ceramics decoration by metallic luster colors. This raise the attention to the role of local environment which surround  $\text{Cu}^+$ ,  $\text{Cu}^{2+}$ ,  $\text{Ag}^+$  and /or metallic stat of this minerals ions inside the glaze.

Gold-like metallic decoration as a luster glaze which was studied from Spanish and Italian styles show that the metallic film indicates the presence of 1-10% of copper and silver. The copper-like luster exhibited Cu /Ag molar ratio  $> 1$ , while the gold-like luster exhibited Cu /Ag molar ratio  $< 1$ . Metallic film of element copper and silver was protected against re-oxidation in air atmosphere after firing by glassy layer from glaze with thickness varying in the rang of 10-20 nm [92].

generally, there are some parameters to control the mechanisms of metallic luster formation that should be taken in account when designing the structure of glaze, as glaze oxides are considered in-put of chemical reactions and the kiln permit to this reactions the conditions to exist. This parameters can be concluded in Cu/Ag ratio as it is the color elements, glaze structure and it oxides, atmosphere of kiln and bath of thermal treatment.

The ratio between silver and copper colorant, wether it was applied in the paint raw or with glaze structure , can be designed to be in range that was discovered by historical and scientific study. Seger formula or oxide analysis can be used to calculate the raw materials in order to apply this discoveries in ceramic industrial and ceramics arts.

State of silvers an copper ions inside the glaze have important role the color and its aspects. The applicable method to control this states are related to kiln technology and glaze structure, where the reduction atmosphere is responsible about transfer silver and coper raw materials in applicable recipes to metallic or ions phases after firing, while the glaze structure is responsible about behavior of silver and copper ions inside the glaze when it was in glassy state. Alkali ratio inside glaze structure is important in this factor. Also, the refractive index of glaze is determined by glaze structure, and the equation (3.5) with the details about the values of refraction index coefficients of oxides which presented in table(3.1) are used to calculate the refraction coefficient of glaze which can

be controlled by designing glaze structure. Another important point in applied reflection metallic luster is the temperature of reduction which is necessary to chemicals reactions between carbon atmosphere and metallic oxides, and the soft state of glaze during these chemical reactions are necessary to ensure the adherence of luster. Therefore the relation between the temperature of reaction and soft state of glaze is an issue to applied metallic luster by using kiln technology. This issue include two methods first is perpetrate the glaze structure according its heat treatment by using equations (3.3 and 3.4) with the value of Lengersdorf factors from table(3.1), second is retention and controlling the conduction of kiln during period of chemical reaction until passing soft point of glaze or paint. The size of colloidal and metallic crystal in glass network is related to firing cycle especially in significant crystal growth rate which is referred in section (3.4). So the technology of metallic luster is divided between glaze design and treatments during firing including atmosphere of kiln and firing cycle.

### **3.7.2 Mechanical treatment**

The main aesthetical treatment which is produced on glaze surface by mechanical treatment is the crackle. It had appeared in the twelfth century in China during the Song Dynasty (960-1279), in some styles of five famous Chinese porcelain. As well as metallic reflection, the crackle is considered as a treatment which exists during firing process. The stress which can be created in glaze layer after glaze maturing can used to create the crackle on surface of glaze. This stress depends on some parameters which is should explained to understand the mechanism of creating net crakes in Ru kiln from China, and also to introduce a new method for enriching the aesthetic of glazes surface by crack net. Some historical documents mentioned that Guan crackle was induced by formulating the glaze to shrink more than the clay body, that caused the glaze to fracture. Ru crackle was got by added grains of agate to its glaze [77]. Chinese culture web sites and online Museums [144, 145] mentioned to an historical knowledge which said that

## SCIENCE OF GLAZES AND PREPARATION FOR TREATMENT DURING OR POST FIRING

---

Zhang Shengyi produced Ge Kiln covered by many crackles, and his technique to create this crackle is accidentally cooled when the porcelains were still too hot. Crackling technique produced in Europe in nineteenth century from 1920 to 1940 when *atelier de faïence* was created, and the sculpture introduced for its new aesthetics in *Sèvres*, made in small batches covered with polychrome enamel or cracked.

From historical study the crackles could be created by preparation glaze structure or by thermal shock during firing process, and scientifically, this is possible. Most of modern crackles technology based on glaze composition where some methods of producing crackle coating in Russia are invented by design glaze batch containing 12-20 % gypsum ( $\text{CaSO}_4 \cdot 2\text{H}_2\text{O}$ ) and preparing to low-melting [146].

Another type of crackle coating includes perlite ( $\text{Na}_2\text{O} \cdot \text{K}_2\text{O} \cdot \text{Al}_2\text{O}_3 \cdot \text{SiO}_2$ ), borax ( $\text{Na}_2\text{O} \cdot 2\text{B}_2\text{O}_3 \cdot 10\text{H}_2\text{O}$ ), zinc oxide ( $\text{ZnO}$ ), and chalk ( $\text{CaCO}_3$ ). The decorative effects of this coating are based on the emergence of crazing after the article is fired, immersed in water, and then immersed in pigment solution and fired. Also other type of crackle coating includes concentrated nepheline, but in order to obtain decorative crackle coating, it is necessary to restrict oneself to the three specified compositions with a firing temperature of 1000 - 1100°C [146]. All of raw materials, gypsum ( $\text{CaSO}_4 \cdot 2\text{H}_2\text{O}$ ) and nepheline ( $\text{K}_2\text{O} \cdot 3\text{Na}_2\text{O} \cdot 4\text{Al}_2\text{O}_3 \cdot 9\text{SiO}_2$ ), which are used in this inventions are sources of some network modifiers/ basic oxides that have high value of thermal expansion coefficient CaO, K<sub>2</sub>O and Na<sub>2</sub>O, so the net cracks which presented on these coating after firing is considered to be related to thermal expansion coefficient of glaze and the the expansion of gases which are be in the glaze layer in form of bubbles that are produced from previous raw materials. The high thermal expansion coefficient of glaze and mechanical phenomena are prospered in this crackle coating.

The composition of glaze determines thermal expansion (TEC) of glaze from equation (3.9) which is suggested by Winkalman and Schott. Glazes are homogeneous amorphous solid solution so the values of TEC of glaze are additive function

## SCIENTIFIC RESEARCHING ON TECHNOLOGY OF ANCIENT CERAMICS

---

of glaze composition at specified temperature rang. The  $\beta$ -factor of volume expansion coefficient( $K^{-1}$ ) calculated from  $\alpha$ -liner thermal expansion coefficient( $K^{-1}$ ) as this equation[147]:

$$\beta \simeq 3\alpha = \sum a_i \beta_i \quad (3.10)$$

where  $\beta_i$  - volume expansion coefficient of the individual compound ( $K^{-1}$ ) and  $a_i$  amount of compound in the glaze (wt.%). The relation between TEC of glaze and appeared crackle on surface of glaze related to the relation between the TEC coefficient and tensile and higher compression stress in glaze. This stress ont related to TEC of glaze only but also the TEC of ceramic body also, and ceramic (clay body) itself belongs to the group of polycrystalline, multiphase materials.The thermal expansion coefficient of ceramic body can be calculated also from additive the function of the TEC of individual solid phases, crystalline and/or amorphous phases, and their volume fraction in material[147]. The cracks forming on glaze if Tensile or higher compression stress are released in the glaze. The compression stress ( $+\sigma$ )arises in the glaze if:

$$\sigma_{glaze} - \sigma_{body} > 0 \quad (3.11)$$

and the value of compression strength of common glazes is in range of 80-320 MPa,where the glaze stress  $\sigma_{glaze}$  is calculated from equation (3.12) and body stress $\sigma_{body}$  is calculated from equation (3.13)which they are suggested by Salmang a Scholzeso this compassion stress exist with the TEC of the glaze is lower than that of the ceramic body[136, 147].

$$\sigma_{glaze} = \frac{(\alpha_{body} - \alpha_{glaze}) \times \Delta T}{\frac{1-\mu_{glaze}}{E_{glaze}} + \frac{1-\mu_{body}}{E_{body}}} \times \frac{d_{glaze}}{d_{body}} \quad (3.12)$$

$$\sigma_{body} = \frac{(\alpha_{glaze} - \alpha_{body}) \times \Delta T}{\frac{1-\mu_{body}}{E_{body}} + \frac{1-\mu_{glaze}}{E_{glaze}}} \times \frac{d_{body}}{d_{glaze}} \quad (3.13)$$

The tensile stress ( $-\sigma$ )arises in the glaze if:

$$\sigma_{glaze} - \sigma_{body} < 0 \quad (3.14)$$



## SCIENCE OF GLAZES AND PREPARATION FOR TREATMENT DURING OR POST FIRING

---

and the value of tensile strength of common glazes is in range of 40-160 MPa, where the glaze stress  $\sigma_{glaze}$  is calculated from equation (3.12) and body stress  $\sigma_{body}$  is calculated from equation (3.13) so this tensile stress exist with the TEC of the glaze is higher than that of the ceramic body.

$\sigma$  ( stress unit is Pa),  $\alpha$  (linear thermal expansion coefficient unite is  $K^{-1}$ ),  $d$  - thickness of body and/or glaze coat,  $E$  – elasticity module ( $E_{glaze}, E_{body}$   $60 \times 10^9$  N/ $m^2$ ) as it can be calculated from equation 3.8,  $\mu$  – Poisson constant ( $\approx 0.20$ ; for the body and the glaze).

The normal glaze has better resists to compression stress than to the tensile stress. Compression stress load capacity of the glaze is 10-15 times higher than for the tensile stress. In fact, The recommended gentle compression stress that glaze can resist without cracks, is about 15-20 MPa, because it has positive influence on the mechanical strength of product. Such stress is arisen in glaze to create crackle when the TEC of the body is about  $5 \times 10^{-7} K^{-1}$  higher than the TEC of the glaze [136, 147].

The excess of the value of compression or tensile strength of the glaze leads to its cracking just during the cooling of the glazed ware, as well as immediately after the firing in case of using the glaze structure to generate tensile or high compression stress. The  $\Delta T$  which can increase the stress in glaze before the finale part of cooling.

From this theoretical description the parameters that effect on crackles treatment on glazed ceramics are: the value of TEC difference between biscuit and glaze, elasticity module for glaze and biscuit, glaze thickness (usual 150 - 250  $\mu m$ ), nature of glaze-biscuit interface which forms during the firing, firing technology especially for glazes and cooling rate during firing process. Therefore the technology of crackle is related to glaze structure, glaze and clay forming and application , and firing technology. These can be explained in, the both of thermal expansion coefficient, young modulus Poisson constant are related to glaze

## SCIENTIFIC RESEARCHING ON TECHNOLOGY OF ANCIENT CERAMICS

---

structure, biscuit thickness and glaze thickness are related to clay and glaze applications and forming, thermal shock or high cooling rate which can be done during firing process.

When scientific studies attempt to discover mechanisms for color and crackle of five famous grade Chinese porcelain or metallic reflection luster, some descriptions of applicable treatments are proposed for artist and ceramists, and they can do them to use the kiln as a tool for creating special aesthetic. This proposition consumes between preparing materials to be ready to such chemical reaction or physical change, designing tools or kiln to permit the conduction of this chemical reaction or physical change, and prepping the glazes as a medium which have to be suitable for permitting to this reaction exists and allow to nanocrystals which are produced by this treatment. Therefore the main results from this previous chapters are chemical reaction and physical properties of glazes materials and kiln technology.



## Chapter 4

# Scientific and Experimental Basics for Treatments During Firing

THIS chapter presents the feedback for using designs of glazes structures to prepare materials based on the different chemical reactions which is proposed during firing process. These materials are designed in order to react with carbon and sulfur in atmosphere of kiln. Phase diagram of iron ores and Ellingham Diagram are used to explain what is expected from chemical reactions during the firing, also the temperature of reactions is determined from this diagrams. The relation between temperature of reaction and firing schedule leads to better treatment. Therefore this scientific study lead to prepare condition and materials that was required to create one or more of glaze colorant, based on chemicals reactions between glaze and atmosphere of kiln. Experimental study to simulate Ru kiln body and glaze was made to prepare materials for new kiln. Thermal shock was experimented as treatment during firing, and the theoretical desecration for doing thermal shock inside the kiln was proposed.

## 4.1 Introduction

Before using the condition of firing to make such aesthetic treatment on ceramics surface, the procedures and applications are required. These procedures are included in materials and condition, especially to obtain special aesthetic treatment on glazed forms. The applicable procedures for materials are based on these simulation for historical materials which can contribute in reducing the researching area about materials that are applicable to give good results. In frits step for re-using the kiln and its technology for achieving special aesthetics. Modern technology and science are responsible about providing theory of improving the idea, methods of application and tools of productions.

Ores of iron can be considered as colorant crystals that are crystalized after reducing the iron and copper oxide to ionic and/or states and then react with sulfur vapor inside the kiln in such temperature as demonstrate in phase diagram of Cu–Fe–S, see figure (4.23). Ellingham diagram instructs to the priority of chemical reactions between the carbon or sulfur and glazes oxides, and it can give clear image about thermodynamics reactions during firing. This order of reactions used to design glaze structure and design inserting carbon or sulfur into the kiln. The Coandă effect\* and cold air front<sup>§</sup> phenomenons are used to apply the thermal shock treatment during firing. The heat transfer and thermal conductivity explain the fraction of this treatment.

---

\*The Coandă effect, also known as "boundary layer attachment", is the tendency of a stream of fluid to stay attached to a convex surface, rather than follow a straight line in its original direction. The principle was named after Romanian discoverer Henri Coandă, who was the first to understand the practical importance of the phenomenon for aircraft development.

§A cold air front is the place where a cold air mass replaces a warm air mass when different air masses do not mix because they have different temperatures and densities, and this happens because the warm air is lighter than cold air which is dense and heavy

Accordingly, the treatments that design of kiln is improved to apply them are classified to thermal shock treatment, and chemical chock treatment.

### 4.2 Simulation study for some ancient ceramics

Clay body and glaze of Ru kiln porcelain, from China in the late Northern Song Dynasty (1086-1125)[101], are simulated for understanding the historical technique which are used to produce crackle on surface of Ru kiln forms, for establishing method to design unity formula and choose raw materials for body and glazes which are fundamental in using kiln as tool for enriching aesthetic of ceramics during firing, and for indicating to the application of these aesthetics.

#### 4.2.1 porcelain body

The data which are used for simulating clay body of Ru kiln porcelain was obtained from " Proton induced X-ray emission (PIXE) analysis of sources of porcelain body of Ru Guan and Jun Guan porcelains " study , where M.Gouxia et la studied the chemical analysis of 50 samples of Jun kiln porcelain body and 34 samples of Ru kiln porcelain body to know the origin of raw materials of Jun Guan Porcelain by comparison with Ru Guan porcelain. The table (4.1) presents major chemical elements for samples which are used in simulation of Ru porcelain body. These samples are chosen depending on the percentages of oxides in 34 samples of Ru kiln which are presented by Gouxia study[101]. The samples which have higher and lower percentage of  $\text{Al}_2\text{O}_3$ ,  $\text{SiO}_2$ ,  $\text{K}_2\text{O}$ ,  $\text{CaO}$ ,  $\text{TiO}_2$ ,  $\text{MnO}$ ,  $\text{Fe}_2\text{O}_3$  oxides from Gouxia study, were calculated for simulation. Therefore, 11 sample from Ru kiln samples are chosen (R40b, R41b, R42b, R43b, R44b, R271b, R275b, R330b, R333b, R339b, R382b).

SCIENTIFIC AND EXCREMENTAL BASICS FOR TREATMENTS DURING FIRING

Table 4.1: Main chemical oxides of Ru Guan porcelain body (RGPD)

| Code No | Name | Body color | (PIXE) oxides analysis         |                  |                  |      |                  |      |                                |      |                                |                  | Compensating oxides analysis |      |                  |      |                                |
|---------|------|------------|--------------------------------|------------------|------------------|------|------------------|------|--------------------------------|------|--------------------------------|------------------|------------------------------|------|------------------|------|--------------------------------|
|         |      |            | Al <sub>2</sub> O <sub>3</sub> | SiO <sub>2</sub> | K <sub>2</sub> O | CaO  | TiO <sub>2</sub> | MnO  | Fe <sub>2</sub> O <sub>3</sub> | LOI  | Al <sub>2</sub> O <sub>3</sub> | SiO <sub>2</sub> | K <sub>2</sub> O             | CaO  | TiO <sub>2</sub> | MnO  | Fe <sub>2</sub> O <sub>3</sub> |
| R40b    | RGPD | ashy gray  | 27.56                          | 65.74            | 1.77             | 0.52 | 1.15             | 0.02 | 1.73                           | 1.51 | 27.98                          | 66.75            | 1.80                         | 0.53 | 1.17             | 0.02 | 1.75                           |
| R41b    | RGPD | ashy gray  | 26.21                          | 66.06            | 2.18             | 0.73 | 1.08             | 0.02 | 2.24                           | 1.48 | 26.60                          | 67.05            | 2.21                         | 0.74 | 1.1              | 0.02 | 2.27                           |
| R42b    | RGPD | ashy gray  | 28.03                          | 65.25            | 1.73             | 0.38 | 1.28             | 0.02 | 1.81                           | 1.50 | 28.46                          | 66.24            | 1.76                         | 0.38 | 1.30             | 0.2  | 1.84                           |
| R43b    | RGPD | ashy gray  | 30.16                          | 62.26            | 1.52             | 1.47 | 1.05             | 0.04 | 2.00                           | 1.50 | 30.62                          | 63.21            | 1.54                         | 1.49 | 1.07             | 0.04 | 2.03                           |
| R44b    | RGPD | ashy gray  | 26.86                          | 65.77            | 1.90             | 0.42 | 1.13             | 0.02 | 2.39                           | 1.51 | 27.27                          | 66.78            | 1.93                         | 0.42 | 1.15             | 0.02 | 2.43                           |
| R47b    | RGPD | ashy gray  | 30.11                          | 61.84            | 2.17             | 1.35 | 1.13             | 0.01 | 1.88                           | 1.51 | 30.57                          | 62.79            | 2.20                         | 1.37 | 1.15             | 0.01 | 1.91                           |
| R271b   | RGPD | ashy gray  | 26.77                          | 66.26            | 1.82             | 0.44 | 1.27             | 0.00 | 1.94                           | 1.50 | 27.18                          | 67.27            | 1.85                         | 0.44 | 1.29             | 0.00 | 1.97                           |
| R275b   | RGPD | ashy gray  | 26.66                          | 66.31            | 1.86             | 0.60 | 1.23             | 0.01 | 1.84                           | 1.49 | 27.06                          | 67.31            | 1.89                         | 0.61 | 1.25             | 0.01 | 1.87                           |
| R330b   | RGPD | ashy gray  | 31.75                          | 60.94            | 1.77             | 0.84 | 1.10             | 0.00 | 2.10                           | 1.50 | 32.23                          | 61.87            | 1.80                         | 0.85 | 1.12             | 0.00 | 2.13                           |
| R333b   | RGPD | ashy gray  | 31.78                          | 61.54            | 1.55             | 0.56 | 1.08             | 0.00 | 1.99                           | 1.48 | 32.26                          | 62.48            | 1.57                         | 0.57 | 1.1              | 0.00 | 2.02                           |
| R339b   | RGPD | ashy gray  | 30.10                          | 62.74            | 1.44             | 1.08 | 1.19             | 0.02 | 1.93                           | 1.50 | 30.56                          | 63.70            | 1.46                         | 1.09 | 1.21             | 0.02 | 1.96                           |
| R382b   | RGPD | ashy gray  | 26.98                          | 64.83            | 1.91             | 1.80 | 1.18             | 0.03 | 1.78                           | 1.49 | 27.39                          | 65.81            | 1.94                         | 1.83 | 1.20             | 0.03 | 1.80                           |

## SIMULATION STUDY FOR SOME ANCIENT CERAMICS

---

The data which are provided by (PIXE) analysis is for samples which are already fired. Therefore, these percentages are after firing and it should be compensated the loss on ignition (LOI) in analysis. To compensate the LOI for each oxide in analysis this equation(4.1) is used[114];

$$\text{Percentage Before Firing} = \frac{\text{Percentage after firing}}{\text{Totale} - \text{LOI}} \quad (4.1)$$

Compensating of loss on ignition for the Ru kiln which is obtained from (PIXE) analysis are calculated by the *Maple<sup>TM</sup>* program . the results are used to simulate clay body of this types of ceramics by mixing kaolin withe others oxides in way to complete the percentage to every oxide which are compensated. This chemical analysis of samples porcelain bodies are transferred to unity formula, and the relative number of its molecule are limited as following:

1. sample N° R40b

$$\left\{ \begin{array}{l} 0,72\text{K}_2\text{O} \\ 0,27\text{CaO} \\ 0,01\text{MnO} \end{array} \right\} \cdot \begin{array}{l} 10,83\text{Al}_2\text{O}_3 \\ 0,38\text{Fe}_2\text{O}_3 \end{array} \cdot \left\{ \begin{array}{l} 42,71\text{SiO}_2 \\ 0,19\text{TiO}_2 \end{array} \right\}$$

2. sample N° R41b

$$\left\{ \begin{array}{l} 0,635\text{K}_2\text{O} \\ 0,357\text{CaO} \\ 0,008\text{MnO} \end{array} \right\} \cdot \begin{array}{l} 7,06\text{Al}_2\text{O}_3 \\ 0,38\text{Fe}_2\text{O}_3 \end{array} \cdot \left\{ \begin{array}{l} 30,16\text{SiO}_2 \\ 0,37\text{TiO}_2 \end{array} \right\}$$

3. sample N° R42b

$$\left\{ \begin{array}{l} 0,72\text{K}_2\text{O} \\ 0,27\text{CaO} \\ 0,01\text{MnO} \end{array} \right\} \cdot \begin{array}{l} 10,83\text{Al}_2\text{O}_3 \\ 0,38\text{Fe}_2\text{O}_3 \end{array} \cdot \left\{ \begin{array}{l} 42,71\text{SiO}_2 \\ 0,63\text{TiO}_2 \end{array} \right\}$$

4. sample N° R43b

$$\left\{ \begin{array}{l} 0,38\text{K}_2\text{O} \\ 0,61\text{CaO} \\ 0,01\text{MnO} \end{array} \right\} \cdot \begin{array}{l} 6,9\text{Al}_2\text{O}_3 \\ 0,29\text{Fe}_2\text{O}_3 \end{array} \cdot \left\{ \begin{array}{l} 24,15\text{SiO}_2 \\ 0,31\text{TiO}_2 \end{array} \right\}$$



## SCIENTIFIC AND EXCREMENTAL BASICS FOR TREATMENTS DURING FIRING

---

5. sample N° R44b

$$\left\{ \begin{array}{l} 0,72\text{K}_2\text{O} \\ 0,27\text{CaO} \\ 0,01\text{MnO} \end{array} \right\} \cdot \begin{array}{l} 9,44\text{Al}_2\text{O}_3 \\ 0,53\text{Fe}_2\text{O}_3 \end{array} \cdot \left\{ \begin{array}{l} 39,16\text{SiO}_2 \\ 0,50\text{TiO}_2 \end{array} \right\}$$

6. sample N° R47b

$$\left\{ \begin{array}{l} 0,488\text{K}_2\text{O} \\ 0,509\text{CaO} \\ 0,003\text{MnO} \end{array} \right\} \cdot \begin{array}{l} 6,26\text{Al}_2\text{O}_3 \\ 0,38\text{Fe}_2\text{O}_3 \end{array} \cdot \left\{ \begin{array}{l} 21,78\text{SiO}_2 \\ 0,30\text{TiO}_2 \end{array} \right\}$$

7. sample N° R271b

$$\left\{ \begin{array}{l} 0,71\text{K}_2\text{O} \\ 0,29\text{CaO} \\ 0,00\text{MnO} \end{array} \right\} \cdot \begin{array}{l} 9,68\text{Al}_2\text{O}_3 \\ 0,45\text{Fe}_2\text{O}_3 \end{array} \cdot \left\{ \begin{array}{l} 40,6\text{SiO}_2 \\ 0,58\text{TiO}_2 \end{array} \right\}$$

8. sample N° R275b

$$\left\{ \begin{array}{l} 0,64\text{K}_2\text{O} \\ 0,35\text{CaO} \\ 0,01\text{MnO} \end{array} \right\} \cdot \begin{array}{l} 8,56\text{Al}_2\text{O}_3 \\ 0,37\text{Fe}_2\text{O}_3 \end{array} \cdot \left\{ \begin{array}{l} 36,08\text{SiO}_2 \\ 0,50\text{TiO}_2 \end{array} \right\}$$

9. sample N° R330b

$$\left\{ \begin{array}{l} 0,56\text{K}_2\text{O} \\ 0,44\text{CaO} \\ 0,00\text{MnO} \end{array} \right\} \cdot \begin{array}{l} 9,24\text{Al}_2\text{O}_3 \\ 0,39\text{Fe}_2\text{O}_3 \end{array} \cdot \left\{ \begin{array}{l} 30,03\text{SiO}_2 \\ 0,40\text{TiO}_2 \end{array} \right\}$$

10. sample N° R333b

$$\left\{ \begin{array}{l} 0,62\text{K}_2\text{O} \\ 0,38\text{CaO} \\ 0,00\text{MnO} \end{array} \right\} \cdot \begin{array}{l} 11,81\text{Al}_2\text{O}_3 \\ 0,47\text{Fe}_2\text{O}_3 \end{array} \cdot \left\{ \begin{array}{l} 38,74\text{SiO}_2 \\ 0,51\text{TiO}_2 \end{array} \right\}$$

11. sample N° R339b

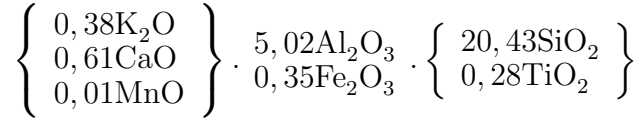
$$\left\{ \begin{array}{l} 0,44\text{K}_2\text{O} \\ 0,55\text{CaO} \\ 0,01\text{MnO} \end{array} \right\} \cdot \begin{array}{l} 8,26\text{Al}_2\text{O}_3 \\ 0,35\text{Fe}_2\text{O}_3 \end{array} \cdot \left\{ \begin{array}{l} 29,98\text{SiO}_2 \\ 0,43\text{TiO}_2 \end{array} \right\}$$

---

**SIMULATION STUDY FOR SOME ANCIENT CERAMICS**

---

12. sample N° R382b



From both of converting chemical analysis to unite formula which are presented above and weight fraction of each oxides components of Ru porcelain body samples which are presented in table(A.13), some values of different properties are calculated and they are shown in table(4.2), where the value of oxygen ratio is calculated according to  $O_{ratio}$  equation (3.2) and the data is obtained from relative number of molecule for Seger formula of Ru porcelain body as well as molar ratio  $\text{SiO}_2/\text{Al}_2\text{O}_3$ .

**Table 4.2:** Calculated values of different properties for Ru porcelain bodies samples

| Code No. | Oxygen ratio | (FT) Temperature of heat treatment °C | Molar ratio $\text{SiO}_2/\text{Al}_2\text{O}_3$ | (TEC) $\alpha \times 10^{-7} \text{ } ^\circ\text{C}^{-1}$ | Young modulus (E) $10^8 \times \text{N/cm}^2$ |
|----------|--------------|---------------------------------------|--|--|---|
| R40b     | 2.82         | 1516                                  | 3.94   | 21.8   | 8.22  |
| R41b     | 2.80         | 1492                                  | 4.27   | 26.4   | 8.15  |
| R42b     | 2.84         | 1516                                  | 3.94   | 21.8   | 8.30  |
| R43b     | 2.96         | 1481                                  | 3.50   | 19.9   | 8.44  |
| R44b     | 2.81         | 1505                                  | 4.15   | 24.1   | 8.18  |
| R47b     | 3.01         | 1464                                  | 3.48   | 23.3   | 8.41  |
| R271b    | 2.80         | 1510                                  | 4.19   | 23.5   | 8.22  |
| R275b    | 2.80         | 1505                                  | 4.21   | 23.9   | 8.24  |
| R330b    | 3.02         | 1495                                  | 3.25   | 19.6   | 8.50  |
| R333b    | 3.00         | 1509                                  | 3.28   | 18.0   | 8.48  |
| R339b    | 2.94         | 1514                                  | 3.53   | 19.3   | 8.59  |
| R382b    | 2.86         | 1457                                  | 4.07   | 24.7   | 8.28  |

---

## SCIENTIFIC AND EXPERIMENTAL BASICS FOR TREATMENTS DURING FIRING

---

The value of (FT) Temperature of heat treatment is calculated by (F) flux factor equation (3.3) and (FT) heat treatment ( $^{\circ}\text{C}$ ) equation(3.4) and data of flux factor of each oxide is obtained from table (3.1) and molar fraction is obtained from Seger formula, but weight fraction is used to calculate thermal expansion coefficient and Young modulus in equation (3.9) and (3.8) respectively.

### 4.2.2 Glaze coating

The data which are used for simulating glaze of Ru kiln porcelain was obtained from "Main chemical ingredients of celadon\* glaze from Qingliangsi kiln and Zhanggongxiang kiln" where in this study, the proton induced X-ray emission (PIXE) is used to determine the main oxides components of Ru glaze, where M.Weijuan et al [149] discovered chemical ingredient of 35 sample Ru Guan porcelain with 28 sample of Ru civile porcelain. They have done the analysis for glaze of same sample that M.Gouxia determined the main chemical ingredients for its porcelain body, so the chemical analysis of samples (R40b, R41b, R42b, R43b, R44b, R271b, R275b, R330b, R333b, R339b, R382b) are known by this study.

---

\*Celadon is type of ceramics which is made by mixing colors with translucent glaze to apply on special body, its glaze is lime-alkali glaze and usually its colorant is 1% of iron oxide fired in reduction. Its color varies from sea-green to a brown-green. Originally, the term celadon was limited to sea-green variety, ultimately this term was used to refer to all wares which are made by the same manners[126, 148].

**Table 4.3:** Main chemical oxides of Ru Guan glaze

| Code No. | (PIXE) oxides analysis         |                  |                  |       |                  |      |                                |      |                                |                  | Compensating oxides analysis |       |                  |      |                                |  |  |
|----------|--------------------------------|------------------|------------------|-------|------------------|------|--------------------------------|------|--------------------------------|------------------|------------------------------|-------|------------------|------|--------------------------------|--|--|
|          | Al <sub>2</sub> O <sub>3</sub> | SiO <sub>2</sub> | K <sub>2</sub> O | CaO   | TiO <sub>2</sub> | MnO  | Fe <sub>2</sub> O <sub>3</sub> | LOI  | Al <sub>2</sub> O <sub>3</sub> | SiO <sub>2</sub> | K <sub>2</sub> O             | CaO   | TiO <sub>2</sub> | MnO  | Fe <sub>2</sub> O <sub>3</sub> |  |  |
| R40G     | 14.90                          | 64.51            | 4.44             | 12.28 | 0.17             | 0.11 | 2.10                           | 1.49 | 15.12                          | 65.49            | 4.51                         | 12.47 | 0.17             | 0.11 | 2.13                           |  |  |
| R41G     | 16.08                          | 63.94            | 5.59             | 10.78 | 0.18             | 0.10 | 1.82                           | 1.51 | 16.33                          | 64.92            | 5.68                         | 10.94 | 0.18             | 0.10 | 1.85                           |  |  |
| R42G     | 14.97                          | 64.74            | 4.77             | 11.92 | 0.16             | 0.16 | 1.88                           | 1.40 | 15.18                          | 65.66            | 4.84                         | 12.09 | 0.16             | 0.16 | 1.91                           |  |  |
| R43G     | 15.46                          | 62.78            | 5.14             | 13.03 | 0.18             | 0.14 | 1.77                           | 1.50 | 15.70                          | 63.73            | 5.22                         | 13.23 | 0.18             | 0.14 | 1.80                           |  |  |
| R44G     | 15.54                          | 64.44            | 5.80             | 10.71 | 0.19             | 0.10 | 1.73                           | 1.49 | 15.78                          | 65.41            | 5.89                         | 10.87 | 0.19             | 0.10 | 1.76                           |  |  |
| R47G     | 15.83                          | 64.79            | 5.23             | 10.44 | 0.17             | 0.18 | 1.87                           | 1.49 | 16.07                          | 65.77            | 5.31                         | 10.60 | 0.17             | 0.18 | 1.90                           |  |  |
| R271G    | 14.76                          | 65.45            | 4.47             | 11.47 | 0.15             | 0.12 | 2.08                           | 1.50 | 14.99                          | 66.45            | 4.54                         | 11.64 | 0.15             | 0.12 | 2.11                           |  |  |
| R275G    | 15.17                          | 63.41            | 4.81             | 12.85 | 0.16             | 0.15 | 1.95                           | 1.50 | 15.40                          | 64.38            | 4.88                         | 13.05 | 0.16             | 0.15 | 1.98                           |  |  |
| R330G    | 15.75                          | 62.64            | 4.28             | 13.59 | 0.18             | 0.13 | 1.90                           | 1.53 | 16.00                          | 63.61            | 4.35                         | 13.80 | 0.18             | 0.13 | 1.93                           |  |  |
| R333G    | 14.68                          | 64.00            | 3.43             | 13.97 | 0.21             | 0.16 | 2.03                           | 1.52 | 14.91                          | 64.99            | 3.48                         | 14.19 | 0.21             | 0.16 | 2.06                           |  |  |
| R339G    | 14.94                          | 61.57            | 4.01             | 15.80 | 0.14             | 0.17 | 1.87                           | 1.51 | 15.17                          | 62.51            | 4.07                         | 16.04 | 0.14             | 0.17 | 1.90                           |  |  |
| R382G    | 15.05                          | 62.12            | 4.34             | 14.82 | 0.22             | 0.20 | 1.76                           | 1.49 | 15.28                          | 63.06            | 4.41                         | 15.04 | 0.22             | 0.20 | 1.79                           |  |  |

## SCIENTIFIC AND EXPERIMENTAL BASICS FOR TREATMENTS DURING FIRING

---

Major chemical elements for samples which are used in simulating Ru porcelain glaze are presented in table (4.3). The data which are provided by (PIXE) analysis is for samples which are already fired, and therefore, these percentages are after firing and it should be compensated the loss on ignition (LOI) in analysis.

The *Maple<sup>TM</sup>* program was used to do (LOI) compensation which is presented in table (4.3). Compensating of loss on ignition for the Ru kiln glaze which is obtained from (PIXE) analysis are calculated by the *Maple<sup>TM</sup>* program . The results are used to simulate glaze of this types of ceramics. This chemical analysis of samples porcelain bodies are transferred to unity formula as following:

1. sample N° R40G

$$\left\{ \begin{array}{l} 0,176\text{K}_2\text{O} \\ 0,818\text{CaO} \\ 0,006\text{MnO} \end{array} \right\} \cdot \begin{array}{l} 0,546\text{Al}_2\text{O}_3 \\ 0,049\text{Fe}_2\text{O}_3 \end{array} \cdot \left\{ \begin{array}{l} 4,010\text{SiO}_2 \\ 0,008\text{TiO}_2 \end{array} \right\}$$

2. sample N° R41G

$$\left\{ \begin{array}{l} 0,236\text{K}_2\text{O} \\ 0,763\text{CaO} \\ 0,001\text{MnO} \end{array} \right\} \cdot \begin{array}{l} 0,63\text{Al}_2\text{O}_3 \\ 0,04\text{Fe}_2\text{O}_3 \end{array} \cdot \left\{ \begin{array}{l} 4,225\text{SiO}_2 \\ 0,009\text{TiO}_2 \end{array} \right\}$$

3. sample N° R42G

$$\left\{ \begin{array}{l} 0,19\text{K}_2\text{O} \\ 0,80\text{CaO} \\ 0,01\text{MnO} \end{array} \right\} \cdot \begin{array}{l} 0,554\text{Al}_2\text{O}_3 \\ 0,044\text{Fe}_2\text{O}_3 \end{array} \cdot \left\{ \begin{array}{l} 4,05\text{SiO}_2 \\ 0,007\text{TiO}_2 \end{array} \right\}$$

4. sample N° R43G

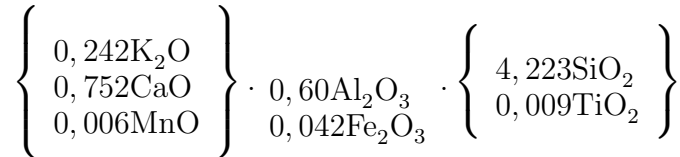
$$\left\{ \begin{array}{l} 0,189\text{K}_2\text{O} \\ 0,804\text{CaO} \\ 0,007\text{MnO} \end{array} \right\} \cdot \begin{array}{l} 0,526\text{Al}_2\text{O}_3 \\ 0,038\text{Fe}_2\text{O}_3 \end{array} \cdot \left\{ \begin{array}{l} 3,616\text{SiO}_2 \\ 0,007\text{TiO}_2 \end{array} \right\}$$

---

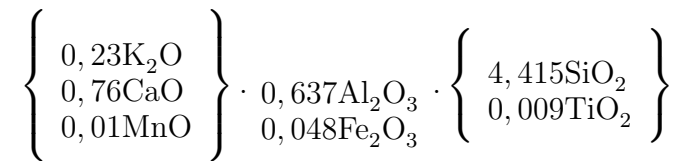
SIMULATION STUDY FOR SOME ANCIENT CERAMICS

---

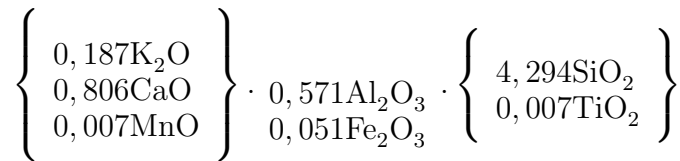
5. sample N° R44G



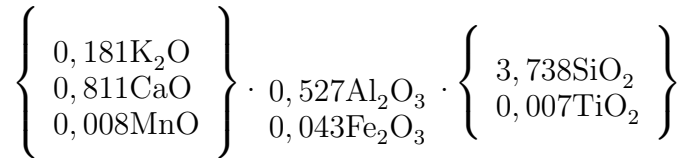
6. sample N° R47G



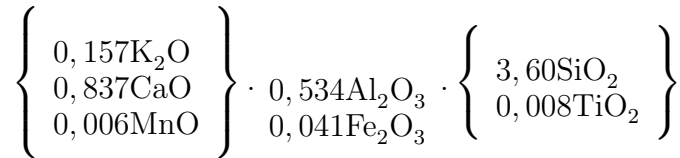
7. sample N° R271G



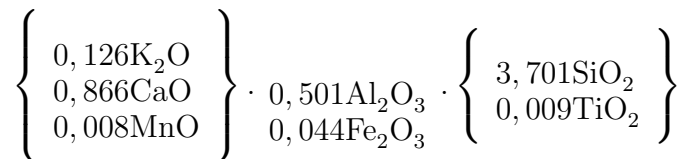
8. sample N° R275G



9. sample N° R330G



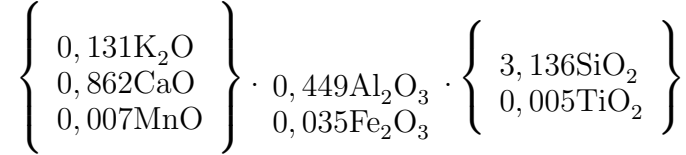
10. sample N° R333G



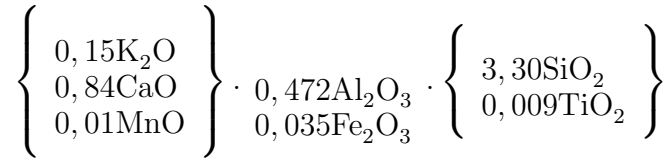
## SCIENTIFIC AND EXCREMENTAL BASICS FOR TREATMENTS DURING FIRING

---

11. sample N° R339G



12. sample N° R382G



From both of converting chemical analysis to unite formula which are presented above, and from weight fraction of each oxide components of Ru kiln glazes samples which are presented in table(A.14), some values of different properties are calculated and they are shown in table(4.4).

**Table 4.4:** Calculated values of different properties for Ru glaze samples)

| Code No. | Oxygen ratio | (FT) Temperature of heat treatment °C | Molar ratio SiO <sub>2</sub> /Al <sub>2</sub> O <sub>3</sub> | (TEC) $\alpha \times 10^{-7}$ °C <sup>-1</sup> | Young modulus (E)10 <sup>8</sup> × N/cm <sup>2</sup> |
|----------|--------------|---------------------------------------|--|--|--|
| R40b     | 2.70         | 1049                                  | 7.33   | 59.12  | 7.71   |
| R41b     | 2.72         | 1081                                  | 6.73   | 63.18  | 7.71   |
| R42b     | 2.70         | 1058                                  | 7.32   | 60.66  | 7.71   |
| R43b     | 2.75         | 1001                                  | 6.88   | 63.07  | 7.94   |
| R44b     | 2.70         | 1080                                  | 7.02   | 64.94  | 7.67   |
| R47b     | 3.00         | 1101                                  | 6.93   | 61.21  | 7.69   |
| R271b    | 2.67         | 1081                                  | 7.51   | 58.84  | 7.68   |
| R275b    | 2.73         | 1016                                  | 7.08   | 61.39  | 7.75   |
| R330b    | 2.76         | 999                                   | 6.73   | 58.23  | 7.84   |
| R333b    | 2.71         | 1008                                  | 7.38   | 54.82  | 7.82   |
| R339b    | 2.79         | 914                                   | 6.98   | 43.47  | 7.89   |
| R382b    | 2.77         | 948                                   | 6.99   | 60.34  | 7.86   |

## SIMULATION STUDY FOR SOME ANCIENT CERAMICS

---

In table above, the value of oxygen ratio is calculated according to  $O_{ratio}$  equation (3.2), and the data is obtained from relative number of molecule for Seger formula of Ru glazes as well as molar ratio  $SiO_2/Al_2O_3$ . Also, the value of (FT) temperature of heat treatment is calculated by (F) flux factor equation (3.3) and (FT) heat treatment ( $^{\circ}C$ ) is calculated by using (3.4) equation and data of flux factor of each oxide is obtained from table (3.1). Molar fraction is obtained from Seger formula, but weight fraction is used to calculate thermal expansion coefficient and Young modulus as demonstrated in equations (3.9) and (3.8) respectively.

From the calculated values of different properties for Ru glaze samples and for Ru porcelain bodies samples in table (4.4) and (4.2) respectively, the difference between the dilatation of Ru porcelain body and Ru glaze in the end cooling with normal rate was calculated, the stress in glaze  $\sigma_{glaze}$  and in porcelain body  $\sigma_{body}$  calculated as proposing the glaze thickness is  $200 \mu$  and body thickness is  $5000\mu$  and the difference between  $\sigma_{glaze}$  and  $\sigma_{body}$ . These values are presented in flowing table (4.5)

The calculated values, for difference between ( $\alpha$ ) linear thermal expansion of Ru porcelain body and Ru glaze in the end of cooling with normal rate, are higher than  $5 \times 10^{-7} K^{-1}$ , therefore the cracking are existed as result of difference between ( $\alpha$ ) thermal expansion coefficient of glaze and porcelain body, also where

---

\*crackle created when the tensile stress above 160 MPa, the tensile strength of common glaze



## SCIENTIFIC AND EXPERIMENTAL BASICS FOR TREATMENTS DURING FIRING

---

**Table 4.5:** Calculated values of mechanical properties in glaze and porcelain body of Ru Guan kiln

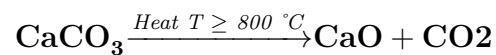
| Code<br>sample<br>No. | $\alpha_{glaze} - \alpha_{body}$<br>$10^{-7} K^{-1}$ | $\sigma_{glaze}$<br>MPs | $\sigma_{body}$<br>MPs | $\sigma_{glaze} - \sigma_{body}$<br>MPs | Note            |
|-----------------------|--|-------------------------|------------------------|---|-----------------|
| R40                   | 37.32  | -184.84                 | 7.39                   | -192.23                                 | tensile stress* |
| R41                   | 36.78  | -182.09                 | 7.28                   | -189.37                                 | tensile stress  |
| R42                   | 38.82  | -192.37                 | 7.69                   | -200.07                                 | tensile stress  |
| R43                   | 43.22  | -220.58                 | 8.82                   | -229.41                                 | tensile stress  |
| R44                   | 40.83  | -201.17                 | 8.04                   | -209.22                                 | tensile stress  |
| R47                   | 37.10  | -183.57                 | 7.34                   | -190.91                                 | tensile stress  |
| R271                  | 35.34  | -174.39                 | 6.97                   | -181.36                                 | tensile stress  |
| R275                  | 37.51  | -186.84                 | 7.47                   | -194.32                                 | tensile stress  |
| R330                  | 34.35  | -195.03                 | 7.80                   | -202.83                                 | tensile stress  |
| R333                  | 36.79  | -185.03                 | 7.40                   | -192.43                                 | tensile stress  |
| R339                  | 24.21  | -122.77                 | 4.91                   | -127.68                                 | tensile stress  |
| R382                  | 35.61  | -179.75                 | 7.19                   | -186.93                                 | tensile stress  |

the values of thermal expansion coefficient of glaze are from  $43.47 \times 10^{-7}$  to  $64.94 \times 10^{-7} K^{-1}$  and this values are in the range of common glazes ( $50 \times 10^{-7}$ - $200 \times 10^{-7}$ ) [136], and the values of thermal expansion coefficient of porcelain are lower enough to create crackle in most of common glaze. So the causing of crackles in Ru kiln glaze is difference between ( $\alpha$ ) linear thermal expansion of Ru porcelain body and Ru glaze. But the thermal shock during firing remains a practical method to create crackle treatment on ceramic glazed surfaces as indicated from

equations of calculated the stress in glaze (3.12) and in body (3.13). The lower thermal expansion coefficient of Ru porcelain body indicates to possibility that Ru porcelain body resites the thermal shock.

### **4.2.3 Raw material for glaze and porcelain body**

Due to the chemical analysis of Ru Guan glaze and porcelain body are free from  $\text{Na}_2\text{O}$ . Most commercial feldspars contain  $\text{Na}_2\text{O}$ , so they are not suitable to simulate Ru kiln which not have sodium in any sample neither porcelain body nor glaze. There are some materials that can give  $\text{CaO}$  with  $\text{SiO}_2$  and  $\text{Al}_2\text{O}_3$  which we can find it in Hey's Chemical Index of Minerals-Group 16.9 (Aluminosilicates of Ca). There are also some materials which can give  $\text{K}_2\text{O}$  with  $\text{SiO}_2$  and  $\text{Al}_2\text{O}_3$  which we can find in Hey's Chemical Index of Minerals-Group 16.3 (Aluminosilicates of K) but this material is not easy to found with economic cost. Therefore the  $\text{CaCO}_3$  is used as source of calcium oxide, although it gives a lot of  $\text{CO}_2$ , where heat treatment for 100.09 parts by weight of  $\text{CaCO}_3$  results 56.08 parts by weight of  $\text{CaO}$  plus 44.01 parts weight of  $\text{CO}_2$  as chemical equation shows below:

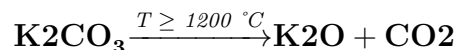


The  $\text{K}_2\text{CO}_3$  is used as source of potassium oxide instead of (Aluminosilicates of K) because of high cost, heat treatment for 138.21 parts by weight of  $\text{K}_2\text{CO}_3$  results 94.2 parts by weight of  $\text{CaO}$  plus 44.01 parts weight of  $\text{CO}_2$  as chemical

## SCIENTIFIC AND EXCREMENTAL BASICS FOR TREATMENTS DURING FIRING

---

equation shows below:



The chemical composition of kaolin used in Ru porcelain body and glaze simulation was determined by the BRGM\*.The table(4.6) shows the realistic and theoretical composition of kaolin d'Arvor, where 100 % of this kaolin give 12.85 % of H<sub>2</sub>O, 47.15 % of SiO<sub>2</sub>, 37.6 % of Al<sub>2</sub>O<sub>3</sub>, 0.95% of K<sub>2</sub>O, < 0.1% of CaO, 0.09 % of TiO<sub>2</sub>, < 0.02% MnO, and 0.78%Fe<sub>2</sub>O<sub>3</sub>. The Mn(NO<sub>3</sub>)<sub>2</sub>.4H<sub>2</sub>O is used as source

**Table 4.6:** The chemical composition of kaolin d'Arvor

|                         | H <sub>2</sub> O | SiO <sub>2</sub>  | Al <sub>2</sub> O <sub>3</sub> | K <sub>2</sub> O | Fe <sub>2</sub> O <sub>3</sub> | CaO   |
|-------------------------|------------------|-------------------|--------------------------------|------------------|--------------------------------|-------|
| Theoretical composition | 14.00            | 46.50             | 39.50                          | 0.00             | 0.00                           | 0.00  |
| Realistic composition   | 12.85            | 47.15             | 37.6                           | 0.95             | 0.78                           | < 0.1 |
|                         | MgO              | Na <sub>2</sub> O | TiO <sub>2</sub>               | MnO              | P <sub>2</sub> O <sub>5</sub>  | FeO   |
| Theoretical composition | 0.00             | 0.00              | 0.00                           | 0.00             | 0.00                           | 0.00  |
| Realistic composition   | < 0.2            | < 0.2             | 0.09                           | < 0.02           | 0.08                           | <0.1  |

of MnO, where heat treatment for 251.024 parts by weight of Mn(NO<sub>3</sub>)<sub>2</sub>.4H<sub>2</sub>O results 86.94 parts by weight of MnO<sub>2</sub> plus 92.02 parts weight of NO<sub>2</sub> gas plus 72.064 parts weight of H<sub>2</sub>O as chemical equation shows below:



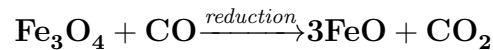
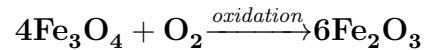

---

\*Bureau de recherches géologiques et minières - The France's leading public institution in Earth science applications in Earth science applications

## SIMULATION STUDY FOR SOME ANCIENT CERAMICS

---

Manganese dioxide  $\text{MnO}_2$  at  $1080^\circ\text{C}$  producing oxygen with formation of stable  $\text{MnO}$ . Titanium dioxide  $\text{TiO}_2$ , magnetic iron oxide  $\text{Fe}_3\text{O}_4$  and silica  $\text{SiO}_2$  is added to complete its percentage in batch recipe of porcelain body or glaze. Magnetic iron oxide converts into one of the other forms by oxidation or reduction. The results of this conversion depend on duration and distinctly of oxidizing or reducing atmosphere in temperature  $\geq 900^\circ\text{C}$ , as chemical equation shows below:



The conversions are possible in ceramic at temperatures over  $1100^\circ\text{C}$  before glass melts have taken place.

### 4.2.4 Calculating the raw materials for batch recipe of porcelain body

In calculating the quantities of raw materials for batch recipe of porcelain body, the quantity of kaolin which gives the percentage of  $\text{Al}_2\text{O}_3$  is first calculated quantity in recipe because it is the suitable source of  $\text{Al}_2\text{O}_3$ , in addition to, it is important for forming property of porcelain body. The chemical analysis of kaolin refer to that 100 parts by weight of kaolin gives 37.6 parts by weight of  $\text{Al}_2\text{O}_3$ . The recipe of R47b sample is calculated from LOI Compensating which

## SCIENTIFIC AND EXCREMENTAL BASICS FOR TREATMENTS DURING FIRING

---

presented in table (4.1), where the percentage of  $\text{Al}_2\text{O}_3$  before firing is 30.57, and therefore, 81.38 parts by weight of kaolin gives 30.57 parts by weight of  $\text{Al}_2\text{O}_3$ . The 81.38 parts by weight of kaolin gives also 38.33 parts by weight of  $\text{SiO}_2$ , 0.08 parts by weight of  $\text{CaO}$ , 0.77 parts by weight of  $\text{K}_2\text{O}$ , 0.01 parts by weight of  $\text{MnO}$ , 0.07 parts by weight of  $\text{TiO}_2$ , and 0.71 parts by weight of  $\text{Fe}_2\text{O}_3$  and  $\text{FeO}$ , see appendix (A.0.1).

The 138.21 parts by weight of  $\text{K}_2\text{CO}_3$  will give 94.2 parts by weight of  $\text{K}_2\text{O}$  and 44.01 parts by weight of  $\text{CO}_2$ . So to obtain 1.43 parts by weight of  $\text{K}_2\text{O}$ , the 2.12 parts by weight of  $\text{K}_2\text{CO}_3$  is used and it gives 0.67 parts by weight of  $\text{CO}_2$ , see appendix (A.0.2).

Also for complete the percent of  $\text{CaO}$  in calculation, 1.29 parts by weight of  $\text{CaO}$  is rustled from 2.30 parts by weight of  $\text{CaCO}_3$ , and this gives 1.01 parts by weight of  $\text{CO}_2$ . But the using calcium carbonate is of 99% purity, so 2.33 parts by weight is used instead of 2.30 parts by weight, see appendix (A.0.3).

No quantity of manganese nitrate is used in this sample because the required quantity of  $\text{MnO}$  = 0.01 parts by weight is given by impurity of kaolin.

For obtaining 1.08 parts by weight of titanium dioxide, the 1.09 parts by weight of  $\text{TiO}_2$  with purity 99 %.  $\text{Fe}_3\text{O}_4$  which convert in oxidizing atmosphere into  $\text{Fe}_2\text{O}_3$ , so to get 1.20 parts by weight of  $\text{Fe}_2\text{O}_3$ , the 1.17 parts by weight of  $\text{Fe}_3\text{O}_4$  is added to recipe weight. The 24.5 parts by weight of silica is added to complete the percentage of  $\text{SiO}_2$  in recipe. The sum of these quantities of raw materials

by weight = 112.45, so it is converted into percentage in table(A.15). This batch recipe was mixed to prepare plate and forms and to experiment the properties of Ru kiln porcelain. The figure (4.1) shows small shape which formed by simulated Ru porcelain body. it is formed by pressing in mold.

### 4.2.5 Calculating the raw recipe of glaze

The main oxides composition of Ru glaze is similar to the main oxides composition of Ru porcelain body, but it is different in quantities. Therefore the raw materials for Ru glaze batch recipe is similar to raw materials of Ru porcelain body. The kaolin is source of  $\text{Al}_2\text{O}_3$ . The quantity of kaolin which give 16.07 parts by weight of  $\text{Al}_2\text{O}_3 = (100 \times 16.07) \div 37.6 = 42.74$  parts by weight of kaolin. The 42.74 parts by weight of kaolin gives also 20.15 parts by weight of  $\text{SiO}_2$ , 0.04 parts by weight of CaO 0.41 parts by weight of  $\text{K}_2\text{O}$ , 0.01 parts by weight of MnO, 0.04 parts by weight of  $\text{TiO}_2$ , and 0.33 parts by weight of  $\text{Fe}_2\text{O}_3$  and FeO, see appendix (A.0.4). Also, the 19.03 parts by weight of  $\text{CaCO}_3$  is added to complete the required percentage of calcium oxide in recipe, see appendix(A.0.5). The 7,27 parts by weight of  $\text{K}_2\text{CO}_3$  is added to complete the required percentage of potassium oxide in recipe, see appendix(A.0.6). The 0.63 parts by weight of  $\text{Mn}(\text{NO}_3)_2 \cdot 4\text{H}_2\text{O}$  is added to recipe to complete the percentage of MnO, see appendix (A.0.7). The 0.14 parts by weight of titanium dioxide with purity 99 % is added to recipe to

SCIENTIFIC AND EXPERIMENTAL BASICS FOR TREATMENTS  
DURING FIRING

---



**Figure 4.1:** Small shape formed from simulated Ru porcelain body before firing

## SIMULATION STUDY FOR SOME ANCIENT CERAMICS

complete the percentage of  $\text{TiO}_2$ . The 1.51 parts by weight of  $\text{Fe}_3\text{O}_4$  is added to recipe weight for resulting 1.56 parts by weight of  $\text{Fe}_2\text{O}_3$ . The 45.62 parts by weight of silica is added to complete the percentage of  $\text{SiO}_2$  in recipe. The sum of these quantities of raw materials by weight = 116.93, so it is converted into percentage in table(A.16). The better firing temperature for biscuit is  $1100^\circ\text{C}$  and  $1215^\circ\text{C}$  for the glaze. The porcelain body have a good resistance to the thermal chock, that appear in the comparison between microscopical photos in figure(4.2) where there is no changing between microscope photo for same area before thermal shock treatment and after thermal shock treatment. There is no great effect on the body according to stress that is created from thermal shock, as well as calculated thermal expansion coefficient refers to lower value equal  $23.27 \times 10^{-7} \text{ }^\circ\text{K}^{-1}$  for R47b sample in table(4.2). The shrinkage coefficient of porcelain body after first firing = 18.93%.

Due to the raw materials of glaze and porcelain body produce by quantity can not be ignored ,therefore the porcelain body have relatively high shrinkage coefficient and the glaze have crawling defect cause to the hight shrinkage, this defect appears in figure (4.3). There are some problems appeared when glaze is applied on the surface of porcelain body. The quantity of  $\text{CaCO}_3$  and  $\text{K}_2\text{CO}_3$  in porcelain body and glaze make bubbles\* especially in high temperatures as shown

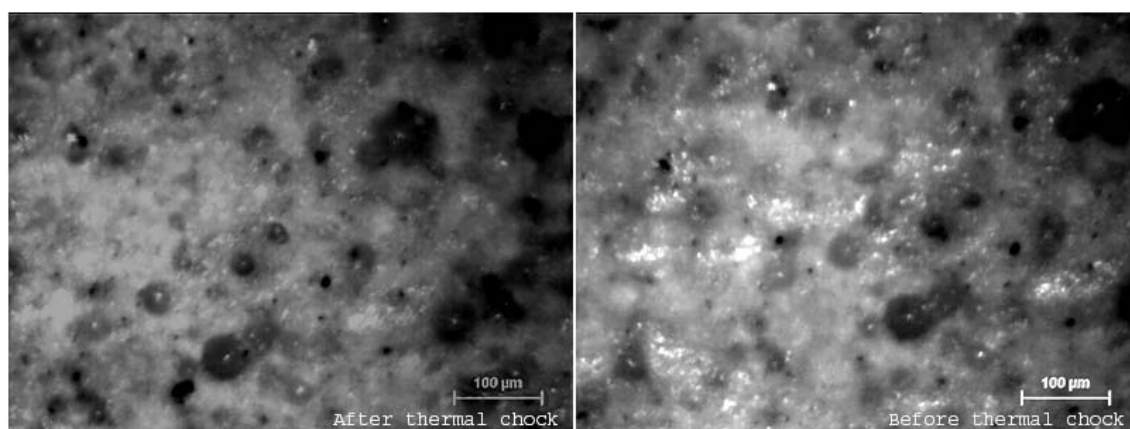
---

\*PV=nRT, Therefore 1 mole of  $\text{K}_2\text{CO}_3 \simeq 138\text{g} \rightarrow 1 \text{ mole CO}_2 \simeq 44\text{g}$  with volume  $\simeq 121\text{L}$  at  $1200^\circ\text{C}$ , the temperature of decomposition. 1 mole of  $\text{CaCO}_3 \simeq 100\text{g} \rightarrow 1 \text{ mole CO}_2 \simeq 44\text{g}$



## SCIENTIFIC AND EXPERIMENTAL BASICS FOR TREATMENTS DURING FIRING

---



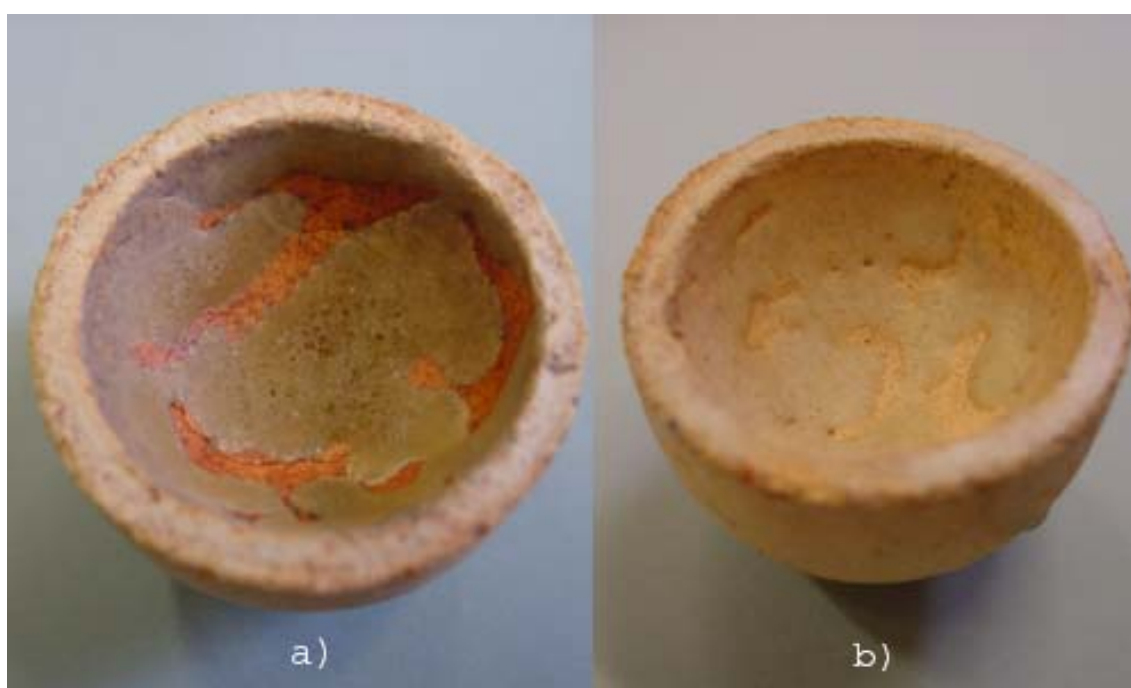
**Figure 4.2:** Two microscopical photos of a sample of simulated Ru porcelain body, before thermal shock and after thermal shock

in figure(4.4), firing in high rate did not provide enough time for converting the  $\text{Fe}_3\text{O}_4$  into one of the other forms of iron oxide. Crawling of glaze led to thick spots of glaze on the surface of the porcelain body, which results after firing in a layer of glaze that was contacted with a thin layer of porcelain body and separated from it. These problems require some procedures:

1. First procedure is firing the glazed Ru porcelain according to a schedule which is prepared depending on the DAT curve to give the opportunity for some reactions to happen before glass melting has taken place to avoid problems in colors and bubbles, where  $\text{CaCO}_3$  and  $\text{K}_2\text{CO}_3$  produce  $\text{CO}_2$ . This procedure of firing solves the problem of bubbles and color, but the other problems of glaze crawling and separating from the porcelain body are re-

---

with volume  $\simeq 88\text{L}$  at  $800^\circ\text{C}$  the temperature of decomposition



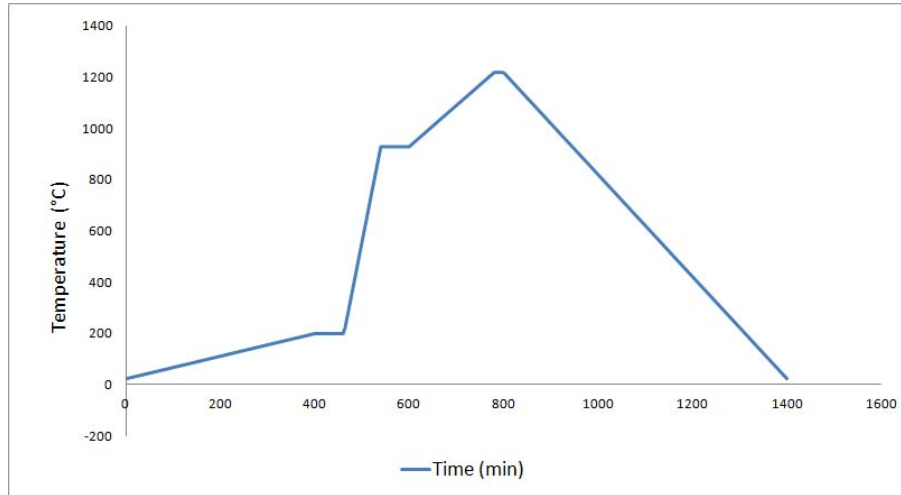
**Figure 4.3:** The simulated Ru glaze recipe R47G fired at 1230 °C a) normal atmosphere b) reduction atmosphere

SCIENTIFIC AND EXPERIMENTAL BASICS FOR TREATMENTS  
DURING FIRING

---



**Figure 4.4:** Apply the simulated glaze of R47G on the surface of simulated R47b porcelain body



**Figure 4.5:** The firing schedule to avoid bubbles appearing

mained occur as shown in figure (4.6). The firing schedule shows the relation between temperature and time and this relation is demonstrated from figure(4.5) Some crackling is appeared and that means a very strong stress happened between the layer of glaze and the layer of porcelain body and also the glaze layer shrink during firing to leave portions of bare clay exposed.

2. Second procedure is a calcination for the raw materials to reduce shrinkage coefficient of glaze , and with this applicable procedure ,an acceptable sample of simulated Ru Guan kiln is obtained as shown in figure (4.7)and figure(4.8)

The simulation of Ru Guan porcelain permits to practice on design clay body and glaze from unity formula, as well as design and limitation of unity formula

## SCIENTIFIC AND EXPERIMENTAL BASICS FOR TREATMENTS DURING FIRING

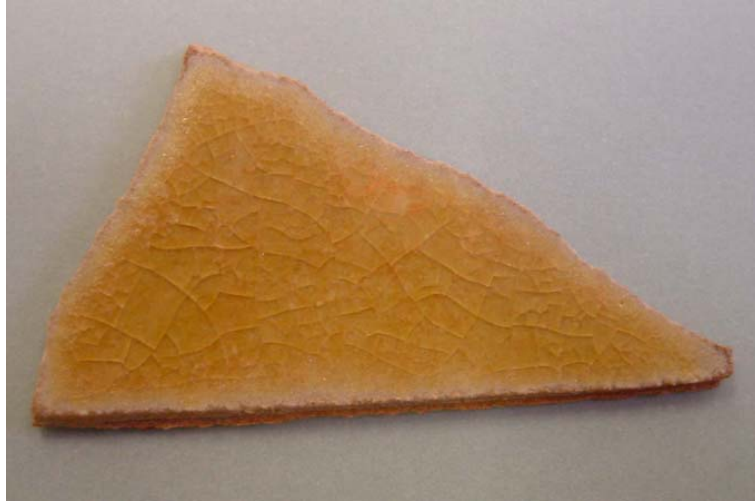
---



**Figure 4.6:** Sample of Simulated Ru Guan porcelain that fired according to the firing schedule (4.5)



**Figure 4.7:** Successful simulated sample (R47) of Ru Guan porcelain with crackle treatment, according to calcined glaze recipe and firing schedule (4.5)



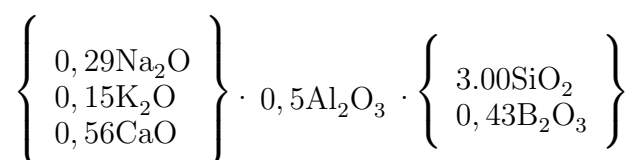
**Figure 4.8:** Successful simulated sample (R47) of Ru Guan porcelain with crackle treatment, according to calcined glaze recipe and firing schedule (4.5), with thermal shock at 100°C

allows to design chemical and mechanical properties for both of glaze and body. This properties is essential for using the kiln as tool for enriching ceramics forms aesthetically by treatments during or after firing. Where in this method the physical properties and chemical reactions of ceramic body and glaze should be prepared to such treatment during cooling period. The simulation of Ru porcelain body supports the technique of using thermal shock to create crackle on glazed ceramics surfaces, where it provides the technical and scientific information for applying porcelain body which resists thermal shock. The table (A.15) presents a raw materials and batch recipe of porcelain body which can resist this treatment. Also, this provides an explanation to history of Ru kiln technology, where the

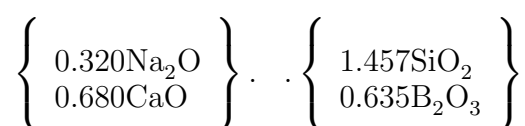
lower thermal expansion coefficient of porcelain body leads to resist thermal shock and increase the tensile stress in layer of Ru glaze which produce crackle.

### 4.3 Thermal shock as new technique to make cracking

Due to the Ru Porcelain body has a property of resisting thermal shock, the other parameter,  $\Delta T$  which influences in the stress in glaze or body according to equations(3.12) and (3.13), can be used to create cracking on glaze surfaces. This technic is experimented by apply other recipe of glaze on Ru porcelain body and treat this glazed porcelain by thermal shock to increase the effect of crack net on surface of glaze. The unite formula of this glaze is :



The percentage analysis of this glaze is : 55,48 %SiO<sub>2</sub>, 15,69 %Al<sub>2</sub>O<sub>3</sub>, 5,53 %Na<sub>2</sub>O, 4,35 %K<sub>2</sub>O, 9,67 %CaO and 9,28 %B<sub>2</sub>O<sub>3</sub>. For calculating the batch recipe for this chemical analysis , the Pemco Frit P-54 which have Equivalent Molecular Weight 189.700 see table(A.12) is used as source of B<sub>2</sub>O<sub>3</sub> with other oxides. The Molecular Formula of Pemco Frit P-54 is :



## THERMAL SHOCK AS NEW TECHNIQUE TO MAKE CRACKING

---

The percentage analysis of this glass is: 46.15 %SiO<sub>2</sub>, 10.44 %Na<sub>2</sub>O, 20.10 %CaO and 23.31 %B<sub>2</sub>O<sub>3</sub>. The raw recipe of this frit (Pemco Frit P-54) is calculated as shown in table(4.7), see appendix (A.0.8). This, batch recipe, is heated until melting, then it is cooled by quenching in water, and ground into a fine powder to use in glaze recipe. The raw recipe of glaze that used to make thermal shock treatment was presented with its calculating in table (4.8). This glaze applied on porcelain body which simulated to sample N° R47b-PGGPD of RU Guan porcelain body. This porcelain body is fired first fired at 1100°C and then fired with glaze at 1150°C, where three samples are treated by thermal shock in different degree 1100°C ,1000°C and 900°C.



## SCIENTIFIC AND EXCREMENTAL BASICS FOR TREATMENTS DURING FIRING

---

**Table 4.7:** Calculating the percentage of raw materials for batch recipe of Pemco

Frit P-54, see appendix (A.0.8).

| Raw materials  | chemical oxides  |                   |       |                               |        | gases                          |                          | % of Raw |
|--|------------------|-------------------|-------|-------------------------------|--------|--------------------------------|--------------------------|----------|
|  | SiO <sub>2</sub> | Na <sub>2</sub> O | CaO   | B <sub>2</sub> O <sub>3</sub> | weight | weight                         | volume                   |          |
| Silicon dioxide<br>SiO <sub>2</sub>  | 46.15            |                   |       |                               | 46.15  |                                |                          | 31.61 %  |
| Sodium tetraborate<br>Na <sub>2</sub> B <sub>4</sub> O <sub>7</sub> ·10 H <sub>2</sub> O |                  | 10.38             |       | 23.31                         | 63.84  | 30.2H <sub>2</sub> O           | 139L <sup>t743 °C</sup>  | 43.74%   |
| Sodium carbonate<br>Na <sub>2</sub> CO <sub>3</sub>                                      |                  | 00.06             |       |                               | 0.10   | 0.04 <sup>CO<sub>2</sub></sup> | 0.08L <sup>t800 °C</sup> | 0.08%    |
| Calcium carbonate<br>CaCO <sub>3</sub>   |                  |                   | 20.10 |                               | 35.87  | 15.8 <sup>CO<sub>2</sub></sup> | 31.7L <sup>t800 °C</sup> | 24,57 %  |
| % of oxide   | 46,15            | 10,44             | 20,10 | 23,31                         |        |                                |                          | 100%     |

**THERMAL SHOCK AS NEW TECHNIQUE TO MAKE  
CRACKING**

**Table 4.8:** Calculating the percentage of raw materials for batch recipe of glaze that is used for thermal shock treatment

| Raw materials  | chemical oxides  |                                |                               |                  |                   |      | gases  |                                |                          |          |
|--|------------------|--------------------------------|-------------------------------|------------------|-------------------|------|--------|--------------------------------|--------------------------|----------|
|  | SiO <sub>2</sub> | Al <sub>2</sub> O <sub>3</sub> | B <sub>2</sub> O <sub>3</sub> | K <sub>2</sub> O | Na <sub>2</sub> O | CaO  | weight | weight                         | volume                   | % of Raw |
| Frit P-54  | 18.37            |                                | 9.28                          |                  | 4.16              | 8.00 | 39.81  | 0.91 <sup>CO<sub>2</sub></sup> | 1.76L <sup>t800 °C</sup> | 37.58%   |
| Sodium carbonate<br>Na <sub>2</sub> CO <sub>3</sub>                                |                  |                                |                               |                  | 1.30              |      | 2.21   |                                |                          | 02.09%   |
| Kaolin<br>Al <sub>2</sub> O <sub>3</sub> · 2 SiO <sub>2</sub> · 2 H <sub>2</sub> O | 5.18             | 4.13                           |                               | 0.10             | 0.02              | 0.02 | 11.0   | 1.41 <sup>H<sub>2</sub>O</sup> | 1.93L <sup>t20 °C</sup>  | 10.38%   |
| Calcium carbonate<br>CaCO <sub>3</sub>   |                  |                                |                               |                  |                   | 1.62 | 2.89   | 1.27 <sup>CO<sub>2</sub></sup> | 2.64L <sup>t800 °C</sup> | 02.70%   |
| Potassium carbonate<br>K <sub>2</sub> CO <sub>3</sub>                              |                  |                                |                               | 3.95             |                   |      | 5.80   | 1.85 <sup>CO<sub>2</sub></sup> | 4.84L <sup>t800 °C</sup> | 05.48%   |
| Silicon dioxide SiO <sub>2</sub>   | 17.43            |                                |                               |                  |                   |      | 1743   |                                |                          | 16.46%   |
| Calcined Kaolin<br>Al <sub>2</sub> O <sub>3</sub> · 2 SiO <sub>2</sub>             | 14.49            | 11.56                          |                               | 0.29             | 0.06              | 0.03 | 26.79  |                                |                          | 25.29%   |
| % of oxide   | 55.48            | 15.69                          | 9.28                          | 4.35             | 5.53              | 9.67 |        |                                |                          | 100%     |



**Figure 4.9:** Esthetic treatment of crackle, created by thermal shock at 900°C.

The esthetic treatment of crackle which is created by thermal shock shown in: figure (4.9) first sample which treated by exiting from kiln at 900°C to room temperature, figure (4.10) second sample which treated by exiting from kiln at 900°C to room temperature for two times with applying two layer of glaze, figure (4.11) third sample which treated by exiting from kiln at 1000°C to room temperature, figure (4.12) fourth sample which treated by exiting from kiln at 1100°C to room temperature, and figure (4.13) fifth sample which not treated by thermal shock, but also it has crackle where the thermal expansion coefficient of this glaze is  $49.45 \times 10^{-7} K^{-1}$ .

An image analysis is done to make a comparison between the shapes and density of net crackle which created by thermal shock in different temperatures

THERMAL SHOCK AS NEW TECHNIQUE TO MAKE  
CRACKING

---



**Figure 4.10:** Esthetic treatment of crackle, created by thermal shock at 900°C.

SCIENTIFIC AND EXPERIMENTAL BASICS FOR TREATMENTS  
DURING FIRING

---



**Figure 4.11:** Esthetic treatment of crackle, created by thermal shock at 1000°C.



**Figure 4.12:** Esthetic treatment of crackle, created by thermal shock at 1100°C.

## THERMAL SHOCK AS NEW TECHNIQUE TO MAKE CRACKING

---



**Figure 4.13:** Esthetic treatment of crackle, created without thermal shock

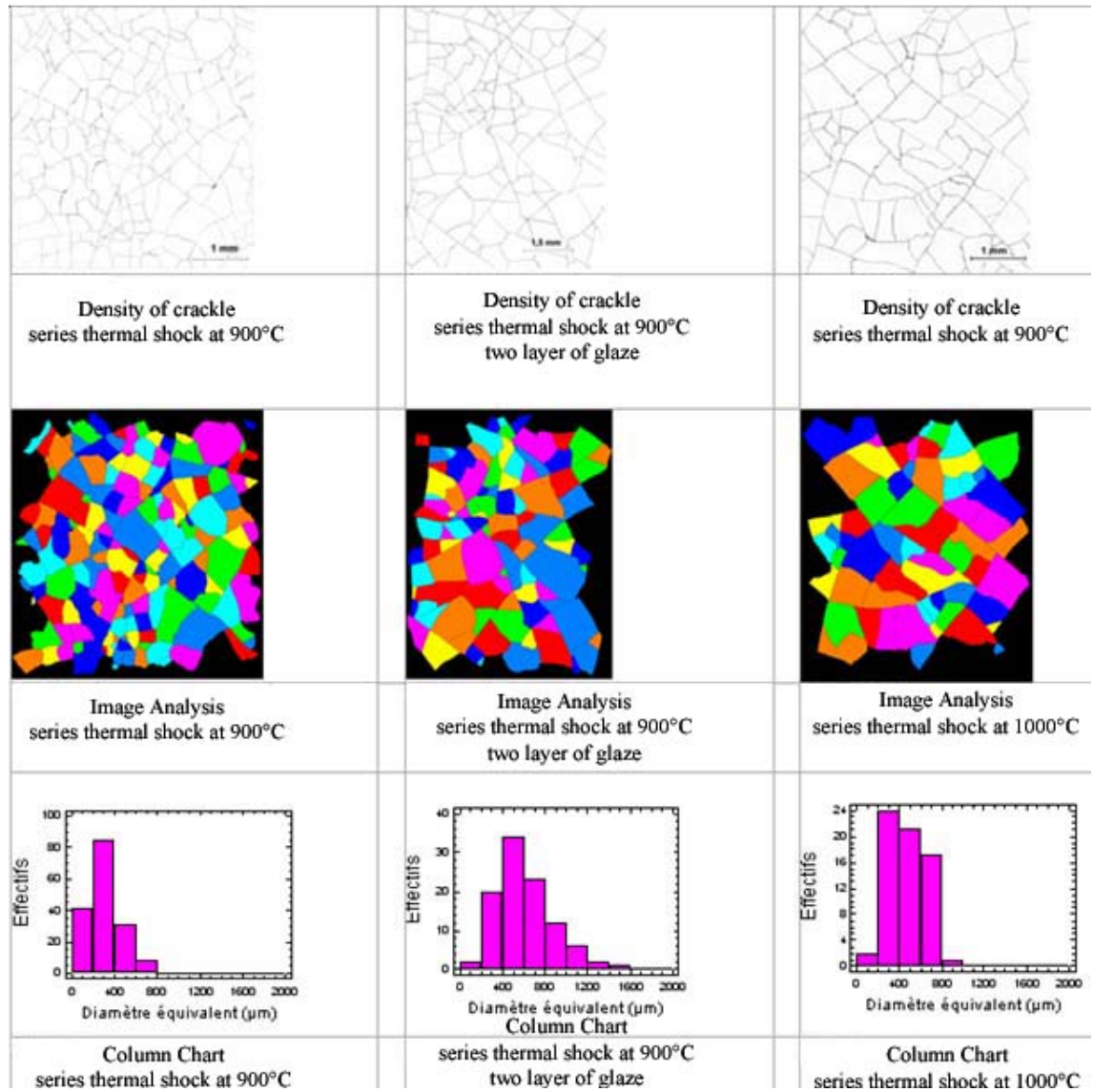
at 900°C, 1000°C and at 1100°C , and which is created by difference in thermal expansion coefficient wether between simulated Ru glaze and porcelain body or between the same glaze which used to thermal shock treatment and porcelain body. The net crackle density, image analysis and column chart to demonstrate the relation between cracks number and equivalent diameter of crack in ( $\mu m$ ) are shown in figure (4.14). The samples presented in this figure are a sample treated by thermal shock at 900°C, a sample treated by thermal shock at 900°C two times with applying two layer of glaze and a sample treated by thermal shock at 1000°C, as well as figure (4.15) presented a sample treated by thermal shock at 1100°C, a sample not treated by thermal shock and sample of simulated Ru Guan porcelain

## SCIENTIFIC AND EXPERIMENTAL BASICS FOR TREATMENTS DURING FIRING

---

R47. The image analysis shows that the result of use thermal shock is significant effect in the size and density of cracks on surface of glaze, where the thermal shock at 900°C high density of crackle from all samples and it has the smaller size of equivalent circle diameter. As well as the thermal shock at 1000°C and 1100°C increase the effect of cracks on surface glaze where thermal shock in different temperature leads to different in density and size of cracks. Also, the significant effect of glaze structure and porcelain body properties refer to the important of calculating and design glaze and porcelain structures to improve the esthetic crackle pattern by using the thermal shock during firing which required design a tool like a jet to treat the forms by thermal shock during firing. In addition to the significant effect of thermal shock in the size and density of cracks on surface of glaze, there is other benefit for this technique, where thermal shock creates cracks on surface of glaze when glazes are in soft state, therefore cracks are created on surface layer of glaze which is affected by cooled air but the deeper layers still soft to fill in the cracking net which is an advanced to create crackle feature without continuing the depth of cracking to porcelain body this observation is shown under microscope in figure (4.16).

## THERMAL SHOCK AS NEW TECHNIQUE TO MAKE CRACKING

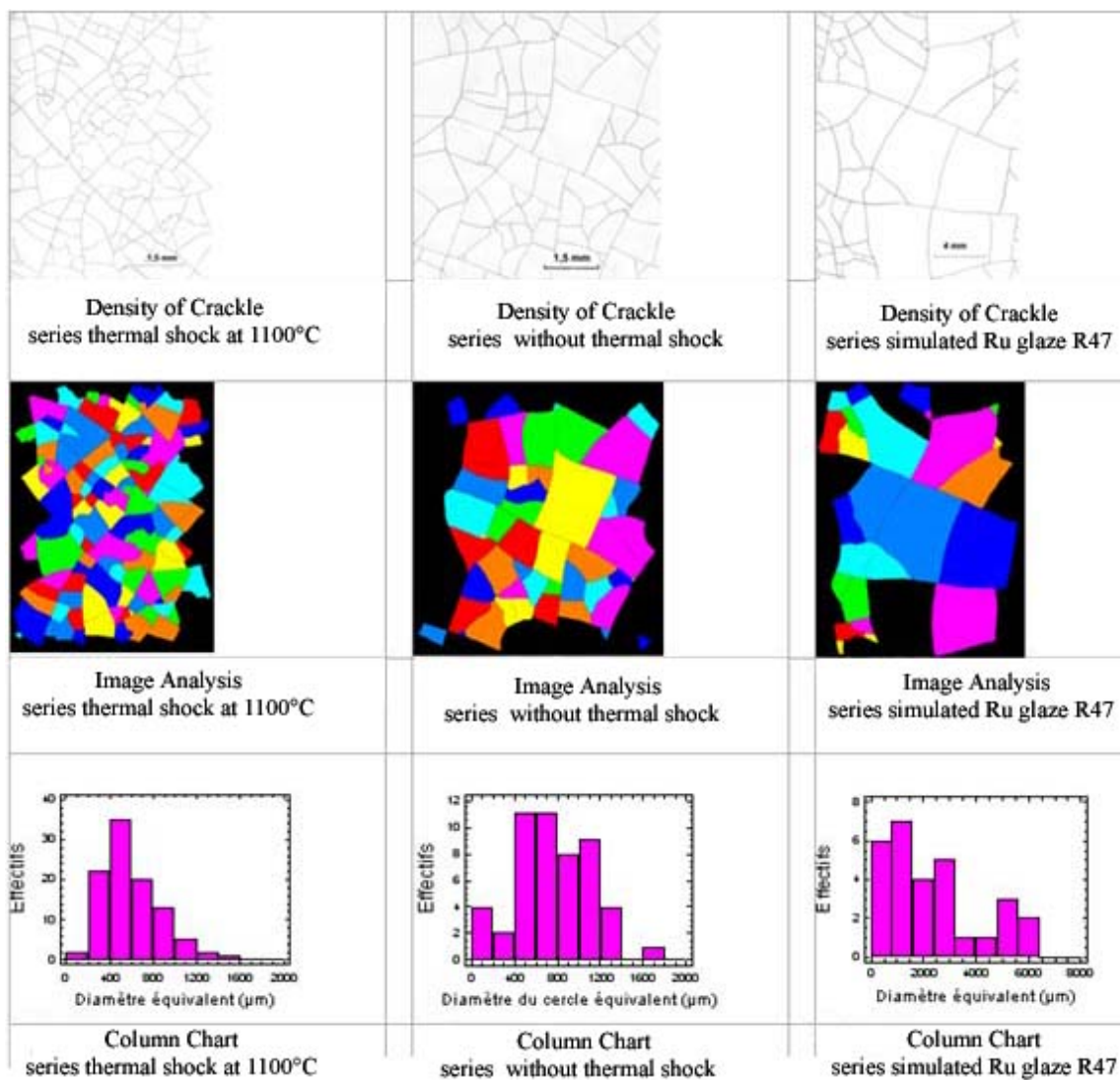


**Figure 4.14:** The net crackle density , image analysis and column chart for samples treated by thermal shock at 900°C ,at 900°C two times with applying two layer of glaze and at 1000°C

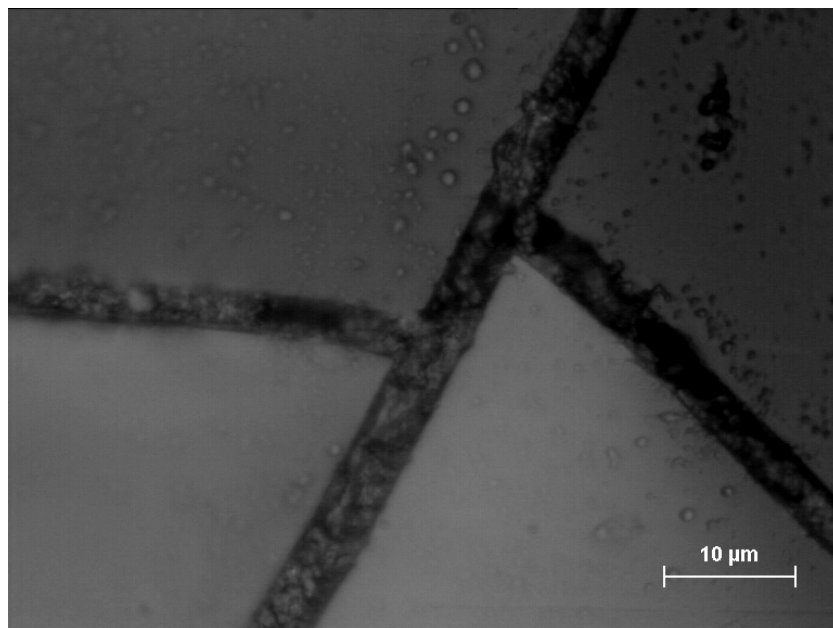


## SCIENTIFIC AND EXPERIMENTAL BASICS FOR TREATMENTS DURING FIRING

---



**Figure 4.15:** The net crackle density , image analysis and column chart for samples treated by thermal shock at 1100°C , sample not treated by thermal shock and sample simulated to R74

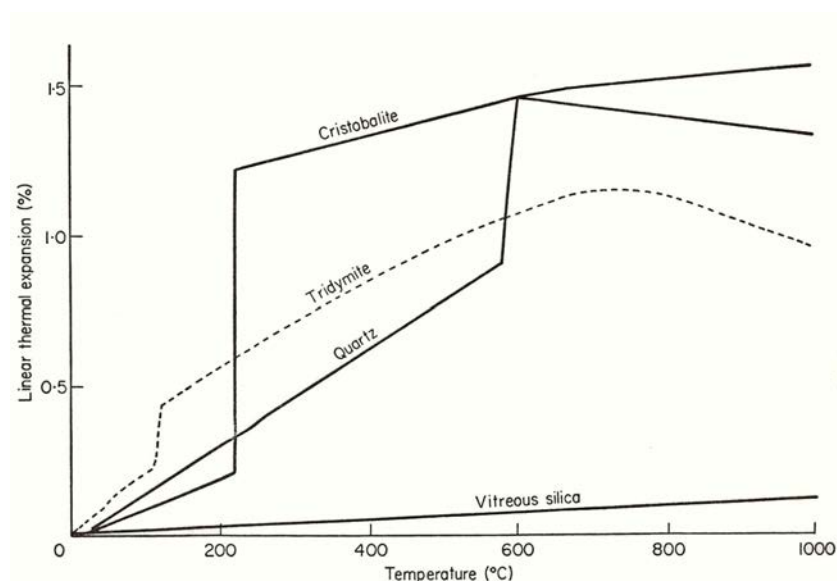


**Figure 4.16:** Typical optical surface morphology of surface crackle glaze is created by thermal at 900°C, shows the filling of the deep of crack

#### 4.4 Crack pattern on ceramics surfaces by modification of kiln structure.

From history of crackling technique and from scientific and experimental study, it became clear that thermal expansion of glaze during firing process, as well as sudden change in temperature, are significant factors in producing crackle treatment on ceramic surface. Therefore the structure of kiln could help in reproduction of that technique and modify it in new design by using new technology. These will be useful to ceramic designer and artists. Especially we can use the variation of linear thermal expansion of the various forms of silica (quartz, cristobalite, tridymite, vitreous silica) [150]. As well as all the forms of silica show high coefficient comparative to vitreous silica which has the lowest linear expansion, about 0.05% between 20 and 1000°C (figure 4.17), and on this account it withstands sudden changes of temperature without shattering [150], but the quartz, cristobalite and tridymite not withstand sudden changes of temperature. Therefore this information permits to use thermal shock for producing esthetic crackle from different density of cracking, or from contrast between cracking and not cracking on surface of once ceramic form. This esthetic depends on design thermal expansion of glaze which is compatible with thermal expansion of porcelain body, and use different forms of silica, vitreous silica who doesn't give cracking and quartz who give cracks. The Seger formula for these recipes is same but the type forme

## CRACK PATTERN ON CERAMICS SURFACES BY MODIFICATION OF KILN STRUCTURE.



**Figure 4.17:** Thermal expansion of the principal forms of silica

of silica is different. So there is two factors is required in production of cracks on glazed surfers, first one is calculating thermal expansion coefficient of glaze by design its chemical composition, second one is design tool to make sudden change in temperature, thermal shock.

The sudden change in temperature during glaze firing inside the kiln is aimed. It can be done by modification of kiln design, for sending cold air inside the kiln from unit filled with compress air, the temperature of which can be cold as 0 °C. That cold air is send to kiln through long tube which is isolated to keep air isolated from room temperature, and it will be in contact with kiln from the ceiling by large jet, as shown in(4.18). This jet is designed to take an especial shape as shown in figure figure(4.19).

SCIENTIFIC AND EXPERIMENTAL BASICS FOR TREATMENTS DURING FIRING

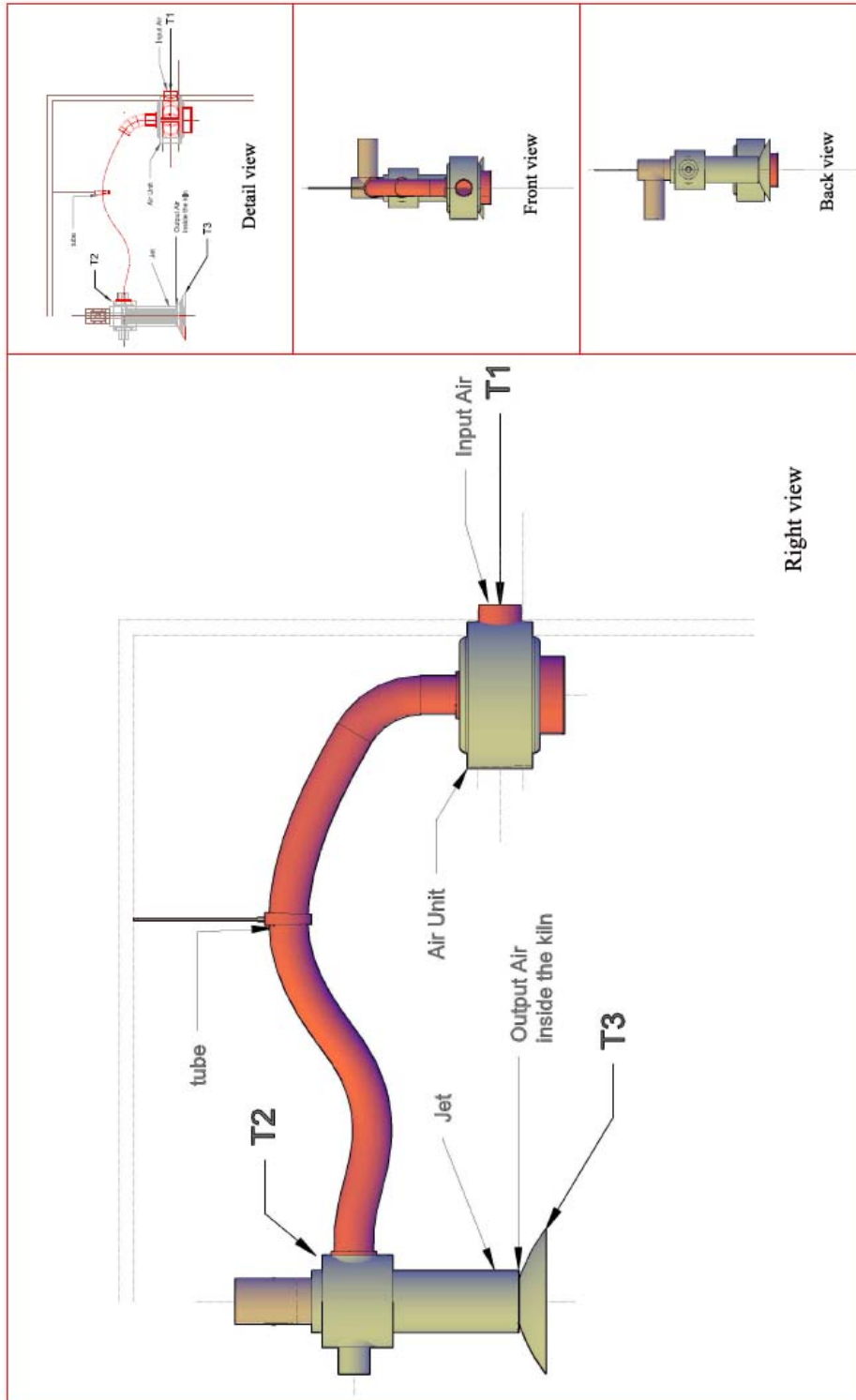


Figure 4.18: Illustration for compressing cold air interior kiln

CRACK PATTERN ON CERAMICS SURFACES BY  
MODIFICATION OF KILN STRUCTURE.

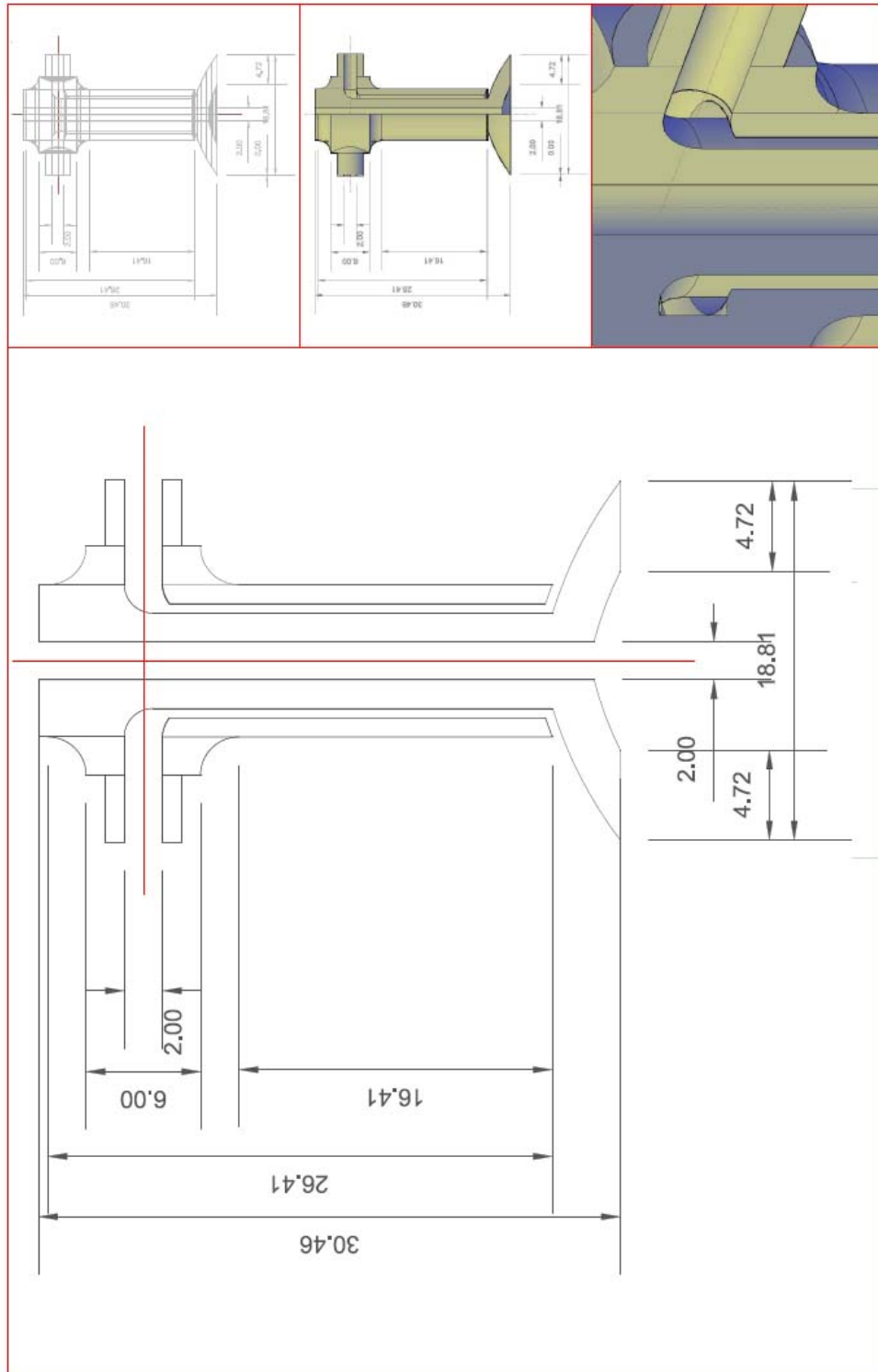


Figure 4.19: The design of jet

## SCIENTIFIC AND EXPERIMENTAL BASICS FOR TREATMENTS DURING FIRING

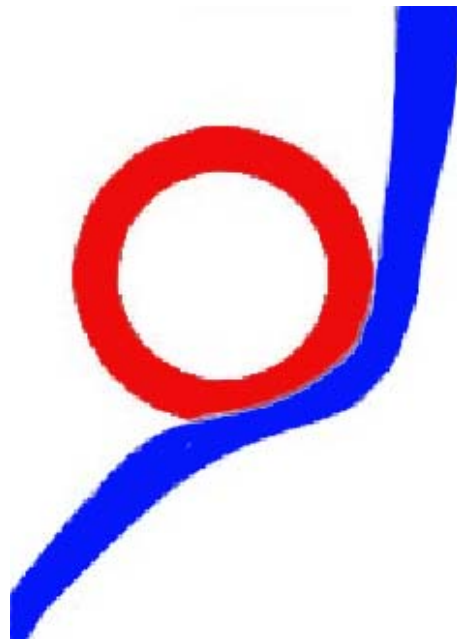
---

Coandă phenomena leads to design the part of jet which is fixed inside the kiln as curved surface to distribute the air. The influx of cold air follows a convex surface of jet, rather than a straight line in its original direction, the figure (4.20) shows a staying of fluid attached to convex surface according to Coandă phenomena[151]. The cold air is injected inside the kiln with particular speed to touch surface of ceramic forms until the temperature of air fluid is still lowest than the temperature of ceramics surface, see figure (4.22).

When injected cold air take its path to go inside the kiln through the tube, its temperature will rise gradually. When it will pass through several hot degrees in the tube, because the heat can be transferred from inside the kiln by convection. The mass of cold air when get out from the jet inside kiln, it is arrived to last point where cold air can be heated by contact with jet part inside the kiln so the air temperature is raised again by radiation and conduction and then it will fluid into atmosphere of kiln with this temperature lower than temperature inside the kiln. Therefore a cold front will be formed, as shown in figure (4.21). The temperature of cold front will make sudden changing in temperature which increases the tensile stress in surface of glaze to give cracks. As well as the mass of cold air which start from compressed unit with temperature  $T_1$ , it will be raised to  $T_2$  at the end of tube, then the temperature will be raised to  $T_3$  when it get out from the jets and the cold front will arrive to touch surface of ceramics with  $T_n$ . The heat

CRACK PATTERN ON CERAMICS SURFACES BY  
MODIFICATION OF KILN STRUCTURE.

---

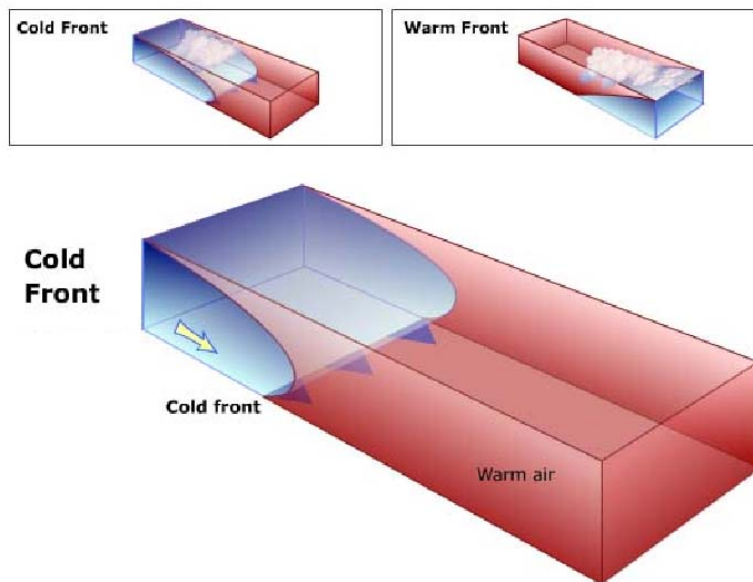


**Figure 4.20:** Illustration of staying of fluid attached to convex surface according to Coandă phenomena



## SCIENTIFIC AND EXPERIMENTAL BASICS FOR TREATMENTS DURING FIRING

---



**Figure 4.21:** Illustration for cold front, the contact between cold mass of air and warm mass of air

## CRACK PATTERN ON CERAMICS SURFACES BY MODIFICATION OF KILN STRUCTURE.

---

conduction is defined by following equation:4.2:

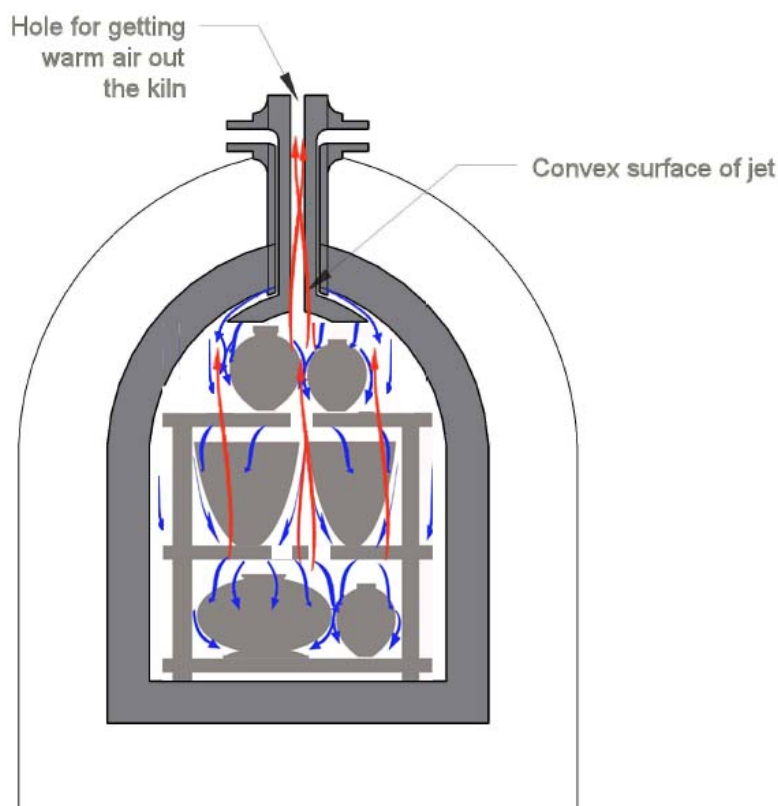
$$\frac{Q}{t} = K \times A \times \frac{\Delta T}{d} \quad (4.2)$$

where Q is heat conduction, t is time, k is a thermal conductivity, A is area,  $\Delta T$  is difference in temperature and d is thickness. Due to the  $K_a$  thermal conductivity of air is 0.025 W/(m.K), while  $K_g$  thermal conductivity of glasses (glaze: ceramics surface) is 1.1 W/(m.K), the temperature of atmosphere inside kiln will be equal to the temperature of ceramics forms, and with injected cold air into kiln in such speed from jet which is designed to affect in thickens and shape of air, the air will arrive to ceramics surfaces with temperature less than their temperature. So the ceramic surface will be effected by cold front more than the mass of cold air in contact with the hot atmosphere of kiln. When the mass of cold air meet a mass of hot air, it will be created a cold front which is shown in figure (4.21). This cold front take the cold air to the bottom of the kiln and warm air will go to the top of the kiln so design of jet has a center tiny hole to let warm air free to get out during cracking treatment. The cold front keeps partly the temperature of mass of cold air less than the ceramic forms surface when it touch them to make stress. This stress creates cracks in glaze layer. The curved surface of jet and curved surface of ceramics forms helps to distribute cold air in atmosphere of kiln, and will touch all forms inside the kiln to get the cracks, as shown in figure (4.22).

This treatment is done when temperature of ceramic forms slow down from

## SCIENTIFIC AND EXPERIMENTAL BASICS FOR TREATMENTS DURING FIRING

---



**Figure 4.22:** Illustration of thermal shock treatment interior kiln

matured temperature to room temperature after that glaze firing is completed. The linear thermal expansion helps to determine when cold air is inserted inside the kiln. Varieties of cracks which is produced by experimental treating will be produced by thermal shock inside kiln. In other words, using quartz, cristobalite or tridymite in glaze structure will give cracks when it was treated by inserting cold air into atmosphere of kiln, for some time, but using vitreous silica in glaze structure will not give cracks in the same firing treatment under the same conditions. So, with design glaze composition and with improved kiln design, esthetic

treatment is obtained as a technique for producing pattern of cracking in part area and not cracking in other part area in same form.

## **4.5 Chemical treatment for producing copper ores as glaze colorant**

This treatment is related to use chemical reactions or their conditions as method to enrich esthetic of glaze by irisation. The reduction atmosphere and temperature are used with iron oxides in Chinese glazes to produce many glaze colors, and they are used also in Iraq to produce many glaze luster and metallic colors. The reaction between carbon gases in atmosphere of kiln and colorant in glaze structure was a common treatment during firing, the effect of this treatment was mentioned in chapter (3) at sections (3.7.1.1) and (3.7.1.2). The influence of this reaction on the esthetic of glaze colors promotes to think about a possibility of improving this technique. Ores of copper have various and esthetic colors which are looked forward to apply in particular glaze. This technique depends on three factors: the first is a glaze structure, the second is an atmosphere which permits to produce ores of copper in glaze as a thin film, and the third is kiln technology which allows to do chemical treatment at time on firing schedule. Duration of this treatment is determined by realization of the balance between the temperature which is required for chemical reaction and the influence of this reaction on glazes

quality and esthetics. The phase diagram of chemical reaction system gives the temperature of reactions and the components necessary and sufficient to create phases of copper ores as nanocrystal colorant in glaze. Ellingham diagram is used to expect the influence of these reactions on glaze and on its chemical ingredients.

### 4.5.1 Sulfide, copper ores

The sulfide iron copper ores ( $\text{Fe}_x\text{Cu}_y\text{S}_z$ ) is an example of these nanocrystal colorant which can be created on surface of glaze by chemical treatment during firing from two reactions, the first is reducing copper oxide and iron oxide to copper ions and iron ions, the second is the reaction between sulfur vapors and copper ions and iron ions. This permits to decorate glaze with very nice colors, where the color of ores which are produced by this technique describe as following:

- Bornite is a copper iron sulfide mineral with chemical formula  $\text{Cu}_5\text{FeS}_4$ . It has a brown to copper-red color on fresh surfaces that tarnishes to various iridescent shades of blue to purple in places. Its striking iridescence gives it the nickname peacock copper or peacock ore [152].
- Chalcopyrite is a copper iron sulfide mineral. It has the chemical formula  $\text{CuFeS}_2$ . It has a brassy to golden yellow color.
- Covellite or covelline is copper sulfide mineral with the formula  $\text{CuS}$ . It has indigo blue color.

## CHEMICAL TREATMENT FOR PRODUCING COPPER ORES AS GLAZE COLORANT

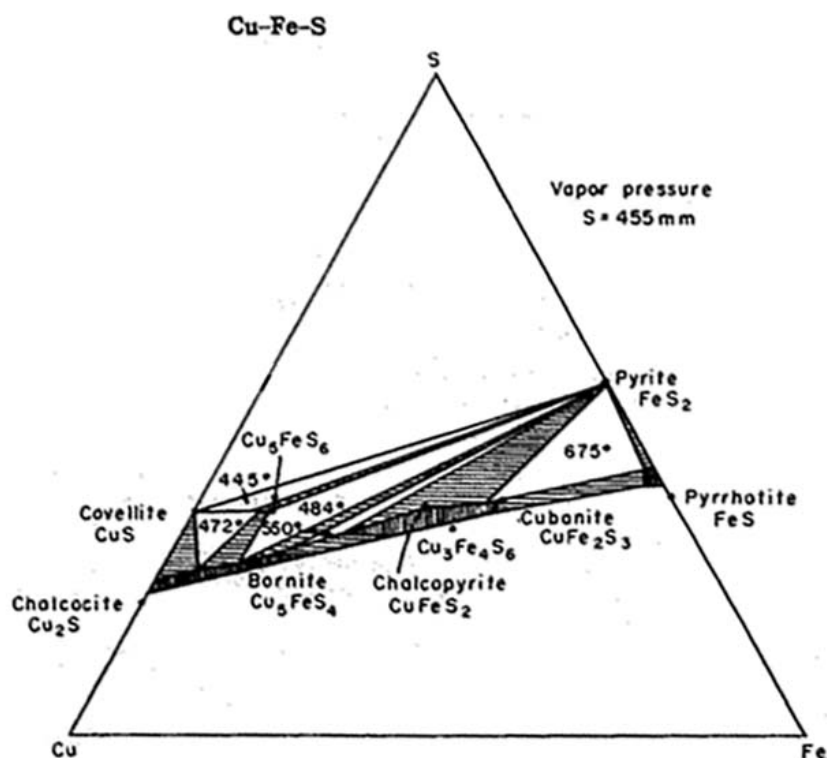
---

- Pyrite, or iron pyrite, is an iron sulfide with the formula  $\text{FeS}_2$ . It has metallic luster and not bright brass-yellow hue, so it earned the nickname fool's gold because of its look like gold.
- Cubanite is a yellow mineral of copper, iron, and sulfur, with chemical formula  $\text{CuFe}_2\text{S}_3$ .
- Chalcocite is a copper(I) sulfide  $\text{Cu}_2\text{S}$ , is opaque, being colored dark-gray to black with a metallic luster.

### 4.5.2 Phase diagram of copper-iron-sulfur system

For producing nice colors of copper iron sulfur ores which are described above, The phase diagram of copper-iron-sulfur system demonstrates the ratios between elements of Cu, Fe and S which is necessary and sufficient to produce each phase of this ores. Also, a particular temperature which is necessary to form each phase is mentioned in same phase diagram, as shown in figure(4.23). The bornite  $\text{Cu}_5\text{FeS}_4$  which has peacock color, is merged from right Cu:Fe:S ratio (5 : 1 : 4) as it is confirmed from chemical formula at  $700^\circ\text{C}$  under constant sulfur vapor pressure of 455 mm Hg (60661.51 Pa). Under the same constant of sulfur vapor pressure with variation in Cu:Fe:S and at different temperature other forms of copper iron sulfur ores will be merged. Chalcopyrite merges with respect to that the Cu:Fe:S ratio is (1:1:2), and it forms at  $557^\circ\text{C}$ . Cubanite merges with right Cu : Fe : S

## SCIENTIFIC AND EXPERIMENTAL BASICS FOR TREATMENTS DURING FIRING



**Figure 4.23:** Cu–Fe–S system under constant sulfur vapor pressure of 455 mm Hg (60661.51 Pa)[20].

ratio (1 : 2 : 3) at 675°C [20, 153, 154]. The Cu-S system demonstrates that Chalcocite  $\text{Cu}_2\text{S}$  is formed at 1130 °C when Cu/S ratio is 2, see figure (4.24). The Covellite is formed at 507 °C when Cu/S ratio is 1. The Fe-S system refers to the temperature and ratio of iron Fe to sulfur S for forming Pyrite  $\text{FeS}_2$  which look like gold at 743 °C with Fe/S ratio equal to 0.5, and pyrrhatite  $\text{FeS}$  is formed at 988 °C with Fe/S ratio equal to 1, as phase diagram Fe-S system shows in figure(4.25)[20, 153, 154]. The pyrrhatite color is similar to pyrite. So the

## CHEMICAL TREATMENT FOR PRODUCING COPPER ORES AS GLAZE COLORANT

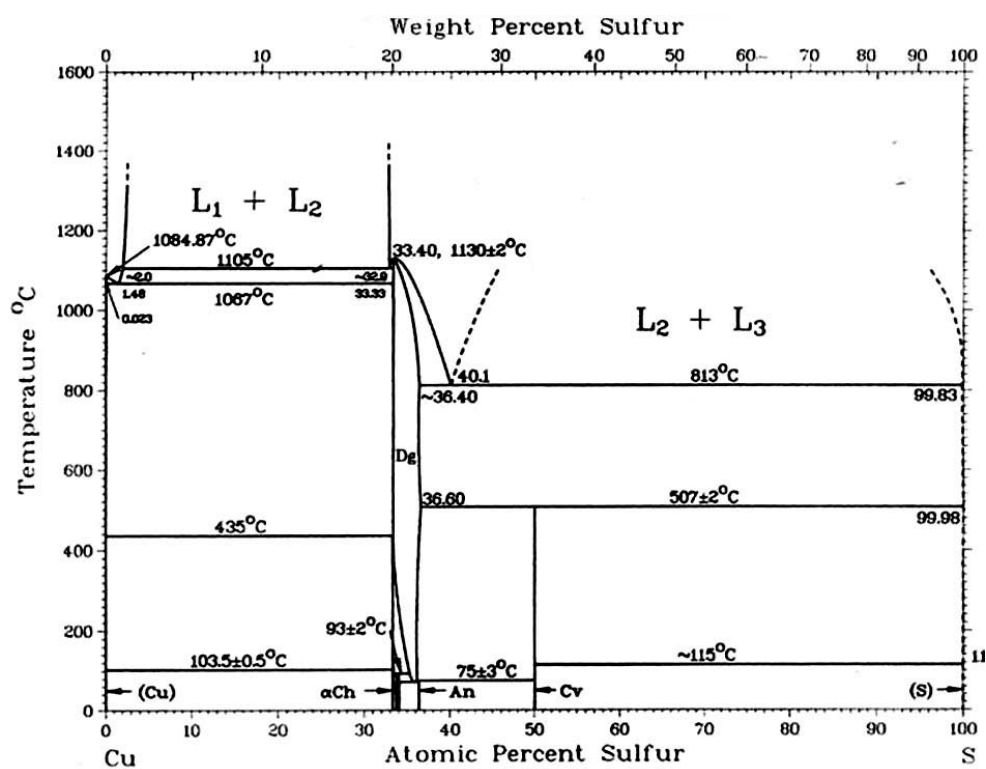


Figure 4.24: System Cu-S [20].



SCIENTIFIC AND EXPERIMENTAL BASICS FOR TREATMENTS DURING FIRING

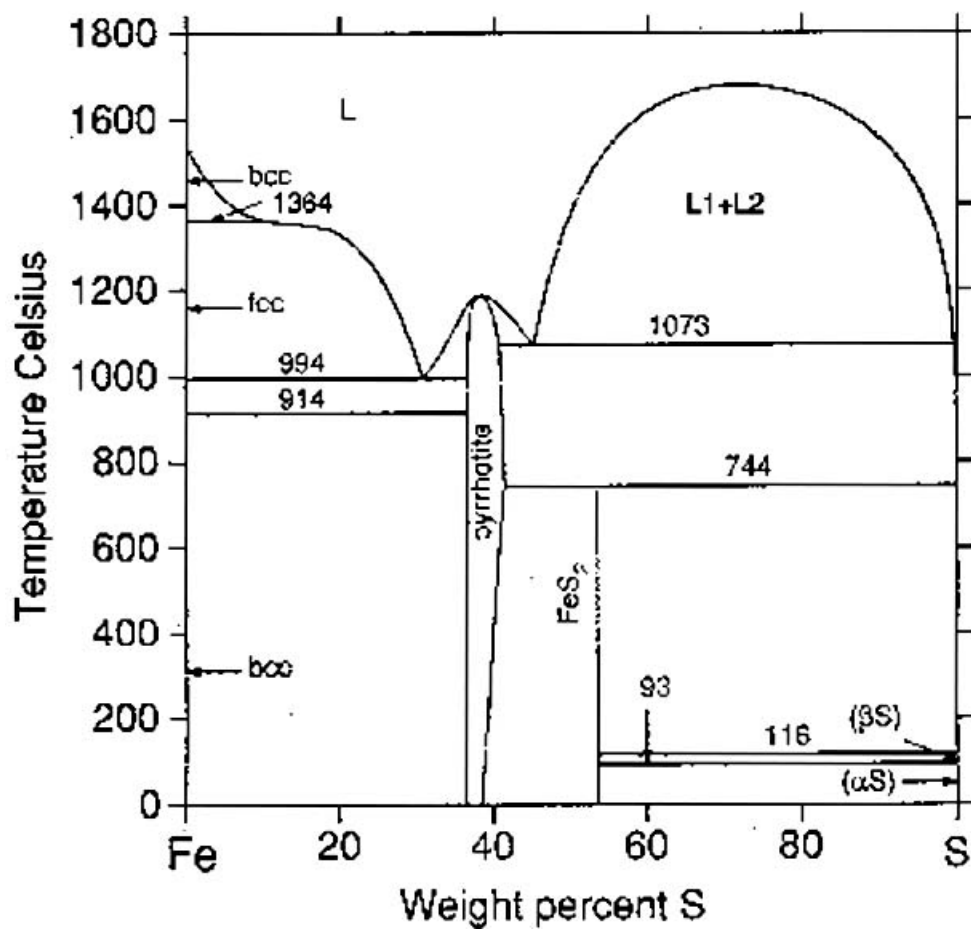


Figure 4.25: System Fe-S[20].

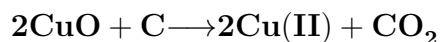
## CHEMICAL TREATMENT FOR PRODUCING COPPER ORES AS GLAZE COLORANT

---

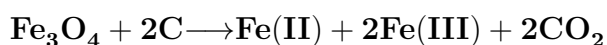
phase diagrams of Cu-S, Fe-S and Cu-Fe-S refers to that the merged phase of copper iron sulfur ore is based on contents of iron copper and sulfur, and based on which temperature and pressure the vapor of sulfur react with copper and iron ions. Therefore these parameter which are related to be treatments during firing to create different nice colors included gold color, metallic reflection colors and peacock color.

Copper and iron ions were used as colorant in glaze of two historical ceramics types which are studied historically and scientifically in this thesis. There techniques based on reaction atmosphere during firing for transferring oxides phases of iron and copper to ions or metallic state.

The states of iron and copper are determined according to the degree of reduction. This is the first treatment which can be followed by another treatment which is sulfur vapor to form copper iron sulfur ores. Nanocrystals of these ores are colorant for glaze. The  $\text{Cu}^{2+}$  ions was obtained in a glass network by reduction treatment.



The  $\text{Fe}^{2+}$  and  $\text{Fe}^{3+}$  ions were obtained in a glass network by reduction treatment.

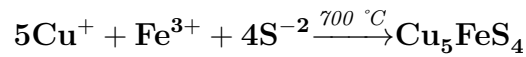


Therefore the  $\text{Cu}^{2+}$ ,  $\text{Fe}^{2+}$  and  $\text{Fe}^{3+}$  can be obtained in frits treatment, redaction

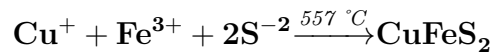
## SCIENTIFIC AND EXPERIMENTAL BASICS FOR TREATMENTS DURING FIRING

---

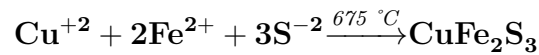
atmosphere. In second treatment, sulfur vapor, nanocrystal of bornite  $\text{Cu}_5\text{FeS}_4$ , can be obtained as shown in following equation:



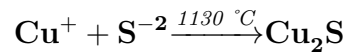
Chalcopyrite  $\text{CuFeS}_2$  can be merged as nanocrystals in glaze network according to following equation:



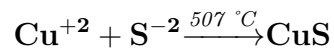
Cubanite  $\text{CuFe}_2\text{S}_3$  reaction shown in following equation:



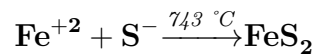
Chalcocite  $\text{Cu}_2\text{S}$  reaction shown in following equation:



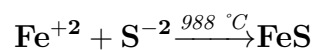
Covellite  $\text{CuS}$  reaction shown in following equation:



Pyrite  $\text{FeS}_2$  reaction shown in following equation:



pyrrhatite  $\text{FeS}$  reaction shown in following equation:



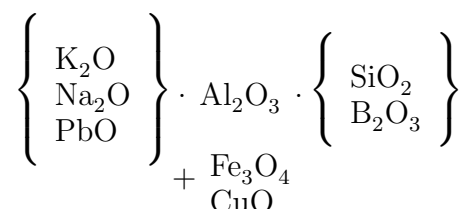
### 4.5.3 Design glaze formula for chemical treatment by sulfur vapor

Copper iron sulfur ores have to be nanocrystals colorants to give to glazes there colors. These nanocrystals have to impeded inside the glaze layers, and this required that glaze should be in soft state when nanocrystals are formed. The exchange ion mechanism between alkaline ions leads coloring crystals to diffuse inside the glaze. Therefore the contents of alkali oxides in glaze is factor which influences in treatment results. In addition to refractive index of glaze which can be calculated from composition chemical oxides of glaze. The lead oxide PbO and B<sub>2</sub>O<sub>3</sub> have important role in value of refractive index of glaze, see section(3.7.1.1). Therefore formula of glaze is limited by calculating the temperature of heat treatment of glaze, permitting colorant to diffuse and impeded in side glaze. Temperature of heat treatment is calculated by flux factor and temperature of heat treatment equations (3.3 and 3.4). This makes relation between the temperature viscosity of glaze, heat treatment of glaze and the temperature of forming copper iron sulfur ores. The additive of lead oxide can be calculated from equation(3.7), and the additive of boron trioxide B<sub>2</sub>O<sub>3</sub> can be calculated according to its effect in thermal expansion coefficient (TEC) of glaze, due to the relation between its percentage in glaze and (TEC) of glaze. Containment of Na<sup>+</sup> and K<sup>+</sup> in glaze is determined by that they are considered the driving force responsible for diffusion

## SCIENTIFIC AND EXPERIMENTAL BASICS FOR TREATMENTS DURING FIRING

---

of silver and copper ions into glaze layer diffusion. Therefore this treatment, as method to produce esthetic metallic colors on glaze surfaces, required that Seger formula glaze contains  $\text{Na}_2\text{O}$ ,  $\text{K}_2\text{O}$  and  $\text{PbO}$  as glass network modifier,  $\text{Al}_2\text{O}_3$  as intermediate former and  $\text{SiO}_2$  and  $\text{B}_2\text{O}_3$  as glass network former. So the basic Seger formula of this glaze as flowing:



It is likely to some modifiers added to formula according to calculate all of flux factor (F) , TEC, refractive index, additive of lead oxide and elasticity of glaze. Also, these calculations determine the limit formulas.

### 4.5.4 Thermodynamic driving force for chemical reaction in these treatments

In this chemical treatment, copper iron sulfur ores are intended as crystal colorants which merge from chemicals reaction between the  $\text{Fe}^{+2,+3}$  and  $\text{Cu}^{+,+2}$  ions in glaze structure and  $\text{S}^{-2}$  ions from atmosphere of kiln. This treatment can be considered as chemical shock to glaze oxides, especially these chemical reaction are in driving seat to react with  $\text{Fe}_2\text{O}_3$  and  $\text{CuO}$  instead of others chemical ingredients of glaze. The Ellingham Diagram represent the thermodynamic driving

## CHEMICAL TREATMENT FOR PRODUCING COPPER ORES AS GLAZE COLORANT

---

force for a particular reaction to occur related to such temperature and pressure, and it relied on the change in free energy  $\Delta G$  as an indicator to chemical reactions. The free energy can be presented in following equation:

$$G = G_{\circ} + RT \ln \left( \frac{p}{p^{\circ}} \right) \quad (4.3)$$

where  $G$  is free enthalpy,  $R$  is ideal gas constant,  $G_{\circ}$  is defined to be the standard free enthalpy at the standard pressure,  $p^{\circ}$ . The difference in free enthalpy between the products of the chemical reaction and the reactants is the free enthalpy change,  $\Delta G$ . There will be a driving force for the reaction to occur if the free enthalpy of the products is less than the free enthalpy of the reactants. The free enthalpy change can be calculated in standard states by following equation:

$$\Delta G = \Delta G_{\circ} + RT \ln \left( \frac{p_{product}}{p_{reactant^A} p_{reactant^B}} \right) \quad (4.4)$$

where the  $p_{product}$  is a product pressure,  $p_{reactant^A}$  is a reactant A pressure and  $p_{reactant^B}$  is a reactant B pressure. The negative value of free enthalpy change  $\Delta G$  means that reaction will occur and the reaction will continue if  $\Delta G$  remains negative until a point of equilibrium, the free enthalpy change  $\Delta G$  for the reaction is equal to zero. Therefore the  $\Delta G_{\circ}$  can be calculated by following equation:

$$\Delta G_{\circ} = -RT \ln \left( \frac{p_{product}}{p_{reactant^A} p_{reactant^B}} \right) = -RT \ln K_p \quad (4.5)$$

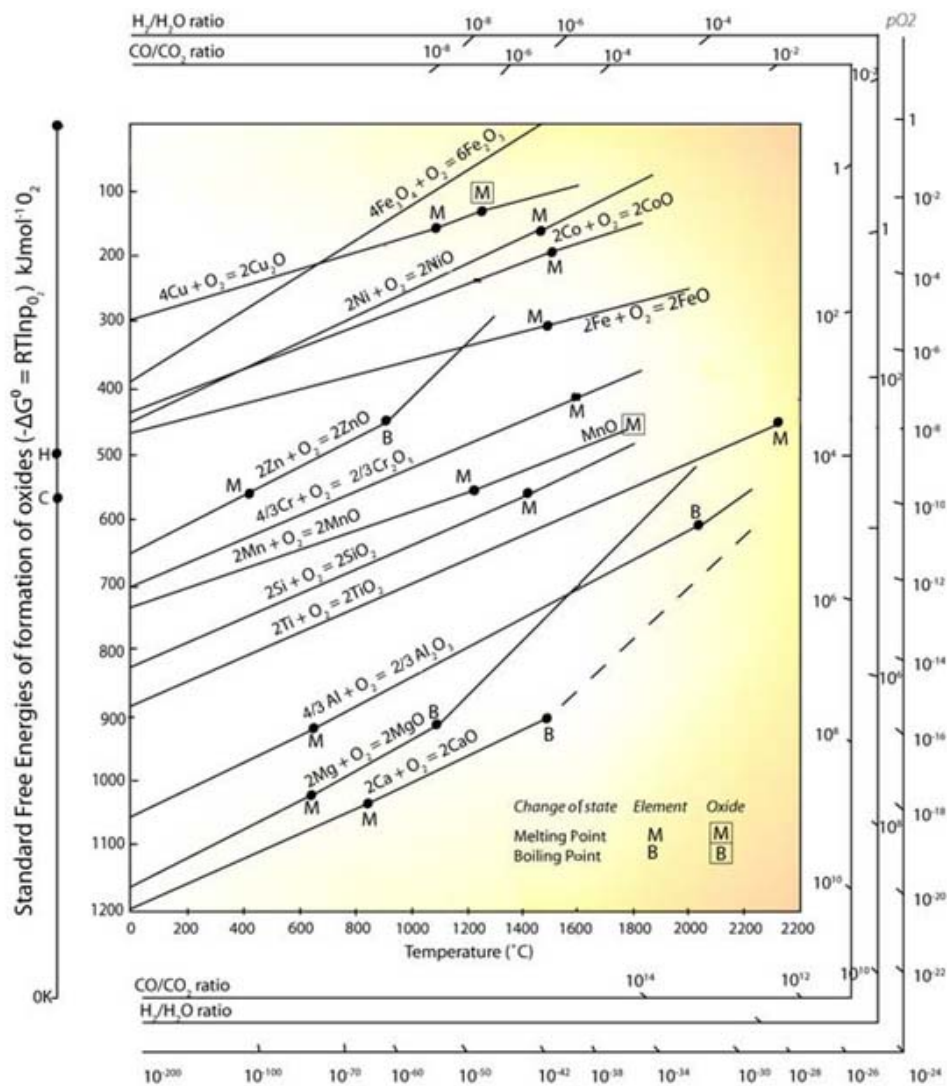
where  $K_p$  is the equilibrium constant for the reaction at constant pressure. The standard free enthalpy change,  $\Delta G_{\circ}$  refers to a link between the thermodynamics

## SCIENTIFIC AND EXPERIMENTAL BASICS FOR TREATMENTS DURING FIRING

---

of a reaction and its chemistry. The Ellingham Diagram present the relation between the  $\Delta G_o$  which indicate to driving force for reactions, and temperature for oxidation and sulphidation reactions for a series of metals as shown in figure(4.26). This diagram demonstrate the value of  $\Delta G_o$  for chemical reactions between series of metals and oxygen or sulfur as function of temperature in particular pressure. This value mentioned to driving force for a oxidation and sulphidation reactions to occur when  $\Delta G_o$  value is negative and the priority of reaction can be inferred by the comparison between the value of  $\Delta G_o$  for each reaction as shown in graph of Ellingham Diagram. The reactions which are represented in inferior position in diagram has a priority to occur before reactions which are represented in superior position in diagram [30]. So this diagram permits to compare between relative stabilities of different ingredient glazes oxides when they are heated in carbon or sulfur atmosphere. The  $\Delta G_o$  value of reaction between carbon and oxygen to produce  $CO_2$  in such temperature is record point in such temperature and record line as a function of temperature. This line divides the diagram to two parts of reactions the reaction in top parts is lower than low part in driving force to react with oxygen. Therefore carbon is show more driving force to react with free oxygen in atmosphere of kiln and then to react with atomic oxygen from element oxides. This means that the glaze oxides which are influenced by carbon treatment are oxides of elements of which reaction with carbon is represented by line above the line of reaction between carbon and oxygen in Ellingham Diagram.

## CHEMICAL TREATMENT FOR PRODUCING COPPER ORES AS GLAZE COLORANT



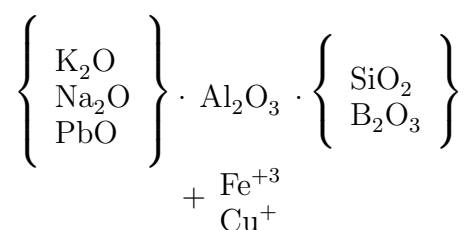
**Figure 4.26:** Ellingham diagram for the free energy change of formation of metallic oxides [30].



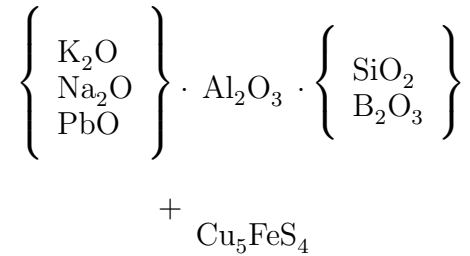
## SCIENTIFIC AND EXPERIMENTAL BASICS FOR TREATMENTS DURING FIRING

---

This also is used to defined wide range of reactions. This comparison for carbon treatment can be demonstrated from figure (A.1) where the free enthalpy change values  $\Delta G$  of iron oxides forms are started to be upper the values of carbon oxides after 999 K in standard state. Therefore the reduction for iron oxide is above 999 K temperature. As well as figure (A.2) shows the wide range of reduction of copper oxides by carbon. the colorant oxides,  $\text{Fe}_2\text{O}_3$  and  $\text{CuO}$ , are affected by the carbon reaction. The influence of carbon reaction can be inferred also by the Ellingham Diagram, where the free enthalpy change values  $\Delta G$  of potassium oxides and sodium oxides forms are under the values of carbon oxides that not include  $\text{Na}_2\text{O}$ , where the the form  $\text{Na}_2\text{O}$  is affected be carbon above 1400 K as shown in figure (A.4). The  $\text{SiO}_2$  and  $\text{B}_2\text{O}_3$  is not affected by carbon redaction as shown in figure(A.5). Therefore the Seger formula of glaze after carbon redaction treatment or hydrogen will be changed to the following formula:



Due to the priority of sulphidation is to react with Fe and Cu , this glaze formula is ready to treat by sulphidation reactions for producing copper iron sulfur ores as colorant, and kind of ore gives its color to glaze and the formula after firing will be as following for peacock color:



The possibility of improving treatments during firing can be achieved by preparation to the glaze composition and by the possibility of expecting the effect of such designed treatment during or post firing. The method which is used to produce copper iron sulfur ores can be used to proper another ores or to defined such reactions which lead to especial esthetic treatment on glaze surfaces.

## 4.6 Conclusion

Using atmosphere of kiln and conditions of firing as treatments to affect in glazes colors and textures were established from determining the factors which effect on crackle and which effect in reflecting metallic colors. The liner thermal expansion coefficient ( $K^{-1}$ ), the temperature change ( $\Delta T$ ) and thickens of glaze layer are the effective factors in the shape of crackle and its density in surface of glaze. the liner expansion coefficient of glaze and clay body are related to the chemical composition of them. The temperature change is related to conditions of firing process and the thickens of glaze layer is related to apply glaze on body. These three factors combined pelmet to control the net of crackle. Therefore the kiln

## SCIENTIFIC AND EXPERIMENTAL BASICS FOR TREATMENTS DURING FIRING

---

structure can be considered a tool to allow thermal shock, the treatment during firing to produce crackle on surface ceramics. The simulation of Ru kiln glaze and porcelain body confirm that the crackle on Ru Guan ceramics is attributed to the low thermal expansion of porcelain body.

The phase state of colorant in glaze and the nature of glaze are the factors which affect in color of glaze. Chemical reaction between the colorant oxides and the atmosphere of kiln determines this state of colorant. The iron ions in Chinese glazes play important role in determination the color and the hue of color, where the ratio between  $Fe^{+2}$  and  $Fe^{+3}$  which related to oxygen probe atmosphere of kiln reading. as well as the the relative concentration of  $Cu/(Cu+Ag)$  and  $Ag/(Cu+Ag)$  ratio determine the luster color and the metallic state of  $Cu^{\circ}$  and  $Ag^{\circ}$  led to diffusion light with the especial esthetic treatment. The chemical reaction for colorants is related to chemical treatment which is related to kiln design and technology. Design glazes as an input of thermodynamic reaction depends on chemical formula which can be converted to weight fraction and to raw materials. This is one of practical application for the science in ceramic art. This also was used in this thesis to simulate ancient ceramics and for design glazes which is the most appropriate for thermal shock treatment, reduction atmosphere treatment as historical treatment, and sulphidation atmosphere treatment as a development for treatments which are made during firing process. The calculations necessary for limit formula and ratios between glass former, intermediate former and

## CONCLUSION

---

modifier former or between RO and  $R_2O$  permeated to relate between esthetic treatment of glaze and its chemicals components. This relation leads to define the conditions that can be affect in chemical and physical proprieties which are closely related to esthetic of glazes and their colors. Also, the process of determination, which oxides of glaze components are stable and which one is effected during the treatment, was based on the free energy change of chemical reaction as function of temperature for each oxide. Therefore the relation between science, technology and art is demonstrated in this technique of doing treatment during firing. As well as, the history of technologies helps in limiting scientific study to glaze and/or porcelain body of Ru kiln and metallic reflection.

Therefore the kiln which permits to this treatments - thermal shock , redaction atmosphere or sulphidation atmosphere- is required to do this treatments.



## Chapter 5

# Design kiln for thermal shock and chemical treatments

**T**HIS chapter aims illustrating the functional analysis and designing conception of new kiln which is attempted to apply the historical treatments during firing and its devolvments. In general rather than in particular, the architecture of an intermittent kiln reformulated in case of additive one of either functions for producing crackle and metallic reflation color on surface of glazed ceramics. Within the framework of functional, the results of historical and experimental studies are represented in part of requirements, expected services, and solutions. The APTE\* method is used to explain the plan of new kiln. Mathematical study

---

\*APTE is application des techniques d'entreprises, a method of functional analysis and value analysis for the project management of innovation and optimization.

## DESIGN KILN FOR THERMAL SHOCK AND CHEMICAL TREATMENTS

---

is used to estimate energy which is required for operating the kiln, and choice refractory materials for building kiln. A finite element programme( ANSYS) is used to evaluate the deformation in kiln structure .

### 5.1 Introduction

The last main step in the manufacture of ceramic forms is the firing process that gives them solidity. In this step, the ceramic forms are treated by heat to obtain the temperatures between 900°C, in case of earthenware, and 1300°C in case of stoneware and porcelain, according to the results of historical and experimental studies, this process is necessary for enriching glaze esthetics treatments. During firing, the ceramics forms are treated by some of the chemical and physical changes, which clearly influence in their aesthetic. Therefore, the aims of the firing process is not only for providing forms to sufficient solidity, but also it is used to give them an aesthetic property.

Brongniart [56] hinted to this when he said

*”Le but essentiel de la cuisson de poteries est leur donner assez de solidité pour qu’on puisse les manier sans les briser et assez de densité pour les rendre plus ou moins imperméables aux liquides. On s’est proposé ensuite de leur donner plus d’éclat, d’aviver certaines, et on a été jusqu’à vouloir donner a la pâte une translucidité flatteuse.”*

During the evolution of ceramic kilns, their atmosphere was exchanged from reducing to oxidizing atmosphere, due to chemical reactions between the glaze and vapor and gases in atmosphere during heat treatment, where some techniques of decorative glaze produced as are depended on change atmosphere of kiln to impact on color and texture of ceramics surfaces, refer to (1.7, and 2.3) section.

These techniques did not continued in history of ceramics, due to difficulties of firing technologies in modern kiln. Despite these difficulties some potters try to emulate these techniques for producing traditional ceramics or using their esthetics treatment, they are still, far from apply them in industry of ceramic. To use these techniques without contamination of the environment, our goal design and produce kiln providing such treatment during or after firing.

From historical study and scientific study, we find that the aesthetic of glazed ceramic forms can be enriched by texture and color treatments which are produced by changes in condition of firing process. There are two changes which are taken in account to design new kiln. First a slow down in temperatures inside the kiln during cooling period of glaze firing, accordingly, an area of crackle will be created to use as decoration on glazed ceramics forms. Second one is chemical treatment which is applied by changing atmosphere of kiln in one firing process from normal condition to reduction or/and sulphidation conduction, so that, the chemical reactions will exist in glaze structure to change the state of colorants ions to give glaze a metallic sheen color.



## DESIGN KILN FOR THERMAL SHOCK AND CHEMICAL TREATMENTS

---

The traditional techniques are developed in new application to glaze structure and treatments during firing, where metallic reflation of the copper plus iron ions which are used in two historical techniques, are prepared in one batch recipe of glaze to treat by carbon, vapor of H<sub>2</sub>O and sulfur. This treatments lead to create nice different colore of iron and copper sulfur ores. Therefore, the especial kiln which allow these treatments in applicable procedures. Therefore determination of requirements, which are necessary in ceramic kiln who can be used as a tool for enriching esthetic treatments of glazed ceramics, are presented as following:

1. Ability to achieve 1300°C or less for firing many types of ceramics from terracotta to pericline.
2. The architecture of this kiln should has the following procedures:
  - (a) Keep the condition of firing process in state of neutral atmosphere during heating process from 20 to 1300°C which is the temperature of glaze maturing.
  - (b) Change the condition of firing process from natural to reduction atmosphere during cooling process from 1300 to 20°C.
  - (c) Allow to insert a few materials inside the kiln which change its atmosphere at appropriate temperature.
  - (d) Allow to inject cold air inside the kiln for treating glazed forms by thermal shock.

- (e) Distribute gases and smoke which interact with ceramics surfaces inside the kiln.
  - (f) Close the kiln tightly during the firing to prevent gases and smoke from leaking into outside air.
3. Chemical treatment of sulfur oxide and carbon dioxide that come out of kiln.

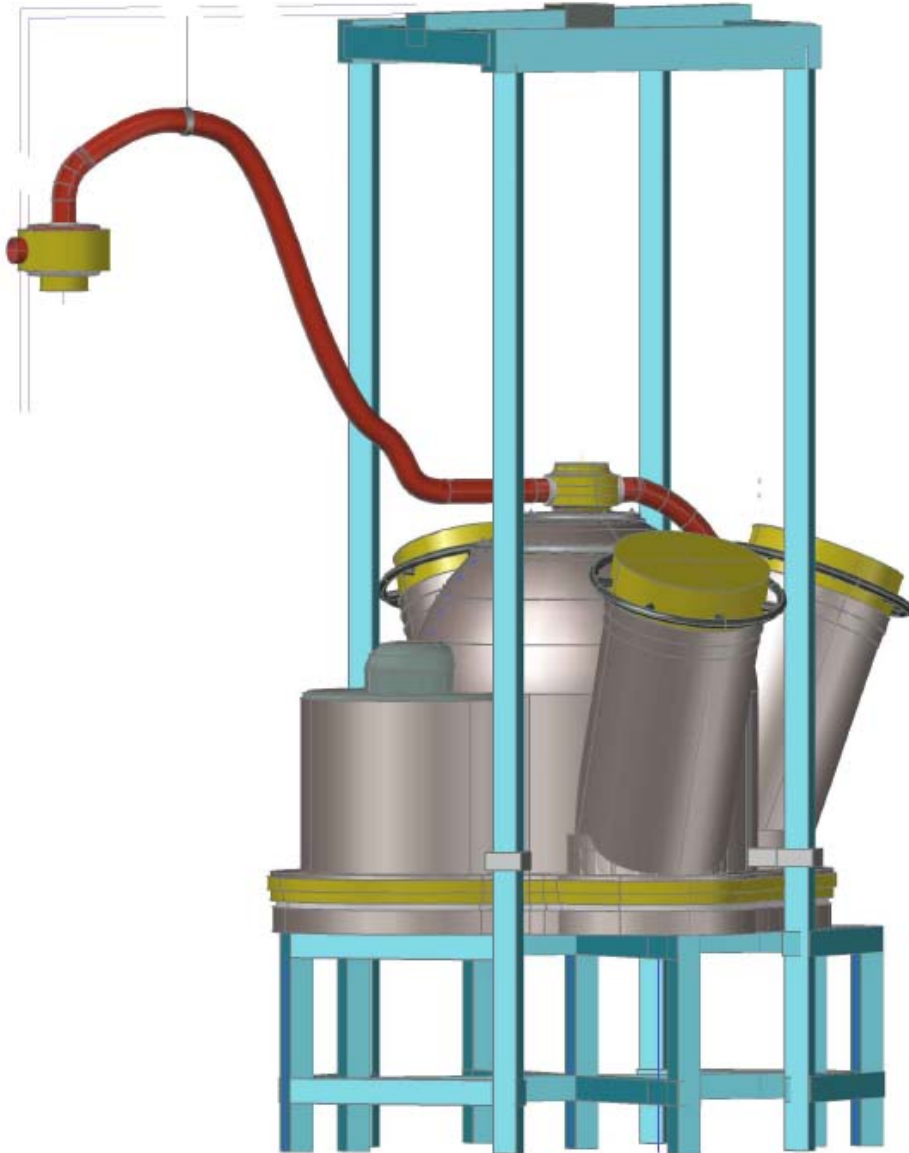
In order to include all this requirements in design of new kiln, the functional analysis and the APTE method are used to explain the system and optimize performances.

## 5.2 presentation of new kiln

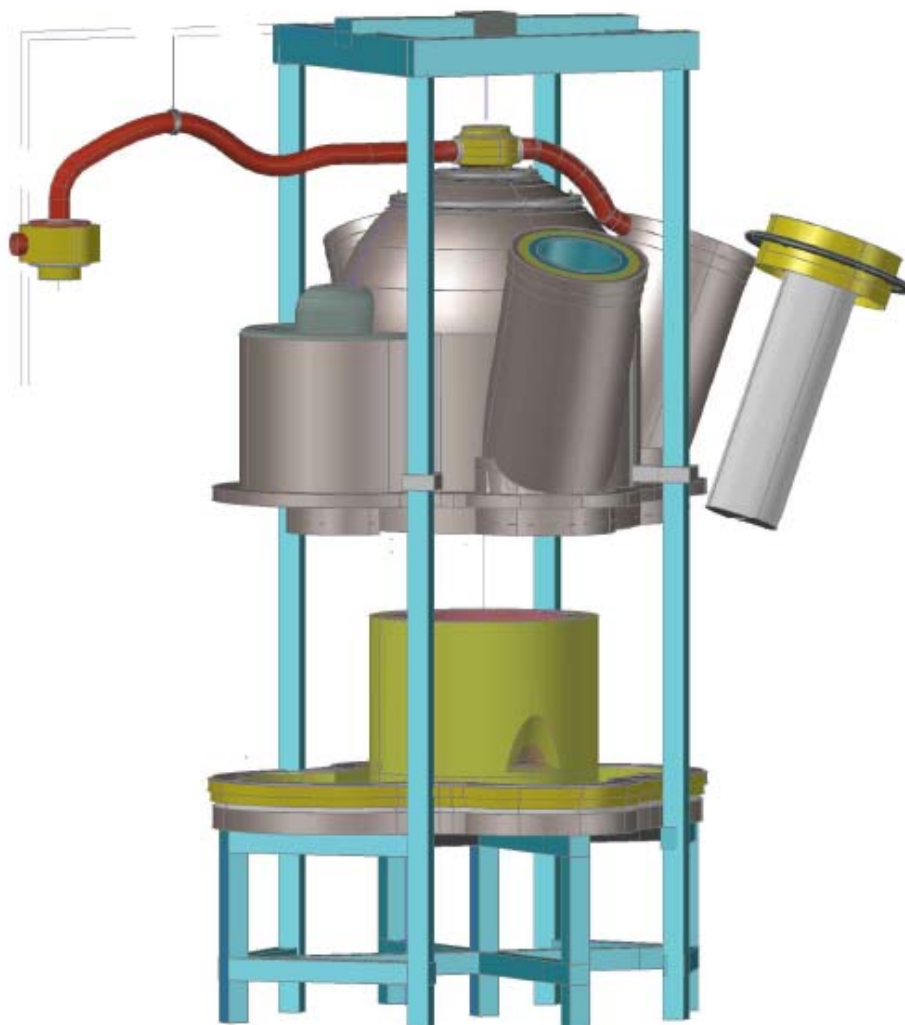
This kiln allows doing chemical treatments and thermal shock treatment during firing. It was designed to resemble an firing condition controller in order to apply metallic reflection colors and crackle on surface of glazes which will be designed as mentioned in section(4.5.3). The user actuates the control conditions of firing according to chemical operations and their results, the Ellingham diagram and phase diagrams of metals guide to determine the accurate time for changing the conditions on firing schedule.

## DESIGN KILN FOR THERMAL SHOCK AND CHEMICAL TREATMENTS

---



**Figure 5.1:** The new kiln for thermal shock and chemical treatments when it is closed



**Figure 5.2:** The new kiln for thermal shock and chemical treatments when it is open

## **5.3 Functional analysis for new kiln**

### **5.3.1 Study boundaries**

A limited study of this kiln consists of firing chamber, the heating element, refractory walls, tools for measuring temperature, tools for changing condition of firing from natural to reduction, unite for treating gases which come out of kiln, and adapt the method of closing the kiln. Kiln is connected to power supply of electricity and control panel.

### **5.3.2 Articulate the requirements**

This kiln allows to treat the glazed ceramics surfaces during firing by some gases and vapors which can interact chemically with some components of glaze, and produces the expected aesthetic appearance. It also allows to treat glazed ceramics surfaces by thermal shock during firing to produce a net of cracks on surface of glaze.

### **5.3.3 Utilization phase of new kiln**

This kiln is used to produce glazed ceramics that can be decorated by metallic reflection, peacock color, indigo blue color, dark-gray to black with a metallic luster and golden yellow colors, or that can be decorated by crackle. Also, it can be used to produce the five grate famous kilns from history of Chinese ceramics,

as well as metallic luster from history of islamic ceramics, refer to (2.3.2.3, 2.3.2.4, 4.5, and 4.4).

### 5.3.4 Octopus diagram of new kiln

This diagram is used to analyze the complex system of new kiln and its environment, where it demonstrate elements of external milieu (*elements du milieu exteroeur-EME*), and their relations with new kiln. In this diagram, the system is organized into the new kiln and external elements which are deal with this kiln.

The various relations between every functions of kiln can be defined into serves function(FS), principle function (FP), or/and constraint function (FC). As shown in figure(5.3), the elements of external environment are glazes, metallic reflection color, crackle, forms, environment, insulation standard, heating standard, control atmosphere, and construction. The principle function:

(FP1) firing biscuit and glaze.

The serves functions:

(FS1) produce glaze which is decorated by metallic luster colors.

(FS2) produce glaze which is decorated by crackle.

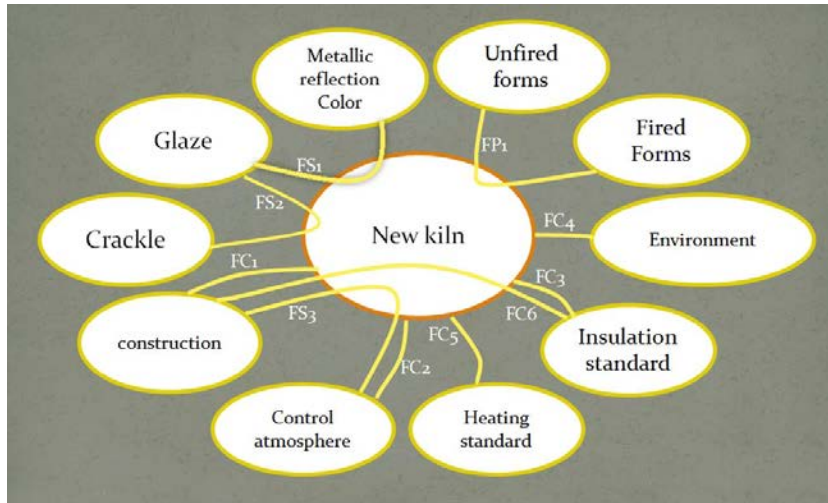
(FS3) change the conditione of firing process.

The constraint function:

(FC1) respect the chemical reactions conditions and physical properties.

## DESIGN KILN FOR THERMAL SHOCK AND CHEMICAL TREATMENTS

---



**Figure 5.3:** Octopus diagram defining the serves function, principal functions and constraints in the environment of new kiln

(FC2) adapt to the environment.

(FC3) design construction of kiln which allows FS1, FS2 and FS3.

(FC4) respect the standards of thermal insulation.

(FC5) respect properties of refractory which are selected for building the contraction of kiln.

(FC6) respect the standards of heating.

According to this diagram, design the kiln is studded to highlight and show production of new kiln.

### 5.3.5 Characterization of elements of external milieu(EME)

Elements of external milieu EME are limited into some qualifications, there criteria, there levels, and/or there flexibilities, as following:

#### 5.3.5.1 Unfired forms

The qualification of unfired forms is volume, maximum width or diameters of cross section of form is 360 mm. The maximum high of form is 530 mm.

#### 5.3.5.2 Fired Forms

The qualification of fired forms is temperature of firing , maximum temperature is 1350°C, and 950°C is acceptable for earthenware.

#### 5.3.5.3 Glaze

The qualification of glaze are Seger formula[127] of glaze and colorant oxides. In Seger formula, components oxides are classified into glass formers or acids  $\text{SiO}_2$ ,  $\text{RO}_2$ , and  $\text{R}_2\text{O}_5$  which are criticized by parties molecular in number 3 molecule minimum 6 molecule maximum, intermediate formers  $\text{Al}_2\text{O}_3$ , and  $\text{R}_2\text{O}_3$  which are criticized by parties molecular in number 0.3 molecule minimum 0.55 molecule maximum and modifier former  $\text{RO}$  and  $\text{R}_2\text{O}$  which are criticized by parties molecular in number, where the sum of all percentages equal 1. The colorant oxides are classified into iron oxides which criticized by parties molecular in number 0.005



## DESIGN KILN FOR THERMAL SHOCK AND CHEMICAL TREATMENTS

---

molecule minimum 0.2 molecule maximum, and copper oxides which criticized by parties molecular in number 0.1 molecule minimum 2 molecule maximum.

### 5.3.5.4 Control atmosphere

The qualifications of atmosphere of firing are classified by carbonic, sulfuric atmosphere and vapor of water. The rosin\* is used as organic materiel for produce carbonic atmosphere where its practical melting point varies from 100 °C to 120 °C. The sulfur is used to produce sulfuric atmosphere, where its practical melting point is 115 °C. Water is used to produce vapor.

### 5.3.5.5 Crackle

The qualifications of crackle are shape and number of crackle on area, where it is criticized by number and length of equivalent diameter on unite of surface.

### 5.3.5.6 Metallic reflections colore

The qualification of metallic reflections is colore which is by  $\lambda$  wavelength in  $\mu\text{m}$ .

---

\*Rosin, colophony or Greek pitch is a solid form of resin obtained from some plants and composed of abietic acid  $\text{C}_{19}\text{H}_{29} \cdot \text{COOH}$ , mostly pines and conifers, produced by heating fresh liquid resin to vaporize the volatile liquid terpene components [155].

### **5.3.5.7 construction**

The qualifications of construction are classified by mass (kg) of construction, and dimensions of construction and distances of its details(mm).

### **5.3.5.8 Others elements of external milieu**

Heating standard , Insulation standard and Environment, the other elements of external milieu, are characterized by international system of units

## **5.3.6 Characterization of functions of serves**

### **5.3.6.1 Permission to fair biscuit and glazed forms (FP1)**

The volume of forms determine the interior dimensions of the kiln. Kiln furniture is used to support wares, it includes kiln shelves, posts, stilts, bead frames. Duration of firing is one of qualifications of this function where the rate of heating is important to make successful firing.

### **5.3.6.2 permission to produce glaze which is decorated by metallic luster colors (FS1).**

The new kiln permit to produce metallic reflection on surface of glaze as well as the color of five grate famous kilns from history. Therefore the qualifications for this function are classified by three treatments. First one is the change atmosphere

## DESIGN KILN FOR THERMAL SHOCK AND CHEMICAL TREATMENTS

---

of kiln to carbon reduction to reduce iron oxides in glaze recipes into  $\text{Fe}^{+2}$  and  $\text{Fe}^{+3}$  ions. The relative intensity of  $\text{Fe}^{+2}/\text{Fe}^{+3}$  is the criterion which determines glaze color after firing. As mentioned in section (3.7.1.1), the level of flexibility and limitation of this relative intensity are from 1.8 to 2.13 for pea green color, from 2.13 to 3.65 for powder green color and from 3.65 to 3.81 for sky green.

Second one is the change atmosphere of kiln to carbon reduction to reduce salts and oxides of copper and silver in glaze recipes into  $\text{Cu}^+$ ,  $\text{Cu}^{+2}$  and  $\text{Ag}^+$  ions. The relative intensity of  $\text{Cu}/\text{Cu}+\text{Ag}$  is the criterion which determines glaze color after firing. As mentioned in section (3.7.1.2), the level of flexibility and limitation of this relative intensity are from 0.064 to 0.37 for metallic luster green color, from 0.69 to 0.82 for metallic luster brown color and from 0.86 to 0.89 for metallic luster ochre yellow color.

Third one is the change atmosphere of kiln to carbon reduction to reduce oxides of copper and iron in glaze recipes into  $\text{Cu}^+$ ,  $\text{Cu}^{+2}$ ,  $\text{Fe}^{2+}$  and  $\text{Fe}^{3+}$  ions, then change atmosphere of kiln to sulphidation to produce sulfide iron copper ores ( $\text{Fe}_x\text{Cu}_y\text{S}_z$ ). The relative intensity of  $\text{Cu}:\text{Fe}:\text{Ag}$  is the criterion which determines glaze color after firing. As mentioned in section (4.5).

**5.3.6.3 permission to produce glaze which is decorated by crackle (FS2).**

The new kiln permit to produce crackles on surface of glazes by thermal shock. In this function there are qualifications related to properties of glaze and clay body and other related to the technique of thermal shock. First one is classified by difference in thermal expansion coefficient( $K^{-1}$ ) between glaze and clay body, (E)Young's modulus(MPa) of glaze and clay body, thickness of clay body and glaze, compression stress ( $+\sigma$ ), tensile stress ( $-\sigma$ ), and Poisson's ratio which is taken as constant  $\approx 0.20$  for glaze and clay body. The second qualification, the thermal shock technique, is classified into the difference in temperature between the chilled air and surface of ceramics  $\Delta T$ , this value depends on convection coefficients for laminar and turbulent chilled air in the fully developed region, mean (average) velocity  $u_m$ , jet design as characteristic length; and mass flow rate[31]. All of this factors are changeable during treatment application except jet design which influences also the temperature of mass flow air. The function of jet is to insert cold air inside kiln. Path of cold air exchange from internal flow inside the jet to external flow at outlet from the first part of jet to carved part of jet, see figure (5.5). In first part, the mean temperature of fluid, cold air, calculated by following equation:

$$T_m = \frac{\int_{A_{c1}}^{A_{c2}} uT dA_c}{u_m A_c} \quad (5.1)$$

## DESIGN KILN FOR THERMAL SHOCK AND CHEMICAL TREATMENTS

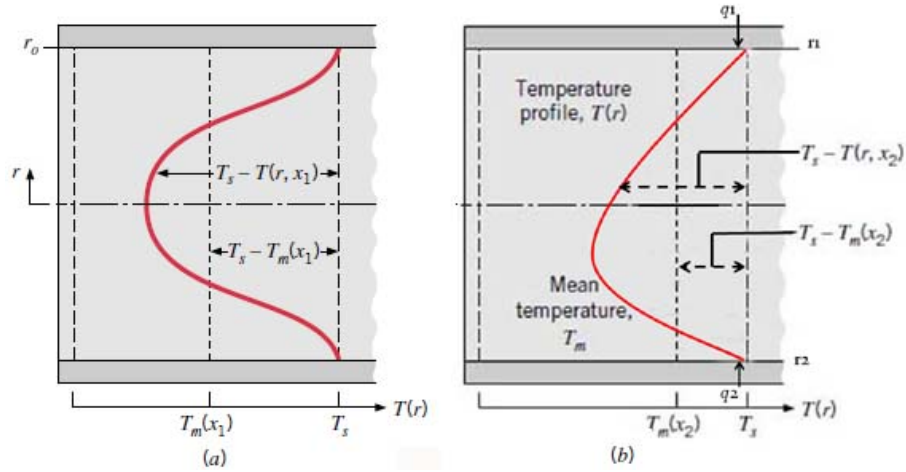
---

. In jet, there are two areas  $A_c$ , one is the area of large circular surface  $A_{c1}$  and other is the area of small circular surface of air channel inside the jet, see figure (5.5). Therefore, air inside the jet has two different regions of boundary layer with asymmetrical temperature profile, due to the difference of surface area between large circular surface  $A_1$  and small circular surface  $A_2$ , where this leads to a difference in convection coefficients and convective heat flux. Therefore the diffusion of  $T(r)$  in the vicinity of large circular surface is not similar to diffusion of  $T(r)$  in the vicinity of small circular surface which leads to a change in the curve of temperature profile of air as shown in figure (5.4). The shape of relative temperature profile of cold air in circular tube before entering the jet is demonstrated in figure (5.4 a)) and it is changed inside the jet as in (5.4 b)).

The mean temperature is fluid reference temperature used to calculate the convection heat rate from the surface of jet to fluid air, Newton's law of cooling and the overall energy balance is used to do this calculation :

$$q_s'' = q_{conv}'' = h(T_s - T_m) \quad (5.2)$$

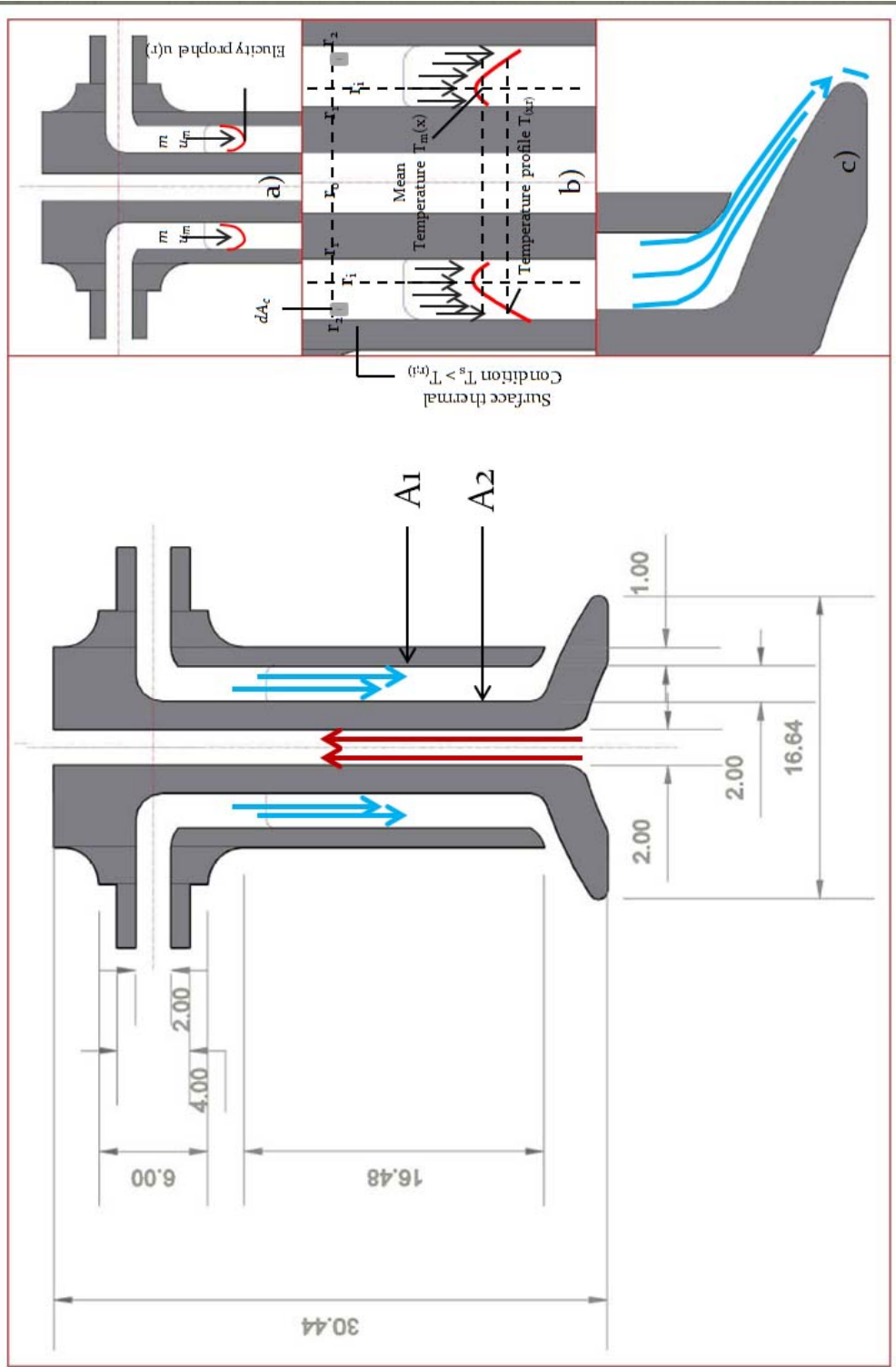
Therefore, the convection heat rate affects the temperature profile of cold air, as well as the relation between surface temperature  $T_s$  and mean temperature  $T_m$ . The  $T_s$  to surface jet is inconstant where it increases in the direction of inside kiln. Accordingly, the mean temperature varies linearly with  $x$  along the jet tube,  $(T_s - T_m)$  increases with  $x$  along the jet tube which maintains the temperature profile to



**Figure 5.4:** relative temperature profile of cold air a) in circular tube b) in jet [31].

inter the kiln with  $T(r)$  and  $T_m$  less than the temperature inside the kiln. The different temperature between  $T_m$  and  $T$  inside kiln will increase with duration of air injection where  $q''_{conv}$  will decrease because  $T_s$  will decrease. The figure (5.5) shows plan section of jet with details; a) the profile of vicinity; b) thermal boundary layer and temperature profile for injected air in jet; c) the convex shape of part of jet with narrow outlet to create long laminar for cold air inside the kiln based upon Coandă effect. It has been taken into account that the surface area has been reduced as much as possible especially in hot zone by slender form for path way of cold air in jet.

# DESIGN KILN FOR THERMAL SHOCK AND CHEMICAL TREATMENTS



**Figure 5.5:** Section plan of developed design of jet with details of heat transfer, temperature and vicinity profile during air injection, and design of convex surface of jet and the outlet hole.

**5.3.6.4 permission to change the condition of firing process (FS3).**

The new kiln permit to change the condition of firing from neutral atmosphere to reduction and/or sulphidation. In these functions there are qualifications related to temperature of treatment and its duration on firing schedule, state of materials which are used to change the atmosphere of kiln, the quantity of these materials and there relation to kiln construction. The criterions of these qualifications depend on design solution for construction of kiln which allows to do this function, see figure (5.6). This solution is an architectural design, the mean idea of this design depends on rotation part of kiln wall. This part should be free to rotate around ball-and-socket fulcrum, and it can be designed from intersection of such circular form with wall of kiln. The circular form permit to rotate and the axis of this rotation is ( $x1$ ) as seen in figure (5.6), which slant on UCS horizontal axis by angle equal  $69^\circ$ . It intersects with UCS vertical axis inside kiln wall in intersection point which permits to remain part of cylinder diameter out of the wall thickness. Wall of cylinder is designed by another circular inside the large circular form. The small circular axis is ( $x2$ ) which is shifted from ( $x1$ ) by 1.18 cm in direction of outside the kiln. Therefore cross section of cylinder wall is crescent and it thickness decreased gradely from 4 cm to 1.5 cm which permits to shift empty space inside the cylinder in direction of outside the kiln to keep large part of this space as possible outside the intersection with kiln wall.



# DESIGN KILN FOR THERMAL SHOCK AND CHEMICAL TREATMENTS

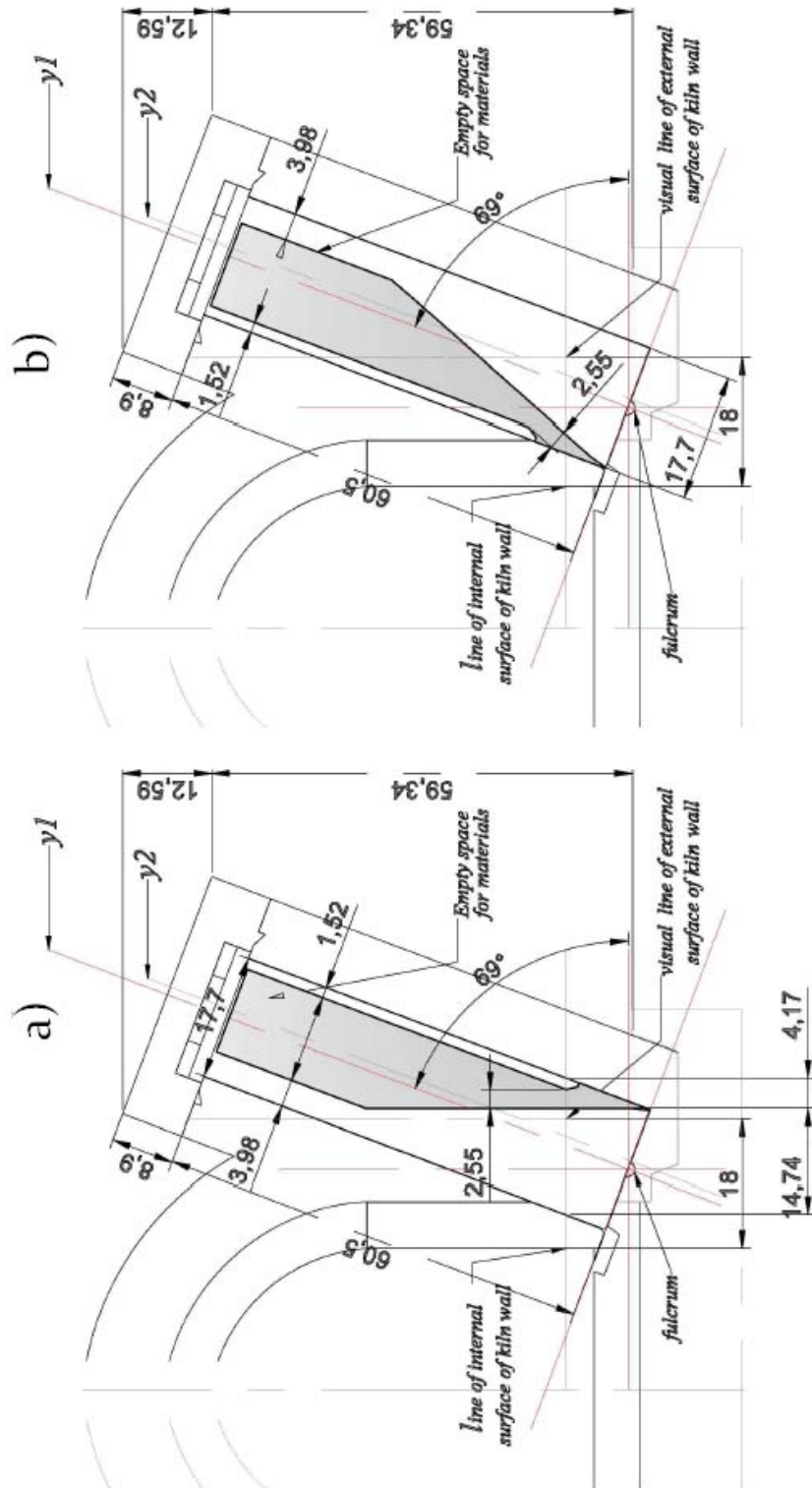


Figure 5.6: Section plan of tool which is designed to change condition of firing by solid materials

## FUNCTIONAL ANALYSIS FOR NEW KILN

---

The intersection part of empty space inside cylinder with the kiln wall transfer in solid part to form a free part of wall kiln that its position is changed with rotation to make the empty space in hot zone. The remaining form of empty space inside cylinder, the gradient shape in figure (5.6), is form of materials that is used to change the atmosphere of kiln. This form in position a) in figure (5.6) keep the materials in temperature of outside the kiln. Therefore atmosphere of kiln remains natural until it changes to position b) where the materials are brought in temperature of inside the kiln. Therefore, these materials will melt and enter to firing chamber from the hole designed in kiln wall in front of another hole in cylinder wall, this in case of used solid materials who change the condition of atmosphere. In case of liquid materials like water the hole is designed on tope of cylinder as shown in figure (5.7). The volume of empty space in cylinder determine the maximum of volume of water and weight of sulfur and rosin. This volume related to geometric design for new kiln, the diameter of cylinder and thickness of kiln wall. This design solution permits to do this treatment in any duration in schedule of firing, and therefore, all types of ceramics which required redaction atmosphere can produced in this kiln as well as the types which required natural atmosphere and types which required the new treatments of sulphidation.

# DESIGN KILN FOR THERMAL SHOCK AND CHEMICAL TREATMENTS

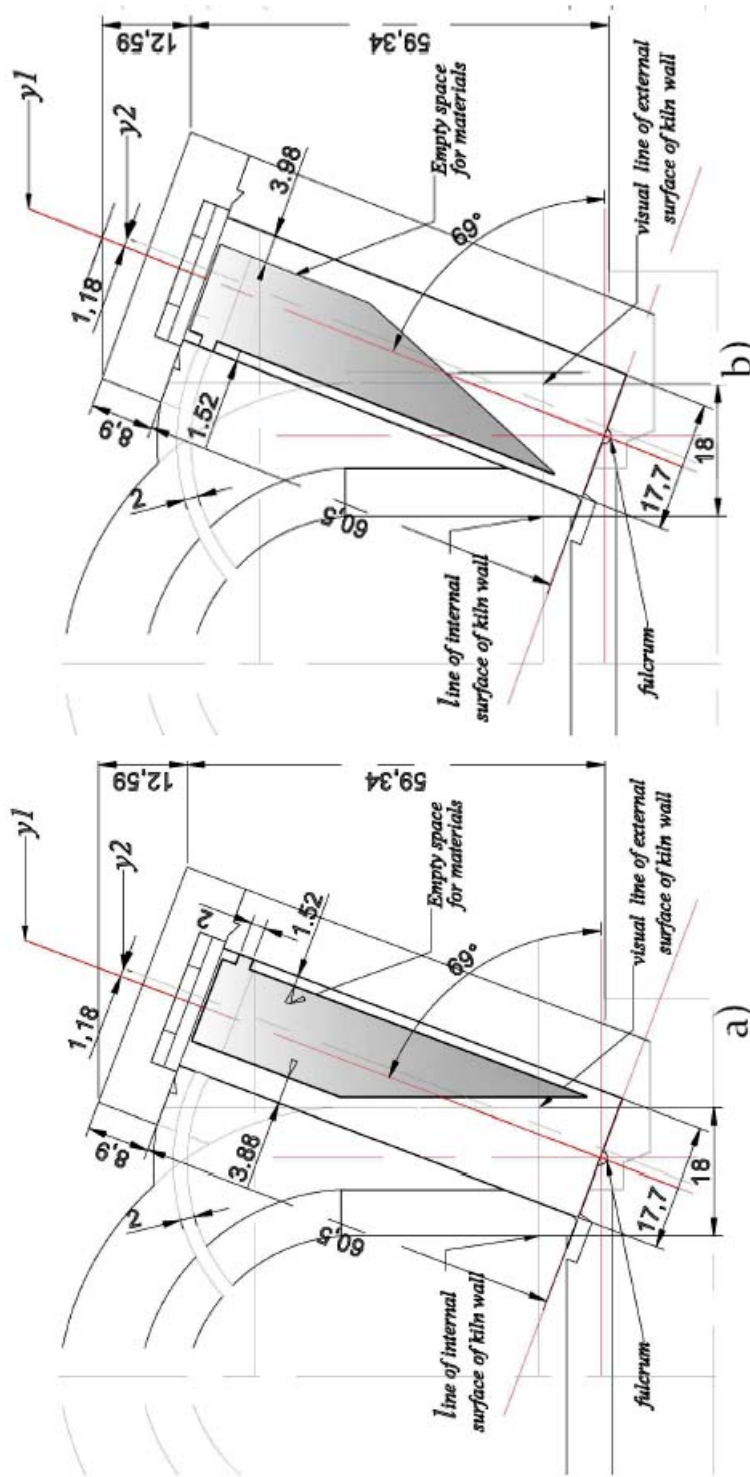
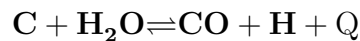


Figure 5.7: Section plan of tool which is designed to change condition of firing liquid materials

**5.3.6.5 Respect the chemical reactions conditions and physical properties (FC1).**

the qualifications of chemical reactions conditions and physical properties, which must be taken into account for using kiln as a tool for affect in ceramics surfaces, are classified into alteration related to condition of firing and other related materials of kiln construction. The ideal temperature for making treatments is determined according to which reaction is prepared. The reaction of H<sub>2</sub>O with carbon gas C above 900°C produce heat and force reduction atmosphere.



The reaction of S, H, and C with glaze produce esthetic treatments. Historical techniques which discussed in Section (2.3), Ellingham Diagram and Phase diagram of copper-iron-sulfur system which discussed in Section( 4.5.2, and 4.5.4) are used for determining the temperature of treatments.

Materials of kiln construction should be resistant withstand high sulphur, reducing atmospheres. The "ABLE CAST 3000" \* is a cast refractory which is suitable for kiln construction especial for inside layer. Heating elements should be stable with carbon gases, sulfured gazes and humidity, the silicon carbide heating element work successfully under these conditions. The dilatation line of materials

---

\*produced by ABLE Supply Company in USA, and its composition and properties is mentioned in appendix A.6

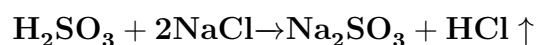
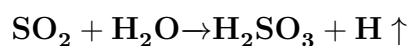
## DESIGN KILN FOR THERMAL SHOCK AND CHEMICAL TREATMENTS

---

which is used in kiln construction also should be taken in account with design of the rotation cylinder and all moving parts of kiln.

### 5.3.6.6 Adapt to the environment (FC2).

The gases which get out from kiln as  $\text{SO}_2$  and  $\text{CO}_2$  is treated by  $\text{H}_2\text{O}$  and  $\text{NaCl}$  to change gas form of sulfur into  $\text{Na}_2\text{SO}_3$  salted form and  $\text{CO}_2$  change from gas form into salted form  $\text{Na}_2\text{CO}_3$ .



The quantity of  $\text{H}_2\text{O}$  and  $\text{NaCl}$  are calculated from these reactions.

### 5.3.6.7 Design appropriate construction of kiln (FC3).

Construction of kiln should has some qualifications to achieve the serves functions. Therefore, they are represented in tight close during the firing to prevent gases and smoke from leaking to outside air, distribute gases and smoke inside the kiln and conceive a construction in order to permit to gases and smoke to leak in  $\text{H}_2\text{O}$  and  $\text{NaCl}$ . Tight closing necessitated that design the kiln as an elevator kiln as shown in figure (5.8) , where a) is position when the kiln is closed and b) is the position when kiln is open. The long outlet of smoke and design three obstacles

## **FUNCTIONAL ANALYSIS FOR NEW KILN**

---

prevent leaking of gases, so it get out only from treating unit. Ball valves is used to close the outlets of jet.

# DESIGN KILN FOR THERMAL SHOCK AND CHEMICAL TREATMENTS

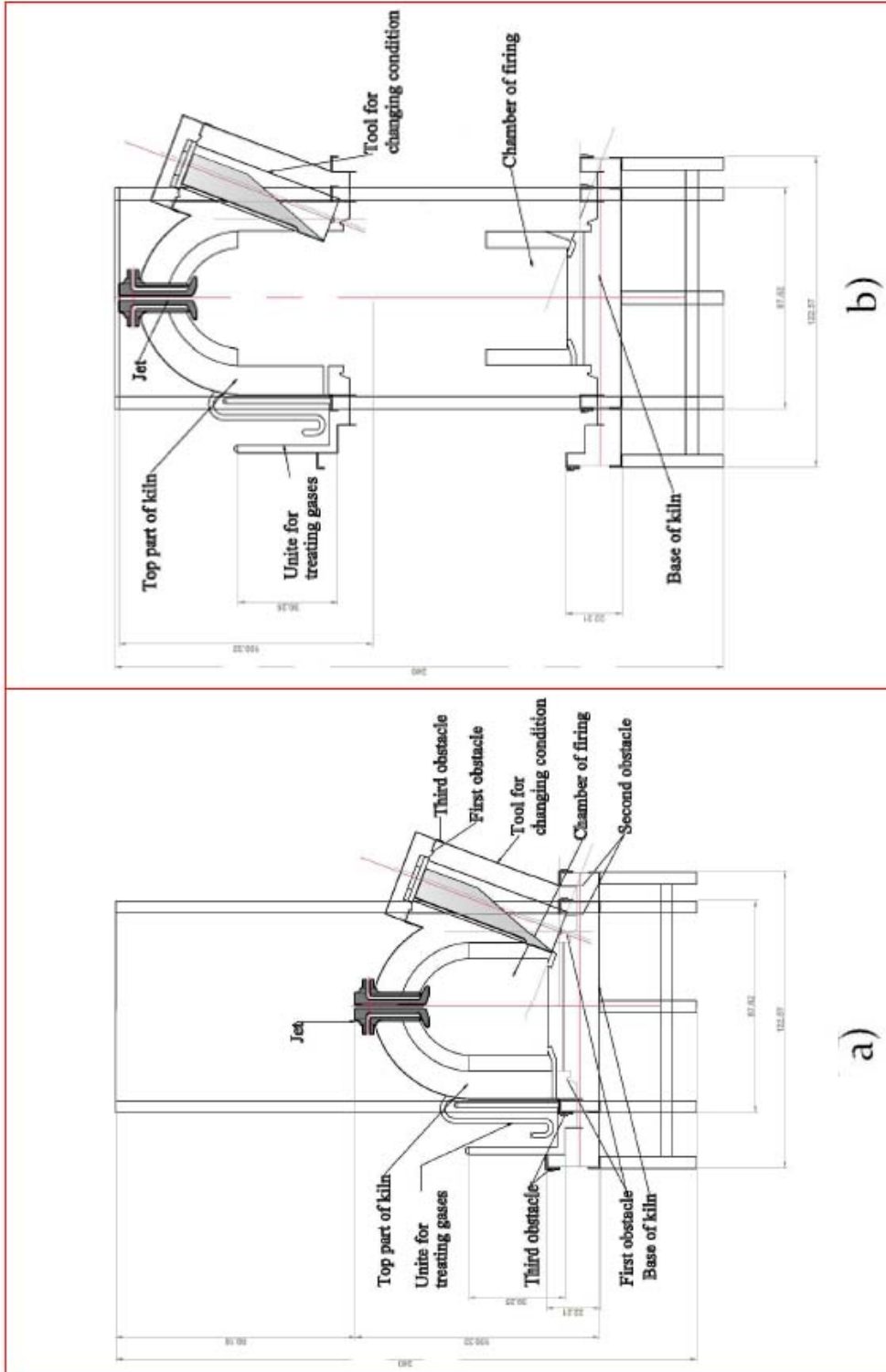
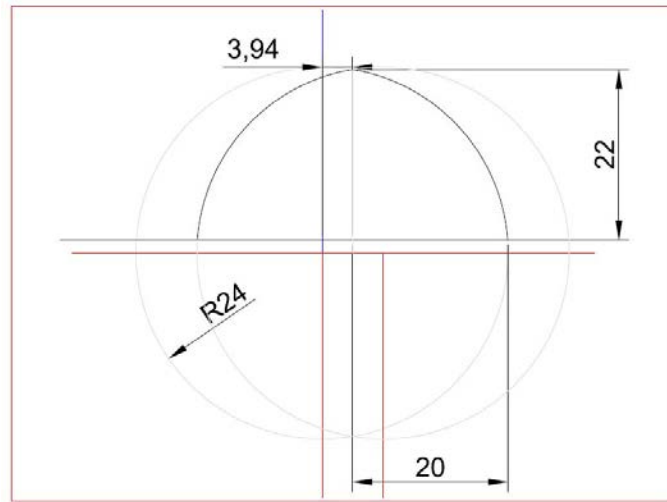


Figure 5.8: section plan of new kiln a) the position when the kiln closed and b) the position when kiln open



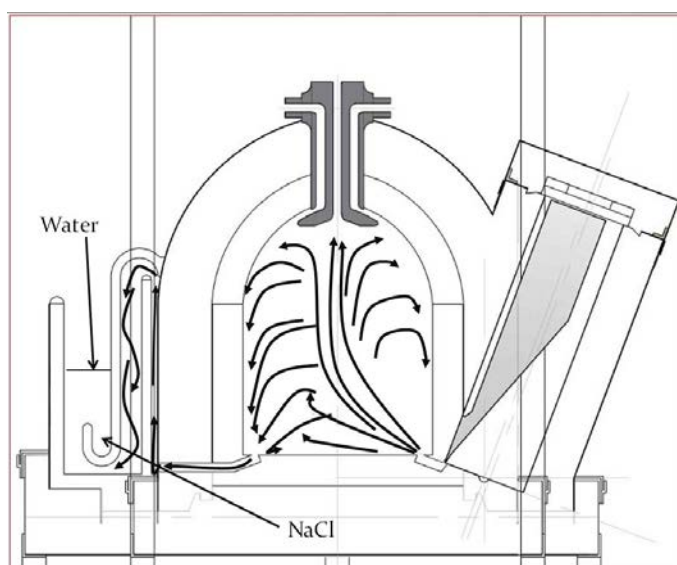
**Figure 5.9:** The masonry illustration of pointed arch which is used to design h thatched of kiln

For distritbuting smoke and gasses, kiln was designed cylinder form, and it was thatched by pointed dome that its section plan is pointed arch like it is used in roman kiln which is mentioned in section (2.5.2). The geometric illustration of this arch is shown in figure(5.9). According to movement of smoke and gasses, inserting solid materials inside the kiln is designed to be from the bottom of the kiln, then naturally vapors and smoke take them place to go up from right side until the top of pointed dome then it return to slow down for get out from holes that designed in left side in the bottom of kiln. Therefore, the kiln is designed as down-draft to distritbute the vapor and smoke, as shown in figure(5.10). This is based on the the historical study, refer to figures (2.53, and 2.51). Vapors and gasses are drafted down from the firing chamber to the treating unit which is



## DESIGN KILN FOR THERMAL SHOCK AND CHEMICAL TREATMENTS

---



**Figure 5.10:** Schematic demonstrate down draft and distribution of smoke and gasses in new kiln

designed to keep gasses in closed outlet until they are treated in water and salts.

### 5.3.6.8 Respect of the standards of thermal insulation (FC4).

The standards of thermal insulation is related to heat flow in the kiln walls, and their criterions determine the resistances power of heating elements which are necessary for heating kiln to required temperature  $1300^{\circ}\text{C}$ . There are some qualifications, which should be taken in account to compleat the design of new kiln, the thermal resistance  $R$  ( $\text{m}^2\cdot\text{K} / \text{W}$ ) of kiln walls', thermal connectivity of kiln wall materials  $\lambda$  ( $\text{W}\text{K}^{-1}\text{m}^{-1}$ ),and the thickness of kiln wale (m). The shape

of kiln is related to this factors where the surfaces of wall is a significant factor in heat transfer as well as boundary temperatures of each part of kiln walls.

Heat flow by conduction in such direction x calculate from Fourier's law of conduction[156] is expressed as flowing:

$$\varphi_x = -\lambda \frac{\delta T}{\delta x} \quad (5.3)$$

the thermal flow density ( $W/m^2$ ) is calculated by flowing equation:

$$\varphi \int_0^e dx = -\lambda \int_{T_1}^{T_2} dT \quad (5.4)$$

and with integration it is equal to:

$$\varphi = \frac{\lambda}{e} (T_1 - T_2) \quad (5.5)$$

the thermal resistance in ( $m^2.K.W^{-1}$ ) is calculated by flowing equation:

$$R_{cd} = \frac{(T_1 - T_2)}{\varphi} = \frac{e}{\lambda} \quad (5.6)$$

and in case of multi layer of insulation materials with different thermal conductivity, the power loss en ( $W/m^2$ ) is calculated by flowing equation:

$$\varphi = \left( \frac{1}{\frac{e_1}{\lambda_1} + \frac{e_2}{\lambda_2} + \dots \frac{e_n}{\lambda_n}} \right) (T_1 - T_2) \quad (5.7)$$

The kiln structure is composed from three parts; first is the base, a wall in circle form , second is cylinder form and the third part is pointed dome. According to heat flow through layer plan, which is calculated by following equation:

$$\phi = \varphi.S = -\lambda.S. \frac{dT}{dx} \quad (5.8)$$

## DESIGN KILN FOR THERMAL SHOCK AND CHEMICAL TREATMENTS

---

Therefore, the power loss by (W) through base of kiln calculated from following equation:

$$\phi_1 = \frac{\lambda \times (T_1 - T_2)}{e} \times S = \frac{\lambda \times \pi r^2 \times (T_1 - T_2)}{e} \quad (5.9)$$

Where the ( $\lambda$ ) is thermal conductivity of kiln wall ( $W.m^{-1}.K^{-1}$ ), (S) is the area of wall surface( $m^2$ ),  $T_1$  is the internal temperature,  $T_2$  is the external temperature, (r) is the radius of the base of kiln and (e) is thickness (m), and thermal resistance  $R_1$  ( $KW^{-1}$ ) for first part, if it is composed from one layer, is calculated from following equation:

$$R_{1 \text{ one layer}} = \frac{(T_1 - T_2)}{\phi_1} = \frac{e}{\lambda \times \pi r^2} \quad (5.10)$$

and in case of multi layer of insulation materials with different thermal conductivity, the power loss en (W) is calculated by flowing equation:

$$\phi = \pi r^2 \left( \frac{1}{\frac{e_1}{\lambda_1} + \frac{e_2}{\lambda_2} + \dots \frac{e_n}{\lambda_n}} \right) (T_1 - T_n) \quad (5.11)$$

So the thermal resistance of first part  $R_1$  ( $KW^{-1}$ ), if it is composed from multi layer, is calculated from following equation:

$$R_{1 \text{ multi layer}} = \frac{1}{\pi r^2} \times R_{cd} = \frac{1}{\pi r^2} \times \left( \frac{e_1}{\lambda_1} + \frac{e_2}{\lambda_2} + \dots \frac{e_n}{\lambda_n} \right) \quad (5.12)$$

,and the temperature (K) between two layers is calculated from following equation:

$$T_i = T_{i-1} - \left( \frac{\Phi_{i-1}}{\pi r^2} \right) \times \left( \frac{e_i}{\lambda_i} \right) \quad (5.13)$$

In the second part of kiln which is a cylinder form, the density of thermal flow is given also by Fourier's law of conduction[156], but the area of cylinder is given by  $2\pi Lr$  where the  $L$  is a length of cylinder wall and  $r$  is radius of cylinder. Therefore the power loss ( $w$ ) in this part can be determine as flowing equations:

$$\phi_2 = -\lambda.2\pi.Lr.\frac{\delta T}{\delta x} \quad (5.14)$$

$$\int_{T_1}^{T_2} dT = \frac{-\phi_2}{\lambda.2\pi.L} \int_{r_1}^{r_2} \frac{dr}{r} \quad (5.15)$$

$$\Phi_2 = \frac{\lambda 2\pi L}{\ln\left(\frac{r_2}{r_1}\right)} \times (T_1 - T_2) \quad (5.16)$$

The thermal resistance of second part  $R_2$  ( $KW^{-1}$ )if it is composed from one layer, is calculated from following equation:

$$R_{2 \text{ one layer}} = \frac{(T_1 - T_2)}{\phi_2} = \frac{\ln\left(\frac{r_2}{r_1}\right)}{\lambda \times 2\pi L} \quad (5.17)$$

for identify the relation between  $R_{cd}$  and  $R_2$ ,where  $r_1$  is internal radius of cylinder,  $r_2$  is is external radius of cylinder, and  $(r_2 - r_1)$  is the thickness of kiln wall in this part, the following equation is used to determine  $R_2$  :

$$R_{2 \text{ one layer}} = \frac{(r_2 - r_1)}{\lambda 2\pi L \frac{(r_2 - r_1)}{\ln\left(\frac{r_2}{r_1}\right)}} = R_{cd} \times \frac{1}{2\pi L \frac{(r_2 - r_1)}{\ln\left(\frac{r_2}{r_1}\right)}} \quad (5.18)$$

when wall of kiln composed of multi layer the power loss in (W) calculated

## DESIGN KILN FOR THERMAL SHOCK AND CHEMICAL TREATMENTS

---

from flowing equation:

$$\Phi_{2 \text{ multi layer}} = \frac{2\pi.L \times (T_1 - T_n)}{\left[ \frac{1}{\lambda_1} \times \ln \left( \frac{r_2}{r_1} \right) + \frac{1}{\lambda_2} \times \ln \left( \frac{r_3}{r_2} \right) .. \frac{1}{\lambda_n} \times \ln \left( \frac{r_{n+1}}{r_n} \right) \right]} \quad (5.19)$$

,and the  $R_2$  ( $KW^{-1}$ ) of wall which composed of multi layer is calculated from flowing equation:

$$R_{2 \text{ multi layer}} = \frac{\left[ \frac{1}{\lambda_1} \times \ln \left( \frac{r_2}{r_1} \right) + \frac{1}{\lambda_2} \times \ln \left( \frac{r_3}{r_2} \right) .. \frac{1}{\lambda_n} \times \ln \left( \frac{r_{n+1}}{r_n} \right) \right]}{2\pi.L} \quad (5.20)$$

the temperature in (K) between two layer is calculated from following equation:

$$T_{n+1} = T_n - \frac{\Phi \ln \left( \frac{r_{n+1}}{r_n} \right)}{2\pi\lambda_n} \quad (5.21)$$

The third part is an pointed dome which is formed from an arch which revolve around the vertical axes (y) in center of the kiln. This arc is a part of circle as shown in figure (5.9), this part of arch who create the surface area of dome as shown in figure (5.11). Since the surface area of pointed dome is a surface of revolution, the equation of revolved curve is required which is have relation with mean circle in figure (5.11). The circle equation with center (0,0) is as following:

$$f(y) = \sqrt{r^2 - y^2} \quad (5.22)$$

Since the arc is part of circle but the center is different, the equation of arch will be a modified to circle equation to adapt with new center (3.94,1.67), therefore the variable value of (y) in circle equation is increased by  $a$  when  $r$  is radius of

circle in  $cm$  and the variable value of  $f(y)$  is decreased by  $b$ . The value of  $a$  and  $b$  can be calculated from as we know from figure (5.11)  $f(y) = 20\text{ cm}$  the internal radius of cylinder - the second part of kiln - when  $y = 0$ ,  $f(y) = 0\text{ cm}$  when  $y = 22$  - the height of pointed dome, and  $r = 24\text{ cm}$ . therefore there are two equations as following:

$$0 = \sqrt{24^2 - (22 + a)^2} - b \quad (5.23)$$

$$0 = \sqrt{24^2 - (a)^2} - b - 20 \quad (5.24)$$

so  $a = 1.674156$  and  $b = 0.941539$  so the curve equation will be as following:

$$f(y) = \sqrt{r^2 - (y + 0.01674156)^2} - 0.03941539 \quad r \geq .24m \quad (5.25)$$

Since the axis of rotation is y-axis, the surface area of revolved curve is calculated from the following equation:

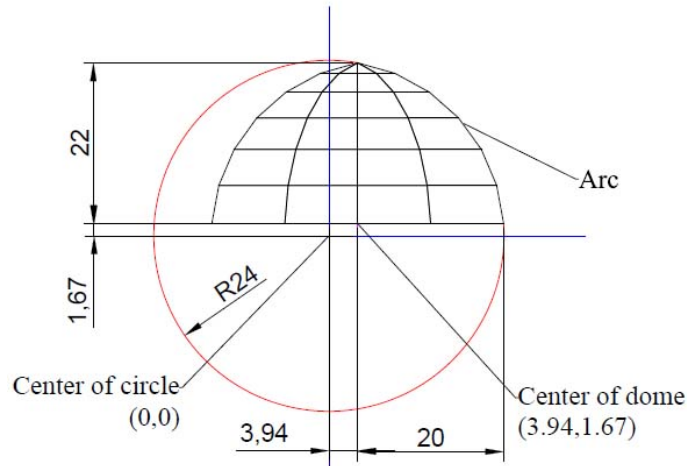
$$A_y = \int_{y_1}^{y_2} \times 2\pi \times f(y) \times \sqrt{1 + (f'(y))^2} \quad (5.26)$$

For getting the equation of surface area as a function of circled radius ( $r$ ) the limits of integral ( $y_1$ - $y_2$ ) were determined from equations (5.23, and 5.24), where  $y_1 = 0$  and  $y_2 = \left( \sqrt{r^2 - (0.03941539)^2} - 0.01674156 \right)$ . *Maple<sup>TM</sup>* program is used to integrate the equations, and the surface area of pointed dome which is the third part of kiln, is calculated from following equation:

$$A_y = 2\pi\beta \quad (5.27)$$

## DESIGN KILN FOR THERMAL SHOCK AND CHEMICAL TREATMENTS

---



**Figure 5.11:** Illustration to determine the equation of arc from relation between the arc and mean circle

where

$$\begin{aligned} \beta &= \left( 0.03941539 \arcsin \left( \frac{0.01674126}{r} \right) r \right) \\ &+ 9.920644763 \cdot 10^{-7} r \\ &\times \sqrt{1.016061984 \cdot 10^{12} r^2 - 1.578526434 \cdot 10^9} - 0.01674126001 r \\ &- 0.03941539000 r \times \arcsin \\ &\left( \frac{8.596485169 \cdot 10^{-20} \left( 1.154035000 \cdot 10^{13} \sqrt{1.016061984 \cdot 10^{12} r^2 - 1.578526434 \cdot 10^9} - 1.60271841 \cdot 10^8 \right)}{r} \right) \end{aligned}$$

$$r^* \geq 0.24$$

Therefore in this part the power loss  $\Phi_3$  in (W), if wall composed from one layer can be determine as flowing equations:

$$\Phi_3 = \frac{2\pi\lambda(T_1 - T_2)}{\int_{r_1}^{r_2} \left(\frac{1}{\beta}\right) dr} \quad (5.28)$$

---

\*r is radius of main circle of arch

,and when wall of kiln composed from multi layer the power loss in (W) calculated from flowing equation:

$$\Phi_3 \text{ multi layer} = \frac{2\pi \cdot (T_1 - T_n)}{\left[ \frac{1}{\lambda_1} \times \left( \int_{r_1}^{r_2} \left( \frac{1}{\beta} \right) dr \right) + \frac{1}{\lambda_2} \times \left( \int_{r_2}^{r_3} \left( \frac{1}{\beta} \right) dr \right) \dots \frac{1}{\lambda_n} \times \left( \int_{r_n}^{r_{n+1}} \left( \frac{1}{\beta} \right) dr \right) \right]} \quad (5.29)$$

the temperature in (K) between two layer is calculated from following equation:

$$T_{n+1} = T_n - \Phi_3 \times \frac{\left( \int_{r_n}^{r_{n+1}} \left( \frac{1}{\beta} \right) dr \right)}{2\pi \lambda_n} \quad (5.30)$$

Total power loss  $\Phi_{Total}$  for the kiln is equal to the sum of three power loss  $\Phi_1$ ,  $\Phi_2$  and  $\Phi_3$  so the power of the resistors can be proposed to be twice that power loss, as well as thermal resistance  $R_{total}$  can be obtained from following equation:

$$\frac{1}{R_{total}} = \frac{1}{R_1} + \frac{1}{R_2} + \frac{1}{R_3}$$

the power loss will be equal to 1524 ( $W/m^2$ ) if the the thermal resistance is equal to 0.84( $m^2KW^{-1}$ ), and maximum temperature is equal 1300°C, so the thickness of wall layers and temperatures between them can be determined when we place in order this layer according to, their thermal conductivity, their maximum temperature limit, their method of lining and their mechanical properties.

### **5.3.6.9 Respect of properties of refractory materials which are selected for building the construction of kiln (FC5).**

This constraint function is related to determine the suitability of refractory materials with serves functions of new kiln, where refractory castables are required to



## DESIGN KILN FOR THERMAL SHOCK AND CHEMICAL TREATMENTS

---

forme the architectural construction of kiln, and the refractory fibres are required to reduce the weight, especially the elevated top part. Therefore the deformation of refractory castables and lining of refractory fibres are important issue to select refractory materials for new kiln, along with standards of thermal insulation and they are used together to determine thickness of kiln.

According to standards of thermal insulation and Respect the chemical reactions conditions, "Able cast 3000" refractory castable (A.6) is chosen for first layer from inside the kiln and second layer is "Firelite 2500<sup>TM</sup>" A.7 refractory castable. This choice is due to their mechanical properties. All these materials have suitable performances in high temperature, the permanent linear change in (%) of Firelite 2500<sup>TM</sup> is negative and the permanent linear change of Able cast 3000 is positive above 1200°C, and therefore they are chosen to be the first two layers in face of high temperature to avoid deformation in refractory castables, which are the supports to maintain the architectural construction of kiln. As well as thermal linear expansion of two refractory castables should be taken in account to avoid deformation in structure.

The permanent linear change in (%) is presented as function of temperature in product information (A.6, and A.7), and therefore, thermal expansion linear is required to present also in(%) to be compared with permanent linear change. Then the difference between permanent linear change, which exists only in first firing, and thermal expansion at 1300°C (the maximum temperature )and 20°C

(the room temperature) create two states of deformation: the first when kiln work at 1300°C; the second when kiln is at room temperature.

Thermal expansion coefficient of refractories as function of temperature can be calculated according to their chemical composition by following equation[32]:

$$\alpha = (10^{-8} \times B) + (2 \times 10^{-10} \times C \times T) + (3 \times 10^{-14} \times D \times T^2) \quad (5.31)$$

where B , C and D are constants calculated according to the data in table (A.8) as function of chemical composition of refractor. and the  $\Delta L_T$  in% can be expressed by the following equation:

$$\Delta L_T \% = 100 \times (10^{-8} \times B) + (2 \times 10^{-10} \times C \times T) + (3 \times 10^{-14} \times D \times T^2) \times (T - 293) \quad (5.32)$$

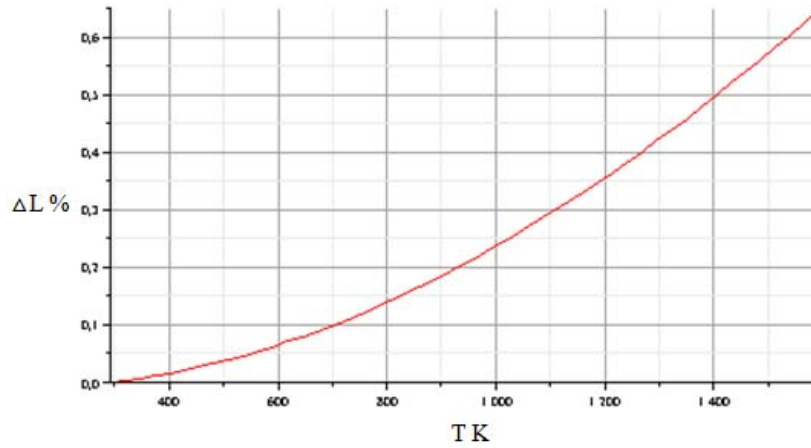
So the  $\Delta L_T$  in (%)of Firelite 2500<sup>TM</sup>, the change in length owing to Thermal expansion can be calculated as function of temperature (K) by the following equation:

$$\begin{aligned} \Delta L_T \% \text{ dialitation Firelite 2500} &= 100 \times (10^{-8} \times (4.23522164)) \\ &+ (2 \times 10^{-10} \times (18.1683977) \times T) \\ &- (3 \times 10^{-14} \times (11.29010320) \times T^2) \\ &\times (T - 293) \end{aligned} \quad (5.33)$$

Figure (5.12) shows the curve of thermal linear expansion in (%) of Firelite 2500<sup>TM</sup> as function of temperature in K . The change in length owing to perma-

## DESIGN KILN FOR THERMAL SHOCK AND CHEMICAL TREATMENTS

---



**Figure 5.12:** Impermanent curve of  $\Delta L \%$  of Firelite 2500<sup>TM</sup> as function of temperature K

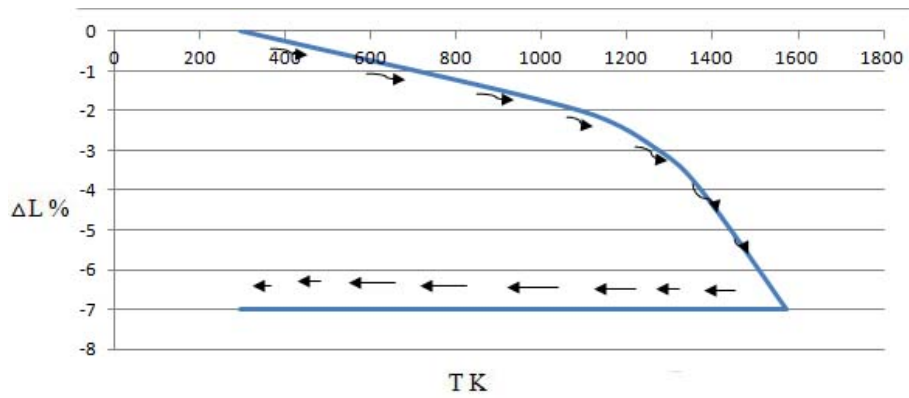
permanent linear change for Firelite 2500<sup>TM</sup> can be calculated as function of temperature in K by the following equation:

$$\begin{aligned} \Delta L_T \% \text{ permanent Firelite 2500} &= \\ &(-0.01) - (0.2 \times 10^{-4} \times T) + (10^{-7} \times T^2) \\ &\quad - (10^{-10} \times T^3) - (8 \times 10^{-14} \times T^4) \end{aligned} \quad (5.34)$$

The figure (5.13) shows the curve of the permanent linear change in (%) of Firelite 2500<sup>TM</sup> as function of temperature in K .

The  $\Delta L_T$  in (%) of Able cast 3000, the change in length owing to Thermal expansion can be calculated as function of temperature in K by the following

## FUNCTIONAL ANALYSIS FOR NEW KILN



**Figure 5.13:** permanent curve of  $\Delta L \%$  of Firelite 2500<sup>TM</sup> as function of temperature K

equation:

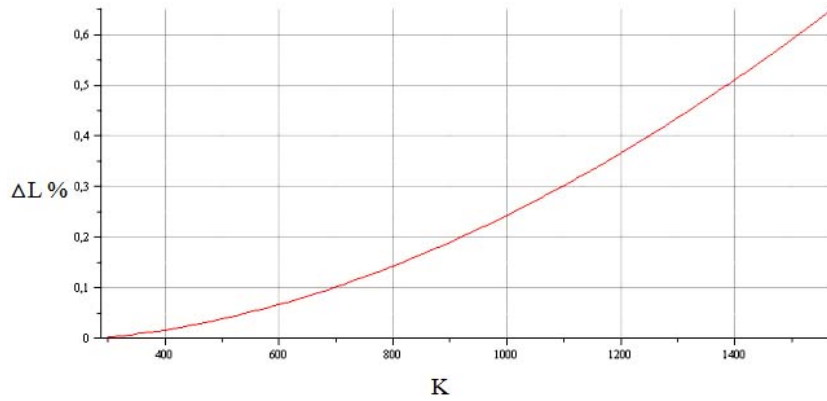
$$\begin{aligned}
 \Delta L_T \text{ \% dialitation of Able cast 3000} &= 100 \times (10^{-8} \times (3.995475703)) \\
 &+ (2 \times 10^{-10} \times (18.52137357) \times T) \\
 &- (3 \times 10^{-14} \times (10.3635449) \times T^2) \\
 &\times (T - 293)
 \end{aligned}
 \tag{5.35}$$

Figure (5.14) shows the curve of thermal linear expansion in (%) of as Able cast 3000 function of temperature (K). The change in length owing to permanent linear change of Able cast 3000, can be calculated as function of temperature in K in duration from 1505 K to 1670 K by the following equation:

$$\Delta L_T \text{ \% permanent of Able cast 3000} = 0.310^{-2}T - 4.8242 \quad [1505, 1670]
 \tag{5.36}$$

## DESIGN KILN FOR THERMAL SHOCK AND CHEMICAL TREATMENTS

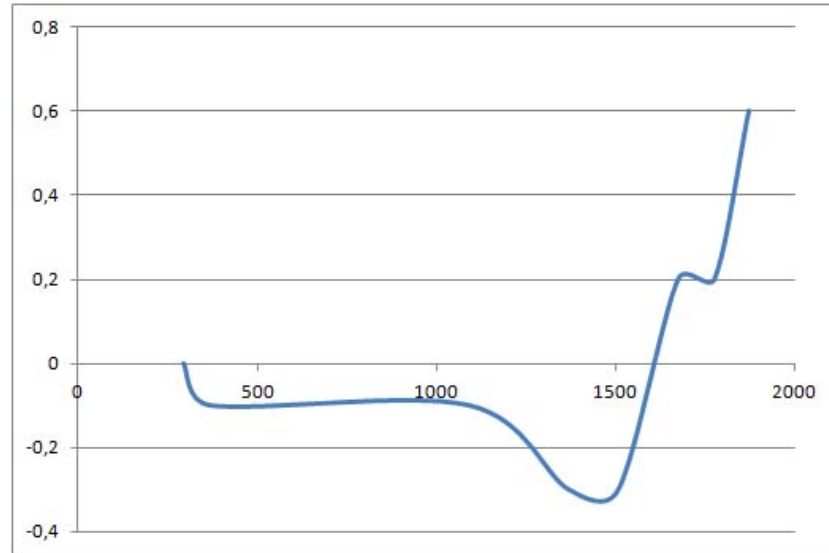
---



**Figure 5.14:** Impermanent curve of  $\Delta L \%$  of Able cast 3000 as function of temperature K

The figure (5.15) shows the curve of the permanent linear change in (%) of Able cast 3000 as a function of temperature in K .

According to the difference of temperature between internal surface and external surface of each refractory (Able cast 3000 and Firelite 2500<sup>TM</sup>), a difference of permanent linear change between the two surfaces of each layer is created whether in layer of Able cast 3000 or the layer of Firelite 2500<sup>TM</sup>. This difference in length creates a force of deformation, but the force which is created in Able cast 3000 will be in direction invert to the direction of force which is created in "Firelite 2500<sup>TM</sup>". The reversible thermal expansion linear for both layers works to reduce the deformation force, where it leads to reduce the  $\Delta L$ . Therefore the thickness of each layer should be determined from the curve of permanent linear change by determination of the temperature of external face of first layer and from equation



**Figure 5.15:** Permanent curve of  $\Delta L\%$  of Able cast 3000 as function of temperature (K).

(5.36) the  $\Delta L_{Ablecast\ external}$  will be calculated in external face of "Able cast 3000" layer, and difference between  $\Delta L_{Able\ cast\ internal}$  and  $\Delta L_{Able\ cast\ external}$  should be equal to the difference between  $\Delta L_{Firelite\ 2500\ internal}$  and  $\Delta L_{Firelite\ 2500\ external}$ . The temperature inside Firelite 2500 is the same than the one of external face of "Able cast 3000". The  $\Delta L_{Firelite\ 2500\ internal}$  is calculated from equation (5.34), and the temperature of external face of "Firelite 2500" layer is calculated from the same equation by the difference of  $\Delta L$  between the internal and external face of Firelite 2500 layer. Once the temperatures of faces and between layers are known the thickness of each layer can be calculated from equation (5.5) where the heat flow is  $1524\ (W/m^2)$  and the thermal conductivity of "Able cast 3000" is 1.2

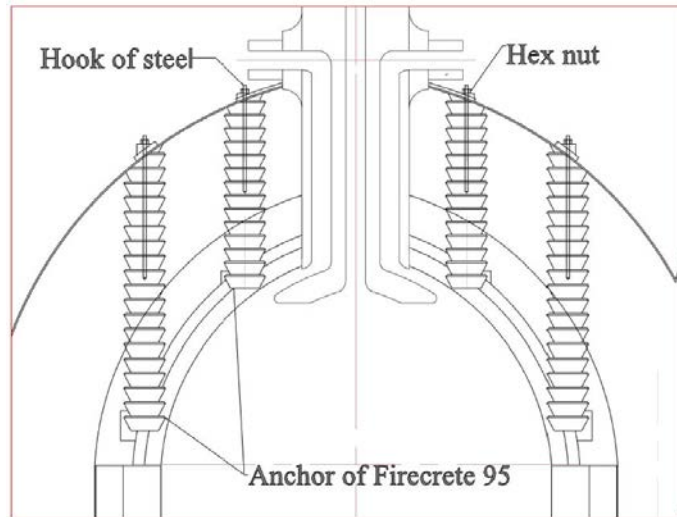
## DESIGN KILN FOR THERMAL SHOCK AND CHEMICAL TREATMENTS

---

( $W.m^{-1}.K^{-1}$ ) at  $1300^{\circ}C$  and it is  $0.44 (W.m^{-1}.K^{-1})$  above  $1000^{\circ}C$  for "Firelite 2500". The suitable thickness for cylinder and base parts which is calculated from the balance between permanent linear change of two refractories, in addition to static young's modulus. "Firelite 2500<sup>TM</sup>", according to **ASTM C401-91**[157], is a regular castable refractory, where it has a total lime (CaO) content greater than 2.5 % and total alumina (Al<sub>2</sub>O<sub>3</sub>) content 44.4%, see (A.7). "Able cast 3000" is an insulating castable refractory, where it has a total alumina (Al<sub>2</sub>O<sub>3</sub>) content 60.17% (A.6). Therefore these monolithics refractories are alumina and aluminosilicate castable refractories which can specify their static young's modulus as function in temperature from figure (5.17). Therefore the Young's modulus of "Able cast 3000" is  $8 \times 10^6$  psi (47.6 GPa) at  $20^{\circ}C$ , and it is  $4.7 \times 10^6$  psi (32.4 GPa) at  $20^{\circ}C$ .

The thickness of "Able cast 3000" can be 17 mm and the thickness of "Firelite 2500" can be 26 mm to avoid deformation in wall. In pointed dome part, the wall thickness of the first two layers must be less thicker than the wall thickness of the first two layers of base, owing to the weight of elevated part of kiln. The thickness of refractory castables in this part can be 10 mm of "Able cast 3000" and 14 mm of "Firelite 2500", its weight is 9.6 kg and it is designed to be supported by 12 anchors as shown in figure(5.16).

Deformation force in dimensions of concrete layers can be calculated by determined the difference between external and internal temperature where equations



**Figure 5.16:** Section plan of pointed dome with anchors which hold the dome part of kiln

(5.33, 5.34, 5.35, and 5.36) defined the relation between temperature and  $\Delta L_{sh}^*$ , and also  $\Delta L_d^\dagger$ . In addition the temperature in layer thickness can be defined from equation (5.5). From this equations  $\Delta L_{total}$  can be calculated as the sum of  $\Delta L_d$  and  $\Delta L_{sh}$ . The  $\Delta L_{total}$  is in maximum value, when kiln is at 20°C. To study the resistance of designed thickness of this castable refractories to deformation, the ANSYS programme ( finite element program ) is used to simulate the mechanical deformations. . .

The surfaces forces which are created from change in vertical linear, are cal-

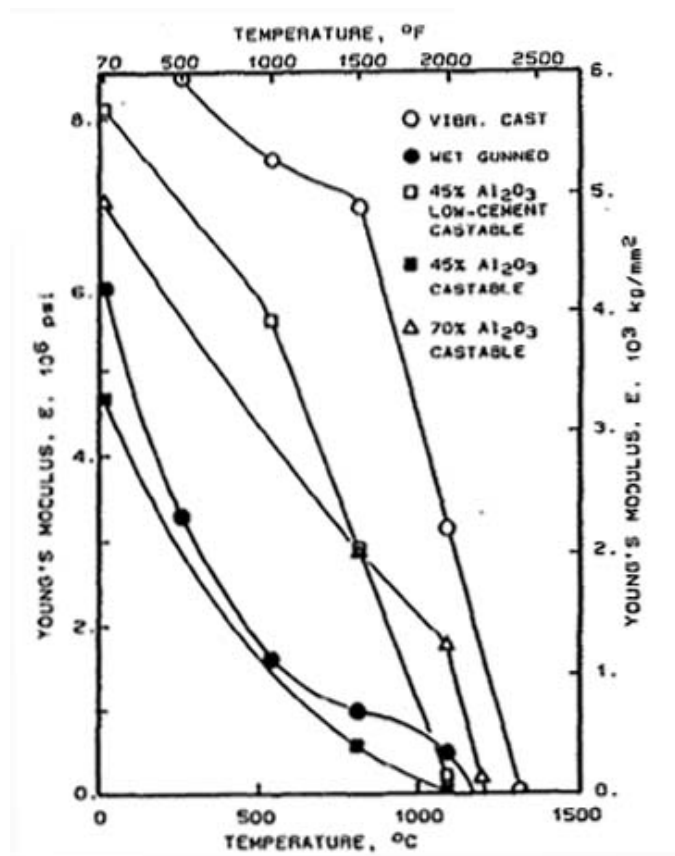
---

\*  $\Delta L_{sh}$  is a permanent liner change

†  $\Delta L_d$  is a reversible dilatation



## DESIGN KILN FOR THERMAL SHOCK AND CHEMICAL TREATMENTS



**Figure 5.17:** Static Young's modulus as function in temperature for monolithics refractories [32]

culated from the flowing equation:

$$F_v = S.E\left(\frac{\Delta L}{h}\right) \quad (5.37)$$

where  $F_v$  is vertical force (N), S surface area ( $m^2$ ) E Young's modulus (Pa),  $\Delta L$  the difference in length (m), and h is length or height (m). The surface forces which are created from change in horizontal linear, is calculated from the flowing equation:

$$F_h = S.G\left(\frac{\Delta e}{e}\right) \quad (5.38)$$

where  $F_h$  is horizontal force (N), S is a surface area ( $m^2$ ) G Shear modulus (Pa),  $\Delta e$  the difference in thickness (m), and e is thickness (m). The table (5.2) introduce the related data to cylinder and base which are inserted to ANSYS program to simulate the total deformations. The equivalent stress and stress intensity, where the thickness of "Able cast 3000" and "Firelite 2500<sup>TM</sup>" is different than the thickness of dome for the same materials, and table (5.2) introduce also the data for pointed dome, top part of kiln. These data is calculate to simulate the surface forces after heating the kiln to first time at 1300°C and return to 20°C.

The total deformations result for cylinder and base parts is shown in figures (5.18), and for the pointed dome is shown in figure (5.21). The maximum of total deformations are in external edges of "Able cast 3000" layer in front of internal edges of "Firelite 2500<sup>TM</sup>". The height values of deformations are in top edge of cylinder because it is not contacted with flat surface as its base. The

## DESIGN KILN FOR THERMAL SHOCK AND CHEMICAL TREATMENTS

**Table 5.1:** The required data to simulate the total deformations, equivalent stress and stress intensity in two parts cylinder and base

| Information     | Able cast 3000 layer     |                           | Firelite 2500 <sup>TM</sup> layer |                          |
|-----------------|--------------------------|---------------------------|-----------------------------------|--------------------------|
|                 | Internal                 | External                  | Internal                          | External                 |
| Thickness e     | 17 mm                    |                           | 26 mm                             |                          |
| Length L        | 320 mm                   |                           | 320 mm                            |                          |
| Temperature     | 1300°C                   | 1278°C                    | 1278°C                            | 1187°C                   |
| $\Delta L_{sh}$ | -0.1%                    | -0.17%                    | -0.64%                            | -0.5%                    |
| $\Delta L_d$    | 0.65%                    | 0.63%                     | 0.61%                             | 0.53%                    |
| $\Delta e_{sh}$ | $-0.49 \cdot 10^{-3} \%$ | $-0.683 \cdot 10^{-3} \%$ | $-0.39 \cdot 10^{-2} \%$          | $-0.33 \cdot 10^{-2} \%$ |
| Surface force   | Cylinder wall            |                           |                                   |                          |
| $F_v$ at 20°C   | $-5.17 \cdot 10^5$ N     | $-9.15 \cdot 10^5$ N      | $-3.77 \cdot 10^6$ N              | $-3.24 \cdot 10^6$ N     |
| $F_h$ at 20°C   | $-3.75 \cdot 10^4$ N     | $-5.66 \cdot 10^4$ N      | $-2.26 \cdot 10^5$ N              | $-2.15 \cdot 10^5$ N     |
|                 | Circle base wall         |                           |                                   |                          |
| $F_v$ at 20°C   | $-2.93 \cdot 10^4$ N     | $-4.08 \cdot 10^4$ N      | $-2.33 \cdot 10^5$ N              | $-1.97 \cdot 10^5$ N     |
| $F_h$ at 20°C   | $2.03 \cdot 10^5$ N      | $3.45 \cdot 10^5$ N       | $1.99 \cdot 10^6$ N               | $1.55 \cdot 10^6$ N      |

horizontal deformation can be considered in equilibrium to choose this thickness as two first layers in structure of kiln wall. The equivalent stress and stress intensity results as shown in figure (5.19) and figure (5.20) refer to equilibrium between the thickness of two layers. While in pointed dome the deformation is height values of deformations are equilibrium, and equivalent stress and stress intensity results as shown in figure (5.22) and figure (5.23) refer to equilibrium between the thickness. therefore these proposed thicknesses are applicable to

## FUNCTIONAL ANALYSIS FOR NEW KILN

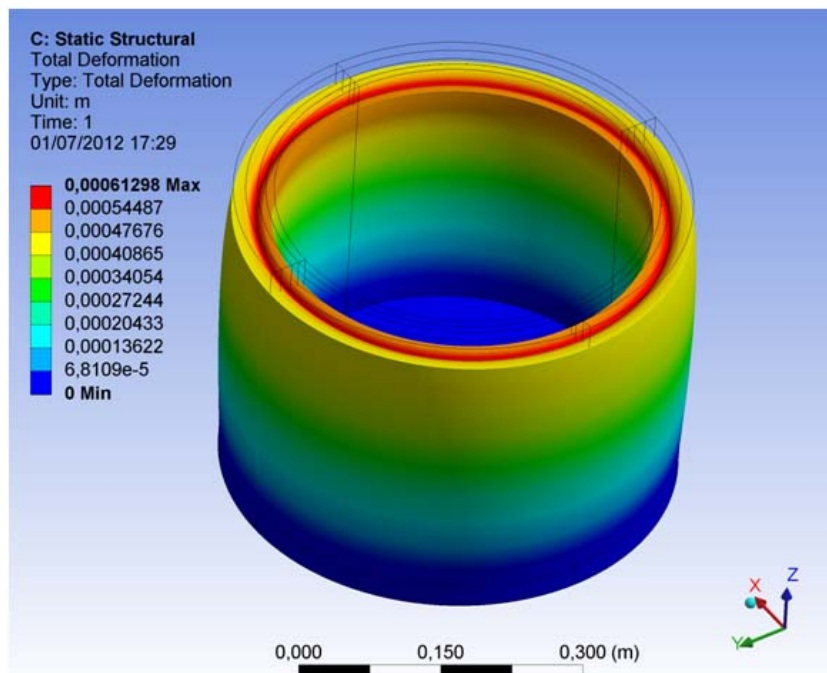
**Table 5.2:** The required data to simulate the total deformations, equivalent stress and stress intensity in dome part of kiln

| Information     | Able cast 3000 layer      |                           | Firelite 2500 <sup>TM</sup> layer |                           |
|-----------------|---------------------------|---------------------------|-----------------------------------|---------------------------|
|                 | Internal                  | External                  | Internal                          | External                  |
| Thickness e     | 10 mm                     |                           | 14 mm                             |                           |
| Temperature     | 1300°C                    | 1287°C                    | 1287°C                            | 1238°C                    |
| $\Delta L_{sh}$ | -0.1%                     | -0.14%                    | -0.65%                            | -0.57%                    |
| $\Delta L_d$    | 0.65%                     | 0.64%                     | 0.61%                             | 0.58%                     |
| $\Delta e_{sh}$ | $-0.027 \cdot 10^{-3} \%$ | $-0.034 \cdot 10^{-3} \%$ | $-0.22 \cdot 10^{-2} \%$          | $-0.204 \cdot 10^{-2} \%$ |
| Pressure        | Pointed dome wall         |                           |                                   |                           |
| $P_v$ at 20°C   | $-4.76 \cdot 10^7$ Pa     | $-6.66 \cdot 10^7$ Pa     | $-1.98 \cdot 10^8$ Pa             | $-1.85 \cdot 10^8$ Pa     |
| $P_h$ at 20°C   | $-5.13 \cdot 10^3$ Pa     | $-6.46 \cdot 10^3$ Pa     | $-2.86 \cdot 10^5$ Pa             | $-2.60 \cdot 10^5$ Pa     |

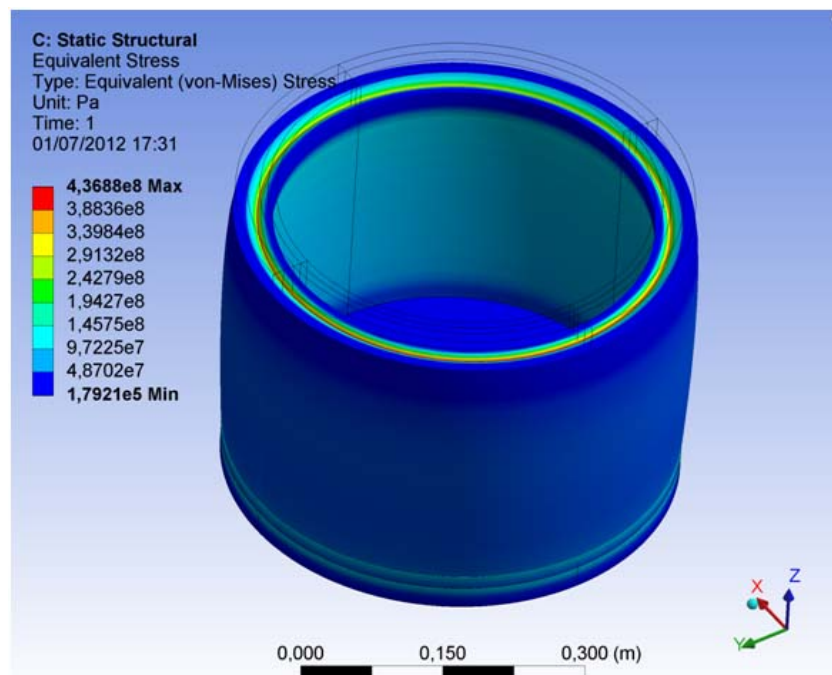
construction of new kiln. The concrete refractory which is the internal structure of kiln in the cylinder and base is composed of 17 mm thickness of "Able cast 3000" with thermal conductivity ( $\lambda$ )  $1.202 (W.m^{-1}.K^{-1})$ , and 26 mm thickness of "Firelite 2500<sup>TM</sup>" with thermal conductivity ( $\lambda$ )  $0.44 (w.m^{-1}.K^{-1})$ . So, the temperature in external surface of this two layers will be 1187°C when kiln is at 1300°C [equation (5.7)]. So the thickness of kiln's wall in this parts can be completed by refractory fiber and other castable refractory to create a temperature profile which is shown in figure (5.24). The third layer is designed to be 25 mm of "Cerachrome <sup>TM</sup> Blanket" with thermal conductivity  $\lambda$  equal  $0.25 (W.m^{-1}.K^{-1})$  to change temperature from 1187°C in internal side to 1035°C

## DESIGN KILN FOR THERMAL SHOCK AND CHEMICAL TREATMENTS

---



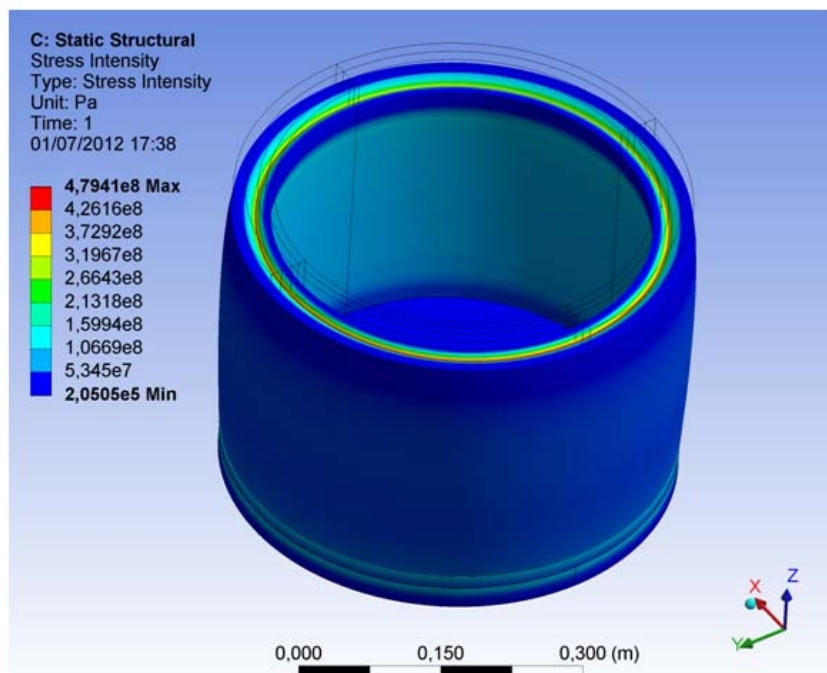
**Figure 5.18:** Result of total deformations in first two layers of cylinder and circle base which are designed to cast from 17 mm of "Able cast 3000" and 26mm "Firelite 2500<sup>TM</sup>"



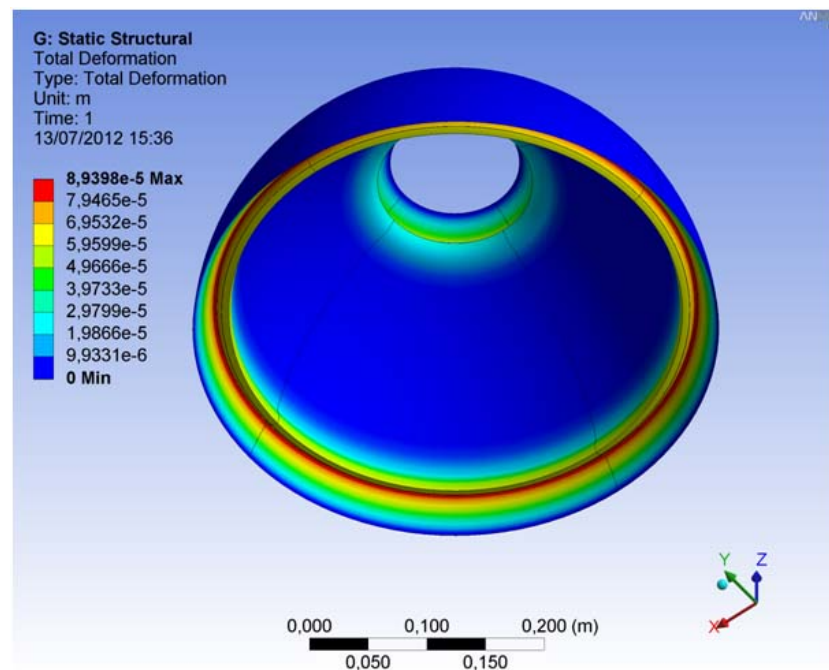
**Figure 5.19:** Result of equivalent stress in first two layers of cylinder and circle base of kiln structure

## DESIGN KILN FOR THERMAL SHOCK AND CHEMICAL TREATMENTS

---



**Figure 5.20:** Result of stress intensity in first two layers of cylinder and circle base of kiln structure

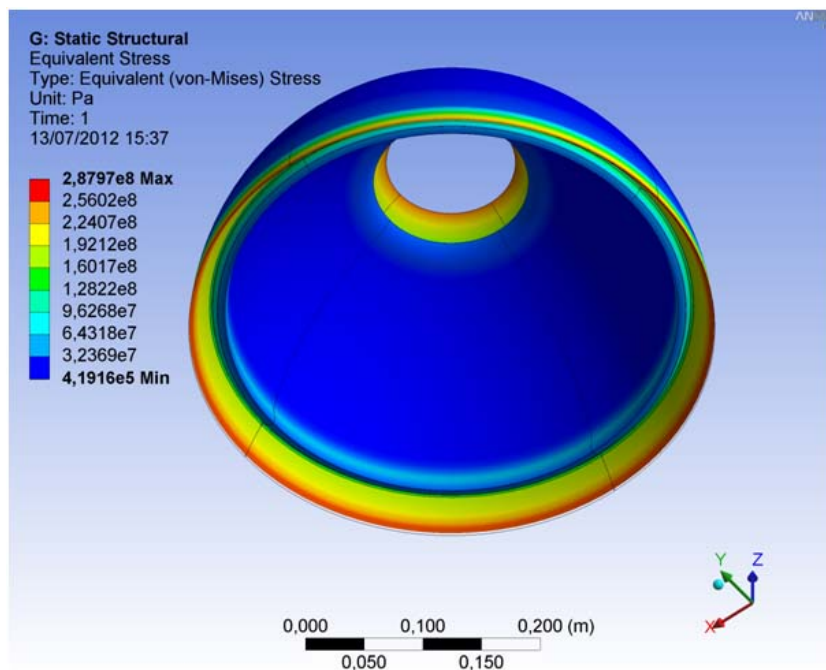


**Figure 5.21:** Result of total deformations in first two layers of pointed dome which are designed to cast from 10 mm of "Able cast 3000" and 14 mm "Firelite 2500<sup>TM</sup>"

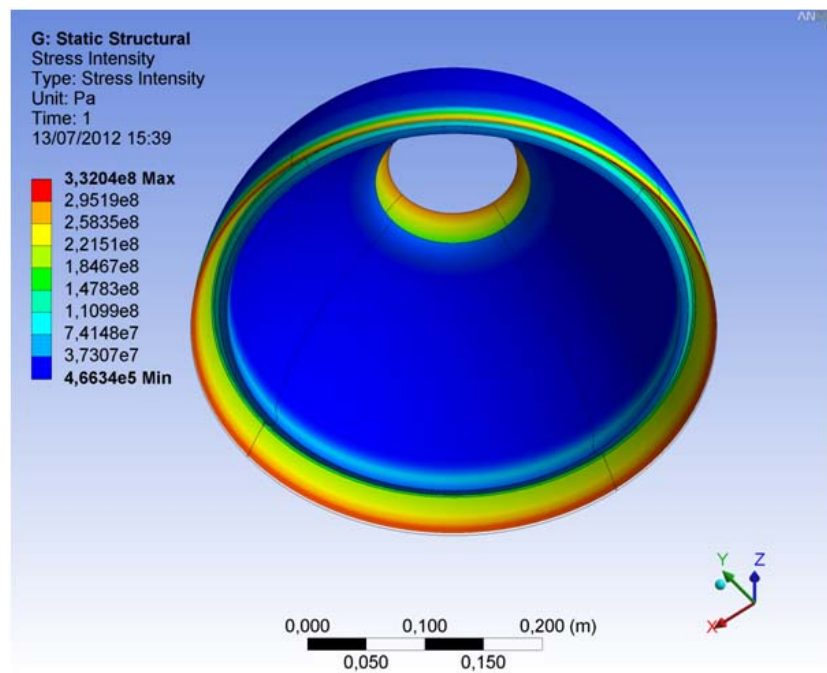


## DESIGN KILN FOR THERMAL SHOCK AND CHEMICAL TREATMENTS

---



**Figure 5.22:** Result of equivalent stress in first two layers of pointed dome of kiln structure



**Figure 5.23:** Result of stress intensity in first two layers of pointed dome of kiln structure

## DESIGN KILN FOR THERMAL SHOCK AND CHEMICAL TREATMENTS

---

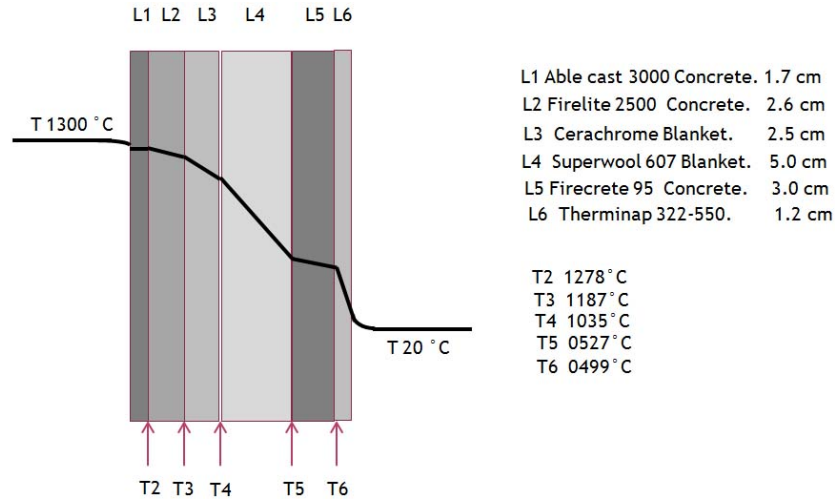
in external side.\*. The fourth layer is "Superwool <sup>TM</sup> 607 <sup>TM</sup> Blanket" with  $\lambda$  equal 0.25 ( $W.m^{-1}.K^{-1}$ ) so 50 mm thickness of this materials is proposed to reduce wall thickness, and change temperature from 1035°C in internal side to 527°C in external side.\*. The fifth layer is designed to be in hard concrete in order to be in contact with the tool of change atmosphere in zone of temperature less than 550°C where the liner change of Firecrete 95 is nearly constant to -0.1% and its resistance to compression is 60.8 MPa at this temperature \*. This layer designed to be 30 mm, and it is used to lining fiber refractory. In this layer the temperature change from 527 in internal side to 499°C in external side where it  $\lambda$  is 1.6 ( $W.m^{-1}.K^{-1}$ ). The last layer is designed of "Therminap 322-550" with low thermal conductivity 0.037 therefore 12 mm thickness is sufficient to change temperature from 499°C in internal side to 20°C in external side. So the total thickness of refractories is 160 mm. . The wall in pointed dome is designed in different order, where most of wall thickness in this part designed to be from refractory fiber. The thickness of first two layers in this part is 24 mm to change temperature from 1300°C inside the kiln to 1238°C in external side of this two layer, the third layer is a 120 mm of "Cerachrome <sup>TM</sup> Blanket" to change the temperature from 1238°C to 477°C and the last layer of refractories is desiend to be 12 mm of "Therminap 322-550", so the total thickness of refractories in this

---

\*The temperature limit of this material is 1424°C.(A.9)

\*The temperature limit of this material is 1100°C. (A.10)

\*The information data of this material is mentioned in (A.17)



**Figure 5.24:** The temperature profile in wall of cylinder and base parts of kiln, and the order of refractory materials

part is 161 mm.

#### 5.3.6.10 Respect of heating standards (FC6).

This function is related to determine electric resistance of heating elements which are required for new kiln. So, the accurate electric power which is used for heating the kiln up to 1300°C is required, and the power for new kiln is 2670 W, so two elements of silicon carbide are designed in parallel to be the heating elements of new kiln. Silicone carbide elements which are recommended to use in this kiln, do not have a specific rating in watts, but the rated power is function of high required temperature and surface loading of element ( $W.cm^2$ ) as mentioned in *KanthalGlobar*<sup>®</sup> SD technical data [33].

## DESIGN KILN FOR THERMAL SHOCK AND CHEMICAL TREATMENTS

---

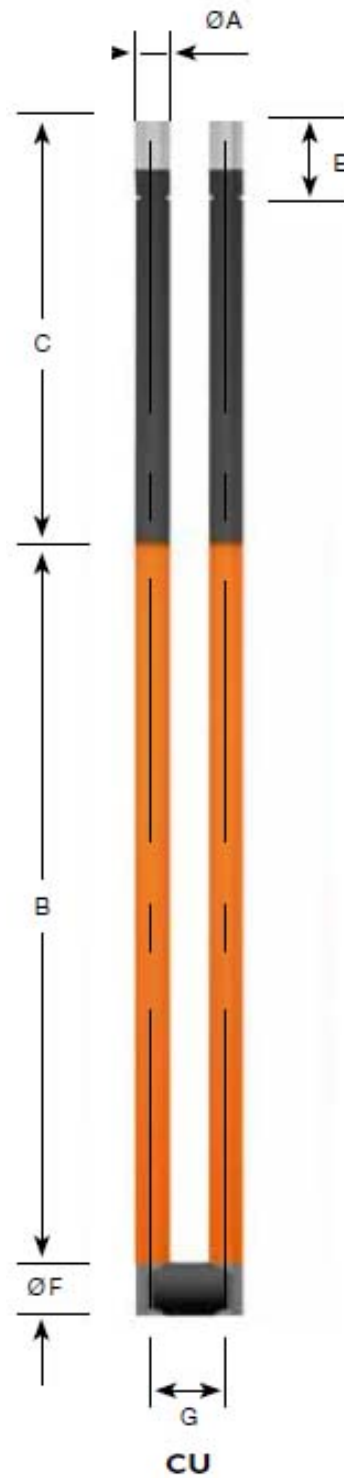
The recommended form to new kiln is CU as shown in figure (5.25), cold ends C is equal to base thickness 160 mm , hot zone B lengths is 260 mm , short end E with aluminum is 40 mm, and the diameter A of legs is 16 mm. Therefore the surface loading of elements recommended to new kiln is  $5 W.cm^2$ , where it is calculated by equation (5.39) and the temperature of each element is  $1365\text{ }^\circ\text{C}$  as mentioned in recommended element loading for *KanthalGlobar*<sup>®</sup> SD operated in air, is shown in figure (5.26).

$$\text{surface loading} = \pi \times A \times B \quad (5.39)$$

Where A is the outer diameter in cm and B is the length of hot zone in cm. the site of elements should be at minimum of 1.5 diameter between element center and any adjacent refractory.

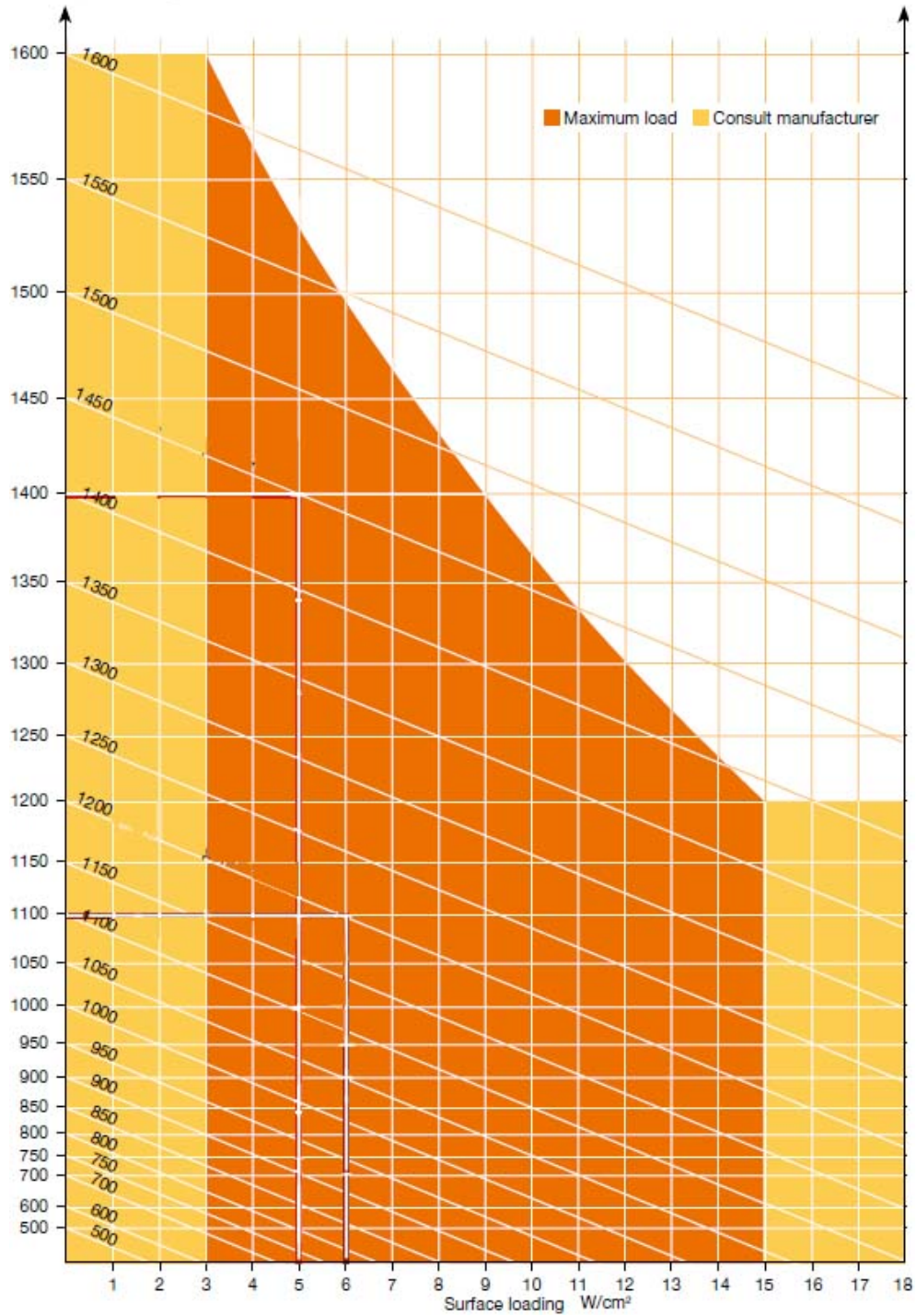
### 5.4 conception of kiln

The determinants of design are known during the study of serves function and external milieu elements. Kiln can be used as a tool to enrich the aesthetic of glaze colors and texture as before in traditional ceramics but with modern technology, and for applying new technique of crackle and metallic reflation. The three cylinders, the tools of changing atmosphere, are charged by material and waiting for change cylinders position, then the solid materials will melt and flow



**Figure 5.25:** Silicone carbide elements in form CU with two leg which is recommended to new kiln

## DESIGN KILN FOR THERMAL SHOCK AND CHEMICAL TREATMENTS



**Figure 5.26:** Chart of surface loading in function of kiln temperature and element temperature (recommended for Kanthal GLOBAR SD operated in air) [33].

## CONCEPTION OF KILN

---

inside the kiln through a breach which is designed in wall, as water will evaporate also inside the kiln through a tube. This function was design solutions which become executable design in following conception and plan.



## DESIGN KILN FOR THERMAL SHOCK AND CHEMICAL TREATMENTS

---

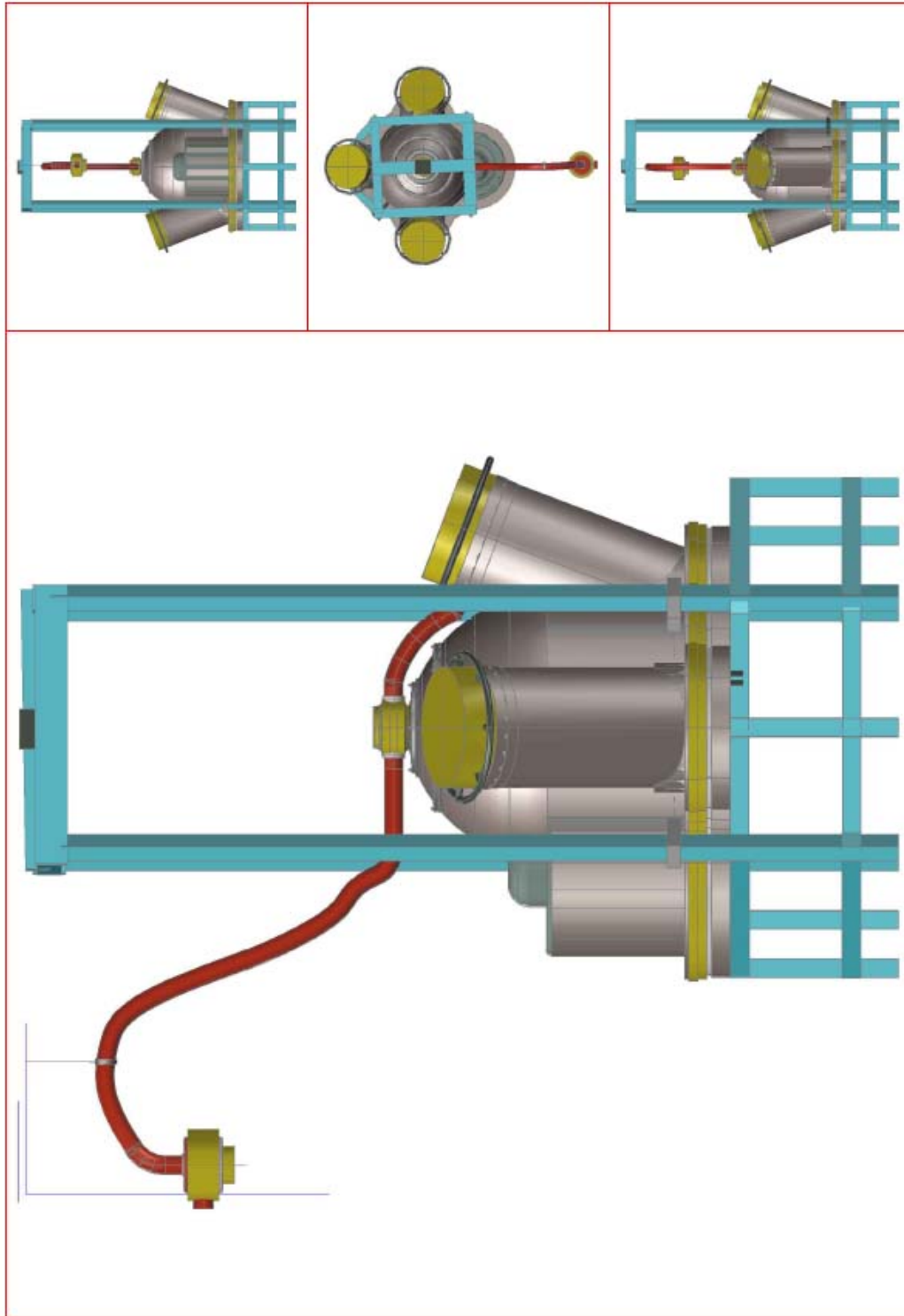


Figure 5.27: Conception of new kiln

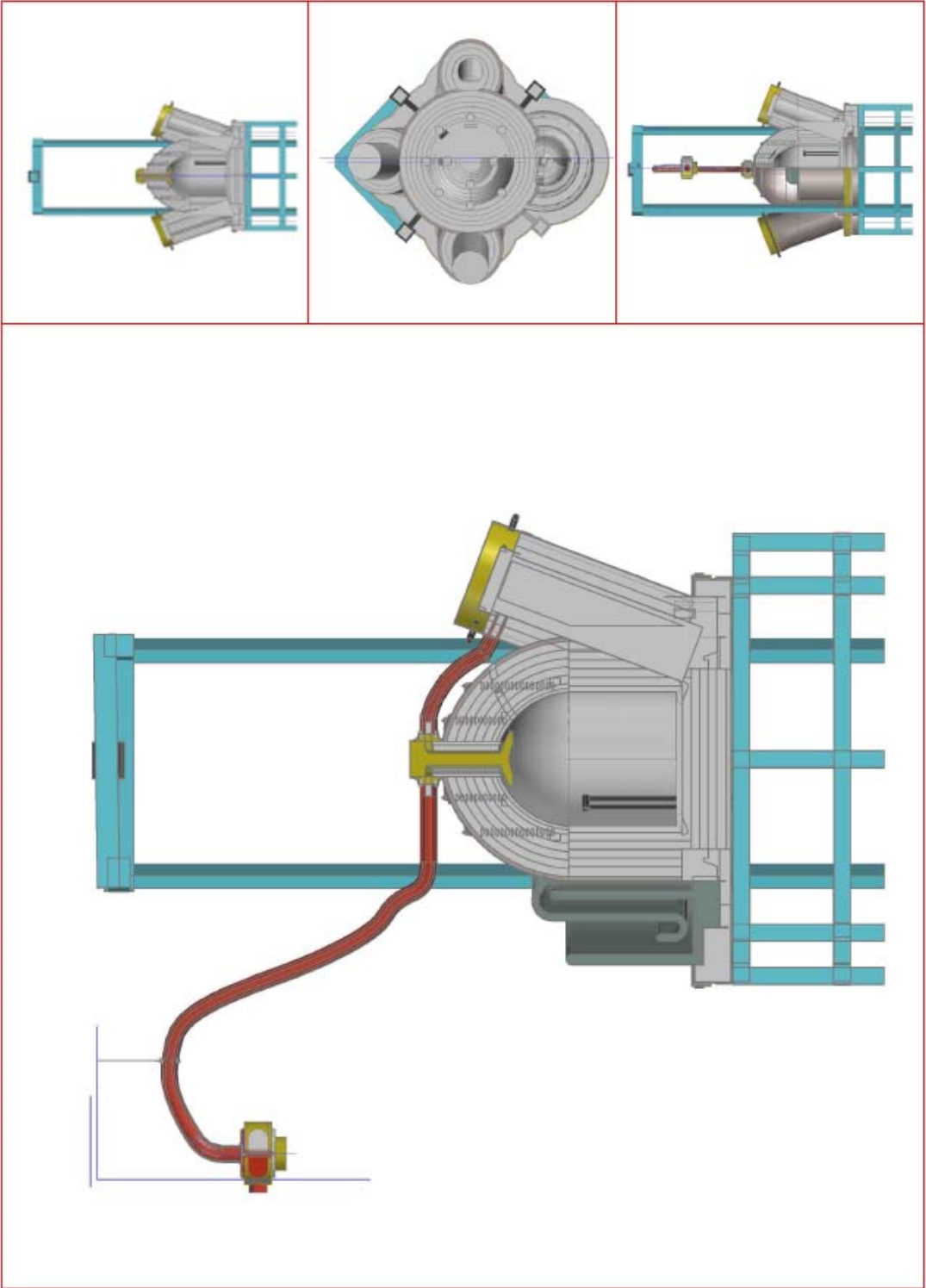


Figure 5.28: Plan of new kiln

## **5.5 Conclusions**

Ceramic kiln can be modified from just a place of heating to a place of create reactions which give ceramics their beauty under condition of heating and atmosphere of heating. This modification was related to historical study and scientific study, and it is achieved in conception which permits to change the condition of firing by dint of design solution, and in order to apply some traditional firing method and new technique of crackle and metallic reflection colors. The behavior of refractories materials which are proposed to build kiln structure is simulated by ANSYS program to test the possibility of producing this kiln, and rustles of this simulation confirmed that this conception of kiln can be produced.

# Conclusions and Perspectives

In this chapter, the main relation between history, art, technology and science are recalled and concern the results of historical and scientific study. The main contributions of this thesis are presented. In addition, some proposals for further research directions are introduced.

## Concluding Remarks

History of ceramics and their scientific conception have to consider the existence of two different disciplines, as the art and sciences. They were separated in Renaissance period. With recognition of this difference, there are common issues between science and human sciences, and research in these issues that can enrich both of them. This interface study concerned with researching the history of kiln technology and firing conduction with the relative effects on aesthetic treatments of ceramics form. Developed technologies lead to improve ceramics technology as well as kiln technology, the order which leads to disappear or modify some

## **CONCLUSIONS AND PERSPECTIVES**

---

technologies, and to produce others. This is what was discovered from historical and scientific study for two historical ceramics types. The first type, with metallic reflection decoration, which appeared in Iraq during Abbasid Caliphate period (750-1258), and the reduction atmosphere of kiln was the main procedure to produce this color. This technology was transferred to Egypt then to north of Africa then to Spain and Italy. During transferring of this technology, its firing condition was changed from reduction to oxidation. The second type, is technology of produce five famous kilns in China during the Sung dynasty (690-1279). Therefore, the reaction atmosphere and structure of kiln affect mainly the production of these styles of ceramics.

As evidenced by historical study that the scientific progress in chemistry of ceramics play important role in producing artificial porcelain in France, England, and Germany. M.Bronghiart mentioned to this role of chemistry in improving the art of ceramics and its applications, as well as color of glaze. This role has had a positive impact in enriching the esthetic treatments in industrial of ceramics and in expressive ceramics art.

This study is related to science and technology of ceramics , where it aims to determine design of kiln that can be used as tool to enrich the aesthetic of ceramics. This is achieved by selecting treatments that can occur during firing, and influencing positively on glaze color. Additionally, scientific study presents the explanation of traditional technology to improve it as a modern technology

## CONCLUSIONS AND PERSPECTIVES

---

of decorate ceramics.

Throughout the thesis, correlations between art, science, history and history of ceramic technology in referring to kiln technology are introduced to explain the philosophy of this recherche. whereas, it is interface research between these disciplines, so relative importance of general factors which affect in productions of promotional ceramics can be defined to classify the traditional styles of ceramics which are decorated by treatments during or after firing process. The relation between ceramics and these disciplines presents a vision about the benefit of correlation between them especially between kiln technology and esthetic treatments of ceramics forms. History of ceramic technology demonstrate development in materials, and production technologies which are necessary to design and produce ceramics, while science presents materials analysis methods, chemicals reactions and physical properties which explain technology of this styles. According to traditional styles of ceramics, treatments during firing was classified to atmosphere of kiln as referring to amount of oxygen, and condition of firing as referring to heating rate and inserting vapor of substances. kiln structure and heating technology determine treatments which can be carried out during firing.

For recognizing styles of firing condition in ceramics history, the classification of different types of ceramics art and pottery as presented by M.Brongniart was studied. Carbon atmosphere of firing was produced in primitive firing and in fuel kilns. The structure of recognized primitive firing affects in degree of reduction

## CONCLUSIONS AND PERSPECTIVES

---

as well as the type of kiln also and fuel. The styles of pottery or fired clay which were decorated by condition of firing, are Jomon pottery which was made in Japan (10,000 BC), Black-topped pottery which made in Egypt and Sudan (3500 BC), Red-black pottery (3500-3300 BC), and anthracite Black pottery. The glazed ceramics styles which were decorated by condition of firing; are Raku ceramics, the stone were with led glaze, Shino ceramics, the stoneware was with feldspathic glaze, metallic reflection the earthenware with luster glaze; As well as the chines porcelain such as Ru Kiln, Jun Kiln, Guan Kiln, and Ge Kiln. The history of firing technology demonstrate the relation between esthetic treatment of these styles and method of firing or kiln structure, where over-ground pit ,and pit with wall firing methods permit to make treatments, while firing in kiln doesn't allow to make this treatments. Therefore the esthetic treatments during history of ceramics were related to the structure of kiln, and its heat source.

Glaze is the material which is treated during firing process. The treatment which affect the glaze aspects can be determined from chemical reactions of its components and from physical properties, so nature and formation of glaze are presented to design glaze which represents as input of chemicals reactions to control aspect of glaze not only by normal composition of glaze but also by conditions of this reactions. A design physical property of glaze based on its components also was presented. The relation between different phases: glass, crystals, and liquid were decreased to design heating and cold rate and firing schedule as an

## CONCLUSIONS AND PERSPECTIVES

---

operation during firing according to network of glaze. Glaze structure expression is presented with limitation of glaze formula. The chemical treatment of ancient metallic reflection glazes and celadon glaze were presented to recognize their glaze composition as discovered by previous studies, as well as its colorant. Where, the composition of ancient glaze can be concluded to propose a raw material from their oxide analysis. The physical treatment of glaze that can produce crackle on surface was presented to design the glaze which can be treated by this aspect. Thus, the theoretical calculation of glaze properties and chemical formula was reorganized to prepare the accurate glaze for such procedures during firing for enriching its esthetic.

Furthermore, calculating glaze structure from oxides analysis was experimented to simulate the Ru kiln sample, and it can be concluded that this sample has porcelain body which resisted thermal shock and it has low thermal expansion coefficient. Therefore, the experimental study to simulate porcelain body and its glaze is significant to produce the clay body and glaze which are suitable to treat by thermal shock as a mechanical treatment. In addition, this study was led to design method to make thermal shock during cooling period. As for the chemicals treatments, method of design glaze permit to prepare glazes which are suitable to react with atmosphere of kiln for producing metallic phases of iron and copper as traditional technique. This metallic phase was designed to react with sulphidation atmosphere to produce sulfide iron-copper ores which give glazes different



## **CONCLUSIONS AND PERSPECTIVES**

---

colors. The Ellingham diagram and Cu:Fe:S system is used to regulate the relation between the glaze structure and the temperature of sulphidation treatment. Therefore, using kiln as tool to controls chemical reactions are modification to historical techniques that can be used today to create new method for gilding surface of ceramics glazes. This is in addition to some others colors as black with a metallic luster, indigo blue, and peacock ore. These are results of design all of glazes as chemical materials, treatments during firing as condition of reaction, and kiln structure to apply the treatments during firing.

In order to apply these new and traditional techniques, the conception of new kiln should be designed for permitting to treat glazed forms by thermal shock and chemical treatments. The process of conception was presented by APTE method for determination of the study boundaries, the requirements, utilization phase, and octopus diagram of new kiln. The service function which links between the kiln and elements of external milieu (EME), are presented to solve all problems and describe details of kiln.

## **Conclusion**

1. Correlations between art, science, history and history of ceramic technology in referring to kiln technology are demonstrated.
2. Treatments during firing were existed in many civilizations over history of

ceramics technology.

3. Historical study was important to limit materials that can be used to improve the tremens during firing as well as improve the kiln technology.
4. Chemical of glaze was important to identify and understand the ancient technology and reproduce it today, as well as to know the reaction during firing.
5. Phases diagrams of Iron copper and sulfur were the main guide to defined the temperature and reactions to create new technique during firing.
6. Mechanical properties of refractory was an issue to improve the kiln technologies.
7. Design solution permit to modify technology of firing when the history information and scientific knowledge are available .

### Future Work

Future work should explore other possibilities and routes in which this thesis could lead to more enriching for ceramics esthetic. Main perspectives should include:

- **The implementation of this kiln:**

Due to the possibility of producing metallic reflections, gilding, and crackle

## CONCLUSIONS AND PERSPECTIVES

---

decorations by this kiln, the implementation of this kiln is necessary. The techniques of thermal shock and chemical shock required this kiln, so the experimental study of these technologies have to continue for applying these techniques and specifying actual palettes and range of colors as function of treatment during firing and glaze compositions. This will lead to discover other uncertainties parameters.

Additionally, search for other metallic ores could be led to other esthetic treatments especial with method of design glaze and using each of Ellingham diagram phase's diagrams. Where this searching can lead to adapt technological production of such color of glaze, or to create new treatments, Where the condition of firing under control used by implementation of new kiln.

- **Verification and evaluation of using technique of crackle in presence of technique of chemical treatments:**

The proposed crackle by using thermal shock could be verified and assessed in presence of chemical treatment to create colored crackle. Research on the compatibility between the resistance of thermal shock and thermal expansion coefficient of glaze and clay body could be led to produce decoration by drawing of crackle on glazed form.

- **Recommendation to more scientific and experimental research on**

## CONCLUSIONS AND PERSPECTIVES

---

### **the history of ceramics techniques :**

Scientific and experimental research on the history of ceramics techniques could be considered as a deriving for artistic practices and applied ceramics, as well as it leads to discover and provide evidence about traditional techniques.



# Appendix A

**Table A.1:** chemical analysis for some clay bodies from Iraq which are covered by luster metallic expressed in oxide percent and normalized to 100%.

| Sample Number | SiO <sub>2</sub> | Na <sub>2</sub> O | MgO  | Al <sub>2</sub> O <sub>3</sub> | K <sub>2</sub> O | CaO   | TiO <sub>2</sub> | MnO  | FeO  | PbO  |
|---------------|------------------|-------------------|------|--------------------------------|------------------|-------|------------------|------|------|------|
| FUA. 06       | 51.60            | 1.20              | 5.90 | 11.90                          | 0.90             | 19.80 | 0.70             | 0.40 | 6.10 | 0.00 |
| FUA. 23       | 50.10            | 1.00              | 6.40 | 12.10                          | 0.70             | 21.50 | 0.60             | 0.30 | 6.40 | 0.00 |
| FUA. 26       | 50.10            | 1.30              | 6.40 | 11.90                          | 1.00             | 21.30 | 0.60             | 0.30 | 5.90 | 0.00 |
| FUA. 25       | 50.30            | 0.20              | 6.30 | 12.10                          | 1.10             | 21.10 | 0.80             | 0.30 | 6.40 | 0.00 |
| FUA. 07       | 49.50            | 1.50              | 6.00 | 12.00                          | 0.80             | 21.50 | 0.70             | 0.20 | 6.20 | 0.00 |

**Table A.2:** chemical analysis for some clay bodies from Kairouan which are covered by luster metallic expressed in oxide percent and normalized to 100% ( $\Delta$  is the standard deviation )

| Sample Number | Na <sub>2</sub> O | MgO  | Al <sub>2</sub> O <sub>3</sub> | SiO <sub>2</sub> | P <sub>2</sub> O <sub>5</sub> | S    | Cl   | K <sub>2</sub> O | CaO   | TiO <sub>2</sub> | Fe <sub>2</sub> O <sub>3</sub> |
|---------------|-------------------|------|--------------------------------|------------------|-------------------------------|------|------|------------------|-------|------------------|--------------------------------|
| BDX 5051      | 1.03              | 6.94 | 12.14                          | 49.04            | 1.28                          | 0.32 | 0.09 | 1.24             | 20.31 | 0.69             | 6.58                           |
| $\Delta$      | 0.12              | 0.48 | 0.44                           | 2.42             | 0.43                          | 0.09 | 0.03 | 0.12             | 1.33  | 0.14             | 0.41                           |
| BDX 6474      | 0.66              | 6.05 | 11.53                          | 44.75            | 2.65                          | 0.00 | 0.16 | 1.98             | 22.05 | 1.19             | 9.00                           |
| $\Delta$      | 0.21              | 0.34 | 0.51                           | 0.85             | 0.30                          | 0.00 | 0.08 | 0.58             | 0.68  | 0.51             | 0.81                           |
| BDX 6476      | 0.73              | 6.08 | 11.84                          | 47.09            | 2.46                          | 0.72 | 0.19 | 2.00             | 21.35 | 0.74             | 6.70                           |
| $\Delta$      | 0.20              | 0.25 | 0.18                           | 0.82             | 0.25                          | 0.18 | 0.06 | 0.28             | 0.78  | 0.09             | 0.21                           |
| BDX 5052      | 0.92              | 6.95 | 12.80                          | 47.95            | 0.71                          | 0.24 | 0.24 | 1.53             | 21.04 | 0.68             | 6.59                           |
| $\Delta$      | 0.31              | 0.57 | 0.84                           | 1.61             | 0.56                          | 0.06 | 0.08 | 0.22             | 1.67  | 0.04             | 0.39                           |
| BDX 6473      | 0.85              | 6.27 | 11.67                          | 47.51            | 1.17                          | 0.00 | 0.00 | 1.46             | 22.53 | 0.69             | 7.85                           |
| $\Delta$      | 0.07              | 0.19 | 0.23                           | 0.52             | 0.14                          | 0.00 | 0.00 | 0.12             | 0.36  | 0.03             | 0.20                           |
| BDX 6475      | 0.78              | 6.05 | 12.00                          | 47.40            | 1.47                          | 0.05 | 0.19 | 1.55             | 22.19 | 0.75             | 7.46                           |
| $\Delta$      | 0.24              | 0.26 | 0.39                           | 1.88             | 0.26                          | 0.13 | 0.04 | 0.37             | 1.34  | 0.07             | 0.46                           |
| BDX 6477      | 2.11              | 7.88 | 11.20                          | 45.26            | 0.00                          | 0.00 | 1.16 | 1.82             | 22.08 | 0.71             | 7.79                           |
| $\Delta$      | 0.49              | 0.54 | 0.68                           | 2.02             | 0.00                          | 0.00 | 0.51 | 0.46             | 1.56  | 0.05             | 0.42                           |
| BDX 6478      | 0.61              | 6.33 | 12.15                          | 48.55            | 1.39                          | 0.00 | 0.00 | 1.70             | 20.67 | 0.72             | 7.88                           |
| $\Delta$      | 0.07              | 0.19 | 0.23                           | 0.52             | 0.14                          | 0.00 | 0.00 | 0.12             | 0.36  | 0.03             | 0.20                           |

**Table A.3:** chemical analysis of glazes with metallic reflection from Kairouan expressed in oxide percent and normalized to 100% ( $\Delta$  is the standard deviation )

| Sample Number | Na <sub>2</sub> O | MgO  | Al <sub>2</sub> O <sub>3</sub> | SiO <sub>2</sub> | P <sub>2</sub> O <sub>5</sub> | Cl   | K <sub>2</sub> O | CaO  | MnO  | Fe <sub>2</sub> O <sub>3</sub> | SnO <sub>2</sub> | PbO  |
|---------------|-------------------|------|--------------------------------|------------------|-------------------------------|------|------------------|------|------|--------------------------------|------------------|------|
| BDX 5051      | 7.64              | 3.48 | 2.13                           | 66.87            | 0.00                          | 0.69 | 3.02             | 4.70 | 0.43 | 0.79                           | 2.63             | 6.92 |
| $\Delta$      | 0.81              | 0.27 | 0.97                           | 1.84             | 0.00                          | 0.06 | 0.20             | 0.28 | 0.07 | 0.10                           | 0.71             | 0.86 |
| BDX 6474      | 5.73              | 2.95 | 1.58                           | 65.95            | 2.49                          | 0.69 | 3.05             | 4.84 | 0.47 | 1.06                           | 1.79             | 9.27 |
| $\Delta$      | 0.22              | 0.28 | 0.53                           | 1.22             | 0.25                          | 0.07 | 0.14             | 0.32 | 0.06 | 0.34                           | 0.97             | 0.84 |
| BDX 6476      | 6.68              | 3.84 | 1.88                           | 66.67            | 0.81                          | 0.64 | 3.14             | 5.63 | 0.49 | 0.97                           | 1.74             | 7.42 |
| $\Delta$      | 0.70              | 0.64 | 0.48                           | 0.73             | 0.61                          | 0.06 | 0.35             | 1.07 | 0.04 | 0.35                           | 0.80             | 1.20 |
| BDX 5052      | 7.79              | 3.32 | 1.58                           | 67.44            | 0.00                          | 0.74 | 2.88             | 4.43 | 0.45 | 0.73                           | 3.02             | 6.87 |
| $\Delta$      | 0.40              | 0.36 | 0.43                           | 2.10             | 0.00                          | 0.08 | 0.20             | 0.46 | 0.05 | 0.09                           | 0.85             | 0.78 |
| BDX 6473      | 7.02              | 3.27 | 1.81                           | 68.08            | 0.34                          | 0.70 | 3.18             | 4.56 | 0.39 | 0.94                           | 2.39             | 7.25 |
| $\Delta$      | 0.45              | 0.56 | 0.68                           | 2.75             | 0.48                          | 0.06 | 0.24             | 1.01 | 0.06 | 0.35                           | 0.98             | 0.71 |
| BDX 6475      | 7.29              | 3.38 | 1.69                           | 66.66            | 0.78                          | 0.72 | 3.56             | 4.88 | 0.48 | 0.75                           | 1.69             | 8.12 |
| $\Delta$      | 0.36              | 0.45 | 0.43                           | 0.82             | 0.46                          | 0.07 | 0.16             | 0.67 | 0.10 | 0.05                           | 0.75             | 0.48 |
| BDX 6477      | 7.23              | 3.42 | 1.46                           | 65.00            | 0.00                          | 0.59 | 3.85             | 4.95 | 0.39 | 0.75                           | 4.31             | 8.05 |
| $\Delta$      | 0.19              | 0.19 | 0.24                           | 1.26             | 0.00                          | 0.06 | 0.14             | 0.31 | 0.04 | 0.10                           | 1.99             | 0.94 |
| BDX 6478      | 7.35              | 3.30 | 1.77                           | 66.51            | 0.99                          | 0.74 | 2.97             | 4.71 | 0.45 | 0.83                           | 2.92             | 7.47 |
| $\Delta$      | 0.35              | 0.46 | 0.61                           | 1.69             | 0.14                          | 0.03 | 0.08             | 0.64 | 0.07 | 0.11                           | 1.59             | 0.63 |



**Table A.4:** chemical analysis of Iraq luster metallic glaze expressed in oxide percent and normalized to 100%.

| Sample Number | SiO <sub>2</sub> | PbO   | Na <sub>2</sub> O | K <sub>2</sub> O | CaO  | Al <sub>2</sub> O <sub>3</sub> | SnO <sub>2</sub> | MgO  | FeO  |
|---------------|------------------|-------|-------------------|------------------|------|--------------------------------|------------------|------|------|
| FUA. 06       | 54.50            | 14.40 | 5.80              | 4.10             | 3.60 | 1.80                           | 13.10            | 2.20 | 0.50 |
| FUA. 23       | 56.60            | 10.10 | 6.50              | 4.70             | 4.10 | 1.90                           | 12.20            | 3.30 | 0.50 |
| FUA. 26       | 59.30            | 8.00  | 7.00              | 4.70             | 4.30 | 2.20                           | 10.60            | 3.40 | 0.60 |
| FUA. 25       | 60.60            | 7.80  | 8.70              | 4.10             | 4.10 | 1.60                           | 9.00             | 3.50 | 0.70 |
| FUA. 07       | 65.30            | 5.80  | 6.40              | 3.40             | 7.30 | 1.20                           | 6.50             | 2.40 | 0.50 |

**Table A.5:** chemical analysis of some kinds of wood ,normalized to 100%.

| Designation<br>of wood fuel | Carbon C | Hydrogen H | Nitrogen N | Oxygen O | Ashes |
|-----------------------------|----------|------------|------------|----------|-------|
| Oak wood                    | 50.44    | 6.01       | 1.06       | 42.49    | 1.69  |
| Birch wood                  | 51.30    | 6.28       | 0.00       | 41.54    | 0.85  |
| Aspen wood                  | 50.35    | 6.28       | 0.82       | 42.55    | 2.11  |
| Fir wood                    | 50.59    | 6.11       | 1.04       | 41.26    | 1.29  |
| Pine wood                   | 51.71    | 6.11       | 0.81       | 41.37    | 1.15  |

---

**Table A.6:** chemical analysis of some kinds of lignite ,normalized to 100%

| Designation          | Carbon C | Hydrogen H | Oxygen O<br>and Nitrogen N | Ashes |
|----------------------|----------|------------|----------------------------|-------|
| Uznach lignite       | 57.29    | 5.83       | 36.88                      | 2.19  |
| Basses-Alpes lignite | 72.19    | 5.36       | 22.45                      | 3.01  |
| Elbong lignite       | 77.64    | 7.85       | 14.51                      | 4.96  |

**Table A.7:** chemical analysis of some kinds of coal ,normalized to 100%

| Designation       | Carbon C | Hydrogen H | Oxygen O<br>and Nitrogen N | Ashes |
|-------------------|----------|------------|----------------------------|-------|
| Saint-Girons coal | 76.05    | 5.69       | 18.26                      | 4.08  |
| Blanzy coal       | 78.26    | 5.35       | 18.39                      | 2.28  |
| Lancashire coal   | 85.81    | 5.85       | 8.34                       | 2.55  |
| Newcastel coal    | 89.19    | 5.31       | 5.50                       | 1.40  |
| Alais coal        | 90.55    | 4.92       | 4.53                       | 1.41  |

---

**Table A.8:** classification for oxide glasses based on single bond strength

| Oxide                               | Oxidation state | Coordination number | Bond strength, relative |
|-------------------------------------|-----------------|---------------------|-------------------------|
| Network formers                     |                 |                     |                         |
| SiO <sub>2</sub>                    | 4               | 4                   | 106                     |
| B <sub>2</sub> O <sub>3</sub>       | 3               | 3                   | 119                     |
| Intermediates                       |                 |                     |                         |
| Al <sub>2</sub> O <sub>3</sub>      | 3               | 4                   | 90                      |
| Al <sub>2</sub> O <sub>3</sub>      | 3               | 6                   | 60                      |
| ZnO                                 | 2               | 2                   | 72                      |
| ZnO                                 | 2               | 4                   | 36                      |
| PbO                                 | 2               | 2                   | 73                      |
| PbO <sub>2</sub>                    | 4               | 6                   | 39                      |
| Modifiers                           |                 |                     |                         |
| Na <sub>2</sub> O                   | 1               | 6                   | 20                      |
| CaO                                 | 2               | 8                   | 32                      |
| Substitutions for Na <sub>2</sub> O |                 |                     |                         |
| K <sub>2</sub> O                    | 1               | 9                   | 13                      |
| Rb <sub>2</sub> O                   | 1               | 10                  | 12                      |
| Cs <sub>2</sub> O                   | 1               | 12                  | 10                      |
| Li <sub>2</sub> O                   | 1               | 4                   | 36                      |
| Substitutions for CaO               |                 |                     |                         |
| MgO                                 | 2               | 6                   | 37                      |
| BaO                                 | 2               | 8                   | 33                      |
| SrO                                 | 2               | 8                   | 32                      |

---

**Table A.9:** Temperature equivalents for Orton standard large cones. Source: American Ceramic Society.

| Low-temperature rang |              |          | Middle-temperature rang |              |          | High-temperature rang |              |          |
|----------------------|--------------|----------|-------------------------|--------------|----------|-----------------------|--------------|----------|
| Cone no              | heating rate | 270°F/hr | Cone no                 | heating rate | 270°F/hr | Cone no               | heating rate | 270°F/hr |
|                      | 150°C/hr     | 270°F/hr |                         | 150°C/hr     | 270°F/hr |                       | 150°C/hr     | 270°F/hr |
| C.010                | 894°C        | 1641°F   | C.4                     | 1186°C       | 2167°F   | C.8                   | 1263°C       | 2305°F   |
| C.09                 | 923°C        | 1693°F   | C.5                     | 1196°C       | 2185°F   | C.9                   | 1280°C       | 2336°F   |
| C.08                 | 955°C        | 1751°F   | C.6                     | 1222°C       | 2232°F   | C.10                  | 1305°C       | 2381°F   |
| C.07                 | 984°C        | 1803°F   | C.7                     | 1240°C       | 2264°F   | C.11                  | 1315°C       | 2399°F   |
| C.06                 | 999°C        | 1830°F   |                         |              |          | C.12                  | 1326°C       | 2419°F   |
| C.05                 | 1046°C       | 1915°F   |                         |              |          | C.13                  | 1346°C       | 2455°F   |
| C.04                 | 1060°C       | 1940°F   |                         |              |          | C.14                  | 1366°C       | 2491°F   |
| C.03                 | 1101°C       | 2014°F   |                         |              |          | C.15                  | 1431°C       | 2608°F   |
| C.02                 | 1120°C       | 2048°F   |                         |              |          |                       |              |          |
| C.01                 | 1137°C       | 2079°F   |                         |              |          |                       |              |          |
| C.1                  | 1154°C       | 2109°F   |                         |              |          |                       |              |          |
| C.2                  | 1162°C       | 2124°F   |                         |              |          |                       |              |          |
| C.3                  | 1168°C       | 2134°F   |                         |              |          |                       |              |          |

**Table A.10:** temperature equivalent for Seger standard cones ,source: Staatliche prozellan-manufaktur, Berlin

| Low-temperature rang |        | Middle-temperature rang |        | High-temperature rang |        |
|----------------------|--------|-------------------------|--------|-----------------------|--------|
| Cone no              |        | Cone no                 |        | Cone no               |        |
| 022                  | 595°C  | 2a                      | 1150°C | 7                     | 1260°C |
| 021                  | 894°C  | 3a                      | 1170°C | 8                     | 1280°C |
| 020                  | 923°C  | 4a                      | 1195°C | 9                     | 1300°C |
| 019                  | 955°C  | 5a                      | 1215°C | 10                    | 1320°C |
| 018                  | 984°C  | 6a                      | 1240   | 11                    | 1340°C |
| 017                  | 999°C  |                         |        |                       |        |
| 016                  | 1046°C |                         |        | 12                    | 1360°C |
| 015a                 | 1060°C |                         |        | 13                    | 1380°C |
| 014a                 | 1101°C |                         |        | 14                    | 1400°C |
| 013a                 | 835°C  |                         |        | 15                    | 1425°C |
| 012a                 | 860°C  |                         |        |                       |        |
| 011a                 | 900°C  |                         |        |                       |        |
| 010a                 | 920°C  |                         |        |                       |        |
| 09a                  | 935°C  |                         |        |                       |        |
| 08a                  | 955°C  |                         |        |                       |        |
| 07a                  | 970°C  |                         |        |                       |        |
| 06a                  | 990°C  |                         |        |                       |        |
| 05a                  | 1000°C |                         |        |                       |        |
| 04a                  | 1025°C |                         |        |                       |        |
| 03a                  | 1055°C |                         |        |                       |        |
| 02a                  | 1085°C |                         |        |                       |        |
| 01a                  | 1105°C |                         |        |                       |        |
| 1a                   | 1125°C |                         |        |                       |        |

---

**Table A.11:** A Cross Reference List Of Comparable Frits

| Pemco    | O-Hommel | Ferro |
|----------|----------|-------|
| P-54     | 14       | 3134  |
| P-25     | 25       | 3269  |
| P-830    | K-3      | 3278  |
| Pb-723   | 437      | 3403  |
| Pb-63    | 24       | 3417  |
| Pb-83    | 33       | 3419  |
| Pb-1307  | 11       | 3470  |
| Pb-1151  | 27       | 3482  |
| Pb-801   | 520      | 3485  |
| Pb-716   |          | 3489  |
| Pb-742   | 373      | 3493  |
| Pb-IK-75 | 474      | 3532  |
| Pb-349   |          | 3565  |
| P-311    | 90       | 3124  |
| P-1409   |          | 3249  |
| P626     | 400      | 3289  |
| P-802    | 378      | 3270  |
| Pb-IR40  |          | 3471  |
|          | 595      | 3496  |

**Table A.12:** Standard glaze frits in order of Fusion temperature from Ferro Company, Composition in Equivalent

| Frit no. | Mol wt | Fusion temp, °F | Coeff. of exp | K <sub>2</sub> O | Na <sub>2</sub> O | Li <sub>2</sub> O | CaO   | MgO   | BaO | SrO | ZnO   | PbO   | Al <sub>2</sub> O <sub>3</sub> | B <sub>2</sub> O <sub>3</sub> | ZrO <sub>2</sub> | SiO <sub>2</sub> | TiO <sub>2</sub> | F     |
|----------|--------|-----------------|---------------|------------------|-------------------|-------------------|-------|-------|-----|-----|-------|-------|--------------------------------|-------------------------------|------------------|------------------|------------------|-------|
| 3453     | 257.4  | 850             | 6.8           |                  |                   |                   |       |       |     |     |       | 1.000 |                                | 0.431                         |                  | 0.07             |                  |       |
| 3419     | 270.8  | 1000            | 8.8           |                  | 0.282             |                   |       |       |     |     |       | 0.718 |                                | 0.564                         |                  | 0.90             |                  |       |
| 3476     | 352.5  | 1050            | 7.1           |                  |                   |                   |       |       |     |     |       | 1.000 |                                | 1.000                         |                  | 1.00             |                  |       |
| 3435     | 302.1  | 1300            | 7.5           | 0.045            | 0.212             |                   | 0.393 |       |     |     |       | 0.350 | 0.065                          | 0.707                         |                  | 2.14             |                  |       |
| 3485     | 335.1  | 1300            | 7.7           |                  | 0.333             |                   |       |       |     |     |       | 0.667 |                                | 0.666                         |                  | 1.98             |                  |       |
| 3545     | 275.6  | 1300            | 7.3           | 0.040            | 0.086             |                   | 0.484 |       |     |     |       | 0.390 | 0.094                          | 0.439                         |                  | 1.87             |                  |       |
| 3369     | 331.7  | 1300            | 9.0           |                  | 0.502             |                   |       |       |     |     |       | 0.498 |                                | 1.004                         |                  | 1.99             |                  |       |
| 3191     | 248.7  | 1300            | 9.2           |                  | 0.501             |                   | 0.499 |       |     |     |       |       | 1.002                          |                               | 2.00             |                  |                  |       |
| 3227     | 372.9  | 1300            | 9.8           |                  | 0.162             | 0.838             |       |       |     |     |       |       | 0.568                          | 1.526                         | 2.36             |                  |                  |       |
| 3205     | 235.5  | 1320            | 11.4          | 0.198            | 0.483             |                   | 0.319 |       |     |     |       |       | 0.286                          | 0.308                         | 1.97             |                  |                  |       |
| 3185     | 807.2  | 1350            | 6.0           |                  | 1.000             |                   |       |       |     |     |       |       |                                | 4.430                         | 7.27             |                  |                  |       |
| 3223     | 505.6  | 1350            | 7.6           |                  | 1.000             |                   |       |       |     |     |       |       |                                | 2.000                         | 5.07             |                  |                  |       |
| 3470     | 232.0  | 1350            | 7.5           |                  | 0.084             |                   | 0.230 |       |     |     | 0.258 | 0.428 | 0.123                          | 0.283                         | 1.07             |                  |                  |       |
| 3403     | 307.0  | 1350            | 7.2           | 0.047            | 0.017             |                   | 0.004 |       |     |     |       | 0.932 | 0.069                          |                               | 1.43             |                  |                  |       |
| 3457     | 235.1  | 1350            | 7.6           |                  | 0.034             |                   | 0.350 |       |     |     |       | 0.616 | 0.053                          |                               | 1.17             |                  |                  |       |
| 3482     | 365.5  | 1400            | 8.3           | 0.152            | 0.159             |                   | 0.212 |       |     |     |       | 0.477 |                                | 0.318                         | 2.62             | 0.442            |                  | 0.424 |
| 3824     | 235.8  | 1400            | 8.3           |                  | 0.346             |                   | 0.188 |       |     |     | 0.465 |       |                                | 0.988                         | 1.62             |                  |                  |       |
| 3264     | 291.6  | 1400            | 11.0          |                  | 0.984             |                   | 0.005 | 0.011 |     |     |       |       | 0.192                          | 0.885                         | 2.47             |                  |                  |       |
| 3278     | 270.6  | 1400            | 9.7           |                  | 0.669             |                   | 0.331 |       |     |     |       |       |                                | 0.842                         | 2.53             |                  |                  |       |
| 3823     | 257.7  | 1400            | 9.7           |                  | 0.621             |                   | 0.379 |       |     |     |       |       |                                | 0.794                         | 2.37             |                  |                  |       |
| 3819     | 328.0  | 1400            | 10.3          | 0.250            | 0.690             |                   | 0.019 |       |     |     | 0.041 |       | 0.404                          | 0.782                         | 2.61             |                  |                  | 0.264 |
| 3269     | 354.5  | 1400            | 11.4          | 0.306            | 0.641             |                   | 0.009 |       |     |     | 0.044 |       | 0.462                          | 0.778                         | 2.95             |                  |                  | 0.300 |
| 3417     | 382.4  | 1400            | 6.7           | 0.077            | 0.095             |                   | 0.306 |       |     |     |       | 0.522 | 0.113                          | 0.691                         | 0.075            | 2.78             |                  |       |
| 3516     | 236.1  | 1400            | 7.6           | 0.044            | 0.040             |                   | 0.517 | 0.001 |     |     |       | 0.398 | 0.061                          | 0.442                         | 1.24             |                  |                  |       |

Continued on next page

Table A.12 – continued from previous page

| Frit no. | Mol wt | Fusion temp, °F | Coeff. of expansion | K <sub>2</sub> O | Na <sub>2</sub> O | Li <sub>2</sub> O | CaO   | MgO   | BaO   | SrO | ZnO   | PbO   | Al <sub>2</sub> O <sub>3</sub> | B <sub>2</sub> O <sub>3</sub> | ZrO <sub>2</sub> | SiO <sub>2</sub> | TiO <sub>2</sub> | F     |
|----------|--------|-----------------|---------------------|------------------|-------------------|-------------------|-------|-------|-------|-----|-------|-------|--------------------------------|-------------------------------|------------------|------------------|------------------|-------|
| 3110     | 260.6  | 1400            | 10.1                | 0.064            | 0.643             |                   | 0.293 |       |       |     |       |       | 0.094                          | 0.098                         |                  | 3.03             |                  |       |
| 3226     | 587.0  | 1450            | 6.3                 |                  | 0.693             |                   | 0.307 |       |       |     |       |       | 0.052                          | 3.067                         |                  | 5.13             |                  |       |
| 3221     | 399.1  | 1450            | 9.4                 | 0.175            | 0.812             |                   | 0.013 |       |       |     |       |       | 0.691                          | 1.501                         |                  | 2.61             |                  |       |
| 3134     | 190.5  | 1450            | 9.6                 |                  | 0.316             |                   | 0.684 |       |       |     |       |       |                                | 0.632                         |                  | 1.47             |                  |       |
| 3454     | 710.4  | 1450            | 5.5                 | 0.125            | 0.215             |                   |       |       |       |     |       | 0.374 | 0.087                          | 3.123                         |                  | 4.85             |                  |       |
| 3361     | 509.0  | 1450            | 5.9                 | 0.055            | 0.217             |                   | 0.354 |       |       |     |       | 0.374 | 0.087                          | 2.238                         |                  | 3.70             |                  |       |
| 3304     | 382.5  | 1500            | 6.6                 |                  | 0.067             |                   |       |       |       |     |       | 0.933 | 0.149                          |                               |                  | 2.58             |                  |       |
| 3489     | 248.3  | 1500            | 7.3                 |                  |                   |                   | 0.248 |       |       |     |       | 0.752 |                                |                               |                  | 1.10             |                  |       |
| 3271     | 247.9  | 1500            | 9.3                 |                  | 0.514             |                   | 0.486 |       |       |     |       |       |                                | 0.768                         |                  | 2.25             |                  |       |
| 3287     | 374.0  | 1500            | 8.2                 |                  | 0.333             |                   |       |       | 0.667 |     |       |       | 0.200                          | 0.667                         |                  | 3.07             |                  |       |
| 3270     | 274.0  | 1500            | 9.4                 | 0.159            | 0.380             |                   | 0.461 |       |       |     |       |       | 0.232                          | 0.648                         |                  | 2.34             |                  |       |
| 3814     | 225.7  | 1500            | 8.9                 | 0.009            | 0.315             |                   | 0.676 |       |       |     |       |       | 0.110                          | 0.624                         |                  | 1.87             |                  |       |
| 3193     | 271.5  | 1500            | 9.0                 | 0.074            | 0.407             |                   | 0.519 |       |       |     |       |       | 0.208                          | 0.610                         |                  | 2.44             |                  |       |
| 5301     | 247.2  | 1500            | 11.6                | 0.134            | 0.765             |                   | 0.101 |       |       |     |       |       | 0.274                          | 0.418                         |                  | 1.72             |                  | 1.151 |
| 3240     | 207.2  | 1500            | 8.6                 | 0.012            | 0.152             |                   | 0.326 |       | 1.107 |     | 0.403 |       | 0.018                          | 0.295                         | 0.172            | 1.36             |                  | 0.209 |
| 3493     | 373.3  | 1500            | 6.7                 | 0.077            | 0.095             |                   | 0.305 |       |       |     |       | 0.523 | 0.113                          | 0.691                         |                  | 2.77             |                  |       |
| 3576     | 339.9  | 1500            | 7.1                 |                  | 0.211             |                   | 0.288 |       |       |     |       | 0.501 | 0.118                          | 0.667                         | 0.022            | 2.28             |                  |       |
| 3471     | 258.1  | 1500            | 8.0                 | 0.071            | 0.022             |                   | 0.302 |       | 0.252 |     |       | 0.353 | 0.098                          | 0.455                         |                  | 1.23             |                  |       |
| 3519     | 270.8  | 1500            | 8.2                 | 0.093            | 0.338             |                   | 0.007 |       |       |     | 0.310 | 0.251 | 0.144                          | 0.424                         |                  | 1.92             |                  |       |
| 3293     | 342.6  | 1550            | 8.9                 |                  | 0.922             |                   | 0.012 | 0.066 |       |     |       |       | 0.200                          |                               |                  | 4.36             |                  |       |
| 3224     | 1022.0 | 1600            | 5.8                 |                  | 0.879             |                   | 0.051 | 0.070 |       |     |       |       | 0.913                          | 3.850                         |                  | 10.00            |                  |       |
| 3241     | 921.0  | 1600            | 4.5                 | 0.152            | 0.836             |                   | 0.012 |       |       |     |       | 0.220 | 2.220                          |                               | 11.36            |                  |                  |       |
| 3815     | 274.6  | 1600            | 7.2                 |                  | 0.270             |                   | 0.205 |       |       |     | 0.525 |       |                                | 1.200                         |                  | 2.00             |                  |       |



**Table A.13:** weight fraction of each oxides components of Ru Guan porcelain body (RGPD)

| Code  | Name | Body color | Compensating oxides analysis of Ru porcelain body |                  |                  |      |                  |      |                                |       |                                |                  | weight fraction of each oxides components |      |                  |      |                                |  |
|-------|------|------------|---|------------------|------------------|------|------------------|------|--------------------------------|-------|--------------------------------|------------------|---|------|------------------|------|--------------------------------|--|
|       |      |            | Al <sub>2</sub> O <sub>3</sub>                    | SiO <sub>2</sub> | K <sub>2</sub> O | CaO  | TiO <sub>2</sub> | MnO  | Fe <sub>2</sub> O <sub>3</sub> | LOI   | Al <sub>2</sub> O <sub>3</sub> | SiO <sub>2</sub> | K <sub>2</sub> O                          | CaO  | TiO <sub>2</sub> | MnO  | Fe <sub>2</sub> O <sub>3</sub> |  |
| R40b  | RGPD | ashy gray  | 27.98   | 66.75            | 1.80             | 0.53 | 1.17             | 0.02 | 1.75                           | 27.56 | 65.74                          | 1.77             | 0.52                                      | 1.15 | 0.02             | 1.73 |                                |  |
| R41b  | RGPD | ashy gray  | 26.60   | 67.05            | 2.21             | 0.74 | 1.1              | 0.02 | 2.27                           | 26.21 | 66.06                          | 2.18             | 0.73                                      | 1.08 | 0.02             | 2.24 |                                |  |
| R42b  | RGPD | ashy gray  | 28.46   | 66.24            | 1.76             | 0.38 | 1.30             | 0.2  | 1.84                           | 28.03 | 65.25                          | 1.73             | 0.38                                      | 1.28 | 0.02             | 1.81 |                                |  |
| R43b  | RGPD | ashy gray  | 30.62   | 63.21            | 1.54             | 1.49 | 1.07             | 0.04 | 2.03                           | 30.16 | 62.26                          | 1.52             | 1.47                                      | 1.05 | 0.04             | 2.00 |                                |  |
| R44b  | RGPD | ashy gray  | 27.27   | 66.78            | 1.93             | 0.42 | 1.15             | 0.02 | 2.43                           | 26.86 | 65.77                          | 1.90             | 0.42                                      | 1.13 | 0.02             | 2.39 |                                |  |
| R47b  | RGPD | ashy gray  | 30.57   | 62.79            | 2.20             | 1.37 | 1.15             | 0.01 | 1.91                           | 30.11 | 61.84                          | 2.17             | 1.35                                      | 1.13 | 0.01             | 1.88 |                                |  |
| R271b | RGPD | ashy gray  | 27.18   | 67.27            | 1.85             | 0.44 | 1.29             | 0.00 | 1.97                           | 26.77 | 66.26                          | 1.82             | 0.44                                      | 1.27 | 0.00             | 1.94 |                                |  |
| R275b | RGPD | ashy gray  | 27.06   | 67.31            | 1.89             | 0.61 | 1.25             | 0.01 | 1.87                           | 26.66 | 66.31                          | 1.86             | 0.60                                      | 1.23 | 0.01             | 1.84 |                                |  |
| R330b | RGPD | ashy gray  | 32.23   | 61.87            | 1.80             | 0.85 | 1.12             | 0.00 | 2.13                           | 31.75 | 60.94                          | 1.77             | 0.84                                      | 1.10 | 0.00             | 2.10 |                                |  |
| R333b | RGPD | ashy gray  | 32.26   | 62.48            | 1.57             | 0.57 | 1.1              | 0.00 | 2.02                           | 31.78 | 61.54                          | 1.55             | 0.56                                      | 1.08 | 0.00             | 1.99 |                                |  |
| R339b | RGPD | ashy gray  | 30.56   | 63.70            | 1.46             | 1.09 | 1.21             | 0.02 | 1.96                           | 30.10 | 62.74                          | 1.44             | 1.08                                      | 1.19 | 0.02             | 1.93 |                                |  |
| R382b | RGPD | ashy gray  | 27.39   | 65.81            | 1.94             | 1.83 | 1.20             | 0.03 | 1.80                           | 26.98 | 64.83                          | 1.91             | 1.80                                      | 1.18 | 0.03             | 1.78 |                                |  |

**Table A.14:** weight fraction of each oxides components of Ru Guan glaze

| Code  | Name | Body color | Compensating oxides analysis of Ru porcelain body |                  |                  |      |                  |      |                                |       |                                |                  | weight fraction of each oxides components |      |                  |      |                                |  |
|-------|------|------------|---|------------------|------------------|------|------------------|------|--------------------------------|-------|--------------------------------|------------------|---|------|------------------|------|--------------------------------|--|
|       |      |            | Al <sub>2</sub> O <sub>3</sub>                    | SiO <sub>2</sub> | K <sub>2</sub> O | CaO  | TiO <sub>2</sub> | MnO  | Fe <sub>2</sub> O <sub>3</sub> | LOI   | Al <sub>2</sub> O <sub>3</sub> | SiO <sub>2</sub> | K <sub>2</sub> O                          | CaO  | TiO <sub>2</sub> | MnO  | Fe <sub>2</sub> O <sub>3</sub> |  |
| R40b  | RGPD | ashy gray  | 27.98   | 66.75            | 1.80             | 0.53 | 1.17             | 0.02 | 1.75                           | 27.56 | 65.74                          | 1.77             | 0.52                                      | 1.15 | 0.02             | 1.73 |                                |  |
| R41b  | RGPD | ashy gray  | 26.60   | 67.05            | 2.21             | 0.74 | 1.1              | 0.02 | 2.27                           | 26.21 | 66.06                          | 2.18             | 0.73                                      | 1.08 | 0.02             | 2.24 |                                |  |
| R42b  | RGPD | ashy gray  | 28.46   | 66.24            | 1.76             | 0.38 | 1.30             | 0.2  | 1.84                           | 28.03 | 65.25                          | 1.73             | 0.38                                      | 1.28 | 0.02             | 1.81 |                                |  |
| R43b  | RGPD | ashy gray  | 30.62   | 63.21            | 1.54             | 1.49 | 1.07             | 0.04 | 2.03                           | 30.16 | 62.26                          | 1.52             | 1.47                                      | 1.05 | 0.04             | 2.00 |                                |  |
| R44b  | RGPD | ashy gray  | 27.27   | 66.78            | 1.93             | 0.42 | 1.15             | 0.02 | 2.43                           | 26.86 | 65.77                          | 1.90             | 0.42                                      | 1.13 | 0.02             | 2.39 |                                |  |
| R47b  | RGPD | ashy gray  | 30.57   | 62.79            | 2.20             | 1.37 | 1.15             | 0.01 | 1.91                           | 30.11 | 61.84                          | 2.17             | 1.35                                      | 1.13 | 0.01             | 1.88 |                                |  |
| R271b | RGPD | ashy gray  | 27.18   | 67.27            | 1.85             | 0.44 | 1.29             | 0.00 | 1.97                           | 26.77 | 66.26                          | 1.82             | 0.44                                      | 1.27 | 0.00             | 1.94 |                                |  |
| R275b | RGPD | ashy gray  | 27.06   | 67.31            | 1.89             | 0.61 | 1.25             | 0.01 | 1.87                           | 26.66 | 66.31                          | 1.86             | 0.60                                      | 1.23 | 0.01             | 1.84 |                                |  |
| R330b | RGPD | ashy gray  | 32.23   | 61.87            | 1.80             | 0.85 | 1.12             | 0.00 | 2.13                           | 31.75 | 60.94                          | 1.77             | 0.84                                      | 1.10 | 0.00             | 2.10 |                                |  |
| R333b | RGPD | ashy gray  | 32.26   | 62.48            | 1.57             | 0.57 | 1.1              | 0.00 | 2.02                           | 31.78 | 61.54                          | 1.55             | 0.56                                      | 1.08 | 0.00             | 1.99 |                                |  |
| R339b | RGPD | ashy gray  | 30.56   | 63.70            | 1.46             | 1.09 | 1.21             | 0.02 | 1.96                           | 30.10 | 62.74                          | 1.44             | 1.08                                      | 1.19 | 0.02             | 1.93 |                                |  |
| R382b | RGPD | ashy gray  | 27.39   | 65.81            | 1.94             | 1.83 | 1.20             | 0.03 | 1.80                           | 26.98 | 64.83                          | 1.91             | 1.80                                      | 1.18 | 0.03             | 1.78 |                                |  |

---

### A.0.1 Calculating partes by of kaolin d'Arvor to give parts by weight of composition oxides for porcelain body

According to chemical analysis of kaolin d'Arvor in table (4.6) the 100 parts by weight of kaolin d'Arvor give 12.85 parts by weight of H<sub>2</sub>O, 47.15 parts by weight of SiO<sub>2</sub>, 37.6 parts by weight of Al<sub>2</sub>O<sub>3</sub>, 0.95 parts by weight of K<sub>2</sub>O, < 0.1 parts by weight of CaO, 0.09 parts by weight of TiO<sub>2</sub>, < 0.02 parts by weight of MnO, and 0.78parts by withe of Fe<sub>2</sub>O<sub>3</sub>. so for preparing such batch recipe which contained 30.57% of Al<sub>2</sub>O<sub>3</sub>, the required partes by weight of Kaolin calculated as following:  
 $(100 \times 30.57) \div 37.6 = 81.3$  partes by weight of Kaolin.

Therefore

81.3 parts by weight of kaolin d'Avron  $\rightarrow$  30.57 parts by weight of Al<sub>2</sub>O<sub>3</sub> which is required to simulate recipe of R47b sample. 81.3 parts by weight of kaolin d'Avron gives parts by weight of others composition oxides which are calculated as following:

100 parts by weight of kaolin d'Arvor  $\rightarrow$  12.85 parts by weight of H<sub>2</sub>O.

So 81.3 gram of kaolin gives  $(81.3 \times 12.85) \div 100 = 10.45$  gram of H<sub>2</sub>O. 1 mole of H<sub>2</sub>O = 18.016 gram, so the 81.3 give 0.58 mole of H<sub>2</sub>O The volume of gas calculated from following equation:

$$V = \frac{nRT}{P} \quad (\text{A.1})$$

---

where  $V$  is volume in  $m^3$ ,  $n$  is units mole,  $R$  is ideal gas constant ( $8.32 \text{ J K}^{-1}$ ),  $T$  temperature in kelvin and  $P$  is the absolute pressure in units Pascals( $101300 \text{ Pa}$ ). The volume of  $0.58$  mole of  $\text{H}_2\text{O}$  vapor at  $20^\circ\text{C}$  which is presented by  $81.38$  gram of kaolin is  $13.9$  liter.

### **A.0.2 Calculating partes by weight of potassium carbonate to give parts by weight of potassium oxide for porcelain body**

Potassium carbonate decomposes into  $\text{CO}_2$  and  $\text{K}_2\text{O}$  as  $138.21\text{g } \mathbf{K}_2\mathbf{CO}_3 \rightarrow 94.2\text{g } \mathbf{K}_2\mathbf{O} + 44.01\text{g } \mathbf{CO}_2$

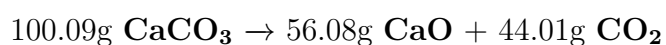
The purity of Potassium carbonate which used is  $\text{K}_2\text{CO}_3$   $99\% + 0.0005\%$  Fe.  $1.43$  parts by weight of  $\text{K}_2\text{O}$  is obtained from parts by weight of  $\text{K}_2\text{CO}_3$  which is calculated as following:

$(1.43 \times 138.21) \div 94.2 = 2.10$  parts by weight of  $\text{K}_2\text{CO}_3$ .  $2.10$  parts by weight of  $\text{K}_2\text{CO}_3$  gives  $(2.10 \times 44.01) \div 138.21 = 0.67$  parts by weight of  $\text{CO}_2$ .  $1$  mole of  $\text{CO}_2 = 44.01$  gram , so the  $0.67$  gram of carbon dioxide is equal to  $0.015$  mole of  $\text{CO}_2$ . The volume of  $0.015$  mole of  $\text{CO}_2$  gas at at  $800^\circ\text{C}$  which is presented by  $2.10$  gram of potassium carbonate is  $1.32$  liter.

---

### A.0.3 Calculating partes by weight of calcium carbonate to give parts by weight of calcium oxide for porce- lain body

Calcium carbonate decomposes into  $\text{CO}_2$  and  $\text{CaO}$  as,



The purity of Potassium carbonate which used is  $\text{CaCO}_3$  99% + 0.001% Fe

1.29 parts by weight of  $\text{CaO}$  is obtained from parts by weight of  $\text{CaCO}_3$  which is calculated as following:

$(1.29 \times 100.09) \div 56.08 = 2.30$  parts by weight of  $\text{CaCO}_3$ . 2.30 parts by weight of  $\text{CaCO}_3$  gives  $(2.30 \times 44.01) \div 100.09 = 1.01$  parts by weight of  $\text{CO}_2$ . 1 mole of  $\text{CO}_2 = 44.01$  gram, so the 1.01 gram f carbon dioxide is equal to 0.023 mole of  $\text{CO}_2$ . The volume of 0.023 mole of  $\text{CO}_2$  gas at  $800^\circ\text{C}$  which is presented by 2.30 gram of calcium carbonate is 2.03 liter.

**Table A.15:** Calculating the percentage of raw materials for batch recipe of R47b

| Raw materials  | chemical oxides  |                                |      |                  |      |                  |                                | parts     |                       | gases                     |          |  |
|--|------------------|--------------------------------|------|------------------|------|------------------|--------------------------------|-----------|-----------------------|---------------------------|----------|--|
|  | SiO <sub>2</sub> | Al <sub>2</sub> O <sub>3</sub> | CaO  | K <sub>2</sub> O | MnO  | TiO <sub>2</sub> | Fe <sub>2</sub> O <sub>3</sub> | by weight | weight                | volume                    | % of Raw |  |
| Silicon dioxide SiO <sub>2</sub>                                       | 24.46            |                                |      |                  |      |                  |                                | 24.46     |                       |                           | 21.75%   |  |
| Kaolin   | 38.33            | 30.57                          | 0.08 | 0.77             | 0.01 | 0.07             | 0.71                           | 81.30     | 10.45H <sub>2</sub> O | 13.9L <sup>#20 °C</sup>   | 72.30%   |  |
| Al <sub>2</sub> O <sub>3</sub> · 2SiO <sub>2</sub> · 2H <sub>2</sub> O |                  |                                |      |                  |      |                  |                                |           |                       |                           |          |  |
| K <sub>2</sub> CO <sub>3</sub>   |                  |                                |      | 1.43             |      |                  |                                | 2.12      | 0.67CO <sub>2</sub>   | 1.32L <sup>#1200 °C</sup> | 1.88%    |  |
| CaCO <sub>3</sub>  |                  |                                | 1.29 |                  |      |                  |                                | 2.33      | 1.01CO <sub>2</sub>   | 2.03L <sup>#800 °C</sup>  | 2.07%    |  |
| TiO <sub>2</sub>   |                  |                                |      |                  |      | 1.08             |                                | 1.09      |                       |                           | 0.97%    |  |
| Fe <sub>3</sub> O <sub>4</sub>   |                  |                                |      |                  |      |                  | 1.20                           | 1.20      |                       |                           | 1.03%    |  |
| % of oxide   | 62.79            | 30.57                          | 1.37 | 2.2              | 0.01 | 1.15             | 1.91                           |           |                       |                           | 100%     |  |

---

#### **A.0.4 Calculating partes by of kaolin d'Arvor to give parts by weight of composition oxides for glaze**

For preparing batch recipe of glaze which contained 16.07% of  $\text{Al}_2\text{O}_3$ , that required partes by weight of Kaolin calculated as following:

$(100 \times 16.07) \div 37.6 = 42.74$  partes by weight of Kaolin. Therefore, 42.74 gram of kaolin d'Avron  $\rightarrow$  16.07 gram of  $\text{Al}_2\text{O}_3$  which is required to simulate 100g of glaze recipe of R47 sample. 42.74 partes by weight of kaolin d'Avron gives partes by weight of others composition oxides which are calculated as following:

100 partes by weight of kaolin d'Arvor  $\rightarrow$  12.85 partes by weight of  $\text{H}_2\text{O}$ .

So 42.74 gram of kaolin gives  $(42.74 \times 12.85) \div 100 = 5.49$  gram of  $\text{H}_2\text{O}$ .

1 mole of  $\text{H}_2\text{O} = 18.016$  gram, so the 42.74 gram of kaolin is equal to 0.31 mole of  $\text{H}_2\text{O}$ . The volume of 0.31 mole of  $\text{H}_2\text{O}$  vapor at  $20^\circ\text{C}$  which is presented by 42.62 gram of kaolin is 7.34 liter.

#### **A.0.5 Calculating partes by weight of calcium carbonate to give partes by weight of calcium oxide for glaze**

10.56 partes by weight of  $\text{CaO}$  is obtained from partes by weight of  $\text{CaCO}_3$  which is calculated as following  $(10.56 \times 100.09) \div 56.08 = 19.03$  partes by weight of  $\text{CaCO}_3$ . 19.03 partes by weight of  $\text{CaCO}_3$  gives  $(19.03 \times 44.01) \div 100.09 = 8.37$

---

parts by weight of CO<sub>2</sub>. 1 mole of CO<sub>2</sub> = 44.01 gram, so the 8.37 gram of carbon dioxide is equal to 0.19 mole of CO<sub>2</sub>. The volume of 0.19 mole of CO<sub>2</sub> gas at 800°C which is presented by 8.37 gram of calcium carbonate is 16.74 liter.

#### **A.0.6 Calculating partes by weight of potassium carbonate to give parts by weight of potassium oxide for glaze**

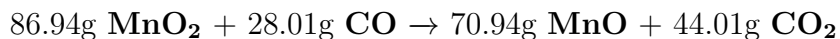
4.90 parts by weight of K<sub>2</sub>O is obtained from parts by weight of K<sub>2</sub>CO<sub>3</sub> which is calculated as following  $(4.90 \times 138.21) \div 94.2 = 7.19$  parts by weight of K<sub>2</sub>CO<sub>3</sub>. 7.19 parts by weight of K<sub>2</sub>CO<sub>3</sub> gives  $(7.19 \times 44.01) \div 138.21 = 2.29$  parts by weight of CO<sub>2</sub>. 1 mole of CO<sub>2</sub> = 44.01 gram, so the 2.29 gram of carbon dioxide is equal to 0.052 mole of CO<sub>2</sub>. The volume of 0.052 mole of CO<sub>2</sub> gas at 1200°C which is presented by 2.10 gram of potassium carbonate is 6.29 liter.

#### **A.0.7 Calculating partes by weight of manganese nitrate hydrate to give parts by weight of oxide for glaze**

Manganese Nitrate Mn(NO<sub>3</sub>)<sub>2</sub>·4H<sub>2</sub>O decomposes into 4 H<sub>2</sub>O, MnO<sub>2</sub> and NO<sub>2</sub> as







The purity of manganese nitrate hydrate which used is  $\text{Mn}(\text{NO}_3)_2 \cdot 4\text{H}_2\text{O}$  98.5% + 0,0005% Fe. 0.17 parts by weight of MnO is obtained from parts by weight of  $\text{Mn}(\text{NO}_3)_2 \cdot 4\text{H}_2\text{O}$  which is calculated as following:

$(0.17 \times 251) \div 70.94 = 0.63$  parts by weight of  $\text{Mn}(\text{NO}_3)_2 \cdot 4\text{H}_2\text{O}$ . 0.63 parts by weight of  $\text{Mn}(\text{NO}_3)_2 \cdot 4\text{H}_2\text{O}$  gives  $(0.63 \times 92) \div 251 = 0.23$  parts by weight of  $\text{NO}_2$ . 1 mole of  $\text{NO}_2 = 46$  gram, so the 0.23 gram of  $\text{NO}_2$  is equal to 0.005 mole of  $\text{NO}_2$ . The volume of 0.005 mole of  $\text{NO}_2$  gas at at  $800^\circ\text{C}$  which is presented by 0.23 gram of manganese nitrate hydrate is 0.44 liter.

0.63 parts by weight of  $\text{Mn}(\text{NO}_3)_2 \cdot 4\text{H}_2\text{O}$  gives  $(0.63 \times 72.06) \div 251 = 0.18$  parts by weight of  $\text{H}_2\text{O}$ . 1 mole of  $\text{H}_2\text{O} = 18.016$  gram, so the 0.23 gram of  $\text{H}_2\text{O}$  is equal to 0.001 mole of  $\text{H}_2\text{O}$ . The volume of 0.001 mole of  $\text{H}_2\text{O}$  gas at at  $20^\circ\text{C}$  which is presented by 0.23 gram of manganese nitrate hydrate is 0.02 liter.

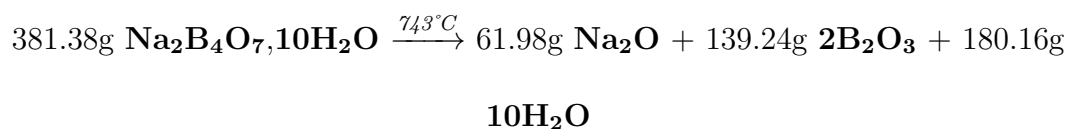
**Table A.16:** Calculating the percentage of raw materials for batch recipe of R47G

| Raw materials  | chemical oxides  |                                |       |                  |      |                  |                                | parts     |                                | gases                     |  | % of Raw |
|--|------------------|--------------------------------|-------|------------------|------|------------------|--------------------------------|-----------|--------------------------------|---------------------------|--|----------|
|  | SiO <sub>2</sub> | Al <sub>2</sub> O <sub>3</sub> | CaO   | K <sub>2</sub> O | MnO  | TiO <sub>2</sub> | Fe <sub>2</sub> O <sub>3</sub> | by weight | weight                         | volume                    |  |          |
| Silicon dioxide SiO <sub>2</sub>   | 45,62            |                                |       |                  |      |                  |                                | 45,62     |                                |                           |  | 39,02%   |
| Kaolin   | 20,15            | 16,07                          | 0,04  | 0,41             | 0,01 | 0,04             | 0,33                           | 42,74     | 5,49 <sup>H<sub>2</sub>O</sup> | 7,34L <sup>t20 °C</sup>   |  | 36,55%   |
| Al <sub>2</sub> O <sub>3</sub> · 2 SiO <sub>2</sub> · 2 H <sub>2</sub> O |                  |                                |       |                  |      |                  |                                |           |                                |                           |  |          |
| K <sub>2</sub> CO <sub>3</sub>   |                  |                                |       | 4,90             |      |                  |                                | 7,27      | 2,29 <sup>CO<sub>2</sub></sup> | 6,29L <sup>t1200 °C</sup> |  | 6,21%    |
| CaCO <sub>3</sub>  |                  | 10,56                          |       |                  |      |                  |                                | 19,03     | 8,37 <sup>CO<sub>2</sub></sup> | 16,74L <sup>t800 °C</sup> |  | 16,27%   |
| Mn(NO <sub>3</sub> ) <sub>2</sub> · 4 H <sub>2</sub> O                   |                  |                                |       | 0,17             |      |                  |                                | 0,63      | 0,23 <sup>NO<sub>2</sub></sup> | 0,44L <sup>t800 °C</sup>  |  | 0,54%    |
| TiO <sub>2</sub>   |                  |                                |       |                  |      | 0,13             |                                | 0,13      | 0,18 <sup>H<sub>2</sub>O</sup> | 0,02L <sup>t20 °C</sup>   |  | 0,12%    |
| Fe <sub>3</sub> O <sub>4</sub>   |                  |                                |       |                  |      |                  | 1,56                           | 1,51      |                                |                           |  | 1,29%    |
| % of oxide   | 65,77            | 16,07                          | 10,60 | 5,31             | 0,18 | 0,17             | 1,90                           |           |                                |                           |  | 100%     |

---

## A.0.8 Calculating the percentage of raw materials for batch recipe of Pemco Frit P-54

Fore calculating the batch recipe of Pemco Frit P-54, borax decahydrate is used as source of B<sub>2</sub>O<sub>3</sub> an Na<sub>2</sub>O. Na<sub>2</sub>B<sub>4</sub>O<sub>7</sub>·10H<sub>2</sub>O decomposes into 10H<sub>2</sub>O, B<sub>2</sub>O<sub>3</sub> and Na<sub>2</sub>O as

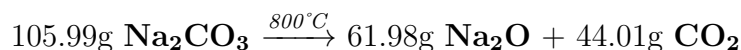


23.31 parts by weight of B<sub>2</sub>O<sub>3</sub> is obtained from parts by weight of Na<sub>2</sub>B<sub>4</sub>O<sub>7</sub>·10H<sub>2</sub>O which is calculated as following:

$(23.31 \times 381.38) \div 139.24 = 63.85$  parts by weight of Borax decahydrate. 63.85 parts by weight of Na<sub>2</sub>B<sub>4</sub>O<sub>7</sub>·10H<sub>2</sub>O gives  $(63.85 \times 61.89) \div 381.38 = 10.36$  parts by weight of Na<sub>2</sub>O. 63.85 parts by weight of Na<sub>2</sub>B<sub>4</sub>O<sub>7</sub>·10H<sub>2</sub>O gives  $(63.85 \times 180.16) \div 381.38 = 30.16$  parts by weight of H<sub>2</sub>O.

1 mole of H<sub>2</sub>O = 18.016 gram, so the 30.16 gram of H<sub>2</sub>O is equal to 1.67 mole of H<sub>2</sub>O. The volume of 1.67 mole of H<sub>2</sub>O vapor at 743°C which is presented 63.85 gram of Borax decahydrate is 139.36 liter.

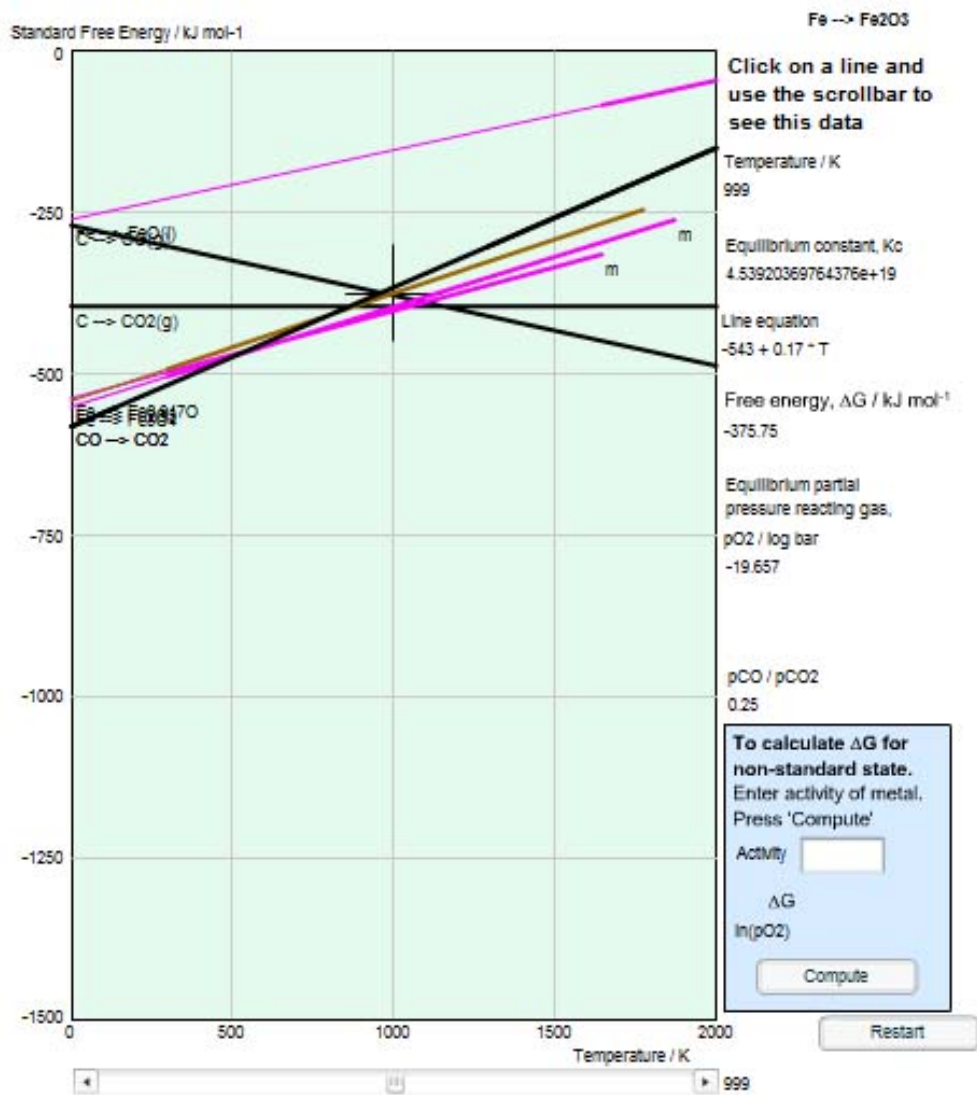
For completing 10.44% of Na<sub>2</sub>O in recipe , it is stile required 0.06% of Na<sub>2</sub>O which can be completed by sodium carbonate Na<sub>2</sub>CO<sub>3</sub>. It decomposes into Na<sub>2</sub>O and CO<sub>2</sub> as



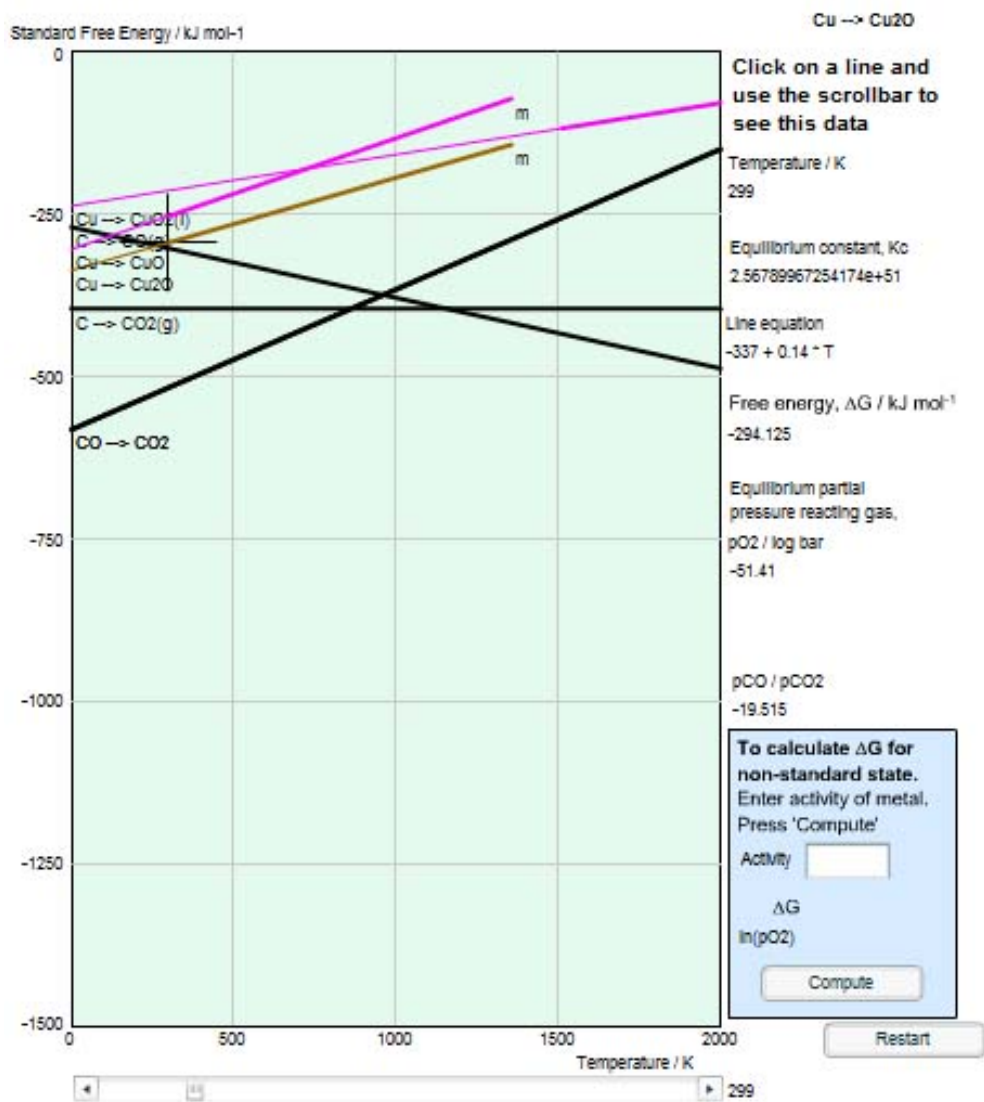
0.06 parts by weight of Na<sub>2</sub>O is obtained from parts by weight of Na<sub>2</sub>CO<sub>3</sub> which is calculated as following:

$(0.06 \times 105.99) \div 61.98 = 0.10$  parts by weight of Na<sub>2</sub>CO<sub>3</sub>, this gives  $(0.10 \times 44.01) \div 105.99 = 0.04$  parts by weight of CO<sub>2</sub>. 1 mole of CO<sub>2</sub> = 44.01 gram, so the 0.04 gram of CO<sub>2</sub> is equal to  $9 \times 10^{-4}$  mole of CO<sub>2</sub>. The volume of  $9 \times 10^{-4}$  mole of CO<sub>2</sub> gas at 800°C which is presented 0.1 gram of sodium carbonate is 0.08 liter.

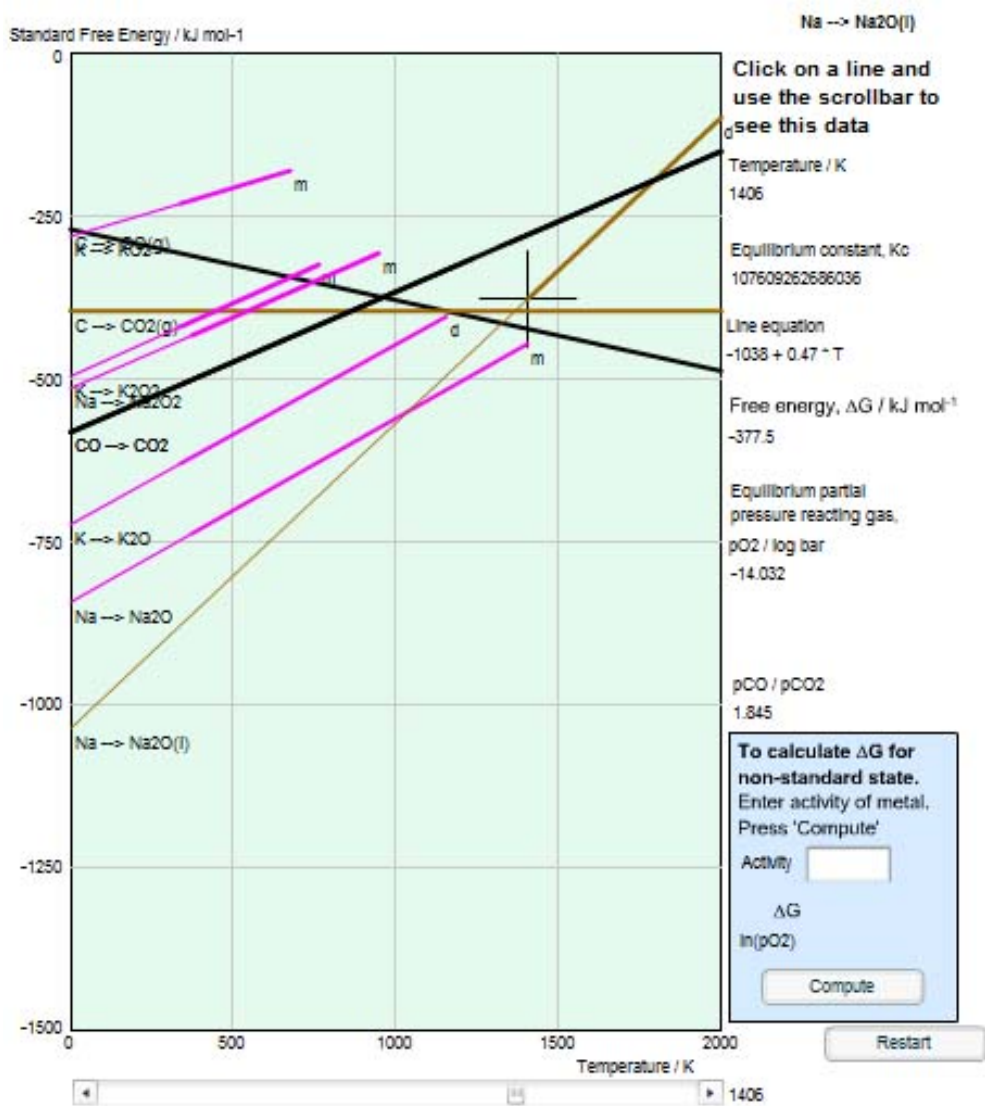
For completing the batch, calcium carbonate is used as source for 20.1% of CaO . It is calculated as following  $(20.1 \times 100.09) \div 56.08 = 35.87$  parts by weight of CaCO<sub>3</sub>. 35.87 parts by weight of CaCO<sub>3</sub> gives  $(35.87 \times 44.01) \div 100.09 = 15.77$  parts by weight of CO<sub>2</sub>. 1 mole of CO<sub>2</sub> = 44.01 gram, so the 15.77 gram of carbon dioxide is equal to 0.36 mole of CO<sub>2</sub>. The volume of 0.36 mole of CO<sub>2</sub> gas at 800°C which is presented by 35.87 gram of calcium carbonate is 31.72 liter. Silica is used as source of SiO<sub>2</sub> where 46.15 part of weight is required for 46.15% of batch recipe.



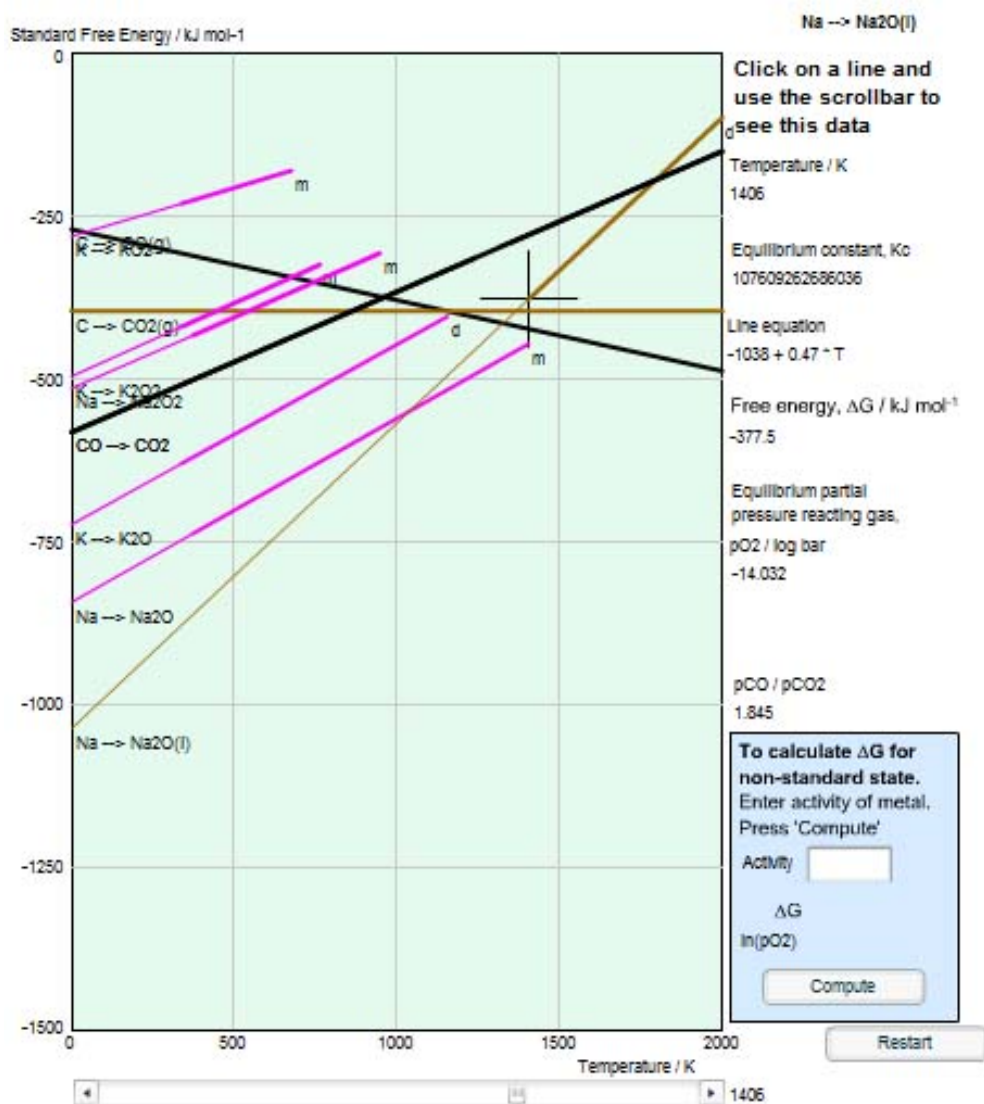
**Figure A.1:** Ellingham diagram for the free energy change of formation of Fe oxides with carbon oxides.



**Figure A.2:** Ellingham diagram for the free energy change of formation of Cu oxides with carbon oxides.

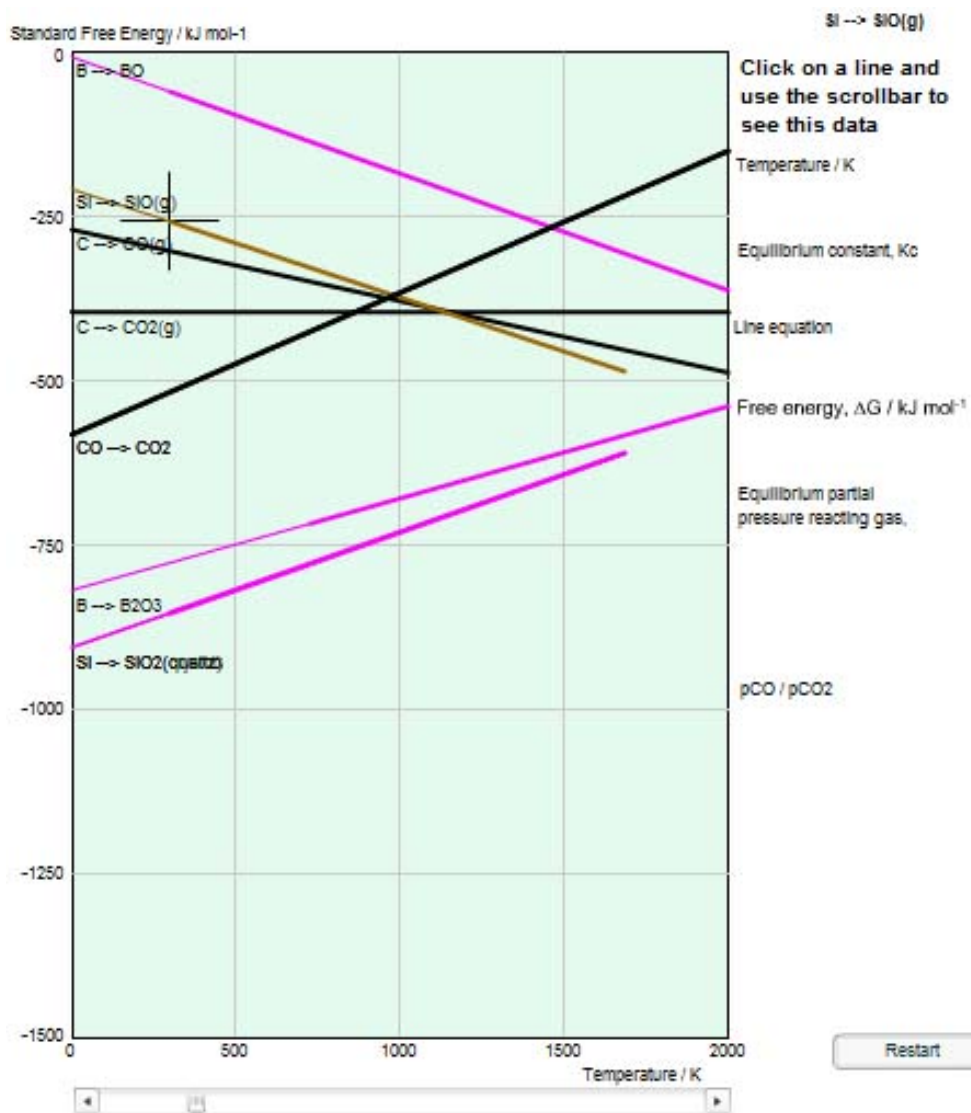


**Figure A.3:** Ellingham diagram for the free energy change of formation of K and Na oxides with carbon oxides.



**Figure A.4:** Ellingham diagram for the free energy change of formation of K and Na oxides with carbon oxides.





**Figure A.5:** Ellingham diagram for the free energy change of B<sub>2</sub>O<sub>3</sub> and SiO<sub>2</sub> with carbon oxides.



## ABLE CAST 3000

ABLE CAST 3000 is a Low Iron, High Purity, 3000 F castable. It is designed to successfully withstand high sulphur fuel, reducing atmospheres, carbon deposition, Erosion and Abrasion. Able Cast 3000 can be used for casting or troweling.

|  |               |
|--|---------------|
| Maximum Recommended Use Limit .....                  | 3000°F        |
| Melting Point .....                                  | 3290 F        |
| Bulk Density after drying lb./ft. <sup>3</sup> ..... | 140 - 145 lbs |

| <u>TEST TEMPERATURE</u> | <u>MODULUS OF RUPTURE, PSI</u> | <u>COLD CRUSH PSI</u> | <u>LINEAR CHANGE %</u> |
|-------------------------|--------------------------------|-----------------------|------------------------|
| 200°F                   | 550-600                        | 1800-2000             | -0.1                   |
| 1500°F                  | 400-500                        | 1200-1300             | -0.1                   |
| 2000°F                  | 300-400                        | 900-1100              | -0.3                   |
| 2250°F                  | 600-750                        | 2200-2400             | -0.3                   |
| 2550°F                  | 1050-1250                      | 3300-3800             | +0.2                   |
| 2732°F                  | 2000-2150                      | 4350-5100             | +0.2                   |
| 2910°F                  | 1800-2000                      | 3900-4600             | +0.6                   |

### CHEMICAL ANALYSIS

|                                |       |
|--------------------------------|-------|
| Al <sub>2</sub> O <sub>3</sub> | 60.17 |
| SiO <sub>2</sub>               | 30.89 |
| Fe <sub>2</sub> O <sub>3</sub> | 1.36  |
| TiO <sub>2</sub>               | 1.76  |
| CaO                            | 3.06  |
| MgO                            | 0.13  |
| Alkalies                       | 0.86  |
| Ign. Loss                      | 0.86  |

### THERMAL CONDUCTIVITY BTU/SQ.FT./HR./IN./°F

|            |      |
|------------|------|
| Mean Temp. | "K"  |
| 500°F      | 9.10 |
| 1000°F     | 8.62 |
| 1500°F     | 8.45 |
| 2000°F     | 8.41 |
| 2300°F     | 8.33 |

|                                       |            |
|---------------------------------------|------------|
| Water required for mixing (by weight) | 10 - 13.0% |
| Quarts of water per 75 lb. Bag        | 3.5 - 5.   |

Figure A.6

## Low Lime Insulating Concretes™

### MAIN PROPERTIES

| Product  |        | 2500                 |       | LW                   |      |
|--|--------|----------------------|-------|----------------------|------|
| Method of application  |        | Cast                 | Gun   | Cast                 | Gun  |
| Temperature limit  | °C     | 1370                 |       | 1320                 |      |
| ASTM-C-401 Class   |        | Q, R                 |       | P, Q                 |      |
| Basic raw material   |        | Insulating Aggregate |       | Insulating Aggregate |      |
| Maximum grain size (mm)  |        | 6                    |       | 6                    |      |
| <b>Properties</b>  |        |                      |       |                      |      |
| • Density (kg/m <sup>3</sup> )   |        |                      |       |                      |      |
| As placed  |        | 1860                 | 1930  | 1740                 | 1760 |
| Oven dried at  | 105°C  | 1420                 | 1500  | 1200                 | 1290 |
| After 5h firing at   | 815°C  | 1340                 | 1420  | 1150                 | 1200 |
| • Cold crushing strength (MPa)**   |        |                      |       |                      |      |
| Oven dried at  | 105°C  | 8.8                  | 10.8  | 4.3                  | 6.4  |
| After 5hr firing at  | 815°C  | 6.9                  | 8.4   | 3.2                  | 5.9  |
|  | 1000°C | 5.1                  | 6.0   | 2.8                  | 5.4  |
|  | 1100°C | -                    | -     | -                    | 4.9  |
|  | 1200°C | 5.9                  | 6.5   | 3.9                  | 4.4  |
|  | 1300°C | 6.9                  | 7.0   | -                    | -    |
| <b>High Temperature Performance</b>  |        |                      |       |                      |      |
| • Permanent linear change (%)  |        |                      |       |                      |      |
| After 5hr firing at  | 815°C  | -0.2                 | -0.2  | -0.2                 | -0.2 |
|  | 1000°C | -0.3                 | -0.3  | -0.3                 | -0.3 |
|  | 1100°C | -0.4                 | -0.5  | -                    | -    |
|  | 1200°C | -                    | -     | -0.6                 | -0.5 |
|  | 1300°C | -0.7                 | -0.7  | -1.0                 | -0.8 |
| • Thermal Conductivity (W/m.K)*  |        |                      |       |                      |      |
| ASTM-C-417-84  |        |                      |       |                      |      |
| At mean temperature of   | 200°C  | 0.34                 | 0.36  | 0.28                 | 0.29 |
|  | 400°C  | 0.37                 | 0.39  | 0.30                 | 0.31 |
|  | 600°C  | 0.40                 | 0.42  | 0.33                 | 0.34 |
|  | 800°C  | 0.42                 | 0.45  | 0.35                 | 0.36 |
|  | 1000°C | 0.44                 | 0.48  | 0.38                 | 0.39 |
| Estimated weight (kg) of dry material required per m <sup>3</sup> of construction (no allowance for waste) |        | 1350                 | 1450  | 1160                 | 1220 |
| Estimated weight (kg) of water required per 100kg dry material   |        | 38                   | 33    | 50                   | 44   |
| <b>Chemical composition</b>  |        |                      |       |                      |      |
| Al <sub>2</sub> O <sub>3</sub>   |        | 44.4                 |       | 46.2                 |      |
| SiO <sub>2</sub>   |        | 34.6                 |       | 34.3                 |      |
| Fe <sub>2</sub> O <sub>3</sub>   |        | 5.4                  |       | 4.7                  |      |
| TiO <sub>2</sub>   |        | 1.5                  |       | 1.4                  |      |
| CaO  |        | 11.7                 |       | 10.1                 |      |
| MgO + K <sub>2</sub> O + Na <sub>2</sub> O   |        | 1.1                  |       | 1.5                  |      |
| lg. Loss   |        | 1.1                  |       | 1.7                  |      |
| <b>Packaging</b>   |        |                      |       |                      |      |
| • In bags  |        | kg                   | 25/50 | 25/50                |      |

### Linear Thermal Expansion of Solid Substances

| $100^D L_T / l_{-293} = A + B(10^{-4}T) + C(10^{-4}T)^2 + D(10^{-4}T)^3$ (T in K) |            |          |         |         |          |      |
|---|------------|----------|---------|---------|----------|------|
|   | M.P., K    | A        | B       | C       | D        | Note |
| Al <sub>2</sub> O <sub>3</sub> (hex.)   | 2327       | -0.180   | +5.494  | +22.520 | -28.940  | 1    |
| CaO   | 3200       | -0.321   | +10.590 | +13.100 | -14.050  |      |
| Cr <sub>2</sub> O <sub>3</sub> (hex.)   | 2603       | -0.280   | +10.380 | -31.220 | +106.200 | 2    |
| Fe <sub>2</sub> O <sub>3</sub> (trig.)  | 1838       | -2.537   | +7.300  | +49.640 | -114.000 | 3    |
| MgO   | 3125       | -0.326   | +10.400 | +25.810 | -28.340  |      |
| SiO <sub>2</sub> (lo qtz.)  | tr.-873    | -0.236   | +6.912  | +0.556  | +1312.00 | 4    |
| SiO <sub>2</sub> (hi qtz.) tr.  | 1743       | +1.040   | +0.068  | +11.660 | +18.000  | Est. |
| SiO <sub>2</sub> (vitr.)  | cr.-1273   | -0.015   | +0.397  | +4.666  | -34.460  |      |
| ZrO <sub>2</sub> (monocl.)  | 2988       | -0.314   | +13.040 | -90.920 | +408.400 | 5    |
| Al <sub>6</sub> Si <sub>2</sub> O <sub>13</sub>                                   | 2193       | -0.0929  | +2.580  | +21.530 | -45.720  |      |
| CaAl <sub>2</sub> O <sub>4</sub>  | 1873       | -0.107   | +2.578  | +39.680 | -90.770  |      |
| Ca <sub>2</sub> SiO <sub>4</sub>  | 2403       | -0.345   | +11.260 | +16.560 | +27.330  |      |
| MgAl <sub>2</sub> O <sub>4</sub>  | 2408       | -0.183   | +5.456  | +28.060 | -41.810  |      |
| Mg <sub>2</sub> Al <sub>4</sub> Si <sub>5</sub> O <sub>18</sub>                   | ~1773      | +0.00911 | -0.912  | +20.640 | -3.921   | 6    |
| MgCr <sub>2</sub> O <sub>4</sub>  | 2673       | -0.176   | +5.822  | +5.580  | +23.360  |      |
| MgFe <sub>2</sub> O <sub>4</sub>  | 2023       | -0.218   | +6.003  | +52.560 | -94.040  |      |
| Mg <sub>2</sub> SiO <sub>4</sub>  | 2183       | -0.238   | +7.166  | +33.810 | -37.970  |      |
| Mg <sub>2</sub> TiO <sub>4</sub>  | -2100      | -0.249   | +8.294  | +4.074  | +94.300  |      |
| ZrSiO <sub>4</sub>  | 2673       | -0.136   | +5.337  | -30.420 | +209.400 |      |
| AlN (hex.)  | -2500      | -0.0809  | +1.806  | +31.760 | -72.560  | 7    |
| B <sub>4</sub> C (rhomboh.)   | 2623       | -0.114   | +3.523  | +12.660 | -5.085   | 8    |
| BN  | subl.~3273 | -0.00133 | -1.278  | +49.110 | -86.350  |      |
| SiC   | dec.~2923  | -0.0991  | +2.970  | +13.880 | -15.480  |      |
| TiC   | ~3410      | -0.177   | +5.710  | +11.740 | +2.412   |      |
| C (graph II)  | ~3900      | -0.0550  | +1.552  | +12.050 | -10.330  | 9    |
| C graph I   | ~3900      | -0.1580  | 5.651   | -8.850  | +35.550  | 9    |
| C (vitr.)   | cr.~2700   | 0.0890   | +3.015  | +1.286  | +17.240  |      |
| Fe  | 1808       | -0.289   | +7.350  | +93.300 | -314.000 | 10   |

Notes:  
 1- Cryst. exp. c/a ~1.1      2- Cryst. exp. a/c ~1.3  
 3- Cryst. exp. a/c ~1.26    4- Cryst. exp. a/c ~1.58  
 5- Cryst. exp. c/b ~2.5      6- Cordierite refractory  
 7- Cryst. exp. a/c ~1.18    8- Cryst. exp. -isotrop.  
 9- Grade ATJ, parallel and perpendicular to the textural "grain," respectively. Cryst. exp. c/a ~10.  
 10- Numerous steels and SS agree with Fe within +/-15%

Figure A.8



**Cerablanket™ / Cerachem™ / Cerachrome™ Blanket**

Product Information

**MAIN PROPERTIES**

|  |                   | Cerablanket™<br>1260        | Cerachem™ Blanket<br>1425            | Cerachrome™ Blanket<br>1425  |
|--|-------------------|-----------------------------|--------------------------------------|------------------------------|
| • Classification temperature   | °C                |                             |                                      |                              |
| <b>Properties Measured at Ambient Conditions (23°C/50% RH)</b>                 |                   |                             |                                      |                              |
| • Colour   |                   | white                       | white                                | blue/green                   |
| • Density (ENV 1094-7)   | kg/m <sup>3</sup> |                             | 64 up to 160 (4 densities available) |                              |
| • Tensile strength (ENV 1094-7)  |                   |                             |                                      |                              |
| 64kg/m <sup>3</sup>  | kPa               | 30                          | 30                                   | 30                           |
| 96kg/m <sup>3</sup>  | kPa               | 70                          | 70                                   | 65                           |
| 128kg/m <sup>3</sup>   | kPa               | 90                          | 90                                   | 85                           |
| 160kg/m <sup>3</sup>   | kPa               | 110                         | 110                                  |                              |
| <b>High Temperature Performance</b>  |                   |                             |                                      |                              |
| • Permanent linear shrinkage (EN 1094-7) after 24 hours isothermal heating at: |                   |                             |                                      |                              |
| 1000°C   | %                 | 1.5                         | -                                    | 1.5                          |
| 1100°C   | %                 | 2.2                         | -                                    | 2.2                          |
| 1200°C   | %                 | 3.0                         | 1.0                                  | 2.7                          |
| 1300°C   | %                 | 5.5                         | 2.0                                  | 3.5                          |
| 1400°C   | %                 | -                           | 3.5                                  | 4.0                          |
| 1500°C   | %                 | -                           | -                                    | 5.0                          |
| • Thermal Conductivity at mean temperature of (all 3 grades):                  |                   |                             |                                      |                              |
| 200°C  | W/m.K             | 64kg/m <sup>3</sup><br>0.07 | 96kg/m <sup>3</sup><br>0.06          | 128kg/m <sup>3</sup><br>0.06 |
| 400°C  | W/m.K             | 0.12                        | 0.11                                 | 0.10                         |
| 600°C  | W/m.K             | 0.20                        | 0.16                                 | 0.15                         |
| 800°C  | W/m.K             | 0.30                        | 0.23                                 | 0.20                         |
| 1000°C   | W/m.K             | 0.43                        | 0.32                                 | 0.27                         |
| • Specific heat at 1090°C (All 3 grades)                                       | kJ/kg.K           |                             | 1.13                                 |                              |
| <b>Chemical composition</b>  |                   |                             |                                      |                              |
| Al <sub>2</sub> O <sub>3</sub>   | %                 | 44                          | 35                                   | 42.7                         |
| SiO <sub>2</sub>   | %                 | 56                          | 50.0                                 | 54.5                         |
| Cr <sub>2</sub> O <sub>3</sub>   | %                 | -                           | -                                    | 2.8                          |
| ZrO <sub>2</sub>   | %                 | -                           | 15                                   | -                            |
| Fe <sub>2</sub> O <sub>3</sub> + TiO <sub>2</sub>                              | %                 | 0.15                        | 0.15                                 | 0.15                         |
| CaO + MgO  | %                 | 0.05                        | 0.09                                 | 0.10                         |
| Na <sub>2</sub> O + K <sub>2</sub> O   | %                 | 0.10                        | 0.10                                 | 0.10                         |

**Availability and Packaging**

Blankets are packed in cartons, on pallets wrapped in stretchable film.

| Thick<br>mm | Cerablanket™ |    |     |     | Cerachem™ Blanket |    |     |     | Cerachrome™<br>Blanket |     | Length<br>mm | Width<br>mm | m <sub>2</sub> /Carton |
|-------------|--------------|----|-----|-----|-------------------|----|-----|-----|------------------------|-----|--------------|-------------|------------------------|
|             | 64           | 96 | 128 | 160 | 64                | 96 | 128 | 160 | 96                     | 128 |              |             |                        |
| 6           |              |    | ○   | ○   |                   |    | ○   | ○   |                        |     | 5500 x 4     | 610         | 13.42                  |
| 10          | ○            | X  | X   | X   | ○                 | X  | X   | X   |                        |     | 18500        | 610         | 11.28                  |
| 13          | X            | X  | X   | X   | X                 | X  | X   | X   | X                      | X   | 14640        | 610         | 8.93                   |
| 19          | ○            | X  | X   | X   | X                 | X  | X   | X   | ○                      | ○   | 9760         | 610         | 5.95                   |
| 25          | X            | X  | X   | X   | X                 | X  | X   | X   | X                      | X   | 7320         | 610         | 4.46                   |
| 38          | X            | X  | X   | X   | X                 | X  | X   | X   |                        |     | 4880         | 610         | 2.98                   |
| 50          | X            | X  | X   | X   | X                 | X  | X   | X   |                        |     | 3660         | 610         | 2.23                   |

Marks (○) and width 1220mm upon request (subject to minimum order requirements).

**Figure A.9**

# Superwool™ 607™ Blanket

## Product Information

### MAIN PROPERTIES

Classification temperature °C 1100

#### Typical Properties

- Colour white
- Density  $\text{kg/m}^3$  64, 96, 128, 160
- Tensile strength (ENV 1094-7) at 128 $\text{kg/m}^3$  kPa 90

#### High Temperature Performance

- Permanent linear shrinkage (ENV 1094-7) after 24 hrs isothermal heating at 1100°C % < 1

Thermal Conductivity has been measured using ASTM C201 test equipment. From 2006, the ENV 1094 test methods for thermal conductivity has been withdrawn as it produces results which can not be compared with the C201 original.

| Chemical Composition |   |       |
|----------------------|---|-------|
| SiO <sub>2</sub>     | % | 62-68 |
| CaO                  | % | 26-32 |
| MgO                  | % | 3-7   |
| Other                | % | < 1   |

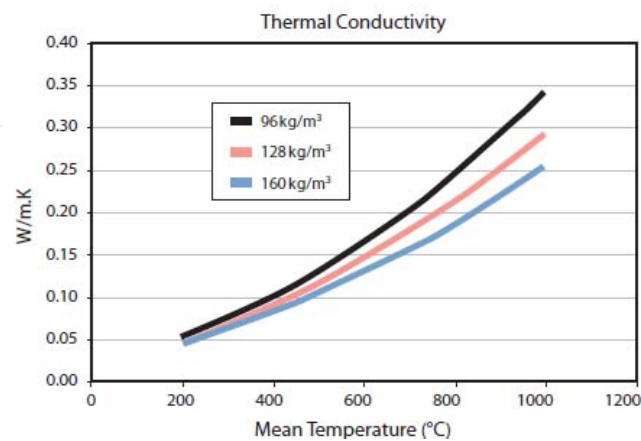


Figure A.10

---

**Table A.17:** Product Information of dense Concretes *Firecrete<sup>TM</sup>* 95

|                                     |                 |
|-------------------------------------|-----------------|
| Characteristics                     |                 |
| Firecrete Type                      | 95              |
| Method of application               | Cast            |
| Max. srv. temperature °C            | 1800            |
| Basic raw material                  | Tabular Alumina |
| Density ( $kg.m^{-3}$ )             |                 |
| • As placed                         | 2830            |
| • Oven dried at 105°C               | 2620            |
| • After 5 h firing at 815°C         | 2550            |
| Cold crushing strength (MPa)        |                 |
| • Oven dried at 105°C               | 66.7            |
| • After 5 hr firing at 815°C        | 60.8            |
|                                     | 1000°C 60.8     |
|                                     | 1200°C 59.8     |
| Permanent linear change (%)         |                 |
| • After 5 hr firing at 815°C        | - 0.1           |
|                                     | 1000°C - 0.1    |
|                                     | 1200°C - 0.1    |
| Thermal Cond. ( $W.m^{-1}.K^{-1}$ ) |                 |
| • At mean temperature of 400°C      | -               |
|                                     | 600°C 1.60      |
|                                     | 800°C 1.45      |
|                                     | 1000°C 1.30     |

# References

- [1] Bernard Palissy. *De l'art de terre, de son utilité, des esmaux et du feu*. J. Haumont, Paris, éd.1941. ix
- [2] Mohammed Mortada Abd El-Raouf El-Gohari. *raitement expérimentaux pour l'enrichissement artistique des pâtes locales pour la création de céramiques contemporaines*. Master's thesis, Faculté d'éducation de l'art, université de Helwan ,(Caire), 2003. xi
- [3] H. Northen. *traduit par Said Hamed el Sadr : Céramiques du céramiste*. Dar El Nahda El Arabia, 1965. xi
- [4] Nicole Coolige Rousmaniere. *Vesseles of Influence Chinese Ceramics Imported into Japan and the Formation of Porcelain Industry*. PhD thesis, the Graduate school of art and Sciences, Harvard University, 1998. xii, 43
- [5] E. Hasaki. *Ceramic Kilns in Ancient Greece: Technology and Organization of Ceramic Workshops*. PhD thesis, Department of Classics of the College



## REFERENCES

---

- of Arts and Sciences, UNIVERSITY OF CINCINNATI, 2002. xii, lxix, 43, 44, 109, 110, 111, 113, 131, 132, 133, 134
- [6] Robert Sanderson Coll Minogue. *Wood-fired ceramics: contemporary practices*. University of Pennsylvania Press, 2000. xiii, lxiii, lxviii, lxix, 117, 118, 119, 120, 121, 122
- [7] John K. Papadopoulos. *Ceramicus redivivus: the early Iron Age potters' field in the area of the classical Athenian Agora*, volume 31. American School of Classical Studies, 2003. xiv, lxiii, lxviii, 23, 111, 113, 114, 115, 116, 117
- [8] Steven Branfman. *Mastering Raku: Making Ware, Glazes, Building Kilns, Firing*. Lark Books (NC), 2009. xx, lxiii, lxvii, 77, 78
- [9] R. Kuroda and T. Murayama. *Classic Stoneware of Japan: Shino and Oribe*. Kodansha International (JPN), 2002. xviii, 80
- [10] L. Frédéric and K. Roth. *Japan encyclopedia*. Belknap Press of Harvard University Press, 2002. xviii, 77, 80
- [11] S. Padovani, C. Sada, P. Mazzoldi, B. Brunetti, I. Borgia, A. Sgamellotti, A. Giulivi, F. d'Acapito, and G. Battaglin. Copper in glazes of renaissance luster pottery: Nanoparticles, ions, and local environment. *Journal of applied physics*, 93:10058, 2003. xx, 84, 91, 194, 195

## REFERENCES

---

- [12] Tony Laverick and P.Andrew Parr. Lustre abbasside. *Revue Céramique & Verre N*, 139:13, 2004. xx, 84, 85, 87, 88, 91
- [13] O. Bobin, M. Schvoerer, C. Ney, M. Rammah, B. Pannequin, E.C. Platomone, A. Daoulatli, and RP Gayraud. The role of copper and silver in the colouration of metallic luster decorations (tunisia, 9th century; mesopotamia, 10th century; sicily, 16th century): A first approach. *Color Research & Application*, 28(5):352–359, 2003. xx, 84, 194, 197
- [14] Chen Kelun. *Chinese porcelain: art, elegance, and appreciation*. Long River Press, 2004. xx, 93, 94, 96, 99
- [15] Weidong Li, Jiazhi Li, Zequn Deng, Jun Wu, and Jingkun Guo. Study on ru ware glaze of the northern song dynasty: One of the earliest crystalline-phase separated glazes in ancient china. *Ceramics international*, 31(3):487–494, 2005. xx, 93, 94
- [16] F.H. Norton. *Fine ceramics: technology and applications*. McGraw-Hill (New York), 4th edition edition, 1970. xxxiv, 59, 60, 163, 164, 165, 167, 168, 172, 180, 182
- [17] R.L. DUMITRACHE and I. TEOREANU. Melting behaviour of feldspar porcelain glazes. xxxiv, 181
- [18] R.L. Dumitrache, I. Teoreanu, and A. Volceanov. Limit molecular formulas

## REFERENCES

---

- and target formulas determination for feldspar porcelain glazes. *Journal of the European Ceramic Society*, 27(2-3):1697–1701, 2007. xxxvi, lxxvii, 60, 173, 182, 184
- [19] Amal Paul. *Chemistry of glasses*. Springer, 1990. xxxvii, lxxvii, lxxviii, 185
- [20] Ernest M. Levin, Cael R. Robbins, and Howard F. McMurdie. *Phase Diagrams for Ceramists 1969 Supplement (Figures 2067-4149)*. American Ceramic Society, Inc., Columbus, OH, 1969. xlv, xlvi, lxiv, lxxii, 256, 257, 258
- [21] T. Préaud and D.E. Ostergard. *The Sèvres porcelain manufactory: Alexandre Brongniart and the triumph of art and industry, 1800-1847*. Yale University Press, 1997. lxv, 20, 21, 22, 23, 24, 25, 26
- [22] J. Britt. *The Complete Guide to High-Fire Glazes: Glazing & Firing at Cone 10*. Lark Books (NC), 2007. lxvi, 3, 46, 48, 49, 50, 83, 178, 179
- [23] R. Hopper. *Functional pottery: Form and aesthetic in pots of purpose*. Krause Pubns Inc, 2000. lxvi, 51
- [24] J.J. Young. *The ceramic art: a compendium of the history and manufacture of pottery and porcelain*. Harper & Brothers(New York), 1878. lxvi, 64, 65
- [25] S. Hendrickx and B. Adams. *Egypt at its origins: studies in memory of Barbara Adams: proceedings of the international conference" Origin of*

## REFERENCES

---

- the State, Predynastic and Early Dynastic Egypt,” Krakow, 28 August-1st September 2002*, volume 138. Peeters Pub & Booksellers, 2004. lxxviii, 65, 69, 105, 106, 107, 108
- [26] Alex. Brongniart. *Traité Des Arts Céramiques ou des Poteries considérées dans Leur Histoire ,Leur Pratique Et Leur Théorie,*, volume Atlas. Dessain et Tolra(Paris), 1977 FAC-Simile de L’Edition De1877. lxxviii, 111, 113, 128, 140, 146, 148
- [27] Christophe Comentale. La céramique néolithique chinoise: utilitaire et esthétique, introduction. *L’Anthropologie*, 112(3):472–500, 2008. lxxviii, 110, 112
- [28] R. Castel and É. André. *Le lac du Bourget: 50 ans de recherches archéologiques, 5000 ans d’histoire*. La Fontaine de Siloé, 2004. lxxix, 138
- [29] J.M. Giorgio. Les journées de la céramique: 15 ans d’expérimentations (1). *ARCHÉO*, 66(23):47–55, 19 janvier 2008. lxxix, 135, 139
- [30] Chiranjib Kumar Gupta. *Chemical metallurgy: Principles and Practice*. Wiley-VCH Verlag GmbH & Co. KGaA (Weinheim), 2003. lxxxii, 264, 265
- [31] Michael J. Moran, Howard N. Shapiro, Bruce R. Munson, and David P. DeWitt. *Introduction to thermal systems engineering*. John Wiley & Sons, Inc, 2003. lxxxiii, 285, 287

## REFERENCES

---

- [32] Stephen C. Carniglia and Gordon L. Barna. *Handbook of industrial refractories technology: principles, types, properties, and applications*. Noyes Publications (New Jersey), 1992. lxxiv, 152, 307, 314
- [33] <http://www.kanthal.com/en/products/download-documentation>.  
lxxiv, 325, 328
- [34] J.A. Barlow, D.L. Bolger, D.R. Bolger, and B. Kling. *Cypriot ceramics: reading the prehistoric record*, volume 74. Univ of Pennsylvania Museum of Archocology and Anthropology (Pliladelphia), 1991. 1
- [35] S. Wilson. *Information arts: intersections of art, science, and technology*. The MIT Press(cambridge,Massachustts), 2002. 2, 15, 16, 17, 18
- [36] A.M. Gibson and A. Woods. *Prehistoric pottery for the archaeologist*. Leicester Univ Press (London), 1997. 3
- [37] S. Baidyanath. *Pottery-Making Cultures And Indian Civilization*. Abhinav Publications (Shakti Malik,New Delhi), 1979. 4, 105, 106, 107, 108
- [38] S. Von Dassow. *Exploring Electric Kiln Techniques: A Collection of Articles from Ceramics Monthly*. American Ceramic Society(Westerville,Ohio,USA), 2002. 4, 44, 56
- [39] N.L. Herron. *The social sciences: a cross-disciplinary guide to selected sources*, volume 3. Libraries Unltd Inc, 2002. 11, 12

## REFERENCES

---

- [40] GW Hegel. *Aesthetics: Lectures on fine art*. Clarendon Press (Oxford), 1975. 12, 13, 14
- [41] C. Zittel. *Philosophies of technology: Francis Bacon and his contemporaries*, volume 1. Brill, 2008. 17
- [42] B.H. Bunch and A. Hellemans. *The history of science and technology: a browser's guide to the great discoveries, inventions, and the people who made them, from the dawn of time to today*. Houghton Mifflin Harcourt, 2004. 17
- [43] TK Derry and T.I. Williams. *A short history of technology from the earliest times to AD 1900*. Clarendon Press (Oxford), 1961. 18, 44
- [44] L.S. Roberts. The londonderry vase: A royal gift to curry favor. *Art Institute of Chicago Museum Studies*, 15(1):69–88, 1989. 19
- [45] Théophile Gautier. *Correspondance générale*, volume 5. Librairie Droz, 1991. 19
- [46] P.A. Cap. *Le muséum d'histoire naturelle: histoire de la fondation et des développements successifs de l'établissement, biographie des hommes célèbres qui y ont contribué par leur enseignement ou par leurs découvertes, histoire des recherches, des voyages, des applications utiles auxquels le*

## REFERENCES

---

- muséum a donné lieu, pour les arts, le commerce et l'agriculture, description des galeries, du jardin, des serres et de la ménagerie.* L. Curmer, 1854. 19
- [47] R.G. Kingsley. *A history of French art, 1100-1899.* Longmans, Green and co., 1899. 19
- [48] Andrew Ayers. *The architecture of Paris: an architectural guide.* Axel Menges, 2004. 19
- [49] J. Lacroix de Marles. *Paris et ses monuments: anciens et modernes. d'après Dubreuil, Sauval, Félibien, Piganiol, Delamare, Jaillot etc., et les historiens modernes de Paris les plus estimés,* volume 3. Pitrat et fils, 1854. 19
- [50] Julius E. Dasch. *Encyclopedia of earth sciences.* Macmillan, 1996. 20
- [51] M.J.S. Rudwick. *Bursting the limits of time: the reconstruction of geohistory in the age of revolution.* University of Chicago Press, 2005. 21
- [52] D. Lardner and A. Genty. *Le muséum des sciences et des arts: choix de traités instructifs sur les sciences physiques et leurs applications aux usages de la vie.* J. Best, 1857. 21
- [53] A. Brongniart and D. Riocreux. *Description méthodique du musée céramique de la manufacture royale de porcelaine de Sèvres,* volume 2. A. Leleux, 1845. 21

## REFERENCES

---

- [54] R.P. de Guillebon. *La porcelaine à paris sous le consulat et l'empire.*  
*Genève, Droz, 1985.* 22
- [55] Blondel, Nicole, Auteur, Blondel, Nicole, Auteur, Doury, François, and  
Illustrateur. *la manufacture national de Sèvres parcours du blanc à l'or.*  
Flohic, Charenton, 1996. 27, 28, 30, 32
- [56] Alex. Brongniart. *Traité Des Arts Céramiques ou des Poteries considérées  
dans Leur Histoire ,Leur Pratique Et Leur Théorie,,* volume Tome I. Des-  
sain et Tolra(Paris), 1977 FAC-Simile de L'Edition De1877. 33, 62, 67, 72,  
74, 109, 110, 111, 116, 127, 128, 134, 140, 155, 156, 272
- [57] W.B. Honey. *French porcelain of the 18th century.* Faber and Faber, 1972.  
33
- [58] Alex. Brongniart. *Traité Des Arts Céramiques ou des Poteries considérées  
dans Leur Histoire ,Leur Pratique Et Leur Théorie,,* volume Tome II. Des-  
sain et Tolra(Paris), 1977 FAC-Simile de L'Edition De1877. 35, 37, 38, 121,  
134, 146
- [59] Desloges et Goupil. *Traité général des peintures vitrifiables sur porcelaine.*  
2 edition, 1866. 38
- [60] C. Watkins, James and Andrew Wandless, Paul. *Alternative Kilns & Firing*



## REFERENCES

---

- Techniques: Raku\* Saggar\* Pit\* Barrel*. Lark Books (New York), 2004. 41, 78, 79
- [61] M. Lancet and M. Kusakabe. *Japanese Wood-Fired Ceramics*. Krause Pubns Inc, 2005. 43, 81, 109, 117
- [62] R. Zakin. *Ceramics: mastering the craft*. Krause Pubns Inc(Iola), 2ed edition edition, 2001. 46, 48, 50, 79
- [63] R. Zakin. *Electric kiln ceramics: a guide to clays and glazes*. Krause Pubns Inc, 2004. 48
- [64] T. Doat. *Grand feu ceramics: a practical treatise on the making of fine porcelain and grès*. Keramic studio publishing company, 1905. 51
- [65] A. Turner. *Pottery making techniques: a pottery making illustrated handbook*. Amer Ceramic Society, 2004. 52
- [66] M. Vukovich Jr. Kiln with ventilation system, December 18 1990. US Patent 4,978,295. 56
- [67] Y.H. Cuff. *Ceramic technology for potters and sculptors*. Univ of Pennsylvania Pr, 1996. 59, 171
- [68] J.M. Cronyn and W.S. Robinson. *The elements of archaeological conservation*. Psychology Press, 1990. 59

## REFERENCES

---

- [69] J.S. Reed. *Principles of ceramics processing*. John Wiley&Sons,Inc (New York), 1995. 59, 163
- [70] L. Froberg, T. Kronberg, L. Hupa, and M. Hupa. Influence of firing parameters on phase composition of raw glazes. *Journal of the European Ceramic Society*, 27(2-3):1671–1675, 2007. 59
- [71] S. Salem, SH Jazayeri, F. Bondioli, A. Allahverdi, and M. Shirvani. Characterizing thermal behavior of ceramic glaze containing nano-sized cobalt-aluminate pigment by hot stage microscopy. *Thermochimica acta*, 521(1-2):191–196, 2011. 60
- [72] Emmanuel Cooper. *Ten thousand years of pottery*. University of Pennsylvania Press, 4th edition edition, 2000. 65
- [73] Suzan Yalman. *The art of the fatimid period (909–1171)*, 2001. 65
- [74] Alfred B. Searle. *An encyclopaedia of the ceramic industries*. Ernest benn(London), 3third edition edition, 1929. 65
- [75] Ruthanne Tudball. *Soda glazing*. A&C Black Publishers Limited(London), 1995. 65
- [76] Jane Perryman. *Smoke firing: contemporary artists and approaches*. University of Pennsylvania Press, 2008. 68, 69, 71, 72

## REFERENCES

---

- [77] J. Needham. *Science and civilisation in China: Chemistry and chemical technology. Spagyric discovery and invention: historical survey, from cinnabar elixirs to synthetic insulin*, volume 5. Cambridge University Press, 1976. 71, 143, 155, 199
- [78] Jean Faucounau. *Les origines grecques à l'Âge de bronze: 3000 à 900 avant notre ère*. Editions L'Harmattan, 2005. 72
- [79] Li Liu. *The Chinese Neolithic: trajectories to early states*. Cambridge University Press(New York), 2004. 72
- [80] M. Vauthey and P. Vauthey. Vi.-étude de la céramique commune et diverse. *Revue archéologique du Centre de la France*, 5(3):204–217, 1966. 72
- [81] Brigitte Gratien. *Les cultures Kerma: essai de classification*. Presses Univ. Septentrion(Lill), 1978. 72
- [82] James Stevenson. *Illustrated catalogue of the collections obtained from the Indians of New Mexico in 1880*. US Government Printing Office(Washington), 1883. 72
- [83] Friedhelm Göldenboth and Werner Mühlbauer. Abaca–cultivation, extraction and processing. *Industrial Applications of Natural Fibres*, pages 163–179, 2010. 74

## REFERENCES

---

- [84] Albert Jacquemart. *History of the ceramic art: A descriptive and philosophical study of the pottery of all ages and all nations*. Sampson Low, Marston, Low, and Searle(London), 1873. Translated by Mrs. Bury Palliser. 76
- [85] DG Whitfield. Raku firing of ceramic ware using a reverberatory furnace. In *Materials Science Forum*, volume 34, pages 1135–1139. Trans Tech Publ, 1991. 78
- [86] M. Jacobson. Black shino. *CERAMICS MONTHLY-OHIO*, 48(10):44–50, 2000. 81
- [87] S.J.E. Tourtillott. *500 cups: ceramic explorations of utility & grace*. Lark Books (NC), 2005. 83
- [88] B. Mason Robert. *Shine like the sun: lustre-painted and associated pottery from the medieval Middle East*. Mazda Pub, 2004. 84, 85, 87
- [89] V. Pomarède, L. Tilliard, J. Rose-Albrecht, and Lyon (France). Musée des beaux arts. *Le calife, le prince et le potier: Les faïences à reflets métalliques:[exposition], Lyon, musée des beaux-arts, 2 mars-22 mai 2002*. Réunion des musées nationaux, 2002. 84, 88
- [90] O. Bobin, M. Schvoerer, C. Ney, M. Rammah, A. Daoulatli, B. Pannequin, and RP Gayraud. Where did the lustre tiles of the sidi oqba mosque (ad

## REFERENCES

---

- 836-63) in kairouan come from?\*. *Archaeometry*, 45(4):569–577, 2003. 84, 85, 87
- [91] Gaston Migeon. Céramique orientale à reflets métalliques à propos d’une acquisition récente au musée du louvre. *Gazette des Beaux-Arts*, 20(6):192–208, 1901. 88
- [92] J. Pérez-Arantegui, J. Molera, A. Larrea, T. Pradell, M. Vendrell-Saz, I. Borgia, B.G. Brunetti, F. Cariati, P. Fermo, M. Mellini, et al. Luster pottery from the thirteenth century to the sixteenth century: a nanostructured thin metallic film. *Journal of the American Ceramic Society*, 84(2):442–46, 2001. 88, 198
- [93] Alan Caiger-Smith. *Lustre pottery: technique, tradition and innovation in Islam and the Western World*. Faber and Faber(London), 1985. 90, 91
- [94] Barber Edwin AtLee. The lustered tiles of persia. *Bulletin of the Pennsylvania Museum*, 8(30):24–29, 1910. 90, 91
- [95] J. Molera, M. VENDRELL-SAZ, M. GARCÍA-VALLÉS, and T. Pradell. Technology and colour development of hispano-moresque lead-glazed pottery. *Archaeometry*, 39(1):23–39, 1997. 91
- [96] T. Pradell, J. Molera, C. Bayés, and P. Roura. Luster decoration of ceram-

## REFERENCES

---

- ics: mechanisms of metallic luster formation. *Applied Physics A: Materials Science & Processing*, 83(2):203–208, 2006. 91, 194, 197
- [97] J.P. Malins and K.H. Tonge. Reduction processes in the formation of lustre glazed ceramics. *Thermochimica acta*, 340:395–405, 1999. 91
- [98] Nigel Wood Joseph Needham, Rose Kerr. *Science and Civilisation in China, Volume 5, Chemistry and Chemical Technology, Part 12: Ceramic Technology*, volume 5. Cambridge University Press, 2004. 93, 94, 102
- [99] Lili Fang. *Chinese ceramics*. Cambridge University Press, 2011. 93, 98
- [100] Lang Ye. *China: five thousand years of history and civilization*. City University of Hong Kong Press, 2007. 93
- [101] G. Li, W. Zhao, R. Li, H. Sun, M. Guo, Y. Wang, H. Liu, Q. Zhao, X. Sun, W. Zhao, et al. Proton induced x-ray emission (pixe) analysis of sources of porcelain body of ru guan and jun guan porcelains. *Science in China Series G: Physics Mechanics and Astronomy*, 49(4):411–420, 2006. 93, 94, 96, 207
- [102] Nigel Wood. *Chinese glazes: their origins, chemistry, and recreation*. University of Pennsylvania Press, 1999. 94, 96, 99
- [103] L.E. Rotondo-McCord and R.D. Mowry. *Heaven and earth seen within:*

## REFERENCES

---

- Song ceramics from the Robert Barron Collection*. Univ. Press of Mississippi, 2000. 96
- [104] C. Songhua, G. Zhengyao, S. Zhongtian, and C. Xiande. Mössbauer study of the firing technology of the moon-white jun porcelain in chinese yuan dynasty. *Hyperfine Interactions*, 91(1):657–661, 1994. 96
- [105] Yang Gen, Zhang Xiqu, and Shao Wengu. *The Ceramics of China: the Yangshao culture, the Song dynasty*. Science Press.Beijing, 1985. 96, 98
- [106] Lu Yaw. *Lee Kong Chian Art Museum: collection of Chinese ceramics, bronze, archaic jade, painting & calligraphy in the light of recent archaeological discoveries*. Singapore University Press, 1990. 98
- [107] Julian Henderson. *The science and archaeology of materials: an investigation of inorganic materials*. Routledge, 2000. 105
- [108] Matthew Stein. *When Technology Fails: A Manual for Self-Reliance, Sustainability, and Surviving the Long Emergency*. Chelsea Green Publishing Comoany, 2008. 107
- [109] Bryant G.Wood. *The sociology of pottery in ancient Palestine: the ceramic industry and the diffusion of ceramic style in the Bronze and Iron Ages*, volume 103. Sheffield Academic Press, 1990. 114, 117

## REFERENCES

---

- [110] H. Miller. *State versus gentry in late Ming Dynasty China, 1572-1644*. Palgrave Macmillan, 2009. 121
- [111] Naoki Kawabuchi Hiromi Itabashi, Roppō Tamura. *Building Your Own Kiln: Three Japanese Potters Give Advice and Instructions*. Kodansha Amer Inc, 2004. 121, 143
- [112] Ken Deaver. Elizabeth Carter. *Excavations at Anshan (Tal-e Malyan): the middle elamite period*, volume 2. Museum of University ,University of Pennsylvania, 1996. 131
- [113] Yves Garidel. Les structures de cuisson à sole perforée. 2011,17 may. 138
- [114] A. Jourdain. *La technologie des produits céramiques réfractaires*. Gauthier-Villars, 1966. 152, 209
- [115] T. Deck. *La faïence*. Maison Quantin, 1887. 159
- [116] P.P. Budnikov et al. *The technology of ceramics and refractories*, volume 165. Massachusetts Institute of Technology, Cambridge ,Massachusetts, 1964. 163, 173, 175, 178, 179, 180
- [117] Linda Fröberg. *Factors Affecting Raw Glaze Properties*. Ph.d thesis, Process Chemistry Center ,Laboratory of Inorganic chemistry,Åbo Akademi. 163



## REFERENCES

---

- [118] G.W. Phelps and J.B. Wachtman Jr. Ceramics, general survey. In *Ullmann's Encyclopedia of Industrial Chemistry*, pages 191–236, 2005. 163, 167
- [119] A. Dodd and D. Murfin. *Dictionary of ceramics*. 1994. 164
- [120] J.E. Shelby. *Introduction to glass science and technology*. Royal Society of Chemistry, 2005. 164
- [121] Reza Abbaschian, Lara Abbaschian, and Robert E.Reed-Hill. *Physical metallurgy principles*. CENGAGE learning, 2008. 164
- [122] Arun K. Varshneya. *Fundamentals of inorganic glasses*. Academic Press,Inc(San Diego), 1994. 164, 165
- [123] Charles A. Harper. *Handbook of ceramics, glasses, and diamonds*. McGraw-Hill Professional, 2001. 167, 169
- [124] Emmanuel Cooper. *The potter's book of glaze recipes*. University of Pennsylvania Press, 2004. 171
- [125] R.B. Harlan. Method of decorating ceramic bodies, February 26 1952. US Patent 2,587,152. 171
- [126] A. Eppler Richard and R. Eppler. Douglas. *Glazes and glass coatings*. The American Ceramic Society, 2000. 173, 212

## REFERENCES

---

- [127] HA Seger. The collected writings of hermann august seger, volume ii. translated by h. hecht and e. cramer, 1902. 174, 281
- [128] William Leslie German. Felix Singer. *Ceramic glazes*. Borax consolidated, 1960. 178
- [129] Frank Hamer and Janet Hamer. *The potter's dictionary of materials and techniques*. University of Pennsylvania Press, 2004. 178
- [130] R.T. Stull and B.S. Radcliffe. Opalescence and the function of boric acid in the glaze. 1910. 178
- [131] Kuzielová Eva, Jana Hrubá, Martin Palou, and Eva Smrcková. Influence of  $p_{2O_5}$  upon the crystallization of lithium disilicate and fluorapatite in bio-glass ceramics. *CERAMICS SILIKATY*, 50(3):159, 2006. 179
- [132] Woldemar A. Weyl. Phosphates in ceramic ware: Ii, role of phosphorus in bone china. *Journal of the American Ceramic Society*, 24(8):245–247, 1941. 179
- [133] H. Norsker and J. Danisch. *Glazes—for the self-reliant potter*. Informatica International, Inc., 1993. 179
- [134] Richard L. Lehman. *Lead Glazes for Ceramic Foodware*. The International Lead Management Center: Research Triangle Park, NC,

## REFERENCES

---

- first edition edition, 2002. <http://www.ilmc.org/Publications/ILMCFinalCombo8-02B.pdf>. 179, 180, 183, 184
- [135] J. Schwarz and H. Ticha. Some optical properties of baopbo-b 2 o 3 glasses. *Journal of Optoelectronics and Advanced Materials*, 5(1):69–74, 2003. 182
- [136] B. PLEŠINGEROVÁ and M. KOVALČÍKOVÁ. Influence of the thermal expansion mismatch between body and glaze on the crack density of glazed ceramics. *Ceramics- Silikáty*, 47(3):100–107, 2003. 184, 201, 202, 218
- [137] Hu Guoju Chen Songhua, Gao Zhengyao and Chen Xiande. Mössbauer analysis of the firing process of the sky-green glaze of the imitative ancient chinese ru porcelain. *Hyperfine Interactions*, 91(1):651–656, 1994. 186, 187
- [138] Chen Songhua, Gao Zhengyao, Sun Zhongtian, and Chen Xiande. Mössbauer study of the firing technology of the moon-white jun porcelain in chinese yuan dynasty. *Hyperfine Interactions*, 91(1):657–661, 1994. 187
- [139] Zhang Bin, Gao Zhengyaob, Zhao Weijuanb, Li Guoxiab, Cheng Huan-shenga, and Zhang Zhengquana. Mössbauer spectroscopy and neutron activation analysis of ancient chinese glazes. *Applied clay science*, 25(3):161–165, 2004. 190, 192
- [140] W. Zhao, G. Li, Z. Gao, B. Zhang, R. Li, X. Wu, G. Yao, X. Jia, S. Han, and Z. Huang. Neutron activation analysis and mössbauer spectroscopy

## REFERENCES

---

- research on coloring mechanism of ancient chinese guan porcelain. *Chinese Science Bulletin*, 45(20):1840–1844, 2000. 192
- [141] N. Brun, L. Mazerolles, and M. Pernot. Microstructure of opaque red glass containing copper. *Journal of materials science letters*, 10(23):1418–1420, 1991. 194
- [142] J. Roqué, J. Molera, P. Sciau, E. Pantos, and M. Vendrell-Saz. Copper and silver nanocrystals in lustre lead glazes: development and optical properties. *Journal of the European Ceramic Society*, 26(16):3813–3824, 2006. 195
- [143] J. Pérez-Arantegui, A. Larrea, J. Molera, T. Pradell, and M. Vendrell-Saz. Some aspects of the characterization of decorations on ceramic glazes. *Applied Physics A: Materials Science & Processing*, 79(2):235–239, 2004. 197
- [144] Web reference:Chinese Tea Culture Online Museum. Crackles like ice – the ge kiln. <http://tea.timzhao.com/ctcom/TEAPOT/ge.html>. Accessed April 4, 2012. 199
- [145] Web reference:Wang Nan (chinaculture.org). Five famous kilns in the song dynasty. [http://www.chinadaily.com.cn/life/2008-04/21/content\\_11570033\\_3.htm](http://www.chinadaily.com.cn/life/2008-04/21/content_11570033_3.htm). Accessed April 4, 2012. 199

## REFERENCES

---

- [146] R.V. Manukyan and N.S. Davydova. “crackle” decorative coating. *Glass and ceramics*, 56(11):401–402, 1999. 200
- [147] B. PLEŠINGEROVÁ, M. KLAPÁČ, and M. KOVALČÍKOVÁ. Moisture expansion of porous biscuit bodies-reason of glaze cracking. *Ceramics- Silikáty*, 46(4):159–165, 2002. 201, 202
- [148] Jennie J. Young. *The ceramic art: a compendium of the history and manufacture of pottery and porcelain*. Sampson, Low, Marston, Searle & Rivington, 1879. 212
- [149] W. Zhao, X. Lu, G. Li, M. Guo, J. Xie, Z. Gao, X. Sun, M. Guo, H. Cheng, and B. Zhang. Main chemical ingredients of the celadon glaze from qingliangsi kiln and zhanggongxiang kiln. *Science in China Series G: Physics Mechanics and Astronomy*, 49(4):487–495, 2006. 212
- [150] W.E. Worrall. *Clays and ceramic raw materials*. Springer, 1986. 244
- [151] H. Coanda. Device for deflecting a stream of, September 1 1936. US Patent 2,052,869. 248
- [152] P. Enghag. *Encyclopedia of the Elements*. Wiley-VCH Weinheim, 2004. 254
- [153] V. Raghavan. Cu-Fe-S (copper-iron-sulfur). *Journal of Phase Equilibria and Diffusion*, 25(5):450–454, 2004. 256

## REFERENCES

---

- [154] Ernest M. Levin and Howard F. McMurdie. *Phase diagrams for ceramists, 1975 Supplement (Figures 4150-4999)*. American Ceramic Society, Inc., Columbus, OH, 1975. 256
- [155] K. Fiebach and D. Grimm. Resins, natural. *Ullmann's Encyclopedia of Industrial Chemistry*, 2003. 282
- [156] Ana-Maria Bianchi, Yves Fautrelle, and Jacqueline Etay. *Transferts thermiques*. presses polytechniques et universitaires romandes, 2004. 299, 301
- [157] American Society for Testing and Materials. Annual book of astm standards: 2004. volume 15.01. American Society for Testing and Materials, 2004. 312



le cnam

Mohammed Mortada Abd El-Raouf El-Gohari  
Design Tools for Enriching the Ceramics Forms  
Aesthetically by Experimental Treatments During and  
Post Firing

le cnam

**Résumé :**

Dans les arts plastiques, le concept de la beauté doit être associé aux techniques sous-jacentes. L'artiste doit choisir et maîtriser ces techniques afin de les appliquer à l'art en vue d'atteindre les résultats esthétiques visés. Une approche scientifique de ces techniques a un rôle important dans l'amélioration de leur application dans les arts plastiques. Les céramiques et poteries sont un domaine complexe où les réactions chimiques et les propriétés physiques des argiles et des glaçures doivent être prises en compte. Dans ce domaine l'histoire de la science était un guide utile dans une telle recherche. Pour les céramiques, les réactions chimiques se produisant à la phase haute température du processus de cuisson déterminent essentiellement l'aspect final de la surface du produit. En conséquence, changer les conditions de ces réactions (profils de température, la nature de l'atmosphère du four) était une bonne méthode pour obtenir de nouveaux aspects de surface. L'atmosphère du four pendant et après la cuisson permettait de contrôler, dans une large mesure, l'aspect final des produits céramiques, et cela dépend à la fois de la conception et de la mise en place du four. L'étude de l'histoire des techniques céramiques, dans différentes civilisations, a conduit à un aperçu des techniques de cuisson. La compréhension scientifique de ces techniques a mené à des stratégies en vue de modifier la conception du four et la pratique de la cuisson.

**Mots clés :**

Craquelés, Cuisson des céramiques, Fissuration, Fours des céramiques, Modélisation des glacures, Reflet métallique,

**Abstract :**

In Plastic arts ; with the concept of beauty there are also techniques, artists choose between these techniques for apply art works matching with aesthetic viewpoint. As well as science have important role in improved applied arts and fine arts techniques. In ceramics and pottery we are confronted with the chemicals reactions and physical properties of clay and glaze which have deep roots in human history, so history techniques will guide us in this research. In ceramic, chemical reactions need high temperature as condition to exist (Firing process), and that have main role in determined final appearance of surface treatments for ceramics forms. When the chemical reactions and physical properties which happen in firing process are responsible of final appearance and aesthetics treatments of ceramics forms, the changing of reactions conditions was used for achieving new treatments for ceramic surface beauty. The atmosphere of kiln during and after firing process whom decide the final appearance for ceramics forms, presented as technique for modifying kiln structure as a factor of enriching aesthetics treatments for ceramic surface. The history and science of ceramics techniques in some civilizations was studied to understand some firing techniques and its roles in ceramic surface esthetics. These provided evidence with experimental study to design a new kiln which can be used as a tool to enrich ceramics forms aesthetically

**Keywords :**

Ceramics kilns, Crackle, Firing ceramics, Glazes design, Metallic reflection.