



HAL
open science

Kinetically constrained models: relaxation to equilibrium and universality results

Laure Marêché

► **To cite this version:**

Laure Marêché. Kinetically constrained models: relaxation to equilibrium and universality results. Probability [math.PR]. Université Paris Cité, 2019. English. NNT: 2019UNIP7125 . tel-03097986

HAL Id: tel-03097986

<https://theses.hal.science/tel-03097986>

Submitted on 5 Jan 2021

HAL is a multi-disciplinary open access archive for the deposit and dissemination of scientific research documents, whether they are published or not. The documents may come from teaching and research institutions in France or abroad, or from public or private research centers.

L'archive ouverte pluridisciplinaire **HAL**, est destinée au dépôt et à la diffusion de documents scientifiques de niveau recherche, publiés ou non, émanant des établissements d'enseignement et de recherche français ou étrangers, des laboratoires publics ou privés.

Université de Paris
École doctorale n° 386 :
Sciences Mathématiques de Paris Centre
Laboratoire de Probabilités, Statistique et
Modélisation

Kinetically constrained models: relaxation to equilibrium and universality results

par Laure MARÊCHÉ

Thèse de doctorat de Mathématiques appliquées

Dirigée par Cristina TONINELLI

Présentée et soutenue publiquement le 5 septembre 2019

Devant un jury composé de

Thierry BODINEAU	Directeur de recherche CNRS École Polytechnique	Rapporteur
Djalil CHAFAÏ	Professeur Université Paris Dauphine	Examineur
Francis COMETS	Professeur Université Paris Diderot	Examineur
Régine MARCHAND	Maîtresse de conférences HDR Université de Lorraine	Examinatrice
Thomas MOUNTFORD	Professeur École Polytechnique Fédérale de Lausanne	Rapporteur
Cristina TONINELLI	Directrice de recherche CNRS Université Paris Dauphine	Directrice



Remerciements

Je voudrais tout d'abord remercier ma directrice de thèse, Cristina Toninelli. Merci de m'avoir initiée à un sujet de recherche intéressant où tant de questions importantes restent à étudier. Merci d'avoir toujours fait le nécessaire en temps et en heure, de vous être préoccupée de mon développement et de mon avenir. Merci enfin d'avoir fait en sorte que j'acquière l'autonomie dont je dispose maintenant, et que je n'aurais probablement pas atteinte si j'avais été encadrée autrement.

Merci à Thomas Mountford et Thierry Bodineau, qui ont accepté le lourd travail de rapporter sur ce manuscrit, ainsi qu'à Francis Comets, Régine Marchand et Djalil Chafaï de me faire l'honneur de participer à mon jury.

I wish to thank those who collaborated with me on this thesis, Fabio Martinelli and Ivailo Hartarsky, for the great mathematics we did together, the precious advice they gave me, as well as for enduring my endless comments with so much good grace. Thanks also for the nice moments spent with you, in particular that week in Roma.

Merci également à mes co-auteurs des journées MAS, Oriane Blondel, Aurélia Deshayes, Cyril Labbé et Marielle Simon.

Mes remerciements vont aussi aux enseignants qui m'ont permis d'en arriver là : les enseignants de Nancy qui m'ont poussée à passer le concours de l'ENS de Lyon et ont fait tout leur possible pour que je le réussisse, les enseignants de Lyon qui m'ont envoyée vers Cristina, et bien sûr tous mes professeurs de probabilités et encadrants de stage qui m'ont intéressée à ce domaine, puis confortée dans cet intérêt.

Je remercie les responsables des enseignements que j'ai effectués pendant les trois années de ma thèse, Samy Abbes, Mathilde Herblot, Cyrille Lucas, Tamara Servi et Pierre Poulain : travailler avec eux a été agréable, et leurs conseils m'ont été très utiles pour apprendre à enseigner. Merci aussi à tous les autres membres des équipes pédagogiques dont j'ai fait partie. Merci également à mes étudiants (sauf ceux qui ne venaient à mes TD que pour les interrogations) : c'est grâce à vous que j'aime l'enseignement.

Je tiens aussi à remercier toute l'équipe administrative, en particulier Na-

thalie Bergame et surtout Valérie Juvé, qui a géré l'ERC de mon encadrante pendant la période où j'ai le plus voyagé, et en conséquence que je suis allée embêter en priorité. Vous êtes des trésors toutes les deux, et les membres du LPSM ont beaucoup de chance de vous avoir.

I wish to thank all those who invited me during this thesis, be it to give a talk or not: Ellen Saada, Clément Guillaume, Oriane Blondel, Sébastien Martineau (désolée de n'avoir pas pu venir, ce n'était pas l'envie qui m'en manquait!), Fabio Toninelli, Jean-Christophe Breton, Fabio Martinelli, Maud Joubaud and Tiffany Cherchi, as well as Prasad Tetali. These experiences brought me a lot. De l'autre côté du miroir, je remercie Clément Cosco, Simon Coste, Paul Melotti et Nicolas Meyer, qui ont organisé le Groupe de Travail des Thésards avec moi pendant ma deuxième année de thèse.

Thanks to Cristina's team, Assaf Shapira, Aurélia Deshayes, Ivailo Hartarsky and Erik Slivken. Good luck to all for the future.

Merci à tous les camarades doctorants côtoyés pendant cette thèse, au laboratoire, Carlo Bellingeri, Cyril Benezet, Anna Ben-Hamou, Lucas Benigni, Clément Bonvoisin, Yann Chiffaudel, Guillaume Conchon-Kerjan, Fabio Coppini, Clément Cosco, Simon Coste, Barbara Dembin, Mi-Song Dupuis, Henri Elad-Altman, Sothea Has, Benjamin Havret, Hiroshi Horii, Come Hure, Ziad Kobeissi, Alexandra Lefebvre, Houzhi Li, Paul Melotti, Verónica Miró Pina, Nathan Noiry, Michel Pain, Marc Pegon, Othmane Safsafi, Assaf Shapira, et pendant les conférences, Clémence, Gustave, Jeanne, Sébastien, Shenglan, Tom, et tous ceux dont je n'ai jamais connu les noms. Vous êtes tellement sympathiques, c'est grâce à vous que j'ai appris que la vie valait la peine d'être vécue.

Je remercie aussi mes amis hors du labo, Clélie, Alice et Fabrice, pour les bons moments que nous avons passés ensemble, pendant les trois dernières années et celles qui les ont précédées.

Une pensée pour mon grand-père, ancien professeur d'université, qui aura été là pour voir le début de cette thèse, mais pas sa fin. *Nous entrerons dans la carrière/Quand nos aînés n'y seront plus...*

Merci à ma sœur Aude, tellement gentille, qui m'a aidée pour mon manuscrit même si elle n'a pas du tout choisi les maths, et qui est là pour me montrer autre chose que des probabilités de temps en temps!

Enfin, merci à mes parents. Pour ne m'avoir jamais, jamais laissée tomber.

Modèles avec contraintes cinétiques : convergence vers l'équilibre et résultats d'universalité

Résumé : Cette thèse étudie la classe de systèmes de particules en interaction appelés modèles avec contraintes cinétiques (KCM). La première question considérée est celle de l'universalité : peut-on classer l'infinité de modèles possibles en un nombre fini de classes selon leurs propriétés? Un tel résultat a été récemment démontré dans une classe de modèles proche, la percolation bootstrap, où les modèles se subdivisent en surcritiques, critiques et sous-critiques. Cette classification s'applique aussi aux KCM, mais elle n'est pas assez fine : les KCM surcritiques doivent être subdivisés en enracinés et non enracinés, et les KCM critiques selon qu'ils ont ou pas une infinité de directions stables. Cette thèse prouve la pertinence de cette classification des KCM et complète la preuve de leur universalité dans les cas surcritique et critique, en démontrant une borne inférieure pour deux grandeurs caractéristiques, le temps de relaxation et le premier temps auquel un site est à 0, dans les cas surcritique enraciné (travail avec F. Martinelli et C. Toninelli, reposant sur un résultat combinatoire réalisé sans collaboration) et critique avec une infinité de directions stables (travail avec I. Hartarsky et C. Toninelli). Elle établit aussi une borne inférieure plus précise dans le cas particulier du modèle de Duarte (travail avec F. Martinelli et C. Toninelli). Dans un deuxième temps, cette thèse montre des résultats de convergence exponentielle vers l'équilibre, pour tous les KCM surcritiques sous certaines conditions et dans le cas particulier du modèle Est en dimension d sans restriction.

Mots-clés : systèmes de particules en interaction, modèles avec contraintes cinétiques, percolation bootstrap, universalité, temps de relaxation, convergence vers l'équilibre.

Kinetically constrained models: relaxation to equilibrium and universality results

Abstract: This thesis studies the class of interacting particle systems called kinetically constrained models (KCMs). It considers first the question of universality: can the infinity of possible models be sorted into a finite number of classes according to their properties? Such a result was recently proven in a related class of models, bootstrap percolation, where models can be divided into supercritical, critical and subcritical. This classification can also be applied to KCMs, but it is not precise enough: supercritical KCMs have to be divided into rooted and unrooted, and critical KCMs depending on them having or not an infinity of stable directions. This thesis shows the relevance of this classification of KCMs and completes the proof of their universality in the supercritical and critical cases, by proving a lower bound for two characteristic scales, the relaxation time and the first time at which a site is at 0, in the supercritical rooted case (work with F. Martinelli and C. Toninelli, relying on a combinatorial result shown without collaboration) and in the case of critical models with an infinity of stable directions (work with I. Hartarsky and C. Toninelli). It also establishes a more precise lower bound in the particular case of the Duarte model (work with F. Martinelli and C. Toninelli). Secondly, this thesis shows results of exponential convergence to equilibrium, for all supercritical KCMs under certain conditions and in the particular case of the d -dimensional East model without restrictions.

Keywords: interacting particle systems, kinetically constrained models, bootstrap percolation, universality, relaxation time, convergence to equilibrium.

Résumé détaillé

Dans cette thèse, on étudie les modèles avec contraintes cinétiques, que l'on appellera KCM (pour *Kinetically Constrained Models*). Les KCM sont des dynamiques sur des graphes, dans lesquelles chaque sommet du graphe (on appelle les sommets des *sites*) peut être dans un état (ou *spin*) 0 ou 1. On ne considère que des KCM sur le graphe \mathbb{Z}^d . Ils sont définis ainsi : chaque site de \mathbb{Z}^d essaie de *mettre à jour* son spin à taux 1, où mettre à jour un spin signifie le remplacer par 0 avec probabilité q et par 1 avec probabilité $1 - q$; cependant, une mise à jour est acceptée si et seulement si une *contrainte* est satisfaite. Cette contrainte est définie par une *famille de mise à jour* $\mathcal{U} = \{X_1, \dots, X_m\}$, où les X_i , appelés *règles de mise à jour*, sont des sous-ensembles finis non vides de $\mathbb{Z}^d \setminus \{0\}$: la contrainte est satisfaite en un site x lorsqu'il existe i tel que tous les sites de $x + X_i$ ont spin 0. La présence de cette contrainte caractérise les KCM.

Les KCM ont été inventés par les physiciens pour modéliser la transition liquide-verre, un important problème ouvert en physique de la matière condensée (voir [BB11, RS03, GST11]). Le phénomène est le suivant. Dans un matériau liquide, il n'y a pas de structure, les molécules ou les atomes qui le constituent bougent de façon désordonnée. Lorsqu'on le refroidit, ce mouvement ralentit, jusqu'à s'arrêter complètement en dessous d'une certaine température. Si le refroidissement est suffisamment lent, les molécules ont le temps de s'organiser ; elles forment alors une structure périodique, un cristal. Par contre, si le refroidissement est trop rapide, cette organisation n'a pas le temps de se mettre en place, et les molécules se figent dans leur état désordonné. On obtient alors un solide sans structure, qui est ce que les physiciens appellent un verre ; le verre de la vie quotidienne en est un exemple, mais il en existe d'autres.

Les KCM modélisent ce phénomène. Chaque site de \mathbb{Z}^d représente une petite région du matériau ; un site avec spin 0 représente une région où les molécules sont assez libres de bouger, tandis qu'un site avec spin 1 représente une région où les mouvements des molécules sont plus contraints. Moins de sites à 0 signifient donc moins de régions où les molécules sont libres

de bouger, donc moins de mouvements, c'est-à-dire une température moins élevée. Comme la contrainte en un site est de la forme « il y a assez de 0 aux alentours du site », le fait que la contrainte doive être satisfaite en un site pour que celui-ci puisse être mis à jour signifie que pour que l'état d'une région du matériau puisse changer, il doit y avoir aux alentours assez de régions où les molécules sont libres de bouger, ce qui est physiquement raisonnable. Les KCM ont la particularité d'avoir une mesure d'équilibre très simple : la mesure μ_q sous laquelle tous les spins sont indépendants et la probabilité qu'un site donné ait spin 0 est q . Toute la complexité du comportement des KCM est donc due à leur dynamique. Malgré cela, les KCM présentent de nombreuses caractéristiques importantes de la transition liquide-verre, telles que le vieillissement de la dynamique (prouvé au moins dans le modèle Est, voir [FMRT13]) et une divergence très rapide du temps de relaxation à basse température, que l'on étudie dans cette thèse.

En plus de leur utilité en physique, les KCM ont également un intérêt mathématique. En effet, ils suivent une dynamique de type Glauber, mais la présence des contraintes les rend très différents des dynamiques de Glauber classiques comme le modèle d'Ising, et empêche l'application des outils développés pour ces modèles classiques. Une des différences les plus importantes est l'existence de configurations bloquées : si un KCM part d'une configuration initiale ne comportant que des 1, aucun $x + X_i$ n'est rempli de 0, donc aucune contrainte n'est satisfaite, et la dynamique est bloquée ; selon le choix de la famille de mise à jour, il peut aussi y avoir d'autres configurations bloquées. Ces configurations bloquées entraînent l'existence de plusieurs mesures invariantes et rendent les analyses « au pire cas » inefficaces. Une autre différence majeure est l'absence de monotonie : dans de nombreuses dynamiques de Glauber, comme le modèle d'Ising, il est possible de coupler l'évolution de la dynamique de sorte qu'un processus qui contient initialement plus de 1 qu'un autre contiendra toujours plus de 1 par la suite, et cette propriété fournit de nombreux outils. Par contre, dans les KCM, si un processus contient initialement plus de 1 qu'un autre, il aura moins de contraintes satisfaites, et il pourra manquer des mises à jour qui créent des 1 dans l'autre processus, donc cette propriété de monotonie n'est pas vérifiée. À cause de ces particularités, l'étude mathématique des KCM nécessite l'invention de nouveaux outils.

Une question majeure pour les KCM, d'un point de vue à la fois physique et mathématique, est de déterminer comment les échelles de temps du processus stationnaire de loi initiale μ_q divergent quand q tend vers 0. L'une des questions les plus intéressantes est celle de l'universalité : est-il possible de classer les modèles en un nombre fini de *classes d'universalité* à l'intérieur desquelles les modèles ont le même comportement ? De tels résultats d'uni-

versalité, en plus d'être mathématiquement élégants, sont très importants pour les physiciens, car ils signifient que le choix arbitraire d'un modèle particulier n'affecte pas ses propriétés ; ces modèles sont donc pertinents pour décrire des phénomènes physiques. Ces résultats mathématiques sont d'autant plus importants que les KCM ont des échelles de temps très longues, ce qui rend difficile l'obtention de résultats numériques. Plusieurs KCM avec des familles de mise à jour particulières ont été étudiés par le passé (voir [AD02, CMRT08, CFM16, MT19]), et ces travaux ont mis en évidence des comportements très différents selon le choix de la famille de mise à jour.

Cependant, un résultat d'universalité a récemment été démontré pour une classe de modèles proche des KCM, la percolation bootstrap. La percolation bootstrap est en quelque sorte une version monotone et déterministe des KCM ; c'est une dynamique à temps discret, dans laquelle chaque site de \mathbb{Z}^d peut être infecté (l'équivalent d'avoir spin 0) ou sain (l'équivalent d'avoir spin 1), définie ainsi : à chaque pas, un site précédemment infecté le reste, et un site x précédemment sain est infecté si et seulement si la contrainte est satisfaite en x , c'est-à-dire si et seulement s'il existe une règle de mise à jour $X_i \in \mathcal{U}$ telle que tous les sites de $x + X_i$ sont infectés, où \mathcal{U} est une famille de mise à jour fixée. La percolation bootstrap est étroitement liée aux KCM : en effet, si on identifie les sites infectés de la percolation bootstrap et les sites avec spin 0 des KCM, on peut voir que la percolation bootstrap infecte tous les sites que le KCM avec la même famille de mise à jour pourrait mettre à jour à 0, donc les sites sains que la percolation bootstrap n'infecte jamais sont les sites avec spin 1 que le KCM ne peut jamais mettre à jour à 0.

Dans [BSU15, BBPS16], Balister, Bollobás, Przykucki, Smith et Uzzell ont démontré que pour la percolation bootstrap, les familles de mise à jour en dimension 2 peuvent être réparties en trois classes d'universalité : *sur-critiques*, *critiques* et *sous-critiques*. Pour définir ces classes, on a besoin de la notion de *direction stable* : une direction $u \in S^1$ est dite *stable* pour une famille de mise à jour \mathcal{U} s'il n'existe pas de règle de mise à jour $X_i \in \mathcal{U}$ telle que $X_i \subset \mathbb{H}_u = \{x \in \mathbb{Z}^2 \mid \langle x, u \rangle < 0\}$; sinon, u est dite *instable*. En particulier, si u est stable, lorsque la percolation bootstrap part d'une configuration ne contenant que des sites sains dans $(\mathbb{H}_u)^c$, elle ne peut infecter aucun de ces sites ; intuitivement, l'infection ne peut pas progresser dans la direction u . Une famille de mise à jour est dite *surcritique* s'il existe un demi-cercle ouvert de directions instables, *critique* si elle n'est pas surcritique mais il existe un demi-cercle ouvert ne contenant qu'un nombre fini de directions stables, et *sous-critique* sinon.

Dans [BSU15, BBPS16], Balister, Bollobás, Przykucki, Smith et Uzzell ont montré que le comportement de la percolation bootstrap est très différent selon la classe à laquelle appartient la famille de mise à jour. La première

question que l'on se pose en percolation bootstrap est : un site donné (par exemple l'origine) sera-t-il infecté par le processus avec probabilité 1, ou y a-t-il une probabilité strictement positive que la dynamique ne l'infecte jamais ? On peut montrer que si le processus part d'une configuration initiale dans laquelle les sites sont indépendamment infectés avec probabilité q , il existe une *probabilité critique* q_c telle que si $q > q_c$, l'origine est infectée avec probabilité 1, et si $q < q_c$, il y a une probabilité strictement positive que la dynamique n'infecte jamais l'origine. [BSU15, BBPS16] ont montré que pour les familles de mise à jour surcritiques et critiques, $q_c = 0$, alors que pour les familles de mise à jour sous-critiques, $q_c > 0$. Par ailleurs, une autre grandeur caractéristique importante en percolation bootstrap est le *temps d'infection* τ^{BP} , c'est-à-dire le premier temps auquel l'origine est infectée. Bollobás, Duminil-Copin, Morris, Smith et Uzzell ont prouvé dans [BSU15, BDCMSar] que quand q tend vers 0, $\tau^{BP} = 1/q^{\Theta(1)}$ lorsque la famille de mise à jour est surcritique et $\tau^{BP} = e^{\Theta(1/q^\alpha)}$ lorsque la famille de mise à jour est critique, où α est un paramètre ne dépendant que de \mathcal{U} appelé *difficulté* de la famille de mise à jour, et $f = \tilde{\Theta}(g)$ signifie $\lim_{q \rightarrow 0} \ln(f(q))/\ln(g(q)) = 1$ (plus précisément, dans [BDCMSar], Bollobás, Duminil-Copin, Morris et Smith ont montré que pour les familles de mise à jour critiques, τ^{BP} est égal soit à $e^{\Theta(1/q^\alpha)}$ soit à $e^{\Theta(\ln(1/q)^2/q^\alpha)}$).

Au vu de ces résultats, il est naturel de se demander s'il existe aussi une classification d'universalité pour les KCM. Répondre à cette question est le premier objectif de cette thèse. Les résultats obtenus prouvent que la répartition en familles de mise à jour surcritiques, critiques et sous-critiques introduite pour la percolation bootstrap doit être améliorée pour décrire le comportement plus riche des KCM.

Ces résultats concernent l'équivalent de τ^{BP} pour les KCM : τ^{KCM} , le premier temps auquel le spin de l'origine est à 0 lorsque la configuration initiale suit la loi μ_q ; il concernent aussi une autre grandeur caractéristique des KCM, le *temps de relaxation* T_{rel} , c'est-à-dire l'inverse du trou spectral du générateur de la dynamique. Ils établissent le comportement de ces deux quantités quand q tend vers 0. D'un point de vue physique, ce régime correspond à la transition liquide-verre ou encore à une température basse ; en effet, les zéros disparaissent, donc les régions où les molécules sont libres de bouger disparaissent, et le matériau se fige.

Dans [MT19], Martinelli et Toninelli ont démontré qu'on avait toujours $\tau^{KCM} = \Omega(\tau^{BP})$ quand q tend vers 0. Cependant, τ^{KCM} n'a pas nécessairement le même comportement que τ^{BP} quand q tend vers 0 : pour certaines familles de mise à jour surcritiques, τ^{KCM} et τ^{BP} divergent à la même vitesse, mais pour d'autres, τ^{KCM} diverge beaucoup plus vite que τ^{BP} , Par

conséquent, savoir qu'un KCM a une famille de mise à jour surcritique ne suffit pas pour prédire son comportement, c'est pourquoi cette classe doit être subdivisée pour l'étude des KCM. Le même phénomène peut être observé pour les familles de mise à jour critiques, qu'il faut donc subdiviser elles aussi.

Le bon raffinement de la classification pour les familles de mise à jour surcritiques est le suivant : une famille de mise à jour surcritique est *enracinée* si elle comporte deux directions stables non opposées, et *non enracinée* dans le cas contraire. Dans cette thèse, on montre le théorème suivant, qui a été prouvé en collaboration avec Fabio Martinelli et Cristina Toninelli dans l'article [MMTar], correspondant au chapitre 2 de cette thèse :

Théorème 1. *Pour toute famille de mise à jour surcritique enracinée, on a $\mathbb{E}_{\mu_q}(\tau^{KCM}) = 1/q^{\Omega(\ln(1/q))}$ quand q tend vers 0, et la même propriété est vraie pour T_{rel} .*

La borne inférieure fournie par le théorème 1 parachève le résultat suivant, qui prouve la pertinence de cette classification d'universalité des familles de mise à jour surcritiques pour les KCM (les bornes supérieures ont été montrées par Martinelli, Morris et Toninelli dans [MMT19]) :

Théorème 2. *Pour toute famille de mise à jour surcritique \mathcal{U} ,*

- *si \mathcal{U} est non enracinée, $\mathbb{E}_{\mu_q}(\tau^{KCM}) = 1/q^{\Theta(1)}$ quand q tend vers 0 ;*
- *si \mathcal{U} est enracinée, $\mathbb{E}_{\mu_q}(\tau^{KCM}) = 1/q^{\Theta(\ln(1/q))}$ quand q tend vers 0,*

et la même propriété est vraie pour T_{rel} .

Le théorème 1 est en fait valable en dimension quelconque pour une généralisation convenable de la définition des familles de mise à jour surcritiques enracinées. Les bornes supérieures de [MMT19] pour les familles de mise à jour surcritiques fonctionnant aussi en dimension 1, le théorème 2 est également vrai en dimension 1.

En termes physiques, les familles de mise à jour non enracinées et enracinées ont respectivement un comportement *Arrhenius* et *super-Arrhenius* des échelles de temps. Les deux comportements sont observés expérimentalement au voisinage de la transition liquide-verre et correspondent respectivement à des *liquides résistants* et *fragiles*.

Pour les familles de mise à jour critiques, le bon raffinement de la classification est de les diviser en familles de mise à jour critiques *avec un nombre fini de directions stables* et *avec un nombre infini de directions stables*. Dans cette thèse, on montre le résultat suivant, qui a été prouvé en collaboration avec Ivailo Hartarsky et Cristina Toninelli dans l'article [HMT19a], correspondant au chapitre 3 de cette thèse :

Théorème 3. *Pour toute famille de mise à jour critique avec un nombre infini de directions stables, $\mathbb{E}_{\mu_q}(\tau^{KCM}) = e^{\Omega(1/q^{2\alpha})}$ quand q tend vers 0, et la même propriété est vraie pour T_{rel} .*

Ce résultat complète la preuve du théorème suivant, qui prouve la classification d'universalité pour les KCM avec familles de mise à jour critiques (les bornes supérieures ont été prouvées par Hartarsky, Martinelli, Morris et Toninelli dans [MMT19, HMT19b]) :

Théorème 4. *Pour toute famille de mise à jour critique \mathcal{U} ,*

- *si \mathcal{U} a un nombre fini de directions stables, $\mathbb{E}_{\mu_q}(\tau^{KCM}) = e^{\tilde{\Theta}(1/q^\alpha)}$ quand q tend vers 0;*
- *si \mathcal{U} a un nombre infini de directions stables, $\mathbb{E}_{\mu_q}(\tau^{KCM}) = e^{\tilde{\Theta}(1/q^{2\alpha})}$ quand q tend vers 0,*

et la même propriété est vraie pour T_{rel} .

Tant pour les familles de mise à jour surcritiques enracinées que pour les familles de mise à jour critiques avec un nombre infini de directions stables, les résultats de cette thèse montrent que les échelles de temps des KCM divergent beaucoup plus vite que celles des modèles de percolation bootstrap correspondants. Ceci est dû à l'existence de *barrières d'énergie*, qui déterminent le comportement dominant dans ces KCM mais n'ont aucune influence sur la dynamique monotone de la percolation bootstrap.

Maintenant que la classification d'universalité des KCM critiques est établie, une question naturelle est de vouloir déterminer les corrections logarithmiques (comme cela a été fait pour les modèles de percolation bootstrap critiques), c'est-à-dire remplacer les $e^{\tilde{\Theta}(1/q^\beta)}$ avec $\beta \in \{\alpha, 2\alpha\}$ par $e^{\Theta(\ln(1/q)^\gamma/q^\beta)}$ avec la bonne puissance γ . Un premier pas dans cette direction est le résultat de cette thèse pour une famille de mise à jour critique spécifique, celle du modèle de Duarte, qui est $\mathcal{U} = \{\text{sous-ensembles à 2 éléments parmi } (0, -1), (-1, 0) \text{ et } (0, 1)\}$; cette famille de mise à jour a un nombre infini de directions stables et une difficulté $\alpha = 1$. Pour l'instant, ce résultat sur le modèle de Duarte est le seul de cette précision pour un modèle critique. Cette thèse montre sa borne inférieure, qui a été prouvée en collaboration avec Fabio Martinelli et Cristina Toninelli dans l'article [MMTar], correspondant au chapitre 2 de cette thèse (la borne supérieure a été démontrée par Martinelli, Morris et Toninelli dans [MMT19]). Le résultat est le suivant :

Théorème 5. *Dans le modèle de Duarte, $\mathbb{E}_{\mu_q}(\tau^{KCM}) = e^{\Theta(\ln(1/q)^4/q^2)}$ quand q tend vers 0, et la même propriété est vraie pour T_{rel} .*

Les bornes inférieures des théorèmes 1, 3 et 5, sur le premier temps auquel le spin de l'origine est à zéro et sur le temps de relaxation, sont prouvées en trouvant une barrière d'énergie explicite, c'est-à-dire un ensemble A de configurations de probabilité très petite tel que pour une configuration initiale typique, avant que le spin de l'origine puisse être à 0, la dynamique doit passer par A . Comme A a une probabilité très petite, il s'écoulera beaucoup de temps avant que la dynamique passe par A , donc avant que le spin de l'origine puisse être à 0. Pour transformer cette intuition en une borne inférieure rigoureuse pour $E_{\mu_q}(\tau^{KCM})$, on utilise un lemme original prouvé en collaboration avec Fabio Martinelli et Cristina Toninelli dans l'article [MMTar], correspondant au chapitre 2 de cette thèse. Cela fournit ensuite une borne inférieure pour T_{rel} grâce à un lemme de Martinelli, Morris et Toninelli [MMT19].

Pour le théorème 1, qui concerne les familles de mise à jour surcritiques enracinées, on trouve A grâce au résultat combinatoire suivant, montré dans l'article [Mar17] correspondant au chapitre 1 de cette thèse :

Théorème 6. *Pour toute famille de mise à jour surcritique enracinée, il existe une constante $\kappa > 0$ telle que pour tout $n \in \mathbb{N}$, si la configuration initiale ne contient que des 1 dans $\{-\lfloor \kappa n 2^n \rfloor, \dots, \lfloor \kappa n 2^n \rfloor\}^2$, la dynamique du KCM doit passer par une configuration contenant strictement plus de n zéros dans $\{-\lfloor \kappa n 2^n \rfloor, \dots, \lfloor \kappa n 2^n \rfloor\}^2$ avant que le spin de l'origine ne puisse être à 0.*

Si $n \sim \varepsilon \ln(1/q)$ avec ε petit, alors une configuration initiale typique ne contient que des 1 dans $\{-\lfloor \kappa n 2^n \rfloor, \dots, \lfloor \kappa n 2^n \rfloor\}^2$, donc avant que le spin de l'origine ne puisse être à 0, la dynamique doit passer par une configuration avec plus de n zéros dans $\{-\lfloor \kappa n 2^n \rfloor, \dots, \lfloor \kappa n 2^n \rfloor\}^2$, ce qui a probabilité environ $q^n = q^{\Omega(\ln(1/q))}$, donc le temps mis par la dynamique pour ce faire est environ $1/q^{\Omega(\ln(1/q))}$, d'où le théorème 1.

En plus de son utilité pour prouver le théorème 1, le théorème 6 a aussi un intérêt propre ; c'est une généralisation d'un résultat combinatoire démontré par Chung, Diaconis et Graham dans [CDG01] pour une famille de mise à jour unidimensionnelle particulière, celle du modèle Est ($\mathcal{U} = \{-1\}$). Le théorème 6 est en fait valide dans un cadre plus général qu'énoncé ci-dessus : pour toutes les familles de mise à jour *qui ne sont pas* surcritiques *non enracinées*, et en dimension quelconque pour une généralisation convenable de la définition d'une famille de mise à jour surcritique non enracinée (définition 1.3 du chapitre 1). Il permet de démontrer le théorème 1 dans ce contexte plus large. Bien qu'il s'agisse d'une généralisation d'un résultat de [CDG01], sa preuve est complètement différente de la preuve de [CDG01], car cette dernière repose sur l'orientation du modèle Est, qui n'est pas vérifiée par les familles de mise à jour surcritiques enracinées générales.

Les preuves des théorèmes 3 et 5 utilisent des résultats similaires, mais plus complexes : les zéros doivent être remplacés par des « structures de zéros », de probabilité $e^{-\Theta(1/q^\alpha)}$ pour le théorème 3 et $e^{-\Theta(\ln(1/q)^2/q)}$ pour le théorème 5. Ces structures de zéros vérifient alors un résultat similaire au théorème 6, ce qui permet d'obtenir une borne inférieure semblable à celle du théorème 1 avec q remplacé par $e^{-\Theta(1/q^\alpha)}$ pour le théorème 3 et $e^{-\Theta(\ln(1/q)^2/q)}$ pour le théorème 5. Ces structures de zéros sont définies grâce à un algorithme, qui représente une importante innovation.

Tous ces résultats concernent uniquement le cas où la configuration initiale a loi μ_q , c'est-à-dire où la dynamique part de la mesure d'équilibre. La dynamique hors équilibre des KCM est encore plus difficile à étudier et moins bien comprise que la dynamique à l'équilibre. La première question que l'on peut se poser à son propos est : le processus convergera-t-il vers l'équilibre, et si oui, quelle est la vitesse de cette convergence ? La réponse dépend beaucoup de la configuration initiale : si elle est bloquée, la dynamique y reste figée, donc ne peut pas converger vers l'équilibre. Il ne peut donc pas y avoir convergence à partir de toute configuration initiale. Les configurations initiales les plus pertinentes d'un point de vue physique sont celles de loi $\mu_{q'}$, $q' \neq q$. En effet, le paramètre q gouverne la proportion de zéros présente dans le système ; c'est donc une mesure de sa température, qui est plus basse lorsque la quantité de zéros diminue. Par conséquent, partir d'une configuration de loi $\mu_{q'}$, $q' \neq q$ signifie partir d'une température différente de la température d'équilibre ; les résultats de convergence à partir de ces lois initiales sont donc physiquement intéressants. Bien sûr, prouver la convergence vers l'équilibre à partir de toute configuration initiale non bloquée est encore mieux. Dans les deux cas, on pense que la convergence vers l'équilibre a bien lieu, avec une vitesse exponentielle, dès lors qu'une configuration de loi μ_q (et $\mu_{q'}$ si on part de $\mu_{q'}$) ne contient pas de sites bloqués pour la dynamique du KCM, ou encore dès lors que $q > q_c$ (et $q' > q_c$ si on part de $\mu_{q'}$). Cependant, de tels résultats sont très difficiles à prouver ; peu ont pu être démontrés, et ils sont restreints à des familles de mise à jour ou des lois initiales particulières (voir [CMST10, BCM⁺13, CFM15, MV19]).

Montrer la convergence exponentielle vers l'équilibre dans des cas plus généraux est le deuxième objectif de cette thèse. On la prouve dans deux nouveaux cas : pour toutes les familles de mise à jour surcritiques lorsque la configuration initiale a loi $\mu_{q'}$ et $q \in [q_0, 1]$ avec $q_0 < 1$, et dans un modèle spécifique, le modèle Est en dimension d , pour toute configuration initiale non bloquée et toute valeur de q .

Le résultat pour les familles de mise à jour surcritiques, qui a été démontré dans l'article [Mar19b] correspondant au chapitre 4 de cette thèse, s'énonce ainsi :

Théorème 7. *Pour toute famille de mise à jour surcritique, pour tout $q' \in]0, 1]$, il existe $q_0 \in [0, 1[$ tel que pour tout $q \in [q_0, 1]$, pour toute fonction locale $f : \{0, 1\}^{\mathbb{Z}^2} \mapsto \mathbb{R}$, il existe deux constantes $c > 0$ et $C > 0$ telles que pour tout $t \geq 0$,*

$$\left| \mathbb{E}_{\mu_{q'}}(f(\omega_t)) - \mu_q(f) \right| \leq C e^{-ct}.$$

Le théorème 7 est le seul résultat de convergence exponentielle vers l'équilibre connu valable pour toute une classe de familles de mise à jour et toute loi initiale $\mu_{q'}$. Il est encore vrai en dimension 1 pour une bonne définition d'une famille de mise à jour surcritique unidimensionnelle (définition 4.2 du chapitre 4), mais pour être étendue en dimension plus grande que 2, sa preuve nécessiterait un équivalent d'une construction bidimensionnelle de [BSU15], et un tel résultat n'est pas encore connu. Le montrer étendrait automatiquement le théorème 7.

Pour prouver le théorème 7, on couple deux processus du KCM, un partant de $\mu_{q'}$ et un à l'équilibre, et on montre que la probabilité qu'ils soient différents en un site donné est en $C e^{-ct}$. Pour cela, on remarque que si les deux processus sont différents en ce site, on peut trouver un « chemin le long duquel les processus sont toujours différents » : on commence par se placer en ce site au temps t et remonter le temps ; on remonte le temps en restant à ce site tant que les deux processus y sont différents, et en passant à un site proche lorsque les deux processus deviennent identiques. Ensuite, on montre que l'existence d'un tel chemin le long duquel les deux processus sont toujours différents a une probabilité très faible, car les processus contiennent tellement de zéros qu'avec grande probabilité, sur chaque chemin possible il y a un point auquel les deux processus sont tous les deux à 0. On prouve ce dernier point en couplant les processus avec un processus de percolation orientée, qui est plus facile à contrôler que les KCM car il est monotone.

Le deuxième résultat de convergence exponentielle vers l'équilibre de cette thèse concerne le modèle Est en dimension d , un modèle défini en dimension quelconque par $\mathcal{U} = \{-e_1\}, \dots, \{-e_d\}$, où $\{e_1, \dots, e_d\}$ est la base canonique. C'est le seul résultat de convergence exponentielle vers l'équilibre connu dans un KCM en dimension plus grande que 1 valable pour toute valeur de q . Il est vrai lorsque la loi ν de la configuration initiale satisfait la condition (C) : $\exists a, A > 0, \forall \ell \geq 0, \nu(\forall x \in \{-[\ell], \dots, 0\}^d, \eta(x) = 1) \leq A e^{-a\ell}$. Cette condition, très faible, inclut les $\mu_{q'}$, $q' \in]0, 1]$, ainsi que toutes les configurations pour lesquelles la dynamique est non bloquée sur $\mathbb{N}^d \setminus \{0\}$. Le résultat, démontré dans l'article [Mar19a] correspondant au chapitre 5 de cette thèse, s'énonce ainsi :

Théorème 8. *Dans le modèle Est en dimension d , pour tout $q \in]0, 1[$, pour toute mesure ν sur $\{0, 1\}^{\mathbb{Z}^d}$ satisfaisant (C), il existe des constantes $\chi > 0$,*

$c > 0$ et $C > 0$ telles que pour tout $t \geq 0$ et toute fonction locale $f : \{0, 1\}^{\mathbb{Z}^d} \mapsto \mathbb{R}$ avec $\text{supp}(f) \subset (\prod_{i=1}^d \{0, \dots, \lfloor \chi t^{1/d} \rfloor\}) \setminus \{(0, \dots, 0)\}$,

$$\int_{\{0,1\}^{\mathbb{Z}^d}} |\mathbb{E}_\omega(f(\omega_t)) - \mu_q(f)| d\nu(\omega) \leq C \|f\|_\infty e^{-ct}.$$

Le théorème 8 fournit également un corollaire portant sur la *fonction de persistance*. La fonction de persistance associée à un temps t la probabilité que t_x , l'instant de la première mise à jour d'un site donné x , soit plus grand que t , ou encore la probabilité que x ne soit pas mis à jour avant le temps t . C'est une mesure de la mobilité du système : moins celui-ci est bloqué, plus il y a de mises à jour, plus la fonction de persistance est proche de zéro. Le théorème 8 permet de montrer que la fonction de persistance décroît à une vitesse exponentielle dans le modèle Est en dimension d lorsque la configuration initiale satisfait (C) :

Corollaire 9. *Dans le modèle Est en dimension d , pour tout $q \in]0, 1[$, pour toute mesure ν sur $\{0, 1\}^{\mathbb{Z}^d}$ satisfaisant (C), il existe des constantes $\chi > 0$, $c > 0$ et $C > 0$ telles que pour tout $t \geq 0$ et tout $x \in (\prod_{i=1}^d \{0, \dots, \lfloor \chi t^{1/d} \rfloor\}) \setminus \{(0, \dots, 0)\}$, $\mathbb{P}_\nu(t_x > t) \leq C e^{-ct}$.*

Le corollaire 9 est le seul résultat connu de déclin exponentiel de la fonction de persistance pour un KCM hors équilibre dans \mathbb{Z}^d avec $d > 1$. Tout comme le théorème 8, il a été démontré dans l'article [Mar19a], qui correspond au chapitre 5 de cette thèse.

La preuve du théorème 8 repose sur l'orientation du modèle Est : on peut voir que la dynamique dans un domaine fini ne dépend pas de ce qui se passe « au-dessus » (dans les directions e_1, \dots, e_d), donc en ignorant ce qui se passe au-dessus et en conditionnant sur ce qui se passe « en dessous » (dans les directions $-e_1, \dots, -e_d$), on peut se ramener à une dynamique en volume fini. De plus, si le spin d'un site bien placé « juste en dessous » du domaine est à 0, cette dynamique en volume fini est irréductible. Grâce à ces propriétés, on peut montrer que si le spin de ce site passe un temps $\Omega(t)$ à 0 avant le temps t , et si le volume du domaine est au plus $O(t)$, la dynamique dans le domaine a de bonnes propriétés, incluant la convergence vers l'équilibre. Il suffit donc de prouver que le spin de l'origine de \mathbb{Z}^d passe un temps $\Omega(t)$ à 0 avant le temps t pour démontrer la convergence exponentielle vers l'équilibre affirmée dans le théorème 8. Pour cela, on commence par montrer qu'il existe un site $(y_1, \dots, y_d) \in (-\mathbb{N})^d$ avec $y_i = O(t)$ dont le spin reste un temps $\Omega(t)$ à 0 avant le temps t , puis on utilise les bonnes propriétés de la dynamique dans le domaine $\{y_1 + 1, \dots, 0\} \times \{y_2\} \times \dots \times \{y_d\}$ pour prouver que le spin de $(0, y_2, \dots, y_d)$ reste un temps $\Omega(t)$ à 0 avant le temps t ; on peut alors itérer

ce dernier argument pour montrer que $(0, 0, y_3, \dots, y_d)$, $(0, 0, 0, y_4, \dots, y_d)$,
 $\dots, (0, \dots, 0)$ restent un temps $\Omega(t)$ à 0 avant le temps t , ce qui conclut la
preuve.

Table des matières

Résumé détaillé	vii
Introduction	1
1 Definitions and tools	6
1.1 Definitions	6
1.2 Bootstrap percolation	9
1.3 Relaxation time	15
2 Universality	16
2.1 Previous results	16
2.2 Advances of the thesis and universality partition	19
2.3 Sketch of proofs	22
3 Convergence to equilibrium	30
3.1 Previous results	30
3.2 Advances of the thesis	34
3.3 Sketch of proofs	36
1 Combinatorics for supercritical rooted kinetically constrained models	43
1.1 Introduction	43
1.2 Notations and result	47
1.3 The one-dimensional case	49
1.4 The general case	54
1.5 Sketch of the proof of proposition 1.6	58
2 Asymptotics for Duarte and supercritical rooted kinetically constrained models	61
2.1 Introduction	62
2.2 Models and notation	65
2.2.1 Notation	65
2.2.2 Models	66
2.3 A variational lower bound for $\mathbb{E}_\mu(\tau_0)$	66

2.4	Supercritical rooted KCMs	69
2.5	The Duarte KCM	72
2.5.1	Preliminary tools: the Duarte bootstrap process	73
2.5.2	Algorithmic construction of the test function and proof of theorem 2.11	76
2.5.3	East-like motion of the arrows and proof of proposition 2.26	81
2.5.4	Density of droplets and proof of proposition 2.27	85
2.5.5	Finishing the proof of proposition 2.27	92
3	Asymptotics for critical kinetically constrained models with an infinite number of stable directions	95
3.1	Introduction	96
3.2	Models and background	100
3.2.1	Bootstrap percolation	100
3.2.2	Kinetically constrained models	103
3.2.3	Result	105
3.3	Sketch of the proof	106
3.4	Preliminaries and notation	108
3.5	Droplet algorithm	110
3.5.1	Clusters and crumbs	111
3.5.2	Distorted Young diagrams	112
3.5.3	Span	115
3.5.4	Droplet algorithm and spanned droplets	117
3.5.5	Properties of the algorithm	118
3.6	Renormalised East dynamics	125
3.6.1	Geometric setup	125
3.6.2	Arrow variables	126
3.6.3	Renormalised East dynamics	130
3.6.4	Proof of theorem 3.8	130
3.7	Open problems	134
4	Convergence to equilibrium in supercritical kinetically constrained models	135
4.1	Introduction	135
4.2	Notations and result	137
4.3	Dual paths	139
4.4	Codings	142
4.5	An auxiliary process	144
4.5.1	Local spread of zeroes	145
4.5.2	Definition of the auxiliary process	147

4.5.3	Properties of the auxiliary process	150
4.6	Proof of proposition 4.11	151
5	Convergence to equilibrium in the d-dimensional East model	157
5.1	Introduction	157
5.2	Notations and results	159
5.3	Proof of theorem 5.2	161
5.3.1	Finding a site that stays at zero for a time $\Omega(t)$	161
5.3.2	Proving the origin stays at zero for a time $\Omega(t)$	165
5.3.3	Ending the proof of theorem 5.2	166
5.4	Proof of corollary 5.4	168

Introduction

In this thesis we study models of statistical mechanics called kinetically constrained models, which we will abbreviate by KCMs. KCMs are dynamics of configurations on a graph, in which each vertex of the graph (we call them *sites*) can have *spin* 0 or 1. Here we will consider only KCMs on \mathbb{Z}^d with $d \geq 1$. Each site of \mathbb{Z}^d tries at rate 1 to *update* its spin, which means to replace it by 0 with probability q and by 1 with probability $1 - q$, but the update is accepted only if a certain *constraint* is satisfied. This constraint is of the form “there are enough zeroes in the neighborhood”, the “enough” being defined by a so-called *update family*. The presence of this constraint is what characterizes KCMs.

KCMs were invented by physicists to understand the liquid-glass transition, an important open problem in condensed matter physics (see [BB11, RS03, GST11]). In a liquid material, there is no structure and the constituent molecules or atoms move in a disordered way. When one cools the liquid, this movement slows down until it stops completely below a certain temperature. If the cooling is slow enough, the molecules have time to organize into a regular structure, a crystal. However, if the temperature drops too quickly, they freeze in their disordered state, forming a structureless solid, which is what the physicists call a glass, and of which the glass of everyday life is just an example.

KCMs model this phenomenon. Each site of \mathbb{Z}^d represents a small region of the material: if it is at spin 0, it means that the molecules in this region are rather free to move, while if it is at spin 1 it means they are rather blocked. More sites at zero mean more regions where molecules are free to move, hence a more liquid material and a higher temperature. The fact that the constraint must be satisfied for an update to be accepted means that for the state of a region to change, there must be enough regions where molecules move freely in the neighborhood, which is physically sound. KCMs display the particularity of having a very simple equilibrium measure: the measure μ_q for which all sites are independently at spin 0 with probability q ; consequently, all the complexity of KCMs is due to their dynamics. Despite

this, they actually display major features of the liquid-glass transitions, such as aging (proven at least in the East model, see [FMRT13]) and very high speed of divergence of relaxation times at low temperature, which is studied in this thesis.

In addition to this physical interest, KCMs are also mathematically challenging. Indeed, they belong to the class of Glauber dynamics, but the presence of the constraints makes them very different from the well-known models of this class such as the Ising model, and prevents us from applying the tools developed for these classical models. One major difference is the existence of blocked configurations: in a KCM, if one starts with all sites at spin 1, there are never enough zeroes in a neighborhood to allow an update, so the configuration remains frozen; depending on the choice of the constraints, there can also be other blocked configurations. These blocked configurations lead to the existence of multiple invariant measures and render worst case analyses ineffective. Another major difference is the lack of monotonicity: in many Glauber dynamics, such as the Ising model, it is possible to couple the evolution of the dynamics so that a process that starts with more 1 than another will always have more 1 in the future, and this property yields a lot of tools. In KCMs, if a process starts with more 1 than another, less constraints will be satisfied, so the process may miss updates that create 1 in the other, breaking the monotonicity. Because of these peculiarities, the mathematical study of KCMs requires the invention of new tools.

One of the key issues from a physical and from a mathematical point of view is to establish how time scales for the stationary process with initial law μ_q diverge when q tends to 0. One of the most interesting questions is universality: can the models be sorted in a limited number of “universality classes” inside which they share the same behavior? Universality results, in addition to being mathematically beautiful, are very important for physicists because they mean the arbitrary choice of a particular model does not affect the properties of the system, which increases the relevance of using it for describing physical phenomena. These mathematical results are especially important because KCMs have very long time scales, which makes it hard to obtain numerical results. In KCMs, several particular update families have been studied in the past (see [AD02, CMRT08, CFM16, MT19]), and these studies found very different behaviors depending of the choice of the update family. However, a universality result was recently proven for a monotone deterministic version of KCMs called bootstrap percolation. Bootstrap percolation is a discrete-time model in which each site of \mathbb{Z}^d can be *infected* or *healthy*; at each step a healthy site becomes infected if there are enough infected sites in its neighborhood, the “enough” being defined as in KCMs, and infected sites remain infected forever. Bootstrap percolation is tightly

connected to KCMs: indeed, if we identify the infected sites of bootstrap percolation and the sites with spin 0 of KCMs, one can see that bootstrap percolation infects all the sites the KCM with the same constraint could update at 0, hence healthy sites that bootstrap percolation never infects are sites with spin 1 that the KCM can never update at 0. In [BSU15, BBPS16], Balister, Bollobás, Przykucki, Smith and Uzzell proved that for bootstrap percolation, the two-dimensional update families can be sorted into three universality classes: *supercritical*, *critical* and *subcritical*, that we are going to present. The first question for any bootstrap percolation model is: if we consider a given site of \mathbb{Z}^d , for example the origin, will the process infect it with probability 1 or is there a positive probability that the process never infects it? It can be proven that if initially the sites are independently infected with probability q , there exists a critical value q_c such that if $q > q_c$ the origin is infected with probability 1 while if $q < q_c$ there is a positive probability that the process never infects the origin. [BSU15, BBPS16] showed that for critical and supercritical update families $q_c = 0$, while for subcritical update families $q_c > 0$. Moreover, an important variable to understand when $q > q_c$ is τ^{BP} , the first time the origin gets infected. In [BSU15, BDCMSar], Bollobás, Duminil-Copin, Morris, Smith and Uzzell showed that when q tends to 0, τ^{BP} behaves as $1/q^{\Theta(1)}$ for supercritical update families and as $e^{\tilde{\Theta}(1/q^\alpha)}$ for critical update families, where α is a parameter called *difficulty* of the update family (see definition 2.2) and $f = \tilde{\Theta}(g)$ means $\lim_{q \rightarrow 0} \ln(f(q))/\ln(g(q)) = 1$ (more precisely, in [BDCMSar], Bollobás, Duminil-Copin, Morris and Smith showed that for critical update families, τ^{BP} behaves either as $e^{\Theta(1/q^\alpha)}$ or as $e^{\Theta(\ln(1/q)^2/q^\alpha)}$).

This breakthrough raises the question: is there a similar universality result for KCMs? The results of this thesis prove that the classification of update families into supercritical, critical and subcritical has to be refined to capture the richer behavior of KCMs. In the same way τ^{BP} was studied for bootstrap percolation, in KCMs it is relevant to consider the first time τ^{KCM} at which the origin is at zero when the initial configuration has law μ_q . In [MT19], Martinelli and Toninelli proved that $\tau^{KCM} \geq \tau^{BP}$ when q is small, but τ^{BP} does not always give the right behavior for τ^{KCM} . Indeed, supercritical update families have to be divided into *rooted* and *unrooted* ones (see definition 2.10), which satisfy that for unrooted update families τ^{KCM} behaves like τ^{BP} , which means as $1/q^{\Theta(1)}$, while for rooted update families τ^{KCM} behaves differently from τ^{BP} , as $1/q^{\Theta(\ln(1/q))}$. In this thesis is established a combinatorial result for supercritical rooted update families (theorem 7) that allows to prove the lower bound on the behavior of τ^{KCM} (theorem 1). Along with the upper bounds proven by Martinelli, Morris and Toninelli in [MMT19], this lower bound proves the universality partition of supercritical

KCMs (theorem 2). In the language of physicists, the unrooted and rooted classes display respectively *Arrhenius* and *super-Arrhenius scalings* of times. Both types of scalings occur in experiments in the vicinity of the liquid-glass transition and correspond respectively to the behavior of the so-called *strong* and *fragile liquids* (see [BB11]). Furthermore, critical update families also have to be divided into two subclasses: update families *with a finite number of stable directions* and update families *with an infinite number of stable directions* (see definition 1.4 for the definition of stable directions). For critical update families with a finite number of stable directions, τ^{KCM} behaves like τ^{BP} , as $e^{\tilde{\Theta}(1/q^\alpha)}$, while for critical update families with an infinite number of stable directions τ^{KCM} behaves differently, as $e^{\tilde{\Theta}(1/q^{2\alpha})}$. This thesis shows the lower bound for update families with an infinite number of stable directions (theorem 3). Along with the upper bounds proven by Hartarsky, Martinelli, Morris and Toninelli in [MMT19, HMT19b], this lower bound proves the universality partition of critical KCMs (theorem 4). For both supercritical rooted update families and critical update families with an infinite number of stable directions, the results of this thesis prove that the time scales of the KCMs diverge much faster than those of the corresponding bootstrap percolation models. This is due to the occurrence of *energy barriers*, which determine the dominant behavior for these KCMs but which do not matter for the monotone bootstrap percolation dynamics.

Now that the complete universality partition of critical KCMs is established, the next natural issue is to determine (as it has been done for critical bootstrap percolation models) the logarithmic corrections, namely to replace the scalings $e^{\tilde{\Theta}(1/q^\beta)}$ with $\beta \in \{\alpha, 2\alpha\}$ by $e^{\Theta(\ln(1/q)^\gamma/q^\beta)}$ with the right power γ . A first step in this direction is the result of this thesis for the Duarte model which, together with the upper bound in [MMT19], allows to prove $\gamma = 4$ for this specific model (theorem 5).

These universality results concern initial configurations of law μ_q , which means the dynamics starts at equilibrium. Out-of-equilibrium dynamics of KCMs is even more complicated and less understood than equilibrium dynamics. The first question one can ask about it is: will the process converge to equilibrium, and if it does, what is the speed of this convergence? The answer depends sharply on the initial configuration: if it is blocked, the dynamics remains there, hence cannot converge, therefore the initial configurations for which convergence may happen are limited. Initial configurations particularly interesting for physicists are the ones with law $\mu_{q'}$, $q' \neq q$. Indeed, the parameter q governs the proportion of zeroes in the system, thus is a measure of its temperature, which is higher the more zeroes are present. Consequently, starting at $\mu_{q'}$ with $q' \neq q$ means starting from a temperature different from the

equilibrium temperature, and convergence results starting from these initial laws are physically interesting. Of course, proving convergence to equilibrium starting from every non-blocked configuration is even better. In both cases we expect convergence to occur at exponential speed as soon as a configuration of law μ_q (and $\mu_{q'}$ if starting from $\mu_{q'}$) contains no blocked sites for the KCM dynamics, or as soon as $q > q_c$ (and $q' > q_c$ if starting from $\mu_{q'}$). However, there have been few results so far (see [CMST10, BCM⁺13, CFM15, MV19]), and they are restricted to particular update families or initial laws.

In this thesis is proven exponential convergence to equilibrium for all supercritical update families when the dynamics starts from an initial configuration of law $\mu_{q'}$, if $q \in [q_0, 1]$ with $q_0 < 1$ (theorem 8). This is the first result of exponential convergence to equilibrium valid for a large class of update families and any initial $\mu_{q'}$. This thesis also establishes exponential convergence to equilibrium in a particular KCM, the d -dimensional East model, for any initial configuration that is not blocked and any q (theorem 9). This is the first proof of exponential convergence in a KCM outside of dimension 1 that is valid for any initial configuration for which convergence is possible and for any q . In the d -dimensional East model, the latter result also allows to prove the exponential decay out of equilibrium of the *persistence function*, which is the probability that a given site was not updated before time t (corollary 10).

This thesis begins with an introduction presenting KCMs, previous results about them, the advances of this thesis and the methods of their proofs. The chapters correspond to the articles written on the results presented here, which contain their detailed proofs. Chapter 1 corresponds to the article *Combinatorics for general kinetically constrained spin models* [Mar17] establishing the combinatorial result that allows to prove the lower bound on τ^{KCM} for supercritical rooted update families. Chapter 2 corresponds to the article *Exact asymptotics for Duarte and supercritical rooted kinetically constrained models* [MMTar], written in collaboration with Fabio Martinelli and Cristina Toninelli, that shows the lower bounds for supercritical rooted and Duarte update families. Chapter 3 corresponds to the article *Universality for critical kinetically constrained models: infinite number of stable directions* [HMT19a], written in collaboration with Ivailo Hartarsky and Cristina Toninelli, which establishes the lower bound for critical update families with an infinite number of stable directions. Chapter 4 corresponds to the article *Exponential convergence to equilibrium in supercritical kinetically constrained models at high temperature* [Mar19b] showing exponential convergence to equilibrium for supercritical update families. Finally, chapter 5 corresponds to the article *Exponential convergence to equilibrium for the d -dimensional East model* [Mar19a] proving exponential convergence to equilibrium in the East model.

In this introduction, we will begin in section 1 by giving rigorous definitions for KCMs, then explain bootstrap percolation with more precision as well as another classical tool, the relaxation time. Afterwards, in section 2 we will detail the universality partition of update families in bootstrap percolation and what it implies about universality in KCMs, after which we will state the KCM universality results and outline the proofs of those that are established in this thesis. Last but not least, in section 3 we will discuss the theorems of convergence to equilibrium known prior to this thesis, state the new results shown in this thesis, and give an idea of their proofs.

1 Definitions and tools

This section is devoted to the introduction of KCMs and of classical tools for their study. We will begin in subsection 1.1 by stating definitions, after which we will explain the tools of bootstrap percolation in subsection 1.2 and relaxation time in subsection 1.3.

1.1 Definitions

In this subsection we give the main definitions for KCMs. Let $d \in \mathbb{N}^*$. The elements of \mathbb{Z}^d will be called *sites*. At each site of \mathbb{Z}^d we want to associate a *spin* 0 or 1, therefore we consider *configurations* that are elements of $\{0, 1\}^{\mathbb{Z}^d}$.

KCMs are continuous-time Markov processes on the configurations, defined for all positive times, with a Glauber dynamics (see [Mar99] for an introduction to Glauber dynamics). To define a KCM, one needs to set an *update family* $\mathcal{U} = \{X_1, \dots, X_m\}$, where $m \in \mathbb{N}^*$ and the X_i are finite nonempty subsets of $\mathbb{Z}^d \setminus \{0\}$, called *update rules*. We say the *constraint* is satisfied at a site x when there exists $i \in \{1, \dots, m\}$ such that all the spins in $x + X_i$ are zeroes (in the literature the roles of zeroes and ones are sometimes reversed). The KCM is then defined thus: any site tries at rate 1 to *update* its spin, which means to replace it by 0 with probability q and by 1 with probability $1 - q$ independently of everything else, with $q \in [0, 1]$ fixed, but the update is accepted only if the constraint at the site is satisfied.

The process can be constructed through its generator by classical arguments (see for example chapter I of [Lig85]). The generator \mathcal{L} can be written as follows. For any site x and configuration ω , we denote $c_x(\omega)$ the indicator that ω satisfies the constraint at x , $\omega(x)$ the spin of ω at x , ω^x the configuration equal to ω everywhere but in x , $\omega_{\{x\}^c} 0_x$ the configuration that coincides with ω outside of x and has spin 0 at x , and similarly with $\omega_{\{x\}^c} 1_x$. Then for any function $f : \{0, 1\}^{\mathbb{Z}^d} \mapsto \mathbb{R}$ that is local (i.e. that depends on a finite set

of spins) and any configuration ω , we have

$$\begin{aligned} \mathcal{L}f(\omega) &= \sum_{x \in \mathbb{Z}^d} c_x(\omega) (q(f(\omega_{\{x\}^c} 0_x) - f(\omega)) + (1 - q)(f(\omega_{\{x\}^c} 1_x) - f(\omega))) \\ &= \sum_{x \in \mathbb{Z}^d} c_x(\omega) ((1 - q)(1 - \omega(x)) + q\omega(x))(f(\omega^x) - f(\omega)). \end{aligned}$$

We denote $(\omega_t)_{t \geq 0}$ the KCM process and $\mathbb{P}_\nu, \mathbb{E}_\nu$ the associated probability and expectation when the initial configuration has law ν ; if the initial configuration is ω , we write $\mathbb{P}_\omega, \mathbb{E}_\omega$.

We are going to present a more explicit way to construct the process, the *Harris graphical construction*. Independently for all $x \in \mathbb{Z}^d$, we take a sequence $(B_{x,k})_{k \in \mathbb{N}^*}$ of independent identically distributed random variables with Bernoulli law of parameter $1 - q$, so the probability that $B_{x,k} = 1$ is $1 - q$ and the probability that $B_{x,k} = 0$ is q ; we also take a *Poisson clock* of parameter 1 independent from $(B_{x,k})_{k \in \mathbb{N}^*}$, which means a sequence of random times $(t_{x,k})_{k \in \mathbb{N}^*}$ such that the $(t_{x,k} - t_{x,k-1})_{k \in \mathbb{N}^*}$ are independent identically distributed with exponential law of parameter 1, writing $t_{x,0} = 0$. We say the clock at x *rings* at the times $t_{x,k}, k \in \mathbb{N}^*$.

The KCM process is defined as follows: for any $x \in \mathbb{Z}^d, k \in \mathbb{N}^*$, we consider the time $t_{x,k}$ of the k -th clock ring at x . If the configuration at time $t_{x,k}$ satisfies the constraint at x , then we say the ring is *legal* and we replace the spin at x by $B_{x,k}$, otherwise we do nothing.

It is not straightforward that this construction is well-defined; indeed, studying the constraint at time $t_{x,k}$ requires to know the configuration at this time, which requires to know what happened at the previous clock rings, which requires to know what happened before these clock rings, etc. and since there is an infinity of independent clocks, there is an infinity of clock rings before $t_{x,k}$. However this problem can be solved; we give below a (classical) proof of the fact that the construction is well-defined.

Proof of Harris graphical construction. It is enough to prove the construction of the dynamics in a time interval $[0, T]$ for $T > 0$; indeed, if we are able to do that, we can then iterate to prove the construction for all positive times. We begin by denoting S_T the set of sites that have a clock ring in $[0, T]$. Since the sites of $\mathbb{Z}^d \setminus S_T$ have no clock ring in $[0, T]$, they necessarily remain in their initial state during the whole time interval, hence it is enough to prove the construction in S_T . Let $\rho = \max\{\|x\|_\infty \mid x \in X_i, i \in \{1, \dots, m\}\}$ where $\|\cdot\|_\infty$ is the ℓ^∞ -norm, and let $G = (V, E)$ be the graph such that $V = \mathbb{Z}^d$ and $E = \{(x, y) \in V^2 \mid \|x - y\|_\infty \leq \rho\}$. If T is small enough, the probability that a given site has a clock ring in the time interval $[0, T]$ is very small, so S_T has

no infinite connected component in G . Indeed, the probability that a given site belongs to an infinite connected component of S_T can be bounded by the probability that there exists a path of arbitrary length in S_T starting from this site, hence it is 0. It is enough to prove the construction of the dynamics in each of the connected components of S_T in G . If Λ is one of these connected components, it is finite hence there is a finite number of clock rings in Λ between times 0 and T . This allows to consider the first such clock ring; the corresponding constraint depends only on the spins of sites that are at distance at most ρ of Λ , thus that are in Λ or in $\mathbb{Z}^d \setminus S_T$, so their state is known. One can then consider the second clock ring, then the third, etc., so the dynamics in Λ is well-constructed, which ends the proof. \square

Remark 1.1. The generator and Harris graphical construction also allow to define the KCM in a finite volume $\Lambda \subset \mathbb{Z}^d$, by fixing a boundary condition: one has to set the value of the spins in $\{x + X_i \mid x \in \Lambda, i \in \{1, \dots, m\}\} \cap \Lambda^c$. With a proper definition of the constraints, one can also construct KCMs on graphs other than \mathbb{Z}^d .

Examples: We are going to present some important KCMs (in what follows, $\{e_1, \dots, e_d\}$ will denote the canonical basis of \mathbb{R}^d):

The East model: This model is defined on \mathbb{Z} by $\mathcal{U} = \{\{-1\}\}$, which means the constraint at a site is satisfied when its left neighbor is at zero. It is the best known KCM (see [FMRT13] for a review of what is known about it), because its one-dimensionality and orientation make its study easier. The orientation is not always the same in the literature; this model was introduced in [JE91] by Jäckle and Eisinger with $\mathcal{U} = \{\{1\}\}$ and was called East model because one had to look at the neighbor on the east to check the constraint.

The d -dimensional East model: This model is defined on \mathbb{Z}^d by $\mathcal{U} = \{\{-e_1\}, \dots, \{-e_d\}\}$, which means the constraint at a site is satisfied when one of its “lower” neighbors is at zero. It is a possible generalization of the East model to higher dimension, introduced by Berthier and Garrahan in [BG05].

The North-East model: This model is defined on \mathbb{Z}^d by the update family $\mathcal{U} = \{\{-e_1, \dots, -e_d\}\}$, which means the constraint at a site is satisfied when all its “lower” neighbors are at zero. It is another possible generalization of the East model to higher dimension, introduced by Reiter, Mauch and Jäckle in [RMJ92]. However, its behavior is very different from the behavior of the d -dimensional East model.

The FA-jf models: The Fredrickson-Andersen j -spin facilitated models are a family of models defined on \mathbb{Z}^d . For $1 \leq j \leq d$, the corresponding \mathcal{U} is the collection of subsets of cardinal j of $\{e_1, \dots, e_d, -e_1, \dots, -e_d\}$, which means the constraint is satisfied at a site when at least j of its neighbors have spin 0. Historically, the FA-jf models were the first KCMs to be introduced, by Fredrickson and Andersen in [FA84]. The behavior of these models depends sharply on j ; the FA-1f model is the best understood.

The Duarte model: This model is defined on \mathbb{Z}^2 by setting \mathcal{U} as the collection of two-elements subsets of $\{-e_1, -e_2, e_2\}$, which means the constraint at a site is satisfied when at least two neighbors among its left, bottom and top ones are at zero. The corresponding update family was introduced by Duarte in [Dua89].

For any $q' \in [0, 1]$, we denote $\mu_{q'}$ the measure on the configuration space under which all spins are independent and have probability q' of being at zero. μ_q is invariant for the dynamics of the KCM, since μ_q is reversible (see section 5 of chapter II in [Lig85]). Indeed, one can check that \mathcal{L} is autoadjoint in $L^2(\mu_q)$, as for any configuration $\eta \in \{0, 1\}^{\mathbb{Z}^d}$, any Λ finite subset of \mathbb{Z}^d and any $x \in \Lambda$, we have $c_x(\eta)((1 - q)(1 - \eta(x)) + q\eta(x))\mu_q(\omega_\Lambda = \eta_\Lambda) = c_x(\eta^x)((1 - q)(1 - (\eta^x)(x)) + q(\eta^x)(x))\mu_q(\omega_\Lambda = (\eta^x)_\Lambda)$ where ω_Λ denotes the restriction of ω to Λ . This allows to show $f\mathcal{L}g = g\mathcal{L}f$ for f and g local, and [VB11] proves that the set of local functions is a core for \mathcal{L} .

μ_q is called the *equilibrium measure*. However, because of the existence of blocked configurations, μ_q is not the only reversible and invariant probability measure. Indeed, the Dirac measure at the configuration containing only ones is also reversible and invariant, and there can also be other more complicated reversible and invariant measures depending on the choice of the update family. These invariant measures complicate a lot the study of out-of-equilibrium KCM dynamics.

1.2 Bootstrap percolation

In this subsection we present bootstrap percolation and its link with KCMs (a richer review of bootstrap percolation can be found in [Mor17b]). Bootstrap percolation can be seen as a discrete-time, monotone, deterministic counterpart of KCMs. It is defined as follows. Each site of \mathbb{Z}^d can be either *infected* or *healthy*; infected and healthy sites are the respective equivalents of zeroes and ones for KCMs (though infected sites are generally denoted by ones in the bootstrap percolation literature). We set $\mathcal{U} = \{X_1, \dots, X_m\}$ an

update family and $A_0 \subset \mathbb{Z}^d$ the set of sites that are infected at time 0. For any $t \in \mathbb{N}^*$, the set A_t of sites that are infected at time t is defined as

$$A_t = A_{t-1} \cup \{x \in \mathbb{Z}^d \mid \exists i \in \{1, \dots, m\}, x + X_i \subset A_{t-1}\}.$$

This means that at any step of the process, the sites that were infected at the previous step remain infected and the sites that were healthy at the previous step become infected if and only if their constraint is satisfied at the previous step. We notice in particular that once a site is infected, it will remain so for ever; this is why the model is said to be monotone.

In what follows, unless otherwise stated, we will consider the bootstrap percolation dynamics when the sites are initially infected with probability q independently of each other with $q \in [0, 1]$ fixed; we call this initial law ν_q . The first question one can ask is if the dynamics will infect a given site with probability 1, or if there is a positive probability that even if we wait for an infinite time the site will never be infected (since the dynamics is deterministic, the answer depends only on the initial configuration). Since the model is invariant by translation, it is enough to answer the question for the origin of \mathbb{Z}^d .

The link between KCMs and bootstrap percolation can be understood intuitively thus: considering a KCM and the bootstrap percolation model defined with the same update family, if the origin is updated in the KCM, then its constraint is satisfied, hence the bootstrap percolation process would have infected it. So if the origin can never be infected by the bootstrap percolation, it cannot be updated in the KCM, so remains blocked, hence the KCM does not relax to equilibrium.

A way to turn this intuition into a rigorous result is to consider the ergodicity and mixing properties of the equilibrium measure μ_q . μ_q is *ergodic* for the dynamics when any $f \in L^2(\mu_q)$ such that $\mathbb{E}(f(\omega_t)) = f(\cdot)$ for all $t > 0$ is μ_q -almost surely constant. Moreover, μ_q is *mixing* for the dynamics when for any $f, g \in L^2(\mu_q)$, $\mathbb{E}_{\mu_q}(f(\omega_0)g(\omega_t))$ tends to $\mu_q(f)\mu_q(g)$ when t tends to $+\infty$. The following property was proven by Cancrini, Martinelli, Roberto and Toninelli in [CMRT08]:

Proposition 1.2 ([CMRT08]). *For $q \in]0, 1]$ there are two possible cases:*

- *if ν_q (the origin is never infected by the bootstrap percolation) > 0 , μ_q is neither ergodic nor mixing for the dynamics of the KCM;*
- *if ν_q (the origin is never infected by the bootstrap percolation) $= 0$, μ_q is ergodic and mixing for the dynamics of the KCM.*

The first case is easily proven; indeed, if f is the indicator that the origin is eventually infected by the bootstrap percolation process, then f is invariant by the dynamics of the KCM, hence $\mathbb{E}(f(\omega_t)) = f$ for all $t > 0$, but f is not μ_q -almost surely constant (because there is a positive probability the origin is initially infected), so μ_q is not ergodic for the dynamics. Furthermore, $\mu_q((1-f)\mathbb{E}(f(\omega_t))) = \mu_q((1-f)f) = 0$ does not tend to $\mu_q(f)\mu_q(1-f)$ when t tends to $+\infty$, so μ_q is not mixing for the dynamics either. The proof of the second case is harder and requires some non trivial spectral theory.

In order to study the probability that the bootstrap percolation model never infects the origin, one can notice the following monotonicity property. If $q < q'$, we can couple the initial configurations of the bootstrap percolation processes starting from ν_q and $\nu_{q'}$ so that the sites that are infected in the initial configuration of the former are infected in the initial configuration of the latter. Then one can check that at any step of the processes the sites that are infected in the process starting from ν_q are infected in the process starting from $\nu_{q'}$, so if the origin is eventually infected in the former, it is eventually infected in the latter. This yields that the probability that the origin is eventually infected increases with q . Therefore there exists a critical probability $q_c \in [0, 1]$ such that

$$\begin{aligned} q_c &= \inf\{q \in [0, 1] \mid \nu_q(\text{the origin is eventually infected}) = 1\} \\ &= \sup\{q \in [0, 1] \mid \nu_q(\text{the origin is eventually infected}) < 1\}. \end{aligned}$$

From this and proposition 1.2 one can deduce

Theorem 1.3 ([CMRT08]). *For any $q \in [0, 1]$,*

- *if $q < q_c$, μ_q is neither ergodic nor mixing for the dynamics of the KCM;*
- *if $q > q_c$, is ergodic and mixing for the dynamics of the KCM.*

Consequently, there is a *phase transition* at q_c between a phase with relaxation towards the equilibrium measure in $L^2(\mu_q)$ and a phase without such relaxation. The behavior of KCMs when q tends to q_c , $q > q_c$ is particularly interesting for physicists, because the regime in which the model approaches the phase where its movement is frozen is the right one to study what happens when the moves of the molecules in a liquid slow down until they stop, forming a glass.

There was a breakthrough recently in the study of two-dimensional bootstrap percolation models: in [BSU15, BBPS16], Balister, Bollobás, Przykucki, Smith and Uzzell proved that all update families could be divided into three universality classes depending on their behavior. We are going to give the definition of these universality classes and state their results. This definition requires the following concept:

Definition 1.4. For $u \in S^1$, we denote $\mathbb{H}_u = \{x \in \mathbb{Z}^2 \mid \langle x, u \rangle < 0\}$ (where $\langle \cdot, \cdot \rangle$ denotes the scalar product) the open half-plane with boundary orthogonal to u . We say that u is a *stable direction* for a two-dimensional update family \mathcal{U} if there is no $X \in \mathcal{U}$ such that $X \subset \mathbb{H}_u$; otherwise u is *unstable*.

In particular, if u is stable and the bootstrap percolation process starts with only healthy sites in $(\mathbb{H}_u)^c$, none of these sites can be infected by the process: intuitively, the infection cannot progress in the direction u .

We can now state the definition of the universality classes:

Definition 1.5. A two-dimensional update family is:

- *supercritical* if there exists an open semicircle of S^1 containing only unstable directions;
- *critical* if there exists an open semicircle of S^1 that contains a finite number of stable directions, but there is no open semicircle of S^1 containing only unstable directions;
- *subcritical* if every open semicircle of S^1 contains an infinite number of stable directions.

The stable directions of the update families of the models presented in subsection 1.1 are shown in figure 1. It can be seen that the 2-dimensional East and FA-1f models have supercritical update families, the Duarte and FA-2f models have critical update families, and the North-East model has a subcritical update family. The bootstrap percolation versions of the FA-jf models are called *j-neighbor bootstrap percolation*.

To state the universality result of [BSU15, BBPS16], we also introduce some asymptotic notation, which will be useful here and throughout this introduction. If f and g are positive functions of $q \in]0, 1[$, we write $f = O(g)$ when q tends to 0 when there exists $C < +\infty$ such that $f(q) \leq Cg(q)$ when q is small enough, $f = \Omega(g)$ when q tends to 0 when there exists $c > 0$ such that $f(q) \geq cg(q)$ when q is small enough, $f = \Theta(g)$ when q tends to 0 when there exist $0 < c \leq C < +\infty$ such that $cg(q) \leq f(q) \leq Cg(q)$ when q is small enough, and $f = \tilde{\Theta}(g)$ when q tends to 0 when $\lim_{q \rightarrow 0} \ln(f(q))/\ln(g(q)) = 1$.

We can now state the universality result of [BSU15, BBPS16], which deals not only with q_c but also with

$$\tau^{BP} = \inf\{t \in \mathbb{N} \mid 0 \in A_t\},$$

the first time at which the origin is infected.

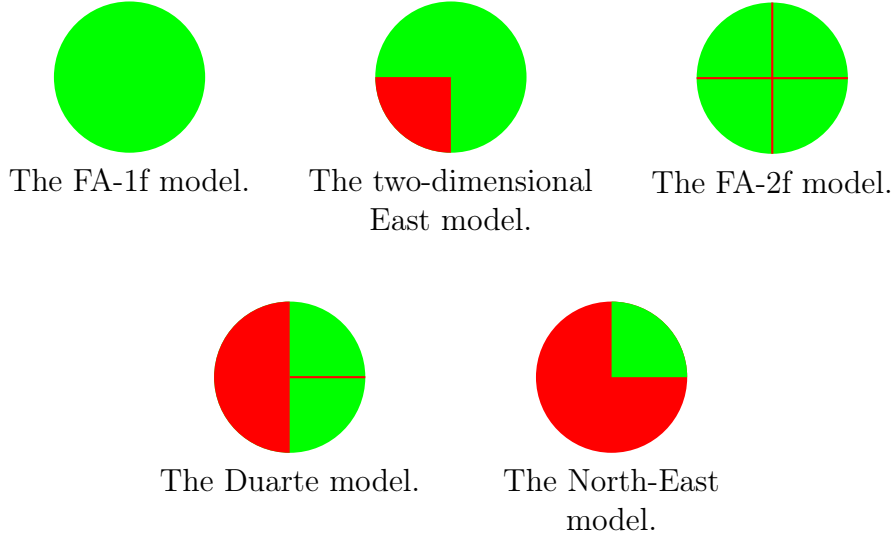

Figure 1: The stable directions of the update families of important KCMs. Stable directions are featured in red and unstable ones in green.

Theorem 1.6 ([BSU15, BBPS16]). *For any two-dimensional update family \mathcal{U} ,*

- *if \mathcal{U} is supercritical, $q_c = 0$ and $\tau^{BP} = 1/q^{\Theta(1)}$ with high probability when q tends to 0;*
- *if \mathcal{U} is critical, $q_c = 0$ and $\tau^{BP} = e^{1/q^{\Theta(1)}}$ with high probability when q tends to 0;*
- *if \mathcal{U} is subcritical, $q_c > 0$.*

By “ $\tau^{BP} = 1/q^{\Theta(1)}$ with high probability when q tends to 0” we mean that there exist two constants $0 < c \leq C < +\infty$ such that the probability that $1/q^c \leq \tau^{BP} \leq 1/q^C$ tends to 1 when q tends to 0, and similarly for the other notations of this kind throughout this thesis.

Theorem 1.6 suggests that the KCMs can be sorted into supercritical, critical and subcritical ones. The classification of KCMs will be explored in section 2 of this introduction.

Remark 1.7. We expect a similar result to hold in dimension greater than 2, but so far it has not been proven. Moreover, in dimension 1 the update families can be classified easily: either they have an update rule contained in \mathbb{N}^* or in $-\mathbb{N}^*$ and they are supercritical, or they have no such update rule

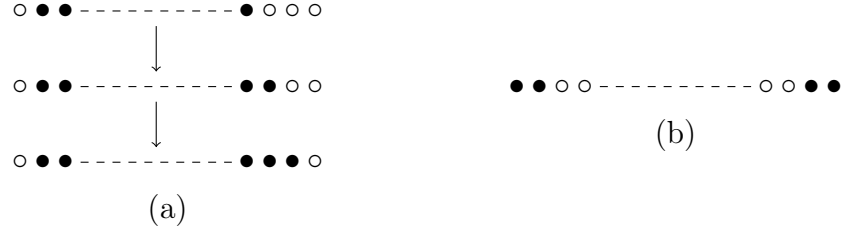

Figure 2: The universality classes in dimension 1. The \bullet represent infected sites and the \circ healthy sites. (a) In a supercritical model with an update rule contained in $-\mathbb{N}^*$, a large interval of infected sites is enough to infect successively the sites at its right. (b) In a subcritical model, since all update rules contain sites of $-\mathbb{N}^*$ and \mathbb{N}^* , a large enough interval of healthy sites can never be infected.

and they are subcritical.

Indeed, if the update family has an update rule contained in \mathbb{N}^* or in $-\mathbb{N}^*$, we may suppose without loss of generality that it is contained in $-\mathbb{N}^*$. Then as soon as we have a large enough interval of infected sites, the site at the right of this interval has its constraint satisfied, so the bootstrap percolation process infects it, then infects the site at its right in the same way, etc. as illustrated in figure 2(a). We deduce a large enough interval of infected sites allows to infect all the sites at its right. Since such an interval of infected sites has probability $q^{\Theta(1)}$, there is one at distance $1/q^{\Theta(1)}$ at the left of the origin, hence the origin is always infected if $q > 0$, in a time at most $1/q^{\Theta(1)}$. Furthermore, we also have $\tau^{BP} \geq 1/q^{\Theta(1)}$, because the initially infected site nearest to the origin is at distance $1/q^{\Theta(1)}$ from it, and any site that is infected by the bootstrap percolation process is at bounded distance from a site that was infected at the previous step, so the infection needs a time $1/q^{\Theta(1)}$ to cross this distance, hence $\tau^{BP} \geq 1/q^{\Theta(1)}$, therefore $\tau^{BP} = 1/q^{\Theta(1)}$. This justifies the use of the appellation “supercritical models”. Moreover, if there is no update rule contained in $-\mathbb{N}^*$ or \mathbb{N}^* , then any update rule contains sites of $-\mathbb{N}^*$ and \mathbb{N}^* , therefore if an interval of healthy sites is large enough, the constraint cannot be satisfied for any of these sites, as can be seen in figure 2(b), hence they can never be infected. Since the probability that the origin is in such an interval is positive for any $q < 1$, we have $q_c = 1$, which justifies the use of the appellation “subcritical models”.

1.3 Relaxation time

In this section, we present the relaxation time and its use for the study of KCMs (a more complete introduction to the relaxation time, or equivalently to its inverse the spectral gap, can be found in chapter 2 of [GZ02]). Though we give definitions for KCMs on the graph \mathbb{Z}^d , they can be stated analogously for KCMs on other graphs. Let us consider a KCM on \mathbb{Z}^d . To define its relaxation time, we need to define its *Dirichlet form* \mathcal{D} as follows: for any function $f : \{0, 1\}^{\mathbb{Z}^d} \mapsto \mathbb{R}$ in the domain of the generator \mathcal{L} of the dynamics, $\mathcal{D}(f) = -\mu_q(f\mathcal{L}f)$. We can now define the relaxation time:

Definition 1.8. The *relaxation time* of the KCM is the nonnegative quantity T_{rel} defined by

$$\frac{1}{T_{\text{rel}}} = \inf_{\text{Var}(f) \neq 0} \frac{\mathcal{D}(f)}{\text{Var}(f)} \quad (1)$$

where the infimum is over functions $f : \{0, 1\}^{\mathbb{Z}^d} \mapsto \mathbb{R}$ in the domain of the generator and the variance is with respect to μ_q . The inverse of the relaxation time is called *spectral gap*.

Remark 1.9. It can be shown using the reversibility of μ_q with respect to the KCM dynamics that if $f : \{0, 1\}^{\mathbb{Z}^d} \mapsto \mathbb{R}$ is a local function, $\mathcal{D}(f) = \sum_{x \in \mathbb{Z}^d} \mu_q(c_x \text{Var}_x(f))$, where $\text{Var}_x(f)(\omega)$ is the variance of f under the measure for which the spin of x has probability q to be at 0 and probability $1 - q$ to be at 1, while the other spins have the value they have in ω .

The interest of the relaxation time as well as its name are justified by the following classical result (property 2.4 of [GZ02]). If we denote $\|\cdot\|_q$ the norm on $L^2(\mu_q)$, we have

Theorem 1.10 (Poincaré inequality). *For any function $f : \{0, 1\}^{\mathbb{Z}^d} \mapsto \mathbb{R}$ in the domain of the generator, for any $t \geq 0$, $\|\mathbb{E}(f(\omega_t)) - \mu_q(f)\|_q \leq e^{-t/T_{\text{rel}}} \|f - \mu_q(f)\|_q$. Moreover, T_{rel} is the smallest quantity satisfying this inequality.*

Consequently, if T_{rel} is finite, there is exponential relaxation to equilibrium of the system on a timescale T_{rel} .

There is also a link between the relaxation time and

$$\tau^{KCM} = \inf\{t \geq 0 \mid \omega_t(0) = 0\},$$

the first time at which the origin is at zero. Indeed, Martinelli, Morris and Toninelli proved the following in section 2.2 of [MMT19]:

Proposition 1.11 ([MMT19]). *For any $q \in]0, 1[$, $t > 0$, $\mathbb{P}_{\mu_q}(\tau^{KCM} > t) \leq e^{-qt/T_{\text{rel}}}$. In particular, $\mathbb{E}_{\mu_q}(\tau^{KCM}) \leq T_{\text{rel}}/q$.*

Therefore if the relaxation time is finite, when the dynamics starts at equilibrium τ^{KCM} has an exponential decaying tail and the relaxation time gives an upper bound on its expectation.

Finally, the relaxation time has also a relationship with the so-called *persistence function*, which is the following function of the time t : the probability that a given site was not updated before time t . It is a measure of the mobility of the system: the less blocked it is, the more likely sites are to be updated, the smaller the persistence function. The relaxation time yields the following upper bound on the persistence function when the dynamics starts at equilibrium, proven by Cancrini, Martinelli, Roberto and Toninelli in [CMRT09] (we denote by t_x the first time a site x is updated):

Proposition 1.12 ([CMRT09]). *For any $x \in \mathbb{Z}^d$ and $t \geq 0$, $\mathbb{P}_{\mu_q}(t_x > t) \leq e^{-qt/T_{\text{rel}}} + e^{-(1-q)t/T_{\text{rel}}}$.*

Consequently, if the relaxation time is finite, the persistence function decays exponentially when the dynamics starts at equilibrium.

The results of this subsection imply that the relaxation time is a very important quantity to study in KCMs.

2 Universality

Proving universality results for KCMs was one of the major objectives of this thesis. The following section is devoted to it. Firstly, in subsection 2.1, we explain what was known prior to this thesis. Then in subsection 2.2 we present the advances of this thesis and the universality partition of KCMs they help to obtain. Finally, in subsection 2.3, we give an idea of the proofs of these results.

2.1 Previous results

In this subsection we present the universality results existing prior to this thesis. No universality results specific to KCMs had been proven at the time, but a rather complete picture was known for bootstrap percolation, which has some consequences for KCMs.

We recall the result proven in [BSU15, BBPS16] by Balister, Bollobás, Przykucki, Smith and Uzzell, that we already presented in subsection 1.2:

Theorem 2.1 ([BSU15, BBPS16]). *For any two-dimensional update family \mathcal{U} ,*

- if \mathcal{U} is supercritical, $q_c = 0$ and $\tau^{BP} = 1/q^{\Theta(1)}$ with high probability when q tends to 0;
- if \mathcal{U} is critical, $q_c = 0$ and $\tau^{BP} = e^{1/q^{\Theta(1)}}$ with high probability when q tends to 0;
- if \mathcal{U} is subcritical, $q_c > 0$.

A refinement of theorem 2.1 for critical models was proven by Bollobás, Duminil-Copin, Morris, and Smith in [BDCMSar]. In order to state it, we need some definitions.

Definition 2.2. Set a two-dimensional update family and $u \in S^1$. The *difficulty* $\alpha(u)$ of u is

- 0 if u is unstable;
- the minimal cardinal of a set K such that the bootstrap percolation process with initially infected sites $\mathbb{H}_u \cup K$ infects infinitely many other sites, if u is an isolated stable direction (in the topological sense);
- $+\infty$ if u belongs to a non-trivial interval of stable directions.

Definition 2.2 is a refinement of the notion of stable/unstable direction: the latter expresses if the infection can progress towards direction u , while $\alpha(u)$ is a measure of how hard it is to progress. The arguments in section 2.4 of [BDCMSar] show that the definition given for isolated stable directions also holds for directions that are unstable or in the inside of an interval of stable directions, but not for the extremities of an interval of stable directions. We are now able to state the following fundamental definition:

Definition 2.3. The *difficulty* α of a two-dimensional update family is defined as follows:

$$\alpha = \min_{C \text{ open semicircle}} \max_{u \in C} \alpha(u).$$

The difficulties of the update families corresponding to the FA-2f and Duarte models, which are critical, are both 1 (see figure 3). To state the result of [BDCMSar] we need the following last definition:

Definition 2.4. A two-dimensional critical update family is:

- *balanced* if there exists a closed semicircle of S^1 in which all directions have difficulty at most α ;
- *unbalanced* otherwise.

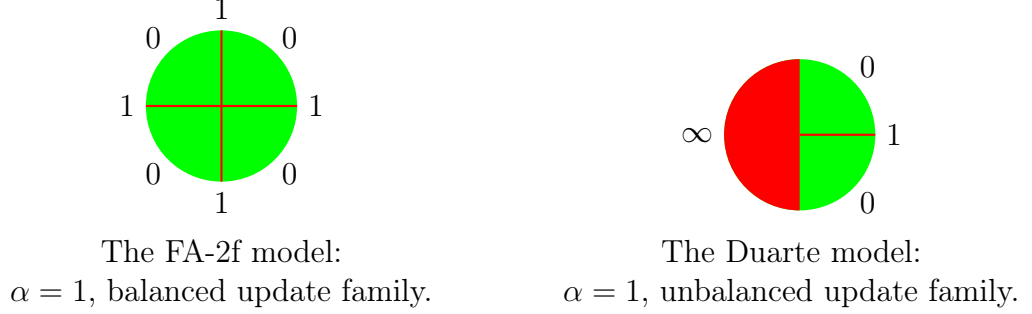

Figure 3: The difficulty picture of the FA-2f and Duarte models. Next to each interval of directions or isolated stable direction is indicated the corresponding difficulty.

It can be seen on figure 3 that the update family of the FA-2f model is balanced and that the one of the Duarte model is unbalanced. We can now state the result of [BDCMSar]:

Theorem 2.5 ([BDCMSar]). *For any two-dimensional critical update family \mathcal{U} ,*

- *if \mathcal{U} is balanced, $\tau^{BP} = e^{\Theta(1/q^\alpha)}$ with high probability when q tends to 0;*
- *if \mathcal{U} is unbalanced, $\tau^{BP} = e^{\Theta(\ln(1/q)^2/q^\alpha)}$ with high probability when q tends to 0.*

Theorem 2.5 allows to deduce results on the KCMs thanks to the following proposition, proven by Martinelli and Toninelli in [MT19]:

Proposition 2.6 ([MT19]). *For any update family there exists a constant $\lambda \in]0, 1[$ such that for any $q \in [0, 1]$, $\mathbb{E}_{\mu_q}(\tau^{KCM}) \geq \lambda \nu_q(\tau^{BP})$.*

Propositions 2.6 and 1.11 together with theorems 2.1 and 2.5 allow to prove

Theorem 2.7 ([BBPS16, BDCMSar, MT19]). *For any two-dimensional update family \mathcal{U} ,*

- *if \mathcal{U} is critical balanced, $\mathbb{E}_{\mu_q}(\tau^{KCM}) = e^{\Omega(1/q^\alpha)}$ when q tends to 0;*
- *if \mathcal{U} is critical unbalanced, $\mathbb{E}_{\mu_q}(\tau^{KCM}) = e^{\Omega(\ln(1/q)^2/q^\alpha)}$ when q tends to 0;*

- if \mathcal{U} is subcritical, $\mathbb{E}_{\mu_q}(\tau^{KCM}) = +\infty$ for $q \in]0, q_c[$,

and the same holds for T_{rel} .

This result is interesting, but gives only a lower bound on the behavior of KCMs, which is not enough to establish their universality classification, since their real behavior could be different from this lower bound. In this thesis, it is proven that there is indeed a whole class of critical models whose behavior is different from this bootstrap percolation lower bound, as we will see in subsection 2.2.

Remark 2.8. One could use theorem 2.1 to obtain similar lower bounds for supercritical models. However, these lower bounds are not very interesting. Indeed, theorem 2.1 yields only $\mathbb{E}_{\mu_q}(\tau^{KCM}) = 1/q^{\Omega(1)}$ when q tends to 0, while it is easy to see $\mathbb{E}_{\mu_q}(\tau^{KCM}) \geq 1/q$ by noticing that τ^{KCM} is bigger than the time of the first clock ring at the origin for which the corresponding Bernoulli variable has value 0. As for T_{rel} , these lower bounds on $\mathbb{E}_{\mu_q}(\tau^{KCM})$ and proposition 1.11 yield only $T_{rel} \geq 1$, while it is easy to see $T_{rel} \geq 1/(mq^{\min_{X \in \mathcal{U}} |X|})$ with m the number of update rules in \mathcal{U} by plugging the test function $\omega \mapsto \omega(0)$ in equation (1).

Remark 2.9. Propositions 2.6 and 1.11 also allow to prove that for one-dimensional subcritical update families (see remark 1.7), $\mathbb{E}_{\mu_q}(\tau^{KCM}) = +\infty$ and $T_{rel} = +\infty$ for $q \in]0, q_c[=]0, 1[$.

2.2 Advances of the thesis and universality partition

In this subsection we present the new results proven in this thesis, as well as the universality classification of KCMs they allow to deduce. They show that though the universality classes observed in bootstrap percolation are relevant and give rise to different behaviors in KCMs, they are not precise enough, because KCMs in the same class may behave differently. Therefore a refinement of this classification was needed for KCMs; the work of this thesis was key in proving this refinement, which is presented below.

We begin by considering supercritical update families. In order to present the refinement of the universality partition introduced for KCMs, we need the following definition for the subclasses:

Definition 2.10. A two-dimensional supercritical update family is:

- *rooted* if it has two non opposite stable directions;
- *unrooted* otherwise.

One can see that the 2-dimensional East model is rooted and that the FA-1f model is unrooted (their stable directions are featured on figure 1). The following result is proven in this thesis:

Theorem 1. *For any two-dimensional supercritical rooted update family, $\mathbb{E}_{\mu_q}(\tau^{KCM}) = 1/q^{\Omega(\ln(1/q))}$ when q tends to 0, and the same holds for T_{rel} .*

Theorem 1 relies on a combinatorial result (theorem 7) proven in the article [Mar17], which corresponds to the chapter 1 of this thesis. Theorem 1 itself was proven in collaboration with Fabio Martinelli and Cristina Toninelli in the article [MMTar], which corresponds to the chapter 2 of this thesis.

Remark 2.11. The proof of theorem 1 works in a more general setting, for all two-dimensional update families that are *not* supercritical unrooted, but the theorem is sharp only for supercritical rooted update families. Contrary to the other universality results proven so far for bootstrap percolation and KCMs, theorem 1 also holds in any dimension with the following generalization of the definition of a supercritical unrooted update family: a d -dimensional update family is supercritical unrooted if there exists a hyperplane of \mathbb{R}^d containing all the stable directions of \mathcal{U} , stable directions being defined in the same way as in dimension 2.

Combining theorem 1 with the upper bounds proven in [MMT19] by Martinelli, Morris and Toninelli (and with the easy lower bounds for supercritical unrooted models mentioned in remark 2.8) allows to prove the following universality result for supercritical KCMs:

Theorem 2. *For any two-dimensional supercritical update family \mathcal{U} ,*

- *if \mathcal{U} is unrooted, $\mathbb{E}_{\mu_q}(\tau^{KCM}) = 1/q^{\Theta(1)}$ when q tends to 0;*
- *if \mathcal{U} is rooted, $\mathbb{E}_{\mu_q}(\tau^{KCM}) = 1/q^{\Theta(\ln(1/q))}$ when q tends to 0,*

and the same holds for T_{rel} .

Remark 2.12. Since theorem 1 holds in any dimension and the upper bounds of [MMT19] for supercritical update families also hold in dimension 1, theorem 2 also holds in dimension 1.

Now we consider critical update families. In order to capture the behavior of the corresponding KCMs, a refinement of the classification is needed here also: the relevant subclasses are critical update families *with a finite number of stable directions* and *with an infinite number of stable directions*. One can see that the FA-2f model has a finite number of stable directions and that the Duarte model has an infinite number of stable directions (see figure 1).

In this thesis is proven the following result, obtained in collaboration with Ivailo Hartarsky and Cristina Toninelli in the article [HMT19a], which corresponds to the chapter 3 of this thesis:

Theorem 3. *For any two-dimensional critical update family with an infinite number of stable directions, $\mathbb{E}_{\mu_q}(\tau^{KCM}) = e^{\Omega(1/q^{2\alpha})}$ when q tends to 0, and the same holds for T_{rel} .*

Theorem 3, together with the bootstrap percolation lower bounds of theorem 2.7 and with the upper bounds proven in [MMT19, HMT19b] by Hartarsky, Martinelli, Morris and Toninelli, allows to prove the following universality result for critical KCMs:

Theorem 4. *For any two-dimensional critical update family \mathcal{U} ,*

- *if \mathcal{U} has a finite number of stable directions, it satisfies $\mathbb{E}_{\mu_q}(\tau^{KCM}) = e^{\tilde{\Theta}(1/q^\alpha)}$ when q tends to 0;*
- *if \mathcal{U} has an infinite number of stable directions, then $\mathbb{E}_{\mu_q}(\tau^{KCM}) = e^{\tilde{\Theta}(1/q^{2\alpha})}$ when q tends to 0,*

and the same holds for T_{rel} ¹.

Remark 2.13. Martinelli, Morris and Toninelli had conjectured (conjecture 3 of [MMT19]) that $\mathbb{E}_{\mu_q}(\tau^{KCM})$ and T_{rel} scale as $e^{\tilde{\Theta}(1/q^\nu)}$ when q tends to 0, ν being determined by the difficulties of the directions of \mathcal{U} . Theorem 3 confirmed their conjecture on the value of ν when \mathcal{U} has an infinite number of stable directions; however, the upper bounds proven by Hartarsky, Martinelli and Toninelli in [HMT19b] disproved it in most cases when \mathcal{U} has a finite number of stable directions.

Theorems 2 and 4, along with the result of theorem 2.7 for subcritical update families, prove that the classification of KCMs into supercritical, critical and subcritical is relevant, since models in different classes display different behaviors. Moreover, they show that this classification is not precise enough to capture the behavior of KCMs, and give the right classification.

For critical update families, one would like to obtain a result even more precise than theorem 4, similar to theorem 2.5 for bootstrap percolation: replacing in the asymptotics these $e^{\tilde{\Theta}(1/q^\beta)}$ by $e^{\Theta(\ln(1/q)^\gamma/q^\beta)}$ with the right γ . A first step in this direction is the following result:

Theorem 5. *For the Duarte model, $\mathbb{E}_{\mu_q}(\tau^{KCM}) = e^{\Theta(\ln(1/q)^4/q^2)}$ when q tends to 0, and the same holds for T_{rel} .*

¹We recall that $f = \tilde{\Theta}(g)$ when q tends to 0 when $\lim_{q \rightarrow 0} \ln(f(q))/\ln(g(q)) = 1$.

Theorem 5 gives the most precise asymptotics known for a critical update family. Its lower bound is proven in this thesis and was obtained in collaboration with Fabio Martinelli and Cristina Toninelli in the article [MMTar], which corresponds to the chapter 2 of this thesis. The upper bound was proven by Martinelli, Morris and Toninelli in [MMT19].

2.3 Sketch of proofs

In this subsection we give an idea of the mechanisms underlying the lower bounds of theorem 1 (supercritical rooted update families), theorem 3 (critical update families with an infinite number of stable directions) and theorem 5 (Duarte model), and of the methods used to prove them. It will be a bit informal, as clarity was privileged over rigor.

These three lower bounds are due to the existence of an *energy barrier*, also called *bottleneck*. This means that typically, before the dynamics can put a zero at the origin, it has to go through a set of configurations with very small probability, or *high energy*, which takes a very long time. To find a lower bound on the time needed for the dynamics to put a zero at the origin, one can then look for the *highest possible energy barrier*: a set of configurations with probability as small as possible such that the dynamics is forced to go through it before infecting the origin.

Mathematically, this boils down to finding a set of configurations $A \subset \{0, 1\}^{\mathbb{Z}^2}$ such that

- the configurations in A have spin 1 at the origin;
- $\mu_q(A)$ is not too small;
- $\mu_q(\partial A)$ is as small as possible,

where $\partial A = \{\omega \in A \mid \exists x \in \mathbb{Z}^2, c_x(\omega) = 1, \omega^x \notin A\}$ is the boundary of A : the set of configurations in A such that the dynamics can get out of A by a single authorized spin change.

Indeed, for such an A , since $\mu_q(A)$ is not too small it is probable that the dynamics will start in A ; since the configurations in A have spin 1 at the origin, if the dynamics starts in A it has to get out of A before putting the origin at zero; and to get out of A , the dynamics has to go through ∂A , which has very small probability. Therefore A (or more accurately ∂A) is a good energy barrier.

To relate such an A to $\mathbb{E}_{\mu_q}(\tau^{KCM})$ in a rigorous way, we use the following novel lemma, proven in [MMTar] and whose proof is spelled out in chapter 2:

Lemma 6. *For any family $\{\phi_q\}$ of functions defined for q small enough such that for any q , $\phi_q : \{0, 1\}^{\mathbb{Z}^2} \mapsto \mathbb{R}$ is local, $\phi_q(\omega) = 0$ for any configuration ω with a zero at the origin, $\mu_q(\phi_q^2) = 1$, $\lim_{q \rightarrow 0} \mathcal{D}(\phi_q) = 0$ and $\lim_{q \rightarrow 0} (\mu_q(\phi_q)^4 / \mathcal{D}(\phi_q)) = +\infty$, it holds*

$$\mathbb{E}_{\mu_q}(\tau^{KCM}) = \Omega \left(\frac{\mu_q(\phi_q)^4}{\mathcal{D}(\phi_q)} \right)$$

when q tends to 0.

Consequently, if we have an energy barrier A satisfying the above properties, we can take $\phi_q = \mathbb{1}_A / \mu_q(A)^{1/2}$ (we need the denominator to have $\mu_q(\phi_q^2) = 1$). A classical argument (see section 3.5 of [CFM16]) shows that if $\mathbb{1}_A$ depends on the spins in a finite domain V , $\mathcal{D}(\mathbb{1}_A) \leq |V| \mu_q(\partial A)$, therefore lemma 6 yields

$$\mathbb{E}_{\mu_q}(\tau^{KCM}) = \Omega \left(\frac{\mu_q(A)^3}{|V| \mu_q(\partial A)} \right).$$

This lower bound on $\mathbb{E}_{\mu_q}(\tau^{KCM})$ then yields a similar lower bound on T_{rel} thanks to proposition 1.11. Therefore $\mathbb{E}_{\mu_q}(\tau^{KCM})$ and T_{rel} will be roughly of order $1/\mu_q(\partial A)$.

Our strategy to find a good energy barrier A is inspired by the one used by Cancrini, Martinelli, Schonmann and Toninelli in [CMST10] for the East model. The idea is to construct A so that the configurations in ∂A have a lot of zeroes, which has small probability. We recall that the East model is one-dimensional and that the constraint at a site is satisfied when its left neighbor is at zero. Since the probability that a given site is initially at zero is q , when c is small enough it is very probable that the initial configuration in $\{-c/q, \dots, c/q\}$ is full of ones (then we call it $\mathbb{1}$). Moreover, a combinatorial result of Chung, Diaconis and Graham ([CDG01]) states that if the dynamics starts from $\mathbb{1}$, it cannot put a zero at the origin before going through a configuration containing more than $\log_2(c/q)$ zeroes in $\{-c/q, \dots, c/q\}$. Therefore we can take $A = \{\omega \mid \text{the dynamics starting from } \mathbb{1} \text{ can reach } \omega \text{ without using more than } \log_2(c/q) \text{ zeroes in } \{-c/q, \dots, c/q\}\}$. Then the configurations in A have spin 1 at the origin by the result of [CDG01] and A contains $\mathbb{1}$ which has high probability under the initial law μ_q , hence $\mu_q(A)$ is not too small. It remains to see that $\mu_q(\partial A)$ is small. Let $\omega \in \partial A$, then $\omega \in A$ and there exists $x \in \mathbb{Z}^2$ satisfying $c_x(\omega) = 1$ and $\omega^x \notin A$. Since $\omega \in A$, the dynamics can go from $\mathbb{1}$ to ω without using more than $\log_2(c/q)$ zeroes in $\{-c/q, \dots, c/q\}$, and it can go from ω to ω^x because $c_x(\omega) = 1$, therefore the dynamics can go from $\mathbb{1}$ to ω^x ; however, since $\omega^x \notin A$, it must use more than $\log_2(c/q)$ zeroes in $\{-c/q, \dots, c/q\}$ to do that, hence ω^x contains at least $\log_2(c/q) + 1$ zeroes

in $\{-c/q, \dots, c/q\}$. Furthermore, ω only differs from ω^x at site x , hence ω contains at least $\log_2(c/q)$ zeroes in $\{-c/q, \dots, c/q\}$, which has probability $q^{\Omega(\log_2(1/q))}$. Consequently, $\mu_q(\partial A)$ has probability $q^{\Omega(\log_2(1/q))}$, which yields a lower bound $1/q^{\Omega(\log_2(1/q))}$ on $\mathbb{E}_{\mu_q}(\tau^{KCM})$ and T_{rel} . The three energy barriers devised to prove theorems 1, 3 and 5 use similar designs, that we are going to present.

Theorem 1: supercritical rooted update families. To find the right energy barrier for the first time at which the origin is at zero, one has to understand the mechanism of propagation of zeroes. For a supercritical rooted update family, it is very similar to that of the East model. Indeed, consider the open semicircle of unstable directions guaranteed by the supercriticality; without loss of generality we can suppose it is $] - \pi/2, \pi/2[$. One can find a rectangle D (we call it a *droplet*) such that if D is initially infected in the bootstrap percolation process, the infection propagates to the right (see section 5 of [BSU15] for a proof); in particular, the process infects an identical droplet D' at the right of D (see figure 4).

Then if D is full of zeroes in the KCM, the dynamics can put zeroes or ones in D' . Indeed, we consider the sequence of sites that are successively infected in the bootstrap percolation process starting with D infected; when they get infected, their constraint is satisfied. Consequently, if the KCM starts with D at zero, the first site of the sequence has its constraint satisfied, hence it can be updated to zero. Then the second site of the sequence has its constraint satisfied, so it can be updated to zero, etc., so all the sites of the sequence can be updated to zero, which fills D' with zeroes. Moreover, once D' is full of zeroes the dynamics can put ones in D' by reversing the process: updating to one the last site that was updated to zero, then the second-to-last site, etc. We deduce that if D is full of zeroes, D' can go from full of ones to full of zeroes and conversely.

Thus a droplet can change state when the droplet at its left is full of zeroes. Furthermore, since the update family is rooted, the semicircle opposite to $] - \pi/2, \pi/2[$ cannot contain only unstable directions, so we cannot repeat the construction to allow a droplet to change state when the droplet at its right is full of zeroes. We deduce that a droplet can change state if and only if the droplet at its left is at zero; this is an East dynamics with droplets instead of sites, which is roughly equivalent, since the probability that a droplet is full of zeroes is $q^{\Theta(1)}$. Consequently, one can expect an energy barrier similar to that of the East model. Indeed, this thesis proves the following combinatorial result, similar to the one proven in [CDG01] for the East model. The proof is spelled out in chapter 1, which corresponds to the article [Mar17].

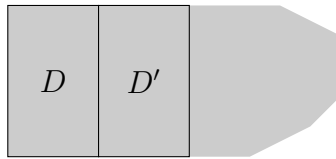

Figure 4: Supercritical rooted update families. A rectangle/droplet D initially full of infected sites allows the infection (in gray) to propagate to the right, hence to infect the identical droplet D' .

Theorem 7. *For any supercritical rooted update family, there exists a constant $\kappa > 0$ such that for any $n \in \mathbb{N}$, the KCM starting with only ones in $\{-\lfloor \kappa n 2^n \rfloor, \dots, \lfloor \kappa n 2^n \rfloor\}^2$ has to go through a configuration containing strictly more than n zeroes in $\{-\lfloor \kappa n 2^n \rfloor, \dots, \lfloor \kappa n 2^n \rfloor\}^2$ before the spin at the origin can be zero.*

Despite the fact theorem 7 generalizes the result of [CDG01], its proof required entirely new arguments, because [CDG01] relied heavily on the strong orientation of the East model, which is not shared by general supercritical rooted update families. These arguments extend to all non supercritical unrooted update families and to any dimension, which allows to prove theorem 1 in the more general setting mentioned in remark 2.11. Theorem 7 is almost optimal, since lemma 6.4 of [CFM16] shows that in the 2-dimensional East model, which is supercritical rooted, the dynamics starting with ones in $\{-2^n + 2, \dots, 2^n - 2\}^2$ can put the origin at zero with only n zeroes.

Theorem 7 allows to choose an A similar to that of the East model: $A = \{\omega \mid \text{the dynamics starting from } \mathbb{1} \text{ can reach } \omega \text{ without using more than } \varepsilon \log_2(1/q) \text{ zeroes in } \{-\kappa \varepsilon \log_2(1/q) 1/q^\varepsilon, \dots, \kappa \varepsilon \log_2(1/q) 1/q^\varepsilon\}\}$ with $\varepsilon > 0$ small (this corresponds to $n = \varepsilon \log_2(1/q)$). Then A has the same energy barrier properties as in the East model and $\mu_q(\partial A) = q^{\Omega(\log_2(1/q))}$, which yields theorem 1.

Theorem 5: the Duarte model. In this KCM, a droplet of constant size full of zeroes is not enough anymore to change the state of the droplet at its right. Indeed, in the bootstrap percolation process with the Duarte update family, if we only have an isolated rectangle of infected sites, the constraints at the sites outside this rectangle are not satisfied (see figure 5(a)). To allow the infection of other sites on the right, a rectangle of infected sites must have an infected site on its right side; then the process can infect the entire right side (see figure 5(b)). One can see the same arguments hold for the KCM: an isolated rectangle of zeroes does not allow to create more zeroes, but if

there is a zero on its right side, the entire right side can be filled with zeroes. Moreover, to have a high probability to find a zero on the right side of the rectangle under law μ_q , this side must have length at least $\Theta((1/q) \ln(1/q))$. Furthermore, the best rectangle to propagate zeroes in the dynamics of the KCM is the one that contains the fewest possible zeroes, since it will be the less improbable one to find. We deduce that the optimal rectangle is a vertical interval of zeroes of height $\Theta((1/q) \ln(1/q))$ (see figure 5(c)).

Vertical intervals of zeroes of height $\Theta((1/q) \ln(1/q))$ will be the equivalent of the droplets of zeroes we had for supercritical rooted update families. Indeed, such an interval has a zero on its right side with high probability, so the dynamics of the KCM can fill its right side with zeroes, creating an identical vertical interval of zeroes; by reversing the process, it can also fill the latter interval with ones. This implies that a vertical interval of height $\Theta((1/q) \ln(1/q))$ can be filled with zeroes or ones if there is a vertical interval of height $\Theta((1/q) \ln(1/q))$ full of zeroes at its left. In addition, since the constraints of the Duarte model do not take into account what is on the right, a vertical interval is not influenced by the intervals on its right. Therefore we have an East dynamics with vertical intervals instead of sites; since each vertical interval has probability $q_{\text{eff}} = q^{\Theta((1/q) \ln(1/q))} = e^{-\Theta((1/q) \ln(1/q)^2)}$, the energy barrier can be expected to satisfy $\mu_q(\partial A) = q_{\text{eff}}^{\log_2(1/q_{\text{eff}})} = e^{-\Theta(\ln(1/q)^4/q^2)}$, hence give a lower bound in $e^{\Theta(\ln(1/q)^4/q^2)}$.

However, this notion of vertical interval is too strict to use in practice. Indeed, one can see in figure 5(c) that the constraint at the sites in the middle of a vertical interval of length $\Theta((1/q) \ln(1/q))$ is satisfied, since their top and bottom neighbors are at zero, therefore it is possible (and even likely) that the dynamics will update them at 1, so we quickly do not have a vertical interval of length $\Theta((1/q) \ln(1/q))$ anymore. Therefore a vertical interval can disappear without the help of a vertical interval at its left, which is not compatible with an East dynamics. The hardest part of the proof of the lower bound in theorem 5 is finding an equivalent to a vertical interval that would not have this problem. The right concept is “a set of zeroes that allows to fill a vertical interval of length $\Theta((1/q) \ln(1/q))$ with zeroes”. However, these sets are not easy to define: if we decide we have spotted such a set each time we see a vertical interval of length $\Theta((1/q) \ln(1/q))$ that can be filled with zeroes, we are confronted with the following problem. This vertical interval is long enough to have a zero on its right side, hence once it is filled with zeroes, the dynamics can also fill its right side, which is another vertical interval of length $\Theta((1/q) \ln(1/q))$. Therefore we find two vertical intervals that can be filled with zeroes, though there is actually a single set of zeroes. The solution is the following algorithm, which was a major innovation: examine

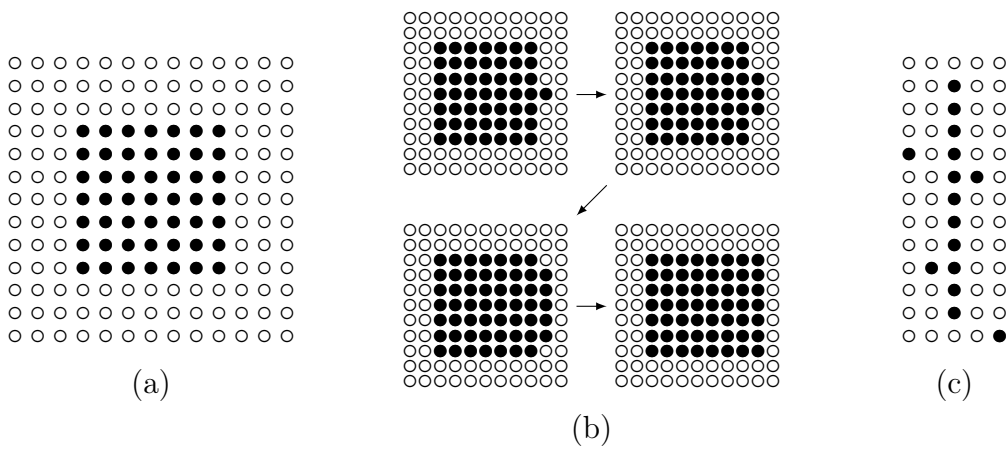

Figure 5: The Duarte model. The ● represent infected sites/sites at 0 and the ○ represent healthy sites/sites at 1. (a) An isolated rectangle of infected sites/zeros is not enough to satisfy the constraint at a site outside the rectangle. (b) If we add an infected site/zero on the right side on the rectangle, its top and bottom neighbors have their constraint satisfied, hence can be infected/updated at zero, after which their respective top and bottom neighbors can also be infected/updated at zero, etc. until the whole right side of the rectangle is infected/at zero. (c) The optimal rectangle of zeroes to propagate zeroes in the dynamics of the KCM: a vertical interval of height $\Theta((1/q) \ln(1/q))$.

the columns of \mathbb{Z}^d one after another, from left to right. Each time you find a vertical interval of length $\Theta((1/q) \ln(1/q))$ that can be filled with zeroes, say the column is *up* and erase all the zeroes that allowed to fill the interval, then continue examining the columns. Then the up-columns follow a roughly East dynamics, and via bootstrap percolation arguments one can show that the probability of each up-column is q_{eff} . This allows to use an energy barrier similar to the one of the East model with up-columns instead of zeroes, which yields the lower bound.

Theorem 3: critical update families with an infinite number of stable directions. Since the Duarte model has a critical update family with an infinite number of stable directions, the mechanism of propagation of zeroes for general critical update families with an infinite number of stable directions is similar to that of the Duarte model, with some adjustments. In the Duarte model, the droplet equivalent is a vertical interval of height $\Theta((1/q) \ln(1/q))$, because such an interval is high enough to have a zero on its right side and that a zero on its right side allows zeroes to propagate to the right. This last point comes from the fact that the direction $(1, 0)$ has difficulty 1 for the update family of the Duarte model (see figure 3), so a single infected site added to $\mathbb{H}_{(1,0)}$ infected is enough to create an infinity of new infections in the bootstrap percolation process, therefore a single site allows to propagate the infection towards direction $(1, 0)$. For a critical update family with difficulty α , to propagate the infection significantly, one needs to be able to propagate it towards a direction with difficulty at least α . Indeed, by the definition of α there exists a set $\{u_i\}_i$ of directions with difficulty at least α such that the origin is in its convex envelope, hence any finite set of infected sites is contained in a finite region directed by the u_i (see figure 6(a)), and for the infection to escape this region, it has to propagate towards one of the u_i . Therefore, in order to propagate the infection significantly, a droplet must be able to propagate it towards a direction of difficulty α ; a group of α infected sites is necessary for that. This implies that to be able to propagate zeroes efficiently in the KCM, a droplet must be big enough to have a high probability to find a group of α zeroes near it, hence must be of size at least $\Theta(1/q^\alpha)$. Consequently, a droplet for a critical update family with an infinite number of stable directions and difficulty α has size $\Theta(1/q^\alpha)$. These droplets will follow an East dynamics; since each of them has probability roughly $q_{\text{eff}} = e^{-\Theta(1/q^\alpha)}$, we can expect an energy barrier A with $\mu_q(\partial A) = q_{\text{eff}}^{\log_2(1/q_{\text{eff}})} = e^{-\Theta(1/q^{2\alpha})}$, hence a lower bound in $e^{\Theta(1/q^{2\alpha})}$.

As for the Duarte model, the crux of the proof is to find an equivalent notion of droplet that can be used in practice. We cannot copy exactly the

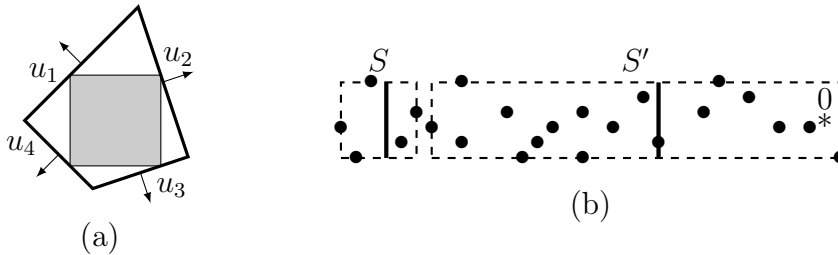

Figure 6: Critical update families with an infinite number of stable directions. (a) There exists a set $\{u_i\}_i$ of directions with difficulty at least α such that the convex envelope of $\{u_i\}_i$ contains the origin. Any finite set of infected sites (in gray) is contained in a finite region (thick outline) directed by the u_i . (b) If we choose as droplet equivalents the sets of zeroes (zeroes are represented by \bullet) allowing to fill a vertical interval of length $\Theta(1/q^\alpha)$ (in thick black) with zeroes, an initial set S may create a set S' near itself so wide that it touches the origin $*$.

strategy of the Duarte model and consider the sets of zeroes allowing to fill a vertical interval of length $\Theta(1/q^\alpha)$ with zeroes. Indeed, these sets can be very wide, hence if the dynamics of the KCM starts with such a set at distance $e^{\Theta(1/q^\alpha)}$ from the origin, which is likely, this set could spawn another set, of width $e^{\Theta(1/q^\alpha)}$, that would directly touch the origin (see figure 6(b)). Therefore the origin would be reached with only two droplets, while our goal is to show that the dynamics has to go through a configuration with many droplets at the same time before a droplet can reach the origin. In the Duarte model, one can prove these sets are never so wide: a set of zeroes allowing to fill a vertical interval of length $\Theta((1/q) \ln(1/q))$ with zeroes does not contain zeroes on the right on this interval because the constraints ignore the sites on the right, so the sites on the right of the interval cannot influence the interval; moreover, a model-specific argument can be used to show that the set does not extend too far on the left. However, none of these two arguments extends to general critical update families with an infinite number of stable directions, so a much more complex definition of the droplets has to be used: a given shape is a droplet if it is contained in the output of an algorithm that construct similar shapes iteratively, starting from building blocks containing at least α sites each and merging two shapes if they intersect. This algorithm is a substantial improvement of the α -covering and u -iceberg algorithms of [BDCMSar]; this improvement was necessary to limit the size of the droplets while keeping the probability of a droplet smaller than $e^{-\Theta(1/q^\alpha)}$.

This definition of droplets allows to use a strategy similar to the one of the Duarte model: we divide \mathbb{Z}^2 into vertical strips, and we unveil the zeroes strip by strip, from left to right; each time unveiling the zeroes of a strip yields a droplet, we declare the strip *up* and remove all the zeroes at its left. Then the up-strips follow a roughly East dynamics, so one can find an energy barrier similar to the one of the East model, which yields the lower bound.

3 Convergence to equilibrium

Section 2 deals only with equilibrium dynamics. The dynamics of KCMs out of equilibrium is much harder to analyze, therefore much less is known about it. Proving results of exponential convergence to equilibrium in KCMs starting out of equilibrium was the second major objective of this thesis, to which the following section is devoted. We will begin by stating the results known before those of this thesis in subsection 3.1, then we will present the advances of this thesis in subsection 3.2, and we will end by giving an idea of their proofs in subsection 3.3.

3.1 Previous results

In this subsection we present the results of convergence to equilibrium existing prior to those of this thesis. KCMs are expected to converge to equilibrium exponentially quickly as soon as they are in the ergodic regime $q > q_c$ (see theorem 1.3) and the initial configuration is not blocked. Initial configurations of law $\mu_{q'}$ with $q' \neq q$ are particularly relevant, because they are physically interesting. However in most models we are very far from proving exponential convergence to equilibrium in any of these cases.

In order to state the known results, we need some notation. For any local function $f : \{0, 1\}^{\mathbb{Z}^d} \mapsto \mathbb{R}$ and $\Lambda \subset \mathbb{Z}^d$, we say the support of f is contained in Λ and we write $\text{supp}(f) \subset \Lambda$ when for any $\omega, \omega' \in \{0, 1\}^{\mathbb{Z}^d}$ coinciding in Λ , $f(\omega) = f(\omega')$. Moreover, we denote $\|f\|_\infty = \sup_{\omega \in \{0, 1\}^{\mathbb{Z}^d}} |f(\omega)|$ the ℓ^∞ -norm of f . These definitions, as well as the definition of a local function, readily extend to more general graphs.

The only KCM for which exponential convergence to equilibrium was proven in the whole ergodic regime and for any non-blocked initial configuration is the East model (apart from some models on trees to which the proof for the East model extends). This result was shown by Cancrini, Martinelli, Schonmann and Toninelli in [CMST10]:

Theorem 3.1 ([CMST10]). *In the East model, for any $q \in]0, 1[$, for any local function $f : \{0, 1\}^{\mathbb{Z}} \mapsto \mathbb{R}$ such that $\text{supp}(f) \subset \{x_-, \dots, x_+\}$ with $x_-, x_+ \in \mathbb{Z}$,*

$x_- \leq x_+$, for any configuration ω such that there exists $x_0 \in \mathbb{Z}$, $x_0 < x_-$ with $\omega(x_0) = 0$, and for any $t \geq 0$,

$$|\mathbb{E}_\omega(f(\omega_t)) - \mu_q(f)| \leq \sqrt{\text{Var}(f)} \left(\frac{1}{\min(q, 1-q)} \right)^{x_+ - x_0} e^{-t/T_{\text{rel}}},$$

where the variance is with respect to μ_q . Furthermore, if $q' \in]0, 1[$, there exists a constant $c = c(q, q') > 0$ such that for any local function $f : \{0, 1\}^{\mathbb{Z}} \mapsto \mathbb{R}$ there exists a constant $C = C(q, q', f) > 0$ such that for any $t \geq 0$,

$$\int_{\{0,1\}^{\mathbb{Z}}} |\mathbb{E}_\omega(f(\omega_t)) - \mu_q(f)| d\mu_{q'}(\omega) \leq C e^{-ct}.$$

Remark 3.2. The assumption “there exists $x_0 < x_-$ with $\omega(x_0) = 0$ ” is equivalent to having the dynamics non-blocked on $\{x_-, \dots, x_+\}$, therefore theorem 3.1 has minimal assumptions.

Indeed, if there does not exist $x_0 < x_-$ with $\omega(x_0) = 0$, then the dynamics starts with $x_- - 1$ at 1, so the constraint at x_- is not satisfied and the spin of x_- cannot change until $x_- - 1$ is set to 0. Moreover, the dynamics starts with $x_- - 2$ at 1, so the spin of $x_- - 1$ cannot change until $x_- - 2$ is set to 0, etc. Therefore all these sites are blocked, including x_- .

Conversely, if there exists $x_0 < x_-$ with $\omega(x_0) = 0$, the constraint at $x_0 + 1$ is satisfied, hence $x_0 + 1$ can be updated to 0, after which the constraint at $x_0 + 2$ is satisfied, hence $x_0 + 2$ can be updated to 0, etc. so all the sites from x_0 to x_+ can be updated to 0, after which $x_+, x_+ - 1, \dots, x_-$ can be successively updated to any desired state, so the dynamics on $\{x_-, \dots, x_+\}$ is not blocked.

The proof of theorem 3.1 relies heavily on the one-dimensionality and strong orientation of the East model. For the d -dimensional East model, which shares this strong orientation, Chleboun, Faggionato and Martinelli proved the following weaker result of *stretched exponential convergence* in [CFM15]:

Theorem 3.3 ([CFM15]). *In the d -dimensional East model, for any $q \in]0, 1[$, there exist constants $c = c(q) > 0$ and $C = C(q) > 0$ such that for any configuration ω with $\omega(0) = 0$, any $t \geq 0$ and any local function $f : \{0, 1\}^{\mathbb{Z}^d} \mapsto \mathbb{R}$ with support in $\{1, \dots, \lceil t^{1/2d} \rceil\}^d$,*

$$|\mathbb{E}_\omega(f(\omega_t)) - \mu_q(f)| \leq C \|f\|_\infty e^{-ct^{1/2d}}.$$

Remark 3.4. The assumptions of theorem 3.3 are almost minimal. Indeed, consider a local function f . There exists a hypercube Λ such that $\text{supp}(f) \subset$

Λ , and the dynamics in Λ is non-blocked when there is an initial zero at a site x_0 such that $\Lambda \subset x_0 + \mathbb{N}^d \setminus \{0\}$ (for the same reasons as the ones explained in remark 3.2 for the East model). Moreover, theorem 3.3 can be applied as soon as there exists an initial zero at x_0 such that $\Lambda \subset x_0 + (\mathbb{N}^*)^d$; indeed, one can then change the coordinates of \mathbb{Z}^d to place the origin at x_0 , and when t is big enough, $\Lambda \subset \{1, \dots, \lceil t^{1/2d} \rceil\}^d$, so we can apply the theorem. Therefore theorem 3.3 can be applied to almost all non-blocked initial configurations.

The stretched exponential convergence of theorem 3.3 is much weaker than the exponential convergence of theorem 3.1; this is due to the one-dimensionality of the East model, which eases its study a lot. The one-dimensionality is such a strong property that it allowed Cancrini, Martinelli, Schonmann and Toninelli to prove the following result in [CMST10]:

Theorem 3.5 ([CMST10]). *For any one-dimensional update family \mathcal{U} , for any $q \in]0, 1[$ such that $T_{\text{rel}} < +\infty$, there exist $\lambda = \lambda(\mathcal{U}, q) > 0$ and $c = c(\mathcal{U}, q) > 0$ such that for any law ν on $\{0, 1\}^{\mathbb{Z}}$ satisfying*

$$\sup_{\ell \in \mathbb{N}} \max_{\eta \in \{0, 1\}^{\{-\ell, \dots, \ell\}}} e^{-\lambda \ell} \frac{\nu(\omega_{\{-\ell, \dots, \ell\}} = \eta)}{\mu_q(\omega_{\{-\ell, \dots, \ell\}} = \eta)} < +\infty$$

and for any local function $f : \{0, 1\}^{\mathbb{Z}} \mapsto \mathbb{R}$, there exists a constant $C = C(\mathcal{U}, q, \nu, f) > 0$ such that for any $t \geq 0$,

$$\int_{\{0, 1\}^{\mathbb{Z}}} |\mathbb{E}_\omega(f(\omega_t)) - \mu_q(f)| d\nu(\omega) \leq C e^{-ct}.$$

Theorem 3.5 is a perturbative result: if the initial law is close enough to the equilibrium measure, then the dynamics converges to equilibrium exponentially quickly.

Finally, there are two convergence results for the FA-1f model. These results hold on more general graphs than \mathbb{Z}^d ; the FA-1f model on a general graph is defined easily (see remark 1.1), by deciding the constraint at a site is satisfied when one of its neighbors is at zero. For the results to hold, the underlying graph has to satisfy some growth conditions. For any $k > 0$ and $D > 0$, a graph is said to have (k, D) -polynomial growth when for any $r \geq 1$, the cardinal of the ball of radius r centered at any vertex of the graph is at most kr^D . Furthermore, for $\theta > 0$, $\tilde{\theta} > 0$ and $\varepsilon \in]0, 1[$, we say a graph satisfies a $(\theta, \tilde{\theta}, \varepsilon)$ -growth condition when for any $r \geq 1$, the cardinal of the ball of radius r centered at any vertex of the graph is at most $\theta e^{\tilde{\theta} r^{1-\varepsilon}}$; thus the growth can be bigger than polynomial, but it is smaller than exponential. In particular, both conditions include \mathbb{Z}^d , but exclude trees. In order to state the results, we need one more notation: for any site x and any configuration

ω , $\xi_x(\omega)$ denotes the (graph) distance from x to the nearest zero in ω . The first result, showed in [MV19] by Mountford and Valle, is as follows:

Theorem 3.6 ([MV19]). *In the FA-1f model on an infinite connected graph $G = (V, E)$ satisfying a $(\theta, \tilde{\theta}, \varepsilon)$ -growth condition with $\theta > 0$, $\tilde{\theta} > 0$ and $\varepsilon \in]0, 1[$, there exists $q_0 = q_0(\theta, \tilde{\theta}, \varepsilon) < 1$ such that for any $q \in]q_0, 1[$, any law ν on $\{0, 1\}^V$ such that there exist $x \in V$ and $m, M > 0$ satisfying that for all $r \geq 1$, $\nu(\xi_x(\eta) \geq r) \leq Me^{-mr}$, and any local function $f : \{0, 1\}^V \mapsto \mathbb{R}$, there exist constants $c = c(\theta, \tilde{\theta}, \varepsilon, q, \nu) > 0$ and $C = C(\theta, \tilde{\theta}, \varepsilon, q, \nu, f) > 0$ such that for any $t \geq 0$,*

$$|\mathbb{E}_\nu(f(\omega_t)) - \mu_q(f)| \leq Ce^{-ct}.$$

In addition, if $\nu = \delta_\omega$ with ω a configuration containing a zero, c does not depend on ν .

Since theorem 3.6 holds when ν is the Dirac measure at a configuration containing a zero, it yields exponential convergence to equilibrium for any non-blocked initial configuration (indeed, the configuration containing only ones is blocked, since the constraint is satisfied nowhere). It is easy to check that $\nu = \mu_{q'}$ with $q' \in]0, 1[$ satisfies also the hypothesis of theorem 3.6, hence theorem 3.6 also gives exponential convergence for such initial measures.

The second convergence result for the FA-1f model was proven by Blondel, Cancrini, Martinelli, Roberto and Toninelli in [BCM⁺13].

Theorem 3.7 ([BCM⁺13]). *In the FA-1f model on an infinite connected graph $G = (V, E)$ that has (k, D) -polynomial growth with $k > 0$, $D > 0$, for any $q \in]1/2, 1[$, any law ν on $\{0, 1\}^V$ such that there exists $\theta > 1$ satisfying $\kappa = \sup_{x \in V} \nu(\theta^{\xi_x(\omega)}) < +\infty$ and any local function $f : \{0, 1\}^V \mapsto \mathbb{R}$ whose support has cardinal K , there exists a constant $c = c(k, D, q, \kappa, K) > 0$ such that for any $t \geq 2$,*

$$|\mathbb{E}_\nu(f(\omega_t)) - \mu_q(f)| \leq c\|f\|_\infty \begin{cases} e^{-t/c} & \text{if } D = 1, \\ e^{-(t/(c \ln t))^{1/D}} & \text{if } D > 1. \end{cases}$$

Therefore, since \mathbb{Z}^d has $(3^d, d)$ -polynomial growth, theorem 3.7 yields exponential convergence to equilibrium when $d = 1$ and stretched exponential convergence to equilibrium when $d > 1$. Theorem 3.7 is valid for less general graphs and initial configurations than theorem 3.6 (though it holds for any initial configuration $\mu_{q'}$ with $q' \in]0, 1[$) and yields poorer bounds; however, it covers a bigger range of q .

Remark 3.8. We cannot expect a convergence to equilibrium quicker than exponential in a KCM. Indeed, the spin of any given site remains in its

initial state until at least the time of its first clock ring, and since this time follows an exponential law with parameter 1, the probability that it is bigger than t is e^{-t} . Consequently, the probability that the site is still in its initial state at time t is at least e^{-t} .

3.2 Advances of the thesis

In this subsection we present the advances of this thesis in the search for exponential convergence to equilibrium. Two convergence results were obtained; the first one applies to general supercritical update families with an initial configuration of law $\mu_{q'}$, $q' \in]0, 1]$ and $q \in [q_0, 1]$ with $q_0 < 1$, while the second applies to the d -dimensional East model and is valid in the whole ergodic regime, for any non-blocked initial configuration, as well as for an initial configuration with law $\mu_{q'}$, $q' \in]0, 1]$. The latter result also yields as a corollary the exponential decay of the persistence function of the d -dimensional East model out of equilibrium with the same assumptions (we recall that the persistence function is the probability that a given site was not updated before time t).

We begin by stating the convergence result that applies to general supercritical update families (we recall that one-dimensional supercritical update families were defined in remark 1.7):

Theorem 8. *If $d = 1$ or 2 , for any supercritical update family \mathcal{U} , for any $q' \in]0, 1]$, there exists $q_0 = q_0(\mathcal{U}, q') \in [0, 1[$ such that for any $q \in [q_0, 1]$, for any local function $f : \{0, 1\}^{\mathbb{Z}^d} \mapsto \mathbb{R}$, there exist two constants $c = c(\mathcal{U}, q') > 0$ and $C = C(\mathcal{U}, q', f) > 0$ such that for any $t \geq 0$,*

$$\left| \mathbb{E}_{\mu_{q'}}(f(\omega_t)) - \mu_q(f) \right| \leq C e^{-ct}.$$

Theorem 8 is the first non-perturbative result of convergence to equilibrium that holds for a whole class of constraints. Its proof can be found in the article [Mar19b], which corresponds to the chapter 4 of this thesis.

Remark 3.9. We expect theorem 8 to hold also for $d \geq 3$ with a suitable generalization of the definition of supercritical update families, which [BDCMSar] conjectured to be “update families with a half-sphere of unstable directions”, a direction $u \in S^{d-1}$ being unstable when there exists an update rule X such that $X \subset \{x \in \mathbb{Z}^d \mid \langle x, u \rangle < 0\}$. The proof of theorem 8 could not be extended to such d because it relies on the existence of a rectangle that, if infected in the bootstrap percolation process, allows to infect an identical rectangle next to it (see figure 4). Such a rectangle is easy to find for $d = 1$ (see remark 1.7 and figure 2(a)), and was constructed in section 5 of [BSU15]

for $d = 2$, but a similar construction is not available for $d \geq 3$. Proving it would automatically extend theorem 8 to higher dimensions.

We now state the results on the d -dimensional East model. In order to do that, we need some notation. For any $r \geq 0$, we denote $\Lambda(r) = (\prod_{i=1}^d \{0, \dots, \lfloor r \rfloor\}) \setminus \{(0, \dots, 0)\}$. Moreover, we say that a probability measure ν on $\{0, 1\}^{\mathbb{Z}^d}$ satisfies condition (\mathcal{C}) when

$$(\mathcal{C}) : \exists a, A > 0, \forall \ell \geq 0, \nu(\forall x \in \{-\lfloor \ell \rfloor, \dots, 0\}^d, \eta(x) = 1) \leq Ae^{-a\ell}.$$

We also recall that for any site $x \in \mathbb{Z}^d$, t_x is the time of the first update at x . We can now state the following two results, that were proven in the article [Mar19a], which corresponds to the chapter 5 of this thesis.

Theorem 9. *In the d -dimensional East model, for any $q \in]0, 1[$, for any measure ν on $\{0, 1\}^{\mathbb{Z}^d}$ satisfying (\mathcal{C}) , there exist constants $\chi = \chi(q) > 0$, $c = c(q, \nu) > 0$ and $C = C(q, \nu) > 0$ such that, for any $t \geq 0$ and any local function $f : \{0, 1\}^{\mathbb{Z}^d} \mapsto \mathbb{R}$ with $\text{supp}(f) \subset \Lambda(\chi t^{1/d})$,*

$$\int_{\{0,1\}^{\mathbb{Z}^d}} |\mathbb{E}_\omega(f(\omega_t)) - \mu_q(f)| d\nu(\omega) \leq C \|f\|_\infty e^{-ct}.$$

So far, theorem 9 is the only result of exponential convergence to equilibrium to hold for a KCM in dimension greater than 1 and for any $q \in]0, 1[$. Since the arguments proving it are very different from those used by [CMST10] to show theorem 3.1, it also yields a new proof of the exponential convergence to equilibrium in the East model.

Corollary 10. *In the d -dimensional East model, for any $q \in]0, 1[$, for any measure ν on $\{0, 1\}^{\mathbb{Z}^d}$ satisfying (\mathcal{C}) , there exist constants $\chi = \chi(q) > 0$, $c = c(q, \nu) > 0$ and $C = C(q, \nu) > 0$ such that for any $t \geq 0$ and any $x \in \Lambda(\chi t^{1/d})$, $\mathbb{P}_\nu(t_x > t) \leq Ce^{-ct}$.*

Corollary 10 is the only known result of exponential decay of the persistence function for a KCM out of equilibrium in \mathbb{Z}^d with $d > 1$.

Remark 3.10. The decay of the persistence function cannot be quicker than exponential; indeed, t_x is at least the time of the first clock ring at site x , which has exponential tail.

(\mathcal{C}) is satisfied by $\mu_{q'}$, $q' \in]0, 1[$, as well as by any Dirac measure at a configuration with a zero in $(-\mathbb{N})^d$, which is the minimal condition for the dynamics not to be blocked on $\Lambda(\chi t^{1/d})$ (see remark 3.4). Therefore theorem 9 and corollary 10 hold with the greatest generality possible.

Remark 3.11. The constant χ is the same in theorem 9 and corollary 10. Furthermore, these two results can be slightly refined: $\Lambda(\chi t^{1/d})$ can be replaced with any box of the form $(\prod_{i=1}^d \{0, \dots, a_i\}) \setminus \{(0, \dots, 0)\}$, $a_1, \dots, a_d \in \mathbb{N}$ such that $\prod_{i=1}^d (a_i + 1) - 1 \leq 2^d \chi^d t$, and a minor modification of the proof of theorem 9 shows the exponential decay of $\int_{\{0,1\}^{\mathbb{Z}^d}} |\mathbb{E}_\omega(f(\omega_t)) - \mu_q(f)|^\gamma d\nu(\omega)$ for any $\gamma > 0$.

3.3 Sketch of proofs

In this subsection we present the ideas of the proofs of theorem 8 (exponential convergence to equilibrium for supercritical update families), theorem 9 (exponential convergence to equilibrium in the d -dimensional East model) and corollary 10 (exponential decay of the persistence function in the d -dimensional East model). The methods used for general supercritical update families are very different from those used for the d -dimensional East model, hence we present them separately. This subsection may be quite informal, as clarity was privileged over rigor.

Theorem 8: general supercritical update families. The argument was inspired by the one used in [MV19] to prove convergence to equilibrium in the FA-1f model (theorem 3.6). We first observe that if $(\bar{\omega}_t)_{t \geq 0}$ and $(\tilde{\omega}_t)_{t \geq 0}$ are KCM processes with respective initial laws $\mu_{q'}$ and μ_q defined on the same probability space, then since μ_q is invariant by the dynamics, $\tilde{\omega}_t$ has law μ_q for any t , hence we have

$$|\mathbb{E}_{\mu_{q'}}(f(\omega_t)) - \mu_q(f)| = |\mathbb{E}(f(\bar{\omega}_t)) - \mathbb{E}(f(\tilde{\omega}_t))| \leq 2\|f\|_\infty \mathbb{P}(\bar{\omega}_t \neq \tilde{\omega}_t \text{ on } \text{supp}(f)).$$

Consequently, it is enough to bound $\mathbb{P}(\bar{\omega}_t(x) \neq \tilde{\omega}_t(x))$ for $x \in \text{supp}(f)$ and a good coupling $(\bar{\omega}_t, \tilde{\omega}_t)_{t \geq 0}$ of the processes starting from $\mu_{q'}$ and μ_q . We will use the coupling that can be obtained from the Harris graphical construction presented in subsection 1.1 by using the same Bernoulli variables and Poisson clocks for $(\bar{\omega}_t)_{t \geq 0}$ and $(\tilde{\omega}_t)_{t \geq 0}$, but different initial configurations.

In order to bound $\mathbb{P}(\bar{\omega}_t(x) \neq \tilde{\omega}_t(x))$, we observe that if $\bar{\omega}_t(x) \neq \tilde{\omega}_t(x)$, we can find a “backward path along which the two processes disagree” as follows. We position ourselves at site x and time t ; we see that at time t , the two processes disagree at x . Then we begin to go backwards in time, staying at x as long as the processes disagree at x . Either we can continue until time 0, and then we have a backward path from time t to time 0 along which the two processes disagree, or there exists a time s at which the two processes stop disagreeing at x . Then at time s the spin of x changed in one of the processes but not the other, hence there was a clock ring at x at time s in

the two processes (we recall that they use the same Poisson clocks), but the clock ring allowed an update in only one of the two. We deduce that at time s , the constraint at x was satisfied in one of the processes but not the other, thus there exists an update rule X such that $x + X$ was full of zeroes at time s in one of the processes but not the other. Consequently, there exists a site $y \in x + X$ which was at zero at time s in one of the processes but not the other, hence the two processes disagree at y at time s . We now jump to y and continue to go backwards in time as long as the two processes disagree at y , etc. We continue until we reach time 0. This yields a backward path along which the two processes disagree.

To prove theorem 8, we show that there are so many zeroes in the processes that with high probability, on each possible backward path there is a point at which both processes are at zero, hence it is not possible to find a backward path along which the two processes disagree, therefore we do not have $\bar{\omega}_t(x) \neq \tilde{\omega}_t(x)$. In order to prove that the processes contain a lot of zeroes, we couple them with a more classical process, oriented percolation, so that the ones in the oriented percolation process translate into zeroes in the KCM processes. Oriented percolation being monotone, it is much better understood than KCMs, and there are results proving that it contains a lot of ones (see [DS88]), hence the KCM processes contain a lot of zeroes, which yields theorem 8.

In what follows, we are going to describe a good coupling between an oriented percolation process and a supercritical KCM process, satisfying that the ones in the oriented percolation process translate into zeroes in the KCM process. Oriented percolation can be seen as a discrete-time process on $\{0, 1\}^{\mathbb{Z}}$ defined as follows (see figure 7(a); a good introduction to oriented percolation can be found in [Dur84]). At time 0, only the origin of \mathbb{Z} is at 1. For any site $z \in \mathbb{Z}$ and any time $n \in \mathbb{N}^*$, the bonds $(z - 1, n - 1) \rightarrow (z, n)$ and $(z + 1, n - 1) \rightarrow (z, n)$ can be randomly *open* or *closed*, and z is at 1 at time n if and only if one of the $\{(z + \varepsilon, n - 1) \rightarrow (z, n)\}$ is open and $z + \varepsilon$ is at 1 at time $n - 1$ occurs for $\varepsilon = 1$ or -1 . Consequently, one can see by induction that z is at 1 at time n when there exists a path of open bonds from $(0, 0)$ to (z, n) .

To couple a supercritical KCM with oriented percolation, we recall a fact seen at the beginning of the part of subsection 2.3 concerning theorem 1: there exists a rectangle D , also called droplet, such that if D is full of zeroes in the KCM process, an identical droplet D' at the right of D can be filled with zeroes by the KCM dynamics if a sequence of updates to zero occurs at the right sites. In addition, if we consider a long enough time interval $[nK, (n + 1)K[$ and q close enough to 1, the probability that there are successive clock rings at these sites during this time interval and that

the corresponding Bernoulli variables are at 0 is very high; we call this event $D \xrightarrow{n} D'$. If D is full of zeroes at time nK and $D \xrightarrow{n} D'$, then in the time interval $[nK, (n+1)K[$ there is a sequence of updates to zero that fill D' with zeroes, hence D' is full of zeroes at time $(n+1)K$. Furthermore, if q is close enough to one, it is highly probable that there will be no clock ring with Bernoulli variable 1 in D during the time interval $[nK, (n+1)K[$; we call this event $D \xrightarrow{n} D$. If D is full of zeroes at time nK and $D \xrightarrow{n} D$, D is still full of zeroes at time $(n+1)K$. If we consider an infinite strip of droplets $(D_z)_{z \in \mathbb{Z}}$ (see figure 7(b)), we can then define a “tilted” oriented percolation process on these droplets thus: the bond $(D_z, n) \rightarrow (D_{z'}, n+1)$ is open when $D_z \xrightarrow{n} D_{z'}$; this process is equivalent to a classical oriented percolation process (see figure 7(b)). Then if a site/droplet D of this oriented percolation process is at 1 at time n , there exists a path of open bonds from $(D_0, 0)$ to (D, n) , hence a sequence of open bonds $(D_0, 0) \rightarrow (D_{z_1}, 1), (D_{z_1}, 1) \rightarrow (D_{z_2}, 2), \dots, (D_{z_{n-1}}, n-1) \rightarrow (D, n)$, so if D_0 is full of zeroes at time 0, D_{z_1} is full of zeroes at time K , D_{z_2} is full of zeroes at time $2K \dots$ and D is full of zeroes at time nK . Consequently, ones in the oriented percolation process translate to zeroes in the KCM process.

Theorem 9 and corollary 10: the d -dimensional East model. We begin by presenting the ideas of the proof of theorem 9. The proof relies on the following orientation property of the d -dimensional East model: the spin of a site x depends only on the dynamics in $x + (-\mathbb{N})^d$. Indeed, the spin of x depends on its initial state, on the clock rings and Bernoulli variables at x , and of the constraint at x . Said constraint depends on the spins of the sites “below x ”: $x - e_1, \dots, x - e_d$ (where $\{e_1, \dots, e_d\}$ is the canonical basis of \mathbb{R}^d); these spins depend on their own initial states, clock rings, Bernoulli variables and constraints, which themselves depend on the state of the sites below them, etc., therefore the spin at x depends only on what happens in $x + (-\mathbb{N})^d$.

This property allows us to work in a finite domain instead of \mathbb{Z}^d . Indeed, if Λ, Λ^- and Λ^+ are defined as on figure 8, the dynamics in $\Lambda \cup \Lambda^+$ does not influence the dynamics in Λ^- , so the configuration in Λ^- can be seen as a boundary condition for the dynamics in $\Lambda \cup \Lambda^+$. Therefore, if we condition on the dynamics in Λ^- , the dynamics we obtain in $\Lambda \cup \Lambda^+$ is a d -dimensional East dynamics with a changing boundary condition. Furthermore, the dynamics in Λ does not depend on what happens in Λ^+ , hence we can consider only the dynamics in Λ , which is a finite volume d -dimensional East dynamics with a changing boundary condition.

This method allows us to work with a finite volume dynamics in $\Lambda(\chi t^{1/d})$

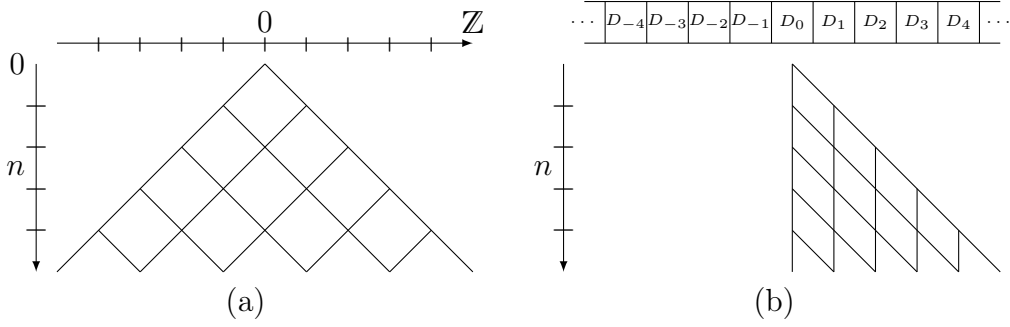

Figure 7: General supercritical update families: coupling with oriented percolation. (a) Oriented percolation. Z is featured in abscissa and the time n in ordinate, from top to bottom. Each bond \setminus or $/$ (oriented downwards) can be open or closed (we represent only the bonds linked to $(0,0)$ by a path of bonds). (b) KCM. If we have an infinite strip of droplets $(D_z)_{z \in \mathbb{Z}}$, we can define a “tilted” oriented percolation process on them by deciding a bond $(D_z, n) \rightarrow (D_{z+1}, n+1)$ is open if and only if $D_z \xrightarrow{n} D_{z+1}$ and a bond $(D_z, n) \rightarrow (D_z, n+1)$ is open if and only if $D_z \xrightarrow{n} D_z$. By applying a linear transformation to the lattice thus obtained, one gets the classical lattice of oriented percolation, so this “tilted” process is equivalent to classical oriented percolation.

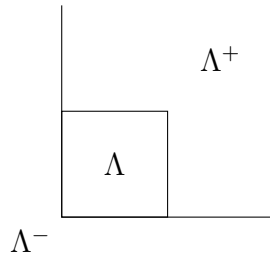

Figure 8: The d -dimensional East model. The dynamics in $\Lambda \cup \Lambda^+$ does not influence the dynamics in Λ^- , and the dynamics in Λ does not depend on what happens in Λ^+ .

with a changing boundary condition. Moreover, in finite volume we can do the following measure-change trick:

$$|\mathbb{E}_\omega(f(\omega_t) - \mu_q(f))| \leq \frac{1}{\min \mu_q(\omega')} \sum_{\omega'} \mu_q(\omega') |\mathbb{E}_{\omega'}(f(\omega_t) - \mu_q(f))| \leq$$

$$\frac{1}{\min \mu_q(\omega')} \left(\sum_{\omega'} \mu_q(\omega') |\mathbb{E}_{\omega'}(f(\omega_t) - \mu_q(f))|^2 \right)^{1/2} = \frac{1}{\min \mu_q(\omega')} \|\mathbb{E}_\cdot(f(\omega_t)) - \mu_q(f)\|_q$$

where $\|\cdot\|_q$ denotes the norm on $L^2(\mu_q)$ (this trick was used in [CFM15] to prove theorem 3.3). In addition, we can use the Poincaré inequality (theorem 1.10) to show $\|\mathbb{E}_\cdot(f(\omega_t)) - \mu_q(f)\|_q \leq 2\|f\|_\infty e^{-t/T_{\text{rel}}}$ where T_{rel} is the relaxation time of the finite volume dynamics. However, this finite volume dynamics has a changing boundary condition, and its relaxation time depends on this boundary condition, so we actually obtain $2\|f\|_\infty e^{-\sum_i (t_{i+1} - t_i)/T_{\text{rel}}^i}$ where T_{rel}^i is the relaxation time between times t_i and t_{i+1} . Thus we need an upper bound on the T_{rel}^i . Actually, T_{rel}^i can be infinite when the boundary conditions yield a non irreducible dynamics; however, when the spin of the origin of \mathbb{Z}^d is at zero, the arguments of part 6.2.2 of [CFM16] show that T_{rel}^i is smaller than a constant T . Therefore $2\|f\|_\infty e^{-\sum_i (t_{i+1} - t_i)/T_{\text{rel}}^i} \leq 2\|f\|_\infty e^{-\mathcal{T}_t/T}$, where \mathcal{T}_t is the time the origin spends at zero before time t . We deduce $|\mathbb{E}_\omega(f(\omega_t) - \mu_q(f))| \leq \frac{2}{\min \mu_q(\omega')} \|f\|_\infty e^{-\mathcal{T}_t/T}$.

Consequently, to prove theorem 9 it is enough to show that the spin of the origin spends a time $\Omega(t)$ at zero before time t . In order to do that, we begin by proving that outside of an event of probability $e^{-\Omega(t)}$ (which is negligible), there exists a site $y \in \{-2t, \dots, 0\}^d$ that spends a time $\Omega(t)$ at zero before time t . Condition (C) on the initial law guarantees that outside of an event of probability Ae^{-at} , there exists a site $x \in \{-t, \dots, 0\}^d$ that is initially at zero. There are two cases: either x remains at zero during the whole time interval $[0, t/2]$, or it is updated in this time interval. In the latter case, the constraint at x is satisfied at the time of the update, so one of the sites below x is at zero. Then either this site is at zero during the whole time interval $[0, t/2]$, or it is updated in this time interval, and in the latter case one of the sites below it is at zero, etc. We proceed for t steps, or until we find a site that is at zero during the whole time interval $[0, t/2]$. In the latter case, this site is a good y . In the former case, we obtain t sites that were updated before time $t/2$. Then at any time bigger than $t/2$, the spin of any of these sites follows a Bernoulli law of parameter $1 - q$, hence it can be expected to be at zero during a proportion q of the time interval $[t/2, t]$, and one can prove that it has a positive probability to be at zero for a time $\Omega(t)$ in this time interval. This yields that the probability that none of these t sites is

at zero for a time $\Omega(t)$ in the time interval $[t/2, t]$ is $e^{-\Omega(t)}$, so outside of an event of probability $e^{-\Omega(t)}$ we can find a good y among them.

The existence of such a y allows to prove that the spin of the origin spends a time $\Omega(t)$ at zero before time t , outside of an event with probability $e^{-\Omega(t)}$ which is negligible. Indeed, if we denote $y = (y_1, \dots, y_d)$, we can prove that outside of an event with probability $e^{-\Omega(t)}$, $(0, y_2, \dots, y_d)$ spends a time $\Omega(t)$ at zero before time t . To do that, we use a finer version of the arguments showing $|\mathbb{E}_\omega(f(\omega_t) - \mu_q(f))| \leq \frac{2}{\min \mu_q(\omega')} \|f\|_\infty e^{-T_t/T}$, considering the dynamics in $\{y_1 + 1, \dots, 0\} \times \{y_2\} \times \dots \times \{y_d\}$ instead of $\Lambda(\chi t^{1/d})$ and applying the Feynmann-Kac formula instead of the Poincaré inequality; we obtain the desired bound because we know that y , which is to $\{y_1 + 1, \dots, 0\} \times \{y_2\} \times \dots \times \{y_d\}$ what the origin is to $\Lambda(\chi t^{1/d})$, spends a time $\Omega(t)$ at zero before time t . Using the same method, we can then prove iteratively that outside of an event with probability $e^{-\Omega(t)}$, $(0, 0, y_3, \dots, y_d)$, $(0, 0, 0, y_4, \dots, y_d)$, $\dots, (0, \dots, 0)$ spend a time $\Omega(t)$ at zero before time t , so the origin spends a time $\Omega(t)$ at zero before time t , which ends the proof of theorem 9.

Remark 3.12. It is impossible to prove in one step that the origin spends a time $\Omega(t)$ at zero between time 0 and time t , because it would require to work with the dynamics in $\{y_1 + 1, \dots, 0\} \times \prod_{i=2}^d \{y_i, \dots, 0\}$, which contains $O(t^d)$ sites, and the measure-change trick brings in a factor $\frac{1}{\min \mu_q(\omega')}$, which would then be $e^{O(t^d)}$, which offsets completely the bound in $e^{-\Omega(t)}$ we can obtain.

Finally, corollary 10 can be easily obtained from theorem 9. Indeed, if $t_x \leq t$, the site x was updated before time t , so at time t its spin follows a Bernoulli law of parameter $1 - q$, thus $\mathbb{E}_\omega(\omega_t(x) | t_x \leq t) = 1 - q$. Moreover, if $t_x > t$, x is still in its initial state at time t , hence $\mathbb{E}_\omega(\omega_t(x) | t_x > t) = \omega(x)$. This yields

$$\begin{aligned} \mathbb{E}_\omega(\omega_t(x)) &= \mathbb{E}_\omega(\omega_t(x) | t_x \leq t) \mathbb{P}_\omega(t_x \leq t) + \mathbb{E}_\omega(\omega_t(x) | t_x > t) \mathbb{P}_\omega(t_x > t) \\ &= (1 - q)(1 - \mathbb{P}_\omega(t_x > t)) + \omega(x) \mathbb{P}_\omega(t_x > t), \end{aligned}$$

therefore

$$(\omega(x) - (1 - q)) \mathbb{P}_\omega(t_x > t) = \mathbb{E}_\omega(\omega_t(x)) - (1 - q) = \mathbb{E}_\omega(\omega_t(x)) - \mu_q(\omega(x))$$

and $|\omega(x) - (1 - q)| \geq \min(q, 1 - q)$, so $\mathbb{P}_\omega(t_x > t) \leq \frac{1}{\min(q, 1 - q)} |\mathbb{E}_\omega(\omega_t(x)) - \mu_q(\omega(x))|$, which allows to deduce corollary 10 from theorem 9.

Chapter 1

Combinatorics for supercritical rooted kinetically constrained models

This chapter corresponds to the article *Combinatorics for general kinetically constrained spin models* [Mar17].

We study the set of possible configurations for a general kinetically constrained model (KCM), a non monotone version of the \mathcal{U} -bootstrap percolation cellular automata. We solve a combinatorial question that is a generalization of a problem addressed by Chung, Diaconis and Graham in [CDG01] for a specific one-dimensional KCM, the East model. Since the general models we consider are in any dimension and lack the oriented character of the East dynamics, we have to follow a completely different route than the one taken by Chung, Diaconis and Graham. Our combinatorial result is used by Marêché, Martinelli and Toninelli in [MMTar]¹ to complete the proof of a conjecture put forward by Morris in [Mor17a].

1.1 Introduction

In this article, we study a generalization of a combinatorial problem addressed by Chung, Diaconis and Graham in [CDG01], that can be formulated as follows. Fix $N \in \mathbb{N}$ and consider that any element of $\{-N, \dots, N\}$ (we call them *sites*) can be in state 0 or 1. The configuration of states can change with respect to the following rules: there cannot be two state changes at the same time, and the state of a site can change only if its left neighbor is in state

¹Chapter 2 of this thesis.

zero. We consider that the sites outside $\{-N, \dots, N\}$ have state 0. One of the questions tackled in [CDG01] is: if the initial configuration contains only ones in $\{-N, \dots, N\}$ and if there can only be n zeroes in $\{-N, \dots, N\}$ at the same time, is it possible to place a zero at the origin with these rules? Chung, Diaconis and Graham proved that it is possible if and only if $N \leq 2^n - 2$: the bigger N is, the bigger n has to be (a non rigorous version of this proof was given previously by Sollich and Evans in [SE99]).

This problem was motivated by the study of the East model [JE91], a stochastic particle system defined as follows: each site of \mathbb{Z} can be in state 0 or 1, and is updated (independently) at rate one by setting it to 0 with probability q and to 1 with probability $1 - q$, if and only if its left neighbor is at zero. Indeed, the above combinatorial result is one of the key ingredients to determine the relevant time scales for the East dynamics [AD02, CMRT08]. The East model belongs to a more general class of interacting particle systems, called kinetically constrained models (KCMs), that were introduced by physicists to model the liquid-glass transition, an important open problem of condensed matter physics (see for example [RS03, BB11] for reviews). In order to construct a different KCM, we use the same dynamics as for East, but with a different choice of the constraint that has to be satisfied to update a site. For example, if one allows a site to change state when its left or its right neighbor is at 0 (this is the choice corresponding to the so-called Fredrickson-Andersen one spin facilitated model (FA-1f)), the behavior is entirely different: for any value of N , two zeroes at the same time are always enough to reach the origin. Indeed, we can put the site $-N$ at 0, then put $-N + 1$ at 0, then put $-N$ at 1, put $-N + 2$ at 0, put $-N + 1$ at 1, etc. and we end up reaching the origin, using never more than two zeroes at the same time.

In this article, we study a generalization of the combinatorial problem of Chung, Diaconis and Graham in higher dimension and with totally general rules. Though our motivation comes from the study of KCMs, we stress that the content of this paper is purely deterministic and requires no probabilistic tools. Let us give a precise definition of the class of rules that we address. We set $d \in \mathbb{N}^*$, $N \in \mathbb{N}$; any site of $\{-N, \dots, N\}^d$ can be in state 0 or 1. There cannot be two state changes at the same time, and the state of a site s can change only if there exists $X \in \mathcal{U}$ such that all the sites of $s + X$ are in state 0, where $\mathcal{U} = \{X_1, \dots, X_m\}$ with $m \in \mathbb{N}^*$ and the X_i are finite nonempty subsets of $\mathbb{Z}^d \setminus \{0\}$ (\mathcal{U} is called an *update family* and the X_i are called *update rules*). As before, the sites outside $\{-N, \dots, N\}^d$ are considered to be in state 0. The rules of the East model correspond to $d = 1$ and $\mathcal{U} = \{\{-1\}\}$, and those of the FA-1f model to $d = 1$ and $\mathcal{U} = \{\{-1\}, \{1\}\}$. If the initial configuration contains only ones in $\{-N, \dots, N\}^d$ and if there can only be

n zeroes in $\{-N, \dots, N\}^d$ at the same time, is it possible to place a zero at the origin?

This generalization has become interesting in recent years. Indeed, until a few years ago, only specific update families had been studied in KCMs. However, there recently was a breakthrough in the study of a monotone deterministic counterpart of KCMs called bootstrap percolation. For any update family \mathcal{U} of \mathbb{Z}^d , the associated bootstrap percolation process is defined as follows: we choose a set $A \subset \mathbb{Z}^d$ of sites that we consider as initially *infected* (the equivalent of being at zero), we set $A_0 = A$, and for any $t \in \mathbb{N}^*$ we define the set A_t of sites that are infected at time t by

$$A_t = A_{t-1} \cup \{s \in \mathbb{Z}^d \mid \exists X \in \mathcal{U}, s + X \subset A_{t-1}\},$$

which means that at each time $t \in \mathbb{N}^*$, the sites that were infected at time $t-1$ remain infected at time t and a site s that was not infected at time $t-1$ becomes infected at time t if and only if there exists $X \in \mathcal{U}$ such that all the sites of $s + X$ are infected at time $t-1$.

The articles [BSU15] by Bollobás, Smith and Uzzell and [BBPS16] by Balister, Bollobás, Przykucki, and Smith tackled general update families for the first time and proved a beautiful universality result. They showed that in \mathbb{Z}^2 , the update families can be sorted into three classes (whose definitions are too technical to be given in this introduction): subcritical, critical and supercritical, which have different behaviors that we are going to describe. The first natural question for a bootstrap percolation model is: if we start the process with each site having probability q to be infected, independently of the others, will the process infect the origin with probability 1 or is there a positive probability that the origin is never infected even if we wait for an infinite time? Moreover, what will be the scale of the first time at which the origin is infected (often called *infection time*)? Since bootstrap percolation is monotone (the more infection we have at the beginning, the more we will have at any stage), it can be seen that there exists a critical probability $q_c \in [0, 1]$ such that if $q < q_c$, the origin is never infected with positive probability and if $q > q_c$ the origin is infected with probability 1. [BSU15, BBPS16] showed that when \mathcal{U} is subcritical, $q_c > 0$, and when \mathcal{U} is critical or supercritical, $q_c = 0$. Moreover, they proved that when q tends to zero, the infection time scales as $1/q^{\Theta(1)}$ when \mathcal{U} is supercritical and as $\exp(1/q^{\Theta(1)})$ when \mathcal{U} is critical (the latter result was later refined by Bollobás, Duminil-Copin, Morris, and Smith in [BDCMSar]).

These results call for the study of KCMs with general update families. As in bootstrap percolation, a key quantity for the study of KCMs is the first time at which the origin is at zero when the process starts with all sites

independently at zero with probability q ; we denote its mean by $\tau(q)$. Understanding the divergence of $\tau(q)$ when q tends to q_c is particularly relevant, because the critical regime $q \downarrow q_c$ is the most interesting for physicists. An easy result proven by Martinelli and Toninelli in [MT19] shows that the infection time in the bootstrap percolation process is a lower bound for $\tau(q)$. However, this lower bound does not always give the actual behavior. Indeed, for the East model, the infection time in the bootstrap percolation scales as $1/q^{\Theta(1)}$ when q tends to 0, but the results of Aldous and Diaconis [AD02] and Cancrini, Martinelli, Roberto and Toninelli [CMRT08] proved that $\tau(q)$ scales as $\exp(\Theta(\log(1/q)^2))$ when q tends to 0. This lead Morris to formulate conjectures on the scaling of $\tau(q)$ when q tends to zero for critical and supercritical update families. His conjecture for supercritical update families (conjecture 2.7 of [Mor17a]) is that they should be divided in two subclasses: supercritical *unrooted* update families for which $\tau(q)$ has the same scaling as the bootstrap percolation infection time, that is $1/q^{\Theta(1)}$, and supercritical *rooted* update families for which $\tau(q)$ has the same scaling as the East model, $\exp(\Theta(\log(1/q)^2))$. Part of this conjecture was proven: the lower bound for supercritical unrooted update families is given by the bootstrap percolation lower bound of [MT19], and the upper bound for supercritical update families both unrooted and rooted was proven by Martinelli, Morris and Toninelli in [MMT19]. However, the lower bound for supercritical rooted update families was still missing. Since a lower bound matching this behavior for the East model was proven in [CMST10] using the combinatorial result of [CDG01], we seeked to generalize this combinatorial result to all supercritical rooted update families.

Indeed, we establish the following result (theorem 1.4): if \mathcal{U} is a supercritical rooted update family, if we start with all the sites of $\{-N, \dots, N\}^2$ at state 1 and if we allow only n zeroes at the same time in $\{-N, \dots, N\}^2$, then to be able to put a zero at the origin, it is necessary to have $N = O(n2^n)$. This result is almost optimal, since [CDG01] proved that for the East model, which is supercritical rooted, $N = 2^n - 2$ allows to put a zero at the origin. Actually, our result is valid in an even larger class, namely for all update families that are not supercritical unrooted. Furthermore, in proposition 1.6 we also explain why our hypothesis is not restrictive, namely why such a result is not valid for supercritical unrooted update families. Our result allows us to complete the proof of the conjecture of Morris (with respect to $\tau(q)$), which we do in theorem 4.2 of [MMTar] with Martinelli and Toninelli. Our result proves even more, since it is valid in any dimension for a natural generalization of the definition of supercritical unrooted update families.

Though we generalize the result of [CDG01], our proof is completely different from theirs, as the proof of [CDG01] relies heavily on the orientation of

the East model and the general update families completely lack orientation. Note that even in dimension 1, it is a substantial generalization of the result of [CDG01], because it applies to a whole class of update families instead of just the East model.

We begin this article by giving the notations and stating the results, then we detail the proof of the result for one-dimensional supercritical rooted update families, then we explain how this proof extends to general dimension, and finally we examine the supercritical unrooted case.

1.2 Notations and result

We fix $d \in \mathbb{N}^*$ and set an update family $\mathcal{U} = \{X_1, \dots, X_m\}$ with the X_i finite nonempty subsets of $\mathbb{Z}^d \setminus \{0\}$. Set $\Lambda \subset \mathbb{Z}^d$. We consider the configurations of states in Λ ; they belong to the set $\{0, 1\}^\Lambda$. We denote by 1_Λ the configuration which contains only ones in Λ , and by 0_Λ (or just 0) the configuration which contains only zeroes in Λ . Furthermore, for all $\eta \in \{0, 1\}^\Lambda$, $s \in \Lambda$, we use the notation η^s for the configuration in $\{0, 1\}^\Lambda$ that is η apart from the state of s that is flipped: $(\eta^s)_{s'} = 1 - \eta_s$ if $s' = s$ and $\eta_{s'}$ if $s' \neq s$. Moreover, if $\Lambda' \subset \Lambda$ and $\eta \in \{0, 1\}^\Lambda$, we denote by $\eta_{\Lambda'}$ its restriction to Λ' . In addition, if $\Lambda' \subset \mathbb{Z}^d$ is disjoint from Λ , for all $\eta \in \{0, 1\}^\Lambda$, $\eta' \in \{0, 1\}^{\Lambda'}$, we denote by $\eta_\Lambda \eta'_{\Lambda'}$ the configuration on $\Lambda \cup \Lambda'$ defined by $(\eta_\Lambda \eta'_{\Lambda'})_s = \eta_s$ if $s \in \Lambda$ and $(\eta_\Lambda \eta'_{\Lambda'})_s = \eta'_s$ if $s \in \Lambda'$.

We say that a move from $\eta \in \{0, 1\}^\Lambda$ to $\eta' \in \{0, 1\}^\Lambda$ is *legal* if $\eta' = \eta$, or if $\eta' = \eta^s$ with $s \in \Lambda$ and there exists an update rule $X \in \mathcal{U}$ such that $(\eta_\Lambda 0_{\Lambda^c})_{s+X} = 0_{s+X}$ (we may also write $(\eta_\Lambda)_{s+X} = 0$ to simplify the notation); that is, a move is legal if it respects the rules described in the introduction, assuming that all sites outside of Λ are zeroes.

Definition 1.1. If $\eta, \eta' \in \{0, 1\}^\Lambda$, a *legal path* from η to η' is a sequence of configurations $(\eta^j)_{0 \leq j \leq m}$ such that $m \in \mathbb{N}^*$, $\eta^0 = \eta$, $\eta^m = \eta'$, and for all $j \in \{0, \dots, m-1\}$, the move from η^j to η^{j+1} is legal.

For any $n \in \mathbb{N}$, we say that $(\eta^j)_{0 \leq j \leq m}$ is an *n-legal path* if for all $j \in \{0, \dots, m\}$, η^j does not contain more than n zeroes in Λ .

In order to have lighter notation, we use the same notation η^j for the j -th step of a path and for the configuration that is equal to η everywhere except at site j . In order to avoid confusion, η^0 , η^j , η^{j+1} and η^m will always denote a step of a path, and no other index will be used to describe a step of a path.

For all $n \in \mathbb{N}$, we define

$$V(n, \Lambda) = \{\eta \in \{0, 1\}^\Lambda \mid \text{there exists an } n\text{-legal path from } 1_\Lambda \text{ to } \eta\}.$$

$V(n, \Lambda)$ is the set of configurations of $\{0, 1\}^\Lambda$ that are attainable from the configuration containing only ones using at most n zeroes. $V(n, \Lambda)$ will be very different depending on the properties of \mathcal{U} . In this article, we will distinguish between two classes of update families. To define them, we recall the concept of stable direction introduced in [BSU15]:

Definition 1.2. For any $u \in S^{d-1}$, let $\mathbb{H}_u = \{x \in \mathbb{R}^d \mid \langle x, u \rangle < 0\}$ the half-space with boundary orthogonal to u . We say that u is a *stable direction* for the update family \mathcal{U} when there does not exist $X \in \mathcal{U}$ such that $X \subset \mathbb{H}_u$.

This implies in particular that if we apply the rules in \mathbb{Z}^d with the update family \mathcal{U} , and if we start with only ones in $(\mathbb{H}_u)^c$, then no zero can appear in $(\mathbb{H}_u)^c$. Intuitively, it means that the zeroes cannot move towards direction u . The following definition is an extension to the dimension d of the definition proposed in [Mor17a]:

Definition 1.3. We say that \mathcal{U} is *supercritical unrooted* if there exists a hyperplane of \mathbb{R}^d that contains all stable directions of \mathcal{U} .

An example of supercritical unrooted update family is the one corresponding to the Fredrickson-Andersen one spin facilitated model, whose one-dimensional version was presented in the introduction, for which we have $\mathcal{U} = \{\{e_1\}, \dots, \{e_d\}, \{-e_1\}, \dots, \{-e_d\}\}$ where $\{e_1, \dots, e_d\}$ is the canonical basis of \mathbb{R}^d . This update family has no stable directions at all.

We are now ready to state our main result, theorem 1.4, which is valid for all update families that *are not* supercritical unrooted. This actually covers many different behaviors; in particular, in two dimensions, according to the classification in [BSU15] they include: supercritical update families which have two non opposite stable directions (called supercritical rooted in [Mor17a]), critical and subcritical update families.

Theorem 1.4. *Let \mathcal{U} be any update family that is not supercritical unrooted. There exists a constant $\kappa > 0$ such that for any $n \in \mathbb{N}$, every configuration $\eta \in V(n, \{-\lfloor \kappa n 2^n \rfloor, \dots, \lfloor \kappa n 2^n \rfloor\}^d)$ satisfies $\eta_0 = 1$.*

Remark 1.5. Our theorem is stated for paths that are n -legal when all sites outside of the box $\{-\lfloor \kappa n 2^n \rfloor, \dots, \lfloor \kappa n 2^n \rfloor\}^d$ are considered to be zeroes; it actually remains valid if we consider the n -legal paths for any configuration of the states outside of the box. Indeed, if we consider that the sites outside of the box are not all zeroes, the possible moves are more restricted, hence a legal path for such a configuration is also a legal path if there are zeroes outside of the box.

The assumption that \mathcal{U} is not supercritical unrooted in theorem 1.4 is not restrictive. Indeed, if \mathcal{U} is supercritical unrooted, the behavior is different:

Proposition 1.6. *If $d = 1$ or 2 , and if \mathcal{U} is supercritical unrooted, there exists $n \in \mathbb{N}^*$ such that for any domain $\Lambda \subset \mathbb{Z}^d$ containing the origin, there exists $\eta \in V(n, \Lambda)$ such that $\eta_0 = 0$.*

Proposition 1.6 means that there exists a finite n such that n zeroes are always enough to bring a zero to the origin. We expect this result to hold also for $d \geq 3$. A sketch of proof can be found in section 1.5.

1.3 The one-dimensional case

Let \mathcal{U} be a one-dimensional, non supercritical unrooted update family. Then \mathcal{U} has at least one stable direction, which can be 1 or -1. Without loss of generality, we may suppose that -1 is a stable direction. We denote r the range of the interactions: $r = \max\{\|x - y\|_\infty \mid x, y \in X \cup \{0\}, X \in \mathcal{U}\}$. Moreover, for all $n \in \mathbb{N}$, we write $a_n = r(2^n - 1)$, $b_n = rn2^{n-1}$ and $\mathcal{P}_n = \{-a_n, \dots, b_n\}$.

We will prove theorem 1.4 by induction. For all $n \in \mathbb{N}$, we denote

$$\mathcal{H}_n = \text{“for any } \Lambda \subset \mathbb{Z} \text{ such that } \mathcal{P}_n \subset \Lambda, \text{ for any } \eta \in V(n, \Lambda), \eta_0 = 1\text{”}.$$

Proving \mathcal{H}_n for all $n \in \mathbb{N}$ will prove the theorem in the one-dimensional case.

In order to do that, we will need the

Lemma 1.7. *Let $n \geq 1$ and suppose \mathcal{H}_{n-1} . Then, for all $\Lambda \subset \mathbb{Z}$ such that $\mathcal{P}_n \subset \Lambda$, for all $\eta \in V(n, \Lambda) \setminus \{1_\Lambda\}$, η has at least one zero in $\Lambda \setminus \mathcal{P}_{n-1}$.*

This lemma means that if \mathcal{H}_{n-1} holds, in a large enough interval, any configuration attainable using no more than n zeroes must have one of its zeroes outside of \mathcal{P}_{n-1} (except the configuration containing only ones, that has no zero at all). This implies that there are at most $n - 1$ zeroes in \mathcal{P}_{n-1} , which will allow us to use \mathcal{H}_{n-1} to prove that the origin cannot be reached by zeroes (see figure 1.1).

We first prove the theorem supposing lemma 1.7 holds; we will prove the lemma afterwards. As we announced, we will show by induction that \mathcal{H}_n holds for any $n \in \mathbb{N}$.

Case $n=0$. This is a simple case: if $\Lambda \subset \mathbb{Z}$, $\mathcal{P}_0 \subset \Lambda$ and $\eta \in V(0, \Lambda)$, then η contains no zero.

Induction. Let $n \geq 1$. We suppose \mathcal{H}_{n-1} . Let us show \mathcal{H}_n . Let $\Lambda \subset \mathbb{Z}$ such that $\mathcal{P}_n \subset \Lambda$, and $\eta \in V(n, \Lambda)$.

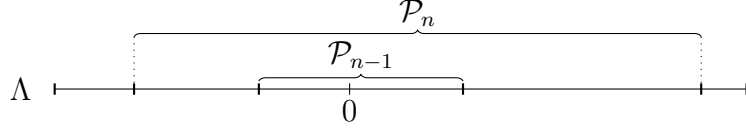

Figure 1.1: Proof of the theorem in the one-dimensional case: there must be a zero in $\Lambda \setminus \mathcal{P}_{n-1}$, hence there can be at most $n - 1$ zeroes in \mathcal{P}_{n-1} . Thus \mathcal{H}_{n-1} implies that there is no zero at 0.

By definition, there exists an n -legal path $(\eta^j)_{0 \leq j \leq m}$ from 1_Λ to η . We will prove that $(\eta_{\mathcal{P}_{n-1}}^j)_{0 \leq j \leq m}$ is an $(n - 1)$ -legal path from $\eta_{\mathcal{P}_{n-1}}^0 = 1_{\mathcal{P}_{n-1}}$ to $\eta_{\mathcal{P}_{n-1}}^m = \eta_{\mathcal{P}_{n-1}}$.

Firstly, for all $j \in \{0, \dots, m - 1\}$, the move from $\eta_{\mathcal{P}_{n-1}}^j$ to $\eta_{\mathcal{P}_{n-1}}^{j+1}$ is legal. Indeed, if $\eta^{j+1} = \eta^j$ or if $\eta^{j+1} = (\eta^j)^z$ with $z \in \Lambda \setminus \mathcal{P}_{n-1}$, $\eta_{\mathcal{P}_{n-1}}^{j+1} = \eta_{\mathcal{P}_{n-1}}^j$ and the move from $\eta_{\mathcal{P}_{n-1}}^{j+1}$ to $\eta_{\mathcal{P}_{n-1}}^j$ is legal. Furthermore, if $\eta^{j+1} = (\eta^j)^z$ with $z \in \mathcal{P}_{n-1}$, $\eta_{\mathcal{P}_{n-1}}^{j+1} = (\eta_{\mathcal{P}_{n-1}}^j)^z$, and since the move from η^j to η^{j+1} is legal, there exists $X \in \mathcal{U}$ such that $(\eta_\Lambda^j 0_{\Lambda^c})_{z+X} = 0$, which implies $(\eta_{\mathcal{P}_{n-1}}^j 0_{(\mathcal{P}_{n-1})^c})_{z+X} = 0$, hence the move from $\eta_{\mathcal{P}_{n-1}}^j$ to $\eta_{\mathcal{P}_{n-1}}^{j+1}$ is legal. Therefore $(\eta_{\mathcal{P}_{n-1}}^j)_{0 \leq j \leq m}$ is a legal path.

Moreover, for all $j \in \{0, \dots, m\}$, $\eta_{\mathcal{P}_{n-1}}^j$ contains at most $n - 1$ zeroes. Indeed, if $\eta^j = 1_\Lambda$, then $\eta_{\mathcal{P}_{n-1}}^j$ contains no zero at all. In addition, if $\eta^j \neq 1_\Lambda$, then $\eta^j \in V(n, \Lambda) \setminus \{1_\Lambda\}$, and since we suppose \mathcal{H}_{n-1} , we can apply lemma 1.7, which yields that η^j has at least one zero in $\Lambda \setminus \mathcal{P}_{n-1}$, hence $\eta_{\mathcal{P}_{n-1}}^j$ contains at most $n - 1$ zeroes.

It follows that $(\eta_{\mathcal{P}_{n-1}}^j)_{0 \leq j \leq m}$ is an $(n - 1)$ -legal path from $1_{\mathcal{P}_{n-1}}$ to $\eta_{\mathcal{P}_{n-1}}$. Thus $\eta_{\mathcal{P}_{n-1}} \in V(n - 1, \mathcal{P}_{n-1})$. Consequently, by \mathcal{H}_{n-1} , $\eta_0 = 1$, which proves \mathcal{H}_n .

This ends the proof of theorem 1.4 given lemma 1.7, so we are only left to prove lemma 1.7.

Proof of lemma 1.7. Let $n \geq 1$ and $\Lambda \subset \mathbb{Z}$ be such that $\mathcal{P}_n \subset \Lambda$.

We will consider a configuration $\eta \in \{0, 1\}^\Lambda$, different from 1_Λ , containing at most n zeroes, such that all of its zeroes are in \mathcal{P}_{n-1} , and we will show that $\eta \notin V(n, \Lambda)$; this is enough to prove the lemma.

We begin by noticing that if there does not exist an n -legal path from η to 1_Λ , then $\eta \notin V(n, \Lambda)$. Indeed, if $\eta \in V(n, \Lambda)$, there exists an n -legal path $(\eta^j)_{0 \leq j \leq m}$ from 1_Λ to η , and one can check that $(\eta^{m-j})_{0 \leq j \leq m}$ is an n -legal path from η to 1_Λ . Therefore, to prove that $\eta \notin V(n, \Lambda)$, it is enough to show that there is no n -legal path from η to 1_Λ . In order to do that, we let

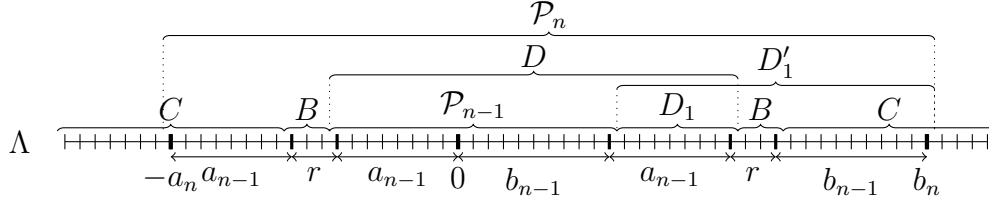

Figure 1.2: The setting of lemma 1.7.

$(\eta^j)_{0 \leq j \leq m}$ be an n -legal path with $\eta^0 = \eta$. We are going to show that η^m cannot be 1_Λ .

To this end, we will denote (see figure 1.2):

$$\begin{aligned} B &= \{-a_n + a_{n-1}, \dots, -a_n + a_{n-1} + r - 1\} \\ &\quad \cup \{b_n - (b_{n-1} + r) + 1, \dots, b_n - b_{n-1}\}, \\ D &= \{-a_n + a_{n-1} + r, \dots, b_n - (b_{n-1} + r)\}, \\ D_1 &= \{b_n - (b_{n-1} + a_{n-1} + r) + 1, \dots, b_n - (b_{n-1} + r)\}, \\ D'_1 &= \{b_n - (b_{n-1} + a_{n-1} + r) + 1, \dots, b_n\} \end{aligned}$$

and $C = \Lambda \setminus (B \cup D)$ (if $n = 1$, D_1 will be empty).

We notice that

$$\begin{aligned} -a_n + a_{n-1} + r &= -r(2^n - 1) + r(2^{n-1} - 1) + r \\ &= -r2^{n-1} + r = -r(2^{n-1} - 1) = -a_{n-1} \end{aligned}$$

and

$$\begin{aligned} b_n - (b_{n-1} + a_{n-1} + r) &= rn2^{n-1} - (r(n-1)2^{n-2} + r(2^{n-1} - 1) + r) \\ &= rn2^{n-2} - r2^{n-2} = r(n-1)2^{n-2} = b_{n-1} \end{aligned}$$

hence $\mathcal{P}_{n-1} = \{-a_n + a_{n-1} + r, \dots, b_n - (b_{n-1} + a_{n-1} + r)\} = D \setminus D_1$.

B will be a “buffer zone”: we will prove that it remains full of ones and prevents the zeroes of C and D from interacting.

There will always be a zero in \mathcal{P}_{n-1} , because the leftmost zero z in \mathcal{P}_{n-1} would need an update rule full of zeroes to disappear. However, there is no zero in B and the thickness of B is larger than the range of the interactions, hence this update rule cannot use zeroes in B or at the left of B . Thus it can use only zeroes in \mathcal{P}_{n-1} or at the right of \mathcal{P}_{n-1} , but z is the leftmost zero in \mathcal{P}_{n-1} . Therefore, the update rule would have to be completely contained in the right of z , which is impossible since we assumed that -1 was a stable direction, hence there is no update rule contained in \mathbb{N}^* . Hence the leftmost

zero in \mathcal{P}_{n-1} cannot disappear, thus there will always be a zero in \mathcal{P}_{n-1} , which implies $\eta^m \neq 1_\Lambda$.

More rigorously, we are going to prove by induction on $j \in \{0, \dots, m\}$ that the property \mathcal{H}'_j holds, where \mathcal{H}'_j consists in:

(P_1^j) $\eta_{\mathcal{P}_{n-1}}^j$ contains a zero.

(P_2^j) $\eta_B^j = 1_B$.

(P_3^j) $\eta_C^j 1_{\Lambda \setminus C} \in V(n-1, \Lambda)$.

(P_4^j) $\eta_{D_1}^j 1_{D_1' \setminus D_1} \in V(n-1, D_1')$.

The last two properties will be used to show that B remains full of ones.

If we can show \mathcal{H}'_j for all $j \in \{0, \dots, m\}$, in particular (P_1^m) will imply that there is a zero in $\eta_{\mathcal{P}_{n-1}}^m$, thus $\eta^m \neq 1_\Lambda$, which is enough to prove the lemma.

Let us prove \mathcal{H}'_j for all $j \in \{0, \dots, m\}$.

Case $j = 0$.

(P_1^0) is true, because $\eta^0 = \eta \neq 1_\Lambda$, so η contains at least a zero, and by assumption all zeroes of η are in \mathcal{P}_{n-1} . (P_2^0) is true because $\eta^0 = \eta$ has no zero in $\Lambda \setminus \mathcal{P}_{n-1}$. (P_3^0) is true because $C \subset \Lambda \setminus \mathcal{P}_{n-1}$, thus $\eta_C = 1_C$, hence $\eta_C^0 1_{\Lambda \setminus C} = 1_\Lambda \in V(n-1, \Lambda)$. (P_4^0) is true, because $D_1 \subset \Lambda \setminus \mathcal{P}_{n-1}$, thus $\eta_{D_1}^0 1_{D_1' \setminus D_1} = 1_{D_1'} \in V(n-1, D_1')$. Consequently, \mathcal{H}'_0 holds.

Induction.

Let j be in $\{0, \dots, m-1\}$. We suppose that \mathcal{H}'_j holds. Let us show \mathcal{H}'_{j+1} .

We know that the move from η^j to η^{j+1} is legal. If $\eta^{j+1} = \eta^j$, \mathcal{H}'_{j+1} holds because \mathcal{H}'_j holds. In the following, we deal with the case $\eta^{j+1} = (\eta^j)^z$ where $z \in \Lambda$ and there exists $X \in \mathcal{U}$ with $(\eta_\Lambda^j)_{z+X} = 0$. The arguments will depend on the position of z .

Case $z \in B$.

We will show that $z \in B$ is impossible: the buffer zone remains preserved at step $j+1$.

By (P_2^j) $\eta_B^j = 1_B$, hence $z + X \subset C \cup \Lambda^c \cup D$. Moreover, if there existed $x \in (z + X) \cap (C \cup \Lambda^c)$ and $y \in (z + X) \cap D$, then we would get $|x - y| > r$, which is impossible by the definition of r . Therefore $z + X \subset C \cup \Lambda^c$ or $z + X \subset D$. We are going to deal with the two cases separately.

We begin with the case $z + X \subset C \cup \Lambda^c$.

We are going to prove that in this case, $(\eta_C^j 1_{\Lambda \setminus C})^z$ would be in $V(n-1, \Lambda)$, which is impossible because it has a zero at z and $z + \mathcal{P}_{n-1} \subset \Lambda$, therefore \mathcal{H}_{n-1} and the invariance by translation of \mathbb{Z} yield a contradiction. Indeed, the move from $\eta_C^j 1_{\Lambda \setminus C}$ to $(\eta_C^j 1_{\Lambda \setminus C})^z$ would be legal. In addition, $(\eta_C^j 1_{\Lambda \setminus C})^z$

would coincide with η^{j+1} on $C \cup B$ by (P_2^j) . Moreover, η^{j+1} contains at most n zeroes, and $\eta_{\mathcal{P}_{n-1}}^{j+1} = \eta_{\mathcal{P}_{n-1}}^j$ would contain at least a zero by (P_1^j) , hence η^{j+1} contains at most $n - 1$ zeroes in $C \cup B$, thus $(\eta_C^j 1_{\Lambda \setminus C})^z$ would contain at most $n - 1$ zeroes. Furthermore by (P_3^j) , $\eta_C^j 1_{\Lambda \setminus C} \in V(n - 1, \Lambda)$. Therefore we could extend an $(n - 1)$ -legal path from 1_Λ to $\eta_C^j 1_{\Lambda \setminus C}$ by adding the move from $\eta_C^j 1_{\Lambda \setminus C}$ to $(\eta_C^j 1_{\Lambda \setminus C})^z$ and still have an $(n - 1)$ -legal path, which would imply $(\eta_C^j 1_{\Lambda \setminus C})^z \in V(n - 1, \Lambda)$, which is impossible.

We now deal with the case $z + X \subset D$.

We argue differently depending on the position of z .

- If z is in the left part of B , we can use the fact that -1 is a stable direction. Indeed, $z + X$ would be at the right of z , hence X would be contained in \mathbb{N}^* , which yields a contradiction.
- If z is in the right part of B , we can use an argument similar to the one we used to deal with the case $z + X \subset C \cup \Lambda^c$: $(\eta_{D_1}^j 1_{D_1' \setminus D_1})^z$ would be in $V(n - 1, D_1')$, which is impossible because it has a zero at z and $z + \mathcal{P}_{n-1} \subset D_1'$, so by \mathcal{H}_{n-1} there is a contradiction. Indeed, $z + X$ would be contained in D which is disjoint from $D_1' \setminus D_1$, hence the move from $\eta_{D_1}^j 1_{D_1' \setminus D_1}$ to $(\eta_{D_1}^j 1_{D_1' \setminus D_1})^z$ would be legal. Furthermore, $(\eta_{D_1}^j 1_{D_1' \setminus D_1})^z$ would coincide with η^{j+1} on $D_1 \cup B$, hence would contain at most $n - 1$ zeroes, and by (P_4^j) $\eta_{D_1}^j 1_{D_1' \setminus D_1} \in V(n - 1, D_1')$. This would allow us to deduce $(\eta_{D_1}^j 1_{D_1' \setminus D_1})^z \in V(n - 1, D_1')$, which is impossible.

We deduce that $z + X \subset D$ is impossible.

Consequently, $z \in B$ is impossible.

Case $z \in C$.

If $z \in C$, (P_1^{j+1}) is true because $\eta_{\mathcal{P}_{n-1}}^{j+1} = \eta_{\mathcal{P}_{n-1}}^j$, (P_2^{j+1}) is true because $\eta_B^{j+1} = \eta_B^j$, and (P_4^{j+1}) is true because $\eta_{D_1}^{j+1} = \eta_{D_1}^j$. The argument to prove (P_3^{j+1}) is almost the same as the one that yielded $(\eta_C^j 1_{\Lambda \setminus C})^z \in V(n - 1, \Lambda)$ in the case $z \in B$ and $z + X \subset C \cup \Lambda^c$. We observe that as $z \in C$, we have $z + X \subset \Lambda^c \cup C \cup B$, and since (P_2^j) implies $\eta_B^j = 1_B$, we get $z + X \subset \Lambda^c \cup C$, so the move from $\eta_C^j 1_{\Lambda \setminus C}$ to $\eta_C^{j+1} 1_{\Lambda \setminus C}$ is legal. Furthermore, $\eta_C^{j+1} 1_{\Lambda \setminus C}$ contains at most $n - 1$ zeroes, and by (P_3^j) we have $\eta_C^j 1_{\Lambda \setminus C} \in V(n - 1, \Lambda)$. This allows us to conclude that $\eta_C^{j+1} 1_{\Lambda \setminus C} \in V(n - 1, \Lambda)$, which is (P_3^{j+1}) . Consequently, \mathcal{H}'_{j+1} holds.

Case $z \in D$.

If $z \in D$, (P_2^{j+1}) is true because $\eta_B^{j+1} = \eta_B^j$, and (P_3^{j+1}) is true because $\eta_C^{j+1} = \eta_C^j$.

Let us prove (P_1^{j+1}) .

If $z \in D_1$, then $\eta_{\mathcal{P}_{n-1}}^{j+1} = \eta_{\mathcal{P}_{n-1}}^j$, hence (P_1^{j+1}) is true. We now suppose $z \in$

\mathcal{P}_{n-1} . We prove (P_1^{j+1}) using the fact that -1 is a stable direction. Indeed, it implies that X is not contained in \mathbb{N}^* , hence since X cannot contain 0 , it contains an element of $-\mathbb{N}^*$, thus there exists $z' \in z + X$ with $z' < z$. In addition, as $z \in \mathcal{P}_{n-1}$ we have $X \subset D \cup B$, and since by (P_2^j) $\eta_B^j = 1_B$, we get $z + X \subset D$, therefore $z' \in D$. Since $z' < z$, $z' \in \mathcal{P}_{n-1}$, and we have $\eta_{z'}^{j+1} = \eta_{z'}^j = 0$. Consequently $\eta_{\mathcal{P}_{n-1}}^{j+1}$ contains a zero, hence (P_1^{j+1}) is true.

Now let us prove (P_4^{j+1}) .

If $z \in \mathcal{P}_{n-1}$, then $\eta_{D_1}^{j+1} = \eta_{D_1}^j$, hence (P_4^{j+1}) is true. In the case $z \in D_1$, we will prove (P_4^{j+1}) with the arguments that gave $(\eta_{D_1}^j 1_{D_1' \setminus D_1})^z \in V(n-1, D_1')$ in the case $z \in B$ and $z + X \subset D$. Since $z \in D_1$, $z + X \subset D \cup B$, and as (P_2^j) implies $\eta_B^j = 1_B$ we get $z + X \subset D$, thus the move from $\eta_{D_1}^j 1_{D_1' \setminus D_1}$ to $\eta_{D_1}^{j+1} 1_{D_1' \setminus D_1}$ is legal, which allows to prove $\eta_{D_1}^{j+1} 1_{D_1' \setminus D_1} \in V(n-1, D_1')$. Therefore (P_4^{j+1}) is true.

This yields that \mathcal{H}'_{j+1} holds.

To conclude, \mathcal{H}'_{j+1} holds in all cases, which ends the proof of the lemma. \square

1.4 The general case

The reasoning to prove theorem 1.4 in general dimension is the same as in dimension 1. However, the geometry is significantly more complicated, which will force us to introduce new notation.

Let \mathcal{U} be a non supercritical unrooted update family. We will need the

Lemma 1.8. *There exist $u_1, \dots, u_d \in S^{d-1}$ stable directions for \mathcal{U} and a normalized basis $\{v_1, \dots, v_d\}$ of \mathbb{R}^d such that for any $i \in \{1, \dots, d\}$, $\mathbb{H}_{u_i} = \{(x_1, \dots, x_d) \in \mathbb{R}^d \mid x_i > 0\}$ in this basis.*

To construct this basis, one takes v_i orthogonal to all u_j with $j \neq i$. A rigorous proof of the construction may be found in the appendix. From now on, we will use the coordinates of the basis $\{v_1, \dots, v_d\}$, but when we say a site is in \mathbb{Z}^d , we will mean that its coordinates in the canonical basis are integers. For any $i \in \{1, \dots, d\}$, since u_i is a stable direction, there is no update rule contained in \mathbb{H}_{u_i} , hence no update rule such that all sites have a positive i -th coordinate.

We denote again by r the range of the interactions: $r = \max\{\|x - y\|_\infty \mid x, y \in X \cup \{0\}, X \in \mathcal{U}\}$ (beware: the range is now defined in our new basis), and for all $n \in \mathbb{N}$, we set again $a_n = r(2^n - 1)$ and $b_n = rn2^{n-1}$. We now have to define \mathcal{P}_n as follows (see figure 1.3):

$$\mathcal{P}_n = \{s \in \mathbb{Z}^d \mid s = (s_1, \dots, s_d), \forall i \in \{1, \dots, d\}, -a_n \leq s_i \leq b_n\}.$$

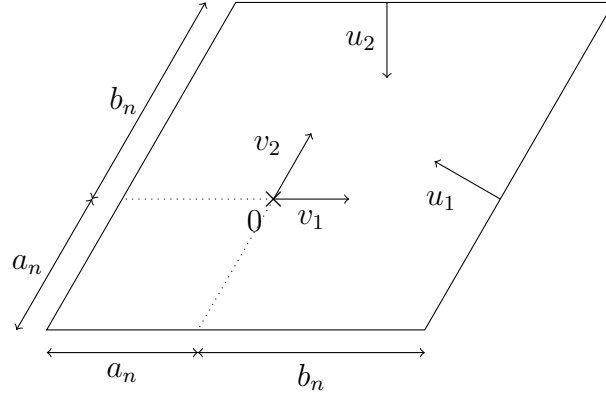
Figure 1.3: \mathcal{P}_n .

We will again prove the theorem by induction: for all $n \in \mathbb{N}$, we denote

$\mathcal{H}_n =$ “for any $\Lambda \subset \mathbb{Z}^d$ such that $\mathcal{P}_n \subset \Lambda$, for any $\eta \in V(n, \Lambda)$, $\eta_0 = 1$ ”.

Proving \mathcal{H}_n for all $n \in \mathbb{N}$ proves theorem 1.4. In order to do that, we need the following equivalent of lemma 1.7:

Lemma 1.9. *Let $n \geq 1$ and suppose \mathcal{H}_{n-1} . Then, for all $\Lambda \subset \mathbb{Z}^d$ such that $\mathcal{P}_n \subset \Lambda$, for all $\eta \in V(n, \Lambda) \setminus \{1_\Lambda\}$, η has at least one zero in $\Lambda \setminus \mathcal{P}_{n-1}$.*

The proof of theorem 1.4 given lemma 1.9 is exactly the same as in the one-dimensional case, therefore it is enough to prove lemma 1.9.

Proof of lemma 1.9. Let $n \geq 1$ and $\Lambda \subset \mathbb{Z}^d$ such that $\mathcal{P}_n \subset \Lambda$.

As in the one-dimensional case, we consider a configuration $\eta \in \{0, 1\}^\Lambda$, different from 1_Λ , containing at most n zeroes, such that all of its zeroes are in \mathcal{P}_{n-1} , and we prove that $\eta \notin V(n, \Lambda)$. As previously, it is enough to let $(\eta^j)_{0 \leq j \leq m}$ be an n -legal path with $\eta^0 = \eta$, and to show that η^m cannot be 1_Λ .

To this end, we denote for all $i \in \{1, \dots, d\}$ (see figure 1.4):

$$D = \{s \in \mathbb{Z}^d \mid s = (s_1, \dots, s_d), \forall j, -a_n + a_{n-1} + r \leq s_j \leq b_n - (b_{n-1} + r)\},$$

$$B = \{s \in \mathbb{Z}^d \mid s = (s_1, \dots, s_d), \forall j, -a_n + a_{n-1} \leq s_j \leq b_n - b_{n-1}\} \setminus D,$$

$$D_i = \{s \in D \mid s = (s_1, \dots, s_d), s_i > b_n - (b_{n-1} + a_{n-1} + r)\},$$

$$D'_i = \{s \in \mathcal{P}_n \mid s = (s_1, \dots, s_d), s_i > b_n - (b_{n-1} + a_{n-1} + r)\}$$

and $C = \Lambda \setminus (B \cup D)$. We also notice that as in dimension 1, $-a_n + a_{n-1} + r = -a_{n-1}$ and $b_n - (b_{n-1} + a_{n-1} + r) = b_{n-1}$, hence

$$\mathcal{P}_{n-1} = \{(s_1, \dots, s_d) \in \mathbb{Z}^d \mid \forall j, -a_n + a_{n-1} + r \leq s_j \leq b_n - (b_{n-1} + a_{n-1} + r)\}$$

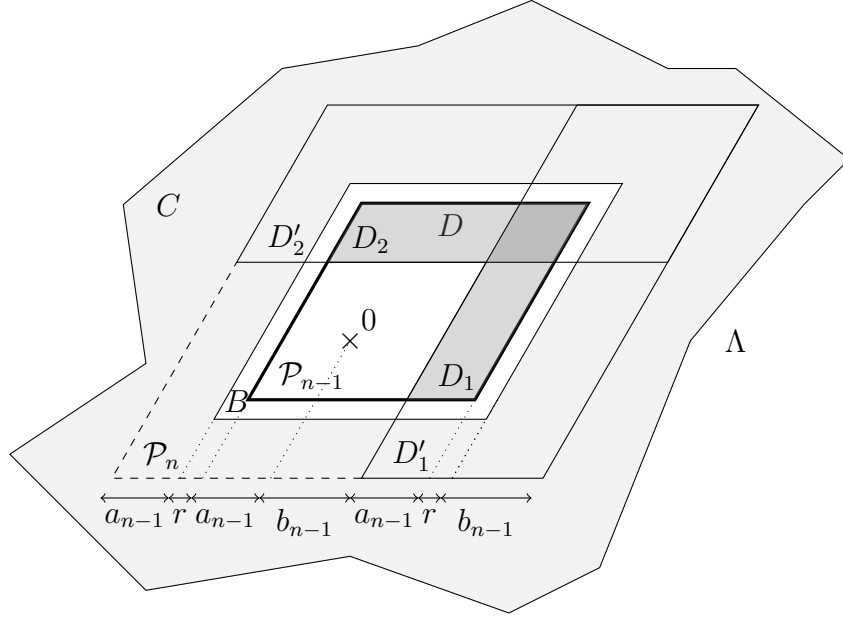

Figure 1.4: The setting of lemma 1.9. C is in light gray, D_1 and D_2 are in darker gray, D is the region with the thick outline.

thus $\mathcal{P}_{n-1} = D \setminus (\bigcup_{i=1}^d D_i)$.

As in the one-dimensional case, B will be a buffer zone preventing the zeroes of C and D from interacting. In that case, the main reason for which no zero could appear in B was that a zero remained trapped in \mathcal{P}_{n-1} , hence there were at most $n - 1$ zeroes elsewhere, and \mathcal{H}_{n-1} limited their possible positions.

Here we cannot keep a zero in \mathcal{P}_{n-1} , but we can keep a zero in all the $D \setminus D_i$. Indeed, initially there is at least a zero in $\mathcal{P}_{n-1} \subset D \setminus D_i$, and at any time, a zero of $D \setminus D_i$ with the lowest i -th coordinate among the zeroes of $D \setminus D_i$ will need an update rule full of zeroes in order to disappear, hence a zero with a i -th coordinate as low as its own because there is no update rule whose sites all have positive i -th coordinate (this is the reason for which we work in the basis $\{v_1, \dots, v_d\}$). This zero cannot be in B since B remains full of ones, hence it is in $D \setminus D_i$ and so remains in $D \setminus D_i$ at the next step of the path. This will have the same practical consequences as the zero trapped in \mathcal{P}_{n-1} had in the one-dimensional case: the presence of a zero in each of the $D \setminus D_i$ prevents η^m from being 1_Λ ; the $n - 1$ zeroes that any of the D_i , or C , may contain will not escape the D_i or C . Moreover, for any $i \in \{1, \dots, d\}$, the argument that in dimension 1 prevented the zeroes of \mathcal{P}_{n-1} from escaping to the left part of B because there were no update rule contained in \mathbb{N}^* will here

prevent zeroes from escaping D via the face with the lowest i -th coordinate to enter B , since there is no update rule whose sites all have positive i -th coordinates. Therefore the buffer zone B will be preserved.

The details of the proof are very similar to those of the proof of lemma 1.7, therefore we only detail the changes.

We have to change the induction hypothesis \mathcal{H}'_j , which becomes:

(P_1^j) For all $i \in \{1, \dots, d\}$, $\eta_{D \setminus D_i}^j$ contains a zero.

(P_2^j) $\eta_B^j = 1_B$.

(P_3^j) $\eta_C^j 1_{\Lambda \setminus C} \in V(n-1, \Lambda)$.

(P_4^j) For all $i \in \{1, \dots, d\}$, $\eta_{D_i}^j 1_{D_i \setminus D_i} \in V(n-1, D_i)$.

When proving the induction, the more complicated geometry forces us to refine the proof of the fact that the case $z \in B$ and $z + X \subset D$ is impossible. Since $z \in B$, if we denote by (z_1, \dots, z_d) the coordinates of z , there would exist $i \in \{1, \dots, d\}$ such that $z_i < -a_n + a_{n-1} + r$ (z is “at the left of B for the i -th coordinate”) or $z_i > b_n - (b_{n-1} + r)$ (z is “at the right of B for the i -th coordinate”).

- If $z_i < -a_n + a_{n-1} + r$, we notice that $z + X \subset D$ would imply that $X \subset \{(x_1, \dots, x_d) \in \mathbb{R}^d \mid x_i > 0\}$, which is impossible because there is no update rule whose sites all have a positive i -th coordinate.
- If $z_i > b_n - (b_{n-1} + r)$, we can use the same argument as in dimension 1 with D_i replacing D_1 , which yields a contradiction.

We deduce a contradiction in both cases, therefore $z + X \subset D$ is indeed impossible.

Finally, the proof of (P_1^{j+1}) when $z \in D$ also deserves a refinement. We set $i \in \{1, \dots, d\}$, let us prove that $\eta_{D \setminus D_i}^{j+1}$ contains a zero. If $z \in D_i$, then $\eta_{D \setminus D_i}^{j+1} = \eta_{D \setminus D_i}^j$, hence by (P_1^j) $\eta_{D \setminus D_i}^{j+1}$ contains a zero. If $z \in D \setminus D_i$, we use the fact that X cannot be contained in $\{(x_1, \dots, x_d) \in \mathbb{R}^d \mid x_i > 0\}$, hence there exists a site $z' \in z + X$ such that the i -th coordinate of z' is less than or equal to the i -th coordinate of z . Moreover, we observe that $z + X \subset D \cup B$, and by (P_2^j) $\eta_B^j = 1_B$, thus $z + X \subset D$, so $z' \in D$. Since the i -th coordinate of z' is less than or equal to the i -th coordinate of z and $z \in D \setminus D_i$, $z' \in D \setminus D_i$. Furthermore, we have $\eta_{z'}^{j+1} = \eta_{z'}^j = 0$. Consequently, $\eta_{D \setminus D_i}^{j+1}$ contains a zero. Therefore $\eta_{D \setminus D_i}^{j+1}$ contains a zero for all $i \in \{1, \dots, d\}$, hence (P_1^{j+1}) is true. \square

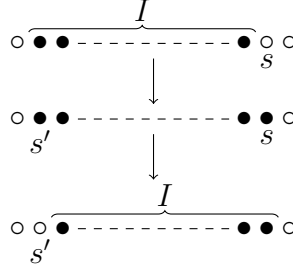

Figure 1.5: A move towards the right of an interval I of zeroes for a one-dimensional supercritical unrooted update family. Zeroes are represented by \bullet and ones by \circ .

1.5 Sketch of the proof of proposition 1.6

For $d = 1$, if \mathcal{U} is a supercritical unrooted family, it has no stable direction, therefore there must be an update rule contained in \mathbb{N}^* and another contained in $-\mathbb{N}^*$. Consequently, as illustrated by figure 1.5, if we have an interval $I \subset \mathbb{Z}$ of zeroes that is sufficiently large, the site s at the right of I can be put at zero with a legal move. Then the site s' at the left of the interval can be put at one by a legal move, and I has moved to the right by one unit. By having I starting from outside the domain (where there are only zeroes) and moving towards the origin in that way, one can put the origin at zero using a bounded number of zeroes, whatever the size of the domain.

For $d = 2$ the mechanism is similar, but requires a more complex construction. In section 5 of [BSU15] (see in particular figure 5 and lemma 5.5 therein), it is proven that if \mathcal{U} is an update family with a semicircle of unstable directions centered on direction u , it is possible to construct a “droplet”: a finite set of zeroes that even if all other sites are at 1, allows us to put more sites at zero in direction u with legal moves, creating a bigger droplet of the same shape, as illustrated on part (a) of figure 1.6. It is the shape of the part of the droplet towards direction u that enables its growth towards this direction. If \mathcal{U} is supercritical unrooted, its stable directions are contained in a hyperplane of \mathbb{R}^2 , which means a straight line, hence there are at most two stable directions, and they must then be opposite. Therefore, there exist two opposite semicircles containing no stable direction, with middles u and $-u$. We can use the construction of [BSU15] to build two droplets, corresponding to the two semicircles, that can grow respectively in the directions u and $-u$ (see part (b) of figure 1.6). Using these two droplets, we can get a combined droplet that can grow in both directions u and $-u$ (part (c) of figure 1.6).

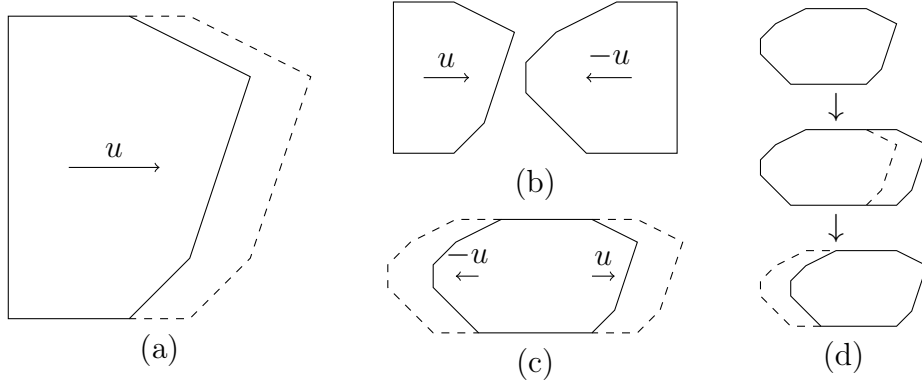

Figure 1.6: The construction of a droplet of zeroes for a two-dimensional supercritical unrooted update family that can move towards u and $-u$. (a) The shape delimited by the solid line is the droplet of [BSU15], that can grow to the shape delimited by the dashed line. (b) The droplets corresponding to the semicircles centered at u and $-u$. (c) The combined droplet. (d) A move of the combined droplet to the right.

Moreover, since our rules allow any change of site state to be reversed, the droplet will also be able to shrink in these directions. Therefore, by having the droplet grow in direction u and shrink in direction $-u$, we can make it move towards direction u (see part (d) of figure 1.6). This allows us to bring it to the origin using a bounded number of zeroes as we did with the interval we had for $d = 1$.

For $d \geq 3$, we expect a similar phenomenon to occur, but we cannot prove it because an equivalent of the construction of [BSU15] is not available yet.

Appendix: proof of lemma 1.8

By assumption, the update family \mathcal{U} is not supercritical unrooted, hence its stable directions are not contained in any hyperplane of \mathbb{R}^d . Therefore, there exist stable directions u_1, \dots, u_d of \mathcal{U} that form a basis of \mathbb{R}^d . For any $u \in S^{d-1}$, we denote \mathcal{H}_u the hyperplane orthogonal to u : $\mathcal{H}_u = \{x \in \mathbb{R}^d \mid \langle x, u \rangle = 0\}$. Then, for any $i \in \{1, \dots, d\}$, $\bigcap_{j \neq i} \mathcal{H}_{u_j}$ is a straight line.² For any $i \in \{1, \dots, d\}$, we define v_i as a unitary vector in $\bigcap_{j \neq i} \mathcal{H}_{u_j}$.

²Indeed, $\bigcap_{j \neq i} \mathcal{H}_{u_j}$ is the intersection of $d - 1$ hyperplanes in \mathbb{R}^d , hence it contains a straight line. Furthermore, $\bigcap_{j \neq i} \mathcal{H}_{u_j}$ is orthogonal to the u_j , $j \neq i$, and since $\{u_1, \dots, u_d\}$ is a basis of \mathbb{R}^d , $\{u_j : j \neq i\}$ generate a vector space of dimension $d - 1$. Therefore $\bigcap_{j \neq i} \mathcal{H}_{u_j}$ is orthogonal to a vector space of dimension $d - 1$. Consequently, it is at most a straight

We are going to show that $\{v_1, \dots, v_d\}$ is a basis of \mathbb{R}^d . For any set of vectors $\{w_1, \dots, w_m\} \subset \mathbb{R}^d$, we denote $\text{Vect}\{w_1, \dots, w_m\}$ the vector space generated by $\{w_1, \dots, w_m\}$. It is enough to prove that $\text{Vect}\{v_1, \dots, v_d\} = \mathbb{R}^d$. In order to do that, we take $v \in \mathbb{R}^d$ a vector orthogonal to $\text{Vect}\{v_1, \dots, v_d\}$. We are going to show that v must be the null vector. For all $i \in \{1, \dots, d\}$, v is orthogonal to v_i . Moreover, the vector space orthogonal to v_i has dimension $d - 1$. Furthermore, $v_i \in \bigcap_{j \neq i} \mathcal{H}_{u_j}$, hence the u_j , $j \neq i$ are orthogonal to v_i . Hence, as the u_j , $j \neq i$ are $d - 1$ linearly independent vectors, the vector space orthogonal to v_i is $\text{Vect}\{u_1, \dots, u_{i-1}, u_{i+1}, \dots, u_d\}$. This implies that v belongs to $\text{Vect}\{u_1, \dots, u_{i-1}, u_{i+1}, \dots, u_d\}$, for any $i \in \{1, \dots, d\}$. As $\{u_1, \dots, u_d\}$ is a basis of \mathbb{R}^d , this yields $v = 0$. Consequently, the vector space orthogonal to $\text{Vect}\{v_1, \dots, v_d\}$ is reduced to $\{0\}$. We deduce $\text{Vect}\{v_1, \dots, v_d\} = \mathbb{R}^d$, thus $\{v_1, \dots, v_d\}$ is a basis of \mathbb{R}^d .

We want a basis such that for any $i \in \{1, \dots, d\}$, $\mathbb{H}_{u_i} = \{(x_1, \dots, x_d) \in \mathbb{R}^d \mid x_i > 0\}$. In $\{v_1, \dots, v_d\}$, $\{(x_1, \dots, x_d) \in \mathbb{R}^d \mid x_i = 0\}$ is generated by the vectors $v_1, \dots, v_{i-1}, v_{i+1}, \dots, v_d$, which are $d - 1$ linearly independent vectors belonging to the hyperplane \mathcal{H}_{u_i} of \mathbb{R}^d , hence they generate \mathcal{H}_{u_i} . This implies $\mathcal{H}_{u_i} = \{(x_1, \dots, x_d) \in \mathbb{R}^d \mid x_i = 0\}$. Therefore, \mathbb{H}_{u_i} is either $\{(x_1, \dots, x_d) \in \mathbb{R}^d \mid x_i > 0\}$ or $\{(x_1, \dots, x_d) \in \mathbb{R}^d \mid x_i < 0\}$. If $\mathbb{H}_{u_i} = \{(x_1, \dots, x_d) \in \mathbb{R}^d \mid x_i < 0\}$, we replace v_i with $-v_i$. Thus we get $\mathbb{H}_{u_i} = \{(x_1, \dots, x_d) \in \mathbb{R}^d \mid x_i > 0\}$.

This method allows us to obtain a basis $\{v_1, \dots, v_d\}$ satisfying that for any $i \in \{1, \dots, d\}$, $\|v_i\|_2 = 1$ and $\mathbb{H}_{u_i} = \{(x_1, \dots, x_d) \in \mathbb{R}^d \mid x_i > 0\}$. \square

Chapter 2

Asymptotics for Duarte and supercritical rooted kinetically constrained models

This chapter corresponds to the article *Exact asymptotics for Duarte and supercritical rooted kinetically constrained models* [MMTar], written in collaboration with Fabio Martinelli and Cristina Toninelli and accepted for publication in *Annals of Probability*.

Kinetically constrained models (KCMs) are a class of interacting particle systems which represent a natural stochastic (and non-monotone) counterpart of the family of cellular automata known as \mathcal{U} -bootstrap percolation. A key issue for KCMs is to identify the divergence of the characteristic time scales when the equilibrium density of empty sites, q , goes to zero. In [MT19, MMT19] a general scheme was devised to determine a sharp upper bound for these time scales. Our paper is devoted to developing a (very different) technique which allows to prove matching lower bounds. We analyse the class of two-dimensional *supercritical rooted KCMs* and the *Duarte KCM*. We prove that the relaxation time and the mean infection time diverge for supercritical rooted KCMs as $e^{\Theta((\log q)^2)}$ and for the Duarte KCM as $e^{\Theta((\log q)^4/q^2)}$ when $q \downarrow 0$. These results prove the conjectures put forward in [Mor17a, MMT19], and establish that the time scales for these KCMs diverge much faster than for the corresponding \mathcal{U} -bootstrap processes, the main reason being the occurrence of energy barriers which determine the dominant behavior for KCMs, but which do not matter for the bootstrap dynamics.

2.1 Introduction

Kinetically constrained models (KCMs) are interacting particle systems on the integer lattice \mathbb{Z}^d , which were introduced in the physics literature in the 1980s in order to model the liquid-glass transition (see e.g. [RS03, GST11] for reviews), a major and still largely open problem in condensed matter physics [BB11]. A generic KCM is a continuous time Markov process of Glauber type characterised by a finite collection of finite subsets of $\mathbb{Z}^d \setminus \{\mathbf{0}\}$, $\mathcal{U} = \{X_1, \dots, X_m\}$, its *update family*. A configuration ω is defined by assigning to each site $x \in \mathbb{Z}^d$ an occupation variable $\omega_x \in \{0, 1\}$, corresponding to an empty or occupied site respectively. Each site $x \in \mathbb{Z}^d$ waits an independent, mean one, exponential time and then, if and only if there exists $X \in \mathcal{U}$ such that $\omega_y = 0$ for all $y \in X + x$, site x is updated to occupied with probability p and to empty with probability $q = 1 - p$. Since each *update set* X_i belongs to $\mathbb{Z}^d \setminus \{\mathbf{0}\}$, the constraints never depend on the state of the to-be-updated site. As a consequence, the dynamics satisfies detailed balance with respect to the product Bernoulli(p) measure, μ , which is therefore a reversible invariant measure. Hence, the process started at μ is stationary.

Both from a physical and from a mathematical point of view, a central issue for KCMs is to determine the speed of divergence of the characteristic time scales when $q \downarrow 0$. Two key quantities are: (i) the *relaxation time* T_{rel} , *i.e.* the inverse of the spectral gap of the Markov generator and (ii) the *mean infection time* $\mathbb{E}_\mu(\tau_0)$, *i.e.* the mean over the stationary process of the first time at which the origin becomes empty. The study of the infection time has been largely addressed for the \mathcal{U} -bootstrap percolation [BDCMSar, BSU15, BBPS16], a class of discrete cellular automata that can be viewed as the monotone deterministic counterpart of KCMs. For the \mathcal{U} -bootstrap, given a set of “infected” sites $A_t \subset \mathbb{Z}^d$ at time t , infected sites remain infected, and a site x becomes infected at time $t + 1$ if the translate by x of one of the update sets in \mathcal{U} belongs to A_t . Thus, if infected (non infected) sites are regarded as empty (respectively occupied) sites, the constraint that has to be satisfied to infect a site for the \mathcal{U} -bootstrap is the same that is required to update the occupation variable for the KCM.

In [MMT19] two of the authors together with R. Morris addressed the problem of identifying the divergence of time scales for two-dimensional KCMs. The first goal of [MMT19] was to identify the correct universality classes, which turn out to be different from those of \mathcal{U} -bootstrap percolation. Then, building on a strategy developed in [MT19] by two of the authors, universal upper bounds on the relaxation and mean infection time within each class were proven and were conjectured to be sharp up to logarithmic corrections [MMT19]. On the other hand, concerning lower bounds, so far

the best general result is

$$T_{\text{rel}} \geq q\mathbb{E}_\mu(\tau_0) = \Omega(T) \quad (2.1)$$

where T denotes the median infection time for the \mathcal{U} -bootstrap process started with distribution μ (*i.e.* sites are initially infected independently with probability q), see the lemma 4.3 of [MT19]. However this lower bound is in general far from optimal. Consider for example the *one-dimensional East model* [JE91] (and [FMRT13] for a review) for which a site can be updated if and only if its left neighbor is empty, namely $\mathcal{U} = \{-\vec{e}_1\}$. As $q \downarrow 0$, it holds

$$\mathbb{E}_\mu^{\text{East}}(\tau_0) = e^{\Theta((\log q)^2)} \quad (2.2)$$

and the scaling holds for T_{rel} , see [CFM14, AD02, CMRT08] where the sharp value of the constant has been determined. This divergence is much faster than for the corresponding \mathcal{U} -bootstrap model, for which it holds $T = \Theta(1/q)$. To understand this difference it is necessary to recall a key combinatorial result ([SE03], Fact 1 of [CDG01]): in order to empty the origin the East process has to go through a configuration with $\lceil \log_2(\ell + 1) \rceil$ simultaneous empty sites in $(-\ell, 0]$, where $-\ell$ is the position of the rightmost empty site on $(-\infty, 0]$. This logarithmic “energy barrier” (to employ the physics jargon) and the fact that at equilibrium typically $\ell \sim 1/q$ yield a divergence of the time scale as $q^{\Theta(\log q)} = e^{\Theta((\log q)^2)}$. In turn, this peculiar scaling is the reason why the East model has been extensively studied by physicists (see [KGC13] and references therein). Indeed, if we set $q := e^{-\beta}$ with β the inverse temperature, we get the so called *super-Arrhenius* divergence $e^{\Theta(\beta^2)}$ which provides a very good fit of the experimental curves for fragile supercooled liquids near the liquid-glass transition [BB11].

In [Mor17a], together with R. Morris, we conjectured that one of the universality classes of two-dimensional KCMs, that we call *supercritical rooted models*, features time scales diverging as for the East model. Our first main result (theorem 2.6) is to establish a lower bound which allows together with the upper bound of the theorem 1 of [MMT19] to prove this conjecture¹, namely we prove

$$\mathbb{E}_\mu^{\mathcal{U}}(\tau_0) = e^{\Theta((\log q)^2)} \quad \forall \mathcal{U} \text{ in the supercritical rooted class}$$

and the same result for T_{rel} . As for the East model, this divergence is much faster than for the corresponding \mathcal{U} -bootstrap process which scales as $T = 1/q^{\Theta(1)}$ [BSU15]. A key input for our theorem 2.6 is a combinatorial result proved by one of the authors in [Mar17]² (see also lemma 2.9 in this pa-

¹Actually, the conjecture in [Mor17a] states that $\tau_0 = e^{\Theta((\log q)^2)}$ with high probability when $q \rightarrow 0$. As explained in remark 2.10, we can also prove this stronger result.

²Chapter 1 of this thesis.

per) which considerably generalises to a higher dimensional and non oriented setting the above recalled combinatorial result for East ³.

The \mathcal{U} -bootstrap results identify another universality class, the so called *critical update families*, which display a much faster divergence. In particular, in [BDCMSar] it was proven that for this class it holds $T = e^{\Theta((\log)^c/q^\alpha)}$ with α a model dependent positive integer and $c = 0$ or $c = 2$. In [MMT19], together with R. Morris, we analysed KCMs with critical update families and we put forward the conjecture that both T_{rel} and $\mathbb{E}_\mu(\tau_0)$ diverge as $e^{\Theta((\log)^{c'}/q^\nu)}$ with ν model dependent and in general different from the exponent α of the corresponding \mathcal{U} -bootstrap process. In [MMT19] we develop a technique to establish sharp upper bounds for these time scales. A matching lower bound exists only for the special class of models for which the general lower bound (2.1) is sharp, which include for example the 2-neighbour model. Here we focus on the most studied update family which does not belong to this special case, the *Duarte update family*, which consists of all the 2-subsets of the North, South and West neighbors of the origin [Dua89]. Our second main result is a sharp lower bound on the infection and relaxation time for the Duarte KCM (theorem 2.11) that, together with the upper bound of theorem 2 of [MMT19], establishes the scaling

$$\mathbb{E}_\mu^{\text{Duarte}}(\tau_0) = e^{\Theta((\log q)^4/q^2)}$$

as $q \downarrow 0$, and the same result holds for T_{rel} . Notice that we identify also the exact power in the logarithmic correction. Finally, notice that the divergence is again much faster than for the corresponding \mathcal{U} -bootstrap model. Indeed, the median of the infection time for the \mathcal{U} -bootstrap Duarte model diverges as $T = e^{\Theta((\log q)^2/q)}$ when $q \downarrow 0$ [Mou95].

Both for Duarte and for supercritical rooted models, the sharper divergence of time scales for KCMs is due to the fact that the infection time is not well approximated by the minimal number of updates needed to infect the origin (as it is for bootstrap percolation), but it is instead the result of a much more complex infection/healing mechanism. In particular, visiting regions of the configuration space with an anomalous amount of infection is heavily penalised and requires a very long time to actually take place ⁴. The basic underlying idea is that the dominant relaxation mechanism is an

³The result in [Mar17] holds also in $d > 2$ on a properly defined class, *i.e.* all models which are not supercritical *unrooted* (see [Mar17] for the precise definition). Our argument immediately extends to this higher dimensional setting yielding the same lower bound as in theorem 2.6 for T_{rel} and $\mathbb{E}_\mu(\tau_0)$.

⁴Borrowing again from physics jargon we could say that “crossing the energy barriers” is heavily penalised.

East-like dynamics for large *droplets* of empty sites. For supercritical rooted models these droplets have a finite (model dependent) size, hence an equilibrium density $q_{\text{eff}} = q^{\Theta(1)}$. For the Duarte model droplets have a size that diverges as $\ell = \frac{\lfloor \log q \rfloor}{q}$ and thus an equilibrium density $q_{\text{eff}} = q^\ell = e^{-(\log q)^2/q}$. Then a (very) rough understanding of our results is obtained by replacing q with q_{eff} in the result for the East model (2.2). One of the key technical difficulties to translate this intuition into a lower bound is that the droplets cannot be identified with a rigid structure, at variance with the East model where the droplets are single empty sites.

2.2 Models and notation

2.2.1 Notation

For the reader's convenience we gather here some of the notation that we use throughout the paper. We will work on the probability space (Ω, μ) , where $\Omega = \{0, 1\}^{\mathbb{Z}^2}$ and μ is the product Bernoulli(p) measure, and we will be interested in the asymptotic regime $q \downarrow 0$, where $q = 1 - p$. Given $\omega \in \Omega$ and $\Lambda \subset \mathbb{Z}^2$, we will often write ω_Λ or $\omega \upharpoonright_\Lambda$ for the collection $\{\omega_x\}_{x \in \Lambda}$ and we shall write $\omega_\Lambda \equiv 0$ to indicate that $\omega_x = 0 \forall x \in \Lambda$. In this case we shall also say that Λ is empty or infected. Similarly for $\omega_\Lambda \equiv 1$ and in this case Λ will be said to be occupied or healthy. We shall write $Y(\omega)$ for the set $\{x \in \mathbb{Z}^2 : \omega_x = 0\}$ and we shall say that $f: \Omega \mapsto \mathbb{R}$ is a *local function* if it depends on finitely many variables $\{\omega_x\}_{x \in \mathbb{Z}^2}$. Given a site $x \in \mathbb{Z}^2$ of the form $x = (a, b)$ with $a, b \in \mathbb{Z}$, we shall sometimes refer to b as the height of x . We shall also refer to a set $I \subset \mathbb{Z}^2$ of the form $I = \{x, x + \vec{e}_i, \dots, x + (n-1)\vec{e}_i\}, x \in \mathbb{Z}^2$, as a (horizontal or vertical) interval of length $n \in \mathbb{N}^*$. Here \vec{e}_1, \vec{e}_2 denote as usual the basis vectors in \mathbb{R}^2 . Finally, we will use the standard notation $[n]$ for the set $\{1, \dots, n\}$.

Throughout this paper we will often make use of standard asymptotic notation. If f and g are positive real-valued functions of $q \in (0, 1)$, then we will write $f = O(g)$ if there exists a constant $C > 0$ such that $f(q) \leq Cg(q)$ for every sufficiently small $q > 0$. We will also write $f = \Omega(g)$ if $g = O(f)$ and $f = \Theta(g)$ if $f = O(g)$ and $g = O(f)$. All constants, including those implied by the notation $O(\cdot)$, $\Omega(\cdot)$ and $\Theta(\cdot)$, will be such with respect to the parameter q .

2.2.2 Models

Fix an *update family* $\mathcal{U} = \{X_1, \dots, X_m\}$, that is, a finite collection of finite nonempty subsets of $\mathbb{Z}^2 \setminus \{\mathbf{0}\}$. Then the KCM with update family \mathcal{U} is the Markov process on Ω associated to the Markov generator

$$(\mathcal{L}f)(\omega) = \sum_{x \in \mathbb{Z}^2} c_x(\omega) (\mu_x(f) - f)(\omega),$$

where $f: \Omega \mapsto \mathbb{R}$ is a local function, $\mu_x(f)$ denotes the average of f with respect to the variable ω_x , and c_x is the indicator function of the event that there exists $X \in \mathcal{U}$ such that $X + x$ is infected *i.e.* $\omega_{X+x} \equiv 0$. In the sequel we will sometimes say that ω satisfies the update rule at x if $c_x(\omega) = 1$.

Informally, this process can be described as follows. Each vertex $x \in \mathbb{Z}^2$, with rate one and independently across \mathbb{Z}^2 , is resampled from $(\{0, 1\}, \text{Ber}(p))$ if and only if the update rule at x was satisfied by the current configuration. In what follows, we will sometimes call such resampling a *legal update* or *legal spin flip*. The general theory of interacting particle systems (see [Lig85]) proves that \mathcal{L} becomes the generator of a reversible Markov process $\{\omega(t)\}_{t \geq 0}$ on Ω , with reversible measure μ . The corresponding Dirichlet form is

$$\mathcal{D}(f) = \sum_{x \in \mathbb{Z}^2} \mu(c_x \text{Var}_x(f)),$$

where $\text{Var}_x(f)$ denotes the variance of the local function f with respect to the variable ω_x conditionally on $\{\omega_y\}_{y \neq x}$. If ν is a probability measure on Ω , the law of the process with initial distribution ν will be denoted by $\mathbb{P}_\nu(\cdot)$ and the corresponding expectation by $\mathbb{E}_\nu(\cdot)$. If ν is concentrated on a single configuration ω we will simply write $\mathbb{P}_\omega(\cdot)$ and $\mathbb{E}_\omega(\cdot)$.

Given a KCM, and therefore an update family \mathcal{U} , the corresponding *\mathcal{U} -bootstrap process* on \mathbb{Z}^2 is defined as follows: given a set $Y \subset \mathbb{Z}^2$ of initially *infected* sites, set $Y(0) = Y$, and define for each $t \geq 0$,

$$Y(t+1) = Y(t) \cup \{x \in \mathbb{Z}^2 : X+x \subseteq Y(t) \text{ for some } X \in \mathcal{U}\}.$$

The set $Y(t)$ will represent the set of infected sites at time t and we write $[Y] = \bigcup_{t \geq 0} Y(t)$ for the *closure* of Y under the \mathcal{U} -bootstrap process. We will also call T the median of the first infection time of the origin when the process is started with sites independently infected (healthy) with probability q (respectively $p = 1 - q$).

2.3 A variational lower bound for $\mathbb{E}_\mu(\tau_0)$

As mentioned in the introduction, our main goal is to prove sharp lower bounds for the characteristic time scales of supercritical rooted KCMS and of

the Duarte KCM. Let us start by defining precisely these time scales, namely the relaxation time T_{rel} (or inverse of the spectral gap) and the mean infection time $\mathbb{E}_\mu(\tau_0)$.

Definition 2.1 (Relaxation time T_{rel}). Given an update family \mathcal{U} and $q \in [0, 1]$, we say that $C > 0$ is a Poincaré constant for the corresponding KCM if, for all local functions f , we have

$$\text{Var}_\mu(f) \leq C \mathcal{D}(f).$$

If there exists a finite Poincaré constant we then define

$$T_{\text{rel}}(q, \mathcal{U}) := \inf \{C > 0 : C \text{ is a Poincaré constant}\}.$$

Otherwise we say that the relaxation time is infinite. We will drop the (q, \mathcal{U}) notation setting $T_{\text{rel}} := T_{\text{rel}}(q, \mathcal{U})$ when confusion does not arise.

A finite relaxation time implies that the reversible measure μ is mixing for the semigroup $P_t = e^{t\mathcal{L}}$ with exponentially decaying time auto-correlations [Lig85].

Definition 2.2 (Mean infection time $\mathbb{E}_\mu(\tau_0)$). Let $A = \{\omega \in \Omega : \omega_0 = 0\}$. Then

$$\tau_0 = \inf \{t \geq 0 : \omega(t) \in A\}.$$

Given an update family \mathcal{U} and $q \in [0, 1]$, we let $\mathbb{E}_\mu^{q, \mathcal{U}}(\tau_0)$ be the mean of the infection time of the origin under the corresponding stationary KCM (*i.e.* when the initial configuration is distributed with Bernoulli($1 - q$)). We will drop the (q, \mathcal{U}) notation setting $\mathbb{E}_\mu(\tau_0) := \mathbb{E}_\mu^{q, \mathcal{U}}(\tau_0)$ when confusion does not arise.

In the physics literature the hitting time τ_0 is closely related to the *persistence time*, *i.e.* the first time that there is a legal update at the origin. All our lower bounds can be easily extended to the persistence time.

It is known that the following inequality holds (its proof can be found in section 2.2 of [MMT19]):

$$\mathbb{E}_\mu(\tau_0) \leq \frac{T_{\text{rel}}(q, \mathcal{U})}{q} \quad \forall q \in (0, 1). \quad (2.3)$$

Therefore we will focus on obtaining lower bounds on $\mathbb{E}_\mu(\tau_0)$ and then use (2.3) to derive the results for T_{rel} (indeed the correction q in the above inequality is largely subdominant with respect to the lower bounds we will obtain). To this aim we establish a variational lower bound on $\mathbb{E}_\mu(\tau_0)$ (lemma 2.3),

which will be our first tool. Recall that $A = \{\omega \in \Omega : \omega_0 = 0\}$ and let H_A be the Hilbert space $\{f \in L^2(\Omega, \mu) : f|_A = 0\}$ with scalar product inherited from the standard one in $L^2(\Omega, \mu)$. Let also \mathcal{L}_A be the negative self-adjoint operator on H_A , whose action on local functions is given by

$$\mathcal{L}_A f(\omega) = \mathbf{1}_{A^c}(\omega) \mathcal{L} f(\omega).$$

It turns out (see e.g. section 3 of [ADP01]) that, for any local function $f \in H_A$ and any $\omega \in A^c$,

$$\mathbb{E}_\omega (f(\omega(t)) \mathbf{1}_{\{\tau_0 > t\}}) = e^{t\mathcal{L}_A} f(\omega).$$

In particular, by choosing $f = \mathbf{1}_{A^c}(\cdot)$, one gets

$$\mathbb{P}_\mu(\tau_0 > t) = \int d\mu(\omega) \mathbf{1}_{A^c}(\omega) e^{t\mathcal{L}_A} \mathbf{1}_{A^c}(\omega) = \langle \mathbf{1}_{A^c}, e^{t\mathcal{L}_A} \mathbf{1}_{A^c} \rangle,$$

where $\langle \cdot, \cdot \rangle$ denotes the scalar product on $L^2(\Omega, \mu)$. Thus

$$\mathbb{E}_\mu(\tau_0) = \int_0^\infty dt \langle \mathbf{1}_{A^c}, e^{t\mathcal{L}_A} \mathbf{1}_{A^c} \rangle \geq \int_0^T dt \langle \mathbf{1}_{A^c}, e^{t\mathcal{L}_A} \mathbf{1}_{A^c} \rangle \quad \forall T > 0. \quad (2.4)$$

Lemma 2.3. *Let $\phi \in H_A$ be a local function such that $\mu(\phi^2) = 1$. Then*

$$\mathbb{E}_\mu(\tau_0) \geq T |\mu(\phi)| \left(|\mu(\phi)| e^{-T\mathcal{D}(\phi)} - (T\mathcal{D}(\phi))^{1/2} \right), \quad \forall T > 0.$$

Proof. Let $\phi \in H_A$ be as in the statement and write

$$\mathbf{1}_{A^c} = \alpha\phi + \psi,$$

where $\alpha = \langle \mathbf{1}_{A^c}, \phi \rangle = \mu(\phi)$ and $\langle \phi, \psi \rangle = 0$. Clearly $\langle \psi, \psi \rangle = \mu(A^c) - \alpha^2$. We claim that, for any $T > 0$ and any $t \in [0, T]$,

$$\langle \mathbf{1}_{A^c}, e^{t\mathcal{L}_A} \mathbf{1}_{A^c} \rangle \geq \alpha^2 e^{-T\mathcal{D}(\phi)} - 2|\alpha| (T\mathcal{D}(\phi))^{1/2},$$

which, combined with (2.4), proves the lemma. To prove the claim we write

$$\begin{aligned} \langle \mathbf{1}_{A^c}, e^{t\mathcal{L}_A} \mathbf{1}_{A^c} \rangle &\geq \alpha^2 \langle \phi, e^{t\mathcal{L}_A} \phi \rangle - 2|\alpha| |\langle \psi, e^{t\mathcal{L}_A} \phi \rangle| \\ &= \alpha^2 \langle \phi, e^{t\mathcal{L}_A} \phi \rangle - 2|\alpha| |\langle \psi, (\mathbb{I} - e^{t\mathcal{L}_A}) \phi \rangle| \\ &\geq \alpha^2 \langle \phi, e^{t\mathcal{L}_A} \phi \rangle - 2|\alpha| \langle \phi, (\mathbb{I} - e^{t\mathcal{L}_A})^2 \phi \rangle^{1/2}. \end{aligned} \quad (2.5)$$

Above we discarded the non-negative term $\langle \psi, e^{t\mathcal{L}_A} \psi \rangle$ in the first line, we used $\langle \phi, \psi \rangle = 0$ in the second line and appealed to the Cauchy-Schwarz inequality together with $\langle \psi, \psi \rangle \leq 1$ in the third line. Let now $\pi(d\lambda)$ be the spectral measure of $-\mathcal{L}_A$ associated to ϕ (see e.g. Chapter VII of [RS73]).

Since $\mu(\phi^2) = 1$, $\pi(d\lambda)$ is a probability measure on $[0, +\infty)$. The functional calculus theorem, together with the Jensen inequality and $(1 - e^{-t\lambda})^2 \leq t\lambda$, implies that for any $t \in [0, T]$

$$\begin{aligned} \text{r.h.s. (2.5)} &= \alpha^2 \int_0^\infty d\pi(\lambda) e^{-t\lambda} - 2|\alpha| \left(\int_0^\infty d\pi(\lambda) (1 - e^{-t\lambda})^2 \right)^{1/2} \\ &\geq \alpha^2 e^{-t\mathcal{D}_A(\phi)} - 2|\alpha| (t\mathcal{D}_A(\phi))^{1/2} \\ &\geq \alpha^2 e^{-T\mathcal{D}(\phi)} - 2|\alpha| (T\mathcal{D}(\phi))^{1/2}, \end{aligned}$$

where $\mathcal{D}_A(\phi) = \langle \phi, -\mathcal{L}_A \phi \rangle = \langle \phi, -\mathcal{L} \phi \rangle = \mathcal{D}(\phi)$ because ϕ is a local function in H_A . The claim is proved. \square

The main strategy to take advantage of lemma 2.3 for q very small is to look for a family of local functions $\{\phi_q\}$ in H_A , normalised in such a way that $\mu(\phi_q^2) = 1$, determining a sharp lower bound when inserted in the inequality of lemma 2.3 with a proper choice of T . More precisely we will use the following easy corollary of lemma 2.3:

Corollary 2.4 (Proxy functions). *For any family of local functions $\{\phi_q\}$ in H_A with $\mu(\phi_q^2) = 1$, it holds*

$$\mathbb{E}_\mu(\tau_0) = \Omega \left(\mu(\phi_q)^4 / \mathcal{D}(\phi_q) \right). \quad (2.6)$$

Proof. The result follows immediately using lemma 2.3 and choosing $T \equiv T(q) = |\mu(\phi_q)|^2 / (16\mathcal{D}(\phi_q))$. \square

Any function $\phi = \phi_q$ with the above properties will be called a *test* or *proxy* function and, in the rest of the paper, we will focus on constructing an efficient test function for the so called *supercritical rooted KCMs* and for the *Duarte KCM*.

2.4 Supercritical rooted KCMs

In order to define the class of *supercritical rooted* update families we should begin by recalling the key geometrical notion of *stable directions* introduced in [BSU15]. Given a unit vector $u \in S^1$, let $\mathbb{H}_u := \{x \in \mathbb{Z}^2 : \langle x, u \rangle < 0\}$ denote the discrete half-plane whose boundary is perpendicular to u . Then, for a given update family \mathcal{U} , the set of stable directions is

$$\mathcal{S} = \mathcal{S}(\mathcal{U}) = \{u \in S^1 : [\mathbb{H}_u] = \mathbb{H}_u\}.$$

The update family \mathcal{U} is *supercritical* if there exists an open semicircle in S^1 that is disjoint from \mathcal{S} . In [BSU15] it was proven that for each supercritical

update family the median of the infection time of the \mathcal{U} -bootstrap process diverges as $1/q^{\Theta(1)}$. In [Mor17a], the author R. Morris, together with two of us, conjectured that not all supercritical update families give rise to the same scaling for KCMS and that the supercritical class should be refined into two subclasses to capture the KCMS scaling as follows.

Definition 2.5. A supercritical two-dimensional update family \mathcal{U} is said to be *supercritical rooted* if there exist two non-opposite stable directions in S^1 . Otherwise it is called *supercritical unrooted*.

An example of supercritical rooted family is the two-dimensional East model, with update family $\mathcal{U} = \{\{-\vec{e}_1\}, \{-\vec{e}_2\}\}$ ⁵. In [MMT19] it was proved that $\mathbb{E}_\mu(\tau_0)$ and T_{rel} diverge as an inverse power of q as $q \rightarrow 0$ in the supercritical *unrooted* case, while in the *rooted* case it satisfies (see theorem 1 (b) of [MMT19])

$$T_{\text{rel}} \leq e^{O((\log q)^2)}$$

and, thanks to (2.3), the same bound holds for $\mathbb{E}_\mu(\tau_0)$. Here we prove a matching lower bound in the rooted case.

Theorem 2.6. *Let \mathcal{U} be a two-dimensional supercritical rooted update family. Then*

$$\mathbb{E}_\mu(\tau_0) \geq e^{\Omega((\log q)^2)} \quad \text{as } q \rightarrow 0.$$

Thus we prove

Corollary 2.7. *Let \mathcal{U} be a two-dimensional supercritical rooted update family. Then*

$$T_{\text{rel}}(q, \mathcal{U}) = e^{\Theta((\log q)^2)} \quad \text{as } q \rightarrow 0.$$

and the same result holds for $\mathbb{E}_\mu(\tau_0)$.

Proof of the corollary. The lower bound follows at once from (2.3) and theorem 2.6. The upper bound was proved by the theorem 1 (b) of [MMT19]. \square

In order to prove theorem 2.6 we will use the variational lower bound of section 2.3 and more precisely look for a proxy function $\phi \equiv \phi_q$ satisfying the hypotheses of corollary 2.4. We first need to introduce the notion of a legal path in Ω .

⁵We stress that the supercritical rooted class contains also update families which do not share the special ‘‘orientation’’ property of the East model, namely the fact that all X_i belong to a half-plane. For example, it is easy to verify that the non oriented update family $\mathcal{U} = \{\{-\vec{e}_1\}, \{-\vec{e}_2\}, \{(\vec{e}_1, \vec{e}_2)\}\}$ has exactly two stable directions, $-\vec{e}_1$ and $-\vec{e}_2$ and, according to our definition 2.5, it is supercritical rooted.

Definition 2.8 (Legal path). Fix an update family \mathcal{U} , then a legal path γ in Ω is a finite sequence $\gamma = (\omega^{(0)}, \dots, \omega^{(n)})$ such that, for each $i \in [n]$, the configurations $\omega^{(i-1)}, \omega^{(i)}$ differ by a legal (with respect to the choice of \mathcal{U}) spin flip at some vertex $v \equiv v(\omega^{(i-1)}, \omega^{(i)})$. A generic ordered (along γ) pair of consecutive configurations in γ will be called an *edge*. Given a set $\hat{\Omega} \subset \Omega$ and a configuration ω , we say that there exists a legal path connecting $\hat{\Omega}$ to ω if there exists a legal path $\gamma = (\omega^{(0)}, \dots, \omega^{(n)})$ such that $\omega^{(0)} \in \hat{\Omega}$ and $\omega^{(n)} = \omega$.

Let \mathcal{U} be a supercritical rooted update family and, for $n \geq 1$ and $\kappa \in \mathbb{N}^*$, let $\Lambda_n := \Lambda_n(\kappa) \subset \mathbb{Z}^2$ be the square centered at the origin, of cardinality $(\kappa n 2^n + 1)^2$. Let also

$$\mathcal{A}_n = \{\omega \in \Omega : (\omega_{\Lambda_n}, \tilde{\omega}_{\Lambda_n^c} \equiv 0) \text{ can be reached from } (\hat{\omega}_{\Lambda_n} \equiv 1, \hat{\omega}_{\Lambda_n^c} \equiv 0) \text{ by a legal path } \gamma \text{ such that any } \omega' \in \gamma \text{ has at most } n-1 \text{ empty vertices in } \Lambda_n\}. \quad (2.7)$$

Recall that $A = \{\omega \in \Omega : \omega_0 = 0\}$. In [Mar17] one of the authors established the following key combinatorial result concerning the structure of the set \mathcal{A}_n :

Lemma 2.9 (Theorem 1 of [Mar17]). *There exists $\kappa_0 = \kappa_0(\mathcal{U}) > 0$ such that, for any $\kappa \geq \kappa_0$ and any $n \in \mathbb{N}^*$,*

$$\mathcal{A}_n \cap A = \emptyset.$$

Lemma 2.9 implies that if $\kappa \geq \kappa_0$, the KCM process started from any configuration with no infection inside the region Λ_n , in order to infect the origin has to leave the set \mathcal{A}_n by going through its boundary set $\partial\mathcal{A}_n$ (see the proof below for a precise definition of this set). In turn, the latter is a subset of

$$\{\omega \in \Omega : \exists \text{ at least } n-1 \text{ infected vertices in } \Lambda_n\}.$$

We will therefore chose a scale n such that $2^n \simeq 1/q^\varepsilon$, namely with high probability with respect to the reversible measure μ there are initially no infected vertices inside Λ_n . Thus, starting from the (likely) event of no infection inside the region Λ_n , in order to infect the origin the process has to go through $\partial\mathcal{A}_n$ which has an anomalous amount, $\Theta(\log q)$, of empty sites. This mechanism, which in the physics jargon would correspond to “crossing an energy barrier” which grows logarithmically in q , is at the root of the scaling $e^{\Theta((\log q)^2)}$. Let us proceed to a proof of this result, namely to the proof of theorem 2.6.

Proof of theorem 2.6. Fix $\varepsilon < 1/2$ and choose $n := n(\varepsilon, q) = \lfloor \varepsilon \log_2(1/q) \rfloor$. Then let

$$\phi(\cdot) := \phi_q(\cdot) = \mathbb{1}_{\mathcal{A}_{\varepsilon, q}}(\cdot) / \mu(\mathcal{A}_{\varepsilon, q})^{1/2}$$

where $\mathcal{A}_{\varepsilon, q} := \mathcal{A}_{n(\varepsilon, q)}$ with \mathcal{A}_n defined in (2.7) and the constant κ that enters in this definition chosen larger than the value κ_0 of lemma 2.9. Then lemma 2.9 implies immediately that $\phi \in H_A$. Moreover, using $\varepsilon < 1/2$ we get

$$\mu(\phi) = \mu(\mathcal{A}_{\varepsilon, q})^{1/2} \geq (1 - q)^{|\Lambda_n|/2} = 1 - o(1),$$

because any configuration identically equal to one in Λ_n belongs to $\mathcal{A}_{\varepsilon, q}$ and $2^{2n} = O(1/q^{2\varepsilon})$. Finally, if

$$\partial\mathcal{A}_{\varepsilon, q} := \{\omega \in \mathcal{A}_{\varepsilon, q} : \exists x \in \Lambda_n \text{ with } c_x(\omega) = 1 \text{ and } \omega^x \notin \mathcal{A}_{\varepsilon, q}\},$$

one easily checks (see e.g. section 3.5 of [CFM16]) that

$$\begin{aligned} \mathcal{D}(\phi) &\leq |\Lambda_n| \mu(\partial\mathcal{A}_{\varepsilon, q}) / \mu(\mathcal{A}_{\varepsilon, q}) \leq |\Lambda_n| \mu(\exists n-1 \text{ zeros in } \Lambda_n) / \mu(\mathcal{A}_{\varepsilon, q}) \\ &\leq O(|\Lambda_n|^n) q^{n-1} = e^{-\Omega((\log q)^2)}, \end{aligned}$$

Thus ϕ satisfies all the hypotheses of corollary 2.4 and the result follows. \square

Remark 2.10. In [Mor17a] it was conjectured that $\tau_0 = e^{\Theta((\log q)^2)}$ with high probability as $q \rightarrow 0$ holds (conjecture 2.7). Actually, we can also prove this stronger result. One bound immediately follows using Markov inequality and our result for the mean, corollary 2.7. The other bound follows by using the fact that (i) the set $\mathcal{A}_{\varepsilon, q}$ has μ -probability $1 - o(1)$ (see the above proof of theorem 2.6) and (ii) the probability of infecting the origin before $e^{\Theta((\log q)^2)}$ starting in $\mathcal{A}_{\varepsilon, q}$ goes to zero as $q \downarrow 0$. The latter result is easily obtained by a union bound on times which yields that the probability to leave $\mathcal{A}_{\varepsilon, q}$ before $e^{\Theta((\log q)^2)}$ (and therefore to infect the origin, thanks to lemma 2.9), goes to zero.

2.5 The Duarte KCM

In this section we analyse the mean infection time for the Duarte KCM. For this model the update family \mathcal{U} consists of the 2-subsets of the North, South and West neighbors of the origin [Dua89]. The infection time for the Duarte bootstrap process is known to scale as $e^{\Theta((\log q)^2/q)}$ [Mou95] (see also [BDCMS17] for sharp results on the critical probability). Concerning the Duarte KCM, in [MMT19] (theorem 2) it was proved that

$$T_{\text{rel}}(q, \mathcal{U}) \leq e^{O((\log q)^4/q^2)} \quad \text{as } q \rightarrow 0.$$

and, thanks to (2.3), the same result holds for $\mathbb{E}_\mu(\tau_0)$. Here we establish a matching lower bound.

Theorem 2.11. *Consider the Duarte KCM. Then*

$$\mathbb{E}_\mu(\tau_0) \geq e^{\Omega((\log q)^4/q^2)} \quad \text{as } q \rightarrow 0.$$

Using (2.3), theorem 2.11 and theorem 2 of [MMT19] we get immediately the following corollary.

Corollary 2.12. *For the Duarte KCM it holds*

$$T_{\text{rel}}(q, \mathcal{U}) = e^{\Theta((\log q)^4/q^2)} \quad \text{as } q \rightarrow 0.$$

and the same result for $\mathbb{E}_\mu(\tau_0)$.

Our result provides the first example of critical α -rooted KCM for which the conjecture for the divergence of time scales that we put forward in [MMT19] (conjecture 3 (a)) together with R. Morris can be proven. Indeed, as explained in [MMT19], the Duarte model is a 1-rooted model and the exponent 2 that we obtain is in agreement with conjecture 3 (a) of [MMT19]. In order to prove theorem 2.11 we will start by the variational lower bound of section 2.3, as for the supercritical rooted class. However, defining the analog of the set \mathcal{A}_n together with the test function ϕ satisfying the hypotheses of corollary 2.4 is much more involved and it requires a subtle algorithmic construction. Before explaining our construction it is useful to make some simple observations on how infection propagates in the Duarte bootstrap process.

2.5.1 Preliminary tools: the Duarte bootstrap process

Given $\Lambda \subset \mathbb{Z}^2$ we write $\partial\Lambda := \partial_{\parallel}\Lambda \cup \partial_{\perp}\Lambda$, where

$$\begin{aligned} \partial_{\parallel}\Lambda &= \{y \in \Lambda^c : y + \vec{e}_1 \in \Lambda\}, \\ \partial_{\perp}\Lambda &= \{y \in \Lambda^c : \{y + \vec{e}_2, y - \vec{e}_2\} \cap \Lambda \neq \emptyset\}. \end{aligned}$$

A configuration $\tau \in \{0, 1\}^{\partial\Lambda}$ will be referred to as a *boundary condition* and we shall write it as $\tau = (\tau_{\parallel}, \tau_{\perp})$, where $\tau_{\parallel} := \tau|_{\partial_{\parallel}\Lambda}$ and similarly for τ_{\perp} .

Definition 2.13. Given a boundary condition τ and $Y \subseteq \Lambda$, let

$$Y^\tau(t+1) = Y^\tau(t) \cup \{x \in \Lambda : X + x \subseteq Y^\tau(t) \text{ for some } X \in \mathcal{U}\} \quad t \geq 0,$$

where $Y^\tau(0) = Y \cup \{x \in \partial\Lambda : \tau_x = 0\}$. We call the process $Y^\tau(t), t \in \mathbb{N}$, the Duarte bootstrap process in Λ with τ boundary condition (for shortness the DB_{Λ}^{τ} -process), and we shall write $[Y]_{\Lambda}^{\tau}$ for $(\bigcup_{t \geq 0} Y^\tau(t)) \cap \Lambda$. Recall also (see section 2.2.2) that $[Y]$ is the analogous quantity for the bootstrap process evolving on \mathbb{Z}^2 .

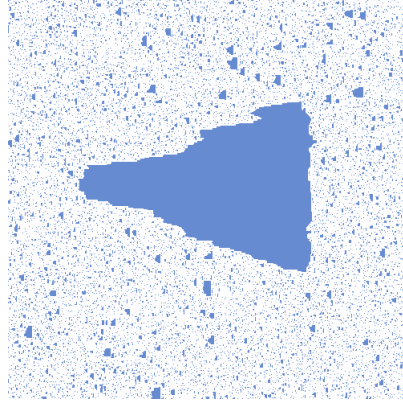

Figure 2.1: A growing droplet under the Duarte bootstrap process (courtesy of P. Smith).

Remark 2.14. Notice that for the DB_{Λ}^{τ} -process the boundary condition τ does not change in time.

Notation warning. If $\tau \equiv 0$ or $\tau \equiv 1$ we shall simply replace it by a 0 or a 1 in our notation. If instead τ is such that $\tau_{\parallel} \equiv 1$ and $\tau_{\perp} \equiv 0$ then it will be replaced by a 1, 0 in the notation.

Lemma 2.15 (Screening property). *Consider a sequence S of sites in \mathbb{Z}^2 given by $S := \{(i, b_i)\}_{i=1}^n$ with $b_{i+1} \leq b_i$ for all $i \in [n-1]$, and let*

$$S_+ = \{(i, j) \in \mathbb{Z}^2 : i \in [n], j > b_i\}, \quad S_- = \{(i, j) \in \mathbb{Z}^2 : i \in [n], j < b_i\}.$$

Let Y, Y' be two arbitrary subsets of \mathbb{Z}^2 such that $Y \supseteq S$ and $Y \cap S_+^c = Y' \cap S_+^c$. Then $[Y] \cap S_- = [Y'] \cap S_-$. Similarly if we assume that $b_{i+1} \geq b_i$ for all $i \in [n-1]$ and we exchange the role of S_+ and S_- .

Proof. We refer to figure 2.2 for a visualisation of the geometric setting. Let Y, Y' be as in the statement and observe that $Y(s)$ and $Y'(s)$ coincide in $\{v \in \mathbb{Z}^2 : v = (a, b), a \leq 0\}$ for all $s \in \mathbb{N}^*$. Let $t \in \mathbb{N}^*$ be the first time at which there exists $y \in S_-$ such that either $y \in Y'(t)$ and $y \notin Y(t)$ or vice versa. Without loss of generality we assume the first case. By construction there exists $z \in \{y \pm \vec{e}_2, y - \vec{e}_1\}$ such that $z \in Y'(t-1)$ and $z \notin Y(t-1)$. Clearly z cannot be of the form $z = (0, b)$ and therefore $z \in S_- \cup S$ because $y \in S_-$. Because of the definition of t , $z \notin S_-$ and $z \notin S$ because $S \subseteq Y(s)$ and $S \subseteq Y'(s)$ for all $s \in \mathbb{N}^*$. \square

Lemma 2.16 (Monotonicity). *Let $\Lambda \subseteq \Lambda'$ be subsets of \mathbb{Z}^2 .*

(A) *Let $\tau, \tau' \in \{0, 1\}^{\partial\Lambda}$. If $\tau_x \leq \tau'_x$ for all $x \in \partial\Lambda$ then*

$$[Y]_{\Lambda}^{\tau'} \subseteq [Y]_{\Lambda}^{\tau}, \quad \forall Y \subseteq \Lambda.$$

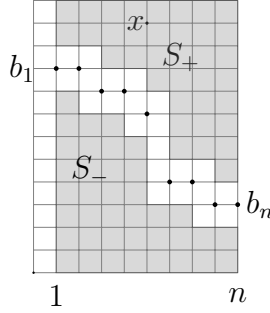

Figure 2.2: The set S (black dots) and the sets S_{\pm} (shaded regions). If the two initial sets Y, Y' of infection contain S and differ at exactly the vertex x , it is clear that the initial discrepancy cannot influence the final infection in S_- .

(B) For all $Y' \subseteq \Lambda'$

$$[Y']_{\Lambda'}^0 \cap \Lambda \subseteq [Y' \cap \Lambda]_{\Lambda}^0 \quad \text{and} \quad [Y']_{\Lambda'}^1 \cap \Lambda \supseteq [Y' \cap \Lambda]_{\Lambda}^1.$$

(C) Suppose that Λ and Λ' are such that $\partial_{\perp} \Lambda \subseteq \partial_{\perp} \Lambda'$. Then for all $Y' \subseteq \Lambda'$

$$[Y' \cap \Lambda]_{\Lambda}^{1,0} \subseteq [Y']_{\Lambda'}^{1,0} \cap \Lambda.$$

Proof. (A) It follows immediately from the fact that the DB_{Λ}^{τ} -process runs with more initial infection than the $DB_{\Lambda'}^{\tau}$ -process.

(B) To prove the first inclusion let $Z = (Y' \cap \Lambda) \cup (\Lambda' \setminus \Lambda)$. Clearly $[Y']_{\Lambda'}^0 \subseteq [Z]_{\Lambda'}^0$, because $Y' \subseteq Z$. It is now sufficient to observe that, by definition,

$$[Z]_{\Lambda'}^0 \cap \Lambda = [Y' \cap \Lambda]_{\Lambda}^0.$$

Similarly one proceeds for the second inclusion with $Z = Y' \cap \Lambda$.

(C) Clearly $[Y' \cap \Lambda]_{\Lambda}^{1,0} \subseteq [Y']_{\Lambda'}^{1,0}$. We claim that

$$[Y']_{\Lambda'}^{1,0} \cap \Lambda \supseteq [Y' \cap \Lambda]_{\Lambda}^{1,0}.$$

That follows immediately from the assumption that $\partial_{\perp} \Lambda' \supseteq \partial_{\perp} \Lambda$ and the fact that the vertices of $\partial_{\parallel} \Lambda \cap \Lambda'$ (if any) are constrained to be healthy for all times under the $DB_{\Lambda}^{1,0}$ -process while they are unconstrained for the $DB_{\Lambda'}^{1,0}$ -process. \square

Lemma 2.17 (Propagation of infection). *Let I be a vertical interval, i.e. $I = \{a, a + \vec{e}_2, \dots, a + n\vec{e}_2\}$, $a \in \mathbb{Z}^2$, and let $v = x + \vec{e}_1$ for some $x \in I$. Suppose that $I \cup \{v\} \subseteq [Y]$ where Y is the initial set of infection. Then $I + \vec{e}_1 \subseteq [Y]$. In particular, if $[Y]$ contains $[n] \times \{1\}$ and $\{1\} \times [m]$ then $[n] \times [m] \subseteq [Y]$.*

As a corollary of the above simple property, let $x, y \in \mathbb{Z}^2$ and suppose that there exists a *Duarte path* Γ between x and y , i.e. $\Gamma := (x^{(1)}, \dots, x^{(n)}) \subseteq \mathbb{Z}^2$ with $x^{(1)} = x$, $x^{(n)} = y$ and $x^{(i+1)} - x^{(i)} \in \{\vec{e}_1, \pm\vec{e}_2\} \forall i \in [n-1]$. Let also I_Γ be the horizontal interval starting at x and reaching the vertical line through y (see figure 2.3).

Corollary 2.18. *Suppose that $\Gamma \subseteq [Y]$. Then $I_\Gamma \subseteq [Y]$.*

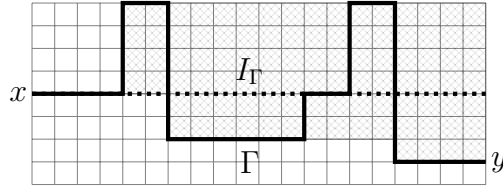

Figure 2.3: A Duarte path Γ (thick polygonal line) and the corresponding horizontal interval I_Γ (dotted line). Clearly, $\Gamma \subseteq [Y]$ implies that $[Y]$ contains the shaded region. In particular $I_\Gamma \subseteq [Y]$.

2.5.2 Algorithmic construction of the test function and proof of theorem 2.11

Fix ε a small positive constant that will be chosen later on and let

$$\ell = \left\lceil \frac{1}{\varepsilon q} \log(1/q) \right\rceil. \quad (2.8)$$

Suppose that a vertical interval I of length ℓ is completely infected. Notice that, with μ -probability going to 1 as $q \downarrow 0$, there is an infected site on the vertical interval sitting on the right, $I + \vec{e}_1$. Therefore, thanks to lemma 2.17, with high probability the infection can propagate to infect $I + \vec{e}_1$. Notice that instead the infection on I does not help infecting the interval on its left, $I - \vec{e}_1$. At this point, recalling the explanation given in the introduction, one might think that the droplets that undergo an East-like dynamics⁶ are the *empty*

⁶Namely a dynamics in which droplets appear/disappear only if there is a droplet on their left, as it occurs for the single empty sites in the one-dimensional East model.

vertical intervals of length at least ℓ . However this is far from true, since these empty intervals might also appear (or disappear) without being facilitated by the presence of an empty interval on their left. For example, if there is an empty interval of length $\ell - 1$ and the site just above has the constraint satisfied, a single legal move may turn it into an empty interval of height ℓ . We have therefore to find a more flexible definition of the droplets respecting three key properties: (i) East-like dynamics; (ii) disjoint occurrence under the equilibrium measure μ and (iii) the density of droplets should scale as $q_{\text{eff}} = q^\ell$ ⁷. Our solution to the problem is the construction of an algorithm that sequentially searches for properly defined droplets on a finite volume, V , containing the origin. We let

$$N = \left\lceil e^{\varepsilon(\log q)^2/q} \right\rceil \quad \text{and} \quad V := V_N = \bigcup_{i=1}^N \mathcal{C}_i, \quad (2.9)$$

where

$$\mathcal{C}_i = \{(i, j) \in \mathbb{Z}^2 : |j| < N^2 - (i-1)N\} - N\vec{e}_1.$$

as in figure 2.4. In the sequel we shall write \bar{V} for the set $V \cup \partial_\perp V$ and we shall refer to $\bar{\mathcal{C}}_i := \mathcal{C}_i \cup \partial_\perp \mathcal{C}_i$ as the i^{th} -column of \bar{V} . By construction the origin coincides with the midpoint of the last column (see figure 2.4). The core of our algorithmic construction (see definition 2.20) consists in associating to each $\omega \in \Omega$ an element $\Phi(\omega) \in \{\downarrow, \uparrow\}^N$ via an iterative procedure based on the DB_Λ^τ -process. These arrow variables are those that satisfy the three key properties announced above, with $\Phi(\omega)_i = \uparrow$ corresponding to the occurrence of a droplet in column i , and we will use them to construct an efficient test function.

Definition 2.19. Given a boundary condition τ and $\omega \in \Omega$, we shall say that $I \subseteq V$ is (ω, τ) -infectable if $I \subseteq [Y(\omega) \cap V]_\tau^I$, where we recall that $Y(\omega)$ is the set of empty vertices of ω .

Before defining the algorithm leading to the construction of an effective test function for the Duarte KCM process, it is useful to notice two simple properties of the DB_V^τ -process.

- (i) Let $I \subseteq \cup_{i=1}^k \mathcal{C}_i$, $k \leq N$. Then the property of being (ω, τ) -infectable for I depends only on the infection of the pair (ω, τ) in $\cup_{i=1}^k \bar{\mathcal{C}}_i$ and on τ_\parallel .

⁷Indeed, since the density of droplets will play the role of the density of empty sites for East, it is natural to expect that the lower bound obtained using the droplets will be of the form (2.2) with q_{eff} replacing q . This in turn yields the result of theorem 2.11 if $q_{\text{eff}} = q^\ell$.

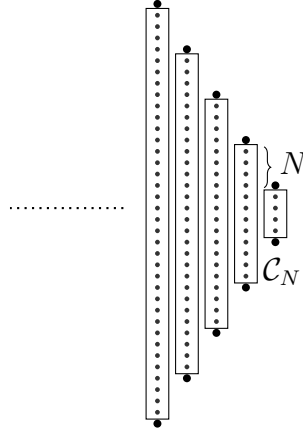

Figure 2.4: A sketchy drawing of the last few columns of the set V . The black dots represent sites belonging to $\partial_{\perp} V$.

- (ii) If $\bar{\mathcal{C}}_i$ is healthy at time $t = 0$ (including the contribution of τ at its top and bottom boundary sites), then it will remain healthy at any later time.

The idea behind the algorithm is the following. It is tempting to decide that there is a droplet/arrow in column i when column i contains an infectable vertical interval of length at least ℓ ; indeed, this has probability close to the probability that the interval is infected, which is q^{ℓ} . However, this brings on the following problem: as explained at the beginning of section 2.5.2, once such an interval I is completely infected by the bootstrap process, with high probability the infection can propagate to $I + \vec{e}_1$, so column $i + 1$ would also contain an infectable vertical interval of length at least ℓ , hence we would detect a second droplet in column $i + 1$ even though the configuration on column $i + 1$ is ordinary. In order to avoid that, before moving on to column $i + 1$, we heal all the infections that allowed to infect I .

Definition 2.20 (The algorithm). Given $\omega \in \Omega$ and $\tau \in \{0, 1\}^{\partial V}$ such that $\tau_{\perp} \equiv 0$ and $\tau_{\parallel} \equiv 1$, the algorithm outputs recursively a sequence $\psi^{(k)} := (\omega^{(k)}, \tau^{(k)})$, $k \in \{0, \dots, N\}$, where $\omega^{(k)} \in \Omega$ and $\tau^{(k)} \in \{0, 1\}^{\partial V}$ is such that $\tau_{\parallel}^{(k)} \equiv 1$. The pair $\psi^{(0)}$ coincides with (ω, τ) and $\psi^{(k)}$ is obtained from $\psi^{(k-1)}$ by healing suitably chosen infected vertices. The iterative step goes as follows. Fix $\ell \in [N]$ and assume that $\psi^{(j)}$ has been defined for all $j = 0, \dots, k-1$, $k \in [N]$. Then:

- (i) if $\bar{\mathcal{C}}_k$ contains an interval I of length at least ℓ which is $\psi^{(k-1)}$ -infectable, we let $\xi_k := \xi_k(\omega) \leq k$ be the largest integer such that, by removing all the empty vertices of the pair $\psi^{(k-1)}$ contained in $\cup_{i=1}^{\xi_k-1} \bar{\mathcal{C}}_i$, the above

property still holds. We then set both $\omega^{(k)}$ and $\tau^{(k)}$ identically equal to one (*i.e.* with no infection) on $\bar{\mathcal{C}}_{\xi_k}, \dots, \bar{\mathcal{C}}_k$ and equal to $\omega^{(k-1)}$ and $\tau^{(k-1)}$ elsewhere;

(ii) if not we set $\psi^{(k)} = \psi^{(k-1)}$.

Remark 2.21. Clearly the above construction depends on the initial ω and we shall sometimes write $\psi^{(k)}(\omega)$ to outline this dependence.

Definition 2.22 (Droplets and their range). Given k such that $\psi^{(k)}(\omega) \neq \psi^{(k-1)}(\omega)$, we define the *droplet* $D_k(\omega)$ and the *range* $r_k(\omega)$ of the k^{th} -column in ω as the set $\cup_{i=\xi_k}^k \bar{\mathcal{C}}_i$ and the integer $k - \xi_k(\omega)$ respectively. If instead $\psi^{(k)}(\omega) = \psi^{(k-1)}(\omega)$, we let $D_k(\omega) = \emptyset$ and $r_k(\omega) = 0$.

Observe that, by construction,

$$\psi^{(j)}(\omega) \upharpoonright_{\bar{V} \setminus \cup_{i=1}^j D_i(\omega)} = \psi^{(0)}(\omega) \upharpoonright_{\bar{V} \setminus \cup_{i=1}^j D_i(\omega)}. \quad (2.10)$$

Definition 2.23 (The mapping Φ). Having defined the sequence $\{\psi^{(k)}\}_{k=1}^N$, we set

$$\Phi(\omega)_k = \begin{cases} \uparrow & \text{if } \psi^{(k)}(\omega) \neq \psi^{(k-1)}(\omega), \\ \downarrow & \text{otherwise,} \end{cases}$$

and $N_{\uparrow}(\omega) = \#\{i \in [N] : \Phi(\omega)_i = \uparrow\}$.

Remark 2.24. Suppose that ω, ω' are such that they coincide over the first i columns. Then $\Phi(\omega)_k = \Phi(\omega')_k$ for all $k \in [i]$.

In the sequel two events will play an important role. The first one, $\mathcal{B}_1(n)$, collects all the ω 's whose image $\Phi(\omega)$ has more than n up-arrows, with $n \in [N]$:

$$\mathcal{B}_1(n) = \{\omega \in \Omega : N_{\uparrow}(\omega) \geq n\}. \quad (2.11)$$

The event $\mathcal{B}_2(n)$, again with $n \in [N]$, collects instead all the $\omega \in \Omega$ such that there exist n consecutive \downarrow -columns which are traversed by an infectable Duarte path. More precisely, for $1 \leq i < j \leq N$, let

$$V_{i,j} = \cup_{k=i}^j \mathcal{C}_k \quad (2.12)$$

and let

$$\mathcal{B}_2(n) = \cup_{j-i \geq n-1} \left(\cap_{k=i}^j \{\omega \in \Omega : \Phi(\omega)_k = \downarrow\} \cap \mathcal{G}_{i,j} \right), \quad (2.13)$$

where

$$\mathcal{G}_{i,j} = \left\{ \omega \in \Omega : \exists \text{ a Duarte path } \Gamma \text{ from } \mathcal{C}_i \text{ to } \mathcal{C}_j \text{ such that } \Gamma \subseteq [Y(\omega) \cap V_{i,j}]_{V_{i,j}}^{1,0} \right\} \quad (2.14)$$

We are now ready to define our test function.

Definition 2.25 (The test function). Let $I_0 = \{(0, k) : |k| \leq \ell\}$ and

$$n_1 = \varepsilon(\log q)^2/2q, \quad n_2 = 1/q^6 \quad (2.15)$$

where ε is the same as in the definition of N (2.9). Let also

$$\Omega_\downarrow = \{\omega \in \Omega : \Phi(\omega) = (\downarrow, \dots, \downarrow)\},$$

$$\Omega_g = \Omega_\downarrow \cap \{\omega \in \Omega : \omega_{I_0} = 1\},$$

$\mathcal{A}_{\varepsilon, q} := \mathcal{A}_{N, \ell, n_1, n_2} = \{\omega \in \Omega : \exists \text{ a legal path } \gamma \text{ connecting } \Omega_g \text{ to } (\omega_V, \tilde{\omega}_{V^c} \equiv 0) \text{ such that } \gamma \cap \mathcal{B}_1(n_1 - 1) = \emptyset \text{ and } \gamma \cap \mathcal{B}_2(n_2 - 1) = \emptyset\}$.

where legal paths have been defined in definition 2.8 and, for any $\mathcal{B} \subset \Omega$, we set $\gamma \cap \mathcal{B} = \emptyset$ if and only if none of the configurations of the path γ belongs to \mathcal{B} . Then we choose as test function

$$\phi(\cdot) := \phi_q(\cdot) = \mathbf{1}_{\mathcal{A}_{\varepsilon, q}}(\cdot) / \mu(\mathcal{A}_{\varepsilon, q})^{1/2}.$$

The rest of the paper is devoted to prove that (i) ϕ satisfies the key hypothesis of corollary 2.4, namely $\phi \in H_A$ and (ii) ϕ is an efficient proxy function, namely the bound (2.6) prove the sharp lower bound of theorem 2.11. More precisely we need to prove the following key propositions:

Proposition 2.26. *There exists $\varepsilon_0 > 0$ such that, for all $\varepsilon \in (0, \varepsilon_0)$ there exists q_ε small enough such that, for all $q \in (0, q_\varepsilon)$,*

$$\mathcal{A}_{\varepsilon, q} \cap A = \emptyset.$$

In particular, $\phi \in H_A$.

Proposition 2.27. *There exists $\varepsilon_0 > 0$ such that, for all $\varepsilon \in (0, \varepsilon_0)$,*

$$\mu(\phi) \geq q^{O(1)} \quad \text{and} \quad \mathcal{D}(\phi) \leq e^{-\Omega(\log(q)^4/q^2)} \quad \text{as } q \rightarrow 0.$$

Once the above propositions are proven, the main result of this section easily follows

Proof of theorem 2.11. The result follows at once using propositions 2.26 and 2.27, together with the general lower bound on $\mathbb{E}_\mu(\tau_0)$ given in (2.6). \square

Let us start with an easy result which will be used in the proof of both propositions

Lemma 2.28 (Disjoint occurrence of the droplets). *For any $\omega \in \Omega$ and any $k \neq j$, $D_k(\omega) \cap D_j(\omega) = \emptyset$.*

Proof. Let k_1, \dots, k_ν be the labels of the columns which are of type \uparrow in $\Phi(\omega)$ (for all the other columns the droplets are the empty set). Using property (ii) of the DB_V^τ -process, $D_{k_\nu}(\omega)$ cannot contain a column which is healthy for the pair $\psi^{(k_\nu-1)}$ because any infection to the left of a healthy column cannot cross the healthy column itself. On the other hand, all the columns of the droplets $D_{k_1}, \dots, D_{k_{\nu-1}}$ are healthy for $\psi^{(k_\nu-1)}$. Thus $D_{k_\nu} \cap D_{k_j} = \emptyset$ for all $j \in [\nu - 1]$. The same reasoning applies to all the other droplets. \square

2.5.3 East-like motion of the arrows and proof of proposition 2.26

Let

$$A_\ell = \{\omega \in \Omega: \omega_{I_0^+} \equiv 0\} \cup \{\omega \in \Omega: \omega_{I_0^-} \equiv 0\},$$

where $I_0^\pm = \{(0, \pm 1), \dots, (0, \pm \ell)\}$. Then it holds

Lemma 2.29. *If $\mathcal{A}_{\varepsilon, q} \cap A \neq \emptyset$ then there exist $\omega \in A_\ell$ and a legal path γ connecting Ω_g to ω such that $\gamma \cap \mathcal{B}_i(n_i) = \emptyset$, $i = 1, 2$.*

Proof. Fix $\omega \in \mathcal{A}_{\varepsilon, q} \cap A$, recall definition 2.25 and let $\tilde{\gamma}$ be a legal path connecting Ω_g to $(\omega_V, \tilde{\omega}_{V^c} \equiv 0)$ such that $\tilde{\gamma} \cap \mathcal{B}_1(n_1 - 1) = \emptyset$ and $\tilde{\gamma} \cap \mathcal{B}_2(n_2 - 1) = \emptyset$. Without loss of generality, we can assume that $\tilde{\gamma}$ ends as soon as the origin is infected. It is easy to verify that $\tilde{\gamma}$ must be able to sequentially infect (and possibly heal later on) the ordered vertices of either I_0^+ starting from $(0, \ell)$ or those of I_0^- starting from $(0, -\ell)$. For simplicity we assume that the first option holds and we let γ be the path obtained from $\tilde{\gamma}$ by deleting all the transitions in which a vertex of I_0^+ is healed.

By construction, the final configuration of γ belongs to A_ℓ . Moreover, γ is a legal path because at each step the infection in the last column of V is larger than or equal to the infection of the corresponding step of $\tilde{\gamma}$. Finally the restriction to $\mathcal{C}_1, \dots, \mathcal{C}_{N-1}$ of any step of γ coincides with the same restriction of the appropriate step of $\tilde{\gamma}$. Using that $\tilde{\gamma} \cap \mathcal{B}_1(n_1 - 1) = \emptyset$ and $\tilde{\gamma} \cap \mathcal{B}_2(n_2 - 1) = \emptyset$, we deduce that $\gamma \cap \mathcal{B}_1(n_1) = \emptyset$ and $\gamma \cap \mathcal{B}_2(n_2) = \emptyset$. \square

The above lemma says that, if there exists a configuration in Ω_g for which we can infect the origin performing a legal path never crossing either $\mathcal{B}_1(n_1 - 1)$ or $\mathcal{B}_2(n_2 - 1)$, then necessarily there exists a legal path never crossing either $\mathcal{B}_1(n_1)$ or $\mathcal{B}_2(n_2)$ and connecting a configuration ω with all columns being \downarrow to a configuration ω with a \uparrow in the N -th column. In order to conclude that

$\mathcal{A}_{\varepsilon,q} \cap A = \emptyset$ and thus prove our proposition 2.26, we will now show that *the existence of a legal path with the above properties is impossible*. It is here that the East-like motion of the droplets emerges and plays a key role. Recall the definitions (2.9), (2.15) and let $m = 4n_1n_2$ and, for simplicity, let us suppose that m divides N . We partition $[N]$ into $M = N/m$ disjoint consecutive blocks $\{B_i\}_{i=1}^M$ of equal cardinality and, with a slight abuse of notation, we identify the columns $\cup_{k \in B_i} \mathcal{C}_k$ with the block B_i itself. Given $\omega \in \Omega$ we write

$$\eta_i(\omega) := \mathbb{1}_{\{\forall j \in B_i: \Phi(\omega)_j = \downarrow\}},$$

and we denote by $\eta(\omega)$ the collection $\{\eta_i(\omega)\}_{i=1}^M$.

Claim 2.30. *Given a legal path γ with the properties stated in lemma 2.29, it is possible to construct a path $\varphi(\gamma) := (\eta^{(0)}, \dots, \eta^{(k)})$ in the space $\{0, 1\}^M$ with the following properties:*

- (1) $\eta_i^{(0)} = 1$ for all $i \in [M]$ and $\eta_M^{(k)} = 0$,
- (2) $\#\{i \in [M]: \eta_i = 0\} \leq n_1$ for all $\eta \in \varphi(\gamma)$,
- (3) for any edge (η, η') of $\varphi(\gamma)$, the configuration η' differs from η in exactly one coordinate. Moreover, if the discrepancy between η and η' occurs at the i^{th} -coordinate and $i \neq 1$, then $\eta_{i-1} = 0$.

Remark 2.31. The path $\varphi(\gamma)$ for the coarse-grained variables $\{\eta_i\}_{i=1}^M$ can be viewed as a legal path for the one-dimensional East model on $[M]$ (see e.g. [FMRT13]).

The proof of our proposition 2.26 then follows by using this connection with the East model, our choices (2.9), (2.15) of the parameters N, n_1, n_2 and the combinatorial result for the East model [SE03, CDG01] that we explained in the introduction. More precisely

Proof of proposition 2.26. In [CDG01] it was proved that a path like $\varphi(\gamma)$ above exists if and only if $n_1 \geq \log_2(M + 1)$. With our choice (2.15) of the scaling as $q \rightarrow 0$ of n_1, n_2, N , the latter condition becomes

$$n_1 \geq \frac{1}{\log 2}(1 + o(1))\varepsilon(\log q)^2/q, \quad \text{as } q \rightarrow 0,$$

violating our choice $n_1 = \varepsilon(\log q)^2/2q$. Thus $\varphi(\gamma)$ cannot exist as well as the path γ . \square

We are therefore left with proving claim 2.30. To this aim we start by stating two preparatory results, lemma 2.32 and lemma 2.33, which will be the key ingredients for the proof of claim 2.30.

Lemma 2.32. *For any $\omega \in \mathcal{B}_2^c(n_2)$ the maximum range of a droplet of ω is $n_2 - 1$.*

Proof. Let $\omega \in \Omega$ such that there exists $j \in [N]$ with $r_j(\omega) \geq n_2$. Denote $i = \xi_j(\omega)$. By the definition of $\xi_j(\omega) = i$, $\bar{\mathcal{C}}_j$ contains an interval I of length at least ℓ which is $\psi^{(j-1)}$ -infectable by the empty sites in $\bigcup_{k=i}^j \bar{\mathcal{C}}_k$, but not by the empty sites in $\bigcup_{k=i+1}^j \bar{\mathcal{C}}_k$. Definition 2.19 implies that any $\psi^{(j-1)}$ -infectable site is in V , hence $I \subseteq \mathcal{C}_j$. Furthermore, for all $k \in \{i, \dots, j-1\}$, $\Phi(\omega)_k = \downarrow$ (since thanks to lemma 2.28 the droplets are disjoint), so by (2.10) $\psi^{(j-1)}$ and $\psi^{(0)}$ coincide on $\bigcup_{k=i}^j \bar{\mathcal{C}}_k$. Therefore I is $\psi^{(0)}$ -infectable by the empty sites in $\bigcup_{k=i}^j \bar{\mathcal{C}}_k$, but not by the empty sites in $\bigcup_{k=i+1}^j \bar{\mathcal{C}}_k$. We deduce that $I \subseteq [Y(\omega) \cap V_{i,j}]_{V_{i,j}}^{1,0}$, but $I \not\subseteq [Y(\omega) \cap V_{i+1,j}]_{V_{i+1,j}}^{1,0}$, see (2.12) for the definition of $V_{i,j}$. Thus, there exists $z \in \mathcal{C}_j$ such that $z \in [Y(\omega) \cap V_{i,j}]_{V_{i,j}}^{1,0} \setminus [Y(\omega) \cap V_{i+1,j}]_{V_{i+1,j}}^{1,0}$. Hence z can not be initially empty for the Duarte bootstrap process in $V_{i,j}$, otherwise it would also be empty for the process in $V_{i+1,j}$, hence the process in $V_{i,j}$ infects z with an update rule, so there exists $z' \in \{z - \bar{e}_1, z \pm \bar{e}_2\}$ in $[Y(\omega) \cap V_{i,j}]_{V_{i,j}}^{1,0} \setminus [Y(\omega) \cap V_{i+1,j}]_{V_{i+1,j}}^{1,0}$. We can iterate, creating a Duarte path in $[Y(\omega) \cap V_{i,j}]_{V_{i,j}}^{1,0} \setminus [Y(\omega) \cap V_{i+1,j}]_{V_{i+1,j}}^{1,0}$. There can be only a finite number of iterations because there is a finite number of sites in $V_{i,j}$, so we will stop, and the site at which we stop has to be initially empty for the process in $V_{i,j}$, but not for the process in $V_{i+1,j}$, therefore it is in $\bar{\mathcal{C}}_i$. This implies the Duarte path can reach \mathcal{C}_i . Consequently, there is a Duarte path in $[Y(\omega) \cap V_{i,j}]_{V_{i,j}}^{1,0} \setminus [Y(\omega) \cap V_{i+1,j}]_{V_{i+1,j}}^{1,0}$ going from \mathcal{C}_i to \mathcal{C}_j . We deduce that there exists a Duarte path in $[Y(\omega) \cap V_{i,j-1}]_{V_{i,j-1}}^{1,0}$ from \mathcal{C}_i to \mathcal{C}_{j-1} , which is $\mathcal{G}_{i,j-1}$. Since $(j-1) - i \geq n_2 - 1$, $\omega \in \mathcal{B}_2(n_2)$. \square

The next lemma is the basic technical step connecting the evolution of the coarse-grained variables $\{\Phi(\omega)_i\}_{i=1}^N$ under the Duarte KCM process to an East-like process. Given $\omega \in \Omega$ and $x \in V$, let ω^x denote the configuration ω flipped at x . We say that x is $\psi^{(k)}(\omega)$ -unconstrained (or infectable in one step) if $\exists X \in \mathcal{U}$ such that $X + x$ is infected for the pair $(\omega^{(k)}, \tau^{(k)})$.

Lemma 2.33 (East-like motion of the arrows). *Fix $\omega \in \Omega$ and let $x \in \mathcal{C}_j$. Then:*

- (a) *Suppose that x is $\psi^{(0)}(\omega)$ -unconstrained. Then $\Phi(\omega^x) \neq \Phi(\omega)$ implies that $j > 1$ and $\Phi(\omega)_{j-1} = \uparrow$;*
- (b) *For $i > j$ suppose that $\Phi(\omega)_i = \uparrow$, $\Phi(\omega^x)_i = \downarrow$ and that $D_i(\omega) \not\ni x$. Then there exists k such that $\bar{\mathcal{C}}_k \subseteq D_i(\omega) \setminus \bar{\mathcal{C}}_i$ and $\Phi(\omega^x)_k = \uparrow$, $\Phi(\omega)_k = \downarrow$.*

Proof. (a) If $j = 1$ then clearly $\Phi(\omega^x) = \Phi(\omega)$ because the site x is $\psi^{(0)}(\omega)$ -unconstrained. Consider now the case $j \neq 1$ and assume that $\Phi(\omega)_{j-1} = \downarrow$. We want to prove that in this case $\Phi(\omega^x) = \Phi(\omega)$ if x is $\psi^{(0)}(\omega)$ -unconstrained.

By construction, the restriction to the first $j - 1$ columns of $\psi^{(k)}(\omega^x)$ and $\psi^{(k)}(\omega)$ coincide for all $k \in [j - 1]$ and, as a consequence, $\Phi(\omega)_k = \Phi(\omega^x)_k \forall k \in [j - 1]$. Let $k_*(\omega) = \min\{k \geq j : \Phi(\omega)_k = \uparrow\}$ and similarly for ω^x . Using (2.10) together with $\Phi(\omega)_{j-1} = \downarrow$, for all $i = j - 1, \dots, k_*(\omega) - 1$ the restriction of $\psi^{(i)}(\omega)$ to the columns $\bar{\mathcal{C}}_{j-1}, \dots, \bar{\mathcal{C}}_N$ coincides with the same restriction of the original pair $\psi^{(0)}(\omega)$. In particular, the fact that x is $\psi^{(0)}(\omega)$ -unconstrained implies that x is also $\psi^{(k_*(\omega)-1)}(\omega)$ -unconstrained. Analogously for the configuration ω^x . Clearly $k_*(\omega^x) \geq k_*(\omega)$. If not, starting from the infection of $\psi^{(j-1)}(\omega)$ we can first make a transition to $\psi^{(j-1)}(\omega^x)$ by legally flipping ω_x and from there infect an interval of length at least ℓ of $\bar{\mathcal{C}}_{k_*(\omega^x)}$ to make it of type \uparrow , a contradiction with the definition of $k_*(\omega)$. By exchanging the role of ω, ω^x we conclude that $k_*(\omega^x) = k_*(\omega)$. Thus $\Phi(\omega)_k = \Phi(\omega^x)_k$ for all $k = 1, \dots, k_*(\omega)$ and, a fortiori, for all $k > k_*(\omega)$.

(b) By assumption the restriction of ω, ω^x to $D_i(\omega)$ coincide. If $\Phi(\omega^x)_k = \downarrow$ for all the columns in $D_i(\omega)$, then $\psi^{(i-1)}(\omega) = \psi^{(i-1)}(\omega^x)$ on the set $D_i(\omega)$ implying that $\Phi(\omega^x)_i = \Phi(\omega)_i$. Thus there exists a column $\bar{\mathcal{C}}_k \subseteq D_i(\omega) \setminus \bar{\mathcal{C}}_i$ such that $\Phi(\omega^x)_k = \uparrow$ and (by the definition of $D_i(\omega)$) $\Phi(\omega)_k = \downarrow$. \square

Corollary 2.34. *Fix $\omega \in \Omega$, $x \in \mathcal{C}_j$. Let also $r_\infty^x = \max_i \max(r_i(\omega), r_i(\omega^x))$ and suppose that $\Phi(\omega)_i = \uparrow, \Phi(\omega^x)_i = \downarrow$, with $i - j \geq m(r_\infty^x + 1), m \in \mathbb{N}^*$. Then*

$$\#\{k \in \{j, \dots, i\} : \Phi(\omega)_k = \uparrow\} + \#\{k \in \{j, \dots, i\} : \Phi(\omega^x)_k = \uparrow\} \geq m.$$

Proof. By construction $D_i(\omega) \not\ni x$. Lemma 2.33 part (b) guarantees that there exists a column $\bar{\mathcal{C}}_k \subseteq D_i(\omega) \setminus \bar{\mathcal{C}}_i$ such that $\Phi(\omega)_k = \downarrow$ and $\Phi(\omega^x)_k = \uparrow$. We can then iterate by exchanging the role of ω, ω^x and replacing i with e.g. the largest of the labels k above. In conclusion, every $r_\infty^x + 1$ steps we are guaranteed to find a discrepancy between $\Phi(\omega)$ and $\Phi(\omega^x)$ and the result follows. \square

We are now ready to conclude the proof of claim 2.30.

Proof of claim 2.30. To prove the claim, let $\gamma = (\omega^{(0)}, \dots, \omega^{(n)})$ and let us consider the sequence $\{\eta(\omega^{(j)})\}_{j=0}^n$. The path $\varphi(\gamma) = (\eta^{(0)}, \dots, \eta^{(k)})$ is then defined recursively by setting $\eta^{(0)} := \eta(\omega^{(0)})$ and $\eta^{(j)} := \eta(\omega^{(i_j)})$, where $i_j = \min\{i > i_{j-1} : \eta(\omega^{(i)}) \neq \eta^{(j-1)}\}$ with $i_0 = 0$, and by stopping the procedure as soon as the set $\{\eta \in \{0, 1\}^M : \eta_M = 0\}$ is reached ($\phi(\gamma)$ is then a function of γ). In other words, we only keep the elements of the sequence $\eta(\omega^{(j)}), j =$

$0, \dots, n$, which change with respect to the previous element. Property (1) of $\varphi(\gamma)$ follows immediately from the fact that γ starts in Ω_\downarrow and ends in A_ℓ . Property (2) follows from the fact that $\gamma \cap \mathcal{B}_1(n_1) = \emptyset$. We now verify the key property (3).

Let (η, η') be an edge of $\varphi(\gamma)$ and let (ω, ω') be the edge of γ such that $\eta(\omega) = \eta$ and $\eta(\omega') = \eta'$. By construction $\Phi(\omega) \neq \Phi(\omega')$. Let also $x \in \mathcal{C}_a$ be such that $\omega' = \omega^x$ and say that a belongs to j^{th} -block. Clearly, $\eta_i = \eta'_i$ for all $i < j$. Moreover, lemma 2.32 and corollary 2.34 imply that $\Phi(\omega)_v = \Phi(\omega')_v$ for all $v \in \cup_{i \geq j+2} B_i$ (if $j+2 \leq N$), since otherwise either ω or ω' would have at least $\lfloor m/2(r_\infty^x + 1) \rfloor \geq \lfloor m/2n_2 \rfloor = 2n_1$ up-arrows, contradicting the assumption $\gamma \cap \mathcal{B}_1(n_1) = \emptyset$. In particular, $\eta_i = \eta'_i$ for all $i \geq j+2$. To complete our analysis we distinguish between two cases.

- 1) $a > 1$. In this case x must be $\psi^{(0)}(\omega)$ -unconstrained and part (a) of lemma 2.33 together with $\Phi(\omega) \neq \Phi(\omega')$ implies that $\Phi(\omega)_{a-1} = \Phi(\omega^x)_{a-1} = \uparrow$. If a is not the beginning of the block B_j then, by definition, $\eta_j = \eta'_j = 0$. Thus η, η' must differ exactly in the $(j+1)^{\text{th}}$ -block and they are both equal to zero in the previous one as required. If a is the beginning of the j^{th} -block, then necessarily $j > 1$. Moreover $\Phi(\omega)_{a-1} = \Phi(\omega^x)_{a-1} = \uparrow$ implies that $\eta_{j-1} = \eta'_{j-1} = 0$. By the same reasoning as before, using corollary 2.34 and lemma 2.32 (recall that $\gamma \cap \mathcal{B}_1(n_1) = \emptyset$) we get that $\Phi(\omega)_v = \Phi(\omega')_v$ for all $v \in \cup_{i > j} B_i$. Thus $\eta_i = \eta'_i$ for all $i \neq j$ and $\eta_{j-1} = \eta'_{j-1} = 0$ as required.
- 2) $a = 1$. Again corollary 2.34 guarantees that $\Phi(\omega)_i = \Phi(\omega^x)_i$ for all $i \in \cup_{j=2}^N B_j$ so that $\eta_b = \eta'_b$ for all $b \geq 2$.

□

2.5.4 Density of droplets and proof of proposition 2.27

The core of the proof of proposition 2.27 consists in bounding from above the probabilities of the events $\mathcal{B}_1, \mathcal{B}_2$ defined in (2.11), (2.13). The first key bound is lemma 2.35, that says that the probability that the $DB_V^{1,0}$ -process restricted to an arbitrary number of consecutive columns of V is able to infect any given interval of the last column of length ℓ is $e^{-\Omega((\log q)^2/q)}$. The second key ingredient is lemma 2.37 that bounds from above the probability of the event $\mathcal{B}_2(n_2 - 1)$. Before stating the lemmas we need some additional notation.

Given $1 \leq i \leq j \leq N$, let $\Lambda = \cup_{k=i}^j \mathcal{L}_k$, where, for each $k = i, \dots, j$, $\mathcal{L}_k \supseteq \mathcal{C}_k$ is a (finite) interval of $\{(k - N, j) : j \in \mathbb{Z}\}$. Let also $I \subseteq \mathcal{C}_j$ be an

interval of length ℓ and $\tau \in \{0, 1\}^{\partial\Lambda}$ a boundary condition. The basic event that we will consider is

$$\mathcal{O}_\Lambda^\tau(I) = \{\omega \in \Omega: I \subseteq [Y(\omega) \cap \Lambda]_\Lambda^\tau\},$$

where we recall $Y(\omega)$ is the set of infected vertices of ω . Notice that $\mathcal{O}_\Lambda^\tau(I)$ is an increasing event (*i.e.* its indicator function is an increasing function) with respect to the partial order: $\omega \prec \omega'$ if and only if $\omega'_x \leq \omega_x \forall x$. Our first main lemma reads as follows.

Lemma 2.35 (Density of up-arrows). *Choose the basic scales N, ℓ, n_1, n_2 as in (2.8), (2.9) and (2.15). Then there exists $c > 0$ such that, for any $\varepsilon > 0$ sufficiently small and any $1 \leq i \leq j \leq N$,*

$$\max_I \mu(\mathcal{O}_{V_{i,j}}^{1,0}(I)) \leq e^{-c(\log q)^2/q}, \quad \text{as } q \rightarrow 0,$$

where $V_{i,j} = \cup_{k=i}^j \mathcal{C}_k$.

Proof of lemma 2.35. Fix $1 \leq i \leq j \leq N$ together with an interval $I \subset \mathcal{C}_j$ of length ℓ and let

$$\Lambda_{1,j} = \cup_{i=1}^j \{(i, k): |k| < N^2\} - N\vec{e}_1.$$

We first claim that

$$\mu(\mathcal{O}_{V_{i,j}}^{1,0}(I)) \leq \mu(\mathcal{O}_{V_{1,j}}^{1,0}(I)) \leq O(1/q^2)\mu(\mathcal{O}_{\Lambda_{1,j}}^1(I)) \quad \text{as } q \rightarrow 0. \quad (2.16)$$

The first inequality follows from (C) in lemma 2.16. To prove the second one, let $G = \cap_{k=1}^{j-1} G_k$, where G_k denotes the event that there is an empty site within the first $\lfloor N/3 \rfloor$ sites and within the last $\lfloor N/3 \rfloor$ sites of \mathcal{C}_k . Then, for any choice of the constant ε appearing in (2.8), (2.9) and (2.15),

$$\mu(G^c) \leq 2N(1-q)^{\frac{N}{3}-1} = o(1) \quad \text{as } q \rightarrow 0.$$

For any $\omega \in G$ and any boundary condition τ for $V_{1,j}$ such that $\tau \equiv 0$ on $\partial_\perp \mathcal{C}_j$ and $\tau_\parallel \equiv 1$, the screening property and translation invariance imply that $[Y(\omega) \cap V_{1,j}]_{V_{1,j}}^\tau \cap \mathcal{C}_j$ does not depend on τ . Hence,

$$\mathcal{O}_{V_{1,j}}^{1,0}(I) \cap G = \mathcal{O}_{V_{1,j}}^\tau(I) \cap G. \quad (2.17)$$

Choose τ equal to one everywhere except for $\partial_\perp \mathcal{C}_j$ where it is equal to zero. Using the FKG inequality and (2.17),

$$\begin{aligned} \mu\left(\mathcal{O}_{V_{1,j}}^{1,0}(I)\right) &\leq \mu\left(\mathcal{O}_{V_{1,j}}^{1,0}(I) \mid G\right) = \mu\left(\mathcal{O}_{V_{1,j}}^\tau(I) \mid G\right) \\ &\leq (1 + o(1))\mu\left(\mathcal{O}_{V_{1,j}}^\tau(I)\right). \end{aligned}$$

We now observe that, starting from $Y(\omega)$, we can construct the set $[Y(\omega) \cap V_{1,j}]_{V_{1,j}}^{\bar{\tau}} \cap \mathcal{C}_j$ as follows. We first output the set $[Y(\omega) \cap V_{1,j-1}]_{V_{1,j-1}}^1$ and we let $\bar{\tau} \in \{0,1\}^{\partial \mathcal{C}_j}$ be such that $\bar{\tau}_\perp \equiv 0$ and $\{x \in \partial \mathcal{C}_j : \bar{\tau}_x = 0\} = [Y(\omega) \cap V_{1,j-1}]_{V_{1,j-1}}^1 \cap \partial \mathcal{C}_j$. Then we output the set $[Y(\omega) \cap \mathcal{C}_j]_{\mathcal{C}_j}^{\bar{\tau}}$ which clearly coincides with $[Y(\omega) \cap V_{1,j}]_{V_{1,j}}^{\bar{\tau}} \cap \mathcal{C}_j$.

Monotonicity and a moment of thought imply that if we repeat the above construction with $V_{1,j-1}, \mathcal{C}_j$ replaced by $\Lambda_{1,j-1}, \{(j-N, k) : |k| < N^2\}$ and $Y(\omega)$ replaced by $Y(\omega) \cup \partial_\perp \mathcal{C}_j$, then the final infection in \mathcal{C}_j cannot decrease. Hence

$$\mu \left(\mathcal{O}_{V_{1,j}}^{\bar{\tau}}(I) \right) \leq \mu \left(\mathcal{O}_{\Lambda_{1,j}}^1(I) \mid \omega_{\partial_\perp \mathcal{C}_j} \equiv 0 \right) \leq \mu \left(\mathcal{O}_{\Lambda_{1,j}}^1(I) \right) / q^2,$$

and (2.16) follows.

Let now $T(\mathcal{U})$ be the median of the infection time of the origin (or of any other vertex of \mathbb{Z}^2 because of translation invariance) for the Duarte bootstrap process in \mathbb{Z}^2 started from $Y(\omega)$ where ω has law μ , and write

$$p(N, \ell) := \max_{j \leq N} \max_I \mu(\mathcal{O}_{\Lambda_{1,j}}^1(I)), \quad (2.18)$$

where \max_I is taken over all intervals $I \subset \mathcal{C}_j$ of length ℓ .

Claim 2.36. *If $\varepsilon < 1/4$ then, for all q small enough,*

$$p(N, \ell) \geq e^{-\frac{1}{16q} \log(q)^2}, \quad (2.19)$$

implies

$$T(\mathcal{U}) \leq O(N^3) e^{\frac{1}{16q} \log(q)^2}.$$

Before proving the claim we conclude the proof of lemma 2.35. It follows from the main result of [BDCMS17] together with a standard (and straightforward) argument that

$$T(\mathcal{U}) \geq e^{(1-o(1)) \log(q)^2 / 8q} \quad \text{as } q \rightarrow 0,$$

implying that for all q small enough

$$p(N, \ell) \leq e^{-\frac{1}{16q} \log(q)^2},$$

if $\varepsilon < 1/48$. □

Proof of the claim. In the sequel it will help to refer to figure 2.5 as a visual guide for the various definitions. Fix q arbitrarily small and let j be such that there exists an interval $I \subset \mathcal{C}_j$ of length ℓ such that

$$\mu(\mathcal{O}_{\Lambda_{1,j}}^1(I)) \geq e^{-\frac{1}{16q} \log(q)^2}. \quad (2.20)$$

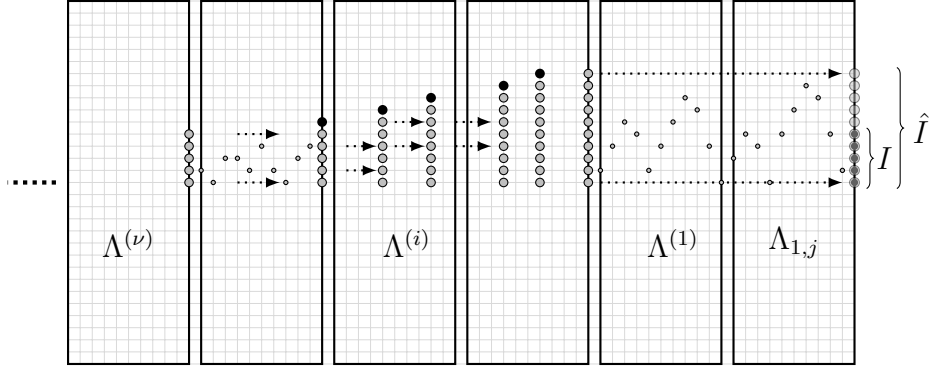

Figure 2.5: A subset of the collection of boxes $\Lambda^{(i)}$ forming \mathcal{M}_t . On the last column of $\Lambda_{1,j}$ the two intervals $\hat{I} \supset I$. The little gray dots denote suitable sparse single infected sites, one for each relevant column, and they have been drawn only for the initial and final stage of the infection process. The large gray dots on the right boundary of $\Lambda^{(\nu)}$ represent a shifted copy of I which is infected by the $DB_{\Lambda^{(\nu)}}^1$ -process. This infected interval propagates to the right until reaching the first site of the empty upward stair (black dots). At this stage the interval grows vertically by one unit. This process continues until the interval has become a shifted copy of the interval \hat{I} . The latter interval is able to continue moving to the right until infecting the interval \hat{I} .

Using the symmetry with respect to the horizontal axis we can assume that x_I , the lowest site of I , has non positive height. Write $\Lambda^{(i)} := \Lambda_{1,j} - ij\vec{e}_1$ and let $\mathcal{M}_t = \cup_{i=0}^t \Lambda^{(i)}$, where $t = 10 \lceil \max(p(N, \ell)^{-1}, 8/q^4) \rceil$. We shall define two increasing events $\mathcal{G}_1, \mathcal{G}_2 \subset \Omega$, depending only on $\omega \upharpoonright_{\mathcal{M}_t}$, such that:

- (a) if $\omega \in \mathcal{G}_1 \cap \mathcal{G}_2$ then the Duarte bootstrap process in \mathbb{Z}^2 is able to infect x_I within time $(2t+1)j(2N^2-1)$.
- (b) $\mu(\mathcal{G}_k) > 3/4$, $k = 1, 2$.

Using the FKG inequality, $\mu(\mathcal{G}_1 \cap \mathcal{G}_2) \geq \mu(\mathcal{G}_1)\mu(\mathcal{G}_2) > 1/2$. Hence

$$T(\mathcal{U}) \leq (2t+1)j(2N^2-1) \leq 60N^3 e^{\frac{1}{16q} \log(q)^2}.$$

In order to define $\mathcal{G}_1, \mathcal{G}_2$, let $\hat{I} \supset I$ be the interval of \mathcal{C}_j of length $\lceil 1/q^3 \rceil$ and whose lowest site is x_I . Then:

$$\begin{aligned} \mathcal{G}_1 &= \{\forall k \in [jt], \text{ the interval } \hat{I} - (k-1)\vec{e}_1 \text{ contains an empty vertex}\}; \\ \mathcal{G}_2 &= \{\exists k \in [jt]: \text{ the } DB_{\mathcal{M}_t}^1\text{-process starting from } Y(\omega) \cap \mathcal{M}_t \\ &\quad \text{is able to infect } \hat{I} - k\vec{e}_1\}. \end{aligned}$$

We now verify properties (a) and (b) above. We observe that the event \mathcal{G}_2 guarantees that there exists a leftmost interval of the form $\hat{I} - k\vec{e}_1$ which is infected by the Duarte bootstrap process within time $(t+1)j(2N^2-1)^8$. The event \mathcal{G}_1 , together with the definition of the Duarte update family \mathcal{U} , makes sure that the infection of $\hat{I} - k\vec{e}_1$ gets propagated forward to $\hat{I} - (k-1)\vec{e}_1, \dots$, until it reaches the original interval \hat{I} in at most $tj(2N^2-1)$ steps. Hence, within time $(2t+1)j(2N^2-1)$ the vertex x_I becomes infected and (a) follows.

It remains to verify (b). The union bound over k gives that for any $\varepsilon > 0$

$$\mu(\mathcal{G}_1^c) \leq jt(1-q)^{\lceil 1/q^3 \rceil} \leq e^{-\Omega(1/q^2)} \quad \text{as } q \rightarrow 0,$$

using (2.19) and $j \leq N$.

In order to bound from below $\mu(\mathcal{G}_2)$, write

$$\nu := \min\{\max\{k \in [t/2, t]: \text{the event } \mathcal{O}_{\Lambda^{(k)}}^1(I - kj\vec{e}_1) \text{ occurs}\}, \infty\},$$

and let $\mathcal{F} = \cap_{i=1}^3 \mathcal{F}_i$ where, on the event $\{\nu < +\infty\}$:

- $\mathcal{F}_1 = \{\nu \leq t\}$;
- $\mathcal{F}_2 = \{\forall k \in \lceil [2/q^4] \rceil \text{ the interval } I - \nu j\vec{e}_1 + k\vec{e}_1 \text{ contains an empty vertex}\}$;
- $\mathcal{F}_3 = \{\exists \text{ an upward empty stair of } n = \lceil 1/q^3 \rceil \text{ sites belonging to the first } \lceil 2/q^4 \rceil \text{ columns of } \mathcal{M}_t \text{ immediately to the right of } \Lambda^{(\nu)}, \text{ i.e. a sequence } (x_1, \dots, x_n) \text{ of empty sites of the form } x_m = (j_m, h_I + m), \text{ where } h_I \text{ is the height of the uppermost site of } I \text{ and } \{j_m\}_{m=1}^n \text{ is a strictly increasing sequence}\}$.

We begin by observing that $\mathcal{F} \subseteq \mathcal{G}_2$. In fact, \mathcal{F}_1 guarantees the right amount of infection of the last column of $\Lambda^{(\nu)}$ under healthier boundary condition than those required by \mathcal{G}_2 . \mathcal{F}_2 ensures that such an infection propagates over to the first $\lceil 2/q^4 \rceil$ columns to the right of $\Lambda^{(\nu)}$ while \mathcal{F}_3 guarantees that each time the infection meets an empty site of the upward stair it grows vertically by one unit (see figure 2.5). Since the stair contains $\lceil 1/q^3 \rceil$ sites, the $\lceil 2/q^4 \rceil^{\text{th}}$ -column of \mathcal{M}_t to the right of $\Lambda^{(\nu)}$ contains an infected interval which is the appropriate horizontal translation of the interval \hat{I} and the inclusion $\mathcal{F} \subseteq \mathcal{G}_2$ follows.

Conditionally on $\{\nu = k\}$, the events $\mathcal{F}_2, \mathcal{F}_3$ coincide with two increasing events depending only on sites to the right of $\Lambda^{(k)}$. Hence, using the FKG

⁸The worst case is when sites are infected one by one.

inequality,

$$\begin{aligned}\mu(\mathcal{G}_2) &\geq \mu(\mathcal{F}) = \sum_{k \in [t/2, t]} \mu(\nu = k) \mu(\mathcal{F}_2 \cap \mathcal{F}_3 \mid \nu = k) \\ &\geq \sum_{k \in [t/2, t]} \mu(\nu = k) \mu(\mathcal{F}_2 \mid \nu = k) \mu(\mathcal{F}_3 \mid \nu = k).\end{aligned}$$

A union bound gives that, uniformly in $k \in [t/2, t]$,

$$\mu(\mathcal{F}_2^c \mid \nu = k) \leq [2/q^4] (1 - q)^\ell \leq [2/q^4] q^{1/\varepsilon} (1 + o(1)) = o(1),$$

if $\varepsilon < 1/4$. Using the fact that $X(\omega) := \min\{i \geq 1 : \omega_{(i,+1)} = 0\}$ is a geometric random variable of parameter q , it is easy to check that

$$\mu(\mathcal{F}_3^c \mid \nu = k) \leq \mathbb{P} \left(\sum_{i=1}^n X_i > [2/q^4] \right),$$

where $\{X_i\}_{i=1}^n$ are i.i.d. copies of X . A standard exponential Markov inequality with $\lambda = \alpha q$, $\alpha \in (0, 1)$, gives

$$\begin{aligned}\mathbb{P} \left(\sum_{i=1}^n X_i > [2/q^4] \right) &\leq e^{-\lambda [2/q^4]} (\mathbb{E} (e^{\lambda X}))^n \\ &\leq \left(\frac{e^{-2\alpha}}{(1 - \alpha)(1 + o(1))} \right)^{1/q^3} < (1 - \alpha/2)^{1/q^3},\end{aligned}$$

for α small enough. In conclusion, if $\varepsilon < 1/4$,

$$\begin{aligned}\mu(\mathcal{G}_2) &\geq (1 - o(1)) \mu(\mathcal{F}_1) \\ &\geq (1 - o(1)) \left(1 - \left(1 - \mu(\mathcal{O}_{\Lambda_{1,j}}^1(I)) \right)^{t/2} \right) \geq (1 - o(1)) (1 - e^{-4})\end{aligned}$$

because of (2.20) and our choice of t . That concludes the proof of property (b). \square

We now turn to the second basic lemma. Recall the definition (2.13) of the event \mathcal{B}_2 .

Lemma 2.37. *Choose the basic scales N, ℓ, n_1, n_2 as in (2.8), (2.9) and (2.15). Then, for ε small enough,*

$$\mu(\mathcal{B}_2(n_2 - 1)) \leq e^{-\Omega(1/q^5)}, \quad \text{as } q \rightarrow 0.$$

Proof of lemma 2.37. Call $\mathcal{H}_{i,j}$ the event $\bigcap_{k=i}^j \{\omega \in \Omega: \Phi(\omega)_k = \downarrow\} \cap \mathcal{G}_{i,j}$, where $\mathcal{G}_{i,j}$ has been defined in (2.14). Clearly

$$\mu(\mathcal{B}_2(n_2 - 1)) \leq \sum_{\substack{i,j \\ j-i \geq n_2-2}} \mu(\mathcal{H}_{i,j}) \leq N^2 \max_{\substack{i,j \in [N] \\ j-i \geq n_2-2}} \mu(\mathcal{H}_{i,j}),$$

and it is enough to prove that

$$\max_{\substack{i,j \in [N] \\ j-i \geq n_2-2}} \mu(\mathcal{H}_{i,j}) \leq e^{-\Omega(1/q^5)}. \quad (2.21)$$

For this purpose we first describe one important implication of the event $\mathcal{H}_{i,j}$.

Claim 2.38. *For any $\omega \in \mathcal{H}_{i,j}$ there exists $h \in \mathbb{Z}$ satisfying $|h| \leq N^2 - (j-1)N + (j-i)\ell$, such that*

$$C_h := \left(\bigcup_{k=i}^j \{(k-N, h)\} \right) \cap V_{i,j} \subseteq [Y(\omega) \cap V_{i,j}]_{V_{i,j}}^{1,0}.$$

Moreover C_h has length at least $(j-i)(1-o(1)) \geq n_2(1-o(1))$ as $q \rightarrow 0$.

Proof of the claim. Given $\omega \in \mathcal{H}_{i,j}$ let $\Gamma = (x^{(1)}, \dots, x^{(n)}) \subseteq [Y(\omega) \cap V_{i,j}]_{V_{i,j}}^{1,0}$ be a Duarte path from \mathcal{C}_i to \mathcal{C}_j . Since $\Phi(\omega)_k = \downarrow$ for all $k \in \{i, \dots, j\}$ necessarily the cardinality of $\Gamma \cap \mathcal{C}_k$ is at most ℓ for all $k \in \{i, \dots, j\}$. Therefore the height h of $x^{(1)}$ satisfies

$$|h| \leq N^2 - (j-1)N + (j-i)\ell,$$

which, in turn, implies that the corresponding interval C_h has length greater than the largest integer m such that

$$N^2 - (i-1)N - mN \geq N^2 - (j-1)N + (j-i)\ell.$$

Using that $m+1$ violates the above inequality we get

$$m \geq (j-i)(1-\ell/N) - 1 \geq (1-o(1))n_2.$$

The fact that $C_h \subseteq [Y(\omega) \cap V_{i,j}]_{V_{i,j}}^{1,0}$ follows from corollary 2.18. \square

It is now easy to finish the proof of the lemma. As in the proof of claim 2.36 and using a union bound over the possible value of the variable h of the claim, with probability larger than

$$1 - 2N^2 e^{-\Omega(qn_2)} \geq 1 - e^{-\Omega(1/q^5)},$$

every interval C_h as above with $|h| \leq N^2 - (j-1)N + (j-i)\ell$ meets an empty upward stair, *i.e.* a sequence (x_1, \dots, x_ℓ) of empty sites belonging to the first $n_2/2$ columns crossed by C_h and such that $x_m = (j_m, h+m)$ with $j_m < j_{m+1}$ for all $m \in [\ell]$. If C_h is also infected, then the presence of the above empty stair implies that there exist $i \leq k \leq i + \frac{2}{3}n_2$ and a vertical interval $I \subseteq \mathcal{C}_k$ of length at least ℓ such that $I \subseteq [Y(\omega) \cap V_{i,j}]_{V_{i,j}}^{1,0}$. The latter property implies that $\Phi(\omega)_k = \uparrow$. Hence $\mu(\mathcal{H}_{i,j})$ satisfies (2.21) uniformly in $j-i \geq n_2 - 2$. \square

2.5.5 Finishing the proof of proposition 2.27

Recall the definition 2.25 of the test function ϕ and of the events $\Omega_g, \Omega_\downarrow$ and $\mathcal{A}_{\varepsilon,q}$. Notice that $\Omega_g \cap \mathcal{B}_2(n_2 - 1)^c \subseteq \mathcal{A}_{\varepsilon,q}$ and that Ω_\downarrow is a decreasing event. Using lemma 2.37 we get

$$\begin{aligned} \mu(\phi) &\geq \mu(\mathcal{A}_{\varepsilon,q}) \geq \mu(\Omega_g \cap \mathcal{B}_2(n_2 - 1)^c) \\ &\geq \mu(\Omega_\downarrow) \mu\left(\prod_{|k| \leq \ell} \omega_{(0,k)} = 1\right) - \mu(\mathcal{B}_2(n_2 - 1)) \\ &\geq \mu(\Omega_\downarrow) (1 - q)^{2\ell+1} - e^{-\Omega(1/q^5)} \geq q^{O(1)} \mu(\Omega_\downarrow) - e^{-\Omega(1/q^5)}, \end{aligned}$$

where in the third inequality we used the FKG inequality. Using lemma 2.35 and a union bound,

$$\begin{aligned} \mu(\Omega_\downarrow) &\geq 1 - \mu\left(\bigcup_{j=1}^N \bigcup_{I \in \mathcal{I}_j(\ell)} \mathcal{O}_{V_{1,j}}^{1,0}(I)\right) \\ &\geq 1 - 4e^{-(c-5\varepsilon)(\log q)^2/q} = 1 - o(1) \end{aligned}$$

if ε is small enough, where we let $\mathcal{I}_j(\ell)$ be the family of intervals of the j^{th} -column whose length is at least ℓ . In conclusion $\mu(\phi) \geq q^{O(1)}$ for ε small enough.

We now turn to bound from above the Dirichlet form $\mathcal{D}(\phi)$. By definition, writing $\mathcal{A} \equiv \mathcal{A}_{\varepsilon,q}$ for notation convenience,

$$\begin{aligned} \mathcal{D}(\phi) &= \sum_{x \in \mathbb{Z}^2} \mu(c_x \text{Var}_x(\phi)) = \sum_{x \in V} \mu(c_x \text{Var}_x(\phi)) \\ &= \mu(\mathcal{A})^{-1} q(1-q) \sum_{x \in V} \mu(c_x(\omega) \mathbb{1}_{\{\omega \in \mathcal{A}\}} \mathbb{1}_{\{\omega^x \notin \mathcal{A}\}} + c_x(\omega) \mathbb{1}_{\{\omega \notin \mathcal{A}\}} \mathbb{1}_{\{\omega^x \in \mathcal{A}\}}) \\ &\leq \mu(\mathcal{A})^{-1} \sum_{x \in V} \mu(c_x(\omega) \mathbb{1}_{\{\omega \in \mathcal{A}\}} \mathbb{1}_{\{\omega^x \notin \mathcal{A}\}}) \end{aligned}$$

where we used the fact that ϕ depends only on $\{\omega_x\}_{x \in V}$ in the second equality and made the change of variable $\omega \rightarrow \omega^x$ in the term $c_x(\omega) \mathbb{1}_{\{\omega \notin \mathcal{A}\}} \mathbb{1}_{\{\omega^x \in \mathcal{A}\}}$ in the inequality. Next we observe that

$$\begin{aligned}
& \sum_{x \in V} \mu \left(c_x(\omega) \mathbb{1}_{\{\omega \in \mathcal{A}\}} \mathbb{1}_{\{\omega^x \notin \mathcal{A}\}} \right) \\
& \leq \sum_{x \in V} \mu \left(c_x(\omega) \mathbb{1}_{\{\omega \in \mathcal{A}\}} \mathbb{1}_{\{\omega^x \in \mathcal{A}^c, \omega^x \in \mathcal{B}_2(n_2-1)^c\}} \right) + \sum_{x \in V} \mu \left(\mathbb{1}_{\{\omega^x \in \mathcal{B}_2(n_2-1)\}} \right) \\
& \leq \sum_{x \in V} \mu \left(c_x(\omega) \mathbb{1}_{\{\omega \in \mathcal{A}\}} \mathbb{1}_{\{\omega^x \in \mathcal{A}^c, \omega^x \in \mathcal{B}_2(n_2-1)^c\}} \right) + |V| \left((1-q)/q \right) \mu \left(\mathcal{B}_2(n_2-1) \right) \\
& \leq \sum_{x \in V} \mu \left(c_x(\omega) \mathbb{1}_{\{\omega \in \mathcal{A}\}} \mathbb{1}_{\{\omega^x \in \mathcal{A}^c, \omega^x \in \mathcal{B}_2(n_2-1)^c\}} \right) + e^{-\Omega(1/q^5)},
\end{aligned} \tag{2.22}$$

where in the last inequality we used lemma 2.37 and the bound $|V| \leq 2N^3 \leq e^{O((\log q)^2/q)}$.

Given $x \in V$, let $\omega \in \mathcal{A}$ be such that $c_x(\omega) = 1$ and $\omega^x \in \mathcal{A}^c \cap \mathcal{B}_2(n_2-1)^c$ and recall that $N_\uparrow(\omega)$ counts the number of up-arrows in $\Phi(\omega)$. We claim that $N_\uparrow(\omega^x) \geq n_1 - 1$. To prove the claim, let γ be a legal path connecting Ω_g to $(\omega_V, \tilde{\omega}_{V^c} \equiv 0)$ such that $\gamma \cap \mathcal{B}_i(n_i - 1) = \emptyset$, $i = 1, 2$ and let γ^x be the path connecting Ω_g to $(\omega_V^x, \tilde{\omega}_{V^c} \equiv 0)$ obtained by adding to γ the transition $(\omega_V, \tilde{\omega}_{V^c} \equiv 0) \rightarrow (\omega_V^x, \tilde{\omega}_{V^c} \equiv 0)$. The path γ^x is legal because γ is legal and $c_x(\omega) = 1$. Moreover $\gamma^x \cap \mathcal{B}_2(n_2 - 1) = \emptyset$ because $\omega^x \notin \mathcal{B}_2(n_2 - 1)$. The assumption $\omega^x \in \mathcal{A}^c$ implies that $\gamma^x \cap \mathcal{B}_1(n_1 - 1) \neq \emptyset$. Using $\gamma \cap \mathcal{B}_1(n_1 - 1) = \emptyset$ the latter requirement becomes $N_\uparrow(\omega^x) \geq n_1 - 1$ and the claim follows.

In conclusion,

$$\begin{aligned}
\sum_{x \in V} \mu \left(c_x(\omega) \mathbb{1}_{\{\omega \in \mathcal{A}\}} \mathbb{1}_{\{\omega^x \in \mathcal{A}^c, \omega^x \in \mathcal{B}_2(n_2-1)^c\}} \right) & \leq \sum_{x \in V} \mu \left(N_\uparrow(\omega^x) \geq n_1 - 1 \right) \\
& \leq |V| \left((1-q)/q \right) \mu \left(N_\uparrow(\omega) \geq n_1 - 1 \right).
\end{aligned}$$

We finally bound from above $\mu \left(N_\uparrow(\omega) \geq n_1 - 1 \right)$ using lemma 2.35. Given $n \geq n_1 - 1$ and $E = \{j_1 < \dots < j_n\}$, $j_i \in [N]$, let \mathcal{N}_E be the event that $\Phi(\omega)_j = \uparrow$ if $j \in E$ and $\Phi(\omega)_j = \downarrow$ otherwise. By construction

$$\mu(\mathcal{N}_E) \leq \mu \left(\bigcap_{k=1}^n \mathcal{Q}_{V_{j_{k-1}+1, j_k}}^{1,0} \right) \leq \left(\max_{i \leq j} \mu(\mathcal{Q}_{V_{i,j}}^{1,0}) \right)^n,$$

where $j_0 := 0$ and

$$\mathcal{Q}_{V_{i,j}}^{1,0} = \{ \exists I \in \mathcal{I}_j(\ell) \text{ such that } I \subseteq [Y(\omega) \cap V_{i,j}]_{V_{i,j}}^{1,0} \}.$$

where we recall that $\mathcal{I}_j(\ell)$ is the family of intervals of the j^{th} -column whose length is at least ℓ . Lemma 2.35 together with a union bound over $I \in \mathcal{I}_j(\ell)$ give

$$\begin{aligned} \max_{i \leq j} \mu \left(\mathcal{Q}_{V_{i,j}}^{1,0} \right) &\leq \max_{i \leq j} \sum_{I \in \mathcal{I}_j(\ell)} \mu \left(I \subseteq [Y(\omega) \cap V_{i,j}]_{V_{i,j}}^{1,0} \right) \\ &\leq 4N^4 \max_{i \leq j} \max_{I \in \mathcal{I}_j(\ell)} \mu \left(I \subseteq [Y(\omega) \cap V_{i,j}]_{V_{i,j}}^{1,0} \right) \leq e^{-(c-4\varepsilon)(\log q)^2/2q}. \end{aligned}$$

In conclusion, for any ε small enough,

$$\begin{aligned} \mu(N_{\uparrow}(\omega) \geq n_1 - 1) &\leq \sum_{n=n_1-1}^N \binom{N}{n} e^{-(c-4\varepsilon)n(\log q)^2/2q} \\ &\leq \sum_{n=n_1-1}^N \left(N e^{-(c-4\varepsilon)(\log q)^2/2q} \right)^n \\ &\leq e^{-\varepsilon \Omega((\log q)^4/q^2)}, \end{aligned}$$

because of the choice of $n_1 = \varepsilon(\log q)^2/2q$. In conclusion, the right-hand side of (2.22) is smaller than $e^{-\varepsilon \Omega((\log q)^4/q^2)}$ and the proof of proposition 2.27 is complete. \square

Chapter 3

Asymptotics for critical kinetically constrained models with an infinite number of stable directions

This chapter corresponds to the article *Universality for critical kinetically constrained models: infinite number of stable directions* [HMT19a], written in collaboration with Ivailo Hartarsky and Cristina Toninelli.

Kinetically constrained models (KCMs) are reversible interacting particle systems on \mathbb{Z}^d with continuous-time constrained Glauber dynamics. They are a natural non-monotone stochastic version of the family of cellular automata with random initial state known as \mathcal{U} -bootstrap percolation. KCMs have an interest in their own right, owing to their use for modelling the liquid-glass transition in condensed matter physics.

In two dimensions there are three classes of models with qualitatively different scaling of the infection time of the origin as the density of infected sites vanishes. Here we study in full generality the class termed “critical”. Together with the companion paper by Martinelli and two of the authors [HMT19b] we establish the universality classes of critical KCMs and determine within each class the critical exponent of the infection time as well as of the spectral gap. In this work we prove that for critical models with an infinite number of stable directions this exponent is twice the one of their bootstrap percolation counterpart. This is due to the occurrence of “energy barriers”, which determine the dominant behavior for these KCMs but which do not matter for the monotone bootstrap dynamics. Our result confirms the conjecture

of Martinelli, Morris and the last author [MMT19], who proved a matching upper bound.

3.1 Introduction

Kinetically constrained models (KCMs) are interacting particle systems on the integer lattice \mathbb{Z}^d , which were introduced in the physics literature in the 1980s by Fredrickson and Andersen [FA84] in order to model the liquid-glass transition (see e.g. [RS03, GST11] for reviews), a major and still largely open problem in condensed matter physics [BB11]. A generic KCM is a continuous-time Markov process of Glauber type characterised by a finite collection \mathcal{U} of finite nonempty subsets of $\mathbb{Z}^d \setminus \{0\}$, its *update family*. A configuration ω is defined by assigning to each site $x \in \mathbb{Z}^d$ an *occupation variable* $\omega_x \in \{0, 1\}$, corresponding to an *empty* or *occupied* site respectively. Each site $x \in \mathbb{Z}^d$ waits an independent, mean one, exponential time and then, if and only if there exists $U \in \mathcal{U}$ such that $\omega_y = 0$ for all $y \in U + x$, site x is updated to empty with probability q and to occupied with probability $1 - q$. Since each $U \in \mathcal{U}$ is contained in $\mathbb{Z}^d \setminus \{0\}$, the constraint to allow the update does not depend on the state of the to-be-updated site. As a consequence, the dynamics satisfies detailed balance with respect to the product Bernoulli($1 - q$) measure, μ , which is therefore a reversible invariant measure. Hence the process started at μ is stationary.

Both from a physical and from a mathematical point of view, a central issue for KCMs is to determine the speed of divergence of the characteristic time scales when $q \rightarrow 0$. Two key quantities are: (i) the *relaxation time* T_{rel} , i.e. the inverse of the spectral gap of the Markov generator (see definition 3.5) and (ii) the *mean infection time* $\mathbb{E}(\tau_0)$, i.e. the mean over the stationary process started at μ of the first time at which the origin becomes empty. Several works have been devoted to the study of these time scales for some specific choices of the constraints [AD02, CMRT08, MMTar, CFM14, CFM16, MT19] (see also [GST11] section 1.4.1 for a non exhaustive list of references in the physics literature). These results show that KCMs exhibit a very large variety of possible scalings depending on the update family \mathcal{U} . A question that naturally emerges, and that has been first addressed in [MMT19], is whether it is possible to group all possible update families into distinct *universality classes* so that all models of the same class display the same divergence of the time scales.

Before presenting the results and the conjectures of [MMT19], we should describe the key connection of KCMs with a class of discrete monotone cellular automata known as \mathcal{U} -bootstrap percolation (or simply bootstrap perco-

lation) [BSU15]. For \mathcal{U} -bootstrap percolation on \mathbb{Z}^d , given an update family \mathcal{U} and a set A_t of sites *infected* at time t , the infected sites in A_t remain infected at time $t + 1$, and every site x becomes infected at time $t + 1$ if the translate by x of one of the sets in \mathcal{U} is contained in A_t . The set of initial infections A is chosen at random with respect to the product Bernoulli measure with parameter $q \in [0, 1]$, which identifies with μ : for every $x \in \mathbb{Z}^d$ we have $\mu(x \in A) = q$. One then defines the *critical probability* $q_c(\mathbb{Z}^d, \mathcal{U})$ to be the infimum of the q such that with probability one the whole lattice is eventually infected, namely $\bigcup_{t \geq 0} A_t = \mathbb{Z}^d$. A key time scale for this dynamics is the first time at which the origin is infected, τ_{BP} . In order to study this infection time for models on \mathbb{Z}^2 , the update families were classified by Bollobás, Smith and Uzzell [BSU15] into three universality classes: *supercritical*, *critical* and *subcritical*, according to a simple geometric criterion (see definition 3.1). In [BSU15] they proved that $q_c(\mathbb{Z}^2, \mathcal{U}) = 0$ if \mathcal{U} is supercritical or critical, and it was proved by Balister, Bollobás, Przykucki and Smith [BBPS16] that $q_c(\mathbb{Z}^2, \mathcal{U}) > 0$ if \mathcal{U} is subcritical. For supercritical update families, [BSU15] proved that $\tau_{\text{BP}} = q^{-\Theta(1)}$ with high probability as $q \rightarrow 0$, while in the critical case $\tau_{\text{BP}} = \exp(q^{-\Theta(1)})$. The result for critical families was later improved by Bollobás, Duminil-Copin, Morris and Smith [BDCMSar], who identified the critical exponent $\alpha = \alpha(\mathcal{U})$ such that $\tau_{\text{BP}} = \exp(q^{-\alpha+o(1)})$.

Back to KCMs, if we fix an update family \mathcal{U} and an initial configuration ω and we identify the empty sites with infected sites, a first basic observation is that the clusters of sites that will never be infected in the \mathcal{U} -bootstrap percolation correspond to clusters of sites which are occupied and will never be emptied under the KCM dynamics. A natural issue is whether there is a direct connection between the infection mechanism of bootstrap percolation and the relaxation mechanism for KCMs, and, more precisely, whether the scaling of T_{rel} and $\mathbb{E}(\tau_0)$ is connected to the typical value of τ_{BP} when the law of the initial infections is μ . It is not difficult to establish that $\mu(\tau_{\text{BP}})$ provides a lower bound for $\mathbb{E}(\tau_0)$ and T_{rel} (see lemma 4.3 of [MT19] and (3.8)), but in general, as we will explain, this lower bound does not provide the correct behavior.

In [MMT19], Martinelli, Morris and the last author proposed that the supercritical class should be refined into *unrooted* supercritical and *rooted* supercritical models in order to capture the richer behavior of KCMs. For unrooted models the scaling is of the same type as for bootstrap percolation, $T_{\text{rel}} \sim \mathbb{E}(\tau_0) = q^{-\Theta(1)}$ as $q \rightarrow 0$ (theorem 1(a) of [MMT19])¹, while for rooted models the divergence is much faster, $\mathbb{E}(\tau_0) \sim T_{\text{rel}} = e^{\Theta((\log q)^2)}$ (see

¹For the lower bound of T_{rel} one does not need to use the bootstrap percolation results, as $T_{\text{rel}} \geq q^{-\min_{U \in \mathcal{U}} |U|/|\mathcal{U}|}$ by plugging the test function $\mathbb{1}_{\{\omega_0=0\}}$ in definition 3.5.

theorem 1(b) of [MMT19] for the upper bound and theorem 4.2 of [MMTar]² for the lower bound).

Concerning the critical class, the lower bound with $\mu(\tau_{\text{BP}})$ mentioned above and the results of [BSU15] on bootstrap percolation imply that T_{rel} and $\mathbb{E}(\tau_0)$ diverge at least as $\exp(q^{-\Theta(1)})$. In [MMT19], an upper bound of the same form was established (theorem 2 of [MMT19]) and a conjecture (conjecture 3 of [MMT19]) was put forward on the value of the critical exponent ν such that both $\mathbb{E}(\tau_0)$ and T_{rel} scale as $\exp(|\log q|^{O(1)}/q^\nu)$, with ν in general different from the exponent of the corresponding bootstrap percolation process. Furthermore, a toolbox was developed for the study of the upper bounds, leading to upper bounds matching this conjecture for all models. The main issue left open in [MMT19] was to develop tools to establish sharp lower bounds. A first step in this direction was done by Martinelli and the last two authors [MMTar] by analyzing a specific critical model known as the Duarte model for which the update family contains all the 2-elements subsets of the North, South and West neighbors of the origin. Theorem 5.1 of [MMTar] establishes a sharp lower bound on the infection and relaxation times for the Duarte KCM that, together with the upper bound in theorem 2(a) of [MMT19], proves $\mathbb{E}^{\text{Duarte}}(\tau_0) = \exp(\Theta((\log q)^4/q^2))$ as $q \rightarrow 0$, and the same result holds for T_{rel} . The divergence is again much faster than for the corresponding bootstrap percolation model, for which it holds $\tau_{\text{BP}} = e^{\Theta((\log q)^2/q)}$ with high probability as $q \rightarrow 0$ [Mou95] (see also [BDCMS17], from which the sharp value of the constant follows), namely the critical exponent for the Duarte KCM is twice the critical exponent for the Duarte bootstrap percolation.

Both for Duarte and for supercritical rooted models, the sharper divergence of time scales for KCMs is due to the fact that the infection time of KCMs is not well approximated by the infection mechanism of the monotone bootstrap percolation process, but is instead the result of a much more complex infection/healing mechanism. Indeed, visiting regions of the configuration space with an anomalous amount of empty sites is heavily penalised and requires a very long time to actually take place. The basic underlying idea is that the dominant relaxation mechanism is an *East-like dynamics* for large *droplets* of empty sites. Here East-like means that the presence of an empty droplet allows to empty (or fill) another adjacent droplet but only in a certain direction (or more precisely in a limited cone of directions). This is reminiscent of the relaxation mechanism for the East model, a prototype one-dimensional KCM for which x can be updated if and only if $x - 1$ is empty, thus a single empty site allows to create/destroy an empty site only on its

²Chapter 2 of this thesis.

right (see [FMRT13] for a review on the East model). For supercritical rooted models, the empty droplets that play the role of the single empty sites for East have a finite (model dependent) size, hence an equilibrium density $q_{\text{eff}} = q^{\Theta(1)}$. For the Duarte model, droplets have a size that diverges as $\ell = |\log q|/q$ and thus an equilibrium density $q_{\text{eff}} = q^\ell = e^{-(\log q)^2/q}$. Then a (very) rough understanding of the results of [MMTar, MMT19] is obtained by replacing q with q_{eff} in the time scale for the East model $T_{\text{rel}}^{\text{East}} = e^{\Theta((\log q)^2)}$ [AD02]. The main technical difficulty to translate this intuition into a lower bound is that the droplets cannot be identified with a rigid structure. In [MMTar] this difficulty for the Duarte model was overcome by an algorithmic construction that allows to sequentially scan the system in search of sets of empty sites that *could* (without violating the constraint) empty a certain rigid structure. These are the droplets that play the role of the empty sites for the East dynamics.

In [MMT19] all critical models which have an *infinite number of stable directions* (see section 3.2.1), of which the Duarte model is but one example, were conjectured to have a critical exponent $\nu = 2\alpha$, with $\alpha = \alpha(\mathcal{U})$ the critical exponent of the corresponding bootstrap percolation dynamics (defined in definition 3.2). The heuristics is the same as for the Duarte model, the only difference being that droplets would have in general size $\ell = |\log q|^{O(1)}/q^\alpha$. However, the technique developed in [MMTar] for the Duarte model relies heavily on the specific form of the Duarte constraint and in particular on its oriented nature³, and it cannot be extended readily to this larger class.

In this work, together with the companion paper by Martinelli and two of the authors [HMT19b], we establish in full generality the universality classes for critical KCMs, determining the critical exponent for each class.

Here we treat all choices of \mathcal{U} for which there is an *infinite number of stable directions* and prove (theorem 3.8) a lower bound for T_{rel} and $\mathbb{E}(\tau_0)$ that, together with the matching upper bound of theorem 2 of [MMT19], yields

$$\mathbb{E}(\tau_0) = e^{|\log q|^{O(1)}/q^{2\alpha}}$$

for $q \rightarrow 0$ and the same result for T_{rel} . Our technique is somewhat inspired by the algorithmic construction of [MMTar], however, the nature of the droplets which move in an East-like way is here much more subtle, and in order to identify them we construct an algorithm which can be seen as a significant improvement on the α -covering and u -iceberg algorithms developed in the context of bootstrap percolation [BDCMSar].

³Note that, since the Duarte update rules contain only the North, South and West neighbors of the origin, the constraint at a site x does not depend on the sites with abscissa larger than the abscissa of x .

In the companion paper [HMT19b] we prove for the complementary class of models, namely all critical models with a *finite number of stable directions*, an upper bound that (together with the lower bound from bootstrap percolation) yields instead

$$\mathbb{E}(\tau_0) = e^{|\log q|^{O(1)}/q^\alpha}$$

for $q \rightarrow 0$ and the same result for T_{rel} .

A comparison of our results with conjecture 3 of [MMT19] is due. The class that we consider here is, in the notation of [MMT19], the class of models with *bilateral difficulty* $\beta = \infty$, hence belong to the α -rooted class defined therein. Therefore, our theorem 3.8 proves conjecture 3(a) in this case. We underline that it is not a limitation of our lower bound strategy that prevents us from proving conjecture 3(a) for the other α -rooted models, namely those with $2\alpha \leq \beta < \infty$. Indeed, as it is proven in the companion paper [HMT19b], in this case the conjecture of [MMT19] is not correct, since it did not take into account a subtle relaxation mechanism which allows to recover the same critical exponent as for the bootstrap percolation dynamics.

The plan of the paper is as follows. In section 3.2 we develop the background for both KCMs and bootstrap percolation needed to state our result, theorem 3.8. In section 3.3 we give a sketch of our reasoning and highlight the important points. In section 3.4 we gather some preliminaries and notation. Section 3.5 is the core of the paper — there we define the central notions and establish their key properties, culminating in the Closure Proposition 3.27. In section 3.6 we establish a connection between the KCM dynamics and an East dynamics and use this to wrap up the proof of theorem 3.8. Finally, in section 3.7 we discuss some open problems.

3.2 Models and background

3.2.1 Bootstrap percolation

Before turning to our models of interest, KCMs, let us recall recent universality results for the intimately connected bootstrap percolation models in two dimensions. \mathcal{U} -bootstrap percolation (or simply bootstrap percolation) is a very general class of monotone transitive local cellular automata on \mathbb{Z}^2 first studied in full generality by Bollobás, Smith and Uzzell [BSU15]. Let \mathcal{U} , called *update family*, be a finite family of finite nonempty subsets, called *update rules*, of $\mathbb{Z}^2 \setminus \{0\}$. Let A , called the set of *initial infections*, be an arbitrary subset of \mathbb{Z}^2 . Then the \mathcal{U} -bootstrap percolation dynamics is the

discrete time deterministic growth of infection defined by $A_0 = A$ and, for each $t \in \mathbb{N}$,

$$A_{t+1} = A_t \cup \{x \in \mathbb{Z}^2 : \exists U \in \mathcal{U}, U + x \subset A_t\}.$$

In other words, at any step each site becomes infected if a rule translated at it is already fully infected, and infections never heal. We define the *closure* of the set A by $[A] = \bigcup_{t \geq 0} A_t$ and we say that A is *stable* when $[A] = A$. The set of initial infections \bar{A} is chosen at random with respect to the product Bernoulli measure μ with parameter $q \in [0, 1]$: for every $x \in \mathbb{Z}^2$ we have $\mu(x \in \bar{A}) = q$.

Arguably, the most natural quantity to consider for these models is the typical (e.g. mean) value of τ_{BP} , the infection time of the origin.

The combined results of Bollobás, Smith and Uzzell [BSU15] and Balister, Bollobás, Przykucki and Smith [BBPS16] yield a pre-universality partition of all update families into three classes with qualitatively different scalings of the median of the infection time as $q \rightarrow 0$. In order to define this partition we will need a few definitions.

For any unitary vector $u \in S^1 = \{z \in \mathbb{R}^2 : \|z\| = 1\}$ ($\|\cdot\|$ denotes the Euclidean norm in \mathbb{R}^2) and any vector $x \in \mathbb{R}^2$ we denote $\mathbb{H}_u(x) = \{y \in \mathbb{R}^2 : \langle u, y - x \rangle < 0\}$ — the open half-plane directed by u passing through x . We also set $\mathbb{H}_u = \mathbb{H}_u(0)$. We say that a direction $u \in S^1$ is *unstable* (for an update family \mathcal{U}) if there exists $U \in \mathcal{U}$ such that $U \subset \mathbb{H}_u$ and *stable* otherwise. The partition is then as follows.

Definition 3.1 (Definition 1.3 of [BSU15]). An update family \mathcal{U} is

- *supercritical* if there exists an open semicircle of unstable directions,
- *critical* if it is not supercritical, but there exists an open semicircle with a finite number of stable directions,
- *subcritical* otherwise.

The main result of [BSU15] then states that in the supercritical case $\tau_{\text{BP}} = q^{-\Theta(1)}$ with high probability as $q \rightarrow 0$, while in the critical one $\tau_{\text{BP}} = \exp(q^{-\Theta(1)})$. The final justification of the partition in definition 3.1 was given by Balister, Bollobás, Przykucki and Smith [BBPS16] who proved that the origin is never infected with positive probability for subcritical models for $q > 0$ sufficiently small, i.e. $q_c(\mathbb{Z}^2, \mathcal{U}) > 0$ if \mathcal{U} is subcritical. From the bootstrap percolation perspective supercritical models are rather simple, while subcritical ones remain very poorly understood (see [Har18]). Nevertheless, most of the non-trivial models considered before the introduction of

\mathcal{U} -bootstrap percolation, including the 2-neighbor model (see [AL88, Hol03] for further results), fall into the critical class, which is also the focus of our work.

Significantly improving the result of [BSU15], Bollobás, Duminil-Copin, Morris and Smith [BDCMSar] found the correct exponent determining the scaling of τ_{BP} for critical families. Moreover, they were able to find $\log \tau_{\text{BP}}$ up to a constant factor. To state their results we need the following crucial notion.

Definition 3.2 (Definition 1.2 of [BDCMSar]). Let \mathcal{U} be an update family and $u \in S^1$ be a direction. Then the *difficulty* of u , $\alpha(u)$, is defined as follows.

- If u is unstable, then $\alpha(u) = 0$.
- If u is an isolated stable direction (isolated in the topological sense), then

$$\alpha(u) = \min\{n \in \mathbb{N} : \exists K \subset \mathbb{Z}^2, |K| = n, |[\mathbb{Z}^2 \cap (\mathbb{H}_u \cup K)] \setminus \mathbb{H}_u| = \infty\}, \quad (3.1)$$

i.e. the minimal number of infections allowing \mathbb{H}_u to grow infinitely.

- Otherwise, $\alpha(u) = \infty$.

We define the *difficulty* of \mathcal{U} by

$$\alpha(\mathcal{U}) = \inf_{C \in \mathcal{C}} \sup_{u \in C} \alpha(u), \quad (3.2)$$

where $\mathcal{C} = \{\mathbb{H}_u \cap S^1 : u \in S^1\}$ is the set of open semicircles of S^1 .

It is not hard to see (theorem 1.10 of [BSU15], lemma 2.6 of [BDCMSar]) that the set of stable directions is a finite union of closed intervals of S^1 and that (lemmas 2.7 and 2.10 of [BDCMSar]) (3.1) also holds for unstable and *strongly stable* directions, that is directions in the interior of the set of stable directions (but not for *semi-isolated stable* directions i.e. endpoints of non-trivial stable intervals). Furthermore (see lemma 2.7 of [BDCMSar], lemma 5.2 of [BSU15]), $1 \leq \alpha(u) < \infty$ if and only if u is an isolated stable direction, so that \mathcal{U} is critical if and only if $1 \leq \alpha(\mathcal{U}) < \infty$. As a final remark we recall that, contrary to determining whether an update family is critical, finding $\alpha(\mathcal{U})$ is a NP-hard question [HM18].

We are now ready to describe the universality results. A weaker form of the result of [BDCMSar] is that $\tau_{\text{BP}} = \exp(q^{-\alpha(\mathcal{U})+o(1)})$ with high probability as $q \rightarrow 0$. For the full result however, we need one last definition.

Definition 3.3. A critical update family \mathcal{U} is *balanced* if there exists a closed semicircle C such that $\max_{u \in C} \alpha(u) = \alpha(\mathcal{U})$ and *unbalanced* otherwise.

Then [BDCMSar] provides that for balanced models, with high probability as $q \rightarrow 0$ one has $\tau_{\text{BP}} = \exp(\Theta(1)/q^{\alpha(\mathcal{U})})$, while for unbalanced ones $\tau_{\text{BP}} = \exp(\Theta((\log q)^2)/q^{\alpha(\mathcal{U})})$. These are the best general estimates currently known. We refer to [Mor17a, Mor17b] for recent surveys on these results as well as on sharper results for some specific models.

3.2.2 Kinetically constrained models

Returning to KCMs, let us first define the general class of KCMs introduced by Cancrini, Martinelli, Roberto and the last author [CMRT08] directly on \mathbb{Z}^2 . Fix a parameter $q \in [0, 1]$ and an update family \mathcal{U} as in the previous section. The corresponding KCM is a continuous-time Markov process on $\Omega = \{0, 1\}^{\mathbb{Z}^2}$ which can be informally defined as follows. A configuration ω is defined by assigning to each site $x \in \mathbb{Z}^2$ an *occupation variable* $\omega_x \in \{0, 1\}$ corresponding to an *empty* (or *infected*) and *occupied* (or *healthy*) site respectively. Each site waits an independent exponentially distributed time with mean 1 before attempting to update its occupation variable. At that time, if the configuration is completely empty on at least one update rule translated at x , i.e. if $\exists U \in \mathcal{U}$ such that $\omega_y = 0$ for all $y \in U + x$, then we perform a *legal update* or *legal spin flip* by setting ω_x to 0 with probability q and to 1 with probability $1 - q$. Otherwise the update is discarded. Since the constraint to allow the update never depends on the state of the to-be-updated site, the product measure μ is a reversible invariant measure and the process started at μ is stationary. More formally, the KCM is the Markov process on Ω with generator \mathcal{L} acting on local functions $f: \Omega \mapsto \mathbb{R}$ as

$$(\mathcal{L}f)(\omega) = \sum_{x \in \mathbb{Z}^2} c_x(\omega) (\mu_x(f) - f)(\omega),$$

where $\mu_x(f)$ denotes the average of f with respect to the variable ω_x conditionally on $\{\omega_y\}_{y \neq x}$, and c_x is the indicator function of the event that there exists $U \in \mathcal{U}$ such that $U + x$ is completely empty, i.e. $\omega_{U+x} \equiv 0$. We refer the reader to chapter I of [Lig85], where the general theory of interacting particle systems is detailed, for a precise construction of the Markov process and the proof that \mathcal{L} is the generator of a reversible Markov process $\{\omega(t)\}_{t \geq 0}$ on Ω with reversible measure μ .

The corresponding Dirichlet form is defined as

$$\mathcal{D}(f) = \sum_{x \in \mathbb{Z}^2} \mu(c_x \text{Var}_x(f)), \quad (3.3)$$

where $\text{Var}_x(f)$ denotes the variance of the local function f with respect to the variable ω_x conditionally on $\{\omega_y\}_{y \neq x}$. The expectation with respect to the stationary process with initial distribution μ will be denoted by $\mathbb{E} = \mathbb{E}_\mu^{q, \mathcal{U}}$. Finally, given a configuration $\omega \in \Omega$ and a site $x \in \mathbb{Z}^2$, we will denote by ω^x the configuration obtained from ω by *flipping* site x , namely by setting $(\omega^x)_x = 1 - \omega_x$ and $(\omega^x)_y = \omega_y$ for all $y \neq x$. For future use we also need the following definition of legal paths, that are essentially sequences of configurations obtained by successive legal updates.

Definition 3.4 (Legal path). Fix an update family \mathcal{U} , then a *legal path* γ in Ω is a finite sequence $\gamma = (\omega_{(0)}, \dots, \omega_{(k)})$ such that, for each $i \in \{1, \dots, k\}$, the configurations $\omega_{(i-1)}$ and $\omega_{(i)}$ differ by a legal (with respect to the choice of \mathcal{U}) spin flip at some vertex $v = v(\omega_{(i-1)}, \omega_{(i)})$.

As mentioned in section 3.1, our goal is to prove sharp bounds on the characteristic time scales of critical KCMS. Let us start by defining precisely these time scales, namely the relaxation time T_{rel} (or inverse of the spectral gap) and the mean infection time $\mathbb{E}(\tau_0)$ (with respect to the stationary process).

Definition 3.5 (Relaxation time T_{rel}). Given an update family \mathcal{U} and $q \in [0, 1]$, we say that $C > 0$ is a *Poincaré constant* for the corresponding KCM if, for all local functions f , we have

$$\text{Var}_\mu(f) = \mu(f^2) - \mu(f)^2 \leq C \mathcal{D}(f).$$

If there exists a finite Poincaré constant, we define

$$T_{\text{rel}} = T_{\text{rel}}(q, \mathcal{U}) = \inf \{C > 0 : C \text{ is a Poincaré constant}\}.$$

Otherwise we say that the relaxation time is infinite.

A finite relaxation time implies that the reversible measure μ is mixing for the semigroup $P_t = e^{t\mathcal{L}}$ with exponentially decaying time auto-correlations (see e.g. section 2.1 of [Bak06]).

Definition 3.6 (Infection time τ_0). The random time τ_0 at which the origin is first infected is given by

$$\tau_0 = \inf \{t \geq 0 : \omega_0(t) = 0\},$$

where we adopt the usual notation letting $\omega_0(t)$ be the value of the configuration $\omega(t)$ at the origin, namely $\omega_0(t) = (\omega(t))_0$.

The East model We close this section by defining a specific example of KCM on \mathbb{Z} , the East model of Jäckle and Eisinger [JE91], which will be crucial to understand our results (KCMs on \mathbb{Z} are defined in the same way as KCMs on \mathbb{Z}^2). It is defined by an update family composed by a single rule containing only the site to the left of the origin (-1). In other words, site x can be updated if and only if $x - 1$ is empty. For this model both T_{rel} and $\mathbb{E}(\tau_0)$ scale as $\exp\left(\frac{(\log q)^2}{2 \log 2}\right)$ as $q \rightarrow 0$ [AD02, CMRT08, CFM14]⁴. One of the key ingredients behind this scaling is the following combinatorial result [SE99] (see Fact 1 of [CDG01] for a more mathematical formulation).

Proposition 3.7. *Consider the East model on $\{1, \dots, M\}$ defined by fixing $\omega_0 = 0$ at all time. Then any legal path γ connecting the fully occupied configuration (namely ω such that $\omega_x = 1$ for all $x \in \{1, \dots, M\}$) to a configuration ω' such that $\omega'_M = 0$ goes through a configuration with at least $\lceil \log_2(M+1) \rceil$ empty sites.*

This logarithmic “energy barrier”, to employ the physics jargon, and the fact that at equilibrium the typical distance to the first empty site is $M = \Theta(1/q)$ are responsible for the divergence of the time scales at speed roughly $1/q^{\lceil \log_2(M+1) \rceil} = e^{\Theta((\log q)^2)}$.

3.2.3 Result

In this paper we study critical KCMs with an infinite number of stable directions or, equivalently, with a non-trivial interval of stable directions.

Theorem 3.8. *Let \mathcal{U} be a critical update family with an infinite number of stable directions. Then there exists a sufficiently large constant $C > 0$ such that*

$$\mathbb{E}(\tau_0) \geq \exp\left(1 / (Cq^{2\alpha(\mathcal{U})})\right),$$

as $q \rightarrow 0$ and the same asymptotics holds for T_{rel} .

This theorem combined with the upper bound of Martinelli, Morris and the last author (theorem 2(a) of [MMT19]), determines the critical exponent of these models to be 2α in the sense of corollary 3.9 below. We thus complete the proof of universality and conjecture 3(a) of [MMT19] for these models⁵.

⁴Actually these references focus on the study of T_{rel} . A matching upper bound for $\mathbb{E}(\tau_0)$ follows from (3.8). The lower bound for $\mathbb{E}(\tau_0)$ follows easily from the lower bound for $\mathbb{P}(\tau_0 > t)$ with $t = \exp(\log(q)^2/2 \log 2)$ obtained in the proof of theorem 5.1 of [CMST10].

⁵The conjecture involuntarily asks for a positive power of $\log q$, which we do not expect to be systematically present (see conjecture 3.42).

Corollary 3.9. *Let \mathcal{U} be a critical update family with an infinite number of stable directions. Then*

$$q^{2\alpha(\mathcal{U})} \log \mathbb{E}(\tau_0) = (-\log q)^{O(1)}$$

as $q \rightarrow 0$ and the same holds for T_{rel} .

Universality for the remaining critical models is proved in a companion paper by Martinelli and the first and third authors [HMT19b] and, in particular, conjecture 3(a) of [MMT19] is disproved for models other than those covered by theorem 3.8. It is important to note that theorem 3.8 significantly improves the best known results for all models with the exception of the recent result of Martinelli and the last two authors [MMTar] for the Duarte model. Indeed, the previous bound had exponent α , and was proved via the general (but in this case far from optimal) lower bound with the mean infection time for the corresponding bootstrap percolation model (lemma 4.3 of [MT19]).

3.3 Sketch of the proof

In this section we outline roughly the strategy to derive our main result, theorem 3.8. The hypothesis of infinite number of stable directions provides us with an interval of stable directions. We can then construct stable “droplets” of shape as in figure 3.3 (see definitions 3.12 and 3.13), where we recall from section 3.2.1 that a set is stable if it coincides with its closure. Thus, if all infections are initially inside a droplet, this will be true at any time under the KCM dynamics. The relevance and advantage of such shapes come from the fact that only infections situated to the left of a droplet can induce growth left. This is manifestly not feasible without the hypothesis of having an interval of stable directions. It is worth noting that these shapes, which may seem strange at first sight, are actually very natural and intrinsically present in the dynamics. Indeed, such is the shape of the stable sets for a representative model of this class — the modified 2-neighbor model with one (any) rule removed, that is the three-rule update family with rules $\{(-1, 0), (0, 1)\}$, $\{(-1, 0), (0, -1)\}$, $\{(0, -1), (1, 0)\}$ (it can also be seen as the modified Duarte model with an additional rule). The stable sets in this case are actually Young diagrams.

We construct a collection of such droplets covering the initial configuration of infections, so that it gives an upper bound on the closure. To do this, we devise an improvement of the α -covering algorithm of Bollobás, Duminil-Copin, Morris and Smith [BDCMSar]. It is important for us not to

overestimate the closure as brutally. Indeed, a key step and the main difficulty of our work is the Closure Proposition 3.27, which roughly states that the collections of droplets associated to the closure of the initial infections is equal to the collection for the initial infections. This is highly non-trivial, as in order not to overshoot in defining the droplets, one is forced to ignore small patches of infections (larger than the ones in [BDCMSar]), which can possibly grow significantly when we take the closure for the bootstrap percolation process and especially so if they are close to a large infected droplet. In order to remedy this problem, we introduce a relatively intrinsic notion of “crumb” (see definition 3.11) such that its closure remains one and does not differ too much from it. A further advantage of our algorithm for creating the droplets over the one of [BDCMSar] is that it is somewhat canonical, with a well-defined unique output, which has particularly nice “algebraic” description and properties (see remark 3.17). Another notable difficulty we face is systematically working in roughly a half-plane (see remark 3.31 for generalisations) with a fully infected boundary condition, but we manage to extend our reasoning to this setting very coherently.

Finally, having established the Closure Proposition 3.27 alongside standard and straightforward results like an Aizenmann-Lebowitz lemma 3.20 and an exponential decay of the probability of occurrence of large droplets (lemma 3.22), we finish the proof via the following approach, inspired by the one developed by Martinelli and the last two authors [MMTar] for the Duarte model. The key step here (see section 3.6) is mapping the KCM legal paths to those of an East dynamics via a suitable renormalisation. Roughly speaking, we say that a renormalised site is empty if it contains a large droplet of infections. However, for the renormalised configuration to be mostly invariant under the original KCM dynamics, we rather look for the droplets in the closure of the original set of infections instead. This is where the Closure Proposition 3.27 is used to compensate the fact that the closure of equilibrium is not equilibrium. In turn, this mapping together with the combinatorial result for the East model recalled in section 3.2.2 (proposition 3.7), yield a bottleneck for our dynamics corresponding to the creation of $\log(1/q_{\text{eff}})$ droplets, where $1/q_{\text{eff}}$ is the equilibrium distance between two empty sites in the renormalized lattice, and $q_{\text{eff}} \sim e^{-1/q^\alpha}$. This provides for the time scales the desired lower bound $q_{\text{eff}}^{\log(q_{\text{eff}})} \sim e^{1/q^{2\alpha}}$ of theorem 3.8. The last part of the proof follows very closely the ideas put forward in [MMTar] for the Duarte model. However, in [MMTar], there was no need to develop a subtle droplet algorithm since, owing to the oriented character of the Duarte constraint, droplets could simply be identified with some large infected vertical segments. It is also worth noting that, thanks to the less rigid notion of droplets that we develop in the general setting, some of the difficulties faced

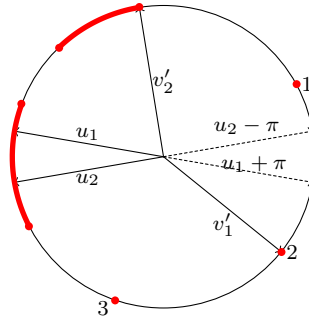

Figure 3.1: Illustration of lemma 3.10 and its proof. Thickened arcs represent intervals of strongly stable directions. Solid dots represent isolated and semi-isolated stable directions. The difficulties of the isolated stable directions are indicated next to them and yield that the difficulty of the model is $\alpha = 2$. The directions chosen in lemma 3.10 are the solid vectors u_1 , u_2 , $v_1 = v'_1$ and a direction v_2 in the strongly stable interval ending at v'_2 sufficiently close to v'_2 . Note that the definition of v'_2 (and v'_1) disregards stable directions with difficulty smaller than α as present on the figure.

in [MMTar] for Duarte are no longer present here.

3.4 Preliminaries and notation

Let us fix a critical update family \mathcal{U} with an infinite number of stable directions for the rest of the paper. We will omit \mathcal{U} from all notation, such as $\alpha(\mathcal{U})$.

The next lemma establishes that one can make a suitable choice of 4 stable directions, which we will use for all our droplets. At this point the statement should look very odd and technical, but it simply reflects the fact that we have a lot of freedom for the choice and we make one which will simplify a few of the more technical points in later stages. Nevertheless, this is to a large extent not needed besides for concision and clarity.

A direction $u \in S^1$ is called *rational* if $\tan u \in \mathbb{Q} \cup \{\infty\}$.

Lemma 3.10. *There exist rational stable directions $\mathcal{S} = \{u_1, u_2, v_1, v_2\}$ (see figure 3.1) with difficulty at least α such that*

- *The directions appear in counterclockwise order u_1, u_2, v_1, v_2 .*
- *No $u \in \mathcal{S}$ is a semi-isolated stable direction.*

- u_{3-i} belongs to the cone spanned by v_i and u_i for $i \in \{1, 2\}$ i.e. the strictly smaller interval among $[v_i, u_i]$ and $[u_i, v_i]$ contains u_{3-i} .
- 0 is contained in the interior of the convex envelope of \mathcal{S} .
- Either $u_2 < v_1 - \pi/2$ or $u_1 > v_2 + \pi/2$.
- $(\mathbb{H}_{u_1} \cup \mathbb{H}_{u_2}) \cap \mathbb{Z}^2$ is stable or, equivalently, $\nexists U \in \mathcal{U}, U \subset \mathbb{H}_{u_1} \cup \mathbb{H}_{u_2}$.
- the directions

$$\begin{aligned} u' &= (u_1 + u_2)/2, \\ u'_1 &= (3u_1 + u_2)/4, \\ u'_2 &= (u_1 + 3u_2)/4 \end{aligned}$$

are rational.

Proof. Since \mathcal{U} has an infinite number of stable directions and they form a finite union of closed intervals with rational endpoints (theorem 1.10 of [BSU15]), there exists a non-empty open interval I''' of stable directions. Further note that the set J of directions u such that there exist a rule $U \in \mathcal{U}$ and $x \in U$ with $\langle x, u \rangle = 0$ is finite, so one can find a non-trivial closed subinterval $I'' \subset I'''$ which does not intersect J . The directions u_1 and u_2 will be chosen in I'' , which clearly implies that they are strongly stable and thus with infinite difficulty. Moreover, if there exists $U \in \mathcal{U}$ with $U \subset \mathbb{H}_{u_1} \cup \mathbb{H}_{u_2}$, by stability of u_2 , we have $U \cap (\mathbb{H}_{u_1} \setminus \mathbb{H}_{u_2}) \neq \emptyset$, which contradicts $I'' \cap J = \emptyset$.

Since \mathcal{U} is critical it does not have two opposite strongly stable directions, so there is no strongly stable direction in $I'' + \pi$. If there are any (isolated or semi-isolated) stable directions in $I'' + \pi$, we can further choose a non-trivial open subinterval $I' \subset I''$, for which this is not the case (there is a finite number of isolated and semi-isolated stable directions). Let $\pi > \delta > 0$ be such that the angle between any two consecutive directions of difficulty at least α is at most $\pi - \delta$ (it is well defined by (3.2)). We then choose a non-trivial closed subinterval $I' \supset I = [u_1, u_2]$ with u_1 rational and $u'_1 = (3u_1 + u_2)/4$ rational and with $0 < u_2 - u_1 < \delta < \pi$. It easily follows from the sum and difference formulas for the tangent function that u' , u'_2 and u_2 are also rational.

Let

$$\begin{aligned} v'_1 &= \max\{v \in (u_2, u_1 + \pi) : \alpha(v) \geq \alpha\}, \\ v'_2 &= \min\{v \in (u_2 - \pi, u_1) : \alpha(v) \geq \alpha\}. \end{aligned}$$

These both exist, since $I + \pi$ does not contain stable directions, both $(u_2, u_2 + \pi)$ and $(u_1 - \pi, u_1)$ contain directions with difficulty at least α by (3.2) and

the set of such directions is closed. If v'_1 is not semi-isolated, we set $v_1 = v'_1$ and similarly for v_2 . Otherwise, we choose a rational strongly stable direction sufficiently close to v'_1 as v_1 and similarly for v_2 . We claim that this choice satisfies all the desired conditions. Indeed, all directions in \mathcal{S} are stable non-semi-isolated rational with difficulty at least α and the last but one condition was already verified.

One does have that u_1 is in the cone spanned by v_2 and u_2 , which is implied by $v_2 \in (u_2 - \pi, u_1)$ and similarly for u_2 , so the third condition is also verified. If $v'_2 - v'_1 \geq \pi$, then there is an open half-circle contained in (v'_1, v'_2) with no direction of difficulty at least α , which contradicts (3.2), so $v_2 - v_1 < \pi$ and the same holds for $u_1 - v_2$, $u_2 - u_1$ and $v_1 - u_2$ by the definition of v'_1 and v'_2 , the fact that v_1 and v_2 are sufficiently close to them and the fact that I was chosen smaller than π . Thus 0 is in the convex envelope of \mathcal{S} .

Finally, if one has both $v_1 - u_2 \leq \pi/2$ and $u_1 - v_2 \leq \pi/2$, then one obtains $v'_2 - v'_1 > \pi - \delta$, since I is smaller than δ . However, v'_1 and v'_2 are consecutive directions of difficulty at least α , which contradicts the definition of δ . \square

For the rest of the paper we fix directions $\mathcal{S} = \{u_1, u_2, v_1, v_2\}$ as in lemma 3.10 and assume without loss of generality that $u_2 < v_1 - \pi/2$.

Let us fix large constants

$$1 \ll C_1 \ll C'_2 \ll C_2 \ll C_3 \ll C'_4 \ll C_4 \ll C_5,$$

each of which can depend on previous ones as well as on \mathcal{U} and \mathcal{S} . We will also use asymptotic notation whose constants can depend on \mathcal{U} and \mathcal{S} , but not on C_1 or the other constants above. All asymptotic notation is with respect to $q \rightarrow 0$, so we assume throughout that $q > 0$ is sufficiently small.

For any two sets $K, \partial \subset \mathbb{R}^2$ we define $[K]_\partial = [(K \cup \partial) \cap \mathbb{Z}^2] \setminus \partial$.

Finally, we make the convention that throughout the article all distances, balls and diameters are Euclidean unless otherwise stated. We say that a set $X \subset \mathbb{R}^2$ is *within distance* δ of a set $Y \subset \mathbb{R}^2$ if $d(x, Y) \leq \delta$ for all $x \in X$ where d is the Euclidean distance.

3.5 Droplet algorithm

In this section we define our main tool — the droplet algorithm. It can be seen as a significant improvement on the α -covering and u -iceberg algorithms (definitions 6.6 and 6.22 of [BDCMSar]), many of whose techniques we adapt to our setting.

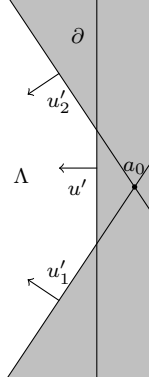

Figure 3.2: The open domain ∂ defined in (3.4) is shaded, while its complement Λ is not. The lines are the boundaries of the three half-planes defining ∂ . Note that if $a_0 \notin \mathbb{H}_{u'}$, then Λ becomes simply a cone.

We will work in an infinite domain Λ defined as follows (see figure 3.2). Fix some vector $a_0 \in \mathbb{R}^2$ and let

$$\begin{aligned}\partial &= \mathbb{H}_{u'} \cup \mathbb{H}_{u'_1}(a_0) \cup \mathbb{H}_{u'_2}(a_0), \\ \Lambda &= \mathbb{R}^2 \setminus \partial\end{aligned}\tag{3.4}$$

where the directions u' , u'_1 and u'_2 are those defined in lemma 3.10. In other words, Λ is a cone with sides perpendicular to u'_1 and u'_2 cut along a line perpendicular to u' . The reader is invited to simply think that ∂ is a half-plane directed by u' , which will not change the reasoning.

3.5.1 Clusters and crumbs

Let Γ be the graph with vertex set \mathbb{Z}^2 but with $x \sim y$ if and only if $\|x - y\| \leq C_2$. Let Γ' be defined similarly with C_2 replaced by C'_2 .

Definition 3.11 (Clusters and crumbs). Fix a finite set $K \subset \Lambda \cap \mathbb{Z}^2$ of infected sites. Let $G \subset K$ be a connected component of the subgraph of Γ induced by K . Then G is a *crumb* if it is at distance more than C_2 from ∂ and there exists a set $P_G \subset \mathbb{Z}^2$ such that $[P_G] \supset G$ and $|P_G| = \alpha - 1$. Let $\kappa \subset K$ be a connected component which is not a crumb. We call *cluster* any $C \subset \kappa$ such that the induced subgraph of Γ is connected and $\text{diam}(C) \leq C_3$ and such that C is maximal with this property. We call *boundary cluster* every cluster at distance at most C_2 from ∂ .

We similarly define *modified crumb*, *modified cluster* and *modified boundary cluster* by replacing Γ and C_2 by Γ' and C'_2 respectively.

Clearly, any (modified) non-boundary cluster has at least α sites. Indeed, if its connected component is of diameter larger than C_3 , then the diameter of the cluster is larger than $C_3 - C_2$, and we can choose C_3 large enough to get $\frac{C_3 - C_2}{C_2} \geq \alpha$, while otherwise the cluster is a connected component which is not a crumb and at distance more than C_2 from ∂ , so by definition has at least α sites. Moreover, a cluster only intersects a bounded number of other clusters, as its diameter is bounded. Also note that crumbs (respectively modified crumbs) are at distance at least C_2 (respectively C'_2) from any other site of $K \cup \partial$ and have diameter much smaller than C_3 , as we shall see in corollary 3.24. The proofs of this corollary and observation 3.23 it follows from are both independent of the rest of the argument and postponed for convenience, but we allow ourselves to use this (easy) result ahead of these proofs.

Let C be a cluster (respectively modified cluster). We denote by $Q(C)$ (respectively $Q'(C)$) the smallest open quadrilateral with sides perpendicular to \mathcal{S} containing the set $\{x \in \mathbb{R}^2 : d(x, C) < C_4\}$ (respectively C'_4). Note that $Q(C) \supset [C]$ (respectively $Q'(C)$), since $Q(C) \cap \mathbb{Z}^2 \supset C$ (respectively $Q'(C)$) is stable and that $\text{diam}(Q(C)) = \Theta(C_4)$ (respectively $\text{diam}(Q'(C)) = \Theta(C'_4)$), as $\text{diam}(C) \leq C_3$. We extend the definition $Q'(C)$ for (non-modified) clusters.

3.5.2 Distorted Young diagrams

We now define the shape that our “droplets” will have, which resembles Young diagrams⁶. The following definitions are illustrated in figure 3.3.

Definition 3.12 (DYD). We call *distorted Young diagram* (DYD) a subset of \mathbb{R}^2 of the form

$$(\mathbb{H}_{v_1}(x) \cap \mathbb{H}_{v_2}(x)) \cap \bigcap_{i \in I} (\mathbb{H}_{u_1}(x_i) \cup \mathbb{H}_{u_2}(x_i)) \quad (3.5)$$

for a finite set I , some set $X = \{x_i : i \in I\}$ of vectors $x_i \in \mathbb{R}^2$ and $x \in \mathbb{R}^2$. The vectors x_i and x are uniquely defined up to redundancy (and up to the convention that all x_i are on the topological boundary of the DYD). An alternative definition of the DYD can also be given as

$$(\mathbb{H}_{v_1}(x) \cap \mathbb{H}_{v_2}(x)) \cap \bigcup_{i \in I} (\mathbb{H}_{u_1}(y_i) \cap \mathbb{H}_{u_2}(y_i)), \quad (3.6)$$

where y_i are the convex corners of the diagram rather than the concave ones.

⁶For the 3-rule model alluded to in section 3.3 stable sets consist precisely of Young diagrams and the directions \mathcal{S} provided by lemma 3.10 can be arbitrarily close to the four axis directions, yielding Young diagrams.

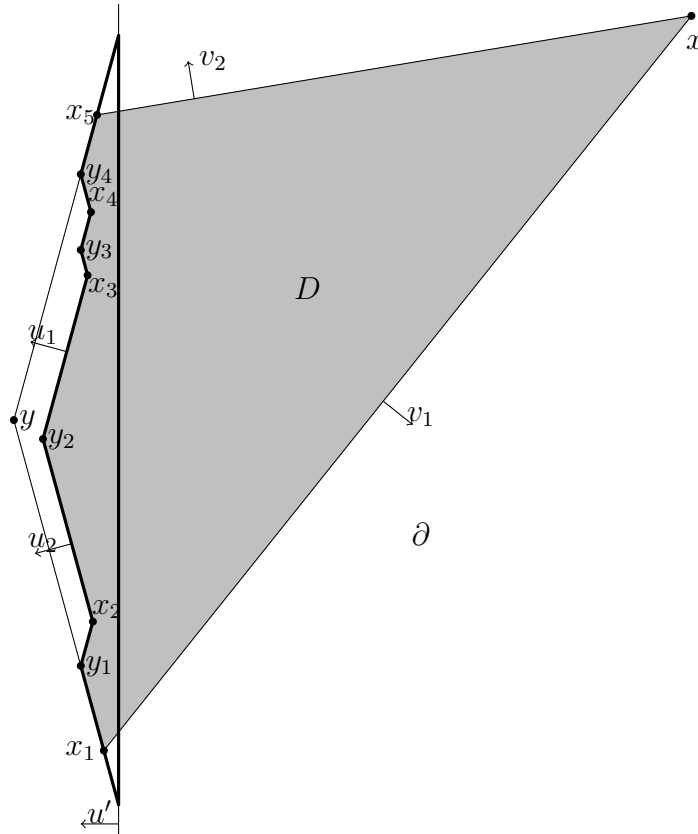

Figure 3.3: The shaded region D is a distorted Young diagram (DYD) as in definition 3.12. The larger quadrilateral with vertices x, x_1, y and x_5 is $Q(D)$. Note that $Q(D)$ can degenerate into a triangle, but we call it a quadrilateral nevertheless. On the figure $|D|$ is the length of the v_1 side, but this is not always the case. The thickened region is the cut distorted Young diagram (CDYD) $C(D)$ of D . The vertical line is the boundary between Λ on its left and ∂ on its right.

For any DYD D we denote by y the vector such that

$$\langle y, u_j \rangle = \sup_{a \in D} \langle a, u_j \rangle = \max_{i \in I} \langle y_i, u_j \rangle$$

for $j \in \{1, 2\}$. We further denote

$$Q(D) = \mathbb{H}_{u_1}(y) \cap \mathbb{H}_{u_2}(y) \cap \mathbb{H}_{v_1}(x) \cap \mathbb{H}_{v_2}(x),$$

i.e. the minimal quadrilateral containing D with sides directed by \mathcal{S} . In these terms, Q (respectively Q') is a DYD and $Q(Q) = Q$.

Definition 3.13 (CDYD). We call *cut distorted Young diagram* (CDYD) a subset of \mathbb{R}^2 of the form

$$\Lambda \cap (\mathbb{H}_{u_1}(y) \cap \mathbb{H}_{u_2}(y)) \cap \bigcap_{i \in I} (\mathbb{H}_{u_1}(x_i) \cup \mathbb{H}_{u_2}(x_i))$$

for a finite set I and some vectors $x_i \in \mathbb{R}^2$ and $y \in \Lambda$. Alternatively, one can write

$$\Lambda \cap \bigcup_{i \in I} (\mathbb{H}_{u_1}(y_i) \cap \mathbb{H}_{u_2}(y_i)),$$

where $y_i \in \Lambda$ are the convex corners.

For a DYD, D , we define $C(D)$ as the CDYD defined by the same x_i and y or the same y_i . We extend the notation $C(D)$ to CDYD by setting $C(D) = D$ if D is a CDYD. Note that by lemma 3.10 all DYD and CDYD are stable for the bootstrap percolation dynamics (restricted to Λ). Also pay attention to the fact that CDYD are not necessarily connected, contrary to DYD.

Definition 3.14 (Size). For a DYD D we set $\pi(D) = \{x \in \mathbb{R} : \exists y \in D, \langle y, v_1 + \pi/2 \rangle = x\}$ to be its *projection* (parallel to v_1) and $|D| = \sup \pi(D) - \inf \pi(D)$ to be its *size* — the length of the projection. For a CDYD D we denote its *size* $|D| = \text{diam}(D)/C_1$.

Note that if D is a DYD, then $|D| = |Q(D)|$ by lemma 3.10 and the assumption we made that $u_2 < v_1 - \pi/2$. Furthermore, for all DYD $\text{diam}(D) = \Theta(|D|)$ again by lemma 3.10 with constants depending only on \mathcal{S} . One should be careful with the meaning of size for disconnected CDYD, but it will not cause problems, as all CDYD arising in our forthcoming algorithm are connected.

Observation 3.15. *Note that for any $d \geq 1$ the number of discretised DYD and CDYD (i.e. intersections of a DYD or CDYD with \mathbb{Z}^2) containing a fixed point $a \in \mathbb{R}^2$ of diameter at most d is less than c^d for some constant c depending only on \mathcal{S} .*

Proof. Note that a DYD or CDYD is uniquely determined by its rugged edge formed by its u_1 and u_2 -sides. However, this edge injectively defines an oriented percolation path with directions perpendicular to u_1 and u_2 on the lattice

$$\{x \in \mathbb{R}^2 : \exists x_1, x_2 \in \mathbb{Z}^2, \langle x, u_1 \rangle = \langle x_1, u_1 \rangle, \langle x, u_2 \rangle = \langle x_2, u_2 \rangle\}$$

(except its endpoints, which lie on similar lattices). Since the graph-length of this path is bounded by $O(d)$ and its endpoints are within distance d from a , the result follows. \square

3.5.3 Span

We next introduce a procedure of merging DYD and CDYD. This will be used only for couples of intersecting ones, but can be defined regardless of whether they intersect. The operation is illustrated in figure 3.4.

Lemma 3.16. *For any two DYD, D_1 and D_2 , the minimal DYD containing $D_1 \cup D_2$ is well defined. We denote it by $D_1 \vee D_2$ and call it their span. The operation \vee is associative⁷ and commutative.*

Proof. Let D_1 be defined by $Y^1 = \{y_i^1 : i \in I\}, x^1$ (see (3.6)) and similarly for D_2 . Let $x \in \mathbb{R}^2$ be the vector such that $\mathbb{H}_{v_i}(x^1) \cup \mathbb{H}_{v_i}(x^2) = \mathbb{H}_{v_i}(x)$ for $i \in \{1, 2\}$. Let Y be the set of $y_i \in Y^1 \cup Y^2$ such that for all $y_j \in Y^1 \cup Y^2$ with $y_i \neq y_j$ we have $\mathbb{H}_{u_1}(y_j) \cap \mathbb{H}_{u_2}(y_j) \not\supset \mathbb{H}_{u_1}(y_i) \cap \mathbb{H}_{u_2}(y_i)$. We denote by D the DYD defined by Y, x and claim that for any DYD $D' \supset D_1 \cup D_2$ we have $D' \supset D$, which is enough to conclude that $D = D_1 \vee D_2$ is well defined. Let D' be defined by Y', x' .

Note that for each $y_i \in Y$ (and in fact in $Y_1 \cup Y_2$) there is a sequence of points in D_1 or D_2 converging to y_i , so that (by extraction of a subsequence) there exists y'_j with $\mathbb{H}_{u_1}(y'_j) \cap \mathbb{H}_{u_2}(y'_j) \supset \mathbb{H}_{u_1}(y_i) \cap \mathbb{H}_{u_2}(y_i)$. Similarly, there is a sequence of points in D_1 or D_2 converging to the boundary of $\mathbb{H}_{v_1}(x)$, so that $\mathbb{H}_{v_1}(x') \supset \mathbb{H}_{v_1}(x)$ and similarly for v_2 . Thus, we do have $D' \supset D$.

Finally, the commutativity is obvious and the associativity follows from the characterisation of $D_1 \vee D_2$ as the minimal DYD containing both D_1 and D_2 . \square

We analogously define the *span* $D_1 \vee D_2$ of two CDYD D_1 and D_2 — the minimal CDYD containing both — and note that it coincides with their union (which is also commutative and associative). We also define the *span* $C \vee D$ of a DYD D and a CDYD C as the minimal CDYD containing $(C \cup D) \setminus \partial$,

⁷Associativity was referred to as commutativity by previous authors [BSU15].

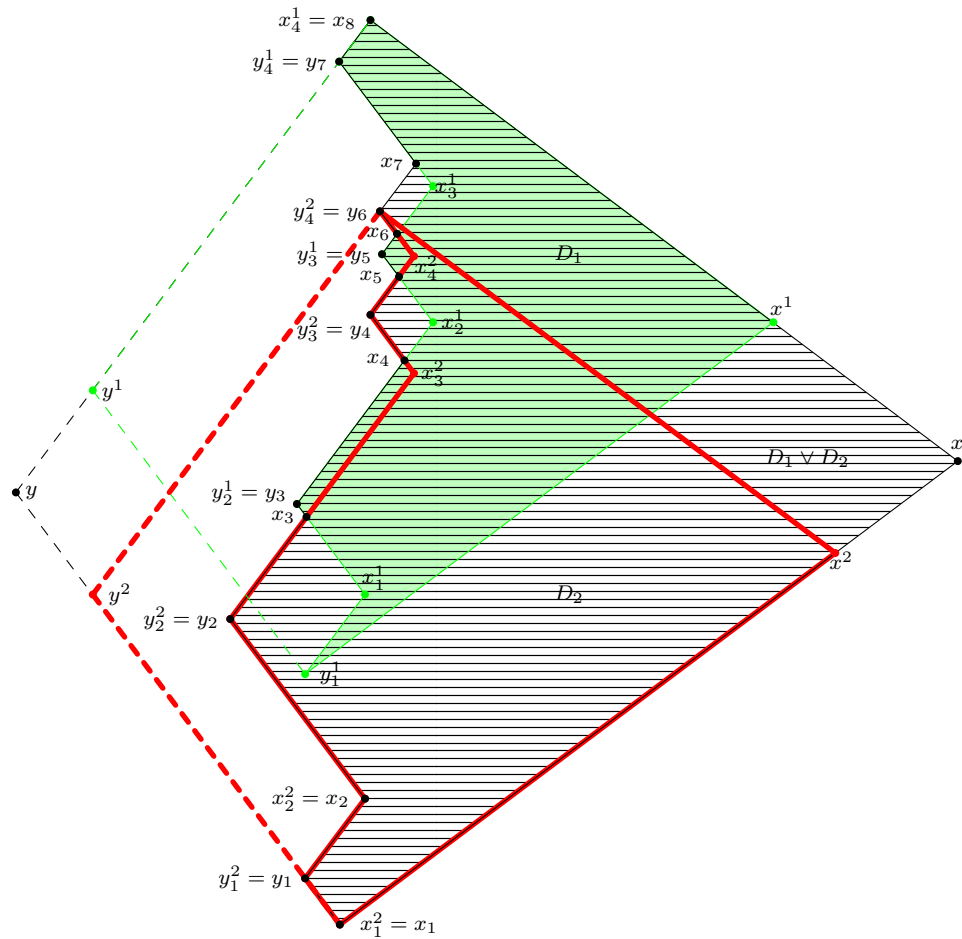

Figure 3.4: The shaded region D_1 and thickened region D_2 are DYD. Their respective quadrilaterals $Q(D_i)$ are completed by dashed lines. Their span $D_1 \vee D_2$ is hatched and its quadrilateral $Q(D_1 \vee D_2)$ is also completed by dashed lines.

which coincides with $C \vee C(D)$. The proof that it is well defined is analogous to lemma 3.16.

We have thus defined an associative and commutative binary operation \vee on all DYD and CDYD. Moreover, the idempotent unary operation $C(\cdot)$ is distributive with respect to \vee and $C(D_1) \vee D_2 = C(D_1 \vee D_2)$. Furthermore, the span of several DYD is the minimal DYD containing all of them, while the span of several DYD and at least one CDYD is the minimal CDYD containing all the corresponding CDYD.

3.5.4 Droplet algorithm and spanned droplets

We call *droplet* a DYD or CDYD included in Λ . We are now ready to define our *droplet algorithm* (respectively *modified droplet algorithm*), which takes as input a finite set $K \subset \Lambda \cap \mathbb{Z}^2$ of infections and outputs a set \mathcal{D} of disjoint connected droplets. It proceeds as follows.

- Form an initial collection of DYD \mathcal{D} consisting of $Q(C)$ (respectively $Q'(C)$) for all clusters (respectively modified clusters) C of K . If a DYD $D \in \mathcal{D}$ intersects ∂ , replace it by its CDYD, $C(D)$, to obtain a droplet.
- As long as it is possible, replace two intersecting droplets of \mathcal{D} by their span. If the span intersects ∂ , replace it by its CDYD to obtain a droplet.
- Output the collection \mathcal{D} obtained when all droplets are disjoint.

The output \mathcal{D} is clearly a collection of disjoint connected droplets. Indeed, by induction all x_i corners of droplets remain in Λ (see figure 3.4), so that DYD remain connected when replaced by CDYD.

Remark 3.17. From the results of section 3.5.3 it is clear that the order of merging does not impact the output of the algorithm, which is thus well defined. It can also be expressed as the minimal collection of disjoint droplets containing the intersection with Λ of the original collection of quadrilaterals. This minimal collection is well defined. Consequently, the union of the output is increasing in the input.

Definition 3.18 (Spanned droplets). Let D be a droplet and K be a finite set. We say that D is *spanned* (respectively *modified spanned*) for K with boundary ∂ if the output of the droplet algorithm (respectively modified droplet algorithm) for $K \cap D$ has a droplet containing D . We omit K and ∂ if they are clear from the context.

Note that, when seen as an event, a droplet being spanned is monotone, contrary to what is the case in [BSU15, BDCMSar], which formally invalidates the proofs therein. It is also clear that each droplet appearing in (the intermediate or final stages of) the droplet algorithm is spanned and similarly for the modified droplet algorithm. Indeed, the clusters responsible for creating a droplet in the course of the algorithm are contained in the droplet, so each of them is still a cluster of $K \cap D$ (recall that crumbs have diameter much smaller than C_3).

3.5.5 Properties of the algorithm

We next establish several properties of the algorithm. The approach is similar to the one of [BDCMSar] with the notable exception of the key Closure Proposition 3.27. We start with the following purely geometric statement.

Lemma 3.19 (Subadditivity). *Let D_1 and D_2 be two DYD or CDYD with non-empty intersection. Then*

$$|D_1 \vee D_2| \leq |D_1| + |D_2|.$$

Furthermore, if D is a DYD intersecting ∂ , then $|C(D)| \leq |D|$.

Proof. First assume that D_1 and D_2 are DYD. Since $|D| = |Q(D)|$ for any DYD D and $D_1 \vee D_2 \subset Q(Q(D_1) \vee Q(D_2))$, it suffices to prove the assertion for merging quadrilaterals instead of DYD. But in that case it is not hard to check directly and is a particular case of lemma 15 of the first arXiv version of [BSU15] (or lemma 23 of the second version). Since similar (but actually slightly more involved) details were omitted in the proof of the corresponding lemma 4.6 of [BSU15] and differed to earlier versions, we will not go into useless detail here either. To give a sketch of a possible argument, one can check that for fixed shapes of $Q(D_1)$ and $Q(D_2)$ the maximal $Q(Q(D_1) \vee Q(D_2))$ is achieved when their intersection is reduced to a vertex. Yet, in those configurations one can obtain the v_1 and v_2 sides of $Q(Q(D_1) \vee Q(D_2))$ as the union of those of $Q(D_1)$ and translates of those of $Q(D_2)$ (see figure 3.4). This concludes the proof, as only v_1 and (possibly) v_2 sides contribute to $|\cdot|$ by lemma 3.10.

Next assume that D_1 is a DYD and D_2 is a CDYD. Let $Y = \{y_i : i \in I\}$ be the set of vectors defining $C(D_1)$ and let $a \in D_1 \cap D_2$. Since $Y \subset \overline{D_1}$, we have that $d(y_i, a) \leq \text{diam}(D_1)$. It then easily follows that the CDYD defined by only one corner, y_i , which we denote $C(y_i)$, is within distance $O(\text{diam}(D_1))$ from $C(a)$. But then $C(D_1) = \bigcup_{i \in I} C(y_i)$ is within distance $O(\text{diam}(D_1))$ from $C(a)$. Thus, $|D_1 \vee D_2| \leq (\text{diam}(D_2) + O(\text{diam}(D_1)))/C_1 \leq |D_2| + |D_1|$,

since $\text{diam}(D_1) = O(|D_1|)$ and all implicit constants depend only on \mathcal{S} and are thus much smaller than C_1 .

Next assume that D_1 and D_2 are CDYD. Then the statement is trivial, because $D_1 \vee D_2 = D_1 \cup D_2$, so $\text{diam}(D_1) + \text{diam}(D_2) \geq \text{diam}(D_1 \vee D_2)$ by the triangle inequality.

Finally, let D be a DYD intersecting ∂ . Then, $|C(Q(D))| \geq |C(D)|$ and $|Q(D)| = |D|$, so we may assume that $D = Q(D)$ and prove $|C(D)| \leq |D|$. But in this case it is easy to see that $\text{diam}(C(D)) = O(\text{diam}(D)) = O(|D|)$ with constants depending only on \mathcal{S} , which concludes the proof. \square

The subadditivity lemma will be used to prove the next two adaptations of classical results.

Lemma 3.20 (Aizenman-Lebowitz). *Let K be a finite set and let D be a spanned (respectively modified spanned) droplet with $|D| \geq C_4^2$. Then for all $C_4^2/C_1 \leq k \leq |D|/C_1$ there exists a connected spanned (respectively modified spanned) droplet D' with $k \leq |D'| \leq 2k$.*

Proof. By lemma 3.19 at each step of the droplet algorithm (respectively modified droplet algorithm) the largest size of a droplet appearing in the collection at most doubles. Initially the largest size is at most C_1C_4 and in the end there is a (unique) droplet $D'' \supset D$, so that $|D''| \geq |D|/C_1 \geq C_4^2/C_1 > C_1C_4$. Then there is a stage of the algorithm at which the maximal size of a droplet in \mathcal{D} is between k and $2k$, which is enough since all droplets appearing in the droplet algorithm (respectively modified droplet algorithm) are connected and spanned (respectively modified spanned). \square

Lemma 3.21 (Extremal). *Let K be a finite set and let D be a spanned droplet. Then there are at least $\text{diam}(D)/C_4^2$ disjoint clusters in D .*

Proof. Assume that at the initial stage of the algorithm there are k clusters (not disjoint). One can then find k/C_4' disjoint ones, since their diameter is at most C_3 . Yet at each step of the algorithm the number of CDYD plus twice the number of DYD decreases by at least 1, so that there are at most $2k - 1$ steps. Furthermore, by lemma 3.19 the total size of droplets in the collection \mathcal{D} is decreasing, so that $|D|/C_1 \leq |D'| \leq kC_1C_4$, where $D' \supset D$ is some droplet in the output of the algorithm. Indeed, $|Q(C)| \leq C_1C_4$ for all clusters C . This concludes the proof, since $|D| \geq \text{diam}(D)/C_1$ for all DYD and CDYD. \square

We next transform this extremal bound into an exponential decay of the probability that a droplet is spanned until saturation at the critical size.

Lemma 3.22 (Exponential decay). *Let D be a droplet with $|D| \leq 2/(C_5q^\alpha)$. Then*

$$\mu(D \text{ is spanned}) \leq \exp(-C_4|D|).$$

Proof. Let D be a droplet with $|D| \leq 2/(C_5q^\alpha)$, so that $\text{diam}(D) = d \leq 2C_1/(C_5q^\alpha)$. By lemma 3.21 if D is spanned, it contains at least d/C_4^2 disjoint clusters, each one having diameter at most C_3 . Each non-boundary cluster has at least α sites, while boundary clusters are non-empty and located at distance at most C_2 from ∂ . Thus, we have the union bound

$$\begin{aligned} \mu(D \text{ is spanned}) &\leq \sum_{l=0}^{d/C_4^2} \binom{C_3^2 d^2}{l} \binom{C_3 d}{d/C_4^2 - l} q^{l\alpha + (d/C_4^2 - l)} \\ &\leq \sum_{l=d/(2C_4^2)}^{d/C_4^2} (C_4' q^\alpha d^2 / l)^l . e^d + \sum_{l'=d/(2C_4^2)}^{d/C_4^2} (C_4' q d / l')^{l'} . e^d \\ &\leq \exp(-C_4 d). \end{aligned}$$

□

Our next aim is to prove that the closure of a set is contained in its droplet collection up to very local infections next to initial ones. To that end we will need some preliminary results, similar to those used by Bollobás, Duminil-Copin, Morris and Smith [BDCMSar].

Observation 3.23 (Lemma 6.5 of [BDCMSar]). *Let u be a rational non-semi-isolated stable direction. Let $K \subset \mathbb{Z}^2$ with $|K| < \alpha(u)$ (if $\alpha(u) = \infty$ the condition is that K is finite, but there is no a priori bound on its size). Then there exists a constant $C(\mathcal{U}, u, |K|)$ not depending on K such that $[K]_{\mathbb{H}_u}$ is within distance $C(\mathcal{U}, u, |K|)$ from K .*

Since we will require some improvements later, we spell out a proof of the above result for completeness (actually our proof is slightly different from the one in [BDCMSar]).

Proof of observation 3.23. We prove the statement by induction on $|K|$. For a $K = \{x\}$ this is easy, since if $\langle x, u \rangle$ is sufficiently large $[K]_{\mathbb{H}_u} = K$ and otherwise there is a single possible configuration for each value of $\langle x, u \rangle$ up to translation. Assume the result holds for $|K| < n$. If one can write $K = K_1 \sqcup K_2$ with $K_1, K_2 \neq \emptyset$ and $d(K_1, K_2) > 2C(\mathcal{U}, u, n-1) + O(1)$, then $[K]_{\mathbb{H}_u} = [K_1]_{\mathbb{H}_u} \sqcup [K_2]_{\mathbb{H}_u}$, since $[K_1]_{\mathbb{H}_u}$ and $[K_2]_{\mathbb{H}_u}$ are at sufficiently large distance, hence no site can use both to become infected. Assume that, on the contrary, there are no large gaps between parts of K . There is a finite

number of such K up to translation and for each of these $[K]$ is finite (e.g. since K is contained in a quadrilateral with sides perpendicular to \mathcal{S}), so within uniformly bounded distance from K . Therefore, if \mathbb{H}_u is sufficiently far from K , $[K]_{\mathbb{H}_u} = [K]$. Otherwise, there is a finite number of possible K up to translation perpendicular to u and for each of them $[K]_{\mathbb{H}_u}$ is finite, so that one can indeed find a finite uniform constant $C(\mathcal{U}, u, n)$ as claimed. \square

A quantitative version of this result was proved by Mezei and the first author [HM18]. An easy corollary of observation 3.23 is the fact that crumbs can only grow very locally (see figure 3.5(a)).

Corollary 3.24. *Let C_1 be sufficiently large depending on \mathcal{U} . Let $K \subset \mathbb{Z}^2$ with $|K| < \alpha$. Then $[K]$ is within distance $C_1/(6\alpha)$ from K . Also, for a (modified) crumb G we have that $\text{diam}([G]) \leq \alpha C_2$ and $[G]$ is within distance C_1 from G .*

Proof. The first assertion follows from observation 3.23, since if it were wrong, one could simply translate a set K sufficiently far from a half-plane yielding a contradiction with the observation.

Next consider a (modified) crumb G and P_G minimal with $|P_G| < \alpha$ and $[P_G] \supset G$. Then $[G] \subset [P_G]$ is within distance $C_1/(6\alpha)$ from P_G . If the sites of P_G are not connected in the graph Γ'' on \mathbb{Z}^2 with connections at distance at most $C_1 + C_2$, then either G is not connected in Γ or P_G is not minimal, which are both contradictions. Similarly, if there is no site of G at distance smaller than $C_1/(2\alpha)$ from a $C_1/(2\alpha)$ -connected component of P_G , that component can be removed from P_G , contradicting minimality. Hence, P_G is within distance $C_1/2$ from G . The result is then immediate, as $[G]$ is within distance $C_1/2 + C_1/(6\alpha)$ from G and its diameter is at most $C_1/(3\alpha) + \text{diam}(P_G)$, while $\text{diam}(P_G) \leq (\alpha - 1)(C_1 + C_2)$. \square

In order to treat infection at the concave corners of droplets we will need the following modification of observation 3.23.

Corollary 3.25. *Let u_1 and u_2 be rational strongly stable directions such that $\mathbb{H}_{u_1} \cup \mathbb{H}_{u_2}$ is stable for the bootstrap percolation dynamics i.e. $\nexists U \in \mathcal{U}, U \subset \mathbb{H}_{u_1} \cup \mathbb{H}_{u_2}$. Let $K \subset \mathbb{Z}^2$ with $|K| \leq \alpha - 1$. Then $[K]_{\mathbb{H}_{u_1} \cup \mathbb{H}_{u_2}}$ is within distance $C(\mathcal{U}, u_1, u_2)$ from K .*

Proof. We apply a similar induction to the one in the proof of observation 3.23. The only difference is that we can no longer use translation invariance. If $d(K, \mathbb{H}_{u_2}) > C(\mathcal{U}, u_1, |K|) + O(1)$, by observation 3.23, we have $[K]_{\mathbb{H}_{u_1} \cup \mathbb{H}_{u_2}} = [K]_{\mathbb{H}_{u_1}}$ and similarly for u_1 and u_2 interchanged. We can thus assume that K is within distance $C'(\mathcal{U}, u_1, u_2)$ from the origin. But then

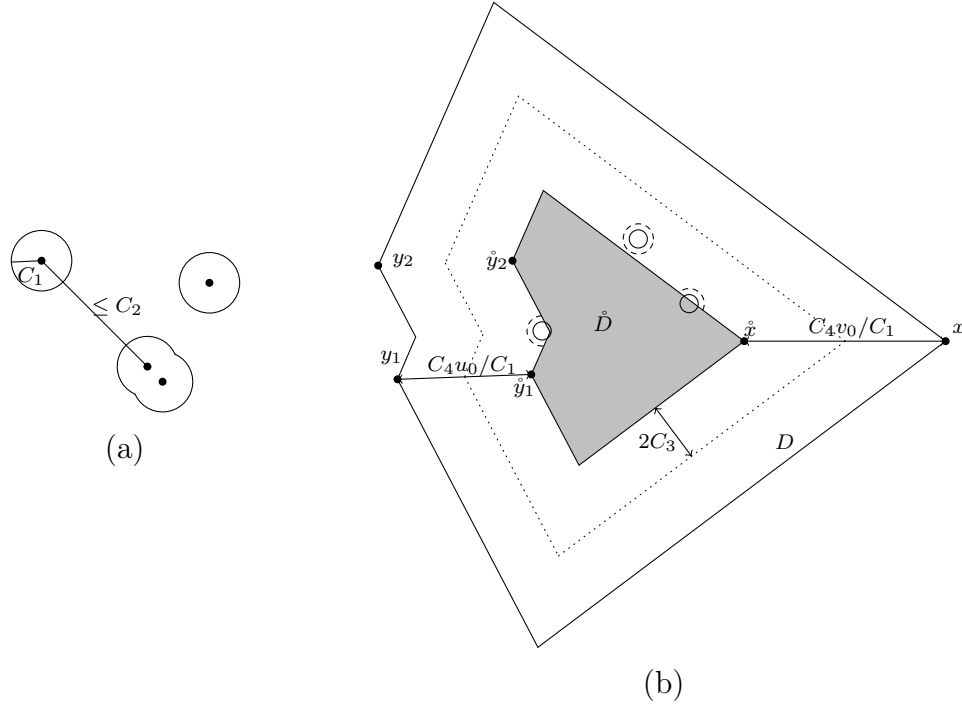

Figure 3.5: Illustrations of corollary 3.24, lemma 3.26 and proposition 3.27. (a) The dots represent the sites of a crumb. The (disconnected) circled shape bounds its closure. Note that crumbs may have gaps of size C_2 while the growth allowed is only $C_1 \ll C_2$. (b) The shaded region is the shrunk DYD \dot{D} of the largest DYD D . The solid circles represent crumbs and the dashed arcs are the bound for their growth provided by lemma 3.26. The modified clusters of the closure are included in the dotted DYD.

$[K \cup \mathbb{H}_{u_1} \cup \mathbb{H}_{u_2}] \subset \mathbb{H}_{u_1} \cup \mathbb{H}_{u_2} \cup \mathbb{H}_{u'}(C''(\mathcal{U}, u_1, u_2)u')$, where $u' = (u_1 + u_2)/2$, since the latter region is stable by the hypothesis on u_1, u_2 . \square

We next transform these results for infinite regions into a result for droplets. It states that a crumb next to a droplet cannot grow significantly (see figure 3.5(b)).

Lemma 3.26. *Let C_1 be sufficiently large depending on \mathcal{U} and \mathcal{S} . Let D be a DYD at distance at least C_3 from ∂ or be a CDYD and let G be a crumb. Then $[G]_{D \cup \partial} = [G]_D$ is within distance C_1 of G .*

Proof. Assume that D is a DYD at distance at least C_3 from ∂ . The proof of lemma 6.10 of [BDCMSar] applies using (3.5), observation 3.23, corollary 3.25

and the arguments in the proof of corollary 3.24 to give the result for $[G]_D$, which is therefore at distance at least $C_2 - C_1$ from ∂ since $d(G, \partial) \geq C_2$, so that in fact $[G]_D = [G]_{D \cup \partial}$.

Assume next that D is a CDYD. Then actually $D \cup \partial$ can be viewed as a DYD on the entire plane without boundary specified by an infinite number of vectors x_i , so that we are in the previous case. In order to avoid introducing the corresponding notion of infinite DYD, one can consider an increasing exhaustive sequence of DYD D_i converging to $D \cup \partial$ in the product topology and apply the previous result for $[G]_{D_i}$, which will thereby apply to $D \cup \partial$. Finally, $[G]_D = [G]_{D \cup \partial}$ follows, since $d([G]_{D \cup \partial}, \partial) \geq C_2 - C_1$. \square

The next proposition is key to making the output of the algorithm essentially invariant under the KCM dynamics without having to pay for the fact that the closure for the bootstrap percolation dynamics of infections at equilibrium is not at all at equilibrium itself. The proof is illustrated in figure 3.5(b).

Proposition 3.27 (Closure). *Let K be a finite set and \mathcal{D}' be the collection of droplets given by the modified droplet algorithm with input $[K]_\partial$. Let \mathcal{D} be the output of the droplet algorithm for K . Then*

$$\forall D' \in \mathcal{D}' \exists D \in \mathcal{D}, D' \subset D.$$

Proof. Let \mathcal{G} be the set of crumbs for K . Set $G_0 = \bigcup_{G \in \mathcal{G}} G$.

Claim 3.28. *For each crumb $G \in \mathcal{G}$ its closure $[G] = [G]_\partial$ consists of at most $\alpha - 1$ modified crumbs all contained within distance C_1 from G .*

Proof of claim 3.28. There exists a set P_G as in definition 3.11, such that $[P_G] \supset G$ and thus $[P_G] \supset [G]$, which proves that all connected components of $[G]$ for Γ' are modified crumbs. The fact that $[G]$ is within distance C_1 of G (and thus at distance at least C'_2 from ∂) was proved in corollary 3.24, which also shows that $[G] = [G]_\partial$, since G is at distance more than C_2 from ∂ . \square

We can thus define $\mathcal{G}'(G)$ to be the set of modified crumbs of $[G]_\partial$, so that their union is disjoint and equal to $[G]_\partial$. Moreover, crumbs in \mathcal{G} are at distance at least C_2 from each other, so for any two of them $G_1 \neq G_2$ we have that any $G'_1 \in \mathcal{G}'(G_1)$ and $G'_2 \in \mathcal{G}'(G_2)$ are at distance at least $C_2 - 2C_1 \gg C'_2$ and also at such distance from ∂ , so that $[G_0]_\partial = \bigcup_{G \in \mathcal{G}} [G]_\partial$ has no modified cluster and consists of modified crumbs at distance at most C_1 from G_0 .

For a droplet $D \in \mathcal{D}$ consider the set of vectors Y and x (x is absent for CDYD) defining it. Then define $\dot{Y} = Y + C_4 u_0 / C_1$ and $\dot{x} = x + C_4 v_0 / C_1$,

where $u_0 \in \mathbb{R}^2$ is the vector such that $\langle u_0, u_1 \rangle = \langle u_0, u_2 \rangle = -1$ and v_0 is defined identically in terms of v_1 and v_2 . We denote \mathring{D} the droplet defined by \mathring{Y} and \mathring{x} and call it *shrunk droplet*. Let $D_0 = \bigcup_{D \in \mathcal{D}} D$ and $\mathring{D}_0 = \bigcup_{D \in \mathcal{D}} \mathring{D}$. It is clear that \mathring{D} is at distance at least C_4/C_1 from $\Lambda \setminus D$ for all droplets D . In particular, all shrunk droplets are at distance at least C_4/C_1 from each other and shrunk DYD are at distance at least C_4/C_1 from ∂ , so that lemma 3.26 applies to them and $[\mathring{D}_0]_\partial = \mathring{D}_0$.

Claim 3.29. $\mathring{D}_0 \cup G_0 \supset K$.

Proof of claim 3.29. Note that it is enough to prove that the clusters of K are contained in \mathring{D}_0 . Assume that there exists $a \in K \setminus \mathring{D}_0$ and $a \in C$ for some cluster. Then, $Q(C) \cap \Lambda$ is contained in some $D \in \mathcal{D}$, which is defined by Y and x (x is absent for CDYD). Then since $a \notin \mathring{D}$, either for all $\mathring{y}_i \in \mathring{Y}$ we have $a \notin \mathbb{H}_{u_1}(\mathring{y}_i) \cap \mathbb{H}_{u_2}(\mathring{y}_i)$ or $a \notin \mathbb{H}_{v_1}(\mathring{x}) \cap \mathbb{H}_{v_2}(\mathring{x})$. In the former case, $a - C_4 u_0 / C_1 \notin \mathbb{H}_{u_1}(y_i) \cap \mathbb{H}_{u_2}(y_i)$ for all $y_i \in Y$. However, $Q(C)$ contains the ball of radius C_4 centered at a and $\|u_0\| = O(1)$, so we get a contradiction. If $a \notin \mathbb{H}_{v_1}(\mathring{x}) \cap \mathbb{H}_{v_2}(\mathring{x})$, the first point on the segment from a to $a - C_4 v_0 / C_1$ that is not in D is in Λ and in $Q(C)$, hence a contradiction. \square

Claim 3.30. *The set $[K]_\partial \setminus [G_0]_\partial$ is within distance C_3 of \mathring{D}_0 .*

Proof of claim 3.30. By claim 3.29 we have $K_0 = \mathring{D}_0 \cup G_0 \supset K$. It then clearly suffices to prove that $[K_0]_\partial \setminus [G_0]_\partial$ is within distance C_3 of \mathring{D}_0 .

Consider a crumb $G \in \mathcal{G}$ at distance at most C_2 from \mathring{D}_0 , so at distance at most C_2 from a shrunk droplet \mathring{D} and necessarily at distance at least $C_4/C_1 - C_2 - C_3$ from any other shrunk droplet and from ∂ if D is a DYD. By lemma 3.26 $[G]_{\mathring{D}} = [G]_{\mathring{D} \cup \partial}$ is within distance C_1 of G . Hence,

$$[K_0 \cup \partial] = \mathring{D}_0 \cup \partial \cup [G_0] \cup \bigcup_{G,D} [G]_{\mathring{D}}, \quad (3.7)$$

where the last union is on couples (G, D) as above. Indeed, all $[G]_{\mathring{D}}$ and $[G]$ (for different G) are at distance at least $C_2 - 2C_1$ from each other and from $\mathring{D}_0 \setminus \mathring{D}$ (by the reasoning above), so for each site of Λ the intersection of the ball of radius $O(1)$ centered at it with the set on the right-hand side of (3.7) coincides with the intersection with one of the sets $[G \cup \mathring{D}]$, $[G]$ or $\mathring{D}_0 \cup \partial$, which are all stable, so no infections occur, which proves (3.7).

The claim follows easily from (3.7), since for every couple G, D the set $[G]_{\mathring{D}}$ is within distance C_1 of G , which is itself at distance at most C_2 from \mathring{D}_0 , and G has diameter much smaller than C_3 by corollary 3.24. \square

We thus have that any modified cluster of $[K]_\partial$ is of diameter at most C_3 (by definition 3.11) and intersects $[K]_\partial \setminus [G_0]_\partial$ (by claim 3.28), which is within distance C_3 of \mathring{D}_0 (by claim 3.30). Hence, any such set is within distance $2C_3$ of \mathring{D}_0 .

Therefore, $\bigcup_{C' \in \mathcal{C}'([K]_\partial)} Q'(C') \subset D_0 \cup \partial$, where the union is over all modified clusters of $[K]_\partial$, since $\text{diam}(Q'(C')) \ll C_4/C_1 \leq d(\mathring{D}_0, \Lambda \setminus D_0)$. As \mathcal{D} is the output of the droplet algorithm, D_0 is the union of disjoint DYD non-intersecting ∂ and CDYD, so it necessarily contains $\bigcup_{D' \in \mathcal{D}} D'$ (see remark 3.17), which concludes the proof. \square

Remark 3.31. It should be noted that the algorithm is more easily and naturally defined with no boundary, but that will not be sufficient for our purposes. However, this “free” algorithm is trivially obtained as a specialisation of ours. It is also possible to deal with more general boundaries, with infinite input sets, as well as with droplets defined by more directions and possibly with several rugged sides.

3.6 Renormalised East dynamics

In this section we map the original dynamics into an East one and conclude the proof of our main result. In section 3.6.1 we introduce the necessary notation for the relevant geometry. In section 3.6.2 we consider a renormalised dynamics on the slices of figure 3.6 by algorithmically selecting certain modified spanned droplets of size $\Omega(1/q^\alpha)$. In section 3.6.3 we further renormalise to recover an exact East dynamics where q is replaced by q_{eff} corresponding to the probability of spanning such a droplet. Finally, in section 3.6.4 we prove theorem 3.8 roughly as in [MMTar].

3.6.1 Geometric setup

Set $L = 1/(C_5 q^\alpha)$ and $\iota = \min\{x \geq 1 : x/(2q^\alpha)u' \in \mathbb{Z}^2\}$, so that $\iota = 1 + O(q^\alpha)$. We consider a triangular domain V (see figure 3.6),

$$V = \mathbb{H}_{u'}(e^L u') \setminus (\mathbb{H}_{u_2}(-\iota/(2q^\alpha)u') \cup \mathbb{H}_{u_1}(-\iota/(2q^\alpha)u')).$$

Let us choose C_5 so that

$$N = e^L q^\alpha / (2\iota) + 1/4 = e^L q^\alpha (1/2 + O(q^\alpha))$$

is an integer. We then partition the domain $V = \bigcup_{i=1}^{2N} \mathcal{C}_i$ into regions with

$$\mathcal{C}_i = \{x \in V : e^L - \iota(i-1)/q^\alpha > \langle x, u' \rangle \geq e^L - \iota i/q^\alpha\},$$

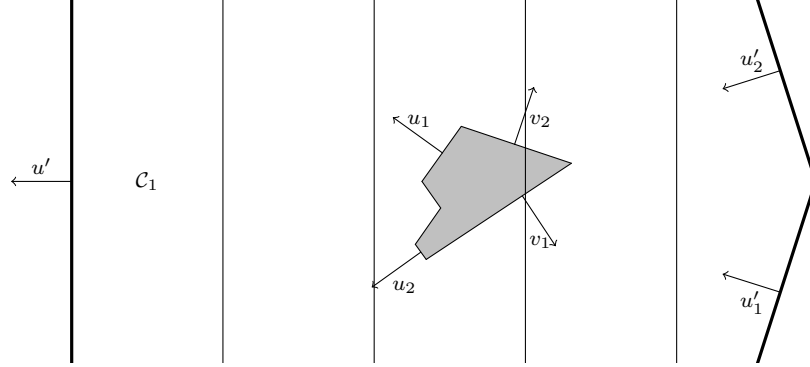

Figure 3.6: The domain V is the thickened triangle, a portion of which is displayed. Solid lines separate columns \mathcal{C}_i . Inside the domain is drawn a DYD, which witnesses $\Phi(\omega)_3 = \uparrow$.

so that 0 is in the middle of \mathcal{C}_{2N} and $e^L u' \in \mathbb{Z}^2$. We shall refer to \mathcal{C}_i as the i -th column. Finally, set

$$\mathbb{H}_i = \mathbb{H}_{u'}((e^L - i/q^\alpha)u')$$

and

$$\partial_i = \mathbb{H}_i \cup \bar{\partial}$$

where

$$\bar{\partial} = \mathbb{H}_{u'_2}(-\iota/(2q^\alpha)u') \cup \mathbb{H}_{u'_1}(-\iota/(2q^\alpha)u').$$

Note that these boundaries are of the form considered in section 3.5.

3.6.2 Arrow variables

Let $\omega \in \Omega$. We will now define a collection of arrow variables which depend only on the restriction of ω to V . We naturally identify the restriction of ω to V with the subset of V where ω is 0 and we use the notation $\omega = \emptyset$ to indicate that all sites are filled (healthy) in V , namely $\omega_x = 1$ for all $x \in V$. Let $\omega^{(0)} = \omega \cap V$. We call position of the first *up-arrow* the smallest index $i_1(\omega) \in \{1, 2, \dots, 2N\}$ such that there is a modified spanned droplet of size at least L for $[\omega^{(0)}]_{\partial_{i_1(\omega)}}$ with boundary $\partial_{i_1(\omega)}$. If no such i_1 exists, we say that there are no up-arrows and set $i_1(\omega) = \infty$. We further denote $\omega^{(1)} = \omega^{(0)} \cap \mathbb{H}_{i_1(\omega)}$ as soon as $i_1(\omega) < \infty$, while otherwise $\omega^{(1)} = \emptyset$.

We define the set $I(\omega) = \{i_1(\omega), i_2(\omega), \dots\} \subset \{1, \dots, 2N\}$ containing the positions of up-arrows recursively as follows. If there are no up-arrows, then $I = \emptyset$. Otherwise, we set $I(\omega) = \{i_1(\omega)\} \cup I(\omega^{(1)})$ and $\omega^{(k)} = (\omega^{(k-1)})^{(1)}$,

which defines $\omega^{(k)}$ for all k . Let us note that if $i_1(\omega) \neq \infty$, then $i_1(\omega) < i_1(\omega^{(1)})$, since by definition $[\omega^{(1)}]_{\partial_{i_1(\omega)}} = \emptyset$. Finally, we define $\Phi(\omega) \in \{\uparrow, \downarrow\}^{\{1, \dots, 2N\}}$ as

$$\Phi(\omega)_k = \begin{cases} \uparrow & \text{if } k \in I(\omega), \\ \downarrow & \text{otherwise.} \end{cases}$$

The next lemma states that the probability to find at least one up-arrow decays as

$$q_{\text{eff}} = e^{-L}.$$

Lemma 3.32.

$$\mu(i_1 < \infty) \leq q_{\text{eff}}.$$

Proof. Fix $1 \leq i \leq 2N$ and consider the event $i_1 = i$. It is clearly included in the event E_i that there is a modified spanned droplet of size at least L for $[\omega^{(0)}]_{\partial_i}$ with boundary ∂_i . By proposition 3.27 there is also a spanned droplet of size at least L/C_1 for $\omega^{(0)} \setminus \partial_i$ with boundary ∂_i . By lemma 3.20 this implies that there is also a spanned connected droplet of size between L/C_1^2 and $2L/C_1^2$. Then one can rewrite E_i as the union over all such droplets D of the event that D is spanned. Note that for each discretised DYD $D \cap \mathbb{Z}^2$ the event that there exists a spanned DYD D' with $D' \cap \mathbb{Z}^2 = D \cap \mathbb{Z}^2$ coincides with the event that a suitably chosen such D'_0 is spanned. Indeed, the intersection of two DYD is a DYD by (3.5) and the spanning of all D' depend only on the finite number of sites in $D \cap \mathbb{Z}^2$, so there is a finite number of possible events associated to different D' and one can consider the intersection of a D' defining each of these events. The same reasoning holds for CDYD and so for each discretised droplet $D \cap \mathbb{Z}^2$ one can bound the probability that there exists a spanned droplet with such discretisation using lemma 3.22. Thus, by the union bound on discretised droplets counted in observation 3.15, one obtains

$$\mu(E_i) \leq |V| \cdot e^L 2e^{-C_4 L/C_1^2} \leq q_{\text{eff}}/(2N).$$

□

We next consider the event of having at least n up-arrows

$$\mathcal{B}(n) = \{\omega \in \Omega : |I(\omega)| \geq n\}.$$

Corollary 3.33. *For any $1 \leq n \leq 2N$ we have*

$$\mu(\mathcal{B}(n)) \leq q_{\text{eff}}^n.$$

Proof. We prove the statement by induction on n . The base, $n = 1$, is given by lemma 3.32. For $n > 1$ we have

$$\begin{aligned} \mu(|I| \geq n) &= \sum_{i=1}^{2N} \mu(i_1(\omega) = i; |I(\omega \cap \mathbb{H}_i)| \geq n-1) \\ &\leq \sum_{i=1}^{2N} \mu(i_1 = i) \mu(|I| \geq n-1) \\ &\leq q_{\text{eff}}^n, \end{aligned}$$

where we used that the event $i_1 = i$ only depends on $\omega \setminus \mathbb{H}_i$ (i_1 is a stopping time for the filtration induced by the columns) and that the event $|I| \geq n-1$ is increasing for the order defined by $\omega \preceq \omega'$ when $\omega \subset \omega'$. \square

We will now state a key deterministic property of the arrows under legal moves of the KCM dynamics.

Lemma 3.34. *Let $\omega \in \Omega$. Let $x \in \mathcal{C}_i$ be such that $\omega_x = 1$ and the constraint at x is satisfied by $\omega \cup \bar{\partial}$. Assume that $\Phi(\omega) \neq \Phi(\omega^x)$. Let $j = \max\{k: \Phi(\omega)_k \neq \Phi(\omega^x)_k\}$. Then*

$$\begin{aligned} \Phi(\omega)_{[i-1,j]} &= (\uparrow, \downarrow, \uparrow, \downarrow, \uparrow, \dots), \Phi(\omega^x)_{[i-1,j]} = (\uparrow, \uparrow, \downarrow, \uparrow, \downarrow, \dots), \\ \Phi(\omega)_{[0,i-1]} &= \Phi(\omega^x)_{[0,i-1]}, \end{aligned}$$

with the convention that $\Phi(\omega)_0 = \uparrow$ for all ω .

Proof. We denote $\Phi := \Phi(\omega)$ and $\Phi' := \Phi(\omega^x)$. Clearly, $\Phi_{[0,i-1]} = \Phi'_{[0,i-1]}$, since those values do not depend on $\omega \cap \mathbb{H}_{i-1}$.

Claim 3.35. *Let $k \geq i$. If $\Phi_k = \uparrow$, then $\Phi_{[k+1,2N]} \geq \Phi'_{[k+1,2N]}$ for the lexicographic order associated to $\uparrow < \downarrow$. If $\Phi'_k = \uparrow$, then $\Phi_{[k+1,2N]} \leq \Phi'_{[k+1,2N]}$.*

Proof of claim 3.35. The two assertions being analogous, we only prove the first one, so assume that $\Phi_k = \uparrow$. Let $j' = \min\{l > k: \Phi_l = \uparrow\}$. Then there is a modified spanned droplet of size at least L for $[\omega^{(0)} \cap \mathbb{H}_k]_{\partial_{j'}}$ with boundary $\partial_{j'}$. But this is also true for ω^x instead of ω , as they coincide in \mathbb{H}_k , and in particular the position of the first up-arrow of Φ' after k is at most j' . \square

Claim 3.36. *Let $k \geq i-1$ be such that $\Phi_k = \Phi'_k = \downarrow$. Then $k > j$ i.e. $\Phi_{[k,2N]} = \Phi'_{[k,2N]}$.*

Proof of claim 3.36. We can clearly assume that $k < 2N$. Further assume for a contradiction that $\Phi_{k+1} = \uparrow$ and $\Phi'_{k+1} = \downarrow$. Let $i' = \max\{l < k: \Phi_l = \uparrow\}$. Then there exists a modified spanned droplet D of size at least L for

$[\omega^{(0)} \cap \mathbb{H}_{i'}]_{\partial_{k+1}}$ with boundary ∂_{k+1} . By lemma 3.20 we can assume that $L \leq |D| \leq C_1 L$. However, if $d(D, \mathcal{C}_{k+1}) > C_5$, then D is also modified spanned for $[\omega^{(0)} \cap \mathbb{H}_{i'}]_{\partial_k}$ with boundary ∂_k , contradicting the definition of i' . Indeed, from the output of the modified droplet algorithm for $[\omega^{(0)} \cap \mathbb{H}_{i'}]_{\partial_k} \cap D$ with boundary ∂_k we can create a collection $\hat{\mathcal{D}}$ of droplets for ∂_{k+1} by extending CDYD appropriately, thus $\hat{\mathcal{D}}$ contains $Q'(C') \setminus \partial_k = Q'(C') \setminus \partial_{k+1}$ for every modified cluster C' of $[\omega^{(0)} \cap \mathbb{H}_{i'}]_{\partial_k} \cap D$. Moreover, the modified clusters of $[\omega^{(0)} \cap \mathbb{H}_{i'}]_{\partial_{k+1}} \cap D$ are contained in the modified clusters of $[\omega^{(0)} \cap \mathbb{H}_{i'}]_{\partial_k} \cap D$, so $\hat{\mathcal{D}}$ contains the output of the modified droplet algorithm for $[\omega^{(0)} \cap \mathbb{H}_{i'}]_{\partial_{k+1}} \cap D$ with boundary ∂_{k+1} by remark 3.17, itself containing D .

Therefore, $d(D, \mathcal{C}_{k+1}) \leq C_5$. Moreover, D is not modified spanned for $[(\omega^x)^{(0)} \cap \mathbb{H}_{k-1}]_{\partial_{k+1}}$ with boundary ∂_{k+1} (otherwise $\Phi'_{[k,k+1]} \neq (\downarrow, \downarrow)$). Therefore, there exists a site $y \in D$ such that

$$y \in [\omega^{(0)} \cap \mathbb{H}_{i'}]_{\partial_{k+1}} \setminus [(\omega^x)^{(0)} \cap \mathbb{H}_{k-1}]_{\partial_{k+1}}.$$

We consider two subcases. First assume that $d(x, \mathbb{R}^2 \setminus \mathbb{H}_{i-1}) \geq C_1$. Then, the constraint at x is satisfied by $(\omega \cap \mathbb{H}_{i-1}) \cup \bar{\partial}$, so $[\omega^{(0)} \cap \mathbb{H}_{k-1}]_{\partial_{k+1}} = [(\omega^x)^{(0)} \cap \mathbb{H}_{k-1}]_{\partial_{k+1}}$, and there is a path

$$P \subset [\omega^{(0)} \cap \mathbb{H}_{i'}]_{\partial_{k+1}} \setminus [(\omega^x)^{(0)} \cap \mathbb{H}_{k-1}]_{\partial_{k+1}}$$

from $\mathbb{R}^2 \setminus \mathbb{H}_{k-1}$ to y such that each two consecutive sites are at distance at most $O(1)$. But $d(y, \mathbb{R}^2 \setminus \mathbb{H}_{k-1}) \geq \iota/q^\alpha - \text{diam}(D) - C_5 \geq C_2(L+1)$, so one can find a subpath $P' \subset \mathcal{C}_k \cap P$ of diameter at least $C_2 L$. Yet, it is clear that $P' \subset [\omega^{(0)} \cap \mathbb{H}_{i'}]_{\partial_k}$ implies the existence of a modified spanned droplet of size larger than L with boundary ∂_k , so one would have an up-arrow of Φ in $[i'+1, k]$ — a contradiction. If, on the contrary, $d(x, \mathbb{R}^2 \setminus \mathbb{H}_{i-1}) \leq C_1$, we can redo the same reasoning, but P needs to extend to either $\mathbb{R}^2 \setminus \mathbb{H}_{k-1}$ or x , both of which are sufficiently far from y .

Thus, $\Phi_{k+1} = \Phi'_{k+1}$, as the case $\Phi_{k+1} = \downarrow, \Phi'_{k+1} = \uparrow$ is treated identically. But then either both are \uparrow , in which case we are done by claim 3.35 or both are \downarrow and we are done by induction. \square

It is easy to see that the only non-identical arrow sequences $\Phi_{[i-1,j]}$ and $\Phi'_{[i-1,j]}$ satisfying the two claims are $(\uparrow, \downarrow, \uparrow, \downarrow, \dots)$ and $(\uparrow, \uparrow, \downarrow, \uparrow, \dots)$ (in this order using that $\omega_x = 1$). Indeed, by claims 3.35 and 3.36 $\Phi_k \neq \Phi'_k$ for all $i \leq k \leq j$, by claim 3.35 one cannot have two consecutive up-arrows neither in Φ nor in Φ' in the interval $[i, j]$ and by claim 3.36 $\Phi_{i-1} = \Phi'_{i-1} = \uparrow$. \square

3.6.3 Renormalised East dynamics

We partition $\{1, \dots, 2N\}$ into blocks $B_i = \{2i - 1, 2i\}$ for $1 \leq i \leq N$. Given $\omega \in \Omega$, we define $\eta(\omega) \in \{0, 1\}^{\{1, \dots, N\}}$ by

$$\eta(\omega)_i = \mathbb{1}_{\{\forall j \in B_i: \Phi(\omega)_j = \downarrow\}}$$

for all $i \in \{1, \dots, N\}$. Let

$$n = \lfloor L \rfloor = \left\lfloor \frac{1}{C_5 q^\alpha} \right\rfloor < \lfloor \log_2 N \rfloor.$$

Recall the definition of legal paths, definition 3.4. Given an event $\mathcal{E} \subset \Omega$ and a legal path $\gamma = (\omega_{(0)}, \dots, \omega_{(k)})$ we will say that $\gamma \cap \mathcal{E} = \emptyset$ if $\omega_{(i)} \notin \mathcal{E}$ for all $i \in \{0, \dots, k\}$. Also, given $\omega \in \Omega$ and $\mathcal{A} \subset \Omega$, we say that γ connects ω to \mathcal{A} if $\omega_{(0)} = \omega$ and $\omega_{(k)} \in \mathcal{A}$. Recall that $\mathcal{B}(n) \subset \Omega$ is the set of configurations with at least n up-arrows. The following is a straightforward but important corollary of lemma 3.34.

Corollary 3.37. *For any legal path $(\omega_{(0)}, \dots, \omega_{(k)})$, the path which is given by $(\eta(\omega_{(0)}), \dots, \eta(\omega_{(k)}))$ is legal for the East model on $\{1, \dots, N\}$ defined by fixing $\eta_0 = 0$.*

Proof. By lemma 3.34 $\eta(\omega_{(j)}) \neq \eta(\omega_{(j+1)})$ implies that $\Phi(\omega_{(j)})$ and $\Phi(\omega_{(j+1)})$ only differ on an alternating chain of arrows ending in some B_i , preceded by \uparrow . Then clearly $\eta(\omega_{(j)})_l = \eta(\omega_{(j+1)})_l$ for all $l \neq i$ and $\eta(\omega_{(j)})_{i-1} = 0$. \square

Let Ω_\downarrow and Ω_\uparrow^{2N} be respectively the set of configurations which do not have up-arrows, and the set of configurations with an up-arrow in the $2N$ -th column, namely

$$\begin{aligned} \Omega_\downarrow &= \{\omega \in \Omega : \Phi(\omega) = (\downarrow, \dots, \downarrow)\}, \\ \Omega_\uparrow^{2N} &= \{\omega \in \Omega : \Phi(\omega)_{2N} = \uparrow\}. \end{aligned}$$

Combining the last corollary with proposition 3.7, we obtain the most important input for the proof of the main result.

Corollary 3.38. *For any $\omega \in \Omega_\downarrow$ there does not exist a legal path γ with $\gamma \cap \mathcal{B}(n+1) = \emptyset$ connecting ω to Ω_\uparrow^{2N} .*

3.6.4 Proof of theorem 3.8

To prove theorem 3.8 it is sufficient to prove the lower bound for the mean infection time and use the following inequality (see theorem 4.4 of [CMRT09] and also section 2.2 of [MMT19])

$$T_{\text{rel}} \geq q\mathbb{E}(\tau_0). \tag{3.8}$$

However, it is instructive to construct at this stage a test function that directly gives the desired lower bound on T_{rel} without going through the comparison with the mean infection time. Indeed, the mechanism will appear more clearly this way.

Proof of theorem 3.8 for T_{rel} We define the event

$$\tilde{\mathcal{A}} = \{\omega \in \Omega : \exists \text{ a legal path } \gamma \text{ with } \gamma \cap \mathcal{B}(n) = \emptyset \\ \text{connecting } \omega \cup (\mathbb{Z}^2 \setminus V) \text{ to } \Omega_{\downarrow}\}$$

and the test function $f : \Omega \rightarrow \{0, 1\}$

$$f = \mathbb{1}_{\tilde{\mathcal{A}}}.$$

Then, by definition 3.5 we get

$$T_{\text{rel}} \geq \frac{\mu(\tilde{\mathcal{A}})(1 - \mu(\tilde{\mathcal{A}}))}{\mathcal{D}(f)}, \quad (3.9)$$

where the Dirichlet form $\mathcal{D}(f)$ is defined in (3.3).

Lemma 3.39 (Bounds on $\mu(\tilde{\mathcal{A}})$).

$$\mu(\tilde{\mathcal{A}}) \left(1 - \mu(\tilde{\mathcal{A}})\right) \geq \exp\left(\frac{\log q}{C_4 q^\alpha}\right).$$

Proof. By lemma 3.32 we have

$$\mu(\tilde{\mathcal{A}}) \geq \mu(\Omega_{\downarrow}) \geq 1 - q_{\text{eff}} \geq 1/2.$$

On the other hand,

$$1 - \mu(\tilde{\mathcal{A}}) \geq \mu(\Omega_{\uparrow}^{2N}) \geq q^{C_1 L} \geq \exp(C_1 \log q / (C_5 q^\alpha)),$$

where we used corollary 3.38 for the first inequality as well as the fact that if $(\omega_{(0)}, \dots, \omega_{(k)})$ is a legal path, then $(\omega_{(k)}, \dots, \omega_{(0)})$ is one as well, and for the second inequality we notice that for the $2N$ -th arrow to be up it is sufficient to have an empty segment of length $C_1 L$ in \mathcal{C}_{2N} . \square

Lemma 3.40 (Estimate of the Dirichlet form). $\mathcal{D}(f) \leq \exp(-1/(C_5^3 q^{2\alpha}))$.

Proof. Using the fact that $f(\omega)$ depends only on the values of ω in V , we get

$$\mathcal{D}(f) = \sum_{x \in V} \mu(c_x \text{Var}_x(f))$$

$$= q(1 - q) \sum_{x \in V} \mu \left(c_x \mathbf{1}_{\{\omega \in \tilde{\mathcal{A}}, \omega^x \notin \tilde{\mathcal{A}}\}} + c_x \mathbf{1}_{\{\omega \notin \tilde{\mathcal{A}}, \omega^x \in \tilde{\mathcal{A}}\}} \right) \leq |V| \mu(\mathcal{B}(n-1)),$$

since, by lemma 3.34 $\|I(\omega)\| - \|I(\omega^x)\| \leq 1$ when $c_x = 1$, so the indicators both imply $\omega \in \mathcal{B}(n-1)$. Indeed, $\omega \in \tilde{\mathcal{A}}$ implies the existence of a legal path γ from Ω_\downarrow to $\omega \cup (\mathbb{Z}^2 \setminus V)$ with each configuration not in $\mathcal{B}(n)$. Since $c_x = 1$, the path $\bar{\gamma}$ obtained by adding the transition from $\omega \cup (\mathbb{Z}^2 \setminus V)$ to $\omega^x \cup (\mathbb{Z}^2 \setminus V)$ is also legal, thus the hypothesis $\omega^x \notin \tilde{\mathcal{A}}$ is not satisfied unless $\omega^x \in \mathcal{B}(n)$ (and similarly for $\omega \notin \tilde{\mathcal{A}}, \omega^x \in \tilde{\mathcal{A}}$). Thus, the result follows by using corollary 3.33. \square

Then the lower bound for T_{rel} of theorem 3.8 follows from (3.9), lemma 3.39 and lemma 3.40. \square

The above proof, together with the matching upper bound of theorem 2(a) of [MMT19] indicate that the bottleneck dominating the time scales is the creation of $\Theta(\log(1/q_{\text{eff}}))$ simultaneous droplets of probability q_{eff} .

Proof of theorem 3.8 for $\mathbb{E}(\tau_0)$ The proof of the lower bound for the infection time follows a similar route, with some complications due to the fact that we have to identify a (sufficiently likely) initial set starting from which we have to go through the bottleneck configurations before infecting the origin.

By corollary 3.4 of [MMTar], to prove the desired lower bound on $\mathbb{E}(\tau_0)$ it suffices to construct a local function $\phi = \phi_q$ such that

- (i). $\mu(\phi^2) = 1$;
- (ii). $\frac{\mu(\phi)^4}{\mathcal{D}(\phi)} \geq \exp(1/(C_5^4 q^{2\alpha}))$;
- (iii). $\phi(\omega) = 0$ if $\omega_0 = 0$.

Inspired by [MMTar] we let

$$\Omega_g = \Omega_\downarrow \cap \{\omega \in \Omega : \omega_{\Lambda_0} = 1\}$$

where $\Lambda_0 = \{x \in \mathbb{Z}^2 : d(x, 0) \leq 1/(4q^\alpha)\} \subset \mathcal{C}_{2N}$ and

$$\mathcal{A} = \{\omega \in \Omega : \exists \text{ a legal path } \gamma \text{ with } \gamma \cap \mathcal{B}(n) = \emptyset \\ \text{connecting } \omega \cup (\mathbb{Z}^2 \setminus V) \text{ to } \Omega_g\}.$$

Then we set

$$\phi(\cdot) = \mathbf{1}_{\mathcal{A}}(\cdot) / \mu(\mathcal{A})^{1/2}. \quad (3.10)$$

We are now left with proving that this function satisfies (i)–(iii) above.

Property (i) follows immediately from (3.10). In order to verify (ii) we start by establishing a lower bound on $\mu(\mathcal{A})$. By definition it holds that

$$\mu(\mathcal{A}) \geq \mu(\Omega_g) \geq \mu(\omega_{\Lambda_0} = 1)\mu(\Omega_{\downarrow}) \geq e^{-O(1)/q^{2\alpha-1}}(1 - q_{\text{eff}}) = e^{-O(1)/q^{2\alpha-1}}, \quad (3.11)$$

where we used Harris' inequality [Har60] ($\{\omega_{\Lambda_0} = 1\}$ and Ω_{\downarrow} are increasing events if we consider that $\omega \leq \omega'$ when $\omega_x \leq \omega'_x$ for all $x \in \mathbb{Z}^2$), lemma 3.32 and $|\Lambda_0| = O(1/q^{2\alpha})$.

Furthermore, one can repeat the proof of lemma 3.40 to obtain

$$\mathcal{D}(\phi) \leq e^{-1/(C_5^3 q^{2\alpha})}.$$

Thus, recalling (3.11), property (ii) holds.

We are therefore only left with proving the next lemma establishing property (iii), completing the proof of theorem 3.8.

Lemma 3.41. *Let ω be such that $\omega_0 = 0$. Then any legal path connecting Ω_g to ω intersects $\mathcal{B}(n)$.*

As in the lower bound on $1 - \mu(\tilde{\mathcal{A}})$ for T_{rel} , the proof relies on corollary 3.38, but an additional complication arises due to the fact that emptying the origin does not a priori require creating a critical droplet nearby.

Proof of lemma 3.41. Suppose for a contradiction that there exist a configuration ω with $\omega_0 = 0$, a configuration $\omega_{(0)} \in \Omega_g$ and a legal path $\gamma = (\omega_{(0)}, \dots, \omega_{(k)})$ with $\omega_{(k)} = \omega$ and $\omega_{(j)} \notin \mathcal{B}(n)$ for all $j \in \{0, \dots, k\}$. Assuming without loss of generality that $\omega_{(j)} \neq \omega_{(j-1)}$ for all j , let x_j be such that $\omega_{(j)} = (\omega_{(j-1)})^{x_j}$. Consider the path $\tilde{\gamma} = (\tilde{\omega}_{(0)}, \dots, \tilde{\omega}_{(k)})$ obtained by performing the same updates as for γ except for flips in the column \mathcal{C}_{2N} , which are performed only if they correspond to emptying sites. More precisely, we let $\tilde{\omega}_{(0)} = \omega_{(0)}$ and

$$\tilde{\omega}_{(j)} = \begin{cases} (\tilde{\omega}_{(j-1)})^{x_j} & \text{if } x_j \notin \mathcal{C}_{2N} \text{ or } (\tilde{\omega}_{(j-1)})_{x_j} = 1, \\ \tilde{\omega}_{(j-1)} & \text{otherwise.} \end{cases}$$

It is not difficult to verify by induction that $\tilde{\gamma}$ is also a legal path with $\tilde{\omega}_{(j)} \leq \omega_{(j)}$ for all j (where $\omega \leq \omega'$ when $\omega_x \leq \omega'_x$ for all $x \in \mathbb{Z}^2$) and that $\tilde{\omega}_{(j)}$ and $\omega_{(j)}$ coincide outside of \mathcal{C}_{2N} . Then $(\tilde{\omega}_{(k)})_0 \leq (\omega_{(k)})_0 = 0$ and by definition $(\tilde{\omega}_{(0)})_{\Lambda_0} = 1$. Therefore, since inside \mathcal{C}_{2N} each site that has been emptied in γ is also empty in $\tilde{\omega}_{(k)}$, we conclude that necessarily $\tilde{\omega}_{(k)} \cap \mathcal{C}_{2N}$ contains a (modified) spanned droplet of size $1/(4C_1 q^\alpha) > L$ with boundary $\partial_{2N} = \bar{\partial}$. Indeed, there is a path of sites x with steps of size $O(1)$ from $\mathbb{Z}^2 \setminus \Lambda_0$ to 0

such that $(\tilde{\omega}_{(k)})_x = 0$. This means that $\tilde{\omega}_{(k)} \in \Omega_{\uparrow}^{2N}$. Furthermore, for all j we have $\Phi(\tilde{\omega}_{(j)})_{[1,2N-1]} = \Phi(\omega_{(j)})_{[1,2N-1]}$, as those do not depend on the sites in \mathcal{C}_{2N} . Thus, using corollary 3.38, together with the facts that $\tilde{\omega}_{(0)} \in \Omega_g \subset \Omega_{\downarrow}$, $\tilde{\omega}_{(k)} \in \Omega_{\uparrow}^{2N}$ and $\tilde{\gamma} \cap \mathcal{B}(n+1) = \emptyset$, we reach a contradiction. \square

3.7 Open problems

With theorem 3.8 the scaling of the infection time is determined up to a polylogarithmic factor. The next natural question is to pursue determining this factor in the spirit of the refined universality result of [BDCMSar]. For the moment there is only one critical model with infinitely many stable directions for which this is known — the Duarte model [MMTar]. In that case the corrective factor is $\Theta((\log q)^4)$. However, for bootstrap percolation there are already two different possible behaviors of this factor depending on whether the model is balanced or unbalanced (see definition 3.3). Based on this one could expect the following.

Conjecture 3.42. *Let \mathcal{U} be a critical update family with an infinite number of stable directions.*

- *If \mathcal{U} is balanced, then*

$$\mathbb{E}(\tau_0) = \exp\left(\frac{\Theta(1)}{q^{2\alpha}}\right).$$

- *If \mathcal{U} is unbalanced, then*

$$\mathbb{E}(\tau_0) = \exp\left(\frac{\Theta((\log q)^4)}{q^{2\alpha}}\right).$$

The same asymptotics hold for T_{rel} .

In other words we expect the lower bound of theorem 3.8 to be sharp for balanced models, while the upper bound of theorem 2(a) of [MMT19] would be sharp for unbalanced ones. The balanced case is not hard and only requires an improvement of the approach of [MMT19]. It will be treated in a future work, since it shares none of the techniques discussed here. In the unbalanced case the $(\log q)^4$ should arise as the square of the $(\log q)^2$ factor for bootstrap percolation, itself caused by the one-dimensional geometry and larger size of critical droplets. This is indeed what happens for the Duarte model [MMTar], an example of unbalanced critical constraint.

Chapter 4

Convergence to equilibrium in supercritical kinetically constrained models

This chapter corresponds to the article *Exponential convergence to equilibrium in supercritical kinetically constrained models at high temperature* [Mar19b].

Kinetically constrained models (KCMs) were introduced by physicists to model the liquid-glass transition. They are interacting particle systems on \mathbb{Z}^d in which each element of \mathbb{Z}^d can be in state 0 or 1 and tries to update its state to 0 at rate q and to 1 at rate $1 - q$, provided that a constraint is satisfied. In this article, we prove the first non-perturbative result of convergence to equilibrium for KCMs with general constraints: for any KCM in the class termed “supercritical” in dimension 1 and 2, when the initial configuration has product Bernoulli($1 - q'$) law with $q' \neq q$, the dynamics converges to equilibrium with exponential speed when q is close enough to 1, which corresponds to the high temperature regime.

4.1 Introduction

Kinetically constrained models (KCMs) are interacting particle systems on \mathbb{Z}^d , in which each element (or *site*) of \mathbb{Z}^d can be in state 0 or 1. Each site tries to update its state to 0 at rate q and to 1 at rate $1 - q$, with $q \in [0, 1]$ fixed, but an update is accepted if and only if a *constraint* is satisfied. This constraint is defined via an *update family* $\mathcal{U} = \{X_1, \dots, X_m\}$, where $m \in \mathbb{N}^*$ and the X_i , called *update rules*, are finite nonempty subsets of $\mathbb{Z}^d \setminus \{0\}$: the

constraint is satisfied at a site x if and only if there exists $X \in \mathcal{U}$ such that all the sites in $x + X$ have state zero. Since the constraint at a site does not depend on the state of the site, it can be easily checked that the product Bernoulli($1 - q$) measure, ν_q , satisfies the detailed balance with respect to the dynamics, hence is reversible and invariant. ν_q is the *equilibrium measure* of the dynamics.

KCMs were introduced in the physics literature by Fredrickson and Andersen [FA84] to model the liquid-glass transition, an important open problem in condensed matter physics (see [RS03, GST11]). In addition to this physical interest, KCMs are also mathematically challenging, because the presence of the constraints make them very different from classical Glauber dynamics and prevents the use of most of the usual tools.

One of the most important features of KCMs is the existence of blocked configurations. These blocked configurations imply that the equilibrium measure ν_q is not the only invariant measure, which complicate a lot the study of the out-of-equilibrium behavior of KCMs; even the basic question of their convergence to ν_q remains open in most cases.

Because of the blocked configurations, one cannot expect such a convergence to equilibrium for all initial laws. Initial measures particularly relevant for physicists are the $\nu_{q'}$ with $q' \neq q$ (see [LMS⁺07]). Indeed, q is a measure of the temperature of the system: the closer q is to 0, the lower the temperature is. Therefore, starting the dynamics with a configuration of law $\nu_{q'}$ means starting with a temperature different from the equilibrium temperature. In this case, KCMs are expected to converge to equilibrium with exponential speed as soon as no site is blocked for the dynamics in a configuration of law ν_q or $\nu_{q'}$. However, there have been few results in this direction so far (see [CMST10, BCM⁺13, CFM15, MV19] and [Mar19a]¹), and they have been restricted to particular update families or initial laws.

Furthermore, general update families have attracted a lot of attention in recent years. Indeed, there recently was a breakthrough in the study of a monotone deterministic counterpart of KCMs called bootstrap percolation. Bootstrap percolation is a discrete-time dynamics in which each site of \mathbb{Z}^d can be *infected* or not; infected sites are the bootstrap percolation equivalent of sites at zero. To define it, we fix an update family \mathcal{U} and choose a set A_0 of initially infected sites; then for any $t \in \mathbb{N}^*$, the set of sites that are infected at time t is

$$A_t = A_{t-1} \cup \{x \in \mathbb{Z}^d \mid \exists X \in \mathcal{U}, x + X \subset A_{t-1}\},$$

which means that the sites that were infected at time $t - 1$ remain infected

¹Chapter 5 of this thesis.

at time t and a site x that was not infected at time $t - 1$ becomes infected at time t if and only if there exists $X \in \mathcal{U}$ such that all sites of $x + X$ are infected at time $t - 1$. Until recently, bootstrap percolation had only been considered with particular update families, but the study of general update families was opened by Bollobás, Smith and Uzzell in [BSU15]. Along with Balister, Bollobás, Przykucki and Smith [BBPS16], they proved that general update families satisfy the following universality result: in dimension 2, they can be sorted into three classes, *supercritical*, *critical* and *subcritical* (see definition 4.2), which display different behaviors (their result for the critical class was later refined by Bollobás, Duminil-Copin, Morris and Smith in [BDCMSar]).

These works opened the study of KCMs with general update families. In [MMT19], [MMTar]², [HMT19a]³ and [HMT19b], Hartarsky, Martinelli, Morris, Toninelli and the author showed that the grouping of two-dimensional update families into supercritical, critical and subcritical is still relevant for KCMs, and established an even more precise classification. However, these results deal only with equilibrium dynamics. Until now, nothing had been shown on out-of-equilibrium KCMs with general update families, apart from a perturbative result in dimension 1 [CMST10].

In this article, we prove that for all supercritical update families, for any initial law $\nu_{q'}$, $q' \in]0, 1]$, when q is close enough to 1, the dynamics of the KCM converges to equilibrium with exponential speed. This result holds in dimension 2 and also in dimension 1 for a good definition of one-dimensional supercritical update families. It is the first non-perturbative result of convergence to equilibrium holding for a whole class of update families.

This result may help to gain a better understanding of the behavior of supercritical KCMs out of equilibrium. In particular, such results of convergence to equilibrium were key in proving “shape theorems” for specific one-dimensional constraints in [Blo13, GLM15, BDT19].

4.2 Notations and result

Let $d \in \mathbb{N}^*$. We denote by $\|\cdot\|_\infty$ the ℓ^∞ -norm on \mathbb{Z}^d . For any set S , $|S|$ will denote the cardinal of S .

For any configuration $\eta \in \{0, 1\}^{\mathbb{Z}^d}$, for any $x \in \mathbb{Z}^d$, we denote $\eta(x)$ the value of η at x . Moreover, for any $S \subset \mathbb{Z}^d$, we denote η_S the restriction of η to S , and 0_S (or just 0 when S is clear from the context) the configuration on $\{0, 1\}^S$ that contains only zeroes.

²Chapter 2 of this thesis.

³Chapter 3 of this thesis.

We set an update family $\mathcal{U} = \{X_1, \dots, X_m\}$ with $m \in \mathbb{N}^*$ and the X_i finite nonempty subsets of $\mathbb{Z}^d \setminus \{0\}$. To describe the classification of update families, we need the concept of *stable directions*.

Definition 4.1. For $u \in S^{d-1}$, we denote $\mathbb{H}_u = \{x \in \mathbb{R}^d \mid \langle x, u \rangle < 0\}$ the half-space with boundary orthogonal to u . We say that u is a *stable direction* for the update family \mathcal{U} if there does not exist $X \in \mathcal{U}$ such that $X \subset \mathbb{H}_u$; otherwise u is *unstable*. We denote by \mathcal{S} the set of stable directions.

[BSU15] gave a classification of two-dimensional update families into supercritical, critical or subcritical depending on their stable directions. Here is the generalization proposed for d -dimensional update families by [BDCMSar] (definition 9.1 therein), where for any $\mathcal{E} \subset S^{d-1}$, $\text{int}(\mathcal{E})$ is the interior of \mathcal{E} in the usual topology on S^{d-1} .

Definition 4.2. A d -dimensional update family \mathcal{U} is

- supercritical if there exists an open hemisphere $C \subset S^{d-1}$ that contains no stable direction;
- critical if every open hemisphere $C \subset S^{d-1}$ contains a stable direction, but there exists a hemisphere $C \subset S^{d-1}$ such that $\text{int}(C \cap \mathcal{S}) = \emptyset$;
- subcritical if $\text{int}(C \cap \mathcal{S}) \neq \emptyset$ for every hemisphere $C \subset S^{d-1}$.

Our result will be valid for supercritical update families.

The KCM process with update family \mathcal{U} can be constructed as follows. We set $q \in [0, 1]$. Independently for all $x \in \mathbb{Z}^d$, we define two independent Poisson point processes \mathcal{P}_x^0 and \mathcal{P}_x^1 on $[0, +\infty[$, with respective rates q and $1 - q$. We call the elements of $\mathcal{P}_x^0 \cup \mathcal{P}_x^1$ *clock rings* and denote them by $t_{1,x} < t_{2,x} < \dots$. The elements of \mathcal{P}_x^0 will be *0-clock rings* and the elements of \mathcal{P}_x^1 will be *1-clock rings*. For any initial configuration $\eta \in \{0, 1\}^{\mathbb{Z}^d}$, we construct the KCM as the continuous-time process $(\eta_t)_{t \in [0, +\infty[}$ on $\{0, 1\}^{\mathbb{Z}^d}$ defined thus: for any $x \in \mathbb{Z}^d$, $\eta_t(x) = \eta_0(x)$ for $t \in [0, t_{1,x}[$, and for any $k \in \mathbb{N}^*$,

- if there exists $X \in \mathcal{U}$ such that $(\eta_{t_{k,x}^-})_{x+X} = 0_{x+X}$, then $\eta_t(x) = \varepsilon$ for $t \in [t_{k,x}, t_{k+1,x}[$, where $t_{x,k}$ is a ε -clock ring, $\varepsilon \in \{0, 1\}$;
- if such an X does not exist, $\eta_t(x) = \eta_{t_{k-1,x}}(x)$ for $t \in [t_{k,x}, t_{k+1,x}[$.

In other words, sites try to update themselves to 0 when there is a 0-clock ring, which happens at rate q , and to 1 when there is a 1-clock ring, which happens at rate $1 - q$, but an update at x is successful if and only if there exists an update rule X such that all sites of $x + X$ are at zero. This construction

is known as *Harris graphical construction*. One can use the arguments in part 4.3 of [Swa17] to see that it is well-defined. We denote by \mathbb{P}_ν the law of $(\eta_t)_{t \in [0, +\infty[}$ when the initial configuration has law ν .

For any $q' \in [0, 1]$, we denote $\nu_{q'}$ the product Bernoulli($1 - q'$) measure. Since the constraint at a site does not depend on the state of the site, it can be easily checked that ν_q satisfies the detailed balance with respect to the dynamics, hence is reversible and invariant. ν_q is called equilibrium measure of the dynamics.

We will say that a function $f : \{0, 1\}^{\mathbb{Z}^d} \mapsto \mathbb{R}$ is *local* if its output depends only on the states of a finite set of sites, and we then denote $\|f\|_\infty = \sup_{\eta \in \{0, 1\}^{\mathbb{Z}^d}} |f(\eta)|$ its norm.

Theorem 4.3. *If $d = 1$ or 2 , for any supercritical update family \mathcal{U} , for any $q' \in]0, 1]$, there exists $q_0 = q_0(\mathcal{U}, q') \in [0, 1[$ such that for any $q \in [q_0, 1]$, for any local function $f : \{0, 1\}^{\mathbb{Z}^d} \mapsto \mathbb{R}$, there exist two constants $c = c(\mathcal{U}, q') > 0$ and $C = C(\mathcal{U}, q', f) > 0$ such that for any $t \in [0, +\infty[$,*

$$\left| \mathbb{E}_{\nu_{q'}}(f(\eta_t)) - \nu_q(f) \right| \leq C e^{-ct}.$$

Remark 4.4. We expect theorem 4.3 to hold also for $d \geq 3$. However, our proof relies on proposition 4.13, which is easy for $d = 1$ and was proven in [BSU15] for $d = 2$, but for which there is no equivalent for $d \geq 3$. Such an equivalent would extend our result to $d \geq 3$.

The remainder of this article is devoted to the proof of theorem 4.3. The argument is based on the proof given in [MV19] for the particular case of the Fredrickson-Andersen one-spin facilitated model, but brings in novel ideas in order to accommodate the much greater complexity of general supercritical models. From now on, we fix $d = 1$ or 2 and \mathcal{U} a supercritical update family in dimension d . We begin in section 4.3 by using the notion of dual paths to reduce the proof of theorem 4.3 to the simpler proof of proposition 4.7. Then in section 4.4 we use the concept of codings to simplify it further, reducing it to the proof of proposition 4.11. In section 4.5 we introduce an auxiliary oriented percolation process, that we use in section 4.6 to prove proposition 4.11 hence theorem 4.3.

4.3 Dual paths

In this section, we use the concept of *dual paths* to reduce the proof of theorem 4.3 to the easier proof of proposition 4.7. Let $q, q' \in [0, 1]$. We notice that the Harris graphical construction allows us to couple a process $(\eta_t)_{t \in [0, +\infty[}$

with initial law $\nu_{q'}$ and a process $(\tilde{\eta}_t)_{t \in [0, +\infty[}$ with initial law ν_q by using the same clock rings but different initial configurations (independent of the clock rings). We denote the joint law by $\mathbb{P}_{q', q}$. We notice that since ν_q is an invariant measure for the dynamics, $\tilde{\eta}_t$ has law ν_q for all $t \in [0, +\infty[$. To prove theorem 4.3, it is actually enough to show

Proposition 4.5. *For any $q' \in]0, 1]$, there exists $q_0 = q_0(\mathcal{U}, q') \in [0, 1[$ such that for any $q \in [q_0, 1]$, there exist two constants $c_1 = c_1(\mathcal{U}, q') > 0$ and $C_1 = C_1(\mathcal{U}, q') > 0$ such that for any $x \in \mathbb{Z}^d$ and $t \in [0, +\infty[$, $\mathbb{P}_{q', q}(\eta_t(x) \neq \tilde{\eta}_t(x)) \leq C_1 e^{-c_1 t}$.*

Indeed, if $f : \{0, 1\}^{\mathbb{Z}^d} \mapsto \mathbb{R}$ is a local function depending of a finite set of sites S ,

$$\begin{aligned} \left| \mathbb{E}_{\nu_{q'}}(f(\eta_t)) - \nu_q(f) \right| &= \left| \mathbb{E}_{q', q}(f(\eta_t)) - \mathbb{E}_{q', q}(f(\tilde{\eta}_t)) \right| \leq \mathbb{E}_{q', q}(|f(\eta_t) - f(\tilde{\eta}_t)|) \\ &\leq 2 \|f\|_\infty \mathbb{P}_{q', q}((\eta_t)_S \neq (\tilde{\eta}_t)_S) \leq 2 \|f\|_\infty \sum_{x \in S} \mathbb{P}_{q', q}(\eta_t(x) \neq \tilde{\eta}_t(x)). \end{aligned}$$

Therefore we will work on proving proposition 4.5.

In order to do that, we need to introduce dual paths. We define the *range* ρ of \mathcal{U} by

$$\rho = \max\{\|x\|_\infty \mid x \in X, X \in \mathcal{U}\}.$$

For any $x \in \mathbb{Z}^d$, $t > 0$ and $0 \leq t' \leq t$, a dual path of length t' starting at (x, t) (see figure 4.1) is a right-continuous path $(\Gamma(s))_{0 \leq s \leq t'}$ that starts at site x at time t , goes backwards, is allowed to jump only when there is a clock ring, and only to a site within ℓ^∞ -distance ρ . To write it rigorously, the path satisfies $\Gamma(0) = x$ and there exists a sequence of times $0 = s_0 < s_1 < \dots < s_n = t'$ satisfying the following properties: for all $0 \leq k \leq n - 1$ and all $s \in [s_k, s_{k+1}[$, $\Gamma(s) = \Gamma(s_k)$, $\Gamma(s_n) = \Gamma(s_{n-1})$ and for all $0 \leq k < n - 1$, $t - s_{k+1} \in \mathcal{P}_{\Gamma(s_k)}^0 \cup \mathcal{P}_{\Gamma(s_k)}^1$ and $\|\Gamma(s_{k+1}) - \Gamma(s_k)\|_\infty \leq \rho$.

We denote $\mathcal{D}(x, t, t')$ the (random) set of all dual paths of length t' starting from (x, t) . A dual path $\Gamma \in \mathcal{D}(x, t, t')$ is called an *activated path* if it “encounters a point at which both processes are at 0”, i.e. if there exists $s \in [0, t']$ such that $\eta_{t-s}(\Gamma(s)) = \tilde{\eta}_{t-s}(\Gamma(s)) = 0$. The set of all activated paths in $\mathcal{D}(x, t, t')$ is called $\mathcal{A}(x, t, t')$. We have the

Lemma 4.6. *For any $x \in \mathbb{Z}^d$ and $t > 0$, if $\eta_t(x) \neq \tilde{\eta}_t(x)$, then for all $0 \leq t' \leq t$, $\mathcal{A}(x, t, t') \neq \mathcal{D}(x, t, t')$.*

Sketch of proof. The proof is the same as for lemma 1 of [MV19], apart from the fact that if the path is at y , it does not necessarily jump to a neighbor

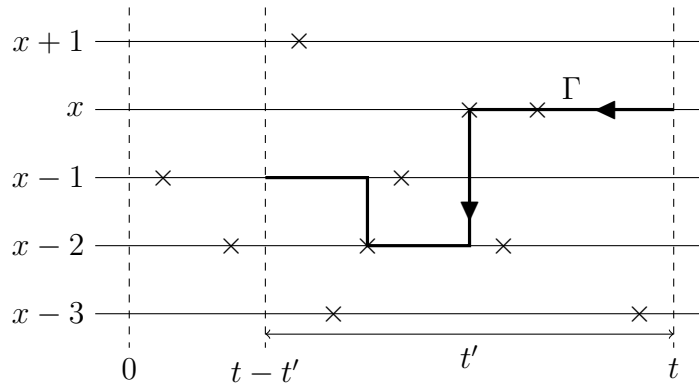

Figure 4.1: Illustration of a dual path Γ of length t' starting at (x, t) for $d = 1$ and $\rho = 2$. Each horizontal line represents the timeline of a site of \mathbb{Z} , the \times representing the clock rings. Γ is the thick polygonal line; it starts at t and ends at $t - t'$. It can jump only when there is a clock ring, and never at a distance greater than $\rho = 2$.

of y , but to an element of $y + X$, $X \in \mathcal{U}$. The idea of the proof is to start a dual path at (x, t) , where the two processes disagree, and, staying at x , to go backwards in time until the processes agree at x . At this time, there was an update at x in one process but not in the other, hence an update rule $x + X$ that was full of zeroes in one process but not in the other, thus a site at distance at most ρ of x at which the two processes disagree. We jump to this site and continue to go backwards. This construction yields a dual path along which the two processes disagree, hence they can not be both at zero, so the path is not activated. \square

Lemma 4.6 implies that to prove proposition 4.5 hence theorem 4.3, it is enough to prove

Proposition 4.7. *For any $q' \in]0, 1]$, there exists $q_0 = q_0(\mathcal{U}, q') \in [0, 1[$ such that for any $q \in [q_0, 1]$, there exist two constants $c_2 = c_2(\mathcal{U}, q') > 0$ and $C_2 = C_2(\mathcal{U}, q') > 0$ such that for any $x \in \mathbb{Z}^d$, $t \in [0, +\infty[$, there exists $0 \leq t' \leq t$ such that $\mathbb{P}_{q', q}(\mathcal{A}(x, t, t') \neq \mathcal{D}(x, t, t')) \leq C_2 e^{-c_2 t}$.*

The remainder of the article will be devoted to the proof of proposition 4.7.

4.4 Codings

This section is devoted to the reduction of the proof of proposition 4.7 (hence of theorem 4.3) to the simpler proof of proposition 4.11, via the use of *codings*. The idea is the following: in order to prove proposition 4.7, it is enough to show that along each dual path, the two processes are at zero at one of the discrete times $0, K, 2K$, etc. hence we only need to consider the positions of the path at these times, which will make up the coding of the path. Let $K \geq 2$ and $t \geq K$. A coding is a sequence $(y_k)_{k \in \{0, \dots, \lfloor \frac{t}{K^2} \rfloor\}}$ of sites in \mathbb{Z}^d . Moreover, for $x \in \mathbb{Z}^d$ and $\Gamma \in \mathcal{D}(x, t, \frac{t}{K})$, the coding $\bar{\Gamma}$ of Γ is the sequence $\{\Gamma(kK)\}_{k \in \{0, \dots, \lfloor \frac{t}{K^2} \rfloor\}}$. If $\gamma = (y_k)_{k \in \{0, \dots, \lfloor \frac{t}{K^2} \rfloor\}}$ is a coding, we define the event $G(\gamma) = \{\exists k \in \{0, \dots, \lfloor \frac{t}{K^2} \rfloor\}, \eta_{t-kK}(y_k) = \tilde{\eta}_{t-kK}(y_k) = 0\}$. If $G(\bar{\Gamma})$ is satisfied, Γ is an activated path.

Therefore, to prove proposition 4.7 hence theorem 4.3, it is enough to prove

Proposition 4.8. *For any $q' \in]0, 1]$, there exists $q_0 = q_0(\mathcal{U}, q') \in [0, 1[$ such that for any $q \in [q_0, 1]$, there exist two constants $c_3 = c_3(\mathcal{U}, q') > 0$ and $C_3 = C_3(\mathcal{U}, q') > 0$ and a constant $K = K(\mathcal{U}, q') \geq 2$ such that for any $x \in \mathbb{Z}^d$ and $t \geq 2K^2$, $\mathbb{P}_{q', q}(\exists \Gamma \in \mathcal{D}(x, t, \frac{t}{K}), G(\bar{\Gamma})^c) \leq C_3 e^{-c_3 t}$.*

Proposition 4.8 holds only for t greater than a constant, but this is enough, since we only have to enlarge C_3 to obtain a bound valid for all t .

In order to prove proposition 4.8, we will define a set $C_K^N(x, t)$ of “reasonable codings” and prove that the probability that there exists a dual path whose coding is not in $C_K^N(x, t)$ decays exponentially in t (lemma 4.9). Then we will count the number of codings in $C_K^N(x, t)$ (lemma 4.10). Therefore it will be enough to give a bound on $\mathbb{P}_{q', q}(G(\gamma)^c)$ for any $\gamma \in C_K^N(x, t)$ to prove proposition 4.8 hence theorem 4.3. Such a bound is stated in proposition 4.11 and will be proven in section 4.6.

For any constant $N > 0$, for any $K \geq 2$, $x \in \mathbb{Z}^d$ and $t \geq K$, the set $C_K^N(x, t)$ of “reasonable codings” is defined as the set of $(y_{j_1 + \dots + j_k})_{k \in \{0, \dots, \lfloor \frac{t}{K^2} \rfloor\}}$ where $(y_i)_{i \in \{0, \dots, I\}}$ is a sequence of sites satisfying $y_0 = x$, $I \leq \frac{Nt}{K}$ and $\|y_{i+1} - y_i\|_\infty \leq \rho$ for all $i \in \{0, \dots, I-1\}$ and where $j_1, \dots, j_{\lfloor \frac{t}{K^2} \rfloor} \in \mathbb{N}$ satisfy $j_1 + \dots + j_{\lfloor \frac{t}{K^2} \rfloor} \leq I$. We can now state lemmas 4.9 and 4.10, as well as proposition 4.11. These statements together prove proposition 4.8.

Lemma 4.9. *For any $q' \in [0, 1]$, there exists $N = N(\mathcal{U}) > 0$ such that for any $K \geq 2$, $q \in [0, 1]$, there exists a constant $\check{c} = \check{c}(\mathcal{U}, K) > 0$ such that for all $x \in \mathbb{Z}^d$ and $t \geq K$, $\mathbb{P}_{q', q}(\exists \Gamma \in \mathcal{D}(x, t, \frac{t}{K}), \bar{\Gamma} \notin C_K^N(x, t)) \leq e^{-\check{c}t}$.*

In the following, N will always be the N given by lemma 4.9.

Lemma 4.10. *There exist constants $\lambda > 0$ and $\beta = \beta(\mathcal{U}) > 0$ such that for any $K \geq 2$, $x \in \mathbb{Z}^d$ and $t \geq 2K^2$, $|C_K^N(x, t)| \leq \lambda(\beta K)^{\frac{(d+1)t}{K^2}}$.*

Proposition 4.11. *For any $q' \in [0, 1]$, there exists a constant $K_0 = K_0(\mathcal{U}) \geq 2$ such that for any $K \geq K_0$, there exists $q_K \in [0, 1[$ such that for any $q \in [q_K, 1]$, there exist two constants $c_4 = c_4(\mathcal{U}, q') > 0$ and $C_4 = C_4(\mathcal{U}, K) > 0$ such that for any $x \in \mathbb{Z}^d$, $t \geq K$ and $\gamma \in C_K^N(x, t)$, $\mathbb{P}_{q', q}(G(\gamma)^c) \leq C_4 e^{-c_4 \frac{t}{K}}$.*

We are now going to prove lemmas 4.9 and 4.10. After that, it will suffice to prove proposition 4.11 to prove theorem 4.3.

Sketch of proof of lemma 4.9. This can be proven with the argument of the lemma 5 of [MV19]; the idea is that if there exists $\Gamma \in \mathcal{D}(x, t, \frac{t}{K})$ with $\bar{\Gamma} \notin C_K^N(x, t)$, there are so many clock rings that the probability becomes very small. Indeed, let us say Γ visits the sites $y_0 = x, y_1, \dots, y_{j_1}$ in the time interval $[0, K]$, then the sites $y_{j_1}, \dots, y_{j_1+j_2}$ in the time interval $[K, 2K]$, etc. until the sites $y_{j_1+\dots+j_{\lfloor \frac{t}{K^2} \rfloor}}, \dots, y_{j_1+\dots+j_{\lfloor \frac{t}{K^2} \rfloor+1}}$ in the time interval $[\lfloor \frac{t}{K^2} \rfloor K, (\lfloor \frac{t}{K^2} \rfloor + 1)K]$. Then the coding of Γ is $\bar{\Gamma} = (y_{j_1+\dots+j_k})_{k \in \{0, \dots, \lfloor \frac{t}{K^2} \rfloor\}}$, hence $\bar{\Gamma} \notin C_K^N(x, t)$ implies $j_1 + \dots + j_{\lfloor \frac{t}{K^2} \rfloor+1} > \frac{Nt}{K}$. It yields that Γ visits more than $\frac{Nt}{K}$ sites in a time $\frac{t}{K}$, and there must be successive clock rings at these sites. The proof of lemma 5 of [MV19] yields that we can choose N large enough depending on ρ , hence on \mathcal{U} , such that the probability of this event is at most $e^{-\check{c}t}$ with $\check{c} = \check{c}(\mathcal{U}, N, K) = \check{c}(\mathcal{U}, K) > 0$. \square

To prove lemma 4.10, we need the following classical combinatorial result, which will also be used in the proof of lemma 4.19.

Lemma 4.12. *For any $I, J \in \mathbb{N}$, $\binom{I}{I} + \binom{I+1}{I} + \dots + \binom{I+J}{I} = \binom{I+J+1}{I+1}$. Moreover, for any $I, J \in \mathbb{N}$, $|\{(j_1, \dots, j_I) \in \mathbb{N}^I \mid j_1 + \dots + j_I = J\}| = \binom{I+J-1}{I-1}$.*

The proof of the first part of lemma 4.12 can be found just before the section 2 of [Jon96] and the proof of the second part in section 1.2 of [Sta11] (weak compositions).

Proof of lemma 4.10. Let $K \geq 2$, $x \in \mathbb{Z}^d$ and $t \geq 2K^2$. By definition, elements of $C_K^N(x, t)$ have the form $(y_{j_1+\dots+j_k})_{k \in \{0, \dots, \lfloor \frac{t}{K^2} \rfloor\}}$ with $(y_i)_{i \in \{0, \dots, I\}}$ satisfying $y_0 = x$, $I \leq \frac{Nt}{K}$ and $\|y_{i+1} - y_i\|_\infty \leq \rho$ for all $i \in \{0, \dots, I-1\}$, and with $j_1, \dots, j_{\lfloor \frac{t}{K^2} \rfloor} \in \mathbb{N}$ satisfying $j_1 + \dots + j_{\lfloor \frac{t}{K^2} \rfloor} \leq I$. Therefore, to count the number of elements of $C_K^N(x, t)$, it is enough to count the number of possible $(j_k)_{k \in \{1, \dots, \lfloor \frac{t}{K^2} \rfloor\}}$ and the number of possible $(y_{j_1+\dots+j_k})_{k \in \{0, \dots, \lfloor \frac{t}{K^2} \rfloor\}}$ given $(j_k)_{k \in \{1, \dots, \lfloor \frac{t}{K^2} \rfloor\}}$.

We begin by counting the number of possible $(j_k)_{k \in \{1, \dots, \lfloor \frac{t}{K^2} \rfloor\}}$. We have $j_1 + \dots + j_{\lfloor \frac{t}{K^2} \rfloor} \leq \frac{Nt}{K}$. Moreover, by the second part of lemma 4.12, for any integer $0 \leq J \leq \frac{Nt}{K}$, the number of possible sequences of integers $(j_k)_{k \in \{1, \dots, \lfloor \frac{t}{K^2} \rfloor\}}$ such that $j_1 + \dots + j_{\lfloor \frac{t}{K^2} \rfloor} = J$ is at most $\binom{\lfloor \frac{t}{K^2} \rfloor + J - 1}{\lfloor \frac{t}{K^2} \rfloor - 1}$, hence the number of possible $(j_k)_{k \in \{1, \dots, \lfloor \frac{t}{K^2} \rfloor\}}$ is at most $\sum_{J=0}^{\lfloor \frac{Nt}{K} \rfloor} \binom{\lfloor \frac{t}{K^2} \rfloor + J - 1}{\lfloor \frac{t}{K^2} \rfloor - 1} = \binom{\lfloor \frac{t}{K^2} \rfloor + \lfloor \frac{Nt}{K} \rfloor}{\lfloor \frac{t}{K^2} \rfloor}$ by the first part of lemma 4.12. Furthermore $\binom{\lfloor \frac{t}{K^2} \rfloor + \lfloor \frac{Nt}{K} \rfloor}{\lfloor \frac{t}{K^2} \rfloor} \leq \frac{(\lfloor \frac{t}{K^2} \rfloor + \lfloor \frac{Nt}{K} \rfloor)^{\lfloor \frac{t}{K^2} \rfloor}}{(\lfloor \frac{t}{K^2} \rfloor)!} \leq \lambda \left(\frac{e(\lfloor \frac{t}{K^2} \rfloor + \lfloor \frac{Nt}{K} \rfloor)}{\lfloor \frac{t}{K^2} \rfloor} \right)^{\lfloor \frac{t}{K^2} \rfloor} \leq \lambda \left(e + e^{\frac{\lfloor \frac{Nt}{K} \rfloor}{\lfloor \frac{t}{K^2} \rfloor}} \right)^{\frac{t}{K^2}}$ by the Stirling formula, where $\lambda > 0$ is a constant. In addition, since $t \geq 2K^2$, $\lfloor \frac{t}{K^2} \rfloor \geq \frac{t}{2K^2}$, hence the number of possible $(j_k)_{k \in \{1, \dots, \lfloor \frac{t}{K^2} \rfloor\}}$ is at most $\lambda \left(e + e^{\frac{Nt}{K} \frac{2K^2}{t}} \right)^{\frac{t}{K^2}} = \lambda (e + 2eKN)^{\frac{t}{K^2}} \leq \lambda (3eKN)^{\frac{t}{K^2}}$ as $K \geq 2$ and N is large.

We now fix a sequence $(j_k)_{k \in \{1, \dots, \lfloor \frac{t}{K^2} \rfloor\}}$ and count the possible sequences $(y_{j_1 + \dots + j_k})_{k \in \{0, \dots, \lfloor \frac{t}{K^2} \rfloor\}}$. We know that $y_0 = x$. Moreover, for all $i \in \{0, \dots, j_1 + \dots + j_{\lfloor \frac{t}{K^2} \rfloor} - 1\}$, $\|y_{i+1} - y_i\|_\infty \leq \rho$, hence for each $k \in \{0, \dots, \lfloor \frac{t}{K^2} \rfloor - 1\}$, we have $\|y_{j_1 + \dots + j_{k+1}} - y_{j_1 + \dots + j_k}\|_\infty \leq \rho j_{k+1}$, so there are at most $(2\rho j_{k+1} + 1)^d$ choices for $y_{j_1 + \dots + j_{k+1}}$ given $y_{j_1 + \dots + j_k}$. Therefore the number of choices for $(y_{j_1 + \dots + j_k})_{k \in \{0, \dots, \lfloor \frac{t}{K^2} \rfloor\}}$ is at most $\prod_{k=1}^{\lfloor \frac{t}{K^2} \rfloor} (2\rho j_k + 1)^d$. Moreover, for any $n \in \mathbb{N}^*$ and any positive x_1, \dots, x_n , we have $x_1 \dots x_n \leq \left(\frac{x_1 + \dots + x_n}{n} \right)^n$, therefore the number of choices is bounded by

$$\left(\frac{\sum_{k=1}^{\lfloor \frac{t}{K^2} \rfloor} (2\rho j_k + 1)}{\lfloor \frac{t}{K^2} \rfloor} \right)^{d \lfloor \frac{t}{K^2} \rfloor} = \left(\frac{2\rho \sum_{k=1}^{\lfloor \frac{t}{K^2} \rfloor} j_k + \lfloor \frac{t}{K^2} \rfloor}{\lfloor \frac{t}{K^2} \rfloor} \right)^{d \lfloor \frac{t}{K^2} \rfloor} \leq \left(\frac{2\rho \frac{Nt}{K} + \lfloor \frac{t}{K^2} \rfloor}{\lfloor \frac{t}{K^2} \rfloor} \right)^{d \frac{t}{K^2}}$$

since $\sum_{k=1}^{\lfloor \frac{t}{K^2} \rfloor} j_k \leq \frac{Nt}{K}$. As $t \geq 2K^2$, $\lfloor \frac{t}{K^2} \rfloor \geq \frac{t}{2K^2}$, thus the number of choices for the sequence $(y_{j_1 + \dots + j_k})_{k \in \{0, \dots, \lfloor \frac{t}{K^2} \rfloor\}}$ given $(j_k)_{k \in \{1, \dots, \lfloor \frac{t}{K^2} \rfloor\}}$ is bounded by $\left(2\rho \frac{Nt}{K} \frac{2K^2}{t} + 1 \right)^{d \frac{t}{K^2}} = (4\rho NK + 1)^{d \frac{t}{K^2}} \leq (5\rho NK)^{d \frac{t}{K^2}}$. \square

4.5 An auxiliary process

In order to prove proposition 4.11, we need to find a mechanism for the zeroes to spread in the KCM process; this mechanism uses novel ideas to deal with the complexity of general supercritical models. We begin in section 4.5.1 by

using the bootstrap percolation results of [BSU15] to find a mechanism allowing the zeroes to spread locally (proposition 4.13). Then we use it in section 4.5.2 to define an auxiliary oriented percolation process which guarantees that if certain conditions are met, the KCM process is at zero at a given time (proposition 4.15). Finally, in section 4.5.3 we prove some properties of this auxiliary process that we will use in section 4.6.

4.5.1 Local spread of zeroes

This is the place where we need the supercriticality of \mathcal{U} . Indeed, since \mathcal{U} is supercritical, the results of [BSU15] yield the following proposition (see figure 4.2):

Proposition 4.13 ([BSU15]). *For $d = 1$ or 2 , there exists $u \in S^{d-1}$, a rectangle R of the following form:*

- if $d = 1$, $R = [0, a_1u[\cap \mathbb{Z}$ with $a_1u \in \mathbb{Z}$;
- if $d = 2$, $R = ([0, a_1[u + [0, a_2]u^\perp) \cap \mathbb{Z}^2$ with $a_1u \in \mathbb{Z}^2$, where u^\perp is a vector orthogonal to u ,

and a sequence of sites $(x_i)_{1 \leq i \leq m}$ in $(a_1u + R) \cup (2a_1u + R)$ such that if the sites of R are at zero and there are successive 0-clock rings at x_1, x_2, \dots, x_m while there is no 1-clock ring in $R \cup \{x_1, \dots, x_m\}$, the sites of $a_1u + R$ are at zero afterwards.

Remark 4.14. For $d \geq 3$, we expect a similar proposition to hold, maybe with $R = [0, a_1[u + \bar{R}$, \bar{R} contained in the hyperplane orthogonal to u , but we can not prove it because an equivalent of the construction of [BSU15] is not available yet. Proving such a construction would be enough to extend our result to any dimension.

Proof of proposition 4.13. We begin with the case $d = 1$. Since \mathcal{U} is supercritical there exists u an unstable direction. Without loss of generality we can say that $u = 1$, therefore there exists an update rule X contained in $-\mathbb{N}^*$. This yields the mechanism illustrated by figure 4.3(a): if $R = \{0, \dots, \ell\}$ is sufficiently large and full of zeroes, $(\ell + 1) + X$ is full of zeroes, hence if the site $\ell + 1$ receives a 0-clock ring, this clock ring puts it at zero. Then $(\ell + 2) + X$ is full of zeroes, thus if $\ell + 2$ receives a 0-clock ring, this clock ring puts it at zero. In the same way, if the sites $\ell + 3, \dots, 2\ell + 1$ receive successive 0-clock rings, these clock rings will put them successively at zero, therefore $\{\ell + 1, \dots, 2\ell + 1\} = (\ell + 1) + R$ will be at zero. This yields the result with $a_1 = \ell + 1$ and $(x_i)_{1 \leq i \leq m} = \ell + 1, \ell + 2, \dots, 2\ell + 1$.

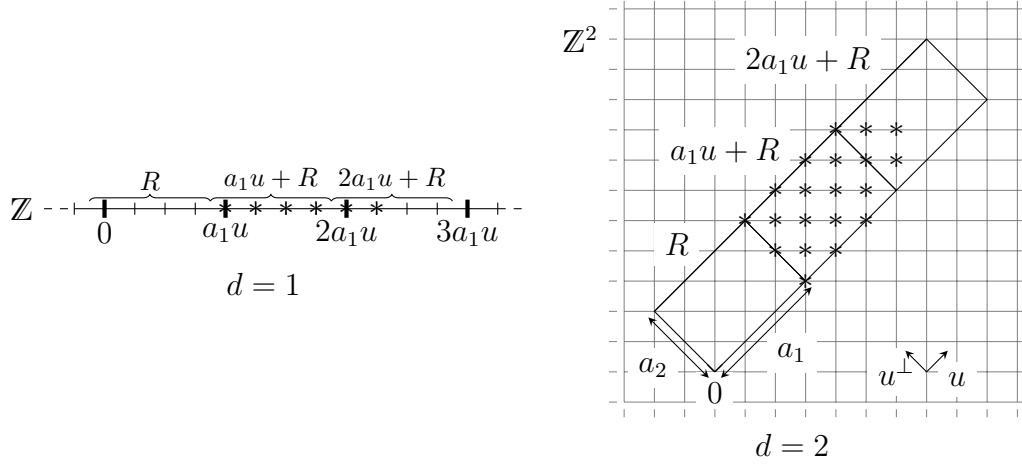

Figure 4.2: Illustration of proposition 4.13. The $*$ represent the sites x_1, \dots, x_m . If we start with the sites of R at zero and there are successive 0-clock rings at x_1, \dots, x_m while there is no 1-clock ring in $R \cup \{x_1, \dots, x_m\}$, these clock rings will put x_1, \dots, x_m at zero, hence the sites of $a_1u + R$ will be put at zero.

We now consider the case $d = 2$. Since \mathcal{U} is supercritical, there exists a semicircle in S^1 that contains no stable direction; we call u its middle. The results of section 5 of [BSU15] (see in particular figure 5 and lemma 5.5 therein) prove that there exists a set of sites, called a *droplet*, such that in the bootstrap percolation dynamics, if we start with all the sites of the droplet infected, other sites in the direction u can be infected, creating a bigger infected droplet with the same shape (see figure 4.3(b)). We can enlarge this droplet into a rectangle $R = [0, a_1[u + [0, a_2]u^\perp]$ as in figure 4.3(c); furthermore u can be chosen rational⁴, hence we may enlarge R enough so that $a_1u \in \mathbb{Z}^2$. Now, since R contains the original droplet, if R is infected the infection can grow from the droplet into a droplet big enough to contain $a_1u + R$ while staying in $R \cup (a_1u + R) \cup (2a_1u + R)$ (see figure 4.3(c)). We call x_1, \dots, x_m the sites that are successively infected during this growth (sites infected at the same time are ordered arbitrarily). Since x_1 is the first site infected by the bootstrap percolation dynamics starting with the sites of R infected, there exists an update rule X such that $x_1 + X \subset R$, therefore if the KCM dynamics starts with all the sites of R at zero and there is a 0-clock ring at

⁴Indeed, theorem 1.10 of [BSU15] states that the set of stable directions is a finite union of closed intervals with rational endpoints, hence the semicircle containing no stable direction can be chosen with rational endpoints.

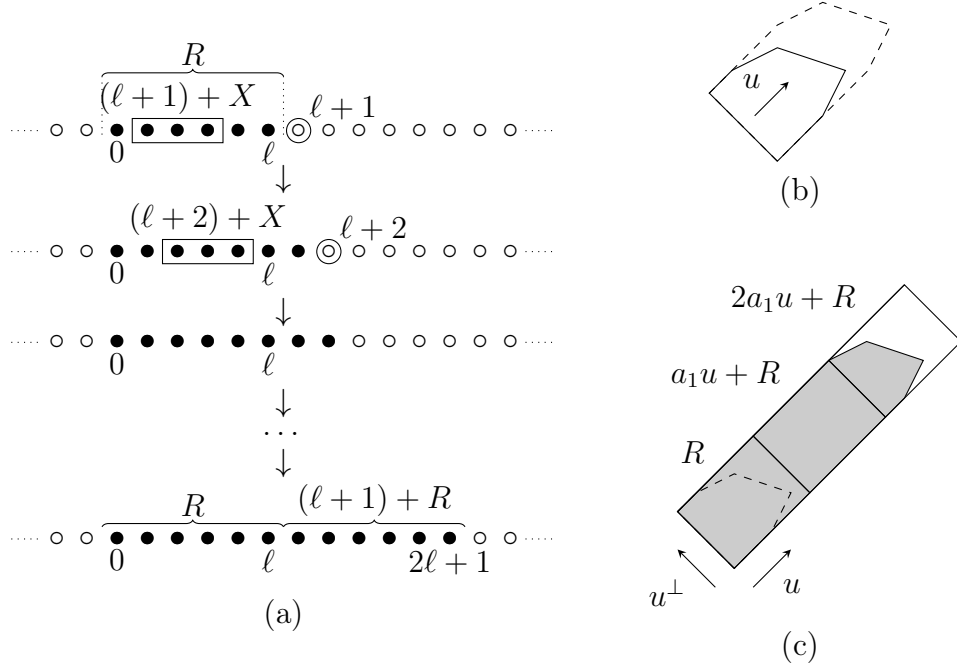

Figure 4.3: The proof of proposition 4.13. (a) The mechanism for $d = 1$; the \bullet represent zeroes and the \circ represent ones. (b) The shape delimited by the solid line is the droplet of [BSU15]; if it is infected in the bootstrap percolation dynamics, the infection can grow to the shape delimited by the dashed line. (c) R contains the original droplet (dashed line), hence if R is infected, the infection can propagate to a bigger droplet (in gray) that contains $a_1u + R$ and is contained in $R \cup (a_1u + R) \cup (2a_1u + R)$.

x_1 , this clock ring sets x_1 to zero. Then, if there is a 0-clock ring at x_2 , it will set x_2 to zero for the same reason, and successive 0-clock rings at x_3, \dots, x_m will set them successively to 0, which puts $a_1u + R$ at zero. \square

4.5.2 Definition of the auxiliary process

Let $K > 0$, $q \in [0, 1]$ and $t \geq K$. For any $y \in \mathbb{Z}^d$ and $k \in \{0, \dots, \lfloor \frac{t}{K} \rfloor\}$, we will define an oriented percolation process $\zeta^{y,k}$ on \mathbb{Z} , from time zero to time $n^{y,k} = \lfloor \frac{t}{K} \rfloor - k$ (see [Dur84] for an introduction to oriented percolation). For $n \in \{1, \dots, n^{y,k}\}$ and $r \in \mathbb{Z}$ with $r + n$ even, the bonds $(r - 1, n - 1) \rightarrow (r, n)$ and $(r + 1, n - 1) \rightarrow (r, n)$ can be *open* or *closed*; we set $\zeta_0^{y,k}(r) = \mathbb{1}_{\{r=0\}}$, and for any $n \in \{1, \dots, n^{y,k}\}$, $r \in \mathbb{Z}$ with $r + n$ even, $\zeta_n^{y,k}(r) = 1$ if and only if $\zeta_{n-1}^{y,k}(r - 1) = 1$ and the bond $(r - 1, n - 1) \rightarrow (r, n)$ is open or $\zeta_{n-1}^{y,k}(r + 1) = 1$

and the bond $(r+1, n-1) \rightarrow (r, n)$ is open.

The state of the bonds is defined as follows. For any $n \in \{1, \dots, n^{y,k}\}$, $r \in \mathbb{Z}$ with $r+n$ even:

- $(r-1, n-1) \rightarrow (r, n)$ is open if and only if

$$\left\{ \forall x \in y + \frac{r-n}{2}a_1u + R,]t - (k+n)K, t - (k+n-1)K] \cap \mathcal{P}_x^1 = \emptyset \right\},$$

i.e. there is no 1-clock ring in $y + \frac{r-n}{2}a_1u + R$ during the time interval $]t - (k+n)K, t - (k+n-1)K]$;

- $(r+1, n-1) \rightarrow (r, n)$ is open if and only if

$$\left\{ \exists t - (k+n)K < t_1 < \dots < t_m \leq t - (k+n-1)K, \right. \\ \left. \forall i \in \{1, \dots, m\}, t_i \in \mathcal{P}_{y + \frac{r-n}{2}a_1u + x_i}^0 \right\}$$

and

$$\left\{ \forall x \in y + \frac{r-n}{2}a_1u + R \cup \{x_1, \dots, x_m\}, \right. \\ \left.]t - (k+n)K, t - (k+n-1)K] \cap \mathcal{P}_x^1 = \emptyset \right\},$$

i.e. there are successive 0-clock rings in the equivalent of x_1, \dots, x_m for $y + \frac{r-n}{2}a_1u + R$ during the time interval $]t - (k+n)K, t - (k+n-1)K]$, and no 1-clock ring at these sites or in $y + \frac{r-n}{2}a_1u + R$ in this time interval.

We notice that if all the sites of $y + \frac{r-n}{2}a_1u + R$ are at zero at time $t - (k+n)K$ and $(r-1, n-1) \rightarrow (r, n)$ is open, the sites of $y + \frac{r-n}{2}a_1u + R$ are still at zero at time $t - (k+n-1)K$. Moreover, by proposition 4.13, if the sites of $y + \frac{r-n}{2}a_1u + R$ are at zero at time $t - (k+n)K$ and $(r+1, n-1) \rightarrow (r, n)$ is open, the sites of $a_1u + (y + \frac{r-n}{2}a_1u + R) = y + \frac{(r+1)-(n-1)}{2}a_1u + R$ are at zero at time $t - (k+n-1)K$. This allows us to deduce (see figure 4.4 for an illustration of the mechanism):

Proposition 4.15. *If there exists $r_0 \in \mathbb{Z}$ such that $\zeta_{n^{y,k}}^{y,k}(r_0) = 1$ and the sites of $y + \frac{r_0-n^{y,k}}{2}a_1u + R$ are at zero at time $t - \lfloor \frac{t}{K} \rfloor K$, then the sites of $y + R$ are at zero at time $t - kK$.*

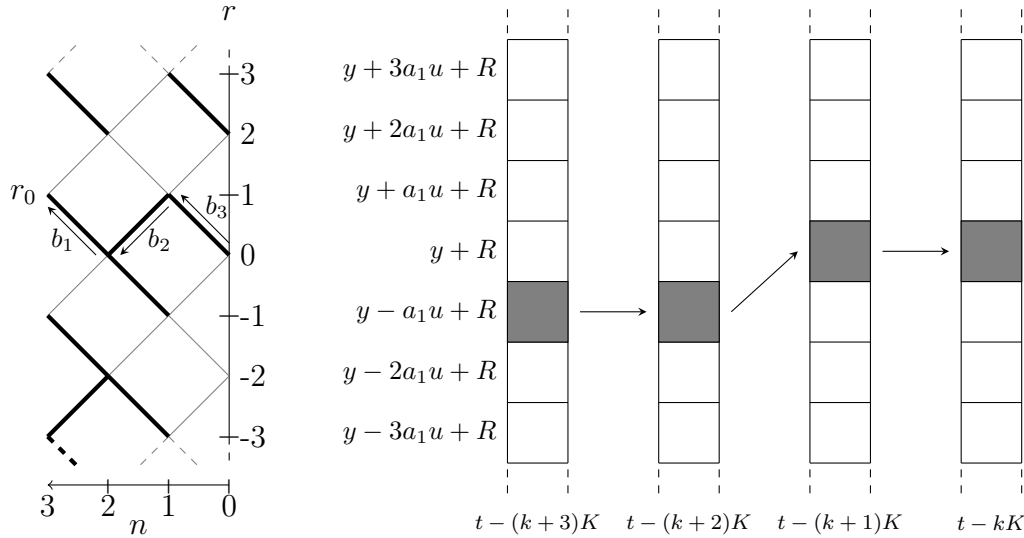

Figure 4.4: An illustration of proposition 4.15 with $n^{y,k} = 3$ and $r_0 = 1$. The figure at the left represents the bonds of the oriented percolation process $\zeta^{y,k}$; the open bonds are the thick ones, and the path of open bonds allowing $\zeta_{n^{y,k}}^{y,k}(r) = 1$ is outlined by arrows. The figure at the right represents the consequences on the KCM process; each vertical strip represents the state of $\bigcup_{i \in \mathbb{Z}} (y + ia_1u + R)$ at a certain time. If at time $t - (k + 3)K$ the rectangle $y + \frac{1-n^{y,k}}{2}a_1u + R = y - a_1u + R$ is at zero (in gray), since the bond $(0, 2) \rightarrow (1, 3)$ (bond b_1) is open, $y - a_1u + R$ is still at zero at time $t - (k + 2)K$. Moreover, since $(1, 1) \rightarrow (0, 2)$ (bond b_2) is open and $y - a_1u + R$ is at zero at time $t - (k + 2)K$, $a_1u + (y - a_1u + R) = y + R$ is at zero at time $t - (k + 1)K$. Finally, since $(0, 0) \rightarrow (1, 1)$ (bond b_3) is open and $y + R$ is at zero at time $t - (k + 1)K$, $y + R$ is still at zero at time $t - kK$.

4.5.3 Properties of the auxiliary process

In this subsection we state the two oriented percolation properties of $\zeta^{y,k}$, propositions 4.17 and 4.18, that we will use in section 4.6 to prove proposition 4.11. In order to do that, we need a bound on the probability that a bond is closed; this will be lemma 4.16. It is there that we need q bigger than a $q_0 > 0$; this is necessary so that the probability that there is no 1-clock ring at the sites we consider is large. For any $K > 0$, we set $q_K = 1 + \frac{1}{3K|R|} \ln(1 - e^{-K})$. We can then state

Lemma 4.16. *There exists a constant $K_p = K_p(\mathcal{U}) > 0$ such that for $K \geq K_p$, $q \in [q_K, 1]$, $t \geq K$, $y \in \mathbb{Z}^d$ and $k \in \{0, \dots, \lfloor \frac{t}{K} \rfloor\}$, the probability that any given bond is closed for the process $\zeta^{y,k}$ is smaller than $e^{-\frac{K}{4}}$.*

Proof. Let $K > 0$, $q \in [q_K, 1]$, $t \geq K$, $y \in \mathbb{Z}^d$ and $k \in \{0, \dots, \lfloor \frac{t}{K} \rfloor\}$. Let $n \in \{1, \dots, n^{y,k}\}$, $r \in \mathbb{Z}$ with $r+n$ even. We notice that if the bond $(r-1, n-1) \rightarrow (r, n)$ is closed, the bond $(r+1, n-1) \rightarrow (r, n)$ is also closed, hence it is enough to bound the probability that $(r+1, n-1) \rightarrow (r, n)$ is closed. Denoting $E_1 = \{\forall x \in y + \frac{r-n}{2}a_1u + R \cup \{x_1, \dots, x_m\},]t - (k+n)K, t - (k+n-1)K] \cap \mathcal{P}_x^1 = \emptyset\}$ and $E_2 = \{\exists t - (k+n)K < t_1 < \dots < t_m \leq t - (k+n-1)K, \forall i \in \{1, \dots, m\}, t_i \in \mathcal{P}_{y + \frac{r-n}{2}a_1u + x_i}^0\}$, we need to bound the probabilities of E_1^c and E_2^c . We begin with E_1^c . The events $]t - (k+n)K, t - (k+n-1)K] \cap \mathcal{P}_x^1 = \emptyset$ are independent and have probability $e^{-(1-q)K}$ each; moreover, x_1, \dots, x_m belong to $(a_1u + R) \cup (2a_1u + R)$, so $|R \cup \{x_1, \dots, x_m\}| \leq 3|R|$; we deduce the probability of E_1 is

$$\begin{aligned} e^{-|R \cup \{x_1, \dots, x_m\}|(1-q)K} &\geq e^{-3|R|(1-q)K} \geq e^{-3|R|(1-q_K)K} \\ &\geq e^{-3|R|(1 - (1 + \frac{1}{3K|R|} \ln(1 - e^{-K})))K} = e^{\ln(1 - e^{-K})} = 1 - e^{-K}, \end{aligned}$$

thus the probability of E_1^c is at most e^{-K} . Moreover, the probability of E_2^c is the probability that a Poisson point process of parameter q has strictly less than m elements in an interval of length K , hence it is $\sum_{i=0}^{m-1} e^{-qK} \frac{(qK)^i}{i!}$. When K is large enough, $q \in [1/2, 1]$, hence this probability is smaller than $e^{-\frac{1}{2}K} \sum_{i=0}^{m-1} \frac{K^i}{i!}$, which is smaller than $e^{-\frac{K}{3}}$ when K is large enough depending on m , hence on \mathcal{U} . Consequently, when K is large enough depending on \mathcal{U} , the probability that $(r+1, n-1) \rightarrow (r, n)$ is closed is smaller than $e^{-K} + e^{-\frac{K}{3}}$, which is smaller than $e^{-\frac{K}{4}}$ when K is large enough. \square

Thanks to lemma 4.16, it is possible to prove two oriented percolation properties of $\zeta^{y,k}$. Firstly, for any $K > 0$, $q \in [q_K, 1]$, $t \geq K$, $y \in \mathbb{Z}^d$ and $k \in \{0, \dots, \lfloor \frac{t}{K} \rfloor\}$, we define $\tau^{y,k} = \inf\{n \in \{0, \dots, n^{y,k}\} \mid \forall r \in \mathbb{Z}, \zeta_n^{y,k}(r) = 0\}$ the time of death of the process $\zeta^{y,k}$ (if the set is empty, $\tau^{y,k}$ is infinite). Since $\zeta_0^{y,k}(r) = \mathbb{1}_{\{r=0\}}$, which is not identically zero, $\tau^{y,k} \geq 1$. Then we have

Proposition 4.17. *For any $q' \in [0, 1]$, there exists a constant $K_c = K_c(\mathcal{U}) > 0$ such that for any $K \geq K_c$, $q \in [q_K, 1]$, $t \geq K$, $y \in \mathbb{Z}^d$, $k \in \{0, \dots, \lfloor \frac{t}{K} \rfloor\}$, $n \in \{0, \dots, n^{y,k}\}$, $\mathbb{P}_{q',q}(n \leq \tau^{y,k} < +\infty) \leq 23^{2n} e^{-\frac{Kn}{24}}$.*

Sketch of proof. The proposition can be proven by a classical contour method like the one presented in section 10 of [Dur84]. The idea is that if $n \leq \tau^{y,k} < +\infty$ we can draw a ‘‘contour of closed bonds’’ around the connected component of ones in $\zeta^{y,k}$, and this contour will have length $\Omega(n)$. Furthermore, it can be seen that bonds separated by at least 5 bonds from each other are independent, because they depend on clock rings in disjoint space-time intervals. Therefore if we keep one bond out of 6, we extract $\Omega(n)$ independent closed bonds from the contour, each of them having probability $e^{-\frac{K}{4}}$ from lemma 4.16 when $K \geq K_p$, hence the bound. \square

$\zeta^{y,k}$ also satisfies a second property. For any $K > 0$, $q \in [q_K, 1]$, $t \geq K$, $y \in \mathbb{Z}^d$ and $k \in \{0, \dots, \lfloor \frac{t}{K} \rfloor\}$, we define a set $\mathcal{X}^{y,k}$ by $\mathcal{X}^{y,k} = \{r \in \{-\lfloor \frac{n^{y,k}}{2} \rfloor, \dots, \lfloor \frac{n^{y,k}}{2} \rfloor\} \mid \zeta_{n^{y,k}}^{y,k}(r) = 1\}$. Then we have

Proposition 4.18. *For any $q' \in [0, 1]$, $\alpha \in]0, 1[$, there exists a constant $K_g(\alpha) = K_g(\mathcal{U}, \alpha) > 0$ such that for any $K \geq K_g(\alpha)$, there exist constants $c_g > 0$ and $C_g = C_g(\mathcal{U}, K, \alpha) > 0$ such that for any $q \in [q_K, 1]$, $t \geq K$, $y \in \mathbb{Z}^d$ and $k \in \{0, \dots, \lfloor \frac{t}{K} \rfloor\}$, $\mathbb{P}_{q',q}(\tau^{y,k} = +\infty, |\mathcal{X}^{y,k}| \leq \frac{\alpha}{2} n^{y,k}) \leq C_g e^{-c_g n^{y,k}}$.*

Sketch of proof. This proposition comes from classical results in oriented percolation. Firstly, if the process survives until time $n^{y,k}$, it has a big ‘‘range’’, which means that if we define $r^{y,k} = \sup\{r \in \mathbb{Z} \mid \zeta_{n^{y,k}}^{y,k}(r) = 1\}$ and $\ell^{y,k} = \inf\{r \in \mathbb{Z} \mid \zeta_{n^{y,k}}^{y,k}(r) = 1\}$, $r^{y,k}$ and $|\ell^{y,k}|$ are so large $\{-\lfloor \frac{n^{y,k}}{2} \rfloor, \dots, \lfloor \frac{n^{y,k}}{2} \rfloor\} \subset \{\ell^{y,k}, \dots, r^{y,k}\}$; this can be proven with the contour argument in section 11 of [Dur84]. Moreover, the argument that proves (1) in [Dur84] also proves that in $\{\ell^{y,k}, \dots, r^{y,k}\}$, $\zeta_{n^{y,k}}^{y,k}$ coincides with the oriented percolation process that has the same bonds, but which starts with all sites at 1 instead of just the origin. Finally, the end of section 5 of [DS88] contains a contour argument for the latter process which allows to prove that it has a lot of ones; we can use this argument with the same adaptations we used for the contours of proposition 4.17. \square

4.6 Proof of proposition 4.11

In this section we use the auxiliary process defined in section 4.5 to give a proof of proposition 4.11. In order to do that, we need some definitions. For any $q' \in]0, 1]$, $K \geq 2$, $q \in [q_K, 1]$, $x \in \mathbb{Z}^d$, $t \geq K$ and $\gamma = (y_k)_{k \in \{0, \dots, \lfloor \frac{t}{K^2} \rfloor\}} \in$

$C_K^N(x, t)$, we define $k(\gamma) = \inf\{k \in \{0, \dots, \lfloor \frac{t}{K^2} \rfloor\} \mid \tau^{y_k, k} = +\infty\}$ if such a k exists; in this case we also denote $y(\gamma) = y_{k(\gamma)}$ (in the following, when we write $k(\gamma)$ or $y(\gamma)$ without more precision, we always assume that they exist). For any $r \in \mathcal{X}^{y(\gamma), k(\gamma)}$ we define the events

$$W^{\gamma, \eta}(r) = \left\{ (\eta_{t - \lfloor \frac{t}{K} \rfloor K})_{y(\gamma) + \frac{r - ny(\gamma), k(\gamma)}{2} a_1 u + R} = 0 \right\},$$

$$W^{\gamma, \tilde{\eta}}(r) = \left\{ (\tilde{\eta}_{t - \lfloor \frac{t}{K} \rfloor K})_{y(\gamma) + \frac{r - ny(\gamma), k(\gamma)}{2} a_1 u + R} = 0 \right\}.$$

By proposition 4.15, if $\{\exists r \in \mathcal{X}^{y(\gamma), k(\gamma)}, W^{\gamma, \eta}(r)\} \cap \{\exists r \in \mathcal{X}^{y(\gamma), k(\gamma)}, W^{\gamma, \tilde{\eta}}(r)\}$, then the sites of $y(\gamma) + R$ are at zero at time $t - k(\gamma)K$ in both processes $(\eta_t)_{t \in [0, +\infty[}$ and $(\tilde{\eta}_t)_{t \in [0, +\infty[}$, in particular $y(\gamma)$ is at zero at time $t - k(\gamma)K$ in both processes, therefore $G(\gamma)$ is satisfied. Consequently,

$$\begin{aligned} \mathbb{P}_{q', q}(G(\gamma)^c) &\leq \mathbb{P}_{q', q}(k(\gamma) \text{ does not exist}) + \mathbb{P}_{q', q}\left(k(\gamma) \text{ exists, } |\mathcal{X}^{y(\gamma), k(\gamma)}| \leq \frac{t}{6K}\right) \\ &\quad + \mathbb{P}_{q', q}\left(\left\{|\mathcal{X}^{y(\gamma), k(\gamma)}| > \frac{t}{6K}\right\} \cap \{\forall r \in \mathcal{X}^{y(\gamma), k(\gamma)}, W^{\gamma, \eta}(r)^c\}\right) \\ &\quad + \mathbb{P}_{q', q}\left(\left\{|\mathcal{X}^{y(\gamma), k(\gamma)}| > \frac{t}{6K}\right\} \cap \{\forall r \in \mathcal{X}^{y(\gamma), k(\gamma)}, W^{\gamma, \tilde{\eta}}(r)^c\}\right). \end{aligned}$$

Therefore we only have to prove the following lemmas 4.19, 4.20 and 4.21 to prove proposition 4.11, thus ending the proof of theorem 4.3:

Lemma 4.19. *For any $q' \in]0, 1]$, there exists a constant $K_1 = K_1(\mathcal{U}) \geq 2$ such that for any $K \geq K_1$, $q \in [q_K, 1]$, there exist constants $\check{c}_1 > 0$ and $\check{C}_1 = \check{C}_1(K) > 0$ such that for any $x \in \mathbb{Z}^d$, $t \geq K$, $\gamma \in C_K^N(x, t)$, we have $\mathbb{P}_{q', q}(k(\gamma) \text{ does not exist}) \leq \check{C}_1 e^{-\check{c}_1 \frac{t}{K}}$.*

Lemma 4.20. *For any $q' \in]0, 1]$, there exists a constant $K_2 = K_2(\mathcal{U}) \geq 2$ such that for any $K \geq K_2$, $q \in [q_K, 1]$, there exist constants $\check{c}_2 > 0$ and $\check{C}_2 = \check{C}_2(\mathcal{U}, K) > 0$ such that for any $x \in \mathbb{Z}^d$, $t \geq K$, $\gamma \in C_K^N(x, t)$, $\mathbb{P}_{q', q}(k(\gamma) \text{ exists, } |\mathcal{X}^{y(\gamma), k(\gamma)}| \leq \frac{t}{6K}) \leq \check{C}_2 e^{-\check{c}_2 \frac{t}{K}}$.*

Lemma 4.21. *For any $q' \in]0, 1]$, $K \geq 2$, $q \in [q_K, 1]$, there exists a constant $\check{c}_3 = \check{c}_3(\mathcal{U}, q') > 0$ such that for any $x \in \mathbb{Z}^d$, $t \geq K$, $\gamma \in C_K^N(x, t)$, we get $\mathbb{P}_{q', q}(\{|\mathcal{X}^{y(\gamma), k(\gamma)}| > \frac{t}{6K}\} \cap \{\forall r \in \mathcal{X}^{y(\gamma), k(\gamma)}, W^{\gamma, \eta}(r)^c\}) \leq e^{-\check{c}_3 \frac{t}{K}}$ and $\mathbb{P}_{q', q}(\{|\mathcal{X}^{y(\gamma), k(\gamma)}| > \frac{t}{6K}\} \cap \{\forall r \in \mathcal{X}^{y(\gamma), k(\gamma)}, W^{\gamma, \tilde{\eta}}(r)^c\}) \leq e^{-\check{c}_3 \frac{t}{K}}$.*

Proof of lemma 4.19. We set $K_1 = \max(K_c, 48(\ln 36 + 1))$, which depends only on \mathcal{U} . Let $q' \in]0, 1]$, $K \geq K_1$, $q \in [q_K, 1]$, $x \in \mathbb{Z}^d$, $t \geq K$ and $\gamma =$

$(y_k)_{k \in \{0, \dots, \lfloor \frac{t}{K^2} \rfloor\}} \in C_K^N(x, t)$. If $k(\gamma)$ does not exist, $\tau^{y_k, k}$ is finite for $k \in \{0, \dots, \lfloor \frac{t}{K^2} \rfloor\}$, therefore if we call $k_1 = 0$ and $k_i = \sum_{j=1}^{i-1} \tau^{y_{k_j}, k_j}$ for $i \geq 2$, $\tau^{y_{k_i}, k_i}$ is finite as long as $k_i \leq \lfloor \frac{t}{K^2} \rfloor$. We will use proposition 4.17 to bound the probability that this happens. We call $L = \max\{i \geq 1 \mid k_i \leq \lfloor \frac{t}{K^2} \rfloor\}$; we then have $\sum_{i=1}^L \tau^{y_{k_i}, k_i} > \lfloor \frac{t}{K^2} \rfloor$, hence if n_L is the integer satisfying $n_L = \lfloor \frac{t}{K^2} \rfloor - \sum_{i=1}^{L-1} \tau^{y_{k_i}, k_i}$, we have $n_L \leq \tau^{y_{k_L}, k_L} < +\infty$. Furthermore, if n_1, \dots, n_{L-1} are integers satisfying $n_i = \tau^{y_{k_i}, k_i}$ for $i \in \{1, \dots, L-1\}$, we get $n_1 + \dots + n_L = \lfloor \frac{t}{K^2} \rfloor$, $k_i = \sum_{j=1}^{i-1} n_j$ for all $i \in \{1, \dots, L\}$ (we denote $\sum_{j=1}^{i-1} n_j = N_i$). In addition, since $\tau^{y_k, k} \geq 1$ for any $k \in \{0, \dots, \lfloor \frac{t}{K^2} \rfloor\}$, $L \leq \lfloor \frac{t}{K^2} \rfloor + 1$. We deduce

$$\begin{aligned} & \mathbb{P}_{q', q}(k(\gamma) \text{ does not exist}) \\ & \leq \sum \mathbb{P}_{q', q}(L = M, \forall 1 \leq i \leq M-1, \tau^{y_{N_i}, N_i} = n_i, n_M \leq \tau^{y_{N_M}, N_M} < +\infty) \end{aligned}$$

where the sum is over the $M \leq \lfloor \frac{t}{K^2} \rfloor + 1$, $n_1 + \dots + n_M = \lfloor \frac{t}{K^2} \rfloor$. Moreover, the events $\{\tau^{y_{N_i}, N_i} = n_i\}$, $i \in \{1, \dots, M-1\}$ and $\{n_M \leq \tau^{y_{N_M}, N_M} < +\infty\}$ depend only on clock rings in the time intervals $]t - (N_i + n_i)K, t - N_i K]$ = $]t - N_{i+1}K, t - N_i K]$, $i \in \{1, \dots, M-1\}$ and $]t - (N_M + n_M)K, t - N_M K]$, which are disjoint, thus the events are independent, hence

$$\begin{aligned} & \mathbb{P}_{q', q}(L = M, \forall 1 \leq i \leq M-1, \tau^{y_{N_i}, N_i} = n_i, n_M \leq \tau^{y_{N_M}, N_M} < +\infty) \\ & \leq \left(\prod_{i=1}^{M-1} \mathbb{P}_{q', q}(\tau^{y_{N_i}, N_i} = n_i) \right) \mathbb{P}_{q', q}(n_M \leq \tau^{y_{N_M}, N_M} < +\infty) \\ & \leq \prod_{i=1}^M \mathbb{P}_{q', q}(n_i \leq \tau^{y_{N_i}, N_i} < +\infty) \\ & \leq \prod_{i=1}^M 23^{2n_i} e^{-\frac{Kn_i}{24}} = 2^M 3^{2 \sum_{i=1}^M n_i} e^{-\frac{K}{24} \sum_{i=1}^M n_i} = 2^M 3^{2 \lfloor \frac{t}{K^2} \rfloor} e^{-\frac{K}{24} \lfloor \frac{t}{K^2} \rfloor} \end{aligned}$$

by proposition 4.17 and since $n_1 + \dots + n_M = \lfloor \frac{t}{K^2} \rfloor$. Consequently,

$$\mathbb{P}_{q', q}(k(\gamma) \text{ does not exist}) \leq \sum_{M \leq \lfloor \frac{t}{K^2} \rfloor + 1, n_1 + \dots + n_M = \lfloor \frac{t}{K^2} \rfloor} 2^M 3^{2 \lfloor \frac{t}{K^2} \rfloor} e^{-\frac{K}{24} \lfloor \frac{t}{K^2} \rfloor}.$$

In addition, lemma 4.12 yields that for any $M \in \{1, \dots, \lfloor \frac{t}{K^2} \rfloor + 1\}$, we have $|\{(n_1, \dots, n_M) \in \mathbb{N}^M \mid n_1 + \dots + n_M = \lfloor \frac{t}{K^2} \rfloor\}| = \binom{M + \lfloor \frac{t}{K^2} \rfloor - 1}{M-1} = \binom{M + \lfloor \frac{t}{K^2} \rfloor - 1}{\lfloor \frac{t}{K^2} \rfloor}$, and by the Stirling formula there exists a constant $\lambda > 0$ such that

$$\binom{M + \lfloor \frac{t}{K^2} \rfloor - 1}{\lfloor \frac{t}{K^2} \rfloor} \leq \frac{(M + \lfloor \frac{t}{K^2} \rfloor - 1)^{\lfloor \frac{t}{K^2} \rfloor}}{\lfloor \frac{t}{K^2} \rfloor!}$$

$$\leq \lambda \left(\frac{e \left(M + \lfloor \frac{t}{K^2} \rfloor - 1 \right)}{\lfloor \frac{t}{K^2} \rfloor} \right)^{\lfloor \frac{t}{K^2} \rfloor} \leq \lambda \left(\frac{e \left(\lfloor \frac{t}{K^2} \rfloor + \lfloor \frac{t}{K^2} \rfloor \right)}{\lfloor \frac{t}{K^2} \rfloor} \right)^{\lfloor \frac{t}{K^2} \rfloor}$$

since $M \leq \lfloor \frac{t}{K^2} \rfloor + 1$. We deduce $|\{(n_1, \dots, n_M) \in \mathbb{N}^M \mid n_1 + \dots + n_M = \lfloor \frac{t}{K^2} \rfloor\}| \leq \lambda(2e)^{\lfloor \frac{t}{K^2} \rfloor}$. Therefore

$$\begin{aligned} \mathbb{P}_{q',q}(k(\gamma) \text{ does not exist}) &\leq \sum_{M=1}^{\lfloor \frac{t}{K^2} \rfloor + 1} \lambda(2e)^{\lfloor \frac{t}{K^2} \rfloor} 2^M 3^{2\lfloor \frac{t}{K^2} \rfloor} e^{-\frac{K}{24}\lfloor \frac{t}{K^2} \rfloor} \\ &\leq \lambda(2e)^{\lfloor \frac{t}{K^2} \rfloor} 2^{\lfloor \frac{t}{K^2} \rfloor + 2} 3^{2\lfloor \frac{t}{K^2} \rfloor} e^{-\frac{K}{24}\lfloor \frac{t}{K^2} \rfloor} = 4\lambda \left(36ee^{-\frac{K}{24}} \right)^{\lfloor \frac{t}{K^2} \rfloor}. \end{aligned}$$

In addition, since $K \geq 48(\ln 36 + 1)$, $36ee^{-\frac{K}{48}} \leq 36ee^{-\ln 36 - 1} = 1$, so $36ee^{-\frac{K}{24}} \leq e^{-\frac{K}{48}}$, hence

$$\mathbb{P}_{q',q}(k(\gamma) \text{ does not exist}) \leq 4\lambda e^{-\frac{K}{48}\lfloor \frac{t}{K^2} \rfloor} \leq 4\lambda e^{-\frac{K}{48}(\frac{t}{K^2} - 1)} = 4\lambda e^{\frac{K}{48}} e^{-\frac{t}{48K}},$$

which is the lemma. \square

Proof of lemma 4.20. This proof is an application of proposition 4.18. We set $K_2 = \max(4, K_g(1/2))$, which depends only on \mathcal{U} . Let $q' \in]0, 1]$, $K \geq K_2$, $q \in [q_K, 1]$ and $x \in \mathbb{Z}^d$. It is enough to prove the lemma for $t \geq \max(K, \frac{3K^2}{K-3})$; indeed, if the lemma holds for $t \geq \max(K, \frac{3K^2}{K-3})$, one has only to enlarge \check{C}_2 to prove it for $t \geq K$. Therefore we set $t \geq \max(K, \frac{3K^2}{K-3})$ and $\gamma = (y_k)_{k \in \{0, \dots, \lfloor \frac{t}{K^2} \rfloor\}} \in C_K^N(x, t)$. If $k(\gamma)$ exists but $|\mathcal{X}^{y(\gamma), k(\gamma)}| \leq \frac{t}{6K}$, we have $\tau^{y(\gamma), k(\gamma)} = +\infty$ and $|\mathcal{X}^{y(\gamma), k(\gamma)}| \leq \frac{t}{6K}$, hence

$$\mathbb{P}_{q',q} \left(k(\gamma) \text{ exists, } |\mathcal{X}^{y(\gamma), k(\gamma)}| \leq \frac{t}{6K} \right) \leq \sum_{k=0}^{\lfloor \frac{t}{K^2} \rfloor} \mathbb{P}_{q',q} \left(\tau^{y_k, k} = +\infty, |\mathcal{X}^{y_k, k}| \leq \frac{t}{6K} \right).$$

We are going to bound the term on the right. For any $k \in \{0, \dots, \lfloor \frac{t}{K^2} \rfloor\}$, we have $n^{y_k, k} = \lfloor \frac{t}{K} \rfloor - k \geq \lfloor \frac{t}{K} \rfloor - \lfloor \frac{t}{K^2} \rfloor \geq \frac{t}{K} - 1 - \frac{t}{K^2}$, and since $t \geq \frac{3K^2}{K-3}$, $(K-3)t \geq 3K^2$ thus $\frac{1}{3}\frac{t}{K} - \frac{t}{K^2} \geq 1$, so $n^{y_k, k} \geq \frac{2}{3}\frac{t}{K}$, hence if we choose $\alpha = \frac{1}{2}$ we have $\frac{\alpha}{2}n^{y_k, k} \geq \frac{t}{6K}$. Therefore by proposition 4.18,

$$\mathbb{P}_{q',q} \left(\tau^{y_k, k} = +\infty, |\mathcal{X}^{y_k, k}| \leq \frac{t}{6K} \right) \leq C_g e^{-c_g n^{y_k, k}} \leq C_g e^{-c_g \frac{2}{3}\frac{t}{K}}$$

since $n^{y_k, k} \geq \frac{2}{3}\frac{t}{K}$. Consequently

$$\mathbb{P}_{q',q} \left(k(\gamma) \text{ exists, } |\mathcal{X}^{y(\gamma), k(\gamma)}| \leq \frac{t}{6K} \right)$$

$$\leq \left(\left\lfloor \frac{t}{K^2} \right\rfloor + 1 \right) C_g e^{-\frac{2c_g}{3} \frac{t}{K}} \leq \left(\frac{t}{K} + 1 \right) C_g e^{-\frac{2c_g}{3} \frac{t}{K}},$$

which yields lemma 4.20. \square

Proof of lemma 4.21. Let $q' \in]0, 1]$, $K \geq 2$, $q \in [q_K, 1]$, $x \in \mathbb{Z}^d$, $t \geq K$ and $\gamma \in C_K^N(x, t)$. The argument is elementary: we notice that there is a positive probability that a rectangle is full of zeroes in the initial configurations of the two processes since they have laws $\nu_{q'}$ and ν_q , as well as a positive probability that there is no 1-clock ring in the rectangle in the time interval $[0, t - K \lfloor \frac{t}{K} \rfloor]$. Therefore there is a positive probability that a rectangle is full of zeroes in both processes at time $t - K \lfloor \frac{t}{K} \rfloor$, so if there are $\frac{t}{6K}$ elements in $\mathcal{X}^{y(\gamma), k(\gamma)}$, the probability that none of the corresponding rectangles is full of zeroes in both processes at time $t - K \lfloor \frac{t}{K} \rfloor$ is of order $e^{-\tilde{c}_3 \frac{t}{K}}$.

We notice that $\mathcal{X}^{y(\gamma), k(\gamma)}$ depends only on clock rings in the time interval $]t - K \lfloor \frac{t}{K} \rfloor, t]$, hence if \mathcal{F} is the σ -algebra generated by the clock rings in $]t - K \lfloor \frac{t}{K} \rfloor, t]$, for $\hat{\eta} = \eta$ or $\tilde{\eta}$, we have

$$\begin{aligned} & \mathbb{P}_{q', q} \left(\left\{ |\mathcal{X}^{y(\gamma), k(\gamma)}| > \frac{t}{6K} \right\} \cap \{ \forall r \in \mathcal{X}^{y(\gamma), k(\gamma)}, W^{\gamma, \hat{\eta}}(r)^c \} \right) \\ &= \mathbb{E}_{q', q} \left(\mathbb{1}_{\{ |\mathcal{X}^{y(\gamma), k(\gamma)}| > \frac{t}{6K} \}} \mathbb{P}_{q', q}(\forall r \in \mathcal{X}^{y(\gamma), k(\gamma)}, W^{\gamma, \hat{\eta}}(r)^c | \mathcal{F}) \right). \end{aligned} \quad (4.1)$$

Moreover,

$$\begin{aligned} & \mathbb{P}_{q', q}(\forall r \in \mathcal{X}^{y(\gamma), k(\gamma)}, W^{\gamma, \hat{\eta}}(r)^c | \mathcal{F}) = \\ & \mathbb{P}_{q', q} \left(\forall r \in \mathcal{X}^{y(\gamma), k(\gamma)}, \exists x' \in y(\gamma) + \frac{r - n^{y(\gamma), k(\gamma)}}{2} a_1 u + R, \hat{\eta}_{t - \lfloor \frac{t}{K} \rfloor K}(x') \neq 0 \mid \mathcal{F} \right) \\ & \leq \mathbb{P}_{q', q} \left(\forall r \in \mathcal{X}^{y(\gamma), k(\gamma)}, \exists x' \in y(\gamma) + \frac{r - n^{y(\gamma), k(\gamma)}}{2} a_1 u + R, \right. \\ & \quad \left. \hat{\eta}_0(x') \neq 0 \text{ or } \mathcal{P}_{x'}^1 \cap \left[0, t - \left\lfloor \frac{t}{K} \right\rfloor K \right] \neq \emptyset \mid \mathcal{F} \right) \\ & = \prod_{r \in \mathcal{X}^{y(\gamma), k(\gamma)}} \mathbb{P}_{q', q} \left(\exists x' \in y(\gamma) + \frac{r - n^{y(\gamma), k(\gamma)}}{2} a_1 u + R, \right. \\ & \quad \left. \hat{\eta}_0(x') \neq 0 \text{ or } \mathcal{P}_{x'}^1 \cap \left[0, t - \left\lfloor \frac{t}{K} \right\rfloor K \right] \neq \emptyset \right) \end{aligned}$$

since the events $\{ \exists x' \in y(\gamma) + \frac{r - n^{y(\gamma), k(\gamma)}}{2} a_1 u + R, \hat{\eta}_0(x') \neq 0 \text{ or } \mathcal{P}_{x'}^1 \cap [0, t - \lfloor \frac{t}{K} \rfloor K] \neq \emptyset \}$ depend only on the state of $\hat{\eta}_0$ and on the clock rings of the

time interval $[0, t - K \lfloor \frac{t}{K} \rfloor]$ at the sites of $y(\gamma) + \frac{r - n^{y(\gamma), k(\gamma)}}{2} a_1 u + R$, so they are mutually independent and independent of \mathcal{F} . Therefore the invariance by translation yields

$$\begin{aligned} & \mathbb{P}_{q', q}(\forall r \in \mathcal{X}^{y(\gamma), k(\gamma)}, W^{\gamma, \hat{\eta}}(r)^c | \mathcal{F}) \\ & \leq \mathbb{P}_{q', q} \left(\exists x' \in R, \hat{\eta}_0(x') \neq 0 \text{ or } \mathcal{P}_{x'}^1 \cap \left[0, t - \left\lfloor \frac{t}{K} \right\rfloor K \right] \neq \emptyset \right)^{|\mathcal{X}^{y(\gamma), k(\gamma)}|} \\ & = \left(1 - \mathbb{P}_{q', q} \left(\forall x' \in R, \hat{\eta}_0(x') = 0, \mathcal{P}_{x'}^1 \cap \left[0, t - \left\lfloor \frac{t}{K} \right\rfloor K \right] = \emptyset \right) \right)^{|\mathcal{X}^{y(\gamma), k(\gamma)}|} \\ & = \left(1 - \left(\mathbb{P}_{q', q}(\hat{\eta}_0(0) = 0) \mathbb{P}_{q', q} \left(\mathcal{P}_0^1 \cap \left[0, t - \left\lfloor \frac{t}{K} \right\rfloor K \right] = \emptyset \right) \right)^{|R|} \right)^{|\mathcal{X}^{y(\gamma), k(\gamma)}|}. \end{aligned}$$

Furthermore, since $t - \lfloor \frac{t}{K} \rfloor K \leq K$ and $q \geq q_K = 1 + \frac{1}{3K|R|} \ln(1 - e^{-K})$,

$$\begin{aligned} & \mathbb{P}_{q', q} \left(\mathcal{P}_0^1 \cap \left[0, t - \left\lfloor \frac{t}{K} \right\rfloor K \right] = \emptyset \right) = e^{-(1-q)(t - \lfloor \frac{t}{K} \rfloor K)} \\ & \geq e^{\frac{1}{3K|R|} \ln(1 - e^{-K}) K} = (1 - e^{-K})^{\frac{1}{3|R|}} \geq \left(\frac{1}{2} \right)^{\frac{1}{3|R|}} \end{aligned}$$

since $K \geq 2$. This implies

$$\mathbb{P}_{q', q}(\forall r \in \mathcal{X}^{y(\gamma), k(\gamma)}, W^{\gamma, \hat{\eta}}(r)^c | \mathcal{F}) \leq \left(1 - \mathbb{P}_{q', q}(\hat{\eta}_0(0) = 0)^{|R|} \left(\frac{1}{2} \right)^{\frac{1}{3}} \right)^{|\mathcal{X}^{y(\gamma), k(\gamma)}|}.$$

In addition, if $\hat{\eta} = \eta$, $\mathbb{P}_{q', q}(\hat{\eta}_0(0) = 0) = q'$, so $1 - \mathbb{P}_{q', q}(\hat{\eta}_0(0) = 0)^{|R|} \left(\frac{1}{2} \right)^{\frac{1}{3}} = 1 - (q')^{|R|} 2^{-\frac{1}{3}}$, and if $\hat{\eta} = \tilde{\eta}$, $1 - \mathbb{P}_{q', q}(\hat{\eta}_0(0) = 0)^{|R|} \left(\frac{1}{2} \right)^{\frac{1}{3}} = 1 - q^{|R|} 2^{-\frac{1}{3}}$. Moreover, since $K \geq 2$, $q \geq q_K = 1 + \frac{1}{3K|R|} \ln(1 - e^{-K}) \geq 1 + \frac{1}{6|R|} \ln(1 - e^{-2}) \geq \frac{1}{2}$, hence $1 - \mathbb{P}_{q', q}(\tilde{\eta}_0(0) = 0)^{|R|} \left(\frac{1}{2} \right)^{\frac{1}{3}} \leq 1 - 2^{-|R| - \frac{1}{3}}$. This implies that if \tilde{c}'_3 is the minimum of $-\ln(1 - (q')^{|R|} 2^{-\frac{1}{3}})$ and $-\ln(1 - 2^{-|R| - \frac{1}{3}})$ (which depends only on \mathcal{U} and q'), for $\hat{\eta} = \eta$ or $\tilde{\eta}$ we have $\mathbb{P}_{q', q}(\forall r \in \mathcal{X}^{y(\gamma), k(\gamma)}, W^{\gamma, \hat{\eta}}(r)^c | \mathcal{F}) \leq e^{-\tilde{c}'_3 |\mathcal{X}^{y(\gamma), k(\gamma)}|}$. Consequently, (4.1) yields

$$\begin{aligned} & \mathbb{P}_{q', q} \left(\left\{ |\mathcal{X}^{y(\gamma), k(\gamma)}| > \frac{t}{6K} \right\} \cap \{ \forall r \in \mathcal{X}^{y(\gamma), k(\gamma)}, W^{\gamma, \hat{\eta}}(r)^c \} \right) \\ & \leq \mathbb{E}_{q', q} \left(\mathbf{1}_{\{ |\mathcal{X}^{y(\gamma), k(\gamma)}| > \frac{t}{6K} \}} e^{-\tilde{c}'_3 |\mathcal{X}^{y(\gamma), k(\gamma)}|} \right) \leq e^{-\tilde{c}'_3 \frac{t}{6K}}, \end{aligned}$$

which is the lemma. \square

Chapter 5

Convergence to equilibrium in the d -dimensional East model

This chapter corresponds to the article *Exponential convergence to equilibrium for the d -dimensional East model* [Mar19a].

Kinetically constrained models (KCMs) are interacting particle systems on \mathbb{Z}^d with a continuous-time constrained Glauber dynamics, which were introduced by physicists to model the liquid-glass transition. One of the most well-known KCMs is the one-dimensional East model. Its generalization to higher dimension, the d -dimensional East model, is much less understood. Prior to this paper, convergence to equilibrium in the d -dimensional East model was proven to be at least stretched exponential, by Chleboun, Faggionato and Martinelli in [CFM15]. We show that the d -dimensional East model exhibits exponential convergence to equilibrium in all settings for which convergence is possible.

5.1 Introduction

Kinetically constrained models (KCMs) are interacting particle systems on graphs, in which each vertex (or *site*) of the graph has state (or *spin*) 0 or 1. Each site tries at rate 1 to *update* its spin, that is to replace it by 1 with probability p and by 0 with probability $1 - p$, but the update is accepted only if a certain *constraint* is satisfied, the constraint being of the form “there are enough sites with spin zero around this site”.

KCMs were introduced by physicists to model the liquid-glass transition, which is an important open problem in condensed matter physics (see [RS03, GST11]). In addition to their physical interest, they are also mathematically

challenging because the presence of the constraints gives them a very different behavior from classical Glauber dynamics and renders most of the usual tools ineffective.

A key feature of KCMs is the existence of blocked spin configurations, which makes the large-time behavior of KCMs hard to study, especially their relaxation to equilibrium when starting out of equilibrium. Indeed, worst case analysis does not help and standard coercive inequalities of the log-Sobolev type also fail. Furthermore, the dynamics of KCMs is not attractive, so coupling arguments that have proven very useful for other types of Glauber dynamics are here inefficient. Because of these difficulties, convergence to equilibrium has been proven only in a few models and under particular conditions (see [CMST10, BCM⁺13, CFM15, MV19]).

There is only one model for which exponentially fast relaxation to equilibrium was proven under general conditions (apart from some models on trees that use the same proof): the East model, whose base graph is \mathbb{Z} and in which an update is accepted when the site at the left has spin 0. Introduced by physicists in [JE91], the East model is the most well-understood KCM (see [FMRT13] for a review).

A natural generalization of the East model to \mathbb{Z}^d , introduced in [BG05], is to accept updates at a site x when $x - e$ has spin 0 for some e in the canonical basis of \mathbb{R}^d . The higher dimension makes this d -dimensional East model much harder to study than the unidimensional one, and until now the relaxation to equilibrium was only proved to be at least stretched exponential ([CFM15]).

In this article, we prove that the relaxation to equilibrium in the d -dimensional East dynamics is exponentially fast as soon as the initial configuration is not blocked. This also allowed us to prove that the *persistence function*, which is the probability that a given site has not yet been updated, decays exponentially with time.

Our results, which are the first to hold for a KCM in dimension greater than 1 and for any p , may help to understand further the out-of-equilibrium behavior of the d -dimensional East model. Indeed, such an exponential relaxation result was key to proving “shape theorems” in one-dimensional models in [Blo13, GLM15, BDT19].

This paper is organized as follows: we begin by presenting the notations and stating our results in section 5.2, then we prove the exponential relaxation to equilibrium in section 5.3, and finally we show the exponential decay of the persistence function in section 5.4.

5.2 Notations and results

We fix $d \in \mathbb{N}^*$. For any $\Lambda \subset \mathbb{Z}^d$, the d -dimensional East model (in the following, we will just call it “East model”) in Λ is a dynamics on $\{0, 1\}^\Lambda$. The elements of Λ will be called sites and the elements of $\{0, 1\}^\Lambda$ will be called configurations. For any $\eta \in \{0, 1\}^\Lambda$, $x \in \Lambda$, the value of η at x will be called the spin of η at x and denoted by $\eta(x)$.

If $f : \{0, 1\}^\Lambda \mapsto \mathbb{R}$ is a function and $\Lambda' \subset \Lambda$, we say the support of f is contained in Λ' and we write $\text{supp}(f) \subset \Lambda'$ when for any $\eta, \eta' \in \{0, 1\}^\Lambda$ coinciding in Λ' , $f(\eta) = f(\eta')$. Moreover, the ℓ^∞ -norm of f , denoted by $\|f\|_\infty$, is $\sup_{\eta \in \{0, 1\}^\Lambda} |f(\eta)|$.

We denote $\{e_1, \dots, e_d\}$ the canonical basis of \mathbb{R}^d . For any $r \in \mathbb{R}^+$, we denote $\Lambda(r) = (\prod_{i=1}^d \{0, \dots, [r]\}) \setminus \{(0, \dots, 0)\}$.

For any set A , $|A|$ will denote the cardinal of A . For $\alpha, \beta \in \mathbb{R}$, we will use the abbreviation $\alpha \wedge \beta = \min(\alpha, \beta)$.

To define the East dynamics in $\Lambda \subset \mathbb{Z}^d$, we begin by fixing $p \in]0, 1[$. Informally, the East dynamics can be seen as follows: each site x , independently of all others, waits for a random time with exponential law of mean 1, then tries to update its spin, that is to replace it by 1 with probability p and by 0 with probability $1 - p$, but the update is accepted if and only if one of the $x - e_i$ is at zero. Then x waits for another random time with exponential law, etc.

More rigorously, independently for each $x \in \Lambda$, we consider a sequence $(B_{x,n})_{n \in \mathbb{N}^*}$ of independent random variables with Bernoulli law of parameter p , and a sequence of times $(t_{x,n})_{n \in \mathbb{N}^*}$ such that, denoting $t_{x,0} = 0$, the $(t_{x,n} - t_{x,n-1})_{n \in \mathbb{N}^*}$ are independent random variables with exponential law of parameter 1, independent from $(B_{x,n})_{n \in \mathbb{N}^*}$. The dynamics is continuous-time, denoted by $(\eta_t)_{t \in \mathbb{R}^+}$, and evolves as follows. For each $x \in \Lambda$, $n \in \mathbb{N}^*$, if there exists $i \in \{1, \dots, d\}$ such that $\eta_{t_{x,n}}(x - e_i) = 0$, then the spin at x is replaced by $B_{x,n}$ at time $t_{x,n}$. We then say there was an update at x at time $t_{x,n}$, or that x was updated at time $t_{x,n}$. (If there are sites $x - e_i$, $x \in \Lambda$, $i \in \{1, \dots, d\}$ that are not in Λ , we need to fix the state of their spins in order to run the dynamics.) One can use the arguments in part 4.3 of [Swa17] to see that this dynamics is well-defined.

For any $\eta \in \{0, 1\}^\Lambda$, we denote the law of the dynamics starting from the configuration η by \mathbb{P}_η , and the associated expectation by \mathbb{E}_η . If the initial configuration follows a law ν on $\{0, 1\}^\Lambda$, the law and expectation of the dynamics will be respectively denoted by \mathbb{P}_ν and \mathbb{E}_ν . In the remainder of this work, we will always consider the dynamics on \mathbb{Z}^d unless stated otherwise.

For any $t \geq 0$ and $\Lambda \subset \mathbb{Z}^d$, we denote $\mathcal{F}_{t,\Lambda} = \sigma(t_{x,n}, B_{x,n}, x \in \Lambda, t_{x,n} \leq t)$

the σ -algebra of the exponential times and Bernoulli variables in the domain Λ between time 0 and time t . We notice that if η_0 is deterministic, for any $x \in \mathbb{Z}^d$, $\eta_t(x)$ depends only on the $t_{x,n}, B_{x,n}$ with $t_{x,n} \leq t$ and on the state of sites “below” x : $x - e_1, \dots, x - e_d$, which in turn depends only on the $\eta_0(x - e_i)$, $t_{x-e_i,n}, B_{x-e_i,n}$ with $t_{x-e_i,n} \leq t$ and on the state of the sites “below” the $x - e_i$, etc. Therefore $\eta_t(x)$ depends only on η_0 and on the $t_{y,n}, B_{y,n}$ with $t_{y,n} \leq t$ and $y \in x + (-\mathbb{N})^d$, hence $\eta_t(x)$ is $\mathcal{F}_{t, x + (-\mathbb{N})^d}$ -measurable.

We will call μ the product Bernoulli(p) measure on the configuration space $\{0, 1\}^\Lambda$. The expectation with respect to μ of a function $f : \{0, 1\}^\Lambda \mapsto \mathbb{R}$, if it exists, will be denoted $\mu(f)$. μ is the equilibrium measure of the dynamics, which can be seen using reversibility, since the detailed balance is satisfied.

We say that a measure ν on $\{0, 1\}^{\mathbb{Z}^d}$ satisfies condition (C) when

$$(C) : \exists a, A > 0, \forall \ell \geq 0, \nu(\forall x \in \{-[\ell], \dots, 0\}^d, \eta(x) = 1) \leq Ae^{-a\ell}.$$

Remark 5.1. The set of measures satisfying (C) includes

- the δ_η for any $\eta \in \{0, 1\}^{\mathbb{Z}^d}$ such that there exists $x = (x_1, \dots, x_d) \in (-\mathbb{N})^d$ with $\eta(x) = 0$. This is the minimal condition on η for which to expect convergence to equilibrium, since if the initial configuration contains only ones, there can be no updates, hence the dynamics is blocked.
- the product Bernoulli(p') measures with $p' \in [0, 1[$, which are particularly relevant for physicists (see [LMS⁺07]).

We can now state the main result of the paper, the convergence of the dynamics to equilibrium:

Theorem 5.2. *For any measure ν on $\{0, 1\}^{\mathbb{Z}^d}$ satisfying (C), there exist constants $\chi = \chi(p) > 0$, $c_1 = c_1(p, \nu) > 0$ and $C_1 = C_1(p, \nu) > 0$ such that, for any $t \geq 0$ and any $f : \{0, 1\}^{\mathbb{Z}^d} \mapsto \mathbb{R}$ with $\text{supp}(f) \subset \Lambda(\chi t^{1/d})$,*

$$\int_{\{0, 1\}^{\mathbb{Z}^d}} |\mathbb{E}_\eta(f(\eta_t)) - \mu(f)| d\nu(\eta) \leq C_1 \|f\|_\infty e^{-c_1 t}.$$

Remark 5.3. With only minor modifications in the proof, one can also show exponential convergence of the quantity $\int_{\{0, 1\}^{\mathbb{Z}^d}} |\mathbb{E}_\eta(f(\eta_t)) - \mu(f)|^\gamma d\nu(\eta)$ for any $\gamma > 0$.

Another quantity of interest is the persistence function. If ν is the law of the initial configuration and $x \in \mathbb{Z}^d$, the corresponding persistence function can be defined as $F_{\nu, x}(t) = \mathbb{P}_\nu(\tau_x > t)$ for any $t \geq 0$, where τ_x is the first

time there is an update at x . The persistence function is a “measure of the mobility of the system”: the more the spin at x can change, the faster it will decrease. Theorem 5.2 allows to prove exponential decay of the persistence function:

Corollary 5.4. *For any measure ν on $\{0, 1\}^{\mathbb{Z}^d}$ satisfying (C), there exist constants $\chi = \chi(p) > 0$, $c_2 = c_2(p, \nu) > 0$ and $C_2 = C_2(p, \nu) > 0$ such that for any $t \geq 0$ and any $x \in \Lambda(\chi t^{1/d})$, $F_{\nu, x}(t) \leq C_2 e^{-c_2 t}$.*

Remark 5.5. The decay of the persistence function can not be faster than exponential, because $\tau_x \geq t_{x,1}$, thus $F_{\nu, x}(t) \geq \mathbb{P}_\nu(t_{x,1} \geq t) = e^{-t}$. Moreover, since the spin of a site x will remain in its initial state until τ_x , the convergence to equilibrium can not be faster than exponential. Consequently, the exponential speed is the actual speed.

Remark 5.6. In theorem 5.2 and corollary 5.4, one could replace $\Lambda(\chi t^{1/d})$ with any box of the form $(\prod_{i=1}^d \{0, \dots, a_i\}) \setminus \{(0, \dots, 0)\}$, $a_1, \dots, a_d \in \mathbb{N}$, $\prod_{i=1}^d (a_i + 1) - 1 \leq 2^d \chi^d t$.

5.3 Proof of theorem 5.2

The proof of the theorem can be divided in three steps. Firstly, we use a novel argument to find a site of $(-\mathbb{N})^d$ at distance $O(t)$ from the origin that remains at zero for a total time $\Omega(t)$ between time 0 and time t (section 5.3.1). Afterwards, we use sequentially a result of [CFM15] to prove that the origin also stays at zero for a time $\Omega(t)$ (section 5.3.2). Finally, we end the proof of the theorem with the help of a formula derived in [CFM15].

5.3.1 Finding a site that stays at zero for a time $\Omega(t)$

For any $t \geq 0$ and $\kappa > 0$, we denote $D = D(t, \kappa) = \{-\lfloor 2d\kappa t \rfloor, \dots, 0\}^d$. For any $x \in \mathbb{Z}^d$, we denote $\mathcal{T}_t(x) = \int_0^t \mathbb{1}_{\{\eta_s(x)=0\}} ds$ the time that x spends at zero between time 0 and time t . We also define $\mathcal{G} = \{\exists x \in D \mid \mathcal{T}_t(x) \geq \frac{1-p}{4}t\}$. We then have

Lemma 5.7. *For any $\kappa > 0$, there exist constants $c_3 = c_3(p, \kappa) > 0$ and $C_3 = C_3(p, \kappa) > 0$ such that for any $t \geq 0$, for any $\eta \in \{0, 1\}^{\mathbb{Z}^d}$ such that there exists $x \in \{-\lfloor \kappa t \rfloor, \dots, 0\}^d$ with $\eta(x) = 0$, $\mathbb{P}_\eta(\mathcal{G}^c) \leq C_3 e^{-c_3 t}$.*

Proof. We set $\kappa > 0$. It is enough to prove the lemma for $t \geq 1/(2d\kappa - \kappa)$, so we fix $t \geq 1/(2d\kappa - \kappa)$. Let $\eta \in \{0, 1\}^{\mathbb{Z}^d}$ with $x \in \{-\lfloor \kappa t \rfloor, \dots, 0\}^d$ such that $\eta(x) = 0$ be the initial configuration. We define $E = \{y \in D \mid \text{there was an}$

update at y in the time interval $[0, t/2]$. Moreover, an *oriented path* will be a sequence of sites $(x^{(1)}, \dots, x^{(n)})$ with $n \in \mathbb{N}^*$ such that for any $k \in \{1, \dots, n-1\}$, there exists $i \in \{1, \dots, d\}$ with $x^{(k+1)} = x^{(k)} - e_i$. Furthermore, writing $\kappa' = 2d\kappa$, we can define $D' = \{-\lfloor \kappa't \rfloor + 1, \dots, 0\}^d$. Since $t \geq 1/(2d\kappa - \kappa)$, $2d\kappa t - 1 \geq \kappa t$, so $-\lfloor \kappa't \rfloor + 1 \leq -\lfloor \kappa t \rfloor$, thus $x \in D'$.

The proof of lemma 5.7 relies on the following auxiliary lemma, whose proof will be postponed until after the proof of lemma 5.7:

Lemma 5.8. *If no site in D stays at zero during the time interval $[0, t/2]$, then there exists an oriented path in E joining x to $D \setminus D'$.*

This auxiliary lemma implies that we either get a site satisfying \mathcal{G} , or a path of $\Omega(t)$ sites that were updated before time $t/2$. In the latter case, the orientation of the model allows us to use a conditioning which yields that the probability that none of the sites of the path stays at zero for a time $\frac{1-p}{4}t$ is the product of the probabilities for each of the sites not to stay at zero for a time $\frac{1-p}{4}t$, and we can prove that this probability is strictly smaller than one. Let us prove lemma 5.7 by writing down the argument.

For any $k \in \{0, \dots, d\lfloor \kappa't \rfloor\}$, we define the ‘‘diagonal hyperplane’’ H_k by $H_k = \{(x_1, \dots, x_d) \in D \mid x_1 + \dots + x_d = -k\}$ and we denote $\mathcal{U}_k = \{H_k \cap E \neq \emptyset\}$. If \mathcal{G}^c occurs, no site of D can stay at zero during the whole time interval $[0, t/2]$, hence by lemma 5.8 there exists an oriented path in E joining x to $D \setminus D'$. Since $x \in \bigcup_{k=0}^{d\lfloor \kappa t \rfloor} H_k$ and $D \setminus D' \subset \bigcup_{k=\lfloor \kappa't \rfloor}^{d\lfloor \kappa't \rfloor} H_k$, E intersects all the H_k for $k \in \{d\lfloor \kappa t \rfloor, \dots, \lfloor \kappa't \rfloor\}$. This implies $\mathcal{G}^c \subset \bigcap_{k=d\lfloor \kappa t \rfloor}^{\lfloor \kappa't \rfloor} \mathcal{U}_k$. Furthermore, for any $k \in \{0, \dots, d\lfloor \kappa't \rfloor\}$, we may define $\mathcal{G}_k = \{\exists x \in H_k, \mathcal{T}_t(x) \geq \frac{1-p}{4}t\}$, then $\mathcal{G}^c \subset \bigcap_{k=d\lfloor \kappa t \rfloor}^{\lfloor \kappa't \rfloor} \mathcal{G}_k^c$. We deduce $\mathcal{G}^c \subset \bigcap_{k=d\lfloor \kappa t \rfloor}^{\lfloor \kappa't \rfloor} (\mathcal{U}_k \cap \mathcal{G}_k^c)$, so

$$\mathbb{P}_\eta(\mathcal{G}^c) \leq \mathbb{E}_\eta \left(\prod_{k=d\lfloor \kappa t \rfloor}^{\lfloor \kappa't \rfloor} (\mathbb{1}_{\mathcal{U}_k} \mathbb{1}_{\mathcal{G}_k^c}) \right).$$

For any $k \in \{d\lfloor \kappa t \rfloor, \dots, \lfloor \kappa't \rfloor\}$, we define a σ -algebra \mathcal{F}_k as follows: $\mathcal{F}_k = \sigma(\mathcal{F}_{t,\Lambda}, \sigma(t_{x,n}, x \in H_k, t_{x,n} \leq t/2))$, where $\Lambda = \{(x_1, \dots, x_d) \in (-\mathbb{N})^d \mid x_1 + \dots + x_d < -k\}$. For any $k' \in \{d\lfloor \kappa t \rfloor, \dots, \lfloor \kappa't \rfloor\}$ with $k' > k$, one can see that everything that happens at the sites in $H_{k'}$ between times 0 and t is \mathcal{F}_k -measurable, thus $\mathcal{U}_{k'}$ and $\mathcal{G}_{k'}^c$ are \mathcal{F}_k -measurable. Moreover, for any $x \in H_k$, the spins of the $x - e_i$, $i \in \{1, \dots, d\}$ in the time interval $[0, t/2]$ are \mathcal{F}_k -measurable and the $t_{x,n} \leq t/2$ are also \mathcal{F}_k -measurable. Therefore the event $\{\text{there was an update at } x \text{ between time } 0 \text{ and time } t/2\}$ is \mathcal{F}_k -measurable,

hence \mathcal{U}_k is \mathcal{F}_k -measurable. Consequently,

$$\mathbb{P}_\eta(\mathcal{G}^c) \leq \mathbb{E}_\eta \left(\mathbb{E}_\eta \left(\mathbb{1}_{\mathcal{G}_{d\lfloor \kappa t \rfloor}^c} \middle| \mathcal{F}_{d\lfloor \kappa t \rfloor} \right) \mathbb{1}_{\mathcal{U}_{d\lfloor \kappa t \rfloor}} \prod_{k=d\lfloor \kappa t \rfloor+1}^{\lfloor \kappa' t \rfloor} (\mathbb{1}_{\mathcal{U}_k} \mathbb{1}_{\mathcal{G}_k^c}) \right).$$

Therefore, if we can find a constant $c'_3 = c'_3(p) > 0$ such that

$$\forall k \in \{d\lfloor \kappa t \rfloor, \dots, \lfloor \kappa' t \rfloor\}, \mathbb{1}_{\mathcal{U}_k} \mathbb{E}_\eta (\mathbb{1}_{\mathcal{G}_k^c} | \mathcal{F}_k) \leq e^{-c'_3} \quad (5.1)$$

then we have

$$\mathbb{P}_\eta(\mathcal{G}^c) \leq e^{-c'_3} \mathbb{E}_\eta \left(\prod_{k=d\lfloor \kappa t \rfloor+1}^{\lfloor \kappa' t \rfloor} (\mathbb{1}_{\mathcal{U}_k} \mathbb{1}_{\mathcal{G}_k^c}) \right),$$

so by a simple induction $\mathbb{P}_\eta(\mathcal{G}^c) \leq e^{-c'_3(\lfloor \kappa' t \rfloor+1-d\lfloor \kappa t \rfloor)} \leq e^{-c'_3(\kappa' t - d\kappa t)} = e^{-c'_3 d\kappa t}$, which is lemma 5.7.

Consequently, we only need to prove (5.1). Let $k \in \{d\lfloor \kappa t \rfloor, \dots, \lfloor \kappa' t \rfloor\}$. For any $x \in H_k$, if the state of the $x - e_i$, $i \in \{1, \dots, d\}$ between time 0 and time t is known, and if the $t_{x,n} \leq t/2$ are also known, the state of x between time 0 and time t depends only on the $t/2 < t_{x,n} \leq t$ and on the $B_{x,n}$ such that $t_{x,n} \leq t$. Therefore, conditionnally on \mathcal{F}_k , the state of x between time 0 and time t depends only on $\{t/2 < t_{x,n} \leq t\} \cup \{B_{x,n} | t_{x,n} \leq t\}$. Moreover, these sets for $x \in H_k$ are mutually independent conditionnally on \mathcal{F}_k , hence the states of the $x \in H_k$ between time 0 and time t are mutually independent conditionnally on \mathcal{F}_k , which implies

$$\mathbb{1}_{\mathcal{U}_k} \mathbb{E}_\eta (\mathbb{1}_{\mathcal{G}_k^c} | \mathcal{F}_k) = \mathbb{1}_{\mathcal{U}_k} \prod_{x \in H_k} \mathbb{P}_\eta \left(\mathcal{T}_t(x) < \frac{1-p}{4} t \middle| \mathcal{F}_k \right).$$

Moreover, we saw that the events $\{x \in E\}$ for $x \in H_k$ are \mathcal{F}_k -measurable, therefore we can write

$$\mathbb{1}_{\mathcal{U}_k} \mathbb{E}_\eta (\mathbb{1}_{\mathcal{G}_k^c} | \mathcal{F}_k) \leq \mathbb{1}_{\mathcal{U}_k} \prod_{x \in H_k \cap E} \mathbb{P}_\eta \left(\mathcal{T}_t(x) < \frac{1-p}{4} t \middle| \mathcal{F}_k \right). \quad (5.2)$$

In addition, for $x \in H_k \cap E$, we have the following (in the second inequality we use the Markov inequality):

$$\begin{aligned} \mathbb{P}_\eta \left(\mathcal{T}_t(x) < \frac{1-p}{4} t \middle| \mathcal{F}_k \right) &\leq \mathbb{P}_\eta \left(\int_{t/2}^t \mathbb{1}_{\{\eta_s(x)=0\}} ds < \frac{1-p}{4} t \middle| \mathcal{F}_k \right) \\ &= \mathbb{P}_\eta \left(\int_{t/2}^t \mathbb{1}_{\{\eta_s(x)=1\}} ds > \frac{t}{2} - \frac{1-p}{4} t \middle| \mathcal{F}_k \right) \leq \frac{\mathbb{E}_\eta \left(\int_{t/2}^t \mathbb{1}_{\{\eta_s(x)=1\}} ds \middle| \mathcal{F}_k \right)}{\frac{t}{2} - \frac{1-p}{4} t} \end{aligned}$$

$$= \frac{\int_{t/2}^t \mathbb{P}_\eta(\eta_s(x) = 1 | \mathcal{F}_k) ds}{\left(1 - \frac{1-p}{2}\right) \frac{t}{2}}.$$

Furthermore, for $s \in [t/2, t]$, since $x \in H_k \cap E$, conditionnally on \mathcal{F}_k we know that there was an update at x before time s , but not the associated Bernoulli variable, hence $\mathbb{P}_\eta(\eta_s(x) = 1 | \mathcal{F}_k) = p$. This implies

$$\mathbb{P}_\eta \left(\mathcal{T}_t(x) < \frac{1-p}{4} t \middle| \mathcal{F}_k \right) \leq \frac{\int_{t/2}^t p ds}{\left(1 - \frac{1-p}{2}\right) \frac{t}{2}} = \frac{p}{1 - \frac{1-p}{2}}.$$

Moreover, $\frac{p}{1 - \frac{1-p}{2}} = \frac{2p}{1+p} < 1$, hence if we write $c'_3 = -\ln\left(\frac{p}{1 - \frac{1-p}{2}}\right)$, we have $c'_3 > 0$ and $\mathbb{P}_\eta(\mathcal{T}_t(x) < \frac{1-p}{4} t | \mathcal{F}_k) \leq e^{-c'_3}$. Consequently, (5.2) yields

$$\mathbb{1}_{\mathcal{U}_k} \mathbb{E}_\eta(\mathbb{1}_{\mathcal{G}_k^c} | \mathcal{F}_k) \leq \mathbb{1}_{\mathcal{U}_k} \prod_{x \in H_k \cap E} e^{-c'_3} = \mathbb{1}_{\mathcal{U}_k} e^{-c'_3 |H_k \cap E|}.$$

Finally, \mathcal{U}_k indicates that $H_k \cap E \neq \emptyset$, thus $\mathbb{1}_{\mathcal{U}_k} \mathbb{E}_\eta(\mathbb{1}_{\mathcal{G}_k^c} | \mathcal{F}_k) \leq \mathbb{1}_{\mathcal{U}_k} e^{-c'_3} \leq e^{-c'_3}$ with $c'_3 > 0$ depending only on p , which is (5.1). \square

Proof of lemma 5.8. Let us suppose that no site of D stays at zero during the time interval $[0, t/2]$. Then E contains x , because $x \in D$ and if there was no update at x between time 0 and time $t/2$, the spin of x would stay during this whole time interval at its initial state of 0, which does not happen by assumption. We are going to show that if we have an oriented path in E starting from x that does not reach $D \setminus D'$, we can add a site at its end in a way we still have an oriented path in E . This is enough, because from the path composed only of x we can do at most $d \lfloor \kappa' t \rfloor$ steps before reaching $D \setminus D'$. Thus we consider an oriented path in E starting from x that does not reach $D \setminus D'$. Let us call y its last site; we have $y \in D'$. Since $y \in E$, y was updated between time 0 and time $t/2$. This implies that one of the $y - e_i$, $i \in \{1, \dots, d\}$, that we may call y' , was at zero at the moment of the update. Moreover, $y \in D'$, hence $y' \in D$. There are two possibilities:

- either the spin of y' was not zero in the initial configuration. Then there was an update at y' before the update at y , hence before time $t/2$, so since $y' \in D$, $y' \in E$.
- or the spin at y' was zero in the initial configuration. In this case, if there was no update at y' before time $t/2$, y' stayed at 0 during the whole time interval $[0, t/2]$. However $y' \in D$, so this is impossible by assumption. Therefore there was an update at y' before time $t/2$, which implies $y' \in E$.

Therefore $y' \in E$ in both cases, which allows to add a site to the path and ends the proof of lemma 5.8. \square

5.3.2 Proving the origin stays at zero for a time $\Omega(t)$

In this section, we will use lemma 5.7 to prove the following result:

Lemma 5.9. *There exist constants $\delta = \delta(p) \in]0, 1[$, $\kappa = \kappa(p) > 0$, $c_4 = c_4(p) > 0$ and $C_4 = C_4(p) > 0$ such that for any $t \geq 0$, for any $\eta \in \{0, 1\}^{\mathbb{Z}^d}$ such that there exists $x \in \{-\lfloor \kappa t \rfloor, \dots, 0\}^d$ with $\eta(x) = 0$, $\mathbb{P}_\eta(\mathcal{T}_t(0) \leq \frac{1-p}{4}\delta^d t) \leq C_4 e^{-c_4 t}$.*

Proof. Let $t \geq 0$. Thanks to lemma 5.7, for any $\kappa > 0$ and $\eta \in \{0, 1\}^{\mathbb{Z}^d}$ such that there exists $x \in \{-\lfloor \kappa t \rfloor, \dots, 0\}^d$ with $\eta(x) = 0$, we have $\mathbb{P}_\eta(\mathcal{G}^c) \leq C_3 e^{-c_3 t}$ with $c_3, C_3 > 0$ depending only on p and κ . Therefore, it is enough to find $\delta = \delta(p) \in]0, 1[$, $\kappa = \kappa(p) > 0$, $C'_4 = C'_4(p) > 0$ and $c'_4 = c'_4(p) > 0$ depending only on p such that for $\eta \in \{0, 1\}^{\mathbb{Z}^d}$ we have $\mathbb{P}_\eta(\mathcal{G}, \mathcal{T}_t(0) \leq \frac{1-p}{4}\delta^d t) \leq C'_4 e^{-c'_4 t}$.

Moreover, for any $\delta \in]0, 1[$, $\kappa > 0$ and $\eta \in \{0, 1\}^{\mathbb{Z}^d}$, we have

$$\mathbb{P}_\eta \left(\mathcal{G}, \mathcal{T}_t(0) \leq \frac{1-p}{4}\delta^d t \right) \leq \sum_{y \in D} \mathbb{P}_\eta \left(\mathcal{T}_t(y) \geq \frac{1-p}{4}t, \mathcal{T}_t(0) \leq \frac{1-p}{4}\delta^d t \right). \quad (5.3)$$

For $y = (y_1, \dots, y_d) \in D$, we define the sequence of sites $y^{(0)} = y, y^{(1)} = (0, y_2, \dots, y_d), y^{(2)} = (0, 0, y_3, \dots, y_d), \dots, y^{(d)} = (0, \dots, 0)$. We then have

$$\begin{aligned} & \mathbb{P}_\eta \left(\mathcal{T}_t(y) \geq \frac{1-p}{4}t, \mathcal{T}_t(0) \leq \frac{1-p}{4}\delta^d t \right) \\ & \leq \sum_{i=1}^d \mathbb{P}_\eta \left(\mathcal{T}_t(y^{(i-1)}) \geq \delta^{i-1} \frac{1-p}{4}t, \mathcal{T}_t(y^{(i)}) \leq \frac{1-p}{4}\delta^i t \right). \end{aligned} \quad (5.4)$$

To deal with this expression, we are going to use the lemma 4.9 of [CFM15]. This lemma yields that there exist constants $\delta \in]0, 1[$ and $c > 0$ depending only on p such that for any $i \in \{1, \dots, d\}$, defining $I_i = \{(0, \dots, j, y_{i+1}, \dots, y_d) \mid j \in \{y_i + 1, \dots, 0\}\}$ if $y_i \neq 0$ and $I_i = \emptyset$ if $y_i = 0$,

$$\mathbb{P}_\eta(\mathcal{T}_t(y^{(i)}) \leq \delta \mathcal{T}_t(y^{(i-1)}) \mid \mathcal{F}_{t, I_i^c}) \leq \frac{1}{(p \wedge (1-p))^{|y_i|}} e^{-c \mathcal{T}_t(y^{(i-1)})}.$$

(Actually, this lemma was proven for a dynamics in \mathbb{N}^d , but the proof works in \mathbb{Z}^d with only minor modifications.)

Therefore we can set δ to the value given by [CFM15], and obtain the following (in the first equality we use that $\mathcal{T}_t(y^{(i-1)})$ is $\mathcal{F}_{t, y^{(i-1)} + (-\mathbb{N})^d}$ -measurable, hence \mathcal{F}_{t, I_i^c} -measurable):

$$\mathbb{P}_\eta \left(\mathcal{T}_t(y^{(i-1)}) \geq \delta^{i-1} \frac{1-p}{4}t, \mathcal{T}_t(y^{(i)}) \leq \frac{1-p}{4}\delta^i t \right)$$

$$\begin{aligned}
&\leq \mathbb{P}_\eta \left(\mathcal{T}_t(y^{(i-1)}) \geq \delta^{i-1} \frac{1-p}{4} t, \mathcal{T}_t(y^{(i)}) \leq \delta \mathcal{T}_t(y^{(i-1)}) \right) \\
&= \mathbb{E}_\eta \left(\mathbf{1}_{\{\mathcal{T}_t(y^{(i-1)}) \geq \delta^{i-1} \frac{1-p}{4} t\}} \mathbb{P}_\eta(\mathcal{T}_t(y^{(i)}) \leq \delta \mathcal{T}_t(y^{(i-1)}) | \mathcal{F}_{t, I_i^c}) \right) \\
&\leq \mathbb{E}_\eta \left(\mathbf{1}_{\{\mathcal{T}_t(y^{(i-1)}) \geq \delta^{i-1} \frac{1-p}{4} t\}} \frac{1}{(p \wedge (1-p))^{|y_i|}} e^{-c \mathcal{T}_t(y^{(i-1)})} \right) \\
&\leq \frac{1}{(p \wedge (1-p))^{|y_i|}} e^{-c \delta^{i-1} \frac{1-p}{4} t} \leq \frac{1}{(p \wedge (1-p))^{|y_i|}} e^{-c \delta^{d-1} \frac{1-p}{4} t}.
\end{aligned}$$

Moreover, since $y \in D$, $|y_i| \leq \lfloor 2d\kappa t \rfloor \leq 2d\kappa t$, so if we set $\kappa = \frac{c(1-p)\delta^{d-1}}{-16d \ln(p \wedge (1-p))}$ (which is positive and depends only on p), we obtain $(p \wedge (1-p))^{|y_i|} \geq e^{-\frac{c(1-p)\delta^{d-1}}{8} t}$, hence

$$\mathbb{P}_\eta \left(\mathcal{T}_t(y^{(i-1)}) \geq \delta^{i-1} \frac{1-p}{4} t, \mathcal{T}_t(y^{(i)}) \leq \frac{1-p}{4} \delta^i t \right) \leq e^{-\frac{c(1-p)\delta^{d-1}}{8} t},$$

so by (5.4)

$$\mathbb{P}_\eta \left(\mathcal{T}_t(y) \geq \frac{1-p}{4} t, \mathcal{T}_t(0) \leq \frac{1-p}{4} \delta^d t \right) \leq d e^{-\frac{c(1-p)\delta^{d-1}}{8} t},$$

therefore by (5.3)

$$\mathbb{P}_\eta \left(\mathcal{G}, \mathcal{T}_t(0) \leq \frac{1-p}{4} \delta^d t \right) \leq |D| d e^{-\frac{c(1-p)\delta^{d-1}}{8} t} = (\lfloor 2d\kappa t \rfloor + 1)^d d e^{-\frac{c(1-p)\delta^{d-1}}{8} t}$$

with $\frac{c(1-p)\delta^{d-1}}{8} > 0$ depending only on p and κ depending only on p , so we get a suitable bound on $\mathbb{P}_\eta(\mathcal{G}, \mathcal{T}_t(0) \leq \frac{1-p}{4} \delta^d t)$. \square

5.3.3 Ending the proof of theorem 5.2

Let ν a measure on $\{0, 1\}^{\mathbb{Z}^d}$ satisfying (C), $t \geq 0$ and $f : \{0, 1\}^{\mathbb{Z}^d} \mapsto \mathbb{R}$ non constant with $\|f\|_\infty < \infty$. We denote $\mathcal{N}(\eta) = \{\exists x \in \{-\lfloor \kappa t \rfloor, \dots, 0\}^d, \eta(x) = 0\}$, where $\kappa = \kappa(p) > 0$ is given by lemma 5.9. We also denote $g = \frac{f - \mu(f)}{\|f - \mu(f)\|_\infty}$. Then

$$\begin{aligned}
&\int_{\{0,1\}^{\mathbb{Z}^d}} |\mathbb{E}_\eta(f(\eta_t)) - \mu(f)| d\nu(\eta) = \|f - \mu(f)\|_\infty \int_{\{0,1\}^{\mathbb{Z}^d}} |\mathbb{E}_\eta(g(\eta_t))| d\nu(\eta) \\
&\leq 2\|f\|_\infty \left(\int_{\{0,1\}^{\mathbb{Z}^d}} |\mathbb{E}_\eta(g(\eta_t))| \mathbf{1}_{\mathcal{N}(\eta)^c} d\nu(\eta) + \int_{\{0,1\}^{\mathbb{Z}^d}} |\mathbb{E}_\eta(g(\eta_t))| \mathbf{1}_{\mathcal{N}(\eta)} d\nu(\eta) \right).
\end{aligned}$$

Moreover, since $\|\mu(g)\|_\infty = 1$ and ν satisfies (\mathcal{C}) , we can see that we have $\int_{\{0,1\}^{\mathbb{Z}^d}} |\mathbb{E}_\eta(g(\eta_t))| \mathbf{1}_{\mathcal{N}(\eta)^c} d\nu(\eta) \leq \nu(\mathcal{N}(\eta)^c) \leq Ae^{-a\kappa t}$ with $A, a > 0$ depending only on ν .

Therefore, to prove theorem 5.2, it is enough to find $\chi > 0$ depending only on p such that for any $f : \{0,1\}^{\mathbb{Z}^d} \mapsto \mathbb{R}$ non constant (if f is constant the theorem is trivially true) with support in $\Lambda(\chi t^{1/d})$ (which automatically gives $\|f\|_\infty < \infty$) and any $\eta \in \{0,1\}^{\mathbb{Z}^d}$ such that $\mathcal{N}(\eta), |\mathbb{E}_\eta(g(\eta_t))| \leq C'_1 e^{-c'_1 t}$ with $C'_1, c'_1 > 0$ depending only on p . For $\chi > 0$, we set such f and η . Since $\|g\|_\infty = 1$, for δ as in lemma 5.9 we have

$$|\mathbb{E}_\eta(g(\eta_t))| \leq \mathbb{P}_\eta \left(\mathcal{T}_t(0) \leq \frac{1-p}{4} \delta^d t \right) + \left| \mathbb{E}_\eta \left(\mathbf{1}_{\{\mathcal{T}_t(0) > \frac{1-p}{4} \delta^d t\}} g(\eta_t) \right) \right|.$$

In addition, since there is $x \in \{-\lfloor \kappa t \rfloor, \dots, 0\}^d$ such that $\eta(x) = 0$, by lemma 5.9 we have $\mathbb{P}_\eta(\mathcal{T}_t(0) \leq \frac{1-p}{4} \delta^d t) \leq C_4 e^{-c_4 t}$ with $C_4, c_4 > 0$ depending only on p . Consequently, it is enough to bound $|\mathbb{E}_\eta(\mathbf{1}_{\{\mathcal{T}_t(0) > \frac{1-p}{4} \delta^d t\}} g(\eta_t))|$.

Writing $\Lambda = \Lambda(\chi t^{1/d})$ for short, we notice that the event $\{\mathcal{T}_t(0) > \frac{1-p}{4} \delta^d t\}$ is $\mathcal{F}_{t,(-\mathbb{N})^d}$ -measurable hence $\mathcal{F}_{t,\Lambda^c}$ -measurable, which implies

$$\left| \mathbb{E}_\eta \left(\mathbf{1}_{\{\mathcal{T}_t(0) > \frac{1-p}{4} \delta^d t\}} g(\eta_t) \right) \right| = \left| \mathbb{E}_\eta \left(\mathbf{1}_{\{\mathcal{T}_t(0) > \frac{1-p}{4} \delta^d t\}} \mathbb{E}_\eta(g(\eta_t) | \mathcal{F}_{t,\Lambda^c}) \right) \right|,$$

therefore

$$\begin{aligned} & \left| \mathbb{E}_\eta \left(\mathbf{1}_{\{\mathcal{T}_t(0) > \frac{1-p}{4} \delta^d t\}} g(\eta_t) \right) \right| \\ & \leq \frac{1}{\min_{\sigma \in \{0,1\}^\Lambda} \mu(\sigma)} \mathbb{E}_\eta \left(\mathbf{1}_{\{\mathcal{T}_t(0) > \frac{1-p}{4} \delta^d t\}} \sum_{\sigma \in \{0,1\}^\Lambda} \mu(\sigma) \mathbb{E}_{\sigma \cdot \eta} (g(\eta_t) | \mathcal{F}_{t,\Lambda^c}) \right), \end{aligned}$$

where $\sigma \cdot \eta$ is the configuration equal to σ in Λ and to η in Λ^c . Furthermore, the reasoning of equation (4.2) of [CFM15] and of the paragraphs around it yields that

$$\sum_{\sigma \in \{0,1\}^\Lambda} \mu(\sigma) \mathbb{E}_{\sigma \cdot \eta} (g(\eta_t) | \mathcal{F}_{t,\Lambda^c}) \leq e^{-\lambda \mathcal{T}_t(0)}$$

where λ is the *spectral gap* of the East dynamics in Λ where the spin of the origin is fixed at 0 and the other spins outside Λ are at 1 (see chapter 2 of [GZ02] for the definition of the spectral gap and part 2.4 of [CMRT08] for an introduction to the spectral gap in the particular context of kinetically constrained models). Moreover, one can use the argument of part 6.2.2 of [CFM16] on our Λ instead of on a cube to obtain that λ is bigger than the spectral gap λ' of the one-dimensional East dynamics in $\{1, \dots, d\lfloor \chi t^{1/d} \rfloor\}$ with the origin fixed at zero. To do that, one can use a forest instead of a

tree and apply the fact that the spectral gap of a product dynamics is the minimum of the spectral gaps of the component dynamics (theorem 2.5 of [GZ02]). Furthermore, equation (3.3) of [CFM16] yields that λ' is bigger than the spectral gap λ'' of the East dynamics in \mathbb{Z} , which depends only on p and is positive by the theorem 6.1 of [CMRT08].

Consequently, we have

$$\begin{aligned} \left| \mathbb{E}_\eta \left(\mathbf{1}_{\{\mathcal{T}_t(0) > \frac{1-p}{4}\delta^d t\}} g(\eta_t) \right) \right| &\leq \frac{1}{\min_{\sigma \in \{0,1\}^\Lambda} \mu(\sigma)} \mathbb{E}_\eta \left(\mathbf{1}_{\{\mathcal{T}_t(0) > \frac{1-p}{4}\delta^d t\}} e^{-\lambda'' \mathcal{T}_t(0)} \right) \\ &\leq \frac{1}{(p \wedge (1-p))^{|\Lambda|}} e^{-\lambda'' \frac{1-p}{4}\delta^d t}. \end{aligned}$$

Moreover, $|\Lambda| \leq (\chi t^{1/d} + 1)^d$ and we can suppose $\chi t^{1/d} \geq 1$, since if $\chi t^{1/d} < 1$, $|\Lambda|$ is empty and there is no non constant function with support in Λ . Therefore we get $|\Lambda| \leq (2\chi t^{1/d})^d = 2^d \chi^d t$. Now, if we set $\chi = \frac{1}{2} \left(\frac{\lambda''(1-p)\delta^d}{-8 \ln(p \wedge (1-p))} \right)^{1/d}$, χ is positive and depends only on p , and we have $(p \wedge (1-p))^{|\Lambda|} \geq e^{-\frac{\lambda''(1-p)\delta^d}{8} t}$, thus

$$\left| \mathbb{E}_\eta \left(\mathbf{1}_{\{\mathcal{T}_t(0) > \frac{1-p}{4}\delta^d t\}} g(\eta_t) \right) \right| \leq e^{-\frac{\lambda''(1-p)\delta^d}{8} t}$$

with $\frac{\lambda''(1-p)\delta^d}{8}$ positive depending only on p , which ends the proof of theorem 5.2. \square

5.4 Proof of corollary 5.4

This proof is inspired from the proof of the lemma A.3 of [CFM16].

Let ν a measure on $\{0,1\}^{\mathbb{Z}^d}$ satisfying (\mathcal{C}) , χ as in the theorem 5.2, $t \geq 0$, $x \in \Lambda(\chi t^{1/d})$. For any $\eta \in \{0,1\}^{\mathbb{Z}^d}$, we have

$$\begin{aligned} \mathbb{E}_\eta(\eta_t(x)) &= \mathbb{E}_\eta(\eta_t(x) | \tau_x \leq t) \mathbb{P}_\eta(\tau_x \leq t) + \mathbb{E}_\eta(\eta_t(x) | \tau_x > t) \mathbb{P}_\eta(\tau_x > t) \\ &= p \mathbb{P}_\eta(\tau_x \leq t) + \eta(x) \mathbb{P}_\eta(\tau_x > t) = p - p \mathbb{P}_\eta(\tau_x > t) + \eta(x) \mathbb{P}_\eta(\tau_x > t) \end{aligned}$$

since if $\tau_x \leq t$, $\eta_t(x)$ is a Bernoulli random variable of parameter p . Therefore,

$$|\mathbb{E}_\eta(\eta_t(x)) - p| = |\eta(x) - p| \mathbb{P}_\eta(\tau_x > t) \geq (p \wedge (1-p)) \mathbb{P}_\eta(\tau_x > t),$$

and we deduce

$$\begin{aligned} F_{\nu,x}(t) &= \mathbb{P}_\nu(\tau_x > t) = \int_{\{0,1\}^{\mathbb{Z}^d}} \mathbb{P}_\eta(\tau_x > t) d\nu(\eta) \\ &\leq \frac{1}{p \wedge (1-p)} \int_{\{0,1\}^{\mathbb{Z}^d}} |\mathbb{E}_\eta(\eta_t(x)) - p| d\nu(\eta) \leq \frac{1}{p \wedge (1-p)} C_1 e^{-c_1 t} \end{aligned}$$

by theorem 5.2 with $C_1 > 0$ and $c_1 > 0$ depending only on p and ν . \square

Bibliography

- [AD02] David Aldous and Persi Diaconis. The asymmetric one-dimensional constrained Ising model: rigorous results. *Journal of statistical physics*, 107(5-6):945–975, 2002.
- [ADP01] Amine Asselah and Paolo Dai Pra. Quasi-stationary measures for conservative dynamics in the infinite lattice. *Annals of probability*, 29(4):1733–1754, 2001.
- [AL88] Michael Aizenman and Joel L. Lebowitz. Metastability effects in bootstrap percolation. *Journal of physics A: mathematical and general*, 21(19):3801, 1988.
- [Bak06] Dominique Bakry. Functional inequalities for Markov semi-groups. In *Probability measures on groups: recent directions and trends*, pages 91–147. Tata Institute of Fundamental Research, 2006.
- [BB11] Ludovic Berthier and Giulio Biroli. Theoretical perspective on the glass transition and amorphous materials. *Reviews of modern physics*, 83(2):587–645, 2011.
- [BBPS16] Paul Balister, Béla Bollobás, Michał Przykucki, and Paul Smith. Subcritical \mathcal{U} -bootstrap percolation models have non-trivial phase transitions. *Transactions of the American Mathematical Society*, 386:7385–7411, 2016.
- [BCM⁺13] Oriane Blondel, Nicoletta Cancrini, Fabio Martinelli, Cyril Roberto, and Cristina Toninelli. Fredrickson-Andersen one spin facilitated model out of equilibrium. *Markov processes and related fields*, 19(3):383–406, 2013.
- [BDCMS17] Béla Bollobás, Hugo Duminil-Copin, Robert Morris, and Paul Smith. The sharp threshold for the Duarte model. *Annals of probability*, 45(6B):4222–4272, 2017.

- [BDCMSar] Béla Bollobás, Hugo Duminil-Copin, Robert Morris, and Paul Smith. Universality of two-dimensional critical cellular automata. *Proceedings of the London Mathematical Society*, to appear.
- [BDT19] Oriane Blondel, Aurélia Deshayes, and Cristina Toninelli. Front evolution of the Fredrickson-Andersen one spin facilitated model. *Electronic journal of probability*, 24:32, 2019.
- [BG05] Ludovic Berthier and Juan P. Garrahan. Numerical study of a fragile three-dimensional kinetically constrained model. *The journal of physical chemistry B*, 109(8):3578–3585, 2005.
- [Blo13] Oriane Blondel. Front progression in the East model. *Stochastic processes and their applications*, 123(9):3430–3465, 2013.
- [BSU15] Béla Bollobás, Paul Smith, and Andrew Uzzell. Monotone cellular automata in a random environment. *Combinatorics, probability and computing*, 24(4):687–722, 2015.
- [CDG01] Fan Chung, Persi Diaconis, and Ronald Graham. Combinatorics for the East model. *Advances in applied mathematics*, 27(1):192–206, 2001.
- [CFM14] Paul Chleboun, Alessandra Faggionato, and Fabio Martinelli. Time scale separation and dynamic heterogeneity in the low temperature East model. *Communications in mathematical physics*, 328(3):955–993, 2014.
- [CFM15] Paul Chleboun, Alessandra Faggionato, and Fabio Martinelli. Mixing time and local exponential ergodicity of the East-like process in \mathbb{Z}^d . *Annales de la faculté des sciences de Toulouse*, 24(4):717–743, 2015.
- [CFM16] Paul Chleboun, Alessandra Faggionato, and Fabio Martinelli. Relaxation to equilibrium of generalized East processes on \mathbb{Z}^d : renormalization group analysis and energy-entropy competition. *Annals of probability*, 44(3):1817–1863, 2016.
- [CMRT08] Nicoletta Cancrini, Fabio Martinelli, Cyril Roberto, and Cristina Toninelli. Kinetically constrained spin models. *Probability theory and related fields*, 140(3-4):459–504, 2008.

- [CMRT09] Nicoletta Cancrini, Fabio Martinelli, Cyril Roberto, and Cristina Toninelli. Facilitated spin models : recent and new results. In *Methods of contemporary mathematical statistical physics*, pages 1–34. Springer, 2009.
- [CMST10] Nicoletta Cancrini, Fabio Martinelli, Roberto H. Schonmann, and Cristina Toninelli. Facilitated oriented spin models: some non equilibrium results. *Journal of statistical physics*, 138(6):1109–1123, 2010.
- [DS88] Richard Durrett and Roberto H. Schonmann. Large deviations for the contact process and two dimensional percolation. *Probability theory and related fields*, 77(4):583–603, 1988.
- [Dua89] José A.M.S. Duarte. Simulation of a cellular automat with an oriented bootstrap rule. *Physica A*, 157(3):1075–1079, 1989.
- [Dur84] Richard Durrett. Oriented percolation in two dimensions. *Annals of probability*, 12(4):999–1040, 1984.
- [FA84] Glenn H. Fredrickson and Hans C. Andersen. Kinetic Ising model of the glass transition. *Physical review letters*, 53:1244, 1984.
- [FMRT13] Alessandra Faggionato, Fabio Martinelli, Cyril Roberto, and Cristina Toninelli. The East model: recent results and new progresses. *Markov processes and related fields*, 19(3):407–452, 2013.
- [GLM15] Shirshendu Ganguly, Eyal Lubetzky, and Fabio Martinelli. Cut-off for the East process. *Communications in mathematical physics*, 335(3):1287–1322, 2015.
- [GST11] Juan P. Garrahan, Peter Sollich, and Cristina Toninelli. Kinetically constrained models. In *Dynamical heterogeneities in glasses, colloids, and granular media*. Oxford University Press, 2011.
- [GZ02] Alice Guionnet and Boguslaw Zegarlinski. Lectures on logarithmic Sobolev inequalities. In *Séminaire de probabilités XXXVI*, pages 1–134. Springer, 2002.
- [Har60] Theodore E. Harris. A lower bound for the critical probability in a certain percolation process. *Proceedings of the Cambridge Philosophical Society*, 56(1):13–20, 1960.

- [Har18] Ivailo Hartarsky. \mathcal{U} -bootstrap percolation: critical probability, exponential decay and applications. *arXiv:1806.11405*, 2018.
- [HM18] Ivailo Hartarsky and Tamás Róbert Mezei. Complexity of 2D bootstrap percolation difficulty: Algorithm and NP-hardness. *arXiv:1809.01525*, 2018.
- [HMT19a] Ivailo Hartarsky, Laure Marêché, and Cristina Toninelli. Universality for critical kinetically constrained models: infinite number of stable directions. *arXiv:1904.09145*, 2019.
- [HMT19b] Ivailo Hartarsky, Fabio Martinelli, and Cristina Toninelli. Universality for critical kinetically constrained models: finite number of stable directions. *In preparation*, 2019.
- [Hol03] Alexander E. Holroyd. Sharp metastability threshold for two-dimensional bootstrap percolation. *Probability theory and related fields*, 125(2):195–224, 2003.
- [JE91] Josef Jäckle and Siegfried Eisinger. A hierarchically constrained kinetic Ising model. *Zeitschrift für physik B condensed matter*, 84(1):115–124, 1991.
- [Jon96] Charles H. Jones. Generalized hockey stick identities and N -dimensional blockwalking. *Fibonacci quarterly*, 34(3):280–288, 1996.
- [KGC13] Aaron S. Keys, Juan P. Garrahan, and David Chandler. Calorimetric glass transition explained by hierarchical dynamic facilitation. *Proceedings of the National Academy of Sciences of the United States of America*, 110(12):4482–4487, 2013.
- [Lig85] Thomas M. Liggett. *Interacting particle systems*, volume 276 of *Grundlehren der mathematischen Wissenschaften, A series of comprehensive studies in mathematics*. Springer-Verlag, 1985.
- [LMS⁺07] Sébastien Léonard, Peter Mayer, Peter Sollich, Ludovic Berthier, and Juan P. Garrahan. Non-equilibrium dynamics of spin facilitated glass models. *Journal of statistical mechanics: theory and experiment*, page 07017, 2007.
- [Mar99] Fabio Martinelli. *Lectures on Glauber dynamics for discrete spin models* in *Lectures on Probability Theory and Statistics*, volume 1717 of *Lecture Notes in Mathematics*, pages 93–191. Springer-Verlag, 1999.

- [Mar17] Laure Marêché. Combinatorics for general kinetically constrained spin models. *arXiv:1707.06924*, 2017.
- [Mar19a] Laure Marêché. Exponential convergence to equilibrium for the d -dimensional East model. *arXiv:1905.00765*, 2019.
- [Mar19b] Laure Marêché. Exponential convergence to equilibrium in supercritical kinetically constrained models at high temperature. *arXiv:1907.05844*, 2019.
- [MMT19] Fabio Martinelli, Robert Morris, and Cristina Toninelli. Universality results for kinetically constrained spin models in two dimensions. *Communications in mathematical physics*, 369(2):761–809, 2019.
- [MMTar] Laure Marêché, Fabio Martinelli, and Cristina Toninelli. Exact asymptotics for Duarte and supercritical rooted kinetically constrained models. *Annals of probability*, to appear.
- [Mor17a] Robert Morris. Bootstrap percolation, and other automata. *European journal of combinatorics*, 66:250–263, 2017.
- [Mor17b] Robert Morris. *Monotone cellular automata* in *Surveys in Combinatorics 2017*, volume 440 of *London Mathematical Society Lecture Note Series*, chapter 7, pages 312–371. Cambridge University Press, 2017.
- [Mou95] Thomas Mountford. Critical length for semi-oriented bootstrap percolation. *Stochastic processes and their applications*, 56(2):185–205, 1995.
- [MT19] Fabio Martinelli and Cristina Toninelli. Towards a universality picture for the relaxation to equilibrium of kinetically constrained models. *Annals of probability*, 47(1):324–361, 2019.
- [MV19] Thomas Mountford and Glauco Valle. Exponential convergence for the Fredrickson-Andersen one spin facilitated model. *Journal of theoretical probability*, 32(1):282–302, 2019.
- [RMJ92] Johannes Reiter, Franz Mauch, and Josef Jäckle. Blocking transitions in lattice spin models with directed kinetic constraints. *Physica A: statistical mechanics and its applications*, 184(3-4):458–476, 1992.

- [RS73] Michael Reed and Barry Simon. *Methods of modern mathematical physics: functional analysis*. Academic Press, 1973.
- [RS03] Felix Ritort and Peter Sollich. Glassy dynamics of kinetically constrained models. *Advances in physics*, 52(4):219–342, 2003.
- [SE99] Peter Sollich and Martin Evans. Glassy time-scale divergence and anomalous coarsening in a kinetically constrained spin chain. *Physical review letters*, 83:3238, 1999.
- [SE03] Peter Sollich and Martin Evans. Glassy dynamics in the asymmetrically constrained kinetic Ising chain. *Physical Review E*, 68(3):031504, 2003.
- [Sta11] Richard P. Stanley. *Enumerative combinatorics: Volume 1*. Cambridge University Press, 2nd edition, 2011.
- [Swa17] Jan M. Swart. A course in interacting particle systems. *arXiv:1703.10007v1*, 2017.
- [VB11] Anja Voss-Böhme. On the core property of the cylinder functions class in the construction of interacting particle systems. *Kybernetika*, 47(6):944–954, 2011.