



**HAL**  
open science

# Techno-functional properties of fractions produced by a biorefinery scheme

Faber Ariel Espinosa Pardo

► **To cite this version:**

Faber Ariel Espinosa Pardo. Techno-functional properties of fractions produced by a biorefinery scheme. Other. Université de Bordeaux, 2020. English. NNT : 2020BORD0205 . tel-03116389

**HAL Id: tel-03116389**

**<https://theses.hal.science/tel-03116389>**

Submitted on 20 Jan 2021

**HAL** is a multi-disciplinary open access archive for the deposit and dissemination of scientific research documents, whether they are published or not. The documents may come from teaching and research institutions in France or abroad, or from public or private research centers.

L'archive ouverte pluridisciplinaire **HAL**, est destinée au dépôt et à la diffusion de documents scientifiques de niveau recherche, publiés ou non, émanant des établissements d'enseignement et de recherche français ou étrangers, des laboratoires publics ou privés.

THÈSE PRÉSENTÉE  
POUR OBTENIR LE GRADE DE  
**DOCTEUR DE**  
**L'UNIVERSITÉ DE BORDEAUX**

ÉCOLE DOCTORALE DES SCIENCES CHIMIQUES

SPÉCIALITÉ : Génie des procédés

Par Faber Ariel ESPINOSA PARDO

**Propriétés techno-fonctionnelles des fractions  
produites par bioraffinerie**

Sous la direction de : Pascale SUBRA-PATERNAULT  
Co-directrice : Christelle HARSCOAT-SCHIAVO

Soutenue le 30 Novembre 2020

Membres du jury :

M. PONTALIER, Pierre-Yves	Maître de Conférences, Toulouse INP	Rapporteur
M. LECOMTE, Jérôme	Chercheur, CIRAD	Rapporteur
Mme. CABANNE, Charlotte	Maître de Conférences, Bordeaux INP	Examineur
Mme. VALLIÈRES, Cécile	Professeur, Université de Lorraine	Examineur
M. LANOISELLÉ, Jean-Louis	Professeur, Université de Bretagne Sud	Président du jury
M. LE NÔTRE, Jérôme	Responsable Innovation, SAS PIVERT	Invité
Mme SUBRA-PATERNAULT, Pascale	Directrice de recherche, CNRS	Directrice de thèse
Mme HARSCOAT-SCHIAVO, Christelle	Chargée de recherche, CNRS	Co-directrice de thèse

## **Propriétés techno-fonctionnelles des fractions produites par bioraffinerie**

Le concept de bioraffinerie désigne le procédé de transformation de la biomasse en divers produits commercialisables et en énergie, l'accumulation d'agro-résidus étant ainsi significativement réduite. Ce travail propose un processus de bioraffinerie du germe de maïs et du tourteau de pressage de noix. Pour le germe de maïs, le procédé comporte une première étape d'extraction d'huile pour laquelle différentes méthodes ont été mises en œuvre, suivie de l'extraction des protéines et de l'évaluation du potentiel stabilisant des résidus solides (émulsions de Pickering). Il a été montré que la méthode d'extraction d'huile influençait les fonctionnalités (solubilité, capacité d'absorption d'eau, propriétés moussantes et émulsifiantes) des protéines et que les farines de germe de maïs étaient des agents stabilisants d'émulsions huile dans eau (H/E) performants. Pour le tourteau de noix, source d'huile et de composés phénoliques antioxydants, le travail s'est focalisé sur l'extraction assistée par ultrasons de composés phénoliques du tourteau deshuilé et l'évaluation des capacités émulsifiantes des résidus solides. Les extraits ont montré une forte capacité à piéger les radicaux libres et les résidus solides ont permis de fabriquer des émulsions H/E fines très stables. L'extraction assistée par ultrasons a également été appliquée à l'extraction des composés phénoliques d'un troisième co-produit, le marc de raisin. Les paramètres statistiquement influents ont été identifiés pour les deux matrices.

**Mots clés** : Émulsion, agents tensio-actifs, co-produits, extraction, protéines, polyphénols

---

## **Techno-functional properties of fractions produced by a biorefinery scheme**

The concept of biorefinery has emerged as an industrial facility where biomass is transformed into a wide range of marketable products and energy, and the accumulation of agro-residues is significantly reduced. This work proposed a biorefinery scheme from corn germ and walnut press-cake as by-products. For corn germ, the scheme involved a first step of oil recovery by different methods followed by protein extraction while solid residues were assessed for stabilizing emulsions (Pickering emulsions). It was demonstrated that protein functionalities (such as solubility, water absorption, foaming and emulsifying capacities) were influenced by oil extraction method, and that corn germ meals showed high capacity to stabilize oil-in-water emulsions. For walnut press-cake, a source of oil and phenolic antioxidants, the scheme focused on ultrasound assisted extraction of phenolics from the defatted cake, and the stabilizing ability of the residue particles. Extracts exhibited a high capacity of scavenging free radicals (DPPH) and walnut cake particles allowed to fabricate highly stable oil-in-water emulsions with fine droplets (1-2  $\mu\text{m}$ ). Ultrasound assisted extraction was also applied to recover phenolics from a third by-product that was a grape pomace. Influential parameters of extraction were statistically identified for both matrices with trends positively modeled by second-order polynomial equations.

**Keywords** : Emulsion, surface-active agents, by-products, extraction, proteins, polyphenols.

---

**Institut de Chimie et Biologie des Membranes et des nano-objets**

UMR 5248. Allée geoffroy Saint Hilaire, B14, 33600 Pessac

## **Acknowledgments**

Throughout the writing of this dissertation, I have received a great deal of support and assistance.

Firstly, I would like to express my sincere gratitude to my supervisors, Christelle HARSCOAT-SCHIAVO and Pascale SUBRA-PATERNAULT, whose expertise was invaluable in formulating the research questions and methodology. Your insightful feedback pushed me to sharpen my thinking and brought my work to a higher level. Christelle thank you also for your help in my adaptation to french life and the personal support.

Besides my advisors, I would like to thank the rest of my thesis committee: Dr. Jérôme LECOMTE, Dr. Pierre-Yves PONTALIER, Dr. Charlotte CABANNE, Prof. Cécile VALLIÈRES, Prof. Jean-Louis LANOISELLÉ and Dr. Jérôme LE NÔTRE for their insightful comments and encouragement, but also for the interesting scientific discussion which incited me to widen my research from various perspectives.

I would like to thank the CLIP'IN permanent members, Raphaëlle SAVOIRE, Julien MONTEIL, Maud CANSELL and Fernando LEAL-CALDERON for their scientific advice and for assisting me with many experiments. Thanks also to Celine and Dominique for their technical support.

My sincere thanks also goes to my lovely wife and colleague Pilar GARCIA who has been my support and inspiration during all this time... Your smile makes my life happier every day. I am also very grateful to my colleagues Ghita, Fatma, Manon, Wafa, Cécile, Esther, etc. for their friendship and support. Thanks to Elie, Laurent, Meilin, Chaminah for their internship work.

To all my family, especially my siblings and parents Amparo and Ariel, thank you very much for always believing in me and supporting me in every dream. Thank you grandma Olga for your love. Grandma Alicia you inspire me and enlighten my way !

I finally want to thank COLFUTURO and MINCIENCIAS from my country, Colombia, for granting my scholarship.

## Table of Contents

Résumé étendu .....	8
Introduction.....	20
<b>Chapter I: LITERATURE REVIEW .....</b>	<b>25</b>
1. Biorefinery concept.....	25
2. Vegetable crops, agro-residues and valuable components .....	31
2.1. Vegetable oils.....	32
2.2. Protein rich meals or vegetable protein extracts .....	37
2.2.1. Solubility of vegetable proteins .....	41
2.2.2. Water Absorption Capacity (WAC) of vegetable proteins .....	43
2.2.3. Emulsifying activity (EA) of vegetable proteins .....	45
2.3. Polyphenol-rich extracts .....	47
2.4. Lignocellulosic fibers for obtaining energy and renewable fuels .....	51
2.5. Use of agricultural residues under a holistic approach - Pickering emulsion.....	53
2.5.1. Main concepts of Pickering emulsions .....	54
2.5.2. Functional properties of Pickering emulsion – Antioxidant effect.....	58
3. Technologies for extracting valuable components .....	61
3.1. Convectional extraction .....	61
3.1.1. Maceration extraction .....	68
3.1.2. Soxhlet extraction .....	69
3.2. Extraction intensification techniques.....	70
3.2.1. Ultrasound Assisted Extraction (UAE).....	72
3.2.2. Supercritical Fluid Extraction (SFE) .....	74
3.2.3. Other intensification techniques .....	77
4. Examples of biorefineries .....	78
5. Conclusion and addressed topics .....	82
<b>Chapter II: MATERIALS AND METHODS .....</b>	<b>101</b>
1. Raw materials.....	101
1.1. Corn germ .....	101
1.2. Walnut press-cake.....	102
1.3. Grape pomace .....	103
1.4. Chemicals and reagents.....	104
2. Methods.....	104
2.1. Characterization of raw materials .....	104
2.1.1. Moisture .....	104
2.1.2. Ash content .....	104
2.1.3. Lipid content .....	105

2.1.4.	Protein content .....	105
2.1.5.	Carbohydrate content .....	106
2.1.6.	Particle size characterization.....	107
2.2.	Recovery of valuable fractions from by-products .....	107
2.2.1.	Oils.....	107
2.2.1.1.	Conventional solid-liquid extraction by organic solvents .....	107
2.2.1.2.	Supercritical Fluid Extraction (SFE) .....	108
2.2.2.	Proteins .....	110
2.2.2.1.	Protein extraction .....	110
2.2.2.2.	Purification of protein extracts (Desalting step) .....	112
2.2.3.	Polyphenol-rich extracts .....	114
2.3.	Pickering emulsions stabilized plant particles .....	117
2.3.1.	Stabilized by corn germ particles.....	117
2.3.2.	Stabilized by walnut particles .....	118
2.4.	Analytical methods for characterizing plant fractions .....	118
2.4.1.	Oil characterization.....	118
2.4.1.1.	Fatty acid composition.....	118
2.4.1.2.	Total phenolic content (TPC).....	119
2.4.2.	Protein extract composition and functionalities.....	120
2.4.2.1.	Protein content and extraction yield .....	120
2.4.2.2.	Molecular weight profile (SDS-PAGE).....	120
2.4.2.3.	Protein solubility profile in water .....	121
2.4.2.4.	Water Absorption Capacity (WAC).....	122
2.4.2.5.	Foaming properties .....	122
2.4.2.6.	Emulsifying capacity .....	123
2.4.2.6.1.	Measurement of droplet size by laser diffraction .....	123
2.4.2.6.2.	Microscope observations .....	125
2.4.3.	Characterization of polyphenol-rich extracts.....	125
2.4.3.1.	Free radical scavenging activity by DPPH method .....	125
2.4.3.2.	Quantification of ellagic acid.....	126
2.4.3.3.	Determination of total anthocyanins.....	126
2.4.4.	Characterization of Pickering emulsions .....	127
2.4.4.1.	Droplet size measurement and microscope observations .....	127
2.4.4.2.	Oxidation of emulsified linseed oil.....	128
2.4.4.2.1.	Conjugated dienes (CD) measurement .....	129
2.4.4.2.2.	Peroxide value (PV) determination.....	129
2.5.	Statistical analysis.....	130

<b>Chapter III. Corn germ biorefinery, from oil and protein extractions to solid particle ability to stabilize emulsions</b> .....	134
1. Introduction.....	134
2. Material composition and particle characterization.....	136
3. Oil recovery and characterization .....	138
4. Protein recovery and functionality.....	141
4.1. Protein content of extracts and protein extraction yield .....	141
4.2. Molecular weight distribution: SDS-PAGE.....	144
4.3. Functional properties of protein extracts .....	145
4.3.1. Protein solubility.....	145
4.3.2. Water Absorption Capacity (WAC).....	147
4.3.3. Foaming Capacity (FC) and Foaming Stability (FS).....	149
4.3.4. Emulsifying Capacity.....	152
4.4. Influence of protein extraction and purification methods.....	158
5. Pickering emulsion stabilized by corn germ particles .....	162
6. Conclusion and perspectives.....	168
<b>Chapter IV: Recovery of valuable fractions from walnut press-cake and stabilization of emulsions by walnut particles</b> .....	175
1. Introduction.....	175
2. Material composition .....	177
3. Oil recovery and characterization .....	178
4. Ultrasound assisted extraction of polyphenols from defatted cake .....	181
4.1. Total Phenolic Content (TPC) .....	183
4.2. Extraction of ellagic acid .....	186
4.3. Free radical scavenging activity (DPPH).....	189
5. Pickering emulsions.....	190
5.1. Physical stability .....	192
5.2. Oxidative stability of dispersed oil .....	199
6. Conclusion and perspectives.....	206
<b>Chapter V: Recovery of polyphenol extracts from grape pomace by ultrasound assisted extraction</b> .....	215
1. Introduction.....	215
2. Ultrasound assisted extraction of polyphenols from grape pomace .....	215
2.1. Total Phenolic Content (TPC) .....	217
2.2. Total Anthocyanin content (TA).....	221
2.3. Free radical scavenging activity (DPPH).....	223
3. Conclusion and perspectives.....	227
<b>General conclusion and perspectives</b> .....	233

## *Dissemination of the results*

### **Scientific articles:**

- F.A. Espinosa-Pardo, R. Savoire, P. Subra-Paternault, C. Harscoat-Schiavo., 2020. Oil and protein recovery from corn germ: Extraction yield, composition and protein functionality. *Food Bioprod. Process.*, 120, 131–142.

- M.D.P Garcia-Mendoza, F.A. Espinosa-Pardo, R. Savoire, C. Harscoat-Schiavo, M. Cansell, P. Subra-Paternault., 2020. Improvement of the oxidative stability of camelina oil by enrichment with phospholipid-quercetin formulations. *Food Chem*, Accepted on September 25<sup>th</sup> 2020.

### **Poster and oral presentations:**

- 24<sup>th</sup> International Congress of Chemical and Process Engineering CHISA 2020 (Prague, Czech Republic, August 23-27<sup>th</sup> 2020, postponed to 2021 due to coronavirus outbreak) – Oral presentation

- CBMN Scientific Day (Bordeaux, France, May 28<sup>th</sup> 2019) – Oral presentation

- 21<sup>ème</sup> Journée Scientifique de l'EDSC (Bordeaux, France, Jun 7<sup>th</sup> 2019) – Poster

- 12<sup>th</sup> Young Scientist Symposium (Bordeaux, France, May 23-24<sup>th</sup> 2019) – Poster

- 14<sup>th</sup> International Symposium on Biochromatography and Nanoseparations (Bordeaux, France, May 14-17<sup>th</sup> 2018) – Poster



## Résumé étendu

Les préoccupations actuelles liées à la croissance de la population mondiale, telles que la sécurité alimentaire, l'épuisement des combustibles fossiles et l'urgence d'atténuer le changement climatique, ont encouragé les innovations technologiques, sociales et politiques destinées à accroître l'efficacité de l'utilisation des ressources naturelles (Holtinger et al., 2014) de façon à réduire la pression sur les matières premières et sur l'environnement. (Tilman et al., 2009). En ce sens, les concepts de bioraffinerie et d'économie durable ont émergé, visant à faire évoluer l'économie linéaire actuelle vers une approche d'économie circulaire qui représente un système basé sur le recyclage et la réutilisation des matières premières tout en maintenant la capacité de restauration de la ressource naturelle (Venkata Mohan et al., 2019).

La biomasse constituée par les sous-produits agro-industriels a depuis plusieurs années attiré l'attention en raison de sa large disponibilité et de son applicabilité potentielle en tant que source durable d'énergie et de matériaux. La FAO a estimé la production de déchets agro-industriels dans le monde à plus de 1,3 milliard de tonnes chaque année, alors qu'Eurostat a estimé que plus de 56 millions de tonnes de déchets végétaux ont été générés en 2016 dans l'Union européenne (UE), ce qui peut engendrer des problèmes environnementaux d'entreposage ou de destruction. À l'inverse, la bioraffinerie apparaît comme une alternative industrielle où la biomasse peut être transformée en un large spectre de produits commercialisables et d'énergie (IEA Bioenergy 2009), intégrant souvent la notion de 'procédés intégrés de conversion' (Herrero & Ibañez, 2018) et de 'produits à haute valeur ajoutée' tels que biocarburants, protéines, lipides, fibres alimentaires pour les constituants majoritaires des agro-résidus végétaux, et antioxydants, huiles essentielles, pigments et autres pour les composés plus minoritaires. La valorisation des résidus agro-industriels permet ainsi de proposer des alternatives pour réduire l'impact environnemental de l'accumulation de biomasse, tout en générant des bénéfices économiques en fournissant des produits d'intérêt pour des applications alimentaires, chimiques ou pharmaceutiques.

L'élaboration d'un schéma de bioraffinage n'est pas une tâche simple car elle implique le développement d'une approche en cascade dans laquelle plusieurs procédés peuvent être conduits pour récupérer progressivement les différents types de produits ou de matériaux à partir d'un même agro-résidu. Chaque processus physique, chimique ou biochimique de la cascade est mené dans des conditions particulières, avec des rendements variables, et est donc

susceptible d'influencer la récupération du produit suivant. Il est donc crucial de considérer le schéma dans son ensemble et d'identifier les interactions entre les opérations unitaires, puisque les conditions optimales pour l'obtention d'un certain type de produits pourraient être nuisible pour d'autres qui sont destinés à être extraits ultérieurement.

En ce sens, les techniques d'extraction à utiliser sont très importantes. Dans une optique de développement durable, les techniques d'extraction doivent tenir compte non seulement du rendement d'extraction mais également de l'impact environnemental et de la consommation d'énergie. Des principes tels que i) utiliser des solvants alternatifs et principalement de l'eau ou des agro-solvants, ii) réduire la consommation d'énergie par la valorisation énergétique et l'utilisation de technologies innovantes, iii) réduire les opérations unitaires et favoriser des procédés sûrs, robustes et maîtrisés, iv) viser un extrait/produit non dénaturé et biodégradable indemne de contaminants, proposés par Herrero & Ibañez, (2018) dans le cas de bioraffinerie se retrouvent dans les principes d'eco-extraction proposés par Chemat et al. (2020). Dans ce contexte, les techniques d'intensification ont gagné en intérêt puisqu'elles permettent non seulement d'extraire les métabolites à valoriser des matrices végétales mais aussi d'intensifier les processus afin d'obtenir une efficacité d'extraction plus élevée et un extrait de meilleure qualité tout en réduisant le temps d'extraction, le nombre d'opérations unitaires, la consommation d'énergie, la quantité de solvant utilisé, l'impact environnemental, les coûts et la quantité de déchets générés (Perino & Chemat, 2019). Parmi les techniques d'intensification figurent l'extraction assistée par micro-ondes et/ou ultrasons, le champ électrique pulsé, l'extraction par fluides supercritiques et l'extraction par solvants pressurisés. Ces stratégies peuvent être adoptées pour améliorer les performances des procédés d'extraction, par exemple en fournissant de nouvelles sources d'énergie (ultrasons ou micro-ondes) (Martinez et al., 2020) ou en modifiant les propriétés physiques des solvants lorsqu'ils sont soumis à des conditions spécifiques de pression et de température. En ce qui concerne les produits, il existe différents produits à valeur ajoutée intéressants pour l'industrie alimentaire, pharmaceutique et chimique (huiles essentielles, protéines, lipides, fibres alimentaires, pigments, composés bioactifs, biocarburants, énergie, matériaux obtenus après modification chimique de l'agro-résidu), tous obtenus à partir de la grande et diversifiée biomasse que constituent des agro-résidus tels que feuilles, racines, tiges, écorces, bagasse, peaux de fruits et légumes, résidus de paille, tourteaux d'oléagineux issus de pressage, résidus de bois, etc.

Dans ce contexte, ce travail vise à proposer un schéma de bioraffinage pour récupérer des produits de valeur ajoutée tels que des huiles végétales, des protéines, des antioxydants et des stabilisants d'émulsion à partir de sous-produits tels que le germe de maïs, le tourteau de noix et le marc de raisin qui sont générés en région Nouvelle Aquitaine. Le fractionnement est basé sur l'utilisation de techniques conventionnelles d'extraction et/ou de techniques intensifiées comme les ultrasons ou le CO<sub>2</sub> supercritique. En outre, l'utilisation des sous-produits solides générés par la bioraffinerie comme ingrédient fonctionnel est également envisagée. Pour atteindre cet objectif, le manuscrit actuel est divisé en cinq chapitres comme suit. Il convient de mentionner que les *Chapitres III, IV et V* présentent des objectifs spécifiques en fonction du type d'agro-résidu à partir duquel les fractions à valeur ajoutée seront obtenues.

*Le Chapitre I* comprend une vaste revue de la littérature des principaux concepts et technologies impliqués dans l'effort de développement d'un schéma de bioraffinage. Les définitions, l'approche et les perspectives clés du concept de bioraffinerie sont détaillées sur la base de la littérature scientifique et des agences européennes. Les caractéristiques, les propriétés fonctionnelles et l'applicabilité des produits qui peuvent être obtenus dans le cadre d'un bioraffinage sont soigneusement décrites. Ces produits sont des huiles végétales, des protéines végétales, des fibres lignocellulosiques, des extraits riches en phénol et des stabilisants d'émulsion (émulsions de Pickering). Cette dernière application propose l'utilisation de résidus végétaux dans une approche holistique. Le principe et les avantages des techniques conventionnelles et nouvelles d'extraction de ces produits sont également largement décrits. Une attention particulière est accordée à l'extraction assistée par ultrasons et aux fluides supercritiques car ils peuvent être considérés comme des techniques intensifiées ou vertes. Les travaux les plus récents sur l'extraction menée dans le cadre d'un schéma de bioraffinerie à partir d'agro-résidus, sont présentés dans ce premier chapitre afin d'avoir un aperçu des principaux facteurs impliqués. Plusieurs exemples de schémas de bioraffinage issus de la littérature récente sont discutés afin de donner un aperçu des avantages et des principaux défis du développement de processus séquentiels en cascade dans le cadre d'une approche de bioraffinage. Ce dernier implique une intégration flexible et séquentielle de différents processus biologiques, chimiques et/ou thermiques visant à produire différents matériaux, biocarburants et biomolécules, etc. afin de maximiser les rendements de production et les revenus (Alibardi et al., 2020).

Le matériel et les méthodes utilisés pour atteindre l'objectif de ce travail sont détaillés au *Chapitre II*. Dans un premier temps, une description globale de l'anatomie, de l'aspect macroscopique ou du prétraitement appliqué aux matrices végétales utilisées à savoir germe de maïs, tourteau de noix et marc de raisin, est fournie. Les méthodes utilisées pour déterminer la composition de ces matières premières sont également décrites. Ensuite, les différentes méthodes d'extraction, les étapes de purification ou de concentration pour récupérer les différentes familles de produits sont décrites dans ce chapitre. Dans ce cadre, les méthodes d'extraction spécifiques à chaque famille (huile, protéines, polyphénols) sont détaillées. Les méthodes et les outils statistiques utilisés pour étudier plus spécifiquement l'influence des différents paramètres d'extraction des polyphénols à partir du tourteau de noix et de marc de raisin sont également présentés. En outre, la méthodologie utilisée pour produire une émulsion de Pickering à partir de particules de maïs et de noix est décrite. Enfin, les méthodes analytiques pour évaluer la composition et les propriétés fonctionnelles des produits/extraits récupérés sont soigneusement rapportées.

Les trois chapitres suivants du manuscrit correspondent aux résultats et discussion spécifiques.

*Le Chapitre III* est centré sur le développement d'un schéma de bioraffinage à partir de germe de maïs. Le germe de maïs résulte de la transformation locale du grain de maïs lors de la fabrication de farine et semoule de maïs. Ce résidu est intéressant pour le bioraffinage puisque la production de maïs en France est estimée à 12 millions de tonnes par an (FAOSTAT) et le germe, en tant que sous-produit, représente environ 13% du poids total de maïs en grains qui est transformé. De plus, le germe de maïs est considéré comme la principale source d'huile de maïs (18-41%) par rapport aux autres parties du grain et sa teneur en protéines varie de 12 à 21% en fonction des conditions météorologiques et de culture, des facteurs génétiques et de la méthode de séparation des germes (Navarro et al., 2016). De nos jours, le germe de maïs est principalement utilisé pour l'extraction d'huile ou pour l'alimentation animale.

L'objectif de ce chapitre est de proposer une cascade d'opérations visant à récupérer différentes fractions du germe de maïs (huile, protéines, résidu solide) en évaluant l'influence des conditions d'extraction de l'huile sur les étapes ultérieures du schéma de bioraffinage. Par conséquent, la première étape consistant à récupérer d'abord l'huile du germe de maïs est réalisée soit par techniques conventionnelles classiques (extraction par macération à l'hexane

à température ambiante et à 45 °C, extraction au Soxhlet à l'hexane et à l'éthanol) soit par CO<sub>2</sub> supercritique à 210 bar et 45 °C. Les tourteaux déshuilés ont ensuite été utilisés pour l'extraction des protéines par macération avec une solution saline de NaCl 0,1 M, suivie de la purification de l'extrait protéique par dialyse ou ultrafiltration. Après lyophilisation des différents extraits protéiques, l'évaluation de leur fonctionnalité a été réalisée. Pour cela, le profil de solubilité, la capacité d'absorption d'eau et les propriétés émulsifiantes et moussantes des extraits ont été évalués. De plus, la pureté (teneur en protéines) et le profil de poids moléculaire des protéines des extraits ont été déterminés. Enfin, divers résidus de germes de maïs (farines déshuilées et déprotéinisées) ont été étudiés pour leur capacité à stabiliser les émulsions huile-dans-eau 1:4 (émulsions de Pickering).

Les principaux résultats du *Chapitre III* ont montré que l'extraction de l'huile par l'hexane était une méthode efficace donnant 23,8 g d'huile/100 g de germe de maïs, mais le principal inconvénient de ce solvant est sa toxicité. L'extraction à l'éthanol par Soxhlet a donné l'huile présentant la plus forte teneur en composés phénoliques (1721 mg GAE/kg d'huile) en raison de la forte polarité de l'éthanol et de la température d'extraction élevée. L'extraction par fluide supercritique n'a donné qu'un deshuilage partiel (16,4 g d'huile/100 g de germe de maïs) en raison notamment de limitations opératoires. Néanmoins, l'huile obtenue a montré une teneur élevée en composés phénoliques (251,8 mg de GAE/kg d'huile). Une pression opératoire supérieure à 210 bars et des durées d'extraction plus importantes sont nécessaires pour obtenir un rendement plus élevé mais les protéines restantes pourraient en être affectées. Quel que soit le mode d'extraction, les huiles de maïs présentaient la même composition en acides gras, principalement des acides gras insaturés (> 80%) avec par ordre décroissant d'importance l'acide linoléique, suivi de l'acide oléique et de l'acide palmitique qui indiquent une possible utilisation en alimentation, applications cosmétiques et nutraceutiques.

Concernant la récupération des protéines, les extraits protéiques obtenus à partir de farines délipidées présentaient une teneur en protéines comprise entre 20% et 48%, la teneur maximale étant obtenue à partir de farine deshuilée par CO<sub>2</sub> supercritique. La farine deshuilée par Soxhlet éthanol a donné les extraits protéiques avec la plus faible teneur en protéines probablement en raison de la perte de solubilité des protéines après contact avec de l'éthanol à haute température (> 75 °C). En ce qui concerne l'évaluation des propriétés, tous ces extraits, excepté celui obtenu après traitement au Soxhlet éthanol, ont présenté une solubilité élevée dans l'eau en conditions alcalines. Les capacités moussantes et émulsifiantes étaient variables

probablement liées au degré de dépliement des protéines résultant du traitement (température, pression) subi par la farine lors de l'étape de deshuilage. Par exemple, l'extrait protéique de farine deshuilée par des fluides supercritiques a montré la meilleure capacité moussante (> 80%) et la meilleure stabilité (> 80%), et l'une des capacités d'absorption d'eau les plus élevées (2,3 g d'eau/g d'extrait sec) et une forte activité émulsifiante (231 m<sup>2</sup>/g de protéines). Bien que l'extraction au Soxhlet éthanol ait mis en évidence une dénaturation des protéines qui altérerait la solubilité, les protéines extraites par la suite présentaient une capacité d'absorption d'eau élevée (14 g d'eau/g de protéines) et une forte activité émulsifiante (246 m<sup>2</sup>/g de protéines). Les émulsions stabilisées par les différents extraits protéiques étaient stables pendant les 45 jours de stockage à 4°C, exceptée l'émulsion stabilisée par l'extrait protéique de farine délipidée par Soxhlet éthanol dont la stabilité était plus courte. La température, la pression ou le contact avec des solvants alcooliques peut engendrer une modification de structure des protéines notamment un dépliage et ainsi modifier la distribution des domaines hydrophiles et hydrophobes à la surface de la molécule et, par conséquent, influencer la fonctionnalité des protéines. Il a ainsi été observé que la méthode d'extraction de l'huile pouvait affecter les caractéristiques de l'huile mais aussi, de manière significative, la fonctionnalité et le rendement des protéines extraites ultérieurement. Concernant la méthode de purification des extraits protéiques (dessalage), la dialyse a conduit à des extraits de plus grande pureté protéiques que l'ultrafiltration. Enfin, les émulsions de Pickering huile-dans-eau fabriquées à partir de diverses particules de germes de maïs étaient stables 120 jours à 4°C, présentant des gouttelettes d'huile d'un diamètre allant de 1 à 15 µm, selon le traitement subi par les particules et la quantité de poudre utilisée. L'émulsion de Pickering avec les gouttelettes les plus fines (1 µm) a été obtenue en augmentant la quantité de particules dans la phase aqueuse de 2,5% à 10% massique. Ces résultats permettent également d'utiliser le germe de maïs dans une approche holistique en évitant l'extraction et la purification de composés spécifiques. Globalement, nous avons réussi à présenter un schéma complet de bioraffinage à partir de germes de maïs en obtenant des produits de valeur pour des applications alimentaires, pharmaceutiques, cosmétiques et chimiques.

*Le Chapitre IV* consistait à récupérer les extraits riches en huile et en polyphénols du tourteau de noix. Le tourteau est le résidu qui résulte de l'extraction de l'huile en pressant les cerneaux dans une presse à vis ou hydraulique. La production mondiale de noix a atteint environ 3,6 millions de tonnes en 2018 dont 11% en France (FAOSTAT). Une partie des noix est utilisée pour produire de l'huile, une huile aromatique de spécialité, essentiellement dans

des moulins artisanaux. Les quantités de tourteaux de pressage générées sont très importantes puisque le rendement massique en huile avoisine les 50%. Ces tourteaux représentent une source bon marché et riche en lipides restants (20-36%), protéines (30-42%), fibres alimentaires, minéraux et composés antioxydants tels que les polyphénols (Bakkalbasi et al., 2015). Le tourteau est souvent jeté ou seulement utilisé en alimentation animale ou épandage (Moghadam et al., 2020).

Dans ce chapitre, le tourteau de noix d'un moulin a d'abord été soumis à l'extraction d'huile par la méthode conventionnelle de Soxhlet en utilisant l'hexane comme solvant. Un autre tourteau de noix, provenant d'une autre huilerie artisanale, a été utilisé pour l'extraction d'huile par CO<sub>2</sub> supercritique. La farine deshuilée à l'hexane a ensuite été utilisée pour l'extraction assistée par ultrasons (UAE) des extraits riches en composés phénoliques, en utilisant des mélanges éthanol-eau comme solvants et différents rapports solide/solvant. Pour cela, une méthodologie de plan composite centré et de surface de réponse a été utilisée pour évaluer l'effet de cinq niveaux ( $-\alpha$ , -1, 0, +1,  $+\alpha$ ) de la puissance, du temps d'extraction et du cycle de fonctionnement sur l'extraction des composés phénoliques totaux, la teneur en acide ellagique et l'activité de piégeage des radicaux libres (DPPH) des extraits. Enfin, la capacité des particules de noix délipidées et déphénolisées par les UAE ou par macération, à stabiliser des émulsions de Pickering ainsi qu'à retarder l'oxydation de l'huile émulsionnée a été évaluée. La stabilité des émulsions fabriquées a été surveillée en mesurant la taille des gouttelettes d'huile pendant plusieurs jours de stockage à 4 °C, et la stabilité à l'oxydation de l'huile dispersée a été évaluée en surveillant la formation de diènes conjugués dans des conditions de chauffage accéléré (60 °C).

Les résultats ont montré qu'environ 37% du tourteau de noix est une huile qui peut être complètement récupérée par extraction conventionnelle au Soxhlet hexane ou partiellement récupérée (24% de l'huile totale contenue dans le second tourteau de noix) au moyen d'une extraction par fluide supercritique. L'huile récupérée par Soxhlet hexane était riche en acides gras polyinsaturés, principalement en oméga-6 (64,5%) et en oméga-3 (11,4%) qui présentent plusieurs bienfaits pour la santé. Après extraction de l'huile, le tourteau deshuilé s'est révélé être une source importante de composés phénoliques. Un mélange d'éthanol-eau à une proportion de 60:40 (v/v) a permis le rendement d'extraction le plus élevé des composés phénoliques en raison de la polarité élevée du solvant. Ces résultats étaient en accord avec plusieurs publications récentes (Bodoira et Maestri, 2020; Odabaş & Koca, 2016). L'utilisation

d'ultrasons pour l'extraction phénolique a permis d'obtenir un rendement d'extraction supérieur d'environ 26% par rapport à l'extraction par macération conventionnelle. L'extraction phénolique du tourteau de noix délipidé par UAE à un rapport solide/solvant de 1:13 variait peu (entre 10,3 et 13,4 mg GAE/g tourteau délipidé) avec les conditions opératoires. La méthodologie de surface de réponse a montré que plus la puissance, le cycle de fonctionnement et la durée d'extraction étaient élevés, plus le rendement d'extraction des polyphénols était élevé. D'autre part, le rapport solide/solvant a influencé de manière significative l'extraction phénolique. Par exemple, en augmentant le rapport solide/solvant de 1:13 à 1:200, le rendement d'extraction phénolique a été multiplié par 2,2. Cependant, des rapports solide/solvant élevés impliquent également l'utilisation d'une grande quantité de solvants et l'obtention d'extraits dilués, ce qui peut être gênant pour le schéma de bioraffinerie.

L'acide ellagique a été identifié comme l'un des principaux composés phénoliques des extraits de noix et s'est révélé fortement corrélé ( $R^2 = 0,90$ ,  $p < 0,05$ ) avec l'activité de piégeage des radicaux libres des extraits de noix (DPPH). Le modèle de prédiction de l'extraction de l'acide ellagique par ultrasons expliquait environ 80% des données expérimentales et montrait que les trois facteurs (puissance, temps et cycle de fonctionnement) influençaient de manière significative l'extraction de l'acide ellagique. Parmi les conditions évaluées, la puissance maximale (220 W), la durée (20 mn) et le cycle (40%) ont abouti à la teneur en composés phénoliques totaux (TPC) et en acide ellagique les plus élevées (13,2 mg de GAE/g et 2,11 mg/g respectivement). Les divers extraits riches en polyphénols obtenus par les UAE ont montré une capacité importante à piéger le radical libre 2,2-diphényl-1-picrylhydrazyle (DPPH) dans une gamme de 83-107  $\mu\text{mol}$  d'équivalent Trolox/g de tourteau. Néanmoins, il n'a pas été possible d'obtenir un bon modèle de prédiction qui corrèle la puissance des ultrasons, la durée d'extraction et le cycle de fonctionnement avec l'activité antioxydante des extraits. D'autre part, il convient de mentionner qu'une forte corrélation positive entre TPC et DPPH a été observée (coefficient de corrélation de Pearson 0,95,  $p < 0,05$ ).

En ce qui concerne l'utilisation de particules de noix pour stabiliser les émulsions huile-dans-eau, les poudres soit seulement délipidées soit délipidées puis déphénolisées (par macération) ont montré une performance élevée puisque de fines gouttelettes d'huile de 1 à 2  $\mu\text{m}$  ont été obtenues et stabilisées plusieurs semaines à 4 °C avec succès. De plus, les émulsions de Pickering stabilisées par des particules de noix à une concentration de 2,5% massique (par rapport à la phase aqueuse) étaient principalement monodisperses, ce qui est caractéristique de



l'émulsion de Pickering fabriquée au moyen de haute pression, et présentaient un faible crémage en raison de la formation d'un réseau de type gel. En revanche, la sonication des particules de noix a partiellement affecté leur fonctionnalité de stabilisation des gouttelettes d'huile, car une plus grande taille de gouttelettes et un indice d'uniformité moindre ont été observés dans l'émulsion stabilisée par des particules de noix deshuilées puis déphénolisées par extraction assistée par ultrasons, par rapport aux émulsions stabilisées par particules de noix non soumises à un traitement par ultrasons. L'adsorption des particules de noix à l'interface des gouttelettes d'huile a probablement également permis de diminuer le taux d'oxydation de l'huile de lin en fournissant une barrière stérique qui limite la diffusion de substances/molécules prooxydantes dans l'huile. Dans ce contexte, les particules de noix seulement délipidées ou délipidées et déphénolisées (à la fois par les UAE et par macération) ont présenté le même effet protecteur contre l'oxydation des lipides lorsque celle-ci a été évaluée dans une gamme de qualité alimentaire, c'est-à-dire des valeurs d'indice de peroxyde de l'huile inférieures à 15  $m_{eq}O_2/kg$ . Par conséquent, on peut affirmer que les composés antioxydants (phénoliques polaires) du tourteau de noix seulement délipidé n'ont pas joué un rôle clé pour inhiber l'oxydation lipidique des gouttelettes d'huile stabilisées par ces particules.

Le dernier chapitre de ce manuscrit (*Chapitre V*) étudie l'extraction de composés phénoliques de marc du raisin par extraction assistée par ultrasons. D'autres propriétés ou produits de valeur du marc de raisin n'ont pas pu être explorés dans le cadre du schéma de bioraffinage en raison des difficultés logistiques et sociales causées par l'épidémie de Covid-19.

Le marc de raisin se compose principalement de la peau, des tiges et des pépins qui restent après la transformation du vin et représente environ 20% de la masse totale de raisins traités (Hogervorst et al., 2017). Ce résidu est une source bon marché de molécules antioxydantes et de pigments naturels, en particulier les anthocyanes. Selon Hogervorst et al. (2017), le marc de raisin rouge, par exemple, peut contenir jusqu'à 9 kg de composés phénoliques par tonne. L'extraction assistée par ultrasons est également utilisée en raison de ses avantages dans l'extraction de composés naturels. Comme au *Chapitre IV*, une méthodologie de plan composite centré et surface de réponse a été utilisée pour évaluer l'effet de cinq niveaux ( $-\alpha$ ,  $-1$ ,  $0$ ,  $+1$ ,  $+\alpha$ ) de puissance, de durée d'extraction et de cycle de fonctionnement sur l'extraction des composés phénoliques totaux, la teneur en anthocyanes et l'activité de piégeage des radicaux libres (DPPH) des extraits. L'éthanol à 60% a également été utilisé comme solvant d'extraction selon les résultats précédents et les conclusions de

Drevelegka & Goula, (2020). Des essais préliminaires d'extraction phénolique du marc de raisin en utilisant de l'éthanol à 60% acidifié comme solvant ont également été réalisés.

Les principaux résultats du *Chapitre V* ont montré qu'un modèle polynomial a été obtenu pour prédire avec succès la teneur en composés phénoliques totaux, la teneur en anthocyanes et le piégeage des radicaux des extraits de raisin récupérés par extraction assistée par ultrasons dans différentes conditions. Théoriquement, l'extraction des composés phénoliques et anthocyanes et l'activité antioxydante des extraits peuvent être maximisées en augmentant la puissance des ultrasons, le cycle d'utilisation et la durée d'extraction. La cavitation produite par des ondes ultrasonores dans le solvant a pu perturber les parois cellulaires et faciliter la libération des composants de la matrice et a donc permis un rendement d'extraction plus élevé que l'extraction par macération conventionnelle. La teneur en composés phénoliques totaux variait entre 2,81 et 5,78 mg GAE/g de résidu humide, tandis que la teneur totale en anthocyanes variait de 7,8 à 22,1 mg M3-G/100 g de résidu humide. Ces valeurs sont inférieures à celles rapportées dans la littérature (Drevelegka & Goula, 2020; Bonfigli et al., 2017) probablement en raison des conditions de stockage de la matière première avant cette étude. De même que pour les extraits issus de la noix, l'activité antioxydante des extraits de marc de raisin était positivement corrélée avec le rendement d'extraction des composés phénoliques (coefficient de Pearson = 0,97) et variait entre 28,1 et 56,0  $\mu$ mol d'équivalent Trolox/g de résidu humide. Enfin, l'acidification du solvant d'extraction (éthanol 60% à 1% HCl (v/v)) a significativement augmenté le rendement d'extraction des composés phénoliques, passant de 5,78 à 10,5 mg GAE/g de résidu.

Enfin, on peut conclure que ce travail a proposé et développé avec succès des exemples de schémas de bioraffinerie à partir de résidus agricoles courants tels que le germe de maïs et le tourteau de noix, et a également commencé des explorations pour récupérer des produits à valeur ajoutée (polyphénols) à partir de marc de raisin. De plus, il a été démontré que lors d'extractions en cascade, les conditions d'extraction pour récupérer certains produits à partir de matrices végétales peuvent influencer de manière significative le rendement et la qualité d'autres produits extraits ultérieurement du même matériau. Les résidus agricoles se sont révélés être une source appropriée de coproduits à valeur ajoutée tels que l'huile, les protéines, les polyphénols et les stabilisants d'émulsion, qui peuvent générer des avantages économiques tout en favorisant une meilleure utilisation des ressources naturelles.

## Références

- Alibardi, L., Astrup, T.F., Asunis, F., Clarke, W.P., De Gioannis, G., Dessì, P., Lens, P.N.L., Lavagnolo, M.C., Lombardi, L., Muntoni, A., Pivato, A., Poletti, A., Pomi, R., Rossi, A., Spagni, A., Spiga, D., 2020. Organic waste biorefineries: Looking towards implementation. *Waste Manag.* 114, 274–286.
- Bakkalbasi, E., Meral, R., Dogan, I.S., 2015. Bioactive compounds, physical and sensory properties of cake made with walnut press-cake. *J. Food Qual.* 38, 422–430.
- Bodoira, R., Maestri, D., 2020. Phenolic compounds from nuts: Extraction, chemical profiles, and bioactivity. *J. Agric. Food Chem.* 68, 927–942.
- Bonfigli, M., Godoy, E., Reinheimer, M.A., Scenna, N.J., 2017. Comparison between conventional and ultrasound-assisted techniques for extraction of anthocyanins from grape pomace. Experimental results and mathematical modeling. *J. Food Eng.* 207, 56–72.
- Celiktas, M.S., Alptekin, F.M., 2017. Biorefinery concept : Current status and future prospects. *Int. Conf. Eng. Technol.* 1, 27-32.
- Chemat, F., Abert Vian, M., Fabiano-Tixier, A.-S., Nutrizio, M., Režek Jambrak, A., Munekata, P.E.S., Lorenzo, J.M., Barba, F.J., Binello, A., Cravotto, G., 2020. A review of sustainable and intensified techniques for extraction of food and natural products. *Green Chem.*
- Drevelegka, I., Goula, A.M., 2020. Recovery of grape pomace phenolic compounds through optimized extraction and adsorption processes. *Chem. Eng. Process. - Process Intensif.* 149, 107845.
- Espinoza Perez, A.T., 2018. Biorefinery supply chain design optimization under sustainability dimensions. Doctoral thesis. Computational engineering, finance, and science, Université de Lorraine.
- FAOSTAT. Statistics division Food and Agriculture Organization of the United Nations. <http://www.fao.org/faostat>
- Herrero, M., Ibañez, E., 2018. Green extraction processes, biorefineries and sustainability: Recovery of high added-value products from natural sources. *J. Supercrit. Fluids* 134, 252–259.
- Hogervorst, J.C., Miljić, U., Puškaš, V., 2017. Extraction of bioactive compounds from grape processing by-products. In: Galanakis, C.M. (Eds.), *Handbook of grape processing by-products*, Academic Press, UK, pp 105-135.
- Höltinger, S., Schmidt, J., Schönhart, M., Schmid, E., 2014. A spatially explicit techno-economic assessment of green biorefinery concepts. *Biofuels, Bioprod. Bioref.* 8, 325–341.

IEA Bioenergy, 2009. Biorefineries: adding value to the sustainable utilisation of biomass, International Energy Agency, Task 42.

Martínez, J., de Aguiar, A.C., Machado, A.P. da F., Barrales, F.M., Viganó, J., dos Santos, P., 2020. Process Integration and Intensification. Ref. Modul. Food Sci. 1–22.

Moghadam, M., Salami, M., Mohammadian, M., Emam-Djomeh, Z., Jahanbani, R., Moosavi-Movahedi, A.A., 2020. Physicochemical and bio-functional properties of walnut proteins as affected by trypsin-mediated hydrolysis. Food Biosci. 36, 100611.

Navarro, S.L.B., Capellini, M.C., Aracava, K.K., Rodrigues, C.E.C., 2016. Corn germ-bran oils extracted with alcoholic solvents: Extraction yield, oil composition and evaluation of protein solubility of defatted meal. Food Bioprod. Process. 100, 185–194.

Odabaş, H.İ., Koca, I., 2016. Application of response surface methodology for optimizing the recovery of phenolic compounds from hazelnut skin using different extraction methods. Ind. Crops Prod. 91, 114–124.

Perino, S., Chemat, F., 2019. Green process intensification techniques for bio-refinery. Curr. Opin. Food Sci. 25, 8–13.

Tilman, D., Socolow, R., Foley, J.A., Hill, J., Larson, E., Lynd, L., Pacala, S., Reilly, J., Searchinger, T., Somerville, C., Williams, R., 2009. Beneficial biofuels - The food, energy, and environment trilemma. Science 325, 270–271.

Venkata Mohan, S., Dahiya, S., Amulya, K., Katakojwala, R., Vanitha, T.K., 2019. Can circular bioeconomy be fueled by waste biorefineries — A closer look. Bioresour. Technol. Reports 7, 100277.

## **Introduction**

Current concerns such as world food security, the depletion of cheap fossil fuels and the urgency for mitigating the climate change, have promoted technological, social, and political innovations intended to increase the efficiency of the use of natural resources (Holtinger et al., 2014). The above has forced to change the international policy agenda for moving the world toward a bio-based economy. The transition towards a sustainable economy consists of changing the current linear economy to a circular economy approach which represents a system based on recycling and reuse of raw materials while maintaining restorative capacity of the natural resource (Venkata Mohan et al., 2019).

Under the trend for developing sustainable process, several natural resources have been investigated. However, biomass has remarkably attracted the attention of researchers because of its widespread availability and its potential applicability as sustainable source of energy and materials (Espinoza Perez, 2018). For instance, corn germ by-product is largely generated during the production of semolina, gritz and flour from corn kernel since it represents about 13% of the total weight of corn kernel that is processed. On the other hand, residues from nuts processing are also currently generated in considerable amounts. In particular, walnut press-cake a by-product from oil extraction is often thrown away without any economic use or used as animal feed or fertilizer (Moghadam et al., 2020). Similarly, a large amount of residues are generated from grape processing during the production of wine and juices. This residue consists of the skin, stems, and seeds from grapes and represents around 20% of the total mass of processed grapes (Hogervorst et al., 2017).

In this context, the biorefinery concept has emerged as an industrial facility where biomass may be transformed into a wide range of marketable products and energy, so that economic benefits can be produced at the same time that the accumulation of agro-residues is significantly reduced. In this sense, several authors have defined the biorefinery concept as “the development of integrated processes for the conversion of biomass into energy and a variety of products, mainly biofuels and added-value co-products, in a sustainable approach” (Herrero & Ibañez, 2018), “a facility, somewhat analogous to the petroleum refinery, which integrates biomass conversion processes and technologies to produce fuels, power and chemicals” (Celiktas et al., 2017), or as “the sustainable processing of biomass into a spectrum of marketable products and energy” (IEA Bioenergy 2009).

On the other hand, developing a biorefinery scheme is not a simple task since it implies the development of a cascade approach in which several processes can be conducted for recovering progressively various types of products or materials from the same by-product. Thus, in an elaborated scheme of a cascade of physical, chemical and biochemical processes, it is crucial to consider the scheme as a whole by identifying the interactions between the unit operations, since the optimal conditions for obtaining a certain type of products might be deleterious for others that are intended to be later extracted.

Conventionally, natural products have been obtained using solid–liquid extraction. Nonetheless, intensification techniques (as ultrasound, microwaves, pulsed electric field, etc.) may be coupled to conventional process in order to obtain higher extraction efficiency and higher quality extract while reducing extraction time, number of unit operations, energy consumption, quantity of solvent used (Perino & Chemat, 2019). Dealing with sustainable processes, the choice of extraction techniques has to consider not only factor such as extraction yield but also environmental impact and energy consumption. The use of alternative solvents and especially water, energy consumption reduction, promotion of safe and controlled processes, and obtention of non-denatured and biodegradable products are some key points when designing a biorefinery scheme. Regarding the products that may be obtained from biorefineries, there are several valuable added products of interest for food, pharmaceutical, and chemical industry: essential oils, proteins, lipids, dietary fibers, pigments, bioactive compounds, biofuels, energy and a variety of materials and chemicals.

In this context, this work aims to propose a biorefinery scheme for recovering valuable products such as vegetable oils, proteins, antioxidants, and emulsion stabilizers from by-products such as corn germ, walnut press-cake and grape pomace which are largely generated by food industries located in Nouvelle-Aquitaine region. For that, a fractionating scheme is developed based on the use of conventional and intensification (green) techniques. The recovery of added value products from agricultural residues allows to propose alternatives for reducing environmental impact of accumulating biomass, meanwhile it generates economic benefits by providing products of interest for food, chemical or pharmaceutical applications. In addition, alternatives for using the by-products “as it”, it means as a functional ingredient, are also considered. Thus, in order to reach this aim, the current manuscript is divided into five chapters as follows. It is worth mentioning that *Chapters III, IV* and *V* present specific goals

## *Introduction*

based on the type of by-product from which the added value fractions are intended to be obtained.

*Chapter I* comprises an extensive literature review of the main concepts and technologies involved in the effort of developing a biorefinery scheme. Key definitions, approach and perspectives of the biorefinery concept are detailed in this chapter. Similarly, features, functional properties and applicability of plant products that may be obtained under a biorefinery scheme are carefully described. The principle and advantages of conventional and novel techniques for extracting these added value products are also widely described. Special attention on ultrasound assisted extraction and supercritical fluids is given since they can be considered intensified or green techniques. In addition, the key points involved in the development of a biorefinery scheme, from the point of view of a sequential cascade process intended to obtain most of the valuable components from a biological material, are discussed.

Materials and methods used for reaching the aim of this work are detailed in *Chapter II*. Firstly, a global description of the anatomy, macroscopic aspect or pretreatment applied to plant matrices concerning this work, i.e. corn germ, walnut cake and grape pomace, is provided. After that, the various extraction methods, purification or concentration steps for recovering valuable products (oils, proteins and polyphenols) are described. In addition, the methodology used for producing Pickering emulsion from plant residues is described, as well as the analytical methods for assessing the composition and functional properties of the recovered products.

The following three chapters of this manuscript correspond to results and discussion as follows.

*Chapter III* comprises the development of a biorefinery scheme from corn germ. Corn germ is considered the main source of corn oil (18-41%) when compared to other parts of the grain and its protein content varies from 12 to 21% (Navarro et al., 2016). The aim of this chapter is to propose a cascade of processes for recovering several fractions from corn germ and therefore assess the influence of oil extraction conditions on subsequent processes of the biorefinery scheme. For that, various oil extraction methods are assessed followed by the protein extraction from defatted corn germ meals. After salt removal and freeze-drying the various protein extracts are assessed regarding their composition and functional properties

## *Introduction*

(solubility profile, water absorption, emulsifying and foaming capacities). Finally, various corn germ residues are assessed for their ability to stabilize 1:4 oil-in-water emulsions (Pickering emulsions).

*Chapter IV* consisted of recovering oil and polyphenol-rich extracts from walnut press-cake. Press-cake is the residue that results from oil extraction by pressing the kernels in a screw or hydraulic press. This by-product represents a cheap and rich source of remaining lipids (20-36%), proteins (30-42%), dietary fiber, minerals and antioxidant compounds such as polyphenols (Bakkalbasi et al., 2015). In this chapter, walnut press-cake is submitted for oil extraction by conventional Soxhlet extraction and supercritical fluids. After that, the defatted meal is addressed to ultrasound assisted extraction (UAE) to recover phenol-rich extracts using ethanol-water mixtures as solvents. In this context, the influence of ultrasound power, extraction time and duty cycle on the extraction of total phenolic compounds, ellagic acid and the free radical scavenging activity (DPPH) of extracts is evaluated. Finally, the ability of walnut particles for stabilizing Pickering emulsion as well as for delaying the oxidation of emulsified oil is evaluated in this chapter.

The last chapter of this manuscript (*Chapter V*) study the extraction of phenolic compounds from grape pomace by ultrasound assisted extraction. Other properties or valuable products from grape pomace could not be explored under the biorefinery scheme due to logistical and social difficulties caused by the Covid-19 outbreak.

Grape pomace is a cheap source of antioxidant molecules and natural pigments, particularly anthocyanins. According to Hogervorst et al. (2017), the red grape pomace, for instance, may content up to 9 kg of phenolics per ton. In this chapter, the ultrasound assisted extraction is also used to recover rich-polyphenol extracts. The influence of power, extraction time and duty cycle on the extraction of total phenolic compounds, total anthocyanin content and the free radical scavenging activity (DPPH) of extracts is also evaluated using a central composite experimental design.

Finally, general conclusions and some perspectives for future works are presented in order to encourage more research in the field of biorefinery which promotes a more efficient use of energy and natural resources.



## **References**

Bakkalbasi, E., Meral, R., Dogan, I.S., 2015. Bioactive compounds, physical and sensory properties of cake made with walnut press-cake. *J. Food Qual.* 38, 422–430.

Celiktas, M.S., Alptekin, F.M., 2017. Biorefinery concept : Current status and future prospects. *Int. Conf. Eng. Technol.* 1, 27-32.

Espinoza Perez, A.T., 2018. Biorefinery supply chain design optimization under sustainability dimensions. Doctoral thesis. Computational engineering, finance, and science, Université de Lorraine.

Herrero, M., Ibañez, E., 2018. Green extraction processes, biorefineries and sustainability: Recovery of high added-value products from natural sources. *J. Supercrit. Fluids* 134, 252–259.

Hogervorst, J.C., Miljić, U., Puškaš, V., 2017. Extraction of bioactive compounds from grape processing by-products. In: Galanakis, C.M. (Eds.), *Handbook of grape processing by-products*, Academic Press, UK, pp 105-135.

Höltinger, S., Schmidt, J., Schönhart, M., Schmid, E., 2014. A spatially explicit techno-economic assessment of green biorefinery concepts. *Biofuels, Bioprod. Bioref.* 8, 325–341.

IEA Bioenergy, 2009. Biorefineries: adding value to the sustainable utilisation of biomass, International Energy Agency, Task 42.

Moghadam, M., Salami, M., Mohammadian, M., Emam-Djomeh, Z., Jahanbani, R., Moosavi-Movahedi, A.A., 2020. Physicochemical and bio-functional properties of walnut proteins as affected by trypsin-mediated hydrolysis. *Food Biosci.* 36, 100611.

Navarro, S.L.B., Capellini, M.C., Aracava, K.K., Rodrigues, C.E.C., 2016. Corn germ-bran oils extracted with alcoholic solvents: Extraction yield, oil composition and evaluation of protein solubility of defatted meal. *Food Bioprod. Process.* 100, 185–194.

Perino, S., Chemat, F., 2019. Green process intensification techniques for bio-refinery. *Curr. Opin. Food Sci.* 25, 8–13.

Venkata Mohan, S., Dahiya, S., Amulya, K., Katakojwala, R., Vanitha, T.K., 2019. Can circular bioeconomy be fueled by waste biorefineries — A closer look. *Bioresour. Technol. Reports* 7, 100277.

## Chapter I: LITERATURE REVIEW

### 1. Biorefinery concept

Nowadays the food, pharmaceutical, cosmetic and energy industries are being reinvented in order to achieve the new demands of consumers and get an enhanced sustainability. The demand for natural compounds and active ingredients along with the global environmental conscience have forced the re-formulation of processing in different fields. The sustainability can be defined as “the development that meets the needs of the present without compromising the ability of future generations to meet their own needs” (World Commission on Environment and Development Report), so that the reduction or even total elimination of wastes became a key point in the sustainable development. In addition, the effect of the growing of global population on the world food security, as well as on the urgency to mitigate the climate change has raised the necessity to increase the efficiency of the use of natural resources.

This leads to the concept of biorefinery or circular economy approach that mainly aim to promote a more efficient use of energy and resources (Herrero & Ibañez, 2018). According to Herrero & Ibañez, (2018), Temelli & Ciftci, (2015) and Forster-Carneiro et al. (2013) the biorefinery can be defined as an integrated, efficient and flexible conversion of biomass feedstocks through a combination of physical, chemical, and biochemical processes into multiple products. The concept of biorefinery is analogue to the petroleum refinery in which oil is transformed in energy, fuels and many chemical products, with the difference that biorefinery includes sustainable management practices and a circular economy approach. Several definitions of biorefinery can be found in literature thus, Table I-1 shows examples of common definitions of biorefinery.

**Table I-1.** Examples of definition of biorefinery

Source	Definition
US Department of Energy (DOE)	“A biorefinery is an overall concept of a processing plant where biomass feedstocks are converted and extracted into a spectrum of valuable products. Its operation is similar to that of petrochemical refineries”.
The US National Renewable Energy Laboratory (NREL)	“A biorefinery is a facility that integrates biomass conversion processes and equipment to produce fuels, power and chemicals from biomass. The biorefinery concept is analogous to today’s petroleum refineries, which produce

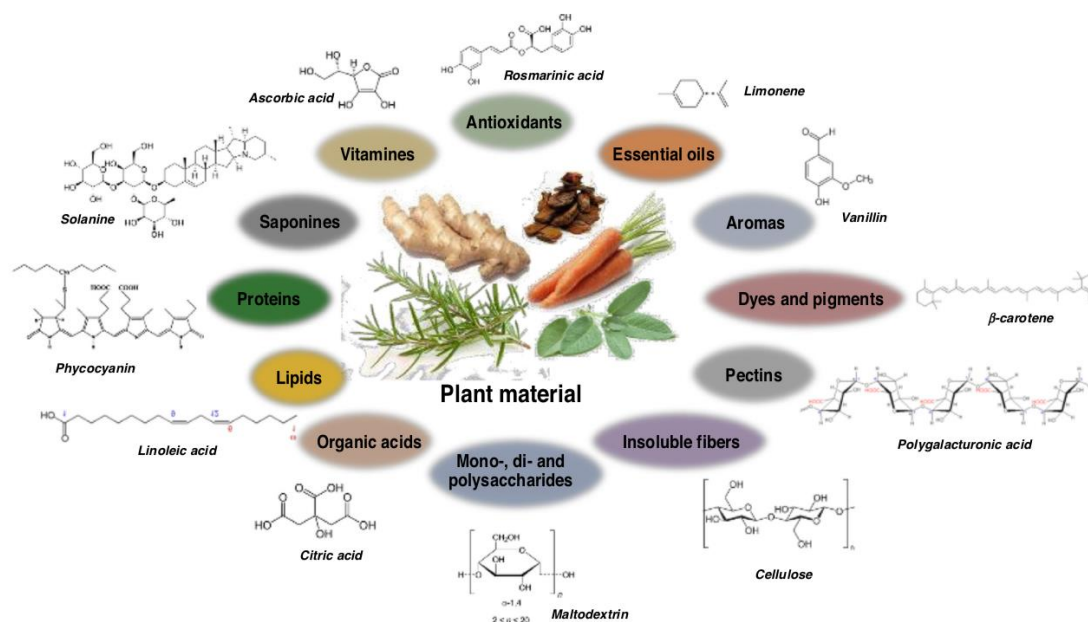
	multiple fuels and products from petroleum. Industrial biorefineries have been identified as the most promising route to the creation of a new domestic biobased industry”
The International Energy Agency (IEA)	“The sustainable processing of biomass into a spectrum of marketable products (food, feed, materials, chemicals) and energy (fuels, power, heat)”
Nacional Non-Food Crop Centre (NNFCC 2007).	“Bio-refining is the sustainable processing of biomass into a spectrum of marketable products (food, feed, fuel, chemicals, heat and electricity). Bio- refineries provide a way by which renewable materials can be integrated and mass-produced, allowing large-scale replacement of fossil fuels and materials”

Adapted from OECD, 2018

A biorefinery approach allows the valorization of majority of secondary and primary metabolites of bio-sources and due to the diversity of biomass resources, multiple conversion technologies can be developed. According to Schieb et al. (2015), biorefineries can be classified on the basis of the raw materials they use as:

- The cereal biorefinery which processes grain and starch.
- The oilseed biorefinery.
- The “green” biorefinery, which processes water-based raw materials.
- The lignocellulose biorefinery, which can process forestry products or straw, corncobs and lignocellulose-rich waste.
- The syngas biorefinery, which produces hydrocarbons or intermediate chemical products by the microbial fermentation of synthesis gas.

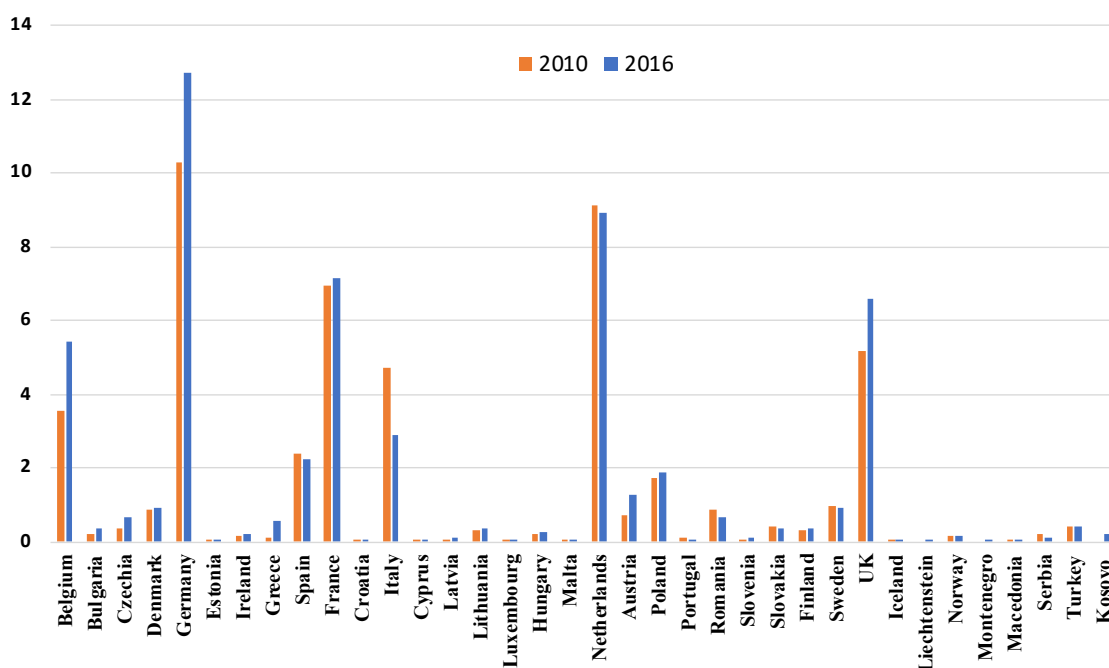
In this context, several end-products with a wide range of properties, chemical structures, and applications may be obtained. Among these metabolites or added value co-products are included antioxidants, essential oils, proteins, lipids, dietary fibers, pigments, etc. (Figure I-1) that are largely used as ingredients in food processing for providing specific texturing, preservative or coloring properties (Perino & Chemat, 2019). As a novel approach, the biorefinery follows six specific principles i) use of renewable plant resources, ii) use of alternative solvents (principally water or GRAS solvents), iii) reduction of energy consumption using innovative technologies, iv) production of co-products instead of wastes, v) reduction of unit operations number and promotion of safe, robust and controlled processes, and vi) aim for a non-denatured and biodegradable extract without contaminants (Herrero & Ibañez, 2018).



**Figure I-1.** Some valuable metabolites from plant materials (Source: Perino & Chemat, 2019)

Among the natural resources recently investigated under the biorefinery concept, the biomass exhibits several advantages as widespread availability and potential applicability as sustainable source of energy and materials. The biomass consist of many and varied wastes from agriculture and food processing as leaves, roots, stalks, bark, bagasse, straw residues, seeds, peels, oil cakes, wood residues, etc. which can be processed to yield a number of valuable added products, such as additives, food, fuel, feed and a variety of chemicals. In Figure I-2 is presented the most recent statics related to the generation of vegetal wastes in European Union (EU) (these statistics consider that the generation of waste is attributed to either production or consumption activities). As can be observed, in 2016 more than 56 million tons were generated in EU of which France had the third largest participation (after Germany and Netherlands) comprising 12.7% of the total waste production. Therefore, the processing of these agro-residues would allow to obtain valuable materials, would support to reduce the deterioration of the environment due to the accumulation of biomass and finally, it would not threaten food security. The plant materials represent one of the most energy-rich resources on the planet since these are rich in organic nature (Singh, 2009) and are largely available, renewable and almost free. The technology for waste processing to achieve valuable co-products or energy conversion varies according to the type of plant material and the target compound (following the principles explained previously). The residues can be classified in

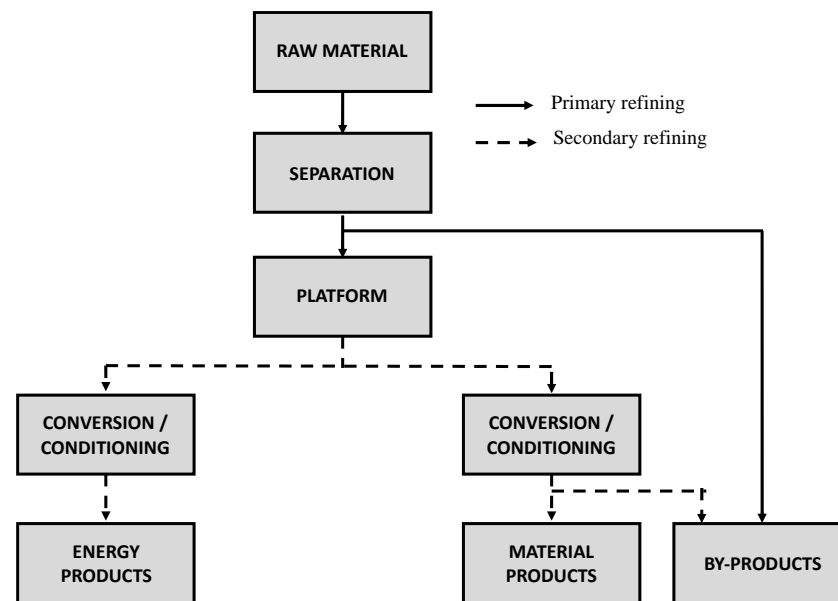
those that are predominantly dry (such as straw) and those that are wet (such as animal slurry) (Singh et al., 2009a).



**Figure I-2.** Generation of vegetable waste in EU, 2010 and 2016. Data in million tons.

(Source: Eurostat)

Because the biorefinery concept comprises direct extraction, physical, chemical, biochemical and/or thermochemical transformations of the biomass, the biorefineries can be classified according to the level of biomass conversion (primary or secondary refining) (Figure I-3). The initial stage of biomass refining (physical transformation, direct extraction) is carried out by most of the traditional biorefineries whereas integrated processing plants include several conversions stages (biochemical and thermochemical transformations) in order to maximize the products and minimize the losses.



**Figure I-3.** Components of the primary and secondary refining in biorefineries (Adapted from Schieb et al., 2015)

### *Circular bioeconomy approach*

The concept of biorefinery is closely related to the circular economy or the bioeconomy approach. In fact, several authors (Carus & Dammer, 2018) have suggested that both concepts should be fully integrated – or in other words that bioeconomy is simply one part of circular economy and should be treated as such. According to the European Commission (2015), the circular economy is defined “as the economic space where the value of products, materials and resources is maintained in the economy for as long as possible, and the generation of waste minimized”.

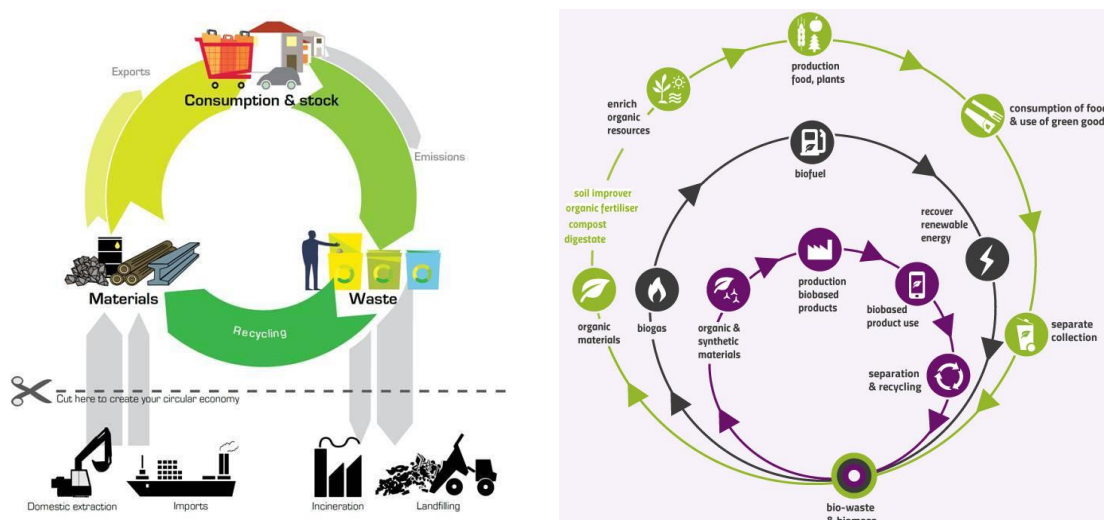
The European Commission (2012) has also encouraged that biorefineries should adopt a cascading approach that favors highest value added and resource efficient products: “Biorefineries should adopt a cascading approach to the use of their inputs, favoring highest value added and resource efficient products, such as bio-based products and industrial materials, over bioenergy and the advantages of the products over conventional products range from more sustainable production processes, to improved functionalities (e.g. enzyme-based detergents that work more efficiently at lower temperatures, save energy and replace phosphorus) and characteristics (e.g. biodegradability, lower toxicity)”. In this sense, the main

target of adopting a cascading approach is an increased resource efficiency that lead to a less demand for fresh materials.

Thus, the bioeconomy intents to:

- i) introduce healthy, safe and nutritious food and animal feed, produce new food supplements;
- ii) provide new chemicals, building-blocks, polymers and other materials providing new properties and functionalities;
- iii) provide bioenergy and biofuels in order to replace fossil energy;
- iv) develop new, more efficient and sustainable agricultural practices, and progress in the development of new process technologies such as industrial biotechnology;
- v) provide solutions for Green and Sustainable Chemistry in order to:
  - contribute for mitigating climate change through the substitution of petrochemicals by materials with lower greenhouse gas emissions and of fossil fuels by biofuels
  - deliver the most important renewable carbon source: biomass is the only source for renewable carbon
  - bring new business opportunities, investment and employment to rural, coastal and marine areas and, fosters regional development.
  -

In Figure I-4 can be observed a schematic representation of the principles in which circular economy is based. Both schemes represent a cycle process with economic benefits, where the value of resources is maintained in the cycle for as long as possible, so that the demand for fresh sources or materials, as well as the generation of wastes are minimized.



**Figure I-4.** Schematic representation of the circular economy approach (adapted from European Compost Network)

In circular bioeconomy, products come up as nutrients (biodegradable materials) which are reutilized and returned to the environment safely for sustainability of the living system. The idea to create a closed loop system for waste material is possible only by two means; recycling or reusing. The implementation of a circular economy would allow us to transform the current manufacturing activity into a more sustainable and competitive agroindustry.

## 2. Vegetable crops, agro-residues and valuable components

In the following section we have detailed the main valuable components or products that can be obtained from biomass under a biorefinery scheme. It has been also listed the vegetable crops mainly used as sources of the different added value products however, in this work, a special attention to by-products generated from local industries has been given; i) corn germ, a by-product from starch-rich flour processing, ii) walnut press-cake, a residue obtained after oil extraction by pressing methods, and iii) grape pomace, a waste of wine and juice industries.

The generation of corn germ residue for instance represents about 5-13% of the total mass of corn kernel processed, usually by wet milling, for the production of starch (Moreau et al., 2013). However, corn germ is the main source of corn oil (18 - 41%) when compared to other parts of the grain (Navarro et al., 2016). According to FAOSTAT, (2019) the world corn production during 2017 was estimated in 1,134 million tons of which approximately 14 million tons were produced in France. Corn germ protein and starch contents may vary from 12 to 21%



and 6 to 21% respectively, influenced by weather and crop conditions, genetic factors and germ separation method (Johnston et al., 2005; Navarro et al., 2016). Currently, corn germ is mainly used for oil extraction by either hexane extraction or mechanical pressing followed by hexane extraction, or for animal feed.

Regarding walnut residues, huge amount of defatted meal is generated during oil production since it requires twice more walnut kernel amount than produced oil volume. The press-cake is often thrown away without any economic use or used as animal feed or fertilizer (Moghadam et al., 2020). World walnut production reached 3 660 000 metric tons in 2018, of which 11% produced in France (FAOSTAT). Walnut press-cake is still remarkably rich in oil (20-36%), proteins (30-42%), dietary fiber, phenolics and minerals (Bakkalbasi et al., 2015).

On the other hand, grape pomace is generated by pressing whole grape bunches during the production of must and represent globally around 20% of the total mass of grapes processed (Hogervorst et al., 2017). According to estimations of Mendes et al. (2013), 25-35 kg of grape pomace is generated per 100 L of produced wine. This yield accounts for 10.5–13.1 Mton of grape pomace in the world annually. Grape pomace is basically composed of 43% of grape skins, 25% of grape stalks and 23% of grape seeds. The main components of grape pomace are moisture (50-72%), while in case of red grape pomace phenolics represent about 9 kg per ton (Hogervorst et al., 2017). The protein content of grape pomace may vary between 6% and 15% (dry mater), the dietary fiber between 43% and 75% (dry matter) (Hogervorst et al., 2017). Nowadays, grape pomace has been used for obtaining bioactive compounds (polyphenol), natural pigments (anthocyanins), dietary fiber, ethanol, citric acid, among others (Schieber, 2019).

## **2.1. Vegetable oils**

Vegetable oils are a group of fats that are derived from some seeds, nuts, cereal grains, and fruits. Most of vegetable oils are obtained from seeds or beans, which simultaneously provide two valuable materials: an oil and a protein-rich meal. According to the Statista Research Department (<https://www.statista.com>) the world production of vegetable oils in 2019 was about 204 million tons, 80% being used for food purposes, 6% for animal feed and the remaining 14% for oleochemical industry. The extraction of oil from vegetable matrices can be achieved by pressing or by solvent extractions (solid-liquid extraction or supercritical

fluid extraction). In Table I-2 is shown the annual average of world production of the main vegetable oils.

**Table I-2.** World production of most produced vegetable oils

Oil	Period of production	
	2006 to 2010	2016 to 2020
Soybean	33.60	41.12
Cottonseed	5.35	6.51
Groundnut	5.72	6.38
Sunflower seed	12.43	16.97
Rapeseed	17.72	22.69
Sesame seed	0.86	0.96
Corn	2.49	3.16
Olive	2.75	2.98
Palm	31.43	43.36
Palmkernel	3.84	5.28
Coconut	3.70	4.55
Linseed	0.81	0.97
Castorseed	0.71	0.78

Adapted from (Gunstone, 2011) and FAOSTAT, production given in million tons

Among the world production of vegetable oils is possible to distinguish three main types of source:

i) By-products: For instance cotton and corn are grown primarily for fiber and for cereal respectively whereas the oil is obtained from the by-products. Some peanuts may be also included in this category since only about one half of the crop is crushed for oil and meal obtaining. Moreover, remaining lipids can be obtained from already press-cake meals of several nuts and oilseeds.

ii) Tree crops: Palm, palmkernel, coconut and olive oils are obtained from trees that have been planted and matured. These types of trees provide continually crops for 25-30 years.

iii) Annual crops: In this category can be find rape, sunflower, linseed among others. Another distinction that may be done is between oilseed crops and those vegetable oils which come from the endosperm such as corn oil.

Vegetable oils are the most energy dense of all the macronutrients providing 37 kJ (9 kcal) per gram, and contain unsaturated fatty acids and polyunsaturated fatty acids (PUFAs) such as  $\alpha$ -linolenic omega-3 and linoleic omega-6, that may prevent degenerative and inflammatory diseases conditions (Krzyżaniak et al., 2019; Moslavac et al., 2014). Fatty acids are long hydrocarbon chains, with a methyl group at one end (the omega or *n*-end) and an acid group at the other end. Moreover, plant oils also contain minor compounds such as tocopherols, tocotrienols, carotenes, sterol and phenolics that are known for exhibiting antioxidant properties (Gunstone, 2011). In this sense, the chemical and physical properties of oils will affect how they can be used in the formulation and manufacture of foods. However, not all of the vegetable oils are produced in commercial quantities, and of those that are, not all are considered to be edible as in the sense of being a typical dietary component. The main properties of edible oils according to Hammond, (2003) are described below.

*Properties of oils and fats*

i) General functionalities: when foods containing significant amounts of added fats are formulated, three main characteristics are affected. The first is processability during preparation, the second is sensory quality such as taste and flavor, and the last one is shelf-life. Particularly, the shelf-life of oily products is related to the time that lasts to become rancid (due to the lipid oxidation). In general, a higher amount of polyunsaturated fatty acid increases the oxidation rate of oils. On the other hand, the melting point of oils is inversely influenced by polyunsaturated which means that as PUFAs content rises, the melting point reduces. The above comparisons of oil properties are expressed as simple links, although in reality the links are more complex. Therefore, the final physical properties of fats and oils depend upon the ‘finer’ chemistry of the structure of triacylglycerols.

ii) Chemical: the main property of oil in this category is the potential for oxidation and the development of rancidity. This chemical reaction is normally termed autooxidation and is an autocatalytic reaction with oxygen. A second chemical property of oils is the potential of hydrolysis which means that the glycerol ester group can be broken either with water, by straight reaction under slightly alkaline conditions, or through the action of lipase enzyme, producing free fatty acids (FFAs).

Regarding to chemical applications, the hydrolysis of lipids is widely used with the aim of obtaining fatty acids, alcohols, or the decomposition of the fat itself in products where the content of fats is undesirable (for example the leather industry). The use of oils for obtaining oleochemical products, such as surfactants among others, by the hydrolysis of triglycerides, has recently increased due to its high demand for applications in pharmaceutical and food industries, soap and laundry detergent, candles, waxes, lubricant, plastics, rubber, paints and coatings

iii) Physical: Among the main physical properties of oil is the melting point. Each type of triacylglycerol has its own melting point however, when mixed with others, such as vegetable oils and fats that are complex mixtures of them, the result is different. Therefore, natural lipids do not have sharp melting points but have a ratio of solid and liquid fat at any given temperature. In this sense, the solid fat content is an important physical property that is used as a standard property when considering the function of fats in making certain foods.

On the other hand, the applicability of vegetable oils for non-food purposes is also wide. Because vegetable oils have a relatively low viscosity-temperature variation, present low volatilities, high dispersancy, are environmentally friendly, renewable, non-toxic and biodegradable, vegetable oils are more appropriate in the formulation of engine lubricants than mineral oils.

Vegetable oils have also been identified as having a lot of potential as alternative diesel engine fuels ("*biodiesel*"), particularly supported by the interest in a cleaner environment, as well as the increasing cost of mineral deposit-based energy. Biodiesel according to Aluyor & Ori-Jesu, (2008) is defined strictly as "...the mono alkyl ester (usually methyl ester) of renewable fats and oils..." and it consists primarily of long chain fatty acid esters, produced by the transesterification reaction of vegetable oils with short chain alcohols.

iv) Another but not less important property of vegetable edible oils is its antiradical activity. In general, fruits, vegetables, oilseeds and herbs naturally present phytochemicals that exhibit antioxidant properties. These antioxidant molecules may function as i) free radical scavengers, ii) reducing agents, iii) complexers of prooxidant metals, and iv) quenchers of the formation of singlet oxygen. As result, the consumption of this type of phytochemicals may provide protection against cancer and cardio- and cerebrovascular diseases since the oxidative

damage of lipids, proteins and nucleic acids of human cells is avoided or delayed (Ramadan & Moersel, 2006), and among the sources of phytochemicals with significant antioxidative properties and health benefits are the vegetable oils.

In addition, the consumption of PUFAs are also related to the prevention of degenerative diseases, including cancers of the colon, breast and prostate, and to reduce cardiovascular disease risks. Replacing saturated fatty acids with either monounsaturated fatty acids or n-6 PUFAs reduces LDL (the ‘bad’) cholesterol, and thus may reduce the risk of developing diseases. The literature also suggests that the consumption of long chain PUFAs might influence positively cognitive functions and behavior since brain cells are especially rich in these type of fatty acids and, because the dietary fat affects a number of different metabolic pathways, such as those involved with glycemic control, it may have a role to play in the management of type 2 diabetes (Lunn & Theobald, 2006). Moreover, there are two essential fatty acids, they are the n-3PUFA  $\alpha$  -linolenic acid and the n-6 PUFA linoleic acid, that must be acquired from the diet (oily food products) since humans lack the enzymes required to produce them. In Table I-3 is shown the typical fatty acid composition of various vegetable oils.

**Table I-3.** Typical fatty acid composition (%) of some edible oils

Oil	8:0	10:0	12:0	14:0	16:0	16:1	18:0	18:1	18:2	18:3	20:0	20:1	22:0	22:1	24:0
<b>Seeds</b>															
Babassu	5.4	6.0	44.3	15.8	8.6		2.9	15.2	1.7		0.1				
Coconut	8.1	6.5	48.6	17.7	8.5		2.5	6.5	1.5		0.1				
Palm kernel	4.0	4.1	49.7	16.0	8.0		2.4	13.7	2.0		0.1				
Sunflower			0.1	0.2	6.8	0.1	4.7	18.6	68.6	0.5	0.4				
Soybean					10.0	0.2	3.5	21.0	55.3	9.2	0.5				
Cotton				1.0	23.9	0.5	2.9	18.5	52.5	0.3	0.4				
<b>Nuts</b>															
Peanut					10.1	0.2	3.5	51.4	27.3	0.1	1.6	1.3	3.1		1.4
Almond			0.1	8.5	1.1	1.0	57.0	31.4	0.6	0.1	0.1	0.1			
Walnut				6.0	<1	2.4	22.5	56.3	12.7	<1	<1	<1			
<b>Cereals</b>															
Corn					10.7	0.2	1.5	30.5	55.9	0.8	0.4				
Rice bran					13.9	1.9	2.7	41.1	36.4	2.3	1.8	0.2			
Wheatgerm			0.2	18.5	0.6	0.5	18.1	55.9	5.3	0.1	0.8				

Fruits									
Palm	1.0	43.8	0.5	5.0	38.5	10.5	0.3	0.4	
Olive		10.8	0.5	3.0	75.5	8.5	0.9	0.4	0.4

Adapted from Hammond, (2003). Walnut fatty acid composition from Bakkalbasi et al., (2015)

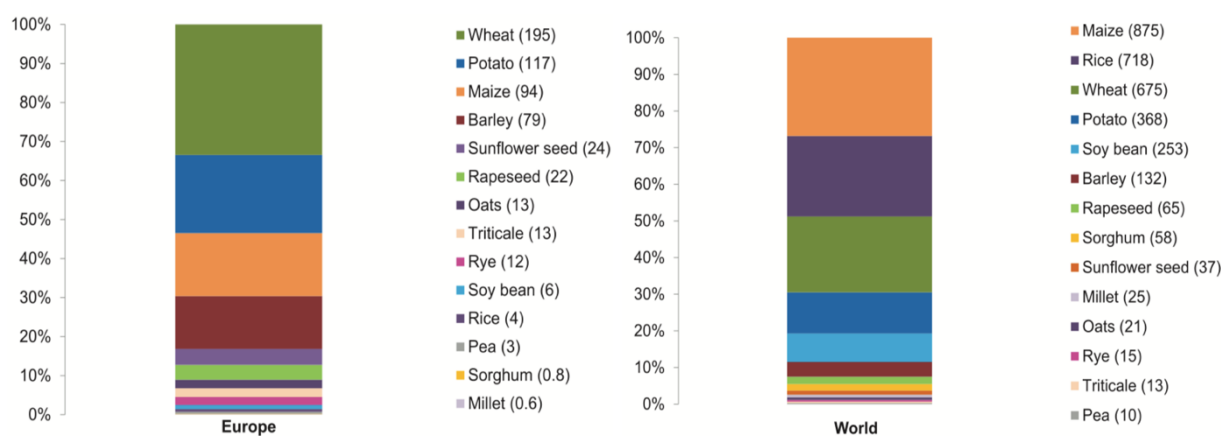
## 2.2. Protein rich meals or vegetable protein extracts

Proteins play a key role in the human and animal diet because of their nutritional value, particularly for those which contain essential amino acids. Protein may be found both in plant and animal sources, however a growing interest for vegetable proteins have been observed since producing proteins for feed and food provides has become an important challenge in relation to development of a future sustainable and climate-neutral agriculture (la Cour et al., 2019). In addition, particularly in Europe, large amounts of soybean are imported from South America to support production of monogastric animals such as pigs and chickens, while local sources of plant proteins are underutilized (la Cour et al., 2019). Therefore, one potential alternative protein source is green protein extracted from green biomasses through a biorefinery process.

In this sense, the extraction of protein from plant material may add value to bioenergy-based value chains, since their functional properties co-valorize biobased products for food, feed or other industrial applications. In this way, plant protein products can be combined to compensate the deficiency or lack of certain amino acids, such as lysine and sulfur amino acids. Moreover, they may be extracted and used in the form of hydrolysates, so that the breakdown of peptide bonds increases the number of free amino acids and carboxyl groups, increasing the solubility, digestibility and even their biological activity (Contreras et al., 2019). On the other hand, plant-based proteins are also interesting for non-food applications, for instance as adhesives, coatings and polymers, where minor antinutrients of protein extracts do not represent any risk for human or animal nutrition. Authors such as Santana-Méridas et al. (2012) distinguish two categories of plant residues that are rich sources of proteins: i) residues from the harvesting, it means primary biomass residues, (e.g. leaves, stalks and straw) and, ii) residues from the post-harvesting and processing of crops or also known as secondary biomass residues. However, another categorization of agro-residues can be done according to their protein content (Contreras et al., 2019): i) residues relatively rich in proteins (> 20%, d.b), such as those from rice and soy bean processing, some seed meals, cereals distiller's grains as corn,

among others, ii) residues with a medium proteins content (20 – 10%, d.b) such as fruit seeds, cereals bran, soybean hulls, etc. and, iii) residues with a low protein content (< 10%, d.b) such as leaves, stems, straw, stalks, etc.

In Figure I-5 is shown the volume of production of the main protein crops in Europe and the world. As can be observed, the largest crop in Europe is wheat, followed by potato, maize and barley. These four crops cover approximately 85% of the production of protein crops. In terms of World production, maize is the largest crop. It is important to keep in mind that crops differ in dry matter and protein content. Nowadays, the largest amount of proteins is used in feed and, according to IEA Bioenergy, (2016) only small amounts of concentrates or isolated proteins are used for food or technical applications (Table I-4). It was estimated that the protein amount used in feed is of approximately 60-70 megaton per year, whereas the amount used in food is of only 20 megaton. As shown in Table I-4, the amount of protein (concentrates and isolates) used worldwide in food is about 1500 kton and in Europe it is of 200 kton.



**Figure I-5.** Production (millions tons) of protein crops in Europe and the world (IEA Bioenergy, 2016)

**Table I-4.** Worldwide use of isolated proteins in human nutrition

Protein	Amount (kton)
Wheat gluten	430
Soy concentrate	360
Casein	250

Soy protein	210
Gelatine	110
Whey protein (isolate/concentrate)	80
Egg albumins	50

Source: IEA Bioenergy, (2016)

In Table I-5 is also shown the protein content of most important protein sources from plant matrices. Although nuts are not presented in Table I-5, they are energy-dense foods that besides the high content in fat, also contain a substantial amount of proteins (rich in tryptophan, arginine and lysine) (IEA Bioenergy, 2016).

**Table I-5.** Protein contents of some cereals, legumes, oil-seeds and vegetables sources

<b>Protein source</b>	<b>Protein content (w.b%)</b>	<b>Other constituents (w.b%)</b>
Rice	7 - 9	90% starch
Wheat (flour)	8 – 15	75% starch, 1-2% lipids, 5% other polysaccharides
Maize	9 - 12	70-75% starch, 3-18% oil from the germ
Sorghum	9 – 17	2% lipids, 70-75% starch
Canola	17 – 26	40% oil, 12-30% non-starch polysaccharides
Chickpea	20 – 25	60% starch, 10% non-starch polysaccharides
Pea	20 – 30	60-65% starch, 5% non-starch polysaccharides
Lupine	35 – 40	10% oil, 35-40% non-starch polysaccharides
Soybean	35 – 40	20% oil, 30% non-starch polysaccharides

Adapted from IEA Bioenergy, (2016)



On the other hand, in order to recover protein from plant-based material it is also important to take into account that plant proteins present diverse physicochemical properties. For example, seed proteins are classified into albumins, globulins, prolamins, and glutelins in function of their solubility in water, salts, alcohol, and acid/alkaline solutions, respectively (Contreras et al., 2019). In this sense, significant amounts of protein can be left unextracted in the matrices if some protein fraction is not soluble in these solvents or conditions thus, the first step for extracting plant proteins is to choose the extraction or solubilization method which may include dry and non-dry conditions. These methods are classified into chemical, biochemical and physical or physical-chemical in function of the main driving-force agent, though a combination of them can also be implemented. Among the methods suitable for protein extraction can be found: i) chemical processes such as extraction with organic solvents and alkaline extractions, ii) biochemical extractions such as enzyme-assisted processes (carbohydrolases, peptidases, combination of carbohydrases and peptidases and other enzymes), iii) physical and physical-chemical treatments such as ultrasound assisted extraction, electro-based extraction, microwave-assisted extraction and screw extrusion, iv) enzyme-assisted processes combined with physical treatments, and v) extraction in drying conditions such as milling and sieving, air classification and electrostatic separations (Contreras et al., 2019). Many of the above methods, which are of great interest, will be further discussed in this manuscript.

The protein recovery from biomass constitutes a cascade process in which a protein concentration step is conducted after protein extraction. Various methods for protein concentration may be also found such as acid precipitation, precipitation with solvents (e.g. acetone and ammonium sulfate), isoelectric precipitation, hydrolysis, purification by means of membranes, chromatography or adsorption, etc. Therefore, the applicability of protein extracts in food or non-food production chains would depend, among other characteristics, on the crude protein content which directly influences the functional properties of protein concentrates or isolates. In the following section has been described the main functional properties of vegetable proteins that play a key role in industrial applications such as biomaterials, nutrition, gluten and meat replacement, bioactive properties for producing functional foods, etc.

### 2.2.1. Solubility of vegetable proteins

The solubility of proteins may be considered as the proportion of nitrogen in a protein product which is soluble in a solution under specific conditions and that is not sedimented by moderate centrifugal forces (Zayas, 1997). Proteins recommended as food additives can be partly or completely soluble or completely insoluble in water. In general, protein solubility is the first functional property determined during development and testing of new protein ingredients because it may provide useful information related to the potential utilization of proteins and their functionality, particularly in emulsions, foams and gels. The protein solubility profile is also an effective indicator of the degree of protein denaturation during processing and may be used in commercial conditions to control emulsification, foaming, extraction, and gelation processes (Zayas, 1997).

The highly soluble proteins are able to give a high dispersibility of protein molecules or particles and consequently, lead to the formation of finely dispersed colloidal systems. The ability of proteins to be soluble in water solution, or whatever, is influenced by various complex factors such as its amino acid composition and sequence, the molecular weight, and conformation and content of polar and nonpolar groups in amino acids. The latter gives the hydrophobic or hydrophilic character to proteins thereby, influencing its solubility. However, the protein structure may be modified during the extraction process, for instance by temperature or pressure treatments. On one hand, aromatic amino acids may be exposed during protein recovery which provides to protein, a higher hydrophobic character. But on the other hand, polar groups of amino acid chain can be also exposed by the effect of temperature, pressure or solvent conditions which favors the solubility of protein in aqueous media (Zayas, 1997). It means that the ability of proteins to be soluble is significantly affected by their net charge (zeta potential). The presence of free sulfhydryl groups in the amino acid chain is also related to the poor ability of plant proteins, especially soybean proteins, to be soluble. In addition to the intrinsic characteristics of plant proteins, the solubility is also highly influenced by environmental factors such as ionic strength, type of dissolution solvent, pH, temperature, and processing conditions.

The *pH* of the medium may be considered as the determining factor of protein solubility because it sets the electrostatic and hydrophobic interactions between the protein molecules. In general, the solubility increases if electrostatic repulsion between the molecules is higher than

hydrophobic interactions (Zayas, 1997), which means that proteins should be able to interact as much as possible with the solvent in order to be more soluble. At the isoelectric point, where the attractive forces predominate, proteins have a net zero charge and consequently, the molecules tend to associate themselves and do not interact with the solvent. Therefore, it is expected that, at pH values higher or lower than the isoelectric point, the protein-water interactions increase because protein carries a positive or negative charge. In consequence, a greater yield of protein extraction at alkaline conditions than acid pH is expected, when the protein molecules are further away from their isoelectric point.

The mechanism of the influence of the *ionic strength* on protein solubility involves solvation, electrostatic and salting in and salting out phenomena (Zayas, 1997). Chloride ions increase solubility by electrostatic repulsion after binding to the positively charged protein groups, thus salts at molarities about 0.1-1.0 M may increase the solubility of proteins. According to Zayas, (1997), concentrations of salt higher than 1.0 M caused a decrease in protein solubility because water molecules are strongly bound to the salt what leads to appear a competition between the salt ions and the protein molecules for binding the water molecules.

The effect of *temperature* on the protein solubility is evidenced by the conformational changes in the structure of proteins. The solubility of plant proteins may vary widely with temperature and time of heating since depending on the degree of the conformational changes in protein structure, diverse and complicated precipitation reactions may occur. The literature (Zayas, 1997) also reports that the molecular structure of most proteins is more susceptible to changes by heating treatment in aqueous medium than by dry heating. In general, the solubility of proteins increases with temperature between 0 and 40-50 °C, whereas at temperatures higher than 40-50 °C, the solubility of proteins is less than that of native proteins.

The *type of dissolution solvent* influences significantly the yield of protein extraction from biological matrices since depending on the class of protein, they are soluble in water, salts, alcohol or alkaline solutions. Although some solvents favor the extraction yield of certain proteins, it can also be deleterious for the proteins remaining in the meal. In some biorefinery schemes a cascade of process can be conducted for recovering progressively various types of proteins or other materials from the same meal. For instance, authors such as Navarro et al., (2016), Wu and Inglett, (1974) and Roberts and Briggs, (1963) have reported the denaturing effect of alcohols especially on globulins, which induces a decrease in their extractability from

plants. The use of certain solvents in a biorefinery scheme may come along with high temperatures of processing which can later lead to significant modifications in the secondary, tertiary or quaternary structure of proteins and consequently, change their functional properties.

Other *processing conditions* such as heating or mechanical treatment (emulsification, grinding, agitation), and drying during their manufacture may influence the physicochemical state of protein molecules and affect either favorably or adversely their solubility (Zayas, 1997). In this sense, the solubility data give useful information for the optimization of the processing procedure. Nevertheless, the functionality of proteins cannot always be enhanced by increased protein solubility. Other factors such as time of extraction, ratio meal/solvent, temperature of extraction, and the added salts besides determining the extractability of protein from plant material, also shape its subsequent solubility profile as a dry protein concentrate.

### **2.2.2. Water Absorption Capacity (WAC) of vegetable proteins**

WAC is also known as water holding, hydration, retention or binding capacity and, it can be defined as the ability of proteins to hold its own and added water during the application of forces, pressing, centrifugation, or heating (Zayas, 1997). This concept is also applicable to food products and other authors have defined it as a physical property related to the ability of a food structure to prevent water from being released from the three-dimensional structure of the protein (Hermansson, 1986). This functional property has an important role in food application since the level of protein hydration and the viscosity of liquid systems in food are highly correlated, in addition protein-water interactions may determine other functional properties of proteins such as swelling, solubility, emulsifying properties, viscosity, gelation, and syneresis (Zayas, 1997). In general, when plant proteins are used in food formulation as a nutritional additive or meat replacement, the WAC plays a major role in the texture, color and sensory properties of food products. Thus, the capacity of plant protein preparations to retain moisture may be transferred to processed foods when these proteins are incorporated. Similarly in other applications, the WAC is used for determining and developing kinds of packaging materials necessary to maintain the required moisture content in the product. The type of protein-water and protein-protein interactions determine whether the protein will function in the food as a gel, insoluble precipitate, or a colloidal dispersion.

Regarding the mechanisms involved in the ability of proteins to hold water, the interactions between molecules of water and hydrophilic groups of the protein side chains occur via hydrogen bonding (Zayas, 1997). Therefore, binding of water to proteins is related to the number and type of polar hydrophilic groups, such as imino, amino, carboxyl, hydroxyl, carbonyl, and sulfhydryl groups, so proteins that contain numerous charged amino acids tend to bind larger amounts of water. According to Kuntz, (1971), who studied by NMR the mechanisms for binding water of various polypeptides of individual amino acids, the nonpolar amino acid side chains such as those of alanine and valine bound one molecule of water, whereas polar side chains bound 2 or 3 molecules of water, and ionic side chains (in aspartic and glutamic acids, and lysine) bound 4 to 7 water molecules/molecule of amino acid. In this context, amino acids may be classified according to their ability to bind water into: i) polar amino acids with the highest water binding; ii) nonionized amino acids, binding intermediate amounts of water; and iii) hydrophobic groups which bind little or no water. The polar groups of proteins are able to bind more water by forming multilayers of water around them, whereas hydrophobic groups may bind one molecule of water only up to the monolayer level (Zayas, 1997). On the other hand the rate of wettability of protein powders is also influenced by size, shape and surface of protein particles and in general, the native proteins possess higher wettability than denatured. However other conditions such as protein concentration, pH, ionic strength, temperature, presence of other components of foods such as hydrophilic polysaccharides, lipids and salts, rate and length of heat treatment, and conditions of storage also influence the water binding capacity of proteins.

A change in *pH* of protein solution causes a change of charged groups on the protein molecule, affecting the conformation of proteins and resulting in exposure or burial of the water binding sites (Zayas, 1997). Moreover changes in pH influence the ionization of amino acid groups. In general the WAC of proteins is low in the isoelectric region since the net protein charge on the protein is zero and protein-protein interactions are maximal. On the other hand, the addition of salts (*ionic strength*) also influences the water binding of proteins because of their effects on electrostatic interactions. It has been reported that up to 2 M, an increase in ionic strength also improves the protein ability to bind water whereas above this limit further increase lead to a decrease in WAC due to competition between salt and amino acids to bind water.

Hydration of proteins and water retention capacity are also influenced by conformational changes of proteins during *food processing*, particularly during heating or pressure exposure. The protein water retention usually decreases with an increase in temperature. Nevertheless, heat treatments may expose groups of polar amino acids that influence positively the ability of plant proteins to hold water.

### **2.2.3. Emulsifying activity (EA) of vegetable proteins**

Protein emulsifying activity is the ability of the protein to participate in emulsion formation and to stabilize the newly created emulsion. The formation of the interfacial film for emulsion stabilization occurs in three steps: i) diffusion of proteins to the interface, ii) protein adsorption at the interface, iii) changes of protein conformation resulted from unfolding and reorientation of protein molecules (Zayas, 1997). The methods used to describe the emulsifying properties of proteins are emulsifying capacity (EC), emulsifying stability (ES), or emulsifying activity (EA). EC is usually presented as the amount of oil (mL) that is emulsified by 1 g of protein under specific conditions, whereas EA is presented as the maximal interfacial area (cm<sup>2</sup>) of an emulsion stabilized by 1 g of protein. In general, the emulsifying capacity of an emulsifier depends on its ability to i) form the adsorption film around the globules, and ii) lower the interfacial tension at the oil-water interface, whereas emulsion stability is the capacity of emulsion droplets to remain dispersed without separation by creaming, coalescence, and flocculation. Proteins are effective surface-active agents because they possess the capacity to lower the interfacial tension between hydrophobic and hydrophilic components in foods. As a functional property of plant proteins, many chemical and physical factors are involved in the formation, stability, and textural properties of protein-fat-water emulsions, for instance EC and ES depend both on the properties of proteins (source of protein, purity, chain of amino acids, molecular flexibility, surface hydrophobicity, etc.) and the conditions of emulsifying (pH, ionic strength (salt type and concentration), temperature, equipment design, viscosity of the system, etc.) (Arif & Pauls, 2018). To produce emulsions in food applications it is desirable that plant protein extract is soluble, has the ability to adsorb rapidly at the interface, has well-distributed charged groups, and has the ability to form a strong cohesive films.

Although the emulsifying capacity is related to hydrophobic as well as to hydrophilic properties of proteins, the EA has been widely studied by establishing a correlation between surface hydrophobicity of proteins and interfacial tension. In this context, proteins with a large

number of non-polar amino acids possess high hydrophobicity and consequently are highly surface active (Zayas, 1997). According to Li-Chan et al. (1984), the total hydrophobicity  $\times$  surface hydrophobicity (SxSo) represents more than 71% of the variability in the emulsifying activity index. Globular proteins with a great surface hydrophobicity, such as lysozyme, ovalbumin and whey proteins may improve their emulsifying capacity by moderate heating and partial unfolding. For instance, caseinates exhibit high EC due to their high solubility and to their dissociated and naturally unfolded structure (Zayas, 1997). In this sense, proteins must possess a well-balanced distribution of hydrophilic and hydrophobic domains in the molecules for exhibiting a high emulsifying activity. In addition, the surface activity, and thus the emulsifying properties may be improved by incorporation of the hydrophobic constituents to a hydrophilic protein.

Factors that may influence significantly the emulsifying properties of plant protein are: i) the *protein concentration* because the stability of emulsions is related to the total content of proteins in the system. Thus in general, it can be expected that protein isolates exhibit greater emulsifying properties than protein concentrates, ii) *pH* of the medium since some proteins have optimal emulsifying properties at the isoelectric point such as egg white and gelatin, whereas others perform better at pH away from the isoelectric point such as soybean and peanut proteins (Zayas, 1997). The positive effect, that may be observed at the isoelectric pH of proteins in diluted emulsions, is because the decrease in repulsions between fat droplets that cause formation of the floccules and emulsion destabilization. Basically, pH influences the emulsifying properties of proteins indirectly by affecting the protein charge, solubility, conformation and surface properties, iii) the addition of salts (*ionic strength*) to protein solutions may enhance the emulsifying properties due to the formation of a more cohesive interfacial protein layer (Zayas, 1997). It means that the addition of salt can impair electrostatic interactions and promote partial unfolding of proteins at the interface which favors the formation of cohesive films, iv) other factors, such as a moderate increase in *temperature* also play a key role in the formation of emulsions by causing an increase in the adsorption of the stabilizer (protein) at the interface. On one hand, the surface activity of proteins may increase as the result of partial denaturation by temperature effect, but on the other hand, aggregation of proteins may reduce the concentration of effective adsorbing proteins causing thereby, lower surface activity. When an improvement of protein functionality by heating is observed, it is probably due to the exposure of the hydrophobic groups of amino acids which increase the total surface activity.

### 2.3. Polyphenol-rich extracts

Polyphenols are abundant micronutrients in our diet. They can be classified as phytochemicals with health benefits, especially in cardiovascular and brain function. Phytochemical may be defined, in the strictest sense, as chemicals produced by plants. Nevertheless, phytochemical is generally used to describe chemicals from plants that may affect health, but are not essential nutrients (El Gharras, 2009). Polyphenols are secondary compounds of plant metabolism (“secondary” because they do not take part in primary metabolism) which are widely distributed in the plant kingdom and chemically represent a large group of ubiquitous phytochemicals that incorporate within their structure at least one phenyl aromatic hydrocarbon ring with at least one hydroxyl group attached (Kennedy, 2014). Polyphenols are divided into several classes according to the chemical structures of the aglycones: i) phenolic acids such as hydroxybenzoic acids and hydroxycinnamic acids, ii) flavonoids such as flavonols, flavones, flavanols, flavanones, isoflavones, anthocyanins, iii) stilbenes such as resveratrol, and iv) lignans such as matairesinol (El Gharras, 2009; Manach et al., 2005).

Phenolic acids are non-flavonoid compounds which can be further divided into benzoic acid and cinnamic acid derivatives based on C1–C6 and C3–C6 backbones. On the other hand, flavonoids have the C6–C3–C6 general structural backbone in which the two C6 units (Ring A and Ring B) are of phenolic nature. Due to the hydroxylation pattern and variations in the chromane ring (Ring C), flavonoids can be further divided into different sub-groups such as anthocyanins, flavan-3-ols, flavones, flavanones and flavonols (Tsao, 2010). It is important to highlight that in plants, most of these compounds exist as glycosides molecules.

Although there are other major classes of secondary metabolites in plants, i.e. alkaloids and terpenes, the phenolics play by far the widest range of ecologic roles (Kennedy, 2014). Phenolic compounds are distributed in plants and food of plant origin because they play ecologic roles, protecting the plant from physical challenges and allowing it to interact with its environment. So, due to the polyphenol are widely distributed in the different tissues of plant matrices, the large amounts of by-products (both solids and liquid) that result after harvesting or/and food processing, such as slurry, leaves, stems, peels, seeds, bagasse, cereal-bran, press-cakes, etc., still represent an important and cheap source of these antioxidant molecules.



The phenolic nature of polyphenols makes them relatively hydrophilic, thus free polyphenols, including aglycones, glycosides, and oligomers, may be extracted using water, polar organic solvents such as methanol, ethanol, acetonitrile and acetone, or their mixture with water. Besides the solvent polarity, pH of the water in the mixture also play a key role in the extraction yield of phenolic compounds. In general, extractions under acidic conditions enhance the yield because polyphenols are generally more stable at low pH, and the acidic condition helps polyphenols remain neutral, thus readily extracted into organic solvents (Tsao, 2010). However, high acid concentration may cause hydrolysis of glycosides or acylglycosides which leads to obtain different phenol profiles than those of native polyphenols. The hydrolysis using acid or alkaline conditions is also used for extracting polyphenols which are bound to structural materials (non-free polyphenols) such as lignans and phenolic acids (ferulic acid, for instance) (Kim et al., 2006). Sometimes, hydrolysis of polyphenols is desirable to obtain aglycones that exhibit a higher antioxidant activity in comparison with the glycoside native form. For that, enzymes such as  $\beta$ -glucosidase, or strong acid such as 2–4 M HCl at high temperature are used (Tsao, 2010).

#### *Functional properties of polyphenols*

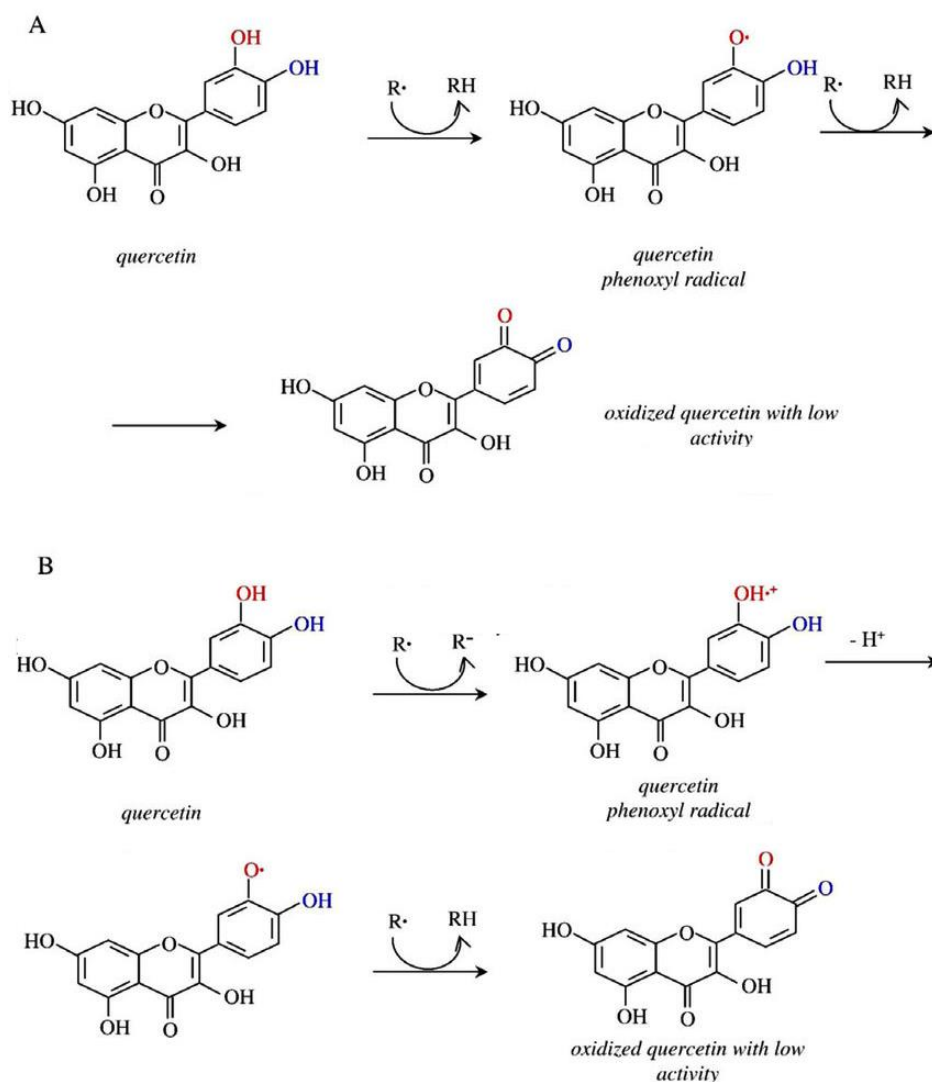
Polyphenols in food exhibit a wide range of properties, depending on their particular structures. First, many polyphenols molecules are pigments responsible for providing desirable color properties such as yellow, orange, red, and blue pigmentation, to food. Nevertheless, these pigment are highly reactive species thus their properties may vary depending on the pH of the medium, food processing, interaction with other molecules such as proteins and polysaccharides, among others. In slightly acidic media, anthocyanins are present mostly in the colorless hemiketal form, in equilibrium with the yellow chalcone isomer, whereas in acid mediums anthocyanins are more stable due to the formation of flavillic ions that result in more intense red colorations of the monomeric anthocyanins (Garcia-Mendoza et al., 2017). Regarding the effect of food processing, the degradation of anthocyanins by temperature treatment may occur through hydrolysis of the glycosidic bond, which releases an aglycone (cyanidin) that discolors much faster than the glucoside form, or by the opening of the heterocyclic ring what leads to the formation of chalcone (colorless structure), which is converted into brown precipitate at high temperatures (Garcia-Mendoza et al., 2017). In addition, phenolic are also highly involved in food flavor. For example, volatile polyphenols, such as vanillin and eugenol (which is responsible for the characteristic odor of cloves), are

extremely potent odorants however, the major flavors associated with polyphenols are bitterness and astringency. The latter is the results of the interaction of polyphenols with proteins such as the astringency perception resulting from interactions of tannins with salivary proteins, in addition the phenol-protein interactions may also result in the formation of haze and precipitates in several beverages (Cheynier, 2005). Cheynier, (2005) also stated that the affinity of proanthocyanidins for proteins and their astringency increased with both the degree of polymerization and the extent of galloylation.

On the other hand, all phenolic compounds are highly unstable and rapidly transformed into various reaction products when the plant cells are damaged. It may be stated that the most important biochemical process in food processing is enzymatic oxidation, which starts as soon as the integrity of the plant cell is broken. The enzymatic oxidation in plant-derived foods results in the browning of the product and it is usually detrimental to quality, particularly in postharvest storage of fresh fruits or juice and puree technology although may be a desirable reaction for other products such as tea, coffee, cocoa, prunes, black figs and raisins (El Gharra, 2009; Cheynier, 2005). Although there are many enzymes such as esterases, glycosidases, and decarboxylases which are involved in the catalyze transformation and degradation of phenolic compounds, the polyphenol oxidase (1,2-benzenediol:oxygen oxidoreductase) can be defined as the main enzyme responsible for the enzymatic browning in plant foods (Taranto et al., 2017; Can et al., 2014; Araj et al., 2014;Whitaker, 1995). Polyphenol oxidase is also known as tyrosinase, phenolase, cresolase and catechol oxidases and it is widely distributed copper containing enzyme in many plant tissues and in some fungi such as mushrooms. The activity of polyphenol oxidase in the presence of molecular oxygen occurs in foods by two different reactions: i) the first activity, monophenolase or cresolase catalyzes the hydroxylation of monophenols to *o*-diphenols and, ii) the second activity, diphenolase or catecholase oxidize the *o*-diphenols to the corresponding *o*-quinones, which are highly reactive molecules and polymerize to brown, red or black pigments depending on natural components of plant matrix (Can et al., 2014; Whitaker, 1995). The browning pigments lead to organoleptic and nutritional modifications, thus compromising the quality of processed food products, particularly because bruises, cuts and other mechanical damage that allow oxygen (O<sub>2</sub>) penetration lead to rapid browning in many fruits and vegetables by the melanin formation. In this sense, one of the most important problems in the fruit juice industry is the presence of seeds and browning occurring during processing, since polyphenol oxidase released from fruit seeds gives juice

unpleasant appearance and taste, particularly in apple, banana, peaches, apricots, grape and strawberry juices.

Regarding to the biological properties of polyphenols, Cheynier, (2005) stated that there is evidence that phenolic substances act as antioxidants by preventing the oxidation of LDL-lipoprotein, platelet aggregation, and damage of red blood cells which reduce the risk of suffering many chronic diseases including cancer, cardiovascular disease, chronic inflammation and many degenerative diseases. The antioxidant properties of polyphenols depend on their chemical structures, particularly on the number and position of the hydroxyl groups, but in general phenolics may act as: i) metal chelators, ii) antimutagens and anticarcinogens, iii) antimicrobial agents and, iv) clarifying agents (El Gharras, 2009). Polyphenols have been found to be strong antioxidants that can neutralize free radicals by donating an electron or hydrogen atom and the highly conjugated system and certain hydroxylation patterns such as the 3-hydroxy group in flavonols are considered highly important in the antioxidant activities. According to Tsao, (2010), polyphenols may suppress the generation of free radicals, thus reducing the rate of oxidation by inhibiting the formation or may act also by deactivating the active species and precursors of free radicals. Phenolic compounds act usually as direct radical scavengers of the lipid peroxidation chain reactions (chain breakers). Chain-breakers donate an electron to the free radical, neutralizing the radicals and themselves becoming stable (less reactive) radicals, thus stopping the chain reactions (Tsao, 2010). Moreover, polyphenols may also chelate metals such as  $Fe^{2+}$  which can directly reduce the rate of Fenton reaction, thus preventing oxidation caused by highly reactive hydroxyl radicals. In Figure I-6 is illustrated the hypothetical mechanisms of action of polyphenol such as quercetin for scavenging free radicals ( $R\cdot$ ). According to Papuc et al. (2017) flavonoids like quercetin may be the terminator in the chain reaction because it may easily scavenge a free radical by hydrogen atom donation from its 3'-hydroxyl and then from its 4'-hydroxyl group (3' and 4' hydroxyl groups are the most active in quercetin), or by electron transfer—proton transfer, forming a quinone (organic molecule derived from aromatic compounds by conversion of an even number of  $-CH=$  groups into  $-C(=O)-$  groups with any necessary rearrangement of double bonds) that exhibits a low activity.

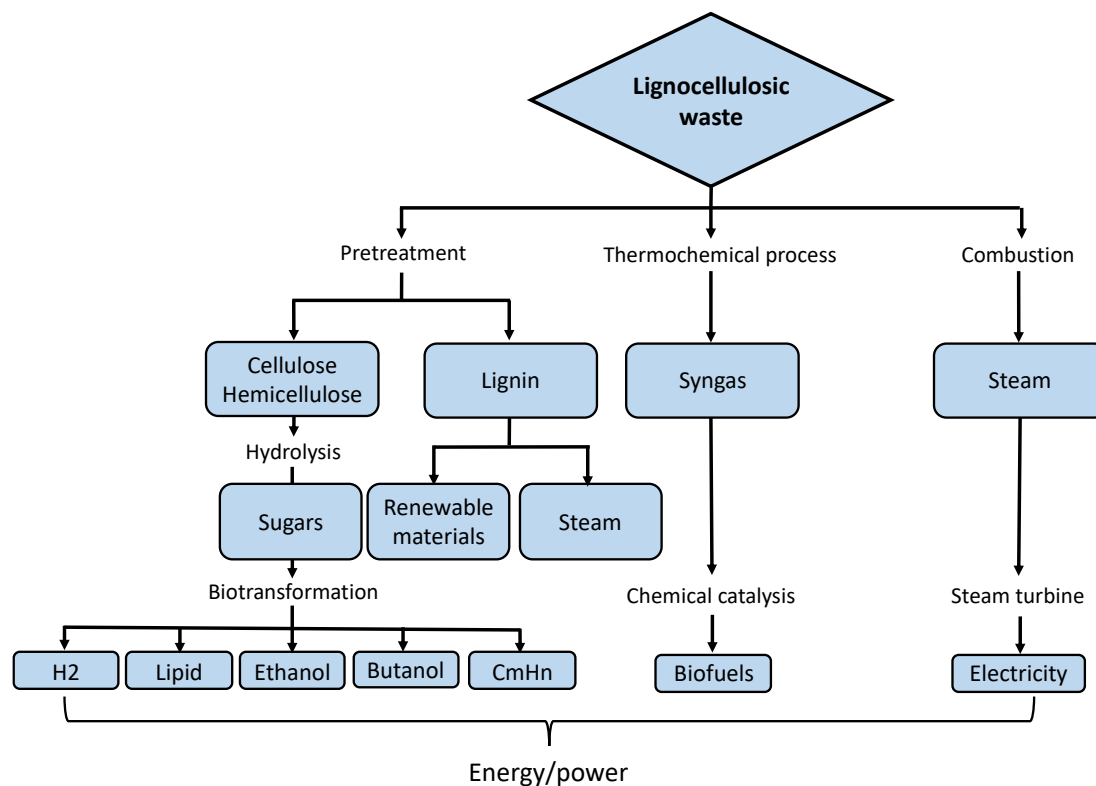


**Figure I-6.** Mechanisms for free radical scavenging activity of polyphenols (quercetin) by (A) hydrogen atom donation or (B) electron transfer—proton transfer (Source: Papuc et al., 2017)

## 2.4. Lignocellulosic fibers for obtaining energy and renewable fuels

Although the developing of renewable fuels from lignocellulosic materials (agricultural residues) was not the aim of this work, this alternative has been widely studied and carried out by many biorefineries in the current days. The use of bioenergy contributes to public energy policies that reduce carbon emissions and environmental pollution, while contributing significantly to the energy matrix through biofuels and biogas (Torres-Mayanga et al., 2019). The biomass resources are multiple and can be applied to the achieving fuels, chemical products and energy sources. On the other hand, animal wastes offer potential directly, both, as a fuel combustible and as an input to produce biogas. In general, agricultural residues are

composed of cellulose, hemicellulose and lignin, exhibiting the following typical composition: 40–50% cellulose, 25–35% hemicellulose, 15–20% lignin, thus these residues represent a great potential resource for energy achievement (Forster-Carneiro et al., 2013). However, most of plant residues should be pretreated in order to convert biomass into a form suitable for fermentation and/or chemical upgrading. Several pretreatments use chemicals, harsh conditions, catalysts that cannot be recycled which is contrary to the concept of biorefinery. Nevertheless, novel and green technologies such as sub/supercritical water have been proposed to overcome this issue (Torres-Mayanga et al., 2019). Globally, it can be stated that common forms of biomass energy include pellets, wood chips, and cellulosic ethanol (Nunes et al., 2020). Nowadays, the following conversion processes are involved in this type of biorefinery: pyrolysis and gasification frequently called thermo-chemical routes (Forster-Carneiro et al., 2013). Pyrolysis is the thermal decomposition of materials at elevated temperatures in an inert atmosphere in order to obtain charcoal (solid), bio-oil (liquid), and fuel gases, whereas gasification is a process in which carbon-rich feedstocks (biomass) are converted into a fuel gas called Syngas, consisting of hydrogen and carbon monoxide under oxygen depleted, high pressure, high-heat and/or steam conditions. The Figure I-7 shows a global scheme related to the utilization of lignocellulosic waste for energy achievement under the biorefinery concept.



**Figure I-7.** Scheme of combined processes for energy achievement from lignocellulosic sources (Adapted from Ankush et al., 2020; Huang & Zhang, 2011)

A great variety of biofuels can be produced from lignocellulose biomass, including cellulosic ethanol, butanol and/or long chain alcohols, electricity, bioalkanes, fatty acid esters, hydrogen, hydrocarbons, and waxes (Huang & Zhang, 2011). Particularly for the processes related to the cellulosic ethanol production, the efficiency of the pretreatment is a crucial step during the biomass conversion process since it will result directly in a single step or indirectly after enzymatic hydrolysis in the sugar-rich medium that will be used for fermentation (Torres-Mayanga et al., 2019). Although the production of some by-products during biomass pretreatment is inevitable, many biological, chemical and thermochemical processes may be introduced to the biorefinery chain in order to add value and applicability to these by-products such as lactic acid, succinic acid, levulinic acid, xylitol, sorbitol, hydroxymethylfurfural and furfural. These chemicals are compounds of great interest both for the scientific research community and in the future development of synthetic processes at the industrial scale (Torres-Mayanga et al., 2019).

Regarding the statistics of global production of fuels from biomass sources, it can be stated that historically, the United States has had the largest installed capacity for cellulosic ethanol production (35%), followed by China (24%), Canada (22%), European Union (9%) and Brazil (9%) (United Nations, 2016).

## **2.5. Use of agricultural residues under a holistic approach - Pickering emulsion**

Until now, it has been widely explained and discussed the approach of biorefineries related to exploit agricultural wastes for providing added value products or materials in addition to promote environmental benefits. Globally, the biorefinery concept mainly aim to promote a more efficient use of energy and resources. Various valuable products or fractions that can be obtained from plant residues under a biorefinery scheme, such as proteins, oil, phytochemicals and fuels have already been mentioned. Nevertheless, to achieve the environmental goal in addition to the expected added value, a possible alternative strategy is minimal processing, i.e. focusing on functionality more than on purity, using a shorter fractionation process (Huc-Mathis et al., 2019). In this sense, plant residues may be potentially used under a holistic approach instead of extracting, fractionating and purifying the components or products of interest what would require added energy. The use of agricultural by-products “as it” as functional ingredient also provide an efficient use of biomass sources in addition to promote a lower energy consumption and important environmental benefits. This concept has already been promoted by several authors such as Huc-Mathis et al. (2019),

Campbell & Jacobson, (2013), Laufenberg et al. (2003) among others, due to its important benefits.

On the other hand, using wastes as functional ingredients may reduce product processing however, plant by-products themselves are more complex materials than purified fractions. The complexity of the plant materials could be an advantage in the formulation of many food and cosmetics products since they may act as texturizers, emulsifiers, foaming agents, pigments in the final product. More benefits of using plant residues “as it” for food and non-food applications, may be added considering that they are biodegradable, biocompatible, renewable, non-toxic and natural sources. In this context, the use of plant residues for stabilizing Pickering emulsions due to their emulsifying properties have recently attracted the attention of researchers because of their advantages over conventional emulsions. Follow below the main concepts or principles of the use of whole plant residues as emulsion stabilizers.

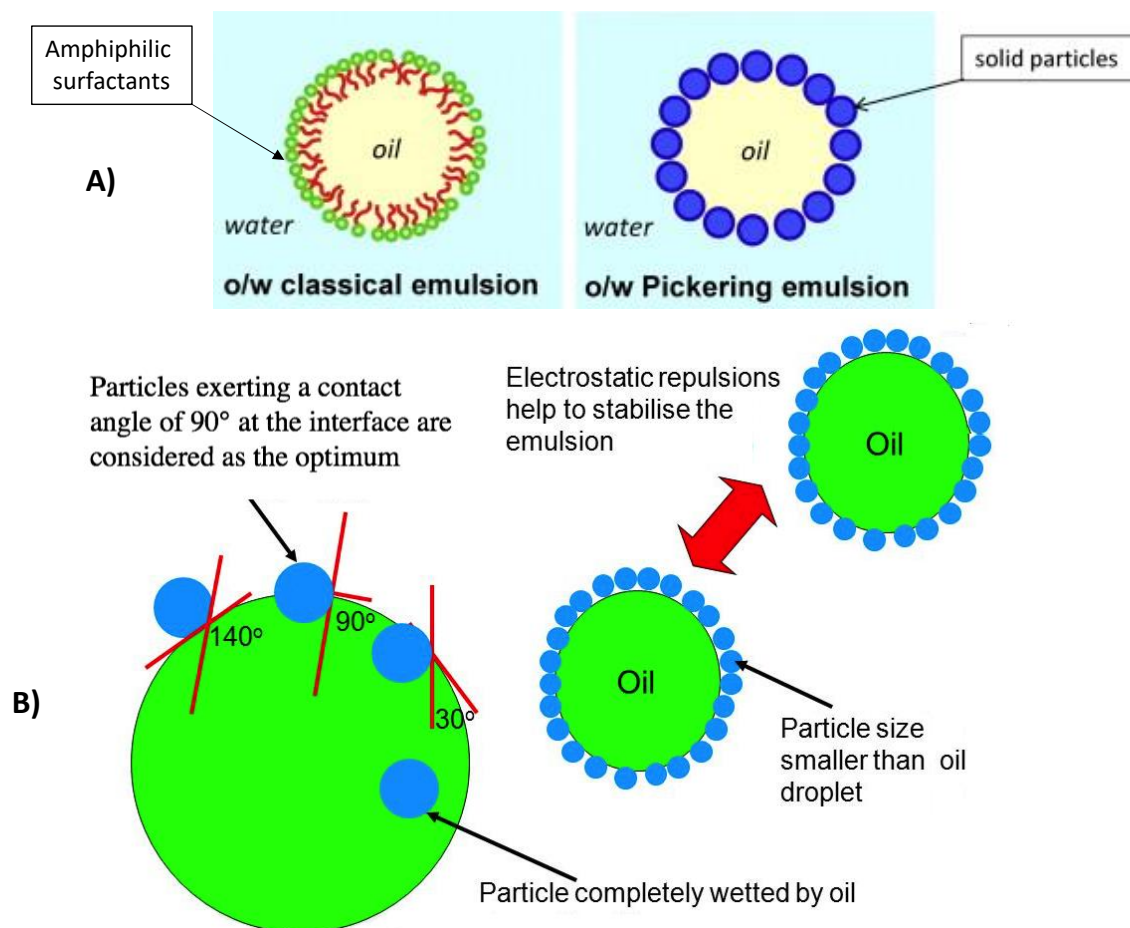
### **2.5.1. Main concepts of Pickering emulsions**

Firstly, an emulsion is a dispersion, made by means of a surfactant compound, of two or more liquids that are normally immiscible. Emulsions are part of a more general class of two-phase systems of matter called colloids and may be stabilized by either small molecular weight surfactants through interfacial tension reduction, or amphiphilic macromolecules, such as proteins and polysaccharides, by forming steric elastic films in addition to the reduction of interfacial tension (Xiao et al., 2016). In this sense, Pickering emulsions may be defined as such emulsions stabilized using solid particles at the interface (Figure I-8A). One of the differences between Pickering emulsions and conventionally stabilized emulsions is at their interface since Pickering stabilized oil droplets have usually a higher surface load and thickness due to the adsorption of particles than normal emulsions (Jafari et al., 2020). In general, any colloidal particles which can inhibit droplet coalescence and phase separation in different types of emulsions, mainly due to steric barrier can be used for the Pickering stabilization. Pickering emulsion definition comes from the observation of Spencer Umfreville Pickering in 1907, who believed that emulsions stabilized using organic substances such as milk, starch and saponin would become spontaneously de-emulsified due to stress conditions, whereas paraffin emulsions prepared by solid particles which were not soluble in the oil phase and had little tendency towards the aqueous phase, were both resistant to coalescence and did not show spontaneous de-emulsification (Pickering, 1907). The main mechanism of solid particles for

stabilizing Pickering emulsions, is by their absorption at the interface between liquids which form an obstacle to limit the merging (coalescence) between droplets (Gonzalez Ortiz et al., 2020; Yang et al., 2017).

According to Xiao et al. (2016), the particles to be capable of Pickering stabilization exhibit specific qualifications: i) particles should not have a tendency (solubility) for neither the hydrophobic nor the hydrophilic phases, meaning that they can be wetted partially by both phases, ii) they should be able to efficiently adsorb at the interface, and iii) the size of particles is believed to be one order of magnitude smaller than that of the ultimate emulsions. It can be stated that the wettability of solid particle is the key property governing the formation and stabilization of Pickering emulsions and three-phase contact angle  $\theta$  which is the angle formed at the three-phase boundary where solid particles, continuous phase and dispersed phase intersect, may be used to semi-quantify this property (Xiao et al., 2016). Theoretically, particles exerting a contact angle of  $90^\circ$  at the interface are considered as the optimum (Figure I-8B) since the free energy of a particle with a  $90^\circ$  contact angle to detach into both phases is equal and thereby this particle mainly deposits at the oil-water interface which is a pre-requisite for Pickering stabilization (Jafari et al., 2020).





**Figure I-8.** Oil droplet stabilize either by conventional amphiphilic surfactants or solid particles (A) and schematic diagram of Pickering emulsion and three phase contact angle (B) (Adapted from Chevalier & Bolzinger, 2013)

In addition to wettability, other factors, such as size, shape and composition of the particles, may also influence the formation and characteristics of Pickering emulsions. In particular, the shape of particles for stabilizing emulsion is defined as the aspect ratio: the length to the width ratio of a particle (Jafari et al., 2020). Nevertheless, it is important to consider that both the continuous and dispersed phase are homogenized to form the emulsions droplets by methods such as high shear homogenizers, which may modify the size distribution of particles before they can adsorb onto the interface.

Plant residues for stabilizing Pickering emulsion have a particularity in comparison with inorganic and synthetic polymers since few food ingredients can simultaneously satisfy the above-mentioned three qualifications. For using any phytoparticle as Pickering emulsifier, they must remain insoluble and intact in both phases over the lifetime of emulsion system

which is not as easy since most of proteins are initially water-soluble while polysaccharides may undergo swelling in aqueous solution (Xiao et al., 2016). Therefore, specific procedures are needed to fabricate Pickering emulsions through these food-grade materials. Despite the inconveniences of introducing food-grade materials as Pickering stabilizers, the concept of food-grade particles-stabilized emulsions is rapidly increasing, particularly to be used in food and cosmetic applications. In this sense, the literature already reports several studies focused on stabilize Pickering emulsion by food-grade particles such as protein, polysaccharide or protein polysaccharide complexes previously extracted from plant materials (Jafari et al., 2020; Burgos-Díaz et al., 2019; Saari et al., 2019; Dai et al., 2018; Yildiz et al., 2018; Dickinson, 2017; Porfiri et al., 2017; Saari et al., 2016; Xiao et al., 2016) however, far fewer studies aimed to stabilize Pickering emulsion by whole plant particles, i.e. neither extraction nor purification of fractions from plant matrix.

Recently, our research group (CLIP'IN team) has investigated the effect of cocoa powder on the properties of Pickering emulsions prepared with three different processes: rotor/stator turbulent homogenization, sonication and microfluidization (Joseph et al., 2019a). Globally, they observed that microfluidization was the most effective emulsification process in reducing the droplet size and that the soluble and insoluble fractions of the particles did not have a significant effect on the emulsification and stability. Nevertheless, Gould et al. (2016) and Gould et al. (2013) used for the first time coffee and cocoa particles respectively, for stabilizing Pickering emulsions. Nushtaeva, (2016) used mustard powder, ground ginger, ground cinnamon, nutmeg powder, potato starch, and talc as solid emulsifier for emulsion stabilization. It was observed that mustard and cinnamon demonstrated the best emulsifying properties remaining stable in test tubes for one month.

In addition, Joseph et al. (2019b) also worked on redispersible dry emulsions stabilized by rapeseed press-cake and cocoa powder and reported that dry-emulsions did not exhibit any clumping even after several months of storage at room temperature and were redispersible in water. Huc-Mathis et al. (2019) assessed the emulsifying properties of apple pomace and oat bran, obtained as agricultural by-products, for stabilizing oil in water emulsions. They reported that the action of the insoluble fibers maintained the stability of the emulsions through Pickering mechanism and that apple powder exhibited better emulsifying potential. Finally, most recently Benitez et al. (2020) explored soybean meal for formulating and stabilizing rice bran oil-in-water emulsions. They assessed the influence of emulsion composition and the

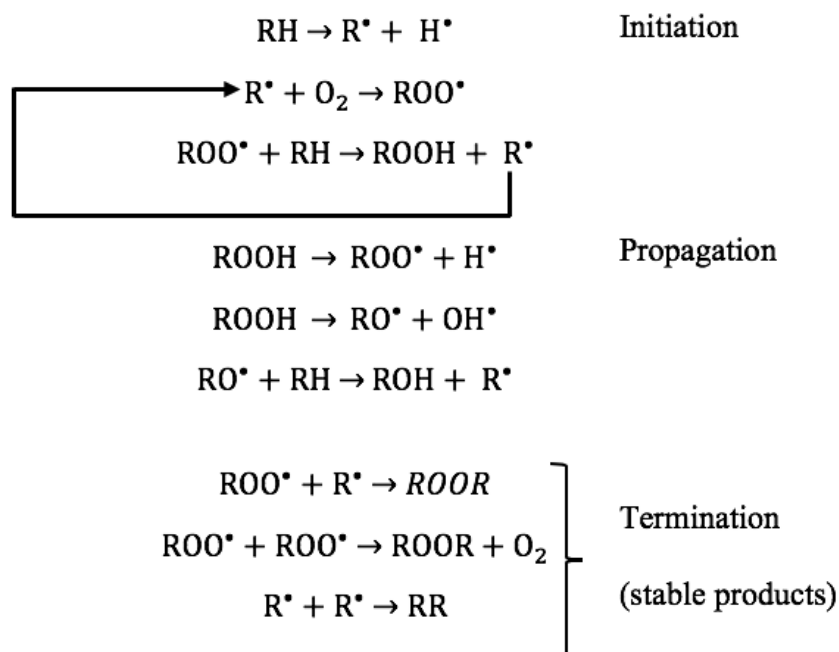
high-pressure homogenization conditions and reported that most of the studied emulsions were stable for seven days of quiescent refrigerated storage, although some changes in its particle size distributions were observed.

### **2.5.2. Functional properties of Pickering emulsion – Antioxidant effect**

Besides the ability of phytoparticles to stabilize different types of water-oil emulsions in a food grade as they are non-toxic, biodegradable, biocompatible and renewable materials, plant particles also may enhance the oxidative stability of oily phase in the emulsion system since they content phytochemicals such as polyphenols, carotenoids, tocopherol or phospholipids which may act as antioxidant agents during storage conditions. Author such as Song et al. (2020) and Joseph, (2018) reported that oil-in-water emulsions stabilized by plant-based particles were able to enhance the oil stability of Pickering emulsions by decreasing the oxidation rate of the oil. Both authors stated that the solid plant particles could provide an interfacial film (a physical barrier) around each oil droplet and hinder the access of free radicals in the chain reaction, thus inhibiting the lipid oxidation of O/W emulsions. Nevertheless, other hypothesis such as unabsorbed particles at the continuous phase increase the viscosity of the system and consequently decrease the diffuse of pro-oxidants may be considered (Song et al., 2020) or that polyphenol compounds, which exhibit antioxidant activity, may be released from the plant material providing then a protective effect against lipid oxidation. In this context, it is worth explaining roughly the mechanism related to lipid oxidation.

#### *Lipid oxidation*

In general, the main mechanism involved in lipid oxidation is called autoxidation or peroxidation in which unsaturated fatty acids of triglycerides are attacked by atmospheric oxygen. Autoxidation is a free-radical chain reaction and it can be initiated by-and produces-hydroperoxides and may therefore be considered an autocatalytic process (Zielinski & Pratt 2017). The mechanism of free radical autoxidation can be understood by a chain process consisting of initiation, propagation and termination steps as shown in Figure I-9.



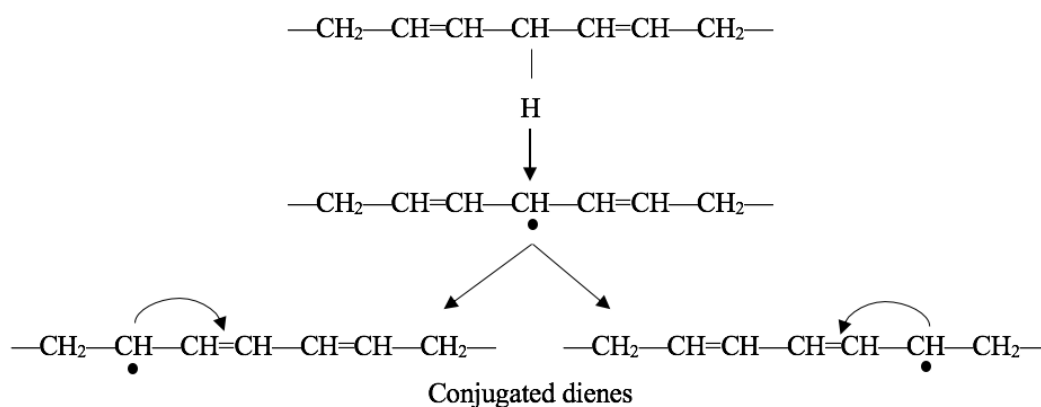
**Figure I-9.** Schematic representation of peroxidation of lipids

*Initiation* takes place by loss of a hydrogen radical ( $H^\bullet$ ) from the allylic carbon (from the double bond) of the fatty acid molecule ( $RH$ ), in the presence of trace metals, light or heat. Multiple endogenous enzymatic systems can also generate free radicals

*Propagation:* The resulting lipid free radicals ( $R^\bullet$ ) react with oxygen to form peroxy radicals ( $ROO^\bullet$ ). Indeed, molecular oxygen is not fixed directly on a native lipidic compound, but on a radical compound. The peroxy radical ( $ROO^\bullet$ ) is the principal chain-carrying species under most circumstances (Yin et al., 2011). The reaction between radical  $R^\bullet$  and  $O_2$  to form peroxy radicals requires very low activation energy whereas the reaction rate is very high when the oxygen content is not limiting (Dridi, 2016).

In the propagation step,  $ROO^\bullet$  then react with more  $RH$  to form lipid hydroperoxides ( $ROOH$ ) and a new unstable free radical. The new lipid radical propagates the cycle by the incorporation of more oxygen to the system. Therefore, lipid hydroperoxides are the fundamental primary products of autoxidation. The effect of antioxidant molecules is because they may break the chain reaction by reacting with  $ROO^\bullet$  to form stable radicals that are either too unreactive or form nonradical products (Frankel, 1984).

Particularly, the oxidation of polyunsaturated fatty acid is accompanied by an electronic rearrangement of the double bonds which pass from the unconjugated position to the conjugated position which produces isomeric hydroperoxides containing diene and trienic conjugated bonds (Figure I-10).



**Figure I-10.** Formation of conjugated dienes as primary products of lipid oxidation (Source: Dridi, 2016)

Since hydroperoxides are unstable, they can undergo various reactions including a decomposition by homolytic cleavage of RO-OH to form alkoxy radicals RO<sup>•</sup>. These radicals undergo carbon-carbon cleavage to form breakdown products including aldehydes, ketones, alcohols, hydrocarbons, esters, furans and lactones (Frankel, 1984). Radicals RO<sup>•</sup> also propagates the oxidation phenomenon by tearing off a hydrogen atom from a fatty acid molecule. Lipid hydroperoxides (ROOH) can also react with oxygen to form secondary products such as epoxyhydroperoxides, ketohydroperoxides, dihydroperoxides, cyclic peroxides and bicyclic endoperoxides (Frankel, 1984).

Once the substrates (double bonds of a fatty acid) are exhausted, the propagation is interrupted by the *termination* step where volatile compounds, polar materials and polymers are formed. Therefore, the termination phase corresponds to the last stage of oxidation during which the radical species react to form non-radical products, which ends the reaction cycles.

### 3. Technologies for extracting valuable components

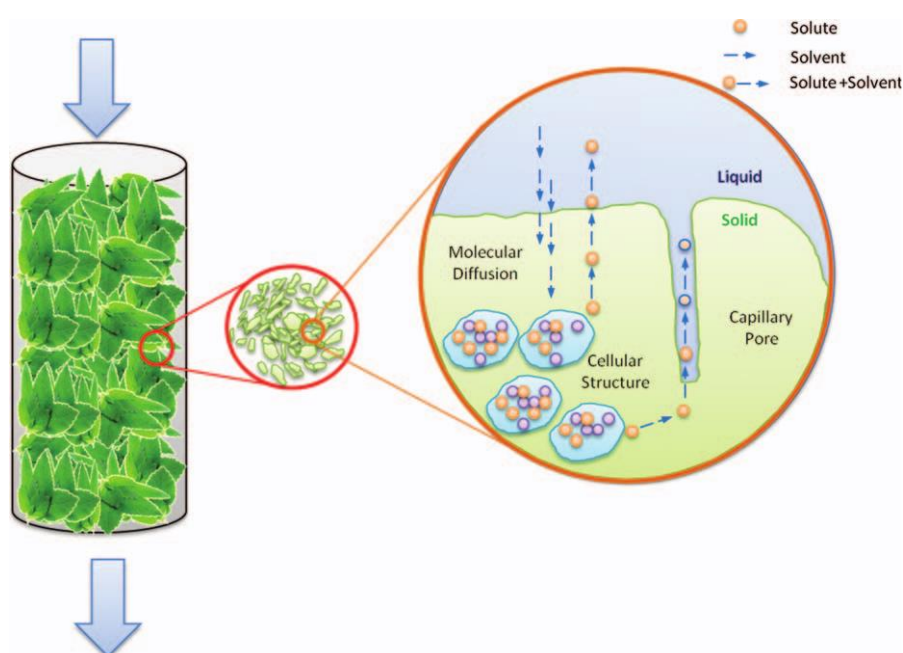
As shown in Figure I-1, a wide range of products can be recovered from plant material under a biorefinery concept. In this sense, some of the technologies used to recover valuable components, which are of greater interest for this work, have been described below.

#### 3.1. Convectioal extraction

As discussed previously, the extraction method to be applied to a particular plant matrix depends on the features of the raw material to be processed and on the target compounds. Although novel intensification methods have been recently used for recovering added value product from plant residues, as discussed in next section, there are several solid–liquid conventional extraction techniques that are still used in lab and industrial scale. There is no single and standard extraction method for obtaining compounds/material from natural sources particularly because each type of method exhibits advantages and disadvantages. Among the most commonly used conventional techniques are soaking or maceration, Soxhlet extraction, and distillation (Palma et al., 2013). In these conventional methods, the performance of the extraction depends on conditions such as temperature, mechanical action (such as pressure and shaking), time, and solvent type. In general, applying heat and agitation usually accelerates extraction kinetics by facilitating the diffusion of the solute from the solid matrix to the fluid phase.

For the industrial production of extracts from plant materials, it is required to achieve an adequate balance between extraction efficiency, extraction yields of the target and co-extracted compounds, and concentration of target compounds, in order to minimize economic costs. In this sense, the main goals of an industrial extraction process are: i) high yield: the target compounds should be exhaustively or approximately exhaustively recovered and ii) high selectivity (purity): the resulting extract has a low amount of interfering or undesirable co-extracted compounds. For achieving these goals, the extraction must be analyzed from a phenomenological point of view, as mass transfer process of one or more components from one phase to another one. When dealing with biomass, in most cases the sample to be extracted is a solid matrix, although in some cases liquid samples are also used. On the other hand, the extracting solvent is usually a liquid, but it can also be a solid or a supercritical fluid. The extraction is mainly influence by the interactions between solute and solvent which are determined by the vapor pressure of the solute, the solubility of the solute in the solvent, the

hydrophobicity, and the acid/base properties of both solute and solvent. The extraction mechanism may be schematically presented as shown in Figure I-11, and consists of the following steps (Palma et al., 2013): (1) the solvent is transferred from the fluid phase to the solid surface and pervades it, (2) the solvent penetrates into the solid matrix by molecular diffusion, (3) the soluble material is solubilized by desorption from the matrix and solvation into the extraction solvent – the breakage of chemicals bonds may be required for desorption of target analytes from the solid matrix, (4) the solution containing the solutes returns to the surface of the solid by molecular diffusion, and (5) the solution is transferred from the solid surface to the bulk fluid by natural or forced convection.



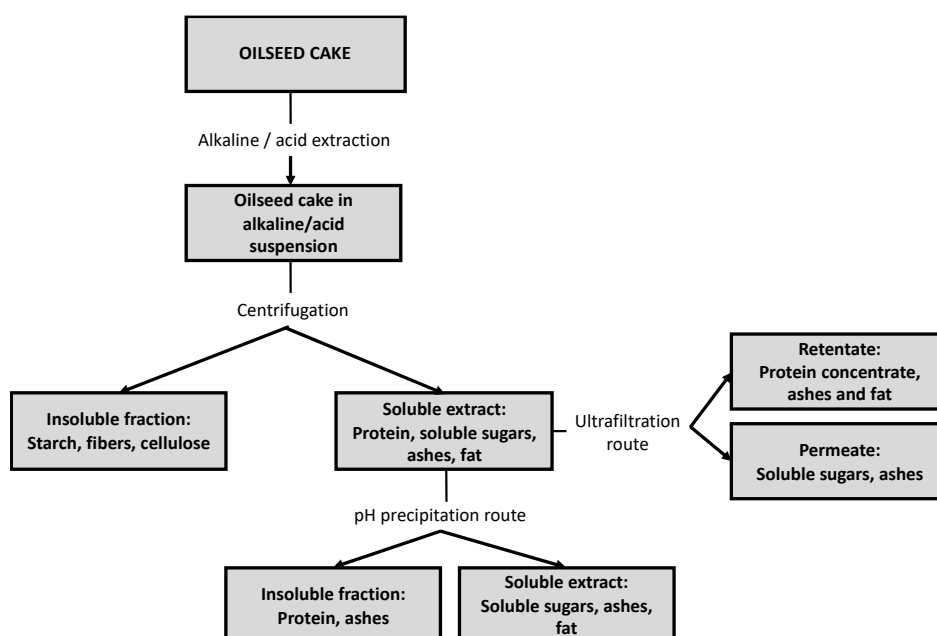
**Figure I-11.** Schematic representation of the extraction mechanism from plant matrices  
(Source Palma et al., 2013)

It is also important to highlight that during extraction process, many target compounds may be not freely available because they interact with other components from the raw material such as proteins, carbohydrates, and lipids, consequently it is also necessary to break the intermolecular interactions between these molecules, by providing energy, before establishing new interactions between the solute and the solvent.

Solid–liquid conventional extraction methods find numerous applications in the food industry; probably the best known example of which is the production of vegetable oils from oleaginous plants (Takeuchi et al., 2009). According to FAO, during large-scale oil production,

the kernels are usually ground to reduce size and cooked with steam, and the oil is then extracted in a screw or hydraulic press. The pressed cake is flaked for later extraction of residual fat with solvents such as "food grade" hexane. Oil can also be directly extracted with solvent from products which are low in oil content, such as soybean, ricebran and corn germ.

Solid-liquid extraction is also widely used for valorizing oil seed press-cakes by recovering vegetable protein. In this sense, Figure I-12 shows the two possible ways for the classical two-steps process fractionation (extraction and isolation) of vegetable proteins by the solid-liquid conventional extraction method. Moreover, in Table I-6 it was already listed various conditions for protein recovery from plant material by solid-liquid extraction, with or without coupled intensification techniques.



**Figure I-12.** Industrial scale extraction and isolation of vegetable protein by solid-liquid method (Adapted from Chéreau et al., 2016)

**Table I-6.** Extraction methods used for protein recovering from various agro-residues

By-product	Extraction and purification method	Protein recovery (PR)/content (PC)	Reference
Wheat bran	Pressure assisted extraction with water (30 bar)	PC: 1.976 g/L	(Celiktas et al., 2014)
	Alkaline extraction and	PC: 60%	(Celus et al., 2009)



	acid precipitation		
Brewer's spent grain	Enzyme assisted extraction (carbohydrolases and peptidases)	PC: 19.2–19.4% PR: > 80%	(Treimo et al., 2009)
	Enzyme-assisted extraction (alcalase)	PR: up to 77%	(Treimo et al., 2008)
	Hydrothermal extraction (60°C)	PR: 64–66% PC: 53.7–54.0%	(Qin et al., 2018)
Rice residue	Alkaline extraction and acid precipitation	PC: 83.2–91.1%	(Hou et al., 2017)
Defatted rice bran	Alkaline extraction and cold precipitation (4°C)	PC: 52.46–58.92%,	(Chandi & Sogi, 2007)
	Microwave assisted extraction (water pH 10)	PC: 71.27% PR: 22.07%	(Phongthai et al., 2016)
	Enzyme-assisted extraction (viscozyme)	PR: 82.6%	(Bandyopadhyay et al., 2012)
	Alkaline extraction and microwave assisted extraction	PR: 82.5%	(Bandyopadhyay et al., 2012)
	Subcritical water extraction (200°C and 101.35 kPa)	PR: ≈100%	(Sereewatthanawut et al., 2008)
Corn germ	Salt solution extraction (0.1 M NaCl) and dialysis	PC: 20-28%	Hojilla-Evangelista, 2012
	Salt solution extraction (0.1 M NaCl) and Ultrafiltration–Diafiltration	PC: 29.2-36.2%	Hojilla-Evangelista, 2014
Rapeseed cake	Enzyme-assisted extraction (pectinase)	PR: 25–53%	(Rommi et al., 2015)
	Alkaline extraction/ enzyme-assisted extraction (Protex)	PR: 15–80%	(Sari et al., 2013)
Sunflower meal	Dry fractionation (grinding and sieving)	PC: 49.9–50.9%	(Banjac et al., 2017)

	Alkaline extraction and acid precipitation	PC: 95%	(Kachrimanidou et al., 2015; Leiva-Candia et al., 2015)
Olive pomace	High pressure assisted extraction (water at 88°C and 220 bar)	PR: 231 mg/L / 10.8%	(Kazan et al., 2015)
Pomegranate seeds	Enzyme assisted extraction ( <i>Aspergillus oryzae</i> protease)	PR: 13.2%	(Talekar et al., 2018)
Peach seeds	Ultrasound assisted extraction (buffer solution pH 7.5)	PC: 43.0% d.b	(Vásquez-Villanueva et al., 2015)
Tomato defatted seed meal	Alkaline extraction and acid precipitation	PC: 43.82–74.13%	(Shao et al., 2014)
	Aqueous extraction and acid precipitation	PC: 80.37%	(Mechmeche et al., 2017)
Pumpkin seed	Microwave and ultrasounds-assisted extraction	PR: 93.95%	(Liu et al., 2017)

Adapted from Contreras et al., (2019)

On the other hand, recovery of phenolic compounds from various by-products has been also widely studied and reported as shown in Table I-7.

**Table I-7.** Phenolic compounds in agri-food by-products (GAE: gallic acid equivalents, CE: catechin equivalents, TAE: tannic acid equivalents, SE: sinapic acid equivalents)

By-product	Major phenolic compounds	Total phenolic content	References
Apple peel	Quercetin, phloretin, catechins, procyanidins, phloridzin, caffeic acid, chlorogenic acid, cyanidin	33.42 mg GAE/g	Wijngaard et al. (2009), Wolfe and Liu (2003)
Apple seed	Amygdalin, phloridzin	2.17 mg/g	Schieber et al. (2003a), Lu and Foo (1998)
Berry pomace	Cyanidin-3-O-glucoside, quercetin-3-O-glucoside, gallic acid, protocatechuic acid	21.7- 47.4 mg GAE/g	Zhou et al. (2009)

Grape pomace	Anthocyanins, catechins, flavonol glycosides, phenolic acids, trans-resveratrol	107.12–376.71 mg GAE/g	Anastasiadi et al. (2009), Yi et al. (2009)
Grape stem	trans-Resveratrol, e-viniferin	367.1–494.2 mg GAE/g	Anastasiadi et al. (2009), Püssa et al. (2006)
Grape seed	Catechin, epicatechin, epicatechin-3-O-gallate, dimeric procyanidins B2 and B3	325.37–811.95 mg GAE/g	Anastasiadi et al. (2009)
Citrus by products (peel)	Hesperidin, narirutin, naringin eriocitrin and their glycosides, hydroxycinnamic acid	24 mg GAE/g	Manthey and Grohmann (2001), Peterson et al. (2006), Sultana et al. (2008)
Mango peel	Flavonol-O-glycosides, xanthone-C-glycosides	55–110 mg GAE/g	Ajila et al. (2007), Schieber et al. (2003b)
Mango seed	Gallic acid, ellagic acid, gallates	117 mg GAE/g	Puravankara et al. (2000), Soong and Barlow (2004)
Pomegranate peel	Punicalagin, punicalin, ellagic acid, gallic acid, quercetin, kaemferol, myricetin	364 mg GAE/g	Sultana et al. (2008)
Banana peel	Dopamine, flavonone glycoside, naringin, rutin	11 mg GAE/g	Kanazawa and Sakakibara (2000), Sultana et al. (2008)
Almond skin	Flavan-3-ols, flavonol glycosides, dihydroflavonols, flavonones, phenolic acid	88 mg CE/g	Siriwardhana and Shahidi (2002)
Hazelnut skin	Phenolic acids	577.7 mg CE/g	Shahidi et al. (2007)
Hazelnut leaf		134.7 mg CE/g	Shahidi et al. (2007)
Cashew nut shell liquid	Anacardic acids, cardols, cardanols	353.6 mg/g	Trevisan et al. (2006)
Pistachio hull	Gallic acid	32.8–34.7 mg TAE/g	Goli et al. (2005), Vahabzadeh et al. (2004)
Walnut skin (pellicle)	Juglone, syringic acid, ellagic acid, hydrolysable tannins, condensed tannins	230-490 mg GAE/g	Colaric et al. (2005), Labuckas et al. (2008)
Moroccan almond press cake	Chlorogenic acid, protocatechuic acid, <i>p</i> -hydrobenzoic acid and <i>p</i> -coumaric acid	13.86 mg/g	Tungmunnithum et al. (2020)

Red onion dry peel	Quercetin, quercetin glycoside	384.7 mg GAE/g	Singh et al. (2009b)
Tomato skin	Quercetin, kaempferol, rutin, phenolic acids, naringenin	0.29 mg GAE/g	Toor and Savage (2005)
Potato peel	Chlorogenic acid, gallic acid, protocatechuic acid, caffeic acid	2.9–4.2 mg/g	Singh and Rajini (2008)
Red Beet pomace	<i>l</i> -Tryptophan, <i>p</i> -coumaric acid, ferulic acid	87–151 mg GAE/g	Peschel et al. (2006)
Carrot peel	Chlorogenic acid, caffeic acid	13.8 mg/g (GAE), 9.79 mg/g (GAE)	Chantaro et al. (2008), Zhang and Hamauzu (2004)
Peanut skin	Caffeic acid, chlorogenic acid, ferulic acid and coumaric acid, catechins, procyanidins, resveratrol	90–125 mg/g, 144.1–158.6 mg/g	Nepote et al. (2002), Yu et al. (2005)
Corn bran	Ferulic acid <i>p</i> -coumeric acid and vannilin	50 mg GAE/g	Ou and Kwok (2004)
Wheat bran	Ferulic, syringic, <i>p</i> -hydroxybenzoic, vanillic, coumaric, caffeic, salicylic, trans-cinnamic acids	4 mg GAE/g	Kim et al. (2006), Ou and Kwok (2004), Sultana et al. (2008)
Buckwheat hull	Quercetin, rutin, hyperin, vitexin, isovitexin, protocatechuic acid, 3,4- dihydroxybenzaldehyde, proanthocyanidins	39 mg/g	Watanabe et al. (1997)
Canola Hull	Phenolic acids, condensed tannin	94.3–296 mg SE/g	Amarowicz et al. (2000), Naczek et al. (2005)
Sunflower seed shell	Chlorogenic acid, <i>o</i> -cinnamic acid, protocatechuic acid, caffeic acid, ferulic acid, syringic acid	0.4–0.86 mg/g	Leonardis et al. (2005), Weisz et al. (2009),
Sesame seed coat	Sesamin, sesamol	146.6–29.7 mg CE/g	Chang et al. (2002), Shahidi et al. (2006)
Cocoa leaves	Epicatechin, epigallocatechin gallate, epigallocatechin, gallic acid, epicatechin gallate	284 mg/g	Osman et al. (2004)

Adapted from Shahidi et al. (2019)

### 3.1.1. Maceration extraction

In this process, the plant material, previously ground, is placed in a container along with the solvent. The method is based on maintain in contact the solid material with the solvent for several hours or even days, during which the soluble compounds are transferred from the plant sample to the fluid phase (solvent). In order to increase the mass transfer rate, some kind of agitation is usually provided since agitation avoids the bed compression and channeling that reduce the process efficiency. In addition, the agitation simultaneously facilitates the contact of the solid with the solvent, which enhance the diffusion of the extracted molecules, and avoids saturation at the surface of the solid. Regarding temperature, maceration is usually performed at room temperature. However, heat may be also used to improve the extraction efficiency. Globally, when working at room temperature, long extraction times are usually needed to achieve high recoveries. However, when thermosensitive compounds are extracted, high temperatures should be avoided.

From the industrial point of view, there are some factors that should be evaluated and optimized because they influence significantly the rate of extraction:

- *Preparation of the solid:* in plant materials, most of the cases the solutes are stored in intracellular spaces, capillaries, or cell structures, therefore the performance of the extraction strongly depends on the solid condition. This way, grinding plant matrices before solvent extraction promotes an increase of the contact area between the solvent and the solid matrix. In addition, grinding step enhances the contact between solvent and solute by breaking the cell structures.
- *Temperature:* Elevated temperature usually enhances extraction yield. Higher temperatures lead to higher mass transfer rate by increasing the solute diffusion into the solvent bulk.
- *Time:* Extraction time is a parameter directly related to temperature. Although longer extraction times may increase the yield, prolonged exposure of the solid material to high temperatures can lead to the degradation of the compounds of interest.
- *Type of solvent:* The selection of the extraction solvent should be based on its physicochemical properties (interfacial tension, viscosity, stability, reactivity, boiling point), selectivity, capability of dissolving the solute, cost and toxicity.

- *Solvent to feed ratio*: In general, the extraction yield tends to increase with solvent to feed ratio (S/F). Nonetheless, high solvent to feed ratio also implies high solvent and energy consumption for further solvent removal. Thus, S/F ratio should be as low as possible, while still ensuring the desired yield for the process.

On the other hand, maceration extraction has some disadvantages such as: i) high time-consuming, use of large volume of solvents and concentration steps are required, ii) high energy demand for the solvent–solute mixture separation, iii) the quality of the product may be degraded by further process such as solvent evaporation, due to the retention of undesirable chemical products and the degradation of thermosensitive compounds and, iv) the mass transfer rate decrease with time because the solvent is continuously enriched with solutes (Palma et al., 2013).

### **3.1.2. Soxhlet extraction**

Soxhlet extraction has been widely used for a long time for extracting natural products from plants and it has been also useful for soil and sediment analysis as well as for food analysis. In addition, Soxhlet may be used as a reference extraction method for evaluating the performance of new solid–liquid extraction techniques, even for the most advanced extraction methods, due to its simplicity, low cost per sample, and the inexpensive and robust extraction apparatus (Palma et al., 2013). However, Soxhlet extraction is limited for the application in the field of extracting thermolabile compounds. The typical Soxhlet apparatus works as follows: i) The ground plant material is placed in a thimble made from thick filter paper placed in an extraction chamber above a flask containing the extracting solvent and below a condenser, ii) the solvent is boiled and the extraction chamber gradually fills with fresh solvent from the distillation flask, iii) when the condensed solvent fills the extraction chamber and reaches a maximum level, it is rinsed back into the distillation flask by a siphon, iv) the cycle is repeated for several hours and finally the solute is separated or concentrated from the solvent by evaporation. According to Palma et al. (2013), Soxhlet extraction is a general and well-established technique that produces higher yields than other conventional extraction techniques and therefore, an exhaustive extraction method. Although Soxhlet has been widely used for extracting natural compounds from plant material, it has been specifically applied to extract vegetable oil and in this application, hexane has been the most commonly used solvent because of the high oil solubility in it. However, several solvents such as water, isopropanol, ethanol,

methanol, acetone, petroleum ether, etc., may be used for extracting plant components. The main disadvantages of using some solvents such as hexane, methanol or petroleum ether is their high toxicity. Other disadvantages of Soxhlet extraction are the long extraction time required, the use of large amount of solvent, absence of agitation and the thermal decomposition of thermolabile compounds. Nevertheless, some assisted techniques may be coupled to Soxhlet such as microwaves (Virot et al., 2007; Priego-Capote & Luque de Castro, 2005) and ultrasound (Luque-Garcia & Luque de Castro, 2004), in order to shorten the extraction times.

Globally, the use of solvents others than hexane leads to lower recovery of the lowest polarity components or may impact negatively the remaining compounds in the plant material due to the use of high extraction temperatures (for solvents, such as ethanol, with a higher boiling temperature than that of hexane). In literature has been widely reported the use of Soxhlet extraction for recovering oils (Mukherjee et al., 2020; Ozcan et al., 2019; Dias et al., 2019; Gu et al., 2019; Sonage et al., 2018; Mackela et al., 2017; Pereira et al., 2017; Palafox et al., 2012) as well as a reference extraction method (Mohammadpour et al., 2019; Gonçalves Rodrigues et al., 2019; Espinosa-Pardo et al., 2017; Garcia-Mendoza et al., 2017; Machado et al., 2017; Machado et al., 2015; Espinosa-Pardo et al., 2014; Paes et al., 2014).

### **3.2. Extraction intensification techniques**

As it has been discussed above, many biomolecules, materials, biochemicals, energy sources, etc. may be recovered from agricultural residues under the biorefinery concept and conventionally, such materials have been obtained using solid–liquid extraction. Besides the only step of extraction, pre-treatment of plant materials (drying, grinding, hydrolysis, etc.) and post-treatment of extracts (filtration, concentration, purification, etc.) are also necessary to ensure global process efficiency. As in any industrial process, the main goal is to obtain a product with well-defined application, potential consumers and economic feasibility. Currently, green extraction techniques for recovering added value plant products represent a comprehensive strategy that promotes energy consumption reduction, process efficiency and minimize environmental impact of manufacturing processes. In this context, plant extraction specialists aimed at using biorefinery concept for not only the valorization of majority of secondary and primary metabolites but also intensifying their processes in order to obtain higher extraction efficiency and higher quality of products while reducing extraction time,

number of unit operations, energy consumption, quantity of solvent, environmental impact, economical costs, and quantity of waste generated (Perino & Chemat, 2019). In other words, the green process intensification aims to maximize output with minimum inputs since the recovery of plant products is not a unit operation but a whole process with variable number of unit operations such as: i) pretreatment: raw materials are dried and ground to increase surface contact area and facilitate solvent diffusion in addition, lignocellulosic matrices must be hydrolyzed to disrupt the material structure, ii) solid–liquid extraction with the appropriate solvent, iii) solid–liquid separation by filtration or centrifugation or iv) purification by solvent removal and recycling under vacuum. Therefore the use of extraction intensification techniques intends to reduce the number of unit operations and the solvent consumption in a biorefinery scheme.

According to Perino & Chemat, (2019) the intensification of extraction processes present essential characteristics such as:

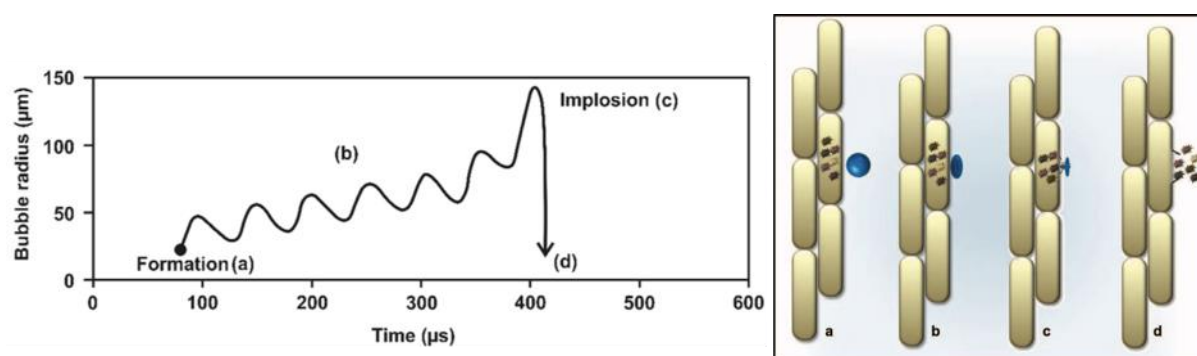
- i) Intensification of global process using innovative technologies such as microwave, ultrasound, pulse electric field, supercritical fluid extraction, and subcritical fluid extraction,
- ii) Development of innovative processes with high energetic efficiency,
- iii) Reduction of the number of unit operations,
- iv) Optimization of energetic resources by favoring energy recovery and reuse,
- v) Optimized management of solvent or water, for example, by recovery of rainwater,
- vi) Development of more compact unit operations.

The use of extraction intensification techniques is applied when conventional extraction processes are not efficient enough to recover acceptable yields of target compounds or products from plant residues and the idea is to assist the conventional process with innovative technologies such as ultrasound or microwave. It is important to clarify that the concept of intensification may be defined as a strategy to increase either extraction rate or yield, in global terms or in a target compound or group and the intensification methods can be applied before or during the extraction (Martinez et al., 2020). Globally, intensification techniques act mainly by modifying the physical and chemical properties of the substrate or the solvent in order to enhance the extraction performance. The intensification techniques most employed recently in biorefinery schemes are described below.



### 3.2.1. Ultrasound Assisted Extraction (UAE)

UAE consist in the application of ultrasonic waves, which are mechanical vibrations, to solids, liquids or gases with frequencies exceeding 20 kHz in order to enhance the extraction yield by increasing the mass transfer between the solvent and plant matrix. Ultrasonic waves cause expansion and compression cycles in the matter. Expansion may create bubbles in a liquid and produce negative pressure, while compression collapses the formed bubbles, causing cavitation. In this manner, the cavitation of bubbles produced in a liquid lead to a cell disruption near the solid surface, which improves the solvent penetration and can also break the cell walls (Martinez et al., 2020). In Figure I-13 is schematically shown the extraction of target compounds from biological matrices assisted by ultrasound technique. As can be observed, in the first stage, bubbles are formed (a) then such bubbles undergo expansion and compression (b), which cause their collapse or implosion (c) finally, the collapse occurs near the array interface, generating shock waves that disrupt the cell wall of the matrix, thus causing the release of the intramolecular material in the solvent (d) (Martinez et al., 2020; Pingret et al., 2013). According to Pingret et al. (2013) there are actually two forms of cavitation bubbles: stable and transient. Stable cavitation bubbles have an existence of many cycles and oscillate often non-linearly around an equilibrium size, while the transient form exist for one, or at most a few, acoustic cycle, during which time they expand to at least double their initial size before collapsing violently into smaller bubbles.

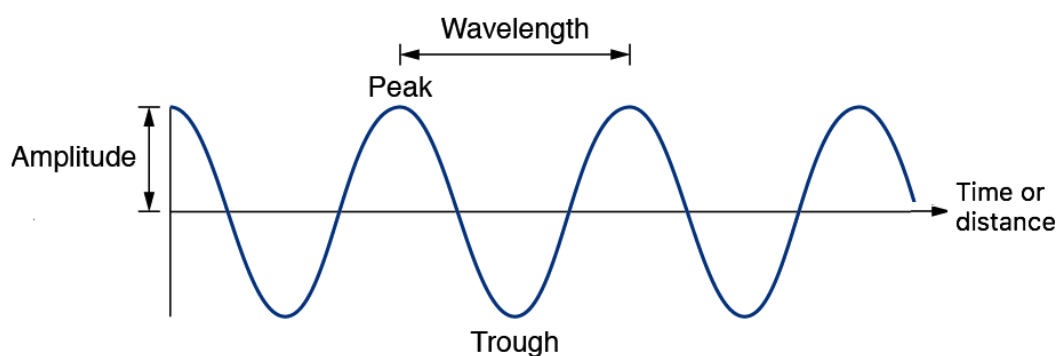


**Figure I-13.** Schematic representation of the effects of ultrasonic waves on plant matrices.

(Adapted from Martinez et al., 2020 and Pingret et al., 2013)

UAE exhibits many advantages such as less dependency of the solvent, enhanced solvent penetration, reduced extraction time and higher yield of extracted compounds and among the disadvantages are the amount of required solvent and degradation of

thermosensitive compounds due to the increase in temperature. The extraction assisted by ultrasound is influenced by many parameters, such as ultrasonic energy, frequency, temperature, extractor configuration, solvents, matrix/solvent ratio, particle size and matrix structure. In Figure I-14 is shown some physical parameters of an ultrasonic wave which influence the extraction yield when applied in matter. Moreover, when UAE is employed, it is necessary to take into account that the goal of process is both to achieve the highest extraction yield and decrease the energy consumption. Due to the wide range of frequencies and power, ultrasound may be applied to different processes, such as cutting, inactivation of microorganisms and enzymes, homogenization, emulsification, crystallization, drying, cooking, degassing, defoaming, oxidating and extracting (Pingret et al., 2013).



**Figure I-14.** Main physical parameters of an ultrasonic wave

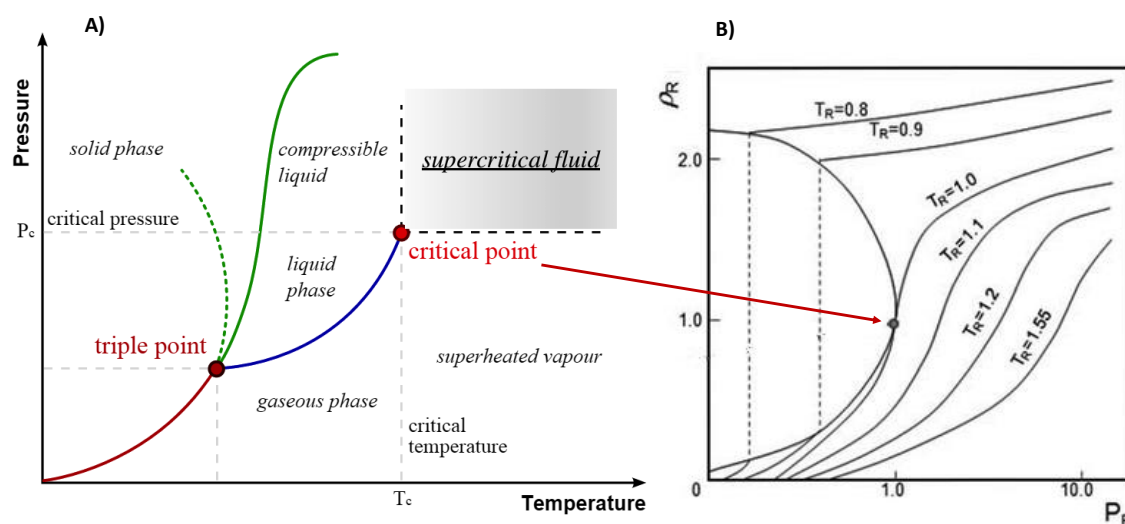
Several works have applied ultrasound for extracting mainly phytochemicals or lipids from several plant origin matrices such as seeds (Morales-Tovar et al., 2020; Sicaire et al., 2016; Szydłowska-Czerniak and Tułodziecka, 2015), fruit and vegetable residues (Alves-Filho et al., 2020; Guandalini et al., 2019; Riciputi et al., 2018; Bonfigli et al., 2017; Garcia-Mendoza et al., 2017; Machado et al., 2017; Rezende et al., 2017; Dahmoune et al., 2013), wine residues (Zhang et al., 2020; Da Porto et al., 2013), flowers (Xu et al., 2017; Xu et al., 2016a), leaves (Contreras et al., 2020; Hashemi et al., 2018), nut residues (Luo et al., 2017; Odabaş & Koca, 2016) and mushroom (Xu et al., 2016b). Most of the author aimed to increase the extraction yield, the biological activity of phytochemicals and the quality of obtained lipids while reducing extraction times applying ultrasonic waves as pretreatment or extraction assistant.

### 3.2.2. Supercritical Fluid Extraction (SFE)

Globally, this technology uses any fluid above its critical point as solvent for extracting target compounds from plant matrices. Figure I-15 shows a typical phase diagram of pure substances when can be observed the supercritical region. Supercritical fluid is a kind of fluid whose temperature and pressure are higher than its critical state in which the fluid begins to exhibit many unique properties. For instance, the density of a supercritical fluid is similar to a liquid while its viscosity is similar to a gas and its diffusivity is placed between gas and liquid. Thermal conductivities are relatively high in supercritical fluids whereas the surface tension is close to zero in the critical point, being similar to gases and much smaller than for liquids (Mendiola et al., 2013). However, viscosity, density, diffusion coefficient, solvation capacity and other properties are very sensitive to the changes in temperature and pressure. Changes in those properties are crucial for the extraction process since they are related to changes in solubility and mass transfer ratios and therefore, may modify the selectivity of the solvent for the target compounds. The solvating power of a supercritical fluid can be estimated by the Hildebrand solubility parameter ( $\delta$ ) as follow.

$$\delta = 1.25 P_c^{1/2} [\rho/\rho_{liq}]$$

where  $P_c$  is the critical pressure,  $\rho$  is the gas density, and  $\rho_{liq}$  is the liquid density. In general, at low pressures, the density of a gas is low, so the solvating power is relatively low whereas near critical conditions, the density increases rapidly approaching that of a liquid and therefore the solubility parameter increases as the critical pressure is approached. This is a key feature of supercritical fluids in extraction process since the solvating power of the fluid may be highly modified by small changes in pressure and temperature, which results in a higher solvent selectivity.



**Figure I-15.** Typical pressure–temperature phase diagram of pure substances (dotted green shows the anomalous behavior of water) (A) and CO<sub>2</sub> density–pressure phase diagram at different temperatures considering reduced variables ( $T_R = T/T_C$ ,  $P_R = P/P_C$  and  $\rho_R = \rho/\rho_C$ ) (B)

Theoretically any fluid may be used in SFE, however green solvents has been suggested as a clean alternative to hazardous processes particularly, in the development of a biorefinery scheme. Among these solvents that are used in SFE, carbon dioxide is for sure the most commonly employed, since CO<sub>2</sub> is inexpensive, environmentally friendly, non-explosive, nontoxic, selective and easily separated from the final extract (Espinosa-Pardo et al., 2017 Garcia-Mendoza et al., 2017; Rosa et al., 2009). In addition CO<sub>2</sub> has a moderate critical condition of temperature and pressure ( $T_c = 31.2^\circ\text{C}$ ,  $P_c = 73.8$  bar) in comparison with other green solvents such as water ( $T_c = 31.2^\circ\text{C}$   $P_c = 220.5$  bar) and ethanol ( $T_c = 240.8^\circ\text{C}$   $P_c = 61.4$  bar). On the other hand, supercritical CO<sub>2</sub> has a low polarity thus, its efficiency to extract polar compounds from plant materials is quite limited nevertheless, in order to overcome this problem, polar co-solvents such as ethanol and water are commonly added in small amounts for increasing the solubility of polar compounds in the supercritical mixture. Such advantages allowed us to integrate supercritical technology in the goal of developing an integrated biorefinery and in this context, biorefineries will most likely employ a combination of conventional unit operations together with supercritical operations. For instance, author such as Temelli & Ciftci, (2015) proposed that the use of supercritical CO<sub>2</sub> may be targeted for extracting lipids, while the remaining proteins and carbohydrates can be further fractionated and recovered using conventional processes. In fact, there are currently several companies dedicated to recover industrially oily products from various plant sources by supercritical

technology (for instance Aromtech in Finland, Flavex and NateCO<sub>2</sub> in Germany, Feyecon in Netherlands, Honsea Sunshine Biotech in China, Valensa International and MOR Supercritical LLC in USA, among others).

In this sense, several authors have recently reported the use of supercritical carbon dioxide for the recovery of various compounds such as anthocyanins (Jiao & Kermanshahi, 2018; Garcia-Mendoza et al., 2017; Monroy et al., 2016), polyphenols (Hatami et al., 2019; Santos-Zea et al., 2019; Valadez-Carmona et al., 2018; Espinosa-Pardo et al., 2017; Garcia-Mendoza et al., 2015; Mushtaq et al., 2015) carotenoids (Sánchez-Camargo et al., 2019; Kehili et al., 2017; Espinosa-Pardo et al., 2014), waxes (Attard et al., 2018; Attard et al., 2016) and oils (Table I-8).

**Table I-8.** Recent publications on supercritical fluid extraction of lipids from agricultural residues

By-product	Conditions used	Extraction yield	Reference
Camelina press-cake	Sc-CO <sub>2</sub> + ethanol (0-30%) at 25 MPa; 45 °C	8-12%	Savoire et al. (2020)
Chanār almonds	Sc-CO <sub>2</sub> at 20-40 MPa; 40-60 °C	8-40%	Salinas et al. (2020)
Cranberry pomace	Sc-CO <sub>2</sub> at 25-55 MPa; 50-80 °C	3.5-11%	Tamkute et al. (2020)
Passion fruit residue	Sc-CO <sub>2</sub> at 25-35 MPa; 40 °C	18-19.1%	Hatami et al. (2020)
	Sc-CO <sub>2</sub> at 17-35 MPa; 40-60 °C	4.4-24%	Viganó et al. (2016)
Passion fruit seed	Sc-CO <sub>2</sub> at 12-29 MPa; 38-53 °C (assisted by ultrasound)	2.5-10.7%	Barrales et al. (2015)
Rapeseed oil waste	Sc-CO <sub>2</sub> + ethanol (2.5-5 %) at 10-40 MPa; 40-80 °C	80-90% of phytosterols and tocopherol extracted	Jafarian Asl et al. (2020)

Raspberry seed	Sc-CO <sub>2</sub> at 25-35 MPa; 40-60 °C	5-17%	Pavlic et al. (2020)
Guava seeds	Sc-CO <sub>2</sub> at 35.7 MPa; 52 °C	8.6%	Narváez-Cuenca et al. (2020)
Pomegranate seed	Sc-CO <sub>2</sub> at 24-32 MPa; 40-60 °C	12-18%	Natolino & Da Porto (2019)
Rice bran	Sc-CO <sub>2</sub> at 10-20 MPa; 40-80 °C	2.6-26% (ethanol was added to raw material)	Trevisani Juchen et al. (2019)
Horchata residue	Sc-CO <sub>2</sub> at 10-40 MPa; 40 °C	1-7.5%	Roselló-Soto et al. (2019)
Citrus by-products	Sc-CO <sub>2</sub> at 20-25 MPa; 45-60 °C	3-30%	Ndayishimiye & Chun (2017); Ndayishimiye et al. (2017)
Muskmelon seeds	Sc-CO <sub>2</sub> at 30-50 MPa; 40-60 °C	11-48%	Maran & Priya, (2015)

### 3.2.3. Other intensification techniques

There are other intensification techniques that although they are not the focus of this work, they are worth mentioning since may be used in a biorefinery scheme.

*Microwave Assisted Extraction* (MAE) consist in the application of electromagnetic waves (microwaves energy) for enhancing the extraction of organic compounds from plant matrices. Microwaves are electromagnetic waves made up of two oscillating perpendicular fields: electrical field and magnetic field. These fields can be used as information carriers or as energy vectors. This second application is the direct action of waves on a material which is able to absorb a part of electromagnetic energy and to transform it into heat (Destandau et al., 2013). In addition, the ion migration favors the solvent penetration into the matrix, and at the same time accelerate the migration of ions initially contained inside the matrix to the solvent (Martinez et al., 2020; Vinatoru et al., 2017) which enhance the extraction yield.

*Ohmic, infrared (IR) and ultraviolet (UV) heating.* These are thermal technologies however, they overcome many disadvantages of convectional thermal processing that involves heat energy transferred through conduction and convection (Chemat et al., 2020). Ohmic, IR and UV heating are faster, more efficient and energy saving methods than convectional thermal techniques.

*High pressure (HP) extraction* consists of applying pressure (usually up to 6 000 bar) to the mixture solid-solvent for few minutes at a defined temperature (usually at or close to room temperature). The principle of HP consists of promote alterations in the existing structure of the cell which may damage the plant cell wall and internal structure of the cell. Therefore, the mass transfer resistance is decreased while the extraction yield is enhanced.

*Pulsed electric field (PEF) and high voltage electrical discharge (HVED)* are non-thermal technologies based on the phenomenon of electroporation. In this case, the electrical field applied to solid matrix forms pores on the cell membrane and thus extraction of intracellular components is enhanced through a diffusion process (Chemat et al., 2020; Martinez et al., 2020).

#### **4. Examples of biorefineries**

As explained before, a biorefinery scheme may comprise a sequential cascade process intended to obtain most of the valuable components from a biological material. This involves the flexible and sequential integration of different biological, chemical and/or thermal processes aimed at producing different materials, biofuels and biomolecules, etc. in order to maximize production yields and incomes (Alibardi et al., 2020). Although obtaining sequentially various products from the same raw material provide an integrated and efficient utilization of natural resources, other factor such as economic viability and energy consumption should be also evaluated. In addition, the extraction methods involved in the cascade process have to be carefully optimized in order to obtain a high extraction yields but also to not significantly affect the quality/properties of material later extracted in the biorefinery chain.

Among the biorefinery schemes reported in recent literature, it can be found sequential cascade process of short chain, as well as schemes with three or more sequential process as listed below.

Regarding short chain cascade process, several works have been published by the research group from the Separation Engineering Laboratory (LES) of University of Sao Paulo, Brazil (Capellini et al., 2019; Navarro et al., 2016; Sawada et al., 2014); for instance, Capellini et al. (2019) studied the alcoholic (ethanol and isopropanol) extraction of oil from sesame seed cake and the influence of oil extraction conditions on the physicochemical characteristics of the oil and defatted meal proteins. They observed that for instance the hydration of the alcoholic solvents exerted a strong negative influence on the oil extraction yield, while increasing temperature from 50 to 90 °C enhanced the oil extraction but decreased the nitrogen solubility index of defatted meals regardless the alcoholic solvent used. In a similar study, Navarro et al. (2016) showed that the extraction yield of oil and carbohydrate from corn germ-bran, are influenced by the type and hydration level of the solvent and temperature. Hydrated solvents lowered oil extraction but increased carbohydrate extraction. The solubility of the proteins present in defatted meal were negatively influenced by oil extraction with alcoholic solvents. Sawada et al. (2014) evaluated the sequential extraction of oil and protein from soybean using ethanol hydrated in a range from 0 to 12% (mass % of water) and temperatures from 40 °C to 90 °C. The authors observed contrary effects of solvent hydration level and temperature on oil and protein extraction. In other words, results showed that an increase in water content of the solvent strongly suppressed oil extraction, whereas increased protein extraction. On the other hand, an increase in temperature decreased the protein content in the extracted phase but increased oil extraction. Results also show feasible to use ethanol in the soybean oil extraction process as alternative for hexane. From this perspective, it is clearly inferred that optimum conditions for recovering some products may be deleterious for the later recovery of other materials.

Teh et al. (2014) studied the effect of the defatting process (Soxhlet hexane), acid and alkali extractions on the physicochemical and functional properties of hemp, flax and canola protein isolates. They reported that defatting process enriched the protein content from 35% to 52–55 % in the defatted oilseed cakes and that alkali extraction produced protein isolates with higher water holding capacity than acid extraction and original oilseed cakes, however both acid and alkali extractions produced protein isolates with the highest emulsifying activity and emulsion stability.

Regarding biorefinery schemes composed of long chain cascade process, Gil-Ramirez et al. (2018) developed an integrated process for sequential extraction of saponins, xylan and



cellulose from quinoa stalks. Saponins were first extracted using pressurized hot water extraction, xylan was then extracted from the residual solid material by an alkaline method at 80 °C. Finally, cellulose was purified from the remaining residuals using acetic and nitric acid at 120 °C. The authors reported that saponin yield significantly increased at temperatures higher than 110 °C, with highest amounts obtained at 195 °C (15.4 mg/g raw material). The yield in the following xylan extraction (maximum 120 mg/g raw material) was however significantly reduced when preceded by pressurized hot water extraction above 110 °C, indicating degradation of the polymer. Regarding cellulose, the maximum recovery was of 296 mg/g raw material and it was less affected by variations in temperature and time in of pressurized hot water extraction. On the other hand, Battista et al. (2020) have recently investigated the effects of the implementation of sequential processes for the recovery of oil, and the production of bioethanol and biogas from coffee spent grounds. They reported that the mixture 50:50 of ethanol-iso-propanol allowed an extraction yield 16% against 10% obtained with hexane. After, the defatted material underwent to an acid-enzymatic hydrolysis process followed by a solid/liquid separation; the liquid fraction was then used for the bioethanol production (fermentation) which reached a maximum concentration of 50 g/L whereas the solid fraction was used for biogas production by anaerobic digestion which produced of about 250 NL<sub>CH<sub>4</sub></sub>/kg<sub>VS</sub>. The author successfully presented a complete train of operations to fully valorize coffee residues. Similar cascade scheme, from coffee grounds, has been proposed for Rajesh Banu et al. (2020). Other multiproduct biorefinery scheme was proposed by Morales et al. (2020) from almond shells in order to recovery the three main components of almond shells; cellulose, hemicellulose and lignin. Firstly, autohydrolysis process allowed the extraction of the hemicellulosic fraction rich in xylooligosaccharides (22.12 g/L). Then, two different delignification processes, alkaline and organosolv treatments, were proposed to obtain a very high purity lignin (≈90%). After that, the delignified solids were valorized by producing cellulose nanocrystals or obtaining glucose by an enzymatic hydrolysis. They observed that for instance the delignification process did not influenced significantly the enzymatic conversion of glucan into glucose, whereas shorter in length nanocrystals were obtained from delignified solids by organosolv treatments.

Zabaniotou et al. (2018) used sunflower meal for proposing a transition from a mono-process pathway to a cascade biorefinery and for that they used physical, biological and thermo- chemical processes (fractionation, fermentation, enzymatic hydrolysis and pyrolysis) for producing various added-value products, biochar and energy carriers. According to these

authors (Zabaniotou et al., 2018) a cascade refining concept from sunflower meal is feasible leading to the production of antioxidants, protein isolate, biochar, bioenergy carriers (pyro-oil and pyro-gas) and microbial oil. Celiktas et al. (2014) also proposed a sequence of high pressure extraction and hydrolysis processes in cascade to create high potential value added products, namely, proteins, fermentable sugars and lignin from wheat bran. They have optimized three sequential steps: i) protein extraction by subcritical water (80 °C / 30 bar) with a maximum recovery of 92% of proteins and 4.31% in reducing sugars, ii) liquid hot water hydrolysis (200 °C / 30 bar) recovering 28.22% of the sugars and, iii) high pressure enzymatic hydrolysis (44 hours, at 51 °C and 139 bar) yielding to a recovery of sugars about 40.04%. Ruthes et al. (2017) have designed a cascade process using subcritical water extraction (160 °C, pH = 7), membrane filtration, and enzymatic treatments for the isolation of functional biomolecules from cereal byproducts. They fractionate hemicelluloses and obtained feruloylated arabinoxylans with high molecular weight and high antioxidant functionalities. The extraction conditions were optimized under subcritical water and compared to the alkaline processes. Membrane filtration was then carried out and different oligosaccharides, such as mixed-linkage  $\beta$ -D-glucan oligosaccharides were recovered. Finally, the residue after subcritical water treated with xylanolytic enzymes to release valuable feruloylated arabinoxylo-oligosaccharides. The oligo- and polysaccharide fractions isolated from this sequential process show great potential for use as prebiotic or platform chemicals.

Larragoiti-Kuri et al. (2017) used a multiobjective optimization framework to obtain valuable products such as bioethanol, lactic acid, succinic acid, xylitol, and liginosulfonates from corn cob. This tool allowed to assess various factors that significantly influence a cascade process such as the economic potential index, the specific energy intensity, and the safety index. What is quite interesting is that the authors observed that there is a trade-off between the aforementioned index and therefore, bioethanol and xylitol production should be favored over succinic acid and lactic acid for obtaining positive utilities. Similar optimization tools have been also reported for designing a biorefinery schemes of several processes in cascade from sugarcane (Moncada et al., 2013).

Several integrated biorefineries schemes from microalgae have been also proposed (Bose et al., 2020; Mitra & Mishra, 2019; Wu & Chang, 2019; Carl Safi, 2013), since these microorganisms are rich in proteins, carbohydrates and lipids. The sequential processing steps for microalgae-to-products chains are denoted as a combination of i) microalgae cultivation,

ii) pre-treatment and, iii) thermochemical, chemical or biochemical biomass conversion process for obtaining mainly biodiesel, bioalcohols, biocrude oil, syngas and biogas. Mitra & Mishra, (2019) has also pointed out the feasibility of developing a cascade scheme of biorefinery from microalgae for recovering proteins and carbohydrates for food applications.

In this work, process in cascade for recovering valuable products such as oil, protein concentrates, polyphenols and emulsion stabilizer from agro residues has been evaluated. From that perspective, an integrated biorefinery process can be proposed in order to promote more efficient use of natural resources.

## **5. Conclusion and addressed topics**

Throughout this chapter it has been discussed the most important concepts around biorefinery, its importance, approach and perspectives based on recent literature and European policy agencies. Since this work aimed at proposing a biorefinery scheme from plant residues such as corn germ, walnut press-cake and grape pomace, an extensive description of valuable products that can be obtain from this type of biomass has been described. A special attention to the products recovered in this work, i.e. oil, protein and natural antioxidants (polyphenols) has been given by describing their main functional properties for food and non-food applications. As the recovering of the aforementioned valuable fractions from plant materials involves an extraction step, we have described the principles and features of conventional extraction techniques (maceration and Soxhlet techniques), as well as of novel and intensification techniques of extraction which are of high interest in this work, i.e. ultrasound assisted extraction and supercritical fluid extraction.

Furthermore, in this work it has been proposed the use of agro residues under a holistic approach through the preparation of Pickering emulsions, therefore the main mechanisms involved in this technique, as well as their functional properties have been carefully addressed. Finally, since the biorefinery schemes proposed in this work, in particular from corn germ, imply the development of a cascade of processes for recovering progressively various types of products or materials from the same material, a literature review with various examples of biorefinery chains were also discussed in this chapter. A cascade of process in a biorefinery scheme intend to maximize production yields and incomes. However, it has been also

highlighted the influence of each extraction step that it may have on the yield and quality of the product/material later extracted from the same matrix.

## References

- Ajila, C.M., Bhat, S.G., Prasada Rao, U.J.S., 2007. Valuable components of raw and ripe peels from two Indian mango varieties. *Food Chem.* 102, 1006–1011.
- Alibardi, L., Astrup, T.F., Asunis, F., Clarke, W.P., De Gioannis, G., Dessì, P., Lens, P.N.L., Lavagnolo, M.C., Lombardi, L., Muntoni, A., Pivato, A., Poletini, A., Pomi, R., Rossi, A., Spagni, A., Spiga, D., 2020. Organic waste biorefineries: Looking towards implementation. *Waste Manag.* 114, 274–286.
- Alonso, E., 2018. The role of supercritical fluids in the fractionation pretreatments of a wheat bran-based biorefinery. *J. Supercrit. Fluids* 133, 603–614.
- Aluyor, E.O., Ori-Jesu, M., 2008. The use of antioxidants in vegetable oils - A review. *African J. Biotechnol.* 7, 4836–4842.
- Alves Filho, E.G., Sousa, V.M., Rodrigues, S., de Brito, E.S., Fernandes, F.A.N., 2020. Green ultrasound-assisted extraction of chlorogenic acids from sweet potato peels and sonochemical hydrolysis of caffeoylquinic acids derivatives. *Ultrason. Sonochem.* 63, 104911.
- Amarowicz, R., Naczek, M., Shahidi, F., 2000. Antioxidant activity of various fractions of non-tannin phenolics of canola hulls. *J. Agric. Food Chem.* 48, 2755–2759.
- Anastasiadi, M., Chorianopoulos, N.G., Nychas, G.J.E., Karoutounian, S.A., 2009. Antilisterial activities of polyphenol-rich extracts of grapes and vinification byproducts. *J. Agric. Food Chem.* 57, 457–463.
- Ankush, Khushboo, Dubey, K.K., 2020. Food industry waste biorefineries: future energy, valuable recovery, and waste treatment. In: Kumar, R.P., Gnansounou, E., Raman, J.K., Baskar, G. (Eds.), *Refining biomass residues for sustainable energy and bioproducts*. Academic press, UK, pp. 391-406.
- Araji, S., Grammer, T.A., Gertzen, R., Anderson, S.D., Mikulic-Petkovsek, M., Veberic, R., Phu, M.L., Solar, A., Leslie, C.A., Dandekar, A.M., Escobar, M.A., 2014. Novel roles for the polyphenol oxidase enzyme in secondary metabolism and the regulation of cell death in walnut. *Plant Physiol.* 164, 1191–1203.
- Arif, M., Pauls, K.P., 2018. Properties of plant proteins. In: Chen, G., Weselake, R.J., Singer, S.D. (Eds.), *Plant bioproducts*, Springer Science, USA, pp. 121-142.
- Attard, T.M., Bukhanko, N., Eriksson, D., Arshadi, M., Geladi, P., Bergsten, U., Budarin, V.L., Clark, J.H., Hunt, A.J., 2018. Supercritical extraction of waxes and lipids from biomass: A valuable first step towards an integrated biorefinery. *J. Clean. Prod.* 177, 684–698.
- Attard, T.M., McElroy, C.R., Gammons, R.J., Slattery, J.M., Supanchaiyamat, N., Kamei, C.L.A., Dolstra, O., Trindade, L.M., Bruce, N.C., McQueen-Mason, S.J., Shimizu, S., Hunt, A.J., 2016.

Supercritical CO<sub>2</sub> extraction as an effective pretreatment step for wax extraction in a miscanthus biorefinery. *ACS Sustain. Chem. Eng.* 4, 5979–5988.

Bandyopadhyay, K., Chakraborty, C., Barman, A.K., 2012. Effect of microwave and enzymatic treatment on the recovery of protein from Indian defatted rice bran meal. *J. Oleo Sci.* 61, 525–529.

Barrales, F.M., Rezende, C.A., Martínez, J., 2015. Supercritical CO<sub>2</sub> extraction of passion fruit (*Passiflora edulis* sp.) seed oil assisted by ultrasound. *J. Supercrit. Fluids* 104, 183–192.

Battista, F., Zanzoni, S., Strazzera, G., Andreolli, M., Bolzonella, D., 2020. The cascade biorefinery approach for the valorization of the spent coffee grounds. *Renew. Energy* 157, 1203–1211.

Benitez, L.O., Castagnini, J.M., Añón, M.C., Salgado, P.R., 2020. Development of oil-in-water emulsions based on rice bran oil and soybean meal as the basis of food products able to be included in ketogenic diets. *LWT* 118, 108809.

Bonfigli, M., Godoy, E., Reinheimer, M.A., Scenna, N.J., 2017. Comparison between conventional and ultrasound-assisted techniques for extraction of anthocyanins from grape pomace. Experimental results and mathematical modeling. *J. Food Eng.* 207, 56–72.

Bose, A., O’Shea, R., Lin, R., Murphy, J.D., 2020. A perspective on novel cascading algal biomethane biorefinery systems. *Bioresour. Technol.* 304, 123027.

Burgos-Díaz, C., Wandersleben, T., Olivos, M., Lichtin, N., Bustamante, M., Solans, C., 2019. Food-grade Pickering stabilizers obtained from a protein-rich lupin cultivar (*AluProt-CGNA*<sup>®</sup>): Chemical characterization and emulsifying properties. *Food Hydrocoll.* 87, 847–857.

Campbell, C.T., Jacobson, H., 2013. *Whole: Rethinking the Science of Nutrition*, Benbella Books, USA.

Can, Z., Dincer, B., Sahin, H., Baltas, N., Yildiz, O., Kolayli, S., 2014. Polyphenol oxidase activity and antioxidant properties of Yomra apple (*Malus communis* L.) from Turkey. *J. Enzyme Inhib. Med. Chem.* 29, 829–835.

Carl Safi, M., 2013. *Microalgae biorefinery: proposition of a fractionation process*. Doctoral thesis. École Doctorale des Sciences de la Matière, Université de Toulouse.

Carus, M., Dammer, L., 2018. The “circular bioeconomy”- concepts, opportunities and limitations, *Nova-Institut* 9, 1-9.

Celiktas, M.S., Kirsch, C., Smirnova, I., 2014. Cascade processing of wheat bran through a biorefinery approach. *Energy Convers. Manag.* 84, 633–639.

Celus, I., Brijs, K., Delcour, J.A., 2009. Fractionation and characterization of brewers’ spent grain protein hydrolysates. *J. Agric. Food Chem.* 57, 5563–5570.

Chandi, G.K., Sogi, D.S., 2007. Functional properties of rice bran protein concentrates. *J. Food Eng.* 79, 592–597.

Chang, L.W., Yen, W.J., Huang, S.C., Duh, P.D., 2002. Antioxidant activity of sesame coat. *Food Chem.* 78: 347–354.

Chantaro, P., Devahastin, S., Chiewchan, N., 2008. Production of antioxidant high dietary fiber powder from carrot peels. *LWT - Food Sci. Technol.* 41, 1987–1994.

Chemat, F., Abert Vian, M., Fabiano-Tixier, A.-S., Nutrizio, M., Režek Jambrak, A., Munekata, P.E.S., Lorenzo, J.M., Barba, F.J., Binello, A., Cravotto, G., 2020. A review of sustainable and intensified techniques for extraction of food and natural products. *Green Chem.*

Chéreau, D., Videcoq, P., Ruffieux, C., Pichon, L., Motte, J.C., Belaid, S., Ventureira, J., Lopez, M., 2016. Combination of existing and alternative technologies to promote oilseeds and pulses proteins in food applications. *OCL*, 23(4), D406.

Chevalier, Y., Bolzinger, M.A., 2013. Emulsions stabilized with solid nanoparticles: Pickering emulsions. *Colloids Surfaces A Physicochem. Eng. Asp.* 439, 23–34.

Cheyrier, V., 2005. Polyphenols in foods are more complex than often thought. *Am. J. Clin. Nutr.* 81, 223–229.

Colaric, M., Veberic, R., Solar, A., Hudina, M., Stampar, F., 2005. Phenolic acids, syringaldehyde, and juglone in fruits of different cultivars of *Juglans regia* L. *J. Agric. Food Chem.* 53, 6390–6396.

Contreras, M. del M., Lama-Muñoz, A., Espínola, F., Moya, M., Romero, I., Castro, E., 2020. Valorization of olive mill leaves through ultrasound-assisted extraction. *Food Chem.* 314, 126218.

Contreras, M. del M., Lama-Muñoz, A., Manuel Gutiérrez-Pérez, J., Espínola, F., Moya, M., Castro, E., 2019. Protein extraction from agri-food residues for integration in biorefinery: Potential techniques and current status. *Bioresour. Technol.* 280, 459–477.

Da Porto, C., Porretto, E., Decorti, D., 2013. Comparison of ultrasound-assisted extraction with conventional extraction methods of oil and polyphenols from grape (*Vitis vinifera* L.) seeds. *Ultrason. Sonochem.* 20, 1076–1080.

Dahmoune, F., Boulekbache, L., Moussi, K., Aoun, O., Spigno, G., Madani, K., 2013. Valorization of Citrus limon residues for the recovery of antioxidants: Evaluation and optimization of microwave and ultrasound application to solvent extraction. *Ind. Crops Prod.* 50, 77–87.

Dai, L., Sun, C., Wei, Y., Mao, L., Gao, Y., 2018. Characterization of Pickering emulsion gels stabilized by zein/gum arabic complex colloidal nanoparticles. *Food Hydrocoll.* 74, 239–248.

Destandau, E., Michel, T., Elfakir, C., 2013. Microwave-assisted Extraction. In: Rostagno, M.A., Prado, J.M. (Eds.), *Natural product extraction: Principles and applications*. RSC Publishing, UK, pp. 113-152.

Dias, J.L., Mazzutti, S., de Souza, J.A.L., Ferreira, S.R.S., Soares, L.A.L., Stragevitch, L., Danielski, L., 2019. Extraction of umbu (*Spondias tuberosa*) seed oil using CO<sub>2</sub>, ultrasound and conventional methods: Evaluations of composition profiles and antioxidant activities. *J. Supercrit. Fluids* 145, 10–18.

Dickinson, E., 2017. Biopolymer-based particles as stabilizing agents for emulsions and foams. *Food Hydrocoll.* 68, 219–231.

Dridi, W., 2016. Influence de la formulation sur l'oxydation des huiles végétales en émulsion eau-dans-huile. Doctoral thesis. École Doctorale des Sciences Chimiques, Université de Bordeaux and, École Doctorale Sciences et Technologie pour l'Ingénieur, Université de Carthage.

El Gharras, H., 2009. Polyphenols: Food sources, properties and applications - A review. *Int. J. Food Sci. Technol.* 44, 2512–2518.

Espinosa-Pardo, F.A., Martinez, J., Martinez-Correa, H.A., 2014. Extraction of bioactive compounds from peach palm pulp (*Bactris gasipaes*) using supercritical CO<sub>2</sub>. *J. Supercrit. Fluids* 93, 2–6.

Espinosa-Pardo, F.A., Nakajima, V.M., Macedo, G.A., Macedo, J.A., Martínez, J., 2017. Extraction of phenolic compounds from dry and fermented orange pomace using supercritical CO<sub>2</sub> and cosolvents. *Food Bioprod. Process.* 101, 1-10.

European Compost Network. <https://www.compostnetwork.info/policy/circular-economy/>

EUROSTAT. European statistics. <https://ec.europa.eu/eurostat/>

FAO. Food and Agriculture Organization of the United Nations. <http://www.fao.org>

FAOSTAT. Statistics division Food and Agriculture Organization of the United Nations. <http://www.fao.org/faostat>

Forster-Carneiro, T., Berni, M.D., Dorileo, I.L., Rostagno, M. a., 2013. Biorefinery study of availability of agriculture residues and wastes for integrated biorefineries in Brazil. *Resour. Conserv. Recycl.* 77, 78–88.

Frankel, E.N., 1984. Lipid oxidation: Mechanisms, products and biological significance. *J. Am. Oil Chem. Soc.* 61, 1908–1917.

Garcia-Mendoza, M. del P., Espinosa-Pardo, F.A., Baseggio, A.M., Barbero, G.F., Maróstica Junior, M.R., Rostagno, M.A., Martínez, J., 2017. Extraction of phenolic compounds and anthocyanins from juçara (*Euterpe edulis* Mart.) residues using pressurized liquids and supercritical fluids. *J. Supercrit. Fluids* 119, 9–16.

Garcia-Mendoza, M.P., Paula, J.T., Paviani, L.C., Cabral, F.A., Martinez-Correa, H.A., 2015. Extracts from mango peel by-product obtained by supercritical CO<sub>2</sub> and pressurized solvent processes. *LWT - Food Sci. Technol.* 62, 131–137.

Gil-Ramirez, A., Salas-Veizaga, D.M., Grey, C., Karlsson, E.N., Rodriguez-Meizoso, I., Linares-Pastén, J.A., 2018. Integrated process for sequential extraction of saponins, xylan and cellulose from quinoa stalks (*Chenopodium quinoa* Willd.). *Ind. Crops Prod.* 121, 54–65.

Goli, A.H., Barzegar, M., Sahari, M.A., 2005. Antioxidant activity and total phenolic compounds of pistachio (*Pistachia vera*) hull extracts. *Food Chem.* 92, 521–525.

Gonçalves Rodrigues, L.G., Mazzutti, S., Vitali, L., Micke, G.A., Ferreira, S.R.S., 2019. Recovery of bioactive phenolic compounds from papaya seeds agroindustrial residue using subcritical water extraction. *Biocatal. Agric. Biotechnol.* 22, 101367.



Gonzalez Ortiz, D., Pochat-Bohatier, C., Cambedouzou, J., Bechelany, M., Miele, P., 2020. Current trends in Pickering emulsions: Particle morphology and applications. *Engineering* 6, 468–482.

Gould, J., Garcia-Garcia, G., Wolf, B., 2016. Pickering particles prepared from food waste. *Materials (Basel)*. 9, 1–14.

Gu, L.B., Zhang, G.J., Du, L., Du, J., Qi, K., Zhu, X.L., Zhang, X.Y., Jiang, Z.H., 2019. Comparative study on the extraction of *Xanthoceras sorbifolia* Bunge (yellow horn) seed oil using subcritical n-butane, supercritical CO<sub>2</sub>, and the Soxhlet method. *LWT* 111, 548–554.

Guandalini, B.B.V., Rodrigues, N.P., Marczak, L.D.F., 2019. Sequential extraction of phenolics and pectin from mango peel assisted by ultrasound. *Food Res. Int.* 119, 455–461.

Gunstone, F.D., 2011. Production and trade of vegetable oils. In: Gunstone, F.D. (Ed.), *Vegetable oils in food technology: composition, properties and uses*, Second edition. Blackwell publishing Ltd., UK, pp. 1-24.

Hammond, E.W., 2003. Vegetable oils / Types and properties. *Ency. Food Sci. Nut.*, Academic Press, USA, pp. 5899-5904.

Hashemi, S.M.B., Mousavi Khaneghah, A., Koubaa, M., Barba, F.J., Abedi, E., Niakousari, M., Tavakoli, J., 2018. Extraction of essential oil from *Aloysia citriodora* Palau leaves using continuous and pulsed ultrasound: Kinetics, antioxidant activity and antimicrobial properties. *Process Biochem.* 65, 197–204.

Hatami, T., dos Santos, L.C., Zabet, G.L., de Almeida Pontes, P.V., Caldas Batista, E.A., Innocentini Mei, L.H., Martínez, J., 2020. Integrated supercritical extraction and supercritical adsorption processes from passion fruit by-product: experimental and economic analyses. *J. Supercrit. Fluids* 162.

Hatami, T., Meireles, M.A.A., Ciftci, O.N., 2019. Supercritical carbon dioxide extraction of lycopene from tomato processing by-products: Mathematical modeling and optimization. *J. Food Eng.* 241, 18–25.

Hermansson, A.M., 1986. Water- and fat holding. In: Mitchell, R., Ledward, D.A. (Eds.), *Functional properties of food macromolecules*, Elsevier, Netherlands, pp. 273-314.

Herrero, M., Ibañez, E., 2018. Green extraction processes, biorefineries and sustainability: Recovery of high added-value products from natural sources. *J. Supercrit. Fluids* 134, 252–259.

Hildebrand, D.H., Terao, J., Kito, M., 1984. Phospholipids plus tocopherols increase soybean oil stability. *J. Am. Oil Chem. Soc.* 61, 552–555.

Hogervorst, J.C., Miljić, U., Puškaš, V., 2017. Extraction of bioactive compounds from grape processing by-products. In: Galanakis, C.M. (Eds.), *Handbook of grape processing by-products*, Academic Press, UK, pp 105-135.

Hojilla-Evangelista, M.P., 2012. Extraction and functional properties of non-zein proteins in corn germ from wet-milling. *J. Am. Oil Chem. Soc.* 89, 167–174.

Hojilla-Evangelista, M.P., 2014. Improved solubility and emulsification of wet-milled corn germ protein recovered by ultrafiltration-diafiltration. *J. Am. Oil Chem. Soc.* 91, 1623–1631.

Hou, F., Ding, W., Qu, W., Oladejo, A.O., Xiong, F., Zhang, W., He, R., Ma, H., 2017. Alkali solution extraction of rice residue protein isolates: Influence of alkali concentration on protein functional, structural properties and lysinoalanine formation. *Food Chem.* 218, 207–215.

Huang, W.D., Zhang, Y.H.P., 2011. Energy efficiency analysis: Biomass-to-wheel efficiency related with biofuels production, fuel distribution, and powertrain systems. *Plos one* 6(7), 1-10.

Huc-Mathis, D., Journet, C., Fayolle, N., Bosc, V., 2019. Emulsifying properties of food by-products: Valorizing apple pomace and oat bran. *Colloids Surfaces A Physicochem. Eng. Asp.* 568, 84–91.

IEA Bioenergy, 2016. Proteins for food, feed and biobased applications. Biorefining of protein containing biomass, International Energy Agency, Task 42.

Jafari, S.M., Sedaghat Doost, A., Nikbakht Nasrabadi, M., Boostani, S., Van der Meeren, P., 2020. Phytosomes for the stabilization of Pickering emulsions in the formulation of novel food colloidal dispersions. *Trends Food Sci. Technol.* 98, 117–128.

Jafarian Asl, P., Niazmand, R., Yahyavi, F., 2020. Extraction of phytosterols and tocopherols from rapeseed oil waste by supercritical CO<sub>2</sub> plus co-solvent: A comparison with conventional solvent extraction. *Heliyon* 6, e03592.

Jiao, G., Kermanshahi pour, A., 2018. Extraction of anthocyanins from haskap berry pulp using supercritical carbon dioxide: Influence of co-solvent composition and pretreatment. *Lwt* 98, 237–244.

Joseph, C., 2018. Emulsions de Pickering stabilisées par des poudres végétales: propriétés et rôle des paramètres de composition et de formulation. Doctoral thesis. École Doctorale des Sciences Chimiques, Université de Bordeaux.

Joseph, C., Savoie, R., Harscoat-Schiavo, C., Pintori, D., Monteil, J., Faure, C., Leal-Calderon, F., 2019b. Redispersible dry emulsions stabilized by plant material: Rapeseed press-cake or cocoa powder. *LWT* 113, 108311.

Joseph, C., Savoie, R., Harscoat-Schiavo, C., Pintori, D., Monteil, J., Leal-Calderon, F., Faure, C., 2019a. O/W Pickering emulsions stabilized by cocoa powder: Role of the emulsification process and of composition parameters. *Food Res. Int.* 116, 755–766.

Kachrimanidou, V., Kopsahelis, N., Alexandri, M., Strati, A., Gardeli, C., Papanikolaou, S., Komaitis, M., Kookos, I.K., Koutinas, A.A., 2015. Integrated sunflower-based biorefinery for the production of antioxidants, protein isolate and poly(3-hydroxybutyrate). *Ind. Crops Prod.* 71, 106–113.

Kanazawa, K., Sakakibara, H., 2000. High content of dopamine, a strong antioxidant, in cavendish banana. *J. Agric. Food Chem.* 48, 844–848.

Kazan, A., Celiktas, M.S., Sargin, S., Yesil-Celiktas, O., 2015. Bio-based fractions by hydrothermal treatment of olive pomace: Process optimization and evaluation. *Energy Convers. Manag.* 103, 366–373.

Kehili, M., Kammlott, M., Choura, S., Zammel, A., Zetzl, C., Smirnova, I., Allouche, N., Sayadi, S., 2017. Supercritical CO<sub>2</sub> extraction and antioxidant activity of lycopene and  $\beta$ -carotene-enriched oleoresin from tomato (*Lycopersicon esculentum* L.) peels by-product of a Tunisian industry. *Food Bioprod. Process.* 102, 340–349.

Kennedy, D.O., 2014. Polyphenols and the human brain: Plant “ secondary metabolite ” ecologic roles and endogenous signaling functions drive benefits. *Adv. Nutr.* 5, 515–533.

Kim, K.H., Tsao, R., Yang, R., Cui, S.W., 2006. Phenolic acid profiles and antioxidant activities of wheat bran extracts and the effect of hydrolysis conditions. *Food Chem.* 95, 466–473.

Krzyżaniak, M., Stolarski, M.J., Tworkowski, J., Puttick, D., Eynck, C., Załuski, D., Kwiatkowski, J., 2019. Yield and seed composition of 10 spring camelina genotypes cultivated in the temperate climate of Central Europe. *Ind. Crops Prod.* 138, 111443.

Kuntz, I.D., 1971. Hydration of macromolecules, III. Hydration of polypeptides, *J. Am. Chem. Soc.* 93, 514-516.

la Cour, R., Schjoerring, J.K., Jørgensen, H., 2019. Enhancing Protein Recovery in Green Biorefineries by Lignosulfonate-Assisted Precipitation. *Front. Sustain. Food Syst.* 3, 1–9.

Labuckas, D.O., Maestri, D.M., Perelló, M., Martínez, M.L., Lamarque, A.L., 2008. Phenolics from walnut (*Juglans regia* L.) kernels: Antioxidant activity and interactions with proteins. *Food Chem.* 107, 607–612.

Larragoiti-Kuri, J., Rivera-Toledo, M., Cocho-Roldán, J., Maldonado-Ruiz Esparza, K., Le Borgne, S., Pedraza-Segura, L., 2017. Convenient Product Distribution for a Lignocellulosic Biorefinery: Optimization through Sustainable Indexes. *Ind. Eng. Chem. Res.* 56, 11388–11397.

Laufenberg, G., Kunz, B., Nystroem, M., 2003. Transformation of vegetable waste into value added products: (A) the upgrading concept; (B) practical implementations. *Bioresour. Technol.* 87, 167–198.

Leiva-Candia, D.E., Tsakona, S., Kopsahelis, N., García, I.L., Papanikolaou, S., Dorado, M.P., Koutinas, A.A., 2015. Biorefining of by-product streams from sunflower-based biodiesel production plants for integrated synthesis of microbial oil and value-added co-products. *Bioresour. Technol.* 190, 57–65.

Li-Chan, E., Nakai, S., Wood, D. F., 1984. Hydrophobicity and solubility of meat proteins and their relationship to emulsifying properties, *J Food Sci.*, 49, 345-350.

Liu, R.L., Yu, P., Ge, X.L., Bai, X.F., Li, X.Q., Fu, Q., 2017. Establishment of an aqueous PEG 200-based deep eutectic solvent extraction and enrichment method for pumpkin (*Cucurbita moschata*) seed protein. *Food Anal. Methods* 10, 1669–1680.

Lu, Y., Yeap Foo, L., 1998. Constitution of some chemical components of apple seed. *Food Chem.* 61, 29–33.

Lunn, J., Theobald, H.E., 2006. The health effects of dietary unsaturated fatty acids. *British Nutri. Found., Nutrition Bulletin*, 31, 178–224.

Luo, Y., Wu, W., Chen, D., Lin, Y., Ma, Y., Chen, C., Zhao, S., 2017. Optimization of simultaneous microwave/ultrasonic-assisted extraction of phenolic compounds from walnut flour using response surface methodology. *Pharm. Biol.* 55, 1999–2004.

Luque-García, J.L., Luque De Castro, M.D., 2004. Ultrasound-assisted Soxhlet extraction: An expeditive approach for solid sample treatment - Application to the extraction of total fat from oleaginous seeds. *J. Chromatogr. A* 1034, 237–242.

Machado, A.P.D.F., Pereira, A.L.D., Barbero, G.F., Martínez, J., 2017. Recovery of anthocyanins from residues of *Rubus fruticosus*, *Vaccinium myrtillus* and *Eugenia brasiliensis* by ultrasound assisted extraction, pressurized liquid extraction and their combination. *Food Chem.* 231, 1–10.

Mackêla, I., Andriekus, T., Venskutonis, P.R., 2017. Biorefining of buckwheat (*Fagopyrum esculentum*) hulls by using supercritical fluid, Soxhlet, pressurized liquid and enzyme-assisted extraction methods. *J. Food Eng.* 213, 38–46.

Manach, C., Williamson, G., Morand, C., Scalbert, A., Rémésy, C., 2005. Bioavailability and bioefficacy of polyphenols in humans. I. Review of 97 bioavailability studies. *Am. J. Clin. Nutr.* 81, 230–242.

Manthey, J.A., Grohmann, K., 2001. Phenols in citrus peel byproducts. Concentrations of hydroxycinnamates and polymethoxylated flavones in citrus peel molasses. *J. Agric. Food Chem.* 49, 3268–3273.

Maran, J.P., Priya, B., 2015. Supercritical fluid extraction of oil from muskmelon (*Cucumis melo*) seeds. *J. Taiwan Inst. Chem. Eng.* 47, 71–78.

Martínez, J., de Aguiar, A.C., Machado, A.P. da F., Barrales, F.M., Viganó, J., dos Santos, P., 2020. Process Integration and Intensification. *Ref. Modul. Food Sci.* 1–22.

Mechmeche, M., Kachouri, F., Chouabi, M., Ksontini, H., Setti, K., Hamdi, M., 2017. Optimization of Extraction Parameters of Protein Isolate from Tomato Seed Using Response Surface Methodology. *Food Anal. Methods* 10, 809–819.

Mendes, J.A.S., Xavier, A.M.R.B., Evtuguin, D. V., Lopes, L.P.C., 2013. Integrated utilization of grape skins from white grape pomaces. *Ind. Crops Prod.* 49, 286–291.

Mendiola, J.A., Herrero, M., Castro-Puyana, M., Ibáñez, E., 2013. Supercritical Fluid Extraction. In: Rostagno, M.A., Prado, J.M. (Eds.), *Natural product extraction: Principles and applications*. RSC Publishing, UK, pp. 196-225.

Mitra, M., Mishra, S., 2019. Multiproduct biorefinery from *Arthrospira* spp. towards zero waste: Current status and future trends. *Bioresour. Technol.* 291, 121928.

Moghadam, M., Salami, M., Mohammadian, M., Emam-Djomeh, Z., Jahanbani, R., Moosavi-Movahedi, A.A., 2020. Physicochemical and bio-functional properties of walnut proteins as affected by trypsin-mediated hydrolysis. *Food Biosci.* 36, 100611.

Mohammadpour, H., Sadrameli, S.M., Eslami, F., Asoodeh, A., 2019. Optimization of ultrasound-assisted extraction of *Moringa peregrina* oil with response surface methodology and comparison with Soxhlet method. *Ind. Crops Prod.* 131, 106–116.

Moncada, J., Matallana, L.G., Cardona, C.A., 2013. Selection of process pathways for biorefinery design using optimization tools: A colombian case for conversion of sugarcane bagasse to ethanol, poly-3-hydroxybutyrate (PHB), and energy. *Ind. Eng. Chem. Res.* 52, 4132–4145.

Monroy, Y.M., Rodrigues, R.A.F., Sartoratto, A., Cabral, F.A., 2016. Influence of ethanol, water, and their mixtures as co-solvents of the supercritical carbon dioxide in the extraction of phenolics from purple corn cob (*Zea mays* L.). *J. Supercrit. Fluids* 118, 11–18.

Morales-Tovar, M.E., Ramos-Ramírez, E.G., Salazar-Montoya, J.A., 2020. Modeling and optimization of the parameters affecting extraction of the chan seed mucilage (*Hyptis suaveolens* (L.) Poit) by mechanical agitation (MA) and ultrasound-assisted extraction (UAE) in a multiple variables system. *Food Bioprod. Process.* 120, 166–178.

Morales, A., Hernández-Ramos, F., Sillero, L., Fernández-Marín, R., Dávila, I., Gullón, P., Erdocia, X., Labidi, J., 2020. Multiproduct biorefinery based on almond shells: Impact of the delignification stage on the manufacture of valuable products. *Bioresour. Technol.* 315, 123896.

Moreau, R.A., Johnston, D.B., Hicks, K.B., Haas, J.H., 2013. Aqueous extraction of corn oil after fermentation in the dry grind ethanol process. In: Farr, W.E, Proctor, A. (Eds.) *Green vegetable oil processing*, AOCS Press, USA, pp. 53-72.

Moslavac, T., Jokić, S., Šubarić, D., Aladić, K., Vukoja, J., Prcce, N., 2014. Pressing and supercritical CO<sub>2</sub> extraction of *Camelina sativa* oil. *Ind. Crops Prod.* 54, 122–129.

Mukherjee, A., Roy, K., Jana, D.K., Hossain, S.A., 2020. Qualitative model optimization of almond (*Terminalia catappa*) oil using Soxhlet extraction in type-2 fuzzy environment. *Soft Comput.* 24, 41–51.

Mushtaq, M., Sultana, B., Anwar, F., Adnan, A., Rizvi, S.S.H., 2015. Enzyme-assisted supercritical fluid extraction of phenolic antioxidants from pomegranate peel. *J. Supercrit. Fluids* 104, 122–131.

Narváez-Cuenca, C.E., Inampues-Charfuelan, M.L., Hurtado-Benavides, A.M., Parada-Alfonso, F., Vincken, J.P., 2020. The phenolic compounds, tocopherols, and phytosterols in the edible oil of guava (*Psidium guava*) seeds obtained by supercritical CO<sub>2</sub> extraction. *J. Food Compos. Anal.* 89, 103467.

Natolino, A., Da Porto, C., 2019. Supercritical carbon dioxide extraction of pomegranate (*Punica granatum* L.) seed oil: Kinetic modelling and solubility evaluation. *J. Supercrit. Fluids* 151, 30–39.

Navarro, S.L.B., Capellini, M.C., Aracava, K.K., Rodrigues, C.E.C., 2016. Corn germ-bran oils extracted with alcoholic solvents: Extraction yield, oil composition and evaluation of protein solubility of defatted meal. *Food Bioprod. Process.* 100, 185–194.

Ndayishimiye, J., Chun, B.S., 2017. Optimization of carotenoids and antioxidant activity of oils obtained from a co-extraction of citrus (*Yuzu ichandrin*) by-products using supercritical carbon dioxide. *Biomass and Bioenergy* 106, 1–7.

Ndayishimiye, J., Getachew, A.T., Chun, B.S., 2017. Comparison of characteristics of oils extracted from a mixture of citrus seeds and peels using hexane and supercritical carbon dioxide. *Waste and Biomass Valorization* 8, 1205–1217.

Nepote, V., Grosso, N.R., Guzman, C.A., 2002. Extraction of antioxidant components from peanut skins. *Grasas y Aceites* 53, 391–395.

Nunes, L.J.R., Causer, T.P., Ciolkosz, D., 2020. Biomass for energy: A review on supply chain management models. *Renew. Sustain. Energy Rev.* 120, 109658.

Nushtaeva, A. V., 2016. Natural food-grade solid particles for emulsion stabilization. *Colloids Surfaces A Physicochem. Eng. Asp.* 504, 449–457.

Odabaş, H.İ., Koca, I., 2016. Application of response surface methodology for optimizing the recovery of phenolic compounds from hazelnut skin using different extraction methods. *Ind. Crops Prod.* 91, 114–124.

OECD, 2018. Meeting policy challenges for a sustainable bioeconomy. OECD Publishing, Paris.

Osman, H., Nasarudin, R., Lee, S.L., 2004. Extracts of cocoa (*Theobroma cacao* L.) leaves and their antioxidation potential. *Food Chem.* 86, 41–46.

Ou, S., Kwok, K.C., 2004. Ferulic acid: Pharmaceutical functions, preparation and applications in foods. *J. Sci. Food Agric.* 84, 1261–1269.

Özcan, M.M., Ghafoor, K., Al Juhaimi, F., Ahmed, I.A.M., Babiker, E.E., 2019. Effect of cold-press and Soxhlet extraction on fatty acids, tocopherols and sterol contents of the Moringa seed oils. *South African J. Bot.* 124, 333–337.

Paes, J., Dotta, R., Barbero, G.F., Martínez, J., 2014. Extraction of phenolic compounds and anthocyanins from blueberry (*Vaccinium myrtillus* L.) residues using supercritical CO<sub>2</sub> and pressurized liquids. *J. Supercrit. Fluids* 95, 8–16.

Palafox, J.O., Navarrete, A., Sacramento-Rivero, J.C., Rubio-Atoche, C., Escoffie, P.A., Rocha-Urbe, J.A., 2012. Extraction and characterization of oil from *Moringa oleifera* using supercritical CO<sub>2</sub> and traditional solvents. *Am. J. Anal. Chem.* 3, 946–949.

Palma, M., Barbero, G.F., Piñeiro, Z., Liazid, A., Barroso, C.G., Rostagno, M.A., Prado, J.M., Meireles, M.A.A., 2013. Extraction of natural products: principles and fundamental aspects. In: Rostagno, M.A., Prado, J.M. (Eds.), *Natural product extraction: Principles and applications*. RSC Publishing, UK, pp. 58-86.

Papuc, C., Goran, G. V., Predescu, C.N., Nicorescu, V., Stefan, G., 2017. Plant polyphenols as antioxidant and antibacterial agents for shelf-life extension of meat and meat products: Classification, structures, sources, and action Mechanisms. *Compr. Rev. Food Sci. Food Saf.* 16, 1243–1268.

Pavlić, B., Pezo, L., Marić, B., Tukuljac, L.P., Zeković, Z., Solarov, M.B., Teslić, N., 2020. Supercritical fluid extraction of raspberry seed oil: Experiments and modelling. *J. Supercrit. Fluids* 157.

Pereira, M.G., Hamerski, F., Andrade, E.F., Scheer, A. de P., Corazza, M.L., 2017. Assessment of subcritical propane, ultrasound-assisted and Soxhlet extraction of oil from sweet passion fruit (*Passiflora alata* Curtis) seeds. *J. Supercrit. Fluids* 128, 338–348.

Perino, S., Chemat, F., 2019. Green process intensification techniques for bio-refinery. *Curr. Opin. Food Sci.* 25, 8–13.

Peschel, W., Sánchez-Rabaneda, F., Diekmann, W., Plescher, A., Gartzía, I., Jiménez, D., Lamuela-Raventós, R., Buxaderas, S., Codina, C., 2006. An industrial approach in the search of natural antioxidants from vegetable and fruit wastes. *Food Chem.* 97, 137–150.

Peterson, J.J., Beecher, G.R., Bhagwat, S.A., Dwyer, J.T., Gebhardt, S.E., Haytowitz, D.B., Holden, J.M., 2006. Flavanones in grapefruit, lemons, and limes: A compilation and review of the data from the analytical literature. *J. Food Compos. Anal.* 19, 74–80.

Phongthai, S., Lim, S.T., Rawdkuen, S., 2016. Optimization of microwave-assisted extraction of rice bran protein and its hydrolysates properties. *J. Cereal Sci.* 70, 146–154.

Pickering, S.U., 1907. CXCVI.–Emulsions. *J. Chem. Soc. Trans.* 91, 2001–2021.

Pingret, D., Fabiano-Tixier, A-S., Chemat, F., 2013. Ultrasound-assisted Extraction. In: Rostagno, M.A., Prado, J.M. (Eds.), *Natural product extraction: Principles and applications*. RSC Publishing, UK, pp. 89-109.

Porfiri, M.C., Vaccaro, J., Stortz, C.A., Navarro, D.A., Wagner, J.R., Cabezas, D.M., 2017. Insoluble soybean polysaccharides: Obtaining and evaluation of their O/W emulsifying properties. *Food Hydrocoll.* 73, 262–273.

Priego-Capote, F., Luque De Castro, M.D., 2005. Focused microwave-assisted Soxhlet extraction: A convincing alternative for total fat isolation from bakery products. *Talanta* 65, 98–103.

Puravankara, D., Boghra, V., Sharma, R.S., 2000. Effect of antioxidant principles isolated from mango (*Mangifera indica* L.) seed kernels on oxidative stability of buffalo ghee (butter-fat). *J. Sci. Food Agric.* 80, 522–526.

Püssa, T., Floren, J., Kuldkepp, P., Raal, A., 2006. Survey of grapevine *Vitis vinifera* stem polyphenols by liquid chromatography-diode array detection-tandem mass spectrometry. *J. Agric. Food Chem.* 54, 7488–7494.

Qin, F., Johansen, A.Z., Mussatto, S.I., 2018. Evaluation of different pretreatment strategies for protein extraction from brewer's spent grains. *Ind. Crops Prod.* 125, 443–453.

Rajesh Banu, J., Kavitha, S., Yukesh Kannah, R., Dinesh Kumar, M., Preethi, Atabani, A.E., Kumar, G., 2020. Biorefinery of spent coffee grounds waste: Viable pathway towards circular bioeconomy. *Bioresour. Technol.* 302.

Ramadan, M.F., Moersel, J.T., 2006. Screening of the antiradical action of vegetable oils. *J. Food Compos. Anal.* 19, 838–842.

Rezende, Y.R.R.S., Nogueira, J.P., Narain, N., 2017. Comparison and optimization of conventional and ultrasound assisted extraction for bioactive compounds and antioxidant activity from agro-industrial acerola (*Malpighia emarginata* DC) residue. *LWT - Food Sci. Technol.* 85, 158–169.

Riciputi, Y., Diaz-de-Cerio, E., Akyol, H., Capanoglu, E., Cerretani, L., Caboni, M.F., Verardo, V., 2018. Establishment of ultrasound-assisted extraction of phenolic compounds from industrial potato by-products using response surface methodology. *Food Chem.* 269, 258–263.

Roberts, R.C., Briggs, D.R., 1963. Characteristics of the various soybean globulin components with respect to denaturation by ethanol. *Sci. J. Ser.* 40, 450–458, University of Minnesota.

Rommi, K., Ercili-Cura, D., Hakala, T.K., Nordlund, E., Poutanen, K., Lantto, R., 2015. Impact of total solid content and extraction pH on enzyme-aided recovery of protein from defatted rapeseed (*Brassica rapa* L.) Press cake and physicochemical properties of the protein fractions. *J. Agric. Food Chem.* 63, 2997–3003.

Rosa, P.T.V., Parajó, J.C., Domínguez, H., Moure, A., Díaz-Reinoso, B., Smith, R.L., Toyomizu, M., Florusse, L.J., Peters, C.J., Goto, M., Lucas, S., Meireles, M.A.A., 2009. Supercritical and pressurized fluid extraction applied to the food industry. In: Meireles, M.A.A. (Ed.), *Extracting Bioactive Compounds for Food Products. Theory and Applications*. CRC Press, USA, pp. 269–401.

Roselló-Soto, E., Barba, F.J., Lorenzo, J.M., Dominguez, R., Pateiro, M., Mañes, J., Moltó, J.C., 2019. Evaluating the impact of supercritical-CO<sub>2</sub> pressure on the recovery and quality of oil from “horchata” by-products: Fatty acid profile,  $\alpha$ -tocopherol, phenolic compounds, and lipid oxidation parameters. *Food Res. Int.* 120, 888–894.

Ruthes, A.C., Martínez-Abad, A., Tan, H.T., Bulone, V., Vilaplana, F., 2017. Sequential fractionation of feruloylated hemicelluloses and oligosaccharides from wheat bran using subcritical water and xylanolytic enzymes. *Green Chem.* 19, 1919–1931.

Saari, H., Heravifar, K., Rayner, M., Wahlgren, M., Sjöö, M., 2016. Preparation and characterization of starch particles for use in Pickering emulsions. *Cereal Chem.* 93, 116–124.

Saari, H., Rayner, M., Wahlgren, M., 2019. Effects of starch granules differing in size and morphology from different botanical sources and their mixtures on the characteristics of Pickering emulsions. *Food Hydrocoll.* 89, 844–855.

Salinas, F., Vardanega, R., Espinosa-Álvarez, C., Jimenez, D., Muñoz, W.B., Ruiz-Domínguez, M.C., Meireles, M.A.A., Cerezal- Mezquita, P., 2020. Supercritical fluid extraction of chañar (*Geoffroea decorticans*) almond oil: Global yield, kinetics and oil characterization. *J. Supercrit. Fluids* 161.

Sánchez-Camargo, A. del P., Gutiérrez, L.F., Vargas, S.M., Martínez-Correa, H.A., Parada-Alfonso, F., Narváez-Cuenca, C.E., 2019. Valorisation of mango peel: Proximate composition, supercritical fluid extraction of carotenoids, and application as an antioxidant additive for an edible oil. *J. Supercrit. Fluids* 152, 104574.



Santana-Méridas, O., González-Coloma, A., Sánchez-Vioque, R., 2012. Agricultural residues as a source of bioactive natural products. *Phytochem. Rev.* 11, 447–466.

Santos-Zea, L., Gutiérrez-Urbe, J.A., Benedito, J., 2019. Effect of ultrasound intensification on the supercritical fluid extraction of phytochemicals from *Agave salmiana* bagasse. *J. Supercrit. Fluids* 144, 98–107.

Sari, Y.W., Bruins, M.E., Sanders, J.P.M., 2013. Enzyme assisted protein extraction from rapeseed, soybean, and microalgae meals. *Ind. Crops Prod.* 43, 78–83.

Savoire, R., Subra-Paternault, P., Bardeau, T., Morvan, E., Grélard, A., Cansell, M., 2020. Selective extraction of phospholipids from food by-products by supercritical carbon dioxide and ethanol and formulating ability of extracts. *Sep. Purif. Technol.* 238, 116394.

Schaich, K.M., 2013. Challenges in elucidating lipid oxidation mechanisms: When, where, and how do products arise?. In: Logan, A., Nienaber, U., Pan, X. (Eds), *Lipid oxidation: Challenges in food systems*. AOCS Press, USA, pp. 1-52.

Schieb, P.-A., Lescieux-Katir, H., Thénot, M., Clément-Larosière, B., 2015. *Biorefinery 2030 - Future prospects for the bioeconomy*. Springer-Verlag Berlin Heidelberg, UK.

Schieber, A., 2019. By-products of plant food processing as a source of valuable compounds. Reference module in food science, ScienceDirect.

Schieber, A., Berardini, N., Carle, R., 2003a. Identification of flavonol and xanthone glycosides from mango (*Mangifera indica* L. cv. “Tommy Atkins”) peels by high-performance liquid chromatography-electrospray ionization mass spectrometry. *J. Agric. Food Chem.* 51, 5006–5011.

Schieber, A., Hilt, P., Endreß, H.U., Rentschler, C., Carle, R., 2003b. A new process for the combined recovery of pectin and phenolic compounds from apple pomace. *Innov. Food Sci. Emerg. Technol.* 4, 99–107.

Sereewatthanawut, I., Prapintip, S., Watchiraruj, K., Goto, M., Sasaki, M., Shotipruk, A., 2008. Extraction of protein and amino acids from deoiled rice bran by subcritical water hydrolysis. *Bioresour. Technol.* 99, 555–561.

Shahidi, F., Alasalvar, C., Liyana-Pathirana, C.M., 2007. Antioxidant phytochemicals in hazelnut kernel (*Corylus avellana* L) and hazelnut byproducts. *J. Agric. Food Chem.* 55, 1212–1220.

Shahidi, F., Liyana-Pathirana, C.M., Wall, D.S., 2006. Antioxidant activity of white and black sesame seeds and their hull fractions. *Food Chem.* 99, 478–483.

Shahidi, F., Varatharajan, V., Oh, W.Y., Peng, H., 2019. Phenolic compounds in agri-food by-products, their bioavailability and health effects. *J. Food Bioact.* 5, 57-119.

Shao, D., Atungulu, G.G., Pan, Z., Yue, T., Zhang, A., Fan, Z., 2014. Characteristics of isolation and functionality of protein from tomato pomace produced with different industrial processing methods. *Food Bioprocess Technol.* 7, 532–541.

Sicaire, A.G., Vian, M.A., Fine, F., Carré, P., Tostain, S., Chemat, F., 2016. Ultrasound induced green solvent extraction of oil from oleaginous seeds. *Ultrason. Sonochem.* 31, 319–329.

Singh, B.N., Singh, B.R., Singh, R.L., Prakash, D., Singh, D.P., Sarma, B.K., Upadhyay, G., Singh, H.B., 2009b. Polyphenolics from various extracts/fractions of red onion (*Allium cepa*) peel with potential antioxidant and antimutagenic activities. *Food Chem. Toxicol.* 47, 1161–1167.

Singh, N., Rajini, P.S., 2008. Antioxidant-mediated protective effect of potato peel extract in erythrocytes against oxidative damage. *Chem. Biol. Interact.* 173, 97–104.

Singh, P.N., 2009. Production of bioactive secondary metabolites. In: Singh, P.N., Pandey, A. (Eds.), *Biotechnology for agro-industrial residues utilisation*. Springer Science, Netherlands, pp. 129-145.

Singh, P.N., Gupta, N., Anthwal, A., 2009a. Pre-treatment of agro-industrial residues. In: Singh, P.N., Pandey, A. (Eds.), *Biotechnology for agro-industrial residues utilisation*. Springer Science, Netherlands, pp. 13-33.

Siriwardhana, S.S.K.W., Shahidi, F., 2002. Antiradical activity of extracts of almond and its by-products. *J. Am. Oil Chem. Soc.* 79, 903-908.

Sonage, S., Warake, S., Barde, D., Chaudhari, K., Jawale, U., Tandale, M., 2018. Optimization of extraction of kusum seed oil through Soxhlet extraction process using n-hexane solvent. In: Pawar, P.M., Ronge, B.P., Balasubramaniam, R., Vibhute, A.S., Apte, S.S. (Eds.), *Techno-Societal*, Springer, pp 301-313.

Song, X., Zheng, F., Ma, F., Kang, H., Ren, H., 2020. The physical and oxidative stabilities of Pickering emulsion stabilized by starch particle and small molecular surfactant. *Food Chem.* 303, 125391.

Soong, Y.Y., Barlow, P.J., 2004. Antioxidant activity and phenolic content of selected fruit seeds. *Food Chem.* 88, 411–417.

Statista Research Department. <https://www.statista.com/statistics/263978/global-vegetable-oil-production-since-2000-2001/>

Sultana, B., Anwar, F., Asi, M.R., Chatha, S.A.S., 2008. Antioxidant potential of extracts from different agro wastes: Stabilization of corn oil. *Grasas y Aceites* 59, 205–217.

Szydłowska-Czerniak, A., Tułodziecka, A., 2015. Optimization of ultrasound-assisted extraction procedure to determine antioxidant capacity of rapeseed cultivars. *Food Anal. Methods* 8, 778–789.

Takeuchi, T.M., Pereira, C.G., Braga, M.E.M., Maróstica Jr, M.R., Leal, P.F., Meireles, M.A.A., 2009. Low-pressure solvent extraction (solid–liquid extraction, microwave assisted, and ultrasound assisted) from condimentary plants. In: Meireles, M.A.A. (Ed.), *Extracting bioactive compounds for food products*. Taylor & Francis Group, UK, pp. 137-211.

Talekar, S., Patti, A.F., Singh, R., Vijayraghavan, R., Arora, A., 2018. From waste to wealth: High recovery of nutraceuticals from pomegranate seed waste using a green extraction process. *Ind. Crops Prod.* 112, 790–802.

Tamkutė, L., Liepuoniūtė, R., Pukalskienė, M., Venskutonis, P.R., 2020. Recovery of valuable lipophilic and polyphenolic fractions from cranberry pomace by consecutive supercritical CO<sub>2</sub> and pressurized liquid extraction. *J. Supercrit. Fluids* 159.

Taranto, F., Pasqualone, A., Mangini, G., Tripodi, P., Miazzi, M.M., Pavan, S., Montemurro, C., 2017. Polyphenol oxidases in crops: Biochemical, physiological and genetic aspects. *Int. J. Mol. Sci.* 18.

Teh, S.S., Bekhit, A.E.D., Carne, A., Birch, J., 2014. Effect of the defatting process, acid and alkali extraction on the physicochemical and functional properties of hemp, flax and canola seed cake protein isolates. *J. Food Meas. Charact.* 8, 92–104.

Temelli, F., Ciftci, O.N., 2015. Developing an integrated supercritical fluid biorefinery for the processing of grains. *J. Supercrit. Fluids* 96, 77–85.

Toor, R.K., Savage, G.P., 2005. Antioxidant activity in different fractions of tomatoes. *Food Res. Int.* 38, 487–494.

Torres-Mayanga, P.C., Lachos-Perez, D., Mudhoo, A., Kumar, S., Brown, A.B., Tyufekchiev, M., Dragone, G., Mussatto, S.I., Rostagno, M.A., Timko, M., Forster-Carneiro, T., 2019. Production of biofuel precursors and value-added chemicals from hydrolysates resulting from hydrothermal processing of biomass: A review. *Biomass and Bioenergy* 130, 105397.

Treimo, J., Westereng, B., Horn, S.J., Forssell, P., Robertson, J.A., Faulds, C.B., Waldron, K.W., Buchert, J., Eijssink, V.G.H., 2009. Enzymatic solubilization of brewers' spent grain by combined action of carbohydrases and peptidases. *J. Agric. Food Chem.* 57, 3316–3324.

Trevisan, M.T.S., Pfundstein, B., Haubner, R., Würtele, G., Spiegelhalder, B., Bartsch, H., Owen, R.W., 2006. Characterization of alkyl phenols in cashew (*Anacardium occidentale*) products and assay of their antioxidant capacity. *Food Chem. Toxicol.* 44, 188–197.

Trevisani Juchen, P., Nolasco Araujo, M., Hamerski, F., Corazza, M.L., Pedersen Voll, F.A., 2019. Extraction of parboiled rice bran oil with supercritical CO<sub>2</sub> and ethanol as co-solvent: Kinetics and characterization. *Ind. Crops Prod.* 139, 111506.

Tsao, R., 2010. Chemistry and biochemistry of dietary polyphenols. *Nutrients* 2, 1231–1246.

Tungmunnithum, D., Ahmed, E., Abid, M., Drouet, S., Reza, K., Garros, L., Kabra, A., Addi, M., Christophe, H., 2020. A quick, green and simple ultrasound-assisted extraction for the valorization of antioxidant phenolic acids from moroccan almond (*Prunus dulcis* (Mill.) D.A.Webb) cold-pressed oil residues. *Appl. Sci.* 10, 3313.

United Nations, 2016. Second generation biofuel markets: state of play, trade and developing country perspectives, United Nations Publication.

Vahabzadeh, F., Mehranian, M., Mofarrah, E., 2004. Antioxidant activity of pistachio hulls. *J. Am. Oil Chem. Soc.* 81, 621–622.

Valadez-Carmona, L., Ortiz-Moreno, A., Ceballos-Reyes, G., Mendiola, J.A., Ibáñez, E., 2018. Valorization of cacao pod husk through supercritical fluid extraction of phenolic compounds. *J. Supercrit. Fluids* 131, 99–105.

Vásquez-Villanueva, R., Marina, M.L., García, M.C., 2015. Revalorization of a peach (*Prunus persica* (L.) Batsch) byproduct: Extraction and characterization of ACE-inhibitory peptides from peach stones. *J. Funct. Foods* 18, 137–146.

Viganó, J., Coutinho, J.P., Souza, D.S., Baroni, N.A.F., Godoy, H.T., Macedo, J.A., Martínez, J., 2016. Exploring the selectivity of supercritical CO<sub>2</sub> to obtain nonpolar fractions of passion fruit bagasse extracts. *J. Supercrit. Fluids* 110, 1–10.

Vinatoru, M., Mason, T.J., Calinescu, I., 2017. Ultrasonically assisted extraction (UAE) and microwave assisted extraction (MAE) of functional compounds from plant materials. *TrAC - Trends Anal. Chem.* 97, 159–178.

Virost, M., Tomao, V., Colnagui, G., Visinoni, F., Chemat, F., 2007. New microwave-integrated Soxhlet extraction. An advantageous tool for the extraction of lipids from food products. *J. Chromatogr. A* 1174, 138–144.

Watanabe, M., Ohshita, Y., Tsushida, T., 1997. Antioxidant compounds from buckwheat (*Fagopyrum esculentum* Möench) hulls. *J. Agric. Food Chem.* 45: 1039–1044.

Weisz, G.M., Kammerer, D.R., Carle, R., 2009. Identification and quantification of phenolic compounds from sunflower (*Helianthus annuus* L.) kernels and shells by HPLC-DAD/ESI-MS<sup>n</sup>. *Food Chem.* 115, 758–765.

Whitaker, J.R., 1995. Polyphenol oxidase. In: Wong, D.W.S. (Ed.), *Food enzymes, structure and mechanism*. Springer science, USA, pp. 271-307.

Wijngaard, H.H., Rößle, C., Brunton, N., 2009. A survey of Irish fruit and vegetable waste and by-products as a source of polyphenolic antioxidants. *Food Chem.* 116, 202–207.

Wolfe, K.L., Liu, R.H., 2003. Apple peels as a value-added food ingredient. *J. Agric. Food Chem.* 51, 1676–1683.

Wu, W., Chang, J.S., 2019. Integrated algal biorefineries from process systems engineering aspects: A review. *Bioresour. Technol.* 291.

Wu, Y.V., Inglett, G.E., 1974. Denaturation of plant proteins related to functionality and food applications. A review. *J. Food Sci.* 39, 218–225.

Xiao, J., Li, Y., Huang, Q., 2016. Recent advances on food-grade particles stabilized Pickering emulsions: Fabrication, characterization and research trends. *Trends Food Sci. Technol.* 55, 48–60.

Xu, D.P., Zheng, J., Zhou, Y., Li, Y., Li, S., Li, H. Bin, 2016b. Extraction of natural antioxidants from the *Thelephora ganbajun* mushroom by an ultrasound-assisted extraction technique and evaluation of antiproliferative activity of the extract against human cancer cells. *Int. J. Mol. Sci.* 17, 1–15.

Xu, D.P., Zheng, J., Zhou, Y., Li, Y., Li, S., Li, H. Bin, 2017. Ultrasound-assisted extraction of natural antioxidants from the flower of *Limonium sinuatum*: Optimization and comparison with conventional methods. *Food Chem.* 217, 552–559.

Xu, D.P., Zhou, Y., Zheng, J., Li, S., Li, A.N., Li, H. Bin, 2016a. Optimization of ultrasound-assisted extraction of natural antioxidants from the flower of *Jatropha integerrima* by response surface methodology. *Molecules* 21, 1–12.

Yang, Y., Fang, Z., Chen, X., Zhang, W., Xie, Y., Chen, Y., Liu, Z., Yuan, W., 2017. An overview of Pickering emulsions: Solid-particle materials, classification, morphology, and applications. *Front. Pharmacol.* 8, 1–20.

Yi, C., Shi, J., Kramer, J., Xue, S., Jiang, Y., Zhang, M., Ma, Y., Pohorly, J., 2009. Fatty acid composition and phenolic antioxidants of winemaking pomace powder. *Food Chem.* 114, 570–576.

Yildiz, G., Ding, J., Andrade, J., Engeseth, N.J., Feng, H., 2018. Effect of plant protein-polysaccharide complexes produced by mano-thermo-sonication and pH-shifting on the structure and stability of oil-in-water emulsions. *Innov. Food Sci. Emerg. Technol.* 47, 317–325.

Yin, H., Xu, L., Porter, N.A., 2011. Free radical lipid peroxidation: Mechanisms and analysis. *Chem. Rev.* 111, 5944–5972.

Yu, J., Ahmedna, M., Goktepe, I., 2005. Effects of processing methods and extraction solvents on concentration and antioxidant activity of peanut skin phenolics. *Food Chem.* 90: 199–206.

Zabaniotou, A., Kamaterou, P., Kachrimanidou, V., Vlysidis, A., Koutinas, A., 2018. Taking a reflexive TRL3-4 approach to sustainable use of sunflower meal for the transition from a mono-process pathway to a cascade biorefinery in the context of Circular Bioeconomy. *J. Clean. Prod.* 172, 4119–4129.

Zayas, J.F., 1997. *Functionality of proteins in food*. Springer-Verlag Berlin Heidelberg, USA.

Zhang, D., Hamauzu, Y., 2004. Phenolic compounds and their anti-oxidant properties in different tissues of carrots. (*Daucus carota* L.). *Food Agri. Environ.* 2, 95–100.

Zhang, L., Fan, G., Khan, M.A., Yan, Z., Beta, T., 2020. Ultrasonic-assisted enzymatic extraction and identification of anthocyanin components from mulberry wine residues. *Food Chem.* 323, 126714.

Zhou, S-h., Fang, Z-x., Lü, Y., Chen, J-c., Liu, D-h., Ye, X-q., 2009. Phenolics and antioxidant properties of bayberry (*Myrica rubra* Sieb. et Zucc.) pomace. *Food Chem.* 112, 394–399.

Zielinski, Z.A.M., Pratt, D.A., 2017. Lipid peroxidation: Kinetics, mechanisms, and products. *J. Org. Chem.* 82, 2817–2825.

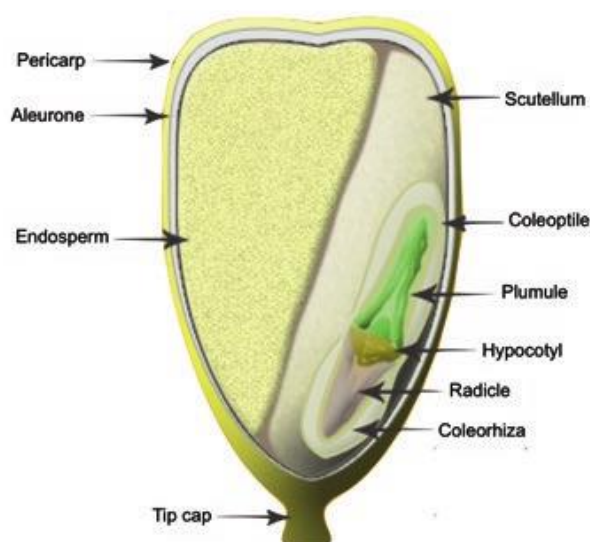
## Chapter II: MATERIALS AND METHODS

### 1. Raw materials

#### 1.1. Corn germ

Corn germ from dry-milling processing was supplied by Castelmaais (Casteljaloux, Nouvelle-Aquitaine) as an agroindustrial by-product generated during manufacturing of corn flour, semolina and grits. When collected in fields, corn kernels exhibited a water content of about 20-25%, before being dried to approximately 15% water content. For the corn germ used in this work, the industrial separation of germ and endosperm was carried out by dry milling, with no soaking nor drying steps. The material was therefore supplied as a dry material, so no other drying step was performed at CBMN.

In Figure II-1 is shown corn kernel anatomy, in which pericarp and tip cap make up the bran, endosperm (fermentable starch) is about 80% of the kernel, while the germ (non-fermentable) represents about 12.5% of total kernel. During large-scale processing, the endosperm is separated mechanically from the germ and bran. However, some endosperm may remain along with corn germ by-product.



**Figure II-1.** Diagrammatic illustration of corn anatomy (Source: Shim et al., 2018)

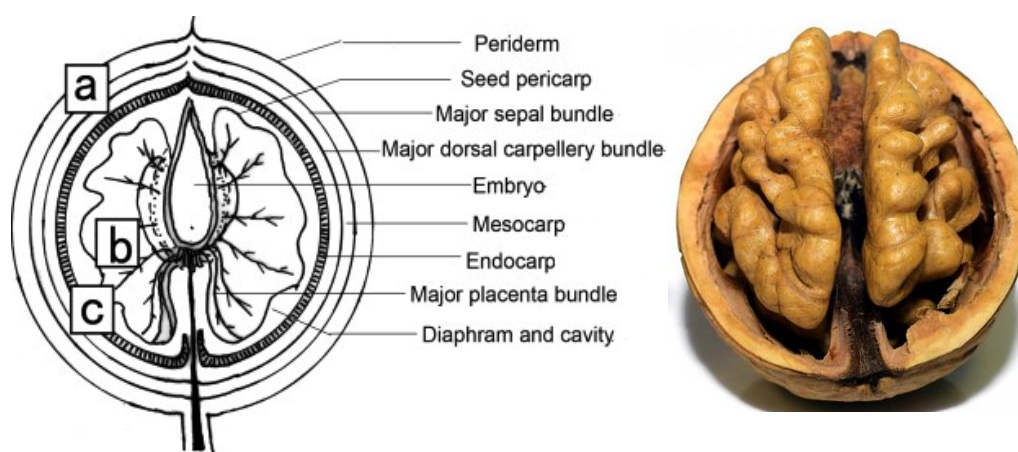
Prior experiments, corn germ was ground using a home mill (Essentiel, EMC 1 model, 150 W, France) in order to increase mass transfer during oil and protein extraction. Right away the material was sieved using a mesh size of 500  $\mu\text{m}$  (Retsch, Germany) and the material that

passed the mesh was collected. The ground and sieved corn germ was stored in individual container as batches of approximately 150 g at -18°C and protected from light and oxygen prior its use. The biorefinery scheme proposed from corn germ forms *Chapter III*.

## 1.2. Walnut press-cake

The walnut cake used in this work was kindly donated by Moulin de la Veysère (Dordogne, Nouvelle-Aquitaine) ([www.moulindeleveysiere.fr](http://www.moulindeleveysiere.fr)) as an agroindustrial by-product generated after oil extraction by pressing under mild heating. The oil content in commercial walnut varieties may range from 620 to 740 g.kg<sup>-1</sup> kernel (Khir & Pan, 2019) (in Figure II-2 is presented the anatomy of a walnut fruit). The fruits (*Juglans regia* L) were grown locally and processed on April 2018. The cake was collected the day after the pressing and since its water content was lower than 5%, it was directly stored at -18°C without drying step. For the supercritical fluid extraction, the walnut cake was provided by Huilerie Monsallier (Grun-bordas, Nouvelle-Aquitaine), due to the large amount of plant material (250 g) to beloaded in the pilot extraction unit (SFE Lab 2L, SFE Process, France).

Before extraction experiments, 100 g of walnut cake were ground using a home mill (Essentiel, EMC 1 model, 150 W, France), sieved below 600 µm (Retsch, Germany) and stored at -18°C, protected from the light and oxygen until use. The biorefinery scheme proposed from walnut press-cake forms *Chapter IV*.

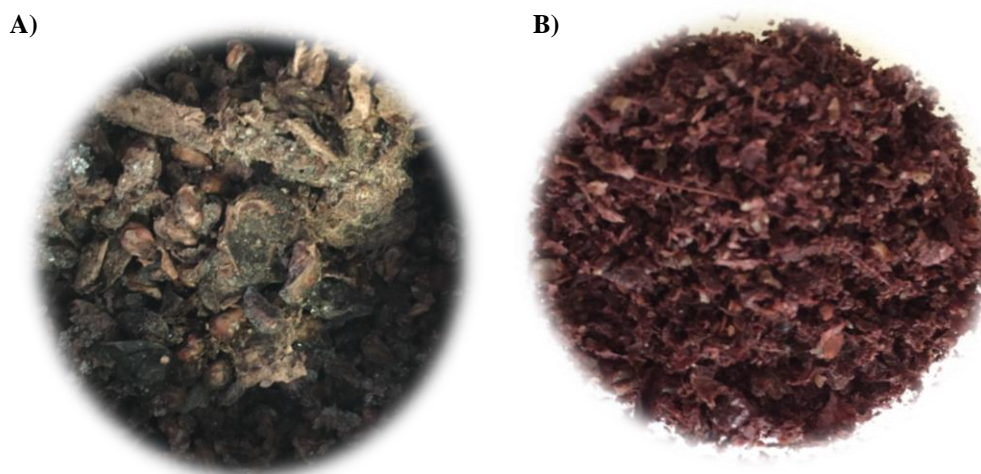


**Figure II-2.** Diagram of the walnut fruit anatomy; outer pericarp layer (husk) (a), cotyledon (kernel) (b) and inner pericarp layer (shell) (c) (Adapted from Wu et al., 2009)

### 1.3. Grape pomace

Grape pomace consisting of skin, stems, and seeds was donated by distillery Union des Coopératives Viticoles d'Aquitaine (UCVA) (Coutras, Nouvelle-Aquitaine) as a residue generated after producing red wine. This bagasse was a mix of by-products from various wine industries located in the area of Bordeaux and Charente and it was previously fermented at room conditions in the distillery. Grape pomace is commonly discarded or used as animal feed or in composting applications. Since grape residue was composed of several plant parts, it exhibited large and non-uniform particle size (Figure II-3), in addition to a high moisture content ( $35.8 \pm 1.0\%$ ). Therefore, the material was frozen at  $-18^{\circ}\text{C}$  and then ground in a home mill (Essentiel, EMC 1 model, 150 W, France) in order to homogenize the material and facilitate the mass transfer during extraction process. After that, the grape pomace was stored in individual container as batches of approximately 100 g at  $-18^{\circ}\text{C}$ , protected from light and oxygen until use.

Since phenolic extraction were performed with hydroalcoholic solutions, the ground grape pomace was not dried (drying processes prior to the extraction of compounds would increase the energy consumption and the economic costs of the process). In this work, the grape residue was used for the recovery of bioactive compounds by ultrasound assisted extraction (Chapter V).



**Figure II-3.** Grape pomace before (A) and after milling (B)



## **1.4. Chemicals and reagents**

The carbon dioxide for the supercritical fluid extraction was acquired from Air Liquide (Floirac, France, 99.5% purity). All reagents were analytical grade from Sigma Chemical Co (St Quentin Fallavier, France) and Scharlab (Barcelona, Spain). Ultrapure water (15 MΩ.cm) (ELGA, Purelab<sup>®</sup> Option, UK) was used to prepare hydroalcoholic solutions, extract proteins and assess functionality properties.

## **2. Methods**

### **2.1. Characterization of raw materials**

Ground and sieved corn germ and walnut cake were characterized regarding their centesimal composition (moisture, lipid, protein, ash and carbohydrate content) as described below. In addition the mean particle size of ground and sieved corn germ was determined. All analyzes were carried out in duplicate. The diameter of walnut particles could not be determined since a great agglomeration of particles during sieving was observed due to their high oil content. Grape pomace was analyzed only in its water content.

#### **2.1.1. Moisture**

The water content was determined using a moisture analyzer balance (Fisher Scientific, Moisture Series, Illkirch, France). The moisture was analytically measured through weight loss during drying at  $105 \pm 1$  °C by halogen heating. Approximately 5 g of material were used for each analysis and the drying time was set to 100 min assuring the complete water evaporation and final constant weight. The water content was calculated as the percentage ratio between the weight loss and the initial mass sample.

#### **2.1.2. Ash content**

The method followed for ash determination was AACC 08-01 (1990) which is based on the muffle incineration of the organic material. For this purpose, porcelain containers with approximately 3 g of material were used. The samples were put in the muffle at  $500 \pm 10$  °C for 24 hours, and then cooled in a desiccator at room temperature. The mineral content was calculated as the percentage ratio between the final mass of ash and the initial sample mass.

### 2.1.3. Lipid content

The lipid content of raw materials was quantified by Soxhlet extraction method using hexane as solvent (Almazan and Adeyeye, 1998). For that, approximately 14 g of raw material were placed in a thimble and extracted into a Soxtec system (1045 extraction unit, Tecator HT 2, Denmark). Over time (4 hours), sufficient solvent (hexane 98.0%) was evaporated from an aluminum extraction beaker and condensed to fill the thimble containing the ground sample.

The unit provides a separated heating system (set at  $130 \pm 3$  °C) to heat the plates in the extraction unit. After 4 hours of continuous extraction the solvent recycling valve was closed while the remaining solvent in the aluminium beaker was evaporated. The lipids in the extraction beaker were left in a fume hood for 2 h to ensure remaining solvent removal. The extraction beakers with the lipids were then weighed. Finally, the lipid content is calculated as percentage ratio between the oil mass recovered and the initial sample mass.

### 2.1.4. Protein content

The protein content of raw materials was estimated following the determination of total nitrogen by the Kjeldahl method (AOAC, 2000). The procedure is based on the digestion of approximately 0.5 g of sample with 10 mL of a sulfuric acid solution (900 mL H<sub>2</sub>SO<sub>4</sub> 96%, 20 mL of perchloric acid 70% (v/v) and 3 g of selenium dioxide (99.0% purity)) in a digestion tube. During 3 hours of digestion at  $320 \pm 2$  °C in a Kjeldhaltherm Digestion System (Gerhardt, UK) the carbon and hydrogen are oxidized to CO<sub>2</sub> and water whereas protein nitrogen is reduced and transformed into ammonium sulfate. Thereafter, the digestion tubes were left at room conditions for 1 hour and 70 mL of distilled water were then added. The digested sample was distilled using a Kjeldahl steam distillation systems (Vapodest<sup>®</sup> 20s, Gerhardt, UK) (Figure II-4) in basic medium by the addition of sodium hydroxide solution (at 32% wt/v) to release the ammonia which was collected in a boric acid solution (4% wt/v) to form ammonium borate. Ammonium borate was quantified by titration with sulfuric acid (0.1 M). A blank (digestion tube without sample) was also analyzed following the same protocol.



**Figure II-4.** Kjeldhal digestion and distillation system

Finally, the total nitrogen content was calculated by Equation II.1 and the protein content was estimated using a conversion factor (CF) of 6.25 or 5.3 for corn germ or walnut cake, respectively (Equation II.2).

$$\text{Nitrogen (\%)} = \left( \frac{(V_t - V_b) \cdot M_{H_2SO_4} \cdot M_N}{m_s} \right) \cdot 100 \quad \text{Equation II.1}$$

$$\text{Protein (\%)} = \text{Nitrogen (\%)} \times \text{CF} \quad \text{Equation II.2}$$

where:  $V_t$  and  $V_b$  are the volumes (L) for the titration of the distilled sample and the blank respectively,  $M_{H_2SO_4}$  is the sulfuric acid molarity (0.1 M),  $M_N$  is the molar mass of nitrogen ( $14 \text{ g mol}^{-1}$ ),  $m_s$  is the mass of sample ( $\approx 0.5 \text{ g}$ ) and CF is the conversion factor.

### 2.1.5. Carbohydrate content

Considering that raw materials are composed of water, lipids, proteins, carbohydrates and minerals, the carbohydrate content was estimated by the mass difference. This is common method for the proximate analysis of raw materials reported by several authors (Capellini et al., 2019; Barrales et al., 2018; Barrales et al., 2015).

### 2.1.6. Particle size characterization

The geometric mean particle diameter of the ground corn germ was determined following the method of ASAE Standards (1998), using 10 g of powder sample and standard mesh Tyler series (Retsch, Germany) from 50 to 500  $\mu\text{m}$  opening size. The sample was sieved for 5 min, and thereafter the mass retained in each sieve was determined. The mean diameter was calculated according to Equation II-3.

$$d_p = \log^{-1} \left[ \frac{\sum_{i=1}^n (w_i \cdot \log \bar{d}_i)}{\sum_{i=1}^n w_i} \right] \quad \text{Equation II-3}$$

where:  $d_p$  represents the geometric mean particle diameter ( $\mu\text{m}$ ),  $\bar{d}_i = (d_i \cdot d_{i+1})^{0.5}$ ,  $d_i$  is the opening size of the  $i$ -th sieve ( $\mu\text{m}$ ), and  $d_{i+1}$  is the opening size of the  $i+1$  sieve ( $\mu\text{m}$ ), and  $W_i$  is the mass of the material retained in the  $i$ -th sieve (g).

## 2.2. Recovery of valuable fractions from by-products

### 2.2.1. Oils

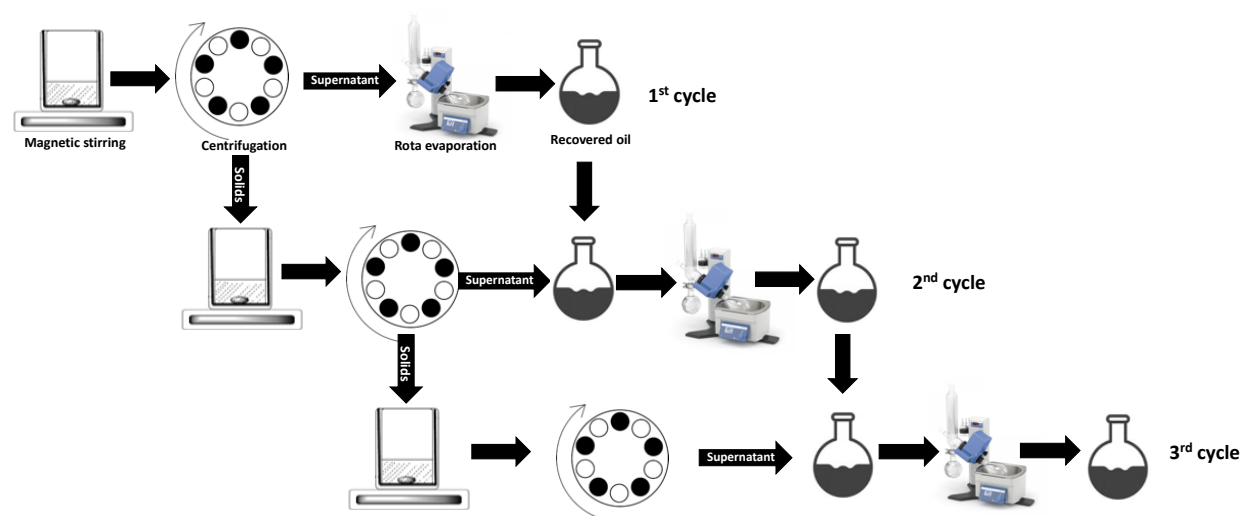
Various convectional solid-liquid extraction methods as well as supercritical fluid extraction were assessed to recover oil from corn germ. On the other hand, only Soxhlet extraction with hexane was used to recover oil from walnut cake. Grape pomace was not submitted to oil extraction. The various oil extraction methods are carefully described below.

#### 2.2.1.1. Conventional solid-liquid extraction by organic solvents

A conventional maceration using hexane at room temperature namely 24 °C (called Hexane RT) and 45°C (called Hexane 45 °C) was conducted. For that, 50 g of ground corn germ and 250 mL of hexane (purity 98.0%) (ratio 1:5 wt/v) were mixed in a 500 mL capped glass bottle. The mixture was stirred (Model C-MAG HS 7, Ika®, Germany) for three sequential extractions of 20 min period at room temperature or at 45  $\pm$  1 °C. After each extraction period, the solid-solvent-oil mixture was centrifuged (Rotanta 460 RF, Hettich, Germany) at 225 g for 2 min and the supernatant was collected in a glass rotary flask, while the solid was addressed to a second and third extraction cycle. Solid to solvent ratio of 1:5 and three cycles ensured complete defatting. The hexane was then removed by roto-evaporation

(RE 300DB, Stuart<sup>®</sup>, UK) under reduced pressure (0.3 bar) at  $38 \pm 1^\circ\text{C}$  and the recovered oil was weighed. The global extraction yield was calculated as the percentage ratio between the mass of oil recovered in the three cycles of extraction and the initial sample mass. Figure II-5 shows the extraction procedure followed for recovering oil by maceration.

The defatted meals were left in fume hood overnight to evaporate the remaining solvent and then stored in individual containers at  $-18^\circ\text{C}$  protected from the light and oxygen until later use. Similarly, the recovered oils were stored in amber sealed container at  $-18^\circ\text{C}$  until analysis. Extractions were performed in duplicate



**Figure II-5.** Schematic representation of oil recovery by maceration

In addition, Soxhlet extraction using hexane (called Soxhlet hexane) and absolute ethanol (called Soxhlet ethanol) were also assessed for extracting oil from corn germ. For that, the same procedure as described in section 2.1.3 was followed, either with hexane or with ethanol.

Among the conventional solid-liquid extraction methods, only Soxhlet hexane was used to recover oil from walnut cake.

### 2.2.1.2. Supercritical Fluid Extraction (SFE)

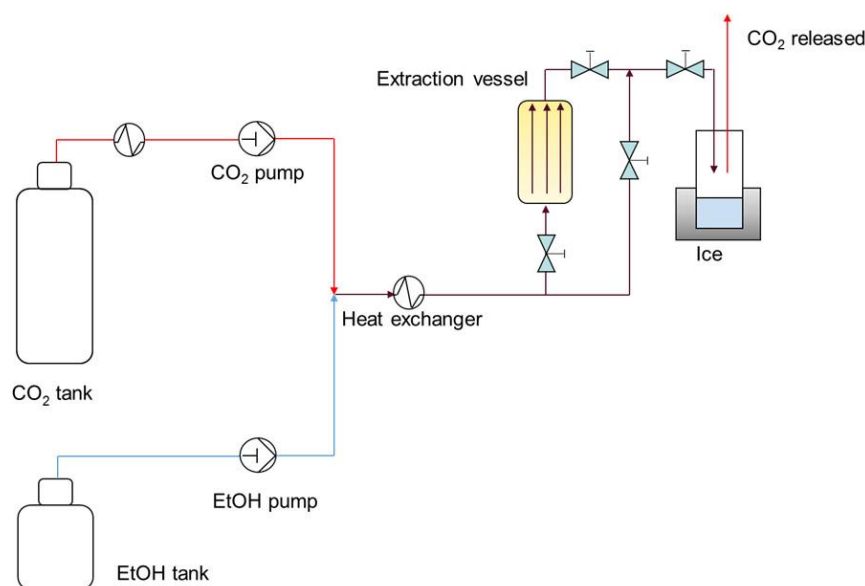
The supercritical carbon dioxide extraction (called Sc-CO<sub>2</sub>) was performed in a home-made equipment that consisted in a 100 mL vessel (inner diameter of 3 cm, TOP Industrie SAS, Vaux le Pénil, France), a pump for the CO<sub>2</sub> delivery (Gilson pump 305, Gilson International-

France S.A.S, France) and various stop valves (Autoclave France, France), heat exchangers, pressure and temperature sensors (Figure II-6).

The extraction process consisted of first cooling the CO<sub>2</sub> (99.5% purity) from reservoir at 0 °C (cooling bath F12, Julabo, France) to enter in liquid state into the CO<sub>2</sub> pump (Gilson International-France S.A.S, France). The pressurized carbon dioxide was then pre-heated in a tubular heat exchanger before flowing through the extraction vessel previously loaded with 30 g of ground corn germ. The temperature of extraction vessel was set at 45 °C using an electrical mantle and monitored by a K-thermocouple (Watlow, France). The pressure was set at 210 bar (PR 711F 400 bar, ASCO, France). The pressure and temperature of Sc-CO<sub>2</sub> were set as moderate conditions considering the operational limitations of the home-made equipment.

The Sc-CO<sub>2</sub> left then the extraction vessel and was depressurized at atmospheric pressure by a metering valve therefore, separating the solute (oil) from the solvent. The CO<sub>2</sub> flow rate was measured after expansion by a flowmeter and was of 5.6 g/min. Finally, the extracted oil was collected, weighed and stored in amber sealed container at -18 °C until analysis. The defatted meal was removed from the extraction vessel and stored at -18 °C until further use.

The extraction yield was calculated as the percentage ratio between the mass of extracted oil and the initial sample mass.



**Figure II-6.** SFE set -up (Adapted from: Bardeau et al., 2015)

On the other hand, SFE from walnut cake (from Moulin de la Veyssère and Huilerie Monsallier) was carried out using a pilot extraction unit (SFE Lab 2L, SFE Process, France) (Figure II-7). For that, pure CO<sub>2</sub> was pressurized at 500 bar and heated at 60 ± 2 °C. The procedure consisted of 160 min of continuous extraction from 253 g of ground and sieved walnut cake at a flow rate of 100 g CO<sub>2</sub>/min. CO<sub>2</sub> flowed from the top to the bottom of extraction vessel, the pilot was equipped with 2 separators (pressure about 60 bar) and CO<sub>2</sub> recycling. After extraction, the extracted oil was collected, weighed and stored in amber sealed container at -18 °C until analysis.



**Figure II-7.** SFE Lab 2L equipment

## **2.2.2. Proteins**

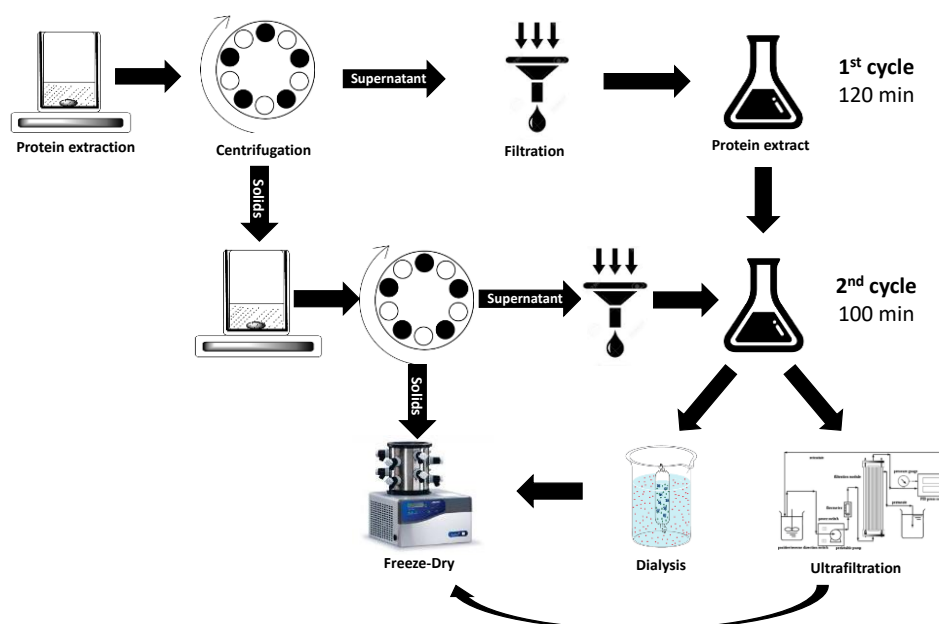
### **2.2.2.1. Protein extraction**

Corn germ meal defatted by the various methods described in sections 2.2.1.1 and 2.2.1.2 were further submitted to protein extraction in order to assess the influence of de-oiling method on protein recovery and functionality. Undefatted corn germ meal was also submitted to protein extraction for comparative purposes. All extractions were done in duplicate.

The method for protein recovery was adapted from Hojilla-Evangelista, (2012 and 2014) with minor variations. Figure II-8 shows the extraction procedure followed to recover proteins from corn germ in which two consecutive solid-liquid extractions were carried out with the same material. The method uses saline solution as extracting solvent considering that the predominant proteins in corn germ are albumins and globulins.

Approximately 20 g of defatted meals were mixed with 200 mL of 0.1 M NaCl (pH 6.7) and stirred for 2 hours at room temperature ( $24 \pm 2$  °C), using a magnetic stirrer (C-MAG HS 7, Ika®, Germany). The slurry was then centrifuged at 13 300 g for 10 min (Rotanta 460 RF, Hettich, Germany) and the supernatant was filtered (filter paper 303, VWR, Belgium), while the solid was subjected to the second extraction with 200 mL of fresh 0.1 M NaCl for 100 min. After the second extraction the mixture was centrifuged, and the supernatant was filtered and pooled with the one recovered previously.

The total volume of supernatants was measured, and then dialyzed or ultra-filtered (procedure described below), while remaining solids were freeze-dried (vacuum  $6.7 \times 10^{-5}$  bar; -85 °C) (Cryotec lyophilizer, Cosmos – 80, France) and stored in sealed containers at room conditions until later use.



**Figure II-8.** Schematic representation of protein recovery from defatted and undefatted corn germ



Moreover, the protein distribution, i.e. the content of albumin/globulin, zein and glutelin, of corn germ defatted by Hexane RT, was also estimated according to Parris et al. (2006). For that, 20 g of defatted meal was added to 200 mL of 0.1 M NaCl and stirred for 1 hour in order to extract albumins and globulins. Right after, the solution was centrifuged at 13 300 g for 10 min, the supernatant was dialyzed and then centrifuged. Both the globulin precipitate and the supernatant, containing the albumin, were freeze-dried. The solids from the salt extraction were added to 300 mL of ethanol 70% (v/v) for zein extraction. After 1 hour of continuous stirring the mixture was centrifuged and the supernatant was recovered, dialyzed and freeze-dried. The solids were submitted to glutelin extraction in 300 mL of 0.1M NaOH for 1 hour. After that, the mixture was centrifuged and the supernatant was dialyzed and then freeze-dried. The final residue was also freeze-dried and stored until protein quantification according to described in section 2.1.4.

#### **2.2.2.2. Purification of protein extracts (Desalting step)**

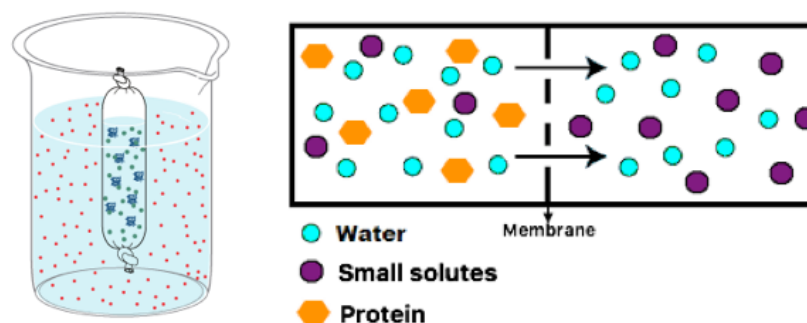
After protein extraction by saline solutions from plant materials, the extracts contain many undesirable impurities, such as minerals, some soluble carbohydrates and minor compounds (phenols, for instance) that should be removed in order to enhance the protein concentration and avoid undesirable effects on the functional properties of freeze-dried extracts. In this sense, dialysis or Ultrafiltration–Diafiltration (UF-DF) were conducted aiming to compare these two purification techniques regarding the protein recovery and functionality. Both desalting methods are described below.

##### ***Dialysis***

Dialysis is a purification technique that separates molecules based on their size. Solvents, ions and small molecules may diffuse easily across the semipermeable membrane, but larger molecules are unable to pass through the pores. Globally, the process consists in the diffusion of solutes across a semi-permeable membrane - substances in water tend to move from an area of high concentration to an area of low concentration – as shown in Figure II-9.

Therefore, after saline protein extraction, the extracts were transferred to a molecular porous membrane tubing (Spectra/Por MWCO 3.5 kDa, USA), properly sealed and dialyzed against deionized water for two days at 4 °C with several changes of water. The conductivity

of deionized water was monitored (Conductivity meter, Mettler Toledo FEP30, USA) along the dialyzing process. After two days, the dialyzing extracts were recovered, freeze-dried (vacuum  $6.7 \times 10^{-5}$  bar;  $-85$  °C) (Cryotec lyophilizer, Cosmos – 80, France) and then stored at room conditions until protein functionality assays.



**Figure II-9.** Schematic representation of desalting process by dialysis

#### ***Ultrafiltration–Diafiltration (UF-DF)***

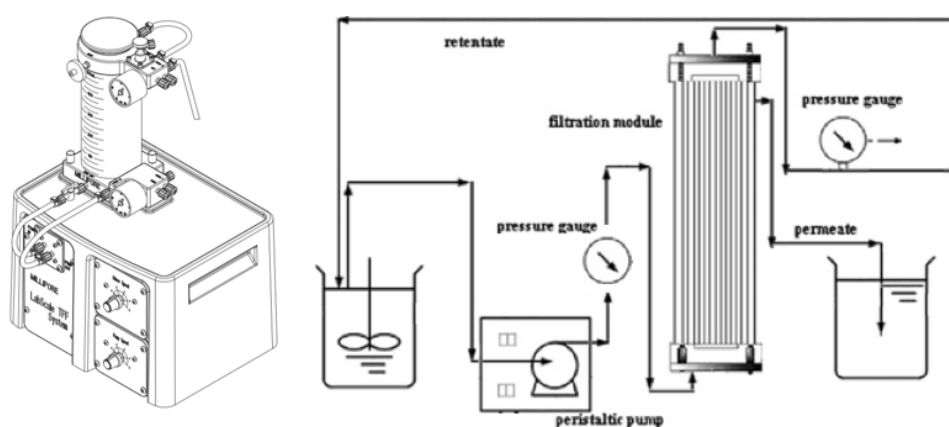
Ultrafiltration and diafiltration processes are used extensively for removal of various small impurities from biological products. Ultrafiltration also consists in a membrane filtration however the separation through a semipermeable membrane occurs by pressure gradient instead of diffusion dynamics. During ultrafiltration, solutes of high molecular weight are retained in the *retentate*, while water and small molecules pass through the membrane in the *permeate* or *filtrate*. This way, the retentate is concentrated with time. When ultrafiltration is conducted in the diafiltration mode, distilled water is continuously added to the retentate at the same flow rate as the permeate, so that retentate volume remains constant.

During diafiltration the retentate is diluted with water and re-ultrafiltered (maintaining a constant retentate volume) in order to reduce the concentration of soluble permeate components and increase further the concentration of retained molecules.

For comparative purposes, a saline protein extract obtained from Sc-CO<sub>2</sub> defatted meal was purified by UF-DF instead of dialysis. An ultrafiltration device consisted of a Labscale™ tangential flow filtration system (Millipore, Molsheim, France) equipped with a Pellicon XL Biomax 5 kDa MWCO polyether-sulfone membrane (surface 50 cm<sup>2</sup>) (Millipore, Molsheim, France) was used. The ultrafiltration was carried out at an inlet pressure of 2.2 bar, an outlet

pressure of 1.2–1.7 bar and an initial permeate flow rate of 1.5 mL/min. Figure II-10 shows the device and the scheme of ultrafiltration used in this work.

Firstly, the protein extract (200 mL) was concentrated two folds (volume 100 mL) and then diafiltered for 5 diavolumes. The salted permeate was discarded whereas the salt free protein extract was freeze-dried and stored at room conditions until use.



**Figure II-10.** Apparatus and flowchart of the tangential flow filtration system (adapted from Huang et al., 2012)

Moreover, owing to the high solubility of corn proteins in basic media (results shown in *Chapter III*), a protein extraction by using NaOH at pH 10 was carried out on the Sc-CO<sub>2</sub> defatted meal. All other conditions described in section 2.2.2 were maintained. After protein extraction, the supernatant (200 mL) was split for purification, one part (100 mL) for being processed by dialysis and the second (100 mL) by UF-DF.

### 2.2.3. Polyphenol-rich extracts

Phenolic compounds were extracted from both defatted walnut cake (Soxhlet hexane) and grape pomace by ultrasound assisted extraction (UAE). UAE is a green intensification technique that displays several advantages since improve global extraction yield by cavitation phenomenon.

For defatted walnut cake, 5 g of meal were placed into a 100 mL plastic beaker containing 64 mL of ethanol 60% (v/v) and the extraction was then conducted in an Ultrasonic processor (Analog Sonifier 450, 450 W, Branson, USA) provided with a 12.7 mm diameter probe. The probe was immersed up to half the height of the sample. All ultrasound assisted extractions were carried out at room temperature ( $24 \pm 1$  °C) and at a fix solid-to-solvent ratio (1/13 wt/v). To avoid temperature rise during extraction, the plastic beaker containing the sample was kept immersed in ice. After extraction procedure, the sample was centrifuged (Rotanta 460 RF, Hettich, Germany) at 13 300 g for 6 min, the supernatant was then filtered on a 0.45  $\mu$ m PVDF syringe filter (Rotilabo-syringe filters, Carl Roth, Germany) and finally stored in amber flask at -18°C until further analysis.

A central composite design was chosen to study the influence of theoretical power (W) ( $X_1$ ), time (min) ( $X_2$ ) and duty cycle (%) ( $X_3$ ) on UAE of total phenolic compounds, ellagic acid and free radical scavenging activity (DPPH). The current design comprised 20 experimental runs with 5 levels (-1.68, -1, 0, +1, + 1.68) for each factor as shown in Table XX. The levels of the independent factors were chosen according to the operational limitations of the sonifier and the duty cycle was set as the percentage fraction of a period of one second in which the ultrasound system is active. The evaluation of the predicted model was done adjusting the response variable to a second-order polynomial model equation (Equation II-4) by response surface methodology using the freeware RStudio (RStudio®, USA). In this sense, a backward-forward method was used to determine the best model fitting the experimental data using AIC criterion as proposed by Akaike, (1974).

$$Y = \beta_0 + \sum_{i=1}^3 \beta_i X_i + \sum_{i=1}^3 \beta_{ii} X_i^2 + \sum_{i=1}^3 \sum_{j=1}^3 \beta_{ij} X_i X_j \quad \text{Equation (II-4)}$$

where Y represents the response variable (total phenolic extraction, ellagic acid extraction and free radical scavenging activity (DPPH));  $\beta_0$ ,  $\beta_i$ ,  $\beta_{ii}$  and  $\beta_{ij}$  are the intercept, linear, quadratic and interaction coefficient, respectively;  $X_i$  and  $X_j$  are the independent factors affecting the response. In order to identify the significant terms, an analysis of variance (ANOVA) has been performed with a confidence level of 95%.

For grape pomace, 0.4 g of sample were extracted with 20 mL of ethanol 60% (v/v) (solid-to-solvent ratio of 1:50 wt/v) in an Ultrasonic processor (Digital Sonifier 450, Branson, USA) provided with a 12.7 mm diameter probe. A digital ultrasonic processor was used aiming at working at higher power and duty cycle than allowed by the Analog Sonifier 450. All other conditions used for phenolic extraction from defatted walnut cake were maintained. In Table II-1 are also shown the coded and natural values of the independent factor studied for UAE from grape pomace whereas the response variables were total phenolic and anthocyanin contents, and free radical scavenging activity (DPPH).

**Table II-1.** Values of independent factors (coded values in brackets) of the central composite design for UAE from defatted walnut cake and grape pomace

Run	Defatted walnut cake			Grape pomace		
	Power (W) (X <sub>1</sub> )	Time (min) (X <sub>2</sub> )	Duty cycle (%) (X <sub>3</sub> )	Power (W) (X <sub>1</sub> )	Time (min) (X <sub>2</sub> )	Duty cycle (%) (X <sub>3</sub> )
1	180 (-1)	10 (-1)	20 (-1)	200 (-1)	3.5 (-1)	30 (-1)
2	220 (+1)	10 (-1)	20 (-1)	360 (+1)	3.5 (-1)	30 (-1)
3	180 (-1)	20 (+1)	20 (-1)	200 (-1)	8.5 (+1)	30 (-1)
4	220 (+1)	20 (+1)	20 (-1)	360 (+1)	8.5 (+1)	30 (-1)
5	180 (-1)	10 (-1)	40 (+1)	200 (-1)	3.5 (-1)	70 (+1)
6	220 (+1)	10 (-1)	40 (+1)	360 (+1)	3.5 (-1)	70 (+1)
7	180 (-1)	20 (+1)	40 (+1)	200 (-1)	8.5 (+1)	70 (+1)
8	220 (+1)	20 (+1)	40 (+1)	360 (+1)	8.5 (+1)	70 (+1)
9	166.4 (-1.68)	15 (0)	30 (0)	160 (-1.68)	6 (0)	50 (0)
10	233.6 (+1.68)	15 (0)	30 (0)	400 (+1.68)	6 (0)	50 (0)
11	200 (0)	6.6 (-1.68)	30 (0)	280 (0)	1.8 (-1.68)	50 (0)
12	200 (0)	23.4 (+1.68)	30 (0)	280 (0)	10.2 (+1.68)	50 (0)
13	200 (0)	15 (0)	13.2 (-1.68)	280 (0)	6 (0)	10 (-1.68)
14	200 (0)	15 (0)	46.8 (+1.68)	280 (0)	6 (0)	90 (+1.68)
15	200 (0)	15 (0)	30 (0)	280 (0)	6 (0)	50 (0)
16	200 (0)	15 (0)	30 (0)	280 (0)	6 (0)	50 (0)
17	200 (0)	15 (0)	30 (0)	280 (0)	6 (0)	50 (0)
18	200 (0)	15 (0)	30 (0)	280 (0)	6 (0)	50 (0)
19	200 (0)	15 (0)	30 (0)	280 (0)	6 (0)	50 (0)
20	200 (0)	15 (0)	30 (0)	280 (0)	6 (0)	50 (0)

Runs 15 to 20 comprised the six replicates at the central point (X<sub>i</sub>=0)

For comparison reasons, conventional maceration extraction was also performed from both defatted walnut cake and grape pomace using ethanol 60% (v/v) as solvent. The same solid-to-solvent ratios was kept (1/13 for walnut cake extraction and 1/50 for grape pomace

extraction) and the extractions were carried out during 20 min at room temperature, under continuous stirring (magnetic stirrer model C-MAG HS 7, Ika<sup>®</sup>, Germany).

### **2.3. Pickering emulsions stabilized plant particles**

#### **2.3.1. Stabilized by corn germ particles**

The oil phase of these emulsions consisted of commercially available sunflower oil (Rustica, France, density: 0.92 g/mL) purchased from a local supermarket. Various corn germ powders were used to stabilize the emulsions. The aqueous phase was a buffer (0.1 M potassium phosphate, pH=7). In some cases, 2% (wt/v) sodium alginate (Sigma-Aldrich, France) solution was added to thicken the aqueous phase. The water used in the experiments was deionized with a resistivity close to 15 MΩ.cm at 20 °C. Sodium azide was added at 0.1% (wt/v) in all aqueous phases as a conservative.

#### *Dispersion of particles in the aqueous phase*

The ground and sieved corn germ meals used were; i) only defatted (as described in section 2.2.1), ii) both defatted and deproteinized (as described in section 2.2.2). All powder concentrations refer to the aqueous phase, varying from 2.5 to 10% (wt/v). The dispersion batches had a total mass of 30 g. The pH of the aqueous phase was set at 7 by means of the phosphate buffer (0.1 M). In order to reduce particle size and avoid further clogging during emulsion preparation, dispersions were prepared and processed by microfluidization prior use. Therefore, powder was first dispersed at appropriate concentration in aqueous phase and stirred for 2 hours, followed by further dispersion using an Ultra-Turrax mixer at 13 400 rpm for 30 min. To limit heating of the dispersion, the container was kept immersed in ice. The dispersion was finally processed through a jet homogenizer (Microfluidizer M-110S, USA) fitted with a Y-single slotted chamber and an intern 75 μm air-gap, at high pressure (1 000 bar). The whole dispersion volume was submitted to 6 passes through the homogenizing chamber.

#### *Emulsion preparation*

Emulsion batches of a total mass of 20 g with 20% (wt/wt) oil content (which refers to the whole emulsion) were prepared by microfluidization. A pre-emulsion was first obtained by

high speed overhead mixing using an Ultra-Turrax mixer. Therefore, the aqueous-particles dispersion was mixed at 12 000 rpm and appropriate amount of sunflower oil was slowly added under mixing. Mixing was extended for 5 min. The pre-emulsion was then homogenized at high pressure (880 bar) using the jet homogenizer. The whole emulsion volume was submitted to 6 passes through the homogenizing chamber. Finally, emulsions were stored for several weeks at 4°C after fabrication to monitor their stability. The characterization of the emulsions stabilized by plant particles is described in section 2.4.4.

### **2.3.2. Stabilized by walnut particles**

For preparing emulsion stabilized by walnut particles a similar procedure as described above in section 2.3.1 was followed. Only the following minor modifications were conducted:

- In this case, the oil phase consisted of virgin linseed oil (Bio Planete, France) purchased from a local supermarket,
- Powder concentration in the aqueous phase was fixed at 2.5% (wt/v) and the dispersion batches had a total mass of 35 g,
- Dispersion and pre-emulsion preparation using the Ultra-Turrax mixer were carried out both at 13 000 rpm,
- The pre-emulsion was then homogenized at high pressure (1 000 bar) using the jet homogenizer,
- Pickering emulsions were fabricated in triplicate; one emulsion was stored for several weeks at 4°C and the other two were submitted to accelerated oxidation at 60 °C as described in section 2.4.4.2.

## **2.4. Analytical methods for characterizing plant fractions**

### **2.4.1. Oil characterization**

#### **2.4.1.1. Fatty acid composition**

Fatty acid composition of different oils was analyzed by gas chromatography according to the method described by Sehl et al., (2018) with minor modification. The lipid fractions were first transmethylated. For that, 5 mg of oil were mixed with 1 mL of BF<sub>3</sub> in methanol solution and 0.5 mL of hexane in a glass tube. The samples were incubated at 100 °C continuously

agitated for 90 min and then cooled in a recipient containing ice. After the addition of 2 mL of hexane and 1 mL of distilled water, the samples were vortexed and centrifuged at 2 300 g for 5 min, and the organic phase containing the Fatty Acid Methyl Esters (FAME) was then collected. The above extraction step was repeated three times by the addition of 2 mL of hexane. The three supernatants (organic phases) were then pooled, concentrated by solvent evaporation under nitrogen flux, washed with 1 mL of distilled water and centrifuged (2 300 g for 5 min) again. The supernatant was recovered, concentrated and analyzed on a gas chromatograph (GC 2010 plus, Shimadzu, Japan) equipped with a flame ionization detector.

FAME were separated on a BPX 70 capillary column (60 m long, 0.25  $\mu\text{m}$  film, 0.22 mm i.d., SGE (Melbourne, Australia)), using nitrogen as carrier gas. The split ratio was 1:33. The injection port and the detector were maintained at 250 °C and 280 °C, respectively. The column temperature program was set as follows: from 160 °C to 180 °C at 1.3 °C/min, maintained for 65 min before increasing at 25 °C/min until 230 °C and maintained for 15 min. The identification of FAME was carried out by comparing their retention times with those of a standard mixture (FAME mix C4-C24, Sigma-Aldrich) and the results were collected and integrated by a GC solution v2.4 integration system (Shimadzu, Japan).

#### **2.4.1.2. Total phenolic content (TPC)**

TPC of oils was estimated using the Folin–Ciocalteu assay (Singleton et al., 1999) with some modifications. Prior the Folin–Ciocalteu assay, polyphenols were extracted from oil by methanolic extraction according to Rombau et al., (2014). For that, approximately 0.2 g of Tween 20 (Sigma, USA) was added to 5 g of oil sample. After adding 10 mL of a methanol/water solution (80:20; v/v), the sample was agitated for 5 min, then sonicated in an ultrasound bath (FB15048, Fisherbrand®, Germany) for 15 min and agitated again for 5 min. The mixture was then centrifuged at 2 000 g for 15 min at room temperature and the supernatant (methanolic phase) was carefully collected. The oily phase was re-extracted following the same procedure from the addition of methanol/water solution. After three consecutive extractions, the supernatants were pooled, and stored at 4 °C until Folin–Ciocalteu assay.

For the Folin–Ciocalteu assay, 50  $\mu\text{L}$  of extract (diluted if necessary) were added to 800  $\mu\text{L}$  of distilled water in an Eppendorf tube. Then, 50  $\mu\text{L}$  of Folin reagent (Sigma, USA) were added and the mixture vortexed. After 3 min, 100  $\mu\text{L}$  of sodium carbonate solution (1 N)



were added to the mixture. The resulting solution was incubated for 2 hours in absence of light, and then, 200  $\mu\text{L}$  of sample were pipetted in a microplate 96 wells. The absorbance was read at 750 nm on a microplate reader (Spark<sup>®</sup> 10M, Tecan, Switzerland). TPC was determined by interpolating the absorbance of the samples based on a calibration curve built using gallic acid as standard (Sigma, USA) in a concentration range of 16–350 mg/L. The results were expressed as mg of Gallic Acid Equivalent (GAE) per kg of oil or raw material, in case of TPC of phenolic extracts.

#### **2.4.2. Protein extract composition and functionalities**

The dry protein extracts obtained from the corn germ defatted by the various methods described in section 2.2.1.1 and 2.2.1.2 (Hexane RT, Hexane 45 °C, Soxhlet hexane, Soxhlet ethanol, Sc-CO<sub>2</sub>) and undefatted meal were characterized regarding their composition and functionalities as follows.

##### **2.4.2.1. Protein content and extraction yield**

The protein content of freeze-dried protein extracts was estimated by the determination of the total nitrogen by the Kjeldahl method as described in section 2.1.4, using a conversion factor of 6.25. On the other hand, the extraction yield (%) was calculated as the mass ratio between the protein recovered in the dry extracts and the total protein in the initial meal.

##### **2.4.2.2. Molecular weight profile (SDS-PAGE)**

The molecular weight profile of proteins contained in extracts was determined by Sodium Dodecyl Sulphate Polyacrylamide Gel Electrophoresis (SDS-PAGE) in reducing conditions. Electrophoresis separates charged molecules through a gel under electric field. Proteins are dissociated in peptide chains under action of SDS and peptides chains are of similar charge/mass ratio. Migration distance is thus only dependent of molar weight. SDS-PAGE was carried out to assess the influence of the different defatting process and the purification method on the molecular weight composition of the obtained dry protein extracts. SDS-PAGE was carried out using Mini-precast gradient gels (Bio-Rad laboratories, Marnes-la-Coquette, France) from 4 to 15% of acrylamide. Given their protein content, dry protein extracts were solubilized so as to provide 2 mg protein /mL in sample buffer solution. This was composed of 0.0625 M Tris-HCl (pH 6.8), 2% SDS, 10% glycerol, 5%  $\beta$ -mercaptoethanol and 0.001%

bromophenol blue as the dye to visualize the electrophoresis course (Laemmli, 1970). The solution was heated at 100 °C for 3 min and 10 µL of sample were loaded onto SDS-gel. Prestained SDS-PAGE Protein Ladder (Fisher Scientific, Illkirch, France) comprising protein standards ranging from 10 to 250 kDa was also included in the gel. Electrophoresis was conducted in a Mini-PROTEAN® Tetra Cell Systems at 40 mA (Bio-Rad laboratories, Marnes-la-Coquette, France) using migration buffer (0.12% glycine (wt/v), 0.25% Tris-Base (wt/v), 0.08% SDS (wt/v)). Gels were stained overnight with 0.1% of Brilliant Blue G250 (Sigma Chemical, St Quentin Fallavier, France) dye and then, washed with distilled water and decolorized with ethanol:acetic acid solution (88:12 v/v) for 1 h.

### **2.4.2.3. Protein solubility profile in water**

Proteins are large biomolecules built by one or more long chains of amino acid residues that may interact with water at the surface. The pH of the aqueous medium influences the amino acid charges and consequently the protein solubility. So, a protein solubility profile in water at different pH values has been performed according to the method described by Ogunwolu et al., (2009) with minor modifications.

Six 10 mL glass recipients were used in each of which 30 mg of dry protein were added to 3 mL of deionized water. The samples were stirred for 5 min and the pH was then adjusted to 2, 4, 6, 8, 10 and 12 by using 1 M and 0.1 M NaOH or 1 M and 0.1 M HCl. The natural pH value of the protein solutions ranged from 5.7 to 6.2.

Samples were stirred at room temperature for 25 min, transferred to falcon tubes and centrifuged at 13 300 g for 20 min. The protein content in the supernatants was determined using the Bradford method (Bradford, 1976). Bradford method consist in the binding of Coomassie Brilliant Blue G-250 to protein causing a shift in the absorption maximum of the dye from 465 to 595 nm. For protein quantification 5 µL of sample (diluted if necessary) were pipetted in a microplate 96 wells followed by the addition of 200 µL of Bradford reagent (Sigma, USA). The solution was carefully mixed and after 5 min in darkness, the absorbance was read at 595 nm on a microplate reader. Protein concentration was determined by interpolating the absorbance of the samples based on a calibration curve built using the protein solution prepared at pH of 12, since in this condition, protein extract was fully soluble.

Protein solubility (%) was then calculated for each value of pH by Equation II-5.

$$\text{Solubility (\%)} = \frac{\text{Protein content in supernatant (mg)}}{\text{Total protein in initial sample (mg)}} \times 100 \quad \text{Equation (II-5)}$$

#### 2.4.2.4. Water Absorption Capacity (WAC)

WAC was determined using the method described by Ogunwolu et al., (2009) with minor modifications. Approximately 100 mg of the various dry protein extracts were added to 1 mL of deionized water in a 3 mL Eppendorf tube (previously weighed) and then carefully mixed for 30 seconds. The Eppendorf tube containing the protein solution was centrifuged at 16 100 g for 15 min and water was then drained at 45° angle for 10 min. The Eppendorf tube with wet protein was weighed and then, freeze-dried at -85 °C under vacuum ( $6.7 \times 10^{-5}$  bar). Absorbed water was determined by weight loss between the wet and the freeze-dried protein extract. The WAC was calculated by dividing the mass of absorbed water by the mass of dry protein extract after experiment (to take into account weight loss due to water-soluble compounds).

#### 2.4.2.5. Foaming properties

Foaming capacity and stability were determined according to the method described by Hojilla-Evangelista, (2012 ) and Ogunwolu et al., (2009) with minor modifications. For that, dry protein extracts were dissolved in deionized water to provide 4 mg protein/mL solution, followed by the adjustment of pH value to 10. The pH was adjusted by using 1 M and 0.1 M NaOH. 25 mL of solution were transferred to a glass graduated cylinder followed by a high speed homogenization with an Ultra-Turrax mixer (Model T25D, Ika®, Germany) at 13 200 rpm for 2 min. The sample was let to settle for 1 hour. The volume of sample was measured just after whipping for estimation of foam capacity and after 1 hour of settling for foam stability. Foam capacity (FC) and foam stability (FS) were then calculated by Equations II-6 and II-7, respectively.

$$\text{FC (\%)} = \frac{(\text{Volume after whipping} - \text{volume before whipping}) (\text{mL})}{(\text{Volume before whipping})(\text{mL})} \times 100 \quad \text{Equation (II-6)}$$

$$\text{FS (\%)} = \frac{\text{Volume after 1 hour settling (mL)}}{\text{Volume after whipping (mL)}} \times 100 \quad \text{Equation (II-7)}$$

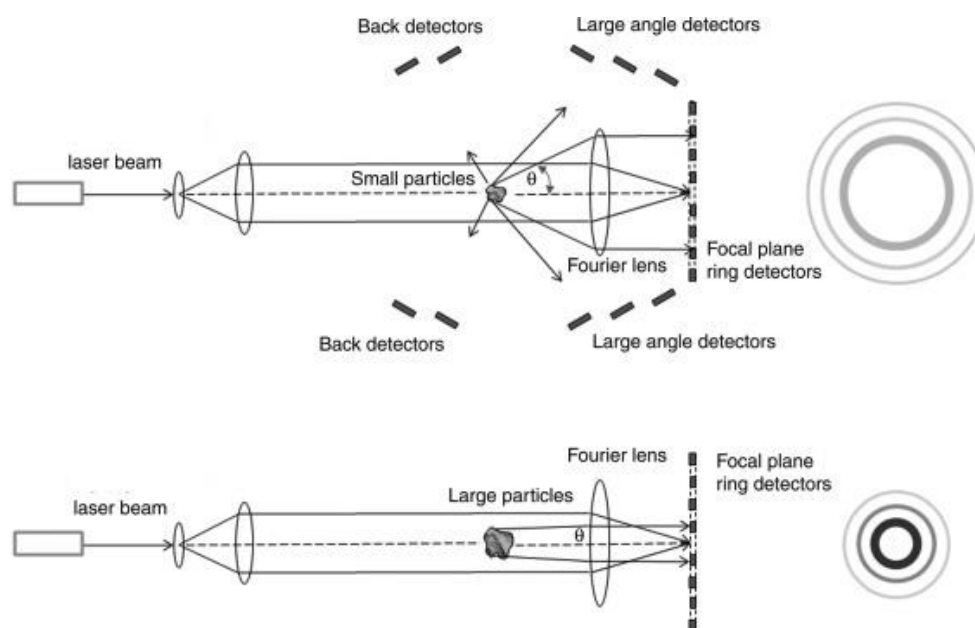
#### 2.4.2.6. Emulsifying capacity

Emulsifying Activity Index (EAI) was determined using the method described by Ogunwolu et al., (2009) and Pearce & Kinsella, (1978) with minor modifications. EAI can be defined as the maximal interfacial area ( $m^2$ ) of emulsion that can be stabilized by 1 g of protein. For that, a 4 mg protein/mL solution with pH value adjusted to 10 was prepared as described in section 2.4.2.5. 26 mL of protein solution were homogenized with an Ultra-Turrax mixer at 12 000 rpm for 1 minute and then, 8.7 mL of sunflower oil were gradually added (3:1 water:oil emulsion). The mixture was further homogenized for 5 min in a cold bath, and an aliquot of 50  $\mu$ L of the emulsion was then mixed with 5 ml of 0.1% sodium dodecyl sulphate (SDS) solution. The absorbance was measured at 500 nm (spectrophotometer Model UH5300, Hitachi, Japan) and the Emulsifying Activity Index (EAI) was calculated as reported by Ogunwolu et al., (2009) (Equation II-8).

$$EAI \left( \frac{m^2}{g} \right) = \frac{2 \times 2.303 \times \text{Absorbance at 500 nm}}{0.25 \times \text{protein weight (g)}} \quad \text{Equation (II-8)}$$

##### 2.4.2.6.1. Measurement of droplet size by laser diffraction

The size distribution of oil droplets after emulsification was determined by static light scattering (Mastersizer 2000 Hydro SM, Malvern, UK). Laser diffraction measures particle size distributions by measuring the angular variation in intensity of light scattered as a laser beam passes through a dispersed particulate sample. Globally, a light beam, mostly supplied by a laser, shines through the sample to be measured and behind it, the intensity distribution caused by the scattering is picked up with a detector. Large particles scatter light at small angles relative to the laser beam and small particles scatter light at large angles, as illustrated below (Figure II-11). The angular scattering intensity data is then analyzed to calculate the size of the particles responsible for creating the scattering pattern, using the Mie theory of light scattering (Mie G, 1908) who considers the 3 modes of light-particle interaction: scattering, diffraction and refraction. The use of Mie theory needs knowledge of the optical properties of both the sample being measured, along with the refractive index of the dispersant. However, modern instruments have in-built databases that include common dispersants. Moreover, the particle collective to be measured should be available sufficiently diluted and should not form clusters or even better said should not create agglomerates.



**Figure II-11.** Light scattering angles of small and large particles

The droplet size distribution of emulsions was determined after emulsification and after 30 and 45 days of a 4 °C storage for stability assessment. A refractive index of 1.47 and 1.33 was set for sunflower oil and water, respectively. The measurement cell was filled with deionized water, and aliquots of emulsion were added directly to the cell under constant stirring (1 500 rpm).

The droplet size distributions were described in terms of their volume-averaged diameter  $D[4,3]$ , surface-averaged diameter  $D[3,2]$  and, uniformity ( $U$ ) calculated by Equations II-9, II-10 and II-11, respectively.

$$D[4,3] = \frac{\sum N_i D_i^4}{\sum N_i D_i^3} \quad \text{Equation (II-9)}$$

$$D[3,2] = \frac{\sum N_i D_i^3}{\sum N_i D_i^2} \quad \text{Equation (II-10)}$$

$$U = \frac{1}{\bar{D}} \frac{\sum N_i D_i^3 (\bar{D} - D_i)}{\sum N_i D_i^3} \quad \text{Equation (II-11)}$$

where  $\bar{D}$  is the value for which the cumulative undersized volume fraction is equal to 50% (median diameter) and,  $N_i$  is the total number of droplets with diameter  $D_i$ . Uniformity characterizes the width of the particle size distribution. Therefore, the higher this value is, the wider the distribution.

#### **2.4.2.6.2. Microscope observations**

Microscope observations of different emulsions were carried out using an optical microscope (Model BX51, Olympus, Germany) equipped with a digital color camera (ColorView, Olympus, Germany). The samples were previously diluted to better distinguish the objects by adding approximately 100  $\mu\text{L}$  of sample in 1 800  $\mu\text{L}$  of distilled water. Samples were deposited on a glass slide and were covered by a cover slip. A specific configuration was adopted in order to avoid sample damage. Indeed, we observed that the shear applied upon spreading of the confined liquid sometimes provoked droplet coalescence on the glass substrate. To avoid this phenomenon, cavity microscopy slides (well slides) with single ground and polished spherical cavities (Marienfeld, Germany) were adopted for observations. The samples were placed in the cavity zone before the cover slip was carefully deposited and several observations were carried out at magnifications from 10X to 100X.

### **2.4.3. Characterization of polyphenol-rich extracts**

Both extracts obtained from defatted walnut cake and grape pomace were analyzed regarding their total phenolic content (as described in section 2.4.1.2) and free radical scavenging activity (DPPH) as described below. In addition, ellagic acid in extracts from defatted walnut cake was quantified by HPLC analysis whereas total anthocyanins were quantified in extracts obtained from grape pomace.

#### **2.4.3.1. Free radical scavenging activity by DPPH method**

The antioxidant activity of the extracts obtained from defatted walnut cake under various conditions was evaluated based on the scavenging activity of the 2,2-diphenyl-1-picrylhydrazyl (DPPH) free radical according to method described by Espinosa-Pardo et al. (2017). Solutions consisting of 50  $\mu\text{L}$  of extract or standard solution (Trolox<sup>®</sup>) and 150  $\mu\text{L}$  of 0.2 mM DPPH in methanol, were prepared in darkness and analyzed on a multimode

microplate reader at 520 nm. Methanol solution (70% v/v) was used as a control. The method was based on the loss of color of the solution analyzed after 35 min of reaction. The antioxidant activity of extracts was calculated by interpolating the absorbance of samples after 35 min of reaction with a calibration curve built with a standard solution of Trolox<sup>®</sup> (Sigma-Aldrich, France) at concentrations in a range of 7 to 300  $\mu\text{mol/L}$ . Free radical scavenging activity (DPPH) was expressed as  $\mu\text{mol}$  of Trolox Equivalent /g of raw material and the measurements were performed in triplicate.

#### **2.4.3.2. Quantification of ellagic acid**

Walnut phenolic extracts are complex mixtures of various phenolics among which ellagic acid could be one of major components. Quantification of ellagic acid was carried out by reverse phase chromatography. For that, an Agilent Infinity 1200 system (Agilent Technologies) equipped with a degaser, a quaternary pump, an automatic injector and a diode array detector (DAD, G1315A) was used. The column was a spherisorb ODS2 C18 (250 x 4.6 mm, 5 $\mu\text{m}$  particle size, Waters, USA) equipped with a guard cartridge column (Waters, USA) and was set at 25°C. The mobile phases consisted of 5% formic acid (A) and methanol MeOH (B). The gradient elution program was: 0 min, 10 % B; 20 min, 30 % B; 35 min, 50 % B; 40 min, 90 % B; 44 min, 10 % B; 60 min, 10 % B. The flow rate was maintained at 1.0 mL/min.

Ellagic acid was identified by its retention time and UV spectrum while its quantification was based on a calibration curve obtained from the standard solution (Extrasynthese, France) in methanol from 4 to 40  $\mu\text{g/mL}$ . Quantification was done at 280 nm and the coefficient of determination of the calibration curve was of 0.99. Analyses were performed in duplicate.

#### **2.4.3.3. Determination of total anthocyanins**

Determination of total anthocyanins in extracts from grape pomace was carried out using the method proposed by Di Stefano et al. (1989) and described by Bonfigli et al. (2017). The method is based on the fact that malvidin exhibits a maximum absorbance at 536-540 nm when diluted in hydrochloric ethanol. Therefore, the procedure consisted of diluting the extracts with a solution of ethanol/water/HCl (69/30/1 v/v/v) and then measuring the absorbance at 540 nm, in a spectrophotometer. The total anthocyanins (TA) content was calculated by means of Equation II-12, as proposed by Di Stefano et al. (1989).

$$TA = 16.7 \times A_{540\text{nm}} \times d \quad \text{Equation II-12}$$

where  $A_{540\text{nm}}$  is the absorbance at 540 nm and  $d$  is the dilution factor. TA content was expressed in mg malvidin-3-glucoside equivalents/100 g residue.

#### **2.4.4. Characterization of Pickering emulsions**

##### **2.4.4.1. Droplet size measurement and microscope observations**

The size of oil droplets after emulsification was determined by static light scattering as already described in section 2.4.2.6.1. The volume-averaged diameter  $D[4,3]$  and uniformity ( $U$ ) were monitored after emulsification and after several weeks of storage at 4 °C. However, a specific protocol was implemented to first desorb the plant particles from the drops before light scattering analysis, since plant particles located at the interfaces of the drops or free in the aqueous phase, diffuse light like oil drops and interfere with the signal.

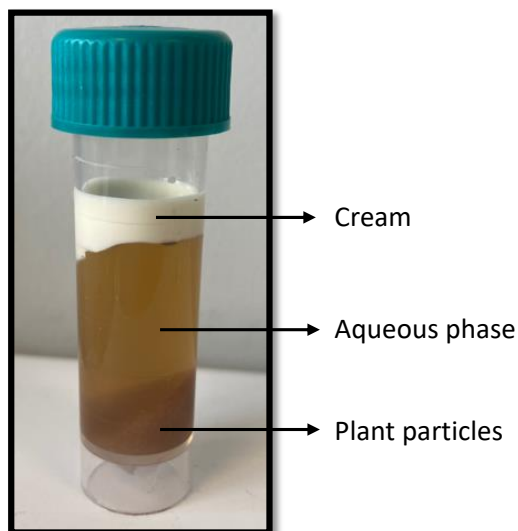
The protocol for removing plant particles does not modify the droplet size distribution of emulsions according to Joseph, (2018). The protocol consisted of diluting approximately 1 g of Pickering emulsion in 3 g of SDS solution (10% wt/v). SDS is a surfactant capable of desorbing species anchored at interfaces, such as proteins, even when their adsorption energy is high (Joseph, 2018). The mixture was gently stirred overnight and then centrifuged at 220 g for 10 min. After centrifugation, the plant particles precipitated at the bottom of the flask, while the oil drops free of particles rise to the surface to form a whitish-looking cream (Figure II-12). An aliquot of 100  $\mu\text{L}$  of this cream (upper phase) was diluted in 1 800  $\mu\text{L}$  of distilled water and then analyzed by light scattering. The measuring cell was filled with distilled water, and aliquots of aforementioned dilution were added directly to the cell under constant stirring (1 500 rpm). A refractive index of 1.47 or 1.48 was set for oil in emulsions prepared with sunflower or linseed oil, respectively, and 1.3 for water (dispersant). Dilution of emulsions were also observed using an optical microscope as described in section 2.4.2.6.2.

##### *Plant particle distribution size in dispersions*

The distribution size of plant particles (corn germ and walnut cake) in the dispersion after microfluidization was also measured by static light scattering using the Fraunhofer



approximation, which is used when the optical properties of the particles are unknown. This model only takes into account light diffraction and the approximation is valid when particles have a diameter greater than 7  $\mu\text{m}$  (Joseph, 2018).



**Figure II-12.** Photograph of a 4:1 w:o emulsion after desorbing walnut particles by SDS and later centrifugation

Finally, different emulsions and plant particles dispersions were observed using a microscope as previously described in section 2.4.2.6.2.

#### **2.4.4.2. Oxidation of emulsified linseed oil**

The oxidation of the oily phase (linseed oil) of Pickering emulsions stabilized by walnut particles (prepared as described in section 2.3.2) was studied through the Schaal oven test (AOCS, 1998). The test consisted of submitting the samples to accelerated oxidation by heating in order to shorten the analysis time. For that, 2.5 g of emulsion were placed in a 45 mL sealed flask, to avoid water evaporation, and heated at 60 °C in a laboratory drying oven (DRY-Line, VWR, UK) for 15 to 168 hours. After 15, 24, 30, 48, 72 and 168 hours of oxidation, one flask was removed from the oven and stored at -80 °C until analysis. As reference, pure linseed oil was also oxidized under the same conditions. The flask contained the same amount of crude oil as in the 4:1 water:oil emulsion that is 0.5 g. The ratio between the air and sample volumes in the flask was of 17 for emulsions and of 89 for oil alone, respectively. According to Joseph, (2018), these conditions assure the excess of oxygen so as not to limit lipid oxidation. The oxidation test was performed in duplicate.

After oxidation, crude linseed oil was analyzed regarding the conjugated dienes (CD) and peroxide value (PV) as described below. CD is a simple method for measuring the primary oxidation products and it is highly correlated to PV (Eliseeva et al., 2017). For emulsions, the oil was previously extracted by adding 5 g of a hexane:isopropanol (3:1 v/v) solution to 2.5 g of emulsion. The mixture was then vortexed for 30 seconds and centrifuged at 4 500 g for 10 min. The supernatant which contained the oil was collected in a 15 mL falcon tube and evaporated under nitrogen flux for at least 3 hours. Finally, the extracted oil was stored at -80 °C until analysis of CD.

#### **2.4.4.2.1. Conjugated dienes (CD) measurement**

The oxidation of polyunsaturated fatty acids is accompanied by an electronic rearrangement of the double bonds which pass from the unconjugated position to the conjugated position. These conjugated dienes have the absorbing property at 233 nm, therefore they were quantified according to AOCS standard method 2.501 (AOCS, 1998). The procedure consisted of diluting 50 mg of oil in 10 mL of hexane in an amber round bottom flask. The solution was then diluted in hexane in a hermetic vial to avoid solvent evaporation, stirred and transferred to quartz cuvettes for absorbance measurement at 233 nm in a spectrophotometer using pure hexane as blank. Absorbance in a range of 0.500 to 0.999 was highly desirable for greater accuracy. CD concentration was expressed as specific absorbance (A.U. 233 nm/mg/mL) normalizing the optical density by the mass of lipids (mg) per unit volume of solution (mL). The evolution of the specific absorbance was plotted as a function of the oxidation time at 60 °C for each formulation.

#### **2.4.4.2.2. Peroxide value (PV) determination**

PV was determined according to standard method ISO 3960 (2017). This method gives a measurement of the extent to which an oil sample has undergone primary oxidation (Rombaut et al., 2017) and it is still the most common chemical method of measuring oxidative deterioration of oils (Reboredo-Rodriguez et al., 2017). The traditional method of determining PV involves a titration of the oil containing potassium iodide in a chloroform–acetic acid mixture. The hydroperoxides oxidize the iodide to iodine, which is determined by titration with sodium thiosulphate.

The procedure consisted of weighing 2 g of oil sample in a capped erlenmeyer flask previously flushed with N<sub>2</sub>. After the addition of 10 mL of chloroform for dissolving the oil, 15 mL of acetic acid were added to the sample using a 25 mL glass pipette. After adding 1 mL of a saturated aqueous solution of potassium iodide (1.5 g/mL) the mixture was vigorously mixed and reserved in darkness for 5 min at room temperature. 75 mL of distilled water were then added to the mixture to stop the reaction and vigorously stirred followed by the addition of Iotect (color indicator) (VWR Chemicals, Belgium). Finally, the free iodine in the mixture was titrated with sodium thiosulphate 0.01 N (Scharlab, Spain). Two determinations were performed from the same oil sample.

Both chloroform and acetic acid were flushed with N<sub>2</sub> prior to use in order to prevent the formation of reducing and oxidizing substances. Finally, the same procedure was followed without the addition of oil as a *blank*. PV was expressed in milliequivalents of active oxygen per kg (m<sub>eq</sub>O<sub>2</sub>/kg) and calculated by the Equation II-13.

$$PV = \left( \frac{V \times N}{m} \right) \times 1\,000 \quad \text{Equation II-13}$$

where V is the volume (mL) of the standard sodium thiosulfate solution used for the titration, N is the normality of the standard sodium thiosulfate solution (0.01 N) and m is the mass (g) of oil sample.

## 2.5. Statistical analysis

Results were expressed as mean ± standard deviation (SD) and were statistically evaluated using the Software Minitab 17<sup>®</sup> (Minitab Inc.). The significant differences (p < 0.05) were analyzed through the Tukey's test.

## References

- AACC., 1990. Approved Methods of the American Association of Cereal Chemists, 8th Ed., Vol 2. St. Paul, Minn. The American Association of Cereal Chemists.
- Akaike, H., 1974. A new look at the statistical model identification. IEEE Trans. on Automat. Contr. 19(6), 716-723.
- Almazan, A.M., Adeyeye, S.O., 1998. Fat and fatty acid concentrations in some green vegetables. J. Food Compos. Anal. 11, 375–380.
- AOAC., 2000. Official Methods of Analysis of Association of Official Analytical Chemists, 17th Ed., Gaithersburg, Method 992.23.
- AOCS. 1998. Official methods and recommended practices of the American Oil Chemists' Society (5th edition). Champaign, Illinois.
- ASAE, 1998. Standards methods of determining and expressing fineness of feed materials by sieving. ASAE, pp. 547 (S319.3).
- Bardeau, T., Savoie, R., Cansell, M., Subra-paternault, P., 2015. 12th Euro fed lipids congress: oils , fats and lipids : from lipidomics to industrial innovation. Recovery of oils from press cakes by CO<sub>2</sub> -based technology. Oilseeds fats Crop. Lipids 22, 1–6.
- Barrales, F.M., Rezende, C.A., Martínez, J., 2015. Supercritical CO<sub>2</sub> extraction of passion fruit (*Passiflora edulis* sp.) seed oil assisted by ultrasound. J. Supercrit. Fluids 104, 183–192.
- Barrales, F.M., Silveira, P., Barbosa, P. de P.M., Ruviano, A.R., Paulino, B.N., Pastore, G.M., Macedo, G.A., Martinez, J., 2018. Recovery of phenolic compounds from citrus by-products using pressurized liquids — An application to orange peel. Food Bioprod. Process. 112, 9–21.
- Bradford, M., 1976. A rapid and sensitive method for the quantitation of microgram quantities of protein utilizing the principle of protein-dye binding. Anal. Biochem. 72, 248–254.
- Capellini, M.C., Chiavoloni, L., Giacomini, V., Rodrigues, C.E.C., 2019. Alcoholic extraction of sesame seed cake oil: Influence of the process conditions on the physicochemical characteristics of the oil and defatted meal proteins. J. Food Eng. 240, 145–152.
- Eliseeva, L., Yurina, O., Hovhannisyan, N., 2017. Nuts as raw material for confectionary industry. Ann. Agrar. Sci. 15, 71–74.
- Espinosa-Pardo, F.A., Nakajima, V.M., Macedo, G.A., Macedo, J.A., Martínez, J., 2017. Extraction of phenolic compounds from dry and fermented orange pomace using supercritical CO<sub>2</sub> and cosolvents. Food Bioprod. Process. 101, 1-10.
- Hojilla-Evangelista, M.P., 2012. Extraction and functional properties of non-zein proteins in corn germ from wet-milling. JAOCS, J. Am. Oil Chem. Soc. 89, 167–174.
- Hojilla-Evangelista, M.P., 2014. Improved solubility and emulsification of wet-milled corn germ protein recovered by ultrafiltration-diafiltration. JAOCS, J. Am. Oil Chem. Soc. 91, 1623–1631.

Huang, C., Chen, X., Liu, T., Yang, Z., Xiao, Y., Zeng, G., Sun, X., 2012. Harvesting of *Chlorella* sp. using hollow fiber ultrafiltration. *Environ. Sci. Pollut. Res.* 19, 1416–1421.

ISO - International organization for standardization-, 2017. Animal and vegetable fats and oils - Determination of peroxide value - Iodometric (visual) endpoint determination ISO/DIS Standard No. 3960.

Joseph, C., 2018. Emulsions de Pickering stabilisées par des poudres végétales: propriétés et rôle des paramètres de composition et de formulation. Doctoral thesis. École Doctorale des Sciences Chimiques, Université de Bordeaux.

Khair, R., Pan, Z., 2019. Walnuts. In: Pan, Z., Zhang, R., Zicari, S. (Eds.), *Integrated processing technologies for food and agricultural by-products*, Academic Press, UK, pp. 391-411.

Laemmli, U.K., 1970. Cleavage of structural proteins during the assembly of the head of bacteriophage T4. *Nature* 227, 680-685.

Mie, G., 1908. Contributions to the optics of turbid media, particularly colloidal metal solutions. *Ann. Phys.* 330, 377–445.

Ogunwolu, S.O., Henshaw, F.O., Mock, H.P., Santos, A., Awonorin, S.O., 2009. Functional properties of protein concentrates and isolates produced from cashew (*Anacardium occidentale* L.) nut. *Food Chem.* 115, 852–858.

Parris, N., Moreau, R.A., Johnston, D.B., Singh, V., Dickey, L.C., 2006. Protein distribution in commercial wet- and dry-milled corn germ. *J. Agric. Food Chem.* 54, 4868–4872.

Pearce, K.N., Kinsella, J.E., 1978. Emulsifying properties of proteins: Evaluation of a turbidimetric technique. *J. Agric. Food Chem.* 26, 716–723.

Reboredo-Rodríguez, P., Figueiredo-González, M., González-Barreiro, C., Simal-Gándara, J., Salvador, M.D., Cancho-Grande, B., Fregapane, G., 2017. State of the art on functional virgin olive oils enriched with bioactive compounds and their properties. *Int. J. Mol. Sci.* 18.

Rombaut, N., Savoie, R., Thomasset, B., Bélliard, T., Castello, J., Van Hecke, É., Lanoisellé, J.L., 2014. Grape seed oil extraction: Interest of supercritical fluid extraction and gas-assisted mechanical extraction for enhancing polyphenol co-extraction in oil. *Comptes Rendus Chim.* 17, 284–292.

Rombaut, N., Savoie, R., Van Hecke, E., Thomasset, B., 2017. Supercritical CO<sub>2</sub> extraction of linseed: Optimization by experimental design with regards to oil yield and composition. *Eur. J. Lipid Sci. Technol.* 119, 1–9.

Sehl, A., Couëdelo, L., Fonseca, L., Vaysse, C., Cansell, M., 2018. A critical assessment of transmethylation procedures for n-3 long-chain polyunsaturated fatty acid quantification of lipid classes. *Food Chem.* 251, 1–8.

Shim, Y.Y., Emami, S., Ratanapariyanuch, K., Reaney, M.J.T., 2018. Biorefinery of plant-based products. In: Chen, G., Weselake, R.J., Singer, S.D (Eds.), *Plant bioproducts*. Springer Science, USA, pp. 201-218.

## *Chapter II: Materials and Methods*

Singleton, V., Orthofer, R., Lamuela-Raventos, R., 1999. Analysis of total phenols and others oxidantion substrates and oxidants by means of Folin-Ciocalteu reagent. *Methods Enzymol.*, 299, 152-178.

Wu, G.L., Liu, Q.L., Teixeira da Silva, J.A., 2009. Ultrastructure of pericarp and seed capsule cells in the developing walnut (*Juglans regia* L.) fruit. *South African J. Bot.* 75, 128–136.

## **Chapter III. Corn germ biorefinery, from oil and protein extractions to solid particle ability to stabilize emulsions**

### **1. Introduction**

In this chapter, biorefinery of corn germ, a by-product from the local corn processing, is studied. It comprises the recovery of oil and protein fractions and also direct use of the co-product itself or after removal of oil /and proteins. In an elaborated scheme of biorefinery, it is crucial to consider the scheme as a whole by identifying the interactions between the unit operations, since the optimal conditions for each individual operation might not be applicable in a sequential process (Gil-Ramirez et al., 2018). Alike, in the scheme for the recovery of oil and protein fractions from corn germ, oil extraction conditions might influence not only the recovered oil quality but also the defatted meal quality and the functional properties of proteins extracted straight after.

On one side, the corn germ is the main source of lipids in corn comprising about 85% of the total kernel oil. The corn oil is allotted important properties for food, cosmetic and pharmaceutical applications due to its high content in unsaturated fatty acids and in tocopherols. Shende & Sidhu, (2015) have reported that corn oil exhibits many health benefits as reducing the risk of chronic diseases, whereas Barrera-Arellano et al. (2019) stated that corn oil also exhibits a long shelf life and high resistance to transformations under harsh conditions of processing. On the other hand, the protein content in the corn germ varies from 12 to 21%, influenced by the weather crop conditions, genetic factors and the germ separation method. Albumins and globulins, the water-soluble and saline-soluble proteins, represent over 60% of the total germ protein. Some studies have explored the influence of defatting method on the oil, on defatted meals characteristics or protein properties (Christianson et al., 1984; Rónyai et al., 1998; Labuckas et al., 2014; Lasztity et al., 1995; Lin & Zayas, 1987; Teh et al., 2014; Tabtabaei & Diosady, 2013) particularly when alcoholic solvents were used for oil extraction (Capellini et al., 2019, 2017; Navarro et al., 2016; Sawada et al., 2014). However most of them have used solid-liquid extraction by hexane solubilization to recover the oil, which can limit its use in food applications.

The biorefinery of residues from agro-industries, as corn germ, is of increasing interest since it offers valorization as added-value products while avoiding the disposal of huge

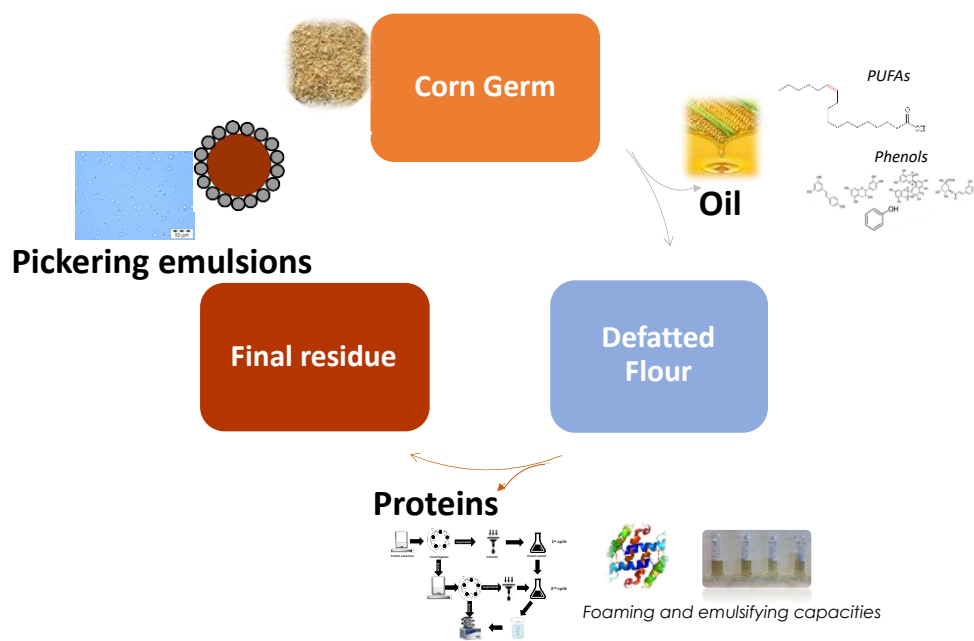
amounts of raw materials. Thus, in the first part of this chapter, we studied the influence of five conditions of oil extraction from corn germ on the yield and quality of the produced oils. Oils were characterized by their fatty acid composition together with their total phenolic content. Various methods of defatting were implemented in order to evaluate the effect of solvent, temperature and pressure on oil extraction. For that, oil extraction by hexane at three temperatures, i.e. room temperature (24 °C), 45 °C and boiling (68 °C) were carried out. In addition, Supercritical Fluid Extraction (SFE) using carbon dioxide and Soxhlet extraction using ethanol were also investigated.

In the second part of this chapter, the corn germ meals defatted under the five conditions were all further extracted by saline solution to recover proteins, which were further desalted. The influence of the defatting method on the protein extraction was assessed by comparing the protein extraction yield, the purity and the functionalities of the protein extracts. For that, the water absorption capacity, solubility profile, foaming and emulsifying capacities and the molecular weight profile of protein extracts were evaluated. Particularly, the ability of corn proteins to stabilize oil in water emulsions was assessed by monitoring the droplet size, through static light scattering analysis and microscope observation, over the 45 days of storage at 4 °C. Moreover, we also investigated the functional properties of proteins when Ultrafiltration-Diafiltration instead of dialysis, was conducted as a desalting step.

Finally, in this chapter can be found the study related to the formulation of oil-in-water emulsions stabilized by various residues of corn germ after oil and/or protein extraction. This section aimed to evaluate the ability of corn germ particles, with various composition, to stabilize Pickering emulsions. Sunflower oil was used as the dispersed phase and phosphate buffer containing sodium azide at pH 7 as the continuous phase. Corn germ residues of various compositions were used to prepare the emulsions by microfluidization and then, the droplet size of emulsion and their polydispersity were monitored throughout storage at 4 °C. This last section proposed a novel application for the valorization of corn germ residues that remain after recovering added value materials, such as oil and protein extracts.

In Figure III-1 is shown a graphical abstract of the biorefinery scheme proposed for corn germ throughout this chapter.

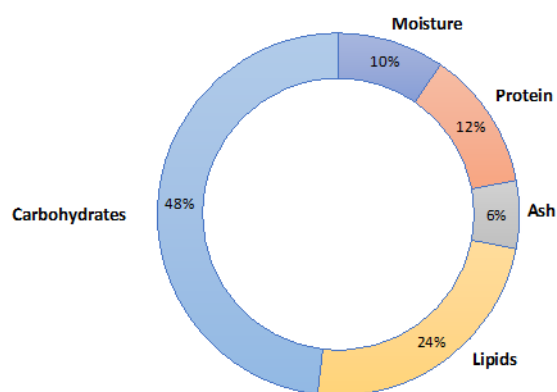




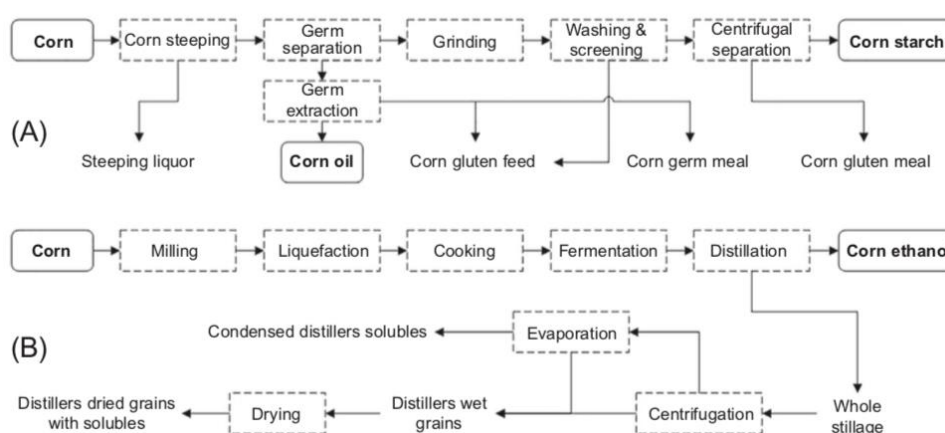
**Figure III-1.** Schematic representation of the biorefinery scheme developed from corn germ

## 2. Material composition and particle characterization

The proximate composition of corn germ used in this work is shown in Figure III-2. The geometric mean particle diameter of corn germ meal after grinding and sieving was  $331 \pm 12 \mu\text{m}$ . When compared to other works, the contents in lipid, protein and ash were significantly higher than those reported by Navarro et al. (2016) for instance, lipids: 10.74%, protein: 10.4% and ash: 2.94%, and similar to those reported by Johnston et al. (2005), 23% of lipid and 15.3% of protein in dry milled germ. On contrary, the carbohydrate content was lower than the 64.69% reported by Navarro et al. (2016). This clearly illustrates the crucial role of industrial process in corn germ composition, as already highlighted by Johnston et al. (2005). Although the corn germ of these three studies were obtained by dry milling, they were not separated from endosperm in the same way. The tempering-degerming process implemented to achieve the corn germ-bran mixture may let more endosperm fractions attached to the germ than the dry mechanical degerming and bran separation implemented by Castelmaïs. In Figure III-3 is shown the typical corn milling process (both wet and dry milling) that is employed industrially. However, as mentioned previously, the germ used in this work was separated from the kernel by a dry method -instead of the classical wet degerming technique- adapted by Castelmaïs to produce corn semolina, grits and flour.



**Figure III-2.** Mass composition on wet basis of corn germ meal



**Figure III-3.** Processing of corn by wet milling (A) and dry milling (B)

\*Dash line frames are the unit operations (Source: Ruan et al., 2019)

Material composition also showed that corn germ as by-product still represents an important source of oil as expected, since it has been reported that germ contains approximately 85% of the total kernel oil (Wang & White, 2019).

On the other hand, the distribution of protein in corn germ defatted by Hexane RT estimated in this work was: Albumin (39.2%), globulin (23.3%), zein (2.7%) and glutelin (34.8%). This results are in agreement with Parris et al. (2006), who reported for commercial dry-milling the following protein distribution: Albumin (34.1%), globulin (28%), zein (4.6%) and glutelin (33.3%).

### 3. Oil recovery and characterization

Traditionally corn germ oil has been extracted by physical (pressing) and chemical methods (solvents). Hexane has been widely employed as extraction solvent due to its effectiveness in oil solubilization and consequently the high extraction yields (Navarro et al., 2016; Rebolleda et al., 2012). However, the influence of extraction temperature on the oil and protein fractions had not been rigorously studied. The global extraction yield, total phenolic content and fatty acid composition of oil fractions obtained from corn germ by different extraction methods are presented in Table III-1. For the oil extraction yield, the temperature of hexane did not show any influence indicating the high oil dissolution capacity of hexane. All lipids contained in the vegetable cells were successfully solubilized by hexane even at room temperature, since higher temperatures did not lead to higher oil recovery yield. A higher temperature of hexane during oil extraction allowed to decrease the extraction time by increasing the mass transfer rate since hexane at 45 °C was able to extract 73% of the total oil during the first cycle of extraction (20 min), against 66% of oil extracted by hexane at room temperature. Moreover, a positive influence of temperature during hexane extraction on oil TPC was observed (Table III-1). The temperature in extraction process increases the vapor pressure of the solutes, improving their solubility in the fluid phase and the yield (Espinosa-Pardo et al., 2017; Garcia-Mendoza et al., 2017; Rosa et al., 2009). Additionally, phenolic compounds are known to be thermostable molecules suitable to be extracted at high temperatures. However, the effect of greater solute solubility was not observed when temperature extraction went from 45°C to 68°C since the Soxhlet hexane extraction (at boiling temperature 68°C) did not lead to higher TPC than hexane at 45°C. It can be assumed that the maximum solubility of phenolic compounds in hexane had been reached at 45°C. The TPC of oil fractions obtained by hexane at 45°C and Soxhlet hexane in this work was also consistent with those reported by Shende & Sidhu, (2015) and Tuan, (2011) for corn oil extracted by hexane (76 to 81 mg GAE/kg oil).

The highest yield of extraction (37.7 g oil/100 g corn germ) was obtained by the Soxhlet ethanol method. The discrepancy between hexane and ethanol extraction yields is attributed to the co-extraction of any polar compounds, lipidic or not, that increased the mass of extracted oil. In addition, the ethanol-extracted oil was turbid contrary to the hexane-extracted one indicating the presence of components at their solubility limit. Among co-extracted substances, the ethanol soluble zein protein was evidenced by SDS-PAGE shown in Figure III-4, but carbohydrates could be present as well according to Navarro et al. (2016). The polarity of the

solvent influenced the total phenolic extraction as well so that the extraction by Soxhlet ethanol produced the oil with the highest TPC content (1 721 mg GAE/kg oil). Supercritical fluid extraction was implemented with neat CO<sub>2</sub> at 45 °C under a moderate pressure of 210 bar due to the pressure-limit of the equipment. The low extraction yield (16.4 g oil/100 g corn germ) obtained by Sc-CO<sub>2</sub> compared to the 24 g oil/100 g yield obtained by hexane maceration could be attributed to the low solubility of oil in Sc-CO<sub>2</sub> that limit the extraction kinetics. Though the Sc-CO<sub>2</sub> extraction was carried out for 5.5 h, the duration was hence insufficient to exhaust the matrix in lipids. Extraction kinetics in SFE mainly depends on the raw material, pressure, temperature solvent flow rate, so that many parameters could be optimized to increase the yields of oil extraction (Rosa et al., 2009; Singh & Avula, 2012). When extraction is limited by solubility, as it is in the first times of the extraction course, the extraction yield could be increased by selecting conditions that increase the lipid solubility such as higher pressure and, above 300-400 bar, higher temperature (Tomita et al., 2014). However, in this work, the objective was to preserve the functionality of corn germ proteins in the treated meal, even if this was at the expenses of the complete oil recovery.

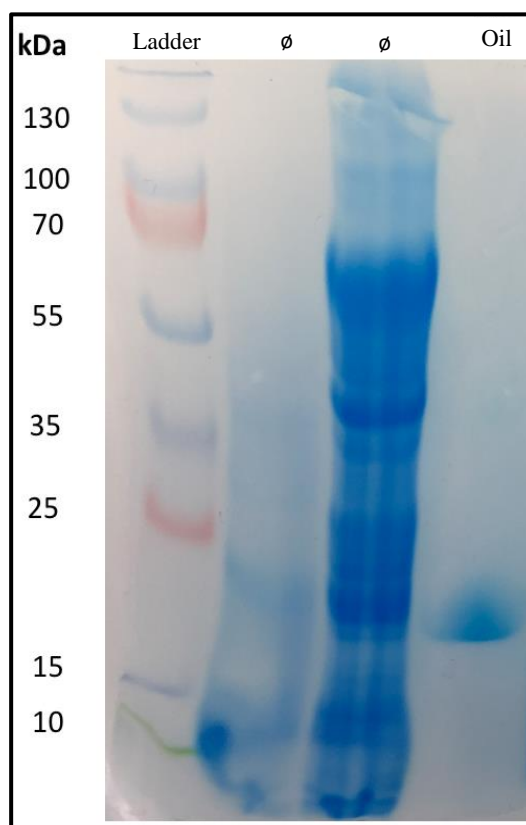
The extracted oil by Sc-CO<sub>2</sub> was however interestingly rich in phenolics compared to oil produced by hexane at 45°C (251.8 and 70 mg GAE/kg oil respectively). Similar results were observed by Belayneh et al. (2017) who increased the TPC in the oil obtained from camelina seed using pure Sc-CO<sub>2</sub> at moderate temperature and pressure (350 bar; 50°C) in comparison with Soxhlet hexane extraction.

**Table III-1.** Oil extraction yield from corn germ and characteristics according to the extraction method

<b>Defatting Method</b>	<b>Yield (g oil/100 g corn germ)</b>	<b>TPC (mg GAE/kg oil)</b>	<b>Fatty acid composition (%)</b>
Hexane RT	23.6 <sup>b</sup> ± 2.0	40.8 <sup>c</sup> ± 3.7	16:0 (13%), 18:0 (2%), 18:1(9c) (29%), 18:2 (6c) (53%), 18:3 (1%)
Hexane 45 °C	23.8 <sup>b</sup> ± 1.6	70.5 <sup>c</sup> ± 0.9	16:0 (11%), 18:0 (1%), 18:1(9c) (30%), 18:2 (6c) (56%), 18:3 (1%)
Soxhlet Hexane	23.8 <sup>b</sup> ± 1.5	68.5 <sup>c</sup> ± 0.5	16:0 (11%), 18:0 (1%), 18:1(9c) (30%), 18:2 (6c) (56%), 18:3 (1%)
Soxhlet Ethanol	37.7 <sup>a</sup> ± 2.0	1721 <sup>a</sup> ± 46	16:0 (11%), 18:0 (1%) 18:1(9c) (29%), 18:2 (6c) (56%), 18:3 (1%)
Sc-CO <sub>2</sub>	16.4 <sup>c</sup> ± 0.8	251.8 <sup>b</sup> ± 17.9	16:0 (12%), 18:0 (1%), 18:1(9c) (30%), 18:2 (6c) (56%), 18:3 (1%)

Values presented as mean ± standard deviation

Equal letters in the same column indicate no significant difference at level of 5% (p < 0.05)



**Figure III-4.** SDS-PAGE of zein co-extracted by Soxhlet ethanol

Regarding the fatty acid profiles (Table 1), five fatty acids were identified among which linoleic acid (18:2) as the major fatty acid (> 50%), followed by oleic acid (18:1) and palmitic acid. Linoleic acid is a polyunsaturated omega-6 fatty acid of an 18-carbon chain with two double bonds in cis configuration and is also one of two essential fatty acids for humans, that must obtain it through their diet.

The recovered oils showed the typical fatty acid composition of corn germ oil according to literature (Johnson, 2000; Rebolleda et al., 2012; Vigh et al., 1993). Data showed that the fatty acid composition was not influenced neither by the defatting method nor by the extraction temperature. Similarly, Rebolleda et al. (2012) did not observe any influence of extraction temperature on the fatty acid composition of corn oil obtained by SFE. On the other hand, Navarro et al. (2016) observed a slight difference in fatty acid composition, mainly in linoleic acid content, of oils extracted with alcoholic solvents when compared to hexane industrially extracted oil (48% and 51% respectively). The fatty acid composition of industrial corn oil reported by Navarro et al. (2016) was similar to that obtained in this work. Corn germ oils

showed a predominance of mono-unsaturated and di-unsaturated fatty acids potentially convenient for nutraceutical applications.

#### **4. Protein recovery and functionality**

In order to assess the potential influence of defatting method on the quality of proteins in defatted meals, this section displays the different efficiency of protein recovery from the various defatted meals, as well as the protein functionality.

The different protein extracts were identified as Hexane RT, Hexane 45 °C, Soxhlet hexane, Soxhlet ethanol, Sc-CO<sub>2</sub> and undefatted, in reference to the defatting process that preceded the protein extraction step. All defatted and undefatted meals were extracted by the protein extraction method described previously in *Chapter II*, section 2.2.2 (called saline extraction).

##### **4.1. Protein content of extracts and protein extraction yield**

The purity of the different protein extracts is shown in Table III-2. The protein content in dry extracts is a key parameter for food industry since it influences both their functionality and nutritional value, therefore purity of extracts also determines their potential industrial applications. In this sense, protein concentrate and protein isolate are terms used in the industry to describe protein purity. Concentrate and isolate refer to the percent amount of protein in the powder/extract. Generally, the protein content in concentrates is of 30% to 80%, whereas the purity of isolates is higher than 90%. After solid-liquid extraction of plant proteins, several techniques may be used for increasing purity of protein extracts by removing most of the water-soluble non-protein components. Among these techniques can be found the acid precipitation, aqueous alcohol leaching, air classification, liquid cyclone fractionation, micellization, and moist heat denaturation followed by water leaching (Buffo & Han, 2005). On the other hand, these techniques may also impact the quality and functionality properties of vegetable proteins due to irreversible denaturation and add energy cost to the process.

In the present study, purification was only based on size exclusion (dialysis). This allowed to remove small molecules including amino acids and salts that were brought by saline extraction solvent. Regarding protein content of extracts obtained in this work, it varied from 19.9% to 48.5%, with maximum achieved for SFE defatted meal, as it can be observed in Table III-2. As a general trend, extracts obtained from defatted meals were of higher protein

content than the one from undefatted meal. However, this assertion is not true when oil extraction has been performed at high temperature. Extracts from Soxhlet defatted meals exhibited similar (hexane: 27.1%) or lower (ethanol: 19.9%) protein contents than extracts from undefatted corn germ (29.1%). High temperature reached during Soxhlet extractions could have damaged proteins, thereby negatively influencing their further extraction.

The negative effect of high temperature on protein solubility has been also reported by Capellini et al. (2017) in the case of alcoholic extractions. The Soxhlet ethanol defatting method led to the extracts with the lowest protein concentration and extraction yield. This can probably be assigned to the poor solubility of proteins in meal after defatting by Soxhlet ethanol (as confirmed below). Ethanol is a denaturing solvent of water-soluble proteins. Denaturation can be defined as any modification of the secondary, tertiary or quaternary structure of the protein. It usually leads to changes in the functional properties of proteins. Several studies reported the denaturing effect of alcohols (Roberts & Briggs, 1963; Navarro et al., 2016; Wu & Inglett, 1974) especially on globulins, what induces a decrease in their extractability from plants (Wu & Inglett, 1974). Soxhlet ethanol thus combined two deleterious conditions for proteins: high temperature and denaturing solvent. All other protein extracts exhibited similar protein contents (from 27.1% to 34.8%).

**Table III-2.** Protein concentration of extracts and extraction yield from different corn germ meals

<b>Defatting method</b>	<b>Protein concentration (% d.b)</b>	<b>Protein extraction yield (%)</b>
Hexane RT	32.7 <sup>b</sup> ± 0.7	19.0 <sup>b</sup> ± 1.0
Hexane 45 °C	34.8 <sup>b</sup> ± 0.7	25.9 <sup>a</sup> ± 1.0
Soxhlet Hexane	27.1 <sup>c</sup> ± 0.5	15.8 <sup>c</sup> ± 0.3
Soxhlet Ethanol	19.9 <sup>d</sup> ± 0.4	7.8 <sup>d</sup> ± 0.2
Sc-CO <sub>2</sub>	48.5 <sup>a</sup> ± 1.0	21.3 <sup>b</sup> ± 0.9
Undefatted	29.2 <sup>c</sup> ± 0.6	19.9 <sup>b</sup> ± 0.4

Values presented as mean ± standard deviation

Equal letters in the same column indicate no significant difference at level of 5% ( $p < 0.05$ )

The yield of protein extraction varied from 7.8% to 25.9% with maximum achieved from the corn germ defatted by hexane at 45 °C. Most of the other defatted and undefatted meals achieved protein extraction yields close to 20%, without any significant difference among them. Protein recovery might be mainly influenced by the protein solubility in the extracted meal. In that sense, the increase in the protein extraction yield between hexane RT and 45 °C, and decrease when boiling hexane was used, are consistent with observations of Zayas, (1997). The use of a moderate temperature (about 45 °C) during the defatting step helped to leave the proteins more extractable by saline solutions. The modification of the structure of the proteins during the thermal treatment - allowing greater exposure of amino acids able to form hydrogen bonds - can be considered. Tao et al. (2019) attributed the increase of okara protein solubility to the decrease of intermolecular interactions between hydrophobic groups on the surface due to the heat treatment at 120 °C for 20 min. Zayas, (1997) reported that solubility of proteins is influenced by temperature, increasing with the temperature between 0 and 40-50°C, while at higher temperatures the solubility of proteins is less than that of native proteins.

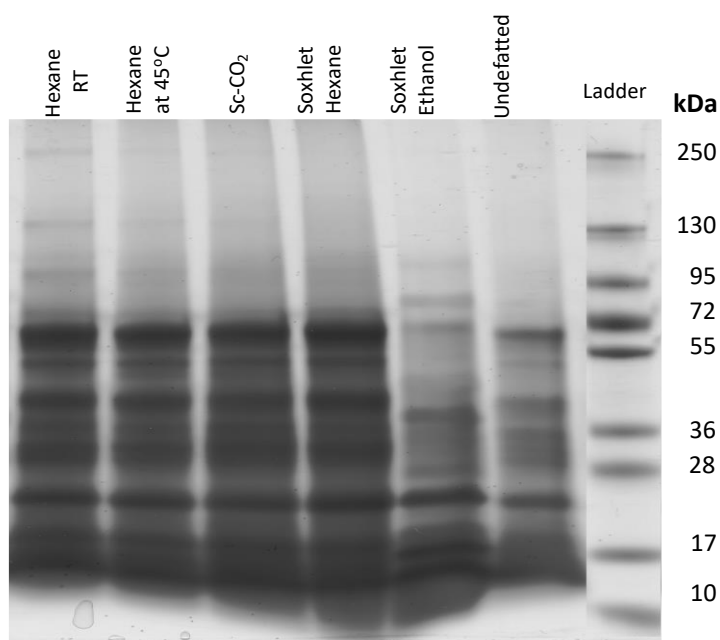
On the other hand, the residual oil content in corn meal after Sc-CO<sub>2</sub> extraction could have affected protein extraction, leading to a slightly lower yield (21.3%) than that from hexane defatted meal at the same temperature. However, no significant difference was observed in the recovery yields between Hexane at RT and undefatted meals (19.0% and 19.9%, respectively). Although oil was removed by Hexane at RT, the high phenolic content remaining in the defatted meal could bind proteins and hinder their solubilization in aqueous solvents (Malik & Saini, 2017). The residual oil and phenolic contents in the meals after defatting treatment could thus play a detrimental and complex role in the protein extractability.

These results are consistent with the 20-28% crude protein extracts and the 25-28% extraction yields reported by Hojilla-Evangelista, (2012) from corn germ defatted by hexane RT. Unlike Hojilla-Evangelista, (2012), this work evaluated the effect of solvent (hexane, ethanol), temperature (24 °C, 45 °C, 68 °C), and high pressure (210 bar) on proteins in corn germ meal after defatting step. Regarding protein concentration of extracts and protein extraction yield, the hardest conditions of defatting, i.e. the use of denaturing solvent (ethanol), along with high extraction temperature (boiling ethanol at ~ 78 °C), led to most significant differences (deleterious effect).



## 4.2. Molecular weight distribution: SDS-PAGE

In addition to the influence of protein concentration on the functional properties of protein concentrates, isolates, etc., the nature and size of the recovered protein also play a key role in the performance of the samples assessed. The electrophoretic profiles of the protein extracts from different defatted meals are shown in Figure III-5. These corn germ proteins were characterized by a number of polypeptide units around 55, 40, 25 and 10 kDa with no sub-unit greater than 60 kDa. These profiles were similar to those found in the literature for corn germ proteins (Hojilla-Evangelista, 2014, 2012; Landry & Moureaux, 1994; Romagnolo et al., 1994). The subunits with molecular mass ranging from 25 kDa to 55 kDa might be ascribed to globulins whereas subunits smaller than 25 kDa might be attributable to albumins. However, there exists an overlap of bands common to both protein classes (Landry & Moureaux, 1994; Romagnolo et al., 1994). The various studied protein extracts showed similar electrophoretic profiles, regardless of the defatting treatment. Moreover, aggregation due to severe denaturation was not observed for any treatment. Nonetheless, proteins extracted from the Soxhlet ethanol defatted meal showed fainter bands between 36 and 55 kDa, indicating that they were composed of lower molecular weight polypeptides than proteins in other extracts.



**Figure III-5.** SDS-PAGE band patterns of proteins obtained from different defatted corn germ meals

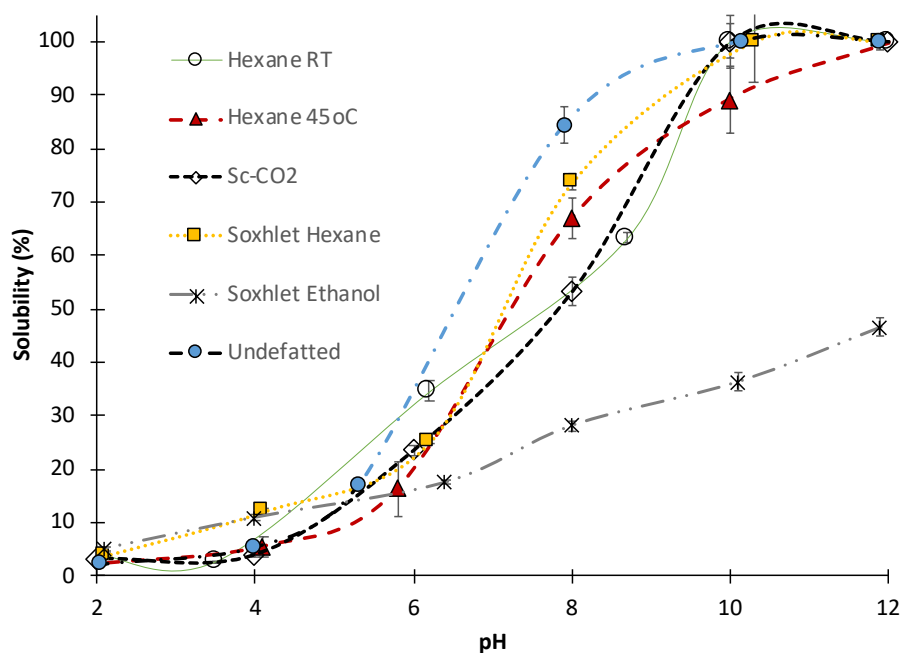
### 4.3. Functional properties of protein extracts

In order to show that protein extracts can be valuable compounds to recover, the assessment of their functional properties has been performed.

#### 4.3.1. Protein solubility

In general, the functional properties of protein extracts primarily determine their utilization in different food products. Particularly, the solubility of proteins is a key factor for their functionality properties and commonly determined during development and testing of new protein ingredients. Indeed, it is determinant to select the applicability of proteins in liquid foods and beverages, for instance. Protein solubility is the portion of protein in a sample that dissolves into solution under specific conditions. In this sense, the protein solubility at different pH values of the various protein extracts is shown in Figure III-6.

All corn germ protein extracts exhibited poor solubility at acid conditions (lower than 12% at pH 4) regardless of the meal they originated from. A higher pH improved the protein solubility, up to complete solubilization at pH 10, except for proteins extracted from corn germ defatted by Soxhlet ethanol. A sharp increase in solubility was observed when pH value of the medium was adjusted to 8, due to the increase in the net electrical charge of the proteins. According to Zayas, (1997) the determining factor of protein solubility is the pH of the medium since it defines the electrostatic and hydrophobic interactions between the protein molecules. Globally, protein solubility increases when electrostatic repulsion between proteins is greater than hydrophobic interactions. On contrary, close to the isoelectric point (close to pH 4 for corn germ proteins), proteins tend to have a net zero charge (attractive forces are predominant) therefore molecules tend to associate thereby decreasing the solubility (Föste et al., 2015). Moreover, the presence of alkali can cause extensive proteolysis and disaggregation that leads to high amounts of soluble proteins (Hojilla-Evangelista, 2012; Zayas, 1997).



**Figure III-6.** Protein solubility profile exhibited by the different protein extracts.  
Experimental points connected for better visualization

Similar works, such as presented by Hojilla-Evangelista, (2014) also reported an increase in solubility of corn germ proteins for alkaline pH, though the solubility of their extracted proteins achieved only 30% at maximum (pH 10). On the other hand, although some studies reported a U-shape solubility profile, with minimum at isoelectric pH around 5 (Nielsen et al., 1973; Zayas, 1997), other authors reported similar profiles as those presented here (Hojilla-Evangelista, 2014; Phillips & Sternberg, 1979; Wang & Zayas, 1991). This supports the assumption that the method of extraction also influenced the protein solubility profile. Phillips & Sternberg, (1979) depicted a corn protein concentrate with poor solubility (below 11%), Wang & Zayas, (1991) found barely 20-30% soluble proteins from corn germ flour, and Navarro et al. (2016) reported Nitrogen Solubility Index from 3% to 11% for corn germ-bran meals defatted by hydro-alcoholic solutions, whereas Nielsen et al. (1973), reported a maximum solubility of 54% for a dry-mill corn germ protein isolate. Protein solubilities exhibited in the present work were thus significantly higher. Therefore, corn germ protein, for instance, may be added to formulations to replace partially the costly meat proteins customarily used.

In addition to the various ways of producing protein extracts (extraction and purification), discrepancies in the solubility of corn germ protein reported in literature might be attributable to differences in the germ separation method – dry or wet milling process, with

or without tempering stage. For instance, wet milling is a process involving separation of the corn kernel into germ, fiber, gluten meal, and starch. This method includes a steeping step, and a grinding and physical separations in water. On the other hand, dry milling is primarily used for processing corn for food purposes which usually includes a water-tempering step where the pericarp/germ stream is dried, cooled, and aspirated to separate the pericarp from the germ (Johnston et al., 2005). In this context, the aforementioned methods may exhibit different separation efficiency and therefore, the wet or dry- milling germs are significantly different in their protein profile/features. Moreover, treatments that include drying steps may modify solubility of corn proteins (denaturation phenomenon) depending on temperature and drying time.

Finally, proteins extracted from the Soxhlet ethanol defatted meal showed a poor solubility even at alkaline pH (below 50%) what is probably due to partial protein denaturation during oil extraction, as already suggested by Navarro et al. (2016) and Zayas, (1997). Navarro et al. (2016) suggested that the decrease in solubility of plant proteins was due to contact with organic solvents that are miscible in water, which denature the proteins at high temperatures.

#### **4.3.2. Water Absorption Capacity (WAC)**

WAC is the ability of protein extract to hold water against gravity and is one of the most critical factors in protein functionality since it influences sensory properties as color and texture of food products (Hojilla-Evangelista, 2014; Wang & Zayas, 1991). On the other hand, during production of films (packaging), WAC is also a key factor that impacts mechanical properties.

The WAC of protein extracts obtained in this work ranged from 1.34 to 2.79 g water/g extract as can be observed in Table III-3. These results were comparable to WAC reported by Phillips & Sternberg, (1979) for corn protein concentrate (2.2 g water/g concentrate) and soy concentrate (1.9 g water/g concentrate). The protein content of corn and soy concentrates reported by Phillips & Sternberg, (1979) was 64% and 68%, respectively. For comparative purpose, WAC\* (g water/g protein) was calculated assuming that water absorption was only due to the protein content (Table III-3). WAC\* of the various extracts ranged from 4.6 to 14 g water/g protein, higher than those reported by Hojilla-Evangelista, (2014) (2.2 to 3.5 g water/g protein) and by Zayas & Lin, (1989a) (2 to 4 g water/g protein), for protein

extracts with a purity of about 30% and 20%, respectively. Protein extract from the Soxhlet ethanol defatted meal exhibited the highest WAC and WAC\* (2.79 g water/g extract and 14 g water/g protein, respectively). Since this extract was of low protein content, its high WAC was attributable to the hydrophilic co-extracted compounds, namely carbohydrates. Indeed, proteins and carbohydrates are of great importance in WAC by providing hydrophilic parts like polar and charged side chains (Hojilla-Evangelista, 2014; Zayas, 1997). Thereby, the co-extracted compounds during protein extraction play a key role in the water binding of plant protein extracts. Zayas & Lin, (1989a) reported similar results considering the role of carbohydrates in the swelling capacity. In spite of their low solubility, Soxhlet ethanol protein extract revealed a high capacity to prevent the three-dimensional structure protein-water-carbohydrate from releasing water. The phenol removal during Soxhlet ethanol extraction could have facilitated the formation of these three-dimensional structures, since polyphenols can establish hydrophobic interactions – and consequently insoluble complexes - with proteins through the aromatic nuclei and the hydroxyl groups of the aromatic ring (Malik & Saini, 2017).

Concerning protein extracts from hexane defatted meals, increasing the defatting temperature enhanced in the extract WAC. High temperature achieved during Soxhlet extraction can partially modify the structure of the proteins, thereby increasing interactions between water and protein polar parts. There was not any significant difference in WAC\* between the protein extracts obtained from the undefatted corn germ and from the other defatted meals (Hexane RT, Hexane 45 °C and Sc-CO<sub>2</sub>), ranging from 4.59 to 5.37 g water/g protein.

**Table III-3.** Water Absorption Capacity (WAC) of protein extracts obtained from different corn germ meals

Defatting method	WAC (g water/g extract)	WAC* (g water/g protein)
Hexane RT	1.52 <sup>d</sup> ± 0.01	4.64 <sup>c</sup> ± 0.04
Hexane 45 °C	1.87 <sup>c</sup> ± 0.04	5.37 <sup>c</sup> ± 0.10
Soxhlet Hexane	2.27 <sup>b</sup> ± 0.10	8.38 <sup>b</sup> ± 0.37
Soxhlet Ethanol	2.79 <sup>a</sup> ± 0.09	14.02 <sup>a</sup> ± 0.46
Sc-CO <sub>2</sub>	2.33 <sup>b</sup> ± 0.01	4.80 <sup>c</sup> ± 0.02
Undefatted	1.34 <sup>d</sup> ± 0.06	4.59 <sup>c</sup> ± 0.21

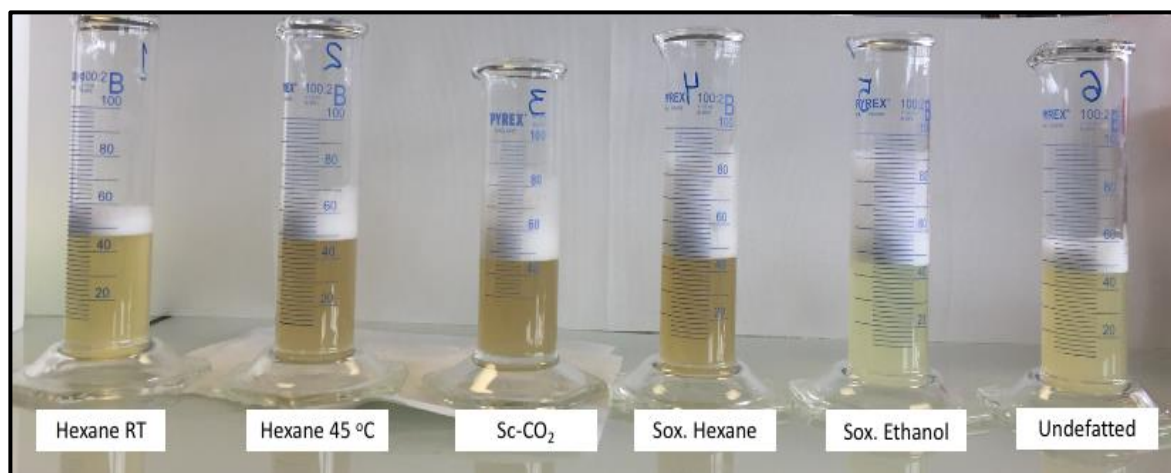
Values presented as mean ± standard deviation

Equal letters in the same column indicate no significant difference at level of 5% ( $p < 0.05$ )

It is also important to consider that different methods and considerations were found in literature to assess the interactions of proteins with water. Terms as water hydration, water holding, water retention, water binding, water imbibing, water adsorption can be found in literature depending on the terminology defined by the author in the protein functionality assessment.

#### 4.3.3. Foaming Capacity (FC) and Foaming Stability (FS)

In general, foams are complex systems that include a mixture of gases, liquids, solids, and surfactants. Foaming properties are important functional characteristics of protein extracts that determine their utilization in food products like ice cream or whipped cream. Proteins are surfactants that contribute to the uniform distribution of fine air cells in the structure of food systems (Zayas, 1997). Their foaming properties depend on several factors among which their source, method of extraction (including protein isolation, temperature of extraction, pH, etc.), protein concentration and operating parameters of whipping. Therefore, comparison with literature is quite complex. In Figure III-7 is shown a photograph of the foam formed after whipping the different solutions of corn germ proteins.

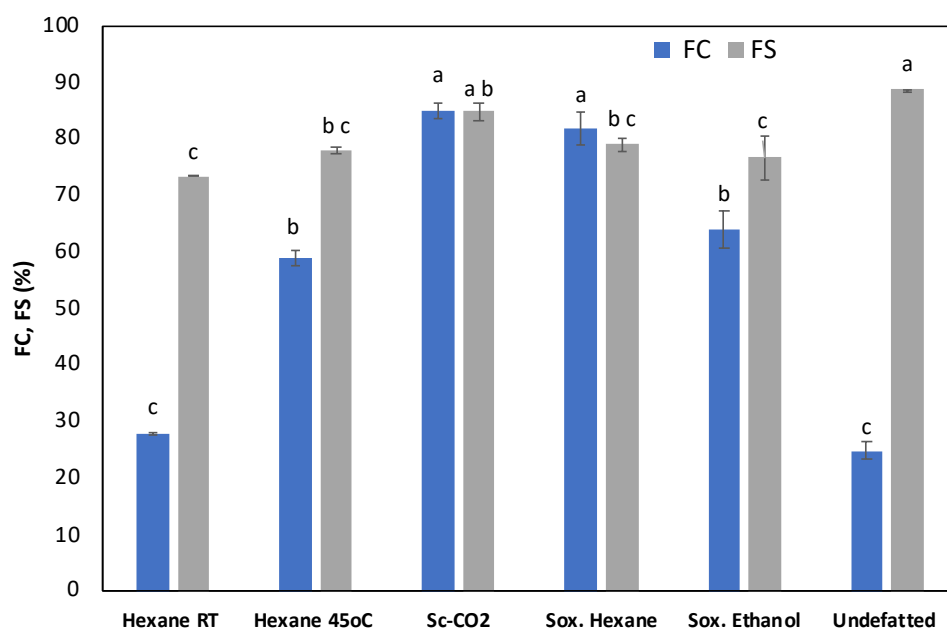


**Figure III-7.** Photograph of the different protein solutions (4 mg/mL) after high-speed homogenization using an Ultra-Turrax

Globally, FC is related to the ability of protein to solubilize in aqueous solution and adsorb at the water-air interface to form a viscous and cohesive film around bubbles (foam formation), whereas FS is related to intermolecular cohesiveness and the capacity to prevent rupture and subsequent coalescence of bubbles through the formation of viscous and elastic enough films (Zayas, 1997; Shevkani et al., 2014). The FC and FS of the protein extracts obtained from different defatted and undefatted corn germ meals are shown in Figure III-8. As can be observed in Figure III-8, FC of protein extracts varied significantly from 25% to 84%. On contrary, FS varied only from 73% to 89%. FC and FS higher than 80% were observed for protein extracts from Sc-CO<sub>2</sub> and Soxhlet hexane defatted meals, suggesting that these extracts are particularly suitable for products where dense and stable foams are desirable. Hojilla-Evangelista, (2014) reported similar FS (84% after 15 min foam standing) for protein extract from hexane defatted corn germ meal. On contrary, protein extract from the undefatted meal showed low FC (25%). An increase in FC from 28% to 59% and then to 82% was observed for protein extracts originating from hexane defatted meals at room temperature (24 °C), 45 °C and boiling temperature (68 °C), respectively. This clearly highlights the impact of temperature, even at moderate conditions (45 °C), on protein conformation. Indeed, heat induces unfolding of the protein what improves interactions. FC is enhanced consequently, provided that heat is limited and does not cause severe denaturation with loss of solubility (Hojilla-Evangelista, 2014, 2012). Zayas, (1997) reported that proteins must unfold to a certain degree in order to be reoriented at the interface and consequently form a continuous film which reduces the surface tension and allows the foam formation. Similarly, Shao et al. (2016)

observed that the foam capacity of soy protein concentrates was strongly and positively correlated with a greater hydrophobic surface due to heat treatments (55-85°C for 10-30 min).

Though Sc-CO<sub>2</sub> defatting was performed at moderate temperature (45 °C), protein extract originating from this defatted meal showed similar FC to that of extract from Soxhlet hexane defatted meal. This suggests that high-pressure treatment during SFE also participated to protein modification. Likewise, Solana et al. (2016) described the protein unfolding phenomenon observed after high-pressure treatment (between 100 and 250 bar) of soy skim with CO<sub>2</sub> in comparison with the non-treated material, and Yamaguchi et al. (1996) showed the change in the state of hydrophobic interaction between protein and water due to the exposure of non-polar groups during high pressure treatment. Some protein and enzyme modifications were also described by Christianson et al. (1984) when dry-milled corn germ was defatted by Sc-CO<sub>2</sub> instead of conventional hexane extraction.



**Figure III-8.** Foaming Capacity and Foaming Stability exhibited by protein extracts from different corn germ meals. Equal letters above the bars indicate no significant difference at level of 5% ( $p < 0.05$ )

On the other hand, the FC (64%) exhibited by the protein extract from meal defatted by Soxhlet ethanol was unexpected considering its poor solubility. Zayas, (1997) pointed out some studies where solubility of proteins and their foaming properties were correlated. However, the FC of this extract could be attributable to carbohydrates comprised in it. Additionally, insoluble



protein particles could also contribute to stabilize foams by creating a physical barrier to prevent bubble coalescence (Zayas, 1997) thus increasing the surface viscosity. Moreover, partial denaturation of proteins tends to form foams of higher stability since it increases viscosity and imparts rigidity to the interfacial film for foam stabilization (Zayas, 1997; Shevkani et al., 2014).

The proteins obtained from the undefatted corn germ and defatted meal by Hexane RT showed the lowest FC (25% and 28%, respectively). This could be assigned to the lack of protein modification by heat. As already discussed, the unfolding of protein structure is desirable to enhance the protein adsorption at the water-air interface during foam formation. In addition, the residual oil content in the extract obtained from the undefatted corn germ could also have negatively influenced the strength and elasticity of the film at the interface and thereby its ability to incorporate air (Hojilla-Evangelista, 2014; Hojilla-Evangelista et al., 2004). Indeed, lipids are more surface active than proteins and are readily adsorbed at interface, thereby inhibiting the adsorption of proteins during foaming (Shevkani et al., 2014).

Whatever the defatting method, corn germ proteins – along with other soluble and insoluble compounds comprising the extracts – were able to form cohesive, strength, elastic and continuous air-impermeable films around each gas bubble (FS > 73%).

#### **4.3.4. Emulsifying Capacity**

The emulsifying capacity of proteins is related to their ability to adsorb on the water-oil interface while the properties of this adsorbed layer are related to the stability of emulsions (Malik & Saini, 2017). The emulsifying capacity of various protein extracts was assessed by measurements of Emulsifying Activity Index (EAI) and droplet size distribution of emulsions right after emulsification, while emulsion stability was assessed by monitoring droplet size over storage. Emulsifying capacity plays a key role in the development of new sources of plant protein products particularly for food and pharmaceutical applications and there are several parameters that interfere on emulsifying capacity as source, concentration and properties of proteins, the emulsification method, pH, ionic strength, viscosity of the system, etc. Globally, a small droplet size distribution (micrometric scale) is highly desirable for food emulsions since it enhances stability as well as textural and flavor properties.

EAI of protein extracts from corn germ varied from 84.8 to 246 m<sup>2</sup>/g protein as can be observed in Table III-4. These results are in the same range as those reported for dry and wet

corn germ proteins (90 to 200 m<sup>2</sup>/g protein, Hojilla-Evangelista, (2014, 2012)) and higher than those for soybean and lupin concentrates (45 to 98 m<sup>2</sup>/g (Hojilla-Evangelista et al., 2004)). In Figure III-9 can be observed the macroscopic aspect of oil-in-water emulsion fabricated with protein extract from undefatted corn germ. It exhibited a white aspect, without suspended particles in aqueous phase, although after several minutes of preparation, a *cream separation* was observed. Additionally, these emulsions were odorless

**Table III-4.** Emulsifying Activity Index (EAI) of protein extracts and droplet size distribution of emulsions stabilized by protein extracts from different corn germ meals

Defatting method	EAI (m <sup>2</sup> /g protein)	D [4,3] (µm)
Hexane RT	109 <sup>b</sup> ± 4	21.60 <sup>c</sup> ± 0.01
Hexane 45 °C	84.8 <sup>b</sup> ± 7.1	38.23 <sup>a</sup> ± 0.03
Soxhlet Hexane	223 <sup>a</sup> ± 5	27.51 <sup>b</sup> ± 0.45
Soxhlet Ethanol	246 <sup>a</sup> ± 11	19.69 <sup>c</sup> ± 0.42
Sc-CO <sub>2</sub>	231 <sup>a</sup> ± 10	26.16 <sup>b</sup> ± 2.04
Undefatted	229 <sup>a</sup> ± 9	19.83 <sup>c</sup> ± 0.22

Values presented as mean ± standard deviation

Equal letters in the same column indicate no significant difference at level of 5% (p < 0.05)



**Figure III-9.** Macroscopic aspect of O/W (1:3) emulsion stabilized by protein extract from undefatted corn germ

Protein extract obtained from the Soxhlet ethanol defatted meal displayed the highest EAI with a value of 246 m<sup>2</sup>/g protein, although without significant difference with those from Sc-CO<sub>2</sub> or Soxhlet hexane defatted meals and from the undefatted meal. Thus, protein extracts yielded after Sc-CO<sub>2</sub>, Soxhlet hexane and Soxhlet ethanol treatment exhibited definitely high capacity to reduce surface tension and form strong and continuous films at water-air (FC) and water-oil (EAI) interfaces. On contrary, protein samples from meal defatted by Hexane RT and 45 °C showed low and statically equal EAI (109 and 84.8 m<sup>2</sup>/g, respectively). These samples have already revealed less capacity to reduce surface tension and form continuous films when FC was assessed. Several studies (Zayas, 1997; Zayas & Lin, 1989b) showed that protein solubility is not necessarily correlated to the emulsifying capacity of vegetable proteins since the emulsification behavior of globular proteins is more associated to surface hydrophobicity and molecular flexibility. Higher surface hydrophobicity subsequent to the partial unfolding of globular proteins due to heating and/or to pressure has been reported to improve the emulsifying capacity of proteins from pea (Peng et al., 2016), soy (Keerati-u-rai & Corredig, 2009; Zayas, 1997), corn (Lin & Zayas, 1987) and rice (Zhu et al., 2017). For instance, Peng et al. (2016) described a higher protein adsorption percentage and creaming stability index of emulsions formed by pea protein submitted to heat treatments in comparison with those formed by unheated proteins. Zhu et al. (2017) produced emulsions with enhanced stability due to the greater surface hydrophobicity when rice proteins were submitted to high pressure treatment from 100 to 400 MPa for 10 min.

It is worth noting that Rónyai et al. (1998) reported contrary results with higher EAI for corn protein isolates extracted after hexane 25 °C treatment than after Sc-CO<sub>2</sub>, though these authors did not provide any explanation. The high emulsifying capacity exhibited by extract from the undefatted corn germ is consistent with previous works that did not observe any decrease in EAI with residual oil content in germ isolates (Lasztity et al., 1995).

Right after emulsification the volume-averaged diameter (D[4,3]) of droplets ranged from 19.69 µm to 38.23 µm (Table III-5), with the finest emulsions observed with proteins extracted from meals defatted by Soxhlet ethanol or Hexane RT, or from undefatted meal. Protein extract from Hexane 45 °C defatted meal yielded the coarsest emulsion (38.23 µm). Correlation of EAI with D[4,3] was slight (correlation of Pearson: -0.586, p < 0.05), whereas this was greater with surface-averaged diameter D[3,2] of emulsions showed in Table III-5

(correlation of Pearson: -0.820,  $p < 0.05$ ). This is consistent with the definition of EAI that evaluates the surface of oil that is stabilized by one gram of protein.

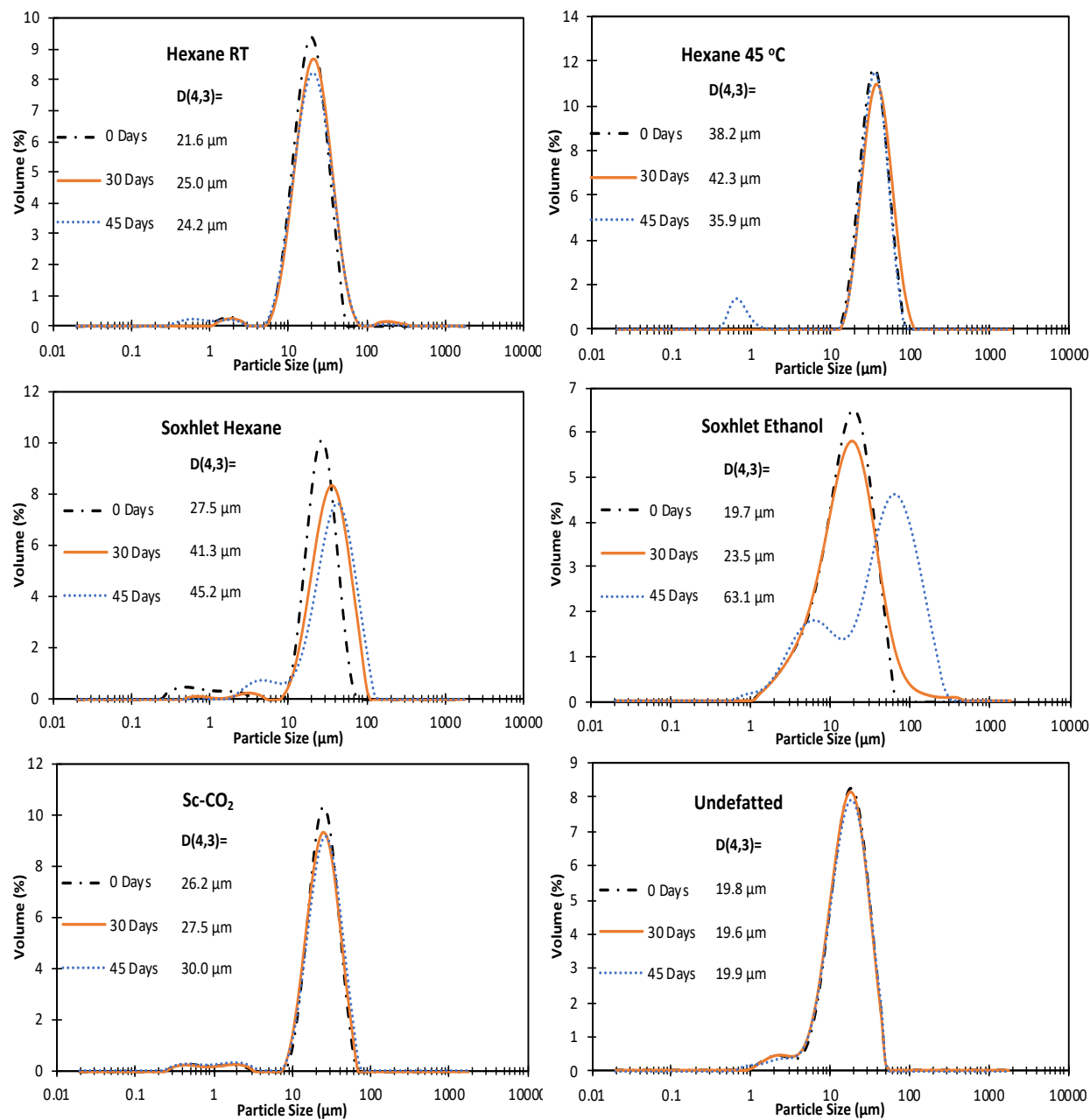
**Table III-5.** Droplet size distributions (surface-averaged diameter D[3,2]) of emulsions stabilized by protein extracts obtained from different corn germ meals

<b>Defatting Method</b>	<b>D [3,2] (<math>\mu\text{m}</math>)</b>
Hexane RT	15.14 <sup>b</sup> $\pm$ 0.00
Hexane 45°C	33.53 <sup>a</sup> $\pm$ 0.03
Soxhlet Hexane	6.09 <sup>f</sup> $\pm$ 0.10
Soxhlet Ethanol	10.76 <sup>d</sup> $\pm$ 0.23
Sc-CO <sub>2</sub>	8.77 <sup>e</sup> $\pm$ 0.67
Undefatted	12.57 <sup>c</sup> $\pm$ 0.14

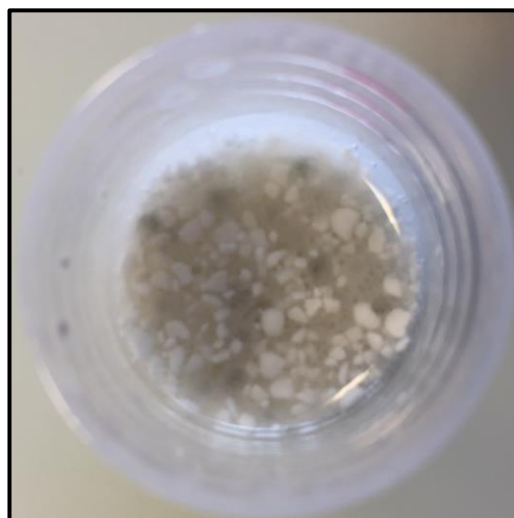
Values presented as mean  $\pm$  standard deviation

Equal letters in the same column indicate no significant difference at level of 5% ( $p < 0.05$ )

In general, the emulsions prepared with the various corn protein extracts exhibited high stability since they remained stable over the 45 day storage monitoring (Figure III-10) except emulsion stabilized by the protein extract from Soxhlet ethanol defatted meal that destabilized after 30 day storage. After 30 days of storage, the appearance of solid particles at the upper phase of emulsion prepared with protein extract from Soxhlet ethanol defatted meal was observed (Figure III-11). As discussed previously, this protein extract exhibited poor solubility due to denaturation that could impact the stability of emulsion. As complementary information to the monitoring of the droplet size distribution of the different emulsions, in Figure III-12 is presented the microscope observation of the same emulsions throughout storage.

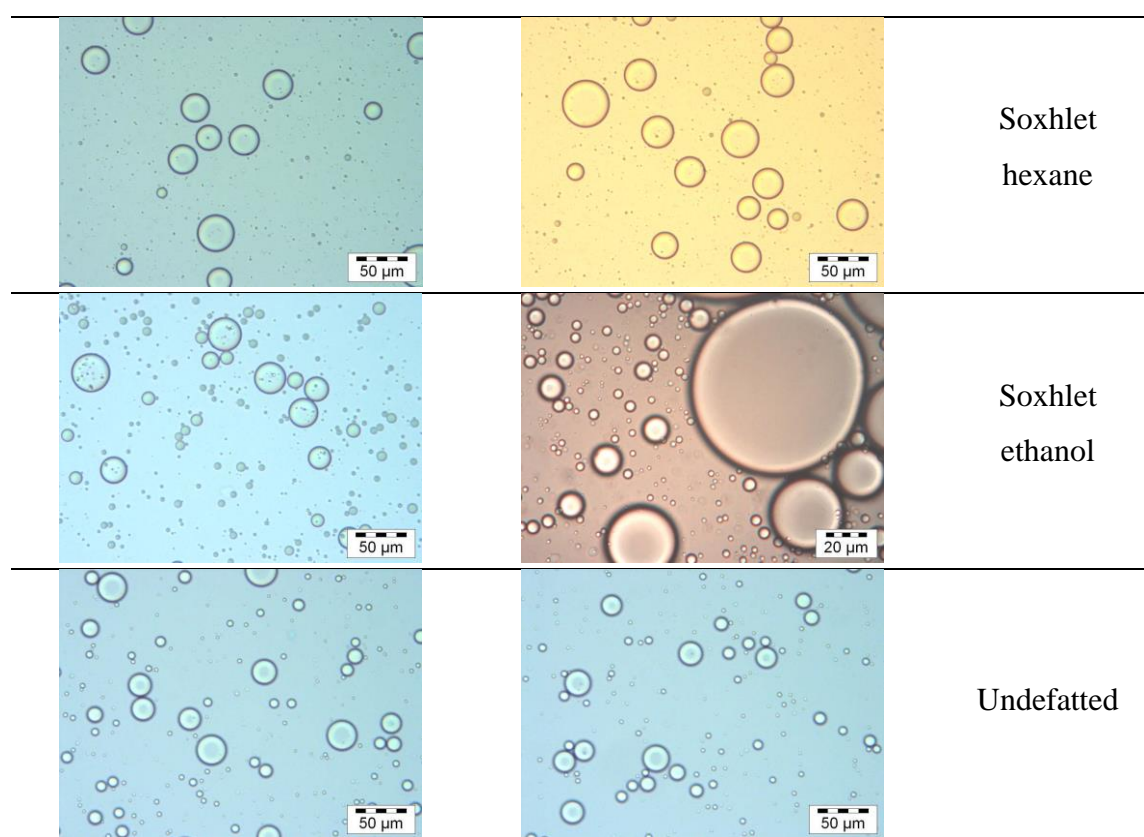


**Figure III-10.** Droplet size distributions of emulsions prepared with different corn germ protein extracts, after different storage durations at 4 °C



**Figure III-11.** Oil-in-water emulsion stabilized by protein extract from Soxhlet ethanol defatted meal after 30 days of storage

Right after emulsification	After 45 days of storage	Emulsion sample
		Hexane RT
		Hexane 45 °C
		Sc-CO <sub>2</sub>



**Figure III-12.** Microscope observations of O/W (1:3) emulsions stabilized by different protein extracts obtained from defatted and undefatted corn germ over storage

#### 4.4. Influence of protein extraction and purification methods

The methods of extraction and of purification that are implemented to recover protein extracts might influence their composition and techno-functional properties. Due to high protein solubility at pH 10, it is of common practice to extract proteins by NaOH solutions at this pH value. Additionally, ultrafiltration-diafiltration (UF-DF) is a scalable separation technique widely used in the pharmaceutical, biotechnological and food industries for purification of biomolecules (Lipnizki, 2005). Therefore, the effect of both alkaline extraction and UF-DF purification on the functionalities of proteins extracted from Sc-CO<sub>2</sub> defatted meal was assessed. Extracts with higher protein concentrations were achieved by dialysis as compared to UF-DF, especially when extraction was performed by 0.1 M NaCl (Table III-6). This result is in contradiction with the slight protein concentration increase by UF-DF reported by Hojilla-Evangelista, (2014). Nevertheless, the theoretical flux capacity and membrane selectivity in ultrafiltration process depend on several parameters (feed and membrane properties, transmembrane pressure, cross-flow rate) that should be optimized to avoid

concentration polarization and fouling of the membrane (Tang et al., 2009). Protein concentration of the diafiltered extracts was about 36%, regardless of the extraction method. However, protein extraction at pH 10 improved significantly the recovery efficiency (from 21% to 56%, Table III-6) due to high protein solubility at alkaline conditions.

**Table III-6.** Protein extraction yield and protein concentration of extracts obtained from Sc-CO<sub>2</sub> defatted corn germ by saline or alkaline solutions and purified by dialysis or UF-DF

Protein extraction by	Protein purification by	Protein concentration (% d.b)	Protein extraction yield (%)
0.1 M NaCl	Dialyzed	48.5 <sup>a</sup> ± 1.0	21.3 <sup>b</sup> ± 0.9
	UF-DF	36.4 <sup>c</sup> ± 1.8	28.7 <sup>b</sup> ± 1.4
pH 10	Dialyzed	39.6 <sup>bc</sup> ± 2.0	56.6 <sup>a</sup> ± 2.8
	UF-DF	35.7 <sup>c</sup> ± 1.8	53.5 <sup>a</sup> ± 2.8

Values presented as mean ± standard deviation

Equal letters in the same column indicate no significant difference at level of 5% ( $p < 0.05$ )

**Table III-7.** WAC and EAI of proteins extracted from Sc-CO<sub>2</sub> defatted corn germ by saline or alkaline solutions and purified by dialysis or UF-DF

Protein extraction by	Protein purification by	WAC (g water/g extract)	WAC* (g water/g protein)	EAI (m <sup>2</sup> /g protein)	D [4,3] (μm)
0.1 M NaCl	Dialyzed	2.33 <sup>a</sup> ± 0.01	4.80 <sup>c</sup> ± 0.02	231 <sup>bc</sup> ± 10	26.16 <sup>b</sup> ± 2.04
	UF-DF	2.80 <sup>a</sup> ± 0.18	7.71 <sup>a</sup> ± 0.49	187 <sup>d</sup> ± 2	26.10 <sup>b</sup> ± 0.34
pH 10	Dialyzed	2.33 <sup>a</sup> ± 0.12	5.87 <sup>abc</sup> ± 0.30	255 <sup>a</sup> ± 2	18.78 <sup>c</sup> ± 0.09
	UF-DF	2.81 <sup>a</sup> ± 0.17	7.88 <sup>a</sup> ± 0.48	245 <sup>ab</sup> ± 7	19.32 <sup>c</sup> ± 0.41

Values presented as mean ± standard deviation

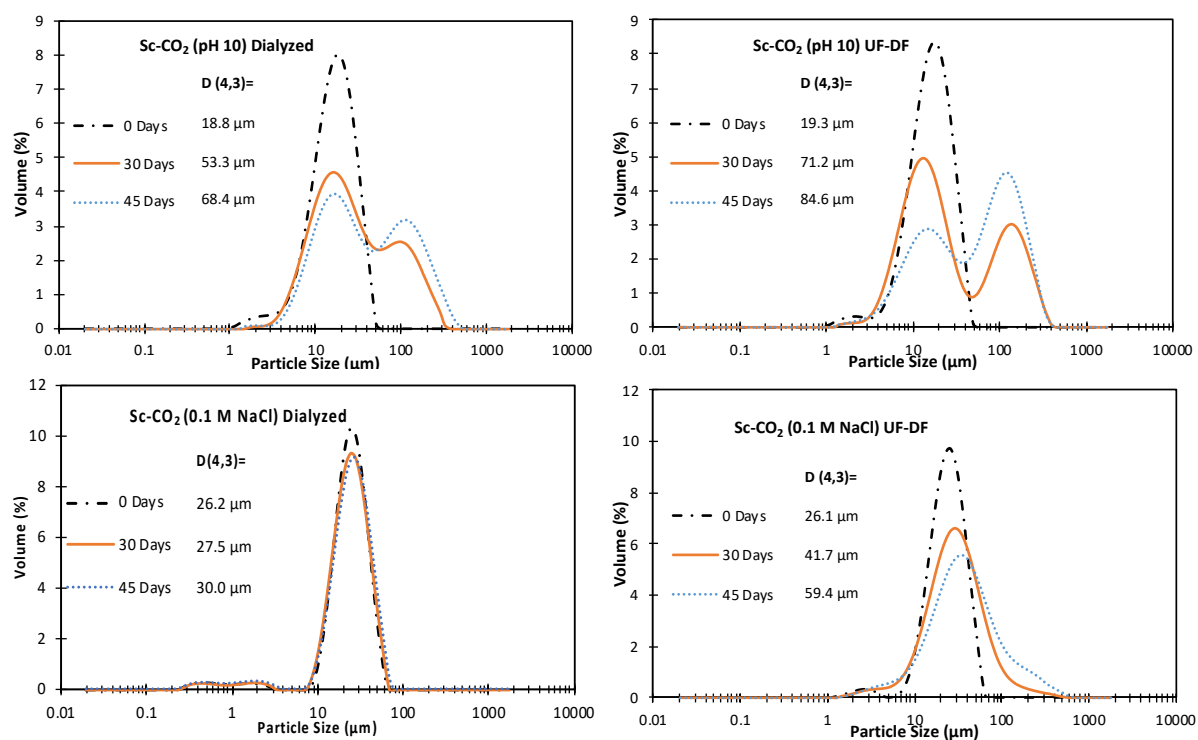
Equal letters in the same column indicate no significant difference at level of 5% ( $p < 0.05$ )

Similarly, WAC did not show significant difference ( $p < 0.05$ ) among UF-DF and dialyzed samples. For the emulsifying activity, the general trend was of higher EAI values and finer emulsions (D[4,3] of 19 μm vs 26 μm) when extraction was performed in alkaline instead of saline conditions (Table III-7). This can be ascribed to higher solubility and unfolding of proteins due to the alkaline pH. However, these emulsions displayed poor stability over time as shown in Figure III-13. Thus, these proteins were not able to produce cohesive, strengthened



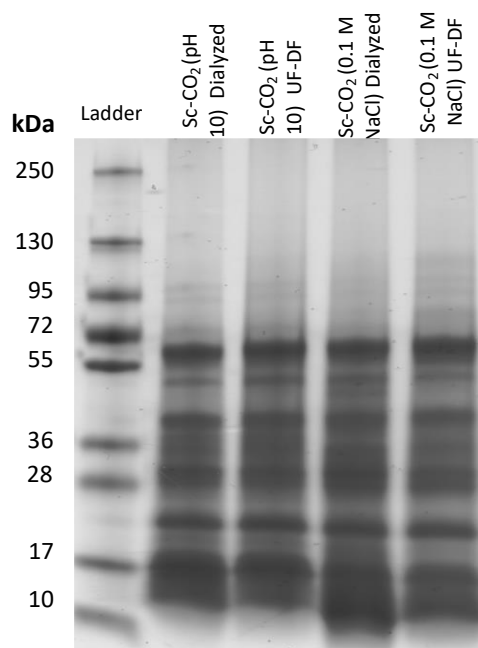
and elastic enough films to ensure emulsion stability. Dialyzed extracts reached slightly higher EAI than their UF-DF counterparts, though no difference in droplet size was observed.

Dialyzed extracts from saline extraction enabled stable emulsions of low dispersity, whereas UF-DF extracts produced initially emulsions with similar size distribution than dialyzed but their polydispersity increased upon storage.

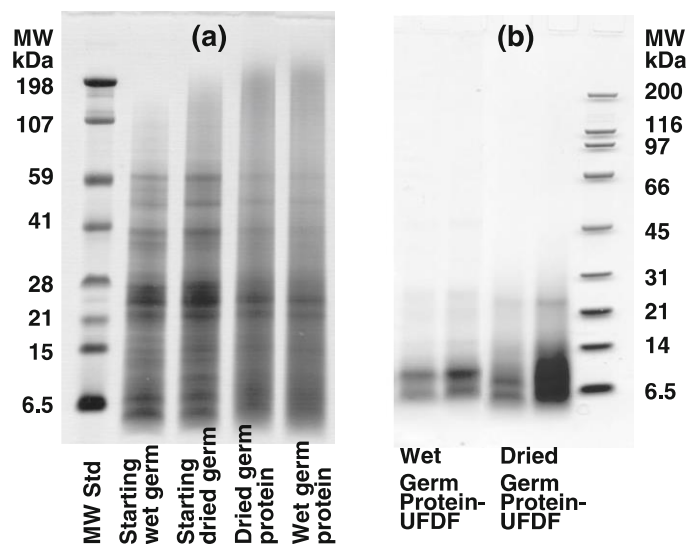


**Figure III-13.** Droplet size distributions of O/W (1:3) emulsions prepared with protein extracts obtained from Sc-CO<sub>2</sub> defatted corn germ by saline (0.1 M NaCl) or alkaline solutions (pH 10) and purified by dialysis or UF-DF, after different storage durations

Regarding the molecular weight distribution, all protein extracts exhibited the same electrophoretic profile (Figure III-14), thus indicating that neither the extraction method nor the purification method influenced this profile. Therefore, ultrafiltration and dialysis membranes retained indistinctly molecules of the same size during the desalting step. Hojilla-Evangelista, (2014) noticed a modified molecular weight profile of UF-DF compared to dialyzed CG concentrates, with the disappearance of bands larger than 31 kDa (Figure III-15), what is rather surprising for 5 kDa membranes. The authors assumed that larger polypeptides (41–59 kDa) could have bound to the membrane during UF-DF.



**Figure III-14.** SDS-PAGE profiles of proteins extracted from Sc-CO<sub>2</sub> defatted meal by means of various protein extraction methods (saline or alkaline) and purification methods (dialyzing or UF-DF)

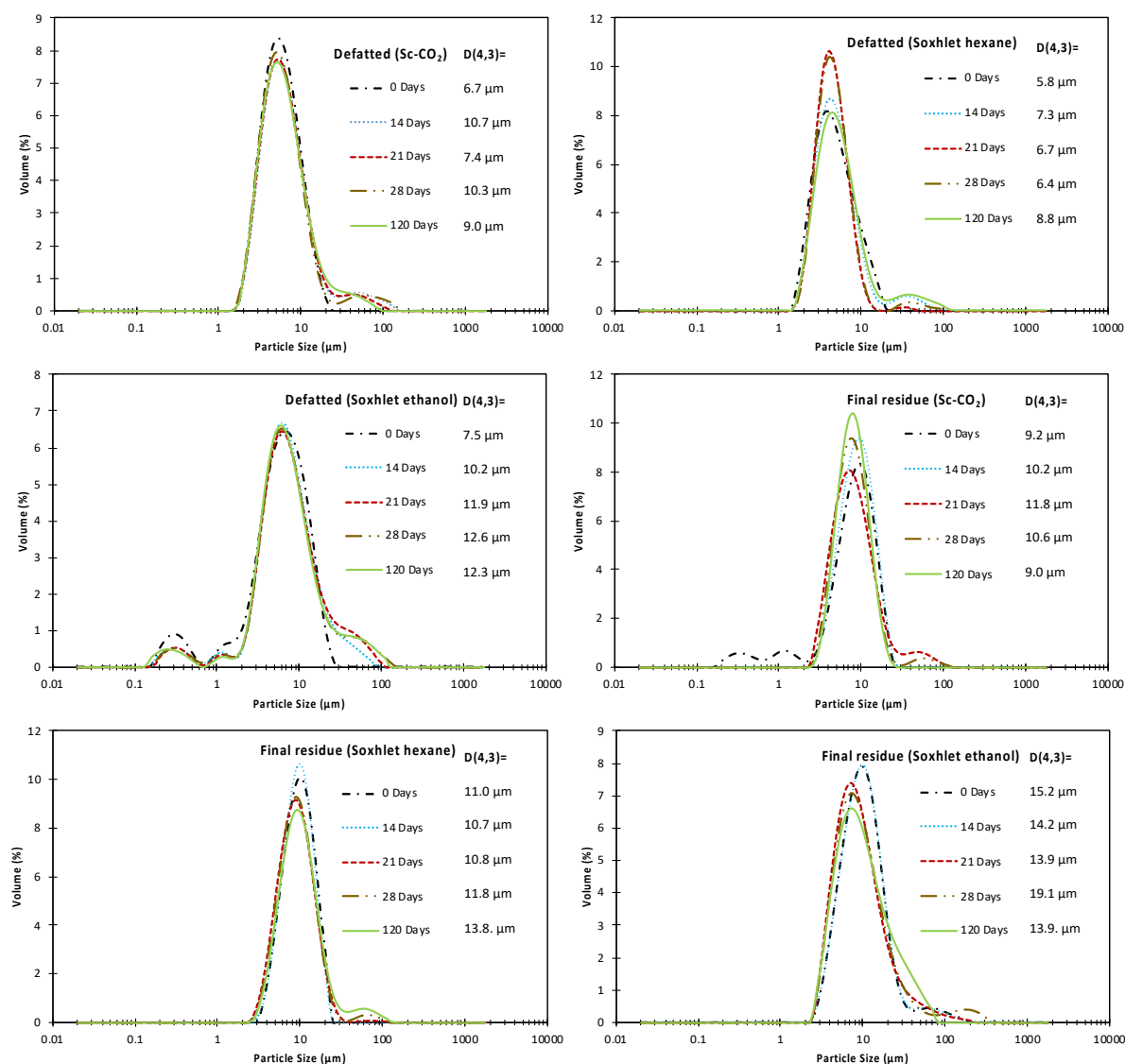


**Figure III-15.** SDS-PAGE reported by Hojilla-Evangelista, (2014) of proteins in wet or dried corn germ extracted by the baseline method (dialyzed) (a), and by the UF-DF method (b).

## **5. Pickering emulsion stabilized by corn germ particles**

As discussed in *Chapter I*, the use of plant residues for stabilizing oil-in-water emulsions is an important alternative in the context of circular economy approach. This application allowed us to use agro residues under a holistic approach and take advantages of functional properties of non-purified plant products, including residual solids after some extraction steps. Furthermore, there is an important background related to Pickering emulsions in CLIPIN'IN team intended to assess the functionality of different solids.

In this sense, oil-in-water emulsions were stabilized by corn germ particles with different compositions. Firstly, the volume-averaged diameter ( $D[4,3]$ ) of droplets of the emulsions stabilized by the following corn germ particles was monitored for several days (shown in Figure III-16); i) meal only defatted by Sc-CO<sub>2</sub>, ii) meal only defatted by Soxhlet hexane, iii) meal only defatted by Soxhlet ethanol, iv) meal defatted by Sc-CO<sub>2</sub> and then deproteinized (called final residue Sc-CO<sub>2</sub>), v) meal defatted by Soxhlet hexane and then deproteinized (called final residue Soxhlet hexane) and, vi) meal defatted by Soxhlet ethanol and then deproteinized (called final residue Soxhlet ethanol). Deproteinized material refers to the meal submitted to protein extraction using 0.1 M NaCl solution as previously described in *Chapter II*, section 2.2.2. Afore-mentioned particles were added at a concentration of 2.5% referred to the aqueous phase. After dispersion by microfluidization, the volume-averaged diameter of these corn germ particles ranged from 15 to 19  $\mu\text{m}$ .



**Figure III-16.** Droplet size distributions of O/W (1:4) emulsions stabilized by either defatted or defatted and deproteinized corn germ particles at a concentration of 2.5%

Globally, the droplet size of O/W (1:4) emulsions stabilized by the different corn germ particles at a concentration of 2.5% varied from 6 to 15  $\mu\text{m}$  (right after emulsification), mainly monodispersed with a uniformity between 0.3 and 0.7. These results were consistent with those showed by Joseph, (2018) for Pickering emulsion prepared under similar conditions; the author reported droplet sizes around 5  $\mu\text{m}$  in emulsions stabilized by cacao and rapeseed particles (2.5% of particles and 20% of oil) through microfluidization (800 bar), and  $\sim 11$   $\mu\text{m}$  for emulsion prepared under same conditions with particles of lupine shell. Joseph et al. (2020) linked the smaller droplet size to higher protein content of plant particles which is in agreement with this study, since a larger droplet size was observed when corn particles were deproteinized. On the other hand, Huc-Mathis et al. (2019) reported droplet size mainly in the

range of 30 to 45  $\mu\text{m}$  in O/W (1:1) emulsions stabilized by apple pomace and oat bran particles, respectively, through high speed homogenization using a rotor-stator device.

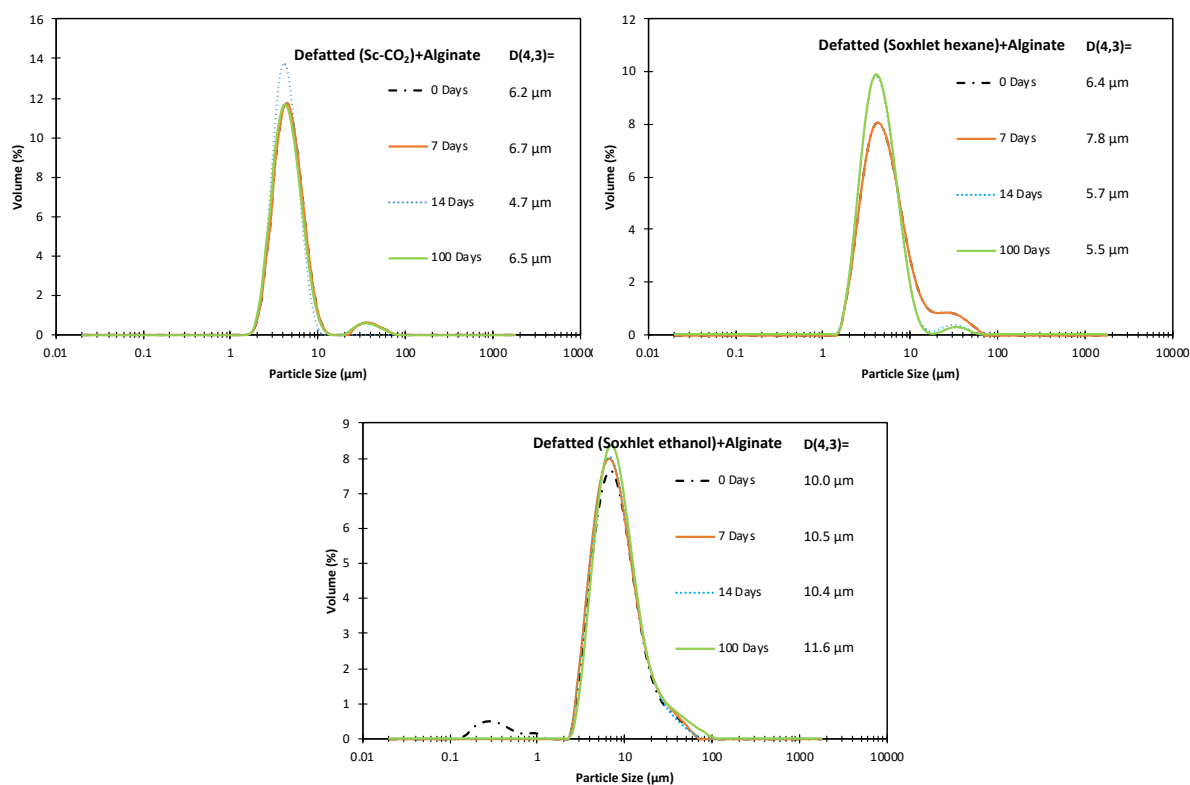
According to Jafari et al. (2006) the microfluidization is superior to the other types of conventional homogenization techniques since it allows to obtain emulsions with droplet size in micrometric or even in nanometric scale. The distributions of particle sizes produced by a microfluidizer appear to be narrower and smaller than the products of traditional homogenization. In addition to the homogenization technique, the droplet size distribution of oil-in-water emulsions may be influenced by time of homogenization, water to oil ratio, type and concentration of surfactant/stabilizer, pH, among others (Joseph, 2018; Gould et al., 2013; Jafari et al., 2006).

Regarding the stability, it can be stated that in general all emulsion exhibited high stability during the 120 days of storage at 4 °C, since the main peak of the size distribution for all emulsions remained stable up to 120 days (Figure III-16). Pickering emulsions are known to be more stable than surfactant stabilized emulsion as once adsorbed a particle is considered to be irreversibly placed at the interface (Gould et al., 2013). This is because the energy of desorption per particle ( $\sim 10^3$  kT) is significantly higher than in the case of interfacially adsorbed surfactants which are considered to be in a state of dynamic equilibrium constantly undergoing adsorption and desorption (Hunter et al., 2008). These diffusion processes facilitate droplet coalescence and Ostwald ripening, whereas the absence of these processes in Pickering emulsions makes the emulsions extremely stable against changes in droplet size distribution (Gould et al., 2013; Hunter et al., 2008).

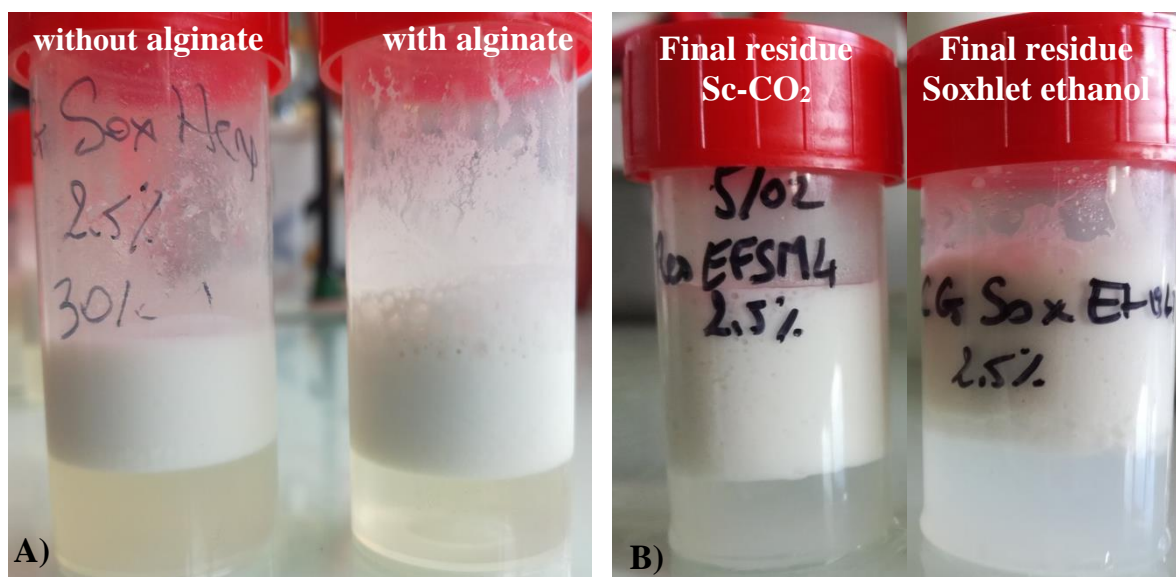
Only in the emulsion stabilized by particles defatted by Soxhlet ethanol was noticed a second population of larger droplets (size > 30  $\mu\text{m}$ ) after 14 days of storage. A partial denaturation of proteins and the partial removal of carbohydrates and other ethanol-soluble compounds from corn germ meal during Soxhlet ethanol extraction, could impact the ability of corn germ particles for stabilizing oil droplets and avoid their coalescence. Globally, the final residues (defatted and then deproteinized corn germ) also exhibited a high capacity for stabilizing oil-in-water emulsions since droplet size distribution stayed stable for 120 days with an average diameter between 10 and 15  $\mu\text{m}$ . The fact that the water-soluble fraction of plant particles was mostly removed during protein extraction, prior to emulsion preparation, did not affect significantly their adsorption at the interface. These observations were consistent with Huc-Mathis et al. (2019) and Joseph, (2018) since they found that stabilization of emulsion by

plant particles from cacao and apple pomace, respectively, was mainly due to their insoluble fraction, with a poor contribution or influence of their water-soluble components.

For Pickering emulsion which were added 2% of sodium alginate did not exhibit significant differences regarding their counterparts, since their droplet size distribution were quite similar and remained stable throughout storage (Figure III-17). As expected, the sodium alginate did not participated in the stabilization of oil droplets and it was added only aiming at thicken the aqueous phase for avoiding gravity dependent phenomena, such as creaming; the dispersed and continuous phases generally have different densities and therefore, because of the gravitational forces, the drops tend to rise to the surface which is known as creaming. However as can be observed in Figure III-18A, the emulsion containing 2.5% of sodium alginate did not significantly avoid the creaming when compared with the emulsion without sodium alginate. Creaming of emulsions can be undesirable, particularly in food products since it impacts their sensory properties, thereby food thickeners such as gum, starch and pectin are highly used in food industry. Nonetheless, sodium alginate at only 2.5% of concentration was not enough to prevent emulsion creaming.



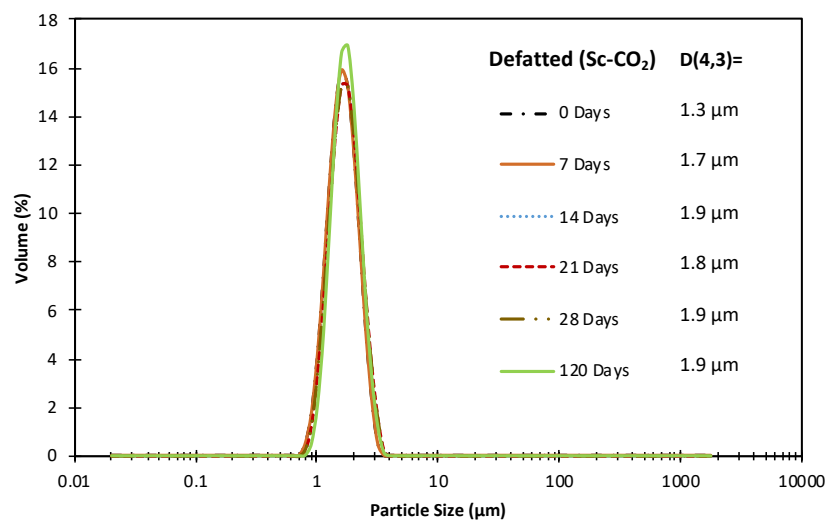
**Figure III-17.** Droplet size distributions of emulsions stabilized by defatted corn germ particles at a concentration of 2.5% and with sodium alginate (2% wt/v)



**Figure III-18.** Macroscopic aspect of O/W (1:4) emulsions stabilized by: corn germ defatted by Soxhlet hexane, containing (2% wt/v) or not sodium alginate (A) final residues (defatted and deproteinized corn germ) (B)

On the other hand, when a higher concentration of corn germ particles (10% referred to the aqueous phase) was assessed for stabilizing O/W (1:4) emulsions, it was observed a finer droplet size (about 1 to 2  $\mu\text{m}$ ) than in those emulsions prepared with 2.5% of plant particles. Moreover, the emulsion was highly monodispersed (uniformity < 0.5) and exhibited a high stability during 120 days of storage at 4 °C as can be observed in Figure III-19. Finer oil droplets involve a higher interfacial area for being stabilized by plant particles. In this context, it can be stated that 10% of corn germ particles was able to sufficiently cover a higher interfacial area and therefore successfully stabilized finer oil droplets avoiding their coalescence for several days. Joseph, (2018) showed that the total area of interface ( $\text{m}^2$ ) stabilized by plant particles increased linearity with the mass of particles adsorbed at the interface, thereby the final size of the droplets is determined by the quantity of particles at the interfaces. In this context, it was expected that maintaining the water to oil ratio, the average size of the oil droplets decreased with a higher particle concentration.

Finally, it is worth mentioning that Pickering emulsions, stabilized by corn germ particles, were odorless which can be desirable for food applications.



**Figure III-19.** Droplet size distributions of emulsions stabilized by defatted corn germ particles (Sc-CO<sub>2</sub>) at a concentration of 10%



## 6. Conclusion and perspectives

In this chapter was described a way to recover and use all fractions from an agroindustrial co-product, namely corn germ. Moreover, we investigated potential consequences of particular conditions for oil extraction on the recovery and quality of subsequent fractions (protein extracts and solid residues).

Firstly, the various oils recovered from the corn germ meals did not exhibit significant differences in fatty acid composition, whereas the extraction yield and phenolic content of oils were influenced by the polarity and temperature of the extraction solvents. Oil extraction by hexane yielded the highest efficiency but the main drawback of this solvent is its toxicity whereas the oil from Soxhlet ethanol extraction showed the highest phenolic content due high polarity of ethanol and high temperature of extraction. Due to equipment limitation as well as to economical and time considerations, extraction by the environmentally, friendly and safe Sc-CO<sub>2</sub> was not conducted to complete defatting, thus providing a partially defatted meal and a high phenolic content oil, concurrently. Regardless the extraction method, corn oils were mainly composed of unsaturated fatty acids among which linoleic acid as the major fatty acid, followed by oleic acid and palmitic acid which may potentiate its use in food, cosmetic and nutraceutical applications.

Regarding the protein recovery, the extracts produced from meals defatted by hexane comprised 27.1% to 34.8% proteins and exhibited varying foaming and emulsifying capacities according to the protein unfolding degree in relation to the operating temperature. Although Soxhlet ethanol extraction evidenced protein denaturation that impaired solubility, the proteins further extracted exhibited high water absorption capacity and emulsifying activity index. It has been widely reported the marked influence of co-extracted compounds, particularly of carbohydrates, on the water holding capacity of protein extracts due to the role of these compounds in the capacity to prevent water from being released from the three-dimensional structures. The protein extract yielded from meal defatted by Sc-CO<sub>2</sub> exhibited the highest protein content over all extracts. It also showed the best foaming capacity and stability, and one of the highest water absorption capacity and emulsifying activity index. Moreover, emulsion stabilized by the various protein extracts were stable over the 45 days of storage, except the emulsion with protein extract from meal defatted by Soxhlet ethanol that exhibited lower stability. It was also shown that partial unfolding of plant proteins due to conditions of high temperature, pressure or contact with hydroalcoholic solvents may modify the distribution

of hydrophilic and hydrophobic domains in the molecule surface and, accordingly influence significantly their functional properties.

The protein extraction at pH 10 improved significantly the recovery efficiency due to high protein solubility at alkaline conditions. However, though proteins extracted in alkaline solution presented higher emulsifying activity index and produced smaller size emulsions, they were not able to ensure the emulsion stability over time. Regarding the desalting method for protein recovery, extracts with higher protein concentrations were achieved by dialysis as compared to UF-DF, especially when extraction was performed by 0.1 M NaCl. Nevertheless, protein purification by UF-DF needs additional study and optimization in order to assess its influence on protein functionality. Under the concept of biorefinery, it can be stated that Sc-CO<sub>2</sub> technology is the best alternative for meeting environmental concerns and the obtention of valuable functional proteins.

Moreover, both defatted and defatted + deproteinized corn germ proved to be efficient for producing Pickering emulsion by stabilizing oil droplets with a diameter size ranging from 1 to 15  $\mu\text{m}$ . The plant particles at the interface successfully avoided droplet coalescence over 120 days of storage at 4 °C and produced finer droplets as the amount of particles increased from 2.5% to 10%. The above allowed us to present an alternative for using plant residues under a holistic approach in case it is required, so that steps such as extraction, concentration and purification for recovering specific materials/compounds could be avoided.

Globally, we have successfully presented a complete biorefinery scheme from by-products such as corn germ, thereby added value products with potential application for food, pharmaceutical, cosmetic and chemical industry, were obtained. Nevertheless, further studies may be developed in order to optimize green technologies of extraction such as Sc-CO<sub>2</sub>, so that oil and protein fraction can be obtained simultaneously by using a co-solvent, for instance. Further assessment of some food applications for protein extracts, such as enriching of food products or fabrication of edible films and coatings, for instance, may add value to the proposed biorefinery scheme. An economical and energy study of each step of the biorefinery scheme for obtaining the various fractions is also highly recommended.

## References

- Barrera-Arellano, D., Badan-Ribeiro, A.P., Serna-Saldivar, S.O., 2019. Corn oil: Composition, processing, and utilization. In: Serna-Saldivar, S.O. (Ed.), *Corn chemistry and technology*. AACC International, UK, pp. 593-613.
- Belayneh, H.D., Wehling, R.L., Reddy, A.K., Cahoon, E.B., Ciftci, O.N., 2017. Ethanol-modified supercritical carbon dioxide extraction of the bioactive lipid components of *Camelina sativa* seed. *JAOCS, J. Am. Oil Chem. Soc.* 94, 855–865.
- Buffo, R.A., Han, J.H., 2005. Edible films and coatings from plant origin proteins. In: Han, J.H. (Ed.), *Innovations in Food Packaging*. Academic Press, UK, pp. 277-300.
- Capellini, M.C., Chiavoloni, L., Giacomini, V., Rodrigues, C.E.C., 2019. Alcoholic extraction of sesame seed cake oil: Influence of the process conditions on the physicochemical characteristics of the oil and defatted meal proteins. *J. Food Eng.* 240, 145–152.
- Capellini, M.C., Giacomini, V., Cuevas, M.S., Rodrigues, C.E.C., 2017. Rice bran oil extraction using alcoholic solvents: Physicochemical characterization of oil and protein fraction functionality. *Ind. Crops Prod.* 104, 133–143.
- Chove, B.E., Grandison, A.S., Lewis, M.J., 2001. Emulsifying properties of soy protein isolate fractions obtained by isoelectric precipitation. *J. Sci. Food Agric.* 81, 759–763.
- Christianson, D.D., Friedrich, J.P., List, G.R., Warner, K., Bagley, E.B., Stringfellow, A.C. and Inglett, G.E., 1984. Supercritical fluid extraction of dry-milled corn germ with carbon dioxide. *J. Food Sci.* 49, 229–232.
- Espinosa-Pardo, F.A., Nakajima, V.M., Macedo, G.A., Macedo, J.A., Martínez, J., 2017. Extraction of phenolic compounds from dry and fermented orange pomace using supercritical CO<sub>2</sub> and cosolvents. *Food Bioprod. Process.*
- Föste, M., Elgeti, D., Brunner, A.K., Jekle, M., Becker, T., 2015. Isolation of quinoa protein by milling fractionation and solvent extraction. *Food Bioprod. Process.* 96, 20–26.
- Garcia-Mendoza, M. del P., Espinosa-Pardo, F.A., Baseggio, A.M., Barbero, G.F., Maróstica Junior, M.R., Rostagno, M.A., Martínez, J., 2017. Extraction of phenolic compounds and anthocyanins from juçara (*Euterpe edulis* Mart.) residues using pressurized liquids and supercritical fluids. *J. Supercrit. Fluids* 119, 9–16.
- Gil-Ramirez, A., Salas-Veizaga, D.M., Grey, C., Karlsson, E.N., Rodriguez-Meizoso, I., Linares-Pastén, J.A., 2018. Integrated process for sequential extraction of saponins, xylan and cellulose T from quinoa stalks (*Chenopodium quinoa* Willd.). *Ind. Crops Prod.* 121, 54–65.
- Gould, J., Vieira, J., Wolf, B., 2013. Cocoa particles for food emulsion stabilisation. *Food Funct.* 4, 1369–1375.

Hojilla-Evangelista, M.P., 2012. Extraction and functional properties of non-zein proteins in corn germ from wet-milling. *JAOCS, J. Am. Oil Chem. Soc.* 89, 167–174.

Hojilla-Evangelista, M.P., 2014. Improved solubility and emulsification of wet-milled corn germ protein recovered by ultrafiltration-diafiltration. *JAOCS, J. Am. Oil Chem. Soc.* 91, 1623–1631.

Hojilla-Evangelista, M.P., Sessa, D.J., Mohamed, A., 2004. Functional properties of soybean and lupin protein concentrates produced by ultrafiltration-diafiltration. *JAOCS, J. Am. Oil Chem. Soc.* 81, 1153–1157.

Huc-Mathis, D., Journet, C., Fayolle, N., Bosc, V., 2019. Emulsifying properties of food by-products: Valorizing apple pomace and oat bran. *Colloids Surfaces A Physicochem. Eng. Asp.* 568, 84–91.

Hunter, T.N., Pugh, R.J., Franks, G. V., Jameson, G.J., 2008. The role of particles in stabilising foams and emulsions. *Adv. Colloid Interface Sci.* 137, 57–81.

Jafari, S.M., He, Y., Bhandari, B., 2006. Nano-emulsion production by sonication and microfluidization - A comparison. *Int. J. Food Prop.* 9, 475–485.

Johnson, L.A., 2000. Corn: the mayor cereal of the Americas. In: Kulp, K., Ponte, J.G. (Eds.), *Handbook of cereal science and technology*. CRC Press, USA, 2000.

Johnston, D.B., McAloon, A.J., Moreau, R.A., Hicks, K.B. and Singh, V., 2005. Composition and economic comparison of germ fractions from modified corn processing technologies. *JAOCS, J. Am. Oil Chem. Soc.* 82, 603–608.

Joseph, C., 2018. Emulsions de Pickering stabilisées par des poudres végétales: propriétés et rôle des paramètres de composition et de formulation. Doctoral thesis. École Doctorale des Sciences Chimiques, Université de Bordeaux.

Joseph, C., Savoie, R., Harscoat-Schiavo, C., Pintori, D., Monteil, J., Faure, C., Leal-Calderon, F., 2020. Pickering emulsions stabilized by various plant materials: Cocoa, rapeseed press cake and lupin hulls. *Lwt* 130, 109621.

Keerati-u-rai, M., Corredig, M., 2009. Heat-induced changes in oil-in-water emulsions stabilized with soy protein isolate. *Food Hydrocoll.* 23, 2141–2148.

Labuckas, D., Maestri, D., Lamarque, A., 2014. Effect of different oil extraction methods on proximate composition and protein characteristics of walnut (*Juglans regia* L.) flour. *LWT - Food Sci. Technol.* 59, 794–799.

Landry, J., Moureaux, T., 1994. Albumins and globulins in maize grains. In: Bajaj, Y.P.S. (Ed.), *Biotechnology in agriculture and forestry 25. Maize*. Springer-Verlag, Germany, pp. 536-554.

Lásztity, R., Tömösközi, S., Nagy, J., Bajkai, T., Sarkadi, L., 1995. Investigation of some functional and nutritive properties of cereal germ proteins. *Period. Polytech. Chem. Eng.* 39, 63–76.

Lin, C.S., Zayas, J., 1987. Protein solubility, emulsifying stability and capacity of two defatted corn germ proteins. *J. Food Sci.* 52, 1615–1619.

Lipnizki, F., 2005. Industrial applications of ultrafiltration in pharmaceutical biotechnology. *Eng. Life Sci.* 5, 81–83.

Malik, M.A., Saini, C.S., 2017. Polyphenol removal from sunflower seed and kernel: Effect on functional and rheological properties of protein isolates. *Food Hydrocoll.* 63, 705–715.

Navarro, S.L.B., Capellini, M.C., Aracava, K.K., Rodrigues, C.E.C., 2016. Corn germ-bran oils extracted with alcoholic solvents: Extraction yield, oil composition and evaluation of protein solubility of defatted meal. *Food Bioprod. Process.* 100, 185–194.

Nielsen, H.C., Inglett, G.E., Wall, J.S., Donaldson, G.L., 1973. Corn germ protein isolate - Preliminary studies on preparation and properties. *Am. Assoc. Cereal Chem.* 50, 435–443.

Parris, N., Moreau, R.A., Johnston, D.B., Singh, V., Dickey, L.C., 2006. Protein distribution in commercial wet- and dry-milled corn germ. *J. Agric. Food Chem.* 54, 4868–4872.

Peng, W., Kong, X., Chen, Y., Zhang, C., Yang, Y., Hua, Y., 2016. Effects of heat treatment on the emulsifying properties of pea proteins. *Food Hydrocoll.* 52, 301–310.

Phillips, R.D., Sternberg, M., 1979. Corn protein concentrate: Functional and nutritional properties, *J. Food Sci.* 44, 1152–1155.

Rebolleda, S., Rubio, N., Beltrán, S., Sanz, M.T., González-Sanjosé, M.L., 2012. Supercritical fluid extraction of corn germ oil: Study of the influence of process parameters on the extraction yield and oil quality. *J. Supercrit. Fluids* 72, 270–277.

Roberts, R.C., Briggs, D.R., 1963. Characteristics of the various soybean globulin components with respect to denaturation by ethanol. *Scientific Journal Series, University of Minnesota* 40, 450–458.

Romagnolo, D., Polan, C.E., Barbeau, W.E., 1994. Electrophoretic analysis of ruminal degradability of corn proteins. *J. Dairy Sci.* 77, 1093–1099.

Rónyai, E., Simándi, B., Tömösközi, S., Deák, A., Vigh, L., Weinbrenner, Zs., 1998. Supercritical fluid extraction of corn germ with carbon dioxide–ethyl alcohol mixture. *J. Supercrit. Fluids.* 14, 75–81.

Rosa, P.T.V., Parajó, J.C., Domínguez, H., Moure, A., Díaz-Reinoso, B., Smith, R.L., Toyomizu, M., Florusse, L.J., Peters, C.J., Goto, M., Lucas, S., Meireles, M.A.A., 2009. Supercritical and pressurized fluid extraction applied to the food industry. In: Meireles, M.A.A. (Ed.), *Extracting Bioactive Compounds for Food Products. Theory and Applications.* CRC Press, USA, pp. 269–401.

Ruan, Z., Wang, X., Liu, Y., Liao, W., (2019). Corn. In: Pan, Z., Zhang, R., Zicari, S. (Eds.), *Integrated processing technologies for food and agricultural by-products.* Academic Press, UK, pp. 59–72.

Sawada, M.M., Venâncio, L.L., Toda, T.A., Rodrigues, C.E.C., 2014. Effects of different alcoholic extraction conditions on soybean oil yield, fatty acid composition and protein solubility of defatted meal. *Food Res. Int.* 62, 662–670.

Shao, Y.Y., Lin, K.H., Kao, Y.J., 2016. Modification of foaming properties of commercial soy protein isolates and concentrates by heat treatments. *J. Food Qual.* 39, 695–706.

Shende, D., Sidhu, G.K., 2015. Effect of process parameters on the oil recovery of maize germ oil. *IJSART* 1, 147-154.

Shevkani, K., Singh, N., Kaur, A., Rana, J.C., 2014. Physicochemical, Pasting, and Functional Properties of Amaranth Seed Flours: Effects of Lipids Removal. *J. Food Sci.* 79, 1271–1277.

Singh, R.K., Avula, R.Y., 2012. Supercritical fluid extraction in food processing. In: Lebovka, N., Vorobiev, E., Chemat, F. (Eds.), *Enhancing extraction processes in the food industry*. CRC Press, USA, pp. 195-222.

Solana, M., Teel, J., Hojilla-Evangelista, M., Bertucco, A., Eller, F., 2016. Counter-current carbon dioxide extraction of fat from soy skim. *J. Supercrit. Fluids* 113, 106–111.

Tabtabaei, S., Diosady, L.L., 2013. Aqueous and enzymatic extraction processes for the production of food-grade proteins and industrial oil from dehulled yellow mustard flour. *Food Res. Int.* 52, 547–556.

Tang, D.S., Yin, G.M., He, Y.Z., Hu, S.Q., Li, B., Li, L., Liang, H.L., Borthakur, D., 2009. Recovery of protein from brewer's spent grain by ultrafiltration. *Biochem. Eng. J.* 48, 1–5.

Tao, X., Cai, Y., Liu, T., Long, Z., Huang, L., Deng, X., Zhao, Q., Zhao, M., 2019. Effects of pretreatments on the structure and functional properties of okara protein. *Food Hydrocoll.* 90, 394–402.

Teh, S.S., Bekhit, A.E.D., Carne, A., Birch, J., 2014. Effect of the defatting process, acid and alkali extraction on the physicochemical and functional properties of hemp, flax and canola seed cake protein isolates. *J. Food Meas. Charact.* 8, 92–104.

Tomita, K., Machmudah, S., Wahyudiono, Fukuzato, R., Kanda, H., Quitain, A.T., Sasaki, M., Goto, M., 2014. Extraction of rice bran oil by supercritical carbon dioxide and solubility consideration. *Sep. Purif. Technol.* 125, 319–325.

Tuan, H.Q., 2011. Characterization of natural edible oils regarding their quality and safety related constituents. Master thesis, Department of food sciences and technology, University of Natural Resources and Life Sciences, Vienna.

Vigh, L., Simandi, B., Deak, A., 1993. Optimization of supercritical fluid extraction of corn germ oil in a multipurpose extractor. In: Applewhite, T.H. (Ed.), *Proceedings of the world conference on oilseed technology and utilization*. AOCS Press, USA, pp. 433-437.

Wang, C.R., Zayas, J.F., 1991. Water retention and solubility of soy proteins and corn germ proteins in a model system, *J. Food Sci.* 56, 455–458.

Wang, T., White, P.J., (2019). Lipids of the Kernel. In: Serna-Saldivar, S.O. (Ed.), *Corn Chemistry and Technology*. AACC International, USA, pp. 337-368.

Wu, Y.V., Inglett, G.E., 1974. Denaturation of plant proteins related to functionality and food applications. A Review, *J. Food Sci.* 39, 218-225.

Yamaguchi, T., Yamada, H., Akasaka, K., 1996. High pressure NMR study of protein unfolding. *High Press. Biosci. Biotechnol.* 9, 141–146.

### *Chapter III: Corn germ*

Zayas, J.F., 1997. *Functionality of proteins in food*. Springer-Verlag Berlin Heidelberg, New York, USA.

Zayas, J.F., Lin, C.S., 1989a. Water retention of two types of hexane-defatted corn germ proteins and soy protein flour. *Cereal Chem.* 66, 51–55.

Zayas, J.F., Lin, C.S., 1989b. Emulsifying properties of corn germ proteins. *Cereal Chem.* 66, 263–267.

Zhu, S.M., Lin, S.L., Ramaswamy, H.S., Yu, Y., Zhang, Q.T., 2017. Enhancement of functional properties of rice bran proteins by high pressure treatment and their correlation with surface hydrophobicity. *Food Bioprocess Technol.* 10, 317–327.

## Chapter IV: Recovery of valuable fractions from walnut press-cake and stabilization of emulsions by walnut particles

### 1. Introduction

Walnut oil is generally extracted by pressing, and the remaining press-cake after oil extraction is still an important source of valuable products such as proteins, remaining oil, carbohydrates, bioactive compounds, etc. Thus, the aim of this chapter is to evaluate the walnut press-cake as a cheap source of valuable fractions, mainly remaining lipids and polyphenol-rich extracts (antioxidant compounds). In addition, the valorization of walnut cake for the stabilization (both physical and oxidative) of oil-in-water emulsions is also proposed and studied in this chapter. The global biorefinery scheme proposed for walnut press-cake is shown in Figure IV-1.

Walnut is the nut of any tree of the genus *Juglans* (Family Juglandaceae) known to be a good source of polyunsaturated fatty acids, particularly of essential linoleic acid, of phytosterols, dietary fiber, phenolics and tocopherols that can be beneficial for health (Fregapane et al., 2020). Thus, authors like Fregapane et al. (2020) have proposed the use of walnut residues to recover phenolic-rich fractions for enriching edible oils, whereas Labuckas et al. (2014) studied the effect of different oil extraction methods on protein characteristics of walnut flour. In addition, Paris et al. (2019) proposed that beside the extraction of antioxidants for nutraceutical and pharmaceutical applications, walnut cake may be also targeted for energy uses.

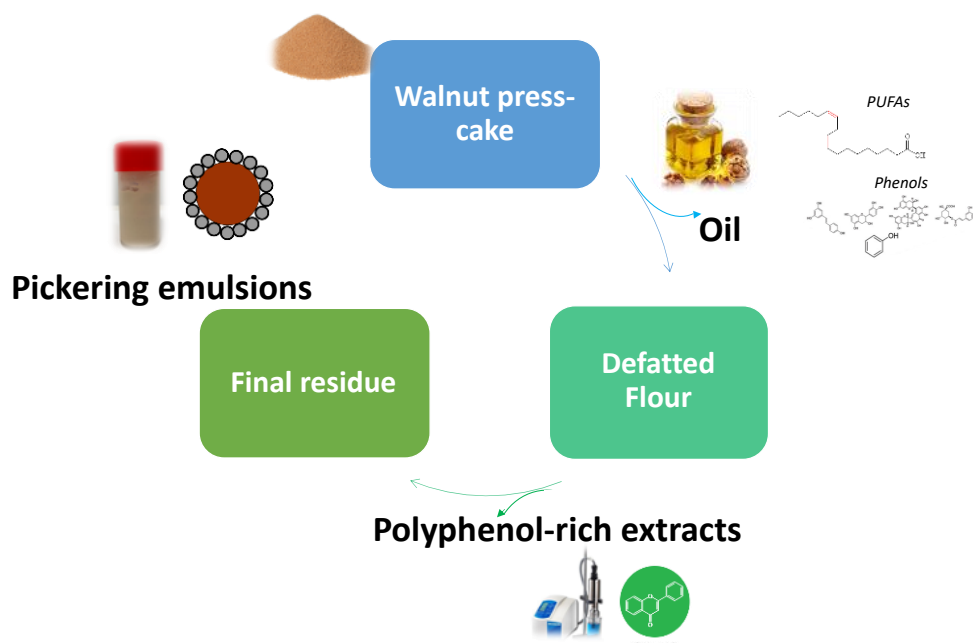
The walnut press-cake is the by-product that remains after oil extraction by cold or hot pressing, nevertheless this press-cake still contains valuable lipids (approximately 35 g of oil per 100 g of press-cake), that may be extracted by convectional solid-liquid extraction methods or by novel techniques such as supercritical fluid extraction. In this context, the first part of this chapter comprises the extraction of remaining oil from walnut press-cake using hexane by Soxhlet extraction as well as by supercritical carbon dioxide (Sc-CO<sub>2</sub>).

In the second part of the chapter, the defatted walnut cake is studied as source of phenolic compounds. For that, Ultrasound Assisted Extraction (UAE) is selected as a green intensification technique for obtaining phenolic-rich extracts. UAE is able to increase the yield



in the solid-liquid extractions and it is based on the formation of ultrasonic waves capable of causing a cavitation phenomenon on molecules due to the appearance of regions of expansion and compression (Pingret et al., 2013). Since many parameters as extraction time, wave amplitude and duty cycle may significantly influence the UAE, response surface methodology is used for evaluating the effect of these parameters, on the extraction yield of phenolic compounds from defatted walnut cake. A mixture of ethanol: water (60:40 v/v) is used as the extraction solvent. This chapter also comprises the quantification of total phenolic compounds (TPC), identification and quantification of the major phenolic compound in walnut extracts by high-performance liquid chromatography (HPLC) and the antioxidant activity based on the scavenging activity of the 2,2-diphenyl-1-picrylhydrazyl (DPPH) free radical, as well.

The last part of this chapter is dedicated to the assessment of the ability of walnut particles to stabilize oil-in-water emulsions (also known as Pickering emulsions). For evaluating the influence of various pre-treatments of walnut cake on the properties of the emulsion and on the protective effect against lipid oxidation, the following walnut cakes are studied: i) cake defatted by Soxhlet hexane, ii) cake defatted by Soxhlet hexane and dephenolized by maceration, and iii) cake defatted by Soxhlet hexane and dephenolized by UAE. Linseed oil is used as the dispersed phase and water containing sodium azide at pH 7 is used as the continuous phase. The emulsions stabilized by these three walnut cakes are fabricated by microfluidization and assessed for physical stability along storage at 4 °C through the monitoring of the droplet size distribution and the creaming phenomenon. Finally, the oxidative stability of dispersed oil is assessed through accelerated oxidation at 60 °C and monitoring of the formation of conjugated dienes over time. This latter assessment aimed at proposing a practical application to take advantage of the antioxidant properties of phenolics from walnut and not only quantify their antioxidant activity by in vitro methods.



**Figure IV-1.** Schematic representation of the biorefinery scheme developed from walnut press-cake

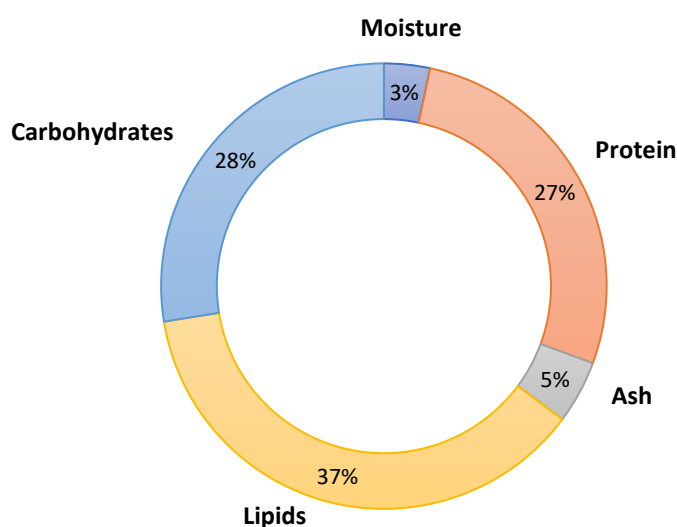
## 2. Material composition

Walnuts (*Juglans regia* L.) are known for their health benefits as a rich source of unsaturated fats, protein, dietary fiber, phytochemicals, and micronutrients (Khir & Pan, 2019). To extract the edible portion (kernel or meat), walnuts must undergo harvesting, hulling, drying, and shelling where considerable quantities of by-products, including leaves, green husks, shells, and broken kernels are produced. In addition, during oil extraction by a screw press or a hydraulic press large amounts of press-cake are also generated, in particular considering that oil production consumes twice as much walnut kernels in mass than it produces oil in volume.

Walnut composition may vary in the following ranges: 3.5-4.5% of water, 14-16% of protein, 63-67% lipids, 1.7-1.9% ash and 12.7-14.1% of carbohydrates (USDA), depending on many factors. In our case, the walnut cake has been provided as a by-product after oil extraction by pressing under mild heating, and its proximate composition is shown in Figure IV-2. Comparing with other works, Bakkalbaşı et al. (2015) reported similar results for walnut cake treated by screw pressing; 6.9% of moisture, 2.6% of ash, 28.3% of protein, 34.3% of oil and 27.9% of carbohydrates (calculated by difference). As can be observed walnut press-cake still contains a high amount of oil (37%) suitable for further use so that it has to be extracted by

means of conventional or novel techniques. Walnut oil is known to exhibit high essential fatty acid content which makes it a good source for commercial production of edible oil and cosmetic applications.

The low water content in the walnut cake (3%) was beneficial since it allowed to maintain more stable the plant material during storage even at room conditions. In addition, a low water content for oil extraction by organic solvents is desired in order to facilitate oil solubilization.



**Figure IV-2.** Mass composition on wet basis of walnut press-cake (from Moulin de la Veyssère)

As can be observed, walnut press-cake is also rich in proteins therefore, it has been employed for formulation of various functional food products such as meat, bakery and dairy products (Labuckas et al., 2014).

### 3. Oil recovery and characterization

As already discussed, oil has been extracted from walnut kernels by cold pressing. However, remaining oil in the press-cake can be later extracted for being used both in food and non-food applications. According to Khir & Pan, (2019), it has been reported that walnut oil is mostly extracted by using the solvent method, a screw press, and supercritical carbon dioxide.

The global extraction yield as well as the fatty acid composition of walnut oils obtained by Soxhlet hexane and Sc-CO<sub>2</sub> are shown in Table IV-1. It is important to clarify that two

walnut cakes from different origin (*Moulin de la Veyssère* and *Huilerie Monsallier*) were evaluated for oil extraction. Therefore, variations in the extraction yield and/or in the fatty acid composition of walnut oils were expected.

**Table IV-1.** Global extraction yield and fatty acid composition of oil obtained from walnut press-cakes

Defatting method	Origin of raw material	Yield (g oil/100 g cake)	Fatty acid composition (%)
Soxhlet hexane	Moulin de la Veyssère	37.2	16:0 (6.5%), 18:0 (2.1%) 18:1(9c) (13.6%), 18:2 (6c) (65%), 18:3 (11.3%)
Sc-CO <sub>2</sub> (500 bar, 60 °C)		36.1	
Soxhlet hexane	Huilerie Monsallier	24.4	16:0 (6.1%), 18:0 (2%) 18:1(9c) (16.8%), 18:2 (6c) (62.6%), 18:3 (11.6%)
Sc-CO <sub>2</sub> (500 bar, 60 °C)		19.9	

The oil extraction from walnuts by solvent method has also been studied by Martinez & Maestri, (2008) at laboratory-scale using hexane, methylene chloride, or chloroform/methanol. The authors stated that this extraction method exhibited a high extraction yield, however its drawback lies in the large quantities of solvent necessary to extract the oil completely. Nevertheless, conventional solvent extraction from walnut press-cake may be suitable since lower amount of solvent is required for extracting the remaining oil from press-cake than from walnut. On the other hand, the Sc-CO<sub>2</sub> (at 500 bar - 60 °C) allowed us to almost exhaust the oil content in both walnut cakes (*Moulin de la Veyssère* and *Huilerie Monsallier*), since a similar extraction yield to that obtained by Soxhlet hexane was achieved by using Sc-CO<sub>2</sub> (Table IV-1). After 160 min of extraction, Sc-CO<sub>2</sub> allowed to recover 97% of the oil of *Moulin de la Veyssère*'s cake and 82% of the oil of *Huilerie Monsallier*'s cake. These results were significantly higher than those obtained from corn germ in which only 69% of the oil was recovered by using Sc-CO<sub>2</sub> (210 bar - 45 °C). This behavior can be mainly attributed to the high level of pressure (500 bar) used for the extraction from walnut cakes that increased the solvating power of the Sc-CO<sub>2</sub>. When the extraction pressure increases the density of Sc-CO<sub>2</sub> increases and therefore, the solubility of oil in the Sc-CO<sub>2</sub> can be enhanced. Moreover, a high flow rate of solvent (100 g CO<sub>2</sub>/min) was also achieved by using the pilot extraction unit (SFE Lab 2L, SFE Process, France) for oil extraction from walnut cakes.

It is worth also noting that Sc-CO<sub>2</sub> exhibits several advantages in comparison with Soxhlet extraction, particularly because it is a Generally Recognized As Safe (GRAS) solvent and avoids steps such as the subsequent concentration or purification of the extract and the desolventization of solid residue.

Regarding the fatty acid composition of walnut oil, both Bakkalbaşı et al. (2015) and Martínez et al. (2013) also reported linoleic acid (18:2) as the major fatty acid (56.27% and 52.42%, respectively), followed by oleic acid (18:1) (22.54% and 22.92%, respectively) and linolenic acid (18:3) (12.70% and 15.24%, respectively). Although in this work has been also found the aforementioned fatty acids as the major constituents, their proportions were a little different with 62-65% linoleic acid, 13-16% oleic acid and 11% linolenic acid. It has been reported that fatty acid composition of vegetal oils may vary due to genetic variations of plants (Rathore et al., 2016), crop areas (Lajara et al., 1990), growing temperature (Canvin, 1965), extraction method, among others. In general, according to Khir & Pan, (2019) walnut oil has a perfect 4:1 ratio of omega-6: omega-3 fatty acids, which was reported to decrease the incidence of cardiovascular risk. This ratio was higher than 4:1 in the oil recovered in this work.

Regarding the minor compounds, the walnut oil extracted from Huilerie Monsallier's cake by Soxhlet hexane and Sc-CO<sub>2</sub>, exhibited a TPC of  $30 \pm 2$  mg GAE/kg and  $24 \pm 1$  mg GAE/kg respectively, which is higher than those reported for other oils such as from coconut (18 mg GAE/kg), rice bran (8.9 mg GAE/kg), mustard (5.6 mg GAE/kg) and sesame (3.3 mg GAE/kg) (Janu et al., 2014). Our results are similar to the TPC of walnut oil reported by Ojeda-Amador et al., (2018) (13-26 mg/kg oil), and higher than that found by Bakkalbaşı, (2018) (9.76 mg GAE/kg oil). Nevertheless, phenolic concentration in vegetable oils may be also influenced by genotype, growing conditions (Tovar et al., 2002) and extraction method (Bakkalbaşı, 2018). Comparing the two methods of oil extraction used in this work, i.e. Soxhlet hexane and Sc-CO<sub>2</sub>, both solvents exhibited similar solvating power for extracting polyphenols. Both hexane and Sc-CO<sub>2</sub> are apolar solvents with a lower affinity for phenolic compounds than would have more polar solvents such as water, methanol, ethanol and hydroalcoholic mixtures. In this context, the aforementioned polar substances have been widely used as cosolvent in supercritical fluid extractions in order to enhance the phenolic concentration in oily fractions (Páramos et al., 2020; Espinosa-Pardo et al., 2017; Santos et al., 2017).

In addition to the phenolic compounds, walnut oil may be also a source of other minor compounds (antioxidants) such as tocopherols (300 to 400 mg/kg oil) (Khir & Pan, 2019; Gharibzahedi et al., 2013; Martinez & Maestri, 2008) which enhance its nutritional value and oxidative stability. It has been also reported that walnut oil exhibits a low concentration in free fatty acid, peroxides, and phosphatides, therefore it may be consumed directly, without refining (Khir & Pan, 2019) Nonetheless, tocopherol, free fatty acids and peroxides were not studied in this work.

#### **4. Ultrasound assisted extraction of polyphenols from defatted cake**

After oil extraction from walnut press-cake (*Moulin de la Veyssère*) by conventional Soxhlet hexane methods, the defatted cake was submitted to phenolic extraction by Ultrasound Assisted Extraction (UAE). The main features and advantages of this green technique were already discussed in *Chapter I*, section 3.2.1. Firstly, a GRAS solvent was selected for phenolic extraction from defatted walnut cake. For that, the extraction efficiency of the following hydroalcoholic solutions were assessed by means of maceration method: ethanol 20% (v/v), ethanol 60% (v/v), ethanol 80% (v/v) and absolute ethanol. After two successive extractions of 45 min each, at room temperature and using a mass-to-solvent ratio of 1/13, the hydroalcoholic solutions at 20%, 60%, and 80% and absolute ethanol were able to extract 9.87, 17.35, 10.65 and 0.9 mg GAE/g of cake, respectively. Thus, ethanol 60% (v/v) exhibited the highest capacity for extracting phenolic compounds from defatted walnut cake. The mixture of water and ethanol at that ratio provided an optimal polarity to the solvent for dissolving polyphenols easily. Bakkalbaşı, (2018) reported that phenolic compounds from defatted walnut flour are mainly polar and therefore, greater extracted by solvent with high polarity and Labuckas et al. (2008) reported a TPC of walnut flour, using ethanol 70%, in a range of 15 to 26 mg GAE/g depending on the walnut variety. Other authors have also reported that the ethanol concentration in a range from 55% to 70% (v/v) is the optimal ratio for extracting polar polyphenols from plant residues such as hazelnut skin (Odabaş & Koca, 2016) and potato pomace (Riciputi et al., 2018).

After having defined the best solvent (ethanol 60% (v/v)) for phenolic recovery, ultrasound assisted extraction from defatted walnut cake was carried out. The central composite design studied the influence of power (166.4-233.6 W), time (6.6- 23.4 min) and duty cycle (13.2-46.8 %) on total phenolic extraction, ellagic acid extraction and free radical scavenging

activity (DPPH) from defatted walnut cake, and the results are presented in Table IV-2. It is worth mentioning that phenolic content, ellagic acid and antioxidant activity were initially estimated in terms of volume of extract, i.e. mg GAE/ml extract, mg ellagic acid/mL extract, and  $\mu\text{mol Trolox Equiv./mL extract}$ , but those results were then normalized by the total extract volume and the mass of cake used for the extraction in order to express the response variables in terms of grams of cake. This facilitate the comparison with literature and provided us the range of extraction yield of phenolics and ellagic acid obtained by UAE.

**Table IV-2.** TPC, ellagic acid extraction and antioxidant activity (DPPH) of defatted walnut cake treated by several conditions of power, time and duty cycle of ultrasound

Run	Independent factors (X)			Response variables (Y)		
	Power (W) (X <sub>1</sub> )	Time (min) (X <sub>2</sub> )	Duty cycle (%) (X <sub>3</sub> )	TPC (mg GAE/g cake)	Ellagic Acid (mg/g cake)	DPPH ( $\mu\text{mol Trolox Equiv./g cake}$ )
1	180 (-1)	10 (-1)	20 (-1)	10.4	1.0	83.0
2	220 (+1)	10 (-1)	20 (-1)	11.5	1.3	87.5
3	180 (-1)	20 (+1)	20 (-1)	11.4	1.4	91.0
4	220 (+1)	20 (+1)	20 (-1)	12.1	1.4	94.8
5	180 (-1)	10 (-1)	40 (+1)	12.3	1.4	103.1
6	220 (+1)	10 (-1)	40 (+1)	13.4	1.8	104.7
7	180 (-1)	20 (+1)	40 (+1)	12.6	1.8	103.3
8	220 (+1)	20 (+1)	40 (+1)	13.1	2.1	102.8
9	166.4 (- $\alpha$ )	15 (0)	30 (0)	12.4	1.5	102.2
10	233.6 (+ $\alpha$ )	15 (0)	30 (0)	13.2	1.8	104.9
11	200 (0)	6.6 (- $\alpha$ )	30 (0)	11.7	1.4	93.5
12	200 (0)	23.4 (+ $\alpha$ )	30 (0)	13.3	1.9	106.9
13	200 (0)	15 (0)	13.2 (- $\alpha$ )	12.0	1.4	104.2
14	200 (0)	15 (0)	46.8 (+ $\alpha$ )	12.9	1.7	107.1
15	200 (0)	15 (0)	30 (0)	12.0	1.8	97.7
16	200 (0)	15 (0)	30 (0)	12.7	1.8	99.3
17	200 (0)	15 (0)	30 (0)	12.2	1.5	103.2
18	200 (0)	15 (0)	30 (0)	12.4	1.6	103.6
19	200 (0)	15 (0)	30 (0)	12.2	1.5	105.5
20	200 (0)	15 (0)	30 (0)	12.9	1.7	104.7

Runs 15 to 20 comprised the six replicates at the central point (X<sub>i</sub>=0)

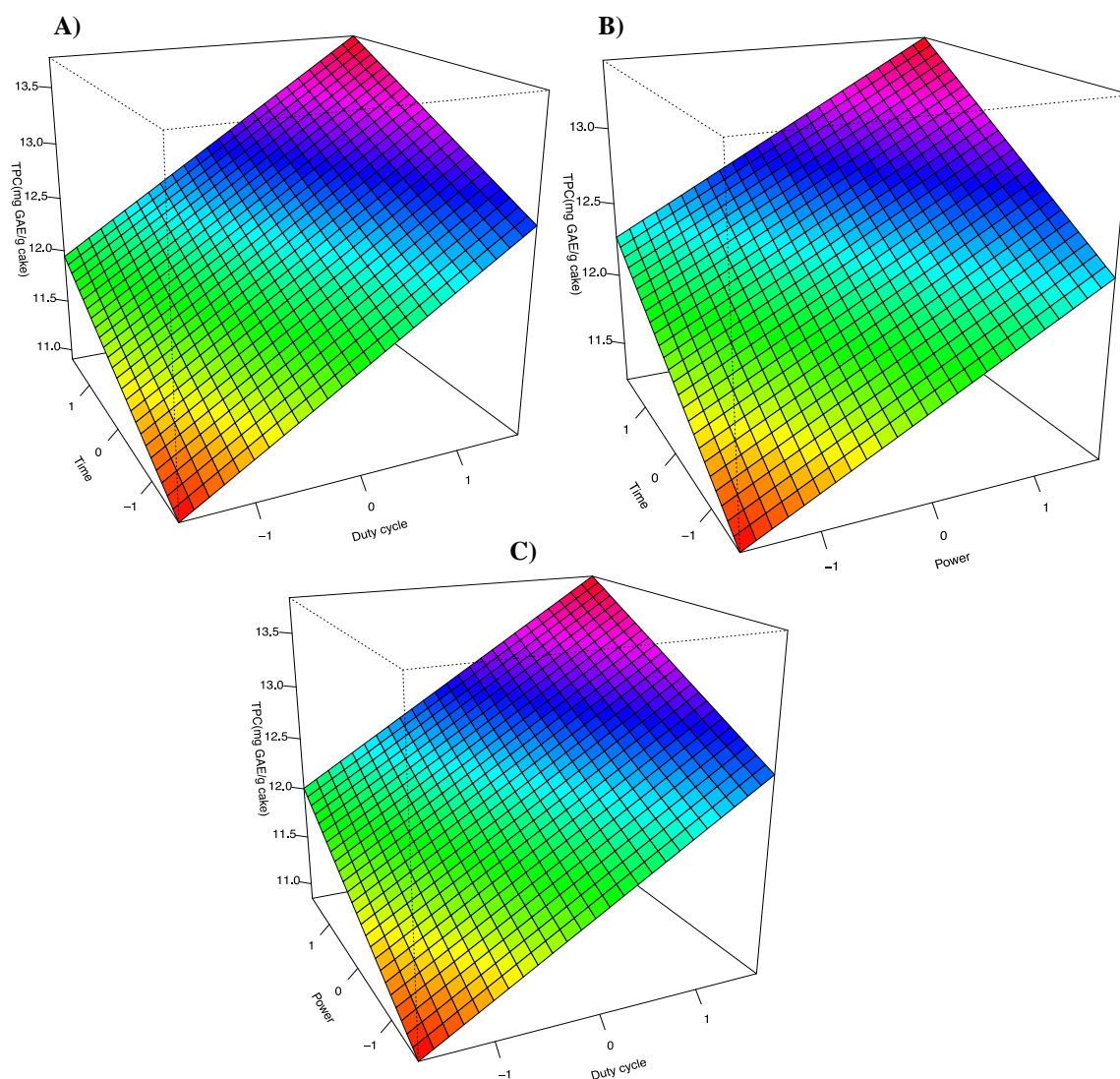
In the next sections, the TPC, ellagic acid extraction and antioxidant activity of extracts obtained by UAE from walnut defatted cake, have been discussed separately.

#### **4.1. Total Phenolic Content (TPC)**

As can be observed in Table IV-2, the TPC varied few between 10.4-13.4 mg GAE/g cake) among the different conditions of time, power and duty cycle of ultrasound. Maceration extraction, i.e. without ultrasound, carried out at the same mass-to-solvent ratio (1/13 wt/v), room temperature and, during 20 min, allowed to extract  $9.7 \pm 0.4$  mg GAE/g cake. Although ultrasound extraction increased the extraction yield of phenolic compounds in comparison with maceration method (increase up to 38%), it also requires of more energy and therefore it is a more expensive process. Greater extraction yield of UAE was expected since the cavitation of bubbles produced by ultrasonic waves led to the cell disruption near the solid surface, breaking the cell walls and therefore facilitating the phenolic extraction. Furthermore, ultrasonic waves probably also released phenolics bound to proteins of walnut cake; according to Labuckas et al. (2016) tannins of walnut can be strongly bound to proteins through ionic interactions and hydrogen bonds. Muñoz-Labrador et al. (2019) have reported the ability of high intensity ultrasound to break molecular complexes of tannins with proteins in other raw materials such as grape seed.

On the other hand, the backward-forward method was used for determining the best model fitting the experimental data using AIC criterion and the response surfaces for TPC are shown in Figure IV-3.





**Figure IV-3.** Response surface plots of the predicted model of time – duty cycle (A), time – power (B) and power - duty cycle (C) for total phenolic extraction from defatted walnut cake by UAE. The third independent factor was set at 0 (coded value) to plot the response surfaces

The predicted model (in coded values) for the phenolic extraction was  $TPC \text{ (mg GAE/g cake)} = 12.33 + 0.35 \text{ power} + 0.31 \text{ time} + 0.54 \text{ duty cycle}$ , and it explained 63% of the variability of phenolic extraction by UAE. It can be stated that the low variation of TPC among the different conditions of UAE influenced significantly the adjusted  $R^2$  of the fitted model. Higher values of power and duty cycle than those studied, may favor a greater variation of TPC. Nonetheless, we were restricted by the capacity of the ultrasonic device.

On the other hand, ANOVA results (Appendix, Table IV-A1) showed that the three factors (power, time and duty cycle) significantly influenced the TPC, nonetheless quadratic

coefficients and those related to the interactions among the different factors were not significant. The model also showed that the influence of power, time and duty cycle was positive which means that the higher the power, time and duty cycle the higher the TPC. In this sense, the maximum TPC would be yielded by UAE carried out at 233.6 Watts and 46.8% of duty cycle for 23.4 min.

Other authors such as Luo et al. (2017) yielded TPC between 19 and 35 mg GAE per gram of walnut flour when simultaneous microwave (75-525 W) and ultrasonic (20-140 W) assisted extraction using methanol 60% was carried out. The combination of both mechanical vibrations (ultrasound waves) and electromagnetic waves could yield higher TPC than this work. Another factors such as the mass-to-solvent ratio (not reported by the authors) and walnut variety may also influence significantly the extraction yield of phenolic compounds.

Due to the low variation of TPC observed among the various levels of power, time and duty cycle of the UAE, it was also studied the influence of the mass-to-solvent ratio aiming at observing greater differences on phenolic extraction. In Table IV-3 is shown the phenolic extraction yield of UAE carried out at the level +1 of power, time and duty cycle and varying the mass-to-solvent ratio. The various mass-to-solvent ratios were assessed by varying the mass of cake whereas the volume of solvent was kept constant (64 mL). As can be observed the extraction of polyphenols was significantly influenced by the ratio between walnut cake and ethanol 60%. As expected, the higher the mass-to-solvent ratio, the higher the recovery of polyphenols from defatted walnut cake, since a higher gradient of concentration is achieved at higher mass-to-solvent ratios. The mass transfer of target compounds from the solid matrix to the solvent is greater away from equilibrium concentrations (saturation).

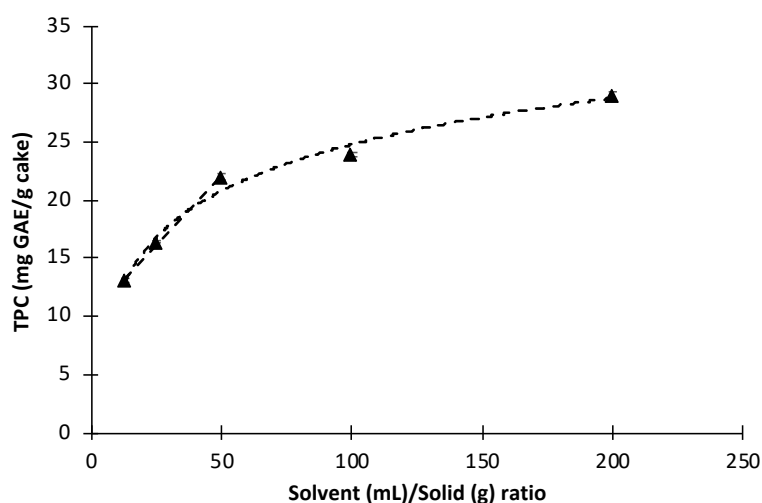
By increasing 3.8-fold the mass-to-solvent ratio, i.e. use ratio 1/50 instead of 1/13, allowed to increase the TPC 1.7-fold. It is worth noting that greater phenolic extraction by increasing the mass-to-solvent ratio also leads to use a larger amount of solvent and consequently to obtain more diluted extracts. Hence, the most appropriate mass-to-solvent ratio will also depend on evaluating the economic and environmental impact of such ratio, as well as on the potential application of these polyphenol extracts. From Figure IV-4, it can be observed that increasing the mass-to-solvent ratio from 1/13 to 1/25 and to 1/50 enhanced the TPC in a greater proportion than at ratios of 1/100 and 1/200 where the gain of TPC began to

reach a plateau. Therefore, mass-to-solvent ratios of 1/25 or 1/50 could be considered more suitable for future works than ratios of 1/100 and 1/200.

**Table IV-3.** TPC obtained by UAE at various mass-to-solvent ratios

Power (W)	Time (min)	Duty cycle (%)	Ratio (wt/v)	TPC <sup>a</sup> (mg GAE/g cake)	Increase*
220	20	40	1/13	13.1 ± 0.1	-
220	20	40	1/25	16.4 ± 0.1	25.2%
220	20	40	1/50	22.0 ± 0.3	67.6%
220	20	40	1/100	23.9 ± 0.2	82.0%
220	20	40	1/200	29.0 ± 0.3	121.4%

<sup>a</sup> Mean values and standard deviations calculated by duplicating the TPC analysis but not the extraction procedure. \* Percentage of increase referred to UAE at power: 220 W, time: 20 min, duty cycle: 40% and mass-to-solvent ratio: 1/13.

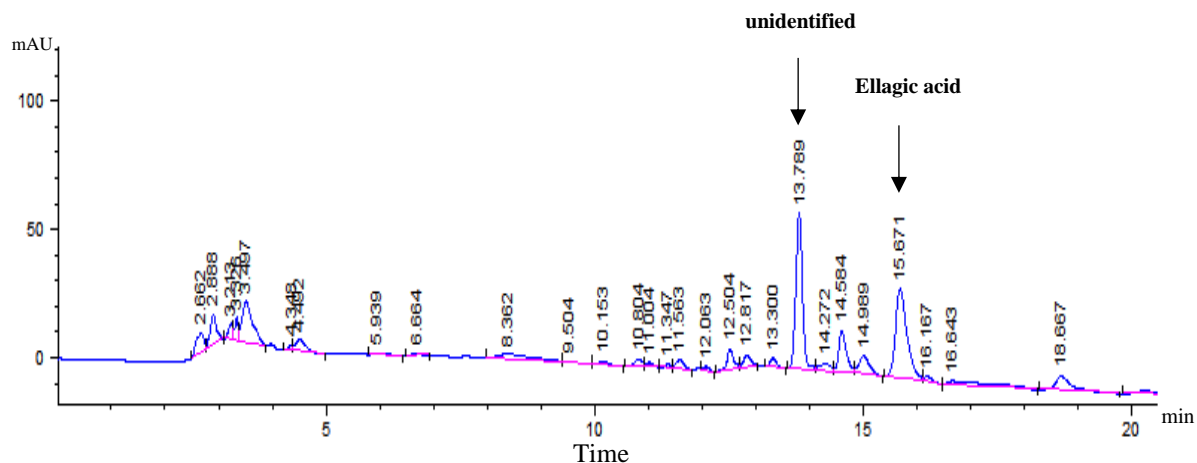


**Figure IV-4.** Influence of the solvent-to-mass ratio in UAE experiments (power: 220 W, time: 20 min, duty cycle: 40%). Experimental points connected for better visualization.

## 4.2. Extraction of ellagic acid

Ellagic acid was quantified in the extracts since it was identified as the main phenolic among the detected compounds along with an unidentified compound eluted at ~13.8 min (Figure IV-5). Similarly, Zhang et al. (2020), Bakkalbaşı et al. (2013, 2018) and Fukuda et al. (2003) reported that ellagitannins (ellagic acid and ellagic acid pentoside) are THE major phenolic compounds among walnut phenolics. Therefore, the unidentified peak in Figure IV-5 may be EA-pentoside or glansrins A, also reported as a major phenolic of walnut (Bakkalbaşı

et al., 2018; Fukuda et al., 2003). Ellagitannins exhibit a high antiradical activity due to the several hydroxyl groups in ortho position that have a higher ability to donate a hydrogen atom and to support the unpaired electron (Bakkalbaşı et al., 2018).



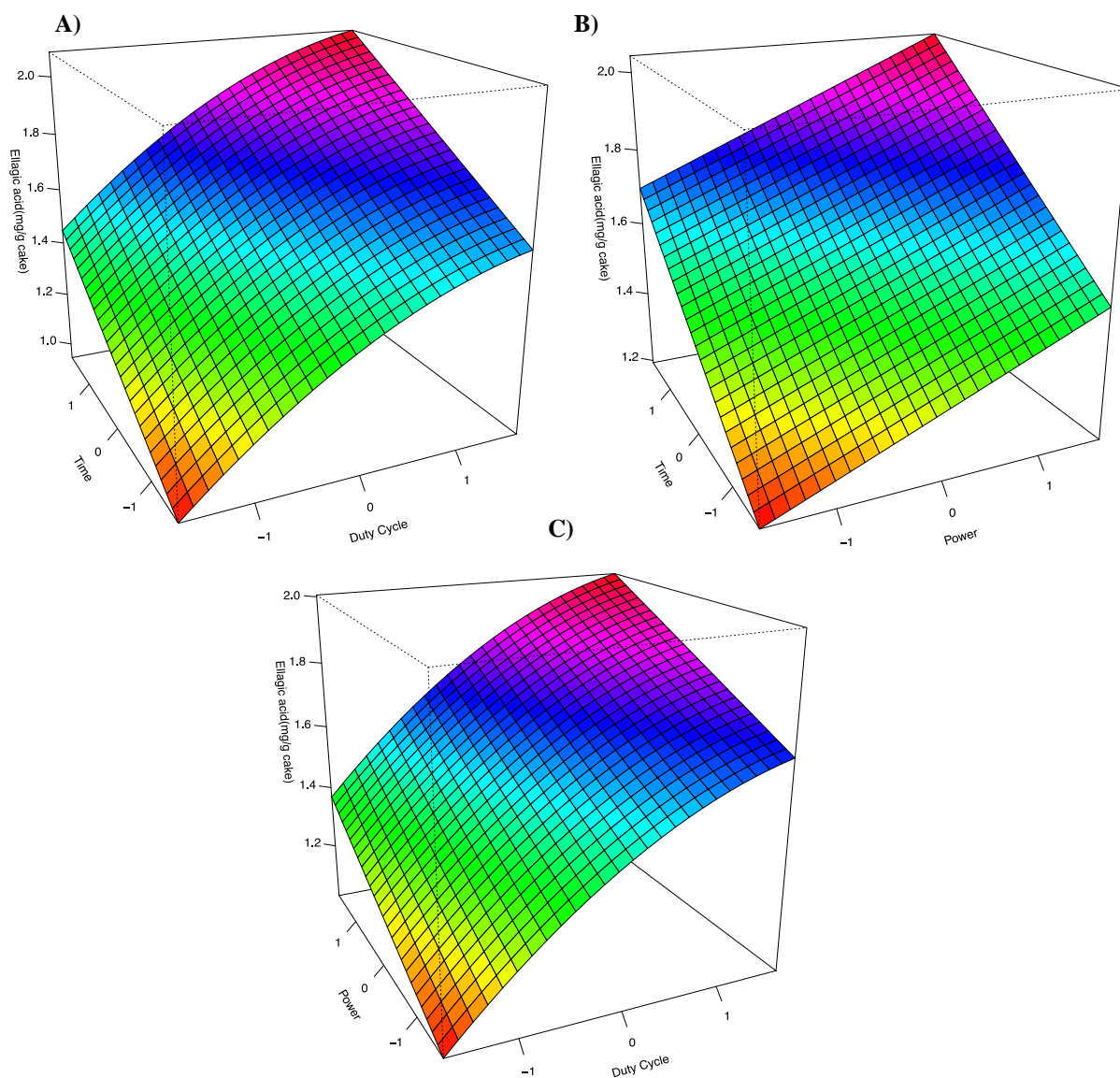
**Figure IV-5.** High performance liquid chromatogram of a polyphenol-rich extract obtained from defatted walnut cake by UAE

Though various experiments of central composite design led to only ~25% of variation in TPC, differences were more pronounced in the extraction of ellagic acid. The extraction of ellagic acid by UAE from defatted walnut cake varied from 1.0 to 2.1 mg/g cake (Table IV-2). Regarding the model for predicting the extraction yield of ellagic acid, it showed that the three factors (power, time and duty cycle) significantly influenced the extraction of ellagic acid. Moreover, the quadratic effect of duty cycle was also significant for extracting this phenolic compound. The model (in coded values) was defined as; Ellagic acid (mg/g cake) = 1.62 + 0.10 power + 0.15 time + 0.19 duty cycle.

This model explained about 80% of the variability of ellagic acid extraction by ultrasound technique (ANOVA results in Appendix, Table IV-A2). This model also confirmed that the influence of power, time and duty cycle was positive which means that the higher the power, time and duty cycle the higher the extraction of ellagic acid. The influence of the independent factors of UAE on ellagic acid extraction was quite similar to that on TPC. It was confirmed by the high coefficient of Pearson found between TPC and ellagic acid (0.89,  $p < 0.05$ ).

In Figure IV-6 is presented the response surfaces for ellagic acid extraction which were similar to those of TPC. Among the evaluated conditions, the maximum power (220 W), time

(20 min) and duty cycle (40%) provided the highest ellagic acid extraction yield (2.1 mg/g) and also among the highest TPC (13.1 mg GAE/g). It can be also observed that ellagic acid, as the major phenolic compound of walnut extracts, represented approximately 16% of the total phenolic content. This is consistent with the 15.8% of ellagic acid among TPC previously reported by Bakkalbaşı et al. (2018) and Fukuda et al. (2004).



**Figure IV-6.** Response surface plots of the predicted model of time – duty cycle (A), time – power (B) and power - duty cycle (C) for ellagic acid extraction from defatted walnut cake by UAE. The third independent factor was set at 0 (coded value) to plot the response surfaces

### 4.3. Free radical scavenging activity (DPPH)

When the antioxidant activity of walnut extracts obtained by UAE were attempted to predict by a polynomial model, it only explained the 36% of the variability of the experimental results and significant at  $p < 0.05$ . In this sense, none of the response surfaces was plotted for the different factors involved in UAE. Although the model had a poor adjusted  $R^2$ , only time and duty cycle appeared as significant factors. Similarly, Odabaş & Koca, (2016) also reported a poor adjusted  $R^2$  (0.53) of the model generated for predicting the DPPH radical scavenging activity ( $1/EC_{50}$ ) of hazelnut skin extracts obtained by UAE.

On the other hand, it is worth mentioning that a strong positive correlation between TPC and DPPH was observed (0.95 Pearson's correlation coefficient,  $p < 0.05$ ). The high and positive correlation between the total phenolic content and the antioxidant activity (DPPH) of several plant extracts has been previously reported by other authors (Piluzza & Bullitta, 2011; Thaipong et al., 2006; Gil et al., 2002). However, it is also reported that the DPPH radical scavenging activity of plant extracts may not necessarily be correlated with TPC but with a specific phenol or antioxidant molecule in the extract (Espinosa-Pardo et al., 2017). For instance, in citrus extracts it has been suggested that the antioxidant activity is more related to the content of ascorbic acid than the total phenolic content (Barros et al., 2012; Rapisarda et al., 2008). In this work, a positive and high correlation between specifically ellagic acid content and the antioxidant activity (DPPH) of the extracts was also found (Pearson's correlation coefficient of 0.90,  $p < 0.05$ ). It means that ellagic acid played a key role on the scavenging activity of walnut extracts obtained by UAE. This behavior was expected since, as already discussed, ellagic acid represented one of the major phenol among the phenolic composition of walnut extracts. In general, a high Pearson's correlation coefficient also may allow us to estimate indirectly the antioxidant activity (evaluated by DPPH assay) of walnut extracts by only measuring their TPC or ellagic acid content. According to Augusto et al. (2014), phenolic compounds are considered the most representative molecules among the bioactive substances with antioxidant activity. On the other hand, the Folin-Ciocalteu method used for phenol quantification is based on an oxidative reaction of phenols (or even other oxidizable substances) by the Folin reagent, therefore this method is also a measurement of the reducing capacity of the extracts (de Oliveira et al., 2012), which is affine to the principle of the scavenging activity of the 2,2-diphenyl-1-picrylhydrazyl (DPPH) free radical.

As can be observed in Table IV-2 the capacity of walnut extract for scavenging DPPH free radicals varied from 83 to 107  $\mu\text{mol Trolox Equiv./g}$  cake. The lowest antioxidant activity was exhibited by extracts obtained at level -1 of ultrasonic power, time and duty cycle (180 W, 10 min and 20%, respectively) (run 1), whereas the highest antiradical ability was achieved at 200 W of power (level 0), 15 min of extraction time (level 0) and maximum duty cycle of 46.8% (level + $\alpha$ ) (run 14). Nonetheless, a similar value (104  $\mu\text{mol Trolox Equiv./g}$  cake) to the maximum antiradical activity (107  $\mu\text{mol Trolox Equiv./g}$  cake) was observed for same conditions of power and time but setting the lowest duty cycle level (13.2%, level - $\alpha$ ). Moreover, the antioxidant activity was also independent of extraction power, since similar values of DPPH (104.9  $\mu\text{mol Trolox Equiv./g}$  cake Vs 102.2  $\mu\text{mol Trolox Equiv./g}$  cake) were obtained at maximum (233.6 W) or at minimum (166.4 W) ultrasonic power, keeping constant a duty cycle of 30% and an extraction time of 15 min (runs 9 and 10). In this sense, the free radical scavenging activity of walnut cake extracts cannot be predicted by the modification of the different factors of UAE. This statement was also discussed above when a poor coefficient of determination was obtained for the fitted model of DPPH.

Nevertheless, the range of antioxidant activity (DPPH) exhibited by the walnut extracts obtained in this work, were similar to those reported by Fregapane, et al. (2020) for walnut press-cake (149  $\mu\text{mol Trolox /g}$ ) and walnut kernel (106  $\mu\text{mol Trolox/g}$ ).

## 5. Pickering emulsions

As the last step of the biorefinery chain proposed for walnut press-cake (as an agro residue), the stabilization of oil-in-water emulsions has been proposed. After oil and phenolic extraction, walnut cake is more concentrated in proteins and polysaccharides useful for stabilizing Pickering emulsions. Though the stabilization could also be performed directly with raw press-cake, this work focused on studying the performance of walnut cake defatted by Soxhlet hexane (called emulsion DW) or defatted and then dephenolized, either by maceration (called emulsion DMW) or UAE (called emulsion DUW).

In Table V-4 was detailed the pretreatments that were addressed to walnut cake prior emulsion stabilization in order to study the influence of phenolic content and sonication of walnut particles on physical and oxidative stability of Pickering emulsion. O/W (1:4) emulsions were then stabilized by the different walnut particles of Table V-4, and both physical

features (oil droplet size and creaming) as well as oxidative stability properties (antioxidant effect) were monitored for the various types of Pickering emulsions.

**Table IV-4.** Walnut cake pretreatments prior to emulsion stabilization

<b>ID emulsion</b>	<b>Pretreatment</b>	<b>Conditions</b>
DW	Only defatted	- The cake was ground, sieved (< 600 $\mu\text{m}$ ) and then defatted by Soxhlet extraction (4 h) using hexane as solvent.
DMW	Defatted and dephenolized by maceration	- The cake was ground, sieved (< 600 $\mu\text{m}$ ) and then defatted by Soxhlet extraction (4 h) using hexane as solvent. - Dephenolization was carried out using ethanol 60% as solvent. The maceration consisted of two sequential extraction cycles of 20 min <sup>a</sup> each one, using a solid-to-solvent ratio of 1/20 (per cycle), at room temperature. Maceration removed $18.1 \pm 0.4$ mg GAE/g cake
DUW	Defatted and dephenolized by UAE <sup>b</sup>	- The cake was ground, sieved (< 600 $\mu\text{m}$ ) and then defatted by Soxhlet extraction (4 h) using hexane as solvent. - Dephenolization was carried out using ethanol 60% as solvent. The UAE consisted of two sequential extraction cycles of 20 min <sup>a</sup> each one; 14 min of contact between solvent and cake (without sonication) plus 6 min of sonication (550 W, 100% duty cycle) at room temperature. A solid-to-solvent ratio of 1/13 (per cycle) was used. UAE removed $18.3 \pm 0.7$ mg GAE/g cake

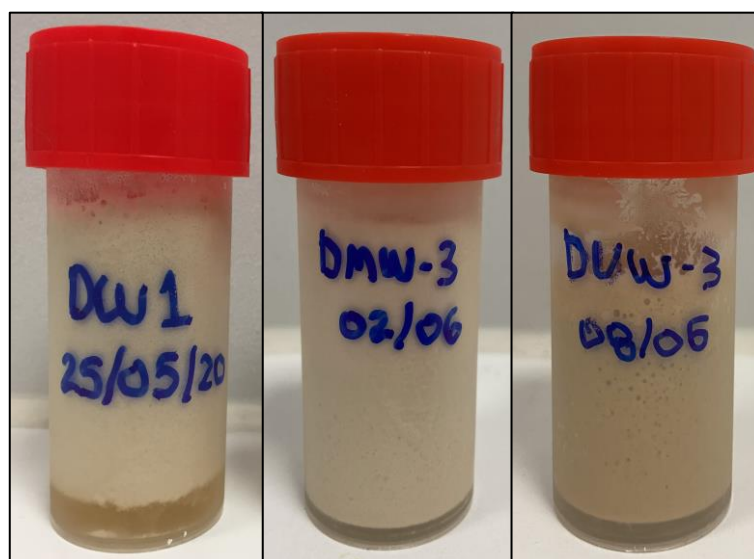
<sup>a</sup> The same extraction period of 20 min was fixed for both maceration and UAE in order to avoid discrepancies related to the total time in which ethanol 60% remained in contact with walnut particles.

<sup>b</sup> UAE was performed using a Sonifier digital 550, Branson, USA. The solid-to-solvent ratio, and the time of sonication were chosen for providing the same amount of phenol removal than in maceration extraction.



### 5.1. Physical stability

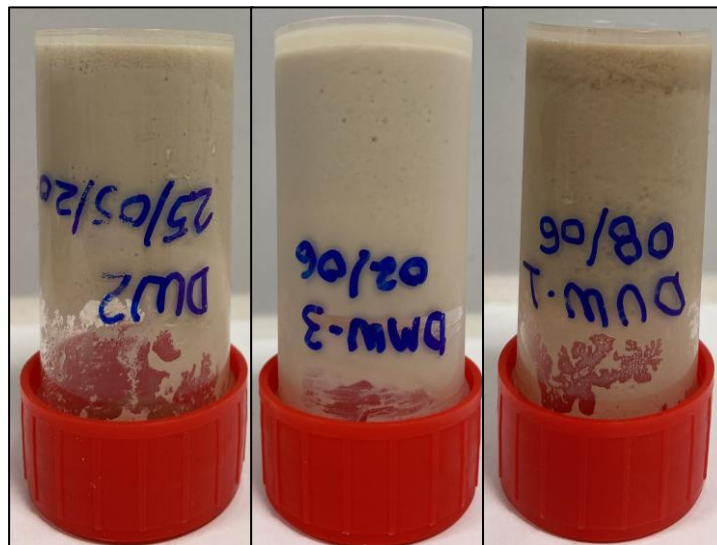
Let us first discuss the macroscopic aspect of the different emulsions presented in Figure IV-7. As it can be observed, the three emulsions fabricated with walnut cake (DW, DMW and DUW) presented a good appearance with a light brown aspect. Regarding the creaming, it was observed a much lower separation of the dispersed phase, due to the gravitational forces, than those emulsion prepared at the same concentration of corn germ particles (*Chapter III*, section 5). As previously discussed in *Chapter III*, creaming of emulsions is globally undesirable. In general, only a thin layer of water on the bottom of the container was observed in DW, DMW and DUW. Furthermore, it was no observed any precipitation of walnut particles during storage, which may mean that; i) all walnut particles participated in the stabilization of oil droplets and therefore are located at the droplet interface, ii) not all particles were absorbed at the droplet interface, however the free particles are participating in the formation of a tridimensional network with already stabilized oil droplets (Gould et al., 2013). Hence, the free particles remains in the cream phase and do not precipitate.



**Figure IV-7.** Macroscopic aspect of 4:1 water:oil emulsions stabilized by walnut particles: only defatted (DW), defatted and then dephenolized by maceration (DMW) or defatted and then dephenolized by ultrasound (DUW)

Moreover, the macroscopic observations noted that emulsions stabilized by walnut particles were highly consistent/thick, and therefore exhibited a poor flow behavior as shown in Figure IV-8. Several factors could influence this behavior; i) generally a fine oil droplet size delays the creaming, ii) a high steady viscosity of the emulsion (Chen et al., 2019) due to the

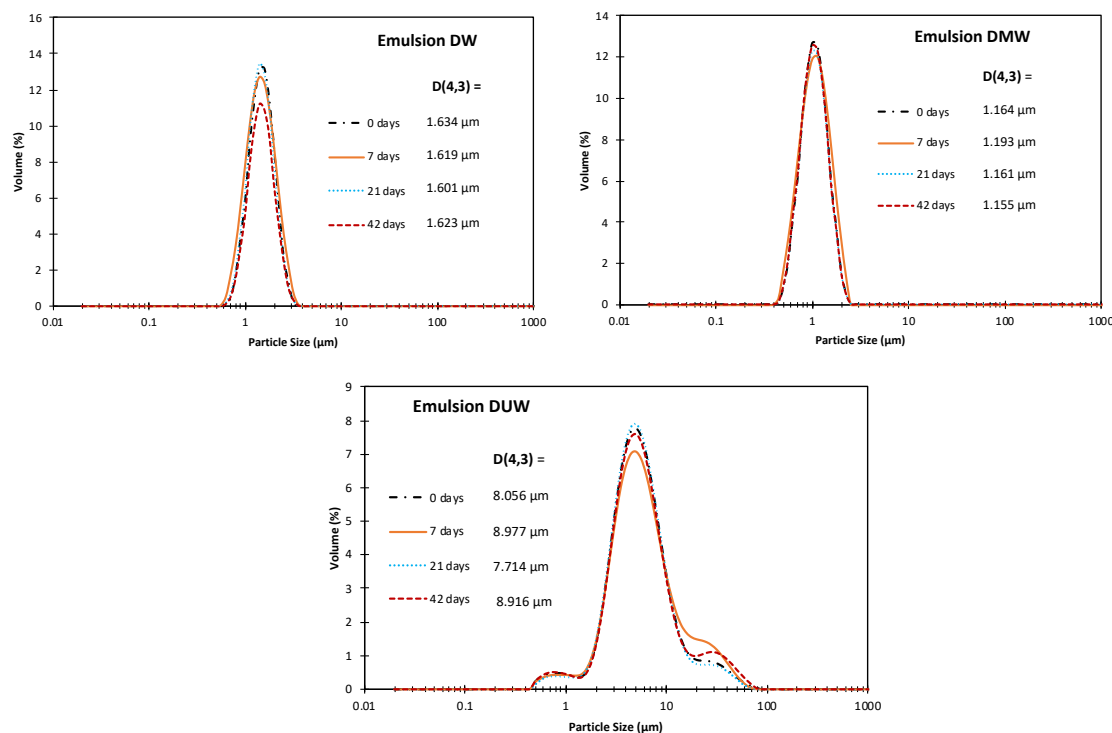
walnut composition and the method of emulsification (microfluidization). In this sense, it can be also argued that some fractions of the walnut powder, mainly proteins and polysaccharides, could favor the formation of a gel-like network in the system thanks to the rise of temperature during microfluidization and then cooling to room temperature. A higher soluble fraction of walnut particles than corn germ, for instance, may also increase the viscosity of the dispersion. It is also worth mentioning that the emulsions fabricated with different walnut cakes presented a pleasant aroma characteristic of nuts.



**Figure IV-8.** Visual observation of the gel-like network in DW, DMW and DUW emulsions

Regarding the monitoring of the volume-averaged diameter ( $D[4,3]$ ) of oil droplets, when the emulsions were stored at 4 °C for several weeks, the results are summarized in Figure IV-9). As can be observed in Figure IV-9, the diameter of oil droplets of emulsion stabilized by only defatted walnut particles (DW) or by defatted then dephenolized by maceration (DMW) exhibited similar size, between 1.1 and 1.6  $\mu\text{m}$ . Both emulsions exhibited actually fine oil droplets which is highly desirable especially for food, cosmetic or pharmaceutical applications. Finer droplets provide emulsions with a greater stability and therefore coalescence is limited (Chen et al., 2019; Usaid et al., 2014). Coalescence of oil droplets in food emulsions during storage is undesirable due to its impact on the organoleptic properties. It is important to highlight that the oil droplet size is also highly influenced by the emulsification technique, i.e. shearing, sonication or high pressure homogenization. Several authors have already reported finer droplets in emulsion fabricated by high pressure

homogenization in comparison with shearing (Ultra-Turrax) and sonication techniques (Chen et al., 2019; Joseph, 2018; Jafari et al., 2006). Thus, the use of microfluidization (at a pressure of 1 000 bar) as emulsification technique in this work, also favored the low size of oil droplets.



**Figure IV-9.** Droplet size distributions of O/W (1:4) emulsions stabilized by defatted walnut particles (DW), or defatted and then dephenolized by either maceration (DMW) or UAE (DUW), at a concentration of 2.5%

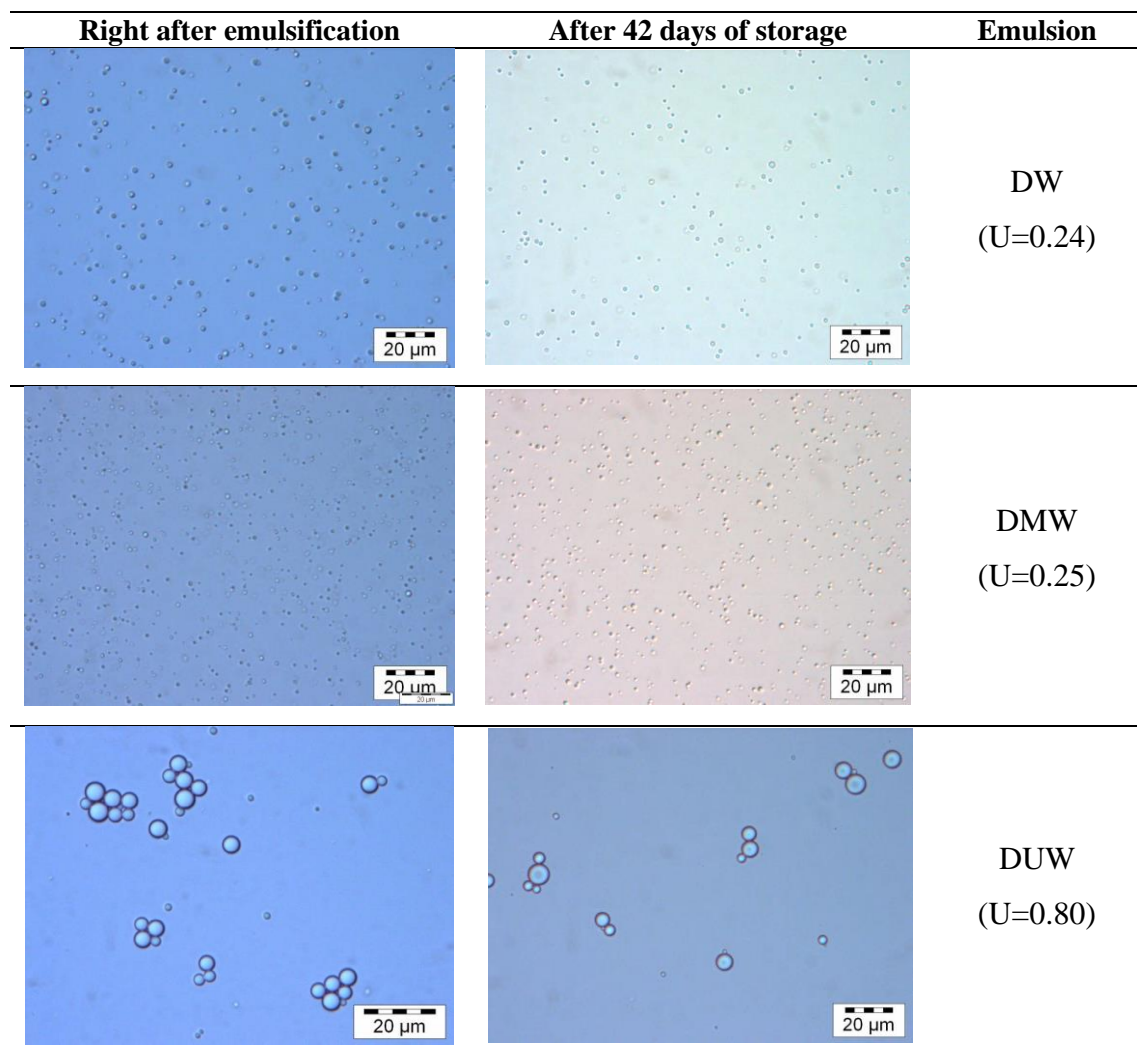
Both the only defatted walnut cake and the defatted and dephenolized by maceration cake also exhibited a better performance in comparison with the different corn germ particles assessed previously in this work (*Chapter III*, section 5), since they allowed to obtain finer droplets (1.1-1.6 µm against 6-10 µm) in similar process conditions. Only when a significantly higher concentration of corn particles (10% referred to the aqueous phase) was used for stabilizing also 4:1 water:oil emulsions, it was achieved a droplet size about 1-2 µm. Emulsions stabilized by cocoa and rapeseed particles under similar conditions than those used in this work, provided oil droplets around 4-5µm, whereas with lupine shell particles the oil droplet size was of ~11 µm (Joseph, 2018). Joseph, (2018) well stated that the size of oil droplets may be influenced by the composition of plant particles, particularly the protein content, since it interferes on the ability of particles to be absorbed at the water-oil interface and then stabilize the oil droplets. In this sense, it is expected that material with lower protein content exhibit a

lower capacity to be absorbed at droplet interface. In emulsions, the smaller the droplet size, the larger the interfacial area to be covered by the stabilizer/emulsifier. Therefore, if two different types of particles are used for stabilizing oil-in-water emulsions (at same powder concentration, process and water-to-oil ratio) and significant differences are observed in the oil droplet size, it can be deduced that particles which provide finer droplets, also exhibit higher performance by being able to anchor more efficiently to oil interface.

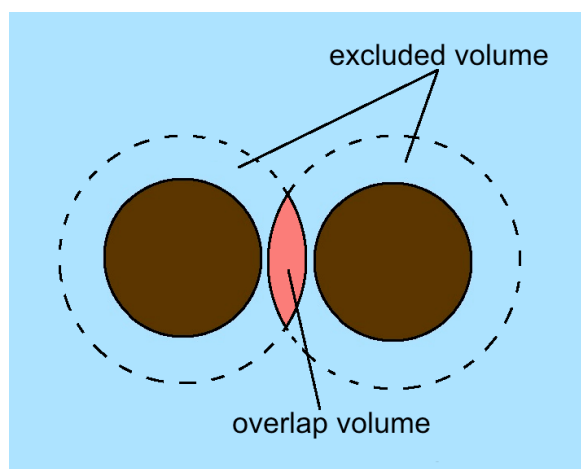
In this context, three different behaviors could be expected related to the dephenolizing treatment of walnut particles prior to emulsion preparation: i) a greater performance of dephenolized walnut particles since a high content of phenols in the matrix may facilitate to establish hydrophobic interactions between proteins and polyphenols, which hinder protein solubilization during dispersion and emulsification by forming insoluble protein complexes (Malik & Saini, 2017). On the other hand, it is also possible that the soluble protein fraction does not play a critical role in droplet stabilization. ii) An impact of maceration or UAE on the functional properties of dephenolized particles, or even on the morphology, of walnut particles that leads to a lower performance of particles for stabilizing oil droplets. For instance, the use of hydroalcoholic solvents during phenolic extraction may promote protein denaturation (Navarro et al., 2016; Sawada et al., 2014) and therefore, could decrease protein functionality which play a key role in emulsion stabilization. In addition, particle aggregation or drastic changes on their surface morphology when walnut cake was first swelled, because of the absorption of solvent, and then freeze-dried, may also occurs. Moreover, the ultrasonic treatment causes severe disruption to the plant tissues and thus, may modify their morphology/shape (Liu et al., 2020; Mohammadpour et al., 2019). The combination of protein denaturation and morphological changes may finally change significantly the efficacy of walnut particles to anchor to the oil-water interface. However, it is important to highlight than an ambiguous effect of UAE can be expected, since the sonication of plant protein may also improve their emulsifying properties by modifying their composition and structure (Sun et al., 2020; Zhu et al., 2018). iii) The last possible behavior is that dephenolizing treatment, either by maceration or UAE, is not enough for causing significant changes on protein solubility and morphology and therefore, the efficacy for stabilizing oil droplets is not affected by dephenolization.

From that perspective, it can be stated that dephenolizing walnut particles by maceration, did not significantly influenced neither the ability of particles to be absorb at water-

oil interface nor the physical stability of emulsion over storage, since its droplet distribution remained constant during 42 days of storage (Figure IV-9, emulsion DMW) and it was similar to emulsion DW. On the other hand, the ultrasonic waves seem to impact the performance of walnut particles for covering the water-oil interface since a different droplet size distribution was observed for emulsion fabricated with particles defatted and dephenolized by UAE (Figure IV-9, emulsion DUW). Larger droplets (mainly between 7 and 8  $\mu\text{m}$ ) were observed when ultrasonicated particles were used. In addition their size distribution was not monodispersed ( $U = 0.80$ ), indicating the presence of other populations of emulsion droplets; one with a diameter size larger than 10  $\mu\text{m}$  (peak on the right of Figure IV-9, emulsion DUW) and other population with fine droplet of diameter size about 1  $\mu\text{m}$  (peak on the left of Figure IV-9, emulsion DUW). This fact evidenced a lower anchoring rate of these particles in comparison with DW and DMW. The lower uniformity of emulsion DUW was confirmed by the microscope observations shown in Figure IV-10, DUW) which revealed droplets with various diameter sizes. In addition the droplets of emulsion DUW tended to form aggregates after desorption of plant particles, using SDS solution (10% wt/v), unlike emulsions DW and DMW. This fact is due to the arise of depletion forces in the colloidal system with droplet of larger size. Depletion force is an effective attractive force that arises between large colloidal particles that are suspended in a dilute solution of depletants such as nonadsorbing polymers, micelles, or smaller hard spheres (in our case the depletant is the SDS), which are smaller solutes that are preferentially excluded from the vicinity of the large particles (Mao et al., 1995). In other words, when droplets get sufficiently close and their excluded volumes overlap (Figure IV-11), depletants are expelled from the interparticle region, which becomes a region of pure solvent. When this occurs, there is a higher depletant concentration in the surrounding solution than in the interparticle region, producing a gradient of concentration and an anisotropic osmotic pressure that acts on the outer sides of the colloids and therefore promotes flocculation (Bechinger et al., 1999).

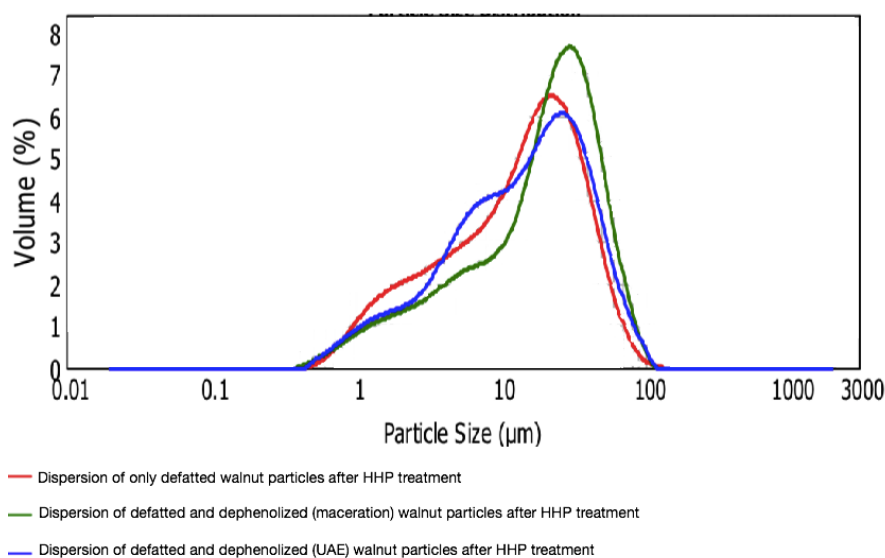


**Figure IV-10.** Microscope observations of 4:1 water:oil emulsions stabilized by different walnut particles



**Figure IV-11.** Overlap of excluded volumes of hard spheres

Our hypothesis for the observation related to emulsion DUW is that ultrasound treatment impacted significantly the walnut functionality possibly by modifying the protein structure, unfolding the structure and hence exposing amino acid with a lower ability to anchor at droplet interface. A different behavior was observed in *Chapter III*, where it was stated that partial unfolding of corn proteins influenced positively their capacity of emulsification. However, only moderate conditions of temperature and pressure were applied to corn germ which may conduct to a less extensive protein denaturation than that produced by ultrasonic waves. Other hypothesis is related to the possible significant damage caused by cavitation to the surface of walnut particles, making them more porous for instance, what decrease their anchoring rate and therefore lowered particle coverage of the droplets. As perspective, further analysis on protein conformation and surface morphology (not only droplet size measurement) should be conducted for understanding the mechanism involved in the loss of functionality of sonicated walnut cake particles. In particular because it was not observed significant modifications in the particle size distribution of the non-sonicated particles versus sonicated ones (Figure IV-12), that can explain the lower functionality of walnut particles dephenolized by ultrasound.



**Figure IV-12.** Particle size distribution of aqueous dispersions after HHP treatment

Finally, it is worth mentioning the recent findings of Meirelles et al. (2020) related to the effect of ultrasound on nanocrystals of cellulose used for stabilizing oil-in-water emulsions. The authors reported that the sonication of nanocrystals induced an increase in their zeta potential up to values between -31 and -33 mV, since the hydrodynamic shear close to the tip

of the probe and greater chaotic contact between cellulose particles and oxygen, favoring the generation of more negative charge on cellulose crystals surface. Thereby, the repulsion between the cellulose particles significantly increased. Since electrostatic mechanism is also involved in the stabilization of oil droplets (Meirelles et al., 2020), the significant modification of the surface charge of walnut particles after sonication, could affect the capacity of these particles to anchor at the droplet interface. The surface charge of walnut particles, before and after sonication, could be evaluated in future tests by measuring their zeta potential.

Nonetheless, despite the lower functionality of sonicated walnut particles, the oil droplets of emulsion DUW were highly stable over time (Figure IV-9) and their coalescence was successfully prevented by the absorbed walnut particles. This was expected under the considerations of Horozov & Binks, (2006), who stated that the particles in the contact region of the droplets stabilized through bridging mechanism, form a dense and stable monolayer as a result of strong capillary attraction caused by the menisci formed around them. Therefore, even emulsion with a low particle coverage of the droplets may be highly stable over time thanks to the formation of bridging particle monolayers (Xiao et al., 2016; Horozov & Binks, 2006).

From a global point of view, all the assessed emulsions, i.e. DW, DMW, DUW, showed a fine droplet size and high stability, at a relatively low particle concentration (2.5% of walnut particles referred to the aqueous phase) which is highly interesting for being used in several food, pharmaceutical and cosmetic applications. As previously mentioned, Pickering emulsions are known to be highly stable since once a particle is adsorbed, it is considered to be irreversibly placed at the interface (Gould et al., 2013). In addition, emulsions DW and DMW were markedly monodisperse systems ( $U = \sim 0.25$ ), what is characteristic of the Pickering emulsion fabricated by means of high pressure (Joseph, 2018).

## **5.2. Oxidative stability of dispersed oil**

In addition to the ability of solid particles to physically stabilize emulsions, they may also contribute to protect oil droplets against oxidative reactions by acting as a physical barrier that limits the diffusion of prooxidant substances/molecules into the oil (Joseph, 2018). On the other hand, it is feasible that oil droplets stabilized by plant matrices can be also protected against lipid oxidation because of the fact that the plant particles (both free particles and those

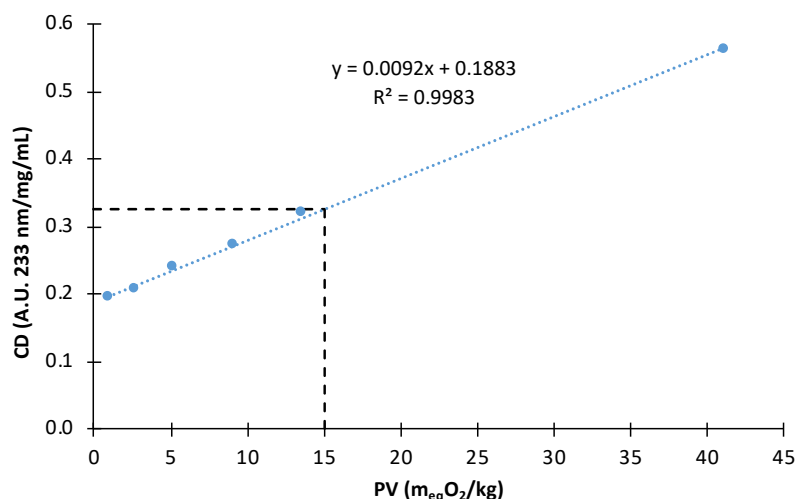


absorbed at the interface), may represent an important source of natural antioxidants able to scavenge free radicals in the system and therefore, delay lipid oxidation.

From that perspective, this section aimed at determining if the high content of polyphenols in walnut cake could be also involved or not in a possible protection of linseed oil droplets against lipid oxidation. For that, the emulsions DW, DMW and DUW were submitted to accelerated oxidation and monitored regarding their oxidative stability by means of the conjugated dienes (CD) formation.

For that, it was first necessary to study the oxidation course of bulk linseed oil. Linseed oil is highly susceptible to oxidation due to its high content (> 65%) of polyunsaturated fatty acids, in particular of linolenic acid (C18:3). The linseed oil used in this work exhibited the following fatty acid composition: C16:0 (5.7%), C18:0 (4.9%), C18:1(9c) (19.9%), C18:2 (6c) (15.8%), C18:3 (52.6%). This results was consistent with that reported by Bayrak et al. (2010) since generally, linseed oil contains approximately 9-11% of saturated fatty acids (5-6% palmitic acid (C16:0) and 4-5% stearic acid (C18:0)) and 75-90% of unsaturated fatty acids (50-55% linolenic acid (C18:3), 13-16% linoleic acid (C18:2) and 15-20% oleic acid (C18:1)).

In Figure IV-13 is presented the correlation between the peroxide value (PV) and the formation of CD during oil oxidation whereas in Figure IV-14 can be observed the monitoring of only conjugated dienes formation during oxidation of bulk linseed oil at 60 °C for 48 hours. The correlation between these indicators of lipid oxidation has been previously reported by several authors (Eliseeva et al., 2017; Marmesat et al., 2009), and it is widely used since it allows to estimate the peroxide value of an oil sample by means of a CD measurement which is an easier and rapid method of analysis than PV determination.



**Figure IV-13.** Correlation between peroxide value and the formation of CD during oxidation of virgin linseed oil at 60 °C

From the correlation in Figure IV-13 and considering that virgin oils above 15 meqO<sub>2</sub>/kg are unfit for human consumption (Codex Alimentarius, 1981), it can be fixed, as a limit of the degree of oil oxidation, the CD value of 0.3263 (A.U. 233 nm/mg/mL). Linseed oil with a concentration of CD higher than this limit is considered out of the minimum conditions of an edible oil and therefore, out of our focus of interest.

Typically, linseed oil contains high amount of polyunsaturated fatty acids (PUFA), especially essential  $\alpha$ -linolenic acid (known as ALA or omega 3) (> 50%), whose level is one of the highest of all edible oils (Symoniuk et al., 2016). Although the intake of oils with a high content of ALA, such as linseed oil, has been associated with beneficial effects on human health, this condition also makes the linseed oil highly susceptible to the oxidation process (Choe & Min, 2006). In fact, linolenic acid oxidizes 20–40 times faster than oleic acid and 2–4 times faster than linoleic acid (Przybylski, 2005). The mechanism involved in oxidation has been already described in section 2.5.2 of *Chapter I*. As can be observed in Figure IV-14, bulk linseed oil (called bulk oil) rapidly oxidized and after 30 hours at 60 °C, it crossed the limit of edibility. Data from Joseph, (2018) reported a less oxidable linseed oil since only after 72 hours under accelerated oxidation at 60 °C, linseed oil exceeded the limit of edibility (PV=15 meqO<sub>2</sub>/kg). However, the oxidative stability of virgin oils obtained from same plant species may vary according to the grown conditions, oil extraction method, differences in the fatty acid composition, content of native antioxidants (such as tocopherol, phenols) or prooxidants substances (such as metal traces), among others (Przybylski, 2005).

On the hand, when the linseed oil in continuous phase was processed by microfluidization (called HHP oil), in order to verify the influence of this emulsification method on the oxidative stability of linseed oil, it was observed a higher oxidation rate of HHP oil compared to unprocessed oil (bulk oil). The microfluidization process decreased the edibility time of linseed oil from 30 hours to only 15 hours (measured under accelerated conditions of oxidation). This behavior was expected under the consideration that microfluidization treatment significantly promoted the increase in temperature of linseed oil and incorporated probably more oxygen to the system, which accelerated the oxidation rate of linseed oil; similar observations were reported by Joseph, (2018). On contrary, the oxidation rate of linseed oil dispersed in the different emulsions (DW, DMW, DUW) was significantly lower than that of HHP oil as observed in Figure IV-14. The oxidation rate of emulsified linseed oil has been compared with HHP oil instead of bulk oil, considering that dispersed oil has been also submitted to the effects promoted by microfluidization when the different emulsions were fabricated. Nonetheless, it is worth mentioning that this comparison is arbitrary since lipid oxidation of bulk oils takes place in a different form than heterogeneous systems (emulsions).

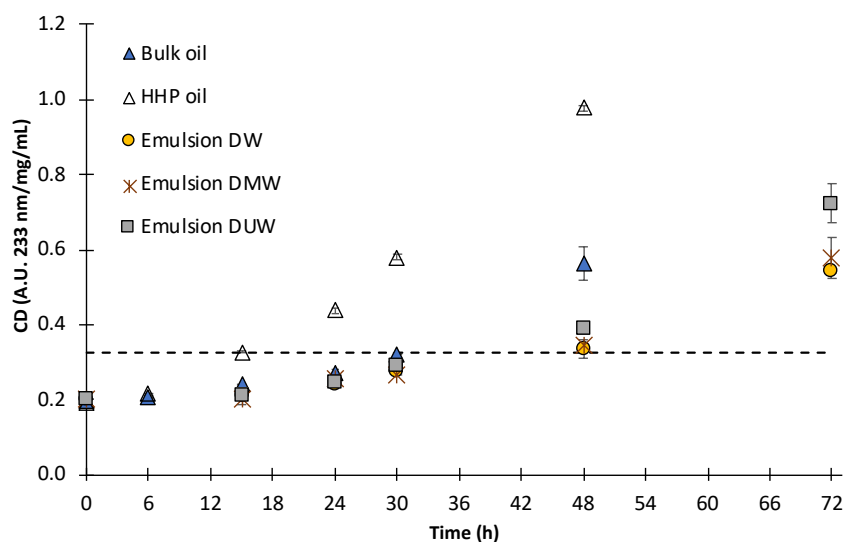
Globally, it can be stated that lipids dispersed in aqueous solution (oil-in-water emulsion) have a higher oxidation rate than bulk oils. Furthermore, heterogeneous lipid dispersions have more factors influencing oxidation kinetics than in bulk oils (da Silveira, et al., 2020; Decker et al., 2017). The main cause of a higher oxidation rate of dispersed lipids is the huge increase in the lipid-water surface area, which is related to the lipid droplet size. It means that the smaller the size of the lipid particles in the dispersion, the larger the specific surface area. A higher specific surface area of oil droplets promotes lipid oxidation because reactants such as hydroperoxides are surface active molecules that tend to accumulate at oil-water interfaces where they interact with transition metals in the surrounding aqueous phase, causing them to decompose into free radicals that propagate the lipid oxidation reaction (Decker et al., 2017). The influence of transition metals in this reaction scheme has been widely demonstrated (Frankel et al., 2002; Mancusco et al., 1999). The diffusion of oxygen, which catalyzes peroxidation, from aqueous phase to lipid phase can be promoted by a higher specific surface area of oil droplets.

However, emulsion stabilized by particles may display significant advantages in comparison with those stabilized by smaller molecular weight surfactant in terms of oxidative stability. For instance, in Pickering emulsion solid particles form a thick interface around the

oil droplets which largely reduces chances of interaction between transition metals (sited in aqueous phase) and lipid hydroperoxide (in oil phase) (Zhao et al., 2020; Xiao et al., 2016). The incorporation of phenolic antioxidants is also an affordable and effective way to prolong the shelf-life of emulsions by enhancing their oxidative stability (Zhao et al., 2020). In this sense, in Figure IV-14 is displayed the oxidation kinetic of linseed oil dispersed in a 4:1 water:oil emulsion stabilized by walnut particles; i) only defatted (emulsion DW), ii) defatted and then dephenolized by maceration (emulsion DMW) and, iii) defatted and then dephenolized by UAE (emulsion DUW). As expected, it can be observed that the stabilization of oil droplet by walnut particles enhanced the oxidative stability of linseed oil in comparison with HHP oil, in agreement with the observation of Joseph, (2018). Nonetheless, the delay of oxidation in Pickering emulsion was not correlated to the type of walnut particle used for stabilizing the oil droplet, since DW, DMW and DUW displayed equal oxidation kinetics, at least until reach the limit of oil edibility (dotted line in Figure IV-14). The three emulsions (DW, DMW and DUW) maintained edible the linseed oil up to 48 hours against the 15 hours observed for HHP oil. Hence, it can be inferred that the content of phenolic antioxidants in the dispersed system did not have a key role in the prevention of lipid oxidation. Although the walnut particles only defatted provided a higher concentration of phenolic compounds in the aqueous phase ( $218 \pm 12$  mg GAE/L) than particles defatted and dephenolized by maceration ( $109 \pm 2$  mg GAE/L) and particles defatted and dephenolized by UAE ( $93 \pm 5$  mg GAE/L), it did not provide a higher protective effect against lipid oxidation.

Our hypothesis for explaining this behavior is that phenolic antioxidants did not play a key role in the prevention of oxidation of the oil droplets since these phytoconstituents probably stayed located physically at the water phase instead of at droplet interface, due to their polar nature. Labuckas et al. (2016) have also reported a low lipophilicity of phenolics from walnut. Phenolic extracts from walnut cake contain ellagitannins such as ellagic acid, glansreginin A, pedunculagin, etc. which are water soluble phenolics with high polarity (Fregapane et al., 2020; Bakkalbaşı et al. (2018). Although the physical location of antioxidant molecules in an emulsion systems is not the only factor influencing the lipid oxidation, it plays an important role in the efficacy of antioxidants for interacting with free radical or prooxidant substances (da Silveira, et al., 2020; Decker et al., 2017). From that perspective, the absence of protective effect of phenolic compounds against lipid oxidation may be explained by the polar paradox. The explanation for the antioxidant polar paradox in lipid dispersions is based on the fact that polar antioxidants (highly soluble in water) would partition into the aqueous phase of oil-in-

water emulsions where they are not able interact with fatty acid radicals (non-polar compounds), whereas non-polar antioxidants would be located at emulsion droplet where they can scavenge lipid soluble free radicals (Porter, 1980).



**Figure IV-14.** Monitoring of CD formation in either bulk linseed oil or dispersed in a 4:1 water:oil emulsion stabilized by walnut particles and submitted to accelerated oxidation at 60 °C. The dotted line indicates the limit of oil edibility.

It is possible that in addition to the different content of phenolic compounds among emulsions DW, DMW and DUW, the distribution/location of these antioxidants was also significantly different in each system owing to variations in the interfacial loading of particles and in surface charge. Although determining which factor dominates the influence on oxidative stability in Pickering emulsion is a quite complex task, since many factors may interfere with each other in comparison with traditional emulsions, it seems that in our case the key factor influencing the lipid oxidation is related to the physical properties of interface layer. This hypothesis can be more evidenced when comparing the lipid oxidation of emulsion DW (which content a high amount of phenolic) with emulsions DMW and DUW, which contents the half of phenolic compounds of emulsion DW but protected equal as DW. Hence, lipid oxidation was probably more regulated by the formation of steric barriers than by the antioxidant action of polyphenols released from walnut particles.

In this sense, it has been reported that emulsions that formed thicker interface layers inhibited lipid oxidation more effectively than those forming thinner barrier, suggesting a key

role of the physical barrier effects (Gumus et al., 2017; Zhao et al., 2015). In turn, the main physical property of interface layers stabilized by plant particles is related to the formation of steric barriers that hinder the diffusion of oxygen, lipid oxidation initiators and prooxidants. Similarly, Joseph, (2018) reported that water-soluble antioxidant compounds (phenols) did not play a key role in the antioxidant mechanism of oil-in-water emulsion stabilized by cocoa particles. On contrary Zhao et al. (2020) found that it was not the physical barrier formed by zein nanoparticles which regulated the oxidative stability of zein nanoparticles-stabilized Pickering emulsions but the interfacial concentration of gallic acid. However, these authors also highlight other important findings such as: i) the physical barrier of zein nanoparticles (in absence of gallic acid) was able to significantly delay lipid oxidation by hindering the formation and diffusion of hydroperoxide and, ii) the concentration of gallic acid at droplet interface was directly correlated with the interfacial loading of zein nanoparticles. On the other hand, there are also some studies (Schröder et al., 2019) which have reported that emulsions stabilized by Pickering mechanisms cannot form an interfacial barrier structurally homogeneous at a very small scale to prevent the diffusion of small pro-oxidant molecules towards the lipid droplets. The diverse findings of the aforementioned works related to the factors involved on the oxidation of heterogeneous lipid system stabilized by particles (Pickering emulsions) evidence the complex mechanisms and interactions occurring and influencing simultaneously the oxidative stability of lipids.

Even though the oxidation rate of emulsion DW, DMW and DUW were equal below the limit of edibility, it was observed that at 72 hours of accelerated oxidation (outside the range of edibility), the emulsion DUW begins to oxidize faster than DW and DMW (Figure IV-14). This behavior would be in accordance with the hypothesis that the main mechanism regulating the lipid oxidation is the steric barrier effect since it was previously stated that a lower anchoring efficiency of plant particles at the droplet interface took place when walnut cake was sonicated. Hence, a less interfacial particle loading could also provide a weaker physical barrier to the diffusion of hydroperoxide and prooxidant substances towards oil droplets. This effect became significant or at least observable only after 72 hours of accelerated oxidation.

## 6. Conclusion and perspectives

Walnut press-cake still constitutes an important source of lipids and protein useful for several industrial applications. Approximately 37% of walnut press-cake is oil which can be completely recovered by conventional Soxhlet extraction or by means of supercritical fluid extraction at high pressure (500 bar). As also stated in *Chapter I*, Sc-CO<sub>2</sub> is a green technology that displays several advantages in comparison with solid-liquid extractions. The walnut oil exhibited a high content of polyunsaturated fatty acids (~74%) with an important concentration of omega 6 and 3 which are related to human health benefits.

Furthermore, defatted walnut cake was also a rich, abundant and inexpensive source of antioxidant molecules, mainly polar polyphenols which can be later used in food, cosmetic or pharmaceutical applications in place of synthetic antioxidants. A mixture of ethanol-water at a proportion of 60:40 (v/v) showed to be highly efficient for solubilizing phenolic compounds from walnut cake thanks to the optimization of the solvent polarity. Ultrasound assisted extraction was employed as novel technique for enhancing extraction yield of phenolic compounds from defatted walnut cake. The influence of parameters such as power of ultrasound, duty cycle and extraction time on phenolic recovery were assessed by means of response surface methodology and the 3D-plots and the statistical analysis showed that the higher the power, duty cycle and time the higher the extraction of polyphenols from defatted walnut cake. However, the solid-to-solvent ratio influenced significantly more the phenolic extraction than power of ultrasound, duty cycle and extraction time; both power of ultrasound and duty cycle were limited by the ultrasonic processor used in this work. From that perspective, the extraction of antioxidant phenols might be also optimized in order to obtain high extraction yields at acceptable energy and environmental cost. Globally, the extraction yield of phenolic compounds varied between 10 and 29 mg GAE/g defatted cake. On the other hand, ellagic acid was identified as one of the major phenolic compound of walnut extracts and showed to be highly correlated ( $R^2 = 0.90$ ,  $p < 0.05$ ) with the free radical scavenging activity of walnut extracts (DPPH). The polyphenol-rich extracts obtained by ultrasound assisted extraction exhibited an important antioxidant activity, however, it was not possible to obtain a good predictive model that correlates the independent factors of ultrasound extraction with the antioxidant activity of extracts. In this sense, the assessment of the influence of higher levels of power, duty cycle and shorter extraction times, on ultrasound assisted extraction of

polyphenol is suggested in order to observe higher variation in the total phenolic content and therefore better predictive models.

As the last process of the biorefinery chain from walnut press-cake, it has been proposed the stabilization of oil-in-water emulsions (Pickering emulsions). This alternative takes advantages of the functionality of plant products under a holistic approach. Both defatted and defatted and then dephenolized walnut particles exhibited a high potential applicability as particles-stabilized Pickering emulsions since fine oil droplets (mainly between 1 and 2  $\mu\text{m}$ ) were successfully stabilized. In addition, the Pickering emulsions displayed high stability during storage for several weeks at 4 °C, limited coalescence and low creaming. The sonication of walnut particles affected their functionality for stabilizing oil droplets in comparison with the non-sonicated ones, since larger droplet size and less uniformity index were observed in the emulsion stabilized by walnut particles defatted and then dephenolized by ultrasound assisted extraction (emulsion DUW). Despite the larger droplets in emulsion DUW, it was not observed neither droplet coalescence nor particle precipitation/flocculation. Furthermore, absorption of walnut particles at the droplet interface promoted a thick interface which largely reduced chances of interaction between transition metals and lipid hydroperoxide and therefore delayed lipid oxidation. Dispersed linseed oil covered by walnut particles showed a slower oxidation rate than bulk oil submitted to microfluidization. However, the antioxidant compounds (polar phenolics) in the heterogenous system did not play a key role for inhibiting lipid oxidation. This behavior could be explained by the polar paradox. As perspective, deeper analysis for studying the partition of polar phenolic in Pickering emulsion are suggested in order to elucidate the factors and mechanism involved in the lipid oxidation of emulsion stabilized by particles.

Finally, it can be concluded globally that the biorefinery scheme proposed in this chapter from walnut cake, offers valuable products for food, pharmaceutical or cosmetic applications and at the same time promote a better use of agricultural residues.



## References

- Augusto, T.R., Scheuermann Salinas, E.S., Alencar, S.M., D'Arce, M.A.B.R., De Camargo, A.C., Vieira, T.M.F. de S., 2014. Phenolic compounds and antioxidant activity of hydroalcoholic extracts of wild and cultivated murtila (*Ugni molinae turcz.*). *Food Sci. Technol.* 34, 667–673.
- Bakkalbasi, E., Meral, R., Dogan, I.S., 2015. Bioactive compounds, physical and sensory properties of cake made with walnut press-cake. *J. Food Qual.* 38, 422–430.
- Bakkalbaşı, E., Yilmaz, Ö.M., Yemiş, O., Artik, N., 2013. Changes in the phenolic content and free radical-scavenging activity of vacuum packed walnut kernels during storage. *Food Sci. Technol. Res.* 19, 105–112.
- Bakkalbaşı, E., 2018. Oxidative stability of enriched walnut oil with phenolic extracts from walnut press-cake under accelerated oxidation conditions and the effect of ultrasound treatment. *J. Food Meas. Charact.* 13, 43–50.
- Barros, H.R., De Castro Ferreira, T.A.P., Genovese, M.I., 2012. Antioxidant capacity and mineral content of pulp and peel from commercial cultivars of citrus from Brazil. *Food Chem.* 134, 1892–1898.
- Bayrak, A., Kiralan, M., Ipek, A., Arslan, N., Cosge, B., Khawar, K.M., 2010. Fatty acid compositions of linseed (*Linum Usitatissimum L.*) genotypes of different origin cultivated in Turkey. *Biotechnol. Biotechnol. Equip.* 24, 1836–1842.
- Bechinger, C., Rudhardt, D., Leiderer, P., Roth, R., Dietrich, S., 1999. Understanding depletion forces beyond entropy. arXiv:cond-mat/9908350.
- Canvin, D.T., 1965. The effect of temperature on the oil content and fatty acid composition of the oils from several oil seed crops. *Canad. J. Botan.* 43(1), 63-69.
- Chen, Q.H., Liu, T.X., Tang, C.H., 2019. Tuning the stability and microstructure of fine Pickering emulsions stabilized by cellulose nanocrystals. *Ind. Crops Prod.* 141, 111733.
- Choe, E., Min, D.B., 2006. Mechanisms and factors for edible oil oxidation. *Compr. Rev. Food Sci. Food Saf.* 5, 169–186.
- Codex Alimentarius Commission (1981). Standard for edible fats and oils not covered by individual standards. CODEX STAN 19-1981, 1-4.
- da Silveira, T.F.F., Cajaíba, L.M., Valentin, L., Baréa, B., Villeneuve, P., Castro, I.A., 2020. Effect of sinapic acid ester derivatives on the oxidative stability of omega-3 fatty acids rich oil-in-water emulsions. *Food Chem.* 309, 125586.
- de Oliveira, A.M.F., Pinheiro, L.S., Pereira, C.K.S., Matias, W.N., Gomes, R.A., Chaves, O.S., de Souza, M. de F.V., de Almeida, R.N., de Assis, T.S., 2012. Total phenolic content and antioxidant activity of some malvaceae family species. *Antioxidants* 1, 33–43.

Decker, E.A., McClements, D.J., Bourlieu-Lacanal, C., Durand, E., Figueroa-Espinoza, M.C., Lecomte, J., Villeneuve, P., 2017. Hurdles in Predicting Antioxidant Efficacy in Oil-in-water emulsions. *Trends Food Sci. Technol.* 67, 183–194.

Eliseeva, L., Yurina, O., Hovhannisyanyan, N., 2017. Nuts as raw material for confectionary industry. *Ann. Agrar. Sci.* 15, 71–74.

Espinosa-Pardo, F.A., Nakajima, V.M., Macedo, G.A., Macedo, J.A., Martínez, J., 2017. Extraction of phenolic compounds from dry and fermented orange pomace using supercritical CO<sub>2</sub> and cosolvents. *Food Bioprod. Process.* 101, 1-10.

Frankel, E.N., Satué-Gracia, T., Meyer, A.S., German, J.B., 2002. Oxidative stability of fish and algae oils containing long-chain polyunsaturated fatty acids in bulk and in oil-in-water emulsions. *J. Agric. Food Chem.* 50, 2094–2099.

Fregapane, G., Guisantes-Batan, E., Ojeda-Amador, R.M., Salvador, M.D., 2020. Development of functional edible oils enriched with pistachio and walnut phenolic extracts. *Food Chem.* 310, 125917.

Fukuda, T., Ito, H., Yoshida, T., 2003. Antioxidative polyphenols from walnuts (*Juglans regia* L.). *Phytochemistry* 63, 795–801.

Fukuda, T., Ito, H., Yoshida, T., 2004. Effect of the walnut polyphenol fraction on oxidative stress in type 2 diabetes mice. *BioFactors* 21, 251–253.

Gharibzahedi, S.M.T., Mousavi, S.M., Hamed, M., Rezaei, K., Khodaiyan, F., 2013. Evaluation of physicochemical properties and antioxidant activities of Persian walnut oil obtained by several extraction methods. *Ind. Crops Prod.* 45, 133–140.

Gil, M.I., Tomás-Barberán, F.A., Hess-Pierce, B., Kader, A.A., 2002. Antioxidant capacities, phenolic compounds, carotenoids, and vitamin C contents of nectarine, peach, and plum cultivars from California. *J. Agric. Food Chem.* 50, 4976–4982.

Gould, J., Vieira, J., Wolf, B., 2013. Cocoa particles for food emulsion stabilisation. *Food Funct.* 4, 1369–1375.

Gumus, C.E., Decker, E.A., McClements, D.J., 2017. Impact of legume protein type and location on lipid oxidation in fish oil-in-water emulsions: Lentil, pea, and faba bean proteins. *Food Res. Int.* 100, 175–185.

Horozov, T.S., Binks, B.P., 2006. Particle-stabilized emulsions: A bilayer or a bridging monolayer? *Angew. Chemie - Int. Ed.* 45, 773–776.

Jafari, S.M., He, Y., Bhandari, B., 2006. Nano-emulsion production by sonication and microfluidization - A comparison. *Int. J. Food Prop.* 9, 475–485.

Janu, C., Kumar, D.R.S., Reshma, M. V., Jayamurthy, P., Sundaresan, A., Nisha, P., 2014. Comparative study on the total phenolic content and radical scavenging activity of common edible vegetable oils. *J. Food Biochem.* 38, 38–49.

Jess Tovar, M., Paz Romero, M., Girona, J., Jos Motilva, M., 2002. L-phenylalanine ammonia-lyase activity and concentration of phenolics in developing olive (*Olea europaea* L. cv Arbequina) fruit grown under different irrigation regimes. *J. Sci. Food Agric.* 82, 892–898.

Joseph, C., 2018. Emulsions de Pickering stabilisées par des poudres végétales: propriétés et rôle des paramètres de composition et de formulation. Doctoral thesis. École Doctorale des Sciences Chimiques, Université de Bordeaux.

Khair, R., Pan, Z., 2019. Walnuts. In: Pan, Z., Zhang, R., Zicari, S. (Eds.), *Integrated processing technologies for food and agricultural by-products*, Academic Press, UK, pp. 391-411.

Labuckas, D., Maestri, D., Lamarque, A., 2016. Molecular characterization, antioxidant and protein solubility-related properties of polyphenolic compounds from walnut (*Juglans regia*). *Nat. Prod. Commun.* 11, 637–640.

Labuckas, D., Maestri, D., Lamarque, A., 2014. Effect of different oil extraction methods on proximate composition and protein characteristics of walnut (*Juglans regia* L.) flour. *LWT - Food Sci. Technol.* 59, 794–799.

Labuckas, D., Maestri, D., Perelló, M., Martínez, M.L., Lamarque, A.L., 2008. Phenolics from walnut (*Juglans regia* L.) kernels: Antioxidant activity and interactions with proteins. *Food Chem.* 107, 607–612.

Lajara, J.R., Diaz, U., Quidiello, R.D., 1990. Definite influence of location and climatic conditions on the fatty acid composition of sunflower seed oil. *JAOCs, J. Am. Oil Chem. Soc.* (67)10, 618-623.

Liu, X., Ou, H., Xiang, Z., Gregersen, H., 2020. Ultrasound pretreatment combined with supercritical CO<sub>2</sub> extraction of *Iberis amara* seed oil. *J. Appl. Res. Med. Aromat. Plants* 100265.

Luo, Y., Wu, W., Chen, D., Lin, Y., Ma, Y., Chen, C., Zhao, S., 2017. Optimization of simultaneous microwave/ultrasonic-assisted extraction of phenolic compounds from walnut flour using response surface methodology. *Pharm. Biol.* 55, 1999–2004.

Malik, M.A., Saini, C.S., 2017. Polyphenol removal from sunflower seed and kernel: Effect on functional and rheological properties of protein isolates. *Food Hydrocoll.* 63, 705–715.

Mancuso, J.R., McClements, D.J., Decker, E.A., 1999. Ability of iron to promote surfactant peroxide decomposition and oxidize  $\alpha$ -tocopherol. *J. Agric. Food Chem.* 47, 4146–4149.

Mao, Y., Cates, M.E., Lekkerkerker, H.N.W., 1995. Depletion force in colloidal systems. *Physica A* 222, 10-24.

Marmesat, S., Morales, A., Velasco, J., Ruiz-Méndez, M. V., Dobarganes, M.C., 2009. Relationship between changes in peroxide value and conjugated dienes during oxidation of sunflower oils with different degree of unsaturation. *Grasas y Aceites* 60, 155–160.

Martínez, M.L., Maestri, D.M., 2008. Oil chemical variation in walnut (*Juglans regia* L.) genotypes grown in Argentina. *Eur. J. Lipid Sci. Technol.* 110, 1183–1189.

Martínez, M.L., Penci, M.C., Ixtaina, V., Ribotta, P.D., Maestri, D., 2013. Effect of natural and synthetic antioxidants on the oxidative stability of walnut oil under different storage conditions. *LWT - Food Sci. Technol.* 51, 44–50.

Meirelles, A.A.D., Costa, A.L.R., Cunha, R.L., 2020. Cellulose nanocrystals from ultrasound process stabilizing O/W Pickering emulsion. *Int. J. Biol. Macromol.* 158, 75–84.

Mohammadpour, H., Sadrameli, S.M., Eslami, F., Asoodeh, A., 2019. Optimization of ultrasound-assisted extraction of *Moringa peregrina* oil with response surface methodology and comparison with Soxhlet method. *Ind. Crops Prod.* 131, 106–116.

Muñoz-Labrador, A., Prodanov, M., Villamiel, M., 2019. Effects of high intensity ultrasound on disaggregation of a macromolecular procyanidin-rich fraction from *Vitis vinifera* L. seed extract and evaluation of its antioxidant activity. *Ultrason. Sonochem.* 50, 74–81.

Navarro, S.L.B., Capellini, M.C., Aracava, K.K., Rodrigues, C.E.C., 2016. Corn germ-bran oils extracted with alcoholic solvents: Extraction yield, oil composition and evaluation of protein solubility of defatted meal. *Food Bioprod. Process.* 100, 185–194.

Odabaş, H.İ., Koca, I., 2016. Application of response surface methodology for optimizing the recovery of phenolic compounds from hazelnut skin using different extraction methods. *Ind. Crops Prod.* 91, 114–124.

Ojeda-Amador, R.M., Salvador, M.D., Gómez-Alonso, S., Fregapane, G., 2018. Characterization of virgin walnut oils and their residual cakes produced from different varieties. *Food Res. Int.* 108, 396–404.

Páramos, P., Granjo, J., Corazza, M., Matos, H., 2020. Extraction of high value products from avocado waste biomass. *J. Supercrit. Fluids* 104988.

Paris, E., Assirelli, A., Carnevale, M., Gallucci, F., Rocuzzo, G., Pagano, M., Santangelo, E., 2019. Residues from harvesting of tree nuts: An appraisal of energy value of walnut and almond husks. *European biomass conference and exhibition proceedings*, pp. 303-306.

Piluzza, G., Bullitta, S., 2011. Correlations between phenolic content and antioxidant properties in twenty-four plant species of traditional ethnoveterinary use in the Mediterranean area. *Pharm. Biol.* 49, 240–247.

Pingret, D., Fabiano-Tixier, A-S., Chemat, F., 2013. Ultrasound-assisted Extraction. In: Rostagno, M.A., Prado, J.M. (Eds.), *Natural product extraction: Principles and applications*. RSC Publishing, UK, pp. 89-109.

Porter, W.L., 1980. Recent trends in food applications of antioxidants. In: Simic, M.G., Karel, M. (Eds.), *Autoxidation in food and biological systems*, Springer, USA, pp. 295–365.

Przybylski, R., 2005. Flax oil and high linolenic oils. In: Shahidi, F. (Ed.), *Bailey's industrial oil and fat products*. John Wiley & Sons, Inc., USA, Vol. 2, pp. 281-302.

Rapisarda, P., Bianco, M. Lo, Pannuzzo, P., Timpanaro, N., 2008. Effect of cold storage on vitamin C, phenolics and antioxidant activity of five orange genotypes [*Citrus sinensis* (L.) Osbeck]. *Postharvest Biol. Technol.* 49, 348–354.

Rathore, S.S., Saxena, S.N., Kakani, R.K., Sharma, L.K., Agrawal, D., Singh, B., 2016. Genetic variation in fatty acid composition of fenugreek (*Trigonella foenum-graecum* L.) seed oil. *Legum. Res.* 40, 609–617.

Riciputi, Y., Diaz-de-Cerio, E., Akyol, H., Capanoglu, E., Cerretani, L., Caboni, M.F., Verardo, V., 2018. Establishment of ultrasound-assisted extraction of phenolic compounds from industrial potato by-products using response surface methodology. *Food Chem.* 269, 258–263.

Santos, K.A., Frohlich, P.C., Hoscheid, J., Tiunan, T.S., Gonçalves, J.E., Cardozo-Filho, L., da Silva, E.A., 2017. Candeia (*Eremanthus erythropappus*) oil extraction using supercritical CO<sub>2</sub> with ethanol and ethyl acetate cosolvents. *J. Supercrit. Fluids* 128, 323–330.

Sawada, M.M., Venâncio, L.L., Toda, T.A., Rodrigues, C.E.C., 2014. Effects of different alcoholic extraction conditions on soybean oil yield, fatty acid composition and protein solubility of defatted meal. *Food Res. Int.* 62, 662–670.

Schröder, A., Sprakel, J., Boerkamp, W., Schroën, K., Berton-Carabin, C.C., 2019. Can we prevent lipid oxidation in emulsions by using fat-based Pickering particles? *Food Res. Int.* 120, 352–363.

Sun, X., Zhang, W., Zhang, L., Tian, S., Chen, F., 2020. Molecular and emulsifying properties of arachin and conarachin of peanut protein isolate from ultrasound-assisted extraction. *Lwt* 132, 109790.

Symoniuk, E., Ratusz, K., Krygier, K., 2016. Comparison of the oxidative stability of linseed (*Linum usitatissimum* L.) oil by pressure differential scanning calorimetry and Rancimat measurements. *J. Food Sci. Technol.* 53, 3986–3995.

Thaipong, K., Boonprakob, U., Crosby, K., Cisneros-Zevallos, L., Hawkins Byrne, D., 2006. Comparison of ABTS, DPPH, FRAP, and ORAC assays for estimating antioxidant activity from guava fruit extracts. *J. Food Compos. Anal.* 19, 669–675.

U.S. Department of Agriculture (USDA). <https://fdc.nal.usda.gov/fdc-app.html#/food-details/170187/nutrients>. Accessed on June 2020.

Usaid A.S., Premkumar, J., Ranganathan, T.V., 2014. Emulsion and its applications in food processing – A review. *Ijera*, 4, 241-248.

Xiao, J., Li, Y., Huang, Q., 2016. Recent advances on food-grade particles stabilized Pickering emulsions: Fabrication, characterization and research trends. *Trends Food Sci. Technol.* 55, 48–60.

Zhang, Y.G., Kan, H., Chen, S.X., Thakur, K., Wang, S., Zhang, J.G., Shang, Y.F., Wei, Z.J., 2020. Comparison of phenolic compounds extracted from *Diaphragma juglandis* fructus, walnut pellicle, and flowers of *Juglans regia* using methanol, ultrasonic wave, and enzyme assisted-extraction. *Food Chem.* 321, 126672.

Zhao, Y., Guan, Y., Pan, Y., Nitin, N., Tikekar, R. V., 2015. Improved oxidative barrier properties of emulsions stabilized by silica-polymer microparticles for enhanced stability of encapsulants. *Food Res. Int.* 74, 269–274.

Zhao, Z., Lu, M., Mao, Z., Xiao, J., Huang, Q., Lin, X., Cao, Y., 2020. Modulation of interfacial phenolic antioxidant distribution in Pickering emulsions via interactions between zein nanoparticles and gallic acid. *Int. J. Biol. Macromol.* 152, 223–233.

Zhu, Z., Zhu, W., Yi, J., Liu, N., Cao, Y., Lu, J., Decker, E.A., McClements, D.J., 2018. Effects of sonication on the physicochemical and functional properties of walnut protein isolate. *Food Res. Int.* 106, 853–861.

## Appendix

**Table IV-A1.** Estimated regression coefficients of the predicted model for TPC

Regression coefficient	TPC (Predicted model)			
	Coefficient	Std. Error	t-value	p-value
Intercept $\beta_0$	12.3305	0.09819	125.572	$< 2 \times 10^{-16}$ ***
Linear $\beta_i$				
X <sub>1</sub>	0.3469	0.11888	2.918	0.010055*
X <sub>2</sub>	0.3098	0.11888	2.606	0.019089*
X <sub>3</sub>	0.5404	0.11888	4.546	0.000331***
<b>Adjusted R<sup>2</sup></b>		0.6344		0.0002294***

\*, \*\*, \*\*\* significant at 0.05, 0.01 and 0.001 level, respectively

**Table IV-A2.** Estimated regression coefficients of the predicted model for extraction of ellagic acid

Regression coefficient	Ellagic acid (Predicted model)			
	Coefficient	Std. Error	t-value	p-value
Intercept $\beta_0$	1.6176	0.0223	72.431	$< 2 \times 10^{-16}$ ***
Linear $\beta_i$				
X <sub>1</sub>	0.1027	0.0211	4.861	$2.44 \times 10^{-5}$ ***
X <sub>2</sub>	0.1499	0.0211	7.093	$2.90 \times 10^{-8}$ ***
X <sub>3</sub>	0.1895	0.0211	8.968	$1.35 \times 10^{-10}$ ***
Quadratic $\beta_{ii}$				
X <sub>33</sub>	-0.0367	0.0204	-1.800	0.0805 •
<b>Adjusted R<sup>2</sup></b>		0.7975		$1.68 \times 10^{-12}$ ***

•, \*, \*\*, \*\*\* significant at 0.1, 0.05, 0.01 and 0.001 level, respectively

## **Chapter V: Recovery of polyphenol extracts from grape pomace by ultrasound assisted extraction**

### **1. Introduction**

Grape pomace consists of the skin, stems, and seeds that remain after processing in the wine industry, where large amounts of residue are generated. This bagasse is commonly discarded or used as animal feed or in composting applications. Nevertheless, grape pomace is a cheap source of polyphenols, particularly anthocyanins, that are characterized by a significant antioxidant capacity and their numerous health-benefit properties. These polyphenols are able to reduce the oxidative stress and scavenge free radicals which help in cancer risk reduction and cholesterol regulation (Bonfigli et al., 2017). Thus, in this chapter the extraction of polyphenols from the grape pomace, that results from a local wine industry, is studied. For that, Ultrasound Assisted Extraction (UAE) is also selected as a green technique for recovering bioactive compounds from grape pomace. Similarly to *Chapter IV*, the response surface methodology is used for studying the effect of ultrasound power, time and duty cycle, on the total phenolic content, total anthocyanin quantification and the antioxidant ability of grape extracts. A mixture of ethanol: water (60:40 v/v) is used as the extraction solvent and a central composite design (3 factor and 3 levels) is chosen for model building.

The total anthocyanin content of grape extracts is evaluated based on the light absorbed at 540 nm by anthocyanins when they are diluted in acid hydroalcoholic solution, whereas the antioxidant activity is assessed based on the scavenging activity of the 2,2-diphenyl-1-picrylhydrazyl (DPPH) free radical.

This chapter is proposed as preliminary work to be continued through future research/works in order to allow the recovery of other valuable fractions and therefore, increase the efficiency of the use of natural resources.

### **2. Ultrasound assisted extraction of polyphenols from grape pomace**

Based on literature (Drevelegka & Goula, 2020; Morelli & Prado, 2012) and on the results of *Chapter IV* related to the high capacity of ethanol 60% (v/v) to extract polyphenols from walnut cake, this hydroalcoholic mixture was chosen for extracting phenolic compounds from



grape pomace. According to Drevelegka & Goula, (2020), hydroalcoholic mixtures in a range of 50–60% ethanol are able to rupture hydrogen bonds and hydrophobic bonds existing between phenolics–proteins and phenolics–cellulose.

The central composite design for studying the influence of power, time and duty cycle on total phenolic content (TPC), total anthocyanins (TA) and free radical scavenging activity (DPPH) are presented in Table V-1. UAE were carried out at room temperature and using a solid-to-solvent ratio of 1:50 (wt/v). The response variables TPC, TA and DPPH in Table V-1 were calculated based on the mass of grape pomace used for the extraction, therefore the results are presented in wet basis (grape pomace consisted of 35.8% of water) and not in dry basis.

**Table V-1.** TPC, TA and antioxidant activity (DPPH) of grape pomace treated by several conditions of power, time and duty cycle of ultrasound

Run	Independent factors (X)			Response variables (Y)		
	Power (W) (X <sub>1</sub> )	Time (min) (X <sub>2</sub> )	Duty cycle (%) (X <sub>3</sub> )	TPC (mg GAE/g residue)	TA (mg M3-G/100 g residue)	DPPH (μmol Trolox Equiv./g residue)
1	200 (-1)	3.5 (-1)	30 (-1)	3.23	11.6	33.5
2	360 (+1)	3.5 (-1)	30 (-1)	3.48	14.5	35.0
3	200 (-1)	8.5 (+1)	30 (-1)	3.11	13.4	34.0
4	360 (+1)	8.5 (+1)	30 (-1)	4.52	16.6	44.4
5	200 (-1)	3.5 (-1)	70 (+1)	3.91	16.4	38.7
6	360 (+1)	3.5 (-1)	70 (+1)	4.88	20.5	48.8
7	200 (-1)	8.5 (+1)	70 (+1)	4.88	19.5	47.6
8	360 (+1)	8.5 (+1)	70 (+1)	5.78	22.1	56.0
9	160 (-α)	6 (0)	50 (0)	3.41	14.3	33.7
10	400 (+α)	6 (0)	50 (0)	4.82	17.5	47.9
11	280 (0)	1.8 (-α)	50 (0)	3.41	12.2	32.7
12	280 (0)	10.2 (+α)	50 (0)	5.55	21.8	50.5
13	280 (0)	6 (0)	10 (-α)	2.81	7.8	28.1
14	280 (0)	6 (0)	90 (+α)	5.56	20.4	51.3
15	280 (0)	6 (0)	50 (0)	4.75	17.5	43.9
16	280 (0)	6 (0)	50 (0)	4.46	17.6	44.8
17	280 (0)	6 (0)	50 (0)	4.18	17.6	41.1
18	280 (0)	6 (0)	50 (0)	4.89	17.8	48.6
19	280 (0)	6 (0)	50 (0)	4.11	18.1	42.4
20	280 (0)	6 (0)	50 (0)	4.41	16.5	50.1

Runs 15 to 20 comprised the six replicates at the central point (X<sub>i</sub>=0)

GAE: Gallic Acid Equivalent, M3-G: Malvidin-3-Glucoside equivalents

In the next sections, the TPC, TA and antioxidant activity of grape pomace extracts obtained by UAE have been discussed separately.

## 2.1. Total Phenolic Content (TPC)

As can be observed in Table V-1, the TPC obtained by UAE from grape pomace varied from 2.81 mg GAE/g residue to 5.78 mg GAE/g wet residue. It is important to highlight that the aforementioned range of TPC is referred per gram of wet residue which contains approximately  $35.8 \pm 1.0\%$  of moisture. Thereby, the range of extraction of phenolic compounds in dry basis varied from 4.38 mg GAE/g to 9.01 mg GAE/g dry residue. This was a larger variation range than that observed in walnut cake (*Chapter IV*). This variation can be related to the higher ultrasound power than can be delivered by the device used for UAE from grape pomace in comparison with that used for walnut cake. Moreover, the greater effect of sonication observed on grape pomace is also related to the intrinsic characteristics of the raw material, since grape pomace was a coarser material (consisting of skin, stems, and seeds) than walnut cake. Thus, the cavitation effect by ultrasonic waves, that leads to a disruption of plant cells, is more relevant in material such as grape pomace than in finer matrices as walnut particles.

Comparing UAE with maceration extraction, this latter allowed to extract 3.2 mg GAE/g wet residue, after 20 min of extraction at room temperature, whereas equal value of TPC was achieved in only 3.5 min when ultrasound was incorporated (200 W; 30% duty cycle; Run 1 in Table V-1). UAE was able to accelerate extraction rate of phenolic compound by promoting the breakdown of cell walls and the penetration of the solvent into plant matrix. Similarly, Bonfigli et al. (2017) reported that the coefficient of diffusivity in UAE from grape pomace is higher than that in conventional extraction methods, in particular at the washing step, i.e. step of constant extraction rate, and González-Centeno et al. (2015) reported that acoustic process (carried out at 87 W of power, solid-to-solvent ratio of 1/20, using water as solvent at 20 °C, 35 °C and 50 °C) required approximately 3 to 8 times less time for recovering similar amount of phenolics (2.3 to 4.8 mg GAE/g dry residue) from grape pomace than by conventional extraction.

The predicted model (in coded values) for the phenolic extraction was: TPC (mg GAE/g residue) =  $4.36 + 0.43 \text{ power} + 0.47 \text{ time} + 0.71 \text{ duty cycle} - 0.11 \text{ power}^2 + 0.14 \text{ power.time} - 0.16 \text{ power.time.duty cycle}$ .

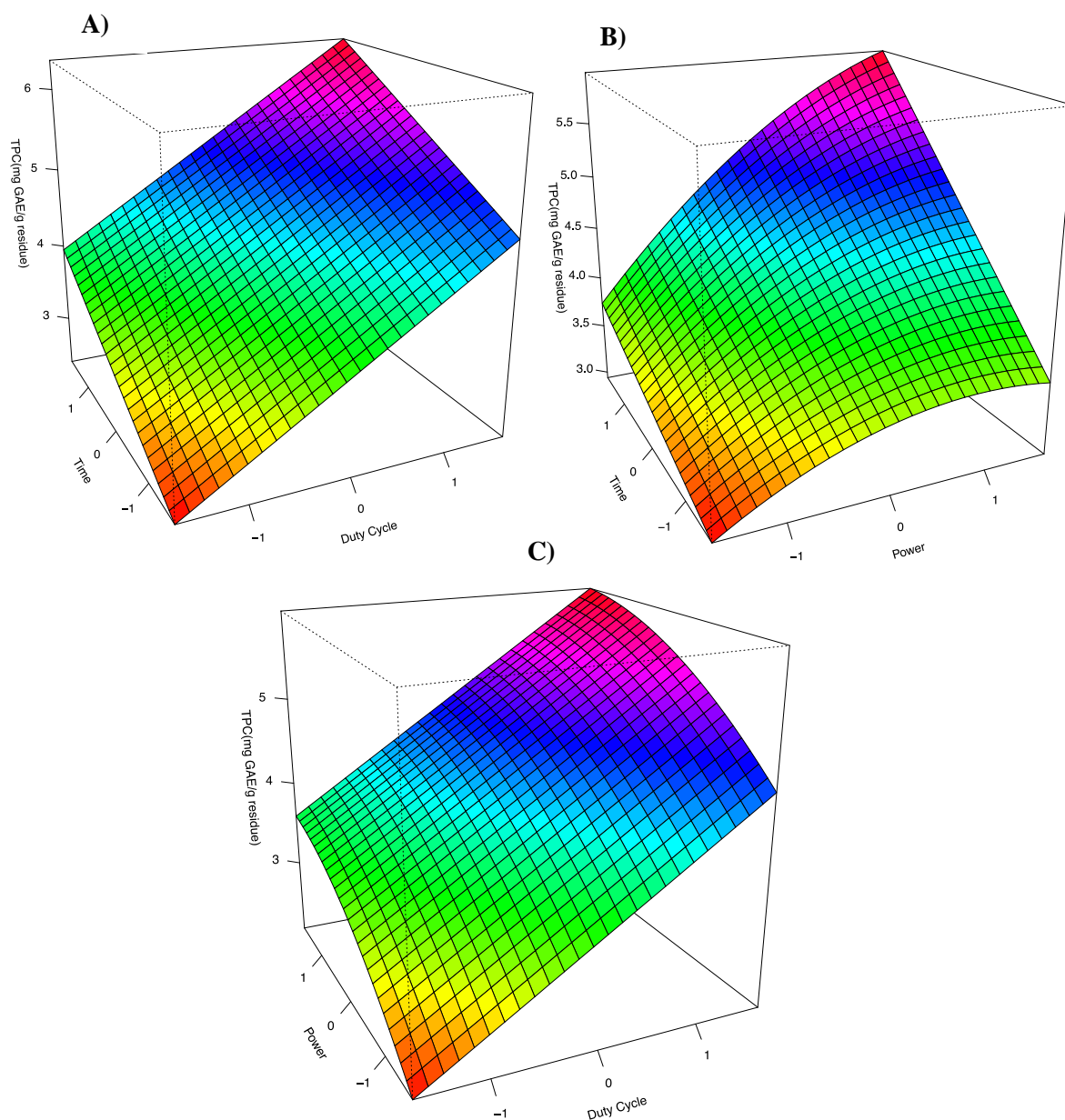
This model fitted well to the experimental data since a coefficient of determination of 0.91 was obtained (ANOVA results in Appendix, Table V-A1). Power of ultrasound, extraction time and duty cycle influenced significantly the extraction of phenolic compounds from grape pomace as expected and in agreement with Goula et al. (2016). From Figure V-1A it can be observed that the extraction of phenolic compounds can be maximized by increasing both time and duty cycle whereas for short extractions the power of ultrasound began to be less significant than the duty cycle (Figures V-1A and V-1B). The quadratic effect of power showed that at a fixed extraction time (Figure V-1B) or duty cycle (Figure V-1C) the TPC increases as power increases, however the trend tends to flatten out at higher levels of power (close to  $+\alpha$ ).

Drevelegka & Goula, (2020) have reported that the extraction yield of phenolic compounds from grape pomace by UAE was time-dependent and increased significantly with extended ultrasonic times from 2 to 20 min. These authors (Drevelegka & Goula, 2020) reported that the ultrasound assisted extraction (power 52 W; solid-to-solvent ratio 1/8; ethanol 50% as extraction solvent at 40 °C; 10 min of extraction) of phenolics had a maximum yield of 33.88 mg GAE/g dry pomace which is significantly higher (3.7-fold) than that reported in this work. However, this discrepancy may come from the initial content of phenolic compound in the grape pomace which varies according to plant variety, growing conditions, grape processing during wine fabrication, among others. On the other hand, González-Centeno et al. (2015) reported more similar extraction yields of phenolic compounds by UAE (4.0-7.8 mg GAE/g dry grape pomace), like Goula et al. (2016) who reported an extraction yield of 9.57 mg GAE/g of dry grape pomace after 10 min of UAE. The aforementioned works (Drevelegka & Goula, 2020; Goula et al., 2016; González-Centeno et al., 2015) also reported the significant influence of temperature on UAE, and globally stated that increasing the temperature (from 20 °C to ~40 °C) the extraction yield is improved since solvent diffuses easier into cells, moreover the vapor pressure of solute increases which enhances the solubilization of target compounds. For instance, González-Centeno et al. (2015) reported that increasing the temperature from 20 °C to 50 °C, the phenolic extraction increased up to 2-fold. Nonetheless, the influence of temperature on TPC was not assessed in this work.

Contrary to Drevelegka & Goula, (2020), in this work the TPC improved as the power increased. This behavior can be explained by the fact that in our case the high level of power of ultrasound did not involve the degradation of the raw material or of the free phenols during the short time of sonication (from 1.8 to 10.2 min), whereas Drevelegka & Goula, (2020)

observed a decrease in phenolic extraction yield after 20 min of sonication. On the other hand, our results were in agreement with the observation of Tao et al. (2014) who reported that the diffusion coefficients of total phenolics increased with acoustic energy, despite the low values of ultrasound power they assessed (1 W to 6 W). Tao et al. (2014) reported an extraction yield of phenolics about 21 mg TPC/g dry grape marc using ethanol 50% as extraction solvent and a solid-to-solvent ratio of 1/20.

It is worth mentioning that authors such as Drevelegka & Goula, (2020) and Tao et al. (2014), which have reported higher extraction yield of TPC than that found in this work, have dried and ground the grape residue prior to UAE thereby, an enhanced phenolic extraction can be expected. Drying and milling of raw materials provide particles with a higher specific surface area, i.e. a larger area of contact between solid and solvent, which improves the extraction rate. In this work, we decided not to dry the grape pomace and only carry out a coarse grinding of the material in order to avoid processes that imply energy, environmental and economic costs to the biorefinery chain.



**Figure V-1.** Response surface plots of the predicted model of time – duty cycle (A), time – power (B) and power - duty cycle (C) for total phenolic extraction from grape pomace by UAE. The third independent factor was set at 0 (coded value) to plot the response surfaces

Finally, some additional tests showed that the acidification of solvent extraction (ethanol 60% at 1% HCl (v/v)) significantly increased the extraction yield of TPC. For instance, the TPC went from 5.78 to 10.5 mg GAE/g wet residue when the extraction solvent was acidified and the UAE was conducted at 360 W (level +1), 70% duty cycle (level +1) and 8.5 min (level +1). An increase of 47% was also achieved for maceration extraction from grape pomace using acidified ethanol 60% (from 3.2 to 4.7 mg GAE/g wet residue). Authors such as

Sánchez Maldonado et al. (2014) have demonstrated that the use of acidified ethanolic solvents for recovering phenolic compound from plant matrices avoids side reactions and allows to obtain more pure and stable phenolic extracts. The enhanced extraction yield of phenolic compounds by using acidified hydroalcoholic solvent mixtures has been particularly observed from anthocyanin-rich matrices (Pereira et al., 2019; Ryu & Koh, 2018; Garcia-Mendoza et al., 2017; Paes et al., 2014). Low pH solvents improve the disruption of cell membranes and the rupture of molecular bonds of sugars and acyl, aryl and alkyl bonds, especially at high temperatures, which facilitate the releasing of phenols from plant matrix to the bulk solvent (Garcia-Mendoza et al., 2017; Machado et al., 2017). Moreover, Garcia-Mendoza et al. (2017) reported that anthocyanins are more stable in acid medium, in which they find favorable conditions for the formation of flavillic ions that result in red colorations of the monomeric anthocyanins.

## 2.2. Total Anthocyanin content (TA)

Anthocyanins are kind of natural pigments (phenol compound) widely distributed in plants such as grape, mulberry, blueberry etc., with numerous biological activities and therapeutic properties, associated with reduced risk of cancer and cardiovascular diseases and improved immune function and glucose control (Zhang et al., 2020). The interest for recovering anthocyanins from plant residues is increasing in particular to be used in food and cosmetics applications as an alternative to synthetic colorants and due to their antioxidant properties. In this context, the total anthocyanin content (TA) was of high interest for this work and therefore it was quantified in the extracts obtained from grape pomace by UAE. As can be observed in Table V-1, the TA varied from 7.8 to 22.1 mg M3-G/100g wet residue (which corresponds to 12.1 to 34.4 mg M3-G/100g dry residue) for the different conditions of power, duty cycle and extraction time assessed in this work. 86% of these experimental results could be explained by the following predicted model (in coded values):  $TA \text{ (mg M3-G/100 g wet residue)} = 17.23 + 1.32 \text{ power} + 1.81 \text{ time} + 3.18 \text{ duty cycle} - 0.88 \text{ duty cycle}^2$  (ANOVA results in Appendix, Table V-A2).

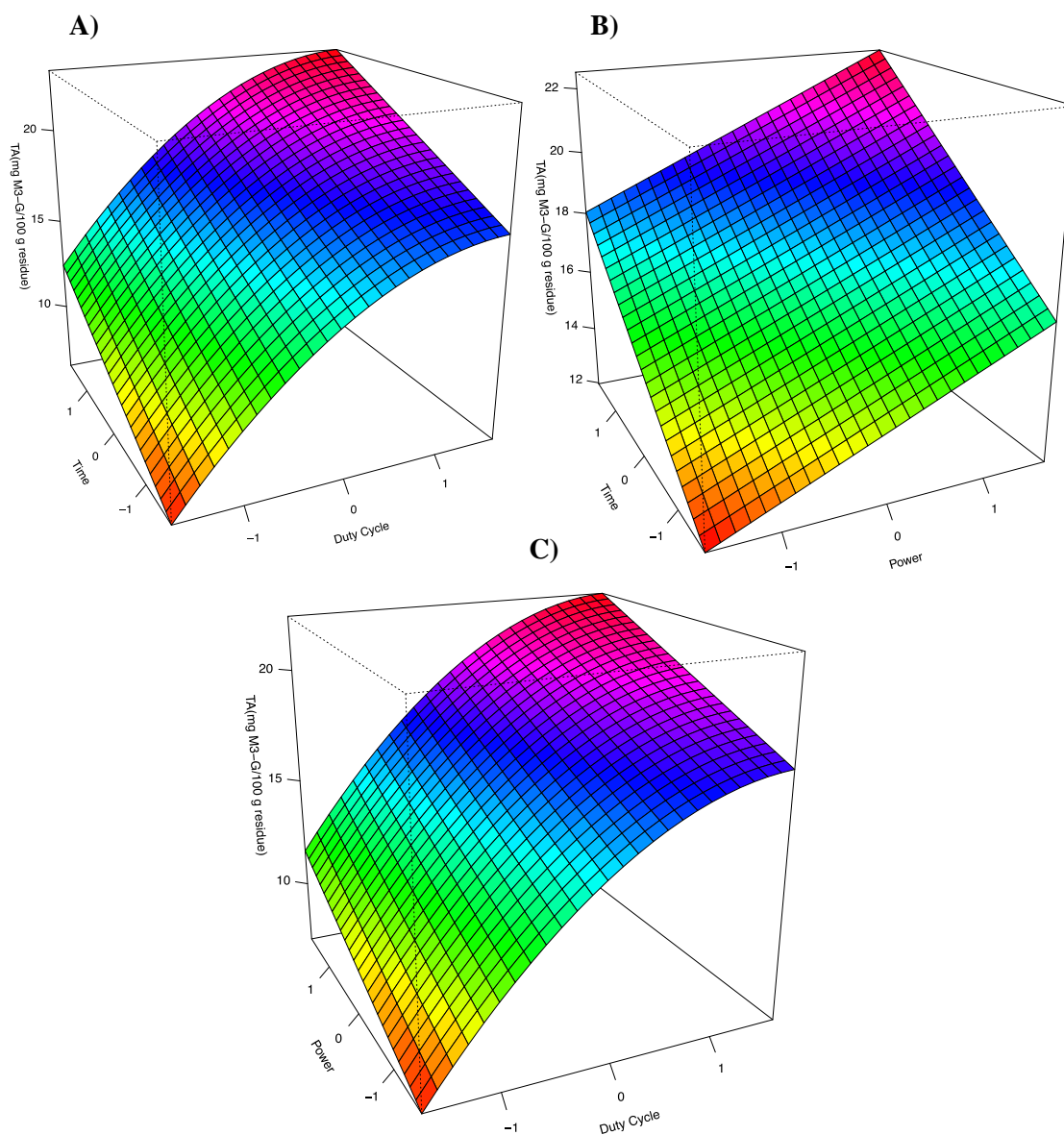
Similar to TPC, power of ultrasound, duty cycle and extraction time significantly influenced the TA. The response surfaces in Figure V-2 show that TA is maximized at highest levels of power, duty cycle and time of UAE. This behavior was expected since TA was directly correlated (Pearson's coefficient = 0.93,  $p < 0.05$ ) with the extraction of total phenolic compounds already discussed in previous section. The extraction yield of anthocyanins of this

work was significantly lower than that reported by Bonfigli et al. (2017) that was about 14.3 mg M3-G/g dry residue, for similar conditions of UAE (160 W, 5 min, 25 °C, ethanol 50% as extraction solvent), and than that reported by Corrales et al. (2008) (11.2 mg cyanidin 3-glucoside equiv./g dry residue) after 1 hour of ultrasonic extraction using ethanol 50% as extraction solvent. Bao et al. (2020), enhanced the extraction yield of anthocyanins from grape pomace from 70 up to 82 mg/100g by applying high voltage atmospheric cold plasma as pretreatment, whereas Pereira et al. (2019) extracted 1.9 mg/g dry grape marc through pressurized liquid extraction using ethanol-water (50%) mixture as solvent. Nonetheless, these variations may come from the initial content of anthocyanins of raw materials or as already stated, because of the pretreatments to raw material prior to extraction such as drying and milling.

According to Sirohi et al. (2020) and Sousa et al. (2014) the total anthocyanin content of grape pomace may vary between 84 and 131 mg/100 g dry matter, what is not consistent with those finding of Bonfigli et al. (2017) and Corrales et al. (2008). On the other hand, this range (84 -131 mg total anthocyanins/100 g dry matter) is closer to that reported by Bao et al. (2020) and Pereira et al. (2019), but still higher than that found in this work, therefore it can be stated that the raw material used in this work exhibited a poor content of anthocyanins. It is worth mentioning that the grape material provided for this work by distillery Union des Coopératives Vinicoles d'Aquitaine (UCVA), was previously submitted to fermentation at room conditions during several days. These conditions should promote degradation of anthocyanins contained in the grape pomace which are known to be very unstable compounds (Muche et al., 2018; Sipahli et al., 2017). For instance, anthocyanins are highly unstable and susceptible to various degradation reactions such as enzymatic or non-enzymatic browning, polymerization and condensation with tannins during processing and storage (Muche et al., 2018). Among the factors that could affect their stability during storage are enzymes, pH, temperature, oxygen and light.

The degradation of anthocyanins prior to their recovery by UAE, highlights the importance of carefully developing the cascade of processes that will integrate the biorefinery scheme. It has been extensively discussed that the cascade process have to be carefully optimized in order to obtain a high extraction yield but also to not significantly affect the quality/properties of material later extracted in the biorefinery chain. From that perspective, the extraction of bioactive compounds and natural pigments from grape residues is suggested

prior to addressing other processes such as fermentation developed in the distillery, in order to preserve the quality or the added-value of these natural compounds.



**Figure V-2.** Response surface plots of the predicted model of time – duty cycle (A), time – power (B) and power - duty cycle (C) for total anthocyanin extraction from grape pomace by UAE. The third independent factor was set at 0 (coded value) to plot the response surfaces

### 2.3. Free radical scavenging activity (DPPH)

The antioxidant activity of grape pomace extracts was evaluated through their capacity to scavenge DPPH free radical. This capacity varied significantly with the power of ultrasound, duty cycle and extraction time and it was predicted by the following model (in coded values);



DPPH ( $\mu\text{mol Trolox Equiv./g residue}$ ) =  $43.08 + 3.99 \text{ power} + 4.09 \text{ time} + 6.09 \text{ duty cycle} - 1.08 \text{ duty cycle}^2$ .

This model explained 87% of the variability of the free radical scavenging activity with the modifications of the independent factors of UAE (ANOVA results in Appendix, Table V-A3). As it can be observed in the response surfaces (Figure V-3), the antiradical activity varied similarly to extraction of TPC with the modification of power, duty cycle and time. In this sense, the highest capacity of grape extracts for scavenging free radicals was achieved at maximum conditions of power of ultrasound, duty cycle and extraction time. The range of the antioxidant activity obtained by UAE was from 28.1 to 56.0  $\mu\text{mol Trolox Equiv./g wet grape pomace}$  (which correspond to 43.8- 87.2  $\mu\text{mol Trolox Equiv./g dry grape pomace}$ ). This range is significantly lower than that obtained from walnut cake discussed in previous chapter. Nonetheless, this behavior was expected since the phenolic content of walnut extracts was significantly higher (about 3-fold) than of grape pomace extracts. Our data was also lower than that reported by Corrales et al. (2008) (300  $\mu\text{mol Trolox Equiv./g dry grape pomace}$ ) who also carried out UAE and Bao et al. (2020) (147-200  $\mu\text{mol Trolox Equiv./g dry grape pomace}$ ) who applied high voltage atmospheric cold plasma as pretreatment for phenolic extraction. However, Bao et al. (2020) and Corrales et al. (2008) were able to extract more phenolic compounds from grape pomace than us (about 3-times and 7-times more, respectively), thereby the report by these author of a higher antioxidant activity was expected.

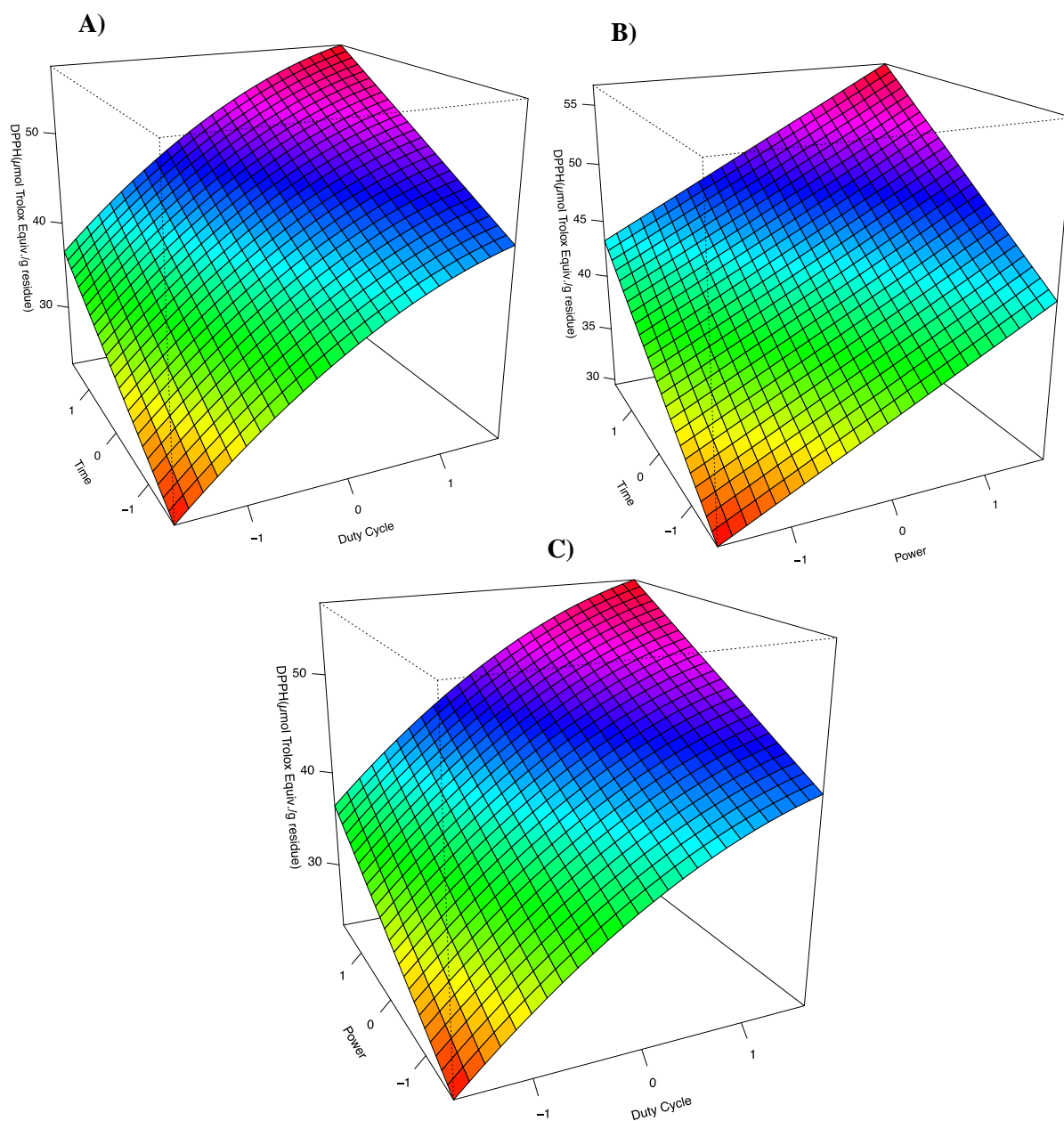
On the other hand, and similar to phenolics from walnut, the antioxidant activity of grape extracts was positively correlated with the extraction yield of phenolic compounds as can be observed in Figure V-A1 (Appendix) (Pearson's coefficient = 0.97). Pereira et al. (2019) have reported that the TPC of grape marc extracts was also highly correlated with their antioxidant activity assessed by ORAC and FRAP assays. On the other hand, Pereira et al. (2019) and Machado et al. (2017) have also reported a poor correlation of the monomeric anthocyanins content with the antioxidant activity (evaluated through ORAC, DPPH and FRAP assays) of the extracts. Our findings showed that TA and free radical scavenging activity (DPPH) was highly correlated (Pearson's coefficient = 0.93). The discrepancies observed between the correlation of the antioxidant activity measured by different methods and the anthocyanins content of grape extracts may be due to the mechanism involved in each analytical assay. For instance, FRAP method is based on the reduction of  $\text{Fe}^{3+}$  to  $\text{Fe}^{2+}$  due to the electron transfer, ORAC measures the absorption capacity of oxygen radicals, whereas

DPPH method is based on the scavenging activity of the 2,2-diphenyl-1-picrylhydrazyl free radical. In this sense, we can state that the anthocyanins participated significantly to the scavenging activity of the DPPH free radical, unlike other works who reported that other phenolic compounds of grape pomace (Pereira et al., 2019), blueberry and grumixama residues (Machado et al., 2017), such as procyanidins, phenolic acids and catechins could be responsible for the antioxidant capacity (measured through DPPH, ABTS and ORAC assays).

On the other hand, studies such as Kharadze et al. (2018) were in agreement with our results since they reported for instance, that the antioxidant activity of wines was directly correlated with their quantitative content of monomeric anthocyanins. Alike, Yuan et al. (2020), who reported a extraction yield of anthocyanins from blueberry peels in a range of 2.0-2.7 mg cyanidin-3-O-glucoside equivalent/g wet material using UAE, found a high correlation between the anthocyanin content and the antioxidant activity of the extracts measured by several methods such as scavenging ability of DPPH, scavenging ability of ABTS<sup>+</sup>, scavenging activity of superoxide anion free radical, inhibition activity of lipid peroxidation and, reducing power of Fe<sup>3+</sup>.

According to Martín et al. (2017), anthocyanins behave as antioxidants by a variety of ways, including direct trapping of reactive oxygen species (ROS), inhibition of enzymes responsible for superoxide anion production, chelation of transition metals involved in processes forming radicals and prevention of the peroxidation process by reducing alkoxy and peroxy radicals. The antioxidant capacity of anthocyanins depends upon their structure, in particular, of the hydrogen atoms of the aromatic group that can be transferred to the free radicals and globally, anthocyanins are very reactive towards ROS because of their electron deficiency (Martín et al., 2017).

In general, the antiradical activity of grape pomace extracts can be also improved by increasing the extraction yield of both total phenolic compounds and anthocyanins since this activity is a concentration-dependent mechanism, thereby it is necessary to avoid the degradation of the bioactive compounds in the raw material prior to extraction process.



**Figure V-3.** Response surface plots of the predicted model of time – duty cycle (A), time – power (B) and power - duty cycle (C) for radical scavenging of grape extracts obtained by UAE. The third independent factor was set at 0 (coded value) to plot the response surfaces

### 3. Conclusion and perspectives

A polynomial model equation was successfully obtained for predicting the total phenolic content, the anthocyanin content and the radical scavenging of grape extracts recovered by ultrasound assisted extraction under different conditions of power, duty cycle and time. The extraction yield of phenolics and anthocyanins as well as the antioxidant activity were maximized at highest levels of power of ultrasound, duty cycle and extraction time. It was observed that ultrasonic waves were able to disrupt the cell wall of plant matrix and therefore facilitated the extraction of phenolic compounds in comparison with the non-sonicated extraction (maceration extraction). However, it was also observed that the grape pomace used for recovering bioactive compounds had a low content of phenolic compound, in particular of anthocyanins, probably due to their significant degradation during fermentation or storage at room conditions at the distillery. Therefore, the extracts recovered in this work exhibited lower phenolic and anthocyanin content than those reported in literature from grape pomace or similar raw materials. In this sense, the order of the cascade processes directly influenced the yield and quality of recovered products from grape pomace. Nonetheless, some other alternatives such as the acidification of the extraction solvent prior to extraction, showed to be an efficient method for enhancing the extraction yield of phenolic compounds from grape pomace and probably also for improving the stability of extracted anthocyanins.

The antioxidant activity of grape extracts, evaluated through the scavenging activity of the 2,2-diphenyl-1-picrylhydrazyl (DPPH) free radical, showed to be highly correlated with both the total content of phenolics and the anthocyanin concentration.

Globally, it was proved that grape pomace can be an inexpensive and abundant source of bioactive compounds and natural pigments which can be extracted for being later used in food, cosmetic or nutraceutical applications. Nonetheless, this chapter should be complemented in order to propose alternatives for the dephenolized material, and simultaneously assess the influence of each processes on the yield and quality of the products later extracted or generated. Grape pomace may be also a source of dietary fiber, unsaturated fatty acids, vitamins and lipophilic antioxidants, as well as of biopolymers. It can be also a raw material for producing biogas and bioethanol. Future works intended to recover the aforementioned added-value products under a biorefinery scheme are suggested. The

assessment of the economic viability of the chain processes of the biorefinery scheme is also highly desirable.

Regarding the recovery of phenolic compounds from grape pomace, the identification separation and quantification of anthocyanins is also recommended for future works.

## References

- Bao, Y., Reddivari, L., Huang, J.Y., 2020. Enhancement of phenolic compounds extraction from grape pomace by high voltage atmospheric cold plasma. *Lwt* 133, 109970.
- Bonfigli, M., Godoy, E., Reinheimer, M.A., Scenna, N.J., 2017. Comparison between conventional and ultrasound-assisted techniques for extraction of anthocyanins from grape pomace. Experimental results and mathematical modeling. *J. Food Eng.* 207, 56–72.
- Corrales, M., Toepfl, S., Butz, P., Knorr, D., Tauscher, B., 2008. Extraction of anthocyanins from grape by-products assisted by ultrasonics, high hydrostatic pressure or pulsed electric fields: A comparison. *Innov. Food Sci. Emerg. Technol.* 9, 85–91.
- Drevelegka, I., Goula, A.M., 2020. Recovery of grape pomace phenolic compounds through optimized extraction and adsorption processes. *Chem. Eng. Process. - Process Intensif.* 149, 107845.
- Garcia-Mendoza, M. del P., Espinosa-Pardo, F.A., Baseggio, A.M., Barbero, G.F., Maróstica Junior, M.R., Rostagno, M.A., Martínez, J., 2017. Extraction of phenolic compounds and anthocyanins from juçara (*Euterpe edulis* Mart.) residues using pressurized liquids and supercritical fluids. *J. Supercrit. Fluids* 119, 9–16.
- González-Centeno, M.R., Comas-Serra, F., Femenia, A., Rosselló, C., Simal, S., 2015. Effect of power ultrasound application on aqueous extraction of phenolic compounds and antioxidant capacity from grape pomace (*Vitis vinifera* L.): Experimental kinetics and modeling. *Ultrason. Sonochem.* 22, 506–514.
- Goula, A.M., Thymiatis, K., Kaderides, K., 2016. Valorization of grape pomace: Drying behavior and ultrasound extraction of phenolics. *Food Bioprod. Process.* 100, 132–144.
- Kharadze, M., Japaridze, I., Kalandia, A., Vanidze, M., 2018. Anthocyanins and antioxidant activity of red wines made from endemic grape varieties. *Ann. Agrar. Sci.* 16, 181–184.
- Machado, A.P.D.F., Pereira, A.L.D., Barbero, G.F., Martínez, J., 2017. Recovery of anthocyanins from residues of *Rubus fruticosus*, *Vaccinium myrtillus* and *Eugenia brasiliensis* by ultrasound assisted extraction, pressurized liquid extraction and their combination. *Food Chem.* 231, 1–10.
- Martín, J., Kuskoski, E.M., Navas, M.J., Asuero, A.G., 2017. Antioxidant capacity of anthocyanin pigments. In: Justino, G. (Ed.), *Flavonoids - from biosynthesis to human health*, IntechOpen, pp. 205-255.
- Morelli, L.L.L., Prado, M.A., 2012. Extraction optimization for antioxidant phenolic compounds in red grape jam using ultrasound with a response surface methodology. *Ultrason. Sonochem.* 19, 1144–1149.

Muche, B.M., Speers, R.A., Rupasinghe, H.P.V., 2018. Storage temperature impacts on anthocyanins degradation, color changes and haze development in juice of “Merlot” and “Ruby” grapes (*Vitis vinifera*). *Front. Nutr.* 5, 1–9.

Paes, J., Dotta, R., Barbero, G.F., Martínez, J., 2014. Extraction of phenolic compounds and anthocyanins from blueberry (*Vaccinium myrtillus* L.) residues using supercritical CO<sub>2</sub> and pressurized liquids. *J. Supercrit. Fluids* 95, 8–16.

Pereira, D.T.V., Tarone, A.G., Cazarin, C.B.B., Barbero, G.F., Martínez, J., 2019. Pressurized liquid extraction of bioactive compounds from grape marc. *J. Food Eng.* 240, 105–113.

Ryu, D., Koh, E., 2018. Application of response surface methodology to acidified water extraction of black soybeans for improving anthocyanin content, total phenols content and antioxidant activity. *Food Chem.* 261, 260–266.

Sánchez Maldonado, A.F., Mudge, E., Gänzle, M.G., Schieber, A., 2014. Extraction and fractionation of phenolic acids and glycoalkaloids from potato peels using acidified water/ethanol-based solvents. *Food Res. Int.* 65, 27–34.

Sipahli, S., Mohanlall, V., Mellem, J.J., 2017. Stability and degradation kinetics of crude anthocyanin extracts from *H. sabdariffa*. *Food Sci. Technol.* 37, 209–215.

Sirohi, R., Tarafdar, A., Singh, S., Negi, T., Gaur, V.K., Gnansounou, E., Bharathiraja, B., 2020. Green processing and biotechnological potential of grape pomace: Current trends and opportunities for sustainable biorefinery. *Bioresour. Technol.* 314, 123771.

Sousa, E.C., Uchôa-Thomaz, A.M.A., Carioca, J.O.B., de Moraes, S.M., de Lima, A., Martins, C.G., Alexandrino, C.D., Ferreira, P.A.T., Rodrigues, A.L.M., Rodrigues, S.P., Silva, J. do N., Rodrigues, L.L., 2014. Chemical composition and bioactive compounds of grape pomace (*Vitis vinifera* L.), Benitaka variety, grown in the semiarid region of Northeast Brazil. *Food Sci. Technol.* 34, 135–142.

Tao, Y., Zhang, Z., Sun, D.W., 2014. Kinetic modeling of ultrasound-assisted extraction of phenolic compounds from grape marc: Influence of acoustic energy density and temperature. *Ultrason. Sonochem.* 21, 1461–1469.

Yuan, J., Li, H., Tao, W., Han, Q., Dong, H., Zhang, J., Jing, Y., Wang, Y., Xiong, Q., Xu, T., 2020. An effective method for extracting anthocyanins from blueberry based on freeze-ultrasonic thawing technology. *Ultrason. Sonochem.* 68, 105192.

Zhang, L., Fan, G., Khan, M.A., Yan, Z., Beta, T., 2020. Ultrasonic-assisted enzymatic extraction and identification of anthocyanin components from mulberry wine residues. *Food Chem.* 323, 126714.

## Appendix

Table V-A1. Estimated regression coefficients of the predicted model for TPC

Regression coefficient	TPC (Predicted model)			
	Coefficient	Std. Error	t-value	p-value
Intercept $\beta_0$	4.36482	0.06465	67.519	$< 2 \times 10^{-16}$ ***
Linear $\beta_i$				
X <sub>1</sub>	0.43279	0.05314	8.144	$9.52 \times 10^{-9}$ ***
X <sub>2</sub>	0.46771	0.05314	8.801	$2.04 \times 10^{-9}$ ***
X <sub>3</sub>	0.71419	0.05314	13.439	$1.78 \times 10^{-13}$ ***
Quadratic $\beta_{ii}$				
X <sub>11</sub>	-0.10605	0.05449	-1.946	0.0621•
Interactions $\beta_{ij}$				
X <sub>12</sub>	0.13687	0.06940	1.972	0.0589•
X <sub>123</sub>	-0.15562	0.06940	-2.242	0.0334*
<b>Adjusted R<sup>2</sup></b>		0.9094		$5.43 \times 10^{-14}$ ****

•, \*, \*\*, \*\*\* significant at 0.1, 0.05, 0.01 and 0.001 level, respectively

Table V-A2. Estimated regression coefficients of the predicted model for TA

Regression coefficient	TA (Predicted model)			
	Coefficient	Std. Error	t-value	p-value
Intercept $\beta_0$	17.2338	0.3346	51.499	$< 2 \times 10^{-16}$ ***
Linear $\beta_i$				
X <sub>1</sub>	1.3274	0.2751	4.825	$4.12 \times 10^{-5}$ ***
X <sub>2</sub>	1.8110	0.2751	6.583	$3.26 \times 10^{-7}$ ***
X <sub>3</sub>	3.1819	0.2751	11.567	$2.20 \times 10^{-12}$ ***
Quadratic $\beta_{ii}$				
X <sub>33</sub>	-0.8801	0.2820	-3.120	0.00406**
<b>Adjusted R<sup>2</sup></b>		0.862		$7.11 \times 10^{-13}$ ****

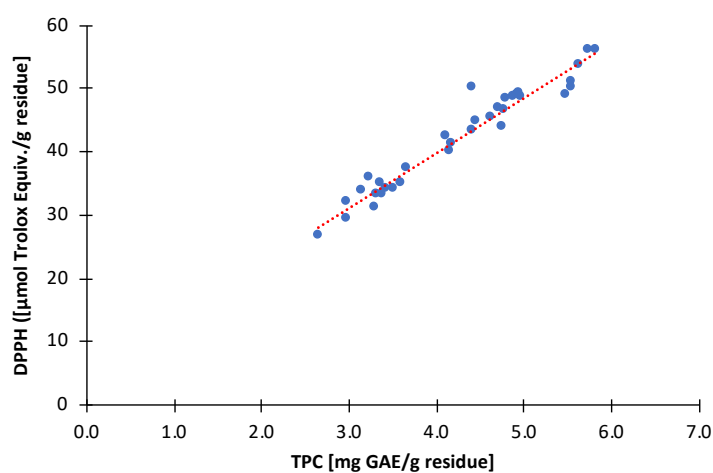
\*, \*\*, \*\*\* significant at 0.05, 0.01 and 0.001 level, respectively



**Table V-A3.** Estimated regression coefficients of the predicted model for DPPH

Regression coefficient	DPPH (Predicted model)			
	Coefficient	Std. Error	t-value	p-value
Intercept $\beta_0$	43.0770	0.6945	62.023	$< 2 \times 10^{-16}$ ***
Linear $\beta_i$				
X <sub>1</sub>	3.9854	0.5709	6.981	$1.13 \times 10^{-7}$ ***
X <sub>2</sub>	4.0911	0.5709	7.166	$6.91 \times 10^{-8}$ ***
X <sub>3</sub>	6.0900	0.5709	10.667	$1.50 \times 10^{-11}$ ***
Quadratic $\beta_{ii}$				
X <sub>33</sub>	-1.0780	0.5854	-1.842	0.0758 •
<b>Adjusted R<sup>2</sup></b>		0.866		$4.67 \times 10^{-13}$ ***

•, \*, \*\*, \*\*\* significant at 0.1, 0.05, 0.01 and 0.001 level, respectively



**Figure V-A1.** Correlation between TPC and antiradical activity of grape pomace extracts obtained by UAE

## **General conclusion and perspectives**

This work successfully proposed and developed a biorefinery scheme from common agro residues such as corn germ and walnut press-cake, and also began some explorations to recover added value products from grape pomace. Various fractions, i.e. oil and protein, were recovered from corn germ by adopting a cascading approach; the first step of this cascading process consisted of oil extraction which significantly influenced the yield and quality of proteins later extracted from defatted meals. Factors such as temperature and type of solvent significantly influenced the extraction of oil and showed an impact on remaining proteins of corn germ. Phenolic content of corn oil was influenced by the extraction solvent contrary to fatty acid composition that was the same regardless the oil extraction method. Protein extracts obtained from raw corn germ and various defatted meals exhibited different functionality (solubility, water absorption, foaming and emulsifying capacities) according to the conditions used previously to recover the oil. Partial denaturation of corn germ proteins may occur when high temperatures and/or alcoholic solvents were used to extract oil. Although, partial denaturation of proteins can be deleterious for some functional properties (as protein solubility), it can also be beneficial for others such as water absorption capacity. The use of green technologies like supercritical carbon dioxide in a biorefinery scheme showed to be an appropriate and advantageous technique to recover valuable products from plant residues.

On the other hand, walnut press-cake showed to be an abundant and inexpensive source of oil and antioxidant compounds namely polyphenols. The oil remaining in walnut press-cake can be recovered by conventional techniques such as Soxhlet extraction or using high pressure techniques like supercritical fluids. Oil from walnut exhibited a high content of polyunsaturated fatty acids. Furthermore, defatted walnut cake was a good source of phenolic compounds with an interesting antiradical activity that can be useful for food, pharmaceutical and cosmetic applications. Although ultrasound assisted extraction (UAE) may enhance the phenolic extraction from walnut cake, the influence of the sonication parameters should be studied using a wide range of power as we proposed for the extraction of phenolics from grape pomace. In this context, a higher magnitude of TPC variation from grape pomace than from walnut cake was observed during UAE; this was probably due to the higher magnitude of the investigated variables (in particular of ultrasound power) when phenolic were extracted from grape pomace than from walnut cake. Globally, the extraction of phenolic compounds from grape pomace was enhanced by using ultrasonic waves but it was also observed that the grape pomace used

## *General conclusion*

in this work had a low content of phenolic compounds, probably due to their significant degradation prior to UAE. Phenolic content of extracts from both walnut cake and grape pomace were directly correlated with the capacity of these extracts to scavenge DPPH free radicals.

Finally, it is worth mentioning that both corn germ and walnut cake fine powders were convenient for the stabilization of oil-in-water emulsions by producing highly stable emulsions with fine oil droplets. However, emulsions stabilized by walnut particles showed finer oil droplets and less creaming probably attributed to higher protein content of walnut cake in comparison to corn germ. Moreover, linseed oil droplets stabilized by walnut particles exhibited a higher oxidative stability than bulk oil; delaying of lipid oxidation in Pickering emulsions was more related to the formation of a steric barrier than to the antioxidant activity of plant polyphenols.

The suggestions for future work are numerous:

- The assessment of some food applications for vegetable protein extracts; for instance by enriching food products or fabrication of edible films and coatings, which would add value to the proposed biorefinery scheme.
- The optimization of supercritical fluid extraction to recover oil fractions and simultaneously explore the co-extraction of protein from plant residues by using co-solvents. Moreover, water as co-solvent for oil and protein extraction could yield emulsions or functional extracts in one-extraction-step which would be of great interest for future works.
- Develop an economical and energy study of each step of the biorefinery scheme in which the various products/materials are obtained in order to assess the economic viability of the process. The use of the Life-cycle assessment method may be a suitable alternative.
- Expand the biorefinery scheme from grape pomace by recovering other valuable fractions such as dietary fiber, unsaturated fatty acids, vitamins, lipophilic antioxidants, biopolymers, etc.
- The accurate identification of phenolic compounds of walnut and grape extracts obtained by hydroalcoholic solutions which are responsible for the antioxidant activity

## *General conclusion*

of the extracts. This could allow proposing processes of greater selectivity or fractional extraction schemes.

- Monitor and model the kinetic extraction of polyphenols from plant materials when intensified techniques as ultrasound assisted extraction are used. This may allow optimizing extraction parameters regarding energy and solvent consumption.
- Characterize the morphology and charge of surface of plant particles after sonication treatment that may explain the loss of functionality to stabilize Pickering emulsion.
- Assess the extraction of phenolic compounds by using acidified solvents and by means of other intensified techniques such as pressurized liquid extraction.
- Assess a sequential high pressure extraction is suggested for the recovery of both non-polar compounds (supercritical carbon dioxide) and polar fractions (pressurized hydroalcoholic solvents).

