



HAL
open science

Tools and results in the study of entropy production

Renaud Raquépas

► **To cite this version:**

Renaud Raquépas. Tools and results in the study of entropy production. Dynamical Systems [math.DS]. Université Grenoble Alpes [2020-..]; McGill university (Montréal, Canada), 2020. English. NNT : 2020GRALM052 . tel-03132942

HAL Id: tel-03132942

<https://theses.hal.science/tel-03132942v1>

Submitted on 5 Feb 2021

HAL is a multi-disciplinary open access archive for the deposit and dissemination of scientific research documents, whether they are published or not. The documents may come from teaching and research institutions in France or abroad, or from public or private research centers.

L'archive ouverte pluridisciplinaire **HAL**, est destinée au dépôt et à la diffusion de documents scientifiques de niveau recherche, publiés ou non, émanant des établissements d'enseignement et de recherche français ou étrangers, des laboratoires publics ou privés.



THÈSE

Pour obtenir le grade de

DOCTEUR DE L'UNIVERSITÉ GRENOBLE ALPES

préparée dans le cadre d'une cotutelle entre
l'Université Grenoble Alpes et

l'Université Mc Gill

Spécialité : Mathématiques

Arrêté ministériel : 25 mai 2016

Présentée par

Renaud RAQUEPAS

Thèse dirigée par **Alain JOYE**, Professeur, Université Grenoble Alpes et codirigée par **Vojkan JAKSIC**, Montréal, Université Mc Gill (Montréal)

préparée au sein des **Laboratoires de l'Institut Fourier** dans les **Écoles Doctorales Mathématiques, Sciences et technologies de l'information, Informatique et le Département Mathématiques et Statistiques de l'Université Mc Gill**

Outils et résultats dans l'étude de la production d'entropie

Tools and results in the study of entropy production

Thèse soutenue publiquement le **6 novembre 2020**, devant le jury composé de :

Monsieur ALAIN JOYE

PROFESSEUR DES UNIVERSITES, UNIVERSITE GRENOBLE ALPES, Directeur de thèse

Monsieur STEPHAN DE BIEVRE

PROFESSEUR DES UNIVERSITES, UNIVERSITE LILLE 1, Rapporteur

Monsieur LOUIGI ADDARIO-BERRY

PROFESSEUR ASSOCIE, UNIVERSITE MCGILL MONTREAL, Rapporteur

Monsieur VOJKAN JAKSIC

PROFESSEUR, UNIVERSITE MCGILL MONTREAL, Directeur de thèse

Monsieur LUC VINET

PROFESSEUR, UNIVERSITE DE MONTREAL - CANADA, Président



TOOLS AND RESULTS
IN THE STUDY OF
ENTROPY PRODUCTION

BY

RENAUD RAQUÉPAS

DEPARTMENT OF MATHEMATICS AND STATISTICS,
McGILL UNIVERSITY, MONTRÉAL

AND

ÉCOLE DOCTORALE MSTII,
UNIVERSITÉ GRENOBLE ALPES, GRENOBLE

A THESIS SUBMITTED TO McGILL UNIVERSITY
IN PARTIAL FULFILLMENT OF THE REQUIREMENTS OF THE DEGREE OF
DOCTOR OF PHILOSOPHY

August 2020 (last revised December 2020)

THÈSE
POUR OBTENIR LE GRADE DE
DOCTEUR

Préparée dans le cadre d'une cotutelle entre
la Communauté Université Grenoble Alpes et l'Université McGill
Spécialité : Mathématiques

Présentée par
Renaud RAQUÉPAS

Dirigée par
Alain JOYE et Vojkan JAKŠIĆ

Préparée
au sein de l'Institut Fourier et dans l'École doctorale MSTII à l'Université Grenoble Alpes
et au sein du Département de Mathématiques et de statistique à l'Université McGill

OUTILS ET RÉSULTATS
DANS L'ÉTUDE DE
LA PRODUCTION D'ENTROPIE



Arrêté ministériel : 6 janvier 2005 — 25 mai 2016

Thèse soutenue publiquement le 6 novembre 2020 devant le jury composé de :

Luc VINET, président du jury
Louigi ADDARIO-BERRY, rapporteur et membre du jury
Stephan de BIÈVRE, rapporteur et membre du jury
Alain JOYE, directeur de thèse
Vojkan JAKŠIĆ, directeur de thèse

AMS Subject Classification (2020): 82C05, 82C31, 60F10, 60H10, 81Q20, 37A25, 93B05, 82C10, 81Q80

© 2020 — R. Raquépas

This thesis contains reproduction of copyrighted material published by Springer Nature Switzerland AG (2019, 2020). This thesis was typeset using \LaTeX with “EB Garamond” by G. Duffner and O. Pardo and “Garamond Math” by Y. Zhao, X. Zeng — both based on works of C. Garamont — with additional glyphs from the AMS Euler and TeX Gyre projects.

Abstract

This thesis consists mainly of a collection of papers on the study of the large-time asymptotics of entropy production and associated mixing problems. After having introduced the central notions, we present, in order: a study of the vanishing-noise limit for the large deviations of entropy production functionals in nondegenerate diffusions; an exponential mixing result for stochastic differential equations driven by degenerate Brownian noise; an exponential mixing result for stochastic differential equations driven by degenerate Poissonian noise; a study of the large-time behaviour of ensembles of fermionic walkers interacting with a structured environment; a study of currents and entropy production in a similar framework.

Résumé

Cette thèse consiste principalement en une collection d'articles portant sur l'étude du comportement asymptotique à temps longs de la production d'entropie et sur des problèmes de mélanges qui y sont associés. Après avoir introduit les notions centrales, on présente, dans l'ordre : une étude de la limite du bruit disparaissant de principes de grandes déviations locaux pour des fonctionnelles de production d'entropie dans le cadre des diffusions non dégénérées; un résultat de mélange exponentiel pour des équations différentielles stochastiques avec bruit brownien dégénéré; un résultat de mélange exponentiel pour des équations différentielles stochastiques avec bruit de Poisson dégénéré; une étude des comportements à temps longs d'ensembles de marcheurs fermioniques interagissant avec un environnement structuré; une étude des courants et de la production d'entropie dans ce même cadre.

Préface

Approaching the end of my graduate studies, I have many people to thank for making this journey worthwhile through its ups and downs. It all started with Vojkan Jakšić giving me outstanding learning opportunities as early as my second year of undergraduate studies at McGill University and quickly introducing me to Alain Joye, who soon became a mentor to me. I could not have hoped for a better pair of supervisors for my Ph D: they have been incredibly helpful, caring and responsive over the years and the value of their knowledge and technical competency can hardly be overstated. One of the most notable additions to the group of people who would end up teaching and supporting me is that of Armen Shirikyan. I am truly grateful for the patience and selflessness he has shown in teaching me and am sincerely looking forward to continue learning from him in the near future. I also wish to thank Vahagn Nersesyan and Simon Andréys for the enthusiasm and hard work they have put in our respective collaborations. I am grateful to Louigi Addario-Berry and Stephan De Bièvre for accepting to report on this thesis.

I have also greatly benefited from interacting with Tristan Benoist, Jean-François Bougron, Laurent Bruneau, Yan Pautrat and Claude-Alain Pillet. Special thanks to Noé Cuneo and Annalisa Panati who, in addition to many insightful discussions on physics and mathematics, have also been generously helping me navigate some of the more human aspects of an early academic career.

Merci à mes parents, Josée et Mario, pour leur amour, leurs sacrifices et leur bienveillance. Merci à Dominique pour son support, sa compréhension et sa douceur. Merci à Erick, Joey, Samuel et Nicolas pour leur honnêteté, leur hospitalité et leurs tableaux blancs. Merci à Émile, Rox-Anne et Stéphanie. Merci à Alexandre, Anthony, Charles, Jie Lee, Maxime, Olivier, Thierry et Thomas.

Statement on financial support

The research of the Ph D candidate presented in this thesis was supported by the National Science and Engineering Research Council of Canada through the Canada Graduate Scholarship Program, Université Grenoble Alpes through an allocation du Vice-président recherche, and the Fonds de recherche du Québec – Nature et technologie through the Programme de bourse de deuxième cycle.¹ The Ph D candidate also received additional funds from the Agence Nationale de la Recherche through the grant *NONSTOPS* (ANR-17-CE40-0006), the Conseil National de la Recherche Scientifique through GDR 3274 *DynQua*, and the Initiative d'excellence Paris-Seine through the grant *Structural properties of non-equilibrium steady states in statistical mechanics*.

As for coauthors, A. Joye was partially supported by the Agence Nationale de la Recherche through the grant *NONSTOPS* (ANR-17-CE40-0006), V. Nersesyan was partially supported by the the Agence Nationale de la Recherche through the grant *NONSTOPS* (ANR-17-CE40-0006) and the Conseil National de la Recherche Scientifique through *PICS Fluctuation theorems in stochastic systems*, S. Andréys was partially supported by the Agence Nationale de la Recherche in the framework of the Investissements d'avenir program (ANR-15-IDEX-02).

Statement on original contributions and authorship

Chapters 1 and 7 were authored by the Ph D candidate and contain no original contribution to knowledge. Chapters 2, 3 and 5 were written by the Ph D candidate are considered original scholarship and distinct contributions to knowledge. Chapter 4 was written by V. Nersesyan and the Ph D candidate as co-first authors and also contains original results, to which each author contributed. Chapter 6 was written by S. Andréys, A. Joye and the Ph D candidate as co-first authors and also contains original results, to which each author contributed.

Although not authors, the following people have provided valuable insights and/or suggestions: N. Cuneo for Chapters 1, 2 and 3; A. Joye for Chapters 2 and 5; V. Jakšić for Chapters 1 and 2; C.-A. Pillet for Chapters 2 and 4; and A. Shirikyan for Chapters 2, 3 and 4.

¹Chapter 3 was initiated before the end of the author's M Sc at McGill University, but completed during the author's doctoral studies.

Contents

1	Introduction	1
1.1	Motivation	1
1.2	A Brief overview of the classical theory of entropy production	2
1.2.1	Some remarks on Hamiltonian systems	2
1.2.2	Hypothesis testing	5
1.2.3	Entropy production in thermostated systems	8
1.2.4	Entropy production in stochastic systems	11
1.3	Entropy production in quantum mechanics	12
1.4	Thermodynamics	12
1.5	Mixing	15
1.5.1	Mixing for stochastic differential equations	15
1.5.2	The Approach of Kuksin and Shirikyan	17
	Bibliography	26
2	The large-time and vanishing-noise limits for entropy production in nondegenerate diffusions	33
2.1	Introduction	34
2.2	Setup, definitions and preliminary results	37
2.2.1	Assumptions on the equation and immediate consequences	37
2.2.2	Time reversal and the canonical entropy production functional	40
2.3	Generalised entropy production functionals	45

2.3.1	Definition and the weak law of large numbers	45
2.3.2	Assumptions on the boundary terms and the initial condition	47
2.3.3	A representation for the moment-generating function	51
2.4	Large deviations in the large-time limit	55
2.5	The linear case	58
2.6	The rate function in the vanishing-noise limit	61
2.7	Convergence in the proof of Proposition 2.6.3	68
	Appendix 2.A Properties of the deformed generators	74
	Bibliography	80
3	A Note on Harris' ergodic theorem, controllability and perturbations of harmonic networks	85
3.1	Introduction	87
3.2	Setup, assumptions and main result	89
3.3	Proof of Theorem 3.2.3	93
3.3.1	Dissipativity and Lyapunov stability	93
3.3.2	Approachability and solid controllability	94
3.3.3	Application of Harris' ergodic theorem	103
3.4	Networks of oscillators	105
3.4.1	The linear chain coupled to Langevin thermostats	105
3.4.2	More general geometries in the Langevin regime	107
3.4.3	Coupling through additional degrees of freedom	109
3.5	The weak Hörmander condition	111
	Appendix 3.A Decomposability properties	115
	Bibliography	116
4	Exponential mixing under controllability conditions for SDEs driven by a degenerate Poisson noise	119
4.1	Introduction	120

4.2	Preliminaries and existence of an invariant measure	125
4.3	Coupling argument and exponential mixing	130
4.3.1	Coupling for the embedded discrete-time process	132
4.3.2	Coupling for the original continuous-time process	136
4.3.3	Concluding the proof of the Main Theorem	137
4.4	Applications	138
4.4.1	Criteria for solid controllability	138
4.4.2	Galerkin approximations of randomly forced PDEs	140
4.4.3	Stochastically driven networks of quasi-harmonic oscillators	143
Appendix 4.A	Exponential estimates on hitting times	148
Appendix 4.B	Controllability of ODEs with polynomially growing nonlinearities	154
Appendix 4.C	Some results from measure theory	158
4.C.1	Maximal couplings	158
4.C.2	Images of measures under regular mappings	158
Bibliography	159
5	On Fermionic walkers interacting with a correlated structured environment	163
5.1	Introduction	164
5.2	The system and its dynamics	166
5.2.1	A quantum walk in a sample	166
5.2.2	Interaction with an environment	168
5.3	The initial state	171
5.4	Asymptotics	173
5.4.1	The state in the sample	174
5.4.2	Flux observables	180
5.5	Examples	183
5.5.1	Quantum walks on a ring	183
5.5.2	A Large sample with disorder	184
Appendix 5.A	Comments on the statistics	186

Bibliography	187
6 Fermionic walkers driven out of equilibrium	190
6.1 Introduction	191
6.1.1 Motivation	191
6.1.2 Illustration	193
6.1.3 Structure of the paper	195
6.2 The setup	196
6.2.1 The spaces and one-particle dynamics	196
6.2.2 The initial state in Fock space	198
6.2.3 Relation to repeated interaction systems	199
6.3 Mixing	200
6.3.1 Scattering and the asymptotic state	201
6.3.2 Fourier representation	206
6.4 Fluxes of particles	208
6.5 Entropy production	210
6.6 Discussion for small coupling strength	212
6.7 Proof of Proposition 6.3.1	220
6.8 Proof of Theorem 6.5.1	222
Bibliography	227
7 Discussion and conclusion	231
Bibliography	232

Chapter 1

Introduction

1.1 Motivation

The goal of this introduction is to motivate some of the objects that are studied in the subsequent chapters and to provide the interested readers additional references on the subject. Discussion of the state of the art for specific problems is postponed to the introductions of the different chapters.

We are interested in mathematical problems that stem from a desire to capture and understand the onset of physical phenomena that can be observed at time scales which — while perhaps small compared to cosmological time scales — are very large when compared to the characteristic time scales for the microscopic dynamics. Such phenomena include heat transfers, membrane transport, electrical currents and chemical reactions.

For the purpose of illustration, consider two large blocks of metal, one hotter than the other, sitting in a room separated by a distance which is small compared to the respective sizes of the blocks, but with little air for heat conduction between them. Upon joining the two blocks with a small metal rod, you expect a heat flow to settle across the rod. If your blocks are very large, the flow should remain relatively steady for a long time before the heat lost by the hotter block lowers its temperature in the bulk, or the heat gained raises that of the colder block. Several questions naturally arise. How fast does the current reach this steady value? How do you describe the state carrying this flow of heat? What are the properties of the statistical fluctuations of this flow? How is the confident prediction

that heat steadily flows from the hotter block to the colder one compatible with the microscopic reversibility of the dynamics?

We will introduce some of the mathematical tools that are used to frame such problems. This introduction is almost exempt of proofs, with the notable exception of a basic result on mixing for Markov chains which serves as an introduction to some of the ideas used in the more complicated settings of Chapters 3 and 4.

1.2 A Brief overview of the classical theory of entropy production

In classical systems, entropy production comes in many guises and — for the reader’s convenience — we briefly motivate different notions of entropy production that appear in the different chapters. We first approach the subject from the point of view of hypothesis testing rather than from a historical perspective. Our starting point will be a way of quantifying how easy it is to guess the original direction of time in a movie possibly shown to us backwards.

The references given are not exhaustive but should allow the reader to get a good idea of the different ideas in the literature.

1.2.1 Some remarks on Hamiltonian systems

We start by discussing what is generally admitted as the proper framework for the time evolution of confined systems in the classical regime: objects moving down inclined planes, masses connected by a set of springs, molecules of a monoatomic gas in a container, etc. From Hamilton’s point of view, the physical time evolution of such a system is expressed in terms of integral curves of a vector field on a *phase space*, which is typically the co-tangent bundle T^*M of a manifold M used to describe the possible configurations in space. In a nutshell, a distinguished function H on T^*M called the *Hamiltonian function* of the system gives rise to a one-form dH which can then be associated to a vector field, called the *Hamiltonian vector field*, using the natural symplectic structure of T^*M .

Consider the manifold \mathbf{R}^N and a smooth function $H : T^*\mathbf{R}^N \rightarrow [0, \infty)$ such that $H^{-1}([0, E])$

is compact for all $E \in \mathbf{R}$ and which is invariant under precomposition with the map θ which changes the sign in the fibre. With suitable coordinates $(q, p) = (q^1, \dots, q^N, p_1, \dots, p_N)$ on $T^*\mathbf{R}^N$, the integral curves for the aforementioned Hamiltonian vector field constructed from H in a canonical way are the solutions to the equations

$$\begin{aligned}\dot{q}^i &= \frac{\partial H}{\partial p_i}, \\ \dot{p}_i &= -\frac{\partial H}{\partial q^i}.\end{aligned}\tag{1.1}$$

These equations are known as *Hamilton's equations of motion* and induce a global flow $(\phi_t)_{t \geq 0}$ on phase space. The following observations are consequences of elementary computations.

(EC) Any curve satisfying (1.1) is forever bound to a compact level set of H specified by its initial condition.

(LT) The flow $(\phi_t)_{t \geq 0}$ generated by Hamilton's equations (1.1) preserves volumes (the Lebesgue measure).

(TRI) If the curve $[0, T] \ni t \mapsto (q(t), p(t))$ solves (1.1), then the curve $[0, T] \ni t \mapsto (\bar{q}(t), \bar{p}(t))$ defined by

$$\bar{q}^i(t) := q^i(T - t) \quad \text{and} \quad \bar{p}_i(t) := -p_i(T - t)$$

also solves (1.1). In other words,

$$\phi_{-t} = \theta \circ \phi_t \circ \theta$$

for all $t \in \mathbf{R}$.

While we considered a particular form of the phase space for simplicity, these observations generalize to the abstract setup of Hamiltonian mechanics on finite-dimensional symplectic manifold — simply referred to as *confined Hamiltonian systems* hereafter —; see e.g. [AM87, §II.3.3] or [Lee13, §22]. They are fundamental properties of the structure of classical mechanics with a finite number of degrees of freedom. The observation (EC) is named after the concept of energy conservation and

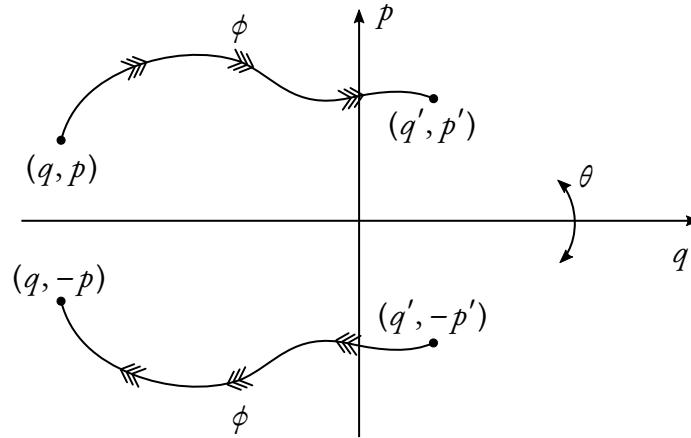

Figure 1.1: Time reversal invariance for Hamiltonian systems: if the physical time evolution ϕ brings an initial condition (q, p) to (q', p') in time T , then this same time evolution also brings $(q', -p')$ to $(q, -p)$ in the same time.

(LT) is called *Liouville's volume theorem*. The property (TRI) is called *time reversal invariance*¹ and is illustrated in Figure 1.1.

While the above description is given in terms of curves in phase space, it is worth noting in passing that, for many applications, it is more convenient to focus on the algebra of physical *observables* of the system, i.e. an algebra of functions on phase space. The flow $(\phi_t)_{t \geq 0}$ on phase space induces a semigroup $(\tau^t)_{t \geq 0}$ acting on functions by precomposition:

$$\tau^t f := f \circ \phi_t.$$

From this point of view, points in phase space are still relevant in that they are associated to evaluation maps, which form a special class of linear functionals on the algebra of functions. More generally, we refer to any normalized positive continuous linear functional on this algebra — that also includes integration against any Borel probability measure — as *states* of the system.

¹Our definition of time reversal involves a change of sign of the momentum variables p_1, \dots, p_N because they are structurally related to the time derivatives of the coordinates q^1, \dots, q^N and $\frac{d}{dt} q^i(T-t) = -\frac{d}{ds} q^i(s)|_{s=T-t}$. In Chapter 2, we consider an approximate dynamics in terms of position variables only, in which case the time reversal takes a simpler form.

1.2.2 Hypothesis testing

Hamilton's equations (1.1), without knowledge of the initial conditions, merely separate the space of curves over an interval $[0, T]$ into two classes: those that are physically admissible and those that can be ruled out. Note that (TRI) tells us that a curve $[0, T] \ni t \mapsto (q(t), p(t))$ is admissible if and only if its reversal $[0, T] \ni t \mapsto (q(T - t), -p(T - t))$ is admissible.

The situation becomes more subtle and interesting if we have a prior on the values of the variables at time $t = 0$: we can compare the likelihood of different admissible paths. Let λ be a probability measure which is invariant under θ and which possesses a continuous positive density with respect to the restriction of the Lebesgue measure to a shell

$$M_{E,\delta} := \{(q, p) : E \leq H(q, p) \leq E + \delta\}$$

for some point E of the range of H and some small number $\delta > 0$. The shell $M_{E,\delta}$ is compact and invariant under $(\phi_t)_{t \geq 0}$ by (EC).²

Knowing λ and given a path $\gamma : [0, T] \rightarrow \mathbf{R}^{2N}$, you are asked to guess according to which of the two following protocols the path γ was generated:

- (H0)** An agent sampled an initial condition $(q(0), p(0))$ from λ , recorded the evolution up to time T according to Hamilton's equation and showed you $\gamma(t) := (q(t), p(t))$,
- (H1)** An agent sampled an initial condition $(q(0), p(0))$ from λ , recorded the evolution up to time T according to Hamilton's equation and showed you $\gamma(t) = (q(T - t), -p(T - t))$.

We call the task of distinguishing between those two hypotheses *hypothesis testing of the arrow of time*.

In other words, with $\Phi_T : (q, p) \mapsto (\phi_t(q, p))_{t \in [0, T]}$ according to Hamilton's equations (1.1) and $\Theta_T : (q(t), p(t))_{t \in [0, T]} \mapsto (q(T - t), -p(T - t))_{t \in [0, T]}$ the operation on paths introduced in (TRI)

²The restriction to an energy shell of small finite width is technically convenient but not necessary. One can consider the whole phase space if making sure that reasonable bounds on the density of λ hold in order to deduce (1.4) from (1.3c) below. If E is a regular value of H , the other limiting case $\delta \rightarrow 0$ is treated considering a reference measure λ equivalent to the surface measure Σ_E on $M_{E,0}$ and using a comparison with \mathcal{A}_E defined by $|\nabla H| d\mathcal{A}_E = d\Sigma_E$ — invariant under $(\phi_t)_{t \geq 0}$ as well — instead of with the volume measure in (1.3a)–(1.3c).

and (H1), the hypothesis (H0) is that γ was sampled from the distribution

$$\mathcal{P}_T^\lambda := \lambda \circ \Phi_T^{-1}$$

and the hypothesis (H1) is that γ was sampled from the distribution

$$\hat{\mathcal{P}}_T^\lambda := \lambda \circ \Phi_T^{-1} \circ \Theta_T^{-1}.$$

Let us assume for simplicity that the two hypotheses are *a priori* equally probable.

With the celebrated result of Neyman and Pearson in mind, you choose to make your guess based on the log-likelihood ratio for a sampled path γ :

$$S_T^\lambda(\gamma) = \log \left(\frac{d\mathcal{P}_T^\lambda}{d\hat{\mathcal{P}}_T^\lambda}(\gamma) \right). \quad (1.2)$$

Given a path γ provided by the agent, you choose to guess (H0) or (H1) according to the outcome of the test

$$\text{NPT}_T^\lambda(\gamma) := \begin{cases} 0 & \text{if } S_T^\lambda(\gamma) \geq 0, \\ 1 & \text{otherwise;} \end{cases}$$

you guess (H0) if $\text{NPT}_T^\lambda(\gamma) = 0$ and (H1) if $\text{NPT}_T^\lambda(\gamma) = 1$. Doing so, you expect to be wrong at a frequency

$$\mathbb{F}[\mathcal{P}_T^\lambda, \hat{\mathcal{P}}_T^\lambda] = \frac{1}{2} \mathcal{P}_T^\lambda\{\gamma : \text{NPT}_T^\lambda(\gamma) = 0\} + \frac{1}{2} \hat{\mathcal{P}}_T^\lambda\{\gamma : \text{NPT}_T^\lambda(\gamma) = 1\}$$

and this number cannot be improved by replacing NPT_T^λ with any other $\{0, 1\}$ -valued function; this is sometimes called a Bayesian version of the *Neyman–Pearson lemma*. It is well known that decay of $\mathbb{F}[\mathcal{P}_T^\lambda, \hat{\mathcal{P}}_T^\lambda]$ as $T \rightarrow \infty$ is intimately linked to the behaviour of the moment-generating function of the log-likelihood ratio in the same regime. The following proposition can be found for example in [CJN⁺20]; also see [JOPS12, BJPP18, BCJP20].

Proposition 1.2.1. *Let $(P_T, Q_T)_{T \geq 0}$ be a family of pairs of mutually absolutely continuous measures on Polish spaces. Suppose that the limit*

$$e(\alpha) := \lim_{T \rightarrow \infty} \frac{1}{T} \log \int e^{-\alpha \log \frac{dP_T}{dQ_T}} dP_T$$

exists for all $\alpha \in [0, 1]$ and defines a continuously differentiable function of $\alpha \in (0, 1)$. Then, the sequence of optimal error frequencies $(F[P_T, Q_T])_{T \geq 0}$ satisfies

$$\lim_{T \rightarrow \infty} T^{-1} \log F[P_T, Q_T] = \inf_{\alpha \in [0, 1]} e(\alpha).$$

The limit in Proposition 1.2.1 is called a *Chernoff error exponent*. In our case, it follows easily from (LT) that

$$S_T^\lambda(\gamma) = \log \frac{d\lambda}{d(\lambda \circ \phi_T)}(\gamma(0)) \tag{1.3a}$$

$$= \log \frac{d\lambda}{d\text{vol}}(\gamma(0)) + \log \frac{d\text{vol}}{d(\text{vol} \circ \phi_T)}(\gamma(0)) + \log \frac{d(\text{vol} \circ \phi_t)}{d(\lambda \circ \phi_T)}(\gamma(0)) \tag{1.3b}$$

$$= \log \frac{d\lambda}{d\text{vol}}(\gamma(0)) - \log \frac{d\lambda}{d\text{vol}}(\gamma(T)) \tag{1.3c}$$

In other words, your best guess for the original direction of a curve in phase space is based on a comparison of the likelihood of the endpoints of the curves as initial conditions. Using continuity and compactness, we conclude that

$$e(\alpha) = \lim_{T \rightarrow \infty} T^{-1} \log \int e^{-\alpha S_T^\lambda(\gamma)} d\mathcal{P}_T^\lambda(\gamma) = 0 \tag{1.4}$$

for all $\alpha \in [0, 1]$.

Hence, we can deduce from the proposition above that $F[\mathcal{P}_T^\lambda, \hat{\mathcal{P}}_T^\lambda]$ does not decay exponentially as $T \rightarrow \infty$, i.e. that the Chernoff error exponent is trivial. In fact, the same arguments can be generalized to rule out any stretched exponential decay. In a nutshell, you do not get much better at guessing the original direction of time by having access to longer and longer footages of a confined Hamiltonian system. The reader familiar with the Gärtner–Ellis theorem will notice that the vanishing of the quantity $e(\alpha)$ is rather singular from the point of view of the analysis of the large deviations of the sequence $(S_T^\lambda(\gamma))_{t \geq 0}$ of random variables.

This lack of improvement is symptomatic of a general issue in mathematical physics: asymptotic results on confined Hamiltonian systems fail to sharply capture empirical observations of nonequilibrium phenomena on what feels, to us, like large time scales.

Sharp results *can* be obtained using the idealized Hamiltonian mechanics of systems with infinitely many degrees of freedom — referred to as *extended Hamiltonian systems* —, but regularity

properties and the choice of a reference measure playing the role of λ are then much more delicate. These considerations are beyond the scope of the present thesis; we refer the interested reader to [Pil01, JPRB11].

Luckily, without introducing as much machinery, one can build what are called *effective* finite-dimensional non-Hamiltonian models for the evolution of a confined system interacting with an infinite-dimensional one, through which it is possible to capture nonequilibrium phenomena such as steady flows and irreversibility. Two classes of such effective descriptions are discussed in the next two subsections.

We emphasize that the discussion of the last three paragraphs should not be interpreted as a stance on the actual number of degrees of freedom in the physical universe or the actual structure of the dynamics of the universe. It is merely a pragmatic statement on the families of mathematical frameworks within which it is possible to capture certain idealized phenomena in nonequilibrium physics in the form of sharp asymptotic results.

1.2.3 Entropy production in thermostated systems

Historically, the first class of effective models were deterministic modifications of the equations of motion (1.1) called *thermostated Hamiltonian systems*. They are obtained by adding terms on the right-hand sides of Hamilton's equations — those terms are sometimes called *phenomenological forces* — in such a way that (EC) and (TRI) still hold while (LT) fails. For example, with a Hamiltonian of the form $H(q, p) = \frac{1}{2} \langle p, p \rangle + V(q)$, one could consider

$$\begin{aligned} \dot{q} &= p, \\ \dot{p}_i &= -\frac{\partial V(q)}{\partial q^i} + b_i(q) - \frac{\langle b(q), p \rangle}{\langle p, p \rangle} p_i, \end{aligned} \tag{1.5}$$

for some suitable nonconservative vector field $b : \mathbf{R}^N \rightarrow \mathbf{R}^N$.

One then defines the log-likelihood ratio S_T^λ between \mathcal{P}_t^λ and $\hat{\mathcal{P}}_t^\lambda$ as the *entropy production* observable; because (1.3a) still holds, we simply write

$$S_T^\lambda(q, p) = \log \left(\frac{d\lambda}{d(\lambda \circ \phi_T)}(q, p) \right)$$

and entropy production is interpreted as function on phase space (or a region thereof) which quantifies the contraction of volumes as measured by the reference measure λ . Here, ϕ_T denotes the flow induced by the system (1.5) after time T .

Because (LT) fails, one cannot pass from (1.3b) to (1.3c): the best guess for the original direction of time depends on more than the endpoints of the curve. Hypothesis testing and large deviations of entropy production can then have nontrivial asymptotics in T — as a sequence of random variables on phase space with respect to λ or any other physically relevant measure.

It is within this setup that two landmark results on entropy production were first discussed. In their own way, they both express a universality in the way in which positive values of entropy production are favored when compared to their negative counterparts.

The finite-time Evans–Searles symmetry

Note that the moment generating function χ_T^λ of the entropy production S_T^λ as a random variable on phase space (an energy shell $M_{E,\delta}$ or all of $(\mathbf{R}^{2N}, \mathcal{B}_{\mathbf{R}^{2N}}, \lambda)$) is a relative Rényi entropy,

$$\chi_T^\lambda(\alpha) = \int_{\mathcal{E}_T} \left(\frac{d\hat{\mathcal{P}}_T^\lambda}{d\mathcal{P}_T^\lambda} \right)^\alpha d\mathcal{P}_T^\lambda,$$

and is a real-analytic function of $\alpha \in (0, 1)$ — at least. Using the sole fact that Θ_T is an involution, we find

$$\begin{aligned} \chi_T^\lambda(1 - \alpha) &= \int_{\mathcal{E}_T} \left(\frac{d(\mathcal{P}_T^\lambda \circ \Theta_T^{-1})}{d\mathcal{P}_T^\lambda} \right)^{1-\alpha} d\mathcal{P}_T^\lambda \\ &= \int_{\mathcal{E}_T} \left(\frac{d(\mathcal{P}_T^\lambda \circ \Theta_T^{-1})}{d\mathcal{P}_T^\lambda} \circ \Theta_T \right)^{1-\alpha} d(\mathcal{P}_T^\lambda \circ \Theta_T^{-1}) \\ &= \int_{\mathcal{E}_T} \left(\frac{d\mathcal{P}_T^\lambda}{d(\mathcal{P}_T^\lambda \circ \Theta_T^{-1})} \right)^{1-\alpha} d(\mathcal{P}_T^\lambda \circ \Theta_T^{-1}) \\ &= \int_{\mathcal{E}_T} \left(\frac{d\mathcal{P}_T^\lambda}{d\hat{\mathcal{P}}_T^\lambda} \right)^{-\alpha} d\mathcal{P}_T^\lambda \\ &= \chi_T^\lambda(\alpha). \end{aligned}$$

One can show that this symmetry of the moment-generating function χ_T implies the following symmetry for Q_T^λ , the distribution of the mean entropy production $T^{-1}S_T$ as a random variable with

respect to \mathcal{P}_T^λ . With \hat{Q}_T^λ that of $-T^{-1}S_T$, we have $\hat{Q}_T^\lambda \ll Q_T^\lambda$ and

$$\frac{d\hat{Q}_T^\lambda}{dQ_T^\lambda}(\zeta) = e^{-T\zeta} \quad (1.6)$$

for Q_T^λ -almost all $\zeta \in \mathbf{R}$. This symmetry is dubbed the transient fluctuation theorem or the *finite-time Evans–Searles symmetry* due to its first derivation in [ES94] using a different argument.

The Gallavotti–Cohen fluctuation theorem

For λ^+ a limit point of the net $(T^{-1} \int_0^T \lambda \circ \phi^{-t} dt)_{T \geq 0}$ in a suitable topology — which is then necessarily invariant under ϕ_t for all t and typically referred to as a nonequilibrium steady state —, we say that a *Gallavotti–Cohen fluctuation theorem* holds in λ^+ if there is a large deviation principle for the sequence $(S_T^\lambda)_{T \geq 0}$ of random variables on phase space with a rate function I satisfying the symmetry

$$I(-\zeta) = I(\zeta) + s. \quad (1.7)$$

for all possible values of s . More explicitly,

$$\begin{aligned} - \inf_{\zeta \in \text{int}(E)} I(\zeta) &\leq \liminf_{T \rightarrow \infty} T^{-1} \log \lambda^+ \{T^{-1} S_T^\lambda \in E\} \\ &\leq \limsup_{T \rightarrow \infty} T^{-1} \log \lambda^+ \{T^{-1} S_T^\lambda \in E\} \leq - \inf_{\zeta \in \text{cl}(E)} I(\zeta) \end{aligned}$$

for all Borel subsets E of \mathbf{R} and the symmetry (1.7) of the rate function gives the heuristics

$$\frac{\lambda^+ \{T^{-1} S_T^\lambda \approx -\zeta\}}{\lambda^+ \{T^{-1} S_T^\lambda \approx \zeta\}} \approx \frac{e^{-TI(-\zeta)}}{e^{-TI(\zeta)}} = e^{-T(I(-\zeta) - I(\zeta))} = e^{-T\zeta},$$

which is reminiscent of (1.6). Such a result was first derived using Anosov diffeomorphisms as a model for the dynamics of a strongly sheared fluid [GC95]. The large deviation principle is typically proved by studying the limit

$$e_+(\alpha) := \lim_{t \rightarrow \infty} \frac{1}{t} \log \int e^{-\alpha S_t^\lambda} d\mathcal{P}_t^{\lambda^+}$$

— referred to as the entropic pressure — and applying a version of the Gärtner–Ellis theorem; see e.g. [DZ10, §2.3]. However, we should note that other routes to the fluctuation theorem have shown to be more powerful in other contexts; see e.g. [CJPS19].

While they are both inspired by the same numerical experiments [ECM93] and capture a similar symmetry, the spirit of the finite-time Evans–Searles symmetry and the Gallavotti–Cohen fluctuation theorem are quite different and authors insist that they should not be confused [CG99, JPRB11, Gal19].

The principal distinction is that the Evans–Searles symmetries are universal — they hold for any TRI dynamical systems for which the objects in question are defined. The mechanism behind Gallavotti–Cohen symmetries a priori could be model dependent and in general they may fail. Perhaps surprisingly, a careful look at all principal classes of models for which the symmetries have been rigorously established reveals that the respective functionals satisfy $e_+(\alpha) = e(\alpha)$ [...] In each single case the strong ergodic properties of the model force [this relation].³

1.2.4 Entropy production in stochastic systems

Later, a second class of effective models started to attract attention: stochastic dynamics [Kur98, LS99, Cro00]. They are again typically obtained by adding terms on the right-hand side of the equation for \dot{p} , but now in the form of a stochastic process. These terms are supposed to mimic the effect of infinitely extended reservoirs in some essentially steady state in certain regimes.

For such systems, the study of is typically focused on the log-likelihood ratio between the distribution of forward and backward trajectories rather than on a notion of contraction of volume in phase space. It is here the noise rather than time reversal invariance which ensures mutual absolute continuity of the distributions associated to the hypotheses to be tested. Again, the finite-time Evans–Searles symmetry holds without any further assumption.

As alluded to above, a key preliminary step to studying the Gallavotti–Cohen fluctuation theorem is to make sure that there indeed is an invariant measure for our process and understand the extent to which it is reasonable to expect the time evolution of a typical initial condition to converge to this invariant measure. This problem alone is the subject of two chapters of this thesis and we

³From [JPRB11], Section 7, pages 735–736.

devote the next section of the present chapter to a short discussion of the tools that are available. Before we do so, let us complete our brief discussion of entropy production by mentioning extensions of the classical theory to quantum systems and links with thermodynamics.

1.3 Entropy production in quantum mechanics

In an algebraic description of nonrelativistic Hamiltonian quantum mechanics, physical *observables* are elements of a C^* -algebra \mathcal{A} , *states* are nonnegative linear functionals on \mathcal{A} which are properly normalized, and the dynamics is a suitably continuous group of $*$ -automorphisms of \mathcal{A} . While this is a structure that is shared with classical mechanics, the fact that the algebras of observables considered in quantum mechanics are noncommutative prevents us from naturally finding an underlying notion of trajectory on which to base our notion of *entropy production*. However, formula (1.3a) can be adapted provided that we have a suitable analogue of the Radon–Nikodym derivative for quantum states. This analogue is the relative modular operator of Tomita–Takesaki theory: this is the approach developed in [Ara76, OHI88, Oji89, Rue01, JP01, Pil01, JP02, TM03]; see [JOPP11] for an overview of the theory for confined quantum systems.

In a certain class of models for a small system interacting with an infinitely extended reservoir, a definition of this type has been successfully linked to a definition at the level of effective Markovian descriptions of the small system alone in the weak coupling limit; see [JKP06, AJPP06, dR07, DdRM08, JPW14].

There has also been a recent interest in the theory of entropy production associated to classical probability measures on shift spaces arising from repeated quantum measurements [Cro08, HP13, BJPP18, HJPR18, CJPS19, BB20].

1.4 Thermodynamics

The notion of entropy production is also used in the context of thermodynamics. In fact, the link between the information-theoretical notion of entropy production and physically relevant quantities from thermodynamics is fundamental. Justice can only be done to this subject in the framework

of extended Hamiltonian systems, but the machinery that is involved in such a discussion is beyond the scope of this introduction. We provide a partial treatment within the confined framework of Subsection 1.2.1 and refer the reader to [Pil01, JPRB11] for more details.

Consider a special case of the Hamiltonian setup of Subsection 1.2.1 in which the Hamiltonian is of the form

$$H = (H_0 + H_1 + H_2) + V$$

where H_i depends only on variables in a subspace K_i with $\mathbf{R}^{2N} = K_0 \oplus K_1 \oplus K_2$ and V is allowed to depend on all the variables.

Also consider a reference probability measure λ of the form

$$d\lambda = Z^{-1} e^{-\beta_1 H_1 - \beta_2 H_2} \text{dvol}$$

for some positive numbers β_1, β_2 and Z , where the “vol” is considered on the whole space. In other words, λ is the product of three measures: a normalized volume measure on K_0 , a measure on K_1 which has maximum entropy among the measures on K_1 giving a fixed mean to H_1 parametrized by β_1 , and a measure on K_2 which has maximum entropy among the measures on K_2 giving a fixed mean to H_2 parametrized by β_2 . The parameters β_1 and β_2 are called inverse temperatures.

If the subspaces K_1 and K_2 have very high dimensions compared to that of K_0 , they are to be thought of as acting as reservoirs of energy and entropy for the latter. Thermodynamics à la Clausius then suggests defining *entropy production* as the weighted sum of the energy flowing into each reservoir by its inverse temperature, that is the observable

$$C_T := \beta_1 (H_1 \circ \phi_T - H_1) + \beta_2 (H_2 \circ \phi_T - H_2).$$

The link with our previous definition of entropy production is made as follows. By (LT), a change of variables gives

$$\begin{aligned} \int f d(\lambda \circ \phi_T) &= \int (f \circ \phi_{-T})(p, q) Z^{-1} e^{-\beta_1 H_1(p, q) - \beta_2 H_2(p, q)} dp dq \\ &= \int f(p, q) Z^{-1} e^{-\beta_1 H_1(\phi_T(p, q)) - \beta_2 H_2(\phi_T(p, q))} dp dq, \end{aligned}$$

so that

$$\frac{d(\lambda \circ \phi_T)}{d\lambda}(p, q) = \frac{e^{-\beta_1 H_1(\phi_T(p, q)) - \beta_2 H_2(\phi_T(p, q))}}{e^{-\beta_1 H_1(p, q) - \beta_2 H_2(p, q)}},$$

or equivalently

$$\log \frac{d\lambda}{d(\lambda \circ \phi_T)} = \beta_1 (H_1 \circ \phi_T - H_1) + \beta_2 (H_2 \circ \phi_T - H_2) = C_T. \quad (1.8)$$

If one modifies the reference state λ by multiplying its density by a function on K_0 , say a constant times $e^{-\beta_0 H_0}$ for some positive number β_0 , this identity must be corrected with terms which should be small compared to C_T for large values of T .

As pointed out in Subsection 1.2.2, one cannot hope C_T to truly display interesting asymptotic properties in the limit $T \rightarrow \infty$ as long as we stay within the framework of confined Hamiltonian systems. Yet, such calculations are good indications of what can be done in important class of examples of extended Hamiltonian systems and suggest interpreting the Gallavotti–Cohen fluctuation theorem as a statement on the universality of statistical fluctuations violating the second law of thermodynamics formulated in terms of thermodynamic affinities; see [JPRB11, §9] and [JPS16].

For effective models introduced in Subsection 1.2.3 and 1.2.4, relations between entropy production and heat currents from thermodynamics can also be exhibited; see e.g. [CELS93, LS99, MNV03]. In Chapter 2, we will see the information-theoretical notion of entropy being linked to the work done by the nonconservative force driving the system out of equilibrium.

One should note that the ease with which one passes from a thermodynamic interpretation of entropy production to the other fundamentally relies on the commutativity of observables in the classical setting. For this reason, many of the basic relations from thermodynamics are much more subtle in the quantum setting. For example, even the very definition of work and heat — let alone the way they relate to each other in closed systems via the first law of thermodynamics beyond the level of averages — requires some care; see e.g. [TLH07, CHT11, BPR19, BPP20].

1.5 Mixing

In all physical paradigms discussed above, the dynamics is ultimately encoded in a suitably continuous semigroup $(\tau^t)_{t \geq 0}$ of operators on an involutive Banach algebra of observables which preserves nonnegativity. In this picture, *states* of the system are continuous linear functionals on the algebra of observables that are nonnegative and normalized. For example, the flow $(\phi_t)_{t \geq 0}$ on a symplectic manifold induced by Hamilton's equations or modifications thereof induces a semigroup of so-called Koopman operators on different reasonable algebras of functions through the formula $\tau^t f := f \circ \phi_t$. In stochastic models, a semigroup of so-called *Markov operators* is constructed from the transition functions P_t through the formula $(\tau^t f)(x) := \int f(y) P_t(x, dy)$. In both cases, the adjoint of τ^t then acts on a space of measures which contains states as we have defined them.

Vaguely speaking, a *mixing result* for a dynamics $(\tau^t)_{t \geq 0}$ and a state ω^+ on \mathcal{A} is a guarantee that

$$\lim_{t \rightarrow \infty} \omega_0(\tau^t f) = \omega^+(f)$$

for important classes of observables f and initial states ω_0 . It is in the state ω^+ that we can expect to measure true nonequilibrium quantities and prove the Gallavotti–Cohen fluctuation theorem.

When dealing with the microscopic description of a system with infinitely many degrees of freedom — classical or quantum — the set of initial conditions ω_0 allowed for convergence crucially depends on ω^+ for genuine physical reasons. Indeed, in the thought experiment of Section 1.1, we expect the state carrying a steady flow of heat to change if we completely change the initial temperature of a block. For stochastic systems with finitely many degrees of freedom — which will be the main focus for the remainder of the chapter —, the “physical” part of this restriction is in some sense already included in the choice of the noise and the only restrictions left will be more technical (e.g. mild regularity and decay assumptions).

1.5.1 Mixing for stochastic differential equations

Consider a stochastic differential equation in \mathbf{R}^M of the form

$$dX_t = c(X_t) dt + Q dY_t$$

where $c : \mathbf{R}^M \rightarrow \mathbf{R}^M$ is a vector field, $(Y_t)_{t \geq 0}$ is an \mathbf{R}^D -valued Lévy process defined on a probability space $(\Omega, \mathcal{F}, \mathbf{P})$, and $Q : \mathbf{R}^D \rightarrow \mathbf{R}^M$ is a linear map.⁴ If c and $(Y_t)_{t \geq 0}$ are nice enough, the solution $(X_t^\lambda)_{t \geq 0}$ will be essentially uniquely specified by any initial condition $X_0^\lambda \sim \lambda$ as a process on $(\Omega, \mathcal{F}, \mathbf{P})$. The transition functions

$$P_t(x, E) = \mathbf{P}[X_t^\lambda \in E \mid X_0^\lambda = x]$$

for Borel sets $E \subseteq \mathbf{R}^M$ can be defined independently of λ and give rise to a semigroup on Borel bounded functions via the formula

$$(\tau^t f)(x) := \int f(y) P_t(x, dy) \quad (1.9)$$

for f bounded and measurable, or equivalently $(\tau^t f)(x) := \mathbf{E}[f(X_t^{\delta_x})]$. An important problem in the study of such equations is to find reasonable conditions on c , Q , $(Y_t)_{t \geq 0}$ and λ that guarantee the convergence

$$\lim_{t \rightarrow \infty} \lambda(\tau^t f) = \lambda^{\text{inv}}(f) \quad (1.10)$$

for some probability measure λ^{inv} common to all f in a large class of functions.

A possible approach is to show that τ^t , considered on a suitable Banach space of functions, converges weakly as $t \rightarrow \infty$ to its rank-one spectral projector for the eigenvalue 1 using general results from the spectral theory of semigroups. This approach is well suited for equations driven by Brownian noises because the infinitesimal generator of the semigroup then admits a nice closed-form expression as a differential operator for which powerful tools have been developed.

Let us sketch how this is done for the simple case where $c(x) = -x$ and $(2^{-1/2} Q Y_t)_{t \geq 0}$ is a standard Brownian motion in \mathbf{R}^M . The formula (1.9) then defines a strongly continuous semigroup on the space $L^2(\mathbf{R}^M, e^{-\frac{1}{2}|x|^2} dx)$ and its generator is a differential operator satisfying

$$(Af)(x) = (\Delta f)(x) - \langle x, (\nabla f)(x) \rangle$$

⁴The dimension M could naturally be $2N$ if the stochastic differential equation is the effective dynamics of the position and momentum variable subject to interaction with reservoirs or N if the equation describes the effective dynamics of the position variables only (e.g. in the Smoluchowski–Kramers limit). However, in some situations, M could be *larger* than $2N$ if additional degrees of freedom are necessary in order to make the effective dynamics Markovian; see e.g. [EPRB99b].

for all $f \in C_c^2(\mathbf{R}^M)$. In fact, this semigroup is immediately infinitely differentiable, thanks to the regularizing properties of the Laplacian; irreducible, thanks to the maximum principle; compact, thanks to Sobolev's embedding and the fact that the potential $V(x) = \frac{1}{2}|x|^2$ from which $c(x)$ derives is coercive. In the general theory of semigroups, these three conditions suffice for convergence to the spectral projector of interest; see e.g. [AGG⁺86, Ch. C-IV] or [EN06, §VI.3]. This approach can be adapted in a straightforward — yet slightly more technical — way to the more general setting of Chapter 2.

Of course, the Laplacian is a very special operator and one should not hope to so easily obtain the result if Q does not have full rank. We call this this obstacle *degeneracy of the noise*: if Q does not have full rank, we do not have linearly independent combinations of the independent one-dimensional Brownian motions explicitly appearing in each of the one-dimensional equations for individual coordinates (referred to as degrees of freedom). Generators associated to degenerate Brownian noises may still enjoy good regularization and irreducibility properties, but both checking and exploiting those properties in a physically relevant context are far from easy. We refer the reader to [Tro77, EPRB99b, EPRB99a, EH00, CEHRB18] for successful analyses along those general lines.

In Chapters 3 and 4 of this thesis, a considerably different route to mixing is taken. It is based on a body of works from S. Kuksin, A. Shirikyan and their coauthors.

1.5.2 The Approach of Kuksin and Shirikyan

In their own words, S. Kuksin and A. Shirikyan, have been working on a

programme whose goal is to develop methods for applying the results and tools of the control theory in the study of mixing properties of flows generated by randomly forced evolution equations.⁵

The biggest successes of this endeavour concern the mixing properties of stochastic partial differential equations (e.g. stochastically driven Navier–Stokes systems) [KS01, AKSS07, Shi07, Shi15,

⁵From [Shi20], page 3.

KNS19, KZ20, Shi20]. However, the approach has also met with success in revisiting stochastic ordinary differential equations: Chapters 3 and 4 are in line with the approach presented in [Shi17].

To motivate the use of different notions of controllability in the study of mixing, let us discuss one of the most basic setups in which one can discuss mixing: Markov chains on a finite set \mathcal{A} of cardinality L . This discussion is centered around a stochastic matrix $P = [p_{i,j}]_{i,j \in \mathcal{A}}$, i.e. an L -by- L matrix with nonnegative entries such that

$$\sum_{i \in \mathcal{A}} p_{i,j} = 1,$$

for each $j \in \mathcal{A}$. We use $p_{i,j}^m$ the (i, j) -th entry of the m -th power of the matrix P . Such a matrix indeed allows us to construct a discrete-time semigroup $(\tau^t)_{t \in \mathbf{N}}$ acting on functions on \mathcal{A} :

$$(\tau^t f)(i) := \sum_{j \in \mathcal{A}} p_{i,j}^t f(j) = \sum_{j_1 \in \mathcal{A}} \sum_{j_2 \in \mathcal{A}} \cdots \sum_{j_t \in \mathcal{A}} p_{i,j_1} p_{j_1,j_2} \cdots p_{j_{t-1},j_t} f(j_t).$$

In this context, it is convenient to identify functions on \mathcal{A} with column vectors in \mathbf{R}^L and states on the algebra of functions on \mathcal{A} with row vectors in \mathbf{R}^L whose components are nonnegative and sum to 1.⁶

The following *mixing result* — whose hypotheses are illustrated in Figure 1.2 — can be proved using a variety of methods. While we will discuss two proof sketches which motivate relevant notions of controllability, we note in passing that a proof appealing to the Perron–Frobenius theorem would, in spirit, be the closest to the method discussed in the previous subsection.

Proposition 1.5.1. *Suppose that there exists a subset B of the state space with the following two properties:*

- (a) *there exists $m \geq 1$ such that $\sum_{j \in B} p_{i,j}^m > 0$ for all i ;*
- (b) *there exists k_0 such that $p_{j,k_0} > 0$ for each $j \in B$.*

Then, there exist a nonnegative row vector $(\lambda_i^+)_{i \in \mathcal{A}}$ whose components sum to 1 and such that

$$\lim_{t \rightarrow \infty} \sum_{j \in \mathcal{A}} p_{i,j}^t f_j = \sum_{j' \in \mathcal{A}} f_{j'} \lambda_{j'}^+ \quad (1.11)$$

⁶In what follows, we always mean by “state” a row vector or the linear functional it represents, even though this name usually refers to an element of \mathcal{A} in the literature on Markov chains.

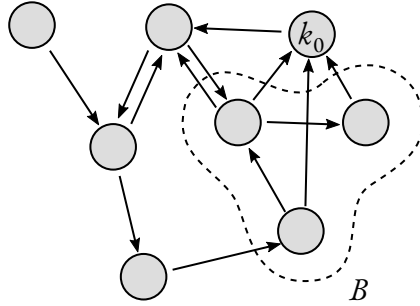

Figure 1.2: A Markov chain on a set A consisting of 8 element represented by gray circles: there is an arrow from the element i to the element j if and only if $p_{i,j} > 0$. The elements inside the dashed contour form a subset B such that (a) starting from any point, there is a path of length $m = 3$ ending in B , and (b) each element in B has a direct edge to the element k_0 .

for all $i \in A$ and all choices of $(f_j)_{j \in A}$.

Remark 1.5.2. *The way the proposition is formulated is not optimal for Markov chains on a finite set A ; hypotheses (a) and (b) together are equivalent to the simpler requirement that $p_{i,k'}^{m'} > 0$ for each $i \in A$ and some fixed $k' \in A$ and $m' \in \mathbf{N}$. The purpose here is to illustrate techniques which we use in Chapters 3 and 4 in situations where mere pointwise positivity of transition functions has to be complemented with different notions of accuracy and uniformity for the analogues of Hypotheses (a) and (b).*

Harris' theorem

A first way of obtaining the result is to appeal to Harris' ergodic theorem. Let us present the version elegantly proved by M. Hairer and J.C. Mattingly [HM11]. The hypotheses are formulated for a semigroup $(\vartheta^n)_{n \in \mathbf{N}}$ acting on bounded measurable function on a (not necessarily finite) space \mathbf{X} and Dirac measures δ_x at points x .

Theorem 1.5.3. *Let $(\vartheta^n)_{n \in \mathbf{N}}$ be the semigroup associated to a discrete-time Markov chain on a space \mathbf{X} . Suppose that there exists a function $V : \mathbf{X} \rightarrow [0, \infty)$ and constants $K \in [0, \infty)$ and $\gamma \in (0, 1)$ such that*

$$(\vartheta^1 V)(x) \leq \gamma V(x) + K$$

for all $x \in \mathbf{X}$ and suppose that there exists a constant $\alpha \in (0, 1)$ and a probability measure ν on \mathbf{X} such that

$$\inf_{x \in V^{-1}([0, R])} (\mathfrak{P}^1)^* \delta_x \geq \alpha \nu$$

for some $R > \frac{2K}{1-\gamma}$, as measures on \mathbf{X} . Then, there exists a unique invariant state λ^+ for the semigroup $(\mathfrak{P}^n)_{n \in \mathbf{N}}$. Furthermore, there exist constants $C, c \in (0, \infty)$ such that

$$\sup_{x \in \mathbf{X}} \frac{|(\mathfrak{P}^n f)(x) - \lambda^+(f)|}{1 + V(x)} \leq C e^{-cn}$$

whenever $n \in \mathbf{N}$ and f is a measurable function such that $|f| \leq 1 + V$.

Now, of course, the first condition — say with $V \equiv 0$ — becomes trivial when $\mathbf{X} = \mathcal{A}$ is a finite set, but is relevant for semigroups arising from stochastic differential equations on noncompact phase space.

Hypothesis (b) of Proposition 1.5.1 gives the bound

$$p_{j,k} \geq \left(\inf_{j \in B} p_{j,k_0} \right) \mathbf{1}_{k,k_0}$$

for each $j \in B$, with a nonzero infimum on the right-hand side. But then,

$$p_{i,k}^{m+1} \geq \sum_{j \in B} p_{i,j}^m p_{j,k} \geq \left(\inf_{i \in \mathcal{A}} \sum_{j \in B} p_{i,j}^m \right) \left(\inf_{j \in B} p_{j,k_0} \right) \mathbf{1}_{k,k_0}$$

for any i , with nonzero infima by the Hypothesis (a). In other words, the evolution for $m+1$ steps of a Dirac measure in i is bounded below by a positive i -independent constant times the Dirac measure in k_0 . With $V \equiv 0$ and any $R > 0$, this is precisely the second hypothesis of Harris' theorem for

$$\mathfrak{P}^n f := \mathbf{P}^{n(m+1)} f.$$

Therefore, there exists a unique state λ^+ such that $\lambda^+ = \lambda^+ \mathbf{P}^{m+1}$, and there exist constants C and c such that

$$\left| \sum_{i,j \in \mathcal{A}} \lambda_j p_{j,i}^{n(m+1)} f_i - \sum_j \lambda_j^+ f_j \right| \leq C e^{-c(m+1)(n+1)}. \quad (1.12)$$

To show that this measure is also invariant for the original chain, and not only its $(m+1)$ -skeleton, take f the indicator of an arbitrary point $i \in \mathcal{A}$:

$$\left| \sum_{j \in \mathcal{A}} \lambda_j p_{j,i}^{n(m+1)} - \lambda_i^+ \right| \leq C e^{-c(m+1)(n+1)}$$

and, in the special case $\lambda = \lambda^+ P^s$ for an arbitrary s ,

$$\left| \sum_{j \in \mathcal{A}} \lambda_j^+ p_{j,i}^{n(m+1)+s} - \lambda_i^+ \right| \leq C e^{-c(n+1)}.$$

But using the semigroup property and the invariance of λ^+ under $\lambda^+ P^{n(m+1)} = \lambda^+$, we obtain

$$\left| \sum_{j \in \mathcal{A}} \lambda_j^+ p_{j,i}^s - \lambda_i^+ \right| \leq C e^{-c(n+1)}.$$

Because the left-hand side is independent of n , we may take $n \rightarrow \infty$ to deduce that $\lambda^+ P^s = \lambda^+$. Given a function f , it is then easy to show using (1.12) and (1.12) with f replaced with $P^1 f$ up to $P^m f$ that (1.11) holds.

Couplings

This second approach is more probabilistic in spirit. We say that a process $(X_i^t)_{t \in \mathbf{N}}$ defined on a probability space $(\Omega, \mathcal{F}, \mathbf{P})$ is a copy of the chain starting in i if it is a \mathcal{A} -valued process with the property that

$$\mathbf{P}[X_i^t = i] = 1 \quad \text{and} \quad \mathbf{P}[X_i^{t+s} = k | X_i^s = j] = p_{j,k}^t$$

whenever $j, k \in \mathcal{A}$ and $s, t \in \mathbf{N}$ are such that $p_{i,j}^s > 0$. We may at will construct such copies for each i in such a way that they are independent of each other on a common space $(\Omega^{\text{ind}}, \mathcal{F}^{\text{ind}}, \mathbf{P}^{\text{ind}})$.

A *coupling* of the chains starting in i and i' is a process $(\mathcal{Z}^t)_{t \in \mathbf{N}}$ on a probability space $(\Omega, \mathcal{F}, \mathbf{P})$, taking values in the product space $\mathcal{A} \times \mathcal{A}$, such that

$$\mathbf{P}[\pi(\mathcal{Z}^0) = i] = 1 \quad \text{and} \quad \mathbf{P}[\pi(\mathcal{Z}^{t+s}) = k | \pi(\mathcal{Z}^s) = j] = p_{j,k}^t$$

whenever $j, k \in \mathcal{A}$ and $s, t \in \mathbf{N}$ are such that $p_{i,j}^s > 0$, and

$$\mathbf{P}[\pi'(\mathcal{Z}^0) = i'] = 1 \quad \text{and} \quad \mathbf{P}[\pi'(\mathcal{Z}^{t+s}) = k | \pi'(\mathcal{Z}^s) = j] = p_{j,k}^t$$

whenever $j, k \in \mathcal{A}$ and $s, t \in \mathbf{N}$ are such that $p_{i',j}^s > 0$. Here and in what follows, π [resp. π'] denotes the projection onto the first component [resp. second component] in the cartesian product $\mathcal{A} \times \mathcal{A}$. For such a coupling, consider the (possibly infinite) random variable on $(\Omega, \mathcal{F}, \mathbf{P})$ defined as

$$\mathcal{T} := \inf\{t \in \mathbf{N} : \pi(\mathcal{Z}^t) = \pi'(\mathcal{Z}^t) \text{ for all } t' \geq t\},$$

i.e. the first time the coupling hits the diagonal in the space $\mathcal{A} \times \mathcal{A}$ and never leaves it, an event referred to as *coalescence*. The key observation about \mathcal{T} is the following.

Lemma 1.5.4. *If \mathcal{T} is the coalescence time of a coupling of the chains starting in i and i' , then*

$$\frac{1}{2} \sum_{j \in \mathcal{A}} |p_{i,j}^t - p_{i',j}^t| \leq \mathbf{P}[\mathcal{T} > t]. \quad (1.13)$$

Proof. Because $\sum_{j \in \mathcal{A}} |p_{i,j}^t - p_{i',j}^t| = 2 \sup_{S \subseteq \Gamma} \sum_{j \in S} p_{i,j}^t - p_{i',j}^t$ and $\mathbf{P}[\pi(\mathcal{Z}^t) \neq \pi'(\mathcal{Z}^t)] \leq \mathbf{P}[\mathcal{T} > t]$, it suffices to show that $\sum_{j \in S} p_{i,j}^t - p_{i',j}^t \leq \mathbf{P}[\pi(\mathcal{Z}^t) \neq \pi'(\mathcal{Z}^t)]$ for an arbitrary subset S of \mathcal{A} . But because \mathcal{Z} is a coupling of the chains starting in i and i' ,

$$\begin{aligned} \sum_{j \in S} p_{i,j}^t - p_{i',j}^t &= \mathbf{E}[\mathbf{1}_S(\pi(\mathcal{Z}^t))] - \mathbf{E}[\mathbf{1}_S(\pi'(\mathcal{Z}^t))] \\ &= \mathbf{E}[\mathbf{1}_{\{\pi(\mathcal{Z}^t) \neq \pi'(\mathcal{Z}^t)\}} (\mathbf{1}_S(\pi(\mathcal{Z}^t)) - \mathbf{1}_S(\pi'(\mathcal{Z}^t)))] \\ &\leq \mathbf{E}[\mathbf{1}_{\{\pi(\mathcal{Z}^t) \neq \pi'(\mathcal{Z}^t)\}}]. \end{aligned}$$

This concludes the proof. \square

Corollary 1.5.5. *Suppose that for any pair $(i, i') \in \mathcal{A} \times \mathcal{A}$, there exists a coupling of the chains starting in i and i' such that its coalescence time satisfies $\lim_{t \rightarrow \infty} \mathbf{P}[\mathcal{T} > t] = 0$, then there exists a state λ^+ such that*

$$\lim_{t \rightarrow \infty} \sum_{j \in \mathcal{A}} p_{i,j}^t f_j = \sum_{j' \in \mathcal{A}} f_{j'} \lambda_{j'}^+ \quad (1.14)$$

for all $i \in \mathcal{A}$ and all choices of $(f_j)_{j \in \mathcal{A}}$.

Proof. By a standard compactness argument of the Bogolyubov–Krylov type (see e.g. Section 2.5.1 in [KS12]), there exists a state $(\lambda_j^+)_{j \in \mathcal{A}}$ such that $\sum_{i \in \mathcal{A}} \lambda_i^+ p_{i,j} = \lambda_j^+$ for all $j \in \mathcal{A}$. Hence, summing (1.13) over i' against $\lambda_{i'}^+$ and using the convergence of $\mathbf{P}[\mathcal{T} > t]$ gives the desired conclusion. \square

Thus, we will be done with the proof of the proposition if, for an arbitrary pair (i, i') , we are able to construct a coupling \mathcal{Z} of the chains starting in i and i' in such a way that it sticks to the diagonal soon enough, often enough. This is where we use our assumptions. The precise construction of \mathcal{Z} involves a fair amount of notation but can be, up to a timing technicality, summarized as follows:

- Step 1.** Launch a copy of the process starting at i as the first component and a copy of the process starting at i' as the second component, independently of one another;
- Step 2.** Wait until the independent components land simultaneously in B (i.e. until the coupling hits the set $B \times B$ in the product space);
- Step 3.** Correlate the two components in order to maximize the probability that they meet (i.e. that the coupling hits the diagonal in the product space) at the next step;
- Step 4.** If they meet, let them be equal forever (i.e. let the coupling stick to the diagonal in the product space); else, go back to 2.

Now, concretely, the process \mathcal{L} is constructed on a product of countably many identical spaces

$$(\Omega_r, \mathcal{F}_r, \mathbf{P}_r) := (\Omega^{\text{ind}}, \mathcal{F}^{\text{ind}}, \mathbf{P}^{\text{ind}}) \times (\Omega^{\text{max}}, \mathcal{F}^{\text{max}}, \mathbf{P}^{\text{max}})$$

where $(\Omega^{\text{max}}, \mathcal{F}^{\text{max}}, \mathbf{P}^{\text{max}})$ denotes the product over pairs of the spaces in the following lemma, which expresses an important relation between the notion of coupling and the total variation distance and is key to Step 3; see for example Section 1.2.4 in [KS12].

Lemma 1.5.6. *For any pair $(j, j') \in \mathcal{A} \times \mathcal{A}$, there exists a $(\mathcal{A} \times \mathcal{A})$ -valued random variable $\mathcal{R}_{j,j'}$ on a probability space space $(\Omega_{j,j'}^{\text{max}}, \mathcal{F}_{j,j'}^{\text{max}}, \mathbf{P}_{j,j'}^{\text{max}})$ such that*

$$\mathbf{P}_{j,j'}^{\text{max}}[\pi(\mathcal{R}_{j,j'}) = k] = p_{j,k},$$

$$\mathbf{P}_{j,j'}^{\text{max}}[\pi'(\mathcal{R}_{j,j'}) = k] = p_{j',k}$$

for all $k \in \mathcal{A}$ and

$$\mathbf{P}_{j,j'}^{\text{max}}[\pi(\mathcal{R}_{j,j'}) \neq \pi'(\mathcal{R}_{j,j'})] = \frac{1}{2} \sum_{k \in \mathcal{A}} |p_{j,k} - p_{j',k}|.$$

We denote $(X_{i,r}^t)_{t \in \mathbf{N}}$ the process on $(\Omega, \mathcal{F}, \mathbf{P}) := \prod_{r \in \mathbf{N}} (\Omega_r, \mathcal{F}_r, \mathbf{P}_r)$ which is a copy of the chain starting at i living on the appropriate space in the r -th spot in the countable product, and

similarly for other random variables. With this notation, we construct $(\mathcal{L}^t)_{t \in \mathbf{N}}$ on $(\Omega, \mathcal{F}, \mathbf{P})$ inductively in r according to the rules

$$\mathcal{L}^{r(m+1)+s} := \begin{cases} (X_{\pi_{\mathcal{L}^{r(m+1)},r}}^s, X_{\pi'_{\mathcal{L}^{r(m+1)},r}}^s) & \text{if } 1 \leq s \leq m, \text{ or } s = m+1 \text{ and } \mathcal{L}^{r(m+1)+m} \notin (B \times B) \\ \mathcal{R}_{\mathcal{L}^{r(m+1)},r} & \text{if } s = m+1 \text{ and } \mathcal{L}^{r(m+1)} \in (B \times B) \setminus \text{diag}(\mathcal{A}), \\ (X_{\pi_{\mathcal{L}^{r(m+1)},r}}^s, X_{\pi'_{\mathcal{L}^{r(m+1)},r}}^s) & \text{if } s = m+1 \text{ and } \mathcal{L}^{r(m+1)} \in (B \times B) \cap \text{diag}(\mathcal{A}). \end{cases}$$

Lemma 1.5.7. *The coupling $(\mathcal{L}^t)_{t \in \mathbf{N}}$ is such that there exist $C \in (0, \infty)$ and $\gamma \in (0, 1)$ depending on i, i' and \mathbf{P} only such that*

$$\mathbf{P}[\mathcal{T} > t] < C\gamma^t$$

for all $t \in \mathbf{N}$.

Proof. For $r \in \mathbf{N}$,

$$\mathbf{P}[\mathcal{L}^{r(m+1)+m} \in B \times B \mid \mathcal{L}^{r(m+1)} \notin \text{diag}(\mathcal{A})] = \left(\sum_{j \in B} p_{\pi_{\mathcal{L}^{r(m+1)},j}}^m \right) \left(\sum_{j' \in B} p_{\pi'_{\mathcal{L}^{r(m+1)},j'}}^m \right). \quad (1.15)$$

by independence, and

$$\mathbf{P}[\mathcal{L}^{r(m+1)+m} \in B \times B \mid \mathcal{L}^{r(m+1)+m} \in \text{diag}(\mathcal{A})] = \sum_{j \in B} p_{\pi_{\mathcal{L}^{r(m+1)},j}}^m. \quad (1.16)$$

Both the right-hand side of (1.15) and the right-hand side of (1.16) can be bounded away from 0, say by a small number $\gamma_1 \in (0, 1)$, thanks to Assumption (a). On the other hand,

$$\mathbf{P}[\mathcal{L}^{(r+1)(m+1)} \in \text{diag}(\mathcal{A}) \mid \mathcal{L}^{r(m+1)+m} \in B \times B] \geq \min_{j,j' \in B} \mathbf{P}_{j,j'}^{\max}[\mathcal{R}_{j,j'} \in \text{diag}(\mathcal{A})],$$

but Lemma 1.5.6 gives

$$\mathbf{P}_{j,j'}^{\max}[\mathcal{R}_{j,j'} \in \text{diag}(\mathcal{A})] \geq \frac{1}{2} \min\{p_{j,k_0}, p_{j',k_0}\}.$$

The right-hand side can be bounded away from 0 by a small number γ_2 which is independent of j and j' in B , thanks to Assumption (b). Hence, by induction,

$$\mathbf{P}[\mathcal{L}^{(r+1)(m+1)} \notin \text{diag}(\mathcal{A})] \leq (1 - \gamma_1\gamma_2)^{r+1}.$$

Therefore,

$$\mathbf{P}[\mathcal{T} > t] \leq \mathbf{P}[\mathcal{T} > \lfloor \frac{t}{m+1} \rfloor (m+1)] \leq \mathbf{P}[Z^{\lfloor \frac{t}{m+1} \rfloor (m+1)} \notin \text{diag}(\mathcal{A})] \leq (1 - \gamma_1\gamma_2)^{\lfloor \frac{t}{m+1} \rfloor}$$

and the proof is complete. \square

Extracting the key steps

In both proofs, the hypotheses on the entries of the stochastic matrix and its powers had the following key consequences:

- (A) For arbitrary large sets of initial conditions, there is a uniform lower bound for transitions to B in some common time step;
- (B) There is a nontrivial measure bounding from below all transitions from B in some common time step.

Back to the context of stochastic differential equations of the form

$$dX_t = c(X_t) dt + Q dY_t,$$

a small ball around a point \hat{x} could play a role similar to that of B provided that the two controllability conditions below are satisfied. To formulate them, let us set

$$\begin{aligned} S_t : \mathbf{R}^M \times E &\rightarrow \mathbf{R}^M \\ (x, \eta) &\mapsto x(t) \end{aligned}$$

to be the map which sends an initial condition $x \in \mathbf{R}^M$ and a *control* η in a space E of functions from $[0, t]$ to \mathbf{R}^d to the solution at time t to

$$\begin{cases} \dot{x}(s) = c(x(s)) + Q\eta(s), \\ x(0) = 0. \end{cases}$$

With this notation, the controllability conditions are:

The system is approximately controllable to \hat{x} : for any number $\varepsilon > 0$ and any radius $R > 0$, we can find a time $T > 0$ such that for any initial point $x \in \mathbf{R}^d$ with $\|x\| \leq R$, there exists a control $\zeta \in C([0, T]; \mathbf{R}^n)$ verifying

$$\|S_T(x, \zeta) - \hat{x}\| < \varepsilon.$$

The system is solidly controllable from \hat{x} : there is a number $\varepsilon_0 > 0$, a time $T_0 > 0$, a compact set \mathcal{H} in $C([0, T_0]; \mathbf{R}^n)$ and a non-degenerate ball G in \mathbf{R}^n such that, for any continuous function $\Phi : \mathcal{H} \rightarrow \mathbf{R}^d$ satisfying the relation

$$\sup_{\eta \in \mathcal{H}} \|\Phi(\eta) - S_{T_0}(\hat{x}, \eta)\| \leq \varepsilon_0,$$

we have $G \subset \Phi(\mathcal{H})$.

Indeed, there is hope that approximate controllability is sufficient to guarantee (A) if enough controls close to ζ are probable enough according to the law ℓ of the noise over the interval $[0, T]$. We emphasize that the existence of a function V as in Harris' theorem is key to making use of this condition with dependence in R in a noncompact space. Such functions appear in Chapters 2, 3 and 4 and are called *Lyapunov functions*.

To see why solid controllability is related to (B), the first step is to note that transition function in time t is the pushforward of ℓ through the map $S_t(x, \cdot)$. Hence, if the Jacobian $DS_t(x, \cdot)$ has full rank and behaves nicely in x near \hat{x} , then it is reasonable to expect that the implicit function theorem and a change of variables can be used to obtain a lower bound on $P_t(x, \cdot)$ that is independent of x close enough to \hat{x} . Therefore, in view of Sard's theorem, it makes sense that a condition saying that maps well approximating $S_{T_0}(\hat{x}, \cdot)$ cover a ball would guarantee (B) for the time T_0 .

Both of these heuristic arguments of course need some assumptions on ℓ to be turned into rigorous proofs. The notion of decomposability of ℓ used by Shirikyan in [Shi07, Shi17] is suitable in many situations, including — up to a minor modification — that of Chapter 3, but does not directly apply to Poisson noises considered in Chapter 4.

Bibliography

- [AGG⁺86] W. Arendt, A. Grabosch, G. Greiner, U. Moustakas, R. Nagel, U. Schlotterbeck, U. Groh, H. P. Lotz, and F. Neubrander. *One-parameter semigroups of positive operators*, volume 1184 of *Lecture Notes in Mathematics*. Springer, 1986.

- [AJPP06] W. Aschbacher, V. Jakšić, Y. Pautrat, and C.-A. Pillet. Topics in non-equilibrium quantum statistical mechanics. In *Open quantum systems. III*, pages 1–66. Springer-Verlag, Berlin, 2006.
- [AKSS07] A. A. Agrachev, S. Kuksin, A. V. Sarychev, and A. Shirikyan. On finite-dimensional projections of distributions for solutions of randomly forced 2D Navier–Stokes equations. *Ann. Inst. Henri Poincaré (B) Probab. Statist.*, 43(4):399–415, 2007.
- [AM87] R. Abraham and J. E. Marsden. *Foundations of mechanics*. Addison-Wesley Publishing Co., 1987.
- [Ara76] H. Araki. Relative entropy of states of von neumann algebras. *Publ. Res. Inst. Math. Sci.*, 11(3):809–833, 1976.
- [BB20] J.-F. Bougron and L. Bruneau. Linear response theory and entropic fluctuations in repeated interaction quantum systems. *J. Stat. Phys.*, 181:1636–1677, 2020.
- [BCJP20] T. Benoist, N. Cuneo, V. Jakšić, and C.-A. Pillet. On entropy production of repeated quantum measurements II: Examples. *arXiv preprint*, 2012.03885 [math-ph], 2020.
- [BJPP18] T. Benoist, V. Jakšić, Y. Pautrat, and C.-A. Pillet. On entropy production of repeated quantum measurements: I. General theory. *Commun. Math. Phys.*, 357(1):77–123, 2018.
- [BPP20] T. Benoist, A. Panati, and Y. Pautrat. Heat conservation and fluctuations between quantum reservoirs in the two-time measurement picture. *J. Stat. Phys.*, 178:893–925, 2020.
- [BPR19] T. Benoist, A. Panati, and R. Raquépas. Control of fluctuations and heavy tails for heat variation in the two-time measurement framework. *Ann. Henri Poincaré*, 20(2):631–674, 2019.
- [CEHRB18] N. Cuneo, J.-P. Eckmann, M. Hairer, and L. Rey-Bellet. Non-equilibrium steady states for networks of oscillators. *Electron. J. Probab.*, 23, 2018.

- [CELS93] N. I. Chernov, G. Eyink, J. L. Lebowitz, and Y. G. Sinai. Steady-state electrical conduction in the periodic Lorentz gas. *Commun. Math. Phys.*, 154(3):569–601, 1993.
- [CG99] E. Cohen and G. Gallavotti. Note on two theorems in nonequilibrium statistical mechanics. *J. Stat. Phys.*, 96(5-6):1343–1349, 1999.
- [CHT11] M. Campisi, P. Hänggi, and P. Talkner. Colloquium: Quantum fluctuation relations: Foundations and applications. *Rev. Mod. Phys.*, 83(3):771, 2011.
- [CJN⁺20] N. Cuneo, V. Jakšić, V. Nersesyan, C.-A. Pillet, and A. Shirikyan. Mathematical theory of the fluctuation theorem. *In preparation*, 2020.
- [CJPS19] N. Cuneo, V. Jakšić, C.-A. Pillet, and A. Shirikyan. Large deviations and fluctuation theorem for selectively decoupled measures on shift spaces. *Rev. Math. Phys.*, 31(10):1950036, 2019.
- [Cro00] G. E. Crooks. Path-ensemble averages in systems driven far from equilibrium. *Phys. Rev. E*, 61(3):2361, 2000.
- [Cro08] G. E. Crooks. Quantum operation time reversal. *Phys. Rev. A*, 77(3):034101, 2008.
- [DdRM08] J. Dereziński, W. de Roeck, and C. Maes. Fluctuations of quantum currents and unravelings of master equations. *J. Stat. Phys.*, 131(2):341–356, 2008.
- [dR07] W. de Roeck. Quantum fluctuation theorem: can we go from micro to meso? *Comptes Rendus Physique*, 8(5-6):674–683, 2007.
- [DZ10] A. Dembo and O. Zeitouni. *Large deviations techniques and applications*, volume 38 of *Stochastic modelling and applied probability*. Springer, 2010.
- [ECM93] D. J. Evans, E. G. D. Cohen, and G. P. Morriss. Probability of second law violations in shearing steady flows. *Phys. Rev. Lett.*, 70:2401, 1993.
- [EH00] J.-P. Eckmann and M. Hairer. Non-equilibrium statistical mechanics of strongly anharmonic chains of oscillators. *Comm. Math. Phys.*, 212(1):105–164, 2000.

- [EN06] K.-J. Engel and R. Nagel. *A Short course on operator semigroups*. Universitext. Springer, 2006.
- [EPRB99a] J.-P. Eckmann, C.-A. Pillet, and L. Rey-Bellet. Entropy production in nonlinear, thermally driven hamiltonian systems. *J. Stat. Phys.*, 95(1):305–331, 1999.
- [EPRB99b] J.-P. Eckmann, C.-A. Pillet, and L. Rey-Bellet. Non-equilibrium statistical mechanics of anharmonic chains coupled to two heat baths at different temperatures. *Commun. Math. Phys.*, 201(3):657–697, 1999.
- [ES94] D. J. Evans and D. J. Searles. Equilibrium microstates which generate second law violating steady states. *Physical Review E*, 50(2):1645, 1994.
- [Gal19] G. Gallavotti. Nonequilibrium and fluctuation relation. *J. Stat. Phys.*, 2019. Online first.
- [GC95] G. Gallavotti and E. G. D. Cohen. Dynamical ensembles in stationary states. *J. Stat. Phys.*, 80(5-6):931–970, 1995.
- [HJPR18] E. P. Hanson, A. Joye, Y. Pautrat, and R. Raquépas. Landauer’s principle for trajectories of repeated interaction systems. *Ann. Henri Poincaré*, 19(7):1939–1991, 2018.
- [HM11] M. Hairer and J. C. Mattingly. Yet another look at Harris’ ergodic theorem for Markov chains. In *Seminar on Stochastic Analysis, Random Fields and Applications VI*, volume 63, pages 109–117. Springer, 2011.
- [HP13] J. M. Horowitz and J. M. Parrondo. Entropy production along nonequilibrium quantum jump trajectories. *N.J. Phys.*, 15(8):085028, 2013.
- [JKP06] V. Jakšić, E. Kritchevski, and C.-A. Pillet. Mathematical theory of the Wigner–Weisskopf atom. In J. Dereziński and H. Siedentop, editors, *Large Coulomb systems*, volume 695 of *Lecture Notes in Physics*, pages 145–215. Springer, 2006.

- [JOPP11] V. Jakšić, Y. Ogata, Y. Pautrat, and C.-A. Pillet. Entropic fluctuations in quantum statistical mechanics an introduction. In J. Frohlich, M. Salmhofer, V. Mastropietro, W. De Roeck, and L. F. Cugliandolo, editors, *Quantum Theory from Small to Large Scales*, volume 95 of *Lecture Notes of the Les Houches Summer School*, pages 213–410. Oxford University Press, 2011.
- [JOPS12] V. Jakšić, Y. Ogata, C.-A. Pillet, and R. Seiringer. Quantum hypothesis testing and non-equilibrium statistical mechanics. *Rev. Math. Phys.*, 24(06):1230002, 2012.
- [JP01] V. Jakšić and C.-A. Pillet. On entropy production in quantum statistical mechanics. *Commun. Math. Phys.*, 217(2):285–293, 2001.
- [JP02] V. Jakšić and C.-A. Pillet. Mathematical theory of non-equilibrium quantum statistical mechanics. *J. Stat. Phys.*, 108(5-6):787–829, 2002.
- [JPRB11] V. Jakšić, C.-A. Pillet, and L. Rey-Bellet. Entropic fluctuations in statistical mechanics: I. Classical dynamical systems. *Nonlinearity*, 24(3):699, 2011.
- [JPS16] V. Jakšić, C.-A. Pillet, and A. Shirikyan. Entropic fluctuations in gaussian dynamical systems. *Rep. Math. Phys.*, 77(3):335–376, 2016.
- [JPW14] V. Jakšić, C.-A. Pillet, and M. Westrich. Entropic fluctuations of quantum dynamical semigroups. *J. Stat. Phys.*, 154(1-2):153–187, 2014.
- [KNS19] S. Kuksin, V. Nersesyan, and A. Shirikyan. Mixing via controllability for randomly forced nonlinear dissipative PDEs. *arXiv preprint*, arXiv:1902.00494 [math.AP], 2019.
- [KS01] S. Kuksin and A. Shirikyan. A coupling approach to randomly forced nonlinear PDE’s. I. *Commun. Math. Phys.*, 221(2):351–366, 2001.
- [KS12] S. Kuksin and A. Shirikyan. *Mathematics of two-dimensional turbulence*, volume 194 of *Cambridge tracts in mathematics*. Cambridge University Press, 2012.

- [Kur98] J. Kurchan. Fluctuation theorem for stochastic dynamics. *J. Phys. A*, 31(16):3719, 1998.
- [KZ20] S. Kuksin and H. Zhang. Exponential mixing for dissipative pdes with bounded non-degenerate noise,. *Stoch. Procc. Appl.*, In press, 2020.
- [Lee13] J. M. Lee. *Introduction to smooth manifolds*, volume 218 of *Graduate texts in mathematics*. Springer, second edition, 2013.
- [LS99] J. L. Lebowitz and H. Spohn. A Gallavotti–Cohen-type symmetry in the large deviation functional for stochastic dynamics. *J. Stat. Phys.*, 95(1–2):333–365, 1999.
- [MNV03] C. Maes, K. Netočný, and M. Verschuere. Heat conduction networks. *J. Stat. Phys.*, 111(5-6):1219–1244, 2003.
- [OHI88] I. Ojima, H. Hasegawa, and M. Ichiyanagi. Entropy production and its positivity in nonlinear response theory of quantum dynamical systems. *J. Stat. Phys.*, 50(3-4):633–655, 1988.
- [Oji89] I. Ojima. Entropy production and nonequilibrium stationarity in quantum dynamical systems. physical meaning of van hove limit. *J. Stat. Phys.*, 56(1-2):203–226, 1989.
- [Pil01] C.-A. Pillet. Entropy production in classical and quantum systems. *Markov Proc. Relat. Fields*, 7(1):145–157, 2001.
- [Rue01] D. Ruelle. Entropy production in quantum spin systems. *Commun. Math. Phys.*, 224(1):3–16, 2001.
- [Shi07] A. Shirikyan. Qualitative properties of stationary measures for three-dimensional Navier–Stokes equations. *J. Funct. Anal.*, 249(2):284–306, 2007.
- [Shi15] A. Shirikyan. Control and mixing for 2D Navier–Stokes equations with space-time localised noise. *Ann. Sci. ENS*, 48:253–280, 2015.

- [Shi17] A. Shirikyan. Controllability implies mixing I. Convergence in the total variation metric. *Uspekhi Mat. Nauk*, 72(5):165–180, 2017.
- [Shi20] A. Shirikyan. Controllability implies mixing II. Convergence in the dual-Lipschitz metric. *J. Euro. Math. Soc.*, 2020. (to appear).
- [TLH07] P. Talkner, E. Lutz, and P. Hänggi. Fluctuation theorems: Work is not an observable. *Phys. Rev. E*, 75(5):050102, 2007.
- [TM03] S. Tasaki and T. Matsui. Fluctuation theorem, nonequilibrium steady states and Maclennan–Zubarev ensembles of a class of large quantum systems. In *Fundamental Aspects of Quantum Physics*, pages 100–119. World Scientific, 2003.
- [Tro77] M. M. Tropper. Ergodic and quasideterministic properties of finite-dimensional stochastic systems. *J. Stat. Phys.*, 17(6):491–509, 1977.

Chapter 2

The large-time and vanishing-noise limits for entropy production in nondegenerate diffusions

Author Renaud Raquépas

arXiv ID 2004.12015

Abstract We investigate the behaviour of a family of entropy production functionals associated to stochastic differential equations of the form $dX_s = -\nabla V(X_s) ds + b(X_s) ds + \sqrt{2\varepsilon} dW_s$, where b is a globally Lipschitz nonconservative vector field keeping the system out of equilibrium, with emphasis on the large-time limit and then the vanishing-noise limit. Different members of the family correspond to different choices of boundary terms. We use techniques from the theory of semigroups and from semiclassical analysis to reduce the description of the asymptotic behaviour of the functional to the study of the leading eigenvalue of a quadratic approximation of a deformation of the infinitesimal generator near critical points of V . Our analysis yields a law of large numbers and a local large deviation principle which does not depend on the choice of boundary terms and which exhibits a Gallavotti–Cohen symmetry.

2.1 Introduction

The study of reversibility of diffusion processes was pioneered by A.N. Kolmogorov in [Kol37], with one of its first basic results being that a diffusion

$$dX_s = c(X_s) ds + \sigma dW_s \quad (2.1)$$

on \mathbf{R}^N with constant diffusion matrix $\sigma > 0$ and initial condition $X_0 \sim \lambda$ is reversible if and only if there exists a function U such that $c = -\sigma\sigma^\top \nabla U$ and λ is the unique probability measure whose density is proportional to $\exp(-\frac{1}{2}U)$. In all other cases, the time reversal of the original diffusion is a Markov process which is different from the original one.

The question whether the reversal of a diffusion is itself a diffusion was explored and understood in the 1980s, most notably by B. D. O. Anderson [And82] and by E. Pardoux and U. Haussmann [HP86]. When it is the case, it is natural to ask how distinguishable the two diffusions are: this more quantitative question — and its connection with thermodynamics — is the subject of the present paper. It has a long history in both the physics and mathematics literature, but we will only give references to the mathematically rigorous works on the particular aspects we are interested in.

Both the original process observed during the interval $[0, t]$ and its time reversal give rise to probability measures on a space of continuous functions; let us call them respectively \mathcal{P}_t and $\mathcal{P}_t \circ \Theta_t^{-1}$. Using statistical tools to distinguish between these two measures is called *hypothesis testing of the arrow of time* in [JOPS12, CJPS20]. To explore the basic questions in the realm of hypothesis testing, the log-likelihood ratio

$$S_t^{\text{LLR}} := \log \frac{d\mathcal{P}_t}{d(\mathcal{P}_t \circ \Theta_t^{-1})} \quad (2.2)$$

and its moment-generating function are of great significance; S_t^{LLR} is sometimes called the *canonical entropy production functional*.

In dimension 2 or 3, the diffusion (2.1) — called an overdamped Langevin equation — is naturally interpreted as a small-inertia approximation of the dynamics of a single particle in the force field c , perturbed by a thermal noise — the matrix $\sigma\sigma^\top$ is related to temperature through an Einstein-type relation. Hence, a thermodynamic notion of entropy production is natural: with b the part

of c which is nonconservative, the integral

$$S_t^{\text{W}} := 2 \int_0^t \langle (\sigma \sigma^{\text{T}})^{-1} b(X_s), \circ dX_s \rangle \quad (2.3)$$

is the work done by the nonconservative force, appropriately rescaled by the temperature [Kur98, LS99]. When considering several particles, $\sigma \sigma^{\text{T}}$ may have different blocks for different particles, each related to a (possibly different) temperature, and the above integral can be split into a sum of the corresponding contributions [LS99, MNV03].

One expects S_t^{LLR} and S_t^{W} to be quantities of order t and only differ by a additive terms that depend on the initial and final conditions of the paths. In the present article, we consider an abstract entropy production functional \mathcal{P}_t corresponding to any sufficiently well-behaved modification of these so-called *boundary terms* and study its behaviour as $t \rightarrow \infty$ and then in the limit as σ vanishes. The way in which we take σ to 0 leaves out some geometric considerations: we consider $\sigma^\varepsilon = \sqrt{2\varepsilon} \mathbf{1}$ and take the scalar parameter ε to 0. Considering the more general case $\sigma^\varepsilon = \sqrt{\varepsilon} \sigma^1$ for some fixed positive-definite matrix σ^1 has been sacrificed for readability and ease of interpretation of the formulas: one can perform a suitable change of variables and carry on with a similar analysis, but one must then be careful with the physical interpretation. Indeed, from the physical point of view, the case we look at here corresponds to situations where the lack of equilibrium comes from a nonconservative driving force and is conceptually different from situations where the lack of equilibrium comes from an imbalance between the sources of thermal fluctuations.

The asymptotic behaviour of entropy functionals as $t \rightarrow \infty$ at fixed $\varepsilon > 0$ was studied by L. Bertini and G. Di Gesù in [BDG15] and by F.Y. Wang, J. Xiong and L. Xu in [WXX16] under more restrictive technical conditions. For a class of *degenerate* linear diffusions, V. Jakšić, C.-A. Pillet and A. Shirikyan have performed a very detailed analysis of the limit $t \rightarrow \infty$ [JPS17]. In [BDG15], the authors also tackled the limit $\varepsilon \rightarrow 0$ at fixed $t > 0$ by means of Freidlin–Wentzell theory and then the limit as $t \rightarrow \infty$ using subadditivity and results on Γ -convergence; also see [RBT00] and [Kur07].

As already discussed by some of these authors, taking $t \rightarrow \infty$ *first* and *then* $\varepsilon \rightarrow 0$ is physically more natural and was left open. This order is the one taken here, revealing a different picture than in [BDG15].

In Section 2.2, we set our assumptions, discuss the basic theory surrounding the time reversal of

the diffusion and rigorously relate (2.2) to (2.3) by boundary terms. In Section 2.3, we introduce a family of entropic functionals $\mathcal{S}_t^\varepsilon$ depending on the choice of boundary terms. We then give a representation for the moment-generating function $\chi_t^\varepsilon(\alpha)$ involving the chosen boundary term and the compact and irreducible semigroup generated by the deformation

$$\mathcal{A}^{\varepsilon, \alpha} = \varepsilon \Delta + \langle c - 2\alpha b, \nabla \rangle - \frac{\alpha(1-\alpha)}{\varepsilon} |b|^2 + \frac{\alpha}{\varepsilon} \langle b, c - b \rangle - \alpha \operatorname{div} b$$

of the generator associated to (2.1). Relevant spectral properties of $\mathcal{A}^{\alpha, \varepsilon}$, including domain technicalities, a Perron–Frobenius-type result for its spectral bound $\operatorname{spb}(\mathcal{A}^{\alpha, \varepsilon})$ and a result of convergence in the large-time limit for the generated semigroup, are given in Appendix 2.A.

In Section 2.4, we study the asymptotics of the moment-generating function as $t \rightarrow \infty$ for fixed $\varepsilon > 0$: we show that

$$\lim_{t \rightarrow \infty} \frac{1}{t} \log \chi_t^\varepsilon(\alpha) = \operatorname{spb}(\mathcal{A}^{\alpha, \varepsilon})$$

for a set of α which depends on the behaviour of the boundary terms at infinity. Our set of assumptions is more general than that of [BDG15]: we most notably allow b to be unbounded; see Assumptions (L0), (L1) and (RB).

If the behaviour at infinity of the boundary terms is suitable — cf. Assumption (IP) —, we prove a local large deviation principle (LDP):

$$\lim_{t \rightarrow \infty} \frac{1}{t} \log \mathbf{P}\{t^{-1} \mathcal{S}_t^\varepsilon \in G\} = - \inf_{\zeta \in G} e_*^\varepsilon(\zeta)$$

for all open sets G close enough to the expectation, where the rate function e_*^ε is the Legendre transform in the variable α of $\operatorname{spb}(\mathcal{A}^{\alpha, \varepsilon})$. At this level of generality, the local nature of the LDP is not merely technical: while we have not focused on enlarging the interval of validity of the principle as much as technically possible, it is known that different choices of boundary terms may give rise to different behaviour of the rate functions far away from the mean; see the pioneering work [vZC03] as well as the mathematical account [JPS17], where many other references are given.

In Section 2.5, we characterise the vanishing of the mean entropy production per unit time and give detailed information on the rate function e_*^ε in the case where the diffusion is linear. In Section 2.6, we use the linear case and a result in semiclassical analysis proved in Section 2.7 to describe

the asymptotic behaviour of the rate function e_*^ε as $\varepsilon \rightarrow 0$ in the general case. Many properties of the limiting rate function can be deduced from the behaviour of the deterministic dynamics near the *local minima* of V . This analysis requires extra conditions on the behaviour of the vector field near the critical points of V ; see Assumption (ND).

2.2 Setup, definitions and preliminary results

We study a stochastic differential equations (SDE) in \mathbf{R}^N of the form

$$dX_s = -\nabla V(X_s) ds + b(X_s) ds + \sqrt{2\varepsilon} dW_s,$$

where V is a coercive Morse function and b is a nonconservative vector field vanishing at the critical points of V , and the log-likelihood ratio (2.2) between the corresponding path measure and its time reversal. We will explicitly keep track of the dependence on the initial condition and on ε as superscripts for relevant quantities.

Remark 2.2.1. *There is some freedom in decomposing a deterministic drift in the form $-\nabla V + b$. Because this drift may already be provided in a given such decomposition coming from a physical context, we facilitate the verification of our hypotheses by avoiding making the assumption that this decomposition is in any sense canonical.*

2.2.1 Assumptions on the equation and immediate consequences

Throughout the paper, $N \geq 2$ is a fixed natural number and the N -dimensional euclidean space \mathbf{R}^N is equipped with an inner product $\langle \cdot, \cdot \rangle$. Let $V : \mathbf{R}^N \rightarrow \mathbf{R}$ be a fixed function of class C^3 and $b : \mathbf{R}^N \rightarrow \mathbf{R}^N$ a fixed globally Lipschitz vector field of class C^2 . We introduce the following assumptions.

Assumption (L0). There exists a positive-definite matrix H_0 and a constant K_0 such that

$$\langle \nabla V(x), H_0 x \rangle \geq |x|^2 - K_0$$

for all $x \in \mathbf{R}^N$ and the function $x \mapsto |\nabla V(x)|^2 - a \|D^2 V(x)\|$ is bounded below for all values of $a \in \mathbf{R}$.

Assumption (L1). There exists a positive-definite matrix H_b and a constant K_b such that

$$\langle \nabla V(x) - b(x), H_b x \rangle \geq |x|^2 - K_b$$

for all $x \in \mathbf{R}^N$.

Assumption (RB). There exist constants $h_b \in (0, \infty)$ and $k_b \in [0, \frac{1}{2})$ such that

$$\langle b(x), \nabla V(x) \rangle \leq k_b |\nabla V(x)|^2 \quad \text{and} \quad |b(x)|^2 \leq h_b |\nabla V(x)|^2$$

for all $x \in \mathbf{R}^N$.

Assumption (ND). The critical points of V form a finite set $\{x_j\}_{j=1}^m$ and

$$\det D^2 V|_{x_j} \neq 0$$

for each $j = 1, \dots, m$.

Assumption (L0) yields a Lyapunov structure for the ordinary differential equation

$$\dot{Y} = -\nabla V(Y)$$

and Assumption (L1) plays the same role for

$$\dot{X} = -\nabla V(X) + b(X).$$

The relative bounds in Assumption (RB) guarantee that these two deterministic dynamics have the same fixed points, which form a finite set $\{x_j\}_{j \in \mathbf{N}}$ and are all nondegenerate by (ND). The regularity assumptions on V and b are made for simplicity of technical estimates and can be relaxed if necessary. For example, in the case of V , class C^2 with $x \mapsto D^2 V|_x$ locally Hölder continuous would only require minor changes to the proofs in Appendix 2.7.

The Lyapunov structure for the ordinary differential equations guarantees the existence and uniqueness of the solution to the SDEs

$$\begin{cases} dY_s^{y,\varepsilon} = -\nabla V(Y_s^{y,\varepsilon}) ds + \sqrt{2\varepsilon} dW_s, \\ Y_0^{y,\varepsilon} = y, \end{cases} \quad (2.4)$$

and

$$\begin{cases} dX_s^{x,\varepsilon} = -\nabla V(X_s^{x,\varepsilon}) ds + b(X_s^{x,\varepsilon}) ds + \sqrt{2\varepsilon} dW_s, \\ X_0^{x,\varepsilon} = x. \end{cases} \quad (2.5)$$

To be more precise, the following consequence of (L1) plays a key role in the proof of existence and uniqueness in [Kha11, §3.3]. We will also use it throughout the paper.

Lemma 2.2.2. *Suppose that Assumption (L1). Then,*

$$\mathbf{P} \left\{ \sup_{s \in [0,t]} |X_s^{x,\varepsilon}| \geq R \right\} \leq \frac{\langle x, H_b x \rangle + 2K_b + 2\varepsilon \operatorname{tr} H_b}{R^2 \inf \operatorname{sp} H_b} e^t$$

for all $t \geq 0$, $x \in \mathbf{R}^N$ and $R > 0$.

Proof. Using (L1), follow the first steps of the proof of Theorem 3.5 in [Kha11, Ch. 3] with the nonnegative function $x \mapsto \langle x, H_b x \rangle + 2K_b + 2\varepsilon \operatorname{tr} H_b$ and $c = 1$. \square

The study of (2.5) is intimately related to partial differential equations involving

$$A^{\varepsilon,0} := \varepsilon \Delta + \langle -\nabla V + b, \nabla \rangle$$

and its adjoint. We refer to [Kha11, §3.6] for the general basic relations and to Appendix 2.A for more precise technical properties of $A^{\varepsilon,0}$ in this specific case.

Finally, let us mention an estimate which — together with the nondegeneracy of the diffusion matrix — is useful in showing that there exists a unique stationary measure $\lambda_{\text{inv}}^\varepsilon$ for (2.5); μ_0^ε for (2.4).

Lemma 2.2.3. *Let H_b be as in Assumption (L1). Then, for all $\varepsilon_0 > 0$, there exist positive constants c and C such that*

$$\inf \operatorname{sp} H_b \mathbf{E} |X_t^{x,\varepsilon}|^2 \leq \mathbf{E} \langle X_t^{x,\varepsilon}, H_b X_t^{x,\varepsilon} \rangle \leq e^{-ct} \langle x, H_b x \rangle + C \quad (2.6)$$

for all $\varepsilon \in (0, \varepsilon_0)$ and $t \geq 0$ and almost all $x \in \mathbf{R}^N$.

Proof. The first inequality in (2.6) is immediate from the fact that H_b is positive definite. Let $f : x \mapsto \langle x, H_b x \rangle$. By Kolmogorov's backwards equation — see e.g. Lemma 3.3 in [Kha11, Ch. 3] —,

$\partial_t \mathbf{E} f_R(X_t^{x,\varepsilon}) = A^{\varepsilon,0} \mathbf{E} f_R(X_t^{x,\varepsilon})$ for any approximation $f_R \in C_c^2(\mathbf{R}^N)$ of f . We show in Appendix 2.A that $(A^{\varepsilon,0}, W^{2,2}(\mathbf{R}^N, d\mu_0^\varepsilon))$ generates a strongly continuous semigroup of bounded linear operators on $L^2(\mathbf{R}^N, d\mu_0^\varepsilon)$. Hence, using basic semigroup properties — see e.g. Proposition 1.6.ii and Theorem 1.7 in [AGG⁺86, Ch. A-I] —, we find

$$\partial_t \mathbf{E} f(X_t^{x,\varepsilon}) = \mathbf{E} [\varepsilon \Delta f(X_t^{x,\varepsilon}) + \langle -\nabla V(X_t^{x,\varepsilon}) + b(X_t^{x,\varepsilon}), \nabla f(X_t^{x,\varepsilon}) \rangle]$$

for almost all x by an approximation argument. Then, by (L1),

$$\begin{aligned} \partial_t \mathbf{E} \langle X_t^x, H_b X_t^x \rangle &\leq 2\varepsilon \operatorname{tr} H_b - 2 \langle X_t^x, X_t^x \rangle + 2K_b \\ &\leq 2\varepsilon \operatorname{tr} H_b + 2K_b - 2\|H_b\|^{-1} \mathbf{E} \langle X_t^x, H_b X_t^x \rangle \end{aligned}$$

for almost all x and the second inequality in (2.6) follows from Grönwall's lemma. \square

Both $\lambda_{\text{inv}}^\varepsilon$ and μ_0^ε possess positive continuous densities with respect to the Lebesgue measure on \mathbf{R}^N , denoted “vol” hereafter. Whenever we write “almost everywhere” or “almost all” without specifying the measure, it is with respect to any of those equivalent measures. While we do not have a general explicit formula for the density of $\lambda_{\text{inv}}^\varepsilon$ — decay and regularity are discussed in Appendix 2.A —, we have

$$\mu_0^\varepsilon(E) := \frac{\int_E e^{-\varepsilon^{-1}V(x)} dx}{\int_{\mathbf{R}^N} e^{-\varepsilon^{-1}V(y)} dy} \quad (2.7)$$

for all Borel subsets E of \mathbf{R}^N .

2.2.2 Time reversal and the canonical entropy production functional

Throughout the paper, we use the shorthand \mathcal{C}_t for the space $C([0, t]; \mathbf{R}^N)$ of continuous paths in \mathbf{R}^N over the time interval $[0, t]$. It is always equipped with the supremum norm $\|\cdot\|_\infty$; the corresponding Borel σ -algebra is denoted \mathcal{B}_t .

We denote the distribution of $(X_s^{x,\varepsilon})_{0 \leq s \leq t}$ in (2.5) by $\mathcal{P}_t^{x,\varepsilon}$. This is a measure on $(\mathcal{C}_t, \mathcal{B}_t)$. With a slight abuse of notation, we define $\mathcal{P}_t^{\lambda,\varepsilon}$ as the analogous object but with random initial condition $X_0^{\lambda,\varepsilon} \sim \lambda$ (independent of W) for a probability measure λ on \mathbf{R}^N . In other words, $\mathcal{P}_t^{\lambda,\varepsilon}$ is the

unique Borel measure on \mathcal{C}_t such that

$$\int_{\mathcal{C}_t} H(\gamma) \mathcal{P}_t^{\lambda, \varepsilon}(\mathrm{d}\gamma) = \int_{\mathbf{R}^N} \left(\int_{\mathcal{C}_t} H(\gamma) \mathcal{P}_t^{x, \varepsilon}(\mathrm{d}\gamma) \right) \lambda(\mathrm{d}x) \quad (2.8)$$

for any nonnegative measurable function $H : \mathcal{C}_t \rightarrow \mathbf{R}$.

The measures $\mathcal{Q}_t^{x, \varepsilon}$ and $\mathcal{Q}_t^{\lambda, \varepsilon}$ are defined analogously using (2.4) i.e. the case $b \equiv 0$. We have mentioned in the Introduction that $\mathcal{Q}_t^{\lambda, \varepsilon}$ is invariant under time reversal if and only if λ possesses a density proportional to $\exp(-\varepsilon^{-1}V)$. This is made more precise as follows. For $s \in [0, t]$, let $\pi_s : \mathcal{C}_t \rightarrow \mathbf{R}^N$ be evaluation map $\gamma \mapsto \gamma(s)$. The *time reversal* is the unique involution $\Theta_t : \mathcal{C}_t \rightarrow \mathcal{C}_t$ determined by the relation $\pi_s \circ \Theta_t = \pi_{t-s}$.

Lemma 2.2.4. *Under Assumption (L0), if λ and the Lebesgue measure are mutually absolutely continuous, then $\mathcal{Q}_t^{\lambda, \varepsilon}$ and $\mathcal{Q}_t^{\lambda, \varepsilon} \circ \Theta_t$ are mutually absolutely continuous and*

$$\log \frac{\mathrm{d}\mathcal{Q}_t^{\lambda, \varepsilon}}{\mathrm{d}(\mathcal{Q}_t^{\lambda, \varepsilon} \circ \Theta_t)}(\gamma) = \log \frac{\mathrm{d}\lambda}{\mathrm{d}\mu_0^\varepsilon}(\gamma(0)) - \log \frac{\mathrm{d}\lambda}{\mathrm{d}\mu_0^\varepsilon}(\gamma(t))$$

for $\mathcal{Q}_t^{\lambda, \varepsilon}$ -almost all $\gamma \in \mathcal{C}_t$.

Proof. Let Γ be a measurable subset of \mathcal{C}_t . Using (2.8),

$$\begin{aligned} \mathcal{Q}_t^{\lambda, \varepsilon}(\Gamma) &= \int_{\mathbf{R}^N} \int_{\mathcal{C}_t} \mathbf{1}_\Gamma(\gamma) \mathbf{1}_{\pi_0^{-1}\{x\}}(\gamma) \mathcal{Q}_t^{x, \varepsilon}(\mathrm{d}\gamma) \frac{\mathrm{d}\lambda}{\mathrm{d}\mu_0^\varepsilon}(x) \mu_0^\varepsilon(\mathrm{d}x) \\ &= \int_{\mathbf{R}^N} \int_{\mathcal{C}_t} \mathbf{1}_\Gamma(\gamma) \frac{\mathrm{d}\lambda}{\mathrm{d}\mu_0^\varepsilon}(\pi_0\gamma) \mathbf{1}_{\pi_0^{-1}\{x\}}(\gamma) \mathcal{Q}_t^{x, \varepsilon}(\mathrm{d}\gamma) \mu_0^\varepsilon(\mathrm{d}x) \\ &= \int_{\mathcal{C}_t} \mathbf{1}_\Gamma(\gamma) \frac{\mathrm{d}\lambda}{\mathrm{d}\mu_0^\varepsilon}(\pi_0\gamma) \mathcal{Q}_t^{\mu_0, \varepsilon}(\mathrm{d}\gamma), \end{aligned}$$

that is

$$\mathcal{Q}_t^{\lambda, \varepsilon}(\mathrm{d}\gamma) = \frac{\mathrm{d}\lambda}{\mathrm{d}\mu_0^\varepsilon}(\pi_0\gamma) \mathcal{Q}_t^{\mu_0, \varepsilon}(\mathrm{d}\gamma).$$

Now, by the celebrated result of Kolmogorov [Kol37], $\mathcal{Q}_t^{\mu_0, \varepsilon} = \mathcal{Q}_t^{\mu_0, \varepsilon} \circ \Theta_t^{-1}$ so that

$$\frac{\mathrm{d}\mathcal{Q}_t^{\lambda, \varepsilon}}{\mathrm{d}(\mathcal{Q}_t^{\lambda, \varepsilon} \circ \Theta_t)} = \frac{\mathrm{d}\mathcal{Q}_t^{\lambda, \varepsilon}}{\mathrm{d}\mathcal{Q}_t^{\mu_0, \varepsilon}} \times \left(\frac{\mathrm{d}\mathcal{Q}_t^{\mu_0, \varepsilon}}{\mathrm{d}\mathcal{Q}_t^{\lambda, \varepsilon}} \circ \Theta_t \right)$$

and we conclude the proof using the identity $\pi_0(\Theta_t\gamma) = \pi_t\gamma$. □

The behaviour of $\mathcal{P}_t^{\lambda,\varepsilon}$ under the time reversal Θ_t is in general more subtle and, consistently with the intuition from thermodynamics, the dependence of the Radon–Nikodym derivative is not limited to the initial and final conditions of the path. The proof we give of the proposition below uses comparison with $\mathcal{Q}_t^{\lambda,\varepsilon}$, as in e.g. [JPS17]. Another possible route is to use the results of [HP86] on the reversal of $(X_s^{\lambda,\varepsilon})_{s \geq 0}$.

Proposition 2.2.5. *Under Assumptions (L0) and (L1), if λ and the Lebesgue measure are mutually absolutely continuous, then $\mathcal{P}_t^{\lambda,\varepsilon}$ and $\mathcal{P}_t^{\lambda,\varepsilon} \circ \Theta^{-1}$ are mutually absolutely continuous and*

$$\log \frac{d\mathcal{P}_t^{\lambda,\varepsilon}}{d(\mathcal{P}_t^{\lambda,\varepsilon} \circ \Theta_t^{-1})}(\gamma) = \log \frac{d\lambda}{d\mu_0^\varepsilon}(\gamma(0)) - \log \frac{d\lambda}{d\mu_0^\varepsilon}(\gamma(t)) + \frac{1}{\varepsilon} \int \langle b(\gamma), \circ d\gamma \rangle \quad (2.9)$$

for $\mathcal{P}_t^{\lambda,\varepsilon}$ -almost all $\gamma \in \mathcal{C}_t$, where μ_0^ε is defined by (2.7). Moreover,

$$\int_{\mathcal{C}_t} \left(\frac{d\mathcal{P}_t^{\lambda,\varepsilon}}{d(\mathcal{P}_t^{\lambda,\varepsilon} \circ \Theta_t^{-1})}(\gamma) \right)^\alpha \mathcal{P}_t^{\lambda,\varepsilon}(d\gamma) = \int_{\mathcal{C}_t} \left(\frac{d\mathcal{P}_t^{\lambda,\varepsilon}}{d(\mathcal{P}_t^{\lambda,\varepsilon} \circ \Theta_t^{-1})}(\gamma) \right)^{1-\alpha} \mathcal{P}_t^{\lambda,\varepsilon}(d\gamma) \quad (2.10)$$

for all $\alpha \in \mathbf{R}$ for which both sides are finite. Both sides of (2.10) are log-convex in α .

Before we proceed with the proof, let us briefly clarify the meaning of the expression (2.9). On the canonical probability space $(\mathcal{C}_t, \mathcal{B}_t, \mathcal{P}_t^{\lambda,\varepsilon})$, the random variable $W = (W_s)_{s \geq 0}$ defined by

$$W_s(\gamma) := \frac{1}{\sqrt{2\varepsilon}} \left(\gamma(s) - \gamma(0) - \int_0^s (-\nabla V(\gamma(r)) + b(\gamma(r))) dr \right) \quad (2.11)$$

is a Brownian motion, the evaluation map π_0 has distribution λ and is independent of W , and the canonical process $(\pi_s)_{s \geq 0}$ is the unique solution to the SDE (2.5) with initial condition λ . Hence, $(\pi_s)_{s \geq 0}$ is a continuous semimartingale and we allow ourselves notational shortcuts such as

$$\int \langle b(\gamma), \circ d\gamma \rangle := \left(\int_0^t \langle b(\pi_s), \circ d\pi_s \rangle \right)(\gamma)$$

and

$$\int \langle b(\gamma), dW(\gamma) \rangle := \left(\int_0^t \langle b(\pi_s), dW_s \rangle \right)(\gamma),$$

where the right-hand sides are defined $\mathcal{P}_t^{\lambda,\varepsilon}$ -almost surely according to the usual theory of, respectively, Stratonovich and Itô stochastic integration with respect to continuous semimartingales [Pro05, §II.4–II.7].

Proof of Proposition 2.2.5. Throughout the proof, we omit keeping explicitly track of the dependence on ε in the notation. We first reduce the general case to the technically easier case where the nonconservative vector field has compact support. For the latter, we suppose that the reader is familiar with Girsanov's theorem and related criteria; see e.g. [Pro05, §III.8]

Once mutual absolute continuity is proved, the symmetry expressed in (2.10) is an immediate consequence of the definition of the Radon–Nikodym derivative and the fact that Θ_t is an involution. Log-convexity is a consequence of Hölder's inequality.

Step 1: Reduction to the case where b has compact support. Suppose that the proposition has been proved in the case where b has compact support. For $R \in \mathbf{N}$, pick a globally Lipschitz vector field b_R satisfying $|b_R(x)| \leq |b(x)|$ for all $|x| \in \mathbf{R}^N$, $b_R(x) = b(x)$ whenever $|x| \leq R - 1$, and $b_R(x) = 0$ whenever $|x| \geq R$.

Let $\mathcal{P}_t^\lambda[R]$ be the path measure associated to the SDE with initial condition λ and drift b_R , and let B_R denote the centered open ball of radius R in \mathcal{C}_t . Observe that B_R is invariant under Θ_t and that

$$\mathcal{P}_t^\lambda[R](\Gamma \cap B_R) = \mathcal{P}_t^\lambda(\Gamma \cap B_R)$$

for all Borel sets $\Gamma \subseteq \mathcal{C}_t$; see e.g. the construction in [Kha11, §3.4]. Hence, by hypothesis, $(\mathcal{P}_t^\lambda \circ \Theta_t^{-1})(B_R \cap \cdot)$ is absolutely continuous with respect to $\mathcal{P}_t^\lambda(B_R \cap \cdot)$ and

$$F_R(\gamma) := \mathbf{1}_{B_R}(\gamma) \frac{d\lambda}{d\mu_0}(\gamma(0)) \frac{d\mu_0}{d\lambda}(\gamma(t)) \exp\left(\frac{1}{\varepsilon} \int \langle b_R(\gamma), \circ d\gamma \rangle\right)$$

is a Radon–Nikodym derivative. Because,

$$\lim_{R \rightarrow \infty} \mathcal{P}_t^\lambda(B_R) = 1$$

by Lemma 2.2.2, we can deduce that $\mathcal{P}_t^\lambda \circ \Theta_t$ is absolutely continuous with respect to \mathcal{P}_t^λ , with a Radon–Nikodym derivative

$$F(\gamma) := \lim_{R \rightarrow \infty} F_R(\gamma).$$

The fact that $F(\gamma)$ is strictly positive and equals the right-hand side of (2.9) follows from basic properties of the exponential, the absolute-continuity assumption and the fact that

$$\lim_{R \rightarrow \infty} \int \langle b_R(\gamma), \circ d\gamma \rangle = \int \langle b(\gamma), \circ d\gamma \rangle$$

for all $\gamma \in \mathcal{C}_t$ (given γ , take $R > \|\gamma\|_\infty$).

Step 2: Proof in the case where b has compact support.

Step 2a: Comparing $\mathcal{P}_t^{\lambda,\varepsilon}$ and $\mathcal{Q}_t^{\lambda,\varepsilon}$. Because b is bounded, Novikov's condition is satisfied and the process $(Z_s)_{s \in [0,t]}$ defined by the Doléans-Dade exponential

$$Z_s(\gamma) := \exp\left(\frac{1}{\sqrt{2\varepsilon}} \int_0^s \langle b(\gamma), dW(\gamma) \rangle - \frac{1}{4\varepsilon} \int_0^s |b(X_r^{\lambda,\varepsilon}(\gamma))|^2 dr\right) \quad (2.12)$$

is a martingale. Hence, by Girsanov's theorem, the process $(w_s)_{s \in [0,t]}$ defined by

$$w_s(\gamma) := W_s(\gamma) - \frac{1}{\sqrt{2\varepsilon}} \int_0^s b(\gamma(r)) dr \quad (2.13)$$

is a Brownian motion with respect to the measure $dP_t = Z_t d\mathcal{Q}_t^{\lambda,\varepsilon}$. Substituting (2.13) into (2.4) and comparing with (2.5), we deduce that $P_t = \mathcal{P}_t^{\lambda,\varepsilon}$, that is

$$\frac{d\mathcal{P}_t^{\lambda,\varepsilon}}{d\mathcal{Q}_t^{\lambda,\varepsilon}}(\gamma) = Z_t(\gamma) > 0.$$

Step 2b: Comparing $\mathcal{P}_t^{\lambda,\varepsilon}$ and $\mathcal{P}_t^{\lambda,\varepsilon} \circ \Theta_t^{-1}$. Combining Lemma 2.2.4 and Step 2a, we have

$$\frac{d\mathcal{P}_t^{\lambda,\varepsilon}}{d\mathcal{P}_t^{\lambda,\varepsilon} \circ \Theta_t^{-1}}(\gamma) = Z_t(\gamma) \frac{d\lambda}{d\mu_0^\varepsilon}(\pi_0\gamma) \frac{d\mu_0^\varepsilon}{d\lambda}(\pi_t\gamma) \frac{1}{Z_t(\Theta_t\gamma)}. \quad (2.14)$$

Using the identity

$$W_s(\Theta_t\gamma) = -(W_{t-s}(\gamma) - W_t(\gamma)) + \frac{2(\pi_s\Theta_t\gamma - \pi_t\gamma)}{\sqrt{2\varepsilon}}$$

following from (2.11) in a sequence of approximations of $Z_t(\Theta_t\gamma)$ by discretisation of $(b \circ \pi_s)_{s \in [0,t]}$ using a random partition of $[0, t]$ tending to the identity in the sense of [Pro05, §II.5], we find

$$\int \langle b(\Theta_t\gamma), dW(\Theta_t\gamma) \rangle = \int \langle b(\gamma), dW(\gamma) \rangle - \frac{2}{\sqrt{2\varepsilon}} \int \langle b(\gamma), \circ d\gamma \rangle.$$

Therefore,

$$\log \frac{Z_t(\gamma)}{Z_t(\Theta_t\gamma)} = \frac{1}{\varepsilon} \int \langle b(\gamma), \circ d\gamma \rangle$$

and taking the logarithm of (2.14) gives the proposed formula. \square

The logarithm of the Radon–Nikodym derivative in Proposition 2.2.5 is called the *canonical entropy production functional* in [JPS17]. We note the following immediate corollary of Proposition 2.2.5, the definition (2.7) of μ_0^ε and well-known properties of Stratonovich integrals; see e.g. [Pro05, §V.5].

Corollary 2.2.6. *Under Assumption (L0) and (L1), if λ and the Lebesgue measure are mutually absolutely continuous, then $\mathcal{P}_t^{\lambda,\varepsilon}$ and $\mathcal{P}_t^{\lambda,\varepsilon} \circ \Theta_t^{-1}$ are mutually absolutely continuous and*

$$\log \frac{d\mathcal{P}_t^{\lambda,\varepsilon}}{d(\mathcal{P}_t^{\lambda,\varepsilon} \circ \Theta_t^{-1})}(\gamma) = \log \frac{d\lambda}{d\text{vol}}(\gamma(0)) - \log \frac{d\lambda}{d\text{vol}}(\gamma(t)) + \frac{1}{\varepsilon} \int \langle -\nabla V(\gamma) + b(\gamma), \circ d\gamma \rangle$$

for $\mathcal{P}_t^{\lambda,\varepsilon}$ -almost all $\gamma \in \mathcal{C}_t$.

2.3 Generalised entropy production functionals

Motivated by the structure revealed in the previous section and by [Kur98, LS99, vZC03, MNV03, JPS17], we introduce a family of entropy production functionals parametrised by the choice of boundary terms. Throughout the remainder of the paper, the function $g : \mathbf{R}^N \rightarrow (0, \infty)$ is continuous and the initial condition λ is absolutely continuous with respect to the Lebesgue measure and has finite variance.

2.3.1 Definition and the weak law of large numbers

Definition 2.3.1. *The entropy production functional associated to the function g is the function $\mathcal{P}_t^\varepsilon$ defined by*

$$\mathcal{P}_t^\varepsilon(\gamma) := \log g(\gamma(0)) - \log g(\gamma(t)) + \frac{1}{\varepsilon} \int \langle b(\gamma), \circ d\gamma \rangle, \quad (2.15)$$

considered as a random variable on \mathcal{C}_t with respect to the probability measure $\mathcal{P}_t^{\lambda,\varepsilon}$. For $\alpha \in \mathbf{R}$, we use

$$\chi_t^\varepsilon(\alpha) := \int_{\mathcal{C}_t} e^{-\alpha \mathcal{P}_t^\varepsilon} d\mathcal{P}_t^{\lambda,\varepsilon}$$

for the MGF of $\mathcal{P}_t^\varepsilon$ in α . We speak of a steady-state functional if the initial condition λ entering the definition of $\mathcal{P}_t^{\lambda,\varepsilon}$ equals the invariant measure $\lambda_{\text{inv}}^\varepsilon$.

Remark 2.3.2. *The choice of $-\alpha$ in the exponent is common in the physics literature and is made here to facilitate the identification of certain symmetries. Indeed, the symmetry noted in Proposition 2.2.5 can be used to deduce $\chi_t^\varepsilon(1 - \alpha) = \chi_t^\varepsilon(\alpha)$ in the case $g = d\lambda / d\mu_0^\varepsilon$. However, this symmetry at finite t is not expected to hold for a generic choice of g . This choice also has an incidence on our choice of sign for the Legendre transform in Sections 2.4 to 2.6.*

We are mainly interested in the large deviations of $\mathcal{P}_t^\varepsilon$ as $t \rightarrow \infty$ and then $\varepsilon \rightarrow 0$. To tackle this problem, we will need additional assumptions on the behaviour of the boundary term g at infinity. Before we do so, let us state and prove a weak law of large numbers which holds under minimal assumptions on the decay of the boundary terms.

Proposition 2.3.3. *Suppose that Assumptions (L0) and (L1) are satisfied and let*

$$\mathbf{m}^\varepsilon := \int_{\mathbf{R}^N} (\varepsilon^{-1} |b|^2 - \varepsilon^{-1} \langle b, \nabla V \rangle) d\lambda_{\text{inv}}^\varepsilon + \int_{\mathbf{R}^N} \text{div } b d\lambda_{\text{inv}}^\varepsilon. \quad (2.16)$$

Then, for all $\delta > 0$,

$$\lim_{t \rightarrow \infty} \mathcal{P}_t^{\lambda, \varepsilon} \left\{ \left| \frac{1}{t} \mathcal{S}_t^\varepsilon - \mathbf{m}^\varepsilon \right| > \delta \right\} = 0. \quad (2.17)$$

Proof. The Stratonovich integral in the definition (2.15) of $t^{-1} \mathcal{S}_t^\varepsilon$ can be decomposed as

$$\begin{aligned} \frac{1}{t} \int_0^t \langle b(\gamma), \circ d\gamma \rangle &= \frac{1}{t} \int_0^t (|b(\pi_s \gamma)|^2 - \langle b(\pi_s \gamma), \nabla V(\pi_s \gamma) \rangle + \varepsilon \text{div } b(\pi_s \gamma)) ds \\ &\quad + \frac{\sqrt{2\varepsilon}}{t} \int_0^t \langle b(\gamma), dW(\gamma) \rangle. \end{aligned}$$

The integral on the first line of the right-hand is admissible for an application of the law of large numbers for continuous functions of X_s^ε — see e.g. Theorem 4.2 in [Kha11, Ch. 4] —, which yields

$$\lim_{t \rightarrow \infty} \mathcal{P}_t^{\lambda, \varepsilon} \left\{ \left| \frac{1}{t} \int_0^t (|b(\pi_s \gamma)|^2 - \langle b(\pi_s \gamma), \nabla V(\pi_s \gamma) \rangle + \varepsilon \text{div } b(\pi_s \gamma)) ds - \mathbf{m}^\varepsilon \right| > \frac{1}{5} \delta \right\} = 0.$$

The integral on the second line of the right-hand side is a martingale. For integer times, the hypotheses of the law of large numbers for discrete-time martingales in [Fel66, §VII.8] are satisfied thanks to the Itô isometry and Lemma 2.2.3. Hence,

$$\lim_{t \rightarrow \infty} \mathcal{P}_t^{\lambda, \varepsilon} \left\{ \left| \frac{\sqrt{2\varepsilon}}{[t]} \int_0^{[t]} \langle b(\gamma), dW(\gamma) \rangle \right| > \frac{1}{5} \delta \right\} = 0.$$

By Chebyshev's inequality and Itô's isometry, we have

$$\mathcal{P}_t^{\lambda, \varepsilon} \left\{ \left| \frac{\sqrt{2\varepsilon}}{[t]} \int_{[t]}^t \langle b(\gamma), dW(\gamma) \rangle \right| > \frac{1}{5} \delta \right\} \leq \frac{50\varepsilon}{\delta^2 [t]^2} \int_{\mathcal{E}_t} \int_{[t]}^t |b(\pi_s \gamma)|^2 ds \mathcal{P}_t^{\lambda, \varepsilon}(d\gamma),$$

with the double integral on the right-hand side being bounded uniformly in t by Tonelli's theorem, Lemma 2.2.3 and the fact that b is globally Lipschitz.

As for the boundary terms in the definition of $t^{-1} \mathcal{P}_t^\varepsilon$, we note that it is no loss of generality to assume that $g(0) = 1$. Then, by positivity and continuity of g , there exists a monotone family $(R_M)_{M>0}$ of radii properly diverging to $+\infty$ with M such that

$$g^{-1}([e^{-M/5}, e^{M/5}]) \supseteq \{x \in \mathbf{R}^N : |x| \leq R_M\}.$$

Using this inclusion with $M = t\delta$,

$$\mathcal{P}_t^{\lambda, \varepsilon} \{ |t^{-1} \log g(\pi_0 \gamma)| > \frac{1}{5} \delta \} \leq \mathcal{P}_t^{\lambda, \varepsilon} \{ |\pi_0 \gamma| \geq R_{t\delta} \} = \lambda \{ x \in \mathbf{R}^N : |x| \geq R_{t\delta} \}$$

converges to 0 as $t \rightarrow \infty$ because $R_{t\delta} \rightarrow \infty$ and the initial condition λ is a probability measure.

Using the same inclusion, Chebyshev's inequality and Lemma 2.2.3,

$$\mathcal{P}_t^{\lambda, \varepsilon} \{ |t^{-1} \log g(\pi_t \gamma)| > \frac{1}{5} \delta \} \leq \mathcal{P}_t^{\lambda, \varepsilon} \{ |\pi_t \gamma| \geq R_{\delta t} \} \leq \frac{\int \langle \gamma, H_b \gamma \rangle \lambda(d\gamma) + C}{R_{\delta t}^2 \inf \text{sp } H_b}$$

also converges to 0 as $t \rightarrow \infty$. The proof is then concluded using the triangle inequality and a union bound. \square

We see from the formula (2.16) that the behaviour as $\varepsilon \rightarrow 0$ of the mean entropy production per unit time \mathfrak{m}^ε will depend on that of $\lambda_{\text{inv}}^\varepsilon$ and hence on the Freidlin–Wentzell quasipotential [VF70, §6–8] associated to the ordinary differential equation, $\dot{X} = -\nabla V(X) + b(X)$. In situations where the quasipotential is proportional to V , more detailed information can be obtained and points where V attains its global minimum play a particular role. We will come back to this in Section 2.6.

2.3.2 Assumptions on the boundary terms and the initial condition

As mentioned in the Introduction, the LDP at the heart of this article is local. At the technical level, this is due to the fact that we are able to prove convergence of the rescaled logarithm of the MGF, $t^{-1} \log \chi_t^\varepsilon(\alpha)$, as $t \rightarrow \infty$ and then as $\varepsilon \rightarrow 0$ only for certain values of α .

In the special case where b is bounded and orthogonal to ∇V , and $g \equiv 1$, L. Bertini and G. Di Gesù have shown convergence as $t \rightarrow \infty$ for all $\alpha \in \mathbf{R}$, bypassing the type of assumption we are about to introduce. However, the analysis of the linear case in [JPS17] shows the intricacies of taking the limit $t \rightarrow \infty$ for $\alpha \notin [0, 1]$ in the case where b is unbounded, as well as the sensitivity of the limit to the choice of boundary terms. Subsequently taking the limit $\varepsilon \rightarrow 0$ for α outside $[0, 1]$ also comes with its own technical complications.

To be more precise, a first obstruction to our methods stems from a change of sign of an auxiliary potential which is central in the study of the limit $\varepsilon \rightarrow 0$; see Section 2.7. We avoid this by restricting our attention to α in the interval

$$\mathcal{A} := \bigcup_{\ell \in (0,1)} \text{int}\{\alpha : \ell \frac{1}{4} |\nabla V(x)|^2 - \frac{1}{2} \langle b, \nabla V(x) \rangle + \alpha(1 - \alpha) |b(x)|^2 \geq 0 \text{ for all } x \in \mathbf{R}^N\}.$$

One can use (RB) to show that if ℓ is close enough to 1, then the quantity of interest is nonnegative for α in an open interval containing $[0, 1]$; see Lemma 2.A.2. The interval \mathcal{A} is symmetric about $\alpha = \frac{1}{2}$. Another possible obstruction is the behaviour of the boundary term g used in the construction of $\mathcal{S}_\ell^\varepsilon$. We introduce the following technical assumption and immediately give more tractable sufficient conditions.

Assumption (IP). There exists an open interval I^ε with $[0, 1] \subset I^\varepsilon \subseteq \mathcal{A}$ and such that the following property holds for all $\alpha \in I^\varepsilon$: there exists $p_\alpha^\varepsilon \in (1, \infty)$ and $\ell_\alpha^\varepsilon \in (0, 1)$ such that

$$\ell_\alpha^\varepsilon \frac{1}{p_\alpha^\varepsilon} \left(1 - \frac{1}{p_\alpha^\varepsilon}\right) |\nabla V(x)|^2 - \frac{1-2\alpha+\alpha p_\alpha^\varepsilon}{p_\alpha^\varepsilon} \langle b(x), \nabla V(x) \rangle + \alpha(1 - \alpha) |b(x)|^2 \geq 0, \quad (2.18)$$

for all $x \in \mathbf{R}^N$, and both

$$g^\alpha \in L^{p_\alpha^\varepsilon}(\mathbf{R}^N, d\mu_0^\varepsilon) \quad \text{and} \quad \frac{d\lambda}{d\mu_0^\varepsilon} g^{-\alpha} \in L^{q_\alpha^\varepsilon}(\mathbf{R}^N, d\mu_0^\varepsilon), \quad (2.19)$$

with $\frac{1}{p_\alpha^\varepsilon} + \frac{1}{q_\alpha^\varepsilon} = 1$.

In the case $g \equiv 1$, we can give a simple condition on the initial condition λ which is sufficient for Assumption (IP) to hold. The proof elucidates why we leave p_α^ε as a parameter instead of fixing $p_\alpha^\varepsilon = q_\alpha^\varepsilon = 2$: it is this parameter which allows us to accomodate measures λ for which $\frac{d\lambda}{d\mu_0^\varepsilon} \in L^{2-\delta}(\mathbf{R}^N, d\mu_0^\varepsilon)$ with $\delta > 0$ small, but not with $\delta = 0$; cf. Lemma 2.A.9.

Lemma 2.3.4. *Suppose that Assumptions (L0), (L1) and (RB) are satisfied and that $g \equiv 1$. With $k_b \in [0, \frac{1}{2})$ as in (RB), if there exists $\delta \in (0, \frac{1}{2})$ such that the initial condition λ satisfies*

$$\frac{d\lambda}{d\mu_0^\varepsilon} \in L^{\frac{1}{1-k_b-\delta}}(\mathbf{R}^N, d\mu_0^\varepsilon), \quad (2.20)$$

then Assumption (IP) is satisfied.

Proof. For any given $p \in (\frac{1}{1-k_b}, \frac{1}{k_b})$, there exists $\ell \in (0, 1)$ such that condition (2.18) holds for all α in an open interval containing $[0, 1]$; see Lemma 2.A.2. Without loss of generality, $\delta > 0$ in (2.20) is small enough that $p = \frac{1}{k_b+\delta}$ is such a value, but then we have $q = \frac{1}{1-k_b-\delta}$ and (2.19) with $g \equiv 1$ reduces to (2.20). \square

In the steady-state canonical case, $g = d\lambda / d\mu_0^\varepsilon$ and $\lambda = \lambda_{\text{inv}}^\varepsilon$, (2.19) is guaranteed to hold for all $\alpha \in [0, 1]$. Indeed, one can apply Lemma 2.A.9 with some p_α^ε close enough to 2 that (2.18) holds. However, obtaining (2.19) outside the interval $[0, 1]$ is in general a delicate task which, to our knowledge, requires extra assumptions.

Lemma 2.3.5. *Suppose that Assumptions (L1) and (RB) are satisfied, that $g = d\lambda / d\mu_0^\varepsilon$ and that the initial condition is $\lambda = \lambda_{\text{inv}}^\varepsilon$. If there exists $c_-, c_+, \gamma_-, \gamma_+ > 0$ and $a \geq 2$ such that*

$$V(x) \geq \gamma_- |x|^a - c_-$$

and

$$|\nabla V(x)|^2 \leq \gamma_+^2 a^2 |x|^{2(a-1)} + c_+$$

for all $x \in \mathbf{R}^N$, then Assumption (IP) is satisfied, uniformly in ε .

Proof. We will show that there exists a nonempty interval of the form $(\alpha_-, 0]$ which does not depend on ε and such that (2.18) and (2.19) hold for all α in this interval, with common p and ℓ . A similar argument can be given to find an interval of the form $[1, \alpha_+)$.

Fix $p = 2 + \delta$ for some $\delta > 0$ small enough that there exists $\ell \in (0, 1)$ such that condition (2.18) holds for all α in a nonempty interval of the form $(\hat{\alpha}_-, 0]$. Then, $q \in (1, 2)$ and the second inclusion

in (2.19) for all α in a nonempty interval of the form $(\tilde{\alpha}_-, 0]$ is guaranteed by Lemma 2.A.9. Finally, we claim that the fact that

$$\left(\frac{d\lambda_{\text{inv}}^\varepsilon}{d\mu_0^\varepsilon}\right)^\alpha \in L^p(\mathbf{R}^N, d\mu_0^\varepsilon) \quad (2.21)$$

for all α in a nonempty interval of the form $(\tilde{\alpha}_-, 0]$ follows from the work [ABG19]. We then take $\alpha_- := \max\{\hat{\alpha}_-, \tilde{\alpha}_-, \bar{\alpha}_-\}$ to complete the proof.

To establish (2.21), pick $M > 0$ such that $|\langle b(x), x \rangle| \leq M|x|^2$ for all $x \in \mathbf{R}^N$. Combining the upper bound with γ_+ and Assumption (RB), we obtain a constant \tilde{c}_+ such that

$$-\frac{1}{4\varepsilon}|\nabla V(x)|^2 + \frac{1}{2\varepsilon}\langle b(x), \nabla V(x) \rangle - \frac{1}{2}\Delta V(x) - \text{div } b(x) \geq -\frac{1}{8\varepsilon}\gamma_+(1 - 2k_b)|x|^{2(a-1)}$$

if $|x|$ is sufficiently large. Set

$$K := \frac{1}{2a}\left(M + \sqrt{M^2 + \gamma_+(1 - 2k_b)}\right).$$

By Theorem 4.1 in [ABG19] applied to the conjugated Fokker–Planck operator

$$\varepsilon\Delta - \langle b, \nabla \rangle - \frac{1}{4\varepsilon}|\nabla V|^2 + \frac{1}{2\varepsilon}\langle b, \nabla V \rangle - \frac{1}{2}\Delta V - \text{div } b,$$

there exists constants $C_\varepsilon > 0$ and $r_\varepsilon > 0$ such that the unique function φ^ε such that

$$\lambda_{\text{inv}}^\varepsilon(dx) = e^{-(2\varepsilon)^{-1}V(x)}\varphi^\varepsilon(x) dx$$

satisfies

$$\varphi^\varepsilon(x) \geq C_\varepsilon e^{-\varepsilon^{-1}K|x|^a}$$

whenever $|x| > r_\varepsilon$; also see Lemma 2.A.8. This last inequality can be rewritten as

$$\frac{d\lambda_{\text{inv}}^\varepsilon}{d\mu_0^\varepsilon}(x) \geq \tilde{C}_\varepsilon e^{-(2\varepsilon)^{-1}V(x)} e^{-\varepsilon^{-1}K|x|^a}$$

with some $\tilde{C}_\varepsilon > 0$. Using the lower bound in γ_- , there exists $\tilde{r}_\varepsilon > 0$ such that

$$\left(\frac{d\lambda_{\text{inv}}^\varepsilon}{d\mu_0^\varepsilon}(x)\right)^{-|\beta|} \leq \tilde{C}_\varepsilon^{-1} \exp\left(\frac{|\beta|}{\varepsilon}\left(\frac{1}{2} + \frac{K}{2\gamma_-}\right)V(x)\right)$$

whenever $|x| > \tilde{r}_\varepsilon$. We conclude that the claim (2.21) indeed holds for all $\alpha \in (\tilde{\alpha}_-, 0]$ with $\tilde{\alpha}_-^{-1} := -p\left(\frac{1}{2} + \frac{K}{2\gamma_-}\right)$. \square

2.3.3 A representation for the moment-generating function

Under Assumption (IP), we prove the validity of a commonly used representation of the MGF $\chi_t^\varepsilon(\alpha)$ in terms of a semigroup of operators acting on $L^{p_\alpha}(\mathbf{R}^N, d\mu_0^\varepsilon)$ obtained by deformation of the infinitesimal generator $A^{\varepsilon,0} = \varepsilon\Delta + \langle -\nabla V + b, \nabla \rangle$ of the semigroup associated to the SDE (2.5). The proof relies on preliminary results on elliptic operators collected in Appendix 2.A, based on [AGG⁺86, Lan97, MPSR05].

Proposition 2.3.6. *Suppose that Assumptions (L0), (L1), (RB) and (IP) are satisfied. Then, for all $\alpha \in I^\varepsilon$, the MGF $\chi_t^\varepsilon(\alpha)$ is finite and can be represented as*

$$\chi_t^\varepsilon(\alpha) = \int_{\mathbf{R}^N} g^{-\alpha} \left(e^{tA^{\varepsilon,\alpha}} g^\alpha \right) d\lambda, \quad (2.22)$$

where $A^{\varepsilon,\alpha}$ is the infinitesimal generator of a semigroup on $L^{p_\alpha}(\mathbf{R}^N, d\mu_0^\varepsilon)$ given by

$$A^{\varepsilon,\alpha} f = \varepsilon\Delta f + \langle -\nabla V + (1 - 2\alpha)b, \nabla f \rangle - \frac{\alpha(1-\alpha)}{\varepsilon} |b|^2 f + \frac{\alpha}{\varepsilon} \langle b, \nabla V \rangle f - \alpha f \operatorname{div} b, \quad (2.23)$$

for all $f \in C_c^2(\mathbf{R}^N)$.

Proof. We use an approximation strategy similar to that in the proof of Proposition 2.2.5 and again omit keeping explicit track of ε .

Step 1: Reduction to the case where b has compact support. Suppose that the proposition has been proved in the case where b has compact support. For a general b , let $(b_R)_{R \in \mathbf{N}}$ be a sequence of compactly supported approximations of b as in the proof of Proposition 2.2.5. Fix α and set

$$A_R^\alpha := \varepsilon\Delta + \langle -\Delta V + (1 - 2\alpha)b_R, \nabla \rangle - \frac{\alpha(1-\alpha)}{\varepsilon} |b_R|^2 + \frac{\alpha}{\varepsilon} \langle b_R, \nabla V \rangle - \alpha \operatorname{div} b_R$$

and

$$A^\alpha := \varepsilon\Delta + \langle -\Delta V + (1 - 2\alpha)b, \nabla \rangle - \frac{\alpha(1-\alpha)}{\varepsilon} |b|^2 + \frac{\alpha}{\varepsilon} \langle b, \nabla V \rangle - \alpha \operatorname{div} b.$$

It is shown in Appendix 2.A that these operators with domain $W^{2,p_\alpha}(\mathbf{R}^N; d\mu_0)$ generate semigroups on $L^{p_\alpha}(\mathbf{R}^N; d\mu_0)$ if $\alpha \in \mathcal{A}$. Hence, in view of (2.19) and the definition of I , the

right-hand side of (2.22) is well defined and finite for all $\alpha \in I$. Therefore, by (2.8), it suffices to show that

$$(e^{tA^\alpha} g^\alpha)(x) = g^\alpha(x) \int_{\mathcal{E}_t} e^{-\alpha \mathcal{P}_t} d\mathcal{P}_t^x \quad (2.24)$$

for almost all $x \in \mathbf{R}^N$.

One can show using the isometry between $L^{p_\alpha}(\mathbf{R}^N, d\mu_0)$ and $L^{p_\alpha}(\mathbf{R}^N, d\text{vol})$ and the second resolvent identity that

$$\text{s. r. -}\lim_{R \rightarrow \infty} A_R^\alpha = A^\alpha.$$

Hence, by Theorem 2.16 in [Kat95, Ch. IX],

$$\text{s. -}\lim_{R \rightarrow \infty} e^{tA_R^\alpha} = e^{tA^\alpha}$$

on $L^{p_\alpha}(\mathbf{R}^N, d\mu_0)$, which contains g^α by (2.19) of Assumption (IP). In particular, there exists a subsequence $(R_k)_{k \in \mathbf{N}}$ properly diverging to $+\infty$ such that

$$(e^{tA^\alpha} g^\alpha)(x) = \lim_{k \rightarrow \infty} (e^{tA_{R_k}^\alpha} g^\alpha)(x)$$

for almost all $x \in \mathbf{R}^N$. Hence, by hypothesis,

$$\begin{aligned} (e^{tA^\alpha} g^\alpha)(x) &= \lim_{k \rightarrow \infty} (e^{tA_{R_k}^\alpha} g^\alpha)(x) \\ &= \lim_{k \rightarrow \infty} g^\alpha(x) \int_{\mathcal{E}_t} e^{-\alpha \mathcal{P}_t} d\mathcal{P}_t^x[R_k] \\ &= g^\alpha(x) \lim_{k \rightarrow \infty} \left(\int_{B_{R_k}} e^{-\alpha \mathcal{P}_t} d\mathcal{P}_t^x[R_k] + \int_{B_{R_k}^c} e^{-\alpha \mathcal{P}_t} d\mathcal{P}_t^x[R_k] \right), \end{aligned}$$

where $\mathcal{P}_t^x[R_k]$ is the measure on the paths associated to the SDE with initial condition x and drift $-\nabla V + b_{R_k}$, and where B_{R_k} denotes the ball of radius R_k in \mathcal{E}_t . Using uniqueness,

$$(e^{tA^\alpha} g^\alpha)(x) = g^\alpha(x) \lim_{k \rightarrow \infty} \left(\int_{B_{R_k}} e^{-\alpha \mathcal{P}_t} d\mathcal{P}_t^x + \int_{B_{R_k}^c} e^{-\alpha \mathcal{P}_t} d\mathcal{P}_t^x[R_k] \right). \quad (2.25)$$

By Lebesgue monotone convergence,

$$\lim_{k \rightarrow \infty} \int_{B_{R_k}} e^{-\alpha \mathcal{P}_t} d\mathcal{P}_t^x = \int_{\mathcal{E}_t} e^{-\alpha \mathcal{P}_t} d\mathcal{P}_t^x. \quad (2.26)$$

Note that this limit must be finite because the left-hand side of (2.25) is finite, $g^\alpha(x)$ is strictly positive and the integral over the complement of the ball on the right-hand side of (2.25) is nonnegative. Because I is open,

$$\int_{\mathcal{E}_t} e^{-(\alpha+\delta\alpha)\mathcal{P}_t} d\mathcal{P}_t^x < \infty$$

as well if $\delta > 0$ is small enough. Hence, we may apply Hölder's inequality with exponents $1 + \delta$ and $(1 - (1 + \delta)^{-1})^{-1}$ to derive

$$\begin{aligned} & \lim_{k \rightarrow \infty} \left| \int_{B_{R_k}^c} e^{-\alpha\mathcal{P}_t} d\mathcal{P}_t^x \right| \\ & \leq \lim_{k \rightarrow \infty} \left| \int_{\mathcal{E}_t} e^{-(\alpha+\delta\alpha)\mathcal{P}_t} d\mathcal{P}_t^x \right|^{\frac{1}{1+\delta}} (1 - \mathcal{P}_t^x[R_k](B_{R_k}))^{1-(1+\delta)^{-1}}, \end{aligned}$$

which is controlled by Lemma 2.2.2. Using this bound and (2.26) in (2.25) yields (2.24) and the proof is concluded.

Step 2: Proof in the case where b has compact support. In view of (2.8), it suffices to show that

$$g^\alpha(x) \int_{\mathcal{E}_t} e^{-\alpha\mathcal{P}_t} d\mathcal{P}_t^x = (e^{tA^\alpha} g^\alpha)(x) \quad (2.27)$$

for almost all $x \in \mathbf{R}^N$, where $(e^{tA^\alpha})_{t \geq 0}$ is the positivity-preserving semigroup generated by A^α on $L^{p_\alpha}(\mathbf{R}^N, d\mu_0)$. By definition of \mathcal{P}_t , this is equivalent to

$$g^\alpha(x) \int_{\mathcal{E}_t} g^{-\alpha}(\gamma(0)) g^\alpha(\gamma(t)) e^{-\alpha \varepsilon^{-1} \int_0^t \langle b(\gamma), \circ d\gamma \rangle} \mathcal{P}_t^x(d\gamma) = (e^{tA^\alpha} g^\alpha)(x). \quad (2.28)$$

Note that the terms $g^\alpha(x)$ and $g^{-\alpha}(\gamma(0))$ cancel each other out.

By Lebesgue monotone convergence and continuity of e^{tA^α} , it is enough to show that

$$\int_{\mathcal{E}_t} (\eta g^\alpha)(\gamma(t)) e^{-\alpha \varepsilon^{-1} \int_0^t \langle b(\gamma), \circ d\gamma \rangle} \mathcal{P}_t^x(d\gamma) = (e^{tA^\alpha} \eta g^\alpha)(x) \quad (2.29)$$

for all smooth functions $0 \leq \eta \leq 1$ with compact support. We will not keep this cutoff function η explicitly in the formulas, but we will use theorems that would generally apply to a continuous compactly supported function g with the understanding that we can obtain the

final result by taking a sequence $(\eta_R)_{R \in \mathbf{N}}$ converging pointwise to the constant function 1 from below.

Set $m(s, x)$ to be the left-hand side of (2.28) with t replaced by $s \in [0, t]$. Because $g^\alpha \in L^p(\mathbf{R}^N, d\mu_0^\varepsilon)$ and because the semigroup generated by \mathcal{A}^α with domain $W^{2,p}(\mathbf{R}^N, d\mu_0^\varepsilon)$ on $L^p(\mathbf{R}^N, d\mu_0^\varepsilon)$ is analytic, $e^{s\mathcal{A}^\alpha} g^\alpha \in W^{2,p}(\mathbf{R}^N, d\mu_0^\varepsilon)$ and

$$\partial_s (e^{s\mathcal{A}^\alpha} g^\alpha) = \mathcal{A}^\alpha e^{s\mathcal{A}^\alpha} g^\alpha$$

for all $s > 0$; see e.g. Proposition 1.6.ii in [AGG⁺86, Ch. A-I]. Hence, (2.28) becomes $m(t, x) = e^{t\mathcal{A}^\alpha} g^\alpha$ and, by uniqueness, we need only show that m also satisfies the partial differential equation

$$\begin{cases} \partial_s m(s, x) = (\mathcal{A}^\alpha m(s, \cdot))(x), & x \in \mathbf{R}^N, s > 0, \\ m(0, x) = g^\alpha(x), & x \in \mathbf{R}^N. \end{cases} \quad (2.30)$$

A straightforward computation shows that

$$\mathcal{A}^\alpha f = \tilde{\mathcal{A}}f - \frac{\alpha(1-\alpha)}{\varepsilon} |b|^2 f + \frac{\alpha}{\varepsilon} \langle b, \nabla V \rangle f - \alpha(\operatorname{div} b)f \quad (2.31)$$

where $\tilde{\mathcal{A}}$ is the infinitesimal generator associated to the deformed SDE

$$d\tilde{Y}_t = -\nabla V(\tilde{Y}_t) dt + (b(\tilde{Y}_t) - 2\alpha b(\tilde{Y}_t)) dt + \sqrt{2\varepsilon} dW_t.$$

Hence, in view of the Feynman–Kac formula — see e.g. Lemma 3.7 in [Kha11, Ch. 3] keeping in mind that b is temporarily assumed to be compactly supported —, (2.30) will hold if

$$m(t, x) = \int_{\mathcal{G}_t} g^\alpha(\gamma(t)) e^{\int_0^t -\frac{\alpha(1-\alpha)}{\varepsilon} |b(\gamma(s))|^2 + \frac{\alpha}{\varepsilon} \langle b(\gamma(s)), \nabla V(\gamma(s)) \rangle - \alpha(\operatorname{div} b)(\gamma(s)) ds} \tilde{\mathcal{Q}}_t^x(d\gamma).$$

But it follows from a Girsanov argument similar to that used in the proof of Proposition 2.2.4 —

recall again that b is temporarily assumed to be compactly supported — that

$$\begin{aligned} & \int_{\mathcal{E}_t} g^\alpha(\gamma(t)) \exp\left(\int_0^t -\frac{\alpha(1-\alpha)}{\varepsilon} |b(\gamma(s))|^2 + \frac{\alpha}{\varepsilon} \langle b(\gamma(s)), (\nabla V)(\gamma(s)) \rangle \right. \\ & \quad \left. - \alpha(\operatorname{div} b)(\gamma(s)) \, ds\right) \tilde{\mathcal{Q}}_t^x(d\gamma) \\ &= \int_{\mathcal{E}_t} g^\alpha(\gamma(t)) \exp\left(\int_0^t -\frac{\alpha(1-\alpha)}{\varepsilon} |b(\gamma(s))|^2 + \frac{\alpha}{\varepsilon} \langle b(\gamma(s)), (\nabla V)(\gamma(s)) \rangle \right. \\ & \quad \left. - \alpha(\operatorname{div} b)(\gamma(s)) \, ds\right) \tilde{Z}_t(\gamma) \mathcal{P}_t^x(d\gamma), \end{aligned}$$

where $\tilde{Z}_t(\gamma) := \exp\left(\frac{\alpha}{\sqrt{2\varepsilon}} \int_0^t \langle b(\gamma), dW(\gamma) \rangle - \frac{\alpha^2}{4\varepsilon} \int_0^t |b(\gamma(r))|^2 \, dr\right)$. The proof is concluded with a standard Itô calculus computation. \square

2.4 Large deviations in the large-time limit

The quantity

$$e^\varepsilon(\alpha) := \sup\{\operatorname{Re} z : z \in \operatorname{sp}(A^{\alpha,\varepsilon}, \mathbb{W}^{2,2}(\mathbf{R}^N, d\mu_0^\varepsilon))\}$$

for $\alpha \in \mathcal{A}$ will play a crucial role in our analysis of the large deviations of $\mathcal{P}_t^\varepsilon$. We will interchangeably refer to this quantity as *the leading eigenvalue* of $A^{\alpha,\varepsilon}$ or as $\operatorname{spb}(A^{\alpha,\varepsilon})$. Let us first state and prove a lemma concerning its regularity in α at fixed $\varepsilon > 0$.

Lemma 2.4.1. *Under Assumptions (L0), (L1) and (RB), the function e^ε is real-analytic on \mathcal{A} .*

Proof. Fix $\alpha_0 \in \mathcal{A}$. The differential operator $A^{\alpha_0,\varepsilon}$ defined by (2.23) on $\mathbb{W}^{2,2}(\mathbf{R}^N, d\mu_0^\varepsilon)$ is closed as an unbounded operator on $L^2(\mathbf{R}^N, d\mu_0^\varepsilon)$; see Appendix 2.A. For $\varkappa \in \mathbf{C}$,

$$B^{\alpha_0,\varepsilon}(\varkappa) := -2\varkappa \langle b, \nabla \rangle - \frac{\varkappa(1-\varkappa-2\alpha_0)}{\varepsilon} |b|^2 + \frac{\varkappa}{\varepsilon} \langle b, \nabla V \rangle - \varkappa \operatorname{div} b$$

is a relatively bounded perturbation of $A^{\alpha_0,\varepsilon}$. The relative bound can be made arbitrarily small by taking $|\varkappa|$ small enough.

Hence, by Theorem 1.1 in [Kat95, Ch. IV], there exists a neighbourhood Ω of α_0 in \mathbf{C} such that the differential operator $A^{\alpha,\varepsilon} = A^{\alpha_0,\varepsilon} + B^{\alpha_0,\varepsilon}(\alpha - \alpha_0)$ on $L^2(\mathbf{R}^N, d\mu_0^\varepsilon)$ with domain $\mathbb{W}^{2,2}(\mathbf{R}^N, d\mu_0^\varepsilon)$ is closed for all $\alpha \in \Omega$. Moreover, a straightforward estimate shows that $\varkappa \mapsto B^{\alpha_0,\varepsilon}(\varkappa)f \in L^2(\mathbf{R}^N, d\mu_0^\varepsilon)$

is holomorphic whenever $f \in \mathbb{W}^{2,2}(\mathbf{R}^N, d\mu_0^\varepsilon)$. Hence, for fixed $\varepsilon > 0$, $\{A^{\alpha,\varepsilon}\}_{\alpha \in \Omega}$ is a holomorphic family of type (A) in the sense of [Kat95, §VII.2.1]. By Proposition 2.A.7, $e^\varepsilon(\alpha_0)$ is a simple eigenvalue of $A^{\alpha_0,\varepsilon}$ and can be separated from the rest of $\text{sp } A^{\alpha_0,\varepsilon}$ by a simple closed curve. Following [Kat95, §VII.2.3], the spectrum of $(A^{\alpha,\varepsilon}, \mathbb{W}^{2,2}(\mathbf{R}^N, d\mu_0^\varepsilon))$ is likewise separated into two parts for $\alpha \in \Omega$ close enough to α_0 , and $\alpha \mapsto e^\varepsilon(\alpha)$ admits an analytic extension to a small complex neighbourhood of α_0 . \square

Lemma 2.4.2. *Under Assumptions (L0), (L1) and (RB),*

$$\mathbf{m}^\varepsilon = -D e^\varepsilon(0).$$

Proof. With the appropriate normalisation, the eigenvector corresponding to the eigenvalue $e^\varepsilon(0) = 0$ is the constant 1 and the corresponding eigenvector of the adjoint (the Fokker–Planck operator) is obtained from $\lambda_{\text{inv}}^\varepsilon$; see the proof of Lemma 2.A.8. Because e^ε is analytic in 0 and is a simple eigenvalue for all α close enough to 0, the derivative can be computed using a formula colloquially known as the Hellmann–Feynman formula:

$$D e^\varepsilon(0) = \int (-2 \langle b, \nabla \rangle - \varepsilon^{-1} |b|^2 + \varepsilon^{-1} \langle b, \nabla V \rangle - \text{div } b) 1 d\lambda_{\text{inv}}^\varepsilon;$$

see (2.33) in [Kat95, §II.2.2] and the argument in [Kat95, §VII.1.3]. \square

Proposition 2.4.3. *Suppose that Assumptions (L0), (L1), (RB) and (IP) are satisfied. Then,*

$$\lim_{t \rightarrow \infty} \frac{1}{t} \log \chi_t^\varepsilon(\alpha) = e^\varepsilon(\alpha) \quad (2.32)$$

for all $\alpha \in I^\varepsilon$.

Proof. Fix $\alpha \in I^\varepsilon$ and pick $p = p_\alpha^\varepsilon$ as in (IP). Let $\psi^{\alpha,\varepsilon}$ [resp. $u^{\alpha,\varepsilon}$] be a strictly positive right [resp. left] eigenvector of $A^{\alpha,\varepsilon}$ for the eigenvalue $e^\varepsilon(\alpha)$ with the properties of Proposition 2.A.7. By Proposition 2.3.6, we have

$$\begin{aligned} & \int_{\mathcal{E}_t} e^{-\alpha \mathcal{P}_t^{\lambda_t^\varepsilon}} d\mathcal{P}_t^{\xi_t, \varepsilon} \\ &= \int_{\mathbf{R}^N} \frac{d\lambda}{d\mu_0^\varepsilon}(x) g^{-\alpha}(x) (e^{tA^\alpha} g^\alpha)(x) \mu_0^\varepsilon(dx) \\ &= e^{te^\varepsilon(\alpha)} \left(\int_{\mathbf{R}^N} \frac{d\lambda}{d\mu_0^\varepsilon}(x) g^{-\alpha}(x) (e^{-te^\varepsilon(\alpha)} e^{tA^\alpha} g^\alpha - \psi^{\varepsilon,\alpha}(u^{\alpha,\varepsilon}, g^\alpha)_{\mu_0^\varepsilon})(x) \mu_0^\varepsilon(dx) + J^{\alpha,\varepsilon} \right), \end{aligned}$$

where $J^{\alpha, \varepsilon}$ is finite, strictly positive and independent of t . Recall that our choice of $\alpha \in I^\varepsilon$ satisfying condition (2.19) guarantees

$$g^\alpha(x) \in L^p(\mathbf{R}^N, d\mu_0^\varepsilon) \quad \text{and} \quad \frac{d\lambda}{d\mu_0^\varepsilon} g^{-\alpha}(x) \in L^p(\mathbf{R}^N, d\mu_0^\varepsilon)^*.$$

Hence, using Hölder's inequality and Proposition 2.A.7 to control the difference in the integrand,

$$\lim_{t \rightarrow \infty} \frac{1}{t} \log \int_{\mathcal{G}_t} e^{-\alpha \mathcal{P}_t^{\lambda, \varepsilon}} d\mathcal{P}_t^{\xi, \varepsilon} = e^\varepsilon(\alpha). \quad \square$$

Remark 2.4.4. *In particular, in this regime, the mean canonical entropy production and the Chernoff and Hoeffding error exponents for the hypothesis testing of the arrow of time do not depend on the specific choice of initial distribution λ , as long as it is mutually absolutely continuous with respect to μ_0^ε . Actually, if one is solely interested in this fact, one only needs the proposition for $\alpha \in [0, 1]$ and can therefore relax Assumption (IP). We refer the reader to [JOPS12, §6], [CJPS20, Ch. I.1].*

Corollary 2.4.5. *Under the same assumptions, the function $e^\varepsilon : \mathcal{A} \rightarrow \mathbf{R}$ is convex and*

$$e^\varepsilon(1 - \alpha) = e^\varepsilon(\alpha)$$

for all $\alpha \in \mathcal{A}$.

Proof. Consider the particular case $g \equiv 1$ and $\lambda = \mu_0^\varepsilon$ and take the appropriate limit in the second part of Proposition 2.2.5 using Proposition 2.4.3. \square

For $\zeta \in \{-De^\varepsilon(\alpha) : \alpha \in \mathcal{A}\}$, set

$$e_*^\varepsilon(\zeta) := \sup_{\alpha \in \mathcal{A}} (-\alpha\zeta - e^\varepsilon(\alpha)). \quad (2.33)$$

It is immediate from Corollary 2.4.5, the symmetry $\mathcal{A} = 1 - \mathcal{A}$ and the definition of e_*^ε that

$$e_*^\varepsilon(\zeta) - e_*^\varepsilon(-\zeta) = -\zeta \quad (2.34)$$

for all $\zeta \in \{-De^\varepsilon(\alpha) : \alpha \in \mathcal{A}\}$. Combining Lemma 2.4.1, Proposition 2.4.3 and a local version of the Gärtner–Ellis theorem (see e.g. [JOPP11, §A.2]), we get the following large deviation result. The symmetry (2.34) of the rate function e_*^ε in this LDP is referred to as the *Gallavotti–Cohen symmetry*.

Proposition 2.4.6. *Under assumptions (L0), (L1), (RB) and (IP), if E is a Borel set with $\text{cl}(E) \subset \{-De^\varepsilon(\alpha) : \alpha \in I^0\}$, then*

$$\begin{aligned} - \inf_{\zeta \in \text{int}(E)} e_*^\varepsilon(\zeta) &\leq \liminf_{t \rightarrow \infty} t^{-1} \log \mathcal{P}_t^\varepsilon \left\{ t^{-1} \mathcal{S}_t^\varepsilon \in E \right\} \\ &\leq \limsup_{t \rightarrow \infty} t^{-1} \log \mathcal{P}_t^\varepsilon \left\{ t^{-1} \mathcal{S}_t^\varepsilon \in E \right\} \leq - \inf_{\zeta \in \text{cl}(E)} e_*^\varepsilon(\zeta). \end{aligned}$$

2.5 The linear case

We have shown in Section 2.4 that the large deviations of $\mathcal{S}_t^\varepsilon$ can be understood in terms of the leading eigenvalue $e^\varepsilon(\alpha)$ of $A^{\alpha, \varepsilon}$ and its Legendre transform (2.33). We devote the present section to the study of these quantities in the case where we make the additional assumptions that V is quadratic and b is linear — equivalently $V(x) = \frac{1}{2} \langle x, D^2Vx \rangle$ and $b(x) = Dbx$. Note that (ND) is then a consequence of (L0), which becomes

$$D^2V > 0. \tag{2.35}$$

Assumption (RB) becomes

$$\langle Dbx, D^2Vx \rangle \leq k_b |D^2Vx|^2 \tag{2.36}$$

for all $x \in \mathbf{R}^N$.

The linear case is particularly important for several reasons. First and foremost, we will see in Sections 2.6 and 2.7 that the general case can be reduced to this one in the limit $\varepsilon \rightarrow 0$. Second, linearity makes computations more tractable and allows to give a characterisation of the vanishing of the mean entropy production per unit time \mathfrak{m}^ε .

Note that the operator $A^{\alpha, \varepsilon}$ introduced in (2.23) is in this case isospectral to the ε -independent operator

$$Q^\alpha = \Delta + \langle \ell_{B^{(\alpha)}}, \nabla \rangle - q_{K^{(\alpha)}} + \frac{1}{2} \text{tr} D^2V - \alpha \text{tr} Db \tag{2.37}$$

where $\ell_{B^{(\alpha)}}$ is the auxiliary linear vector field $x \mapsto B^{(\alpha)}x$ and $q_{K^{(\alpha)}}$ is the auxiliary quadratic potential $x \mapsto \langle x, K^{(\alpha)}x \rangle$, with

$$B^{(\alpha)} := (1 - 2\alpha)Db$$

and

$$K^{(\alpha)} := \frac{1}{4}(D^2V)^2 - \frac{1}{4}(Db^\top D^2V + D^2VDb) + \alpha(1 - \alpha)Db^\top Db.$$

To see this, conjugate with the Gaussian weight $e^{-(2\varepsilon)^{-1}V}$ and its inverse and then make a change of variable $x \mapsto \varepsilon^{1/2}x$.

Such elliptic operators with quadratic symbols have been fairly well understood since the seminal work of [Sjö74]. Here, inspired by [FS97, JPS17], we emphasise a slightly different point of view, which relies on the study of the corresponding *algebraic Riccati equation* (ARE)

$$X^2 - \frac{1}{2}(B^{(\alpha)})^\top X - \frac{1}{2}XB^{(\alpha)} - K^{(\alpha)} = 0 \quad (2.38)$$

for a symmetric matrix X . The general theory of such equations is discussed in [LR95]. See [BCX20] for yet another approach in a special case.

Proposition 2.5.1. *For all $\alpha \in \mathcal{A}$, the ARE (2.38) admits a maximal solution $X^{(\alpha)}$ and*

$$\text{spb } Q^\alpha = -\text{tr } X^{(\alpha)} + \frac{1}{2} \text{tr } D^2V - \alpha \text{tr } Db.$$

Moreover, $\alpha \mapsto \text{tr } X^{(\alpha)}$ defines a real-analytic function on \mathcal{A} and we have the identity

$$\text{tr } X^{(\alpha)} = -\frac{1}{2} \left(\text{tr } B^{(\alpha)} - \sum_{\lambda^{(\alpha)} \in \text{sp } \mathcal{H}_{\text{Ham}}^{(\alpha)}} |\text{Re } \lambda^{(\alpha)}| \right) \quad (2.39)$$

where

$$\mathcal{H}_{\text{Ham}}^{(\alpha)} := \begin{bmatrix} -\frac{1}{2}B^{(\alpha)} & \mathbf{1} \\ K^{(\alpha)} & \frac{1}{2}(B^{(\alpha)})^\top \end{bmatrix}. \quad (2.40)$$

Proof. Consider $\phi_X(x) := \exp(-\frac{1}{2} \langle x, Xx \rangle)$ for some positive-definite matrix X and compute

$$\begin{aligned} (Q^\alpha \phi_X)(x) &= -\text{tr } X \phi_X(x) + \langle Xx, Xx \rangle \phi_X(x) - \langle B^{(\alpha)}x, Xx \rangle \phi_X(x) \\ &\quad - \langle x, K^{(\alpha)}x \rangle \phi_X(x) + \left(\frac{1}{2} \text{tr } D^2V - \alpha \text{tr } Db \right) \phi_X(x). \end{aligned}$$

Note that ϕ_X is an eigenvector with eigenvalue $-\text{tr } X + \frac{1}{2} \text{tr } D^2V - \alpha \text{tr } Db$ if

$$R(\alpha, X) := X^2 - \frac{1}{2}(B^{(\alpha)})^\top X - \frac{1}{2}XB^{(\alpha)} - K^{(\alpha)} = 0. \quad (2.41)$$

Because $K^{(\alpha)}$ is positive definite for all $\alpha \in \mathcal{A}$, $R(\alpha, 0) < 0$. Therefore, there exists a maximal positive-definite matrix $X^{(\alpha)}$ such that $R(\alpha, X^{(\alpha)}) = 0$, and $-X^{(\alpha)} + \frac{1}{2}B^{(\alpha)}$ is stable [LR95, §9.1]. This argument is valid for all $\alpha \in \mathcal{A}$ and $X^{(\alpha)}$ is a real-analytic function of $\alpha \in \mathcal{A}$ [LR95, §11.3].

In $\alpha = \frac{1}{2}$, we have $R(\frac{1}{2}, X) = X^2 - K^{(1/2)}$ and the square root of $K^{(1/2)}$ clearly is the maximal solution to the ARE $R(\frac{1}{2}, X) = 0$. But the trace of this maximal solution coincides with the smallest eigenvalue of the quantum harmonic oscillator $-\Delta + q_{K^{(1/2)}}$. Thus, first part of the lemma follows by simplicity and continuity of $\text{spb } Q^\alpha$. Relations between the eigenvalues of $-X^{(\alpha)} + \frac{1}{2}B^{(\alpha)}$ and those of the matrix (2.40) are discussed in [LR95, §8.3]. \square

Remark 2.5.2. Note that once a Gaussian weight is introduced to define Q^α , the method for obtaining the formula for its leading eigenvalue does not appeal to the fact $D^2V > 0$, but only to the fact that $(D^2V)^2 > 0$.

Proposition 2.5.3. Under the assumptions of Proposition 2.4.3 and the additional assumption that V is quadratic and b is linear,

$$\lim_{t \rightarrow \infty} \frac{1}{t} \log \chi_t^\varepsilon(\alpha) = -\text{tr } X^{(\alpha)} + \frac{1}{2} \text{tr } D^2V - \alpha \text{tr } Db, \quad (2.42)$$

for all $\alpha \in \mathcal{A}$. Moreover,

- i. if the matrix Db is not symmetric, then the mean entropy production per unit time \mathfrak{m}^ε is strictly positive and independent of ε and the rate function e_*^ε in Proposition 2.4.6 is strictly convex and independent of ε ;
- ii. if the matrix Db is symmetric, then $\mathfrak{m}^\varepsilon = 0$.

Proof. Combining Proposition 2.4.3 and Proposition 2.5.1 with the fact that

$$e^\varepsilon(\alpha) = \text{spb } Q^\alpha$$

immediately gives (2.42). It follows from Corollary 2.4.5 that e^ε is convex on \mathcal{A} and that $e^\varepsilon(0) = e^\varepsilon(1) = 0$. Hence, by analyticity, it will fail to be strictly convex if and only if it vanishes identically, which is in turn equivalent to $e^\varepsilon(\frac{1}{2}) = 0$. This last condition takes the explicit form

$$\text{tr} \sqrt{(D^2V - Db)^\top (D^2V - Db)} = \text{tr}(D^2V - Db).$$

Let $A := D^2V - Db$ and $|A| := \sqrt{A^\top A}$. We can find orthonormal bases $\{v_i\}_{i=1}^N$ and $\{w_i\}_{i=1}^N$ of \mathbf{C}^N such that $A = \sum_{i=1}^N \mu_i v_i \langle w_i, \cdot \rangle$ and $|A| = \sum_{i=1}^N \mu_i w_i \langle w_i, \cdot \rangle$, where $\{\mu_i\}_{i=1}^N$ are the singular values of A listed with multiplicity; see e.g. [Sim15, §3.5]. Computing traces in the basis $\{w_i\}_{i=1}^N$ and using $\mu_i \geq 0$, we find that $\text{tr } A = \text{tr } |A|$ implies $\langle v_i, w_i \rangle = 1$ for each i such that $\mu_i \neq 0$. Because $|w_i| = |v_i| = 1$, $\langle v_i, w_i \rangle = 1$ implies $w_i = v_i$ and we conclude that $A = |A|$. Of course, $A = |A|$ implies $\text{tr } A = \text{tr } |A|$.

Since D^2V is already symmetric, $A = |A|$ if and only if $Db^\top = Db$ and all the eigenvalues of $D^2V - Db$ are nonnegative. For the second condition only to fail, we would need a nonzero vector u and a strictly positive number λ such that $(D^2V - Db)u = -\lambda u$. Taking an inner product with D^2Vu in this eigenvalue equation gives

$$\langle Db u, D^2Vu \rangle = |D^2Vu|^2 + \lambda \langle u, D^2Vu \rangle,$$

which contradicts (2.35)–(2.36). □

Note that Case i in Proposition 2.5.3 occurs if and only if the linear vector field b is nonconservative; Case ii, if b is conservative. To see this, recall that the Hessian of a sufficiently regular function is always symmetric and that the gradient of a function of the form $x \mapsto \frac{1}{2} \langle x, Bx \rangle$ is the linear vector field $x \mapsto \frac{1}{2}(B + B^\top)x$. In view of this, we will say that a nonlinear vector field b *behaves like a gradient near a point x* if $Db|_x$ is symmetric.

2.6 The rate function in the vanishing-noise limit

We consider the limit $\varepsilon \rightarrow 0$. The main result of this section is the local LDP of Theorem 2.6.5, but we also discuss the behaviour of the mean entropy production per unit time. It is reasonable to allow the initial condition λ and the function g to change with ε — it is in fact necessary if one wants to study the steady-state canonical entropy production. We require Assumption (IP) to hold with a certain uniformity in ε .

Assumption (IP $_\varepsilon$). There exists an open interval I^0 containing 0 and 1, and whose closure is contained in $\liminf_{\varepsilon \rightarrow 0} I^\varepsilon$, where I^ε is as in Assumption (IP) with g replaced with g^ε and λ re-

placed with λ^ε .

Before we proceed to the general statements and proofs, let us illustrate the main points with an example.

Example 2.6.1. *Let V be a potential satisfying our general assumptions and suppose that its global minimum is achieved in a single point x_{j^*} . Suppose that b satisfies our general assumptions, $\operatorname{div} b \equiv 0$ and $\langle b, \nabla V \rangle \equiv 0$, and consider the steady-state functional with $g \equiv 1$. This is a situation in which one can easily show that $\lambda = \lambda_{\text{inv}}^\varepsilon = \mu_0^\varepsilon$.*

At the level of the mean entropy production per unit time, one can show the convergence $\mathbf{m}^\varepsilon \rightarrow \mathbf{m}_{j^}$, where \mathbf{m}_{j^*} is as in Section 2.5 for the linear problem near x_{j^*} . In particular, we have strict positivity of the limit if and only if b does not behave like a gradient near x_{j^*} . This strict positivity is a key signature of nonequilibrium.*

At the level of the fluctuations, the situation is the following. If $|\alpha|$ is small enough, $e^\varepsilon(\alpha) \rightarrow \max_j e_j(\alpha)$, where the maximum is taken over indices j corresponding to all local minima of V and e_j is as in Section 2.5 for the linear problem near x_{j^} . Therefore, with e_* the Legendre transform of $\alpha \mapsto \max_j e_j(\alpha)$, the rate functions $e_*^\varepsilon(\zeta)$ converge to $e_*(\zeta)$ for all ζ in an interval Σ . In cases where there is at least one index j' corresponding to local minimum such that $De_{j'}(0) \neq 0$, the interval Σ has nonempty interior. Hence, as far as the rate of exponential suppression of fluctuations is concerned, there is no discrimination between the global and local minima of V .*

In cases where there are indices j' and j'' corresponding to local minima such that $De_{j'}(0) \neq De_{j''}(0)$, then $e_{j'}$ and $e_{j''}$ cross in $\alpha = 0$. Such a crossing necessarily yields a nondegenerate closed interval strictly contained in Σ on which the rate function e_ vanishes. Hence, by tuning the behaviour of b near the critical points of a potential V with a single global minimum and other local minima, one can construct examples where $\lim_\varepsilon \mathbf{m}^\varepsilon$ lies at either end of this vanishing piece as well as examples where it lies in the interior.*

Back to the general case, recall that we have successfully reduced the study of the rate function to that of the leading eigenvalue $e^\varepsilon(\alpha)$ of the deformed generator $\mathcal{A}^{\varepsilon, \alpha}$ and its Legendre transform in

the variable α . Because

$$\begin{aligned} e^{-(2\varepsilon)^{-1}V} \mathcal{A}^{\varepsilon, \alpha} (e^{(2\varepsilon)^{-1}V} f) &= \varepsilon \Delta f + \langle (1 - 2\alpha)b, \nabla f \rangle - \frac{1}{4\varepsilon} |\nabla V|^2 f \\ &+ \frac{1}{2\varepsilon} \langle b, \nabla V \rangle f - \frac{\alpha(1-\alpha)}{\varepsilon} |b|^2 f + \frac{1}{2} f \Delta V - \alpha f \operatorname{div} b \end{aligned} \quad (2.43)$$

for sufficiently regular f , the semiclassical folklore suggests that the quadratic approximations near the zeroes of $\frac{1}{4} |\nabla V|^2 - \frac{1}{2} \langle b, \nabla V \rangle + \alpha(1 - \alpha) |b|^2$ — which coincide with the critical points of V for $\alpha \in \mathcal{A}$ — should play an important role as $\varepsilon \rightarrow 0$. While it is possible that Proposition 2.6.3 below is known to workers in the field of semiclassical analysis, we were not able to track a convenient reference and hence provide a complete proof in Section 2.7.

Such a quadratic approximation of the deformed conjugated generator near a critical point x_j is of the form treated in Section 2.5. In view of this analysis, we define

$$e_j(\alpha) := -\operatorname{tr} X_j^{(\alpha)} + \operatorname{tr} \frac{1}{2} D^2 V|_{x_j} - \alpha \operatorname{tr} D b|_{x_j}, \quad (2.44)$$

for $\alpha \in \mathcal{A}$, where $X_j^{(\alpha)}$ is the maximal solution to the ARE

$$(X_j^{(\alpha)})^2 - \frac{1}{2} (B_j^{(\alpha)})^\top X_j^{(\alpha)} - \frac{1}{2} X_j^{(\alpha)} B_j^{(\alpha)} - K_j^{(\alpha)} = 0 \quad (2.45)$$

with $B_j^{(\alpha)} := (1 - 2\alpha) D b|_{x_j}$ and

$$K_j^{(\alpha)} := \frac{1}{4} D^2 V|_{x_j}^\top D^2 V|_{x_j} - \frac{1}{4} (D b|_{x_j}^\top D^2 V|_{x_j} + D^2 V|_{x_j}^\top D b|_{x_j}) + \alpha(1 - \alpha) D b|_{x_j}^\top D b|_{x_j}.$$

We give an example in Figure 2.1.

Lemma 2.6.2. *Suppose that Assumptions (RB) and (ND) are satisfied. Then, $e_j(0) \leq 0$ with equality if and only if x_j is a local minimum of V .*

Proof. One can check directly that $\frac{1}{2} D^2 V|_{x_j}$ is a symmetric solution to (2.45) with $\alpha = 0$, so that $X_j^{(0)} \geq \frac{1}{2} D^2 V|_{x_j}$ and

$$e_j(0) = -\operatorname{tr} X_j^{(0)} + \frac{1}{2} \operatorname{tr} D^2 V|_{x_j} \leq 0. \quad (2.46)$$

On the other hand, Assumption (RB) yields that the matrix 0 is a subsolution to (2.45) with $\alpha = 0$, which implies that

$$X_j^{(0)} \geq 0.$$

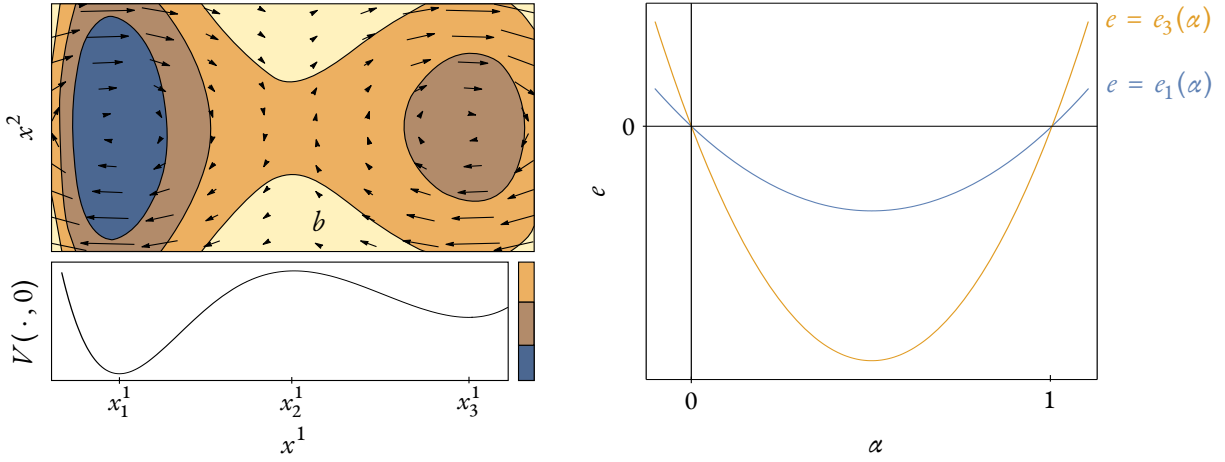

Figure 2.1: We consider a polynomial potential $V : \mathbf{R}^2 \rightarrow \mathbf{R}$ with a global minimum in $x_1 = (x_1^1, 0)$, a saddle point in $x_2 = (x_2^1, 0)$ and a local minimum in $x_3 = (x_3^1, 0)$. On the left: the profile of V for $x^2 \equiv 0$ as well as a nonconservative vector field b which is stationary in all those critical points superimposed on a contour plot of V . On the right: e_1 and e_3 from (2.44) are plotted as functions of α ; e_2 lies below the visible region.

If x_j is not local minimum, then $D^2V|_{x_j}$ is not positive semidefinite by (ND) and the inequality (2.46) must be strict. \square

Proposition 2.6.3. *Suppose that Assumptions (L0), (L1), (RB) and (ND) are satisfied. Then, for all $\alpha \in \mathcal{A}$,*

$$\lim_{\varepsilon \rightarrow 0} e^\varepsilon(\alpha) = \max_{j=1, \dots, m} e_j(\alpha). \quad (2.47)$$

The convergence is uniform on compact subsets of \mathcal{A} . The limit defines a convex and piecewise real-analytic function $e : \mathcal{A} \rightarrow \mathbf{R}$ satisfying the symmetry $e(1 - \alpha) = e(\alpha)$, and $De^\varepsilon(\alpha)$ converges to $De(\alpha)$ for all α in a dense subset of \mathcal{A}

Proof. By (2.43), Proposition 2.5.1 and Remark 2.5.2,

$$\max_{j=1, \dots, m} e_j(\alpha) = \max_{j=1, \dots, m} \text{spb } Q_j^\alpha \quad (2.48)$$

for all $\alpha \in \mathcal{A}$, where Q_j^α has the form

$$Q_j^\alpha := \Delta + \langle \ell_{B_j^{(\alpha)}}, \nabla \rangle - q_{K_j^{(\alpha)}} + \frac{1}{2} \text{tr } D^2V|_{x_j} - \alpha \text{tr } Db|_{x_j}. \quad (2.49)$$

We postpone the proof of the fact that

$$\lim_{\varepsilon \rightarrow 0} e^\varepsilon(\alpha) = \max_{j=1, \dots, m} \text{spb } Q_j^\alpha \quad (2.50)$$

to Section 2.7.

Let \bar{J} be a compact subset of \mathcal{A} . The fact that the convergence is uniform on \bar{J} and that the derivatives converge on a dense subset are well-known consequences of convexity. Each e_j is real analytic on \mathcal{A} by Proposition 2.5.1. Hence, the difference between any two e_j and $e_{j'}$ is real analytic and therefore has finitely many zeroes on \bar{J} , or $e_j \equiv e_{j'}$ on \mathcal{A} . It is no loss of generality to exclude the second case. There must be at most finitely many points in \bar{J} where the maximum in (2.48) changes index. We conclude that e is piecewise real analytic. \square

Proposition 2.6.3 has the following important consequences. Note that Lemma 2.6.2 implies that the maximum in Proposition 2.6.3 must be achieved for an index j corresponding to a local minimum if α is close enough to 0. Thus, using Lemma 2.4.2,

$$\min_{j \text{ loc. min.}} \mathbf{m}_j \leq \liminf_{\varepsilon \rightarrow 0} \mathbf{m}^\varepsilon \leq \limsup_{\varepsilon \rightarrow 0} \mathbf{m}^\varepsilon \leq \max_{j \text{ loc. min.}} \mathbf{m}_j, \quad (2.51)$$

where

$$\mathbf{m}_j := -De_j(\alpha)|_{\alpha=0} \quad (2.52)$$

for indices j that correspond to local minima of V . The fact that we are not able to generally strengthen (2.51) by taking the minimum and maximum only over indices corresponding to *global* minimisation of V as in Example 2.6.1 is a drawback of the freedom of the decomposition mentioned in Remark 2.2.1. To see this, consider a potential V with its global minimum achieved in two points x_{j^*} and $x_{j^{\dots}}$. The changes $V \mapsto V + \delta \eta_*$ and $b \mapsto b + \delta \nabla \eta_*$ for a small positive number δ and a suitable bump function η_* centered at x_{j^*} do not change the dynamics nor the validity of the assumptions, but the new potential does not achieve its global minimum in $x_{j^{\dots}}$. Such a freedom is gone if we restrict our attention to decompositions where the Freidlin–Wentzell quasipotential [VF70] is proportional to V — as is the case in Example 2.6.1.

Recall that Proposition 2.5.3 gives that \mathbf{m}_j in (2.52) is nonnegative and equals zero if and only if $D^2b|_{x_j}$ is symmetric. Therefore, the mean entropy production per unit time \mathbf{m}^ε vanishes as $\varepsilon \rightarrow 0$

if b behaves like a gradient near each local minimum of V . On the other hand, \mathfrak{m}^ε is bounded away from 0 as $\varepsilon \rightarrow 0$ if there is no local minimum of V near which b behaves like a gradient. From a thermodynamical point of view, strict positivity of the mean entropy production per unit time \mathfrak{m}^ε is a key signature of nonequilibrium.

The nonvanishing of \mathfrak{m}^ε also ensures that the content of our LDP is nontrivial. Indeed, the intervals

$$\Sigma := \liminf_{\varepsilon \rightarrow 0} \{-De^\varepsilon(\alpha) : \alpha \in \mathcal{A}\}$$

and

$$\Sigma^0 := \liminf_{\varepsilon \rightarrow 0} \{-De^\varepsilon(\alpha) : \alpha \in I^0\},$$

are always nonempty, but could a priori be singletons; strict positivity of \mathfrak{m}^ε in the limit $\varepsilon \rightarrow 0$ rules out this possibility. More generally, degeneracy of these intervals is ruled out whenever there exist a local minimum of V near which b does not behave like a gradient.

Proposition 2.6.4. *Suppose that Assumptions (L0), (L1), (RB), (ND) and (IPu) are satisfied. If E is a Borel set with $\text{cl}(E) \subset \text{int}(\Sigma)$, then*

$$\liminf_{\varepsilon \rightarrow 0} \inf_{\zeta \in E} e_*^\varepsilon(\zeta) = \inf_{\zeta \in E} e_*(\zeta) \quad (2.53)$$

where

$$e_*(\zeta) := \sup_{\alpha \in \mathcal{A}} (-\alpha\zeta - e(\alpha))$$

defines a convex and nonnegative function of $\zeta \in \Sigma$.

Proof. The proposition is vacuously true if Σ has empty interior. Let us now consider that $\text{int}(\Sigma)$ is nonempty. Convexity of e_* follows from that of e . Since $\text{cl}(E) \subset \text{int}(\Sigma)$, Proposition 2.6.3 ensures that we may pick α_1 and α_2 in \mathcal{A} such that

$$\inf \Sigma < -De(\alpha_1) < \inf E \leq \sup E < -De(\alpha_2) < \sup \Sigma$$

while

$$\lim_{\varepsilon \rightarrow 0} -De^\varepsilon(\alpha_1) = -De(\alpha_1) \quad \text{and} \quad \lim_{\varepsilon \rightarrow 0} -De^\varepsilon(\alpha_2) = -De(\alpha_2).$$

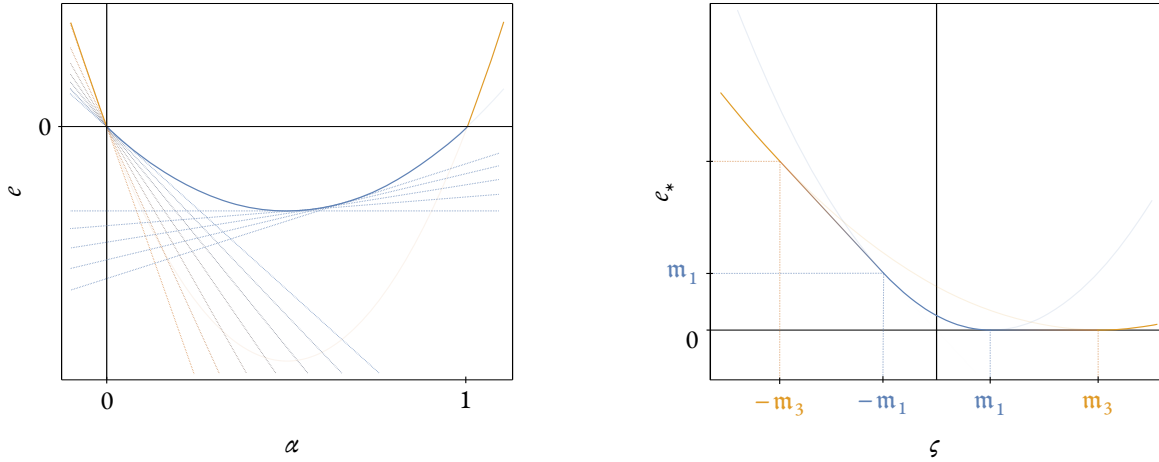

Figure 2.2: In the case of the function e on the left, obtained by taking the maximum of e_1, e_2 and e_3 in Figure 2.1, the jump in the derivative from $-m_3$ to $-m_1$ at the origin causes e_* to vanish on the interval $[m_1, m_3]$. The Legendre transform e_* is sketched on the right.

Then, for any $\zeta \in E$ and $\varepsilon > 0$ small enough, we have

$$-De^\varepsilon(\alpha_1) < \zeta < -De^\varepsilon(\alpha_2).$$

Therefore,

$$e_*(\zeta) = \sup_{\alpha \in \mathcal{A}} (-\alpha\zeta - e(\alpha)) = \sup_{\alpha \in [\alpha_2, \alpha_1]} (-\alpha\zeta - e(\alpha))$$

and

$$e_*^\varepsilon(\zeta) = \sup_{\alpha \in \mathcal{A}} (-\alpha\zeta - e^\varepsilon(\alpha)) = \sup_{\alpha \in [\alpha_2, \alpha_1]} (-\alpha\zeta - e^\varepsilon(\alpha))$$

for $\varepsilon > 0$ sufficiently small. The result thus follows from the uniform convergence of e^ε to e on the compact interval $[\alpha_2, \alpha_1]$ in Proposition 2.6.3. \square

The interest of Proposition 2.6.4 of course is that it can be used in conjunction with the local LDP of Proposition 2.4.6 for fixed $\varepsilon > 0$. The last part of the following theorem is illustrated by an example sketched in Figure 2.2.

Theorem 2.6.5. *If Assumptions (L0), (L1), (RB), (ND) and (IPu) are satisfied and E is a Borel set*

with $\text{cl}(E) \subset \text{int}(\Sigma^0)$, then

$$\begin{aligned} - \inf_{\zeta \in \text{int}(E)} e_*(\zeta) &\leq \lim_{\varepsilon \rightarrow 0} \liminf_{t \rightarrow \infty} t^{-1} \log \mathcal{P}_t^\varepsilon \left\{ t^{-1} \mathcal{F}_t^\varepsilon \in E \right\} \\ &\leq \lim_{\varepsilon \rightarrow 0} \limsup_{t \rightarrow \infty} t^{-1} \log \mathcal{P}_t^\varepsilon \left\{ t^{-1} \mathcal{F}_t^\varepsilon \in E \right\} \leq - \inf_{\zeta \in \text{cl}(E)} e_*(\zeta). \end{aligned}$$

and the function $e_* : \Sigma^0 \rightarrow [0, \infty)$ is continuous and satisfies the Gallavotti–Cohen symmetry

$$e_*(\zeta) - e_*(-\zeta) = -\zeta.$$

If $\min_j \text{loc. min. } \mathbf{m}_j \neq \max_j \text{loc. min. } \mathbf{m}_j$, then these two values define a nondegenerate interval in Σ^0 on which e_* vanishes.

Remark 2.6.6. Recall that the rate function e_* is the Legendre transform of e , which is in turn the pointwise maximum among the family $\{e_j\}_{j=1}^m$. Therefore, e_* can be computed as the convex hull of the family $\{(e_j)_*\}_{j=1}^m$ of Legendre transforms coming from the linearised problems near the critical points of V ; see Theorem 16.5 in [Roc70, Pt. III]

2.7 Convergence in the proof of Proposition 2.6.3

We devote this section to proving the semicalssical result at the core of Proposition 2.6.3, that is the convergence expressed in (2.50) for $e^\varepsilon(\alpha) := \text{spb } \mathcal{A}^{\varepsilon, \alpha}$. Our proof of the lower bound

$$\liminf_{\varepsilon \rightarrow 0} \text{spb}(\mathcal{A}^{\varepsilon, \alpha}) \geq \max_{j=1, \dots, m} \text{spb}(Q_j^\alpha)$$

uses the Protter–Weinberger characterisation of the spectral bound and follows some ideas borrowed from [BNV94]. The Protter–Weinberger characterisation is a variational principle which states that

$$\text{spb } Q_j^\alpha = \inf_{u \gg 0} \sup_x \frac{(Q_j^\alpha u)(x)}{u(x)},$$

where the infimum is taken over all strictly positive function u of class C^2 , and similarly for other uniformly elliptic operators; see [PW66, DV75, NP92]. Our proof of the upper bound

$$\limsup_{\varepsilon \rightarrow 0} \text{spb}(\mathcal{A}^{\varepsilon, \alpha}) \leq \max_{j=1, \dots, m} \text{spb}(Q_j^\alpha)$$

is inspired by B. Simon's localisation argument in the self-adjoint case [Sim83], with the Rayleigh–Ritz principle replaced by the Protter–Weinberger principle.

Let us mention that the selfadjoint case was also covered by B. Helffer and J. Sjöstrand in a series of papers starting with [HS84] using different methods. In the non-selfadjoint case, a collection of similar results are available, even beyond the elliptic case, but under some extra smoothness and growth conditions; see e.g. [HSS05, HPS13]. Under minimal regularity assumptions for the quadratic expansion to make sense, W. H. Fleming and Sh.-J. Sheu proved a similar result in the case of a single minimum; see [FS97].

We fix $\alpha \in \mathcal{A}$ for the rest of the section and omit the corresponding superscript from the notation. We show in Appendix 2.A (take $p = 2$ there) that the spectral properties of \mathcal{A}^ε can be deduced from those of the operator

$$A^\varepsilon := \varepsilon \Delta + \langle F, \nabla \rangle - \varepsilon^{-1} W_0 - W_1$$

on the space $L^2(\mathbf{R}^N, \text{dvol})$, with domain

$$D^2 := \{f \in W^{2,2}(\mathbf{R}^N, \text{dvol}) : |\nabla V|^2 f \in L^2(\mathbf{R}^N, \text{dvol})\},$$

with the auxiliary vector field

$$F := (1 - 2\alpha)b$$

and the auxiliary potentials

$$W_0 := \frac{1}{4} |\nabla V|^2 - \frac{1}{2} \langle b, \nabla V \rangle + \alpha(1 - \alpha)|b|^2 \quad \text{and} \quad W_1 := -\frac{1}{2} \Delta V + \alpha \operatorname{div} b.$$

We will use the fact that, F , W_0 and W_1 are of class C^2 , C^3 and C^1 respectively, but these assumptions can be slightly relaxed if necessary. With

$$\ell_j(x) := DF|_{x_j}(x - x_j),$$

$$q_j(x) := \frac{1}{2} \langle x - x_j, D^2 W_0|_{x_j}(x - x_j) \rangle$$

and

$$w_j := -\frac{1}{2} \operatorname{tr} D^2 V|_{x_j} + \alpha \operatorname{tr} D b|_{x_j}$$

for each index $j = 1, \dots, m$, we set

$$Q_j^\varepsilon := \varepsilon \Delta + \langle \ell_j, \nabla \rangle - \varepsilon^{-1} q_j - w_j.$$

This is the best approximation of A^ε near x_j which is of the form considered in Section 2.5. Its leading eigenvalue admits $\phi_j^\varepsilon := \exp(-(2\varepsilon)^{-1} \langle x - x_j, X_j(x - x_j) \rangle)$ as an eigenvector, where X_j is positive definite and satisfies the ARE

$$X_j^2 - \frac{1}{2} DF|_{x_j}^\top X_j - \frac{1}{2} X_j DF|_{x_j} = \frac{1}{2} D^2 W_0|_{x_j}. \quad (2.54)$$

Note that Q_j defined in (2.49) coincides with Q_j^1 and that the leading eigenvalue $\text{spb } Q_j^\varepsilon$ is independent of ε .

Lower bound. If Assumptions (L0), (L1), (RB) and (ND) are satisfied, then

$$\liminf_{\varepsilon \rightarrow 0} \text{spb}(A^\varepsilon) \geq \max_{j=1, \dots, m} \text{spb}(Q_j).$$

Let $j \in \{1, \dots, m\}$ and $K \in (0, \infty)$ be arbitrary. Then,

$$\inf_{u \gg 0} \sup_{x \in B(x_j, K)} \frac{(Q_j u)(x)}{u(x)} = \inf_{u \gg 0} \sup_{x \in B(x_j, \varepsilon^{1/2} K)} \frac{(Q_j^\varepsilon u)(x)}{u(x)},$$

with the infimum taken over all strictly positive functions u of class C^2 . In view of Lemma 2.A.6, we may pick a strictly positive eigenfunction ψ^ε for the eigenvalue $\text{spb}(A^\varepsilon)$ of A^ε which is of class C^2 . Hence,

$$\inf_{u \gg 0} \sup_{x \in B(x_j, K)} \frac{(Q_j u)(x)}{u(x)} \leq \sup_{x \in B(x_j, \varepsilon^{1/2} K)} \frac{(Q_j^\varepsilon (\psi^\varepsilon)^a)(x)}{(\psi^\varepsilon(x))^a}. \quad (2.55)$$

Now, by the chain rule and Young's inequality,

$$\begin{aligned} \frac{(Q_j^\varepsilon (\psi^\varepsilon)^a)(x)}{(\psi^\varepsilon(x))^a} - \frac{a(A^\varepsilon \psi^\varepsilon)(x)}{(\psi^\varepsilon(x))} &= \frac{a(Q_j^\varepsilon \psi^\varepsilon)(x)}{(\psi^\varepsilon(x))} + \frac{\varepsilon a(a-1)|\nabla \psi^\varepsilon(x)|^2}{(\psi^\varepsilon(x))^2} - \frac{a(A^\varepsilon \psi^\varepsilon)(x)}{(\psi^\varepsilon(x))} \\ &\leq \varepsilon^{-1} |W_0(x) - q_j(x)| + |W_1(x) - w_j(x)| \\ &\quad + \frac{|F(x) - \ell_j(x)| |\nabla \psi^\varepsilon(x)|}{\psi^\varepsilon(x)} - \frac{\varepsilon a |1-a| |\nabla \psi^\varepsilon(x)|^2}{|\psi^\varepsilon(x)|^2} \\ &\leq \varepsilon^{-1} |W_0(x) - q_j(x)| + |W_1(x) - w_j(x)| + \frac{|F(x) - \ell_j(x)|^2}{4\varepsilon a |1-a|}. \end{aligned}$$

Using the above in (2.55) and exploiting the regularity of F , W_0 and W_1 , we deduce that

$$\inf_{u \gg 0} \sup_{x \in B(x_j, K)} \frac{(Q_j u)(x)}{u(x)} \leq a \operatorname{spb}(A^\varepsilon) + C \left(\varepsilon^{3r-1} + \varepsilon^r + \frac{1}{4a(1-a)} \varepsilon^{4r-1} \right).$$

for some constant C which is uniform in a and ε . Taking $\varepsilon \rightarrow 0$ and then $a \rightarrow 1$ and using the Protter–Weinberger principle for the leading eigenvalue, we obtain

$$\operatorname{spb}(Q_j \upharpoonright_{B(x_j, K)}) \leq \liminf_{\varepsilon \rightarrow 0} \operatorname{spb}(A^\varepsilon).$$

Here, “ $\upharpoonright_{B(x_j, K)}$ ” denotes the restriction to $B(x_j, K)$ with Dirichlet boundary condition. Taking $K \rightarrow \infty$ gives the desired lower bound.

Upper bound. If Assumptions (L0), (L1), (RB) and (ND) are satisfied, then

$$\limsup_{\varepsilon \rightarrow 0} \operatorname{spb}(A^\varepsilon) \leq \max_{j=1, \dots, m} \operatorname{spb}(Q_j).$$

Let $\chi : [0, \infty) \rightarrow [0, 1]$ be a function of class C^2 such that $\chi(\rho) = 1$ for $\rho \in [0, 1]$, χ is strictly decreasing on $(1, 4)$ and $\chi(\rho) = 0$ for $\rho \in [4, \infty)$. Note that the following quantity defined for $\beta \in [\frac{1}{2}, 1)$ vanishes as $\beta \rightarrow 1$:

$$\gamma_\beta := \sup_{\chi(\rho) \geq \beta} |\nabla \chi(\rho)| + |\Delta \chi(\rho)|.$$

In order to focus on small neighbourhoods around the minima of W_0 , but which yet are large compared to the width of the eigenfunction ϕ_j^ε of Q_j^ε , we fix some

$$r \in \left(\frac{1}{3}, \frac{1}{2} \right)$$

and set

$$\eta_j^\varepsilon(x) := \chi(\varepsilon^{-2r} \langle x - x_j, X_j(x - x_j) \rangle)$$

for $j = 1, \dots, m$, and

$$\eta_0^\varepsilon(x) := 1 - \sum_{j=1}^m \eta_j^\varepsilon(x).$$

We consider $\varepsilon \in (0, \varepsilon_0)$ with $\varepsilon_0 > 0$ small enough to guarantee $\text{supp } \eta_j^\varepsilon \cap \text{supp } \eta_{j'}^\varepsilon = \emptyset$ if $1 \leq j < j' \leq m$. We set

$$f_\beta^\varepsilon(x) := \kappa_\beta^\varepsilon \eta_0^\varepsilon(x) + \sum_{j=1}^m \eta_j^\varepsilon(x) \phi_j^\varepsilon(x),$$

where

$$\kappa_\beta^\varepsilon := e^{-\frac{1}{2}\chi^{-1}(\beta)\varepsilon^{2r-1}}.$$

By the Protter–Weinberger principle,

$$\begin{aligned} \text{spb } A^\varepsilon &\leq \sup_{x \in \mathbf{R}^N} \frac{(A^\varepsilon f_\beta^\varepsilon)(x)}{f_\beta^\varepsilon(x)} \\ &= \max \left\{ \sup_{x: \eta_0^\varepsilon(x) > 1-\beta} \frac{(A^\varepsilon f_\beta^\varepsilon)(x)}{f_\beta^\varepsilon(x)}, \max_{j=1, \dots, m} \left\{ \sup_{x: \eta_j^\varepsilon(x) \geq \beta} \frac{(A^\varepsilon f_\beta^\varepsilon)(x)}{f_\beta^\varepsilon(x)} \right\} \right\}. \end{aligned} \quad (2.56)$$

Using Lemmas 2.7.2 and 2.7.3 below in (2.56) and taking $\varepsilon \rightarrow 0$ yields

$$\limsup_{\varepsilon \rightarrow 0} \text{spb } A^\varepsilon \leq \max_{j=1, \dots, m} \beta \text{spb } Q_j + (\beta^{-1} - \beta)|w_j| + C\gamma_\beta$$

for some positive constant C independent of β . Because $\beta \in [\frac{1}{2}, 1)$ was arbitrary and both $\gamma_\beta \rightarrow 0$ and $\beta^{-1} - \beta \rightarrow 0$ as $\beta \rightarrow 1$, we conclude that

$$\limsup_{\varepsilon \rightarrow 0} \text{spb } A^\varepsilon \leq \max_{j=1, \dots, m} \text{spb } Q_j.$$

Before we state and prove Lemmas 2.7.2 and 2.7.3 to conclude the proof of the upper bound, let us give a collection of bounds which follow from the observation that $\eta_j^\varepsilon(x) \geq \beta$ if and only if $\phi_j^\varepsilon(x) \geq \kappa_\beta^\varepsilon$.

Lemma 2.7.1. *There exists a constant C with the following property:*

i. if $\eta_0^\varepsilon(x) > 1 - \beta$, then $0 < \frac{\phi_j^\varepsilon(x)}{f_\beta^\varepsilon(x)} < \frac{\kappa_\beta^\varepsilon}{f_\beta^\varepsilon(x)} < \frac{1}{1-\beta}$ and $\varepsilon^r |\nabla \eta_j^\varepsilon(x)| + \varepsilon^{2r} |\Delta \eta_j^\varepsilon(x)| \leq C$ for each $j \in \{1, \dots, m\}$;

ii. if $\eta_j^\varepsilon(x) \geq \beta$, then $0 \leq \frac{\kappa_\beta^\varepsilon}{f_\beta^\varepsilon(x)} \leq 1 \leq \frac{\phi_j^\varepsilon(x)}{f_\beta^\varepsilon(x)} \leq \frac{1}{\beta}$ and $\varepsilon^r |\nabla \eta_j^\varepsilon(x)| + \varepsilon^{2r} |\Delta \eta_j^\varepsilon(x)| \leq C\gamma_\beta$.

Lemma 2.7.2. *There exists strictly positive constants C and δ such that*

$$\sup_{x: \eta_0^\varepsilon(x) > 1-\beta} \frac{(A^\varepsilon f_\beta^\varepsilon)(x)}{f_\beta^\varepsilon(x)} \leq -(1 - \beta)\delta \varepsilon^{2r-1} + C$$

for all $\varepsilon \in (0, \varepsilon_0)$ and all $\beta \in [\frac{1}{2}, 1)$.

Proof. Let x such that $\eta_0^\varepsilon(x) > 1 - \beta$ be arbitrary. Throughout the proof, the big O notation refers to constants that are uniform in x , ε and β . We compute

$$\nabla f_\beta^\varepsilon(x) = \kappa_\beta^\varepsilon \nabla \eta_0^\varepsilon(x) + \sum_{j=1}^m \phi_j^\varepsilon(x) \nabla \eta_j^\varepsilon(x) - \varepsilon^{-1} \eta_j^\varepsilon(x) \phi_j^\varepsilon(x) X_j(x - x_j), \quad (2.57)$$

$$\begin{aligned} \Delta f_\beta^\varepsilon(x) &= \kappa_\beta^\varepsilon \Delta \eta_0^\varepsilon(x) + \sum_{j=1}^m \phi_j^\varepsilon(x) \Delta \eta_j^\varepsilon(x) + 2\varepsilon^{-1} \langle \phi_j^\varepsilon(x) X_j(x - x_j), \nabla \eta_j^\varepsilon(x) \rangle \\ &\quad - \varepsilon^{-1} \eta_j^\varepsilon(x) \phi_j^\varepsilon(x) \operatorname{tr} X_j + \varepsilon^{-2} \eta_j^\varepsilon(x) \phi_j^\varepsilon(x) |X_j(x - x_j)|^2. \end{aligned} \quad (2.58)$$

Hence, using Lemma 2.7.1.i and the fact that $|F(x)| = O(\varepsilon^r)$ on $\operatorname{supp} \nabla \eta_0^\varepsilon$ and $\operatorname{supp} \nabla \eta_j^\varepsilon$,

$$\frac{\varepsilon \Delta f_\beta^\varepsilon(x) + \langle F(x), \nabla f_\beta^\varepsilon(x) \rangle}{f_\beta^\varepsilon} = \sum_{j=1}^m \frac{\phi_j^\varepsilon(x) \eta_j^\varepsilon(x)}{\varepsilon f_\beta^\varepsilon(x)} \langle x - x_j, X_j^2(x - x_j) - X_j F(x) \rangle + O(1).$$

Using $|F - \ell_j| = O(\varepsilon^{2r})$ on $\operatorname{supp} \eta_j^\varepsilon$ and then the ARE, we obtain

$$\frac{\varepsilon \Delta f_\beta^\varepsilon(x) + \langle F(x), \nabla f_\beta^\varepsilon(x) \rangle}{f_\beta^\varepsilon} = \varepsilon^{-1} \sum_{j=1}^m \frac{\phi_j^\varepsilon(x) \eta_j^\varepsilon(x)}{f_\beta^\varepsilon(x)} q_j(x) + O(1).$$

Using Lemma 2.7.1.i again,

$$\frac{\varepsilon \Delta f_\beta^\varepsilon(x) + \langle F(x), \nabla f_\beta^\varepsilon(x) \rangle}{f_\beta^\varepsilon} \leq \varepsilon^{-1} \beta \sum_{j=1}^m \mathbf{1}_{\operatorname{supp} \eta_j^\varepsilon} q_j(x) + O(1). \quad (2.59)$$

Subtracting

$$\varepsilon^{-1} W_0 + W_1 \geq \varepsilon^{-1} \beta \left(\sum_{j=1}^m \mathbf{1}_{\operatorname{supp} \eta_j^\varepsilon} W_0 \right) + (1 - \beta) W_0 + O(1)$$

— we have used (L0) and $\alpha \in \mathcal{A}$ to obtain $\beta \varepsilon^{-1} (1 - \sum_j \mathbf{1}_{\operatorname{supp} \eta_j^\varepsilon}) W_0 + W_1 \geq O(1)$ — from (2.59), we obtain

$$\frac{(A^\varepsilon f_\beta^\varepsilon)(x)}{f_\beta^\varepsilon(x)} \leq \varepsilon^{-1} \sum_{j=1}^m \beta \mathbf{1}_{\operatorname{supp} \eta_j^\varepsilon}(x) (q_j(x) - W_0(x)) - \varepsilon^{-1} (1 - \beta) W_0(x) + O(1).$$

Now, because $|W_0 - q_j| = O(\varepsilon^{3r})$ on $\operatorname{supp} \eta_j^\varepsilon$, we have

$$\frac{(A^\varepsilon f_\beta^\varepsilon)(x)}{f_\beta^\varepsilon(x)} \leq \varepsilon^{-1} \beta O(\varepsilon^{3r}) - \varepsilon^{-1} (1 - \beta) W_0(x) + O(1).$$

Because $W_0 \geq 0$ with nondegenerate zeroes precisely in $\{x_j\}_{j=1}^m$, and because the set $\{x : \eta_j^\varepsilon(x) < \beta\}$ excludes a ball of radius of order ε^r around x_j , there exists a strictly positive constant $\delta > 0$ such that $W_0(x) > \delta \varepsilon^{2r}$ for all x such that $\eta_0^\varepsilon(x) > 1 - \beta$. \square

Lemma 2.7.3. *There exists a positive constant C such that*

$$\sup_{\{\eta_j^\varepsilon(x) \geq \beta\}} \frac{(A^\varepsilon f_\beta^\varepsilon)(x)}{f_\beta^\varepsilon(x)} \leq \beta \operatorname{spb} Q_j^\varepsilon + (\beta^{-1} - \beta)|w_j| + C(\gamma_\beta(1 + \beta^{-1})(1 + \varepsilon^{1-2r}) + \varepsilon^{3r-1} + \varepsilon^r).$$

for all $\varepsilon \in (0, \varepsilon_0)$ and all $\beta \in [\frac{1}{2}, 1)$.

Proof. Let x such that $\eta_j^\varepsilon(x) \geq \beta$ be arbitrary. In particular, $|x - x_j| = O(\varepsilon^r)$. Throughout the proof, the big O notation refers to constants that are independent of x , ε and β . By (2.57), (2.58), Lemma 2.7.1.ii and the fact that $|F| = O(\varepsilon^r)$,

$$\left| \frac{(A^\varepsilon f_\beta^\varepsilon)(x)}{f_\beta^\varepsilon(x)} - \frac{\eta_j^\varepsilon(x)(A^\varepsilon \phi_j^\varepsilon)(x)}{f_\beta^\varepsilon(x)} \right| \leq C\gamma_\beta(1 + \beta^{-1})(\varepsilon^{1-2r} + 1). \quad (2.60)$$

Now, using $|F(x) - \ell_j(x)| = O(\varepsilon^{2r})$, $\nabla \phi_j^\varepsilon(x)/\phi_j^\varepsilon(x) = \varepsilon^{-1}O(\varepsilon^r)$, $|W_0(x) - q_j(x)| = O(\varepsilon^{3r})$ and $|W_1(x) - w_j(x)| = O(\varepsilon^r)$ for $x \in \operatorname{supp} \eta_j^\varepsilon$,

$$\frac{\eta_j^\varepsilon(x)(A^\varepsilon \phi_j^\varepsilon)(x)}{f_\beta^\varepsilon(x)} = \frac{\eta_j^\varepsilon(x)\phi_j^\varepsilon(x)}{f_\beta^\varepsilon(x)} \left(\frac{([Q_j^\varepsilon - |w_j|]\phi_j^\varepsilon)(x)}{\phi_j^\varepsilon(x)} + |w_j| + \varepsilon^{-1}O(\varepsilon^{3r}) + O(\varepsilon^r) \right).$$

Because ϕ_j^ε is an eigenvector of $[Q_j^\varepsilon - |w_j|]$ with eigenvalue $\operatorname{spb} Q_j - |w_j| \leq 0$ and because the prefactor on the right-hand side lies in the interval $[\beta, \beta^{-1}]$ by Lemma 2.7.1.ii, we have

$$\frac{\eta_j^\varepsilon(x)(A^\varepsilon \phi_j^\varepsilon)(x)}{f_\beta^\varepsilon(x)} \leq \beta \operatorname{spb} Q_j + (\beta^{-1} - \beta)|w_j| + C(\varepsilon^{3r-1} + \varepsilon^r). \quad (2.61)$$

Combining (2.60) and (2.61) and using the fact that $\eta_j^\varepsilon(x) \geq \beta$ implies $|F(x)| = O(\varepsilon^r)$, we conclude that a bound of the proposed form indeed holds. \square

2.A Properties of the deformed generators

In this appendix, we collect some results from the theory of semigroups applied to partial differential equations involving elliptic operators of the form

$$A^{\varepsilon, \alpha} := \varepsilon \Delta + \langle -\nabla V + (1 - 2\alpha)b, \nabla \rangle - \frac{\alpha(1-\alpha)}{\varepsilon} |b|^2 + \frac{\alpha}{\varepsilon} \langle b, \nabla V \rangle - \alpha \operatorname{div} b \quad (2.62)$$

appearing in Sections 2.4, 2.6 and 2.7 of the paper, similarly as in Appendix A of [BDG15] (the case where b is bounded). They are deformations of the infinitesimal generator of the semigroup associated to (2.5).

We use technical results from the article [MPSR05], Chapter 1 of [Lan97] and Chapters A-I, C-IV and B-IV of [AGG⁺86]. Throughout this section, whenever we refer to V and b , we assume that (L0), (L1) and (RB) hold. Also, we write $L^p(\mathbf{R}^N)$ for $L^p(\mathbf{R}^N, d\text{vol})$, and similarly for the Sobolev spaces. For the spaces $C(\mathbf{R}^N)$ of continuous functions and $C^k(\mathbf{R}^N)$ of k -times differentiable functions, the subscript “0” is used for “vanishing at infinity”, and “c” for “compactly supported”.

For $p \in (1, \infty)$, a straightforward computation shows that

$$e^{-(p\varepsilon)^{-1}V} \mathcal{A}^{\alpha, \varepsilon}(e^{(p\varepsilon)^{-1}V} f) = \varepsilon \Delta f + \langle F_p, \nabla f \rangle - \Omega_p f$$

for all $f \in C_c^2(\mathbf{R}^N)$, where

$$F_p := \left(\frac{2}{p} - 1\right) \nabla V + (1 - 2\alpha)b,$$

$$\Omega_p := \frac{1}{\varepsilon} W_0 - \frac{1}{p} \Delta V + \alpha \operatorname{div} b$$

and

$$W_0 := \frac{1}{p} \left(1 - \frac{1}{p}\right) |\nabla V|^2 - \frac{1-2\alpha+\alpha p}{p} \langle b, \nabla V \rangle + \alpha(1-\alpha) |b|^2.$$

For technical reasons, we need to restrict our attention to a certain α -dependent set of powers p . We introduce an admissibility condition for the pair (α, p) .

Definition 2.A.1. *The pair $(\alpha, p) \in \mathbf{R} \times (1, \infty)$ is said to be admissible if there exists $\ell \in (0, 1)$ such that*

$$\ell \frac{1}{p} \left(1 - \frac{1}{p}\right) |\nabla V(x)|^2 - \frac{1-2\alpha+\alpha p}{p} \langle b(x), \nabla V(x) \rangle + \alpha(1-\alpha) |b(x)|^2 \geq 0$$

for all $x \in \mathbf{R}^N$.

The next lemma — whose proof follows from straightforward applications of (RB) and the Cauchy–Schwarz inequality — gives concrete sufficient conditions for admissibility. These conditions are illustrated in Figure 2.3.

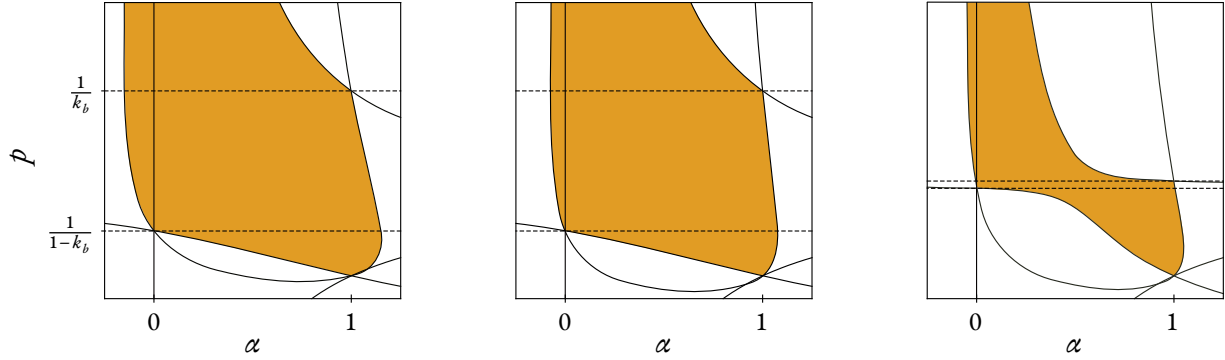

Figure 2.3: The orange region enclosed in the solid contours is the set of values allowed in Lemma 2.A.2 computed for $(k_b, h_b) = (0.33, 0.75), (0.33, 1.5)$ and $(0.49, 1.5)$ — from left to right.

Lemma 2.A.2. *Let $k_b \in [0, \frac{1}{2})$ and $h_b \in [0, \infty)$ be as in assumption (RB). If*

$$1 - 2\alpha + \alpha p \geq 0$$

and either

i. we have $\alpha(1 - \alpha) \geq 0$ and $1 - p^{-1} - (1 - 2\alpha + \alpha p)k_b > 0$ or

ii. we have $\alpha(1 - \alpha) < 0$ and $1 - p^{-1} - (1 - 2\alpha + \alpha p)k_b - p\alpha(\alpha - 1)h_b > 0$,

then the pair (α, p) is admissible. In particular, if p is fixed in the interval $(\frac{1}{1-k_b}, \frac{1}{k_b})$, then the pair (α, p) is admissible for all α in an open interval containing $[0, 1]$.

Until further notice, we fix α, p and ℓ as in the admissibility condition. By Assumption (L0) and the fact that F is globally Lipschitz, there exist c_p^0 and $\theta \in (0, 1)$ such that

$$|\operatorname{div} F_p| \leq \theta \left((1 - \ell) \frac{1}{\varepsilon p} \left(1 - \frac{1}{p} \right) |\nabla V|^2 + c_p^0 \right). \quad (2.63)$$

Set

$$U_p := (1 - \ell) \frac{1}{\varepsilon p} \left(1 - \frac{1}{p} \right) |\nabla V|^2 + c_p^0.$$

Using the same properties again, we may pick κ such that

$$|F_p| \leq \kappa U_p^{\frac{1}{2}}. \quad (2.64)$$

Using Assumption (L0) and the admissibility condition, we can pick positive constants c_p and c_p^1 such that

$$U_p \leq \Omega_p + c_p \leq c_p^1 U_p. \quad (2.65)$$

Lemma 2.A.3. *Suppose that the pair (α, p) is admissible. Then, the operator*

$$A_p := \varepsilon \Delta + \langle F_p, \nabla \rangle - \Omega_p - c_p$$

with domain

$$D^q := \{f \in W^{2,q}(\mathbf{R}^N) : U_p f \in L^q(\mathbf{R}^N)\}$$

is closed as an unbounded operator on $L^q(\mathbf{R}^N)$ and generates an analytic, compact, positivity-preserving semigroup on $L^q(\mathbf{R}^N)$ for all $q \in (1, \infty)$. With domain

$$D^\infty := \{f \in C_0(\mathbf{R}^N) : f \in W_{\text{loc}}^{2,q} \text{ for all } q \in (1, \infty) \text{ and } \Delta f, U_p f \in C_0(\mathbf{R}^N)\},$$

it is closed as an unbounded operator on $C_0(\mathbf{R}^N)$ and generates a positivity-preserving semigroup on $C_0(\mathbf{R}^N)$ which is analytic and compact.

Proof. For any real number $r > 0$, by (L0) and Cauchy's inequality, there exists $C_{p,r} > 0$ such that

$$|\nabla U_p| \leq 16r U_p^{\frac{3}{2}} + C_{p,r}. \quad (2.66)$$

The bounds (2.63)–(2.66) precisely give hypotheses (H2)–(H5) of [MPSR05]. Therefore, Theorem 3.4 in [MPSR05] gives that (A_p, D^q) generates a holomorphic positivity-preserving semigroup on $L^q(\mathbf{R}^N)$, and Theorem 4.4 in [MPSR05] gives that (A_p, D^∞) generates a holomorphic positivity-preserving semigroup on $C_0(\mathbf{R}^N)$. Compactness follows from Proposition 6.4 in [MPSR05]. \square

Lemma 2.A.4. *The semigroups in Lemma 2.A.3 coincide on the intersection of their spaces of definition and are all irreducible (positivity improving) on their respective spaces.*

Proof. The first part of the lemma is proved as Lemma 4.3 in [MPSR05]. The second part follows from the strong maximal principle; see Step 6 in the proof of Lemma A.1 in [BDG15]. \square

Lemma 2.A.5. *Suppose that the pair (α, p) is admissible and let*

$$s_p := \sup\{\operatorname{Re} z : z \in \operatorname{sp}(A_p, D^p)\}.$$

Then, s_p is a simple isolated eigenvalue and there exist a strictly positive vector $\tilde{\psi}_p \in D^p$ and a strictly positive functional \tilde{u}_p on $L^p(\mathbf{R}^N)$ such that

$$\lim_{t \rightarrow \infty} \|e^{-ts_p} e^{tA_p} f - \tilde{\psi}_p(\tilde{u}_p, f)\|_p = 0 \quad (2.67)$$

for all $f \in L^p(\mathbf{R}^N)$.

Proof. The first part of the lemma is a well-established consequence of irreducibility, compactness and preservation of positivity; see Theorem 2.1 and Remark 2.2(e) in [AGG⁺86, Ch. C-IV]. \square

Lemma 2.A.6. *For all $f \in C_c(\mathbf{R}^N)$, the convergence expressed in (2.67) holds in the norm $\|\cdot\|_q$ for all $q \in (1, \infty]$. Moreover, the vector $\tilde{\psi}_p$ has a representative which is strictly positive, twice continuously differentiable, vanishes at infinity and belongs to $L^q(\mathbf{R}^N)$ for all $q \in (1, \infty]$. If (α, p) and (α, p') are both admissible, then $s_p + c_p$ coincides with $s_{p'} + c_{p'}$.*

Proof. By the same argument giving Lemma 2.A.5, there exist a real number $\bar{s}_{p,q}$, a strictly positive vector $\bar{\psi}_{p,q} \in D^q$ and a strictly positive functional $\bar{u}_{p,q}$ on $L^q(\mathbf{R}^N)$ or $C_0(\mathbf{R}^N)$ such that

$$\lim_{t \rightarrow \infty} \|e^{-t\bar{s}_{p,q}} e^{tA_p} f - \bar{\psi}_{p,q}(\bar{u}_{p,q}, f)\|_q = 0 \quad (2.68)$$

for all f in $L^q(\mathbf{R}^N)$ or $C_0(\mathbf{R}^N)$; see Corollary 2.2 in [AGG⁺86, Ch. B-IV] for $q = \infty$. Taking a common nonnegative $f \in C_c(\mathbf{R}^N) \setminus \{0\}$ in both (2.67) and (2.68) and using Lemma 2.A.4 gives $\bar{s}_{p,q} = s_p$ and $\bar{\psi}_{p,q} \propto \tilde{\psi}_p$. Because $A_p + c_p$ and $A_{p'} + c_{p'}$ are related by a conjugation which preserves $C_c(\mathbf{R}^N)$, a similar argument also yields that e.g. $\bar{s}_{p,\infty} + c_p$ coincides with $\bar{s}_{p',\infty} + c_{p'}$.

Note that $\tilde{\psi}_2$ is in a Hölder space $C^{1,\beta}(\mathbf{R}^N)$ with $\beta \in (0, 1)$ by a Sobolev embedding. The approximation method for inferring that $\tilde{\psi}_2$ belongs to $C^{2,\beta}(\mathbf{R}^N)$ via classical interior Schauder estimates and the maximum principle is carried out in [Lan97, §1.8]. \square

It is proved as part of Theorem 7.4 in [MPSR05] that the isometry $f \mapsto e^{(p\varepsilon)^{-1}V} f$ between the Banach spaces $L^p(\mathbf{R}^N)$ and $L^p(\mathbf{R}^N, d\mu_0^\varepsilon)$ used to introduce A_p maps the domain D^p to the

space $W^{2,p}(\mathbf{R}^N, d\mu_0^\varepsilon)$. Hence, it follows immediately from Lemmas 2.A.3 and 2.A.4 that $A^{\alpha,\varepsilon}$ with domain $W^{2,p}(\mathbf{R}^N, d\mu_0^\varepsilon)$ is the generator of an analytic semigroup which is compact and irreducible, provided that (α, p) is admissible. Also, by Lemmas 2.A.5 and 2.A.6,

$$e^\varepsilon(\alpha) := \sup\{\operatorname{Re} z : z \in \operatorname{sp}(A^{\alpha,\varepsilon}, W^{2,p}(\mathbf{R}^N, d\mu_0^\varepsilon))\}$$

is indeed independent of p and admits an eigenvector with the properties stated in the proposition below.

Proposition 2.A.7. *Let the pair (α, p) be admissible. Then, $e^\varepsilon(\alpha)$ is a simple isolated eigenvalue of $(A^{\alpha,\varepsilon}, W^{2,p}(\mathbf{R}^N, d\mu_0^\varepsilon))$ and there exists a strictly positive associated eigenfunction $\psi^{\alpha,\varepsilon} \in C^2(\mathbf{R}^N) \cap W^{2,p}(\mathbf{R}^N, d\mu_0^\varepsilon)$ and a strictly positive linear functional $u^{\alpha,\varepsilon}$ on $L^p(\mathbf{R}^N, d\mu_0^\varepsilon)$ such that*

$$\lim_{t \rightarrow \infty} \|e^{-te^\varepsilon(\alpha)} e^{tA^{\alpha,\varepsilon}} f - \psi^{\alpha,\varepsilon}(u^{\alpha,\varepsilon}, f)_{\mu_0^\varepsilon}\|_{L^p(\mathbf{R}^N, d\mu_0^\varepsilon)} = 0$$

for all $f \in L^p(\mathbf{R}^N, d\mu_0^\varepsilon)$.

Lemma 2.A.8. *The measure $\lambda_{\text{inv}}^\varepsilon$ is of the form*

$$\lambda_{\text{inv}}^\varepsilon(dx) = e^{-(2\varepsilon)^{-1}V(x)} \varphi^\varepsilon(x) dx$$

for some strictly positive function $\varphi^\varepsilon \in C_0^2(\mathbf{R}^N) \cap L^2(\mathbf{R}^N)$.

Proof. Consider the operator (A_2, D^2) introduced in the case $\alpha = 1$, that is

$$A_2 = \varepsilon\Delta - \langle b, \nabla \rangle - \frac{1}{4\varepsilon} |\nabla V|^2 + \frac{1}{2\varepsilon} \langle b, \nabla V \rangle + \frac{1}{2} \Delta V - \operatorname{div} b - c_2.$$

One can show that its adjoint has domain D^2 and is given by the formula

$$A_2^* = \varepsilon\Delta + \langle b, \nabla \rangle - \frac{1}{4\varepsilon} |\nabla V|^2 + \frac{1}{2\varepsilon} \langle b, \nabla V \rangle + \frac{1}{2} \Delta V - c_2.$$

Note that A_2^* just as well satisfies (H1)–(H5) in [MPSR05] and thus generates a semigroup with the same properties. Note that $e^{-(2\varepsilon)^{-1}V}$ is a strictly positive eigenvector of (A_2^*, D^2) with eigenvalue $-c_2$. But it is easy to show by contradiction that $\operatorname{spb}(A_2^*, D^2)$ is the *only* eigenvalue of A_2^* admitting a strictly positive eigenvector. Hence, we have $\operatorname{spb}(A_2, D^2) = \operatorname{spb}(A_2^*, D^2) = -c_2$.

Therefore, there exists a strictly positive function $\phi^\varepsilon \in C_0^2(\mathbf{R}^N) \cap L^2(\mathbf{R}^N)$ such that $A_2\phi^\varepsilon = -c_2\phi^\varepsilon$. Then, $\rho^\varepsilon := e^{-(2\varepsilon)^{-1}V}\phi^\varepsilon$ satisfies the stationary Fokker–Planck equation

$$(\varepsilon\Delta + \langle \nabla V - b, \nabla \rangle + \Delta V - \operatorname{div} b)\rho^\varepsilon = 0,$$

to which the density of $\lambda_{\text{inv}}^\varepsilon$ is — up to normalisation — the unique bounded solution; see for example Lemma 4.16 in [Kha11, Ch. 4]. \square

Lemma 2.A.9. *For all $\beta \in (0, 2)$, $(d\lambda_{\text{inv}}^\varepsilon / d\mu_0^\varepsilon)^\beta \in L^1(\mathbf{R}^N, d\mu_0^\varepsilon)$.*

Proof. Set $r := 2\beta^{-1}$ and let φ^ε be as in Lemma 2.A.8. Then, by Hölder’s inequality,

$$\begin{aligned} \int_{\mathbf{R}^N} \left| \frac{d\lambda_{\text{inv}}^\varepsilon}{d\mu_0^\varepsilon} \right|^\beta d\mu_0^\varepsilon &= \int_{\mathbf{R}^N} |\varphi^\varepsilon|^\beta e^{\beta(2\varepsilon)^{-1}V} e^{-\varepsilon^{-1}V} d\operatorname{vol} \\ &\leq \left(\int_{\mathbf{R}^N} |\varphi^\varepsilon|^{\beta r} d\operatorname{vol} \right)^{\frac{1}{r}} \left(\int_{\mathbf{R}^N} e^{-\varepsilon^{-1}(1-r^{-1})^{-1}(1-\frac{1}{2}\beta)V} d\operatorname{vol} \right)^{1-\frac{1}{r}}. \end{aligned}$$

Since $\beta r = 2$, the first integral is a power of the $L^2(\mathbf{R}^N)$ -norm of φ^ε , which is finite by Lemma 2.A.8.

The second integral is finite because $(1 - r^{-1})(1 - \frac{1}{2}\beta)$ is strictly positive and V satisfies (L0). \square

Bibliography

- [ABG19] A. Arapostathis, A. Biswas, and D. Ganguly. Certain Liouville properties of eigenfunctions of elliptic operators. *Trans. Amer. Math. Soc.*, 371(6):4377–4409, 2019.
- [AGG⁺86] W. Arendt, A. Grabosch, G. Greiner, U. Moustakas, R. Nagel, U. Schlotterbeck, U. Groh, H. P. Lotz, and F. Neubrander. *One-parameter semigroups of positive operators*, volume 1184 of *Lecture Notes in Mathematics*. Springer, 1986.
- [And82] B. D. O. Anderson. Reverse-time diffusion equation models. *Stoch. Process. Their Appl.*, 12(3):313–326, 1982.
- [BCX20] A. Budhiraja, Y. Chen, and L. Xu. Large deviations and fluctuation theorem for the entropy production rate of a stochastic particle system in magnetic field. *arXiv preprint*, page 2004.08754 [math.PR], 2020.

- [BDG15] L. Bertini and G. Di Gesù. Small noise asymptotic of the Gallavotti–Cohen functional for diffusion processes. *ALEA, Lat. Am. J. Probab. Math. Stat*, 12:743–763, 2015.
- [BNV94] H. Berestycki, L. Nirenberg, and S. R. S. Varadhan. The principal eigenvalue and maximum principle for second-order elliptic operators in general domains. *Commun. Pure Appl. Math.*, 47(1):47–92, 1994.
- [CJPS20] N. Cuneo, V. Jakšić, C.-A. Pillet, and A. Shirikyan. *What is a Fluctuation Theorem?* SpringerBriefs in Mathematical Physics. Springer, 2020.
- [DV75] M. D. Donsker and S. R. S. Varadhan. On a variational formula for the principal eigenvalue for operators with maximum principle. *Proc. Nat. Acad. Sci. USA*, 72(3):780–783, 1975.
- [Fel66] W. Feller. *An Introduction to probability theory and its applications, Vol. II.* Wiley series in probability and statistics. John Wiley & Sons, 1966.
- [FS97] W. H. Fleming and S.-J. Sheu. Asymptotics for the principal eigenvalue and eigenfunction of a nearly first-order operator with large potential. *Ann. Probab.*, 25(4):1953–1994, 1997.
- [HP86] U. G. Haussmann and E. Pardoux. Time reversal of diffusions. *Ann. Probab.*, 14(4):1188–1205, 1986.
- [HPS13] M. Hitrik and K. Pravda-Starov. Eigenvalues and subelliptic estimates for non-selfadjoint semiclassical operators with double characteristics. *Ann. Inst. Fourier*, 63(3):985–1032, 2013.
- [HS84] B. Helffer and J. Sjöstrand. Multiple wells in the semi-classical limit I. *Commun. Partial Differ. Equ.*, 9(4):337–408, 1984.
- [HSS05] F. Hérau, J. Sjöstrand, and C. C. Stolk. Semiclassical analysis for the Kramers–Fokker–Planck equation. *Commun. Partial Differ. Equ.*, 30(5-6):689–760, 2005.

- [JOPP11] V. Jakšić, Y. Ogata, Y. Pautrat, and C.-A. Pillet. Entropic fluctuations in quantum statistical mechanics an introduction. In J. Frohlich, M. Salmhofer, V. Mastropietro, W. De Roeck, and L. F. Cugliandolo, editors, *Quantum Theory from Small to Large Scales*, volume 95 of *Lecture Notes of the Les Houches Summer School*, pages 213–410. Oxford University Press, 2011.
- [JOPS12] V. Jakšić, Y. Ogata, C.-A. Pillet, and R. Seiringer. Quantum hypothesis testing and non-equilibrium statistical mechanics. *Rev. Math. Phys.*, 24(06):1230002, 2012.
- [JPS17] V. Jakšić, C.-A. Pillet, and A. Shirikyan. Entropic fluctuations in thermally driven harmonic networks. *J. Stat. Phys.*, 166(3):926–1015, Feb 2017.
- [Kat95] T. Kato. *Perturbation theory for linear operators*, volume 132 of *Grundlehren der mathematischen Wissenschaften*. Springer, second edition, 1995.
- [Kha11] R. Khasminskii. *Stochastic stability of differential equations*, volume 66 of *Stochastic modeling and applied probability*. Springer, second edition, 2011.
- [Kol37] A. N. Kolmogoroff. Zur Umkehrbarkeit der statistischen Naturgesetze. *Math. Ann.*, 113:766–772, 1937. Engl.: On the Reversibility of the statistical laws of nature.
- [Kur98] J. Kurchan. Fluctuation theorem for stochastic dynamics. *J. Phys. A*, 31(16):3719, 1998.
- [Kur07] J. Kurchan. Gallavotti–Cohen theorem, chaotic hypothesis and the zero-noise limit. *J. Stat. Phys.*, 128(6):1307–1320, 2007.
- [Lan97] E. M. Landis. *Second order equations of elliptic and parabolic type*, volume 171 of *Translations of mathematical monographs*. Amer. Math. Soc., 1997.
- [LR95] P. Lancaster and L. Rodman. *The algebraic Riccati equation*. Calderon Press, 1995.
- [LS99] J. L. Lebowitz and H. Spohn. A Gallavotti–Cohen-type symmetry in the large deviation functional for stochastic dynamics. *J. Stat. Phys.*, 95(1–2):333–365, 1999.

- [MNV03] C. Maes, K. Netočný, and M. Verschuere. Heat conduction networks. *J. Stat. Phys.*, 111(5-6):1219–1244, 2003.
- [MPSR05] G. Metafune, J. Prüss, R. Schnaubelt, and A. Rhandi. L^p -regularity for elliptic operators with unbounded coefficients. *Adv. Differ. Equ.*, 10(10):1131–1164, 2005.
- [NP92] R. D. Nussbaum and Y. Pinchover. On variational principles for the generalized principal eigenvalue of second order elliptic operators and some applications. *J. Anal. Math.*, 59(1):161–177, 1992.
- [Pro05] P. E. Protter. *Stochastic integration and differential equations*, volume 21 of *Stochastic modeling and applied probability*. Springer, second edition, 2005.
- [PW66] M. H. Protter and H. F. Weinberger. On the spectrum of general second order operators. *Bull. Amer. Math. Soc.*, 72(2):251–255, 1966.
- [RBT00] L. Rey-Bellet and L. E. Thomas. Asymptotic behavior of thermal nonequilibrium steady states for a driven chain of anharmonic oscillators. *Commun. Math. Phys.*, 215(1):1–24, 2000.
- [Roc70] R. T. Rockafellar. *Convex analysis*. Princeton University Press, 1970.
- [Sim83] B. Simon. Semiclassical analysis of low lying eigenvalues I. *Ann. Inst. Henri Poincaré A: Phys. théor.*, 38(3):295–308, 1983.
- [Sim15] B. Simon. *Operator theory*, volume 4 of *A Comprehensive course in analysis*. Amer. Math. Soc., 2015.
- [Sjö74] J. Sjöstrand. Parametrics for pseudodifferential operators with multiple characteristics. *Ark. Mat.*, 12(1):85–130, 1974.
- [VF70] A. D. Ventcel’ and M. I. Freidlin. On small random perturbations of dynamical systems. *Russ. Math. Surv.*, 25(1):1–55, 1970.

- [vZC03] R. van Zon and E. G. D. Cohen. Extension of the fluctuation theorem. *Phys. Rev. Lett.*, 91(11):110601, 2003.
- [WXX16] F.-Y. Wang, J. Xiong, and L. Xu. Asymptotics of sample entropy production rate for stochastic differential equations. *J. Stat. Phys.*, 163(5):1211–1234, 2016.

Chapter 3

A Note on Harris' ergodic theorem, controllability and perturbations of harmonic networks

Author Renaud Raquépas

arXiv ID 1801.05375

Year published 2019

Journal Ann. Henri Poincaré 20(2):605–629

Abstract We show that elements of control theory, together with an application of Harris' ergodic theorem, provide an alternate method for showing exponential convergence to a unique stationary measure for certain classes of networks of quasi-harmonic classical oscillators coupled to heat baths. With the system of oscillators expressed in the form $dX_t = AX_t dt + F(X_t) dt + B dW_t$ in \mathbf{R}^d , where A encodes the harmonic part of the force and $-F$ corresponds to the gradient of the anharmonic part of the potential, the hypotheses under which we obtain exponential mixing are the following: A is dissipative, the pair (A, B) satisfies the Kalman condition, F grows sufficiently slowly at infinity (depending on the dimension d), and the vector fields in the equation of motion satisfy the weak Hörmander condition in at least one point of the phase space.

3.1 Introduction

Thermally driven networks of oscillators play an important role in the investigation of various aspects of nonequilibrium statistical mechanics. On a mathematical level, a driven network of classical harmonic oscillators can be modeled as a d -dimensional process $(X_t)_{t \geq 0}$ described by a linear stochastic differential equation (SDE) of the form

$$dX_t = AX_t dt + B dZ_t,$$

where the linear operators A and B satisfy certain structural conditions and where $(Z_t)_{t \geq 0}$ is a given n -dimensional stochastic process describing the noise due to thermal fluctuations. The integer $n \leq d$ is the number of degrees of freedom of the network that are coupled to heat baths. The noise is often taken to be a Wiener process, but other types of noise are physically interesting. A particularly important question regarding such systems and perturbations thereof is that of invariant measures.

In this work, we consider A and B satisfying the *Kalman condition*, a smooth globally Lipschitz perturbing vector field $x \mapsto F(x)$ that grows slower than $|x|^{1/2d}$ at infinity¹ and $(W_t)_{t \geq 0}$ a Wiener process, and show with arguments from control theory and an application of Hairer and Mattingly's version of Harris' ergodic theorem that the process described by the SDE

$$dX_t = AX_t dt + F(X_t) dt + B dW_t$$

admits a unique stationary measure when A is *dissipative* and a *weak Hörmander condition* on the vector fields in the SDE holds in at least one point x_0 of the phase space. Moreover, the convergence to this stationary measure then happens exponentially fast. The abstract mathematical setup and the result are made more precise in Section 3.2. The proof is provided in Section 3.3.

In Section 3.4, we introduce the mathematical description of perturbed networks of harmonic oscillators in this framework, both in the Langevin regime and in the so-called semi-Markovian regime, and for geometries that go beyond the 1-dimensional chain. In this context, the matrix A

¹The power $\frac{1}{2d}$ is generically not optimal. As we will see, d can be replaced by an integer d_* appearing in the formulation of the Kalman rank condition. In all cases $d_* \leq d$.

encodes the friction, kinetic and harmonic terms (both the pinning and the interaction) while the perturbation F corresponds to minus the gradient of the anharmonic part of the potential.

In the case of a 1-dimensional chain of oscillators connected to heat baths at both ends, results of this type have been established for a very general class of quasi-homogeneous potentials [EPRB99b, EPRB99a, EH00, RBT02, Car07]. The recent paper [CEHRB18] extends these results to more complicated networks. Roughly speaking, these results require that the pinning potential grows as $|q|^{k_1}$ at infinity, that the interaction potential grows as $|q|^{k_2}$ with $k_2 \geq k_1 \geq 2$, and that the interaction part of the potential has no flat piece or infinitely degenerate points. While our growth condition is considerably more restrictive than the ones found in these works, the form of local nondegeneracy that we require is weaker: we only need a weak Hörmander condition to hold at a single point. Moreover, our setup accommodates a wide variety of geometries and bounded many-body interaction terms (beyond pinning and two-body interactions).

Such results typically involve carefully studying smoothing properties of the associated Markov semigroup. The strategy here is different and instead relies on recent developments on the use of solid controllability in the study of mixing properties of random dynamical systems [AS05, AKSS07, Shi07, Shi17]. The simplicity of the argument can in itself justify the presentation of such an application.

Another advantage is that our general strategy is not based on the Gaussian structure of Brownian motion and can thus be more easily adapted to different types of noise that are physically relevant. Similar arguments can be used to discuss the analogous problem with compound Poisson processes; this type of problem will be analyzed in a subsequent work.

The proof can be summarized as follows. For a discrete-time Markov process, Harris' theorem states that the existence and uniqueness of an invariant measure, with exponentially fast convergence in the total variation metric, can be obtained from the existence of a suitable Lyapunov function and a minorization for the transition probabilities starting from any point in the interior of a suitable level set of that Lyapunov function. The precise statement we use is the one formulated in [HM11]; also see [Har56] and [MT12]. We then pass from discrete to continuous time.

The function $V(x) := \int_0^\infty |e^{sA} x|^2 ds$ is shown to be a suitable Lyapunov function using dis-

sipativity of A , the behaviour of F at infinity, and basic Itô calculus. The details are given in Section 3.3.1.

In order to prove the lower bound on transitions, we use the Kalman condition on the pair (A, B) and again the estimate on the behaviour of F at infinity. These hypotheses yield that the point x_0 in which the weak Hörmander condition holds can be approached from $\{V \leq R\}$ with a uniform lower bound on the probability. On the other hand, the weak Hörmander condition in x_0 implies solid controllability from x_0 and we can combine solid controllability and approachability to obtain the desired lower bound. The details are given in Section 3.3.2.

Different sufficient conditions for the hypotheses of the main theorem to hold are given in more concrete terms throughout Sections 3.4 and 3.5. In the former, we give criteria for the dissipativity, Kalman and growth conditions in terms of more physical quantities for networks of oscillators based on [JPS17]. In the latter, we give a perturbative condition for the weak Hörmander condition to hold.

3.2 Setup, assumptions and main result

Notation Throughout the paper, we use: $\|\cdot\|$ to denote the operator norm of linear maps; $\{e_i\}_{i=1}^n$ for the standard orthonormal basis of \mathbf{R}^n ; $|\cdot|$ to denote the euclidean norm on \mathbf{R}^d (arising from the standard inner product $\langle \cdot, \cdot \rangle$); $B(x, r)$ for the open ball of radius $r > 0$ centered at the point x in \mathbf{R}^d ; $C_0^k([0, T]; \mathbf{R}^n)$ to denote the space of k times continuously differentiable functions $\eta : [0, T] \rightarrow \mathbf{R}^n$ with $\eta(0) = 0$; $\text{Prob}(\mathbf{R}^d)$ for the space of Borel probability measures on \mathbf{R}^d ; \mathcal{L}_G for the Lie derivative with respect to the vector field G ; $\mathbf{1}_S$ to denote the indicator function of the set S . The natural numbers \mathbf{N} start at 1. The underlying probability space is $(\Omega, \mathcal{F}, \mathbf{P})$ and we use the letter ω to denote elementary events there.

Let d and n be natural numbers with $n \leq d$ and let $\omega \mapsto (W_t(\omega))_{t \geq 0}$ be a Wiener process in \mathbf{R}^n . We are interested in the d -dimensional diffusion process $\omega \mapsto (X_t(x^{\text{in}}, \omega))_{t \geq 0}$ governed by

the equation

$$X_t(x^{\text{in}}, \omega) = x^{\text{in}} + \int_0^t AX_s(x^{\text{in}}, \omega) + F(X_s(x^{\text{in}}, \omega)) \, ds + BW_t(\omega) \quad (3.1)$$

where $B : \mathbf{R}^n \rightarrow \mathbf{R}^d$ is a linear map, $A : \mathbf{R}^d \rightarrow \mathbf{R}^d$ is a linear map, F is a smooth globally Lipschitz vector field on \mathbf{R}^d , and $x^{\text{in}} \in \mathbf{R}^d$ is an initial condition. We often omit writing explicitly the dependence on x^{in} or ω and write the equation in differential notation. We assume the following dissipativity and controllability conditions on the linear maps A and B .

- (D) the eigenvalues of the linear map A (considered over \mathbf{C}^d) each have strictly negative real part.
- (K) the pair (A, B) satisfies the *Kalman condition*, meaning that the columns of B, AB, A^2B, A^3B and so forth span \mathbf{R}^d .

Then, by the Cayley–Hamilton theorem, there exists $d_* \leq d$ such that

$$\text{span}\{Be_i, AB e_i, A^2B e_i, \dots, A^{d_*-1}B e_i : i = 1, \dots, n\} = \mathbf{R}^d.$$

The Kalman condition is commonly used in the basic theory of controllability for linear systems (i.e. when $F \equiv 0$); it is then equivalent to several notions of controllability [Cor07, §§1.2–1.3].

We further assume that the perturbing vector field F satisfies the following growth condition.

- (G) there exists a constant $a \in [0, \frac{1}{2d_*})$ such that

$$\sup_{x \in \mathbf{R}^d} \frac{|F(x)|}{(1 + |x|)^a} < \infty. \quad (3.2)$$

Finally, we suppose the existence of a point x_0 where the *weak Hörmander condition* on the vector fields appearing in the stochastic equation (3.1) is satisfied.

- (H) there exists a point $x_0 \in \mathbf{R}^d$ in which the family

$$\{V_0, \mathcal{L}_{V_2}V_1, \mathcal{L}_{V_3}\mathcal{L}_{V_2}V_1, \dots : V_0 \in \mathcal{B} \text{ and } V_1, V_2, V_3, \dots \in \mathcal{B} \cup \{A + F\}\}$$

of vector fields spans $T_{x_0}\mathbf{R}^d \cong \mathbf{R}^d$, where $\mathcal{B} = \{Be_1, \dots, Be_n\}$.

Remark 3.2.1. *In the linear case (i.e. when $F \equiv 0$), a straightforward computation shows that the Kalman condition (K) implies the weak Hörmander condition (H). This suggests that the latter can be obtained from a perturbative argument in a point x_0 far from the origin if F can be neglected at infinity in a suitable sense; see Section 3.5.*

It is convenient to study the properties of such a diffusion process through the corresponding controlled equation

$$\begin{cases} \dot{x}(t) = Ax(t) + F(x(t)) + B\dot{\eta}(t), \\ x(0) = x^{\text{in}}, \end{cases} \quad (3.3)$$

understood as

$$x(t) = x^{\text{in}} + \int_0^t Ax(s) + F(x(s)) \, ds + B(\eta(t) - \eta(0))$$

when η is a merely continuous function. We define, for $0 \leq t \leq T$,

$$\begin{aligned} S_t^F : \mathbf{R}^d \times C_0([0, T]; \mathbf{R}^n) &\rightarrow \mathbf{R}^d \\ (x^{\text{in}}, \eta) &\mapsto x(t) \end{aligned}$$

giving the solution at time t of this problem. We refer to the second argument as the *control*. The function S_t^F is uniformly continuous in each argument. It is also Fréchet differentiable. We will make use of these regularity properties in Section 3.3.2.

Remark 3.2.2. *The law for $\eta \in C_0([0, T]; \mathbf{R}^n)$ corresponding to the Wiener process $W_t(\omega)$ restricted to the interval $[0, T]$ in (3.1), which we denote by ℓ , is decomposable in the following sense.*

There exist a sequence $(F_N)_{N \in \mathbf{N}}$ of nested finite-dimensional subspaces and a sequence $(F'_N)_{N \in \mathbf{N}}$ of closed subspaces of the Banach space $C_0([0, T]; \mathbf{R}^n)$ such that

(i) *the union $\bigcup_{N \in \mathbf{N}} F_N$ is dense in $C_0([0, T]; \mathbf{R}^n)$;*

(ii) *the space $C_0([0, T]; \mathbf{R}^n)$ decomposes as the direct sum $F_N \oplus F'_N$ for each $N \in \mathbf{N}$, with corresponding (bounded) projections Π_N and Π'_N , and the measure ℓ decomposes as the product $\ell_N \otimes \ell'_N$ of its projected measures;*

(iii) the projected measure ℓ_N possesses a smooth positive density ρ_N with respect to the Lebesgue measure on the finite-dimensional space F_N .

The requirement of [Sbi17] that $\Pi_N \zeta \rightarrow \zeta$ in norm does not hold for all controls $\zeta \in C_0([0, T]; \mathbf{R}^n)$. However, the convergence will hold true on nice enough subsets — which suffices for our endeavour. These decomposability properties play a central role in the arguments of [Sbi07, Sbi17] and are discussed here in Appendix 3.A.

We use $P_t^F(x^{\text{in}}, \cdot)$ to denote the distribution of the random variable $\omega \mapsto X_t(x^{\text{in}}, \omega)$ defined by (3.1). Then, P_t^F satisfies the Chapman–Kolmogorov equation:

$$P_T^F(x, \Gamma) = \int_{\mathbf{R}^d} P_{T-t}^F(y, \Gamma) P_t^F(x, dy)$$

for all times $0 \leq t \leq T$, all $x \in \mathbf{R}^d$ and all Borel sets $\Gamma \subseteq \mathbf{R}^d$. We are interested in the large-time behaviour of P_t^F . Our main result is the following.

Theorem 3.2.3. *Suppose that the SDE*

$$dX_t = AX_t dt + F(X_t) dt + B dW_t$$

satisfies the conditions (D), (K), (G) and (H). Then, it admits a unique invariant measure $\mu^{\text{inv}} \in \text{Prob}(\mathbf{R}^d)$. Moreover, the function $V : \mathbf{R}^d \rightarrow [0, \infty)$ defined by

$$x \mapsto \int_0^\infty \langle e^{sA} x, e^{sA} x \rangle ds$$

is integrable with respect to μ^{inv} and there exist constants $c, C > 0$ such that

$$\left| \int_{\mathbf{R}^d} f(y) P_t^F(x^{\text{in}}, dy) - \int_{\mathbf{R}^d} f(y) \mu^{\text{inv}}(dy) \right| \leq C(1 + V(x^{\text{in}}))e^{-ct} \quad (3.4)$$

for all $x^{\text{in}} \in \mathbf{R}^d$, all $t \geq 0$ and all measurable functions f with $|f| \leq 1 + V$.

The proof of this theorem is developed throughout Section 3.3. The last key step there is an application of Hairer and Mattingly’s version of Harris’ ergodic theorem [HM11]. It requires two hypotheses: the existence of constants $\gamma \in (0, 1)$ and $K > 0$ such that

$$\left| \int_{\mathbf{R}^d} V(y) P_t^F(x, dy) \right| \leq \gamma^t V(x) + K \quad (3.5)$$

for all $x \in \mathbf{R}^d$ and all $t \geq 0$, and the existence of a positive measure bounding from below the probability of reaching a set when starting from the interior of a suitable level set of V :

$$P_T^F(x, \cdot) \geq \nu_T \quad (3.6)$$

for all $x \in \mathbf{R}^d$ such that $V(x) \leq 1 + 2K(1 - \gamma)^{-1}$. The first one is dealt with in Section 3.3.1; the second one, in Section 3.3.2.

3.3 Proof of Theorem 3.2.3

3.3.1 Dissipativity and Lyapunov stability

Condition (D) ensures that the integral defining $V : x \mapsto \int_0^\infty |e^{sA}x|^2 ds$ converges. To this function V is naturally associated a positive definite matrix M such that $V(x) = \langle x, Mx \rangle$. We wish to show that, under the conditions (D) and (G), this function satisfies the inequality (3.5) for some constants $\gamma \in (0, 1)$ and $K > 0$ that do not depend on x .

Lemma 3.3.1. *Under the conditions (D) and (G), there exist constants $K > 0$ and $\gamma \in (0, 1)$ such that the function V satisfies*

$$\left| \int_{\mathbf{R}^d} V(y) P_t^F(x, dy) \right| \leq \gamma^t V(x) + K$$

for all $x \in \mathbf{R}^d$ and all $t \geq 0$.

Proof. Fix an initial condition $X_0 \in \mathbf{R}^d$. First note that we have

$$\langle D_x V(x), Ax \rangle = 2 \langle x, MAx \rangle = \int_0^\infty \frac{d}{ds} \langle e^{sA}x, e^{sA}x \rangle ds = -|x|^2.$$

On the other hand, by assumption (G), there exists $c_1 > 0$ such that $|F(x)| \leq \frac{1}{8\|M\|} |x| + c_1$ and thus there exists a constant $c_2 > 0$ depending on c_1 and $\|M\|$ such that

$$\langle D_x V(x), Ax + F(x) \rangle \leq -\frac{1}{2}|x|^2 + c_2.$$

for all $x \in \mathbf{R}^d$.

By Itô's lemma applied to the smooth function V (with no explicit t -dependence),

$$dV(X_t) = \langle DV(X_t), AX_t + F(X_t) \rangle dt + 2 \langle MX_t, B dW_t \rangle + \text{tr}(M B B^*) dt$$

and thus

$$\mathbf{E}V(X_t) \leq V(X_0) + \int_0^t \left(-\frac{1}{2} \mathbf{E}|X_s|^2 + c_2\right) ds + \text{tr}(M B B^*)t.$$

Since e^{sA} is nonsingular for any $s \in [0, 1]$ by assumption (D), there exists $c_3 > 0$ depending on the eigenvalues of A such that

$$V(x) \geq \int_0^1 |e^{sA} x|^2 \geq c_3 |x|^2$$

for all $x \in \mathbf{R}^d$. Hence,

$$\mathbf{E}V(X_t) \leq V(X_0) - \int_0^t \frac{1}{2c_3} \mathbf{E}V(X_s) ds + (c_2 + \text{tr}(M B B^*))t$$

By Grönwall's inequality, we conclude that there exists a constant $K > 0$ (independent of X_0) such that

$$\mathbf{E}V(X_t) \leq e^{-\frac{t}{2c_3}} V(X_0) + K. \quad \square$$

3.3.2 Approachability and solid controllability

The goal of this section is to show the existence of a time $T > 0$ and a nontrivial measure ν_T on \mathbf{R}^d such that the bound

$$P_T^F(x, \cdot) \geq \nu_T$$

holds for all $x \in \mathbf{R}^d$ such that $V(x) \leq 1 + 2K(1 - \gamma)^{-1}$, where γ and K are as in Lemma 3.3.1. This is done in two steps: we first control the probability of reaching neighbourhoods of x_0 where (H) holds, and then the probability of reaching an arbitrary set when starting from x' close enough to x_0 .

Throughout this section, the controlled nonlinear system (3.3) is to be thought of as a perturbation of the controlled linear system

$$\begin{cases} \dot{z}(t) = Az(t) + B\dot{\eta}(t), \\ z(0) = x^{\text{in}}. \end{cases} \quad (3.7)$$

For $\eta \in C_0([0, T]; \mathbf{R}^n)$ and $0 \leq t \leq T$, $S_T(x^{\text{in}}, \eta)$ is defined as the solution at time t of the problem (3.7).

We set $R := 1 + 2K(1 - \gamma)^{-1}$. We make extensive use of the compact set $\{x \in \mathbf{R}^d : V(x) \leq R\}$, which we often write as $\{V \leq R\}$ for short.

We start by showing that the point x_0 in which the weak Hörmander condition (H) holds can be approximately reached with suitable control when starting from $\{V \leq R\}$.² To do this, we need a technical lemma on a matrix often referred to as the *controllability Gramian*, which is used to construct relevant controls; see e.g. [Cor07, §§1.2–1.3].

Lemma 3.3.2. *If A and B are such that the Kalman condition (K) is satisfied with d_* , then the symmetric positive definite matrix*

$$Q_T = \int_0^T e^{tA} B B^* e^{tA^*} dt$$

has full rank and $\|Q_T^{-1}\| = O(T^{1-2d_})$ as $T \rightarrow 0$.*

Proof. Because Q_T is symmetric and by real-analyticity of the maps $(0, 1) \ni T \mapsto \langle x, Q_T x \rangle \in \mathbf{R}_+$, it suffices to show that for each $x \in \mathbf{R}^d$ with $|x| = 1$, there exists $k \leq 2d_* - 1$ such that

$$\partial_T^k \langle x, Q_T x \rangle |_{T=0} \neq 0.$$

Suppose for contradiction that there exists such x with $|x| = 1$ and $0 = \partial_T^k \langle x, Q_T x \rangle$ for each $k \leq 2d_* - 1$. From the first derivative, we have

$$B^* x = 0.$$

From the third derivative, we have

$$\langle x, B B^* (A^*)^2 x \rangle + 2 \langle x, A B B^* A^* x \rangle + \langle x, A^2 B B^* x \rangle = 0,$$

but then, using again the consequence of the vanishing first derivative, we have

$$B^* A^* x = 0.$$

²This part of the argument actually holds for any $x_0 \in \mathbf{R}^d$, regardless of the Hörmander condition.

Inductively, from the $(2j + 1)$ th derivative, we have

$$B^*(A^*)^j x = 0,$$

for $j = 0, 1, \dots, d_* - 1$. We conclude that

$$x \in \bigcap_{j=0}^{d_*-1} \ker(B^*(A^*)^j) = \bigcap_{j=0}^{d_*-1} (\text{ran}(A^j B))^\perp,$$

contradicting the Kalman condition. \square

Proposition 3.3.3. *Fix $x_0 \in \mathbf{R}^d$. If the growth condition (G) and the Kalman condition (K) hold, then for any $x \in \mathbf{R}^d$, $\delta > 0$ and $T > 0$ there exists a control $\eta_{x,\delta,T} \in C_0^1([0, T]; \mathbf{R}^n)$ such that $S_T^F(x, \eta_{x,\delta,T}) \in B(x_0, \frac{1}{2}\delta)$.*

Proof. Let $x \in \mathbf{R}^d$ and $\delta > 0$ be arbitrary. Because the Kalman condition (K) holds, for any $T \in (0, 1]$, the control

$$\zeta_{x,T}(t) := \int_0^t B^* e^{(T-s)A^*} Q_T^{-1} (x_0 - e^{-TA} x) ds$$

is such that $S_T(x, \zeta_{x,T}) = x_0$; see e.g. [Cor07, §1.2]. We immediately have the bound

$$|\dot{\zeta}_{x,T}(t)| \leq \|B\| e^{T\|A\|} \|Q_T^{-1}\| (|x_0| + e^{T\|A\|} |x|)$$

and the hypotheses yield through Lemma 3.3.2 the existence of a constant $C > 0$ depending on A and B such that

$$|\dot{\zeta}_{x,T}(t)| \leq C(|x| + |x_0|)T^{-m}$$

for all $T \in (0, 1]$, where $m := 2d_* - 1$.

With $z_T(t) := S_t(x, \zeta_{x,T})$, $x_T(t) := S_t^F(x, \zeta_{x,T})$ and $y_T(t) := x_T(t) - z_T(t)$, we have

$$\dot{y}_T(t) = Ay_T(t) + F(x_T(t)),$$

$$y_T(0) = 0.$$

Then, for $t \in [0, T]$,

$$y_T(t) = \int_0^t e^{(t-s)A} F(x_T(s)) ds = \int_0^t e^{(t-s)A} F(y_T(s) + z_T(s)) ds.$$

By (G), there exists $C' > 0$ depending on A and F only such that

$$|y_T(t)| \leq C' \int_0^t 1 + |y_T(s)|^a + |z_T(s)|^a \, ds.$$

On the other hand,

$$\begin{aligned} |z_T(t)| &\leq |e^{tA}x| + \int_0^t |e^{(t-s)A}B\dot{\zeta}_{x,T}(s)| \, ds \\ &\leq C'|x| + tCe^{T\|A\|}\|B\|(|x| + |x_0|)T^{-m}. \end{aligned}$$

Combining these two inequalities, there exists a constant $C'' > 0$ such that

$$|y_T(t)| \leq C'' \int_0^t |y_T(s)| \, ds + tC''(1 + |x| + |x_0|)(1 + T^{a(1-m)})$$

Recall that $0 \leq a < \frac{1}{2d_*}$ and $m = 2d_* + 1$. Hence,

$$a(1 - m) + 1 > 0$$

and, by Grönwall's inequality, there exists $T_{x,\delta} \in (0, 1]$ small enough, depending continuously on x and δ , such that $|S_T^F(x, \zeta_{x,T}) - x_0| = |y_T(T)| < \frac{1}{4}\delta$ for all $0 < T \leq T_{x,\delta}$.

If $T \leq T_{x,\delta}$, pick $\eta_{x,\delta,T} = \zeta_{x,T}$. If $T > T_{x,\delta}$, let

$$r_T := \sup_{0 \leq t \leq T} |S_t(x, 0)| \quad \text{and} \quad s_T = \min\left\{\frac{1}{2}T, \inf_{|y| \leq r_{x,T}} T_{y,\delta}\right\}.$$

Then, $|S_{T-s_T}(x, 0)| < r_T$ and by the above $\zeta_{S_{T-s_T}(x,0),s_T}$ is such that

$$S_{s_T}(S_{T-s_T}(x, 0), \zeta_{S_{T-s_T}(x,0),s_T}) \in B(x_0, \frac{1}{4}\delta).$$

This corresponds to the control

$$\tilde{\eta}_{x,\delta,T}(t) := \mathbf{1}_{[T-s_T,T]}(t) \zeta_{S_{T-s_T}(x,0),s_T}(t - (T - s_T))$$

defined on $[0, T]$. A $C_0^1([0, T]; \mathbf{R}^n)$ regularisation $\eta_{x,\delta,T}$ of $\tilde{\eta}_{x,\delta,T}$ will then satisfy $S_T(x, \eta_{x,\delta,T}) \in B(x_0, \frac{1}{2}\delta)$. \square

Proposition 3.3.4. *Fix $x_0 \in \mathbf{R}^d$ and $\delta > 0$ and suppose that the conditions (G) and (K) hold. Then, the function*

$$(x, T) \mapsto P_T^F(x, B(x_0, \delta))$$

is positive and jointly lower semicontinuous.

Proof. For any $x \in \mathbf{R}^d$ and $T > 0$, there exists $\eta_{x,\delta,T} \in C_0^1([0, T]; \mathbf{R}^n)$ such that $S_T^F(x, \eta_{x,\delta,T}) \in B(x_0, \frac{1}{2}\delta)$. By the Stroock–Varadhan support theorem,³ the support of the distribution of paths $[0, T] \ni t \mapsto X_t(x, \omega)$ contains the closure of $\{[0, T] \ni t \mapsto S_t^F(x, \eta) : \eta \in C_0^1([0, T]; \mathbf{R}^n)\}$ with respect to the supremum norm on $C_0([0, T]; \mathbf{R}^d)$. In particular, $P_T^F(x, B(x_0, \delta)) > 0$.

For \mathbf{P} -almost every $\omega \in \Omega$, the path $t \mapsto W_t(\omega)$ is continuous. Since X_t satisfies the integral equation

$$X_t(x, \omega) = x + \int_0^t AX_s(x, \omega) + F(X_s(x, \omega)) ds + BW_t(\omega)$$

with $y \mapsto Ay + F(y)$ globally Lipschitz and $t \mapsto BW_t(\omega)$ continuous, a standard argument shows that the map $(x, T) \mapsto X_T(x, \omega)$ is jointly continuous. Therefore, the function

$$(x, T) \mapsto \mathbf{1}_{\{\omega' \in \Omega : X_T(x, \omega') \in B(x_0, \delta)\}}(\omega)$$

is jointly lower semicontinuous for \mathbf{P} -almost all $\omega \in \Omega$. Then, so is the map

$$(x, T) \mapsto \int_{\Omega} \mathbf{1}_{\{\omega' \in \Omega : X_T(x, \omega') \in B(x_0, \delta)\}}(\omega) d\mathbf{P}(\omega)$$

by Fatou's lemma. □

Now that we have established that, starting from $\{V \leq R\}$, any neighbourhood of x_0 can be suitably reached, we seek a minorization for transitions from points close to x_0 to arbitrary points of the space. In [Shi17]'s study of SDEs on compact manifolds, the notions of decomposability and *solid controllability* are used to show that the weak Hörmander condition (H) in x_0 is sufficient to provide appropriate control of the transition probabilities from points x' close enough to x_0 .

(sC) a system $S : \mathbf{R}^d \times E \rightarrow \mathbf{R}^d$, where E is a Banach space, is said to be *solidly controllable* from x_0 , with compact $Q \Subset E$, if there is a ball G in \mathbf{R}^d and a number $\varepsilon > 0$ such that if a continuous map $\Phi : Q \rightarrow \mathbf{R}^d$ satisfies

$$\sup_{\zeta \in Q} |\Phi(\zeta) - S(x_0, \zeta)| \leq \varepsilon,$$

then $\Phi(Q) \supseteq G$.

³In the case of an additive noise, the Stroock–Varadhan support theorem can be given a direct proof by continuity arguments even if the vector field is unbounded, as long as the solutions are defined globally in time.

Most of the ideas for the next three results are present in different parts of [Shi17]; also see [Shi07]. We retrieve the key steps and repiece them in a way that is suitable for our endeavour.

Lemma 3.3.5. *If there exists a closed ball $D \in \mathbf{R}^d$ and a continuous function $f : D \rightarrow E$ such that $S(x_0, f(x)) = x$ for all $x \in D$, then S satisfies the solid controllability condition (sC) from x_0 , with $Q = f(D)$.*

Proof. Take $\varepsilon < \frac{1}{4} \text{diam}(D)$ and set $G := \{x \in D : d(x, \partial D) \geq \varepsilon\}$. Let Φ be a continuous map on $f(D)$ such that

$$\sup_{\zeta \in f(D)} |\Phi(\zeta) - S(x_0, \zeta)| \leq \varepsilon.$$

Then, for any $x' \in G$, the continuous function $\Psi_{x'}$ defined on D by

$$\Psi_{x'}(x) = x' - \Phi(f(x)) + x$$

maps D to itself. Indeed,

$$\begin{aligned} |x' - \Psi_{x'}(x)| &= |x' - (x' - \Phi(f(x)) + x)| \\ &= |\Phi(f(x)) - S(x_0, f(x))| \leq \sup_{\zeta \in f(D)} |\Phi(\zeta) - S(x_0, \zeta)| \leq \varepsilon. \end{aligned}$$

Hence, by the Brouwer fixed point theorem, there exists $x \in D$ such that $x = \Psi_{x'}(x)$, i.e. such that $x' = \Phi(f(x))$. We conclude $G \subseteq \Phi(f(D))$. \square

We will use this for S_1^F defined in Section 3.2. In this case, the Banach space E of controls is $C_0([0, 1]; \mathbf{R}^n)$ equipped with the supremum norm.

Proposition 3.3.6. *If the weak Hörmander condition (H) is satisfied in x_0 , then S_1^F is solidly controllable from x_0 , with a set Q consisting of functions that are all Lipschitz with a common Lipschitz constant κ .*

Proof. By the previous lemma, to show solid controllability, it suffices to provide a ball $D \in \mathbf{R}^d$ and a continuous function $f : D \rightarrow C_0([0, 1]; \mathbf{R}^n)$ such that $S_1^F(x_0, f(x_*)) = x_*$ for all $x_* \in D$.

As part of Theorem 2.1 in [Shi17, §2.2], it is shown in a similar setting that the Hörmander condition implies the existence of a ball $D \Subset \mathbf{R}^d$ and a continuous function $\tilde{f} : D \rightarrow L^2([0, 1]; \mathbf{R}^n)$ such that the solution of

$$\begin{cases} \dot{x} = Ax + F(x) + B\tilde{f}(x_*) \\ x(0) = x_0 \end{cases}$$

satisfies $x(1) = x_*$. Moreover, $\kappa := \sup_{x_* \in D} \|\tilde{f}(x_*)\|_{C_0} < \infty$. The construction of D and \tilde{f} uses local arguments and can be directly translated to our setup.

The idea behind the proof is the following. Consider the following extended problem for $y(t) = (x(t), s(t))$ in $\mathbf{R}^d \times \mathbf{R}$:

$$\begin{cases} \dot{y} = (Ax + F(x), 1) + (B\xi, 0) \\ y(0) = (x_0, 0) \end{cases}, \quad (3.8)$$

where the control ξ is taken in $L^2([0, 1]; \mathbf{R}^n)$. The Hörmander condition implies that the Lie algebra generated by the family $\{\tilde{V}_\eta(x, s) = (Ax + F(x), 1) + (B\eta, 0) : \eta \in \mathbf{R}^n\}$ of vector fields has full rank at the point $(x_0, 0)$. Hence, one can show using ideas from the proof of Krener's theorem that there exists a choice of small intervals $(a_l, b_l) \subset [0, 1]$ and vectors $\eta_l \in \mathbf{R}^n$ for $l = 0, 1, \dots, d$ such that the parallelepiped

$$\tilde{I} = \{\alpha = (\alpha_0, \alpha_1, \dots, \alpha_d) \in \mathbf{R}^{d+1} : \alpha_l \in (a_l, b_l)\}$$

embeds into $\mathbf{R}^d \times \mathbf{R}$ via the map

$$\begin{aligned} \phi : \tilde{I} &\rightarrow \mathbf{R}^d \times \mathbf{R} \\ \alpha &\mapsto (e^{\alpha_d \tilde{V}_{\eta_d}} \circ \dots \circ e^{\alpha_0 \tilde{V}_{\eta_0}})(x_0, 0). \end{aligned}$$

In other words, ϕ takes α to the solution y at time $T_\alpha := \alpha_0 + \alpha_1 + \dots + \alpha_d$ of the extended problem (3.8) with the control

$$\xi_\alpha(t) = \mathbf{1}_{[0, \alpha_0)}(t)\eta_0 + \sum_{l=1}^d \mathbf{1}_{[\alpha_0 + \dots + \alpha_{l-1}, \alpha_0 + \dots + \alpha_{l-1} + \alpha_l)}(t)\eta_l. \quad (3.9)$$

Fixing an $\hat{\alpha} \in \tilde{I}$ with corresponding $T_{\hat{\alpha}} \in (0, 1]$, one finds that the solutions at time $T_{\hat{\alpha}}$ of the problem

$$\begin{cases} \dot{x} = Ax + F(x) + B\xi_{\hat{\alpha}} \\ x(0) = x_0 \end{cases}$$

provide a diffeomorphism between a neighbourhood of $\hat{\alpha}$ in $\{\alpha \in \tilde{I} : T_\alpha = T_{\hat{\alpha}}\}$ and an open set $O \subset \mathbf{R}^d$. Inverting this diffeomorphism, one finds a function that associates to each point $x_* \in O$ a control $\xi_{\alpha(x_*)} \in L^2([0, T_{\hat{\alpha}}]; \mathbf{R}^n)$ of the form (3.9). By construction,

$$S_{T_{\hat{\alpha}}}^F \left(x_0, \int_0^{\cdot} \xi_{\alpha(x_*)}(s) \, ds \right) = x_*$$

for all $x_* \in O$. A standard argument then allows to find a closed ball $D \Subset \mathbf{R}^d$ and a continuous function $\tilde{f} : D \rightarrow L^2([0, 1]; \mathbf{R}^n)$ such that

$$S_1^F \left(x_0, \int_0^{\cdot} (\tilde{f}(x_*))(s) \, ds \right) = x_*$$

for all $x_* \in D$. The supremum κ is bounded by the sum of the $|\eta_l|$ used in the construction of the embedding ϕ .

Let $f : D \rightarrow C_0([0, 1]; \mathbf{R}^n)$ be defined by $f(x_*) := \int_0^{\cdot} (\tilde{f}(x_*))(s) \, ds$. Then,

$$\begin{aligned} \|f(x_*) - f(x_{**})\|_{C_0} &= \sup_{t \in [0, 1]} \left| \int_0^t (\tilde{f}(x_*))(s) \, ds - \int_0^t (\tilde{f}(x_{**}))(s) \, ds \right| \\ &\leq \|\tilde{f}(x_*) - \tilde{f}(x_{**})\|_{L^2} \end{aligned}$$

so that f is continuous. We conclude that S_1^F is solidly controllable from x_0 , with $Q = f(D)$. The constant κ is a common Lipschitz constant for all functions in Q . \square

Proposition 3.3.7. *If the weak Hörmander condition (H) is satisfied in x_0 , then there exist $\delta_0 > 0$ and a nonzero Borel measure $\tilde{\nu}$ on \mathbf{R}^d such that*

$$P_1^F(x', \cdot) \geq \tilde{\nu}$$

for all $x' \in B(x_0, \delta_0)$.

Proof. By the previous proposition, we have solid controllability of the system S_1^F from the point x_0 , with a set Q consisting of Lipschitz functions. Then, the strategy of [Shi17, §1.2] (also see [Shi07, §2.1]) yields the desired measure. We outline the argument for completeness and to emphasize that we do not need the full strength of the decomposability assumption made there.

Let Π_N be as in Remark 3.2.2 and Appendix 3.A. Because all controls in Q have a common Lipschitz constant κ , we have

$$\lim_{N \rightarrow \infty} \sup_{\zeta \in Q} \|\zeta - \Pi_N \zeta\|_{C_0} = 0$$

by Lemma 3.A.1. Then, because $S_1^F(x_0, \cdot) : C_0([0, 1]; \mathbf{R}^n) \rightarrow \mathbf{R}^d$ is uniformly continuous, there exists $N \in \mathbf{N}$ large enough that

$$\sup_{\zeta \in Q} |S_1^F(x_0, \Pi_N \zeta) - S_1^F(x_0, \zeta)| < \varepsilon,$$

for the ε in (sC). Taking $\Phi = S_1^F(x_0, \Pi_N \cdot)$ there, $\Phi(Q)$ contains a ball (which has positive measure).

By Sard's theorem, there exists a point $\zeta_0 \in Q$ in which $D\Phi$ has full rank. Because $\Phi \circ \Pi_N = \Phi$, this property still holds true if we restrict Φ to $F_N = \text{ran } \Pi_N$. There then exists a d -dimensional subspace $F_N^1 \subseteq F_N$ such that $D\Phi|_{\zeta_0}(F_N^1) = \mathbf{R}^d$. Let F_N^2 be such that $F_N^1 \oplus F_N^2 = F_N$. We will write $\zeta \in F_N$ as (ζ^1, ζ^2) according to this decomposition. More generally, we will write a generic element of C_0 as $(\zeta^1, \zeta^2, \zeta')$ with $\zeta' \in F_N'$. The Jacobian of the map $S_1^F(x_0, (\cdot, \zeta_0^2, 0)) : F_N^1 \rightarrow \mathbf{R}^d$ at the point ζ_0^1 is a linear isomorphism between F_N^1 and \mathbf{R}^d .

By the implicit function theorem, there exist neighbourhoods V^1 of ζ_0^1 , V^2 of ζ_0^2 , V' of 0, W of x_0 , U of $S_1^F(x_0, (\zeta_0^1, \zeta_0^2, 0))$; and a continuously differentiable function $g : W \times U \times V^2 \times V' \rightarrow V^1$ such that, for points in the appropriate open sets, $S_1^F(x', (\zeta^1, \zeta^2, \zeta')) = x_*$ is equivalent to $\zeta^1 = g(x', x_*, \zeta^2, \zeta')$.

Recall that ℓ equals the product measure $\ell_N \times \ell'_N$ with ℓ_N possessing a continuous and positive density ρ_N on F_N . Let $\chi : \mathbf{R}^d \times C_0 \rightarrow [0, 1]$ be continuous, supported in $W \times V^1 \times V^2 \times V'$, and equal to 1 at $(x_0, \zeta_0^1, \zeta_0^2, 0)$. Then, for any Borel set $\Gamma \subseteq \mathbf{R}^d$,

$$\begin{aligned} P_1^F(x', \Gamma) &\geq \iiint_{S_1^F(x', \cdot)^{-1}(\Gamma)} \chi(x', \zeta^1, \zeta^2, \zeta') \rho_N(\zeta^1, \zeta^2) d\zeta^1 d\zeta^2 \ell'_N(d\zeta') \\ &= \iint_{V^2 \times V'} \int_{\Gamma} \frac{\chi(x', g(x', x_*, \zeta^2, \zeta'), \zeta^2, \zeta') \rho_N(g(x', x_*, \zeta^2, \zeta'), \zeta^2)}{\det[DS_1^F(x', (\cdot, \zeta^2, \zeta'))|_{g(x', x_*, \zeta^2, \zeta')}] } dx_* \\ &\quad d\zeta^2 \ell'_N(d\zeta') \end{aligned}$$

for all $x' \in W$.

By continuity, there exist numbers $\delta_0 > 0$ and $\alpha > 0$ such that

$$P_1^F(x', \Gamma) \geq \alpha \operatorname{vol}(\Gamma \cap B(S_1^F(x_0, \zeta_0), \delta_0))$$

for all $x' \in B(x_0, \delta_0)$ and all Borel sets $\Gamma \subseteq \mathbf{R}^d$. □

Then, by the Chapman–Kolmogorov equation,

$$\begin{aligned} P_{T+1}^F(x, \Gamma) &\geq \int_{x' \in B(x_0, \delta_0)} P_T^F(x, dx') P_1^F(x', \Gamma) \\ &\geq \int_{x' \in B(x_0, \delta_0)} P_T^F(x, dx') \tilde{\nu}(\Gamma) = P_T^F(x, B(x_0, \delta_0)) \tilde{\nu}(\Gamma) \end{aligned}$$

for any Borel set $\Gamma \subseteq \mathbf{R}^d$ and any $T > 0$. We conclude that for any $T > 1$ the nontrivial measure

$$\nu_T := \left(\inf_{x \in \{V \leq R\}} P_{T-1}^F(x, B(x_0, \delta_0)) \right) \tilde{\nu}$$

is such that

$$P_T^F(x, \cdot) \geq \nu_T$$

for all $x \in \mathbf{R}^d$ such that $V(x) \leq R$. The infimum in the definition of ν_T is positive by Proposition 3.3.4.

3.3.3 Application of Harris' ergodic theorem

Recall that, by Lemma 3.3.1, the conditions (D) and (G) ensure the existence of constants $K > 0$ and $\gamma \in (0, 1)$ such that the function V satisfies

$$\left| \int_{\mathbf{R}^d} V(y) P_t^F(x, dy) \right| \leq \gamma^t V(x) + K \tag{3.10}$$

for all $x \in \mathbf{R}^d$ and all $t > 0$. Using the conditions (G) and (K), we also showed in Proposition 3.3.4 that, for any $\delta > 0$, $(x, T) \mapsto P_T^F(x, B(x_0, \delta))$ is positive and jointly lower semicontinuous. Then, we concluded from this, hypothesis (H) and the arguments of [Shi17] that, for any $T > 1$, there is a nontrivial measure ν_T such that

$$P_T^F(x, \cdot) \geq \nu_T \tag{3.11}$$

for all $x \in \mathbf{R}^d$ such that $V(x) \leq R$.

The existence of a function V satisfying the condition (3.10) and a nontrivial measure ν_T satisfying (3.11) are precisely the hypotheses we need to apply Harris' theorem.

Indeed, considering the T -skeleton of our diffusion process⁴ for $T = 2$, Theorem 1.2 in [HM11] yields constants $c, C > 0$ and a stationary measure $\mu^{\text{inv}} \in \text{Prob}(\mathbf{R}^d)$ against which V is integrable and such that

$$\sup_{|f| \leq 1+V} \left| \int_{\mathbf{R}^d} f(y) [P_{2m}^F(x, dy) - \mu^{\text{inv}}(dy)] \right| \leq C e^{-c(2m+2)} (1 + V(x)) \quad (3.12)$$

for all $x \in \mathbf{R}^d$ and all $m \in \mathbf{N} \cup \{0\}$.

The measure μ^{inv} is the unique stationary probability measure for the 2-skeleton, but it could a priori depend on our choice of T -skeleton. However, we can show that this measure is actually stationary, not only for the 2-skeleton, but also for the continuous-time process.

Note that with $f = \mathbf{1}_\Gamma$ the characteristic function of any Borel set $\Gamma \subseteq \mathbf{R}^d$, integrating (3.12) in the variable x yields that

$$\left| \int_{\mathbf{R}^d} P_{2m}^F(x, \Gamma) \lambda(dx) - \mu^{\text{inv}}(\Gamma) \right| \leq C e^{-c(2m+2)} \left(1 + \int_{\mathbf{R}^d} V(x) \lambda(dx) \right) \quad (3.13)$$

for any measure $\lambda \in \text{Prob}(\mathbf{R}^d)$.

Putting λ defined by $\lambda(\Gamma) = \int P_s^F(x, \Gamma) \mu^{\text{inv}}(dx)$ in (3.13) for some $s \geq 0$, we have by the Chapman–Kolmogorov equation that

$$\begin{aligned} & \left| \int_{\mathbf{R}^d} P_{2m+s}^F(x, \Gamma) \mu^{\text{inv}}(dx) - \mu^{\text{inv}}(\Gamma) \right| \\ & \leq C e^{-c(2m+2)} \left(1 + \int_{\mathbf{R}^d} \int_{\mathbf{R}^d} V(y) P_s^F(x, dy) \mu^{\text{inv}}(dx) \right). \end{aligned}$$

Using (3.10),

$$\begin{aligned} & \left| \int_{\mathbf{R}^d} P_{2m+s}^F(x, \Gamma) \mu^{\text{inv}}(dx) - \mu^{\text{inv}}(\Gamma) \right| \\ & \leq C e^{-c(2m+2)} \left(1 + K + \int_{\mathbf{R}^d} V(x) \mu^{\text{inv}}(dx) \right). \end{aligned}$$

⁴By T -skeleton of a (continuous time) stochastic process, we mean the restriction to times in the countable set $T\mathbf{N}$.

But the left-hand side does not depend on $m \in \mathbf{N}$ because μ^{inv} is invariant for the 2-skeleton. We therefore have $\int P_s^F(x, \cdot) \mu^{\text{inv}}(dx) = \mu^{\text{inv}}$ for all $s \geq 0$, i.e. that μ^{inv} is stationary for the original continuous-time process.

Now, for any $|f| \leq 1 + V$, $s \in [0, 2)$ and $m \in \mathbf{N} \cup \{0\}$,

$$\begin{aligned} & \left| \int_{\mathbf{R}^d} f(y) [P_{2m+s}^F(x, dy) - \mu^{\text{inv}}(dy)] \right| \\ &= \left| \int_{\mathbf{R}^d} \int_{\mathbf{R}^d} f(y) P_{2m}^F(x, dz) P_s^F(z, dy) - f(y) P_s^F(z, dy) \mu^{\text{inv}}(dz) \right| \\ &= \left| \int_{\mathbf{R}^d} \left(\int_{\mathbf{R}^d} f(y) P_s^F(z, dy) \right) [P_{2m}^F(x, dz) - \mu^{\text{inv}}(dz)] \right|. \end{aligned}$$

Since $|f| \leq 1 + V$, we have by (3.10) that

$$\left| \int_{\mathbf{R}^d} f(y) P_s^F(z, dy) \right| \leq \int_{\mathbf{R}^d} (1 + V(y)) P_s^F(z, dy) \leq (K + 1)(1 + V(z)).$$

Therefore, we may apply (3.12) with f replaced by $\frac{1}{K+1} \int f(y) P_s^F(\cdot, dy)$ to get

$$\left| \int_{\mathbf{R}^d} f(y) [P_{2m+s}^F(x, dy) - \mu^{\text{inv}}(dy)] \right| \leq (K + 1) C e^{-c(2m+2)} (1 + V(x)).$$

Because any time $t > 0$ can be written as $2m + s$ with $s \in [0, 2)$, this is — up to a relabeling of the constants — the assertion of Theorem 3.2.3.

3.4 Networks of oscillators

We introduce the mathematical description of important physical systems that our main result covers, from the simplest to the most intricate. Based on [JPS17], we also discuss the assumptions (K), (D) and (G) of our main result in this context. Discussion of the weak Hörmander condition (H) is postponed to the next section.

3.4.1 The linear chain coupled to Langevin thermostats

Consider L unit masses, each labelled by an index in $\{1, 2, \dots, L - 1, L\}$ and whose position is restricted to a line. For $i = 1, 2, \dots, L - 1$, the i th mass is attached to the $(i + 1)$ th mass by a spring of

$$B = \begin{pmatrix} \sqrt{2\gamma_1\theta_1} & 0 \\ 0 & 0 \\ \vdots & \vdots \\ 0 & 0 \\ 0 & \sqrt{2\gamma_L\theta_L} \\ & \\ & 0 \end{pmatrix}$$

and $F(X) = F(p, q) = -\nabla_q U(q)$.

The Kalman condition (K) is met for the pair (A, B) (with $d_* \leq L$) as soon as $k > 0$ and the eigenvalues of A then have strictly negative real part (condition (D) holds) [JPS17].

The growth condition (G) on the vector field F in the general setting is to be imposed on the gradient $\nabla_q U$ of the perturbing potential U for the chain of oscillators: we require that it is Lipschitz and that there exists $a \in [0, \frac{1}{2d_*})$ such that $|\nabla_q U(q)| = O(1 + |q|)^a$ as $|q| \rightarrow \infty$. This potential is not restricted to one-body (pinning) or two-body interaction terms; it can for example include a sum of bounded three-body interaction terms.

3.4.2 More general geometries in the Langevin regime

Let I be a finite set and distinguish a nonempty subset $J \subset I$ of the sites, where the thermal noise will act. Fix a temperature $\theta_j > 0$ for the bath associated to each site $j \in J$. We can then generalize the above model to different geometries and different spring constants by considering

$$X = \begin{pmatrix} p \\ \omega q \end{pmatrix}, \quad A = \begin{pmatrix} -\frac{1}{2}u^* & -\omega^* \\ \omega & 0 \end{pmatrix}, \quad B = \begin{pmatrix} \iota \\ 0 \end{pmatrix} \mathcal{G}^{1/2}, \quad (3.14)$$

and $F(p, \omega q) = -\nabla_q U(q)$, where

$$\omega : \mathbf{R}^I \rightarrow \mathbf{R}^I,$$

is a nonsingular linear map⁵ and where \mathfrak{g} and ι are of the form

$$\begin{aligned}\mathfrak{g} : \quad \mathbf{R}^J &\rightarrow \mathbf{R}^J \\ (u_j)_{j \in J} &\mapsto (\theta_j u_j)_{j \in J},\end{aligned}$$

and

$$\begin{aligned}\iota : \quad \mathbf{R}^J &\rightarrow \mathbf{R}^I \\ (u_j)_{j \in J} &\mapsto (\sqrt{2\gamma_j} u_j)_{j \in J} \oplus 0_{I \setminus J}.\end{aligned}$$

Again, γ_j is the coupling constant for the j th oscillator of the boundary. More explicitly, the equations of motion then take the familiar form

$$\begin{aligned}dq &= p \, dt, \\ dp &= -\omega^* \omega q \, dt - \nabla_q U(q) \, dt - \frac{1}{2} \iota^* p \, dt + \iota \mathfrak{g}^{1/2} dW_t.\end{aligned}$$

Lemma 4.1 in [JPS17] states that if the pair $(\omega^* \omega, \iota)$ satisfies the Kalman condition (K), then the pair (A, B) defined by (3.14) also satisfies the Kalman condition. By Theorem 5.1(2) there, it then immediately implies the dissipativity condition (D). In Section 4.1 there, the case of the triangular network is treated and explicit sufficient conditions for the Kalman condition are given in terms of the spring constants. Again, the growth condition (G) is to be imposed on the gradient $\nabla_q U$ of the perturbing potential U .

As mentioned in the introduction, the recent work [CEHRB18] of Cuneo, Eckmann, Hairer and Rey-Bellet provides a result of existence, uniqueness and exponentially fast convergence in a similar setup. Their conditions C3–C5 on the behaviour of the potential at infinity are significantly less restrictive than our conditions (D) and (G), allowing for strong anharmonicity. However, their nondegeneracy condition C2 is needed in all points of the phase space while our Hörmander condition (H) is only needed in one point. Their controllability condition C1 on the topology of the graph plays a role similar to that of our Kalman condition (K).

⁵We use the symbol ω for the linear map encoding the frequencies of the system in order to ease the comparison with other works to which we refer. Unfortunately, ω is also standard notation for elements of the underlying probability space. We trust that the meaning of the symbol is clear from the context.

3.4.3 Coupling through additional degrees of freedom

As pointed out e.g. in [JPS17], models where the noise acts through auxiliary degrees of freedom enjoy the same structural properties, and are thus also suitable for our framework. We refer the reader to [FKM65, Tro77, EPRB99b] for discussions of the physical interpretation and derivation of such models. Because of these auxiliary degrees of freedom, the model is sometimes said to be semi-Markovian.

Let I and J be finite sets as above and consider $X = (r, p, \omega q) \in \mathbf{R}^J \oplus \mathbf{R}^I \oplus \mathbf{R}^I$ for some nonsingular linear map $\omega : \mathbf{R}^I \rightarrow \mathbf{R}^I$. In addition, let $A : \mathbf{R}^J \rightarrow \mathbf{R}^I$ be a linear injection and let $\iota : \mathbf{R}^J \rightarrow \mathbf{R}^J$ and $\mathfrak{g} : \mathbf{R}^J \rightarrow \mathbf{R}^J$ be linear bijections. We set

$$A = \begin{pmatrix} -\frac{1}{2}\iota^* & -A^* & 0 \\ A & 0 & -\omega^* \\ 0 & \omega & 0 \end{pmatrix} \quad \text{and} \quad B = \begin{pmatrix} \iota \\ 0 \\ 0 \end{pmatrix} \mathfrak{g}^{1/2}; \quad (3.15)$$

the important structural constraints are

$$\mathfrak{g} > 0, \quad B^* B > 0, \quad (3.16)$$

$$\ker(A - A^*) \cap \ker B^* = \{0\}, \quad A + A^* = -B \mathfrak{g}^{-1} B^*. \quad (3.17)$$

The perturbation F is taken to be of the form

$$F : X = (r, p, \omega q) \mapsto -\nabla_q U(q)$$

for some smooth potential $U : \mathbf{R}^I \rightarrow \mathbf{R}$ encoding the anharmonic part of both the interaction and the pinning potential. More explicitly, the equations of motion then read

$$\begin{aligned} dq &= p \, dt, \\ dp &= -\omega^* \omega q \, dt - \nabla_q U(q) \, dt + A r(t) \, dt, \\ dr &= -\frac{1}{2} \iota^* \iota r \, dt - A^* p \, dt - \iota \mathfrak{g}^{1/2} \, dW_t. \end{aligned}$$

Proposition 3.4.1. *If the pair $(\omega^* \omega, A)$ satisfies the Kalman condition, then the pair (A, B) also satisfies the Kalman condition (K).*

Proof. Let $(\hat{r}, \hat{p}, \omega \hat{q})$ be a target for the system in time $T > 0$. If $(\omega^* \omega, A)$ satisfies the Kalman condition, there exists $\eta_1 \in C_0^1([0, T]; \mathbf{R}^n)$ such that the solution $(p_1(t), q_1(t))$ of

$$\begin{aligned} \dot{p}_1 &= -\omega^* \omega q_1 + A \dot{\eta}_1, & p_1(0) &= 0, \\ \dot{q}_1 &= p_1, & q_1(0) &= 0, \end{aligned}$$

satisfies $(p_1(T), q_1(T)) = (\hat{p}, \hat{q})$. Note that $(\frac{t}{T} \hat{r}, p_1(t), q_1(t))$ is then a solution of the system

$$\begin{aligned} \dot{r}_2 &= -\frac{1}{2} \iota^* (r_2 + \dot{\eta}_2) - A^* p_2 + \iota \mathfrak{D}^{1/2} \dot{\zeta}_2, & r_2(0) &= 0, \\ \dot{p}_2 &= -\omega^* \omega q_2 + A (r_2 + \dot{\eta}_2), & p_2(0) &= 0, \\ \dot{q}_2 &= p_2 & q_2(0) &= 0, \end{aligned}$$

for the choices of control

$$\begin{aligned} \eta_2(t) &= \eta_1(t) - \int_0^t \frac{s}{T} \hat{r} \, ds, \\ \zeta_2(t) &= (\iota \mathfrak{D}^{1/2})^{-1} \int_0^t \frac{1}{T} \hat{r} + \frac{1}{2} \iota^* \dot{\eta}_1(s) + A^* p_1(s) \, ds, \end{aligned}$$

hitting the prescribed target at time $t = T$.

Finally, note that with $\tilde{\eta}$ a smooth approximation of $\dot{\eta}_2$ that is 0 at times $t = 0$ and $t = T$, $(r_2(t) + \tilde{\eta}(t), p_2(t), q_2(t))$ is an approximate solution of

$$\begin{aligned} \dot{r} &= -\frac{1}{2} \iota^* r - A^* p + \iota \mathfrak{D}^{1/2} \dot{\zeta}, & r(0) &= 0, \\ \dot{p} &= -\omega^* \omega q + A r, & p(0) &= 0, \\ \dot{q} &= p, & q(0) &= 0, \end{aligned}$$

for the choice of control

$$\zeta(t) = \zeta_2(t) + (\iota \mathfrak{D}^{1/2})^{-1} \tilde{\eta}(t).$$

Therefore, the original system is approximately controllable from 0. Because the system is linear, we conclude that the pair (A, B) satisfies the Kalman condition. \square

Then, Theorem 5.1(2) of [JPS17] states that, in this setup, the Kalman condition (K) implies that all the eigenvalues of A have strictly negative real part, i.e. condition (D).

In particular, for A and B arising from a pair $(\omega^* \omega, A)$ satisfying the Kalman condition (K), as long as $|\nabla_q U(q)| = O(1 + |q|)^a$ as $|q| \rightarrow \infty$, and as long as there exists a point where the weak Hörmander condition holds, the field $q \mapsto \omega^* \omega q + \nabla_q U(q)$ is allowed to be degenerate in non-negligible regions of the position space. This is to be compared the nondegeneracy hypothesis H2) in [EPRB99b, RBT02, Car07] and C2 in [CEHRB18] that are needed everywhere.

3.5 The weak Hörmander condition

As a starting point, we note that under the assumption (K), the condition (H) is automatically satisfied for any F with compact support or any F whose derivatives up to order $d - 1$ vanish at a point. Also note that a standard perturbative argument shows that if the conditions (D), (K) and (G) are satisfied, then there exists $\lambda_0 > 0$ such that the system

$$dX_t = AX_t dt + \lambda F(X_t) dt + B dW_t$$

admits a unique invariant measure satisfying (3.4) as soon as $0 < \lambda < \lambda_0$.

A more subtle perturbative argument is presented in Proposition 3.5.1. We then give an example of a physically motivated potential to which this proposition applies in the context of networks of oscillators.

In view of the definition of the weak Hörmander condition, we are interested in the part of the tangent space spanned by Lie derivatives. The Lie derivatives $\mathcal{L}_G b, \mathcal{L}_G^2 b, \dots, \mathcal{L}_G^{d-1} b$ with $G : x \mapsto Ax + F(x)$ and b a constant vector field will play a particularly important role. A direct computation shows

$$\begin{aligned} \mathcal{L}_G b &= -DG[b], \\ \mathcal{L}_G^2 b &= +DG^2[b] - D^2G[b, G], \\ \mathcal{L}_G^3 b &= -DG^3[b] + 2DG[D^2G[b, G]] \\ &\quad + D^2G[DG[b], G] - D^3G[b, G, G] - D^2G[b, DG[G]], \end{aligned}$$

and so forth. Here, the point of the space at which the vectors fields are taken is implicit and we use

$$D^j G[\cdot, \cdot, \dots, \cdot] : \underbrace{\mathbf{R}^d \times \mathbf{R}^d \times \dots \times \mathbf{R}^d}_{j \text{ times}} \rightarrow \mathbf{R}^d$$

for the j th Fréchet derivative of the map $G : \mathbf{R}^d \rightarrow \mathbf{R}^d$ at this point. The above pattern generalises in the following way.

Claim. The difference between $\mathcal{L}_G^k b$ and $(-1)^k DG^k[b]$ is a linear combination over \mathbf{Z} of compositions of Fréchet derivatives of G with b . In each term, b appears once, G appears N_0 times, DG appears N_1 times, ..., $D^k G$ appears N_k times, with $N_1 \neq k$ and

$$\sum_{j=0}^k N_j = \sum_{j=0}^k j N_j = k. \quad (3.18)$$

Proof. We proceed by induction on k . For $k = 1$ we have

$$\mathcal{L}_G b = -DG[b],$$

which satisfies the claim. Assume now that the result holds for some $k \in \mathbf{N}$ so that $\mathcal{L}_G^k b - (-1)^k DG^k[b]$ is a sum of terms satisfying (3.18). Since

$$\mathcal{L}_G^{k+1} b = -DG[\mathcal{L}_G^k b] + D(\mathcal{L}_G^k b)[G],$$

the first term yields $-(-1)^k DG[DG^k[b]]$ and terms with the same form as those of $\mathcal{L}_G^k b$, but with the changes $k \mapsto k + 1$ (adding $N_{k+1} = 0$) and $N_1 \mapsto N_1 + 1$. It indeed satisfies the right condition on the N 's if $\mathcal{L}_G^k b$ does. As for the second term, by the product rule, each term in $\mathcal{L}_G^k b$ yields a sum of terms undergoing $N_0 \mapsto N_0 + 1$ and $N_j \mapsto N_j - 1$ and $N_{j+1} \mapsto N_{j+1} + 1$ for one and only one $j \in \{1, \dots, k\}$. \square

Proposition 3.5.1. *Suppose that the pair (A, B) satisfies the Kalman condition (K) and that there exists a sequence $(y^{(n)})_{n \in \mathbf{N}}$ in \mathbf{R}^d that is bounded away from 0 and such that*

$$\lim_{n \rightarrow \infty} |y^{(n)}|^{k-1} \|D^k F(y^{(n)})\| = 0$$

for each $k = 1, 2, \dots, d_* - 1$. Then, there exists a point $x_0 \in \mathbf{R}^d$ where the weak Hörmander condition (H) is satisfied.

Proof. Let G denote $y \mapsto Ay + F(y)$ and let b stand for a column of B . By our previous claim, we have the bound

$$\begin{aligned} & |(\mathcal{L}_G^k b)(y) - (-1)^k (DG(y))^k [b]| \\ & \leq \sum_{N \in \mathcal{A}} |C_N| \|b\| |G(y)|^{N_0} \|DG(y)\|^{N_1} \|D^2 G(y)\|^{N_2} \dots \|D^k G(y)\|^{N_k} \\ & \leq \sum_{N \in \mathcal{A}} |C_N| \|b\| (\|A\| |y| + \frac{1}{8} \|M\|^{-1} |y| + c_1)^{N_0} \\ & \quad \|DG(y)\|^{N_1} \|D^2 G(y)\|^{N_2} \dots \|D^k G(y)\|^{N_k} \end{aligned}$$

where $\mathcal{A} := \{N = (N_0, N_1, \dots, N_k) \in (\mathbf{N} \cup \{0\})^k \text{ satisfying (3.18) and } N_1 \neq k\}$ and C_N is a combinatorial factor in \mathbf{Z} .

By condition (3.18),

$$\begin{aligned} & |y|^{N_0} \|DG(y)\|^{N_1} \|D^2 G(y)\|^{N_2} \dots \|D^k G(y)\|^{N_k} \\ & = |y|^{\sum_{j=2}^k (j-1)N_j} \prod_{j=1}^k \|D^j G(y)\|^{N_j} \\ & = \|DG(y)\|^{N_1} \prod_{j=2}^k |y|^{(j-1)N_j} \|D^j G(y)\|^{N_j}. \end{aligned}$$

Along the subsequence $(y^{(n)})_{n \in \mathbf{N}}$ in the hypothesis, for each $j \geq 2$,

$$\lim_{n \rightarrow \infty} |y^{(n)}|^{j-1} \|D^j G(y^{(n)})\| = \lim_{n \rightarrow \infty} |y^{(n)}|^{j-1} \|D^j F(y^{(n)})\| = 0.$$

In the case $j = 1$, we have

$$\limsup_{n \rightarrow \infty} \|DG(y^{(n)})\| \leq \|A\| + \limsup_{n \rightarrow \infty} \|DF(y^{(n)})\| = \|A\|.$$

Therefore,

$$\lim_{n \rightarrow \infty} |(\mathcal{L}_G^k b)(y^{(n)}) - (-1)^k (DG(y^{(n)}))^k [b]| = 0$$

for $k = 1, 2, \dots, d_* - 1$, and for n large enough,

$$\text{span}\{b, \mathcal{L}_G b, \dots, \mathcal{L}_G^{d_*-1} b\}_{y=y^{(n)}} = \text{span}\{b, DG(y)b, \dots, (DG(y))^{d_*-1} b\}_{y=y^{(n)}}.$$

Finally note that

$$\lim_{n \rightarrow \infty} \|(DG(y^{(n)}))^k b - A^k b\| \leq \limsup_{n \rightarrow \infty} \sum_{j=1}^k \binom{k}{j} \|A\|^{k-j} \|DF(y^{(n)})\|^j = 0.$$

We conclude from the Kalman condition that for $N \in \mathbf{N}$ large enough

$$\text{span}\{b, DG(y)b, \dots, (DG(y))^{d_*-1} b : b \in \text{ran } B\}_{y=y^{(N)}}$$

coincides with

$$\text{ran}\{B, AB, \dots, A^{d_*-1} B\} = \mathbf{R}^d.$$

The results holds with $x_0 = y^{(N)}$. □

Example 3.5.2. Consider that the masses in the models of Section 3.4, although restricted to a single spatial degree of freedom, live in 3-dimensional space and each hold an electric charge of Gaussian density

$$\rho_i(\cdot) = \frac{Q}{(2\pi)^{3/2} \sigma^3} \exp\left(-\frac{|\cdot - (q_i + q_i^{\text{eq}})|^2}{2\sigma^2}\right)$$

where σ is a parameter with dimension of length and Q is the electric charge of each mass. In view of Poisson's equation in \mathbf{R}^3 , this gives rise to the term

$$U(q) = \sum_{i \in I} \sum_{\substack{i' \in I \\ i' \neq i}} \frac{Q^2}{4\pi\epsilon_0 |q_i + q_i^{\text{eq}} - (q_{i'} + q_{i'}^{\text{eq}})|} \frac{2}{\sqrt{\pi}} \int_0^{\frac{|(q_i + q_i^{\text{eq}}) - (q_{i'} + q_{i'}^{\text{eq}})|}{\sqrt{2}\sigma}} e^{-s^2} ds$$

in the Hamiltonian. This potential satisfies the condition of the previous proposition: take for example a sequence with $q_i^{(n)} = i n \sigma$.

For the sake of matching exactly the setup of [EPRB99b, RBT02, Car07], consider that $I = \{1, \dots, L\}$ and $J = \{1, L\}$ and that only nearest neighbours interact through the Coulomb force. Let us use the shorthand $\tilde{q}_i := q_i + q_i^{\text{eq}}$. Then, the corresponding perturbing potential

$$U^{\text{n.n.}}(q) = \sum_{i=1}^{L-1} \frac{Q^2}{4\pi\epsilon_0 |\tilde{q}_i - \tilde{q}_{i+1}|} \frac{2}{\sqrt{\pi}} \int_0^{\frac{|\tilde{q}_i - \tilde{q}_{i+1}|}{\sqrt{2}\sigma}} e^{-s^2} ds$$

also satisfies the hypotheses of our previous proposition. However, note that

$$\partial_{q_2} \partial_{q_3} U^{\text{n.n.}}(q) = \frac{Q^2}{4\pi^{\frac{3}{2}} \epsilon_0 \sigma^3} \left(-\frac{4 \int_0^{\frac{|\tilde{q}_2 - \tilde{q}_3|}{\sqrt{2}\sigma}} e^{-s^2} ds}{|\tilde{q}_2 - \tilde{q}_3|^3 / \sigma^3} + \frac{2\sqrt{2} e^{-\frac{|\tilde{q}_2 - \tilde{q}_3|^2}{2\sigma^2}}}{|\tilde{q}_2 - \tilde{q}_3|^2 / \sigma^2} + \sqrt{2} e^{-\frac{|\tilde{q}_2 - \tilde{q}_3|^2}{2\sigma^2}} \right)$$

does not have a definite sign. Hence, for large values of $Q^2 \sigma^{-3}$ (very concentrated charge distribution), the uniform condition H2) in [EPRB99b, EPRB99a, RBT02, Car07] is not satisfied.

3.A Decomposability properties

We devote this appendix to the decomposability properties of ℓ in Remark 3.2.2. We consider the case $T = 1$ and $n = 1$ but the argument can be easily adapted to the general case. Although we use results from the theory of Gaussian measures to show the decomposability properties, these properties are not specific to Gaussian processes and can be proved for other types of noises.

The Wiener process restricted to the interval $[0, 1]$ is a nondegenerate Gaussian measure on the Banach space $C_0([0, 1]; \mathbf{R})$. It has as its Cameron–Martin space the space $W_0^{1,2}([0, 1]; \mathbf{R})$ equipped with the inner product

$$\langle \eta, \zeta \rangle_{W_0^{1,2}} = \int_0^1 \dot{\eta}(s) \dot{\zeta}(s) \, ds.$$

This Hilbert space has orthonormal basis $\{\psi_m\}_{m \in \mathbf{N}}$ where

$$\psi_m(t) = \int_0^t \phi_m(s) \, ds$$

and where $\{\phi_m\}_{m \in \mathbf{N}}$ is a Fourier basis for $L^2([0, 1]; \mathbf{R})$. It is dense as a subspace of $C_0([0, 1]; \mathbf{R})$ equipped with the supremum norm.

Let $F_N := \text{span}\{\psi_m : m \leq N\}$ and let F'_N be the closure in $C_0([0, 1]; \mathbf{R})$ of the linear span of $\{\psi_m : m > N\}$. These sequences of subspaces satisfy (i) and provide a decomposition $F_N \oplus F'_N$: any $\eta \in C_0([0, 1]; \mathbf{R})$ can be written in a unique way as $\eta_N + \eta'_N$ with $\eta_N \in F_N$ and $\eta'_N \in F'_N$. To this decomposition are associated the projectors Π_N and Π'_N .

By the general theory of Gaussian measures (see e.g. [Bog98, §3.5]), Brownian motion can be represented as the almost surely convergent sum

$$W_t(\omega) = \sum_{m \leq N} \Xi_m(\omega) \psi_m(t) + \sum_{m > N} \Xi_m(\omega) \psi_m(t),$$

where $(\Xi_m)_{m \in \mathbf{N}}$ is a sequence of independent scalar standard normal random variables. The two sums are independent and provide the decomposition (ii) of ℓ as the product of the projected laws. Property (iii) clearly holds.

These abstract results from the theory of Gaussian measures do not provide strong convergence of Π_N to the identity operator on the Banach space $C_0([0, 1]; \mathbf{R})$ as $N \rightarrow \infty$ (or boundedness of the set of norms $\{\|\Pi_N\| : N \in \mathbf{N}\}$, which is used in [Shi17]). However, we have the following weaker convergence result for regular enough sets of functions.

Lemma 3.A.1. *If Q is a subset of $C_0([0, 1]; \mathbf{R})$ that is bounded in the norm induced by the inner product $\langle \cdot, \cdot \rangle_{W_0^{1,2}}$, then*

$$\lim_{N \rightarrow \infty} \sup_{\eta \in Q} \|\eta - \Pi_N \eta\|_{C_0} = 0.$$

Proof. First note that by construction of the basis,

$$\sum_{m \in \mathbf{N}} \|\psi_m\|_{C_0}^2 < \infty.$$

For $\eta \in W_0^{1,2}([0, 1]; \mathbf{R})$, the decomposition into the two subspaces can be made explicit:

$$\eta(t) = \sum_{m \leq N} \psi_m(t) \int_0^1 \phi_m(s) \dot{\eta}(s) \, ds + \sum_{m > N} \psi_m(t) \int_0^1 \phi_m(s) \dot{\eta}(s) \, ds$$

and by the Cauchy–Schwarz inequality

$$\begin{aligned} \|\eta - \Pi_N \eta\|_{C_0} &\leq \left(\sum_{m > N} \|\psi_m\|_{C_0}^2 \right)^{\frac{1}{2}} \left(\sum_{m > N} \left| \int_0^1 \phi_m(s) \dot{\eta}(s) \, ds \right|^2 \right)^{\frac{1}{2}} \\ &\leq \left(\sum_{m > N} \|\psi_m\|_{C_0}^2 \right)^{\frac{1}{2}} \|\eta\|_{W_0^{1,2}}. \end{aligned}$$

The convergence thus follows from the hypothesis $\sup_{\eta \in Q} \|\eta\|_{W_0^{1,2}} < \infty$. □

Bibliography

- [AKSS07] A. A. Agrachev, S. Kuksin, A. V. Sarychev, and A. Shirikyan. On finite-dimensional projections of distributions for solutions of randomly forced 2D Navier–Stokes equations. *Ann. Inst. Henri Poincaré (B) Probab. Statist.*, 43(4):399–415, 2007.
- [AS05] A. A. Agrachev and A. V. Sarychev. Navier–Stokes equations: controllability by means of low modes forcing. *J. Math. Fluid Mech.*, 7(1):108–152, 2005.

- [Bog98] V. I. Bogachev. *Gaussian measures*, volume 62 of *Mathematical Surveys and Monographs*. Amer. Math. Soc., 1998.
- [Car07] P. Carmona. Existence and uniqueness of an invariant measure for a chain of oscillators in contact with two heat baths. *Stochastic Processes and their Applications*, 117(8):1076–1092, 2007.
- [CEHRB18] N. Cuneo, J.-P. Eckmann, M. Hairer, and L. Rey-Bellet. Non-equilibrium steady states for networks of oscillators. *Electron. J. Probab.*, 23(Paper No. 55):1–28, 2018.
- [Cor07] J.-M. Coron. *Control and nonlinearity*, volume 136 of *Mathematical Surveys and Monographs*. Amer. Math. Soc., 2007.
- [EH00] J.-P. Eckmann and M. Hairer. Non-equilibrium statistical mechanics of strongly anharmonic chains of oscillators. *Commun. Math. Phys.*, 212(1):105–164, 2000.
- [EPRB99a] J.-P. Eckmann, C.-A. Pillet, and L. Rey-Bellet. Entropy production in nonlinear, thermally driven Hamiltonian systems. *J. Stat. Phys.*, 95(1-2):305–331, 1999.
- [EPRB99b] J.-P. Eckmann, C.-A. Pillet, and L. Rey-Bellet. Non-equilibrium statistical mechanics of anharmonic chains coupled to two heat baths at different temperatures. *Commun. Math. Phys.*, 201(3):657–697, 1999.
- [FKM65] G. W. Ford, M. Kac, and P. Mazur. Statistical mechanics of assemblies of coupled oscillators. *J. Math. Phys.*, 6:504–515, 1965.
- [Har56] T. E. Harris. The existence of stationary measures for certain Markov processes. In *Proceedings of the Third Berkeley Symposium on Mathematical Statistics and Probability*, volume 2, pages 113–124, 1956.
- [HM11] M. Hairer and J. C. Mattingly. Yet another look at Harris’ ergodic theorem for Markov chains. In *Seminar on Stochastic Analysis, Random Fields and Applications VI*, volume 63, pages 109–117. Springer, 2011.

- [JPS17] V. Jakšić, C.-A. Pillet, and A. Shirikyan. Entropic fluctuations in thermally driven harmonic networks. *J. Stat. Phys.*, 166(3):926–1015, Feb 2017.
- [MT12] S. P. Meyn and R. L. Tweedie. *Markov chains and stochastic stability*. Communications and Control Engineering Series. Springer Science & Business Media, 2012.
- [RBT02] L. Rey-Bellet and L. E. Thomas. Exponential convergence to non-equilibrium stationary states in classical statistical mechanics. *Commun. Math. Phys.*, 225(2):305–329, 2002.
- [Shi07] A. Shirikyan. Qualitative properties of stationary measures for three-dimensional Navier-Stokes equations. *J. Funct. Anal.*, 249(2):284–306, 2007.
- [Shi17] A. Shirikyan. Controllability implies mixing. I. Convergence in the total variation metric. *Uspekhi Mat. Nauk*, 72(5(437)):165–180, 2017.
- [Tro77] M. M. Tropper. Ergodic and quasideterministic properties of finite-dimensional stochastic systems. *J. Stat. Phys.*, 17(6):491–509, 1977.

Chapter 4

Exponential mixing under controllability conditions for SDEs driven by a degenerate Poisson noise

Authors Vahagn Nersesyan and Renaud Raquépas

arXiv ID 1903.08089

Abstract We prove existence and uniqueness of the invariant measure and exponential mixing in the total-variation norm for a class of stochastic differential equations driven by degenerate compound Poisson processes. In addition to mild assumptions on the distribution of the jumps for the driving process, the hypotheses for our main result are that the corresponding control system is dissipative, approximately controllable and solidly controllable. The solid controllability assumption is weaker than the well-known parabolic Hörmander condition and is only required from a single point to which the system is approximately controllable. Our analysis applies to Galerkin projections of stochastically forced parabolic partial differential equations with asymptotically polynomial nonlinearities and to networks of quasi-harmonic oscillators connected to different Poissonian baths.

4.1 Introduction

Motivated by applications to thermally driven harmonic networks and to Galerkin approximations of partial differential equations (PDEs) randomly forced by degenerate noise, we consider a stochastic differential equation (SDE) of the form

$$dX_t = f(X_t) dt + B dY_t, \quad (4.1)$$

where $f : \mathbf{R}^d \rightarrow \mathbf{R}^d$ is a smooth vector field, $B : \mathbf{R}^n \rightarrow \mathbf{R}^d$ is a linear map, and $(Y_t)_{t \geq 0}$ is an n -dimensional *compound Poisson process* of the form

$$Y_t = \sum_{k=1}^{\infty} \eta_k \mathbf{1}_{[\tau_k, \infty)}(t). \quad (4.2)$$

Throughout the paper, the jump displacements $\{\eta_k\}_{k \in \mathbf{N}}$ are independent and identically distributed random variables with law ℓ and the waiting times separating the jumps, defined as $t_1 = \tau_1$ and $t_k = \tau_k - \tau_{k-1}$ for $k \geq 2$, form a sequence $\{t_k\}_{k \in \mathbf{N}}$ of independent exponentially distributed random variables with common rate parameter $\lambda > 0$. Moreover, the sequences $\{\eta_k\}_{k \in \mathbf{N}}$ and $\{t_k\}_{k \in \mathbf{N}}$ are independent from one another. We are interested in the *noise-degenerate* case, that is when $\text{rank}(B) < d$.

The aim of this paper is to establish exponential mixing for the SDE (4.1) under some mild dissipativity and controllability conditions. The precise hypotheses are the following.

(C1) There are numbers $\alpha > 0$ and $\beta > 0$ such that

$$\langle f(y), y \rangle \leq -\alpha \|y\|^2 + \beta \quad (4.3)$$

for all $y \in \mathbf{R}^d$, where $\langle \cdot, \cdot \rangle$ and $\|\cdot\|$ are a scalar product and the associated norm in \mathbf{R}^d .

Combined with the regularity of f and the fact that $\sum_{k=1}^{\infty} t_k = +\infty$ with probability 1, it ensures the global well-posedness of the SDE (4.1). It also strongly suggests the norm squared as a candidate Lyapunov function. The other two conditions are related to the controllability of the system: we ask that there exists a point $\hat{x} \in \mathbf{R}^d$ such that the system is *both* approximately controllable to \hat{x} and solidly controllable from \hat{x} . To formulate these conditions more precisely, we introduce the

following (deterministic) mapping. For $T > 0$ a given time,

$$\begin{aligned} S_T : \mathbf{R}^d \times C([0, T]; \mathbf{R}^n) &\rightarrow \mathbf{R}^d, \\ (x, \zeta) &\mapsto y_T, \end{aligned} \tag{4.4}$$

where $(y_t)_{t \in [0, T]}$ is the solution of the controlled problem

$$\begin{cases} \dot{y}_t = f(y_t) + B\zeta_t, \\ y_0 = x. \end{cases} \tag{4.5}$$

Accordingly, we will refer to the first argument of $S_T(\cdot, \cdot)$ as an initial condition and to the second one as a control.

(C2) The system is *approximately controllable to* $\hat{x} \in \mathbf{R}^d$: for any number $\varepsilon > 0$ and any radius $R > 0$, we can find a time $T > 0$ such that for any initial point $x \in \mathbf{R}^d$ with $\|x\| \leq R$, there exists a control $\zeta \in C([0, T]; \mathbf{R}^n)$ verifying

$$\|S_T(x, \zeta) - \hat{x}\| < \varepsilon. \tag{4.6}$$

(C3) The system is *solidly controllable from* \hat{x} : there is a number $\varepsilon_0 > 0$, a time $T_0 > 0$, a compact set \mathcal{H} in $C([0, T_0]; \mathbf{R}^n)$ and a non-degenerate ball G in \mathbf{R}^d such that, for any continuous function $\Phi : \mathcal{H} \rightarrow \mathbf{R}^d$ satisfying the relation

$$\sup_{\zeta \in \mathcal{H}} \|\Phi(\zeta) - S_{T_0}(\hat{x}, \zeta)\| \leq \varepsilon_0,$$

we have $G \subset \Phi(\mathcal{H})$.

Condition (C2) is a well-known controllability property, and (C3) is an accessibility property that is weaker than the weak Hörmander condition at the point \hat{x} (see Section 4.4.1 for a discussion).

We denote by (X_t, \mathbf{P}_x) the Markov family associated with the SDE (4.1) parametrised by the time $t \geq 0$ and the initial condition $x \in \mathbf{R}^d$, by $P_t(x, \cdot)$ the corresponding transition function, and by \mathfrak{P}_t and \mathfrak{P}_t^* the Markov semigroups

$$\mathfrak{P}_t g(x) = \int_{\mathbf{R}^d} g(y) P_t(x, dy) \quad \text{and} \quad \mathfrak{P}_t^* \mu(\Gamma) = \int_{\mathbf{R}^d} P_t(y, \Gamma) \mu(dy),$$

where $g \in L^\infty(\mathbf{R}^d)$ and $\mu \in \mathcal{P}(\mathbf{R}^d)$. Recall that a measure $\mu^{\text{inv}} \in \mathcal{P}(\mathbf{R}^d)$ is said to be *invariant* if $\mathfrak{P}_t^* \mu^{\text{inv}} = \mu^{\text{inv}}$ for all $t \geq 0$.

Main Theorem. *Assume that Conditions (C1)–(C3) are satisfied and that the law of η_k has finite variance and possesses a continuous positive density with respect to the Lebesgue measure on \mathbf{R}^n . Then, the semigroup $(\mathfrak{P}_t^*)_{t \geq 0}$ admits a unique invariant measure $\mu^{\text{inv}} \in \mathcal{P}(\mathbf{R}^d)$. Moreover, there exist constants $C > 0$ and $c > 0$ such that*

$$\|\mathfrak{P}_t^* \mu - \mu^{\text{inv}}\|_{\text{var}} \leq C e^{-ct} \left(1 + \int_{\mathbf{R}^d} \|x\| \mu(dx) \right) \quad (4.7)$$

for any $\mu \in \mathcal{P}(\mathbf{R}^d)$ and $t \geq 0$.

In the literature, the problem of ergodicity for SDEs driven by a degenerate noise is mostly considered when the perturbation is a Brownian motion, the system admits a Lyapunov function, and the Hörmander condition is satisfied at all the points of the state space. Under these assumptions, the transition function of the underlying Markov process has a smooth density with respect to Lebesgue measure which is almost surely positive. This implies that the process is *strong Feller* and *irreducible*, so it has a unique invariant measure by Doob's theorem (see Theorem 4.2.1 in [DPZ96] and [MT93, Kha12] for related results).

Even with the assumption that the noise is Gaussian, there are only few papers that consider the problem of ergodicity for an SDE without the Hörmander condition being satisfied everywhere. In [AK87], the uniqueness property for invariant measures is proved for degenerate diffusions, under the assumption that the Hörmander condition holds at one point and that the process is irreducible. The proof relies heavily on the Gaussian nature of the noise. In the paper [Shi17], an approach based on controllability and a coupling argument is given for a study of dynamical systems on compact metric spaces subject to a more general degenerate noise: under the controllability assumptions (C2) and (C3) and a *decomposability* assumption on the noise, exponential mixing in the total-variation metric is established. This approach can be carried to problems on a non-compact space, provided a dissipativity of the type of (C1) holds; see [Raq19] for a study of networks of quasi-harmonic oscillators. The class of decomposable noises includes — but is not limited to — Gaussian measures.

The present paper falls under the continuity of the study carried out in these references. The main difficulty in our case comes from the fact that the Poisson noise we consider, in addition to being degenerate, does not have a decomposability structure; also see [Ner08], where polynomial mixing is proved for the complex Ginzburg–Landau equation driven by a non-degenerate compound Poisson process. Yet, the methods we use still stem from a control and coupling approach, which we outline in the following paragraphs; also see the beginning of Section 4.3. Indeed, the combination of coupling and controllability arguments has the advantage of yielding rather simple proofs of otherwise very technical results and also accommodates a wide variety of (non-Gaussian) noises for which other methods fail.

We hope that treating a relatively tractable problem in an essentially self-contained way will help interested readers in making their way to understanding technically more difficult problems for which methods of the same flavour are used.

For a discrete-time Markov family on a compact state space \mathcal{X} , existence of an invariant measure can be obtained from a Bogolyubov–Krylov argument and it is typical to derive uniqueness and mixing from a uniform upper bound on the total-variation distance between the transition functions from different points. One way to prove uniqueness using such a uniform *squeezing* estimate is through a so-called Doeblin coupling argument, where one constructs a Markov family on $\mathcal{X} \times \mathcal{X}$ whose projections to each copy of \mathcal{X} have the same distribution as the original Markov family, and with the property that it hits the diagonal $\{(x, x) : x \in \mathcal{X}\}$ soon enough, often enough. We refer the interested reader to the paper [Gri75] and to Chapter 3 of the monograph [KS12] for an introduction to these ideas, which go back to Doeblin, Harris, and Vaserstein.

When the state space \mathcal{X} is not compact, existence of an invariant measure requires additional arguments and one can rarely hope to prove squeezing estimates which hold uniformly on the whole state space. The Bogolyubov–Krylov argument for existence can be adapted provided that one has a suitable Lyapunov structure. As for uniqueness and mixing, the coupling argument will go through with a squeezing estimate which only holds for points in a small ball, provided that one can obtain good enough estimates on the hitting time of that ball. Over the past years, it has become evident that control theory provides a good framework for formulating conditions that are sufficient for this

endeavor when the noise is degenerate.

Acknowledgements This research was supported by the Agence Nationale de la Recherche through the grant NONSTOPS (ANR-17-CE40-0006-01, ANR-17-CE40-0006-02, ANR-17-CE40-0006-03). VN was supported by the CNRS PICS *Fluctuation theorems in stochastic systems*. The research of RR was supported by the National Science and Engineering Research Council (NSERC) of Canada. Both authors would like to thank Noé Cuneo, Vojkan Jakšić, Claude-Alain Pillet and Armen Shirikyan for discussions and comments on this manuscript.

Notation

For (\mathcal{X}, d) a Polish space, we shall use the following notation throughout the paper:

- $B_{\mathcal{X}}(x, \varepsilon)$ for the closed ball in \mathcal{X} of radius ε centered at x (we shall simply write $B(x, \varepsilon)$ in the special case $\mathcal{X} = \mathbf{R}^d$);
- $\mathcal{B}(\mathcal{X})$ for its Borel σ -algebra;
- $L^\infty(\mathcal{X})$ for the space of all bounded Borel-measurable functions $g : \mathcal{X} \rightarrow \mathbf{R}$, endowed with the norm $\|g\|_\infty = \sup_{y \in \mathcal{X}} |g(y)|$;
- $\mathcal{P}(\mathcal{X})$ for the set of Borel probability measures on \mathcal{X} , endowed with the total variation norm: for $\mu_1, \mu_2 \in \mathcal{P}(\mathcal{X})$,

$$\begin{aligned} \|\mu_1 - \mu_2\|_{\text{var}} &:= \frac{1}{2} \sup_{\|g\|_\infty \leq 1} |\langle g, \mu_1 \rangle - \langle g, \mu_2 \rangle| \\ &= \sup_{\Gamma \in \mathcal{B}(\mathcal{X})} |\mu_1(\Gamma) - \mu_2(\Gamma)|, \end{aligned}$$

where $\langle g, \mu \rangle = \int_{\mathcal{X}} g(y) \mu(dy)$ for $g \in L^\infty(\mathcal{X})$ and $\mu \in \mathcal{P}(\mathcal{X})$.

Let (\mathcal{Y}, d') be another Polish space. The image of a measure $\mu \in \mathcal{P}(\mathcal{X})$ under a Borel-measurable mapping $F : \mathcal{X} \rightarrow \mathcal{Y}$ is denoted by $F_*\mu \in \mathcal{P}(\mathcal{Y})$.

On any space, $\mathbf{1}_\Gamma$ stands for the indicator function of the set Γ .

We use \mathbf{Z} for the set of integers and \mathbf{N} for the set of natural numbers (without 0). For any $m \in \mathbf{N}$, we set

$$\mathbf{N}_m := \{n \cdot m : n \in \mathbf{N}\} \quad \text{and} \quad \mathbf{N}_m^0 := \mathbf{N}_m \cup \{0\}. \quad (4.8)$$

We use $a \vee b$ [resp. $a \wedge b$] for the maximum [resp. minimum] of the numbers $a, b \in \mathbf{R}$.

4.2 Preliminaries and existence of an invariant measure

The SDE (4.1) has a unique càdlàg solution satisfying the initial condition $X_0 = x$. It is given by

$$X_t = \begin{cases} S_{t-\tau_k}(X_{\tau_k}) & \text{if } t \in [\tau_k, \tau_{k+1}), \\ S_{t_{k+1}}(X_{\tau_k}) + B\eta_{k+1} & \text{if } t = \tau_{k+1}, \end{cases} \quad (4.9)$$

where $\tau_0 = 0$ and $S_t(x) = S_t(x, 0)$ is the solution of the undriven equation. Relation (4.9) will allow us to reduce the study of the ergodicity of the full process $(X_t)_{t \geq 0}$ to that of the embedded process $(X_{\tau_k})_{k \in \mathbf{N}}$ obtained by considering its values at jump times τ_k . The strong Markov property implies that the latter is a Markov process with respect to the filtration generated by the random variables $\{t_j, \eta_j\}_{j=1}^k$. We denote by \hat{P}_k the corresponding transition function: for $x \in \mathbf{R}^d$ and $\Gamma \in \mathcal{B}(\mathbf{R}^d)$,

$$\hat{P}_k(x, \Gamma) := \mathbf{P}_x \{X_{\tau_k} \in \Gamma\}. \quad (4.10)$$

The key consequences of the dissipativity Condition (C1) are the moment estimates of the following lemma. They imply, in particular, existence of a suitable Lyapunov structure given by the norm squared.

Lemma 4.2.1. *Under Condition (C1), we have the following bounds:*

(i) *for any $\varepsilon > 0$, there exists a constant $C_\varepsilon > 0$ such that*

$$\|X_{\tau_k}\|^2 \leq (1 + \varepsilon)^k e^{-2\alpha\tau_k} \|X_0\|^2 + C_\varepsilon \sum_{j=1}^k e^{-2\alpha(\tau_k - \tau_j)} (1 + \varepsilon)^{k-j} (1 + \|\eta_j\|^2) \quad (4.11)$$

for all $x \in \mathbf{R}^d$ and $k \in \mathbf{N}$;

(ii) there are numbers $\gamma \in (0, 1)$ and $C > 0$ such that

$$\mathbf{E}_x \|X_{\tau_k}\|^2 \leq \gamma^k \|x\|^2 + C(1 + \mathcal{A}), \quad (4.12)$$

$$\mathbf{E}_x \|X_t\|^2 \leq (1 - \gamma)^{-1} \|x\|^2 + C(1 + \mathcal{A}) \quad (4.13)$$

for all $x \in \mathbf{R}^d$, $k \in \mathbf{N}$, and $t \geq 0$, where $\mathcal{A} := \mathbf{E} \|\eta_1\|^2$ and \mathbf{E}_x is the expectation with respect to \mathbf{P}_x .

Proof. First note that Condition (C1) implies the following estimate for the solution to the undriven equation:

$$\|S_t(x)\|^2 \leq e^{-2\alpha t} \|x\|^2 + \beta \alpha^{-1} \quad (4.14)$$

for all $x \in \mathbf{R}^d$ and $t \geq 0$. Let $\varepsilon > 0$ be arbitrary. Combining (4.9) and (4.14), we find a positive constant C_ε such that

$$\|X_{\tau_k}\|^2 \leq (1 + \varepsilon) e^{-2\alpha t_k} \|X_{\tau_{k-1}}\|^2 + C_\varepsilon (1 + \|\eta_k\|^2).$$

Iterating this inequality, we get (4.11). Taking expectation in (4.11) and using the independence of the sequences $\{\eta_k\}$ and $\{\tau_k\}$, we obtain

$$\mathbf{E}_x \|X_{\tau_k}\|^2 \leq (1 + \varepsilon)^k \left(\frac{\lambda}{\lambda + 2\alpha} \right)^k \|x\|^2 + C_\varepsilon \sum_{j=1}^k \left(\frac{\lambda}{\lambda + 2\alpha} \right)^{k-j} (1 + \varepsilon)^{k-j} (1 + \mathcal{A}).$$

Choosing $\varepsilon > 0$ so small that $\gamma := (1 + \varepsilon) \frac{\lambda}{\lambda + 2\alpha} \in (0, 1)$ yields (4.12). To prove (4.13), we introduce the random variable

$$\mathcal{N}_t := \max\{k \geq 0 : \tau_k \leq t\}$$

and use (4.14):

$$\mathbf{E}_x \|X_t\|^2 \leq \mathbf{E}_x \|X_{\tau_{\mathcal{N}_t}}\|^2 + \beta \alpha^{-1} = \sum_{k=0}^{\infty} \mathbf{E}_x \left(\mathbf{1}_{\{\mathcal{N}_t = k\}} \|X_{\tau_k}\|^2 \right) + \beta \alpha^{-1}. \quad (4.15)$$

Inequality (4.11) and the independence of $\{\eta_k\}$ and $\{\tau_k\}$ imply

$$\mathbf{E}_x \left(\mathbf{1}_{\{\mathcal{N}_t = k\}} \|X_{\tau_k}\|^2 \right) \leq \gamma^k \|x\|^2 + C_\varepsilon (1 + \mathcal{A}) \sum_{j=1}^k (1 + \varepsilon)^{k-j} \mathbf{E} \left(\mathbf{1}_{\{\mathcal{N}_t = k\}} e^{-2\alpha(\tau_k - \tau_j)} \right) \quad (4.16)$$

and

$$\sum_{k=1}^{\infty} \sum_{j=1}^k (1 + \varepsilon)^{k-j} \mathbf{E} \left(\mathbf{1}_{\{\mathcal{N}_t = k\}} e^{-2\alpha(\tau_k - \tau_j)} \right) = \sum_{k=0}^{\infty} (1 + \varepsilon)^k \mathbf{E} \left(e^{-2\alpha\tau_k} \right) = \sum_{k=0}^{\infty} (1 + \varepsilon)^k \left(\frac{\lambda}{\lambda + 2\alpha} \right)^k,$$

which is finite by our choice of ε . Combining this with (4.15) and (4.16), we get (4.13) and complete the proof of the lemma. \square

As mentioned in the introduction, the dissipativity Condition (C1) guarantees the existence of an invariant measure. Indeed, the last lemma, combined with a Bogolyubov–Krylov argument and Fatou’s lemma yields the following result. We refer the reader to [KS12, §2.5.2] for more details.

Lemma 4.2.2. *Under Condition (C1), the semigroup $(\mathfrak{P}_t^*)_{t \geq 0}$ admits at least one invariant measure $\mu^{\text{inv}} \in \mathcal{P}(\mathbf{R}^d)$. Moreover, any invariant measure $\mu \in \mathcal{P}(\mathbf{R}^d)$ has a finite second moment, that is*

$$\int_{\mathbf{R}^d} \|y\|^2 \mu(dy) < \infty. \quad (4.17)$$

We now turn to an important consequence of the solid controllability Condition (C3). The main ideas in its proof are borrowed from [Shi17, §1] (also see the earlier works [AKSS07, §2] and [KS12, Ch. 3]). Such results are sometimes referred to as squeezing estimates, a concept to which we have referred in the introduction. This lemma is used to prove a key property of the coupling constructed in the next section.

We consider the family of maps $F_k : \mathbf{R}^d \times (\mathbf{R}_+)^{\mathbf{N}} \times (\mathbf{R}^n)^{\mathbf{N}} \rightarrow \mathbf{R}^d$ defined by

$$\begin{cases} F_0(x, \mathbf{s}, \boldsymbol{\xi}) = x, \\ F_k(x, \mathbf{s}, \boldsymbol{\xi}) = S_{s_k}(F_{k-1}(x, \mathbf{s}, \boldsymbol{\xi})) + B \xi_k \end{cases} \quad (4.18)$$

for $k \in \mathbf{N}$, $x \in \mathbf{R}^d$, $\mathbf{s} = (s_j)_{j \in \mathbf{N}} \in (\mathbf{R}_+)^{\mathbf{N}}$, and $\boldsymbol{\xi} = (\xi_j)_{j \in \mathbf{N}} \in (\mathbf{R}^n)^{\mathbf{N}}$; see Figure 4.1. Because F_k does not depend on $\{s_j, \xi_j\}_{j \geq k+1}$, i.e. the times and displacements for kicks that happen later than the k -th kick, we will often consider the domain of F_k to be $\mathbf{R}^d \times (\mathbf{R}_+)^m \times (\mathbf{R}^n)^m$ for some natural number $m \geq k$.

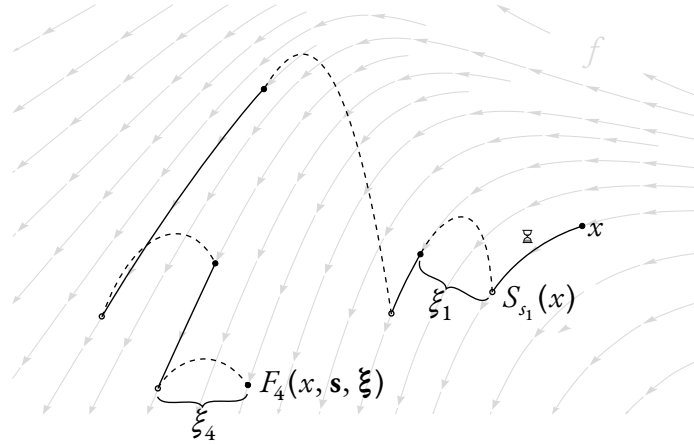

Figure 4.1: The map F_k takes as an input a point x , a sequence \mathbf{s} of times and a sequence ξ of displacement vectors and outputs the final position of a test particle which starts at x , follows the integral curves of f for a time s_1 , is immediately displaced by ξ_1 , follows the integral curves of f for a time s_2 , is immediately displaced by ξ_2 , and so on until it is finally displaced by ξ_k . We have sketched this for $k = 4$.

Lemma 4.2.3. *Suppose that \hat{x} is as in Condition (C3). Then, there exist numbers $m \in \mathbf{N}$, $r > 0$, and $p \in (0, 1)$ and a non-degenerate ball¹ Σ in $[0, T_0]^m$ such that*

$$\|F_m(x, \mathbf{s}, \cdot)_*(\ell^m) - F_m(x', \mathbf{s}, \cdot)_*(\ell^m)\|_{\text{var}} \leq p \quad (4.19)$$

for all $\mathbf{s} \in \Sigma$ and $x, x' \in B(\hat{x}, r)$, where $F_m(x, \mathbf{s}, \cdot)_*(\ell^m)$ is the image of ℓ^m (the m -fold product of the law ℓ with itself) under the mapping $F_m(x, \mathbf{s}, \cdot) : (\mathbf{R}^n)^m \rightarrow \mathbf{R}^d$.

Proof. Let us fix ε_0 , \mathcal{H} , and G as in Condition (C3). To simplify the presentation, we assume that $T_0 = 1$. For any $m \in \mathbf{N}$ and $\zeta \in C([0, 1]; \mathbf{R}^n)$, let $\iota_m(\zeta) : [0, 1] \rightarrow \mathbf{R}^n$ be the step function

$$\iota_m(\zeta) = \sum_{j=0}^{m-1} \mathbf{1}_{[\frac{j}{m}, \frac{j+1}{m})} \int_0^{\frac{j}{m}} \zeta(s) \, ds,$$

and let \mathcal{H}_m be the set $\iota_m(\mathcal{H})$. If ζ is a continuous function which allows the system to be controlled from \hat{x} to some target in time 1, then $\iota_m(\zeta)$ is a discretization in time of the antiderivative of ζ and we expect that feeding its jump discontinuities to F_m would result in a final position which is close

¹Here $[0, T_0]^m$ is endowed with the metric inherited from \mathbf{R}^m .

to the target if m is large enough. With this in mind, we often identify the function $\iota_m(\zeta)$ with the m -tuple of vectors in \mathbf{R}^n consisting of its jumps at the times $\frac{1}{m}, \frac{2}{m}, \dots, \frac{m}{m}$.

We proceed in three steps. First, we show that Condition (C3) implies that the set $F_m(\hat{x}, \hat{\mathbf{s}}, \mathcal{H}_m)$ contains a ball in \mathbf{R}^d . Then, combining this with Sard's theorem and some properties of images of measures under regular mappings, we show a uniform lower bound on $F_m(x, \mathbf{s}, \cdot)_*(\ell^m)$ for (x, \mathbf{s}) close enough to $(\hat{x}, \hat{\mathbf{s}})$ where $\hat{\mathbf{s}} := (\frac{1}{m}, \dots, \frac{1}{m}) \in [0, 1]^m$. Finally, from this uniform lower bound we derive the desired estimate in total variation.

Step 1: Solid controllability. Let S_T be the mapping defined by (4.4). By the compactness of \mathcal{H} , for any $\varepsilon > 0$, there exists $m_0(\varepsilon) \in \mathbf{N}$ such that

$$\sup_{\zeta \in \mathcal{H}} \left\| \iota_m \zeta - \int_0^\cdot \zeta(s) \, ds \right\|_{L^\infty([0,1], \mathbf{R}^n)} \leq \varepsilon$$

whenever $m \geq m_0(\varepsilon)$. Hence, taking $m \geq m_0(\varepsilon)$ for sufficiently small ε , we have

$$\sup_{\zeta \in \mathcal{H}} \|F_m(\hat{x}, \hat{\mathbf{s}}, \iota_m \zeta) - S_1(\hat{x}, \zeta)\| \leq \varepsilon_0,$$

where we use the aforementioned identification of functions in \mathcal{H}_m with m -tuples of displacement vectors in \mathbf{R}^n . Using the continuity of $F_m(\hat{x}, \hat{\mathbf{s}}, \iota_m \cdot) : \mathcal{H} \rightarrow \mathbf{R}^d$ and Condition (C3), we conclude that $F_m(\hat{x}, \hat{\mathbf{s}}, \mathcal{H}_m)$ contains a ball in \mathbf{R}^d . Until the end of the proof, we fix $m \geq m_0(\varepsilon)$ for such a small ε .

Step 2: Uniform lower bound. We want to apply Lemma 4.C.2 with $\mathcal{X} = B(\hat{x}, 1) \times [0, 1]^m$, $\mathcal{Y} = \mathbf{R}^d$, and $\mathcal{U} = (\mathbf{R}^n)^m$ and the map $F_m : \mathcal{X} \times \mathcal{U} \rightarrow \mathcal{Y}$ as before. As $F_m(\hat{x}, \hat{\mathbf{s}}, \mathcal{H}_m)$ contains a ball in \mathbf{R}^d , Sard's theorem yields the existence of a point $\hat{u} \in \mathcal{H}_m \subset \mathcal{U}$ in which the derivative $D_{\xi} F_m(\hat{x}, \hat{\mathbf{s}}, \cdot)$ has full rank. Hence, by Lemma 4.C.2, there exists a continuous function $\psi : \mathcal{X} \times \mathcal{Y} \rightarrow \mathbf{R}_+$ and a radius $r_m > 0$ such that

$$\psi((\hat{x}, \hat{\mathbf{s}}), F_m(\hat{x}, \hat{\mathbf{s}}, \hat{u})) > 0$$

and

$$(F_m(x, \mathbf{s}, \cdot)_*(\ell^m))(dy) \geq \psi((x, \mathbf{s}), y) \, dy$$

(as measures, with y ranging over \mathbf{R}^d) whenever $x \in B(\hat{x}, r_m)$ and $\mathbf{s} \in B_{\mathbf{R}^m}(\hat{\mathbf{s}}, r_m)$.

Step 3: Estimate in total variation. Shrinking r_m if necessary, Step 2 yields positive numbers $\varepsilon_{m,1}$ and $\varepsilon_{m,2}$ and a non-degenerate ball $\Sigma \subset [0, 1]^m$ such that

$$F_m(x, \mathbf{s}, \cdot)_*(\ell^m) \wedge F_m(x', \mathbf{s}, \cdot)_*(\ell^m) \geq \varepsilon_{m,1} \text{Vol}_{\mathbf{R}^d}(\cdot \cap B(F_m(\hat{x}, \hat{\mathbf{s}}, \hat{u}), \varepsilon_{m,2}))$$

whenever $x, x' \in B(\hat{x}, r_m)$ and $\mathbf{s} \in \Sigma$. Therefore,

$$\|F_m(x, \mathbf{s}, \cdot)_*(\ell^m) - F_m(x', \mathbf{s}, \cdot)_*(\ell^m)\|_{\text{var}} \leq 1 - \varepsilon_{m,1} \varepsilon_{m,2}^d \frac{\pi^{\frac{d}{2}}}{\Gamma(\frac{d}{2} + 1)} =: p_m$$

whenever $x, x' \in B(\hat{x}, r_m)$ and $\mathbf{s} \in \Sigma$. This proves (4.19) with $r = r_m$ and $p = p_m$. \square

4.3 Coupling argument and exponential mixing

In this section, we shall always assume that Conditions (C1)–(C3) are satisfied. The Main Theorem is established by using the *coupling method*, which consists in proving uniqueness and convergence to an invariant measure for a Markov family by using the inequality

$$\|P_t(x, \cdot) - P_t(x', \cdot)\|_{\text{var}} \leq \mathbf{P}\{\mathcal{T} > t\},$$

where \mathcal{T} is a random time given by

$$\mathcal{T} := \inf \{s \geq 0 : Z_u = Z'_u \text{ for all } u \geq s\} \quad (4.20)$$

and $(Z_t, Z'_t)_{t \geq 0}$ is any $(\mathbf{R}^d \times \mathbf{R}^d)$ -valued random process defined on a space $(\Omega, \mathcal{F}, \mathbf{P}_{(x,x')})$ with $\mathbf{P}_{(x,x')}(Z_t \in \Gamma) = P_t(x, \Gamma)$ and $\mathbf{P}_{(x,x')}(Z'_t \in \Gamma) = P_t(x', \Gamma)$ for all $t \geq 0$ and all measurable $\Gamma \subseteq \mathbf{R}^d$. This inequality is of course most useful when the process $(Z_t, Z'_t)_{t \geq 0}$, called a *coupling*, is constructed in a such a way that $\mathbf{P}\{\mathcal{T} > t\}$ decays as fast as possible as $t \rightarrow \infty$, with a reasonable dependence on x and x' . To do so, one usually uses at some point a general result of the type of Lemma 4.C.1 on the existence of so-called *maximal couplings* (see [KS12, Chapter 3]).

We first proceed to construct a coupling of two embedded discrete-time processes as introduced at the beginning of Section 4.2, but with different initial conditions: given x and x' in \mathbf{R}^d , we define a sequence $(z_k, z'_k)_{k \in \mathbf{N}}$ of $(\mathbf{R}^d \times \mathbf{R}^d)$ -valued random variables on a probability space $(\Omega, \mathcal{F}, \mathbf{P}_{(x,x')})$

with $\mathbf{P}_{(x,x')}(z_k \in \Gamma) = \hat{P}_k(x, \Gamma)$ and $\mathbf{P}_{(x,x')}(z'_k \in \Gamma) = \hat{P}_k(x', \Gamma)$ for all $k \in \mathbf{N}$ and measurable $\Gamma \subseteq \mathbf{R}^d$. In this context, we call $(z_k)_{k \in \mathbf{N}}$ [resp. $(z'_k)_{k \in \mathbf{N}}$] the first [resp. second] *component* of the coupling $(z_k, z'_k)_{k \in \mathbf{N}}$. The structure of the waiting times and the relation (4.9) then allow us to recover estimates for the original continuous-time process. The construction of this coupling is inductive and relies on the numbers $m \in \mathbf{N}$ and $r > 0$ in Lemma 4.2.3 and correlates the two components in a different way according to three cases: for $j \in \mathbf{N}_m^0$,

- if $z_j = z'_j$, then $z_k = z'_k$ for all $k \in \mathbf{N}$ with $k \geq j$;
- if z_j and z'_j are different but both in $B(\hat{x}, r)$, then the next m jumps are synchronous and, given the times of these jumps, z_{j+m} and z'_{j+m} are maximally coupled in the sense of Lemma 4.C.1;
- if z_j and z'_j are different and not both in $B(\hat{x}, r)$, then the next m jumps are synchronous, but the respective jump displacements are independent.

In essence, the worst-case scenario is when the initial conditions x and x' are different and very far from the origin, but the number

$$I := \min\{i \in \mathbf{N}_m^0 : (z_i, z'_i) \in B(0, R) \times B(0, R)\} \quad (4.21)$$

of jumps needed for both components to enter a large² compact set around the origin is controlled by the Lyapunov structure inherited from (C1). Then, the approximate controllability assumption (C2) allows us to prove an estimate for an exponential moment of the number

$$J := \min\{j \in \mathbf{N}_m^0 : (z_j, z'_j) \in B(\hat{x}, r) \times B(\hat{x}, r)\} \quad (4.22)$$

of jumps needed for both components to simultaneously enter $B(\hat{x}, r)$. Finally, combining this with the solid controllability assumption (C3), we control the probability distribution of the number

$$\begin{aligned} K &:= \min\{k \in \mathbf{N}_m^0 : z_k = z'_k\} \\ &= \min\{k \in \mathbf{N}_m^0 : z_\ell = z'_\ell \text{ for all } \ell \in \mathbf{N} \text{ with } \ell \geq k\} \end{aligned} \quad (4.23)$$

of jumps after which the two components coincide.

²The radius R of this compact set will be chosen to suitably fit the Lyapunov structure; cf. Corollary 4.A.2.

Alternatively, in a language which avoids the particularities of the coupling method, one could rephrase the above strategy by saying that combining (C2) and the consequence of (C3) expressed in Lemma 4.2.3 gives a *local Doeblin condition* in $B(0, R)$ which, when combined with the Lyapunov structured conferred by (C1), yields exponential mixing by Meyn–Tweedie-type arguments [MT12].

4.3.1 Coupling for the embedded discrete-time process

In this section, we construct a coupling $(z_k, z'_k)_{k \in \mathbf{N}}$ for the embedded discrete-time process in such a way that the random time after which the two components coincide has an exponential moment which we can estimate in terms of the initial conditions (see Proposition 4.3.2).

Let us fix the numbers m, r , and p as in Lemma 4.2.3. The coupling is constructed by blocks of m steps as follows. Let $\mathcal{X} = \mathbf{R}^d \times (\mathbf{R}_+)^m \times (\mathbf{R}^n)^m$, $\mathcal{Y} = \mathbf{R}^d$, and $\mathcal{U} = \mathbf{R}^d \times \mathbf{R}^d \times (\mathbf{R}_+)^m$. Recall that the functions $F_i : \mathcal{X} \rightarrow \mathcal{Y}$ are defined by (4.18) for $i = 1, \dots, m$. We consider two random probability measures $u \in \mathcal{U} \mapsto \mu(u, \cdot), \mu'(u, \cdot)$ on \mathcal{X} given by

$$\mu(u, \cdot) := \delta_z \times \delta_s \times \ell^m \quad \text{and} \quad \mu'(u, \cdot) := \delta_{z'} \times \delta_s \times \ell^m$$

for $u = (z, z', \mathbf{s}) \in \mathcal{U}$, where δ_z is the Dirac measure at $z \in \mathbf{R}^d$ and δ_s is the Dirac measure at $\mathbf{s} \in (\mathbf{R}_+)^m$. By Lemma 4.C.1 applied to F_m , there exist a probability space $(\tilde{\Omega}, \tilde{\mathcal{F}}, \tilde{\mathbf{P}})$ and measurable mappings $\xi, \xi' : \mathcal{U} \times \tilde{\Omega} \rightarrow \mathcal{X}$ such that

$$\xi(u, \cdot)_* \tilde{\mathbf{P}} = \delta_z \times \delta_s \times \ell^m, \quad \xi'(u, \cdot)_* \tilde{\mathbf{P}} = \delta_{z'} \times \delta_s \times \ell^m,$$

and

$$\tilde{\mathbf{P}}\{\tilde{\omega} : F_m(\xi(u, \tilde{\omega})) \neq F_m(\xi'(u, \tilde{\omega}))\} = \|F_m(z, \mathbf{s}, \cdot)_*(\ell^m) - F_m(z', \mathbf{s}, \cdot)_*(\ell^m)\|_{\text{var}} \quad (4.24)$$

for each $u = (z, z', \mathbf{s}) \in \mathcal{U}$. Replacing $\tilde{\Omega}$ with a bigger space (still referred to as $\tilde{\Omega}$) if necessary, we may find a third measurable mapping $\xi'' : \mathcal{U} \times \tilde{\Omega} \rightarrow \mathcal{X}$ with the same distribution as ξ' , but

independent from ξ .³ We set

$$\mathcal{P}_i(z, z', \mathbf{s}, \tilde{\omega}) := F_i(\xi(z, z', \mathbf{s}, \tilde{\omega}))$$

and

$$\mathcal{P}'_i(z, z', \mathbf{s}, \tilde{\omega}) := \begin{cases} F_i(\xi(z, z', \mathbf{s}, \tilde{\omega})) & \text{if } z = z', \\ F_i(\xi'(z, z', \mathbf{s}, \tilde{\omega})) & \text{if } z \neq z' \text{ both in } B(\hat{x}, r), \\ F_i(\xi''(z, z', \mathbf{s}, \tilde{\omega})) & \text{if } z \neq z' \text{ not both in } B(\hat{x}, r) \end{cases}$$

for each $(z, z', \mathbf{s}, \tilde{\omega}) \in \mathbf{R}^d \times \mathbf{R}^d \times (\mathbf{R}_+)^m \times \tilde{\Omega}$ and $i = 1, \dots, m$. Now, let \mathcal{E}_λ^m be the m -fold direct product of exponential laws with rate parameter λ . We denote by $(\Omega, \mathcal{F}, \mathbf{P}_{(x, x')})$ the direct product of the probability space $(\mathbf{R}^d \times \mathbf{R}^d, \mathcal{B}(\mathbf{R}^d) \times \mathcal{B}(\mathbf{R}^d), \delta_x \times \delta_{x'})$ with countably many copies of the probability space

$$((\mathbf{R}_+)^m \times \tilde{\Omega}, \mathcal{B}((\mathbf{R}_+)^m) \times \tilde{\mathcal{F}}, \mathcal{E}_\lambda^m \times \tilde{\mathbf{P}}),$$

and define the process $(z_k(\omega), z'_k(\omega))_{k \in \mathbf{N}}$ inductively. First, set $(z_0(\omega), z'_0(\omega)) = (y, y')$ where $\omega = (y, y', \omega_0, \omega_1, \dots) \in \Omega$ with $\omega_j = (\mathbf{s}_j, \tilde{\omega}_j) \in (\mathbf{R}_+)^m \times \tilde{\Omega}$, $j = 0, 1, 2, \dots$, and $i = 1, \dots, m$. Then,

$$\begin{aligned} z_{jm+i}(\omega) &:= \mathcal{P}_i(z_{jm}(\omega), z'_{jm}(\omega), \mathbf{s}_j, \tilde{\omega}_j), \\ z'_{jm+i}(\omega) &:= \mathcal{P}'_i(z_{jm}(\omega), z'_{jm}(\omega), \mathbf{s}_j, \tilde{\omega}_j). \end{aligned}$$

By construction, the pair (z_k, z'_k) , $k \in \mathbf{N}$ is a coupling for the embedded process:

$$\mathbf{P}_{(x, x')} \{\omega \in \Omega : z_k \in \Gamma\} = \hat{P}(x, \Gamma) \quad \text{and} \quad \mathbf{P}_{(x, x')} \{\omega \in \Omega : z'_k \in \Gamma\} = \hat{P}(x', \Gamma) \quad (4.25)$$

for all measurable $\Gamma \subseteq \mathbf{R}^d$.

We now state and prove two important properties of the constructed coupling. The first one relies on (C3) and elucidates the choice of a construction by blocks of m steps with m as in Lemma 4.2.3. The second combines this first property and some technical consequences of Condition (C1) and

³For example, one can take as a new $(\tilde{\Omega}, \tilde{\mathcal{F}}, \tilde{\mathbf{P}})$ the product of the old $(\tilde{\Omega}, \tilde{\mathcal{F}}, \tilde{\mathbf{P}})$ with itself and set $\xi_{\text{new}}(u, \tilde{\omega}_1, \tilde{\omega}_2) = \xi_{\text{old}}(u, \tilde{\omega}_1)$, $\xi'_{\text{new}}(u, \tilde{\omega}_1, \tilde{\omega}_2) = \xi'_{\text{old}}(u, \tilde{\omega}_1)$ and $\xi''_{\text{new}}(u, \tilde{\omega}_1, \tilde{\omega}_2) = \xi'_{\text{old}}(u, \tilde{\omega}_2)$ where $(\tilde{\omega}_1, \tilde{\omega}_2)$ is a generic element of the product of the old space with itself.

Condition (C2) proved in Appendix 4.A to establish an estimate on the time K needed for the coupling to hit the diagonal, i.e. for the two coupled components to coincide; see (4.23). This will be crucial in the proof of the Main Theorem.

Proposition 4.3.1. *There is a number $\hat{p} \in (0, 1)$ such that*

$$\mathbf{P}_{(x,x')} \{z_m \neq z'_m\} < \hat{p} \quad (4.26)$$

for all $x, x' \in B(\hat{x}, r)$.

Proof. With Σ as in and Lemma 4.2.3, the equality (4.24) gives

$$\begin{aligned} & (\mathcal{E}_\lambda^m \times \tilde{\mathbf{P}}) \{(\mathbf{s}, \tilde{\omega}) : F_m(\xi(x, x', \mathbf{s}, \tilde{\omega})) \neq F_m(\xi'(x, x', \mathbf{s}, \tilde{\omega}))\} \\ & \leq \mathcal{E}_\lambda^m(\Sigma) \sup_{\mathbf{s} \in \Sigma} \tilde{\mathbf{P}} \{\tilde{\omega} : F_m(\xi(x, x', \mathbf{s}, \tilde{\omega})) \neq F_m(\xi'(x, x', \mathbf{s}, \tilde{\omega}))\} + (1 - \mathcal{E}_\lambda^m(\Sigma)) \\ & = \mathcal{E}_\lambda^m(\Sigma) \sup_{\mathbf{s} \in \Sigma} \|F_m(x, \mathbf{s}, \cdot)_*(\ell^m) - F_m(x', \mathbf{s}, \cdot)_*(\ell^m)\|_{\text{var}} + (1 - \mathcal{E}_\lambda^m(\Sigma)) \end{aligned}$$

whenever x and x' are in the ball $B(\hat{x}, r)$. Therefore,

$$\mathbf{P}_{(x,x')} \{z_m \neq z'_m\} \leq 1 - \mathcal{E}_\lambda^m(\Sigma)(1 - p) =: \hat{p}$$

by Lemma 4.2.3. □

Proposition 4.3.2. *There are positive constants θ_1 and A_1 such that*

$$\mathbf{E}_{(x,x')} e^{\theta_1 K} \leq A_1 (1 + \|x\| + \|x'\|) \quad (4.27)$$

for all $x, x' \in \mathbf{R}^d$.

Proof. Under Condition (C1), $(x, x') \mapsto 1 + \|x\|^2 + \|x'\|^2$ is a Lyapunov function for the coupling $(z_k, z'_k)_{k \in \mathbf{N}}$. As a consequence of this, we control an exponential moment of the number I of jumps needed to enter a ball of large radius R around the origin (see Corollary 4.A.2). On the other hand, Condition (C2) guarantees the existence of a number $M \in \mathbf{N}_m$ of jumps in which transition probabilities from points in $B(0, R)$ to the ball $B(\hat{x}, r)$ are uniformly bounded from below (see Lemma 4.A.5).

Combining these results, we get the following bound on an exponential moment of the first simultaneous hitting time of the ball $B(\hat{x}, r)$: there exist positive constants θ_2 and A_2 such that

$$\mathbf{E}_{(x,x')} e^{\theta_2 J} \leq A_2 (1 + \|x\|^2 + \|x'\|^2). \quad (4.28)$$

This is stated and proved as Proposition 4.A.6 in the first appendix. Then, we introduce a sequence of random times defined inductively by $J_0 := 0$ and

$$J_i := \min \{j \in \mathbf{N}_m : z_j, z'_j \in B(\hat{x}, r) \text{ and } j > J_{i-1}\}$$

for $i \geq 1$. Using the strong Markov property and applying the inequality (4.28) repeatedly gives

$$\mathbf{E}_{(x,x')} e^{\theta_2 J_i} \leq \mathbf{E} \left(e^{\theta_2 J_{i-1}} \mathbf{E}_{(z_{J_{i-1}}, z'_{J_{i-1}})} e^{\theta_2 J_1} \right) \leq \hat{C}^i (1 + \|x\|^2 + \|x'\|^2) \quad (4.29)$$

for some positive constant \hat{C} .

Note that Proposition 4.3.1 implies that K is almost surely finite for all $x, x' \in \mathbf{R}^d$. Indeed,

$$\begin{aligned} \mathbf{P}_{(x,x')} \{K > J_i\} &\leq \mathbf{P}_{(x,x')} \{z_{J_i+m} \neq z'_{J_i+m}\} \\ &= \mathbf{P}_{(x,x')} \left(\{z_{J_i+m} \neq z'_{J_i+m}\} \mid \{z_{J_i} \neq z'_{J_i}\} \right) \mathbf{P}_{(x,x')} \{z_{J_i} \neq z'_{J_i}\} \\ &\leq \hat{p} \mathbf{P}_{(x,x')} \{z_{J_i} \neq z'_{J_i}\} \\ &\leq \hat{p} \mathbf{P}_{(x,x')} \{z_{J_{i-1}+m} \neq z'_{J_{i-1}+m}\} \\ &\leq \hat{p}^i \end{aligned} \quad (4.30)$$

and almost-sure finiteness follows from the Borel–Cantelli lemma. Now, by Hölder’s inequality,

$$\begin{aligned} \mathbf{E}_{(x,x')} e^{\theta_1 K} &\leq 1 + \sum_{i=0}^{\infty} \mathbf{E}_{(x,x')} \left(\mathbf{1}_{\{J_i < K \leq J_{i+1}\}} e^{\theta_1 J_{i+1}} \right) \\ &\leq 1 + \sum_{i=0}^{\infty} \left(\mathbf{P}_{(x,x')} \{K > J_i\} \right)^{1-\frac{1}{q}} \left(\mathbf{E}_{(x,x')} e^{q\theta_1 J_{i+1}} \right)^{\frac{1}{q}} \end{aligned}$$

for any $q \geq 1$. In each summand, the first term is controlled by the inequality (4.30) and the second one by (4.29), provided that $\theta_1 \leq \theta_2/q$:

$$\mathbf{E}_{(x,x')} e^{\theta_1 K} \leq 1 + \hat{C}^{\frac{1}{q}} \hat{p}^{\frac{1}{q}-1} (1 + \|x\|^2 + \|x'\|^2)^{\frac{1}{q}} \sum_{i=0}^{\infty} \left(\hat{C}^{\frac{1}{q}} \hat{p}^{1-\frac{1}{q}} \right)^i.$$

The proposition follows by taking $q \geq 2$ large enough that $\hat{C}^{\frac{1}{q}} \hat{p}^{1-\frac{1}{q}} < 1$. □

4.3.2 Coupling for the original continuous-time process

Let the probability space $(\Omega, \mathcal{F}, \mathbf{P}_{(x,x')})$ and the process (z_k, z'_k) be as in the previous subsection. Recall that an element ω of Ω consists in an initial condition in $\mathbf{R}^d \times \mathbf{R}^d$ and a sequence $(\mathbf{s}_j, \tilde{\omega}_j)_{j \in \mathbf{N}}$ of elements in $(\mathbf{R}_+)^m \times \tilde{\Omega}$ for some other probability space $\tilde{\Omega}$ we have constructed. Let $\tau_{j_{m+i}}(\omega)$ be the positive real obtained by summing all the entries of $\mathbf{s}_1, \mathbf{s}_2, \dots, \mathbf{s}_j$ and the first i entries of \mathbf{s}_{j+1} . Then, it follows from the construction of $\mathbf{P}_{(x,x')}$ that the sequence $(\tau_k)_{k \in \mathbf{N}}$ of random variables on $(\Omega, \mathcal{F}, \mathbf{P}_{(x,x')})$ has independent increments distributed according to an exponential distribution with rate parameter λ .

We define

$$Z_t(\omega) := \begin{cases} z_k(\omega) & \text{if } t = \tau_k(\omega), \\ S_{t-\tau_k(\omega)}(z_k(\omega)) & \text{if } t \in (\tau_k(\omega), \tau_{k+1}(\omega)) \end{cases}$$

and

$$Z'_t(\omega) := \begin{cases} z'_k(\omega) & \text{if } t = \tau_k(\omega), \\ S_{t-\tau_k(\omega)}(z'_k(\omega)) & \text{if } t \in (\tau_k(\omega), \tau_{k+1}(\omega)). \end{cases}$$

Then, (4.9), (4.10) and (4.25) imply that (Z_t, Z'_t) is a coupling of X_t and X'_t .

Proposition 4.3.3. *Under Conditions (C1)–(C3), there exist positive constants C and c such that*

$$\mathbf{P}_{(x,x')} \{\mathcal{T} > t\} \leq C(1 + \|x\| + \|x'\|)e^{-ct} \quad (4.31)$$

for any $x, x' \in \mathbf{R}^d$ and $t \geq 0$.

Proof. Let K be defined by (4.23). As τ_k is a sum of k independent exponentially distributed random variables with parameter λ , the expectation of $e^{2c\tau_k}$ can be computed explicitly for c in the interval $(0, \frac{1}{2}\lambda)$, and τ_K is also almost-surely finite. For such a number c , the Cauchy–Schwarz inequality yields

$$\mathbf{E}_{(x,x')} e^{c\tau_K} = \sum_{k=0}^{\infty} \mathbf{E}_{(x,x')} (e^{c\tau_k} \mathbf{1}_{\{K=k\}}) \leq \sum_{k=0}^{\infty} (\mathbf{E}_{(x,x')} e^{2c\tau_k})^{\frac{1}{2}} (\mathbf{P}_{(x,x')} \{K = k\})^{\frac{1}{2}}.$$

On the other hand, we control $\mathbf{P}_{(x,x')}\{K \geq k\}$ by Proposition 4.3.2 and Chebyshev's inequality. Therefore,

$$\begin{aligned} \mathbf{E}_{(x,x')} e^{c\tau_K} &\leq \sum_{k=0}^{\infty} \left(\frac{\lambda}{\lambda - 2c} \right)^{\frac{k}{2}} \left(e^{-\theta_1 k} A_1 (1 + \|x\| + \|x'\|) \right)^{\frac{1}{2}} \\ &\leq A_1^{\frac{1}{2}} (1 + \|x\| + \|x'\|) \sum_{k=0}^{\infty} \left(\frac{\lambda e^{-\theta_1}}{\lambda - 2c} \right)^{\frac{k}{2}}, \end{aligned}$$

where θ_1 and A_1 are as in Proposition 4.3.2. The series will converge for $c > 0$ small enough; fix such a value of c . By Chebyshev's inequality, we find $C > 0$ such that

$$\mathbf{P}_{(x,x')}\{\tau_K > t\} \leq C(1 + \|x\| + \|x'\|)e^{-ct}$$

for all $x, x' \in \mathbf{R}^d$. By construction, we have $\mathcal{F} \leq \tau_K$ almost surely and therefore

$$\mathbf{P}_{(x,x')}\{\mathcal{F} > t\} \leq C(1 + \|x\| + \|x'\|)e^{-ct}.$$

This completes the proof of the proposition. □

4.3.3 Concluding the proof of the Main Theorem

In view of Lemma 4.2.2, if we can find constants $C > 0$ and $c > 0$ such that

$$\|\mathfrak{P}_t^* \partial_x - \mathfrak{P}_t^* \partial_{x'}\|_{\text{var}} \leq C(1 + \|x\| + \|x'\|)e^{-ct}$$

for all $x, x' \in \mathbf{R}^d$ and all $t \geq 0$, then integrating in x against μ and in x' against μ^{inv} gives the desired bound (4.7) with a different constant C . By construction of the coupling $(Z_t, Z'_t)_{t \geq 0}$, we have

$$(\mathfrak{P}_t g)(x) - (\mathfrak{P}_t g)(x') = \mathbf{E}_{(x,x')} (g(Z_t) - g(Z'_t))$$

for all $g \in L^\infty(\mathbf{R}^d)$. Therefore,

$$\begin{aligned} \|\mathfrak{P}_t^* \partial_x - \mathfrak{P}_t^* \partial_{x'}\|_{\text{var}} &= \frac{1}{2} \sup_{\|g\|_\infty \leq 1} |(\mathfrak{P}_t g)(x) - (\mathfrak{P}_t g)(x')| \\ &\leq \frac{1}{2} \sup_{\|g\|_\infty \leq 1} \mathbf{E}_{(x,x')} |g(Z_t) - g(Z'_t)| \\ &= \frac{1}{2} \sup_{\|g\|_\infty \leq 1} \mathbf{E}_{(x,x')} \left\{ \mathbf{1}_{\{Z_t \neq Z'_t\}} |g(Z_t) - g(Z'_t)| \right\} \\ &\leq \mathbf{P}_{(x,x')}\{Z_t \neq Z'_t\} \leq \mathbf{P}_{(x,x')}\{\mathcal{F} > t\} \end{aligned}$$

for all $x, x' \in \mathbf{R}^d$ and $t \geq 0$, and the result follows from Proposition 4.3.3.

4.4 Applications

In this section, we apply the Main Theorem to the Galerkin approximations of PDES and to stochastically driven quasi-harmonic networks. For the Galerkin approximations we give a detailed derivation of the controllability conditions and in the case of the networks we appeal to the results obtained in [Raq19]. Before we do so, we briefly discuss the solid controllability assumption (C3).

4.4.1 Criteria for solid controllability

The notion of solid controllability was introduced by Agrachev and Sarychev in [AS05] (see also the survey [AS08]) in the context of the controllability of the 2D Navier–Stokes and Euler systems. It has been used in [AKSS07] to prove the existence of density for finite-dimensional projections of the laws of the solutions of randomly forced PDES. In [Shi17], solid controllability is used to establish exponential mixing for some random dynamical systems in a compact space, and in [Raq19], for some classes of quasi-harmonic networks of oscillators driven by a degenerate Brownian motion. It is the degeneracy allowed by this condition which sets our work apart from previous works on SDES driven by compound Poisson processes (that are too numerous to be cited here).

We compare it to two related well-known properties, which might be more straightforward to check in some applications.

(C3') *Continuous exact controllability from \hat{x}* : there exists a nondegenerate closed ball $D \subset \mathbf{R}^d$, a time $T_0 > 0$, and a continuous function $\Psi : D \rightarrow C([0, T_0]; \mathbf{R}^n)$ such that $S_{T_0}(\hat{x}, \Psi(x)) = x$ for all $x \in D$.

(C3'') *Weak Hörmander condition at \hat{x}* : the vector space spanned by the family of vector fields

$$\{V_0, [V_1, V_2], [V_1, [V_2, V_3]], \dots : V_0 \in \mathbf{B}, V_1, V_2, \dots \in \mathbf{B} \cup \{f\}\} \quad (4.32)$$

at the point \hat{x} coincides with \mathbf{R}^d , where \mathbf{B} is the set of constant vector fields formed by the columns of the matrix B and $[U, V](x)$ is the *Lie bracket* of the vector fields U and V in the

point x :

$$[U, V](x) = DV(x)U(x) - DU(x)V(x).$$

Here, $DU(x)$ is the Jacobian matrix of U at x .

It is shown in [Shi17, §2.2] that (C3'') implies (C3') with arbitrary T_0 , and that (C3') in turn implies (C3) with the same T_0 ; see also [Raq19, §3.2]. The first implication appeals to some ideas from geometric control theory. The second implication can be seen from a degree theory argument (or alternatively from an application of Brouwer's fixed point theorem).

The weak Hörmander condition, also known as the parabolic Hörmander condition, has many important applications both in control theory (e.g., see [Jur97, Ch. 5]) and stochastic analysis (e.g., see [Nua06, §2.3 in Ch. 2] and [Hai11]). It is often assumed to hold in *all* points of the state space. For finite-dimensional control systems, it ensures the global exact controllability; for Itô diffusions, it guarantees existence and smoothness of the density of solutions with respect to the Lebesgue measure — a major step towards proving important ergodic properties. We emphasize that we bypass the study of smoothing properties of the transition function of our Markov process and that the conditions stated need only hold in *one* point of the state space (where Condition (C2) is also satisfied).

Recall that a pair of matrices, $A : \mathbf{R}^d \rightarrow \mathbf{R}^d$ and $B : \mathbf{R}^n \rightarrow \mathbf{R}^d$, is said to satisfy the Kalman condition if any $x \in \mathbf{R}^d$ can be written as $x = By_0 + AB y_1 + \dots + A^{d-1} B y_{d-1}$ for some $y_0, \dots, y_{d-1} \in \mathbf{R}^n$. For a linear control system of the form $\dot{X} = AX + B\zeta$, the Kalman condition implies (C3'') in all points through a straightforward computation of the Lie brackets; see [Cor07, §1.2–1.3] for other well-known implications. When f is a linear vector field $x \mapsto Ax$ plus a perturbation, Condition (C3'') can be deduced at a point \hat{x} far from the origin by perturbing the Kalman condition on the pair (A, B) , provided that one has good control on the decay of derivatives of the perturbation along a sequence of points [Raq19, §5].

4.4.2 Galerkin approximations of randomly forced PDEs

In this section, we apply the Main Theorem to the Galerkin approximations of the following parabolic PDE on the torus $\mathbf{T}^D := \mathbf{R}^D / 2\pi\mathbf{Z}^D$:

$$\partial_t u(t, x) - \nu \Delta_x u(t, x) + F(u(t, x)) = b(x) + \zeta(t, x), \quad x \in \mathbf{T}^D, \quad (4.33)$$

where $\nu > 0$ is a constant, $b : \mathbf{T}^D \rightarrow \mathbf{R}$ is a given smooth function, and $F : \mathbf{R} \rightarrow \mathbf{R}$ is a function of the form

$$F(u) = au^p + g(u). \quad (4.34)$$

We assume that $a > 0$ is an arbitrary constant, $p \geq 3$ is an odd integer, and $g : \mathbf{R} \rightarrow \mathbf{R}$ is a smooth function satisfying the following two conditions⁴:

(i) there is a constant $C > 0$ such that

$$|g(u)| \leq C(1 + |u|)^{p-1}$$

for all $u \in \mathbf{R}$.

(ii) with $g^{(p)}$ the p -th derivative of g , the following limit holds

$$\lim_{u \rightarrow \pm\infty} g^{(p)}(u) = 0.$$

For any $N \in \mathbf{N}$, consider the following finite-dimensional subspace of $L^2(\mathbf{T}^D)$:

$$H_N := \text{span}\{s_k, c_k : k \in \mathbf{Z}^D, |k| \leq N\},$$

where $s_k(x) := \sin\langle x, k \rangle$, $c_k(x) := \cos\langle x, k \rangle$, $\langle x, k \rangle := x_1 k_1 + \dots + x_D k_D$ and $|k| := |k_1| + \dots + |k_D|$ for any multi-index $k = (k_1, \dots, k_D) \in \mathbf{Z}^D$ and any vector $x \in \mathbf{T}^D$. In particular, c_0 is the constant function 1. This subspace is endowed with the scalar product $\langle \cdot, \cdot \rangle_{L^2}$ and the norm $\|\cdot\|_{L^2}$ inherited from $L^2(\mathbf{T}^D)$. Let P_N be the orthogonal projection onto H_N in $L^2(\mathbf{T}^D)$. The Galerkin approximations of (4.33) are given by

$$\dot{u}(t) - \nu \Delta u(t) + P_N F(u(t)) = b + \zeta(t), \quad (4.35)$$

⁴The results of this subsection remain true under weaker assumptions on the function g . This setting is chosen for the simplicity of presentation.

where u is an unknown H_N -valued function, b is an arbitrary vector in H_N and ζ is a continuous H_1 -valued function.

Let us emphasize that the space H_1 for the driving ζ is the same for any level $N \geq 1$ of approximation, any value of the constant ν and any function g satisfying (i) and (ii).

The main interest of the example considered in this section is that the perturbation term g in (4.34) is quite general. In particular, we may have $F(u) = 0$ in a large ball, so that the weak Hörmander condition is not necessarily satisfied at all the points of the state space.

Theorem 4.4.1. *Suppose that (i) and (ii) hold. Let $(Y_t)_{t \geq 0}$ be an H_1 -valued compound Poisson with jump distribution ℓ of finite variance and possessing a positive continuous density with respect to the Lebesgue measure on H_1 . Then, the semigroup $(\mathfrak{P}_t^*)_{t \geq 0}$ for the SDE*

$$du - \nu \Delta u \, dt + P_N F(u) \, dt = b \, dt + dY$$

in H_N admits a unique invariant measure $\mu^{\text{inv}} \in \mathcal{P}(H_N)$. Moreover, it is exponentially mixing in the sense that (4.7) holds for some constants $C > 0$ and $c > 0$, any measure $\mu \in \mathcal{P}(H_N)$, and any time $t \geq 0$.

Proof. The SDE under consideration is of the form (4.1) with $d = \dim H_N$, $n = \dim H_1 = 2D + 1$, a smooth function $f_N : H_N \rightarrow H_N$ given by

$$f_N(u) = \nu \Delta u - P_N F(u) + b, \quad (4.36)$$

and $B : H_1 \rightarrow H_N$ the natural embedding operator. Let us show that Conditions (C1)–(C3) are verified. Using the assumption (i), the fact that s_k and c_k are eigenfunctions of the Laplacian, and the Cauchy–Schwarz inequality, we get

$$\begin{aligned} \langle f(u), u \rangle_{L^2} &= \langle \nu \Delta u - P_N F(u) + b, u \rangle_{L^2} \\ &\leq -\nu \int_{\mathbf{T}^D} |u(x)|^2 \, dx - C_1 \int_{\mathbf{T}^D} |u(x)|^{p+1} \, dx + C_2 \\ &\leq -\nu \|u\|_{L^2}^2 + C_2, \end{aligned}$$

where $C_1 > 0$ and $C_2 > 0$ are some constants and $u \in H_N$ is arbitrary. This implies Condition (C1).

Condition (C2) (to all points) is a consequence of the global approximate controllability property of Proposition 4.4.2 below, whose proof is given in Appendix 4.B. Since it is proved in [Shi17, §2.2] that the weak Hörmander condition implies solid controllability, Proposition 4.4.3 below yields Condition (C3).

Thus, Conditions (C1)–(C3) are satisfied and the proof of Theorem 4.4.1 is completed by applying our Main Theorem. \square

Proposition 4.4.2. *Equation (4.35) is approximately controllable: for any number $\varepsilon > 0$, any time $T > 0$, any initial condition $u_0 \in H_N$, and any target $\hat{u} \in H_N$, there exists a control $\zeta \in C([0, T]; H_1)$ such that the solution u of (4.35) with $u(0) = u_0$ satisfies*

$$\|u(T) - \hat{u}\|_{L^2} < \varepsilon.$$

Proposition 4.4.3. *There is a number $R > 0$ such that the weak Hörmander Condition (C3'') is satisfied for equation (4.35) at any point $\hat{u} \in H_N$ with $\|\hat{u}\|_{L^2} \geq R$.*

Proof of Proposition 4.4.3. In view of the weak Hörmander condition, we are interested in the nested subspaces $\{\mathcal{V}_i\}_{i \geq 0}$ of H_N defined by $\mathcal{V}_0 = H_1$ and

$$\mathcal{V}_{i+1}(\hat{u}) := \text{span}(\mathcal{V}_i \cup \{[V, f_N](\hat{u}) : V \in \mathcal{V}_i(\hat{u})\}),$$

where we at times identify the vector $V \in \mathcal{V}_i(\hat{u})$ with the corresponding constant vector field on H_N . Clearly, showing that $\mathcal{V}_i(\hat{u}) = H_N$ for some i large enough shows that the weak Hörmander condition (C3'') holds in \hat{u} . We show in two steps that, indeed, $\mathcal{V}_{(N-1)p}(\hat{u}) = H_N$ if $\|\hat{u}\|_{L^2}$ is sufficiently large.

Step 1: Polynomial nonlinearity. In this step, we assume that $g \equiv 0$, so that

$$f_N(u) = \nu \Delta u - a P_N(u^p) + b. \quad (4.37)$$

In this case, Lie brackets with constant vector fields are especially straightforward to compute because Δ is a linear operator and b is a constant vector. In particular, for any constant vector fields $V_1, \dots, V_{p-2}, V_{p-1}$ and V_p ,

$$[V_1, \dots, [V_{p-2}, [V_{p-1}, [V_p, f_N]]] \dots](\hat{u}) = -a p! P_N(V_1 \dots V_{p-2} V_{p-1} V_p), \quad (4.38)$$

where the product $V_1 \dots V_{p-2} V_{p-1} V_p$ is understood as a pointwise multiplication of functions.

We claim that, for each multi-index m with $0 < |m| \leq N$, the vectors c_m and s_m are in $\mathcal{V}_{(|m|-1)p}(\hat{u})$ for all $\hat{u} \in H_N$. To start, note that if $|l| \leq 1$, then c_l and s_l are in H_1 and thus in $\mathcal{V}_i(\hat{u})$ for each i .

Suppose now that c_m and s_m are in $\mathcal{V}_{(|m|-1)p}(\hat{u})$. As noted above, for all multi-indices l with $|l| \leq 1$, the vectors c_l and s_l are also in $\mathcal{V}_{(|m|-1)p}(\hat{u})$. Therefore, combining the computation (4.38) with trigonometric identities yields that

$$\begin{aligned} P_N c_{m \pm l} &= P_N(1 \dots 1 c_l c_m) \mp P_N(1 \dots 1 s_l s_m) \\ &= \frac{-1}{a p!} [c_0, \dots [c_0, [c_l, [c_m, f_N]]] \dots](\hat{u}) \pm \frac{1}{a p!} [c_0, \dots [c_0, [s_l, [s_m, f_N]]] \dots](\hat{u}) \end{aligned} \quad (4.39)$$

and

$$\begin{aligned} P_N s_{m \pm l} &= P_N(1 \dots 1 s_l c_m) \pm P_N(1 \dots 1 c_l s_m) \\ &= \frac{-1}{a p!} [c_0, \dots [c_0, [s_l, [c_m, f_N]]] \dots](\hat{u}) \pm \frac{-1}{a p!} [c_0, \dots [c_0, [c_l, [s_m, f_N]]] \dots](\hat{u}) \end{aligned} \quad (4.40)$$

are in $\mathcal{V}_{(|m|-1)p+p}(\hat{u})$. The result thus holds by induction on $|m|$.

Step 2: The General case. Let \tilde{f}_N be the vector field given by (4.37). If we consider the same Lie brackets as in Step 1, but now for the sum $\tilde{f}_N + P_N g$, the contribution of $P_N g$ will vanish as $\hat{u} \rightarrow \infty$, thanks to assumption (ii). Therefore, $\mathcal{V}_{(|N|-1)p}(\hat{u}) = H_N$, provided that $\|\hat{u}\|_{L^2}$ is sufficiently large. \square

4.4.3 Stochastically driven networks of quasi-harmonic oscillators

Stochastically driven networks of oscillators play an important role in the investigation of various aspects of nonequilibrium statistical mechanics. In its simplest form, the setup can be described as follows. Consider L unit masses, each labelled by an index $i \in \{1, \dots, L\}$ restricted to move in one dimension. Each of them is pinned by a spring of unit spring constant and, for $i \neq L$, the i th mass is connected to the $(i + 1)$ th mass by a spring of unit spring constant. The equations of motion for

the positions and momenta, $(q_i, p_i)_{i=1}^L$, are the Hamilton equations

$$\begin{cases} dq_i = p_i dt, & dp_i = -(3q_i - q_{i-1} - q_{i+1}) dt, & 1 < i < L, \\ dq_1 = p_1 dt, & dp_1 = -(2q_1 - q_2) dt, \\ dq_L = p_L dt, & dp_L = -(2q_L - q_{L-1}) dt. \end{cases}$$

Coupling the 1st [resp. the L th] oscillator to a fluctuating bath with dissipation constant γ_1 [resp. γ_L] leads to the SDE

$$\begin{cases} dq_i = p_i dt, & dp_i = -(3q_i - q_{i-1} - q_{i+1}) dt, & 1 < i < L, \\ dq_1 = p_1 dt, & dp_1 = -(2q_1 - q_2) dt - \gamma_1 p dt + dZ_{1,t}, \\ dq_L = p_L dt, & dp_L = -(2q_L - q_{L-1}) dt - \gamma_L p dt + dZ_{L,t}, \end{cases} \quad (4.41)$$

or variants thereof, where Z_1 and Z_2 are independent one-dimensional stochastic processes describing the fluctuations in the baths.

In the mathematical physics literature, many authors have considered nonlinear variants of this model where the thermal fluctuations — either acting on the momenta (the Langevin regime, as above) or on auxiliary degrees of freedom — are described by white noise, $Z_{j,t} = \sqrt{2\gamma_j \theta_j} W_{j,t}$, with $W_{j,t}$ a standard Wiener process. We refer the interested reader to [FKM65, Tro77] for introductions to these models and discussions of their ergodic properties at thermal equilibrium; also see [JP97, JP98] for a generalization to non-Markovian models. The existence and uniqueness of the invariant measure is much more problematic out of equilibrium; see [SL77, EPRB99b, EPRB99a, EH00, RBT02, CEHRB18]. However, interesting phenomena pointed out in the physics literature for a single particle in a non-Gaussian bath [BC09, TC09, MQSP11, MG12] motivate a rigorous study of the mixing properties of corresponding networks. While the methods used for most of the previously cited existence and uniqueness results are not suitable to deal with compound Poisson processes, most of the ideas of [Shi17, Raq19] are. We develop the strategy to be followed in the present section.

Allowing for different spring constants and different ways of connecting the masses while staying in the Langevin regime leads us to considering the following generalization of (4.41). Let I be a

finite set and distinguish a nonempty subset $J \subset I$, where masses will be coupled to fluctuating baths. We use $\{\delta_i\}_{i \in I}$ [resp. $\{\delta_j\}_{j \in J}$] as the standard basis for \mathbf{R}^I [resp. \mathbf{R}^J]. Let $\omega : \mathbf{R}^I \rightarrow \mathbf{R}^I$ be a nonsingular linear map and let $\iota_j : \mathbf{R}^J \rightarrow \mathbf{R}^I$ be the rank-one map $\delta_j \langle \delta_j, \cdot \rangle$ for each $j \in J \subset I$.

The SDE

$$d \begin{pmatrix} p \\ \omega q \end{pmatrix} = \begin{pmatrix} -\sum_{j \in J} \gamma_j \iota_j \iota_j^* & -\omega^* \\ \omega & 0 \end{pmatrix} \begin{pmatrix} p \\ \omega q \end{pmatrix} dt + \sum_{j \in J} \begin{pmatrix} \iota_j \\ 0 \end{pmatrix} dZ_j$$

in $\mathbf{R}^{2|I|}$ then describes the positions q and momenta p of $|I|$ masses connected to each other and pinned according to the matrix ω , with the j th oscillator being coupled to a Langevin bath with dissipation controlled by the constant $\gamma_j > 0$ and fluctuations described by the process Z_j .

In Proposition 4.4.4 and Corollary 4.4.5, we consider a nonlinear version of this SDE where the quadratic potential resulting from the springs is now perturbed by a potential $U : \mathbf{R}^d \rightarrow \mathbf{R}$. Their proofs are omitted since they are essentially the same as those of Proposition 4.4.6 and Corollary 4.4.7 respectively. We start with dissipativity and controllability properties of the control system.

Proposition 4.4.4. *Let I, J, ω and $(\gamma_j)_{j \in J}$ be as above. Then, the conditions*

(K) *the pair $(\omega^* \omega, \sum_{j \in J} \iota_j \iota_j^*)$ satisfies the Kalman condition;*

(G) *the gradient of U is a smooth globally Lipschitz vector field growing strictly slower than $q \mapsto 1 + |q|^{\frac{1}{4|I|}}$;*

(pH) *there exists a sequence $\{q^{(n)}\}_{n \in \mathbf{N}}$ of points in \mathbf{R}^I , bounded away from 0, such that*

$$\lim_{n \rightarrow \infty} |q^{(n)}|^k \|D^{k+1} U(q^{(n)})\| = 0$$

for each $k = 0, 1, \dots, d - 1$;

imply that the control system

$$\begin{pmatrix} \dot{p} \\ \omega \dot{q} \end{pmatrix} = \begin{pmatrix} -\sum_{j \in J} \gamma_j \iota_j \iota_j^* & -\omega^* \\ \omega & 0 \end{pmatrix} \begin{pmatrix} p \\ \omega q \end{pmatrix} - \begin{pmatrix} \nabla U(q) \\ 0 \end{pmatrix} + \sum_{j \in J} \begin{pmatrix} \iota_j \\ 0 \end{pmatrix} \zeta$$

satisfies the conditions (C1), (C2) and (C3).

The exponent in the formulation of the growth condition is typically not optimal; see [Raq19] for a formulation in terms of a power related to the Kalman condition. The following mixing result for the corresponding SDE with Poissonian noise essentially follows from our Main Theorem (see the proof of Corollary 4.4.7).

Corollary 4.4.5. *Under the same assumptions, if $(N_j)_{j \in J}$ is a collection of $|J|$ independent one-dimensional compound Poisson processes with jump distributions with finite variance and continuous positive densities with respect to the Lebesgue measure on \mathbf{R} , then the SDE*

$$d \begin{pmatrix} p \\ \omega q \end{pmatrix} = \begin{pmatrix} -\sum_{j \in J} \gamma_j \iota_j \iota_j^* & -\omega^* \\ \omega & 0 \end{pmatrix} \begin{pmatrix} p \\ \omega q \end{pmatrix} dt - \begin{pmatrix} \nabla U(q) \\ 0 \end{pmatrix} dt + \sum_{j \in J} \begin{pmatrix} \iota_j \\ 0 \end{pmatrix} \delta_j dN_j$$

admits a unique stationary measure $\mu^{\text{inv}} \in \mathcal{P}(\mathbf{R}^I \oplus \mathbf{R}^I)$. Moreover, it is exponentially mixing in the sense that (4.7) holds for some constants $C > 0$ and $c > 0$, any measure $\mu \in \mathcal{P}(\mathbf{R}^I \oplus \mathbf{R}^I)$, and any time $t \geq 0$.

In addition to the notation used so far, let $(\lambda_j)_{j \in J}$ be small positive numbers and let us use the shorthand $\gamma \iota^*$ for $\sum_j \gamma_j \iota_j \iota_j^*$, the shorthand $\lambda \iota^* \iota$ for $\sum_j \lambda_j \iota_j^* \iota_j$, and so on. The SDE

$$d \begin{pmatrix} r \\ p \\ \tilde{\omega} q \end{pmatrix} = \begin{pmatrix} -\gamma \iota^* & \lambda \iota^* & 0 \\ -\lambda \iota^* \iota & 0 & -\tilde{\omega}^* \\ 0 & \tilde{\omega} & 0 \end{pmatrix} \begin{pmatrix} r \\ p \\ \tilde{\omega} q \end{pmatrix} dt + \begin{pmatrix} \sqrt{2\gamma \theta} \iota^* \iota \\ 0 \\ 0 \end{pmatrix} dW$$

can be derived as the effective equation for the positions q and momenta p of a network of $|I|$ masses connected to each other and pinned according to the matrix ω , with the j th oscillator being coupled to a classical Gaussian field at temperature θ_j under some particular conditions on the coupling; see [EPRB99b]. The $|J|$ auxiliary degrees of freedom $r \in \mathbf{R}^J$ are introduced to make the process Markovian. The parameters λ_j and γ_j describe the coupling and dissipation for the j th bath. Here, the matrix $\tilde{\omega}$ encodes an effective quadratic potential and is such that $\tilde{\omega}^* \tilde{\omega} = \omega^* \omega - \lambda^2 \iota^*$ (λ is small), where ω encodes the original quadratic potential.

Proposition 4.4.6. *Let I, J, ω and $(\gamma_j)_{j \in J}$ be as above. Then, for $(\lambda_j)_{j \in J}$ small enough, the conditions (K), (G) and (pH) as in the previous proposition imply that the control system*

$$\begin{pmatrix} \dot{r} \\ \dot{p} \\ \tilde{\omega} \dot{q} \end{pmatrix} = \begin{pmatrix} -\gamma \iota^* & \lambda \iota^* & 0 \\ -\lambda \iota^* \iota & 0 & -\tilde{\omega}^* \\ 0 & \tilde{\omega} & 0 \end{pmatrix} \begin{pmatrix} r \\ p \\ \tilde{\omega} q \end{pmatrix} - \begin{pmatrix} 0 \\ \nabla U(q) \\ 0 \end{pmatrix} + \begin{pmatrix} \mathbf{1} \\ 0 \\ 0 \end{pmatrix} \zeta$$

satisfies the conditions (C1), (C2) and (C3).

Proof. If λ is small enough, the Kalman condition on the pair $(\omega^* \omega, \iota^*)$ implies the Kalman condition on the pair $(\tilde{\omega}^* \tilde{\omega}, \iota^*)$. This in turn implies that the pair

$$(A, B) := \left(\begin{pmatrix} -\gamma \iota^* & \lambda \iota^* & 0 \\ -\lambda \iota^* \iota & 0 & -\tilde{\omega}^* \\ 0 & \tilde{\omega} & 0 \end{pmatrix}, \begin{pmatrix} \mathbf{1} \\ 0 \\ 0 \end{pmatrix} \right)$$

also satisfies the Kalman condition; see Proposition 4.1 in [Raq19]. It follows by Lemma 5.1(2) in [JPS17] that the eigenvalues of A then have strictly negative real part. Combined with the growth assumption (G), the negativity of the eigenvalues implies (C1) for a suitable inner product; see Lemma 3.1 in [Raq19]. Proposition 3.3 in [Raq19] says that the Kalman condition on (A, B) and the growth condition (G) on ∇U give (C2) everywhere. The fact that the Kalman condition on (A, B) and assumption (pH) give the weak Hörmander condition (C3'') in one point is the content of Proposition 5.1 in [Raq19]. But, as previously mentioned, the weak Hörmander condition implies solid controllability. \square

Concerning the corresponding SDE with Poissonian noise, we have the following mixing result — which again parallels that of [Raq19] — as a corollary of the controllability properties.

Corollary 4.4.7. *Under the same assumptions, if $(N_j)_{j \in J}$ is a collection of $|J|$ independent one-dimensional compound Poisson processes with jump distributions with finite variances and continuous positive densities with respect to the Lebesgue measure on \mathbf{R} , then the SDE*

$$d \begin{pmatrix} r \\ p \\ \tilde{\omega} q \end{pmatrix} = \begin{pmatrix} -\gamma \iota^* & \lambda \iota^* & 0 \\ -\lambda \iota^* \iota & 0 & -\tilde{\omega}^* \\ 0 & \tilde{\omega} & 0 \end{pmatrix} \begin{pmatrix} r \\ p \\ \tilde{\omega} q \end{pmatrix} dt - \begin{pmatrix} 0 \\ \nabla U(q) \\ 0 \end{pmatrix} dt + \begin{pmatrix} \mathbf{1} \\ 0 \\ 0 \end{pmatrix} \sum_{j \in J} \delta_j dN_j.$$

admits a unique stationary measure $\mu^{\text{inv}} \in \mathcal{P}(\mathbf{R}^J \oplus \mathbf{R}^I \oplus \mathbf{R}^I)$. Moreover, it is exponentially mixing in the sense that (4.7) holds for some constants $C > 0$ and $c > 0$, any $\mu \in \mathcal{P}(\mathbf{R}^J \oplus \mathbf{R}^I \oplus \mathbf{R}^I)$, and any time $t \geq 0$.

Proof sketch. If the noise $\sum_{j \in J} \delta_j N_j$ were replaced by a single compound Poisson process whose jump distribution possesses a finite second moment and a positive continuous density with respect to the Lebesgue measure on \mathbf{R}^J , then our Main Theorem would apply.

Although the probability that jumps in the different baths occur simultaneously is zero by independence, there is a positive probability that they occur arbitrarily close to simultaneity. Since an independent sum of a jump from each distribution gives a random variable with a finite variance and a positive continuous density with respect to the Lebesgue measure on \mathbf{R}^J , our control arguments can be adapted by continuity. \square

4.A Exponential estimates on hitting times

In this appendix, we present results on hitting times for the coupling (z_k, z'_k) constructed in Subsection 4.3.1. Loosely speaking, estimates on the hitting times of a small ball near \hat{x} are obtained by combining a lower bound on the hitting time of a (large) compact around the origin and a lower bound on the probability of making a transition from the aforementioned compact to the small ball. We shall assume that Conditions (C1)–(C3) are satisfied and fix the parameters m , r , and p as in Lemma 4.2.3.

We provide an estimate for the first simultaneous hitting time I of a ball of large radius R around the origin. To do this, we use the preliminary estimates of Lemma 4.2.1 to exhibit the existence of a suitable Lyapunov structure and conclude with a standard argument.

Lemma 4.A.1. *The function V defined by $V(y, y') := 1 + \|y\|^2 + \|y'\|^2$ is a Lyapunov function in the sense that there exist positive constants R and C_* and a constant $0 < a < 1$ such that*

$$\mathbf{E}_{(x, x')} V(z_m, z'_m) \leq a V(x, x') \quad \text{for } \|x\| \vee \|x'\| \geq R, \quad (4.42)$$

$$\mathbf{E}_{(x, x')} V(z_k, z'_k) \leq C_* \quad \text{for } \|x\| \vee \|x'\| < R, k \geq 0. \quad (4.43)$$

Proof. By Lemma 4.2.1, there is $\gamma \in (0, 1)$ such that

$$\begin{aligned} \mathbf{E}_{(x,x')}(1 + \|z_k\|^2 + \|z'_k\|^2) &= 1 + \mathbf{E}_x \|X_{\tau_k}\|^2 + \mathbf{E}_{x'} \|X_{\tau_k}\|^2 \\ &\leq 1 + \gamma^k (\|x\|^2 + \|x'\|^2) + 2C(1 + A) \end{aligned} \quad (4.44)$$

for all $k \in \mathbf{N}$ and $x, x' \in \mathbf{R}^d$. Taking $k = m$, any $a \in (0, \gamma^m)$, and any $x, x' \in \mathbf{R}^d$ such that

$$\|x\| \vee \|x'\| \geq (a - \gamma^m)^{-1/2} (1 - a + 2C(1 + A))^{1/2} =: R,$$

we get

$$\mathbf{E}_{(x,x')}(1 + \|z_m\|^2 + \|z'_m\|^2) \leq a (1 + \|x\|^2 + \|x'\|^2).$$

Thus, (4.42) holds. In the case $\|x\| \vee \|x'\| \leq R$, by (4.44), we have

$$\mathbf{E}_{(x,x')}(1 + \|z_k\|^2 + \|z'_k\|^2) \leq 1 + 2R^2 + 2C(1 + A) =: C_*.$$

This gives (4.43) and completes the proof of the lemma. \square

It is well known that the Lyapunov structure of the previous lemma implies a bound on an exponential moment for the time needed to reach a large enough level set of the Lyapunov function V . While arguments for this implication can be found in [MT12], we give a brief proof sketch and refer the reader to Proposition 3.1 in [Shi08] for a statement and complete proof which more precisely reflects our approach.

Corollary 4.A.2. *There exist positive constants R , c_1 , and C_1 such that*

$$\mathbf{E}_{(x,x')} e^{c_1 I} \leq C_1 (1 + \|x\|^2 + \|x'\|^2)$$

for all $x, x' \in \mathbf{R}^d$, where

$$I := \min\{j \in \mathbf{N}_m^0 : z_j, z'_j \in B(0, R)\}$$

Proof sketch. One can show using the Markov property and (4.42) repeatedly that

$$\mathbf{E}_{(x,x')} [\mathbf{1}_{\{I > nm\}} V(z_{nm}, z'_{nm})] \leq a^n V(x, x')$$

and deduce using $V \geq 1$ that

$$\mathbf{P}_{(x,x')}[I > nm] \leq a^n V(x, x'). \quad (4.45)$$

By (4.45) and the Borel–Cantelli lemma, I is almost surely finite. Therefore, one can use

$$\mathbf{E}_{(x,x')} e^{c_1 I} \leq 1 + \sum_{n=1}^{\infty} \mathbf{E}_{(x,x')} [\mathbf{1}_{\{I=nm\}} e^{c_1 I}]$$

and, for c_1 small enough, the right-hand side can be bounded using (4.45) in terms of $V(x, x')$ and a convergent geometric series. \square

In what follows R , c_1 and C_1 will be as in Corollary 4.A.2. We continue with another estimate on an exponential moment.

Lemma 4.A.3. *For any $M \in \mathbf{N}$, there is a constant $C_2 > 0$ such that*

$$\mathbf{E}_{(x,x')} e^{c_1 I_i} \leq C_2^i (1 + \|x\|^2 + \|x'\|^2) \quad (4.46)$$

for all $x, x' \in \mathbf{R}^d$ and $i \in \mathbf{N}$, where $I_0 := 0$ and

$$I_i := \min \{j \in \mathbf{N}_m : j \geq I_{i-1} + M \text{ and } z_j, z'_j \in B(0, R)\}.$$

Remark 4.A.4. *The stopping time I_i depends on both M and R . The value of R was already fixed in Corollary 4.A.2 and, in our application, M will be as in Lemma 4.A.5. It is important that the constant C_2 does not depend on x and x' .*

Proof. By our last corollary, the Markov property, and (4.12) in Lemma 4.2.1, we have

$$\begin{aligned} \mathbf{E}_{(x,x')} e^{c_1 I_1} &= e^{c_1 M} \mathbf{E}_{(x,x')} \left(\mathbf{E}_{(z_M, z'_M)} e^{c_1 I} \right) \\ &\leq C_1 e^{c_1 M} \mathbf{E}_{(x,x')} (1 + \|z_M\|^2 + \|z'_M\|^2) \\ &\leq C_1 e^{c_1 M} (1 + \gamma^M \|x\|^2 + \gamma^M \|x'\|^2 + 2C(1 + A)) \\ &\leq \tilde{C}_1 (1 + \|x\|^2 + \|x'\|^2) \end{aligned} \quad (4.47)$$

for \tilde{C}_1 a combination of C , C_1 and A . In particular, for any $x, x' \in B(0, R)$,

$$\mathbf{E}_{(x,x')} e^{c_1 I_1} \leq \tilde{C}_1 (1 + R^2 + R^2) =: C_2.$$

Then $z_{I_{i-1}}, z'_{I_{i-1}} \in B(0, R)$ for any $i > 1$, and therefore

$$\mathbf{E}_{(x,x')} e^{c_1 I_i} = \mathbf{E}_{(x,x')} \left(e^{c_1 I_{i-1}} \mathbf{E}_{(z_{I_{i-1}}, z'_{I_{i-1}})} e^{c_1 I_1} \right) \leq C_2 \mathbf{E}_{(x,x')} e^{c_1 I_{i-1}} \leq C_2^{i-1} \mathbf{E}_{(x,x')} e^{c_1 I_1}.$$

Finally, using (4.47), we obtain (4.46). \square

Lemma 4.A.5. *Consider the random variable*

$$J := \min \left\{ j \in \mathbf{N}_m^0 : z_j, z'_j \in B(\hat{x}, r) \right\},$$

where \hat{x} is as in Condition (C2). There exists $M \in \mathbf{N}_m$ such that

$$0 < q := \inf_{x, x' \in B(0, R)} \mathbf{P}_{(x, x')} \{ J \leq M \}. \quad (4.48)$$

Proof. Let T be the time in Condition (C2) for $\varepsilon = \frac{r}{2}$ and radius R . To simplify the presentation, we assume that $T = 1$.

Step 1: controlling a single trajectory of the SDE (4.1). First, let us show an inequality like (4.48) for a single trajectory of the SDE (4.1). Take an initial condition $x \in B(0, R)$. By Condition (C2), there exists a control $\zeta_x \in C([0, 1]; \mathbf{R}^n)$ such that

$$\|S(x, \zeta_x) - \hat{x}\| < \frac{r}{2}. \quad (4.49)$$

By a standard continuity and compactness argument, we can find a finite set

$$Z := \{ \zeta_i : i \in I \} \subset C([0, 1]; \mathbf{R}^n)$$

such that the control ζ_x in (4.49) can be chosen from Z for any $x \in B(0, R)$. For any integer $M \geq 1$, let the mapping $F_M : \mathbf{R}^d \times (\mathbf{R}_+)^M \times (\mathbf{R}^n)^M \rightarrow \mathbf{R}^d$ be defined by (4.18), let ι_M be as in Lemma 4.2.3, and consider the sets

$$\begin{aligned} \mathcal{A} &:= \left\{ \mathbf{s} = (s_j)_{j=1}^M \in (\mathbf{R}_+)^M : s_j \in \left(\frac{1-\delta}{M}, \frac{1}{M} \right), \quad j = 1, \dots, M \right\}, \\ \Xi_x &:= \left\{ \xi = (\xi_j)_{j=1}^M \in (\mathbf{R}^n)^M : \|\iota_M(\zeta_x) - \xi\|_{(\mathbf{R}^n)^M} < \delta, \quad j = 1, \dots, M \right\} \end{aligned}$$

for any $\delta > 0$. Again by a continuity and compactness argument, it is not hard to see that

$$\mathcal{A} \times \Xi_x \subset \left\{ \mathbf{s} \in (\mathbf{R}_+)^M, \xi \in (\mathbf{R}^n)^M : \|F_M(x, \mathbf{s}, \xi) - \hat{x}\| < r \right\}$$

for sufficiently large $M \in \mathbf{N}_m$, small $\delta > 0$, and any $x \in B(0, R)$. Note that $F_M(x, \mathbf{s}, \boldsymbol{\xi}) = X_{\tau_M}$ when $\mathbf{s} = (t_j)_{j=1}^M$ and $\boldsymbol{\xi} = (\eta_j)_{j=1}^M$. By our assumptions on the laws of t_j and η_j , it is clear that⁵

$$\mathcal{E}_\lambda^M(\mathcal{A}) = \prod_{j=1}^M \left(e^{-\lambda \frac{1-\delta}{M}} - e^{-\lambda \frac{1}{M}} \right) > 0,$$

$$\inf_{x \in B(0, R)} \ell^M(\Xi_x) > 0,$$

since there is only a finite number of sets Ξ_x for x in $B(0, R)$. We conclude that

$$0 < \inf_{x \in B(0, R)} \mathbf{P}_x \left\{ \|X_{\tau_M} - \hat{x}\| < r \right\}. \quad (4.50)$$

Step 2: case of coupling trajectories. We consider three cases.

- If $x = x'$, then the trajectories z_j and z'_j coincide for all j and the result follows immediately from (4.50).

- If $x \neq x'$ with $x, x' \in B(\hat{x}, r)$, then

$$\mathbf{P}_{(x, x')} \{J = 0\} = 1.$$

- If $x \neq x'$ not both in $B(\hat{x}, r)$, consider $\mathbf{s} \in \mathcal{A}$, $\boldsymbol{\xi} \in \Xi_x$, and $\boldsymbol{\xi}' \in \Xi_{x'}$. By construction, both $F_M(x, \mathbf{s}, \boldsymbol{\xi})$ and $F_M(x', \mathbf{s}, \boldsymbol{\xi})$ lie in $B(\hat{x}, r)$. Then, there exists a minimal $k \in \mathbf{N}_m$ such that both $F_k(x, \mathbf{s}, \boldsymbol{\xi})$ and $F_k(x', \mathbf{s}, \boldsymbol{\xi})$ lie in $B(\hat{x}, r)$. Necessarily, k satisfies $k \leq M$. Therefore, the construction of the coupling⁶ implies that z_k, z'_k are guaranteed to be in $B(\hat{x}, r)$ for some $k \leq M$ for all $\omega = (x, x', (\mathbf{s}_j, \tilde{\omega}_j)_{j \in \mathbf{N}})$ such that $(\mathbf{s}_j)_{j=1}^{M/m}$ lies in \mathcal{A} and such that $(\xi(x, x', \mathbf{s}_j, \tilde{\omega}_j))_{j=1}^{M/m}$ and $(\xi''(x, x', \mathbf{s}_j, \tilde{\omega}_j))_{j=1}^{M/m}$ lie respectively in Ξ_x and $\Xi_{x'}$. By construction,

$$\tilde{\mathbf{P}} \left\{ \tilde{\omega}_j : \xi(x, x', \mathbf{s}_j, \tilde{\omega}_j) \in \Xi_x \right\} = \ell^M(\Xi_x),$$

$$\tilde{\mathbf{P}} \left\{ \tilde{\omega}_j : \xi''(x, x', \mathbf{s}_j, \tilde{\omega}_j) \in \Xi_{x'} \right\} = \ell^M(\Xi_{x'}),$$

⁵Recall that \mathcal{E}_λ^M and ℓ^M stand for the M -fold products of the exponential distribution and ℓ , respectively.

⁶When the coupling starts with $x \neq x'$ not both in $B(\hat{x}, r)$, the first m jumps are independent. The probability of $z_m = z'_m$ is zero by our assumptions on ℓ . Thus going by blocks of m steps, we see that the jumps are independent until both trajectories simultaneously hit $B(\hat{x}, r)$ at a time which is a multiple of m .

and

$$\mathcal{E}_\lambda^M(\mathcal{A}) = \prod_{j=1}^M \left(e^{-\lambda \frac{1-\beta}{M}} - e^{-\lambda \frac{1}{M}} \right).$$

Then, independence gives

$$\mathbf{P}_{(x,x')} \{J \leq M\} \geq \ell^M(\Xi_x) \ell^M(\Xi_{x'}) \prod_{j=1}^M \left(e^{-\lambda \frac{1-\beta}{M}} - e^{-\lambda \frac{1}{M}} \right) > 0.$$

The uniformity in x and x' follows from the fact that there is only a finite number of sets Ξ_x and $\Xi_{x'}$ to consider as x and x' range over the set $B(0, R)$. \square

The main result of this appendix is the following exponential-moment bound on the random variable J . The argument used to deduce the proposition from the previous lemmas is well known and is for example discussed in depth in Section 3.3.2 in [KS12].

Proposition 4.A.6. *There are constants $\theta_2 > 0$ and $A_2 > 0$ such that*

$$\mathbf{E}_{(x,x')} e^{\theta_2 J} \leq A_2 (1 + \|x\|^2 + \|x'\|^2) \quad (4.51)$$

for all $x, x' \in \mathbf{R}^d$.

Proof. Let I_i be defined as in Lemma 4.A.3 with constant $M \in \mathbf{N}_m$ as in Lemma 4.A.5. Then

$$\mathbf{P}_{(x,x')} \{J > k\} \leq \mathbf{P}_{(x,x')} \{I_i < J\} + \mathbf{P}_{(x,x')} \{I_i \geq k\}$$

for any choice of integers $i, k \geq 1$. To control the first term, note that the Markov property and Lemma 4.A.5 imply

$$\mathbf{P}_{(x,x')} \{I_i < J\} \leq (1 - q) \mathbf{P}_{(x,x')} \{I_{i-1} < J\} \leq (1 - q)^{i-1}.$$

For the second term, we have the bound

$$\mathbf{P}_{(x,x')} \{I_i \geq k\} \leq C_2^i e^{-c_1 k} (1 + \|x\|^2 + \|x'\|^2)$$

by Chebyshev's inequality and Lemma 4.A.3. In particular, taking i scaling like εk for ε small enough, we find

$$\begin{aligned} \mathbf{P}_{(x,x')} \{J > k\} &\leq (1 - q)^{\varepsilon k - 1} + C_2^{\varepsilon k} e^{-c_1 k} (1 + \|x\|^2 + \|x'\|^2) \\ &\leq a^k (1 + \|x\|^2 + \|x'\|^2) \end{aligned}$$

for some $a \in (0, 1)$. This exponential decay of the probability yields the proposition for θ_2 small enough and A_2 large enough. \square

4.B Controllability of ODEs with polynomially growing nonlinearities

When the perturbation term g in (4.34) is a polynomial, this result follows from [JK85, Thm. 3] or [Jur97, Thm. 11 in Ch. 5] and the system is even exactly controllable. In the general case, when g is an arbitrary smooth function satisfying (i) and (ii), these results cannot be applied since the Hörmander condition is not necessarily satisfied at all the points. We adapt an argument used in [Ner20, Thm. 2.5] which is particularly simple in the case of ordinary differential equations. Let us consider the equation

$$\dot{u}(t) - \nu \Delta(u(t) + \xi(t)) + P_N F(u(t) + \xi(t)) = b + \zeta(t), \quad (4.52)$$

with two controls ξ and ζ in $C([0, T]; H_N)$.⁷ We denote by $S_t(u_0, \xi, \zeta)$ the solution of (4.52) satisfying the initial condition $u(0) = u_0$. To simplify the presentation, we shall assume that $a = 1$ in (4.34). Let us define a sequence $\{\mathcal{H}_i\}_{i \geq 1}$ of subspaces of H_N as follows: $\mathcal{H}_1 = H_1$ and

$$\mathcal{H}_i = \text{span} \left\{ P_N(\varphi_1 \cdot \dots \cdot \varphi_p) : \varphi_j \in \mathcal{H}_{i-1}, j = 0, \dots, p \right\}$$

for $i \geq 2$. The trigonometric identities (4.39) and (4.40) give that $s_{l \pm m}, c_{l \pm m} \in \mathcal{H}_i$, provided that $s_l, s_m, c_l, c_m \in \mathcal{H}_{i-1}$. Recalling the definition of H_1 , it is easy to infer that

$$\mathcal{H}_i = H_N \quad \text{for sufficiently large } i \geq 1. \quad (4.53)$$

We will also use another form of these subspaces:

$$\mathcal{H}_i = \text{span} \left\{ \varphi_0, P_N \varphi^p : \varphi_0, \varphi \in \mathcal{H}_{i-1} \right\} \quad (4.54)$$

for $i \geq 2$, which can be verified as in Lemma 4.2 in [Ner20].

⁷The idea of introducing the second control ξ comes from [AS05] and is nowadays extensively used in the control theory of PDEs with finite-dimensional controls (see the surveys [AS08, Shi18]).

The following lemma will play an important role in the proof of Proposition 4.4.2. It is established at the end of this subsection.

Lemma 4.B.1. *Under the conditions of Theorem 4.4.1, for any vectors $u_0, \varphi, \psi \in H_N$, we have*

$$S_{\delta}(u_0, \delta^{-1/p} \varphi, \delta^{-1} \psi) \rightarrow u_0 + \psi - P_N \varphi^p \quad \text{in } H_N \text{ as } \delta \rightarrow 0. \quad (4.55)$$

Proof of Proposition 4.4.2. By a general argument (see for example Step 4 in the proof of Theorem 2.3 in [Ner20]) approximate controllability in any fixed time $T > 0$ can be obtained from controllability in arbitrarily small time.

Lemma 4.B.1 gives that for all $u_0 \in H_N$, $\psi \in H_1 = \mathcal{H}_1$, $\varepsilon > 0$, and $T > 0$, there exists $\zeta \in C([0, \delta]; H_1)$ with $0 < \delta < T$ such that

$$\|S_{\delta}(u_0, \zeta) - (u_0 + \psi)\|_{L^2} < \varepsilon. \quad (4.56)$$

Because $H_N = \mathcal{H}_i$ for some i , we may proceed by induction on i : let us suppose that for all $u_0 \in H_N$, $\psi \in \mathcal{H}_{i-1}$, $\varepsilon > 0$, and $T > 0$, there exists $\zeta \in C([0, \delta]; H_1)$ with $0 < \delta < T$ such that (4.56) holds; we will show that this property then also holds for i , and the proof of the proposition will be complete.

Fix $u_0 \in H_N$. By (4.54), any $\psi \in \mathcal{H}_i$ can be written as a linear combination of elements of the form $P_N \varphi^p$ with $\varphi \in \mathcal{H}_{i-1}$, plus a vector in \mathcal{H}_{i-1} . Hence, by an iteration argument, it suffices to consider vectors ψ of the form $-P_N \varphi^p$ for some $\varphi \in \mathcal{H}_{i-1}$. Let $\varepsilon > 0$ and $T > 0$ be arbitrary. By Lemma 4.B.1, there exists $\delta_2 \in (0, \frac{1}{3}T)$ such that

$$\|S_{\delta_2}(u_0, \delta_2^{-1/p} \varphi, 0) - (u_0 - P_N \varphi^p)\|_{L^2} < \frac{1}{4} \varepsilon.$$

On the other hand, a change of variable shows

$$S_{\delta_2}(u_0, \delta_2^{-1/p} \varphi, 0) = S_{\delta_2}(u_0 + \delta_2^{-1/p} \varphi, 0) - \delta_2^{-1/p} \varphi$$

so that

$$\|S_{\delta_2}(u_0 + \delta_2^{-1/p} \varphi, 0) - (u_0 - P_N \varphi^p + \delta_2^{-1/p} \varphi)\|_{L^2} < \frac{1}{4} \varepsilon.$$

By continuity, there exists a radius $\rho > 0$ such that

$$\|S_{\delta_2}(u, 0) - (u_0 - P_N \varphi^p + \delta_2^{-1/p} \varphi)\|_{L^2} < \frac{1}{2} \varepsilon$$

for all u with

$$\|u - (u_0 + \delta_2^{-1/p} \varphi)\|_{L^2} < \rho.$$

By the induction hypothesis, there exists $\tilde{\zeta}_1 \in C([0, \delta_1]; H_1)$ with $0 < \delta_1 < \frac{1}{3}T$ such that $\|S_{\delta_1}(u_0, \tilde{\zeta}_1) - (u_0 + \delta_2^{-1/p} \varphi)\|_{L^2} < \rho$, and therefore such that

$$\|S_{\delta_2}(S_{\delta_1}(u_0, \tilde{\zeta}_1), 0) - (u_0 - P_N \varphi^p + \delta_2^{-1/p} \varphi)\|_{L^2} < \frac{1}{2} \varepsilon.$$

Yet again by the induction hypothesis, there exists $\tilde{\zeta}_3 \in C([0, \delta_3]; H_1)$ with $0 < \delta_3 < \frac{1}{3}T$ such that

$$\|S_{\delta_3}(S_{\delta_2}(S_{\delta_1}(u_0, \tilde{\zeta}_1), 0), \tilde{\zeta}_3) - (S_{\delta_2}(S_{\delta_1}(u_0, \tilde{\zeta}_1), 0) - \delta_2^{-1/p} \varphi)\|_{L^2} < \frac{1}{4} \varepsilon.$$

Therefore, by the triangle inequality,

$$\|S_{\delta_3}(S_{\delta_2}(S_{\delta_1}(u_0, \tilde{\zeta}_1), 0), \tilde{\zeta}_3) - (u_0 - P_N \varphi^p)\|_{L^2} < \frac{3}{4} \varepsilon.$$

We conclude that (4.56) holds with $\zeta \in C([0, \delta_1 + \delta_2 + \delta_3]; H_1)$ a good enough continuous approximation of the function $\mathbf{1}_{[0, \delta_1]} \tilde{\zeta}_1 + \mathbf{1}_{[\delta_1 + \delta_2, \delta_1 + \delta_2 + \delta_3]} \tilde{\zeta}_3(\cdot - (\delta_1 + \delta_2))$. Note that $0 < \delta_1 + \delta_2 + \delta_3 < T$ by construction. \square

Proof of Lemma 4.B.1. Fix $\varphi, \psi \in H_N$ and let $u(t) = S_t(u_0, \xi, \zeta)$ with the constant controls $\xi(t) \equiv \varphi$ and $\zeta(t) \equiv \psi$. Also let

$$w(t) := u_0 + t(\psi - P_N \varphi^p) \quad \text{and} \quad v(t) := u(\delta t) - w(t).$$

Clearly, the fact that u solves (4.52) with $u(0) = u_0$ implies that v solves

$$\dot{v}(t) - \nu \delta \Delta(v(t) + w(t) + \delta^{-1/p} \varphi) + \delta P_N F(v(t) + w(t) + \delta^{-1/p} \varphi) - P_N \varphi^p = \delta b$$

with $v(0) = 0$. Taking the scalar product in L^2 of this equation with $v(t)$, applying the Cauchy–Schwarz inequality, and dropping the arguments (t) for notational simplicity, we get

$$\frac{1}{2} \frac{d}{dt} \|v\|_{L^2}^2 \leq \left(\nu \delta \|\Delta w\|_{L^2} + \nu \delta^{1-1/p} \|\Delta \varphi\|_{L^2} + \delta \|b\|_{L^2} \right. \tag{4.57}$$

$$\left. + \|\delta P_N F(v + w + \delta^{-1/p} \varphi) - P_N \varphi^p\|_{L^2} \right) \|v\|_{L^2} \\ \leq C_1 \left(\delta^{1-1/p} + \|\delta P_N F(v + w + \delta^{-1/p} \varphi) - P_N \varphi^p\|_{L^2} \right) \|v\|_{L^2} \tag{4.58}$$

for any $t \leq 1$ and $\delta \leq 1$. Using the assumption (i) and the Young inequality, we obtain

$$\begin{aligned} \|\delta \mathbf{P}_N F(v + w + \delta^{-1/p} \varphi) - \mathbf{P}_N \varphi^p\|_{L^2} &\leq C_2 \delta \left(\|v\|_{L^2}^p + \|w\|_{L^2}^p + \delta^{-(p-1)/p} \|\varphi\|_{L^2}^{p-1} + 1 \right) \\ &\leq C_3 \delta \left(\|v\|_{L^2}^p + \delta^{-(p-1)/p} + 1 \right). \end{aligned} \quad (4.59)$$

Combining (4.58) and (4.59), we see that

$$\frac{d}{dt} \|v(t)\|_{L^2}^2 \leq C_4 \delta^{1/p} \left(\|v(t)\|_{L^2}^{p+1} + 1 \right). \quad (4.60)$$

Let us set $A_\delta := C_4 \delta^{1/p}$ and

$$\Phi(t) := A_\delta + A_\delta \int_0^t \|v(s)\|_{L^2}^{p+1} ds. \quad (4.61)$$

Then, (4.60) is equivalent to

$$(\dot{\Phi})^{2/(p+1)} \leq A_\delta^{2/(p+1)} \Phi,$$

and

$$\frac{\dot{\Phi}}{\Phi^{(p+1)/2}} \leq A_\delta.$$

Integrating this inequality, we derive

$$\Phi(t) \leq A_\delta \left(1 - \frac{p-1}{2} A_\delta^{(p+1)/2} t \right)^{-2/(p-1)}$$

for all $0 \leq t < 1 \wedge T_*(\delta)$, where

$$T_*(\delta) := \left(\frac{p-1}{2} A_\delta^{(p+1)/2} \right)^{-1}.$$

Because $T_*(\delta) \uparrow \infty$ monotonically as $\delta \downarrow 0$, there exists $\delta_0 > 0$ small enough that

$$\Phi(t) \leq 2A_\delta \quad (4.62)$$

for all $0 \leq t \leq 1$, whenever $0 < \delta \leq \delta_0$. Then, combining (4.60)–(4.62), we obtain

$$\|v(1)\|_{L^2}^2 \leq C_5 \delta^{1/p}$$

for some constant C_5 independent of δ . Thus $v(1) \rightarrow 0$ as $\delta \rightarrow 0$, which implies (4.55). \square

4.C Some results from measure theory

4.C.1 Maximal couplings

Let \mathcal{X} , \mathcal{Y} , and \mathcal{U} be Polish spaces endowed with their Borel σ -algebras, $u \in \mathcal{U} \mapsto \mu(u, \cdot)$, $\mu'(u, \cdot)$ be two random probability measures on \mathcal{X} , and $F : \mathcal{X} \rightarrow \mathcal{Y}$ be a measurable mapping. We denote by $F_*\mu(u, \cdot)$ the image of $\mu(u, \cdot)$ under F (similarly for μ'). The following lemma on the existence of maximal couplings is a particular case of Exercise 1.2.30.ii in [KS12] (see the last section of the book for a proof).

Lemma 4.C.1. *There is a probability space $(\Omega, \mathcal{F}, \mathbf{P})$ and measurable mappings $\xi, \xi' : \mathcal{U} \times \Omega \rightarrow \mathcal{X}$ such that the following two properties are satisfied:*

- for all $u \in \mathcal{U}$, $(\xi(u, \cdot), \xi'(u, \cdot))$ is a coupling of $\mu(u, \cdot)$ and $\mu'(u, \cdot)$ in the sense that

$$\xi(u, \cdot)_* \mathbf{P} = \mu(u, \cdot) \quad \text{and} \quad \xi'(u, \cdot)_* \mathbf{P} = \mu'(u, \cdot); \quad (4.63)$$

- for all $u \in \mathcal{U}$, $(F(\xi(u, \cdot)), F(\xi'(u, \cdot)))$ is a maximal coupling of $F_*\mu(u, \cdot)$ and $F_*\mu'(u, \cdot)$ in the sense that

$$\mathbf{P}(\{\omega \in \Omega : F(\xi(u, \omega)) \neq F(\xi'(u, \omega))\}) = \|F_*\mu(u, \cdot) - F_*\mu'(u, \cdot)\|_{\text{var}} \quad (4.64)$$

and the random variables $F(\xi(u, \cdot))$ and $F(\xi'(u, \cdot))$ conditioned on the event

$$\{\omega \in \Omega : F(\xi(u, \omega)) \neq F(\xi'(u, \omega))\}$$

are independent.

4.C.2 Images of measures under regular mappings

Let \mathcal{X} be a compact metric space, \mathcal{Y} and \mathcal{U} be finite-dimensional spaces, and $F : \mathcal{X} \times \mathcal{U} \rightarrow \mathcal{Y}$ be a continuous mapping. The following is a consequence of a more general result proved in Theorem 2.4 in [Shi07] (see also Chapter 9 of [Bog10]). In this simplified context in finite dimension, it can be proven directly from the implicit function theorem and a change of variable.

Lemma 4.C.2. *Assume that the mapping $F(x, \cdot) : \mathcal{U} \rightarrow \mathcal{Y}$ is differentiable for any $x \in \mathcal{X}$, the derivative $D_u F$ is continuous on $\mathcal{X} \times \mathcal{U}$, the image of the linear operator $(D_u F)(\hat{x}, \hat{u})$ has full rank for some $(\hat{x}, \hat{u}) \in \mathcal{X} \times \mathcal{U}$, and $\rho \in \mathcal{P}(\mathcal{U})$ is a measure possessing a positive continuous density with respect to the Lebesgue measure on \mathcal{U} . Then there is a continuous function $\psi : \mathcal{X} \times \mathcal{Y} \rightarrow \mathbf{R}_+$ and a number $r > 0$ such that*

$$\psi(\hat{x}, F(\hat{x}, \hat{u})) > 0,$$

and

$$(F_*(x, \cdot)\rho)(dy) \geq \psi(x, y) dy$$

(as measures on \mathcal{Y}) for all $x \in B_{\mathcal{X}}(\hat{x}, r)$.

Bibliography

- [AK87] L. Arnold and W. Kliemann. On unique ergodicity for degenerate diffusions. *Stochastics*, 21(1):41–61, 1987.
- [AKSS07] A. A. Agrachev, S. Kuksin, A. V. Sarychev, and A. Shirikyan. On finite-dimensional projections of distributions for solutions of randomly forced 2D Navier–Stokes equations. *Ann. Inst. Henri Poincaré (B) Probab. Statist.*, 43(4):399–415, 2007.
- [AS05] A. A. Agrachev and A. V. Sarychev. Navier–Stokes equations: controllability by means of low modes forcing. *J. Math. Fluid Mech.*, 7(1):108–152, 2005.
- [AS08] A. A. Agrachev and A. V. Sarychev. Solid controllability in fluid dynamics. In *Instability in Models Connected with Fluid Flows. I*, volume 6 of *Int. Math. Ser.*, pages 1–35. Springer, New York, 2008.
- [BC09] A. Baule and E. G. D. Cohen. Fluctuation properties of an effective nonlinear system subject to poisson noise. *Phys. Rev. E*, 79:030103, 2009.
- [Bog10] V. I. Bogachev. *Differentiable measures and the Malliavin calculus*, volume 164 of *Mathematical Surveys and Monographs*. Amer. Math. Soc., 2010.

- [CEHRB18] N. Cuneo, J.-P. Eckmann, M. Hairer, and L. Rey-Bellet. Non-equilibrium steady states for networks of oscillators. *Electron. J. Probab.*, 23(Paper No. 55):1–28, 2018.
- [Cor07] J.-M. Coron. *Control and nonlinearity*, volume 136 of *Mathematical Surveys and Monographs*. Amer. Math. Soc., 2007.
- [DPZ96] G. Da Prato and J. Zabczyk. *Ergodicity for infinite dimensional systems*, volume 229 of *London Math. Soc. Lecture Notes Series*. Cambridge University Press, 1996.
- [EH00] J.-P. Eckmann and M. Hairer. Non-equilibrium statistical mechanics of strongly anharmonic chains of oscillators. *Commun. Math. Phys.*, 212(1):105–164, 2000.
- [EPRB99a] J.-P. Eckmann, C.-A. Pillet, and L. Rey-Bellet. Entropy production in nonlinear, thermally driven Hamiltonian systems. *J. Stat. Phys.*, 95(1-2):305–331, 1999.
- [EPRB99b] J.-P. Eckmann, C.-A. Pillet, and L. Rey-Bellet. Non-equilibrium statistical mechanics of anharmonic chains coupled to two heat baths at different temperatures. *Commun. Math. Phys.*, 201(3):657–697, 1999.
- [FKM65] G. W. Ford, M. Kac, and P. Mazur. Statistical mechanics of assemblies of coupled oscillators. *J. Math. Phys.*, 6:504–515, 1965.
- [Gri75] D. Griffeath. A maximal coupling for Markov chains. *Z. Wahrscheinlichkeitstheorie und Verw. Gebiete*, 31:95–106, 1974/75.
- [Hai11] M. Hairer. On Malliavin’s proof of Hörmander’s theorem. *Bull. Sci. Math.*, 135(6-7):650–666, 2011.
- [JK85] V. Jurdjevic and I. Kupka. Polynomial control systems. *Math. Ann.*, 272(3):361–368, 1985.
- [JP97] V. Jakšić and C.-A. Pillet. Ergodic properties of the non-Markovian Langevin equation. *Lett. Math. Phys.*, 41(1), 1997.
- [JP98] V. Jakšić and C.-A. Pillet. Ergodic properties of classical dissipative systems I. *Acta Math.*, 181(2):245–282, 1998.
- [JPS17] V. Jakšić, C.-A. Pillet, and A. Shirikyan. Entropic fluctuations in thermally driven harmonic networks. *J. Stat. Phys.*, 166(3):926–1015, Feb 2017.

- [Jur97] V. Jurdjevic. *Geometric control theory*, volume 52 of *Cambridge Studies in Advanced Mathematics*. Cambridge University Press, 1997.
- [Kha12] R. Khasminskii. *Stochastic stability of differential equations*, volume 66 of *Stochastic Modelling and Applied Probability*. Springer, Heidelberg, second edition, 2012. With contributions by G. N. Milstein and M. B. Nevelson.
- [KS12] S. Kuksin and A. Shirikyan. *Mathematics of two-dimensional turbulence*, volume 194 of *Cambridge Tracts in Mathematics*. Cambridge University Press, 2012.
- [MG12] W. A. M. Morgado and T. Guerreiro. A study on the action of non-Gaussian noise on a Brownian particle. *Physica A Stat. Mech. Appl.*, 391(15):3816–3827, 2012.
- [MQSP11] W. A. M. Morgado, S. M. D. Queirós, and D. O. Soares-Pinto. On exact time averages of a massive Poisson particle. *J. Stat. Mech. Theory Exp.*, 2011(06):P06010, 2011.
- [MT93] S. P. Meyn and R. L. Tweedie. *Markov Chains and Stochastic Stability*. Springer-Verlag, 1993.
- [MT12] S. P. Meyn and R. L. Tweedie. *Markov chains and stochastic stability*. Communications and Control Engineering Series. Springer Science & Business Media, 2012.
- [Ner08] V. Nersesyan. Polynomial mixing for the complex Ginzburg-Landau equation perturbed by a random force at random times. *J. Evol. Equ.*, 8(1):1–29, 2008.
- [Ner20] V. Nersesyan. Approximate controllability of nonlinear parabolic PDEs in arbitrary space dimension. *Math. Control Relat. Fields*, To appear, 2020.
- [Nua06] D. Nualart. *The Malliavin Calculus and Related Topics*. Springer-Verlag, Berlin, 2006.
- [Raq19] R. Raquépas. A note on Harris’ ergodic theorem, controllability and perturbations of harmonic networks. *Ann. Henri Poincaré*, 20(2):605–629, 2019.
- [RBT02] L. Rey-Bellet and L. E. Thomas. Exponential convergence to non-equilibrium stationary states in classical statistical mechanics. *Commun. Math. Phys.*, 225(2):305–329, 2002.
- [Shi07] A. Shirikyan. Qualitative properties of stationary measures for three-dimensional Navier-Stokes equations. *J. Funct. Anal.*, 249(2):284–306, 2007.

- [Shi08] A. Shirikyan. Exponential mixing for randomly forced partial differential equations: method of coupling. In *Instability in models connected with fluid flows. II*, volume 7 of *Int. Math. Ser. (N. Y.)*, pages 155–188. Springer, New York, 2008.
- [Shi17] A. Shirikyan. Controllability implies mixing. I. Convergence in the total variation metric. *Uspekhi Mat. Nauk*, 72(5(437)):165–180, 2017.
- [Shi18] A. Shirikyan. Control theory for the Burgers equation: Agrachev-Sarychev approach. *Pure Appl. Funct. Anal.*, 3(1):219–240, 2018.
- [SL77] H. Spohn and J. L. Lebowitz. Stationary non-equilibrium states of infinite harmonic systems. *Commun. Math. Phys.*, 54(2):97–120, 1977.
- [TC09] H. Touchette and E. G. D. Cohen. Anomalous fluctuation properties. *Phys. Rev. E*, 80:011114, Jul 2009.
- [Tro77] M. M. Tropper. Ergodic and quasideterministic properties of finite-dimensional stochastic systems. *J. Stat. Phys.*, 17(6):491–509, 1977.

Chapter 5

On Fermionic walkers interacting with a correlated structured environment

Author Renaud Raquépas

arXiv ID 1902.03703

Year published 2020

Journal Lett. Math. Phys. 110(1):121–145

Abstract We study the large-time behaviour of a sample \mathcal{S} consisting of an ensemble of fermionic walkers on a graph interacting with a structured infinite reservoir of fermions \mathcal{E} through an exchange of particles in preferred states. We describe the asymptotic state of \mathcal{S} in terms of the initial state of \mathcal{E} , with especially simple formulae in the limit of small coupling strength. We also study the particle fluxes into the different parts of the reservoir.

5.1 Introduction

At times arising as successful approximations of continuous-time quantum evolutions that are of interest to experimental and theoretical physicists, at times arising as natural quantum counterparts of classical discrete-time processes in different sciences, discrete-time quantum evolutions have become an extensively studied topics in mathematical physics. Examples of the first kind appear in the effective description of quantum systems that repeatedly interact with probes [KM00, BJM14], quantum systems that undergo time-periodic driving [How74, Yaj77] or models related to the quantum Hall effect, where strong perpendicular magnetic fields are involved [CC88, KOK05]; examples of the second kind can be found in quantum information science [Mey96, Wat01].

Discrete-time quantum evolutions where the dynamics for a single time step only couples neighbouring sites of a (possibly infinite) graph are often referred to as *quantum walks* and have been studied extensively in the last twenty years; see for example [AAKV01, Kem03, VA12, Por13]. Most works on the subject consider a single particle, called a *quantum walker*. However, interesting phenomena arise when two walkers are coupled [AAM⁺12, SBP⁺17] and natural questions concerning the collective behaviour of a variable number of walkers arise, especially by analogy with phenomena of Hamiltonian quantum statistical mechanics such as return to equilibrium, existence of nonequilibrium steady states, entropy production, et cetera. This was initiated by Hamza and Joye in the work [HJ17], where they prove a form of return to equilibrium for ensembles of walkers interacting with a chain of auxiliary fermions in two special cases of the model considered here.

The main model under consideration concerns a finite graph on which a variable number of noninteracting fermions may hop to a neighbouring vertex at discrete times. We call this component of the system the sample \mathcal{S} . The free dynamics in Fock space is given by the second quantization of a one-particle unitary matrix W . To model the interaction with an environment, we introduce an auxiliary bi-infinite chain \mathcal{E} of sites where fermions are forced to hop to their left at discrete times. The free dynamics there is thus described by the second quantization of a shift operator S . These two components of the system then interact through a term which allows the exchange of particles in preferred states. The intensity of this exchange is controlled by a coupling constant α . They undergo a step of free evolution, a step of interaction evolution, a step of free evolution, and so on.

We consider the case in which the environment \mathcal{E} is in an initial state which is translational-invariant,

gauge-invariant (GI) and quasi-free (QF), described at the one-particle level by a function F of the shift operator S . Most notably, we show that the asymptotic state in the sample \mathcal{S} is then also GIQF and completely described by its own dynamics \mathcal{W} and the same function F , up to an interaction-dependent deformation which vanishes in the limit $\alpha \rightarrow 0$. This deformation is explicit. This is a generalization of the results of Hamza and Joye in [HJ17]: they had covered the cases where the sites in the environment \mathcal{E} are uncorrelated or where the free hopping in the sample \mathcal{S} is a uni-directional shift on a ring.

We further generalize to more complicated structured environments by considering $m \geq 1$ internal degrees of freedom at each site of the bi-infinite chain and a dynamics determined at the one-particle level by $S \otimes U$ for some unitary m -by- m matrix U with simple eigenvalues. Invariance of the state under the dynamics and under translations along the chain yield a set $(\pi_i)_{i=1}^m$ of rank-one projections such that the symbol describing the initial state of the environment \mathcal{E} is $\sum_{i=1}^m (2 \operatorname{Re} F_i(S^* \otimes U^*)) (\mathbf{1} \otimes \pi_i)$ for some family $(F_i)_{i=1}^m$ of functions. In this generalized version of the model, the asymptotic state in the sample \mathcal{S} is again GIQF and completely described by its own dynamics \mathcal{W} and the functions $(F_i)_{i=1}^m$ — again up to an explicit α -dependent correction — ; see Theorem 5.4.3. We can also study the flux of particles into the different parts $(\mathcal{E}_i)_{i=1}^m$ of the environment \mathcal{E} and determine — for small enough couplings — the signs by comparing the values of the functions $(F_i)_{i=1}^m$ at the point 1.

In Section 5.2, we introduce more precisely the description of the spaces, observables and dynamics; we leave some comments on the choice of quantum statistics and interaction for Appendix 5.A. We devote Section 5.3 to a discussion of the initial state of the system. This is where we introduce the decomposition of the translation-invariant environment \mathcal{E} into different parts $(\mathcal{E}_i)_{i=1}^m$, to each of which is associated a scalar function F_i . In Section 5.4, we state our main results on the asymptotic state in the sample and asymptotic fluxes out of the different parts of the environment. We present more concrete examples with $m = 1$ in Section 5.5. For a model on a ring, we get an explicit expression for the profile of the particle density as a function of the node of the graph and for the corresponding correlations between the occupation of two nodes. We also study the role of disorder and of the essential range of the function F in the limit of an infinitely large sample.

5.2 The system and its dynamics

5.2.1 A quantum walk in a sample

In this subsection, we introduce the description of the sample, which is the small system of interest interacting with an environment. We start by considering a single walker for two classes of graphs, and then introduce our general assumptions and the passage to a variable number of fermionic walkers.

The coined walk on a cycle

We first wish to start by describing the motion of a spin- $\frac{1}{2}$ quantum walker on a cycle of n vertices. Let $\{\delta_0, \delta_1, \dots, \delta_{n-1}\}$ be an orthonormal basis for \mathbf{C}^n , the Hilbert space for the position, and let $\{e_{-1}, e_{+1}\}$ be an orthonormal basis for \mathbf{C}^2 , the Hilbert space for the spin. The unitary

$$W_1 := \sum_{\nu=0}^{n-1} \sum_{\tau=\pm 1} \delta_{\nu+\tau} \otimes e_{\tau} \langle \delta_{\nu} \otimes e_{\tau}, \cdot \rangle,$$

on $\mathbf{C}^n \otimes \mathbf{C}^2$, with the arithmetics on the index ν understood modulo n , can be interpreted as follows. If a walker is located on the site ν with its spin up [resp. down], it moves clockwise [resp. counter-clockwise] and its spin variable is unchanged. A second unitary

$$W_2 := \sum_{\nu=0}^{n-1} \delta_{\nu} \langle \delta_{\nu}, \cdot \rangle \otimes C_{\nu},$$

where each C_{ν} is a 2-by-2 unitary called a coin matrix, is used to locally change the spin variable. The so-called Hadamard coin $\frac{1}{\sqrt{2}} \begin{pmatrix} 1 & 1 \\ -1 & 1 \end{pmatrix}$ is most often considered in the literature.

The product

$$W := W_1 W_2,$$

a unitary on the finite dimensional Hilbert space $\mathcal{H}_{\mathcal{S}} = \mathbf{C}^n \otimes \mathbf{C}^2$, gives a dynamics for a single time step where a quantum coin is shuffled, and the walker hops to a neighbouring site or the other depending on the outcome of the coin.

If each coin matrix C_{ν} is such that $\langle e_{+1}, C_{\nu} e_{+1} \rangle \langle e_{+1}, C_{\nu} e_{-1} \rangle \neq 0$, then the vector $\psi_* = \delta_0 \otimes e_{-1}$ is cyclic for W . Such a preferred state will be used later to introduce exchange of particles with the environment, and cyclicity will ensure good propagation of the interaction.

Coined walks on some more general graphs

We now treat a second class of graphs, called class-1 regular graphs in [Por13], for which we can give a precise description of the dynamics without introducing too much machinery from graph theory.

Let G be a finite r -regular graph with n vertices whose edges can be coloured with r colours, $a = 0, \dots, r-1$, and consider the unitary

$$W_1 := \sum_{\nu=0}^{n-1} \sum_{a=0}^{r-1} \delta_{\nu'(\nu,a)} \otimes e_a \langle \delta_\nu \otimes e_a, \cdot \rangle$$

on $\mathbf{C}^n \otimes \mathbf{C}^r$, where $\nu'(\nu, a)$ is the unique vertex such that (ν, ν') is an edge of colour a . By a standard result, the colouring property forces n to be even. The action of W_1 is interpreted as follows. If a walker is at the node ν , looking along the edge of color a , after one time step, it will go to the node ν' at the other end of this edge, now facing where it came from.

We also introduce a unitary coin matrix C_ν at each node ν and the unitary

$$W_2 := \sum_{\nu=0}^{n-1} \delta_\nu \langle \delta_\nu, \cdot \rangle \otimes C_\nu.$$

on $\mathbf{C}^n \otimes \mathbf{C}^r$. The role of the coin matrix is to change the direction in which the walker is looking into a normalized superposition of directions.

Finally, we set

$$W := W_1 W_2.$$

This unitary matrix W on the finite-dimensional Hilbert space $\mathcal{H}_\varphi = \mathbf{C}^n \otimes \mathbf{C}^r$ of dimension $d = nr$ describes the discrete-time dynamics for a single walker on the graph G . Under generic assumptions on the coin matrices, the matrix W will admit a cyclic vector ψ_* .

General formulation and second quantization

Quantum walks on more general classes of finite graphs can be given a similar description using slightly heavier machinery from graph theory; see for example Chapter 7 in [Por13]. Any description of a quantum walk on a (directed) graph $G = (V, E)$ should involve a unitary W on a space of the form $\mathbf{C}^{|V|} \otimes \mathbf{C}^r$ whose matrix elements $\langle \delta_{\nu'} \otimes w, W(\delta_\nu \otimes w) \rangle$ vanish unless (ν, ν') is in the set E of (directed) edges of G .

The specific structure of W inherited from the graph is irrelevant for most of our computations and results and will only be used in the interpretation of some asymptotic results, especially in Section 5.5. Hence,

for the rest of the paper we will consider that the one-particle dynamics W on a d -dimensional Hilbert space \mathcal{H}_φ and the unit vector $\psi_* \in \mathcal{H}_\varphi$ are admissible whenever W is unitary and ψ_* is cyclic for W .

A variable number of non-interacting fermionic walkers are then described on the algebra $\text{CAR}(\mathcal{H}_\varphi)$ of canonical anti-commutation relations, which we represent on the fermionic Fock space $\Gamma^-(\mathcal{H}_\varphi)$, with the creation [resp. annihilation] operator associated to the one-particle state $\psi \in \mathcal{H}_\varphi$ denoted by $a^*(\psi)$ [resp. $a(\psi)$]. We have the usual norm identity $\|a^\#(\psi)\| = \|\psi\|$ for each $\psi \in \mathcal{H}_\varphi$. Here and in what follows, $a^\#$ is used as a placeholder for either a^* or a .

The discrete-time dynamics there is given by

$$a^\#(\psi) \mapsto a^\#(W^* \psi)$$

for all $\psi \in \mathcal{H}_\varphi$, extended by linearity to $\text{CAR}(\mathcal{H}_\varphi)$. We refer to this as the free dynamics in the *sample* \mathcal{S} .

5.2.2 Interaction with an environment

To model interaction of the sample \mathcal{S} with an environment \mathcal{E} , we introduce the Hilbert space $\mathcal{H}_\mathcal{E} := \ell^2(\mathbf{Z}) \otimes \mathbf{C}^m$ and the one-particle dynamics $S \otimes U$ there, where S is the shift $\delta_\ell \mapsto \delta_{\ell-1}$ on $\ell^2(\mathbf{Z}) = \{\sum_{\ell \in \mathbf{Z}} a_\ell \delta_\ell : \{a_\ell : \ell \in \mathbf{Z}\} \subset \mathbf{C}, \sum_{\ell \in \mathbf{Z}} |a_\ell|^2 < \infty\}$ and U is an arbitrary unitary on \mathbf{C}^m with simple eigenvalues.

A variable number of walkers in this environment are then described on the algebra $\text{CAR}(\mathcal{H}_\mathcal{E})$ with discrete-time dynamics given by

$$b^\#(\varphi) \mapsto b^\#((S^* \otimes U^*)\varphi)$$

for all $\varphi \in \mathcal{H}_\mathcal{E}$, extended by linearity to $\text{CAR}(\mathcal{H}_\mathcal{E})$.¹ We refer to this as the free dynamics in the *environment* \mathcal{E} .

Recall that we assume that the unitary W used to describe the free dynamics in the sample \mathcal{S} admits a cyclic vector $\psi_* \in \mathcal{H}_\varphi$. We use this vector to construct the interaction unitary

$$K_\alpha := \exp[-i\alpha(b^*(\delta_0 \otimes v) \otimes a(\psi_*) + b(\delta_0 \otimes v) \otimes a^*(\psi_*))]$$

on $\text{CAR}(\mathcal{H}_\mathcal{E}) \otimes \text{CAR}(\mathcal{H}_\varphi)$, where $v \in \mathbf{C}^m$ is a unit vector and where $\alpha \in \mathbf{R} \setminus \pi\mathbf{Z}$ is a coupling constant. The environment and the interaction remain simple enough to yield one of the rare analytical results

¹We represent the CAR in the environment \mathcal{E} on $\Gamma^-(\mathcal{H}_\mathcal{E})$ and use $b^*(\varphi)$ [resp. $b(\varphi)$] for the creation [resp. annihilation] operator associated to the vector $\varphi \in \mathcal{H}_\mathcal{E}$. We use $b^\#$ as a placeholder for either b^* or b .

on such systems, yet possess enough parameters to allow an investigation of interesting phenomena which should arise similarly in more complex systems. By considering the algebra $\text{CAR}(\mathcal{H}_{\mathcal{E}}) \otimes \text{CAR}(\mathcal{H}_{\mathcal{S}})$, we are specifying that the fermions in the sample and in the environment are distinguishable. Folklore suggests that such details of the description of the environment should not influence the asymptotics in the sample \mathcal{S} ; see Appendix 5.A for a further discussion. We will often omit tensored identities and tensor products between $a^\#$ s and $b^\#$ s.

To the unitary K_α is closely related the rank-one operator

$$\begin{aligned} \iota : \mathcal{H}_{\mathcal{S}} &\rightarrow \mathcal{H}_{\mathcal{E}} \\ \psi &\mapsto \delta_0 \otimes v \langle \psi_*, \psi \rangle \end{aligned}$$

and its adjoint ι^* . We introduce the shorthands P for the projector $\iota^* \iota$ on $\mathcal{H}_{\mathcal{S}}$ and Q for the projector $\iota \iota^*$ on $\mathcal{H}_{\mathcal{E}}$.

We consider the following coupled discrete-time Heisenberg dynamics:

$$\tau(X) := K_\alpha^* (\Gamma(S^* \otimes U^*) \otimes \Gamma(W^*)) X (\Gamma(S \otimes U) \otimes \Gamma(W)) K_\alpha$$

for all observables X in $\text{CAR}(\mathcal{H}_{\mathcal{E}}) \otimes \text{CAR}(\mathcal{H}_{\mathcal{S}})$. This describes a dynamics where both the sample and the environment first evolve independently, and then are allowed to interact through a term which exchanges particles in the state $\psi_* \in \mathcal{H}_{\mathcal{S}}$ and the state $\delta_0 \otimes v \in \mathcal{H}_{\mathcal{E}}$. This dynamics preserves the total number of fermions and the strength of the interaction is controlled by the coupling constant α .

The joint dynamics is given by a product of unitaries which cannot be written as the exponential of a sum of physically significant free Hamiltonians and an interaction potential. For this reason, many of the tools and definitions from Hamiltonian quantum statistical mechanics — most notably the notion of temperature — are not available.

We have the following lemmas, which will serve as building blocks for our computation of the evolution of observables of interest. As can be seen from the formulae, the case $\alpha \in \pi\mathbf{Z}$ is in some sense trivial and we later exclude it from our analysis.

Lemma 5.2.1. *For all $\psi \in \mathcal{H}_{\mathcal{S}}$*

$$K_\alpha a^\#(\psi) K_\alpha = a^\#((\mathbf{1} + (\cos \alpha - 1)P)\psi) - i \sin \alpha b^\#(\iota\psi), \quad (5.1)$$

and for all $\varphi \in \mathcal{H}_{\mathcal{E}}$

$$K_\alpha b^\#(\varphi) K_\alpha = b^\#((\mathbf{1} + (\cos \alpha - 1)Q)\varphi) - i \sin \alpha a^\#(\iota^*\varphi). \quad (5.2)$$

Proof. The functions $\alpha \mapsto K_\alpha b^\#(\varphi)K_\alpha$ and $\alpha \mapsto K_\alpha a^\#(\psi)K_\alpha$ are real-analytic and hence completely determined by their derivatives in $\alpha = 0$. Both formulae in the lemma are obtained by differentiating and exploiting the canonical anticommutation relations $\{a^*(\psi_1), a(\psi_2)\} := a^*(\psi_1)a(\psi_2) + a(\psi_2)a^*(\psi_1) = \langle \psi_2, \psi_1 \rangle \mathbf{1}$ and $\{a(\psi_1), a(\psi_2)\} = 0$ and the commutation relation $b^{\#1}(\varphi_1)a^{\#2}(\psi_2) = a^{\#2}(\psi_2)b^{\#1}(\varphi_1)$ for all $\psi_1, \psi \in \mathcal{H}_\mathcal{F}$ and $\varphi_1 \in \mathcal{H}_\mathcal{G}$. We omit the subscript α to lighten the notation.

Indeed, differentiating,

$$\begin{aligned} \frac{d}{d\alpha} K a^*(\psi) K &= -iK \{b(\partial_0 \otimes v) a^*(\psi_*) + b^*(\partial_0 \otimes v) a(\psi_*), a^*(\psi)\} K \\ &= -iK \langle \psi_*, \psi \rangle b^*(\partial_0 \otimes v) K \\ &= -iK b^*(\iota\psi) K. \end{aligned}$$

Similarly,

$$\frac{d}{d\alpha} K b^*(\varphi) K = -iK a^*(\iota^* \varphi) K.$$

As a consequence of the definition of $P = \iota^* \iota$ and the identity $\iota \iota^* \iota = \iota$, for all $n \geq 0$,

$$\begin{aligned} \frac{d^{2n+1}}{d\alpha^{2n+1}} K a^*(\psi) K &= (-i)^{2n+1} K b^*(\iota\psi) K, \\ \frac{d^{2n+2}}{d\alpha^{2n+2}} K a^*(\psi) K &= (-i)^{2n+2} K a^*(P\psi) K \end{aligned}$$

so that

$$K a^*(\psi) K = a^*(\psi) + \sum_{n \geq 0} \frac{(-i\alpha)^{2n+1}}{(2n+1)!} b^*(\iota\psi) + \frac{(-i\alpha)^{2n+2}}{(2n+2)!} a^*(P\psi).$$

The other formula is obtained similarly. □

Lemma 5.2.2. *For all $\psi_1, \psi_2 \in \mathcal{H}_\mathcal{F}$*

$$\begin{aligned} &\tau(a^{\#1}(\psi_1)a^{\#2}(\psi_2)) \\ &= a^{\#1}((\mathbf{1} + (\cos \alpha - 1)P)W^* \psi_1) a^{\#2}((\mathbf{1} + (\cos \alpha - 1)P)W^* \psi_2) \\ &\quad + i \sin \alpha a^{\#1}((\mathbf{1} + (\cos \alpha - 1)P)W^* \psi_1) b^{\#2}(\iota W^* \psi_2) \\ &\quad - i \sin \alpha b^{\#1}(\iota W^* \psi_1) a^{\#2}((\mathbf{1} + (\cos \alpha - 1)P)W^* \psi_2) \\ &\quad + \sin^2 \alpha b^{\#1}(\iota W^* \psi_1) b^{\#2}(\iota W^* \psi_2) \end{aligned} \tag{5.3}$$

and, for all $\varphi_1, \varphi_2 \in \mathcal{H}_{\mathcal{E}}$,

$$\begin{aligned} & \tau(b^{\#1}(\varphi_1)b^{\#2}(\varphi_2)) \\ &= b^{\#1}((\mathbf{1} + (\cos \alpha - 1)Q)S^*U^*\varphi_1)b^{\#2}((\mathbf{1} + (\cos \alpha - 1)Q)S^*U^*\varphi_2) \\ & \quad - i \sin \alpha a^{\#1}(i^*S^*U^*\varphi_1)b^{\#2}((\mathbf{1} + (\cos \alpha - 1)Q)S^*U^*\varphi_2) \\ & \quad + i \sin \alpha b^{\#1}((\mathbf{1} + (\cos \alpha - 1)Q)S^*U^*\varphi_1)a^{\#2}(i^*S^*U^*\varphi_2) \\ & \quad + \sin^2 \alpha a^{\#1}(i^*S^*U^*\varphi_1)a^{\#2}(i^*S^*U^*\varphi_2). \end{aligned}$$

Moreover, for all $\psi_1 \in \mathcal{H}_{\mathcal{F}}$ and $\varphi_2 \in \mathcal{H}_{\mathcal{E}}$,

$$\begin{aligned} & \tau(b^{\#1}(\varphi_1)a^{\#2}(\psi_2)) \\ &= b^{\#1}((\mathbf{1} + (\cos \alpha - 1)Q)S^*U^*\varphi_1)a^{\#2}((\mathbf{1} + (\cos \alpha - 1)P)W^*\psi_2) \\ & \quad + i \sin \alpha a^{\#1}(i^*S^*U^*\varphi_1)a^{\#2}((\mathbf{1} + (\cos \alpha - 1)P)W^*\psi_2) \\ & \quad - i \sin \alpha b^{\#1}((\mathbf{1} + (\cos \alpha - 1)Q)S^*U^*\varphi_1)b^{\#2}(iW^*\psi_2) \\ & \quad + \sin^2 \alpha a^{\#1}(i^*S^*U^*\varphi_1)b^{\#2}(iW^*\psi_2). \end{aligned}$$

Proof. Because

$$(\Gamma(S^* \otimes U^*) \otimes \Gamma(W^*))a^{\#}(\psi)(\Gamma(S \otimes U) \otimes \Gamma(W)) = a^{\#}(W^*\psi)$$

and

$$(\Gamma(S^* \otimes U^*) \otimes \Gamma(W^*))b^{\#}(\varphi)(\Gamma(S \otimes U) \otimes \Gamma(W)) = b^{\#}((S^* \otimes U^*)\varphi),$$

the formulae follow from the previous lemma and the fact that τ is a morphism. \square

5.3 The initial state

The initial state of the compound system is taken to be a tensor product of an arbitrary even state ρ on the algebra $\text{CAR}(\mathcal{H}_{\mathcal{F}})$ with a GIQF state ω_{Σ} on $\text{CAR}(\mathcal{H}_{\mathcal{E}})$ with symbol Σ in $\mathcal{B}(\mathcal{H}_{\mathcal{E}})$. In other words, the state ρ vanishes on all monomials of odd degree,

$$\rho(a^{\#1}(\psi_1)a^{\#2}(\psi_2) \dots a^{\#2N+1}(\psi_{2N+1})) = 0,$$

and there exists $\Sigma \in \mathcal{B}(\mathcal{H}_{\mathcal{E}})$, called the *density* or *symbol* of the state ω_{Σ} , such that

$$\omega_{\Sigma}(b^*(\varphi_1) \dots b^*(\varphi_N)b(\varphi'_{N'}) \dots b(\varphi'_1)) = \delta_{NN'} \det[(\varphi_{\mu}, \Sigma \varphi'_{\mu'})]_{\mu, \mu'=1}^N.$$

In addition to the usual requirement that $0 \leq \Sigma \leq \mathbf{1}$, we require that the symbol is translation invariant, in the sense that

$$[\Sigma, S \otimes \mathbf{1}] = 0, \quad (5.4)$$

and invariant under the one-particle free dynamics in the environment, i.e.

$$[\Sigma, S \otimes U] = 0. \quad (5.5)$$

Finally, we assume that

$$\sum_{\ell \in \mathbf{Z}} |\langle \delta_{-\ell} \otimes w, \Sigma(\delta_0 \otimes w') \rangle| < \infty \quad (5.6)$$

for all $w, w' \in \mathbf{C}^m$. This is a technical assumption that will ensure absolute convergence of important series. It can be interpreted as a decay of spatial correlations in the environment.

Remark 5.3.1. *The case $m = 1$ (and $U = 1$) is the one considered in [HJ17]. They proved a special case of Theorem 5.4.3 below in two situations: when the symbol Σ is proportional to the identity or when W is a shift on \mathcal{H}_φ .*

Allowing Σ to have off-diagonal terms allows us to study the effect of correlations in the structured environment \mathcal{E} (absent in repeated interaction systems) on the asymptotics of the sample \mathcal{P} , and considering $m > 1$ is a first step towards studying non-equilibrium situations.

Recall that we assumed U to have simple eigenvalues: its spectral projectors π_i , for $i = 1, \dots, m$, have rank one and each of them corresponds to a unit eigenvector x_i for a distinct eigenvalue. Then, for any indices $k \in \mathbf{Z}$ and $i \in \{1, \dots, m\}$, we have

$$\begin{aligned} \Sigma(\delta_k \otimes x_i) &= \sum_{\ell \in \mathbf{Z}} \sum_{j=1}^m \delta_{\ell+k} \otimes x_j \langle \delta_{\ell+k} \otimes x_j, \Sigma(\delta_k \otimes x_i) \rangle \\ &= \sum_{\ell \in \mathbf{Z}} \delta_{\ell+k} \otimes x_i \langle \delta_{\ell+k} \otimes x_i, \Sigma(\delta_k \otimes x_i) \rangle \\ &= \sum_{\ell \in \mathbf{Z}} \langle \delta_0 \otimes x_i, \Sigma(S \otimes U)^\ell(\delta_0 \otimes x_i) \rangle (S^* \otimes U^*)^\ell(\delta_k \otimes x_i) \\ &= 2 \operatorname{Re} \left(\frac{1}{2} \langle \delta_0 \otimes x_i, \Sigma(\delta_0 \otimes x_i) \rangle \right. \\ &\quad \left. + \sum_{\ell=1}^{\infty} \langle \delta_0 \otimes x_i, \Sigma(S \otimes U)^\ell(\delta_0 \otimes x_i) \rangle (S^* \otimes U^*)^\ell \right) (\delta_k \otimes x_i). \end{aligned}$$

The coefficients in the sum on the right-hand side define analytic functions in the unit disk,

$$F_i(\zeta) := \frac{1}{2} \langle \delta_0 \otimes x_i, \Sigma(\delta_0 \otimes x_i) \rangle + \sum_{\ell=1}^{\infty} \langle \delta_0 \otimes x_i, \Sigma(S \otimes U)^\ell(\delta_0 \otimes x_i) \rangle \zeta^\ell, \quad (5.7)$$

which extend continuously up to the boundary. In particular, the real number

$$2F_i(0) = \langle \delta_0 \otimes x_i, \Sigma(\delta_0 \otimes x_i) \rangle$$

is the translation-invariant particle density in the i th subspace of the reservoir.

Note that the one-particle operator Σ specifying the initial state of the environment \mathcal{E} is a sum of functions of the dynamics $S^* \otimes U^*$:

$$\Sigma = \sum_{i=1}^m (2 \operatorname{Re} F_i(S^* \otimes U^*)) (\mathbf{1} \otimes \pi_i). \quad (5.8)$$

One of the main results of this paper is that the asymptotic state in the sample is a GIQF state whose density can be expressed as a sum of those same functions, but now of a matrix describing the dynamics in the sample. As discussed in Appendix 5.A, this state remains the same when one considers some variants of this model.

Remark 5.3.2. *The meaning of $F_i(B)$ for a linear operator B with $\|B\| \leq 1$ is given through the power series (5.7). Convergence in norm holds by our assumption (5.6) on the decay of correlations. The real part of $F_i(B)$ is simply the self-adjoint operator $\frac{1}{2}(F_i(B) + (F_i(B))^*)$.*

If the function extends analytically to a disk of radius $r > \operatorname{spr}(B)$, then we have the integral formula

$$F_i(B) = \frac{1}{2\pi i} \oint_{r\mathbf{S}^1} F_i(\zeta) R(\zeta, B) d\zeta \quad (5.9)$$

by the residue theorem and the Neumann series $R(\zeta, B) = \frac{1}{\zeta} \sum_{\ell=0}^{\infty} \zeta^{-\ell} B^\ell$ for the resolvent of B for $|\zeta| > \operatorname{spr} B$.

5.4 Asymptotics

We are interested in the behaviour of the system in the limit $t \rightarrow \infty$ along \mathbf{N} . In particular, we study the behaviour of the state in the sample \mathcal{S} and flux observables.

Throughout the section, we will use the following hypotheses: with W a unitary on \mathbf{C}^d , Σ a non-negative definite bounded operator on $\ell^2(\mathbf{Z}) \otimes \mathbf{C}^m$, U a simple unitary on \mathbf{C}^m and α the coupling constant for the interaction,

- (i) the initial state for the compound system is the tensor product of the GIQF state ω_Σ on the algebra $\operatorname{CAR}(\ell^2(\mathbf{Z}) \otimes \mathbf{C}^m)$, where Σ satisfies $[\Sigma, S \otimes U] = [\Sigma, S \otimes \mathbf{1}] = 0$, with an even state ρ on $\operatorname{CAR}(\mathbf{C}^d)$;
- (ii) the decay condition (5.6) on Σ holds;

- (iii) the vector ψ_* used to define the interaction is cyclic for W ;
- (iv) the coupling constant α is not an integer multiple of π .

5.4.1 The state in the sample

In what follows, we use

$$M := W(\mathbf{1} + (\cos \alpha - 1)P)$$

for the matrix appearing in the formulae from Section 5.2 for time-evolved creation and annihilation operators. The dependence on the coupling constant α is not apparent in this notation but should be kept in mind. Consequently, we will write statements such as $M \rightarrow W$ as $\alpha \rightarrow 0$, referring to the initial dependence of M on α .

Since W is a unitary and $P = \iota^* \iota$ is an orthogonal projector, the operator norm of the matrix M is necessarily bounded by 1. We have the following stronger property, which is proved in [HJ17].

Lemma 5.4.1 (Lemma 4.11 in [HJ17]). *Under assumptions (iii) and (iv),*

$$\text{spr } M < 1.$$

In particular $\|M^t\|$ converges exponentially fast to 0 as $t \rightarrow \infty$ along \mathbf{N} .

We also introduce the shorthand $\mathcal{H}_{\mathbb{Z}}^+$ for the closure of the linear span of vectors of the form $\delta_\ell \otimes w$ for $\ell \geq 0$ and arbitrary $w \in \mathbf{C}^m$. It corresponds to one side of the bi-infinite environment. Combining Lemmas 5.2.2 and 5.4.1, we have the following proposition on the long-time evolution of pairs of creation and annihilation operators.

Proposition 5.4.2. *For all $t \in \mathbf{N}$, under assumptions (ii)–(iv), we have:*

1. for all $\psi_1, \psi_2 \in \mathcal{H}_{\mathcal{F}}$,

$$\begin{aligned} & \tau^t(a^{\#1}(\psi_1)a^{\#2}(\psi_2)) \\ &= \sin^2 \alpha \sum_{s', t'=1}^t b^{\#1}((S \otimes U)^{s'-t} \iota W^* M^{*s'-1} \psi_1) b^{\#2}((S \otimes U)^{t'-t} \iota W^* M^{*t'-1} \psi_2) + O(t \|M^t\|); \end{aligned}$$

2. for all $\varphi_1 \in \mathcal{H}_{\mathbb{Z}}^+$ and $\psi_2 \in \mathcal{H}_{\mathcal{F}}$,

$$\tau^t(b^{\#1}(\varphi_1)a^{\#2}(\psi_2)) = -i \sin \alpha \sum_{t'=1}^t b^{\#1}((S \otimes U)^{-t} \varphi_1) b^{\#2}((S \otimes U)^{t'-t} \iota W^* M^{*t'-1} \psi_2) + O(t \|M^t\|);$$

3. for all $\varphi_1, \varphi_2 \in \mathcal{H}_{\mathcal{E}}^+$,

$$\tau^t(b^{\#1}(\varphi_1)b^{\#2}(\varphi_2)) = b^{\#1}((S \otimes U)^{-t}\varphi_1)b^{\#2}((S \otimes U)^{-t}\varphi_2).$$

The notation $O(t\|M^t\|)$ stands for error terms which are bounded in norm by $t\|M^t\|$ times a numerical constant that is independent of the vectors under consideration, as long as they are normalized.

Proof. In the second and third part of the proposition, we are considering $\varphi_i \in \mathcal{H}_{\mathcal{E}}^+$ because those are the ones that appear in the time evolution of pairs of creation and annihilation operators in the sample (see Lemma 5.2.2). They have the property that $\iota^* S^* U^* \varphi_i = 0$, which makes the computations more tractable. We prove the claims in a different order.

3. The formula follows directly from applying the formula in Proposition 5.2.2 and the identity

$$\iota^* S^* U^* \varphi_i = 0.$$

2. Using $\iota^* S^* U^* \varphi_1 = 0$, Proposition 5.2.2 yields

$$\tau(b^{\#1}(\varphi_1)a^{\#2}(\psi_2)) = b^{\#1}(S^* U^* \varphi_1)a^{\#2}(M^* \psi_2) - i \sin \alpha b^{\#1}(S^* U^* \varphi_1)b^{\#2}(\iota W^* \psi_2),$$

and again $S^* U^* \varphi_1 \in \mathcal{H}_{\mathcal{E}}^+$. Hence, for any $t \in \mathbf{N}$,

$$\begin{aligned} \tau^t(b^{\#1}(\varphi_1)a^{\#2}(\psi_2)) &= b^{\#1}((S^* U^*)^t \varphi_1)a^{\#2}((M^*)^t \psi_2) \\ &\quad - \sum_{t'=1}^t i \sin \alpha b^{\#1}((S^* U^*)^{t'} \varphi_1)b^{\#2}((S^* U^*)^{t-t'} \iota W^* M^{*t'-1} \psi_2). \end{aligned}$$

Because $\|a^{\#}(\psi)\| = \|\psi\|$ for any $\psi \in \mathcal{H}_{\mathcal{S}}$ and similarly for $b^{\#}$, we have the bound

$$\|b^{\#1}((S^* U^*)^t \varphi_1)a^{\#2}((M^*)^t \psi_2)\| \leq \|(S^* U^*)^t \varphi_1\| \|(M^*)^t \psi_2\| \leq \|M^t\|.$$

1. Again by Proposition 5.2.2,

$$\begin{aligned} \tau(a^{\#1}(\psi_1)a^{\#2}(\psi_2)) &= a^{\#1}(M^* \psi_1)a^{\#2}(M^* \psi_2) + i \sin \alpha a^{\#1}(M^* \psi_1)b^{\#2}(\iota W^* \psi_2) \\ &\quad - i \sin \alpha b^{\#1}(\iota W^* \psi_1)a^{\#2}(M^* \psi_2) + \sin^2 \alpha b^{\#1}(\iota W^* \psi_1)b^{\#2}(\iota W^* \psi_2), \end{aligned}$$

with ${}_iW^* \psi_1, {}_iW^* \psi_2 \in \mathcal{H}_{\mathcal{E}}^+$. Hence, for any $t \in \mathbf{N}$,

$$\begin{aligned}
& \tau(a^{\#1}(\psi_1)a^{\#2}(\psi_2)) \\
&= a^{\#1}(M^{*t} \psi_1)a^{\#2}(M^{*t} \psi_2) \\
&+ \sum_{t'=1}^t i \sin \alpha a^{\#1}(M^{*t} \psi_1)b^{\#2}((S^* U^*)^{t-t'} {}_iW^* M^{*t'-1} \psi_2) \\
&- \sum_{s'=1}^t i \sin \alpha b^{\#1}((S^* U^*)^{t-s'} {}_iW^* M^{*s'-1} \psi_1)a^{\#2}(M^{*t} \psi_2) \\
&+ \sum_{s'=1}^t \sum_{t'=1}^t \sin^2 \alpha b^{\#1}((S^* U^*)^{t-s'} {}_iW^* (M^*)^{s'-1} \psi_1) \\
&\quad b^{\#2}((S^* U^*)^{t-t'} {}_iW^* (M^*)^{t'-1} \psi_2).
\end{aligned}$$

The norm estimates are obtained with similar bounds as in the previous part. \square

The main result of this section is the following theorem. It states that, under our ongoing assumptions, the limiting state of the sample \mathcal{S} is GIQF and completely described by its own dynamics W and the same scalar functions $(F_i)_{i=1}^m$, up to an interaction-dependent deformation which vanishes in the limit $\alpha \rightarrow 0$.

Theorem 5.4.3. *Under hypotheses (i)–(iv) stated at the beginning of the section, the limit*

$$\rho_\infty(A) := \lim_{t \rightarrow \infty} (\omega_\Sigma \otimes \rho)(\tau^t(\mathbf{1} \otimes A))$$

exists for all $A \in \text{CAR}(\mathcal{H}_\varphi)$ and ρ_∞ defines a GIQF state on \mathcal{S} with symbol

$$\Delta := \sum_{i=1}^m \|\pi_i v\|^2 2 \operatorname{Re} F_i(M^*), \quad (5.10)$$

where $M = W(\mathbf{1} + (1 - \cos \alpha)P)$. Moreover, the convergence $\operatorname{tr}_{\text{CAR}(\mathcal{H}_{\mathcal{E}})}((\omega_\Sigma \otimes \rho) \circ \tau^t) \rightarrow \rho_\infty$ happens exponentially fast in norm.

Before we proceed with the proof, let us make a few comments on the result. The fact that the asymptotic density Δ in the sample \mathcal{S} can be rewritten in terms of the functions F_i defined by (5.7) (also see Remark 5.3.2) is to be compared with the formula

$$\Sigma = \sum_{i=1}^m 2 \operatorname{Re} F_i(S^* \otimes U^*)(\mathbf{1} \otimes \pi_i)$$

for the symbol for the initial state ω_Σ of the environment \mathcal{E} .

Note that \mathcal{A} depends on the coupling constant α through the matrix M . In the small coupling limit $\alpha \rightarrow 0$, we have $M^* \rightarrow W^*$ and thus

$$\mathcal{A} \rightarrow \sum_{i=1}^m \|\pi_i v\|^2 2 \operatorname{Re} F_i(W^*).$$

In this regime, the asymptotic of the sample is completely determined by its free dynamics, the functions defining the initial state of the environment, and the ratios between the coupling with the different parts of the environment. This state is of course invariant under the free dynamics in the sample \mathcal{S} .

Typically, for $\psi_1, \psi_2 \in \mathcal{B}_{\mathcal{S}}$,

$$(\omega_{\Sigma} \otimes \rho_{\infty})(\tau(a^*(\psi_1)a(\psi_2))) \neq \rho_{\infty}(a^*(\psi_1)a(\psi_2)). \quad (5.11)$$

This is not surprising since it can be seen from the formula (5.3) that the reduced dynamics corresponding to one step of time evolution with a fresh environment only sees the first coefficient in the expansion for the state of the environment. However, equality holds for all $\psi_1, \psi_2 \in \mathcal{B}_{\mathcal{S}}$ when the functions F_i are constant — that is when there are no correlations in the environment \mathcal{E} . Also, in any case, both sides converge to the same quantity in the limit $\alpha \rightarrow 0$.

Proof of Theorem 5.4.3. It is sufficient to prove the result for observables A which are monomials in creation and annihilation operators in the sample \mathcal{S} . The convergence in norm will then be immediate from the convergence of the matrix elements because we are working on a CAR for a finite number of degrees of freedom.

We proceed in four steps. First, we show that the fact that the initial state is a tensor product of two even states implies that $A \mapsto (\omega_{\Sigma} \otimes \rho)(\tau^t(\mathbf{1} \otimes A))$ is an even state on $\operatorname{CAR}(\mathcal{B}_{\mathcal{S}})$ for all $t \geq 0$. Then, we need only consider the asymptotic evolution of monomials of even degree in a and a^* . We simplify the formula at the last step.

Throughout the proof, whenever a product $\prod_i a^{\#i}(e_{k_i})$ appears in a formula, it is ordered with the term for $i + 1$ to the right of the term for i .

Step 1: the asymptotic state is even. Since the dynamics $(\tau^t)_{t \in \mathbb{N}}$ preserves the total number of particles, τ maps monomials of odd degree in a and a^* to a linear combination of monomials of odd degree in a, a^*, b and b^* . Then, each monomial is either of odd degree in a and a^* or of odd degree in b and b^* . Since both ρ and ω_{Σ} are even states, this implies

$$(\omega_{\Sigma} \otimes \rho)\left(\tau^t\left(\prod_{i=1}^{2N+1} a^{\#i}(\psi_i)\right)\right) = 0.$$

and thus

$$\rho_\infty\left(\prod_{i=1}^{2N+1} a^{\#i}(\psi_i)\right) = \lim_{t \rightarrow \infty} (\omega_\Sigma \otimes \rho)\left(\tau^t\left(\prod_{i=1}^{2N+1} a^{\#i}(\psi_i)\right)\right) = 0. \quad (5.12)$$

for any $m \in \mathbf{N}$ and any choices of $\psi_1, \dots, \psi_{2N+1} \in \mathcal{H}_{\mathcal{F}}$.

Step 2: the asymptotic time evolution of monomials of even degree. Using the appropriate formula from Proposition 5.4.2 and the fact that τ^t is a morphism, we have

$$\tau^t\left(\prod_{i=1}^{2N} a^{\#i}(\psi_i)\right) = \prod_{i=1}^{2N} \left(\sum_{t_i=1}^t \sin \alpha b^{\#i}((S \otimes U)^{t_i-t} {}_iW^* M^{*t_i-1} \psi_i) + O(t\|M^t\|) \right). \quad (5.13)$$

Step 3: the asymptotic state is a gauge-invariant quasi-free state. From the previous step, we have

$$\begin{aligned} \rho_\infty\left(\prod_{i=1}^{2N} a^{\#i}(\psi_i)\right) &= \lim_{t \rightarrow \infty} (\omega_\Sigma \otimes \rho)\left(\tau^t\left(\prod_{i=1}^{2N} a^{\#i}(\psi_i)\right)\right) \\ &= \lim_{t \rightarrow \infty} \omega_\Sigma\left(\prod_{i=1}^{2N} \sum_{t_i=1}^t \sin \alpha b^{\#i}((S \otimes U)^{t_i-t} {}_iW^* M^{*t_i-1} \psi_i)\right). \end{aligned}$$

Using the definition of ω_Σ as a gauge-invariant quasi-free state with density Σ ,

$$\begin{aligned} &\rho_\infty(a^*(\psi_1) \cdots a^*(\psi_N) a(\psi'_N) \cdots a(\psi'_1)) \\ &= \lim_{t \rightarrow \infty} \det \left[\sum_{s', t'=1}^t \sin^2 \alpha \left\langle (S \otimes U)^{t'-t} {}_iW^* M^{*t'-1} \psi'_\nu, \Sigma(S \otimes U)^{s'-t} {}_iW^* M^{*s'-1} \psi'_\mu \right\rangle \right]_{\mu, \nu=1}^N. \end{aligned}$$

Using $[\Sigma, S^* \otimes U^*] = 0$, and omitting the details of the indexation of the matrix considered for the determinant,

$$\begin{aligned} &\rho_\infty(a^*(\psi_1) \cdots a^*(\psi_N) a(\psi'_N) \cdots a(\psi'_1)) \\ &= \lim_{t \rightarrow \infty} \det \left[\sum_{s', t'=1}^t \sin^2 \alpha \left\langle \psi'_\nu, M^{t'-1} W {}_i^* \Sigma(S \otimes U)^{s'-t'} {}_iW^* M^{*s'-1} \psi'_\mu \right\rangle \right]_{\mu, \nu} \\ &= \det \left[\left\langle \psi'_\nu, \sum_{s', t'=1}^\infty \sin^2 \alpha \langle \partial_0 \otimes v, \Sigma(S^{s'-t'} \partial_0 \otimes U^{s'-t'} v) \rangle M^{t'-1} W {}_i^* {}_iW^* M^{*s'-1} \psi'_\mu \right\rangle \right]_{\mu, \nu}. \end{aligned}$$

The fact that

$$\rho_\infty(a^*(\psi_1) \cdots a^*(\psi_N) a(\psi'_{N'}) \cdots a(\psi'_1)) = 0$$

whenever $N \neq N'$ follows from (5.12) of Step 1 if $N + N'$ is odd, and from (5.13) of Step 2 and the fact that ω_Σ is a gauge-invariant quasi-free state if $N + N'$ is even. We conclude that $\rho_\infty : A \mapsto \lim_{t \rightarrow \infty} (\omega_\Sigma \otimes \rho)(\tau^t(\mathbf{1} \otimes A))$ is a gauge-invariant quasi-free state with density

$$\sum_{s', t'=1}^\infty \langle \partial_0 \otimes v, \Sigma(S^{s'-t'} \partial_0 \otimes U^{s'-t'} v) \rangle M^{t'-1} \sin^2 \alpha W P W^* M^{*s'-1}.$$

Step 4: the alternate formula. By definition, $M = W(\mathbf{1} + (\cos \alpha - 1)P)$. Using the fact that W is unitary and basic trigonometry, we find the identity

$$\sin^2 \alpha W P W^* = \mathbf{1} - M M^*.$$

The formula (5.10) for Δ given in the statement of the proposition then follows from a telescoping and reindexing of the summation. \square

This knowledge of the asymptotic state in the sample \mathcal{S} allows us to investigate the number of particles there. We give more details on the particle number at each node ν of the graph in a more concrete example in Section 5.5.

Corollary 5.4.4. *Under assumptions (i)–(iv), in the limit $t \rightarrow \infty$, the number of particles in the sample is distributed as a sum of d independent Bernoulli random variables with parameters $\lambda_0, \dots, \lambda_{d-1} \in (0, 1)$ that are the eigenvalues of the self-adjoint matrix Δ .*

Proof. By a standard continuity argument (see e.g. [DFP08, §IV.A]), we need only consider the case $0 < \Delta < \mathbf{1}$.

By standard results on GIQF states (see e.g. [JOPP11, §4.7.3] or [DFP08, §IV.A]), the quasi-free state is associated to the density matrix

$$\rho_\infty = \det(\mathbf{1} - \Delta) \bigoplus_{p=0}^d \left(\frac{\Delta}{\mathbf{1} - \Delta} \right)^{\wedge p}.$$

Therefore, the probability of observing p particles in the sample is given by

$$\mathbf{P}(p) = \det(\mathbf{1} - \Delta) \operatorname{tr} \left(\left(\frac{\Delta}{\mathbf{1} - \Delta} \right)^{\wedge p} \right).$$

Diagonalizing Δ , labeling its eigenvalues $\lambda_0, \dots, \lambda_{d-1}$ and using cyclicity of the trace yields

$$\begin{aligned} \mathbf{P}(p) &= (1 - \lambda_0) \cdots (1 - \lambda_{d-1}) \sum_{k_1 < \cdots < k_p} \frac{\lambda_{k_1} \cdots \lambda_{k_d}}{(1 - \lambda_{k_1}) \cdots (1 - \lambda_{k_d})} \\ &= \sum_{k_1 < \cdots < k_p} \lambda_{k_1} \cdots \lambda_{k_d} \prod_{j \notin \{k_n\}_{n=1}^p} (1 - \lambda_j). \end{aligned}$$

This probability mass function is precisely that of a sum of d independent Bernoulli random variables $(X_i)_{i=1}^d$ where $X_i \sim \operatorname{Ber}(\lambda_i)$, also known as Poisson binomial distribution of parameter $(\lambda_0, \dots, \lambda_{d-1})$. \square

5.4.2 Flux observables

Recall that U is a unitary on \mathbf{C}^m and $\{\pi_i\}_{i=1}^m$ is its set of spectral rank-one projectors associated to distinct eigenvalues $\{e^{i\gamma_i}\}_{i=1}^m$. The commutation relation

$$[\Sigma, \mathbf{1} \otimes \pi_i] = 0$$

for each i suggest a decomposition of the Hilbert space $\mathcal{H}_{\mathcal{E}}$ into m infinite-dimensional subspaces, in which we can formally count the number of particles. Lemma 5.2.2 allows us to formally compute the difference

$$\sum_{\ell \in \mathbf{Z}} \tau(b^*(\partial_\ell \otimes x_i)b(\partial_\ell \otimes x_i)) - b^*(\partial_\ell \otimes x_i)b(\partial_\ell \otimes x_i)$$

in the number of particles in those subspaces between two time steps. The result of this computation yields a bona fide bounded self-adjoint operator and we define

$$\begin{aligned} \Phi_i &:= (\cos \alpha - 1)^2 \|\pi_i v\|^2 b^*(\partial_0 \otimes v)b(\partial_0 \otimes v) \\ &\quad + (\cos \alpha - 1)b^*(\partial_0 \otimes \pi_i v)b(\partial_0 \otimes v) + (\cos \alpha - 1)b^*(\partial_0 \otimes v)b(\partial_0 \otimes \pi_i v) \\ &\quad + i \sin \alpha (\cos \alpha - 1) \|\pi_i v\|^2 (b(\partial_0 \otimes v)a^*(\psi_*) - b^*(\partial_0 \otimes v)a(\psi_*)) \\ &\quad + i \sin \alpha (b(\partial_0 \otimes \pi_i v)a^*(\psi_*) - b^*(\partial_0 \otimes \pi_i v)a(\psi_*)) \\ &\quad + \sin^2 \alpha \|\pi_i v\|^2 a^*(\psi_*)a(\psi_*), \end{aligned}$$

the flux observable into the i th subreservoir, \mathcal{E}_i , accordingly. Summing over the indices $i = 1, 2, \dots, m$, we get the observable

$$\begin{aligned} \Phi_{\mathcal{E}} &:= (\cos^2 \alpha - 1)b^*(\partial_0 \otimes v)b(\partial_0 \otimes v) + \sin^2 \alpha a^*(\psi_*)a(\psi_*) \\ &\quad + i \sin \alpha \cos \alpha (b(\partial_0 \otimes v)a^*(\psi_*) - b^*(\partial_0 \otimes v)a(\psi_*)), \end{aligned}$$

for the flux into the whole environment. This is in agreement² with formula (28) in [HJ17] and with a similar computation that can be done for the flux out of the sample. Of course, $\lim_{t \rightarrow \infty} (\omega_\Sigma \otimes \rho) \tau^t(\Phi_{\mathcal{E}}) = 0$.

In order to compute the limiting expectation of the flux operators Φ_1, \dots, Φ_m , we need the long-time evolution of the quadratic monomials appearing in the defining formula. The following result follows directly from Proposition 5.4.2 and the definition of ω_Σ .

Corollary 5.4.5. *Under assumptions (i)–(iv), we have*

²up to a change of sign of the coupling constant α

1. for all $\psi_1, \psi_2 \in \mathcal{H}_{\mathcal{F}}$,

$$\begin{aligned} & \lim_{t \rightarrow \infty} (\omega_{\Sigma} \otimes \rho) \tau^t (a^*(\psi_1) a(\psi_2)) \\ &= \sum_{s', t'=1}^{\infty} \sin^2 \alpha \langle S^{t'} \delta_0 \otimes U^{t'} v, \Sigma(S^{s'} \delta_0 \otimes U^{s'} v) \rangle \langle \psi_2, M^{t'-1} W P W^* M^{*s'-1} \psi_1 \rangle; \end{aligned}$$

2. for all $\varphi_1 \in \mathcal{H}_{\mathcal{G}}^+$ and $\psi_2 \in \mathcal{H}_{\mathcal{F}}$,

$$\lim_{t \rightarrow \infty} (\omega_{\Sigma} \otimes \rho) \tau^t (b^*(\varphi_1) a(\psi_2)) = -i \sin \alpha \sum_{t'=1}^{\infty} \langle S^{t'} \delta_0 \otimes U^{t'} v, \Sigma \varphi_1 \rangle \overline{\langle \psi_2, W^* M^{*t'-1} \psi_2 \rangle};$$

3. for all $\varphi_1, \varphi_2 \in \mathcal{H}_{\mathcal{G}}^+$,

$$\lim_{t \rightarrow \infty} (\omega_{\Sigma} \otimes \rho) \tau^t (b^*(\varphi_1) b(\varphi_2)) = \langle \varphi_2, \Sigma \varphi_1 \rangle.$$

We may then compute the asymptotics of the flux Φ_i into the i th part of the environment. If the coupling constant α is small enough, we may then determine the sign of this flux by comparing $F_i(1)$ with the different $F_j(1)$, $j \neq i$, weighted by the appropriate scalar products; see the remark below.

Proposition 5.4.6. *Under assumptions (i)–(iv), we have*

$$\begin{aligned} \lim_{t \rightarrow \infty} (\omega_{\Sigma} \otimes \rho) \tau^t (\Phi_i) &= (2 - 2 \cos \alpha) (\|\pi_i v\|^2 \langle \delta_0 \otimes v, \Sigma(\delta_0 \otimes v) \rangle - \langle \delta_0 \otimes \pi_i v, \Sigma(\delta_0 \otimes \pi_i v) \rangle) \\ &\quad + 2 \operatorname{Re} \sin^2 \alpha \sum_{t'=1}^{\infty} \langle \psi_*, M^{t'-1} W \psi_* \rangle \\ &\quad (\|\pi_i v\|^2 \langle S^{t'} \delta_0 \otimes U^{t'} v, \Sigma(\delta_0 \otimes v) \rangle - \langle S^{t'} \delta_0 \otimes U^{t'} \pi_i v, \Sigma(\delta_0 \otimes \pi_i v) \rangle). \end{aligned}$$

Remark 5.4.7. *For $\alpha \ll 1$, we have $2 - 2 \cos \alpha = \alpha^2 + O(\alpha^3)$ and hence*

$$\lim_{\alpha \rightarrow 0} \lim_{t \rightarrow \infty} \frac{(\omega_{\Sigma} \otimes \rho) \tau^t (\Phi_i)}{\alpha^2} = \|\pi_i v\|^2 (1 - \|\pi_i v\|^2) 2 \operatorname{Re} \left(\left(\sum_{j \neq i} \frac{\|\pi_j v\|^2}{1 - \|\pi_j v\|^2} F_j(1) \right) - F_i(1) \right),$$

assuming $v \neq \pi_i v$ for each i . Therefore, for small enough coupling, the sign of the flux into the i th subreservoir is given by that of

$$\left(\sum_{j \neq i} \frac{\|\pi_j v\|^2}{1 - \|\pi_j v\|^2} \operatorname{Re} F_j(1) \right) - \operatorname{Re} F_i(1),$$

which is simply the sign of $\operatorname{Re} F_j(1) - \operatorname{Re} F_i(1)$ in the case of two subreservoirs. This gives interpretation of the number $2 \operatorname{Re} F_i(1)$. Recall that $2F_i(0)$ is the average particle density in the i th subreservoir.

Proof of Proposition 5.4.6. From the definition of Φ_i

$$\begin{aligned}
\lim_{t \rightarrow \infty} (\omega_\Sigma \otimes \rho) \tau^t(\Phi_i) &= (\cos \alpha - 1)^2 \|\pi_i v\|^2 \lim_{t \rightarrow \infty} (\omega_\Sigma \otimes \rho) \tau^t(b^*(\delta_0 \otimes v)b(\delta_0 \otimes v)) \\
&\quad + (\cos \alpha - 1) \lim_{t \rightarrow \infty} (\omega_\Sigma \otimes \rho) \tau^t(b^*(\delta_0 \otimes \pi_i v)b(\delta_0 \otimes v)) \\
&\quad + (\cos \alpha - 1) \lim_{t \rightarrow \infty} (\omega_\Sigma \otimes \rho) \tau^t(b^*(\delta_0 \otimes v)b(\delta_0 \otimes \pi_i v)) \\
&\quad + i \sin \alpha (\cos \alpha - 1) \|\pi_i v\|^2 \lim_{t \rightarrow \infty} (\omega_\Sigma \otimes \rho) \tau^t(b(\delta_0 \otimes v)a^*(\psi_*)) \\
&\quad - i \sin \alpha (\cos \alpha - 1) \|\pi_i v\|^2 \lim_{t \rightarrow \infty} (\omega_\Sigma \otimes \rho) \tau^t(b^*(\delta_0 \otimes v)a(\psi_*)) \\
&\quad + i \sin \alpha \lim_{t \rightarrow \infty} (\omega_\Sigma \otimes \rho) \tau^t(b(\delta_0 \otimes \pi_i v)a^*(\psi_*)) \\
&\quad - i \sin \alpha \lim_{t \rightarrow \infty} (\omega_\Sigma \otimes \rho) \tau^t(b^*(\delta_0 \otimes \pi_i v)a(\psi_*)) \\
&\quad + \sin^2 \alpha \|\pi_i v\|^2 \lim_{t \rightarrow \infty} (\omega_\Sigma \otimes \rho) \tau^t(a^*(\psi_*)a(\psi_*)).
\end{aligned}$$

Using Corollary 5.4.5 for each term gives

$$\begin{aligned}
&\lim_{t \rightarrow \infty} (\omega_\Sigma \otimes \rho) \tau^t(\Phi_i) \\
&= (\cos \alpha - 1)^2 \|\pi_i v\|^2 \langle \delta_0 \otimes v, \Sigma(\delta_0 \otimes v) \rangle + 2(\cos \alpha - 1) \operatorname{Re} \langle \delta_0 \otimes v, \Sigma(\delta_0 \otimes \pi_i v) \rangle \\
&\quad - 2 \sin^2 \alpha (\cos \alpha - 1) \|\pi_i v\|^2 \operatorname{Re} \sum_{t'=1}^{\infty} \overline{\langle \psi_*, W^* M^{*t'-1} \psi_* \rangle} \langle S^{t'} \delta_0 \otimes U^{t'} v, \Sigma(\delta_0 \otimes v) \rangle \\
&\quad - 2 \sin^2 \alpha \operatorname{Re} \sum_{t'=1}^{\infty} \overline{\langle \psi_*, W^* M^{*t'-1} \psi_* \rangle} \langle S^{t'} \delta_0 \otimes U^{t'} v, \Sigma(\delta_0 \otimes \pi_i v) \rangle \\
&\quad + \sin^4 \alpha \|\pi_i v\|^2 \sum_{s', t'=1}^{\infty} \langle \delta_0 \otimes v, \Sigma(S^{s'-t'} \delta_0 \otimes U^{s'-t'} v) \rangle \langle \psi_*, M^{t'-1} W {}_t W^* M^{*s'-1} \psi_* \rangle.
\end{aligned}$$

Using the commutation relation $[\Sigma, \mathbf{1} \otimes \pi_i] = 0$, we have

$$\begin{aligned}
&\lim_{t \rightarrow \infty} (\omega_\Sigma \otimes \rho) \tau^t(\Phi_i) \\
&= (\cos \alpha - 1)^2 \|\pi_i v\|^2 \langle \delta_0 \otimes v, \Sigma(\delta_0 \otimes v) \rangle + 2(\cos \alpha - 1) \langle \delta_0 \otimes \pi_i v, \Sigma(\delta_0 \otimes \pi_i v) \rangle \\
&\quad - 2 \sin^2 \alpha (\cos \alpha - 1) \|\pi_i v\|^2 \operatorname{Re} \sum_{t'=1}^{\infty} \langle \psi_*, M^{t'-1} W \psi_* \rangle \langle S^{t'} \delta_0 \otimes U^{t'} v, \Sigma(\delta_0 \otimes v) \rangle \\
&\quad - 2 \sin^2 \alpha \operatorname{Re} \sum_{t'=1}^{\infty} \langle \psi_*, M^{t'-1} W \psi_* \rangle \langle S^{t'} \delta_0 \otimes U^{t'} \pi_i v, \Sigma(\delta_0 \otimes \pi_i v) \rangle \\
&\quad + \sin^4 \alpha \|\pi_i v\|^2 \sum_{s', t'=1}^{\infty} \langle \delta_0 \otimes v, \Sigma(S^{s'-t'} \delta_0 \otimes U^{s'-t'} v) \rangle \langle \psi_*, M^{t'-1} W P W^* M^{*s'-1} \psi_* \rangle.
\end{aligned}$$

The identity $\sin^2 \alpha W P W^* = \mathbf{1} - M M^*$ then implies

$$\begin{aligned}
& \lim_{t \rightarrow \infty} (\omega_\Sigma \otimes \rho) \tau^t(\Phi_i) \\
&= (\cos \alpha - 1)^2 \|\pi_i v\|^2 \langle \delta_0 \otimes v, \Sigma(\delta_0 \otimes v) \rangle + 2(\cos \alpha - 1) \langle \delta_0 \otimes \pi_i v, \Sigma(\delta_0 \otimes \pi_i v) \rangle \\
&\quad - 2 \sin^2 \alpha (\cos \alpha - 1) \|\pi_i v\|^2 \operatorname{Re} \sum_{t'=1}^{\infty} \langle \psi_*, M^{t'-1} W \psi_* \rangle \langle S^{t'} \delta_0 \otimes U^{t'} v, \Sigma(\delta_0 \otimes v) \rangle \\
&\quad - 2 \sin^2 \alpha \operatorname{Re} \sum_{t'=1}^{\infty} \langle \psi_*, M^{t'-1} W \psi_* \rangle \langle S^{t'} \delta_0 \otimes U^{t'} \pi_i v, \Sigma(\delta_0 \otimes \pi_i v) \rangle \\
&\quad + \sin^2 \alpha \|\pi_i v\|^2 \langle \delta_0 \otimes v, \Sigma \delta_0 \otimes v \rangle \\
&\quad + 2 \sin^2 \alpha \|\pi_i v\|^2 \operatorname{Re} \sum_{t'=1}^{\infty} \langle S^{t'} \delta_0 \otimes U^{t'} v, \Sigma(\delta_0 \otimes v) \rangle \langle \psi_*, M^{t'} \psi_* \rangle.
\end{aligned}$$

Using the identities $\sin^2 \alpha + (\cos \alpha - 1)^2 = 2 - 2 \cos \alpha$ and $\cos \alpha W \psi_* = M \psi_*$, we conclude

$$\begin{aligned}
& \lim_{t \rightarrow \infty} (\omega_\Sigma \otimes \rho) \tau^t(\Phi_i) \\
&= -2(\cos \alpha - 1) \|\pi_i v\|^2 \langle \delta_0 \otimes v, \Sigma(\delta_0 \otimes v) \rangle \\
&\quad + 2(\cos \alpha - 1) \langle \delta_0 \otimes \pi_i v, \Sigma(\delta_0 \otimes \pi_i v) \rangle \\
&\quad + 2 \sin^2 \alpha \|\pi_i v\|^2 \operatorname{Re} \sum_{t'=1}^{\infty} \langle \psi_*, M^{t'-1} W \psi_* \rangle \langle S^{t'} \delta_0 \otimes U^{t'} v, \Sigma(\delta_0 \otimes v) \rangle \\
&\quad - 2 \sin^2 \alpha \operatorname{Re} \sum_{t'=1}^{\infty} \langle \psi_*, M^{t'-1} W \psi_* \rangle \langle S^{t'} \delta_0 \otimes U^{t'} \pi_i v, \Sigma(\delta_0 \otimes \pi_i v) \rangle. \quad \square
\end{aligned}$$

5.5 Examples

To give more detailed information on the profile of the particle density on the graph and to give further interpretation of other related quantities, we restrict our attention to simple models in which $m = 1$.

5.5.1 Quantum walks on a ring

Consider the first example, the case of spin- $\frac{1}{2}$ quantum walkers on a cycle of n vertices. We use the short-hands $e_{\nu, \pm}$ for the vector $\delta_\nu \otimes e_{\pm 1}$ and n_ν for the observable $a^*(e_{\nu, +})a(e_{\nu, +}) + a^*(e_{\nu, -})a(e_{\nu, -})$. Under the hypotheses of our results, the particle density at the vertex ν ,

$$p_t(\nu) := (\omega_\Sigma \otimes \rho) \tau^t(n_\nu),$$

converges to

$$\rho_\infty(n_\nu) = \langle e_{\nu,+}, \Delta e_{\nu,+} \rangle + \langle e_{\nu,-}, \Delta e_{\nu,-} \rangle$$

as $t \rightarrow \infty$. We refer to the function of the node ν defined by this limit as the profile p .

Note that the block structure of M implies $\langle e_{\nu,\pm}, M^{2j+1} e_{\nu,\pm} \rangle = 0$ for each natural number j . Therefore, the asymptotic profile p of the particle density in the sample is independent of the odd coefficients in the series (5.7) describing the symbol Σ (the initial state in the reservoir) via (5.8).

We can also consider the position correlations

$$C_t(\nu, \nu) = (\omega_\Sigma \otimes \rho)(\tau^t(n_\nu n_\nu)) - (\omega_\Sigma \otimes \rho)(\tau^t(n_\nu))(\omega_\Sigma \otimes \rho)(\tau^t(n_\nu)).$$

In the large time limit, a standard computation shows

$$\begin{aligned} \lim_{t \rightarrow \infty} C_t(\nu, \nu) &= \rho_\infty(n_\nu n_\nu) - \rho_\infty(n_\nu) \rho_\infty(n_\nu) \\ &= - \sum_{\tau_\nu, \tau_\nu \in \{+, -\}} |\langle e_{\nu, \tau_\nu}, \Delta e_{\nu, \tau_\nu} \rangle|^2 \end{aligned}$$

for $\nu \neq \nu$. Note the definite sign.

Example 5.5.1. Consider the case where each coin unitary is a rotation matrix of angle $\theta_\nu \notin \frac{\pi}{2}\mathbf{Z}$, i.e. $C_\nu = \begin{pmatrix} \cos \theta_\nu & -\sin \theta_\nu \\ \sin \theta_\nu & \cos \theta_\nu \end{pmatrix}$. If the series (5.7) terminates after the quadratic term ($\ell = 2$), we can compute explicitly

$$p(\nu) = \begin{cases} 2F(0) - \operatorname{Re} F^{(2)}(0)(\cos \alpha \sin \theta_n \sin \theta_1 + \sin \theta_1 \sin \theta_2) & 1 = \nu \\ 2F(0) - \operatorname{Re} F^{(2)}(0)(\sin \theta_{\nu-1} \sin \theta_\nu + \sin \theta_\nu \sin \theta_{\nu+1}) & 1 < \nu < n \\ 2F(0) - \operatorname{Re} F^{(2)}(0)(\sin \theta_{n-1} \sin \theta_n + \cos \alpha \sin \theta_n \sin \theta_1) & \nu = n \end{cases}$$

In the limit $\alpha \rightarrow 0$, we simply get

$$\lim_{\alpha \rightarrow 0} p(\nu) = 2F(0) - (\operatorname{Re} F^{(2)}(0))(\sin \theta_{\nu-1} \sin \theta_\nu + \sin \theta_\nu \sin \theta_{\nu+1}).$$

5.5.2 A Large sample with disorder

We wish to consider a large ring with the coin matrix C_ν at each vertex ν independently sampled from a common distribution. To this end, we consider a probability measure μ on $[0, 2\pi]$ and introduce the product measure $(\mu \times \mu)^{\times \mathbf{Z}}$ on the product space $\Omega := ([0, 2\pi] \times [0, 2\pi])^{\mathbf{Z}}$. We denote elements ω of Ω in the form $(\omega_\nu^+, \omega_\nu^-)_{\nu \in \mathbf{Z}}$. We also fix real numbers t and r with $tr \neq 0$ and $t^2 + r^2 = 1$.

Then, according to a random element ω we set

$$C_\nu(\omega) = \begin{pmatrix} e^{-i\omega_\nu^+ t} & -e^{-i\omega_\nu^+ r} \\ e^{-i\omega_\nu^- r} & e^{-i\omega_\nu^- t} \end{pmatrix}$$

and the unitary

$$\mathcal{W}(\omega) = \sum_{\nu \in \mathbf{Z}} \sum_{\tau = \pm 1} \delta_{\nu+\tau} \langle \delta_\nu, \cdot \rangle \otimes e_\tau \langle e_\tau, C_\nu(\omega) \cdot \rangle.$$

on $\ell^2(\mathbf{Z}) \otimes \mathbf{C}^2$. This is the form of quantum walk discussed in [JM10] (also see [Joy04, ASW11]); it arises as the general form (up to unitary equivalence) of a disordered quantum walk on \mathbf{Z} where the quantum amplitudes of the transitions the right and to the left are independent random variables and the quantum transition probabilities between neighbouring sites are deterministic and independent of the site.

Note that

$$(S_{\mathcal{F}} \otimes \mathbf{1}) \mathcal{W}(\omega) (S_{\mathcal{F}}^* \otimes \mathbf{1}) = \mathcal{W}(\phi \omega) \quad (5.14)$$

where ϕ is the shift $(\omega_\nu^+, \omega_\nu^-)_{\nu \in \mathbf{Z}} \mapsto (\omega_{\nu+1}^+, \omega_{\nu+1}^-)_{\nu \in \mathbf{Z}}$ on Ω and $S_{\mathcal{F}}^*$ is the periodic shift on \mathbf{C}^n .

The corresponding walk on a ring of n sites has one-particle dynamics prescribed by the unitary

$$\begin{aligned} W^{(n)}(\omega) &= \delta_{n-1} \langle \delta_0, \cdot \rangle e_{-1} \langle e_{-1}, C_0(\omega) \cdot \rangle + \delta_1 \langle \delta_0, \cdot \rangle e_{+1} \langle e_{+1}, C_0(\omega) \cdot \rangle \\ &\quad + \sum_{\nu=1}^{n-2} \sum_{\tau=\pm 1} \delta_{\nu+\tau} \langle \delta_\nu, \cdot \rangle \otimes e_\tau \langle e_\tau, C_\nu(\omega) \cdot \rangle \\ &\quad + \delta_{n-2} \langle \delta_{n-1}, \cdot \rangle e_{-1} \langle e_{-1}, C_{n-1}(\omega) \cdot \rangle \\ &\quad + \delta_0 \langle \delta_{n-1}, \cdot \rangle e_{+1} \langle e_{+1}, C_{n-1}(\omega) \cdot \rangle. \end{aligned}$$

on $\ell^2(\{0, 1, \dots, n-1\}) \otimes \mathbf{C}^2$. If we chose the state $\psi_* = \delta_0 \otimes e_{-1}$ for the coupling with the environment \mathcal{E} , we have to consider the random contraction $M^{(n)}(\omega)$ defined by $M^{(n)} = (\mathbf{1} + (\cos \alpha - 1)(\delta_0 \otimes e_{-1}) \langle \delta_0 \otimes e_{-1}, \cdot \rangle) W^{(n)}$.

Let us suppose for simplicity that the support of μ is a small nondegenerate interval. Let us also suppose that the series (5.7) terminates after finitely many terms. Adapting slightly the arguments of [Joy04] and [ASW11], we see that since \mathcal{W} is a band unitary matrix satisfying (5.14) and since $M^{(n)}$ is a rank-six perturbation of $(\mathbf{1}_{[0, n-1]} \otimes \mathbf{1}) \mathcal{W} (\mathbf{1}_{[0, n-1]} \otimes \mathbf{1})$, it follows from Birkhoff's ergodic theorem that

$$\lim_{n \rightarrow \infty} \frac{1}{2n} \operatorname{tr}(f(M^{(n)}(\omega))) = \lim_{n \rightarrow \infty} \frac{1}{2n} \operatorname{tr}((\mathbf{1}_{[0, n-1]} \otimes \mathbf{1}) f(\mathcal{W}(\omega)) (\mathbf{1}_{[0, n-1]} \otimes \mathbf{1}))$$

for any polynomial f and for $\mu^{\times \mathbf{Z}}$ -almost all $\omega \in \Omega$. The right-hand side is usually written as the integral

$$\int_{\mathbf{S}^1} f(e^{i\theta}) \, dk(\theta)$$

of f against the density of state k for \mathcal{W} , defined through the Riesz–Markov representation theorem and which is an almost sure quantity in the sense that it is the same for $\mu^{\times \mathbf{Z}}$ -almost all $\omega \in \Omega$. In particular, this gives us, for large n , an approximation of the asymptotic (in time) averaged (over the vertices of the graph) particle number density:

$$\lim_{t \rightarrow \infty} \frac{1}{n} \sum_{\nu=0}^{n-1} p_t(\nu) = \frac{1}{n} \operatorname{tr}(2 \operatorname{Re} F(\mathcal{M}^{(n)})) = 2 \int_{\mathbf{S}^1} 2 \operatorname{Re} F(e^{i\theta}) \, dk(\theta) + o(1)$$

as $n \rightarrow \infty$.

The techniques of [Joy04, ABJ15] give us detailed information on the support of the density of states k for \mathcal{W} . Indeed, the spectrum of the operator for ω identically 0 is made of the two bands

$$A_{\pm} = \{x \pm i\sqrt{1-x^2} : x \in [-|t|, |t|]\}.$$

Hence, a standard perturbation argument yields that for μ supported on a small enough interval,

$$\operatorname{sp}(\mathcal{W}(\omega)) \subseteq \left(\bigcup_{\theta \in \operatorname{supp} \mu} e^{i\theta} A_+ \right) \cup \left(\bigcup_{\theta \in \operatorname{supp} \mu} e^{i\theta} A_- \right)$$

almost surely.

Therefore, by tuning t and μ and taking n large enough, one can bring the asymptotic average density $\lim_{t \rightarrow \infty} \frac{1}{n} \sum_{\nu=0}^{n-1} p_t(\nu)$ arbitrarily close to any value in the essential range of the function $\mathbf{S}^1 \ni z \mapsto 2 \operatorname{Re} F(z) \in \mathbf{R}$.

5.A Comments on the statistics

Following [HJ17], we have made the choice of considering different species of fermions for the sample \mathcal{S} and the environment \mathcal{E} . Considering the same species for both components of the system would have amounted to imposing the anticommutation relation $\{a^{\#}(\psi), \tilde{b}(\varphi)\} = 0$ for all $\psi \in \mathcal{H}_{\mathcal{S}}$ and $\varphi \in \mathcal{H}_{\mathcal{E}}$ instead of the commutation relation $[a^{\#}(\psi), b(\varphi)] = 0$. This is realized on the Fock space $\Gamma^{-}(\mathcal{H}_{\mathcal{E}}) \otimes \Gamma^{-}(\mathcal{H}_{\mathcal{S}})$ by setting $\tilde{b}(\varphi) := b(\varphi) \otimes (-1)^{\operatorname{d}\Gamma(\mathbf{1})}$. In this case, one finds with the same techniques formulae such as

$$\tilde{K}_{\alpha}^* a^*(\psi) \tilde{K}_{\alpha} = a^*((\mathbf{1} + (\cos \alpha - 1)P)\psi) + i \sin \alpha \tilde{b}^*(\iota\psi),$$

leading to the same formulae as in Lemma 5.2.2. Therefore, the asymptotics of the state in the sample \mathcal{S} and the fluxes are the same.

With this choice of statistics, one may alternatively view \tilde{K}_α as arising from the second quantization of a one-body operator on $\mathcal{H}_\mathcal{E} \oplus \mathcal{H}_\mathcal{F}$:

$$\tilde{K}_\alpha = \mathcal{U} \Gamma(\mathbf{1} + (\cos \alpha - 1)(\iota^* \iota + \iota \iota^*) - i \sin \alpha (\iota^* + \iota)) \mathcal{U}^*,$$

where $\mathcal{U} : \Gamma^-(\mathcal{H}_\mathcal{E} \oplus \mathcal{H}_\mathcal{F}) \rightarrow \Gamma^-(\mathcal{H}_\mathcal{E}) \otimes \Gamma^-(\mathcal{H}_\mathcal{F})$ is the usual fermionic exponential map; see for example [AJPP06, §5.1]. The dynamics implemented by the unitary $\Gamma((S \otimes U \oplus W)e^{-i\alpha(\iota + \iota^*)})$ gives rise to a quasi-free dynamics and the corresponding one-particle Møller operator

$$\Omega_+ = \mathfrak{s}\text{-}\lim_{t \rightarrow \infty} (S \otimes U \oplus W)^t ((S \otimes U \oplus W)e^{-i\alpha(\iota + \iota^*)})^{-t}$$

exists and satisfies

$$\Omega_+(0 \oplus \mathbf{1}) = i \sin \alpha \sum_{t'=0}^{\infty} (S \otimes U)^{t'+1} \iota W^* ((\mathbf{1} + (\cos \alpha - 1)\iota^* \iota W^*)^{t'}).$$

In particular, one quickly recovers

$$(0 \oplus \mathbf{1}) \Omega_+^*(\Sigma \oplus \Xi) \Omega_+(0 \oplus \mathbf{1}) = 0 \oplus \mathcal{A}$$

for all $\Xi \in \mathcal{B}(\mathcal{H}_\mathcal{F})$, showing that — at least when the initial state in the sample is a GIQF state associated to a density Ξ invariant for the free dynamics — the limiting state is the same as in the case previously considered. This reduction to a one-body problem also suggests the same behaviour for Bose statistics.

Bibliography

- [AAKV01] D. Aharonov, A. Ambainis, J. Kempe, and U. Vazirani. Quantum walks on graphs. In *Proceedings of the thirty-third annual ACM symposium on Theory of computing*, pages 50–59. ACM, 2001.
- [AAM⁺12] A. Ahlbrecht, A. Alberti, D. Meschede, V. B. Scholz, A. H. Werner, and R. F. Werner. Molecular binding in interacting quantum walks. *New J. Phys.*, 14(7):073050, 2012.
- [ABJ15] J. Asch, O. Bourget, and A. Joye. Spectral stability of unitary network models. *Rev. Math. Phys.*, 27(07):1530004, 2015.

- [AJPP06] W. Aschbacher, V. Jakšić, Y. Pautrat, and C.-A. Pillet. Topics in non-equilibrium quantum statistical mechanics. In S. Attal, A. Joye, and C.-A. Pillet, editors, *Open Quantum Systems III*, pages 1–66. Springer, 2006.
- [ASW11] A. Ahlbrecht, V. B. Scholz, and A. H. Werner. Disordered quantum walks in one lattice dimension. *J. Math. Phys.*, 52(10):102201, 2011.
- [BJM14] L. Bruneau, A. Joye, and M. Merkli. Repeated interactions in open quantum systems. *J. Math. Phys.*, 55(7):075204, 2014.
- [CC88] J. T. Chalker and P. D. Coddington. Percolation, quantum tunnelling and the integer Hall effect. *J. Phys. C: Solid State Phys.*, 21(14):2665, 1988.
- [DFP08] B. Dierckx, M. Fannes, and M. Pogorzelska. Fermionic quasifree states and maps in information theory. *J. Math. Phys.*, 49(3):032109, 2008.
- [HJ17] E. Hamza and A. Joye. Thermalization of fermionic quantum walkers. *J. Stat. Phys.*, 166(6):1365–1392, 2017.
- [How74] J. S. Howland. Stationary scattering theory for time-dependent Hamiltonians. *Math. Annal.*, 207(4):315–335, 1974.
- [JM10] A. Joye and M. Merkli. Dynamical localization of quantum walks in random environments. *J. Stat. Phys.*, 140(6):1025–1053, 2010.
- [JOPP11] V. Jakšić, Y. Ogata, Y. Pautrat, and C.-A. Pillet. Entropic fluctuations in quantum statistical mechanics an introduction. In J. Frohlich, M. Salmhofer, V. Mastropietro, W. De Roeck, and L. F. Cugliandolo, editors, *Quantum Theory from Small to Large Scales*, volume 95 of *Lecture Notes of the Les Houches Summer School*, pages 213–410. Oxford University Press, 2011.
- [Joy04] A. Joye. Density of states and Thouless formula for random unitary band matrices. *Ann. Henri Poincaré*, 5(2):347–379, 2004.
- [Kem03] J. Kempe. Quantum random walks: an introductory overview. *Contemp. Phys.*, 44(4):307–327, 2003.

- [KM00] B. Kümmerer and H. Maassen. A scattering theory for Markov chains. *Infin. Dimensional Anal. Quantum Probab. Relat. Top.*, 3(01):161–176, 2000.
- [KOK05] B. Kramer, T. Ohtsuki, and S. Kettemann. Random network models and quantum phase transitions in two dimensions. *Phys. Rep.*, 417(5-6):211–342, 2005.
- [Mey96] D. A. Meyer. From quantum cellular automata to quantum lattice gases. *J. Math. Phys.*, 85(5-6):551–574, 1996.
- [Por13] R. Portugal. *Quantum walks and search algorithms*. Springer Science & Business Media, 2013.
- [SBP⁺17] I. Siloi, C. Benedetti, E. Piccinini, J. Piilo, S. Maniscalco, M. G. Paris, and P. Bordone. Noisy quantum walks of two indistinguishable interacting particles. *Phys. Rev. A*, 95(2):022106, 2017.
- [VA12] S. E. Venegas-Andraca. Quantum walks: a comprehensive review. *Quantum Inf. Process.*, 11(5):1015–1106, 2012.
- [Wat01] J. Watrous. Quantum simulations of classical random walks and undirected graph connectivity. *J. Comput. Syst. Sci.*, 62(2):376–391, 2001.
- [Yaj77] K. Yajima. Scattering theory for Schrödinger equations with potentials periodic in time. *J. Math. Soc. Japan*, 29(4):729–743, 1977.

Chapter 6

Fermionic walkers driven out of equilibrium

Author Simon Andréys, Alain Joye and Renaud Raquépas

arXiv ID 2009.00604

Abstract We consider a discrete-time non-Hamiltonian dynamics of a quantum system consisting of a finite sample locally coupled to several bi-infinite reservoirs of fermions with a translation symmetry. In this setup, we compute the asymptotic state, mean fluxes of fermions into the different reservoirs, as well as the mean entropy production rate of the dynamics. The direction of the mean fluxes is sensitive to the details of the internal dynamics of the sample.

6.1 Introduction

6.1.1 Motivation

The mathematical description of the long time dynamics of many-body quantum systems coupled to several infinite reservoirs, and of the transport properties of non-equilibrium steady states they give rise to, is a long standing problem in quantum statistical mechanics, see *e.g.* [AJP06], [JOPP11]. To achieve a better understanding of those important conceptual issues, many efforts have been devoted to the construction and analysis of models in various contexts and regimes. Following Jakšić and Pillet [JP01, JP02], the main objectives for these models considered in the framework of open quantum systems are to establish the validity of the laws of thermodynamics, to derive the positivity of the entropy production rate and to analyse its fluctuations. It is desirable too to grasp model dependent salient features of the corresponding non-equilibrium steady states and currents they induce between the reservoirs. See the following papers for a non exhaustive list of works dedicated to those questions in different contexts and regimes: [Spo78, SL78, DdRM08, JPW14], [AJPP06, AJPP07, JOPP11], [Rue00, Rue01, AP03, JLP13], [BJM06, BJM14, HJPR17, HJPR18, BJPP18, And20, BB20], [MMS07b, MMS07a],... In these works, the quantum dynamics of these systems derives from their Hamiltonians.

The last two decades have seen the emergence of a class of non-Hamiltonian models that proves efficient in modelling the quantum dynamics of complex systems, namely quantum walks. A quantum walk (QW for short) arises as a unitary operator defined on a Hilbert space with basis elements associated to the vertices of an infinite graph, matrix elements coupling vertices of the graph a finite distance away from each other only. The QW discrete time dynamics implemented by iteration of the unitary operator has finite speed of propagation, and yields a dynamical system easily amenable to numerical investigation. By contrast to the models mentioned above, there is no Hamiltonian with natural physical meaning attached to a QW. It was demonstrated over the years that QW provide useful approximations in various physical contexts and regimes, see *e.g.* [CC88, KFC⁺09, SVA⁺13, ZKG⁺10, SAM⁺19, WM13, TMT20]. Furthermore, QW play an important role in quantum computing [AAKV01, Kem03, San08, Por13], and they are also considered a quantum counterparts of classical random walks [Gud08, Kon08, APSS12]; see also the reviews [VA12, ABJ15].

Given the versatility of QW and the wide range of physical situations they model and claims regarding different notions of quantum transport [KAG12, MNŠJ20], it is natural to investigate their collective dynamical behaviour within the framework of open quantum systems when considered as indistinguishable quantum

particles (quantum walkers) interacting with reservoirs. The first steps in this direction were performed in the work [HJ17] and its generalisation [Raq20]. They analyse the discrete time dynamics of an ensemble of fermionic QW on a finite sample, exchanging particles with an infinite reservoir of quasifree QW, and establish a form of return to equilibrium of the system. From a different perspective, these efforts can be viewed as an extension to discrete-time dynamics of a program which has mainly been carried out in Hamiltonian continuous-time settings.

Building on [HJ17, Raq20], our aim is twofold. First we generalize the framework to the genuinely out of equilibrium situation in which the fermionic QW on the finite sample interact with several different quasifree QW reservoirs. Second, we analyse the onset of a non-equilibrium steady state in the sample and reservoirs, the development of related particle currents between the reservoirs, and establish strict positivity of the entropy production rate, in keeping with the program above. This closely parallels the work [AJPP07] on a Hamiltonian continuous-time model called the “electronic black box”.

More precisely, each reservoir consists in noninteracting fermionic QW on a bi-infinite chain, forced to hop to their left at discrete times. Hence the reservoirs free dynamics is the second quantization of a shift operator S , while the free dynamics on the finite sample is the second quantization of an arbitrary one-particle unitary matrix W . The interaction between the sample and each reservoir is given at the one-particle level by a unitary operator exchanging particles at specific sites of the sample and the reservoir, whose intensity is monitored by some coupling constant α . The overall discrete dynamics is defined by one step of interaction, one step of free evolution, one step of interaction, one step of free evolution and so on. Considering an initial state $\rho(0)$ given by a product of quasifree states in each reservoir defined by a translation invariant symbol T (two-point function), and an arbitrary (even) state $\rho_S(0)$ in the sample, we determine the evolved state $\rho(t)$ for all time $t \in \mathbf{N}$.

Under mild assumptions, we prove that $\rho(t)$ converges as $t \rightarrow \infty$ to a quasifree state, irrespective of the initial state in the sample, which allows us to determine the reduced asymptotic states in the sample and in the reservoirs. We extend the results of [HJ17, Raq20] to our multi-reservoir setup by showing that the reduced asymptotic states in the sample is also a quasifree non-equilibrium state whose symbol \mathcal{L}^∞ is fully parametrized by T , W and the coupling terms. Then, we turn to the flux into the different reservoirs and determine the steady state quantum mechanical expectation value of the flux observables, or QW currents. We establish the validity of the first law of thermodynamics under very general conditions, and describe the conditions on the initial state $\rho(0)$ that induce nontrivial currents between the reservoirs. Assuming $\rho_S(0)$ is quasifree as well and

considering the entropy production rate $\sigma(t)$ defined in terms the relative entropy between the symbols for the quasifree states at time 0 and t , we prove that the asymptotic entropy production rate $\sigma^+ = \lim_{t \rightarrow \infty} \sigma(t)$ exists and we characterize its strict positivity as a function of the initial state T of the reservoirs, the dynamics \mathcal{W} in the sample and the couplings. Finally, we express the asymptotic entropy production rate σ^+ in terms of the asymptotic currents between the reservoirs through the sample.

6.1.2 Illustration

For concreteness, let us illustrate our main results in the case of an environment composed of two reservoirs. We consider that the Hilbert space of the environment is the fermionic second quantization of the space $\ell^2(\mathbf{Z}) \otimes \mathbf{C}^2$ with a basis $\{\delta_l : l \in \mathbf{Z}\}$ of $\ell^2(\mathbf{Z})$ and a basis $\{\psi_L, \psi_R\}$ for \mathbf{C}^2 . Heuristically $\ell^2(\mathbf{Z}) \otimes \{\psi_L\}$ supports the one-particle space a reservoir situated to the left of the sample and $\ell^2(\mathbf{Z}) \otimes \{\psi_R\}$ the one-particle space a reservoir situated to the right of the sample. The Hilbert space of the sample is the fermionic second quantization of \mathcal{H}_S , a finite-dimensional space, so that the full one-particle space representing the sample and the environment is $\mathcal{H}_{\text{tot}} = \ell^2(\mathbf{Z}) \otimes \mathbf{C}^2 \oplus \mathcal{H}_S$. The free evolution of the sample is defined by a fixed one-particle unitary operator W on \mathcal{H}_S , while that of the reservoirs is described by the one-particle shift operator on $\ell^2(\mathbf{Z})$:

$$S \delta_l = \delta_{l-1}.$$

To make the sample interact with the environment, we fix two orthonormal vectors ϕ_L and ϕ_R of \mathcal{H}_S , representing the position of the sample which are in contact respectively with the left and the right reservoir, and we suppose that walkers in the sample which are in the state ϕ_L [resp. ϕ_R] can jump to the left reservoir [resp. the right reservoir], at the position indexed by zero in the environment. For a given coupling strength α , we describe the interaction by the one-particle unitary operator

$$e^{i\alpha((\partial_0 \otimes \psi_L) \phi_L^* + (\partial_0 \otimes \psi_R) \phi_R^* + \text{h.c.})},$$

where

$$(\partial_0 \otimes \psi_L) \phi_L^* : \eta \otimes \psi \oplus \varphi \mapsto \langle \phi_L, \varphi \rangle \delta_0 \otimes \psi_L \oplus 0$$

for all $\eta \in \ell^2(\mathbf{Z})$, $\psi \in \mathbf{C}^2$, $\varphi \in \mathcal{H}_S$, and similarly for the index R . Here “h.c.” stands for hermitian conjugate, *i.e.* adjoint. Eventually, each step of the overall evolution is represented by the fermionic second quantization of the unitary operator

$$\mathfrak{U} = ((S \otimes \mathbf{1}) \oplus W) e^{i\alpha((\partial_0 \otimes \psi_L) \phi_L^* + (\partial_0 \otimes \psi_R) \phi_R^* + \text{h.c.})}.$$

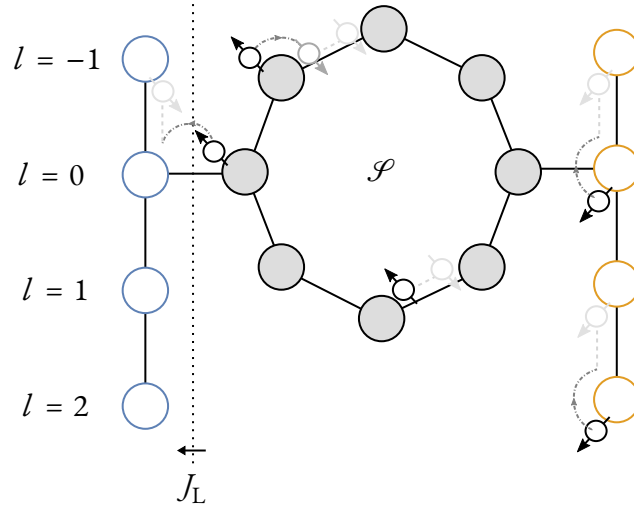

Figure 6.1: The setup we are using to illustrate our results: walkers in a sample \mathcal{S} consisting of a cycle with 8 vertices can hop to and from two environments, one on the left and one on the right. Walkers at sites with a positive index l in the environment cannot have interacted with the sample yet.

Suppose that, at the level of Fock spaces, the left [resp. right] reservoir is initially a quasifree state with translation invariant symbol that has sufficiently regular Fourier transform f_L [resp. f_R] defined on $[0, 2\pi]$ and the sample is initially in an arbitrary even state. Then, under some generic assumptions on \mathcal{W} , the total system relaxes to a quasifree state whose zeroth order approximation in α depends only on \mathcal{W} , f_L and f_R and not on the initial state on the sample. Moreover, a steady current of particles settles across the sample. Assuming that \mathcal{W} has only simple eigenvalues $\lambda_1, \dots, \lambda_n$ with normalized eigenvectors χ_1, \dots, χ_n we can express the current into the right reservoir in the limit $\alpha \rightarrow 0$ as

$$J_R = \alpha^2 \sum_{i=1}^n \frac{|\langle \chi_i, \phi_R \rangle|^2 |\langle \chi_i, \phi_L \rangle|^2}{|\langle \chi_i, \phi_R \rangle|^2 + |\langle \chi_i, \phi_L \rangle|^2} (f_L(\log \lambda_i) - f_R(\log \lambda_i)) + O(\alpha^3),$$

while the current J_L into the right reservoir is such that $J_L + J_R = 0$. If $f_L(\theta) > f_R(\theta)$ for all $\theta \in \mathbf{R}$ then the current is necessarily directed from the left to the right. However, if the function f_R and f_L cannot be compared on the unit circle, then we may choose the sign of the current J_R by tuning the eigenvalues of \mathcal{W} . This last property occurs when considering for example the one-particle free dynamics \mathcal{W} of a coined spin- $\frac{1}{2}$ quantum walk on the sample provided by a cycle with an even number n of vertices sketched in Figure 6.1.

With a basis $\{x_\nu \otimes e_\tau : \nu = 0, 1, \dots, n-1; \tau = -1, +1\}$ of $\mathcal{H}_S = \ell^2(\{0, 1, \dots, n-1\}) \otimes \mathbf{C}^2$, an oft-studied

model for the one-particle dynamics is given by the unitary

$$W := W_1 W_2$$

where

$$W_1 := \sum_{\nu=0}^{n-1} \sum_{\tau=\pm 1} x_{\nu+\tau} \otimes e_{\tau} \langle x_{\nu} \otimes e_{\tau}, \cdot \rangle$$

is a spin-dependent shift and

$$W_2 := \sum_{\nu=0}^{n-1} x_{\nu} x_{\nu}^* \otimes C_{\nu}$$

encodes the rotation of a possibly position-dependent coin. In the special case where

$$C_{\nu} = \begin{pmatrix} e^{i\beta} \cos \varphi & \sin \varphi \\ -\sin \varphi & e^{-i\beta} \cos \varphi \end{pmatrix}$$

for some real parameters $\beta, \varphi \in (0, \frac{1}{2}\pi)$ independent of ν , the spectrum of W is easily shown to be contained in $\{e^{i\mu} : \mu \in \pm\pi - \varphi\}$ and is simple if $\beta \notin (2\pi/n)\mathbf{Z}$.

Before each step of the free walk, spin-up walkers located at sites 0 or $\frac{1}{2}n$ of the ring can be exchanged with those of the left or the right reservoirs. That means the interaction term above has

$$\phi_L = x_0 \otimes e_{+1}, \quad \phi_R = x_{n/2} \otimes e_{+1}.$$

Moreover, the eigenvectors of W being explicitly computable, the current into the right reservoir eventually takes the form

$$J_R = \alpha^2 \sum_{\lambda_i \in \text{sp } W} \frac{\sin^2(2\varphi) |\sin \varphi - 1 + \lambda_i|^2}{4} (f_L(\log \lambda_i) - f_R(\log \lambda_i)) + O(\alpha^3).$$

Therefore, if $f_L > f_R$ holds on open neighbourhoods of $\pi/2$ and $-\pi/2$, while $f_L < f_R$ on open neighbourhoods of 0 and π , choosing the parameter φ small enough, one gets that $J_R > 0$, while considering iW instead of W yields $J_R < 0$, for the same reservoirs, at small coupling; see Figure 6.2.

6.1.3 Structure of the paper

The paper is organized as follows: The next section is devoted to the description of our quantum dynamical system in a fairly general abstract framework. The long time asymptotic state is determined in Section 3, together with its restrictions to the sample and the reservoirs. Section 4 analyses the properties of the steady

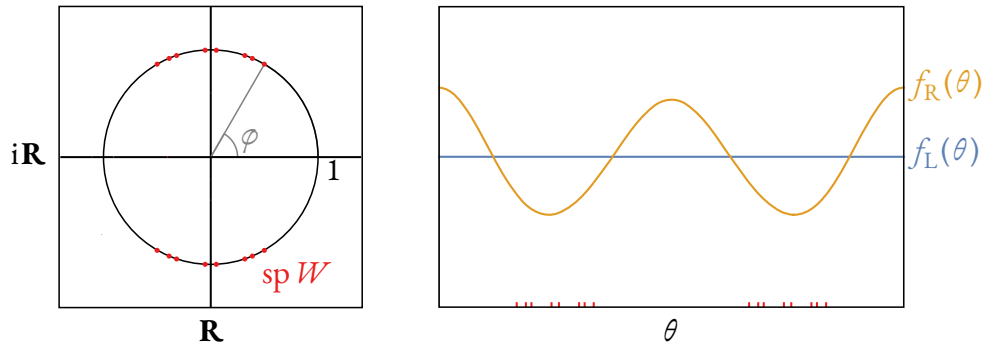

Figure 6.2: Still in the setup of Figure 6.1, with $\varphi = \frac{1}{3}\pi$ and $\beta = 0.1$, the spectrum of W (on the left, in red) lies in closed cones of opening $\pi - 2\varphi$ about the imaginary axis. The corresponding arguments are values of θ for which $f_L(\theta) > f_R(\theta)$ (on the right). Multiplying W by a phase of i amounts to a rotation by quarter turn of the spectrum on the left and to a horizontal shift for the arguments on the right, leading to the opposite inequality.

state currents of particles across the sample, while the study of the entropy production rate is conducted in Section 5. Eventually, the small coupling regime is analyzed in Section 6, and the paper closes with the proofs of certain results.

6.2 The setup

6.2.1 The spaces and one-particle dynamics

Let \mathcal{H}_S be a finite-dimensional Hilbert space. Throughout the paper, our terminology implicitly relies on the assumption that \mathcal{H}_S is the appropriate Hilbert space for the description of a quantum walker on a finite graph, sometimes referred to as a *sample*. An evolution for a quantum walker on a slight extension of this sample could be encoded in a unitary operator Z on a Hilbert space of the form $\mathcal{H}_B \oplus \mathcal{H}_S$ where \mathcal{H}_B is the

Hilbert space associated the extension. With respect to this direct sum decomposition, the blocks of Z , say

$$Z = \begin{pmatrix} C & Z_{\text{BS}} \\ Z_{\text{SB}} & M \end{pmatrix}, \quad (6.1)$$

should satisfy

$$\begin{cases} C^*C + Z_{\text{SB}}^*Z_{\text{SB}} = \mathbf{1}, & C^*Z_{\text{BS}} + Z_{\text{BS}}^*M = 0, \\ Z_{\text{BS}}^*C + M^*Z_{\text{SB}} = 0, & Z_{\text{BS}}^*Z_{\text{BS}} + M^*M = \mathbf{1}, \end{cases} \quad (6.2)$$

for the identity $Z^*Z = \mathbf{1}$ to hold (and similarly for $ZZ^* = \mathbf{1}$). The off-diagonal blocks Z_{BS} and Z_{SB} describe the coupling between the sample and its extension and the block M is thought of as an effective perturbation of a unitary W on \mathcal{H}_{S} .

The Hilbert space

$$\mathcal{H}_{\text{tot}} := (\ell^2(\mathbf{Z}) \otimes \mathcal{H}_{\text{B}}) \oplus \mathcal{H}_{\text{S}}$$

for some finite-dimensional Hilbert space \mathcal{H}_{B} is instead suitable for the description of situations where the sample is interacting with an infinite environment which has a certain translation-invariant structure. Let us construct a single-particle unitary operator \mathfrak{U} on \mathcal{H}_{tot} such that powers of \mathfrak{U} can be interpreted as successive interactions of the type encoded in Z with different blocks of this infinite environment.

Let $(\delta_l)_{l \in \mathbf{Z}}$ be the canonical basis of $\ell^2(\mathbf{Z})$ and let

$$\begin{aligned} S : \ell^2(\mathbf{Z}) &\rightarrow \ell^2(\mathbf{Z}) \\ \delta_l &\mapsto \delta_{l-1} \end{aligned}$$

be the shift operator and $U : \mathcal{H}_{\text{B}} \rightarrow \mathcal{H}_{\text{B}}$ be an arbitrary unitary operator. We set

$$\mathfrak{U} := \begin{pmatrix} (S \otimes U)(P_0^\perp \otimes \mathbf{1} + P_0 \otimes C) & S\delta_0 \otimes UZ_{\text{BS}} \\ \delta_0^* \otimes Z_{\text{SB}} & M \end{pmatrix}, \quad (6.3)$$

on \mathcal{H}_{tot} where $P_0 : \ell^2(\mathbf{Z}) \rightarrow \ell^2(\mathbf{Z})$ is the orthogonal projector on the span of δ_0 and $P_0^\perp := \mathbf{1} - P_0$. Here, $\delta_0 \in \ell^2(\mathbf{Z})$ is identified with a linear operator from \mathbf{C} to $\ell^2(\mathbf{Z})$, so that e.g. $\delta_0 \otimes Z_{\text{BS}}$ can indeed be considered as an operator from $\mathcal{H}_{\text{S}} \simeq \mathbf{C} \otimes \mathcal{H}_{\text{S}}$ to $\ell^2(\mathbf{Z}) \otimes \mathcal{H}_{\text{B}}$. The unitary operator \mathfrak{U} is quite natural to consider: it acts as the unitary operator Z on the space $\{\delta_0\} \otimes \mathcal{H}_{\text{B}} \oplus \mathcal{H}_{\text{S}} \simeq \mathcal{H}_{\text{B}} \oplus \mathcal{H}_{\text{S}}$ and then as the free evolution $S \otimes U$ on $\ell^2(\mathbf{Z}) \otimes \mathcal{H}_{\text{B}}$; see Section 6.6 for the discussion of the explicit link with the Introduction.

We make the following assumptions on the effective dynamics in the sample which was previously discussed in [HJ17, Raq20] in important examples.

Assumption (Sp) The spectrum of M is contained in the interior of the unit disk.

6.2.2 The initial state in Fock space

To describe the evolution of a varying number of fermionic walkers in the system we consider observables in the canonical anticommutation algebra $\text{CAR}(\mathcal{H}_{\text{tot}})$ represented on the fermionic Fock space $\Gamma^-(\mathcal{H}_{\text{tot}})$.

The fermionic Fock space $\Gamma^-(\mathcal{H}_{\text{tot}})$ is unitarily equivalent to the tensor product $\Gamma^-(\ell^2(\mathbf{Z}) \otimes \mathcal{H}_{\text{B}}) \otimes \Gamma^-(\mathcal{H}_{\text{S}})$ of Fock spaces through a map E such that

$$Ea^*(v \oplus w)E^{-1} = a^*(v) \otimes \mathbf{1} + (-1)^{\text{d}\Gamma(\mathbf{1})} \otimes a^*(w)$$

for all $v \in \ell^2(\mathbf{Z}) \otimes \mathcal{H}_{\text{B}}$ and $w \in \mathcal{H}_{\text{S}}$. This map associates quasifree states on $\text{CAR}(\mathcal{H}_{\text{tot}})$ with a symbol of the form $T \oplus \mathcal{A}$ for some suitable $T : \ell^2(\mathbf{Z}) \otimes \mathcal{H}_{\text{B}} \rightarrow \ell^2(\mathbf{Z}) \otimes \mathcal{H}_{\text{B}}$ and $\mathcal{A} : \mathcal{H}_{\text{S}} \rightarrow \mathcal{H}_{\text{S}}$ with the product of the corresponding quasifree states on $\text{CAR}(\ell^2(\mathbf{Z}) \otimes \mathcal{H}_{\text{B}})$ and $\text{CAR}(\mathcal{H}_{\text{S}})$ respectively. We refer the reader to [AJPP06, §5.1,6.3] for a more thorough discussion.

We recall that ω_T is a gauge-invariant quasifree state on $\text{CAR}(\ell^2(\mathbf{Z}) \otimes \mathcal{H}_{\text{B}})$ with symbol $0 \leq T \leq \mathbf{1}$ if

$$\omega_T[a^*(v_n) \cdots a^*(v_1)a(u_1) \cdots a(u_m)] = \delta_{n,m} \det[\langle u_i, T v_j \rangle]$$

for all choices of $v_1, \dots, v_n, u_1, \dots, u_m \in \ell^2(\mathbf{Z}) \otimes \mathcal{H}_{\text{B}}$, where a^* and a are the usual Fock space creation and annihilation operators — and similarly for other spaces. We refer the reader to [DFP08] for the basic theory of such states.

We will always make either of the following two assumptions on the initial state of the system, the second being technically more convenient and allowing simpler expressions for quantities of interest:

Assumption (IC) The initial state of the joint system is of the form

$$\rho(0) = E^{-1}(\omega_T \otimes \rho_{\text{S}})E$$

where ρ_{S} is an even state on the algebra $\text{CAR}(\mathcal{H}_{\text{S}})$ and ω_T is a gauge-invariant quasifree state on the algebra $\text{CAR}(\ell^2(\mathbf{Z}) \otimes \mathcal{H}_{\text{B}})$ with symbol $T : \ell^2(\mathbf{Z}) \otimes \mathcal{H}_{\text{B}} \rightarrow \ell^2(\mathbf{Z}) \otimes \mathcal{H}_{\text{B}}$, $0 \leq T \leq \mathbf{1}$ such that

$$[T, S \otimes U] = 0.$$

In addition, we assume that

$$\sum_{l \in \mathbf{Z}} |l| \|(\partial_0^* \otimes \mathbf{1})T(\partial_l \otimes \mathbf{1})\| < \infty.$$

Assumption (IC+) The initial state of the joint system is as in (IC) with ρ_S also quasifree, with a symbol $\mathcal{A} : \mathcal{H}_S \rightarrow \mathcal{H}_S$; equivalently, the initial state is a quasifree state with a density of the form $T \oplus \mathcal{A}$. Moreover, it is bounded away from 0 and $\mathbf{1}$ in the sense that there exists $\varepsilon > 0$ such that $\varepsilon \mathbf{1} \leq T \leq (1 - \varepsilon) \mathbf{1}$.

We also suppose that

Assumption (BI) There exists a family $\{\Pi_k\}_{k=1}^{n_B}$ of orthogonal projections summing to the identity on \mathcal{H}_B such that

$$[U, \Pi_k] = 0,$$

and

$$[T, \mathbf{1} \otimes \Pi_k] = 0$$

for each $k = 1, \dots, n_B$.

Note that Assumption (BI) technically always holds with $n_B = 1$ and $\Pi_1 = \mathbf{1}$, but is thought of as a separation of the environment into n_B different bi-infinite reservoirs of fermions, with their own dynamics, which only interact through the sample.

In terms of the linear operators

$$T_{n,m} := (\partial_n^* \otimes \mathbf{1})T(\partial_m \otimes \mathbf{1}) \quad (6.4)$$

on \mathcal{H}_B , referred to as *blocks*, the commutation assumption in (IC) becomes the requirement that

$$T_{n,m} = U^{-n} T_{0,m-n} U^n. \quad (6.5)$$

for all $n, m \in \mathbf{Z}$.

6.2.3 Relation to repeated interaction systems

To clarify the place of our model in the zoo of discrete-time quantum dynamics, we comment on its relation to *repeated interaction systems* (RIS). This subsection can be skipped on a first reading. Consider the effective one-step dynamics in the sample

$$\mathcal{A}_1(\rho) := \text{tr}_{\Gamma^-(\ell^2(\mathbf{Z}) \otimes \mathcal{H}_B)}[\Gamma(\mathfrak{U}^*)(\omega_T \otimes \rho)\Gamma(\mathfrak{U})],$$

starting with an initial state as in Assumption (IC+). A straightforward computation making use of the Bogolyubov relation shows that $\mathcal{A}_1(\rho)$ is a quasifree state with symbol

$$\mathcal{A}^1 = M\mathcal{A}M^* + Z_{\text{SB}}T_{0,0}Z_{\text{SB}}^*.$$

Repeatedly applying the map \mathcal{A}_1 , say t times to obtain a quasifree state with symbol

$$\mathcal{A}_{\text{RIS}}^t = M^t\mathcal{A}(M^*)^t + \sum_{m=0}^{t-1} M^m Z_{\text{SB}}T_{0,0}Z_{\text{SB}}^*(M^*)^m,$$

is an instance of a RIS, as noted in the single reservoir setups of [HJ17, Raq20]. One can show that this RIS picture coincides precisely with what happens at the level of the sample in the setup of Subsections 6.2.1 and 6.2.2 if $T_{n,m} = 0$ whenever $n \neq m$. For example, compare our setup with $Z = \exp[-i\tau(k_{\text{E}} \oplus k_{\text{S}} + \lambda v)]$ for some one-particle selfadjoints operators k_{E} , k_{S} and v and compare the resulting dynamics on Fock space to the content of Section II of [BJM14] using the exponential law for fermions.

However, in general, the effective dynamics in the sample

$$\mathcal{A}_t(\rho) := \text{tr}_{\Gamma^-(\ell^2(\mathbf{Z}) \otimes \mathcal{H}_{\text{B}})}[\Gamma(\mathfrak{U}^*)^t(\omega_T \otimes \rho)\Gamma(\mathfrak{U})^t]$$

need not enjoy the semigroup property $\mathcal{A}_{t+t'} = \mathcal{A}_t \circ \mathcal{A}_{t'}$. Indeed, we will see in Remark 6.3.5 below that, under Assumption (IC+), $\mathcal{A}_t(\rho)$ is a quasifree state with density

$$\mathcal{A}^t = M^t\mathcal{A}(M^*)^t + \sum_{m=0}^{t-1} \sum_{n=0}^{t-1} M^m Z_{\text{SB}}T_{0,m-n}U^{n-m}Z_{\text{SB}}^*(M^*)^n.$$

The difference between $\mathcal{A}_{\text{RIS}}^t$ obtained in the RIS scenario and our general \mathcal{A}^t amounts to the terms with $n \neq m$ in the latter, which generically do not cancel out. More generally, tracing out at steps that are multiples of a number $\tau \geq 2$ for which $T_{0,m} = 0$ for $m > \tau$, a similar computation shows that the dynamics differs from the original one by terms with no particular structure for cancellation.

On the other hand, the fact that we obtain our dynamics from the second quantization of a one-body operator imposes a conservation law which rules out certain RIS scenarios where nontrivial entropy production rates arise from interaction with a single reservoir; see e.g. the discussions surrounding Lemma 6.5 in [HJPR17] and Section 3.4 in [BB20].

6.3 Mixing

We present several results on the large-time behaviour of the system. While explicit formulae using the canonical relations in Fock space have proved to be useful in [HJ17, Raq20], we here focus on a scattering approach

to the problem. We set

$$Y_0 := C \quad (6.6)$$

and

$$Y_m := Z_{\text{BS}} M^{m-1} Z_{\text{SB}} \quad (6.7)$$

for $m \geq 1$. Heuristically, Y_m encodes what happens to the wave function of a fermion from a reservoir which enters the sample, spends $m - 1$ more time steps there and then exits the sample.

6.3.1 Scattering and the asymptotic state

It is straightforward to check by induction that

$$\begin{aligned} \mathfrak{U}^t - \sum_{n \neq 0, \dots, t-1} \delta_{n-t} \delta_n^* \otimes U^t \oplus 0 \\ = \begin{pmatrix} \sum_{l=0}^{t-1} \sum_{m=0}^{t-l-1} \delta_{l-t+m} \delta_l^* \otimes U^{t-l-m} Y_m U^l & \sum_{m=0}^{t-1} \delta_{-t+m} \otimes U^{t-m} Z_{\text{BS}} M^m \\ \sum_{m=0}^{t-1} \delta_{t-m-1}^* \otimes M^m Z_{\text{SB}} U^{t-m-1} & M^t \end{pmatrix}. \end{aligned} \quad (6.8)$$

for all $t \geq 0$. As is customary, we investigate the behaviour of \mathfrak{U}^t for large t through Møller-like operators. Multiplying (6.8) by $(S \otimes U \oplus \mathbf{1})^{-t}$ on the right and performing a reindexation to eliminate explicit occurrences of t in the summand for the double sum, we find

$$\begin{aligned} \mathfrak{U}^t (S \otimes U \oplus \mathbf{1})^{-t} - \sum_{n \neq -t, \dots, -1} \delta_n \delta_n^* \otimes \mathbf{1} \oplus 0 \\ = \begin{pmatrix} \sum_{m=0}^{t-1} \sum_{l=1}^{t-m} \delta_{-l} \delta_{-m-l}^* \otimes U^l Y_m U^{-m-l} & \sum_{m=0}^{t-1} \delta_{-t+m} \otimes U^{t-m} Z_{\text{BS}} M^m \\ \sum_{m=0}^{t-1} \delta_{-m-1}^* \otimes M^m Z_{\text{SB}} U^{-m-1} & M^t \end{pmatrix} \end{aligned} \quad (6.9)$$

for $t \geq 0$. Multiplying the adjoint of (6.8) by $(S \otimes U \oplus \mathbf{1})^t$ on the right and performing a reindexation, we find a similar formula for $\mathfrak{U}^{-t} (S \otimes U \oplus \mathbf{1})^t$ with $t \geq 0$.

Under Assumption (Sp), it is thus easy to see from the matrix elements that the limits

$$\Omega_U^\pm := \text{w-lim}_{t \rightarrow \mp \infty} \mathfrak{U}^t (S \otimes U \oplus \mathbf{1})^{-t} \quad (6.10)$$

exist and are given by the explicit expressions

$$\Omega_U^- = \begin{pmatrix} \sum_{n \geq 0} \delta_n \delta_n^* \otimes \mathbf{1} & 0 \\ 0 & 0 \end{pmatrix} + \sum_{m \geq 0} \begin{pmatrix} \sum_{l \geq 1} \delta_{-l} \delta_{-m-l}^* \otimes U^l Y_m U^{-m-l} & 0 \\ \delta_{-m-1}^* \otimes M^m Z_{\text{SB}} U^{-m-1} & 0 \end{pmatrix} \quad (6.11)$$

and

$$\Omega_U^+ = \begin{pmatrix} \sum_{n' \leq -1} \delta_{n'} \delta_{n'}^* \otimes \mathbf{1} & 0 \\ 0 & 0 \end{pmatrix} + \sum_{m' \geq 0} \begin{pmatrix} \sum_{l' \geq m'} \delta_{l'-m'} \delta_{l'}^* \otimes U^{m'-l'} Y_{m'}^* U^{l'} & 0 \\ \delta_{m'}^* \otimes (M^*)^{m'} Z_{\text{BS}}^* U^{m'} & 0 \end{pmatrix}. \quad (6.12)$$

Note that we have not yet projected onto $\ell^2(\mathbf{Z}) \otimes \mathcal{H}_{\text{B}}$, i.e. the subspace associated to the absolutely continuous spectrum of $(S \otimes U \oplus \mathbf{1})$, but have used the weak operator topology. As expected, strong convergence holds on the appropriate subspace; the proof of the following proposition concerning Ω_U^- is postponed to Section 6.7. While not needed in what follows, an analogue result holds for Ω_U^+ .

Proposition 6.3.1. *Suppose that Assumption (Sp) holds. Then, both*

$$\text{s-lim}_{t \rightarrow \infty} \mathfrak{U}^t (S \otimes U \oplus \mathbf{1})^{-t} (\mathbf{1} \otimes \mathbf{1} \oplus 0) = \Omega_U^- (\mathbf{1} \otimes \mathbf{1} \oplus 0)$$

and

$$\text{s-lim}_{t \rightarrow \infty} (\mathfrak{U}^t (S \otimes U \oplus \mathbf{1})^{-t})^* = (\Omega_U^-)^*.$$

The scattering matrix

$$\mathfrak{W}_U := (\mathbf{1} \otimes \mathbf{1} \oplus 0) (\Omega_U^+)^* \Omega_U^- (\mathbf{1} \otimes \mathbf{1} \oplus 0)$$

on $\ell^2(\mathbf{Z}) \otimes \mathcal{H}_{\text{B}}$ will also frequently appear in the sequel. The following lemma makes its structure more explicit. A direct proof that \mathfrak{W}_U is unitary is given in the next section.

Lemma 6.3.2. *Under Assumption (Sp),*

$$\mathfrak{W}_U = \sum_{m \geq 0} \sum_{l \in \mathbf{Z}} \delta_l \delta_{l-m}^* \otimes U^{-l} Y_m U^{l-m}. \quad (6.13)$$

Proof. We expand

$$\begin{aligned} & (\mathbf{1} \otimes \mathbf{1} \oplus 0) (\Omega_U^+)^* \Omega_U^- (\mathbf{1} \otimes \mathbf{1} \oplus 0) \\ &= \sum_{m \geq 0} \sum_{l \geq 1} \delta_{-l} \delta_{-m-l}^* \otimes U^l Y_m U^{-m-l} + \sum_{m' \geq 0} \sum_{l' \geq m'} \delta_{l'} \delta_{l'-m'}^* \otimes U^{-l'} Y_{m'} U^{-m'+l'} \\ & \quad + \sum_{m' \geq 0} \sum_{m \geq 0} \delta_{m'} \delta_{-m-1}^* \otimes U^{-m'} Z_{\text{BS}} M^{m'} M^m Z_{\text{SB}} U^{-m-1}. \end{aligned}$$

Rewriting the double sum on the last line in terms of $Y_{m''}$ with $m'' = m + m'$ yields the desired formula. \square

We use a subscript U on some of the objects introduced in this section because it is at times convenient to factor out the contribution from the unitary U and then consider the special case $U = \mathbf{1}$. For example,

$$\Omega_U^- = \left(\sum_{m \in \mathbf{Z}} P_m \otimes U^m \oplus \mathbf{1} \right)^* \Omega_{\mathbf{1}}^- \left(\sum_{n \in \mathbf{Z}} P_n \otimes U^n \oplus \mathbf{1} \right)$$

and

$$\mathfrak{Y}_U = \left(\sum_{m \in \mathbf{Z}} P_m \otimes U^m \right)^* \mathfrak{Y}_{\mathbf{1}} \left(\sum_{n \in \mathbf{Z}} P_n \otimes U^n \right). \quad (6.14)$$

In view of this factorization, we introduce a modification of T which absorbs part of the free dynamics in the environment:

$$\Xi := \left(\sum_{n \in \mathbf{Z}} P_n \otimes U^n \right) T \left(\sum_{m \in \mathbf{Z}} P_m \otimes U^m \right)^*, \quad (6.15)$$

so that

$$\Xi = \sum_{n, m \in \mathbf{Z}} \delta_n \delta_m^* \otimes \Xi_{m-n},$$

where

$$\Xi_n := T_{0,n} U^{-n}.$$

Note that Ξ is selfadjoint and commutes with $S \otimes \mathbf{1}$ and $\mathbf{1} \otimes \Pi_k$, $k = 1, \dots, n_B$.

Proposition 6.3.3. *Under Assumptions (IC) and (Sp), the limit*

$$\rho(\infty)[A] := \lim_{t \rightarrow \infty} \rho(0)[\Gamma(\mathfrak{U})^{-t} A \Gamma(\mathfrak{U})^t] \quad (6.16)$$

exists for all $A \in \text{CAR}(\mathfrak{H}_{\text{tot}})$ and defines a quasifree state with symbol

$$T_{\text{tot}}^\infty := \Omega_U^-(T \oplus 0)(\Omega_U^-)^*. \quad (6.17)$$

Proof. To prove the proposition it suffices to show that

$$\lim_{t \rightarrow \infty} \rho(0) \left[\Gamma(\mathfrak{U}^*)^t \left(\prod_{b=1}^N a(V_b) \right)^* \left(\prod_{b'=1}^{N'} a(V_{b'}) \right) \Gamma(\mathfrak{U})^t \right] = \delta_{N, N'} \det[\langle V_{b'}, T_{\text{tot}}^\infty V_b \rangle]_{b, b'=1}^N$$

for an arbitrary choice of $N, N' \geq 0$ and $V_1, \dots, V_N, V_{1'}, \dots, V_{N'}$ $\in \mathfrak{H}_{\text{tot}}$. Because T commutes with $S \otimes U$, we have

$$\rho(0)[A] = \rho(0)[\Gamma(S \otimes U \oplus \mathbf{1})^t A \Gamma(S^* \otimes U^* \oplus \mathbf{1})^t]$$

for all $A \in \text{CAR}(\mathfrak{H}_{\text{tot}})$ and the Bogolyubov relation gives that the identity to be shown is equivalent to

$$\lim_{t \rightarrow \infty} \rho(0) \left[\left(\prod_{b=1}^N a((\Omega_U^t)^* V_b) \right)^* \prod_{b'=1}^{N'} a((\Omega_U^t)^* V_{b'}) \right] = \delta_{N, N'} \det[\langle V_{b'}, T_{\text{tot}}^\infty V_b \rangle]_{b, b'=1}^N, \quad (6.18)$$

where

$$\Omega_U^{(t)} := \mathfrak{U}^t(S \otimes U \oplus \mathbf{1})^{-t}.$$

First note that

$$\lim_{t \rightarrow \infty} \|(\Omega_U^{(t)})^* V_b - (\mathbf{1} \otimes \mathbf{1} \oplus 0)(\Omega_U^{(t)})^* V_b\| = 0$$

for each $b = 1, \dots, N$ by Proposition 6.3.1, and similarly with primes. Hence, by continuity of the fermionic creation and annihilation operators as functions from $(\mathcal{H}_{\text{tot}}, \|\cdot\|)$ to $(\mathcal{B}(\Gamma^-(\mathcal{H}_{\text{tot}})), \|\cdot\|)$, the limit in (6.18) will exist if and only if the limit

$$\lim_{t \rightarrow \infty} \omega_T \left[\left(\prod_{b=1}^N a((\mathbf{1} \otimes \mathbf{1} \oplus 0)(\Omega_U^{(t)})^* V_b) \right)^* \prod_{b'=1}^{N'} a((\mathbf{1} \otimes \mathbf{1} \oplus 0)(\Omega_U^{(t)})^* V_{b'}) \right]$$

exists, in which case they will coincide. In particular, we may as well assume that the initial state $\rho_S(0)$ is quasifree with vanishing symbol.

Under this extra assumption, the state $\rho(t)$ is quasifree for all $t \in \mathbf{N}$ and has symbol $T_{\text{tot}}(t)$:

$$\rho(0) \left[\left(\prod_{b=1}^N a((\Omega_U^{(t)})^* V_b) \right)^* \prod_{b'=1}^{N'} a((\Omega_U^{(t)})^* V_{b'}) \right] = \delta_{N, N'} \det[(V_{b'}, T_{\text{tot}}(t)V_b)]_{b, b'=1}^N,$$

where

$$T_{\text{tot}}(t) = \Omega_U^{(t)}(T \oplus 0)(\Omega_U^{(t)})^*.$$

Therefore, we will be done if we can show that $T_{\text{tot}}(t)$ converges weakly to the proposed limit T_{tot}^∞ . But this is easily deduced from Proposition 6.3.1. \square

We are now in a position to get the symbol of the restriction of the state to the sample, i.e.

$$\mathcal{A}^\infty := (0 \oplus \mathbf{1})T_{\text{tot}}^\infty(0 \oplus \mathbf{1}). \quad (6.19)$$

Proposition 6.3.4. *Suppose that Assumption (Sp) holds and let*

$$\Psi(X) := \sum_{k=0}^{\infty} M^k X (M^*)^k$$

for $X : \mathcal{H}_S \rightarrow \mathcal{H}_S$. Then,

$$\mathcal{A}^\infty = \Psi(G + G^*),$$

where

$$G := \frac{1}{2} Z_{\text{SB}} \Xi_0 Z_{\text{SB}}^* + \sum_{l=1}^{\infty} M^l Z_{\text{SB}} \Xi_l Z_{\text{SB}}^*.$$

Proof. Since,

$$(0 \oplus \mathbf{1})\Omega_U^-(\mathbf{1} \oplus 0) = \sum_{m=0}^{\infty} \delta_{-m-1}^* \oplus M^m Z_{\text{SB}} U^{-m-1}$$

by Proposition 6.3.1, (6.19) gives

$$\begin{aligned} \Delta^\infty &= \sum_{m,n=0}^{\infty} M^m Z_{\text{SB}} U^{-m-1} T_{-m-1,-n-1} U^{n+1} Z_{\text{SB}}^*(M^*)^n \\ &= \sum_{m,n=0}^{\infty} M^m Z_{\text{SB}} \Xi_{m-n} Z_{\text{SB}}^*(M^*)^n \end{aligned}$$

using $T_{-m-1,-n-1} = U^{m+1} \Xi_{m-n} U^{-n-1}$. Splitting the contributions with $m-n > 0$, $m-n = 0$ and $m-n < 0$ and reindexing with $l = |m-n|$ gives the proposed formula. \square

Remark 6.3.5. *If Assumption (IC+) holds, the symbol of the restriction to the sample at time t reads*

$$\Delta^t = M^t \Delta(M^*)^t + \sum_{m=0}^{t-1} \sum_{n=0}^{t-1} M^m Z_{\text{SB}} T_{0,m-n} U^{n-m} Z_{\text{SB}}^*(M^*)^n.$$

We now turn our attention to the block

$$T_{\text{E}}^\infty := (\mathbf{1} \otimes \mathbf{1} \oplus 0) T_{\text{tot}}^\infty (\mathbf{1} \otimes \mathbf{1} \oplus 0)$$

of T_{tot} corresponding to the environment. As a direct consequence of Proposition 6.3.1, we have the following corollary.

Corollary 6.3.6. *Suppose that Assumption (Sp) holds and let $\rho(0)$ be an initial state on $\Gamma^-(\mathcal{H}_{\text{tot}})$ as in Assumption (IC). Then,*

$$\delta_n^* T_{\text{E}}^\infty \delta_m = \begin{cases} U^{-n} \left(\sum_{l,l' \geq 0} Y_l \Xi_{l-l'+m-n} Y_{l'}^* \right) U^m & n < 0, m < 0, \\ U^{-n} \left(\sum_{l \geq 0} Y_l \Xi_{l+m-n} \right) U^m & n < 0, m \geq 0, \\ U^{-n} \Xi_{m-n} U^m & n \geq 0, m \geq 0. \end{cases} \quad (6.20)$$

In particular, $\delta_n^ T_{\text{E}}^\infty \delta_m = \delta_n^* T \delta_m$ for $n, m \geq 0$.*

Note that the asymptotic symbol T_{E}^∞ needs not commute with $S \otimes U$; blocks corresponding to positions having already interacted (negative indices) are given a different expression than those corresponding to position which have not yet interacted. This is inherent to our choice of dynamics in the environment, which prevents the effects of the interaction taking place at the site zero to affect the state at locations that have not yet been in contact with the sample. We will come back to this point in the next subsection.

6.3.2 Fourier representation

Many of the expressions call for a representation in Fourier space that we will take advantage of in what follows. We introduce the unitary map $\mathcal{F} : \ell^2(\mathbf{Z}) \otimes \mathcal{H}_B \rightarrow L^2([0, 2\pi]; \mathcal{H}_B)$ as follows: for $\psi = \sum_{l \in \mathbf{Z}} \delta_l \otimes \psi_l$ with $\sum_{l \in \mathbf{Z}} \|\psi_l\|^2 < \infty$ and $\theta \in [0, 2\pi]$, we set

$$(\mathcal{F}\psi)(\theta) := \sum_{l \in \mathbf{Z}} e^{il\theta} \psi_l.$$

In practice, we will more often use the notation

$$\hat{\psi} := \mathcal{F}\psi.$$

Let $R : \ell^2(\mathbf{Z}) \otimes \mathcal{H}_B \rightarrow \ell^2(\mathbf{Z}) \otimes \mathcal{H}_B$ have the form

$$R = \sum_{n, m \in \mathbf{Z}} \delta_n \delta_m^* \otimes R_{n-m} \quad (6.21)$$

for some norm-summable sequence $(R_l)_{l \in \mathbf{Z}}$ of operators on \mathcal{H}_B — hereafter referred to as Fourier coefficients —, so that $\|R\| \leq \sum_{l \in \mathbf{Z}} \|R_l\|$. Then,

$$(\mathcal{F}R\psi)(\theta) = ((\mathcal{F}R\mathcal{F}^{-1})(\mathcal{F}\psi))(\theta) = \hat{R}(\theta)\hat{\psi}(\theta),$$

where $\hat{R} : L^2([0, 2\pi]; \mathcal{H}_B) \rightarrow L^2([0, 2\pi]; \mathcal{H}_B)$ is the multiplication operator by

$$\hat{R}(\theta) := \sum_{l \in \mathbf{Z}} e^{-il\theta} R_l.$$

Also note that R is selfadjoint if and only if $R_{-l} = R_l^*$ for each $l \in \mathbf{Z}$, in which case $\hat{R}(\theta)$ is real for all $\theta \in [0, 2\pi]$.

We will make use of this representation for \mathcal{E} :

$$\hat{\mathcal{E}}(\theta) = \sum_{l \in \mathbf{Z}} e^{il\theta} \mathcal{E}_l.$$

Recall That \mathcal{E} is of the form (6.21) by construction (under Assumption (IC)), with blocks

$$\mathcal{E}_{m-n} = U^n T_{n,m} U^{-m}. \quad (6.22)$$

Then, with

$$\hat{\mathfrak{Y}}(\theta) := \sum_{l \geq 0} e^{-il\theta} Y_l$$

(note the sign of i/θ), we set

$$\hat{\Xi}^\infty(\theta) := \hat{\mathfrak{Y}}(\theta)\hat{\Xi}(\theta)\hat{\mathfrak{Y}}(\theta)^*.$$

Equivalently, $\hat{\Xi}^\infty(\theta)$ is the Fourier representation of an operator Ξ^∞ of the form (6.21) with blocks

$$\Xi_m^\infty = \sum_{l, l' \geq 0} Y_l \Xi_{l-l'+m} Y_{l'}^* \quad (6.23)$$

for all $m \in \mathbf{Z}$. To see this, integrate $\hat{\mathfrak{Y}}(\theta)\hat{\Xi}(\theta)\hat{\mathfrak{Y}}(\theta)^*$ against $\frac{1}{2\pi}e^{-im\theta}$ to find the m -th block.

Note that combining (6.20) and (6.23) gives

$$\Xi_{m-n}^\infty = U^n \delta_n^* T_E^\infty \delta_m U^{-m} \quad (6.24)$$

if $n < 0$ and $m < 0$. In other words, Ξ^∞ is translation invariant, but as far as blocks that have been affected by the interaction with the sample, Ξ^∞ is to T_E^∞ as Ξ is to T ; compare (6.24) to (6.22). Note that $T_E^\infty = T$ implies $\Xi^\infty = \Xi$; the converse implication fails.

Lemma 6.3.7. *The operator \mathfrak{Y}_U is unitary.*

Proof. In view of (6.14) and (6.15), it suffices to prove the lemma with $U = \mathbf{1}$. Let

$$\hat{\mathfrak{Y}}(\theta) := \sum_{l \geq 0} e^{-il\theta} Y_l$$

be as in the previous lemma; it is clear that it suffices to show that $\hat{\mathfrak{Y}}(\theta)$ for all $\theta \in \mathbf{R}$.

Given the definitions $Y_0 := C$ and $Y_l := Z_{\text{BS}} M^{l-1} Z_{\text{SB}}$ for $l \geq 1$, the operator $\hat{\mathfrak{Y}}(\theta)$ can be expressed in terms of resolvents of M :

$$\hat{\mathfrak{Y}}(\theta) = C + \sum_{l \geq 0} e^{-i\theta} e^{-il\theta} Z_{\text{BS}} M^l Z_{\text{SB}} = C - Z_{\text{BS}} (M - e^{i\theta})^{-1} Z_{\text{SB}} \quad (6.25)$$

an expression which is well defined for all $\theta \in \mathbf{R}$ under Assumption (Sp). The operators involved correspond to the block representation (6.1) of the unitary operator Z . Unitarity of $\hat{\mathfrak{Y}}$ is given by the next lemma and the present lemma follows. \square

Lemma 6.3.8. *Let Z be a unitary operator with block decomposition $Z = \begin{pmatrix} a & b \\ c & d \end{pmatrix}$ with respect to an orthogonal direct sum decomposition of a finite-dimensional Hilbert space. Then, for all $\eta \in \mathbf{R}$, the bounded operator $s(\eta) := a - b(d - e^{i\eta})^{-1}c$ is a unitary operator on the first subspace in the decomposition.*

Proof. Simply expand the expression $s(\eta)s(\eta)^*$ and make use of the relation satisfied by a, b, c and d as a consequence of unitarity of Z as well as of the identity $d(d - e^{i\eta})^{-1} = \mathbf{1} + e^{i\eta}(d - e^{i\eta})^{-1}$. \square

6.4 Fluxes of particles

We associate to a bounded selfadjoint operator $X : \mathcal{H}_B \rightarrow \mathcal{H}_B$ the flux

$$\Phi_X = d\Gamma(\mathfrak{U}^*(\mathbf{1} \otimes X \oplus 0)\mathfrak{U} - \mathbf{1} \otimes X \oplus 0).$$

Using the block form of \mathfrak{U} , one can check that

$$\mathfrak{U}^*(\mathbf{1} \otimes X \oplus 0)\mathfrak{U} - \mathbf{1} \otimes X \oplus 0 = \begin{pmatrix} P_0 \otimes X + P_0 \otimes C^*XC & \delta_0 \otimes C^*XZ_{BS} \\ \delta_0^* \otimes Z_{BS}^*XC & Z_{BS}^*XZ_{BS} \end{pmatrix}$$

is trace class. The interest of such quantities is best seen through the case of particle fluxes between the different parts of the environment, hereafter referred to as *reservoirs*, whose definition requires the structure in Assumption (Bl). Such a structure is evidently present in the special case discussed in the introduction. Formally, the (infinite) number of fermions in the reservoir $\ell^2(\mathbf{Z}) \otimes \Pi_k \mathcal{H}_B$ is given by the observable $d\Gamma(\mathbf{1} \otimes \Pi_k \oplus 0)$, and the number of fermions that enter this reservoir in one time step is given by the observable

$$\Phi_k \equiv \Phi_{\Pi_k} = \Gamma(\mathfrak{U}^*) d\Gamma(\mathbf{1} \otimes \Pi_k \oplus 0) \Gamma(\mathfrak{U}) - d\Gamma(\mathbf{1} \otimes \Pi_k \oplus 0)$$

on $\Gamma^-(\mathcal{H}_{\text{tot}})$.

Back to the general observable X , we know from Section 6.3.1 that the asymptotic state of the full system, denoted $\rho(\infty)$, is quasifree with symbol $T_{\text{tot}}^\infty = \Omega_U^-(T \oplus 0)(\Omega_U^-)^*$ if $\rho(0)$ satisfies Assumption (IC). Hence, the steady-state expectation value of the flux Φ_X , or current, is given by

$$\begin{aligned} J_X &:= \rho(\infty)[\Phi_X] \\ &= \text{tr}_{\mathcal{H}_{\text{tot}}} [T_{\text{tot}}^\infty \{\mathfrak{U}^*(\mathbf{1} \otimes X \oplus 0)\mathfrak{U} - \mathbf{1} \otimes X \oplus 0\}]. \end{aligned} \tag{6.26}$$

Using the decomposition

$$T_{\text{tot}}^\infty = \begin{pmatrix} T_E^\infty & T_{ES}^\infty \\ T_{SE}^\infty & \mathcal{A}^\infty \end{pmatrix}, \tag{6.27}$$

we get

$$\begin{aligned} J_X &= \text{tr}_{\ell^2(\mathbf{Z}) \otimes \mathcal{H}_B} (T_E^\infty (P_0 \otimes (CXC^* - X)) + T_{ES}^\infty (\delta_0^* \otimes Z_{BS}^*)XC) \\ &\quad + \text{tr}_{\mathcal{H}_S} (T_{SE}^\infty) (\delta_0 \otimes C^*XZ_{BS} + \mathcal{A}^\infty Z_{BS}^*XZ_{BS}). \end{aligned} \tag{6.28}$$

This expression serves as a basis for obtaining more transparent expressions.

Proposition 6.4.1. *Under Assumptions (IC) and (Sp), if $X : \mathcal{H}_B \rightarrow \mathcal{H}_B$ is a bounded observable, then*

$$J_X = \operatorname{tr} \left[X \int_0^{2\pi} (\hat{\mathfrak{Y}}(\theta) \hat{\Xi}(\theta) \hat{\mathfrak{Y}}^*(\theta) - \hat{\Xi}(\theta)) \frac{d\theta}{2\pi} \right].$$

Proof sketch. We consider the case $U = \mathbf{1}$ to lighten the notation. Use cyclicity of the trace to rewrite the trace over \mathcal{H}_S as a trace over $\ell^2(\mathbf{Z}) \otimes \mathcal{H}_B$. Then, expand the formulae for T_E^∞ , T_{ES}^∞ , T_{SE}^∞ and \mathcal{L}^∞ . The part on $\ell^2(\mathbf{Z})$ is restricted to the span of δ_0 and we are left with a trace on \mathcal{H}_B . Rewrite this trace gathering all occurrences of Y_m defined by (6.6)–(6.7):

$$J_X = \operatorname{tr}_{\mathcal{H}_B} \left[X \left(\sum_{n,m \geq 0} Y_n \Xi_{n-m} Y_m^* - \Xi_0 \right) \right]. \quad (6.29)$$

Conclude using the identity (6.23). □

For the currents $J_k \equiv J_{\Pi_k}$ associated to the projectors Π_k , $k = 1, \dots, n_B$, we immediately get the two following consequences.

Corollary 6.4.2. *Under Assumptions (IC), (Sp) and (Bl), we have*

$$\sum_{k=1}^{n_B} J_k = 0.$$

More precisely, for each $k = 1, \dots, n_B$,

$$J_k = \sum_{k' \neq k} \int \operatorname{tr}[\hat{\mathfrak{Y}}^*(\theta) \Pi_k \hat{\mathfrak{Y}}(\theta) \Pi_{k'} \hat{\Xi}(\theta)] - \operatorname{tr}[\hat{\mathfrak{Y}}^*(\theta) \Pi_{k'} \hat{\mathfrak{Y}}(\theta) \Pi_k \hat{\Xi}(\theta)] \frac{d\theta}{2\pi}$$

and, with the additional assumption that each $\{\Pi_k\}_{k=1}^{n_B}$ has rank one,

$$J_k = \int \sum_{k' \neq k} C_{k,k'}(\theta) (f_{k'}(\theta) - f_k(\theta)) \frac{d\theta}{2\pi}, \quad (6.30)$$

where $f_k(\theta) := \operatorname{tr}[\Pi_k \hat{\Xi}(\theta)]$ and $C_{k,k'}(\theta) := \operatorname{tr}[\hat{\mathfrak{Y}}^*(\theta) \Pi_k \hat{\mathfrak{Y}}(\theta) \Pi_{k'}]$ are nonnegative, and satisfy

$$\sum_{k'=1}^{n_B} C_{k,k'}(\theta) = \sum_{k=1}^{n_B} C_{k,k'}(\theta) = 1.$$

Remark 6.4.3. *Formula (6.30) in the case where each Π_k has rank one implies in particular that if one of the functions $f_k : \theta \mapsto \operatorname{tr}[\Pi_k \hat{\Xi}(\theta)]$ satisfies $f_k(\theta) \geq f_{k'}(\theta)$ for all $k' \neq k$, then the flux of particles is necessarily going out of the k -th reservoir (i.e. $J_k \leq 0$).*

Remark 6.4.4. We may think of the $C_{k',k}(\theta)$ as some effective conductance at frequency θ . This is similar to the Landauer–Büttiker formula presented in [AJPP07] (Corollary 4.2), with the following differences: the context in [AJPP07] is in continuous time and not in discrete time, and the free dynamics on the reservoir number k is generated by some Hamiltonian h_k instead of the shift S . The flux of some observable q is then expressed as a sum of integrals over $\text{sp}_{\text{ac}}(h_k) \cap \text{sp}_{\text{ac}}(h_{k'})$, where $\text{sp}_{\text{ac}}(h_{k'})$ is the absolutely continuous spectrum of the Hamiltonian $h_{k'}$ of another reservoir, while in our expression we integrate over the spectrum of S , i.e. the unit circle.

Proof of Corollary 6.4.2. We have $J_k = J_{\Pi_k}$, which by Proposition 6.4.1 gives

$$J_k = \int_0^{2\pi} \text{tr} [\Pi_k \hat{\mathfrak{Y}}(\theta) \hat{\Xi}(\theta) \hat{\mathfrak{Y}}^*(\theta) - \Pi_k \hat{\Xi}(\theta)] \frac{d\theta}{2\pi}.$$

Since $\sum_{k'=1}^{n_B} \Pi_k = \mathbf{1}$ and $\hat{\mathfrak{Y}}(\theta)$ is unitary for all θ , we have $\sum_{k=1}^{n_B} J_k = 0$. Now by assumption (Bl) we have $\Xi = \sum_{k'=1}^{n_B} \Pi_{k'} \Xi \Pi_{k'} = \sum_{k'=1}^{n_B} \Pi_{k'} \Xi$ hence

$$J_k = \int_0^{2\pi} \sum_{k'=1}^{n_B} \text{tr} [\Pi_k \hat{\mathfrak{Y}}(\theta) \Pi_{k'} \hat{\Xi}(\theta) \hat{\mathfrak{Y}}^*(\theta) - \Pi_k \hat{\Xi}(\theta)] \frac{d\theta}{2\pi}$$

and by the properties of Π_k and $\hat{\mathfrak{Y}}(\theta)$ we have

$$\text{tr} [\Pi_k \hat{\Xi}(\theta)] = \sum_{k'=1}^{n_B} \text{tr} [\hat{\mathfrak{Y}}^*(\theta) \Pi_{k'} \hat{\mathfrak{Y}}(\theta) \Pi_k \hat{\Xi}(\theta)].$$

This proves that $J_k = \sum_{k' \neq k} A_{k,k'} - A_{k',k}$ for $A_{k',k} = \text{tr}[\hat{\mathfrak{Y}}^*(\theta) \Pi_k \hat{\mathfrak{Y}}(\theta) \Pi_{k'} \hat{\Xi}(\theta)]$. Moreover, in the case where the Π_k are of rank one, we have

$$\Pi_k \hat{\Xi}(\theta) = \Pi_k \hat{\Xi}(\theta) \Pi_k = \text{tr}[\Pi_k \hat{\Xi}(\theta)] \Pi_k$$

and, restoring the summation to all indices,

$$\sum_{k'} \text{tr} [\hat{\mathfrak{Y}}^*(\theta) \Pi_{k'} \hat{\mathfrak{Y}}(\theta) \Pi_k] = \text{tr}[\Pi_k] = \sum_{k'} \text{tr} [\hat{\mathfrak{Y}}(\theta) \Pi_{k'} \hat{\mathfrak{Y}}^*(\theta) \Pi_k],$$

which gives the second formula for J_k and the summation property of $C_{k,k'}(\theta)$. \square

6.5 Entropy production

Since nontrivial asymptotic currents can develop between the reservoirs of the system at hand, we expect that the total system genuinely settles into a nonequilibrium steady state. Another key signature of such states is

the nontrivial entropy production rate they give rise to. We prove here the existence and strict positivity of the asymptotic entropy production rate related to the convergence towards the nonequilibrium steady state. More precisely, we work under Assumption (IC+) and provide a convergence result for the quantity

$$\sigma(t) := t^{-1} (S[T_{\text{tot}}(t)|T_{\text{tot}}(0)] + S[\mathbf{1} - T_{\text{tot}}(t)|\mathbf{1} - T_{\text{tot}}(0)]), \quad (6.31)$$

where $T_{\text{tot}}(t) := \Omega_U^{(t)}(T \oplus \mathcal{A})(\Omega_U^{(t)})^*$ and

$$S[X|Y] := \text{tr}[X(\log X - \log Y)]$$

for any trace-class operators X and Y with $\varepsilon \leq X, Y \leq \mathbf{1} - \varepsilon$ on some common Hilbert space. This definition is motivated by a formula for the relative entropy between quasifree states which is well established for finite-dimensional systems [DFP08, §IV.B] and the observation that $\Omega_U^{(t)}$ is a finite-rank perturbation of the identity. It will also be a posteriori justified by the relation to fluxes established in Corollary 6.5.3.

The following theorem states that the entropy production rate converges to the integral of the relative entropies of matrices related to the initial and asymptotic states of the environment introduced in Section 6.3.2. Its proof is postponed to Section 6.8.

Theorem 6.5.1. *Under Assumption (IC+), $T_{\text{tot}}(t) - T_{\text{tot}}(0)$ has finite rank and $\sigma(t)$ in (6.31) is well defined for all $t \in \mathbf{N}$. If, in addition, Assumption (Sp) holds, then the limit*

$$\sigma^+ := \lim_{t \rightarrow \infty} \sigma(t)$$

exists and is given by

$$\sigma^+ = \int_0^{2\pi} S[\hat{\mathfrak{Y}}(\theta)\hat{\Xi}(\theta)\hat{\mathfrak{Y}}^*(\theta)|\hat{\Xi}(\theta)] \frac{d\theta}{2\pi} + \int_0^{2\pi} S[\mathbf{1} - \hat{\mathfrak{Y}}(\theta)\hat{\Xi}(\theta)\hat{\mathfrak{Y}}^*(\theta)|\mathbf{1} - \hat{\Xi}(\theta)] \frac{d\theta}{2\pi}. \quad (6.32)$$

Moreover, $\sigma^+ \geq 0$ with equality if and only if $\hat{\Xi}(\theta) = \hat{\mathfrak{Y}}(\theta)\hat{\Xi}(\theta)\hat{\mathfrak{Y}}^*(\theta)$ for Lebesgue-almost all $\theta \in [0, 2\pi]$.

Remark 6.5.2. *Recall that $\theta \mapsto \hat{\mathfrak{Y}}(\theta)\hat{\Xi}(\theta)\hat{\mathfrak{Y}}^*(\theta)$ is the Fourier transform of a translation-invariant operator Ξ^∞ which, up to the transformation which relates Ξ to T , shares its blocks with T_E^∞ .*

The following reformulation of the result is closer to typical formulations in terms of currents and thermodynamic potentials (see for example Equation (17) in [JPW14]), albeit frequency-wise. It can be compared to Corollary 4.3 of [AJPP07]; see also Remark 6.4.3.

Corollary 6.5.3. *Suppose that Assumptions (IC+), (Sp) and (Bl) hold with the projectors Π_1, \dots, Π_{n_B} having rank one. Then we have the identity*

$$\sigma^+ = \sum_{k=1}^{n_B} \int_0^{2\pi} \mu_k(\theta) \hat{j}_k(\theta) \frac{d\theta}{2\pi}, \quad (6.33)$$

where

$$\mu_k(\theta) := \log \frac{1 - f_k(\theta)}{f_k(\theta)}$$

and $\hat{j}_k(\theta)$ denotes the integrand of the expression (6.30) for the k -th flux of particles.

Remark 6.5.4. *In the case where each f_k is constant in θ , the formula simplifies to*

$$\begin{aligned} \sigma_+ &= \sum_{k=1}^{n_B} \sum_{k'=1}^{n_B} \mu_k(f_{k'} - f_k) \int C_{k,k'}(\theta) \frac{d\theta}{2\pi} \\ &= \sum_{k=1}^{n_B} \sum_{k'=1}^{n_B} \mu_k(f_{k'} - f_k) \sum_{l \geq 0} \text{tr}[Y_l^* \Pi_k Y_l \Pi_{k'}]. \end{aligned}$$

At this stage, the picture of entropy production is still short of a study of the statistical fluctuations in measurement processes of physical observable properly related to the “information-theoretical” notion of entropy production; see e.g. [JOPP11, §4.4.5].

6.6 Discussion for small coupling strength

In order to investigate the regime where the interaction between the sample and its environment is weak, we will consider a special case where the unitary operator Z on $\mathcal{H}_B \oplus \mathcal{H}_S$ is of the form

$$Z = \begin{pmatrix} \mathbf{1} & 0 \\ 0 & W \end{pmatrix} \exp \left[-i\alpha \begin{pmatrix} 0 & A^* \\ A & 0 \end{pmatrix} \right]$$

for some unitary operator $W : \mathcal{H}_S \rightarrow \mathcal{H}_S$ which represents the free evolution on the sample, some bounded operator $A : \mathcal{H}_B \rightarrow \mathcal{H}_S$ which couples sites of the sample and sites of the environment, and some coupling strength $\alpha \in \mathbf{R}$. Computing the exponential, we obtain

$$\begin{aligned} C &= \cos(\alpha \sqrt{A^* A}) & Z_{BS} &= -iA^* \frac{\sin(\alpha \sqrt{A A^*})}{\sqrt{A A^*}} \\ Z_{SB} &= -iW \frac{\sin(\alpha \sqrt{A A^*})}{\sqrt{A A^*}} A & M &= W \cos(\alpha \sqrt{A A^*}). \end{aligned}$$

In this particular setup, we can give a more tractable condition for the Assumption (Sp) to hold true as well as more explicit formulas as the coupling strength α tends to 0.

Proposition 6.6.1. *Let us consider $M(\alpha) := W \cos(\alpha \sqrt{AA^*})$ for $\alpha \in \mathbf{R}$, and write $\mathcal{V} \subseteq \mathcal{R}_{\mathcal{S}}$ the range of A . Then, there exists $\alpha_A > 0$ depending on A only such that the following properties are equivalent:*

1. *The spectrum of $M(\alpha)$ is contained in the interior of the unit disc for all $\alpha \in (-\alpha_A, \alpha_A)$,*
2. *The subspace \mathcal{V} is contained in no strict subspace of $\mathcal{R}_{\mathcal{S}}$ which is stable by W ,*
3. *We have*

$$\operatorname{span}_{i=0, \dots, \dim \mathcal{R}_{\mathcal{S}}} W^i \mathcal{V} = \mathcal{R}_{\mathcal{S}},$$

The equivalence between the second and third property is well known and only included because of its relation to linear control theory, where it is called the Kalman condition.

Proof. Let $\{\mu_i\}_{i \geq 0}$ be the (nonnegative) eigenvalues of $\sqrt{AA^*}$ and let $\{p_i\}_{i \geq 0}$ be the corresponding spectral projectors. We include 0 as μ_0 , possibly at the cost of having $p_0 = 0$. Choose $\alpha_A > 0$ small enough that $|\alpha \mu_i| < \pi$ whenever $|\alpha| < \alpha_A$. Then, with $v_i := \cos(\alpha \mu_i)$, we have

$$\cos(\alpha \sqrt{AA^*}) = p_0 + \sum_{i=1}^l v_i p_i.$$

Note that p_0 is the orthogonal projection onto the kernel of $\sqrt{AA^*}$, which coincides with the orthogonal complement of \mathcal{V} .

If the first property is not satisfied, then there exists a normalized eigenvector ϕ of $M(\alpha)$ with eigenvalue λ with $|\lambda| \geq 1$ for some $\alpha \in (-\alpha_A, \alpha_A)$. Then,

$$|\lambda|^2 = \langle M(\alpha)\phi, M(\alpha)\phi \rangle = \langle \phi, p_0\phi \rangle + \sum_{i \geq 1} v_i^2 \langle \phi, p_i\phi \rangle$$

and since $\sum_{i \geq 0} \langle \phi, p_i\phi \rangle = 1$ this implies that $|\lambda|^2 = 1$, $p_0\phi = \phi$ and $\sum_{i \geq 1} p_i\phi = 0$. Then, ϕ is in the orthogonal complement of \mathcal{V} and is also an eigenvector of W since

$$\lambda\phi = M(\alpha)\phi = W \left(p_0 + \sum_{i \geq 1} v_i p_i \right) \phi = W\phi.$$

We conclude that \mathcal{V} is contained in the orthogonal complement of the span of ϕ , which is stable by W since ϕ is an eigenvector of W . Thus the second property is not satisfied.

Conversely, if the second property is not satisfied, then there exists an eigenvector ϕ of W in the orthogonal complement of \mathcal{V} . Then, ϕ is clearly an eigenvector of $M(\alpha)$ with eigenvalue on the unit circle for all α , which implies in particular that the first property is not satisfied. \square

In order to carry some usual procedures from perturbation theory, we will need a semisimplicity and regularity assumption on the spectral decomposition of the family of operators $M(\alpha)$ analytic in the coupling strength α .

Assumption ($\frac{1}{2}$ Sim) There exists a punctured neighbourhood Ω of 0 in \mathbf{C} such that the eigenvalues of $M(\alpha)$ are semisimple for all $\alpha \in \Omega$ and there is a decomposition

$$M(\alpha) = \sum_{j \in I} \lambda_j(\alpha) Q_j(\alpha) \quad (6.34)$$

with scalar functions $\lambda_j : \Omega \mapsto \mathbf{C}$ and projection-valued functions $Q_j : \Omega \rightarrow \mathcal{B}(\mathcal{H}_S)$ which are analytic for each j in a finite set I . Moreover, we assume that 0 is a removable singularity of all functions Q_j and λ_j .

Note that $Q_j(\alpha)$ need not be selfadjoint. Also note that $W = M(0)$ may have degenerate eigenvalues which split as α moves away from 0. With $\lambda_1, \dots, \lambda_r$ the distinct eigenvalues of W and Q_1, \dots, Q_r the associated orthogonal projectors, we may write $I = \bigcup_{i=1}^r I_i$ with $\lambda_j(0) = \lambda_i$ if and only if $j \in I_i$. Then, $Q_i = \sum_{j \in I_i} Q_j(0)$ and $\{\lambda_j\}_{j \in I_i}$ is called the λ_i -group in the terminology of Kato. The Assumption ($\frac{1}{2}$ Sim) is more general than the following simplicity assumption, which is already rather generic from a topological point of view and sometimes easier to verify.

Assumption (Sim) Each eigenvalue λ_i of W is simple in the sense that the associated spectral projector Q_i is of the form $\chi_i \chi_i^*$ for some unit vector $\chi_i \in \mathcal{H}_S$.

One interesting advantage of Assumption ($\frac{1}{2}$ Sim) over (Sim) is that it can be inferred from a simple condition on AA^* , thanks to the following lemma.

Lemma 6.6.2. *If $\kappa^{-1}AA^*$ is an orthogonal projection for some nonzero $\kappa \in \mathbf{R}$, then Assumption ($\frac{1}{2}$ Sim) is satisfied.*

Proof. Analytically extend $M(\alpha)$ to the complex plane and consider the set $\mathcal{C} := \{\alpha \in \mathbf{C} : |\cos(\alpha\kappa)| = 1\}$. Then, $M(\alpha)$ is unitary for $\alpha \in \mathcal{C}$. It can be shown that \mathcal{C} contains nontrivial curves and hence has at least one accumulation point. The lemma thus follows from Theorem 1.1 in [Kat95, §II.1.6]. \square

Now that we have clarified our assumptions, we can proceed to give the limiting behaviour of the formula for the reduced asymptotic symbol in the sample in Proposition 6.3.4 and for the asymptotic currents in Corollary 6.4.2 as $\alpha \rightarrow 0$.

Theorem 6.6.3. *Suppose that Assumption (Sp) holds for all $\alpha \in \Omega \cap \mathbf{R}$, that Assumptions (IC) and $(\frac{1}{2}\text{Sim})$ hold. Then, the symbol Δ_α^∞ in Proposition 6.3.4, which depends on the coupling strength α , admits an expansion*

$$\Delta_\alpha^\infty = \sum_{i=1}^r \sum_{j,j' \in I_i} \frac{2}{c_j + c_{j'}} Q_j(0) A \hat{\Xi}(\log \lambda_i) A^* Q_{j'}(0) + O(\alpha)$$

where

$$c_j := \text{tr}[Q_j(0)AA^*] > 0.$$

Before we proceed with the proof, let us remark that the appearance of a logarithm is due to the fact that we have defined our Fourier representation on the interval rather than on the unit circle. By periodicity of $\hat{\Xi}$ and the fact that λ_i is on the unit circle, the choice of logarithm is irrelevant.

Proof of Theorem 6.6.3. By Proposition 6.6.1, Assumption (Sp) implies that the image of AA^* is contained in no nontrivial subspace which is stable by W . Hence, $c_j := \text{tr}[Q_j(0)AA^*] > 0$ for each j . Since, $M(\alpha) = W(\mathbf{1} - \frac{1}{2}\alpha^2 AA^*) + O(\alpha^4)$, standard perturbation theory gives

$$j \in I_i \quad \Rightarrow \quad \lambda_j(\alpha) = \lambda_i(1 - \frac{1}{2}\alpha^2 c_j) + O(\alpha^4). \quad (6.35)$$

Claim. The map Ψ introduced in Proposition 6.3.4 is such that

$$\lim_{\alpha \rightarrow 0} \alpha^2 \Psi(X) = \sum_{i=1}^r \sum_{j,j' \in I_i} \frac{2}{c_j + c_{j'}} Q_j(0) X Q_{j'}(0)$$

for any linear map X on \mathcal{H}_S .

Accepting this claim, we need only note that

$$Z_{\text{SB}} = -iW \frac{\sin(\alpha \sqrt{AA^*})}{\sqrt{AA^*}} A = -i\alpha W A + O(\alpha^3)$$

and the summability condition in Assumption (IC) imply that the map G appearing in Proposition 6.3.4 has the expansion

$$G = \alpha^2 \left(\frac{1}{2} W A \Xi_0 A^* W^* + \sum_{k=1}^{\infty} W^{k+1} A \Xi_k A^* W^* \right) + O(\alpha^4)$$

to conclude the proof.

Proof of Claim. Inserting the spectral decomposition (6.34) of M in Assumption $(\frac{1}{2}\text{Sim})$ in the definition

of $\Psi(X) := \sum_{m=0}^{\infty} M^m X (M^*)^m$ yields

$$\begin{aligned} \Psi(X) &= \sum_{j,j' \in I} \sum_{m=0}^{\infty} \lambda_j(\alpha)^m \overline{\lambda_{j'}(\alpha)^m} Q_j(\alpha) X Q_{j'}(\alpha)^* \\ &= \sum_{j,j' \in I} \frac{1}{1 - \lambda_j(\alpha) \overline{\lambda_{j'}(\alpha)}} Q_j(\alpha) X Q_{j'}(\alpha)^*. \end{aligned}$$

Since W is unitary we have $Q_j(0)^* = Q_j(0)$ and $\overline{\lambda_{j'}(0)} = \lambda_{j'}(0)^{-1}$. If $\lambda_j(0) \neq \lambda_{j'}(0)$, the expansion (6.35) gives

$$\frac{1}{1 - \lambda_j(\alpha)\overline{\lambda_{j'}(\alpha)}} = \frac{1}{1 - \lambda_j(0)\lambda_{j'}(0)^{-1}} + O(\alpha^2)$$

which, multiplied by α^2 , vanishes as $\alpha \rightarrow 0$. This leaves the terms for which $\lambda_j(0) = \lambda_{j'}(0)$ (i.e. $j, j' \in I_i$ for some i), for which we have

$$\lambda_j(\alpha)\overline{\lambda_{j'}(\alpha)} = 1 - \frac{1}{2}\alpha^2(c_j + c_{j'}) + O(\alpha^4).$$

by (6.35). Hence,

$$\frac{\alpha^2}{1 - \lambda_j(\alpha)\overline{\lambda_{j'}(\alpha)}} = \frac{1}{c_j + c_{j'}} + O(\alpha^2)$$

whenever $j, j' \in I_i$ for some common i . □

And the Claim yields the Proposition. □

Proposition 6.6.4. *Suppose that Assumption (Sp) for all $\alpha \in \Omega \cap \mathbf{R}$ and that Assumptions (IC) and $(\frac{1}{2}\text{Sim})$ hold. Then, with J_k as in Corollary 6.4.2 depending on α , we have*

$$J_k = \alpha^2 \text{tr}(\Pi_k D) + O(\alpha^3), \quad (6.36)$$

as $\Omega \ni \alpha \rightarrow 0$, where

$$D = \sum_{b=1}^r \left(-A^* Q_b A \hat{\Xi}(\log \lambda_b) + \sum_{j, j' \in I_b} \frac{2}{c_j + c_{j'}} A^* Q_j(0) A \hat{\Xi}(\log \lambda_b) A^* Q_{j'}(0) A \right).$$

Proof. The starting point is the expression (6.29) for J_k .

$$Y_0 = C = \cos(\alpha \sqrt{A^* A}) = I - \frac{\alpha^2}{2} A^* A + O(\alpha^4)$$

$$Y_l = Z_{\text{BS}} M^{l-1} Z_{\text{SB}} = -\alpha^2 A^* M^{l-1} W A + O(\alpha^3 \|M^{l-1}\|),$$

where $M^{l-1} = M(\alpha)^{l-1}$ is such that $\|M(\alpha)^{l-1}\|$ is uniformly bounded in $l > 0$ and $\alpha \in \Omega$. Thus, using Equation (6.29) we have

$$J_k = \text{tr}_{\mathcal{H}_B} \left[\Pi_k \left(-\frac{\alpha^2}{2} (A^* A \Xi_0 + \Xi_0 A^* A) + \sum_{l=1}^{+\infty} Y_l \Xi_l C + C \sum_{l=1}^{+\infty} \Xi_{-l} Y_l^* + \sum_{l, l' > 0} Y_l \Xi_{l-l'} Y_{l'}^* \right) \right] + O(\alpha^4). \quad (6.37)$$

Let us estimate the first sum, making use of Assumptions (IC) and ($\frac{1}{2}$ Sim)

$$\begin{aligned} \sum_{l=1}^{+\infty} Y_l \Xi_l C &= -\alpha^2 \sum_{l=1}^{+\infty} \sum_{j \in I} A^* Q_j(\alpha) W A \lambda_j(\alpha)^{l-1} \Xi_l + O(\alpha^3) \\ &= -\alpha^2 \sum_{j \in I} \frac{1}{\lambda_j(\alpha)} A^* Q_j(\alpha) W A \left(\sum_{l=1}^{+\infty} \lambda_j(\alpha)^l \Xi_l \right) + O(\alpha^3). \end{aligned}$$

Thanks to $\Xi_l^* = \Xi_{-l}$, we have $\hat{\Xi}(\theta) = F(\theta) + F(\theta)^* = 2 \operatorname{Re}(F(\theta))$, where

$$F(\theta) = \frac{1}{2} \Xi_0 + \sum_{l \geq 1} e^{il\theta} \Xi_l.$$

Now, $\frac{1}{\lambda_j(\alpha)} Q_j(\alpha) W = Q_j(0) + O(\alpha)$, and F is differentiable (since $\sum_{k \in \mathbf{Z}} |k| \|\Xi_k\| < +\infty$) so $F(\log \lambda_j(\alpha)) = F(\log \lambda_b) + O(\alpha)$ where b is such that $j \in I_b$. Taking into account the identity $\sum_{j \in I} Q_j(0) = \mathbf{1}$, and repeating the argument for the second sum, we get

$$\begin{aligned} \frac{\alpha^2}{2} (A A^* \Xi_0 + \Xi_0 A A^*) - \sum_{l=1}^{+\infty} Y_l \Xi_l C - C \sum_{l=1}^{+\infty} \Xi_{-l} Y_l^* \\ = \alpha^2 \sum_{b=1}^r 2 \operatorname{Re}(A^* Q_b A F(\log \lambda_b)) + O(\alpha^3). \end{aligned}$$

The only thing left is the double sum. We consider the cases where $l = l', l < l'$ and $l > l'$ separately to write

$$\sum_{l, l' > 0} Y_l \Xi_{l-l'} Y_{l'}^* = \sum_{l=1}^{+\infty} Y_l \Xi_0 Y_l^* + 2 \operatorname{Re} \left(\sum_{d > 0} \sum_{l > 0} Y_{l+d} \Xi_d Y_l^* \right).$$

Writing $M = \sum_{j \in I} \lambda_j(\alpha) Q_j(\alpha)$ and performing the summations as in the proof of Theorem 6.6.3, we obtain

$$\sum_{l=1}^{+\infty} Y_l \Xi_0 Y_l^* = \sum_{j, j' \in I} \frac{1}{\lambda_j(\alpha) \bar{\lambda}_{j'}(\alpha)} \frac{1}{1 - \lambda_j(\alpha) \bar{\lambda}_{j'}(\alpha)} Z_{\text{BS}} Q_j(\alpha) Z_{\text{SB}} \Xi_0 Z_{\text{SB}}^* Q_{j'}(\alpha)^* Z_{\text{BS}}^*.$$

We also saw in the proof of Theorem 6.6.3 that as $\alpha \rightarrow 0$

$$\frac{\alpha^2}{1 - \lambda_j(\alpha) \bar{\lambda}_{j'}(\alpha)} = \begin{cases} \frac{2}{(c_j + c_{j'})} + O(\alpha^2) & \text{if } \lambda_j(0) = \lambda_{j'}(0) \\ O(\alpha^2) & \text{if } \lambda_j(0) \neq \lambda_{j'}(0) \end{cases}$$

and since $Z_{\text{SB}} = -i\alpha W A + O(\alpha^3)$ and $Z_{\text{BS}} = -i\alpha A^* + O(\alpha^3)$ we obtain

$$\sum_{l=1}^{+\infty} Y_l \Xi_0 Y_l^* = \alpha^2 \sum_{b=1}^r \sum_{j, j' \in I_b} \frac{2}{c_j + c_{j'}} A^* Q_j(0) A \Xi_0 A^* Q_{j'}(0) A + O(\alpha^3).$$

Similarly, using the differentiability of $z \mapsto \sum_{d>0} z^d \Xi_d$ we have

$$\sum_{d>0} \sum_{l>0} Y_{l+d} \Xi_d Y_l^* = \alpha^2 \sum_{b=1}^r \sum_{j, j' \in I_b} \frac{2}{c_j + c_{j'}} A^* Q_j(0) A \left(\sum_{d>0} \lambda_b^d \Xi_d \right) A^* Q_{j'}(0) A + O(\alpha^3).$$

Adding up all the previous estimates we get for the order- α^2 term in parentheses in (6.37)

$$\sum_{b=1}^r 2 \operatorname{Re} \left\{ -A^* Q_b A F(\log \lambda_b) + \sum_{j, j' \in I_b} \frac{2}{c_j + c_{j'}} A^* Q_j(0) A F(\log \lambda_b) A^* Q_{j'}(0) A \right\}.$$

Finally, the relation $[I\Gamma_k, F(\theta)] = 0$ and the cyclicity of the trace in the definition of the current proves the proposition. \square

For the remainder of the section, we fix

$$A = \sum_{k=1}^{n_B} \phi_k \psi_k^* \quad (6.38)$$

for an orthonormal basis $(\psi_k)_{k=1}^{n_B}$ of \mathcal{H}_B and an orthonormal family $(\phi_k)_{k=1}^{n_B}$ in \mathcal{H}_S , and assume that

$$\hat{T}(\theta) = \sum_{k=1}^{n_B} f_k(\theta) \psi_k \psi_k^*$$

for some scalar functions $f_k : [0, 2\pi] \rightarrow [0, 1]$. This corresponds to the situation from the introduction. Note that AA^* being an orthogonal projector on \mathcal{H}_S , Lemma 6.6.2 applies.

The following proposition expresses, to leading order in the coupling parameter α , the currents as a sum of the contributions from channels corresponding to the eigenvalues $\{\lambda_i\}_{i \in I}$ associated to normalized eigenvectors $\{\chi_i\}_{i \in I}$ of W , each expressed in terms of a simple star-shaped linear circuit.

Proposition 6.6.5. *Suppose that Assumption (Sp) holds for all $\alpha \in \Omega \cap \mathbf{R}$ and that Assumptions (IC) and (Sim) are satisfied in the setup described above. Then the symbol Δ_α^∞ admits an expansion*

$$\Delta_\alpha^\infty = \sum_{i=1}^r \sum_{k=1}^{n_B} \frac{|\langle \chi_i, \phi_k \rangle|^2}{\sum_{k'=1}^{n_B} |\langle \chi_i, \phi_{k'} \rangle|^2} f_k(\log \lambda_i) \chi_i \chi_i^* + O(\alpha)$$

and the k -th current admits an expansion

$$J_k = \alpha^2 \sum_{i \in I} J_{k,i}^{(2)} + O(\alpha^3)$$

where

$$J_{k,i}^{(2)} = \sum_{k'} \frac{|\langle \phi_k, \chi_i \rangle|^2 |\langle \phi_{k'}, \chi_i \rangle|^2}{\sum_{k''=1}^{n_B} |\langle \phi_{k''}, \chi_i \rangle|^2} (f_{k'}(\log \lambda_i) - f_k(\log \lambda_i)). \quad (6.39)$$

Equivalently, the last equation states that the currents $\{J_{k,i}^{(2)}\}_{k=1}^{n_b}$ are the solutions to the classical Kirchhoff problem in Figure 6.3 with voltage sources $\{f_k(\log \lambda_i)\}_{k=1}^{n_B}$ and resistors $\{|\langle \phi_k, \chi_i \rangle|^{-2}\}_{k=1}^{n_B}$.

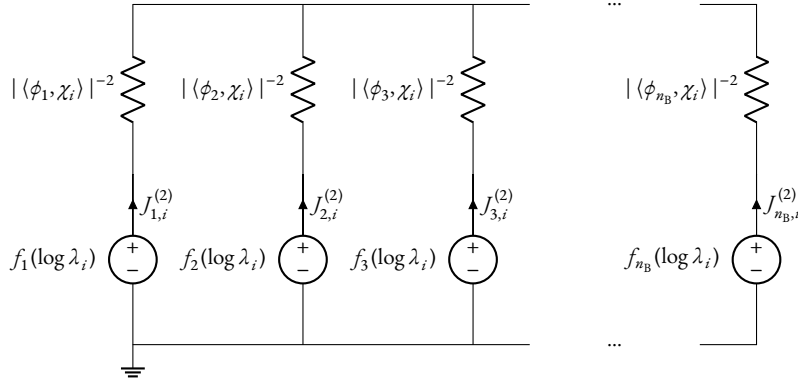

Figure 6.3: The currents $(J_{k,i}^{(2)})_{k=1}^{n_B}$ in Proposition 6.6.5 are the steady-state solutions to a linear circuit with voltage sources $(f_k(\log \lambda_i))_{k=1}^{n_B}$ and resistors $(|\langle \phi_k, \chi_i \rangle|^{-2})_{k=1}^{n_B}$. Such a circuit is associated to each eigenvalue λ_i of \mathcal{W} .

The sign of the currents is not completely determined by the properties of the initial state of the different reservoirs. In keeping with the illustration of the introduction, consider $\mathcal{H}_B = \mathbf{C}^2$, with orthonormal basis $\{\psi_1, \psi_2\}$ and note that if the functions f_1 and f_2 in the decomposition

$$\hat{T}(\theta) = f_1(\theta)\psi_1\psi_1^* + f_2(\theta)\psi_2\psi_2^*$$

of $T : \ell^2(\mathbf{Z}) \times \mathbf{C}^2 \rightarrow \ell^2(\mathbf{Z}) \times \mathbf{C}^2$ are such that neither $f_1 \geq f_2$ or $f_1 \leq f_2$ everywhere, then we can construct a unitary one-particle dynamics $W_{\rightarrow} : \mathcal{H}_S \rightarrow \mathcal{H}_S$ in the sample and a bounded operator $A_{\rightarrow} : \mathbf{C}^2 \rightarrow \mathcal{H}_S$ of the form (6.38) such that $J_1 > 0$ for all nonzero $\alpha \in \Omega$ sufficiently small, as well as a unitary dynamics $W_{\leftarrow} : \mathcal{H}_S \rightarrow \mathcal{H}_S$ in the sample and a bounded operator $A_{\leftarrow} : \mathbf{C}^2 \rightarrow \mathcal{H}_S$ of the form (6.38) such that $J_1 < 0$ for all nonzero $\alpha \in \Omega$ sufficiently small. Indeed, we can choose \mathcal{W} to have simple eigenvalues associated to eigenvectors $(\chi_i)_{i \in I}$ such that $\langle \chi_i, \phi_k \rangle \neq 0$ for both $k = 1$ and $k = 2$. Then, by (6.39), choosing the eigenvalues in $\{z \in \mathbf{S}^1 : f_1(\log z) < f_2(\log z)\}$ [resp. $f_1(\log z) > f_2(\log z)$] gives $J_1 > 0$ [resp. $J_1 < 0$] for α small enough.

Remark 6.6.6. In case $f_k(\theta) \equiv f_k$ for all k , Proposition 6.6.5 and Corollary 6.5.3 provide the following small coupling expression of the entropy production rate

$$\sigma_+ = \alpha^2 \sum_{k=1}^{n_B} \sum_{k'=1}^{n_B} \mu_k(f_{k'} - f_k) \sum_{i \in I} \frac{|\langle \phi_k, \chi_i \rangle|^2 |\langle \phi_{k'}, \chi_i \rangle|^2}{\sum_{k''=1}^{n_B} |\langle \phi_{k''}, \chi_i \rangle|^2} + O(\alpha^3)$$

Setting $C_{k,k'}^{(2)} := \sum_{i \in I} \frac{|\langle \phi_k, \chi_i \rangle|^2 |\langle \phi_{k'}, \chi_i \rangle|^2}{\sum_{k''=1}^{n_B} |\langle \phi_{k''}, \chi_i \rangle|^2} > 0$, we have $C_{k,k'}^{(2)} = C_{k',k}^{(2)}$, $\sum_k C_{k,k'}^{(2)} = 1$ and

$$\sigma_+ = \frac{\alpha^2}{2} \sum_{k \neq k'} (\mu_k - \mu_{k'}) (f_{k'} - f_k) C_{k,k'}^{(2)} + O(\alpha^3).$$

where the leading term is zero if and only if the summand vanishes for all pairs $k \neq k'$. Because $C_{k,k'}^{(2)} > 0$ and because the function $(0, 1) \ni f \mapsto \log((1-f)/f)$ defining μ is strictly decreasing, this is in turn equivalent to $f_k = f_{k'}$ for each pair (k, k') .

6.7 Proof of Proposition 6.3.1

The following lemma is straightforward, but we give a proof for lack of convenient reference. It can alternatively be shown to be a consequence of the Riemann–Lebesgue lemma.

Lemma 6.7.1. *Let $\mathbf{x} = (x_n)_{n \geq 1}$ and $\mathbf{y} = (y_n)_{n \geq 1}$ be two square-summable sequences. Then,*

$$\lim_{t \rightarrow \infty} \sum_{n=1}^t |x_n y_{t-n}| = 0.$$

Proof. Clearly, it is sufficient to show that the limit vanishes along the subsequence with even values of t .

Now, for t even, we have

$$\begin{aligned} \sum_{n=1}^t |x_n y_{t-n}| &\leq \sum_{d=0}^{t/2} |x_{t/2+d} y_{t/2-d}| + \sum_{d=1}^{t/2} |x_{t/2-d} y_{t/2+d}| \\ &\leq \left(\sum_{d=0}^{t/2} |x_{t/2+d}|^2 \right)^{\frac{1}{2}} \left(\sum_{d=0}^{t/2} |y_{t/2-d}|^2 \right)^{\frac{1}{2}} + \left(\sum_{d=1}^{t/2-1} |x_{t/2-d}|^2 \right)^{\frac{1}{2}} \left(\sum_{d=1}^{t/2} |y_{t/2+d}|^2 \right)^{\frac{1}{2}} \\ &\leq \left(\sum_{m \geq \frac{1}{2}t} |x_m|^2 \right)^{\frac{1}{2}} \|\mathbf{y}\|_{\ell^2} + \|\mathbf{x}\|_{\ell^2} \left(\sum_{m > \frac{1}{2}t} |y_m|^2 \right)^{\frac{1}{2}}. \end{aligned}$$

Hence, the result follows from square summability. \square

Proof of Proposition 6.3.1. The selfadjoint term being subtracted on the left-hand side of (6.9) obviously converges strongly to $\sum_{n \geq 0} \delta_n \delta_n^* \otimes \mathbf{1} \oplus 0$ as $t \rightarrow \infty$. The only explicit t -dependence in summands on the right-hand side of (6.9) is in the upper-right block, but the adjoint of this contribution vanishes strongly as $t \rightarrow \infty$. To see this, combine Lemma 6.7.1 with the estimate

$$\left\| \sum_{m=0}^{t-1} (\partial_{-t+m}^* \otimes (M^*)^m Z_{\text{BS}}^* U^{m-t}) v \right\| \leq \sum_{n=1}^t \|M^{t-n}\| \|(\partial_{-n} \otimes \mathbf{1}) v\|$$

keeping in mind that the facts that $v \in \ell^2(\mathbf{Z}) \otimes \mathcal{H}_B$ and that Assumption (Sp) holds imply respectively that $\sum_{m \geq 0} \|\mathcal{M}^m\|^2 < \infty$ and $\sum_{n \geq 0} \|(\delta_{-n}^* \otimes \mathbf{1})v\|^2 < \infty$.

Thus, in order to prove the proposition, it is sufficient to show the uniform convergences

$$\lim_{t \rightarrow \infty} \sum_{m=0}^{t-1} \sum_{l=1}^{t-m} \text{ULB}_{m,l}^- = \sum_{m \geq 0} \sum_{l \geq 1} \text{ULB}_{m,l}^-, \quad \lim_{t \rightarrow \infty} \sum_{m=0}^{t-1} \text{LLB}_m^- = \sum_{m \geq 0} \sum_{l \geq 1} \text{LLB}_m^-,$$

where $\text{ULB}_{m,l}^-$ and LLB_m^- are respectively the summands in the upper-left and lower left-block on the right-hand side of (6.9).

For the upper-left block, we will make use of the shorthand

$$\mathbf{T}_t := \{(m, l) : 0 \leq m \leq t-1; 1 \leq l \leq t-m\}.$$

We want to show that the sequence of partial sums is Cauchy for the uniform operator topology. For $0 < t < u$, we have

$$\begin{aligned} \left\| \sum_{m,l \in \mathbf{T}_u} \text{ULB}_{m,l}^- - \sum_{m,l \in \mathbf{T}_t} \text{ULB}_{m,l}^- \right\| \\ = \sup_{\substack{\sum_{n,j} |a_{n,j}|^2 = 1 \\ \sum_{n',j'} |c_{n',j'}|^2 = 1}} \left| \left\langle \sum_{n,j} a_{n,j} \delta_n \otimes \phi_j, \sum_{m,l \in \mathbf{T}_u \setminus \mathbf{T}_t} \text{ULB}_{m,l}^- \sum_{n',j'} c_{n',j'} \delta_{n'} \otimes \phi_{j'} \right\rangle \right| \end{aligned}$$

where n and n' are understood to range over \mathbf{Z} ; j and j' , to range over the index set for the orthonormal basis $\{\phi_j\}_j$ of \mathcal{H}_B . Because of δ_{-m-l}^* and δ_{-l} in the expression for $\text{ULB}_{m,l}^-$ for fixed m and l , we have

$$\left\langle \sum_{n,j} a_{n,j} \delta_n \otimes \phi_j, \text{ULB}_{m,l}^- \sum_{n',j'} c_{n',j'} \delta_{n'} \otimes \phi_{j'} \right\rangle \leq \sum_j |c_{-m-l,j}| \|Y_m\| \sum_{j'} |a_{-l,j'}|$$

and thus

$$\begin{aligned} \left\| \sum_{m,l \in \mathbf{T}_u} \text{ULB}_{m,l}^- - \sum_{m,l \in \mathbf{T}_t} \text{ULB}_{m,l}^- \right\| &\leq \sup_{\substack{\sum_{n,j} |a_{n,j}|^2 = 1 \\ \sum_{n',j'} |c_{n',j'}|^2 = 1}} \sum_{\substack{m \geq t \\ 1 \leq m+l \leq \infty}} \sum_{j,j'} |a_{-l,j}| \|Y_m\| |c_{-m-l,j'}| \\ &\leq \sup_{\substack{\sum_{n,j} |c_{n,j}|^2 = 1 \\ \sum_{n',j'} |a_{n',j'}|^2 = 1}} \sum_{m \geq t} \|Y_m\| \sum_{d \geq 1} \sum_{j,j'} |a_{m-d,j}| |c_{d,j'}| \\ &\leq (\dim \mathcal{H}_B) \sum_{m \geq t} \|Y_m\|, \end{aligned}$$

thanks to the Cauchy–Schwarz inequality and the fact that

$$\sum_j \left(\sum_d |a_{d,j}|^2 \right)^{1/2} \leq \left(\sum_{d,j} |a_{d,j}|^2 \right)^{1/2} \left(\sum_j 1 \right)^{1/2}.$$

Hence, the Cauchy property of the sequence of double sums, follows from the fact that the sequence $(\|Y_m\|)_{m \geq 1}$, like $(\|M^m\|)_{m \geq 1}$, is summable.

For the lower left-block, note that, for $0 < t < u$,

$$\left\| \sum_{m=0}^{u-1} \text{LLB}_m^- - \sum_{m=0}^{t-1} \text{LLB}_m^- \right\| \leq \sum_{m=t}^{\infty} \|\text{LLB}_m^-\|,$$

with

$$\|\text{LLB}_m^-\| = \|\delta_{-m-1}^* \otimes M^m Z_{\text{SB}} U^{-m-1}\| \leq \|M^m\|.$$

Again because the sequence $(\|Y_m\|)_{m \geq 1}$ is summable, the sequence of partial sums is Cauchy in the uniform operator topology. \square

6.8 Proof of Theorem 6.5.1

We will make use of the following technical lemma.

Lemma 6.8.1. *If $\varepsilon \leq T \leq (1 - \varepsilon)\mathbf{1}$ for some $\varepsilon > 0$ and Ω is a unitary operator such that $\Omega - \mathbf{1}$ is trace class, then*

$$\text{tr}[\Omega T \Omega^* (\log(\Omega T \Omega^*) - \log T)] = \text{tr}[(T - \Omega T \Omega^*) \log T] < \infty.$$

Proof. Let Θ be the trace-class operator such that $\Omega = \mathbf{1} + \Theta$. Then,

$$\begin{aligned} \Omega T \Omega^* (\log(\Omega T \Omega^*) - \log T) &= (\mathbf{1} + \Theta) T \log T (\mathbf{1} + \Theta^*) - (\mathbf{1} + \Theta) T (\mathbf{1} + \Theta^*) \log T \\ &= \Theta T \log T + T \log T \Theta^* + \Theta T \log T \Theta^* \\ &\quad - \Theta T \log T - T \Theta^* \log T - \Theta T \Theta^* \log T. \end{aligned}$$

On the other hand,

$$\begin{aligned} (T - \Omega T \Omega^*) \log T &= (\mathbf{1} + \Theta^*) (\mathbf{1} + \Theta) T \log T - (\mathbf{1} + \Theta^*) T (\mathbf{1} + \Theta) \log T \\ &= \Theta^* T \log T + \Theta T \log T + \Theta^* \Theta T \log T \\ &\quad - \Theta T \log T - T \Theta^* \log T - \Theta T \Theta^* \log T. \end{aligned}$$

All terms are trace class in each right-hand side since T and $\log T$ are bounded. Hence, using linearity and cyclicity of the trace and the fact that $[T, \log T] = 0$, we get

$$\begin{aligned} \text{tr}[\Omega T \Omega^* (\log(\Omega T \Omega^*) - \log T)] &= \text{tr}[(\Theta^* \Theta T - \Theta T \Theta^*) \log T] \\ &= \text{tr}[(T - \Omega T \Omega^*) \log T]. \end{aligned} \quad \square$$

Let us recall that we are looking at the relative entropy between the quasifree states associated to the symbols T_{tot} and $T_{\text{tot}}(t) = \Omega(t)T_{\text{tot}}\Omega^*(t)$ — we have dropped some indices for readability — assuming that T_{tot} has the block diagonal form

$$T_{\text{tot}} = \begin{pmatrix} T_{\text{E}} & 0 \\ 0 & T_{\text{S}} \end{pmatrix}.$$

We also decompose the unitary

$$\Omega(t) = \begin{pmatrix} \Omega_{\text{E}}(t) & \Omega_{\text{ES}}(t) \\ \Omega_{\text{SE}}(t) & \Omega_{\text{S}}(t) \end{pmatrix}.$$

It is easy to see from Proposition 6.3.1 that $\Omega_{\text{ES}}(t)$, $\Omega_{\text{SE}}(t)$ and $\Omega_{\text{S}}(t)$ have their rank bounded by $\dim \mathcal{H}_{\text{S}}$, uniformly in $t \geq 0$.

Let us introduce

$$\mathfrak{Y}_t := \sum_{l=0}^{t-1} \sum_{m=1}^{t-l} \delta_{-m} \delta_{-m-l}^* \otimes Y_l. \quad (6.40)$$

Then, $\text{rk } \mathfrak{Y}_t \leq t \dim \mathcal{H}_{\text{S}}$ and Proposition 6.3.1 gives $\Omega_{\text{E}}(t) - \mathbf{1}_{\text{E}} = -P_{[-t,-1]} \otimes \mathbf{1} + \mathfrak{Y}_t$. Hence, Lemma 6.8.1 applies and

$$\sigma(t) = t^{-1} \text{tr}[(T_{\text{tot}} - \Omega(t)T_{\text{tot}}\Omega^*(t)) \log T_{\text{tot}}] + [T_{\text{tot}} \mapsto \mathbf{1} - T_{\text{tot}}], \quad (6.41)$$

where “ $+ [T_{\text{tot}} \mapsto \mathbf{1} - T_{\text{tot}}]$ ” means to we add the same term with $\mathbf{1} - T_{\text{tot}}$ instead of T_{tot} . We will show how to deal with the first of the two traces, the other one being similar. The term $\log T_{\text{tot}}$ being bounded, we consider the following representation of its multiplier

$$\begin{aligned} & T_{\text{tot}} - \Omega(t)T_{\text{tot}}\Omega^*(t) \\ &= \begin{pmatrix} \Omega_{\text{E}}(t)T_{\text{E}}\Omega_{\text{E}}^*(t) + \Omega_{\text{ES}}T_{\text{S}}\Omega_{\text{ES}}^*(t) - T_{\text{E}} & \Omega_{\text{E}}(t)T_{\text{E}}\Omega_{\text{SE}}^*(t) + \Omega_{\text{ES}}(t)T_{\text{S}}\Omega_{\text{S}}^*(t) \\ \Omega_{\text{SE}}(t)T_{\text{E}}\Omega_{\text{E}}^*(t) + \Omega_{\text{S}}(t)T_{\text{S}}\Omega_{\text{ES}}^*(t) & \Omega_{\text{SE}}(t)T_{\text{E}}\Omega_{\text{SE}}^*(t) + \Omega_{\text{S}}(t)T_{\text{S}}\Omega_{\text{S}}^*(t) - T_{\text{S}} \end{pmatrix}. \end{aligned}$$

Note that the rank of the lower-right block is bounded by $\dim \mathcal{H}_{\text{S}}$ and hence cannot contribute to the limit of (6.41). The same is true for each term in which T_{S} appears. Hence, provided that the limit exists, we must have

$$\sigma^+ = \lim_{t \rightarrow \infty} t^{-1} \text{tr}[(T_{\text{E}} - \Omega(t)T_{\text{E}}\Omega^*(t)) \log T_{\text{E}}] + [T_{\text{E}} \mapsto \mathbf{1} - T_{\text{E}}]. \quad (6.42)$$

Proposition 6.3.1 yields

$$\begin{aligned} \Omega_{\text{E}}(t)T_{\text{E}}\Omega_{\text{E}}^*(t) - T_{\text{E}} &= (P_{[-t,-1]}^\perp \otimes \mathbf{1})T_{\text{E}}(P_{[-t,-1]}^\perp \otimes \mathbf{1}) - T_{\text{E}} \\ &\quad + \mathfrak{Y}_t T_{\text{E}}(\mathbf{1}_{\text{E}} - P_{[-t,-1]} \otimes \mathbf{1}) + (\mathbf{1}_{\text{E}} - P_{[-t,-1]} \otimes \mathbf{1})T_{\text{E}}\mathfrak{Y}_t^* + \mathfrak{Y}_t T_{\text{E}}\mathfrak{Y}_t^*, \end{aligned}$$

where the operator on the second line has finite rank since \mathfrak{Y}_t does. The first line of the right hand side above writes

$$(P_{[-t,-1]}^\perp \otimes \mathbf{1})T_E(P_{[-t,-1]}^\perp \otimes \mathbf{1}) - T_E = (P_{[-t,-1]} \otimes \mathbf{1})T_E(P_{[-t,-1]} \otimes \mathbf{1}) - T_E(P_{[-t,-1]} \otimes \mathbf{1}) - (P_{[-t,-1]} \otimes \mathbf{1})T_E, \quad (6.43)$$

where $P_{[-t,-1]}$ has rank t , so that altogether, each term in this composition of $\Omega(t)T_E\Omega^* - T_E$ has finite rank of order t .

Let us now spell out what is left of the (first) trace in (6.42) dropping the tensored identities for readability:

$$\begin{aligned} & \operatorname{tr}[T_E P_{[-t,-1]} \log(T_E)] + \operatorname{tr}[P_{[-t,-1]} T_E P_{[-t,-1]}^\perp \log(T_E)] \\ & - \operatorname{tr}[\mathfrak{Y}_t T_E P_{[-t,-1]}^\perp \log(T_E) + \text{h.c.}] - \operatorname{tr}[\mathfrak{Y}_t T_E \mathfrak{Y}_t^* \log(T_E)]. \end{aligned}$$

We have used yet again cyclicity of the trace, as well as the identity

$$\mathfrak{Y}_t = P_{[-t,-1]} \mathfrak{Y}_t P_{[-t,-1]}$$

following immediately from the definition.

Lemma 6.8.2. *Under the ongoing hypotheses,*

$$\lim_{t \rightarrow \infty} t^{-1} \operatorname{tr}[P_{[-t,-1]} T_E \log(T_E)] = \int_0^{2\pi} \operatorname{tr}[\hat{\Xi}(\theta) \log \hat{\Xi}(\theta)] \frac{d\theta}{2\pi}$$

with $\hat{\Xi}$ the Fourier of transform of Ξ according to the conventions of Section 6.3.2.

Proof. Because T_E is invariant under translations, it has a decomposition of the form

$$T_E = \sum_k \Xi^{(k)} \otimes \psi_k \psi_k^*$$

with $\{\psi_k\}_k$ an orthonormal basis of \mathcal{H}_B and $\Xi^{(k)}$ an operator on $\ell^2(\mathbf{Z})$ whose representation in Fourier space is a multiplication operator. Then,

$$T_E \log T_E = \sum_k \Xi^{(k)} \log \Xi^{(k)} \otimes \psi_k \psi_k^* \quad (6.44)$$

with $\log \Xi^{(k)}$ also a multiplication operator in Fourier representation; the matrix elements for the summands satisfy

$$\delta_n^* \Xi^{(k)} \log(\Xi^{(k)}) \delta_m = \delta_0^* \Xi^{(k)} \log(\Xi^{(k)}) \delta_{m-n} =: G_0^k(m-n) \quad (6.45)$$

for $m, n \in \mathbf{Z}$. Hence, taking the trace using the basis $\{\delta_m \otimes \psi_k\}_{m,k}$

$$t^{-1} \operatorname{tr}[P_{[-t,-1]} T_E \log(T_E)] = t^{-1} \sum_k \sum_{m=1}^t G_0^k(0) = \sum_k G_0^k(0). \quad \square$$

Lemma 6.8.3. *Under the ongoing hypotheses,*

$$\lim_{t \rightarrow \infty} t^{-1} \operatorname{tr}[P_{[-t,-1]} T_E P_{[-t,-1]}^\perp \log(T_E)] = 0.$$

Proof. In view of Lemma 6.8.2 and the definition of $P_{[-t,-1]}^\perp$, the claim will be proved if we can show that

$$\lim_{t \rightarrow \infty} t^{-1} \operatorname{tr}[P_{[-t,-1]} T_E P_{[-t,-1]} \log(T_E)] = \int_0^{2\pi} \operatorname{tr}[\hat{\Xi}(\theta) \log \hat{\Xi}(\theta)] \frac{d\theta}{2\pi}.$$

What was said about the function $G_0(x) \mapsto x \log x$ in (6.44)–(6.45) equally holds for $G_1 : x \mapsto x$ and $G_2 : x \mapsto \log x$. In this language,

$$\operatorname{tr}[P_{[-t,-1]} T_E P_{[-t,-1]} \log(T_E)] = \sum_k \sum_{n=1}^t \sum_{m=1}^t G_1^k(n-m) G_2^k(m-n)$$

and reindexing the sum in m with $l = n - m$ yields

$$\begin{aligned} \sum_{n=1}^t \sum_{m=1}^t G_1^k(n-m) G_2^k(m-n) &= \sum_{n=1}^t \sum_{l=n-t}^{n-1} G_1^k(l) G_2^k(-l) \\ &= \sum_{l=0}^{t-1} (t-l) G_1^k(l) G_2^k(-l) + \sum_{l=1-t}^{-1} (t+l) G_1^k(l) G_2^k(-l) \\ &= \sum_{l=1-t}^{t-1} t G_1^k(l) G_2^k(-l) + O\left(\sum_{l \in \mathbf{Z}} |l| |G_1^k(l)| |G_2^k(-l)|\right). \end{aligned}$$

Now, the second sum is absolutely convergent if $|G_1^k(l)|$ decays fast enough in l , in which case it cannot contribute to the limit of interest. Hence, the lemma follows from the relation

$$\sum_{l \in \mathbf{Z}} G_1^k(l) G_2^k(m-l) = (G_1^k G_2^k)(m) = G_0^k(m) \quad (6.46)$$

for discrete convolutions. □

Lemma 6.8.4. *Under the ongoing hypotheses,*

$$\lim_{t \rightarrow \infty} t^{-1} \operatorname{tr}[\mathfrak{Y}_t T_E P_{[-t,-1]}^\perp \log(T_E)] = 0.$$

Proof. Keeping with the notation used in the proof of the previous lemma, splitting the projector $P_{[-t,-1]}^\perp$ as

$$\mathbf{1} - \sum_{n=1}^t \delta_{-n} \delta_{-n}^*$$

$$\begin{aligned} \mathrm{tr}[\mathfrak{Y}_t T_E P_{[-t,-1]}^\perp \log(T_E)] &= \sum_k \sum_{l=0}^{t-1} \sum_{m=1}^{t-l} Y_l^k G_0^k((-m) - (-m-l)) \\ &\quad + \sum_k \sum_{l=0}^{t-1} \sum_{m=1}^{t-l} \sum_{n=1}^t Y_l^k G_1^k((-n) - (-m-l)) G_2^k(-m - (-n)) \end{aligned} \quad (6.47)$$

The first term on the right-hand side in (6.47) simplifies to

$$\sum_{l=0}^{t-1} \sum_{m=1}^{t-l} Y_l^k G_0^k((-m) - (-m-l)) = \sum_{l=0}^{t-1} t Y_l^k G_0^k(l) + O\left(\sum_{l=0}^{t-1} |l| |Y_l^k| |G_0^k(l)|\right)$$

with $|Y_l^k|$ decaying exponentially fast in l thanks to Assumption (Sp).

Reindexing the second term in (6.47), we obtain a term which — thanks again to (6.46) — cancels the first term of (6.47) up to an error term which can be shown to not contribute in the limit with similar arguments. \square

Lemma 6.8.5. *Under the ongoing hypotheses,*

$$\lim_{t \rightarrow \infty} t^{-1} \mathrm{tr}[\mathfrak{Y}_t T_E \mathfrak{Y}_t^* \log(T_E)] = \int_0^{2\pi} \mathrm{tr}[\hat{\mathfrak{Y}}(\theta) \hat{\Xi}(\theta) \hat{\mathfrak{Y}}^*(\theta) \log(\hat{\Xi}^*(\theta))] \frac{d\theta}{2\pi}.$$

Proof. Keeping with the notation used in the proof of the previous lemmata,

$$\mathrm{tr}[\mathfrak{Y}_t T_E \mathfrak{Y}_t^* \log(T_E)] = \sum_{k,k'} \sum_{l,l'=0}^{t-1} \sum_{m=0}^{t-l} \sum_{m'=0}^{t-l'} Y_l^{k,k'} G_1^{k'}(l+m-(l'+m')) Y_{l'}^{*,k',k} G_2^k(m'-m).$$

Performing a reindexation similar to that of the previous lemma, we find

$$\begin{aligned} &\sum_{k,k'} \sum_{l,l'=0}^{t-1} \sum_{m=0}^{t-l} \sum_{m'=0}^{t-l'} Y_l^{k,k'} G_1^{k'}(l+m-(l'+m')) Y_{l'}^{*,k',k} G_2^k(m'-m) \\ &= \sum_{k,k'} \sum_{l,l'=0}^{t-1} \sum_{b=l-(t-1)}^{t-1-l'} t Y_l^{k,k'} G_1^{k'}(b) Y_{l'}^{*,k',k} G_2^k(l-l'-b) \\ &\quad + O\left(\sum_{l,l' \in \mathbf{N}} \sum_{b \in \mathbf{Z}} (\dim \mathcal{H}_B)^2 (l+l'+|b|) \|Y_l\| \|Y_{l'}\| \sup_{k,k'} |G_1^{k'}(b)| |G_2^k(l-l'-b)|\right). \end{aligned}$$

Note that the first sum on the left-hand side is, up to truncation and multiplication by t , a sum of products of Fourier coefficients whose indices sum to 0, which coincides with the integral in the statement of the lemma. Once divided by t , the error due to truncation and the second sum on the right-hand side both vanish as $t \rightarrow \infty$ thanks to the decay of $\|Y_l\|$ in l , $\|Y_{l'}\|$ in l' and $|G_1^{k'}(b)|$ in b . \square

Bibliography

- [AAKV01] D. Aharonov, A. Ambainis, J. Kempe, and U. Vazirani. Quantum walks on graphs. In *Proceedings of the thirty-third annual ACM symposium on Theory of computing*, pages 50–59. ACM, 2001.
- [ABJ15] J. Asch, O. Bourget, and A. Joye. Spectral stability of unitary network models. *Rev. Math. Phys.*, 27(07):1530004, 2015.
- [AJP06] S. Attal, A. Joye, and C.-A. Pillet, editors. *Open quantum systems. III Recent developments*, volume 1882 of *Lecture Notes in Mathematics*. Springer-Verlag, 2006. Lecture notes from the Summer School held in Grenoble, June 16–July 4, 2003.
- [AJPP06] W. Aschbacher, V. Jakšić, Y. Pautrat, and C.-A. Pillet. Topics in non-equilibrium quantum statistical mechanics. In *Open quantum systems. III*, pages 1–66. Springer-Verlag, Berlin, 2006.
- [AJPP07] W. Aschbacher, V. Jakšić, Y. Pautrat, and C.-A. Pillet. Transport properties of quasi-free fermions. *J. Math. Phys.*, 48(3):032101, 2007.
- [And20] S. Andréys. Repeated interaction processes in the continuous-time limit, applied to quadratic fermionic systems. *Ann. Henri Poincaré*, 21(1):115–154, 2020.
- [AP03] W. H. Aschbacher and C.-A. Pillet. Non-equilibrium steady states of the XY chain. *J. Stat. Phys.*, 112:1153–1175, 2003.
- [APSS12] S. Attal, F. Petruccione, C. Sabot, and I. Sinayskiy. Open quantum random walks. *J. Stat. Phys.*, 147(4):832–852, 2012.
- [BB20] J.-F. Bougron and L. Bruneau. Linear response theory and entropic fluctuations in repeated interaction quantum systems. *J. Stat. Phys.*, 181:1636–1677, 2020.
- [BJM06] L. Bruneau, A. Joye, and M. Merkli. Asymptotics of repeated interaction quantum systems. *J. Funct. Anal.*, 239(1):310–344, 2006.
- [BJM14] L. Bruneau, A. Joye, and M. Merkli. Repeated interactions in open quantum systems. *J. Math. Phys.*, 55(7):075204, 2014.

- [BJPP18] T. Benoist, V. Jakšić, Y. Pautrat, and C.-A. Pillet. On entropy production of repeated quantum measurements i. general theory. *Commun. Math. Phys.*, 357(1):77–123, 2018.
- [CC88] J. T. Chalker and P. D. Coddington. Percolation, quantum tunnelling and the integer Hall effect. *J. Phys. C: Solid State Phys.*, 21(14):2665, 1988.
- [DdRM08] J. Dereziński, W. de Roeck, and C. Maes. Fluctuations of quantum currents and unravelings of master equations. *J. Stat. Phys.*, 131(2):341–356, 2008.
- [DFP08] B. Dierckx, M. Fannes, and M. Pogorzelska. Fermionic quasifree states and maps in information theory. *J. Math. Phys.*, 49(3):032109, 2008.
- [Gud08] S. Gudder. Quantum Markov chains. *J. Math. Phys.*, 49(7):072105, 2008.
- [HJ17] E. Hamza and A. Joye. Thermalization of fermionic quantum walkers. *J. Stat. Phys.*, 166(6):1365–1392, 2017.
- [HJPR17] E. P. Hanson, A. Joye, Y. Pautrat, and R. Raquépas. Landauer’s principle in repeated interaction systems. *Commun. Math. Phys.*, 349(1):285–327, 2017.
- [HJPR18] E. P. Hanson, A. Joye, Y. Pautrat, and R. Raquépas. Landauer’s principle for trajectories of repeated interaction systems. *Ann. Henri Poincaré*, 19(7):1939–1991, 2018.
- [JLP13] V. Jakšić, B. Landon, and C.-A. Pillet. Entropic fluctuations in xy chains and reflectionless jacobi matrices. *Ann. Henri Poincaré*, 14(7):1775–1800, 2013.
- [JOPP11] V. Jakšić, Y. Ogata, Y. Pautrat, and C.-A. Pillet. Entropic fluctuations in quantum statistical mechanics an introduction. In J. Fröhlich, M. Salmhofer, V. Mastropietro, W. De Roeck, and L. F. Cugliandolo, editors, *Quantum Theory from Small to Large Scales*, volume 95 of *Lecture Notes of the Les Houches Summer School*, pages 213–410. Oxford University Press, 2011.
- [JP01] V. Jakšić and C.-A. Pillet. On entropy production in quantum statistical mechanics. *Commun. Math. Phys.*, 217(2):285–293, 2001.
- [JP02] V. Jakšić and C.-A. Pillet. Mathematical theory of non-equilibrium quantum statistical mechanics. *J. Stat. Phys.*, 108(5-6):787–829, 2002.

- [JPW14] V. Jakšić, C.-A. Pillet, and M. Westrich. Entropic fluctuations of quantum dynamical semi-groups. *J. Stat. Phys.*, 154(1-2):153–187, 2014.
- [KAG12] I. Kassal and A. Aspuru-Guzik. Environment-assisted quantum transport in ordered systems. *New J. Phys.*, 14(5):053041, 2012.
- [Kat95] T. Kato. *Perturbation theory for linear operators*, volume 132 of *Grundlehren der mathematischen Wissenschaften*. Springer, second edition, 1995.
- [Kem03] J. Kempe. Quantum random walks: an introductory overview. *Contemp. Phys.*, 44(4):307–327, 2003.
- [KFC⁺09] M. Karski, L. Förster, J.-M. Choi, A. Steffen, W. Alt, D. Meschede, and A. Widera. Quantum walk in position space with single optically trapped atoms. *Science*, 325(5937):174–177, 2009.
- [Kon08] N. Konno. Quantum walks. In *Quantum potential theory*, pages 309–452. Springer, 2008.
- [MMS07a] M. Merkli, M. Mück, and I. Sigal. Instability of equilibrium states for coupled heat reservoirs at different temperatures. *J. Funct. Anal.*, 243(1):87–120, 2007.
- [MMS07b] M. Merkli, M. Mück, and I. M. Sigal. Theory of non-equilibrium stationary states as a theory of resonances. *Ann. Henri Poincaré*, 8(8):1539–1593, 2007.
- [MNŠJ20] J. Mareš, J. Novotný, M. Štefaňák, and I. Jex. Counterintuitive role of geometry in transport by quantum walks. *Phys. Rev. A*, 101(3):032113, 2020.
- [Por13] R. Portugal. *Quantum walks and search algorithms*. Springer Science & Business Media, 2013.
- [Raq20] R. Raquépas. On fermionic walkers interacting with a correlated structured environment. *Lett. Math. Phys.*, 110(1):121–145, 2020.
- [Rue00] D. Ruelle. Natural nonequilibrium states in quantum statistical mechanics. *J. Stat. Phys.*, 98(1-2):57–75, 2000.
- [Rue01] D. Ruelle. Entropy production in quantum spin systems. *Commun. Math. Phys.*, 224(1):3–16, 2001.

- [SAM⁺19] M. Sajid, J. K. Asbóth, D. Meschede, R. F. Werner, and A. Alberti. Creating anomalous floquet chern insulators with magnetic quantum walks. *Phys. Rev. B*, 99:214303, 2019.
- [San08] M. Santha. Quantum walk based search algorithms. In *International Conference on Theory and Applications of Models of Computation*, pages 31–46. Springer, 2008.
- [SL78] H. Spohn and J. L. Lebowitz. Irreversible thermodynamics for quantum systems weakly coupled to thermal reservoirs. *Adv. Chem. Phys.*, 38:109–142, 1978.
- [Spo78] H. Spohn. Entropy production for quantum dynamical semigroups. *J. Math. Phys.*, 19(5):1227–1230, 1978.
- [SVA⁺13] N. Spagnolo, C. Vitelli, L. Aparo, P. Mataloni, F. Sciarrino, A. Crespi, R. Ramponi, and R. Osellame. Three-photon bosonic coalescence in an integrated tritter. *Nature Commun.*, 4(1):1–6, 2013.
- [TMT20] M. Tamura, T. Mukaiyama, and K. Toyoda. Quantum walks of a phonon in trapped ions. *Phys. Rev. Lett.*, 124:200501, 2020.
- [VA12] S. E. Venegas-Andraca. Quantum walks: a comprehensive review. *Quantum Inf. Process.*, 11(5):1015–1106, 2012.
- [WM13] J. Wang and K. Manouchehri. *Physical implementation of quantum walks*. Springer, 2013.
- [ZKG⁺10] F. Zähringer, G. Kirchmair, R. Gerritsma, E. Solano, R. Blatt, and C. Roos. Realization of a quantum walk with one and two trapped ions. *Phys. Rev. Lett.*, 104(10):100503, 2010.

Chapter 7

Discussion and conclusion

We have focused our attention on effective finite-dimensional descriptions of classical systems and on a very particular case of a truly infinite-dimensional quantum system. For stochastic systems with a nondegenerate Brownian noise, we have been able to perform a detailed analysis of the fluctuations of entropy production and study the vanishing-noise limit whereas we only reached an understanding of the basic ergodicity properties when the noise is degenerate — save the linear case [JPS17]. For ensembles of fermionic walkers, we have tackled the basic ergodicity properties as well as mean properties of entropy production and their relations to currents of particles.

While the general mathematical structure of the relations between the different notions of entropy production and the fluctuation theorems for extended classical systems is relatively well understood [JPRB11], this is far from being the case for quantum systems. This is partly due to the impressive amount of preliminary notions from the theory of von Neumann algebras that is needed to even frame the discussion. Meanwhile, the study of toy models such as the electronic black box model [AJPP06, AJPP07, JOPP11], the XY spin chain [JLP13], repeated interaction systems [BJM14, HJPR17, HJPR18, BB20] and the model of Chapters 5 and 6 remains important: they provide explicit cases where the assumptions in the abstract theory holds — when it exists — and allow for the analysis of model-dependent physical phenomena.

On the more concrete side, as far as the precise class of models in Chapters 5 and 6 are concerned, there is much left to be understood. Most notably, one should investigate whether the information-theoretical notion of entropy production can be related to the statistics of a physically relevant measurement process. Also, the infinite-volume limit of the sample should be considered — with and without disorder — and the

links between spectral and transport properties should be studied.

Perhaps the most obvious technical open problem related to Chapters 2 and 3 is to study the vanishing-noise limit of the rate function for entropy production in degenerate diffusions enjoying good controllability properties. Another interesting problem related to Chapter 2 is that the SDE at the heart of the paper is physically relevant as a small-mass limit of a Langevin equation which is itself obtained from an open system through yet another limiting procedure: the interchangeability of those limits with the vanishing-noise limit poses important technical difficulties. This could clarify the relevance of the stochastic model when in the appropriate regime.

Bibliography

- [AJPP06] W. Aschbacher, V. Jakšić, Y. Pautrat, and C.-A. Pillet. Topics in non-equilibrium quantum statistical mechanics. In *Open quantum systems. III*, pages 1–66. Springer-Verlag, Berlin, 2006.
- [AJPP07] W. Aschbacher, V. Jakšić, Y. Pautrat, and C.-A. Pillet. Transport properties of quasi-free fermions. *J. Math. Phys.*, 48(3):032101, 2007.
- [BB20] J.-F. Bougron and L. Bruneau. Linear response theory and entropic fluctuations in repeated interaction quantum systems. *J. Stat. Phys.*, 181:1636–1677, 2020.
- [BJM14] L. Bruneau, A. Joye, and M. Merkli. Repeated interactions in open quantum systems. *J. Math. Phys.*, 55(7):075204, 2014.
- [HJPR17] E. P. Hanson, A. Joye, Y. Pautrat, and R. Raquépas. Landauer’s principle in repeated interaction systems. *Commun. Math. Phys.*, 349(1):285–327, 2017.
- [HJPR18] E. P. Hanson, A. Joye, Y. Pautrat, and R. Raquépas. Landauer’s principle for trajectories of repeated interaction systems. *Ann. Henri Poincaré*, 19(7):1939–1991, 2018.
- [JLP13] V. Jakšić, B. Landon, and C.-A. Pillet. Entropic fluctuations in xy chains and reflectionless jacobi matrices. *Ann. Henri Poincaré*, 14(7):1775–1800, 2013.
- [JOPP11] V. Jakšić, Y. Ogata, Y. Pautrat, and C.-A. Pillet. Entropic fluctuations in quantum statistical mechanics an introduction. In J. Frohlich, M. Salmhofer, V. Mastropietro, W. De Roeck, and

L. F. Cugliandolo, editors, *Quantum Theory from Small to Large Scales*, volume 95 of *Lecture Notes of the Les Houches Summer School*, pages 213–410. Oxford University Press, 2011.

- [JPRB11] V. Jakšić, C.-A. Pillet, and L. Rey-Bellet. Entropic fluctuations in statistical mechanics: I. Classical dynamical systems. *Nonlinearity*, 24(3):699, 2011.
- [JPS17] V. Jakšić, C.-A. Pillet, and A. Shirikyan. Entropic fluctuations in thermally driven harmonic networks. *J. Stat. Phys.*, 166(3):926–1015, 2017.

Index

- Chernoff error exponent, 7, 57
- coalescence, 22, 130
- controllability
 - approximate, 25, 96, 121
 - solid, 26, 98, 121, 138
- coupling, 21, 123, 130
- entropy production, 8, 11–13, 34, 45, 211
- extended Hamiltonian systems, 7
- finite-time Evans–Searles symmetry, 10, 42, 46
- Gallavotti–Cohen fluctuation theorem, 10, 33, 57, 67
- Hamilton’s equations of motion, 3, 144
 - modified, 8, 11, 106, 144
- Hamiltonian
 - function, 2, 106
 - vector field, 2
- Hamiltonian systems, 2
 - confined, 3, 13, 14
 - extended, 7, 13, 14
 - thermostated, 8
- Harris’ theorem, 19, 92
- hypothesis testing of the arrow of time, 5, 34, 57
- large deviation principle, 7, 9, 10, 36, 58, 67
- Liouville’s volume theorem, 4
- Lyapunov function, 26, 38, 39, 88, 93, 125, 148
- Markov operators, 15, 16, 39, 75, 121
- mixing result, 15, 18, 19, 39, 79, 92, 122, 176, 203
- Neyman–Pearson lemma, 6
- observables, 4, 12, 169, 198
- phase space, 2, 9
- states, 4, 12, 15
- time reversal invariance, 4