



HAL
open science

On the modeling and control of extended Timed Event Graphs in dioids

Johannes Trunk

► **To cite this version:**

Johannes Trunk. On the modeling and control of extended Timed Event Graphs in dioids. Automatic Control Engineering. Université d'Angers; Production technology Center PTC(Technische Universität Berlin) (Berlin (Allemagne)), 2019. English. NNT : 2019ANGE0068 . tel-03150919

HAL Id: tel-03150919

<https://theses.hal.science/tel-03150919>

Submitted on 24 Feb 2021

HAL is a multi-disciplinary open access archive for the deposit and dissemination of scientific research documents, whether they are published or not. The documents may come from teaching and research institutions in France or abroad, or from public or private research centers.

L'archive ouverte pluridisciplinaire **HAL**, est destinée au dépôt et à la diffusion de documents scientifiques de niveau recherche, publiés ou non, émanant des établissements d'enseignement et de recherche français ou étrangers, des laboratoires publics ou privés.



Université
franco-allemande
Deutsch-Französische
Hochschule

Thèse de Doctorat en cotutelle

Johannes Trunk

Mémoire présenté en vue de l'obtention
du grade de Docteur de l'Université d'Angers
Sous le label de l'Université Nantes Angers Le Mans

Spécialité: Automatique Productique et Robotique
Laboratoire: Laboratoire Angevin de Recherche en Ingénierie des Systèmes LARIS EA 7315

Soutenue le 28.10.2019

École doctorale: ED STIM

ON THE MODELING AND CONTROL OF EXTENDED TIMED EVENT GRAPHS IN DIOIDS

JURY

Rapporteurs:	Stephane GAUBERT	Professeur, Ecole polytechnique, UMR 7641 CNRS
	Thomas MOOR	Professeur, Universität Erlangen-Nürnberg
Examineurs:	Bertrand COTTENCEAU	Professeur, Université d'Angers
	Sergio LUCIA	Professeur, Technische Universität Berlin
Directeurs de thèse:	Laurent HARDOUIN	Professeur, Université d'Angers
	Jörg RAISCH	Professeur, Technische Universität Berlin

Laboratoire Angevin de Recherche en Ingénierie des Systèmes, Université d'Angers
62 Avenue Notre-Dame du Lac, 49000 Angers, France

ii Fachgebiet Regelungssysteme, Fakultät IV - Elektrotechnik und Informatik
Technische Universität Berlin, Einsteinufer 17, 10587 Berlin, Germany

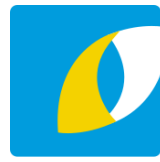

Université
franco-allemande
Deutsch-Französische
Hochschule

ON THE MODELING AND CONTROL OF EXTENDED TIMED EVENT GRAPHS IN DIOIDS

Vorgelegt von
M.Sc. Johannes Trunk

von der Fakultät IV - Elektrotechnik und Informatik
der Technischen Universität Berlin
zur Erlangung des akademischen Grades

Doktor der Ingenieurwissenschaften
- Dr.-Ing. -

genehmigte Dissertation

Promotionsausschuss:

Vorsitzender:	Prof. Sergio LUCIA	Technische Universität Berlin
stellv. Vorsitzende:	Prof. Bertrand COTTENCEAU	Université d'Angers
Gutachter:	Prof. Dr.-Ing. Jörg RAISCH	Technische Universität Berlin
Gutachter:	Prof. Laurent HARDOUIN	Université d'Angers
Gutachter:	Prof. Thomas MOOR	Universität Erlangen-Nürnberg
Gutachter:	Prof. Stephane GAUBERT	Ecole polytechnique, UMR 7641 CNRS

Tag der wissenschaftliche Aussprache: 28.10.2019

Berlin 2019

PhD Thesis

**ON THE MODELING AND CONTROL OF
EXTENDED TIMED EVENT GRAPHS IN DIOIDS**

JOHANNES TRUNK

Johannes Trunk: *On the Modeling and Control of extended Timed Event Graphs in Dioids*
PhD Thesis, © December 2019

SUPERVISORS:

Prof. Dr.-Ing. Jörg Raisch
Prof. Laurent Hardouin

LOCATIONS:

Fachgebiet Regelungssysteme, Fakultät IV - Elektrotechnik und Informatik, Technische
Universität Berlin, Einsteinufer 17, 10587 Berlin, Germany

Laboratoire Angevin de Recherche en Ingénierie des Systèmes, Université d'Angers, 62
Avenue Notre-Dame du Lac, 49000 Angers, France

SUPPORT:

Université franco-allemande, Deutsch-Französische Hochschule, Kohlweg 7 / Villa Eu-
ropa, 66123 Saarbrücken, Germany

Abstract

Various kinds of manufacturing systems can be modeled and analyzed by Timed Event Graphs (TEGs). These TEGs are a particular class of timed Discrete Event Systems (DESs), whose dynamic behavior is characterized only by synchronization and saturation phenomena. A major advantage of TEGs over many other timed DES models is that their earliest behavior can be described by linear equations in some *tropical* algebra structures called dioids. This has led to a broad theory for linear systems over dioids where many concepts of standard systems theory were introduced for TEGs. For instance, with the $(\max, +)$ -algebra linear state-space models for TEGs were established. These linear models provide an elegant way to do performance evaluation for TEGs. Moreover, based on transfer functions in dioids several control problems for TEGs were addressed. However, the properties of TEGs, and thus the systems which can be described by TEGs, are limited. To enrich these properties, two main extensions for TEGs were introduced. First, Weighted Timed Event Graphs (WTEGs) which, in contrast to ordinary TEGs, exhibit event-variant behaviors. In WTEGs integer weights are considered on the arcs whereas TEGs are restricted to unitary weights. For instance, these integer weights make it straightforward to model a cutting process in a production line. Second, a new kind of synchronization called partial synchronization (PS) was introduced for TEGs. PS is useful to model systems where specific events can only occur in a particular time window. For example, consider a crossroad controlled by a traffic light: the green phase of the traffic light provides a time window in which a vehicle is allowed to cross. Clearly, PS leads to time-variant behavior. As a consequence, WTEGs and TEGs under PS are not $(\max, +)$ -linear anymore.

In this thesis, WTEGs and TEGs under PS are studied in a dioid structure. Based on these dioid models for WTEGs a decomposition of the dynamic behavior into an event-variant and an event-invariant part is proposed. Under some assumptions, it is shown that the event-variant part is "invertible". Hence, based on this model, optimal control and model reference control, which are well known for ordinary TEGs, are generalized to WTEGs. Similarly, a decomposition model is introduced for TEGs under PS in which the dynamic behavior is decomposed into a time-variant and time-invariant part. Again, under some assumptions, it is shown that the time-variant part is invertible. Subsequently, optimal control, as well as model reference control for TEGs under PS is addressed.

Zusammenfassung

Viele Produktions- und Fertigungsanlagen können mit Hilfe von Synchronisationsgraphen modelliert und analysiert werden. Diese Synchronisationsgraphen sind eine spezielle Klasse der zeitbehafteten Ereignisdiskreten Systemen, deren dynamisches Verhalten nur durch Synchronisations- und Sättigungsphänomene gekennzeichnet ist. Ein Vorteil dieser Synchronisationsgraphen gegenüber vielen anderen Modellen besteht darin, dass ihr schnellstes Verhalten durch lineare Gleichungen in einigen „tropischen“ Algebren, den sogenannten Dioiden, beschrieben werden kann. Dies hat zu der Entwicklung einer umfangreichen Theorie für lineare Systeme in Dioiden geführt, wobei viele Konzepte aus der Standard Systemtheorie auf Synchronisationsgraphen übertragen wurden. Zum Beispiel die $(\max,+)$ Algebra bietet elegante Analyseverfahren und Reglerentwurfsverfahren für Synchronisationsgraphen. Allerdings ist die Systemklasse, die mit Hilfe von Synchronisationsgraphen beschrieben werden kann, eingeschränkt. Zum Beispiel lassen sich Fertigungsanlagen mit Gruppierungs- oder Vereinzelungsschritten nicht mit Synchronisationsgraphen modellieren. Daher wurden einige Erweiterungen für Synchronisationsgraphen eingeführt. Zum einen wurden die Kanten von Synchronisationsgraphen mit ganzzahligen Gewichten erweitert. Diese gewichteten Synchronisationsgraphen weisen im Gegensatz zu gewöhnlichen Synchronisationsgraphen ereignisvariantes Verhalten auf und ermöglichen es nun Gruppierungs- oder Vereinzelungsschritte zu beschreiben. Des Weiteren wurde eine neue Art der Synchronisation namens partieller Synchronisation (PS) eingeführt. Diese PS ist nützlich für die Modellierung von zeitvarianten Systemen, bei denen bestimmte Ereignisse nur in einem bestimmten Zeitfenster auftreten können. Ein solches Verhalten tritt zum Beispiel an einer Kreuzung mit Ampelsteuerung auf, die Grünphase der Ampeln beschreibt das Zeitfenster, in dem ein Fahrzeug die Kreuzung überqueren darf.

Aufgrund ihres ereignisvarianten bzw. zeitvarianten Verhalten können gewichteten Synchronisationsgraphen sowie Synchronisationsgraphen unter PS nicht mehr mit linearen Gleichungen in der $(\max,+)$ Algebra beschrieben werden. In dieser Arbeit werden gewichteten Synchronisationsgraphen und Synchronisationsgraphen unter PS in Dioiden modelliert. Basierend auf dieser Modellierung wird eine Zerlegung des dynamischen Verhaltens von gewichteten Synchronisationsgraphen in einen ereignisvarianten und einen ereignisinvarianten Teil vorgestellt. Analog wird für Synchronisationsgraphen unter PS gezeigt, dass ihr dynamisches Verhalten in einem zeitvarianten und zeitinvarianten Teil zerlegt werden kann. Unter speziellen Voraussetzungen wird gezeigt, dass dieser ereignisvarianten bzw. zeitvarianten Teile „invertierbar“ ist. Dies ermöglicht die Übertragung von etablierten Analyse- und Regelungsentwurfsverfahren von gewöhnlichen Synchronisationsgraphen auf die allgemeineren Klassen der gewichteten Synchronisationsgraphen und Synchronisationsgraphen unter PS.

Résumé

De nombreux systèmes de production peuvent être modélisés et analysés à l'aide de graphes d'événements temporisés (GET). Les GET forment une classe de systèmes à événements discrets temporisés (SED_T), dont la dynamique est définie uniquement par des phénomènes de synchronisation et de saturation. Un avantage majeur des GET par rapport à d'autres classes de SED_T est qu'ils admettent, sous certaines conditions, un modèle linéaire dans des espaces algébriques particuliers : les dioïdes. Ceci a conduit au développement d'une théorie des systèmes linéaires dans les dioïdes, grâce à laquelle de nombreux concepts de l'automatique classique ont été adaptés aux GET. Par exemple, l'algèbre $(\max, +)$ (i.e., le dioïde basé sur les opérations $(\max, +)$) offre des techniques élégantes pour l'analyse et le contrôle de GET. Cependant, les conditions nécessaires pour modéliser un système à événements discrets par un GET sont très restrictives. Pour élargir la classe de systèmes concernés, deux extensions principales ont été développées. D'une part, les GET valués ont été introduits pour décrire des phénomènes d'assemblage et de séparation dans les systèmes de production. Cette extension se traduit par l'association de coefficients entiers aux arrêtes d'un graphe d'événements. Contrairement aux GET, ces systèmes ne sont pas invariants par rapport aux événements et ne peuvent donc pas être décrits par des équations linéaires dans l'algèbre $(\max, +)$. D'autre part, la synchronisation partielle (PS) a été introduite pour modéliser des systèmes dans lesquels certains événements ne peuvent se produire que pendant des intervalles prédéfinis. Par exemple, dans une intersection réglée par un feu tricolore, une voiture peut traverser l'intersection lorsque le feu est vert. Contrairement aux GET, ces systèmes ne sont pas invariants dans le domaine temporel et ne peuvent donc pas être décrits par des équations linéaires dans l'algèbre $(\max, +)$. Dans cette thèse, une modélisation des GET valués et des GET avec PS dans des dioïdes adaptés est présentée. A l'aide de ces dioïdes, une décomposition pour les GET valués (resp. GET avec PS) en un GET et une partie non-invariante dans le domaine des événements (resp. dans le domaine temporel) est introduite. Sous certaines conditions, la partie invariante est "invertible". Dans ce cas, les modèles et contrôleurs pour le GET valué ou le GET sous PS peuvent être directement dérivés des modèles et contrôleurs obtenus pour le GET associé.

Publications

Some ideas, results and figures have appeared previously in the following publications. The novel ideas, results and writing of publications [65,66,67,68,69] came from the first author. The second, third and fourth author provided a critical review to these publications and gave guidance on research direction.

[65] Johannes Trunk, Bertrand Cottenceau, Laurent Hardouin, and Jörg Raisch. Model Decomposition of Weight-Balanced Timed Event Graphs in Dioids: Application to Control Synthesis. In 20th IFAC World Congress 2017, pages 13995–14002, Toulouse, 2017

[66] Johannes Trunk, Bertrand Cottenceau, Laurent Hardouin, and Jörg Raisch. Output reference control for weight-balanced timed event graphs. pages 4839–4846. IEEE, December 2017. ISBN 978-1-5090-2873-3. doi: 10.1109/CDC.2017.8264374

[67] Johannes Trunk, Bertrand Cottenceau, Laurent Hardouin, and Jörg Raisch. Model Decomposition of Timed Event Graphs under Partial Synchronization. In Preprints of the 14th Workshop on Discrete Event Systems pages 209–216, Sorrento Coast, Italy, May 2018.

[68] Johannes Trunk, Bertrand Cottenceau, Laurent Hardouin, and Jörg Raisch. Modelling and control of periodic time-variant event graphs in dioids. Discrete Event Dynamic Systems, submitted.

[69] Johannes Trunk, Bertrand Cottenceau, Laurent Hardouin, and Jörg Raisch. Output reference control of timed event graphs under partial synchronization. Discrete Event Dynamic Systems, submitted.

Acknowledgments

At this point I would like to say *thank you* to all the people, who supported me during my Ph.D. In particular, I am deeply grateful to my French supervisors Prof. Bertrand Cottenceau and Prof. Laurent Hardouin, for many discussions of my work, for helping me with all the administration stuff at Université d'Angers, for supporting me in some many different situations, especially during my stays in Angers.

In the same manner, I would like to thank my German supervisor Prof. Jörg Raisch for giving me the opportunity to work in this interesting field of research and for many discussions of my work. I am greatly indebted to Behrang for his guidance during my master thesis and to Xavier for his support and guidance during my first year of my Ph.D.

I would like to say *vielen Dank* to the members of the Control Systems Group at TU Berlin and *merci beaucoup* to the members of the Laboratoire Angevin de Recherche en Ingénierie des Systèmes at Université d'Angers, for letting me be a part of the groups. A very special *thank you* deserve Soraia, Philip, Arne, and Germano for many discussion and their support during my research. From my French colleagues, I would like particular thank Marcelo, Jean-Louis, Frank, and Remi for their friendship, for their support during my stays in Angers, for taking me climbing, and showing me the small crags around Angers.

I would also like to express my deep gratitude to Ulrike Locherer and Nicole Lotode for their support with many administration issues at TU Berlin and Université d'Angers.

And finally, I would like to thank my Family for all the support.

Berlin, December, 2019

J. T.

Contents

1. Introduction	1
2. Mathematical Preliminaries	11
2.1. Dioid Theory	11
2.1.1. Order Relation in Dioids	12
2.1.2. Matrix Dioids	14
2.1.3. Quotient Dioids	15
2.1.4. Dioid of Formal Power Series	16
2.1.5. Mappings over Dioids	17
2.2. Residuation Theory	19
2.3. Dioid of two Dimensional Power Series $\mathcal{M}_{\text{in}}^{\text{ax}}[[\gamma, \delta]]$	22
3. Dioids $(\mathcal{E}, \oplus, \otimes)$ and $(\mathcal{E}[[\delta]], \oplus, \otimes)$	27
3.1. Dioid $(\mathcal{E}[[\delta]], \oplus, \otimes)$	27
3.1.1. Dioid of Event Operators	31
3.1.2. Dioid of Formal Power Series $(\mathcal{E}[[\delta]], \oplus, \otimes)$	38
3.2. $(\mathcal{M}_{\text{in}}^{\text{ax}}[[\gamma, \delta]], \oplus, \otimes)$ as a Subdioid of $(\mathcal{E}[[\delta]], \oplus, \otimes)$	44
3.3. Core Decomposition of Elements in $\mathcal{E}_{\text{m b}}[[\delta]]$	53
3.3.1. Calculation with the Core Decomposition	60
3.4. Matrices with entries in $\mathcal{E}_{\text{m b}}[[\delta]]$	68
3.4.1. Decomposition of Consistent Matrices	70
3.4.2. Calculation with Matrices	75
4. Dioids $(\mathcal{T}, \oplus, \otimes)$ and $(\mathcal{T}[[\gamma]], \oplus, \otimes)$	81
4.1. Dioid $(\mathcal{T}[[\gamma]], \oplus, \otimes)$	81
4.1.1. Dioid of Time Operators	84
4.1.2. Dioid of Formal Power Series $(\mathcal{T}[[\gamma]], \oplus, \otimes)$	89
4.2. Core Decomposition of Elements in $\mathcal{T}_{\text{per}}[[\gamma]]$	93
4.2.1. Calculation with the Core Decomposition	98
4.3. Matrices with entries in $(\mathcal{T}_{\text{per}}[[\gamma]], \oplus, \otimes)$	103
4.4. Subdioids of $(\mathcal{T}_{\text{per}}[[\gamma]], \oplus, \otimes)$	104
5. Dioid $(\mathcal{E}\mathcal{T}, \oplus, \otimes)$	113
5.1. Dioid $\mathcal{E}\mathcal{T}$	113
5.2. Core Decomposition of Series in $\mathcal{E}\mathcal{T}_{\text{per}}$	118
5.2.1. Calculation with the Core Decomposition	127

6. Model of Discrete Event Systems	133
6.1. Petri Nets and Timed Event Graphs	133
6.1.1. Weighted Timed Event Graphs	135
6.1.2. Timed Event Graphs under Partial Synchronization	140
6.1.3. Periodic Time-variant Event Graphs	143
6.2. Dioid Model of Timed Event Graphs	152
6.2.1. Dater and Counter	152
6.2.2. Dioid Model of ordinary Timed Event Graphs	154
6.2.3. Dioid Model of Weighted Timed Event Graphs	157
6.2.4. Dioid Model of Timed Event Graphs under Partial Synchronization	162
6.2.5. Dioid Model of Periodic Time-variant Event Graphs	166
6.2.6. Dioid Model of Weighted Timed Event Graphs under periodic Partial Synchronization	172
7. Control	181
7.1. Optimal Control	181
7.2. Model Reference Control	185
7.2.1. Feedforward	185
7.2.2. Feedback	188
8. Conclusion	197
A. Formula for Residuation	201
B. Formula for Floor and Ceil Operations	203
C. Proofs	205
C.1. Proofs of Section 3.1	205
C.1.1. Proof of Prop. 28	206
C.1.2. Proof of Prop. 30	208
C.1.3. Proof of Prop. 38	209
C.2. Proofs of Section 4.1	210
C.2.1. Proof of Prop. 56	210
C.2.2. Proof of Prop. 61	212
C.2.3. Proof of Prop. 64	213
C.3. Proofs of Chapter 5	215
C.3.1. Proof of Prop. 78	216
C.3.2. Proof of Prop. 83	217
Bibliography	221

Acronyms

TEG Timed Event Graph
WTEG Weighted Timed Event Graph
WBTEG Weight-Balanced Timed Event Graph
TEG_{PS} Timed Event Graph under Partial Synchronization
TEG_{sPS} Timed Event Graphs under Partial Synchronization
PS partial synchronization
CWTEG Cyco-Weighted Timed Event Graph
SISO single-input and single-output
MIMO multiple-input and multiple-output
DES Discrete Event System
SDF Synchronous Data-Flow
CSDF Cyclo-Static Synchronous Data-Flow
PTEG Periodic Time-variant Event Graph
FIFO first-in-first-out

Notations

\mathbb{N}	natural numbers
\mathbb{N}_0	natural numbers including 0
\mathbb{Z}	integer numbers
$\overline{\mathbb{Z}}_{\max}$	$\mathbb{Z} \cup \{\infty\} \cup \{-\infty\}$
$\overline{\mathbb{Z}}_{\min}$	$\mathbb{Z} \cup \{\infty\} \cup \{-\infty\}$
\mathbb{Q}	rational numbers
\mathbf{A}	matrices and vectors are bold
$(\mathbf{A})_{i,j}$	$(i, j)^{\text{th}}$ entry of matrix \mathbf{A}
$(\mathbf{A})_{i,:}$	i^{th} row of matrix \mathbf{A}
$(\mathbf{A})_{:,j}$	j^{th} column of matrix \mathbf{A}
\mathbf{A}^T	transposed of matrix \mathbf{A}
$(\mathcal{D}, \oplus, \otimes)$	dioid over the set \mathcal{D}
\oplus	addition in a dioid
\otimes	multiplication in a dioid
ε	zero element in a dioid
e	identity element in a dioid
\top	top element in a complete dioid
\wedge	greatest lower bound in a complete dioid
\bowtie (resp. \lrcorner)	left division in a complete dioid
\oslash (resp. \rceil)	right division in a complete dioid
γ^n	event-shift operator
δ^t	time-shift operator
μ_m	event-multiplication operator
β_b	event-division operator
$\Delta_{\omega \omega}$	time-division/multiplication operator

Introduction

Discrete Event Systems (DESs), *e.g.*[9], are systems where the dynamic behaviors are described by the occurrence of asynchronous discrete events. This class of systems is useful to model man-made systems - such as complex manufacturing lines, computer networks, and transportation networks - on a high level of abstraction. Typically, signals of such systems take discrete values that mostly belong to countable sets; for instance, the state of a machine could be busy, idle or broken. Furthermore, state changes are given by asynchronous events. For example, an operator can start a working process when the machine state is idle. At this particular time, the state of the machine changes from idle to busy. Many different modeling approaches have been introduced for DESs, among which are Petri nets and finite-state automata. These models give a formal way to describe how events are related to each other. Besides the logical order in which the events occur, in many applications, the time which elapses between consecutive events is important. In this case, the dynamic behavior of the system is described by timed DESs, *e.g.* by timed Petri nets or timed finite-state automata.

This thesis focuses on a particular class of timed DESs, where the dynamic behaviors are only governed by synchronization phenomena. Synchronization is essential in many systems; for instance, in public transportation networks, at a train station, the departure of trains may be synchronized with the arrival of other trains. In manufacturing systems, in order to start a task, the raw material is needed, and the required production machines must be ready. In a computer system, to perform a computation, data and the processing unit must be available. The time behavior of those systems can be naturally described by a subclass of timed Petri nets called Timed Event Graphs (TEGs). More precisely, TEGs are timed Petri nets where each place has exactly one upstream and one downstream transition and all arcs have the weight 1. An advantage of TEGs over the more general class of timed Petri nets is that the evolution of events can be described by recursive linear equations in a *tropical* algebra called $(\max,+)$ -algebra [40], or more generally in dioids [1]. Within the last decades, this has led to the development of a broad theory of linear systems in dioids, including many methods for performance evaluation and controller synthesis. *E.g.* throughput analysis for TEGs can be stated as an eigenvalue problem in the $(\max,+)$ -algebra. The transfer function of a TEG is described by an ultimately cyclic series in a specific dioid called $(\mathcal{M}_{\text{in}}^{\text{ax}}[\gamma, \delta], \oplus, \otimes)$ [1]. Moreover, many control methods for linear systems in dioids have been studied, among which are: optimal feedforward control [12, 51], state and output feedback control [25, 15, 47, 48, 34] as well as observer based control [33, 35]. Moreover, in [59, 60], model predictive control for $(\max,+)$ -linear systems was introduced. It was also

shown that the obtained results are suitable to handle scheduling problems in complex real-world systems. For instance, in [7] dioid theory was applied to the modeling and the control of high throughput screening systems. These systems are used in the field of drug discovery of chemical and biological industries.

However, TEGs are quite restrictive in terms of their modeling capabilities. To enrich the model properties it is reasonable to consider weights (values in $\mathbb{N} = \{1, 2, \dots\}$) on the arcs of TEGs. This leads to Weighted Timed Event Graphs (WTEGs), which have clearly more expressiveness and allow us to describe a wider class of systems. The weights are suitable to express batch (resp. split) processes; for instance, when several occurrences of events are needed to induce a following event or when one event can result in several following events. Clearly, such batch and split processes are quite common in many manufacturing systems; for instance, when a workpiece is cut into several parts. Another example in the field of computer science is provided by data streams in multirate digital signal processing. The weights are suitable to model data flow caused by up- and down-sampling. Unlike TEGs, WTEGs have an event-variant behavior and cannot be described by $(\min, +)$ -linear or $(\max, +)$ -linear systems anymore [14]. Another restrictive property of TEGs is that they can only represent time-invariant systems. In order to describe time-variant behavior, in [20], a new form of synchronization, called partial synchronization (PS), has been introduced for TEGs. Such a partial synchronization is useful to describe systems where particular events can only occur in a specific time window. To motivate the practical relevance, let us consider an intersection controlled by a traffic light. A vehicle which arrives at the traffic light can only cross when the traffic light is green. If the vehicle arrives in the red phase, it has to wait for the next green phase. Therefore, the vehicle is delayed by a time that depends on its time of arrival at the intersection. The traffic light control causes a time-variant behavior which cannot be modeled by an ordinary TEG. In this thesis, dioid theory is applied to study the behavior of WTEGs as well as the behavior of TEGs under PS. Moreover, results for control synthesis of TEGs are generalized to the more general classes of WTEGs and TEGs under PS.

Motivation

A TEG can be conveniently modeled as a linear system over some dioids. For this, a counter function $\chi : \mathbb{Z} \rightarrow \overline{\mathbb{Z}}_{\min}$, with $\overline{\mathbb{Z}}_{\min} = \mathbb{Z} \cup \{\pm\infty\}$, is associated with each transition giving the accumulated number of firings up to a time t . Using the particular dioid $(\mathcal{M}_{\text{in}}^{\text{ax}}[\gamma, \delta], \oplus, \otimes)$, it is straightforward to obtain transfer functions for TEGs. *E.g.*, the earliest firing relation between an input transition and an output transition of a TEG is modeled by an ultimately cyclic series $h \in \mathcal{M}_{\text{in}}^{\text{ax}}[\gamma, \delta]$. This transfer function h maps an input counter function into an output counter function, which are respectively associated with the input transition and output transition of the TEG. The dioid $(\mathcal{M}_{\text{in}}^{\text{ax}}[\gamma, \delta], \oplus, \otimes)$ was formally introduced in [1, 12] and is based on the event-shift operator γ^ν and time-shift operator δ^τ with $\tau, \nu \in \mathbb{Z}$.

These operators map counter functions to counter functions in the following way:

$$(\gamma^v x)(t) = x(t) + v \quad \text{and} \quad (\delta^\tau x)(t) = x(t - \tau). \quad (1.1)$$

Time-shift operators model holding times associated with places and event-shift operators model initial markings of the places. For instance, see Figure 1.1, where x_1 and x_2 are associated with transition t_1 and t_2 .

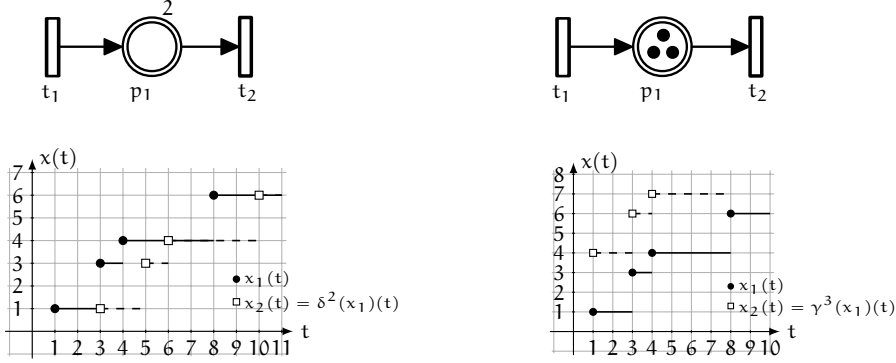

Figure 1.1. – Manipulation of the counter function x_1 by the δ^2 and γ^3 operators. The δ^2 and γ^3 operators model the earliest behavior between input transition t_1 and output transition t_2 in the TEGs above. The holding time of two time units is modeled by the δ^2 operator and the three initial tokens by the γ^3 operator.

Moreover, by considering sums and compositions of these operators it is possible to describe the complete dynamic behavior of an ordinary TEG. As in conventional systems theory, transfer functions are convenient to solve some control problems. For instance, model reference control introduced for TEGs in [46, 15, 47] and [34] needs such an input-output representation in the dioid $(\mathcal{M}_{\text{in}}^{\text{ax}}[\gamma, \delta], \oplus, \otimes)$. Usually, the reference model describes the desired behavior and is as well specified in the dioid $(\mathcal{M}_{\text{in}}^{\text{ax}}[\gamma, \delta], \oplus, \otimes)$. To enforce this behavior, a controller is computed such that the closed-loop behavior follows the behavior of the reference model as close as possible, but is not slower than the reference. Therefore, it is also known as a model matching control problem. This control method is of practical interest for manufacturing systems. For instance, we can specify the desired throughput behavior of a production line in a reference model. The controller obtained from this reference optimizes the production process under the "just-in-time" criterion while guaranteeing the specified throughput. Thus, materials spend the minimum required time in the production line, which leads to a reduction of internal stocks.

The aim of this thesis is to describe the transfer behavior of extended TEGs, namely WTEGs and TEGs under PS, with a similar set of operators. This is necessary to extend the result for model reference control to the more general classes of WTEGs and TEGs under PS. In order to model the weights on the arcs in WTEGs, two new operators are considered,

1. Introduction

namely μ_m (event duplication) and β_b (event division). These operators are given by, for $m, b \in \mathbb{N}$,

$$(\mu_m(x))(t) = m \times x(t) \quad \text{and} \quad (\beta_b(x))(t) = \left\lfloor \frac{x(t)}{b} \right\rfloor.$$

See Figure 1.2, for an example of how these operators can be used to manipulate a counter function. The dynamic behavior of a WTEG can then be described by sums and compositions

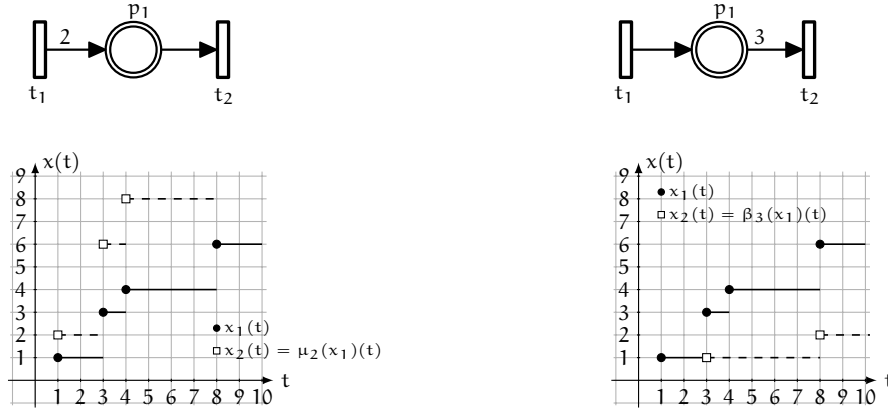

Figure 1.2. – Manipulation of the counter function x_1 by the μ_2 and β_3 operators. The μ_2 and β_3 operators model the earliest behavior between input transition t_1 and output transition t_2 in the WTEGs above.

of the operators $\{\gamma^\vee, \delta^\tau, \mu_m, \beta_b\}$ in a dioid called $(\mathcal{E}[\![\delta]\!], \oplus, \otimes)$.

To model the behavior of TEGs under PS, it is more convenient to associate dater functions instead of counter functions, with transitions. A dater function is a function $\chi : \mathbb{Z} \rightarrow \overline{\mathbb{Z}}_{\max}$, with $\overline{\mathbb{Z}}_{\max} = \mathbb{Z} \cup \{\pm\infty\}$, where $\chi(k)$ gives the time when the transition fires for the $(k+1)^{\text{st}}$ time. To model periodic time-variant phenomena with dater functions, a new operator is introduced, *i.e.*, for $\omega \in \mathbb{N}$

$$(\Delta_{\omega|\omega}\chi)(k) = \lceil \chi(k)/\omega \rceil \omega.$$

Observe that this operator models a synchronization of the dater function with times $t \in \{\omega k \mid k \in \overline{\mathbb{Z}}_{\max}\}$. For instance, see Figure 1.3 where the operator $\Delta_{3|3}$ is applied to a dater function x_1 , thus the values $\Delta_{3|3}(x_1)(k) \in \{3k \mid k \in \overline{\mathbb{Z}}_{\max}\}$. Therefore, with the $\Delta_{3|3}$ operator, we can model the earliest functioning of the TEG under PS given in Figure 1.4, where the PS of transition t_2 is given by a signal $\mathcal{S}_2 : \mathbb{Z} \rightarrow \{0, 1\}$ where $\mathcal{S}_2(t) = 1$ for $t \in \{3k \mid k \in \mathbb{Z}\}$ and 0 otherwise. This signal enables the firing of transition t_2 at time $t \in \mathbb{Z}$ where $\mathcal{S}_2(t) = 1$.

The dynamic behavior of a subclass of TEGs under PS, *i.e.* the class where PS of transitions are given by periodic signals, can be modeled by sums and compositions of the operators $\{\gamma^\vee, \delta^\tau, \Delta_{\omega|\omega}\}$ in a dioid called $(\mathcal{T}[\![\gamma]\!], \oplus, \otimes)$.

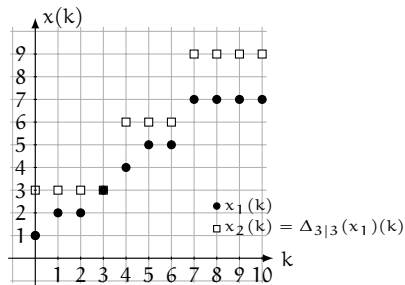

Figure 1.3. – Manipulation of the dater function x_1 by the $\Delta_{3|3}$ operator.

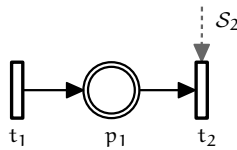

Figure 1.4. – Simple TEG under PS.

Related Work

Weighted Timed Event Graph

For manufacturing systems and embedded applications, buffer size, throughput, and latency times are key features which can be analyzed and optimized. In general, we want to maximize the production rate (or data throughput) while keeping buffer size as small as possible. This kind of optimization problems have been widely studied in the context of WTEGs. Note that WTEGs are also referred to as Timed Weighted Marked Graphs and Timed Weighted Event Graphs in literature. In [53, 55], an important subclass of WTEGs, which we will call consistent WTEGs, is studied. For this class of WTEGs, it is possible to define a firing sequence which involves all transitions in the WTEG, and if it occurs from marking \mathcal{M} , it leaves \mathcal{M} invariant. In other words, these WTEGs exhibit T-semiflows. In [53] and [55], a transformation of a consistent WTEG to an "equivalent" TEG was established, which is in particular useful for the performance analysis of the original WTEG. However, in general, this transformation significantly increases the number of transitions in the corresponding TEG and therefore does not scale very well when increasing the size of the original WTEG. In [55], it is shown that the computational complexity of this transformation is polynomial with respect to the 1-norm of the T-semiflow of the original WTEG.

In [50], complexity results for cyclic scheduling problems for WTEGs are provided. This includes, for instance, throughput computation and buffer minimization with respect to throughput constraints, also often referred to as marking optimization. In this work, it is implicitly assumed that the successive firings of a transition in the WTEG do not overlap. More precisely, holding times are only modeled with transitions, and a self-loop at each tran-

sition with one place and one token in the place is implicitly assumed. As a consequence, the considered models are a subclass of WTEGs, where it is assumed that a transition can potentially fire infinitely often concurrently.

Marking optimization for WTEGs are studied in [58, 64, 37, 38, 39]. One main problem is to determine a minimal admissible marking for a given WTEG such that a given throughput is guaranteed. In the context of manufacturing systems, for instance, this yields a minimization of internal buffer sizes in an assembly line. In [64], the problem is addressed based on a branch and bound algorithm. In [58] and [37], heuristic methods are presented. In [38], the heuristic methods are compared to the optimal approach which is based on the transformation given in [55] and has high complexity.

Dioid models of WTEG

For ordinary TEGs, it is known that their behavior can be described by linear equations over some dioids (or idempotent semirings) [1, 40]. In [14] and [16], dioids based on a specific set of operators are introduced to describe the dynamic behavior of WTEGs. In [14], a fluid version of WTEGs is investigated for which recurrent equations are obtained. Fluid WTEGs can be seen as continuous approximations of the WTEGs discussed in this thesis. A linearization is introduced for fluid WTEGs. Therefore, the behavior of a fluid WTEG can be analyzed by a $(\min, +)$ -linear system and approximate results can be obtained for the original WTEG. However, in some cases, the results obtained for the fluid WTEG are quite far from the original WTEG, for instance, a WTEG which is blocking may have a fluid approximation which is alive. In [31, 30], "just-in-time" control for WTEGs are studied in a similar dioid of operators, called $(\mathcal{D}_{\min} \llbracket \delta \rrbracket, \oplus, \otimes)$. In [16, 17], a slightly different dioid is introduced to describe the dynamic behavior of WTEGs. This dioid is denoted $(\mathcal{E} \llbracket \delta \rrbracket, \oplus, \otimes)$ and based on the operators $\{\gamma^\vee, \delta^\top, \mu_m, \beta_b\}$. In these works, an important subclass of WTEGs - the class of WTEGs where parallel paths have balanced weights - are studied. This class is therefore called Weight-Balanced Timed Event Graphs (WBTEGs). It is shown that the input-output behavior of WBTEGs can be described by ultimately cyclic series in this dioid. Subsequently, based on these series an interpretation of the impulse response for WBTEGs is given [17] and some model matching control problems for WBTEGs are addressed [16, 65].

Synchronous Data-Flow (SDF) Graphs

In the field of computer science, an equivalent graphical representation for WTEGs is known as SDF Graphs [61]. In this model, edges are associated with places, actors are associated with transitions and data exchange between actors are associated with tokens. These graphs were introduced in [44, 43] to model data flow in digital signal processing applications. They are useful tools to obtain, optimize and verify scheduling algorithms for parallel processing [26]. Moreover, SDF Graphs are suitable to obtain performance bounds for the underlying systems. Clearly, an important performance indicator is the throughput of a sys-

tem, *i.e.*, the maximal rate at which a system produces an output. Unsurprisingly, lots of research focuses on throughput analysis of SDF Graphs. In [28, 62], an algorithm is introduced to explore the state space of an SDF Graph. The basic idea is to obtain the throughput based on the simulation of the SDF Graph. In [23], an approach is presented based on the $(\max,+)$ -algebra. Buffer size minimization, with respect to throughput constraints, for SDF Graphs have been studied in [27]. Clearly, minimizing buffer size is important for embedded systems due to the high costs for memory.

Time-variant Timed Event Graphs

Time-varying DESs have been studied in [5, 6, 10, 42]. The models considered in these works are TEGs in which holding times of places change periodically based on event sequences. Therefore, these systems can describe event-variant time behaviors. For these TEGs, places must respect a first-in-first-out (FIFO) behavior, in other words, tokens must not overtake each other. In [42], optimal feedforward control problems for these systems are studied. In [17], it is shown that the input-output behavior of these systems can be represented by WTEGs. Another class of time-variant DESs has been discussed in [20, 19]. There, TEGs are extended by allowing a weaker form of synchronization, called partial synchronization (PS). PS of a transition means that the transition can only fire when it is enabled by an external signal $\mathcal{S} : \mathbb{Z} \rightarrow \{0, 1\}$. \mathcal{S} enables the firing of the transition at times $t \in \mathbb{Z}$ where $\mathcal{S}(t) = 1$. Such time-variant behaviors occurring in TEG under PS can be modeled as a $(\max,+)$ -linear systems under additional constraints [21]. In the case where such signals are predefined and ultimately periodic, it is possible to obtain transfer functions for TEGs under PS [21, 19]. Moreover, some control problems for TEGs under PS have been tackled in [21, 22]. A similar extension was introduced in [60], where TEGs with hard and soft synchronization are studied.

Contribution

The main contribution of this work relates to modeling and control of extended TEGs, namely Weighted Timed Event Graphs (WTEGs) and Periodic Time-variant Event Graphs (PTEGs), in dioids. First based on dioid theory, a decomposition model for consistent WTEGs is introduced, in which the event-variant and the event-invariant parts are separated. It is shown that the event-variant part is "invertible", thus many tools developed for analysis and control of ordinary TEGs can be directly applied to the more general class of consistent WTEGs. In particular, based on this model decomposition, optimal feedforward control and model matching control for TEGs are generalized to WTEGs. Second, to describe the time-variant behavior of some DESs, Periodic Time-variant Event Graphs (PTEGs) are introduced. PTEGs are an alternative model to TEGs under PS to describe periodic time-variant behaviors. In PTEGs, holding times of places depending on the firing times of their upstream transitions. More precisely, the holding time $\mathcal{H}(t)$ is time-variant and immediately periodic,

i.e. $\mathcal{H}(t + \omega) = \mathcal{H}(t)$. The current delay is then determined by the firing time t of the corresponding upstream transition. In contrast to FIFO TEGs considered in [42], which are event-variant, PTEGs have a time-variant behavior. However, in PTEGs places must respect a FIFO behavior as well which implies a constraint on holding time values. A comparison between TEGs under PS and PTEGs is provided. The input-output behavior of PTEGs can be described by ultimately cyclic series in a new dioid denoted $(\mathcal{T}[\![\gamma]\!], \oplus, \otimes)$. Similarly, it is shown how TEGs under periodic PS can be modeled in this dioid $(\mathcal{T}[\![\gamma]\!], \oplus, \otimes)$.

As for consistent WTEGs with a dioid model in $(\mathcal{E}[\![\delta]\!], \oplus, \otimes)$, a decomposition for series in $\mathcal{T}[\![\gamma]\!]$ is introduced, where the time-invariant part can be separated from the time-variant part. The time-variant part is "invertible", therefore many problems concerning performance analysis and control synthesis for PTEGs (resp. TEGs under periodic PS) can be reduced to the case of an ordinary TEG, and solved efficiently by applying the already established tools for TEGs. Especially, optimal feedforward control and model reference control for PTEGs (resp. TEGs under periodic PS) are studied. Based on the dioids $(\mathcal{E}[\![\delta]\!], \oplus, \otimes)$ and $(\mathcal{T}[\![\gamma]\!], \oplus, \otimes)$ similarities between WTEGs and PTEGs (resp. TEGs under periodic PS) are investigated. Finally, the results for WTEGs and PTEGs (resp. TEGs under periodic PS) can be combined, so that a class of periodic time-variant and event-variant TEGs can be handled in a new dioid structure. These TEGs can model synchronization, time delay, batch/split and also some periodic time-variant behavior which, for instance, arises in traffic light control.

Outline

This thesis is structured in two parts, Chapter 2, Chapter 3, Chapter 4 and Chapter 5, introducing the dioids $(\mathcal{M}_{\text{in}}^{\text{ax}}[\![\gamma, \delta]\!], \oplus, \otimes)$, $(\mathcal{E}[\![\delta]\!], \oplus, \otimes)$, $(\mathcal{T}[\![\gamma]\!], \oplus, \otimes)$ and $(\mathcal{ET}, \oplus, \otimes)$, respectively. In Chapter 6 and Chapter 7, these dioids are then applied to the modeling and the control of WTEGs, TEGs under PS and PTEGs.

Part 1 Algebraic Tools

Chapter 2 summarizes fundamentals of dioids and residuation theory. The chapter begins with explaining the general properties of dioids and recalls the $(\max, +)$ - and $(\min, +)$ -algebra. Then more sophisticated dioid structures such as dioids of formal power series are given. Moreover, residuation theory is introduced to give an approximate inverse of some mappings defined over complete dioids. Finally, the particular dioid $(\mathcal{M}_{\text{in}}^{\text{ax}}[\![\gamma, \delta]\!], \oplus, \otimes)$ is recalled, which is useful to analyze TEGs and plays a key role in this thesis.

Chapter 3 introduces the dioid $(\mathcal{E}[\![\delta]\!], \oplus, \otimes)$. This dioid is based on the operators $\{\gamma^\vee, \delta^\top, \mu_m, \beta_b\}$. Moreover, in Section 3.3, it is shown that under some conditions all relevant operations $(\oplus, \otimes, \backslash, /)$ on elements in $\mathcal{E}[\![\delta]\!]$ can be reduced to operations on matrices with entries in $\mathcal{M}_{\text{in}}^{\text{ax}}[\![\gamma, \delta]\!]$.

Chapter 4 introduces the dioid $(\mathcal{T}[\![\gamma]\!], \oplus, \otimes)$. This dioid is comprised of the basic operators $\{\gamma^\vee, \delta^\tau, \Delta_{\omega|\omega}\}$. This dioid is used to model the time-variant behavior of PTEGs, and TEGs under PS. As for the dioid $(\mathcal{E}[\![\delta]\!], \oplus, \otimes)$, it is shown that under some conditions all relevant operations $(\oplus, \otimes, \setminus, \phi)$ on elements in $\mathcal{T}[\![\gamma]\!]$ can be reduced to operations on matrices with entries in $\mathcal{M}_{\text{in}}^{\text{ax}}[\![\gamma, \delta]\!]$.

Chapter 5 combines the results obtained in Chapter 3 and Chapter 4. The dioid $(\mathcal{ET}, \oplus, \otimes)$ is introduced, which can be seen as the combination of the dioids $(\mathcal{E}[\![\delta]\!], \oplus, \otimes)$ and $(\mathcal{T}[\![\gamma]\!], \oplus, \otimes)$. This permits the description of event-variant and time-variant behaviors in the same dioid structure. Therefore, it is applicable for the modeling and the control of WTEG under PS.

Part 2 Modeling and Control

Chapter 6 shows how the earliest behavior of TEGs, WTEGs, PTEGs, and TEGs under PS can be modeled in a dioid structure. In particular, the input-output behavior of a WTEG can be modeled by a matrix where the entries are ultimately cyclic series in $\mathcal{E}[\![\delta]\!]$. These transfer function matrices are used to compute the output for a given input of a system. Subsequently, the relation between the transfer function and the impulse response of a system is elaborated. Similar to WTEGs, the input-output behavior of PTEGs and TEGs under PS are modeled by ultimately cyclic series in $\mathcal{T}[\![\gamma]\!]$. Moreover, an interpretation of the impulse response is given for these systems. In the last part of this chapter, the modeling of WTEGs under PS in the dioid $(\mathcal{ET}, \oplus, \otimes)$ is addressed.

Chapter 7 generalizes some control approaches already introduced for ordinary TEGs to the more general classes of WTEGs, PTEGs, and TEGs under PS. The control problems are stated in a dioid framework and are efficiently solved by applying residuation theory. In particular, optimal control and model reference control are investigated.

Mathematical Preliminaries

This chapter introduces the basic mathematical concepts needed to understand this thesis. In particular, dioid and residuation theory are recalled. Dioids are suitable to obtain linear models for particular DESs where dynamic behaviors are only governed by synchronization and saturation phenomena. Furthermore, residuation theory has an application in the controller design process and the performance evaluation of DESs modeled in a dioid setting. Most of the following results are taken from the literature, especially from [1]. For a broader overview on dioids and residuation theory, see [1, 4, 11, 12, 40].

2.1. Dioid Theory

Definition 1 (Monoid). *A monoid is a set \mathcal{M} endowed with a binary associative operation $+$ and an identity element 0 such that $\forall a \in \mathcal{M}, a + 0 = 0 + a = a$. A monoid is denoted by $(\mathcal{M}, +, 0)$.*

A monoid $(\mathcal{M}, +, 0)$ is said to be commutative if the binary operation $+$ is commutative. And a commutative monoid is said to be idempotent if $+$ is idempotent, i.e., $\forall a \in \mathcal{M}, a + a = a$.

Definition 2 (Dioid). *A dioid is a set \mathcal{D} endowed with two binary operations, denoted \oplus (called addition) and \otimes (called multiplication), such that*

- \oplus is associative, commutative and idempotent, i.e. $\forall a \in \mathcal{D}, a \oplus a = a$, moreover \oplus admits a neutral element denoted ε .
- \otimes is associative, distributive over \oplus and \otimes admits a neutral element denoted e .
- ε is absorbing for \otimes , i.e., $\forall a \in \mathcal{D}, a \otimes \varepsilon = \varepsilon \otimes a = \varepsilon$.

Moreover, ε is called the zero element and e is called the unit element of \mathcal{D} . A dioid is denoted by $(\mathcal{D}, \oplus, \otimes)$.

Clearly, let $(\mathcal{D}, \oplus, \otimes)$ be a dioid, then $(\mathcal{D}, \oplus, \varepsilon)$ is a commutative idempotent monoid and $(\mathcal{D}, \otimes, e)$ is a monoid. If multiplication \otimes is commutative, then dioid $(\mathcal{D}, \oplus, \otimes)$ is said to be commutative. Note that, as in conventional algebra, the multiplication symbol \otimes is often omitted.

Example 1 ((max,+)-algebra $(\mathbb{Z}_{\max}, \oplus, \otimes)$). *The (max,+)-algebra is the set $\mathbb{Z}_{\max} := \mathbb{Z} \cup \{-\infty\}$ endowed with \max as addition \oplus and $+$ as multiplication \otimes , e.g., $5 \otimes 4 \oplus 7 = \max(5 + 4, 7) = 9$. Moreover, the zero element is $\varepsilon = -\infty$ and the unit element is $e = 0$, respectively.*

Example 2 ((min,+)-algebra $(\mathbb{Z}_{\min}, \oplus, \otimes)$). Conversely, the (min,+)-algebra is the set $\mathbb{Z}_{\min} := \mathbb{Z} \cup \{\infty\}$ endowed with min as addition \oplus and + as multiplication \otimes , e.g., $5 \otimes 4 \oplus 7 = \min(5 + 4, 7) = 7$. The zero element is $\varepsilon = \infty$ and the unit element is $e = 0$, respectively.

Example 3 (Boolean Dioid $(\mathbb{B}, \oplus, \otimes)$). The set $\mathbb{B} = \{\varepsilon, e\}$, consisting of the zero and the unit element, with the two binary operations addition \oplus and multiplication \otimes constitute the Boolean dioid. Since the zero element ε is absorbing for \otimes and neutral for \oplus , the operations \oplus and \otimes are defined by $\varepsilon \otimes e = e \otimes \varepsilon = \varepsilon$ and $\varepsilon \oplus e = e \oplus \varepsilon = e$.

Definition 3 (\mathcal{D} -Semimodule [56]). Let $(\mathcal{D}, \oplus, \otimes)$ be a dioid with unit element e and zero element ε . A \mathcal{D} -semimodule is a commutative monoid $(\mathcal{M}, +, 0)$ with an external operation $\cdot : \mathcal{D} \times \mathcal{M} \rightarrow \mathcal{M}$, $(a, x) \mapsto a \cdot x$, called scalar-multiplication, such that the following conditions hold $\forall a, b \in \mathcal{D}$ and $\forall x, y \in \mathcal{M}$

$$\begin{aligned} (a \otimes b) \cdot x &= a \cdot (b \cdot x), \\ a \cdot (x + y) &= (a \cdot x) + (a \cdot y), \\ (a \oplus b) \cdot x &= (a \cdot x) + (b \cdot y), \\ \varepsilon \cdot x &= a \cdot 0 = 0, \\ e \cdot x &= x. \end{aligned}$$

Subdioids

Definition 4 (Subdioid). Let $(\mathcal{D}, \oplus, \otimes)$ be a dioid with unit element e and zero element ε , then a subset \mathcal{S} of \mathcal{D} is a subdioid of $(\mathcal{D}, \oplus, \otimes)$ if $e, \varepsilon \in \mathcal{S}$ and \mathcal{S} is closed for \otimes and \oplus , that is $\forall a, b \in \mathcal{S}$, $a \oplus b \in \mathcal{S}$ and $a \otimes b \in \mathcal{S}$.

Example 4. Consider the dioid $(\mathbb{Z}_{\max}, \oplus, \otimes)$, the dioid $(\mathbb{N}_{\max}, \oplus, \otimes)$ with $\mathbb{N}_{\max} = \mathbb{N}_0 \cup -\infty$, is a subdioid of $(\mathbb{Z}_{\max}, \oplus, \otimes)$.

2.1.1. Order Relation in Dioids

An order relation \leq on a set \mathcal{S} is a binary relation which is reflexive, i.e., $\forall a \in \mathcal{S}$, $a \leq a$, transitive, i.e., $\forall a, b, c \in \mathcal{S}$, $a \leq b$ and $b \leq c \Rightarrow a \leq c$ and anti-symmetric, i.e., $\forall a, b \in \mathcal{S}$, $a \leq b$ and $b \leq a \Rightarrow a = b$. A set \mathcal{S} is called *totally ordered* if for every pair of elements $a, b \in \mathcal{S}$ we can either write $a \geq b$ or $a \leq b$. Moreover, if a pair of elements $a, b \in \mathcal{S}$ exists, for which $a \not\leq b$, $a \not\geq b$, the set \mathcal{S} is called *partially ordered*.

The idempotent characteristic of the addition induces a canonical order relation on dioids. Let $(\mathcal{D}, \oplus, \otimes)$ be a dioid, then $\forall a, b \in \mathcal{D}$, the relation \leq defined by

$$\forall a, b \in \mathcal{D}, \quad a \oplus b = b \Leftrightarrow a \leq b, \tag{2.1}$$

is an order relation. In general in a dioid $(\mathcal{D}, \oplus, \otimes)$ with $a, b \in \mathcal{D}$, the sum $a \oplus b$ is not equal to either a or b . Thus, general dioids are only partially ordered, i.e., $a \not\leq b$, $a \not\geq b$.

However, the sum $a \oplus b \in \mathcal{D}$ gives a natural upper bound for the set $\{a, b\}$. Therefore, with ε as bottom element, i.e. $\forall a \in \mathcal{D}, a \geq \varepsilon$ a dioid is an ordered set.

Complete Dioids

Definition 5 (Complete Dioid). A dioid $(\mathcal{D}, \oplus, \otimes)$ is said to be complete if it is closed for infinite sums and if \otimes distributes over infinite sums, i.e., for all subsets S of \mathcal{D} and for all $a \in \mathcal{D}$,

$$a \otimes \left(\bigoplus_{b \in S} b \right) = \bigoplus_{b \in S} (a \otimes b), \quad \left(\bigoplus_{b \in S} b \right) \otimes a = \bigoplus_{b \in S} (b \otimes a).$$

Remark 1. Similarly, an idempotent commutative monoid $(\mathcal{M}, \oplus, \varepsilon)$ is said to be complete if it is closed for infinite sums.

A complete dioid $(\mathcal{D}, \oplus, \otimes)$ admits a top element $\top = \bigoplus_{a \in \mathcal{D}} a \in \mathcal{D}$ which is given by the sum over all elements in the dioid. Furthermore, in a complete dioid the infimum operator is defined as, $a, b \in \mathcal{D}$,

$$a \wedge b = \bigoplus \{x \in \mathcal{D} \mid x \oplus a \leq a, x \oplus b \leq b\}.$$

The \wedge operator is associative, commutative, idempotent and admits \top as neutral element, i.e., $\forall a \in \mathcal{D}, a \wedge \top = a$. Then, for complete dioids the \wedge operation defines a lower bound for the set $\{a, b\}$. Thus for a complete dioid $(\mathcal{D}, \oplus, \otimes)$ with $a, b \in \mathcal{D}$,

$$a \geq b \Leftrightarrow a = a \oplus b \Leftrightarrow b = a \wedge b.$$

One can show that a complete dioid equipped with \wedge and \top is a complete lattice, for a more exhaustive description see [1, 3].

Note that in general for a partially ordered dioid $(\mathcal{D}, \oplus, \otimes)$ multiplication is not distributive over \wedge , but one can show that for $a, b, c \in \mathcal{D}$,

$$c(a \wedge b) \leq ca \wedge cb \text{ and } (a \wedge b)c \leq ac \wedge bc. \quad (2.2)$$

Furthermore, distributivity of \wedge with respect to \oplus and conversely \oplus with respect to \wedge is not given either. However, for $a, b, c \in \mathcal{D}$, the following inequalities are satisfied,

$$\begin{aligned} (a \wedge b) \oplus c &\leq (a \oplus c) \wedge (b \oplus c), \\ (a \oplus b) \wedge c &\geq (a \wedge c) \oplus (b \wedge c). \end{aligned}$$

Example 5. The $(\max, +)$ -algebra extended with the top element $\top = \infty$ is a complete dioid. Since the zero element ε is absorbing for multiplication one has, $\top \otimes \varepsilon = \varepsilon$ or differently $-\infty \otimes \infty = -\infty$. This dioid is denoted by $(\overline{\mathbb{Z}}_{\max}, \oplus, \otimes)$, with $\overline{\mathbb{Z}}_{\max} = \mathbb{Z} \cup \{-\infty, +\infty\}$. Conversely, the $(\min, +)$ -algebra with $\top = -\infty$ is a complete dioid, denoted by $(\overline{\mathbb{Z}}_{\min}, \oplus, \otimes)$, with $\overline{\mathbb{Z}}_{\min} = \mathbb{Z} \cup \{-\infty, +\infty\}$.

Example 6. The Boolean dioid $(\mathbb{B}, \oplus, \otimes)$ is a complete dioid where the top element is equal to the unit element, i.e., $\top = e$.

Kleene Star

Definition 6. Let $(\mathcal{D}, \oplus, \otimes)$ be a complete dioid, the Kleene star of an element $a \in \mathcal{D}$ is defined as,

$$a^* = \bigoplus_{i=0}^{\infty} a^i, \quad \text{where } a^0 = e \text{ and } a^{i+1} = a \otimes a^i.$$

Theorem 2.1 ([1]). In a complete dioid $(\mathcal{D}, \oplus, \otimes)$ with $a, b \in \mathcal{D}$, $x = a^*b$ is the least solution of the implicit equation $x = ax \oplus b$.

The Kleene Star satisfies the following relations, for a complete dioid $(\mathcal{D}, \oplus, \otimes)$ with $a, b \in \mathcal{D}$

$$(a^*)^* = a^*, \tag{2.3}$$

$$a^* a^* = a^*, \tag{2.4}$$

$$a(ba)^* = (ab)^* a, \tag{2.5}$$

$$(a \oplus b)^* = (a^*b)^* a^* = b^*(ab^*)^*, \tag{2.6}$$

$$(ab^*)^* = e \oplus a(a \oplus b)^*. \tag{2.7}$$

Furthermore, for a commutative complete dioid $(\mathcal{D}, \oplus, \otimes)$, with $a, b \in \mathcal{D}$, $ab = ba$,

$$(a \oplus b)^* = a^* b^*. \tag{2.8}$$

For the proofs of these relations see [1].

Rational Closure

Definition 7 (Rational closure). Let S be a subset of a complete dioid $(\mathcal{D}, \oplus, \otimes)$, such that S contains the zero and unit elements ε and e . The rational closure of S , denoted by S^* , is the least subdioid of $(\mathcal{D}, \oplus, \otimes)$ containing all finite combinations of sums, products, and Kleene stars over S . The subset S is rationally closed if $S = S^*$.

2.1.2. Matrix Dioids

Addition \oplus and multiplication \otimes can be extended to matrices with entries in a dioid $(\mathcal{D}, \oplus, \otimes)$. For matrices $\mathbf{A}, \mathbf{B} \in \mathcal{D}^{m \times n}$, $\mathbf{C} \in \mathcal{D}^{n \times q}$ and a scalar $\lambda \in \mathcal{D}$, matrix addition and multiplication are defined by

$$(\mathbf{A} \oplus \mathbf{B})_{i,j} := (\mathbf{A})_{i,j} \oplus (\mathbf{B})_{i,j}, \tag{2.9}$$

$$(\mathbf{A} \otimes \mathbf{C})_{i,j} := \bigoplus_{k=1}^n ((\mathbf{A})_{i,k} \otimes (\mathbf{C})_{k,j}), \tag{2.10}$$

$$(\lambda \otimes \mathbf{A})_{i,j} := \lambda \otimes (\mathbf{A})_{i,j}.$$

The order relation in the matrix case coincides with the element-wise order, *i.e.*, for $\mathbf{A}, \mathbf{B} \in \mathcal{D}^{m \times n}$, $\mathbf{A} \geq \mathbf{B}$ iff $\forall i, j$ $(\mathbf{A})_{i,j} \geq (\mathbf{B})_{i,j}$. The identity matrix, denoted by \mathbf{I} , is a square matrix with e on the diagonal and ε elsewhere. The zero matrix, denoted by ε , has only ε entries.

Proposition 1 ([1]). *The set of square matrices, denoted $\mathcal{D}^{n \times n}$, with entries in a dioid $(\mathcal{D}, \oplus, \otimes)$, endowed with (2.9) as addition and (2.10) as multiplication is a dioid denoted by $(\mathcal{D}^{n \times n}, \oplus, \otimes)$. The unit and zero element is \mathbf{I} and ε , respectively. Moreover, if $(\mathcal{D}, \oplus, \otimes)$ is complete then $(\mathcal{D}^{n \times n}, \oplus, \otimes)$ is complete.*

Remark 2. *Note that non-square matrices can be included by adding additional rows (resp. columns) with ε .*

Furthermore, if we assume that $(\mathcal{D}, \oplus, \otimes)$ is a complete dioid the Kleene star can be extended to square matrices $\mathbf{A} \in \mathcal{D}^{n \times n}$. For this, $\mathbf{A} \in \mathcal{D}^{n \times n}$ is partitioned into sub-matrices as follows,

$$\mathbf{A} = \begin{bmatrix} \mathbf{B} & \mathbf{C} \\ \mathbf{D} & \mathbf{E} \end{bmatrix},$$

where $\mathbf{B} \in \mathcal{D}^{n_1 \times n_1}$, $\mathbf{C} \in \mathcal{D}^{n_1 \times n_2}$, $\mathbf{D} \in \mathcal{D}^{n_2 \times n_1}$ and $\mathbf{E} \in \mathcal{D}^{n_2 \times n_2}$ and $n = n_1 + n_2$. Then \mathbf{A}^* can be written as

$$\mathbf{A}^* = \begin{bmatrix} \mathbf{B}^* \oplus \mathbf{B}^* \mathbf{C} (\mathbf{D} \mathbf{B}^* \mathbf{C} \oplus \mathbf{E})^* \mathbf{D} \mathbf{B}^* & \mathbf{B}^* \mathbf{C} (\mathbf{D} \mathbf{B}^* \mathbf{C} \oplus \mathbf{E})^* \\ (\mathbf{D} \mathbf{B}^* \mathbf{C} \oplus \mathbf{E})^* \mathbf{D} \mathbf{B}^* & (\mathbf{D} \mathbf{B}^* \mathbf{C} \oplus \mathbf{E})^* \end{bmatrix}. \quad (2.11)$$

Clearly, if we assume $\mathbf{A} \in \mathcal{D}^{2 \times 2}$, then \mathbf{B} , \mathbf{C} , \mathbf{D} , and \mathbf{E} are scalars in \mathcal{D} and the Kleene star of the matrix \mathbf{A} is obtained by sum, product, and Kleene star operations between scalars. Thus for a square matrix $\mathbf{A} \in \mathcal{D}^{n \times n}$ with arbitrary dimension, the star \mathbf{A}^* can be obtained in a recursive way.

Additionally, for $(\mathcal{D}, \oplus, \otimes)$ a complete dioid the infimum operation is extended to matrices as follows, for $\mathbf{A}, \mathbf{B} \in \mathcal{D}^{m \times n}$,

$$(\mathbf{A} \wedge \mathbf{B})_{i,j} = (\mathbf{A})_{i,j} \wedge (\mathbf{B})_{i,j}. \quad (2.12)$$

2.1.3. Quotient Dioids

Definition 8 (Congruence [1]). *A congruence relation in a dioid $(\mathcal{D}, \oplus, \otimes)$ is an equivalence relation \mathcal{R} which satisfies $\forall a, b, c \in \mathcal{D}$,*

$$a \mathcal{R} b \Rightarrow \begin{cases} (a \oplus c) \mathcal{R} (b \oplus c), \\ (a \otimes c) \mathcal{R} (b \otimes c), \\ (c \otimes a) \mathcal{R} (c \otimes b). \end{cases}$$

For a dioid $(\mathcal{D}, \oplus, \otimes)$ with an equivalence relation \mathcal{R} the equivalence class of $a \in \mathcal{D}$ is defined by $[a]_{\mathcal{R}} := \{b \in \mathcal{D} \mid a \mathcal{R} b\}$.

Proposition 2 ([1]). *The quotient of a dioid $(\mathcal{D}, \oplus, \otimes)$ by a congruence relation \mathcal{R} is again a dioid, denoted by $(\mathcal{D}_{\mathcal{R}}, \oplus, \otimes)$, with addition and multiplication given by,*

$$[a]_{\mathcal{R}} \oplus [b]_{\mathcal{R}} = [a \oplus b]_{\mathcal{R}} \quad \text{and} \quad [a]_{\mathcal{R}} \otimes [b]_{\mathcal{R}} = [a \otimes b]_{\mathcal{R}}.$$

The zero element ε and unit element e in $\mathcal{D}_{\mathcal{R}}$ correspond to the equivalence classes $[\varepsilon]_{\mathcal{R}}$ and $[e]_{\mathcal{R}}$ of \mathcal{D} .

Remark 3. *Let $(\mathcal{D}, \oplus, \otimes)$ be a complete (resp. commutative) dioid, then $(\mathcal{D}_{\mathcal{R}}, \oplus, \otimes)$ is a complete (resp. commutative) dioid.*

2.1.4. Dioid of Formal Power Series

Definition 9 (Formal Power Series [1](Chap. 4.7)). *A formal power series in p commutative variables with coefficients in a dioid $(\mathcal{D}, \oplus, \otimes)$ is a mapping from \mathbb{Z}^p into \mathcal{D} , i.e., $s : \mathbb{Z}^p \rightarrow \mathcal{D}$. The variables are denoted by z_1, \dots, z_p and $\forall \mathbf{k} = (k_1, \dots, k_p) \in \mathbb{Z}^p$, $s(\mathbf{k})$ represents the coefficient of $z_1^{k_1} \dots z_p^{k_p}$. An equivalent compact representation of s is*

$$s = \bigoplus_{\mathbf{k} \in \mathbb{Z}^p} s(\mathbf{k}) z_1^{k_1} \dots z_p^{k_p}.$$

Definition 10 (Support, Degree, and Valuation). *Support (supp), degree (deg) and valuation (val) of a formal power series s are defined as*

- $\text{supp}(s) = \{\mathbf{k} \in \mathbb{Z}^p \mid s(\mathbf{k}) \neq \varepsilon\}$,
- $\text{deg}(s)$ is the least upper bound of $\text{supp}(s)$,
- $\text{val}(s)$ is the greatest lower bound of $\text{supp}(s)$.

A polynomial (resp. monomial) is a formal power series with finite support (resp. the support is reduced to only one element).

The set of formal power series with coefficients in a dioid $(\mathcal{D}, \oplus, \otimes)$ and variables z_1, \dots, z_p is denoted by $\mathcal{D} \llbracket z_1, \dots, z_p \rrbracket$. On this set addition \oplus is defined as, for $s_1, s_2 \in \mathcal{D} \llbracket z_1, \dots, z_p \rrbracket$,

$$\forall \mathbf{k} \in \mathbb{Z}^p, \quad (s_1 \oplus s_2)(\mathbf{k}) = s_1(\mathbf{k}) \oplus s_2(\mathbf{k}). \quad (2.13)$$

Additionally, multiplication \otimes is defined by the Cauchy product, thus

$$\forall \mathbf{k} \in \mathbb{Z}^p, \quad (s_1 \otimes s_2)(\mathbf{k}) = \bigoplus_{\mathbf{i}+\mathbf{j}=\mathbf{k}} s_1(\mathbf{i}) \otimes s_2(\mathbf{j}). \quad (2.14)$$

Proposition 3 ([1]). *Let $(\mathcal{D}, \oplus, \otimes)$ be a complete dioid, then the set $\mathcal{D} \llbracket z_1, \dots, z_p \rrbracket$, endowed with addition and multiplication defined by (2.13) and (2.14) is a complete dioid.*

In [1] it is shown that in general Prop. 3 holds only for complete dioids since the definition of the product (2.14) includes infinite sums. In the dioid $(\mathcal{D} \llbracket z_1, \dots, z_p \rrbracket, \oplus, \otimes)$ the zero element $\varepsilon(\mathbf{k})$ is defined by, $\forall \mathbf{k} \in \mathbb{Z}^p$, $\varepsilon(\mathbf{k}) = \varepsilon$. Likewise, the unit element $e(\mathbf{k})$ in $\mathcal{D} \llbracket z_1, \dots, z_p \rrbracket$ is defined as

$$e(\mathbf{k}) = \begin{cases} e & \text{for } \mathbf{k} = \mathbf{0} \text{ (the zero vector),} \\ \varepsilon & \text{otherwise.} \end{cases}$$

The top element $\top(\mathbf{k})$ in $\mathcal{D} \llbracket z_1, \dots, z_p \rrbracket$ is defined by $\top(\mathbf{k}) = \top$, $\forall \mathbf{k} \in \mathbb{Z}^p$.

Since $(\mathcal{D} \llbracket z_1, \dots, z_p \rrbracket, \oplus, \otimes)$ is a complete dioid the greatest lower bound of two series $s_1, s_2 \in \mathcal{D} \llbracket z_1, \dots, z_p \rrbracket$ is given by

$$\forall \mathbf{k} \in \mathbb{Z}^p, \quad (s_1 \wedge s_2)(\mathbf{k}) = s_1(\mathbf{k}) \wedge s_2(\mathbf{k}).$$

Moreover, if the dioid $(\mathcal{D}, \oplus, \otimes)$ is commutative and the variables z_1, \dots, z_p also commute, then the dioid $(\mathcal{D} \llbracket z_1, \dots, z_p \rrbracket, \oplus, \otimes)$ is commutative as well.

Proposition 4 ([19]). *Let $(\mathcal{S}, \oplus, \otimes)$ be a complete subdioid of a complete dioid $(\mathcal{D}, \oplus, \otimes)$, then $(\mathcal{S} \llbracket z_1, \dots, z_p \rrbracket, \oplus, \otimes)$ is a complete subdioid of $(\mathcal{D} \llbracket z_1, \dots, z_p \rrbracket, \oplus, \otimes)$.*

2.1.5. Mappings over Dioids

Definition 11. *On a dioid $(\mathcal{D}, \oplus, \otimes)$ the identity mapping, denoted by $\text{Id}_{\mathcal{D}}$, is a mapping from \mathcal{D} into itself defined as,*

$$\forall a \in \mathcal{D}, \quad \text{Id}_{\mathcal{D}}(a) = a.$$

Definition 12. *Let $f : \mathcal{D} \rightarrow \mathcal{C}$ be a mapping from a dioid $(\mathcal{D}, \oplus, \otimes)$ into a dioid $(\mathcal{C}, \oplus, \otimes)$, then f is a \oplus -morphism if*

$$\forall a, b \in \mathcal{D}, \quad f(a \oplus b) = f(a) \oplus f(b) \text{ and } f(\varepsilon) = \varepsilon.$$

Definition 13. *Let $f : \mathcal{D} \rightarrow \mathcal{C}$ be a mapping from a dioid $(\mathcal{D}, \oplus, \otimes)$ into a dioid $(\mathcal{C}, \oplus, \otimes)$, then f is a \otimes -morphism if*

$$\forall a, b \in \mathcal{D}, \quad f(a \otimes b) = f(a) \otimes f(b) \text{ and } f(e) = e.$$

A mapping f is said to be a homomorphism if it is both a \oplus -morphism and a \otimes -morphism. A homomorphism $f : \mathcal{D} \rightarrow \mathcal{D}$ is called an endomorphism. Furthermore, if f is a homomorphism and the inverse of f is defined and itself a homomorphism then f is called an isomorphism.

Definition 14 (Isotony). *A mapping f from a complete dioid $(\mathcal{D}, \oplus, \otimes)$ into a complete dioid $(\mathcal{C}, \oplus, \otimes)$ is called isotone (or order preserving) if*

$$\forall a, b \in \mathcal{D}, \quad a \geq b \Rightarrow f(a) \geq f(b).$$

Definition 15 (Antitony). A mapping f from a complete dioid $(\mathcal{D}, \oplus, \otimes)$ into a complete dioid $(\mathcal{C}, \oplus, \otimes)$ is called antitone (or order reversing) if

$$\forall a, b \in \mathcal{D}, \quad a \geq b \Rightarrow f(a) \leq f(b).$$

Definition 16 (Lower semi-continuity). A mapping f from a complete dioid $(\mathcal{D}, \oplus, \otimes)$ into a complete dioid $(\mathcal{C}, \oplus, \otimes)$ is called lower semi-continuous if

$$\forall \mathcal{S} \subseteq \mathcal{D}, \quad f\left(\bigoplus_{a \in \mathcal{S}} a\right) = \bigoplus_{a \in \mathcal{S}} f(a).$$

Definition 17 (Upper semi-continuity). A mapping f from a complete dioid $(\mathcal{D}, \oplus, \otimes)$ into a complete dioid $(\mathcal{C}, \oplus, \otimes)$ is called upper semi-continuous if

$$\forall \mathcal{S} \subseteq \mathcal{D}, \quad f\left(\bigwedge_{a \in \mathcal{S}} a\right) = \bigwedge_{a \in \mathcal{S}} f(a).$$

A mapping f which is both, upper semi-continuous and lower semi-continuous is called continuous. A lower semi-continuous mapping f such that $f(\varepsilon) = \varepsilon$ is a \oplus -morphism. Moreover, f is a \oplus -morphism implies that f is an isotone mapping. Note that in general the opposite is not true, however, an isotone mapping $f : \mathcal{D} \rightarrow \mathcal{C}$ satisfies $\forall a, b \in \mathcal{D}, f(a \oplus b) \geq f(a) \oplus f(b)$. In the particular case where $f : \mathcal{D} \rightarrow \mathcal{C}$ is an isotone mapping and the dioid $(\mathcal{D}, \oplus, \otimes)$ is a totally ordered set, i.e., for $a, b \in \mathcal{D}$ the sum $a \oplus b$ is either equal to a or b , f is a \oplus -morphism.

In analogy with the definition of endomorphism for dioids one can define endomorphism for a monoid $(\mathcal{M}, \oplus, \varepsilon)$ and lower semi-continuity for complete monoids.

Definition 18. A mapping $f : \mathcal{M} \rightarrow \mathcal{M}$, from a monoid $(\mathcal{M}, \oplus, \varepsilon)$ into itself, is called an endomorphism if,

$$\forall a, b \in \mathcal{M}, \quad f(a \oplus b) = f(a) \oplus f(b) \text{ and } f(\varepsilon) = \varepsilon.$$

Definition 19. A mapping $f : \mathcal{M} \rightarrow \mathcal{M}$, from a complete monoid $(\mathcal{M}, \oplus, \varepsilon)$ into itself, is called lower semi-continuous if,

$$\forall \mathcal{S} \subseteq \mathcal{M}, \quad f\left(\bigoplus_{a \in \mathcal{S}} a\right) = \bigoplus_{a \in \mathcal{S}} f(a).$$

Proposition 5 ([52]). Let $(\mathcal{M}, \oplus, \varepsilon)$ be a commutative monoid and \mathcal{S} be the set of its endomorphisms. The set \mathcal{S} endowed with addition and multiplication defined by

$$\begin{aligned} f_1, f_2 \in \mathcal{S}, \quad \forall x \in \mathcal{M} : \quad (f_1 \oplus f_2)(x) &= f_1(x) \oplus f_2(x), \\ f_1, f_2 \in \mathcal{S}, \quad \forall x \in \mathcal{M} : \quad (f_1 \otimes f_2)(x) &= f_1(f_2(x)), \end{aligned}$$

is a dioid. The zero and unit element are given by the mappings $\forall x \in \mathcal{M}, \varepsilon(x) = \varepsilon$ and $\forall x \in \mathcal{M}, e(x) = x$, respectively.

2.2. Residuation Theory

In general, the product \otimes in a dioid is not invertible. However, since a complete dioid is a complete lattice, then residuation theory, see e.g. [4, 11], is applicable to define an approximate mapping inverse for particular mappings defined between complete dioids. More precisely this theory yields the greatest solution of the inequality $f(a) \leq b$, with a, b are elements in a complete dioid. By defining the product \otimes in a complete dioid as a mapping, i.e., $R_a : x \mapsto a \otimes x$, residuation theory is in particular useful to obtain an approximate inverse of the product. In other words, we can determine the greatest solution for x of the inequality $a \otimes x \leq b$ (note that a solution always exists, ε at least). In this section, we give the conditions under which mappings between complete dioids are residuated and recall some useful properties of residuation theory.

Definition 20 (Residuated Mapping). *A mapping $f : \mathcal{D} \rightarrow \mathcal{C}$, with $(\mathcal{D}, \oplus, \otimes)$ and $(\mathcal{C}, \oplus, \otimes)$ complete dioids, is said to be residuated if*

1. f is isotone and,
2. for all $y \in \mathcal{C}$, the inequality $f(x) \leq y$ has a greatest solution in \mathcal{D} .

Theorem 2.2 ([1, 11]). *Let $f : \mathcal{D} \rightarrow \mathcal{C}$ be a residuated mapping from a complete dioid $(\mathcal{D}, \oplus, \otimes)$ into a complete dioid $(\mathcal{C}, \oplus, \otimes)$ then, there exists a unique mapping $f^\#$ from \mathcal{C} into \mathcal{D} which satisfies,*

$$f \circ f^\# \leq \text{Id}_{\mathcal{C}} \quad (\text{Id}_{\mathcal{C}} \text{ identity mapping in } (\mathcal{C}, \oplus, \otimes)), \quad (2.15)$$

$$f^\# \circ f \geq \text{Id}_{\mathcal{D}} \quad (\text{Id}_{\mathcal{D}} \text{ identity mapping in } (\mathcal{D}, \oplus, \otimes)). \quad (2.16)$$

The mapping $f^\# : \mathcal{C} \rightarrow \mathcal{D}$ is called the residual of f .

Remark 4. From (2.15) and (2.16) it follows that $\forall x \in \mathcal{D}$ and $\forall y \in \mathcal{C}$,

$$x \leq f^\#(f(x)), \quad y \geq f(f^\#(y)), \quad (2.17)$$

$$f(x) = f(f^\#(f(x))), \quad f^\#(y) = f^\#(f(f^\#(y))). \quad (2.18)$$

Conversely, one can define dual residuation which yields the least solution of the inequality $f(a) \geq b$, where a, b are elements in a complete dioid.

Definition 21 (Dually Residuated Mapping). *A mapping $f : \mathcal{D} \rightarrow \mathcal{C}$, with $(\mathcal{D}, \oplus, \otimes)$ and $(\mathcal{C}, \oplus, \otimes)$ complete dioids, is said to be dually residuated if*

1. f is isotone and,
2. for all $y \in \mathcal{C}$, the inequality $f(x) \geq y$ has a least solution in \mathcal{D} .

Theorem 2.3 ([1]). Let $f : \mathcal{D} \rightarrow \mathcal{C}$ be a dually residuated mapping from a complete dioid $(\mathcal{D}, \oplus, \otimes)$ into a complete dioid $(\mathcal{C}, \oplus, \otimes)$ then, there exists a unique mapping f^b from \mathcal{C} into \mathcal{D} which satisfies,

$$f \circ f^b \geq \text{Id}_{\mathcal{C}} \quad (\text{Id}_{\mathcal{C}} \text{ identity mapping in } (\mathcal{C}, \oplus, \otimes)), \quad (2.19)$$

$$f^b \circ f \leq \text{Id}_{\mathcal{D}} \quad (\text{Id}_{\mathcal{D}} \text{ identity mapping in } (\mathcal{D}, \oplus, \otimes)). \quad (2.20)$$

The mapping $f^b : \mathcal{C} \rightarrow \mathcal{D}$ is called the dual residual of f .

Remark 5. From (2.19) and (2.20) it follows that $\forall x \in \mathcal{D}$ and $\forall y \in \mathcal{C}$,

$$x \geq f^b(f(x)), \quad y \leq f(f^b(y)), \quad (2.21)$$

$$f(x) = f(f^b(f(x))), \quad f^b(y) = f^b(f(f^b(y))). \quad (2.22)$$

The following theorems give a link between the lower (rep. upper) semi-continuous property and the residuated (rep. dually residuated) property of a mapping.

Theorem 2.4 ([1]). A mapping $f : \mathcal{D} \rightarrow \mathcal{C}$, with $(\mathcal{D}, \oplus, \otimes)$ and $(\mathcal{C}, \oplus, \otimes)$ complete dioids, is residuated, iff $f(\varepsilon) = \varepsilon$ and f is lower semi-continuous. Furthermore, the corresponding residual $f^\#$ is upper semi-continuous.

Theorem 2.5 ([1]). A mapping $f : \mathcal{D} \rightarrow \mathcal{C}$, with $(\mathcal{D}, \oplus, \otimes)$ and $(\mathcal{C}, \oplus, \otimes)$ complete dioids, is dually residuated iff $f(\top) = \top$ and f is upper semi-continuous. Furthermore, the corresponding dual residual f^b is lower semi-continuous.

Clearly, Theorem 2.4 and Theorem 2.5 implies that the residual $f^\#$ of a mapping f is dually residuated and thus $(f^\#)^b = f$. Conversely, the dual residual g^b of a mapping g is residuated and thus $(g^b)^\# = g$.

Residuation of Multiplication

On a complete dioid the mappings $R_a : x \mapsto xa$, (right multiplication by a) and $L_a : x \mapsto ax$ (left multiplication by a) are lower semi-continuous and therefore residuated. The residual mappings are denoted $R_a^\#(b) = b \not\phi a = \bigoplus \{x | xa \leq b\}$ (right division by a) and $L_a^\#(b) = a \not\psi b = \bigoplus \{x | ax \leq b\}$ (left division by a). An alternative notation for the left and right division by a are $\frac{b}{a}$ and $\frac{b}{\leftarrow a}$, respectively.

The following two relations give some useful properties of left and right division in combination with the Kleene star.

$$a = a^* \Leftrightarrow a = a \not\psi a = (a \not\psi a)^* \quad a = a^* \Leftrightarrow a = a \not\phi a = (a \not\phi a)^* \quad (2.23)$$

Additionally, for $(\mathcal{D}, \oplus, \otimes)$ a complete dioid left-division and right-division are extended to matrices as follows, for $\mathbf{A} \in \mathcal{D}^{m \times n}$, $\mathbf{B} \in \mathcal{D}^{m \times q}$, $\mathbf{C} \in \mathcal{D}^{n \times q}$,

$$(\mathbf{A} \backslash \mathbf{B})_{i,j} = \bigwedge_{k=1}^m (\mathbf{A})_{k,i} \backslash (\mathbf{B})_{k,j}, \quad (\mathbf{B} / \mathbf{C})_{i,j} = \bigwedge_{k=1}^q (\mathbf{B})_{i,k} / (\mathbf{C})_{j,k}. \quad (2.24)$$

In Appendix A we provide a list with some basic relations of left and right division in complete dioids. A more detailed presentation can be found in [1].

In general, in a complete dioid $(\mathcal{D}, \oplus, \otimes)$, left and right division do not distribute over \oplus , however for $a, b, x \in \mathcal{D}$

$$x \backslash (a \oplus b) \geq x \backslash a \oplus x \backslash b, \quad (a \oplus b) / x \geq a / x \oplus b / x,$$

see [1]. Moreover, when we deal with dioids of power series the following proposition provides a useful result for division between power series.

Proposition 6 ([1], Remark 4.95). *Let $(\mathcal{D}[[z]], \oplus, \otimes)$ be a complete dioid of formal power series in one variable z and exponents in \mathbb{Z} , see Prop. 3. Let $f(m)z^m$ be a monomial and $\bigoplus_i h(i)z^i$ be a series in $\mathcal{D}[[z]]$, then*

$$\frac{\bigoplus_i h(i)z^i}{f(m)z^m} = \bigoplus_i \frac{h(i)}{f(m)} z^{i-m}, \quad \frac{\bigoplus_i h(i)z^i}{f(m)z^m} = \bigoplus_i \frac{h(i)}{f(m)} z^{i-m}.$$

Residuation of the Canonical Injection

Definition 22. *Let $(\mathcal{S}, \oplus, \otimes)$ be a complete subdioid of a complete dioid $(\mathcal{D}, \oplus, \otimes)$. The canonical injection, from $(\mathcal{S}, \oplus, \otimes)$ into $(\mathcal{D}, \oplus, \otimes)$ is a mapping defined by,*

$$\text{Inj} : \mathcal{S} \rightarrow \mathcal{D}, \quad \forall x \in \mathcal{S}, \text{Inj}(x) = x.$$

Clearly, the canonical injection is lower-semi continuous and therefore it is residuated.

Proposition 7. ([1]) *The canonical injection $\text{Inj} : \mathcal{S} \rightarrow \mathcal{D}$, as defined in Definition 22, is residuated. The corresponding residual $\text{Inj}^\sharp : \mathcal{D} \rightarrow \mathcal{S}$ is a projection and satisfies the following conditions:*

1. $\text{Inj}^\sharp \circ \text{Inj}^\sharp = \text{Inj}^\sharp$,
2. $\text{Inj}^\sharp \leq \text{Id}_{\mathcal{D}}$,
3. $x \in \mathcal{S} \Leftrightarrow \text{Inj}^\sharp(x) = x$.

Conversely, if $(\mathcal{S}, \oplus, \otimes)$ and $(\mathcal{D}, \oplus, \otimes)$ have the same top element \top the canonical injection $\text{Inj} : \mathcal{S} \rightarrow \mathcal{D}$ is dually residuated. Moreover, for the dual residual Inj^\flat the following conditions hold

1. $\text{Inj}^\flat \circ \text{Inj}^\flat = \text{Inj}^\flat$,
2. $\text{Inj}^\flat \geq \text{Id}_{\mathcal{D}}$,
3. $x \in \mathcal{S} \Leftrightarrow \text{Inj}^\flat(x) = x$.

2.3. Dioid of two Dimensional Power Series $\mathcal{M}_{\text{in}}^{\text{ax}}[[\gamma, \delta]]$

The dioid $(\mathcal{M}_{\text{in}}^{\text{ax}}[[\gamma, \delta]], \oplus, \otimes)$ is useful for modeling and control of some DESs, e.g. [1], and plays a major role in this thesis. Here we briefly introduce the dioid $(\mathcal{M}_{\text{in}}^{\text{ax}}[[\gamma, \delta]], \oplus, \otimes)$ and we give some basic results. These results are mainly based on [1]. For a more comprehensive representation, the reader is invited to consult [1, 12].

$(\mathcal{M}_{\text{in}}^{\text{ax}}[[\gamma, \delta]], \oplus, \otimes)$ is a quotient dioid of formal power series in two variables γ and δ and Boolean coefficients. We first introduce the dioid $(\mathbb{B}[[\gamma, \delta]], \oplus, \otimes)$ and then develop $(\mathcal{M}_{\text{in}}^{\text{ax}}[[\gamma, \delta]], \oplus, \otimes)$ by introducing a congruence relation on $(\mathbb{B}[[\gamma, \delta]], \oplus, \otimes)$.

Definition 23 (Dioid $(\mathbb{B}[[\gamma, \delta]], \oplus, \otimes)$). *We denote by $(\mathbb{B}[[\gamma, \delta]], \oplus, \otimes)$ the dioid of formal power series in the two commutative variables γ and δ with Boolean coefficients, i.e., $\mathbb{B} = \{e, \varepsilon\}$ and exponents in \mathbb{Z} . An element $s \in \mathbb{B}[[\gamma, \delta]]$ is represented as $s = \bigoplus_{\nu, \tau \in \mathbb{Z}} s(\nu, \tau) \gamma^\nu \delta^\tau$, with $s(\nu, \tau) \in \{e, \varepsilon\}$. The zero element is $\varepsilon = \bigoplus_{\nu, \tau \in \mathbb{Z}} \varepsilon \gamma^\nu \delta^\tau$ and the unit element $e = e \gamma^0 \delta^0$.*

Moreover, we write only the elements of a series $s = \bigoplus_{\nu, \tau \in \mathbb{Z}} s(\nu, \tau) \gamma^\nu \delta^\tau$, for which $s(\nu, \tau) = e$, therefore a monomial $m \in \mathbb{B}[[\gamma, \delta]]$ is represented as $\gamma^{\nu_1} \delta^{\tau_1}$. Since, $(\mathbb{B}, \oplus, \otimes)$ is a complete dioid and due to Prop. 3 the dioid $(\mathbb{B}[[\gamma, \delta]], \oplus, \otimes)$ is complete as well. Moreover, since the variable γ and δ commute and $(\mathbb{B}, \oplus, \otimes)$ is a commutative dioid, the dioid $(\mathbb{B}[[\gamma, \delta]], \oplus, \otimes)$ is a commutative dioid.

Example 7. *A series $s \in \mathbb{B}[[\gamma, \delta]]$ has a natural graphical representation in the \mathbb{Z}^2 -plane. For instance, the series $s = \gamma^1 \delta^1 \oplus \gamma^2 \delta^3 \oplus \gamma^3 \delta^4$ is shown in Figure 2.1.*

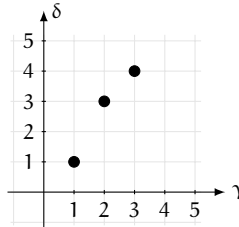

Figure 2.1. – Graphical illustration of $s = \gamma^1 \delta^1 \oplus \gamma^2 \delta^3 \oplus \gamma^3 \delta^4 \in \mathbb{B}[[\gamma, \delta]]$.

Definition 24 (Dioid $(\mathcal{M}_{\text{in}}^{\text{ax}}[[\gamma, \delta]], \oplus, \otimes)$). *$(\mathcal{M}_{\text{in}}^{\text{ax}}[[\gamma, \delta]], \oplus, \otimes)$ is the quotient dioid of $(\mathbb{B}[[\gamma, \delta]], \oplus, \otimes)$ induced by the equivalence relation, for $a, b \in \mathbb{B}[[\gamma, \delta]]$,*

$$a \mathcal{R} b \Leftrightarrow \gamma^* (\delta^{-1})^* a = \gamma^* (\delta^{-1})^* b.$$

The zero and unit element in $\mathcal{M}_{\text{in}}^{\text{ax}}[[\gamma, \delta]]$ are equal to the zero and unit element in $\mathbb{B}[[\gamma, \delta]]$, and thus $\varepsilon = \bigoplus_{\nu, \tau \in \mathbb{Z}} \varepsilon \gamma^\nu \delta^\tau$ and $e = e \gamma^0 \delta^0$, respectively. Due to Remark 3 the dioid $(\mathcal{M}_{\text{in}}^{\text{ax}}[[\gamma, \delta]], \oplus, \otimes)$ inherits the commutative and completeness properties from the dioid $(\mathbb{B}[[\gamma, \delta]], \oplus, \otimes)$.

Two series $s_1, s_2 \in \mathcal{M}_{\text{in}}^{\text{ax}}[[\gamma, \delta]]$ belong to the same equivalence class if $\gamma^*(\delta^{-1})^* s_1 = \gamma^*(\delta^{-1})^* s_2$. A canonical representative of an equivalence class is defined to be the series of the class with minimal support. Differently speaking the series in the equivalence class with the minimal number of elements is the canonical representative of the equivalence class. For instance consider the following two series $s_1, s_2 \in \mathcal{M}_{\text{in}}^{\text{ax}}[[\gamma, \delta]]$

$$\begin{aligned} s_1 &= \gamma^1 \delta^1 \oplus \gamma^2 \delta^3, \\ s_2 &= \gamma^1 \delta^1 \oplus \gamma^2 \delta^3 \oplus \gamma^3 \delta^1, \end{aligned}$$

both series belong to the same equivalence class but s_1 is the canonical representative of the class since s_1 has minimal support. This equivalence relation has a graphical interpretation in the \mathbb{Z}^2 -plane, unlike to $\mathbb{B}[[\gamma, \delta]]$ where a monomial represents a point in the \mathbb{Z}^2 -plane, a monomial in $\mathcal{M}_{\text{in}}^{\text{ax}}[[\gamma, \delta]]$ represents the south-east cone of a point in the \mathbb{Z}^2 -plane. Respectively, a series in $\mathcal{M}_{\text{in}}^{\text{ax}}[[\gamma, \delta]]$ represents the union of the south-east cones of its elements. If two series cover the same area in the \mathbb{Z}^2 -plane, then they belong to the same equivalence class. For instance, the series s_1 and s_2 , shown in Figure 2.2, cover the same area. Note that

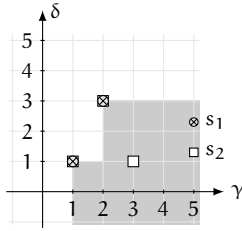

Figure 2.2. – Graphical illustration of the equivalence class represented by $s_1 = \gamma^1 \delta^1 \oplus \gamma^2 \delta^3 \in \mathcal{M}_{\text{in}}^{\text{ax}}[[\gamma, \delta]]$. The series $s_2 = \gamma^1 \delta^1 \oplus \gamma^2 \delta^3 \oplus \gamma^3 \delta^1$ belongs to the same equivalence class, since both series s_1, s_2 cover the same area in the \mathbb{Z}^2 -plane.

$\gamma^2 \delta^3$ dominates $\gamma^3 \delta^1$, since

$$\begin{aligned} \gamma^2 \delta^3 (\gamma^1)^* (\delta^{-1})^* &= \gamma^2 \delta^3 \oplus \gamma^3 \delta^3 \oplus \gamma^4 \delta^3 \oplus \dots \\ &\quad \oplus \gamma^2 \delta^2 \oplus \gamma^3 \delta^2 \oplus \gamma^4 \delta^2 \oplus \dots \\ &\quad \oplus \gamma^2 \delta^1 \oplus \gamma^3 \delta^1 \oplus \gamma^4 \delta^1 \oplus \dots \\ &\quad \dots \end{aligned}$$

Therefore, this equivalence relation leads to the following simplification rules for monomials in $\mathcal{M}_{\text{in}}^{\text{ax}}[[\gamma, \delta]]$,

$$\delta^{\tau_1} \oplus \delta^{\tau_2} = \delta^{\max(\tau_1, \tau_2)}, \quad (2.25)$$

$$\gamma^{\nu_1} \oplus \gamma^{\nu_2} = \gamma^{\min(\nu_1, \nu_2)}. \quad (2.26)$$

The order relation on the dioid $(\mathcal{M}_{\text{in}}^{\text{ax}}[\gamma, \delta], \oplus, \otimes)$, induced by the \oplus operation, is partial. This can be illustrated on monomial. Let $\gamma^{\nu_1} \delta^{\tau_1}, \gamma^{\nu_2} \delta^{\tau_2} \in \mathcal{M}_{\text{in}}^{\text{ax}}[\gamma, \delta]$ then $\gamma^{\nu_1} \delta^{\tau_1} \geq \gamma^{\nu_2} \delta^{\tau_2}$ if and only if $\tau_1 \geq \tau_2$ and $\nu_1 \leq \nu_2$. For instance, consider the monomials $\gamma^1 \delta^1, \gamma^2 \delta^3, \gamma^3 \delta^1 \in \mathcal{M}_{\text{in}}^{\text{ax}}[\gamma, \delta]$, $\gamma^1 \delta^1 \geq \gamma^3 \delta^1$, and $\gamma^2 \delta^3 \geq \gamma^3 \delta^1$ but $\gamma^1 \delta^1 \not\geq \gamma^2 \delta^3$ and $\gamma^1 \delta^1 \not\geq \gamma^2 \delta^3$. Moreover, multiplication \otimes , addition \oplus , and the infimum operation \wedge between monomial in $\mathcal{M}_{\text{in}}^{\text{ax}}[\gamma, \delta]$ satisfy the following relations

$$\gamma^{\nu_1} \delta^{\tau_1} \otimes \gamma^{\nu_2} \delta^{\tau_2} = \gamma^{\nu_1 + \nu_2} \delta^{\tau_1 + \tau_2}, \quad (2.27)$$

$$\gamma^{\nu} \delta^{\tau_1} \oplus \gamma^{\nu} \delta^{\tau_2} = \gamma^{\nu} \delta^{\max(\tau_1, \tau_2)}, \quad (2.28)$$

$$\gamma^{\nu_1} \delta^{\tau} \oplus \gamma^{\nu_2} \delta^{\tau} = \gamma^{\min(\nu_1, \nu_2)} \delta^{\tau}, \quad (2.29)$$

$$\gamma^{\nu_1} \delta^{\tau_1} \wedge \gamma^{\nu_2} \delta^{\tau_2} = \gamma^{\max(\nu_1, \nu_2)} \delta^{\min(\tau_1, \tau_2)}. \quad (2.30)$$

Recall that a polynomial is a series with finite support, *i.e.*, a polynomial in $\mathcal{M}_{\text{in}}^{\text{ax}}[\gamma, \delta]$ can be written as a finite sum $\bigoplus_{i=0}^I \gamma^{\nu_i} \delta^{\tau_i}$, with $I \in \mathbb{N}$.

Definition 25 (Ultimately Cyclic Series). A series $s = \bigoplus_i \gamma^{\nu_i} \delta^{\tau_i} \in \mathcal{M}_{\text{in}}^{\text{ax}}[\gamma, \delta]$ is called ultimately cyclic if s can be written as $s = p \oplus q(\gamma^{\nu} \delta^{\tau})^*$, where p and q are polynomials in $\mathcal{M}_{\text{in}}^{\text{ax}}[\gamma, \delta]$ and $\nu, \tau \in \mathbb{N}$. The asymptotic slope of s is defined by $\sigma(s) = \tau/\nu$. The polynomial p (*resp.* q) is called transient (*resp.* cyclic-pattern) and the monomial $(\gamma^{\nu} \delta^{\tau})$ is called growing-term.

Example 8. Consider the following ultimately cyclic series $s = (e \oplus \gamma^1 \delta^1 \oplus \gamma^2 \delta^3) \oplus (\gamma^4 \delta^4 \oplus \gamma^5 \delta^6)(\gamma^2 \delta^3)^*$ in $\mathcal{M}_{\text{in}}^{\text{ax}}[\gamma, \delta]$. The asymptotic slope $\sigma(s) = 3/2$, the transient part is given by $(e \oplus \gamma^1 \delta^1 \oplus \gamma^2 \delta^3)$ and the cyclic-pattern is $(\gamma^4 \delta^4 \oplus \gamma^5 \delta^6)$, which is repeated by a shift of 2 units in the γ -domain and 3 units in the δ -domain.

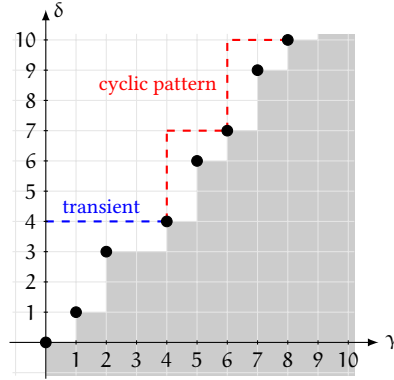

Figure 2.3. – Ultimately cyclic series $s = (e \oplus \gamma^1 \delta^1 \oplus \gamma^2 \delta^3) \oplus (\gamma^4 \delta^4 \oplus \gamma^5 \delta^6)(\gamma^2 \delta^3)^*$ in $\mathcal{M}_{\text{in}}^{\text{ax}}[\gamma, \delta]$.

In the following theorem, we give the basic results for calculations with ultimately cyclic series in $\mathcal{M}_{\text{in}}^{\text{ax}}[\gamma, \delta]$.

Theorem 2.6 ([1]). Let $s_1 = p_1 \oplus q_1(\gamma^{\nu_1} \delta^{\tau_1})^*$ and $s_2 = p_2 \oplus q_2(\gamma^{\nu_2} \delta^{\tau_2})^*$ be two ultimately cyclic series in $\mathcal{M}_{\text{in}}^{\text{ax}}[[\gamma, \delta]]$, where p_1, q_1, p_2, q_2 are polynomials in $\mathcal{M}_{\text{in}}^{\text{ax}}[[\gamma, \delta]]$ and $\nu_1, \nu_2, \tau_1, \tau_2 \in \mathbb{N}$. Furthermore, $s_1 \neq \varepsilon$, $s_2 \neq \varepsilon$ and the asymptotic slope of s_1 is defined by $\sigma(s_1) = \tau_1/\nu_1$ (resp. $\sigma(s_2) = \tau_2/\nu_2$), then

- $s_1 \oplus s_2$ is an ultimately cyclic series such that $\sigma(s_1 \oplus s_2) = \max(\sigma(s_1), \sigma(s_2))$.
- $s_1 \otimes s_2$ is an ultimately cyclic series such that $\sigma(s_1 \otimes s_2) = \max(\sigma(s_1), \sigma(s_2))$.
- $(s_1)^*$ is an ultimately cyclic series.
- $s_1 \wedge s_2$ is an ultimately cyclic series such that $\sigma(s_1 \wedge s_2) = \min(\sigma(s_1), \sigma(s_2))$.
- $s_2 \setminus s_1$ (resp. $s_1 \setminus s_2$) is an ultimately cyclic series such that $s_2 \setminus s_1 = s_1 \setminus s_2 = \varepsilon$ if $\sigma(s_1) < \sigma(s_2)$ and $\sigma(s_2 \setminus s_1) = \sigma(s_1 \setminus s_2) = \sigma(s_1)$ otherwise.

Definition 26 (Causal Series in $\mathcal{M}_{\text{in}}^{\text{ax}}[[\gamma, \delta]]$ [1], [7]). A series $s \in \mathcal{M}_{\text{in}}^{\text{ax}}[[\gamma, \delta]]$ is said to be causal if $s \in \varepsilon$ or both $\text{val}_{\gamma}(s) \geq 0$ and $s \geq \gamma^{\text{val}_{\gamma}(s)} \delta^0$, where $\text{val}_{\gamma}(s)$ refers to the valuation in γ of series s . The set of causal series, denoted by $\mathcal{M}_{\text{in}}^{\text{ax}+}[[\gamma, \delta]]$, is a complete subdioid of $(\mathcal{M}_{\text{in}}^{\text{ax}}[[\gamma, \delta]], \oplus, \otimes)$ denoted by $(\mathcal{M}_{\text{in}}^{\text{ax}+}[[\gamma, \delta]], \oplus, \otimes)$.

Remark 6 ([7]). The canonical injection $\text{Inj} : \mathcal{M}_{\text{in}}^{\text{ax}+}[[\gamma, \delta]] \rightarrow \mathcal{M}_{\text{in}}^{\text{ax}}[[\gamma, \delta]]$ is residuated and its residual is called causal projection, which is denoted by $\text{Pr}^+ : \mathcal{M}_{\text{in}}^{\text{ax}}[[\gamma, \delta]] \rightarrow \mathcal{M}_{\text{in}}^{\text{ax}+}[[\gamma, \delta]]$. Therefore, $\text{Pr}^+(s)$ is the greatest causal series less than or equal to $s \in \mathcal{M}_{\text{in}}^{\text{ax}}[[\gamma, \delta]]$.

Example 9. Consider the series $s = \gamma^{-3} \delta^{-4} \oplus \gamma^{-2} \delta^1 \oplus \gamma^3 \delta^4 \in \mathcal{M}_{\text{in}}^{\text{ax}}[[\gamma, \delta]]$, then the causal projection $\text{Pr}^+(s) = \gamma^0 \delta^1 \oplus \gamma^3 \delta^4 \in \mathcal{M}_{\text{in}}^{\text{ax}+}[[\gamma, \delta]]$. In Figure 2.4a and Figure 2.4b the causal projection of this series s is illustrated.

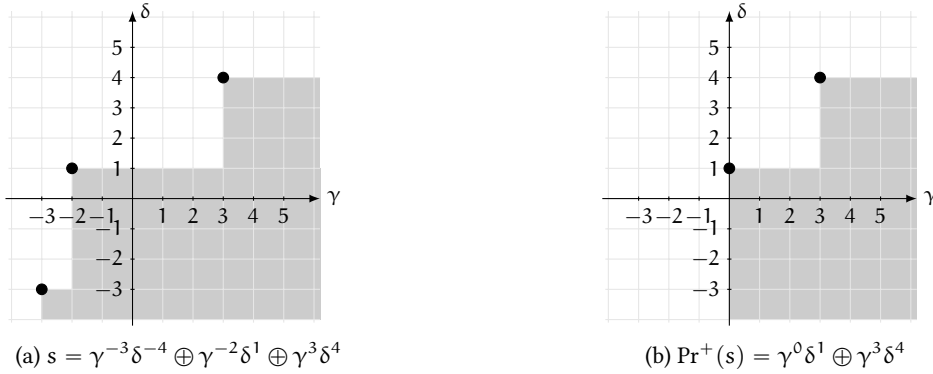

Figure 2.4. – Illustration of the causal projection $\text{Pr}^+(\gamma^{-3} \delta^{-4} \oplus \gamma^{-2} \delta^1 \oplus \gamma^3 \delta^4)$.

Remark 7. In [7] a different definition of causality for series in $\mathcal{M}_{\text{in}}^{\text{ax}}[[\gamma, \delta]]$ was given. These series are called transfer series.

A transfer series $s \in \mathcal{M}_{\text{in}}^{\text{ax}}[[\gamma, \delta]]$ is called causal if $s \in \varepsilon$ or if $s \geq \gamma^{\text{val}_{\gamma}(s)}$, i.e., the exponents of δ of s are greater than or equal to zero. The set of causal transfer series, denoted by

2. Mathematical Preliminaries

$\mathcal{M}_{\text{in}}^{\text{ax}\mp}[\gamma, \delta]$, is a complete subdioid of $(\mathcal{M}_{\text{in}}^{\text{ax}}[\gamma, \delta], \oplus, \otimes)$ denoted by $(\mathcal{M}_{\text{in}}^{\text{ax}\mp}[\gamma, \delta], \oplus, \otimes)$ [7].

This definition allows negative exponents for the variable γ and is motivated by expressing negative tokens in TEGs. Subsequently, $\text{Pr}_{\text{caus}}^{\mp} : \mathcal{M}_{\text{in}}^{\text{ax}}[\gamma, \delta] \rightarrow \mathcal{M}_{\text{in}}^{\text{ax}\mp}[\gamma, \delta]$ is a projection from $\mathcal{M}_{\text{in}}^{\text{ax}}[\gamma, \delta]$ into $\mathcal{M}_{\text{in}}^{\text{ax}\mp}[\gamma, \delta]$, with $\text{Pr}_{\text{caus}}^{\mp}(s)$ is the greatest causal transfer series less than or equal to $s \in \mathcal{M}_{\text{in}}^{\text{ax}}[\gamma, \delta]$.

Dioids $(\mathcal{E}, \oplus, \otimes)$ and $(\mathcal{E}[[\delta]], \oplus, \otimes)$

In the first part of this chapter, Section 3.1, the dioid $(\mathcal{E}[[\delta]], \oplus, \otimes)$ is recalled. It was introduced in [16] and is useful to model Weighted Timed Event Graphs (WTEGs). In particular, the transfer function of a single-input and single-output (SISO) WTEG corresponds to an ultimately cyclic series $s \in \mathcal{E}[[\delta]]$. In Section 3.2 it is shown that the dioid $(\mathcal{M}_{\text{in}}^{\text{ax}}[[\gamma, \delta]], \oplus, \otimes)$ introduced in Section 2.3 is a subdioid of $(\mathcal{E}[[\delta]], \oplus, \otimes)$. Moreover, particular mappings between $\mathcal{E}[[\delta]]$ and $\mathcal{M}_{\text{in}}^{\text{ax}}[[\gamma, \delta]]$ are studied - which have an application in optimal control of WTEGs. Some first results of this section have been published in [66]. In the third part of this chapter, Section 3.3, it is shown that under some conditions all relevant operations $(\oplus, \otimes, \setminus, \rho)$ on $\mathcal{E}[[\delta]]$ can be reduced to operations between matrices with entries in $\mathcal{M}_{\text{in}}^{\text{ax}}[[\gamma, \delta]]$, some results of this section have previously appeared in [65].

3.1. Dioid $(\mathcal{E}[[\delta]], \oplus, \otimes)$

The firings of a transition in a WTEG can be naturally described by a counter function $x : \mathbb{Z} \rightarrow \overline{\mathbb{Z}}_{\min}$, with $x(t)$ is the accumulated number of firings up to a time t . Let us recall that the order in $\overline{\mathbb{Z}}_{\min}$ is reverse to the natural order, *i.e.*, let $x_1, x_2 \in \overline{\mathbb{Z}}_{\min}$, then $x_1 \geq x_2 \Leftrightarrow x_1 \leq x_2$. Subsequently, counter functions are antitone mappings. In the following the dioid $(\mathcal{E}[[\delta]], \oplus, \otimes)$ is defined as a set of operators on counter functions.

The set of antitone mappings from \mathbb{Z} into $\overline{\mathbb{Z}}_{\min}$ is denoted by Σ . On this set addition is defined to be the pointwise addition in the dioid $(\overline{\mathbb{Z}}_{\min}, \oplus, \otimes)$, thus for $x_1, x_2 \in \Sigma$,

$$\forall t \in \mathbb{Z}, \quad (x_1 \oplus x_2)(t) := x_1(t) \oplus x_2(t) = \min(x_1(t), x_2(t)). \quad (3.1)$$

Moreover, scalar multiplication is defined as, for $\lambda \in \overline{\mathbb{Z}}_{\min}$,

$$\forall t \in \mathbb{Z}, \quad (\lambda \otimes x_1)(t) := \lambda + x_1(t). \quad (3.2)$$

The zero and top mappings on Σ , denoted by $\tilde{\varepsilon}$ resp. $\tilde{\top}$, are defined by

$$\begin{aligned} \forall t, \quad \tilde{\varepsilon}(t) &:= \varepsilon \quad (\text{recall that in } \overline{\mathbb{Z}}_{\min}, \varepsilon = \infty), \\ \forall t, \quad \tilde{\top}(t) &:= \top \quad (\text{recall that in } \overline{\mathbb{Z}}_{\min}, \top = -\infty). \end{aligned}$$

Note that equipped with the operation \oplus and the scalar multiplication \otimes the set Σ is a $\overline{\mathbb{Z}}_{\min}$ -semimodule (see Definition 3), where $(\Sigma, \oplus, \tilde{\varepsilon})$ is an idempotent commutative monoid. Moreover, by including the top mapping $\tilde{\top}$, $(\Sigma, \oplus, \tilde{\varepsilon})$ is a complete monoid.

The order relation on Σ , naturally induced by \oplus , is the order in the dioid $(\overline{\mathbb{Z}}_{\min}, \oplus, \otimes)$, i.e., $\forall x_1, x_2 \in \Sigma$,

$$\begin{aligned} x_1 \leq x_2 &\Leftrightarrow x_1 \oplus x_2 = x_2, & (3.3) \\ &\Leftrightarrow x_1(t) \oplus x_2(t) = x_2(t), \quad \forall t \in \mathbb{Z}, \\ &\Leftrightarrow \min(x_1(t), x_2(t)) = x_2(t), \quad \forall t \in \mathbb{Z}, \\ &\Leftrightarrow x_1(t) \geq x_2(t), \quad \forall t \in \mathbb{Z}. \end{aligned}$$

The infimum (\wedge operator) on the set Σ is defined by

$$\forall t \in \mathbb{Z}, \quad (x_1 \wedge x_2)(t) := x_1(t) \wedge x_2(t) = \max(x_1(t), x_2(t)).$$

Definition 27 (Operator). *An operator is a lower semi-continuous mapping $f : \Sigma \rightarrow \Sigma$ from the set Σ into itself, such that $f(\tilde{\varepsilon}) = \tilde{\varepsilon}$. Including the property $f(\tilde{\varepsilon}) = \tilde{\varepsilon}$ implies that f is an endomorphism. The set of these operators is denoted by \mathcal{O} .*

Proposition 8 ([16]). *The set of operators \mathcal{O} , equipped with multiplication and addition as follows,*

$$f_1, f_2 \in \mathcal{O}, \quad \forall x \in \Sigma \quad (f_1 \oplus f_2)(x) := f_1(x) \oplus f_2(x), \quad (3.4)$$

$$f_1, f_2 \in \mathcal{O}, \quad \forall x \in \Sigma \quad (f_1 \otimes f_2)(x) := f_1(f_2(x)), \quad (3.5)$$

is a complete dioid.

Proof. This proof is based on a slightly different version given in [1][Chap. 4, Lemma 4.46] and [19][Chap. 2, Proposition 5]. There, the set of lower semi-continuous mappings from a complete dioid into itself is studied.

First, due to Prop. 5 the set of endomorphisms \mathcal{S} over the monoid $(\Sigma, \oplus, \tilde{\varepsilon})$ is a dioid with the zero mapping and unit mapping given by $\forall x \in \Sigma$,

$$\hat{\varepsilon}(x) := \tilde{\varepsilon}, \quad \hat{e}(x) := x. \quad (3.6)$$

Furthermore, the set of operators \mathcal{O} (lower semi-continuous mapping over Σ), such that $\forall f \in \mathcal{O}$, $f(\tilde{\varepsilon}) = \tilde{\varepsilon}$, is a subset of \mathcal{S} which contains the zero and unit mapping. We have to show that $(\mathcal{O}, \oplus, \otimes)$ is a complete subdioid of $(\mathcal{S}, \oplus, \otimes)$. \mathcal{O} is closed for addition and multiplication, since the lower semi-continuous property is preserved for both operations, i.e., for $f_1, f_2 \in \mathcal{O}$ and $\mathcal{X} \subseteq \Sigma$, for addition:

$$\begin{aligned} (f_1 \oplus f_2)\left(\bigoplus_{x \in \mathcal{X}} x\right) &= f_1\left(\bigoplus_{x \in \mathcal{X}} x\right) \oplus f_2\left(\bigoplus_{x \in \mathcal{X}} x\right) \quad \text{due to (3.4)} \\ &= \bigoplus_{x \in \mathcal{X}} f_1(x) \oplus \bigoplus_{x \in \mathcal{X}} f_2(x) \quad f_1, f_2 \text{ are lower semi-continuous} \\ &= \bigoplus_{x \in \mathcal{X}} (f_1 \oplus f_2)(x) \quad \text{again due to (3.4)}. \end{aligned}$$

Multiplication:

$$\begin{aligned}
 (f_1 \otimes f_2)\left(\bigoplus_{x \in \mathcal{X}} x\right) &= f_1\left(f_2\left(\bigoplus_{x \in \mathcal{X}} x\right)\right) \quad \text{due to (3.5)} \\
 &= f_1\left(\bigoplus_{x \in \mathcal{X}} f_2(x)\right) \quad f_2 \text{ is lower semi-continuous} \\
 &= \bigoplus_{x \in \mathcal{X}} f_1(f_2(x)) \quad f_1 \text{ is lower semi-continuous} \\
 &= \bigoplus_{x \in \mathcal{X}} (f_1 \otimes f_2)(x) \quad \text{again due to (3.5)}.
 \end{aligned}$$

For completeness it remains to show that \mathcal{O} is closed for infinite sums and left (resp. right) multiplication distributes over infinite sums. Clearly, the set Σ is closed for infinite sums, therefore $\forall \mathcal{X} \subseteq \Sigma$ and $\mathcal{F} \subseteq \mathcal{O}$,

$$\bigoplus_{f \in \mathcal{F}} \left(f\left(\bigoplus_{x \in \mathcal{X}} x\right)\right) = \bigoplus_{f \in \mathcal{F}} \bigoplus_{x \in \mathcal{X}} f(x) = \bigoplus_{x \in \mathcal{X}} \bigoplus_{f \in \mathcal{F}} f(x) = \bigoplus_{x \in \mathcal{X}} g(x), \quad \text{with } g(x) = \bigoplus_{f \in \mathcal{F}} f(x),$$

and thus the dioid $(\mathcal{O}, \oplus, \otimes)$ is closed for infinite sums as well. Right multiplication distributes over addition due to the definition of \oplus and \otimes , i.e., for $\mathcal{F} \subseteq \mathcal{O}$, $\forall g \in \mathcal{O}$, $\forall x \in \Sigma$,

$$\left(\left(\bigoplus_{f \in \mathcal{F}} f\right) \otimes g\right)(x) = \bigoplus_{f \in \mathcal{F}} f(g(x)) = \bigoplus_{f \in \mathcal{F}} (f \otimes g)(x).$$

Distributivity of left multiplication is given, since we consider lower semi-continuous mappings, i.e., for $\mathcal{F} \subseteq \mathcal{O}$, $\forall g \in \mathcal{O}$, $\forall x \in \Sigma$,

$$\left(g \otimes \left(\bigoplus_{f \in \mathcal{F}} f\right)\right)(x) = g\left(\bigoplus_{f \in \mathcal{F}} f(x)\right) = \bigoplus_{f \in \mathcal{F}} (g \otimes f)(x).$$

□

To simplify notation we sometimes omit the multiplication symbol \otimes , e.g., for $f_1, f_2 \in \mathcal{O}$, $x \in \Sigma$, $f_1(f_2(x)) = (f_1 \otimes f_2)(x)$ we write $f_1 f_2(x)$. Moreover, for $f \in \mathcal{O}$, $x \in \Sigma$ we sometimes write fx instead of $f(x)$. Due to (2.1) the \oplus operation induces a partial order relation on \mathcal{O} , defined by

$$\begin{aligned}
 f_1 \geq f_2 &\Leftrightarrow f_1 \oplus f_2 = f_1, \\
 &\Leftrightarrow (f_1 x)(t) \oplus (f_2 x)(t) = (f_1 x)(t), \quad \forall x \in \Sigma, \forall t \in \mathbb{Z}, \\
 &\Leftrightarrow \min\left((f_1 x)(t), (f_2 x)(t)\right) = (f_1 x)(t) \quad \forall x \in \Sigma, \forall t \in \mathbb{Z}. \tag{3.7}
 \end{aligned}$$

Subsequently, two operators $f_1, f_2 \in \mathcal{O}$ are equal iff $\forall x \in \Sigma$, $\forall t \in \mathbb{Z}$: $(f_1 x)(t) = (f_2 x)(t)$. Since $(\mathcal{O}, \oplus, \otimes)$ is a complete dioid the top mapping is given by, $\forall x \in \Sigma$,

$$\hat{\uparrow}(x) = \begin{cases} \tilde{\varepsilon} & \text{for } x = \tilde{\varepsilon}, \\ \tilde{\top} & \text{otherwise,} \end{cases} \tag{3.8}$$

and the infimum is defined as, for $f_1, f_2 \in \mathcal{O}$,

$$f_1 \wedge f_2 = \bigoplus \{f_3 \in \mathcal{O} \mid f_3 \oplus f_1 \leq f_1, f_3 \oplus f_2 \leq f_2\}.$$

Proposition 9. *The following operators are both endomorphisms and lower semi-continuous mappings, and thus operators in \mathcal{O} .*

$$m \in \mathbb{N} \quad \mu_m : \forall x \in \Sigma, t \in \mathbb{Z} \quad (\mu_m(x))(t) = m \times x(t), \quad (3.9)$$

$$b \in \mathbb{N} \quad \beta_b : \forall x \in \Sigma, t \in \mathbb{Z} \quad (\beta_b(x))(t) = \left\lfloor \frac{x(t)}{b} \right\rfloor, \quad (3.10)$$

$$\nu \in \mathbb{Z} \quad \gamma^\nu : \forall x \in \Sigma, t \in \mathbb{Z} \quad (\gamma^\nu(x))(t) = \nu + x(t). \quad (3.11)$$

Note that $\lfloor a \rfloor$ denotes the greatest integer smaller than or equal to a .

Proof. The mapping μ_m is an endomorphism, first, recall that $\forall t \in \mathbb{Z}$, $\tilde{\varepsilon}(t) = \infty$ and $m \in \mathbb{N}$ is a finite positive integer, therefore, $\forall t \in \mathbb{Z}$, $(\mu_m(\tilde{\varepsilon}))(t) = m \times \tilde{\varepsilon}(t) = m \times \infty = \infty$, and thus $(\mu_m(\tilde{\varepsilon}))(t) = \tilde{\varepsilon}(t)$. Second $\forall t \in \mathbb{Z}$:

$$\begin{aligned} (\mu_m(x_1 \oplus x_2))(t) &= m \times (x_1 \oplus x_2)(t), \quad \text{due to (3.9)} \\ &= m \times \min(x_1(t), x_2(t)), \quad \text{due to (3.1)} \\ &= \min(m \times x_1(t), m \times x_2(t)), \\ &= \min((\mu_m(x_1))(t), (\mu_m(x_2))(t)), \quad \text{due to (3.9)} \\ &= (\mu_m(x_1))(t) \oplus (\mu_m(x_2))(t), \quad \text{again due to (3.1)}. \end{aligned}$$

Of course, this extends to all finite and infinite subsets $\mathcal{X} \subseteq \Sigma$, i.e.,

$$\begin{aligned} (\mu_m(\bigoplus_{x \in \mathcal{X}} x))(t) &= m \times (\bigoplus_{x \in \mathcal{X}} x)(t) = m \times \min_{x \in \mathcal{X}}(x(t)), \\ &= \min_{x \in \mathcal{X}}(m \times x(t)) = \min_{x \in \mathcal{X}}((\mu_m(x))(t)), \\ &= (\bigoplus_{x \in \mathcal{X}} \mu_m(x))(t), \end{aligned}$$

which shows that μ_m is lower semi-continuous. For the mapping $(\beta_b(x))(t)$, again $b \in \mathbb{N}$ is a finite positive integer, therefore $\forall t \in \mathbb{Z}$, $(\beta_b(\tilde{\varepsilon}))(t) = \lfloor \tilde{\varepsilon}(t)/b \rfloor = \lfloor \infty/b \rfloor = \infty$, thus $(\beta_b(\tilde{\varepsilon}))(t) = \tilde{\varepsilon}(t)$. Moreover, for all finite and infinite subsets $\mathcal{X} \subseteq \Sigma$,

$$\begin{aligned} (\beta_b(\bigoplus_{x \in \mathcal{X}} x))(t) &= \left\lfloor \frac{(\bigoplus_{x \in \mathcal{X}} x)(t)}{b} \right\rfloor = \left\lfloor \frac{\min_{x \in \mathcal{X}}(x(t))}{b} \right\rfloor, \\ &= \min_{x \in \mathcal{X}} \left(\left\lfloor \frac{x(t)}{b} \right\rfloor \right) = \min_{x \in \mathcal{X}} ((\beta_b(x))(t)), \\ &= (\bigoplus_{x \in \mathcal{X}} \beta_b(x))(t), \end{aligned}$$

which proves that β_b is lower semi-continuous. For the proof of γ^ν , since $\nu \in \mathbb{Z}$ is an integer then $\forall t \in \mathbb{Z}$, $(\gamma^\nu(\tilde{\varepsilon}))(t) = \nu + \tilde{\varepsilon}(t) = \nu + \infty = \infty$, thus $(\gamma^\nu(\tilde{\varepsilon}))(t) = \tilde{\varepsilon}(t)$. To prove lower semi-continuity of γ^ν we have for all finite and infinite subsets $\mathcal{X} \subseteq \Sigma$,

$$\begin{aligned} \left(\gamma^\nu\left(\bigoplus_{x \in \mathcal{X}} x\right)\right)(t) &= \nu + \left(\bigoplus_{x \in \mathcal{X}} x\right)(t) = \nu + \min_{x \in \mathcal{X}}(x(t)) = \min_{x \in \mathcal{X}}(\nu + x(t)) \\ &= \left(\bigoplus_{x \in \mathcal{X}} \gamma^\nu(x)\right)(t). \end{aligned}$$

□

Proposition 10 ([16]). *The operators γ^ν , μ_m and β_b introduced in Prop. 9 satisfy the following relations,*

$$\gamma^\nu \gamma^{\nu'} = \gamma^{\nu+\nu'}, \quad \gamma^\nu \oplus \gamma^{\nu'} = \gamma^{\min(\nu, \nu')}, \quad (3.12)$$

$$\mu_m \gamma^n = \gamma^{n \times m} \mu_m, \quad \gamma^n \beta_b = \beta_b \gamma^{n \times b}. \quad (3.13)$$

Proof. For the proof of (3.12), recall (3.5) and (3.11), then $\forall x \in \Sigma, \forall t \in \mathbb{Z}$,

$$(\gamma^\nu \gamma^{\nu'} x)(t) = (\gamma^\nu(\gamma^{\nu'} x))(t) = \nu + (\gamma^{\nu'} x)(t) = \nu + \nu' + x(t) = (\gamma^{\nu+\nu'} x)(t),$$

and since (3.4), (3.1) and (3.11), then $\forall x \in \Sigma, \forall t \in \mathbb{Z}$,

$$\begin{aligned} ((\gamma^\nu \oplus \gamma^{\nu'}) x)(t) &= (\gamma^\nu x \oplus \gamma^{\nu'} x)(t) = \min((\gamma^\nu x)(t), (\gamma^{\nu'} x)(t)), \\ &= \min(\nu + x(t), \nu' + x(t)) = \min(\nu, \nu') + x(t), \\ &= (\gamma^{\min(\nu, \nu')} x)(t). \end{aligned}$$

For the proof of (3.13), since (3.9) and (3.11), then $\forall x \in \Sigma, \forall t \in \mathbb{Z}$,

$$((\mu_m \gamma^n) x)(t) = m \times (n + x(t)) = mn + m \times x(t) = ((\gamma^{n \times m} \mu_m) x)(t),$$

and, since (3.10) and (3.11), then $\forall x \in \Sigma, \forall t \in \mathbb{Z}$,

$$((\gamma^n \beta_b) x)(t) = n + \left\lfloor \frac{x(t)}{b} \right\rfloor = \left\lfloor \frac{x(t) + nb}{b} \right\rfloor = ((\beta_b \gamma^{n \times b}) x)(t).$$

□

3.1.1. Dioid of Event Operators

Definition 28 (Dioid of Event Operators, [16]). *The dioid of event operators, denoted by $(\mathcal{E}, \oplus, \otimes)$, is defined by sums and compositions over the set $\{\hat{\varepsilon}, \hat{\varepsilon}, \mu_m, \beta_b, \gamma^\nu, \hat{\uparrow}\}$ with $m, b \in \mathbb{N}$, $\nu \in \mathbb{Z}$, equipped with addition and multiplication defined in (3.4) and (3.5), respectively.*

An element $w \in \mathcal{E}$ is called E-operator (E for event) in the sequel. The dioid $(\mathcal{E}, \oplus, \otimes)$ is a complete subdioid of $(\mathcal{O}, \oplus, \otimes)$ [16]. Note that the dioid $(\mathcal{E}, \oplus, \otimes)$ is not commutative, *i.e.*, in general for $w_1, w_2 \in \mathcal{E}$, $w_1 w_2 \neq w_2 w_1$. For instance, consider the operators μ_2 and γ^1 , according to (3.9) and (3.11), $(\mu_2 \gamma^1 x)(t) = 2 \times (1 + x(t))$ and $(\gamma^1 \mu_2 x)(t) = 1 + 2 \times x(t)$, these two expressions are clearly not equal for arbitrary $x \in \Sigma$.

Again, the \oplus operation induces a partial order relation on \mathcal{E} , defined by

$$\begin{aligned} w_1 \geq w_2 &\Leftrightarrow w_1 \oplus w_2 = w_1, \\ &\Leftrightarrow (w_1 x)(t) \oplus (w_2 x)(t) = (w_1 x)(t), \quad \forall x \in \Sigma, \forall t \in \mathbb{Z}, \\ &\Leftrightarrow \min\left((w_1 x)(t), (w_2 x)(t)\right) = (w_1 x)(t) \quad \forall x \in \Sigma, \forall t \in \mathbb{Z}. \end{aligned} \quad (3.14)$$

Note that operators in \mathcal{E} only manipulate values of the mapping $x \in \Sigma$, therefore an E-operator can be equally described by a function $\mathcal{F} : \overline{\mathbb{Z}}_{\min} \rightarrow \overline{\mathbb{Z}}_{\min}$. The value $x(t)$ is called counter-value. And the function associated with an operator $w \in \mathcal{E}$ is called C/C (counter-value to counter-value) function, see the following definition.

Definition 29 ((C/C)-Function [16]). *The function $\mathcal{F}_w : \overline{\mathbb{Z}}_{\min} \rightarrow \overline{\mathbb{Z}}_{\min}, k_i \mapsto k_o$ maps counter-value to counter-value and is defined by an E-operator $w \in \mathcal{E}$ such that*

$$\forall k_i \in \overline{\mathbb{Z}}_{\min}, \mathcal{F}_w(k_i) := (w(x))(t), \quad \text{for } x(t) = k_i \text{ and } x \in \Sigma.$$

In other words $x(t)$ is replaced by k_i in the expression $(w(x))(t)$.

There is an isomorphism between the set of E-operators and the set of (C/C)-functions. Thus, the order relation over the dioid $(\mathcal{E}, \oplus, \otimes)$, see (3.14), corresponds to the order induced by the min operation on (C/C)-functions, $\forall w_1, w_2 \in \mathcal{E}$,

$$\begin{aligned} w_1 \geq w_2 &\Leftrightarrow w_1 \oplus w_2 = w_1, \\ &\Leftrightarrow \mathcal{F}_{w_1}(k) \geq \mathcal{F}_{w_2}(k), \quad \forall k \in \overline{\mathbb{Z}}_{\min}, \\ &\Leftrightarrow \min\left(\mathcal{F}_{w_1}(k), \mathcal{F}_{w_2}(k)\right) = \mathcal{F}_{w_1}(k), \quad \forall k \in \overline{\mathbb{Z}}_{\min}, \\ &\Leftrightarrow \mathcal{F}_{w_1}(k) \leq \mathcal{F}_{w_2}(k), \quad \forall k \in \overline{\mathbb{Z}}_{\min}. \end{aligned} \quad (3.15)$$

Note that the order in $\overline{\mathbb{Z}}_{\min}$ is the reverse of the natural order. The (C/C)-functions provide a graphical representation of E-operators in $\overline{\mathbb{Z}}_{\min}^2$, which is useful to compare E-operators. In this graphical representation the horizontal axis is labeled by I-count and the vertical axis is labeled by O-count, which stand for input counter-value and output counter-value, respectively.

Example 10. *Let us consider the following operator $\gamma^3 \mu_2 \beta_3 \gamma^1 \oplus \gamma^2 \mu_2 \beta_2 \gamma^1$ with a corresponding (C/C)-function*

$$\mathcal{F}_{\gamma^3 \mu_2 \beta_3 \gamma^1 \oplus \gamma^2 \mu_2 \beta_2 \gamma^1}(k) = \min\left(3 + 2 \left\lfloor \frac{k+1}{3} \right\rfloor, 2 + 2 \left\lfloor \frac{k+1}{2} \right\rfloor\right).$$

This function is shown in Figure 3.1b and is the minimum of the functions $\mathcal{F}_{\gamma^3\mu_2\beta_3\gamma^1}$ and $\mathcal{F}_{\gamma^2\mu_2\beta_2\gamma^1}$, see Figure 3.1a. In Figure 3.1b the operators $\gamma^7\mu_2\beta_2$ and $\gamma^3\mu_2\beta_3\gamma^1 \oplus \gamma^2\mu_2\beta_2\gamma^1$ are compared. The gray area in Figure 3.1b corresponds to the domain of (C/C)-functions less than or equal to $\mathcal{F}_{\gamma^3\mu_2\beta_3\gamma^1 \oplus \gamma^2\mu_2\beta_2\gamma^1}$ or equivalently to operators $w \in \mathcal{E}$ less than or equal to $\gamma^3\mu_2\beta_3\gamma^1 \oplus \gamma^2\mu_2\beta_2\gamma^1$.

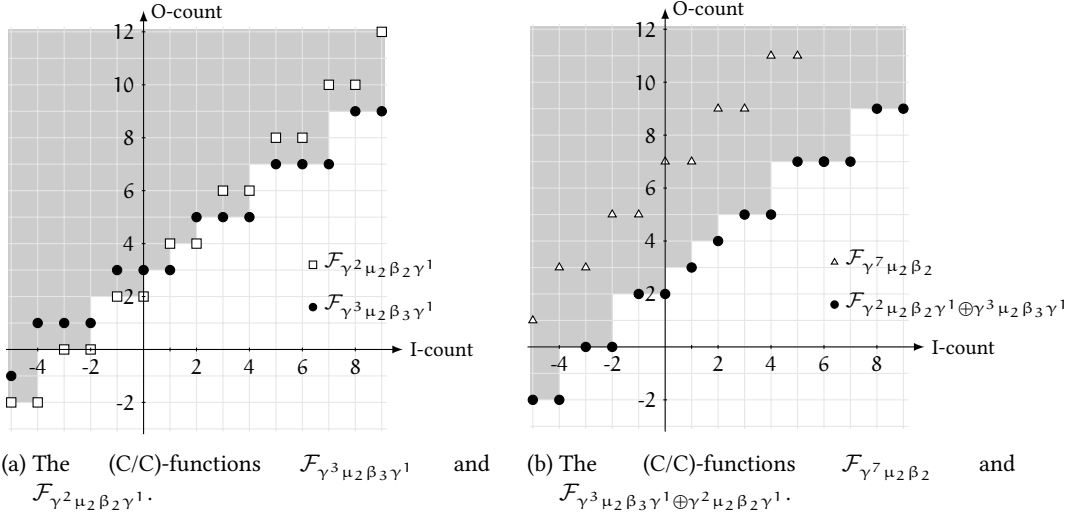

Figure 3.1. – In (a) $\min(\mathcal{F}_{\gamma^3\mu_2\beta_3\gamma^1}, \mathcal{F}_{\gamma^2\mu_2\beta_2\gamma^1})$ is equal to the function $\mathcal{F}_{\gamma^3\mu_2\beta_3\gamma^1 \oplus \gamma^2\mu_2\beta_2\gamma^1}$ given in (b). In (b) the (C/C)-function $\mathcal{F}_{\gamma^7\mu_2\beta_2}$ lies in the gray area shaped by the $\mathcal{F}_{\gamma^3\mu_2\beta_3\gamma^1 \oplus \gamma^2\mu_2\beta_2\gamma^1}$ function, thus $\mathcal{F}_{\gamma^7\mu_2\beta_2} > \mathcal{F}_{\gamma^3\mu_2\beta_3\gamma^1 \oplus \gamma^2\mu_2\beta_2\gamma^1}$, in $(\min, +)$ $\mathcal{F}_{\gamma^7\mu_2\beta_2} < \mathcal{F}_{\gamma^3\mu_2\beta_3\gamma^1 \oplus \gamma^2\mu_2\beta_2\gamma^1}$ and thus $\gamma^7\mu_2\beta_2 < \gamma^3\mu_2\beta_3\gamma^1 \oplus \gamma^2\mu_2\beta_2\gamma^1$.

Periodic E-operators

Definition 30. An E-operator $w \in \mathcal{E}$ is said to be (m, b) -periodic if $\exists m, b \in \mathbb{N}$ such that, $\forall x \in \Sigma, \forall t \in \mathbb{Z}, (w(b \otimes x))(t) = m \otimes (w(x))(t)$. The set of (m, b) -periodic E-operators is denoted by $\mathcal{E}_{m|b}$.

Definition 31. A (C/C)-function \mathcal{F} is said to be quasi (m, b) -periodic if $\exists m, b \in \mathbb{N}$ such that $\mathcal{F}(k \otimes b) = m \otimes \mathcal{F}(k), \forall k \in \overline{\mathbb{Z}}_{\min}, (\mathcal{F}(k + b) = m + \mathcal{F}(k), \forall k \in \overline{\mathbb{Z}}_{\min})$.

Recall that the \otimes operation in the dioid $(\overline{\mathbb{Z}}_{\min}, \oplus, \otimes)$ corresponds to the standard $+$ operation. In the sequel, both representations are used.

Remark 8. Since the periodic property does only depend on the value $x(t)$ we can neglect the time t for examining the periodic property of an E-operator. Therefore, an E-operator $w \in \mathcal{E}$ is (m, b) -periodic if and only if the corresponding (C/C)-function \mathcal{F}_w is quasi (m, b) -periodic.

Definition 32. The gain of an (m, b) -periodic operator $w \in \mathcal{E}_{m|b}$, denoted by $\Gamma(w)$, is defined by the ratio $\Gamma(w) = m/b$.

Example 11. The γ^ν operator, with $\nu \in \mathbb{Z}$ is $(1, 1)$ -periodic, since $\forall k \in \overline{\mathbb{Z}}_{\min}$, $\mathcal{F}_{\gamma^\nu}(k) = k + \nu$ and therefore, $\mathcal{F}_{\gamma^\nu}(k + 1) = (k + 1) + \nu = 1 + \mathcal{F}_{\gamma^\nu}(k)$. The $\gamma^2\beta_3\gamma^1\mu_2$ operator is $(2, 3)$ -periodic, for which the corresponding (C/C)-function is illustrated in Figure 3.2. In contrast, the $\gamma^3\mu_2\beta_3\gamma^1 \oplus \gamma^2\mu_2\beta_2\gamma^1$ operator, shown in Figure 3.1b, is not periodic.

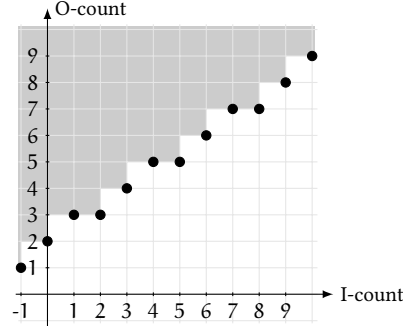

Figure 3.2. $(2,3)$ -periodic (C/C)-function $\mathcal{F}_{\gamma^2\beta_3\gamma^1\mu_2}$.

In the following E-operators of the form $\bigoplus_{i=1}^I \gamma^{\nu_i} \mu_m \beta_b \gamma^{\nu'_i}$ are studied. Recall that $\gamma^m \mu_m \beta_b = \mu_m \beta_b \gamma^b$ (3.13), thus $\gamma^\nu \mu_m \beta_b \gamma^{\nu'}$ can be written such that $0 \leq \nu' < b$. This form is particularly useful to check the ordering of E-operators. Given two E-operators $\gamma^{\nu_1} \mu_m \beta_b \gamma^{\nu'_1}, \gamma^{\nu_2} \mu_m \beta_b \gamma^{\nu'_2} \in \mathcal{E}_{m|b}$, with $0 \leq \nu'_1, \nu'_2 < b$, then

$$\gamma^{\nu_1} \mu_m \beta_b \gamma^{\nu'_1} \geq \gamma^{\nu_2} \mu_m \beta_b \gamma^{\nu'_2} \Leftrightarrow \begin{cases} \nu_1 \leq \nu_2 \text{ and } \nu'_1 \leq \nu'_2, \\ \text{or } \nu_1 - m \leq \nu_2. \end{cases} \quad (3.16)$$

Proposition 11 ([16]). A periodic E-operator $w \in \mathcal{E}_{m|b}$ has a canonical form, which is a finite sum $w = \bigoplus_{i=1}^I \gamma^{\nu_i} \mu_m \beta_b \gamma^{\nu'_i}$ such that $0 \leq \nu'_i < b$, $\nu_i \in \mathbb{Z}$ and $I \leq \min(m, b)$.

Proof. Let us define an operator $\tilde{w} = \bigoplus_{i=0}^{b-1} \tilde{w}_i$, with $\tilde{w}_i = \gamma^{\mathcal{F}_w(i)} \mu_m \beta_b \gamma^{b-1-i}$. Then, first we show that any (m, b) -periodic operator $w \in \mathcal{E}_{m|b}$ can be expressed by $\tilde{w} \in \mathcal{E}_{m|b}$, i.e., $w = \tilde{w}$. Recall the isomorphism between an E-operator and the (C/C)-function thus it is equivalent to show that $\mathcal{F}_w = \mathcal{F}_{\tilde{w}}$. The (C/C)-function to \tilde{w}_i is $\mathcal{F}_{\tilde{w}_i} = \left\lfloor \frac{k+(b-1)-i}{b} \right\rfloor m + \mathcal{F}_w(i)$ and therefore the (C/C)-function $\mathcal{F}_{\tilde{w}}(k)$ can be written as

$$\mathcal{F}_{\tilde{w}} = \min \left(\left\lfloor \frac{k+(b-1)}{b} \right\rfloor m + \mathcal{F}_w(0), \left\lfloor \frac{k+(b-2)}{b} \right\rfloor m + \mathcal{F}_w(1), \dots, \left\lfloor \frac{k}{b} \right\rfloor m + \mathcal{F}_w(b-1) \right).$$

Let us recall that \mathcal{F}_w is an isotone function and satisfies

$$\mathcal{F}_w(0) \leq \mathcal{F}_w(1) \leq \dots \leq \mathcal{F}_w(b-1) \leq m + \mathcal{F}_w(0) \leq \dots . \quad (3.17)$$

Since \mathcal{F}_w and $\mathcal{F}_{\tilde{w}}$ are quasi (m, b) -periodic functions it is sufficient to show that $\mathcal{F}_w(k) = \mathcal{F}_{\tilde{w}}(k)$ for all $k \in \{0, \dots, b-1\}$. We now evaluate $\mathcal{F}_{\tilde{w}}(k)$ for $k = 0$,

$$\begin{aligned} \mathcal{F}_{\tilde{w}}(0) &= \min \left(\left\lfloor \frac{(b-1)}{b} \right\rfloor m + \mathcal{F}_w(0), \left\lfloor \frac{(b-2)}{b} \right\rfloor m + \mathcal{F}_w(1), \dots \right. \\ &\quad \left. , \left\lfloor \frac{0}{b} \right\rfloor m + \mathcal{F}_w(b-1) \right), \\ &= \min \left(\mathcal{F}_w(0), \mathcal{F}_w(1), \dots, \mathcal{F}_w(b-1) \right) \\ &= \mathcal{F}_w(0), \quad \text{since } \mathcal{F}_w \text{ is isotone, see (3.17).} \end{aligned}$$

Similarly we can show that for $k \in \{1, \dots, b-1\}$,

$$\begin{aligned} \mathcal{F}_{\tilde{w}}(1) &= \min \left(\left\lfloor \frac{b}{b} \right\rfloor m + \mathcal{F}_w(0), \left\lfloor \frac{b-1}{b} \right\rfloor m + \mathcal{F}_w(1), \dots, \left\lfloor \frac{1}{b} \right\rfloor m + \mathcal{F}_w(b-1) \right), \\ &= \min \left(m + \mathcal{F}_w(0), \mathcal{F}_w(1), \dots, \mathcal{F}_w(b-1) \right) = \mathcal{F}_w(1), \quad \text{see (3.17),} \\ &\dots \\ \mathcal{F}_{\tilde{w}}(b-1) &= \min \left(m + \mathcal{F}_w(0), \dots, m + \mathcal{F}_w(b-2), \mathcal{F}_w(b-1) \right) = \mathcal{F}_w(b-1). \end{aligned}$$

The canonical form can then be obtained by removing redundant terms according to (3.16). \square

Example 12. Consider the $\gamma^2\beta_3\gamma^1\mu_2$ operator with a (C/C)-function shown in Figure 3.2. This operator is $(2, 3)$ -periodic. Moreover, the (C/C)-function $\mathcal{F}_{\gamma^2\beta_3\gamma^1\mu_2}$ evaluated on t leads to,

$$\begin{aligned} \mathcal{F}_{\gamma^2\beta_3\gamma^1\mu_2}(0) &= 2, \\ \mathcal{F}_{\gamma^2\beta_3\gamma^1\mu_2}(1) &= 3, \\ \mathcal{F}_{\gamma^2\beta_3\gamma^1\mu_2}(2) &= 3, \\ \mathcal{F}_{\gamma^2\beta_3\gamma^1\mu_2}(3) &= \mathcal{F}_{\gamma^2\beta_3\gamma^1\mu_2}(0) + 2 = 4, \\ \mathcal{F}_{\gamma^2\beta_3\gamma^1\mu_2}(4) &= \mathcal{F}_{\gamma^2\beta_3\gamma^1\mu_2}(1) + 2 = 5, \\ &\dots \end{aligned}$$

Therefore, the operator $\gamma^2\beta_3\gamma^1\mu_2$ can be written as,

$$\gamma^2\mu_2\beta_3\gamma^2 \oplus \gamma^3\mu_2\beta_3\gamma^1 \oplus \gamma^3\mu_2\beta_3\gamma^0.$$

3. Dioids $(\mathcal{E}, \oplus, \otimes)$ and $(\mathcal{E}[[\delta]], \oplus, \otimes)$

Since, $\gamma^3 \mu_2 \beta_3 \gamma^1 \oplus \gamma^3 \mu_2 \beta_3 \gamma^0 = \gamma^3 \mu_2 \beta_3 (\gamma^1 \oplus \gamma^0) = \gamma^3 \mu_2 \beta_3 \gamma^0$, this expression is simplified to

$$\gamma^2 \mu_2 \beta_3 \gamma^2 \oplus \gamma^3 \mu_2 \beta_3 \gamma^0,$$

which is the canonical representation of $\gamma^2 \beta_3 \gamma^1 \mu_2$. Figure 3.3 shows the (C/C)-functions $\mathcal{F}_{\gamma^3 \mu_2 \beta_3}$ and $\mathcal{F}_{\gamma^2 \mu_2 \beta_3 \gamma^2}$ of the operators $\gamma^3 \mu_2 \beta_3$ and $\gamma^2 \mu_2 \beta_3 \gamma^2$, respectively. The intersection of the area beneath $\mathcal{F}_{\gamma^3 \mu_2 \beta_3}$ and $\mathcal{F}_{\gamma^2 \mu_2 \beta_3 \gamma^2}$ is equal to the area beneath the (C/C)-function $\mathcal{F}_{\gamma^2 \beta_3 \gamma^1 \mu_2}$ shown in Figure 3.2. Thus, $\min(\mathcal{F}_{\gamma^3 \mu_2 \beta_3}, \mathcal{F}_{\gamma^2 \mu_2 \beta_3 \gamma^2}) = \mathcal{F}_{\gamma^3 \mu_2 \beta_3 \oplus \gamma^2 \mu_2 \beta_3 \gamma^2} = \mathcal{F}_{\gamma^2 \beta_3 \gamma^1 \mu_2}$.

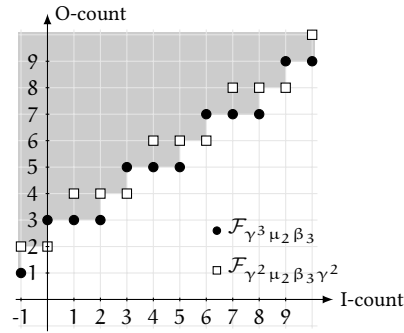

Figure 3.3. $-(2,3)$ -periodic (C/C)-functions $\mathcal{F}_{\gamma^3 \mu_2 \beta_3}$ and $\mathcal{F}_{\gamma^2 \mu_2 \beta_3 \gamma^2}$. One has $\min(\mathcal{F}_{\gamma^3 \mu_2 \beta_3}, \mathcal{F}_{\gamma^2 \mu_2 \beta_3 \gamma^2}) = \mathcal{F}_{\gamma^3 \mu_2 \beta_3 \oplus \gamma^2 \mu_2 \beta_3 \gamma^2}$. Or in other words, the intersection of the area beneath $\mathcal{F}_{\gamma^3 \mu_2 \beta_3}$ and $\mathcal{F}_{\gamma^2 \mu_2 \beta_3 \gamma^2}$ is equal to the area beneath $\mathcal{F}_{\gamma^2 \beta_3 \gamma^1 \mu_2} = \mathcal{F}_{\gamma^3 \mu_2 \beta_3 \oplus \gamma^2 \mu_2 \beta_3 \gamma^2}$.

Remark 9. Clearly an (m, b) -periodic operator is also (nm, nb) -periodic. Thus, an (m, b) -periodic operator $w \in \mathcal{E}_{m|b}$ can be represented in a (nm, nb) -periodic form given by

$$w = \bigoplus_{i=0}^{nb-1} \gamma^{\mathcal{F}_w(i)} \mu_{nm} \beta_{nb} \gamma^{nb-1-i}.$$

Proposition 12 ([16]). The (m, b) -periodic $\mu_m \beta_b$ operator can be expressed in the following (nm, nb) -periodic form

$$\mu_m \beta_b = \bigoplus_{i=0}^{n-1} \gamma^{im} \mu_{nm} \beta_{nb} \gamma^{(n-1-i)b}. \quad (3.18)$$

Proof. Recall that the (C/C)-function of the $\mu_m \beta_b$ operator is given by $\mathcal{F}_{\mu_m \beta_b} = [k/b]m$.

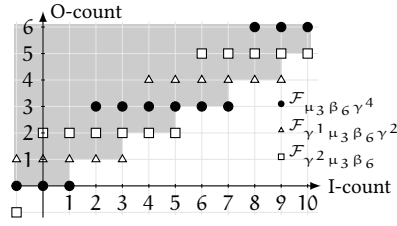

Figure 3.4. $\mathcal{F}_{\mu_1 \beta_2}$ is equal to $\min(\mathcal{F}_{\mu_3 \beta_6 \gamma^4}, \mathcal{F}_{\gamma^1 \mu_3 \beta_6 \gamma^2}, \mathcal{F}_{\gamma^2 \mu_3 \beta_6})$.

Due to Remark 9 the (nm, nb) -periodic representation of this operator is given by

$$\begin{aligned} \mu_m \beta_b &= \bigoplus_{k=0}^{nb-1} \gamma^{\lfloor k/b \rfloor m} \mu_{nm} \beta_{nb} \gamma^{nb-1-k}, \\ &= \bigoplus_{i=0}^{n-1} \bigoplus_{j=0}^{b-1} \gamma^{\lfloor (ib+j)/b \rfloor m} \mu_{nm} \beta_{nb} \gamma^{nb-1-(ib+j)}, \quad \text{with } k = ib + j, \\ &= \bigoplus_{i=0}^{n-1} \bigoplus_{j=0}^{b-1} \gamma^{im} \mu_{nm} \beta_{nb} \gamma^{nb-1-(ib+j)}, \quad \text{since for } j \in \{0, \dots, b-1\}, \lfloor (ib+j)/b \rfloor = i. \end{aligned}$$

Due to the order relation for monomials in \mathcal{E} , see (3.16), we have

$$\bigoplus_{j=0}^{b-1} \gamma^{im} \mu_{nm} \beta_{nb} \gamma^{nb-1-(ib+j)} = \gamma^{im} \mu_{nm} \beta_{nb} \gamma^{nb-1-(ib+b-1)} = \gamma^{im} \mu_{nm} \beta_{nb} \gamma^{(n-1-i)b}$$

and thus

$$\mu_m \beta_b = \bigoplus_{i=0}^{n-1} \gamma^{im} \mu_{nm} \beta_{nb} \gamma^{(n-1-i)b}.$$

□

Example 13. For instance, with $n = 3$, the operator $\mu_1 \beta_2$ can be written as $\mu_3 \beta_6 \gamma^4 \oplus \gamma^1 \mu_3 \beta_6 \gamma^2 \oplus \gamma^2 \mu_3 \beta_6$. Clearly $\mu_1 \beta_2 \in \mathcal{E}_{1|2}$ and $\mu_1 \beta_2 \in \mathcal{E}_{3|6}$ as well. Figure 3.4 illustrates this extension of the $\mu_1 \beta_2$ operator.

Definition 33. The minimal representative of a periodic operator $w \in \mathcal{E}_{m|b}[\delta]$ is defined such that w is expressed in a canonical form and the period (m, b) is minimal.

In the algorithm 1 we show how to obtain this form. In this algorithm, we check for all common divisors n of m and b if an (m, b) -periodic operator $w \in \mathcal{E}_{m|b}[\delta]$ can be represented in an $(m/n, b/n)$ -periodic form.

Input: Operator $w \in \mathcal{E}_{m|b}[[\delta]]$

Output: Minimal form of $w \in \mathcal{E}_{m|b}[[\delta]]$

Calculate the set $\mathcal{S} := \{n \in \mathbb{N} | m/n \in \mathbb{N} \text{ and } b/n \in \mathbb{N}\}$ of all common divisors of (m, b) . Store the set \mathcal{S} in a vector \mathbf{k} in descending order.

$j = 0$;

do

$m_t = m/\mathbf{k}[j]$;
 $b_t = b/\mathbf{k}[j]$;
 $\mathbf{a} = \bigoplus_{i=0}^{b_t-1} \gamma^{\mathcal{F}_w(i)} \mu_{m_t} \beta_{b_t} \gamma^{b_t-1-i}$;
 $j = j + 1$;

while $w \neq \mathbf{a}$;

return \mathbf{a} ;

Algorithm 1: Minimal representative of a periodic operator $w \in \mathcal{E}_{m|b}[[\delta]]$.

Proposition 13. Given two periodic operators $w_1 \in \mathcal{E}_{m_1|b_1}$, $w_2 \in \mathcal{E}_{m_2|b_2}$ such that $w_1 \neq \varepsilon$, $w_2 \neq \varepsilon$ and $\frac{m_1}{b_1} > \frac{m_2}{b_2}$. Then, w_1 and w_2 are not ordered, i.e., $w_1 \not\leq w_2$ and $w_1 \not\geq w_2$.

Proof. Due to Remark 9 and by choosing $\bar{b} = \text{lcm}(b_1, b_2)$ we can represent $w_1 \in \mathcal{E}_{m_1|b_1}$ as an (\bar{m}_1, \bar{b}) -periodic operator and $w_2 \in \mathcal{E}_{m_2|b_2}$ as an (\bar{m}_2, \bar{b}) -periodic operator with corresponding quasi periodic (C/C)-functions

$$\mathcal{F}_{w_1}(k + \bar{b}) = \mathcal{F}_{w_1}(k) + \bar{m}_1, \quad \mathcal{F}_{w_2}(k + \bar{b}) = \mathcal{F}_{w_2}(k) + \bar{m}_2.$$

Then by evaluating the functions for $k = j\bar{b}$, $j \in \mathbb{Z}$ we obtain

$$\mathcal{F}_{w_1}(j\bar{b}) = \mathcal{F}_{w_1}(0) + j\bar{m}_1, \quad \mathcal{F}_{w_2}(j\bar{b}) = \mathcal{F}_{w_2}(0) + j\bar{m}_2.$$

Since $\mathcal{F}_{w_1}(0)$ and $\mathcal{F}_{w_2}(0)$ are finite and $\bar{m}_1 > \bar{m}_2$ there exists a positive integer j such that $\mathcal{F}_{w_1}(j\bar{b}) > \mathcal{F}_{w_2}(j\bar{b})$ and a negative integer j such that $\mathcal{F}_{w_1}(j\bar{b}) < \mathcal{F}_{w_2}(j\bar{b})$. Thus, the operators w_1 and w_2 are not ordered. \square

Example 14. Consider the $(2, 3)$ -periodic operator $\gamma^3 \mu_2 \beta_3 \gamma^1$ and the $(2, 2)$ -periodic operator $\gamma^2 \mu_2 \beta_2 \gamma^1$. In the graphical representation of the corresponding (C/C)-function, Figure 3.5, one can see that these two operators are not ordered, for instance, for all $k < 0$ one has $\mathcal{F}_{\gamma^2 \mu_2 \beta_2 \gamma^1}(k) < \mathcal{F}_{\gamma^3 \mu_2 \beta_3 \gamma^1}(k)$ and for all $k > 3$ one has $\mathcal{F}_{\gamma^2 \mu_2 \beta_2 \gamma^1}(k) > \mathcal{F}_{\gamma^3 \mu_2 \beta_3 \gamma^1}(k)$.

3.1.2. Dioid of Formal Power Series $(\mathcal{E}[[\delta]], \oplus, \otimes)$

Besides E-operators introduced in the last section, we now define the time-shift operator δ^τ as a mapping over Σ as follows

$$\tau \in \mathbb{Z} \quad \delta^\tau : \forall x \in \Sigma, t \in \mathbb{Z} \quad (\delta^\tau x)(t) = x(t - \tau). \quad (3.19)$$

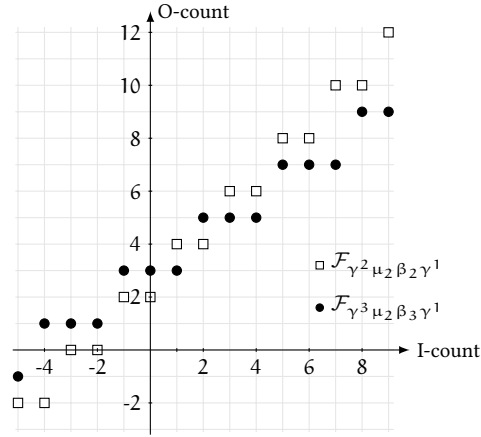

Figure 3.5. – Quasi (2,3)-periodic (C/C)-functions $\mathcal{F}_{\gamma^3 \mu_2 \beta_3 \gamma^1}$ and quasi (2,2)-periodic (C/C)-function $\mathcal{F}_{\gamma^2 \mu_2 \beta_2 \gamma^1}$. For $k < 0$: $\mathcal{F}_{\gamma^2 \mu_2 \beta_2 \gamma^1}(k) < \mathcal{F}_{\gamma^3 \mu_2 \beta_3 \gamma^1}(k)$ and for $k > 3$: $\mathcal{F}_{\gamma^2 \mu_2 \beta_2 \gamma^1}(k) > \mathcal{F}_{\gamma^3 \mu_2 \beta_3 \gamma^1}(k)$.

Clearly, the δ^τ mapping is lower-semi continuous, since for all finite and infinite subsets $\mathcal{X} \subseteq \Sigma$

$$\begin{aligned} \left(\delta^\tau \left(\bigoplus_{x \in \mathcal{X}} x \right) \right) (t) &= \left(\bigoplus_{x \in \mathcal{X}} x \right) (t - \tau), \\ &= \bigoplus_{x \in \mathcal{X}} x(t - \tau), \quad \text{due to (3.1),} \\ &= \bigoplus_{x \in \mathcal{X}} (\delta^\tau x)(t), \quad \text{due to (3.19).} \end{aligned}$$

Furthermore, $(\delta^\tau(\tilde{\varepsilon}))(t) = \tilde{\varepsilon}(t - \tau)$ and since $\tilde{\varepsilon}(t) = \infty$, $\forall t \in \mathbb{Z}$ and $\tau \in \mathbb{Z}$ then $(\delta^\tau(\tilde{\varepsilon}))(t) = \tilde{\varepsilon}(t)$, thus δ^τ is an endomorphism. Consequently, the time-shift operator $\delta^\tau \in \mathcal{O}$. Moreover, the time-shift operator commutes with all E-operators [16], i.e., $\forall w \in \mathcal{E}$, $w\delta^\tau = \delta^\tau w$.

$$\begin{aligned} ((\delta^\tau w)x)(t) &= (\delta^\tau(wx))(t), \quad \text{due to (3.5),} \\ &= (wx)(t - \tau), \quad \text{due to (3.19),} \\ &= (w\delta^\tau x)(t), \quad \text{again due to (3.19).} \end{aligned}$$

Definition 34 ([16]). We denote by $(\mathcal{E}[[\delta]], \oplus, \otimes)$ the quotient dioid in the set of formal power series in one variable δ with exponents in \mathbb{Z} and coefficients in the non-commutative complete dioid $(\mathcal{E}, \oplus, \otimes)$ induced by the equivalence relation $\forall s \in \mathcal{E}[[\delta]]$,

$$s = (\delta^{-1})^* s = s(\delta^{-1})^*. \quad (3.20)$$

Hence we identify two series $s_1, s_2 \in \mathcal{E}[[\delta]]$ with the same equivalence class if $s_1(\delta^{-1})^* = s_2(\delta^{-1})^*$. It is helpful to think of $s(\delta^{-1})^*$ as the representative of the equivalence class of s .

A series $s \in \mathcal{E}[[\delta]]$ is expressed as $s = \bigoplus_{\tau \in \mathbb{Z}} s(\tau) \delta^\tau$, with $s(\tau) \in \mathcal{E}$. Recall (2.13) and (2.14) for the definition of addition and multiplication in dioids of formal power series. Therefore, given two series $s_1, s_2 \in \mathcal{E}[[\delta]]$,

$$\begin{aligned} s_1 \oplus s_2 &= \bigoplus_{\tau \in \mathbb{Z}} (s_1(\tau) \oplus s_2(\tau)) \delta^\tau, \\ s_1 \otimes s_2 &= \bigoplus_{\tau} \left(\bigoplus_{t+t'=\tau} s_1(t) \otimes s_2(t') \right) \delta^\tau. \end{aligned}$$

Due to the quotient structure (3.20) of the dioid $(\mathcal{E}[[\delta]], \oplus, \otimes)$ the variable δ in $\mathcal{E}[[\delta]]$ matches with the operator $\delta \in \mathcal{O}$ defined in (3.19). Moreover, the zero and unit element in $\mathcal{E}[[\delta]]$ are given by the zero and unit element of \mathcal{O} , i.e., $\forall x \in \Sigma$, $\varepsilon(x) = \varepsilon$ and $e(x) = x$, see (3.6).

Monomial, Polynomial and ultimately cyclic Series in $\mathcal{E}_{m|b}[[\delta]]$

The subset of $\mathcal{E}[[\delta]]$ obtained by restricting the coefficients $s(\tau)$ to $\mathcal{E}_{m|b}$, i.e. the set of (m, b) -periodic operators, is denoted by $\mathcal{E}_{m|b}[[\delta]]$. For instance, $\mu_2 \beta_3 \gamma^1 \delta^2 \in \mathcal{E}_{2|3}[[\delta]]$, since the $\mu_2 \beta_3 \gamma^1$ E-operator is $(2, 3)$ -periodic. A monomial in $\mathcal{E}_{m|b}[[\delta]]$ is defined as $w \delta^\tau$ where $w \in \mathcal{E}_{m|b}$. A polynomial in $\mathcal{E}_{m|b}[[\delta]]$ is a finite sum of monomials $p = \bigoplus_{i=1}^I w_i \delta^{\tau_i}$ such that $\forall i \in \{1, \dots, I\}$, $w_i \in \mathcal{E}_{m|b}$. For instance, $\mu_2 \beta_3 \gamma^1 \delta^2 \oplus \mu_2 \beta_3 \gamma^2 \delta^3 \in \mathcal{E}_{2|3}[[\delta]]$, but the polynomial $\mu_2 \beta_3 \gamma^1 \delta^2 \oplus \mu_3 \beta_4 \gamma^2 \delta^3 \notin \mathcal{E}_{m|b}[[\delta]]$. Moreover, the gain of an element $s \in \mathcal{E}_{m|b}[[\delta]]$ is defined to the gain of its coefficients $s(\tau)$, i.e., $\Gamma(s) = \Gamma(s(\tau))$, for instance, $\Gamma(\mu_2 \beta_3 \gamma^1 \delta^2) = \Gamma(\mu_2 \beta_3 \gamma^1) = 2/3$.

Graphical Representation

An element $s \in \mathcal{E}[[\delta]]$ can be graphically represented in $\overline{\mathbb{Z}}_{\min} \times \overline{\mathbb{Z}}_{\min} \times \mathbb{Z}$. For a series $s = \bigoplus_{i \in \mathbb{Z}} w_i \delta^i \in \mathcal{E}[[\delta]]$ this graphical representation is constructed by depicting for every i the corresponding (C/C)-function \mathcal{F}_{w_i} of the coefficient w_i in the (I-count/O-count)-plane of i .

Example 15. For the graphical representation of $p = (\mu_3 \beta_3 \gamma^2 \oplus \gamma^1 \mu_3 \beta_3 \gamma^1) \delta^2 \oplus \mu_3 \beta_3 \gamma^2 \delta^3 \in \mathcal{E}_{3|3}[[\delta]]$, respectively its representative $p(\delta^{-1})^*$ see in Figure 3.6, with the (I-count/O-count)-plane for $t \leq 2$ (resp. $t = 3$) shown in Figure 3.7a (resp. Figure 3.7b). To improve readability, the graphical representation for elements $s \in \mathcal{E}[[\delta]]$ has been truncated to non-negative values in Figure 3.6.

The ordering of two monomials $w_1 \delta^{\tau_1}, w_2 \delta^{\tau_2} \in \mathcal{E}_{m|b}[[\delta]]$ can be checked by

$$w_1 \delta^{\tau_1} \geq w_2 \delta^{\tau_2} \Leftrightarrow \tau_1 \geq \tau_2 \text{ and } w_1 \geq w_2. \quad (3.21)$$

Proposition 14 ([16]). Let $p \in \mathcal{E}_{m|b}[[\delta]]$, then p has a canonical form $p = \bigoplus_{j=1}^J w'_j \delta^{t'_j}$ such that the (m, b) -periodic E-operator w'_j is in canonical form of Prop. 11, and coefficients and exponents are strictly ordered, for $j \in \{1, \dots, J-1\}$, $t'_j < t'_{j+1}$ and $w'_j > w'_{j+1}$.

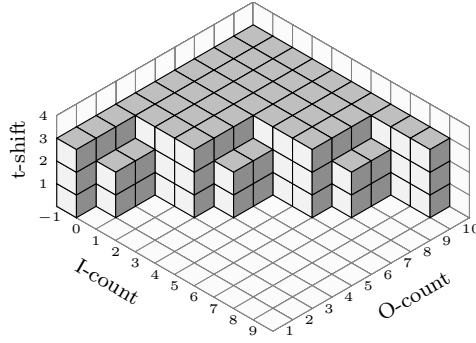
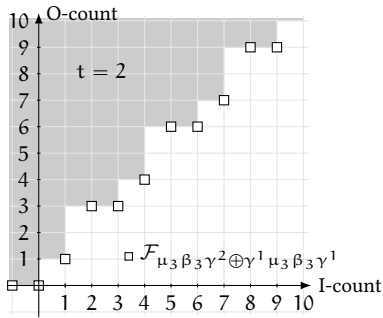
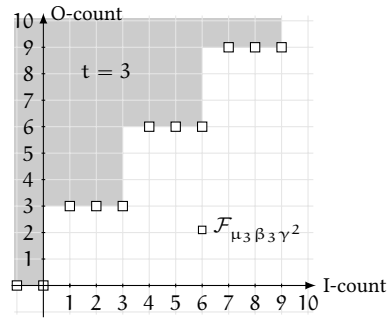

 Figure 3.6. – 3D representation of polynomial $(\mu_3\beta_3\gamma^2 \oplus \gamma^1\mu_3\beta_3\gamma^1)\delta^2 \oplus \mu_3\beta_3\gamma^2\delta^3$.

 (a) (I/O-count)-plane for $t \leq 2$

 (b) (I/O-count)-plane for $t = 3$

 Figure 3.7. – Slices of the coefficients in the (I/O-count)-plane of the polynomial $(\mu_3\beta_3\gamma^2 \oplus \gamma^1\mu_3\beta_3\gamma^1)\delta^2 \oplus \mu_3\beta_3\gamma^2\delta^3$

Proof. Without loss of generality, we can assume that $p = \bigoplus_{i=1}^I w_i \delta^{t_i}$, with $t_i < t_{i+1}$ for $i = 1, \dots, I-1$. As $p \in \mathcal{E}[\delta]$, we can identify s with their maximal representative $s(\delta^{-1})^*$, we can also identify p and

$$p' = \bigoplus_{i=1}^I \underbrace{\left(\bigoplus_{j=i}^I w_j \right)}_{w'_i} \delta^{t_i}$$

as $p(\delta^{-1})^* = p'(\delta^{-1})^*$. Therefore, $w'_i \geq w'_{i+1}$. If $w'_i = w'_{i+1}$ we can write $w'_i \delta^{n_i} \oplus w'_{i+1} \delta^{n_{i+1}} = w'_i (\delta^{n_i} \oplus \delta^{n_{i+1}}) = w'_i \delta^{n_{i+1}}$. For this reason, we can write p' as $\bigoplus_{j=1}^J w'_j \delta^{t'_j}$ with $w'_j > w'_{j+1}$ and $J \leq I$. \square

Definition 35 (Ultimately Cyclic Series). A series $s \in \mathcal{E}_{m|b}[\delta]$ is said to be ultimately cyclic if it can be written as $s = p \oplus q(\gamma^\nu \delta^\tau)^*$, where $\nu, \tau \in \mathbb{N}_0$ and p, q are polynomials in $\mathcal{E}_{m|b}[\delta]$, i.e., p and q have the same period. The expression $(\gamma^\nu \delta^\tau)^*$ is called growing term.

Proposition 15 ([16]). *An ultimately cyclic series $s \in \mathcal{E}_{m|b}[[\delta]]$ has a left- and right-cyclic form given by:*

$$\begin{aligned} s &= p \oplus (\gamma^{\nu_l} \delta^{\tau_l})^* q_l, & (\text{left-cyclic form}) \\ s &= p \oplus q_r (\gamma^{\nu_r} \delta^{\tau_r})^*, & (\text{right-cyclic form}) \end{aligned}$$

where $p, q_l, q_r \in \mathcal{E}_{m|b}[[\delta]]$ are polynomials and $\tau_l, \nu_l, \tau_r, \nu_r \in \mathbb{N}_0$. The left- and right-asymptotic slopes are respectively defined by $\sigma_l(s) = \tau_l/\nu_l$ and $\sigma_r(s) = \tau_r/\nu_r$. The asymptotic slopes of an ultimately cyclic series $s \in \mathcal{E}_{m|b}[[\delta]]$ satisfy the following property

$$m/b = \sigma_r(s)/\sigma_l(s).$$

Proof. Consider an ultimately cyclic series $s = p \oplus q_r (\gamma^{\nu_r} \delta^{\tau_r})^* \in \mathcal{E}_{m|b}[[\delta]]$ in a right-cyclic form. Since, the dioid $(\mathcal{E}[[\delta]], \oplus, \otimes)$ is not commutative in general the growing term $(\gamma^{\nu_r} \delta^{\tau_r})^*$ does not commute with the q_r polynomial, i.e., $q_r (\gamma^{\nu_r} \delta^{\tau_r})^* \neq (\gamma^{\nu_r} \delta^{\tau_r})^* q_r$. However, due to (3.13), for specific growing terms given by $(\gamma^{nb} \delta^{\tau})^*$ with $n \in \mathbb{N}_0$ we have $q_r (\gamma^{nb} \delta^{\tau})^* = (\gamma^{nb} \delta^{\tau})^* q_r$. For an arbitrary series $s = p \oplus q_r (\gamma^{\nu_r} \delta^{\tau_r})^* \in \mathcal{E}_{m|b}[[\delta]]$ in a right-cyclic form we can rewrite q_r and $(\gamma^{\nu_r} \delta^{\tau_r})^*$ such that the conversion is possible. With $n\nu_r = \text{lcm}(b, \nu_r)$ the growing term can be expressed as

$$\begin{aligned} (\gamma^{\nu_r} \delta^{\tau_r})^* &= (e \oplus \gamma^{\nu_r} \delta^{\tau_r} \oplus \gamma^{2\nu_r} \delta^{2\tau_r} \oplus \dots \oplus \gamma^{(n-1)\nu_r} \delta^{(n-1)\tau_r}) (\gamma^{n\nu_r} \delta^{n\tau_r})^* \\ &= \tilde{q} (\gamma^{n\nu_r} \delta^{n\tau_r})^*. \end{aligned}$$

Since $n\nu_r$ is a multiple of b , we have

$$q_r \tilde{q} (\gamma^{n\nu_r} \delta^{n\tau_r})^* = (\gamma^{(n\nu_r/b)m} \delta^{n\tau_r})^* q_r \tilde{q}.$$

Then by choosing $q_l = q_r \tilde{q}$, $\nu_l = (n\nu_r/b)m$ and $n\tau_r = \tau_l$ the series s can be represented in a left-cyclic form

$$s = p \oplus (\gamma^{\nu_l} \delta^{\tau_l})^* q_l = p \oplus (\gamma^{(n\nu_r/b)m} \delta^{\tau_l})^* q_r \tilde{q}.$$

Furthermore, $\sigma_r(s) = \tau_r/\nu_r$ and $\sigma_l(s) = (n\tau_r)/((n\nu_r/b)m)$ and thus

$$\frac{\sigma_r(s)}{\sigma_l(s)} = \frac{\frac{\tau_r}{\nu_r}}{\frac{n\tau_r}{(n\nu_r/b)m}} = \frac{m}{b}.$$

The conversion of an ultimately cyclic series from a left-cyclic form into a right-cyclic one can be shown analogously. \square

Example 16. Consider the following series $s = \gamma^1 \mu_3 \beta_2 \gamma^1 \delta^2 \oplus (\gamma^3 \mu_3 \beta_2 \gamma^1 \oplus \gamma^5 \mu_3 \beta_2) \delta^3 (\gamma^1 \delta^1)^*$ in a right-cyclic form. By extending the “growing-term” $(\gamma^1 \delta^1)^* = (e \oplus \gamma^1 \delta^1) (\gamma^2 \delta^2)^*$ the series can be expressed in a left-cyclic form as follows

$$s = \gamma^1 \mu_3 \beta_2 \gamma^1 \delta^2 \oplus (\gamma^3 \delta^2)^* ((\gamma^3 \mu_3 \beta_2 \gamma^1 \oplus \gamma^5 \mu_3 \beta_2) \delta^3 \oplus (\gamma^6 \mu_3 \beta_2 \oplus \gamma^5 \mu_3 \beta_2 \gamma^1) \delta^4).$$

The left- and right asymptotic slopes are $\sigma_l(s) = 2/3$ and $\sigma_r(s) = 1/1$, respectively. This series has a graphical representation given in Figure 3.8, with the left- asymptotic slope indicated by the red stairs in the (O-count/t-shift)-plane (I-count value -1) and the right asymptotic slope indicated by the blue stairs in the (I-count/t-shift)-plane (O-count value 15).

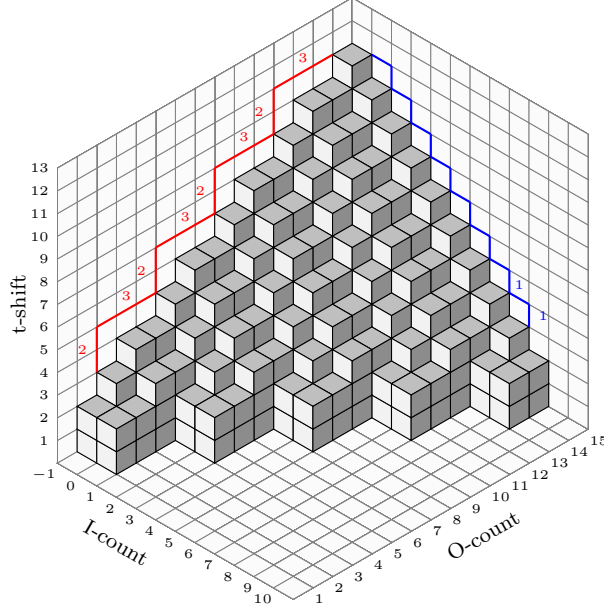

Figure 3.8. – Graphical representation of series $s = \gamma^1 \mu_3 \beta_2 \gamma^1 \delta^2 \oplus (\gamma^3 \mu_3 \beta_2 \gamma^1 \oplus \gamma^5 \mu_3 \beta_2) \delta^3 (\gamma^1 \delta^1)^*$.

Clearly, a polynomial $p = \bigoplus_{i=1}^I w_i \delta^{\tau_i}$ can be considered as a specific ultimately cyclic series such that $s = (\bigoplus_{i=1}^I w_i \delta^{\tau_i}) (\gamma^0 \delta^0)^*$. Let us note that the set of (b, b)-periodic operators, *i.e.* the set $\mathcal{E}_{b|b}[\delta]$, endowed with \oplus and \otimes is a complete subdioid of $(\mathcal{E}[\delta], \oplus, \otimes)$, but in general the set $\mathcal{E}_{m|b}[\delta]$ endowed with the \oplus and \otimes is not a dioid since it is not closed for the \otimes -operation. For instance, consider the operator $\mu_1 \beta_2 \gamma^1 \delta^2 \in \mathcal{E}_{1|2}[\delta]$ the product

$$\begin{aligned} \mu_1 \beta_2 \gamma^1 \delta^2 \otimes \mu_1 \beta_2 \gamma^1 \delta^2 &= \mu_1 \beta_2 \gamma^1 \delta^2 \otimes (\mu_2 \beta_4 \gamma^3 \oplus \gamma^1 \mu_2 \beta_4 \gamma^1) \delta^2 \\ &\text{since } \mu_1 \beta_2 = \mu_2 \beta_4 \gamma^2 \oplus \gamma^1 \mu_2 \beta_4 \text{ see Prop. 12} \\ &= \mu_1 \beta_2 \gamma^1 \mu_2 \beta_4 \gamma^3 \delta^4 \oplus \mu_1 \beta_2 \gamma^2 \mu_2 \beta_4 \gamma^1 \delta^4 \\ &= \mu_1 \beta_4 \gamma^3 \delta^4 \oplus \mu_1 \beta_4 \gamma^5 \delta^4 \\ &= \mu_1 \beta_4 \gamma^3 \delta^4 \quad \text{due to (3.21)} \end{aligned}$$

this operator is (1,4)-periodic and therefore in $\mathcal{E}_{1|4}[\delta]$ and not in $\mathcal{E}_{1|2}[\delta]$. Clearly since an element $s \in \mathcal{E}_{m|b}[\delta]$ is also an element in $\mathcal{E}[\delta]$, addition, and multiplication between

elements in $\mathcal{E}_{m|b}[\![\delta]\!]$ are defined, however, the result is not necessarily in $\mathcal{E}_{m|b}[\![\delta]\!]$. In the following proposition, we summarize the conditions under which sum, product, and infimum of ultimately cyclic series in $\mathcal{E}_{m|b}[\![\delta]\!]$ are again ultimately cyclic series in $\mathcal{E}_{m|b}[\![\delta]\!]$. The proofs for these propositions are given later in Section 3.3.

Proposition 16 ([16]). *Let $s_1 \in \mathcal{E}_{m_1|b_1}[\![\delta]\!]$, $s_2 \in \mathcal{E}_{m_2|b_2}[\![\delta]\!]$ be two ultimately cyclic series with equal gain, i.e. $\Gamma(s_1) = \Gamma(s_2) = m_1/b_1 = m_2/b_2$, then $(s_1 \oplus s_2) \in \mathcal{E}_{m|b}[\![\delta]\!]$ is an ultimately cyclic series with gain $\Gamma(s_1 \oplus s_2) = \Gamma(s_1) = \Gamma(s_2)$.*

Proposition 17 ([16]). *Let $s_1 \in \mathcal{E}_{m_1|b_1}[\![\delta]\!]$, $s_2 \in \mathcal{E}_{m_2|b_2}[\![\delta]\!]$ be two ultimately cyclic series with equal gain, i.e. $\Gamma(s_1) = \Gamma(s_2) = m_1/b_1 = m_2/b_2$, then $(s_1 \wedge s_2) \in \mathcal{E}_{m|b}[\![\delta]\!]$ is an ultimately cyclic series with gain $\Gamma(s_1 \wedge s_2) = \Gamma(s_1) = \Gamma(s_2)$.*

Proposition 18 ([16]). *Let $s_1 \in \mathcal{E}_{m_1|b_1}[\![\delta]\!]$ and $s_2 \in \mathcal{E}_{m_2|b_2}[\![\delta]\!]$ be two ultimately cyclic series then $(s_1 \otimes s_2) \in \mathcal{E}_{m_1 m_2 | b_1 b_2}[\![\delta]\!]$ is an ultimately cyclic series. Moreover, since $\Gamma(s_1) = m_1/b_1$ and $\Gamma(s_2) = m_2/b_2$ the gain $\Gamma(s_1 \otimes s_2) = (m_1 m_2)/(b_1 b_2) = \Gamma(s_1) \times \Gamma(s_2)$.*

Proposition 19 ([16]). *Let $s \in \mathcal{E}_{b|b}[\![\delta]\!]$ be an ultimately cyclic series then $s^* \in \mathcal{E}_{b|b}[\![\delta]\!]$ is an ultimately cyclic series.*

Division in $(\mathcal{E}[\![\delta]\!], \oplus, \otimes)$

Recall Section 2.2, since $(\mathcal{E}, \oplus, \otimes)$ (resp. $(\mathcal{E}[\![\delta]\!], \oplus, \otimes)$) is a complete dioid right and left multiplication are residuated. We obtain the following results for the left (resp. right) division of periodic elements. Again the proofs of the following propositions are provided in Section 3.3.

Proposition 20 ([16]). *Let $s_1 \in \mathcal{E}_{m|b_1}[\![\delta]\!]$ and $s_2 \in \mathcal{E}_{m|b_2}[\![\delta]\!]$ be two ultimately cyclic series then $(s_2 \setminus s_1) \in \mathcal{E}_{b_2|b_1}[\![\delta]\!]$ is an ultimately cyclic series. Moreover, since $\Gamma(s_1) = m/b_1$ and $\Gamma(s_2) = m/b_2$ the gain $\Gamma(s_2 \setminus s_1) = b_2/b_1 = \Gamma(s_1)/\Gamma(s_2)$.*

Proposition 21 ([16]). *Let $s_1 \in \mathcal{E}_{m_1|b}[\![\delta]\!]$ and $s_2 \in \mathcal{E}_{m_2|b}[\![\delta]\!]$ be two ultimately cyclic series then $(s_1 \not\setminus s_2) \in \mathcal{E}_{m_1|m_2}[\![\delta]\!]$ is an ultimately cyclic series. Moreover, since $\Gamma(s_1) = m_1/b$ and $\Gamma(s_2) = m_2/b$ the gain $\Gamma(s_1 \not\setminus s_2) = m_1/m_2 = \Gamma(s_1)/\Gamma(s_2)$.*

3.2. $(\mathcal{M}_{\text{in}}^{\text{ax}}[\![\gamma, \delta]\!], \oplus, \otimes)$ as a Subdioid of $(\mathcal{E}[\![\delta]\!], \oplus, \otimes)$

Let us recall the dioid $(\mathcal{M}_{\text{in}}^{\text{ax}}[\![\gamma, \delta]\!], \oplus, \otimes)$ introduced in Section 2.3. The dioid $(\mathcal{M}_{\text{in}}^{\text{ax}}[\![\gamma, \delta]\!], \oplus, \otimes)$ is a subdioid of $(\mathcal{E}[\![\delta]\!], \oplus, \otimes)$. More precisely $\mathcal{M}_{\text{in}}^{\text{ax}}[\![\gamma, \delta]\!]$ is the set $\mathcal{E}_{|1|}[\![\delta]\!]$, i.e., the set of $(1, 1)$ -periodic series. Then according to Definition 22 the canonical injection from $\mathcal{M}_{\text{in}}^{\text{ax}}[\![\gamma, \delta]\!]$ into $\mathcal{E}[\![\delta]\!]$ is defined by

$$\text{Inj} : \mathcal{M}_{\text{in}}^{\text{ax}}[\![\gamma, \delta]\!] \rightarrow \mathcal{E}[\![\delta]\!], \quad x \mapsto \text{Inj}(x) = x.$$

For instance, $\text{Inj}(\gamma^1 \delta^2) = \gamma^1 \mu_1 \beta_1 \delta^2 = \gamma^1 \delta^2$. In the following example, we give a graphical interpretation of this injection.

Example 17. Consider the series $s = \gamma^1 \delta^2 \oplus (\gamma^3 \delta^3 \oplus \gamma^5 \delta^4) (\gamma^3 \delta^2)^* \in \mathcal{M}_{\text{in}}^{\text{ax}}[\gamma, \delta]$, the graphical representation of s is shown in Figure 3.9a. Moreover, the graphical representation of the canonical injection $\text{Inj}(s) \in \mathcal{E}[\delta]$ is shown in Figure 3.9b. The series $s \in \mathcal{M}_{\text{in}}^{\text{ax}}[\gamma, \delta]$ (Figure 3.9a) corresponds to the (O-count/t-shift)-plane for the (I-count) value 0 of the 3D representation of the series $\text{Inj}(s) \in \mathcal{E}[\delta]$ (Figure 3.9b). Moreover, the canonical injection $\text{Inj}(s) \in \mathcal{E}[\delta]$ is $(1,1)$ -periodic, therefore the (O-count/t-shift)-plane for the (I-count) value 1 corresponds to the series $\gamma^1 s \in \mathcal{M}_{\text{in}}^{\text{ax}}[\gamma, \delta]$ and for the (I-count) value 2 to the series $\gamma^2 s \in \mathcal{M}_{\text{in}}^{\text{ax}}[\gamma, \delta]$, etc. Observe that the left-cyclic form and the right-cyclic form are the same since $(\mathcal{M}_{\text{in}}^{\text{ax}}[\gamma, \delta], \oplus, \otimes)$ is commutative.

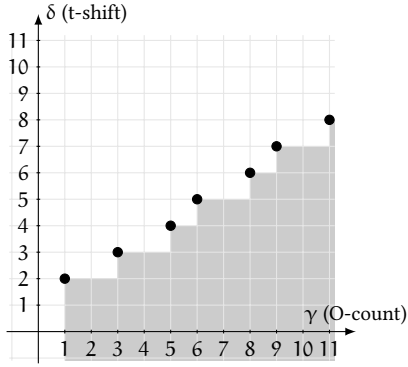

(a) Graphical representation of $s \in \mathcal{M}_{\text{in}}^{\text{ax}}[\gamma, \delta]$.

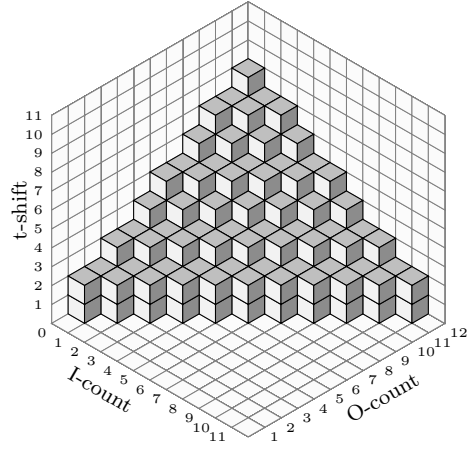

(b) Graphical representation of $\text{Inj}(s) \in \mathcal{E}[\delta]$.

Figure 3.9. – Illustration of the canonical injection $\text{Inj} : \mathcal{M}_{\text{in}}^{\text{ax}}[\gamma, \delta] \rightarrow \mathcal{E}[\delta]$.

The canonical injection $\text{Inj} : \mathcal{M}_{\text{in}}^{\text{ax}}[\gamma, \delta] \rightarrow \mathcal{E}[\delta]$ is continuous and thus it is both residuated and dually residuated, see the following propositions.

Lemma 1. Let $w\delta^\tau \in \mathcal{E}_{\text{b|b}}[\delta]$ be a (b, b) -periodic monomial. Then residual $\text{Inj}^\#(w\delta^\tau)$ and dual residual $\text{Inj}^b(w\delta^\tau)$ are given by

$$\text{Inj}^\#(w\delta^\tau) = \gamma^{\max_{k=0}^{\text{b}-1} (\mathcal{F}_w(k) - k)} \delta^\tau, \quad (3.22)$$

$$\text{Inj}^b(w\delta^\tau) = \gamma^{\min_{k=0}^{\text{b}-1} (\mathcal{F}_w(k) - k)} \delta^\tau. \quad (3.23)$$

Proof. By definition, the residuated mapping $\text{Inj}^\#(w\delta^\tau)$ is the greatest solution x of the following inequality

$$w\delta^\tau \geq \text{Inj}(x) = \text{Inj}\left(\bigoplus_i \gamma^{\nu_i} \delta^{\zeta_i}\right) = \bigoplus_i \gamma^{\nu_i} \delta^{\zeta_i}, \quad (3.24)$$

where $\bigoplus_i \gamma^{\nu_i} \delta^{\zeta_i} \in \mathcal{M}_{\text{in}}^{\text{ax}}[\![\gamma, \delta]\!]$. Clearly, the greatest ζ_i such that the inequality (3.24) holds is τ and thus,

$$w\delta^\tau \geq \bigoplus_i (\gamma^{\nu_i} \delta^\tau) = \gamma^\nu \delta^\tau, \quad \text{see, (2.29)}. \quad (3.25)$$

Since $w\delta^\tau \geq \gamma^\nu \delta^\tau \Leftrightarrow w \geq \gamma^\nu$, it remains to find the least ν such that (3.25) holds. By considering the isomorphism between E-operators and (C/C)-functions, see (3.14), this is equivalent to $\mathcal{F}_w(k) \geq \mathcal{F}_{\gamma^\nu}(k)$ ($\mathcal{F}_w(k) \leq \mathcal{F}_{\gamma^\nu}(k)$), $\forall k \in \overline{\mathbb{Z}}_{\text{min}}$. Note that in $\overline{\mathbb{Z}}_{\text{min}}$ the order is reverse to the natural order. By using $\mathcal{F}_{\gamma^\nu}(k) = \nu + k$, see (3.12), we obtain

$$\mathcal{F}_w(k) \leq \nu + k \Leftrightarrow \nu \geq \mathcal{F}_w(k) - k, \quad \forall k \in \overline{\mathbb{Z}}_{\text{min}}. \quad (3.26)$$

Since \mathcal{F}_w is a quasi (b, b) -periodic function it is sufficient to evaluate the function for $\forall k \in \{0, \dots, b-1\}$. Therefore, the least ν such that (3.26) (resp. (3.25)) holds is

$$\nu = \max_{k=0}^{b-1} (\mathcal{F}_w(k) - k).$$

Similarly, for (3.23), $\text{Inj}^\flat(w\delta^\tau)$ is the least solution x of the inequality

$$w\delta^\tau \leq \text{Inj}(x) = \text{Inj}\left(\bigoplus_i \gamma^{\nu_i} \delta^{\zeta_i}\right) = \bigoplus_i \gamma^{\nu_i} \delta^{\zeta_i}. \quad (3.27)$$

Then, the least ζ_i such that the inequality (3.27) holds is τ and thus,

$$w\delta^\tau \leq \bigoplus_i (\gamma^{\nu_i} \delta^\tau) = \gamma^\nu \delta^\tau, \quad \text{see, (2.29)}. \quad (3.28)$$

Again since $w\delta^\tau \leq \gamma^\nu \delta^\tau \Leftrightarrow w \leq \gamma^\nu$, it remains to find the greatest ν such that (3.28) holds. Therefore, $\forall k \in \overline{\mathbb{Z}}_{\text{min}}$

$$\mathcal{F}_w(k) \geq \mathcal{F}_{\gamma^\nu}(k) \Leftrightarrow \mathcal{F}_w(k) \geq \nu + k \Leftrightarrow \nu \leq \mathcal{F}_w(k) - k. \quad (3.29)$$

By considering that \mathcal{F}_w is a quasi (b, b) -periodic function the greatest ν such that (3.29) (resp. (3.28)) holds is

$$\nu = \min_{k=0}^{b-1} (\mathcal{F}_w(k) - k).$$

□

Example 18. For the monomial $\gamma^1 \mu_3 \beta_3 \gamma^1 \delta^2 \in \mathcal{E}_{3|3}[\![\delta]\!]$, see Figure 3.10b, the residual

$$\text{Inj}^\sharp(\gamma^1 \mu_3 \beta_3 \gamma^1 \delta^2) = \gamma^{\max_{i=0}^2 (\mathcal{F}_{\gamma^1 \mu_3 \beta_3 \gamma^1}(i) - i)} \delta^2 = \gamma^{\max(1,0,2)} \delta^2 = \gamma^2 \delta^2.$$

We now compare $\gamma^1 \mu_3 \beta_3 \gamma^1 \delta^2$ to $\text{Inj}(\text{Inj}^\sharp(\gamma^1 \mu_3 \beta_3 \gamma^1 \delta^2))$ and show that $s \geq \text{Inj}(\text{Inj}^\sharp(s))$ is satisfied, see Remark 4. The canonical injection $\text{Inj}(\text{Inj}^\sharp(\gamma^1 \mu_3 \beta_3 \gamma^1 \delta^2)) = \text{Inj}(\gamma^2 \delta^2) = \gamma^2 \delta^2$

is shown in Figure 3.10a. Clearly, $\text{Inj}(\gamma^2 \delta^2) = \gamma^2 \delta^2 \leq \gamma^1 \mu_3 \beta_3 \gamma^1 \delta^2$ this is illustrated in Figure 3.11a where the (C/C)-functions $\mathcal{F}_{\gamma^1 \mu_3 \beta_3 \gamma^1}$ and \mathcal{F}_{γ^2} , are shown. Obviously, $\mathcal{F}_{\gamma^2} \leq \mathcal{F}_{\gamma^1 \mu_3 \beta_3 \gamma^1}$ ($\mathcal{F}_{\gamma^2} \geq \mathcal{F}_{\gamma^1 \mu_3 \beta_3 \gamma^1}$), in particular, \mathcal{F}_{γ^2} is the greatest quasi (1,1)-periodic (C/C)-function which is less than $\mathcal{F}_{\gamma^1 \mu_3 \beta_3 \gamma^1}$. Therefore, $\gamma^2 \delta^2$ is the greatest operator in $\mathcal{E}_{1|1} \llbracket \delta \rrbracket$ which is less than $\gamma^1 \mu_3 \beta_3 \gamma^1 \delta^2$. The dual residual of the monomial $\gamma^1 \mu_3 \beta_3 \gamma^1 \delta^2 \in \mathcal{E}_{3|3} \llbracket \delta \rrbracket$ is given by

$$\text{Inj}^{\flat}(\gamma^1 \mu_3 \beta_3 \gamma^1 \delta^2) = \gamma^{\min(1,0,2)} \delta^2 = \gamma^0 \delta^2 = \delta^2.$$

Again we compare $\gamma^1 \mu_3 \beta_3 \gamma^1 \delta^2$ to $\text{Inj}(\text{Inj}^{\flat}(\gamma^1 \mu_3 \beta_3 \gamma^1 \delta^2))$ and show that $s \leq \text{Inj}(\text{Inj}^{\flat}(s))$ is satisfied, see Remark 5. The canonical injection $\text{Inj}(\text{Inj}^{\flat}(\gamma^1 \mu_3 \beta_3 \gamma^1 \delta^2)) = \text{Inj}(\delta^2) = \delta^2$ is shown in Figure 3.10c. Clearly, $\text{Inj}(\delta^2) = \delta^2 \geq \gamma^1 \mu_3 \beta_3 \gamma^1 \delta^2$ this is illustrated in Figure 3.11b where the (C/C)-functions $\mathcal{F}_{\gamma^1 \mu_3 \beta_3 \gamma^1}$ and \mathcal{F}_{γ^0} , are shown. Obviously, $\mathcal{F}_{\gamma^1 \mu_3 \beta_3 \gamma^1} \leq \mathcal{F}_{\gamma^0}$ ($\mathcal{F}_{\gamma^1 \mu_3 \beta_3 \gamma^1} \geq \mathcal{F}_{\gamma^0}$), in particular, \mathcal{F}_{γ^0} is the least quasi (1,1)-periodic (C/C)-function which is greater than $\mathcal{F}_{\gamma^1 \mu_3 \beta_3 \gamma^1}$ and therefore $\gamma^0 \delta^2$ is the least operator in $\mathcal{E}_{1|1} \llbracket \delta \rrbracket$ which is greater than $\gamma^1 \mu_3 \beta_3 \gamma^1 \delta^2$.

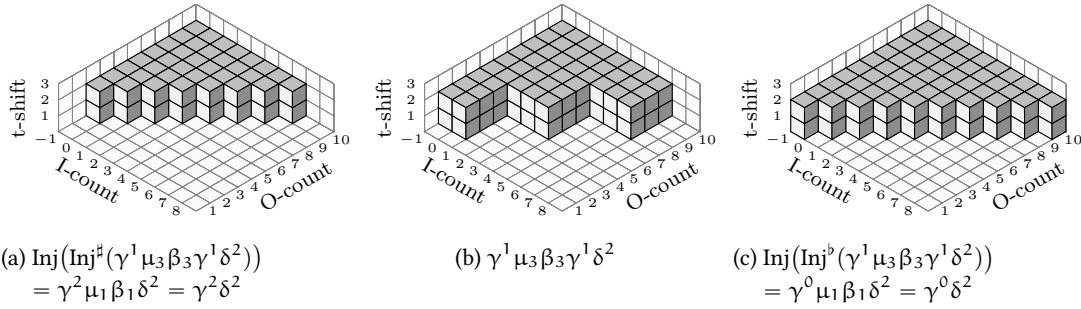

Figure 3.10. – Graphical comparison of $\gamma^1 \mu_3 \beta_3 \gamma^1 \delta^2$, $\text{Inj}(\text{Inj}^{\#}(\gamma^1 \mu_3 \beta_3 \gamma^1 \delta^2))$ and $\text{Inj}(\text{Inj}^{\flat}(\gamma^1 \mu_3 \beta_3 \gamma^1 \delta^2))$. For all $t \in \mathbb{Z}$ the slices in the (I/O-count)-planes of $\gamma^1 \mu_3 \beta_3 \gamma^1 \delta^2$ cover the slices of $\text{Inj}(\text{Inj}^{\#}(\gamma^1 \mu_3 \beta_3 \gamma^1 \delta^2))$, but are covered by the slices of $\text{Inj}(\text{Inj}^{\flat}(\gamma^1 \mu_3 \beta_3 \gamma^1 \delta^2))$, see Figure 3.11.

Proposition 22. Let $s = \bigoplus_i w_i \delta^{\tau_i} \in \mathcal{E}_{b|b} \llbracket \delta \rrbracket$ be a (b, b)-periodic series in the canonical representation, see Prop. 14, extended to infinite sums, then

$$\text{Inj}^{\#}(s) = \text{Inj}^{\#}\left(\bigoplus_i w_i \delta^{\tau_i}\right) = \bigoplus_i \gamma^{\max_{k=0}^{b-1} (\mathcal{F}_{w_i}(k) - k)} \delta^{\tau_i}, \quad (3.30)$$

Second, for $s \in \mathcal{E} \llbracket \delta \rrbracket$ but $s \notin \mathcal{E}_{b|b} \llbracket \delta \rrbracket$,

$$\text{Inj}^{\#}(s) = \varepsilon. \quad (3.31)$$

Proof. For (3.30): Consider $s = \bigoplus_i w_i \delta^{\tau_i}$ in the canonical form, such that $\tau_i < \tau_{i+1}$ and $w_i > w_{i+1}$ and let \mathcal{F}_{w_i} be the (C/C)-function associated with w_i . Recall that $\text{Inj}^{\#}(s)$ is the greatest solution x in $\mathcal{M}_{\text{in}}^{\text{ax}} \llbracket \gamma, \delta \rrbracket$ of inequality $\text{Inj}(x) \leq s$. This is given by $\bigoplus_i \gamma^{n_i} \delta^{\tau_i}$

3. Dioids $(\mathcal{E}, \oplus, \otimes)$ and $(\mathcal{E}[[\delta]], \oplus, \otimes)$

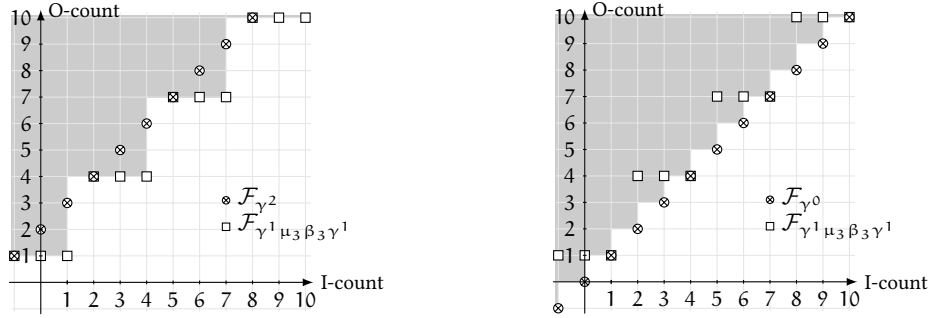

(a) Graphical illustration of $\text{Inj}^\#(\gamma^1 \mu_3 \beta_3 \gamma^1 \delta^2) = \gamma^2 \delta^2$ in the (I/O-count)-planes for $t \leq 2$ (b) Graphical illustration of $\text{Inj}^b(\gamma^1 \mu_3 \beta_3 \gamma^1 \delta^2) = \gamma^0 \delta^2$ in the (I/O-count)-planes for $t \leq 2$

Figure 3.11. – Comparison of $\text{Inj}^\#(\gamma^1 \mu_3 \beta_3 \gamma^1 \delta^2)$ and $\text{Inj}^b(\gamma^1 \mu_3 \beta_3 \gamma^1 \delta^2)$ in the (I/O-count)-planes for $t \leq 2$. In (a) the (C/C)-function \mathcal{F}_{γ^2} lies in the gray area shaped by the $\mathcal{F}_{\gamma^1 \mu_3 \beta_3 \gamma^1}$ function, thus $\mathcal{F}_{\gamma^2} \leq \mathcal{F}_{\gamma^1 \mu_3 \beta_3 \gamma^1}$ and $\gamma^2 \leq \gamma^1 \mu_3 \beta_3 \gamma^1$. In (b) the (C/C)-function $\mathcal{F}_{\gamma^1 \mu_3 \beta_3 \gamma^1}$ lies in the gray area shaped by the \mathcal{F}_{γ^0} function, thus $\mathcal{F}_{\gamma^1 \mu_3 \beta_3 \gamma^1} \leq \mathcal{F}_{\gamma^0}$ and $\gamma^1 \mu_3 \beta_3 \gamma^1 \leq \gamma^0$.

where n_i is the greatest integer such that $\gamma^{n_i} \leq w_i$. Repeating the first step of the proof of Lemma 1, this is given by $n_i = \max_{k=0}^{b-1} (\mathcal{F}_{w_i}(k) - k)$. To prove (3.31), recall that $\forall s \in \mathcal{E}[[\delta]]$ we must satisfy the following inequality, see (2.17) in Remark 4,

$$s \geq \text{Inj}(\text{Inj}^\#(s)). \quad (3.32)$$

Now let us consider two series $s_1 \in \mathcal{E}_{m_1|b_1}[[\delta]]$ and $s_2 \in \mathcal{E}_{m_2|b_2}[[\delta]]$ such that $s_1 \neq \varepsilon$, $s_2 \neq \varepsilon$ and $\frac{m_1}{b_1} \neq \frac{m_2}{b_2}$. Then s_1 and s_2 are not ordered, i.e., $s_1 \not\leq s_2$ and $s_1 \not\geq s_2$ (see Prop. 13). The canonical injection $\text{Inj}(\tilde{s})$ of an arbitrary series $\tilde{s} \in \mathcal{M}_{\text{in}}^{\text{ax}}[[\gamma, \delta]]$ is (1, 1)-periodic, i.e., $\text{Inj}(\tilde{s}) \in \mathcal{E}_{1|1}[[\delta]]$. Thus, for $s \notin \mathcal{E}_{b|b}[[\delta]]$, s and $\text{Inj}(\tilde{s})$ are not ordered and (3.32) holds if and only if $\text{Inj}^\#(s) = \varepsilon$. \square

Proposition 23. Let $s = \bigoplus_i w_i \delta^{\tau_i} \in \mathcal{E}_{b|b}[[\delta]]$ be a (b, b)-periodic series in the canonical representation, see Prop. 14, extended to infinite sums, then

$$\text{Inj}^b(s) = \text{Inj}^b\left(\bigoplus_i w_i \delta^{\tau_i}\right) = \bigoplus_i \gamma^{\min_{k=0}^{b-1} (\mathcal{F}_{w_i}(k) - k)} \delta^{\tau_i}, \quad (3.33)$$

Second, for $s \in \mathcal{E}[[\delta]]$ but $s \notin \mathcal{E}_{b|b}[[\delta]]$,

$$\text{Inj}^b(s) = \varepsilon. \quad (3.34)$$

Proof. The proof is similar to the proof of Prop. 22. \square

Example 19. Consider the polynomial $p = \gamma^1 \mu_3 \beta_3 \gamma^1 \delta^2 \oplus \mu_3 \beta_3 \gamma^2 \delta^3 \in \mathcal{E}_{3|3}[[\delta]]$ with a canonical form $p = (\mu_3 \beta_3 \gamma^2 \oplus \gamma^1 \mu_3 \beta_3 \gamma^1) \delta^2 \oplus \mu_3 \beta_3 \gamma^2 \delta^3$ and a graphical representation given in Figure 3.12a. Then, $\text{Inj}^\#(p) = \gamma^1 \delta^2 \oplus \gamma^2 \delta^3$ and $\text{Inj}(\text{Inj}^\#(p)) = \gamma^1 \delta^2 \oplus \gamma^2 \delta^3$ are shown in

Figure 3.12b. Moreover, Figure 3.13a illustrates $\text{Inj}^\sharp((\mu_3\beta_3\gamma^2 \oplus \gamma^1\mu_3\beta_3\gamma^1)\delta^2) = \gamma^1\delta^2$ for the (I/O-count)-plane at $t = 2$ and Figure 3.13b illustrates $\text{Inj}^\sharp(\mu_3\beta_3\gamma^2\delta^3) = \gamma^2\delta^3$ for the (I/O-count)-plane at $t = 3$, respectively.

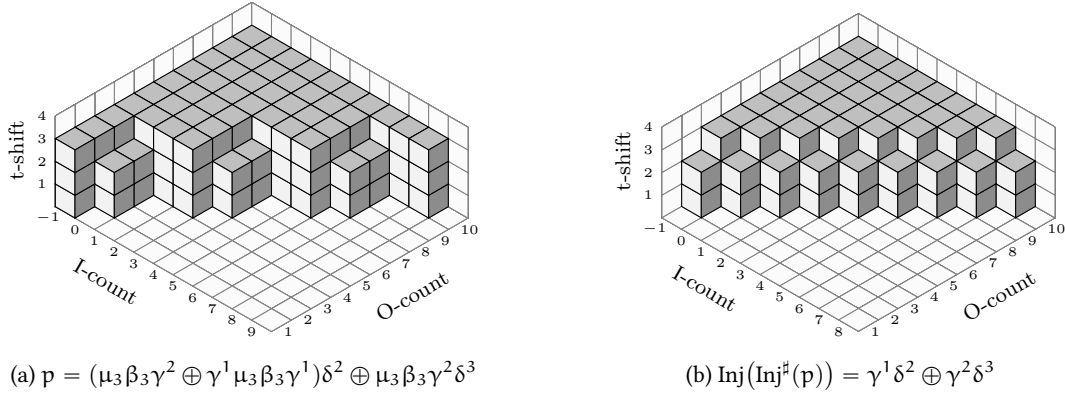

Figure 3.12. – Graphical comparison of the polynomial $p = (\mu_3\beta_3\gamma^2 \oplus \gamma^1\mu_3\beta_3\gamma^1)\delta^2 \oplus \mu_3\beta_3\gamma^2\delta^3$ and $\text{Inj}(\text{Inj}^\sharp(p))$. For all $t \in \mathbb{Z}$ the slices in the (I/O-count)-planes of p cover the slices of $\text{Inj}(\text{Inj}^\sharp(p))$, see Figure 3.13.

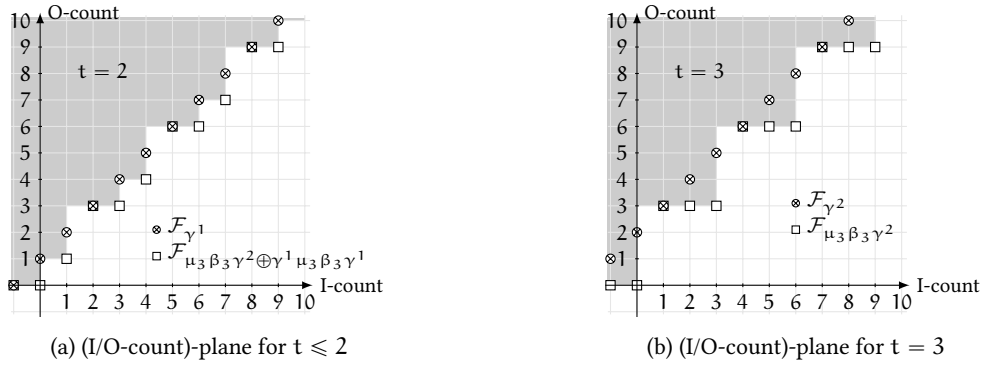

Figure 3.13. – Graphical illustration of $\text{Inj}^\sharp(p) = \gamma^1\delta^2 \oplus \gamma^2\delta^3$.

Zero slice Mapping $\Psi_{m|b} : \mathcal{E}_{m|b}[\delta] \rightarrow \mathcal{M}_{\text{in}}^{\text{ax}}[\gamma, \delta]$

In addition to the canonical injection $\text{Inj} : \mathcal{M}_{\text{in}}^{\text{ax}}[\gamma, \delta] \rightarrow \mathcal{E}[\delta]$, we define a mapping: $\Psi_{m|b} : \mathcal{E}_{m|b}[\delta] \rightarrow \mathcal{M}_{\text{in}}^{\text{ax}}[\gamma, \delta]$.

Definition 36. Let $s = \bigoplus_i w_i \delta^{t_i} \in \mathcal{E}_{m|b}[\delta]$ be an (m, b) -periodic series, then

$$\Psi_{m|b}(s) = \Psi_{m|b}\left(\bigoplus_i w_i \delta^{t_i}\right) = \bigoplus_i \gamma^{\mathcal{F}_{w_i}(0)} \delta^{t_i}. \quad (3.35)$$

This mapping $\Psi_{m|b}$ has a graphical interpretation. If we take the 3D representation of a series $s \in \mathcal{E}_{m|b}[[\delta]]$ the series $\tilde{s} = \Psi_{m|b}(s) \in \mathcal{M}_{in}^{\alpha x}[[\gamma, \delta]]$ corresponds to the slice in the (O-count/t-shift)-plane of the 3D representation at the I-count value 0, therefore this mapping is also called zero-slice mapping.

Example 20. Consider the following series $s \in \mathcal{E}_{3|2}[[\delta]]$,

$$s = \gamma^1 \mu_3 \beta_2 \gamma^1 \delta^2 \oplus (\gamma^3 \delta^2)^* ((\gamma^3 \mu_3 \beta_2 \gamma^1 \oplus \gamma^5 \mu_3 \beta_2) \delta^3 \oplus (\gamma^6 \mu_3 \beta_2 \oplus \gamma^5 \mu_3 \beta_2 \gamma^1) \delta^4).$$

with a graphical representation given in Example 16 in Figure 3.8.

$$\Psi_{3|2}(s) = \gamma^1 \delta^2 \oplus (\gamma^3 \delta^2)^* (\gamma^3 \delta^3 \oplus \gamma^5 \delta^4)$$

The series $\Psi_{3|2}(s) \in \mathcal{M}_{in}^{\alpha x}[[\gamma, \delta]]$ corresponds to the slice ((O-count/t-shift)-plane) for the I-count value 0 of the 3D representation of s , see Figure 3.14a and Figure 3.14b. Moreover, the asymptotic slope of $\Psi_{3|2}(s) \in \mathcal{M}_{in}^{\alpha x}[[\gamma, \delta]]$ is the same as the left-asymptotic slope of $s \in \mathcal{E}_{3|2}[[\delta]]$, i.e., $\sigma(\Psi_{3|2}(s)) = \sigma_1(s) = 2/3$.

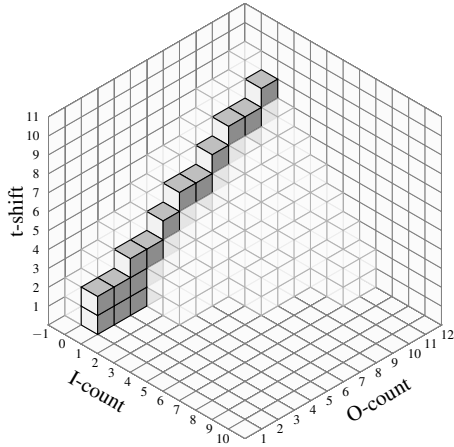

(a) 3D representation of s

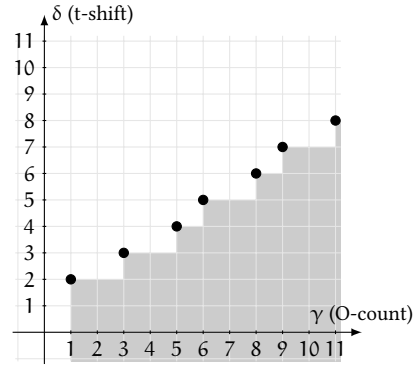

(b) The (O-count/t-shift)-plane for the I-count value 0

Figure 3.14. – Illustration of the zero-slice mapping $\Psi_{3|2}(s)$.

The mapping $\Psi_{m|b}$ is by definition lower-semicontinuous, see Definition 36, therefore $\Psi_{m|b}$ is residuated.

Proposition 24. Let $s = \bigoplus_i \gamma^{\nu_i} \delta^{\tau_i} \in \mathcal{M}_{in}^{\alpha x}[[\gamma, \delta]]$. The residual $\Psi_{m|b}^\#(s) \in \mathcal{E}_{m|b}[[\delta]]$ of s is a series defined by

$$\Psi_{m|b}^\# \left(\bigoplus_i \gamma^{\nu_i} \delta^{\tau_i} \right) = \bigoplus_i \gamma^{\nu_i} \delta^{\tau_i} \mu_m \beta_b = s \mu_m \beta_b. \quad (3.36)$$

Proof. By definition of the residuated mapping, $\Psi_{m|b}^{\#}(\bigoplus_i \gamma^{\nu_i} \delta^{\tau_i}) \in \mathcal{E}_{m|b}[\delta]$ is the greatest solution of the following inequality

$$s = \bigoplus_i \gamma^{\nu_i} \delta^{\tau_i} \geq \Psi_{m|b}(x) = \Psi_{m|b}\left(\bigoplus_j w_j \delta^{\zeta_j}\right), \quad (3.37)$$

where $x = \bigoplus_j w_j \delta^{\zeta_j} \in \mathcal{E}_{m|b}[\delta]$. First, we show that (3.36) satisfies (3.37) with equality.

$$\Psi_{m|b}\left(\bigoplus_i \gamma^{\nu_i} \delta^{\tau_i} \mu_m \beta_b\right) = \bigoplus_i \gamma^{\mathcal{F}_{\gamma^{\nu_i} \mu_m \beta_b}(0)} \delta^{\tau_i} = \bigoplus_i \gamma^{\nu_i} \delta^{\tau_i},$$

since $\mathcal{F}_{\gamma^{\nu_i} \mu_m \beta_b}(0) = \nu_i + [0/b]m = \nu_i$, see (3.11), (3.9) and (3.10). Taking into account that $\Psi_{m|b}$ is isotone, it remains to show that $\bigoplus_i \gamma^{\nu_i} \delta^{\tau_i} \mu_m \beta_b$ is the greatest solution of

$$\bigoplus_i \gamma^{\nu_i} \delta^{\tau_i} = \Psi_{m|b}(x) = \Psi_{m|b}\left(\bigoplus_j w_j \delta^{\zeta_j}\right) = \bigoplus_j \gamma^{\mathcal{F}_{w_j}(0)} \delta^{\zeta_j}. \quad (3.38)$$

Clearly, to achieve equality we need $\zeta_j = \tau_i$ and $\mathcal{F}_{w_j}(0) = \nu_i$. Furthermore, we are looking for the greatest $w_j \in \mathcal{E}_{m|b}[\delta]$, such that $\nu_i = \mathcal{F}_{w_j}(0)$. Due to the canonical form Prop. 11 we can write an (m, b) -periodic E-operator as $\bigoplus_{i=1}^b \gamma^{n_i} \mu_m \beta_b \gamma^{n'_i}$ with $0 \leq n'_i < b$. This operator corresponds to the (C/C)-function

$$\mathcal{F}(k) = \min_{i=1}^b \left(n_i + \left\lfloor \frac{n'_i + k}{b} \right\rfloor m \right).$$

Now we examine $\mathcal{F}(k)$ for $k = 0$, thus

$$\mathcal{F}(0) = \min_{i=1}^b \left(n_i + \left\lfloor \frac{n'_i}{b} \right\rfloor m \right).$$

Recall that $0 \leq n'_i < b$, hence $\mathcal{F}_{w_j}(k) = \nu_i + [(0+k)/b]m$ is the least quasi (m, b) -periodic (C/C)-function such that (3.38) holds, i.e., $\mathcal{F}_{w_j}(0) = \mathcal{F}_{\gamma^{\nu_i} \mu_m \beta_b}(0) = \nu_i + [0/b]m = \nu_i$. This function corresponds to the operator $\gamma^{\nu_i} \mu_m \beta_b$. \square

Example 21. Recall Example 20 with,

$$\begin{aligned} s &= \gamma^1 \mu_3 \beta_2 \gamma^1 \delta^2 \oplus (\gamma^3 \delta^2)^* ((\gamma^3 \mu_3 \beta_2 \gamma^1 \oplus \gamma^5 \mu_3 \beta_2) \delta^3 \oplus (\gamma^6 \mu_3 \beta_2 \oplus \gamma^5 \mu_3 \beta_2 \gamma^1) \delta^4), \\ \tilde{s} &= \Psi_{3|2}(s) = \gamma^1 \delta^2 \oplus (\gamma^3 \delta^2)^* (\gamma^3 \delta^3 \oplus \gamma^5 \delta^4). \end{aligned}$$

The residual $\Psi_{3|2}^{\#}(\tilde{s})$ is given by

$$\begin{aligned} \Psi_{3|2}^{\#}(\tilde{s}) &= \left(\gamma^1 \delta^2 \oplus (\gamma^3 \delta^2)^* (\gamma^3 \delta^3 \oplus \gamma^5 \delta^4) \right) \mu_3 \beta_2, \\ &= \gamma^1 \mu_3 \beta_2 \delta^2 \oplus (\gamma^3 \delta^2)^* (\gamma^3 \mu_3 \beta_2 \delta^3 \oplus \gamma^5 \mu_3 \beta_2 \delta^4). \end{aligned}$$

In Figure 3.15a and Figure 3.15b, s and $\Psi_{3|2}^{\#}(\Psi_{3|2}(s))$ are compared, as required $s \leq \Psi_{3|2}^{\#}(\Psi_{3|2}(s))$, see (2.17).

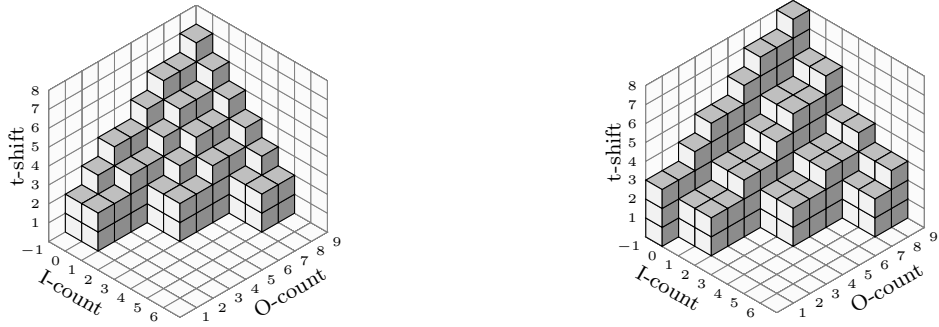

$$(a) s = \gamma^1 \mu_3 \beta_2 \gamma^1 \delta^2 \oplus (\gamma^3 \delta^2) * ((\gamma^3 \mu_3 \beta_2 \gamma^1 \oplus \gamma^5 \mu_3 \beta_2) \delta^3 \oplus (\gamma^6 \mu_3 \beta_2 \oplus \gamma^5 \mu_3 \beta_2 \gamma^1) \delta^4).$$

$$(b) \Psi_{3|2}^\#(\Psi_{3|2}(s)) = \gamma^1 \mu_3 \beta_2 \delta^2 \oplus (\gamma^3 \delta^2) * (\gamma^3 \mu_3 \beta_2 \delta^3 \oplus \gamma^5 \mu_3 \beta_2 \delta^4)$$

Figure 3.15. – For a comparison of the series s and $\Psi_{3|2}^\#(\Psi_{3|2}(s))$ we examine the slices in the (O-count/t-shift)-planes for all I-count values $k \in \overline{\mathbb{Z}}_{\min}$ of the graphical representation of s and $\Psi_{3|2}^\#(\Psi_{3|2}(s))$. Clearly, for all I-count values $k \in \overline{\mathbb{Z}}_{\min}$ the corresponding slice of $\Psi_{3|2}^\#(\Psi_{3|2}(s))$ covers the corresponding slice of s , therefore as required $s \leq \Psi_{3|2}^\#(\Psi_{3|2}(s))$.

Proposition 25. Let $s = \bigoplus_i \gamma^{\nu_i} \delta^{\tau_i} \in \mathcal{M}_{\text{in}}^{\text{ax}}[\![\gamma, \delta]\!]$. The dual residual $\Psi_{m|b}^b(s) \in \mathcal{E}_{m|b}[\![\delta]\!]$ of s is a series defined by

$$\Psi_{m|b}^b\left(\bigoplus_i \gamma^{\nu_i} \delta^{\tau_i}\right) = \bigoplus_i \gamma^{\nu_i} \delta^{\tau_i} \mu_m \beta_b \gamma^{b-1} = s \mu_m \beta_b \gamma^{b-1}. \quad (3.39)$$

Proof. The proof is similar to the proof of Prop. 24, with the difference that instead of finding the greatest solution we are now looking for the least solution, denoted by $\Psi_{m|b}^b(\bigoplus_i \gamma^{\nu_i} \delta^{\tau_i}) \in \mathcal{E}_{m|b}[\![\delta]\!]$, of the following inequality

$$s = \bigoplus_i \gamma^{\nu_i} \delta^{\tau_i} \leq \Psi_{m|b}(x) = \Psi_{m|b}\left(\bigoplus_j w_j \delta^{\zeta_j}\right). \quad (3.40)$$

Again we show that (3.39) satisfies (3.40) with equality.

$$\Psi_{m|b}\left(\bigoplus_i \gamma^{\nu_i} \delta^{\tau_i} \mu_m \beta_b \gamma^{b-1}\right) = \bigoplus_i \gamma^{\mathcal{F}_{\gamma^{\nu_i} \mu_m \beta_b \gamma^{b-1}}(0)} \delta^{\tau_i} = \bigoplus_i \gamma^{\nu_i} \delta^{\tau_i},$$

since $\mathcal{F}_{\gamma^{\nu_i} \mu_m \beta_b \gamma^{b-1}}(0) = \nu_i + \lfloor (b-1)/b \rfloor m = \nu_i$, see (3.11), (3.9) and (3.10). Taking into account that $\Psi_{m|b}$ is isotone, it remains to show that $\bigoplus_i \gamma^{\nu_i} \delta^{\tau_i} \mu_m \beta_b \gamma^{b-1}$ is the least solution of

$$\bigoplus_i \gamma^{\nu_i} \delta^{\tau_i} = \Psi_{m|b}(x) = \Psi_{m|b}\left(\bigoplus_j w_j \delta^{\zeta_j}\right) = \bigoplus_j \gamma^{\mathcal{F}_{w_j}(0)} \delta^{\zeta_j}. \quad (3.41)$$

Clearly, to achieve equality we need $\zeta_j = \tau_i$ and $\mathcal{F}_{w_j}(0) = \nu_i$. Furthermore, we are looking for the smallest $w_j \in \mathcal{E}_{m|b}[\![\delta]\!]$, such that $\nu_i = \mathcal{F}_{w_j}(0)$. Due to the canonical form Prop. 11

an (m, b) -periodic E-operator can be written as $\bigoplus_{i=1}^b \gamma^{n_i} \mu_m \beta_b \gamma^{n'_i}$ with $0 \leq n'_i < b$. This operator corresponds to a (C/C) -function

$$\mathcal{F}(k) = \min_{i=1}^b \left(n_i + \left\lfloor \frac{n'_i + k}{b} \right\rfloor m \right).$$

Now we examine $\mathcal{F}(k)$ for $k = 0$, thus

$$\mathcal{F}(0) = \min_{i=1}^b \left(n_i + \left\lfloor \frac{n'_i}{b} \right\rfloor m \right).$$

Recall that $0 \leq n'_i < b$, hence $\mathcal{F}_{w_j}(k) = v_i + \lfloor ((b-1) + k)/b \rfloor m$ is the smallest (*i.e.* smallest in the order in $\overline{\mathbb{Z}}_{\min}$, hence greatest in the natural order in \mathbb{Z}) quasi (m, b) -periodic (C/C) -function such that (3.41) holds, *i.e.*, $\mathcal{F}_{w_j}(0) = \mathcal{F}_{\gamma^{v_i} \mu_m \beta_b \gamma^{b-1}}(0) = v_i + \lfloor (b-1)/b \rfloor m = v_i$. This function corresponds to the operator $\gamma^{v_i} \mu_m \beta_b \gamma^{b-1}$. \square

Example 22. Recall Example 20 with,

$$\begin{aligned} s &= \gamma^1 \mu_3 \beta_2 \gamma^1 \delta^2 \oplus (\gamma^3 \delta^2)^* ((\gamma^3 \mu_3 \beta_2 \gamma^1 \oplus \gamma^5 \mu_3 \beta_2) \delta^3 \oplus (\gamma^6 \mu_3 \beta_2 \oplus \gamma^5 \mu_3 \beta_2 \gamma^1) \delta^4), \\ \tilde{s} &= \Psi_{3|2}(s) = \gamma^1 \delta^2 \oplus (\gamma^3 \delta^2)^* (\gamma^3 \delta^3 \oplus \gamma^5 \delta^4). \end{aligned}$$

The dual residual $\Psi_{3|2}^b(\tilde{s})$ is given by

$$\begin{aligned} \Psi_{3|2}^b(\tilde{s}) &= (\gamma^1 \delta^2 \oplus (\gamma^3 \delta^2)^* (\gamma^3 \delta^3 \oplus \gamma^5 \delta^4)) \mu_3 \beta_2 \gamma^1, \\ &= \gamma^1 \mu_3 \beta_2 \gamma^1 \delta^2 \oplus (\gamma^3 \delta^2)^* (\gamma^3 \mu_3 \beta_2 \gamma^1 \delta^3 \oplus \gamma^5 \mu_3 \beta_2 \gamma^1 \delta^4). \end{aligned}$$

See Figure 3.16 for a graphical comparison of the series s and the series $\Psi_{3|2}^b(\Psi_{3|2}(s))$.

3.3. Core Decomposition of Elements in $\mathcal{E}_{m|b}[[\delta]]$

This section focuses on a specific decomposition of series in $\mathcal{E}_{m|b}[[\delta]]$. This decomposition is a factorization of an element in $\mathcal{E}_{m|b}[[\delta]]$, where the core part is a matrix in $\mathcal{M}_{in}^{\alpha x}[[\gamma, \delta]]$. Based on this decomposition it is shown that operations on ultimately cyclic series in $\mathcal{E}_{m|b}[[\delta]]$ can be reduced to operations on matrices with entries in $\mathcal{M}_{in}^{\alpha x}[[\gamma, \delta]]$.

A series $s \in \mathcal{E}_{m|b}[[\delta]]$ can always be represented as $\mathbf{m}_m \mathbf{Q} \mathbf{b}_b$, where \mathbf{Q} is a matrix with entries in $\mathcal{M}_{in}^{\alpha x}[[\gamma, \delta]]$, called core matrix, of size $m \times b$. \mathbf{m}_m is a row vector defined by

$$\mathbf{m}_m := \left[\mu_m \quad \gamma^1 \mu_m \quad \cdots \quad \gamma^{m-1} \mu_m \right],$$

and \mathbf{b}_b is a column vector defined by

$$\mathbf{b}_b := \left[\beta_b \gamma^{b-1} \quad \cdots \quad \beta_b \gamma^1 \quad \beta_b \right]^T.$$

3. Dioids $(\mathcal{E}, \oplus, \otimes)$ and $(\mathcal{E}[[\delta]], \oplus, \otimes)$

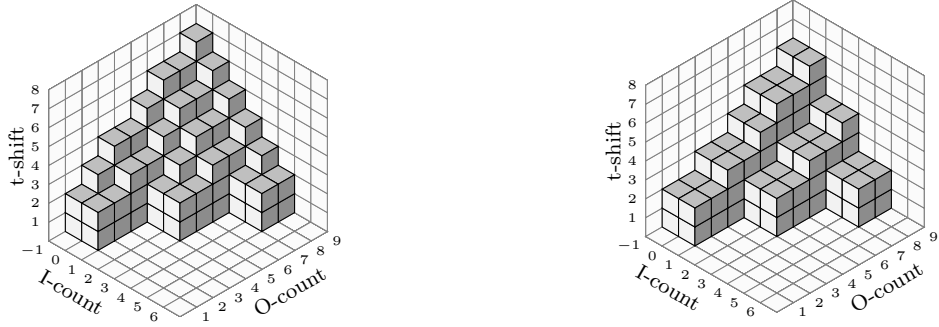

$$(a) s = \gamma^1 \mu_3 \beta_2 \gamma^1 \delta^2 \oplus (\gamma^3 \delta^2)^* ((\gamma^3 \mu_3 \beta_2 \gamma^1 \oplus \gamma^5 \mu_3 \beta_2) \delta^3 \oplus (\gamma^6 \mu_3 \beta_2 \oplus \gamma^5 \mu_3 \beta_2 \gamma^1) \delta^4).$$

$$(b) \Psi_{3|2}^b(\Psi_{3|2}(s)) = \gamma^1 \mu_3 \beta_2 \gamma^1 \delta^2 \oplus (\gamma^3 \delta^2)^* (\gamma^3 \mu_3 \beta_2 \gamma^1 \delta^3 \oplus \gamma^5 \mu_3 \beta_2 \gamma^1 \delta^4).$$

Figure 3.16. – For a comparison of the series s and $\Psi_{3|2}^b(\Psi_{3|2}(s))$ we examine the slices in the (O-count/t-shift)-planes for all I-count values $k \in \mathbb{Z}_{\min}$ of the graphical representation of s and $\Psi_{3|2}^b(\Psi_{3|2}(s))$. Clearly, for all I-count values $k \in \mathbb{Z}_{\min}$ the corresponding slice of s covers the corresponding slice of $\Psi_{3|2}^b(\Psi_{3|2}(s))$, therefore as required $s \geq \Psi_{3|2}^b(\Psi_{3|2}(s))$, see (2.21).

The index b (resp. m) determines the division (resp. multiplication) coefficient and gives the dimension of the vector. First, we illustrate how to obtain this representation on a small example and then provide a formal proof.

Example 23. Consider the following series $s \in \mathcal{E}_{2|2}[[\delta]]$,

$$s = \gamma^1 \mu_2 \beta_2 \oplus (\gamma^2 \delta^2)^* (\mu_2 \beta_2 \gamma^1 \oplus \gamma^2 \mu_2 \beta_2 \delta^2).$$

Due to (3.13), $\gamma^{m \times n} \mu_m = \mu_m \gamma^n$, this series can be written as

$$s = \gamma^1 \mu_2 \underbrace{\quad}_{M_1} \beta_2 \oplus \mu_2 \underbrace{(\gamma^1 \delta^2)^* \quad}_{S_1} \beta_2 \gamma^1 \oplus \mu_2 \gamma^1 \delta^2 \underbrace{(\gamma^1 \delta^2)^* \quad}_{S_2} \beta_2.$$

Clearly, $M_1, S_1, S_2 \in \mathcal{M}_{\text{in}}^{\text{ax}}[[\gamma, \delta]]$. Furthermore, in this form the entries of the \mathbf{m}_2 -vector and \mathbf{b}_2 -vector appear on the left and on the right of M_1, S_1, S_2 . We now can write s in the core-form $\mathbf{m}_2 \mathbf{Q} \mathbf{b}_2$ as follows,

$$s = \underbrace{\begin{bmatrix} \mu_2 & \gamma^1 \mu_2 \end{bmatrix}}_{\mathbf{m}_2} \underbrace{\begin{bmatrix} (\gamma^1 \delta^2)^* & \gamma^1 \delta^2 (\gamma^1 \delta^2)^* \\ \varepsilon & e \end{bmatrix}}_{\mathbf{Q}} \underbrace{\begin{bmatrix} \beta_2 \gamma^1 \\ \beta_2 \end{bmatrix}}_{\mathbf{b}_2}.$$

It is easy to check that this expression $\mathbf{m}_2\mathbf{Q}\mathbf{b}_2$, indeed represents the series s , since

$$\begin{aligned}\mathbf{m}_2\mathbf{Q}\mathbf{b}_2 &= \begin{bmatrix} \mu_2(\gamma^1\delta^2)^* \oplus \gamma^1\mu_2\varepsilon & \mu_2\gamma^1\delta^2(\gamma^1\delta^2)^* \oplus \gamma^1\mu_2e \end{bmatrix} \begin{bmatrix} \beta_2\gamma^1 \\ \beta_2 \end{bmatrix}, \\ &= \begin{bmatrix} (\gamma^2\delta^2)^*\mu_2 & \gamma^2\delta^2(\gamma^2\delta^2)^*\mu_2 \oplus \gamma^1\mu_2 \end{bmatrix} \begin{bmatrix} \beta_2\gamma^1 \\ \beta_2 \end{bmatrix}, \\ &= (\gamma^2\delta^2)^*\mu_2\beta_2\gamma^1 \oplus \gamma^2\delta^2(\gamma^2\delta^2)^*\mu_2\beta_2 \oplus \gamma^1\mu_2\beta_2, \\ &= \gamma^1\mu_2\beta_2 \oplus (\gamma^2\delta^2)^*(\mu_2\beta_2\gamma^1 \oplus \gamma^2\mu_2\beta_2\delta^2) = s.\end{aligned}$$

Proposition 26. Let $s = \bigoplus_i w_i \delta^i \in \mathcal{E}_{m|b}[[\delta]]$ be an (m, b) -periodic series, then s can be written as $s = \mathbf{m}_m\mathbf{Q}\mathbf{b}_b$, where $\mathbf{Q} \in \mathcal{M}_{\text{in}}^{\text{ax}}[[\gamma, \delta]]^{m \times b}$.

Proof. s being an (m, b) -periodic series implies that all coefficients w_i of s are (m, b) -periodic E-operators. Then due to Prop. 11 all coefficients can be expressed in canonical form $w_i = \bigoplus_{j=1}^{J_i} \gamma^{v_{ij}} \mu_m \beta_b \gamma^{v'_{ij}}$ with $J_i \leq \min(m, b)$ and $0 \leq v'_{ij} < b$. Therefore, s can be rewritten as

$$s = \bigoplus_i \left(\bigoplus_{j=1}^{J_i} \gamma^{v_{ij}} \mu_m \beta_b \gamma^{v'_{ij}} \right) \delta^i.$$

Due to (3.13) and the fact that $\forall w \in \mathcal{E}$, $w\delta = \delta w$, the series s can be written as

$$s = \bigoplus_i \left(\bigoplus_{j=1}^{J_i} \gamma^{\tilde{v}_{ij}} \mu_m \gamma^{\hat{v}_{ij}} \delta^i \beta_b \gamma^{v'_{ij}} \right),$$

where $0 \leq \tilde{v}_{ij} = v_{ij} - \lfloor v_{ij}/m \rfloor m < m$ and $\hat{v}_{ij} = \lfloor v_{ij}/m \rfloor$. Observe that $0 \leq \tilde{v}_{ij} < m$ and $0 \leq v'_{ij} < b$, hence s is expressed by

$$s = \begin{bmatrix} \mu_m & \gamma^1\mu_m & \cdots & \gamma^{m-1}\mu_m \end{bmatrix} \bigoplus_i \left(\bigoplus_{j=1}^{J_i} \mathbf{Q}_{ij} \right) \begin{bmatrix} \beta_b \gamma^{b-1} \\ \cdots \\ \beta_b \gamma^1 \\ \beta_b \end{bmatrix},$$

where the entry $(\mathbf{Q}_{ij})_{1+\tilde{v}_{ij}, b-v'_{ij}} = \gamma^{\hat{v}_{ij}} \delta^i$ and all other entries of \mathbf{Q}_{ij} are equals ε . Finally s is in the required form $s = \mathbf{m}_m\mathbf{Q}\mathbf{b}_b$, where $\mathbf{Q} = \bigoplus_i \left(\bigoplus_{j=1}^{J_i} \mathbf{Q}_{ij} \right)$. \square

For the particular case, where $s \in \mathcal{E}_{m|b}[[\delta]]$ is a periodic ultimately cyclic series the core-form can be obtained as follows. Given an ultimately cyclic series $s = \bigoplus_{k=1}^K w_k \delta^{t_k} \oplus$

3. Dioids $(\mathcal{E}, \oplus, \otimes)$ and $(\mathcal{E}[[\delta]], \oplus, \otimes)$

$\bigoplus_{l=1}^L w'_l \delta^{t'_l} (\gamma^\nu \delta^\tau)^* \in \mathcal{E}_{m|b}[[\delta]]$, we can always write s such that all coefficients w_k, w'_l are in the (m, b) -periodic canonical form of Prop. 11, *i.e.*,

$$s = \bigoplus_{i=1}^I \gamma^{n_i} \mu_m \beta_b \gamma^{n'_i} \delta^{t_i} \oplus \bigoplus_{j=1}^J \gamma^{N_j} \mu_m \beta_b \gamma^{N'_j} \delta^{T_j} (\gamma^\nu \delta^\tau)^*.$$

Recall that $\gamma^m \mu_m = \mu_m \gamma^1$ and $\beta_b \gamma^b = \gamma^1 \beta_b$, see (3.13). Moreover, we can always represent an ultimately cyclic series $s \in \mathcal{E}_{m|b}[[\delta]]$ such that ν is a multiple of b , *i.e.*, we can extend $(\gamma^{\tilde{\nu}} \delta^{\tilde{\tau}})^*$ such that, $\nu = \tilde{\nu}l = \text{lcm}(\tilde{\nu}, b)$

$$\begin{aligned} (\gamma^{\tilde{\nu}} \delta^{\tilde{\tau}})^* &= (e \oplus \gamma^{\tilde{\nu}} \delta^{\tilde{\tau}} \oplus \dots \oplus \gamma^{(l-1)\tilde{\nu}} \delta^{(l-1)\tilde{\tau}}) (\gamma^{l\tilde{\nu}} \delta^{l\tilde{\tau}})^*, \\ &= (e \oplus \gamma^{\tilde{\nu}} \delta^{\tilde{\tau}} \oplus \dots \oplus \gamma^{(l-1)\tilde{\nu}} \delta^{(l-1)\tilde{\tau}}) (\gamma^\nu \delta^\tau)^*. \end{aligned}$$

Therefore, in the following we assume $\nu/b \in \mathbb{N}$ and thus $\beta_b (\gamma^\nu \delta^\tau)^* = (\gamma^{\nu/b} \delta^\tau)^* \beta_b$. It follows that s can be written as,

$$s = \bigoplus_{i=1}^I \gamma^{\tilde{n}_i} \mu_m \underbrace{\gamma^{\tilde{n}_i} \delta^{t_i}}_{M_i} \beta_b \gamma^{\tilde{n}'_i} \oplus \bigoplus_{j=1}^J \gamma^{\tilde{N}_j} \mu_m \underbrace{\gamma^{\tilde{N}_j} \delta^{T_j} (\gamma^{\nu/b} \delta^\tau)^*}_{S_j} \beta_b \gamma^{\tilde{N}'_j}, \quad (3.42)$$

where $0 \leq \tilde{n}'_i, \tilde{N}'_j < b$ and $0 \leq \tilde{n}_i, \tilde{N}_j < m$. Clearly, in this representation, M_i are monomials and S_j are series in the dioid $(\mathcal{M}_{\text{in}}^{\alpha\alpha}[[\gamma, \delta]], \oplus, \otimes)$. Moreover, the entries of the \mathbf{b}_b -vector appear on the right and the entries of the \mathbf{m}_m -vector appear on the left of monomial M_i (resp. series S_j). For a given s we denote the set of monomials by $\mathcal{M} = \{M_i, \dots, M_I\}$ and the set of series by $\mathcal{S} = \{S_j, \dots, S_J\}$. Furthermore, the subsets $\mathcal{M}_{l,k}$ (resp. $\mathcal{S}_{l,k}$) are defined as

$$\begin{aligned} \forall l \in \{0, \dots, m-1\}, \forall g \in \{0, \dots, b-1\}, \\ \mathcal{M}_{l,g} &:= \{M_i \in \mathcal{M} \mid \gamma^l \mu_m M_i \beta_b \gamma^g \in \bigoplus_{i=1}^I \gamma^{\tilde{n}_i} \mu_m M_i \beta_b \gamma^{\tilde{n}'_i}\}, \\ \mathcal{S}_{l,g} &:= \{S_j \in \mathcal{S} \mid \gamma^l \mu_m S_j \beta_b \gamma^g \in \bigoplus_{j=1}^J \gamma^{\tilde{N}_j} \mu_m S_j \beta_b \gamma^{\tilde{N}'_j}\}. \end{aligned}$$

The element $(\mathbf{Q})_{l+1, b-g}$ of the core matrix is then obtained by

$$(\mathbf{Q})_{l+1, b-g} = \bigoplus_{M \in \mathcal{M}_{l,g}} M \oplus \bigoplus_{S \in \mathcal{S}_{l,g}} S.$$

In other words, monomial M_i and series S_j are "dispatched" in \mathbf{Q} depending on the left factor $\gamma^i \mu_m$ and the right factor $\beta_b \gamma^j$ of each term of s in (3.42).

Remark 10. Note that, for $s = \mathbf{m}_m \mathbf{Q} \mathbf{b}_b$ be an ultimately cyclic series in $\mathcal{E}_{m|b}[[\delta]]$, the entries of \mathbf{Q} are ultimately cyclic series in $\mathcal{M}_{\text{in}}^{\text{ax}}[[\gamma, \delta]]$.

Example 24. Consider the following series

$$s_1 = \gamma^1 \mu_3 \beta_2 \gamma^1 \delta^2 \oplus (\gamma^3 \mu_3 \beta_2 \gamma^1 \oplus \gamma^5 \mu_3 \beta_2) \delta^3 (\gamma^1 \delta^1)^* \in \mathcal{E}_{3|2}[[\delta]].$$

We first extend $(\gamma^1 \delta^1)^* = (\mathbf{e} \oplus \gamma^1 \delta^1)(\gamma^2 \delta^2)^*$, because in this example $b = 2$. This leads to

$$\begin{aligned} s_1 &= \gamma^1 \mu_3 \beta_2 \gamma^1 \delta^2 \oplus (\gamma^3 \mu_3 \beta_2 \gamma^1 \oplus \gamma^5 \mu_3 \beta_2) \delta^3 (\mathbf{e} \oplus \gamma^1 \delta^1)(\gamma^2 \delta^2)^* \\ &= \gamma^1 \mu_3 \beta_2 \gamma^1 \delta^2 \oplus (\gamma^3 \mu_3 \beta_2 \gamma^1 \delta^3 \oplus \gamma^5 \mu_3 \beta_2 \delta^3 \oplus \\ &\quad \gamma^3 \mu_3 \beta_2 \gamma^2 \delta^4 \oplus \gamma^5 \mu_3 \beta_2 \gamma^1 \delta^4)(\gamma^2 \delta^2)^* \\ &= \gamma^1 \mu_3 \beta_2 \gamma^1 \delta^2 \oplus ((\gamma^3 \mu_3 \beta_2 \gamma^1 \oplus \gamma^5 \mu_3 \beta_2) \delta^3 \oplus (\gamma^6 \mu_3 \beta_2 \oplus \gamma^5 \mu_3 \beta_2 \gamma^1) \delta^4)(\gamma^2 \delta^2)^*. \end{aligned}$$

Now every term in the sum is rewritten as follows

$$\begin{aligned} \gamma^1 \mu_3 \beta_2 \gamma^1 \delta^2 &= \gamma^1 \mu_3 \delta^2 \beta_2 \gamma^1, \\ \gamma^3 \mu_3 \beta_2 \gamma^1 \delta^3 (\gamma^2 \delta^2)^* &= \mu_3 \gamma^1 \delta^3 (\gamma^1 \delta^2)^* \beta_2 \gamma^1, \\ \gamma^5 \mu_3 \beta_2 \delta^3 (\gamma^2 \delta^2)^* &= \gamma^2 \mu_3 \gamma^1 \delta^3 (\gamma^1 \delta^2)^* \beta_2, \\ \gamma^6 \mu_3 \beta_2 \delta^4 (\gamma^2 \delta^2)^* &= \mu_3 \gamma^2 \delta^4 (\gamma^1 \delta^2)^* \beta_2, \\ \gamma^5 \mu_3 \beta_2 \gamma^1 \delta^4 (\gamma^2 \delta^2)^* &= \gamma^2 \mu_3 \gamma^1 \delta^4 (\gamma^1 \delta^2)^* \beta_2 \gamma^1. \end{aligned}$$

Therefore, s_1 can be rephrased as,

$$\begin{aligned} s_1 &= \gamma^1 \mu_3 \underbrace{\delta^2}_{\mathcal{M}_1} \beta_2 \gamma^1 \oplus \mu_3 \underbrace{(\gamma^2 \delta^4 (\gamma^1 \delta^2)^*)}_{\mathcal{S}_1} \beta_2 \oplus \mu_3 \underbrace{(\gamma^1 \delta^3 (\gamma^1 \delta^2)^*)}_{\mathcal{S}_2} \beta_2 \gamma^1 \\ &\quad \oplus \gamma^2 \mu_3 \underbrace{(\gamma^1 \delta^3 (\gamma^1 \delta^2)^*)}_{\mathcal{S}_3} \beta_2 \oplus \gamma^2 \mu_3 \underbrace{(\gamma^1 \delta^4 (\gamma^1 \delta^2)^*)}_{\mathcal{S}_4} \beta_2 \gamma^1. \end{aligned}$$

For this series we obtain the following subsets

$$\begin{aligned} \mathcal{M}_{1,1} &= \{\delta^2\}, \quad \mathcal{M}_{0,0} = \mathcal{M}_{0,1} = \mathcal{M}_{1,0} = \mathcal{M}_{2,0} = \mathcal{M}_{2,1} = \{\varepsilon\}, \\ \mathcal{S}_{0,0} &= \{\gamma^2 \delta^4 (\gamma^1 \delta^2)^*\}, \quad \mathcal{S}_{0,1} = \{\gamma^1 \delta^3 (\gamma^1 \delta^2)^*\}, \\ \mathcal{S}_{2,0} &= \{\gamma^1 \delta^3 (\gamma^1 \delta^2)^*\}, \quad \mathcal{S}_{2,1} = \{\gamma^1 \delta^4 (\gamma^1 \delta^2)^*\}, \\ \mathcal{S}_{1,0} &= \mathcal{S}_{1,1} = \{\varepsilon\}. \end{aligned}$$

The core-form of the series s_1 is given by $\mathbf{m}_3 \mathbf{Q} \mathbf{b}_2$ where

$$\mathbf{Q} = \begin{bmatrix} \gamma^1 \delta^3 (\gamma^1 \delta^2)^* & \gamma^2 \delta^4 (\gamma^1 \delta^2)^* \\ \delta^2 & \varepsilon \\ \gamma^1 \delta^4 (\gamma^1 \delta^2)^* & \gamma^1 \delta^3 (\gamma^1 \delta^2)^* \end{bmatrix}.$$

Properties of the \mathbf{m}_m -vector and the \mathbf{b}_b -vector

In the following, we elaborate some properties of the \mathbf{m}_m -vector and the \mathbf{b}_b -vector, which are useful for computations for series $s \in \mathcal{E}_{m|b}[[\delta]]$. Consider the \mathbf{m}_i -vector and the \mathbf{b}_i -vector with same index i , i.e., \mathbf{m}_i -vector and \mathbf{b}_i -vector have the same length. The scalar product $\mathbf{m}_i \otimes \mathbf{b}_i$ is the identity e , since Prop. 12,

$$\mathbf{m}_i \otimes \mathbf{b}_i = \mu_i \beta_i \gamma^{i-1} \oplus \gamma^1 \mu_i \beta_i \gamma^{i-2} \oplus \cdots \oplus \gamma^{i-1} \mu_i \beta_i = e. \quad (3.43)$$

The dyadic product $\mathbf{b}_i \otimes \mathbf{m}_i$ is a square matrix in $\mathcal{M}_{in}^{\text{ax}}[[\gamma, \delta]]$, denoted by \mathbf{E} .

$$\begin{aligned} \mathbf{E} = \mathbf{b}_i \otimes \mathbf{m}_i &= \begin{bmatrix} \beta_i \gamma^{i-1} \mu_i & \gamma^1 \beta_i \mu_i & \gamma^1 \beta_i \gamma^1 \mu_i & \cdots & \gamma^1 \beta_i \gamma^{i-2} \mu_i \\ \beta_i \gamma^{i-2} \mu_i & \beta_i \gamma^{i-1} \mu_i & \gamma^1 \beta_i \mu_i & \cdots & \gamma^1 \beta_i \gamma^{i-3} \mu_i \\ \vdots & \vdots & \vdots & & \vdots \\ \beta_i \gamma^1 \mu_i & \beta_i \gamma^2 \mu_i & \beta_i \gamma^3 \mu_i & \cdots & \gamma^1 \beta_i \mu_i \\ \beta_i \mu_i & \beta_i \gamma^1 \mu_i & \beta_i \gamma^2 \mu_i & \cdots & \beta_i \gamma^{i-1} \mu_i \end{bmatrix}, \\ &= \begin{bmatrix} e & \gamma^1 & \cdots & \gamma^1 \\ \vdots & \ddots & \ddots & \vdots \\ \vdots & & \ddots & \gamma^1 \\ e & \cdots & \cdots & e \end{bmatrix}, \end{aligned} \quad (3.44)$$

since $\beta_i \gamma^n \mu_i = e$ for $0 \leq n < i$. If necessary, the dimension of \mathbf{E} is stated as an index, e.g., $\mathbf{E}_i = \mathbf{b}_i \mathbf{m}_i \in \{e, \gamma^1\}^{i \times i}$.

Proposition 27. *For the \mathbf{E} matrix, the following relations hold*

$$\mathbf{E}_i \otimes \mathbf{E}_i = \mathbf{E}_i, \quad (3.45)$$

$$\mathbf{E}_i \otimes \mathbf{b}_i = \mathbf{b}_i, \quad (3.46)$$

$$\mathbf{m}_i \otimes \mathbf{E}_i = \mathbf{m}_i. \quad (3.47)$$

Proof. Because of $\mathbf{m}_i \mathbf{b}_i = e$, see (3.43), we have

$$\mathbf{E}_i \otimes \mathbf{E}_i = \mathbf{b}_i \otimes \mathbf{m}_i \otimes \mathbf{b}_i \otimes \mathbf{m}_i = \mathbf{b}_i \otimes e \otimes \mathbf{m}_i = \mathbf{E}_i,$$

$$\mathbf{E}_i \otimes \mathbf{b}_i = \mathbf{b}_i \otimes \mathbf{m}_i \otimes \mathbf{b}_i = \mathbf{b}_i \otimes e = \mathbf{b}_i,$$

$$\mathbf{m}_i \otimes \mathbf{E}_i = \mathbf{m}_i \otimes \mathbf{b}_i \otimes \mathbf{m}_i = e \otimes \mathbf{m}_i = \mathbf{m}_i.$$

□

Corollary 1. *Observe that $\mathbf{I} \oplus \mathbf{E} = \mathbf{E}$ and $\mathbf{E} = \mathbf{E}\mathbf{E}$, as a consequence,*

$$\begin{aligned} \mathbf{E} &= \mathbf{I} \oplus \mathbf{E} \oplus \mathbf{E}\mathbf{E} \oplus \mathbf{E}\mathbf{E}\mathbf{E} \oplus \cdots \\ &= \mathbf{E}^*. \end{aligned} \quad (3.48)$$

Since the scalar product $\mathbf{m}_i \mathbf{b}_i = e$ (3.43) and $\mathbf{E} = \mathbf{E}^*$ (3.48), under some conditions the left product and right product of matrices with entries in $\mathcal{E}[\delta]$ by \mathbf{m}_m and \mathbf{b}_b are invertible, see the following proposition.

Proposition 28. For $\mathbf{D} \in \mathcal{E}[\delta]^{1 \times n}$ and $\mathbf{P} \in \mathcal{E}[\delta]^{n \times 1}$, we have

$$\mathbf{m}_m \backslash \mathbf{D} = \mathbf{b}_m \otimes \mathbf{D}, \quad \mathbf{P} / \mathbf{b}_b = \mathbf{P} \otimes \mathbf{m}_b. \quad (3.49)$$

For $\mathbf{O} \in \mathcal{E}[\delta]^{n \times m}$, $\mathbf{N} \in \mathcal{E}[\delta]^{b \times n}$, we have

$$(\mathbf{O}\mathbf{E}) / \mathbf{m}_m = \mathbf{O}\mathbf{E} \otimes \mathbf{b}_m, \quad \mathbf{b}_b \backslash (\mathbf{E}\mathbf{N}) = \mathbf{m}_b \otimes \mathbf{E}\mathbf{N}. \quad (3.50)$$

Proof. See Section C.1.1 in the appendix. \square

Corollary 2. For $\mathbf{D} \in \mathcal{E}[\delta]^{m \times b}$, $\mathbf{E} \backslash (\mathbf{E}\mathbf{D}) = \mathbf{E}\mathbf{D}$ and $(\mathbf{D}\mathbf{E}) / \mathbf{E} = \mathbf{D}\mathbf{E}$.

Proof.

$$\begin{aligned} \mathbf{E} \backslash (\mathbf{E}\mathbf{D}) &= (\mathbf{b}_m \mathbf{m}_m) \backslash (\mathbf{E}\mathbf{D}), \\ &= \mathbf{m}_m \backslash (\mathbf{b}_m \backslash (\mathbf{E}\mathbf{D})), \quad \text{since } (\mathbf{a}\mathbf{b}) \backslash \mathbf{x} = \mathbf{b} \backslash (\mathbf{a} \backslash \mathbf{x}), \text{ see (A.5) in Appendix A} \\ &= \mathbf{m}_m \backslash (\mathbf{m}_m \mathbf{E}\mathbf{D}), \quad \text{since (3.50)} \\ &= \mathbf{b}_m (\mathbf{m}_m \mathbf{E}\mathbf{D}), \quad \text{since (3.49)} \\ &= \mathbf{E}\mathbf{E}\mathbf{D} = \mathbf{E}\mathbf{D}. \end{aligned}$$

The proof of the right division $(\mathbf{D}\mathbf{E}) / \mathbf{E} = \mathbf{D}\mathbf{E}$ is analogous. \square

Greatest Core-Form

Given a series $s = \mathbf{m}_m \mathbf{Q} \mathbf{b}_b \in \mathcal{E}_{m|b}[\delta]$, in general, the core-matrix \mathbf{Q} is not unique, i.e., $s = \mathbf{m}_m \mathbf{Q} \mathbf{b}_b = \mathbf{m}_m \mathbf{Q}' \mathbf{b}_b$, where $\mathbf{Q} \neq \mathbf{Q}'$. In the following, we prove that s admits a unique greatest core, denoted $\hat{\mathbf{Q}} \in \mathcal{M}_{\text{in}}^{\text{ax}}[\gamma, \delta]^{m \times b}$ (greatest with respect to the order relation in the dioid $\mathcal{M}_{\text{in}}^{\text{ax}}[\gamma, \delta]$, i.e., $\hat{\mathbf{Q}} \geq \mathbf{Q}$ and $\hat{\mathbf{Q}} \geq \mathbf{Q}'$).

Proposition 29. Let $s = \mathbf{m}_m \mathbf{Q} \mathbf{b}_b \in \mathcal{E}_{m|b}[\delta]$ be a decomposition of $s \in \mathcal{E}_{m|b}[\delta]$. The greatest core matrix is given by,

$$\hat{\mathbf{Q}} = \mathbf{E}_m \mathbf{Q} \mathbf{E}_b. \quad (3.51)$$

Proof. Consider the inequality $\mathbf{m}_m \tilde{\mathbf{X}} \mathbf{b}_b \leq \mathbf{m}_m \mathbf{Q} \mathbf{b}_b = s$. Then because of Prop. 28, the greatest solution for $\tilde{\mathbf{X}}$ is

$$\mathbf{m}_m \backslash \mathbf{m}_m \mathbf{Q} \mathbf{b}_b / \mathbf{b}_b = \mathbf{b}_m \mathbf{m}_m \mathbf{Q} \mathbf{b}_b \mathbf{m}_b = \mathbf{E}_m \mathbf{Q} \mathbf{E}_b = \hat{\mathbf{Q}}.$$

Furthermore, because of $\mathbf{m}_m = \mathbf{m}_m \mathbf{E}_m$ (3.47) and $\mathbf{b}_b = \mathbf{E}_b \mathbf{b}_b$ (3.46),

$$\mathbf{m}_m \hat{\mathbf{Q}} \mathbf{b}_b = \mathbf{m}_m \mathbf{E}_m \mathbf{Q} \mathbf{E}_b \mathbf{b}_b = \mathbf{m}_m \mathbf{Q} \mathbf{b}_b = s.$$

\square

Remark 11. The greatest core matrix $\hat{\mathbf{Q}}$ has the following properties. Since $\mathbf{E} \otimes \mathbf{E} = \mathbf{E}$, then $\mathbf{E}\hat{\mathbf{Q}} = \mathbf{E}\mathbf{E}\mathbf{Q}\mathbf{E} = \hat{\mathbf{Q}}$ and $\hat{\mathbf{Q}}\mathbf{E} = \mathbf{E}\mathbf{Q}\mathbf{E}\mathbf{E} = \hat{\mathbf{Q}}$. As a consequence, $\mathbf{E}\hat{\mathbf{Q}}\mathbf{E} = \hat{\mathbf{Q}}$.

Remark 12. Due to the order of the entries in the \mathbf{E} matrix, the left and right multiplications of the core matrix with the \mathbf{E} matrix induce ordering of the entries in the greatest core $\hat{\mathbf{Q}}$. More precisely, in every row the entries are in descending order, i.e. $\forall i \in \{1, \dots, m\}, \forall j \in \{1, \dots, b-1\} (\hat{\mathbf{Q}})_{i,j} \geq (\hat{\mathbf{Q}})_{i,j+1}$ and in every column the entries are in an ascending order, i.e. $\forall i \in \{1, \dots, m-1\}, \forall j \in \{1, \dots, b\} (\hat{\mathbf{Q}})_{i,j} \leq (\hat{\mathbf{Q}})_{i+1,j}$. Furthermore, all entries of the greatest core have the same asymptotic slope. Thus, the greatest core is highly redundant. When we think about software tools it is desirable to reduce memory usage. Therefore, for implementation the order in $\hat{\mathbf{Q}}$ can be used to define a lean representation of $\hat{\mathbf{Q}}$.

Example 25. The greatest core of the series considered in Example 24 is given by

$$\begin{aligned} \hat{\mathbf{Q}} &= \mathbf{E}_3 \mathbf{Q} \mathbf{E}_2, \\ &= \begin{bmatrix} e & \gamma^1 & \gamma^1 \\ e & e & \gamma^1 \\ e & e & e \end{bmatrix} \begin{bmatrix} \gamma^1 \delta^3 (\gamma^1 \delta^2)^* & \gamma^2 \delta^4 (\gamma^1 \delta^2)^* \\ \delta^2 & \varepsilon \\ \gamma^1 \delta^4 (\gamma^1 \delta^2)^* & \gamma^1 \delta^3 (\gamma^1 \delta^2)^* \end{bmatrix} \begin{bmatrix} e & \gamma^1 \\ e & e \end{bmatrix}, \\ &= \begin{bmatrix} \gamma^1 \delta^3 (\gamma^1 \delta^2)^* & \gamma^2 \delta^4 (\gamma^1 \delta^2)^* \\ \delta^2 \oplus \gamma^1 \delta^3 (\gamma^1 \delta^2)^* & \gamma^1 \delta^2 (\gamma^1 \delta^2)^* \\ \delta^2 (\gamma^1 \delta^2)^* & \gamma^1 \delta^3 (\gamma^1 \delta^2)^* \end{bmatrix}. \end{aligned}$$

Note that all entries have the same asymptotic slope $(\gamma^1 \delta^2)^*$. Moreover, observe that the entries in $\hat{\mathbf{Q}}$ are ordered, e.g., $(\hat{\mathbf{Q}})_{1,1} \geq (\hat{\mathbf{Q}})_{1,2}$, as $\gamma^1 \delta^3 (\gamma^1 \delta^2)^* \geq \gamma^2 \delta^4 (\gamma^1 \delta^2)^*$, respectively $(\hat{\mathbf{Q}})_{1,2} \leq (\hat{\mathbf{Q}})_{2,2}$, as $\gamma^2 \delta^4 (\gamma^1 \delta^2)^* \leq \gamma^1 \delta^2 (\gamma^1 \delta^2)^*$, etc.

3.3.1. Calculation with the Core Decomposition

To perform addition between two series $s_1 = \mathbf{m}_{m_1} \hat{\mathbf{Q}}_1 \mathbf{b}_{b_1} \in \mathcal{E}_{m_1|b_1}[[\delta]]$, $s_2 = \mathbf{m}_{m_2} \hat{\mathbf{Q}}_2 \mathbf{b}_{b_2} \in \mathcal{E}_{m_2|b_2}[[\delta]]$ with equal gain, i.e. $m_1/b_1 = m_2/b_2$, in the core-form it is necessary to express the core matrices $\hat{\mathbf{Q}}_1 \in \mathcal{M}_{\text{in}}^{\text{ax}}[[\gamma, \delta]]^{m_1 \times b_1}$ and $\hat{\mathbf{Q}}_2 \in \mathcal{M}_{\text{in}}^{\text{ax}}[[\gamma, \delta]]^{m_2 \times b_2}$ with equal dimensions. This is possible by expressing both series with their least common period $m = \text{lcm}(m_1, m_2)$, see the following proposition.

Proposition 30. A series $s = \mathbf{m}_m \hat{\mathbf{Q}} \mathbf{b}_b \in \mathcal{E}_{m|b}[[\delta]]$ can be expressed with a multiple period (nm, nb) by extending the core matrix $\hat{\mathbf{Q}}$, i.e., $s = \mathbf{m}_m \hat{\mathbf{Q}} \mathbf{b}_b = \mathbf{m}_{nm} \hat{\mathbf{Q}}' \mathbf{b}_{nb}$, where $\hat{\mathbf{Q}}' \in$

$\mathcal{M}_{\text{in}}^{\text{ax}}[[\gamma, \delta]]^{nm \times nb}$ and is given by

$$\hat{\mathbf{Q}}' = \begin{bmatrix} \beta_n \gamma^{n-1} \hat{\mathbf{Q}} \mu_n & \beta_n \gamma^{n-1} \hat{\mathbf{Q}} \gamma^1 \mu_n & \cdots & \beta_n \gamma^{n-1} \hat{\mathbf{Q}} \gamma^{n-1} \mu_n \\ \beta_n \gamma^{n-2} \hat{\mathbf{Q}} \mu_n & \beta_n \gamma^{n-2} \hat{\mathbf{Q}} \gamma^1 \mu_n & \cdots & \beta_n \gamma^{n-2} \hat{\mathbf{Q}} \gamma^{n-1} \mu_n \\ \vdots & \vdots & & \vdots \\ \beta_n \hat{\mathbf{Q}} \mu_n & \beta_n \hat{\mathbf{Q}} \gamma^1 \mu_n & \cdots & \beta_n \hat{\mathbf{Q}} \gamma^{n-1} \mu_n \end{bmatrix}.$$

Proof. See Section C.1.2 in the appendix. \square

Proposition 31. Let $s = \mathbf{m}_m \mathbf{Q} \mathbf{b}_b$, $s' = \mathbf{m}_m \mathbf{Q}' \mathbf{b}_b \in \mathcal{E}_{m|b}[[\delta]]$ be two ultimately cyclic series, the sum $s \oplus s' = \mathbf{m}_m \mathbf{Q}'' \mathbf{b}_b \in \mathcal{E}_{m|b}[[\delta]]$ is an ultimately cyclic series, where $\mathbf{Q}'' = (\mathbf{Q} \oplus \mathbf{Q}')$.

Proof.

$$s \oplus s' = \mathbf{m}_m \mathbf{Q} \mathbf{b}_b \oplus \mathbf{m}_m \mathbf{Q}' \mathbf{b}_b = \mathbf{m}_m (\mathbf{Q} \oplus \mathbf{Q}') \mathbf{b}_b = \mathbf{m}_m \mathbf{Q}'' \mathbf{b}_b$$

Clearly, the entries of the core matrices \mathbf{Q} and \mathbf{Q}' are ultimately cyclic series in $\mathcal{M}_{\text{in}}^{\text{ax}}[[\gamma, \delta]]$. Because of Theorem 2.6 the sum of two ultimately cyclic series in $\mathcal{M}_{\text{in}}^{\text{ax}}[[\gamma, \delta]]$ is again an ultimately cyclic series. Therefore, \mathbf{Q}'' is composed of ultimately cyclic series in $\mathcal{M}_{\text{in}}^{\text{ax}}[[\gamma, \delta]]$ and thus $s \oplus s' = \mathbf{m}_m \mathbf{Q}'' \mathbf{b}_b$ is an ultimately cyclic series in $\mathcal{E}_{m|b}[[\delta]]$. \square

Corollary 3. Let $s = \mathbf{m}_m \hat{\mathbf{Q}} \mathbf{b}_b$, $s' = \mathbf{m}_m \hat{\mathbf{Q}}' \mathbf{b}_b \in \mathcal{E}_{m|b}[[\delta]]$ be two ultimately cyclic series, with $\hat{\mathbf{Q}}, \hat{\mathbf{Q}}'$ are greatest cores, the sum $s \oplus s' = \mathbf{m}_m \hat{\mathbf{Q}}'' \mathbf{b}_b \in \mathcal{E}_{m|b}[[\delta]]$ is an ultimately cyclic series, where $\hat{\mathbf{Q}}'' = (\hat{\mathbf{Q}} \oplus \hat{\mathbf{Q}}')$ is again a greatest core.

Proof.

$$s \oplus s' = \mathbf{m}_m \hat{\mathbf{Q}} \mathbf{b}_b \oplus \mathbf{m}_m \hat{\mathbf{Q}}' \mathbf{b}_b = \mathbf{m}_m (\mathbf{E} \hat{\mathbf{Q}} \mathbf{E} \oplus \mathbf{E} \hat{\mathbf{Q}}' \mathbf{E}) \mathbf{b}_b = \mathbf{m}_m \underbrace{\mathbf{E} (\hat{\mathbf{Q}} \oplus \hat{\mathbf{Q}}') \mathbf{E}}_{\hat{\mathbf{Q}}''} \mathbf{b}_b$$

\square

To perform multiplication between two series $s_1 = \mathbf{m}_{m_1} \hat{\mathbf{Q}}_1 \mathbf{b}_{b_1} \in \mathcal{E}_{m_1|b_1}[[\delta]]$, $s_2 = \mathbf{m}_{m_2} \hat{\mathbf{Q}}_2 \mathbf{b}_{b_2} \in \mathcal{E}_{m_2|b_2}[[\delta]]$ in the core-form it is necessary to express the core matrices with appropriate dimensions. Due to Prop. 30 and by choosing $\mathbf{b} = \text{lcm}(b_1, m_2)$ we can express s_1, s_2 such that $s_1 = \mathbf{m}_{m_1'} \hat{\mathbf{Q}}_1' \mathbf{b}_b$ and $s_2 = \mathbf{m}_b \hat{\mathbf{Q}}_2' \mathbf{b}_{b_2'}$, with $m_1' = m_1 \times \text{lcm}(b_1, m_2)/b_1$ and $b_2' = b_2 \times \text{lcm}(b_1, m_2)/m_2$.

Proposition 32. Let $s = \mathbf{m}_m \mathbf{Q} \mathbf{b}_b \in \mathcal{E}_{m|b}[[\delta]]$ and $s' = \mathbf{m}_b \mathbf{Q}' \mathbf{b}_{b'} \in \mathcal{E}_{b|b'}[[\delta]]$ be two ultimately cyclic series, the product $s \otimes s' = \mathbf{m}_m \mathbf{Q}'' \mathbf{b}_{b'} \in \mathcal{E}_{m|b'}[[\delta]]$ is an ultimately cyclic series, where $\mathbf{Q}'' = \mathbf{Q} \mathbf{E} \mathbf{Q}'$.

Proof.

$$s \otimes s' = \mathbf{m}_m \mathbf{Q} \mathbf{b}_b \mathbf{m}_b \mathbf{Q}' \mathbf{b}_{b'} = \mathbf{m}_m \mathbf{Q} \mathbf{E} \mathbf{Q}' \mathbf{b}_{b'} = \mathbf{m}_m \mathbf{Q}'' \mathbf{b}_{b'}$$

Moreover, the entries of the core matrices \mathbf{Q} and \mathbf{Q}' are ultimately cyclic series in $\mathcal{M}_{\text{in}}^{\text{ax}}[[\gamma, \delta]]$. Because of Theorem 2.6 the sum and product of ultimately cyclic series in $\mathcal{M}_{\text{in}}^{\text{ax}}[[\gamma, \delta]]$ are again ultimately cyclic series in $\mathcal{M}_{\text{in}}^{\text{ax}}[[\gamma, \delta]]$. Therefore, entries of \mathbf{Q}'' are ultimately cyclic series in $\mathcal{M}_{\text{in}}^{\text{ax}}[[\gamma, \delta]]$ and the product $s \otimes s' = \mathbf{m}_m \mathbf{Q}'' \mathbf{b}_{b'}$ is an ultimately cyclic series in $\mathcal{E}_{m|b'}[[\delta]]$. \square

Corollary 4. *Let $s = \mathbf{m}_m \hat{\mathbf{Q}} \mathbf{b}_b \in \mathcal{E}_{m|b}[[\delta]]$ and $s' = \mathbf{m}_b \hat{\mathbf{Q}}' \mathbf{b}_{b'} \in \mathcal{E}_{b|b'}[[\delta]]$ be two ultimately cyclic series, with $\hat{\mathbf{Q}}, \hat{\mathbf{Q}}'$ are greatest cores, the product $s \otimes s' = \mathbf{m}_m \hat{\mathbf{Q}}'' \mathbf{b}_{b'} \in \mathcal{E}_{m|b'}[[\delta]]$ is an ultimately cyclic series, where $\hat{\mathbf{Q}}'' = \hat{\mathbf{Q}} \hat{\mathbf{Q}}'$ is again a greatest core.*

Proof.

$$s \otimes s' = \mathbf{m}_m \hat{\mathbf{Q}} \mathbf{b}_b \mathbf{m}_b \hat{\mathbf{Q}}' \mathbf{b}_{b'} = \mathbf{m}_m \hat{\mathbf{Q}} \mathbf{E} \hat{\mathbf{Q}}' \mathbf{b}_{b'} = \mathbf{m}_m \hat{\mathbf{Q}} \hat{\mathbf{Q}}' \mathbf{b}_{b'},$$

$$\text{Furthermore: } \hat{\mathbf{Q}} \hat{\mathbf{Q}}' = \mathbf{E} \hat{\mathbf{Q}} \mathbf{E} \hat{\mathbf{Q}}' \mathbf{E} = \hat{\mathbf{Q}}''.$$

\square

Proposition 33. *Let $s = \mathbf{m}_b \mathbf{Q} \mathbf{b}_b \in \mathcal{E}_{b|b}[[\delta]]$. Then, $s^* = \mathbf{m}_b (\mathbf{Q} \mathbf{E})^* \mathbf{b}_b \in \mathcal{E}_{b|b}[[\delta]]$ is an ultimately cyclic series.*

Proof. In this case, $\Gamma(s) = b/b = 1$ means that \mathbf{Q} is a square matrix. Moreover, recall that $\mathbf{E} \mathbf{b}_b = \mathbf{b}_b$ (3.44) and therefore $s = \mathbf{m}_b \mathbf{Q} \mathbf{E} \mathbf{b}_b$.

$$s^* = e \oplus \mathbf{m}_b \mathbf{Q} \mathbf{E} \mathbf{b}_b \oplus \mathbf{m}_b \mathbf{Q} \mathbf{E} \mathbf{b}_b \mathbf{m}_b \mathbf{Q} \mathbf{E} \mathbf{b}_b \oplus \dots$$

Since, $e = \mathbf{m}_b \mathbf{b}_b$ (3.43), $\mathbf{E} = \mathbf{b}_b \mathbf{m}_b$ (3.44) and $\mathbf{E} = \mathbf{E}^* = \mathbf{E} \mathbf{E}$ (3.48),

$$\begin{aligned} s^* &= \mathbf{m}_b \mathbf{b}_b \oplus \mathbf{m}_b \mathbf{Q} \mathbf{E} \mathbf{b}_b \oplus \mathbf{m}_b \mathbf{Q} \mathbf{E} \mathbf{E} \mathbf{Q} \mathbf{E} \mathbf{b}_b \oplus \dots \\ &= \mathbf{m}_b (\mathbf{I} \oplus \mathbf{Q} \mathbf{E} \oplus (\mathbf{Q} \mathbf{E})^2 \oplus \dots) \mathbf{b}_b \\ &= \mathbf{m}_b (\mathbf{Q} \mathbf{E})^* \mathbf{b}_b. \end{aligned}$$

Again due to Theorem 2.6 the Kleene star, sum, and product of ultimately cyclic series in $\mathcal{M}_{\text{in}}^{\text{ax}}[[\gamma, \delta]]$ are ultimately cyclic series in $\mathcal{M}_{\text{in}}^{\text{ax}}[[\gamma, \delta]]$ and therefore, $s^* = \mathbf{m}_b (\mathbf{Q} \mathbf{E})^* \mathbf{b}_b$ is an ultimately cyclic series in $\mathcal{E}_{b|b}[[\delta]]$. \square

Remark 13. *Let $s = \mathbf{m}_b \hat{\mathbf{Q}} \mathbf{b}_b \in \mathcal{E}_{b|b}[[\delta]]$ be an ultimately cyclic series expressed with a greatest core. Then, $s^* = \mathbf{m}_b \hat{\mathbf{Q}}^* \mathbf{b}_b \in \mathcal{E}_{b|b}[[\delta]]$ is an ultimately cyclic series. However, in general, $\hat{\mathbf{Q}}^* \leq \mathbf{E} \hat{\mathbf{Q}}^* \mathbf{E}$ as:*

$$\begin{aligned} \hat{\mathbf{Q}}^* &= \mathbf{I} \oplus \hat{\mathbf{Q}} \oplus \hat{\mathbf{Q}}^2 \dots \\ &= \mathbf{I} \oplus \mathbf{E} \hat{\mathbf{Q}} \mathbf{E} \oplus \mathbf{E} \hat{\mathbf{Q}}^2 \mathbf{E} \dots \end{aligned}$$

Whereas,

$$\begin{aligned} \widehat{Q}^* E &= EIE \oplus E\widehat{Q}E \oplus E\widehat{Q}^2 E \dots \\ &= E \oplus \widehat{Q} \oplus \widehat{Q}^2 \dots \end{aligned}$$

However, $\widehat{Q}^* E = (E\widehat{Q}^* E)^*$ as $E = E \oplus I$ and $E\widehat{Q}^* E E\widehat{Q}^* E = E\widehat{Q}^* E$. For an illustration, consider the star of the zero element ε , clearly $(\varepsilon)^* = e$. In the core-form, with $m = b = 2$, this can be written as

$$(\varepsilon)^* = \mathbf{m}_2 \begin{bmatrix} \varepsilon & \varepsilon \\ \varepsilon & \varepsilon \end{bmatrix}^* \mathbf{b}_2 = \mathbf{m}_2 \begin{bmatrix} e & \varepsilon \\ \varepsilon & e \end{bmatrix} \mathbf{b}_2.$$

Note that in this case, I is not the greatest core, i.e. $I < EIE = E$.

In general, for complete partially ordered dioids, such as $(\mathcal{E}[[\delta]], \oplus, \otimes)$, multiplication is not distributive over \wedge , see (2.2). However, in the following lemmas, we show that distributivity holds for left multiplication by the \mathbf{m}_m -vector and right multiplication by the \mathbf{b}_m -vector for specific matrices with entries in $\mathcal{E}[[\delta]]$.

Lemma 2. Let $Q_1, Q_2 \in \mathcal{E}[[\delta]]^{m \times b}$, then

$$\mathbf{m}_m(EQ_1 \wedge EQ_2) = \mathbf{m}_mEQ_1 \wedge \mathbf{m}_mEQ_2.$$

Proof. The proof is similar to the proof of Lemma 4.36 in [1][Chap 4.3]. There distributivity is proven for $c(a \wedge b) = ca \wedge cb$ for the case that c admits a left and right inverse. For this proof, recall that $e = \mathbf{m}_m \mathbf{b}_m$ (3.43), $E = \mathbf{b}_m \mathbf{m}_m$ (3.44) and $E = EE$ (3.45). Moreover, recall that inequality $c(a \wedge b) \leq ca \wedge cb$ holds for a, b, c elements in a partially ordered dioid, see (2.2). Now let us define $\mathbf{q}_1 = \mathbf{m}_mEQ_1$ and $\mathbf{q}_2 = \mathbf{m}_mEQ_2$, then

$$\mathbf{q}_1 \wedge \mathbf{q}_2 = e(\mathbf{q}_1 \wedge \mathbf{q}_2) = \mathbf{m}_m \mathbf{b}_m(\mathbf{q}_1 \wedge \mathbf{q}_2) \leq \mathbf{m}_m(\mathbf{b}_m \mathbf{q}_1 \wedge \mathbf{b}_m \mathbf{q}_2).$$

Inserting $\mathbf{q}_1 = \mathbf{m}_mEQ_1$ and $\mathbf{q}_2 = \mathbf{m}_mEQ_2$ lead to,

$$\begin{aligned} \mathbf{m}_m(\mathbf{b}_m \mathbf{q}_1 \wedge \mathbf{b}_m \mathbf{q}_2) &= \mathbf{m}_m(\mathbf{b}_m \mathbf{m}_mEQ_1 \wedge \mathbf{b}_m \mathbf{m}_mEQ_2), \\ &= \mathbf{m}_m(EEQ_1 \wedge EEQ_2), \\ &= \mathbf{m}_m(EQ_1 \wedge EQ_2). \end{aligned}$$

Finally,

$$\mathbf{m}_m(EQ_1 \wedge EQ_2) \leq \mathbf{m}_mEQ_1 \wedge \mathbf{m}_mEQ_2 = \mathbf{q}_1 \wedge \mathbf{q}_2.$$

Hence, equality holds throughout. □

Lemma 3. Let $Q_1, Q_2 \in \mathcal{E}[[\delta]]^{m \times b}$, then

$$(Q_1 E \wedge Q_2 E) \mathbf{b}_b = Q_1 E \mathbf{b}_b \wedge Q_2 E \mathbf{b}_b.$$

Proof. The proof is similar to the proof of Lemma 2. \square

Proposition 34. Let $s = \mathbf{m}_m \hat{Q} \mathbf{b}_b$, $s' = \mathbf{m}_m \hat{Q}' \mathbf{b}_b \in \mathcal{E}_{m|b}[[\delta]]$ be two ultimately cyclic series, then $s \wedge s' = \mathbf{m}_m \hat{Q}'' \mathbf{b}_b \in \mathcal{E}_{m|b}[[\delta]]$ is an ultimately cyclic series, where $\hat{Q}'' = (\hat{Q} \wedge \hat{Q}')$ is again a greatest core.

Proof. Let us recall that $\hat{Q} = E \hat{Q} E$, then according to Lemma 2 and Lemma 3 we can write

$$\begin{aligned} s \wedge s' &= \mathbf{m}_m \hat{Q} \mathbf{b}_b \wedge \mathbf{m}_m \hat{Q}' \mathbf{b}_b = \mathbf{m}_m E \hat{Q} E \mathbf{b}_b \wedge \mathbf{m}_m E \hat{Q}' E \mathbf{b}_b = \mathbf{m}_m (E \hat{Q} E \wedge E \hat{Q}' E) \mathbf{b}_b \\ &= \mathbf{m}_m (\hat{Q} \wedge \hat{Q}') \mathbf{b}_b \\ &= \mathbf{m}_m (\hat{Q}'') \mathbf{b}_b. \end{aligned}$$

It remains to be shown that $\hat{Q}'' = (\hat{Q} \wedge \hat{Q}')$ is a greatest core. Clearly, $E = E^* = I \oplus E$ implies that $\hat{Q}'' \leq E \hat{Q}'' E$. Then, according to Lemma 2 and Lemma 3,

$$E \hat{Q}'' E = E (\hat{Q} \wedge \hat{Q}') E = \mathbf{b}_m \mathbf{m}_m (\hat{Q} \wedge \hat{Q}') \mathbf{b}_b \mathbf{m}_b = \mathbf{b}_m (\mathbf{m}_m \hat{Q} \mathbf{b}_b \wedge \mathbf{m}_m \hat{Q}' \mathbf{b}_b) \mathbf{m}_b.$$

Recall, $c(a \wedge b) \leq ca \wedge cb$ and $(a \wedge b)c \leq ac \wedge bc$ (2.2), therefore

$$\mathbf{b}_m (\mathbf{m}_m \hat{Q} \mathbf{b}_b \wedge \mathbf{m}_m \hat{Q}' \mathbf{b}_b) \mathbf{m}_b \leq \mathbf{b}_m \mathbf{m}_m \hat{Q} \mathbf{b}_b \mathbf{m}_b \wedge \mathbf{b}_m \mathbf{m}_m \hat{Q}' \mathbf{b}_b \mathbf{m}_b = \hat{Q} \wedge \hat{Q}' = \hat{Q}''.$$

Hence, equality holds throughout. Moreover, note that due to Theorem 2.6 \hat{Q}'' is a matrix where entries are ultimately cyclic series in $\mathcal{M}_{\text{in}}^{\text{ax}}[[\gamma, \delta]]$, hence $s \wedge s' = \mathbf{d}_\omega \hat{Q}'' \mathbf{p}_\omega$ is an ultimately cyclic series in $\mathcal{E}_{m|b}[[\delta]]$. \square

Division in the Core Form

Proposition 35. Let $s = \mathbf{m}_m \hat{Q} \mathbf{b}_b \in \mathcal{E}_{m|b}[[\delta]]$, $s' = \mathbf{m}_m \hat{Q}' \mathbf{b}_{b'} \in \mathcal{E}_{m|b'}[[\delta]]$ be two ultimately cyclic series. Then,

$$s' \setminus s = \mathbf{m}_{b'} (\hat{Q}' \setminus \hat{Q}) \mathbf{b}_b = \mathbf{m}_{b'} \hat{Q}'' \mathbf{b}_b,$$

is an ultimately cyclic series in $\mathcal{E}_{b'|b}[[\delta]]$, where $\hat{Q}'' = \hat{Q}' \setminus \hat{Q}$ is again a greatest core.

Proof. First, it is shown that

$$\hat{Q}' \setminus \hat{Q} = E_{b'} (\hat{Q}' \setminus \hat{Q}) E_b. \quad (3.52)$$

For this,

$$\begin{aligned}
 (\mathbf{E}_{b'}(\hat{\mathbf{Q}}' \backslash \hat{\mathbf{Q}})) \mathbf{E}_b &= (\mathbf{E}_{b'} \backslash (\mathbf{E}_{b'}(\hat{\mathbf{Q}}' \backslash \hat{\mathbf{Q}}))) \mathbf{E}_b, \quad \text{since: Corollary 2} \\
 &= (\mathbf{E}_{b'} \backslash (\mathbf{E}_{b'}((\hat{\mathbf{Q}}' \mathbf{E}_{b'}) \backslash \hat{\mathbf{Q}}))) \mathbf{E}_b, \quad \text{since: } \hat{\mathbf{Q}} = \hat{\mathbf{Q}} \mathbf{E} \\
 &= (\mathbf{E}_{b'} \backslash (\mathbf{E}_{b'}(\mathbf{E}_{b'} \backslash (\hat{\mathbf{Q}}' \backslash \hat{\mathbf{Q}})))) \mathbf{E}_b, \\
 &\quad \text{since: } (ab) \backslash x = b \backslash (a \backslash x) \text{ (A.5)} \\
 &= (\mathbf{E}_{b'} \backslash (\hat{\mathbf{Q}}' \backslash \hat{\mathbf{Q}})) \mathbf{E}_b, \quad \text{since: } a \backslash (a \backslash x) = a \backslash x \text{ (A.4)} \\
 &= ((\hat{\mathbf{Q}}' \mathbf{E}_{b'}) \backslash \hat{\mathbf{Q}}) \mathbf{E}_b = (\hat{\mathbf{Q}}' \backslash \hat{\mathbf{Q}}) \mathbf{E}_b, \\
 &\quad \text{since: } (ab) \backslash x = b \backslash (a \backslash x) \text{ (A.5) and } \hat{\mathbf{Q}} = \hat{\mathbf{Q}} \mathbf{E} \\
 &= ((\hat{\mathbf{Q}}' \backslash (\hat{\mathbf{Q}} \backslash \mathbf{E}_b)) \mathbf{E}_b) \backslash \mathbf{E}_b, \quad \text{since: Corollary 2 twice} \\
 &= (((\hat{\mathbf{Q}}' \backslash \hat{\mathbf{Q}}) \backslash \mathbf{E}_b) \mathbf{E}_b) \backslash \mathbf{E}_b, \quad \text{since: } (a \backslash x) \backslash b = a \backslash (x \backslash b) \text{ (A.6)} \\
 &= (\hat{\mathbf{Q}}' \backslash \hat{\mathbf{Q}}) \backslash \mathbf{E}_b, \quad \text{since: } ((x \backslash a) a) \backslash a = x \backslash a \text{ (A.4)} \\
 &= \hat{\mathbf{Q}}' \backslash (\hat{\mathbf{Q}} \backslash \mathbf{E}_b) = \hat{\mathbf{Q}}' \backslash \hat{\mathbf{Q}}, \\
 &\quad \text{since: } (a \backslash x) \backslash b = a \backslash (x \backslash b) \text{ (A.6) and Corollary 2.}
 \end{aligned}$$

Second,

$$\begin{aligned}
 (\mathbf{m}_m \hat{\mathbf{Q}}' \mathbf{b}_{b'}) \backslash (\mathbf{m}_m \hat{\mathbf{Q}} \mathbf{b}_b) &= (\hat{\mathbf{Q}}' \mathbf{b}_{b'}) \backslash (\mathbf{m}_m \backslash (\mathbf{m}_m \hat{\mathbf{Q}} \mathbf{b}_b)), \quad \text{because of (A.5),} \\
 &= (\hat{\mathbf{Q}}' \mathbf{b}_{b'}) \backslash (\mathbf{b}_m \mathbf{m}_m \hat{\mathbf{Q}} \mathbf{b}_b), \quad \text{because of (3.49),} \\
 &= (\hat{\mathbf{Q}}' \mathbf{b}_{b'}) \backslash (\hat{\mathbf{Q}} \mathbf{b}_b), \quad \text{as } \mathbf{b}_m \mathbf{m}_m \hat{\mathbf{Q}} = \hat{\mathbf{Q}} \text{ Remark 11,} \\
 &= (\hat{\mathbf{Q}}' \mathbf{b}_{b'}) \backslash (\hat{\mathbf{Q}} \backslash \mathbf{m}_b), \quad \text{from (3.50) and Remark 11,} \\
 &= \mathbf{b}_{b'} \backslash (\hat{\mathbf{Q}}' \backslash (\hat{\mathbf{Q}} \backslash \mathbf{m}_b)), \quad \text{because of (A.5),} \\
 &= \mathbf{b}_{b'} \backslash ((\hat{\mathbf{Q}}' \backslash \hat{\mathbf{Q}}) \backslash \mathbf{m}_b), \quad \text{because of (A.6),} \\
 &= \mathbf{m}_{b'}(\hat{\mathbf{Q}}' \backslash \hat{\mathbf{Q}}) \mathbf{b}_b, \quad \text{because of (3.50) and (3.52).}
 \end{aligned}$$

Due to Theorem 2.6, the quotient $\hat{\mathbf{Q}} \backslash \hat{\mathbf{Q}}'$ is a matrix composed of ultimately cyclic series in $\mathcal{M}_{\text{in}}^{\text{ax}}[[\gamma, \delta]]$ and therefore the quotient $s' \backslash s = \mathbf{m}_{b'}(\hat{\mathbf{Q}}' \backslash \hat{\mathbf{Q}}) \mathbf{b}_b$ is an ultimately cyclic series in $\mathcal{E}_{b'|b}[[\delta]]$. \square

Proposition 36. Let $s = \mathbf{m}_m \hat{\mathbf{Q}} \mathbf{b}_b \in \mathcal{E}_{m|b}[\![\delta]\!]$, $s' = \mathbf{m}_{m'} \hat{\mathbf{Q}}' \mathbf{b}_b \in \mathcal{E}_{m'|b}[\![\delta]\!]$ be two ultimately cyclic series. Then,

$$s \not\leq s' = \mathbf{m}_m (\hat{\mathbf{Q}} \hat{\mathbf{Q}}') \mathbf{b}_{m'} = \mathbf{m}_m \hat{\mathbf{Q}}'' \mathbf{b}_{m'},$$

is an ultimately cyclic series in $\mathcal{E}_{m|m'}[\![\delta]\!]$, where $\hat{\mathbf{Q}}'' = \hat{\mathbf{Q}} \hat{\mathbf{Q}}'$ is again a greatest core.

Proof. The proof is analogous to the proof of Prop. 35. \square

Remark 14. Let us note that to compute the infimum and the quotient of two series in the core-form both series must be represented with their greatest cores.

Minimal Core-Form

In contrast, to extending a core, see Prop. 30, we can check if a series $s \in \mathcal{E}_{m|b}[\![\delta]\!]$ can be represented by a core-matrix with smaller dimensions. In the following, we prove that a series $s \in \mathcal{E}_{m|b}[\![\delta]\!]$ can be uniquely represented by a greatest core with minimal dimension.

Proposition 37. An ultimately cyclic series $s \in \mathcal{E}_{m|b}[\![\delta]\!]$ has the minimal core-form $s = \mathbf{m}_m \hat{\mathbf{Q}} \mathbf{b}_b$, where $\hat{\mathbf{Q}} \in \mathcal{M}_{\text{in}}^{\text{ax}}[\![\gamma, \delta]\!]^{m \times b}$ is a canonical matrix of minimal dimensions $m \times b$.

Proof. In the following, we give an algorithm to obtain the minimal core-form. Given a series $s = \mathbf{m}_m \hat{\mathbf{Q}} \mathbf{b}_b \in \mathcal{E}_{m|b}[\![\delta]\!]$, with $\mathcal{K} = \{n \in \mathbb{N} \mid m/n \in \mathbb{N} \text{ and } b/n \in \mathbb{N}\}$ is the set of all common divisors of m and b . The biggest $n \in \mathcal{K}$ such that $s = \mathbf{m}_m \hat{\mathbf{Q}} \mathbf{b}_b = \mathbf{m}_{m/n} \hat{\mathbf{Q}}' \mathbf{b}_{b/n}$ determines the canonical core-form of s . One can check for every $n \in \mathcal{K}$ if s can be represented with a smaller core $\hat{\mathbf{Q}}' \in \mathcal{M}_{\text{in}}^{\text{ax}}[\![\gamma, \delta]\!]^{m/n \times b/n}$. First a core candidate $\tilde{\mathbf{Q}}' \in \mathcal{M}_{\text{in}}^{\text{ax}}[\![\gamma, \delta]\!]^{m/n \times b/n}$ is computed based on the first m/n rows of $\hat{\mathbf{Q}}$. Second, the candidate $\tilde{\mathbf{Q}}'$ is extended by n , see Prop. 30. Therefore, $\tilde{s} = \mathbf{m}_{m/n} \tilde{\mathbf{Q}}' \mathbf{b}_{b/n} = \mathbf{m}_m \tilde{\mathbf{Q}} \mathbf{b}_b$. If $\tilde{\mathbf{Q}} = \hat{\mathbf{Q}}$, then s can be represented by $s = \mathbf{m}_{m/n} \tilde{\mathbf{Q}}' \mathbf{b}_{b/n}$. To obtain a core candidate we partition the core $\hat{\mathbf{Q}}$ into submatrices of size $m/n \times b/n$.

$$\hat{\mathbf{Q}} = \left[\begin{array}{cccc} \mathbf{Q}_{11} & \mathbf{Q}_{12} & \cdots & \mathbf{Q}_{1n} \\ \mathbf{Q}_{21} & \mathbf{Q}_{22} & \cdots & \mathbf{Q}_{2n} \\ \vdots & \vdots & & \vdots \\ \mathbf{Q}_{n1} & \mathbf{Q}_{n2} & \cdots & \mathbf{Q}_{nn} \end{array} \right] \left. \begin{array}{l} \left. \left. \left. \left. \right\} m/n \right. \right. \right. \right. \left. \right\} m \\ \left. \left. \left. \left. \right\} m/n \right. \right. \right. \left. \right\} m \\ \left. \left. \left. \left. \right\} m/n \right. \right. \right. \left. \right\} m \end{array} \right],$$

$$\underbrace{\underbrace{\underbrace{\quad}_{b/n} \quad \underbrace{\quad}_{b/n} \quad \underbrace{\quad}_{b/n}}_b}}_{b}$$

where for $\forall i, j \in \{1, \dots, n\}$, $\mathbf{Q}_{ij} \in \mathcal{M}_{in}^{\text{ax}}[[\gamma, \delta]]^{m/n \times b/n}$. Then a core candidate $\tilde{\mathbf{Q}}$ is computed based on the matrices $\mathbf{Q}_{11}, \mathbf{Q}_{12}, \dots, \mathbf{Q}_{1n}$ as follows,

$$\begin{aligned} \tilde{s} &= \begin{bmatrix} \mu_{1n} & \cdots & \gamma^{l-1} \mu_{1n} \end{bmatrix} \mathbf{Q}_{11} \begin{bmatrix} \beta_{ng} \gamma^{ng-1} \\ \vdots \\ \beta_{ng} \gamma^{ng-n} \end{bmatrix} \oplus \cdots \\ &\quad \oplus \begin{bmatrix} \mu_{1n} & \cdots & \gamma^{l-1} \mu_{1n} \end{bmatrix} \mathbf{Q}_{1n} \begin{bmatrix} \beta_{ng} \gamma^{g-1} \\ \vdots \\ \beta_{ng} \end{bmatrix}, \\ &= \mathbf{m}_l \mu_n \mathbf{Q}_{11} \beta_n \gamma^{n-1} \mathbf{b}_g \oplus \cdots \oplus \mathbf{m}_l \mu_n \mathbf{Q}_{1n} \beta_n \mathbf{b}_g, \\ &= \mathbf{m}_l \left(\mu_n \mathbf{Q}_{11} \beta_n \gamma^{n-1} \oplus \cdots \oplus \mu_n \mathbf{Q}_{1n} \beta_n \right) \mathbf{b}_g, \\ &= \mathbf{m}_l \tilde{\mathbf{Q}} \mathbf{b}_g. \end{aligned}$$

□

Definition 37 (Causal Series in $\mathcal{E}_{m|b}[[\delta]]$). A series $s = \bigoplus_{i \in \mathbb{Z}} w_i \delta^i \in \mathcal{E}_{m|b}[[\delta]]$, with $w_{i+1} \leq w_i$, is said to be causal, if $s = \varepsilon$ or for all $i < 0$, $w_i = \varepsilon$ and for all $i \geq 0$, $w_i \leq \mu_m \beta_b$. The subset of causal (m, b) -periodic series of $\mathcal{E}_{m|b}[[\delta]]$ is denoted by $\mathcal{E}_{m|b}^+[[\delta]]$.

Remark 15. The causal projection $\text{Pr}_{m|b}^+ : \mathcal{E}_{m|b}[[\delta]] \rightarrow \mathcal{E}_{m|b}^+[[\delta]]$, is given by, for $s = \mathbf{m}_m \hat{\mathbf{Q}} \mathbf{b}_b \in \mathcal{E}_{m|b}[[\delta]]$

$$\text{Pr}_{m|b}^+(s) = \text{Pr}_{m|b}^+(\mathbf{m}_m \hat{\mathbf{Q}} \mathbf{b}_b) = \mathbf{m}_m \text{Pr}^+(\hat{\mathbf{Q}}) \mathbf{b}_b,$$

where $\text{Pr}^+(\hat{\mathbf{Q}}) \in \mathcal{M}_{in}^{\text{ax}+}[[\gamma, \delta]]^{m \times b}$ is the causal projection of the greatest core $\hat{\mathbf{Q}}$ in the dioid $\mathcal{M}_{in}^{\text{ax}}[[\gamma, \delta]]$, see Remark 6.

Example 26. Consider the operator $\gamma^{-1} \delta^0 \in \mathcal{E}_{1|1}[[\delta]]$, clearly, this operator is not causal since the exponent of γ is -1 , i.e., $\mu_1 \beta_1 = e = \gamma^0 \leq \gamma^{-1}$. The causal projection $\text{Pr}_{1|1}^+(\gamma^{-1} \delta^0) = \gamma^0 \delta^0 = e$. Therefore, e is the greatest $(1, 1)$ -periodic causal operator smaller than $\gamma^{-1} \delta^0$. This coincides with the causal projection of the operator $\gamma^{-1} \delta^0 \in \mathcal{M}_{in}^{\text{ax}}[[\gamma, \delta]]$, i.e., $\text{Pr}^+(\gamma^{-1} \delta^0) = \gamma^0 \delta^0 = e$, see Remark 6. However, if we express $\gamma^{-1} \delta^0$ in its $(2, 2)$ -periodic form, i.e., $(\gamma^{-1} \mu_2 \beta_2 \gamma^1 \oplus \mu_2 \beta_2) \delta^0$, and then perform the causal projection, i.e.,

$$\text{Pr}_{2|2}^+ \left((\gamma^{-1} \mu_2 \beta_2 \gamma^1 \oplus \mu_2 \beta_2) \delta^0 \right) = \mu_2 \beta_2 \delta^0$$

we obtain $\mu_2 \beta_2 \delta^0$. Observe that $\mu_2 \beta_2 \delta^0 > e = (\mu_2 \beta_2 \gamma^1 \oplus \gamma^1 \mu_2 \beta_2) \delta^0$ and hence $\text{Pr}_{2|2}^+(\gamma^{-1} \delta^0) > \text{Pr}_{1|1}^+(\gamma^{-1} \delta^0)$. $\mu_2 \beta_2 \delta^0$ is the greatest $(2, 2)$ -periodic causal operator smaller than $\gamma^{-1} \delta^0$.

As shown in Example 26, for $s \in \mathcal{E}_{m|b}[[\delta]]$, the causal projection $\text{Pr}_{m|b}^+(s)$ only provides the greatest causal (m, b) -periodic series such that $\text{Pr}_{m|b}^+(s) \leq s$, in general, there might be a causal (nm, nb) -periodic series s' such that $\text{Pr}_{m|b}^+(s) < s' \leq s$.

Remark 16. Let $s = \bigoplus_{i \in \mathbb{Z}} w_i \delta^i \in \mathcal{E}_{m|b}[[\delta]]$, with $w_{i+1} \leq w_i$, and for all $i \geq 0$, $w_i \leq \mu_m \beta_b$, then the causal (m, b) -periodic series $\text{Pr}_{m|b}^+(s)$ is the greatest causal series such that $\text{Pr}_{m|b}^+(s) \leq s$.

3.4. Matrices with entries in $\mathcal{E}_{m|b}[[\delta]]$

In the last section the core decomposition for series in $\mathcal{E}_{m|b}[[\delta]]$ was introduced. This section extends the core representation to matrices with entries in $\mathcal{E}_{m|b}[[\delta]]$. We first give the decomposition for a trivial example and then show how arbitrary matrices $\mathbf{A} \in \mathcal{E}_{m|b}[[\delta]]^{g \times p}$ can be handled. However, the focus of this section lies on a particular subclass of matrices with entries in $\mathcal{E}_{m|b}[[\delta]]$, called consistent matrices. The study of this subclass is motivated by the modeling of consistent WTEGs in the dioid $(\mathcal{E}[[\delta]], \oplus, \otimes)$, see Section 6.2. Similarly to Section 3.3 it is shown that all relevant operations on consistent matrices with entries in $\mathcal{E}_{m|b}[[\delta]]$ can be reduced to operations on matrices with entries in $\mathcal{M}_{\text{in}}^{\text{ax}}[[\gamma, \delta]]$.

Example 27. Let us first consider the trivial case, in which all entries of a matrix are (m, b) -periodic series in $\mathcal{E}_{m|b}[[\delta]]$. For instance, the following matrix $\mathbf{A} \in \mathcal{E}_{m|b}[[\delta]]^{2 \times 2}$ with (m, b) -periodic entries $a_{11}, a_{12}, a_{21}, a_{22} \in \mathcal{E}_{m|b}[[\delta]]$.

$$\mathbf{A} = \begin{bmatrix} a_{11} & a_{12} \\ a_{21} & a_{22} \end{bmatrix} = \begin{bmatrix} \mathbf{m}_m \mathbf{Q}_{11} \mathbf{b}_b & \mathbf{m}_m \mathbf{Q}_{12} \mathbf{b}_b \\ \mathbf{m}_m \mathbf{Q}_{21} \mathbf{b}_b & \mathbf{m}_m \mathbf{Q}_{22} \mathbf{b}_b \end{bmatrix}.$$

This matrix can be represented in the following decomposed form

$$\mathbf{A} = \begin{bmatrix} \mathbf{m}_m & \varepsilon \\ \varepsilon & \mathbf{m}_m \end{bmatrix} \underbrace{\begin{bmatrix} \mathbf{Q}_{11} & \mathbf{Q}_{12} \\ \mathbf{Q}_{21} & \mathbf{Q}_{22} \end{bmatrix}}_{\mathbf{Q}} \begin{bmatrix} \mathbf{b}_b & \varepsilon \\ \varepsilon & \mathbf{b}_b \end{bmatrix}.$$

Clearly, \mathbf{Q} is a matrix with entries in $\mathcal{M}_{\text{in}}^{\text{ax}}[[\gamma, \delta]]$ of size $2m \times 2b$.

In general, for matrices with entries in $\mathcal{E}_{m|b}[[\delta]]$, the entries may have different periods. For instance, consider the matrix

$$\mathbf{A} = \begin{bmatrix} a_{11} & a_{12} \\ a_{21} & a_{22} \end{bmatrix} = \begin{bmatrix} \mathbf{m}_3 \mathbf{Q}_{11} \mathbf{b}_2 & \mathbf{m}_2 \mathbf{Q}_{12} \mathbf{b}_3 \\ \mathbf{m}_4 \mathbf{Q}_{21} \mathbf{b}_5 & \mathbf{m}_3 \mathbf{Q}_{22} \mathbf{b}_3 \end{bmatrix}.$$

For this matrix, the decomposition as shown in Example 27 is not possible. However, we can decompose an arbitrary matrix $\mathbf{A} \in \mathcal{E}_{m|b}[[\delta]]^{M \times N}$ as follows,

$$\mathbf{A} = \begin{bmatrix} a_{11} & \cdots & a_{1N} \\ \vdots & & \vdots \\ a_{M1} & \cdots & a_{MN} \end{bmatrix} = \begin{bmatrix} \mathbf{m}_{m_{11}} \mathbf{Q}_{11} \mathbf{b}_{b_{11}} & \cdots & \mathbf{m}_{m_{1N}} \mathbf{Q}_{1N} \mathbf{b}_{b_{1N}} \\ \vdots & & \vdots \\ \mathbf{m}_{m_{M1}} \mathbf{Q}_{M1} \mathbf{b}_{b_{M1}} & \cdots & \mathbf{m}_{m_{MN}} \mathbf{Q}_{MN} \mathbf{b}_{b_{MN}} \end{bmatrix}$$

$$= \mathbf{M}_L \mathbf{Q} \mathbf{B}_R$$

where,

$$\mathbf{M}_L = \begin{bmatrix} \begin{bmatrix} \mathbf{m}_{m_{11}} & \cdots & \mathbf{m}_{m_{1N}} \\ \varepsilon & \cdots & \varepsilon \\ \vdots & \ddots & \vdots \\ \varepsilon & \cdots & \varepsilon \end{bmatrix} & \cdots & \begin{bmatrix} \varepsilon & \cdots & \varepsilon \\ \vdots & \ddots & \vdots \\ \varepsilon & \cdots & \varepsilon \\ \mathbf{m}_{m_{M1}} & \cdots & \mathbf{m}_{m_{MN}} \end{bmatrix} \end{bmatrix}$$

$$\mathbf{B}_R = \begin{bmatrix} \begin{bmatrix} \mathbf{b}_{b_{11}} & \varepsilon & \cdots & \varepsilon \\ \varepsilon & \ddots & \ddots & \vdots \\ \vdots & \ddots & \ddots & \varepsilon \\ \varepsilon & \cdots & \varepsilon & \mathbf{b}_{b_{1N}} \end{bmatrix} \\ \vdots \\ \begin{bmatrix} \mathbf{b}_{b_{M1}} & \varepsilon & \cdots & \varepsilon \\ \varepsilon & \ddots & \ddots & \vdots \\ \vdots & \ddots & \ddots & \varepsilon \\ \varepsilon & \cdots & \varepsilon & \mathbf{b}_{b_{MN}} \end{bmatrix} \end{bmatrix}$$

$$\mathbf{Q} = \begin{bmatrix} \mathbf{Q}_{11} & \varepsilon & \cdots & \cdots & \cdots & \cdots & \varepsilon \\ \varepsilon & \ddots & \ddots & & & & \vdots \\ \vdots & \ddots & \mathbf{Q}_{1N} & \ddots & & & \vdots \\ \vdots & & \ddots & \ddots & \ddots & & \vdots \\ \vdots & & & \ddots & \mathbf{Q}_{M1} & \ddots & \vdots \\ \vdots & & & & \ddots & \ddots & \varepsilon \\ \varepsilon & \cdots & \cdots & \cdots & \cdots & \varepsilon & \mathbf{Q}_{MN} \end{bmatrix}.$$

In this form, \mathbf{Q} is a block diagonal matrix again with entries in $\mathcal{M}_{\text{in}}^{\text{ax}}[[\gamma, \delta]]$.

3.4.1. Decomposition of Consistent Matrices

Definition 38. The gain of a matrix $\mathbf{A} \in \mathcal{E}_{m|b}[[\delta]]^{p \times g}$, denoted by $\Gamma(\mathbf{A}) \in \mathbb{Q}^{p \times g}$, is defined by

$$(\Gamma(\mathbf{A}))_{i,j} := \Gamma((\mathbf{A})_{i,j}).$$

Remark 17. Note that, because for an (m, b) -periodic element $a \in \mathcal{E}_{m|b}[[\delta]]$, m and b are strictly positive integers, therefore the entries of $\Gamma(\mathbf{A}) \in \mathbb{Q}^{p \times g}$ are again strictly positive.

Definition 39. A matrix $\mathbf{A} \in \mathcal{E}_{m|b}[[\delta]]^{p \times g}$ is called consistent, if $\text{rank}(\Gamma(\mathbf{A})) = 1$, i.e., the rank of its corresponding gain matrix is 1.

Remark 18. When we consider matrices with entries in $\mathcal{E}_{m|b}[[\delta]]$ and some entries equal to the zero element ε , the gain to these elements can be freely chosen to any positive value in \mathbb{Q} . Recall that $\forall k \in \overline{\mathbb{Z}}_{\min}$, $\mathcal{F}_\varepsilon(k) = \infty$ and therefore $\forall k \in \overline{\mathbb{Z}}_{\min}$, $\forall m, b \in \mathbb{N}$, $\mathcal{F}_\varepsilon(k + b) = m + \mathcal{F}_\varepsilon(k) = \infty$. Hence, we can choose any period for the ε operator (Remark 8). Now recall that for $s \in \mathcal{E}_{m|b}[[\delta]]$, $\Gamma(s) = m/b$ (Definition 32), therefore the gain $\Gamma(\varepsilon)$ can be chosen to any value in \mathbb{Q} . Thus, if we check (minimize) the rank of the matrix $\Gamma(\mathbf{A})$ the entries $(\mathbf{A})_{i,j}$ equal to ε are variables.

Example 28. Consider the following matrix $\mathbf{A} \in \mathcal{E}_{m|b}[[\delta]]^{2 \times 2}$,

$$\mathbf{A} = \begin{bmatrix} \varepsilon & \mu_2 \beta_3 \delta^2 \\ \varepsilon & \mu_4 \beta_1 \delta^3 \end{bmatrix}.$$

The corresponding gain matrix $\Gamma(\mathbf{A})$ is

$$\Gamma(\mathbf{A}) = \begin{bmatrix} 1 & \frac{2}{3} \\ \alpha & 4 \end{bmatrix},$$

where $\alpha \in \mathbb{Q}$, $\alpha > 0$ is variable. Clearly, for $\alpha = 6$, the matrix $\Gamma(\mathbf{A})$ has rank 1 and thus the matrix \mathbf{A} is consistent.

We use the adjective consistent for matrices with entries in $\mathcal{E}_{m|b}[[\delta]]$ since a consistent WTEG admits a consistent transfer function matrix $\mathbf{H} \in \mathcal{E}_{m|b}[[\delta]]$, this is shown in Section 6, Prop. 95. In the sequel, we elaborate the core decomposition for consistent matrices with entries in $\mathcal{E}_{m|b}[[\delta]]$. Furthermore, we give the conditions under which the sum, product, and quotient of consistent matrices are again consistent matrices.

Theorem 3.1 ([41](0.4.6(e))). Let $\mathbf{N} \in \mathbb{Q}^{p \times g}$ be a matrix of rank 1, then \mathbf{N} can be written as a product: $\mathbf{N} = \mathbf{L}\mathbf{R}$ where $\mathbf{L} \in \mathbb{Q}^{p \times 1}$ and $\mathbf{R} \in \mathbb{Q}^{1 \times g}$.

Remark 19. The full-rank factorization of \mathbf{N} is not unique. Therefore, given a matrix $\mathbf{N} \in \mathbb{Q}^{p \times g}$ be of rank 1, then \mathbf{N} can be written as $\mathbf{N} = \mathbf{L}\mathbf{R}$, where $\mathbf{L} \in \mathbb{Z}^{p \times 1}$ and $\mathbf{R} = [1/r_1 \ \cdots \ 1/r_g] \in \mathbb{Q}^{1 \times g}$, where $\forall i \in \{1, \dots, g\}$, $r_i \in \mathbb{Z}$.

Remark 20. Recall the fact that the gain of an element $\mathbf{a} \in \mathcal{E}_{m|b}[[\delta]]$ is a strictly positive value. Therefore, given a consistent matrix $\mathbf{A} \in \mathcal{E}_{m|b}[[\delta]]^{p \times q}$ we can express the gain $\Gamma(\mathbf{A}) \in \mathbb{Q}^{p \times q}$ by the product $\mathbf{a}_c \mathbf{a}_r$ where $\mathbf{a}_c \in \mathbb{Q}^{p \times 1}$ is a column vector with strictly positive entries and $\mathbf{a}_r \in \mathbb{Q}^{1 \times q}$ is a row vector with strictly positive entries.

In general, a consistent matrix $\mathbf{A} \in \mathcal{E}_{m|b}[[\delta]]^{g \times p}$ can be decomposed into a $\mathcal{M}_{\text{in}}^{\text{ax}}[[\gamma, \delta]]$ matrix (core), a matrix \mathbf{M}_w and a matrix $\mathbf{B}_{w'}$, which are block diagonal matrix where the entries are \mathbf{m}_m -vectors and \mathbf{b}_b -vectors, i.e.,

$$\mathbf{M}_w = \begin{bmatrix} \mathbf{m}_{m_1} & \varepsilon & \cdots & \varepsilon \\ \varepsilon & \ddots & \ddots & \vdots \\ \vdots & \ddots & \ddots & \varepsilon \\ \varepsilon & \cdots & \varepsilon & \mathbf{m}_{m_p} \end{bmatrix}, \quad \mathbf{B}_{w'} = \begin{bmatrix} \mathbf{b}_{b_1} & \varepsilon & \cdots & \varepsilon \\ \varepsilon & \ddots & \ddots & \vdots \\ \vdots & \ddots & \ddots & \varepsilon \\ \varepsilon & \cdots & \varepsilon & \mathbf{b}_{b_g} \end{bmatrix}.$$

The indices $\mathbf{w} = [m_1 \cdots m_p]$ and $\mathbf{w}' = [b_1 \cdots b_g]$ are vectors, the entries of which represent the multiplication and division coefficients.

Example 29.

$$\mathbf{M}_{[3 \ 2]} = \begin{bmatrix} \begin{bmatrix} \mu_3 & \gamma^1 \mu_3 & \gamma^2 \mu_3 \end{bmatrix} & \varepsilon \\ & \begin{bmatrix} \mu_2 & \gamma^1 \mu_2 \end{bmatrix} \end{bmatrix}$$

$$\mathbf{B}_{[2 \ 3]} = \begin{bmatrix} \begin{bmatrix} \beta_2 \gamma^1 \\ \beta_2 \end{bmatrix} & \varepsilon \\ \varepsilon & \begin{bmatrix} \beta_3 \gamma^2 \\ \beta_3 \gamma^1 \\ \beta_3 \end{bmatrix} \end{bmatrix}$$

Similarly to the scalar case, where $\mathbf{m}_i \mathbf{b}_i = e$ and $\mathbf{b}_i \mathbf{m}_i = \mathbf{E}$, the product $\mathbf{M}_w \mathbf{B}_{w'}$ and $\mathbf{B}_{w'} \mathbf{M}_w$ are specific matrices. Let us consider a specific matrix \mathbf{M}_w and a specific matrix $\mathbf{B}_{w'}$ such that $\mathbf{w} = \mathbf{w}'$, thus both matrices have the same weight vector \mathbf{w} . Then, by recalling that $\mathbf{m}_{m_i} \mathbf{b}_{m_i} = e$ (3.43),

$$\mathbf{M}_w \mathbf{B}_w = \begin{bmatrix} \mathbf{m}_{m_1} \mathbf{b}_{m_1} & \varepsilon & \cdots & \varepsilon \\ \varepsilon & \ddots & \ddots & \vdots \\ \vdots & \ddots & \ddots & \varepsilon \\ \varepsilon & \cdots & \varepsilon & \mathbf{m}_{m_p} \mathbf{b}_{m_p} \end{bmatrix} = \begin{bmatrix} e & \varepsilon & \cdots & \varepsilon \\ \varepsilon & \ddots & \ddots & \vdots \\ \vdots & \ddots & \ddots & \varepsilon \\ \varepsilon & \cdots & \varepsilon & e \end{bmatrix} = \mathbf{I}.$$

Moreover, because of $\mathbf{b}_{m_i} \mathbf{m}_{m_i} = \mathbf{E}_{m_i}$ (3.44),

$$\mathbf{B}_w \mathbf{M}_w = \begin{bmatrix} \mathbf{b}_{m_1} \mathbf{m}_{m_1} & \varepsilon & \cdots & \varepsilon \\ \varepsilon & \ddots & \ddots & \vdots \\ \vdots & \ddots & \ddots & \varepsilon \\ \varepsilon & \cdots & \varepsilon & \mathbf{b}_{m_p} \mathbf{m}_{m_p} \end{bmatrix} = \begin{bmatrix} \mathbf{E}_{m_1} & \varepsilon & \cdots & \varepsilon \\ \varepsilon & \ddots & \ddots & \vdots \\ \vdots & \ddots & \ddots & \varepsilon \\ \varepsilon & \cdots & \varepsilon & \mathbf{E}_{m_p} \end{bmatrix}.$$

This product $\mathbf{B}_w \mathbf{M}_w$ is denoted by \mathbf{E}_w . As in the scalar case, one has $\mathbf{E}_w \mathbf{E}_w = \mathbf{E}_w$; $\mathbf{M}_w \mathbf{E}_w = \mathbf{M}_w$ and $\mathbf{E}_w' \mathbf{B}_w' = \mathbf{B}_w'$.

Proposition 38. For \mathbf{M}_w (resp. \mathbf{B}_w') we have

$$\mathbf{M}_w \setminus \mathbf{D} = \mathbf{B}_w \mathbf{D}, \quad \mathbf{O} \setminus \mathbf{B}_w' = \mathbf{O} \mathbf{M}_w', \quad (3.53)$$

$$(\mathbf{N} \mathbf{E}_w) \setminus \mathbf{M}_w = (\mathbf{N} \mathbf{E}_w) \mathbf{B}_w, \quad \mathbf{B}_w' \setminus (\mathbf{E}_w' \mathbf{G}) = \mathbf{M}_w' (\mathbf{E}_w' \mathbf{G}), \quad (3.54)$$

where \mathbf{D} , \mathbf{O} , \mathbf{N} and \mathbf{G} are matrices of appropriate size and with entries in $\mathcal{E}[[\delta]]$.

Proof. See Section C.1.3 in the Appendix. \square

Proposition 39. Let $\mathbf{A} \in \mathcal{E}_{m|b}[[\delta]]^{p \times g}$ be a consistent matrix, then \mathbf{A} can be decomposed in the following form:

$$\begin{aligned} \mathbf{A} &= \begin{bmatrix} a_{11} & \cdots & a_{1n} \\ \vdots & & \vdots \\ a_{p1} & \cdots & a_{pn} \end{bmatrix} = \begin{bmatrix} \mathbf{m}_{m_1} \hat{\mathbf{Q}}_{11} \mathbf{b}_{b_1} & \cdots & \mathbf{m}_{m_1} \hat{\mathbf{Q}}_{1g} \mathbf{b}_{b_g} \\ \vdots & & \vdots \\ \mathbf{m}_{m_p} \hat{\mathbf{Q}}_{p1} \mathbf{b}_{b_1} & \cdots & \mathbf{m}_{m_p} \hat{\mathbf{Q}}_{pg} \mathbf{b}_{b_g} \end{bmatrix}, \\ &= \underbrace{\begin{bmatrix} \mathbf{m}_{m_1} & \varepsilon & \cdots & \varepsilon \\ \varepsilon & \ddots & \ddots & \vdots \\ \vdots & \ddots & \ddots & \varepsilon \\ \varepsilon & \cdots & \varepsilon & \mathbf{m}_{m_p} \end{bmatrix}}_{\mathbf{M}_w} \underbrace{\begin{bmatrix} \hat{\mathbf{Q}}_{11} & \cdots & \hat{\mathbf{Q}}_{1g} \\ \vdots & & \vdots \\ \hat{\mathbf{Q}}_{p1} & \cdots & \hat{\mathbf{Q}}_{pg} \end{bmatrix}}_{\hat{\mathbf{Q}}} \underbrace{\begin{bmatrix} \mathbf{b}_{b_1} & \varepsilon & \cdots & \varepsilon \\ \varepsilon & \ddots & \ddots & \vdots \\ \vdots & \ddots & \ddots & \varepsilon \\ \varepsilon & \cdots & \varepsilon & \mathbf{b}_{b_g} \end{bmatrix}}_{\mathbf{B}_w'}. \end{aligned} \quad (3.55)$$

Proof. Due to Theorem 3.1 one can represent all entries of a row $(\mathbf{A})_{i,:}$ with the same \mathbf{m}_i -vector. Similarly one can represent all entries of a column $(\mathbf{A})_{:,i}$ with the same \mathbf{b}_i -vector. Then the \mathbf{m}_i -vector are factored out on the left in the \mathbf{M}_w -matrix and the \mathbf{b}_i -vector are factored out on the right in the \mathbf{B}_w' -matrix. \square

Example 30. Consider the following matrix $\mathbf{A} \in \mathcal{E}_{m|b}[[\delta]]^{2 \times 2}$,

$$\mathbf{A} = \begin{bmatrix} (\mu_3 \beta_2 \gamma^1 \oplus \gamma^2 \mu_2 \beta_3) \delta^1 (\gamma^1 \delta^1)^* & \mu_3 \beta_2 \delta^2 \\ \mu_4 \beta_1 & \mu_4 \beta_1 \delta^3 \end{bmatrix}.$$

Expressing all elements of the matrix in the core form leads to,

$$\mathbf{A} = \left[\begin{array}{cc} \mathbf{m}_3 \begin{bmatrix} \delta^1(\gamma^1\delta^2)^* & \gamma^1\delta^2(\gamma^1\delta^2)^* \\ \varepsilon & \varepsilon \\ \delta^2(\gamma^1\delta^2)^* & \delta^1(\gamma^1\delta^2)^* \end{bmatrix} \mathbf{b}_2 & \mathbf{m}_3 \begin{bmatrix} \varepsilon & \delta^2 \\ \varepsilon & \varepsilon \\ \varepsilon & \varepsilon \end{bmatrix} \mathbf{b}_2 \\ \mathbf{m}_4 \begin{bmatrix} e \\ \varepsilon \\ \varepsilon \\ \varepsilon \end{bmatrix} \mathbf{b}_1 & \mathbf{m}_4 \begin{bmatrix} \delta^3 \\ \varepsilon \\ \varepsilon \\ \varepsilon \end{bmatrix} \mathbf{b}_1 \end{array} \right].$$

The gain matrix $\Gamma(\mathbf{A})$ of matrix \mathbf{A} is,

$$\Gamma(\mathbf{A}) = \begin{bmatrix} \frac{3}{2} & \frac{3}{2} \\ 4 & 4 \end{bmatrix} = \begin{bmatrix} 3 \\ 8 \end{bmatrix} \begin{bmatrix} \frac{1}{2} & \frac{1}{2} \end{bmatrix}.$$

Clearly, $\Gamma(\mathbf{A})$ has rank 1, thus \mathbf{A} is consistent. Moreover, $\Gamma(\mathbf{A})$ has a rank 1 factorization given by the vectors $\begin{bmatrix} 3 & 8 \end{bmatrix}^\top$ and $\begin{bmatrix} 1/2 & 1/2 \end{bmatrix}$. According to the entries of $\begin{bmatrix} 3 & 8 \end{bmatrix}^\top$ all entries of the first row of matrix \mathbf{A} are expressed with the \mathbf{m}_3 -vector and all entries of the second row with the \mathbf{m}_8 -vector. Respectively, according to the entries of $\begin{bmatrix} 1/2 & 1/2 \end{bmatrix}$ all entries of the first column of matrix \mathbf{A} are expressed with the \mathbf{b}_2 -vector and all entries of the second column with the \mathbf{b}_1 -vector. This is achieved by extending the core-matrices of the entries $(\mathbf{A})_{1,2}$ and $(\mathbf{A})_{2,2}$, Prop. 30 and leads to,

$$\mathbf{A} = \left[\begin{array}{cc} \mathbf{m}_3 \begin{bmatrix} \delta^1(\gamma^1\delta^2)^* & \gamma^1\delta^2(\gamma^1\delta^2)^* \\ \delta^1(\gamma^1\delta^2)^* & \gamma^1\delta^2(\gamma^1\delta^2)^* \\ \delta^2(\gamma^1\delta^2)^* & \delta^1(\gamma^1\delta^2)^* \end{bmatrix} \mathbf{b}_2 & \mathbf{m}_3 \begin{bmatrix} \delta^2 & \delta^2 \\ \delta^2 & \delta^2 \\ \delta^2 & \delta^2 \end{bmatrix} \mathbf{b}_2 \\ \mathbf{m}_8 \begin{bmatrix} e & \gamma^1 \\ e & \gamma^1 \\ e & \gamma^1 \\ e & \gamma^1 \\ e & e \\ e & e \\ e & e \\ e & e \end{bmatrix} \mathbf{b}_2 & \mathbf{m}_8 \begin{bmatrix} \delta^3 & \gamma^1\delta^3 \\ \delta^3 & \gamma^1\delta^3 \\ \delta^3 & \gamma^1\delta^3 \\ \delta^3 & \gamma^1\delta^3 \\ \delta^3 & \delta^3 \\ \delta^3 & \delta^3 \\ \delta^3 & \delta^3 \\ \delta^3 & \delta^3 \end{bmatrix} \mathbf{b}_2 \end{array} \right].$$

Note that in this form the entries are expressed with their greatest core-matrices. This matrix

can now be written as a product in the following form,

$$\mathbf{A} = \underbrace{\begin{bmatrix} \mathbf{m}_3 & \varepsilon \\ \varepsilon & \mathbf{m}_8 \end{bmatrix}}_{\mathbf{M}_{[3 \ 8]}} \underbrace{\begin{bmatrix} \delta^1(\gamma^1\delta^2)^* & \gamma^1\delta^2(\gamma^1\delta^2)^* & \delta^2 & \delta^2 \\ \delta^1(\gamma^1\delta^2)^* & \gamma^1\delta^2(\gamma^1\delta^2)^* & \delta^2 & \delta^2 \\ \delta^2(\gamma^1\delta^2)^* & \delta^1(\gamma^1\delta^2)^* & \delta^2 & \delta^2 \\ e & \gamma^1 & \delta^3 & \gamma^1\delta^3 \\ e & \gamma^1 & \delta^3 & \gamma^1\delta^3 \\ e & \gamma^1 & \delta^3 & \gamma^1\delta^3 \\ e & \gamma^1 & \delta^3 & \gamma^1\delta^3 \\ e & e & \delta^3 & \delta^3 \\ e & e & \delta^3 & \delta^3 \\ e & e & \delta^3 & \delta^3 \\ e & e & \delta^3 & \delta^3 \end{bmatrix}}_{\mathbf{Q}} \underbrace{\begin{bmatrix} \mathbf{b}_2 & \varepsilon \\ \varepsilon & \mathbf{b}_2 \end{bmatrix}}_{\mathbf{B}_{[2 \ 2]}}.$$

Clearly in this form \mathbf{Q} is a matrix with entries in $\mathcal{M}_{\text{in}}^{\text{ax}}[\![\gamma, \delta]\!]$.

Greatest Core-Matrix in the Matrix Case

As in the scalar case, where $\hat{\mathbf{Q}} = \mathbf{E}\mathbf{Q}\mathbf{E}$ is the greatest core of the series $s = \mathbf{m}_m\mathbf{Q}\mathbf{b}_b \in \mathcal{E}_{\text{m|b}}[\![\delta]\!]$, it can be shown that $\mathbf{E}_w\mathbf{Q}\mathbf{E}_{w'}$ is the greatest core of the consistent matrix $\mathbf{A} = \mathbf{M}_w\mathbf{Q}\mathbf{B}_{w'} \in \mathcal{E}_{\text{m|b}}[\![\delta]\!]^{p \times g}$.

Proposition 40. *Let $\mathbf{A} = \mathbf{M}_w\mathbf{Q}\mathbf{B}_{w'} \in \mathcal{E}_{\text{m|b}}[\![\delta]\!]^{p \times g}$ be the decomposition of $\mathbf{A} \in \mathcal{E}_{\text{m|b}}[\![\delta]\!]^{p \times g}$. Then the greatest core matrix is given by*

$$\hat{\mathbf{Q}} := \mathbf{E}_w\mathbf{Q}\mathbf{E}_{w'}. \quad (3.56)$$

Proof. Consider the inequality $\mathbf{M}_w\tilde{\mathbf{X}}\mathbf{B}_{w'} \leq \mathbf{M}_w\mathbf{Q}\mathbf{B}_{w'} = \mathbf{A}$. The greatest solution for $\tilde{\mathbf{X}}$ is

$$\mathbf{M}_w \setminus (\mathbf{M}_w\mathbf{Q}\mathbf{B}_{w'}) / \mathbf{B}_{w'} = \mathbf{B}_w\mathbf{M}_w\mathbf{Q}\mathbf{B}_{w'}\mathbf{M}_{w'} = \mathbf{E}_w\mathbf{Q}\mathbf{E}_{w'} = \hat{\mathbf{Q}}.$$

Furthermore, $\hat{\mathbf{Q}}$ is indeed a core of $\mathbf{A} \in \mathcal{E}_{\text{m|b}}[\![\delta]\!]^{p \times g}$, as $\mathbf{M}_w = \mathbf{M}_w\mathbf{E}_w$ and $\mathbf{B}_{w'} = \mathbf{E}_{w'}\mathbf{B}_{w'}$, therefore

$$\mathbf{M}_w\hat{\mathbf{Q}}\mathbf{B}_{w'} = \mathbf{M}_w\mathbf{E}_w\mathbf{Q}\mathbf{E}_{w'}\mathbf{B}_{w'} = \mathbf{M}_w\mathbf{Q}\mathbf{B}_{w'} = \mathbf{A}.$$

□

Prop. 40 implies that $\mathbf{E}_w\hat{\mathbf{Q}} = \hat{\mathbf{Q}}\mathbf{B}_{w'} = \hat{\mathbf{Q}}$. Similarly to the core extension in Prop. 30 the core $\hat{\mathbf{Q}}$ can be extended as follows.

Proposition 41. A consistent matrix $\mathbf{A} = \mathbf{M}_w \hat{\mathbf{Q}} \mathbf{B}_{w'} \in \mathcal{E}_{m|b}[[\delta]]^{p \times g}$ can be expressed with multiple periods by extending the core matrix $\hat{\mathbf{Q}}$, i.e.,

$$\begin{aligned} \mathbf{A} &= \underbrace{\begin{bmatrix} \mathbf{m}_{m_1} & \varepsilon & \cdots & \varepsilon \\ \varepsilon & \ddots & \ddots & \vdots \\ \vdots & \ddots & \ddots & \varepsilon \\ \varepsilon & \cdots & \varepsilon & \mathbf{m}_{m_p} \end{bmatrix}}_{\mathbf{M}_w} \underbrace{\begin{bmatrix} \hat{\mathbf{Q}}_{11} & \cdots & \hat{\mathbf{Q}}_{1g} \\ \vdots & & \vdots \\ \hat{\mathbf{Q}}_{p1} & \cdots & \hat{\mathbf{Q}}_{pg} \end{bmatrix}}_{\hat{\mathbf{Q}}} \underbrace{\begin{bmatrix} \mathbf{b}_{b_1} & \varepsilon & \cdots & \varepsilon \\ \varepsilon & \ddots & \ddots & \vdots \\ \vdots & \ddots & \ddots & \varepsilon \\ \varepsilon & \cdots & \varepsilon & \mathbf{b}_{b_g} \end{bmatrix}}_{\mathbf{B}_{w'}}, \\ &= \underbrace{\begin{bmatrix} \mathbf{m}_{nm_1} & \varepsilon & \cdots & \varepsilon \\ \varepsilon & \ddots & \ddots & \vdots \\ \vdots & \ddots & \ddots & \varepsilon \\ \varepsilon & \cdots & \varepsilon & \mathbf{m}_{nm_p} \end{bmatrix}}_{\mathbf{M}_{(nw)}} \underbrace{\begin{bmatrix} \hat{\mathbf{Q}}'_{11} & \cdots & \hat{\mathbf{Q}}'_{1g} \\ \vdots & & \vdots \\ \hat{\mathbf{Q}}'_{p1} & \cdots & \hat{\mathbf{Q}}'_{pg} \end{bmatrix}}_{\hat{\mathbf{Q}}'} \underbrace{\begin{bmatrix} \mathbf{b}_{nb_1} & \varepsilon & \cdots & \varepsilon \\ \varepsilon & \ddots & \ddots & \vdots \\ \vdots & \ddots & \ddots & \varepsilon \\ \varepsilon & \cdots & \varepsilon & \mathbf{b}_{nb_g} \end{bmatrix}}_{\mathbf{B}_{(nw')}}. \end{aligned}$$

Proof. $\forall i \in \{1, \dots, p\}, \forall j \in \{1, \dots, g\}, \hat{\mathbf{Q}}'_{ij}$ can be obtained by extending $\hat{\mathbf{Q}}_{ij}$, see Prop. 30. \square

3.4.2. Calculation with Matrices

Sum and Product in the Matrix Case

Proposition 42. Let $\mathbf{A}, \mathbf{P} \in \mathcal{E}_{m|b}[[\delta]]^{m \times p}$ be two consistent matrices, then the sum $\mathbf{A} \oplus \mathbf{P}$ is a consistent matrix if and only if $\Gamma(\mathbf{A}) = \Gamma(\mathbf{P})$.

Proof. This follows from Prop. 16, all entries $(\mathbf{A} \oplus \mathbf{P})_{i,j}$ must satisfy $\Gamma((\mathbf{A} \oplus \mathbf{P})_{i,j}) = \Gamma((\mathbf{A})_{i,j}) = \Gamma((\mathbf{P})_{i,j})$. \square

Recall that due to Prop. 41, by extending the core-form if necessary, two consistent matrices with equal gain can be expressed with their least common period.

Proposition 43 (Sum of Matrices). Let $\mathbf{A} = \mathbf{M}_w \hat{\mathbf{Q}} \mathbf{B}_{w'}$, $\mathbf{P} = \mathbf{M}_w \hat{\mathbf{Q}}' \mathbf{B}_{w'} \in \mathcal{E}_{m|b}[[\delta]]^{m \times p}$ be two consistent matrices satisfying Prop. 42, then the sum $\mathbf{A} \oplus \mathbf{P} = \mathbf{M}_w \hat{\mathbf{Q}}'' \mathbf{B}_{w'}$, where $\hat{\mathbf{Q}}'' = \hat{\mathbf{Q}} \oplus \hat{\mathbf{Q}}'$ is again a greatest core.

Proof.

$$\begin{aligned} \mathbf{M}_w \hat{\mathbf{Q}} \mathbf{B}_{w'} \oplus \mathbf{M}_w \hat{\mathbf{Q}}' \mathbf{B}_{w'} &= \mathbf{M}_w (\mathbf{E}_w \mathbf{Q} \mathbf{E}_{w'} \oplus \mathbf{E}_w \mathbf{Q}' \mathbf{E}_{w'}) \mathbf{B}_{w'} \\ &= \mathbf{M}_w \underbrace{\mathbf{E}_w (\mathbf{Q} \oplus \mathbf{Q}') \mathbf{E}_{w'}}_{\hat{\mathbf{Q}}''} \mathbf{B}_{w'} \end{aligned}$$

\square

Clearly, the product of two consistent matrices is not necessarily consistent itself. In the following proposition, the conditions are given under which the product of two consistent matrices is again consistent.

Proposition 44. *Let $\mathbf{A} \in \mathcal{E}_{m|b}[[\delta]]^{p \times g}$ and $\mathbf{P} \in \mathcal{E}_{m|b}[[\delta]]^{g \times l}$ be two consistent matrices, then the product $\mathbf{A} \otimes \mathbf{P}$ is consistent if and only if $\forall k \in \{2, \dots, g\}$,*

$$(\Gamma(\mathbf{A}))_{1,k}(\Gamma(\mathbf{P}))_{k,1} = (\Gamma(\mathbf{A}))_{1,1}(\Gamma(\mathbf{P}))_{1,1}. \quad (3.57)$$

Proof. Recall $(\mathbf{A} \otimes \mathbf{P})_{i,j} = \bigoplus_{k=1}^g ((\mathbf{A})_{i,k} \otimes (\mathbf{P})_{k,j})$ (2.10), this sum is in $\mathcal{E}_{m|b}[[\delta]]$ iff $\forall k \in \{1, \dots, g\}$,

$$\Gamma((\mathbf{A})_{i,k})\Gamma((\mathbf{P})_{k,j}) = \Gamma((\mathbf{A})_{i,1})\Gamma((\mathbf{P})_{1,j}),$$

see Prop. 18. It is sufficient to check this property for $i = j = 1$, i.e., for the first row of matrix $\Gamma(\mathbf{A})$ and first column of matrix $\Gamma(\mathbf{P})$, since both matrices have rank 1 and therefore all rows/columns are linearly dependent. \square

Corollary 5. *Let $\mathbf{A} \in \mathcal{E}_{m|b}[[\delta]]^{p \times g}$ and $\mathbf{P} \in \mathcal{E}_{m|b}[[\delta]]^{g \times l}$ be consistent matrices satisfying Prop. 44. Then, $\Gamma(\mathbf{A}) = \mathbf{a}_c \mathbf{a}_r$ and $\Gamma(\mathbf{P}) = \mathbf{p}_c \mathbf{p}_r$, where $\mathbf{a}_c \in \mathbb{Q}^{p \times 1}$, $\mathbf{a}_r \in \mathbb{Q}^{1 \times g}$, $\mathbf{p}_c \in \mathbb{Q}^{g \times 1}$ and $\mathbf{p}_r \in \mathbb{Q}^{1 \times l}$ (Remark 20). Then, \mathbf{a}_r is linearly dependent to every row of $\Gamma(\mathbf{A})$ and \mathbf{p}_c is linearly dependent to every column of $\Gamma(\mathbf{P})$. Therefore, (3.57) can be written as,*

$$(\mathbf{a}_r)_1(\mathbf{p}_c)_1 = (\mathbf{a}_r)_k(\mathbf{p}_c)_k, \quad \forall k \in \{1, \dots, g\}. \quad (3.58)$$

Then gain matrix $\Gamma(\mathbf{AP})$ is given by

$$\Gamma(\mathbf{AP}) = \mathbf{a}_c((\mathbf{a}_r)_1(\mathbf{p}_c)_1)\mathbf{p}_r. \quad (3.59)$$

Proof. Form (3.57) follows that,

$$\begin{aligned} (\Gamma(\mathbf{AP}))_{i,j} &= (\Gamma(\mathbf{A}))_{i,1}(\Gamma(\mathbf{P}))_{1,j} \\ &= (\mathbf{a}_c)_i(\mathbf{a}_r)_1(\mathbf{p}_c)_1(\mathbf{p}_r)_j. \end{aligned}$$

Hence $\Gamma(\mathbf{AP}) = \mathbf{a}_c((\mathbf{a}_r)_1(\mathbf{p}_c)_1)\mathbf{p}_r$. \square

Proposition 45 (Product of Matrices). *Let $\mathbf{A} = \mathbf{M}_w \hat{\mathbf{Q}} \mathbf{B}_{w'}$, $\mathbf{P} = \mathbf{M}_{w'} \hat{\mathbf{Q}}' \mathbf{B}_{w''} \in \mathcal{E}_{m|b}[[\delta]]$ be two consistent matrices satisfying Prop. 44, then the product $\mathbf{AP} = \mathbf{M}_w \hat{\mathbf{Q}}'' \mathbf{B}_{w''}$, where $\hat{\mathbf{Q}}'' = \hat{\mathbf{Q}} \hat{\mathbf{Q}}'$ is again a greatest core.*

Proof. Because of, $\mathbf{B}_{w'} \mathbf{M}_{w'} = \mathbf{E}_{w'}$ and $\hat{\mathbf{Q}} \mathbf{E}_{w'} = \hat{\mathbf{Q}}$,

$$\mathbf{M}_w \hat{\mathbf{Q}} \mathbf{B}_{w'} \mathbf{M}_{w'} \hat{\mathbf{Q}}' \mathbf{B}_{w''} = \mathbf{M}_w \hat{\mathbf{Q}} \mathbf{E}_{w'} \hat{\mathbf{Q}}' \mathbf{B}_{w''} = \mathbf{M}_w \hat{\mathbf{Q}} \hat{\mathbf{Q}}' \mathbf{B}_{w''},$$

$$\text{Furthermore: } \hat{\mathbf{Q}} \hat{\mathbf{Q}}' = \mathbf{E}_w \mathbf{Q} \mathbf{E}_{w'} \mathbf{E}_{w'} \mathbf{Q}' \mathbf{E}_{w''} = \hat{\mathbf{Q}}''.$$

\square

Proposition 46. Let $\mathbf{A} \in \mathcal{E}_{m|b}[[\delta]]^{n \times n}$ be a consistent matrix, then the Kleene star \mathbf{A}^* is a consistent matrix if and only if $\Gamma(\mathbf{A}) = \mathbf{a}_c \mathbf{a}_r$, where $\mathbf{a}_c \in \mathbb{Q}^{n \times 1}$ and $\mathbf{a}_r \in \mathbb{Q}^{1 \times n}$ such that $(\mathbf{a}_c)_i = ((\mathbf{a}_r)_i)^{-1}$, $\forall i \in \{1, \dots, n\}$.

Proof. The Kleene star of matrix \mathbf{A} is computed by

$$\mathbf{A}^* = \mathbf{I} \oplus \mathbf{A} \oplus \mathbf{A}\mathbf{A} \oplus \dots$$

According to Prop. 42 and Prop. 44 we need

1. $\Gamma(\mathbf{I}) = \Gamma(\mathbf{A})$,
2. $\Gamma(\mathbf{A}) = \Gamma(\mathbf{A}\mathbf{A})$.

To satisfy (1) the diagonal entries of $\Gamma(\mathbf{A})$ must be equal to 1, i.e., $\forall i \in \{1, \dots, n\}$, $\Gamma(\mathbf{A})_{i,i} = (\mathbf{a}_c)_i \times (\mathbf{a}_r)_i = 1$. Clearly, this condition is satisfied if $(\mathbf{a}_c)_i = ((\mathbf{a}_r)_i)^{-1}$. Moreover, (3.58) and Prop. 44 is satisfied as well. Then for (2) recall Corollary 5, thus

$$\Gamma(\mathbf{A}\mathbf{A}) = \mathbf{a}_c ((\mathbf{a}_r)_1 (\mathbf{a}_c)_1) \mathbf{a}_r = \mathbf{a}_c \mathbf{a}_r = \Gamma(\mathbf{A}),$$

since $(\mathbf{a}_r)_1 (\mathbf{a}_c)_1 = (\mathbf{a}_r)_1 ((\mathbf{a}_r)_1)^{-1} = 1$. □

Corollary 6. Let $\mathbf{A} \in \mathcal{E}_{m|b}[[\delta]]^{p \times q}$ be a consistent matrix satisfying Prop. 46, then $\Gamma(\mathbf{A}) = \Gamma(\mathbf{A}^*)$.

Proposition 47 (Kleene Star of a Matrix). Let $\mathbf{A} = \mathbf{M}_w \hat{\mathbf{Q}} \mathbf{B}_w \in \mathcal{E}_{m|b}[[\delta]]^{n \times n}$ be a consistent matrix satisfying Prop. 46, then $\mathbf{A}^* = \mathbf{M}_w \hat{\mathbf{Q}}^* \mathbf{B}_w$.

Proof. Note that, \mathbf{M}_w -matrix and the \mathbf{B}_w -matrix having the same weight vector \mathbf{w} , implies that $\hat{\mathbf{Q}}$ is a square matrix. Then since, $\mathbf{M}_w \mathbf{B}_w = \mathbf{I}$, $\mathbf{B}_w \mathbf{M}_w = \mathbf{E}_w$ and $\mathbf{E}_w \hat{\mathbf{Q}} = \hat{\mathbf{Q}}$,

$$\begin{aligned} \mathbf{A}^* &= \mathbf{I} \oplus \mathbf{M}_w \hat{\mathbf{Q}} \mathbf{B}_w \oplus \mathbf{M}_w \hat{\mathbf{Q}} \mathbf{B}_w \mathbf{M}_w \hat{\mathbf{Q}} \mathbf{B}_w \oplus \dots \\ &= \mathbf{M}_w \mathbf{B}_w \oplus \mathbf{M}_w \hat{\mathbf{Q}} \mathbf{B}_w \oplus \mathbf{M}_w \hat{\mathbf{Q}}^2 \mathbf{B}_w \oplus \dots, \\ &= \mathbf{M}_w (\mathbf{I} \oplus \hat{\mathbf{Q}} \oplus \hat{\mathbf{Q}}^2 \oplus \dots) \mathbf{B}_w, \\ &= \mathbf{M}_w \hat{\mathbf{Q}}^* \mathbf{B}_w. \end{aligned}$$

□

Again note that $\hat{\mathbf{Q}}^* \leq \mathbf{E}_w \hat{\mathbf{Q}}^* \mathbf{E}_w$, hence $\hat{\mathbf{Q}}^*$ is not the greatest core of \mathbf{A}^* .

Division in the Matrix Case

Proposition 48. Let $\mathbf{A} \in \mathcal{E}_{m|b}[[\delta]]^{p \times q}$ and $\mathbf{P} \in \mathcal{E}_{m|b}[[\delta]]^{p \times 1}$ be consistent matrices, then the left division $\mathbf{A} \setminus \mathbf{P}$ is consistent iff $\exists c \in \mathbb{Q}$, $c > 0$ such that,

$$c(\Gamma(\mathbf{A}))_{k,1} = (\Gamma(\mathbf{P}))_{k,1}, \quad \forall k \in \{1, \dots, p\}.$$

Proof. Let us recall that $(\mathbf{A} \backslash \mathbf{P})_{i,j} = \bigwedge_{k=1}^p ((\mathbf{A})_{k,i} \backslash (\mathbf{P})_{k,j})$ (2.24), this infimum is in $\mathcal{E}_{m|b}[\![\delta]\!]$ iff $\forall k \in \{1, \dots, p\}$,

$$\Gamma((\mathbf{A})_{k,i} \backslash (\mathbf{P})_{k,j}) = \Gamma((\mathbf{A})_{1,i} \backslash (\mathbf{P})_{1,j}).$$

Moreover, recall $\Gamma(s_2 \backslash s_1) = \Gamma(s_1)/\Gamma(s_2)$ (Prop. 20), thus $\forall k \in \{1, \dots, p\}$,

$$\begin{aligned} \Gamma((\mathbf{A})_{k,i} \backslash (\mathbf{P})_{k,j}) = \Gamma((\mathbf{A})_{1,i} \backslash (\mathbf{P})_{1,j}) &\Leftrightarrow \frac{\Gamma((\mathbf{P})_{k,j})}{\Gamma((\mathbf{A})_{k,i})} = \frac{\Gamma((\mathbf{P})_{1,j})}{\Gamma((\mathbf{A})_{1,i})} \\ &\Leftrightarrow \frac{(\Gamma(\mathbf{P}))_{k,j}}{(\Gamma(\mathbf{A}))_{k,i}} = \frac{(\Gamma(\mathbf{P}))_{1,j}}{(\Gamma(\mathbf{A}))_{1,i}}. \end{aligned}$$

Finally, $\forall k \in \{1, \dots, p\}$,

$$(\Gamma(\mathbf{P}))_{k,j} = \frac{(\Gamma(\mathbf{P}))_{1,j}}{(\Gamma(\mathbf{A}))_{1,i}} (\Gamma(\mathbf{A}))_{k,i} = c_{ij} (\Gamma(\mathbf{A}))_{k,i},$$

where $c_{ij} = (\Gamma(\mathbf{P}))_{1,j}/(\Gamma(\mathbf{A}))_{1,i} \in \mathbb{Q}$. Since the equation above must hold $\forall k \in \{1, \dots, p\}$ this condition can be expressed by,

$$(\Gamma(\mathbf{P}))_{:,j} = c_{ij} (\Gamma(\mathbf{A}))_{:,i}.$$

Recall that $\Gamma(\mathbf{A})$ and $\Gamma(\mathbf{P})$ have rank 1, therefore all columns of $\Gamma(\mathbf{A})$ (resp. $\Gamma(\mathbf{P})$) are linearly dependent. Hence, it is sufficient to consider

$$(\Gamma(\mathbf{P}))_{:,1} = c_{11} (\Gamma(\mathbf{A}))_{:,1}.$$

Or differently,

$$(\Gamma(\mathbf{P}))_{k,1} = c_{11} (\Gamma(\mathbf{A}))_{k,1}, \quad \forall k \in \{1, \dots, p\}.$$

□

Differently stated, the left division $\mathbf{A} \backslash \mathbf{P}$ is consistent if and only if every column of matrix $\Gamma(\mathbf{A})$ is linearly dependent to every column of matrix $\Gamma(\mathbf{P})$. Note that since both matrices have rank 1 it is sufficient to check linear dependence for the first column of matrix $\Gamma(\mathbf{A})$ and $\Gamma(\mathbf{P})$.

Corollary 7. *Let $\mathbf{A} \in \mathcal{E}_{m|b}[\![\delta]\!]^{p \times g}$ and $\mathbf{P} \in \mathcal{E}_{m|b}[\![\delta]\!]^{p \times l}$ be consistent matrices satisfying Prop. 48. Moreover, $\Gamma(\mathbf{A}) = \mathbf{a}_c \mathbf{a}_r$ and $\Gamma(\mathbf{P}) = \mathbf{p}_c \mathbf{p}_r$, with $\mathbf{a}_c, \mathbf{p}_c \in \mathbb{Q}^{p \times 1}$, $\mathbf{a}_r \in \mathbb{Q}^{1 \times g}$ and $\mathbf{p}_r \in \mathbb{Q}^{1 \times l}$. The gain matrix $\Gamma(\mathbf{A} \backslash \mathbf{P})$ is given by*

$$\Gamma(\mathbf{A} \backslash \mathbf{P}) = \bar{\mathbf{a}}_c \frac{(\mathbf{a}_c)_1}{(\mathbf{p}_c)_1} \mathbf{p}_r, \tag{3.60}$$

where $\bar{\mathbf{a}}_c = [((\mathbf{a}_r)_1)^{-1} ((\mathbf{a}_r)_1)^{-1} \dots ((\mathbf{a}_r)_g)^{-1}]^T$.

Proposition 49. Let $\mathbf{A} \in \mathcal{E}_{m|b}[[\delta]]^{p \times g}$ and $\mathbf{P} \in \mathcal{E}_{m|b}[[\delta]]^{l \times g}$ be consistent matrices, then the right division $\mathbf{A} \not\!/\! \mathbf{P}$ is consistent iff, $\exists c \in \mathbb{Q}$, $c > 0$ such that

$$c(\Gamma(\mathbf{A}))_{1,k} = (\Gamma(\mathbf{P}))_{1,k}, \quad \forall k \in \{1, \dots, g\}.$$

Proof. The proof is analogous to the proof of Prop. 48. \square

Differently stated, the right division $\mathbf{A} \not\!/\! \mathbf{P}$ is consistent if and only if every row of matrix $\Gamma(\mathbf{A})$ is linearly dependent to every row of matrix $\Gamma(\mathbf{P})$. Then again since $\Gamma(\mathbf{A})$ and $\Gamma(\mathbf{P})$ have rank 1 it is sufficient to check linear dependence for the first row of matrices $\Gamma(\mathbf{A})$ and $\Gamma(\mathbf{P})$.

Corollary 8. Let $\mathbf{A} \in \mathcal{E}_{m|b}[[\delta]]^{p \times g}$ and $\mathbf{P} \in \mathcal{E}_{m|b}[[\delta]]^{l \times g}$ be consistent matrices, satisfying Prop. 49. Moreover, $\Gamma(\mathbf{A}) = \mathbf{a}_c \mathbf{a}_r$ and $\Gamma(\mathbf{P}) = \mathbf{p}_c \mathbf{p}_r$, with $\mathbf{a}_r, \mathbf{p}_r \in \mathbb{Q}^{1 \times g}$, $\mathbf{a}_c \in \mathbb{Q}^{p \times 1}$ and $\mathbf{p}_c \in \mathbb{Q}^{l \times 1}$. The gain matrix $\Gamma(\mathbf{A} \not\!/\! \mathbf{P})$ is given by

$$\Gamma(\mathbf{A} \not\!/\! \mathbf{P}) = \mathbf{a}_c \frac{(\mathbf{a}_r)_1}{(\mathbf{p}_r)_1} \bar{\mathbf{p}}_r, \quad (3.61)$$

where $\bar{\mathbf{p}}_r = [(\mathbf{p}_c)_1]^{-1} (\mathbf{p}_c)_2]^{-1} \dots (\mathbf{p}_c)_l]^{-1}]$.

Proposition 50 (Left Division of Matrices). Let $\mathbf{A} \in \mathcal{E}_{m|b}[[\delta]]^{p \times g}$ and $\mathbf{P} \in \mathcal{E}_{m|b}[[\delta]]^{p \times l}$ be consistent matrices satisfying Prop. 48. The quotient $\mathbf{P} \not\!/\! \mathbf{A}$ is computed based on their core-forms, i.e. $\mathbf{A} = \mathbf{M}_w \hat{\mathbf{Q}} \mathbf{B}_{w'}$, $\mathbf{P} = \mathbf{M}_w \hat{\mathbf{Q}}' \mathbf{B}_{w''}$, in the following way

$$\mathbf{P} \not\!/\! \mathbf{A} = \mathbf{M}_{w''} (\hat{\mathbf{Q}}' \not\!/\! \hat{\mathbf{Q}}) \mathbf{B}_{w'}.$$

Proof. The proof is analogous to Prop. 35. \square

Proposition 51 (Right Division of Matrices). Let $\mathbf{A} \in \mathcal{E}_{m|b}[[\delta]]^{p \times g}$ and $\mathbf{P} \in \mathcal{E}_{m|b}[[\delta]]^{l \times g}$ be consistent matrices, satisfying Prop. 49. The quotient $\mathbf{P} \not\!/\! \mathbf{A}$ is computed based on their core-forms, i.e. $\mathbf{A} = \mathbf{M}_w \hat{\mathbf{Q}} \mathbf{B}_{w'}$, $\mathbf{P} = \mathbf{M}_w \hat{\mathbf{Q}}' \mathbf{B}_{w''}$ in the following way

$$\mathbf{A} \not\!/\! \mathbf{P} = \mathbf{M}_w (\hat{\mathbf{Q}} \not\!/\! \hat{\mathbf{Q}}') \mathbf{B}_{w''}.$$

Proof. The proof is analogous to Prop. 35. \square

Dioids $(\mathcal{T}, \oplus, \otimes)$ and $(\mathcal{T}[\![\gamma]\!], \oplus, \otimes)$

In this chapter, the dioids $(\mathcal{T}, \oplus, \otimes)$ and $(\mathcal{T}[\![\gamma]\!], \oplus, \otimes)$ are introduced. These dioids have an application in the modeling and the control of Periodic Time-variant Event Graphs (PTEGs) (resp. Timed Event Graphs (TEGs) under partial synchronization (PS)). The dioids $(\mathcal{T}, \oplus, \otimes)$ and $(\mathcal{T}[\![\gamma]\!], \oplus, \otimes)$ are the counterpart to the dioids $(\mathcal{E}, \oplus, \otimes)$ and $(\mathcal{E}[\![\delta]\!], \oplus, \otimes)$ studied in Chapter 3. In contrast to $(\mathcal{E}[\![\delta]\!], \oplus, \otimes)$, which consists of specific event-variant operators, the dioid $(\mathcal{T}[\![\gamma]\!], \oplus, \otimes)$ consists of specific time-variant operators. Therefore, many results are similar to the results obtained for the dioid $(\mathcal{E}[\![\delta]\!], \oplus, \otimes)$ in Chapter 3. Specifically, in Section 4.2 the core-form for periodic elements in $\mathcal{T}[\![\gamma]\!]$ is similar to the core-form for periodic elements in $\mathcal{E}_{\text{m|b}}[\![\delta]\!]$, see Section 3.3. It is shown that for periodic elements in $\mathcal{T}[\![\gamma]\!]$ all relevant operations $(\oplus, \otimes, \setminus, \rho)$ in $\mathcal{T}[\![\gamma]\!]$ can be reduced to operations between matrices with entries in $\mathcal{M}_{\text{in}}^{\text{ax}}[\![\gamma, \delta]\!]$. The presented results in this chapter have partially been published in [67, 68, 69].

4.1. Dioid $(\mathcal{T}[\![\gamma]\!], \oplus, \otimes)$

The firing of a transition in a PTEG, respectively in a TEG under PS can be naturally described by a dater function $x : \mathbb{Z} \rightarrow \overline{\mathbb{Z}}_{\text{max}}$. For these functions, $x(k)$ represents the time of the $(k + 1)^{\text{st}}$ firing of the associated transition. Note that dater functions are isotone. In the following the dioid $(\mathcal{T}[\![\gamma]\!], \oplus, \otimes)$ is introduced as a set of operators on dater functions. We denote by Ξ the set of isotone mappings from \mathbb{Z} into $\overline{\mathbb{Z}}_{\text{max}}$. This set Ξ is a $\overline{\mathbb{Z}}_{\text{max}}$ -semimodule equipped with addition, defined to the pointwise addition in the dioid $(\overline{\mathbb{Z}}_{\text{max}}, \oplus, \otimes)$, thus for $x_1, x_2 \in \Xi$

$$\forall k \in \mathbb{Z}, \quad (x_1 \oplus x_2)(k) := x_1(k) \oplus x_2(k) = \max(x_1(k), x_2(k)), \quad (4.1)$$

and a scalar multiplication defined by, for $\lambda \in \overline{\mathbb{Z}}_{\text{max}}$ and $x_1 \in \Xi$,

$$\forall k \in \mathbb{Z}, \quad (\lambda \otimes x_1)(k) := \lambda + x_1(k). \quad (4.2)$$

The zero and top mapping on Ξ , denoted by $\tilde{\varepsilon}$ resp. $\tilde{\top}$, are defined by

$$\begin{aligned} \forall k \in \mathbb{Z}, \quad \tilde{\varepsilon}(k) &:= \varepsilon \quad (\text{Recall that in } \overline{\mathbb{Z}}_{\text{max}}, \varepsilon = -\infty), \\ \forall k \in \mathbb{Z}, \quad \tilde{\top}(k) &:= \top \quad (\text{Recall that in } \overline{\mathbb{Z}}_{\text{max}}, \top = \infty). \end{aligned}$$

Clearly, $(\Xi, \oplus, \tilde{\varepsilon})$ is a complete idempotent commutative monoid, see Definition 3. The order relation on Ξ coincides with the order in the dioid $(\overline{\mathbb{Z}}_{\max}, \oplus, \otimes)$, i.e., the standard order on \mathbb{Z} . Thus, for $x_1, x_2 \in \Xi$,

$$\begin{aligned} x_1 \leq x_2 &\Leftrightarrow x_1 \oplus x_2 = x_2, \\ &\Leftrightarrow x_1(k) \oplus x_2(k) = x_2(k), \quad \forall k \in \mathbb{Z}, \\ &\Leftrightarrow \max(x_1(k), x_2(k)) = x_2(k), \quad \forall k \in \mathbb{Z}, \\ &\Leftrightarrow x_1(k) \leq x_2(k), \quad \forall k \in \mathbb{Z}. \end{aligned} \tag{4.3}$$

The infimum (\wedge operator) on the set Ξ is defined by

$$\forall k \in \mathbb{Z}, \quad (x_1 \wedge x_2)(k) := x_1(k) \wedge x_2(k) = \min(x_1(k), x_2(k)).$$

Definition 40 (Operator). *An operator is a lower semi-continuous mapping $f : \Xi \rightarrow \Xi$ from the set Ξ into itself, such that $f(\tilde{\varepsilon}) = \tilde{\varepsilon}$. Including the property $f(\tilde{\varepsilon}) = \tilde{\varepsilon}$ implies that f is an endomorphism. The set of these operators is denoted by \mathcal{O} .*

Proposition 52 ([16]). *The set of operators \mathcal{O} , equipped with multiplication and addition as follows,*

$$f_1, f_2 \in \mathcal{O}, \quad \forall x \in \Xi \quad (f_1 \oplus f_2)(x) := f_1(x) \oplus f_2(x), \tag{4.4}$$

$$f_1, f_2 \in \mathcal{O}, \quad \forall x \in \Xi \quad (f_1 \otimes f_2)(x) := f_1(f_2(x)), \tag{4.5}$$

is a complete dioid.

Proof. The proof is equivalent to the proof of Prop. 8 in Section 3.1. □

Recall Prop. 5, therefore the zero and unit element of \mathcal{O} are given by, $\forall x \in \Xi$, $\hat{\varepsilon}(x) := \tilde{\varepsilon}$ and $\hat{\varepsilon}(x) := x$. Again, to simplify notation the multiplication symbol \otimes is often omitted and we write usually f_x instead of $f(x)$. Due to (2.1) the \oplus operation induces a partial order relation on \mathcal{O} , defined by

$$\begin{aligned} f_1 \geq f_2 &\Leftrightarrow f_1 \oplus f_2 = f_1, \\ &\Leftrightarrow (f_1 x)(k) \oplus (f_2 x)(k) = (f_1 x)(k), \quad \forall x \in \Xi, \quad \forall k \in \mathbb{Z}, \\ &\Leftrightarrow \min((f_1 x)(k), (f_2 x)(k)) = (f_1 x)(k) \quad \forall x \in \Xi, \quad \forall k \in \mathbb{Z}. \end{aligned} \tag{4.6}$$

Subsequently, two operators $f_1, f_2 \in \mathcal{O}$ are equal iff $\forall x \in \Xi, \quad \forall k \in \mathbb{Z}: (f_1 x)(k) = (f_2 x)(k)$.

Moreover, $(\mathcal{O}, \oplus, \otimes)$ is a complete dioid, thus the top mapping is given by, $\forall x \in \Xi$,

$$\hat{\top}(x) = \begin{cases} \tilde{\varepsilon} & \text{for: } x = \tilde{\varepsilon}, \\ \tilde{\top} & \text{otherwise,} \end{cases} \tag{4.7}$$

and the infimum is defined as, for $f_1, f_2 \in \mathcal{O}$,

$$f_1 \wedge f_2 = \bigoplus \{f_3 \in \mathcal{O} \mid f_3 \oplus f_1 \leq f_1, f_3 \oplus f_2 \leq f_2\}.$$

Proposition 53. *The following operators are both endomorphic and lower semi-continuous and thus in \mathcal{O} .*

$$\tau \in \mathbb{Z}, \delta^\tau : \forall x \in \Xi, (\delta^\tau x)(k) = x(k) + \tau, \quad (4.8)$$

$$\omega, \varpi \in \mathbb{N}, \Delta_{\omega|\varpi} : \forall x \in \Xi, (\Delta_{\omega|\varpi} x)(k) = \lceil x(k)/\varpi \rceil \omega, \quad (4.9)$$

where $\lceil a \rceil$ is the least integer greater than or equal to a .

Proof. The mapping δ^τ is an endomorphism and it is lower semi-continuous. First, since $\tau \in \mathbb{Z}$ is an integer $\forall k \in \mathbb{Z}$, $(\delta^\tau(\tilde{\varepsilon}))(k) = \tau + \tilde{\varepsilon}(k) = \tau + (-\infty) = -\infty$, thus $(\delta^\tau(\tilde{\varepsilon}))(k) = \tilde{\varepsilon}(k)$. Moreover, for all finite and infinite subsets $\mathcal{X} \subseteq \Xi$,

$$\begin{aligned} \left(\delta^\tau \left(\bigoplus_{x \in \mathcal{X}} x \right) \right)(k) &= \tau + \left(\bigoplus_{x \in \mathcal{X}} x \right)(k) = \tau + \max_{x \in \mathcal{X}} (x(k)) = \max_{x \in \mathcal{X}} (\tau + x(k)) \\ &= \left(\bigoplus_{x \in \mathcal{X}} \delta^\tau x \right)(k), \end{aligned}$$

which proves the lower semi-continuity of δ^τ . For the mapping $\Delta_{\omega|\varpi}$ again $\omega, \varpi \in \mathbb{N}$ are finite positive integers, therefore $\forall k \in \mathbb{Z}$, $(\Delta_{\omega|\varpi}(\tilde{\varepsilon}))(k) = \lceil \tilde{\varepsilon}(k)/\varpi \rceil \omega = \lceil (-\infty)/\varpi \rceil \omega = -\infty$ and $(\Delta_{\omega|\varpi}(\tilde{\varepsilon}))(k) = \tilde{\varepsilon}(k)$. Moreover, for all finite and infinite subsets $\mathcal{X} \subseteq \Xi$,

$$\begin{aligned} \left(\Delta_{\omega|\varpi} \left(\bigoplus_{x \in \mathcal{X}} x \right) \right)(k) &= \left\lceil \frac{\left(\bigoplus_{x \in \mathcal{X}} x \right)(k)}{\varpi} \right\rceil \omega = \left\lceil \frac{\max_{x \in \mathcal{X}} (x(k))}{\varpi} \right\rceil \omega, \\ &= \max_{x \in \mathcal{X}} \left(\left\lceil \frac{x(k)}{\varpi} \right\rceil \omega \right) = \max_{x \in \mathcal{X}} \left((\Delta_{\omega|\varpi} x)(k) \right), \\ &= \left(\bigoplus_{x \in \mathcal{X}} \Delta_{\omega|\varpi} x \right)(k). \end{aligned}$$

□

Proposition 54. *The operators δ^τ and $\Delta_{\omega|\varpi}$ introduced in Prop. 53 satisfy the following relations*

$$\delta^\tau \delta^{\tau'} = \delta^{\tau+\tau'}, \quad \delta^\tau \oplus \delta^{\tau'} = \delta^{\max(\tau, \tau')}, \quad (4.10)$$

$$\Delta_{\omega|\varpi} \delta^\omega = \delta^\omega \Delta_{\omega|\varpi}. \quad (4.11)$$

Proof. For the proof of $\delta^\tau \delta^{\tau'} = \delta^{\tau+\tau'}$, since (4.5) and (4.8), then $\forall x \in \Xi, \forall k \in \mathbb{Z}$,

$$(\delta^\tau \delta^{\tau'} x)(k) = (\delta^\tau(\delta^{\tau'} x))(k) = \tau + (\delta^{\tau'} x)(k) = \tau + \tau' + x(k) = (\delta^{\tau+\tau'} x)(k).$$

For the proof of $\delta^\tau \oplus \delta^{\tau'} = \delta^{\max(\tau, \tau')}$, since (4.4), (4.1) and (4.8), then $\forall x \in \Xi, \forall k \in \mathbb{Z}$,

$$\begin{aligned} ((\delta^\tau \oplus \delta^{\tau'}) x)(k) &= (\delta^\tau x \oplus \delta^{\tau'} x)(k) = \max((\delta^\tau x)(k), (\delta^{\tau'} x)(k)) \\ &= \max(\tau + x(k), \tau' + x(k)) = \max(\tau, \tau') + x(k) \\ &= (\delta^{\max(\tau, \tau')} x)(k). \end{aligned}$$

For the proof of (4.11), recall (4.8) and (4.9), then $\forall x \in \Xi, \forall k \in \mathbb{Z}$,

$$\begin{aligned} (\Delta_{\omega|\omega} \delta^{\omega} x)(k) &= \left\lceil \frac{x(k) + \omega}{\omega} \right\rceil \omega = \left\lceil \frac{x(k)}{\omega} + 1 \right\rceil \omega = \left\lceil \frac{x(k)}{\omega} \right\rceil \omega + \omega \\ &= (\delta^{\omega} \Delta_{\omega|\omega} x)(k). \end{aligned}$$

□

Remark 21. (4.11) implies that for $-b < \tau \leq 0$, $\Delta_{\omega|b} \delta^{\tau} \Delta_{b|\omega} = \Delta_{\omega|\omega}$, since,

$$\begin{aligned} (\Delta_{\omega|b} \delta^{\tau} \Delta_{b|\omega} x)(k) &= \left\lceil \frac{\lceil x(k)/\omega \rceil b + \tau}{b} \right\rceil \omega, \\ &= \left\lceil \left\lceil \frac{x(k)}{\omega} \right\rceil + \frac{\tau}{b} \right\rceil \omega, \\ &= \left\lceil \frac{x(k)}{\omega} \right\rceil \omega, \quad \text{since } -1 < \frac{\tau}{b} \leq 0, \\ &= (\Delta_{\omega|\omega} x)(k). \end{aligned}$$

4.1.1. Dioid of Time Operators

Definition 41 (Dioid of Time Operators). *The dioid of time operators, denoted by $(\mathcal{T}, \oplus, \otimes)$, is defined by sums and compositions over the set $\{\hat{e}, \hat{\varepsilon}, \hat{\uparrow}, \delta^{\tau}, \Delta_{\omega|\omega}\}$ with $\omega, \varpi \in \mathbb{N}$, $\tau \in \mathbb{Z}$, equipped with addition and multiplication defined in (4.4) and (4.5), respectively.*

Clearly $(\mathcal{T}, \oplus, \otimes)$ is a complete subdioid of $(\mathcal{O}, \oplus, \otimes)$. Similarly to the dioid $(\mathcal{E}, \oplus, \otimes)$, introduced in Section 3.1.1, the dioid $(\mathcal{T}, \oplus, \otimes)$ is not commutative, i.e. let $v_1, v_2 \in \mathcal{T}$, then in general $v_1 v_2 \neq v_2 v_1$. The order on \mathcal{T} , naturally induced by \oplus is as follows. Let $v_1, v_2 \in \mathcal{T}$ then $\forall x \in \Xi, \forall k \in \mathbb{Z}$,

$$\begin{aligned} v_1 \geq v_2 &\Leftrightarrow v_1 \oplus v_2 = v_1, \\ &\Leftrightarrow v_1 x \oplus v_2 x = v_1 x, \\ &\Leftrightarrow (v_1 x)(k) \oplus (v_2 x)(k) = (v_1 x)(k), \\ &\Leftrightarrow \max\left((v_1 x)(k), (v_2 x)(k)\right) = (v_1 x)(k). \end{aligned}$$

Recall that $x : \mathbb{Z} \rightarrow \overline{\mathbb{Z}}_{\max}$ is an isotone mapping, an operator $v \in \mathcal{T}$ only manipulates the value of the mapping x . Therefore, we can associate a function $\mathcal{R}_v : \overline{\mathbb{Z}}_{\max} \rightarrow \overline{\mathbb{Z}}_{\max}$ to a T-operator $v \in \mathcal{T}$. This function \mathcal{R}_v is obtained by replacing $x(k)$ by t in the expression $v(x)(k)$. For example $((\Delta_{3|4} \delta^1 \oplus \delta^2 \Delta_{3|3})x)(k) = \max(\lceil (x(k) + 1)/4 \rceil 3, 2 + \lceil x(k)/3 \rceil 3)$ and therefore $\mathcal{R}_{\Delta_{3|4} \delta^1 \oplus \delta^2 \Delta_{3|3}}(t) = \max(\lceil (t + 1)/4 \rceil 3, 2 + \lceil t/3 \rceil 3)$. We denote by \mathcal{R} the set of functions generated by all operators in \mathcal{T} . Since T-operators are lower-semi continuous,

then functions in \mathcal{R} are lower-semi continuous and isotone. For a reason explained later on in Section 6.1.3, we call functions in \mathcal{R} release-time function. Clearly, the set \mathcal{R} and the set of T-operators \mathcal{T} are isomorphic, therefore the order relation over the dioid $(\mathcal{T}, \oplus, \otimes)$ corresponds to the order induced by the max operation on \mathcal{R} . For $\nu_1, \nu_2 \in \mathcal{T}$,

$$\begin{aligned} \nu_1 \geq \nu_2 &\Leftrightarrow \nu_1 \oplus \nu_2 = \nu_1 \\ &\Leftrightarrow (\nu_1 x)(k) \oplus (\nu_2 x)(k) = (\nu_1 x)(k) \quad \forall x \in \Xi, \forall k \in \mathbb{Z}, \\ &\Leftrightarrow \mathcal{R}_{\nu_1}(t) \geq \mathcal{R}_{\nu_2}(t) \quad \forall t \in \mathbb{Z}_{\max}, \\ &\Leftrightarrow \mathcal{R}_{\nu_1}(t) \geq \mathcal{R}_{\nu_2}(t), \quad \forall t \in \mathbb{Z}_{\max}. \end{aligned} \quad (4.12)$$

The release-time function \mathcal{R}_ν provides a graphical representation of a T-operator $\nu \in \mathcal{T}$. Moreover, the order relation on \mathcal{T} has a graphical interpretation which is shown in the following example.

Example 31. Figure 4.1a illustrates the release-time function $\mathcal{R}_{\delta^2 \Delta_{4|4} \delta^{-1}}$ associated to the T-operator $\delta^2 \Delta_{4|4} \delta^{-1} \in \mathcal{T}$. The gray area shaped by $\mathcal{R}_{\delta^2 \Delta_{4|4} \delta^{-1}}$ corresponds to the domain of release-time functions (resp. T-operators) less than or equal to $\mathcal{R}_{\delta^2 \Delta_{4|4} \delta^{-1}}$ (resp. $\delta^2 \Delta_{4|4} \delta^{-1}$). Consider now the release-time function $\mathcal{R}_{\delta^1 \Delta_{4|4} \delta^{-2}}$ associated to the operator $\delta^1 \Delta_{4|4} \delta^{-2}$. $\mathcal{R}_{\delta^1 \Delta_{4|4} \delta^{-2}}$ lies in the area shaped by $\mathcal{R}_{\delta^2 \Delta_{4|4} \delta^{-1}}$ ($\mathcal{R}_{\delta^1 \Delta_{4|4} \delta^{-2}}$ is beneath $\mathcal{R}_{\delta^2 \Delta_{4|4} \delta^{-1}}$) and therefore $\delta^1 \Delta_{4|4} \delta^{-2} \leq \delta^2 \Delta_{4|4} \delta^{-1}$. In contrast, consider the operators $\delta^{-3} \Delta_{4|4}$ and $\Delta_{4|4} \delta^{-1}$ with corresponding release-time functions shown in Figure 4.1b. $\mathcal{R}_{\delta^{-3} \Delta_{4|4}}$ does not cover and is not covered by $\mathcal{R}_{\Delta_{4|4} \delta^{-1}}$, therefore $\delta^{-3} \Delta_{4|4} \not\leq \Delta_{4|4} \delta^{-1}$ and $\delta^{-3} \Delta_{4|4} \not\geq \Delta_{4|4} \delta^{-1}$.

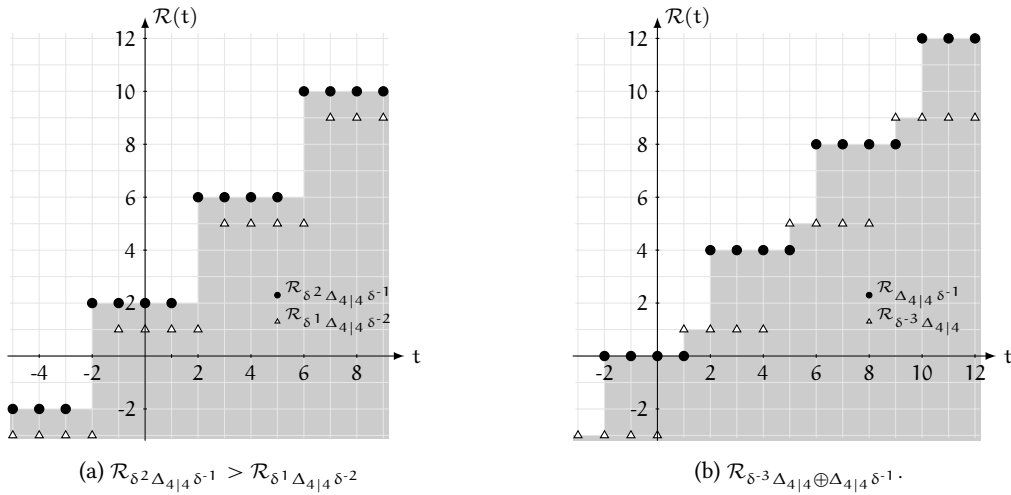

Figure 4.1. – (a) $\mathcal{R}_{\delta^2 \Delta_{4|4} \delta^{-1}}$ covers $\mathcal{R}_{\delta^1 \Delta_{4|4} \delta^{-2}}$. (b) $\mathcal{R}_{\delta^{-3} \Delta_{4|4}}$ does not cover and is not covered by $\mathcal{R}_{\Delta_{4|4} \delta^{-1}}$.

Periodic T-operators

Definition 42. A T-operator $\nu \in \mathcal{T}$ is said to be ω -periodic if $\exists \omega \in \mathbb{N}$ such that, $\forall x \in \Xi, \forall k \in \mathbb{Z}, (\nu(\omega \otimes x))(k) = \omega \otimes (\nu(x))(k)$. The set of ω -periodic T-operators is denoted by \mathcal{T}_ω . Moreover, the set of periodic operators is defined by $\mathcal{T}_{\text{per}} = \bigcup_{\omega \in \mathbb{N}} \mathcal{T}_\omega$.

Definition 43. A release-time function $\mathcal{R} : \overline{\mathbb{Z}}_{\text{max}} \rightarrow \overline{\mathbb{Z}}_{\text{max}}$ is called quasi ω -periodic if $\exists \omega \in \mathbb{N}$ such that $\forall t \in \mathbb{Z}_{\text{max}}, \mathcal{R}_\nu(t + \omega) = \omega + \mathcal{R}_\nu(t)$.

Remark 22. Since the periodic property does only depend on the value $x(k)$ (the time) we can neglect the argument k for examining the periodic property of a T-operator. Therefore, a T-operator $\nu \in \mathcal{T}$ is ω -periodic if its corresponding release-time function \mathcal{R}_ν is quasi ω -periodic.

Example 32. The δ^τ operator, with $\tau \in \mathbb{Z}$ is (1)-periodic since $\mathcal{R}_{\delta^\tau}(t) = t + \tau$ one has $\mathcal{R}_{\delta^\tau}(t + 1) = (t + 1) + \tau = 1 + \mathcal{R}_{\delta^\tau}(t)$. For example, see Figure 4.2a for the graphical representation of the δ^3 operator. The $\delta^2 \Delta_{2|2} \delta^{-1}$ operator is (2)-periodic, with a graphical illustration given in Figure 4.2b. In contrast, the $\Delta_{2|1}$ operator, shown in Figure 4.2c, is according to Definition 42 not periodic since $\mathcal{R}_{\Delta_{2|1}}(t) = \lceil t/1 \rceil 2$ and therefore $\forall t \in \mathbb{Z}_{\text{max}}, \mathcal{R}_{\Delta_{2|1}}(t + 1) = 2 + \mathcal{R}_{\Delta_{2|1}}(t)$.

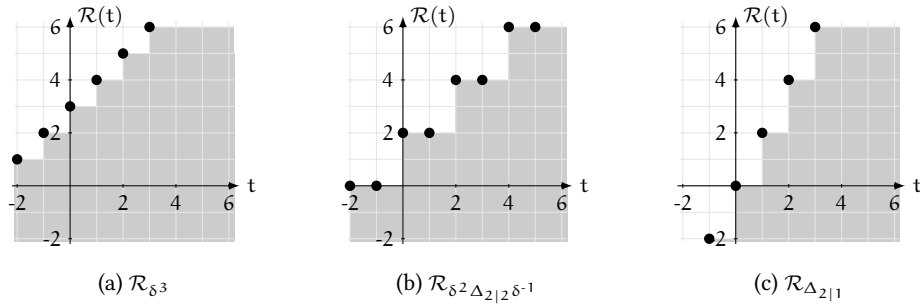

Figure 4.2. – In (a) the function \mathcal{R}_{δ^3} is quasi (1)-periodic. In (b) the function $\mathcal{R}_{\delta^2 \Delta_{2|2} \delta^{-1}}$ is quasi (2)-periodic. (c) the function $\mathcal{R}_{\Delta_{2|1}}$ is not quasi ω -periodic.

Proposition 55 (Canonical form of an ω -periodic T-operator). An ω -periodic T-operator $\nu \in \mathcal{T}_{\text{per}}$ has a canonical form given by a finite sum $\bigoplus_{i=1}^I \delta^{\tau_i} \Delta_{\omega|\omega} \delta^{\tau'_i}$. Moreover, the sum is strictly ordered such that $\forall i \in \{1, \dots, I - 1\}, \tau_i < \tau_{i+1}$ and $1 - \omega < \tau' \leq 0$.

Proof. We first show that an ω -periodic T-operator $\nu \in \mathcal{T}_{\text{per}}$ can be represented as

$$\nu = \bigoplus_{i=0}^{\omega-1} \delta^{\mathcal{R}_\nu(-i)} \Delta_{\omega|\omega} \delta^{i-\omega+1}. \quad (4.13)$$

For this, we consider the operator $w = \bigoplus_{i=0}^{\omega-1} w_i$ with $w_i = \delta^{\mathcal{R}_v(-i)} \Delta_{\omega|\omega} \delta^{i-\omega+1}$. The release-time function associated to w_i is

$$\mathcal{R}_{w_i}(t) = \mathcal{R}_v(-i) + \left\lceil \frac{t+i-\omega+1}{\omega} \right\rceil \omega.$$

Hence, \mathcal{R}_w is given by

$$\begin{aligned} \mathcal{R}_w(t) = \max \left(\mathcal{R}_v(0) + \left\lceil \frac{t-\omega+1}{\omega} \right\rceil \omega, \mathcal{R}_v(-1) + \left\lceil \frac{t-\omega+2}{\omega} \right\rceil \omega, \dots \right. \\ \left. \mathcal{R}_v(1-\omega) + \left\lceil \frac{t}{\omega} \right\rceil \omega \right). \end{aligned} \quad (4.14)$$

Clearly, \mathcal{R}_w is a quasi ω -periodic function. To prove that v can be represented as (4.13) we have to show that $\mathcal{R}_w(t) = \mathcal{R}_v(t)$. Because \mathcal{R}_w and \mathcal{R}_v are both quasi ω -periodic functions it is sufficient to check $\mathcal{R}_w(t) = \mathcal{R}_v(t)$ for $t = \{1-\omega, \dots, 0\}$. Let us remark that \mathcal{R}_v is isotone and thus,

$$\dots \leq \mathcal{R}_v(0) - \omega \leq \mathcal{R}_v(1-\omega) \leq \dots \leq \mathcal{R}_v(0) \leq \mathcal{R}_v(1-\omega) + \omega \leq \dots$$

We evaluate (4.14) for $t = 0$, this leads to

$$\begin{aligned} \mathcal{R}_w(0) &= \max \left(\mathcal{R}_v(0) + \left\lceil \frac{1-\omega}{\omega} \right\rceil \omega, \mathcal{R}_v(-1) + \left\lceil \frac{2-\omega}{\omega} \right\rceil \omega, \dots \right. \\ &\quad \left. \mathcal{R}_v(1-\omega) + \left\lceil \frac{0}{\omega} \right\rceil \omega \right) \\ &= \max (\mathcal{R}_v(0), \mathcal{R}_v(-1), \dots, \mathcal{R}_v(1-\omega)) \\ &= \mathcal{R}_v(0). \end{aligned}$$

Similarly, one can show that for $t \in \{1-\omega, \dots, -1\}$, $\mathcal{R}_w(t) = \mathcal{R}_v(t)$. For this, recall (4.14)

$$\begin{aligned} \mathcal{R}_w(t) &= \max \left(\mathcal{R}_v(0) + \left\lceil \frac{t+1-\omega}{\omega} \right\rceil \omega, \mathcal{R}_v(-1) + \left\lceil \frac{t+2-\omega}{\omega} \right\rceil \omega, \dots \right. \\ &\quad \left. \mathcal{R}_v(1-\omega) + \left\lceil \frac{t}{\omega} \right\rceil \omega \right). \end{aligned}$$

For $1 \leq j \leq \omega$ and $1-\omega \leq t \leq -1$ observe that,

$$\left\lceil \frac{t+j-\omega}{\omega} \right\rceil \omega = \begin{cases} -\omega, & \text{for } t+j < 0 \\ 0, & \text{for } t+j \geq 0, \end{cases}$$

therefore,

$$\begin{aligned} \mathcal{R}_w(t) &= \max (\mathcal{R}_v(0) - \omega, \dots, \mathcal{R}_v(t+1) - \omega, \mathcal{R}_v(t), \dots \\ &\quad \dots, \mathcal{R}_v(1-\omega)), \\ &= \mathcal{R}_v(t), \end{aligned}$$

and $v = w = \bigoplus_{i=0}^{\omega-1} w_i = \bigoplus_{i=0}^{\omega-1} \delta^{\mathcal{R}_v(-i)} \Delta_{\omega|\omega} \delta^{i-\omega+1}$. The canonical representation is the one obtained by removing redundant w_i according to the order relation given in (4.12). \square

Remark 23. Clearly, an ω -periodic operator is also $n\omega$ -periodic. Therefore, an ω -periodic operator v is represented in a $n\omega$ -periodic form given by

$$v = \bigoplus_{i=0}^{n\omega-1} \delta^{\mathcal{R}_v(-i)} \Delta_{n\omega|n\omega} \delta^{i-n\omega+1}.$$

Proposition 56. The ω -periodic $\Delta_{\omega|\omega}$ operator can be represented in an expended $n\omega$ -periodic form by the sum

$$\Delta_{\omega|\omega} = \bigoplus_{i=0}^{n-1} \delta^{-i\omega} \Delta_{n\omega|n\omega} \delta^{-(n-1-i)\omega}.$$

Proof. See Section C.2.1 in the appendix. □

Corollary 9. The 1-periodic identity operator $e = \Delta_{1|1}$ can be represented in the specific form

$$e = \bigoplus_{i=0}^{\omega-1} \delta^{-i} \Delta_{\omega|\omega} \delta^{1+i-\omega}.$$

Example 33. The 1-periodic identity operator $e = \Delta_{1|1}$ is represented in a 3-periodic form given by $e = \Delta_{3|3} \delta^{-2} \oplus \delta^{-1} \Delta_{3|3} \delta^{-1} \oplus \delta^{-2} \Delta_{3|3}$, see Figure 4.3.

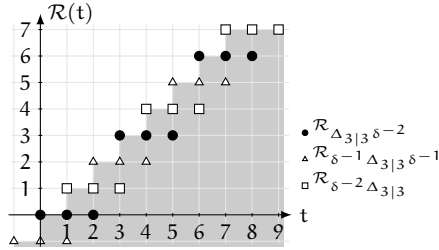

Figure 4.3. $\mathcal{R}_e(t)$ is equal to $\max(\mathcal{R}_{\Delta_{3|3} \delta^{-2}}(t), \mathcal{R}_{\delta^{-1} \Delta_{3|3} \delta^{-1}}(t), \mathcal{R}_{\delta^{-2} \Delta_{3|3}}(t))$.

Proposition 57. The set of periodic operators \mathcal{T}_{per} equipped with addition and multiplication defined in (4.4) and (4.5) is a complete subdioid of $(\mathcal{T}, \oplus, \otimes)$.

Proof. Clearly, the unit, zero and top element e , ε and \top belong to \mathcal{T}_{per} . Moreover, due to Definition 4 one has to show that the set of periodic operators \mathcal{T}_{per} are closed for addition and multiplication. Given two periodic operators $v_1, v_2 \in \mathcal{T}_{\text{per}}$, due to Remark 23, v_1 and v_2 are expressed with their least common period ω in the following form

$$v_1 = \bigoplus_{i=1}^I \delta^{\tau_i} \Delta_{\omega|\omega} \delta^{\tau'_i}, \quad v_2 = \bigoplus_{j=1}^J \delta^{t_j} \Delta_{\omega|\omega} \delta^{t'_j}.$$

Then the sum, $v_1 \oplus v_2 = \bigoplus_{i=1}^I \delta^{\tau_i} \Delta_{\omega|\omega} \delta^{\tau'_i} \oplus \bigoplus_{j=1}^J \delta^{t_j} \Delta_{\omega|\omega} \delta^{t'_j}$ is clearly an ω -periodic operator. This also holds for infinite sums. The product $v_1 \otimes v_2$ is as well ω -periodic, recall that $\Delta_{\omega|\omega} \delta^\tau \Delta_{\omega|\omega} = \Delta_{\omega|\omega}$ for $-\omega < \tau \leq 0$ (Remark 21), hence,

$$\begin{aligned} v_1 \otimes v_2 &= \left(\bigoplus_{i=1}^I \delta^{\tau_i} \Delta_{\omega|\omega} \delta^{\tau'_i} \right) \otimes \left(\bigoplus_{j=1}^J \delta^{t_j} \Delta_{\omega|\omega} \delta^{t'_j} \right), \\ &= \bigoplus_{i=1}^I \bigoplus_{j=1}^J \delta^{\tau_i} \Delta_{\omega|\omega} \delta^{\tau'_i} \delta^{t_j} \Delta_{\omega|\omega} \delta^{t'_j}, \\ &= \bigoplus_{i=1}^I \bigoplus_{j=1}^J \delta^{\tau_i + \lceil (\tau_i + t_j) / \omega \rceil \omega} \Delta_{\omega|\omega} \delta^{t'_j}. \end{aligned}$$

The distributivity of left and right multiplication over infinite sums are carried over from the dioid $(\mathcal{T}, \oplus, \otimes)$. \square

Corollary 10. *The set of ω -periodic operators \mathcal{T}_ω equipped with addition and multiplication defined in (4.4) and (4.5) is a complete subdioid of $(\mathcal{T}, \oplus, \otimes)$ and $(\mathcal{T}_{\text{per}}, \oplus, \otimes)$.*

Causal T-Operators

Definition 44. *A T-operator $v \in \mathcal{T}$ is said to be causal if $v = \varepsilon$ or if its corresponding release-time function satisfies, $\forall t \in \overline{\mathbb{Z}}_{\text{max}}$,*

$$\mathcal{R}_v(t) \geq t. \quad (4.15)$$

Clearly, the least causal operator in \mathcal{T} (except ε) is the unit operator e with the release-time function, $\mathcal{R}_e(t) = t$.

4.1.2. Dioid of Formal Power Series $(\mathcal{T}[[\gamma]], \oplus, \otimes)$

The event-shift operator γ^η is defined as a mapping over Ξ as follows,

$$\eta \in \mathbb{Z} \quad \gamma^\eta : \forall x \in \Xi, k \in \mathbb{Z} \quad (\gamma^\eta x)(k) = x(k - \eta). \quad (4.16)$$

Clearly, the γ^η mapping is lower-semi continuous, since for all finite and infinite subsets $\mathcal{X} \subseteq \Xi$

$$\begin{aligned} \left(\gamma^\eta \left(\bigoplus_{x \in \mathcal{X}} x \right) \right)(k), &= \left(\bigoplus_{x \in \mathcal{X}} x \right)(k - \eta) \\ &= \bigoplus_{x \in \mathcal{X}} x(k - \eta), \quad \text{due to (4.1),} \\ &= \bigoplus_{x \in \mathcal{X}} (\gamma^\eta x)(k), \quad \text{due to (4.16).} \end{aligned}$$

Furthermore, $(\gamma^\eta \tilde{\varepsilon})(k) = \tilde{\varepsilon}(k - \eta)$ and since $\forall k \in \mathbb{Z}$, $\tilde{\varepsilon}(k) = -\infty$, then $\eta \in \mathbb{Z}$, $\forall k \in \mathbb{Z}$, $(\gamma^\eta \tilde{\varepsilon})(k) = \tilde{\varepsilon}(k - \eta) = \tilde{\varepsilon}(k) = -\infty$. Therefore, the event-shift operator is an endomorphism, i.e., $\gamma^\eta \in \mathcal{O}$. Moreover, the event-shift operator commutes with all T-operators, i.e., $\forall v \in \mathcal{T}$, $v\gamma^\eta = \gamma^\eta v$, since,

$$\begin{aligned} ((\gamma^\eta v)x)(k) &= (\gamma^\eta(vx))(k), & \text{since (4.5),} \\ &= (vx)(k - \eta), & \text{since (4.16),} \\ &= (v(\gamma^\eta x))(k), & \text{again (4.16),} \\ &= ((v\gamma^\eta)x)(k), & \text{again (4.5).} \end{aligned}$$

Definition 45. (Dioid $(\mathcal{T}[[\gamma]], \oplus, \otimes)$) We denote by $(\mathcal{T}[[\gamma]], \oplus, \otimes)$ the quotient dioid in the set of formal power series in one variable γ with exponents in \mathbb{Z} and coefficients in the non-commutative complete dioid $(\mathcal{T}, \oplus, \otimes)$ induced by the equivalence relation $\forall s \in \mathcal{T}[[\gamma]]$,

$$s = (\gamma^1)^* s = s(\gamma^1)^*. \quad (4.17)$$

Hence we identify two series s_1 , s_2 with the same equivalence class if $s_1\gamma^* = s_2\gamma^*$. It is helpful to think of $s\gamma^*$ as the representative of the equivalence class of s . Note that we can interpret elements in $\mathcal{T}[[\gamma]]$ as isotone functions $s : \mathbb{Z} \rightarrow \mathcal{T}$, where $s(\eta)$ refers to the coefficient of γ^η . Hence, $\forall \eta \in \mathbb{Z}$, $s(\eta) \leq s(\eta + 1)$. The quotient structure (4.17) allows assimilating the variable γ to the event-shift operator $\gamma \in \mathcal{O}$, defined in (4.16). Recall the definition for addition and multiplication on formal power series (2.13) and (2.14), respectively. Therefore we obtain the following definition for addition and multiplication in the dioid $(\mathcal{T}[[\gamma]], \oplus, \otimes)$.

Definition 46. Let $s_1, s_2 \in \mathcal{T}[[\gamma]]$, then addition and multiplication are defined by

$$\begin{aligned} s_1 \oplus s_2 &= \bigoplus_{\eta \in \mathbb{Z}} (s_1(\eta) \oplus s_2(\eta)) \gamma^\eta, \\ s_1 \otimes s_2 &= \bigoplus_{\eta \in \mathbb{Z}} \left(\bigoplus_{n+n'=\eta} (s_1(n) \otimes s_2(n')) \right) \gamma^\eta. \end{aligned}$$

As before, \oplus defines an order on $\mathcal{T}[[\gamma]]$, i.e., $a, b \in \mathcal{T}[[\gamma]] : a \oplus b = b \Leftrightarrow a \leq b$.

Remark 24. Recall that $(\mathcal{T}_{\text{per}}, \oplus, \otimes)$ and $(\mathcal{T}_\omega, \oplus, \otimes)$ are complete subdioids of $(\mathcal{T}, \oplus, \otimes)$, then from Prop. 4 it follows that $(\mathcal{T}_{\text{per}}[[\gamma]], \oplus, \otimes)$ and $(\mathcal{T}_\omega[[\gamma]], \oplus, \otimes)$ are complete subdioids of $(\mathcal{T}[[\gamma]], \oplus, \otimes)$. Moreover, $(\mathcal{T}_\omega[[\gamma]], \oplus, \otimes)$ is a complete subdioid of $(\mathcal{T}_{\text{per}}[[\gamma]], \oplus, \otimes)$.

Monomial, Polynomial and ultimately cyclic Series in $\mathcal{T}[[\gamma]]$

A monomial in $\mathcal{T}[[\gamma]]$ is defined by $v\gamma^\eta$, where $v \in \mathcal{T}$. A polynomial is a finite sum of monomials, i.e., $\bigoplus_{i=1}^I v_i \gamma^{\eta_i}$. The ordering of two periodic monomials $v_1 \gamma^{\eta_1}, v_2 \gamma^{\eta_2} \in \mathcal{T}[[\gamma]]$

can be checked as follows,

$$v_1 \gamma^{\eta_1} \leq v_2 \gamma^{\eta_2} \Leftrightarrow \begin{cases} v_1 \leq v_2, \\ \eta_1 \geq \eta_2. \end{cases} \quad (4.18)$$

Proposition 58. *Let $p \in \mathcal{T}_{\text{per}}[\llbracket \gamma \rrbracket]$, then p has a canonical form $p = \bigoplus_{j=1}^J v'_j \gamma^{\eta'_j}$ such that $\forall j \in \{1, \dots, J\}$, the ω -periodic T -operator v'_j is in the canonical form of Prop. 55, and coefficients and exponents are strictly ordered, i.e., for $j \in \{1, \dots, J-1\}$, $\eta'_j < \eta'_{j+1}$ and $v'_j < v'_{j+1}$.*

Proof. Without loss of generality, we can assume that $p = \bigoplus_{i=1}^I v_i \gamma^{\eta_i}$, with $\eta_i < \eta_{i+1}$, $i = 1, \dots, I-1$. As $p \in \mathcal{T}_{\text{per}}[\llbracket \gamma \rrbracket]$, we identify all elements s with their maximal representation $s\gamma^*$, we can also identify p and

$$p' = \bigoplus_{i=1}^I \left(\underbrace{\bigoplus_{j=1}^i v_j}_{v'_i} \right) \gamma^{\eta_i}$$

as $p\gamma^* = p'\gamma^*$. Hence, $v'_i \leq v'_{i+1}$. If $v'_i = v'_{i+1}$ we can write $v'_i \gamma^{\eta_i} \oplus v'_{i+1} \gamma^{\eta_{i+1}} = v'_i (\gamma^{\eta_i} \oplus \gamma^{\eta_{i+1}}) = v'_i \gamma^{\eta_i}$. For that we can write p' as $\bigoplus_{j=1}^J v'_j \gamma^{\eta'_j}$ with $v'_j < v'_{j+1}$ and $J \leq I$. \square

Definition 47. (*Ultimately Cyclic Series in $\mathcal{T}[\llbracket \gamma \rrbracket]$*): A series $s \in \mathcal{T}[\llbracket \gamma \rrbracket]$ is said to be ultimately cyclic if it can be written as $s = p \oplus q(\gamma^{\eta} \delta^{\tau})^*$, where $\eta, \tau \in \mathbb{N}_0$ and p, q are polynomials in $\mathcal{T}[\llbracket \gamma \rrbracket]$.

Note that a polynomial $p = \bigoplus_{i=0}^I v_i \gamma^{\eta_i}$ can be considered as a specific ultimately cyclic series $s = \varepsilon \oplus p(\gamma^0 \delta^0)^*$ where $\eta = 0$ and $\tau = 0$.

Similarly to $\mathcal{E}[\llbracket \delta \rrbracket]$, an element $s \in \mathcal{T}[\llbracket \gamma \rrbracket]$ has a graphical representation in the $\overline{\mathbb{Z}}_{\max} \times \overline{\mathbb{Z}}_{\max} \times \mathbb{Z}$. Given a series $s = \bigoplus_i v_i \gamma^i \in \mathcal{T}[\llbracket \gamma \rrbracket]$, this graphical representation is obtained by depicting for every i the release-time function \mathcal{R}_{v_i} of the coefficient v_i in the (input-time / output-time)-plane of i .

Example 34. *For the graphical representation of the polynomial $p = (\delta^1 \Delta_{4|4} \delta^{-1} \oplus \delta^{-2} \Delta_{4|4}) \gamma^0 \oplus (\delta^5 \Delta_{4|4} \delta^{-1} \oplus \delta^2 \Delta_{4|4}) \gamma^2 \oplus (\delta^5 \Delta_{4|4} \oplus \delta^6 \Delta_{4|4} \delta^{-1}) \gamma^4 \in \mathcal{T}_{\text{per}}[\llbracket \gamma \rrbracket]$, respectively its representative $p\gamma^*$ see Figure 4.4. The slices in the (I/O-time)-plane for the event-shift values $k = 0, 1$ are illustrated in Figure 4.5a. These slices correspond to the release-time function $\mathcal{R}_{\delta^1 \Delta_{4|4} \delta^{-1} \oplus \delta^{-2} \Delta_{4|4}}$ of the coefficient $\delta^1 \Delta_{4|4} \delta^{-1} \oplus \delta^{-2} \Delta_{4|4}$ for γ^0 (resp. γ^1) in p . The slices for $k = 2, 3$ and $k \geq 4$ are shown in Figure 4.5b and Figure 4.5c. To improve readability, the graphical representation for elements $s \in \mathcal{T}[\llbracket \gamma \rrbracket]$ has been truncated to non-negative values in Figure 4.4 and Figure 4.5.*

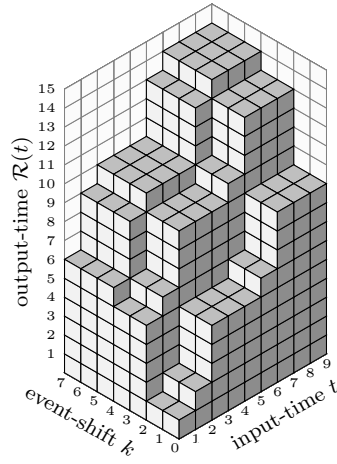

Figure 4.4. – 3D representation of polynomial $p = (\delta^1 \Delta_{4|4} \delta^{-1} \oplus \delta^{-2} \Delta_{4|4}) \gamma^0 \oplus (\delta^5 \Delta_{4|4} \delta^{-1} \oplus \delta^2 \Delta_{4|4}) \gamma^2 \oplus (\delta^5 \Delta_{4|4} \oplus \delta^6 \Delta_{4|4} \delta^{-1}) \gamma^4$.

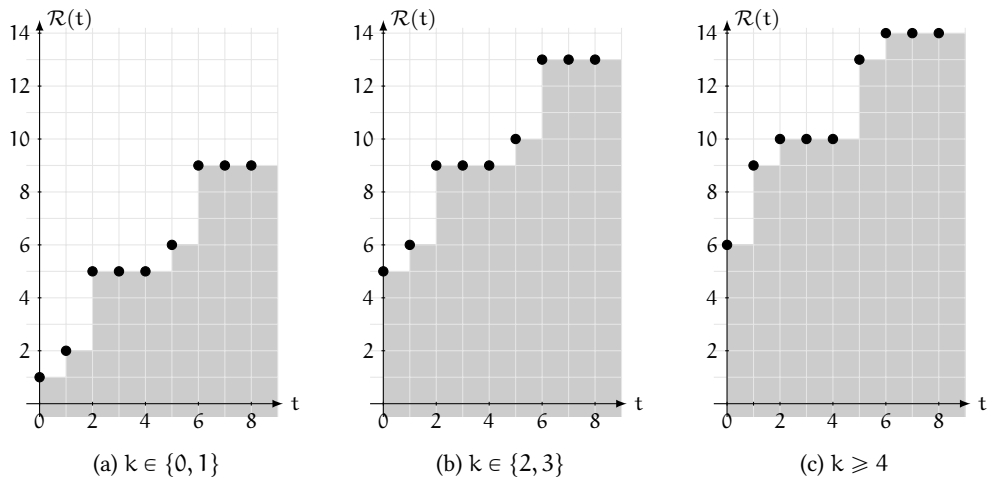

Figure 4.5. – Slices of the coefficients of p in the (I/O-time)-plane. (a) $\mathcal{R}_{\delta^1 \Delta_{4|4} \delta^{-1} \oplus \delta^{-2} \Delta_{4|4}}$, (b) $\mathcal{R}_{\delta^5 \Delta_{4|4} \delta^{-1} \oplus \delta^2 \Delta_{4|4}}$ and (c) $\mathcal{R}_{\delta^5 \Delta_{4|4} \oplus \delta^6 \Delta_{4|4} \delta^{-1}}$

4.2. Core Decomposition of Elements in $\mathcal{T}_{\text{per}}[[\gamma]]$

Similarly to Section 3.3, in this section, a specific decomposition of series in $\mathcal{T}_{\text{per}}[[\gamma]]$ is proposed. It is shown that a periodic series $s \in \mathcal{T}_{\text{per}}[[\gamma]]$ can always be represented as $s = \mathbf{d}_\omega \mathbf{Q} \mathbf{p}_\omega$ where \mathbf{Q} is a square matrix in $\mathcal{M}_{\text{in}}^{\text{ax}}[[\gamma, \delta]]$ of size $\omega \times \omega$, \mathbf{d}_ω is a row vector defined as

$$\mathbf{d}_\omega := \left[\Delta_{\omega|1} \quad \delta^{-1}\Delta_{\omega|1} \quad \cdots \quad \delta^{1-\omega}\Delta_{\omega|1} \right],$$

and \mathbf{p}_ω is a column vector defined as

$$\mathbf{p}_\omega := \left[\Delta_{1|\omega}\delta^{1-\omega} \quad \cdots \quad \Delta_{1|\omega}\delta^{-1} \quad \Delta_{1|\omega} \right]^\top.$$

The index ω determines the dimension of the vectors. It is important to note that in this form the core matrix \mathbf{Q} is a matrix with entries in $\mathcal{M}_{\text{in}}^{\text{ax}}[[\gamma, \delta]]$. An advantage of this representation is that all relevant operations on periodic series $s \in \mathcal{T}_{\text{per}}[[\gamma]]$ can be reduced to operations on square matrices with entries in $\mathcal{M}_{\text{in}}^{\text{ax}}[[\gamma, \delta]]$. In the following, this decomposition is first demonstrated on a small example.

Example 35. Consider the following series in $\mathcal{T}_{\text{per}}[[\gamma]]$,

$$s = \Delta_{2|2} \oplus \delta^1 \Delta_{2|2} \delta^{-1} \oplus \delta^2 \Delta_{2|2} \gamma^2 (\delta^2 \gamma^2)^*$$

Because of $\Delta_{\omega|a} = \Delta_{\omega|b} \Delta_{b|a}$ (Remark 21), $\delta^\omega \Delta_{\omega|a} = \Delta_{\omega|a} \delta^\omega$ (4.11) and $\forall v \in \mathcal{T}$, $v\gamma = \gamma v$, this series can be rewritten as

$$s = \Delta_{2|1} \underbrace{\mathbf{e}}_{M_1} \Delta_{1|2} \oplus \delta^{-1} \Delta_{2|1} \underbrace{\delta^1}_{M_2} \Delta_{1|2} \delta^{-1} \oplus \Delta_{2|1} \underbrace{\delta^1 \gamma^2 (\delta^1 \gamma^2)^*}_{S_1} \Delta_{1|2}.$$

Clearly M_1, M_2 and S_1 are elements in $\mathcal{M}_{\text{in}}^{\text{ax}}[[\gamma, \delta]]$. We now can rewrite s in the core representation,

$$\begin{aligned} s &= \left[\Delta_{2|1} \quad \delta^{-1} \Delta_{2|1} \right] \begin{bmatrix} \varepsilon & \mathbf{e} \oplus \delta^1 \gamma^2 (\delta^1 \gamma^2)^* \\ \delta^1 & \varepsilon \end{bmatrix} \begin{bmatrix} \Delta_{1|2} \delta^{-1} \\ \Delta_{1|2} \end{bmatrix}, \\ &\text{due to } \mathbf{e} \oplus \delta^1 \gamma^2 (\delta^1 \gamma^2)^* = (\delta^1 \gamma^2)^*, \\ s &= \underbrace{\left[\Delta_{2|1} \quad \delta^{-1} \Delta_{2|1} \right]}_{\mathbf{d}_2} \underbrace{\begin{bmatrix} \varepsilon & (\delta^1 \gamma^2)^* \\ \delta^1 & \varepsilon \end{bmatrix}}_{\mathbf{Q}} \underbrace{\begin{bmatrix} \Delta_{1|2} \delta^{-1} \\ \Delta_{1|2} \end{bmatrix}}_{\mathbf{p}_2}, \end{aligned}$$

which is in the required form.

Proposition 59. *Let $s = \bigoplus_i v_i \gamma^i \in \mathcal{T}_{\text{per}}[[\gamma]]$ be an ω -periodic series, then s can be written as $s = \mathbf{d}_\omega \mathbf{Q} \mathbf{p}_\omega$, where $\mathbf{Q} \in \mathcal{M}_{\text{in}}^{\text{ax}} [[\gamma, \delta]]^{\omega \times \omega}$.*

Proof. s being an ω -periodic series implies that all coefficients v_i of s are ω -periodic \mathbb{T} -operators. Then due to Prop. 55 all coefficients can be expressed in canonical form $v_i = \bigoplus_{j=1}^{J_i} \delta^{\tau_{ij}} \Delta_{\omega|\omega} \delta^{\tau'_{ij}}$ with $J_i \leq \omega$ and $-\omega < \tau'_{ij} \leq 0$. Then s can be rewritten as

$$s = \bigoplus_i \left(\bigoplus_{j=1}^{J_i} \delta^{\tau_{ij}} \Delta_{\omega|\omega} \delta^{\tau'_{ij}} \right) \gamma^i.$$

By using $\Delta_{\omega|\omega} = \Delta_{\omega|1} \Delta_{1|\omega}$ (Remark 21), $\delta^\omega \Delta_{\omega|1} = \Delta_{\omega|1} \delta^1$ (4.11) and $v\gamma = \gamma v$, $\forall v \in \mathcal{T}$, the series s is written as

$$s = \bigoplus_i \left(\bigoplus_{j=1}^{J_i} \delta^{\tilde{\tau}_{ij}} \Delta_{\omega|1} \delta^{\hat{\tau}_{ij}} \gamma^i \Delta_{1|\omega} \delta^{\tau'_{ij}} \right),$$

where $-\omega < \tilde{\tau}_{ij} = \tau_{ij} - \lceil \tau_{ij}/\omega \rceil \omega \leq 0$ and $\hat{\tau}_{ij} = \lceil \tau_{ij}/\omega \rceil$. Observe that $-\omega < \tilde{\tau}_{ij}, \tau'_{ij} \leq 0$ hence we can express s by

$$s = \begin{bmatrix} \Delta_{\omega|1} & \delta^{-1} \Delta_{\omega|1} & \cdots & \delta^{1-\omega} \Delta_{\omega|1} \end{bmatrix} \bigoplus_i \left(\bigoplus_{j=1}^{J_i} \mathbf{Q}_{i_j} \right) \begin{bmatrix} \Delta_{1|\omega} \delta^{1-\omega} \\ \cdots \\ \Delta_{1|\omega} \delta^{-1} \\ \Delta_{1|\omega} \end{bmatrix},$$

where the entry $(\mathbf{Q}_{i_j})_{1-\tilde{\tau}_{ij}, \omega+\tau'_{ij}} = \delta^{\hat{\tau}_{ij}} \gamma^i$ and all other entries of \mathbf{Q}_{i_j} are equals ε . Finally s is in the required form $s = \mathbf{d}_\omega \mathbf{Q} \mathbf{p}_\omega$, where $\mathbf{Q} = \bigoplus_i \left(\bigoplus_{j=1}^{J_i} \mathbf{Q}_{i_j} \right)$. \square

For the particular case of an ultimately cyclic series $s \in \mathcal{T}_{\text{per}}[[\gamma]]$, the core-matrix \mathbf{Q} is obtained as follows. The ultimately cyclic series $s = \bigoplus_i v_i \gamma^{n_i} \oplus \bigoplus_j v'_j \gamma^{n'_j} (\delta^\tau \gamma^\nu)^* \in \mathcal{T}_{\text{per}}[[\gamma]]$ is written, such that all coefficients v_i and v'_j are represented with their least common period (Remark 23), i.e.,

$$s = \bigoplus_{l=1}^L \delta^{t_l} \Delta_{\omega|\omega} \delta^{t'_l} \gamma^{n_l} \oplus \bigoplus_{k=1}^K \delta^{\xi_k} \Delta_{\omega|\omega} \delta^{\xi'_k} \gamma^{n_k} (\delta^\tau \gamma^\nu)^*.$$

Recall that $\Delta_{\omega|\omega} = \Delta_{\omega|b} \Delta_{b|\omega}$ (Remark 21) therefore,

$$s = \bigoplus_{l=1}^L \delta^{t_l} \Delta_{\omega|1} \Delta_{1|\omega} \delta^{t'_l} \gamma^{n_l} \oplus \bigoplus_{k=1}^K \delta^{\xi_k} \Delta_{\omega|1} \Delta_{1|\omega} \delta^{\xi'_k} \gamma^{n_k} (\delta^\tau \gamma^\nu)^*.$$

Note that the δ^ω operator commutes with $\Delta_{\omega|\omega}$, i.e., $\delta^\omega \Delta_{\omega|\omega} = \Delta_{\omega|\omega} \delta^\omega$ (4.11). Moreover, we can always represent an ultimately cyclic series $s \in \mathcal{T}_{\text{per}}[[\gamma]]$ such that τ is a multiple of ω , i.e., we can extend $(\gamma^\nu \delta^{\tilde{\tau}})^*$ such that, $\tau = l\tilde{\tau} = \text{lcm}(\tilde{\tau}, \omega)$

$$\begin{aligned} (\gamma^\nu \delta^{\tilde{\tau}})^* &= (e \oplus \gamma^\nu \delta^{\tilde{\tau}} \oplus \dots \oplus \gamma^{(l-1)\nu} \delta^{(l-1)\tilde{\tau}}) (\gamma^{l\nu} \delta^{l\tilde{\tau}})^* \\ &= (e \oplus \gamma^\nu \delta^{\tilde{\tau}} \oplus \dots \oplus \gamma^{(l-1)\nu} \delta^{(l-1)\tilde{\tau}}) (\gamma^{l\nu} \delta^\tau)^*. \end{aligned}$$

Therefore, in the following we assume $\tau/\omega \in \mathbb{N}$, thus $\Delta_{1|\omega} (\delta^\tau \gamma^\nu)^* = (\delta^{\tau/\omega} \gamma^\nu)^* \Delta_{1|\omega}$. This leads to

$$s = \bigoplus_{l=1}^L \delta^{\tilde{t}_l} \Delta_{\omega|1} \underbrace{\delta^{\tilde{t}_l} \gamma^{n_l}}_{M_l} \Delta_{1|\omega} \delta^{\tilde{t}'_l} \oplus \bigoplus_{k=1}^K \delta^{\tilde{\xi}_k} \Delta_{\omega|1} \underbrace{\delta^{\tilde{\xi}_k} \gamma^{n_k} (\delta^{\tau/\omega} \gamma^\nu)^*}_{S_k} \Delta_{1|\omega} \delta^{\tilde{\xi}'_k},$$

with $-\omega < \tilde{t}_l, \tilde{t}'_l, \tilde{\xi}_k, \tilde{\xi}'_k \leq 0$. In this representation M_l are monomials and S_k are series in $\mathcal{M}_{\text{in}}^{\text{ax}}[[\gamma, \delta]]$. Moreover, the entries of the \mathbf{p}_ω -vector appear on the right and the entries of the \mathbf{d}_ω -vector appear on the left of monomial M_l (resp. series S_k). For a given s we denote the set of monomials by $\mathcal{M} = \{M_1, \dots, M_L\}$ and the set of series by $\mathcal{S} = \{S_1, \dots, S_K\}$. Furthermore, the subsets $\mathcal{M}_{i,j}$ (resp. $\mathcal{S}_{i,j}$) are defined as, $\forall i, j \in \{0, \dots, \omega - 1\}$

$$\begin{aligned} \mathcal{M}_{i,j} &:= \{M_l \in \mathcal{M} \mid \delta^{-i} \Delta_{\omega|1} M_l \Delta_{1|\omega} \delta^{-j} \in \bigoplus_{l=1}^L \delta^{\tilde{t}_l} \Delta_{\omega|1} M_l \Delta_{1|\omega} \delta^{\tilde{t}'_l}\}, \\ \mathcal{S}_{i,j} &:= \{S_k \in \mathcal{S} \mid \delta^{-i} \Delta_{\omega|1} S_k \Delta_{1|\omega} \delta^{-j} \in \bigoplus_{k=1}^K \delta^{\tilde{\xi}_k} \Delta_{\omega|1} S_k \Delta_{1|\omega} \delta^{\tilde{\xi}'_k}\}. \end{aligned}$$

The entry $(\mathbf{Q})_{i+1, \omega-j}$ of the core matrix is then given by

$$(\mathbf{Q})_{i+1, \omega-j} = \bigoplus_{M \in \mathcal{M}_{i,j}} M \oplus \bigoplus_{S \in \mathcal{S}_{i,j}} S.$$

Remark 25. Note that, for series $s = \mathbf{d}_\omega \mathbf{Q} \mathbf{p}_\omega \in \mathcal{T}_{\text{per}}[[\gamma]]$ be an ultimately cyclic series, the entries of \mathbf{Q} are ultimately cyclic series in $\mathcal{M}_{\text{in}}^{\text{ax}}[[\gamma, \delta]]$.

Properties of \mathbf{d}_ω and \mathbf{p}_ω

In the following, we elaborate some properties of the \mathbf{d}_ω -vector and \mathbf{p}_ω -vector, which are necessary for computations in the core-form. The scalar product $\mathbf{d}_\omega \otimes \mathbf{p}_\omega$ of these two vectors is the identity e :

$$\begin{aligned} \mathbf{d}_\omega \otimes \mathbf{p}_\omega &= \delta^0 \Delta_{\omega|1} \Delta_{1|\omega} \delta^{1-\omega} \oplus \dots \oplus \delta^{1-\omega} \Delta_{\omega|1} \Delta_{1|\omega} \delta^0 \\ &= \delta^0 \Delta_{\omega|\omega} \delta^{1-\omega} \oplus \dots \oplus \delta^{1-\omega} \Delta_{\omega|\omega} \delta^0 = e, \end{aligned} \tag{4.19}$$

where the latter inequalities hold because of $\Delta_{\omega|1}\Delta_{1|\omega} = \Delta_{\omega|\omega}$ (Remark 21) and Corollary 9. For an illustration see Example 33. The dyadic product $\mathbf{p}_\omega \otimes \mathbf{d}_\omega$ is a square matrix with entries in $\mathcal{M}_{\text{in}}^{\text{ax}}[\![\gamma, \delta]\!]$ denoted by \mathbf{N} . For $i, j \in \{1, \dots, \omega\}$, the entry $(\mathbf{p}_\omega \otimes \mathbf{d}_\omega)_{i,j}$ is given by,

$$(\mathbf{N})_{i,j} = (\mathbf{p}_\omega \otimes \mathbf{d}_\omega)_{i,j} = \Delta_{1|\omega} \delta^{(i-j)+(1-\omega)} \Delta_{\omega|1}.$$

Then, because of $\Delta_{1|\omega} \delta^{-\omega} = \delta^{-1} \Delta_{1|\omega}$ and $\Delta_{1|\omega} \delta^{-n} \Delta_{\omega|1} = \Delta_{1|1} = e$ for $-\omega < -n \leq 0$, see Remark 21,

$$\mathbf{N} = \mathbf{p}_\omega \otimes \mathbf{d}_\omega = \begin{bmatrix} e & \delta^{-1} & \cdots & \delta^{-1} \\ \vdots & \ddots & \ddots & \vdots \\ \vdots & & \ddots & \delta^{-1} \\ e & \cdots & \cdots & e \end{bmatrix}. \quad (4.20)$$

Proposition 60. *For the \mathbf{N} matrix the following relations hold*

$$\mathbf{N} \otimes \mathbf{N} = \mathbf{N}, \quad (4.21)$$

$$\mathbf{N} \otimes \mathbf{p}_\omega = \mathbf{p}_\omega, \quad (4.22)$$

$$\mathbf{d}_\omega \otimes \mathbf{N} = \mathbf{d}_\omega. \quad (4.23)$$

Proof.

$$\mathbf{N} \otimes \mathbf{N} = \mathbf{p}_\omega \otimes \mathbf{d}_\omega \otimes \mathbf{p}_\omega \otimes \mathbf{d}_\omega = \mathbf{p}_\omega \otimes e \otimes \mathbf{d}_\omega = \mathbf{N},$$

$$\mathbf{N} \otimes \mathbf{p}_\omega = \mathbf{p}_\omega \otimes \mathbf{d}_\omega \otimes \mathbf{p}_\omega = \mathbf{p}_\omega \otimes e = \mathbf{p}_\omega,$$

$$\mathbf{d}_\omega \otimes \mathbf{N} = \mathbf{d}_\omega \otimes \mathbf{p}_\omega \otimes \mathbf{d}_\omega = e \otimes \mathbf{d}_\omega = \mathbf{d}_\omega.$$

□

Corollary 11. *Observe that $\mathbf{I} \oplus \mathbf{N} = \mathbf{N}$ and $\mathbf{N} \otimes \mathbf{N} = \mathbf{N}$, hence*

$$\begin{aligned} \mathbf{N} &= \mathbf{I} \oplus \mathbf{N} \oplus \mathbf{N}\mathbf{N} \oplus \cdots \\ &= \mathbf{N}^*. \end{aligned} \quad (4.24)$$

Due to the scalar product $\mathbf{d}_\omega \mathbf{p}_\omega = e$ (3.43) and $\mathbf{N} = \mathbf{N}^*$ (4.24), under some conditions the left and right product of elements in $\mathcal{T}[\![\gamma]\!]$ by \mathbf{d}_ω and \mathbf{p}_ω are invertible, see the following proposition.

Proposition 61. *For $\mathbf{A} \in \mathcal{T}[\![\gamma]\!]^{1 \times \omega}$ and $\mathbf{G} \in \mathcal{T}[\![\gamma]\!]^{\omega \times 1}$, we have*

$$\mathbf{d}_\omega \backslash \mathbf{A} = \mathbf{p}_\omega \otimes \mathbf{A}, \quad \mathbf{G} / \mathbf{p}_\omega = \mathbf{G} \otimes \mathbf{d}_\omega. \quad (4.25)$$

For $\mathbf{O} \in \mathcal{T}[\![\gamma]\!]^{\omega \times \omega}$ we have

$$(\mathbf{O}\mathbf{N}) / \mathbf{d}_\omega = (\mathbf{O}\mathbf{N}) \otimes \mathbf{p}_\omega, \quad \mathbf{p}_\omega \backslash (\mathbf{N}\mathbf{O}) = \mathbf{d}_\omega \otimes (\mathbf{N}\mathbf{O}). \quad (4.26)$$

Proof. See Section C.2.2 in the appendix. \square

Proposition 62. For $\mathbf{D} \in \mathcal{T}[[\gamma]]^{\omega \times \omega}$, $\mathbf{N} \backslash (\mathbf{N}\mathbf{D}) = \mathbf{N}\mathbf{D}$ and $(\mathbf{D}\mathbf{N}) / \mathbf{N} = \mathbf{D}\mathbf{N}$.

Proof. Recall, that $\mathbf{N} = \mathbf{N}^*$ (4.24) and that $\mathbf{a}^* \backslash (\mathbf{a}^* \chi) = \mathbf{a}^* \chi$ (resp. $(\mathbf{a}^* \chi) / \mathbf{a}^* = \chi \mathbf{a}^*$), see (A.9), which completes the proof. \square

Greatest Core of a Series $s \in \mathcal{T}_{\text{per}}[[\gamma]]$

In general a series $s \in \mathcal{T}_{\text{per}}[[\gamma]]$ may have several core-representations. In the following it is shown that a series $s \in \mathcal{T}_{\text{per}}[[\gamma]]$ admits a unique greatest core, denoted $\hat{\mathbf{Q}}$, i.e., $s = \mathbf{d}_\omega \hat{\mathbf{Q}} \mathbf{p}_\omega$ and $\hat{\mathbf{Q}} \geq \mathbf{Q}$ for all core matrices \mathbf{Q} such that $s = \mathbf{d}_\omega \mathbf{Q} \mathbf{p}_\omega$. Note that the greatest core is referred to the order relation in the dioid $(\mathcal{M}_{\text{in}}^{\text{ax}}[[\gamma, \delta]], \oplus, \otimes)$.

Proposition 63. Let $s = \mathbf{d}_\omega \mathbf{Q} \mathbf{p}_\omega \in \mathcal{T}_{\text{per}}[[\gamma]]$ be a decomposition of $s \in \mathcal{T}_{\text{per}}[[\gamma]]$. The greatest core matrix is given by

$$\hat{\mathbf{Q}} = \mathbf{N}_\omega \mathbf{Q} \mathbf{N}_\omega. \quad (4.27)$$

Proof. Consider the inequality $\mathbf{d}_\omega \tilde{\mathbf{X}} \mathbf{p}_\omega \leq \mathbf{d}_\omega \mathbf{Q} \mathbf{p}_\omega = s$. Then, because of Prop. 61 the greatest solution for $\tilde{\mathbf{X}}$ is

$$\mathbf{d}_\omega \backslash \mathbf{d}_\omega \mathbf{Q} \mathbf{p}_\omega / \mathbf{p}_\omega = \mathbf{p}_\omega \mathbf{d}_\omega \mathbf{Q} \mathbf{p}_\omega \mathbf{d}_\omega = \mathbf{N}_\omega \mathbf{Q} \mathbf{N}_\omega = \hat{\mathbf{Q}}.$$

Furthermore, because of $\mathbf{d}_\omega = \mathbf{d}_\omega \mathbf{N}_\omega$ and $\mathbf{p}_\omega = \mathbf{N}_\omega \mathbf{p}_\omega$ (Prop. 60),

$$\mathbf{d}_\omega \hat{\mathbf{Q}} \mathbf{p}_\omega = \mathbf{d}_\omega \mathbf{N}_\omega \mathbf{Q} \mathbf{N}_\omega \mathbf{p}_\omega = \mathbf{d}_\omega \mathbf{Q} \mathbf{p}_\omega = s.$$

\square

Remark 26. The greatest core matrix $\hat{\mathbf{Q}}$ has the following properties. Since: $\mathbf{N} \otimes \mathbf{N} = \mathbf{N}$, $\mathbf{N}\hat{\mathbf{Q}} = \mathbf{N}\mathbf{N}\mathbf{Q}\mathbf{N} = \hat{\mathbf{Q}}$; $\hat{\mathbf{Q}}\mathbf{N} = \mathbf{N}\mathbf{Q}\mathbf{N}\mathbf{N} = \hat{\mathbf{Q}}$.

Example 36. The greatest core of the series considered in Example 35 is given by

$$\begin{aligned} \hat{\mathbf{Q}} = \mathbf{N}\mathbf{Q}\mathbf{N} &= \begin{bmatrix} \mathbf{e} & \delta^{-1} \\ \mathbf{e} & \mathbf{e} \end{bmatrix} \begin{bmatrix} \varepsilon & (\delta^1 \gamma^2)^* \\ \delta^1 & \varepsilon \end{bmatrix} \begin{bmatrix} \mathbf{e} & \delta^{-1} \\ \mathbf{e} & \mathbf{e} \end{bmatrix} \\ &= \begin{bmatrix} (\delta^1 \gamma^2)^* & (\delta^1 \gamma^2)^* \\ \delta^1 \oplus \delta^1 \gamma^2 (\delta^1 \gamma^2)^* & (\delta^1 \gamma^2)^* \end{bmatrix}. \end{aligned}$$

4.2.1. Calculation with the Core Decomposition

Sum and Product of Periodic Series in $\mathcal{T}_{\text{per}}[[\gamma]]$

In this section, it is shown that operations on ultimately cyclic series in $\mathcal{T}_{\text{per}}[[\gamma]]$ can be reduced to operations on matrices with entries in $\mathcal{M}_{\text{in}}^{\text{ax}}[[\gamma, \delta]]$.

To perform addition and multiplication of two series $s_1 = \mathbf{m}_{\omega_1} \hat{\mathbf{Q}}_1 \mathbf{b}_{\omega_1}$, $s_2 = \mathbf{m}_{\omega_2} \hat{\mathbf{Q}}_2 \mathbf{b}_{\omega_2} \in \mathcal{T}_{\text{per}}[[\gamma]]$ in the core-form it is necessary to express the core matrices $\hat{\mathbf{Q}}_1 \in \mathcal{M}_{\text{in}}^{\text{ax}}[[\gamma, \delta]]^{\omega_1 \times \omega_1}$ and $\hat{\mathbf{Q}}_2 \in \mathcal{M}_{\text{in}}^{\text{ax}}[[\gamma, \delta]]^{\omega_2 \times \omega_2}$ with equal dimensions. This is possible by expressing both series with their least common period $\omega = \text{lcm}(\omega_1, \omega_2)$, see the following proposition.

Proposition 64. *An ultimately cyclic series $s = \mathbf{d}_{\omega} \hat{\mathbf{Q}} \mathbf{p}_{\omega} \in \mathcal{T}_{\text{per}}[[\gamma]]$ can be expressed with a multiple period $n\omega$ by extending the core matrix $\hat{\mathbf{Q}}$, i.e., $s = \mathbf{d}_{\omega} \hat{\mathbf{Q}} \mathbf{p}_{\omega} = \mathbf{m}_{n\omega} \hat{\mathbf{Q}}' \mathbf{b}_{n\omega}$, where $\hat{\mathbf{Q}}' \in \mathcal{M}_{\text{in}}^{\text{ax}}[[\gamma, \delta]]^{n\omega \times n\omega}$ and is given by*

$$\hat{\mathbf{Q}}' = \begin{bmatrix} \Delta_{1|n} \delta^{1-n} \hat{\mathbf{Q}} \Delta_{n|1} & \Delta_{1|n} \delta^{1-n} \hat{\mathbf{Q}} \delta^{-1} \Delta_{n|1} & \cdots & \Delta_{1|n} \delta^{1-n} \hat{\mathbf{Q}} \delta^{1-n} \Delta_{n|1} \\ \Delta_{1|n} \delta^{2-n} \hat{\mathbf{Q}} \Delta_{n|1} & \Delta_{1|n} \delta^{2-n} \hat{\mathbf{Q}} \delta^{-1} \Delta_{n|1} & \cdots & \Delta_{1|n} \delta^{2-n} \hat{\mathbf{Q}} \delta^{1-n} \Delta_{n|1} \\ \vdots & \vdots & & \vdots \\ \Delta_{1|n} \hat{\mathbf{Q}} \Delta_{n|1} & \Delta_{1|n} \hat{\mathbf{Q}} \delta^{-1} \Delta_{n|1} & \cdots & \Delta_{1|n} \hat{\mathbf{Q}} \delta^{1-n} \Delta_{n|1} \end{bmatrix}.$$

Proof. See Section C.2.3. □

Proposition 65. *Let $s = \mathbf{d}_{\omega} \mathbf{Q} \mathbf{p}_{\omega}$, $s' = \mathbf{d}_{\omega} \mathbf{Q}' \mathbf{p}_{\omega}$ be two ultimately cyclic series in $\mathcal{T}_{\text{per}}[[\gamma]]$, the sum $s \oplus s' = \mathbf{d}_{\omega} \mathbf{Q}'' \mathbf{p}_{\omega}$, where $\mathbf{Q}'' = \mathbf{Q} \oplus \mathbf{Q}'$, is again an ultimately cyclic series in $\mathcal{T}_{\text{per}}[[\gamma]]$.*

Proof.

$$s \oplus s' = \mathbf{d}_{\omega} \mathbf{Q} \mathbf{p}_{\omega} \oplus \mathbf{d}_{\omega} \mathbf{Q}' \mathbf{p}_{\omega} = \mathbf{d}_{\omega} (\mathbf{Q} \oplus \mathbf{Q}') \mathbf{p}_{\omega} = \mathbf{d}_{\omega} \mathbf{Q}'' \mathbf{p}_{\omega}.$$

Clearly, the entries of the core matrices \mathbf{Q} and \mathbf{Q}' are ultimately cyclic series in $\mathcal{M}_{\text{in}}^{\text{ax}}[[\gamma, \delta]]$. Because of Theorem 2.6, the sum of two ultimately cyclic series in $\mathcal{M}_{\text{in}}^{\text{ax}}[[\gamma, \delta]]$ is again an ultimately cyclic series. Therefore, \mathbf{Q}'' is composed of ultimately cyclic series in $\mathcal{M}_{\text{in}}^{\text{ax}}[[\gamma, \delta]]$ and thus $s \oplus s' = \mathbf{d}_{\omega} \mathbf{Q}'' \mathbf{p}_{\omega}$ is an ultimately cyclic series in $\mathcal{T}_{\text{per}}[[\gamma]]$. □

Corollary 12. *Let $s = \mathbf{d}_{\omega} \hat{\mathbf{Q}} \mathbf{p}_{\omega}$, $s' = \mathbf{d}_{\omega} \hat{\mathbf{Q}}' \mathbf{p}_{\omega} \in \mathcal{T}_{\text{per}}[[\gamma]]$ be two ultimately cyclic series, with $\hat{\mathbf{Q}}$, $\hat{\mathbf{Q}}'$ are greatest cores, the sum $s \oplus s' = \mathbf{d}_{\omega} \hat{\mathbf{Q}}'' \mathbf{p}_{\omega} \in \mathcal{T}_{\text{per}}[[\gamma]]$ is an ultimately cyclic series, where $\hat{\mathbf{Q}}'' = (\hat{\mathbf{Q}} \oplus \hat{\mathbf{Q}}')$ is again a greatest core.*

Proof.

$$s \oplus s' = \mathbf{d}_{\omega} \hat{\mathbf{Q}} \mathbf{p}_{\omega} \oplus \mathbf{d}_{\omega} \hat{\mathbf{Q}}' \mathbf{p}_{\omega} = \mathbf{d}_{\omega} (\mathbf{N} \hat{\mathbf{Q}} \mathbf{N} \oplus \mathbf{N} \hat{\mathbf{Q}}' \mathbf{N}) \mathbf{p}_{\omega} = \mathbf{d}_{\omega} \underbrace{\mathbf{N} (\hat{\mathbf{Q}} \oplus \hat{\mathbf{Q}}') \mathbf{N}}_{\hat{\mathbf{Q}}''} \mathbf{p}_{\omega}$$

□

Proposition 66. Let $s = \mathbf{d}_\omega \mathbf{Q} \mathbf{p}_\omega$, $s' = \mathbf{d}_\omega \mathbf{Q}' \mathbf{p}_\omega$ be two ultimately cyclic series in $\mathcal{T}_{\text{per}}[[\gamma]]$, the product $s \otimes s' = \mathbf{d}_\omega \mathbf{Q}'' \mathbf{p}_\omega$, where $\mathbf{Q}'' = \mathbf{Q} \mathbf{N} \mathbf{Q}'$, is again an ultimately cyclic series in $\mathcal{T}_{\text{per}}[[\gamma]]$.

Proof. Recall that $\mathbf{p}_\omega \mathbf{d}_\omega = \mathbf{N}$ (4.20), then

$$s \otimes s' = \mathbf{d}_\omega \mathbf{Q} \mathbf{p}_\omega \mathbf{d}_\omega \mathbf{Q}' \mathbf{p}_\omega = \mathbf{d}_\omega \mathbf{Q} \mathbf{N} \mathbf{Q}' \mathbf{p}_\omega = \mathbf{d}_\omega \mathbf{Q}'' \mathbf{p}_\omega.$$

Moreover, the entries of the core matrices \mathbf{Q} and \mathbf{Q}' are ultimately cyclic series in $\mathcal{M}_{\text{in}}^{\text{ax}}[[\gamma, \delta]]$. Because of Theorem 2.6, the sum and product of ultimately cyclic series in $\mathcal{M}_{\text{in}}^{\text{ax}}[[\gamma, \delta]]$ are again ultimately cyclic series in $\mathcal{M}_{\text{in}}^{\text{ax}}[[\gamma, \delta]]$. Therefore, entries of \mathbf{Q}'' are ultimately cyclic series in $\mathcal{M}_{\text{in}}^{\text{ax}}[[\gamma, \delta]]$ and the product $s \otimes s' = \mathbf{d}_\omega \mathbf{Q}'' \mathbf{p}_\omega$ is an ultimately cyclic series in $\mathcal{T}_{\text{per}}[[\gamma]]$. \square

Corollary 13. Let $s = \mathbf{d}_\omega \hat{\mathbf{Q}} \mathbf{p}_\omega$, $s' = \mathbf{d}_\omega \hat{\mathbf{Q}}' \mathbf{p}_\omega$ be two ultimately cyclic series, with $\hat{\mathbf{Q}}$, $\hat{\mathbf{Q}}'$ are greatest cores, the product $s \otimes s' = \mathbf{d}_\omega \hat{\mathbf{Q}}'' \mathbf{p}_\omega \in \mathcal{T}_{\text{per}}[[\gamma]]$ is an ultimately cyclic series, where $\hat{\mathbf{Q}}'' = \hat{\mathbf{Q}} \hat{\mathbf{Q}}'$ is again a greatest core.

Proof. Because of $\mathbf{N} \mathbf{N} = \mathbf{N}$ (Prop. 60),

$$\hat{\mathbf{Q}} \hat{\mathbf{Q}}' = \mathbf{N} \mathbf{Q} \mathbf{N} \mathbf{N} \mathbf{Q}' \mathbf{N} = \hat{\mathbf{Q}}''.$$

\square

Proposition 67. Let $s = \mathbf{d}_\omega \mathbf{Q} \mathbf{p}_\omega \in \mathcal{T}_{\text{per}}[[\gamma]]$ be an ultimately cyclic series in $\mathcal{T}_{\text{per}}[[\gamma]]$. Then,

$$s^* = \mathbf{d}_\omega (\mathbf{Q} \mathbf{N})^* \mathbf{p}_\omega, \quad (4.28)$$

is an ultimately cyclic series in $\mathcal{T}_{\text{per}}[[\gamma]]$.

Proof. Clearly, $\mathbf{Q} \mathbf{N}$ is a core of $s \in \mathcal{T}_{\text{per}}[[\gamma]]$, since $\mathbf{e} = \mathbf{d}_\omega \mathbf{p}_\omega$ and $\mathbf{N} = \mathbf{p}_\omega \mathbf{d}_\omega$ then $\mathbf{d}_\omega \mathbf{Q} \mathbf{p}_\omega \mathbf{e} = \mathbf{d}_\omega \mathbf{Q} \mathbf{p}_\omega \mathbf{d}_\omega \mathbf{p}_\omega = \mathbf{d}_\omega \mathbf{Q} \mathbf{N} \mathbf{p}_\omega$. The Kleene star of series s can be written as

$$s^* = \mathbf{e} \oplus \mathbf{d}_\omega \mathbf{Q} \mathbf{N} \mathbf{p}_\omega \oplus \mathbf{d}_\omega \mathbf{Q} \mathbf{N} \mathbf{p}_\omega \mathbf{d}_\omega \mathbf{Q} \mathbf{N} \mathbf{p}_\omega \oplus \cdots$$

Recall that \mathbf{Q} is a square matrix, $\mathbf{e} = \mathbf{d}_\omega \mathbf{p}_\omega$ (4.19), $\mathbf{N} = \mathbf{p}_\omega \mathbf{d}_\omega$ (4.20) and $\mathbf{N} = \mathbf{N}^* = \mathbf{N} \mathbf{N}$ (4.24), therefore

$$\begin{aligned} s^* &= \mathbf{d}_\omega \mathbf{p}_\omega \oplus \mathbf{d}_\omega \mathbf{Q} \mathbf{N} \mathbf{p}_\omega \oplus \mathbf{d}_\omega \mathbf{Q} \mathbf{N} \mathbf{N} \mathbf{Q} \mathbf{N} \mathbf{p}_\omega \oplus \cdots \\ &= \mathbf{d}_\omega (\mathbf{I} \oplus \mathbf{Q} \mathbf{N} \oplus (\mathbf{Q} \mathbf{N})^2 \oplus \cdots) \mathbf{p}_\omega \\ &= \mathbf{d}_\omega (\mathbf{Q} \mathbf{N})^* \mathbf{p}_\omega. \end{aligned}$$

Again, due to Theorem 2.6 the Kleene star, sum, and product of ultimately cyclic series in $\mathcal{M}_{\text{in}}^{\text{ax}}[[\gamma, \delta]]$ are ultimately cyclic series in $\mathcal{M}_{\text{in}}^{\text{ax}}[[\gamma, \delta]]$ and therefore, $s^* = \mathbf{d}_\omega (\mathbf{Q} \mathbf{N})^* \mathbf{p}_\omega$ is an ultimately cyclic series in $\mathcal{T}_{\text{per}}[[\gamma]]$. \square

Remark 27. Let $s = \mathbf{d}_\omega \hat{\mathbf{Q}} \mathbf{p}_\omega \in \mathcal{T}_{\text{per}}[[\gamma]]$ be an ultimately cyclic series, where $\hat{\mathbf{Q}}$ is a greatest core, i.e., $\hat{\mathbf{Q}} = \mathbf{N} \hat{\mathbf{Q}} \mathbf{N}$. Then, $s^* = \mathbf{d}_\omega \hat{\mathbf{Q}}^* \mathbf{p}_\omega \in \mathcal{T}_{\text{per}}[[\gamma]]$ is an ultimately cyclic series. However, in general, $\hat{\mathbf{Q}}^*$ is not the greatest core of the series s^* .

$$\begin{aligned} \hat{\mathbf{Q}}^* &= \mathbf{I} \oplus \hat{\mathbf{Q}} \oplus \hat{\mathbf{Q}}^2 \dots \\ &= \mathbf{I} \oplus \mathbf{N} \hat{\mathbf{Q}} \mathbf{N} \oplus \mathbf{N} \hat{\mathbf{Q}}^2 \mathbf{N} \dots \end{aligned}$$

Whereas,

$$\begin{aligned} \mathbf{N} \hat{\mathbf{Q}}^* \mathbf{N} &= \mathbf{N} \mathbf{I} \mathbf{N} \oplus \mathbf{N} \hat{\mathbf{Q}} \mathbf{N} \oplus \mathbf{N} \hat{\mathbf{Q}}^2 \mathbf{N} \dots \\ &= \mathbf{N} \oplus \hat{\mathbf{Q}} \oplus \hat{\mathbf{Q}}^2 \dots \end{aligned}$$

Moreover, $\mathbf{N} \hat{\mathbf{Q}}^* \mathbf{N} = (\mathbf{N} \hat{\mathbf{Q}}^* \mathbf{N})^*$, since $\mathbf{N} \hat{\mathbf{Q}}^* \mathbf{N} = \mathbf{I} \oplus \mathbf{N} \hat{\mathbf{Q}}^* \mathbf{N}$ and $\mathbf{N} \hat{\mathbf{Q}}^* \mathbf{N} \mathbf{N} \hat{\mathbf{Q}}^* \mathbf{N} = \mathbf{N} \hat{\mathbf{Q}}^* \mathbf{N}$.

In general, multiplication does not distribute with respect to \wedge in the dioid $(\mathcal{T}[[\gamma]], \oplus, \otimes)$. However, as shown for the dioid $(\mathcal{E}[[\delta]], \oplus, \otimes)$ in Lemma 2 and Lemma 3, distributivity holds for left multiplication by the \mathbf{d}_ω -vector and right multiplication by the \mathbf{p}_ω -vector for specific matrices with entries in $\mathcal{T}[[\gamma]]$.

Lemma 4. Let $\mathbf{Q}_1, \mathbf{Q}_2 \in \mathcal{T}[[\gamma]]^{\omega \times \omega}$, then

$$\begin{aligned} \mathbf{d}_\omega(\mathbf{N} \mathbf{Q}_1 \wedge \mathbf{N} \mathbf{Q}_2) &= \mathbf{d}_\omega \mathbf{N} \mathbf{Q}_1 \wedge \mathbf{d}_\omega \mathbf{N} \mathbf{Q}_2, \\ (\mathbf{Q}_1 \mathbf{N} \wedge \mathbf{Q}_2 \mathbf{N}) \mathbf{p}_\omega &= \mathbf{Q}_1 \mathbf{N} \mathbf{p}_\omega \wedge \mathbf{Q}_2 \mathbf{N} \mathbf{p}_\omega. \end{aligned}$$

Proof. The proof is similar to the proof of Lemma 2. Recall that $\mathbf{e} = \mathbf{d}_\omega \mathbf{p}_\omega$ (4.19), $\mathbf{N} = \mathbf{p}_\omega \mathbf{d}_\omega$ (4.20) and $\mathbf{N} = \mathbf{N} \mathbf{N}$ Prop. 60. Moreover, recall that inequality $c(a \wedge b) \leq ca \wedge cb$ holds for a, b, c elements in a complete dioid, see (2.2). Now let us define $\mathbf{q}_1 = \mathbf{d}_\omega \mathbf{N} \mathbf{Q}_1$ and $\mathbf{q}_2 = \mathbf{d}_\omega \mathbf{N} \mathbf{Q}_2$, then

$$\mathbf{q}_1 \wedge \mathbf{q}_2 = \mathbf{e}(\mathbf{q}_1 \wedge \mathbf{q}_2) = \mathbf{d}_\omega \mathbf{p}_\omega (\mathbf{q}_1 \wedge \mathbf{q}_2) \leq \mathbf{d}_\omega (\mathbf{p}_\omega \mathbf{q}_1 \wedge \mathbf{d}_\omega \mathbf{q}_2).$$

Inserting $\mathbf{q}_1 = \mathbf{d}_\omega \mathbf{N} \mathbf{Q}_1$ and $\mathbf{q}_2 = \mathbf{d}_\omega \mathbf{N} \mathbf{Q}_2$ leads to,

$$\begin{aligned} \mathbf{d}_\omega (\mathbf{p}_\omega \mathbf{q}_1 \wedge \mathbf{d}_\omega \mathbf{q}_2) &= \mathbf{d}_\omega (\mathbf{p}_\omega \mathbf{d}_\omega \mathbf{N} \mathbf{Q}_1 \wedge \mathbf{p}_\omega \mathbf{d}_\omega \mathbf{N} \mathbf{Q}_2), \\ &= \mathbf{d}_\omega (\mathbf{N} \mathbf{N} \mathbf{Q}_1 \wedge \mathbf{N} \mathbf{N} \mathbf{Q}_2), \\ &= \mathbf{d}_\omega (\mathbf{N} \mathbf{Q}_1 \wedge \mathbf{N} \mathbf{Q}_2). \end{aligned}$$

Finally,

$$\mathbf{d}_\omega (\mathbf{N} \mathbf{Q}_1 \wedge \mathbf{N} \mathbf{Q}_2) \leq \mathbf{d}_\omega \mathbf{N} \mathbf{Q}_1 \wedge \mathbf{d}_\omega \mathbf{N} \mathbf{Q}_2 = \mathbf{q}_1 \wedge \mathbf{q}_2.$$

Hence, equality holds throughout. The proof for $(\mathbf{Q}_1 \mathbf{N} \wedge \mathbf{Q}_2 \mathbf{N}) \mathbf{p}_\omega = \mathbf{Q}_1 \mathbf{N} \mathbf{p}_\omega \wedge \mathbf{Q}_2 \mathbf{N} \mathbf{p}_\omega$ is similar. \square

Proposition 68. Let $s = \mathbf{d}_\omega \widehat{\mathbf{Q}} \mathbf{p}_\omega$, $s' = \mathbf{d}_\omega \widehat{\mathbf{Q}}' \mathbf{p}_\omega \in \mathcal{T}_{\text{per}}[[\gamma]]$ be two ultimately cyclic series, then $s \wedge s' = \mathbf{d}_\omega \widehat{\mathbf{Q}}'' \mathbf{p}_\omega \in \mathcal{T}_{\text{per}}[[\gamma]]$ is an ultimately cyclic series, where $\widehat{\mathbf{Q}}'' = (\widehat{\mathbf{Q}} \wedge \widehat{\mathbf{Q}}')$ is again a greatest core.

Proof. Again, this proof is similar to the proof of Prop. 34. Let us recall that $\widehat{\mathbf{Q}} = \mathbf{N} \widehat{\mathbf{Q}} \mathbf{N}$, then according to Lemma 4 we can write

$$\begin{aligned} s \wedge s' &= \mathbf{d}_\omega \widehat{\mathbf{Q}} \mathbf{p}_\omega \wedge \mathbf{d}_\omega \widehat{\mathbf{Q}}' \mathbf{p}_\omega = \mathbf{d}_\omega \mathbf{N} \widehat{\mathbf{Q}} \mathbf{N} \mathbf{p}_\omega \wedge \mathbf{d}_\omega \mathbf{N} \widehat{\mathbf{Q}}' \mathbf{N} \mathbf{p}_\omega = \mathbf{d}_\omega (\mathbf{N} \widehat{\mathbf{Q}} \mathbf{N} \wedge \mathbf{N} \widehat{\mathbf{Q}}' \mathbf{N}) \mathbf{p}_\omega \\ &= \mathbf{d}_\omega (\widehat{\mathbf{Q}} \wedge \widehat{\mathbf{Q}}') \mathbf{p}_\omega. \end{aligned}$$

It remains to be shown that $\widehat{\mathbf{Q}}'' = (\widehat{\mathbf{Q}} \wedge \widehat{\mathbf{Q}}')$ is a greatest core. First, $\mathbf{N} = \mathbf{N}^*$, therefore, $\mathbf{I} \oplus \mathbf{N} = \mathbf{N}$, and $\widehat{\mathbf{Q}}'' \leq \mathbf{N} \widehat{\mathbf{Q}}'' \mathbf{N}$. Then, according to Lemma 4,

$$\mathbf{N} \widehat{\mathbf{Q}}'' \mathbf{N} = \mathbf{N} (\widehat{\mathbf{Q}} \wedge \widehat{\mathbf{Q}}') \mathbf{N} = \mathbf{p}_\omega \mathbf{d}_\omega (\widehat{\mathbf{Q}} \wedge \widehat{\mathbf{Q}}') \mathbf{p}_\omega \mathbf{d}_\omega = \mathbf{p}_\omega (\mathbf{d}_\omega \widehat{\mathbf{Q}} \mathbf{p}_\omega \wedge \mathbf{d}_\omega \widehat{\mathbf{Q}}' \mathbf{p}_\omega) \mathbf{d}_\omega.$$

Recall, $c(a \wedge b) \leq ca \wedge cb$ and $(a \wedge b)c \leq ac \wedge bc$ (2.2), therefore

$$\mathbf{p}_\omega (\mathbf{d}_\omega \widehat{\mathbf{Q}} \mathbf{p}_\omega \wedge \mathbf{d}_\omega \widehat{\mathbf{Q}}' \mathbf{p}_\omega) \mathbf{d}_\omega \leq \mathbf{p}_\omega \mathbf{d}_\omega \widehat{\mathbf{Q}} \mathbf{p}_\omega \mathbf{d}_\omega \wedge \mathbf{p}_\omega \mathbf{d}_\omega \widehat{\mathbf{Q}}' \mathbf{p}_\omega \mathbf{d}_\omega = \widehat{\mathbf{Q}} \wedge \widehat{\mathbf{Q}}' = \widehat{\mathbf{Q}}''.$$

Hence, equality holds throughout. Moreover, note that due to Theorem 2.6 $\widehat{\mathbf{Q}}''$ is a matrix where entries are ultimately cyclic series in $\mathcal{M}_{\text{in}}^{\text{ax}}[[\gamma, \delta]]$, hence $s \wedge s' = \mathbf{d}_\omega \widehat{\mathbf{Q}}'' \mathbf{p}_\omega$ is an ultimately cyclic series in $\mathcal{T}_{\text{per}}[[\gamma]]$. \square

Division of Series in $\mathcal{T}_{\text{per}}[[\gamma]]$

Proposition 69. Let $s = \mathbf{d}_\omega \widehat{\mathbf{Q}} \mathbf{p}_\omega$, $s' = \mathbf{d}_\omega \widehat{\mathbf{Q}}' \mathbf{p}_\omega$ be two ultimately cyclic series in $\mathcal{T}_{\text{per}}[[\gamma]]$. Then,

$$s' \setminus s = \mathbf{d}_\omega (\widehat{\mathbf{Q}}' \setminus \widehat{\mathbf{Q}}) \mathbf{p}_\omega, \quad s \setminus s' = \mathbf{d}_\omega (\widehat{\mathbf{Q}} \setminus \widehat{\mathbf{Q}}') \mathbf{p}_\omega,$$

are ultimately cyclic series in $\mathcal{T}_{\text{per}}[[\gamma]]$.

Proof. First, we show that

$$\widehat{\mathbf{Q}}' \setminus \widehat{\mathbf{Q}} = \mathbf{N} (\widehat{\mathbf{Q}}' \setminus \widehat{\mathbf{Q}}) \mathbf{N}. \tag{4.29}$$

For this,

$$\begin{aligned}
 (\mathbf{N}(\widehat{\mathbf{Q}}' \backslash \widehat{\mathbf{Q}})) \mathbf{N} &= (\mathbf{N} \backslash (\mathbf{N}(\widehat{\mathbf{Q}}' \backslash \widehat{\mathbf{Q}}))) \mathbf{N}, \quad \text{because of Prop. 62} \\
 &= (\mathbf{N} \backslash (\mathbf{N}((\widehat{\mathbf{Q}}' \mathbf{N}) \backslash \widehat{\mathbf{Q}}))) \mathbf{N}, \quad \text{because of } \widehat{\mathbf{Q}} = \widehat{\mathbf{Q}} \mathbf{N} \\
 &= (\mathbf{N} \backslash (\mathbf{N}(\mathbf{N} \backslash (\widehat{\mathbf{Q}}' \backslash \widehat{\mathbf{Q}})))) \mathbf{N}, \\
 &\quad \text{since: } (ab) \backslash x = b \backslash (a \backslash x) \text{ (A.5)} \\
 &= (\mathbf{N} \backslash (\widehat{\mathbf{Q}}' \backslash \widehat{\mathbf{Q}})) \mathbf{N}, \quad \text{because of } a \backslash (a \backslash x) = a \backslash x \text{ (A.4)} \\
 &= ((\widehat{\mathbf{Q}}' \mathbf{N}) \backslash \widehat{\mathbf{Q}}) \mathbf{N} = (\widehat{\mathbf{Q}}' \backslash \widehat{\mathbf{Q}}) \mathbf{N}, \\
 &\quad \text{since: } (ab) \backslash x = b \backslash (a \backslash x) \text{ (A.5) and } \widehat{\mathbf{Q}} = \widehat{\mathbf{Q}} \mathbf{N} \\
 &= ((\widehat{\mathbf{Q}}' \backslash (\widehat{\mathbf{Q}} \mathbf{N})) \mathbf{N}) \backslash \mathbf{N}, \quad \text{since: Prop. 62 twice} \\
 &= (((\widehat{\mathbf{Q}}' \backslash \widehat{\mathbf{Q}}) \backslash \mathbf{N}) \backslash \mathbf{N}) \backslash \mathbf{N}, \quad \text{since: } (a \backslash x) \backslash b = a \backslash (x \backslash b) \text{ (A.6)} \\
 &= (\widehat{\mathbf{Q}}' \backslash \widehat{\mathbf{Q}}) \backslash \mathbf{N}, \quad \text{because } ((x \backslash a) \backslash a) \backslash a = x \backslash a \text{ (A.4)} \\
 &= \widehat{\mathbf{Q}}' \backslash (\widehat{\mathbf{Q}} \backslash \mathbf{N}) = \widehat{\mathbf{Q}}' \backslash \widehat{\mathbf{Q}}, \\
 &\quad \text{since: } (a \backslash x) \backslash b = a \backslash (x \backslash b) \text{ (A.6) and Prop. 62 .}
 \end{aligned}$$

Second,

$$\begin{aligned}
 (\mathbf{d}_\omega \widehat{\mathbf{Q}}' \mathbf{p}_\omega) \backslash (\mathbf{d}_\omega \widehat{\mathbf{Q}} \mathbf{p}_\omega) &= (\widehat{\mathbf{Q}}' \mathbf{p}_\omega) \backslash (\mathbf{d}_\omega \backslash (\mathbf{d}_\omega \widehat{\mathbf{Q}} \mathbf{p}_\omega)), \quad \text{because of (A.5),} \\
 &= (\widehat{\mathbf{Q}}' \mathbf{p}_\omega) \backslash (\mathbf{p}_\omega \mathbf{d}_\omega \widehat{\mathbf{Q}} \mathbf{p}_\omega), \quad \text{because of (4.25)} \\
 &= (\widehat{\mathbf{Q}}' \mathbf{p}_\omega) \backslash (\widehat{\mathbf{Q}} \mathbf{p}_\omega), \quad \text{as } \mathbf{p}_\omega \mathbf{d}_\omega \widehat{\mathbf{Q}} = \widehat{\mathbf{Q}} \text{ Remark 26,} \\
 &= (\widehat{\mathbf{Q}}' \mathbf{p}_\omega) \backslash (\widehat{\mathbf{Q}} \backslash \mathbf{d}_\omega), \quad \text{from (4.26) and Remark 26,} \\
 &= \mathbf{p}_\omega \backslash (\widehat{\mathbf{Q}}' \backslash (\widehat{\mathbf{Q}} \backslash \mathbf{d}_\omega)), \quad \text{because of (A.5),} \\
 &= \mathbf{p}_\omega \backslash ((\widehat{\mathbf{Q}}' \backslash \widehat{\mathbf{Q}}) \backslash \mathbf{d}_\omega), \quad \text{because of (A.6),} \\
 &= \mathbf{d}_\omega (\widehat{\mathbf{Q}}' \backslash \widehat{\mathbf{Q}}) \mathbf{p}_\omega, \quad \text{because of (4.26) and (4.29).}
 \end{aligned}$$

Due to Theorem 2.6, the quotient $\widehat{\mathbf{Q}} \backslash \widehat{\mathbf{Q}}'$ is a matrix composed of ultimately cyclic series in $\mathcal{M}_{\text{in}}^{\text{ax}}[[\gamma, \delta]]$ and therefore the quotient $s' \backslash s = \mathbf{d}_\omega (\widehat{\mathbf{Q}}' \backslash \widehat{\mathbf{Q}}) \mathbf{p}_\omega$ is an ultimately cyclic series in $\mathcal{T}_{\text{per}}[[\gamma]]$. The proof of $s \backslash s' = \mathbf{d}_\omega (\widehat{\mathbf{Q}} \backslash \widehat{\mathbf{Q}}') \mathbf{p}_\omega$ is analogous. \square

Definition 48 (Causal Series in $\mathcal{T}_{\text{per}}[[\gamma]]$). A series $s = \bigoplus_{i \in \mathbb{Z}} v_i \gamma^i \in \mathcal{T}_{\text{per}}[[\gamma]]$, with $v_i \leq v_{i+1}$, is said to be causal, if $s = \varepsilon$ or for all $i < 0$, $v_i = \varepsilon$ and for all $i \geq 0$, $v_i \leq e$. The subset of causal periodic series of $\mathcal{T}_{\text{per}}[[\gamma]]$ is denoted by $\mathcal{T}_{\text{per}}^+[[\gamma]]$.

Remark 28. The causal projection $\text{Pr}^+ : \mathcal{T}_{\text{per}}[[\gamma]] \rightarrow \mathcal{T}_{\text{per}}^+[[\gamma]]$, is given by, for $s = \bigoplus_{i \in \mathbb{Z}} v_i \gamma^i \in \mathcal{T}_{\text{per}}[[\gamma]]$, with $v_i \leq v_{i+1}$,

$$\text{Pr}^+(s) = \text{Pr}^+\left(\bigoplus_{i \in \mathbb{Z}} v_i \gamma^i\right) = \bigoplus_{i \in \mathbb{Z}} s_+(i) \gamma^i$$

where,

$$s_+(i) = \begin{cases} v_i, & \text{if } i \geq 0 \text{ and } v_i \geq \varepsilon, \text{ i.e., } v_i \text{ is a causal } T\text{-operator,} \\ \varepsilon, & \text{otherwise.} \end{cases}$$

4.3. Matrices with entries in $(\mathcal{T}_{\text{per}}[[\gamma]], \oplus, \otimes)$

Recall that the sum, product, Kleene star as well as left and right division of ultimately cyclic series in $\mathcal{T}_{\text{per}}[[\gamma]]$ are again ultimately cyclic series in $\mathcal{T}_{\text{per}}[[\gamma]]$. Therefore, the extension of the basic operations $(\oplus, \otimes, \backslash, /)$ to matrices with entries in $\mathcal{T}_{\text{per}}[[\gamma]]$ is straightforward. Additionally, the core representation of series in $\mathcal{T}_{\text{per}}[[\gamma]]$ is extended to the matrix case. Therefore, consider a matrix $\mathbf{A} \in \mathcal{T}_{\text{per}}[[\gamma]]^{n \times m}$ where the entries are in the core-form, i.e.,

$$\mathbf{A} = \begin{bmatrix} \mathbf{d}_{\omega_{1,1}} \hat{\mathbf{Q}}_{1,1} \mathbf{p}_{\omega_{1,1}} & \cdots & \mathbf{d}_{\omega_{1,m}} \hat{\mathbf{Q}}_{1,m} \mathbf{p}_{\omega_{1,m}} \\ \vdots & & \vdots \\ \mathbf{d}_{\omega_{n,1}} \hat{\mathbf{Q}}_{n,1} \mathbf{p}_{\omega_{n,1}} & \cdots & \mathbf{d}_{\omega_{n,m}} \hat{\mathbf{Q}}_{n,m} \mathbf{p}_{\omega_{n,m}} \end{bmatrix}.$$

Due to Prop. 64 all entries of \mathbf{A} can be represented with a common \mathbf{d}_ω -vector and a common \mathbf{p}_ω -vector, where $\omega = \text{lcm}(\omega_{1,1}, \dots, \omega_{n,m})$. This leads to,

$$\begin{aligned} \mathbf{A} &= \begin{bmatrix} \mathbf{d}_\omega \hat{\mathbf{Q}}'_{1,1} \mathbf{p}_\omega & \cdots & \mathbf{d}_\omega \hat{\mathbf{Q}}'_{1,m} \mathbf{p}_\omega \\ \vdots & & \vdots \\ \mathbf{d}_\omega \hat{\mathbf{Q}}'_{n,1} \mathbf{p}_\omega & \cdots & \mathbf{d}_\omega \hat{\mathbf{Q}}'_{n,m} \mathbf{p}_\omega \end{bmatrix}, \\ &= \underbrace{\begin{bmatrix} \mathbf{d}_\omega & \varepsilon & \cdots & \varepsilon \\ \varepsilon & \ddots & \ddots & \vdots \\ \vdots & \ddots & \ddots & \varepsilon \\ \varepsilon & \cdots & \varepsilon & \mathbf{d}_\omega \end{bmatrix}}_{\mathbf{D}_\omega} \underbrace{\begin{bmatrix} \hat{\mathbf{Q}}'_{1,1} & \cdots & \hat{\mathbf{Q}}'_{1,m} \\ \vdots & & \vdots \\ \hat{\mathbf{Q}}'_{n,1} & \cdots & \hat{\mathbf{Q}}'_{n,m} \end{bmatrix}}_{\hat{\mathbf{Q}}} \underbrace{\begin{bmatrix} \mathbf{p}_\omega & \varepsilon & \cdots & \varepsilon \\ \varepsilon & \ddots & \ddots & \vdots \\ \vdots & \ddots & \ddots & \varepsilon \\ \varepsilon & \cdots & \varepsilon & \mathbf{p}_\omega \end{bmatrix}}_{\mathbf{P}_{\omega'}}. \end{aligned} \quad (4.30)$$

The size of $\hat{\mathbf{Q}}$ is then $\omega n \times \omega n$. Note that in contrast to the decomposition of matrices with entries $s \in \mathcal{E}_{m|b}[[\delta]]$, see Section 3.4.1, the decomposition of matrices with entries in $\mathcal{T}_{\text{per}}[[\gamma]]$

is simpler. Unlike to (3.55) in Prop. 39 the matrices \mathbf{D}_w and \mathbf{P}_w' are block diagonal matrices with same entries \mathbf{d}_w and \mathbf{p}_w . Moreover, note that the core representation in (4.30) is clearly not the most efficient one in terms of expressing \mathbf{A} with a core $\hat{\mathbf{Q}} \in \mathcal{M}_{\text{in}}^{\text{ax}}[[\gamma, \delta]]$ of minimal dimensions.

4.4. Subdioids of $(\mathcal{T}_{\text{per}}[[\gamma]], \oplus, \otimes)$

Recall that $(\mathcal{T}_w[[\gamma]], \oplus, \otimes)$ is a complete subdioid of $(\mathcal{T}_{\text{per}}[[\gamma]], \oplus, \otimes)$ (Remark 24). The subdioid $(\mathcal{T}_1[[\gamma]], \oplus, \otimes)$ of $(\mathcal{T}_{\text{per}}[[\gamma]], \oplus, \otimes)$, i.e. the set of 1-periodic series endowed with addition and multiplication, is the dioid $(\mathcal{M}_{\text{in}}^{\text{ax}}[[\gamma, \delta]], \oplus, \otimes)$. Moreover, $(\mathcal{M}_{\text{in}}^{\text{ax}}[[\gamma, \delta]], \oplus, \otimes)$ is a subdioid of $(\mathcal{T}_w[[\gamma]], \oplus, \otimes)$, e.g., a subdioid of $(\mathcal{T}_3[[\gamma]], \oplus, \otimes)$, $(\mathcal{T}_4[[\gamma]], \oplus, \otimes)$ etc.

Example 37. Figure 4.6 illustrates the subdioid structure of $(\mathcal{T}_{\text{per}}[[\gamma]], \oplus, \otimes)$. It is shown that $(\mathcal{M}_{\text{in}}^{\text{ax}}[[\gamma, \delta]], \oplus, \otimes)$, $(\mathcal{T}_3[[\gamma]], \oplus, \otimes)$ and $(\mathcal{T}_4[[\gamma]], \oplus, \otimes)$ are subdioids of $(\mathcal{T}_{\text{per}}[[\gamma]], \oplus, \otimes)$. Moreover, $(\mathcal{M}_{\text{in}}^{\text{ax}}[[\gamma, \delta]], \oplus, \otimes)$ is a subdioid of $(\mathcal{T}_3[[\gamma]], \oplus, \otimes)$ and $(\mathcal{T}_4[[\gamma]], \oplus, \otimes)$.

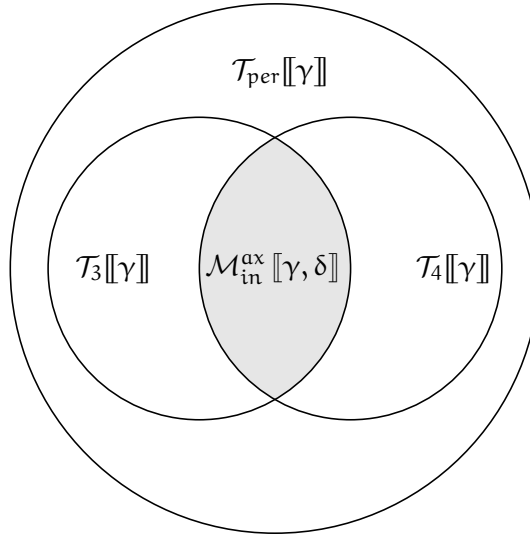
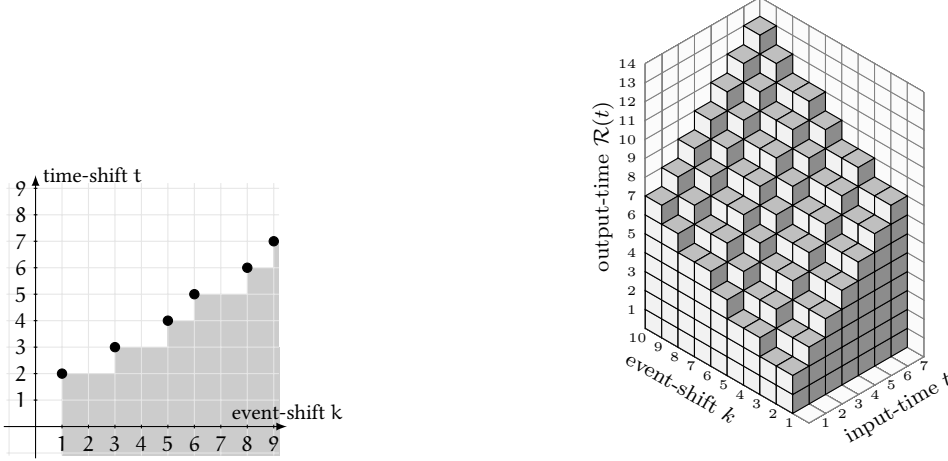

Figure 4.6. – Subdioid structure of $(\mathcal{T}_{\text{per}}[[\gamma]], \oplus, \otimes)$.

Due to the subdioid structure of $(\mathcal{T}_{\text{per}}[[\gamma]], \oplus, \otimes)$, one can define the canonical injection $\text{Inj} : \mathcal{M}_{\text{in}}^{\text{ax}}[[\gamma, \delta]] \rightarrow \mathcal{T}_{\text{per}}[[\gamma]]$, $x \mapsto \text{Inj}(x) = x$. For a graphical illustration of this canonical injection see the following example.

Example 38. Recall the series $s = \gamma^1 \delta^2 \oplus (\gamma^3 \delta^3 \oplus \gamma^5 \delta^4)(\gamma^3 \delta^2)^* \in \mathcal{M}_{\text{in}}^{\text{ax}}[[\gamma, \delta]]$ (Example 17) with a graphical representation of s given in Figure 4.7a. Then, the graphical representation of the canonical injection $\text{Inj}(s) \in \mathcal{T}_{\text{per}}[[\gamma]]$ is shown in Figure 4.7b. The series $s \in \mathcal{M}_{\text{in}}^{\text{ax}}[[\gamma, \delta]]$ (Figure 4.7a) corresponds to the (event-shift/output-time)-plane for the (input-time) value 0 of

the 3D representation of the series $\text{Inj}(s) \in \mathcal{T}_{\text{per}}[[\gamma]]$ (Figure 4.7b). Moreover, the canonical injection $\text{Inj}(s) \in \mathcal{T}_{\text{per}}[[\gamma]]$ is (1)-periodic, therefore the (event-shift/output-time)-plane for the (input-time) value 1 corresponds to the series $\delta^1 s \in \mathcal{M}_{\text{in}}^{\text{ax}}[[\gamma, \delta]]$ and for the (input-time) value 2 to the series $\delta^2 s \in \mathcal{M}_{\text{in}}^{\text{ax}}[[\gamma, \delta]]$, etc.



(a) Graphical representation of $s \in \mathcal{M}_{\text{in}}^{\text{ax}}[[\gamma, \delta]]$.

(b) Graphical representation of $\text{Inj}(s) \in \mathcal{T}_{\text{per}}[[\gamma]]$.

Figure 4.7. – Illustration of the canonical injection $\text{Inj} : \mathcal{M}_{\text{in}}^{\text{ax}}[[\gamma, \delta]] \rightarrow \mathcal{T}_{\text{per}}[[\gamma]]$ of the series $s = \gamma^1 \delta^2 \oplus (\gamma^3 \delta^3 \oplus \gamma^5 \delta^4)(\gamma^3 \delta^2)^* \in \mathcal{M}_{\text{in}}^{\text{ax}}[[\gamma, \delta]]$.

Lemma 5. Let $v\gamma^n \in \mathcal{T}_{\omega}[[\gamma]]$ be an ω -periodic monomial. Then residual $\text{Inj}^{\sharp}(v\gamma^n)$ and the dual residual $\text{Inj}^{\flat}(v\gamma^n)$ are given by

$$\text{Inj}^{\sharp}(v\gamma^n) = \delta^{\min_{t=0}^{\omega-1} (\mathcal{R}_v(t)-t)} \gamma^n, \quad (4.31)$$

$$\text{Inj}^{\flat}(v\gamma^n) = \delta^{\max_{t=0}^{\omega-1} (\mathcal{R}_v(t)-t)} \gamma^n. \quad (4.32)$$

Proof. By definition, the residuated mapping $\text{Inj}^{\sharp}(v\gamma^n)$ is the greatest solution x of the following inequality

$$v\gamma^n \geq \text{Inj}(x) = \text{Inj}\left(\bigoplus_i \gamma^{\eta_i} \delta^{\zeta_i}\right) = \bigoplus_i \gamma^{\eta_i} \delta^{\zeta_i}, \quad (4.33)$$

where $\bigoplus_i \gamma^{\eta_i} \delta^{\zeta_i} \in \mathcal{M}_{\text{in}}^{\text{ax}}[[\gamma, \delta]]$. Clearly, the least η_i such that the inequality (4.33) holds is n and thus,

$$v\gamma^n \geq \bigoplus_i (\gamma^n \delta^{\zeta_i}) = \gamma^n \delta^{\tau}, \quad \text{see, (2.28)}. \quad (4.34)$$

Since $v\gamma^n \geq \gamma^n \delta^{\tau} \Leftrightarrow v \geq \delta^{\tau}$, it remains to find the greatest τ such that (4.34) holds. By considering the isomorphism between T-operators and release-time functions, see (4.12), this

is equivalent to $\mathcal{R}_v(t) \geq \mathcal{R}_{\delta^\tau}(t)$, $\forall t \in \overline{\mathbb{Z}}_{\max}$. By using $\mathcal{R}_{\delta^\tau}(t) = \tau + t$, see (4.8), one obtains

$$\mathcal{R}_v(t) \geq \tau + t \Leftrightarrow \tau \leq \mathcal{R}_v(t) - t, \quad \forall t \in \overline{\mathbb{Z}}_{\max}. \quad (4.35)$$

Since \mathcal{R}_v is a quasi ω -periodic function it is sufficient to evaluate the function for $\forall t \in \{0, \dots, \omega - 1\}$. Therefore the greatest τ such that (4.35) (resp. (4.34)) holds is

$$\tau = \min_{t=0}^{\omega-1} (\mathcal{R}_v(t) - t).$$

Similarly, for (4.32), $\text{Inj}^b(v\gamma^n)$ is the least solution x of the inequality

$$v\gamma^n \leq \text{Inj}(x) = \text{Inj}\left(\bigoplus_i \delta^{\zeta_i} \gamma^{n_i}\right) = \bigoplus_i \gamma^{n_i} \delta^{\zeta_i}. \quad (4.36)$$

Then, the greatest n_i such that the inequality (4.36) holds is n and thus,

$$v\gamma^n \leq \bigoplus_i (\gamma^n \delta^{\zeta_i}) = \gamma^n \delta^\tau, \quad \text{see, (2.28)}. \quad (4.37)$$

Again, since $v\gamma^n \leq \gamma^n \delta^\tau \Leftrightarrow v \leq \gamma^\tau$, it remains to find the least τ such that (4.37) holds. Therefore $\forall t \in \overline{\mathbb{Z}}_{\max}$

$$\mathcal{R}_v(t) \leq \mathcal{R}_{\delta^\tau}(t) \Leftrightarrow \mathcal{R}_v(t) \leq \tau + t \Leftrightarrow \tau \geq \mathcal{R}_v(t) - t. \quad (4.38)$$

By considering that \mathcal{R}_v is a quasi ω -periodic function the least τ such that (4.38) (resp. (4.37)) holds is

$$\tau = \max_{t=0}^{\omega-1} (\mathcal{R}_v(t) - t).$$

□

Proposition 70. *Let $s = \bigoplus_i v_i \gamma^{n_i} \in \mathcal{T}_\omega[[\gamma]]$ be an ω -periodic series in the canonical representation, see Prop. 58, extended to infinite sums, then*

$$\text{Inj}^\sharp(s) = \text{Inj}^\sharp\left(\bigoplus_i v_i \gamma^{n_i}\right) = \bigoplus_i \delta^{\min_{t=0}^{\omega-1} (\mathcal{R}_{v_i}(t) - t)} \gamma^{n_i}, \quad (4.39)$$

$$\text{Inj}^b(s) = \text{Inj}^b\left(\bigoplus_i v_i \gamma^{n_i}\right) = \bigoplus_i \delta^{\max_{t=0}^{\omega-1} (\mathcal{R}_{v_i}(t) - t)} \gamma^{n_i}. \quad (4.40)$$

Proof. For (4.39): Consider $s = \bigoplus_i v_i \gamma^{n_i}$ in the canonical form, such that $n_i < n_{i+1}$ and $v_i < v_{i+1}$ and let \mathcal{R}_{v_i} be the release-time function associated to the operator v_i . Recall that $\text{Inj}^\sharp(s)$ is the greatest solution $x \in \mathcal{M}_{\text{in}}^{\text{ax}}[[\gamma, \delta]]$ of inequality $\text{Inj}^\sharp(x) \leq s$. This is given by $\bigoplus_i \delta^{\tau_i} \gamma^{n_i}$ where τ_i is the greatest integer such that $\delta^{\tau_i} \leq v_i$. Repeating the first step of Lemma 5, this is given by $\tau_i = \min_{t=0}^{\omega-1} (\mathcal{R}_{v_i}(t) - t)$. The proof of (4.40) is analogous. □

Example 39. *Recall the polynomial $p = (\delta^1 \Delta_{4|4} \delta^{-1} \oplus \delta^{-2} \Delta_{4|4}) \gamma^0 \oplus (\delta^5 \Delta_{4|4} \delta^{-1} \oplus \delta^2 \Delta_{4|4}) \gamma^2 \oplus (\delta^5 \Delta_{4|4} \oplus \delta^6 \Delta_{4|4} \delta^{-1}) \gamma^4 \in \mathcal{T}_{\text{per}}[[\gamma]]$ with a graphical representation given in Figure 4.8a. Moreover, recall the function $\mathcal{R}_{\delta^1 \Delta_{4|4} \delta^{-1} \oplus \delta^{-2} \Delta_{4|4}}$ (resp. $\mathcal{R}_{\delta^5 \Delta_{4|4} \delta^{-1} \oplus \delta^2 \Delta_{4|4}}$ and $\mathcal{R}_{\delta^5 \Delta_{4|4} \oplus \delta^6 \Delta_{4|4} \delta^{-1}}$) shown in Figure 4.5a (resp. Figure 4.5b and Figure 4.5c). The residual of the canonical injection is $\text{Inj}^\sharp(p) = \delta^1 \gamma^0 \oplus \delta^2 \gamma^2 \oplus \delta^5 \gamma^4$, which is shown in Figure 4.8b. In Figure 4.8 and Figure 4.9 the polynomial p is compared to $\text{Inj}(\text{Inj}^\sharp(p))$, as required $p \geq \text{Inj}(\text{Inj}^\sharp(p))$ (2.17).*

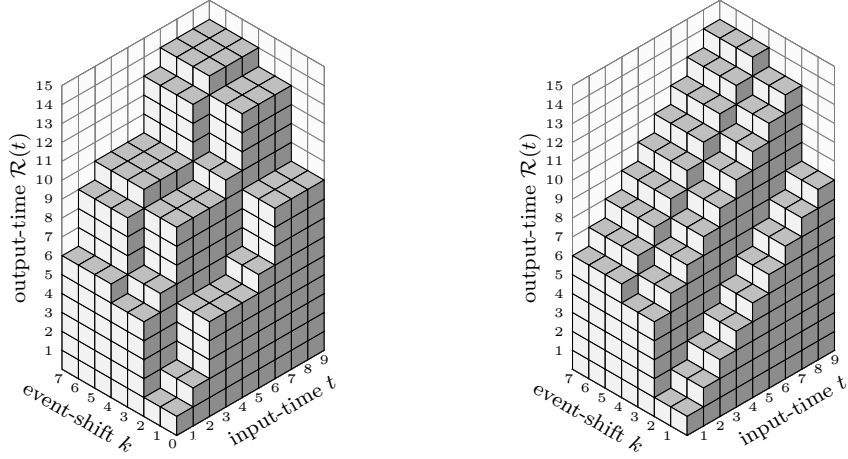

(a) 3D representation of polynomial $p = (\delta^1 \Delta_{4|4} \delta^{-1} \oplus \delta^{-2} \Delta_{4|4}) \gamma^0 \oplus (\delta^5 \Delta_{4|4} \delta^{-1} \oplus \delta^2 \Delta_{4|4}) \gamma^2 \oplus (\delta^5 \Delta_{4|4} \oplus \delta^6 \Delta_{4|4} \delta^{-1}) \gamma^4$.
 (b) 3D representation of $\text{Inj}(\text{Inj}^\#(p)) = \delta^1 \gamma^0 \oplus \delta^2 \gamma^2 \oplus \delta^5 \gamma^4$.

Figure 4.8. – Comparison of the polynomial $p = (\delta^1 \Delta_{4|4} \delta^{-1} \oplus \delta^{-2} \Delta_{4|4}) \gamma^0 \oplus (\delta^5 \Delta_{4|4} \delta^{-1} \oplus \delta^2 \Delta_{4|4}) \gamma^2 \oplus (\delta^5 \Delta_{4|4} \oplus \delta^6 \Delta_{4|4} \delta^{-1}) \gamma^4$ and $\text{Inj}(\text{Inj}^\#(p))$. For all $k \in \mathbb{Z}$ the slices in the (input-time/output-time)-plane of p cover the slices of $\text{Inj}(\text{Inj}^\#(p))$, see Figure 4.9.

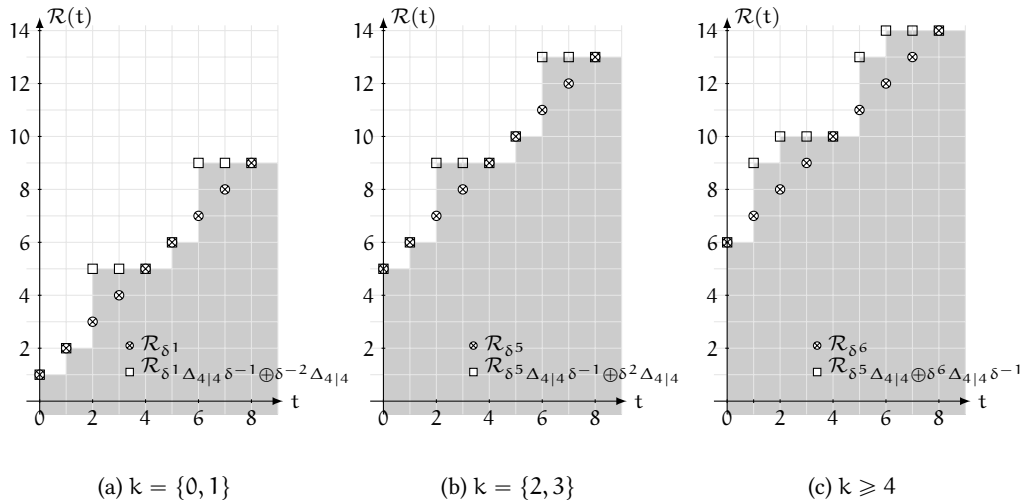

(a) $k = \{0, 1\}$ (b) $k = \{2, 3\}$ (c) $k \geq 4$

Figure 4.9. – Graphical illustration of $\text{Inj}^\#(p) = \gamma^0 \delta^1 \oplus \gamma^2 \delta^5 \oplus \gamma^4 \delta^6$.

Zero slice Mapping $\Psi_\omega : \mathcal{T}_\omega[[\gamma]] \rightarrow \mathcal{M}_{\text{in}}^{\text{ax}}[[\gamma, \delta]]$

Recall that $(\mathcal{M}_{\text{in}}^{\text{ax}}[[\gamma, \delta]], \oplus, \otimes)$ is a subdioid of $(\mathcal{T}_\omega[[\gamma]], \oplus, \otimes)$, hence we define a specific projection from $\mathcal{T}_\omega[[\gamma]]$ into $\mathcal{M}_{\text{in}}^{\text{ax}}[[\gamma, \delta]]$ as follows.

Definition 49. Let $s = \bigoplus_i v_i \gamma^{n_i} \in \mathcal{T}_\omega[[\gamma]]$ be an ω -periodic series, then

$$\Psi_\omega(s) = \Psi_\omega\left(\bigoplus_i v_i \gamma^{n_i}\right) = \bigoplus_i \gamma^{n_i} \delta^{\mathcal{R}_{v_i}(0)}. \quad (4.41)$$

This projection Ψ_ω has a graphical interpretation, for a given $s \in \mathcal{T}_\omega[[\gamma]]$ the series $\tilde{s} = \Psi_\omega(s) \in \mathcal{M}_{\text{in}}^{\text{ax}}[[\gamma, \delta]]$ corresponds to the slice in the (event/output-time)-plane of the 3D representation of $s \in \mathcal{T}_\omega[[\gamma]]$ at the input-time value 0, thus this projection is also called zero-slice mapping. Note that in contrast to the zero-slice mapping $\Psi_{m|b} : \mathcal{E}_{m|b}[[\delta]] \rightarrow \mathcal{M}_{\text{in}}^{\text{ax}}[[\gamma, \delta]]$ defined in Section 3.2, the mapping Ψ_ω is a projection because $\mathcal{M}_{\text{in}}^{\text{ax}}[[\gamma, \delta]]$ is a subset of $\mathcal{T}_\omega[[\gamma]]$ and Ψ_ω satisfies $\Psi_\omega = \Psi_\omega \circ \Psi_\omega$. However, this is not the case for the set $\mathcal{E}_{m|b}[[\delta]]$, for instance, $\mathcal{M}_{\text{in}}^{\text{ax}}[[\gamma, \delta]]$ is not a subset of $\mathcal{E}_{3|2}[[\delta]]$ and therefore the concatenation of the mappings $\Psi_{3|2} \circ \Psi_{3|2}$ is not defined (possible).

Example 40. Recall the polynomial $p = (\delta^1 \Delta_{4|4} \delta^{-1} \oplus \delta^{-2} \Delta_{4|4}) \gamma^0 \oplus (\delta^5 \Delta_{4|4} \delta^{-1} \oplus \delta^2 \Delta_{4|4}) \gamma^2 \oplus (\delta^5 \Delta_{4|4} \oplus \delta^6 \Delta_{4|4} \delta^{-1}) \gamma^4 \in \mathcal{T}_{\text{per}}[[\gamma]]$ with a graphical representation given in Figure 4.4. Then,

$$\Psi_4(p) = \delta^1 \gamma^0 \oplus \delta^5 \gamma^2 \oplus \delta^6 \gamma^4.$$

The series $\Psi_4(p)$ corresponds to the slice in the (event-shift/output-time)-plane for the input-time value $t = 0$ in the 3D representation of p , see Figure 4.10a and Figure 4.10b.

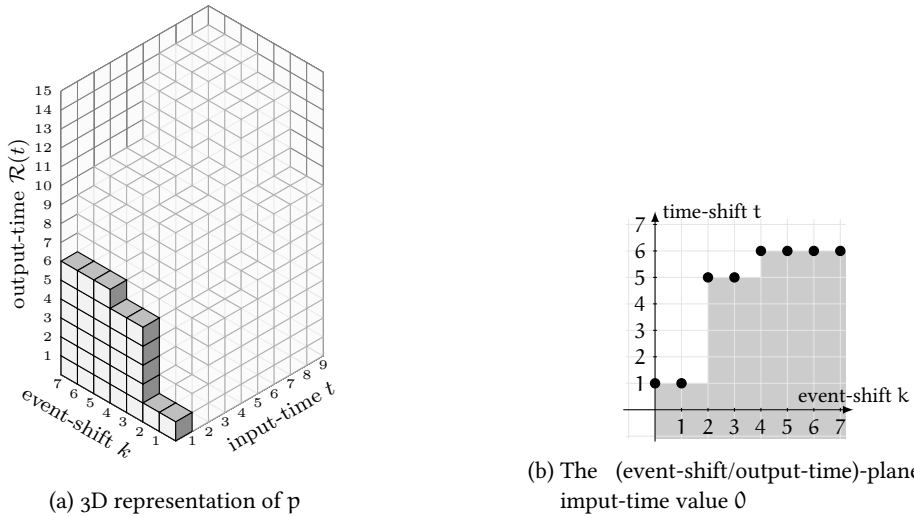

Figure 4.10. – Illustration of the Projection $\Psi_4(p)$.

The projection Ψ_ω is by definition lower-semicontinuous, see Definition 49, therefore Ψ_ω is residuated.

Proposition 71. *Let $s = \bigoplus_i \gamma^{n_i} \delta^{\tau_i} \in \mathcal{M}_{\text{in}}^{\text{ax}} [[\gamma, \delta]]$. The residual $\Psi_\omega^\#(s) \in \mathcal{T}_\omega [[\gamma]]$ of s is a series defined by*

$$\Psi_\omega^\# \left(\bigoplus_i \gamma^{n_i} \delta^{\tau_i} \right) = \bigoplus_i \gamma^{n_i} \delta^{\tau_i} \Delta_{\omega|\omega} = s \Delta_{\omega|\omega}. \quad (4.42)$$

Proof. By definition of the residuated mapping, $\Psi_\omega^\# \left(\bigoplus_i \gamma^{n_i} \delta^{\tau_i} \right) \in \mathcal{T}_\omega [[\gamma]]$ is the greatest solution of the following inequality

$$\bigoplus_i \gamma^{n_i} \delta^{\tau_i} \geq \Psi_\omega(x) = \Psi_\omega \left(\bigoplus_j v_j \gamma^{\eta_j} \right), \quad (4.43)$$

where $x = \bigoplus_j v_j \gamma^{\eta_j} \in \mathcal{T}_\omega [[\gamma]]$. First we show that (4.42) satisfies (4.43) with equality.

$$\Psi_\omega \left(\bigoplus_i \gamma^{n_i} \delta^{\tau_i} \Delta_{\omega|\omega} \right) = \bigoplus_i \gamma^{n_i} \delta^{\mathcal{R}_{\delta^{\tau_i} \Delta_{\omega|\omega}}(0)} = \bigoplus_i \gamma^{n_i} \delta^{\tau_i},$$

since $\mathcal{R}_{\delta^{\tau_i} \Delta_{\omega|\omega}}(0) = \tau_i + [0/\omega]\omega = \tau_i$, see (4.8) and (4.9). Taking into account that Ψ_ω is isotone, it remains to show that $\bigoplus_i \gamma^{n_i} \delta^{\tau_i} \Delta_{\omega|\omega}$ is the greatest solution of

$$\bigoplus_i \gamma^{n_i} \delta^{\tau_i} = \Psi_\omega(x) = \Psi_\omega \left(\bigoplus_j v_j \gamma^{\eta_j} \right) = \bigoplus_j \gamma^{\eta_j} \delta^{\mathcal{R}_{v_j}(0)}. \quad (4.44)$$

Clearly, to achieve equality we need $\eta_j = n_i$ and $\mathcal{R}_{v_j}(0) = \tau_i$. Furthermore, we are looking for the greatest $v_j \in \mathcal{T}_\omega$, such that $\tau_i = \mathcal{R}_{v_j}(0)$. Due to the canonical form Prop. 55 we can write an ω -periodic T-operator as $\bigoplus_{i=1}^\omega \delta^{\zeta_i} \Delta_{\omega|\omega} \gamma^{\zeta'_i}$ with $-\omega < \zeta'_i \leq 0$. This operator corresponds to the release-time function

$$\mathcal{R}(t) = \max_{i=1}^\omega \left(\zeta_i + \left\lceil \frac{\zeta'_i + t}{\omega} \right\rceil \omega \right).$$

Now we examine $\mathcal{R}(t)$ for $t = 0$, thus

$$\mathcal{R}(0) = \max_{i=1}^\omega \left(\zeta_i + \left\lceil \frac{\zeta'_i}{\omega} \right\rceil \omega \right).$$

Recall that $-\omega < \zeta'_i \leq 0$, hence $\mathcal{R}_{v_j}(t) = \tau_i + [(0+t)/\omega]\omega$ is the greatest quasi ω -periodic release-time function such that (4.44) holds, i.e., $\mathcal{R}_{v_j}(0) = \mathcal{R}_{\delta^{\tau_i} \Delta_{\omega|\omega}}(0) = \tau_i + [0/\omega]\omega = \tau_i$. This function corresponds to the operator $\delta^{\tau_i} \Delta_{\omega|\omega}$. \square

Proposition 72. *Let $s = \bigoplus_i \gamma^{n_i} \delta^{\tau_i} \in \mathcal{M}_{\text{in}}^{\text{ax}} [[\gamma, \delta]]$. The dual residual $\Psi_\omega^b(s) \in \mathcal{T}_\omega [[\gamma]]$ of s is a series defined by*

$$\Psi_\omega^b \left(\bigoplus_i \gamma^{n_i} \delta^{\tau_i} \right) = \bigoplus_i \gamma^{n_i} \delta^{\tau_i} \Delta_{\omega|\omega} \delta^{1-\omega} = s \Delta_{\omega|\omega} \delta^{1-\omega}. \quad (4.45)$$

Proof. The proof is similar to the proof of Prop. 71, with the difference that instead of finding the greatest solution we are now looking for the least solution, denoted by $\Psi_\omega^\flat(\bigoplus_i \gamma^{n_i} \delta^{\tau_i}) \in \mathcal{T}_\omega[[\gamma]]$, of the following inequality

$$\bigoplus_i \gamma^{n_i} \delta^{\tau_i} \leq \Psi_\omega(x) = \Psi_\omega\left(\bigoplus_j v_j \gamma^{\eta_j}\right). \quad (4.46)$$

Again, we show that (4.45) satisfies (4.46) with equality.

$$\Psi_\omega\left(\bigoplus_i \gamma^{v_i} \delta^{\tau_i} \Delta_{|\omega} \delta^{1-\omega}\right) = \bigoplus_i \gamma^{\mathcal{R}_{\delta^{\tau_i} \Delta_{|\omega} \delta^{1-\omega}}(0)} \delta^{\tau_i} = \bigoplus_i \gamma^{v_i} \delta^{\tau_i},$$

since $\mathcal{R}_{\delta^{\tau_i} \Delta_{|\omega} \delta^{1-\omega}}(0) = \tau_i + [(1 - \omega)/\omega]\omega = \tau_i$, see (4.8) and (4.9). Taking into account that Ψ_ω is isotone, it remains to show that $\bigoplus_i \gamma^{n_i} \delta^{\tau_i} \Delta_{|\omega} \delta^{1-\omega}$ is the least solution of

$$\bigoplus_i \gamma^{n_i} \delta^{\tau_i} = \Psi_\omega(x) = \Psi_\omega\left(\bigoplus_j v_j \gamma^{\eta_j}\right) = \bigoplus_j \gamma^{\eta_j} \delta^{\mathcal{R}_{v_j}(0)}. \quad (4.47)$$

Clearly, to achieve equality we need $\eta_j = n_i$ and $\mathcal{R}_{v_j}(0) = \tau_i$. Furthermore, we are looking for the least $v_j \in \mathcal{T}_\omega[[\gamma]]$, such that $\tau_i = \mathcal{R}_{v_j}(0)$. Due to the canonical form Prop. 55 we can write an ω -periodic T-operator as $\bigoplus_{i=1}^\omega \delta^{\zeta_i} \Delta_{|\omega} \delta^{\zeta'_i}$ with $-\omega < \zeta'_i \leq 0$. This operator corresponds to the release-time function

$$\mathcal{R}(t) = \max_{i=1}^\omega \left(\zeta_i + \left\lceil \frac{\zeta'_i + t}{\omega} \right\rceil \omega \right).$$

Now we examine $\mathcal{R}(t)$ for $t = 0$, thus

$$\mathcal{R}(0) = \max_{i=1}^\omega \left(\zeta_i + \left\lceil \frac{\zeta'_i}{\omega} \right\rceil \omega \right).$$

Let us recall that $-\omega < \zeta'_i \leq 0$, hence $\mathcal{R}_{v_j}(t) = \tau_i + [((1 - \omega) + t)/\omega]\omega$ is the least ω -periodic release-time function such that (3.41) holds, i.e., $\mathcal{R}_{v_j}(0) = \mathcal{R}_{\delta^{\tau_i} \Delta_{|\omega} \delta^{1-\omega}}(0) = \tau_i + [(1 - \omega)/\omega]\omega = \tau_i$. This function corresponds to the operator $\delta^{\tau_i} \Delta_{|\omega} \delta^{1-\omega}$. \square

Example 41. Let us consider the polynomial $p = (\delta^1 \Delta_{4|4} \delta^{-1} \oplus \delta^{-2} \Delta_{4|4}) \gamma^0 \oplus (\delta^5 \Delta_{4|4} \delta^{-1} \oplus \delta^2 \Delta_{4|4}) \gamma^2 \oplus (\delta^5 \Delta_{4|4} \oplus \delta^6 \Delta_{4|4} \delta^{-1}) \gamma^4 \in \mathcal{T}_{\text{per}}[[\gamma]]$ with a projection $\Psi_4(p) = \delta^1 \gamma^0 \oplus \delta^5 \gamma^2 \oplus \delta^6 \gamma^4$. The residual of the projection $\Psi_4(p)$, is given by

$$\Psi_4^\sharp(\Psi_4(p)) = (\delta^1 \gamma^0 \oplus \delta^5 \gamma^2 \oplus \delta^6 \gamma^4) \Delta_{4|4}.$$

See Figure 4.11 and Figure 4.12 for a comparison of p and $\Psi_4^\sharp(\Psi_4(p))$, as required $p \leq \Psi_4^\sharp(\Psi_4(p))$ (2.17).

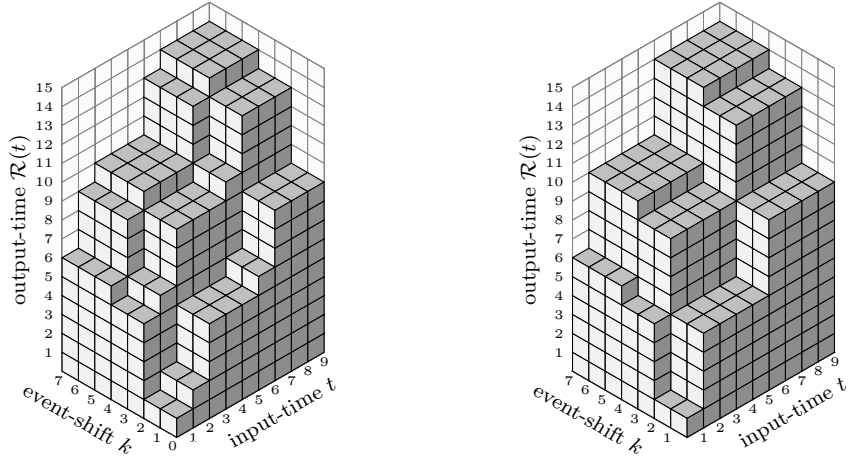

(a) 3D representation of polynomial $p = (\delta^1 \Delta_{4|4} \delta^{-1} \oplus \delta^{-2} \Delta_{4|4}) \gamma^0 \oplus (\delta^5 \Delta_{4|4} \delta^{-1} \oplus \delta^2 \Delta_{4|4}) \gamma^2 \oplus (\delta^5 \Delta_{4|4} \oplus \delta^6 \Delta_{4|4} \delta^{-1}) \gamma^4$. (b) 3D representation of $\Psi_4^\#(\Psi_4(p)) = (\delta^1 \gamma^0 \oplus \delta^5 \gamma^2 \oplus \delta^6 \gamma^4) \Delta_{4|4}$.

Figure 4.11. – Comparison of the polynomial $p = (\delta^1 \Delta_{4|4} \delta^{-1} \oplus \delta^{-2} \Delta_{4|4}) \gamma^0 \oplus (\delta^5 \Delta_{4|4} \delta^{-1} \oplus \delta^2 \Delta_{4|4}) \gamma^4 \oplus (\delta^5 \Delta_{4|4} \oplus \delta^6 \Delta_{4|4} \delta^{-1}) \gamma^6$ and $\text{Inj}(\text{Inj}^\#(p))$. For all $k \in \mathbb{Z}$ the slices in the (input-time/output-time)-plane of $\Psi_4^\#(\Psi_4(p))$ cover the slices of p , see Figure 4.12.

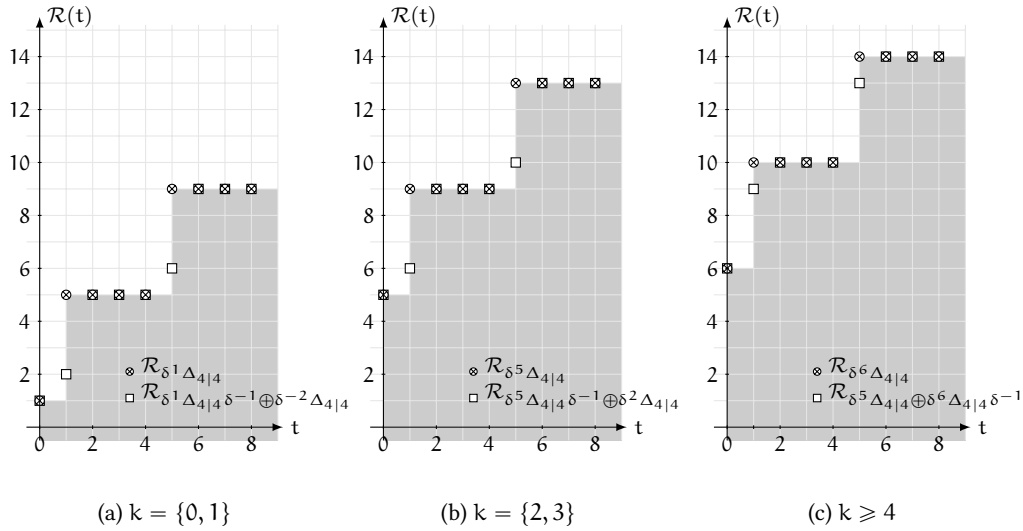

Figure 4.12. – Graphical illustration of $\Psi_4^\#(\Psi_4(p)) = (\delta^1 \gamma^0 \oplus \delta^5 \gamma^2 \oplus \delta^6 \gamma^4) \Delta_{4|4}$.

Dioid $(\mathcal{ET}, \oplus, \otimes)$

In this chapter, the dioid $(\mathcal{ET}, \oplus, \otimes)$ is introduced. This dioid is used for the modeling and the control of Weighted Timed Event Graphs under partial synchronization. The dioid $(\mathcal{ET}, \oplus, \otimes)$ consists of specific event-variant and time-variant operators, in other words, it is a composition of the dioids $(\mathcal{E}[\![\delta]\!], \oplus, \otimes)$ and $(\mathcal{T}[\![\gamma]\!], \oplus, \otimes)$ introduced in Chapter 3 and Chapter 4. Note that many results are similar to the results obtained for the dioid $(\mathcal{E}[\![\delta]\!], \oplus, \otimes)$ and $(\mathcal{T}[\![\gamma]\!], \oplus, \otimes)$. In particular, just as for periodic elements in $\mathcal{E}[\![\delta]\!]$ and $\mathcal{T}[\![\gamma]\!]$, a core decomposition is introduced for periodic elements in \mathcal{ET} . Again, it is shown that all relevant operations $(\oplus, \otimes, \setminus, \phi)$ on periodic elements in \mathcal{ET} can be reduced to operations on matrices with entries in $\mathcal{M}_{\text{in}}^{\text{ax}}[\![\gamma, \delta]\!]$.

5.1. Dioid \mathcal{ET}

Let us first recall some results from Section 3.1. The set of antitone mappings $\Sigma : \mathbb{Z} \rightarrow \overline{\mathbb{Z}}_{\min}$ is a idempotent commutative monoid, denoted $(\Sigma, \oplus, \tilde{\epsilon})$. An operator is defined as a lower semi-continuous mapping from the set Σ into itself, see Definition 27. The set of operators \mathcal{O} is a complete dioid denoted $(\mathcal{O}, \oplus, \otimes)$, see Prop. 8. On this dioid the order introduced by \oplus is partial and given by, for $f_1, f_2 \in \mathcal{O}$

$$\begin{aligned} f_1 \geq f_2 &\Leftrightarrow f_1 \oplus f_2 = f_1, \\ &\Leftrightarrow (f_1x)(t) \oplus (f_2x)(t) = (f_1x)(t), \quad \forall x \in \Sigma, \forall t \in \mathbb{Z}, \\ &\Leftrightarrow \min\left((f_1x)(t), (f_2x)(t)\right) = (f_1x)(t) \quad \forall x \in \Sigma, \forall t \in \mathbb{Z}. \end{aligned}$$

Then, two operators $f_1, f_2 \in \mathcal{O}$ are equal iff $\forall x \in \Sigma, \forall t \in \mathbb{Z}: (f_1x)(t) = (f_2x)(t)$. In the following proposition, some specific operators in \mathcal{O} are recalled and the $\Delta_{\omega|\varpi}$ operator is redefined.

Proposition 73. *The following elementary operators are endomorphisms and lower semi-con-*

tinuous mappings and therefore operators in \mathcal{O} .

$$m, b \in \mathbb{N} \quad \nabla_{m|b} : \forall x \in \Sigma, t \in \mathbb{Z} \quad (\nabla_{m|b}(x))(t) = m \times \left\lfloor \frac{x(t)}{b} \right\rfloor, \quad (5.1)$$

$$\omega, \varpi \in \mathbb{N} \quad \Delta_{\omega|\varpi} : \forall x \in \Sigma, t \in \mathbb{Z} \quad (\Delta_{\omega|\varpi}(x))(t) = x \left(\varpi \times \left\lfloor \frac{t-1}{\omega} \right\rfloor + 1 \right), \quad (5.2)$$

$$v \in \mathbb{Z} \quad \gamma^v : \forall x \in \Sigma, t \in \mathbb{Z} \quad (\gamma^v(x))(t) = v + x(t), \quad (5.3)$$

$$\tau \in \mathbb{Z} \quad \delta^\tau : \forall x \in \Sigma, t \in \mathbb{Z} \quad (\delta^\tau(x))(t) = x(t - \tau). \quad (5.4)$$

Proof. For the proof of (5.3) see the proof of Prop. 9. For the proof of (5.4) see (3.19) and the following paragraph in Section 3.1.2. Note that the $\nabla_{m|b}$ operator is nothing but the composition $\mu_m \beta_b$, with μ_m and β_b defined in Prop. 9. The mapping $\nabla_{m|b}$ is a \oplus -morphism, since first $\forall t \in \mathbb{Z}$, $\tilde{\varepsilon}(t) = \infty$ and $m, b \in \mathbb{N}$ are finite positive integers, thus $(\nabla_{m|b}(\tilde{\varepsilon}))(t) = m \times \lfloor \tilde{\varepsilon}(t)/b \rfloor = \tilde{\varepsilon}(t)$. Moreover, for all finite and infinite subsets $\mathcal{X} \subseteq \Sigma$,

$$\begin{aligned} \left(\nabla_{m|b} \left(\bigoplus_{x \in \mathcal{X}} x \right) \right) (t) &= m \times \left\lfloor \frac{\left(\bigoplus_{x \in \mathcal{X}} x \right) (t)}{b} \right\rfloor = m \times \left\lfloor \frac{\min_{x \in \mathcal{X}} (x(t))}{b} \right\rfloor, \\ &= \min_{x \in \mathcal{X}} \left(m \times \left\lfloor \frac{x(t)}{b} \right\rfloor \right) = \min_{x \in \mathcal{X}} \left((\nabla_{m|b}(x))(t) \right), \\ &= \left(\bigoplus_{x \in \mathcal{X}} \nabla_{m|b}(x) \right) (t), \end{aligned}$$

which proves the lower semi-continuity property. Note that in contrast to Prop. 53 in Section 4.1 here the $\Delta_{\omega|\varpi}$ operator is defined on the set Σ instead of Ξ , *i.e.*, the set of isotone mappings from \mathbb{Z} into $\overline{\mathbb{Z}}_{\max}$. In the current form, it manipulates the domain \mathbb{Z} of a mapping $x : \mathbb{Z} \rightarrow \overline{\mathbb{Z}}_{\min}$ whereas for mappings $\bar{x} \in \Xi$, $\bar{x} : \mathbb{Z} \rightarrow \overline{\mathbb{Z}}_{\max}$ the $\Delta_{\omega|\varpi}$ operator manipulates the codomain $\overline{\mathbb{Z}}_{\max}$ of \bar{x} , see Prop. 53. The $\Delta_{\omega|\varpi}$ operator defined in (5.2) is lower semi-continuous and endomorphic. First, we have to prove that, $\Delta_{\omega|\varpi}(\tilde{\varepsilon}) = \tilde{\varepsilon}$. Clearly, since $\omega, \varpi \in \mathbb{N}$ are finite positive integers then $\forall t \in \mathbb{Z}$, $\omega \lfloor (t-1)/\omega \rfloor + 1 \in \mathbb{Z}$. Then $\forall t \in \mathbb{Z}$, $\tilde{\varepsilon}(t) = \infty$ and therefore $\forall t \in \mathbb{Z}$, $(\Delta_{\omega|\varpi}(\tilde{\varepsilon}))(t) = \tilde{\varepsilon}(\omega \lfloor (t-1)/\omega \rfloor + 1) = \infty$. Second, for all finite and infinite subsets $\mathcal{X} \subseteq \Sigma$ and $\forall t \in \mathbb{Z}$,

$$\begin{aligned} \left(\Delta_{\omega|\varpi} \left(\bigoplus_{x \in \mathcal{X}} x \right) \right) (t) &= \left(\bigoplus_{x \in \mathcal{X}} x \right) \left(\varpi \times \left\lfloor \frac{t-1}{\omega} \right\rfloor + 1 \right) \quad \text{due to (5.2),} \\ &= \bigoplus_{x \in \mathcal{X}} x \left(\varpi \times \left\lfloor \frac{t-1}{\omega} \right\rfloor + 1 \right) \quad \text{due to (3.4),} \\ &= \bigoplus_{x \in \mathcal{X}} \left(\Delta_{\omega|\varpi}(x) \right) (t) \quad \text{due to (5.2).} \end{aligned}$$

□

Note that the identity operator $e : (ex)(t) = x(t)$ can be written as $\Delta_{1|1}$ and $\nabla_{1|1}$, *i.e.*, $(\Delta_{1|1}x)(t) = x(1 \times \lfloor (t-1)/1 \rfloor + 1) = x(t)$ and $(\nabla_{1|1}x)(t) = 1 \times \lfloor x(t)/1 \rfloor = x(t)$.

Remark 29. Note that in analogy with Section 4.1, these operators can be defined on the set Ξ in the following form,

$$m, b \in \mathbb{N} \quad \nabla_{m|b} : \forall x \in \Xi, k \in \mathbb{Z} \quad (\nabla_{m|b}(x))(k) = x\left(b \times \left\lceil \frac{k+1}{m} \right\rceil - 1\right), \quad (5.5)$$

$$\omega, \varpi \in \mathbb{N} \quad \Delta_{\omega|\varpi} : \forall x \in \Xi, k \in \mathbb{Z} \quad (\Delta_{\omega|\varpi}x)(k) = \left\lceil \frac{x(k)}{\omega} \right\rceil \varpi, \quad (5.6)$$

$$\nu \in \mathbb{Z} \quad \gamma^\nu : \forall x \in \Xi, k \in \mathbb{Z} \quad (\gamma^\nu(x))(k) = x(k - \nu), \quad (5.7)$$

$$\tau \in \mathbb{Z} \quad \delta^\tau : \forall x \in \Xi, k \in \mathbb{Z} \quad (\delta^\tau(x))(k) = x(k) + \tau. \quad (5.8)$$

Proposition 74. The elementary operators satisfy the following relations

$$\gamma^\nu \oplus \gamma^{\nu'} = \gamma^{\min(\nu, \nu')}, \quad \gamma^\nu \gamma^{\nu'} = \gamma^{\nu+\nu'}, \quad (5.9)$$

$$\delta^\tau \oplus \delta^{\tau'} = \delta^{\max(\tau, \tau')}, \quad \delta^\tau \delta^{\tau'} = \delta^{\tau+\tau'}, \quad (5.10)$$

$$\Delta_{\omega|\varpi} \delta^\omega = \delta^\omega \Delta_{\omega|\varpi} \quad \nabla_{m|b} \gamma^b = \gamma^m \nabla_{m|b}. \quad (5.11)$$

Proof. For the proof of (5.9) see Prop. 10. For the proof of $\delta^\tau \oplus \delta^{\tau'} = \delta^{\max(\tau, \tau')}$, recall (3.4), (3.1) and (5.4), then $\forall x \in \Sigma, \forall t \in \mathbb{Z}$,

$$\begin{aligned} ((\delta^\tau \oplus \delta^{\tau'}))(t) &= ((\delta^\tau x) \oplus (\delta^{\tau'} x))(t) = (\delta^\tau x)(t) \oplus (\delta^{\tau'} x)(t) \\ &= \min(x(t - \tau), x(t - \tau')) = x(t - \max(\tau, \tau')) = (\delta^{\max(\tau, \tau')} x)(t). \end{aligned}$$

For the proof of $\delta^\tau \delta^{\tau'} = \delta^{\tau+\tau'}$, recall (3.5) and (5.4), then $\forall x \in \Sigma, \forall t \in \mathbb{Z}$,

$$((\delta^\tau \delta^{\tau'})x)(t) = ((\delta^\tau(\delta^{\tau'} x))(t) = (\delta^{\tau'} x)(t - \tau) = x(t - (\tau + \tau')) = (\delta^{\tau+\tau'} x)(t).$$

For the proof of $\Delta_{\omega|\varpi} \delta^\omega = \delta^\omega \Delta_{\omega|\varpi}$, recall (3.5), (5.2) and (5.4), then first $\forall x \in \Sigma, \forall t \in \mathbb{Z}$,

$$\begin{aligned} (\Delta_{\omega|\varpi} \delta^\omega x)(t) &= (\Delta_{\omega|\varpi}(\delta^\omega x))(t) = (\delta^\omega x)\left(\varpi \left\lceil \frac{t-1}{\omega} \right\rceil + 1\right) \\ &= x\left(\varpi \left\lceil \frac{t-1}{\omega} \right\rceil - \omega + 1\right). \end{aligned}$$

Second,

$$\begin{aligned} x\left(\varpi \left\lceil \frac{t-1}{\omega} \right\rceil - \omega + 1\right) &= x\left(\varpi \left(\left\lceil \frac{t-1}{\omega} \right\rceil - 1\right) + 1\right) = x\left(\varpi \left\lceil \frac{t-\omega-1}{\omega} \right\rceil + 1\right) \\ &= (\delta^\omega \Delta_{\omega|\varpi} x)(t). \end{aligned}$$

For the proof of $\nabla_{m|b} \gamma^b = \gamma^m \nabla_{m|b}$, recall that $\nabla_{m|b} = \mu_m \beta_b$, $\gamma^m \mu_m = \mu_m \gamma^1$ and $\gamma^1 \beta_b = \beta_b \gamma^b$ (3.13), therefore $\mu_m \beta_b \gamma^b = \mu_m \gamma^1 \beta_b = \gamma^m \mu_m \beta_b$ and $\nabla_{m|b} \gamma^b = \gamma^m \nabla_{m|b}$. \square

Remark 30. (5.11) implies that for $0 \leq n < i$, $\nabla_{m|i}\gamma^n\nabla_{i|b} = \nabla_{m|b}$, since,

$$\begin{aligned} (\nabla_{m|i}\gamma^n\nabla_{i|b}x)(t) &= \left\lfloor \frac{\lfloor x(t)/b \rfloor i + n}{i} \right\rfloor m, \\ &= \left\lfloor \left\lfloor \frac{x(t)}{b} \right\rfloor + \frac{n}{i} \right\rfloor m, \\ &= \left\lfloor \frac{x(t)}{b} \right\rfloor m, \quad \text{since } 0 \leq \frac{n}{i} < 1. \end{aligned}$$

Moreover, for $-i < \tau \leq 0$, $\Delta_{\omega|i}\delta^\tau\Delta_{i|\omega} = \Delta_{\omega|\omega}$, since

$$\begin{aligned} (\Delta_{\omega|i}\delta^\tau\Delta_{i|\omega}x)(t) &= (\delta^\tau\Delta_{i|\omega}x)\left(i\left\lfloor \frac{t-1}{\omega} \right\rfloor + 1\right), \\ &= (\Delta_{i|\omega}x)\left(i\left\lfloor \frac{t-1}{\omega} \right\rfloor - \tau + 1\right), \\ &= x\left(\omega\left\lfloor \frac{i\lfloor (t-1)/\omega \rfloor - \tau + 1 - 1}{i} \right\rfloor + 1\right), \\ &= x\left(\omega\left\lfloor \left\lfloor \frac{t-1}{\omega} \right\rfloor - \frac{\tau}{i} \right\rfloor + 1\right), \quad \text{since } 0 \leq \frac{-\tau}{i} < 1, \\ &= x\left(\omega\left\lfloor \frac{t-1}{\omega} \right\rfloor + 1\right), \\ &= (\Delta_{\omega|\omega}x)(t). \end{aligned}$$

In general mappings (operators) in \mathcal{O} do not commute, i.e., $f_1, f_2 \in \mathcal{O}$ and $x \in \Sigma$ in general $f_1(f_2(x)) \neq f_2(f_1(x))$, however, the following proposition gives some properties regarding the commutation of the elementary operators.

Proposition 75. The operators introduced in Prop. 73 commute according to the following rules,

$$\delta^1\gamma^1 = \gamma^1\delta^1, \quad \Delta_{\omega|\omega}\nabla_{m|b} = \nabla_{m|b}\Delta_{\omega|\omega}, \quad (5.12)$$

$$\nabla_{m|b}\delta^1 = \delta^1\nabla_{m|b}, \quad \Delta_{\omega|\omega}\gamma^1 = \gamma^1\Delta_{\omega|\omega}. \quad (5.13)$$

Proof. For the proof of $\delta^1\gamma^1 = \gamma^1\delta^1$, recall (3.5), (5.3) and (5.4), then $\forall x \in \Sigma, \forall t \in \mathbb{Z}$,

$$\begin{aligned} ((\delta^1\gamma^1)x)(t) &= (\delta^1(\gamma^1x))(t) = (\gamma^1x)(t-1) = 1 + x(t-1) = 1 + (\delta^1x)(t), \\ &= ((\gamma^1\delta^1)x)(t). \end{aligned}$$

The proofs for the right equation of (5.12) and the equations of (5.13) are similar. □

Proposition 76. The $\nabla_{m|b}$ and the $\Delta_{\omega|\omega}$ operator are expressed in the following forms

$$\nabla_{m|b} = \bigoplus_{i=0}^{n-1} \gamma^{im} \nabla_{nm|nb} \gamma^{(n-1-i)b}, \quad (5.14)$$

$$\Delta_{\omega|\omega} = \bigoplus_{i=0}^{n-1} \delta^{-i\omega} \Delta_{n\omega|n\omega} \delta^{-(n-1-i)\omega}. \quad (5.15)$$

Proof. For the proof of (5.14) see Prop. 12 and the proof of (5.15) is similar to the proof of Prop. 56 in Appendix Section C.2.1. \square

Example 42. The identity operator $e = \nabla_{1|1} \Delta_{1|1}$ is represented with $n = 2$ in an extended form

$$\begin{aligned} \nabla_{1|1} \Delta_{1|1} &= (\nabla_{2|2} \gamma^1 \oplus \gamma^1 \nabla_{2|2}) (\Delta_{2|2} \delta^{-1} \oplus \delta^{-1} \Delta_{2|2}), \\ &= \nabla_{2|2} \Delta_{2|2} \gamma^1 \delta^{-1} \oplus \delta^{-1} \nabla_{2|2} \Delta_{2|2} \gamma^1 \oplus \gamma^1 \nabla_{2|2} \Delta_{2|2} \delta^{-1} \oplus \gamma^1 \delta^{-1} \nabla_{2|2} \Delta_{2|2}. \end{aligned}$$

Definition 50 (Dioid \mathcal{ET}). The dioid $(\mathcal{ET}, \oplus, \otimes)$ is defined by sums and compositions over the set $\{\hat{e}, \hat{\varepsilon}, \hat{\uparrow}, \nabla_{m|b}, \gamma^\nu, \Delta_{\omega|\omega}, \delta^\tau\}$ with $m, b, \omega, \omega \in \mathbb{N}$, $\nu, \tau \in \mathbb{Z}$ and addition and multiplication defined in (3.4) and (3.5).

The dioid $(\mathcal{ET}, \oplus, \otimes)$ is a complete subdioid of $(\mathcal{O}, \oplus, \otimes)$. Again the \oplus operation defines a natural order on \mathcal{ET} , therefore for $a, b \in \mathcal{ET}$, $a \oplus b = a \Leftrightarrow a \geq b$. Note that, in contrast to $\mathcal{E}[[\delta]]$ and $\mathcal{T}[[\gamma]]$, an element $s \in \mathcal{ET}$ does not have the structure of a formal power series, see Definition 9. However, a basic element in $(\mathcal{ET}, \oplus, \otimes)$ is defined as $\gamma^n \delta^\tau \nabla_{m|b} \Delta_{\omega|\omega} \gamma^{n'} \delta^{\tau'}$. A basic sum is defined as a finite sum of basic elements in \mathcal{ET} , i.e., $\bigoplus_{i=0}^I \gamma^{\nu_i} \delta^{\tau_i} \nabla_{m_i|b_i} \Delta_{\omega_i|\omega_i} \gamma^{n'_i} \delta^{\tau'_i}$ and an infinite sum $\bigoplus_i \gamma^{\nu_i} \delta^{\tau_i} \nabla_{m_i|b_i} \Delta_{\omega_i|\omega_i} \gamma^{n'_i} \delta^{\tau'_i}$ is called a series.

Proposition 77. A basic element $\gamma^n \delta^\tau \nabla_{m|b} \Delta_{\omega|\omega} \gamma^{n'} \delta^{\tau'} \in \mathcal{ET}$ has a canonical form such that $0 \leq n' < b$ and $-\omega < \tau' \leq 0$.

Proof. The canonical form is obtained by applying (5.11). \square

The ordering of two canonical basic elements $m_1 = \gamma^{\nu_1} \delta^{\tau_1} \nabla_{m|b_1} \Delta_{\omega|\omega_1} \gamma^{\nu'_1} \delta^{\tau'_1}$, $m_2 = \gamma^{\nu_2} \delta^{\tau_2} \nabla_{m|b_2} \Delta_{\omega|\omega_2} \gamma^{\nu'_2} \delta^{\tau'_2} \in \mathcal{ET}$ with equal indices m, ω can be checked by

$$m_1 \geq m_2 \Leftrightarrow \begin{cases} b_1 = b_2 \text{ and } \omega_1 = \omega_2 \text{ and} \\ \left(\gamma^{\nu_1} \delta^{\tau_1} \geq \gamma^{\nu_2} \delta^{\tau_2} \text{ and } \gamma^{\nu'_1} \delta^{\tau'_1} \geq \gamma^{\nu'_2} \delta^{\tau'_2} \right. \\ \text{or } \gamma^{\nu_1+m} \delta^{\tau_1} \geq \gamma^{\nu_2} \delta^{\tau_2} \text{ and } \gamma^{\nu'_1-b_1} \delta^{\tau'_1} \geq \gamma^{\nu'_2} \delta^{\tau'_2} \\ \text{or } \gamma^{\nu_1} \delta^{\tau_1-\omega} \geq \gamma^{\nu_2} \delta^{\tau_2} \text{ and } \gamma^{\nu'_1} \delta^{\tau'_1+\omega_1} \geq \gamma^{\nu'_2} \delta^{\tau'_2} \\ \left. \text{or } \gamma^{\nu_1+m} \delta^{\tau_1-\omega} \geq \gamma^{\nu_2} \delta^{\tau_2} \text{ and } \gamma^{\nu'_1-b_1} \delta^{\tau'_1+\omega_1} \geq \gamma^{\nu'_2} \delta^{\tau'_2} \right). \end{cases}$$

Proposition 78. [Standard Form] All elements $s \in \mathcal{ET}$ can be expressed by a finite or infinite sum of basic elements, i.e., $s = \bigoplus_i \gamma^{v_i} \delta^{\tau_i} \nabla_{m|b_i} \Delta_{\omega|\omega_i} \gamma^{n'_i} \delta^{\tau'_i}$, such that all basic elements have the same m and ω indices, are in the canonical form of (Prop. 77) and are not ordered.

Proof. See Section C.3.1. □

The standard form is used to check the ordering of two basic sums. Consider two sums $s_1 = \bigoplus_i \gamma^{v_{1i}} \delta^{\tau_{1i}} \nabla_{m_1|b_{1i}} \Delta_{\omega_1|\omega_{1i}} \gamma^{n'_{1i}} \delta^{\tau'_{1i}}$ and $s_2 = \bigoplus_j \gamma^{v_{2j}} \delta^{\tau_{2j}} \nabla_{m_2|b_{2j}} \Delta_{\omega_2|\omega_{2j}} \gamma^{n'_{2j}} \delta^{\tau'_{2j}}$ in the standard form (Prop. 78). Due to (5.14), (5.15) and by choosing $\omega = \text{lcm}(\omega_1, \omega_2)$ and $m = \text{lcm}(m_1, m_2)$, s_1 and s_2 can be rewritten as

$$s_1 = \bigoplus_k \gamma^{v_{1k}} \delta^{\tau_{1k}} \nabla_{m|b_{1k}} \Delta_{\omega|\omega_{1k}} \gamma^{n'_{1k}} \delta^{\tau'_{1k}}, \quad (5.16)$$

$$s_2 = \bigoplus_l \gamma^{v_{2l}} \delta^{\tau_{2l}} \nabla_{m|b_{2l}} \Delta_{\omega|\omega_{2l}} \gamma^{n'_{2l}} \delta^{\tau'_{2l}}. \quad (5.17)$$

Then the sum s_1 is greater than or equal to the sum s_2 if and only if, every basic element in (5.17) is smaller than or equal to at least one basic element in (5.16). Clearly, two sums $s_1, s_2 \in \mathcal{ET}$ are equal if $s_1 \leq s_2$ and $s_2 \leq s_1$.

Definition 51. An element $s \in \mathcal{ET}$ is called (m, b, ω) -periodic if its standard form is written as $\bigoplus_i \gamma^{v_i} \delta^{\tau_i} \nabla_{m|b} \Delta_{\omega|\omega} \gamma^{v'_i} \delta^{\tau'_i}$, i.e., all basic elements in the sum have the same m, b, ω indices. Furthermore, the gain of s is then defined by $\Gamma(s) = m/b$.

The set of periodic operators, denoted by $\mathcal{ET}_{\text{per}}$, is a subset of \mathcal{ET} .

Definition 52 (Ultimately cyclic series in $\mathcal{ET}_{\text{per}}$). A series $s \in \mathcal{ET}_{\text{per}}$ is said to be ultimately cyclic if it can be written as $p \oplus q(\gamma^v \delta^\tau)^*$ where $v, \tau \in \mathbb{N}_0$ and p, q are (m, b, ω) -periodic finite basic sums in $\mathcal{ET}_{\text{per}}$ (p and q must have the same period).

5.2. Core Decomposition of Series in $\mathcal{ET}_{\text{per}}$

This section introduces the core-form of series in $\mathcal{ET}_{\text{per}}$. This core-form is orthogonal to the core-forms of series $s \in \mathcal{E}_{m|b}[[\delta]]$ and series $s' \in \mathcal{T}_{\text{per}}[[\gamma]]$ introduced in Section 3.3 and Section 4.2. Hence, the following results are orthogonal to the results obtained in Section 3.3 and Section 4.2. However, to improve the readability of this section again all propositions with proofs in the introduced notation are provided. Note that most of the presented propositions and proof are similar to those given in Section 3.3 and Section 4.2. Recall that an ultimately cyclic series $s \in \mathcal{E}_{m|b}[[\delta]]$ can always be expressed as $\mathbf{m}_m \mathbf{Q} \mathbf{b}_b$ with \mathbf{Q} a matrix in $\mathcal{M}_{\text{in}}^{\alpha \times} [[\gamma, \delta]]$ and

$$\mathbf{m}_m := \left[\nabla_{m|1} \quad \gamma^1 \nabla_{m|1} \quad \cdots \quad \gamma^{m-1} \nabla_{m|1} \right], \quad (5.18)$$

$$\mathbf{b}_b := \left[\nabla_{1|b} \gamma^{b-1} \quad \cdots \quad \nabla_{1|b} \gamma^1 \quad \nabla_{1|b} \right]^T. \quad (5.19)$$

Respectively, an ultimately cyclic series $s \in \mathcal{T}_{\text{per}}[[\gamma]]$ can always be expressed as $\mathbf{d}_\omega \mathbf{Q} \mathbf{p}_\omega$ again with \mathbf{Q} a matrix in $\mathcal{M}_{\text{in}}^{\text{ax}}[[\gamma, \delta]]$ and

$$\begin{aligned} \mathbf{d}_\omega &:= \begin{bmatrix} \Delta_{\omega|1} & \delta^{-1}\Delta_{\omega|1} & \cdots & \delta^{1-\omega}\Delta_{\omega|1} \end{bmatrix}, \\ \mathbf{p}_\omega &:= \begin{bmatrix} \Delta_{1|\omega}\delta^{1-\omega} & \cdots & \Delta_{1|\omega}\delta^{-1} & \Delta_{1|\omega} \end{bmatrix}^\top. \end{aligned}$$

Similarly to the core representation of $s \in \mathcal{E}_{\text{m|b}}[[\delta]]$ and $s' \in \mathcal{T}_{\text{per}}[[\gamma]]$, in this section, a core representation for series $s \in \mathcal{ET}_{\text{per}}$ is introduced. It is shown that an ultimately cyclic series $s \in \mathcal{ET}_{\text{per}}$ can always be written as a product $\mathbf{m}_{\text{m},\omega} \mathbf{Q} \mathbf{b}_{\text{b},\omega}$ where \mathbf{Q} is a matrix in $\mathcal{M}_{\text{in}}^{\text{ax}}[[\gamma, \delta]]$ and

$$\mathbf{b}_{\text{b},\omega} := \begin{bmatrix} \Delta_{1|\omega}\delta^{1-\omega}\mathbf{b}_{\text{b}}^\top & \cdots & \Delta_{1|\omega}\mathbf{b}_{\text{b}}^\top \end{bmatrix}^\top, \quad (5.20)$$

$$\mathbf{m}_{\text{m},\omega} := \begin{bmatrix} \Delta_{\omega|1}\mathbf{m}_{\text{m}} & \cdots & \delta^{1-\omega}\Delta_{\omega|1}\mathbf{m}_{\text{m}} \end{bmatrix}. \quad (5.21)$$

Based on this representation all operations on series $s \in \mathcal{ET}_{\text{per}}$ can be reduced to operations on matrices in $\mathcal{M}_{\text{in}}^{\text{ax}}[[\gamma, \delta]]$. For an illustration of this core-form, see the following example.

Example 43. Consider a series $s = \delta^2 \nabla_{3|2} \Delta_{2|2} \gamma^1 \delta^{-1} \oplus (\gamma^3 \delta^3 \nabla_{3|2} \Delta_{2|2} \delta^{-1}) (\gamma^1 \delta^2)^*$. By using $(\gamma^1 \delta^2)^* = (\mathbf{e} \oplus \gamma^1 \delta^2) (\gamma^2 \delta^4)^*$, this series is rephrased as,

$$s = \delta^2 \nabla_{3|2} \Delta_{2|2} \gamma^1 \delta^{-1} \oplus (\gamma^3 \delta^3 \nabla_{3|2} \Delta_{2|2} \delta^{-1} \oplus \gamma^3 \delta^5 \nabla_{3|2} \Delta_{2|2} \gamma^1 \delta^{-1}) (\gamma^2 \delta^4)^*.$$

Because of $\Delta_{2|2} = \Delta_{2|1} \Delta_{1|2}$ and $\nabla_{3|2} = \nabla_{3|1} \nabla_{1|2}$ (Remark 30) one has,

$$\begin{aligned} s &= \delta^2 \nabla_{3|1} \nabla_{1|2} \Delta_{2|1} \Delta_{1|2} \gamma^1 \delta^{-1} \oplus (\gamma^3 \delta^3 \nabla_{3|1} \nabla_{1|2} \Delta_{2|1} \Delta_{1|2} \delta^{-1} \oplus \\ &\quad \gamma^3 \delta^5 \nabla_{3|1} \nabla_{1|2} \Delta_{2|1} \Delta_{1|2} \gamma^1 \delta^{-1}) (\gamma^2 \delta^4)^*. \end{aligned}$$

Recall, $\nabla_{2|1} \gamma^1 = \gamma^2 \nabla_{2|1}$, $\Delta_{2|1} \delta^1 = \delta^2 \Delta_{2|1}$ (5.11) and the commutation laws for elementary operators (Prop. 75), therefore s can be rephrased as

$$\begin{aligned} s &= \nabla_{3|1} \Delta_{2|1} \underbrace{\delta^1}_{M_1} \nabla_{1|2} \Delta_{1|2} \gamma^1 \delta^{-1} \oplus \delta^{-1} \nabla_{3|1} \Delta_{2|1} \underbrace{\gamma^1 \delta^2 (\gamma^1 \delta^2)^*}_{S_1} \nabla_{1|2} \Delta_{1|2} \delta^{-1} \oplus \\ &\quad \delta^{-1} \nabla_{3|1} \Delta_{2|1} \underbrace{\gamma^1 \delta^3 (\gamma^1 \delta^2)^*}_{S_2} \nabla_{1|2} \Delta_{1|2} \gamma^1 \delta^{-1}. \end{aligned}$$

Observe that M_1, S_1 and S_2 are elements in $\mathcal{M}_{\text{in}}^{\text{ax}}[[\gamma, \delta]]$, and that the entries of the $\mathbf{m}_{3,2}$ -vector (resp. $\mathbf{b}_{2,2}$ -vector) appear on the left (resp. right) of M_1, S_1, S_2 . The series s is now expressed in

the core representation $\mathbf{m}_{3,2}\mathbf{Qb}_{2,2}$ where,

$$\mathbf{Q} = \begin{bmatrix} \delta^1 & \varepsilon & \varepsilon & \varepsilon \\ \varepsilon & \varepsilon & \varepsilon & \varepsilon \\ \varepsilon & \varepsilon & \varepsilon & \varepsilon \\ \gamma^1\delta^3(\gamma^1\delta^2)^* & \gamma^1\delta^2(\gamma^1\delta^2)^* & \varepsilon & \varepsilon \\ \varepsilon & \varepsilon & \varepsilon & \varepsilon \\ \varepsilon & \varepsilon & \varepsilon & \varepsilon \end{bmatrix}.$$

A formal method to obtain the core representation for an arbitrary ultimately cyclic series $s \in \mathcal{E}\mathcal{T}_{\text{per}}$ is given in the following.

Core-Equation for a Series in $\mathcal{E}\mathcal{T}_{\text{per}}$

The decomposition of an ultimately cyclic series $s \in \mathcal{E}\mathcal{T}_{\text{per}}$ is carried out according to the following equation

$$s = \mathbf{m}_{m,\omega}\mathbf{Xb}_{b,\omega}. \quad (5.22)$$

This equation is called core-equation. Then, $\mathbf{Q} \in \mathcal{M}_{\text{in}}^{\text{ax}}[[\gamma, \delta]]^{m\omega \times b\omega}$ is called a core of $s \in \mathcal{E}\mathcal{T}_{\text{per}}$, if \mathbf{Q} is a solution of (5.22), i.e., $s = \mathbf{m}_{m,\omega}\mathbf{Qb}_{b,\omega}$. In general, there exists several cores \mathbf{Q} which solve (5.22). A solution \mathbf{Q} for an arbitrary ultimately cyclic $s \in \mathcal{E}\mathcal{T}_{\text{per}}$ can be obtained as follows. A series $s = p \oplus q(\gamma^\nu\delta^\tau)^* \in \mathcal{E}\mathcal{T}_{\text{per}}$ can be expressed as

$$s = \bigoplus_{i=1}^I \gamma^{n_i} \delta^{\sigma_i} \nabla_{m|1} \Delta_{\omega|1} \underbrace{\gamma^{\bar{n}_i} \delta^{\bar{\sigma}_i}}_{M_i} \nabla_{1|b} \Delta_{1|\omega} \gamma^{n'_i} \delta^{\sigma'_i} \oplus \bigoplus_{j=1}^J \gamma^{N_j} \delta^{t_j} \nabla_{m|1} \Delta_{\omega|1} \underbrace{\gamma^{\bar{N}_j} \delta^{\bar{t}_j} (\gamma^\nu \delta^\tau)^*}_{S_j} \nabla_{1|b} \Delta_{1|\omega} \gamma^{N'_j} \delta^{t'_j}.$$

where M_i is a monomial and S_j is a series in $\mathcal{M}_{\text{in}}^{\text{ax}}[[\gamma, \delta]]$. Furthermore $0 \leq n_i, N_j < m$, $0 \leq n'_i, N'_j < b$ and $-\omega < \sigma_i, \sigma'_i, t_j, t'_j \leq 0$. In this form, the entries of the $\mathbf{m}_{m,\omega}$ -vector appear on the left of monomials M_i and series S_j . Respectively, the entries of the $\mathbf{b}_{b,\omega}$ -vector appear on the right of monomials M_i and series S_j . Note that in general, the growing-term $(\gamma^\nu\delta^\tau)^*$ of a series $s \in \mathcal{E}\mathcal{T}_{\text{per}}$ does not commute with the $\nabla_{1|b}\Delta_{1|\omega}$ (resp. $\nabla_{m|1}\Delta_{\omega|1}$) operator. To bring the growing-term $(\gamma^\nu\delta^\tau)^*$ of a series to the left-hand side of the $\nabla_{1|b}\Delta_{1|\omega}$ operator ν must be a multiple of b and τ must be a multiple of ω , see (5.11). However, any series $s \in \mathcal{E}\mathcal{T}_{\text{per}}$ can be rewritten such that the growing-term commutes with $\nabla_{1|b}\Delta_{1|\omega}$ by extending $(\gamma^\nu\delta^\tau)^*$ such that, $l = \text{lcm}(l_1, l_2)$ with $l_1 = \text{lcm}(\nu, b)/\nu$, $l_2 = \text{lcm}(\tau, \omega)/\tau$

$$(\gamma^\nu\delta^\tau)^* = (e \oplus \gamma^\nu\delta^\tau \oplus \dots \oplus \gamma^{(l-1)\nu}\delta^{(l-1)\tau})(\gamma^{l\nu}\delta^{l\tau})^*.$$

For an illustration see Example 43. We denote the set of monomials by $\mathcal{M} = \{M_1, \dots, M_I\}$ and the set of series by $\mathcal{S} = \{S_1, \dots, S_J\}$. Furthermore, the subsets $\mathcal{M}_{l,k,g,p}$ (resp. $\mathcal{S}_{l,k,g,p}$) are defined as

$$\begin{aligned} \forall l \in \{0, \dots, m-1\}, \forall g \in \{0, \dots, b-1\}, \forall k, p \in \{0, \dots, \omega-1\}, \\ \mathcal{M}_{l,k,g,p} = \{M_i \in \mathcal{M} \mid \gamma^l \delta^{-k} \nabla_{m|1} \Delta_{\omega|1} M_i \nabla_{1|b} \Delta_{1|\omega} \gamma^g \delta^{-p} \in \\ \bigoplus_{i=1}^I \gamma^{n_i} \delta^{\sigma_i} \nabla_{m|1} \Delta_{\omega|1} M_i \nabla_{1|b} \Delta_{1|\omega} \gamma^{n'_i} \delta^{\sigma'_i}\}, \\ \mathcal{S}_{l,k,g,p} = \{S_j \in \mathcal{S} \mid \gamma^l \delta^{-k} \nabla_{m|1} \Delta_{\omega|1} S_j \nabla_{1|b} \Delta_{1|\omega} \gamma^g \delta^{-p} \in \\ \bigoplus_{j=1}^J \gamma^{N_j} \delta^{t_j} \nabla_{m|1} \Delta_{\omega|1} S_j \nabla_{1|b} \Delta_{1|\omega} \gamma^{N'_j} \delta^{t'_j}\}. \end{aligned} \quad (5.23)$$

The entry $(\mathbf{Q})_{mk+l+1, b(\omega-p)-g}$ of the core matrix is then obtained by

$$(\mathbf{Q})_{mk+l+1, b(\omega-p)-g} = \bigoplus_{M \in \mathcal{M}_{l,k,g,p}} M \oplus \bigoplus_{S \in \mathcal{S}_{l,k,g,p}} S. \quad (5.24)$$

Hence, a series s is represented by $s = \mathbf{m}_{m,\omega} \mathbf{Q} \mathbf{b}_{b,\omega}$. The entries of the matrix \mathbf{Q} are ultimately cyclic series in the dioid $(\mathcal{M}_{\text{in}}^{\text{ax}} \llbracket \gamma, \delta \rrbracket, \oplus, \otimes)$.

Properties of $\mathbf{m}_{m,\omega}$ and $\mathbf{b}_{b,\omega}$.

Recall the definition of $\mathbf{b}_{b,\omega}$ - and $\mathbf{m}_{m,\omega}$ -vector,

$$\begin{aligned} \mathbf{b}_{b,\omega} &:= \left[\Delta_{1|\omega} \delta^{1-\omega} \mathbf{b}_b^T \quad \dots \quad \Delta_{1|\omega} \mathbf{b}_b^T \right]^T, \\ \mathbf{m}_{m,\omega} &:= \left[\Delta_{\omega|1} \mathbf{m}_m \quad \dots \quad \delta^{1-\omega} \Delta_{\omega|1} \mathbf{m}_m \right]. \end{aligned}$$

Now let us consider a $\mathbf{m}_{i,\omega}$ -vector and a $\mathbf{b}_{i,\omega}$ -vector with equal indices, *i.e.*, this implies that the $\mathbf{m}_{i,\omega}$ -vector and the $\mathbf{b}_{i,\omega}$ -vector have the same length. Then since, $\mathbf{m}_m \mathbf{b}_m = \mathbf{e}$ (3.43) and (5.14) the scalar product,

$$\begin{aligned} \mathbf{m}_{i,\omega} \mathbf{b}_{i,\omega} &= \mathbf{m}_i \mathbf{b}_i (\Delta_{\omega|1} \Delta_{1|\omega} \delta^{1-\omega} \oplus \delta^{-1} \Delta_{\omega|1} \Delta_{1|\omega} \delta^{2-\omega} \oplus \dots \\ &\quad \oplus \delta^{1-\omega} \Delta_{\omega|1} \Delta_{1|\omega}) \\ &= \mathbf{m}_i \mathbf{b}_i (\Delta_{\omega|\omega} \delta^{1-\omega} \oplus \dots \oplus \delta^{1-\omega} \Delta_{\omega|\omega}) \\ &= \mathbf{e}, \end{aligned} \quad (5.25)$$

The dyadic product $\mathbf{b}_{i,\omega} \mathbf{m}_{i,\omega}$ is a particular matrix in $\mathcal{M}_{\text{in}}^{\text{ax}}[\gamma, \delta]$ of size $i\omega \times i\omega$ denoted by \mathfrak{E} . Recall that,

$$\mathbf{E} = \mathbf{b}_m \mathbf{m}_m = \begin{bmatrix} e & \gamma^1 & \cdots & \gamma^1 \\ \vdots & \ddots & \ddots & \vdots \\ \vdots & & \ddots & \gamma^1 \\ e & \cdots & \cdots & e \end{bmatrix},$$

(3.44) in Section 3.3, $\Delta_{1|\omega} \delta^{-\omega} = \delta^{-1} \Delta_{1|\omega}$ and $\Delta_{1|\omega} \delta^j \Delta_{\omega|1} = e$ for $-\omega < j \leq 0$ see Remark 30, hence

$$\begin{aligned} \mathfrak{E} = \mathbf{b}_{i,\omega} \otimes \mathbf{m}_{i,\omega} &= \begin{bmatrix} \Delta_{1|\omega} \delta^{1-\omega} \mathbf{b}_i \\ \cdots \\ \Delta_{1|\omega} \mathbf{b}_i \end{bmatrix} \begin{bmatrix} \Delta_{\omega|1} \mathbf{m}_i & \cdots & \delta^{1-\omega} \Delta_{\omega|1} \mathbf{m}_i \end{bmatrix}, \\ &= \begin{bmatrix} \Delta_{1|\omega} \delta^{1-\omega} \Delta_{\omega|1} \mathbf{b}_i \mathbf{m}_i & \cdots & \Delta_{1|\omega} \delta^{1-\omega} \delta^{1-\omega} \Delta_{\omega|1} \mathbf{b}_i \mathbf{m}_i \\ \vdots & & \vdots \\ \Delta_{1|\omega} \Delta_{\omega|1} \mathbf{b}_i \mathbf{m}_i & \cdots & \Delta_{1|\omega} \delta^{1-\omega} \Delta_{\omega|1} \mathbf{b}_i \mathbf{m}_i \end{bmatrix}, \\ &= \begin{bmatrix} \mathbf{E} & \delta^{-1} \mathbf{E} & \cdots & \delta^{-1} \mathbf{E} \\ \vdots & \ddots & \ddots & \vdots \\ \vdots & & \ddots & \delta^{-1} \mathbf{E} \\ \mathbf{E} & \cdots & \cdots & \mathbf{E} \end{bmatrix}. \end{aligned} \tag{5.26}$$

Proposition 79. For \mathfrak{E} the following relations hold

$$\mathfrak{E} \otimes \mathfrak{E} = \mathfrak{E}, \tag{5.27}$$

$$\mathfrak{E}_{i,\omega} \otimes \mathbf{b}_{i,\omega} = \mathbf{b}_{i,\omega}, \tag{5.28}$$

$$\mathbf{m}_{i,\omega} \otimes \mathfrak{E}_{i,\omega} = \mathbf{m}_{i,\omega}. \tag{5.29}$$

Proof.

$$\mathfrak{E}_{i,\omega} \otimes \mathfrak{E}_{i,\omega} = \mathbf{b}_{i,\omega} \mathbf{m}_{i,\omega} \mathbf{b}_{i,\omega} \mathbf{m}_{i,\omega} = \mathbf{b}_{i,\omega} \otimes e \otimes \mathbf{m}_{i,\omega} = \mathfrak{E}_{i,\omega},$$

$$\mathfrak{E}_{i,\omega} \otimes \mathbf{b}_{i,\omega} = \mathbf{b}_{i,\omega} \mathbf{m}_{i,\omega} \mathbf{b}_{i,\omega} = \mathbf{b}_{i,\omega} \otimes e = \mathbf{b}_{i,\omega},$$

$$\mathbf{m}_{i,\omega} \otimes \mathfrak{E}_{i,\omega} = \mathbf{m}_{i,\omega} \mathbf{b}_{i,\omega} \mathbf{m}_{i,\omega} = e \otimes \mathbf{m}_{i,\omega} = \mathbf{m}_{i,\omega}.$$

□

Corollary 14. Note that $\mathfrak{E} = \mathfrak{E}^*$, because of $\mathfrak{E}\mathfrak{E} = \mathfrak{E}$ and $\mathfrak{E} = \mathbf{I} \oplus \mathfrak{E}$.

Due to $\mathbf{m}_{i,\omega}\mathbf{b}_{i\omega} = \mathbf{e}$ (5.25) and $\mathfrak{E}\mathfrak{E} = \mathfrak{E}$ (Prop. 79), under some conditions the left and right product of matrices with entries in \mathcal{ET} by the $\mathbf{m}_{m,\omega}$ -vector and the $\mathbf{b}_{b,\omega}$ -vector are invertible, see the following proposition.

Proposition 80. For $\mathbf{D} \in \mathcal{ET}^{1 \times m\omega}$ and $\mathbf{P} \in \mathcal{ET}^{b\omega \times 1}$ one has,

$$\mathbf{m}_{m,\omega} \backslash \mathbf{D} = \mathbf{b}_{m,\omega} \otimes \mathbf{D}, \quad \mathbf{P} \backslash \mathbf{b}_{b,\omega} = \mathbf{P} \otimes \mathbf{m}_{b,\omega}. \quad (5.30)$$

For $\mathbf{O} \in \mathcal{ET}^{n \times m\omega}$ and $\mathbf{G} \in \mathcal{ET}^{b\omega \times n}$ one has

$$(\mathbf{O}\mathfrak{E}) \backslash \mathbf{m}_{m,\omega} = \mathbf{O}\mathfrak{E} \otimes \mathbf{b}_{m,\omega} \quad \mathbf{b}_{b,\omega} \backslash (\mathfrak{E}\mathbf{G}) = \mathbf{m}_{b,\omega} \otimes (\mathfrak{E}\mathbf{G}). \quad (5.31)$$

Proof. By definition, the residuated mapping $\mathbf{m}_{m,\omega} \backslash \mathbf{D}$ is the greatest solution of the inequality

$$\mathbf{m}_{m,\omega} \otimes \mathbf{X} \leq \mathbf{D}. \quad (5.32)$$

Clearly since $\mathbf{m}_{m,\omega}\mathbf{b}_{m,\omega} = \mathbf{e}$, $\mathbf{b}_{m,\omega}\mathbf{D}$ satisfies (5.32) with equality. It remains to be shown that $\mathbf{b}_{m,\omega}\mathbf{D}$ is the greatest solution of (5.32). Next, assume that exists $\mathbf{X}' \geq \mathbf{b}_{m,\omega}\mathbf{D}$ solving (5.32), i.e., $\mathbf{m}_{m,\omega} \otimes \mathbf{X}' \leq \mathbf{D}$. Multiplication is order preserving hence multiplication by $\mathbf{b}_{m,\omega}$ results in

$$\mathbf{b}_{m,\omega}\mathbf{m}_{m,\omega} \otimes \mathbf{X}' = \mathfrak{E} \otimes \mathbf{X}' \leq \mathbf{b}_{m,\omega}\mathbf{D}$$

Furthermore, $\mathbf{X}' \leq \mathfrak{E}\mathbf{X}'$ as $\mathfrak{E} = \mathbf{I} \oplus \mathfrak{E}$. Hence, $\mathbf{X}' \leq \mathbf{b}_{m,\omega}\mathbf{D}$ and therefore, $\mathbf{X}' = \mathbf{b}_{m,\omega}\mathbf{D}$. This proves that $\mathbf{b}_{m,\omega}\mathbf{D}$ is indeed the greatest solution of (5.32). Similarly, $\mathbf{X} = \mathbf{P} \otimes \mathbf{m}_{b,\omega}$ solves $\mathbf{X}\mathbf{b}_{b,\omega} \leq \mathbf{P}$ with equality. Assume that $\mathbf{X}' = \mathbf{P} \otimes \mathbf{m}_{b,\omega}$ is a solution, i.e., $\mathbf{X}' \otimes \mathbf{b}_{b,\omega} \leq \mathbf{P}$. Multiplication by $\mathbf{m}_{b,\omega}$ gives

$$\mathbf{X}' \leq \mathbf{X}'\mathfrak{E} \leq \mathbf{P} \otimes \mathbf{m}_{b,\omega}.$$

Therefore $\mathbf{X}' = \mathbf{P} \otimes \mathbf{m}_{b,\omega}$ and $\mathbf{P} \otimes \mathbf{m}_{b,\omega}$ is indeed the greatest solution.

To prove $(\mathbf{O}\mathfrak{E}) \backslash \mathbf{m}_{m,\omega} = \mathbf{O}\mathfrak{E} \otimes \mathbf{b}_{m,\omega}$, because of $\mathbf{b}_{m,\omega}\mathbf{m}_{m,\omega} = \mathfrak{E} = \mathfrak{E}\mathfrak{E}$ and $\mathbf{P}\mathbf{m}_{m,\omega} = \mathbf{P} \backslash \mathbf{b}_{b,\omega}$ (5.30) one has

$$(\mathbf{O}\mathfrak{E}) \backslash \mathbf{m}_{m,\omega} = (\mathbf{O}\mathfrak{E}\mathbf{b}_{m,\omega}\mathbf{m}_{m,\omega}) \backslash \mathbf{m}_{m,\omega} = ((\mathbf{O}\mathfrak{E}\mathbf{b}_{m,\omega}) \backslash \mathbf{b}_{m,\omega}) \backslash \mathbf{m}_{m,\omega}.$$

Since, $(x \backslash a) \backslash b = x \backslash (ba)$ (A.1) and $\mathbf{m}_{m,\omega}\mathbf{b}_{m,\omega} = \mathbf{e}$ (see 5.38),

$$((\mathbf{O}\mathfrak{E}\mathbf{b}_{m,\omega}) \backslash \mathbf{b}_{m,\omega}) \backslash \mathbf{m}_{m,\omega} = (\mathbf{O}\mathfrak{E}\mathbf{b}_{m,\omega}) \backslash (\mathbf{m}_{m,\omega}\mathbf{b}_{m,\omega}) = (\mathbf{O}\mathfrak{E}\mathbf{b}_{m,\omega}) \backslash \mathbf{e} = \mathbf{O}\mathfrak{E}\mathbf{b}_{m,\omega}.$$

The proof of $\mathbf{b}_{b,\omega} \backslash (\mathfrak{E}\mathbf{G}) = \mathbf{m}_{b,\omega} \otimes (\mathfrak{E}\mathbf{G})$ is analogous. \square

Proposition 81. Let $s = \mathbf{m}_{m,\omega}\mathbf{Q}\mathbf{b}_{b,\omega} \in \mathcal{ET}_{\text{per}}$, core equation $s = \mathbf{m}_{m,\omega}\mathbf{X}\mathbf{b}_{b,\omega}$ has a unique greatest solution, denoted $\hat{\mathbf{Q}}$ and given by

$$\hat{\mathbf{Q}} = \mathfrak{E}_{m,\omega}\mathbf{Q}\mathfrak{E}_{b,\omega}. \quad (5.33)$$

Proof. Consider the inequality $\mathbf{m}_{m,\omega} \tilde{\mathbf{X}} \mathbf{b}_{b,\omega} \leq \mathbf{m}_{m,\omega} \mathbf{Q} \mathbf{b}_{b,\omega} = s$. Recall Prop. 80, therefore the greatest solution for $\tilde{\mathbf{X}}$ is

$$\begin{aligned} \tilde{\mathbf{X}} &\leq \mathbf{m}_{m,\omega} \backslash \mathbf{m}_{m,\omega} \mathbf{Q} \mathbf{b}_{b,\omega} / \mathbf{b}_{b,\omega} = \mathbf{b}_{m,\omega} \mathbf{m}_{m,\omega} \mathbf{Q} \mathbf{b}_{b,\omega} \mathbf{d}_{b,\omega} \\ &= \mathfrak{E}_{m,\omega} \mathbf{Q} \mathfrak{E}_{b,\omega} = \hat{\mathbf{Q}}. \end{aligned}$$

Furthermore, $\hat{\mathbf{Q}}$ solves (5.22) with equality, recall that, $\mathbf{m}_{m,\omega} = \mathbf{m}_{m,\omega} \mathfrak{E}_{m,\omega}$, $\mathbf{b}_{b,\omega} = \mathfrak{E}_{b,\omega} \mathbf{b}_{b,\omega}$ (Prop. 79), therefore,

$$\mathbf{m}_{m,\omega} \hat{\mathbf{Q}} \mathbf{b}_{b,\omega} = \mathbf{m}_{m,\omega} \mathfrak{E}_{m,\omega} \mathbf{Q} \mathfrak{E}_{b,\omega} \mathbf{b}_{b,\omega} = \mathbf{m}_{m,\omega} \mathbf{Q} \mathbf{b}_{b,\omega} = s.$$

□

Remark 31. Since, $\mathfrak{E} \otimes \mathfrak{E} = \mathfrak{E}$ (Prop. 79) the greatest core $\hat{\mathbf{Q}}$ satisfies the following relations,

$$\begin{aligned} \mathfrak{E} \hat{\mathbf{Q}} &= \mathfrak{E} \mathfrak{E} \mathbf{Q} \mathfrak{E} = \hat{\mathbf{Q}}, \\ \hat{\mathbf{Q}} \mathfrak{E} &= \mathfrak{E} \mathbf{Q} \mathfrak{E} \mathfrak{E} = \hat{\mathbf{Q}}. \end{aligned}$$

Alternative Core-Form

An alternative core form is defined by replacing the $\mathbf{m}_{m,\omega}$ -vector and $\mathbf{b}_{b,\omega}$ -vector by

$$\mathbf{d}_{\omega,m} := \left[\nabla_{m|1} \mathbf{d}_{\omega} \quad \cdots \quad \gamma^{m-1} \nabla_{m|1} \mathbf{d}_{\omega} \right], \quad (5.34)$$

$$\mathbf{p}_{\omega,b} := \left[\nabla_{1|b} \gamma^{b-1} \mathbf{p}_{\omega}^T \quad \cdots \quad \nabla_{1|b} \mathbf{p}_{\omega}^T \right]^T. \quad (5.35)$$

Observes that, the difference between the vectors $\mathbf{m}_{m,\omega}$ and $\mathbf{d}_{\omega,m}$ (resp. $\mathbf{b}_{b,\omega}$ and $\mathbf{p}_{\omega,b}$) is just the ordering of its entries. Thus, the alternative core equation for an ultimately cyclic series $s \in \mathcal{E}\mathcal{T}_{\text{per}}$ is

$$s = \mathbf{d}_{\omega,m} \mathbf{X} \mathbf{p}_{\omega,b}. \quad (5.36)$$

A solution of (5.36) is denoted by \mathbf{U} . Note again that $\mathbf{U} \in \mathcal{M}_{\text{in}}^{\text{ax}} [[\gamma, \delta]]^{m\omega \times b\omega}$. Recall the sets $\mathcal{M}_{l,k,g,p}$ and $\mathcal{S}_{l,k,g,p}$ for an ultimately cyclic series $s \in \mathcal{E}\mathcal{T}_{\text{per}}$ (5.23). A solution of (5.36) for s is then obtained by

$$\begin{aligned} \forall l \in \{0, \dots, m-1\}, \forall g \in \{0, \dots, b-1\}, \forall k, p \in \{0, \dots, \omega-1\}, \\ (\mathbf{U})_{\omega l+k+1, \omega(b-g)-p} = \bigoplus_{M \in \mathcal{M}_{l,k,g,p}} M \oplus \bigoplus_{S \in \mathcal{S}_{l,k,g,p}} S. \end{aligned} \quad (5.37)$$

This alternative core form is sometimes preferable over the core form $\mathbf{m}_{m,\omega} \mathbf{Q} \mathbf{b}_{b,\omega}$ for calculations with $s \in \mathcal{E}\mathcal{T}_{\text{per}}$. Consider a $\mathbf{d}_{\omega,i}$ -vector and the $\mathbf{p}_{\omega,i}$ -vector with same indices, i.e., the $\mathbf{d}_{\omega,i}$ -vector and the $\mathbf{p}_{\omega,i}$ -vector the have same size. The scalar product,

$$\begin{aligned} \mathbf{d}_{\omega,i} \mathbf{p}_{\omega,i} &= \mathbf{d}_{\omega} \mathbf{p}_{\omega} (\mu_i \beta_i \gamma^{i-1} \oplus \gamma^1 \mu_i \beta_i \gamma^{i-2} \oplus \cdots \\ &\quad \oplus \gamma^{i-1} \mu_i \beta_i) = e. \end{aligned} \quad (5.38)$$

Recall that,

$$\mathbf{N} = \mathbf{p}_{\omega} \mathbf{d}_{\omega} = \begin{bmatrix} e & \delta^{-1} & \dots & \delta^{-1} \\ \vdots & \ddots & \ddots & \vdots \\ \vdots & & \ddots & \delta^{-1} \\ e & \dots & \dots & e \end{bmatrix},$$

thus the dyadic product,

$$\mathbf{p}_{\omega,i} \otimes \mathbf{d}_{\omega,i} = \begin{bmatrix} \mathbf{N} & \gamma^1 \mathbf{N} & \dots & \gamma^1 \mathbf{N} \\ \vdots & \ddots & \ddots & \vdots \\ \vdots & & \ddots & \gamma^1 \mathbf{N} \\ \mathbf{N} & \dots & \dots & \mathbf{N} \end{bmatrix}. \quad (5.39)$$

This matrix is denoted by \mathfrak{N} . Then similar to Prop. 81 the greatest solution of (5.36) is $\mathfrak{N} \mathbf{U} \mathfrak{N}$, which is denoted by $\hat{\mathbf{U}}$.

Proposition 82. For matrices $\mathbf{D} \in \mathcal{ET}^{1 \times m\omega}$, $\mathbf{P} \in \mathcal{ET}^{b\omega \times 1}$, $\mathbf{O} \in \mathcal{ET}^{n \times m\omega}$ and $\mathbf{G} \in \mathcal{ET}^{b\omega \times n}$ one obtains the following results for left and right division by the $\mathbf{d}_{\omega,m}$ - and $\mathbf{p}_{\omega,b}$ -vector.

$$\begin{aligned} \mathbf{d}_{\omega,m} \backslash \mathbf{D} &= \mathbf{p}_{\omega,m} \otimes \mathbf{D}, & \mathbf{P} / \mathbf{p}_{\omega,b} &= \mathbf{P} \otimes \mathbf{p}_{\omega,b} \\ (\mathbf{O} \mathfrak{N}) / \mathbf{d}_{\omega,m} &= \mathbf{O} \mathfrak{N} \otimes \mathbf{d}_{\omega,m}, & \mathbf{p}_{\omega,b} \backslash (\mathfrak{N} \mathbf{G}) &= \mathbf{p}_{\omega,b} \otimes (\mathfrak{N} \mathbf{G}). \end{aligned}$$

Proof. The proof is analogous to the proof of Prop. 80. □

Core Transformation

The transformation between the two core representations is achieved by reordering the entries in the core matrix \mathbf{Q} (respectively \mathbf{U}). The relation between the two cores \mathbf{Q} and \mathbf{U} is given by (5.24) and (5.37). Hence, let $s = \mathbf{m}_{m,\omega} \mathbf{Q} \mathbf{b}_{b,\omega} \in \mathcal{ET}_{\text{per}}$, then s is written as $\mathbf{d}_{\omega,m} \mathbf{U} \mathbf{p}_{\omega,b}$, where

$$\begin{aligned} \forall l \in \{0, \dots, m-1\}, \forall g \in \{0, \dots, b-1\}, \forall k, p \in \{0, \dots, \omega-1\}, \\ (\mathbf{U})_{\omega l+k+1, \omega(b-g)-p} &= (\mathbf{Q})_{mk+l+1, b(\omega-p)-g}. \end{aligned}$$

By choosing

$$\begin{aligned} k &= i - 1 - \left\lfloor \frac{i-1}{\omega} \right\rfloor \omega, \\ l &= \left\lfloor \frac{i-1}{\omega} \right\rfloor, \\ p &= \omega b - j - \left\lfloor \frac{\omega b - j}{\omega} \right\rfloor \omega, \\ g &= \left\lfloor \frac{\omega b - j}{\omega} \right\rfloor, \end{aligned}$$

one can establish for $i \in \{1, \dots, m\omega\}$, $j \in \{1, \dots, b\omega\}$,

$$(\mathbf{U})_{i,j} = (\mathbf{Q})_{m(i-1-\lfloor \frac{i-1}{\omega} \rfloor \omega) + \lfloor \frac{i-1}{\omega} \rfloor + 1, b(\omega - \omega b + j + \lfloor \frac{\omega b - j}{\omega} \rfloor \omega) - \lfloor \frac{\omega b - j}{\omega} \rfloor}. \quad (5.40)$$

Conversely, let $s = \mathbf{d}_{\omega, m} \mathbf{U} \mathbf{p}_{\omega, b} \in \mathcal{E}\mathcal{T}_{\text{per}}$, then s is written as $\mathbf{m}_{m, \omega} \mathbf{Q} \mathbf{b}_{b, \omega}$ where for $i \in \{1, \dots, m\omega\}$, $j \in \{1, \dots, b\omega\}$

$$(\mathbf{Q})_{i,j} = (\mathbf{U})_{\omega(i-1-\lfloor \frac{i-1}{m} \rfloor m) + \lfloor \frac{i-1}{m} \rfloor + 1, \omega(b - \omega b + j + \lfloor \frac{\omega b - j}{b} \rfloor b) - \lfloor \frac{\omega b - j}{b} \rfloor}. \quad (5.41)$$

Example 44. Recall the series $s = \delta^2 \nabla_{3|2} \Delta_{2|2} \gamma^1 \delta^{-1} \oplus (\gamma^3 \delta^3 \nabla_{3|2} \Delta_{2|2} \delta^{-1})(\gamma^1 \delta^2)^*$ of Example 43. The alternative core-form of s is $\mathbf{d}_{2,3} \mathbf{U} \mathbf{p}_{2,2}$, where

$$\mathbf{U} = \begin{bmatrix} \delta^1 & \varepsilon & \varepsilon & \varepsilon \\ \gamma^1 \delta^3 (\gamma^1 \delta^2)^* & \varepsilon & \gamma^1 \delta^2 (\gamma^1 \delta^2)^* & \varepsilon \\ \varepsilon & \varepsilon & \varepsilon & \varepsilon \\ \varepsilon & \varepsilon & \varepsilon & \varepsilon \\ \varepsilon & \varepsilon & \varepsilon & \varepsilon \\ \varepsilon & \varepsilon & \varepsilon & \varepsilon \end{bmatrix}.$$

Let $s = \mathbf{m}_{m, \omega} \mathbf{Q} \mathbf{b}_{b, \omega} \in \mathcal{E}\mathcal{T}_{\text{per}}$ be an ultimately cyclic series. Clearly, since $\mathbf{d}_{\omega, m} \mathbf{p}_{\omega, b} = \mathbf{e}$, we can express s as

$$s = \underbrace{\mathbf{d}_{\omega, m} \mathbf{p}_{\omega, m}}_{\mathbf{e}} \mathbf{m}_{m, \omega} \mathbf{Q} \mathbf{b}_{b, \omega} \underbrace{\mathbf{d}_{\omega, b} \mathbf{p}_{\omega, b}}_{\mathbf{e}}.$$

Clearly, $\mathbf{p}_{\omega, m} \mathbf{m}_{m, \omega} \mathbf{Q} \mathbf{b}_{b, \omega} \mathbf{d}_{\omega, b}$ is a solution of the alternative core equation (5.36). Moreover, it can be shown that

$$\hat{\mathbf{U}} = \underbrace{\mathbf{p}_{\omega, m} \mathbf{m}_{m, \omega}}_{\mathbf{T}_{\text{QU}_1}} \underbrace{\mathbf{Q} \mathbf{b}_{b, \omega} \mathbf{d}_{\omega, b}}_{\mathbf{T}_{\text{QU}_2}},$$

is the greatest solution of (5.36), for details see Section C.3.2. $\mathbf{T}_{\text{QU}_1} = \mathbf{p}_{\omega, m} \mathbf{m}_{m, \omega}$ and $\mathbf{T}_{\text{QU}_2} = \mathbf{b}_{b, \omega} \mathbf{d}_{\omega, b}$ are matrices with entries in $\mathcal{M}_{\text{in}}^{\text{ax}} \llbracket \gamma, \delta \rrbracket$, see Section C.3.2. Respectively,

$$\hat{\mathbf{Q}} = \underbrace{\mathbf{b}_{b, \omega} \mathbf{p}_{\omega, b}}_{\mathbf{T}_{\text{UQ}_1}} \mathbf{U} \underbrace{\mathbf{d}_{\omega, m} \mathbf{m}_{m, \omega}}_{\mathbf{T}_{\text{UQ}_2}}.$$

Again, \mathbf{T}_{UQ_1} and \mathbf{T}_{UQ_2} are matrices with entries in $\mathcal{M}_{\text{in}}^{\text{ax}} \llbracket \gamma, \delta \rrbracket$, see Section C.3.2. The transformation between the core-matrices $\hat{\mathbf{Q}}$ and $\hat{\mathbf{U}}$ is necessary to express an ultimately cyclic series $s \in \mathcal{ET}_{\text{per}}$ with a multiple period in the core form.

Proposition 83. *A series $s = \mathbf{m}_{m, \omega} \hat{\mathbf{Q}} \mathbf{b}_{b, \omega} \in \mathcal{ET}_{\text{per}}$ can be expressed with a multiple period $(m, b, n\omega)$ by extending the core matrix $\hat{\mathbf{Q}}$, i.e., $s = \mathbf{m}_{m, \omega} \hat{\mathbf{Q}} \mathbf{b}_{b, \omega} = \mathbf{m}_{mn, \omega} \hat{\mathbf{Q}}' \mathbf{b}_{bn, \omega}$, where $\hat{\mathbf{Q}}' \in \mathcal{M}_{\text{in}}^{\text{ax}} \llbracket \gamma, \delta \rrbracket^{mn\omega \times bn\omega}$ and is given by*

$$\hat{\mathbf{Q}}' = \begin{bmatrix} \Delta_{1|n} \delta^{1-\omega} \hat{\mathbf{Q}} \Delta_{n|1} & \cdots & \Delta_{1|n} \delta^{1-\omega} \hat{\mathbf{Q}} \delta^{1-\omega} \Delta_{n|1} \\ \vdots & & \vdots \\ \Delta_{1|n} \hat{\mathbf{Q}} \Delta_{n|1} & \cdots & \Delta_{1|n} \hat{\mathbf{Q}} \delta^{1-\omega} \Delta_{n|1} \end{bmatrix}.$$

Proof. See Section C.3.2 □

Proposition 84. *A series $s = \mathbf{d}_{\omega, m} \hat{\mathbf{U}} \mathbf{p}_{\omega, b} \in \mathcal{ET}_{\text{per}}$ can be expressed with a multiple period (nm, nb, ω) by extending the core matrix $\hat{\mathbf{U}}$, i.e., $s = \mathbf{d}_{\omega, m} \hat{\mathbf{U}} \mathbf{p}_{\omega, b} = \mathbf{d}_{n\omega, m} \hat{\mathbf{U}}' \mathbf{p}_{n\omega, b}$, where $\hat{\mathbf{U}}' \in \mathcal{M}_{\text{in}}^{\text{ax}} \llbracket \gamma, \delta \rrbracket^{nm\omega \times nb\omega}$ and is given by*

$$\hat{\mathbf{U}}' = \begin{bmatrix} \nabla_{1|n} \gamma^{n-1} \hat{\mathbf{U}} \nabla_{n|1} & \cdots & \nabla_{1|n} \gamma^{n-1} \hat{\mathbf{U}} \gamma^{n-1} \nabla_{n|1} \\ \vdots & & \vdots \\ \nabla_{1|n} \hat{\mathbf{U}} \nabla_{n|1} & \cdots & \nabla_{1|n} \hat{\mathbf{U}} \gamma^{n-1} \nabla_{n|1} \end{bmatrix}.$$

Proof. The proof is analogous to the proof of Prop. 83, given in Section C.3.2. □

Therefore, a series $s = \mathbf{m}_{m, \omega} \hat{\mathbf{Q}} \mathbf{b}_{b, \omega}$ can be expressed as $\mathbf{m}_{n_1 m, n_2 \omega} \hat{\mathbf{Q}} \mathbf{b}_{n_1 b, n_2 \omega}$ with a multiple period $(n_1 m, n_1 b, n_2 \omega)$.

5.2.1. Calculation with the Core Decomposition

This section illustrates how to perform the basic operations $(\oplus, \otimes, \wp, \wp)$ on series in $\mathcal{ET}_{\text{per}}$, based on the core decomposition.

Sum and Product of Series in $\mathcal{E}\mathcal{T}_{\text{per}}$

Due to Prop. 83 and Prop. 84, by extending the core-form if necessary, two ultimately cyclic series $s, s' \in \mathcal{E}\mathcal{T}_{\text{per}}$ with equal gain can be expressed with their least common period, i.e., $s = \mathbf{m}_{m,\omega} \hat{\mathbf{Q}} \mathbf{b}_{b,\omega}, s' = \mathbf{m}_{m,\omega} \hat{\mathbf{Q}}' \mathbf{b}_{b,\omega}$. Then observe that matrices $\hat{\mathbf{Q}}$ and $\hat{\mathbf{Q}}'$ have equal dimensions.

Proposition 85 (Sum of Series). *Let $s = \mathbf{m}_{m,\omega} \hat{\mathbf{Q}} \mathbf{b}_{b,\omega}, s' = \mathbf{m}_{m,\omega} \hat{\mathbf{Q}}' \mathbf{b}_{b,\omega} \in \mathcal{E}\mathcal{T}_{\text{per}}$, be two ultimately cyclic series, then the sum $s \oplus s' = \mathbf{m}_{m,\omega} \hat{\mathbf{Q}}'' \mathbf{b}_{b,\omega}$, where $\hat{\mathbf{Q}}'' = \hat{\mathbf{Q}} \oplus \hat{\mathbf{Q}}'$, is again an ultimately cyclic series in $\mathcal{E}\mathcal{T}_{\text{per}}$.*

Proof.

$$\begin{aligned} s \oplus s' &= \mathbf{m}_{m,\omega} \hat{\mathbf{Q}} \mathbf{b}_{b,\omega} \oplus \mathbf{m}_{m,\omega} \hat{\mathbf{Q}}' \mathbf{b}_{b,\omega} = \mathbf{m}_{m,\omega} (\mathbf{e} \hat{\mathbf{Q}} \mathbf{e} \oplus \mathbf{e} \hat{\mathbf{Q}}' \mathbf{e}) \mathbf{b}_{b,\omega} \\ &= \mathbf{m}_{m,\omega} \underbrace{\mathbf{e} (\hat{\mathbf{Q}} \oplus \hat{\mathbf{Q}}') \mathbf{e}}_{\hat{\mathbf{Q}}''} \mathbf{b}_{b,\omega} \end{aligned}$$

Clearly, the entries of the core matrices $\hat{\mathbf{Q}}, \hat{\mathbf{Q}}'$ are ultimately cyclic series in $\mathcal{M}_{\text{in}}^{\text{ax}}[\gamma, \delta]$ and because of Theorem 2.6 the sum of two ultimately cyclic series in $\mathcal{M}_{\text{in}}^{\text{ax}}[\gamma, \delta]$ is again an ultimately cyclic series. Therefore, $\hat{\mathbf{Q}}''$ is composed of ultimately cyclic series in $\mathcal{M}_{\text{in}}^{\text{ax}}[\gamma, \delta]$ and thus $s \oplus s' = \mathbf{d}_{\omega} \hat{\mathbf{Q}}'' \mathbf{p}_{\omega}$ is an ultimately cyclic series in $\mathcal{E}\mathcal{T}_{\text{per}}$. \square

Again, because of Prop. 83 and Prop. 84, two ultimately cyclic series $s, s' \in \mathcal{E}\mathcal{T}_{\text{per}}$ can be written such that s is (m, b, ω) -periodic and s' is (b, b', ω) -periodic, i.e., $s = \mathbf{m}_{m,\omega} \hat{\mathbf{Q}} \mathbf{b}_{b,\omega}$ and $s' = \mathbf{m}_{b,\omega} \hat{\mathbf{Q}}' \mathbf{b}_{b',\omega}$, where $\hat{\mathbf{Q}} \in \mathcal{M}_{\text{in}}^{\text{ax}}[\gamma, \delta]^{m\omega \times b\omega}$ and $\hat{\mathbf{Q}}' \in \mathcal{M}_{\text{in}}^{\text{ax}}[\gamma, \delta]^{b\omega \times b'\omega}$.

Proposition 86 (Product of Series). *Let $s = \mathbf{m}_{m,\omega} \hat{\mathbf{Q}} \mathbf{b}_{b,\omega} \in \mathcal{E}\mathcal{T}_{\text{per}}$ and $s' = \mathbf{m}_{b,\omega} \hat{\mathbf{Q}}' \mathbf{b}_{b',\omega} \in \mathcal{E}\mathcal{T}_{\text{per}}$, be two ultimately cyclic series, then the product $s \otimes s' = \mathbf{m}_{m,\omega} \hat{\mathbf{Q}}'' \mathbf{b}_{b',\omega}$, where $\hat{\mathbf{Q}}'' = \hat{\mathbf{Q}} \hat{\mathbf{Q}}'$, is again an ultimately cyclic series in $\mathcal{E}\mathcal{T}_{\text{per}}$.*

Proof. Recall that $\mathbf{b}_{b,\omega} \mathbf{m}_{b,\omega} = \mathbf{e}$ (5.26) and $\hat{\mathbf{Q}} \mathbf{e} = \hat{\mathbf{Q}}$ (Remark 31), then

$$\begin{aligned} s \otimes s' &= \mathbf{m}_{m,\omega} \hat{\mathbf{Q}} \mathbf{b}_{b,\omega} \mathbf{m}_{b,\omega} \hat{\mathbf{Q}}' \mathbf{b}_{b',\omega} = \mathbf{m}_{m,\omega} \hat{\mathbf{Q}} \mathbf{e} \hat{\mathbf{Q}}' \mathbf{b}_{b',\omega} \\ &= \mathbf{m}_{m,\omega} \hat{\mathbf{Q}} \hat{\mathbf{Q}}' \mathbf{b}_{b',\omega}. \end{aligned}$$

Furthermore, because of $\mathbf{e} \mathbf{e} = \mathbf{e}$ (Prop. 79),

$$\hat{\mathbf{Q}} \hat{\mathbf{Q}}' = \mathbf{e} \hat{\mathbf{Q}} \mathbf{e} \mathbf{e} \hat{\mathbf{Q}}' \mathbf{e} = \hat{\mathbf{Q}}''.$$

Recall that, the entries of the core matrices $\hat{\mathbf{Q}}, \hat{\mathbf{Q}}'$ are ultimately cyclic series in $\mathcal{M}_{\text{in}}^{\text{ax}}[\gamma, \delta]$ and because of Theorem 2.6 the sum and product of ultimately cyclic series in $\mathcal{M}_{\text{in}}^{\text{ax}}[\gamma, \delta]$ are again ultimately cyclic series in $\mathcal{M}_{\text{in}}^{\text{ax}}[\gamma, \delta]$. Therefore, entries of the matrix $\hat{\mathbf{Q}}''$ are ultimately cyclic series in $\mathcal{M}_{\text{in}}^{\text{ax}}[\gamma, \delta]$ and the product $s \otimes s'$ is an ultimately cyclic series in $\mathcal{E}\mathcal{T}_{\text{per}}$. \square

Proposition 87. Let $s = \mathbf{m}_{m,\omega} \hat{\mathbf{Q}} \mathbf{b}_{m,\omega} \in \mathcal{ET}_{\text{per}}$ be an ultimately cyclic series, then

$$s^* = \mathbf{m}_{m,\omega} \hat{\mathbf{Q}}^* \mathbf{b}_{m,\omega}. \quad (5.42)$$

is again an ultimately cyclic series in $\mathcal{ET}_{\text{per}}$.

Proof. In this case, $\Gamma(s) = 1$ means that $\hat{\mathbf{Q}}$ is a square matrix. The Kleene star of a series in the core representation can be written as,

$$s^* = e \oplus \mathbf{m}_{m,\omega} \hat{\mathbf{Q}} \mathbf{b}_{m,\omega} \oplus \mathbf{m}_{m,\omega} \hat{\mathbf{Q}} \mathbf{b}_{m,\omega} \mathbf{m}_{m,\omega} \hat{\mathbf{Q}} \mathbf{b}_{m,\omega} \oplus \dots$$

Recall that, $e = \mathbf{m}_{m,\omega} \mathbf{b}_{m,\omega}$ (5.25), $\mathfrak{E} = \mathbf{b}_{m,\omega} \mathbf{m}_{m,\omega}$ (5.26) and $\mathfrak{E} \hat{\mathbf{Q}} = \hat{\mathbf{Q}}$ Remark 31,

$$\begin{aligned} s^* &= \mathbf{m}_{m,\omega} \mathbf{b}_{m,\omega} \oplus \mathbf{m}_{m,\omega} \hat{\mathbf{Q}} \mathbf{b}_{m,\omega} \oplus \mathbf{m}_{m,\omega} \hat{\mathbf{Q}}^2 \mathbf{b}_{m,\omega} \oplus \dots \\ &= \mathbf{m}_{m,\omega} (\mathbf{I} \oplus \hat{\mathbf{Q}} \oplus \hat{\mathbf{Q}}^2 \oplus \dots) \mathbf{b}_{m,\omega} \\ &= \mathbf{m}_{m,\omega} \hat{\mathbf{Q}}^* \mathbf{b}_{m,\omega} \end{aligned}$$

Again, due to Theorem 2.6 the Kleene star, sum, and product of ultimately cyclic series in $\mathcal{M}_{\text{in}}^{\text{ax}} \llbracket \gamma, \delta \rrbracket$ are ultimately cyclic series in $\mathcal{M}_{\text{in}}^{\text{ax}} \llbracket \gamma, \delta \rrbracket$ and therefore, $s^* = \mathbf{m}_{m,\omega} \hat{\mathbf{Q}}^* \mathbf{b}_{m,\omega}$ is an ultimately cyclic series in $\mathcal{ET}_{\text{per}}$. \square

Note that $\hat{\mathbf{Q}}^*$ is not the greatest core of s^* as $\hat{\mathbf{Q}}^* \leq \mathfrak{E} \hat{\mathbf{Q}}^* \mathfrak{E}$. In general, multiplication does not distribute with respect to \wedge in the dioid $(\mathcal{ET}, \oplus, \otimes)$. However, as shown for the dioid $(\mathcal{E} \llbracket \delta \rrbracket, \oplus, \otimes)$ in Lemma 2 and Lemma 3, distributivity holds for left multiplication by the $\mathbf{m}_{m,\omega}$ -vector and right multiplication by the $\mathbf{b}_{b,\omega}$ -vector for specific matrices with entries in \mathcal{ET} .

Lemma 6. Let $\mathbf{Q}_1, \mathbf{Q}_2$ be two matrices of appropriate dimension, then

$$\begin{aligned} \mathbf{m}_{m,\omega} (\mathfrak{E} \mathbf{Q}_1 \wedge \mathfrak{E} \mathbf{Q}_2) &= \mathbf{m}_{m,\omega} \mathfrak{E} \mathbf{Q}_1 \wedge \mathbf{m}_{m,\omega} \mathfrak{E} \mathbf{Q}_2, \\ (\mathbf{Q}_1 \mathfrak{E} \wedge \mathbf{Q}_2 \mathfrak{E}) \mathbf{b}_{b,\omega} &= \mathbf{Q}_1 \mathfrak{E} \mathbf{b}_{b,\omega} \wedge \mathbf{Q}_2 \mathfrak{E} \mathbf{b}_{b,\omega}. \end{aligned}$$

Proof. The proof is similar to the proof of Lemma 2. Recall that $e = \mathbf{m}_{m,\omega} \mathbf{b}_{m,\omega}$ (4.19), $\mathfrak{E} = \mathbf{b}_{m,\omega} \mathbf{m}_{m,\omega}$ (4.20) and $\mathfrak{E} = \mathfrak{E} \mathfrak{E}$ Prop. 60. Moreover, recall that inequality $c(a \wedge b) \leq ca \wedge cb$ holds for a, b, c elements in a complete dioid, see (2.2). Now let us define $\mathbf{q}_1 = \mathbf{m}_{m,\omega} \mathfrak{E} \mathbf{Q}_1$ and $\mathbf{q}_2 = \mathbf{m}_{m,\omega} \mathfrak{E} \mathbf{Q}_2$, then

$$\mathbf{q}_1 \wedge \mathbf{q}_2 = e(\mathbf{q}_1 \wedge \mathbf{q}_2) = \mathbf{m}_{m,\omega} \mathbf{b}_{m,\omega} (\mathbf{q}_1 \wedge \mathbf{q}_2) \leq \mathbf{m}_{m,\omega} (\mathbf{b}_{m,\omega} \mathbf{q}_1 \wedge \mathbf{m}_{m,\omega} \mathbf{q}_2).$$

Inserting $\mathbf{q}_1 = \mathbf{m}_{m,\omega} \mathfrak{E} \mathbf{Q}_1$ and $\mathbf{q}_2 = \mathbf{m}_{m,\omega} \mathfrak{E} \mathbf{Q}_2$ lead to,

$$\begin{aligned} \mathbf{m}_{m,\omega} (\mathbf{b}_{m,\omega} \mathbf{q}_1 \wedge \mathbf{m}_{m,\omega} \mathbf{q}_2) &= \mathbf{m}_{m,\omega} (\mathbf{b}_{m,\omega} \mathbf{m}_{m,\omega} \mathfrak{E} \mathbf{Q}_1 \wedge \mathbf{b}_{m,\omega} \mathbf{m}_{m,\omega} \mathfrak{E} \mathbf{Q}_2), \\ &= \mathbf{m}_{m,\omega} (\mathfrak{E} \mathfrak{E} \mathbf{Q}_1 \wedge \mathfrak{E} \mathfrak{E} \mathbf{Q}_2), \\ &= \mathbf{m}_{m,\omega} (\mathfrak{E} \mathbf{Q}_1 \wedge \mathfrak{E} \mathbf{Q}_2). \end{aligned}$$

Finally,

$$\mathbf{m}_{m,\omega}(\mathfrak{E}\mathbf{Q}_1 \wedge \mathfrak{E}\mathbf{Q}_2) \leq \mathbf{m}_{m,\omega}\mathfrak{E}\mathbf{Q}_1 \wedge \mathbf{m}_{m,\omega}\mathfrak{E}\mathbf{Q}_2 = \mathbf{q}_1 \wedge \mathbf{q}_2.$$

Hence, equality holds throughout. The proof for $(\mathbf{Q}_1\mathfrak{E} \wedge \mathbf{Q}_2\mathfrak{E})\mathbf{b}_{b,\omega} = \mathbf{Q}_1\mathfrak{E}\mathbf{b}_{b,\omega} \wedge \mathbf{Q}_2\mathfrak{E}\mathbf{b}_{b,\omega}$ is similar. \square

Proposition 88. *Let $s = \mathbf{m}_{m,\omega}\widehat{\mathbf{Q}}\mathbf{b}_{b,\omega}$, $s' = \mathbf{m}_{m,\omega}\widehat{\mathbf{Q}}'\mathbf{b}_{b,\omega} \in \mathcal{E}\mathcal{T}_{\text{per}}$ be two ultimately cyclic series, then $s \wedge s' = \mathbf{m}_{m,\omega}\widehat{\mathbf{Q}}''\mathbf{b}_{b,\omega} \in \mathcal{E}\mathcal{T}_{\text{per}}$ is an ultimately cyclic series, where $\widehat{\mathbf{Q}}'' = (\widehat{\mathbf{Q}} \wedge \widehat{\mathbf{Q}}')$ is again a greatest core.*

Proof. Again, this proof is similar to the proof of Prop. 34. Let us recall that $\widehat{\mathbf{Q}} = \mathfrak{E}\widehat{\mathbf{Q}}\mathfrak{E}$, then according to Lemma 4 we can write

$$\begin{aligned} s \wedge s' &= \mathbf{m}_{m,\omega}\widehat{\mathbf{Q}}\mathbf{b}_{b,\omega} \wedge \mathbf{m}_{m,\omega}\widehat{\mathbf{Q}}'\mathbf{b}_{b,\omega} \\ &= \mathbf{m}_{m,\omega}\mathfrak{E}\widehat{\mathbf{Q}}\mathfrak{E}\mathbf{b}_{b,\omega} \wedge \mathbf{m}_{m,\omega}\mathfrak{E}\widehat{\mathbf{Q}}'\mathfrak{E}\mathbf{b}_{b,\omega} = \mathbf{m}_{m,\omega}(\mathfrak{E}\widehat{\mathbf{Q}}\mathfrak{E} \wedge \mathfrak{E}\widehat{\mathbf{Q}}'\mathfrak{E})\mathbf{b}_{b,\omega} \\ &= \mathbf{m}_{m,\omega}(\widehat{\mathbf{Q}} \wedge \widehat{\mathbf{Q}}')\mathbf{b}_{b,\omega}. \end{aligned}$$

It remains to be shown that $\widehat{\mathbf{Q}}'' = (\widehat{\mathbf{Q}} \wedge \widehat{\mathbf{Q}}')$ is a greatest core. First, $\mathfrak{E} = \mathfrak{E}^*$, therefore, $\mathbf{I} \oplus \mathfrak{E} = \mathfrak{E}$, and $\widehat{\mathbf{Q}}'' \leq \mathfrak{E}\widehat{\mathbf{Q}}''\mathfrak{E}$. Then, according to Lemma 4,

$$\begin{aligned} \mathfrak{E}\widehat{\mathbf{Q}}''\mathfrak{E} &= \mathfrak{E}(\widehat{\mathbf{Q}} \wedge \widehat{\mathbf{Q}}')\mathfrak{E} = \mathbf{b}_{m,\omega}\mathbf{m}_{m,\omega}(\widehat{\mathbf{Q}} \wedge \widehat{\mathbf{Q}}')\mathbf{b}_{b,\omega}\mathbf{m}_{b,\omega} \\ &= \mathbf{b}_{m,\omega}(\mathbf{m}_{m,\omega}\widehat{\mathbf{Q}}\mathbf{b}_{b,\omega} \wedge \mathbf{m}_{m,\omega}\widehat{\mathbf{Q}}'\mathbf{b}_{b,\omega})\mathbf{m}_{b,\omega}. \end{aligned}$$

Recall, $c(a \wedge b) \leq ca \wedge cb$ and $(a \wedge b)c \leq ac \wedge bc$ (2.2), therefore

$$\begin{aligned} &\mathbf{b}_{m,\omega}(\mathbf{m}_{m,\omega}\widehat{\mathbf{Q}}\mathbf{b}_{b,\omega} \wedge \mathbf{m}_{m,\omega}\widehat{\mathbf{Q}}'\mathbf{b}_{b,\omega})\mathbf{m}_{b,\omega} \\ &\leq \mathbf{b}_{m,\omega}\mathbf{m}_{m,\omega}\widehat{\mathbf{Q}}\mathbf{b}_{b,\omega}\mathbf{m}_{b,\omega} \wedge \mathbf{b}_{m,\omega}\mathbf{m}_{m,\omega}\widehat{\mathbf{Q}}'\mathbf{b}_{b,\omega}\mathbf{m}_{b,\omega} = \widehat{\mathbf{Q}} \wedge \widehat{\mathbf{Q}}' = \widehat{\mathbf{Q}}''. \end{aligned}$$

Hence, equality holds throughout. \square

Division in $\mathcal{E}\mathcal{T}_{\text{per}}$

Proposition 89. *Let $s = \mathbf{m}_{m,\omega}\widehat{\mathbf{Q}}\mathbf{b}_{b,\omega}$, $s' = \mathbf{m}_{m,\omega}\widehat{\mathbf{Q}}'\mathbf{b}_{b',\omega}$ be ultimately periodic series in $\mathcal{E}\mathcal{T}_{\text{per}}$ where s is (m, b, ω) -periodic and s' is (m, b', ω) -periodic then*

$$s' \setminus s = \mathbf{m}_{b',\omega}(\widehat{\mathbf{Q}}' \setminus \widehat{\mathbf{Q}})\mathbf{b}_{b,\omega},$$

is an ultimately cyclic series in $\mathcal{E}\mathcal{T}_{\text{per}}$.

Proof. First, it is shown that

$$\hat{\mathbf{Q}}' \backslash \hat{\mathbf{Q}} = \mathbf{e}_{b',\omega} (\hat{\mathbf{Q}}' \backslash \hat{\mathbf{Q}}) \mathbf{e}_{b,\omega}. \quad (5.43)$$

For this,

$$\begin{aligned} (\mathbf{e}_{b',\omega} (\hat{\mathbf{Q}}' \backslash \hat{\mathbf{Q}})) \mathbf{e}_{b,\omega} &= (\mathbf{e}_{b',\omega} \backslash (\mathbf{e}_{b',\omega} (\hat{\mathbf{Q}}' \backslash \hat{\mathbf{Q}}))) \mathbf{e}_{b,\omega}, \\ &\quad \text{since: } \mathbf{e} \backslash (\mathbf{e} \hat{\mathbf{Q}}) = \mathbf{e} \hat{\mathbf{Q}} \\ &= (\mathbf{e}_{b',\omega} \backslash (\mathbf{e}_{b',\omega} ((\hat{\mathbf{Q}}' \mathbf{e}_{b',\omega}) \backslash \hat{\mathbf{Q}}))) \mathbf{e}_{b,\omega}, \\ &\quad \text{since: } \hat{\mathbf{Q}} = \hat{\mathbf{Q}} \mathbf{e} \\ &= (\mathbf{e}_{b',\omega} \backslash (\mathbf{e}_{b',\omega} (\mathbf{e}_{b',\omega} \backslash (\hat{\mathbf{Q}}' \backslash \hat{\mathbf{Q}})))) \mathbf{e}_{b,\omega}, \\ &\quad \text{since: } (ab) \backslash x = b \backslash (a \backslash x) \text{ (A.5)} \\ &= (\mathbf{e}_{b',\omega} \backslash (\hat{\mathbf{Q}}' \backslash \hat{\mathbf{Q}})) \mathbf{e}_{b,\omega}, \\ &\quad \text{since: } a \backslash (a (a \backslash x)) = a \backslash x \text{ (A.4)} \\ &= ((\hat{\mathbf{Q}}' \mathbf{e}_{b',\omega}) \backslash \hat{\mathbf{Q}}) \mathbf{e}_{b,\omega} = (\hat{\mathbf{Q}}' \backslash \hat{\mathbf{Q}}) \mathbf{e}_{b,\omega}, \\ &\quad \text{since: } (ab) \backslash x = b \backslash (a \backslash x) \text{ (A.5) and } \hat{\mathbf{Q}} = \hat{\mathbf{Q}} \mathbf{e} \\ &= ((\hat{\mathbf{Q}}' \backslash (\hat{\mathbf{Q}} \mathbf{e}_{b,\omega})) \mathbf{e}_{b,\omega}) \mathbf{e}_{b,\omega}, \\ &\quad \text{since: } (\hat{\mathbf{Q}} \mathbf{e}) \mathbf{e} = \hat{\mathbf{Q}} \mathbf{e} \\ &= (((\hat{\mathbf{Q}}' \backslash \hat{\mathbf{Q}}) \mathbf{e}_{b,\omega}) \mathbf{e}_{b,\omega}) \mathbf{e}_{b,\omega}, \\ &\quad \text{since: } (a \backslash x) \mathbf{e} b = a \backslash (x \mathbf{e} b) \text{ (A.6)} \\ &= (\hat{\mathbf{Q}}' \backslash \hat{\mathbf{Q}}) \mathbf{e}_{b,\omega}, \\ &\quad \text{since: } ((x \mathbf{e} a) \mathbf{e}) \mathbf{e} = x \mathbf{e} a \text{ (A.4)} \\ &= \hat{\mathbf{Q}}' \backslash (\hat{\mathbf{Q}} \mathbf{e}_{b,\omega}) = \hat{\mathbf{Q}}' \backslash \hat{\mathbf{Q}}, \\ &\quad \text{since: } (a \backslash x) \mathbf{e} b = a \backslash (x \mathbf{e} b) \text{ (A.6) and} \\ &\quad \hat{\mathbf{Q}} \mathbf{e} = \hat{\mathbf{Q}} \mathbf{e} = \hat{\mathbf{Q}}. \end{aligned}$$

Second,

$$\begin{aligned}
 (\mathbf{m}_{m,\omega} \hat{\mathbf{Q}}' \mathbf{b}_{b',\omega}) \setminus (\mathbf{m}_{m,\omega} \hat{\mathbf{Q}} \mathbf{b}_{b,\omega}) &= (\hat{\mathbf{Q}}' \mathbf{b}_{b',\omega}) \setminus (\mathbf{m}_{m,\omega} \setminus (\mathbf{m}_{m,\omega} \hat{\mathbf{Q}} \mathbf{b}_{b,\omega})), \\
 &\quad \text{because of (A.5),} \\
 &= (\hat{\mathbf{Q}}' \mathbf{b}_{b',\omega}) \setminus (\mathbf{b}_{m,\omega} \mathbf{m}_{m,\omega} \hat{\mathbf{Q}} \mathbf{b}_{b,\omega}), \\
 &\quad \text{because of (5.30),} \\
 &= (\hat{\mathbf{Q}}' \mathbf{b}_{b',\omega}) \setminus (\hat{\mathbf{Q}} \mathbf{b}_{b,\omega}), \\
 &\quad \text{as } \mathbf{b}_{m,\omega} \mathbf{m}_{m,\omega} \hat{\mathbf{Q}} = \hat{\mathbf{Q}} \text{ Remark 31,} \\
 &= (\hat{\mathbf{Q}}' \mathbf{b}_{b',\omega}) \setminus (\hat{\mathbf{Q}} \setminus \mathbf{m}_b), \\
 &\quad \text{from (5.31) and Remark 31,} \\
 &= \mathbf{b}_{b',\omega} \setminus (\hat{\mathbf{Q}}' \setminus (\hat{\mathbf{Q}} \setminus \mathbf{m}_b)), \\
 &\quad \text{because of (A.5),} \\
 &= \mathbf{b}_{b',\omega} \setminus ((\hat{\mathbf{Q}}' \setminus \hat{\mathbf{Q}}) \setminus \mathbf{m}_b), \\
 &\quad \text{because of (A.6),} \\
 &= \mathbf{m}_{b',\omega} (\hat{\mathbf{Q}}' \setminus \hat{\mathbf{Q}}) \mathbf{b}_{b,\omega}, \\
 &\quad \text{because of (5.31) and (5.43).}
 \end{aligned}$$

Due to Theorem 2.6, the quotient $\hat{\mathbf{Q}} \setminus \hat{\mathbf{Q}}'$ is a matrix composed of ultimately cyclic series in $\mathcal{M}_{\text{in}}^{\text{ax}} \llbracket \gamma, \delta \rrbracket$ and therefore the $s' \setminus s = \mathbf{m}_{m,\omega} (\hat{\mathbf{Q}}' \setminus \hat{\mathbf{Q}}) \mathbf{b}_{b,\omega}$ is an ultimately cyclic series in $\mathcal{E}\mathcal{T}_{\text{per}}$. \square

Proposition 90. *Let $s = \mathbf{m}_{m,\omega} \hat{\mathbf{Q}} \mathbf{b}_{b,\omega}$, $s' = \mathbf{m}_{m',\omega} \hat{\mathbf{Q}}' \mathbf{b}_{b',\omega}$ be ultimately cyclic series in $\mathcal{E}\mathcal{T}_{\text{per}}$ where s is (m, b, ω) -periodic and s' is (m', b, ω) -periodic then*

$$s \setminus s' = \mathbf{m}_{m,\omega} (\hat{\mathbf{Q}}' \setminus \hat{\mathbf{Q}}) \mathbf{b}_{m',\omega},$$

is an ultimately cyclic series in $\mathcal{E}\mathcal{T}_{\text{per}}$.

Proof. The proof is analogous to the proof of Prop. 89. \square

Matrices with entries in $\mathcal{E}\mathcal{T}_{\text{per}}$

In analogy with Section 3.4 the operations $(\oplus, \otimes, *, \setminus, \setminus')$ can be generalized to matrices with entries in $\mathcal{E}\mathcal{T}_{\text{per}}$.

Model of Discrete Event Systems

In this chapter, Timed Event Graphs (TEGs) and their weighted extension, Weighted Timed Event Graphs (WTEGs) are studied. TEGs and WTEGs are a subclass of timed Petri nets, which are commonly used to model timed Discrete Event Systems (DESSs), where the dynamic behavior is only governed by synchronization and saturation effects. Whereas the behavior of TEGs is event-invariant, due to the weight on the arcs in WTEGs, WTEGs exhibit event-variant behavior. In the first part of this chapter Petri nets, TEGs and WTEGs are recalled. Next, time-variant TEGs are studied. Two time-variant extensions of TEGs are considered in this chapter. First, TEGs are expanded with a specific form of synchronization, which is referred to as partial synchronization (PS) [20] and is associated with transitions in TEGs. Second, the time-variant behavior is modeled with a time-variant holding time of places in TEGs. This leads to the introduction of Periodic Time-variant Event Graphs (PTEGs). The second part of this chapter focuses on dioid models for TEGs, WTEGs, TEGs under PS, and PTEGs. Clearly, the earliest functioning of TEGs can be described by linear equations over some dioids, *e.g.*, the $(\max, +)$ -algebra. Due to the event-variant (resp. time-variant) behavior, this is not the case for WTEGs (resp. PTEGs). However, the input-output behavior of WTEGs can be described by ultimately cyclic series in the dioid $(\mathcal{E}[\delta], \oplus, \otimes)$, respectively for PTEGs and TEGs under periodic PS in the dioid $(\mathcal{T}_{\text{per}}[\gamma], \oplus, \otimes)$. In Section 6.2, the modeling process of TEGs and WTEGs in the dioids $(\mathcal{M}_{\text{in}}^{\text{ax}}[\gamma, \delta], \oplus, \otimes)$ and $(\mathcal{E}[\delta], \oplus, \otimes)$ is presented. This section is mainly based on [16, 17, 65, 66]. Section 6.2.4 studies Timed Event Graphs under Partial Synchronization, which were first introduced in [20]. In this section it is shown how the earliest functioning of a TEG under periodic PS can be modeled in the dioid $(\mathcal{T}_{\text{per}}[\gamma], \oplus, \otimes)$. In Section 6.2.6, partial synchronization is introduced for WTEGs. Again, it is shown that under some constraints the earliest functioning of WTEGs under periodic PS can be modeled in the dioid $(\mathcal{ET}, \oplus, \otimes)$. Some ideas, results, and figures presented in this chapter have appeared previously in [66, 65, 67, 68, 69].

6.1. Petri Nets and Timed Event Graphs

In the following, necessary facts on Petri nets TEGs and WTEGs are restated, for a comprehensive overview for Petri nets in general see, *e.g.*, [54, 9] and in particular for TEGs [1, 40], for WTEGs respectively [16, 50, 63]. Note also that, equivalent graphical models for WTEGs are known as SDF graphs. SDF graphs are used in the field of computer science, for instance to model data flow applications in embedded systems. For a detailed description on

SDF graphs see, e.g., [26, 44, 61].

Definition 53. A Petri net graph is a directed bipartite graph $\mathcal{N} = (P, T, w)$, where:

- $P = \{p_1, p_2, \dots, p_n\}$ is the finite set of places.
- $T = \{t_1, t_2, \dots, t_m\}$ is the finite set of transitions.
- $w : (P \times T) \cup (T \times P) \rightarrow \mathbb{N}_0$ is the weight function.

$A := \{(p_i, t_j) | w(p_i, t_j) > 0\} \cup \{(t_j, p_i) | w(t_j, p_i) > 0\}$ is the arc set, and $\mathbf{W} \in \mathbb{Z}^{n \times m}$, where $(\mathbf{W})_{i,j} = w(t_j, p_i) - w(p_i, t_j)$, is the incidence matrix of the Petri net graph \mathcal{N} . Furthermore,

- $\bullet p_i := \{t_j \in T | (t_j, p_i) \in A\}$ is the set of upstream transitions of p_i ,
- $p_i^\bullet := \{t_j \in T | (p_i, t_j) \in A\}$ is the set of downstream transitions of place p_i .

Conversely,

- $\bullet t_j := \{p_i \in P | (p_i, t_j) \in A\}$ is the set of upstream places of transition t_j ,
- $t_j^\bullet := \{p_i \in P | (t_j, p_i) \in A\}$ is the set of downstream places of transition t_j .

A Petri net consists of a Petri net graph \mathcal{N} and a vector of initial markings $\mathcal{M}_0 \in \mathbb{N}_0^n$, i.e. an initial distribution of tokens over places in \mathcal{N} . A transition t_j can fire, iff $\forall p_i \in \bullet t_j, (\mathcal{M})_i \geq w(p_i, t_j)$. If a transition t_j fires, the marking is changing according to $\mathcal{M}' = \mathcal{M} + (\mathbf{W})_{:,j}$, where \mathcal{M} and \mathcal{M}' are the markings before and after the firing of t_j . A potential firing sequence can be encoded by a vector $\mathbf{t} \in \mathbb{N}_0^m$ (called Parikh vector), where $(\mathbf{t})_i$ gives the number of firings of t_i in the sequence. E.g., for the Petri net shown in Figure 6.1, a firing sequence $t_1 t_2 t_2 t_3$ is described by $\mathbf{t} = [1 \ 2 \ 1]^T$. If the encoded firing sequence can actually occur when marking is \mathcal{M} , the new marking is obtained as $\mathcal{M}' = \mathcal{M} + \mathbf{W}\mathbf{t}$. A Petri net is said to be bounded if the marking in all places is bounded. Moreover, a Petri net is said to be live if any transition can ultimately fire from any reachable marking [63]. The structural properties of a Petri net can be analyzed by linear algebraic techniques. In particular, the right and left null spaces of the incidence matrix \mathbf{W} reveal invariants of the net structure.

Definition 54. A vector ξ is called T(ransition)-semiflow if $\xi \in \mathbb{N}^{m \times 1}$ and $\mathbf{W}\xi = \mathbf{0}$, where $\mathbf{0}$ denotes the zero vector.

Note that a T-semiflow is a strictly positive integer vector. A T-semiflow, therefore, describes a firing sequence which involves all transitions in the Petri net and, if it can occur at marking \mathcal{M} , leaves the latter invariant, i.e., $\mathcal{M} = \mathcal{M} + \mathbf{W}\xi$. It can then of course be repeated indefinitely and is therefore also called repetitive vector.

Example 45. Consider the Petri net shown in Figure 6.1. The incidence matrix of the corresponding Petri net graph is

$$\mathbf{W} = \begin{bmatrix} 2 & -1 & 0 \\ 0 & 1 & -2 \\ -1 & 0 & 1 \end{bmatrix}.$$

Then the vector $\xi = [1 \ 2 \ 1]^T$ is a T-semiflow for the Petri net shown in Figure 6.1, since $W\xi = \mathbf{0}$ and all entries of ξ are strictly positive integers. The initial marking of the Petri net is $\mathcal{M}_0 = [0 \ 0 \ 1]$. Clearly, the firing of ξ , i.e. the firing of the sequence $t_1 t_2 t_2 t_3$, results again in the marking $\mathcal{M}_0 = [0 \ 0 \ 1]$.

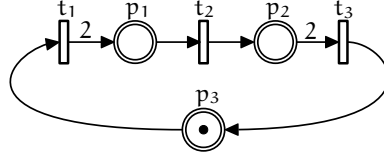

Figure 6.1. – Simple Petri net with a T-semiflow $\xi = [1 \ 2 \ 1]^T$.

A timed Petri net with holding times is a triple $(\mathcal{N}, \mathcal{M}_0, \Phi)$, where $(\mathcal{N}, \mathcal{M}_0)$ is a Petri net and $\Phi \in \mathbb{N}_0^n$ represents the holding times of the places, i.e., $(\Phi)_i$ is the time a token has to remain in place p_i before it contributes to the firing of a transition in p_i^\bullet . We can divide the set of transitions of a Petri net into input, output and internal transitions. Input transitions are transitions without upstream places. Output transitions are transitions without downstream places and internal transitions are transitions with both upstream and downstream places. A single-input and single-output (SISO) Petri net has exactly one input and one output transition. If a Petri net has several input or output transitions it is referred to as multiple-input and multiple-output (MIMO) Petri net.

6.1.1. Weighted Timed Event Graphs

Definition 55. A timed Petri net $(\mathcal{N}, \mathcal{M}_0, \Phi)$ is called *Weighted Timed Event Graph*, if every place has exactly one upstream and one downstream transition i.e., $\forall p_i \in P : |p_i^\bullet| = |\bullet p_i| = 1$.

Definition 56. An (ordinary) *Timed Event Graph* is a WTEG, where all arcs have weight 1, i.e., $\forall (p_i, t_j), (t_j, p_i) \in A, w(p_i, t_j) = w(t_j, p_i) = 1$.

Definition 57 (Earliest Functioning Rule). A WTEG is operating under the *earliest functioning rule* if all internal and output transitions fire as soon as they are enabled.

Let $t_{\underline{i}}$ and $t_{\bar{i}}$ be the unique upstream respectively downstream transition of place p_i , i.e., $\{t_{\underline{i}}\} = \bullet p_i$ and $\{t_{\bar{i}}\} = p_i^\bullet$.

Definition 58. $t_{\underline{i}} \rightarrow p_i \rightarrow t_{\bar{i}}$ is said to be a *basic directed path*, denoted by π_i . The *gain* of π_i is

$$\Gamma(\pi_i) = \frac{w(t_{\underline{i}}, p_i)}{w(p_i, t_{\bar{i}})}.$$

Hence, the gain of a basic directed path is a positive rational number. It is interpreted as follows: if the upstream transition $t_{\underline{i}}$ fires $w(p_i, t_{\bar{i}})$ times, this deposits $w(t_{\underline{i}}, p_i) \times w(p_i, t_{\bar{i}})$ tokens in place p_i , and this, in turn, leads to $w(t_{\underline{i}}, p_i)$ firings of the downstream transition $t_{\bar{i}}$.

Definition 59. A directed path is a sequence $\pi = \pi_{i_1} \cdots \pi_{i_q}$ with $i_j \neq i_k$, $j, k \in \{1, \dots, q\}$, such that $\bar{i}_j = i_{j+1}$, $\forall j \in \{1, \dots, q-1\}$. Its gain is the product of the gains of its constituent basic directed paths, i.e.,

$$\Gamma(\pi) = \prod_{j=1}^q \Gamma(\pi_{i_j}).$$

It should be clear that every path in an ordinary TEG has gain 1.

Definition 60. A WTEG is called

- strongly connected, if $\forall t_j, t_l \in T$ there exists a directed path from t_j to t_l .
- consistent if there exists a T-semiflow.

In this thesis, only consistent WTEGs are considered since a non-consistent WTEG is either not live or not bounded [63].

Proposition 91. Let $(\mathcal{N}, \mathcal{M}_0, \Phi)$ be a consistent WTEG with T-semiflow ξ . Then the diverted directed path $\pi = \pi_{i_1} \cdots \pi_{i_q}$ has gain

$$\Gamma(\pi) = \frac{(\xi)_{\bar{i}_q}}{(\xi)_{i_1}}.$$

Proof. According to the definition of T-semiflows, ξ is a positive integer vector such that

$$\mathbf{W}\xi = \mathbf{0}, \tag{6.1}$$

where $\mathbf{W} \in \mathbb{Z}^{n \times m}$ is the incidence matrix of the WTEG. Lines i_j , $j \in \{1, \dots, q\}$ of (6.1) read as follows:

$$\begin{aligned} w(t_{i_j}, p_{i_j})(\xi)_{i_j} - w(p_{i_j}, t_{i_{j+1}})(\xi)_{i_{j+1}} &= 0, \quad \text{for } j = 1, \dots, q-1 \\ w(t_{i_j}, p_{i_j})(\xi)_{i_j} - w(p_{i_j}, t_{\bar{i}_j})(\xi)_{\bar{i}_j} &= 0, \quad \text{for } j = q. \end{aligned}$$

Equivalently,

$$\begin{aligned} \frac{(\xi)_{i_{j+1}}}{(\xi)_{i_j}} &= \frac{w(t_{i_j}, p_{i_j})}{w(p_{i_j}, t_{i_{j+1}})} = \Gamma(\pi_{i_j}), \quad \text{for } j = 1, \dots, q-1 \\ \frac{(\xi)_{\bar{i}_q}}{(\xi)_{i_q}} &= \frac{w(t_{i_q}, p_{i_q})}{w(p_{i_q}, t_{\bar{i}_q})} = \Gamma(\pi_{i_q}). \end{aligned}$$

Therefore:

$$\Gamma(\pi) = \prod_{j=1}^q \Gamma(\pi_{i_j}) = \frac{(\xi)_{\bar{i}_q}}{(\xi)_{\underline{i}_1}}.$$

□

A WBTEG, introduced in [16], is defined as follows.

Definition 61 (Weight-Balanced Timed Event Graph). *Two paths $\pi = \pi_{i_1} \cdots \pi_{i_q}$ and $\pi' = \pi_{i'_1} \cdots \pi_{i'_q}$ are called parallel if they start and end in the same transition, i.e., if $\underline{i}_1 = \underline{i}'_1$ and $\bar{i}_q = \bar{i}'_q$. A WTEG is called Weight-Balanced Timed Event Graph (WBTEG), if all parallel paths have identical gain.*

Proposition 92. *A consistent WTEG is a WBTEG.*

Proof. Let $\pi = \pi_{i_1} \cdots \pi_{i_q}$ and $\pi' = \pi_{i'_1} \cdots \pi_{i'_q}$ be parallel paths. Then according to Prop. 91 and Definition 61,

$$\Gamma(\pi) = \frac{(\xi)_{\bar{i}_q}}{(\xi)_{\underline{i}_1}} = \frac{(\xi)_{\bar{i}'_q}}{(\xi)_{\underline{i}'_1}} = \Gamma(\pi').$$

□

Remark 32. *Note that in general, the opposite is not true, i.e. consistent WTEGs are a strict subclass of WBTEGs.*

Example 46. *Figure 6.2a shows a consistent WBTEG, where Figure 6.2b depicts a non-consistent one. Note that the only difference is the weight of arc (t_1, p_2) . In Figure 6.2a, $w(t_1, p_2) = 4$, while in Figure 6.2b $w(t_1, p_2) = 1$. In case (a) this leads to an incidence matrix*

$$\mathbf{W} = \begin{bmatrix} 3 & 0 & 0 & 0 & -1 \\ 4 & 0 & 0 & -1 & 0 \\ 0 & -2 & 3 & 0 & 0 \\ 0 & 0 & 4 & -1 & 0 \\ 0 & 0 & 0 & 0 & 0 \\ 0 & -2 & 0 & 0 & 1 \end{bmatrix}$$

\mathbf{W} has rank 4 and the vector $\xi = [2 \ 3 \ 2 \ 8 \ 6]^T$ satisfies $\mathbf{W}\xi = \mathbf{0}$ and is therefore a T-semiflow. It can be easily checked that the firing of $\xi = [2 \ 3 \ 2 \ 8 \ 6]^T$ results again in the initial marking

$\mathcal{M}_0 = [0\ 0\ 0\ 0\ 3\ 1]^T$. In case (b) the incidence matrix is

$$W = \begin{bmatrix} 3 & 0 & 0 & 0 & -1 \\ 1 & 0 & 0 & -1 & 0 \\ 0 & -2 & 3 & 0 & 0 \\ 0 & 0 & 4 & -1 & 0 \\ 0 & 0 & 0 & 0 & 0 \\ 0 & -2 & 0 & 0 & 1 \end{bmatrix}$$

and $\text{rank } W = 5$. Therefore no T-semiflow exists and the WBTEG is not consistent. The operation of this WBTEG leads to an irreversible accumulation of tokens in the system, i.e. after the firing of any transition, the initial marking \mathcal{M}_0 cannot be reached anymore.

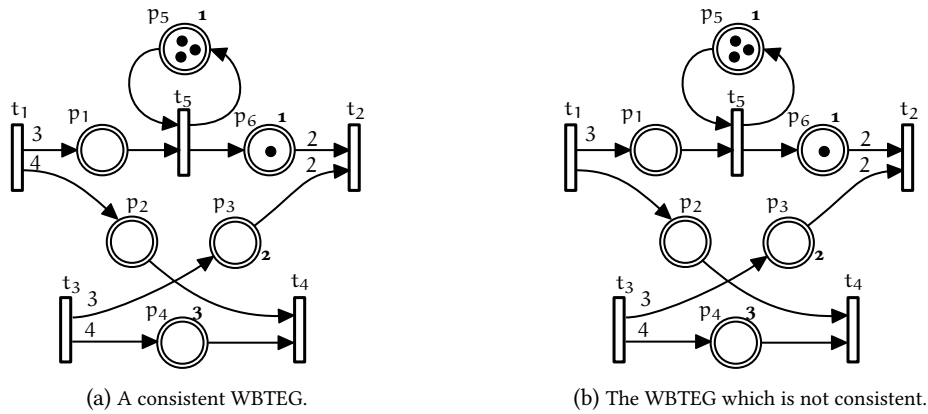

Figure 6.2. – Examples for consistent and non-consistent WBTEG.

Transformation of consistent WTEGs to TEGs

Particular properties of consistent WTEGs can be analyzed on the basis of standard TEGs. For this a transformation from a consistent WTEG into a TEG was introduced in [53, 55]. Then specific performance indicators of the WTEG can be computed by using this transformation. For instance, in [55] it was shown that the throughput, i.e., the maximal firing rate of transitions, of a consistent WTEG can be computed on the basis of the transformed TEG. The transformation is based on the T-semiflow of a consistent WTEG. Each transition in the WTEG is duplicated by its corresponding entry in the T-semiflow. A drawback of the transformation is that the number of transitions and places can significantly increase for the transformed TEG. More precisely, the number of transitions in the transformed TEG is $|\xi|$ and the number of places is at most $2|\xi|$, where $|\xi|$ is the 1-norm of the T-semiflow of the original consistent WTEG. Moreover, note that the $|\xi|$ can grow exponentially independent

of the net size of the WTEG, for more details see [55]. Also note that, as input and output transitions are duplicated, in general the corresponding TEG has a different input-output behavior as the original WTEG. For SDF graphs a similar transformation is given in [61]. For an illustration of this transformation see the following example. The TEG was obtained based on the algorithm published in [61].

Example 47. Consider the consistent WTEG shown in Figure 6.3. Its incidence matrix is

$$W = \begin{bmatrix} 1 & -2 & 0 & 0 \\ 3 & 0 & -1 & 0 \\ 0 & 0 & 0 & 0 \\ 0 & 0 & 0 & 0 \\ 0 & 3 & 0 & -1 \\ 0 & 0 & 1 & -2 \end{bmatrix}.$$

The vector $\xi = [2 \ 1 \ 6 \ 3]^T$ is a T-semiflow for the WTEG, since

$$W\xi = \begin{bmatrix} 1 & -2 & 0 & 0 \\ 3 & 0 & -1 & 0 \\ 0 & 0 & 0 & 0 \\ 0 & 0 & 0 & 0 \\ 0 & 3 & 0 & -1 \\ 0 & 0 & 1 & -2 \end{bmatrix} \begin{bmatrix} 2 \\ 1 \\ 6 \\ 3 \end{bmatrix} = \begin{bmatrix} 0 \\ 0 \\ 0 \\ 0 \\ 0 \\ 0 \end{bmatrix}.$$

This WTEG can be transformed into the TEG shown in Figure 6.4. The transition t_1 in Fig-

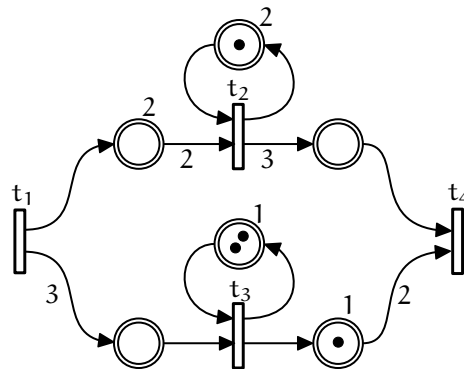

Figure 6.3. – A simple consistent WTEG, example is taken from [16].

ure 6.3 is duplicated twice, since the first entry of ξ being 2. The transition t_1 corresponds to the

transitions t_{1_1} and t_{1_2} in the corresponding TEG (Figure 6.4). Respectively, transition t_2 corresponds to transition t_{2_1} , transition t_3 is duplicated 6 times and corresponds to the transitions $t_{3_1}, t_{3_2}, t_{3_3}, t_{3_4}, t_{3_5}, t_{3_6}$ and transition t_4 is duplicated 3 times and corresponds to transitions $t_{4_1}, t_{4_2}, t_{4_3}$. Clearly, this transformation significantly increases the number of transitions in the corresponding TEG. Observe that the WTEG is a SISO system, whereas the corresponding TEG is a MIMO system with 2 input and 3 output transitions. As a consequence, the input-output behavior of the WTEG is different from the input-output behavior of the corresponding TEG. However, the maximal throughput of the WTEG can be studied based on its corresponding TEG. For instance in this example, the maximal throughput of transition t_2 in the WTEG is equal to the maximal throughput of transition t_{2_1} in the TEG. Similarly, the maximal throughput of transition t_3 in the WTEG is six times the maximal throughput of transition t_{3_1} , respectively transitions $t_{3_2}, t_{3_3}, t_{3_4}, t_{3_5}, t_{3_6}$, in the TEG.

6.1.2. Timed Event Graphs under Partial Synchronization

To express systems with time-variant behaviors, a new form of synchronization, called PS, has been introduced for TEGs [20, 21, 22]. Unlike exact synchronization, where two transitions t_1, t_2 can only fire if both transitions are simultaneously enabled, PS of transition t_1 by transition t_2 means that t_1 can fire only when transition t_2 fires, but t_1 does not influence the firing of t_2 . TEGs under PS provide a suitable model for some time-variant discrete event systems. In the following, a brief introduction is given.

Considering the TEG in Figure 6.5a, assuming the earliest functioning rule, incoming tokens in place p_1 are immediately transferred to place p_2 by the firing of transition t_2 , as the holding time of place p_1 is zero. Note that zero holding times are, by convention, not indicated in visual illustrations of TEGs. In contrast, Figure 6.5b illustrates a TEG with PS of transition t_2 by transition t_a . This means that t_2 can only fire if t_a fires, but the firing of t_a does not depend on t_2 . In this example, place p_3 (equipped with a holding time of ω) and transition t_a , together with the corresponding arcs, constitute an autonomous TEG. Under the earliest functioning rule, the firing of transition t_a generates a periodic signal \mathcal{S}_ω with a period $\omega \in \mathbb{N}$. Therefore, the PS of t_2 by t_a can also be described by a predefined signal $\mathcal{S}_\omega: \mathbb{Z} \mapsto \{0, 1\}$, enabling the firing of t_2 at times t where $\mathcal{S}_\omega(t) = 1$. The signal $\mathcal{S}_\omega(t) = 1$ if $t \in \{j\omega, \text{ with } j \in \mathbb{Z}\}$ and 0 otherwise.

Definition 62. *A Timed Event Graph under Partial Synchronization is a TEG where some internal and output transitions are subject to partial synchronization.*

Note that the assumption that only internal and output transitions are subject to PS is not restrictive since it is always possible to add new input transitions and extend the set of internal transitions by the former input transitions. In [21], ultimately periodic signals are considered for PS of transitions. It was shown that the behavior of a TEG under PS can be described by recursive equations in a state space form. This thesis focuses on (immediately) periodic signals for PS of transitions.

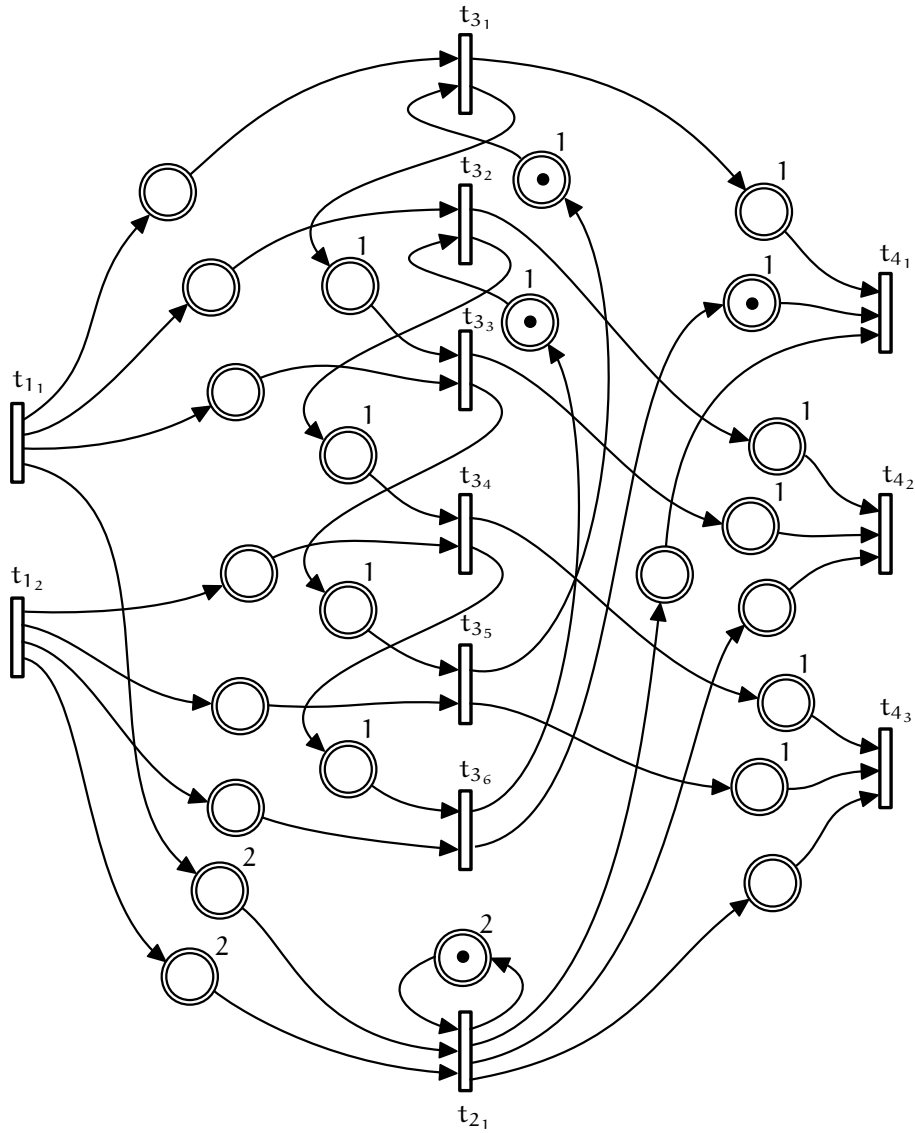

Figure 6.4. – Transformed TEG corresponding to the consistent WTEG shown in Figure 6.3.

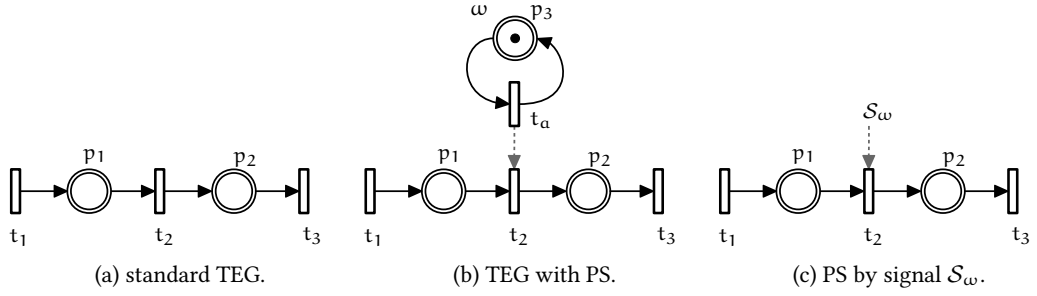

Figure 6.5. – (a) standard TEG. (b) PS of t_2 by t_a , triggered every ω time units. (c) equivalent PS expressed by a signal S_ω .

Definition 63. A periodic signal $S : \mathbb{Z} \rightarrow \{0, 1\}$ is defined by a string $\{n_0, n_1, \dots, n_I\} \in \mathbb{N}_0$ and a period $\omega \in \mathbb{N}$, such that

$$S(t) = \begin{cases} 1 & \text{if } t \in \{n_0 + \omega j, n_1 + \omega j, \dots, n_I + \omega j \mid j \in \mathbb{Z}\}, \\ 0 & \text{otherwise,} \end{cases}$$

where the string $\{n_0, n_1, \dots, n_I\}$ is strictly ordered, i.e., $\forall i \in \{1, \dots, I\}$, $n_{i-1} < n_i$, and $n_I < \omega$.

Example 48. The signal

$$S_1(t) = \begin{cases} 1 & \text{if } t \in \{\dots, -3, 0, 1, 4, 5, 8, 9, \dots\}, \\ 0 & \text{otherwise,} \end{cases}$$

is a periodic signal with a period $\omega = 4$ and a string $\{0, 1\}$. Therefore,

$$S_1(t) = \begin{cases} 1 & \text{if } t \in \{0 + 4j, 1 + 4j \mid j \in \mathbb{Z}\}, \\ 0 & \text{otherwise.} \end{cases} \quad (6.2)$$

In the following, only PS of transitions by periodic signals as given in Definition 63 are considered. Such a PS is called periodic PS. Considering only periodic PS allows us to model the earliest functioning of a Timed Event Graph under Partial Synchronization (TEGPS) in the dioid $(\mathcal{T}[[\gamma]], \oplus, \otimes)$, see Chapter 4. In particular, we can show that the transfer behavior of a TEG under periodic PS is described by a rational power series of an ultimately cyclic form in this dioid. Note that focusing on periodic signals for a PS of a transition is not overly restrictive as periodic schedules are common in many applications.

Example 49. Such periodic timing phenomena occur for instance in traffic networks. As an example, let us consider a crossroad which is controlled by a traffic light. A vehicle can only cross

during the green phase. If it reaches the crossing during this phase, it can immediately proceed. But if it reaches the cross in the red phase, it has to wait for the next green phase. The vehicle is delayed by a time that depends on its time of arrival. Under the assumption that the behavior of the traffic light is periodic, the crossroad can be modeled as a TEGPS where the timing behavior of the traffic light is described by a periodic PS. For instance, the TEGPS given in Figure 6.6 with the signal,

$$\mathcal{S}_2(t) = \begin{cases} 1 & \text{if } t \in \{0 + 4j, 1 + 4j \mid j \in \mathbb{Z}\}, \\ 0 & \text{otherwise,} \end{cases}$$

models such a time-variant behavior of a crossroad. According to the signal \mathcal{S}_2 , at time instances $\{0, 1, 4, 5, \dots\}$ the traffic light is green and the vehicle can proceed without being delayed. In contrast at time instances $\{2, 3, 6, 7, \dots\}$ the traffic light is red and the vehicle is delayed by one or two time units.

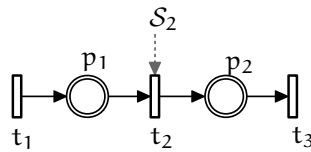

Figure 6.6. – Traffic light model with a PS.

6.1.3. Periodic Time-variant Event Graphs

An alternative way to model periodic time-variant behavior with TEGs is to consider time-variant holding times in places. Then holding times of places depend on the firing times of their upstream transitions. More precisely, the holding time $\mathcal{H}(t)$ is time-variant and immediately periodic, *i.e.* $\mathcal{H}(t + \omega) = \mathcal{H}(t)$. The current delay is then determined by the firing time t of the corresponding upstream transition. Such a time-variant holding time is described by a periodic function $\mathcal{H} : \mathbb{Z} \rightarrow \mathbb{Z}$, called holding-time function, which is defined as follows.

Definition 64 (Holding-time function \mathcal{H}). *A holding-time function $\mathcal{H} : \mathbb{Z} \rightarrow \mathbb{Z}$ is an ω -periodic function, *i.e.* $\exists \omega \in \mathbb{N}, \forall t \in \mathbb{Z} : \mathcal{H}(t) = \mathcal{H}(t + \omega)$.*

Hence, $\forall j \in \mathbb{Z}$

$$\mathcal{H}(t) = \begin{cases} \bar{n}_0 & \text{if } t = 0 + \omega j, \\ \bar{n}_1 & \text{if } t = 1 + \omega j, \\ \vdots & \\ \bar{n}_{\omega-1} & \text{if } t = (\omega - 1) + \omega j, \end{cases} \quad (6.3)$$

where for $i \in \{0, \dots, \omega - 1\}$, $\bar{n}_i \in \mathbb{Z}$ are the holding times in each period.

The short form of a holding-time function is defined as a string $\langle \bar{n}_0 \bar{n}_1 \dots \bar{n}_{\omega-1} \rangle$. The period ω is implicitly given by the number of elements in the string. For the modeling process of TEGs in the $(\max, +)$ -algebra, it is necessary that tokens must enter and leave each place in the same order [1]. In other words, a place must respect FIFO behavior. This property leads to the following constraint on holding-time functions

$$\forall t \in \mathbb{Z}, \mathcal{H}(t+1) + 1 \geq \mathcal{H}(t). \quad (6.4)$$

A holding-time function which respects (6.4) is called FIFO holding-time function. Moreover, a holding-time function is called causal if all holding times are nonnegative, i.e., $\forall i \in \{0, \dots, \omega - 1\}$, $\bar{n}_i \in \mathbb{N}_0$.

Definition 65 (Periodic Time-variant Event Graph). *A PTEG is a TEG where the holding times of places are given by causal FIFO holding-time functions.*

Example 50. *Consider the PTEG in Figure 6.7a where the holding time of p_1 is changing according to, $\forall j \in \mathbb{Z}$*

$$\mathcal{H}_1(t) = \langle 0 \ 0 \ 2 \ 1 \rangle = \begin{cases} 0 & \text{if } t = 0 + 4j, \\ 0 & \text{if } t = 1 + 4j, \\ 2 & \text{if } t = 2 + 4j, \\ 1 & \text{if } t = 3 + 4j. \end{cases}$$

This holding-time function satisfies (6.4) hence the holding time is such that tokens enter and leave place p_1 in the same order. In contrast, let us consider the TEG in Figure 6.7b, where the holding time of place p_2 is changing according to $\mathcal{H}_2(t) = \langle 3 \ 0 \ 2 \ 1 \rangle$. In this case, tokens which enter the place p_2 at time instant $t = 0$ enable the firing of transition t_4 at time instant $0 + \mathcal{H}_2(0) = 3$. Tokens which enter the place p_2 at time instant $t = 1$ immediately enable the firing of t_4 , since $\mathcal{H}_2(1) = 0$. The function \mathcal{H}_2 violates the FIFO condition of p_2 , and therefore the TEG in Figure 6.7b is not in the class of PTEGs.



Figure 6.7. – In (a) $\mathcal{H}_1 = \langle 0 \ 0 \ 2 \ 1 \rangle$ satisfies the FIFO condition. In (b) $\mathcal{H}_2 = \langle 3 \ 0 \ 2 \ 1 \rangle$ violates the FIFO condition.

Definition 66 (Release-time function \mathcal{R}). A release-time function $\mathcal{R} : \overline{\mathbb{Z}}_{\max} \rightarrow \overline{\mathbb{Z}}_{\max}$ is an isotone function defined as,

$$\mathcal{R}(t) = \begin{cases} -\infty & \text{if } t = -\infty, \\ \mathcal{H}(t) + t & \text{if } t \in \mathbb{Z}, \\ \infty & \text{if } t = \infty, \end{cases}$$

where \mathcal{H} is a FIFO holding-time function. A release-time function is called causal if $\mathcal{R}(t) \geq t$, $\forall t \in \overline{\mathbb{Z}}_{\max}$.

As $\mathcal{H}(t+1) + 1 \geq \mathcal{H}(t)$, it follows that

$$\mathcal{R}(t+1) = \mathcal{H}(t+1) + t+1 \geq \mathcal{H}(t) + t = \mathcal{R}(t),$$

i.e. \mathcal{R} is isotone. The release-time function can be seen as an alternative representation of the time-variant behavior of a place in a PTEG. This function describes the time when a token in a place is available to contribute to the firing of the downstream transition of the place. The argument of this function is the time t when the token enters the place and its value is the time when the token is available to leave the place. By defining $n_i = \bar{n}_i + i$, we can express a release-time function as

$$\mathcal{R}(t) = \mathcal{H}(t) + t = \begin{cases} n_0 + \omega j & \text{if } t = 0 + \omega j, \text{ with } j \in \overline{\mathbb{Z}}_{\max} \\ n_1 + \omega j & \text{if } t = 1 + \omega j, \text{ with } j \in \overline{\mathbb{Z}}_{\max} \\ \vdots & \\ n_{\omega-1} + \omega j & \text{if } t = (\omega - 1) + \omega j, \text{ with } j \in \overline{\mathbb{Z}}_{\max}. \end{cases} \quad (6.5)$$

Clearly, nonnegative holding-times \bar{n}_i (causal holding-time functions) lead to causality of \mathcal{R} .

Example 51 (PTEG). Figure 6.8 shows a PTEG with holding-time functions of places p_1, p_2, p_3 given by

$$\mathcal{H}_1 = \langle 0 \ 0 \ 2 \ 1 \rangle, \mathcal{H}_2 = \langle 1 \rangle, \mathcal{H}_3 = \langle 1 \ 3 \ 2 \ 1 \rangle.$$

The corresponding release-time functions are, $\forall j \in \overline{\mathbb{Z}}_{\max}$

$$\mathcal{R}_1(t) = \begin{cases} 0 + 4j & \text{if } t = 0 + 4j, \\ 1 + 4j & \text{if } t = 1 + 4j, \\ 4 + 4j & \text{if } t = 2 + 4j, \\ 4 + 4j & \text{if } t = 3 + 4j, \end{cases}$$

$$\mathcal{R}_2(t) = 1 + t,$$

$$\mathcal{R}_3(t) = \begin{cases} 1 + 4j & \text{if } t = 0 + 4j, \\ 4 + 4j & \text{if } t = 1 + 4j, \\ 4 + 4j & \text{if } t = 2 + 4j, \\ 4 + 4j & \text{if } t = 3 + 4j. \end{cases}$$

In this example, place p_2 has a constant holding time, whereas the holding times of places p_1 and p_3 are changing periodically with period 4. $\mathcal{R}_1, \mathcal{R}_3$, respectively $\mathcal{H}_1, \mathcal{H}_3$, are illustrated in Figure 6.9a, respectively, Figure 6.9b. The place p_1 can be interpreted as the model of a traffic

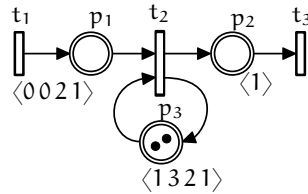
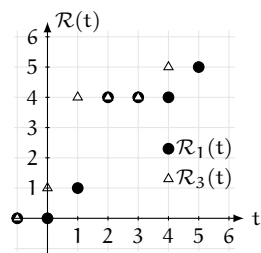
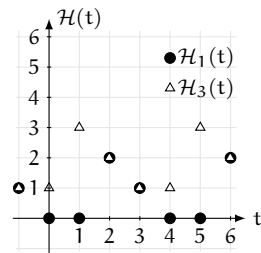

Figure 6.8. – PTEG with holding-time functions of places p_1, p_2, p_3 expressed in the short form at each place.



(a) Release-time functions



(b) Holding-time functions

Figure 6.9. – Release-time function $\mathcal{R}_1, \mathcal{R}_3$ and holding-time functions $\mathcal{H}_1, \mathcal{H}_3$ of places p_1, p_3 .

light which is green for time instants $\{0, 1, 4, 5, \dots\}$ and red for time instants $\{2, 3, 6, 7, \dots\}$.

Therefore, if a car arrives at times $2, 6, \dots$ it has to wait for 2 time instants, if it arrives at times $3, 7, \dots$, it has to wait for 1 time instant.

Remark 33. The behavior of a TEG under periodic PS operating under the earliest functioning rule can be modeled by an "equivalent" PTEG. For this, the time-variant delays caused by periodic PSs of the transitions are shifted to the upstream places of the transitions. For instance consider the simple TEG shown in Figure 6.10 with a periodic PS of transition t_2 by an arbitrary periodic signal S_2 , see Definition 63. To this signal a release-time function $\mathcal{R}_{S_2} : \overline{\mathbb{Z}}_{\max} \rightarrow \overline{\mathbb{Z}}_{\max}$

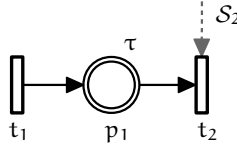

Figure 6.10. – Simple TEGPS with a periodic PS of t_2 .

is associated, defined by, $\forall j \in \overline{\mathbb{Z}}_{\max}$,

$$\mathcal{R}_{S_2}(t) = \begin{cases} n_0 + \omega j & \text{if } (n_1 - \omega) + \omega j < t \leq n_0 + \omega j, \\ n_1 + \omega j & \text{if } n_0 + \omega j < t \leq n_1 + \omega j, \\ \vdots & \\ n_{l-1} + \omega j & \text{if } n_{l-1} + \omega j < t \leq n_l + \omega j, \end{cases} \quad (6.6)$$

The value of \mathcal{R}_{S_2} can be interpreted as the next time when the signal S_2 enables the firing of the corresponding transition. Clearly, an ω -periodic signal S_2 leads to a corresponding function \mathcal{R}_{S_2} which satisfies $\forall t \in \overline{\mathbb{Z}}_{\max}, \mathcal{R}_{S_2}(t + \omega) = \omega + \mathcal{R}_{S_2}(t)$. Then the time-variant delay caused by the periodic PS is modeled by the holding-time function

$$\mathcal{H}_{p_1}(t) = \mathcal{R}_{S_2}(t + \tau) - t$$

of the upstream place p_1 of transition t_2 . As the place p_1 may already have a constant holding time τ , this holding time must be considered by the transformation, i.e. the argument of \mathcal{R}_{S_2} must be shifted by τ time units.

Example 52. The function $\mathcal{R}_{S_1}(t)$ (Figure 6.11b) associated with the signal S_1 (Figure 6.11a) given in Example 48 is

$$\mathcal{R}_{S_1}(t) = \begin{cases} -\infty & \text{if } t = -\infty \\ 0 + 4j & \text{if } -3 + 4j < t \leq 0 + 4j, \quad \text{with } j \in \overline{\mathbb{Z}}_{\max} \\ 1 + 4j & \text{if } 0 + 4j < t \leq 1 + 4j, \quad \text{with } j \in \overline{\mathbb{Z}}_{\max} \\ \infty & \text{if } t = \infty. \end{cases}$$

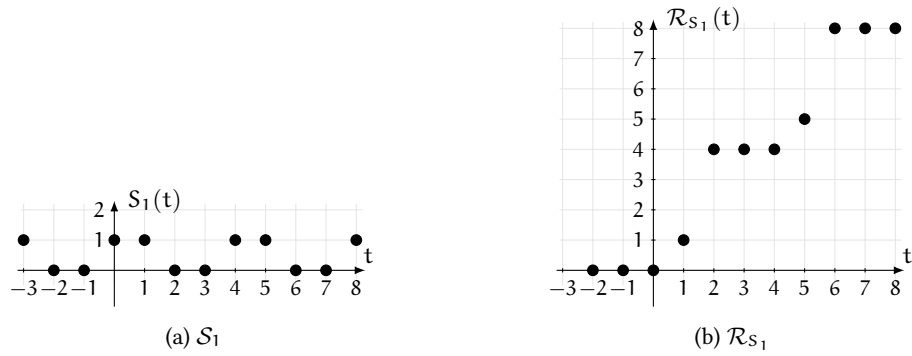

Then, for $\tau = 1$ the release-time function of place p_1 is given by, for $j \in \overline{\mathbb{Z}}_{\max}$,

$$\mathcal{R}_{p_1}(t) = \mathcal{R}_{S_1}(t + \tau) = \begin{cases} 1 + 4j & \text{if } t = 0 + 4j, \\ 4 + 4j & \text{if } t = 1 + 4j, \\ 4 + 4j & \text{if } t = 2 + 4j, \\ 4 + 4j & \text{if } t = 3 + 4j. \end{cases}$$

Finally, $\mathcal{H}_{p_1}(t) = \mathcal{R}_{p_1}(t) - t = \langle 1 \ 3 \ 2 \ 1 \rangle$.

Remark 34. Conversely, the earliest functioning of a PTEG can be modeled by a TEG under periodic PS. Therefore, release-time functions associated with places in the PTEG are converted to periodic signals. Consider the following simple PTEG with a release-time function

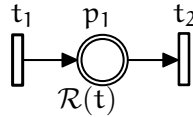

Figure 6.12. – Simple PTEG with release-time function $\mathcal{R}(t)$ of place p_1 .

$$\mathcal{R}(t) = \begin{cases} n_0 + \omega j & \text{if } t = 0 + \omega j, & \text{with } j \in \overline{\mathbb{Z}}_{\max} \\ n_1 + \omega j & \text{if } t = 1 + \omega j, & \text{with } j \in \overline{\mathbb{Z}}_{\max} \\ \vdots & \\ n_{\omega-1} + \omega j & \text{if } t = (\omega - 1) + \omega j & \text{with } j \in \overline{\mathbb{Z}}_{\max}. \end{cases}$$

First, this function is partitioned into a constant offset τ and a remaining causal release-time

function,

$$\mathcal{R}(t) = \tau + \mathcal{R}'(t) = \min_{i=0}^{\omega-1} (n_i - i) + \begin{cases} n'_0 + \omega j & \text{if } t = 0 + \omega j, \\ n'_1 + \omega j & \text{if } t = 1 + \omega j, \\ \vdots & \\ n'_{\omega-1} + \omega j & \text{if } t = (\omega - 1) + \omega j. \end{cases}$$

where $\forall i \in \{0, \dots, \omega - 1\}, n'_i = n_i - \tau$ and $\tau = \min(n_i - i)$. Then, the PTEG shown in Figure 6.12 can be modeled by the TEG under periodic PS shown in Figure 6.13, where the periodic signals $\mathcal{S}_0, \mathcal{S}_1, \dots, \mathcal{S}_{\omega-1}$ are given by, $\forall j \in \mathbb{Z}$

$$\mathcal{S}_0(t) = \begin{cases} 1 & \text{if } t \in \{ \mathcal{R}'(0) + \omega j, \\ & \max(\mathcal{R}'(0), 1) + \omega j, \\ & \dots, \\ & \max(\mathcal{R}'(0), \omega - 1) + \omega j \} \\ 0 & \text{otherwise.} \end{cases}$$

$$\mathcal{S}_1(t) = \begin{cases} 1 & \text{if } t \in \{ \max(\mathcal{R}'(1) - \omega, 0) + \omega j, \\ & \mathcal{R}'(1) + \omega j, \\ & \max(\mathcal{R}'(1), 2) + \omega j, \\ & \dots \\ & \max(\mathcal{R}'(1), \omega - 1) + \omega j \} \\ 0 & \text{otherwise.} \end{cases}$$

$$\vdots$$

$$\mathcal{S}_{\omega-1}(t) = \begin{cases} 1 & \text{if } t \in \{ \max(\mathcal{R}'(\omega - 1) - \omega, 0) + \omega j, \\ & \max(\mathcal{R}'(\omega - 1) - \omega, 1) + \omega j, \\ & \dots \\ & \max(\mathcal{R}'(\omega - 1) - \omega, \omega - 2) + \omega j, \\ & \mathcal{R}'(\omega - 1) + \omega j \} \\ 0 & \text{otherwise.} \end{cases}$$

A similar problem is studied in [19][Chapter 4.5], there realizability for series in the dioid

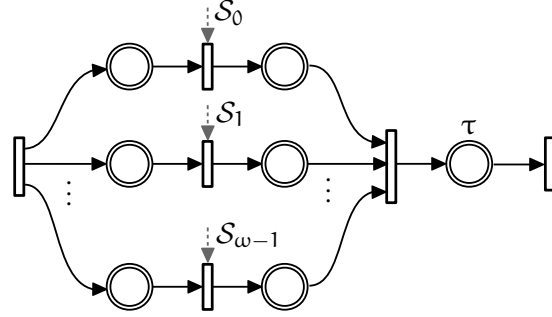

Figure 6.13. – TEG under periodic PS associated with the PTEG of Figure 6.12.

$(\mathcal{F}_{\mathbb{N}}[\gamma], \oplus, \otimes)$ is discussed. This dioid $(\mathcal{F}_{\mathbb{N}}[\gamma], \oplus, \otimes)$ is an alternative to the dioid $(\mathcal{T}_{\text{per}}[\gamma], \oplus, \otimes)$ to model TEG under PS.

Example 53. Consider the simple PTEG shown in Figure 6.14a with a holding time function $\langle 1 \ 0 \ 2 \ 2 \rangle$ of place p_1 . The release-time function to $\langle 1 \ 0 \ 2 \ 2 \rangle$ is

$$\mathcal{R}_{p_1}(t) = \begin{cases} 1 + 4j & \text{if } t = 0 + 4j, \text{ with } j \in \overline{\mathbb{Z}}_{\max}, \\ 1 + 4j & \text{if } t = 1 + 4j, \text{ with } j \in \overline{\mathbb{Z}}_{\max} \\ 4 + 4j & \text{if } t = 2 + 4j, \text{ with } j \in \overline{\mathbb{Z}}_{\max} \\ 5 + 4j & \text{if } t = 3 + 4j, \text{ with } j \in \overline{\mathbb{Z}}_{\max}. \end{cases}$$

For this example, $\tau = 0$, since $n_1 - 1 = 1 - 1 = 0$, and therefore $\mathcal{R}'_{p_1}(t) = \mathcal{R}_{p_1}(t)$. Then the periodic signals \mathcal{S}_0 , \mathcal{S}_1 , \mathcal{S}_2 and \mathcal{S}_3 are

$$\begin{aligned} \mathcal{S}_0(t) &= \begin{cases} 1 & \text{if } t \in \{1 + 4j, 1 + 4j, 2 + 4j, 3 + 4j \mid j \in \mathbb{Z}\}, \\ 0 & \text{otherwise.} \end{cases} \\ \mathcal{S}_1(t) &= \begin{cases} 1 & \text{if } t \in \{0 + 4j, 1 + 4j, 2 + 4j, 3 + 4j \mid j \in \mathbb{Z}\}, \\ 0 & \text{otherwise.} \end{cases} \\ \mathcal{S}_2(t) &= \begin{cases} 1 & \text{if } t \in \{0 + 4j, 1 + 4j, 4 + 4j, 4 + 4j \mid j \in \mathbb{Z}\}, \\ 0 & \text{otherwise.} \end{cases} \\ \mathcal{S}_3(t) &= \begin{cases} 1 & \text{if } t \in \{1 + 4j, 1 + 4j, 4 + 4j, 5 + 4j \mid j \in \mathbb{Z}\}, \\ 0 & \text{otherwise.} \end{cases} \end{aligned}$$

These signals are simplified to

$$\mathcal{S}_0(t) = \begin{cases} 1 & \text{if } t \in \{1 + 4j, 2 + 4j, 3 + 4j \mid j \in \mathbb{Z}\}, \\ 0 & \text{otherwise.} \end{cases}$$

$$\mathcal{S}_1(t) = \begin{cases} 1 & \text{if } t \in \{0 + 4j, 1 + 4j, 2 + 4j, 3 + 4j \mid j \in \mathbb{Z}\}, \\ 0 & \text{otherwise.} \end{cases}$$

$$\mathcal{S}_2(t) = \begin{cases} 1 & \text{if } t \in \{0 + 4j, 1 + 4j \mid j \in \mathbb{Z}\}, \\ 0 & \text{otherwise.} \end{cases}$$

$$\mathcal{S}_3(t) = \begin{cases} 1 & \text{if } t \in \{1 + 4j, 2 + 4j \mid j \in \mathbb{Z}\}, \\ 0 & \text{otherwise.} \end{cases}$$

Note that the transition subjected to PS by the signals $\mathcal{S}_0, \mathcal{S}_1, \mathcal{S}_2, \mathcal{S}_3$ are placed in parallel paths, see Figure 6.13. Therefore, the path with the signal \mathcal{S}_1 is redundant and can be removed. Then, the earliest functioning of the PTEG shown in Figure 6.14a is modeled by the TEG under periodic PS shown in Figure 6.14b.

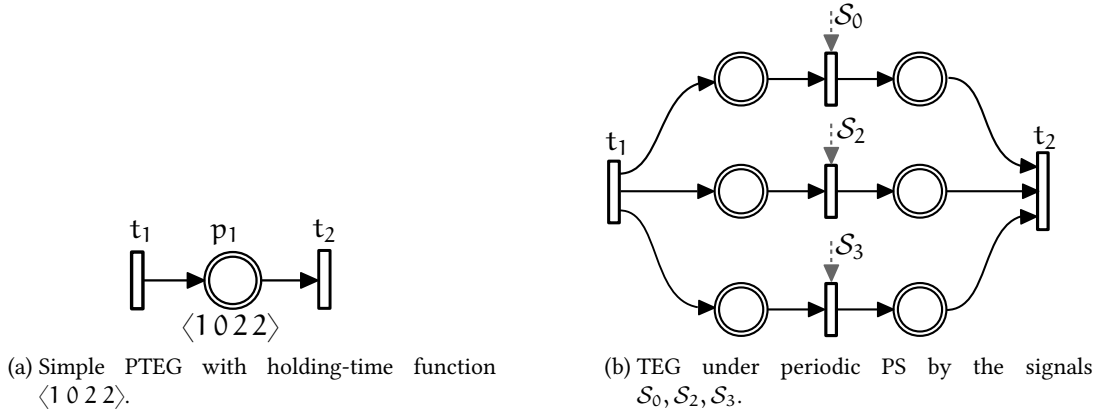

Figure 6.14. – In (a) PTEG and in (b) TEG under periodic PS, both models have the same input/output behavior when operating under the earliest functioning rule.

Indeed Remark 34 shows that the earliest functioning of a PTEG can be modeled by a TEG under periodic PS. However as indicated in Example 53, PTEGs can model certain time-variant behavior in a more compact form. Finally, let us note that PTEGs can be seen as the counterpart to Cyclo-Weighted Timed Event Graphs (CWTEGs) [18]. CWTEGs are an extension of WTEGs, where weights on the arcs are changing periodically depending on firing sequences of transitions attached to these arcs [18]. A similar extension is known for

SDF Graphs, called Cyclo-Static Synchronous Data-Flow (CSDF) Graphs. This system class was studied, e.g. in [2, 24, 57].

6.2. Dioid Model of Timed Event Graphs

6.2.1. Dater and Counter

In analogy with [1], in the following dater and counter functions are briefly introduced. For a more exhaustive representation, the reader is invited to consult [1][Chap. 5]. An event can be seen as an instantaneous action, such as the push of a button, the start of a production process or the successive firings of a transition in a Petri net. For timed DESs the occurrences of an event can be described by a *sequence* generated by an increasing counting mechanism over time. For instance, the successive firings of a transition in a Petri net can be described by a time sequence, e.g. $(k_0, t_0)(k_0 + 1, t_1)(k_0 + 2, t_2) \dots$, where the firings are enumerated starting from an arbitrary value $k_0 \in \mathbb{Z}$. Then the pair (k_i, t_i) is interpreted as: The firing numbered by k_i has taken place at time t_i . For instance, the sequence $(0, 2), (1, 3), (2, 3)$, where k_0 is chosen to 0, means the first firing of a transition, numbered by 0, has taken place at time instant 2, the second and third firings numbered by 1 and 2 have taken place at time instant 3. This kind of sequences can either be represented by a dater function $k \mapsto d(k)$ in the "event-domain" or equivalently as a counter function $t \mapsto c(t)$ in the "time-domain". The following section introduces dater and counter functions for the purpose of modeling WTEGs (resp. PTEGs) in dioids.

Dater

A dater is defined as a mapping $d : \mathbb{Z} \rightarrow \overline{\mathbb{Z}}_{\max}, k \mapsto d(k)$, where the index $k \in \mathbb{Z}$ numbers the consecutive firings of a transition starting from an initial value $k_0 = 0$ and $d(k)$ is the time when the firing numbered by k has taken place. It is important to mention that by convention the first firing of a transition is numbered by 0. Therefore, $d(k)$ is the time when the $(k + 1)^{\text{st}}$ firing of the transition has taken place. More precisely,

$$d(k) = \begin{cases} -\infty \quad (\text{resp. } \varepsilon), & \text{if } k < 0, \\ +\infty \quad (\text{resp. } \top), & \text{if the } (k + 1)^{\text{st}} \text{ firing never took place,} \\ \in \mathbb{Z}, & \text{if the } (k + 1)^{\text{st}} \text{ firing occurred at time } d(k). \end{cases}$$

Note that, the time is given by a discrete value $d(k) \in \overline{\mathbb{Z}}_{\max}$ rather than by a continuous value in \mathbb{R} . Furthermore, it should be clear that dater functions are naturally isotone. An

impulse is represented as a specific dater function given by,

$$\mathcal{I}(k) = \begin{cases} -\infty \text{ (resp. } \varepsilon), & \text{for } k < 0, \\ 0 \text{ (resp. } e), & \text{for } k \geq 0. \end{cases} \quad (6.7)$$

According to the representation of a dater function, this means an infinity of firings of the corresponding transition at time $t = 0$.

Dater and Series in $\mathcal{M}_{\text{in}}^{\text{ax}}[\gamma, \delta]$

Proposition 93 ([1]). *A dater function $d : \mathbb{Z} \rightarrow \overline{\mathbb{Z}}_{\text{max}}$ can be expressed as a series $s_d \in \mathcal{M}_{\text{in}}^{\text{ax}}[\gamma, \delta]$, such that,*

$$s_d = \left(\bigoplus_{\{k \in \mathbb{Z} \mid -\infty < d(k) < +\infty\}} \gamma^k \delta^{d(k)} \right) \oplus \left(\bigoplus_{\{k \in \mathbb{Z} \mid d(k) = +\infty\}} \gamma^k \delta^* \right). \quad (6.8)$$

Therefore, the series in $\mathcal{M}_{\text{in}}^{\text{ax}}[\gamma, \delta]$ corresponding to an impulse $\mathcal{I}(k)$, see (6.7), is the unit element $e = \gamma^0 \delta^0$ in the dioid $(\mathcal{M}_{\text{in}}^{\text{ax}}[\gamma, \delta], \oplus, \otimes)$. For a more detailed description of the transformation, see e.g. [1, 13].

Counter

A counter is defined as a mapping $c : \mathbb{Z} \rightarrow \overline{\mathbb{Z}}_{\text{min}}, t \rightarrow c(t)$, where the time $t \in \mathbb{Z}$ is given by a discrete value and $c(t)$ is the accumulated number of firings strictly before time t .

$$c(t) = \begin{cases} \leq 0, & \text{if no firing occurred strictly before or at time } t, \\ +\infty \text{ (resp. } \varepsilon), & \text{if an infinity of firings occurred strictly before time } t, \\ \in \mathbb{N}, & \text{exact } c(t) \text{ firings occurred strictly before time } t. \end{cases}$$

For instance the following counter function,

$$c(t) = \begin{cases} 0 & \text{for } t \leq 1, \\ 1 & \text{for } t = 2, \\ 3 & \text{for } t = 3, \\ 4 & \text{for } t \geq 4, \end{cases}$$

is interpreted as: No firing before time 1. The first firing is at time $t = 1$, the second and third firing at time $t = 2$. The fourth firing at time $t = 3$ and after time $t = 4$ there is no

additional firing. In contrast to dater function, counter functions are antitone rather than isotone. An impulse is represented as a specific counter function $\mathcal{I}(t)$, defined as

$$\mathcal{I}(t) = \begin{cases} 0 \text{ (resp. } e) & \text{for } t \leq 0, \\ +\infty \text{ (resp. } \varepsilon) & \text{for } t > 0. \end{cases} \quad (6.9)$$

Counter and Series in $\mathcal{M}_{\text{in}}^{\text{ax}}[\gamma, \delta]$

As for dater functions, counter functions can be represented as series in $\mathcal{M}_{\text{in}}^{\text{ax}}[\gamma, \delta]$, see [1, 13]. The counter functions c canonically associated with a series $s_c \in \mathcal{M}_{\text{in}}^{\text{ax}}[\gamma, \delta]$ is such that

$$s_c = \left(\bigoplus_{\{t \in \mathbb{Z} \mid -\infty < c(t) < +\infty\}} \gamma^{c(t)} \delta^t \right) \oplus \left(\bigoplus_{\{k \in \mathbb{Z} \mid c(t) = -\infty\}} (\gamma^{-1})^* \delta^t \right). \quad (6.10)$$

Then the series in $\mathcal{M}_{\text{in}}^{\text{ax}}[\gamma, \delta]$ associated with the impulse $\mathcal{I}(t)$, see (6.9), is again the unit element $e = \gamma^0 \delta^0$ in the dioid $(\mathcal{M}_{\text{in}}^{\text{ax}}[\gamma, \delta], \oplus, \otimes)$.

Notation

Expressing counter and dater functions as series in $\mathcal{M}_{\text{in}}^{\text{ax}}[\gamma, \delta]$ is convenient for calculations with transfer function models of TEGs in $\mathcal{M}_{\text{in}}^{\text{ax}}[\gamma, \delta]$. From now on a counter function is denoted by a small letter with a tilde and the associated series in $\mathcal{M}_{\text{in}}^{\text{ax}}[\gamma, \delta]$ by a small letter, e.g., \tilde{x} denotes the counter function canonically associated with the series $x \in \mathcal{M}_{\text{in}}^{\text{ax}}[\gamma, \delta]$. Respectively, a dater function is denoted by a small letter with a bar and the associated series in $\mathcal{M}_{\text{in}}^{\text{ax}}[\gamma, \delta]$ by a small letter, e.g., \bar{x} denotes the dater function canonically associated with the series $x \in \mathcal{M}_{\text{in}}^{\text{ax}}[\gamma, \delta]$.

6.2.2. Dioid Model of ordinary Timed Event Graphs

In this section dioid models for TEGs are recalled. For a more detailed representation, see e.g., [1, 40, 36]. For the purpose of modeling a TEG, a dater function $\bar{x} : \mathbb{Z} \rightarrow \overline{\mathbb{Z}}_{\text{max}}$ is associated with each transition. $\bar{x}(k)$ gives the time (or date) when the transition fires the $(k+1)^{\text{st}}$ time, recall that the first firing is numbered by 0, see Section 6.2.1.

Example 54. Consider the TEG of Figure 6.15. By assigning $\bar{u}_1(k)$ (resp. $\bar{u}_2(k)$) to the input transition t_1 (resp. t_2), $\bar{x}_1(k)$ (resp. $\bar{x}_2(k)$) to internal transition t_3 (resp. t_4) and $\bar{y}(k)$ to the output transition t_5 , the behavior of the TEG can be described by the following inequalities

$$\begin{aligned} \bar{x}_1(k) &\geq \max(\bar{x}_2(k-2), \bar{u}_1(k) + 1, \bar{u}_2(k-1) + 3), \\ \bar{y}(k) &\geq \bar{x}_2(k) \geq \bar{x}_1(k) + 2. \end{aligned}$$

If the TEG operates under the earliest functioning rule, its behavior is described by equations

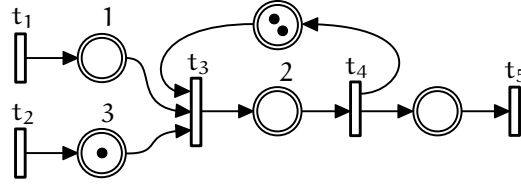

Figure 6.15. – A simple TEG.

instead of inequalities,

$$\begin{aligned}\bar{x}_1(k) &= \max(\bar{x}_2(k-2), \bar{u}_1(k) + 1, \bar{u}_2(k-1) + 3), \\ \bar{y}(k) &= \bar{x}_2(k) = 2 + \bar{x}_1(k).\end{aligned}\quad (6.11)$$

Obviously, due to the max operation, these equations are nonlinear in conventional algebra. In the (max,+)-algebra, the system (6.11) is expressed as

$$\begin{aligned}\bar{x}_1(k) &= \bar{x}_2(k-2) \oplus 1\bar{u}_1(k) \oplus 3\bar{u}_2(k-1), \\ \bar{y}(k) &= \bar{x}_2(k) = 2\bar{x}_1(k).\end{aligned}\quad (6.12)$$

It is easy to see that the equations in (6.12) are linear. Therefore, the system in (6.12) is also called "max-plus linear system". With the event-shift operator γ and time shift operator δ , system (6.12) can be expressed by $\bar{x}_1 = \gamma^2\bar{x}_2 \oplus \delta^1\bar{u}_1 \oplus \gamma^1\delta^3\bar{u}_2$, $\bar{y} = \bar{x}_2 = \delta^2\bar{x}_1$. Or, equivalently, with $\bar{\mathbf{x}} = [\bar{x}_1 \ \bar{x}_2]^T$ and $\bar{\mathbf{u}} = [\bar{u}_1 \ \bar{u}_2]^T$, in matrix form $\bar{\mathbf{x}} = \mathbf{A}\bar{\mathbf{x}} \oplus \mathbf{B}\bar{\mathbf{u}}$; $\bar{\mathbf{y}} = \mathbf{C}\bar{\mathbf{x}}$, where

$$\mathbf{A} = \begin{bmatrix} \varepsilon & \gamma^2 \\ \delta^2 & \varepsilon \end{bmatrix}, \quad \mathbf{B} = \begin{bmatrix} \delta^1 & \gamma^1\delta^3 \\ \varepsilon & \varepsilon \end{bmatrix}, \quad \mathbf{C} = \begin{bmatrix} \varepsilon & e \end{bmatrix}.$$

Due to Theorem 2.1, the least solution for the output $\bar{\mathbf{y}}$ is given by, $\bar{\mathbf{y}} = \mathbf{H}\bar{\mathbf{u}}$, with transfer function matrix

$$\mathbf{H} = \mathbf{C}\mathbf{A}^*\mathbf{B} = \begin{bmatrix} \delta^3(\gamma^2\delta^2)^* & \gamma^1\delta^5(\gamma^2\delta^2)^* \end{bmatrix}.$$

For some applications, it is more convenient to model the evolution of a TEG in the "time-domain" rather than in the "event-domain". Then a counter function $\tilde{x} : \mathbb{Z} \rightarrow \bar{\mathbb{Z}}_{\min}$ is associated with each transition of the TEG. Recall that the counter value $\tilde{x}(t)$ describes the accumulated number of firings strictly before time t . The earliest functioning of a TEG is then described by a linear model in the (min,+)-algebra instead of the (max,+)-algebra, see the following example.

Example 55. Consider the TEG of Figure 6.15, by assigning the counter function $\tilde{u}_1(t)$ (resp. $\tilde{u}_2(t)$) to the input transition t_1 (resp. t_2), $\tilde{x}_1(t)$ (resp. $\tilde{x}_2(t)$) to internal transition t_3 (resp. t_4)

and $\tilde{y}(t)$ to the output transition t_5 , the earliest functioning of the TEG can be described by

$$\begin{aligned}\tilde{x}_1(t) &= \min(\tilde{x}_2(t) + 2, \tilde{u}_1(t-1), \tilde{u}_2(t-3) + 1), \\ \tilde{y}(t) &= \tilde{x}_2(t) = \tilde{x}_1(t-2).\end{aligned}\tag{6.13}$$

Then in the $(\min,+)$ -algebra, the system given in (6.13) is expressed as

$$\begin{aligned}\tilde{x}_1(t) &= 2\tilde{x}_2(t) \oplus \tilde{u}_1(t-1) \oplus 1\tilde{u}_2(t-3), \\ \tilde{y}(t) &= \tilde{x}_2(t) = \tilde{x}_1(t-2).\end{aligned}\tag{6.14}$$

Again by considering the time- and event-shift operators, the system can be rephrased in the dioid $(\mathcal{M}_{\text{in}}^{\text{ax}}[\gamma, \delta], \oplus, \otimes)$. Let $\tilde{\mathbf{x}} = [\tilde{x}_1 \ \tilde{x}_2]^T$ and $\tilde{\mathbf{u}} = [\tilde{u}_1 \ \tilde{u}_2]^T$, then the system (6.13) is represented in matrix form $\tilde{\mathbf{x}} = \mathbf{A}\tilde{\mathbf{x}} \oplus \mathbf{B}\tilde{\mathbf{u}}$; $\tilde{y} = \mathbf{C}\tilde{\mathbf{x}}$, where

$$\mathbf{A} = \begin{bmatrix} \varepsilon & \gamma^2 \\ \delta^2 & \varepsilon \end{bmatrix}, \quad \mathbf{B} = \begin{bmatrix} \delta^1 & \gamma^1\delta^3 \\ \varepsilon & \varepsilon \end{bmatrix}, \quad \mathbf{C} = \begin{bmatrix} \varepsilon & e \end{bmatrix}.$$

Note that the $\mathcal{M}_{\text{in}}^{\text{ax}}[\gamma, \delta]$ model of a TEG is the same in the counter and dater representation. Therefore, the transfer function matrix for the counter representation is again,

$$\mathbf{H} = \mathbf{C}\mathbf{A}^*\mathbf{B} = \begin{bmatrix} \delta^3(\gamma^2\delta^2)^* & \gamma^1\delta^5(\gamma^2\delta^2)^* \end{bmatrix}.$$

Output Computation and Impulse Response of Timed Event Graphs

In the following, it is shown how to compute the output of a SISO TEG based on its transfer function $h \in \mathcal{M}_{\text{in}}^{\text{ax}}[\gamma, \delta]$. Note that the following results can be easily extended to MIMO TEGs. As a SISO TEG is a time-invariant and event-invariant system, its transfer function h satisfies $\gamma^1 h = h\gamma^1$ and $\delta^1 h = h\delta^1$. Moreover, similarly to conventional systems theory, the system response $h\mathcal{I}$ to an impulse \mathcal{I} describes the complete transfer behavior of the corresponding SISO TEG [1, 13]. Therefore, the transfer function $h \in \mathcal{M}_{\text{in}}^{\text{ax}}[\gamma, \delta]$ of the system is the series in $\mathcal{M}_{\text{in}}^{\text{ax}}[\gamma, \delta]$ corresponding to the impulse response $h\mathcal{I}$, see Prop. 93. Then the output dater function \tilde{y} induced by an input dater function \tilde{u} is nothing but the $(\max,+)$ -convolution of the impulse response and the input, *i.e.*,

$$\tilde{y}(k) = \bigoplus_{n \in \mathbb{Z}} (h\mathcal{I})(k-n)\tilde{u}(n).$$

By expressing this input and output dater functions as series $y, u \in \mathcal{M}_{\text{in}}^{\text{ax}}[\gamma, \delta]$ the output y induced by the input u is obtained by

$$y = h \otimes u,$$

or equivalent, the output dater function \tilde{y} is obtained by

$$\tilde{y}(k) = ((h \otimes u)\mathcal{I})(k).$$

6.2.3. Dioid Model of Weighted Timed Event Graphs

In the last section, it was shown how the earliest functioning of an ordinary TEG can be modeled linearly in the $(\max,+)$ -algebra as well as in the $(\min,+)$ -algebra. Moreover, the transfer behavior of an ordinary TEG refers to an ultimately cyclic series in $\mathcal{M}_{\text{in}}^{\text{ax}}[[\gamma, \delta]]$. Unfortunately, the weights on the arcs of WTEG lead to event-variant behavior. Therefore, the earliest functioning of a WTEG can in general not be modeled by linear equations in the $(\max,+)$ -algebra nor in the $(\min,+)$ -algebra. However, in [16] it was shown that the input-output behavior of WTEGs is described by series in $\mathcal{E}[[\delta]]$. See Chapter 3 for the definition of the dioid $(\mathcal{E}[[\delta]], \oplus, \otimes)$. In the following the modeling process of consistent WTEGs based on operators in $\mathcal{E}[[\delta]]$ is recalled. Moreover, let us recall the core decomposition of periodic elements in $\mathcal{E}[[\delta]]$, Section 3.3. Based on this decomposition the dynamic behavior of a consistent WTEG can be decomposed into an event-variant and an event-invariant part. This event-invariant part is described by a matrix with entries in $\mathcal{M}_{\text{in}}^{\text{ax}}[[\gamma, \delta]]$. As the event-variant part is invertible, see Prop. 28, the tools for performance evaluation introduced for ordinary TEGs in the dioid $(\mathcal{M}_{\text{in}}^{\text{ax}}[[\gamma, \delta]], \oplus, \otimes)$ can be applied to the more general class of consistent WTEGs.

For the purpose of modeling a consistent WTEG in the dioid $(\mathcal{E}[[\delta]], \oplus, \otimes)$ a counter function $\tilde{x} : \mathbb{Z} \rightarrow \overline{\mathbb{Z}}_{\min}$ is associated with each transition. Recall that an operator in $\mathcal{E}[[\delta]]$ is defined as a mapping from the set of counter functions into itself, Section 3.1. Then for a consistent WTEG operating under the earliest functioning rule, the firing relation between transitions can be described by operators in $\mathcal{E}_{\text{m|b}}[[\delta]]$ (the subset of periodic operators in $\mathcal{E}[[\delta]]$). Consider a basic path $\pi_i : t_{\underline{i}} \rightarrow p_i \rightarrow t_{\bar{i}}$. The influence of transition $t_{\underline{i}}$ on transition $t_{\bar{i}}$ is described by the following operator,

$$\tilde{x}_{\bar{i}} = \beta_{w(p_i, t_{\bar{i}})} \delta^{(\Phi)_i} \gamma^{(\mathcal{M}_0)_i} \mu_{w(t_{\underline{i}}, p_i)} \tilde{x}_{\underline{i}}, \quad (6.15)$$

where $\tilde{x}_{\bar{i}}$ and $\tilde{x}_{\underline{i}}$ refer to the counter functions of transition $t_{\bar{i}}$ and $t_{\underline{i}}$, $w(t_{\underline{i}}, p_i)$ and $w(p_i, t_{\bar{i}})$ are weights of the arcs $(t_{\underline{i}}, p_i)$ and $(p_i, t_{\bar{i}})$, $(\Phi)_i$ is the holding time of place p_i and $(\mathcal{M}_0)_i$ is the initial marking of p_i . As E-operators and the time-shift operator commute,

$$\beta_{w(p_i, t_{\bar{i}})} \delta^{(\Phi)_i} \gamma^{(\mathcal{M}_0)_i} \mu_{w(t_{\underline{i}}, p_i)} = \beta_{w(p_i, t_{\bar{i}})} \gamma^{(\mathcal{M}_0)_i} \mu_{w(t_{\underline{i}}, p_i)} \delta^{(\Phi)_i}.$$

For instance, consider the following basic path, the firing relation between t_1 and t_2 corre-

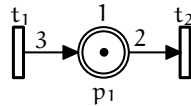

Figure 6.16. – A basic path $\pi_1 : t_1 \rightarrow p_1 \rightarrow t_2$.

sponds to an operator representation $\tilde{x}_2 = \beta_2 \gamma^1 \mu_3 \delta^1 \tilde{x}_1$.

Remark 35. Observe that the gain of the path $\pi_1 : t_1 \rightarrow p_1 \rightarrow t_2$ coincides with the gain of the operator $\beta_2\gamma^1\mu_3\delta^1$, i.e., $\Gamma(\pi_1) = \Gamma(\beta_2\gamma^1\mu_3\delta^1) = 3/2$. This holds for any path in a consistent WTEG [16].

Based on the operator representation of a basic path (6.15), the firing relation between internal, input and output transitions in a consistent WTEG can be described by:

$$\tilde{\mathbf{x}} = \mathbf{A}\tilde{\mathbf{x}} \oplus \mathbf{B}\tilde{\mathbf{u}}, \quad \tilde{\mathbf{y}} = \mathbf{C}\tilde{\mathbf{x}}, \quad (6.16)$$

where $\tilde{\mathbf{x}}$ (resp. $\tilde{\mathbf{u}}, \tilde{\mathbf{y}}$) refers to the vector of counter functions of internal (resp. input, output) transitions and \mathbf{A}, \mathbf{B} and \mathbf{C} are matrices with entries in $\mathcal{E}_{m|b}[[\delta]]$ of appropriate size. Clearly, $\mathbf{A}^*\mathbf{B}$ is the least solution of the implicit equation in (6.16), Theorem 2.1. Therefore the transfer function matrix of a consistent WTEG is obtained by $\mathbf{H} = \mathbf{C}\mathbf{A}^*\mathbf{B}$. Moreover, this matrix is a consistent matrix with entries in $\mathcal{E}_{m|b}[[\delta]]$, see the following propositions.

Proposition 94 ([16]). For a g inputs and p outputs WBTEG, the entries of the transfer matrix $\mathbf{H} = \mathbf{C}\mathbf{A}^*\mathbf{B}$ are ultimately cyclic series in $\mathcal{E}_{m|b}[[\delta]]$.

Proposition 95. Let $(\mathcal{N}, \mathcal{M}_0, \Phi)$ be a consistent WTEG with g input and p output transitions, then its transfer matrix $\mathbf{H} \in \mathcal{E}_{m|b}[[\delta]]^{p \times g}$ is consistent.

Proof. Since consistent WTEGs are a strict subclass of WBTEGs (Prop. 92) the transfer function matrix \mathbf{H} is composed of ultimately cyclic series in $\mathcal{E}_{m|b}[[\delta]]$, see Prop. 94. It remains to show that $\mathbf{H} \in \mathcal{E}_{m|b}[[\delta]]^{p \times g}$ is consistent. Recall, Remark 35 the gain of a path is equivalent to the gain of its operational representation. Moreover, \mathcal{N} admits a T-semiflow ξ , with subvectors $\xi_{t_i} = [\xi_{i_1} \cdots \xi_{i_g}]$ associated with input transitions and $\xi_{t_o} = [\xi_{o_1} \cdots \xi_{o_p}]$ associated with output transitions. Due to Prop. 91, the relation between gain and T-semiflow must hold for all paths in \mathcal{N} . Therefore, the gain matrix $\Gamma(\mathbf{H})$ is of rank 1 and is given by

$$\begin{aligned} \Gamma(\mathbf{H}) &= \begin{bmatrix} \xi_{o_1} & \cdots & \xi_{o_p} \end{bmatrix}^T \begin{bmatrix} \frac{1}{\xi_{i_1}} & \cdots & \frac{1}{\xi_{i_g}} \end{bmatrix}, \\ &= \begin{bmatrix} \frac{\xi_{o_1}}{\xi_{i_1}} & \cdots & \frac{\xi_{i_1}}{\xi_{i_g}} \\ \vdots & & \vdots \\ \frac{\xi_{o_p}}{\xi_{i_g}} & \cdots & \frac{\xi_{o_p}}{\xi_{i_g}} \end{bmatrix}. \end{aligned}$$

□

Example 56. [This example is taken from [16]] Consider the consistent WTEG in Figure 6.3. By assigning the counter function \tilde{u}_1 to the input transition t_1 , the counter function $\tilde{\mathbf{x}} = [\tilde{x}_1 \ \tilde{x}_2]^T$ to the internal transition t_2 and t_3 and the counter function \tilde{y} to the output transition t_4 , the

firing relations are written down as,

$$\begin{aligned}\tilde{\mathbf{x}} &= \begin{bmatrix} \gamma^1 \delta^2 & \epsilon \\ \epsilon & \gamma^2 \delta^1 \end{bmatrix} \tilde{\mathbf{x}} \oplus \begin{bmatrix} \beta_2 \delta^2 \\ \mu_3 \end{bmatrix} \tilde{\mathbf{u}} \\ \tilde{\mathbf{y}} &= \begin{bmatrix} \mu_3 & \beta_2 \gamma^1 \delta^1 \end{bmatrix} \tilde{\mathbf{x}}.\end{aligned}$$

Solving the implicit equation leads to the following transfer function of the system.

$$\begin{aligned}h &= \mu_3 \beta_2 \delta^2 \oplus (\gamma^2 \mu_3 \beta_2 \gamma^1 \oplus \gamma^3 \mu_3 \beta_2) \delta^3 \oplus \gamma^3 \mu_3 \beta_2 \delta^4 \oplus (\gamma^4 \mu_3 \beta_2 \gamma^1 \oplus \gamma^6 \mu_3 \beta_2) \delta^5 \\ &\quad \oplus (\gamma^5 \mu_3 \beta_2 \gamma^1 \oplus \gamma^6 \mu_3 \beta_2) \delta^6 \oplus (\gamma^1 \delta^1)^* ((\gamma^6 \mu_3 \beta_2 \gamma^1 \oplus \gamma^8 \mu_3 \beta_2) \delta^7)\end{aligned}\quad (6.17)$$

This transfer function h describes the firing relation between input transition t_1 and output transition t_4 and has a graphical representation given in Figure 6.18a. For example, in the case where the consistent WTEG is describing a production line, this transfer function describes the relation between incoming raw materials and finished parts. The left asymptotic growth rate of this transfer series is $(\gamma^1 \delta^1)^*$ therefore the maximal throughput of the system is 1 piece per time unit. The gain of the transfer series is $\Gamma(h) = \frac{3}{2}$ and therefore in average 2 input pieces generate 3 output pieces.

Example 57. The core representation of the transfer function (6.17) obtained in Example 56 is given by

$$\begin{aligned}h &= \mathbf{m}_3 \mathbf{Q} \mathbf{b}_2, \\ &= \mathbf{m}_3 \begin{bmatrix} \gamma^2 \delta^7 (\gamma^1 \delta^3)^* & \delta^2 \oplus \gamma^1 \delta^4 \oplus \gamma^2 \delta^6 \oplus \gamma^3 \delta^8 (\gamma^1 \delta^3)^* \\ \gamma^1 \delta^5 (\gamma^1 \delta^3)^* & \epsilon \\ \delta^3 & \gamma^2 \delta^7 (\gamma^1 \delta^3)^* \end{bmatrix} \mathbf{b}_2.\end{aligned}$$

This core representation is realized in the consistent WTEG shown in Figure 6.17. Note that the realization has two basic paths from the input transition t_1 to the first layer of internal transitions (t_2, t_3) . These two paths represent the \mathbf{b}_2 -vector and both paths have gain $1/2$. Furthermore, the realized WTEG has three basic paths between the last layer of internal transitions (t_8, t_9, t_{10}) and the output transition t_{11} . These three paths represent the \mathbf{m}_3 -vector and all three paths have gain 3. Moreover, the core matrix \mathbf{Q} is realized by the internal transitions and all paths between them. Clearly, the entries of the core matrix are elements in $\mathcal{M}_{\text{in}}^{\text{ax}}[\gamma, \delta]$, therefore the internal transitions (t_2, \dots, t_{10}) together with the paths between them constitute an ordinary TEG. Moreover, observe that the event variant behavior of this WTEG is only modeled by the realization of the \mathbf{b}_2 - and \mathbf{m}_3 -vector and that holding times are only attached to places between internal transitions. Subsequently, the internal dynamics are modeled by an ordinary TEG.

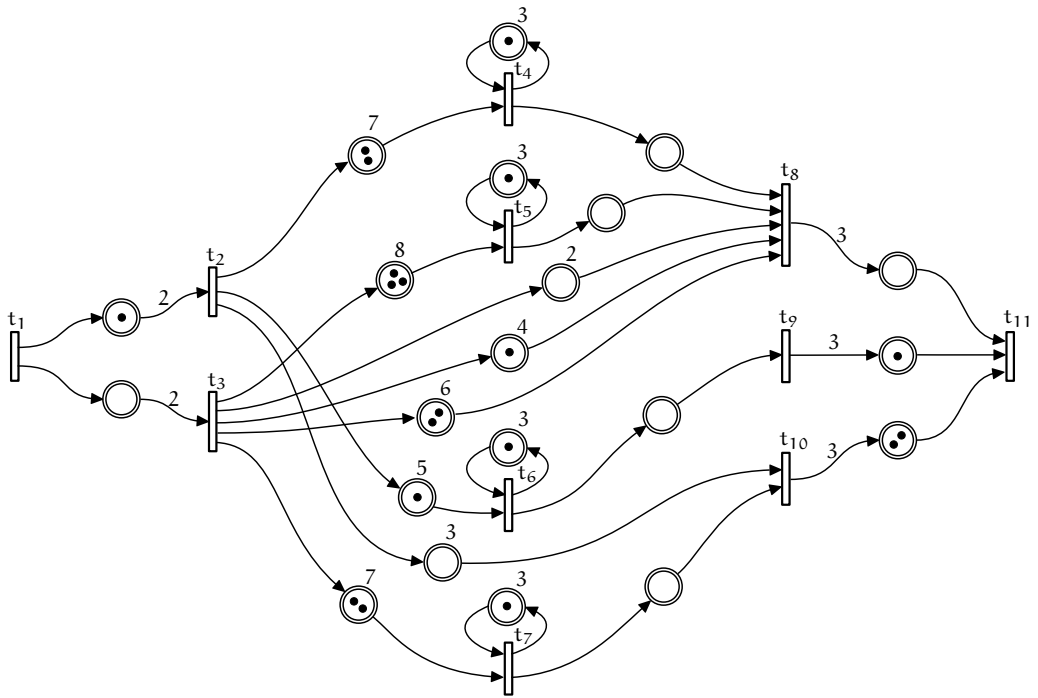

Figure 6.17. – Realization of the core-representation of the transfer function (6.17).

Output Computation and Impulse Response of Consistent Weighted Timed Event Graphs

As shown in Section 6.2.2 the impulse response of an ordinary TEG describes its complete transfer behavior. However, this is not the case for a consistent WTEG, because they are event-variant systems. In general for a consistent WTEG with transfer function $h \in \mathcal{E}_{m|b}[[\delta]]$, $\gamma^1 h \neq h \gamma^1$. In [17] it is shown that the impulse response of a consistent WTEG with a transfer function $h = \bigoplus_i w_i \delta^{t_i} \in \mathcal{E}_{m|b}[[\delta]]$ can be obtained by

$$\bigoplus_i w_i \delta^{t_i} \mathcal{I}(t) = \bigoplus_i \gamma^{\mathcal{F}_{w_i}(0)} \delta^{t_i} \mathcal{I}(t) = \bigoplus_i \mathcal{I}(t - t_i) \otimes \mathcal{F}_{w_i}(0).$$

This impulse response is a sum of time- and event-shifted impulses and gives us partial information about the transfer behavior of the consistent WTEG. Indeed, it can be shown that the complete transfer behavior can be constructed from a finite set of event-shifted impulse responses, for a more exhaustive presentation see [17]. The following remark gives a link between the impulse response of a consistent SISO WTEG and the zero slice mapping, $\Psi_{m|b} : \mathcal{E}_{m|b}[[\delta]] \rightarrow \mathcal{M}_{in}^{\alpha x}[\gamma, \delta]$, introduced in Section 3.2.

Remark 36. *Given a transfer function $h \in \mathcal{E}_{m|b}[[\delta]]$, then $\Psi_{m|b}(h)$ is the series in $\mathcal{M}_{in}^{\alpha x}[\gamma, \delta]$ associated with the impulse response $(h\mathcal{I})$, i.e.,*

$$(h\mathcal{I})(t) = (\Psi_{m|b}(h)\mathcal{I})(t).$$

As consistent WTEGs are event-variant, the output \tilde{y} induced by an arbitrary input \tilde{u} is not simply the $(\min, +)$ -convolution of the impulse response $h\mathcal{I}$ with the input \tilde{u} . To compute the response to an arbitrary input counter function \tilde{u} , this counter function is represented as a sum of time- and event-shifted impulses. The output of the system is then obtained by the sum of these time- and event-shifted impulses responses. Differently stated, let \tilde{u} be a counter function with a corresponding series $u = \bigoplus_i \gamma^{v_i} \delta^{t_i} \in \mathcal{M}_{in}^{\alpha x}[\gamma, \delta]$ and $h \in \mathcal{E}_{m|b}[[\delta]]$ be the transfer function of a consistent WTEG, then

$$\tilde{y}(t) = (h\tilde{u})(t) = \left(h \left(\bigoplus_i \gamma^{v_i} \delta^{t_i} \mathcal{I} \right) \right)(t),$$

as h is lower semi-continuous,

$$\tilde{y}(t) = \left(\bigoplus_i h(\gamma^{v_i} \delta^{t_i} \mathcal{I}) \right)(t).$$

A more convenient way to obtain the output of a consistent WTEG is to represent the input counter function \tilde{u} and the output counter function \tilde{y} as series $u, y \in \mathcal{M}_{in}^{\alpha x}[\gamma, \delta]$.

Proposition 96. *For a consistent SISO WTEG with an (m, b) -periodic transfer function $h \in \mathcal{E}_{m|b}[[\delta]]$ and an input $u \in \mathcal{M}_{in}^{\alpha x}[\gamma, \delta]$, the output $y \in \mathcal{M}_{in}^{\alpha x}[\gamma, \delta]$ is obtained by*

$$y = \Psi_{m|b}(h \otimes \text{Inj}(u)).$$

Proof. First, let us recall the canonical injection from $\mathcal{M}_{\text{in}}^{\text{ax}} \llbracket \gamma, \delta \rrbracket$ into $\mathcal{E} \llbracket \delta \rrbracket$, see Section 3.2, thus we can represent the input $\mathbf{u} \in \mathcal{M}_{\text{in}}^{\text{ax}} \llbracket \gamma, \delta \rrbracket$ as an element in $\mathcal{E}_{\text{m|b}} \llbracket \delta \rrbracket$. Then,

$$\begin{aligned} \tilde{\mathbf{y}}(t) &= (\mathbf{h}\tilde{\mathbf{u}})(t) = (\mathbf{h}(\mathbf{u}\mathcal{I}))(t) = (\mathbf{h}(\text{Inj}(\mathbf{u})\mathcal{I}))(t) \\ &= ((\mathbf{h} \otimes \text{Inj}(\mathbf{u}))\mathcal{I})(t). \end{aligned}$$

Due to Remark 36, this is equivalent to $\mathbf{y} = \Psi_{\text{m|b}}(\mathbf{h} \otimes \text{Inj}(\mathbf{u}))$. \square

Clearly, Prop. 96 can be extended to a consistent MIMO WTEG with a transfer function matrix $\mathbf{H} \in \mathcal{E}_{\text{m|b}} \llbracket \delta \rrbracket^{p \times q}$.

Example 58. The series $\mathbf{y}_{\mathcal{I}} \in \mathcal{M}_{\text{in}}^{\text{ax}} \llbracket \gamma, \delta \rrbracket$ corresponding to the impulse response of the consistent WTEG shown in Figure 6.2b with a transfer function (6.17) is given by

$$\begin{aligned} \mathbf{y}_{\mathcal{I}} &= \Psi_{3|2} \left(\mu_3 \beta_2 \delta^2 \oplus (\gamma^2 \mu_3 \beta_2 \gamma^1 \oplus \gamma^3 \mu_3 \beta_2) \delta^3 \oplus \gamma^3 \mu_3 \beta_2 \delta^4 \oplus \right. \\ &\quad \left. (\gamma^4 \mu_3 \beta_2 \gamma^1 \oplus \gamma^6 \mu_3 \beta_2) \delta^5 \oplus (\gamma^5 \mu_3 \beta_2 \gamma^1 \oplus \gamma^6 \mu_3 \beta_2) \delta^6 \oplus \right. \\ &\quad \left. (\gamma^1 \delta^1)^* ((\gamma^6 \mu_3 \beta_2 \gamma^1 \oplus \gamma^8 \mu_3 \beta_2) \delta^7) \right) \\ &= \delta^2 \oplus \gamma^2 \delta^3 \oplus \gamma^3 \delta^4 \oplus \gamma^4 \delta^5 \oplus \gamma^5 \delta^6 \oplus \gamma^6 \delta^7 (\gamma^1 \delta^1)^* \\ &= \delta^2 \oplus \gamma^2 \delta^3 (\gamma^1 \delta^1)^*. \end{aligned}$$

This series $\mathbf{y}_{\mathcal{I}}$ corresponds to the slice at the (I -count) value 0 in the graphical representation of the transfer function \mathbf{h} , see Figure 6.18b.

Example 59. Consider the input $\mathbf{u} = \delta^1 \oplus \gamma^1 \delta^4 (\gamma^2 \delta^2)^* \in \mathcal{M}_{\text{in}}^{\text{ax}} \llbracket \gamma, \delta \rrbracket$ for a consistent WTEG with a transfer series $\mathbf{h} = (\mu_3 \beta_2 \gamma^1 \oplus \gamma^2 \mu_3 \beta_2) \delta^1 (\gamma^1 \delta^1)^*$. For this input, the response $\mathbf{y} \in \mathcal{M}_{\text{in}}^{\text{ax}} \llbracket \gamma, \delta \rrbracket$ of the WTEG is given by

$$\begin{aligned} \mathbf{y} &= \Psi_{3|2}(\mathbf{h} \otimes \text{Inj}(\mathbf{u})) \\ &= \Psi_{3|2} \left((\mu_3 \beta_2 \gamma^1 \oplus \gamma^2 \mu_3 \beta_2) \delta^1 (\gamma^1 \delta^1)^* \otimes (\delta^1 \oplus \gamma^1 \delta^4 (\gamma^2 \delta^2)^*) \right) \\ &= \Psi_{3|2} \left(((\mu_3 \beta_2 \gamma^1 \oplus \gamma^2 \mu_3 \beta_2) \delta^2 \oplus (\gamma^2 \mu_3 \beta_2 \gamma^1 \oplus \gamma^3 \mu_3 \beta_2) \delta^5) (\gamma^1 \delta^1)^* \right) \\ &= (\delta^2 \oplus \gamma^2 \delta^5) (\gamma^1 \delta^1)^* \\ &= \delta^2 \oplus \gamma^1 \delta^3 \oplus \gamma^2 \delta^5 (\gamma^1 \delta^1)^*. \end{aligned}$$

6.2.4. Dioid Model of Timed Event Graphs under Partial Synchronization

Unlike ordinary TEGs, TEGs under PS are time-variant systems. Therefore, their earliest functioning cannot be modeled as a $(\max, +)$ -linear nor a $(\min, +)$ -linear system. However, the operators introduced in Chapter 4 are suitable to model the input-output behavior of TEGs under periodic PS. More precisely, the time-variant behavior caused by a periodic PS of a

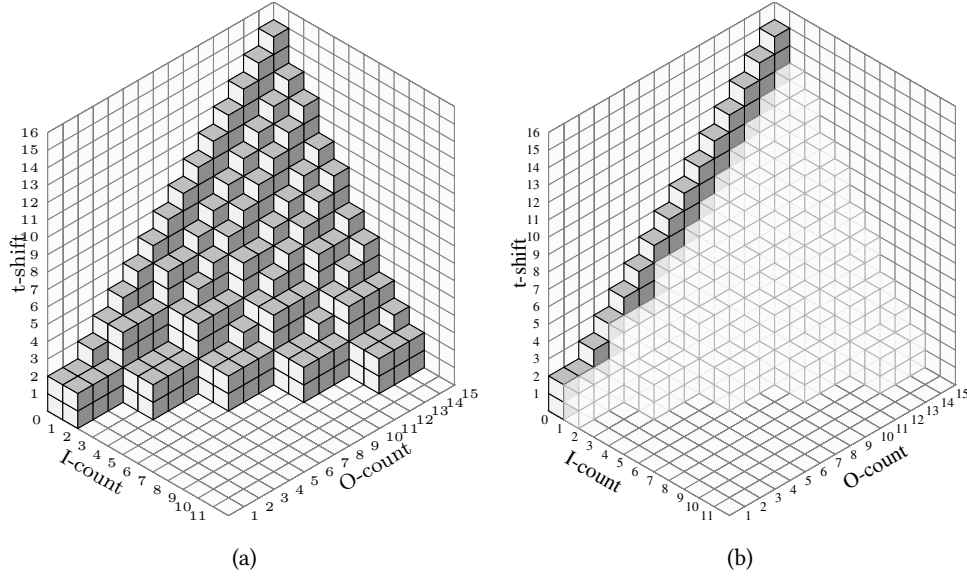

Figure 6.18. – (a) 3D representation of the transfer function (6.17) of the consistent WTEG given in Figure 6.3. (b) the gray slice at (I-count) value 0 in the (O-count/t-shift)-plane corresponds to the impulse response $(h\mathcal{L})(t)$ of the system.

transition can be modeled in the dioid $(\mathcal{T}, \oplus, \otimes)$, see Chapter 4. To show this, recall that a periodic signal \mathcal{S} can be associated with a release-time function $\mathcal{R}_{\mathcal{S}} : \overline{\mathbb{Z}}_{\max} \rightarrow \overline{\mathbb{Z}}_{\max}$, see (6.6). To prove that a periodic PS of a transition (*i.e.* the PS is specified by a periodic signal \mathcal{S}) admits an operator representation in \mathcal{T} , it has to be shown that an operator $\nu \in \mathcal{T}$ exists, such that $\mathcal{R}_{\nu} = \mathcal{R}_{\mathcal{S}}$.

Proposition 97. *A periodic partial synchronization of a transition by signal \mathcal{S} in Definition 63 has an operator representation in \mathcal{T} , given by*

$$\nu = \delta^{n_0} \Delta_{\omega|\omega} \delta^{-n_I} \oplus \delta^{n_1 - \omega} \Delta_{\omega|\omega} \delta^{-n_0} \oplus \dots \oplus \delta^{n_{I-1} - \omega} \Delta_{\omega|\omega} \delta^{-n_{(I-1)}}. \quad (6.18)$$

Proof. Let us recall that a periodic signal \mathcal{S} corresponds to a quasi-periodic function $\mathcal{R}_{\mathcal{S}}$, see (6.6). Moreover, there is an isomorphism between the function \mathcal{R}_{ν} and the T-operator ν . It remains to show that $\mathcal{R}_{\nu} = \mathcal{R}_{\mathcal{S}}$. The function \mathcal{R}_{ν} is given by

$$\begin{aligned} \mathcal{R}_{\nu}(t) = \max & \left(n_0 + \left\lceil \frac{t - n_I}{\omega} \right\rceil \omega, n_1 - \omega + \left\lceil \frac{t - n_0}{\omega} \right\rceil \omega, \dots \right. \\ & \left. \dots, n_{I-1} - \omega + \left\lceil \frac{t - n_{(I-1)}}{\omega} \right\rceil \omega \right). \end{aligned} \quad (6.19)$$

To show equality, \mathcal{R}_{ν} is evaluated for intervals defined in (6.6). *E.g.*, for the interval $(n_I -$

$\omega) + \omega j < t \leq n_0 + \omega j$, observe that

$$\left\lceil \frac{t - n_i}{\omega} \right\rceil = j, \quad i = 0, \dots, I,$$

hence

$$\begin{aligned} \mathcal{R}_v(t) &= \max(n_0 + j\omega, n_1 - \omega + j\omega, \dots, n_I - \omega + j\omega) \\ &= n_0 + j\omega. \end{aligned}$$

Second, for $(n_0 + \omega j) < t \leq n_1 + \omega j$, one has

$$\left\lceil \frac{t - n_i}{\omega} \right\rceil = \begin{cases} j + 1, & \text{for } i = 0 \\ j, & \text{for } i = 1, \dots, I, \end{cases}$$

hence

$$\begin{aligned} \mathcal{R}_v(t) &= \max(n_0 + j\omega, n_1 + j\omega, n_2 - \omega + j\omega, \dots \\ &\quad \dots, n_I - \omega + j\omega) \\ &= n_1 + j\omega. \end{aligned}$$

By going through the remaining intervals defined in (6.6) it is established that,

$$\mathcal{R}_v(t) = \mathcal{R}_S(t), \quad \forall t \in \overline{\mathbb{Z}}_{\max}.$$

□

Example 60. Consider the TEG under periodic PS shown in Figure 6.19, where the signal \mathcal{S}_1 is given in (6.2) in Example 48. The dater function $\bar{x}_1(k)$ (resp. $\bar{x}_2(k)$) is associated with transition t_1 (resp. t_2). According to Prop. 98, the behavior of the periodic PS of transition t_2 is modeled by the following operator:

$$v_{S_1} = \delta^0 \Delta_{4|4} \delta^{-1} \oplus \delta^{-3} \Delta_{4|4} \delta^{-0} = \delta^{-3} \Delta_{4|4} \oplus \Delta_{4|4} \delta^{-1},$$

where the latter equality holds as $\delta^0 = e$. This operator describes the firing relation between t_1 and t_2 , i.e. $\bar{x}_2 = (\delta^{-3} \Delta_{4|4} \oplus \Delta_{4|4} \delta^{-1}) \bar{x}_1$. Therefore, $\bar{x}_2(k) = \max(-3 + \lceil \bar{x}_1(k)/4 \rceil 4, \lceil (\bar{x}_1(k) - 1)/4 \rceil 4)$.

Remark 37. Due to the influence of the PS, this firing relation between t_1 and t_2 is time-variant. Note again that, $\bar{x}_1(k)$ indicates the $(k + 1)^{\text{st}}$ firing of t_1 . Then for instance, if the $(k + 1)^{\text{st}}$ firing of t_1 is at time instant $\bar{x}_1(k) = 1$, then the $(k + 1)^{\text{st}}$ firing of t_2 is at $\bar{x}_2(k) = 1$, i.e., we have no delay. In contrast, if the $(k + 1)^{\text{st}}$ firing of t_1 is at time instant $\bar{x}_1(k) = 2$, then the $(k + 1)^{\text{st}}$ firing of t_2 is at $\bar{x}_2(k) = 4$, and the delay is 2.

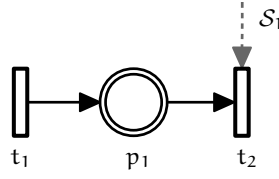
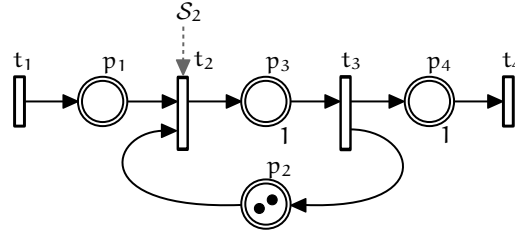

 Figure 6.19. – Simple TEG with a periodic PS of t_2 .

Figure 6.20. – Example of a TEG under periodic PS.

A TEG under periodic PS operating under the earliest functioning rule admits a representation in $\mathcal{T}_{\text{per}}[[\gamma]]$, given by,

$$\bar{\mathbf{x}} = \mathbf{A}\bar{\mathbf{x}} \oplus \mathbf{B}\bar{\mathbf{u}}, \quad \bar{\mathbf{y}} = \mathbf{C}\bar{\mathbf{x}}, \quad (6.20)$$

where $\bar{\mathbf{x}}$ (resp. $\bar{\mathbf{u}}, \bar{\mathbf{y}}$) refers to the vector of dater functions of internal (resp. input, output) transitions. The matrices $\mathbf{A} \in \mathcal{T}_{\text{per}}[[\gamma]]^{n \times n}$, $\mathbf{B} \in \mathcal{T}_{\text{per}}[[\gamma]]^{n \times g}$ and $\mathbf{C} \in \mathcal{T}_{\text{per}}[[\gamma]]^{p \times n}$ describe the influence of transitions on each other, encoded by operators in $\mathcal{T}_{\text{per}}[[\gamma]]$. Let $t_{\underline{i}} \rightarrow p_i \rightarrow t_{\bar{i}}$ constitute a basic path. The influence of transition $t_{\underline{i}}$ on transition $t_{\bar{i}}$ is coded as an operator

$$v_{t_{\bar{i}}} \delta^{(\Phi)_i} \gamma^{(\mathcal{M}_0)_i}$$

where $v_{t_{\bar{i}}}$ is the operator representation of the signal $S_{\bar{i}}$ corresponding to the PS of $t_{\bar{i}}$ (see Example 60), $(\Phi)_i$ is the holding time of place p_i and $(\mathcal{M}_0)_i$ is the initial marking of p_i .

Example 61. Consider the TEGPS in Figure 6.20 with PS of transition t_2 by the signal

$$S_2(t) = \begin{cases} 1 & \text{if } t \in \{1 + 2j \mid j \in \mathbb{Z}\}, \\ 0 & \text{otherwise.} \end{cases}$$

As $\omega = 2$, $I = 0$, $n_0 = 1$ according to Prop. 98 $v_{S_2} = v_{t_2} = \delta^1 \Delta_{2|2} \delta^{-1}$. For the path $t_3 \rightarrow p_2 \rightarrow t_2$, the influence of t_3 on transition t_2 corresponds to an operator representation $v_{t_2} \delta^0 \gamma^2 = v_{t_2} \gamma^2 = \delta^1 \Delta_{2|2} \delta^{-1} \gamma^2$. Moreover, by assigning a dater function $\bar{\mathbf{u}}(k)$ (resp. $\bar{x}_1(k), \bar{x}_2(k), \bar{y}(k)$) to transition t_1 (resp. t_2, t_3, t_4), the earliest functioning of the TEGPS is described by $\bar{\mathbf{x}} = \mathbf{A}\bar{\mathbf{x}} \oplus \mathbf{B}\bar{\mathbf{u}}$; $\bar{\mathbf{y}} = \mathbf{C}\bar{\mathbf{x}}$, where

$$\mathbf{A} = \begin{bmatrix} \varepsilon & \delta^1 \Delta_{2|2} \delta^{-1} \gamma^2 \\ \delta^1 & \varepsilon \end{bmatrix}, \quad \mathbf{B} = \begin{bmatrix} \delta^1 \Delta_{2|2} \delta^{-1} \\ \varepsilon \end{bmatrix}, \quad \mathbf{C} = \begin{bmatrix} \varepsilon & \delta^1 \end{bmatrix}.$$

6.2.5. Dioid Model of Periodic Time-variant Event Graphs

As for TEGs under periodic PS the earliest functioning of PTEGs can be modeled in the dioid $(\mathcal{T}[\llbracket \gamma \rrbracket], \oplus, \otimes)$.

Proposition 98. *A release-time function $\mathcal{R}(t)$, as given in (6.5), can be expressed by a T -operator $\nu \in \mathcal{T}$ in the following form:*

$$\begin{aligned} \nu = & \delta^{n_0} \Delta_{\omega|\omega} \delta^{1-\omega} \oplus \delta^{n_1-\omega} \Delta_{\omega|\omega} \oplus \delta^{n_2-\omega} \Delta_{\omega|\omega} \delta^{-1} \oplus \\ & \dots \oplus \delta^{n_{\omega-1}-\omega} \Delta_{\omega|\omega} \delta^{2-\omega}. \end{aligned} \quad (6.21)$$

Proof. First recall that release-time functions are isotone, therefore in (6.5), $n_{\omega-1} - \omega \leq n_0 \leq n_1 \leq \dots \leq n_{\omega-1} \leq n_0 + \omega$. Moreover, recall that the release-time function $\mathcal{R}_{\delta^\sigma \Delta_{\omega|\omega} \delta^{\sigma'}}(t)$ of an operator $\delta^\sigma \Delta_{\omega|\omega} \delta^{\sigma'}$ is defined by

$$\mathcal{R}_{\delta^\sigma \Delta_{\omega|\omega} \delta^{\sigma'}}(t) = \sigma + \left\lceil \frac{t + \sigma'}{\omega} \right\rceil \omega,$$

where $t = \bar{x}(k)$ is a date. Thus, \mathcal{R}_ν associated with (6.21) is

$$\begin{aligned} \mathcal{R}_\nu(t) = & \max(n_0 + \left\lceil \frac{t - (\omega - 1)}{\omega} \right\rceil \omega, n_1 - \omega + \left\lceil \frac{t}{\omega} \right\rceil \omega, \\ & \dots, n_{\omega-1} - \omega + \left\lceil \frac{t - (\omega - 2)}{\omega} \right\rceil \omega). \end{aligned} \quad (6.22)$$

We can evaluate the expression (6.22) for all dates t . If we choose $t = j\omega$, $\forall j \in \mathbb{Z}_{\max}$, we can show that:

$$\begin{aligned} \mathcal{R}_\nu(j\omega) = & \max(n_0 + \left\lceil \frac{j\omega - (\omega - 1)}{\omega} \right\rceil \omega, n_1 - \omega + \left\lceil \frac{j\omega}{\omega} \right\rceil \omega, \\ & \dots, n_{\omega-1} - \omega + \left\lceil \frac{j\omega - (\omega - 2)}{\omega} \right\rceil \omega) \\ = & \max(n_0 + j\omega, n_1 - \omega + j\omega, \dots, n_{\omega-1} - \omega + j\omega) \\ = & n_0 + j\omega. \end{aligned}$$

Similarly, we can show, that $\forall i = \{1, \dots, (\omega - 1)\}$,

$$\begin{aligned} \mathcal{R}_\nu(i + j\omega) = & \max\left(n_0 + \left\lceil \frac{i + j\omega - (\omega - 1)}{\omega} \right\rceil \omega, n_1 - \omega + \left\lceil \frac{i + j\omega}{\omega} \right\rceil \omega, \right. \\ & \left. \dots, n_{\omega-1} - \omega + \left\lceil \frac{i + j\omega - (\omega - 2)}{\omega} \right\rceil \omega\right) \\ = & n_i + j\omega. \end{aligned}$$

Hence we have shown that,

$$\mathcal{R}_v(t) = \begin{cases} n_0 + \omega j & \text{if } t = 0 + \omega j, \\ n_1 + \omega j & \text{if } t = 1 + \omega j, \\ \vdots & \\ n_{\omega-1} + \omega j & \text{if } t = (\omega - 1) + \omega j. \end{cases}$$

□

Corollary 15. *Since $\mathcal{H}(t) = \mathcal{R}(t) - t$, the T-operator associated with a holding-time function $\langle \bar{n}_0 \bar{n}_1 \cdots \bar{n}_{\omega-1} \rangle$ can be obtained by*

$$p = \delta^{\bar{n}_0} \Delta_{\omega|\omega} \delta^{1-\omega} \oplus \bigoplus_{i=1}^{\omega-1} \delta^{\bar{n}_i + (i-\omega)} \Delta_{\omega|\omega} \delta^{1-i}.$$

Note that the operator representation of a causal release-time function \mathcal{R} , i.e. $\mathcal{R}(t) \geq t$, leads to a periodic and causal T-operator.

Example 62. *Consider $\mathcal{H}_1(t) = \langle 0021 \rangle$ given in Example 51. This holding-time function corresponds to an operator given by*

$$\begin{aligned} v &= \delta^0 \Delta_{4|4} \delta^{-3} \oplus \delta^{-3} \Delta_{4|4} \delta^0 \oplus \delta^0 \Delta_{4|4} \delta^{-1} \oplus \delta^0 \Delta_{4|4} \delta^{-2}, \\ &= \delta^{-3} \Delta_{4|4} \delta^0 \oplus \delta^0 \Delta_{4|4} \delta^{-1} \oplus \delta^0 \Delta_{4|4} \delta^{-2} \oplus \delta^0 \Delta_{4|4} \delta^{-3}, \\ &= \delta^{-3} \Delta_{4|4} \oplus \Delta_{4|4} (\delta^{-1} \oplus \delta^{-2} \oplus \delta^{-3}) = \delta^{-3} \Delta_{4|4} \oplus \Delta_{4|4} \delta^{-1}, \end{aligned}$$

because of (4.10): $\delta^{-1} \oplus \delta^{-2} \oplus \delta^{-3} = \delta^{-1}$. Respectively, $\mathcal{H}_3(t) = \langle 1321 \rangle$ corresponds to the operator $\Delta_{4|4} \oplus \delta^1 \Delta_{4|4} \delta^{-3}$.

We can use T-operators and the event shift operator γ to describe the transfer behavior of PTEGs. The firing-relation between the two transitions $t_{\bar{i}}$, $t_{\underline{i}}$ in Figure 6.21 is represented

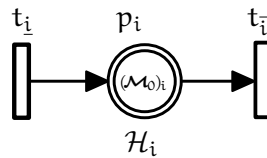

Figure 6.21. – Simple PTEG with holding-time function.

by $\bar{x}_{\bar{i}} = v_i \gamma^{(\mathcal{M}_0)_i} \bar{x}_{\underline{i}}$, where $(\mathcal{M}_0)_i$ is the initial marking in place p_i , v_i is the T-operator associated with the holding-time function \mathcal{H}_i of place p_i and $\bar{x}_{\bar{i}}$, $\bar{x}_{\underline{i}}$ are the dater functions

associated with $t_{\bar{i}}$, t_i . Thus, the relation between input, output and internal transitions of a general PTEG can be modeled by

$$\bar{x} = \mathbf{A}\bar{x} \oplus \mathbf{B}\bar{u}, \quad \bar{y} = \mathbf{C}\bar{x},$$

where \bar{x} (resp. \bar{u} , \bar{y}) refers to a vector of dater functions of the n internal (resp. m input, p output) transitions of the PTEG. The relations between internal transitions can be modeled by a system matrix $\mathbf{A} \in \mathcal{T}_{\text{per}}[[\gamma]]^{n \times n}$, the relation between input and internal transitions by an input matrix $\mathbf{B} \in \mathcal{T}_{\text{per}}[[\gamma]]^{n \times m}$, and the relation between internal and output transitions by an output matrix $\mathbf{C} \in \mathcal{T}_{\text{per}}[[\gamma]]^{p \times n}$.

Example 63. Consider the PTEG in Figure 6.8 of Example 51. The firing relation between its transitions can be modeled by

$$\begin{aligned} x &= \left[(\Delta_{4|4} \oplus \delta^1 \Delta_{4|4} \delta^{-3}) \gamma^2 \right] x \oplus \left[\delta^{-3} \Delta_{4|4} \oplus \Delta_{4|4} \delta^{-1} \right] u, \\ y &= \left[\delta^1 \right] x, \end{aligned}$$

where $\Delta_{4|4} \oplus \delta^1 \Delta_{4|4} \delta^{-3}$ and $\delta^{-3} \Delta_{4|4} \oplus \Delta_{4|4} \delta^{-1}$ are the T-operators corresponding to $\mathcal{H}_3 = \langle 1321 \rangle$ and $\mathcal{H}_1 = \langle 0021 \rangle$, see Example 62.

Transfer Functions Matrices for TEGs under periodic PS and PTEGs

Theorem 6.1 (Transfer function matrix of PTEG). *The input-output behavior of a g -input and p -output PTEG can be described by a transfer function matrix $\mathbf{H} \in \mathcal{T}_{\text{per}}[[\gamma]]^{p \times g}$ of ultimately cyclic series in $\mathcal{T}_{\text{per}}[[\gamma]]$. This transfer function matrix is obtained by $\mathbf{H} = \mathbf{C}\mathbf{A}^*\mathbf{B}$.*

Proof. The holding-time functions in PTEGs correspond to causal periodic T-operators, see Prop. 98. As every monomial/polynomial in $\mathcal{T}_{\text{per}}[[\gamma]]$ is a specific ultimately cyclic series, the entries of the \mathbf{A} , \mathbf{B} and \mathbf{C} matrices are ultimately cyclic series in $\mathcal{T}_{\text{per}}[[\gamma]]$. The sum (resp. product, Kleene star) of ultimately cyclic series in $\mathcal{T}_{\text{per}}[[\gamma]]$ are again ultimately cyclic series in $\mathcal{T}_{\text{per}}[[\gamma]]$, see Prop. 65 (resp. Prop. 66, Prop. 67). Thus, the transfer matrix $\mathbf{C}\mathbf{A}^*\mathbf{B}$ is also composed of ultimately cyclic series in $\mathcal{T}_{\text{per}}[[\gamma]]$. \square

Corollary 16. *For a g -input p -output TEG under periodic PS, see Definition 63, the transfer function matrix is given by $\mathbf{H} = \mathbf{C}\mathbf{A}^*\mathbf{B} \in \mathcal{T}_{\text{per}}[[\gamma]]^{p \times g}$. Moreover, the entries of the transfer function matrix \mathbf{H} are ultimately cyclic series in $\mathcal{T}_{\text{per}}[[\gamma]]$.*

Example 64. Let us recall the TEG under periodic PS given in Example 61, the transfer function for this system is obtained by

$$\begin{aligned} h &= \mathbf{C}\mathbf{A}^*\mathbf{B} = \begin{bmatrix} \varepsilon & \delta^1 \end{bmatrix} \begin{bmatrix} \varepsilon & \delta^1 \Delta_{2|2} \delta^{-1} \gamma^2 \\ \delta^1 & \varepsilon \end{bmatrix}^* \begin{bmatrix} \delta^1 \Delta_{2|2} \delta^{-1} \\ \varepsilon \end{bmatrix} \\ &= \delta^1 (\mathbf{A}^*)_{2,1} \delta^1 \Delta_{2|2} \delta^{-1}, \end{aligned}$$

where $(\mathbf{A}^*)_{2,1} = (\delta^2 \Delta_{2|2} \delta^{-1} \gamma^2)^* \delta^1$, see (2.11). To express \mathfrak{h} as an ultimately cyclic series we rewrite $(\mathbf{A}^*)_{2,1}$ in the core-form and compute the Kleene star based on the core matrix $\hat{\mathbf{Q}} \in \mathcal{M}_{\text{in}}^{\alpha \times} \llbracket \gamma, \delta \rrbracket$ with the toolbox MinmaxGD [32]. Recall Prop. 33, therefore

$$\begin{aligned} (\mathbf{A}^*)_{2,1} &= (\mathbf{d}_2 \begin{bmatrix} \gamma^2 \delta^1 & \varepsilon \\ \varepsilon & \varepsilon \end{bmatrix} \mathbf{p}_2)^* \delta^1 = \mathbf{d}_2 (\mathbf{N} \begin{bmatrix} \gamma^2 \delta^1 & \varepsilon \\ \varepsilon & \varepsilon \end{bmatrix} \mathbf{N})^* \mathbf{p}_2 \delta^1 \\ &= \mathbf{d}_2 \begin{bmatrix} (\gamma^2 \delta^1)^* & \gamma^2 (\gamma^2 \delta^1)^* \\ \gamma^2 \delta^1 (\gamma^2 \delta^1)^* & \varepsilon \oplus \gamma^4 \delta^1 (\gamma^2 \delta^1)^* \end{bmatrix} \mathbf{p}_2 \delta^1. \end{aligned}$$

Then, after multiplication,

$$\mathfrak{h} = \delta^3 (\gamma^2 \delta^2)^* \Delta_{2|2} \delta^{-1}.$$

Example 65. Consider the PTEG in Figure 6.8 of Example 51. We can describe the firing relation between input transition t_1 and output transition t_3 by a transfer function in $\mathcal{T}_{\text{per}} \llbracket \gamma \rrbracket$, i.e. $\bar{y} = \mathfrak{h} \bar{u}$, where

$$\begin{aligned} \mathfrak{h} &= \delta^1 [(\delta^1 \Delta_{4|4} \delta^{-3} \oplus \Delta_{4|4}) \gamma^2]^* (\delta^{-3} \Delta_{4|4} \oplus \Delta_{4|4} \delta^{-1}) \\ &= (\gamma^4 \delta^4)^* \left((\delta^1 \Delta_{4|4} \delta^{-1} \oplus \delta^{-2} \Delta_{4|4}) \oplus (\delta^1 \Delta_{4|4} \oplus \delta^2 \Delta_{4|4} \delta^{-1}) \gamma^2 \right). \end{aligned}$$

Impulse Responses of TEGs under periodic PS and PTEGs

As shown in Section 6.2.2, the impulse response of a TEG system provides complete knowledge of the input-output behavior [1]. In contrast, the impulse response of a PTEG (resp. TEGPS) is not sufficient to describe its complete behavior, because it is a time-variant system. The moment when the impulse is applied matters. One single impulse gives only partial information. In order to obtain the complete knowledge, we need the system responses of ω consecutive time-shifted impulses, i.e. $\delta^\tau \mathcal{I}$, $\tau \in \{0, \dots, \omega - 1\}$. Each single response corresponds then to one slice in the 3D representation of the transfer function. The impulse response for a SISO PTEG (resp. TEGPS) with a transfer function $\mathfrak{h} = \bigoplus_i v_i \gamma^{n_i} \in \mathcal{T}_{\text{per}} \llbracket \gamma \rrbracket$ is obtained by

$$(\mathfrak{h} \mathcal{I})(\mathbf{k}) = \left(\bigoplus_i v_i \gamma^{n_i} \mathcal{I} \right)(\mathbf{k}) = \left(\bigoplus_i \delta^{\mathcal{R}_{v_i}(0)} \gamma^{n_i} \mathcal{I} \right)(\mathbf{k}) = \bigoplus_i (\mathcal{I}(\mathbf{k} - n_i) \otimes \mathcal{R}_{v_i}(0)).$$

Note that the impulse response is a sum of time- and event-shifted impulses. Moreover, recall the zero slice mapping $\Psi_\omega : \mathcal{T}_{\text{per}} \llbracket \gamma \rrbracket \rightarrow \mathcal{M}_{\text{in}}^{\alpha \times} \llbracket \gamma, \delta \rrbracket$, Section 4.4, therefore the series $\Psi_\omega(\mathfrak{h}) \in \mathcal{M}_{\text{in}}^{\alpha \times} \llbracket \gamma, \delta \rrbracket$ corresponds to the impulse response $(\mathfrak{h} \mathcal{I})(\mathbf{k})$ of the system.

Example 66 (Transfer function and impulse response). Consider the PTEG in Figure 6.8 of Example 51 with a transfer function obtained in Example 65.

$$\begin{aligned} h &= (\gamma^4 \delta^4)^* \left(\delta^1 \Delta_{4|4} \delta^{-1} \oplus \delta^{-2} \Delta_{4|4} \oplus (\delta^1 \Delta_{4|4} \oplus \delta^2 \Delta_{4|4} \delta^{-1}) \gamma^2 \right) \\ &= \left(\delta^1 \Delta_{4|4} \delta^{-1} \oplus \delta^{-2} \Delta_{4|4} \right) \gamma^0 \oplus \left(\delta^1 \Delta_{4|4} \oplus \delta^2 \Delta_{4|4} \delta^{-1} \right) \gamma^2 \oplus \\ &\quad \left(\delta^5 \Delta_{4|4} \delta^{-1} \oplus \delta^2 \Delta_{4|4} \right) \gamma^4 \oplus \left(\delta^5 \Delta_{4|4} \oplus \delta^6 \Delta_{4|4} \delta^{-1} \right) \gamma^6 \oplus \dots \end{aligned}$$

This transfer function has a graphical representation, see Figure 6.22a. The response of an im-

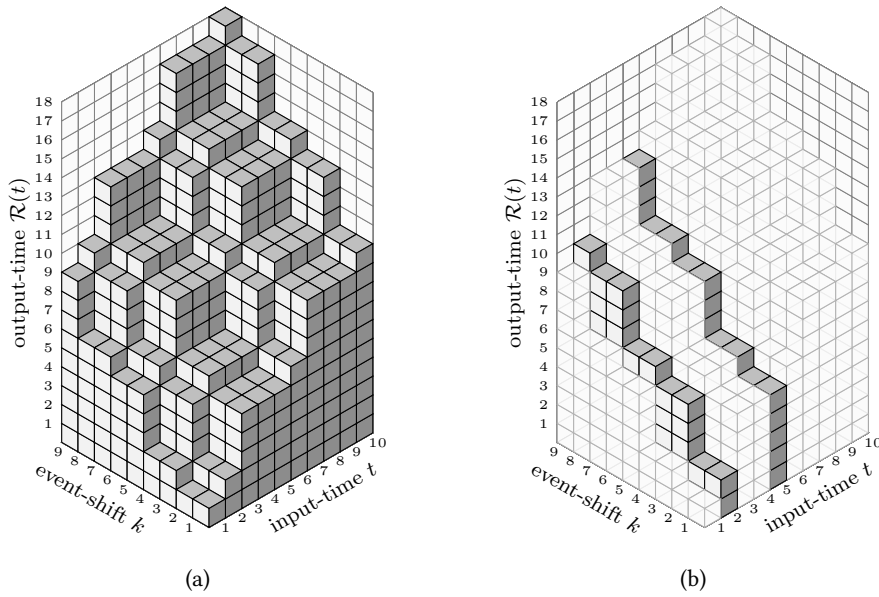

Figure 6.22. – (a) transfer function h of Example 65. (b) the gray slice at input time 1 (resp. time 5) (event-shift/output-time)-plane correspond to the response to an impulse at time 1: $\delta^1 \mathcal{I}$ (resp. time 5: $\delta^5 \mathcal{I}$) of the system.

pulse at time 1, i.e. $h \delta^1 \mathcal{I}$, is $(\delta^2 \oplus \delta^5 \gamma^2)(\gamma^4 \delta^4)^* \mathcal{I}$. This response corresponds to the slice at input-time 1 (event-shift/output-time)-plane in Figure 6.22b. Furthermore, the system response to an impulse at time 5 is $(\delta^5 \oplus \delta^6 \gamma^2)(\gamma^4 \delta^4)^* \mathcal{I}$. Therefore, the 3D representation of a transfer function in $h \in \mathcal{T}_{\text{per}}[\llbracket \gamma \rrbracket]$ is interpreted as the juxtaposition of its time-shifted impulse responses.

Output computation

Again, as PTEGs (resp. TEGs under PS) are time-variant systems, the output to an arbitrary input dater function cannot simply be obtained by the (max,+)-convolution of the impulse response and the input. To compute the output of a PTEG (resp. TEG under periodic PS) caused by input dater function \bar{u} , this input dater function \bar{u} is expressed as a series $u \in$

$\mathcal{M}_{\text{in}}^{\text{ax}}[\gamma, \delta]$. Since, $(\mathcal{M}_{\text{in}}^{\text{ax}}[\gamma, \delta], \oplus, \otimes)$ is a subdioid of $(\mathcal{T}_{\text{per}}[\gamma], \oplus, \otimes)$ and by using the canonical injection Inj , the input can be represented as a series $\text{Inj}(\mathbf{u}) \in \mathcal{T}_{\text{per}}[\gamma]$. The output $\mathbf{y} \in \mathcal{M}_{\text{in}}^{\text{ax}}[\gamma, \delta]$ of the system is then computed as follows

$$\mathbf{y} = \Psi_{\omega}(\mathbf{h} \otimes \text{Inj}(\mathbf{u})). \quad (6.23)$$

Example 67. Recall the transfer function $\mathbf{h} = \delta^3(\gamma^2\delta^2)^*\Delta_{2|2}\delta^{-1}$ of the TEGPS shown in Figure 6.20. Moreover, consider the input dater function,

$$\bar{\mathbf{u}}(k) = \begin{cases} -\infty & \text{for } k < 0; \\ 0 & \text{for } k = 0; \\ 2 & \text{for } k = 1, 2; \\ 3 & \text{for } k = 3, 4, 5, 6; \\ \infty & \text{for } k \geq 7. \end{cases}$$

The series $\mathbf{u} \in \mathcal{M}_{\text{in}}^{\text{ax}}[\gamma, \delta]$ to this dater function is $\mathbf{u} = \gamma^0\delta^0 \oplus \gamma^1\delta^2 \oplus \gamma^3\delta^3 \oplus \gamma^7\delta^*$. The output $\mathbf{y} \in \mathcal{M}_{\text{in}}^{\text{ax}}[\gamma, \delta]$ of the system is then

$$\begin{aligned} \mathbf{y} &= \Psi_{\omega}(\mathbf{h} \otimes \text{Inj}(\mathbf{u})) \\ &= \Psi_{\omega}(\delta^3(\gamma^2\delta^2)^*\Delta_{2|2}\delta^{-1} \otimes (\gamma^0\delta^0 \oplus \gamma^1\delta^2 \oplus \gamma^3\delta^3 \oplus \gamma^7\delta^*)) \\ &= \Psi_{\omega}(\delta^3\Delta_{2|2}\delta^{-1}(\gamma^2\delta^2)^* \otimes (\gamma^0\delta^0 \oplus \gamma^1\delta^2 \oplus \gamma^3\delta^3 \oplus \gamma^7\delta^*)) \\ &= \Psi_{\omega}((\delta^3\Delta_{2|2}\delta^{-1} \oplus \delta^5\Delta_{2|2}\delta^{-1}\gamma^1 \oplus \delta^6\Delta_{2|2}\delta^{-1}\gamma^3)(\gamma^2\delta^2)^* \\ &\quad \oplus \delta^3\Delta_{2|2}\delta^{-1}\gamma^7(\gamma^2\delta^2)^*\delta^*) \\ &= \Psi_{\omega}((\delta^3\Delta_{2|2}\delta^{-1} \oplus \delta^5\Delta_{2|2}\delta^{-1}\gamma^1 \oplus \delta^6\Delta_{2|2}\delta^{-1}\gamma^3)(\gamma^2\delta^2)^* \oplus \delta^3\Delta_{2|2}\delta^{-1}\gamma^7\delta^*) \\ &= (\delta^3 \oplus \delta^5\gamma^1 \oplus \delta^6\gamma^3)(\gamma^2\delta^2)^* \oplus \delta^3\gamma^7\delta^* \\ &= (\delta^3 \oplus \delta^5\gamma^1)(\gamma^2\delta^2)^* \oplus \delta^3\delta^*\gamma^7 \\ &= (\delta^3 \oplus \delta^5\gamma^1 \oplus \delta^7\gamma^3 \oplus \delta^9\gamma^5 \oplus \delta^{11}\gamma^7 \oplus \dots) \oplus \delta^3\delta^*\gamma^7 \\ &= \delta^3 \oplus \delta^5\gamma^1 \oplus \delta^7\gamma^3 \oplus \delta^9\gamma^5 \oplus \delta^*\gamma^7. \end{aligned}$$

Moreover, \bar{y} is the series in $\mathcal{M}_{\text{in}}^{\text{ax}}[\gamma, \delta]$ associated with the dater function,

$$\bar{y}(k) = \begin{cases} -\infty & \text{for } k < 0; \\ 3 & \text{for } k = 0; \\ 5 & \text{for } k = 1, 2; \\ 7 & \text{for } k = 3, 4; \\ 9 & \text{for } k = 5, 6; \\ \infty & \text{for } k \geq 7. \end{cases}$$

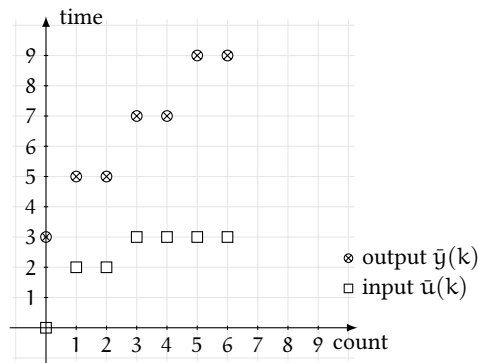

Figure 6.23. – System response \bar{y} to the input \bar{u} .

6.2.6. Dioid Model of Weighted Timed Event Graphs under periodic Partial Synchronization

In analogy to the modeling process of consistent WTEGs in the dioid $(\mathcal{E}[\delta], \oplus, \otimes)$ and Timed Event Graphs under Partial Synchronization (TEGsPS) in the dioid $(\mathcal{T}_{\text{per}}[\gamma], \oplus, \otimes)$, the earliest functioning of consistent WTEGs under periodic PS can be modeled in the dioid $(\mathcal{ET}, \oplus, \otimes)$. For this, a counter function is associated with each transition. Then the influence of transitions on each other are coded as operators in \mathcal{ET} , see Chapter 5 for the definition of the dioid $(\mathcal{ET}, \oplus, \otimes)$.

PS and Counters

Section 6.2.4 describes how the time-variant behavior of a periodic PS is expressed in the "event-domain" based on dater functions. In the following, a periodic PS is expressed in the "time-domain" based on counter functions. For this the $\Delta_{\omega|\omega}$ is redefined as a mapping from the set Σ into itself, see (5.2). Moreover, recall that Σ is the set of antitone mappings

from \mathbb{Z} into $\overline{\mathbb{Z}}_{\min}$. This redefinition of the $\Delta_{\omega|\omega}$ operator allows to model the event- and time-variant behavior of consistent WTEGs under periodic PS in the dioid $(\mathcal{ET}, \oplus, \otimes)$.

Example 68. Consider the simple TEGPS, shown in Figure 6.24, with a periodic PS of transition t_2 by,

$$S_2 = \begin{cases} 1 & \text{if } t \in \{0 + 3j\}, \\ 0 & \text{otherwise.} \end{cases} \quad (6.24)$$

Moreover, \tilde{x}_1 and \tilde{x}_2 are counter functions associated to the transitions t_1 and t_2 . Table 6.1

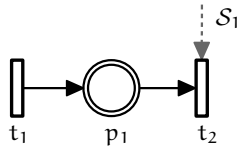

Figure 6.24. – Simple TEGPS with a periodic PS of t_2 .

gives the response \tilde{x}_2 induced by the counter function \tilde{x}_1 under the assumption that the TEGPS is operating under the earliest functioning rule. Recall that the value $\tilde{x}(t)$ of a counter function

t	$\tilde{x}_1(t)$	$\tilde{x}_2(t)$
-1	0	0
0	0	0
1	0	0
2	1	0
3	1	0
4	2	2
5	2	2
6	2	2
7	3	3
8	3	3
\vdots	\vdots	\vdots

Table 6.1. – Response \tilde{x}_2 induced by the counter function \tilde{x}_1 .

gives the accumulated number of firings strictly before time t . Therefore, the counter function \tilde{x}_1 is interpreted as, no firing of transition t_1 before time $t = 1$. Exactly one firing at time $t = 1$ and one additional firing at time $t = 3$ (resp. time $t = 6$). The counter function \tilde{x}_2 is interpreted as, no firing of transition t_2 before time $t = 3$. Two firings at time $t = 3$ and one additional

firing at time $t = 6$. Observe that, a firing of a transition at time t is represented in the counterfunction at time $t + 1$. Or differently, $\tilde{x}(t - 1)$ gives the accumulated number of firings up to (including) time t . Hence, the firing relation between transition t_1 and t_2 is described by,

$$\tilde{x}_2(t) = \tilde{x}_1\left(\left\lfloor \frac{t-1}{3} \right\rfloor \times 3 + 1\right).$$

To describe the time-variant behavior of a PS caused by an arbitrary periodic signal \mathcal{S} , a function $\mathcal{K}_{\mathcal{S}}(t) : \mathbb{Z} \rightarrow \mathbb{Z}$ is associated to this periodic signal \mathcal{S} . This function is defined by, $\forall j \in \mathbb{Z}$,

$$\mathcal{K}_{\mathcal{S}}(t) = \begin{cases} n_0 + \omega j & \text{if } n_0 + \omega j < t \leq n_1 + \omega j, \\ n_1 + \omega j & \text{if } n_1 + \omega j < t \leq n_2 + \omega j, \\ \vdots & \\ n_I + \omega j & \text{if } n_I + \omega j < t \leq (n_o + \omega) + \omega j. \end{cases} \quad (6.25)$$

Again, if the signal \mathcal{S} is ω -periodic then the corresponding function $\mathcal{K}_{\mathcal{S}}(t)$ satisfies $\forall t \in \mathbb{Z}$, $\mathcal{K}_{\mathcal{S}}(t + \omega) = \omega + \mathcal{K}_{\mathcal{S}}(t)$. The value of $\mathcal{K}_{\mathcal{S}}(t)$ can be interpreted as the last time when the signal \mathcal{S} enabled the firing of the corresponding transition. Then the firing relation between t_1 and t_2 is described by

$$\tilde{x}_2(t) = \tilde{x}_1(\mathcal{K}_{\mathcal{S}_2}(t) + 1), \quad (6.26)$$

where $\mathcal{K}_{\mathcal{S}_2}$ is associated to the signal \mathcal{S}_2 .

Example 69. Recall Example 68 with the signal \mathcal{S}_2 given in (6.24). The function $\mathcal{K}_{\mathcal{S}_2}(t)$ associated with \mathcal{S}_2 is then, since $\omega = 3$ and $n_1 = 0$,

$$\begin{aligned} \mathcal{K}_{\mathcal{S}_2}(t) &= 3j, & \text{if } 3j < t \leq 3 + 3j, \\ &= \left\lfloor \frac{t-1}{3} \right\rfloor \times 3. \end{aligned}$$

Therefore, $\tilde{x}_2(t) = \tilde{x}_1(\lfloor (t-1)/3 \rfloor \times 3 + 1)$.

To prove that a periodic PS of a transition admits an operator representation in the dioid $(\mathcal{ET}, \oplus, \otimes)$ we must show that an operator $\nu \in \mathcal{ET}$ exists such that, $\nu \tilde{x}_1(t) = \tilde{x}_1(\mathcal{K}_{\mathcal{S}_2}(t) + 1)$. For this recall the definition of the $\Delta_{\omega|\omega}$ operator and the δ^τ operator in \mathcal{ET} , see Prop. 73,

$$\begin{aligned} \omega, \varpi \in \mathbb{N} \quad \Delta_{\omega|\varpi} : \forall \tilde{x} \in \Sigma, t \in \mathbb{Z} \quad (\Delta_{\omega|\varpi}(\tilde{x}))(t) &= \tilde{x}\left(\varpi \times \left\lfloor \frac{t-1}{\omega} \right\rfloor + 1\right), \\ \tau \in \mathbb{Z} \quad \delta^\tau : \forall \tilde{x} \in \Sigma, t \in \mathbb{Z} \quad (\delta^\tau(\tilde{x}))(t) &= \tilde{x}(t - \tau). \end{aligned}$$

We have to show that the behavior of a periodic PS can be expressed by sum and composition of the δ^τ and $\Delta_{\omega|\omega}$ operators.

Proposition 99. *A periodic partial synchronization of a transition by signal \mathcal{S} , see Definition 63, has an operator representation in \mathcal{ET} , given by*

$$v_{\mathcal{S}} = \delta^{n_0} \Delta_{\omega|\omega} \delta^{-n_I} \oplus \delta^{n_1 - \omega} \Delta_{\omega|\omega} \delta^{-n_0} \oplus \dots \oplus \delta^{n_I - \omega} \Delta_{\omega|\omega} \delta^{-n_{(I-1)}}. \quad (6.27)$$

Proof. This proof is similar to the proof of Prop. 97. There a periodic PS is modeled by an operator in \mathcal{T} .

$$(v_{\mathcal{S}} \tilde{x})(t) = ((\delta^{n_0} \Delta_{\omega|\omega} \delta^{-n_I} \oplus \delta^{n_1 - \omega} \Delta_{\omega|\omega} \delta^{-n_0} \oplus \dots \oplus \delta^{n_I - \omega} \Delta_{\omega|\omega} \delta^{-n_{(I-1)}}) \tilde{x})(t)$$

Because of (3.4) and (3.1),

$$\begin{aligned} (v_{\mathcal{S}} \tilde{x})(t) &= (\delta^{n_0} \Delta_{\omega|\omega} \delta^{-n_I} \tilde{x})(t) \oplus (\delta^{n_1 - \omega} \Delta_{\omega|\omega} \delta^{-n_0} \tilde{x})(t) \oplus \dots \\ &\quad \dots \oplus (\delta^{n_I - \omega} \Delta_{\omega|\omega} \delta^{-n_{(I-1)}} \tilde{x})(t), \\ &= \min \left((\delta^{n_0} \Delta_{\omega|\omega} \delta^{-n_I} \tilde{x})(t), (\delta^{n_1 - \omega} \Delta_{\omega|\omega} \delta^{-n_0} \tilde{x})(t), \dots \right. \\ &\quad \left. \dots, (\delta^{n_I - \omega} \Delta_{\omega|\omega} \delta^{-n_{(I-1)}} \tilde{x})(t) \right). \end{aligned}$$

Recall (5.2) and (5.4), therefore

$$\begin{aligned} (v_{\mathcal{S}} \tilde{x})(t) &= \min \left(\tilde{x} \left(\omega \left\lfloor \frac{t - n_0 - 1}{\omega} \right\rfloor + n_I + 1 \right), \tilde{x} \left(\omega \left\lfloor \frac{t - n_1 + \omega - 1}{\omega} \right\rfloor + n_0 + 1 \right), \right. \\ &\quad \left. \dots, \tilde{x} \left(\omega \left\lfloor \frac{t - n_{I-1} + \omega - 1}{\omega} \right\rfloor + n_{I-1} + 1 \right) \right) \\ &= \tilde{x} \left(\min \left(\omega \left\lfloor \frac{t - n_0 - 1}{\omega} \right\rfloor + n_I + 1, \omega \left\lfloor \frac{t - n_1 + \omega - 1}{\omega} \right\rfloor + n_0 + 1, \dots \right. \right. \\ &\quad \left. \left. \dots, \omega \left\lfloor \frac{t - n_{I-1} + \omega - 1}{\omega} \right\rfloor + n_{I-1} + 1 \right) \right) \\ &= \tilde{x} \left(\min \left(\omega \left\lfloor \frac{t - n_0 - 1}{\omega} \right\rfloor + n_I + 1, \omega \left\lfloor \frac{t - n_1 - 1}{\omega} \right\rfloor + n_0 + \omega + 1, \dots \right. \right. \\ &\quad \left. \left. \dots, \omega \left\lfloor \frac{t - n_{I-1} - 1}{\omega} \right\rfloor + n_{I-1} + \omega + 1 \right) \right). \end{aligned}$$

Recall (6.26), it remains to show that $(v_{\mathcal{S}} \tilde{x})(t) = \tilde{x}(\mathcal{K}_{\mathcal{S}}(t) + 1)$. For this $(v_{\mathcal{S}} \tilde{x})(t)$ is evaluated for intervals defined in (6.25). E.g. for the interval $n_0 + \omega j < t \leq n_1 + \omega j$ observe that,

$$\begin{aligned} \left\lfloor \frac{t - n_i - 1}{\omega} \right\rfloor &= \left\lfloor \frac{t - n_i - \omega}{\omega} \right\rfloor \quad \text{because of } \lfloor n/\omega \rfloor = \lceil (n - \omega + 1)/\omega \rceil. \\ &= \begin{cases} j & \text{for } i = 0 \\ j - 1 & \text{for } i = 1, \dots, I \end{cases} \end{aligned}$$

hence,

$$\begin{aligned} (v_{\mathcal{S}} \tilde{x})(t) &= \tilde{x}(\min(\omega j + n_I + 1, \omega j + n_0 + 1, \dots, \omega j + n_{I-1} + 1)) \\ &= \tilde{x}(n_0 + \omega j + 1). \end{aligned}$$

Second, for $n_1 + \omega j < t \leq n_2 + \omega j$,

$$\begin{aligned} \left\lfloor \frac{t - n_i - 1}{\omega} \right\rfloor &= \left\lceil \frac{t - n_i - \omega}{\omega} \right\rceil \\ &= \begin{cases} j & \text{for } i = 0, 1 \\ j - 1 & \text{for } i = 2, \dots, I \end{cases} \end{aligned}$$

and therefore,

$$\begin{aligned} (v_S \tilde{x})(t) &= \tilde{x}(\min(\omega j + n_1 + 1, \omega(j + 1) + n_0 + 1, \omega j + n_1 + 1, \dots, \omega j + n_{I-1})) \\ &= \tilde{x}(n_1 + \omega j + 1). \end{aligned}$$

By going through the remaining intervals it is shown that,

$$(v_S \tilde{x})(t) = \tilde{x}(\mathcal{K}_S(t) + 1),$$

where $\mathcal{K}_S(t)$ is given by, $\forall j \in \mathbb{Z}$

$$\mathcal{K}_S(t) = \begin{cases} n_0 + \omega j & \text{if } n_0 + \omega j < t \leq n_1 + \omega j, \\ n_1 + \omega j & \text{if } n_1 + \omega j < t \leq n_2 + \omega j, \\ \vdots & \\ n_I + \omega j & \text{if } n_I + \omega j < t \leq (n_0 + \omega) + \omega j. \end{cases}$$

□

Modeling of consistent WTEGs under periodic PS in \mathcal{ET}

Let us consider a basic path $t_{\underline{i}} \rightarrow p_i \rightarrow t_{\bar{i}}$ in a consistent WTEG with a periodic PS of transition $t_{\bar{i}}$ by a signal $\mathcal{S}_{\bar{i}}$. The influence of transition $t_{\underline{i}}$ on transition $t_{\bar{i}}$ is described by the following operator,

$$\tilde{x}_{\bar{i}} = v_{t_{\bar{i}}} \nabla_{1|w(p_i, t_{\bar{i}})} \delta^{(\Phi)_i} \gamma^{(\mathcal{M}_0)_i} \nabla_{w(t_{\underline{i}}, p_i)} |1 \tilde{x}_{\underline{i}},$$

where $\tilde{x}_{\underline{i}}$ and $\tilde{x}_{\bar{i}}$ refer to the counter functions of transition $t_{\underline{i}}$ and $t_{\bar{i}}$, $v_{t_{\bar{i}}}$ is the operator representation of the signal $\mathcal{S}_{\bar{i}}$ corresponding to the PS of $t_{\bar{i}}$, $w(t_{\underline{i}}, p_i)$ and $w(p_i, t_{\bar{i}})$ are weights of the arcs $(t_{\underline{i}}, p_i)$ and $(p_i, t_{\bar{i}})$, $(\Phi)_i$ is the holding time of place p_i and $(\mathcal{M}_0)_i$ is the initial marking of p_i . For instance, consider the basic path given in Figure 6.25, with a PS of transition t_2 by the periodic signal

$$\mathcal{S}_2(t) = \begin{cases} 1 & \text{if } t \in \{1 + 3j, 2 + 3j\}, \\ 0 & \text{otherwise.} \end{cases}$$

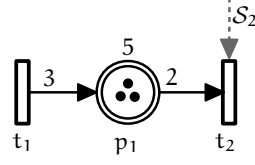
 Figure 6.25. – A simple WTEG with a periodic PS of transition t_2 .

As $\omega = 3$, $I = 1$, $n_0 = 1$ and $n_1 = 2$ according to Prop. 99, $v_{S_2} = v_{t_2} = \delta^1 \Delta_{3|3} \delta^{-2} \oplus \delta^{-1} \Delta_{3|3} \delta^{-1}$. Therefore,

$$\begin{aligned}
 \tilde{x}_2 &= v_{t_2} \nabla_{1|2} \delta^5 \gamma^3 \nabla_{3|1} \tilde{x}_1 \\
 &= (\delta^1 \Delta_{3|3} \delta^{-2} \oplus \delta^{-1} \Delta_{3|3} \delta^{-1}) \nabla_{1|2} \delta^5 \gamma^3 \nabla_{3|1} \tilde{x}_1 \\
 &= (\delta^4 \Delta_{3|3} \oplus \delta^5 \Delta_{3|3} \delta^{-2}) \nabla_{1|2} \nabla_{3|1} \gamma^1 \tilde{x}_1 \\
 &\quad \text{since, } \gamma^3 \nabla_{3|1} = \nabla_{3|1} \gamma^1, \delta^1 \Delta_{3|3} \delta^3 = \delta^4 \Delta_{3|3} \text{ and } \delta^{-1} \Delta_{3|3} \delta^4 = \delta^5 \Delta_{3|3} \delta^{-2} \\
 &= (\delta^4 \Delta_{3|3} \oplus \delta^5 \Delta_{3|3} \delta^{-2}) (\gamma^3 \nabla_{3|2} \oplus \gamma^1 \nabla_{3|2} \gamma^1) \tilde{x}_1 \\
 &\quad \text{since, } \nabla_{1|2} \nabla_{3|1} = (\nabla_{3|6} \gamma^4 \oplus \gamma^1 \nabla_{3|6} \gamma^2 \oplus \gamma^2 \nabla_{3|6}) (\nabla_{6|2} \gamma^1 \oplus \gamma^3 \nabla_{6|2}) \\
 &\quad \quad \quad = \nabla_{3|2} \gamma^1 \oplus \gamma^1 \nabla_{3|2} \\
 &= (\delta^4 \gamma^3 \Delta_{3|3} \nabla_{3|2} \oplus \delta^5 \gamma^3 \Delta_{3|3} \nabla_{3|2} \delta^{-2} \oplus \delta^4 \gamma^1 \Delta_{3|3} \nabla_{3|2} \gamma^1 \oplus \delta^5 \gamma^1 \Delta_{3|3} \nabla_{3|2} \delta^{-2} \gamma^1) \tilde{x}_1.
 \end{aligned}$$

Observe that $\delta^4 \gamma^3 \Delta_{3|3} \nabla_{3|2} \oplus \delta^5 \gamma^3 \Delta_{3|3} \nabla_{3|2} \delta^{-2} \oplus \delta^4 \gamma^1 \Delta_{3|3} \nabla_{3|2} \gamma^1 \oplus \delta^5 \gamma^1 \Delta_{3|3} \nabla_{3|2} \delta^{-2} \gamma^1$ is the standard form, which was introduced in Prop. 78. Clearly based on this operator representation for a basic path, the earliest functioning of a consistent WTEG under periodic PS can be described by

$$\tilde{x} = \mathbf{A}\tilde{x} \oplus \mathbf{B}\tilde{u}, \quad \tilde{y} = \mathbf{C}\tilde{x},$$

where \tilde{x} (resp. \tilde{u} , \tilde{y}) refers to the vector of counter functions of internal (resp. input, output) transitions and \mathbf{A} , \mathbf{B} and \mathbf{C} are matrices with entries in $\mathcal{ET}_{\text{per}}$ of appropriate size.

Theorem 6.2. *For a consistent g -input p -output WTEG under periodic PSs, see Definition 63, the transfer function matrix is given by $\mathbf{H} = \mathbf{CA}^* \mathbf{B} \in \mathcal{ET}_{\text{per}}^{p \times g}$. Moreover, the entries of the transfer function matrix \mathbf{H} are ultimately cyclic series in $\mathcal{ET}_{\text{per}}$.*

Proof. First, periodic PS of a transition by a periodic signal refers to a periodic \mathcal{ET} -operator, see Prop. 99. Then, as every basic sum in $\mathcal{ET}_{\text{per}}$ is a specific ultimately cyclic series, the entries of the \mathbf{A} , \mathbf{B} and \mathbf{C} matrices are ultimately cyclic series in $\mathcal{ET}_{\text{per}}$. The sum (resp. product, Kleene star) of ultimately cyclic series in $\mathcal{ET}_{\text{per}}$ are again ultimately cyclic series in $\mathcal{ET}_{\text{per}}$, see Prop. 85 (resp. Prop. 86, Prop. 87). Hence, the entries of the transfer matrix $\mathbf{CA}^* \mathbf{B}$ are ultimately cyclic series in $\mathcal{ET}_{\text{per}}$. \square

Example 70. Consider the consistent WTEG shown in Figure 6.26 with a PS of transition t_2 by the signal

$$S_2(t) = \begin{cases} 1 & \text{if } t \in \{1 + 2j\}, \\ 0 & \text{otherwise.} \end{cases}$$

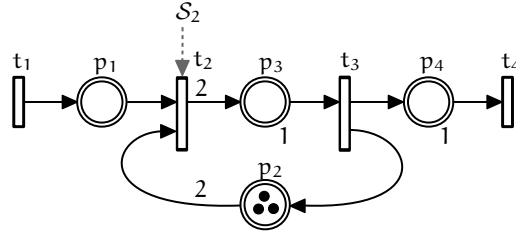

Figure 6.26. – Example of a WTEG under periodic PS.

The earliest functioning of the system is modeled by

$$\mathbf{x} = \mathbf{A}\mathbf{x} \oplus \mathbf{B}\mathbf{u}; \quad \mathbf{y} = \mathbf{C}\mathbf{x}, \quad (6.28)$$

where,

$$\mathbf{A} = \begin{bmatrix} \varepsilon & \delta^1 \Delta_{2|2} \delta^{-1} \nabla_{1|2} \gamma^3 \\ \nabla_{2|1} \delta^1 & \varepsilon \end{bmatrix}, \quad \mathbf{B} = \begin{bmatrix} \delta^1 \Delta_{2|2} \delta^{-1} \\ \varepsilon \end{bmatrix}, \quad \mathbf{C} = \begin{bmatrix} \varepsilon & \delta^1 \end{bmatrix}.$$

Solving the implicit equation (6.28) leads to the transfer function of the system,

$$\begin{aligned} \mathbf{h} &= \mathbf{C}\mathbf{A}^*\mathbf{B} = \begin{bmatrix} \varepsilon & \delta^1 \end{bmatrix} \begin{bmatrix} \varepsilon & \delta^1 \Delta_{2|2} \delta^{-1} \nabla_{1|2} \gamma^3 \\ \nabla_{2|1} \delta^1 & \varepsilon \end{bmatrix}^* \begin{bmatrix} \delta^1 \Delta_{2|2} \delta^{-1} \\ \varepsilon \end{bmatrix} \\ &= \delta^1 (\mathbf{A}^*)_{2,1} \delta^1 \Delta_{2|2} \delta^{-1}. \end{aligned}$$

Let us recall (2.11), hence $(\mathbf{A}^*)_{2,1} = (\gamma^2 \delta^2 \nabla_{2|2} \Delta_{2|2} \gamma^1 \delta^{-1})^* \nabla_{2|1} \delta^1$. Then

$$\begin{aligned} (\gamma^2 \delta^2 \nabla_{2|2} \Delta_{2|2} \gamma^1 \delta^{-1})^* &= \mathbf{e} \oplus \gamma^2 \delta^2 \nabla_{2|2} \Delta_{2|2} \gamma^1 \delta^{-1} \\ &\quad \oplus \gamma^2 \delta^2 \nabla_{2|2} \Delta_{2|2} \gamma^1 \delta^{-1} \gamma^2 \delta^2 \nabla_{2|2} \Delta_{2|2} \gamma^1 \delta^{-1} \\ &\quad \oplus \dots \end{aligned}$$

Recall, Remark 30 hence,

$$\begin{aligned} (\gamma^2 \delta^2 \nabla_{2|2} \Delta_{2|2} \gamma^1 \delta^{-1})^* &= \mathbf{e} \oplus \gamma^2 \delta^2 \nabla_{2|2} \Delta_{2|2} \gamma^1 \delta^{-1} \\ &\quad \oplus \gamma^2 \delta^2 \gamma^2 \delta^2 \nabla_{2|2} \Delta_{2|2} \gamma^1 \delta^{-1} \\ &\quad \oplus \dots \end{aligned}$$

and thus $(\gamma^2\delta^2\nabla_{2|2}\Delta_{2|2}\gamma^1\delta^{-1})^* = \mathbf{e} \oplus \gamma^2\delta^2(\gamma^2\delta^2)^*\nabla_{2|2}\Delta_{2|2}\gamma^1\delta^{-1}$. Finally,

$$\begin{aligned} \mathbf{h} &= \delta^1(\mathbf{e} \oplus \gamma^2\delta^2(\gamma^2\delta^2)^*\nabla_{2|2}\Delta_{2|2}\gamma^1\delta^{-1})\nabla_{2|1}\delta^1\delta^1\Delta_{2|2}\delta^{-1} \\ &= \delta^3\nabla_{2|1}\Delta_{2|2}\delta^{-1} \oplus \gamma^2\delta^5(\gamma^2\delta^2)^*\nabla_{2|1}\Delta_{2|2}\delta^{-1}. \end{aligned}$$

In this chapter, some control problems for Weighted Timed Event Graphs (WTEGs), Periodic Time-variant Event Graphs (PTEGs) and Timed Event Graphs (TEGs) under periodic partial synchronization (PS) are addressed. Over the last three decades, several control strategies have been established for TEGs, among them are optimal feedforward control [12, 51], state feedback, output feedback control [15, 25, 47, 34, 48], and observer-based control [33, 35, 36]. In [51], an optimal control strategy for TEGs has been studied. For this control strategy, an output reference signal for a system is assumed to be a priori known, and the controller aims to schedule the input events of the system as late as possible, but under the restriction that output events do not occur later than specified by the reference signal. In the context of manufacturing systems, this strategy is called "just-in-time" production. In [25], an output feedback strategy for TEGs is introduced which leads to a strongly connected closed-loop system. The controller inserts additional places to the system with a sufficient amount of initial tokens such that a given throughput of the closed-loop system can be guaranteed. In [15, 46], model reference control was introduced for TEGs. The purpose of the controller is to modify the system dynamics such that the system matches as close as possible the behavior of the reference model. The key difference to optimal control, where an optimal input is computed and then is chosen directly as the control action, is that the (potentially unknown) input is first filtered and then applied to the system. In the following, optimal control, as well as model reference control, are generalized to the case of consistent WTEGs, PTEGs, and TEGs under periodic PS. Subsequently, it is shown that these control problems can be reduced to the case of ordinary TEGs. Therefore, the existing tools for control synthesis for ordinary TEGs can be directly applied to consistent WTEGs, PTEGs, and TEGs under periodic PS. Some ideas, results, and figures presented in this chapter have appeared previously in [66, 65, 68, 69].

7.1. Optimal Control

Optimal Control for WTEGs

For a consistent WTEG with a transfer function $h \in \mathcal{E}_{m|b}[[\delta]]$, the optimal control problem can be stated by the inequality

$$\tilde{z}(t) \geq (h\tilde{u})(t), \quad (7.1)$$

where \tilde{z} is a counter function describing the desired output schedule - *a priori* known signal - and \tilde{u} is the unknown input - a counter function describing the input schedule - that we want to optimize under the "just-in-time" criterion. Let us recall the calculation of a system output in Prop. 96 and the relation between counter functions and $\mathcal{M}_{\text{in}}^{\text{ax}}[[\gamma, \delta]]$ series. Hence, (7.1) can be written as,

$$z \geq \Psi_{m|b}(h \otimes \text{Inj}(u)), \quad (7.2)$$

where z, u are series in $\mathcal{M}_{\text{in}}^{\text{ax}}[[\gamma, \delta]]$ corresponding to the counter functions \tilde{z} and \tilde{u} . Note that for $h \in \mathcal{E}_{m|b}[[\delta]]$ and $u \in \mathcal{M}_{\text{in}}^{\text{ax}}[[\gamma, \delta]]$, $\text{Inj}(u) \in \mathcal{E}_{1|1}[[\delta]]$ and thus the product $h \otimes \text{Inj}(u) \in \mathcal{E}_{m|b}[[\delta]]$, see Prop. 18. In other words, the periodicity of h and $h \otimes \text{Inj}(u)$ are the same. Finding the optimal input in (7.2), according to the "just-in-time" criterion, amounts to compute the following sum

$$\bigoplus_u \{u | \Psi_{m|b}(h \otimes \text{Inj}(u)) \leq z\}.$$

Proposition 100. *The greatest solution of $z \geq \Psi_{m|b}(h \otimes \text{Inj}(u))$, (7.2), is given by*

$$u_{\text{opt}} = \text{Inj}^{\#}(h \backslash \Psi_{m|b}^{\#}(z)).$$

Proof. Since $h \in \mathcal{E}_{m|b}[[\delta]]$ and $\Psi_{m|b}^{\#}(z) \in \mathcal{E}_{m|b}[[\delta]]$, *i.e.*, they have the same period, $u = h \backslash \Psi_{m|b}^{\#}(z) \in \mathcal{E}_{b|b}[[\delta]]$ is (b, b) -periodic, see Prop. 20, which is the required form for a potential non zero solution of $\text{Inj}^{\#}(u)$, see Prop. 22. \square

Example 71. *Let us consider the consistent WTEG of Example 56 with a transfer function $h \in \mathcal{E}_{3|2}[[\delta]]$ given by*

$$\begin{aligned} h = & \mu_3 \beta_2 \delta^2 \oplus (\gamma^2 \mu_3 \beta_2 \gamma^1 \oplus \gamma^3 \mu_3 \beta_2) \delta^3 \oplus \gamma^3 \mu_3 \beta_2 \delta^4 \oplus (\gamma^4 \mu_3 \beta_2 \gamma^1 \oplus \gamma^6 \mu_3 \beta_2) \delta^5 \\ & \oplus (\gamma^5 \mu_3 \beta_2 \gamma^1 \oplus \gamma^6 \mu_3 \beta_2) \delta^6 \oplus (\gamma^1 \delta^1)^* (\gamma^6 \mu_3 \beta_2 \gamma^1 \oplus \gamma^8 \mu_3 \beta_2) \delta^7. \end{aligned}$$

Moreover, consider the following reference counter function,

$$\tilde{z}(t) = \begin{cases} 0 & \text{for } t \leq 3, \\ 3 & \text{for } 4 \leq t \leq 6, \\ 4 + j & \text{for } 7 + 2j \leq t \leq 8 + 2j \text{ with } j \in \mathbb{N}_0. \end{cases}$$

This counter function corresponds to the series $z = \delta^3 \oplus \gamma^3 \delta^6 (\gamma^1 \delta^2)^ \in \mathcal{M}_{\text{in}}^{\text{ax}}[[\gamma, \delta]]$. Then $\Psi_{3|2}^{\#}(z) = \mu_3 \beta_2 \delta^3 \oplus (\gamma^1 \delta^2)^* (\gamma^3 \mu_3 \beta_2 \delta^6)$ and*

$$u_{\text{opt}} = \text{Inj}^{\#}(h \backslash \Psi_{3|2}^{\#}(z)) = e \oplus \gamma^1 \delta^1 \oplus \gamma^2 \delta^4 (\gamma^2 \delta^6)^*.$$

The response y of the consistent WTEG to the optimal input u_{opt} is

$$y = \Psi_{3|2}(h \otimes \text{Inj}(u_{\text{opt}})) = \delta^3 \oplus (\gamma^3 \delta^6 \oplus \gamma^5 \delta^7)(\gamma^3 \delta^6)^*.$$

This series corresponds to the counter function,

$$\tilde{y}(t) = \begin{cases} 0 & \text{for } t \leq 3, \\ 3 & \text{for } 4 \leq t \leq 6, \\ 5 + 3j & \text{for } t = 7 + 6j \text{ with } j \in \mathbb{N}_0, \\ 6 + 3j & \text{for } 8 + 6j \leq t \leq 12 + 6j \text{ with } j \in \mathbb{N}_0. \end{cases}$$

Figure 7.1 illustrates the reference output \tilde{z} and the system output \tilde{y} resulting from the optimal input \tilde{u} . Note that in $(\min, +)$ the order is reversed, one can see that, in Figure 7.1 it is indeed true that $\tilde{z} \geq \tilde{y}$. For all t , the number of outputs $\tilde{y}(t)$ is greater than the wanted outputs $\tilde{z}(t)$. In other words, if we number the events, then the $(k+1)^{\text{st}}$ output \tilde{y} occurs before or at the time instant of the $(k+1)^{\text{st}}$ wanted output \tilde{z} .

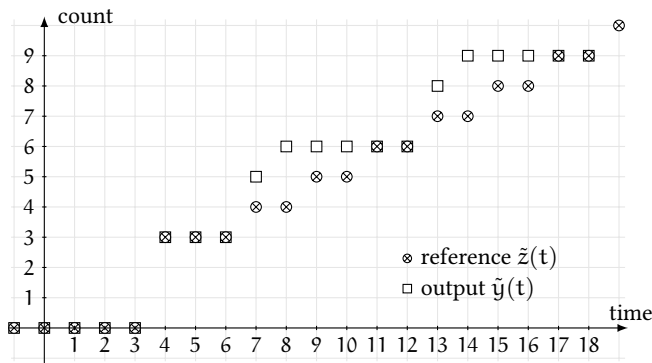

Figure 7.1. – Comparison between the reference output \tilde{z} and the system response \tilde{y} to the optimal input \tilde{u} . As required, the condition $\tilde{z} \geq \tilde{y}$ is satisfied.

Optimal Control for TEGs under periodic PS

Similarly to optimal control of consistent WTEGs, for a TEG under periodic PS (resp. a PTEG) with a transfer function $h \in \mathcal{T}_{\text{per}}[\gamma]$ the optimal control problem can be stated by the inequality

$$\bar{z}(k) \geq (h\bar{u})(k), \quad (7.3)$$

where \bar{z} is a dater function describing the desired output schedule (*a priori* known signal) and \bar{u} is the unknown input schedule, which is supposed to be optimized under the "just-in-time" criterion. Let us recall the calculation of a system output in (6.23) where the input and

output are represented as series in the dioid $\mathcal{M}_{\text{in}}^{\text{ax}}[[\gamma, \delta]]$. Then (7.3) is rephrased as

$$z \geq \Psi_{\omega}(\mathfrak{h} \otimes \text{Inj}(\mathfrak{u})), \quad \mathfrak{u}, z \in \mathcal{M}_{\text{in}}^{\text{ax}}[[\gamma, \delta]], \quad \mathfrak{h} \in \mathcal{T}_{\text{per}}[[\gamma]], \quad (7.4)$$

where the series $z, \mathfrak{u} \in \mathcal{M}_{\text{in}}^{\text{ax}}[[\gamma, \delta]]$ correspond to the dater functions \bar{z} and $\bar{\mathfrak{u}}$.

Proposition 101. *The greatest solution of $z \geq \Psi_{\omega}(\mathfrak{h} \otimes \text{Inj}(\mathfrak{u}))$, (7.4), is given by*

$$\mathfrak{u}_{\text{opt}} = \text{Inj}^{\sharp}(\mathfrak{h} \backslash \Psi_{\omega}^{\sharp}(z)).$$

Proof. The proof is similar to the proof of Prop. 100. □

Example 72. *Let us consider the TEG under periodic PS of Example 64 with a transfer function $\mathfrak{h} \in \mathcal{T}_{\text{per}}[[\gamma]]$ given by*

$$\mathfrak{h} = \delta^3(\gamma^2\delta^2)^* \Delta_{2|2} \delta^{-1}.$$

Moreover, consider the following reference dater function,

$$\bar{z}(k) = \begin{cases} -\infty & \text{for } k < 0, \\ 3 & \text{for } k = 0, 1, \\ 6 + 2j & \text{for } k = 2 + j \text{ with } j \in \mathbb{N}_0. \end{cases}$$

This dater function corresponds to the series $z = \delta^3 \oplus \gamma^2\delta^6(\gamma^1\delta^2)^ \in \mathcal{M}_{\text{in}}^{\text{ax}}[[\gamma, \delta]]$. Then $\Psi_2^{\sharp}(z) = \delta^3\Delta_{2|2} \oplus (\gamma^1\delta^2)^*(\gamma^2\delta^6\Delta_{2|2})$ and*

$$\mathfrak{u}_{\text{opt}} = \text{Inj}^{\sharp}(\mathfrak{h} \backslash \Psi_2^{\sharp}(z)) = \delta^1 \oplus \gamma^2\delta^3(\gamma^1\delta^2)^*.$$

The response \mathfrak{y} of the TEG under periodic PS to the optimal input $\mathfrak{u}_{\text{opt}}$ is

$$\mathfrak{y} = \Psi_2(\mathfrak{h} \otimes \text{Inj}(\mathfrak{u}_{\text{opt}})) = \delta^3 \oplus \gamma^2\delta^5(\gamma^1\delta^2)^*.$$

This series corresponds to the dater function,

$$\bar{\mathfrak{y}}(k) = \begin{cases} -\infty & \text{for } k < 0, \\ 3 & \text{for } k = 0, 1, \\ 5 + 2j & \text{for } k = 2 + j \text{ with } j \in \mathbb{N}_0. \end{cases}$$

Figure 7.2 illustrates the reference output \bar{z} and the system output $\bar{\mathfrak{y}}$ resulting from the optimal input $\bar{\mathfrak{u}}_{\text{opt}}$, clearly $\bar{z} \geq \bar{\mathfrak{y}}$.

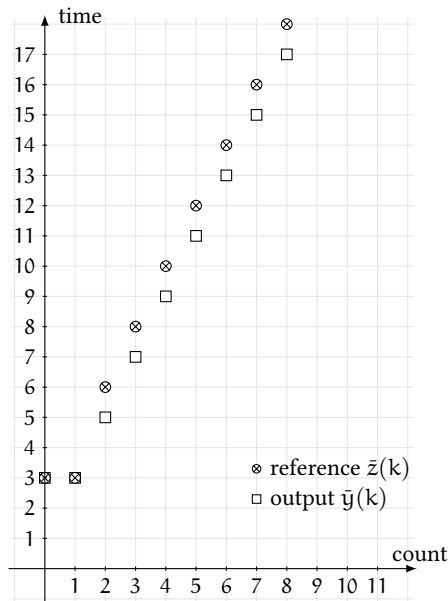

Figure 7.2. – Comparison between the reference output \bar{z} and the system response \tilde{y} to the optimal input \tilde{u} . As required, the condition $\bar{z} \geq \tilde{y}$ is satisfied.

7.2. Model Reference Control

In many applications, it is desirable to control the system such that a given reference model is matched. The control problem is then to modify the system dynamics such that for any input the output of the system matches as close as possible the output of the reference. In the following, a feedforward and an output feedback approach are presented to solve the problem of model reference control for consistent WTEGs (resp. PTEG, TEGsPS). For this, it is considered that the input/output behavior of the consistent WTEG (resp. PTEG, TEGPS) is described by a transfer function matrix \mathbf{H} with entries in $\mathcal{E}_{m|b}[[\delta]]$ (resp. with entries in $\mathcal{T}_{per}[[\gamma]]$).

7.2.1. Feedforward

In Figure 7.3 an open-loop control structure is given. In this structure, a prefilter, described by a matrix $\mathbf{P} \in \mathcal{E}_{m|b}[[\delta]]^{g \times g}$, is placed at the input of the system $\mathbf{H} \in \mathcal{E}_{m|b}[[\delta]]^{p \times g}$. The control input is chosen to $\tilde{\mathbf{u}} = \mathbf{P}\tilde{\mathbf{v}}$, where $\tilde{\mathbf{v}}$ denotes the external inputs. The transfer matrix of the overall system is then $\mathbf{H} \otimes \mathbf{P}$ and the output $\tilde{\mathbf{y}}$ is, therefore

$$\tilde{\mathbf{y}} = (\mathbf{H} \otimes \mathbf{P})(\tilde{\mathbf{v}}).$$

The reference model can be specified by a consistent transfer function matrix $\mathbf{G} \in \mathcal{E}_{m|b}[[\delta]]^{p \times g}$.

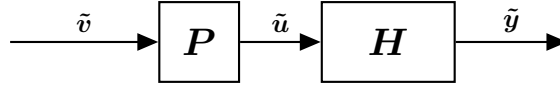
Figure 7.3. – Open-loop control structure with a prefilter \mathbf{P} and plant model \mathbf{H} .

The control problem is then to find a prefilter \mathbf{P} for a plant model \mathbf{H} such that the overall system \mathbf{HP} satisfies,

$$\mathbf{HP} \leq \mathbf{G}. \quad (7.5)$$

Moreover, we are looking for the greatest possible prefilter \mathbf{P} in order to guaranty the optimal behavior under the "just-in-time" criterion. As \mathbf{H} and \mathbf{G} are matrices with entries in $\mathcal{E}_{m|b}[[\delta]]$ and $\mathcal{E}_{m|b}[[\delta]]$ is a strict subset of the complete dioid $(\mathcal{E}[[\delta]], \oplus, \otimes)$, residuation theory is suitable to obtain the greatest solution for \mathbf{P} in (7.5). Therefore, the optimal prefilter is

$$\mathbf{P}_{\text{opt}} = \mathbf{H} \backslash \mathbf{G}. \quad (7.6)$$

To realize the prefilter by a consistent WTEG and to guarantee that the overall system is again consistent, \mathbf{P} must be designed such that \mathbf{P} and \mathbf{HP} are consistent matrices with entries in $\mathcal{E}_{m|b}[[\delta]]$. Hence, the matrices \mathbf{H} and \mathbf{P} must satisfy Prop. 44. This leads to the following restrictions on the reference model \mathbf{G} .

Proposition 102. *Let $\mathbf{H} \in \mathcal{E}_{m|b}[[\delta]]^{p \times 9}$ and $\mathbf{G} \in \mathcal{E}_{m|b}[[\delta]]^{p \times 9}$ be to consistent matrices, then the open loop transfer matrix \mathbf{HP}_{opt} , with $\mathbf{P}_{\text{opt}} = \mathbf{H} \backslash \mathbf{G}$, is a consistent matrix with entries in $\mathcal{E}_{m|b}[[\delta]]$, if and only if, $\exists c \in \mathbb{Q}, c > 0$ such that,*

$$c\Gamma(\mathbf{G})_{k,1} = \Gamma(\mathbf{H})_{k,1}, \quad \forall k \in 1, \dots, p. \quad (7.7)$$

In other words, all columns of $\Gamma(\mathbf{G})$ must be linearly dependent to all columns of $\Gamma(\mathbf{H})$ (recall that $\Gamma(\mathbf{H})$ and $\Gamma(\mathbf{G})$ have rank 1).

Proof. This follows immediately from Prop. 48. □

Moreover, note that \mathbf{P}_{opt} may not be causal, *i.e.* the matrix is not realizable by a consistent WTEG. Hence the optimal causal (m, b) -periodic prefilter $\mathbf{P}_{\text{opt}}^+$ is obtained by

$$\mathbf{P}_{\text{opt}}^+ = \text{Pr}_{m|b}^+(\mathbf{H} \backslash \mathbf{G}),$$

where $\text{Pr}_{m|b}^+ : \mathcal{E}_{m|b}[[\delta]] \rightarrow \mathcal{E}_{m|b}^+[[\delta]]$ is the causal projection, see Remark 15. Note that as shown in Example 26 the obtained causal prefilter is in general only the greatest (m, b) -periodic causal prefilter. In the particular case, where the optimal non-causal prefilter satisfies Remark 16, the greatest (m, b) -periodic causal prefilter is the greatest causal prefilter which satisfies $\text{Pr}_{m|b}^+(\mathbf{P}_{\text{opt}}) \leq \mathbf{P}_{\text{opt}}$.

Example 73. Let us consider the consistent WTEG of Figure 6.2a with a transfer matrix \mathbf{H} given by

$$\mathbf{H} = \begin{bmatrix} (\mu_3\beta_2\gamma^1 \oplus \gamma^2\mu_3\beta_2)\delta^1(\gamma^1\delta^1)^* & \mu_3\beta_2\delta^2 \\ \mu_4\beta_1 & \mu_4\beta_1\delta^3 \end{bmatrix},$$

with a gain matrix

$$\Gamma(\mathbf{H}) = \begin{bmatrix} \frac{3}{2} & \frac{3}{2} \\ 4 & 4 \end{bmatrix}.$$

The reference model is specified by the following matrix

$$\mathbf{G} = \begin{bmatrix} \delta^2(\gamma^3\delta^2)^*\mu_3\beta_4 & \delta^2(\gamma^3\delta^2)^*\mu_3\beta_2 \\ \delta^2(\gamma^2\delta^2)^*\mu_2\beta_1 & \delta^4(\gamma^4\delta^2)^*\mu_4\beta_1 \end{bmatrix}$$

with a gain matrix

$$\Gamma(\mathbf{G}) = \begin{bmatrix} \frac{3}{4} & \frac{3}{2} \\ 2 & 4 \end{bmatrix}.$$

Clearly, $\Gamma(\mathbf{G})$ has rank 1 and all columns of $\Gamma(\mathbf{G})$ and $\Gamma(\mathbf{H})$ are linearly dependent, since

$$2 \times \begin{bmatrix} \frac{3}{4} \\ 2 \end{bmatrix} = \begin{bmatrix} \frac{3}{2} \\ 4 \end{bmatrix}.$$

Thus, the specification \mathbf{G} satisfies the structural property, given by (7.7), and therefore it is an admissible reference model for the plant \mathbf{H} . The optimal prefilter \mathbf{P}_{opt} is given by

$$\begin{aligned} (\mathbf{P}_{\text{opt}})_{1,1} &= \beta_2\gamma^1 \oplus (\gamma^1\mu_2\beta_4\gamma^1 \oplus \gamma^2\mu_2\beta_4)\delta^1 \oplus (\gamma^1\delta^1)^*(\gamma^2\mu_2\beta_4\delta^2), \\ (\mathbf{P}_{\text{opt}})_{1,2} &= \mathbf{e} \oplus (\gamma^1\delta^1)^*(\gamma^1\mu_2\beta_2\delta^1), \\ (\mathbf{P}_{\text{opt}})_{2,1} &= \beta_2\gamma^1\delta^{-1} \oplus \gamma^1\beta_2 \oplus \gamma^2\mu_2\beta_4\delta^1 \oplus (\gamma^2\mu_2\beta_4\gamma^1 \oplus \gamma^3\mu_2\beta_4)\delta^2 \oplus (\gamma^2\delta^2)^*(\gamma^4\mu_2\beta_4\delta^4), \\ (\mathbf{P}_{\text{opt}})_{2,2} &= \mathbf{e} \oplus (\gamma^2\delta^2)^*(\gamma^2\mu_2\beta_2\delta^2). \end{aligned}$$

The optimal causal (m, b) -periodic prefilter $\mathbf{P}_{\text{opt}}^+$ is given by

$$\mathbf{P}_{\text{opt}}^+ = \text{Pr}_{m|b}^+(\mathbf{H} \setminus \mathbf{G}),$$

with

$$\begin{aligned} (\mathbf{P}_{\text{opt}}^+)_{1,1} &= \beta_2\gamma^1 \oplus (\gamma^1\mu_2\beta_4\gamma^1 \oplus \gamma^2\mu_2\beta_4)\delta^1 \oplus (\gamma^1\delta^1)^*(\gamma^2\mu_2\beta_4\delta^2), \\ (\mathbf{P}_{\text{opt}}^+)_{1,2} &= \mathbf{e} \oplus (\gamma^1\delta^1)^*(\gamma^1\mu_2\beta_2\delta^1), \\ (\mathbf{P}_{\text{opt}}^+)_{2,1} &= \gamma^1\beta_2 \oplus \gamma^2\mu_2\beta_4\delta^1 \oplus (\gamma^2\mu_2\beta_4\gamma^1 \oplus \gamma^3\mu_2\beta_4)\delta^2 \oplus (\gamma^2\delta^2)^*(\gamma^4\mu_2\beta_4\delta^4), \\ (\mathbf{P}_{\text{opt}}^+)_{2,2} &= \mathbf{e} \oplus (\gamma^2\delta^2)^*(\gamma^2\mu_2\beta_2\delta^2). \end{aligned}$$

Note that in this case the greatest causal $(2, 4)$ -periodic (resp. $(2, 2)$ -periodic) prefilter, it is the greatest causal prefilter, since all coefficients of the optimal non-causal prefilter \mathbf{P}_{opt} are smaller than or equal to $\mu_2\beta_4$, (resp. $\mu_2\beta_2$). A graphical representation of the overall system is given in Figure 7.4.

Remark 38. (Optimal prefilter for PTEGs and TEGs under periodic PS) Clearly, the design process for an optimal prefilter for a PTEG (resp. TEG under periodic PS) with a transfer function matrix $\mathbf{H} \in \mathcal{T}_{\text{per}}[[\gamma]]^{p \times 9}$ is analogous. For these systems, the reference model is specified by a matrix $\mathbf{G} \in \mathcal{T}_{\text{per}}[[\gamma]]^{p \times 9}$. Note that in the case of PTEGs the reference model can be freely chosen to any matrix $\mathbf{G} \in \mathcal{T}_{\text{per}}[[\gamma]]^{p \times 9}$. There is no additional condition as in the case of consistent WTEG. Therefore, the optimal causal prefilter is obtained by,

$$\mathbf{P}_{\text{opt}}^+ = \text{Pr}^+(\mathbf{H} \setminus \mathbf{G}).$$

7.2.2. Feedback

Feedback control allows the system to react on unforeseen disturbances during runtime. One approach is output feedback, which leads to the control structure shown in Figure 7.5. The closed-loop transfer function matrix to this control structure is given by

$$\bar{\mathbf{H}} = \mathbf{H}(\mathbf{F}\mathbf{H})^* \mathbf{P}. \quad (7.8)$$

As in the feedforward case, the reference model is as well specified by a consistent transfer function matrix $\mathbf{G} \in \mathcal{E}_{\text{m|b}}[[\delta]]^{p \times 9}$. The control problem is then to find an output feedback \mathbf{F} and a prefilter \mathbf{P} for a plant model $\mathbf{H} \in \mathcal{E}_{\text{m|b}}[[\delta]]^{p \times 9}$ such that the closed-loop system $\bar{\mathbf{H}}$ satisfies $\bar{\mathbf{H}} \leq \mathbf{G}$. According to the definition of the Kleene star, the closed-loop system can be written as $\bar{\mathbf{H}} = \mathbf{H}(\mathbf{I} \oplus \mathbf{F}\mathbf{H} \oplus (\mathbf{F}\mathbf{H})^2 \oplus \dots) \mathbf{P}$ this implies that the prefilter \mathbf{P} must satisfy the following inequality

$$\mathbf{H}\mathbf{P} \oplus \mathbf{H}\mathbf{F}\mathbf{H}\mathbf{P} \oplus \mathbf{H}(\mathbf{F}\mathbf{H})^* \mathbf{P} \dots \leq \mathbf{G}. \quad (7.9)$$

Clearly, \mathbf{P} must satisfy the first element of the sum, i.e.,

$$\mathbf{H}\mathbf{P} \leq \mathbf{G}. \quad (7.10)$$

The greatest solution of (7.10) is given by $\mathbf{P}_{\text{opt}} = \mathbf{H} \setminus \mathbf{G}$, see (7.6), furthermore in [34] it is shown that this \mathbf{P}_{opt} is also the greatest solution for \mathbf{P} in (7.9). Therefore, the optimal prefilter is equivalent to the optimal prefilter in the feedforward case. Again, in order to guaranty that the overall system is consistent, the reference model \mathbf{G} and the transfer function matrix \mathbf{H} of the plant must satisfy (7.7). It remains to find the greatest feedback \mathbf{F} such that

$$\mathbf{H}(\mathbf{F}\mathbf{H})^* \mathbf{P}_{\text{opt}} \leq \mathbf{G}. \quad (7.11)$$

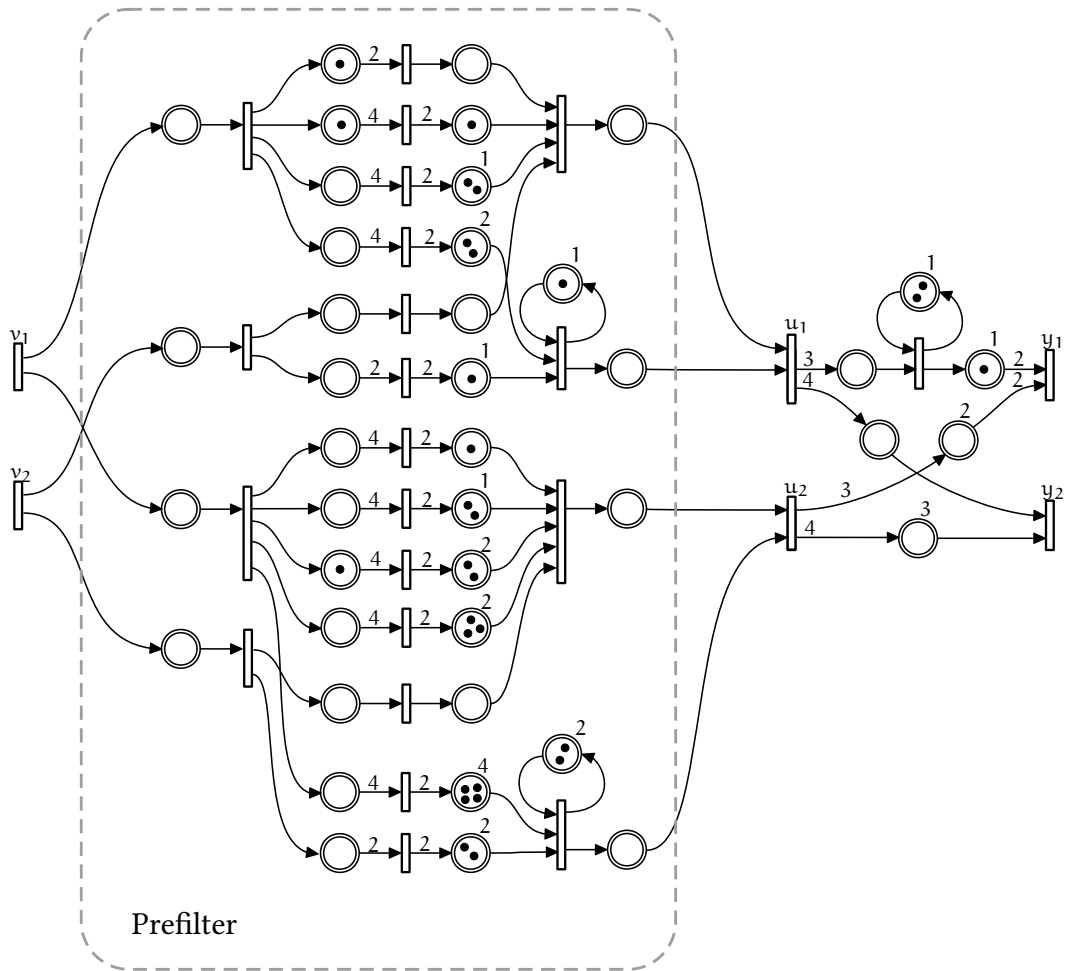
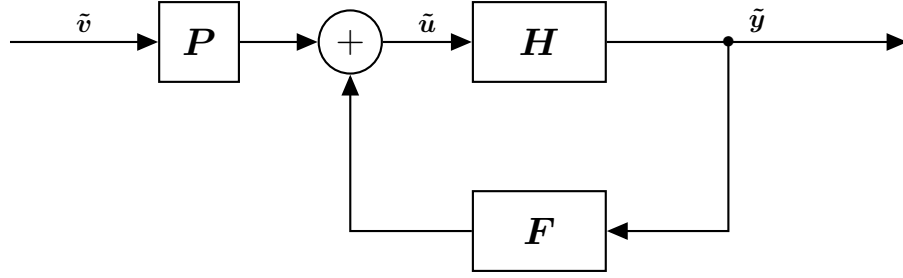

Figure 7.4. – Overall system with a prefilter.

Figure 7.5. – Closed-Loop structure with plant model \mathbf{H} , feedback \mathbf{F} and prefilter \mathbf{P} .

Proposition 103 ([34]). *The greatest solution of the inequality $\mathbf{H}(\mathbf{F}\mathbf{H})^*\mathbf{P}_{\text{opt}} \leq \mathbf{G}$ is given by*

$$\mathbf{F}_{\text{opt}} = (\mathbf{P}_{\text{opt}} \oslash \mathbf{P}_{\text{opt}}) \oslash \mathbf{H}.$$

Proof. By left division by \mathbf{H} and right division by \mathbf{P}_{opt} the inequality $\mathbf{H}(\mathbf{F}\mathbf{H})^*\mathbf{P}_{\text{opt}} \leq \mathbf{G}$ can be written as

$$(\mathbf{F}\mathbf{H})^* \leq (\mathbf{H} \oslash \mathbf{G}) \oslash \mathbf{P}_{\text{opt}} = \mathbf{P}_{\text{opt}} \oslash \mathbf{P}_{\text{opt}}.$$

Since $\mathbf{P}_{\text{opt}} \oslash \mathbf{P}_{\text{opt}} = (\mathbf{P}_{\text{opt}} \oslash \mathbf{P}_{\text{opt}})^*$ we obtain

$$\mathbf{F}\mathbf{H} \leq \mathbf{P}_{\text{opt}} \oslash \mathbf{P}_{\text{opt}}.$$

Therefore, the greatest solution \mathbf{F}_{opt} for the feedback \mathbf{F} in (7.11) (resp. (7.9)) is

$$\mathbf{F}_{\text{opt}} = (\mathbf{P}_{\text{opt}} \oslash \mathbf{P}_{\text{opt}}) \oslash \mathbf{H}.$$

□

Finally, we check whether \mathbf{F}_{opt} and the closed-loop transfer matrix $\mathbf{H}(\mathbf{F}_{\text{opt}}\mathbf{H})^*\mathbf{P}_{\text{opt}}$ are consistent matrices with entries in $\mathcal{E}_{\mathfrak{m}|\mathfrak{b}}[[\delta]]$.

Proposition 104. *The optimal feedback $\mathbf{F}_{\text{opt}} = (\mathbf{P}_{\text{opt}} \oslash \mathbf{P}_{\text{opt}}) \oslash \mathbf{H}$, with $\mathbf{P}_{\text{opt}} = \mathbf{H} \oslash \mathbf{G}$ and the closed-loop system transfer matrix $\mathbf{H}(\mathbf{F}_{\text{opt}}\mathbf{H})^*\mathbf{P}_{\text{opt}}$ are consistent matrices with entries in $\mathcal{E}_{\mathfrak{m}|\mathfrak{b}}[[\delta]]$, if and only if the transfer function matrix \mathbf{H} and the reference model \mathbf{G} satisfy (7.7).*

Proof. Recall that $\Gamma(\mathbf{G}) = \mathbf{g}_c \mathbf{g}_r$ and $\Gamma(\mathbf{H}) = \mathbf{h}_c \mathbf{h}_r$ with $\mathbf{g}_c, \mathbf{h}_c \in \mathbb{Q}^{p \times 1}$ and $\mathbf{g}_r, \mathbf{h}_r \in \mathbb{Q}^{1 \times m}$. Then because of (3.60),

$$\Gamma(\mathbf{P}_{\text{opt}}) = \Gamma(\mathbf{H} \oslash \mathbf{G}) = \bar{\mathbf{h}}_c \begin{pmatrix} \mathbf{g}_c \\ \mathbf{h}_c \end{pmatrix}_1 \mathbf{g}_r,$$

where $\bar{\mathbf{h}}_c = [((\mathbf{h}_r)_1)^{-1} ((\mathbf{h}_r)_2)^{-1} \cdots ((\mathbf{h}_r)_m)^{-1}]^T$. Then $\Gamma(\mathbf{P}_{\text{opt}}) = \mathbf{p}_c \mathbf{p}_r$, where $\mathbf{p}_c = \bar{\mathbf{h}}_c$ and $\mathbf{p}_r = (\mathbf{g}_c)_1 / (\mathbf{h}_c)_1 \mathbf{g}_r$. Because of (3.61),

$$\Gamma(\mathbf{P}_{\text{opt}} \cancel{\mathbf{P}}_{\text{opt}}) = \mathbf{p}_c \frac{(\mathbf{p}_r)_1}{(\mathbf{p}_r)_1} \bar{\mathbf{p}}_r,$$

where $\bar{\mathbf{p}}_r = [((\mathbf{p}_c)_1)^{-1} ((\mathbf{p}_c)_2)^{-1} \cdots ((\mathbf{p}_c)_m)^{-1}]$. Clearly $(\mathbf{p}_r)_1 / (\mathbf{p}_r)_1 = 1$ and therefore $\Gamma(\mathbf{P}_{\text{opt}} \cancel{\mathbf{P}}_{\text{opt}}) = \mathbf{p}_c \bar{\mathbf{p}}_r$ and as

$$\begin{aligned} \bar{\mathbf{p}}_r &= \left[((\mathbf{p}_c)_1)^{-1} \quad ((\mathbf{p}_c)_2)^{-1} \quad \cdots \quad ((\mathbf{p}_c)_m)^{-1} \right] \\ &= \left[(((\mathbf{h}_r)_1)^{-1})^{-1} \quad (((\mathbf{h}_r)_2)^{-1})^{-1} \quad \cdots \quad (((\mathbf{h}_r)_m)^{-1})^{-1} \right] \\ &= \left[(\mathbf{h}_r)_1 \quad (\mathbf{h}_r)_2 \quad \cdots \quad (\mathbf{h}_r)_m \right] \\ &= \mathbf{h}_r \end{aligned}$$

Then $\Gamma(\mathbf{P}_{\text{opt}} \cancel{\mathbf{P}}_{\text{opt}}) = \bar{\mathbf{h}}_c \mathbf{h}_r$. Therefore, the matrices $\mathbf{P}_{\text{opt}} \cancel{\mathbf{P}}_{\text{opt}}$ and \mathbf{H} satisfy Prop. 49 and \mathbf{F}_{opt} is a consistent matrix with entries in $\mathcal{E}_{m|b}[\delta]$. Furthermore, $\Gamma(\mathbf{F}_{\text{opt}}) = \Gamma((\mathbf{P}_{\text{opt}} \cancel{\mathbf{P}}_{\text{opt}}) \cancel{\mathbf{H}}) = \bar{\mathbf{h}}_c \bar{\mathbf{h}}_r$ and thus $\Gamma(\mathbf{F}_{\text{opt}})_{i,j} = (\Gamma(\mathbf{H})_{j,i})^{-1}$.

Then recall (5), hence

$$\begin{aligned} \Gamma(\mathbf{H} \mathbf{F}_{\text{opt}}) &= \mathbf{h}_c (\mathbf{h}_r)_1 (\bar{\mathbf{h}}_c)_1 \bar{\mathbf{h}}_r, \\ &= \mathbf{h}_c \mathbf{h}_c (\mathbf{h}_r)_1 ((\mathbf{h}_r)_1)^{-1} \bar{\mathbf{h}}_r = \mathbf{h}_c \bar{\mathbf{h}}_r. \end{aligned}$$

Second,

$$\begin{aligned} \Gamma(\mathbf{H} \mathbf{F}_{\text{opt}} \mathbf{H}) &= \mathbf{h}_c (\bar{\mathbf{h}}_r)_1 (\mathbf{h}_c)_1 \mathbf{h}_r \\ &= \mathbf{h}_c ((\mathbf{h}_c)_1)^{-1} (\mathbf{h}_c)_1 \mathbf{h}_r \\ &= \mathbf{h}_c \mathbf{h}_r = \Gamma(\mathbf{H}). \end{aligned}$$

This implies that the sum $\mathbf{H} \oplus \mathbf{H} \mathbf{F}_{\text{opt}} \mathbf{H} \oplus \cdots$ is again a consistent matrix and therefore the closed-loop transfer matrix $\mathbf{H}(\mathbf{F}_{\text{opt}} \mathbf{H})^* \mathbf{P}_{\text{opt}}$ is consistent as well. \square

Again in order to guaranty that \mathbf{F}_{opt} is realizable by a consistent WTEG only the causal part is considered:

$$\mathbf{F}_{\text{opt}}^+ = \text{Pr}_{m|b}^+(\mathbf{F}_{\text{opt}}) = \text{Pr}_{m|b}^+((\mathbf{P}_{\text{opt}} \cancel{\mathbf{P}}_{\text{opt}}) \cancel{\mathbf{H}}).$$

Then again as indicated in Example 26 the obtained causal feedback is in general only the greatest (m, b) -periodic causal feedback. However, if the entries of \mathbf{F}_{opt} satisfy the condition laid out in Remark 16, then the greatest (m, b) -periodic causal feedback $\text{Pr}_{m|b}^+(\mathbf{F}_{\text{opt}})$ is the greatest causal feedback which satisfies $\text{Pr}_{m|b}^+(\mathbf{F}_{\text{opt}}) \leq \mathbf{F}_{\text{opt}}$.

Remark 39. (Neutral Feedback) A particular case of model reference control is to consider the transfer function matrix \mathbf{H} as the reference model, i.e., $\mathbf{G} = \mathbf{H}$. The optimal (m, b) -periodic feedback $\mathbf{F}_{\text{opt}}^+ = \text{Pr}_{m|b}^+(\mathbf{H} \setminus \mathbf{H} \setminus \mathbf{H})$ is the one which delays all firings of input transitions as much as possible while preserving the transfer behavior of the system. It is said neutral for this reason. This feedback minimizes internal stock without slowing down the system.

Example 74. Recall Example 73 with the reference model

$$\mathbf{G} = \begin{bmatrix} \delta^2(\gamma^3\delta^2)^* \mu_3\beta_4 & \delta^2(\gamma^3\delta^2)^* \mu_3\beta_2 \\ \delta^2(\gamma^2\delta^2)^* \mu_2\beta_1 & \delta^4(\gamma^4\delta^2)^* \mu_4\beta_1 \end{bmatrix},$$

the transfer function matrix,

$$\mathbf{H} = \begin{bmatrix} (\mu_3\beta_2\gamma^1 \oplus \gamma^2\mu_3\beta_2)\delta^1(\gamma^1\delta^1)^* & \mu_3\beta_2\delta^2 \\ \mu_4\beta_1 & \mu_4\beta_1\delta^3 \end{bmatrix}.$$

and the optimal prefilter \mathbf{P}_{opt} with,

$$\begin{aligned} (\mathbf{P}_{\text{opt}})_{1,1} &= \beta_2\gamma^1 \oplus (\gamma^1\mu_2\beta_4\gamma^1 \oplus \gamma^2\mu_2\beta_4)\delta^1 \oplus (\gamma^1\delta^1)^*(\gamma^2\mu_2\beta_4\delta^2), \\ (\mathbf{P}_{\text{opt}})_{1,2} &= e \oplus (\gamma^1\delta^1)^*(\gamma^1\mu_2\beta_2\delta^1), \\ (\mathbf{P}_{\text{opt}})_{2,1} &= \beta_2\gamma^1\delta^{-1} \oplus \gamma^1\beta_2 \oplus \gamma^2\mu_2\beta_4\delta^1 \oplus (\gamma^2\mu_2\beta_4\gamma^1 \oplus \gamma^3\mu_2\beta_4)\delta^2 \oplus (\gamma^2\delta^2)^*(\gamma^4\mu_2\beta_4\delta^4), \\ (\mathbf{P}_{\text{opt}})_{2,2} &= e \oplus (\gamma^2\delta^2)^*(\gamma^2\mu_2\beta_2\delta^2). \end{aligned}$$

The optimal feedback \mathbf{F}_{opt} of the closed-loop system is computed by

$$\mathbf{F}_{\text{opt}} = (\mathbf{P}_{\text{opt}} \setminus \mathbf{P}_{\text{opt}}) \setminus \mathbf{H},$$

which results in

$$\begin{aligned} (\mathbf{F}_{\text{opt}})_{1,1} &= (\gamma^1\delta^1)^*(\gamma^1\mu_2\beta_3\delta^{-1}), \\ (\mathbf{F}_{\text{opt}})_{1,2} &= \beta_4\delta^{-3} \oplus (\gamma^1\delta^1)^*(\gamma^1\mu_2\beta_8\delta^{-2}), \\ (\mathbf{F}_{\text{opt}})_{2,1} &= \gamma^1\mu_2\beta_3\delta^{-3} \oplus (\gamma^1\mu_2\beta_3\gamma^1 \oplus \gamma^2\mu_2\beta_3)\delta^{-2} \oplus (\gamma^2\delta^2)^*(\gamma^2\mu_2\beta_3), \\ (\mathbf{F}_{\text{opt}})_{2,2} &= \beta_4\delta^{-3} \oplus (\gamma^2\delta^2)^*(\gamma^2\mu_2\beta_8\delta^{-1}). \end{aligned}$$

Then optimal causal feedback $\mathbf{F}_{\text{opt}}^+$ of the closed-loop system is

$$\begin{aligned} \mathbf{F}_{\text{opt}}^+ &= \text{Pr}_{m|b}^+((\mathbf{P}_{\text{opt}} \setminus \mathbf{P}_{\text{opt}}) \setminus \mathbf{H}) \\ &= \begin{bmatrix} \gamma^2(\gamma^1\delta^1)^* \mu_2\beta_3 & \gamma^3(\gamma^1\delta^1)^* \mu_2\beta_8 \\ \gamma^2(\gamma^2\delta^2)^* \mu_2\beta_3 & \gamma^4\delta^1(\gamma^2\delta^2)^* \mu_2\beta_8 \end{bmatrix}. \end{aligned}$$

Again, note that for this example the greatest $(2, 3)$ -periodic (resp. $(2, 8)$ -periodic) causal feedback $\mathbf{F}_{\text{opt}}^+$ is the greatest causal feedback. The closed-loop system with the prefilter and feedback is shown in Figure 7.6.

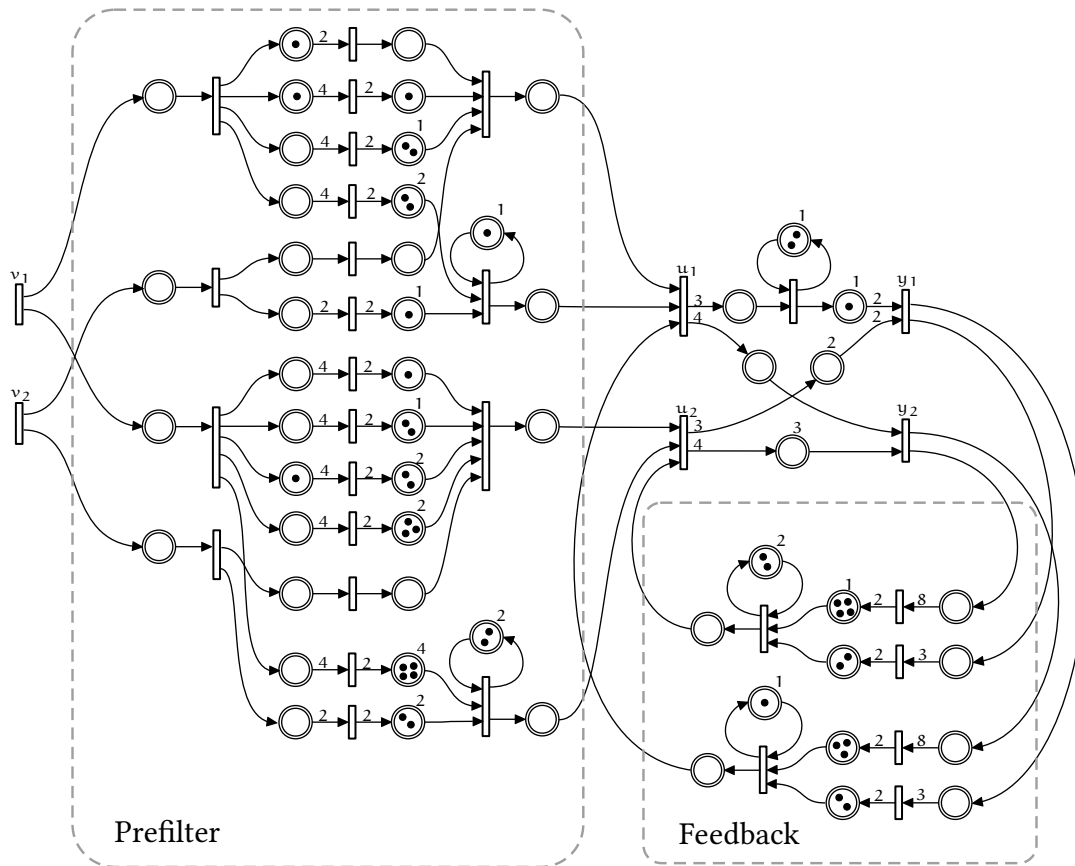

Figure 7.6. – Overall system with a prefilter and a feedback.

Example 75. Consider the PTEG given in Figure 6.8 with transfer function,

$$h = \delta^1 [(\delta^1 \Delta_{4|4} \delta^{-3} \oplus \Delta_{4|4}) \gamma^2]^* (\delta^{-3} \Delta_{4|4} \oplus \Delta_{4|4} \delta^{-1}).$$

For this system, the neutral "just-in-time" feedback is:

$$\begin{aligned} f_{\text{opt}} &= h \setminus h \phi h \\ &= (\gamma^4 \delta^4)^* ((\delta^{-3} \Delta_{4|4} \delta^{-1} \oplus \Delta_{4|4} \delta^{-2}) \oplus (\Delta_{4|4} \delta^{-1} \oplus \delta^1 \Delta_{4|4} \delta^{-2}) \gamma^2) \end{aligned}$$

After the causal projection,

$$f_{\text{opt}}^+ = \text{Pr}^+(f_{\text{opt}}) = (\gamma^4 \delta^4)^* ((\Delta_{4|4} \delta^{-1} \oplus \delta^1 \Delta_{4|4} \delta^{-2}) \gamma^2 \oplus (\delta^1 \Delta_{4|4} \delta^{-1} \oplus \delta^4 \Delta_{4|4} \delta^{-2}) \gamma^4).$$

Recall the control law $u = f_{\text{opt}}^+ y \oplus v$. To realize the feedback f_{opt}^+ , $f_{\text{opt}}^+ y$ is written as

$$\begin{aligned} \rho &= f_{\text{opt}}^+ y \\ &= (\gamma^4 \delta^4)^* [(\Delta_{4|4} \delta^{-1} \oplus \delta^1 \Delta_{4|4} \delta^{-2}) \gamma^2 \oplus (\delta^1 \Delta_{4|4} \delta^{-1} \oplus \delta^4 \Delta_{4|4} \delta^{-2}) \gamma^4] y. \end{aligned}$$

The former expression is the solution of the following implicit equation

$$\rho = [\gamma^4 \delta^4] \rho \oplus [(\Delta_{4|4} \delta^{-1} \oplus \delta^1 \Delta_{4|4} \delta^{-2}) \gamma^2 \oplus (\delta^1 \Delta_{4|4} \delta^{-1} \oplus \delta^4 \Delta_{4|4} \delta^{-2}) \gamma^4] y.$$

From this expression the feedback f_{opt}^+ can be implemented by a PTEG as follows: The feedback has one transition, denoted by t_c , associated with the dater-function ρ . Because of operator $\gamma^4 \delta^4$ transition t_c is attached with a self-loop, constituted by place p_{c1} with 4 initial tokens and a constant holding time of 4 time units. The polynomial $(\Delta_{4|4} \delta^{-1} \oplus \delta^1 \Delta_{4|4} \delta^{-2}) \gamma^2 \oplus (\delta^1 \Delta_{4|4} \delta^{-1} \oplus \delta^4 \Delta_{4|4} \delta^{-2}) \gamma^4$ describes the influence of the plant output transition t_3 onto the transition t_c of the feedback. Observe that we have two monomials, therefore we obtain two parallel paths between t_3 and t_c , each with one place. First, $(\Delta_{4|4} \delta^{-1} \oplus \delta^1 \Delta_{4|4} \delta^{-2}) \gamma^2$ is described by the place p_{c2} and the arcs (t_3, p_{c2}) and (p_{c2}, t_c) . Because of the exponent of γ^2 the place p_{c2} contains 2 initial tokens. The holding-time function of p_{c2} is determined by the T-operator $\Delta_{4|4} \delta^{-1} \oplus \delta^1 \Delta_{4|4} \delta^{-2}$ as follows:

$$\begin{aligned} \mathcal{H}_{p_{c2}}(t) &= \max \left(\mathcal{R}_{\Delta_{4|4} \delta^{-1}}(t), \mathcal{R}_{\delta^1 \Delta_{4|4} \delta^{-2}}(t) \right) - t, \\ &= \max \left(\left\lfloor \frac{t-1}{4} \right\rfloor 4, 1 + \left\lfloor \frac{t-2}{4} \right\rfloor 4 \right) - t, \\ &= \langle 1 \ 0 \ 2 \ 2 \rangle \end{aligned}$$

Respectively, $(\delta^1 \Delta_{4|4} \delta^{-1} \oplus \delta^4 \Delta_{4|4} \delta^{-2}) \gamma^4$ is described by the place p_{c3} and the arcs (t_3, p_{c3}) and (p_{c3}, t_c) . Because of the exponent of γ^4 the place p_{c3} contains 4 initial tokens. Moreover,

the holding-time-function of p_{c3} is

$$\begin{aligned} \mathcal{H}_{p_{c3}}(t) &= \max \left(\mathcal{R}_{\delta^1 \Delta_{4|4} \delta^{-1}}(t), \mathcal{R}_{\delta^4 \Delta_{4|4} \delta^{-2}}(t) \right) - t, \\ &= \max \left(1 + \left\lfloor \frac{t-1}{4} \right\rfloor 4, 4 + \left\lfloor \frac{t-2}{4} \right\rfloor 4 \right) - t, \\ &= \langle 4 \ 3 \ 3 \ 5 \rangle \end{aligned}$$

The controller is connected to the plant input transition t_1 via the arcs (t_c, p_{c4}) and (p_{c4}, t_1) . Finally, transition t_v is associated with the new input v and is connected to the plant input transition t_1 via the arcs (t_v, p_v) and (p_v, t_1) . Figure 7.7 illustrates the closed-loop system. The feedback keeps the number of tokens in places p_1, p_2 as small as possible, while the throughput of the system is preserved.

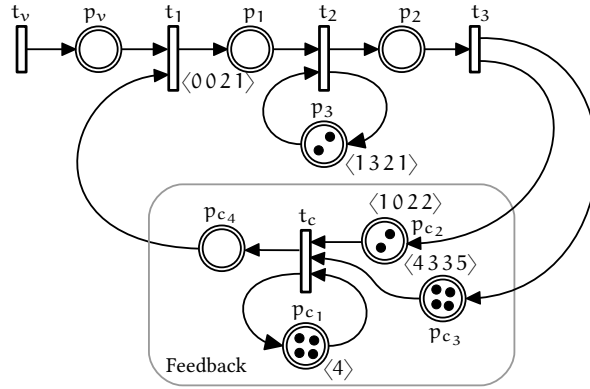

Figure 7.7. – Closed loop system.

Clearly, model reference control can be generalized to consistent WTEGs under periodic PS. In this case the reference model is specified in the dioid $(\mathcal{ET}, \oplus, \otimes)$ and must satisfy a similar condition as given in Prop. 102.

Remark 40. Finally, note that an alternative interpretation for causality of transfer functions in $\mathcal{M}_{in}^{ax}[\gamma, \delta]$ was introduced in [7]. In short, this causal transfer functions $h \in \mathcal{M}_{in}^{ax}[\gamma, \delta]$ may contain monomials $\gamma^n \delta^\tau$, for which the exponents of γ are in \mathbb{Z} , see Remark 7. Then to realize such a transfer function by a TEG, negative tokens must be introduced. A similar alternative interpretation can be given for transfer functions $h \in \mathcal{E}_{m|b}[\delta]$, then $h = \bigoplus_{i \in \mathbb{Z}} w_i \delta^i$, with $w_i \geq w_{i+1}$ is a causal transfer function, if for all $i < 0$, $w_i = \varepsilon$. Hence, h may contain monomials, for which the coefficient $w_i \geq \mu_m \beta_b$, e.g., $\gamma^{-1} \mu_m \beta_b \gamma^{-2}$. Again to give a realization of such a transfer function negative tokens must be considered.

Timed Event Graphs (TEGs) are a subclass of Discrete Event Systems (DESs) whose behaviors are solely described by synchronization phenomena. An advantage of TEGs is that they have linear expressions in some *tropical* algebras called dioids [1, 40]. Therefore, TEGs are considered popular tools for analyzing systems governed by synchronization, such as complex manufacturing processes, transport networks, and computer systems. Over the last decades, a comprehensive linear system theory for TEGs has been developed where basic concepts of traditional system theory such as state space representation, spectral analysis and transfer functions have been adapted to TEGs [1, 40]. However, many applications have event-variant and time-variant behavior, which cannot be described by an ordinary TEG. Therefore, TEGs have been extended by introducing integer weights on the arcs. This leads to Weighted Timed Event Graphs (WTEGs) which are suitable to model event-variant phenomena in DESs. Similarly, to express some time-variant behavior, TEGs were expanded by a weaker form of synchronization called partial synchronization (PS). Clearly, WTEGs and TEGs under PS can express a wider class of systems compared to ordinary TEGs, but cannot be described as a linear system in dioids anymore. Nevertheless, transfer functions were introduced for WTEGs and TEGs under PS in specific dioids. These dioids are based on a specific set of operators. In this thesis, WTEGs and TEGs under PS are studied in a dioid framework, in particular, the control of these systems in dioids is addressed.

The first contribution relates to the modeling of WTEGs in dioids. Based on the dioid $(\mathcal{E}[\![\delta]\!], \oplus, \otimes)$ a decomposition model is introduced for consistent WTEGs, in which the event-variant part and the event-invariant part are separated. The event-invariant part is modeled by a matrix with entries in $\mathcal{M}_{in}^{\alpha \times}[\![\gamma, \delta]\!]$. Moreover, it is shown that the event-variant part is "invertible", hence the problem of model reference control for consistent WTEGs can be reduced to the case of ordinary TEGs. Furthermore, it is shown that all relevant operations $(\oplus, \otimes, \backslash, \phi)$ on periodic elements in the dioid $(\mathcal{E}[\![\delta]\!], \oplus, \otimes)$ can be reduced to operations on matrices with entries in $\mathcal{M}_{in}^{\alpha \times}[\![\gamma, \delta]\!]$. In analogy to consistent WTEGs, consistent matrices are defined in the dioid $(\mathcal{E}[\![\delta]\!], \oplus, \otimes)$. A matrix with entries in $\mathcal{E}[\![\delta]\!]$ is called consistent if its entries are periodic and its gain matrix has rank 1. It is shown that a consistent WTEG admits a consistent transfer function matrix with periodic entries in $\mathcal{E}[\![\delta]\!]$. Moreover, the conditions under which product, sum, and quotient of consistent matrices are again consistent matrices are elaborated. This is needed for control synthesis; *e.g.*, when we compute a controller in the dioid $(\mathcal{E}[\![\delta]\!], \oplus, \otimes)$, the computed matrix must be consistent in order to obtain a controller realizable by a consistent WTEG.

The second main contribution of this work is to show that the input/output behavior of Periodic Time-variant Event Graphs (PTEGs) (resp. TEGs under periodic PS) can be described by ultimately cyclic series in a new dioid denoted $(\mathcal{T}_{\text{per}}\llbracket\gamma\rrbracket, \oplus, \otimes)$. Just like WTEGs, a decomposition model is introduced for PTEGs, where the transfer function is decomposed into a time-variant part and a time-invariant part. The time-variant part is "invertible" and therefore many tools for performance analysis and controller synthesis, developed for ordinary TEGs, can be directly applied to PTEGs. Moreover, in this work, the impulse response of a PTEG (resp. TEGs under periodic PS) and the relation to its transfer function is discussed. It is shown that the transfer function of the system can be interpreted as the juxtaposition of its time-shifted impulse responses. In general, for computations in the dioid $(\mathcal{T}_{\text{per}}\llbracket\gamma\rrbracket, \oplus, \otimes)$, it is shown that all relevant operations $(\oplus, \otimes, \setminus, \phi)$ on elements in $\mathcal{T}_{\text{per}}\llbracket\gamma\rrbracket$ can be reduced to operations on matrices with entries in $\mathcal{M}_{\text{in}}^{\text{ax}}\llbracket\gamma, \delta\rrbracket$.

The third main contribution is motivated by modeling a class of event-variant and time-variant DESs in the same dioid setting. The dioid $(\mathcal{ET}, \oplus, \otimes)$ was introduced which can be seen as the combination of the dioids $(\mathcal{E}\llbracket\delta\rrbracket, \oplus, \otimes)$ and $(\mathcal{T}\llbracket\gamma\rrbracket, \oplus, \otimes)$. It was shown that the transfer behavior of WTEGs under periodic PS can be described by ultimately cyclic series in \mathcal{ET} . Moreover, the decomposition model can be applied to consistent WTEG under periodic PS as well. Thus, many tools developed for TEGs can be applied to analyze and to control consistent WTEGs under periodic PS.

Finally, it is shown how this transfer function representation of WTEGs, PTEGs, and TEGs under periodic PS can be used to solve some control problems for these systems. Optimal control was studied in which a reference output is defined for the system and an optimal input is computed, which schedules all input events as late as possible under the constraint that the output events occur not later than defined by the reference. The second control approach which was extended to WTEGs, PTEGs, and TEGs under periodic PS is model reference control. Here the reference model is specified by a transfer function matrix in the dioid $(\mathcal{E}\llbracket\delta\rrbracket, \oplus, \otimes)$, respectively for PTEGs and TEGs under periodic PS in the dioid $(\mathcal{T}_{\text{per}}\llbracket\gamma\rrbracket, \oplus, \otimes)$. The controller, based on this reference, modifies the system dynamics such that the system matches the behavior of the reference model as close as possible. To achieve this, an output feedback and a prefilter are computed and realized. For consistent WTEGs, the specified reference model must satisfy some additional conditions regarding its gain. This is needed to obtain an admissible prefilter and feedback which are realizable by consistent WTEGs. Note that this is not the case for ordinary TEGs.

In the following, some suggestions for further work are given. Second order theory for TEGs is useful to obtain tight bounds for the number of tokens in places and the sojourn times of tokens in places when TEGs are operating under the earliest functioning rule [13]. For this method the TEG is modeled in the dioid $(\mathcal{M}_{\text{in}}^{\text{ax}}\llbracket\gamma, \delta\rrbracket, \oplus, \otimes)$, then residuation theory is applied to obtain these bounds [13]. It is of interest to study second-order theory for WTEGs (resp. PTEGs) based on their dioid model in $(\mathcal{E}\llbracket\delta\rrbracket, \oplus, \otimes)$ (resp. $(\mathcal{T}_{\text{per}}\llbracket\gamma\rrbracket, \oplus, \otimes)$).

For consistent WTEGs the transfer function can be interpreted as a juxtaposition of its event-shifted impulse responses. Similarly, for TEGs under periodic PS, the transfer function

can be interpreted as a juxtaposition of its time-shifted impulse responses. The relation of the impulse responses and the transfer function of a WTEG under periodic PS can be addressed in further works. For TEGs many control approaches beyond optimal control and model reference control, studied in this thesis, were investigated. Among them are robust control [45], control of TEG under additional time constraints [49, 8, 7], and observer-based control [33, 35]. Based on the decomposition model, these control strategies can be generalized to consistent WTEGs, PTEGs, and TEGs under periodic PS in further works.

Formula for Residuation

The following list provides some basic relations of left and right division, for the proofs and a more detailed list the reader is invited to consult [1][Chap. 4]. For a complete dioid \mathcal{D} with $a, b, x, y \in \mathcal{D}$,

$$a(a \setminus x) \leq x \qquad (x \setminus a)a \leq x, \qquad (\text{A.1})$$

$$a \setminus (ax) \geq x \qquad (xa) \setminus a \geq x, \qquad (\text{A.2})$$

$$a(a \setminus (ax)) = ax \qquad ((xa) \setminus a)a = xa, \qquad (\text{A.3})$$

$$a \setminus (a(a \setminus x)) = a \setminus x \qquad ((x \setminus a)a) \setminus a = x \setminus a, \qquad (\text{A.4})$$

$$(ab) \setminus x = b \setminus (a \setminus x) \qquad x \setminus (ba) = (x \setminus a) \setminus b \qquad (\text{A.5})$$

$$(a \setminus x) \setminus b = a \setminus (x \setminus b) \qquad a \setminus (x \setminus b) = (a \setminus x) \setminus b \qquad (\text{A.6})$$

$$(a \oplus b) \setminus x = (a \setminus x) \wedge (b \setminus x) \qquad x \setminus (a \oplus b) = (x \setminus a) \wedge (x \setminus b) \qquad (\text{A.7})$$

$$a \setminus (x \wedge y) = a \setminus x \wedge a \setminus y \qquad (x \wedge y) \setminus a = x \setminus a \wedge y \setminus a \qquad (\text{A.8})$$

$$a^* \setminus (a^* x) = a^* x \qquad (a^* x) \setminus a^* = xa^* \qquad (\text{A.9})$$

Formula for Floor and Ceil Operations

The following list provides some basic relations of floor and ceil operations for proofs and a more detailed list see [29]. For $x \in \mathbb{R}$,

$$\lfloor \lfloor x \rfloor \rfloor = \lfloor x \rfloor, \quad \lceil \lceil x \rceil \rceil = \lceil x \rceil.$$

For $x \in \mathbb{R}$, $m \in \mathbb{Z}$ and $n \in \mathbb{N}$,

$$\left\lfloor \frac{x+m}{n} \right\rfloor = \left\lfloor \frac{\lfloor x \rfloor + m}{n} \right\rfloor, \quad \left\lceil \frac{x+m}{n} \right\rceil = \left\lceil \frac{\lceil x \rceil + m}{n} \right\rceil.$$

For $m \in \mathbb{Z}$ and $n \in \mathbb{N}$,

$$\left\lfloor \frac{m}{n} \right\rfloor = \left\lfloor \frac{m-n+1}{n} \right\rfloor, \quad \left\lceil \frac{m}{n} \right\rceil = \left\lceil \frac{m+n-1}{n} \right\rceil.$$

C.1. Proofs of Section 3.1

Lemma 7 ([16]). *Let $w \in \mathcal{E}$, then:*

$$\mu_m \downarrow w = \beta_m \gamma^{m-1} w, \quad w \downarrow \beta_b = w \gamma^{b-1} \beta_m. \quad (\text{C.1})$$

Proof. This proof is taken from [16]. To prove the left equation of (C.1), by definition of the residuated mapping the greatest solution for x of the following inequality

$$w \geq \mu_m x \quad (\text{C.2})$$

is given by

$$\begin{aligned} \mu_m \downarrow w &= \bigoplus \{u \in \mathcal{E} \mid \mu_m u \leq w\}, \\ &= \bigoplus \{u \in \mathcal{E} \mid \mathcal{F}_{\mu_m u} \geq \mathcal{F}_w\}. \end{aligned}$$

Therefore, the (C/C)-function $\mathcal{F}_{\mu_m \downarrow w}(k)$ must satisfy: $\forall k \in \overline{\mathbb{Z}}_{\min}, \mathcal{F}_{\mu_m \downarrow w}(k) \geq \mathcal{F}_w(k)$, which leads to

$$\mathcal{F}_u(k) \times m \geq \mathcal{F}_w(k) \Leftrightarrow \mathcal{F}_u(k) \geq \mathcal{F}_w(k)/m$$

Since $\mathcal{F}_u(k)$ is an integer we can write

$$\mathcal{F}_u(k) \geq \mathcal{F}_w(k)/m \Leftrightarrow \mathcal{F}_u(k) \geq \lceil \mathcal{F}_w(k)/m \rceil \Leftrightarrow \mathcal{F}_u(k) \geq \left\lfloor \frac{\mathcal{F}_w(k) + m - 1}{m} \right\rfloor.$$

Therefore, the operator $\beta_m \gamma^{m-1} w$, corresponding to the function $\lfloor (\mathcal{F}_w(k) + m - 1)/m \rfloor$, is the greatest x such that (C.2) holds. To prove the right equation of (C.1), again $w \downarrow \beta_b$ denotes the greatest solution of the inequality,

$$w \geq x \beta_b. \quad (\text{C.3})$$

The greatest x such that (C.3) holds is given by

$$\begin{aligned} w \downarrow \beta_b &= \bigoplus \{u \in \mathcal{E} \mid \mathcal{F}_{u \beta_b} \geq \mathcal{F}_w\}, \\ &= \bigoplus \{u \in \mathcal{E} \mid \forall k \in \overline{\mathbb{Z}}_{\min}, \mathcal{F}_u(\lfloor k/b \rfloor) \geq \mathcal{F}_w(k)\}, \end{aligned}$$

with a (C/C) function $\mathcal{F}_{w\beta_b}$. Clearly, if we consider the interval $0 \leq k < b$ we have $\mathcal{F}_u(0) \geq \mathcal{F}_w(k)$ thus in general for $n \in \overline{\mathbb{Z}}_{\min}$ the (C/C)-function \mathcal{F}_u must satisfy, for $nb \leq k < (n+1)b$, $\mathcal{F}_u(n) \geq \mathcal{F}_w(k)$. Recall that \mathcal{F}_w is isotone, therefore it is sufficient to consider $k = (n+1)b - 1$, i.e., the greatest argument in the interval. Then,

$$\mathcal{F}_u(n) \geq \mathcal{F}_w((n+1)b - 1). \quad (\text{C.4})$$

The smallest function such that (C.4) holds is therefore

$$\mathcal{F}_{w\beta_b}(k) = \mathcal{F}_w((k+1)b - 1) = \mathcal{F}_w(kb + (b-1)) = \mathcal{F}_w(\mathcal{F}_{\mu_b\gamma^{b-1}}(k)) = \mathcal{F}_{w\mu_b\gamma^{b-1}}(k).$$

This corresponds to an operator representation $w\beta_b = w\mu_b\gamma^{b-1}$. \square

Proposition 105 ([16]). *Let s be a series in $\mathcal{E}[[\delta]]$, then*

$$\gamma^i \backslash s = \gamma^{-i} s, \quad s \beta \gamma^i = s \gamma^{-i}, \quad (\text{C.5})$$

$$\delta^\tau \backslash s = \delta^{-\tau} s, \quad s \beta \delta^\tau = s \delta^{-\tau}, \quad (\text{C.6})$$

$$\beta_b \backslash s = \mu_b s, \quad s \beta \mu_m = s \beta_m, \quad (\text{C.7})$$

$$\mu_m \backslash s = \beta_m \gamma^{m-1} s, \quad s \beta \beta_b = s \gamma^{b-1} \mu_b. \quad (\text{C.8})$$

Proof. This proof is taken from [16]. For the proof of (C.5) and (C.6), the operators γ^i and δ^τ are invertible, since $\delta^\tau \delta^{-\tau} = \gamma^i \gamma^{-i} = e$. Moreover, to prove (C.7) the right product by μ_m and the left product by β_b are invertible, since $\beta_m \mu_m = e$. For the proof of (C.8), recall Lemma 7 $\mu_m \backslash w = \beta_m \gamma^{m-1} w$ with $w \in \mathcal{E}$ and Prop. 6. Thus for a series $s = \bigoplus_i w_i \delta^{\tau_i} \in \mathcal{E}[[\delta]]$ one has

$$\begin{aligned} \mu_m \backslash s &= \mu_m \delta^0 \backslash \left(\bigoplus_i w_i \delta^{\tau_i} \right) = \bigoplus_i \left(\mu_m \backslash w_i \right) \delta^{\tau_i - 0} = \bigoplus_i \beta_m \gamma^{m-1} w_i \delta^{\tau_i}, \\ &= \beta_m \gamma^{m-1} s. \end{aligned}$$

The proof for $s \beta \beta_b = s \gamma^{b-1} \mu_b$ is analogous. \square

C.1.1. Proof of Prop. 28

Proof. For the proof of the left product by \mathbf{m}_m (3.49), by definition of the residual mapping $\mathbf{m}_m \backslash \mathbf{D}$ is the greatest solution of the following inequality

$$\mathbf{m}_m \otimes \mathbf{X} \leq \mathbf{D}, \quad (\text{C.9})$$

$$\mathbf{m}_m \begin{bmatrix} x_{1,1} & \cdots & x_{1,n} \\ \vdots & \ddots & \vdots \\ x_{m,1} & \cdots & x_{m,n} \end{bmatrix} \leq [d_1 \cdots d_n]. \quad (\text{C.10})$$

This matrix inequality can be transformed into a set of n inequalities,

$$\begin{aligned} \mu_m x_{1,1} \oplus \gamma^1 \mu_m x_{2,1} \oplus \cdots \oplus \gamma^{m-1} \mu_m x_{m,1} &\leq d_1, \\ \mu_m x_{1,2} \oplus \gamma^1 \mu_m x_{2,2} \oplus \cdots \oplus \gamma^{m-1} \mu_m x_{m,2} &\leq d_2, \\ &\vdots \\ \mu_m x_{1,n} \oplus \gamma^1 \mu_m x_{2,n} \oplus \cdots \oplus \gamma^{m-1} \mu_m x_{m,n} &\leq d_n. \end{aligned}$$

Because of Prop. 105, for each inequality $i \in \{1, \dots, n\}$ we obtain

$$\begin{aligned} x_{1,i} &\leq \mu_m \setminus d_i = \beta_m \gamma^{m-1} d_i, \\ x_{2,i} &\leq \gamma^1 \mu_m \setminus d_i = \beta_m \gamma^{m-1} \gamma^{-1} d_i = \beta_m \gamma^{m-2} d_i, \\ &\vdots \\ x_{m,i} &\leq (\gamma^{m-1} \mu_m) \setminus d_i = \beta_m d_i. \end{aligned}$$

Rewriting the inequalities into matrix form leads to

$$\mathbf{X} \leq \mathbf{m}_m \setminus \mathbf{D} = \begin{bmatrix} \beta_m \gamma^{m-1} \\ \beta_m \gamma^{m-2} \\ \vdots \\ \beta_m \end{bmatrix} \mathbf{D} = \mathbf{b}_m \otimes \mathbf{D}.$$

Moreover, $\mathbf{b}_m \mathbf{D}$ satisfies (C.9) with equality, since $\mathbf{m}_m \mathbf{b}_m = \mathbf{e}$. For the inequality

$$\mathbf{X} \otimes \mathbf{b}_b \leq \mathbf{P}$$

We have,

$$\begin{aligned} \mathbf{X} \mathbf{b}_b \leq \mathbf{P} &\Leftrightarrow \mathbf{X} \leq \mathbf{P} \setminus \mathbf{b}_b, \\ \begin{bmatrix} x_{1,1} & \cdots & x_{1,n} \\ \vdots & \ddots & \vdots \\ x_{m,1} & \cdots & x_{m,n} \end{bmatrix} \mathbf{b}_b &\leq \begin{bmatrix} p_1 \\ \vdots \\ p_n \end{bmatrix} \Leftrightarrow \begin{bmatrix} x_{1,1} & \cdots & x_{1,n} \\ \vdots & \ddots & \vdots \\ x_{m,1} & \cdots & x_{m,n} \end{bmatrix} \leq \begin{bmatrix} p_1 \\ \vdots \\ p_n \end{bmatrix} \setminus \mathbf{b}_b. \end{aligned}$$

We obtain for each $i \in \{1, \dots, n\}$ the following inequalities

$$\begin{aligned} x_{i,1} &\leq p_i \setminus (\beta_b \gamma^{b-1}) = p_i \mu_b, \\ x_{i,2} &\leq p_i \setminus (\beta_b \gamma^{b-2}) = p_i \gamma^1 \mu_b, \\ &\vdots \\ x_{i,n} &\leq p_i \setminus \beta_b = p_i \gamma^{b-1} \mu_b. \end{aligned}$$

This can be rewritten in matrix form

$$\mathbf{X} \leq \mathbf{P}\phi\mathbf{b}_b = \mathbf{P} \begin{bmatrix} \mu_b & \gamma^1 \mu_b & \cdots & \gamma^{b-1} \mu_b \end{bmatrix} = \mathbf{P} \otimes \mathbf{m}_b.$$

Again, $\mathbf{P}\mathbf{b}_b$ satisfies (C.1.1) with equality, since $\mathbf{m}_b\mathbf{b}_b = \mathbf{e}$. To prove (3.50), since $\mathbf{b}_m\mathbf{m}_m = \mathbf{E} = \mathbf{E}\mathbf{E}$ and due to (3.49) $\mathbf{P}\mathbf{m}_m = \mathbf{P}\phi\mathbf{b}_m$ we can write

$$(\mathbf{O}\mathbf{E})\phi\mathbf{m}_m = (\mathbf{O}\mathbf{E}\mathbf{b}_m\mathbf{m}_m)\phi\mathbf{m}_m = ((\mathbf{O}\mathbf{E}\mathbf{b}_m)\phi\mathbf{b}_m)\phi\mathbf{m}_m.$$

Since $(x\phi a)\phi b = x\phi(ba)$ (A.1) and $\mathbf{m}_m\mathbf{b}_m = \mathbf{e}$ (see 3.43),

$$((\mathbf{O}\mathbf{E}\mathbf{b}_m)\phi\mathbf{b}_m)\phi\mathbf{m}_m = (\mathbf{O}\mathbf{E}\mathbf{b}_m)\phi(\mathbf{m}_m\mathbf{b}_m) = (\mathbf{O}\mathbf{E}\mathbf{b}_m)\phi\mathbf{e} = \mathbf{O}\mathbf{E}\mathbf{b}_m.$$

The proof of $\mathbf{b}_b \setminus (\mathbf{E}\mathbf{N}) = \mathbf{m}_b \otimes \mathbf{E}\mathbf{N}$ is analogous. □

C.1.2. Proof of Prop. 30

Proof. We can extend a core matrix \mathbf{Q} of a series, i.e.,

$$s = \mathbf{m}_m\mathbf{Q}\mathbf{b}_b = \mathbf{m}_{nm} \underbrace{\mathbf{b}_{nm}\mathbf{m}_m\mathbf{Q}\mathbf{b}_b\mathbf{m}_{nb}}_{\hat{\mathbf{Q}}'} \mathbf{b}_{nb}.$$

Since, $\beta_{nm}\gamma^{mn-1} = \beta_n\beta_m\gamma^{m(n-1)}\gamma^{m-1} = \beta_n\gamma^{n-1}\beta_m\gamma^{m-1}$ then

$$\mathbf{b}_{nm} = \begin{bmatrix} \begin{bmatrix} \beta_n\gamma^{n-1}\beta_m\gamma^{m-1} \\ \beta_n\gamma^{n-1}\beta_m\gamma^{m-2} \\ \vdots \\ \beta_n\gamma^{n-1}\beta_m \end{bmatrix} \\ \vdots \\ \begin{bmatrix} \beta_n\beta_m\gamma^{m-1} \\ \beta_n\beta_m\gamma^{m-2} \\ \vdots \\ \beta_n\beta_m \end{bmatrix} \end{bmatrix} = \begin{bmatrix} \beta_n\gamma^{n-1}\mathbf{b}_m \\ \beta_n\gamma^{n-2}\mathbf{b}_m \\ \vdots \\ \beta_n\mathbf{b}_m \end{bmatrix}.$$

This leads to

$$\mathbf{b}_{nm}\mathbf{m}_m = \begin{bmatrix} \beta_n\gamma^{n-1}\mathbf{E} \\ \beta_n\gamma^{n-2}\mathbf{E} \\ \vdots \\ \beta_n\mathbf{E} \end{bmatrix}.$$

Respectively $\mathbf{b}_b \mathbf{m}_{nb}$ is given by

$$\mathbf{b}_b \mathbf{m}_{nb} = \begin{bmatrix} \mathbf{E} \mu_n & \mathbf{E} \mu_n \gamma^1 & \cdots & \mathbf{E} \gamma^{n-1} \mu_n \end{bmatrix}.$$

Finally, we obtain

$$\begin{aligned} \hat{\mathbf{Q}}' &= \begin{bmatrix} \beta_n \gamma^{n-1} \mathbf{E} \\ \beta_n \gamma^{n-2} \mathbf{E} \\ \vdots \\ \beta_n \mathbf{E} \end{bmatrix} \mathbf{Q} \begin{bmatrix} \mathbf{E} \mu_n & \mathbf{E} \mu_n \gamma^1 & \cdots & \mathbf{E} \gamma^{n-1} \mu_n \end{bmatrix}, \\ &= \begin{bmatrix} \beta_n \gamma^{n-1} \hat{\mathbf{Q}} \mu_n & \beta_n \gamma^{n-1} \hat{\mathbf{Q}} \gamma^1 \mu_n & \cdots & \beta_n \gamma^{n-1} \hat{\mathbf{Q}} \gamma^{n-1} \mu_n \\ \beta_n \gamma^{n-2} \hat{\mathbf{Q}} \mu_n & \beta_n \gamma^{n-2} \hat{\mathbf{Q}} \gamma^1 \mu_n & \cdots & \beta_n \gamma^{n-2} \hat{\mathbf{Q}} \gamma^{n-1} \mu_n \\ \vdots & \vdots & & \vdots \\ \beta_n \hat{\mathbf{Q}} \mu_n & \beta_n \hat{\mathbf{Q}} \gamma^1 \mu_n & \cdots & \beta_n \hat{\mathbf{Q}} \gamma^{n-1} \mu_n \end{bmatrix}. \end{aligned}$$

The extended core is a matrix with entries in $\mathcal{M}_{\text{in}}^{\text{ax}}[[\gamma, \delta]]$, since $\beta_n \gamma^\nu \mu_n = \gamma^{|\nu/n|n}$. Furthermore, the extended core \mathbf{Q}' is a greatest core. For this, one has to show that $\hat{\mathbf{Q}}'' = \mathbf{E} \hat{\mathbf{Q}}' \mathbf{E} = \hat{\mathbf{Q}}'$.

$$\begin{aligned} \hat{\mathbf{Q}}'' &= \mathbf{E} \mathbf{b}_{nm} \mathbf{m}_m \mathbf{Q} \mathbf{b}_b \mathbf{m}_{nb} \mathbf{E}, \\ &= \mathbf{b}_{nm} \underbrace{\mathbf{m}_{nm} \mathbf{b}_{nm}}_e \mathbf{m}_m \mathbf{Q} \mathbf{b}_b \underbrace{\mathbf{m}_{nb} \mathbf{b}_{nb}}_e \mathbf{m}_{nb}, \\ &= \mathbf{b}_{nm} \mathbf{m}_m \mathbf{Q} \mathbf{b}_b \mathbf{m}_{nb} = \hat{\mathbf{Q}}'. \end{aligned}$$

□

C.1.3. Proof of Prop. 38

Proof. (3.53) for the left product, by definition of the residual mapping $\mathbf{M} \setminus \mathbf{D}$ is the greatest solution of the following inequality:

$$\begin{aligned} \mathbf{M}_w \mathbf{X} \leq \mathbf{D} & \tag{C.11} \\ \begin{bmatrix} \mathbf{m}_{m_1} \mathbf{x}_{11} & \cdots & \mathbf{m}_{m_1} \mathbf{x}_{1g} \\ \vdots & & \vdots \\ \mathbf{m}_{m_p} \mathbf{x}_{p1} & \cdots & \mathbf{m}_{m_p} \mathbf{x}_{pg} \end{bmatrix} \leq \begin{bmatrix} d_{11} & \cdots & d_{1g} \\ \vdots & & \vdots \\ d_{p1} & \cdots & d_{pg} \end{bmatrix} \end{aligned}$$

For every row $i \in \{1, \dots, p\}$ we obtain the following inequality

$$\begin{bmatrix} \mathbf{m}_{m_i} \mathbf{x}_{i1} & \cdots & \mathbf{m}_{m_i} \mathbf{x}_{ip} \end{bmatrix} \leq \begin{bmatrix} d_{i1} & \cdots & d_{ip} \end{bmatrix}$$

Due to (3.49) the greatest solution for this inequality is given by

$$\begin{bmatrix} x_{i1} & \cdots & x_{ip} \end{bmatrix} \leq \begin{bmatrix} \mathbf{b}_{m_i} d_{i1} & \cdots & \mathbf{b}_{m_i} d_{ip} \end{bmatrix}$$

Therefore the greatest solution for the matrix inequality in (C.11) is

$$\mathbf{X} \leq \mathbf{M}_w \mathbf{D} = \begin{bmatrix} \mathbf{b}_{m_1} & \varepsilon & \cdots & \varepsilon \\ \varepsilon & \ddots & \ddots & \vdots \\ \vdots & \ddots & \ddots & \varepsilon \\ \varepsilon & \cdots & \varepsilon & \mathbf{b}_{m_p} \end{bmatrix} \mathbf{D} = \mathbf{B}_w \mathbf{D}.$$

Note that $\mathbf{B}_w \mathbf{D}$ satisfies (C.11) with equality since $\mathbf{M}_b \mathbf{B}_w = \mathbf{I}$. The proof of $\mathbf{O} \not\leq \mathbf{B}_{w'} = \mathbf{O} \mathbf{M}_{w'}$ is analogous. To prove (3.54), since $\mathbf{E}_w = \mathbf{B}_w \mathbf{M}_w = \mathbf{E}_w \mathbf{B}_w \mathbf{M}_w$ and due to (3.53) $\mathbf{O} \mathbf{M}_w = \mathbf{O} \not\leq \mathbf{B}_w$ we can write

$$(\mathbf{N} \mathbf{E}_w) \not\leq \mathbf{M}_w = (\mathbf{N} \mathbf{E}_w \mathbf{B}_w \mathbf{M}_w) \not\leq \mathbf{M}_w = ((\mathbf{N} \mathbf{E}_w \mathbf{B}_w) \not\leq \mathbf{B}_w) \not\leq \mathbf{M}_w.$$

Since $(x \not\leq a) \not\leq b = x \not\leq (ba)$ (A.1) and $\mathbf{M}_w \mathbf{B}_w = \mathbf{I}$,

$$\begin{aligned} ((\mathbf{N} \mathbf{E}_w \mathbf{B}_w) \not\leq \mathbf{B}_w) \not\leq \mathbf{M}_w &= (\mathbf{N} \mathbf{E}_w \mathbf{B}_w) \not\leq (\mathbf{M}_w \mathbf{B}_w) \\ &= (\mathbf{N} \mathbf{E}_w \mathbf{B}_w) \not\leq \mathbf{I} = \mathbf{N} \mathbf{E}_w \mathbf{B}_w. \end{aligned}$$

The proof of $\mathbf{B}_{w'} \not\leq (\mathbf{E}_{w'} \mathbf{G}) = \mathbf{M}_{w'} \otimes \mathbf{E}_{w'} \mathbf{G}$ is analogous. □

C.2. Proofs of Section 4.1

C.2.1. Proof of Prop. 56

Proof. Let us recall that the release-time function of the $\Delta_{\omega|\omega}$ operator is given by $\mathcal{R}_{\Delta_{\omega|\omega}}(\mathbf{t}) = \lceil \mathbf{t}/\omega \rceil \omega$. Due to Remark 23 the $(n\omega, n\omega)$ -periodic representation of this operator is

$$\begin{aligned} \Delta_{\omega|\omega} &= \bigoplus_{t=0}^{n\omega-1} \delta^{\lceil -t/\omega \rceil \omega} \Delta_{n\omega|n\omega} \delta^{t-n\omega+1}, \\ &= \bigoplus_{i=0}^{n-1} \bigoplus_{j=0}^{\omega-1} \delta^{\lceil (-i\omega-j)/\omega \rceil \omega} \Delta_{n\omega|n\omega} \delta^{i\omega+j-n\omega+1}, \quad \text{with } \mathbf{t} = i\omega + j, \\ &= \bigoplus_{i=0}^{n-1} \bigoplus_{j=0}^{\omega-1} \delta^{-i\omega} \Delta_{n\omega|n\omega} \delta^{i\omega+j-n\omega+1} \end{aligned}$$

since $\forall j \in \{0, \dots, \omega-1\}, \lceil (-i\omega-j)/\omega \rceil = -i$.

Due to the order relation in \mathcal{T} see (4.12) we have

$$\bigoplus_{j=0}^{\omega-1} \delta^{-i\omega} \Delta_{n\omega|n\omega} \delta^{i\omega+j-n\omega+1} = \delta^{-i\omega} \Delta_{n\omega|n\omega} \delta^{i\omega+\omega-1-n\omega+1} = \delta^{-i\omega} \Delta_{n\omega|n\omega} \delta^{-(n-1-i)\omega},$$

and thus

$$\Delta_{\omega|\omega} = \bigoplus_{i=0}^{n-1} \delta^{-i\omega} \Delta_{n\omega|n\omega} \delta^{-(n-1-i)\omega}.$$

□

Lemma 8. *Let $v \in \mathcal{T}$, then:*

$$\Delta_{\omega|\omega} \backslash v = \Delta_{\omega|\omega} \delta^{1-\omega} v, \quad v \not\leq \Delta_{\omega|\omega} = v \delta^{1-\omega} \Delta_{\omega|\omega}. \quad (\text{C.12})$$

Proof. To prove (C.12), recall that by definition of the residuated mapping, $\Delta_{\omega|\omega} \backslash v$ is the greatest solution of the inequality $v \geq \Delta_{\omega|\omega} x$. This greatest solution is given by

$$\Delta_{\omega|\omega} \backslash v = \bigoplus \{u \in \mathcal{T} \mid \Delta_{\omega|\omega} u \leq v\} = \bigoplus \{u \in \mathcal{T} \mid \mathcal{R}_{\Delta_{\omega|\omega} u}(t) \leq \mathcal{R}_v(t), \forall t \in \bar{\mathbb{Z}}_{\max}\}.$$

Therefore, $\forall t \in \bar{\mathbb{Z}}_{\max}$

$$\mathcal{R}_{\Delta_{\omega|\omega} \backslash v}(t) = \max\{\mathcal{R}_u(t) \mid \lceil \mathcal{R}_u(t) / \omega \rceil \omega \leq \mathcal{R}_v(t)\}$$

Observe that,

$$\begin{aligned} & \left\lceil \frac{\mathcal{R}_u(t)}{\omega} \right\rceil \omega \leq \mathcal{R}_v(t) \\ \Leftrightarrow & \left\lceil \frac{\mathcal{R}_u(t)}{\omega} \right\rceil \leq \frac{\mathcal{R}_v(t)}{\omega} \\ \Leftrightarrow & \frac{\mathcal{R}_u(t)}{\omega} \leq \left\lfloor \frac{\mathcal{R}_v(t)}{\omega} \right\rfloor = \left\lfloor \frac{\mathcal{R}_v(t) - \omega + 1}{\omega} \right\rfloor \\ \Leftrightarrow & \mathcal{R}_u(t) \leq \left\lfloor \frac{\mathcal{R}_v(t) - \omega + 1}{\omega} \right\rfloor \omega \end{aligned}$$

where the equality above chain of equivalence follows from the basic properties of the "floor" and "ceiling" operations listed in Appendix B. Consequently

$$\begin{aligned} \mathcal{R}_{\Delta_{\omega|\omega} \backslash v}(t) & \leq \left\lfloor \frac{\mathcal{R}_v(t) - \omega + 1}{\omega} \right\rfloor \omega, \quad \forall t \in \bar{\mathbb{Z}}_{\max} \\ \Leftrightarrow \omega \backslash v & = \Delta_{\omega|\omega} \delta^{1-\omega} v. \end{aligned}$$

The proof for $v \not\leq \Delta_{\omega|\omega} = v \delta^{1-\omega} \Delta_{\omega|\omega}$ is analogous.

□

Proposition 106. *Let s be a series in $\mathcal{T}[[\gamma]]$, then*

$$\gamma^\eta \backslash s = \gamma^{-\eta} s, \quad s \not\backslash \gamma^\eta = s \gamma^{-\eta}, \quad (\text{C.13})$$

$$\delta^\tau \backslash s = \delta^{-\tau} s, \quad s \not\backslash \delta^\tau = s \delta^{-\tau}, \quad (\text{C.14})$$

$$\Delta_{\omega|\omega} \backslash s = \Delta_{\omega|\omega} \delta^{1-\omega} s, \quad s \not\backslash \Delta_{\omega|\omega} = s \delta^{1-\omega} \Delta_{\omega|\omega}. \quad (\text{C.15})$$

Proof. For the proof of (C.13) and (C.14), the operators δ^τ and γ^η are invertible, since $\delta^\tau \delta^{-\tau} = \gamma^\eta \gamma^{-\eta} = e$. Moreover, for the proof of (C.15), recall Lemma 8 $\Delta_{\omega|\omega} \backslash v = \Delta_{\omega|\omega} \delta^{1-\omega} v$ with $v \in \mathcal{T}$ and Prop. 6. Therefore, for a series $s = \bigoplus_i v_i \gamma^{n_i} \in \mathcal{T}[[\gamma]]$ one has

$$\begin{aligned} \Delta_{\omega|\omega} \backslash s &= \Delta_{\omega|\omega} \gamma^0 \backslash \left(\bigoplus_i v_i \gamma^{n_i} \right) = \bigoplus_i \left(\Delta_{\omega|\omega} \backslash v_i \right) \gamma^{n_i-0} = \bigoplus_i \Delta_{\omega|\omega} \delta^{1-\omega} v_i \gamma^{n_i}, \\ &= \Delta_{\omega|\omega} \delta^{1-\omega} s. \end{aligned}$$

The proof for $s \not\backslash \Delta_{\omega|\omega} = s \delta^{1-\omega} \Delta_{\omega|\omega}$ is analogous. \square

C.2.2. Proof of Prop. 61

Proof. Note that this proof is similar to the proof of Prop. 28. For the proof of (4.25), by definition of the residual mapping $\mathbf{d}_\omega \backslash \mathbf{A}$ is the greatest solution of the following inequality

$$\begin{aligned} \mathbf{d}_\omega \otimes \mathbf{X} &\leq \mathbf{A}, \quad (\text{C.16}) \\ \mathbf{d}_\omega \begin{bmatrix} x_{1,1} & \cdots & x_{1,n} \\ \vdots & \ddots & \vdots \\ x_{\omega,1} & \cdots & x_{\omega,n} \end{bmatrix} &\leq \begin{bmatrix} a_1 & \cdots & a_n \end{bmatrix}. \end{aligned}$$

This matrix inequality can be transformed into a set of n inequalities,

$$\begin{aligned} \Delta_{\omega|1} x_{1,1} \oplus \delta^{-1} \Delta_{\omega|1} x_{2,1} \oplus \cdots \oplus \delta^{1-\omega} \Delta_{\omega|1} x_{m,1} &\leq a_1, \\ \Delta_{\omega|1} x_{1,2} \oplus \delta^{-1} \Delta_{\omega|1} x_{2,2} \oplus \cdots \oplus \delta^{1-\omega} \Delta_{\omega|1} x_{m,2} &\leq a_2, \\ &\vdots \\ \Delta_{\omega|1} x_{1,n} \oplus \delta^{-1} \Delta_{\omega|1} x_{2,n} \oplus \cdots \oplus \delta^{1-\omega} \Delta_{\omega|1} x_{m,n} &\leq a_n. \end{aligned}$$

Because of Prop. 106, for each inequality $i \in \{1, \dots, n\}$ we obtain

$$\begin{aligned} x_{1,i} &\leq \Delta_{\omega|1} \backslash a_i = \Delta_{1|\omega} \delta^{1-\omega} a_i, \\ x_{2,i} &\leq \delta^{-1} \Delta_{\omega|1} \backslash a_i = \Delta_{1|\omega} \delta^{1-\omega} \delta^1 a_i = \Delta_{1|\omega} \delta^{2-\omega} a_i, \\ &\vdots \\ x_{m,i} &\leq (\delta^{1-\omega} \Delta_{\omega|1}) \backslash a_i = \Delta_{1|\omega} a_i. \end{aligned}$$

Rewriting the inequalities into matrix form leads to

$$\mathbf{X} \leq \mathbf{d}_\omega \backslash \mathbf{A} = \begin{bmatrix} \Delta_{1|\omega} \delta^{1-\omega} \\ \Delta_{1|\omega} \delta^{2-\omega} \\ \vdots \\ \Delta_{1|\omega} \end{bmatrix} \mathbf{A} = \mathbf{p}_\omega \otimes \mathbf{A}.$$

Note that $\mathbf{p}_\omega \mathbf{A}$ satisfies (C.16) with equality, since $\mathbf{d}_\omega \mathbf{p}_\omega = \mathbf{e}$. For the inequality

$$\mathbf{X} \otimes \mathbf{p}_\omega \leq \mathbf{G}, \tag{C.17}$$

where \mathbf{X} is of size $n \times m$ and \mathbf{G} is of size $n \times 1$. Then,

$$\mathbf{X} \mathbf{p}_\omega \leq \mathbf{G} \Leftrightarrow \mathbf{X} \leq \mathbf{G} \backslash \mathbf{p}_\omega.$$

We obtain for each $i \in \{1, \dots, n\}$ the following inequalities

$$\begin{aligned} x_{i,1} &\leq g_i \backslash (\Delta_{1|\omega} \delta^{1-\omega}) = g_i \Delta_{\omega|1}, \\ &\vdots \\ x_{i,n} &\leq g_i \backslash \Delta_{1|\omega} = g_i \delta^{1-\omega} \Delta_{\omega|1}. \end{aligned}$$

This can be expressed in matrix form

$$\mathbf{X} \leq \mathbf{G} \backslash \mathbf{p}_\omega = \mathbf{G} \begin{bmatrix} \Delta_{\omega|1} & \delta^{-1} \Delta_{\omega|1} & \dots & \delta^{1-\omega} \Delta_{\omega|1} \end{bmatrix} = \mathbf{G} \otimes \mathbf{d}_\omega.$$

Again $\mathbf{G} \mathbf{d}_\omega$ satisfies (C.17) with equality, since $\mathbf{d}_\omega \mathbf{p}_\omega = \mathbf{e}$. To prove (4.26), since $\mathbf{p}_\omega \mathbf{d}_\omega = \mathbf{N} = \mathbf{N} \mathbf{N}$ and due to $\mathbf{G} \mathbf{d}_\omega = \mathbf{G} \backslash \mathbf{p}_\omega$ (4.25) we can write

$$(\mathbf{O} \mathbf{N}) \backslash \mathbf{d}_\omega = (\mathbf{O} \mathbf{N} \mathbf{p}_\omega \mathbf{d}_\omega) \backslash \mathbf{d}_\omega = ((\mathbf{O} \mathbf{N} \mathbf{p}_\omega) \backslash \mathbf{p}_\omega) \backslash \mathbf{d}_\omega.$$

Since, $(x \backslash a) \backslash b = x \backslash (ba)$ (A.5) and $\mathbf{d}_\omega \mathbf{p}_\omega = \mathbf{e}$ (4.19),

$$\begin{aligned} ((\mathbf{O} \mathbf{N} \mathbf{p}_\omega) \backslash \mathbf{p}_\omega) \backslash \mathbf{d}_\omega &= (\mathbf{O} \mathbf{N} \mathbf{p}_\omega) \backslash (\mathbf{d}_\omega \mathbf{p}_\omega) \\ &= (\mathbf{O} \mathbf{N} \mathbf{p}_\omega) \backslash \mathbf{e} = \mathbf{O} \mathbf{N} \mathbf{p}_\omega. \end{aligned}$$

The proof of $\mathbf{p}_\omega \backslash (\mathbf{N} \mathbf{O}) = \mathbf{d}_\omega \otimes \mathbf{N} \mathbf{O}$ is analogous. □

C.2.3. Proof of Prop. 64

Proof. We can extend the core matrix \mathbf{Q} of a series, i.e.,

$$s = \mathbf{d}_\omega \mathbf{Q} \mathbf{p}_\omega = \mathbf{d}_{n\omega} \underbrace{\mathbf{p}_{n\omega} \mathbf{d}_\omega \mathbf{Q} \mathbf{p}_\omega \mathbf{d}_{n\omega}}_{\hat{\mathbf{Q}}'} \mathbf{p}_{n\omega}.$$

Since, $\Delta_{1|n\omega}\delta^{1-n\omega} = \Delta_{1|n}\Delta_{1|\omega}\delta^{-\omega(n-1)}\delta^{1-\omega} = \Delta_{1|n}\delta^{1-n}\Delta_{1|\omega}\delta^{1-\omega}$ then

$$\mathbf{p}_{n\omega} = \begin{bmatrix} \begin{bmatrix} \Delta_{1|n}\delta^{1-n}\Delta_{1|\omega}\delta^{1-\omega} \\ \Delta_{1|n}\delta^{1-n}\Delta_{1|\omega}\delta^{2-\omega} \\ \vdots \\ \Delta_{1|n}\delta^{1-n}\Delta_{1|\omega} \end{bmatrix} \\ \vdots \\ \begin{bmatrix} \Delta_{1|n}\Delta_{1|\omega}\delta^{1-\omega} \\ \Delta_{1|n}\Delta_{1|\omega}\delta^{2-\omega} \\ \vdots \\ \Delta_{1|n}\Delta_{1|\omega} \end{bmatrix} \end{bmatrix} = \begin{bmatrix} \Delta_{1|n}\delta^{1-n}\mathbf{p}_\omega \\ \Delta_{1|n}\delta^{2-n}\mathbf{p}_\omega \\ \vdots \\ \Delta_{1|n}\mathbf{p}_\omega \end{bmatrix}.$$

This leads to

$$\mathbf{p}_{n\omega}\mathbf{d}_\omega = \begin{bmatrix} \Delta_{1|n}\delta^{1-n}\mathbf{N} \\ \Delta_{1|n}\delta^{2-n}\mathbf{N} \\ \vdots \\ \Delta_{1|n}\mathbf{N} \end{bmatrix}.$$

Respectively, $\mathbf{p}_\omega\mathbf{d}_{n\omega}$ is given by

$$\mathbf{p}_\omega\mathbf{d}_{n\omega} = \begin{bmatrix} \mathbf{N}\Delta_{n|1} & \mathbf{N}\delta^{-1}\Delta_{n|1} & \cdots & \mathbf{N}\delta^{1-n}\Delta_{n|1} \end{bmatrix}.$$

Finally, we obtain

$$\begin{aligned} \hat{\mathbf{Q}}' &= \begin{bmatrix} \Delta_{1|n}\delta^{1-n}\mathbf{N} \\ \Delta_{1|n}\delta^{2-n}\mathbf{N} \\ \vdots \\ \Delta_{1|n}\mathbf{N} \end{bmatrix} \mathbf{Q} \begin{bmatrix} \mathbf{N}\Delta_{n|1} & \mathbf{N}\delta^{-1}\Delta_{n|1} & \cdots & \mathbf{N}\delta^{1-n}\Delta_{n|1} \end{bmatrix}, \\ &= \begin{bmatrix} \Delta_{1|n}\delta^{1-n}\hat{\mathbf{Q}}\Delta_{n|1} & \Delta_{1|n}\delta^{1-n}\hat{\mathbf{Q}}\delta^{-1}\Delta_{n|1} & \cdots & \Delta_{1|n}\delta^{1-n}\hat{\mathbf{Q}}\delta^{1-n}\Delta_{n|1} \\ \Delta_{1|n}\delta^{2-n}\hat{\mathbf{Q}}\Delta_{n|1} & \Delta_{1|n}\delta^{2-n}\hat{\mathbf{Q}}\delta^{-1}\Delta_{n|1} & \cdots & \Delta_{1|n}\delta^{2-n}\hat{\mathbf{Q}}\delta^{1-n}\Delta_{n|1} \\ \vdots & \vdots & & \vdots \\ \Delta_{1|n}\hat{\mathbf{Q}}\Delta_{n|1} & \Delta_{1|n}\hat{\mathbf{Q}}\delta^{-1}\Delta_{n|1} & \cdots & \Delta_{1|n}\hat{\mathbf{Q}}\delta^{1-n}\Delta_{n|1} \end{bmatrix}. \end{aligned}$$

The extended core is a matrix with entries in $\mathcal{M}_{\text{in}}^{\text{ax}}[\gamma, \delta]$, since $\Delta_{1|n}\delta^\tau\Delta_{n|1} = \delta^{[\tau/n]n}$ (Remark 21). Furthermore, the extended core $\hat{\mathbf{Q}}'$ is a greatest core. For this one has to show that

$$\widehat{\mathbf{Q}}'' = \mathbf{N}\widehat{\mathbf{Q}}'\mathbf{N} = \widehat{\mathbf{Q}}'.$$

$$\begin{aligned}\widehat{\mathbf{Q}}'' &= \mathbf{N}\mathbf{p}_{n\omega}\mathbf{d}_\omega\mathbf{Q}\mathbf{p}_\omega\mathbf{d}_{n\omega}\mathbf{N}, \\ &= \mathbf{p}_{n\omega}\underbrace{\mathbf{d}_{n\omega}\mathbf{p}_{n\omega}}_e\mathbf{d}_\omega\mathbf{Q}\mathbf{p}_\omega\underbrace{\mathbf{d}_{n\omega}\mathbf{p}_{n\omega}}_e\mathbf{d}_{n\omega}, \\ &= \mathbf{p}_{n\omega}\mathbf{d}_\omega\mathbf{Q}\mathbf{p}_\omega\mathbf{d}_{n\omega} = \widehat{\mathbf{Q}}'.\end{aligned}$$

□

C.3. Proofs of Chapter 5

Lemma 9. *All elementary operators introduced in Prop. 73 can be represented as basic elements in \mathcal{ET} .*

Proof. Recall that a basic element in \mathcal{ET} is expressed as $\gamma^n\delta^\tau\nabla_{m|b}\Delta_{\omega|\omega}\gamma^{n'}\delta^{\tau'}$. Moreover, the unit operator can be written as $e = \gamma^0 = \delta^0 = \nabla_{1|1} = \Delta_{1|1} = \gamma^0\delta^0\nabla_{1|1}\Delta_{1|1}\gamma^0\delta^0$. Then the elementary operators can be rephrased as follows,

$$\begin{aligned}(\nabla_{m|b}(x))(t) &= (\gamma^0\delta^0\nabla_{m|b}\Delta_{1|1}\gamma^0\delta^0(x))(t), \\ (\Delta_{\omega|\omega}(x))(t) &= (\gamma^0\delta^0\nabla_{1|1}\Delta_{\omega|\omega}\gamma^0\delta^0(x))(t), \\ (\gamma^\nu(x))(t) &= (\gamma^\nu\delta^0\nabla_{1|1}\Delta_{1|1}\gamma^0\delta^0(x))(t), \\ (\delta^\tau(x))(t) &= (\gamma^0\delta^\tau\nabla_{1|1}\Delta_{1|1}\gamma^0\delta^0(x))(t).\end{aligned}$$

□

Lemma 10. *The product of two basic elements in \mathcal{ET} is a finite sum of basic elements in \mathcal{ET} .*

Proof. Consider the following product of two basic elements in \mathcal{ET} .

$$\gamma^{\nu_1}\delta^{\tau_1}\nabla_{m_1|b_1}\Delta_{\omega_1|\omega_1}\gamma^{\nu'_1}\delta^{\tau'_1} \otimes \gamma^{\nu_2}\delta^{\tau_2}\nabla_{m_2|b_2}\Delta_{\omega_2|\omega_2}\gamma^{\nu'_2}\delta^{\tau'_2} \quad (\text{C.18})$$

We chose $\omega = \text{lcm}(\omega_1, \omega_2)$, $c_3 = \omega/\omega_1$, $c_4 = \omega/\omega_2$ and $m = \text{lcm}(b_1, b_2)$, $c_1 = m/b_1$ and $c_2 = m/b_2$ then due to (5.14) and (5.15) this product can be written as

$$\begin{aligned}&\gamma^{\nu_1}\delta^{\tau_1}\left(\bigoplus_{i=0}^{c_1-1}\gamma^{im_1}\nabla_{c_1m_1|m}\gamma^{(c_1-1-i)b_1}\right)\left(\bigoplus_{l=0}^{c_3-1}\delta^{-l\omega_1}\Delta_{c_3\omega_1|\omega}\delta^{-(c_3-1-l)\omega_1}\right)\gamma^{\nu'_1}\delta^{\tau'_1}\otimes \\ &\gamma^{\nu_2}\delta^{\tau_2}\left(\bigoplus_{j=0}^{c_2-1}\gamma^{jm_2}\nabla_{m|c_2b_2}\gamma^{(c_2-1-j)b_2}\right)\left(\bigoplus_{g=0}^{c_4-1}\delta^{-g\omega_2}\Delta_{\omega|c_4\omega_2}\delta^{-(c_4-1-g)\omega_2}\right)\gamma^{\nu'_2}\delta^{\tau'_2}\end{aligned}$$

Due to distributivity holds for the following operators, $\gamma \nabla_{m|b} \gamma \delta \Delta_{\omega|\omega} \delta = \delta \Delta_{\omega|\omega} \delta \gamma \nabla_{m|b} \gamma$ (Prop. 75), (C.18) is written as

$$\begin{aligned} & \gamma^{\nu_1} \delta^{\tau_1} \left(\bigoplus_{i=0}^{c_1-1} \gamma^{im_1} \nabla_{c_1 m_1 | m} \gamma^{(c_1-1-i)b_1} \right) \gamma^{\nu'_1 + \nu_2} \left(\bigoplus_{j=0}^{c_2-1} \gamma^{jm_2} \nabla_{m | c_2 b_2} \gamma^{(c_2-1-j)b_2} \right) \otimes \\ & \left(\bigoplus_{l=0}^{c_3-1} \delta^{-l\omega_1} \Delta_{c_3 \omega_1 | \omega} \delta^{-(c_3-1-l)\omega_1} \right) \delta^{\tau'_1 + \tau_2} \left(\bigoplus_{g=0}^{c_4-1} \delta^{-g\omega_2} \Delta_{\omega | c_4 \omega_2} \delta^{-(c_4-1-g)\omega_2} \right) \gamma^{\nu'_2} \delta^{\tau'_2} \end{aligned}$$

Recall that $\nabla_{m|b} \gamma^b = \gamma^m \nabla_{m|b}$ (resp. $\Delta_{\omega|\omega} \delta^\omega = \delta^\omega \Delta_{\omega|\omega}$) (5.11) and for $0 \leq n < i$, $\nabla_{m|i} \gamma^n \nabla_{i|b} = \nabla_{m|b}$ (resp. $-i < \tau \leq 0$, $\Delta_{\omega|i} \delta^\tau \Delta_{i|\omega} = \Delta_{\omega|\omega}$) (Remark 30). Therefore the expression above is rephrased as,

$$\begin{aligned} & \bigoplus_{i=0}^{c_1-1} \bigoplus_{j=0}^{c_2-1} \gamma^{im_1 + \nu_1 + [(c_1-1-i)b_1 + \nu'_1 + \nu_2 + jm_2]/m} \nabla_{c_1 m_1 | c_2 b_2} \gamma^{(c_2-1-j)b_2 + \nu'_2} \otimes \\ & \bigoplus_{l=0}^{c_3-1} \bigoplus_{g=0}^{c_4-1} \delta^{\tau_1 - l\omega_1 + [-(c_3-1-l)\omega_1 + \tau'_1 + \tau_2 - g\omega_2]/\omega} \Delta_{c_3 \omega_1 | c_4 \omega_2} \delta^{-(c_4-1-g)\omega_2 + \tau_2} \end{aligned}$$

Again, because distributivity holds for $\delta^\tau \gamma^\nu \nabla_{m|b} = \gamma^\nu \nabla_{m|b} \delta^\tau$ and $\gamma^\nu \delta^\tau \Delta_{\omega|\omega} = \delta^\tau \Delta_{\omega|\omega} \gamma^\nu$ (Prop. 75) the product (C.18) is written as

$$\begin{aligned} & \bigoplus_{i=0}^{c_1-1} \bigoplus_{j=0}^{c_2-1} \bigoplus_{l=0}^{c_3-1} \bigoplus_{g=0}^{c_4-1} \gamma^{im_1 + \nu_1 + [(c_1-1-i)b_1 + \nu'_1 + \nu_2 + jm_2]/m} \otimes \\ & \delta^{\tau_1 - l\omega_1 + [-(c_3-1-l)\omega_1 + \tau'_1 + \tau_2 - g\omega_2]/\omega} \otimes \\ & \nabla_{c_1 m_1 | c_2 b_2} \Delta_{c_3 \omega_1 | c_4 \omega_2} \gamma^{(c_2-1-j)b_2 + \nu'_2} \delta^{-(c_4-1-g)\omega_2 + \tau_2} \end{aligned}$$

which is in the required form. \square

C.3.1. Proof of Prop. 78

Proof. Because of Lemma 9 all elementary operators introduced in Prop. 73 can be represented by basic elements in \mathcal{ET} . Moreover the product of two basic elements is a finite sum of basic elements, see Lemma 10. Therefore, any element $s \in \mathcal{ET}$ can be written as a finite (resp. infinite) sum of basic elements, i.e., $s = \bigoplus_i \gamma^{\nu_i} \delta^{\tau_i} \nabla_{m_i | b_i} \Delta_{\omega_i | \bar{\omega}_i} \gamma^{n'_i} \delta^{\tau'_i}$. Recall (5.14) and (5.15), then by choosing $m = \text{lcm}(m_i)$ and $\omega = \text{lcm}(\omega_i)$, s can be rephrased as $s = \bigoplus_j \gamma^{\nu_j} \delta^{\tau_j} \nabla_{m | \bar{b}_j} \Delta_{\omega | \bar{\omega}_j} \gamma^{\bar{n}'_j} \delta^{\bar{\tau}'_j}$, which is the required from. \square

C.3.2. Proof of Prop. 83

Proof. Since, $\mathbf{m}_{m,n\omega}\mathbf{b}_{b,n\omega} = e$ an ultimately cyclic series $s \in \mathcal{ET}_{\text{per}}$ can be expressed as,

$$\begin{aligned} s &= \mathbf{m}_{m,\omega}\hat{\mathbf{Q}}\mathbf{b}_{b,\omega} \\ &= \mathbf{m}_{m,n\omega}\underbrace{\mathbf{b}_{b,n\omega}\mathbf{m}_{m,\omega}\hat{\mathbf{Q}}\mathbf{b}_{b,\omega}\mathbf{m}_{b,n\omega}}_{\hat{\mathbf{Q}}'}\mathbf{b}_{b,n\omega}. \end{aligned}$$

In the following it is shown that $\hat{\mathbf{Q}}'$ is again a matrix with entries in $\mathcal{M}_{\text{in}}^{\text{ax}}[[\gamma, \delta]]$. Since, $\Delta_{1|n\omega}\delta^{1-n\omega} = \Delta_{1|n}\Delta_{1|\omega}\delta^{-\omega(n-1)}\delta^{1-\omega} = \Delta_{1|n}\delta^{1-n}\Delta_{1|\omega}\delta^{1-\omega}$, then

$$\mathbf{b}_{m,n\omega} = \begin{bmatrix} \left[\begin{array}{c} \Delta_{1|n}\delta^{1-n}\Delta_{1|\omega}\delta^{1-\omega}\mathbf{b}_m \\ \vdots \\ \Delta_{1|n}\delta^{1-n}\Delta_{1|\omega}\mathbf{b}_m \end{array} \right] \\ \left[\begin{array}{c} \Delta_{1|n}\Delta_{1|\omega}\delta^{1-\omega}\mathbf{b}_m \\ \vdots \\ \Delta_{1|n}\Delta_{1|\omega}\mathbf{b}_m \end{array} \right] \end{bmatrix} = \begin{bmatrix} \Delta_{1|n}\delta^{1-n}\mathbf{b}_{m,\omega} \\ \vdots \\ \Delta_{1|n}\mathbf{b}_{m,\omega} \end{bmatrix}$$

Hence, for $\mathbf{b}_{b,n\omega}\mathbf{m}_{m,\omega}$ we obtain,

$$\mathbf{b}_{m,n\omega}\mathbf{m}_{m,\omega} = \begin{bmatrix} \Delta_{1|n}\delta^{1-n}\mathbf{e} \\ \vdots \\ \Delta_{1|n}\mathbf{e} \end{bmatrix}$$

Respectively $\mathbf{b}_{b,\omega}\mathbf{m}_{b,n\omega}$ is given by,

$$\mathbf{b}_{b,\omega}\mathbf{m}_{b,n\omega} = \left[\mathbf{e}\Delta_{n|1} \quad \cdots \quad \mathbf{e}\delta^{1-n}\Delta_{n|1}\gamma^{1-n} \right].$$

Finally,

$$\begin{aligned} \hat{\mathbf{Q}}' &= \begin{bmatrix} \Delta_{1|n}\delta^{1-n}\mathbf{e} \\ \vdots \\ \Delta_{1|n}\mathbf{e} \end{bmatrix} \mathbf{Q} \left[\mathbf{e}\Delta_{n|1} \quad \cdots \quad \mathbf{e}\delta^{1-n}\Delta_{n|1} \right] \\ &= \begin{bmatrix} \Delta_{1|n}\delta^{1-n}\hat{\mathbf{Q}}\Delta_{n|1} & \cdots & \Delta_{1|n}\gamma^{1-n}\hat{\mathbf{Q}}\delta^{1-n}\Delta_{n|1} \\ \vdots & & \vdots \\ \Delta_{1|n}\hat{\mathbf{Q}}\Delta_{n|1} & \cdots & \Delta_{1|n}\hat{\mathbf{Q}}\delta^{1-n}\Delta_{n|1} \end{bmatrix}. \end{aligned}$$

The extended core is a matrix with entries in $\mathcal{M}_{\text{in}}^{\text{ax}}[[\gamma, \delta]]$, since $\Delta_{|n|} \delta^\tau \Delta_{|n|} = \delta^{\lceil \tau/n \rceil n}$ Remark 30. The extended core $\hat{\mathbf{Q}}'$ is a greatest core. Consider $\hat{\mathbf{Q}}'' = \mathfrak{E} \hat{\mathbf{Q}}' \mathfrak{E}$, then

$$\begin{aligned} \hat{\mathbf{Q}}'' &= \mathfrak{E} \mathbf{b}_{m,n\omega} \mathbf{m}_{m,\omega} \mathbf{Q} \mathbf{b}_{b,\omega} \mathbf{m}_{b,n\omega} \mathfrak{E}, \\ &= \mathbf{b}_{m,n\omega} \underbrace{\mathbf{m}_{m,n\omega} \mathbf{b}_{m,n\omega}}_e \mathbf{m}_{m,\omega} \mathbf{Q} \mathbf{b}_{b,\omega} \underbrace{\mathbf{m}_{b,n\omega} \mathbf{b}_{b,n\omega}}_e \mathbf{m}_{b,n\omega}, \\ &= \mathbf{b}_{m,n\omega} \mathbf{m}_{m,\omega} \mathbf{Q} \mathbf{b}_{b,\omega} \mathbf{m}_{b,n\omega} = \hat{\mathbf{Q}}'. \end{aligned}$$

□

Transformation between the core matrices Q and U

Clearly, an ultimately cyclic series $s = \mathbf{m}_{m,\omega} \mathbf{Q} \mathbf{b}_{b,\omega} = \mathbf{d}_{\omega,m} \mathbf{U} \mathbf{p}_{\omega,b} \in \mathcal{E}\mathcal{T}_{\text{per}}$ can be expressed in the alternative core representation (resp. core representation) as follows,

$$\begin{aligned} s &= \mathbf{d}_{\omega,m} \underbrace{\mathbf{p}_{\omega,m} \mathbf{m}_{m,\omega} \mathbf{Q} \mathbf{b}_{b,\omega} \mathbf{d}_{\omega,b}}_{\hat{\mathbf{U}}'} \mathbf{p}_{\omega,b}, \\ s &= \mathbf{m}_{m,\omega} \underbrace{\mathbf{b}_{m,\omega} \mathbf{d}_{\omega,m} \mathbf{U} \mathbf{p}_{\omega,b} \mathbf{m}_{b,\omega}}_{\hat{\mathbf{Q}}'} \mathbf{b}_{b,\omega}. \end{aligned}$$

Then the matrix

$$\hat{\mathbf{U}}' = \underbrace{\mathbf{p}_{\omega,m} \mathbf{m}_{m,\omega}}_{\text{T}_{\text{QU}_1}} \underbrace{\mathbf{Q} \mathbf{b}_{b,\omega} \mathbf{d}_{\omega,b}}_{\text{T}_{\text{QU}_2}}$$

is the greatest solutions of the alternative core equations $= \mathbf{d}_{\omega,m} \mathbf{X} \mathbf{p}_{\omega,b}$ (5.36). For this consider the solution $\hat{\mathbf{U}}'' = \mathfrak{N} \hat{\mathbf{U}}' \mathfrak{N}$, then

$$\begin{aligned} \hat{\mathbf{U}}'' &= \mathfrak{N} \mathbf{p}_{\omega,nm} \mathbf{m}_{m,\omega} \mathbf{Q} \mathbf{b}_{b,\omega} \mathbf{d}_{\omega,nb} \mathfrak{N}, \\ &= \mathbf{p}_{\omega,nm} \underbrace{\mathbf{d}_{\omega,nm} \mathbf{p}_{\omega,nm}}_e \mathbf{m}_{m,\omega} \mathbf{Q} \mathbf{b}_{b,\omega} \underbrace{\mathbf{d}_{\omega,nb} \mathbf{p}_{\omega,nb}}_e \mathbf{d}_{\omega,nb}, \\ &= \mathbf{p}_{nm\omega} \mathbf{d}_{\omega,m} \mathbf{Q} \mathbf{b}_{b,\omega} \mathbf{d}_{\omega,nb} = \hat{\mathbf{U}}'. \end{aligned}$$

Respectively,

$$\hat{\mathbf{Q}}' = \underbrace{\mathbf{b}_{m,\omega} \mathbf{d}_{\omega,m}}_{\text{T}_{\text{UQ}_1}} \underbrace{\mathbf{U} \mathbf{p}_{\omega,b} \mathbf{m}_{b,\omega}}_{\text{T}_{\text{UQ}_2}}$$

is the greatest solutions of the core equation $s = \mathbf{m}_{m,\omega} \tilde{\mathbf{X}} \mathbf{b}_{b,\omega}$ (5.22).

The matrices \mathbf{T}_{QU_1} , \mathbf{T}_{QU_2} , \mathbf{T}_{UQ_1} and \mathbf{T}_{UQ_2} are matrices with entries in $\mathcal{M}_{\text{in}}^{\text{ax}}[[\gamma, \delta]]$ given by,

$$\mathbf{T}_{QU_1} = \begin{bmatrix} \nabla_{1|m} \gamma^{m-1} \mathbf{p}_\omega \Delta_{\omega|1} \mathbf{m}_m & \cdots & \nabla_{1|m} \gamma^{m-1} \mathbf{p}_\omega \delta^{1-\omega} \Delta_{\omega|1} \mathbf{m}_m \\ \vdots & & \vdots \\ \nabla_{1|m} \mathbf{p}_\omega \Delta_{\omega|1} \mathbf{m}_m & \cdots & \nabla_{1|m} \mathbf{p}_\omega \delta^{1-\omega} \Delta_{\omega|1} \mathbf{m}_m \end{bmatrix}$$

$$\mathbf{T}_{QU_2} = \begin{bmatrix} \Delta_{1|\omega} \delta^{1-\omega} \mathbf{b}_b \mu_b \Delta_{\omega|1} & \cdots & \Delta_{1|\omega} \delta^{1-\omega} \mathbf{b}_b \gamma^{b-1} \mu_b \Delta_{\omega|1} \\ \vdots & & \vdots \\ \Delta_{1|\omega} \mathbf{b}_b \mu_b \Delta_{\omega|1} & \cdots & \Delta_{1|\omega} \mathbf{b}_b \gamma^{b-1} \mu_b \Delta_{\omega|1} \end{bmatrix}$$

$$\mathbf{T}_{UQ_1} = \begin{bmatrix} \Delta_{1|\omega} \delta^{1-\omega} \mathbf{b}_m \nabla_{m|1} \Delta_{\omega|1} & \cdots & \Delta_{1|\omega} \delta^{1-\omega} \mathbf{b}_m \gamma^{m-1} \nabla_{m|1} \Delta_{\omega|1} \\ \vdots & & \vdots \\ \Delta_{1|\omega} \mathbf{b}_m \nabla_{m|1} \Delta_{\omega|1} & \cdots & \Delta_{1|\omega} \mathbf{b}_m \gamma^{m-1} \nabla_{m|1} \Delta_{\omega|1} \end{bmatrix}$$

$$\mathbf{T}_{UQ_2} = \begin{bmatrix} \nabla_{1|b} \gamma^{b-1} \mathbf{p}_\omega \Delta_{\omega|1} \mathbf{m}_b & \cdots & \nabla_{1|b} \gamma^{b-1} \mathbf{p}_\omega \delta^{1-\omega} \Delta_{\omega|1} \mathbf{m}_b \\ \vdots & & \vdots \\ \nabla_{1|b} \mathbf{p}_\omega \Delta_{\omega|1} \mathbf{m}_b & \cdots & \nabla_{1|b} \mathbf{p}_\omega \delta^{1-\omega} \Delta_{\omega|1} \mathbf{m}_b \end{bmatrix}$$

and for $0 \leq a < \omega$ and $0 \leq c < i$

$$\nabla_{1|i} \gamma^c \mathbf{p}_\omega \delta^{-a} \Delta_{\omega|1} \mathbf{m}_i = \underbrace{\begin{bmatrix} \delta^{-1} & \cdots & \delta^{-1} & \gamma \delta^{-1} & \cdots & \gamma \delta^{-1} \\ \vdots & & \vdots & \vdots & & \vdots \\ \delta^{-1} & \cdots & \delta^{-1} & \gamma \delta^{-1} & \cdots & \gamma \delta^{-1} \\ \mathbf{e} & \cdots & \mathbf{e} & \gamma & \cdots & \gamma \\ \vdots & & \vdots & \vdots & & \vdots \\ \mathbf{e} & \cdots & \mathbf{e} & \gamma & \cdots & \gamma \end{bmatrix}}_{i-b} \left. \begin{array}{l} \right\} a \\ \left. \right\} \omega - a$$

$$\Delta_{1|\omega} \delta^{-a} \mathbf{b}_i \gamma^c \nabla_{i|1} \mathbf{d}_\omega = \underbrace{\begin{bmatrix} e & \cdots & e & \delta^{-1} & \cdots & \delta^{-1} \\ \vdots & & \vdots & \vdots & & \vdots \\ e & \cdots & e & \delta^{-1} & \cdots & \delta^{-1} \\ \gamma & \cdots & \gamma & \gamma \delta^{-1} & \cdots & \gamma \delta^{-1} \\ \vdots & & \vdots & \vdots & & \vdots \\ \gamma & \cdots & \gamma & \gamma \delta^{-1} & \cdots & \gamma \delta^{-1} \end{bmatrix}}_{\omega-b} \underbrace{\left. \begin{array}{l} \right\} i-a \\ \left. \right\} a \end{array} \right\}$$

Bibliography

- [1] F. Baccelli, G. Cohen, G. J. Olsder, and J. P. Quadrat. *Synchronisation and Linearity: An Algebra for Discrete Event Systems*. John Wiley and Sons, New York, 1992. (Cited on pages 1, 2, 6, 11, 13, 14, 15, 16, 17, 19, 20, 21, 22, 25, 28, 63, 133, 144, 152, 153, 154, 156, 169, 197, and 201.)
- [2] G. Bilsen, M. Engels, R. Lauwereins, and J. Peperstraete. Cycle-static dataflow. *IEEE Transactions on Signal Processing*, 44(2):397–408, Feb 1996. ISSN 1053-587X. doi: 10.1109/78.485935. (Cited on page 152.)
- [3] T. S. Blyth. *Lattices and ordered algebraic structures*. Springer, London, 2005. ISBN 978-1-85233-905-0. (Cited on page 13.)
- [4] T. S. Blyth and M. F. Janowitz. *Residuation theory*. International series of monographs in pure and applied mathematics. Pergamon Press, 1972. (Cited on pages 11 and 19.)
- [5] G. P. Brat and V. K. Garg. Analyzing non-deterministic real-time systems with $(\max,+)$ algebra. In *Proceedings 19th IEEE Real-Time Systems Symposium (Cat. No.98CB36279)*, pages 210–219, Dec 1998. doi: 10.1109/REAL.1998.739747. (Cited on page 7.)
- [6] G. P. Brat and V. K. Garg. A $(\max,+)$ Algebra for Non-Stationary Periodic Timed Discrete Event Systems. In *In Proceedings of the International Workshop on Discrete Event Systems*, pages 237–242, 1998. (Cited on page 7.)
- [7] T. Brunsch. *Modeling and control of complex systems in a dioid framework*. Ph.D. dissertation, Technische Universität Berlin, Germany and Université d’Angers, France, January 2014. (Cited on pages 2, 25, 26, 195, and 199.)
- [8] T. Brunsch, L. Hardouin, C. A. Maia, and J. Raisch. Duality and interval analysis over idempotent semirings. *Linear Algebra and its Applications*, 437(10):2436 – 2454, 2012. ISSN 0024-3795. doi: 10.1016/j.laa.2012.06.025. (Cited on page 199.)
- [9] C. G. Cassandras and S. Lafortune. *Introduction to Discrete Event Systems*. Springer US, Boston, MA, 1999. ISBN 978-1-4757-4070-7. doi: 10.1007/978-1-4757-4070-7_1. (Cited on pages 1 and 133.)
- [10] D. D. Cofer and V. K. Garg. A generalized max-algebra model for performance analysis of timed and untimed discrete event systems. In *1993 American Control Conference*, pages 2288–2292, June 1993. doi: 10.23919/ACC.1993.4793294. (Cited on page 7.)

- [11] G. Cohen. Residuation and Applications. In *Algèbres Max-Plus et applications en informatique et automatique, Ecole de printemps d'informatique théorique*, 1998. (Cited on pages 11 and 19.)
- [12] G. Cohen, P. Moller, J. P. Quadrat, and M. Viot. Algebraic tools for the performance evaluation of discrete event systems. *Proceedings of the IEEE*, 77(1):39–85, Jan 1989. ISSN 0018-9219. doi: 10.1109/5.21069. (Cited on pages 1, 2, 11, 22, and 181.)
- [13] G. Cohen, S. Gaubert, R. Nikoukhah, and J. P. Quadrat. Second order theory of min-linear systems and its application to discrete event systems. In *Proceedings of the 30th IEEE Conference on Decision and Control*, pages 1511–1516 vol.2, Dec 1991. doi: 10.1109/CDC.1991.261654. (Cited on pages 153, 154, 156, and 198.)
- [14] G. Cohen, S. Gaubert, and J. P. Quadrat. Timed-event graphs with multipliers and homogeneous min-plus systems. *IEEE Transactions on Automatic Control*, 43(9):1296–1302, Sep. 1998. ISSN 0018-9286. doi: 10.1109/9.718621. (Cited on pages 2 and 6.)
- [15] B. Cottenceau, L. Hardouin, J.-L. Boimond, and J.-L. Ferrier. Model reference control for timed event graphs in dioids. *Automatica*, 37(9):1451 – 1458, 2001. ISSN 0005-1098. doi: doi.org/10.1016/S0005-1098(01)00073-5. (Cited on pages 1, 3, and 181.)
- [16] B. Cottenceau, L. Hardouin, and J. Boimond. Modeling and control of weight-balanced timed event graphs in dioids. *IEEE Transactions on Automatic Control*, 59(5):1219–1231, May 2014. ISSN 0018-9286. doi: 10.1109/TAC.2013.2294822. (Cited on pages 6, 27, 28, 31, 32, 34, 36, 39, 40, 42, 44, 82, 133, 137, 139, 157, 158, 205, and 206.)
- [17] B. Cottenceau, S. Lahaye, and L. Hardouin. Modeling of time-varying (max,+) systems by means of weighted timed event graphs. *IFAC Proceedings Volumes*, 47(2):465 – 470, 2014. ISSN 1474-6670. doi: 10.3182/20140514-3-FR-4046.00014. 12th IFAC International Workshop on Discrete Event Systems (2014). (Cited on pages 6, 7, 133, and 161.)
- [18] B. Cottenceau, L. Hardouin, and J. Trunk. Weight-balanced timed event graphs to model periodic phenomena in manufacturing systems. *IEEE Transactions on Automation Science and Engineering*, 14(4):1731–1742, Oct 2017. ISSN 1545-5955. doi: 10.1109/TASE.2017.2729894. (Cited on page 151.)
- [19] X. David-Henriet. *Discrete event systems with standard and partial synchronizations*. Ph.D. dissertation, Technische Universität Berlin, Germany and Université d'Angers, France, April 2015. (Cited on pages 7, 17, 28, and 149.)
- [20] X. David-Henriet, J. Raisch, L. Hardouin, and B. Cottenceau. Modeling and control for max-plus systems with partial synchronization. *IFAC Proceedings Volumes*, 47(2): 105 – 110, 2014. ISSN 1474-6670. doi: 10.3182/20140514-3-FR-4046.00025. 12th IFAC International Workshop on Discrete Event Systems (2014). (Cited on pages 2, 7, 133, and 140.)

-
- [21] X. David-Henriet, J. Raisch, L. Hardouin, and B. Cottenceau. Modeling and control for (max, +)-linear systems with set-based constraints. In *2015 IEEE International Conference on Automation Science and Engineering (CASE)*, pages 1369–1374, Aug 2015. doi: 10.1109/CoASE.2015.7294289. (Cited on pages 7 and 140.)
- [22] X. David-Henriet, L. Hardouin, J. Raisch, and B. Cottenceau. Model predictive control for discrete event systems with partial synchronization. *Automatica*, 70:9 – 13, 2016. ISSN 0005-1098. doi: 0.1016/j.automatica.2015.12.006. (Cited on pages 7 and 140.)
- [23] R. de Groote, J. Kuper, H. Broersma, and G. J. M. Smit. Max-plus algebraic throughput analysis of synchronous dataflow graphs. In *2012 38th Euromicro Conference on Software Engineering and Advanced Applications*, pages 29–38, Sep. 2012. doi: 10.1109/SEAA.2012.20. (Cited on page 7.)
- [24] R. de Groote, P. K. F. Hölzenspies, J. Kuper, and G. J. M. Smit. Multi-rate equivalents of cyclo-static synchronous dataflow graphs. In *2014 14th International Conference on Application of Concurrency to System Design*, pages 62–71, June 2014. doi: 10.1109/ACSD.2014.24. (Cited on page 152.)
- [25] S. Gaubert. Resource optimization and (min,+) spectral theory. *IEEE Transactions on Automatic Control*, 40(11):1931–1934, Nov 1995. ISSN 0018-9286. doi: 10.1109/9.471219. (Cited on pages 1 and 181.)
- [26] M. Geilen. Synchronous dataflow scenarios. *ACM Transactions on Embedded Computing Systems*, 10(2):16:1–16:31, Jan. 2011. ISSN 1539-9087. doi: 10.1145/1880050.1880052. (Cited on pages 6 and 134.)
- [27] M. Geilen, T. Basten, and S. Stuijk. Minimising buffer requirements of synchronous dataflow graphs with model checking. In *Proceedings. 42nd Design Automation Conference, 2005.*, pages 819–824, June 2005. doi: 10.1145/1065579.1065796. (Cited on page 7.)
- [28] A. H. Ghamarian, M. Geilen, S. Stuijk, T. Basten, B. D. Theelen, M. R. Mousavi, A. J. M. Moonen, and M. J. G. Bekooij. Throughput analysis of synchronous data flow graphs. In *Proceedings of the Sixth International Conference on Application of Concurrency to System Design, ACSD '06*, pages 25–36, Washington, DC, USA, 2006. IEEE Computer Society. ISBN 0-7695-2556-3. doi: 10.1109/ACSD.2006.33. (Cited on page 7.)
- [29] R. L. Graham, D. E. Knuth, and O. Patashnik. *Concrete Mathematics: A Foundation for Computer Science*. Addison-Wesley Longman Publishing Co., Inc., Boston, MA, USA, 1989. ISBN 0-201-14236-9. (Cited on page 203.)
- [30] S. Hamaci, J.-L. Boimond, and S. Lahaye. Modeling and control of hybrid timed event graphs with multipliers using (min, +) algebra. *Discrete Event Dynamic Systems*, 16(2): 241–256, Apr 2006. ISSN 1573-7594. (Cited on page 6.)

- [31] S. Hamaci, J.-L. Boimond, and S. Lahaye. On modeling and control of discrete timed event graphs with multipliers using $(\min, +)$ algebra. In *Informatics in Control, Automation and Robotics I*, pages 211–216, Dordrecht, 2006. Springer Netherlands. ISBN 978-1-4020-4543-1. (Cited on page 6.)
- [32] L. Hardouin, E. Le Corrond, and B. Cottenceau. Minmaxgd a Software Tools to Handle Series in $(\max, +)$ Algebra. In *SIAM Conference on Computational Science and Engineering*, Miami, USA, 2009. (Cited on page 169.)
- [33] L. Hardouin, C. A. Maia, B. Cottenceau, and M. Lhommeau. Observer design for $(\max, +)$ linear systems. *IEEE Transactions on Automatic Control*, 55(2):538–543, 2010. (Cited on pages 1, 181, and 199.)
- [34] L. Hardouin, O. Boutin, B. Cottenceau, T. Brunsch, and J. Raisch. *Discrete-Event Systems in a Dioid Framework: Control Theory*. Springer London, London, 2013. doi: 10.1007/978-1-4471-4276-8_22. (Cited on pages 1, 3, 181, 188, and 190.)
- [35] L. Hardouin, Y. Shang, C. A. Maia, and B. Cottenceau. Observer-based controllers for max-plus linear systems. *IEEE Transactions on Automatic Control*, 62(5):2153–2165, May 2017. ISSN 0018-9286. doi: 10.1109/TAC.2016.2604562. (Cited on pages 1, 181, and 199.)
- [36] L. Hardouin, B. Cottenceau, Y. Shang, and J. Raisch. Control and state estimation for max-plus linear systems. *Foundations and Trends® in Systems and Control*, 6(1):1–116, 2018. ISSN 2325-6818. doi: 10.1561/2600000013. (Cited on pages 154 and 181.)
- [37] Z. He, Z. Li, and A. Giua. Optimization of deterministic timed weighted marked graphs. *IEEE Transactions on Automation Science and Engineering*, 14(2):1084–1095, April 2017. ISSN 1545-5955. doi: 10.1109/TASE.2015.2490538. (Cited on page 6.)
- [38] Z. He, Z. Li, and A. Giua. Performance optimization for timed weighted marked graphs under infinite server semantics. *IEEE Transactions on Automatic Control*, 63(8):2573–2580, Aug 2018. ISSN 0018-9286. doi: 10.1109/TAC.2017.2766202. (Cited on page 6.)
- [39] Z. He, M. Liu, Z. Ma, Z. Li, and A. Giua. An improved approach for marking optimization of timed weighted marked graphs. *Discrete Event Dynamic Systems*, Feb 2019. ISSN 1573-7594. doi: 10.1007/s10626-019-00278-w. (Cited on page 6.)
- [40] B. Heidergott, G. J. Olsder, and J. W. v. d. Woude. *Max Plus at work: modeling and analysis of synchronized systems: a course on Max-Plus algebra and its applications*. Princeton series in applied mathematics. Princeton University Press, Princeton, 2006. ISBN 978-0-691-11763-8. (Cited on pages 1, 6, 11, 133, 154, and 197.)
- [41] R. A. Horn and C. R. Johnson. *Matrix analysis*. Cambridge University Press, New York, second edition, 2013. ISBN 978-0-521-54823-6. (Cited on page 70.)

-
- [42] J. Komenda, S. Lahaye, J.-L. Boimond, and T. van den Boom. Max-plus algebra and discrete event systems. *IFAC-PapersOnLine*, 50(1):1784 – 1790, 2017. ISSN 2405-8963. doi: 10.1016/j.ifacol.2017.08.163. 20th IFAC World Congress. (Cited on pages 7 and 8.)
- [43] E. A. Lee and D. G. Messerschmitt. Static scheduling of synchronous data flow programs for digital signal processing. *IEEE Transactions on Computers*, C-36(1):24–35, Jan 1987. ISSN 0018-9340. doi: 10.1109/TC.1987.5009446. (Cited on page 6.)
- [44] E. A. Lee and D. G. Messerschmitt. Synchronous data flow. *Proceedings of the IEEE*, 75(9):1235–1245, Sep. 1987. ISSN 0018-9219. doi: 10.1109/PROC.1987.13876. (Cited on pages 6 and 134.)
- [45] M. Lhommeau, L. Hardouin, B. Cottenceau, and L. Jaulin. Interval analysis and dioid: application to robust controller design for timed event graphs. *Automatica*, 40(11):1923 – 1930, 2004. ISSN 0005-1098. doi: 10.1016/j.automatica.2004.05.013. (Cited on page 199.)
- [46] L. Libeaut and J. J. Loiseau. Model matching for timed event graphs. *IFAC Proceedings Volumes*, 29(1):4807 – 4812, 1996. ISSN 1474-6670. doi: 10.1016/S1474-6670(17)58441-4. 13th World Congress of IFAC, 1996, San Francisco USA. (Cited on pages 3 and 181.)
- [47] C. A. Maia, L. Hardouin, R. S. Mendes, and B. Cottenceau. Optimal closed-loop control of timed event graphs in dioids. *IEEE Transactions on Automatic Control*, 48(12):2284–2287, 2003. (Cited on pages 1, 3, and 181.)
- [48] C. A. Maia, L. Hardouin, R. Santos-Mendes, and B. Cottenceau. On the model reference control for max-plus linear systems. In *Proceedings of the 44th IEEE Conference on Decision and Control*, pages 7799–7803, Dec 2005. doi: 10.1109/CDC.2005.1583422. (Cited on pages 1 and 181.)
- [49] C. A. Maia, C. R. Andrade, and L. Hardouin. On the control of max-plus linear system subject to state restriction. *Automatica*, 47(5):988 – 992, 2011. ISSN 0005-1098. doi: 10.1016/j.automatica.2011.01.047. (Cited on page 199.)
- [50] O. Marchetti and A. Munier-Kordon. Complexity results for weighted timed event graphs. *Discrete Optimization*, 7(3):166 – 180, 2010. ISSN 1572-5286. doi: 10.1016/j.disopt.2010.03.006. (Cited on pages 5 and 133.)
- [51] E. Menguy, J. L. Boimond, L. Hardouin, and J. L. Ferrier. Just-in-time control of timed event graphs: update of reference input, presence of uncontrollable input. *IEEE Transactions on Automatic Control*, 45(11):2155–2159, Nov 2000. ISSN 0018-9286. doi: 10.1109/9.887652. (Cited on pages 1 and 181.)
- [52] P. Moller. *Théorie algébrique des systèmes à événements discrets*. Ph.D. dissertation (in French), École des Mines de Paris, 1988. (Cited on page 18.)

- [53] A. Munier. Régime asymptotique optimal d'un graphe d'évènement temporisé généralisé: application à un problème d'assemblage. *RAIRO-APII*, 27(5):487–513, 1993. (Cited on pages 5 and 138.)
- [54] T. Murata. Petri nets: Properties, analysis and applications. *Proceedings of the IEEE*, 77(4):541–580, April 1989. ISSN 0018-9219. doi: 10.1109/5.24143. (Cited on page 133.)
- [55] M. Nakamura and M. Silva. Cycle time computation in deterministically timed weighted marked graphs. In *1999 7th IEEE International Conference on Emerging Technologies and Factory Automation. Proceedings ETFA '99 (Cat. No.99TH8467)*, volume 2, pages 1037–1046 vol.2, Oct 1999. doi: 10.1109/ETFA.1999.813105. (Cited on pages 5, 6, 138, and 139.)
- [56] A. D. Nola and C. Russo. Semiring and semimodule issues in mv-algebras. *Communications in Algebra*, 41(3):1017–1048, 2013. doi: 10.1080/00927872.2011.610074. (Cited on page 12.)
- [57] T. M. Parks, J. L. Pino, and E. A. Lee. A comparison of synchronous and cycle-static dataflow. In *Conference Record of The Twenty-Ninth Asilomar Conference on Signals, Systems and Computers*, volume 1, pages 204–210 vol.1, Oct 1995. doi: 10.1109/ACSSC.1995.540541. (Cited on page 152.)
- [58] N. Sauer. Marking optimization of weighted marked graphs. *Discrete Event Dynamic Systems*, 13(3):245–262, Jul 2003. ISSN 1573-7594. doi: 10.1023/A:1024055724914. (Cited on page 6.)
- [59] B. D. Schutter and T. van den Boom. Model predictive control for max-plus-linear discrete event systems. *Automatica*, 37(7):1049 – 1056, 2001. ISSN 0005-1098. doi: 10.1016/S0005-1098(01)00054-1. (Cited on page 1.)
- [60] B. D. Schutter and T. van den Boom. Mpc for discrete-event systems with soft and hard synchronization constraints. *International Journal of Control*, 76(1):82–94, 2003. doi: 10.1080/0020717021000049188. (Cited on pages 1 and 7.)
- [61] S. Sriram and S. S. Bhattacharyya. *Embedded Multiprocessors: Scheduling and Synchronization*. Marcel Dekker, Inc., New York, USA, 1st edition, 2000. ISBN 0-8247-9318-8. (Cited on pages 6, 134, and 139.)
- [62] S. Stuijk, M. Geilen, and T. Basten. Exploring trade-offs in buffer requirements and throughput constraints for synchronous dataflow graphs. In *2006 43rd ACM/IEEE Design Automation Conference*, pages 899–904, July 2006. doi: 10.1145/1146909.1147138. (Cited on page 7.)
- [63] E. Teruel, P. Chrzastowski-Wachtel, J. M. Colom, and M. Silva. On weighted t-systems. In *Application and Theory of Petri Nets 1992*, pages 348–367, Berlin, Heidelberg, 1992. Springer Berlin Heidelberg. ISBN 978-3-540-47270-4. (Cited on pages 133, 134, and 136.)

-
- [64] L. Toursi and N. Sauer. Branch and bound approach for marking optimization problem of weighted marked graphs. In *2004 IEEE International Conference on Systems, Man and Cybernetics (IEEE Cat. No.04CH37583)*, volume 2, pages 1777–1782 vol.2, Oct 2004. doi: 10.1109/ICSMC.2004.1399900. (Cited on page 6.)
- [65] J. Trunk, B. Cottenceau, L. Hardouin, and J. Raisch. Model decomposition of weight-balanced timed event graphs in dioids: Application to control synthesis. *IFAC-PapersOnLine*, 50(1):13453 – 13460, 2017. ISSN 2405-8963. doi: 10.1016/j.ifacol.2017.08.2309. 20th IFAC World Congress. (Cited on pages 6, 27, 133, and 181.)
- [66] J. Trunk, B. Cottenceau, L. Hardouin, and J. Raisch. Output reference control for weight-balanced timed event graphs. In *2017 IEEE 56th Annual Conference on Decision and Control (CDC)*, pages 4839–4846, Dec 2017. doi: 10.1109/CDC.2017.8264374. (Cited on pages 27, 133, and 181.)
- [67] J. Trunk, B. Cottenceau, L. Hardouin, and J. Raisch. Model decomposition of timed event graphs under partial synchronization in dioids. *IFAC-PapersOnLine*, 51(7):198 – 205, 2018. ISSN 2405-8963. doi: 10.1016/j.ifacol.2018.06.301. 14th IFAC Workshop on Discrete Event Systems WODES 2018. (Cited on pages 81 and 133.)
- [68] J. Trunk, B. Cottenceau, L. Hardouin, and J. Raisch. Modelling and control of periodic time-variant event graphs in dioids. *Discrete Event Dynamic Systems*, submitted. (Cited on pages 81, 133, and 181.)
- [69] J. Trunk, B. Cottenceau, L. Hardouin, and J. Raisch. Output reference control of timed event graphs under partial synchronization. *Discrete Event Dynamic Systems*, submitted. (Cited on pages 81, 133, and 181.)

Declaration

I declare that this thesis has been composed by myself, that the work contained herein is my own except where explicitly stated otherwise, and that this work has not been submitted for any other degree or professional qualification except as specified.

Berlin, July 2019

Johannes Trunk