



HAL
open science

Performance Estimation, Testing, and Control of Cyber-Physical Systems Employing Non-ideal Communications Networks

Richard Candell

► **To cite this version:**

Richard Candell. Performance Estimation, Testing, and Control of Cyber-Physical Systems Employing Non-ideal Communications Networks. Signal and Image Processing. Université Bourgogne Franche-Comté, 2020. English. NNT : 2020UBFCK017 . tel-03155090

HAL Id: tel-03155090

<https://theses.hal.science/tel-03155090>

Submitted on 1 Mar 2021

HAL is a multi-disciplinary open access archive for the deposit and dissemination of scientific research documents, whether they are published or not. The documents may come from teaching and research institutions in France or abroad, or from public or private research centers.

L'archive ouverte pluridisciplinaire **HAL**, est destinée au dépôt et à la diffusion de documents scientifiques de niveau recherche, publiés ou non, émanant des établissements d'enseignement et de recherche français ou étrangers, des laboratoires publics ou privés.

**THÈSE DE DOCTORAT DE L'ÉTABLISSEMENT UNIVERSITÉ BOURGOGNE
FRANCHE-COMTÉ**

PRÉPARÉE À L'UNIVERSITÉ DE BOURGOGNE

École doctorale n°37

Sciences Pour l'Ingénieur et Microtechniques

Doctorat d'Informatique

par

RICHARD CANDELL

**Performance Estimation, Testing, and Control of Cyber-Physical
Systems Employing Non-Ideal Communications Networks**

Thèse présentée et soutenue à Dijon, le 28 Sep 2020

Composition du Jury :

FOUFOU SEBTI	Professeur à l'Université de Bourgogne	Directeur de thèse
MOALLA NEJIB	Professeur à l'University Lumière Lyon 2	President
DRIRA KHALIL	Professeur à l'Université de Toulouse	Rapporteur
AMIRA ABBES	Professeur à De Montfort University	Rapporteur
BENBERNOU SALIMA	Université de Paris	Examinatrice
SAVONNET MARINETTE	Université de Bourgogne Franche-Comté	Examinatrice

Title: Performance Estimation, Testing, and Control of Cyber-Physical Systems Employing Non-Ideal Communications Networks

Keywords: industrial wireless, smart manufacturing, systems modeling, machine learning, graph database, industrial wireless testbed

Abstract:

Wireless technology is a key enabler of the promises of Industry 4.0 (Smart Manufacturing). As such, wireless technology will be adopted as a principal mode of communication within the factory beginning with the factory enterprise and eventually being adopted for use within the factory workcell. Factory workcell communication has particular requirements on latency, reliability, scale, and security that must first be met by the wireless communication technology used. Wireless is considered a non-ideal form of communication in that when compared to its wired counterparts, it is considered less reliable (lossy) and less secure. These

possible impairments lead to delay and loss of data in industrial automation systems where determinism, security, and safety are considered paramount. This thesis investigates the wireless requirements of the factory workcell and applicability of existing wireless technology, presents a modeling approach to discovery of architecture and data flows using SysML, provides a method for the use of graph databases to the organization and analysis of performance data collected from a testbed environment, and, finally, provides an approach to using machine learning in the evaluation of cyber-physical system performance.

Titre : Performance Estimation, Testing, and Control of Cyber-Physical Systems Employing Non-Ideal Communications Networks

Mots-clés : communications sans fil industriel, fabrication intelligente, apprentissage automatique, modélisation système, base de données graphe, banc d'essai sans fil industriel

Résumé :

La technologie sans fil est un catalyseur clé des promesses de l'industrie 4.0 (fabrication intelligente). En tant que telle, la technologie sans fil sera adoptée comme mode de communication principal au sein de l'usine en général et dans les unités de production en particulier. La communication des unités de production en usine a des exigences particulières en matière de latence, de fiabilité, d'échelle et de sécurité qui doivent d'abord être satisfaites par la technologie de communication sans fil utilisée. Le sans fil est considéré comme une forme de communication non idéale dans la mesure où par rapport aux communications câblées, il est considéré comme moins fiable (avec perte) et moins sécurisé. Ces dégradations possibles entraînent un retard et une perte de données

dans un système d'automatisation industrielle où le déterminisme, la sécurité et la sûreté sont considérés comme primordiaux. Cette thèse étudie les exigences d'une communication sans fil dans les unités de production et l'applicabilité de la technologie sans fil existante dans ce domaine. Elle présente une modélisation SysML de l'architecture du système et des flux de données. Elle fournit une méthode d'utilisation des bases de données de type graphe pour l'organisation et l'analyse des données de performance collectées à partir d'un environnement de test. Enfin, la thèse décrit une approche utilisant l'apprentissage automatique pour l'évaluation des performances d'un système d'objets connectés dans le domaine de fabrication.

DEDICATION

To my daughter, Erin, who was always there with me at my side connecting wires, laughing at Dwight, and applauding Captain Sisko: You are my best buddy.

ACKNOWLEDGMENTS

I have been blessed by God with intelligence and creativity sufficient to perceive a vision, communicate that vision, and then direct a team more capable than myself to implement that vision. I would like to extend my deepest thanks to my research team. Without their help during trying times, this thesis would not have been possible. I would like to acknowledge my advisor, Professor Fofou, whose guidance and steadfast encouragement to persevere has not gone unnoticed. I would finally like to acknowledge all of the members of my doctoral review committee for their time and attention in reviewing my work and providing their kind recommendations to improve the finalization of my thesis.

CONTENTS

I	Context and Problem Statement	1
1	Introduction	3
1.1	Industrial Revolutions	5
1.2	Industry 4.0 and Smart Manufacturing	8
1.3	The Importance of Wireless in Smart Manufacturing	10
1.4	Challenges in Industrial Wireless Networks	11
1.5	Wireless Key Performance Indicators	15
1.6	Research Objectives	19
1.7	Contribution Summary and Thesis Organization	21
2	State of the Art	25
2.1	Industrial Wireless Requirements Space	25
2.1.1	Literature Review	26
2.1.2	Industry Requirements Perspectives	27
2.1.3	An Industry Requirements Perspective	30
2.2	Systems Modeling	32
2.2.1	Modeling Languages	33
2.2.2	Systems Modeling Using SysML	35
2.3	Use of Databases for Performance Analysis	37
2.4	Machine Learning in Performance Estimation	39

- II Thesis Contributions 43**

- 3 Industrial Wireless Technology And Applications 45**
 - 3.1 Introduction 45
 - 3.2 Problem Space 46
 - 3.2.1 Introduction and Success Considerations 46
 - 3.2.2 Use Cases 47
 - 3.3 Technical Considerations 52
 - 3.3.1 Radio Frequency Environment 52
 - 3.3.2 Device Characteristics 52
 - 3.3.3 Network Characteristics 52
 - 3.4 Wireless Technology Applicability 55
 - 3.5 Subsequent Work of Note 55
 - 3.6 Conclusions 55

- 4 Workcell Architectural Decomposition 59**
 - 4.1 Introduction 59
 - 4.2 Conceptual Representation 61
 - 4.2.1 Packages 61
 - 4.2.2 Conceptual Architecture 63
 - 4.3 Detailed Model Decomposition 64
 - 4.3.1 General Package 65
 - 4.3.2 Application 69
 - 4.3.3 Industrial Wireless Network 71
 - 4.3.4 Devices 73
 - 4.3.5 Robotics 74
 - 4.3.6 PLC 78

4.3.7	Safety	78
4.3.8	Vision	79
4.3.9	Spectrum Monitoring System	80
4.3.10	Human	80
4.4	Results of a Workcell Case Study	81
4.5	Discussion and Conclusions	84
5	Application of Graph Databases	87
5.1	Introduction	87
5.2	Related Work	88
5.3	Graph Databases	89
5.4	Case Study: Robotic Machine-tending	89
5.4.1	Workcell Design	89
5.4.2	Database Schema	91
5.4.3	Information Workflow	95
5.4.4	Sample of a Resulting Graph	96
5.4.5	Calculation of Metrics	99
5.5	Case Study Elaborated: Robotic Machine-tending	100
5.5.1	Workcell Physical Implementation and Measurements	100
5.5.2	Equipment Used	102
5.5.3	Building the Graph	102
5.5.4	Results	107
5.6	Future Direction	111
5.7	Conclusions	112
6	Machine Learning Application: Force Seeking System	115
6.1	Introduction	116

6.2	Robot Arm Force-Seeking Application	117
6.2.1	General Construction and Operation	117
6.2.2	Components	118
6.2.3	Robot Arm Motion Control	120
6.2.4	RF Emulation Scenario	120
6.3	Initial Investigations	122
6.3.1	Data Analysis	122
6.3.2	Feature Extraction	122
6.3.3	Results	125
6.3.4	Conclusion	128
6.4	Subsequent Investigations	129
6.4.1	Data Analysis	130
6.4.2	Results	131
6.4.3	Conclusion	140
III	Conclusions	141
7	Conclusions	143
7.1	Requirements Mapping	144
7.2	Modeling using SysML	145
7.3	Graph Database Application	149
7.4	Machine Learning Applications	153
7.5	Future Recommended Work	153
7.6	Closing Remarks	155

I

CONTEXT AND PROBLEM STATEMENT

INTRODUCTION

A Cyber physical system (CPS) is defined as a holistic integration of computing, networking, and physical processes. Implicit within these systems are feedback connections in which the computing and networking devices affect the physical systems directly [1]. Traditionally, industrial computation was performed using dedicated electronics with analog process variables and control signals being communicated over twisted-pair wires. As automation capabilities evolved, serial communications architectures such as the common field-bus were adopted. With the advent of the Internet and Cloud Computing, Internet Protocol (IP) was adopted for more advanced data collection and control applications. In such applications, reliability and latency requirements were not overly difficult to achieve given the existing technologies; however applications requiring tight feedback timing and reliability were not addressed as the protocols primarily targeted slower flow-based processes and building automation. Discrete manufacturing requirements remained largely unaddressed. To answer the call of discrete manufacturing requirements, routable industrial IP protocols such as common internet protocol (CIP), SERCOS III, and Profinet by Siemens were developed to guarantee latency, reliability, and interoperability between systems. However, given that these protocols are often IP-routable and share a common communication medium, these types of systems are limited in their ability to meet the performance demands of the physical systems or guarantee security. These wired protocols can lack flexibility and mobility demanded by modern industrial applications [2, 3].

Communication strategies that jointly address reliability, timing, scale, and power are needed to meet the needs of future industrial control systems. Proponents of advanced manufacturing systems such as those defined by Industry 4.0 and the Industrial Internet Consortium state that existing protocols are not capable of meeting all the demands of industry. The future factory will require untethered situationally-aware communications, heavy reliance on automation to include robotics, and an increased cognitive cyber-security posture. It is not certain if feed-

back control of robot motion is necessary; however, future communication systems must address strict latency and data reliability requirements for discrete sensors, actuators, and robot end-effectors while maintaining security. With the adoption of wireless communications in the factory, existing protocols such as Institute of Electrical and Electronics Engineers (IEEE) 802.11 and IEEE 802.15.4 are not be capable of meeting reliability demands, round-trip latencies under 10ms, or scalability to dozens of devices within individual workcells and hundreds or thousands of devices within an entire factory system [4, 5].

Wireless communications is inherently more prone to latency and delay than wired counterparts. In addition, wireless communication implies the utilization of the electromagnetic spectrum which is a publicly accessible medium with constrained capacity and more prone to cyber-attack [6]. While transmitted data can be digitally protected through authentication and encryption, wireless devices are prone to interference and jamming by both rogue and friendly emitters, exacerbating the reliability and latency concern impacting factory performance without compromising data security. Wireless communication in factories is often constrained by battery life and most certainly constrained by the availability of the electromagnetic spectrum. As the reliance on wireless devices within the factory continues, steps toward developing a more robust wireless factory communications network must be developed [7]. These steps include:

- The automation system must become state aware and adaptive to knowledge of the trends in electromagnetic spectrum occupancy and acute events;
- Intelligence of the automation system must move closer to the physical system. This means moving the intelligence for control to the actuator; and
- Performance test methods must be developed and incorporated into the industrial fringe devices. The test methods must be dependable and at the same time easy to use by factory personal not trained in the technicalities of wireless communication.
- Existing Wireless communications protocols must be analyzed and adapted, and new protocols must be developed to balance reliability, latency, and scalability.
- Security of the network must be maintained and must include availability as a paramount characteristic.

The proposed thesis presents the development of test approaches for measuring the performance of industrial wireless networks (IWNs) deployed within smart

manufacturing workcells. Thus the primary goal of this thesis is the discovery of methods and approaches to the evaluation of industrial uses cases performance for those use case in which wireless communication technology is used as the principal mode of communications. The primary motivation of the research has been to discover practical test and evaluation methods for assessing performance of an industrial workcell thereby improving security, safety, and reliability. Findings and results of the thesis work are included within this thesis and published as journal articles and conference proceedings. These references are noted through the text and bibliography.

1.1/ INDUSTRIAL REVOLUTIONS

Major advances in manufacturing of goods for the betterment of humanity have occurred many times in the last two hundred and fifty years in the history of humanity. These advancements occurred of science and technology occurred as revolutionary events at different times. The first revolution occurred at the edge of the eightieth century primarily in England but also in France, Germany, and the United States with the applicant of automatic mechanization of large machines using coal powered steam engines. These machines were mainly used for the processing of cotton, wool, and silks in the production of textiles for export throughout the world. Advancements during this period included uses of coal to produce steam power, the production of iron, steel, and other rudimentary alloys, and, very importantly, the engineering advancements of tool making. The advancements of the first industrial revolution paved the way for the centralization and mass production of goods.

The next century was marked by the development of scientific and engineering advancements in chemistry, physics, and engineering. Experimentation with electricity and the production thereof led to the eventual explosion of industrial machinery, tooling, electrification, chemical manufacture, petroleum refinement, rail and marine transportation, the automobile, agriculture, and telecommunications by wire over long distances. This period of discovery culminated with rapid expansion of industrialization through the world, especially in North America and Japan up until the beginning of World War I.

The third industrial revolution began in the years immediately following the second world war with the rapid advancement of pure and applied sciences. These advancements were driven primarily by the cold war and the space race between the United States and the USSR. This period of advancement was marked by many discoveries and scientific applications such as the development of telecommunications theories (e.g., by Claude Shannon), advancement of radio and wired communica-

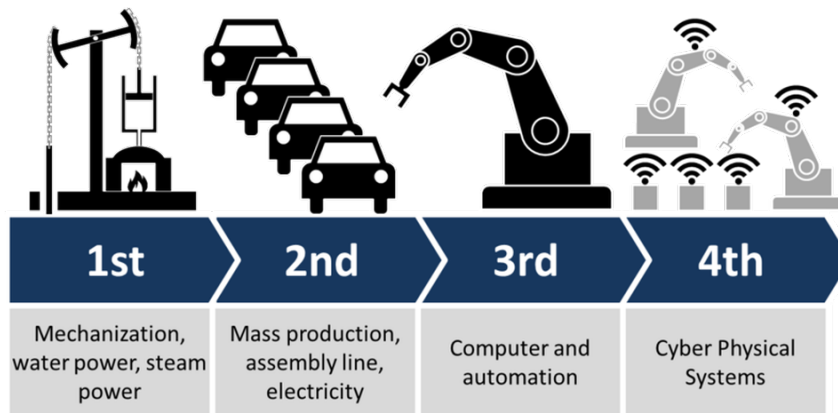

Figure 1.1: Industry 4.0: Wireless is a key enabler in the 4th industrial revolution. Many industrial revolutions have occurred with the most recent revolution taking place with the advent of CPSs. Image credit: Christoph Roser [8].

tions, the discovery of the transistor, and the rapid expansion of computers and information technology in business and defense. Also during these years, came the application of computing within manufacturing and process control settings. Computers slowly began to replace the basic relay circuit in control systems. By utilizing the programmable logic controller (PLC), manufacturers gained the ability to control their processes more easily and develop control strategies that were once more difficult to implement in the past with dedicated, specialized equipment. PLCs offered both the ability to more easily adapt processes to information gathered directly from the factory operation as well as slowly collect and store information electronically. However, electronic storage of this information was still both difficult and expensive as telecommunications technology was yet relatively slow and storage expensive. Over the years following through the 1980's until today, computers have followed closely Moore's "Law" which states according to the the perception of Intel Corporation founder, Gordon E. Moore, that the number of transistors on a microchip doubles roughly every two years, although that assertion no longer appears applicable. This paradigm of exponential growth in digital computing technology in terms of computing speed, storage, and efficiency has created a world in which computers and computing devices have become ubiquitous, surrounding practically every aspect of human endeavors and leading to the latest installment of industrial advancement, the 4th Industrial Revolution, a result of the Information Revolution which is currently ongoing.

The Information Revolution is defined by a culture that is highly interconnected and data-dependent. Clearly, the modern world is dominated by the Internet, high-performance computers, and personal mobile communications devices such as cell phones developed over the last several decades. Within the hands of each

individual, one may find a smartphone capable of performing computing and communications tasks not even imaginable fifty years ago. Indeed, within each of these devices resides a powerful microprocessor capable of clocking speeds in the gigahertz, offline storage spanning gigabytes, at-least one high-resolution camera, and communication components enabling high-speed connectivity capability. These personal devices are smart and easily re-programmable by downloading of new applications, i.e., apps enabling users to produce and consume information rapidly. Users enjoy the ability to speak together at any moment from virtually any location, send brief messages using apps such as WhatsApp™, download videos, play games, and store documents, music, photographs, and videos within "the cloud." Within office and business enterprises, a personal computer is within reach of every employee and is the tool used for information production. The data produced is stored within the cloud and usually produced and maintained locally, although the services of data production are quickly shifting to the cloud as well depending on the needs of the end user.

These capabilities have also been permeating industrial environments, although at a slower rate, given the inherent conservatism of industrial establishments. Industrial environments include aerospace and automotive manufacturing, electrical power production, food processing, petroleum and chemical production. That is not to say that industrial establishments are not open to technological change, but that established production system can be difficult or risky to modify once they are operational. While industrial operations have distinctly different requirements than office businesses; analogues may be made between the computing constructs found within the personal/business computing domains and those constructs found within the industrial computing domains. For example, within a factory production enterprise, the Internet itself exists as an outside entity providing global connectivity, hosting, storage, computing resource, and analysis tools. These services are often replicated within the business enterprise of the factory operation and extended into the factory environment to some degree from the factory management system to the factory floor.

In addition, with the explosiveness of ubiquitous, low-cost computing devices, the modern factory operation is changing to include more intelligence and adaptability at the factory edge. This change includes discrete devices such as sensors and actuators, collaborative robots, autonomous gantry systems, intelligent vehicular systems, tracking and inventory systems, and the like. These systems coupled with the plethora of computing resources have the potential to create an enormous amount of information as well as the opportunities for greater control over the factory enterprise. It is just a matter of tapping the information within the factory and bringing that information to a useful purpose. Where the third industrial

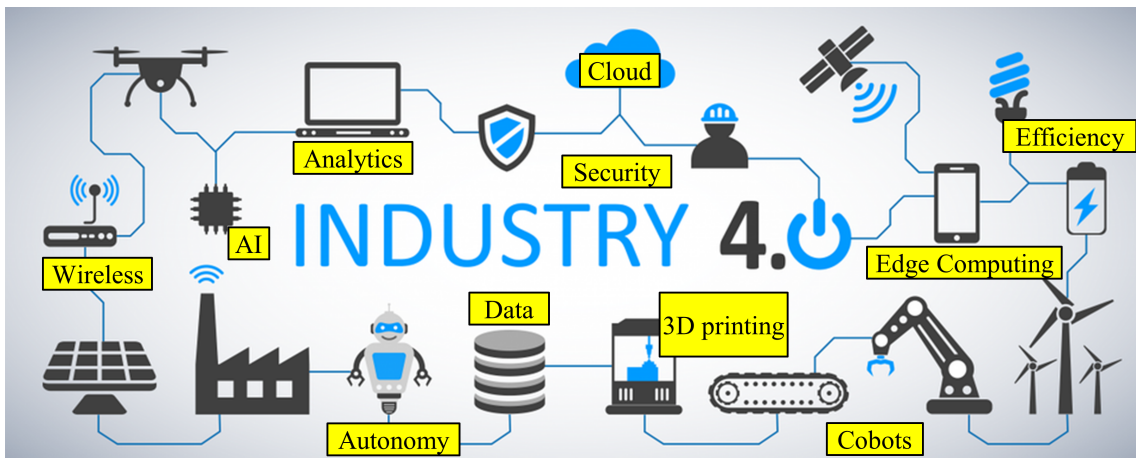

Figure 1.2: Industry 4.0: Incorporating the benefits of machine learning, massive data, mobility, and autonomy within the modern factory. The major contribution of Industry 4.0 is the introduction of massive connectedness and information-based awareness within the factory enterprise. Image credit: Adapted from Forbes [12].

revolution brought computing and automation to the factory, the fourth industrial revolution will improve upon the automation found within the factory by adding intelligence, autonomy, and machine learning powered by data. This data-centricity defines Industry 4.0.

1.2/ INDUSTRY 4.0 AND SMART MANUFACTURING

Industry 4.0 was officially launched by President Barack Obama of the United States and Chancellor Angela Merkel of Germany at the Hannover Messe industry show on April 24, 2016 [9,10]. Smart manufacturing is a term used to describe the ongoing efforts within academia, government, and private industry to improve upon existing and future factory operations by incorporating the latest advances and design principals in computing, storage, and communication such as interoperability, virtualization, decentralization, distributed control, real-time processing and communication, service oriented architecture, easy use and maintenance, cost savings, and modularity of design. With Industry 4.0, the industrial internet of things (IIoT) and industrial CPSs are expected to make large sweeping changes in efficiency, reliability, and capability of the future factory [11].

Propelled by economic pressure toward greater efficiency, factory agility, and product customization, future factories will have the technological ability to adapt quickly to customer demands, modify manufacturing processes automatically based on quality feedback, and fabricate products with a reduced environmental

impact. Technological application and advances required for smart manufacturing to be truly successful include collaborative and mobile robotics, distributed machine autonomy based on artificial intelligence, and a high degree of inter-connectivity of among the automation resources. Some of the important technologies and capabilities within a smart factory are listed below. This is certainly not an exhaustive list of what is required to achieve the goals of Industry 4.0, but it highlights some of the fundamentals that are pertinent to this thesis [13–16].

- **Data:** Quantities, signals, states, and situational awareness are essential to the goals of smart manufacturing. This knowledge will be central to the on-goings of the future factory. Data will be produced rapidly, transmitted, accumulated in large quantities, analyzed, and acted upon continuously; and the behavior of the smart factory will rely heavily on this data to operate.
- **The Cloud:** These are the resources required for storage, processing, analysis, and presentation of data produced by the factory enterprise. The resources of "The Cloud" will include elements associated with the infrastructure and services offered. These types of services would be augmented to meet the needs of the factory enterprise.
- **Edge Computing:** While much data will be stored within cloud resources, other forms of data will be migrated toward the "edge" on the floor of the factory. Edge computing will increase efficiency making data more rapidly accessible for automation and control within the workcell. Moving data between automation actors within the factory quickly will be essential. Identifying the kinds of data and communications needs is equally important.
- **Robots:** The smart factory will be replete with robots of all kinds including stationary and mobile arms, cranes, lifts, etc. The robots will be mostly collaborative in that they will coexist with other robots as well as humans as they perform their own tasks or cooperate to complete them together. Robots will have the ability to roam between work-cells within a factory, learn its role quickly, become aware of edge devices, and communicate with other actors within the workcell to accomplish its goals. Current manufacturing architectures use wired connectivity through field bus and industrialized Ethernet for sensing and real-time control of robotics resources. By mobilizing robot resources, cables will be eliminated; therefore, reliable, high-performance wireless communication becomes essential.
- **Artificial intelligence (AI):** Computing resources within the factory will be supplied with some form of intelligence. The level of intelligence will depend on the applications required and the level of advancement of machine learning

in general. Much of the intelligence will be centralized in the beginning, but as the capabilities of edge devices evolve and improve, AI will migrate more towards the edge including mobile actors such as robots. And since mobility is also essential to the goals of smart manufacturing, wireless performance will be important to enabling rapid and reliable communication between intelligence centers and mobile actors such as robots and other untethered machines.

- **Wireless Communication:** A central concept to all of the previous content is the movement of data between autonomous and mobile actors within the smart factory environment. Wireless communication is key to achieving this vision as it pertains to the transfer of information between two or more points without cables "over the air" typically using the propagation of modulated electromagnetic waves.

1.3/ THE IMPORTANCE OF WIRELESS IN SMART MANUFACTURING

The concept of Industry 4.0 is centered around the smart factory in which autonomous actors permeate the factory. Wireless communications technology [17] is an essential requirement for all interconnected things that are wireless. CPS, i.e., systems in which the networking, computation, and the physical world are tightly integrated will dominate the factory. Whereas the factory of the past was predicated on centralized design based on limited data and knowledge of the past, present, and future states of the business enterprise, decision making within the smart factory will be highly decentralized. Information will likely be stored in the cloud; however, the actors making decisions will be located in throughout the factory itself at the edge. Wireless technology will be used for two main categories within the smart manufacturing enterprise and are described as follows:

- **Cable Elimination:** Substitution with a wireless technology where once a wire existed in an existing industrial system. This often occurs when the cost of installing a cable is either infeasible or prohibitively expensive but the cost of not replacing the wire would cost more. Cable substitution with wireless could be envisioned where once a cabinet existed as a nexus point for input/output (IO) end-points. If a legacy product fails thus rendering the nexus non-functional, wireless could be used to replace the connections between a computing device and the various I/O endpoints. This scenario is often cited in industry as a high-likelihood scenario for both sensing applications and sensing with control applications where the I/O end-points are stationary. Wireless will be used to circumvent future failure or will be used as a rapid replacement measure for a failed system.

- **Mobility Enablement:** Support of one or more untethered actors such as a robotic arm or heavy lift machine to assist in the movement of materials or the tending of other processes. In these applications, the untethered actors require, at a minimum, instructions to perform their tasks. More than likely, the mobile actor will need to remain aware of itself and its surroundings, communicate to a supervisor or other mobile actors. Interconnection with the factory safety systems will likely be a necessity.

1.4/ CHALLENGES IN INDUSTRIAL WIRELESS NETWORKS

Since the development of wireless sensor networks (WSNs) beginning in the early 2000's much excitement has been generated by its promises [18]. Development of IEEE 802.15.4 brought about such standards as WirelessHART [19], ISA100.11a [20], and Zigbee as low-power mesh networking options for industry. Other similar wireless networking technologies include LoRAWAN, Sigfox, 6TiSCH, and Wireless Fidelity (Wi-Fi) to name a few. These WSNs technologies were all designed primarily with the main goal of collecting information or transmitting large amounts of data rapidly in the special case of Wi-Fi. Industrial WSN technologies were not really intended to command or control devices, although they have been at times adapted to do so. For example, WirelessHART and ISA100.11a have the primitives (i.e., the "hooks" to do so) and some valve control and other applications have been realized using these protocols. These types of WSN technologies were designed to support sensing with some supervisory or human-in-the-loop control with command decisions rarely occurring and without demanding reliability or latency requirements placed on the communication system. Indeed, WSN's typically operate with 75% link-to-link packet success rates at the physical layer. With the advent of Fifth-generation cellular (5G) communications, which in this context includes both cellular and IWNS such as Wi-Fi (e.g., IEEE 802.11ax), much work has been done to characterize the wireless requirements landscape for industry as summarized in [5]. The requirements landscape for industrial wireless can be organized into two main categories: 1) sensing and data gathering, and 2) control. For the first category, many technologies already exist to support these applications, and rarely is reliability or latency a major concern for these applications. The second category, control has garnered interest within the academic and industrial communities because of the promises of eliminating cables and enabling mobility, and hence, autonomy.

However, the adoption of wireless for control applications has been rare to date [21]. The primary reasons for its evident failure is most likely reluctance on the part of control designers to use a mode of communication that on the surface appears brittle and unreliable regardless of the truthfulness behind these assumptions.

Wireless technology in general has the following perceived shortcomings that need to be addressed by the research and development community before its widespread adoption comes to fruition. These shortcomings include the following:

- **Choices, Obsolescence, Interoperability:** Many wireless alternatives exist, and the market is ever changing. The number of choices can be confusing for factory operators trying to implement a solution that will last 10 years or more. In comparison, wired networks are typically built on the same Ethernet or field-bus backbones that have existed for decades. When factory control engineers select networking equipment for a factory installation, they intend for those devices to last for at least ten years or more. With a plethora of selections in the wireless market, the marketing hype surrounding those devices, and the rapidity by which technology changes, the reluctance to adopt wireless becomes clear.
- **Link Performance:** Information flow between actors within a factory operation. Since wireless communication is by definition communication without wires across a shared physical medium, it is perceived (correctly) that wireless is not as reliable as wired modes. This perception of a difference in reliability fuels the reluctance of wireless adoption within factories although the strong desire exists to do so.
- **Security:** Factory operators want their networks to have the same level of security as their wired networks. The very nature of wireless is open in terms of access to the physical communication media. Essentially, this leaves wireless open for eavesdropping attacks assuming that the underlying encryption can be hacked. If strong encryption is used, the wireless network can still be compromised by jamming or interference. Security of the wireless network includes immunity from interference, fitness of data, and privacy. Indeed, the concept of security can be extended to include all aspects of reliability, data integrity, privacy, safety, and stability of the factory operation touched by the wireless network.

The use of wires precludes mobility and makes deployment of edge devices more expensive as each device requires power, wires, and conduit for communication. By adopting wireless for both sensing and control of machines within the workcell, a lower-cost, untethered operation becomes achievable. Once wireless is adopted as the primary mode of communication, questions arise as to the required latency, reliability, scale, and security of the wireless network especially when the network is used for the control of machines and the assurance of safety.

In a factory operation where wireless is used as a primary mode of communication, performance of the wireless network becomes paramount and the ability to assess that performance becomes equally important. Performance of the wireless network depends on many factors that are impossible to define here within this thesis; however, an introduction on industrial wireless deployments which includes an excellent primer on radio communication can be found in [22] which is a primary contribution to industry. Nevertheless, the main categories of factors that impact an IWN are provided as follows.

Propagation Loss Wireless communication as compared to wired modes of communication is considered "lossy". The probability of error for any wireless communication is governed by the amount of power detected by a receiving radio and the competing noise and interference observed by the receiver. It is essentially a matter of maintaining an acceptable signal-to-noise ratio (SNR). The amount of loss between a transmitter and receiver is governed by the general equation $L = 10 \log_{10} \left(\left(\frac{4\pi df}{c} \right)^n \right)$ where d is the distance between transmitter and receiver, f is the frequency transmission, and n is the path loss exponent for a particular environment. Thus, the SNR drops with distance for a given frequency. Whereas cables typically experience very little loss, wireless modes of communication experience loss very rapidly depending on the frequency of transmission as shown in Fig. 1.3 as negative path gain. The figure shows the typical loss curve for a particular factory at 2245 MHz near the common 2400-2500 MHz Industrial, Scientific, and Medical (ISM) band used by Wi-Fi, Zigbee, and WirelessHART, and ISA100.11a.

Multi-path Objects within the surrounding environment determine the behavior of the waves as they propagate through the environment. Shown in Fig. 1.4 is a simplified model of a radio channel. When radio frequency (RF) energy is transmitted, it will travel in the direction determined by the antenna gain pattern. Objects in the environment may obstruct, attenuate, or reflect RF energy. Reflections contribute to a phenomenon known as multi-path. Edges of objects may also result in diffraction even if a line-of-sight (LOS) path exists. At the receiver end, direct path and reflected energy is detected and decoded into useful information if the signal energy was high enough to overcome naturally and artificially occurring noise and interference. Multi-path reflections may result in significant information loss even if signal power is high. Multi-path is severe within factories due to the large highly-metallic structures that exist in those environments [23–25]; therefore, industrial wireless systems (IWSs) must anticipate and accommodate these effects.

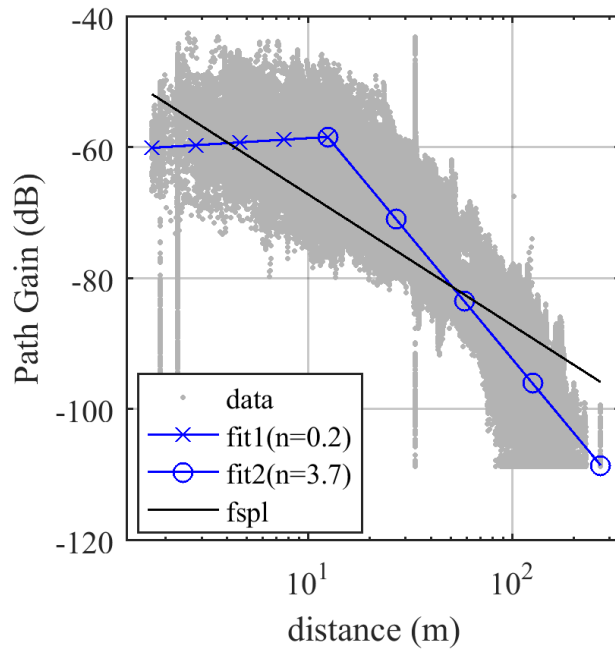

Figure 1.3: Example of radio propagation path loss for 2245 MHz transmissions within a factory environment. Reproduced from National Institute of Standards and Technology (NIST) Technical Note 1951 [23]

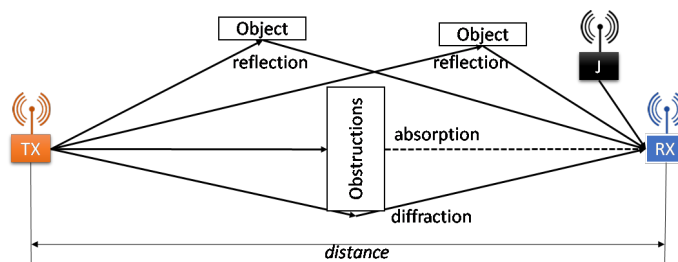

Figure 1.4: Wireless range, obstructions, absorption, reflection, diffraction, and jamming/interference are all sources of wireless channel degradation within the factory environment. Reflection and jamming are of special concern within the highly obstructed, metal-rich environment found in the typical factory.

Interference Electromagnetic interference (EMI) is always present to some degree in a wireless network. EMI when in the radio frequency spectrum creates a disturbance that disrupts intended communications. The disturbance can degrade performance by introducing RF energy into the circuits of wireless devices. When the disturbance is strong enough to overcome the intended signal, communication loss will result. Sources of EMI include both man-made and natural sources. Natural radio sources typically will not interfere with network operation as the devices or deployment locations are designed to accommodate some natural interference. Man-made interference can include other competing radio devices that operate in the same frequency band or nearby in frequency. Noise from rotating electrical motors can also occur and typically affects radio bands below 400 MHz. Common interference sources include personal devices such as cell-phones when a Wi-Fi hotspot is enabled. It can also include non-communication devices such as micro-wave ovens. EMI can also emanate from intentional radio jammers designed to disrupt communications, and this can be classified as a security issue.

Wireless Protocols Used Each wireless protocol has been designed with its own target application and ambient environment for performance. Each protocol is designed with a method for accessing the radio media, organizing data for transmission, methods for receiving transmissions, and recovering from interruptions. For example, IEEE 802.11 also known as Wi-Fi was designed primarily for home and office use for the transfer of large amounts of data rapidly. Wi-Fi typically uses 20 to 40 MHz of bandwidth and employs high order modulation and coding schemes. Wi-Fi works well to transfer files and stream video, and serves well where traditional Ethernet is used; however, Wi-Fi operates within public radio bands and is prone to interference, contention, and non-determinism of response times. In contrast, other protocols such as WirelessHART and ISA100.11a are designed specifically for industrial wireless sensor networks (IWSNs). These protocols use low-order modulation schemes with frequency hopping and are by design more resilient to interference. They also offer substantially better determinism but are limited in data throughput.

1.5/ WIRELESS KEY PERFORMANCE INDICATORS

Given the challenges described in the previous section, assessing the performance of the wireless system becomes a matter of defining and then measuring key performance indicator (KPI) relevant to the success of a given wireless deployment. A KPI can be considered a requirement of an industrial system if that KPI is used to specify a condition or capability needed by a stakeholder to solve a problem or achieve an objective within the factory enterprise. Requirements considerations for

designing or implementing a wireless communication system in a factory workcell include latency, reliability, scalability, range, payload size, update rate, operation and implementation cost, security, and system resiliency. These requirements are important aspects of a wireless network [7]. These requirements have particularly influential roles in implementing a wireless communications system within a factory environment and then assess the success of that wireless deployment. The following paragraphs define the key performance indicators (which may be considered as requirements) for an IWS.

Latency Latency is defined as the period of time between information transmission and reception between two actors. Most non-industrial wireless systems are designed for higher data rates without regard for latency. However, for industrial applications, low latency is an important factor in control-based tasks as transmissions that occur outside of the latency threshold are considered failed transmissions. Industrial applications use smaller packet sizes with precise timings, signifying the criticality of latency.

Definition 1: Latency

The time between transmission of the first bit of information to the time in which that information is received by its intended recipient.

Reliability Industrial functions such as safety transmissions or critical control processes are examples of functions that require an extremely high degree of reliability because a “missing” transmission could have severe consequences to safety, production, and/or equipment integrity. High-reliability in industrial communication is crucial for numerous mission-critical applications.

Definition 2: Reliability

The probability of loss of information due to any source of noise or exceeded latency.

Scalability Scale, in an industrial wireless point-of-view, is the number of devices that can be deployed on the network while retaining reliability, speed, and data-rate at set requirements. Scalability is important for dynamic networks where devices come-in and go-out of use. One distinct advantage of wireless communications is the ease with which nodes can be added to the network without the need for laying wire or cable.

Definition 3: Scale

The number of participating devices within a network.

Range Range is the maximum distance to which a wireless link can extend while maintaining all other requirements. In general, as the distance of the wireless link increases, the channel losses increase and the signal power between nodes decreases. Excess range affects the reliability and latency of transmission.

Definition 4: Range

The maximum distance to which a wireless link can extend while maintaining all other requirements

Payload Size Payload size is the size, in bytes, of the information portion of a transmission; however, the payload excludes header, framing, and error-correction information. Differentiating the payload size from the overall individual packet size allows the designer to ascertain the size of the information portion of the transmission. For many industrial applications, such as safety and control applications, the payload size is very small.

Definition 5: Payload Size

The informational length of information to be transmitted not including all overhead associated with the protocol used for transmission.

Update Rate Certain manufacturing applications require higher update rates to achieve desired workcell performance. A wireless network must support the required update rates needed by all the applications on that wireless network. For example, a force feedback control application that utilizes a wireless force-torque sensor may require 125 Hz sample rate. A torque control application could require between 500 and 1000 Hz. An example of such an application may be found in reference [26]. Update rate is an important factor that impacts the deployment and configuration of wireless networks and it dictates the effectiveness of frequency planning [22].

Definition 6: Update Rate

Rate of transmission for a particular process variable.

Operation and Implementation Costs A consideration for implementing industrial wireless communications is the cost savings. For a wireless communications system, there is no need to install and, later, replace cabling due to degradation and wear. In wireless communications, redundancy can be achieved without cables. Wireless communications require lower labor costs as remote monitoring and control extend the ability to monitor and manage remote sites; onsite personnel is unnecessary. Electricity cost is lower for wireless installations, due to the relatively low power draw of wireless communications.

Security Security in wireless communications is not equivalent to security in wired communications in that wireless networks offer a different potential for exploitation; wireless uses air for communication which provides easier access to remote foreign actors. Along with the threat of remote jamming, there exists the possibility, absent adequate security protection, that wireless networks could be accessed if the keys to the public-key cryptography are discovered and encrypted transmissions are revealed. Wireless for industrial applications must be reliant to security related threats as the loss of communication can be costly and may damage equipment or harm personnel. Detailed requirements for wireless security are not discussed further in this thesis but more information can be found in [27].

System Resiliency Overall system resiliency in a factory environment must be considered as issues with networking may lead to unnecessary inefficiency. For example, if power is disrupted, a network must be able to re-establish connectivity within seconds. Intelligent applications may also be required to overcome network communication issues. Achieving a resilient network is not trivial as current wireless devices may require long periods of time to re-establish connections within the network. For example, mesh networks based on low-data-rate protocols can often take minutes or hours to reestablish an operational network after just an intermittent loss of power. System resiliency is outside the scope of this report; however, system resiliency issues such as recovery time after power loss must be considered in the design of wireless technology for use in factory workcells.

Power and Battery Life Often overlooked is the power efficiency of wireless devices. In factories in which power is readily available such as in a workcell or on a mobile cart platform, power efficiency is not often considered. In scenarios where devices are deployed over large distances such as in a oil refinery or water purification plant, battery life becomes important. Battery life can also be important for large scale deployments in factories with thousands of devices. In those scenarios, the frequency of battery change or failure can drive costs substantially. Therefore, power efficiency

and the impact of design factors on battery life can be equally as important as communications reliability in an IWS deployment.

These requirements vary greatly depending on the class of industrial application and much work has been done to try to make sense of the classes of applications and their subsequent requirements. An illustrative perspective of these is given in Fig. 1.5 showing both typical and worst case specifications and how each relate. Development and interpretation of industrial wireless user requirements is an ongoing area of research and is elaborated more in Chapter 2.1.

1.6/ RESEARCH OBJECTIVES

Given the many different and competing parameters of industrial wireless deployments such as reliability, latency, scale, etc. along with the many impacting factors to performance such as interference and multi-path fading as well as a clear need for test methodologies that do not solely account for the performance of the communication network, the research objectives of this thesis were mostly exploratory and experimental in nature based on traditional systems engineering principles of understanding the requirements, decomposing the system into its constituent components and interfaces, and then analyzing that system through experimentation and analysis of the results. The following describe our goals of conducting the research described in this thesis.

- **Exploration of Requirements:** Industrial applications vary widely depending on the needs of the application. Applications may range from condition monitoring (CM) in which the required reliability and tolerable latency is high to applications such as hard real-time applications for safety integrated systems (SIS) in which reliability and latency are strictly controlled. Much of the information regarding communications requirements of these widely varying applications are based on opinion with little validation specified. Moreover, the information found can be confused by media hype and speculation. Therefore, a very important and first step in the research was to explore the requirements as stated by reputable sources such as international standards organizations and peer-reviewed papers and provide a distilled, realistic perspective uncluttered by hype and supported by experimental data or analysis of the underlying use cases.
- **Architectural Decomposition:** The next important element within the research was to understand the composition of a factory workcell to include its constituent parts and interfaces. The goal in doing so was to discover and model

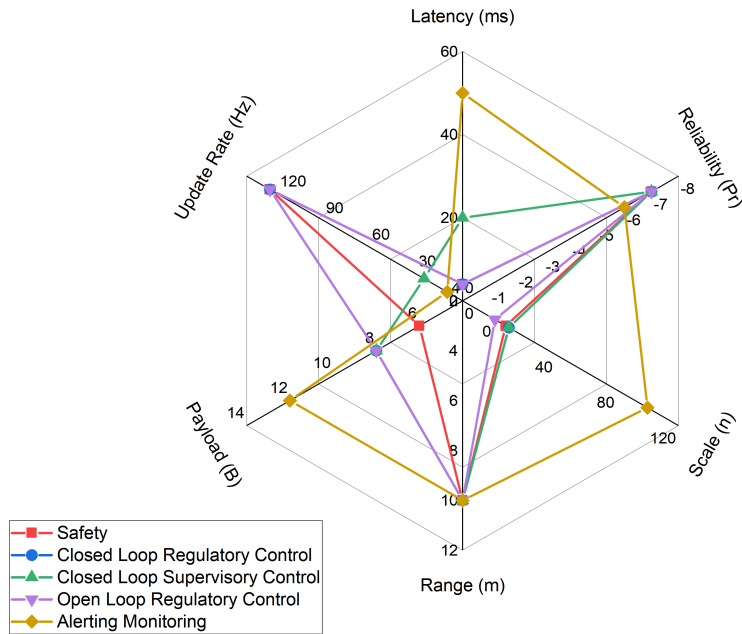

(a) Typical

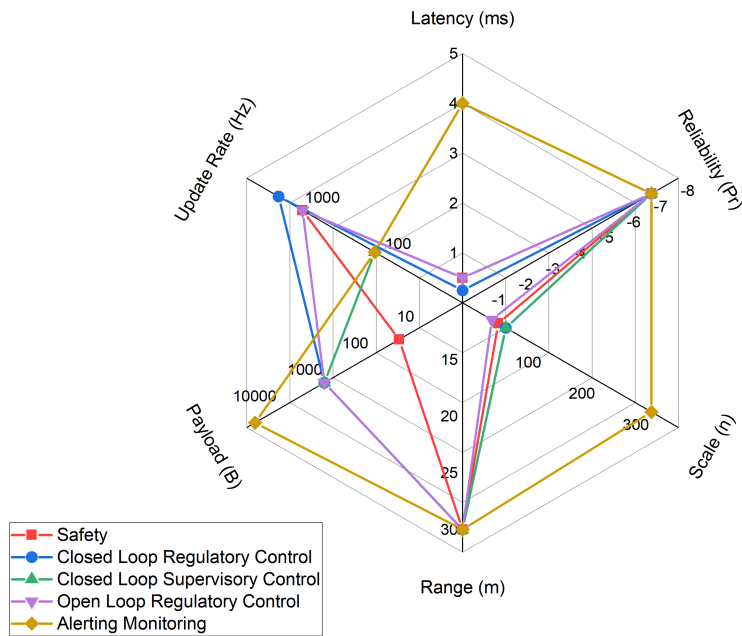

(b) Worst Case

Figure 1.5: Typical (a) and Worst Case (b) key performance indicators for industrial wireless use cases presented in [5]. Industrial wireless use cases differ greatly from that of the home or office business environment. These IWNs are characterized by short bursts of information, periodically transmitted, and requiring varying degrees of arrival reliability within a predetermined soft or hard deadline.

the important CPS elements of a factory workcell and how those elements connect, interrelate, and conduct information in a general sense. Therefore, our objective was to create a reusable exploratory model of the CPS that is a factory workcell in which wireless communication is the primary mode of communication.

- **Discovery by Prototyping:** During the discover process of the research work, we aimed to perform our research using real-world data from physical experiments. Since the required resources were available and at our disposal, our research objective was to conduct as much of the research using actual devices such as industrial automation and communication equipment as possible.
- **Non-traditional Analysis:** Our final goal was to explore through experimentation the use of new data organization methods and learning approaches to analyze data taken from laboratory experiments. Therefore, our research objective was to apply database technology and machine learning algorithms in ways that had not yet been adopted or used for analysis of CPS performance analysis.

1.7/ CONTRIBUTION SUMMARY AND THESIS ORGANIZATION

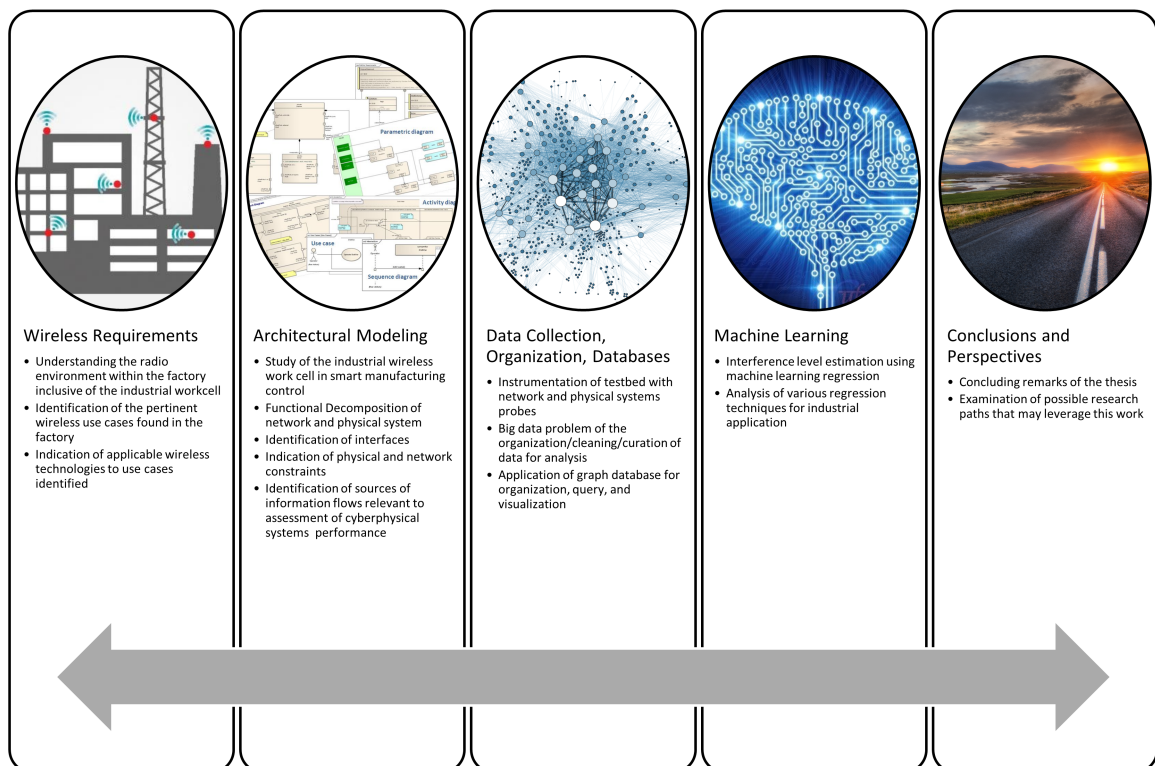

Figure 1.6: Contribution areas and organization of this thesis.

This thesis is presented in three major parts. The first part, Part I, Context and Problem Statement provides a historical introduction to the context of smart manufacturing. It presents the premises of industrial wireless technology, key challenges to using wireless within a factory environment, and the accepted indicators that are currently used in the application of wireless within factory environments. In Part I, the existing state of the art is also presented in Chapter 2. This state of the art includes a discussion of the industrial wireless technology landscape, standards, and a tentative mapping of those technologies to application domains. A discussion of the systems modeling approaches is then provided with a focus on the Systems Markup Language (SysML). A discussion of approaches to the use of databases follows. In Part II, Thesis Contributions, the technical contributions of this thesis are presented, providing a detailed discussion of the four major contributions of this thesis work. The thesis contributions are presented as follows:

- Requirements: [7] [5] [22] [28] An examination of the wireless technology landscape is conducted. Existing and future wireless technologies are assessed for their appropriate applicability to industrial use cases. In [22], the authors produced a major contribution for the manufacturing industry to effectively design and deploy IWNs used for sensing, control, monitoring, and surveillance. In [28], our guidelines are presented to the academic community as a peer-reviewed article.
- Modeling: [29] [30] In an effort to better understand the architectural composition of the workcell using industrial wireless communication, modeling techniques are used to identify and decomposed the parts, interfaces, and data flows. SysML is adopted for this process and a proposed modeling library is created and presented. The model with conceptual diagram is made publicly available independent of the tool that was used to create the model.
- Application of Graph Database: [31] [32] A method is developed for collecting, cleaning, organizing, and presenting the cyber-physical performance indicators of experiments run within the NIST Industrial Wireless Testbed. The method developed utilizes the Neo4j graph database (GDB) and is presented as a novel approach as compared to traditional approaches using relational database, spreadsheets, and raw file processing.
- Machine Learning: [33] [34] A machine learning technique is used to predict signal-to-interference ratio (SIR) levels within a wireless factory workcell network employing a robot arm within a force-seeking apparatus. The machine learning method allows a trained network to accurately determine the SIR level using the physical state of the robot arm rather than the state of the wireless link itself.

Subsequently, in [35], we present a new industrial wireless testbed design that motivates academic research and is relevant to the needs of industry. The testbed is designed to serve as both a demonstration and research platform for the wireless workcell. The work leverages lessons learned from past incarnations that included a dual robot machine tending scenario and a force-torque seeking robot arm apparatus. This version of the testbed includes computational and communication elements such that the operation of the physical system is noticeably degraded under the influence of radio interference, competing network traffic, and radio propagation effects applied within the lab. Key performance indicators of the testbed are selected and presented which include communication, computational, and physical systems indicators. This new testbed will be used to perform future research motivated by this thesis.

An additional contribution is cited here [36]. In this work, we have designed, constructed, and executed an experiment in which a typical two-dimensional gantry apparatus was controlled by a local controller which received G-code commands wirelessly over a Wi-Fi network. The industrial wireless channel was replicated using a RF channel emulator where various scenarios were considered and various wireless channel parameters were studied. The movement of the gantry system tool was tracked using a vision tracking system to quantify the impact of the wireless channel on the system performance. Numerical results were presented including the total run time of an industrial process and the dwell times at various positions through the process. This contribution is not discussed within the thesis.

Finally, this thesis concludes in Part III. Our concluding remarks and recommended future direction are provided.

STATE OF THE ART

This chapter present the reader with background conducted during the thesis investigations. The chapter is presented as a "State-of-the-art" but it can also be considered as a a compilation of the related work previously performed by other interested researchers within the field. The content, therefore, of this chapter contains a summary of the previous works discovered for the contributions presented in Part II. The chapter is divided into three main sections: 1) an exploration of industrial wireless requirements with a mapping of those requirements to existing and future wireless technologies; 2) system modeling of the factory with specific mention of the wireless workcell; 3) the organization of data for the collection and analysis of performance data of CPSs found in factory workcells; and, finally, 4) applications of machine learning for the prediction of wireless network performance within factory workcells.

2.1/ INDUSTRIAL WIRELESS REQUIREMENTS SPACE

The use of IWNs has been studied in many works in the literature and industry. However, no comprehensive survey of the holistic problem space of industrial communications has been performed. The following chapter provides background into the evolving landscape of industrial wireless requirements. It should be noted that the requirements perspective is often influenced by hype in the marketplace, and often the requirements that are stated are unrealistic or impossible to meet within reasonable price points. First, a literature review has been provided which was the result of the work presented in [7]. This literature review will be followed by an elaborated perspective provide in NIST 300-8 [5] of which the candidate took a lead role in leading, contributing, and writing. Within that work, a picture of the wireless requirements landscape is provided based on inputs from the International Society of Automation (ISA) and the European Telecommunications Standards Institute (ETSI). The work then provides a more distilled view of the requirements perspec-

tive with rationale. This distilled perspective serves as both a state of the art of industrial user requirements viewed by ETSI and ISA, but it also serves as a major contribution in that it provides validated requirements that are usable to build realistic and functional wireless systems. This is ultimately the goal of performing a rigorous review of the requirements landscape and producing saner perspective. A clearer concept of the requirements will not only allow for the development of realistic wireless systems, but it is also essential in the construction of more accurate models, the conduct of more effective testing, and better analysis of the performance measurement data that results.

2.1.1/ LITERATURE REVIEW

This section provides an overview of the literature review conducted for the work performed in [7] in which the broad landscape of industrial wireless use cases were considered and then matched with potentially applicable wireless technologies that existed or were in the process of standardization or development.

In [37], the authors introduce a comparison between the commercial and industrial communications networks where an industrial network has been divided to five different levels. These levels include field equipment, controller, application, supervisory, and external networks. The differences in requirements between different levels are discussed.

Three types of information are considered which are control, diagnostic, and safety information as described in [38]. Within this reference, the authors categorize the types of industrial control network their applications within a reconfigurable factory testbed developed at the University of Michigan. While all these levels of industrial networks are mentioned in [37], the article focuses only on the manufacturing and instrumentation communications and does not consider other types of communications networks that exist in industrial environments.

In [39], and online tutorial describing industrial protocol, three levels of communications are considered which are device, control, and information levels. Current wired industrial technologies for these levels are discussed briefly.

In [40], provides a survey on real-time communication using Ethernet technologies in industrial automation environments. In this work, the communication between field devices was studied where the requirements for a large number of nodes may not be achieved. The use of fieldbus solutions limit the scalability and resilience and hence industrial Ethernet capabilities are introduced in this article. While limited insight into wireless solutions is provided, the article provides insight

into the key performance criteria for real-time protocols in general.

Moreover, in [41], the communication for monitoring and control operations is discussed and an introductory discussion for wireless adoption for these use case classes is provided. A comparison between fieldbus technologies, industrial Ethernet, and wireless solutions is performed. The author discusses the use of Wi-Fi, Bluetooth, ZigBee, and WirelessHART technologies in industrial applications.

In [42] the authors consider the industrial communications networks requirements in process automation specifically at field devices level. The authors provide a survey of opportunities, requirements, concerns and challenges of wireless in process automation, the relative standings of existing short-range wireless network technologies, and their perceived shortcomings. The authors also provide an examination of emerging industrial wireless standards which are designed to address the harsh performance requirements of the process industry given the ambient environment of those factories.

Finally, in [43], the authors perform an expansive survey on WSNs and provide a systemic mapping of research in this area. The authors show trends within the research community and demonstrate the importance of developing new protocols that are resilient to the harsh transmission media found in factories. The authors also indicate that a star topology of IWNs may be the more appropriate selection for most latency and reliability constraints.

2.1.2/ INDUSTRY REQUIREMENTS PERSPECTIVES

In the following discussions, a presentation of different perspectives of various user requirements provided by industry is given based on industry reports from two noteworthy organizations. These perspectives differ from the perspectives provided by the academia in Section 2.1.1 in that the contributors of these reports were individuals working directly within factory organizations or suppliers of products and services used by factory controls engineers. The first discussion in Section 2.1.2.1 focuses on the requirements work performed by the standards organization, the International Society of Automation. The second discussion given in Section 2.1.2.2 focuses on work performed by ETSI regarding high-reliability, low-latency communications requirements for industrial applications, and in particular for the 5th generation wireless evolution known as 5G. The third discussion provided in Section 2.1.3 while an academic article was the result of research performed by engineers developing wireless products for high-performance wireless networks used to control industrial operations by latency constraints within the microsecond range. Finally, a consolidated and actionable perspective is provided which serves as both background

material and our contribution. The consolidated perspective of the requirements and implied architecture were useful in the development of the SysML model presented in Chapter 4.

2.1.2.1/ ISA REQUIREMENTS PERSPECTIVE

The ISA is a non-profit standardization body that produced Wireless User Requirements for Factory Automation [10]. The ISA provided classes that categorized industrial applications and use cases, and assigned wireless user requirements for latency, jitter, and block error rate (BLER). Table 2.1, adapted from [44], provides usage classes with their respective descriptions; these classes are grouped by domain, in factory automation use cases. It is important to note that the “Factory Automation Use Cases” column references “Clauses” which describe applications in the usage classes in detail and are not discussed in this report. The Clauses discuss various industrial applications and such applications apply to different classes. For example, the robot end-effector (REEF) for Class 1, track-mounted equipment and rotary equipment for Class 2, track-mounted equipment and rotary equipment, but with a human in the loop for Class 3; torque and gauge tools, mobile material containers, mobile high value assets (molds, dies, etc.), and mobile test and calibration fixtures for Class 4. Note that the report references similar applications for Class 4 as for Class 5, except with the purpose of logging, downloading, and uploading; also note that Class 0 presented in this thesis, was not discussed in the report. The ISA requirements, adapted in Table 2.2, define BLER as the probability of an erroneous block received at the application layer. It should be noted that all usage classes have a requirement of 10^{-9} BLER, an assumed requirement, without justification, in the ISA’s report.

2.1.2.2/ ETSI REQUIREMENTS PERSPECTIVE

ETSI produced a requirements report titled "Reconfigurable Radio Systems (RRS)"; Feasibility study on temporary spectrum access for local high-quality wireless networks [11]. The ETSI report includes a detailed table, reproduced here in 2.3, which categorizes specific industrial scenarios and listed certain requirement metrics such as latency, reliability, data rate, packet size, communication range, device mobility, device density, and energy efficiency. The ETSI report appears to be very detailed; however, justification of specific values and their derivations are not disclosed.

ETSI industrial wireless communications requirements are separated into different sections, depending on the application. Under Monitoring and Diagnostics, the application is focused on remote sensors that do not have strict latency

Table 2.1: ISA Descriptions of Wireless Requirements Classes

Domain	Usage Class	Description	Factory Automation Use Cases
Safety	Class 0: Emergency action	Always critical	
	Class 1: Closed loop regulatory control	Often critical	Clause 5.3
Control	Class 2: Closed loop supervisory control	Usually non-critical	Clause 5.4 Clause 5.5
	Class 3: Open loop control	Human in the loop	Clause 5.4 Clause 5.5
Monitoring	Class 4: Alerting	Short-term operational consequence (e.g., event-based maintenance)	Clause 5.6 Clause 5.7 Clause 5.8 Clause 5.9
	Class 5: Logging, Downloading, and Uploading	No immediate operational consequence (e.g., history collection, sequence of events, preventive maintenance)	Clause 5.6 Clause 5.7 Clause 5.8 Clause 5.9

Table 2.2: ISA Wireless Requirements Perspective

Use Case Class	Latency (ms)	Jitter (%)	BLER
Class 0	ND	ND	ND
Class 1	10	± 10	10^{-9}
Class 2 and 3	10 to 100	< 10	10^{-9}
Class 4 and 5	100 avg.	± 10	10^{-9}

or reliability requirements, compared to other applications. The column, Condition Monitoring, includes applications that report physical parameters, such as temperature, humidity, vibration, acceleration, etc., and the column has similar wireless network requirements to Process Automation. In discrete manufacturing, a countable number of items are produced which may take many steps to complete. In discrete manufacturing, machine tools, robots, sensors, and PLCs exchange small packets with short intervals, which requires low-latency communications. Motion Control has more strict latency requirements than general discrete manufacturing. Examples for Motion Control include a controller for an electric motor in an assembly line or a hydraulic cylinder controller for a press [45].

The Logistics and Warehouse category is separated into mobile vehicles,

Table 2.3: ETSI Industrial Wireless Requirements Perspective

Key Performance Indicator	Monitoring & Diagnostics		Discrete Manufacturing		Logistics and Warehouse			Process Automation	Augmented Reality	Functional Safety
	General	Condition Monitoring	General	Motion Control	General	AGV	Cranes			
Latency/Cycle Time (ms)	> 20	100	1 – 12	250 μ s – 1 ms	> 50	15 – 20	15 – 20	50 – X s	10	10
Reliability (PER)	10^{-4}	10^{-5}	10^{-9}	10^{-9}	$>10^{-2}$	$>10^{-6}$	$>10^{-6}$	10^{-5}	10^{-5}	10^{-9}
Data Rate (bits/sec, bps)	Kbps-Mbps	Kbps	Kbps-mbps	Kbps-Mbps	Kbps-Mbps	Kbps-Mbps	Kbps-Mbps	Kbps	Mbps-Gbps	Kbps
Packet Size (bytes, B)	> 200 B	1-50 B	20-50 B	20-50 B	< 300 B	< 300 B	< 300 B	< 80 B	> 200 B	< 8 B
Communication Range (m)	< 100	100 m – 1 km	< 100	< 50	< 200	~2	< 100	100 m -1 km	< 100	< 10
Device Mobility (m/s)	0	< 10	< 10	< 10	< 40	< 10	< 5	< 10	< 3	< 10
Device Density (m ⁻²)	0.33 – 3	10 – 20	0.33-3	< 5	~ 0.1	~ 0.1	~ 0.1	10000/ Factory	> 0.33 – 0.02	> 0.33 – 0.02
Energy Efficiency	n/a	10 years	n/a	n/a	n/a	< 8 hours	n/a	10 years	1 day	n/a

automated guided vehicles (AGVs), and static systems such as cranes. AGVs can be mobile robots, transport vehicles, and mobile working platforms. It is stated that a latency of 15 ms – 20 ms and a reliability requirement of 10^{-6} should be ensured. The General subcategory for “Logistics and Warehouse” is not discussed or justified within the ETSI report. Process Automation typically involves chemical processes engineering, for example, oil and gas production or the generation of electricity. In the Process Automation category, steps are sequential, continuous, and irreversible. Process Automation applications can tolerate less deterministic delivery of transmissions, thus, the relaxed latency requirements and reliability. The Augmented Reality category includes computer-assisted extension of reality. The Functional Safety category requires high reliability (10^{-9}) and low latency of 10 ms. Safety is critical to protect people, machines, and production environments, hence the stricter performance requirements.

2.1.3/ AN INDUSTRY REQUIREMENTS PERSPECTIVE

Another industry perspective presented in [6], targeted ultra-high-performance wireless for various scenarios ranging from building automation to the switching of power electronics equipment. An example of system-level requirements for different industrial communication scenarios is captured in Table 2.4. The scenario Building Automation consists of all control operations performed within buildings, such as lighting, heating, surveillance, energy management, etc. Process Automation is involved in chemical, mining, oil, and metallurgic processes. Factory Automation

Table 2.4: An Industry Requirements Perspective of Different Industrial Communication Scenarios as presented in [6].

Scenario	# of nodes	Update rate, Hz	Goodput, bps	System range, m
Building Automation	Au- $10^2 - 10^3$	10^{-1}	$10^3 - 10^4$	10-100
Process Automation	Au- $10^2 - 10^3$	10	$10^5 - 10^6$	10-100
Factory Automation	$10^2 - 10^3$	10^3	$10^7 - 10^8$	10-100
Power Systems Automation	$10^1 - 10^2$	10^4	$10^7 - 10^8$	$10^2 - 10^3$
Power Electronics Control	$10^2 - 10^3$	10^5	$10^9 - 10^{10}$	10-100

is a general term referring to the factory production line, such as assembly and packaging. More demanding scenarios include Power Systems Automation in which control for power distribution is performed. Power Electronics Control focuses on the synchronized control of power electronic devices. All these scenarios have distinct requirements. Luvisotto states that for a wireless high performance system, a packet error rate (PER) of 10^{-9} is perceived as tolerable [6]. It is important to clarify this PER is at the application layer and it is possible to have a high PER at the physical layer and still achieve 10^{-8} at the application layer with transmission and information redundancy. It is proposed that a latency requirement of $10\mu s$ is required for power electronics applications. It is stated that Factory Automation, Power Systems Automation, and Power Electronics Control are the scenarios where their particular technology is applicable. The power electronics industry is very distinctive in the difficulty in meeting their challenges requirements; however, these requirements are not typical of all industry scenarios.

2.1.3.1/ NIST VALIDATED REQUIREMENTS PERSPECTIVE

Using requirements from standardization bodies such as ISA [44], ETSI [45], and industry, a distilled and validated set of requirements is produced in Table 2.5. The same ISA class-labeling scheme from Table 1 has been adopted to categorize applications. The ISA classification scheme groups applications according to mission-criticality. Class 5 is not included in Table 6 because the requirements were not adequately supported by existing wireless standards. It is believed that existing wireless standards do not jointly meet the requirements for all the industrial use

Table 2.5: NIST Wireless Requirements Perspective as presented in [5].

User Requirement		Class 0:	Class 1:	Class 2:	Class 3:	Class 4:
Latency (ms)	Typical	4	4	20	4	50
	Minimum	0.5	0.25	4	0.5	4
Reliability (Pr. Loss)	Typical	10^{-7}	10^{-7}	10^{-7}	10^{-7}	10^{-6}
	Minimum	10^{-7}	10^{-7}	10^{-7}	10^{-7}	10^{-7}
Scale (# of links)	Typical	8	10	10	1	100
	Maximum	16	30	30	4	300
Range (m)	Typical	10	10	10	10	10
	Maximum	30	30	30	30	30
Payload (B)	Minimum	6	8	8	8	12
	Maximum	24	1024	1024	1024	33000
Update Rate (Hz)	Typical	125	125	25	125	10
	Maximum	1000	2000	125	1000	125

case classes presented; however, the design of new wireless technology that applies to industry can be accomplished using the requirements in Table 6. The authors based the user requirements, shown in Table 2.5, on what is believed to be necessary for effective and realizable communications within factory workcells. Latency and reliability are fundamental requirements for time-sensitive applications. Latency and reliability can often be considered jointly as information that is delayed beyond a time threshold may be considered as lost information. Scale is important to enable large enough capacity for a network, while maintaining latency and reliability targets. Range provides a maximum expected distance between linked nodes before the network can no longer guarantee performance of the IWV. These requirements were developed based on the philosophy of avoiding excessive and unreasonable performance expectations on the wireless systems. For instance, requiring a range of 100 meters for a workcell device that only needs to operate within 10 meters would be unreasonably strict and would be considered overkill for many applications where shorter range would be sufficient and more practical. Justification for requirements is provided in [5].

2.2/ SYSTEMS MODELING

Systems modeling is the process of developing abstract representations of a system to analyze its features, strengths, and weaknesses, or to communicate its design. Systems models are uniquely useful when a system is large or complex, and the

interactions of among components within the system are unknown or difficult to understand. With CPSs in which the behavior of a physical system is strongly tied to the behavior of a computing or communication system, systems modeling is useful in identifying components and understanding cyber-physical links and data flows. This chapter provides a background to the reader in the state of the art in systems modeling. Particular attention is given on the research done to how modeling tools and techniques are applied to the problem of the wireless smart manufacturing workcell, the components of such a workcell, or the data flows within the workcell. The SysML model was developed to formalize and identify key components, interfaces, and constraints of the factory workcell. The model developed is intended to include elements of both the physical system and network controlling behavior. Therefore, the state of the art explored focuses on research performed to model both domains simultaneously capturing architecture and behavior. The exploration of the literature is divided into two components: 1) modeling languages in general, and 2) the use of SysML in modeling systems.

2.2.1/ MODELING LANGUAGES

Current modeling work on factory workcells is mainly aimed at defining and characterizing the subsystems, such as human staff, robots, and machine tools, in individual applications. By following blueprints (schematics) of production tasks, the work flow can be divided into separate assignments which are distributed by a task dispatch system to individual machines [46]. Analytical models are thus obtained for performance analysis in workcells. As an example, a mathematical model for real-time performance analysis of a gantry workcell with robots is established with the timing and the randomness of tasks and disruptions are captured in [47]. In [48], the same model is used to investigate the natural system properties such the system cycle and waiting times and to identify bottlenecks through studying the sensitivity of each machine. Similarly, the steady state analysis for production lines with uncertainties is performed through various decomposition methods [49–51]. In [49], a decomposition method is presented for the analysis of continuous flow lines. The presented model is used to analyze flow lines with single and multiple failure mode machines and machines subject to aging and having up and down times. This work in particular was useful in the application of models to process control applications. In [50], a model to evaluate the performance of transfer lines with unreliable machines and finite transfer-delay buffers is presented. A decomposition method is introduced to model the transfer line, using the general-exponential distributions instead of the exponential distributions to approximate the repair time distributions of the fictitious machines. In [51], the authors present a model for evaluating the production rate and distribution of inventory of a closed-loop manufacturing system with unreliable

machines and finite buffers. The model accounts for the different sets of machines that could cause blockage or starvation to other machines. In [52, 53], the performance analysis modeling for serial production lines with disruptions is explored by studying the impact of each individual downtime event in terms of permanent production loss and financial cost. These analytical models generally work well for simple systems with small number of components or few interactions between various equipment. Also, the analytical models can be used to abstract industrial systems to understand various performance trends without studying various details. As a result, a comprehensive model that include network and production impacts on the industrial workcell is introduced.

Furthermore, the reconfigurable workcell architecture is widely considered for automated manufacturing. The main advantage of reconfigurable workcells lies in the flexibility of reconfiguration of workcell components to adapt to varying production requirements where the assembly of the work cell is optimized for each specific task [54]. In the workcell that hosts robots, robots are installed therein to allow for autonomous configuration within their workspace [55–57]. Approaches and performance criteria for reconfigurable robotic systems have recent developments in control architectures to achieve various levels of reconfigurability [58]. The NIST has defined a network of things (NoT) model which can depict the structure of workcells by a group of NoT building blocks and model the behaviors of individual components in a workcell [59]. The NIST NoT model is focused primarily on sensor networks and the collection of data rather than the collection and then subsequent action on data. Actuation is cursorily noted, and, as such, cross-domain interactions between the physical system and the network are not addressed. Several other robotic workcell architectures are discussed in the literature. In [60], a reference model for a control system functional architecture applied to open architecture robot controllers is presented. In [61], a methodology to develop self-adaptive factory automation solutions is illustrated, using a novel modular simulation-based method. With the increase in complexity and reconfigurability of workcells, studying various production criteria and network impacts requires introducing new models to capture these interactions and requires sufficient abstraction to model different configurations and scenarios of industrial work-cells.

In a workcell model, data flows are used to capture the trajectory of system information exchange between workcell components and identify their roles in specific operations [60]. For example, safety-related operations may employ vision systems and various proximity sensors that generate proximity data and transmit them to the safety manager to define safety zones in an automotive assembly work-cell [62]. In another example, data flows are enabled in a workcell to capture human operator gestures from embedded cameras in human-robot collaborations [63]. These gestures

can be later regenerated in simulators based on the transmitted position data from the field to optimize workcell safety operations [64]. Currently, most of the workcell information in these scenarios are transmitted by wired networks. Wireless networks have gained increasing attention to enable data flows in the highly connected workcells. Wireless standard bodies have proposed their network reference models in factory environments which include the workcell cases in the data-centric architecture [65,66]. In these models, individual workcells are treated as a subnetwork of field instruments attached with data aggregations that manage network connections and transfer data traffic to edge and cloud servers in various applications. Wireless connections are featured with flexible network topology to agree with a variety of transmission needs, especially in reconfigurable workcells. Meanwhile, data traffic flows are characterized by select performance metrics, such as transmission latency and link reliability, to categorize industrial use cases [66].

Current modeling efforts set the boundaries of their systems of study at the edge devices without further discussions on the impact of wireless performance on the operations of industrial systems. For example, the abstracted disruptions in [52,53] that cause plant down-times may include wireless network impacts which are not yet distinguishable with specific characteristics of wireless networks. As indicated by the earlier empirical studies [67], such physical systems may have different responses to network performance which will vary with the operational configuration such as the served application and the deployed control algorithms.

Therefore, much research has been done in the area of modeling of complex systems; however, an opportunity exists for exploring applying systems modeling to the industrial workcell. In particular, those workcells that have strong network interactions have been left unstudied. It is also necessary to incorporate the features of wireless communications networks into the modeling architecture of physical workcells such that cross-domain interactions between the physical system and the network may be studied.

2.2.2/ SYSTEMS MODELING USING SYSML

The primary goal of modeling a system is to capture knowledge of a process in a simplified way [68]. A secondary goal of a system model is to provide a level of abstraction that may allow for the discovery of new knowledge such as how two systems will interact. There are multiple ways of designing and presenting system models. Well-behaved systems can be represented by a system of equations using mathematical tools [69]. Such models provide excellent constraint definition, but equations alone lack the semantics to describe architecture and detailed information flow of a realizable system.

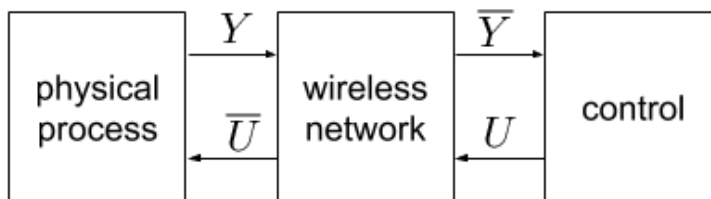

Figure 2.1: Functional block diagram of a CPS in which a physical process and an automation system interact through a wireless network. In a CPS, the automation/control system acts using estimated and/or delayed versions of the process variables, whereas, the physical process uses estimated and/or delayed versions of commands from the controller.

Moreover, by deploying functional block diagrams, major functional components and flow of information or material are captured. As shown in Fig. 2.1, a physical process interacts with a control system through a wireless network. Measured values, Y , from sensors flow to the controller through a wireless network and arrive at the controller delayed and modified, \bar{Y} . Similarly, commands, U , flows from the controller to the actuators through the wireless network. Such diagrams may be used to model feedback control systems in which the origination and routing of information are immaterial for study. However, the architecture and interfaces remain at a very high level of abstraction making analysis difficult. In such cases, delay and loss using such tools are often modeled stochastically. Using architectural diagrams helps identify components, interfaces, and information flow. For factory systems, architectural block diagrams are often manifested as schematics. However, such diagrams have their own limits in industrial practices. On one hand, they lack the semantics necessary to describe the constraints that formal equations and functional block diagrams offer. Meanwhile, they also lack the capability of capturing behaviors or complex interactions between the physical system and the information infrastructure such as a wireless network.

An alternative to schematic diagrams is SysML [70]. SysML is a general purpose modeling language that is often used for Model-based Systems Engineering (MBSE) practice within industrial systems [71]. SysML provides structural, behavioral, and parametric semantics for the analysis of complex systems. For examples, systems analysis using SysML enables capturing and communicating system requirements and design which include hardware, software, firmware, information flows, and processes with graphical notations. Within the factory automation industry, engineers are adopting SysML in the form of MBSE to develop realizable operational models of the factory and data flow processes. MBSE models address verification of design through executable simulations depending on the modeling tool. The SysML specification is defined in [70]. In SysML, the basic semantic constructs of the language are Packages, Blocks, Ports, Interfaces, and Constraints, in addition to the

constructs provided by the Unified Modeling Language (UML). Packages are logical grouping of model elements. Package relationships are captured using the package definition diagram (PKG). Relationships of these constructs are captured in the block definition diagram (BDD). The internal composition and connectivity of parts are captured in the internal block diagram (IBD). SysML includes other types of diagrams and semantic constructs that are not required for this analysis and are not explained here. The SysML modeling language is comprehensive; however, the size and number of diagrams within the model are too extensive to include here in this thesis. Therefore, the reader is encouraged to explore the SysML model defined in [30]. A useful primer on SysML may be found in [72].

Examples of the use cases and methodologies of using different graphical models for the analysis of manufacturing systems are explored in [73–76]. In [77], SysML is used to capture both composition and behavior of an additive manufacturing workcell. A survey of applying graphical modeling languages in capturing information flows within a product service system which may be applied to manufacturing enterprises [78]. This approach compliments these previous examples by combining the operational and wireless information transport systems together in a single model, thereby facilitating a single model that may be used for simulation and other systems engineering analyses. While various architectures for the workcell exist as exemplified in the literature, a common language and framework for communicating architecture and information flow has not been established for cross-domain interactions between the manufacturing system and its supporting communication networks.

SysML contains the semantics for such engineering capture and provides an industry accepted language for communicating composition, interfaces, and information flow. Moreover, SysML provides the semantics for assigning properties to any model element such that those properties are made available for analysis using other tools such as Protégé [79] and the Web Ontology Language (OWL) [80]. It is important to understand that while SysML provides semantics for a formal capture of architecture, information flow, and parametric constraints, it may also be used for a higher-degree of abstraction provided by the functional block diagrams.

2.3/ USE OF DATABASES FOR PERFORMANCE ANALYSIS

GDBs were employed within this thesis to better organize the copious amounts of experimental data resulting from experiments run within the industrial wireless testbed. Therefore, an investigation into the application of data management approaches was conducted. This investigation included the application of GDBs for the

problem of data curation and organization of large amounts of network and physical systems performance data that had correlation between events occurring in time.

The GDB is a class of the non-SQL (NoSQL) database. The NoSQL database is a non-relational database in which the structure data is not predetermined and cannot be enforced by the database. Due to its advantages including scalability, efficiency, and flexibility, NoSQL databases are a popular alternative to relational databases in the case of large amounts of data in various applications [81]. The GDB is a kind of NoSQL database approach that additionally handles complex relationships [82]. GDBs are widely adopted in various industry-related applications and use cases such as network operations, fraud detection, and asset and data management [83]. Relationships in social networks have been modeled using a GDB for structural information mining and marketing [84]. On the other hand, business solutions for scenarios with multiple large data sources require distributed processing in decision making for various problems such as fraud detection, trend prediction, and product recommendation [85].

Multiple surveys regarding GDBs are presented to describe the associated models, tools, and their features in [86–88]. In [86] the graph database is introduced as a technology that experienced as many technologies do, some hype, and early death, and then a later resurrection. Graph databases have recently regained some interest in industrial and cyber-physical research because of the amount of data resulting from big-data and the internet of things (IoT)/IIoT. Data in which graph-like qualities exist are presented as candidates for use by the database technology. In [88], a performance study is performed to make the case for using graph databases to enhance query speed for interconnected data. The study showed a strong preference for using graph databases in place of the relational database. The performance of different GDB tools and methodologies is analyzed and compared in [89, 90]. Multiple comparisons in these articles have shown improved performance of Neo4j in the general features for data storing and querying, and data modeling features such as data structures, query languages and integrity constraints.

Examples of applications and implementations of GDBs are presented in [91] to show their use on enterprise data, social networks, and determining security and access rights. It was found that GDBs provide the much needed structure for storing data and incorporating a dynamic schema. On the other hand, query languages are used to extract data including traversing the database, comparing nodes properties, and subgraph matching [92]. While GDB are of particular interest in traversing and querying interconnected dataset found within social networks, it is proposed that data resulting from CPSs is not entirely similar, and therefore, use of the graph database for analyzing performance measurement data from the factory workcell is explored.

Furthermore, industrial data analytics play an essential role in achieving the smart factory vision and improving decision-making in various industrial applications. Five main industrial data methodologies are generally studied including highly distributed data ingestion, data repository, large-scale data management, data analytics, and data governance [93]. Industrial data processing offers valuable information about various sections of industrial applications including inefficiencies in industrial processes, costly failures and down-times, and effective maintenance decisions [11,94]. The methods of industrial data analytics can be split into different categories such as descriptive, diagnostic, predictive, and prescriptive analytics [95]. Descriptive and diagnostic analytics are responsible for analyzing historic data and the causes of events and behaviors. Predictive and prescriptive analytics require more processing power, anticipate the trends of data, and deploy the historical data in making decisions to achieve production goals. Examples of industrial data analytics frameworks are found in [96–99]. In [96], a platform for performing industrial big data analysis is presented where the performance requirements are introduced to achieve a cost-effective operation. In [100], a manufacturing big data solution for active preventive maintenance in manufacturing environments is proposed. Various other frameworks for industrial data analysis can be found, where the importance of using data analysis in decision making is emphasized.

Due to their advantages including scalability, efficiency, and flexibility, NoSQL databases are a popular alternative to relational databases in the case of large amounts of data in various applications [81]. The GDB is one kind of NoSQL database approaches that additionally handles complex relationships [82]. GDBs are widely adopted in various industry-related applications and use cases such as network operations, fraud detection, and asset and data management [83]. In [101], authors have proposed a new object tracking approach for surveillance applications. The GDB approach is selected to contribute to the scalability of the proposed scheme and support the required connectivity analysis for the object tracking. Moreover, relationships in social networks have been modeled using a GDB for structural information mining and marketing [84]. On the other hand, GDBs are also deployed in business solutions for scenarios with multiple large data sources which require distributed processing in decision making for various problems such as fraud detection, trend prediction, and product recommendation [85].

2.4/ MACHINE LEARNING IN PERFORMANCE ESTIMATION

In the literature, two types of interference signals are considered, namely, intentional or unintentional interference. Methods to estimate, avoid, or mitigate interference are required for the deployment of reliable and deterministic IWSs. Machine learn-

ing has been widely used to detect and estimate interference information to enhance the performance of interference management algorithms. Machine was investigated and applied to the problem of inferring wireless link quality from observations of the physical system without expensive, highly complex spectrum analysis tools. Furthermore, factory technicians are typically not trained in wireless interference estimation or radio engineering. A need to assess performance of the wireless network within factories is needed; however the cost of radio equipment stationed within the factory workcell can be cost-prohibitive and detrimental to the adoption of wireless technology within the factory. Therefore, machine learning, e.g., artificial intelligence, can be a valuable tool. In this chapter, the state of machine learning application to wireless performance estimation is presented.

The interference analysis in CPSs is considered in multiple works for various scenarios. In [102], in-network interference mitigation techniques are discussed for ultra reliable low-latency wireless communications systems. The work focuses on mutual interference mitigation in an industrial automation setting, where multiple transmissions from controllers to actuators interfere with each other. In [103], an interference mitigating receiver architecture is proposed. The application scenarios are smart homes and modern factories where dense wireless communications devices exist. Moreover, in [104], interference cancellation of transmissions from neighboring cells in a 5G cellular network is presented. In [105], a method using a dedicated node for link quality estimation (LQE) obtained through received data packets to identify interference and multi-path without introducing additional traffic is presented. In [106], a taxonomy of channel link quality techniques is presented providing a valuable survey on LQE algorithms and asserting the importance of LQE in IWSs. In [107], failure analysis and wireless network troubleshooting are performed whenever the CPS is not functioning properly. Interference analysis is one major part of the troubleshooting procedure which is performed through traffic patterns and wireless spectrum analysis. Also, in [108], the use of spectrum analysis for interference detection and estimation is proposed for IWSs.

On the other hand, intended interference (i.e., jamming) can lead to service denial or poor performance in wireless networks. In [109], a literature review is presented which includes an overview of recent research efforts on networked control systems under denial-of-service attacks such as jamming attacks in wireless channels. One of the discussed challenges is how to achieve ultra-reliable low-latency "signalling" within industrial applications. In [110], a discussion is also provided on the recent developments concerning the design of attack-resilient control and communication protocols. Generally, a jamming attacker can block transmission of packets by emitting strong interference signals to a wireless channel [111, 112]. Jamming attacks can target various wireless technologies and hence can become a

major concern for control systems, since they are easy to launch [112]. It is shown in [113] that off-the-shelf hardware can be used for generating jamming attacks on wireless networks. In cases of physical-layer attacks, the jamming attacker targets a frequency band and is not required to follow the wireless protocol where it can cause a decrease in the SIR thus preventing the receiver from successfully detecting transmitted packets [113]. In the case of medium access control (MAC)-layer attacks, both the packet sender and the jamming attacker operate on the same channel; the jamming attacker's goal is to cause packet collisions.

In [114], the authors evaluate the CPS resilience to jamming attacks that disrupt wireless communications. They considered three jamming strategies which are the constant, random, and protocol-aware jamming. They showed through experimental results that various CPS control schemes are susceptible to constant and random jamming while the time-triggered control schemes are susceptible to protocol-aware jamming. Moreover, resilience of CPSs is also considered in [115–118] where periodic jamming is considered in [115] while the jamming strategy in [116–118] is unknown.

Machine learning has been used for detection and estimation of jamming attacks. In [119], an unsupervised machine learning algorithm based on a multi-layer auto-encoder is used to extract the interference source spectrum features. These features are then used to distinguish interference sources type and location without labeling measured data. In [120], an unsupervised approach using a recurrent neural network is used to detect anomalies in the CPS performance and identify attacked sensors. In [121], a behavior based machine learning intrusion detection approach is proposed to detect attacks at the physical process layer. The results are validated through experimental study of a real modern water treatment facility. In [122], the viability of machine learning methods in detecting the new threat scenarios of command and data injection is assessed. In that work, command and control communications in a critical infrastructure setting are monitored and vetted against examples of benign and malicious command traffic to identify potential attack events. In [123], the authors assess discriminating types of power system disturbances through machine learning by detecting jamming attacks. They evaluate various machine learning methods as disturbance discriminators and discuss the practical implications for deploying machine learning systems as an enhancement to existing power system architectures.

Therefore, in the literature, it is shown that LQE through direct observation is one important but insufficient aspect of assessing the impact of link quality on a CPS. It is asserted that by jointly observing the performance of the physical and wireless components of a CPS, the complete perspective of the quality of the wireless link and its impact on physical performance can be obtained. Since inter-

ference is such an important topic in the wireless CPS, a novel method is proposed in [26, 34] presented in Chapter 6 in which a learning network simultaneously (1) makes observations of the physical system using ground truth measurements, and (2) infers the quality of the wireless communication system in terms of SIR using an experimental model of a relevant use case found in industry.

II

THESIS CONTRIBUTIONS

INDUSTRIAL WIRELESS TECHNOLOGY AND APPLICATIONS

The use of wireless technologies within factories demands a comprehensive understanding of the problems and potential solutions associated with the rigors of the manufacturing environment. A clearly defined problem space would significantly ease the selection and deployment of appropriate wireless solutions to connected factory systems. A mapping of potential technologies to classes of use cases within the problem space will be useful to factory operators, system integrators, and wireless systems manufacturers. Identification of use cases, not addressed by existing technologies, may be used to spur targeted innovation where reliability, resilience, latency, and scalability are joint concerns. Motivated by the industry need for independent practical guidelines and solutions to difficult wireless control problems, this chapter provides a classification of the problem categories where networking technologies may be deployed. It then maps specific technologies that may serve as interim or terminal solutions for those use cases identified within the problem space taxonomy. This chapter is intended to provide a detailed exposition of the requirements directed towards industrial wireless. It draws on various sources of requirements captured by academic literature, industry organizations, and standards institutes. The work therefore presents a picture of the requirements landscape at the beginning of this research. Further work in this area is found in [5] and [11].

3.1/ INTRODUCTION

Industrial wireless is a key enabling technology for the IIoTs. The IIoT promises lower costs of deployment, increased mobility of factory assets, massive interconnectivity, improved situational awareness, increased efficiency of the operation, and improved operations analytics. IIoT and advanced manufacturing technology seek to improve competitiveness, productivity, and responsiveness to customer needs.

However, it is often stated that where wireless is deployed, factory enhancements fail to meet expectations typically in areas of reliability, resilience, and scalability. Moreover, transmission security is often cited as an area of concern. Risk averse organizations will establish policies that preclude wireless to be deployed for specific types of applications such as feedback control or safety. Yet, factory operators are increasingly demanding that wireless be deployed for critical and sometimes conceivably dangerous applications. For this reason, NIST is developing best practice guidelines to help factory operators select appropriate wireless systems for their particular use case and then deploy that solution effectively. Such a mission requires participation by factory operators, system integrators, and device manufacturers. A comprehensive taxonomy of the existing problem space within industry and a survey of existing and missing technologies are necessary to the success of such a mission. This chapter provides our classification of industrial wireless cases and links current technologies to those use cases if applicable.

3.2/ PROBLEM SPACE

3.2.1/ INTRODUCTION AND SUCCESS CONSIDERATIONS

Implementing a factory enhancement program requires economic and technical planning, and justification. Wireless technologies by themselves are interesting and can provide value; however, it is incumbent upon plant leadership to fully assess the potential risks and benefits of the enhancement before proceeding with deployment. Wireless technologies are often deployed as a means to monitor or control factory process. They have the potential to unlock improved observability and control. By understanding the problem space and the risks and benefits of potential wireless solutions, factory operators can assess if the rewards outweigh the risks. In navigating the risk/reward question, it is asserted that any wireless program must address one or more of the following success criteria before embarking on an enhancement involving wireless communications. These criteria are defined as follows:

Reliability Wireless systems can be deployed to add redundancy or replace faulty wired solutions with a more reliable wireless solution for particularly harsh industrial environments where temperature, pressure, vibration, radiation, and chemistry may make wired communication unreliable.

Safety Wireless systems may be used to detect or prevent injury to humans. They may be used as backup to wired systems or serve as the primary communication

system.

Production Cost Wireless systems can increase observability and the resulting data may be used for precise optimization of the factory operations, machine scheduling, and maintenance.

Quality Various measurements are possible to improve quality of the factory output. Using wireless solutions may make deployment of sensors and inspection equipment more practical.

Environment Wireless sensors and control mechanisms may be used to detect toxic conditions and prevent environmental accidents from occurring. Wireless actuation devices may serve to improve reliability and address environmental mitigation control.

Regulations In some scenarios, government regulations may require specific sensor instrumentation to be deployed for certain scenarios. Wireless solutions could make regulatory compliance practical or cost effective in some cases.

3.2.2/ USE CASES

Once a plant upgrade enhancement program is initiated, and some type of wireless technology is anticipated, the first step in realizing the program is defining and understanding the problem space where wireless technologies will be used. To support this assessment, a taxonomy of industrial use cases to which wireless communication may be employed is given. The industrial wireless landscape is diverse, and a classification of those technologies can be helpful in mapping particular technologies to an application. Our classification is shown in Fig. 3.1 and includes instrumentation, safety, and back-haul connectivity, among others. Each class of the problem space is explained in the following subsections.

3.2.2.1/ MANUFACTURING INSTRUMENTATION

Manufacturing instrumentation includes devices commonly known as sensors and actuators. Sensors transmit measured variables from the physical process. Actuators receive manipulation variables from a controller and apply changes to the physical

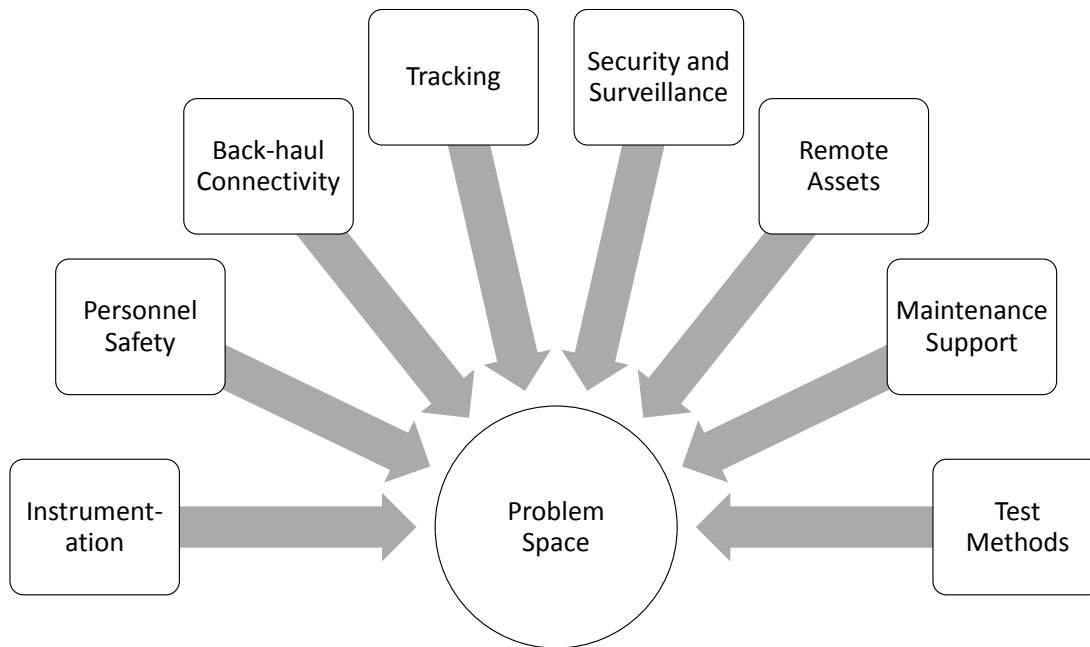

Figure 3.1: Industrial wireless technologies are applicable across most aspects of the industrial automation problem space.

process. This class of application demands typically a very low latency and high reliability communication channel.

3.2.2.2/ PERSONNEL SAFETY

Industrial settings can be hazardous to both humans and machines. For humans, conditions may arise that pose a substantial risk for injury or death. For machines, conditions may develop that cause substantial damage requiring extensive repair or replacement. Prevention of industrial accidents is therefore of paramount importance within factories [124]. Slips, trips, and falls on the same level are commonly cited as lead causes of injury [125]. Falls from higher levels are of great concern to the aerospace industry [126] as inspection teams must work on elevated levels where falls prove fatal. Within the oil and gas industry, safety concerns include air toxicity and combustibility in both open and confined spaces where reliable monitoring and reporting save lives. Wireless gas leak detection and leak localization provide important and effective safety enhancements to such systems [127]. Within smart manufacturing systems where humans and robots work closely and even within traditional robot environments, safety systems provide an added layer of protection to prevent human injury [128], [129]. Within these human-robot environments, it is clear that reliable, low-latency communication is an important aspect of safety implementation, and, as mobility of robots within the factory increases, reliable low-latency wireless networks will become increasingly important to safety imple-

mentation.

3.2.2.3/ BACK-HAUL CONNECTIVITY

The back-haul is generally defined as the network that connects a lower level network to a higher level network [130]. Back-haul connectivity is usually characterized by large amounts of transferred data. In industrial environments, various types of back-haul scenarios are needed to be deployed for the operation of industrial communication networks. One can divide the back-haul problem space into three partitions which are i) nearby or indoor back-hauls, ii) distant back-hauls, and iii) geographically remote back-hauls. This categorization is based on the distance over which data is transferred.

First, the indoor back-haul networks are used in factory floors or process plants for data transfer between the control level networks to data centers, and higher level application layer networks. Second, the distant back-hauls are used for information transfer between various buildings in a plant where the two ends may have a LOS or need a non-line-of-sight (NLOS) technology [131]. Finally, the geographically remote back-hauls are used for information transfer between sites in different cities or even countries such as data transfer to headquarters. Various technologies which are currently used for back-haul networks are discussed in [131].

3.2.2.4/ TRACKING

Tracking in industrial environments is employed to follow the states of inventory, personnel, and tools which help in process control and factory management [132]. The focus of this class of the problem space is the set of transmissions related to the tracking process itself and not the recovered data transmissions back to higher levels. Wireless tracking systems are subdivided into the following divisions based on various requirements: i) materials tracking, ii) personnel tracking, iii) tools tracking, iv) inventory management, v) localization, and vi) identification.

Materials, personnel, and tools tracking is focused on following the state and the location of the tracked item. The selection of the used technology will depend on the tracked item characteristics including its speed, required accuracy level, and scalability. Inventory management includes the decisions related to the change of inventory status over time. Identification and localization are required for the determination of the position and identity of a person or an item at a specific situation or time. It can be important in safety and security related applications.

The characteristics and applications of various tracking, localization, and identification technologies are discussed in [132]. These technologies include the use of specific wireless communications technologies like Global Positioning System (GPS), and Radio Frequency Identification (RFID) or deploying the general-purpose technologies like Wi-Fi, Bluetooth, and the cellular-based technologies. Moreover, examples of the existing products for assets tracking and their performance are compared in [133].

3.2.2.5/ SECURITY AND SURVEILLANCE

Industrial installations require protection of the physical grounds, the operation, and the data produced from the installation. This protection requires surveillance of the property and implementation of network security controls. Guidance on selecting which controls are applicable to a specific risk level may be found in [27]. Assessment of the security robustness of specific wireless technologies is outside the scope of this work; however, the implementation of physical security controls such as personnel authorization and grounds protection requires transmission of varying amounts of data. Transmission of such data includes voice traffic, video, and status information. In some installations, security and surveillance transmissions will coexist with factory instrumentation. This is sometimes the case with IEEE 802.11 mesh networks carrying voice, video, and instrumentation traffic.

3.2.2.6/ REMOTE ASSETS

Remote monitoring and control extend the range of the management to remote sites, especially in the process industry. Industrial remote communications provide access to widely distributed assets such as wellhead and pipeline monitoring [134]. The main goals of employing remote monitoring and control are minimizing labor cost, improved operations of remote sites, and prevention of unplanned failures [135].

The use of wireless networks in remote monitoring and control reduces the installation and maintenance cost significantly. However, the main challenge for industrial wireless remote monitoring and control is security and hence encryption and authentication protocols are deployed. Examples of remote assets communications are discussed in [134].

3.2.2.7/ MAINTENANCE SUPPORT

Factories require maintenance teams to keep machinery operating efficiently. Machines may be instrumented with sensors that measure machine health data such as vibration levels or current calibration values. Using this information, machines can be scheduled for maintenance prior to failure thereby allowing the factory to operate without unexpected interruption. Maintenance of the factory may also include automation of the building and infrastructure for climate control. Heating ventilation and air-conditioning (HVAC) systems can be automated such that the ambient conditions are controlled. Augmented reality is an emerging technology that promises to bring knowledge to the factory floor allowing maintenance personnel to gain access to information during uncertain situations [136]. Augmented reality is a high-bandwidth application that requires high-reliability, high-throughput wireless connectivity within the factory.

3.2.2.8/ TEST METHODS

Industrial control systems are often intolerant of communication faults and network latency, and often require very high transmission reliability [137]. Depending on the purpose of the wireless network (monitoring, supervisory control, feedback control, or safety monitoring), understanding the system performance of the network may be critical. For feedback control and safety monitoring systems, understanding the performance of the network from the perspective of the industrial controller or safety alarm system is essential. Factory operators, system integrators, and control systems designers are rarely experts in wireless communications systems. Considerations such as electromagnetic propagation, antenna efficiency, path loss exponents, packet error rates, and medium access are often foreign concepts to factory engineers. If factory engineers are expert in wireless theory and design practice, the information that they need to make educated decisions are usually unavailable. When available, link quality metrics such as packet loss ratios are informative but can be difficult to understand with complex mesh architectures and routing algorithms.

Moreover, it is generally difficult to measure these quantities for operational networks. The control system designer will only need to know the statistical distribution of latency and reliability of information through the network to design a controller that is robust. Therefore, practical methods for characterizing the performance of the wireless network that do not require an in-depth understanding of wireless communications or electromagnetic wave propagation are needed.

A clear need for accessible test methods exists in the wireless CPSs space in which the tester need not be an expert in wireless communications or radio wave propagation.

3.3/ TECHNICAL CONSIDERATIONS

3.3.1/ RADIO FREQUENCY ENVIRONMENT

Using wireless communications in industrial environments requires the knowledge of the RF environment characteristics and their behavior under the added wireless networks. The first step is obtaining and modeling field data in industrial environments. In [23], the RF environments of multiple examples of industrial scenarios were studied where models and characterization parameters have been derived. Moreover, theoretical models are proposed to model the RF channel such as the IEEE802.15.4a model including its channel impulse response [138]. In characterizing the RF environments, various parameters should be included, such as the multi-path, the interference sources, the mobility, and shadowing effects. Moreover, the operating frequency band can play an important role based on the required performance and the nature of RF activity in a certain environment.

3.3.2/ DEVICE CHARACTERISTICS

Another important aspect while deploying wireless networks in industrial environments is the used devices characteristics. Typically, the harsh industrial environments in many applications require higher ratings of the used devices. The considered device characteristics include size, weight, power, cost, safety, and ingress protection ratings. Based on the application requirements and the physical environments, these device requirements are determined.

3.3.3/ NETWORK CHARACTERISTICS

Table 3.1 lists requirements typically expected of a network based on its intended purpose and problem domain. Industrial networks will have three basic characteristics: reliability, latency, and scale. These characteristics are described in the following subsections. The numbers listed in the table are based on existing applications. It is difficult to provide a standard metric for all use cases as each will impose different requirements on the network. In some cases, the control algorithm can be

designed to adapt to information loss and delay, thereby improving the performance of the physical system.

3.3.3.1/ LATENCY

Latency is a measure of the delay that information takes to arrive at its destination. Latency, l , is defined as the measured delay from the time of an event to the time in which knowledge of that event is made available to an application. Using the Open Systems Interconnection (OSI) model as a guide, latency would be measured at the application layer. In a packaging system, an example of measured latency would be the time between a proximity event and the time knowledge of that event is received by a PLC.

3.3.3.2/ RELIABILITY

Reliability is a measure of the likelihood of data loss within the industrial network. Reliability, r , is defined as the probability that a block of transmitted data is delayed long enough to become obsolete or lost due to noise. Similar to latency, reliability is measured at the application layer thereby ignoring technology-specific issues such as data segmentation and retries similar to the approach taken in the developing 5G cellular networks for machine-to-machine communications [4].

3.3.3.3/ SCALE

Scale is a measure of the number of devices that may be deployed within a network without sacrificing reliability or latency. The network size will often dictate the maximum bandwidth allotted to any one node. The larger the network, the less bandwidth is allotted for transmissions between nodes. The complexity of a fully interconnect mesh will theoretically exhibit factorial growth in network interconnections. In practice, SNRs between nodes, programming within the governing network controller, and provisioned constraints will limit the number of interconnections. Most WSN specifications such as WirelessHART, ISA100.11a, and Zigbee provide support for large scale deployments; however, in such deployments, the network infrastructure must support the throughput load of the network and the scan rate requirements of the factory application [139]. The ISA100.11a standard provides support for distributed access points, prescribed routing, and a partitioned architecture to allow for large-scale deployments.

Table 3.1: Industrial control latency, error rate, and scalability considerations for wireless deployments as presented in [7] show important and competing considerations of industrial wireless deployments. Other considerations not shown include battery life, update rate, and security, among others.

	Latency, l ms	Pr. Loss, r	Scale, s
Monitoring	$l < 1000$	$r < 10^{-5}$	$s < 10,000$
Supervisory Control			
Flow-based	$l < 1000$	$r < 10^{-6}$	$s < 30$
Job-based	$l < 100$	$r < 10^{-7}$	$s < 10$
Feedback Control			
Flow-based	$l < 1000$	$r < 10^{-6}$	$s < 100$
Job-based	$l < 10$	$r < 10^{-7}$	$s < 10$
Safety	$l < 10$	$r < 10^{-7}$	$s < 10$

3.3.3.4/ INTEROPERABILITY

In a factory application, easy integration of devices is essential to the flow of data through a network. While many wireless standards exist, making physical layer integration of devices within the wireless domain easier, most industrial networks fail to address the application layer well. WirelessHART describes an application layer interface, while ISA100.11a provides the constructs for such an interface. ZigBee and Wi-Fi provide neither the interface nor the constructs for an application layer protocol. On the back-haul side of wireless networks which usually begins at a wireless gateway and ends at an automation server, many protocols such as Open Platform Communications (OPC) and Modbus make integration easier; however, again, they fail to specify the interface but instead provide the constructs. The authors assert that a standardization of the automation interface (gateway to automation server) is needed to provide such interoperability.

3.3.3.5/ SECURITY

Prescribing security controls within an automation system requires understanding of the risk of not implementing these controls and the impacts of them on the physical process. Work is being undertaken to measure the impacts of cyber-security controls on the physical process as explained in [140] and [141]. In addition, the work is being undertaken to assess the impacts of stealthy attacks as described in [142]. NIST Special Publication 800-82 and International Electrotechnical Commission (IEC)-62443 provide best practice guidelines for the implementation of a cyber-security program in an automation system.

3.4/ WIRELESS TECHNOLOGY APPLICABILITY

Many existing wireless technologies could be applied to the use cases in Section II. Others may be applicable with limitations, and others are not applicable entirely. Table 3.2 captures mapping of technologies to applicable use cases. This table represents assertions by the authors of applicability of wireless technologies to industrial control systems problem domains based on industry practice and original intent of the technology. The authors assert that the problem domains and wireless technologies included within this table represent the majority of problems found within industry and the existing technologies that may be applied. Technologies were evaluated based on original design intent, latency, reliability, energy, and practicality. Modifications may be made to the listed technologies resulting in applicability to a specified problem; however, possible modifications were not considered. Very low bit rate (VLBR) wide area networks (WANs) are assumed to have an infrastructure-based topology and support a bit rate of under 600bps.

3.5/ SUBSEQUENT WORK OF NOTE

Since the investigation conducted regarding industrial wireless requirements as presented here in this thesis, the authors expanded on the research and published their findings in [5]. The requirements presented therein are reproduced in 3.3, and justifications for the requirements presented are explained within the reference. However, while the technical requirements have been updated in the new work, the classes of use cases and mappings of use cases to technologies remained relatively unchanged. In fact, the work in [7] served as a research source for the subsequent finding in [5]. Therefore, the architectural modeling work presented in the following chapter was unaffected.

3.6/ CONCLUSIONS

This work represents a step toward employing wireless technologies in industrial environments where all classes of problems for which wireless technologies can be used to solve have been comprehensively and collectively discussed. The success criteria and the technical aspects for employing wireless technologies in various scenarios have been considered briefly. More work is needed where success criteria are to be quantified and prioritized for various industrial scenarios. More detailed discussion is needed regarding technical considerations while employing wireless networking, including the physical environmental aspects such as the factory floor parameters,

Table 3.2: Applicability of wireless technologies from [7]. Presented are recommendations of direct applicability of various technologies to the industrial user problem space with little to no modification.

		Process Monitoring	Supervisory Control	Feedback Control	Alarm Conditions	In-situ Inspection	Factory Monitoring	Assembly: Sensing	Assembly: Actuation	Robots: Supervision	Robots: Feedback Control	Quality Inspection	Fall Prevention	Confined Spaces	Critical Event Detection	Human-Machine Collocation	Nearby or Indoor	Distant: LOS	Distant: BLOS	Geographically Remote	Indoor Machine Localization	Materials in Storage	Materials in Production	Tools	Personnel	Voice and Video Communication	Video Surveillance	Drone-based Surveillance	Grounds Control	Spectrum Monitoring Data	Personnel Authorization	Well-head Monitoring	Pipeline Monitoring	Tank Level Monitoring	Machine Health Monitoring	Building Automation	Augmented Reality			
		Flow-based	Job-based	Safety	Back-haul	Tracking	Security	Remote	Maint.																															
Home/Office	IEEE 802.11	●●●●●	●●●●●	○●●●○	○●●●○	○●●●○	○●●●○	○●●●○	○●●●○	○●●●○	○●●●○	○●●●○	○●●●○	○●●●○	○●●●○	○●●●○	○●●●○	○●●●○	○●●●○	○●●●○	○●●●○	○●●●○	○●●●○	○●●●○	○●●●○	○●●●○	○●●●○	○●●●○	○●●●○	○●●●○	○●●●○	○●●●○	○●●●○	○●●●○	○●●●○	○●●●○	○●●●○	○●●●○	○●●●○	
	IEEE 802.15.1	○●●●○	○●●●○	○●●●○	○●●●○	○●●●○	○●●●○	○●●●○	○●●●○	○●●●○	○●●●○	○●●●○	○●●●○	○●●●○	○●●●○	○●●●○	○●●●○	○●●●○	○●●●○	○●●●○	○●●●○	○●●●○	○●●●○	○●●●○	○●●●○	○●●●○	○●●●○	○●●●○	○●●●○	○●●●○	○●●●○	○●●●○	○●●●○	○●●●○	○●●●○	○●●●○	○●●●○	○●●●○	○●●●○	○●●●○
Industrial	IEEE 802.15.4 TDMA	●●●●●	●●●●●	○●●●○	○●●●○	○●●●○	○●●●○	○●●●○	○●●●○	○●●●○	○●●●○	○●●●○	○●●●○	○●●●○	○●●●○	○●●●○	○●●●○	○●●●○	○●●●○	○●●●○	○●●●○	○●●●○	○●●●○	○●●●○	○●●●○	○●●●○	○●●●○	○●●●○	○●●●○	○●●●○	○●●●○	○●●●○	○●●●○	○●●●○	○●●●○	○●●●○	○●●●○	○●●●○	○●●●○	○●●●○
	IEEE 802.15.4 CSMA	○●●●○	○●●●○	○●●●○	○●●●○	○●●●○	○●●●○	○●●●○	○●●●○	○●●●○	○●●●○	○●●●○	○●●●○	○●●●○	○●●●○	○●●●○	○●●●○	○●●●○	○●●●○	○●●●○	○●●●○	○●●●○	○●●●○	○●●●○	○●●●○	○●●●○	○●●●○	○●●●○	○●●●○	○●●●○	○●●●○	○●●●○	○●●●○	○●●●○	○●●●○	○●●●○	○●●●○	○●●●○	○●●●○	○●●●○
	IEEE 802.11 TDMA	* * * * *	* * * * *	* * * * *	* * * * *	* * * * *	* * * * *	* * * * *	* * * * *	* * * * *	* * * * *	* * * * *	* * * * *	* * * * *	* * * * *	* * * * *	* * * * *	* * * * *	* * * * *	* * * * *	* * * * *	* * * * *	* * * * *	* * * * *	* * * * *	* * * * *	* * * * *	* * * * *	* * * * *	* * * * *	* * * * *	* * * * *	* * * * *	* * * * *	* * * * *	* * * * *	* * * * *	* * * * *		
	VLBR WAN	●●●●●	●●●●●	○●●●○	○●●●○	○●●●○	○●●●○	○●●●○	○●●●○	○●●●○	○●●●○	○●●●○	○●●●○	○●●●○	○●●●○	○●●●○	○●●●○	○●●●○	○●●●○	○●●●○	○●●●○	○●●●○	○●●●○	○●●●○	○●●●○	○●●●○	○●●●○	○●●●○	○●●●○	○●●●○	○●●●○	○●●●○	○●●●○	○●●●○	○●●●○	○●●●○	○●●●○	○●●●○	○●●●○	○●●●○
Satellite	Geostationary	○●●●○	○●●●○	○●●●○	○●●●○	○●●●○	○●●●○	○●●●○	○●●●○	○●●●○	○●●●○	○●●●○	○●●●○	○●●●○	○●●●○	○●●●○	○●●●○	○●●●○	○●●●○	○●●●○	○●●●○	○●●●○	○●●●○	○●●●○	○●●●○	○●●●○	○●●●○	○●●●○	○●●●○	○●●●○	○●●●○	○●●●○	○●●●○	○●●●○	○●●●○	○●●●○	○●●●○	○●●●○	○●●●○	○●●●○
	Low-earth Orbit	○●●●○	○●●●○	○●●●○	○●●●○	○●●●○	○●●●○	○●●●○	○●●●○	○●●●○	○●●●○	○●●●○	○●●●○	○●●●○	○●●●○	○●●●○	○●●●○	○●●●○	○●●●○	○●●●○	○●●●○	○●●●○	○●●●○	○●●●○	○●●●○	○●●●○	○●●●○	○●●●○	○●●●○	○●●●○	○●●●○	○●●●○	○●●●○	○●●●○	○●●●○	○●●●○	○●●●○	○●●●○	○●●●○	○●●●○
	VLBR WAN	○●●●○	○●●●○	○●●●○	○●●●○	○●●●○	○●●●○	○●●●○	○●●●○	○●●●○	○●●●○	○●●●○	○●●●○	○●●●○	○●●●○	○●●●○	○●●●○	○●●●○	○●●●○	○●●●○	○●●●○	○●●●○	○●●●○	○●●●○	○●●●○	○●●●○	○●●●○	○●●●○	○●●●○	○●●●○	○●●●○	○●●●○	○●●●○	○●●●○	○●●●○	○●●●○	○●●●○	○●●●○	○●●●○	○●●●○
Tracking	RFID	- - - - -	- - - - -	- - - - -	- - - - -	- - - - -	- - - - -	- - - - -	- - - - -	- - - - -	- - - - -	- - - - -	- - - - -	- - - - -	- - - - -	- - - - -	- - - - -	- - - - -	- - - - -	- - - - -	- - - - -	- - - - -	- - - - -	- - - - -	- - - - -	- - - - -	- - - - -	- - - - -	- - - - -	- - - - -	- - - - -	- - - - -	- - - - -	- - - - -	- - - - -	- - - - -	- - - - -	- - - - -		
Optical	Indoor Dispersive	* * * * *	* * * * *	* * * * *	* * * * *	* * * * *	* * * * *	* * * * *	* * * * *	* * * * *	* * * * *	* * * * *	* * * * *	* * * * *	* * * * *	* * * * *	* * * * *	* * * * *	* * * * *	* * * * *	* * * * *	* * * * *	* * * * *	* * * * *	* * * * *	* * * * *	* * * * *	* * * * *	* * * * *	* * * * *	* * * * *	* * * * *	* * * * *	* * * * *	* * * * *	* * * * *	* * * * *	* * * * *		
	Free-space	○●●●○	○●●●○	○●●●○	○●●●○	○●●●○	○●●●○	○●●●○	○●●●○	○●●●○	○●●●○	○●●●○	○●●●○	○●●●○	○●●●○	○●●●○	○●●●○	○●●●○	○●●●○	○●●●○	○●●●○	○●●●○	○●●●○	○●●●○	○●●●○	○●●●○	○●●●○	○●●●○	○●●●○	○●●●○	○●●●○	○●●●○	○●●●○	○●●●○	○●●●○	○●●●○	○●●●○	○●●●○	○●●●○	○●●●○
Cellular	Legacy	○●●●○	○●●●○	○●●●○	○●●●○	○●●●○	○●●●○	○●●●○	○●●●○	○●●●○	○●●●○	○●●●○	○●●●○	○●●●○	○●●●○	○●●●○	○●●●○	○●●●○	○●●●○	○●●●○	○●●●○	○●●●○	○●●●○	○●●●○	○●●●○	○●●●○	○●●●○	○●●●○	○●●●○	○●●●○	○●●●○	○●●●○	○●●●○	○●●●○	○●●●○	○●●●○	○●●●○	○●●●○	○●●●○	○●●●○
	4G	○●●●○	○●●●○	○●●●○	○●●●○	○●●●○	○●●●○	○●●●○	○●●●○	○●●●○	○●●●○	○●●●○	○●●●○	○●●●○	○●●●○	○●●●○	○●●●○	○●●●○	○●●●○	○●●●○	○●●●○	○●●●○	○●●●○	○●●●○	○●●●○	○●●●○	○●●●○	○●●●○	○●●●○	○●●●○	○●●●○	○●●●○	○●●●○	○●●●○	○●●●○	○●●●○	○●●●○	○●●●○	○●●●○	○●●●○
	5G	* * * * *	* * * * *	* * * * *	* * * * *	* * * * *	* * * * *	* * * * *	* * * * *	* * * * *	* * * * *	* * * * *	* * * * *	* * * * *	* * * * *	* * * * *	* * * * *	* * * * *	* * * * *	* * * * *	* * * * *	* * * * *	* * * * *	* * * * *	* * * * *	* * * * *	* * * * *	* * * * *	* * * * *	* * * * *	* * * * *	* * * * *	* * * * *	* * * * *	* * * * *	* * * * *	* * * * *	* * * * *		
Land-mobile	All types	○●●●○	○●●●○	○●●●○	○●●●○	○●●●○	○●●●○	○●●●○	○●●●○	○●●●○	○●●●○	○●●●○	○●●●○	○●●●○	○●●●○	○●●●○	○●●●○	○●●●○	○●●●○	○●●●○	○●●●○	○●●●○	○●●●○	○●●●○	○●●●○	○●●●○	○●●●○	○●●●○	○●●●○	○●●●○	○●●●○	○●●●○	○●●●○	○●●●○	○●●●○	○●●●○	○●●●○	○●●●○	○●●●○	○●●●○
Specialty	Leaky Coax	○●●●○	○●●●○	○●●●○	○●●●○	○●●●○	○●●●○	○●●●○	○●●●○	○●●●○	○●●●○	○●●●○	○●●●○	○●●●○	○●●●○	○●●●○	○●●●○	○●●●○	○●●●○	○●●●○	○●●●○	○●●●○	○●●●○	○●●●○	○●●●○	○●●●○	○●●●○	○●●●○	○●●●○	○●●●○	○●●●○	○●●●○	○●●●○	○●●●○	○●●●○	○●●●○	○●●●○	○●●●○	○●●●○	

Legend: ●: Technology fully supports problem domain, ○: Supports problem domain with practicality, throughput, latency, reliability, or energy limitations, ⚡: Energy requirements of assumed battery-powered devices prevent applicability, ⊕: Latency prevent applicability, ▼: Throughput prevents applicability, *: Emerging technology or evolution may support problem domain, ○: Not recommended, -: Not considered by authors.

Table 3.3: Enhanced Wireless User Requirements for the Factory Workcell.

User Requirement ^{1,2}		Class 0:	Class 1:	Class 2:	Class 3:	Class 4:
Latency (ms)	Typical	4	4	20	4	50
	Minimum	0.5	0.25	4	0.5	4
Reliability ³ (Pr. Loss)	Typical	-7	-7	-7	-7	-6
	Minimum	-7	-7	-7	-7	-7
Scale (# of links)	Typical	8	10	10	1	100
	Maximum	16	30	30	4	300
Range (m)	Typical	10	10	10	10	10
	Maximum	30	30	30	30	30
Payload (B)	Minimum	6	8	8	8	12
	Maximum	24	1024	1024	1024	33000
Update Rate (Hz)	Typical	125	125	25	125	10
	Maximum	1000	2000	125	1000	125

¹ This table has been adapted from [5].

² The use case classes are defined as follows: Class 0: Safety, Class 1: Closed Loop Regulatory Control, Class 2: Closed Loop Supervisory Control, Class 3: Open Loop Regulatory Control, and Class 4: Alerting Monitoring.

³ The reliability specifications presented indicate a probability of information loss (not packet loss) where the probability is 10^X where X is the number indicated.

obstructions, data models, and interaction between various items within the factory floor. Finally, a mapping between technologies and the discussed problem classes has been introduced to highlight various industrial problems which can be solved or need more work while employing wireless technologies. Multiple comparisons between the current technologies exist in the literature. However, this work initiates consideration of the problem space where wireless technologies are employed. We have introduced this work while continuing to develop capabilities as described in [141] to explore applicability of wireless technologies to specific industrial scenarios capable of replication within a laboratory space. An RF channel emulator is used to simulate the RF environment to include fading and multi-path. An international technical working group was created to directly address the needs of the wireless users employing wireless within their factories.

WORKCELL ARCHITECTURAL DECOMPOSITION

Smart Manufacturing provides a vision of future manufacturing systems that incorporate highly dynamic physical systems, robust and responsive communications systems, and computing paradigms to maximize efficiency, enable mobility, and realize the promises of the digital factory. Wireless technology is a key enabler of that vision. A comprehensive graphical model is developed for a generic wireless factory workcell which employs the SysML, a standardized and semantically rich modeling language, to link the physical and network domains in such a CPS. The model identifies the structural primitives, interfaces, and behaviors of the highly-connected factory workcell in which wireless technology is used for significant data flows involved in control algorithms. The model presented here includes parametric definitions to encapsulate information loss, delay, and mutation associated with the wireless network, and it identifies pertinent wireless information flows. Use of this model is helpful in communicating architecture, interfaces, limitations, and sources of information within a workcell. The model was developed to provide a perspective of the smart manufacturing workcell which did not yet exist.

4.1/ INTRODUCTION

The fourth industrial revolution promises unparalleled productivity and capability advances in manufacturing. To support the manufacturing industry in this conversion, various programs have been established in several countries such as Smart Manufacturing in the U.S. [143] and Industry 4.0 in Europe [144, 145]. Propelled by economic pressure toward greater efficiency, factory agility, and product customization, future factories will have the technological ability to adapt to customer demands quickly, modify manufacturing processes automatically based on quality feedback, and fabricate products with a reduced environmental impact. Technologi-

cal advances required for smart manufacturing to be successful include collaborative and mobile robotics [146], distributed machine autonomy based on artificial intelligence [147], improved process observability [148], and a high degree of interconnectivity among automation resources [149]. Workcells are self-contained units of operation within a factory as described in [54], [150], and [57]. These workcells are composed of various machines, conveyors, motors, edge devices, and robots. Robots will work together and with people to accomplish complex tasks or to tending to other machines within the workcell. Robots will have the ability to roam between workcells within a factory, learn their roles quickly, become aware of edge devices, and communicate with other actors within the workcell to accomplish their goals. Efficient communications between robots and the other players in the workcell are essential to the fulfillment of the robot-related tasks.

Current manufacturing architectures use wired connections through field-bus and industrial Ethernet protocols for sensing and real-time control [151, 152]. Indeed, through advances in time-sensitive networking, many of the promises of smart manufacturing are being realized; however, the true goals of smart manufacturing require a large deployment of sensing and actuation devices and mobile, perhaps autonomous, robotics actors [149]. The use of wires precludes mobility and makes deployment of edge devices more expensive as each requires power, cables, and conduit for communication. By adopting wireless for both sensing and control of machines within the workcell, a lower-cost, untethered operation is achievable¹. Once wireless is adopted as the primary mode of communication, questions arise as to the required latency, reliability, and scale of the wireless network especially when the network is used for the control of machines and the assurance of safety [149].

The work presented here addresses the present need for a comprehensive architectural model of the factory workcell in which wireless is a preferred mechanism for carrying information within the workcell. It begins with an architectural analysis of the future collaborative workcell that includes edge devices, robots, vision systems, and supervisory controllers. The architectural analysis includes structural components, information flows, and parametric elements of the workcell. Factors that limit reliability, latency, and scalability of the wireless network are identified concluding with a discussion of significant information flows. Significant information flows are defined as operationally critical or safety-related. The contributions of this part of the thesis are as follows:

- ▷ First, a comprehensive and extensible architectural model using the SysML that provides primitives for describing the physical and networking components

¹The power for untethered operation can be achieved through the use of rechargeable batteries to power the untethered machine or robot for enough operating period.

of a workcell with parametric constraints is developed²;

- ▷ Second, a framework for analyzing cross-domain interactions of complex wireless workcell deployments is provided; and
- ▷ Third, significant information flows are identified, annotated with rate constraints.

4.2/ CONCEPTUAL REPRESENTATION

The remainder of this work describes a reusable model for representing a comprehensive wireless factory workcell using the semantic constructs of SysML. An exposition of the model beginning with the conceptual model followed by a detailed description of each component within the model is given. When discussing the model, the SysML term, block, is omitted for the sake of brevity where the meaning is clear.

4.2.1/ PACKAGES

The factory workcell is decomposed into one general and nine major structural packages as shown in Fig. 4.1. Packages include major logical groupings of structure within the model. These packages are enumerated in the following paragraphs.

- **General:** A set of reusable structural elements that is used for conceptual modeling or extended to produce more complex model elements. Each of the sub-packages within the General package extends basic features. The sub-packages within General include time and constraints for data, electromagnetism, and motion.
- **Network:** Describes the components, blocks, interfaces, and limiting factors of the IWN. The IWN is modeled as the radio channel and the services provided by the network. Limiting factors are modeled as parametric equations associated with the radio channel and the services.
- **Application:** This package contains the model elements describing a component of behavioral functionality typically implemented within software or firmware but could be implemented in hardware. It describes the features and constraints of factory operation such as the logic of a supervisory controller or the feedback controller of a robot arm. The Application sets the performance

²the model is made publicly available for download. A valid license of MagicDraw 18.5 is required to use the model. A web-based report of the model is provided for read-only access.

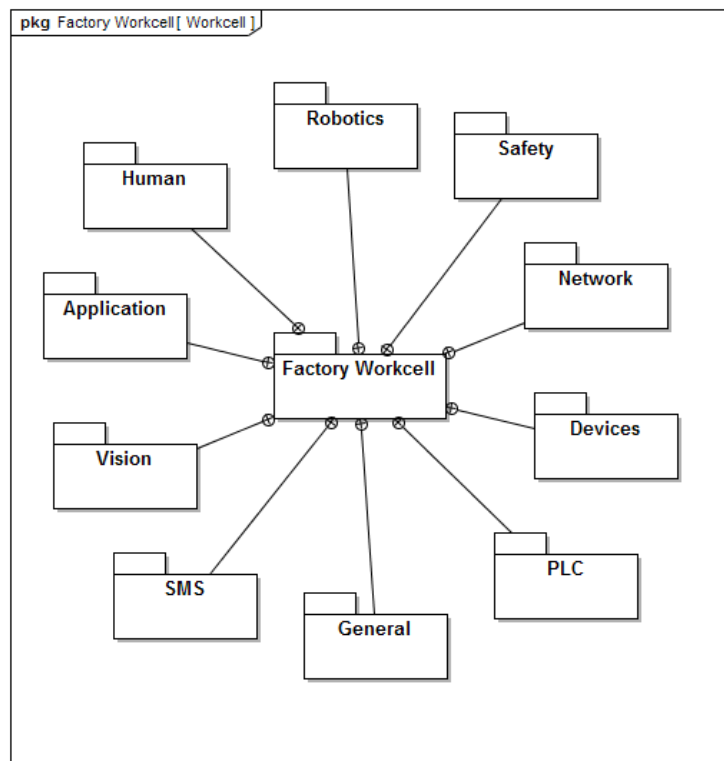

Figure 4.1: SysML package definition diagram (PKG) showing the logical containment of the factory workcell structural elements. The SysML model is organized according to the package hierarchy shown.

requirements of the wireless network, i.e., the factory network performance requirements are derived from the requirements of the applications deployed to a workcell.

- **Devices:** Describes the types of devices found within the factory workcell to include any device that interacts with the environment such as wired and IO devices including sensors and actuators.
- **Robotics:** Describes the computational and communicative components of robot control including sensing, actuation, and command. Description of the robot itself is inconsequential to communication and therefore not included in the model.
- **PLC:** Describes the supervisory control components commonly handled by one or more PLC components. This package includes the elements responsible for coordination of actors and handling of most input-output.
- **Safety:** Describes the allocation of safety qualities typically included in the supervisory controller. The Safety package includes devices, monitoring, and actuation of the safety behaviors within the factory workcell.

- Vision: Describes the allocation of features to optical monitoring and tracking which are typical to the collaborative robotic workcell.
- Spectrum monitoring system (SMS): Describes the qualities and interfaces of a factory spectrum monitoring system projected into the factory workcell. The spectrum monitoring system (SMS) includes monitoring nodes and agents localized to the workcell and connected to the automation system for real-time adaptation to changing multi-path and interference.
- Human: Describes the features associated with human beings such as human motion, tasks, and carried equipment such as portable computing and communication devices.

Several examples of how to use the model are provided within the model [153]. Examples include: a robotic force-torque leader-follower, a robotic force-torque limiter, a collision avoidance, and a robotic pick and place workcell. The parametric constraints are provided as examples and are intended to be used for communication to project stakeholders or replaced with executable computer code such as MATLAB or Python scripts, thereby making the model useful for simulation depending on the modeling tool selected.

4.2.2/ CONCEPTUAL ARCHITECTURE

The conceptual architecture of the wireless workcell model is depicted in Fig. 4.2. All the packages are included in this architecture, and the connections and relations between blocks are defined using the SysML semantics. This figure serves to orient the reader during the presentation of detailed model decomposition in Section 4.3. The workcell model is composed of at least one IWN block and at least one Device block. More IWN blocks are used when multiple wireless networks coexist within the industrial workcell. Applications are associated with Devices and performance constraints are applied to Applications. In this model, the Wireless Device is a subclass of Device, and the Controller is a further derivation of the wireless device. Moreover, the Controller is an abstract specialization of a wireless device that represents all types of devices intended to control other processes. The behavior of a PLC or Robot is represented through two packages in the model. The production related behavior is represented through the corresponding packages and the connectivity behavior is represented through Devices such as the Robot Controller and the PLC which are special classes of Wireless Device containing all of the structure and behavior of the wireless device. Finally, an often overlooked component of any industrial wireless deployment is the spectrum monitoring system represented by the

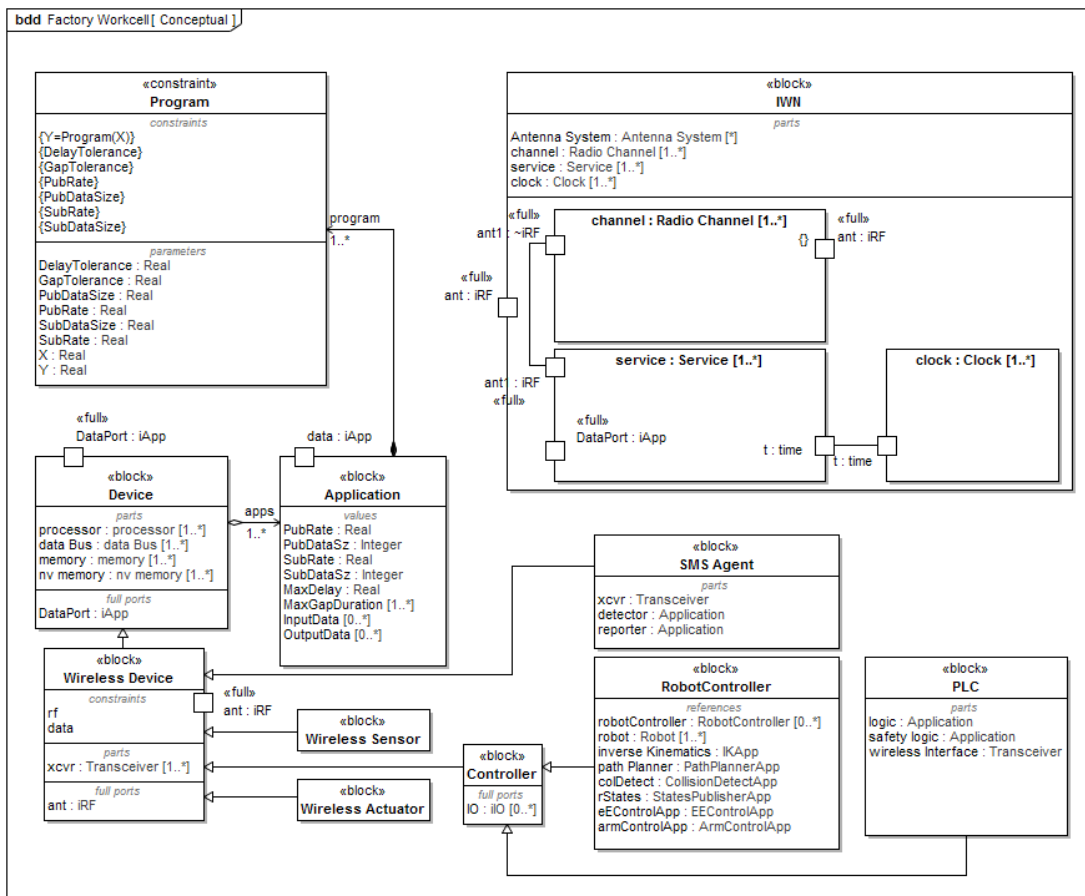

Figure 4.2: Architecture of the conceptual workcell captured as a SysML block definition diagram (BDD). In this diagram, only the most generalized blocks necessary to construct a workcell scenario are shown. More application-specific scenarios may be developed by deriving new blocks from the constructs shown here. The shapes and connectors used for expressing this model are defined in the SysML specification [70].

SMS Agent. Blocks in the model communicate through ports such as the ant port which represents the antenna or waveguide interface. Architectural composition is further implied by the parts, constraints, and parameters associated with each block. These are listed within the compartments of each block.

4.3/ DETAILED MODEL DECOMPOSITION

In this section, the decomposition of the model packages is described in detail. The decomposition of each package includes the properties and the components of the package where the relation between the package and physical industrial workcells is illustrated. Moreover, some of the packages may have various types with different properties and hence sub-packages are defined for these packages. This section also includes a general explanation of the packages rules in the workcell and the

behavioral interactions between the packages.

4.3.1/ GENERAL PACKAGE

The General package contains the reusable elements of the model. In particular, the General package contains elements that are not particular to any one workcell component but can be reused or applied across several. The concepts of time, clocks, and synchronization are included within General. Moreover, several types of constraints are defined.

4.3.1.1/ TIME

Time is an important construct within communication systems as well as industrial control systems. Time is realized as a set of one or more clocks. A workcell will contain one to several clocks typically embedded within each device to allow those devices to synchronize to a common clock. The local clocks within the workcell devices will synchronize to a master reference clock and usually one with a high degree of precision, accuracy, and stability. The degree to which the local clocks synchronize to the master will depend on the requirements of the applications that the local clocks serve. Clock synchronization can be costly in power, size, and monetary cost of the devices, but it may be necessary depending on the applications using a clock. Clock performance is a key driver of size and power consumption, and synchronization of clocks across a wireless network can be a challenge and is a highly studied field [154,155]. Moreover, the Time package includes a constraint, Clock Performance, to represent the production of time and synchronization with a master clock.

4.3.1.2/ CONSTRAINTS

Constraints provide limitations on the performance of an element within the model. Within General, several constraints are defined which may be applied to any block within the model. These constraints include motion constraints, radio channel constraints, and networking constraints as shown in Fig. 4.3a through 4.3c.

Motion Constraints When applied, these constraints provide the bounds of dynamical performance. For example, motion constraints determine the positions, velocities, and accelerations on a rigid body. The force vector equations ^(4.1) are the general governing dynamic laws of motion as forces on a vector of joints as exerted

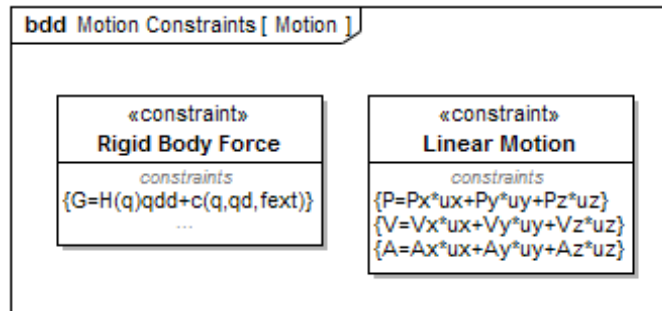

(a) Motion Constraints

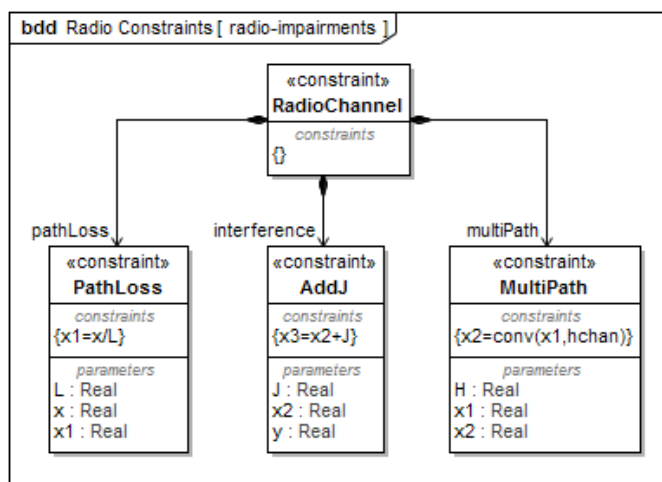

(b) Radio Channel Constraints

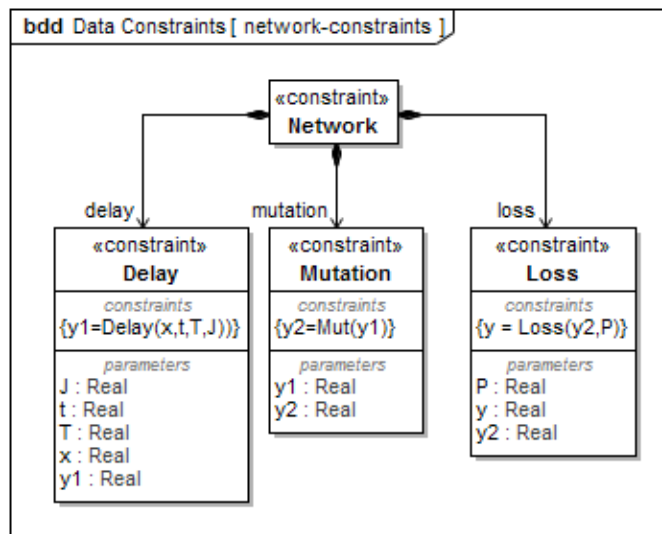

(c) [Networking Service Constraints

Figure 4.3: Generalized network constraints consisting of rigid body motion (a), the radio channel (b) and the network services (c). These constraints are meant to communicate or simulate the effects of an IWN on the performance of the CPS.

by the end-effector or set of end-effectors on the environment. The equations constrain the robot to operate according to the laws of physics, where the joint-space inertia matrix, H , is an $n \times n$ symmetric, positive-definite matrix, and q , \dot{q} , and \ddot{q} are vectors of position, velocity, and acceleration, respectively. The variable f_{ext} is the six degrees-of-freedom (DOF) force acting on the end-effector, and c is the joint-space bias force required to produce a zero sum force on the end-effector [156].

$$\Gamma = H(q)\ddot{q} + c(q, \dot{q}, f_{ext}) \quad (4.1)$$

where Γ is the vector of forces exerted by the end-effectors.

This system of equations is controlled using a combination of digital feed-forward and feedback compensation in which the communication mechanism of the robot states directly impacts the controller's effectiveness. Joint control via a wireless network connection is typically avoided; however, monitoring of the linear and angular forces represented by f_{ext} as sensed by a 6-DOF wireless force-torque sensor (FTS) can be advantageous for many industrial applications. As such, the performance of the wireless connection between a FT sensor and the controller can be a limiting factor in the performance of force-sensitive applications. Such a constraint may be applied to robot manipulators as defined in Section 4.3.5.

Radio Channel Constraint The radio channel constraint limits wireless information flow to the laws of propagation which includes path loss, reflection, diffraction, and interference. By applying this constraint to Wireless Devices described in Section 4.3.4.2, such devices experience the effects of a lossy communication medium. The radio channel when applied to a wireless communication link within the workcell manifests itself in accordance of the illustration of Fig. 4.4. The parametric equations for the radio channel include path loss, multi-path, and interference. Path loss is generically modeled as the input signal divided by the bulk power loss in the channel. Path loss is often characterized as a two-piece linear function of distance [23]. Multi-path is modeled as convolution of the transmitted radio signal with a linear time-varying impulse response characterizing the electromagnetic propagation between transmitter and receiver antenna systems. Interference is then modeled as an additive component with power, bandwidth, and probability of excitation.

Data Constraints Delay, mutation, and loss of information within the IWN are encapsulated by the Network constraints block. The Network constraint is applied to wireless devices within the network and represents the impacts of the radio channel and network components and protocols. These constraints are illustrated in a parametric diagram of Fig. 4.5 in which the rules for delay, mutation, and loss are

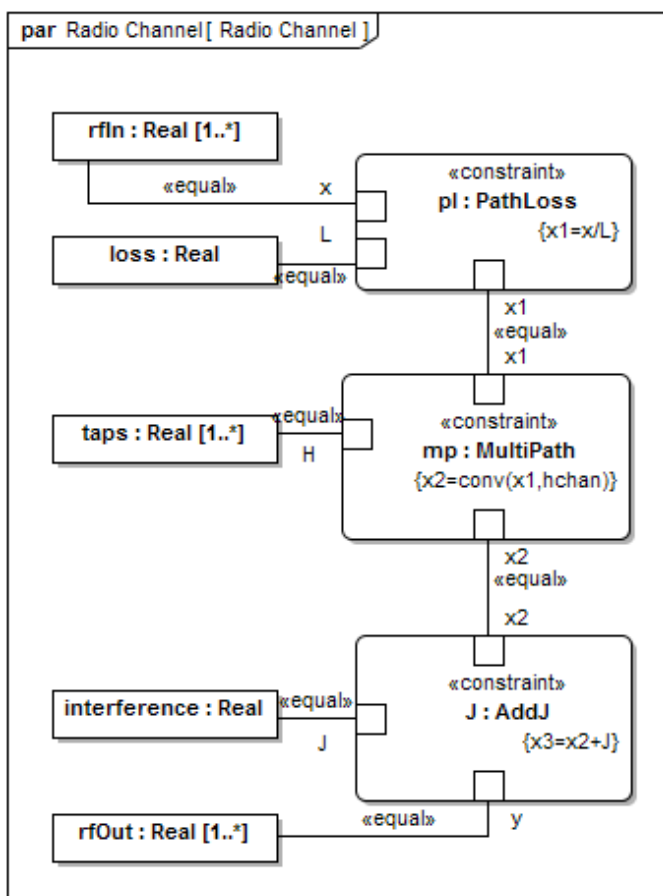

Figure 4.4: SysML parametric diagram (PAR) of the radio channel constraints of the IWN. Parametric equations used to express the constraints within the CPS are elaborated using the parametric diagram (PAR).

applied to a service of an industrial wireless network within a workcell. As with any constraint, the rules for data loss may be modeled as equations, pseudocode, or executable computer code such as MATLAB script or C. These rules decide if information is lost due to delay or mutation. While it is easy to understand how mutation leads to loss through a mechanism such as a checksum, unacceptable delay can also lead to loss of data.

Delay is simply a function of time, the physical environment of the factory workcell, and state of the network at time, t . Many features of the network and the physical environment will have an impact on the output of the delay equation and will include data transmission duration, radio wave propagation delay, SNR, protocol for reliability, routing, internal queuing, and processing. A generalized equation for information delay by the wireless network is given as the sum of processing delay, queuing delay, transmission delay, and propagation delay. Subsequently, information loss is modeled as a set of rules governed by the attributes of the network infrastructure, transport medium, and protocols shown in ^(4.2). These rules may include

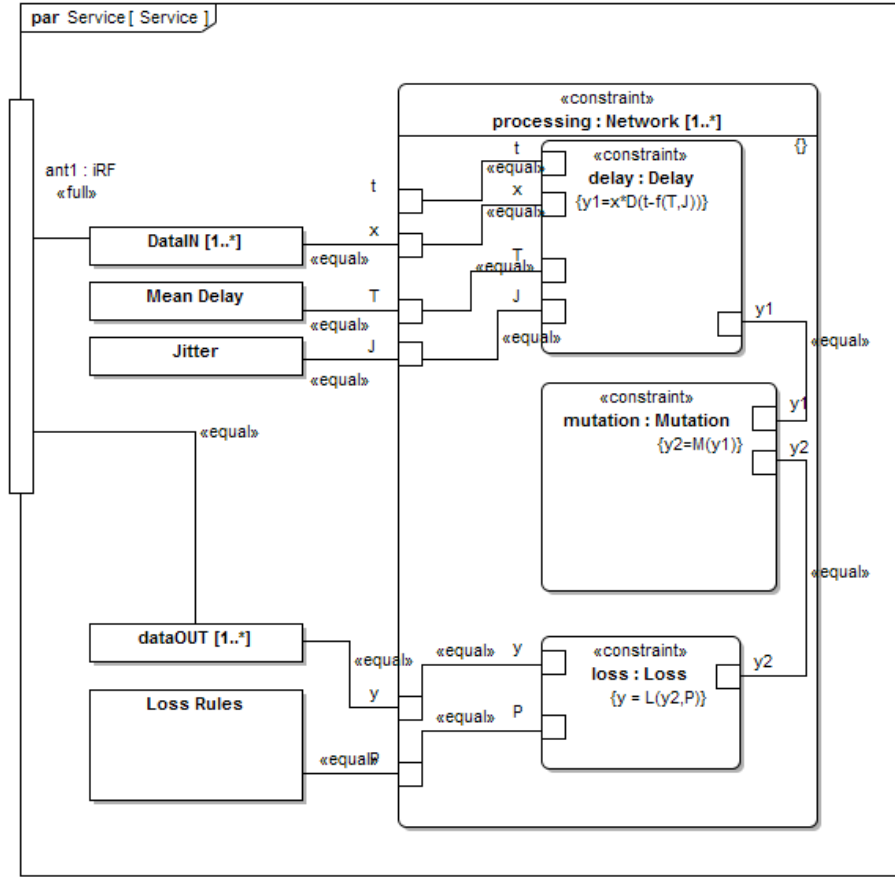

Figure 4.5: SysML parametric diagram (PAR) of the data constraints applied to the IWN.

thresholds for unacceptable delay and the ability of the network to correct for data mutation or loss in the physical channel (i.e. the air interface).

$$\mathcal{Y}(t, \mathcal{X}, \mathcal{N}) = \begin{cases} \mathcal{X} & \text{if } \mathcal{X} \vdash \mathcal{L}(t, \mathcal{X}, \mathcal{N}) \\ \emptyset & \text{otherwise} \end{cases} \quad (4.2)$$

where \mathcal{X} and \mathcal{Y} are blocks of data traversing the network and \mathcal{N} is the state of the network at time, t . The loss constraints are modeled as a general set of rules, \mathcal{L} , taking into account that each network system will have a different set of configuration attributes and protocols. The rules will, therefore, change for each operational system and the networks used. When the rules for loss are applied, the output of the network, \mathcal{Y} , becomes the input to the network, \mathcal{X} , when \mathcal{X} satisfies $\mathcal{L}(t, \mathcal{X}, \mathcal{N})$.

4.3.2/ APPLICATION

Applications, commonly implemented as software and firm-ware, represent the intelligence of devices. The application defines the behavior and the information flow

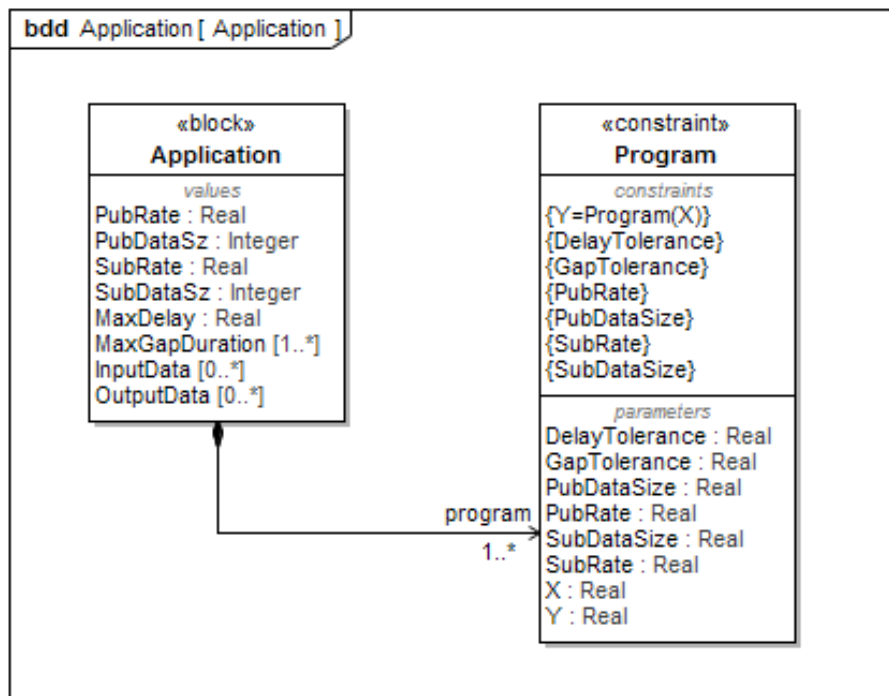

Figure 4.6: Block definition diagram (BDD) of the Application.

Table 4.1: Constraints Pertaining to a Collision Detector

Constraint Property	Typical Value
Input Payload Size	1 KB
Subscription rate	125 Hz
Maximum Delay Tolerance	47 μ s
Maximum Loss Duration	275 ms

requirements of the workcell [157–159]. As defined in the model, without Applications implemented in software, firmware, or hardware, the workcell devices would not function. The definition of the Application block is shown in Fig. 4.6. The Application block is constrained by the Program constraint which defines the logic of the program, its expected data flow input rates, and its tolerances to delay and information loss. Devices host multiple applications each with a unique set of constraint properties. It is essential when constructing a workcell model that each application is identified and modeled appropriately. An example of an Application is a collision detection system within a robot controller. Table 4.1 illustrates sample parameters used in the collision detector Application.

Specification of Application constraints provides a clear picture of the requirements of the factory automation system which can be projected on the wireless network. Through this process, it is possible to determine such requirements as scalability, throughput, reliability, and latency of the supporting network services

modeled as radio and data constraints in Section 4.3.1.2. Indeed, as the manufacturing system becomes more complex and wireless becomes essential to communication, the projection of manufacturing requirements onto the wireless communication system becomes less clear. Frequency planning, transmission scheduling, and error correction schemes become less obvious, and considerations of power, reliability, latency, and scale become optimization trade-offs. Such analyses are not within the scope of this work but are important considerations for future research of manufacturing systems. As such, the architectural elements and information flows exposed by an abstract model are a necessary first step.

4.3.3/ INDUSTRIAL WIRELESS NETWORK

Central to the automation system is connectivity among devices and controllers [160]. More specifically, modern automation systems often employ networks to conduct inter-device communication [161]. The term inter-device is appropriate as the Device block serves as the basis for all other components that communicate through the network. This model of the IWN is composed simply as a radio channel, a set of services, and a set of clocks as shown in Fig. 4.7a. This simplification of the model is necessary to allow the users of the model to provide as much or as little detail of the implementations of the radio channel and underlying services as required for their implementations.

Connectivity of a constructed IWN is shown in Fig. 4.7b. An IWN is internally modeled such that information flows as RF energy through the ant port. A radio channel is applied, theoretically for each pairwise link, and the modified signal is passed to the services for processing. Network processing is modeled by the properties of network constraints as defined in Section 4.3.1.2. Once processed by network services, information is routed back through the radio channel through the ant port to other Devices connected to the IWN. Moreover, the Service block includes a parametric model as shown in Fig. 4.7. This IBD with exposed parametrics exemplifies the inclusion parameters such as information delay and loss caused by the IWN, but it also exemplifies the impact of protocols and infrastructure (throughput, memory, etc.) within the network. These effects are modeled as rules of loss shown in ^(4.2).

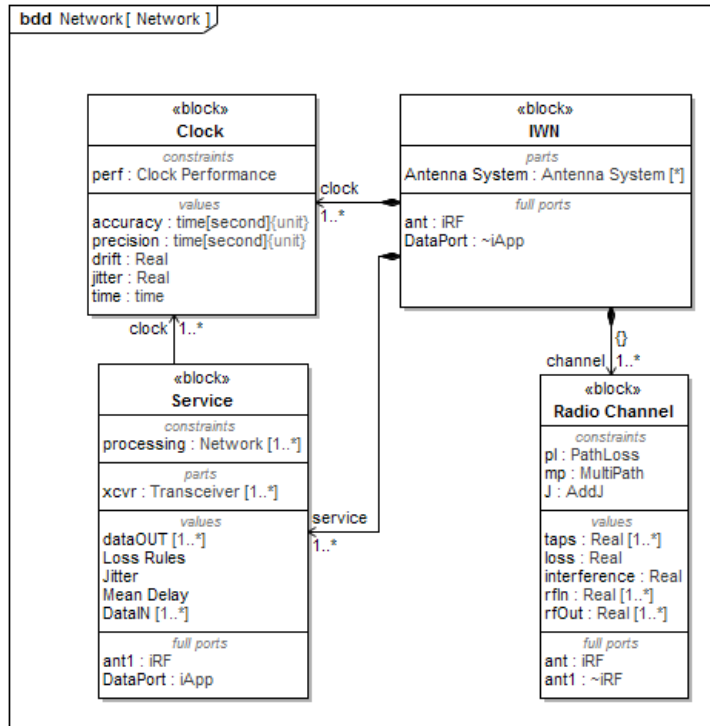

(a) BDD of the IWN.

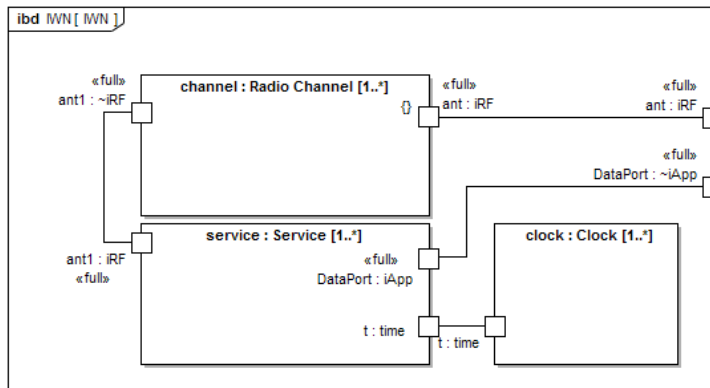

(b) IBD of the IWN.

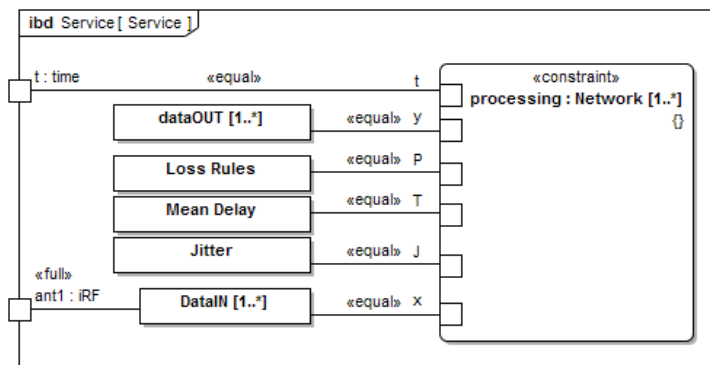

(c) Parametric IBD of the Service block within an IWN.

Figure 4.7: The BDD (a) and IBD (b) of the IWN with parametric IBD (c) of the Services block.

4.3.4/ DEVICES

4.3.4.1/ DEVICE

A Device, defined in Fig. 4.8, is generic construct representing an element within the workcell with processing, memory, and storage capability. Devices have the capability to run applications as defined in Section 4.3.2. Devices are sub-classed into (Wireless) Sensor and (Wireless) Actuator devices which generically refer to any type of sensor or actuator, and, in particular, the wired variety. The Device is further sub-classed to the Wireless Device which is the central theme of this analysis. Derived from the Wired Device are the Wireless Sensor and Wireless Actuator as well as the Controller. The Controller represents the base class for deriving workcell devices such as the PLC and the Robot Controller, sections 4.3.6 and 4.3.5, respectively, and provides support for external IO.

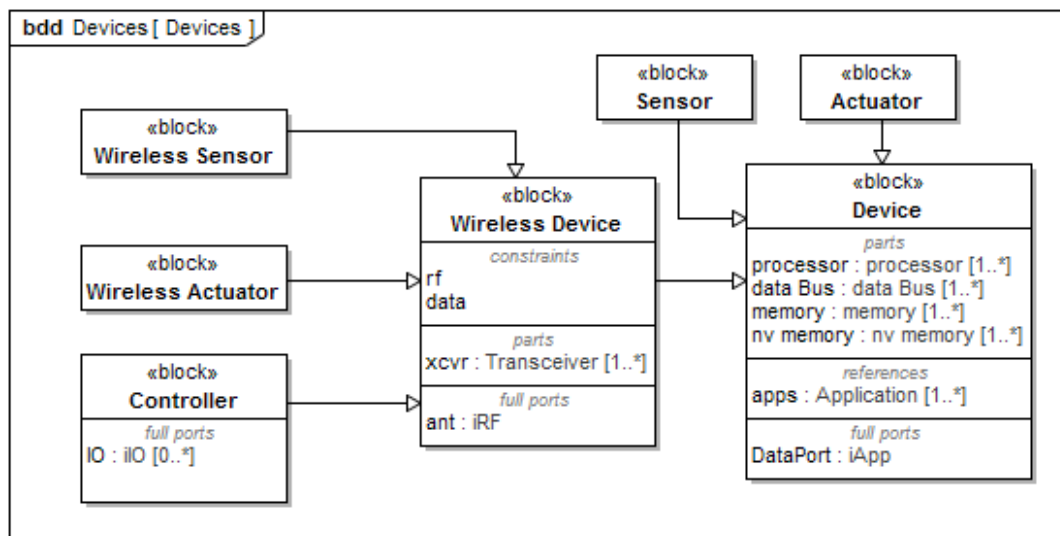

Figure 4.8: SysML block definition diagram (BDD) of wireless devices within the factory workcell.

4.3.4.2/ WIRELESS DEVICES

A Wireless Device is a subclass of Device that contains the various components necessary for untethered communication. These devices then communicate with each other through one or more IWNs which contains antenna systems, transceivers, protocols, and network services. The relationships and composition of the Wireless Device are illustrated in Fig. 4.9. As shown, the wireless device is composed of at least one transceiver and each transceiver is composed of at least one antenna system which is composed of at least one antenna element. The antenna system is

constrained by its gain profile.

4.3.4.3/ TEST DEVICE

The Test Device is a subclass of Device that represents devices used for calibration or ground truth testing of properties of a workcell. The block definition and internal configuration are illustrated in Fig. 4.10. A Test Device is constrained by its accuracy and precision as well as the algorithm for controlling measurement. An example of a test device is a calibrated force sensor that may be used as comparison to a 6-DOF wireless sensor mounted on the wrist of a robot arm as shown in the top left of Fig. 4.14. Test devices are useful and necessary elements of the wireless testbed to establish accurate and repeatable ground truth measurements. For example, a stationary precision force sensor may be used to establish a ground truth force value, and a high-accuracy vision tracking system is used for truth in position. Test devices are modeled such that measurements may traverse the operational wireless network or a stand-alone wired interface.

4.3.5/ ROBOTICS

The robotics package contains elements specific to robot systems. Robot systems are composed of at least one robot controller associated with one or more robots, as shown in Fig. 4.11a. In manufacturing, robots interact with their surrounding to accomplish assigned tasks such as tending machinery, moving materials, welding, and inspecting. Robot controllers provide support for external IO devices. In addition, modern robot controllers will support a variety of open and proprietary network protocols allowing for interaction with other actors in the workcell. The robot controller's main task is control of the rigid body dynamics of the robots which is usually conducted via real-time communication over a high-throughput serial field-bus. While joint control is conducted using wires, the robot controller is responsible for other tasks requiring reliable, low-latency communication in which wireless may serve a role. These tasks are captured in the model as applications (Fig. 4.11b) and explained as follows.

- Robot States Publisher: Transmission of robot states to external actors such as other robot controllers, supervisors, and safety systems.
- Arm Controller: Also known as manipulator control, serves to accept position commands as Cartesian or joint space trajectories and waypoints from other actors within the workcell.

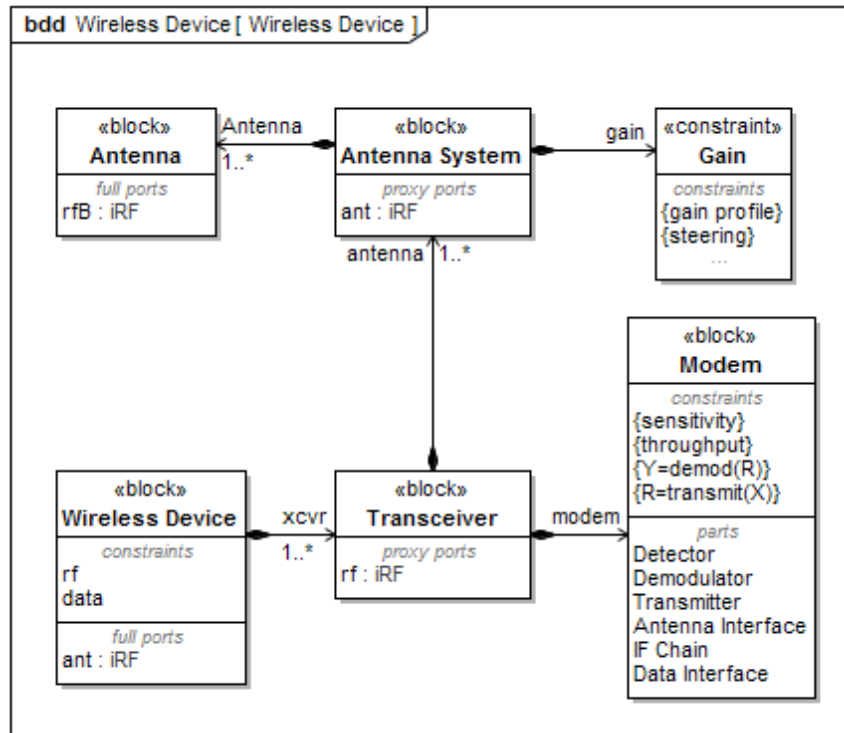

(a) BDD of the Wireless Device

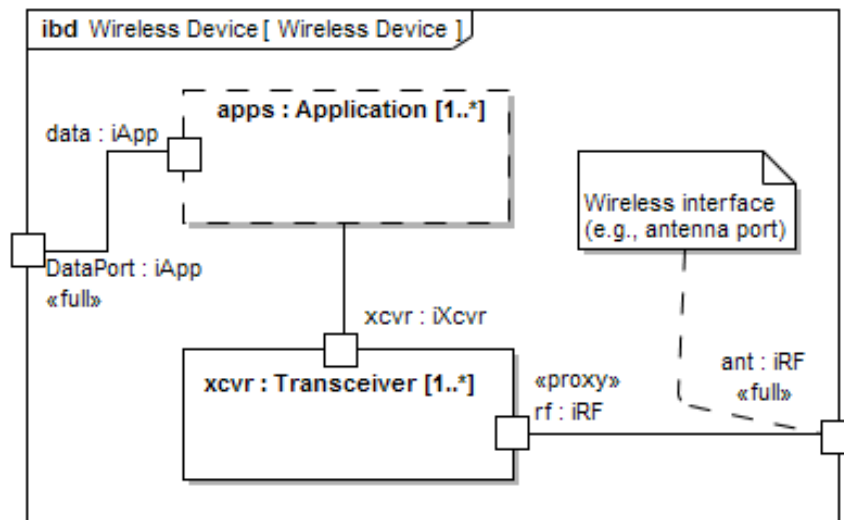

(b) IBD of the Wireless Device

Figure 4.9: BDD (a) and the IBD (b) of Wireless Device. All Wireless Device components contain at least one Transceiver which conveys information to and from one or more Application components. Intermediate general processing by a central processing unit (CPU) is not assumed in this model although it could be adapted to do so with additional constraints.

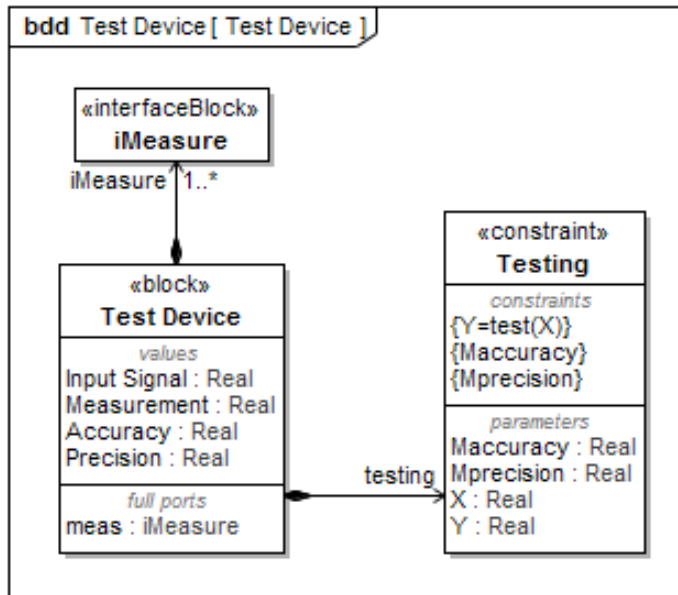

(a) BDD of the Test Device

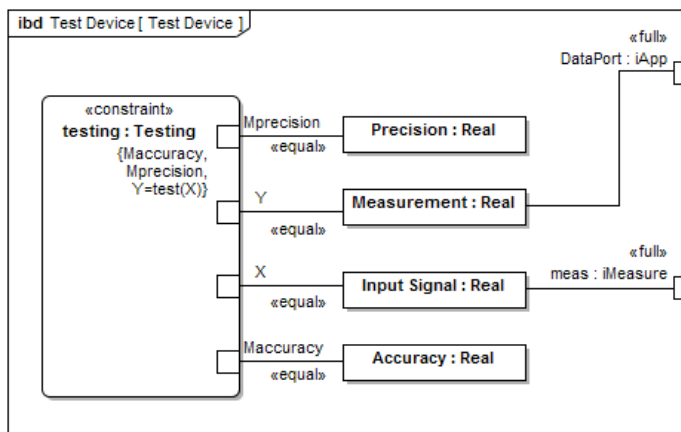

(b) IBD of the Test Device

Figure 4.10: BDD (a) and the IBD (b) of Test Device.

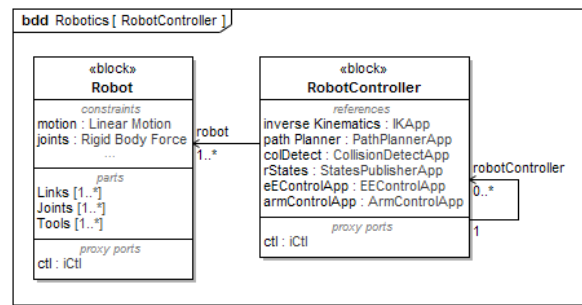

(a) BDD of the Robot Controller

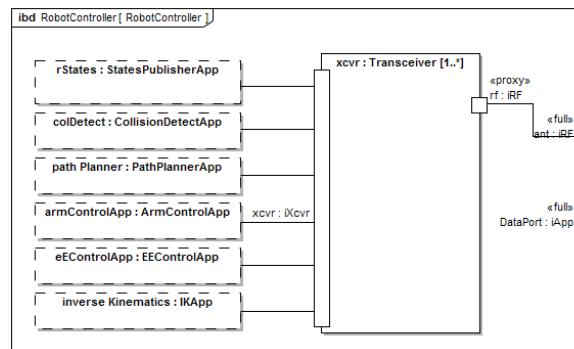

(b) IBD of the Robot Controller

Figure 4.11: The BDD (a), IBD (b) of the Robot controller (RC). The RC contains all of the application logic to control the physical robot. It is assumed that the communication between the RC and the robot is near-ideal for the purpose of this model as that reflects the current direction of industry. It is not anticipated that physical joint control will be controlled wirelessly in the near-future.

- **End Effector Control:** Command and control of the robot end-effector such as a gripper or sensor. The end-effector may be equipped with a high-throughput wireless sensor necessitating reliable communication.
- **Inverse Kinematics:** Converts Cartesian coordinates of the end-effector into joint positions.
- **Path Planner:** Determines the optimal geometrical trajectory to achieve a final pose given knowledge of self-collision and real-time knowledge of the surround environment. Path planning is a sophisticated part of a robot system and may be allocated to an external system depending on throughput and latency requirements.
- **Collision Detector:** This application monitors the states of other actors and obstructions within the workcell. If possibility of collision is detected, the collision detector takes action.

These applications within the robotic workcell define many information flows requiring careful analysis to achieve reliability and latency necessary for the

safety and control of the manufacturing process. Information flows are identified in Section 4.4.

4.3.6/ PLC

The PLC is a specialized class of Controller. PLCs were originally developed to mirror relay circuits in software; however, the modern PLC is much more advanced and is usually equipped with multiple processors, a real-time operating system (RTOS), and capabilities to support various types of industrial IO devices. In addition, modern PLCs (also called automation servers) include both a general purpose operating system (OS) with a real-time kernel and multiple network interfaces. Many network-routable protocols are also supported. With the addition of wireless protocols, PLCs now have the ability to support IO devices connected remotely without wires. Supervision of untethered robots is also possible using PLCs. The PLC is modeled as a Controller device with the workcell model. Shown in Fig. 4.12, the PLC is modeled as a wireless device with transceiver, logic application, and safety applications. More sophisticated PLCs may be modeled by extending the PLC block. As applications, the logic and safety functions are constrained by application constraints. Finally, as Controller devices, PLCs are modeled with an IO port, thus IO can be connected to the PLC by wires or by wireless network connection.

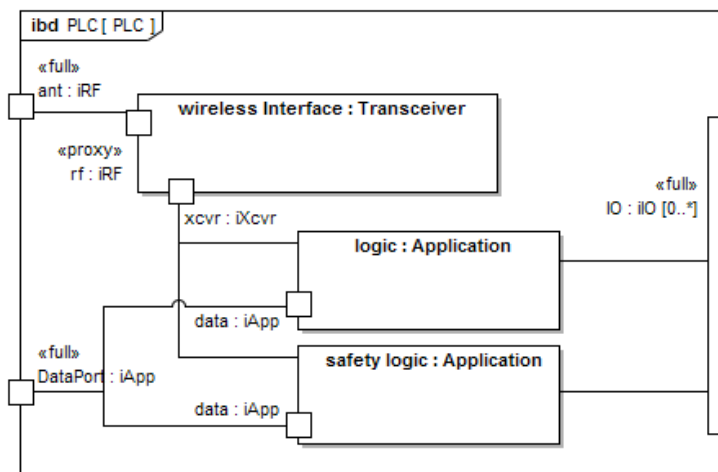

Figure 4.12: The IBD of the PLC showing composition and connectivity of the control logic and safety logic Application instantiations to the Transceiver interface.

4.3.7/ SAFETY

In a workcell with interacting humans and robots, functional safety requirements are typically strict by specifying the rules related to four main safety criteria, namely,

monitored stops, controlled speeds, separation distances, and power and force limits in order to prevent injury for humans and damage for equipment. The wireless safety package is composed of a safety controller and safety devices. Traditionally, the safety requirements of the workcell is fixed and managed by the safety controller which receives safety-related measurements and takes the corresponding actions. Alternatively, the safety controller may be connected to the PLC where the current workcell activities are supervised. The PLC will determine the required safety rating and the safety controller behaves accordingly. The dedicated safety controller is needed to achieve the required high reliability and low latency safety requirements and it can be a general PLC with safety modules.

The safety devices include non-safety-rated devices such as the various workcell sensors and actuators and safety-rated input and output devices. Safety control input devices include Emergency-stop and enabling buttons while output devices include relays and switches for various workcell equipment. The use of wireless in safety control loops allows installing a larger number of sensing devices including vision systems to monitor the human and robots activities, velocity and proximity sensors, and machine status sensors. Moreover, wireless allows to have mobile control panels where workers can activate a safety device at any time and location within the workcell.

4.3.8/ VISION

The vision system considered in this subsection is the one used for workcell monitoring and general object detection. It does not cover the machine-embedded vision systems which can be used for inspection and characterization of objects such as the shape, color, texture, or size of processed materials. The data collected by the workcell vision system can be used for parts and mobile robots tracking, collision avoidance, object detection, security identification systems, and augmented reality devices and systems. The vision system communicates with the supervisory control, robotic controller, and the safety system to provide the workcell state which contains the positions of various equipment, robots, and humans.

The vision system is composed of optical devices, vision processing unit, and interfaces to various workcell systems. The optical devices are the cameras for capturing images at high enough speed to track and detect various objects. These cameras have wireless network interfaces to be connected to the vision processing unit to allow collaborative processing of the captured images and obtaining precise workcell state. The vision processing unit performs data acquisition from the distributed optical devices and feature extraction to detect and track the positions of various entities in the workcell.

The vision system communicates the corresponding data to the supervisory control, robotic control, and the safety system for decision making based on the captured workcell state. The supervisory controller uses vision system data for robots and workers localization, parts detection and identification, and schedules tasks using this information. The robotics controller uses these data for motion control, path planning, and collision detection. Finally, the safety controller uses these data for safety requirements implementation such as enforcing safety stops, controlling the speeds of moving objects, and limiting power and forces of various workcell components.

4.3.9/ SPECTRUM MONITORING SYSTEM

A SMS is an often overlooked yet valuable part of the wireless factory workcell with requirements specified in [162]. The SMS is modeled as an atomic agent within the workcell. The SMS Agent is one component in a larger enterprise-level spectrum monitoring deployment. The SMS agent shown in Fig. 4.13 includes a transceiver, an event detector, and a reporting agent. The transceiver can be implemented as an RF-to-baseband converter. The detector application is responsible for detection and estimation of anomalous spectral events and may employ machine learning to accurately detect anomalies and report localized spectral events.

The reporter application collects, filters, and reports event information to a central management console. SMSs reports support identification of long-term patterns such as growth trends in particular wireless bands. Since the SMS Agent is part of a larger network of spectrum monitoring, it is presumed that reports are wirelessly transmitted back to the enterprise management console. These reporting events use bandwidth otherwise used for the factory operation, thus reports must be made concise and infrequent. This implies substantial filtering and intelligence in the local SMS agents This may provide opportunities for research.

Detection events may be routed to the local supervisor, robot controller, and safety system. By leveraging spectral awareness, workcells can be made safer and more reliable. As SMS are not yet widespread in industrial applications; thus, standardized protocols are needed for reporting and integration with automation systems.

4.3.10/ HUMAN

Humans can exist in a modern workcell for short or long periods of time depending on the required task. Two categories of human-related aspects are captured in the

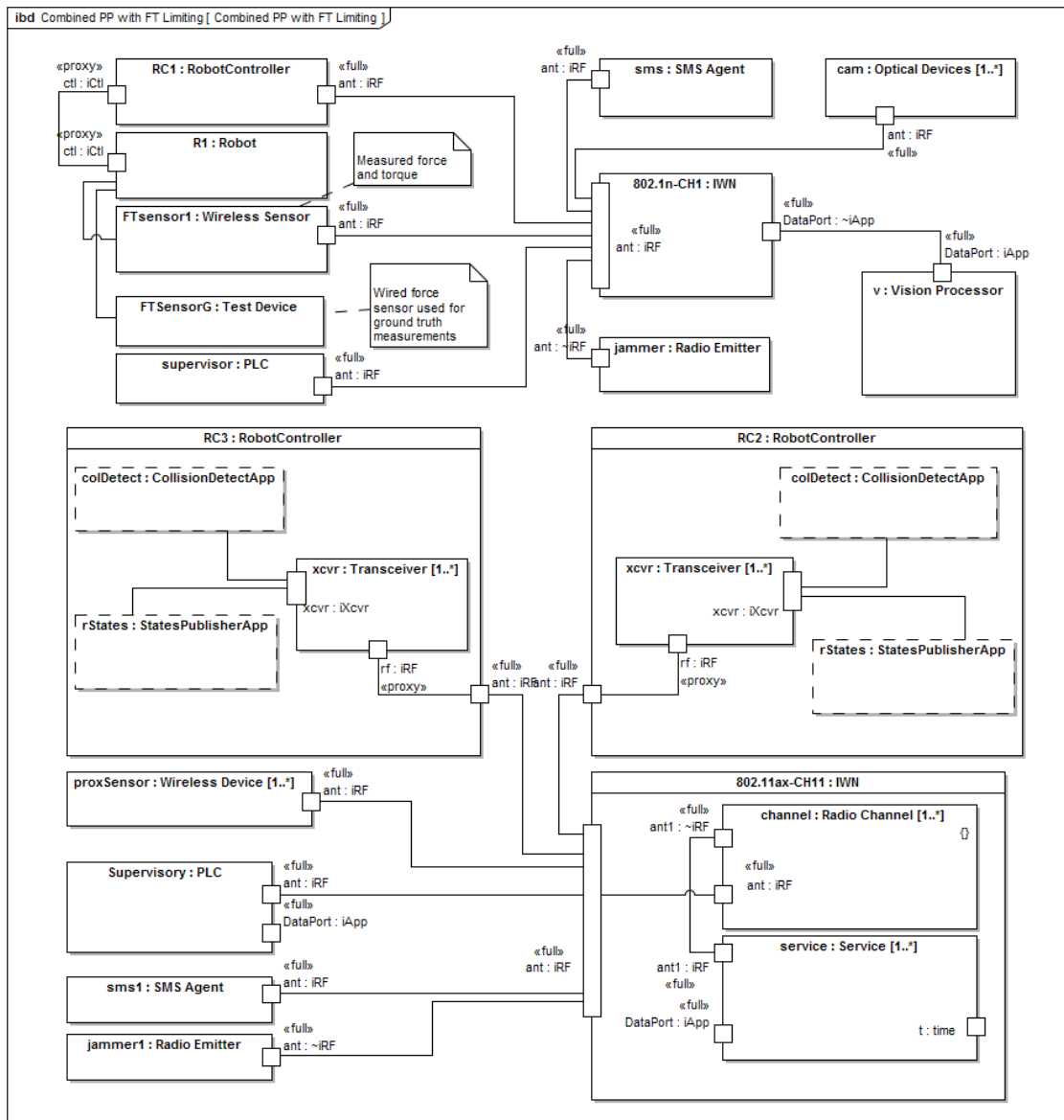

Figure 4.14: Example IBD of a workcell employing multiple networks in a collaborative robot operation coexisting with robot force limiting inspection station.

surement. An SMS agent monitors the electromagnetic spectrum. A Radio Emitter is included to model the transmission of interference. An IEEE 802.11n network is represented in the model by an IWNs block. Properties of the radio channel and services of the communication system are therefore represented. Similarly, another example is implemented in [153] for a pick-and-place scenario where the model is composed of two robots, a PLC, an IWN, and an SMS Agent in addition to proximity sensors and an IEEE 802.11ax network.

Referring to these examples, typical information flows are easily identified as connections between Wireless Device blocks and the antenna port, ant, of the IWN. Recall that the IWN includes radio channel and services offered by the network itself. Therefore, all wireless information flows will traverse the IWN through the ant port. Applications are implied and produce and consume the information according to associated constraint properties. Information flows are generated by the interactions between actors and include the following:

- **Robot States:** The geometry states of the robot such as position, velocity, and acceleration of each joint or end-effector. Robot states may include Cartesian or joint space readings depending on the need of other applications or the capabilities of publisher. Robot states are usually transmitted at 30 Hz or faster [163].
- **Force Sensor Readings:** The readings from a sensor mounted on the wrist of each robot arm. These readings are typically in the format of wrenches (linear and angular forces) and are transmitted at rates from 15 Hz for monitoring applications up to 500 Hz for force limiting and control applications [164]. Other sensors may produce data in the system such as proximity sensors which can generate data in the range of 1-50 Hz [165] and Tactile sensors which can have information flow rates faster than 1000 Hz [166].
- **Machine Health Monitoring:** Readings from sensors mounted within machinery such as mills, routers, and lathes used to sense and predict deviations of mechanical components from design tolerances. Readings for prognostics and health monitoring are often aggregated at the source with statistical metrics being communicated to a factory enterprise application; however, non-aggregated readings may also be transmitted to a remote signal analyzer. Health monitoring sensors measure temperature, vibration, acceleration, inclination, position, and rates of change of angles. Information flows from a single aggregation point may reach 200 kB/s on average for a 6-DOF sensor apparatus described in [167]. While the outputs of health monitoring sensors are usually wired into a local aggregation devices, it is desirable to transmit these readings to an on-line optimizer or PLC within the workcell [168].

- **IO States and Supervisory Messages:** These contain both the Boolean-valued readings and commands from sensors, and task orders in the form of short commands and lists of instructions which can originate from any supervisor within the network such as a PLC or other controller. Sensor readings (inputs) and actuation commands (outputs) are transmitted in periodically or pseudo-randomly at rates indicative of movements of machinery and materials through the manufacturing process. Typical analog and boolean IO states range from 10 Hz to 100 Hz depending on the manufacturing process.
- **SMS Events:** The SMS agent will communicate state information and directives to controllers within the workcell. These messages allow the automation system to react under anomalous spectrum conditions within the workcell. These information flows may be necessary for safe operation of the workcell. The data rate of reports from an SMS agent without processing or compression can be in the range of 1 to 10 megabits per second (Mbps) [169].
- **Vision Applications:** The vision system will communicate videos or images for processing and decision making. Typical Video flows can have the rates of 30 Hz for surveillance and 125 Hz for motion capturing [170]. Information flow for Object tracking systems can have the rate of 10-200 Hz depending on the tracked objects and the required accuracy.

4.5/ DISCUSSION AND CONCLUSIONS

A model was developed using SysML. The developed model is constructed of the elements necessary to construct useful representations of factory workcells in which wireless networks are used to transport information necessary for automated control system operation. Reusable, derivable elements are developed and then extended to represent the constructs of the workcell such as robot control, supervisory control, vision, safety, and spectrum monitoring. An IWN is then developed and constraints of the radio channel and network services are formalized. Using the architectural model, information flows are explored and incorporated within.

It is important to mention that this model includes an often overlooked component of any industrial wireless deployment which is the spectrum monitoring system and also considers the human-robot and robot-robot interactions in industrial environments. The current model includes various systems constraints including motion constraints, radio channel constraints, and networking constraints. The parametric constraints are provided as examples and can be replaced with executable computer code thereby making the model useful for simulation depending on the modeling tool selected. Furthermore, the applications within the robotic workcell

define many information flows requiring careful analysis to achieve reliability and latency necessary for the safety and control of the manufacturing process.

With increased dependency on wireless communications for more complex manufacturing systems, the projection of manufacturing requirements onto the wireless communication system becomes less obvious. Such analysis of this projection is essential for future research of manufacturing systems. As such, the architectural elements and information flows exposed by an abstract model are a necessary first step. The model in its current state of development is comprehensive enough to support architectural and ontological analyses of the factory workcell. As such, information about the relationships between components of a workcell and attributes related to the wireless network may be discovered. Therefore, the model serves as a foundation for future systems engineering analyses. Moreover, the model may be used as a tool for academic and industry exploration of wireless testbed development.

APPLICATION OF GRAPH DATABASES

The workcell is considered a main building block of various industrial settings. Hence, it is examined as a primary testing environment for studying wireless communication techniques in factory automation processes. A new testbed was recently designed and developed to facilitate such studies in workcells by replicating various data flows in an emulated production environment. Within this chapter, an approach to storing and analyzing network performance data from a manufacturing factory workcell is introduced. A robotic testbed was constructed using two collaborative grade robot arms, machine emulators, and wireless communication devices. A GDB approach was implemented to capture network and operational event data among the components within the testbed. A schema is proposed, developed, and elaborated; a database is then populated with events from the testbed, and the resulting graph is presented. Query commands are then presented as a means to examine and analyze network performance and relationships within the components of the network. Additionally, this work demonstrates how to extract correlations between receive signal power and network delay within the testbed using the graph database query language. Finally, using the inherently interconnected nature of the graph database, the work demonstrates how one might apply the graph database approach toward examining more complex relationships between the wireless communications network and the operational system.

5.1/ INTRODUCTION

Wireless communication is a key enabling technology for the modernization of factory workcells. Modern factory workcells are highly-interconnected networked control systems in which various devices interact and collaborate to accomplish complex and adaptive production orders. The workcell often contains mobile robots that collaborate with other robots or human beings. Requirements of the workcell include the incorporation of mobile collaborative robotics with real-time coordination

of motion and tool actuation. As such, the communication of sensor and control information must be ultra-reliable and of low-latency to assure trustworthy operation [161]. Due to an increased demand for ease of installation, reduced costs of deployment and maintenance, and flexibility, wired networks are being gradually replaced with wireless networks. This presents a real challenge for networks and control systems. Compared with wired connections, wireless links have their unique advantages in connecting field sensors and actuators with reduced cabling costs and natural support of mobility [149]; however, most current communications systems lack the latency and reliability supports [45] mandated by factory owners [143,144]. New wireless protocols are being designed to address reliability and latency concerns of real-time systems such as those in manufacturing automation. These new protocols include advancements, such as the IEEE 802.11ax standard and 5G cellular evolution as defined by the International Mobile Telecommunications-2020 (IMT-2020) Standard. Both of these two standards employ improved diversity techniques for multiple access of devices as well as 1 ms latency and greatly improved reliability [171].

Evaluation of such systems used in manufacturing environments requires not only rigorously analyzing network performance, but also studying the impacts of networks on manufacturing systems. Additionally, industry lacks effective and easy-to-use strategies for test and evaluation of such systems in a way that correlates network performance with operational performance. Furthermore, since factory operators desire the ability to control operations within the workcell using wireless technology, the work presents a novel method to simultaneously capture network and operational event information using a GDB. The use of a GDB allows for more intuitive inferences to be made through the stored relationships and graph theoretic models [86]. In this chapter, a GDB approach to the capture and analysis of factory workcell performance utilizing the Neo4j database platform is presented. A proposed schema of the database, the process for capturing both network and operational events, and examples of querying the database for cyber-physical performance evaluation of the workcell for the collaborative two-robot machine-tending workcell [172] are provided.

5.2/ RELATED WORK

Previous work related to the application of GDBs was presented in the Chapter 2 Section 2.2.

5.3/ GRAPH DATABASES

A GDB is the type of databases that uses nodes, edges, and properties to store and present data. A GDB is a part of a family of databases known as NoSQL databases that are used often to represent complex interrelated structures of data and their relationships. This can be very difficult with traditional relational databases. The GDB places a high priority on the relationships (edges) between units of information. In addition, the GDB does not enforce any particular schema or structure, and, therefore, provides greater flexibility in storing and representing information in which the parts of information may vary among units. The relationships within a GDB are efficiently queried because they are persistently stored within the database. In a GDB, queries can be made based on relationships. This, in particular, presents an advantage when storing information regarding systems with correlations that are apparent but difficult to visualize or quantify. The GDB approach was chosen for this specific purpose—to quantify and visualize relationships between non-ideal communications within a workcell and their impact on the physical system.

5.4/ CASE STUDY: ROBOTIC MACHINE-TENDING

In this section, this work presents a two-robot machine tending workcell case study. It first presents the design of the workcell followed by an elaboration of the database design called a schema. The information work-flow, i.e., the process for collecting, processing, and analyzing the network event data is presented. It then provides examples of the resulting graph and results of targeted queries that demonstrate the purpose of the database.

5.4.1/ WORKCELL DESIGN

To facilitate wireless network research and showcase the power of wireless technologies in industrial practices, a testbed shown in Fig. 5.1 has been developed at the SysML as described in [172]. The testbed is composed of two collaboration-grade robots, a supervisory PLC used for the control of the workcell, four smaller PLCs serving as CNC machine emulators, and a human machine interface (HMI). Each robot is equipped with a six DOF FTS and a two-finger gripper. A Modbus over Transport Control Protocol (Modbus/TCP) server is included within the supervisor PLC and is used for communication between the supervisor and the robots. The PLCs themselves communicate to each other using the Beckhoff Automation Device Specification (ADS) protocol. All elements within the workcell are synchronized to a

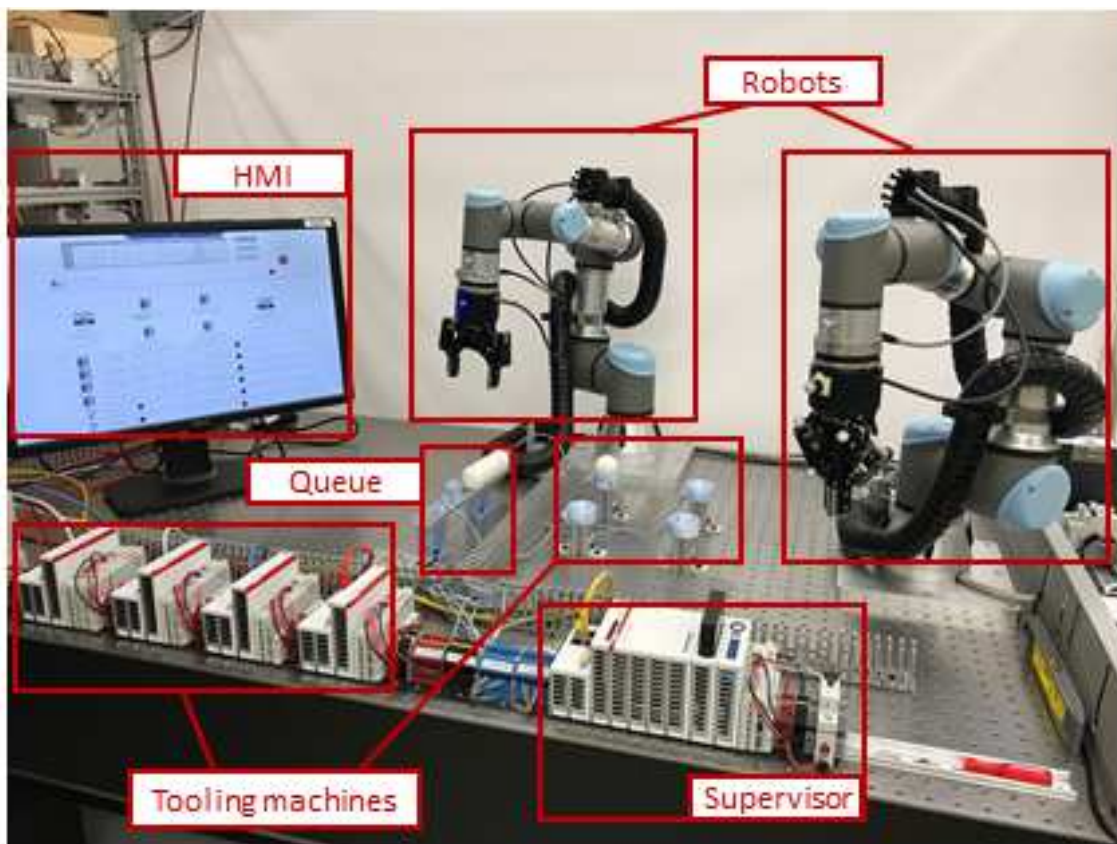

Figure 5.1: Testbed of a collaborative robotic workcell. Depicted are two robots working together to load, inspect, and unload materials from emulated computer numerical control (CNC) machines. PLCs are used to emulate the behavior of the CNCs and the supervisory controller.

stable and accurate grand-master clock. Therefore, as described in [172], the operational, network, and measurement elements are all synchronized to the grand-master clock through a Precision Time Protocol (PTP)-capable switch.

Work-orders for the workcell are submitted through the supervisor. Each work-order consists of a work-plan for a part, and the work-plan determines how each part moves through the workcell until it is completed. The inspection of each part is conducted at each machining station, and after the final inspection, the part is placed back into the input queue. Under normal operating conditions, the work continues until all work-orders have been processed. This continuous form of operation provides ample opportunity to collect statistically significant metrics of both the network and the operation of the workcell.

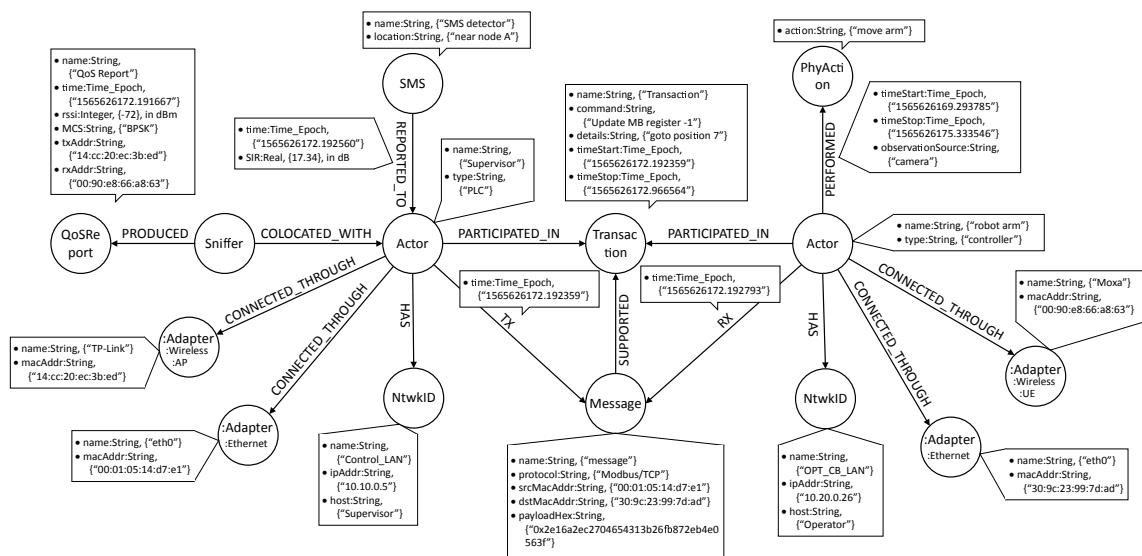

Figure 5.2: The intended schema (i.e., pseudo-schema) of the GDB used for each operational run of the NIST wireless factory testbed. The graph is organized into nodes and edges, where the edges signify relationships among network elements and physical operational elements. Note that GDBs do not have enforced schemas; therefore, it is possible that the database have data and relationships violating the intended schema. This flexibility is acceptable.

5.4.2/ DATABASE SCHEMA

GDBs are NoSQL databases such that the database does not contain any predefined structure or rules to enforce such structure. This is a major difference between relational databases and GDBs. Nevertheless, it was necessary to sketch a pseudo-schema to capture the intended nodes and relationships that would be stored within the database (the terms pseudo-schema and schema will be used interchangeably). Before describing the schema itself, it is necessary to first explain the requirements of the schema. Therefore, the requirements for the schema are as follows:

- **Time:** Any manufacturing automation system is indeed a time-varying control system with network and operational events. The database schema must necessarily support time-based queries and, specifically, time-windowed queries.
- **Operational Events:** The schema must represent operational events such as the movement of a robot arm or the movement of a part.
- **Network Events:** The schema must represent network events such as the transmission of packets.
- **Message Grouping:** The schema must support grouping of logically related events such that those events can be correlated to a specific occurrence within the testbed.

- **Wireless Support:** The schema must support the capture of both wired and wireless network traffic without special provisions within queries for either.
- **Quality of service (QoS) Support:** The schema must allow for the capture of QoS data when available.
- **Spectrum Monitoring:** The schema must support the capture and association of network events with observations from a SMS if that information is available.

5.4.2.1/ NODE DESIGN

Given the fore-mentioned requirements, a sample pseudo-schema is shown in Fig. 5.2, which represents the intended structure of the information within the GDB. It is important to remember that since GDB schemas are not really schemas, such as those found in relational databases, but representations of intent, the schema represented here should be considered a notional example of the final product. Within the graphs, nodes represent logical elements, and edges represent the relationships between those elements. Both nodes and edges may contain properties providing more description and labels that define categories or classes of the said nodes or edges. The schema is designed such that the data within the graph is intuitive to understand and allows for time-based queries to occur. The facilitation of time-based queries was an essential requirement of the database design. The schema is represented using the following node labels:

- **Actor:** A physical component within the factory workcell such as a robot, PLC, or other networked item.
- **NtwkID:** A network address item for an actor such as an IP address.
- **Transaction:** A complete information exchange between two or more actors (multiple actors may participate in a transaction).
- **Message:** A network transmission event that occurs between two actors (messages are essentially packet transmissions captured at the transport layer; multiple messages support a transaction).
- **Physical Action:** A physical occurrence within a factory workcell associated with actors through multiple time based relationships.
- **SMS:** An SMS observes and records significant spectral events within the workcell and may report those events to actors within the workcell.

- Sniffer: A measurement device that records all transmissions conducted over the wireless medium and includes wireless header information for each wireless transmission detected.
- Adapter: A device that serves to connect an actor to a network (adapters are divided into sub-categories depending on the type of interface to a network).
- Adapter:Ethernet: A subcategory of adapter representing an Ethernet interface.
- Adapter:Wireless: A subcategory of adapter representing a wireless interface.
- Adapter:Wireless:AP: A subcategory of adapter representing a wireless access point (WAP) interface.
- Adapter:Wireless:UE: A subcategory of adapter representing a wireless user equipment interface.
- QoS Report: A QoS report of a message (not all messages will have a QoS report).

It is important to note that most network infrastructure components are not captured within the graph, but, instead, only basic interfaces between actors and the network are captured. The intention when designing the graph was to make the graph network and protocol agnostic, such that the network is viewed as a black-box. Accordingly, the captured events of the physical system and the network are considered useful for the analysis of performance.

5.4.2.2/ RELATIONSHIPS (GRAPH EDGES)

Relationships are edges within the graph that capture the informational interactions between nodes. Relationships, like nodes, can contain labels and properties. As shown in Fig. 5.2, nodes are connected through defined relationships. A subset of the relationships are defined as follows:

- PARTICIPATED_IN: Actors will participate in transactions. A transaction exists for each logical set of messages between actors such as the setting of a Modbus register or the sending of a command to a robot. Therefore, actors will participate in many transactions, and multiple actors may participate in a single transaction.

- **SUPPORTED:** Messages (i.e., packets between actors) are associated with transactions through the SUPPORTED relationship. Depending on the protocol and the quality of the channel, a single transaction could have one or many messages connected through this relationship.
- **Transmit (TX)/Receive (RX):** An actor may either TX or RX a message. Both the TX and RX relationships contain a timestamp in the format of an epoch time which is a floating point number in seconds since January 1, 1970, with a resolution of microseconds.
- **PERFORMED:** When an actor performs a physical action, a relationship is created between the actor and the physical action node. This relationship contains start and stop time properties as well as the source of the observation such as a networked camera.
- **REPORTED_TO:** An SMS may be a passive or active listener within a work-cell. When an SMS operates as an active listener, spectral reports from the SMS may be sent to an actor such that the actor can respond intelligently to the spectral event. Reports from an SMS to an actor are captured within this relationship.

Other relationships shown in the schema of Fig. 5.2 but not explained above are considered self-explanatory.

5.4.2.3/ CLOSER EXAMINATION

Examining the sample schema more closely, two actor nodes are represented. In this case, Actor A is the supervisory controller, and Actor B is a robot arm. Both nodes participate in a transaction, which, in this example, is a Modbus/TCP exchange. The transaction itself is associated with one or more messages (i.e., packets). Each message associated with a transaction manifests itself as a node in the graph. Multiple message nodes will exist for each transaction. Additionally, QoS reports may be associated with each actor node through a collocated sniffer node. By keeping QoS reports separate, the flexibility of supporting different wired and wireless protocols within the same graph is maintained. Recall, that a GDB has no enforceable structure and thus affords this type of flexibility. Each actor node may have network identities associated with it through the use of network identifier nodes. Each network identifier node may contain address information such as a hardware address or a network address; however, this is dependent on the protocols and addressing schemes being used, and a node could have many different identification nodes.

5.4.2.4/ PHYSICAL ACTIONS

Finally, each actor in the graph may associate with physical actions. These actions exist in the database as automatons such that every time a new action occurs, a new edge would be added between the actor and the physical action. Timestamps within the graph represent “measurement time” denoting that all timestamps are accurately synchronized to the grand-master clock. The method of synchronization is outside the scope of this work; however, it is explained fully in [172]. This work describes the database structure and the process for preparing and inserting the data into the database, which is described in the following subsection.

5.4.3/ INFORMATION WORKFLOW

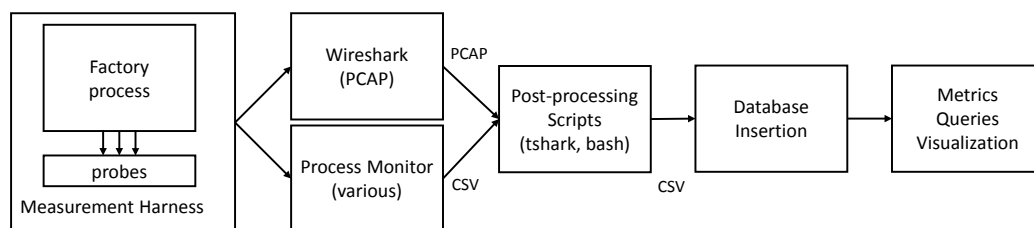

Figure 5.3: Data processing flow from factory workcell to database. The process includes data collection, data cleaning and preparation, database formation, and finally analysis through queries and visualization.

The workflow for collecting, processing, and inserting measurement data into the GDB is multi-pronged, as shown in Fig. 5.3. The workcell, which in this case study is a two-robot workcell with four CNC machines, is instrumented with network probes that capture transmitted and received packets as well as probes to capture operational movements such as arm robot position and the state of the supervisor PLC. Network data is stored in packet capture file (PCAP) files, while operational data is stored in comma-separated value (CSV) files. Bash scripts were developed to extract relevant information and prepare the data for insertion into the database. The scripts also contain rules for grouping packets together as transactions based on the application protocol and time. The scripts produce CSV files that are ready for insertion into the Neo4j database. Once the data resides within the database, queries are applied to extract information for the evaluation of workcell performance and visualization of network and operational events within the workcell. By tracking paths through the relationships within the graph, discerning how a network event such as interference is related to physical events such as position uncertainty or part throughput is possible. Various impairments may be introduced as a part of workcell operation. Examples of such impairments include competing wireless traffic, radio interference, and reflections and diffraction due to the multi-path environment [23].

It is also feasible to implement such impairments and measure the resulting physical performance manifestation [172]. This is accomplished through the use of a radio channel emulator as demonstrated in [33].

5.4.4/ SAMPLE OF A RESULTING GRAPH

In the following, this investigation shows the results from a trial run of the NIST industrial wireless testbed. In this trial run, a single physical wireless link is used between a wireless adapter connected directly to the supervisor and a WAP connected to all the other actors in the testbed. The wireless nodes represent IEEE 802.11b/g/n devices and are connected through a variable RF attenuator that allows us to vary the channel quality. During the trial run, the production of 10 parts was emulated, which resulted in approximately 10 minutes of network activity.

After populating the database with data captured from the trial run, the resulting realized schema is shown in Fig. 5.4. The schema visualization is produced by invoking the command

```
call db.schema.visualization()
```

in Neo4j. It is important to note that a realized schema shows only one representation of each node and relationship whereas the intended pseudo-schema shown in Fig. 5.2 was developed to exemplify the relationships between types of nodes, labels, and relationships. Where label inheritance is employed, such as the case for different adapter types, relationships are reproduced; however, this is a result of the visualization tool rather than the schema itself. Fig. 5.4 serves, therefore, to validate that the intended schema was indeed realized by the insertion of event data from the testbed. In the realized schema, inherited labels are shown as separate nodes.

As described in Section 5.4.2, the database includes every network transaction that occurs during the operation of the testbed. This includes any logical transaction nodes inserted into the database and any associated packets that happened to traverse the network. Therefore, for a short duration of time depending on packet transmission rates, the amount of data stored in the database can grow quickly. This presents a visualization challenge that graphs are designed to handle. A sample graph is shown in Fig. 5.5, which represents only 1 second of wired and wireless network data captured from the NIST two-robot pick-and-place wireless testbed described in [172].

This visualization is produced by calling the following query in the Neo4j.

```
MATCH p=(a:Actor {name:'Supervisor'})--(t:Transaction)--(b:
```



Figure 5.4: Realized schema of the GDB fully populated after capturing network and operational data from the NIST industrial wireless testbed. GDBs do not have enforced schemas; therefore, the schema depict represents the data as is.

```

↪ Actor) , p2=(m:Message)-->(t) WHERE t.timeStart>T AND
↪ t.timeStop<T+1
RETURN p,p2

```

The colors of the resulting nodes follow the realized schema in Fig. 5.4 while only the actors, transactions, and messages are visualized in Fig. 5.5. The relationships between the messages and transactions are shown where a single transaction is connected to at least two messages to represent the communications between any two actors. The variable T in the query represents an arbitrary time variable in seconds within the trial run to capture the data within 1 second only.

The visualization then show a more detailed visualization for all the nodes and relationships corresponding to a single transaction. It is produced by calling the following query where Ts is an arbitrary time variable to specify the timeStart value for the single transaction.

```

MATCH p=(a:Actor {name:'Supervisor'})-->(t:Transaction {
  ↪ timeStart:Ts})<--(b:Actor {name:"CNC-1"})
WITH p, a, b, t
MATCH p1=(a)-->(m:Message)<--(b), p2=(m)-->(t), p3=(a)-[:

```

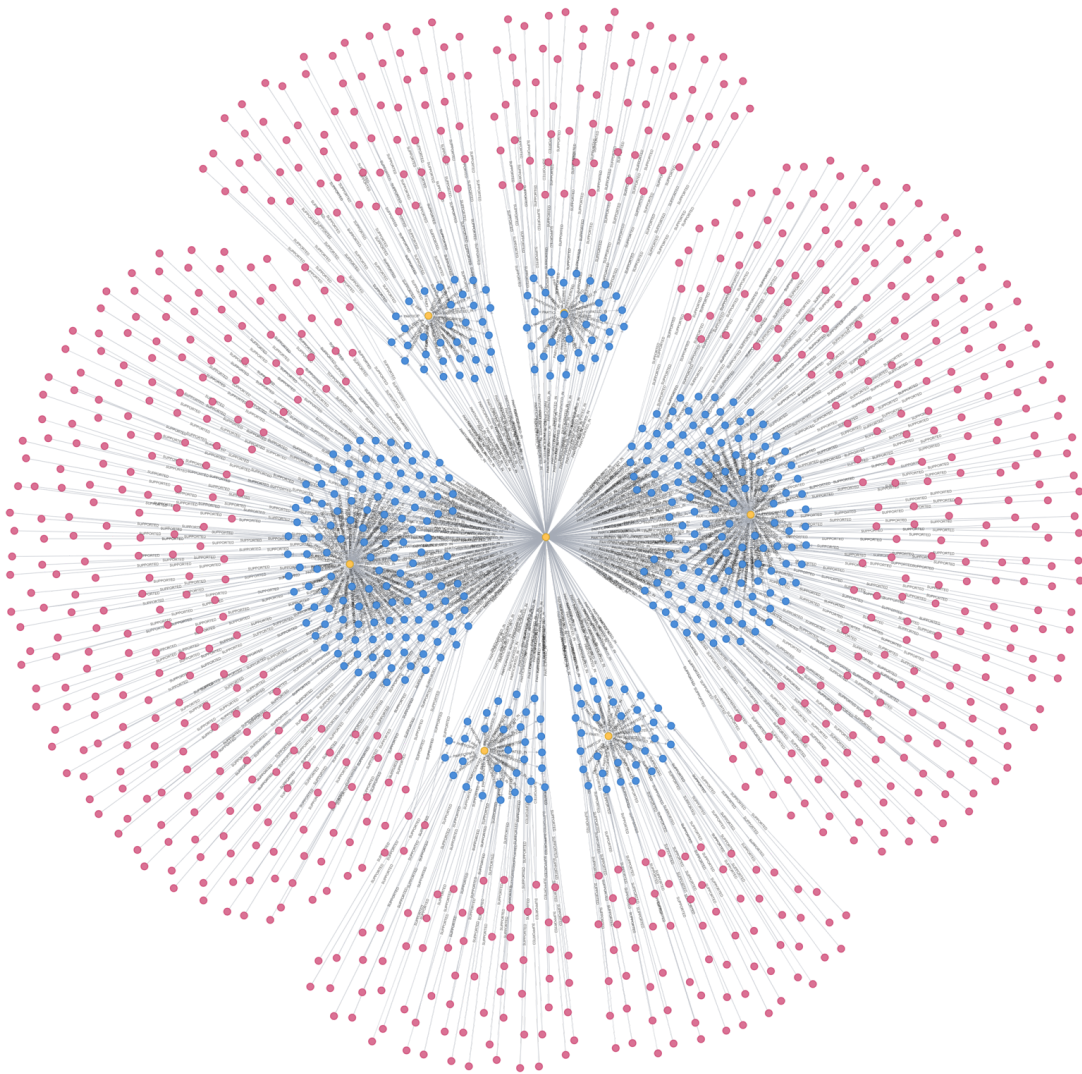

Figure 5.5: Visualization of a node graph resulting from a testbed experiment.

```

↪ HAS]-(), p4=(a) <-[:COLOCATED_WITH]-()-[:PRODUCED]->(q:
↪ QoSReport), p5=(a)-[:CONNECTED_THROUGH]-(), p6=(b)-[:
↪ HAS]-(), p7=(b)-[:CONNECTED_THROUGH]-()
WHERE q.time>t.timeStart AND q.time<t.timeStop
RETURN p,p1,p2,p3,p4,p5,p6,p7

```

In Fig. 5.6, the actor nodes are labeled by their names CNC-1 and Supervisor, the transaction is labeled by its type ADS, the messages are labeled by their transmission role Request and Response, the NtwkIDs are labeled by their IP addresses, the Ethernet adapters are labeled by their names eth0, the wireless adapters are labeled by their names Moxa and TP-Link, the sniffer is labeled by its name WLS1, and the QoS reports are labeled by the received signal strength indicator (RSSI) value in dBm. This visualization includes only the QoS reports

generated within the duration of the corresponding transaction.

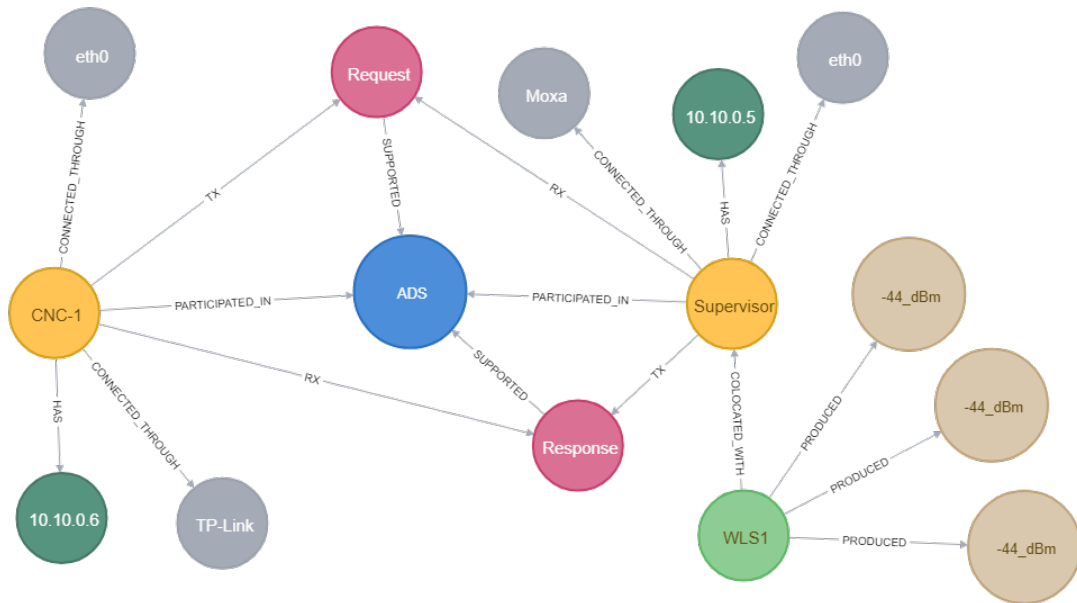

Figure 5.6: A detailed visualization resulting from a testbed experiment for all the nodes and relationships corresponding to a single transaction. A single transaction may contain several messages, associated actors, and LQE reports. Work performed in [32] extends this graph to include the associated GPS events.

5.4.5/ CALCULATION OF METRICS

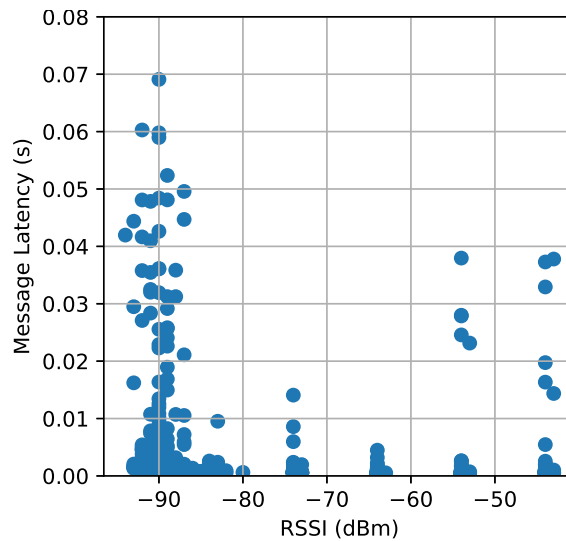

Figure 5.7: Correlation between the message latency and the RSSI values by the sniffer. Extracting LQE estimations for messages and transaction is made easier by using the GDB.

An example of deploying the proposed GDB approach in industrial wireless analysis is now presented. During the trial run time, an RF attenuator value is varied

for the single wireless link. The attenuation can take the values $\{0, 10, 20, 30, 40, 50, 60\}$ dB. Message latency is evaluated as the difference between the receive and transmit times of a message including transmission, processing, and retransmission times. Each message has been coupled to a QoS report that is the one reported at the closest time instant before the message transmit time. One of the parameters in the QoS report is the RSSI value captured by the Sniffer colocated with the supervisor's wireless adapter.

In Fig. 5.7, a scatter plot is presented showing the correlation between the message latency in seconds to the measured RSSI values by the sniffer in dBm. The figure shows that the latency is higher at the lower RSSI values due to the increased number of retransmissions. Generally, an IEEE 802.11 transmission can occur using different IEEE 802.11 mode and modulation and coding scheme (MCS) based on the channel quality. At the RSSI of -90 dBm, the receiver should operate at the most robust communications mode and the lowest MCS index. However, retransmissions still occur due to having the received power near the sensitivity of the supervisor's wireless adapter. As shown in Fig. 5.7, retransmissions may occur at other RSSI values as well when the transmitter selects a higher mode of transmission and a higher MCS index. In this case, it is asserted that the receiver is operating close to the marginal sensitivity for a given mode (e.g., 802.11n) and MCS index. It is observed that the transmitter switches to a lower MCS index for the retransmitted messages, which supports the supposition. Therefore, latency can in fact be high for better RSSI values. This effect is illustrated in Fig. 5.7 where certain messages can have latency values at -43 dBm, which are comparable to those in the case of -90 dBm.

5.5/ CASE STUDY ELABORATED: ROBOTIC MACHINE-TENDING

In this section, we present a two-robot machine tending workcell case study as an elaboration of the previous study. The two case studies are almost identical; however, they were conducted sequentially as separate investigations. In this study, the design of the workcell, measurement system, and equipment used are presented along with the additional information within the results discussion.

5.5.1/ WORKCELL PHYSICAL IMPLEMENTATION AND MEASUREMENTS

A workcell was constructed to perform a dual robot pick-and-place task that is controlled by a supervisor programmable logic controller (PLC). The robots have six degrees-of-freedom which utilize Modbus/TCP communication messages to receive

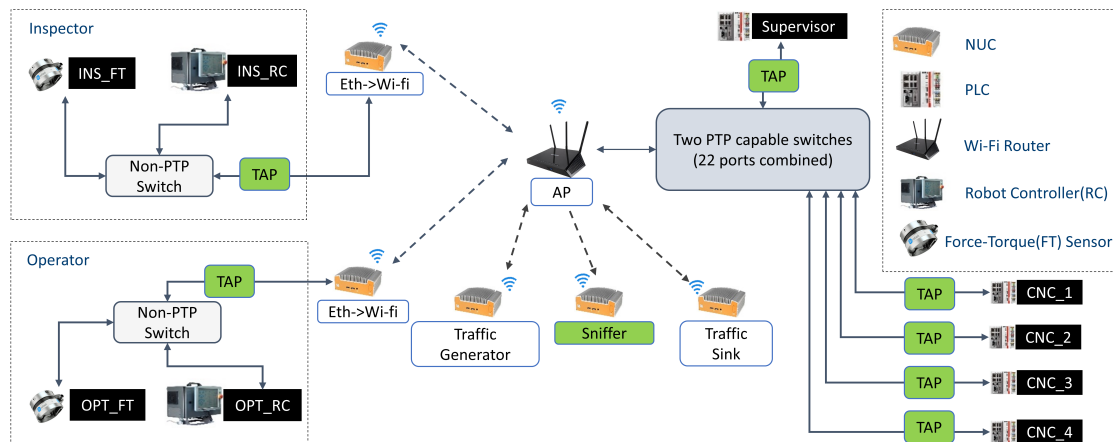

Figure 5.8: Network diagram of the industrial wireless testbed at NIST. Solid lines represent Ethernet based communications and dashed lines represent wireless based communications.

and then execute assigned tasks from the supervisor PLC. There are also four emulated computer numerical control (CNC) machines that detect the physical state of the testbed with proximity sensors. The workflow of the pick and place task involves the Operator moving parts from the queue ramp to each of the emulated CNC machines and back to the queue ramp. Between the Operator movements, the Inspector performs a force seeking action to detect if the part is in the correct location before the Operator proceeds. More details on the exact workflow and a photograph of the testbed can be found in [172].

All communicating devices on the testbed have been originally designed to use Ethernet TCP/IP for communication. To enable wireless within the testbed, Ethernet-WiFi bridges are utilized for wireless communications through a common access point (AP). To establish these Ethernet-WiFi bridges, Next-line-of-Computing (NUC) computers, are used. NUCs are a line of small-form-factor bare-bone computer kits designed by Intel. Each NUC in our experiments is configured in one of various forms as a bridge, a wireless sniffer, a traffic generator, or a traffic sink. These configurations in the network are shown in Fig. 5.8.

There are three different types of measurements (network, robot, and PLC state data) collected on the testbed. Network traffic data is captured using seven test access point (TAP) devices and a wireless sniffer, shown in Fig. 5.8 with green labels. A machine running Ubuntu 18.04, not shown, is used to capture all wired network traffic on the testbed. The position and robot state data is captured from the robot controllers using the real-time data exchange (RTDE) protocol [173]. RTDE data is also captured on the Linux machine using the connected switches to each of the robot controllers. Lastly, the PLC state data is captured locally on the supervisor

PLC during the experiment. These three types of measurements (network, robot, and PLC state data) have a shared precise time from the synchronization to the grand master time server. The design adopts the IEEE 1588 PTP to allow synchronized distributed clocks to stamp the accurate time to the measured network and operational events in the testbed [174].

5.5.2/ EQUIPMENT USED

The following equipment are illustrated in Fig. 5.8 for reference. To enable wireless on the testbed, Intel NUCs running Ubuntu 14.04 are used which communicate through a common AP. The AP is a Netgear AC1900 wireless router. For the wired communications, we use two Cisco IE 4000 industrial grade Ethernet switches that are PTP compatible for time synchronization. The collaborative robots that perform the pick and place task are Universal Robots “UR3” CB series. The robots are also equipped with OnRobot HEX-H Force/Torque sensors which are used by the Inspector to inspect parts. The Supervisor PLC is a Beckhoff CX2020 with a EL6688 PTP module for time synchronization. The CNC simulators are Beckhoff CX9020 PLCs. The seven TAP devices on the testbed are SharkTap Gigabit Network Sniffers. To synchronize the timing of the devices while taking measurements, a Meinberg Lantime M900 grand master time server is used. Lastly, the Operator and Inspector each use a D-link DGS-108 8-port unmanaged Ethernet switch for wired communications between the robot controller and force-torque sensor and for the Linux machine to collect RTDE data through a wired connection.

5.5.3/ BUILDING THE GRAPH

A GDB was built to manage data collected from testbed measurements of both network traffic and physical operations. In this section, we briefly introduce graph components developed for our testbed and the data processing flow that transforms measurement results to graph entities.

5.5.3.1/ REFERENCE DATA MODEL

In the previous case study, we identified the requirements of a GDB data model and built a graph containing nodes and relationships that mainly exhibit information around networked industrial devices in a factory workcell. In this continuation of the work, we further populate the earlier defined workcell data graph by introducing additional node types characterizing physical actions that are newly captured.

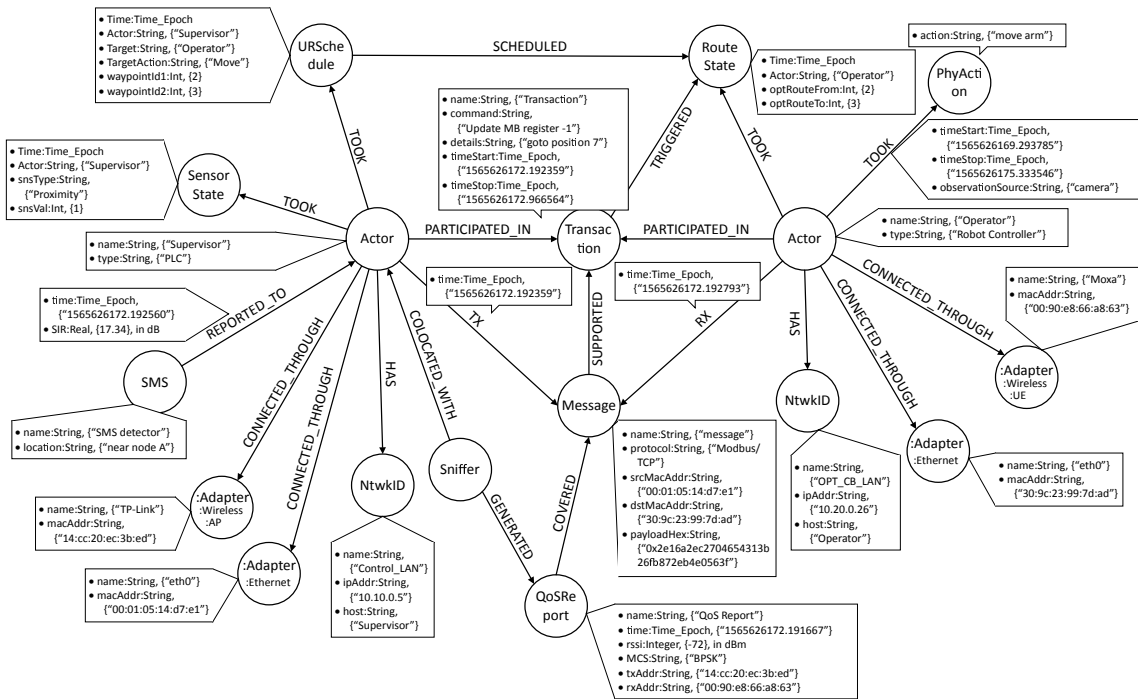

Figure 5.9: The data model of the graph database used for each operational run of the NIST wireless factory testbed. The graph is organized into nodes and edges, where the edges signify relationships among network elements and physical operational elements. This graph was extended from the work in [31] to include better integration of physical events occurring within the CPS.

Accordingly, we update the relationships, such as associating individual quality of service (QoS) report data from the wireless sniffer with the packets captured at the collocated receiver. The updated data model provides a comprehensive view of production operations, information flows, and wireless channel variations in the testbed which facilitates further analysis work.

As shown in Fig. 5.9, an example is illustrated here that summarizes nodes, relationships, and their key properties used in the GDB. We will elaborate the definition and use of these entities in the remainder of this section.

Node Design Nodes are GDB elements that are used to identify testbed components, device states, and messages that store snapshots of the testbed for further analysis. They can be found in two main classes depending on what type of objects the node represents.

The class of static nodes covers testbed setup profiles which contain testbed components, network interfaces, and their settings. These entities are normally predetermined or collected in the initialization of each measurement. They usually remain constant in each round of measurements. This class includes Actor, Network

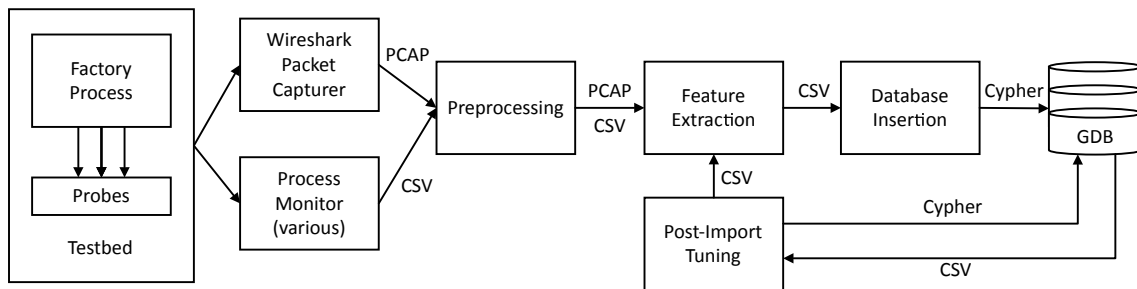

Figure 5.10: Data processing flow from factory workcell to database. Improvements to feature extraction were made to

ID (NtwkID), Spectrum Management System (SMS), Sniffer, and Adapter in the GDB. The Adapter nodes can further have additional labels to identify their network interfaces and the roles they play, such as Ethernet/Wireless and AP/user equipment (UE).

The class of dynamic nodes in the graph captures various system events such as machine status reports, network traffic, and information flows in the testbed. These nodes are dynamically added into the graph whose quantities and properties are determined by the measured data. Such node labels include Transaction, Message, QoSReport, and Physical Action (PhyAction). Considering the diversity of measured testbed operations, PhyAction nodes have sub-class labels including URSchedule (for the Supervisor), SensorState (for CNC), and RouteState (for robots).

Graph Relationships A relationship in the graph denotes an action taken to associate two nodes, either homogeneous or heterogeneous ones, which shows their connections in the topology, timeline, or affiliation. The relationships used in the GDB were introduced in [31]. As shown in Fig. 5.9, most of them are self-explanatory.

Closer Examination The graph data model is designed in a way where nodes and relationships are centered around Actors. Actors have dual roles in the workcell operations. In the factory system, Actors participate in the production operations. In the example of Fig. 5.9, two Actor nodes are presented. In this case, Actor “Supervisor” is the supervisory controller, and Actor “Operator” is a robot arm. The Supervisor schedules the production, collects the other Actors’ states, and hosts supportive services, such as SMS. The Operator follows the instructions of the Supervisor and moves parts between work stations. Meanwhile, Actors also act as communication nodes which exchange messages between each other through various network interfaces. In Fig. 5.9, Actors participate in a transaction, which, in this example, is a Modbus/TCP exchange. The transaction itself is associated with one or

more messages (i.e., packets). Each message associated with a transaction manifests itself as a node in the graph. Multiple message nodes will exist for each transaction. Additionally, QoS reports may be associated with each actor node through a collocated sniffer node.

Dynamic event nodes in the measurement, i.e., physical actions, network messages, information transactions, and QoSReport records, have timestamps representing “measurement time” of the recorded events. Once a new event occurs, a proper relationship would be added between the actor and the physical/network event node. All timestamps are accurately synchronized to the grand-master clock.

5.5.3.2/ INFORMATION WORKFLOW

A multi-stage workflow is deployed to feed the graph with instances of nodes, relationships, and their properties that are extracted from measurement data, as shown in Fig. 5.10. In the measurement data set, network data from distributed network probes in selected links is stored in PCAP files, while operational data that comes from different PLC and robot controllers is stored in the format of CSV files. The whole process contains four steps including data preprocessing, feature extraction, database insertion, and post-import tuning. Such conversion from raw data to the ready-to-go graph has been done by running automated scripts on a host machine which maintains data repositories of measurement results and deploys the Neo4j desktop application. The functions and operation features in individual steps are discussed next.

Data Preprocessing Data preprocessing is the first step where measurement data is verified, cleaned, and formatted to facilitate the following processing steps. As fore-mentioned, measurement data contains results collected from heterogeneous modules/devices in the testbed which may adopt different data types, sampling rates, time and metric resolution, and file formats. For example, different machines may represent and store the record timestamps in various formats depending on local clock settings. Once we obtained the data, we unified the time representation in the entire data set using the time epoch that has microsecond resolution. In another example, we deployed packet filters to remove unrelated packet captures. In treating measurement data, e.g., experimenting with single or double wireless interference links, we managed to reduce the sniffer data in the order of gigabytes to only a few megabytes while keeping all signaling handshakes of interest in the studied links.

Feature Extraction Feature extraction refers to the process of extracting relevant information from measurement data and prepare the data for insertion into the database. Nodes and relationships are defined by a set of features that share common views. We developed bash and Python scripts that pick the desired features to produce CSV files that are ready for insertion into the Neo4j database. In this step, a bash script was developed running the tshark tool to extract fields of protocol headers in packet captures and save the field information into CSV files. Each line in these CSV records will create one Message node instance as a sender or receiver copy of the packet through a link. A Python script was also used to detect state switches in the physical action data and label these moments which were triggered by testbed communications.

Graph Insertion We load the prepared data into the Neo4j GDB using bulk importing which can create one or multiple nodes and/or relationships in the graph by reading a CSV file once. Neo4j uses Cypher to construct GDB queries to import data. As the output of feature extraction, each line of the CSV file can create one new node entity and/or generate the criteria of linking two qualified nodes for a new relationship. Properties of new entities can be assigned explicitly by the column values of records or inferred from predetermined rules such as some fixed combination of nodes and edges in the graph. Multiple types of nodes can be created from the same data file using one common node template in which each node type has its own subgroup of properties. For example, Modbus and ADS packets use the same Message node structure in our graph to manage the common transmission information such as IP addresses and TCP session identification. Meanwhile, each of these Messages maintains its own application layer header information in the node properties, e.g., Modbus register addresses and ADS function codes.

Post-Import Tuning Post-import tuning refers to any additional modification in the graph after CSV data is imported. This step treats a few cases where raw data work with current graph insights to obtain new ones. First, in the additive insertion case, i.e., when new data is added into the graph, it links the newly added nodes to the existing ones following necessary relationships between them. Time series data often use this method to link consecutive event nodes in the recorded process. Second, it is the case in which higher level features are needed in the graph which can be abstracted from the imported data. For example, Transaction nodes are built upon Message nodes who participate in the same application transactions; Message nodes themselves are also the summary of packet data, i.e., packet copies at link transceivers. Third, it can feed feature extraction with pieces of information in the current graph for purposes such as coupling data records. For example, coupling



Figure 5.11: Realized schema of the graph database fully populated after capturing network and operational data from the NIST industrial wireless testbed. The realized schema matches the intended schema. Using the database, it is now possible to correlate IWN performance to physical events of the CPS, such as the location of material, through simple database queries.

QoS reports and Messages in their observation windows used to be an extremely time-consuming process. On one hand, each Message raw data, i.e., the transmitter or receiver copy, contains only half of the transmission time window information. On the other hand, the Cypher query takes a long time to find all eligible relationships as Neo4j would generate a huge Cartesian product when treating the large sample set. We solved this issue by obtaining qualified Message nodes and feeding them into feature extraction where a more efficient Python script finds all Message-QoS Report pairs and later presents them in the graph as new COVERED relationships.

The above four steps can perform multiple iterations to treat data and refine the graph according to the data complexity and requirements.

5.5.4/ RESULTS

Once the data resides within the database, we apply queries to extract information for the evaluation of workcell performance and visualization of network and operational events within the workcell. By tracking paths through the relationships

within the graph, discerning how a network event such as interference relates to physical events such as position uncertainty or part throughput is possible. Various impairments may be introduced as a part of workcell operation. Examples of such impairments include competing wireless traffic, radio interference, and reflections and diffraction due to the multi-path environment [23]. We have shown that it is feasible to implement such impairments and measure the resulting physical performance manifestation [172].

In the following, we show results from an experimental scenario of the NIST industrial wireless testbed. In this scenario, two wireless links are used to connect the robot controllers and the wireless AP that is connected to all the other actors in the testbed. The wireless nodes are IEEE 802.11b/g/n devices. During each run of this experimental scenario, the production of 20 parts was emulated, which resulted in 12 minutes of network activity. We performed 4 different experimental cases with respect to the communications network, namely, 1) wired baseline where all links are connected using Ethernet cables to act as a benchmark for performance comparison, 2) wireless baseline where the robots traffic is the only traffic transferred over the wireless network, 3) with 2500 packets per second (pps) wireless traffic where a pair of a source and a sink operate simultaneously with the robots traffic over the wireless network, and 4) with 2x1250 pps traffic where two communications pairs of a source and a sink that each source generates 1250 pps traffic simultaneously with the robots traffic. These external traffic pairs have packet size of 1000 Bytes.

5.5.4.1/ REALIZED SCHEMA

After populating the database with data captured from the experiment runs, the resulting realized schema is shown in Fig. 5.11. The schema visualization is produced by invoking the command

```
call db.schema.visualization()
```

in Neo4j. It is important to note that, in comparison to the data model shown in Fig. 5.9, a realized schema shows only one representation of each node and relationship. Where label inheritance is employed, such as the case for different adapter types, relationships are reproduced; however, this is a result of the visualization tool rather than the schema itself. Fig. 5.11 serves, therefore, to validate that the intended data model was indeed realized by the insertion of event data from the testbed. In the realized schema, inherited labels are shown as separate nodes.

5.5.4.2/ PHYSICAL ACTIONS PROCESSING

In this subsection, we use the extracted data from the GDB to study the impact of the wireless communications on the physical action performance. We focus our analysis in this subsection on the URSchedule and RouteState progress over time where URSchedule is the dynamic node to represent a physical action decision at the supervisor and RouteState is the dynamic node to represent a physical action command received by one of the robots where the command parameters are stored at the robot registers. Note here that the transaction between a robot controller and the supervisor is initiated by a request message from the robot controller and terminated by correctly receiving a response message from the supervisor to the robot controller as well.

The Supervisor takes decisions based on available information about the testbed. Once it makes a decision, it is reflected on the value of the URSchedule. We define the Supervisor processing time as the time from the instant the decision is taken to the instant when the wireless transaction is initiated to request a new physical action and it is denoted by T_{Sup} . Then, the transaction latency is the time between the instant the wireless transaction is initiated by the robot to require a new action till it is the data is received at the intended robot controller and it is denoted by T_{W} . The robot processing time is the time between the instant the wireless data is received by the robot to the instant where the RouteState register is updated to reflect the required action and hence the physical action starts. The robot processing time is denoted by T_{Rob} . The total physical action time which represents the time needed for a supervisor command to be reflected at the corresponding robot is denoted by T_{Act} and evaluated through

$$T_{\text{Act}} = T_{\text{Sup}} + T_{\text{W}} + T_{\text{Rob}}. \quad (5.1)$$

In Fig. 5.12, we present the values of the three components of the action processing time for each run of the testbed. The horizontal axis represents the action index for all the Operator and Inspector actions while the corresponding time components are shown in the vertical figure axis.

The wired baseline performance is presented in Fig. 5.12a where the transaction latency has very low variance (i.e., better determinism). Once a wireless network is introduced in Fig. 5.12b-5.12e, more randomness in the transaction latency is introduced. Adding the coexisting interference increases the randomness in the transaction latency as shown. We can also notice that when a wireless transaction has a higher latency, the corresponding value of the robot response time is lowered such that the sum of $T_{\text{W}} + T_{\text{Rob}}$ has almost a fixed value. This value repre-

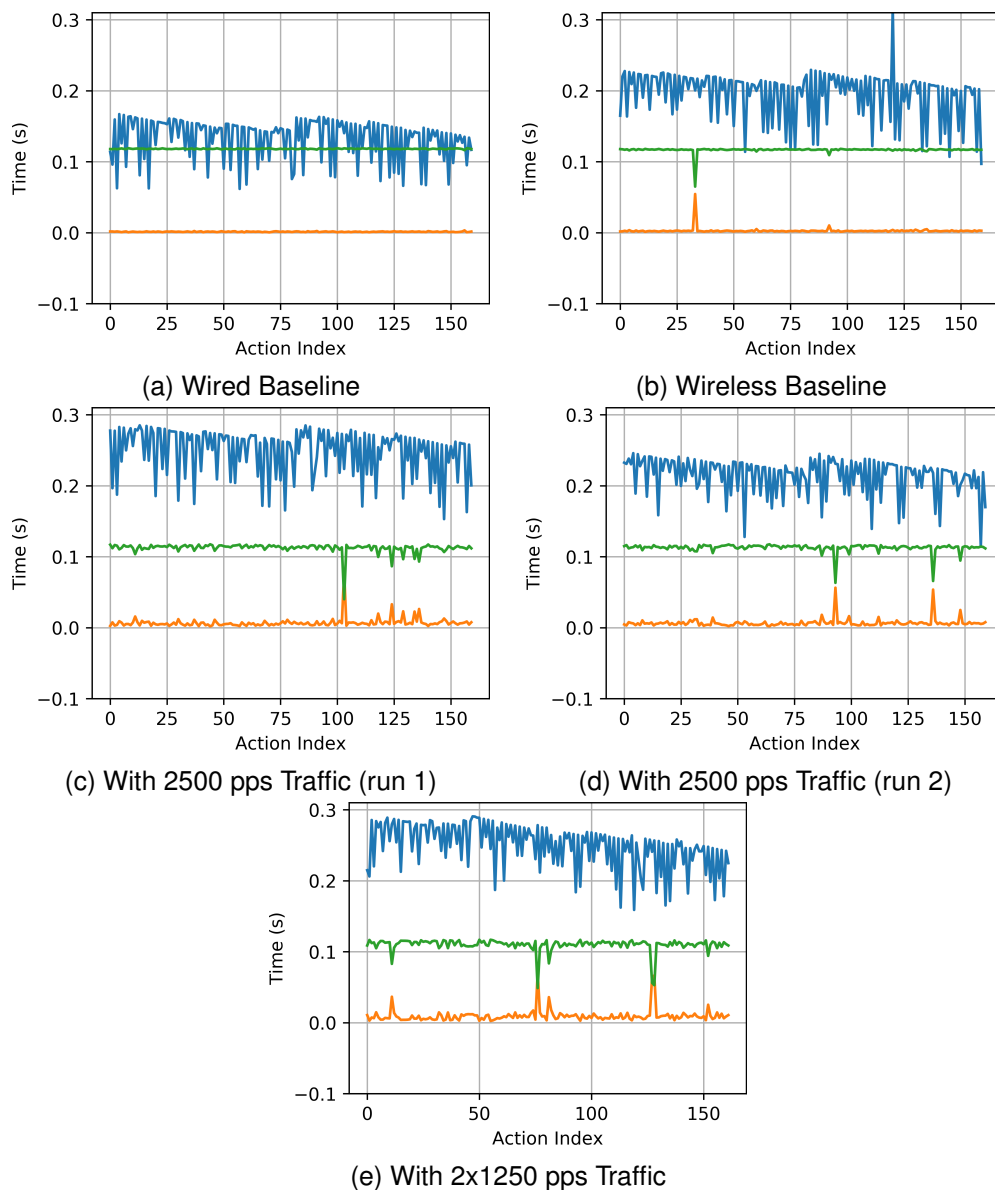

Figure 5.12: Components of the Physical Action Time for Various Experimental Scenarios. Performance metrics for the wired baseline measurements are shown in (a). Performance for a wireless baseline is shown in (b). Varying levels of competing wireless traffic are then introduced in the subsequent graphs. The supervisor PLC processing time in blue appears unchanged by the IWN latencies. The transaction latency in orange is clearly impacted by the wireless channel; however, the robot controller shown in green appears to compensate for transaction latency variance such that the sum of transaction latency and robot processing time remains constant. This indicates that wireless should be a good candidate for this control system as physical latencies do not increase under these scenarios.

sents the time needed for one loop through the robot script to scan various registers and initiate the corresponding actions which equals almost 120 ms. In a single loop both the transaction is initiated and the RouteState is updated. Hence in this use case, if the wireless transaction latency value is lower than the robot loop time, the physical action processing time will not be impacted by the wireless transaction latency. On the other hand, most of the randomness in the action processing time results from the supervisor processing time. We also notice that the randomness in the supervisor processing time is not impacted by the wireless channel where multiple runs of the same wireless case with the same interfering traffic have completely different supervisor processing time performance as shown in Fig. 5.12c and 5.12d.

5.5.4.3/ STOCHASTIC DISTRIBUTION OF ACTION PROCESSING TIME

In this subsection, we present the normalized histograms of the transaction latency and the total physical action time in Fig. 5.13 and 5.14, respectively. In Fig. 5.13, we notice the clear impact of the communication channel and interference on the histogram of the transaction latency where the mean and the variance are clearly impacted by the wireless parameters. On the other hand, the total physical action time is not impacted directly by the communications channel in this use case due to the fact that the robot processing loop compensate of any transaction latency below the loop time of 120 ms.

5.6/ FUTURE DIRECTION

A general architecture of a performance evaluation database has been presented. Future work will include developing query algorithms for the calculation of performance metrics as well as correlation of network events to the physical performance of the manufacturing system. Algorithms will be developed to indicate locations in time of lost information making more direct performance correlations possible. Beyond performance evaluation of the manufacturing system, the GDB approach may enable anomaly detection because relationships within the data are intrinsically stored and thus efficiently queried. The structure of the information is important within a graph database, and defining the relationships such that the paths through nodes may be discovered is essential to efficient queries and discovery of hidden correlations. Therefore, more research will be done in the modification of the presented schema. Machine learning will be applied for the detection of anomalies, performance degradation, signal quality, and network performance enhancement through more efficient resource allocation. Future plans also include online database insertions to enable the demonstration of online operation of the database. It is also possible to examine

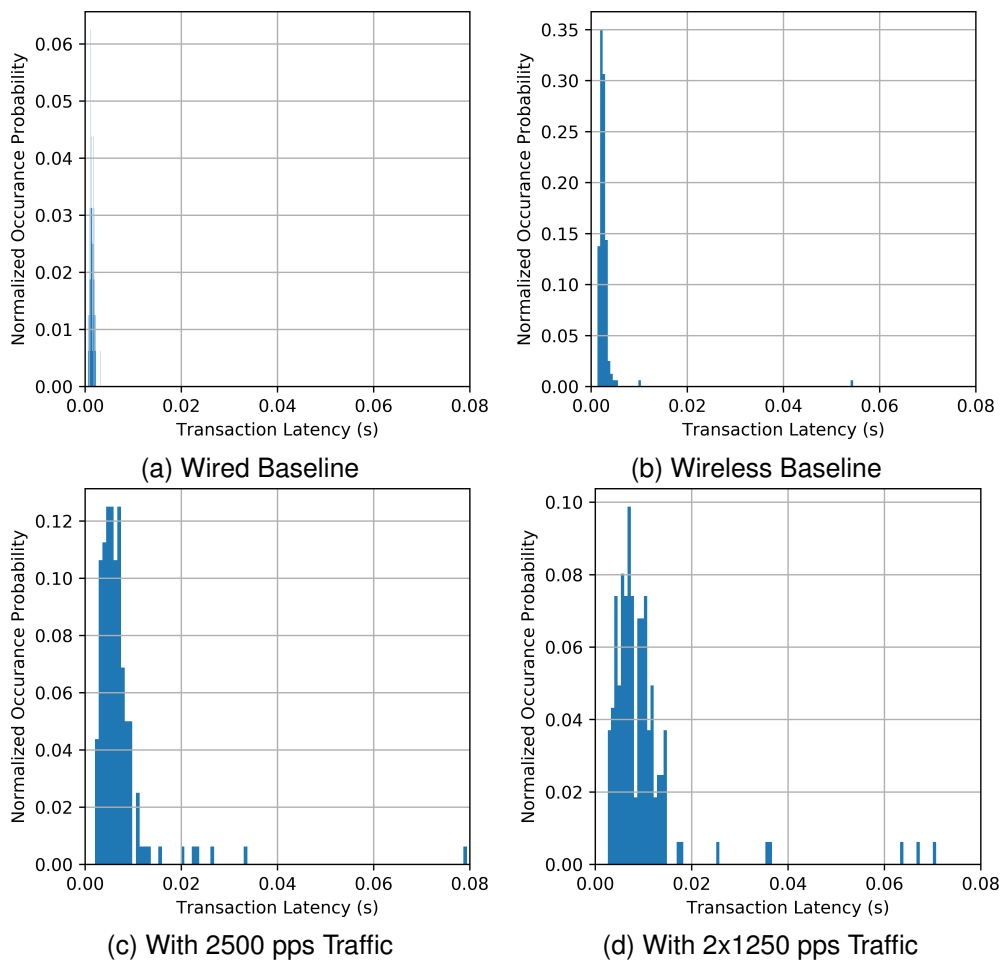

Figure 5.13: Histograms of Transaction Latency for Various Experimental Scenarios. Transaction latency is shown to increase as more competing wireless traffic is introduced.

the development of better control system strategies that mitigate network losses and delays. Since this approach is indifferent to the communications protocols used, it is intended to extend the database approach to include various protocols, radio bands such as millimeter wave bands for 5G communications, and different use cases to include mobile robotic platforms and safety critical systems.

5.7/ CONCLUSIONS

In this chapter, a novel approach was presented for capturing network and operational event information from a factory workcell with the purposes of 1) capturing and storing network and operational events, 2) calculating performance metrics of the network, and 3) discovering performance dependencies between the network and the physical assembly of the workcell. Using a GDB, we have demonstrated that it is possible to construct such a database, compute network performance metrics and

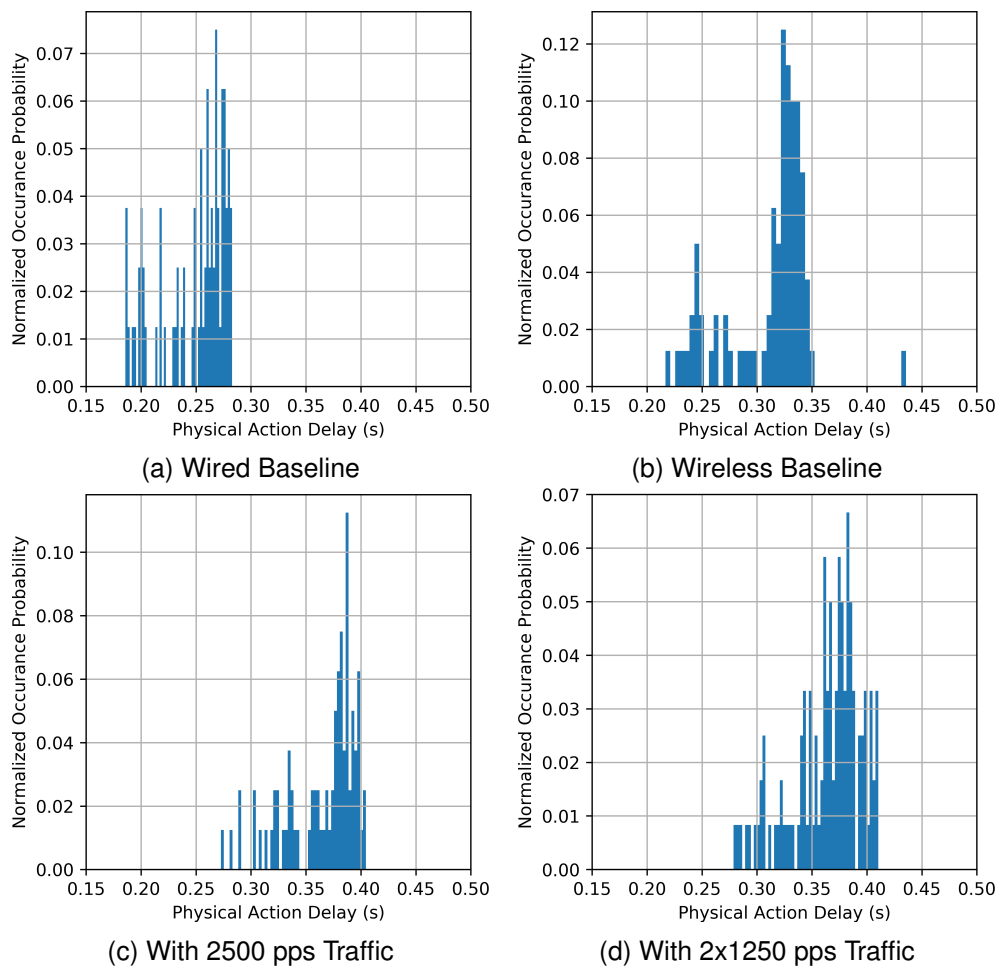

Figure 5.14: Histograms of Action Processing Time for Various Experimental Scenarios. Physical action latency of the CPS is shown to increase as more competing wireless traffic is introduced. An educated decision can then be made using this data to determine if the increased physical action delay is acceptable.

discover correlations. We have also developed the capability of examining the correlation between network events and the performance of physical actions. We have tested this approach in an emulated robotic manufacturing factory workcell that has two collaborative grade robot arms for a pick-and-place task. We have shown that wireless transaction latency has a minimal impact on the physical actions processing time in this use case. This behavior is expected to occur in many similar use cases in which the physical action is performed after a loop scan for the action triggering parameters.

MACHINE LEARNING APPLICATION: FORCE SEEKING SYSTEM

Wireless communications plays an essential role in the vision of future CPSs which includes having more sensors and actuators, and, hence, more information transferred wirelessly. Many system and environmental features of industrial CPSs affect the success of wireless communications on the factory floor. In this chapter, we consider a representative industrial CPS use case of a robot arm control system equipped with a force-torque sensor. Movement of the arm is controlled by a robot controller applying a downward pressure on a spring assembly until a predetermined force is detected. This movement of the robot arm is tracked by a vision-based ground truth measurement system. This remote observer provides readings about the position of the robot arm where these readings are used to estimate the SIR of the wireless link. By using readings from the remote observer, an estimation system is developed using machine learning regression techniques. This work demonstrates the practicality of combining statistical analysis with machine learning to indirectly estimate SIR of the wireless communication link using measurements from the remote observer. Results from the statistical analysis and the performance of the machine learning system are presented. A supervised machine learning (ML) approach is used for the wireless channel quality estimation. the impact of selected system features on the estimation performance of various ML algorithms and compare their performance is studied. Moreover, we investigate the impact of the training and the estimation period on the performance of the proposed approach. The results provide insights about the impact of wireless communications on CPSs and an example of employing machine learning to improve industrial wireless deployments.

6.1/ INTRODUCTION

IWSs are being deployed in various industrial environments due to the advances of wireless protocols and devices for CPSs. Application domains for IWSs include flexible manufacturing, safety, process control, alerting and monitoring [22]. The advantages of deploying wireless communications in industrial applications due to the absence of cabling include ease of scale, flexibility, and lower cost compared the wired counterpart. Nevertheless, there are challenges in wireless deployments [175–177]. The main cause of these challenges is the unpredictable and random nature of wireless channels. Challenges include latency uncertainty, error uncertainty, and increased information loss when operating in the presence of significant interference and limited spectral resources [178]. In addition, the quality of wireless data communications is impacted by various wireless channel impairments such as path loss, fading, multi-path, and interference. As a result, a careful design of wireless communications and control networks is required to deal with these impairments [179, 180].

One of the major challenges in designing IWSs and the underlying industrial systems is interference detection and mitigation. Interference can result from various narrow-band or wide-band sources including coexisting wireless systems, intentional jamming sources, and non-communications intended devices such as industrial equipment and microwave ovens [181]. Interference can degrade the communication QoS significantly and hence IWS designers consider various interference management techniques.

First, in this work, we present a method using random forest regression to estimate the SIR ratio of the communication channel within a robotic arm force-seeking scenario in which the force signal is transmitted over a Wireless Local Area Network (WLAN) [182]. Position data from a vision-based tracking system, a distant observer, is used to train a channel quality estimator to infer the SIR of the wireless channel. The experiment is designed so that the small perturbations in the wireless channel resulting from interference will present position uncertainty in the physical system. Next, the same testbed setup is deployed to explore, in more detail, the impact of machine learning on the performance of the detection algorithm. It is also endeavored to understand the impact of various features in the training data set. Hence, position data is used from a vision-based tracking system, a distant observer, to train a channel quality estimator to infer the SIR experienced by both the WAP and the wireless station used within the experiment. Five different features are extracted from the position data captured by the vision system.

The contributions of this chapter are summarized as follows:

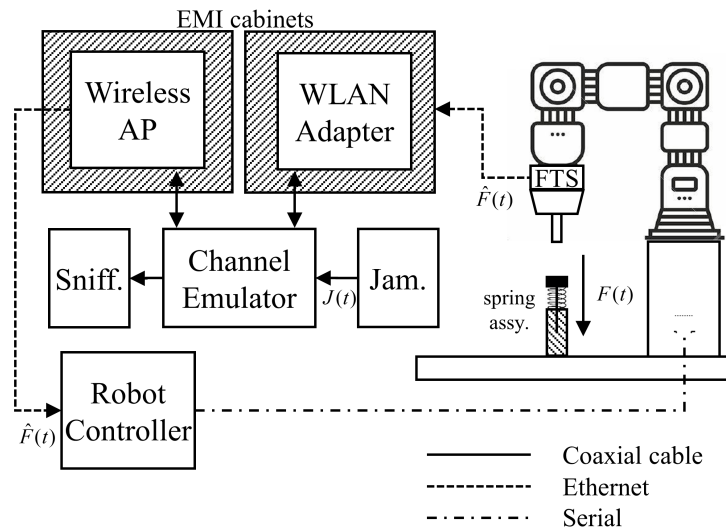

Figure 6.1: Robot force-seeking spring system with controlled wireless channel emulation and interference injection.

- The work explains in detail the proposed algorithm for SIR estimation, the testbed setup, and the features extracted from the position data. Results of the algorithm are presented demonstrating the effectiveness of the machine learning algorithm.
- Various machine learning regression schemes are compared for SIR estimation, thereby demonstrating the superior performance of various ensemble-based approaches.
- Impact of individual features are studied regarding the performance of the proposed algorithm to understand the correlation between the interference level to each of these features. Hence, the correlation between physical systems behavior and the underlying quality of the wireless communications channel is better understood.
- Finally, an analysis on the impacts of measurement interval and the training set size on the performance of the ML algorithms is provided.

6.2/ ROBOT ARM FORCE-SEEKING APPLICATION

6.2.1/ GENERAL CONSTRUCTION AND OPERATION

A robotic force-seeking apparatus is constructed using a Universal Robots UR-3 collaborative robot. As illustrated in Fig. 6.1, the robot is fitted with a six DOF FTS followed by a probe. The robot is programmed to apply a downward force,

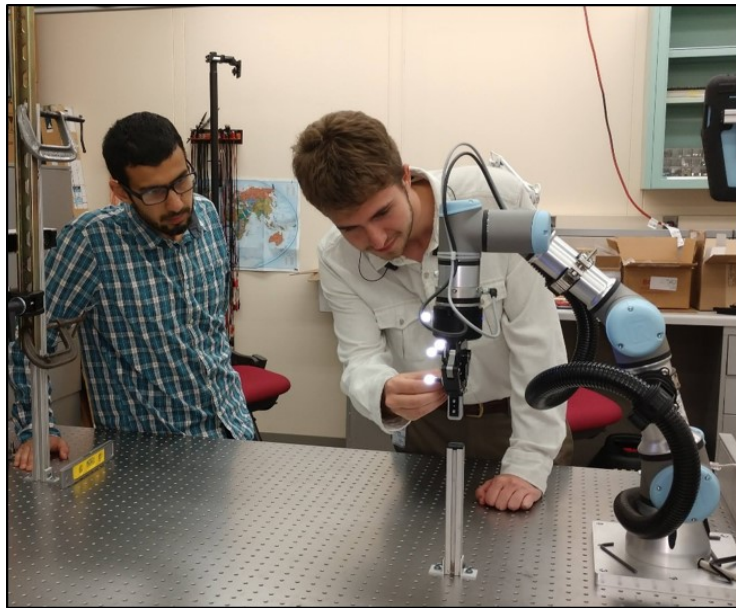

Figure 6.2: A photograph of the robot force-seeking experiment shows the robotic arm, the spring-based plunger, and the visual markers used for position tracking. The glowing points of light are the reflective tracking spheres used by the vision tracking system to produce the ground-truth measurements of the REEF position.

$F(t)$, in the z direction until a force exceeding a threshold, F_t , is reported to the controller. The robot encounters the force threshold through a fixed plunger-spring assembly. The force in the spring is governed by the equation $F(t) = kl$ where k is the spring constant and l is the spring deflection. The robot will push the spring downward repeatedly for the duration of 30 minutes. Plunger movement is limited by a hard stop which will reset the height of the robot arm. A photograph of the force-seeking apparatus is shown in Fig. 6.2. The illuminated spheres shown in the photo are infrared markers used by the remote observer to track the position of the probe.

6.2.2/ COMPONENTS

Referring again to Fig. 6.1, the system is composed of the following components:

- Robot: The robotic arm applies a downward force along the z -axis to the plunger-spring assembly. The robot is a 6-DOF rigid body manipulator in which all joints have a full 360 degrees of motion. For the experiment, the robot is configured such that it would replicate the action of a robot applying a force to push a small part into place within an automotive assembly work-cell [183]. The robot is mounted on a motionless optics table in which mechanical vibration is dampened.

- Robot Controller: The RC provides the motion control function of all joints on the robot. The RC is responsible for controlling motion while searching for a force feedback signal.
- Force Torque Sensor: The FTS provides continuous force and torque readings at a rate of 125 Hz. Readings from the FTS include force measurements in Newtons along the three Cartesian axes, x , y , and z , and three torque readings in Newton-meters (N-m) about each axis. The FTS is designed to communicate with the RC through an Ethernet connection.
- Robot End-effector: The REEF is a rigid body probe attached to the end of the robot arm just after the FTS. The REEF is used to make contact with the plunger-spring assembly.
- Wireless Components: The wireless Ethernet adapter (WEA) replaces the Ethernet connection between the FTS and the RC with a Wi-Fi connection. The adapter supports the IEEE 802.11 b, g, n, and ac modes. The WEA connects to the RC through a WAP.
- Jammer: The jammer provides the source of interference, J , which is directly injected into the wireless channel. For simplicity, interference is injected as non-modulated additive white Gaussian noise (AWGN). The power of J at each receiver is determined by its distance to the jammer.
- Channel Emulator: The channel emulator (CE) provides the capability to control the electromagnetic channel between the WEA and the WAP. The CE supports frequencies between 1 GHz and 6 GHz and has an instant bandwidth of 250 MHz. It also supports a channel impulse response of 13 taps with a minimum time resolution of 4 ns making the replication of close-quarter multi-path reflections possible. As shown in Fig. 6.1, all wireless devices are connected to the CE.
- Electromagnetic Interference Cabinets: The EMI cabinets provide isolation between devices such that communication between devices does not occur through radiated leakage.
- Wireless Sniffer: A wireless sniffer (WS) is used to monitor wireless traffic during operation. The sniffer is connected to a laptop computer running Wireshark, and packet logs are used for offline analysis of network events.
- Vision Tracking System: An OptiTrack VS120 Trio is used as the vision tracking system (VTS) to produce accurate ground truth measurements of the probe position. Position estimates along the z -axis are captured at the maximum video frame rate of 120 frames per second. Each estimate includes time and position.

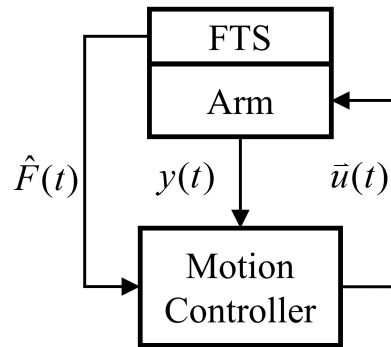

Figure 6.3: Feedback signal flow model of the force-seeking controller

6.2.3/ ROBOT ARM MOTION CONTROL

A diagram of the control system for the robotic manipulator is shown in Fig. 6.3. The UR-3 is constructed of the manipulator assembly and the RC assembly. The internal construction of the robot arm is irrelevant for this experiment, but it is assumed that the arm produces encoder positions $y(t)$ for each joint. It is also assumed that the robot arm accepts actuation signals $\vec{u}(t)$ from the motor drives located in the RC. Both $y(t)$ and $\vec{u}(t)$ are conveyed through wired connections. The force sensor signal $\hat{F}(t)$ is produced by the FTS and is conveyed via an IEEE 802.11 wireless connection. The RC is programmed to move a probe connected to the end of the manipulator downward along a linear path until a force of at least 5 N is detected. The RC will not move the arm during the force-seeking operation unless it receives an FTS signal; therefore, the duration and continuity of the movement of the arm will be impacted by unreliable communication between the FTS and the RC.

6.2.4/ RF EMULATION SCENARIO

The CE is programmed using a graphical user interface in which the wireless scenario is modeled. Scenarios are composed of radios, platforms, and links. Platforms represent the physical machine on which a radio may be deployed. Platforms may be mobile or stationary, ground-based or aerial. Radios are assigned to platforms, and each radio is associated to a physical port on the emulator. Links are representations of the physical connections between radios. Each link has an associated path loss and multi-path representation. Path loss is implemented according to Friis equation [184] simplified as $P_r = P_t + C - 10\gamma \log_{10}(d)$, where P_r is the received power, P_t is the transmitted power, C is a characteristic constant representing characteristics of the channel and electronics, γ is the path loss exponent, and d is the distance between

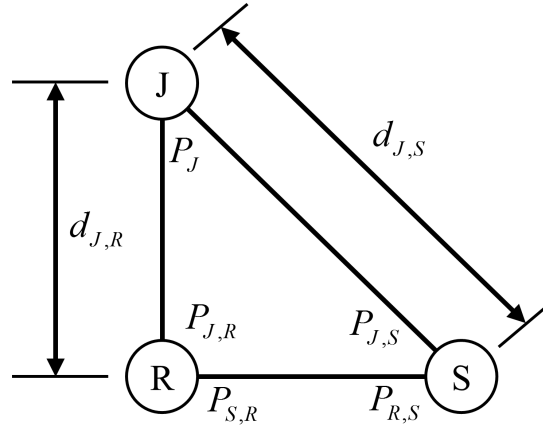

Figure 6.4: RF emulation scenario design of the robotic force-seeking scenario. An RF channel emulator is used to automate the radio effect of distances between router, station, and jammer.

transmitter and receiver. For simplicity, it is assumed that path loss occurs in accordance with the square of the distance ($\gamma = 2$); however, in practice, the path loss exponent is usually greater, causing a more rapid loss of signal power over the same distance [23]. Since the focus of this work is to infer signal quality from ground truth measurements, the path loss exponent is inconsequential to this analysis.

Shown in Fig. 6.4 is the general scenario for the wireless communication system employed for the force feedback control system. In the figure, there are three nodes, a wireless router (R), a wireless station (S), and a jammer (J). The router and station transmit with nominal power that is dependent upon the 802.11 protocol. The jammer transmits with constant power, and its impact on the scenario depends on its position relative to the other nodes. The distance between J and R is denoted by $d_{J,R}$, and the distance between the J and S is denoted by $d_{J,S}$. The resulting SIR for the router is defined in decibels as $SIR_{J,R} = P_{S,R} - P_{J,R}$ which is the power received by the router of the station signal divided by the power of interference experienced at the router. Similarly, the SIR experienced at the station is defined as $SIR_{J,S} = P_{R,S} - P_{J,S}$ which is the received signal power of the router at the station divided by the interference power experienced at the station.

For each experiment, the location of the J is adjusted to produce a desired SIR. Each time the location of J is changed, the robot is allowed to operate for a period of 30 minutes. This included periods of inaction by the robot when the SIR prohibits movement of the arm. The SIR setting was validated for each run using a real-time spectrum analyzer connected directly to the emulator.

6.3/ INITIAL INVESTIGATIONS

The contents of this section explain the approach, methodology, and results of the initial investigations using machine learning to infer the SIR of a single radio link using situational awareness information from a camera system as published in [33] with data made available at <https://doi.org/10.18434/m32077>.

6.3.1/ DATA ANALYSIS

The data analysis process for the experiment is divided into four parts: raw data collection, data cleaning and feature extraction, training, and the operation of the SIR estimation. The raw data was produced as an output of the VTS as a time series of z-axis position. Feature extraction was conducted in MATLAB by following the time series and extracting or calculating features for each iteration. Once features were extracted, a statistical analysis of the features was conducted to determine the variability of the features as a function of SIR. Statistical analyses included visual inspection of histograms of each factor and an inspection of the correlation coefficients over the range of SIRs. A discussion of the statistical results is provided in 6.3.3.1 which demonstrates suitability of the use of position measurements for machine learning. Training of a machine learning algorithm followed. The machine learning algorithm was programmed in Python using the Sci-kit Learn software library.

6.3.2/ FEATURE EXTRACTION

Feature extraction begins with a time series of position of the probe through successive iterations of the plunger applying force to the spring and then returning to its home position. A sample time series of the z-axis position of the probe is as shown in Fig. 6.5a. Rather than using the time series directly, a more convenient and practical solution is to extract features that represent aspects that may be useful for analysis and machine learning algorithms. This reduces the number of learning dimensions and usually improves computation efficiency. The selected features are illustrated in Fig. 6.5b. Shown in the model, the probe begins at its home position, a. It will not begin its downward motion until it receives sufficient FTS readings. Marker b indicates the beginning of the probes descent. Marker c represents that point in which the probe descends below a predetermined threshold, and marker d represents the position in which the probe begins its return ascent to the home position. Finally the probe returns to the home position as indicated by marker e. Therefore, the extracted features of each successive iteration is defined as follows:

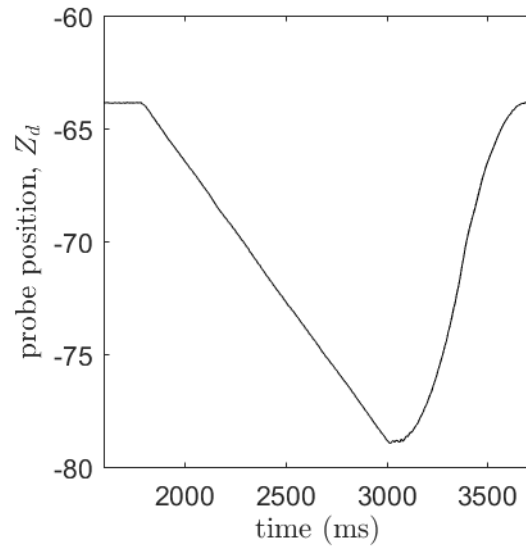

(a) sample time series of probe position in mm

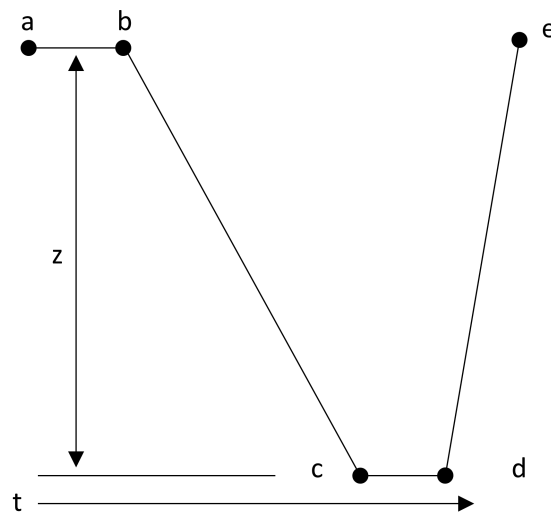

(b) feature extraction model

Figure 6.5: A time-series sample (a) of a single iteration of the measured z-axis probe position and (b) the corresponding REEF trajectory model used for feature extraction.

- Feature Z_d : The length of the probe's descent measured in millimeters,
- Feature Δt_{ab} : The duration in seconds the the robot waits before moving the probe along its descent,
- Feature Δt_{bc} : The duration in seconds of the time that the robot takes to move the probe beyond the threshold, Z_{th} , of -77 mm,
- Feature Δt_{cd} : The duration in which the probe dwells below Z_{th} and the speed of the probe remains under 0.15 mm/sec,

- Feature Δt_{ae} : The duration of the full iteration as measured from the home position, a, to the next home position, e.

6.3.2.1/ STATISTICAL ANALYSIS

Each factor was visually examined to assess its variability as a function of the SIR. In order to predict the SIR given a set of measurements of the dynamics of the physical system, sufficient variability is needed. This assessment was performed visually using histograms as a basis for comparison. The factors Z_d and Δt_{bc} were used for examination of the data using histograms.

In addition, it would be helpful to show that the factors are uncorrelated as a function of SIR demonstrating a further level of confidence that each factor will be useful to a machine learning algorithm. This assessment was accomplished by computing the correlation coefficient matrix of the extracted factors as defined by the Pearson product-moment method [185]. The correlation coefficient matrix is a covariance matrix that is normalized by the product of the standard deviations of two factors being compared according to $\rho_{X,Y} = cov(X,Y)/(\sigma_X\sigma_Y)$. Since each factor correlates exactly with itself, a correlation matrix should have values of 1 along the diagonal. Other elements of the matrix will take on values between -1 and 1. A visual inspection of the coefficient matrices will show how strongly selected factors vary together. Correlation can be viewed as a function of SIR to verify that factors are independently applicable to a learning algorithm. The objective of factor selection is, therefore, to choose factors that are highly uncorrelated and yet still vary appreciably [186].

6.3.2.2/ MACHINE LEARNING

In order to learn the SIR level from observing the various features, the random forest model is leveraged [187]. The random forest was selected based on a review of training literature, specifically the review given in [188], showing the random forest as a popular and power regression algorithm. Random forests benefit from the variance reducing advantage of combining the decisions produced by many different models. Random forests are ensembles of decision trees with random feature selection which can be used for classification or regression based on the predicted output space. Deploying random forests in machine learning has been successful in various applications such as described in [189], [190], and [191]. Its main advantages are that it is stable, fast to compute, and less susceptible to over-fitting in that weak learners are combined to produce a stronger learning collective.

In this work, the random forest model is deployed for SIR regression using the five features defined in 6.3.2. These features are evaluated for each iteration of the probe movement. A data segment is defined which is composed of a number of successive iterations. The segment size is denoted by M . As a result, the random forest regression model is used to get an input vector of size $5M$ and regression output of the corresponding SIR value. The random forest is selected because it is computationally efficient with high-dimensional data and it is robust for outliers and data non-linearity.

The random forest regression model is first trained by taking a fixed number of segments for each SIR labelled data. The size of the training set for each SIR level is denoted by T . The rest of the measurements are used for testing. In general, the proposed machine learning approach will deploy a sliding window approach of size M to collect the features of the force-seeking use case to estimate the current level of SIR at various nodes of the wireless network.

6.3.3/ RESULTS

The results in this section are presented from an experimental run in which the jammer J interferes with the router, R, while communication is conducted using a mixed mode of IEEE 802.11 b and g [182]. Analyses using histograms and covariance are presented in Section 6.3.3.1 followed by results of the machine learning application in Section 6.3.3.2.

6.3.3.1/ STATISTICAL ANALYSIS

Analysis of Factors Using Histograms The results of the histogram analyses for the z-axis position of the probe and the probe descent delay are shown in Fig. 6.6a and Fig. 6.6b, respectively. The expectation of the histogram analysis was that Z_d and the ΔT_{bc} would exhibit appreciable variation that may be observed through a visual inspection. This was indeed the case. Referring to Fig. 6.6a, a visual inspection reveals that the minimum z-axis position for each iteration skews to lower positions for lower SIR values and higher positions for higher SIR values. This implies that the controller algorithm responds faster to force sensor readings at higher SIR values than lower values. Similarly, by observing the plunge delay, Δt_{bc} , the controller takes more time to respond at lower SIR values than at higher values. This behavior is exemplified by the probability skew shown in the histograms.

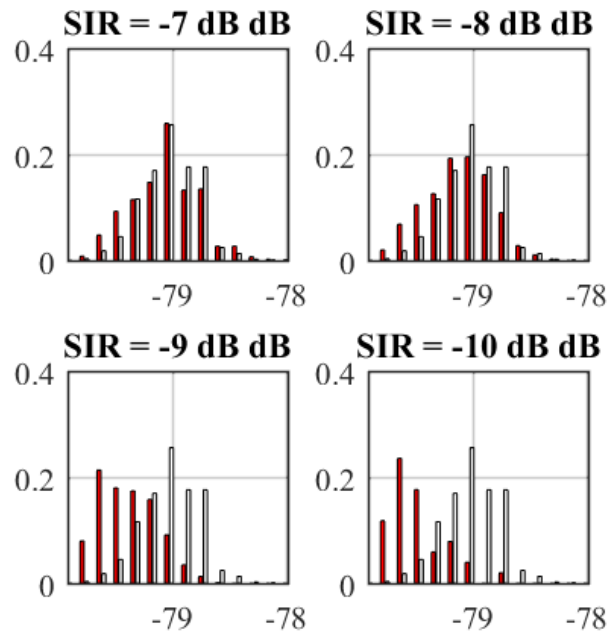

(a) z-axis positione

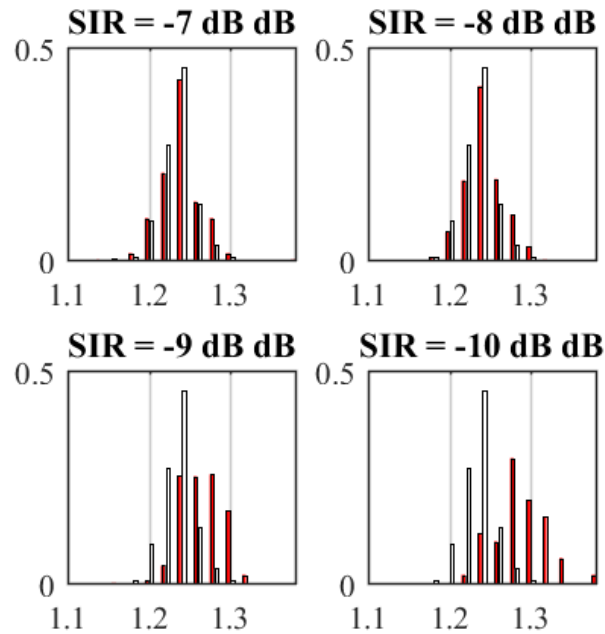

(b) Plunge delay

Figure 6.6: Variations in probability distributions of the z-axis position (a) and the plunge delay (b) indicate that machine learning may be effective in inferring information about the underlying communication channel. In the figure, the baseline case of infinite SIR is depicted as a histogram with white bars, and the experimental case is depicted as a histogram with red bars.

Table 6.1: Correlation Coefficients for -9 dB SIR

	Δt_{ab}	Δt_{bc}	Z_d	Δt_{cd}	Δt_{ae}
Δt_{ab}	1	0.04	0.04	0	0.56
Δt_{bc}	0.04	1	-0.96	-0.08	0.18
Z_d	0.04	-0.96	1	0.03	-0.01
Δt_{cd}	0	-0.08	0.03	1	0
Δt_{ae}	0.56	0.18	-0.01	0	1

Table 6.2: Correlation Coefficients for -8 dB SIR

	Δt_{ab}	Δt_{bc}	Z_d	Δt_{cd}	Δt_{ae}
Δt_{ab}	1	0.01	-0.05	-0.06	0.58
Δt_{bc}	0.01	1	-0.99	-0.13	0.1
Z_d	-0.05	-0.99	1	0.07	-0.1
Δt_{cd}	-0.06	-0.13	0.07	1	-0.03
Δt_{ae}	0.58	0.1	-0.1	-0.03	1

Table 6.3: Correlation Coefficients for -7 dB SIR

	Δt_{ab}	Δt_{bc}	Z_d	Δt_{cd}	Δt_{ae}
Δt_{ab}	1	-0.05	-0.04	0.09	0.01
Δt_{bc}	-0.05	1	-0.93	-0.17	0.05
Z_d	-0.04	-0.93	1	0.08	-0.05
Δt_{cd}	0.09	-0.17	0.08	1	-0.02
Δt_{ae}	0.01	0.05	-0.05	-0.02	1

Factor Correlation Coefficient Analysis Correlation coefficients were calculated for each of the five factors defined in Section 6.3.2 and correlation coefficient matrices were produced for each of the SIR values used. The correlation coefficient matrices for SIR values of -9, -8, and -7 are shown in Tables 6.1-6.3, respectively. Inspection of the correlation coefficient tables indicate that the factors are mostly uncorrelated across SIR values except for the clear correlation between plunge delay and plunge depth. Low correlation values demonstrate a necessary but not sufficient condition for the independent applicability factors to machine learning. If desired, either Δt_{bc} or Z_d could be omitted as they are strongly correlated and therefore provide redundant information.

6.3.3.2/ MACHINE LEARNING RESULTS

The proposed machine learning approach is deployed for three values of the SIR, -9, -8, and -7 dB. First the output of the random forest regression model for two values of the segment size M is shown. The training set size $T = 200$ is set for each SIR value. The random forest model is used with a number of estimators of 500 and a tree

depth of 5. In Fig. 6.7, the box plots of the predicted SIRs are presented against the correct value of the corresponding SIR for $M = 100$ and $M = 1$. Generally, increasing the value of M increases the acquisition time for the input data for the random forest model while enhancing the performance of the algorithm. By setting $M = 1$, it is evident the predicted values of SIR are widely spread around the median and a large number of outliers exists. However, increasing M reduces variations in the predicted SIRs and a smaller number of outliers.

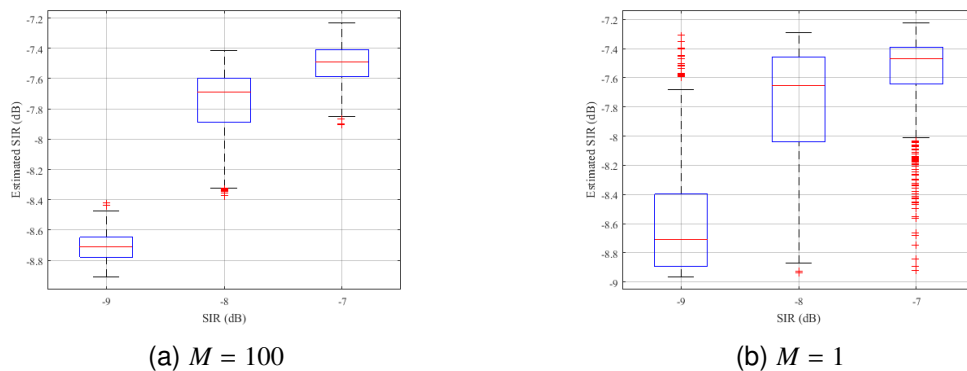

Figure 6.7: Predicted SIR versus actual SIR for the cases of (a) $M = 100$ and (b) $M = 1$. The box plots show the median value while the bottom and top edges of the box indicate the 25th and 75th percentiles. Statistical outliers are shown as red + signs.

In Fig. 6.8, the two criteria for measuring the performance of the proposed SIR estimation algorithm is presented. The performance against the segment size M is shown. The first criterion is the mean squared error where the mean of the squared error between the estimated SIR and the actual SIR values is calculated. The second criterion is the variance score which is a statistical measure of how close the data are to the fitted regression line. The r-squared variance score is used which is defined as the ratio between the total variance explained by model and total variance of the data [192]. In this figure the improvement in the performance against the segment size is demonstrated.

6.3.4/ CONCLUSION

This investigation presented a practical use case of a wireless force-torque feedback control system that could be deployed in a manufacturing assembly system such as a pick-and-place or assembly operation. A 6-DOF force sensor was connected to a robot controller tasked with moving a probe along a linear path until an opposing force exceeding 5 N was detected. It is demonstrated that the reliability of the wireless communication system directly impacts the repeatability performance of the physical system. It is also demonstrated that the quality of the underlying wireless channel may be inferred by observing the position of the probe along a single spatial

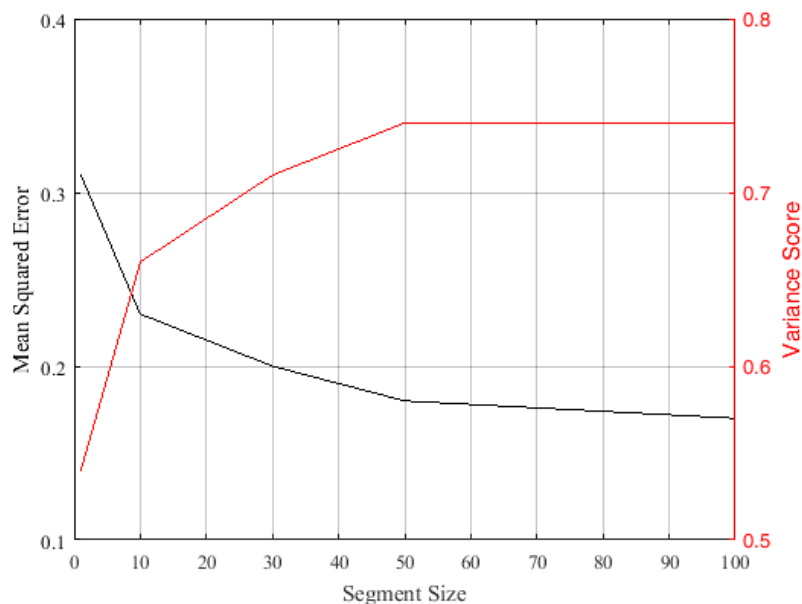

Figure 6.8: The performance of the random forest regression model against segment size, M . As M increases, error is reduced but variance increases shown a tendency to over-fit as the training window is increased.

dimension and applying machine learning to predict the SIR. The findings provide motivation for applying machine learning to larger more complex systems with high degrees of freedom. Future work will extend to the inclusion of more descriptive factors, the addition of network information such as the wireless protocol mode, and the addition of a larger number of variables tracked by many remote observers. Experimentation with neural networks and deep learning to improve prediction accuracy and better generalization will be of great values to wireless operations in factories. Finally, the applications of online machine learning techniques to this and other use cases could provide significant benefits to the manufacturing community.

6.4/ SUBSEQUENT INVESTIGATIONS

The contents of this section explain the subsequent analysis expanding on the approach, methodology, and results of the initial investigations using ML to infer the SIR of a single radio link using situational awareness information from a camera system as published in [33]. In this further investigation, the performance of the ML algorithms themselves were investigated to determine optimal selection given the particular use case. Publication is forthcoming [34].

6.4.1/ DATA ANALYSIS

The data analysis process for the experiment is divided into four parts: raw data collection, data cleaning and feature extraction, training, and the operation of the SIR estimation. The raw data was produced as an output of the VTS as a time series of z-axis position. Feature extraction was conducted in MATLAB by following the time series and extracting or calculating features for each iteration. Once features were extracted, a statistical analysis of the features was conducted to determine the variability of the features as a function of SIR [26]. Training of a ML algorithm followed. The ML algorithm was programmed in Python using the Sci-kit Learn library [193].

6.4.1.1/ FEATURE EXTRACTION

Refer to Section 6.3.2 for a discussion on how features used for training were extracted. As stated in the previous discussion, rather than using the entire time series directly, a more convenient and practical solution is to extract features that represent aspects that may be useful for analysis and ML algorithms. By using features rather than the time series, we reduce the number of learning dimensions and usually improve computation efficiency. The selected features are illustrated in Fig. 6.5b.

6.4.1.2/ ML-BASED SIR ESTIMATION

In order to learn the SIR level from observing the various features, it is possible to leverage supervised ML regression schemes. This work compares the deployment of various ML algorithms for SIR regression using the five features defined in 6.4.1.1. These features are evaluated for each iteration of the probe movement. A data segment is defined as a number of successive iterations and the segment size is denoted by M . As a result, each regression model is used to get an input vector of size $5M$ and the regression output of the corresponding SIR value.

One starts by training each regression model by taking a fixed number of segments for each SIR labeled data. The size of the training set for each SIR level is denoted by T . The rest of the measurements are used for testing. In general, the proposed ML approach will deploy a sliding window approach of size M to collect the features of the force-seeking use case to estimate the current level of SIR at various nodes of the wireless network.

6.4.2/ RESULTS

In this section, the experimental results for 4 different settings are considered. The four settings are defined as follows: i) setting b/g-Router: the jamming signal impacts the router and IEEE 802.11 b/g is deployed [182], ii) setting b/g-Station: the jamming signal impacts the station and IEEE 802.11 b/g is deployed, iii) setting b/g/n-Router: the jamming signal impacts the router and IEEE 802.11 b/g/n is deployed, and iv) setting b/g/n-Station: the jamming signal impacts the station and IEEE 802.11 b/g/n is deployed.

When the jamming signal has an impact on the router, this work considers 3 values of the SIR which are -9, -8, -7 dB while having 1, 2, 3 dB for the settings in which jamming has an impact on the station. Except otherwise mentioned, $M = 50$ and $T = 200$ are used.

6.4.2.1/ MACHINE LEARNING ALGORITHM COMPARISON

In this subsection, various regression approaches are compared using two performance criteria, namely, the logarithmic mean square error (MSLE)^(6.1) and the R-squared variance score^(6.2) [192]. R-squared variance score indicates the percentage of the variance in the dependent variable that the independent variables explain collectively. It is equivalent to how R-squared is used in financial investments to explain how one security explains the performance of an entire portfolio. The used version of R-squared in the Sci-kit Learn library measures the strength of the relationship between the model used and the dependent variable on a convenient -1 to 1 scale. The best possible outcome is 1 when predicted values capture the variance of the independent variable. It takes a value of 0 when the predicted value is constant and negative values when the regression model cannot follow the trend of the data. The performance for different values of M is presented. The compared algorithms are the random forest, gradient boosting machine (GBM), extreme gradient boosting machine (XGBM), decision tree, support vector machine (SVM), k-nearest neighbor, kernel ridge, and linear ridge [193, 194].

$$\text{MSLE}(y, \hat{y}) = \frac{1}{n_{\text{samples}}} \sum_{i=0}^{n_{\text{samples}}-1} (\log_e(1 + y_i) - \log_e(1 + \hat{y}_i))^2. \quad (6.1)$$

$$R^2(y, \hat{y}) = 1 - \frac{\sum_{i=1}^n (y_i - \hat{y}_i)^2}{\sum_{i=1}^n (y_i - \bar{y})^2} \quad (6.2)$$

Table 6.4: MSE values of various ML algorithms for jamming setting b/g-Router

	$M = 1$	$M = 10$	$M = 30$	$M = 50$	$M = 100$
Random Forest	0.61	0.54	0.49	0.48	0.46
Gradient Boosting	0.56	0.55	0.47	0.45	0.44
XGBM	0.62	0.53	0.45	0.43	0.41
Decission Tree	1.07	0.99	0.87	0.91	0.97
SVM	0.92	0.99	0.98	0.97	0.96
KNN	0.73	0.74	0.73	0.74	0.77
Kernal Ridge	0.97	0.73	0.71	0.71	0.71
Linear Ridge	0.7	0.7	0.7	0.71	0.71

In Table 6.4, the MSE performance of various algorithms are presented for setting a 802.11 b/g mode setting at the router. The ensemble-based algorithms, which are the random forest, gradient boosting, and XGBM, perform better than non-ensemble algorithms. This happens because the ensemble-based algorithms learn from the training data without having an initial model to fit thus allowing for capturing the randomness impacts on the collected data. Moreover, the XGBM gives slightly better performance than the random forest and gradient boosting algorithms except at $M = 1$. The XGBM performs gradient boosting over random set of trees and hence the superior performance. It also has superior variance score as well in Table 6.5. Generally, in Table 6.5, similar trends as Table 6.4 can be found for various ML algorithms where ensemble-based algorithms have the best performance among others and their performance is enhanced by increasing the segment size M of the measured data.

Similarly, in Table 6.6, the ensemble-based algorithms perform better than other algorithms and the XGBM is the best among them. In this setting b/g/n-Station, the interference impacts the router and hence the MSE values generally higher than the corresponding cases in setting b/g-Router. In this case, the interference has a larger impact and hence larger MSE. That leads to larger distinction between the performance of the ML algorithms.

Table 6.5: Variance score values of various ML algorithms for jamming setting b/g-Router

	M = 1	M = 10	M = 30	M = 50	M = 100
Random Forest	0.15	0.2	0.3	0.35	0.35
Gradient Boosting	0.02	0.2	0.34	0.37	0.42
XGBM	0.12	0.25	0.36	0.4	0.43
Decision Tree	-0.57	-0.44	-0.36	-0.3	-0.22
SVM	-0.34	-0.38	-0.37	-0.37	-0.32
KNN	-0.05	-0.02	-0.02	-0.08	-0.04
Kernal Ridge	-0.48	-0.05	0	0	0
Linear Ridge	0.01	0.01	0	-0.01	0

Table 6.6: MSE values of various ML algorithms for jamming setting b/g-Station

	M = 1	M = 10	M = 30	M = 50	M = 100
Random Forest	0.88	0.79	0.76	0.69	0.7
Gradient Boosting	0.95	0.71	0.61	0.56	0.56
XGBM	0.85	0.73	0.59	0.52	0.48
Decision Tree	1.48	1.46	1.33	1.33	1.32
SVM	1.34	1.36	1.36	1.39	1.49
KNN	1.01	1.04	1.03	1.05	1.13
Kernal Ridge	4.42	1.25	0.98	0.97	0.99
Linear Ridge	0.93	0.94	0.94	0.95	0.99

6.4.2.2/ TUNING THE RANDOM FOREST AND GRADIENT BOOSTING REGRESSORS

In this subsection, the impacts of the number of estimators and the depth for gradient boosting and random forest algorithms are studied. The XGBM parameters are optimized automatically when the function is called to be executed. The work

shows that the MSE performance results for setting b/g-Router while same trend holds for other system settings as well.

For random forest algorithm, Table 6.7 shows that the tree depth has more impact on the performance than the number of the estimators (# est.). However, increasing the depth improves the performance till the value of 5 where increasing the depth cause slight improvements.

Table 6.7: MSE of Random Forrest regression parameters for jamming setting b/g-Router

Depth \ # est.	100	200	300	400	500	600
1	0.64	0.64	0.64	0.63	0.63	0.63
3	0.53	0.53	0.53	0.53	0.53	0.52
5	0.5	0.5	0.5	0.48	0.48	0.48
7	0.49	0.49	0.48	0.48	0.48	0.48
9	0.48	0.48	0.47	0.47	0.47	0.47

For gradient boosting, Table 6.8 shows that a similar trend as a random forest exists where depth has a larger impact on the performance. However, increasing the depth more than 7 causes the MSE performance to degrade significantly.

Table 6.8: MSE of Gradient Boosting regression parameters for jamming setting b/g-Router

Depth \ # est.	100	200	300	400	500	600
1	0.48	0.47	0.46	0.46	0.45	0.46
3	0.47	0.47	0.47	0.47	0.46	0.47
5	0.48	0.47	0.47	0.47	0.47	0.47
7	0.48	0.48	0.48	0.48	0.46	0.49
9	0.58	0.51	0.5	0.5	0.57	0.58

6.4.2.3/ IMPACT OF DATA SEGMENT SIZE M

In this section, the performance of the ensemble-based algorithms against the segment size M is studied. It was shown in [26] that increasing the value of M increases the acquisition time of measurement data used for decision making and lowers the spread of predicted values around the correct value for various SIR values. In this continuation of the work, the impact of the three optimized algorithms employing

the MSE and the variance score as performance metrics is studied.

In Fig. 6.9, the performance of the random forest, gradient boosting, XGBM, and the linear ridge regressors is presented. The linear ridge is used as a simple model-based regressor which practically cannot not be used for prediction while it is used for comparison. In this figure, increasing the value of M enhances the performance of the ensemble-based algorithms significantly. Generally, the prediction accuracy increases when multiple measurement cycles are deployed in decision making with diminishing improvement as M increases. The linear ridge algorithm shows no improvement with increasing M implying that SIR does not vary linearly with the feature set presented.

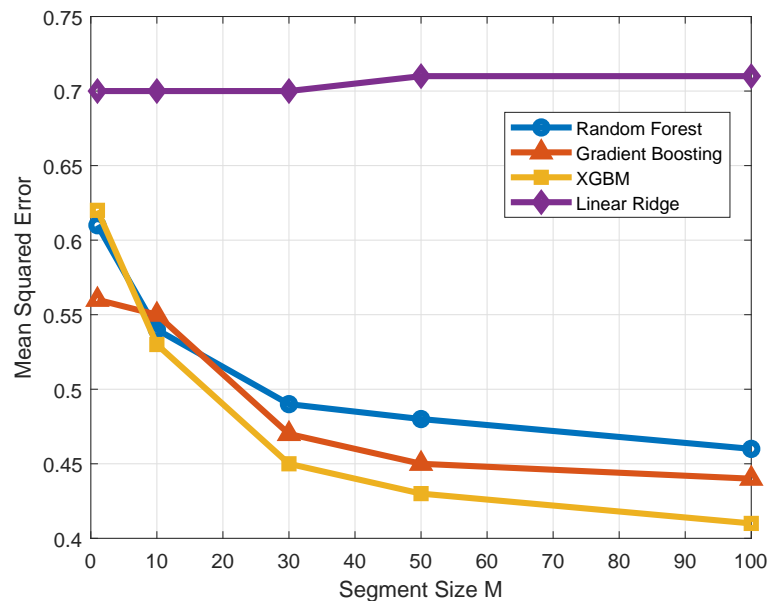

Figure 6.9: The mean squared error performance with jamming imposed on b/g-Router of various algorithms against segment size, M .

Fig. 6.10 presents the variance score for the same setting b/g-Router where a similar trend is found. The ensemble-based algorithms can achieves a variance score above 0.35 when M is larger than 50.

In Fig. 6.11, the MSE of the ensemble-based algorithms is shown for Setting b/g-station where the router is impacted by the jamming signal. The MSE values in this setting are lower than those of setting b/g-Router where the predicted SIR values are smaller because the router has better capabilities to detect signals at lower SIRs.

Finally, in Fig. 6.12, a similar scenario to Fig. 6.11 is presented where the router is impacted by the jamming signal. The difference is that at setting b/g/n-Station, a mixed IEEE802.11 b/g/n mode is allowed instead the IEEE802.11 b/g

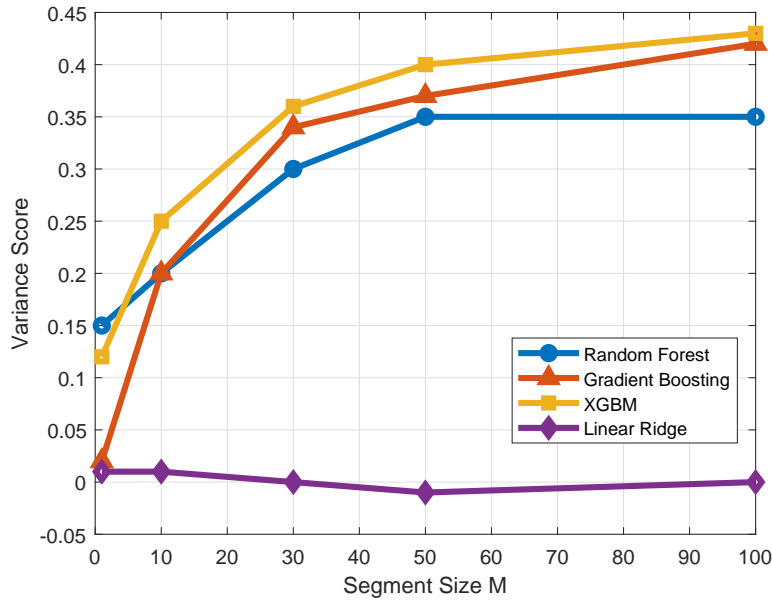

Figure 6.10: The variance score performance with jamming imposed on b/g-Router of various algorithms against segment size, M .

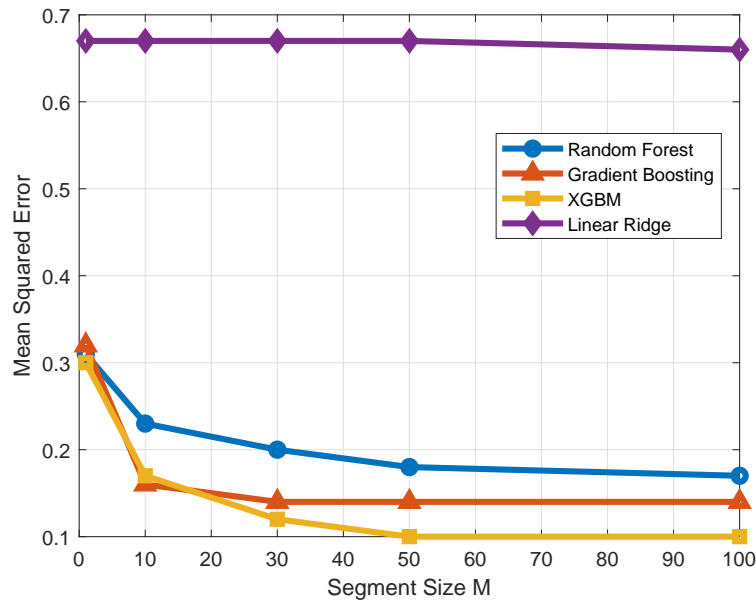

Figure 6.11: The mean squared error performance with jamming imposed on b/g-Station of various algorithms against segment size, M .

mode in setting b/g-Station. By allowing the IEEE 802.11n mode, the signal is more susceptible to interference and hence it is harder to predict the same SIR values.

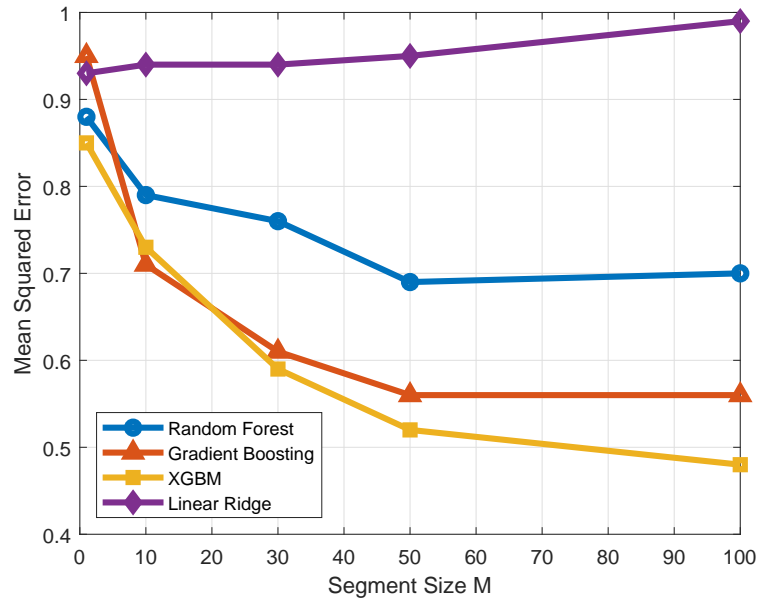

Figure 6.12: The mean squared error performance with jamming imposed on b/g/n-Station of various algorithms against segment size, M .

6.4.2.4/ IMPACT OF TRAINING SEQUENCE LENGTH T

This subsection briefly discuss the impact of the training length on the performance of various algorithm. The parameter T is the length of the training sequence where each element contains M of the force seeking cycles. The following figures show the MSE performance curves against T for $M = 30$ and 100.

In Fig. 6.13, it is shown that increasing the training size T can improve the prediction performance significantly. Gradient boosting and XGBM have higher improvement rate with T than the random forest algorithm.

6.4.2.5/ IMPACT OF INDIVIDUAL FEATURES

In this subsection, the impact of the individual features on the performance of the ensemble-based ML algorithms is studied. Understanding the importance of each feature on the prediction algorithms is essential in selection of features and hence reducing the required processing power for an algorithm. The results for XGBM algorithm are shown for brevity and also because it exemplifies the similarity in performance of various ensemble-based algorithms.

In Fig. 6.14, 6.15, and 6.16, presented are the MSE performance for setting b/g-Router, the variance score for setting b/g-Router, and the MSE for setting

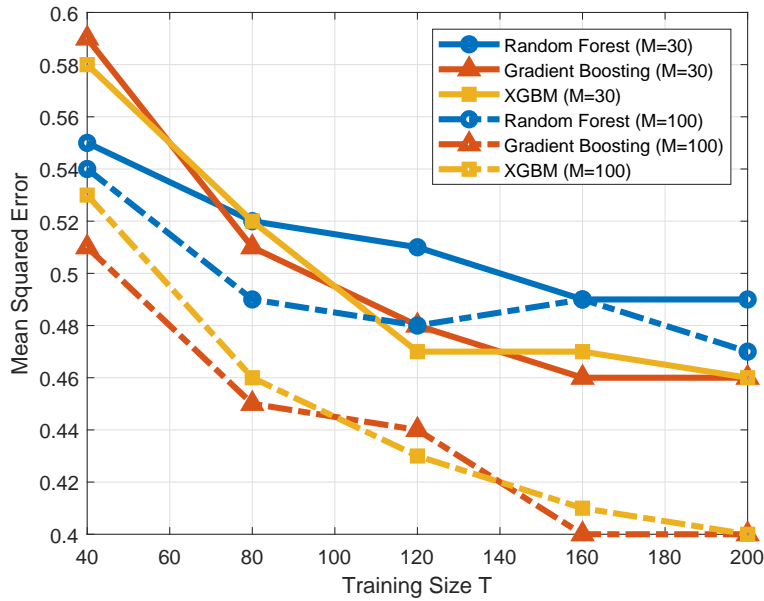

Figure 6.13: The mean squared error performance for jamming setting b/g-Router of various algorithms against training sequence length, T for various segment sizes, M .

b/g/n-Station, respectively, against the segment size M . In all the three figures, Δt_{ab} , Δt_{bc} , Z_d , Δt_{cd} , and Δt_{ae} are reference by "t_high", "t_plunge", "Descent Distance", "t_bottom", and "Total Cycle", respectively.

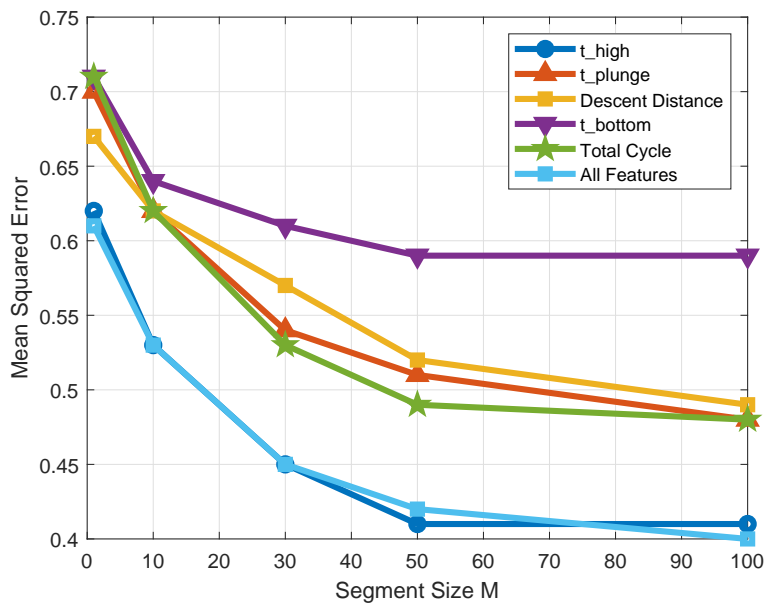

Figure 6.14: The MSE performance for jamming setting b/g-Router of XGBM algorithm against M including individual features impact. As indicated in the figure, the feature Δt_{ab} is most predictive of the SIR level as compared to all of the features together. It appears that the only the dwell time before REEF plunge is required to predict SIR in this scenario.

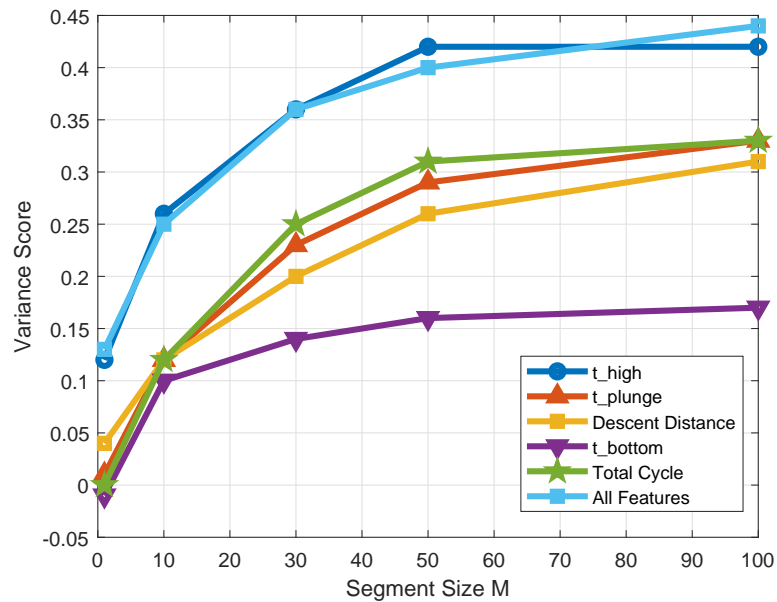

Figure 6.15: The variance score performance for jamming setting b/g-Router of XGBM algorithm against M including individual features impact.

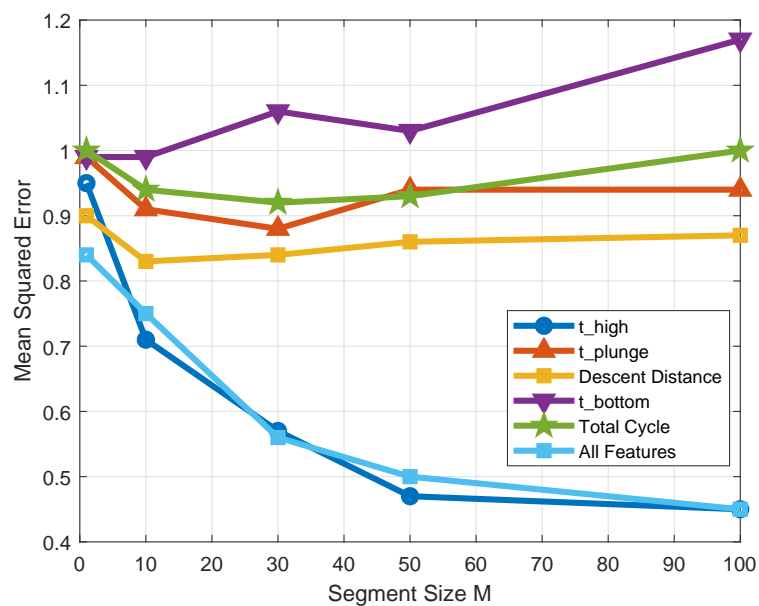

Figure 6.16: The mean squared error performance for jamming setting b/g/n-Station of XGBM algorithm against M including individual features impact.

The feature Δt_{ab} is the most one impacted by the SIR value where the prediction performance by using this individual feature is almost identical to the performance of using all the features. This result can be explained by knowing that in the robot arm force seeking program, the FTS has to be zeroed before resuming the loop and hence there is a direct impact of the wireless transmissions and the

value Δt_{ab} . On the other hand, the feature Δt_{bc} is the least one impacted by the SIR value. This feature is defined as the reflection time of the robot arm to reverse its direction and hence it is minimally impacted by the SIR value. The rest of the features are impacted by the SIR to a certain level. Generally, adding an unnecessary feature can degrade the performance. As a result, in this work, it is concluded that using Δt_{ab} can substitute all the five features to get the same MSE and variance score performance with much less processing.

6.4.3/ CONCLUSION

This work presents a practical use case of a wireless force-torque feedback control system that could be deployed in a manufacturing assembly system such as a pick-and-place or assembly operation. A 6-DOF force-torque sensor was connected to a robot controller tasked with moving a probe along a linear path until an opposing force exceeding 5 N was detected. The reliability of the wireless communication system directly impacts the repeatability performance of the physical system are demonstrated. Also demonstrated was that the quality of the underlying wireless channel may be inferred by observing the position of the probe along a single spatial dimension and applying ML to predict the SIR. As a result of our exploration of various ML algorithms on the prediction of signal quality, it was found that ensemble-based algorithms have superior performance compared to other regression algorithms for data presented. Additionally, the analysis shows that careful study of the MSE and variance score is useful in selection of features used for training the algorithms. The work concludes that for this particular force-torque control system scenario that the dwell time of the robot before descending was the most useful feature for training the algorithm. The findings provide motivation for applying ML to larger more complex systems with higher degrees of freedom. Furthermore, the works indicates that future experimentation with neural networks and deep learning to improve prediction accuracy could be of value to improving the reliability of wireless operations in factories. The applications of online ML techniques to this and other use cases could provide significant benefits to the manufacturing community through integration of link quality detection with programmable controllers.



CONCLUSIONS

CONCLUSIONS

In this thesis, several original contributions were presented, and these contributions are listed as follows:

- **Technological Mapping by Use Case:** The landscape of industrial wireless technology is explored and a mapping of the classes of industrial automation use cases are described and mapped to potential wireless candidates for use within industrial environments which is presented in [7]. Additional significant contributions are made in [5, 22, 178].
- **Systems Modeling using SysML:** SysML was used to construct an extensible framework for comprehensively communicating the design of a CPS using SysML as presented in [29] and [195]. This framework allows one to model a workcell application inclusive of the network and physical elements. The proposed model allows the user to link network and computational domain performance to physical domain performance.
- **Database Application:** A GDB is used to collect CPS performance data from a wireless robotic workcell [31]. It is demonstrated that the graph database is a useful candidate for storage, organizing, and exploring the data that results from the operation of a cyberphysical system such as a robotic workcell employing wireless as a primary mode of communication. Furthermore, it is shown that the wireless network selected negligibly impacts physical performance thus demonstrating one class of application of wireless to industrial automation.
- **Machine Learning Application:** A neural network is successfully applied in the prediction of SIR using camera monitors of robot arm position [33, 34]. This demonstrated the successful application of machine learning to a class of use cases (i.e. force seeking applications) commonly found within a factory workcell. Furthermore, various machine learning candidates are explored and their applicable performance is presented. It is shown that in this analysis

that ensemble-based algorithms have superior performance compared to other regression algorithms for data presented.

These contributions are each part of a comprehensive exploration of the problem of performance estimation, testing, and control of CPSs employing non-ideal communications networks which is the title of this thesis.

7.1/ REQUIREMENTS MAPPING

The first contribution was an exposition of the various wireless technologies that were either developed specifically for industrial use or have a tangential use within industry [7]. Classes of industrial use cases were defined and a mapping of the applicability of each wireless technology to class of use case was provided. This mapping represented our opinion based on our experience and knowledge of wireless technology at the time that our contribution was made. This exploration represented a major contribution to the distillation of the plethora of performance requirements found in literature and in trade articles regarding the performance expectations of IWNs and the driving requirements behind the use cases employing them. In our work, success considerations are presented for the deployment of wireless in factories and factory workcells including those envisioned for smart manufacturing. The performance indicator, reliability, is a main consideration within this thesis and represents the bulk of concern for wireless deployments. Reliability includes any element that impact information flow within a CPS such as information loss and delay.

In this contribution, several components comprising the problem space of wireless deployments are declared of which two resound critically important to the work addressed by this thesis. The first is the problem of instrumentation that includes all elements within the factory that include sensing and actuation. The second and critical component is the assessment of cyber-physical performance which includes test methods for which this thesis addresses through identification of the information flows and then subsequently the evaluation of the performance of those information flows and their impacts on physical performance. Therefore, this contribution is necessarily important as it provides an essential perspective of the problem of deploying industrial wireless systems and then the motivation behind modeling, database application, and machine learning to the assessment of network performance. The contribution of this work illustrates the clear need for an understanding of requirements and creative test methods for the examination of wireless CPSs. It was clear from this contribution that easy-to-use test methods were essential; however, it was not a goal of this thesis. Essentially, this contribution introduces the

problem of selecting and deploying wireless networking in factories. It describes the technical aspects to be considered. Finally, it provides a starting point for the applicability of wireless technologies to classes of use cases, and, in doing so, provides the motivation for gaining a clearer understanding of the workcell through a formal decomposition and creation of a framework for communicating those ideas [31].

7.2/ MODELING USING SYSML

The second contribution was an abstraction of the industrial CPS that is the factory work using SysML. In this work, a model was constructed using primitives representing each major architectural component of the workcell and interfaces within the workcell and to systems outside the workcell. These interfaces are used to represent elements of information flow. The information flows shown represent the performance of the supporting network. Subsequently, the physical system that operates using that network has its own performance that is directly connected to the performance of the network. Each information flow identified using the SysML model represents an opportunity of study. For example, in the system elaborated by the IBD in Fig. 7.1, each of the main actors (Robot Controller 1, Robot Controller 2, and Supervisor) are all connected to an 802.11ax network.

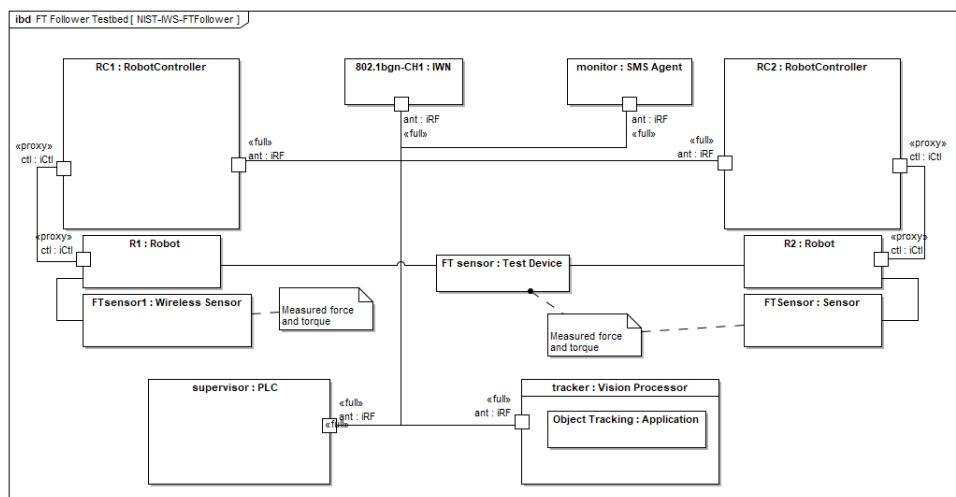

Figure 7.1: Internal block diagram of a workcell equipped with a robotic leader-follower lift application. This model is indicative of the testbed scenario currently being developed within the NIST IWS testbed.

And as shown in Fig. 7.7, each controller block such as a Robot Controller or a PLC (Fig. 7.2) inherits its structure and behavior from the Controller block. As such, the PLC and the Robot Controller have an Application and an interface to the wireless network. Each application is linked to the wireless network through a Transceiver block (refer to 7.2) which intuitively governs its own receiver perfor-

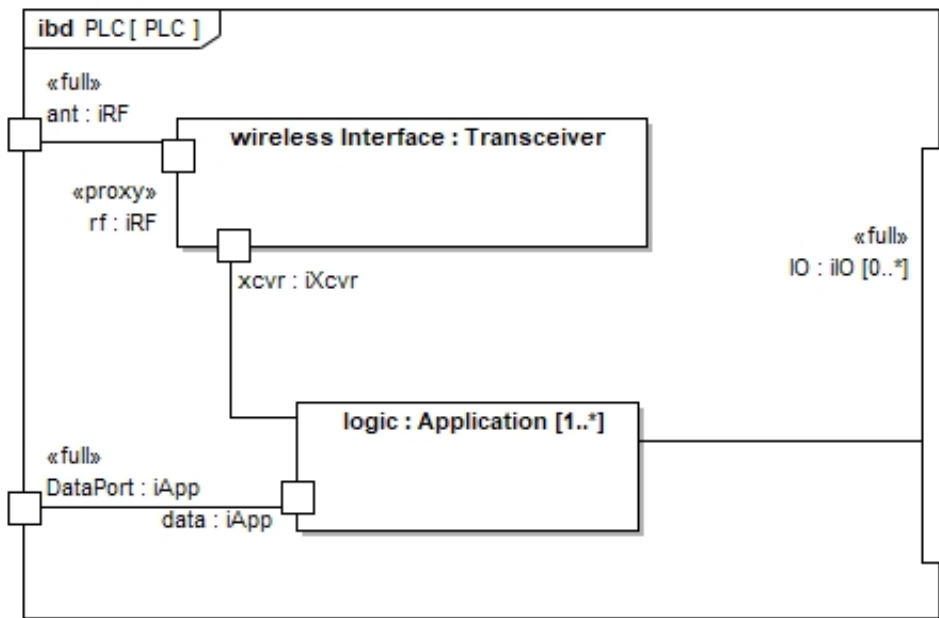

Figure 7.2: Internal block diagram of a PLC.

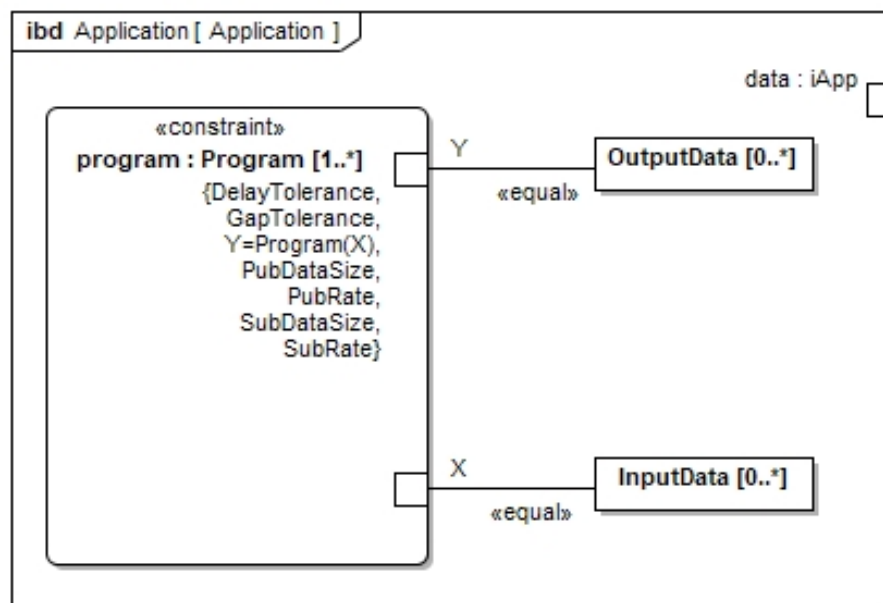

Figure 7.3: Internal block diagram of an Application showing the parametrics constraints of its one or more programs.

mance as impacted by the radio channel. The radio channel is an element of the IWN block shown in Fig. 7.4 which is connected directly to a set of IWN services as shown in Fig. 7.6. The service block of the IWN is modeled as a generic sets of constraints that could be implemented as code or mathematical limitations.

One can see that the complete path of information flow within the model proposed traverses the radio medium, the IWN, the embedded transceivers, and

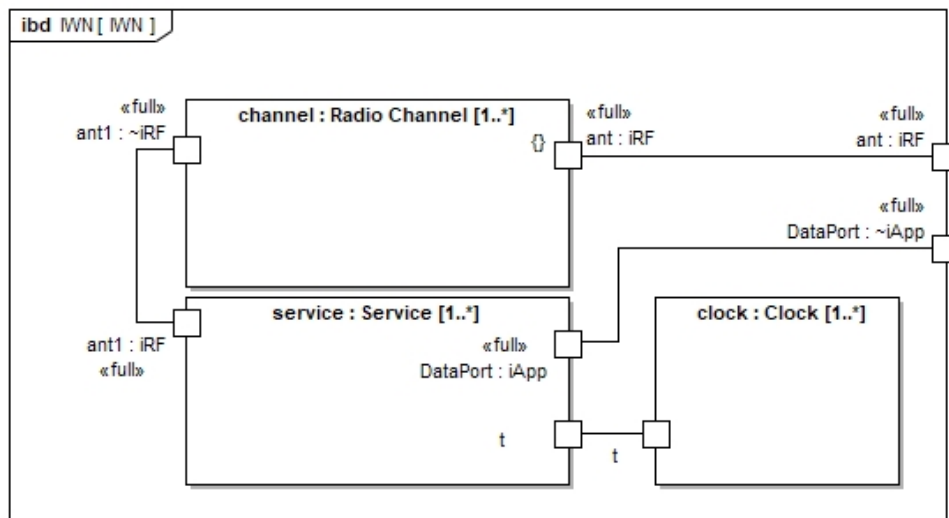

Figure 7.4: Internal block diagram of an IWN showing the parametric constraints of its one or more programs.

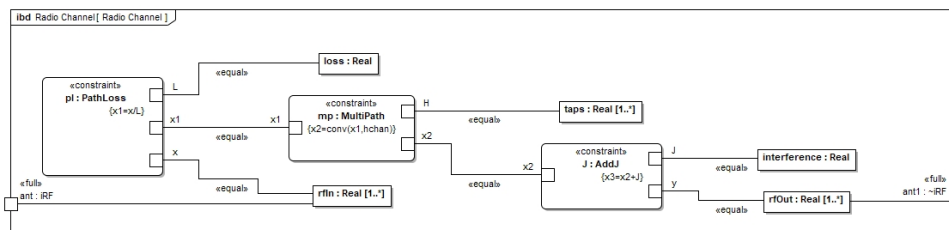

Figure 7.5: Internal block diagram of an Radio Channel showing the parametric constraints of the radio medium.

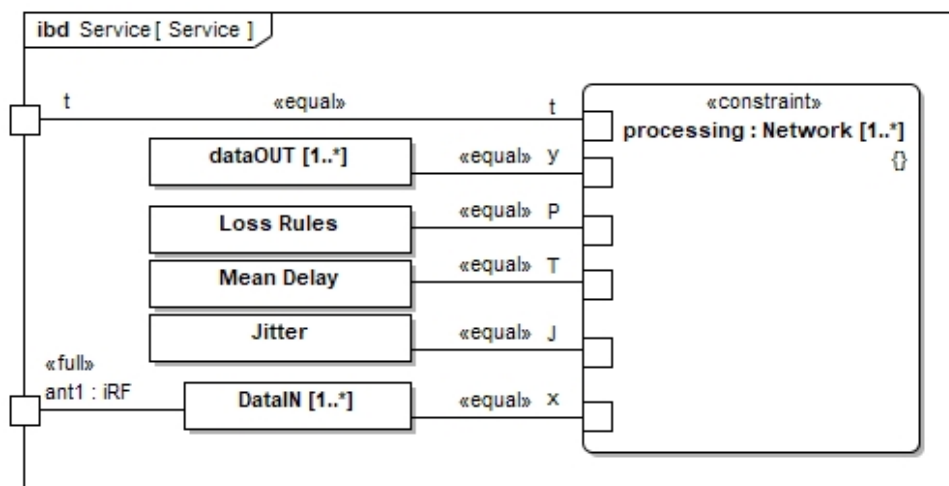

Figure 7.6: Internal block diagram of an IWN Service showing the parametric constraints of the behavior of a network service as generic processing.

each of the control applications. Therefore, it is possible using this proposed model to represent the radio channel, model its performance impacts on the wireless network, and subsequently the impacts of the performance of the wireless network on

the performance of the control applications themselves. Such an interdisciplinary modeling effort is not an easy prospect and could be quite challenging; however, with the modeling framework presented as a part of this work, it becomes easier. This represents an opportunity for refinement of the proposed model to be more intuitive and perhaps easier to use. The contribution is made publicly available through Internet download through the URL provided in [195].

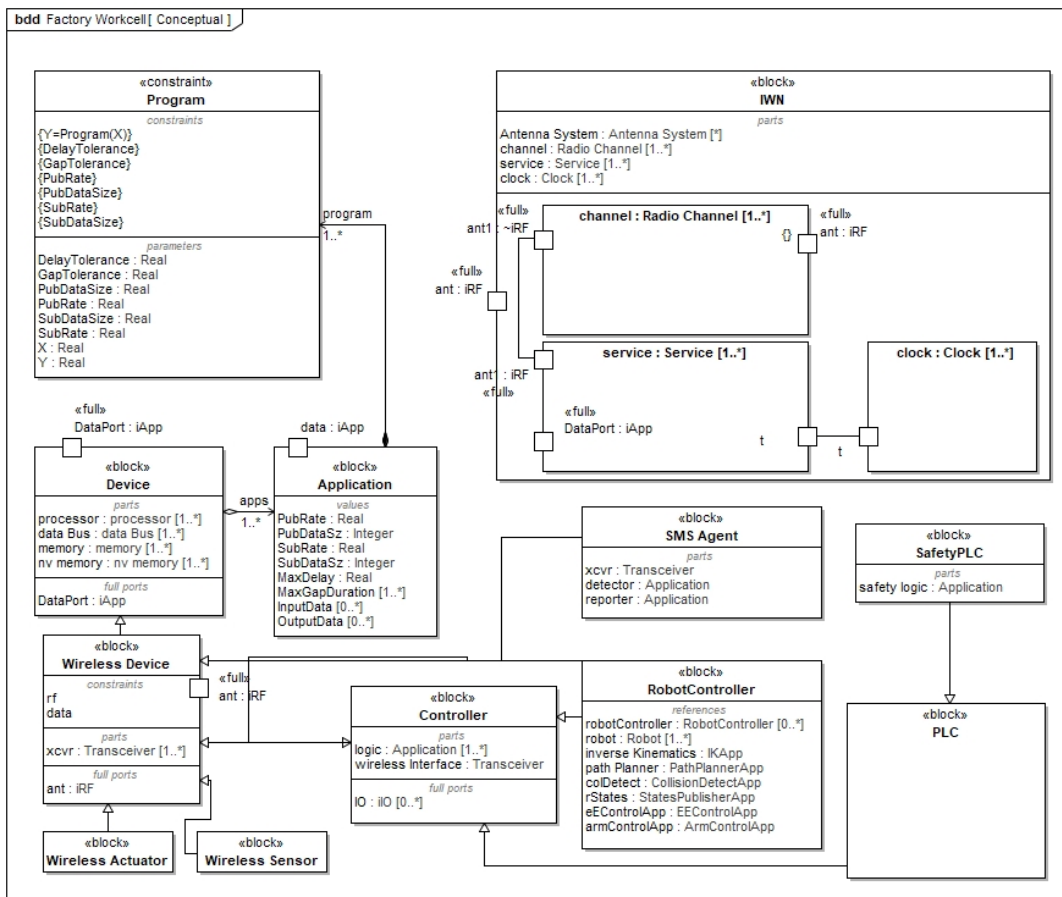

Figure 7.7: BBD of the conceptual relationships of model primitives

Our model was developed using SysML. The developed model is constructed of the elements necessary to construct useful representations of factory workcells in which wireless networks are used to transport information necessary for automated control system operation. Reusable, derivable elements are developed and then extended to represent the constructs of the workcell such as robot control, supervisory control, vision, safety, and spectrum monitoring. An IWN is then developed and constraints of the radio channel and network services are formalized. Using the architectural model, information flows are explored and incorporated within.

It is important to mention that our model includes an often overlooked component of any IWS deployment which is the spectrum monitoring system. Our model also considers the human-robot and robot-robot interactions in industrial environ-

ments. The current model includes various systems constraints including motion constraints, radio channel constraints, and networking constraints. The parametric constraints are provided as examples and can be replaced with executable computer code thereby making the model useful for simulation depending on the modeling tool selected. Furthermore, the applications within the robotic work-cell define many information flows requiring careful analysis to achieve reliability and latency necessary for the safety and control of the manufacturing process.

With increased dependency on wireless communications for more complex manufacturing systems, the projection of manufacturing requirements onto the wireless communication system becomes less obvious. Understanding the connection between the communication system and the operational system is not always obvious. Such analysis of this projection is essential for future research of manufacturing systems. As such, the architectural elements and information flows exposed by an abstract model are a necessary first step. The model in its current state of development is comprehensive enough to support architectural and ontological analyses of the factory workcell. As such, information about the relationships between components of a workcell and attributes related to the wireless network may be discovered. Therefore, the model serves as a foundation for future systems engineering analyses. Moreover, the model may be used as a tool for academic and industry exploration of wireless testbed development.

7.3/ GRAPH DATABASE APPLICATION

Graph databases are designed to provide a powerful modeling framework for the storage and visualization of data in which relationships and connections between data could be significant but difficult to detect or visualize in the real world. When one hears the word "database," typically one envisions a relational database such as MySQL or Oracle in which the database stores information in a highly structured manner in which tables are constructed in a predetermined fashion with columns, rows, and rigidly defined data types. In contrast, GDBs are not rigid in their structure and organization. Data in graph databases are intrinsically stored within nodes and vertices (connections). Each node and vertex can have associated properties and thus store data as shown in Fig. 7.8 which illustrates the common notion of a graph database. In the graph units of information (nodes) exist with relationships lines between those units of information depicted as lines. The connecting lines represent relationships which are the essential building block used within the contribution presented in the thesis [31].

The GDB was employed within the work of this thesis. It was demonstrated

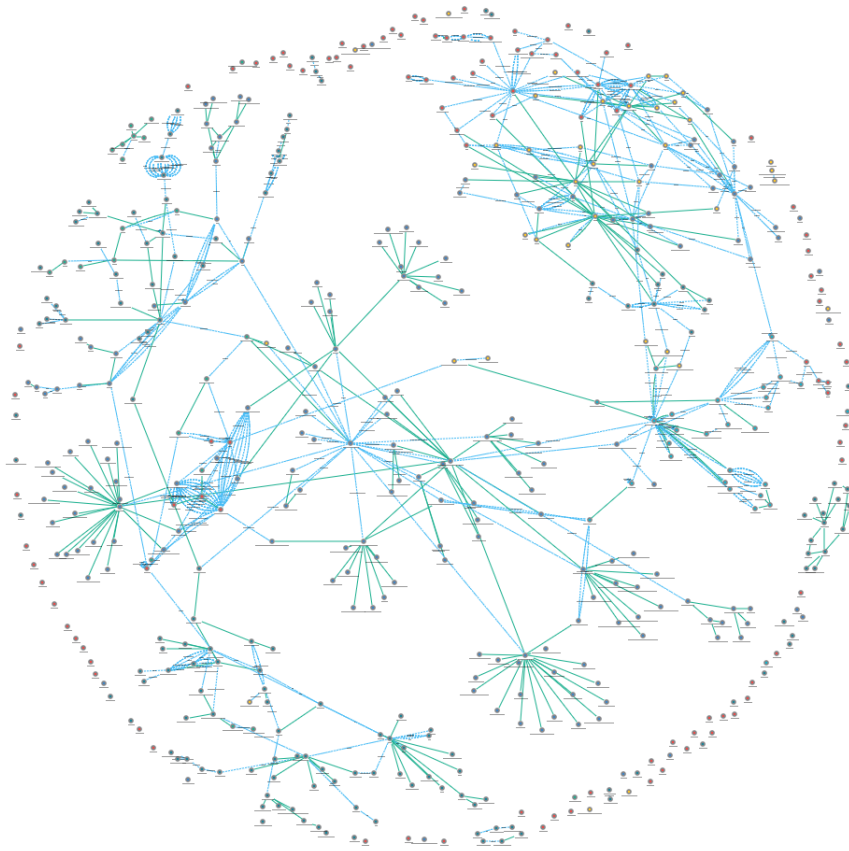

Figure 7.8: A notional spherical graph depicting nodes and vertices.

as an effective tool to model and capture performance information for research and possibly for situational awareness of factory operation. The objective of using a graph database was essentially to 1) leverage the inherent connectivity of the data resulting from the experiments being performed within the NIST Industrial Wireless Laboratory, and 2) demonstrate that wireless networks could be used for a significant class of use case without impacting physical system performance. To support the research performed for this contribution, a testbed was constructed. This testbed was described in Chapter 5 and is illustrated in the photo provided in Fig. 5.1. The design of the testbed is captured in Fig. 7.9. Two robot arms were used to move and inspect parts through a series of four (4) CNC machines. Each robot is equipped with a 6-DOF force torque sensor in its wrist. Joint control of each robots is conducted through a separate robot controller computer assembly. A PLC was used to supervise activity within the workcell and was called the Supervisor. The network and physical performance of the simulated workcell was captured completely agnostic of the type of communication network being used. Through the use of adapter and network TAP devices shown in the diagram, it was possible to capture packet flight data in a way such that the type of technology used for communication did not alter routing of information. By doing this, the schema of the graph database

was left relatively unchanged across experiments while different wired and wireless protocols were investigated. Many instances of graph databases were produced for each experiment conducted using the testbed.

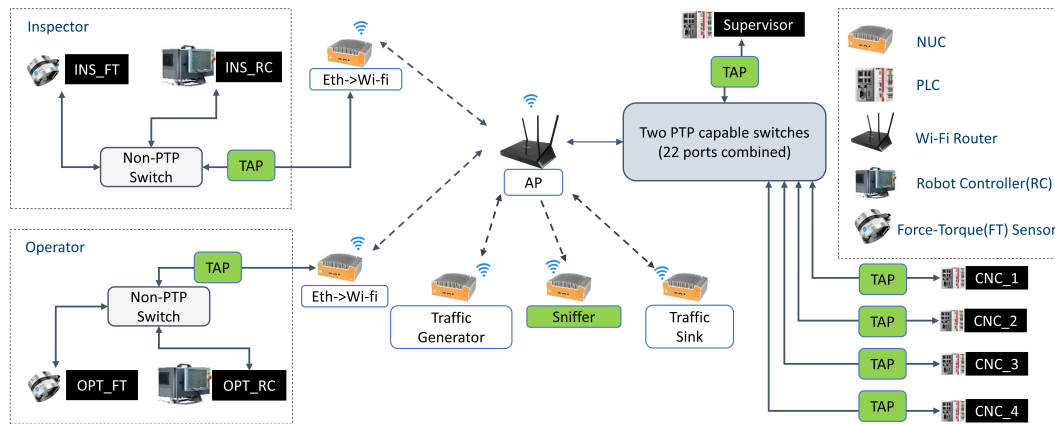

Figure 7.9: Experiment design used for capture of performance data throughout most of the research.

This shows what is important: the connection between physical actions and the transactions that support them. Transactions are grouping of information transmissions (i.e., packets) that traverse the wireless network. Factors that impact reliability of transactions such as message (i.e. packet) loss or message delay indirectly impact start and stop times of physical actions. These relationships are directly captured within a graph and thus the applicability of a GDB to the investigation of CPS performance becomes evident. Ultimately, one could argue that the primary contribution of this component of the thesis is to demonstrate the interconnection between the industrial (wireless) network and physical operations through the modeling and capture of the performance data, the data relationships, and the analysis of physical action performance when network performance is degraded. The use of the graph database makes that possible. As an example, the schema shown in Fig. 7.10 was produced by querying the schema of a single database with hundreds of physical actions and hundreds of thousands of supporting transactions. By querying the data represented by this structure, it was demonstrated that the wireless network employed did not prohibitively impact operation. It was also demonstrated that through querying of the performance outliers that network events such as loss in signal strength or an increase in interference could be linked to a delay in the actuation of a robot action. This type of event discovery and correlation to the physical world is particularly advantageous to facilitating the adoption of wireless in smart manufacturing.

It is my opinion that the relationships between the physical actions through the FOLLOWED and NEXT relationships as shown in Fig. 7.10 and the TRIGGER

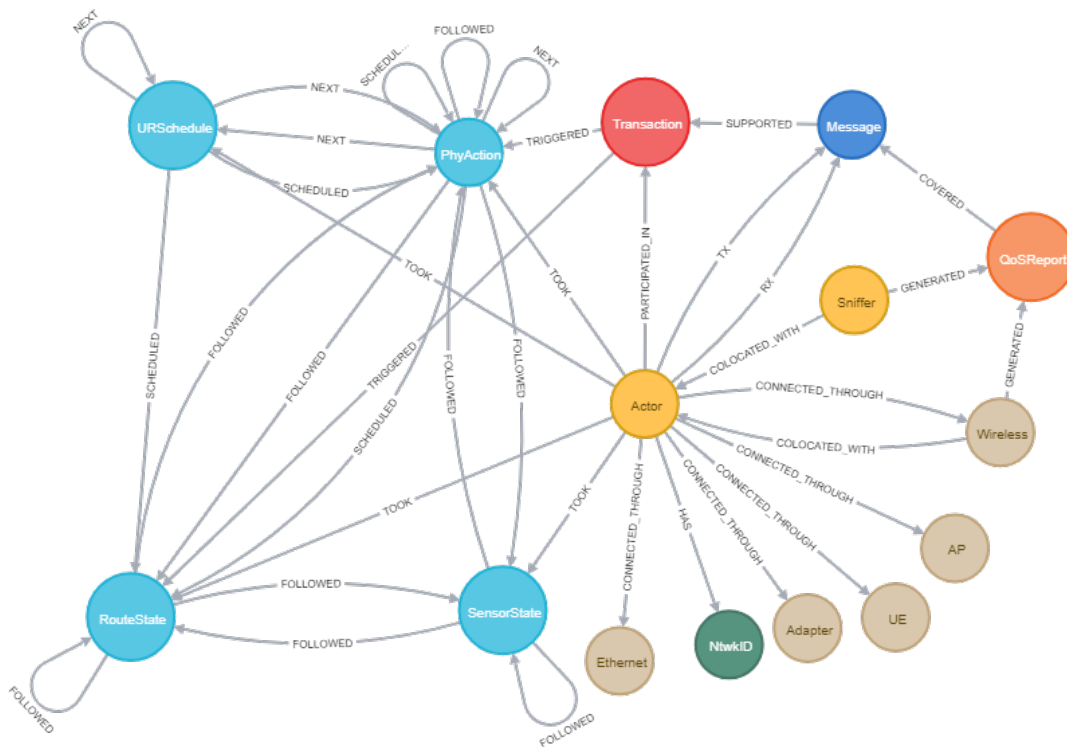

Figure 7.10: Experiment design used for capture of performance data.

relationships between physical actions and Transactions present a significant component of discovery within the results of this contribution. It is through the TRIGGER and FOLLOWED relationships that one can ascertain the impacts of network performance on physical systems performance. These are difficult to model with relationship databases. It is possible to do so, but it is not inherent in the nature of the database itself to store such relationships. When a triggering Transaction is correlated to a physical action using these relationships, it is then possible to follow the nodes backward in the graph to associated Message nodes and the QoS reports associated with those messages. These QoS reports provide evidence of degradation within the communication network during operation. It is important to note that the QoS reports used for this investigation were produced externally using wireless sniffer devices that were co-located with transceiver equipment. This was done due to the implementation difficulty in extracting QoS header information for each wireless packet received at each actor. Since the experiments were performed, a method to extract wireless QoS header data at each transceiver was discovered. Capture of wireless header information would enrich the data with more accurate QoS reports applicable directly to informational messages and thus allow for the construction of a more accurate data graph.

7.4/ MACHINE LEARNING APPLICATIONS

Machine learning (ML) is a large field of science and engineering that deals with the application of computing algorithms to perform actions without being explicitly programmed to do so. In general applications, ML is used from applications ranging from voice recognition in personal electronics, spam filtering in email, and performing traffic prediction for commuters to providing services such as friend identification and face recognition in social media. In industrial applications, machine learning has the promise of a wide range of applications such as robot autonomy and detection of security anomalies. In this thesis, a machine learning framework was demonstrated for the prediction of the SIR within a communications link used for the control of a robot arm depressing a spring apparatus. Our ML framework is shown to be useful and accurate in the prediction of link quality. LQE is an important metric in wireless communication system. It is a general term used to describe the level of quality of a communication link. The SIR metric is a ratio between the intended signal being transmitted and the level of interference competing with the intended signal. Interference, whether caused by malicious jamming or not, is an impeding factor in the adoption of wireless in smart manufacturing systems. Therefore, having a clear situational awareness picture of the level of interference and the quality of communication links being used is of clear interest.

7.5/ FUTURE RECOMMENDED WORK

The contribution presented within this thesis addresses the described needs directed toward CPS test and performance assessment methodologies. However, more work is need to improve upon the work presented here and expand upon its possibilities for application in live automation systems. We believe that the following ideas and topics are worthy of additional exploration by future students and researchers.

- **SysML Modeling Enhancements:** Application of the model described may be improved upon and incorporated into CPS simulations. By using the model and associated constraints, it should be possible to use the blocks defined to parameterize the simulation variables. Additionally, moving beyond simulation which uses simulation to understand complex systems through empirical analysis, complete mathematical analytical models could be constructed if the fidelity of the SysML model is sufficiently refined.
- **GDB Real-time Integrations:** A logical next step in applying GDBs to CPSs is to move its application from a post-experiment analysis to a real-time analysis

of a live system. Such an analysis could prove insightful in the prediction of factory workcell performance at near-real-time. Parallel data collection, cleaning, and insertion strategies could be considered. Further integration and feedback into the production system of information learned from real-time queries is possible to improve overall live performance of the factory.

- **GDB Schema Improvements:** During the experimentation with the Cipher query language, we found that some queries led to unusually large and intractable intermediate result sets which resulted in a computer crash regardless of the organization of the query statements themselves. This problem resulted from a Cartesian product explosion that was never sufficiently explained such that a resolution could be implemented. It was not clear if this was a result of normalization of the query within the Cipher interpreter or a result of the schema that we developed. Reorganization of our queries did not help to alleviate this problem which ultimately limited the usefulness of the GDB. The use of GDBs was nevertheless proven as it was an essential aid in organization of our very large CPS data sets produced from experimentation. For a scientist interested in such deep-dive questions related to database query languages or schema development, this would be an interesting problem.
- **ML Add More Dimensions:** Application of our ML framework to a system with more degrees of freedom such as the entire workcell. In our contributions, the ML framework was applied to a single wireless communication link used to control one robot arm. When expanded the framework to systems with more dimensions, the application of neural networks with deep learning may be beneficial.
- **Apply ML to Spectrum Monitoring System:** Application of online learning techniques such that our ML framework can learn and adapt as the workcell operates would be beneficial as well. In the current contribution, the ML framework learns offline from training data and then applies its knowledge to an active system. This prohibits the system from learning as the wireless network changes over time. Online techniques could allow for the ML framework to account for a changing spectral environment.
- **Integrate ML with the Control System:** Integration of our ML framework with the workcell control system such that the control system can adapt dynamically to interference for example to allow the control system to task preventative actions for safety or to operate in a reduced performance mode.

7.6/ CLOSING REMARKS

This thesis began with the very broad objective of investigating the area of performance estimation, testing, and control of CPSs employing non-ideal communications networks. An ideal communication network is one in which all data arrives reliably and on-time. In industrial settings, an ideal network is usually a wired networks built upon fieldbus protocols such as EtherCAT and CANbus or switched protocols founded upon Ethernet. Ethernet and fieldbus are not 100% reliable but their performance is nearly ideal for their intended applications. Co-design, therefore, of the control system with the industrial network is often an unnecessary consideration in a wired network. Enter industrial communication networks built upon wireless technology, and the situation appears very different. While wireless technology provides key benefits in mobility and cost reduction, reliability of the network as compared to wired counterparts drops dramatically. While wired network solutions can more easily transport data with more reliability and determinism, wireless solutions are built upon a shared limited physical medium, the electromagnetic spectrum, that is finite in bandwidth and is easily inhibited by distance, interference, and the structure of the surround environment. Much hype exists surrounding the benefits of use of wireless in factories for collecting information about the operation and more recently for control of the factory itself. Therefore, it becomes important to understand the operational requirements of the factory and then develop methods for assessing the performance of the factory network employing non-ideal communication such as that IWN. This thesis has contributed to this undertaking by doing the following:

1. In Part I, an historical account of the past four industrial revolutions is provided. In addition, the thesis introduces the reader to the importance of wireless networking in smart manufacturing and the main challenges that it faces toward widespread adoption. A review of the state-of-the-art of the requirements of industrial requirements, systems modeling, application of GDBs to the problem of CPSs, and machine learning are also presented. Within this look at the state of the art, our contribution within this thesis to wireless user requirements is also presented.
2. In Part II, we provide the technical contributions of this thesis. Contributions in the areas of requirements, systems modeling, GDB application, and machine learning are presented. Each of the four chapters within Part II describe our novel contributions as follows:
 1. Chapter 3 explored the vast and continually changing landscape of wireless technology and provided new perspective of the applicability of existing and emerging technologies to classes of industrial sensing and control ap-

plications.

2. Chapter 4, presented a new framework for the modeling of CPSs employing wireless communication as the primary mode of data transfer using SysML.
3. Chapter 5 presented the work of applying the GDB to the problem of storing and querying performance data of the CPS. Cyberphysical system performance data is highly connected, and thus the graph database was demonstrated to be a viable means of storing the data and discovering correlations within the data between network performance and operational performance.
4. Finally, Chapter 6 presented the work of applying machine learning to prediction of QoS of wireless communication links within a representative industrial use case, a force seeking apparatus.

BIBLIOGRAPHY

- [1] S. S. Sunder and E. A. Lee, “Cyber-Physical Systems - a Concept Map.” [Online]. Available: <https://ptolemy.berkeley.edu/projects/cps/>
- [2] B. Galloway and G. P. Hancke, “Introduction to industrial control networks,” *IEEE Communications Surveys Tutorials*, vol. 15, no. 2, pp. 860–880, 2013.
- [3] “Industrial Network Security,” *Network Security*, 2015.
- [4] B. Holfeld, D. Wieruch, T. Wirth, L. Thiele, S. A. Ashraf, J. Huschke, I. Aktas, and J. Ansari, “Wireless communication for factory automation: an opportunity for lte and 5g systems,” *IEEE Communications Magazine*, vol. 54, no. 6, pp. 36–43, Jun. 2016.
- [5] K. Montgomery, R. Candell, Y. Liu, and M. Hany, “Wireless User Requirements for the Factory Work-cell,” *Tech. Rep.*, 2019. [Online]. Available: <https://www.nist.gov/publications/wireless-user-requirements-factory-workcell>
- [6] M. Luvisotto, Z. Pang, and D. Dzung, “Ultra High Performance Wireless Control for Critical Applications: Challenges and Directions,” *IEEE Transactions on Industrial Informatics*, vol. 13, no. 3, pp. 1448–1459, Jun. 2017. [Online]. Available: <http://ieeexplore.ieee.org/document/7589996/>
- [7] R. Candell and M. Kashef, “Industrial wireless: Problem space, success considerations, technologies, and future direction,” in *2017 Resilience Week (RWS)*, Sep. 2017, pp. 133–139.
- [8] C. Roser, “Industry 4.0 – The Fourth Industrial Revolution,” 2019. [Online]. Available: <https://www.renaix.com/industry-4-0-the-fourth-industrial-revolution/>
- [9] “HANNOVER MESSE abuzz with Industry 4.0 and Partner Country USA,” available at <http://hannovermesse.events/hannover-messe-abuzz-with-industry-4-0-and-partner-country-usa/>.
- [10] “An American in Germany: Lessons from Hannover Messe 2016 | Machine Design,” 2016. [Online]. Available: <https://www.machinedesign.com/community/editorial-comment/article/21835229/an-american-in-germany-lessons-from-hannover-messe-2016>

- [11] T. P. Raptis, A. Passarella, and M. Conti, "Data management in industry 4.0: State of the art and open challenges," *IEEE Access*, vol. 7, pp. 97052–97093, 2019.
- [12] B. Marr, "What is Industry 4.0? Here's A Super Easy Explanation For Anyone," 2018. [Online]. Available: <https://www.forbes.com/sites/bernardmarr/2018/09/02/what-is-industry-4-0-heres-a-super-easy-explanation-for-anyone/{#}5c7254889788>
- [13] E. Mueller, X.-L. Chen, and R. Riedel, "Challenges and Requirements for the Application of Industry 4.0: A Special Insight with the Usage of Cyber-Physical System," *Chinese Journal of Mechanical Engineering*, vol. 30, no. 5, pp. 1050–1057, sep 2017. [Online]. Available: <http://link.springer.com/10.1007/s10033-017-0164-7>
- [14] P. Zheng, H. Wang, Z. Sang, R. Y. Zhong, Y. Liu, C. Liu, K. Mubarak, S. Yu, and X. Xu, "Smart manufacturing systems for Industry 4.0: Conceptual framework, scenarios, and future perspectives," *Frontiers of Mechanical Engineering*, vol. 13, no. 2, pp. 137–150, jun 2018. [Online]. Available: <http://link.springer.com/10.1007/s11465-018-0499-5>
- [15] Y. Liu, M. Kashef, K. B. Lee, L. Benmohamed, and R. Candell, "Wireless Network Design for Emerging IIoT Applications: Reference Framework and Use Cases," *Proceedings of the IEEE*, vol. 107, no. 6, pp. 1166–1192, jun 2019. [Online]. Available: <https://ieeexplore.ieee.org/document/8692410/>
- [16] J. Cheng, W. Chen, F. Tao, and C.-L. Lin, "Industrial IoT in 5G environment towards smart manufacturing," *Journal of Industrial Information Integration*, vol. 10, pp. 10–19, jun 2018. [Online]. Available: <https://linkinghub.elsevier.com/retrieve/pii/S2452414X18300049>
- [17] J. Proakis, *Digital Communications*, ser. Communications and signal processing. McGraw-Hill, 1995. [Online]. Available: <https://books.google.com/books?id=cIqYQgAACAAJ>
- [18] "Industrial WSN Report 2014," ON World, San Diego, CA, Tech. Rep., 2014.
- [19] J. Song, S. Han, A. Mok, D. Chen, M. Lucas, M. Nixon, and W. Pratt, "WirelessHART: Applying Wireless Technology in Real-Time Industrial Process Control," in *2008 IEEE Real-Time and Embedded Technology and Applications Symposium*. IEEE, Apr. 2008, pp. 377–386. [Online]. Available: <http://ieeexplore.ieee.org/lpdocs/epic03/wrapper.htm?arnumber=4550808>
- [20] "ANSI/ISA-100.11a-2011 Wireless systems for industrial automation: Process control and related applications," The International Society of Automation,

- Research Triangle Park, Tech. Rep., 2011. [Online]. Available: <https://www.isa.org/>
- [21] B. Martinez, C. Cano, and X. Vilajosana, “A square peg in a round hole: The complex path for wireless in the manufacturing industry,” *IEEE Communications Magazine*, vol. 57, no. 4, pp. 109–115, Apr. 2019.
- [22] R. Candell, M. Hany, K. B. Lee, Y. Liu, J. Quimby, and K. Remley, “Guide to industrial wireless systems deployments,” National Institute of Standards and Technology, Gaithersburg, MD, Tech. Rep., Apr. 2018. [Online]. Available: <http://nvlpubs.nist.gov/nistpubs/ams/NIST.AMS.300-4.pdf>
- [23] R. Candell, C. Remley, J. Quimby, D. Novotny, A. Curtin, P. Papazian, G. Koepke, J. Diener, and M. Kashef, “Industrial wireless systems: Radio propagation measurements,” National Institute of Standards and Technology, Gaithersburg, MD, Tech. Rep., 2017. [Online]. Available: <http://nvlpubs.nist.gov/nistpubs/TechnicalNotes/NIST.TN.1951.pdf>
- [24] T. S. Rappaport, S. Y. Seidel, and K. Takamizawa, “Statistical Channel Impulse Response Models for Factory and Open Plan Building Radio Communication System Design,” *IEEE Transactions on Communications*, vol. 39, no. 5, pp. 794–807, 1991.
- [25] K. A. Remley, J. Coder, C. A. Grosvenor, R. T. Johnk, G. H. Koepke, J. M. Ladbury, and D. Camell, “NIST-TN-1550 NIST tests of the wireless environment in automobile manufacturing facilities,” National Bureau of Standards, Gaithersburg, MD, Tech. Rep., 2008. [Online]. Available: <http://nvlpubs.nist.gov/nistpubs/Legacy/TN/nbstechnicalnote1550.pdf>
- [26] R. Candell, K. Montgomery, M. Kashef, Y. Liu, and S. Fofou, “Wireless interference estimation using machine learning in a robotic force-seeking scenario,” in *2019 IEEE 28th International Symposium on Industrial Electronics (ISIE)*, Jun. 2019, pp. 1334–1341.
- [27] K. Stouffer, V. Pillitteri, S. Lightman, M. Abrams, and A. Hahn, “Guide to Industrial Control Systems (ICS) Security,” National Institute of Standards and Technology, Gaithersburg, MD, Tech. Rep., Jun. 2015. [Online]. Available: <http://nvlpubs.nist.gov/nistpubs/SpecialPublications/NIST.SP.800-82r2.pdf>
- [28] R. Candell, M. Kashef, Y. Liu, K. B. Lee, and S. Fofou, “Industrial wireless systems guidelines: Practical considerations and deployment life cycle,” in *IEEE Industrial Electronics Magazine*, vol. 12, no. 4, pp. 6–17, Dec. 2018.
- [29] R. Candell, M. Kashef, Y. Liu, and S. Fofou, “A sysml representation of the wireless factory work cell,” *The International Journal of Advanced Manufacturing Technology*, pp. 1–22, 2019.

- [30] R. Candell, "A SysML Model of the Wireless Factory Work-cell," NIST Journal of Research, 2018, available at <https://doi.org/10.1007/s00170-019-03629-x>.
- [31] R. Candell, M. Kashef, Y. Liu, K. Montgomery, and S. Foufou, "A graph database approach to wireless iiot work-cell performance evaluation," in Proceedings of the 2020 IEEE International Conference on Industrial Technology, Feb. 2020.
- [32] M. Kashef, Y. Liu, K. Montgomery, and R. Candell, "Wireless Cyber-Physical Systems Performance Evaluation through a Graph Database Approach," Journal of Computing and Information Science in Engineering, pp. 1–19, 08 2020. [Online]. Available: <https://doi.org/10.1115/1.4048205>
- [33] R. Candell, K. Montgomery, M. Kashef, Y. Liu, and S. Foufou, "Wireless interference estimation using machine learning in a robotic force-seeking scenario," in 2019 IEEE 28th International Symposium on Industrial Electronics (ISIE), Jun. 2019, pp. 1334–1341.
- [34] R. Candell, M. Kashef, Y. Liu, K. Montgomery, and S. Foufou, "Interference level estimation using machine learning in a robotic force-seeking scenario," ISA Transactions (Submitted), 2020.
- [35] Smart Manufacturing Testbed for the Advancement of Wireless Adoption in the Factory, ser. International Conference on Product Lifecycle Management, 07 2020.
- [36] On the Impact of Wireless Communications on Controlling a Two-Dimensional Gantry System, ser. International Manufacturing Science and Engineering Conference, vol. Volume 1: Additive Manufacturing; Manufacturing Equipment and Systems; Bio and Sustainable Manufacturing, 06 2019. [Online]. Available: <https://doi.org/10.1115/MSEC2019-2896>
- [37] B. Galloway and G. P. Hancke, "Introduction to industrial control networks," IEEE Communications Surveys Tutorials, vol. 15, no. 2, pp. 860–880, Second 2013.
- [38] J. R. Moyne and D. M. Tilbury, "The emergence of industrial control networks for manufacturing control, diagnostics, and safety data," Proceedings of the IEEE, vol. 95, no. 1, pp. 29–47, Jan. 2007.
- [39] "What are industrial communication networks? an overview," <http://www.electricaltechnology.org/2016/12/industrial-communication-networks-systems.html>, accessed: 2017-04-20.

- [40] P. Danielis, J. Skodzik, V. Altmann, E. B. Schweissguth, F. Golatowski, D. Timmermann, and J. Schacht, "Survey on real-time communication via ethernet in industrial automation environments," in Proceedings of the 2014 IEEE Emerging Technology and Factory Automation (ETFA), Sep. 2014, pp. 1–8.
- [41] "Connectivity provides the lifeline of industrial control," <http://electronicdesign.com/industrial/connectivity-provides-lifeline-industrial-control>, accessed: 2017-04-20.
- [42] W. Ikram and N. F. Thornhill, "Wireless communication in process automation: A survey of opportunities, requirements, concerns and challenges," in UKACC International Conference on Control 2010, Sep. 2010, pp. 1–6.
- [43] D. V. Queiroz, M. S. Alencar, R. D. Gomes, I. E. Fonseca, and C. Benavente-Peces, "Survey and systematic mapping of industrial wireless sensor networks," *Journal of Network and Computer Applications*, vol. 97, pp. 96–125, 2017. [Online]. Available: <http://www.sciencedirect.com/science/article/pii/S1084804517302771>
- [44] "Wireless User Requirements for Factory Automation," The International Society of Automation, Research Triangle Park, Tech. Rep., 2011. [Online]. Available: <https://www.isa.org/>
- [45] (ETSI), "Etsi tr 103 588 reconfigurable radio systems (rrs); feasibility study on temporary spectrum access for local high-quality wireless networks," European Telecommunications Standards Institute (ETSI), Sophia-Antipolis, Tech. Rep., 2018.
- [46] R. A. Knepper, T. Layton, J. Romanishin, and D. Rus, "Ikeabot: An autonomous multi-robot coordinated furniture assembly system," in 2013 IEEE International Conference on Robotics and Automation, May 2013, pp. 855–862.
- [47] X. Ou, Q. Chang, J. Zou, J. Arinez, and G. Xiao, "Modeling and performance diagnostics of composite work cells with gantries," *IEEE Transactions on Automation Science and Engineering*, vol. 15, no. 3, pp. 1230–1242, Jul. 2018.
- [48] X. Ou, J. Arinez, Q. Chang, and J. Zou, "Performance analysis of a composite work cell with a gantry and system reconfiguration," *Journal of Manufacturing Systems*, vol. 45, pp. 212–221, 2017. [Online]. Available: <http://www.sciencedirect.com/science/article/pii/S0278612517301334>
- [49] M. Colledani and S. B. Gershwin, "A decomposition method for approximate evaluation of continuous flow multi-stage lines with general markovian machines," *Annals of Operations Research*, vol. 209, no. 1, pp. 5–40, Oct. 2013. [Online]. Available: <https://doi.org/10.1007/s10479-011-0961-9>

- [50] B. Xia, L. Xi, B. Zhou, and S. Du, “An efficient analytical method for performance evaluation of transfer lines with unreliable machines and finite transfer-delay buffers,” *International Journal of Production Research*, vol. 51, no. 6, pp. 1799–1819, 2013. [Online]. Available: <https://doi.org/10.1080/00207543.2012.713137>
- [51] S. B. Gershwin and L. M. Werner, “An approximate analytical method for evaluating the performance of closed-loop flow systems with unreliable machines and finite buffers,” *International Journal of Production Research*, vol. 45, no. 14, pp. 3085–3111, 2007. [Online]. Available: <https://doi.org/10.1080/00207540500385980>
- [52] Q. Chang, S. Biller, G. Xiao, and J. Liu, “Transient analysis of downtimes and bottleneck dynamics in serial manufacturing systems,” vol. 132, 10 2010.
- [53] J. Liu, Q. Chang, G. Xiao, and S. Biller, “The costs of downtime incidents in serial multistage manufacturing systems,” *Journal of Manufacturing Science and Engineering*, vol. 134, no. 2, pp. 021 016–021 016–10, Apr. 2012. [Online]. Available: <http://dx.doi.org/10.1115/1.4005789>
- [54] I. Chen, “Rapid response manufacturing through a rapidly reconfigurable robotic workcell,” *Robotics and Computer-Integrated Manufacturing*, vol. 17, no. 3, pp. 199–213, 2001. [Online]. Available: <http://www.sciencedirect.com/science/article/pii/S0736584500000284>
- [55] T. Gaspar, B. Ridge, R. Bevec, M. Bem, I. Kovač, A. Ude, and . Gosar, “Rapid hardware and software reconfiguration in a robotic workcell,” in 2017 18th International Conference on Advanced Robotics (ICAR), Jul. 2017, pp. 229–236.
- [56] E. Molina, O. Lazaro, M. Sepulcre, J. Gozalvez, A. Passarella, T. P. Raptis, A. Ude, B. Nemeč, M. Rooker, F. Kirstein, and E. Mooij, “The autoware framework and requirements for the cognitive digital automation,” in *Collaboration in a Data-Rich World*, L. M. Camarinha-Matos, H. Afsarmanesh, and R. Fornasiero, Eds. Cham: Springer International Publishing, 2017, pp. 107–117.
- [57] P. Ferreira, V. Reyes, and J. Mestre, “Control architecture for a supervised industrial robotic workcell integration,” in ETFA2011, Sep. 2011, pp. 1–4.
- [58] M. Fulea, S. Popescu, E. Brad, B. Mocan, and M. Murar, “A literature survey on reconfigurable industrial robotic work cells,” vol. 762, pp. 233–241, 5 2015.
- [59] J. Voas, “NIST-SP-800-183 Networks of ‘Things’,” National Institute of Standards and Technologies, Gaithersburg, MD, Tech. Rep., 2016. [Online]. Available: <https://nvlpubs.nist.gov/nistpubs/SpecialPublications/NIST.SP.800-183.pdf>

- [60] A. Oliveira, E. D. Pieri, and U. Moreno, "An open-architecture robot controller applied to interaction tasks," in *Advances in Robot Manipulators*, E. Hall, Ed. Rijeka: InTech, 2010, ch. 5.
- [61] E. Carpanzano and F. Jovane, "Advanced automation solutions for future adaptive factories," *CIRP Annals*, vol. 56, no. 1, pp. 435–438, 2007. [Online]. Available: <http://www.sciencedirect.com/science/article/pii/S0007850607001059>
- [62] G. Michalos, S. Makris, P. Tsarouchi, T. Guasch, D. Kontovrakis, and G. Chryssolouris, "Design considerations for safe human-robot collaborative workplaces," *Procedia CIRP*, vol. 37, pp. 248–253, 2015, *cIRPe 2015 - Understanding the life cycle implications of manufacturing*. [Online]. Available: <http://www.sciencedirect.com/science/article/pii/S2212827115008550>
- [63] J. T. C. Tan, F. Duan, Y. Zhang, K. Watanabe, R. Kato, and T. Arai, "Human-robot collaboration in cellular manufacturing: Design and development," in *2009 IEEE/RSJ International Conference on Intelligent Robots and Systems*, Oct. 2009, pp. 29–34.
- [64] F. Duan, J. T. C. Tan, and T. Arai, "Using motion capture data to regenerate operator's motions in a simulator in real time," in *2008 IEEE International Conference on Robotics and Biomimetics*, Feb. 2009, pp. 102–107.
- [65] "Electromagnetic Compatibility And Radio Spectrum Matters (Erm); System Reference Document; Short Range Devices (Srd); Part 2: Technical Characteristics For Srd Equipment For Wireless Industrial Applications Using Technologies Different From Ultra-wide Ban," Sophia-Antipolis, 2011. [Online]. Available: https://www.etsi.org/deliver/etsi_tr/102800_102899/10288902/01.01.01_60/tr_10288902v010101p.pdf
- [66] 3GPP, Service requirements for the 5G system; Stage 1 (Release 16), 3GPP, Mar. 2018, v16.3.0.
- [67] Y. Liu, R. Candell, K. Lee, and N. Moayeri, "A simulation framework for industrial wireless networks and process control systems," in *2016 IEEE World Conference on Factory Communication Systems (WFCS)*. IEEE, May 2016, pp. 1–11. [Online]. Available: <http://ieeexplore.ieee.org/document/7496495/>
- [68] M. Pidd, *Systems modelling : theory and practice*. Chichester : Wiley, 2004, formerly CIP.
- [69] A. M. Law and D. M. Kelton, *Simulation Modeling and Analysis*, 3rd ed. McGraw-Hill Higher Education, 1999.

- [70] (Object Management Group), “OMG Systems Modeling Language,” 2017. [Online]. Available: <https://www.omg.org/spec/SysML/1.5>
- [71] L. E. Hart, “Introduction to model-based system engineering (mbse) and sysml,” 2015. [Online]. Available: <https://www.incose.org/docs/default-source/delaware-valley/mbse-overview-incose-30-july-2015.pdf>
- [72] S. Friedenthal, A. Moore, and R. Steiner, *A Practical Guide to SysML*, 3rd ed., Boston, 2015.
- [73] M. Lütjen and D. Rippel, “GRAMOSA framework for graphical modelling and simulation-based analysis of complex production processes,” *The International Journal of Advanced Manufacturing Technology*, vol. 81, no. 1-4, pp. 171–181, Oct. 2015. [Online]. Available: <http://link.springer.com/10.1007/s00170-015-7037-y>
- [74] A. Lüder, E. Estévez, L. Hundt, and M. Marcos, “Automatic transformation of logic models within engineering of embedded mechatronical units,” *The International Journal of Advanced Manufacturing Technology*, vol. 54, no. 9-12, pp. 1077–1089, Jun. 2011. [Online]. Available: <http://link.springer.com/10.1007/s00170-010-3010-y>
- [75] M. Jia, G. Ding, S. Qin, R. Li, and Y. He, “Research of design and analysis integrated information modeling framework for multibody mechanical system: with its application in the LHD design,” *The International Journal of Advanced Manufacturing Technology*, vol. 66, no. 9-12, pp. 2107–2122, Jun. 2013. [Online]. Available: <http://link.springer.com/10.1007/s00170-012-4485-5>
- [76] M. L. Alvarez, E. Estévez, I. Sarachaga, A. Burgos, and M. Marcos, “A novel approach for supporting the development cycle of automation systems,” *The International Journal of Advanced Manufacturing Technology*, vol. 68, no. 1-4, pp. 711–725, Sep. 2013. [Online]. Available: <http://link.springer.com/10.1007/s00170-013-4793-4>
- [77] Y. Quinsat, L. Dubreuil, and C. Lartigue, “A novel approach for in-situ detection of machining defects,” *The International Journal of Advanced Manufacturing Technology*, vol. 90, no. 5-8, pp. 1625–1638, May 2017. [Online]. Available: <http://link.springer.com/10.1007/s00170-016-9478-3>
- [78] C. Durugbo, A. Tiwari, and J. R. Alcock, “A review of information flow diagrammatic models for product–service systems,” *The International Journal of Advanced Manufacturing Technology*, vol. 52, no. 9-12, pp. 1193–1208, Feb. 2011. [Online]. Available: <http://link.springer.com/10.1007/s00170-010-2765-5>

- [79] Stanford University, “Protege, A free, open-source ontology editor and framework for building intelligent systems,” available at <https://protege.stanford.edu/>.
- [80] W3C, “Web Ontology Language (OWL),” 2012, available at <https://www.w3.org/OWL/>.
- [81] J. Pokorny, “NoSQL databases: a step to database scalability in web environment,” *International Journal of Web Information Systems*, vol. 9, no. 1, pp. 69–82, 2013. [Online]. Available: <https://doi.org/10.1108/17440081311316398>
- [82] Z. J. Zhang, “Graph databases for knowledge management,” *IT Professional*, vol. 19, no. 6, pp. 26–32, Nov. 2017.
- [83] J. Webber and I. Robinson, “The top 5 use cases of graph databases,” white paper, Neo4j, 2015.
- [84] M. Gomez-Rodriguez, J. Leskovec, and A. Krause, “Inferring networks of diffusion and influence,” *ACM Trans. Knowl. Discov. Data*, vol. 5, no. 4, pp. 21:1–21:37, Feb. 2012. [Online]. Available: <http://doi.acm.org/10.1145/2086737.2086741>
- [85] S. Skhiri and S. Jouili, *Large Graph Mining: Recent Developments, Challenges and Potential Solutions*. Berlin, Heidelberg: Springer Berlin Heidelberg, 2013, pp. 103–124. [Online]. Available: https://doi.org/10.1007/978-3-642-36318-4_5
- [86] R. Angles and C. Gutierrez, “Survey of graph database models,” *ACM Comput. Surv.*, vol. 40, no. 1, pp. 1:1–1:39, Feb. 2008. [Online]. Available: <http://doi.acm.org/10.1145/1322432.1322433>
- [87] R. Kumar Kaliyar, “Graph databases: A survey,” in *International Conference on Computing, Communication Automation*, May 2015, pp. 785–790.
- [88] H. R. Vyawahare and P. P. Karde, “An overview on graph database model,” *International Journal of Innovative Research in Computer and Communication Engineering (IJIRCCE)*, vol. 3, pp. 7454–7457, Aug. 2015.
- [89] P. S. Jadhav and R. K. Oberoi, “Comparative analysis of graph database models using classification and clustering by using weka tool,” 2015.
- [90] P. Macko, D. Margo, and M. Seltzer, “Performance introspection of graph databases,” in *Proceedings of the 6th International Systems and Storage Conference*, ser. SYSTOR '13. New York, NY, USA: ACM, 2013, pp. 18:1–18:10. [Online]. Available: <http://doi.acm.org/10.1145/2485732.2485750>

- [91] K. N. Satone, “Modern graph databases models,” *International Journal of Engineering Research and Applications (IJERA)*, pp. 19–24, 2014.
- [92] P. T. Wood, “Query languages for graph databases,” *SIGMOD Record*, vol. 41, pp. 50–60, 2012.
- [93] J. Wang, W. Zhang, Y. Shi, S. Duan, and J. Liu, “Industrial big data analytics: Challenges, methodologies, and applications,” *CoRR*, vol. abs/1807.01016, 2018. [Online]. Available: <http://arxiv.org/abs/1807.01016>
- [94] J. Lee, *Industrial Big Data* (Mechanical Industry Press, China), 7 2015.
- [95] H.-N. Dai, H. Wang, G. Xu, J. Wan, and M. Imran, “Big data analytics for manufacturing internet of things: opportunities, challenges and enabling technologies,” *Enterprise Information Systems*, vol. 0, no. 0, pp. 1–25, 2019. [Online]. Available: <https://doi.org/10.1080/17517575.2019.1633689>
- [96] (GE), “Unlocking machine data to turn insights into powerful outcomes,” available at <https://www.ge.com/digital/>.
- [97] J. Wan, S. Tang, D. Li, S. Wang, C. Liu, H. Abbas, and A. V. Vasilakos, “A manufacturing big data solution for active preventive maintenance,” *IEEE Transactions on Industrial Informatics*, vol. 13, no. 4, pp. 2039–2047, Aug. 2017.
- [98] B. Courtney, “Industrial big data analytics: The present and future,” *InTech Magazine*, 2019, available at <https://www.isa.org/intech/20140801>.
- [99] (ABB), “Big Data and decision-making in industrial plants,” available at <https://new.abb.com/cpm/production-optimization/big-data-analytics-decision-making>.
- [100] J. Wan, S. Tang, D. Li, S. Wang, C. Liu, H. Abbas, and A. V. Vasilakos, “A manufacturing big data solution for active preventive maintenance,” *IEEE Transactions on Industrial Informatics*, vol. 13, no. 4, pp. 2039–2047, Aug. 2017.
- [101] C. Küçükkeçeci and A. Yazici, “Multilevel object tracking in wireless multimedia sensor networks for surveillance applications using graph-based big data,” *IEEE Access*, vol. 7, pp. 67818–67832, 2019.
- [102] S. A. Ayoughi, W. Yu, S. R. Khosravirad, and H. Viswanathan, “Interference mitigation for ultrareliable low-latency wireless communication,” *IEEE Journal on Selected Areas in Communications*, vol. 37, no. 4, pp. 869–880, Apr. 2019.

- [103] S. Kumar, F. Kaltenberger, A. Ramirez, and B. Kloiber, “An SDR implementation of wifi receiver for mitigating multiple co-channel zigbee interferers,” *EURASIP Journal on Wireless Communications and Networking*, vol. 2019, no. 1, p. 224, Sep. 2019. [Online]. Available: <https://doi.org/10.1186/s13638-019-1512-3>
- [104] N. Bhushan, Junyi Li, D. Malladi, R. Gilmore, D. Brenner, A. Damnjanovic, R. Sukhavasi, C. Patel, and S. Geirhofer, “Network densification: the dominant theme for wireless evolution into 5G,” *IEEE Communications Magazine*, vol. 52, no. 2, pp. 82–89, Feb. 2014. [Online]. Available: <http://ieeexplore.ieee.org/document/6736747/>
- [105] R. D. Gomes, D. V. Queiroz, A. C. Lima Filho, I. E. Fonseca, and M. S. Alencar, “Real-time link quality estimation for industrial wireless sensor networks using dedicated nodes,” *Ad Hoc Networks*, vol. 59, pp. 116–133, May 2017. [Online]. Available: <https://linkinghub.elsevier.com/retrieve/pii/S1570870517300434>
- [106] N. Baccour, A. Koubâa, L. Mottola, M. A. Zúñiga, H. Youssef, C. A. Boano, and M. Alves, “Radio link quality estimation in wireless sensor networks,” *ACM Transactions on Sensor Networks*, vol. 8, no. 4, pp. 1–33, Sep. 2012. [Online]. Available: <http://dl.acm.org/citation.cfm?doid=2240116.2240123>
- [107] U. Wetzker, I. Splitt, M. Zimmerling, C. A. Boano, and K. Romer, “Troubleshooting Wireless Coexistence Problems in the Industrial Internet of Things,” in *Proceedings - 19th IEEE International Conference on Computational Science and Engineering, 14th IEEE International Conference on Embedded and Ubiquitous Computing and 15th International Symposium on Distributed Computing and Applications to Business*, Engi, 2017.
- [108] G. H. Koepke, W. F. Young, J. M. Ladbury, and J. B. Coder, “Interference and Coexistence of Wireless Systems in Critical Infrastructure,” National Institute of Standards and Technology, Gaithersburg, MD, Tech. Rep., Jul. 2015. [Online]. Available: <https://nvlpubs.nist.gov/nistpubs/TechnicalNotes/NIST.TN.1885.pdf>
- [109] A. AHMADI, M. MORADI, C. CHERIFI, V. CHEUTET, and Y. OUZROUT, “Wireless connectivity of cps for smart manufacturing: A survey,” in *2018 12th International Conference on Software, Knowledge, Information Management Applications (SKIMA)*, Dec. 2018, pp. 1–8.
- [110] A. Cetinkaya, H. Ishii, and T. Hayakawa, “An overview on denial-of-service attacks in control systems: Attack models and security analyses,” *Entropy*, vol. 21, no. 2, p. 210, Feb. 2019. [Online]. Available: <http://dx.doi.org/10.3390/e21020210>

- [111] Wenyuan Xu, Ke Ma, W. Trappe, and Yanyong Zhang, “Jamming sensor networks: attack and defense strategies,” *IEEE Network*, vol. 20, no. 3, pp. 41–47, May 2006.
- [112] K. Pelechrinis, M. Iliofotou, and S. V. Krishnamurthy, “Denial of service attacks in wireless networks: The case of jammers,” *IEEE Communications Surveys and Tutorials*, vol. 13, no. 2, pp. 245–257, Feb. 2011.
- [113] A. Fragkiadakis, I. Askoxylakis, and P. Chatziadam, “Denial-of-service attacks in wireless networks using off-the-shelf hardware,” in *Distributed, Ambient, and Pervasive Interactions*, N. Streitz and P. Markopoulos, Eds. Cham: Springer International Publishing, 2014, pp. 427–438.
- [114] I. Tomić, M. J. Breza, G. Jackson, L. Bhatia, and J. A. McCann, “Design and evaluation of jamming resilient cyber-physical systems,” in *2018 IEEE International Conference on Internet of Things (iThings) and IEEE Green Computing and Communications (GreenCom) and IEEE Cyber, Physical and Social Computing (CPSCom) and IEEE Smart Data (SmartData)*, Jul. 2018, pp. 687–694.
- [115] H. Shisheh Feroosh and S. Martínez, “On event-triggered control of linear systems under periodic denial-of-service jamming attacks,” in *2012 IEEE 51st IEEE Conference on Decision and Control (CDC)*, Dec. 2012, pp. 2551–2556.
- [116] C. D. Persis and P. Tesi, “Resilient control under denial-of-service,” *IFAC Proceedings Volumes*, vol. 47, no. 3, pp. 134–139, 2014, 19th IFAC World Congress. [Online]. Available: <http://www.sciencedirect.com/science/article/pii/S1474667016416058>
- [117] A. Cetinkaya, H. Ishii, and T. Hayakawa, “Event-triggered control over unreliable networks subject to jamming attacks,” in *2015 54th IEEE Conference on Decision and Control (CDC)*, Dec. 2015, pp. 4818–4823.
- [118] V. S. Dolk, P. Tesi, C. De Persis, and W. P. M. H. Heemels, “Event-triggered control systems under denial-of-service attacks,” *IEEE Transactions on Control of Network Systems*, vol. 4, no. 1, pp. 93–105, Mar. 2017.
- [119] Y. Chen, T. Du, C. Jiang, and S. Sun, “Indoor location method of interference source based on deep learning of spectrum fingerprint features in smart cyber-physical systems,” *EURASIP Journal on Wireless Communications and Networking*, vol. 2019, no. 1, p. 47, Feb. 2019. [Online]. Available: <https://doi.org/10.1186/s13638-019-1363-y>
- [120] J. Goh, S. Adepu, M. Tan, and Z. S. Lee, “Anomaly detection in cyber physical systems using recurrent neural networks,” in *2017 IEEE 18th International Symposium on High Assurance Systems Engineering (HASE)*, Jan. 2017, pp. 140–145.

- [121] K. N. Junejo and D. K. Y. Yau, "Data driven physical modelling for intrusion detection in cyber physical systems," in SG-CRC, 2016.
- [122] J. M. Beaver, R. C. Borges-Hink, and M. A. Buckner, "An evaluation of machine learning methods to detect malicious scada communications," in Proceedings of the 2013 12th International Conference on Machine Learning and Applications - Volume 02, ser. ICMLA '13. Washington, DC, USA: IEEE Computer Society, 2013, pp. 54–59. [Online]. Available: <http://dx.doi.org/10.1109/ICMLA.2013.105>
- [123] R. C. Borges Hink, J. M. Beaver, M. A. Buckner, T. Morris, U. Adhikari, and S. Pan, "Machine learning for power system disturbance and cyber-attack discrimination," in 2014 7th International Symposium on Resilient Control Systems (ISRCS), Aug. 2014, pp. 1–8.
- [124] D. Smith, B. Veitch, F. Khan, and R. Taylor, "Understanding industrial safety: Comparing fault tree, bayesian network, and {FRAM} approaches," Journal of Loss Prevention in the Process Industries, vol. 45, pp. 88–101, 2017. [Online]. Available: <http://www.sciencedirect.com/science/article/pii/S0950423016304260>
- [125] W.-R. Chang, S. Leclercq, T. E. Lockhart, and R. Haslam, "State of science: occupational slips, trips and falls on the same level," Ergonomics, vol. 59, no. 7, pp. 861–883, 2016, pMID: 26903401. [Online]. Available: <http://dx.doi.org/10.1080/00140139.2016.1157214>
- [126] R. Candell, "NIST-IR Report on Industrial Wireless Systems Workshop," 2017.
- [127] F. Chraim, Y. B. Erol, and K. Pister, "Wireless gas leak detection and localization," IEEE Transactions on Industrial Informatics, vol. 12, no. 2, pp. 768–779, Apr. 2016.
- [128] A. Huber and A. Weiss, "Developing human-robot interaction for an industry 4.0 robot: How industry workers helped to improve remote-hri to physical-hri," in Proceedings of the Companion of the 2017 ACM/IEEE International Conference on Human-Robot Interaction, ser. HRI '17. New York, NY, USA: ACM, 2017, pp. 137–138. [Online]. Available: <http://doi.acm.org/10.1145/3029798.3038346>
- [129] A. M. Zanchettin, N. M. Ceriani, P. Rocco, H. Ding, and B. Matthias, "Safety in human-robot collaborative manufacturing environments: Metrics and control," IEEE Transactions on Automation Science and Engineering, vol. 13, no. 2, pp. 882–893, Apr. 2016.

- [130] M. Jaber, M. A. Imran, R. Tafazolli, and A. Tukmanov, "5g backhaul challenges and emerging research directions: A survey," *IEEE Access*, vol. 4, pp. 1743–1766, 2016.
- [131] "Wireless backhaul spectrum policy recommendations and analysis," <http://www.gsma.com/spectrum/wp-content/uploads/2014/12/Wireless-Backhaul-Spectrum-Policy-Recommendations-and-Analysis-Report.-Nov14.pdf>, accessed: 2017-04-20.
- [132] A. Khudhair, S. Jabbar, M. Sulttan, and D. Wang, "Wireless indoor localization systems and techniques: Survey and comparative study," *Indonesian Journal of Electrical Engineering and Computer Science*, vol. 3, no. 2, pp. 392–409, Aug. 2016.
- [133] "Asset tracking and inventory systems market survey report," <https://www.dhs.gov/sites/default/files/publications/AssetTrackingandInventorySystemsMarketSurveyReportDecember2016.pdf>, accessed: 2017-04-20.
- [134] "Industrial remote communication: Efficient remote access to plants, machines and mobile applications," https://www.industry.usa.siemens.com/automation/us/en/industrial-communications/remote/Documents/E20001-A660-P820-X-7600_WS_Remote_Communication_web.pdf, accessed: 2017-04-20.
- [135] G. Philbrook, "Remote monitoring technologies lower costs, improve operations," <http://www.plantengineering.com/single-article/remote-monitoring-technologies-lower-costs-improve-operations/8242e6952a7fd3ded0e608602cef4f3d.html>, accessed: 2017-04-20.
- [136] V. Paelke, "Augmented reality in the smart factory: Supporting workers in an industry 4.0. environment," in *19th IEEE International Conference on Emerging Technologies and Factory Automation, ETFA 2014*, 2014.
- [137] L. Zhang, H. Gao, and O. Kaynak, "Network-Induced Constraints in Networked Control Systems: A Survey," *IEEE Transactions on Industrial Informatics*, vol. 9, no. 1, pp. 403–416, 2013.
- [138] A. F. Molisch, "IEEE 802.15.4a channel model-final report IEEE P802 15.04," *Tech. Rep.*, 2004.
- [139] Q. Wang and J. Jiang, "Comparative examination on architecture and protocol of industrial wireless sensor network standards," *IEEE Communications Surveys Tutorials*, vol. 18, no. 3, pp. 2197–2219, thirdquarter 2016.

- [140] R. Candell, T. Zimmerman, and K. Stouffer, “An industrial control system cybersecurity performance testbed,” National Institute of Standards and Technology. NISTIR, vol. 8089, 2015.
- [141] R. Candell and K. Lee, “Measuring the effect of wireless sensor network communications on industrial process performance,” in 2015 ISA process control and safety symposium, Houston, TX, 2015.
- [142] D. I. Urbina, J. A. Giraldo, A. A. Cardenas, N. O. Tippenhauer, J. Valente, M. Faisal, J. Ruths, R. Candell, and H. Sandberg, “Limiting the impact of stealthy attacks on industrial control systems,” in Proceedings of the 2016 ACM SIGSAC Conference on Computer and Communications Security. ACM, 2016, pp. 1092–1105.
- [143] A. Barnard Feeney, S. Frechette, and V. Srinivasan, Cyber-Physical Systems Engineering for Manufacturing. Cham: Springer International Publishing, 2017, pp. 81–110. [Online]. Available: https://doi.org/10.1007/978-3-319-42559-745_54
- [144] H. Kagermann, W. Wahlster, and J. Helbig, “Recommendations for implementing the strategic initiative industrie 4.0 – securing the future of german manufacturing industry,” acatech – National Academy of Science and Engineering, München, Final Report of the Industrie 4.0 Working Group, Apr. 2013. [Online]. Available: http://forschungsunion.de/pdf/industrie_4_0_final_report.pdf
- [145] J. Lee, B. Bagheri, and H.-A. Kao, “A cyber-physical systems architecture for industry 4.0-based manufacturing systems,” Manufacturing Letters, vol. 3, pp. 18–23, 2015. [Online]. Available: <http://www.sciencedirect.com/science/article/pii/S221384631400025X>
- [146] A. Grau, M. Indri, L. L. Bello, and T. Sauter, “Industrial robotics in factory automation: From the early stage to the internet of things,” in IECON 2017 - 43rd Annual Conference of the IEEE Industrial Electronics Society, Oct. 2017, pp. 6159–6164.
- [147] P. Leitão, “Agent-based distributed manufacturing control: A state-of-the-art survey,” Engineering Applications of Artificial Intelligence, vol. 22, no. 7, pp. 979–991, 2009, distributed Control of Production Systems. [Online]. Available: <http://www.sciencedirect.com/science/article/pii/S0952197608001437>
- [148] E. Sisinni, A. Saifullah, S. Han, U. Jennehag, and M. Gidlund, “Industrial internet of things: Challenges, opportunities, and directions,” IEEE Transactions on Industrial Informatics, vol. 14, no. 11, pp. 4724–4734, Nov. 2018.

- [149] V. K. L. Huang, Z. Pang, C. A. Chen, and K. F. Tsang, "New trends in the practical deployment of industrial wireless: From noncritical to critical use cases," *IEEE Industrial Electronics Magazine*, vol. 12, no. 2, pp. 50–58, Jun. 2018.
- [150] J. A. Marvel and R. Norcross, "Implementing speed and separation monitoring in collaborative robot workcells," *Robotics and Computer-Integrated Manufacturing*, vol. 44, pp. 144–155, 2017. [Online]. Available: <http://www.sciencedirect.com/science/article/pii/S0736584516302617>
- [151] D. Orfanus, R. Indergaard, G. Prytz, and T. Wien, "Ethercat-based platform for distributed control in high-performance industrial applications," in *2013 IEEE 18th Conference on Emerging Technologies Factory Automation (ETFA)*, Sep. 2013, pp. 1–8.
- [152] M. Weiner, M. Jorgovanovic, A. Sahai, and B. Nikolić, "Design of a low-latency, high-reliability wireless communication system for control applications," in *2014 IEEE International Conference on Communications (ICC)*, Jun. 2014, pp. 3829–3835.
- [153] R. Candell, "GitHub Repository of the Model of the Wireless Factory Work-cell using the Systems Modeling Language," 2018, available at <https://github.com/usnistgov/wireless-factory-sysml>.
- [154] A. Mahmood, R. Exel, H. Trsek, and T. Sauter, "Clock Synchronization Over IEEE 802.11—A Survey of Methodologies and Protocols," *IEEE Transactions on Industrial Informatics*, vol. 13, no. 2, pp. 907–922, Apr. 2017. [Online]. Available: <http://ieeexplore.ieee.org/document/7782431/>
- [155] D. D. Geetha and N. Tabassum, "A survey on clock synchronization protocols in wireless sensor networks," in *2017 International Conference On Smart Technologies For Smart Nation (SmartTechCon)*. IEEE, Aug. 2017, pp. 504–509. [Online]. Available: <https://ieeexplore.ieee.org/document/8358424/>
- [156] R. Featherstone, "Robot dynamics," *Scholarpedia*, vol. 2, no. 10, p. 3829, 2007, revision #91723.
- [157] R. D. Quinn, G. C. Causey, F. L. Merat, D. M. Sargent, N. A. Barendt, W. S. Newman, V. B. Velasco, A. Podgurski, , and L. S. S. and, "Design of an agile manufacturing workcell for light mechanical applications," in *Proceedings of IEEE International Conference on Robotics and Automation*, vol. 1, Apr. 1996, pp. 858–863 vol.1.
- [158] and J. A. Gaines and B. J. Nelson, "A flexible experimental workcell for efficient and reliable wafer-level 3d micro-assembly," in *Proceedings 2001 ICRA*. IEEE

- International Conference on Robotics and Automation (Cat. No.01CH37164), vol. 1, May 2001, pp. 133–138 vol.1.
- [159] N. Papakostas, G. Michalos, S. Makris, D. Zouzas, and G. Chryssolouris, “Industrial applications with cooperating robots for the flexible assembly,” *International Journal of Computer Integrated Manufacturing*, vol. 24, no. 7, pp. 650–660, 2011. [Online]. Available: <https://doi.org/10.1080/0951192X.2011.570790>
- [160] J. Chen, X. Cao, P. Cheng, Y. Xiao, and Y. Sun, “Distributed collaborative control for industrial automation with wireless sensor and actuator networks,” *IEEE Transactions on Industrial Electronics*, vol. 57, no. 12, pp. 4219–4230, Dec. 2010.
- [161] L. L. Bello, J. Akerberg, M. Gidlund, and E. Uhlemann, “Guest editorial special section on new perspectives on wireless communications in automation: From industrial monitoring and control to cyber-physical systems,” *IEEE Transactions on Industrial Informatics*, vol. 13, no. 3, pp. 1393–1397, Jun. 2017.
- [162] R. Candell and M. Aksu, “Requirements for spectrum monitoring in industrial environments,” National Institute of Standards and Technology, Gaithersburg, MD, Tech. Rep., Nov. 2017. [Online]. Available: <https://nvlpubs.nist.gov/nistpubs/ir/2017/NIST.IR.8195.pdf>
- [163] J. A. Marvel and R. Norcross, “Implementing speed and separation monitoring in collaborative robot workcells,” *Robotics and Computer-Integrated Manufacturing*, vol. 44, pp. 144–155, 2017. [Online]. Available: <http://www.sciencedirect.com/science/article/pii/S0736584516302617>
- [164] (OnRobot), “Hex-h sensor 2.0 datasheet,” available at https://onrobot.com/wp-content/uploads/2018/06/hex-h_sensor_2-0_datasheet_june_2018.pdf.
- [165] (Automation Direct), “C5 series stainless steel photoelectric sensors,” available at <https://cdn.automationdirect.com/static/specs/pe5mmc5.pdf>.
- [166] G. P. Fettweis, “The tactile internet: Applications and challenges,” *IEEE Vehicular Technology Magazine*, vol. 9, no. 1, pp. 64–70, Mar. 2014.
- [167] G. Qiao and B. Weiss, “Monitoring, Diagnostics, and Prognostics for Robot Tool Center Accuracy Degradation,” in 2018 ASME International Manufacturing Science and Engineering Conference. ASME, Jun. 2018.
- [168] B. A. Weiss, M. Helu, G. Vogl, and G. Qiao, “Use Case Development to Advance Monitoring, Diagnostics, and Prognostics in Manufacturing Operations,” *IFAC-PapersOnLine*, vol. 49, no. 31, pp. 13–18, 2016. [Online]. Available: <http://linkinghub.elsevier.com/retrieve/pii/S2405896316328257>

- [169] J. L. Cuevas-Ruiz and P. Garcia-Alba-Idunate, "Spectrum monitoring. an approach based on people-centric sensing (smopec)," Nov. 2015. [Online]. Available: https://www.thinkmind.org/index.php?view=article&articleid=centric_2015_4_20_30057
- [170] (Bosch), "MIC Series 612 Thermal Camera," available at <https://us.boschsecurity.com/en/products/videosystems/analogcameras/ptzcameras/micseries612thermalcamera/micseries612thermalcamera{ }20139>.
- [171] Wireless Broadband Alliance (WBA), "Enhanced Wi-Fi - 802.11ax Decoded: Overview, Features, Use Cases and 5G Context," available at <https://www.wballiance.com/wp-content/uploads/2018/09/Enhanced-802.11ax-Overview-Use-Cases-Features-5G-Context-v1.asd-Final-Clean.pdf>.
- [172] Y. Liu, R. Candel, M. Kashef, and K. Montgomery, "A collaborative work cell testbed for industrial wireless communications — the baseline design," in 2019 IEEE 28th International Symposium on Industrial Electronics (ISIE), Jun. 2019, pp. 1315–1321.
- [173] Universal Robots, Real-Time Data Exchange (RTDE) Guide. [Online]. Available: <https://www.universal-robots.com/how-tos-and-faqs/how-to/ur-how-tos/real-time-data-exchange-rtde-guide-22229/>
- [174] "IEEE standard for a precision clock synchronization protocol for networked measurement and control systems - redline," IEEE Std 1588-2008 (Revision of IEEE Std 1588-2002) - Redline, pp. 1–300, July 2008.
- [175] E. Sisinni, A. Saifullah, S. Han, U. Jennehag, and M. Gidlund, "Industrial Internet of Things: Challenges, Opportunities, and Directions," IEEE Transactions on Industrial Informatics, 2018.
- [176] L. L. Bello, J. Kerberg, M. Gidlund, and E. Uhlemann, "Guest Editorial Special Section on New Perspectives on Wireless Communications in Automation: From Industrial Monitoring and Control to Cyber-Physical Systems," IEEE Transactions on Industrial Informatics, vol. 13, no. 3, pp. 1393–1397, 2017.
- [177] Z. Pang, M. Luvisotto, and D. Dzung, "Wireless High-Performance Communications: The Challenges and Opportunities of a New Target," IEEE Industrial Electronics Magazine, vol. 11, no. 3, pp. 20–25, 2017.
- [178] R. Candell, "Industrial wireless systems workshop proceedings," National Institute of Standards and Technology, Gaithersburg, MD, Tech. Rep., May 2017. [Online]. Available: <https://nvlpubs.nist.gov/nistpubs/ir/2017/NIST.IR.8174.pdf>

- [179] C. Lu, A. Saifullah, B. Li, M. Sha, H. Gonzalez, D. Gunatilaka, C. Wu, L. Nie, and Y. Chen, "Real-Time Wireless Sensor-Actuator Networks for Industrial Cyber-Physical Systems," *Proceedings of the IEEE*, vol. 104, no. 5, pp. 1013–1024, May 2016. [Online]. Available: <http://ieeexplore.ieee.org/document/7348717/>
- [180] D. Kim, Y. Won, Y. Eun, and K.-J. Park, "W-Simplex: Resilient network and control co-design under wireless channel uncertainty in cyber-physical systems," in *2017 IEEE Conference on Control Technology and Applications (CCTA)*. IEEE, Aug. 2017, pp. 49–54. [Online]. Available: <http://ieeexplore.ieee.org/document/8062439/>
- [181] T. M. Chiwewe, C. F. Mbuya, and G. P. Hancke, "Using Cognitive Radio for Interference-Resistant Industrial Wireless Sensor Networks: An Overview," *IEEE Transactions on Industrial Informatics*, vol. 11, no. 6, pp. 1466–1481, Dec. 2015. [Online]. Available: <http://ieeexplore.ieee.org/document/7299315/>
- [182] IEEE Standards Association, *Part 11: Wireless LAN Medium Access Control (MAC) and Physical Layer (PHY) Specifications; Amendment 4: Enhancements for Very High Throughput for Operation in Bands below 6 GHz*, 2013.
- [183] M. L. T. Cossio, L. F. Giesen, G. Araya, M. L. S. Pérez-Cotapos, R. L. VERGARA, M. Manca, R. A. Tohme, S. D. Holmberg, T. Bressmann, D. R. Lirio, J. S. Román, R. G. Solís, S. Thakur, S. N. Rao, E. L. Modelado, A. D. E. La, C. Durante, U. N. A. Tradición, M. En, E. L. Espejo, D. E. L. A. S. Fuentes, U. A. D. Yucatán, C. M. Lenin, L. F. Cian, M. J. Douglas, L. Plata, and F. Héritier, *Springer Handbook of Robotics*, B. Siciliano and O. Khatib, Eds. Springer International Publishing, 2016. [Online]. Available: <http://link.springer.com/10.1007/978-3-319-32552-1>
- [184] J. A. Shaw, "Radiometry and the Friis transmission equation," *American Journal of Physics*, vol. 81, no. 1, pp. 33–37, Jan. 2013. [Online]. Available: <http://aapt.scitation.org/doi/10.1119/1.4755780>
- [185] K. Yeager, "Libguides: Spss tutorials: Pearson correlation," 2013, available at <https://libguides.library.kent.edu/SPSS/PearsonCorr>. [Online]. Available: <https://libguides.library.kent.edu/SPSS/PearsonCorr>
- [186] J. Lee Rodgers and W. Alan Nice Wander, "Thirteen ways to look at the correlation coefficient," *American Statistician*, pp. 59–66, 1988.
- [187] L. Breiman, "Random forests," *Machine Learning*, vol. 45, no. 1, pp. 5–32, Oct. 2001. [Online]. Available: <https://doi.org/10.1023/A:1010933404324>

- [188] A. Géron, *Hands-on Machine Learning with Scikit-Learn and TensorFlow: Concepts, Tools, and Techniques to Build Intelligent Systems*. O'Reilly Media, 2017. [Online]. Available: <https://books.google.com/books?id=I6qkDAEACAAJ>
- [189] X. Zhen, Z. Wang, M. Yu, and S. Li, "Supervised descriptor learning for multi-output regression," in *2015 IEEE Conference on Computer Vision and Pattern Recognition (CVPR)*, Jun. 2015, pp. 1211–1218.
- [190] J. Shotton, A. Fitzgibbon, M. Cook, T. Sharp, M. Finocchio, R. Moore, A. Kipman, and A. Blake, "Real-time human pose recognition in parts from single depth images," in *CVPR 2011*, Jun. 2011, pp. 1297–1304.
- [191] X. Zhen, Z. Wang, A. Islam, M. Bhaduri, I. Chan, and S. Li, "Direct estimation of cardiac bi-ventricular volumes with regression forests," in *Medical Image Computing and Computer-Assisted Intervention – MICCAI 2014*, P. Golland, N. Hata, C. Barillot, J. Hornegger, and R. Howe, Eds. Cham: Springer International Publishing, 2014, pp. 586–593.
- [192] S. Deb, "A novel robust r-squared measure and its applications in linear regression," in *Computational Intelligence in Information Systems*, S. Phon-Amnuaisuk, T.-W. Au, and S. Omar, Eds. Cham: Springer International Publishing, 2017, pp. 131–142.
- [193] "scikit-learn: machine learning in Python," available at <http://scikit-learn.org/stable/>. [Online]. Available: <http://scikit-learn.org/stable/>
- [194] T. Chen and C. Guestrin, "Xgboost: A scalable tree boosting system," in *Proceedings of the 22nd ACM SIGKDD International Conference on Knowledge Discovery and Data Mining*, ser. KDD '16. New York, NY, USA: ACM, 2016, pp. 785–794. [Online]. Available: <http://doi.acm.org/10.1145/2939672.2939785>
- [195] R. Candell, "A SysML Model of the Wireless Factory Work-cell," Gaithersburg, MD, 2018, available at <https://catalog.data.gov/dataset/model-of-the-wireless-factory-work-cell-using-the-systems-modeling-language>.

LIST OF FIGURES

1.1	Industry 4.0: Wireless is a key enabler in the 4th industrial revolution. Many industrial revolutions have occurred with the most recent revolution taking place with the advent of CPSs. Image credit: Christoph Roser [8].	6
1.2	Industry 4.0: Incorporating the benefits of machine learning, massive data, mobility, and autonomy within the modern factory. The major contribution of Industry 4.0 is the introduction of massive connectedness and information-based awareness within the factory enterprise. Image credit: Adapted from Forbes [12].	8
1.3	Example of radio propagation path loss for 2245 MHz transmissions within a factory environment. Reproduced from NIST Technical Note 1951 [23]	14
1.4	Wireless range, obstructions, absorption, reflection, diffraction, and jamming/interference are all sources of wireless channel degradation within the factory environment. Reflection and jamming are of special concern within the highly obstructed, metal-rich environment found in the typical factory.	14
1.5	Typical (a) and Worst Case (b) key performance indicators for industrial wireless use cases presented in [5]. Industrial wireless use cases differ greatly from that of the home or office business environment. These IWNs are characterized by short bursts of information, periodically transmitted, and requiring varying degrees of arrival reliability within a predetermined soft or hard deadline.	20
1.6	Contribution areas and organization of this thesis.	21

2.1	Functional block diagram of a CPS in which a physical process and an automation system interact through a wireless network. In a CPS, the automation/control system acts using estimated and/or delayed versions of the process variables, whereas, the physical process uses estimated and/or delayed versions of commands from the controller. .	36
3.1	Industrial wireless technologies are applicable across most aspects of the industrial automation problem space.	48
4.1	SysML package definition diagram (PKG) showing the logical containment of the factory workcell structural elements. The SysML model is organized according to the package hierarchy shown.	62
4.2	Architecture of the conceptual workcell captured as a SysML block definition diagram (BDD). In this diagram, only the most generalized blocks necessary to construct a workcell scenario are shown. More application-specific scenarios may be developed by deriving new blocks from the constructs shown here. The shapes and connectors used for expressing this model are defined in the SysML specification [70].	64
4.3	Generalized network constraints consisting of rigid body motion (a), the radio channel (b) and the network services (c). These constraints are meant to communicate or simulate the effects of an IWN on the performance of the CPS.	66
4.4	SysML parametric diagram (PAR) of the radio channel constraints of the IWN. Parametric equations used to express the constraints within the CPS are elaborated using the PAR.	68
4.5	SysML parametric diagram (PAR) of the data constraints applied to the IWN.	69
4.6	Block definition diagram (BDD) of the Application.	70
4.7	The BDD (a) and IBD (b) of the IWN with parametric IBD (c) of the Services block.	72
4.8	SysML block definition diagram (BDD) of wireless devices within the factory workcell.	73

4.9	BDD (a) and the IBD (b) of Wireless Device. All Wireless Device components contain at least one Transceiver which conveys information to and from one or more Application components. Intermediate general processing by a CPU is not assumed in this model although it could be adapted to do so with additional constraints.	75
4.10	BDD (a) and the IBD (b) of Test Device.	76
4.11	The BDD (a), IBD (b) of the RC. The RC contains all of the application logic to control the physical robot. It is assumed that the communication between the RC and the robot is near-ideal for the purpose of this model as that reflects the current direction of industry. It is not anticipated that physical joint control will be controlled wirelessly in the near-future.	77
4.12	The IBD of the PLC showing composition and connectivity of the control logic and safety logic Application instantiations to the Transceiver interface.	78
4.13	SMS Agent composed of transceiver, detection application, and reporting application. The SMS is an essential part of any robust industrial wireless deployment intended to be permanent. The output of the SMS may be used by a SMS condition monitoring system or by the control system to enhance reliability during spectral events.	81
4.14	Example IBD of a workcell employing multiple networks in a collaborative robot operation coexisting with robot force limiting inspection station.	82
5.1	Testbed of a collaborative robotic workcell. Depicted are two robots working together to load, inspect, and unload materials from emulated CNC machines. PLCs are used to emulate the behavior of the CNCs and the supervisory controller.	90
5.2	The intended schema (i.e., pseudo-schema) of the GDB used for each operational run of the NIST wireless factory testbed. The graph is organized into nodes and edges, where the edges signify relationships among network elements and physical operational elements. Note that GDBs do not have enforced schemas; therefore, it is possible that the database have data and relationships violating the intended schema. This flexibility is acceptable.	91

- 5.3 Data processing flow from factory workcell to database. The process includes data collection, data cleaning and preparation, database formation, and finally analysis through queries and visualization. 95
- 5.4 Realized schema of the GDB fully populated after capturing network and operational data from the NIST industrial wireless testbed. GDBs do not have enforced schemas; therefore, the schema depict represents the data as is. 97
- 5.5 Visualization of a node graph resulting from a testbed experiment. . . 98
- 5.6 A detailed visualization resulting from a testbed experiment for all the nodes and relationships corresponding to a single transaction. A single transaction may contain several messages, associated actors, and LQE reports. Work performed in [32] extends this graph to include the associated CPS events. 99
- 5.7 Correlation between the message latency and the RSSI values by the sniffer. Extracting LQE estimations for messages and transaction is made easier by using the GDB. 99
- 5.8 Network diagram of the industrial wireless testbed at NIST. Solid lines represent Ethernet based communications and dashed lines represent wireless based communications. 101
- 5.9 The data model of the graph database used for each operational run of the NIST wireless factory testbed. The graph is organized into nodes and edges, where the edges signify relationships among network elements and physical operational elements. This graph was extended from the work in [31] to include better integration of physical events occurring within the CPS. 103
- 5.10 Data processing flow from factory workcell to database. Improvements to feature extraction were made to 104
- 5.11 Realized schema of the graph database fully populated after capturing network and operational data from the NIST industrial wireless testbed. The realized schema matches the intended schema. Using the database, it is now possible to correlate IWN performance to physical events of the CPS, such as the location of material, through simple database queries. 107

5.12	Components of the Physical Action Time for Various Experimental Scenarios. Performance metrics for the wired baseline measurements are shown in (a). Performance for a wireless baseline is shown in (b). Varying levels of competing wireless traffic are then introduced in the subsequent graphs. The supervisor PLC processing time in blue appears unchanged by the IWN latencies. The transaction latency in orange is clearly impacted by the wireless channel; however, the robot controller shown in green appears to compensate for transaction latency variance such that the sum of transaction latency and robot processing time remains constant. This indicates that wireless should be a good candidate for this control system as physical latencies do not increase under these scenarios.	110
5.13	Histograms of Transaction Latency for Various Experimental Scenarios. Transaction latency is shown to increase as more competing wireless traffic is introduced.	112
5.14	Histograms of Action Processing Time for Various Experimental Scenarios. Physical action latency of the CPS is shown to increase as more competing wireless traffic is introduced. An educated decision can then be made using this data to determine if the increased physical action delay is acceptable.	113
6.1	Robot force-seeking spring system with controlled wireless channel emulation and interference injection.	117
6.2	A photograph of the robot force-seeking experiment shows the robotic arm, the spring-based plunger, and the visual markers used for position tracking. The glowing points of light are the reflective tracking spheres used by the vision tracking system to produce the ground-truth measurements of the REEF position.	118
6.3	Feedback signal flow model of the force-seeking controller	120
6.4	RF emulation scenario design of the robotic force-seeking scenario. An RF channel emulator is used to automate the radio effect of distances between router, station, and jammer.	121
6.5	A time-series sample (a) of a single iteration of the measured z-axis probe position and (b) the corresponding REEF trajectory model used for feature extraction.	123

- 6.6 Variations in probability distributions of the z-axis position (a) and the plunge delay (b) indicate that machine learning may be effective in inferring information about the underlying communication channel. In the figure, the baseline case of infinite SIR is depicted as a histogram with white bars, and the experimental case is depicted as a histogram with red bars. 126
- 6.7 Predicted SIR versus actual SIR for the cases of (a) $M = 100$ and (b) $M = 1$. The box plots show the median value while the bottom and top edges of the box indicate the 25th and 75th percentiles. Statistical outliers are shown as red + signs. 128
- 6.8 The performance of the random forest regression model against segment size, M . As M increases, error is reduced but variance increases shown a tendency to over-fit as the training window is increased. . . 129
- 6.9 The mean squared error performance with jamming imposed on b/g-Router of various algorithms against segment size, M 135
- 6.10 The variance score performance with jamming imposed on b/g-Router of various algorithms against segment size, M 136
- 6.11 The mean squared error performance with jamming imposed on b/g-Station of various algorithms against segment size, M 136
- 6.12 The mean squared error performance with jamming imposed on b/g/n-Station of various algorithms against segment size, M 137
- 6.13 The mean squared error performance for jamming setting b/g-Router of various algorithms against training sequence length, T for various segment sizes, M 138
- 6.14 The MSE performance for jamming setting b/g-Router of XGBM algorithm against M including individual features impact. As indicated in the figure, the feature Δt_{ab} is most predictive of the SIR level as compared to all of the features together. It appears that the only the dwell time before REEF plunge is required to predict SIR in this scenario. 138
- 6.15 The variance score performance for jamming setting b/g-Router of XGBM algorithm against M including individual features impact. . . 139

6.16	The mean squared error performance for jamming setting $b/g/n$ -Station of XGBM algorithm against M including individual features impact.	139
7.1	Internal block diagram of a workcell equipped with an robotic leader-follower lift application. This model is indicative of the testbed scenario currently being developed within the NIST IWS testbed. . . .	145
7.2	Internal block diagram of a PLC.	146
7.3	Internal block diagram of an Application showing the parametrics constraints of its one or more programs.	146
7.4	Internal block diagram of an IWN showing the parametric constraints of its one or more programs.	147
7.5	Internal block diagram of an Radio Channel showing the parametric constraints of the radio medium.	147
7.6	Internal block diagram of an IWN Service showing the parametric constraints of the behavior of a network service as generic processing.	147
7.7	BBD of the conceptual relationships of model primitives	148
7.8	A notional spherical graph depicting nodes and vertices.	150
7.9	Experiment design used for capture of performance data throughout most of the research.	151
7.10	Experiment design used for capture of performance data.	152

LIST OF TABLES

2.1	ISA Descriptions of Wireless Requirements Classes	29
2.2	ISA Wireless Requirements Perspective	29
2.3	ETSI Industrial Wireless Requirements Perspective	30
2.4	An Industry Requirements Perspective of Different Industrial Communication Scenarios as presented in [6].	31
2.5	NIST Wireless Requirements Perspective as presented in [5].	32
3.1	Industrial control latency, error rate, and scalability considerations for wireless deployments as presented in [7] show important and competing considerations of industrial wireless deployments. Other considerations not shown include battery life, update rate, and security, among others.	54
3.2	Applicability of wireless technologies from [7]. Presented are recommendations of direct applicability of various technologies to the industrial user problem space with little to no modification.	56
3.3	Enhanced Wireless User Requirements for the Factory Workcell.	57
4.1	Constraints Pertaining to a Collision Detector	70
6.1	Correlation Coefficients for -9 dB SIR	127
6.2	Correlation Coefficients for -8 dB SIR	127
6.3	Correlation Coefficients for -7 dB SIR	127
6.4	MSE values of various ML algorithms for jamming setting b/g-Router	132
6.5	Variance score values of various ML algorithms for jamming setting b/g-Router	133

6.6	MSE values of various ML algorithms for jamming setting b/g-Station	133
6.7	MSE of Random Forrest regression parameters for jamming setting b/g-Router	134
6.8	MSE of Gradient Boosting regression parameters for jamming setting b/g-Router	134

LIST OF DEFINITIONS

1	Definition: Latency	16
2	Definition: Reliability	16
3	Definition: Scale	17
4	Definition: Range	17
5	Definition: Payload Size	17
6	Definition: Update Rate	17

LIST OF ACRONYMS

5G	Fifth-generation cellular.
ADS	Automation Device Specification.
AGV	automated guided vehicle.
AI	artificial intelligence.
AWGN	additive white Gaussian noise.
BDD	block definition diagram.
BLER	block error rate.
CE	channel emulator.
CIP	common internet protocol.
CM	condition monitoring.
CNC	computer numerical control.
CPS	cyber physical system.
CPU	central processing unit.
CSV	comma-separated value.
DOF	degrees-of-freedom.
EMI	electromagnetic interference.
ETSI	European Telecommunications Standards Institute.
FTS	force-torque sensor.
GBM	gradient boosting machine.
GDB	graph database.
GPS	Global Positioning System.
HMI	human machine interface.
HVAC	heating ventilation and air-conditioning.
IBD	internal block diagram.

IEC	International Electrotechnical Commission.
IEEE	Institute of Electrical and Electronics Engineers.
IIoT	industrial internet of things.
IO	input/output.
IoT	internet of things.
IP	Internet Protocol.
ISA	International Society of Automation.
IWN	industrial wireless network.
IWS	industrial wireless system.
IWSN	industrial wireless sensor network.
KPI	key performance indicator.
LOS	line-of-sight.
LQE	link quality estimation.
MAC	medium access control.
MBSE	Model-based Systems Engineering.
MCS	modulation and coding scheme.
ML	machine learning.
Modbus/TCP	Modbus over Transport Control Protocol.
MSE	mean square error.
NIST	National Institute of Standards and Technology.
NLOS	non-line-of-sight.
NoSQL	non-SQL.
NoT	network of things.
OPC	Open Platform Communications.
OS	operating system.
OSI	Open Systems Interconnection.
OWL	Web Ontology Language.
PAR	parametric diagram.
PCAP	packet capture file.
PER	packet error rate.
PKG	package definition diagram.

PLC	programmable logic controller.
PTP	Precision Time Protocol.
QoS	quality of service.
RC	robot controller.
REEF	robot end-effector.
RF	radio frequency.
RFID	Radio Frequency Identification.
RSSI	received signal strength indicator.
RTDE	real-time data exchange.
RTOS	real-time operating system.
RX	receive.
SIR	signal-to-interference ratio.
SMS	spectrum monitoring system.
SNR	signal-to-noise ratio.
SVM	support vector machine.
SysML	Systems Markup Language.
TAP	test access point.
TX	transmit.
UML	Unified Modeling Language.
VLBR	very low bit rate.
VTS	vision tracking system.
WAN	wide area network.
WAP	wireless access point.
WEA	wireless Ethernet adapter.
Wi-Fi	Wireless Fidelity.
WLAN	Wireless Local Area Network.
WS	wireless sniffer.
WSN	wireless sensor network.
XGBM	extreme gradient boosting machine.