



**HAL**  
open science

# Feedback linearization of mechanical control systems

Marcin Nowicki

► **To cite this version:**

Marcin Nowicki. Feedback linearization of mechanical control systems. General Mathematics [math.GM]. Normandie Université, 2020. English. NNT : 2020NORMIR15 . tel-03224819

**HAL Id: tel-03224819**

**<https://theses.hal.science/tel-03224819v1>**

Submitted on 12 May 2021

**HAL** is a multi-disciplinary open access archive for the deposit and dissemination of scientific research documents, whether they are published or not. The documents may come from teaching and research institutions in France or abroad, or from public or private research centers.

L'archive ouverte pluridisciplinaire **HAL**, est destinée au dépôt et à la diffusion de documents scientifiques de niveau recherche, publiés ou non, émanant des établissements d'enseignement et de recherche français ou étrangers, des laboratoires publics ou privés.

## THESE

Pour obtenir le diplôme de doctorat

Spécialité Mathématiques

Préparée au sein de l'Institut National des Sciences Appliquées de Rouen Normandie  
et de la Poznan University of Technology

## Feedback Linearization of Mechanical Control Systems

Présentée et soutenue par  
**Marcin NOWICKI**

Thèse soutenue publiquement le 10 novembre 2020  
devant le jury composé de

M. Dariusz HORLA	Professeur, Poznan University of Technology, Pologne	Président
M. Pierre ROUCHON	Professeur, MINES ParisTech	Rapporteur
M. Krzysztof TCHOŃ	Professeur, Wrocław University of Science and Technology, Pologne	Rapporteur
M. Andrzej BARTOSZEWICZ	Professeur, Lodz University of Technology, Pologne	Examineur
M. Pascal MORIN	Professeur, Sorbonne Université	Examineur
M. Dariusz PAZDERSKI	MCF HDR, Poznan University of Technology, Pologne	Examineur
M. Witold RESPONDEK	Professeur, INSA de Rouen Normandie	Directeur de thèse
M. Krzysztof KOZŁOWSKI	Professeur, Poznan University of Technology, Pologne	Codirecteur de thèse

Thèse dirigée par M. Witold RESPONDEK,  
Laboratoire de Mathématiques de l'INSA de Rouen Normandie - LMI (EA 3226)  
et par M. Krzysztof KOZŁOWSKI,  
Institute of Automatic Control and Robotics, Poznan University of Technology





INSTITUT NATIONAL DES SCIENCES APPLIQUÉES  
DE ROUEN  
AND  
POLITECHNIKA POZNAŃSKA

DOCTORAL THESIS

---

# Feedback Linearization of Mechanical Control Systems

---

*Author:*  
Marcin NOWICKI

*Supervisors:*  
Krzysztof KOZŁOWSKI  
Witold RESPONDEK

October 11, 2020



# Acknowledgements

First and foremost, I would like to express my sincere gratitude to both Supervisors.

To Professor Witold Respondek for his comprehensive contribution to developing a scientific way of thinking in me. His extraordinary insights and mathematical discipline during our lengthy discussions had a great impact on the quality of this thesis. Finally, for his openness and cordiality reaching beyond mentoring.

To Professor Krzysztof Kozłowski for introducing me to the wonders of control theory and giving me the freedom to choose my research topic. His encouragement and continuous support towards my work kept me focused all these years. His thoughtful advice and guidance always came at the right time.

And to both of Them, for not minding that I also have *the Other Supervisor*.

I am particularly grateful to Professor Pierre Rouchon and Professor Krzysztof Tchoń for having accepted to be reviewers of my thesis and for their willingness and effort despite the uncertain global situation. On the same note I would like to extend my thanks to the members of my thesis committee.

During my years at Poznań University of Technology I had the opportunity to meet and collaborate with many amazing scientists to whom I owe a debt of gratitude for providing a stimulating and healthy environment for work and play. I wish to give my thanks to a special to my heart group of colleagues that have supported me from day one. To Marta Drażkowska, Marianna Parzych, Wojciech Adamski, Rafał Madoński, and Mateusz Przybyła for being wonderful friends and enthusiastic young scientists. They are a constant source of inspiration to me. To Dariusz Pazderski for his altruistic help, compelling conversations, and for showing keen interest in my work. To Tomasz Jedwabny for our open-minded discussions during countless coffee breaks. To my office mates, Wojciech Kowalczyk and Paweł Szulczyński for not minding my ridiculous working hours. Finally, to Joanna Gawęcka for her everyday kindness and smile.

I would like to express my gratitude to the whole personnel of INSA de Rouen, especially to the members of LMI for their hospitality and friendliness during my several visits in Rouen. Special thanks to doctoral students Yahao Chen and Timothée Schmoderer. I would like to thank Ewa Respondek for heartwarming hospitality and emotional support during the time away from home.

On a personal note, I would like to express my most sincere appreciation to my parents Małgorzata and Stanisław and the rest of my big family. Your firm belief in me and unconditional love enabled me to finish this work.



# Abstract

Marcin NOWICKI

*Feedback Linearization of Mechanical Control Systems*

This thesis is devoted to a study of mechanical control systems, which are defined in local coordinates  $x = (x^1, \dots, x^n)$  on a smooth configuration manifold  $Q$ . They take the form of second-order differential equations<sup>1</sup>

$$\ddot{x}^i = -\Gamma_{jk}^i(x)\dot{x}^j\dot{x}^k + e^i(x) + \sum_{r=1}^m g_r^i(x)u_r, \quad 1 \leq i \leq n,$$

where  $\Gamma_{jk}^i(x)$  are the Christoffel symbols corresponding to Coriolis and centrifugal terms,  $e(x)$  is an uncontrolled vector field on  $Q$  representing the influence of external positional forces acting on the system (e.g. gravitational or elasticity), and  $g_r(x)$  are controlled vector fields in  $Q$ . Equivalently, a mechanical control system can be described by a first-order system on the tangent bundle  $TQ$  which is the state space of the system using coordinates  $(x, y) = (x^1, \dots, x^n, y^1, \dots, y^n)$

$$(\mathcal{MS}) : \quad \begin{aligned} \dot{x}^i &= y^i \\ \dot{y}^i &= -\Gamma_{jk}^i(x)y^j y^k + e^i(x) + \sum_{r=1}^m g_r^i(x)u_r \end{aligned} \quad 1 \leq i \leq n.$$

The main problem considered in this thesis is mechanical feedback linearization (shortly MF-linearization) by applying to the mechanical system the following transformations:

- (i) changes of coordinates given by diffeomorphisms

$$\begin{aligned} \Phi : \quad TQ &\rightarrow T\tilde{Q} \\ (x, y) &\mapsto (\tilde{x}, \tilde{y}) = (\phi(x), D\phi(x)y); \end{aligned}$$

- (ii) mechanical feedback transformations, denoted  $(\alpha, \beta, \gamma)$ , of the form

$$u_r = \gamma_{jk}^r(x)y^j y^k + \alpha^r(x) + \sum_{s=1}^m \beta_s^r(x)\tilde{u}_s,$$

where  $\gamma_{jk}^r = \gamma_{kj}^r$ ,

---

<sup>1</sup>Throughout we use Einstein summation convention.



such that the transformed system is linear and mechanical

$$\begin{aligned} \dot{\tilde{x}}^i &= \tilde{y}^i \\ (\mathcal{LMS}) : \quad \dot{\tilde{y}}^i &= E_j^i \tilde{x}^j + \sum_{s=1}^m b_s^i \tilde{u}_s. \end{aligned}$$

Here, we briefly overview main results of the thesis.

In Chapter 5 we present two new results concerning mechanical state space linearization (shortly MS-linearization) by means acting on  $(\mathcal{MS})$  by a change of coordinates  $\Phi : Q \rightarrow \tilde{Q}$  only. For the controllable case we have

**Theorem.** *A mechanical control system  $(\mathcal{MS})$  is, locally around  $x_0 \in Q$ , MS-linearizable to a linear controllable mechanical control system  $(\mathcal{LMS})$  if and only if it satisfies, in a neighbourhood of  $x_0$ , the following conditions:*

$$(MS1)' \dim \text{span} \{ad_e^q g_r, 0 \leq q \leq n-1, 1 \leq r \leq m\} = n,$$

$$(MS2)' [ad_e^p g_r, ad_e^q g_s] = 0 \quad \text{for } 0 \leq p, q \leq n, 1 \leq r, s \leq m,$$

$$(MS3)' \langle ad_e^j g_r : ad_e^k g_s \rangle = 0 \quad \text{for } 0 \leq j, k \leq n, 1 \leq r, s \leq m,$$

where  $ad_e^q g_r = [e, ad_e^{q-1} g_r]$  is the iterative Lie bracket of the vector fields  $e$  and  $g_r$  and  $\langle ad_e^j g_r : ad_e^k g_s \rangle$  is the symmetric bracket of them.

It is somehow remarkable, that the problem of MS-linearization can be solved with no controllability assumption. It turns out, the crucial operator is the total covariant derivative  $\nabla$  and the Riemann curvature tensor  $R$  of the configuration manifold  $Q$ .

**Theorem.** *A mechanical control system  $(\mathcal{MS})$  is, locally around  $x_0 \in Q$ , MS-linearizable to a linear, possibly non-controllable, mechanical control system  $(\mathcal{LMS})$  if and only if it satisfies, in a neighbourhood of  $x_0$ , the following conditions:*

$$(MNS1) R = 0,$$

$$(MNS2) \nabla g_r = 0 \quad \text{for } 1 \leq r \leq m,$$

$$(MNS3) \nabla^2 e = 0.$$

In Chapter 6, which is the heart of the thesis, we develop a theory of MF-linearization of  $(\mathcal{MS})$ . Again, first we consider  $(\mathcal{MS})$  with the controllability assumption. Define a sequence of nested distributions  $\mathcal{E}^j$

$$\begin{aligned} \mathcal{E}^0 &= \text{span} \{g_r, 1 \leq r \leq m\} \\ \mathcal{E}^j &= \text{span} \{ad_e^i g_r, 1 \leq r \leq m, 0 \leq i \leq j\}. \end{aligned}$$

For systems with a single control ( $m = 1$ ) we have

**Theorem.** *Assume  $n \geq 3$ ; a mechanical control system  $(\mathcal{MS})$  with a single control  $m = 1$ , locally around  $x_0 \in Q$ , MF-linearizable to a controllable  $(\mathcal{LMS})$  if and only if it satisfies, in a neighbourhood of  $x_0$ , the following conditions:*

$$(MC1) \text{rank } \mathcal{E}^{n-1} = n,$$

$$(MC2) \mathcal{E}^j \text{ is involutive and of constant rank, for } 0 \leq j \leq n-2,$$

$$(MC3) \nabla_{ad_e^i g} g \in \mathcal{E}^0 \quad \text{for } 0 \leq i \leq n-1,$$

(MC4)  $\nabla_{ad_e^k g, ad_e^j g}^2 e \in \mathcal{E}^1$  for  $0 \leq k, j \leq n-1$ .

Another formulation of MF-linearization can be done using the concept of linearizing outputs.

**Definition.** *The mechanical control system  $(\mathcal{MS})$  with  $m$  configuration (output) functions  $h_1(x), \dots, h_m(x) \in C^\infty(Q)$  has a vector relative half-degree  $(\bar{\nu}_1, \dots, \bar{\nu}_m)$  around  $x_0$  if*

$$(i) \quad L_{g_r} L_e^k h_i = 0,$$

for  $1 \leq i, r \leq m$  and  $0 \leq k \leq \bar{\nu}_i - 2$ ,

(ii) the  $m \times m$  decoupling matrix

$$D(x) = \left( L_{g_r} L_e^{\bar{\nu}_i - 1} h_i \right) (x)$$

is of full rank equal to  $m$ , around  $x_0$ .

The following result applies to the multi-input case.

**Theorem.** *The mechanical control system  $(\mathcal{MS})$  is, locally around  $x_0$ , MF-linearizable if and only if there exist  $m$  functions  $h_1(x), \dots, h_m(x) \in C^\infty(Q)$  satisfying in a neighbourhood of  $x_0$*

(MR1) the vector relative half-degree  $(\bar{\nu}_1, \dots, \bar{\nu}_m)$  with  $\sum_{i=1}^m \bar{\nu}_i = n$ .

(MR2) the functions  $h_i(x)$  and their successive  $\bar{\nu}_i - 2$  Lie derivatives with respect to  $e$  are covariantly linear, i.e.

$$\nabla(dL_e^k h_i) = 0 \quad \text{for } 0 \leq k \leq \bar{\nu}_i - 2.$$

Finally, we have the following result to the case of  $(\mathcal{MS})$  without the controllability assumption.

**Theorem.** *A mechanical system  $(\mathcal{MS})_{(n,m)}$  is, locally around  $x_0 \in Q$ , MF-linearizable if and only if it satisfies, in a neighbourhood of  $x_0$ , the following conditions:*

(ML0)  $\mathcal{E}^0$  and  $\mathcal{E}^1$  are of constant rank,

(ML1)  $\mathcal{E}^0$  is involutive,

(ML2)  $\text{ann } \mathcal{E}^0 \subset \text{ann } R$ ,

(ML3)  $\text{ann } \mathcal{E}^0 \subset \text{ann } \nabla g_r$  for  $1 \leq r \leq m$ ,

(ML4)  $\text{ann } \mathcal{E}^1 \subset \text{ann } \nabla^2 e$ ,

where annihilators of the following objects are defined as

- $\text{ann } \mathcal{E}^0 = \{\omega \in \Lambda(Q) : \omega(g_r) = 0, 1 \leq r \leq m\}$
- $\text{ann } R = \{\omega \in \Lambda(Q) : \omega(R) = 0\}$
- $\text{ann } \nabla g_r = \{\omega \in \Lambda(Q) : \omega(\nabla g_r) = 0, 1 \leq r \leq m\}$
- $\text{ann } \nabla^2 e = \{\omega \in \Lambda(Q) : \omega(\nabla^2 e) = 0\}$ .

Our study of  $(\mathcal{MS})$  would not be possible without investigations of  $(\mathcal{LMS})$ . In Chapter 4, we classify controllable linear mechanical systems under linear changes of coordinates and feedback. This work is analogous to celebrated Brunovský classification. Consider two controllable linear mechanical systems

$$(\mathcal{LMS}) : \quad \begin{aligned} \dot{x} &= y \\ \dot{y} &= Ex + Bu, \end{aligned} \quad (\widetilde{\mathcal{LMS}}) : \quad \begin{aligned} \dot{\tilde{x}} &= \tilde{y} \\ \dot{\tilde{y}} &= \tilde{E}\tilde{x} + \tilde{B}\tilde{u}, \end{aligned}$$

where  $E, \tilde{E} \in \mathbb{R}^{n \times n}$ ,  $B, \tilde{B} \in \mathbb{R}^{n \times m}$ ,  $\hat{A} = \begin{pmatrix} 0 & I_n \\ E & 0 \end{pmatrix}$ ,  $\hat{B} = \begin{pmatrix} 0 \\ B \end{pmatrix}$ .

We say that  $(\mathcal{LMS})$  and  $(\widetilde{\mathcal{LMS}})$  are *linear mechanical feedback equivalent*, shortly LMF-equivalent, if there exists a linear change of coordinates  $\tilde{x} = Tx$ ,  $\tilde{y} = Ty$  and an invertible feedback  $u = Fx + G\tilde{u}$ , such that

$$\begin{aligned} \dot{\tilde{x}} &= T\dot{y} = \tilde{y} \\ \dot{\tilde{y}} &= T(E + BF)T^{-1}\tilde{x} + TBG\tilde{u} = \tilde{E}\tilde{x} + \tilde{B}\tilde{u}. \end{aligned}$$

Attach to the system  $(\mathcal{LMS})$  an  $n$ -tuple of indices  $\bar{r}_i$

$$\begin{aligned} \bar{r}_0 &= \text{rank}(B), \\ \bar{r}_i &= \text{rank}(B, EB, \dots, E^i B) - \text{rank}(B, EB, \dots, E^{i-1} B), \end{aligned}$$

for  $1 \leq i \leq n-1$ . Furthermore define the dual indices

$$\bar{\rho}_j = \text{card}(\bar{r}_i \geq j : 0 \leq i \leq n-1) \quad \text{for } 1 \leq j \leq m.$$

These integers are mechanical analogues of controllability (Brunovský, Kronecker) indices  $\rho_i$ , and we call them *mechanical half-indices*. We denote the sequences as  $\bar{\mathcal{R}}(E, B) = (\bar{r}_0, \dots, \bar{r}_{n-1})$ ,  $\bar{\mathcal{P}}(E, B) = (\bar{\rho}_1, \dots, \bar{\rho}_m)$ , and  $\mathcal{P}(\hat{A}, \hat{B}) = (\rho_1, \dots, \rho_m)$ .

**Theorem.** Consider two controllable linear mechanical systems  $(\mathcal{LMS})$  and  $(\widetilde{\mathcal{LMS}})$ , represented by pairs  $(E, B)$  and  $(\tilde{E}, \tilde{B})$ , respectively. The following conditions are equivalent:

- (i) The systems  $(\mathcal{LMS})$  and  $(\widetilde{\mathcal{LMS}})$  are LMF-equivalent,
- (ii)  $\bar{\mathcal{R}}(E, B) = \bar{\mathcal{R}}(\tilde{E}, \tilde{B})$ ,
- (iii)  $\bar{\mathcal{P}}(E, B) = \bar{\mathcal{P}}(\tilde{E}, \tilde{B})$ , i.e. the mechanical half-indices coincide,
- (iv)  $\mathcal{P}(\hat{A}, \hat{B}) = \mathcal{P}(\hat{\tilde{A}}, \hat{\tilde{B}})$ , i.e. the controllability indices coincide,

The thesis ends up with extensive simulation studies of three mechanical systems that are MF-linearizable, namely the Inertia Wheel Pendulum, the TORA system, and the single link manipulator with joint elasticity. We show how our theoretical results applies in the engineering practise to solve several control problems. In total we presented results of 13 simulation control scenarios.

# Streszczenie

Marcin NOWICKI

*Linearyzacja przez sprzężenie zwrotne mechanicznych systemów sterowania*

Praca jest poświęcona analizie mechanicznych systemów sterowania, które w lokalnych współrzędnych  $x = (x^1, \dots, x^n)$  na gładkiej rozmaitości konfiguracyjnej  $Q$ , mają formę równań różniczkowych drugiego rzędu<sup>1</sup>

$$\ddot{x}^i = -\Gamma_{jk}^i(x)\dot{x}^j\dot{x}^k + e^i(x) + \sum_{r=1}^m g_r^i(x)u_r, \quad 1 \leq i \leq n,$$

gdzie  $\Gamma_{jk}^i(x)$  są symbolami Christoffela odpowiadającymi siłom Coriolisa i odśrodkowym,  $e(x)$  jest niesterowanym polem wektorowym na  $Q$  opisującym wpływ zewnętrznych sił pozycyjnych działających na system (np., grawitacyjne lub sprężystości), a  $g_r(x)$  są sterowanymi polami wektorowymi na  $Q$ . Równoważnie, mechaniczny układ sterowania można opisać za pomocą równań różniczkowych pierwszego rzędu na wiązce stycznej  $TQ$  będącej przestrzenią stanu systemu, używając współrzędnych  $(x, y) = (x^1, \dots, x^n, y^1, \dots, y^n)$

$$\begin{aligned} \dot{x}^i &= y^i \\ (\mathcal{MS}) : \quad \dot{y}^i &= -\Gamma_{jk}^i(x)y^j y^k + e^i(x) + \sum_{r=1}^m g_r^i(x)u_r \quad 1 \leq i \leq n. \end{aligned}$$

Głównym problemem rozważanym w pracy jest mechaniczna linearyzacja przez sprzężenie zwrotne (MF-linearyzacja), która polega na zastosowaniu do układu mechanicznego następujących przekształceń:

- (i) zmian układu współrzędnych danych przez dyfeomorfizm

$$\begin{aligned} \Phi : \quad TQ &\rightarrow T\tilde{Q} \\ (x, y) &\mapsto (\tilde{x}, \tilde{y}) = (\phi(x), D\phi(x)y) \end{aligned}$$

- (ii) mechanicznego sprzężenia zwrotnego  $(\alpha, \beta, \gamma)$  w postaci

$$u_r = \gamma_{jk}^r(x)y^j y^k + \alpha^r(x) + \sum_{s=1}^m \beta_s^r(x)\tilde{u}_s,$$

gdzie  $\gamma_{jk}^r = \gamma_{kj}^r$ ,

---

<sup>1</sup>W całej pracy zastosowano konwencję sumacyjną Einsteina.

tak, że przekształcony układ jest liniowy i mechaniczny

$$\begin{aligned} \dot{\tilde{x}}^i &= \tilde{y}^i \\ (\mathcal{LMS}) : \quad \tilde{y}^i &= E_j^i \tilde{x}^j + \sum_{s=1}^m b_s^i \tilde{u}_s. \end{aligned}$$

Poniżej podsumowano główne wyniki pracy. W rozdziale 5 sformułowano dwa nowe wyniki dotyczące mechanicznej linearyzacji w przestrzeni stanu (w skrócie MS-linearyzacji) poprzez zmianę współrzędnych  $\Phi : Q \rightarrow \tilde{Q}$ . Zakładając przypadek sterowalny, mamy następujące

**Twierdzenie.** *Mechaniczny system sterowania ( $\mathcal{MS}$ ) jest, lokalnie wokół  $x_0 \in Q$ , MS-linearyzowalny do liniowego sterowalnego mechanicznego systemu sterowania ( $\mathcal{LMS}$ ) wtedy i tylko wtedy, gdy spełnia, wokół  $x_0$  następujące warunki:*

$$\begin{aligned} (MS1)' \quad \dim \text{span} \{ad_e^q g_r, 0 \leq q \leq n-1, 1 \leq r \leq m\} &= n, \\ (MS2)' \quad [ad_e^p g_r, ad_e^q g_s] &= 0 \quad \text{dla } 0 \leq p, q \leq n, 1 \leq r, s \leq m, \\ (MS3)' \quad \langle ad_e^j g_r : ad_e^k g_s \rangle &= 0 \quad \text{dla } 0 \leq j, k \leq n, 1 \leq r, s \leq m, \end{aligned}$$

gdzie  $ad_e^q g_r = [e, ad_e^{q-1} g_r]$  jest iterowanymi nawiesem Liego pól  $e$  i  $g_r$  oraz  $\langle ad_e^j g_r : ad_e^k g_s \rangle$  jest ich nawiasem symetrycznym.

Zaskakującym jest, że problem MS-linearyzacji można rozwiązać bez założenia sterowalności. Okazuje się, że kluczową operacją jest pochodna kowariantna  $\nabla$ , zaś kluczowym narzędziem tensor krzywizny Riemanna  $R$ .

**Twierdzenie.** *Mechaniczny system sterowania ( $\mathcal{MS}$ ) jest, lokalnie wokół  $x_0 \in Q$ , MS-linearyzowalny do liniowego, możliwie niesterowalnego, mechanicznego systemu sterowania ( $\mathcal{LMS}$ ) wtedy i tylko wtedy, gdy spełnia, wokół  $x_0$  następujące warunki:*

$$\begin{aligned} (MNS1) \quad R &= 0, \\ (MNS2) \quad \nabla g_r &= 0 \quad \text{dla } 1 \leq r \leq m, \\ (MNS3) \quad \nabla^2 e &= 0. \end{aligned}$$

W rozdziale 6, który stanowi trzon pracy, przedstawiono teorię MF-linearyzacji systemów mechanicznych ( $\mathcal{MS}$ ). Ponownie, najpierw rozpatrzono wariant sterowalny. Zdefiniowano sekwencję dystrybucji zagnieżdżonych  $\mathcal{E}^j$

$$\begin{aligned} \mathcal{E}^0 &= \text{span} \{g_r, 1 \leq r \leq m\} \\ \mathcal{E}^j &= \text{span} \{ad_e^i g_r, 1 \leq r \leq m, 0 \leq i \leq j\}. \end{aligned}$$

Dla systemów mechanicznych z jednym sterowaniem ( $m = 1$ ) sformułowano twierdzenie

**Twierdzenie.** *Załóżmy  $n \geq 3$ . Mechaniczny system sterowania ( $\mathcal{MS}$ ) z jednym sterowaniem  $m = 1$  jest, lokalnie wokół  $x_0 \in Q$ , MF-linearyzowalny do sterowalnego ( $\mathcal{LMS}$ ) wtedy i tylko wtedy, gdy spełnia, wokół  $x_0$ , następujące warunki:*

$$\begin{aligned} (MC1) \quad \text{rank } \mathcal{E}^{n-1} &= n, \\ (MC2) \quad \mathcal{E}^j &\text{ są inwolutywne i stałego rzędu, dla } 0 \leq j \leq n-2, \\ (MC3) \quad \nabla_{ad_e^i g} g &\in \mathcal{E}^0 \quad \text{dla } 0 \leq i \leq n-1, \end{aligned}$$

$$(MC4) \quad \nabla_{ad_e^k, ad_e^j}^2 e \in \mathcal{E}^1 \quad \text{dla } 0 \leq k, j \leq n-1.$$

Alternatywne sformułowanie MF-linearyzacji można dokonać stosując koncepcje wyjść linearyzujących.

**Definicja.** *Mechaniczny system sterowania*  $(\mathcal{MS})$  z  $m$  konfiguracyjnymi wyjściami  $h_1(x), \dots, h_m(x) \in C^\infty(Q)$  ma wektorowy pół-rząd względny  $(\bar{\nu}_1, \dots, \bar{\nu}_m)$  wokół  $x_0$  jeśli

$$(i) \quad L_{g_r} L_e^k h_i = 0,$$

$$\text{dla } 1 \leq i, r \leq m \text{ oraz } 0 \leq k \leq \bar{\nu}_i - 2,$$

(ii)  $m \times m$  macierz odsprężania

$$D(x) = \left( L_{g_r} L_e^{\bar{\nu}_i - 1} h_i \right) (x)$$

jest pełnego rzędu równego  $m$ , wokół  $x_0$ .

Następujące twierdzenie zachodzi dla systemu wielowejsciowego.

**Twierdzenie.** *Mechaniczny system sterowania*  $(\mathcal{MS})$  jest, lokalnie wokół  $x_0 \in Q$ , MF-linearyzowalny wtedy i tylko wtedy, gdy istnieje  $m$  funkcji  $h_1(x), \dots, h_m(x) \in C^\infty(Q)$  spełniających, wokół  $x_0$ , następujące warunki:

(MR1) wektorowy pół-rząd względny jest równy  $(\bar{\nu}_1, \dots, \bar{\nu}_m)$  oraz  $\sum_{i=1}^m \bar{\nu}_i = n$ .

(MR2) funkcje  $h_i(x)$  oraz ich kolejne  $\bar{\nu}_i - 2$  pochodne Liego wzdłuż  $e$  są kowariantnie liniowe, tzn.

$$\nabla(dL_e^k h_i) = 0, \quad \text{dla } 0 \leq k \leq \bar{\nu}_i - 2.$$

Następne twierdzenie charakteryzuje MF-linearyzowalność bez założenia dotyczącego sterowalności systemu.

**Twierdzenie.** *Mechaniczny system sterowania*  $(\mathcal{MS})_{(n,m)}$  jest, lokalnie wokół  $x_0 \in Q$ , MF-linearyzowalny wtedy i tylko wtedy, gdy spełnia, wokół  $x_0$ , następujące warunki:

(ML0)  $\mathcal{E}^0$  oraz  $\mathcal{E}^1$  są stałego rzędu,

(ML1)  $\mathcal{E}^0$  jest inwolutywna,

(ML2)  $\text{ann } \mathcal{E}^0 \subset \text{ann } R$ ,

(ML3)  $\text{ann } \mathcal{E}^0 \subset \text{ann } \nabla g_r$  for  $1 \leq r \leq m$ ,

(ML4)  $\text{ann } \mathcal{E}^1 \subset \text{ann } \nabla^2 e$ ,

gdzie anihilatory danych obiektów zdefiniowane są następująco

- $\text{ann } \mathcal{E}^0 = \{\omega \in \Lambda(Q) : \omega(g_r) = 0, 1 \leq r \leq m\}$
- $\text{ann } R = \{\omega \in \Lambda(Q) : \omega(R) = 0\}$
- $\text{ann } \nabla g_r = \{\omega \in \Lambda(Q) : \omega(\nabla g_r) = 0, 1 \leq r \leq m\}$
- $\text{ann } \nabla^2 e = \{\omega \in \Lambda(Q) : \omega(\nabla^2 e) = 0\}$ .

Przeprowadzone badania systemów mechanicznych ( $\mathcal{MS}$ ) nie byłyby możliwe bez analizy liniowych systemów mechanicznych ( $\mathcal{LMS}$ ). W rozdziale 4 sklasyfikowano sterowalne liniowe systemy mechaniczne za pomocą liniowej zmiany współrzędnych i sprzężenia. Wynik ten jest analogiczny do klasycznego wyniku Brunovského. Rozważmy dwa liniowe mechaniczne systemy

$$(\mathcal{LMS}) : \quad \begin{aligned} \dot{x} &= y \\ \dot{y} &= Ex + Bu, \end{aligned} \quad (\widetilde{\mathcal{LMS}}) : \quad \begin{aligned} \dot{\tilde{x}} &= \tilde{y} \\ \dot{\tilde{y}} &= \tilde{E}\tilde{x} + \tilde{B}\tilde{u}, \end{aligned}$$

gdzie  $E, \tilde{E} \in \mathbb{R}^{n \times n}$ ,  $B, \tilde{B} \in \mathbb{R}^{n \times m}$ ,  $\hat{A} = \begin{pmatrix} 0 & I_n \\ E & 0 \end{pmatrix}$ ,  $\hat{B} = \begin{pmatrix} 0 \\ B \end{pmatrix}$ .

Powiemy, że  $(\mathcal{LMS})$  oraz  $(\widetilde{\mathcal{LMS}})$  są *liniowo mechanicznie równoważne*, krótko LMF-równoważne, jeżeli istnieje liniowa zmiana współrzędnych  $\tilde{x} = Tx$ ,  $\tilde{y} = Ty$  oraz odwracalne sprzężenie zwrotne  $u = Fx + G\tilde{u}$ , takie że

$$\begin{aligned} \dot{\tilde{x}} &= T\dot{y} = \tilde{y} \\ \dot{\tilde{y}} &= T(E + BF)T^{-1}\tilde{x} + TBG\tilde{u} = \tilde{E}\tilde{x} + \tilde{B}\tilde{u}. \end{aligned}$$

Dla systemu  $(\mathcal{LMS})$  definiujemy  $n$ -tkę indeksów  $\bar{r}_i$

$$\begin{aligned} \bar{r}_0 &= \text{rank}(B), \\ \bar{r}_i &= \text{rank}(B, EB, \dots, E^i B) - \text{rank}(B, EB, \dots, E^{i-1} B), \end{aligned}$$

dla  $1 \leq i \leq n-1$ . Następnie definiujemy dualne indeksy

$$\bar{\rho}_j = \text{card}(\bar{r}_i \geq j : 0 \leq i \leq n-1) \quad \text{for } 1 \leq j \leq m.$$

Indeksy te są mechanicznymi analogami indeksów sterowalności (Brunovského, Krouneckera)  $\rho_i$ , zatem nazwane zostały *mechanicznymi pół-indeksami*. Oznaczmy  $\bar{\mathcal{R}}(E, B) = (\bar{r}_0, \dots, \bar{r}_{n-1})$ ,  $\bar{\mathcal{P}}(E, B) = (\bar{\rho}_1, \dots, \bar{\rho}_m)$  oraz  $\mathcal{P}(\hat{A}, \hat{B}) = (\rho_1, \dots, \rho_m)$ .

**Twierdzenie.** *Rozważmy dwa sterowalne liniowe mechaniczne systemy  $(\mathcal{LMS})$  oraz  $(\widetilde{\mathcal{LMS}})$ , zdefiniowane przez, odpowiednio, pary  $(E, B)$  oraz  $(\tilde{E}, \tilde{B})$ . Następujące warunki są równoważne:*

- (i) *systemy  $(\mathcal{LMS})$  oraz  $(\widetilde{\mathcal{LMS}})$  są LMF-równoważne,*
- (ii)  $\bar{\mathcal{R}}(E, B) = \bar{\mathcal{R}}(\tilde{E}, \tilde{B})$ ,
- (iii)  $\bar{\mathcal{P}}(E, B) = \bar{\mathcal{P}}(\tilde{E}, \tilde{B})$ , *tnz. mechaniczne pół-indeksy są identyczne,*
- (iv)  $\mathcal{P}(\hat{A}, \hat{B}) = \mathcal{P}(\hat{\tilde{A}}, \hat{\tilde{B}})$ , *tnz. indeksy sterowalności są identyczne.*

Praca kończy się szeroko zakrojonymi badaniami symulacyjnymi przeprowadzonymi dla trzech układów mechanicznych, które są MF-linearyzowalne, tj. wahadło z kołem bezwładnościowym, system TORA oraz manipulator z pojedynczym ogniwem z elastycznością w złączu. Pokazujemy, w jaki sposób nasze wyniki teoretyczne mają zastosowanie w praktyce inżynierskiej do rozwiązywania konkretnych problemów sterowania. Przedstawiono wyniki 13 scenariuszy omawiających różne aspekty sterowania.

# Résumé

Marcin NOWICKI

*Linéarisation par bouclage des systèmes mécaniques de contrôle*

Cette thèse est consacrée à l'étude des systèmes mécaniques de contrôle qui sont définis sur une variété différentielle de configuration  $Q$  munie des coordonnées locales  $x = (x^1, \dots, x^n)$ . Dans ces coordonnées, ils prennent la forme d'équation différentielle d'ordre deux<sup>1</sup>:

$$\ddot{x}^i = -\Gamma_{jk}^i(x)\dot{x}^j\dot{x}^k + e^i(x) + \sum_{r=1}^m g_r^i(x)u_r, \quad 1 \leq i \leq n,$$

où les coefficients  $\Gamma_{jk}^i(x)$  sont les symboles de Christoffel correspondant aux forces de Coriolis et centrifuges,  $e(x)$  est un champ de vecteurs représentant l'influence des forces externes (par exemple, la gravité ou l'élasticité) et les  $g_r(x)$  sont des champs de vecteurs contrôlés.

De manière équivalente nous pouvons décrire les trajectoires d'un système mécanique de contrôle par un système d'équations différentielles ordinaires sur le fibré tangent  $TQ$  muni des coordonnées  $(x, y) = (x^1, \dots, x^n, y^1, \dots, y^n)$ :

$$(\mathcal{MS}) : \quad \begin{aligned} \dot{x}^i &= y^i \\ \dot{y}^i &= -\Gamma_{jk}^i(x)y^jy^k + e^i(x) + \sum_{r=1}^m g_r^i(x)u_r \end{aligned} \quad 1 \leq i \leq n.$$

Le problème central étudié dans cette thèse est la linéarisation mécanique par bouclage des systèmes mécaniques de contrôle (MF-linéarisation) en appliquant les transformations suivantes:

- (i) le changement de coordonnées par difféomorphisme

$$\begin{aligned} \Phi : \quad TQ &\rightarrow T\tilde{Q} \\ (x, y) &\mapsto (\tilde{x}, \tilde{y}) = (\phi(x), D\phi(x)y); \end{aligned}$$

- (ii) la transformation par bouclage mécanique  $(\alpha, \beta, \gamma)$  de la forme

$$u_r = \gamma_{jk}^r(x)y^jy^k + \alpha^r(x) + \sum_{s=1}^m \beta_s^r(x)\tilde{u}_s,$$

où  $\gamma_{jk}^r = \gamma_{kj}^r$ ,

de sorte que le système transformé soit linéaire et mécanique

---

<sup>1</sup>Nous utilisons tout au long de la convention de sommation d'Einstein.



$$(\mathcal{LMS}) : \begin{aligned} \dot{\tilde{x}}^i &= \tilde{y}^i \\ \dot{\tilde{y}}^i &= E_j^i \tilde{x}^j + \sum_{s=1}^m b_s^i \tilde{u}_s. \end{aligned}$$

Ici, nous présentons brièvement les principaux résultats de la thèse.

Dans le Chapitre 5, nous présentons deux nouveaux résultats concernant la linéarisation mécanique dans l'espace d'état (MS-linéarisation) en agissant sur  $(\mathcal{MS})$  uniquement par un changement de coordonnées. En supposant que le système est contrôlable nous avons :

**Théorème.** *Le système mécanique de contrôle  $(\mathcal{MS})$  est localement MS-linéarisable, autour de  $x_0 \in Q$ , si et seulement si dans un voisinage de  $x_0$  il satisfait les conditions:*

$$(MS1)' \dim \text{span} \{ad_e^q g_r, 0 \leq q \leq n-1, 1 \leq r \leq m\} = n,$$

$$(MS2)' [ad_e^p g_r, ad_e^q g_s] = 0 \quad 0 \leq p, q \leq n, 1 \leq r, s \leq m,$$

$$(MS3)' \langle ad_e^j g_r : ad_e^k g_s \rangle = 0 \quad 0 \leq j, k \leq n, 1 \leq r, s \leq m,$$

où  $ad_e^q g_r = [e, ad_e^{q-1} g_r]$  est le crochet de Lie itéré des champs de vecteurs  $e$  et  $g_r$ , et  $\langle ad_e^j g_r : ad_e^k g_s \rangle$  est le produit symétrique.

Il est remarquable que le problème de MS-linéarisation puisse être résolu sans l'hypothèse de contrôlabilité. Il se trouve que l'opérateur crucial est la dérivée covariante  $\nabla$  et le tenseur de courbure de Riemann  $R$  de l'espace de configuration  $Q$ .

**Théorème.** *Le système mécanique de contrôle  $(\mathcal{MS})$  est localement MS-linéarisable (( $\mathcal{LMS}$ ) éventuellement incontrôlable), autour de  $x_0 \in Q$ , si et seulement si dans un voisinage de  $x_0$  il satisfait les conditions:*

$$(MNS1) R = 0,$$

$$(MNS2) \nabla g_r = 0, \quad 1 \leq r \leq m,$$

$$(MNS3) \nabla^2 e = 0.$$

Dans le Chapitre 6, qui est au cœur de la thèse, nous développons une théorie de la MF-linéarisation pour les systèmes mécaniques de contrôle.

Supposons que  $(\mathcal{MS})$  est contrôlable. Soit la séquence de distributions  $\mathcal{E}^j$  donnée par

$$\begin{aligned} \mathcal{E}^0 &= \text{span} \{g_r, 1 \leq r \leq m\} \\ \mathcal{E}^j &= \text{span} \left\{ ad_e^i g_r, 1 \leq r \leq m, 0 \leq i \leq j \right\}. \end{aligned}$$

Pour le système avec un seul contrôle ( $m = 1$ ) nous avons

**Théorème.** *Supposons que  $n \geq 3$ ; le système mécanique de contrôle  $(\mathcal{MS})$  avec un contrôle ( $m = 1$ ) est localement MF-linéarisable, autour de  $x_0 \in Q$ , si et seulement si dans un voisinage de  $x_0$  il satisfait les conditions:*

$$(MC1) \text{rank } \mathcal{E}^{n-1} = n,$$

$$(MC2) \mathcal{E}^j \text{ est involutif et de rang constant, } 0 \leq j \leq n-2,$$

$$(MC3) \nabla_{ad_e^i g} g \in \mathcal{E}^0, \quad 0 \leq i \leq n-1,$$

$$(MC4) \quad \nabla_{ad^k g, ad^j g}^2 e \in \mathcal{E}^1, \quad 0 \leq k, j \leq n-1.$$

Nous formulons une autre version de MF-linéarisation à l'aide du concept des "sorties linéarisantes".

**Définition.** *Nous disons que le système mécanique de contrôle (MS) avec  $m$  fonctions de configuration (sorties)  $h_1(x), \dots, h_m(x) \in C^\infty(Q)$  possède le vecteur des demi-degrés relatifs  $(\bar{\nu}_1, \dots, \bar{\nu}_m)$  dans un voisinage de  $x_0$  si*

$$(i) \quad L_{g_r} L_e^k h_i = 0,$$

$$1 \leq i, r \leq m \text{ et } 0 \leq k \leq \bar{\nu}_i - 2,$$

(ii) la matrice de découplage de taille  $m$

$$D(x) = \left( L_{g_r} L_e^{\bar{\nu}_i - 1} h_i \right) (x)$$

est inversible en  $x_0$ .

Le résultat suivant s'applique aux systèmes à entrées multiples.

**Théorème.** *Le système mécanique de contrôle (MS) est localement MF-linéarisable, autour de  $x_0 \in Q$ , si et seulement si il existe  $m$  fonctions  $h_1(x), \dots, h_m(x) \in C^\infty(Q)$  satisfaisant*

(MR1) le vecteur des demi-degrés relatifs  $(\bar{\nu}_1, \dots, \bar{\nu}_m)$  avec  $\sum_{i=1}^m \bar{\nu}_i = n$ .

(MR2) les fonctions  $h_i(x)$  et leurs  $\bar{\nu}_i - 2$  dérivées de Lie successives le long de  $e$  sont covariantement linéaires, c'est-à-dire

$$\nabla(dL_e^k h_i) = 0 \quad \text{for } 0 \leq k \leq \bar{\nu}_i - 2.$$

Enfin, nous avons le résultat suivant le cas sans l'hypothèse de contrôlabilité.

**Théorème.** *Le système mécanique de contrôle (MS) est localement MF-linéarisable, autour de  $x_0 \in Q$ , si et seulement si dans un voisinage de  $x_0$  il satisfait les conditions:*

(ML0)  $\mathcal{E}^0$  et  $\mathcal{E}^1$  sont de rang constant,

(ML1)  $\mathcal{E}^0$  est involutive,

(ML2)  $\text{ann } \mathcal{E}^0 \subset \text{ann } R$ ,

(ML3)  $\text{ann } \mathcal{E}^0 \subset \text{ann } \nabla g_r$  pour  $1 \leq r \leq m$ ,

(ML4)  $\text{ann } \mathcal{E}^1 \subset \text{ann } \nabla^2 e$ ,

où les annulateurs précédents sont définis par

- $\text{ann } \mathcal{E}^0 = \{\omega \in \Lambda(Q) : \omega(g_r) = 0, 1 \leq r \leq m\}$
- $\text{ann } R = \{\omega \in \Lambda(Q) : \omega(R) = 0\}$
- $\text{ann } \nabla g_r = \{\omega \in \Lambda(Q) : \omega(\nabla g_r) = 0, 1 \leq r \leq m\}$
- $\text{ann } \nabla^2 e = \{\omega \in \Lambda(Q) : \omega(\nabla^2 e) = 0\}$ .

Notre étude des systèmes  $(\mathcal{MS})$  ne serait pas possible sans analyse des systèmes linéaires  $(\mathcal{LMS})$ . Dans le Chapitre 4, nous classifions les systèmes mécaniques linéaires contrôlables sous l'action des changements de coordonnées linéaires et du bouclage linéaire. Ce résultat est analogue à la classification de Brunovský.

Considérons deux systèmes mécaniques linéaires contrôlables

$$(\mathcal{LMS}) : \quad \begin{aligned} \dot{x} &= y \\ \dot{y} &= Ex + Bu, \end{aligned} \quad (\widetilde{\mathcal{LMS}}) : \quad \begin{aligned} \dot{\tilde{x}} &= \tilde{y} \\ \dot{\tilde{y}} &= \tilde{E}\tilde{x} + \tilde{B}\tilde{u}, \end{aligned}$$

où  $E, \tilde{E} \in \mathbb{R}^{n \times n}$ ,  $B, \tilde{B} \in \mathbb{R}^{n \times m}$ ,  $\hat{A} = \begin{pmatrix} 0 & I_n \\ E & 0 \end{pmatrix}$ ,  $\hat{B} = \begin{pmatrix} 0 \\ B \end{pmatrix}$ . L'équivalence par bouclage linéaire mécanique (LMF-équivalence) entre  $(\mathcal{LMS})$  et  $(\widetilde{\mathcal{LMS}})$  est définie par le changement linéaire de coordonnées  $\tilde{x} = Tx$ ,  $\tilde{y} = Ty$  et le bouclage linéaire  $u = Fx + G\tilde{u}$ , tel que

$$\begin{aligned} \dot{\tilde{x}} &= T\dot{y} = \tilde{y} \\ \dot{\tilde{y}} &= T(E + BF)T^{-1}\tilde{x} + TBG\tilde{u} = \tilde{E}\tilde{x} + \tilde{B}\tilde{u}. \end{aligned}$$

Nous attachons au système  $(\mathcal{LMS})$  le  $n$ -uplet d'indices  $\bar{r}_i$  donné par

$$\begin{aligned} \bar{r}_0 &= \text{rank}(B), \\ \bar{r}_i &= \text{rank}(B, EB, \dots, E^i B) - \text{rank}(B, EB, \dots, E^{i-1} B), \end{aligned}$$

pour  $1 \leq i \leq n-1$ . De plus, nous définissons les indices duals

$$\bar{\rho}_j = \text{card}(\bar{r}_i \geq j : 0 \leq i \leq n-1) \quad \text{for } 1 \leq j \leq m.$$

Ces entiers sont des analogues mécaniques aux indices de contrôlabilité  $\rho_i$  (Brunovský, Kronecker). Nous les appelons des demi-indices mécaniques. Soit les séquences  $\bar{\mathcal{R}}(E, B) = (\bar{r}_0, \dots, \bar{r}_{n-1})$ ,  $\bar{\mathcal{P}}(E, B) = (\bar{\rho}_1, \dots, \bar{\rho}_m)$ , and  $\mathcal{P}(\hat{A}, \hat{B}) = (\rho_1, \dots, \rho_m)$ .

**Théorème.** *Considérons deux systèmes mécaniques linéaires contrôlables  $(\mathcal{LMS})$  et  $(\widetilde{\mathcal{LMS}})$ , représentés par les paires  $(E, B)$  et  $(\tilde{E}, \tilde{B})$ . Les conditions suivantes sont équivalentes:*

- (i) *Les systèmes  $(\mathcal{LMS})$  et  $(\widetilde{\mathcal{LMS}})$  sont LMF-équivalents,*
- (ii)  $\bar{\mathcal{R}}(E, B) = \bar{\mathcal{R}}(\tilde{E}, \tilde{B})$ ,
- (iii)  $\bar{\mathcal{P}}(E, B) = \bar{\mathcal{P}}(\tilde{E}, \tilde{B})$ , *c'est à dire les demi-indices mécaniques coïncident,*
- (iv)  $\mathcal{P}(\hat{A}, \hat{B}) = \mathcal{P}(\hat{\tilde{A}}, \hat{\tilde{B}})$ , *c'est à dire les indices contrôlables coïncident.*

La thèse se termine par une études de simulation numérique des systèmes mécaniques de contrôle, à savoir le pendule inversé stabilisé par volant d'inertie, le système TORA, et le manipulateur avec articulation flexible. Nous montrons comment nos résultats théoriques s'appliquent dans des problématiques d'ingénierie. Au total, nous présentons les résultats de la simulation de 13 scénarios.

# Contents

<b>Abstract</b>	<b>v</b>
<b>Streszczenie</b>	<b>ix</b>
<b>Résumé</b>	<b>xiii</b>
<b>1 Introduction</b>	<b>1</b>
1.1 Preface . . . . .	1
1.2 Motivation and statement of contribution . . . . .	2
1.3 Applicability and technical comments . . . . .	3
1.4 Outline of the thesis . . . . .	4
<b>2 Preliminaries</b>	<b>5</b>
2.1 Differential geometry . . . . .	5
2.1.1 Manifolds and tensor fields . . . . .	5
2.1.2 Differential operations on vector fields . . . . .	7
2.1.3 Distributions and Integrable Manifolds . . . . .	9
2.2 Riemannian Geometry . . . . .	10
2.3 Control-affine systems . . . . .	19
<b>3 Mechanical control systems and their structure</b>	<b>25</b>
3.1 Mechanical Control Systems . . . . .	25
3.2 Lagrange formalism . . . . .	27
3.3 Examples of models of mechanical control systems . . . . .	29
3.3.1 Robotic manipulators . . . . .	29
3.3.2 The two-link manipulator . . . . .	30
3.3.3 The Inertia Wheel Pendulum . . . . .	32
3.3.4 The TORA system . . . . .	33
3.3.5 The single link manipulator with joint elasticity . . . . .	34
<b>4 Linear mechanical control systems</b>	<b>35</b>
4.1 Linear Mechanical Control Systems ( $\mathcal{LMS}$ ) . . . . .	35
4.2 Classification of controllable ( $\mathcal{LMS}$ ) . . . . .	36
4.3 Lagrangian Linear Mechanical Systems . . . . .	42
4.4 Examples of Linear Mechanical Control System . . . . .	43
<b>5 Mechanical state-space linearization</b>	<b>45</b>
5.1 Mechanical state-space equivalence . . . . .	45
5.2 MS-linearization of controllable mechanical systems . . . . .	48
5.3 MS-linearization of non-controllable mechanical systems . . . . .	50

<b>6</b>	<b>Mechanical Feedback linearization</b>	<b>53</b>
6.1	MF-equivalence of Mechanical Systems . . . . .	53
6.2	MF-equivalence of mechanical distributions . . . . .	58
6.3	MF-linearization of controllable Mechanical Systems . . . . .	59
6.3.1	Normalization of $(\mathcal{MS})$ . . . . .	59
6.3.2	MF-Linearization to controllable $(\mathcal{LMS})$ . . . . .	61
6.3.3	Linearization outputs and Input-Output Linearization . . . . .	69
6.4	MF-linearization of non-controllable Mechanical Systems . . . . .	81
6.4.1	Potential-free $(\mathcal{MS})$ . . . . .	89
<b>7</b>	<b>Examples and control problems solved using linearization</b>	<b>91</b>
7.1	Examples . . . . .	91
7.2	Control Problems . . . . .	98
7.2.1	Stabilization . . . . .	100
7.2.2	Point-to-point controllability (a motion planning) . . . . .	101
7.2.3	Trajectory tracking . . . . .	102
7.3	The Inertia Wheel Pendulum . . . . .	103
7.3.1	MF-linearization . . . . .	103
7.3.2	Stabilization . . . . .	105
7.3.3	Motion planning and trajectory tracking . . . . .	110
7.4	The TORA system . . . . .	115
7.4.1	MF-linearization . . . . .	116
7.4.2	Stabilization . . . . .	117
7.4.3	Motion planning and trajectory tracking . . . . .	120
7.5	The single link manipulator with joint elasticity . . . . .	121
7.5.1	MF-linearization . . . . .	122
7.5.2	Stabilization . . . . .	122
7.5.3	Motion planning and trajectory tracking . . . . .	125
7.6	Construction the underactuated two-link manipulator . . . . .	128
<b>8</b>	<b>Conclusions and further research</b>	<b>131</b>

# List of Figures

3.1	The two-link manipulator . . . . .	30
3.2	The inertia wheel pendulum . . . . .	32
3.3	The TORA system . . . . .	33
3.4	The single link manipulator with joint elasticity . . . . .	34
4.1	The $n$ -coupled spring-mass system . . . . .	43
7.1	Robot cart propelled by a blower. . . . .	91
7.2	Cart-pole system. . . . .	95
7.3	The cascade controller for MF-linearizable ( $\mathcal{MS}$ ). . . . .	99
7.4	The simulation scheme for stabilization of the Inertia Wheel Pendulum. . . . .	106
7.5	S1a. The simulation results for the Inertia Wheel Pendulum with the natural frequency tuning. . . . .	107
7.6	S1b. The simulation results for the Inertia Wheel Pendulum with pole placement tuning. . . . .	107
7.7	S1c. The simulation results for the Inertia Wheel Pendulum with LQR tuning. . . . .	108
7.8	S2. The simulation results for the Inertia Wheel Pendulum with the parametric uncertainties of 1000%. . . . .	109
7.9	S3. The simulation results for the Inertia Wheel Pendulum outside the origin. . . . .	110
7.10	The simulation scheme for trajectory tracking of the Inertia Wheel Pendulum. . . . .	111
7.11	S4. Rest-to-rest trajectory tracking for Inertia Wheel Pendulum. . . . .	112
7.12	S5a. Trajectory tracking for matched initial conditions of the Inertia Wheel Pendulum. . . . .	113
7.13	S5b. Trajectory tracking for mismatched initial conditions of the Inertia Wheel Pendulum. . . . .	113
7.14	S6. Tracking the trajectory that passes through the singularity of the Inertia Wheel Pendulum. . . . .	114
7.15	S7. Sinusoidal trajectory tracking of the Inertia Wheel Pendulum. . . . .	115
7.16	The simulation scheme for stabilization of the TORA system. . . . .	118
7.17	S8a. The simulation results for the TORA system with the natural frequency tuning. . . . .	119
7.18	S8b. The simulation results for the TORA system with the pole placement tuning. . . . .	119
7.19	The simulation scheme for trajectory tracking of the TORA system. . . . .	120
7.20	S9. Sinusoidal trajectory tracking of the TORA system. . . . .	121
7.21	The simulation scheme for the FLEX system. . . . .	123
7.22	S10a. The simulation results for the FLEX system with the natural frequency tuning. . . . .	124
7.23	S10b. The simulation results for the FLEX system with pole placement tuning. . . . .	124

7.24	S11. The simulation results for the FLEX system outside the origin. .	125
7.25	The simulation scheme for trajectory tracking for the FLEX system. .	126
7.26	S12. Rest-to-rest trajectory tracking for the FLEX system. . . . .	127
7.27	S13. Sinusoidal trajectory tracking of the FLEX system. . . . .	128

# List of Symbols

$A^T$	transpose of a matrix $A$
$\nabla$	covariant derivative, 13,14,17
$\nabla^2$	second covariant derivative, 17
$C^\infty(Q)$	the set of smooth real-valued functions on a manifold $Q$
$C^\infty(TQ)$	the set of smooth real-valued functions on a tangent bundle $TQ$
$\partial_i := \frac{\partial}{\partial x^i}$	the $i$ -th unity vector field in a coordinate system $x = (x^1, \dots, x^n)$
$dx^i$	the $i$ -th unity covector field in a coordinate system $x = (x^1, \dots, x^n)$
$\delta_{ij}, \delta_j^i$	the $(i, j)$ -element of the Kronecker delta tensor
$\mathcal{D}, \mathcal{E}$	typically, distribution on a manifold, 9
$\Gamma_{jk}^i$	Christoffel symbols of the second kind, 16
$I_n$	$n \times n$ identity matrix
$\Lambda(Q)$	the set of smooth one-forms on a manifold $Q$ , 6
$L_X \alpha$	Lie derivative, 8
$[X, Y], ad_X Y$	Lie bracket, 8
$\mathfrak{m}$	metric tensor, 11
$\flat, \sharp$	musical isomorphisms, 11
$\phi$	a diffeomorphism of $Q$ , 7
$\Phi$	a diffeomorphism of $TQ$ , 46
$D\phi = \frac{\partial \phi}{\partial x}$	the Jacobian matrix of a diffeomorphism $\phi$ , 7
$\frac{\partial \tilde{x}^i}{\partial x^j} := \frac{\partial \phi_i}{\partial x^j}$	the $(i, j)$ -element of the Jacobian matrix $D\phi$ , where $\tilde{x} = \phi(x)$ , 7
$\frac{\partial x^j}{\partial \tilde{x}^i}$	the $(j, i)$ -element of the inverse of the Jacobian matrix $D\phi$ , 11
$\pi$	typically, canonical projection, 15
$Q$	configuration manifold, 5
$R$	Riemann curvature tensor, 16
$\langle X, Y \rangle$	symmetric bracket, 15
$T_x Q$	tangent space at $x \in Q$ , 5
$TQ$	tangent bundle of $Q$ , 5
$T^* Q$	cotangent bundle of $Q$ , 6
$\mathcal{T}_s^r(Q)$	the set of smooth $r$ -contravariant, $s$ -covariant tensor fields on a manifold $Q$ , shortly, $(r, s)$ -tensor fields on $Q$ , 6
$\mathcal{V}$	vertical distribution, 15
$lift$	vertical lift, 15
$x = (x^1, \dots, x^n)$	local coordinate system on $Q$ , 5
$\mathfrak{X}(Q)$	the set of smooth vector fields on a manifold $Q$ , 5
$\mathfrak{X}(TQ)$	the set of smooth second order vector fields on tangent bundle $TQ$





## Chapter 1

# Introduction

### 1.1 Preface

A problem that is considered in this thesis, at its core, reveals a dual nature. The dualism is manifested in several ways.

The subject of our study are mechanical control systems. As the name suggests, it constitutes an interplay of mechanics and control theory. The history of the former dates back to Newton, Euler, Lagrange, Laplace, Hamilton and many others, and is inseparably connected with the development of mathematics. Then, at the turn of the 20th century, it was Poincaré who brought a new insight into mechanics by introducing a geometric point of view. His works connected mechanics with differential geometry and thus enabled to benefit from the works of Gauss, Riemann, Ricci, Levi-Civita in order to study mechanics.

The history of geometric control theory is a newer subject beginning in the 1970's with pioneering works of Brockett, Hermann, Hermes, Lobry, Sussmann, Isidori, Krener and many others. Together they introduced geometric control theory into the "golden ages" in the 1980's and 1990's when it proved its power by both a mathematical elegance and countless applications in engineering problems. As an example of a product of this era may serve the classical theory of feedback linearization of control systems (by Jakubczyk, Respondek and Hunt, Su), whose fruitful results are consumed to this days.

Then, at the turn of 21th century this two fields (i.e. mechanics and geometric control theory) collide by the crucial impulse carried out by Brockett, Marsden, Crouch, Bloch, van der Schaft, Bullo, Lewis that constitutes the field of geometric control of mechanical control systems. Finally, we would like to mention Respondek and his collaborators who study equivalence problems of mechanical control systems. This thesis is a natural continuation of their previous works.

Another duality of this thesis is more subtle. It concerns the second subject of interest in this thesis, namely the concept of feedback linearization. Firstly, feedback is the most natural tool of control engineering, often identified with the very idea of the control itself. Secondly, from the geometric control theory standpoint, the notion of feedback is that of a group of transformations that act on the system. While the transformations of the state space are somehow embedded (by the word geometric) in this field, the transformations of the input space, i.e. feedback, are the very core that distinguishes the study of control systems from the study of dynamical systems.

Finally, the linearization itself exhibits a certain duality. From a practical point of view, it is a control technique that enables (whenever applicable) a systematic synthesis of control. Its constructive solution enables to transform a control task for a nonlinear system into a relatively easy task for a linear one. The usefulness of this approach cannot be overestimated and it has proved its importance in numerous engineering applications. From a theoretical point of view, however, the linearization

constitutes a part of the classification problem for nonlinear control systems. Apart from the obvious pure cognitive ideal, i.e. understanding how the universe around us works, it serves also as an indicator whenever the control problem is easy (it can be brought to a linear problem) or not.

All these dualities described above are both very rewarding and challenging at the same time. Rewarding in the sense that the obtained results have always physical interpretation (due to the subject of the research, i.e. mechanical systems). The process of translating mathematical results into physical phenomena is very inspiring and motivating. At the same time, the process is challenging since it often requires a multidisciplinary knowledge. Moreover, the challenge that we face comes from, possibly, various scientific backgrounds of the reader since the presented results may potentially interest scientist from both (theoretical and practical) areas. Aware of this, we put an effort to present our results so that both communities could completely follow our presentation.

## 1.2 Motivation and statement of contribution

Consider a mechanical control system that can be represented as a control system using coordinates  $(x, y) = (x^1, \dots, x^n, y^1, \dots, y^n)$ , where  $x^i$  are configurations and  $y^i$  are the corresponding velocities,

$$\begin{aligned} \dot{x}^i &= y^i \\ \dot{y}^i &= -\Gamma_{jk}^i(x)y^j y^k + e^i(x) + \sum_{r=1}^m g_r^i(x)u_r, \quad 1 \leq i \leq n. \end{aligned} \quad (1.1)$$

We consider the problem of mechanical feedback linearization by applying to system (1.1) the following transformations:

- (i) changes of coordinates given by

$$\begin{aligned} \Phi : \quad \text{T}Q &\rightarrow \text{T}\tilde{Q} \\ (x, y) &\mapsto (\tilde{x}, \tilde{y}) = (\phi(x), D\phi(x)y) \end{aligned}$$

where  $\phi : Q \rightarrow \tilde{Q}$  is a diffeomorphism,

- (ii) mechanical feedback transformations, denoted  $(\alpha, \beta, \gamma)$ , of the form

$$u_r = \gamma_{jk}^r(x)y^j y^k + \alpha^r(x) + \sum_{s=1}^m \beta_s^r(x)\tilde{u}_s,$$

where  $\gamma_{jk}^r = \gamma_{kj}^r$ ,

such that the transformed system is linear and mechanical

$$\begin{aligned} \dot{\tilde{x}}^i &= \tilde{y}^i \\ \dot{\tilde{y}}^i &= E_j^i \tilde{x}^j + \sum_{s=1}^m b_s^i \tilde{u}_s. \end{aligned}$$

The research hypothesis is formulated as follows:

*It is possible to formulate a theory of mechanical feedback linearization of mechanical control systems using techniques of geometric control theory and differential geometry.*

### 1.3 Applicability and technical comments

In this section, we formulate several remarks that apply to the whole thesis.

1. A class of mechanical control systems that we study is quite broad and needs to be specified. As equation (1.1) indicates, the controls enter the system in an affine way, multiplying terms that depend on  $x$ -only. This corresponds to an action of positional forces on a mechanical system. Moreover there are no terms linear with respect to velocities that represent dissipative-type forces. On the other hand, we do not assume that the connection is a metric connection. This allows to precompensate (if possible) the dissipative terms in the system by a preliminary feedback. In Conclusions we discuss this topic further.

2. The classical linearization theorems give conditions for equivalence to linear controllable systems. The controllability assumption is important because it refers to constructing a canonical frame, given by iterative Lie brackets, consisting of  $n$  independent vector fields that ensure that the linearized system is controllable. One of the main contribution of the thesis is a formulation of results for mechanical feedback linearization in two cases: one devoted to controllable systems (as in the classical results) and another for which the controllability assumption can be dropped. The latter can be applied to both, controllable and noncontrollable systems, although we will call it, shortly, the non-controllable case.

3. The results obtained in this thesis are local in the sense that linearizing diffeomorphisms are defined on local neighbourhoods of the points around which are applied. This is quite standard in the classical linearization theory, as the global results are known in a few limited cases. Thus all diffeomorphisms  $\phi : Q \rightarrow \tilde{Q}$  are assumed to be local, and map open sets of  $Q$  into open sets of  $\tilde{Q}$ . Therefore, whenever we give a local result around  $x_0$ , by  $C^\infty(Q)$ ,  $\mathfrak{X}(Q)$ , etc. we will mean smooth functions, vector fields, etc. on a neighbourhood of  $x_0$ . However, we will present in a forthcoming paper the global version of our mechanical state-space linearization.

4. Throughout this thesis we assume that all objects are always  $C^\infty$ -smooth. Most theory and results work under weaker assumptions but we will not precise the actual regularity class  $C^l$  needed in each particular argument.

5. The Einstein summation convention is assumed throughout, i.e. any expression containing a repeated index (upper and lower) implies summation over that index up to  $n$ :

$$\omega_i X^i = \sum_{i=1}^n \omega_i X^i.$$

Whenever the summation is taken over another indexing set, we will use the summation symbol, e.g. in terms involving controls and control vector fields,  $\sum_{r=1}^m g_r(x) u_r$ .

6. It was brought to our attention that there exist some ambiguity in terms of the concepts of degrees of freedom and underactuation. While we appreciate the usefulness of those other definitions in terms of nonholonomic systems, here we define those as follows

- (i) the number of degrees of freedom - the dimension of the configuration space  $Q$ , i.e.  $\dim(Q) = n$ ,
- (ii) underactuation - the property of the system that it has less controls than degrees of freedom, i.e.  $m < n$ .

## 1.4 Outline of the thesis

A brief outline of the following chapters is as follows:

**Chapter 2** The chapter presents necessary mathematical preliminaries and tools that we use in the thesis.

**Chapter 3** There we define a mechanical control systems and study some of their geometrical properties.

**Chapter 4** In that chapter we study a class of linear mechanical control systems and formulate a classification theorem.

**Chapter 5** The chapter formulates the problem of mechanical state-space linearization and presents our new results in this field.

**Chapter 6** The chapter contains main results of the thesis. Here we formulate and solve the problem of mechanical feedback linearization in three main cases, namely controllable, non-controllable and for the mechanical input-output linearization.

**Chapter 7** In that chapter we use our results to solve control problems for several examples of mechanical control systems and discuss the applicability and practicality of our theoretical results.

**Chapter 8** There we conclude our research and point some directions for future research.

## Chapter 2

# Preliminaries

In this chapter, we review some mathematical tools from differential geometry, tensor analysis, and Riemannian geometry that are necessary to formulate our results. Together with mathematical definitions we give some intuitions and interpretations in the language of mechanics and robotics. Therefore, some remarks may lack a mathematical rigour and use terminology that has not been precisely introduced earlier, however is commonly used in the field of mechanics and robotics.

### 2.1 Differential geometry

#### 2.1.1 Manifolds and tensor fields

A basic object is a smooth differentiable manifold, which is the arena of events. A definition of a manifold can be found e.g. in [21]. Instead, we give alternate definition that follows from Whitney embedding theorem [21]. In our investigations, all manifolds are, actually, smooth submanifolds of  $\mathbb{R}^d$  formalized as follows.

**Definition 2.1.** *A subset  $Q \subset \mathbb{R}^d$  is called a (differentiable) submanifold of  $\mathbb{R}^d$  if for any point of  $Q$  there exists a neighbourhood  $U \subset \mathbb{R}^d$ , such that,  $Q \cap U = \{p \in U : \phi(p) = 0\}$ , where  $\phi : U \rightarrow \mathbb{R}^k$  is a  $C^\infty$ -differentiable map that satisfies  $\text{rank } D\phi(x) = k$ , for any  $x \in Q \cap U$ . The dimension of the manifold  $Q$  is  $\dim Q = n = d - k$ .*

Since  $Q \cap U$  locally resembles  $\mathbb{R}^n$ , it can be parametrized by a local coordinate system  $x = (x^1, \dots, x^n)$  and we will identify points of  $Q$  with their coordinates  $x$ .

In other words, a manifold is embedded in  $\mathbb{R}^d$ , with a sufficiently large  $d$ , and we define it by imposing  $k$  independent constraints. Whenever we think of a manifold we can visualize an  $n$ -dimensional continuous space where our system lives. Points of  $Q$  are *configurations (positions)* of the investigated system. Trajectories of the system are time parametrized curves  $x(t) \in Q$ . This definition resembles the concept of a configuration space with generalized coordinates and that is exactly what we mean by a *configuration manifold* in the case of mechanical systems with  $n$  degrees of freedom.

To formalize the concept of *velocities* as the rate of change of positions, take all trajectories  $x(t)$  passing at  $t_0 = 0$  through a point  $x \in Q$ , that is,  $x(0) = x$ . All velocities  $\dot{x}(0)$  form the *tangent space*  $T_x Q$  at the point  $x$ , whose elements are *tangent vectors*  $\dot{x}(0)$ , that is, velocity vectors at the point  $x$ . We introduce natural coordinates on  $TQ$ , defined as  $y = (y^1, \dots, y^n) := (\dot{x}^1, \dots, \dot{x}^n)$ . The union over all  $x \in Q$  of all tangent spaces (tangent spaces at all points) is called *the tangent bundle*  $TQ = \bigcup_{x \in Q} T_x Q$ .

Let  $X \in \mathfrak{X}(Q)$  be a *vector field* on  $Q$ , that is a map that assigns to each point  $x \in Q$  a tangent vector  $X(x) \in T_x Q$ . Note that, vector fields evaluated at a point are simply

column vectors, that is, vector fields are contravariant tensors. In coordinates  $x$ , a vector field  $X = (X^1(x), \dots, X^n(x))^T$  will also be denoted

$$X = X^i(x) \frac{\partial}{\partial x^i},$$

where the components  $X^i(x) \in C^\infty(Q)$  are smooth functions. The  $i$ -th component of a contravariant vector  $X$  is denoted with an upper index  $X^i$ .

By the natural duality we can introduce the concept of the cotangent space  $T_x^*Q = (T_xQ)^*$ , i.e. the set of all linear functionals on  $T_xQ$ . Accordingly, we define the *cotangent bundle*  $T^*Q = \bigcup_{x \in Q} T_x^*Q$  as the union of cotangent spaces. If  $Q$  is the configuration space of a mechanical system then the elements of the cotangent bundle  $T^*Q$  can be interpreted as *momenta* of the system.

The dual objects to vector fields are *one-forms*  $\omega \in \Lambda(Q)$ , i.e. maps that associate to each  $x \in Q$  a cotangent vector  $\omega(x) \in T_x^*Q$ , which pointwise is covariant (i.e. a row) vector. In the natural dual basis  $(dx^1, \dots, dx^n)$ , where  $dx^i \left( \frac{\partial}{\partial x^j} \right) = \delta_j^i$ , the Kronecker delta, a one-form  $\omega$  reads

$$\omega = \omega_i(x) dx^i,$$

where  $\omega_i(x) \in C^\infty(Q)$  are smooth functions. The  $i$ -th component of the covariant vector  $\omega$  is denoted with a lower index as  $\omega_i$ . An important class of one-forms are differentials of functions, called *exact differentials*. Given a function  $\alpha \in C^\infty(Q)$  we define its differential  $d\alpha = \frac{\partial \alpha}{\partial x^i} dx^i$ <sup>1</sup>. In mechanics, differential forms can be interpreted as *forces*: potential forces, those that are exact differentials, and those that are not, as non-potential forces.

The canonical pairing (sometimes called the contraction) of one-forms and vector fields is simply the scalar multiplication of row and column vectors

$$\omega(X) = \omega_i dx^i X^j \frac{\partial}{\partial x^j} = \omega_i X^j \delta_j^i = \omega_i X^i \in C^\infty(Q).$$

We can generalize the above considerations to multi-linear maps and introduce the concept of a tensor field.

**Definition 2.2.** A  $(r, s)$ -tensor field  $\tau \in \mathcal{T}_s^r(Q)$  assigns to each point  $x \in Q$  a multi-linear map  $\tau : T^*Q \times \dots \times T^*Q \times TQ \times \dots \times TQ \rightarrow \mathbb{R}$  (with  $r$  copies of  $T^*Q$  and  $s$  copies of  $TQ$ ).

Pointwise these are multidimensional matrices with  $r$  contravariant and  $s$  covariant indices, that in coordinates read

$$\tau = \tau_{j_1 j_2 \dots j_s}^{i_1 i_2 \dots i_r}(x) \frac{\partial}{\partial x^{i_1}} \otimes \dots \otimes \frac{\partial}{\partial x^{i_r}} \otimes dx^{j_1} \otimes \dots \otimes dx^{j_s}.$$

Therefore, vector fields are examples of  $(1, 0)$ -tensor fields, one-forms are  $(0, 1)$ -tensor fields, and scalars are  $(0, 0)$ -tensor fields. Another example that will be discussed later in detail is a mass matrix (i.e. a Riemannian metric tensor), which is a  $(0, 2)$ -tensor field.

Up to this point, we considered one set of coordinates on  $Q$ , namely  $x = (x^1, \dots, x^n)$ . It is common in mechanics to work with different coordinate systems, therefore we formalize the concept of a *change of coordinates*.

<sup>1</sup>Quite often, this object is called the gradient of  $\alpha$ . It is, however, the gradient corresponding to the euclidean metric and, in general, the *geometric* gradient depends on the metric tensor [4].

Let  $Q$  and  $\tilde{Q}$  be smooth manifolds of dimension  $n$  and consider a diffeomorphism, i.e. a differentiable map that is bijective and has a differentiable inverse

$$\begin{aligned}\phi: Q &\rightarrow \tilde{Q} \\ x &\mapsto \tilde{x} = \phi(x).\end{aligned}$$

If  $Q = \tilde{Q}$  then  $\tilde{x} = (\tilde{x}^1, \dots, \tilde{x}^n) = \phi(x)$  introduces a change of coordinates on  $Q$  (local, if  $\phi$  is a local diffeomorphism).

The corresponding change of coordinates in tensor bundles is straightforward since tensor fields are multi-linear maps. Consider a vector field  $X$  on  $Q$  and its image under  $\phi$  that is

$$\phi_*X(\tilde{x}) = D\phi\left(\phi^{-1}(\tilde{x})\right)X\left(\phi^{-1}(\tilde{x})\right),$$

where  $D\phi$  (also denoted as  $\frac{\partial\phi}{\partial x}$ ,  $\left(\frac{\partial\phi_i}{\partial x^j}\right)$ , or  $\left(\frac{\partial\tilde{x}^i}{\partial x^j}\right)$ ) is the Jacobian matrix of the diffeomorphism  $\phi$ . The vector field  $\phi_*X$  is called *the push-forward* of the vector field  $X$ . Therefore the components  $X^i$  of the vector field  $X$  transform according to the following transformation law

$$\tilde{X}^i = \frac{\partial\tilde{x}^i}{\partial x^j}X^j.$$

Somehow inverse operation is *the pull-back*. Take a one-form  $\omega$  and its image under  $\phi$

$$\phi^*\omega(\tilde{x}) = D\phi^{-1}(\tilde{x})\omega\left(\phi^{-1}(\tilde{x})\right),$$

where  $D\phi^{-1} = (D\phi)^{-1} = \left(\frac{\partial x^j}{\partial\tilde{x}^i}\right)$  is the inverse of the Jacobian matrix. Therefore the components  $\omega_i$  transform by

$$\tilde{\omega}_i = \frac{\partial x^j}{\partial\tilde{x}^i}\omega_j.$$

It is immediate to see how arbitrary tensor fields are transformed. Consider a  $(r, s)$ -tensor and evaluate it on  $r$  one-forms  $\omega_1, \dots, \omega_r$  and  $s$  vector fields  $X_1, \dots, X_s$  to get a scalar. Now apply the diffeomorphism  $\phi$

$$\phi^*\tau(\omega_1, \dots, \omega_r, X_1, \dots, X_s) = \tilde{\tau}(\phi^*\omega_1, \dots, \phi^*\omega_r, \phi_*X_1, \dots, \phi_*X_s)$$

therefore it is apparent that the components of the transformed tensor  $\tilde{\tau} = \phi^*\tau$  are obtained by multiplying  $r$ -times by the Jacobian matrix and  $s$ -times by its inverse

$$\tilde{\tau}_{j_1 \dots j_s}^{i_1 \dots i_r} = \frac{\partial\tilde{x}^{i_1}}{\partial x^{k_1}} \cdots \frac{\partial\tilde{x}^{i_r}}{\partial x^{k_r}} \frac{\partial x^{l_1}}{\partial\tilde{x}^{j_1}} \cdots \frac{\partial x^{l_s}}{\partial\tilde{x}^{j_s}} \tau_{l_1 \dots l_s}^{k_1 \dots k_r}.$$

### 2.1.2 Differential operations on vector fields

The canonical pairing of vector fields and exact differential one-forms can be viewed as a differentiation of the corresponding function. Namely, given a function  $\alpha \in C^\infty(Q)$  and its exact differential  $d\alpha$ , we define the Lie derivative  $L_X\alpha$  of  $\alpha$  along a vector



field  $X$  by

$$L_X\alpha := d\alpha(X),$$

with the following properties:

- $L_{(\beta_1 X + \beta_2 Y)}\alpha = \beta_1 L_X\alpha + \beta_2 L_Y\alpha,$
- $L_X(\alpha\beta) = \beta L_X\alpha + \alpha L_X\beta,$

where  $\alpha, \beta, \beta_1, \beta_2 \in C^\infty(Q).$

Throughout the thesis we will repeatedly use the fact that the Lie derivative is a geometric object, i.e. it is invariant under diffeomorphisms. It is worth showing this elementary calculation. Consider a change of coordinates  $\tilde{x} = \phi(x)$  and calculate  $L_X\alpha$  in the new coordinates

$$L_{\tilde{X}}\tilde{\alpha} = \frac{\partial\tilde{\alpha}}{\partial\tilde{x}}\tilde{X} = \frac{\partial\alpha}{\partial x} \frac{\partial x}{\partial\tilde{x}} \frac{\partial\tilde{x}}{\partial x} X = \frac{\partial\alpha}{\partial x} X = L_X\alpha.$$

Often we will use the following notation for the *iterative Lie derivatives*

$$\begin{aligned} L_X^0\alpha &= \alpha \\ L_X^1\alpha &= L_X\alpha \\ L_X^2\alpha &= L_X L_X\alpha \\ L_X^{j+1}\alpha &= L_X L_X^j\alpha, \quad j > 0. \end{aligned}$$

Given a pair of vector fields  $X, Y \in \mathfrak{X}(Q),$  we define the *Lie bracket of  $X$  and  $Y$*  as a new vector field  $[X, Y]$  such that

$$L_{[X, Y]}\alpha = L_X L_Y\alpha - L_Y L_X\alpha, \quad \forall \alpha \in C^\infty(Q). \quad (2.1)$$

In coordinates, the Lie bracket reads

$$[X, Y](x) = DY(x)X(x) - DX(x)Y(x),$$

where  $DX(x) = \left(\frac{\partial X^i}{\partial x^j}\right)(x)$  and  $DY(x) = \left(\frac{\partial Y^i}{\partial x^j}\right)(x)$  denote the Jacobi matrix of  $X$  and  $Y,$  respectively. For  $X, Y, Z \in \mathfrak{X}(Q)$  and  $\alpha, \beta \in C^\infty(Q),$  we have the following properties

- $[X, Y] = -[Y, X]$  (skew-symmetry),
- $[X + Y, Z] = [X, Z] + [Y, Z]$  (additivity),
- $[\alpha X, \beta Y] = \alpha\beta[X, Y] + \alpha(L_X\beta)Y - \beta(L_Y\alpha)X,$
- $[X, [Y, Z]] + [Y, [Z, X]] + [Z, [X, Y]] = 0$  (Jacobi identity),
- $\phi_*[X, Y] = [\phi_*X, \phi_*Y]$  (compatible with a diffeomorphism  $\phi$ ).

Often we will use the following notation for the *iterative Lie bracket*

$$\begin{aligned} ad_X^0 Y &= Y \\ ad_X Y &= [X, Y] \\ ad_X^{j+1} Y &= [X, ad_X^j Y], \quad j > 0. \end{aligned}$$

### 2.1.3 Distributions and Integrable Manifolds

A *distribution*  $\mathcal{D}$  on  $Q$  is a subbundle of the tangent bundle  $TQ$ , that is a map that to each point  $x \in Q$  associates a linear subspace  $\mathcal{D}(x)$  of the tangent space  $T_x Q$ . We say that  $\mathcal{D}$  is of constant *rank*  $m$  if  $\dim \mathcal{D}(x) = m$  for all  $x \in Q$ . Locally, given a family of  $m$  independent vector fields  $\{X_1, \dots, X_m\}$  (called *generators of  $\mathcal{D}$* ), we can define a distribution that is spanned by them

$$\mathcal{D} = \text{span} \{X_1, \dots, X_m\},$$

i.e.  $\mathcal{D}(x) = \text{vect}_{\mathbb{R}} \{X_1(x), \dots, X_m(x)\}$ . Hence, we assume that span is taken over the set of all smooth functions  $C^\infty(Q)$ , i.e. elements  $\tilde{X}$  of  $\mathcal{D}$  are

$$\tilde{X}(x) = \sigma_1(x)X_1(x) + \sigma_2(x)X_2(x) + \dots + \sigma_m(x)X_m(x), \quad x \in Q,$$

where  $\sigma_i \in C^\infty(Q)$ , for  $1 \leq i \leq m$ . We say that a vector field  $X$  belongs to a distribution  $\mathcal{D}$ , and denote it by  $X \in \mathcal{D}$ , if  $X(x) \in \mathcal{D}(x)$ .

We say that a distribution  $\mathcal{D} = \text{span} \{X_1, \dots, X_m\}$  is *involutive* if for all  $X_i, X_j \in \mathcal{D}$  their Lie bracket also belongs to  $\mathcal{D}$ , i.e.

$$[X_i, X_j] \in \mathcal{D}, \quad \text{or equivalently,} \quad [X_i, X_j] = \sum_{l=1}^m \sigma_{ij}^l X_l,$$

that is,  $\mathcal{D}$  is *closed* under the Lie bracket. The functions  $\sigma_{ij}^l \in C^\infty(Q)$  are called *structural functions*.

An *integral manifold* of  $\mathcal{D}$  is an  $m$ -dimensional submanifold  $N \subset Q$  such that its tangent space  $T_p N = \mathcal{D}(p)$  for all  $p \in N$ . In general,  $N$  is an immersed submanifold only, not necessary embedded, meaning that the topology of  $N$  is not inherited from  $Q$ . A distribution  $\mathcal{D}$  is called *integrable* if for each  $x \in Q$ , there exist an integral manifold  $N$  of  $\mathcal{D}$  passing through  $x$ . For a given distribution  $\mathcal{D}$  we can define its *annihilator*  $\text{ann } \mathcal{D}$  as a set of one forms  $\omega$  such that

$$\text{ann } \mathcal{D} := \{\omega \in \Lambda(Q) : \omega(X) = 0, \forall X \in \mathcal{D}\}.$$

**Theorem 2.3** (Frobenius Theorem). *Let  $\mathcal{D}$  be a smooth distribution of constant rank  $m$ . Then, the following statements are equivalent:*

- (i)  $\mathcal{D}$  is integrable,
- (ii)  $\mathcal{D}$  is involutive,
- (iii) Locally, there exists a coordinate system  $x = (x^1, \dots, x^n)$  in which  $\mathcal{D}$  is rectified, i.e.

$$\mathcal{D} = \text{span} \left\{ \frac{\partial}{\partial x^1}, \frac{\partial}{\partial x^2}, \dots, \frac{\partial}{\partial x^m} \right\}$$

- (iv) Locally, there exist  $n - m$  functions  $\alpha_1, \dots, \alpha_{n-m}$ , whose exact differentials  $d\alpha_i$  are linearly independent and belong to the annihilator of  $\mathcal{D}$ , i.e.

$$d\alpha_i(X) = 0, \quad \forall X \in \mathcal{D}, \quad 1 \leq i \leq n - m.$$

Analogously to the notion of a distribution, we can define a *codistribution*  $\Omega$  as a subbundle of the cotangent bundle  $T^*Q$ , i.e. a map that to each point  $x \in Q$

associates a linear subspace  $\Omega(x)$  of the cotangent space  $T_x^*Q$ . If  $\text{rank } \Omega = l$ , then, locally,  $\Omega$  is spanned by a set of  $l$  one-forms  $\{\omega_1, \dots, \omega_l\}$

$$\Omega = \text{span} \{\omega_1, \dots, \omega_l\}.$$

The vector fields that annihilate  $\Omega$  form the *kernel* of the codistribution  $\Omega$ , that is,

$$\ker \Omega := \{X \in \mathfrak{X}(Q) : \omega(X) = 0, \forall \omega \in \Omega\}.$$

Given a distribution  $\mathcal{D} = \text{span} \{g_1, \dots, g_m\}$ ,  $g_i \in \mathfrak{X}(Q)$ , we consider actions of diffeomorphisms  $\phi : Q \rightarrow Q$  and matrix valued functions  $\beta = (\beta_j^i) : Q \rightarrow \text{Gl}(m, \mathbb{R})$  on the  $m$ -tuples of generators  $g = (g_1, \dots, g_m)$  by

$$g_j \mapsto \phi_* \left( \sum_{i=1}^m \beta_j^i g_i \right) = \tilde{g}_j$$

or, using the vector notation,  $\tilde{g} = \phi_*(g\beta)$ , where  $\tilde{g} = (\tilde{g}_1, \dots, \tilde{g}_m)$ . Notice that rectifying  $\mathcal{D}$  means applying a pair  $(\phi, \beta)$ , where  $\tilde{x} = \phi(x)$ , such that  $\tilde{g}_j = \frac{\partial}{\partial \tilde{x}^j}$  for  $1 \leq j \leq m$ . Below we present a proof of the implication  $(iv) \implies (iii)$  of Theorem 2.3 that gives a constructive rectification of  $\mathcal{D}$ .

**Constructive rectification** An integrable distribution  $\mathcal{D} = \text{span} \{g_1, \dots, g_m\}$  of rank  $m$  has an annihilator  $\text{ann } \mathcal{D}$ , which is locally spanned by  $n - m$  smooth exact differentials, that is, there exist  $n - m$  exact differentials  $d\alpha_i$ , satisfying:

$$d\alpha_i(g_j) = 0 \quad \text{for } 1 \leq i \leq n - m \text{ and } 1 \leq j \leq m. \quad (2.2)$$

Given  $\alpha_1, \dots, \alpha_{n-m}$ , whose differentials are independent, and they satisfy (2.2) we can complete them to a local coordinate system by choosing  $m$  functions  $\alpha_{n-m+1}, \dots, \alpha_n$  such that  $d\alpha_1, \dots, d\alpha_n$  are independent. Applying the diffeomorphism  $\phi = (\alpha_1, \dots, \alpha_n)^T$  to  $g = (g_1, \dots, g_m)$  we get

$$\frac{\partial \phi}{\partial x}(x) \cdot g(x) = \begin{pmatrix} \frac{\partial \alpha_1}{\partial x^1} & \cdots & \frac{\partial \alpha_1}{\partial x^n} \\ \vdots & \ddots & \vdots \\ \frac{\partial \alpha_n}{\partial x^1} & \cdots & \frac{\partial \alpha_n}{\partial x^n} \end{pmatrix} \cdot \begin{pmatrix} g_1^1 & \cdots & g_m^1 \\ \vdots & \ddots & \vdots \\ g_1^n & \cdots & g_m^n \end{pmatrix} = \begin{pmatrix} \mathbf{0}_{n-m \times m} \\ \mathbf{G}_{m \times m} \end{pmatrix},$$

where  $\mathbf{G}_{m \times m} = \mathbf{G}(x)$  is an invertible matrix (because  $g_1, \dots, g_m$  are independent). Therefore, in order to rectify the distribution  $\mathcal{D}$ , set  $\beta := \mathbf{G}^{-1}(x)$ . Then in the coordinates  $\tilde{x} = \phi(x)$ , we have

$$\frac{\partial \phi}{\partial x}(x) \cdot g(x) \cdot \beta(x) = \begin{pmatrix} \mathbf{0}_{n-m \times m} \\ \mathbf{G}_{m \times m} \end{pmatrix} (\mathbf{G}^{-1}) = \begin{pmatrix} \mathbf{0}_{n-m \times m} \\ \mathbf{I}_{m \times m} \end{pmatrix},$$

implying  $\phi_* \left( \sum_{i=1}^m \beta_j^i g_i \right) = \frac{\partial}{\partial \tilde{x}^j}$  for  $1 \leq j \leq m$ .

## 2.2 Riemannian Geometry

We start our considerations with a definition of an additional structure, fundamental in Riemannian geometry, namely a Riemannian metric.

**Definition 2.4.** A Riemannian metric (a metric tensor)  $\mathfrak{m} \in \mathcal{T}_2^0(Q)$  is a  $(0, 2)$ -tensor field on  $Q$ , that associates to each tangent space  $T_x Q$  an inner product, i.e.  $\mathfrak{m}(X, Y)$  for  $X, Y \in T_x Q$ , that is

- symmetric, i.e.  $\mathfrak{m}(X, Y) = \mathfrak{m}(Y, X)$ ,
- positive definite, i.e.  $\mathfrak{m}(X, X) > 0$  if  $X \neq 0$ .

In a coordinate system  $x = (x^1, \dots, x^n)$ ,  $\mathfrak{m}$  reads

$$\mathfrak{m} = \mathfrak{m}_{ij} dx^i \otimes dx^j,$$

which, since  $\mathfrak{m}$  is symmetric ( $\mathfrak{m}_{ij} = \mathfrak{m}_{ji}$ ), is denoted by  $\mathfrak{m} = \mathfrak{m}_{ij} dx^i dx^j$ .

From a mechanical point of view a Riemannian metric is nothing more than an inertia tensor (or a mass matrix). In order to see that the latter is indeed a  $(0, 2)$ -tensor field let us evaluate it at a point and apply it to a velocity vector  $y = \dot{x}$ . The result is well known and yields the (doubled) kinetic energy  $2KE = y^T \mathfrak{m}(x) y = \dot{x}^T \mathfrak{m}(x) \dot{x}$ , which is a scalar.

A pair  $(Q, \mathfrak{m})$  consisting of a manifold  $Q$  together with a Riemannian metric  $\mathfrak{m}$  is called a *Riemannian manifold*.

**Example Euclidean space.** The simplest example of a Riemannian manifold is the Euclidean space  $(\mathbb{R}^n, \delta)$ , which is a flat  $n$ -dimensional space with the natural identification  $T_x \mathbb{R}^n = \mathbb{R}^n$ , that induces usual inner product, the so called the Euclidean metric, which in coordinates reads

$$\delta = \delta_{ij} dx^i dx^j = \sum_{i=1}^n dx^i dx^i.$$

Using a metric tensor we can convert vectors into covectors and vice versa. We define two mutually inverse maps called *musical isomorphisms*.

**Definition 2.5.** Let  $X \in \mathfrak{X}(Q)$  be a vector field and  $\omega \in \Lambda(Q)$  be a one-form. Define two maps:

- flat (lowering an index)

$$\flat : TQ \rightarrow T^*Q$$

$$X^\flat = \mathfrak{m}(X^i \frac{\partial}{\partial x^i}, \cdot) = \mathfrak{m}_{ij} X^i dx^j \in \Lambda(Q)$$

or, equivalently using matrix notation,  $X^\flat = X^T \mathfrak{m}$ ,

- sharp (raising an index)

$$\sharp : T^*Q \rightarrow TQ$$

$$\omega^\sharp = \mathfrak{m}^{-1}(\omega_i dx^i, \cdot) = \mathfrak{m}^{ij} \omega_i \frac{\partial}{\partial x^j} \in \mathfrak{X}(Q),$$

where  $\mathfrak{m}^{ij} = (\mathfrak{m}_{ij})^{-1}$  is the inverse of the metric tensor  $\mathfrak{m}$ . Equivalently, using matrix notation, we have  $\omega^\sharp = \mathfrak{m}^{-1} \omega^T$ .

From the definition we conclude that the conversion between vectors and covectors is done with the help of the metric tensor  $\mathfrak{m}$ . Indeed, multiplying a metric tensor by a

vector results in a covector and conversely. The canonical example is the equation for momenta  $p_i = m_{ij}\dot{x}^j$  that transforms velocities (vectors) into momenta (covectors) or Newton's Second Law, i.e.  $m_{ij}\ddot{x}^j = F_i$ , that relates forces (covectors) and accelerations (vectors).

Actually, the musical isomorphisms work for arbitrary tensors. Indeed, consider a  $(r, s)$ -tensor  $\tau \in \mathcal{T}_s^r(Q)$ . Then,  $\tau^\sharp$  is a  $(r+1, s-1)$ -tensor and  $\tau^\flat$  is a  $(r-1, s+1)$ -tensor. Note that, there is no a canonical way of rising and lowering indices for tensors, where  $r, s > 1$ , since we choose which indices are to be contracted.

There is no a canonical way to compare tangent vectors (that is, velocities) belonging to different tangent spaces. In order to understand what it means in practice let us consider the following example.

**Example Polar coordinates.** Consider a unit mass particle moving on a plane along a circle with a constant angular velocity. Its configuration manifold is  $Q = \mathbb{R}^2$  with Cartesian coordinates  $x = (x^1, x^2)$ . Now consider a circular trajectory  $x(t)$  of this system given in coordinates by

$$\begin{aligned}x^1(t) &= \cos t \\x^2(t) &= \sin t.\end{aligned}$$

We want to calculate its velocity and acceleration, therefore we differentiate  $x(t)$  twice.

$$\begin{aligned}\dot{x}^1 &= -\sin t & \ddot{x}^1 &= -\cos t \\ \dot{x}^2 &= \cos t & \ddot{x}^2 &= -\sin t.\end{aligned}$$

The results are easy to interpret. The velocity vector  $\dot{x} = (\dot{x}^1, \dot{x}^2)^T$  is tangent to the trajectory at each point  $x(t)$  (it is an element of the tangent space  $T_{x(t)}Q$ ). And the acceleration vector  $\ddot{x} = (\ddot{x}^1, \ddot{x}^2)^T$  is pointing to the origin (which is interpreted as a centripetal acceleration). Now we change the coordinates to the polar coordinates  $(r, \theta) \in \mathbb{R}_+ \times \mathbb{S}$  by

$$\begin{aligned}x^1 &= r \cos \theta \\x^2 &= r \sin \theta.\end{aligned}$$

The trajectory in new coordinates is given by

$$\begin{aligned}r(t) &= \sqrt{\cos^2 t + \sin^2 t} = 1 \\ \theta(t) &= \arctan \frac{\sin t}{\cos t} = t \pmod{2\pi}.\end{aligned}$$

Now we differentiate it in new coordinates

$$\begin{aligned}\dot{r} &= 0 & \ddot{r} &= 0 \\ \dot{\theta} &= 1 & \ddot{\theta} &= 0.\end{aligned}$$

We see that the velocity vector  $(\dot{r}, \dot{\theta})^T = (0, 1)^T$  is still tangent, however the second derivatives  $(\ddot{r}, \ddot{\theta})$  equal to zero. Therefore, we see a contradiction in the description of the same physical motion in different coordinates. Moreover, it can be concluded that the acceleration defined as the second derivative of a position is not a vector (or any tensor) since it is zero in one coordinate system and non-zero in another.

Therefore, we realize that there is a need for another structure in order to be able to compare vectors (for instance, velocities) at different tangent spaces or, so to speak, to *connect* the nearby tangent spaces. More precisely, for a vector field  $Y(x(t)) \in T_{x(t)}Q$  along a curve  $x(t)$  we will introduce the (*covariant*) *derivative*  $\frac{DY}{dt}$ , with the help of an additional structure, namely that of a *connection*. Thus it will allow us to define intrinsically the acceleration as  $\frac{D\dot{x}}{dt}$ . Finally, we will present the equation of geodesics, which are zero-acceleration curves, or intuitively, curves that are the straightest and that turn out to be also the shortest on the manifold  $Q$ .

**Definition 2.6.** *An affine connection on  $Q$  is a smooth map that assigns to a pair of vector fields  $X, Y \in \mathfrak{X}(Q)$  a third smooth vector field  $\nabla_X Y$ , called the covariant derivative of the vector field  $Y$  in the direction of  $X$ , i.e.*

$$\begin{aligned} \nabla : \mathfrak{X}(Q) \times \mathfrak{X}(Q) &\rightarrow \mathfrak{X}(Q) \\ (X, Y) &\mapsto \nabla_X Y, \end{aligned}$$

that satisfies the following conditions:

(i) *linearity over  $C^\infty(Q)$  in  $X$ :*

$$\nabla_{\alpha_1 X_1 + \alpha_2 X_2} Y = \alpha_1 \nabla_{X_1} Y + \alpha_2 \nabla_{X_2} Y$$

(ii) *linearity over  $\mathbb{R}$  in  $Y$ :*

$$\nabla_X (aY_1 + bY_2) = a\nabla_X Y_1 + b\nabla_X Y_2$$

(iii) *the product rule:*

$$\nabla_X (\alpha Y) = \alpha \nabla_X Y + (L_X \alpha) Y,$$

for  $X_i, Y_i \in \mathfrak{X}(Q)$ ,  $\alpha, \alpha_i \in C^\infty(Q)$ , and  $a, b \in \mathbb{R}$ .

In local coordinates on  $Q$ , an affine connection is determined by its *Christoffel symbols* of the second kind, namely

$$\nabla_{\frac{\partial}{\partial x^j}} \frac{\partial}{\partial x^k} = \Gamma_{jk}^i \frac{\partial}{\partial x^i}. \quad (2.3)$$

Using (2.3) and the properties from Definition 2.6, we obtain the covariant derivative of  $Y = Y^i \frac{\partial}{\partial x^i}$  with respect to  $X = X^j \frac{\partial}{\partial x^j}$  in coordinates

$$\nabla_X Y = \left( \frac{\partial Y^i}{\partial x^j} X^j + \Gamma_{jk}^i X^j Y^k \right) \frac{\partial}{\partial x^i}. \quad (2.4)$$

Next, we define the covariant derivative of a vector field  $Y(x(t)) \in T_{x(t)}Q$  along a curve  $x(t) : I \subset \mathbb{R} \rightarrow Q$  in the following way

$$I \ni t \mapsto \frac{DY}{dt} = \nabla_{\dot{x}(t)} Y(x(t)) \in T_{x(t)}Q,$$

therefore the resultant vector field measures the rate of change of  $Y$  along a curve  $x(t)$ . Now it is apparent how to define *geometric accelerations*, i.e. vector fields that

measure the rate of change of the velocity vectors

$$\frac{D\dot{x}}{dt} = \nabla_{\dot{x}(t)}\dot{x}(t) = \left( \ddot{x}^i + \Gamma_{jk}^i \dot{x}^j \dot{x}^k \right) \frac{\partial}{\partial x^i}. \quad (2.5)$$

We say that  $Y$  is *parallel along a curve*  $x(t)$  if  $\nabla_{\dot{x}(t)}Y = 0$ . Further natural question is how to describe a vector field that is parallel along any curve on  $Q$ . Using the first properties of Definition 2.6, we can construct a  $(1,1)$ -tensor field called *the total covariant derivative*. This object can be viewed as a matrix of covariant derivative in the directions of  $\frac{\partial}{\partial x^i}$ .

**Definition 2.7.** Let  $\nabla$  be an affine connection and  $Y \in \mathfrak{X}(Q)$  be a vector field on  $Q$ . The total covariant derivative of  $Y$  is the  $(1,1)$ -tensor field given by

$$\nabla Y = \nabla_j Y^i \frac{\partial}{\partial x^i} \otimes dx^j,$$

where

$$\nabla_j Y^i = \frac{\partial Y^i}{\partial x^j} + \Gamma_{jk}^i Y^k. \quad (2.6)$$

The total covariant derivative satisfies the following properties:

(i) linearity:

$$\nabla(X + Y) = \nabla X + \nabla Y$$

(ii) product rule:

$$\nabla(\alpha X) = \alpha \nabla X + d\alpha \otimes X, \quad (2.7)$$

for  $X, Y \in \mathfrak{X}(Q)$  and  $\alpha \in C^\infty(Q)$ . We say that a vector field  $Y$  is *parallel* on  $Q$  if and only if  $\nabla Y = 0$ .

A *geodesic* of  $\nabla$  on  $Q$  is a smooth curve  $x(t)$  satisfying *the geodesic equation*

$$\nabla_{\dot{x}(t)}\dot{x}(t) = 0,$$

which can be represented in coordinates using (2.4) as a system of second-order differential equations

$$\ddot{x}^i + \Gamma_{jk}^i \dot{x}^j \dot{x}^k = 0, \quad (2.8)$$

whose solutions  $x(t)$  are zero acceleration curves (see (2.5)). By introducing  $2n$  coordinates  $(x, y) := (x, \dot{x})$  on the tangent bundle  $\mathrm{T}Q$ , system (2.8) is equivalent to a system of first-order differential equations on  $\mathrm{T}Q$

$$\begin{aligned} \dot{x}^i &= y^i \\ \dot{y}^i &= -\Gamma_{jk}^i y^j y^k, \end{aligned}$$

that defines a vector field  $S$  on  $\mathrm{T}Q$  called the *geodesic spray*, which in coordinates reads

$$S = y^i \frac{\partial}{\partial x^i} - \Gamma_{jk}^i y^j y^k \frac{\partial}{\partial y^i}.$$

The integral curves of  $S$  are curves on  $\mathrm{T}Q$  and can be projected onto the geodesics on  $Q$  under the *canonical projection*

$$\begin{aligned}\pi : \mathrm{T}Q &\rightarrow Q \\ \pi(x, y) &= x,\end{aligned}$$

which simply assigns to the pair  $v_x = (x, y)$  the point  $x$  at which  $v_x$  is attached.

At first sight, vector fields on  $\mathrm{T}Q$  might seem unusual, however their existence is straightforward since  $\mathrm{T}Q$  has a structure of a differential manifold, that is  $S \in \mathfrak{X}(\mathrm{T}Q)$ . Moreover, there is an operation of *lifting* vector fields on  $Q$  to vector fields on  $\mathrm{T}Q$ . Let  $g \in \mathfrak{X}(Q)$ , we define its *vertical lift*  $G = g^{v\text{lift}} \in \mathfrak{X}(\mathrm{T}Q)$  by

$$G(v_x) = g^{v\text{lift}}(v_x) = \frac{d}{dt}(v_x + tg(x))|_{t=0}, \quad v_x \in \mathrm{T}_x Q.$$

This operation is straightforward in coordinates, for  $g(x) = g^i(x) \frac{\partial}{\partial x^i}$ , we have

$$G(x, y) = g^{v\text{lift}}(x) = g^i(x) \frac{\partial}{\partial y^i}.$$

We say that  $G \in \mathfrak{X}(\mathrm{T}Q)$  is *vertical* if it has zero horizontal part, i.e.  $G = 0 \frac{\partial}{\partial x^i} + g^i(x, y) \frac{\partial}{\partial y^i}$ . It is clear that not every vertical vector field on  $\mathrm{T}Q$  come from vector fields on  $Q$  via the vertical lift, but only those of the form  $G = 0 \frac{\partial}{\partial x^i} + g^i(x) \frac{\partial}{\partial y^i}$ , that is, those whose components  $g^i$  depend on  $x$  only.

The tangent bundle of the manifold  $\mathrm{T}Q$  is called the *double (second) tangent bundle*  $\mathrm{TT}Q = \bigcup_{(x,y) \in \mathrm{T}Q} T_{(x,y)}\mathrm{T}Q$ .

The *vertical distribution*  $\mathcal{V}$  consists of vector fields tangent to  $\mathrm{T}_x Q$ . Recall  $\pi : \mathrm{T}Q \rightarrow Q$  denotes the canonical projection. Then we have  $\pi_* : \mathrm{TT}Q \rightarrow \mathrm{T}Q$  and the vertical distribution can be defined by  $\mathcal{V} = \pi_*^{-1}(0)$ . Locally, in  $(x, y)$ -coordinates, it is given by

$$\mathcal{V} = \text{span} \left\{ \frac{\partial}{\partial y^1}, \dots, \frac{\partial}{\partial y^n} \right\}$$

implying that  $\mathcal{V}$  is an involutive distribution of rank  $n$  on  $\mathrm{T}Q$ .

Using the vertical distribution  $\mathcal{V}$ , we can geometrically characterize vector fields on  $\mathrm{T}Q$  that are vertical lifts. Indeed,  $G \in \mathfrak{X}(\mathrm{T}Q)$  is a vertical lift of  $g \in \mathfrak{X}(Q)$  if and only if  $G \in \mathcal{V}$  and for a geodesic spray  $S$  (one and thus any) it satisfies

$$[\mathcal{V}, [G, S]] \subset \mathcal{V},$$

where  $[\mathcal{V}, [G, S]] = \{[V_i, [G, S]] : V_i \in \mathcal{V}\}$ .

Having an affine connection  $\nabla$  on  $Q$ , the *symmetric bracket*  $\langle X : Y \rangle$  assigns to vector fields  $X, Y \in \mathfrak{X}(Q)$  the vector field  $\langle X : Y \rangle = \nabla_X Y + \nabla_Y X$ .

The symmetric bracket was introduced by Crouch in [10] and since then has been used in nonlinear control to study local controllability [6], [38], geodesic invariance [24], gradient control system [10] and more.

Now, we introduce a special kind of a affine connection, that agrees with a Riemannian metric on a Riemannian manifold. This compatibility can be viewed as follows. Given any two vector fields  $X(t)$  and  $Y(t)$  that are parallel along a curve  $x(t)$ , i.e.  $\nabla_{\dot{x}(t)} X = \nabla_{\dot{x}(t)} Y = 0$ , their scalar product given by  $\mathfrak{m}$  should be preserved, that is,



$\mathfrak{m}(X(t), Y(t)) = \text{const}$ . Such connections play important role in geometric mechanics and we will use them in the next chapter to study *mechanical control systems*.

**Theorem 2.8** (Fundamental theorem of Riemannian Geometry). *Let  $(Q, \mathfrak{m})$  be a Riemannian manifold. Then there exists a unique affine connection  $\nabla$  called the Levi-Civita connection that agrees with the Riemannian metric  $\mathfrak{m}$  and it is symmetric (i.e.  $\Gamma_{jk}^i = \Gamma_{kj}^i$ ).*

The proof of above theorem is quite technical and is omitted here; it can be found in [22]. An important corollary of the proof is the representation of Christoffel symbols of the compatible connection  $\nabla$ , in terms of the metric tensor

$$\Gamma_{jk}^i = \frac{1}{2} \mathfrak{m}^{il} \left( \frac{\partial \mathfrak{m}_{lk}}{\partial x^j} + \frac{\partial \mathfrak{m}_{lj}}{\partial x^k} - \frac{\partial \mathfrak{m}_{jk}}{\partial x^l} \right). \quad (2.9)$$

Now, let us return to geodesic equation (2.8). We remind that geodesics are zero acceleration curves. Moreover if an affine connection is a Levi-Civita connection, then geodesics are also the shortest paths between two points on  $Q$ . Mechanically, we can think of a mass particle that moves along a curve on  $Q$  which is not subject to any external forces. In this context, we see geodesics as a generalization of straight lines.

**Example Euclidean space cont'd.** For the Euclidean space  $(\mathbb{R}^n, \delta)$  we have the following metric tensor  $\delta = \sum_{i=1}^n dx^i dx^i$ . It is straightforward to calculate, using (2.9), that the Levi-Civita connection is given by the Christoffel symbols  $\Gamma_{jk}^i = 0$ . Therefore the geodesic equation (2.8) simply reads  $\ddot{x}^i = 0$ , which describes straight lines. Moreover, let  $Y$  be a vector field on  $(\mathbb{R}^n, \delta)$ . The total covariant derivative of  $Y$  is

$$\nabla Y = \frac{\partial Y^i}{\partial x^j} \frac{\partial}{\partial x^i} \otimes dx^j$$

which is the Jacobian matrix of  $Y$ . The parallel vector fields on  $(\mathbb{R}^n, \delta)$  are given by  $\frac{\partial Y^i}{\partial x^j} = 0$ , which describes constant vector fields.

Finally, we formulate the celebrated Riemann theorem and define its crucial object, namely the Riemann curvature tensor.

**Definition 2.9.** The Riemann curvature  $(1, 3)$ -tensor is a map

$$\begin{aligned} R: \quad \mathfrak{X}(Q) \times \mathfrak{X}(Q) \times \mathfrak{X}(Q) &\rightarrow \mathfrak{X}(Q) \\ R(X, Y)Z &= \nabla_X \nabla_Y Z - \nabla_Y \nabla_X Z - \nabla_{[X, Y]} Z. \end{aligned}$$

It can be written in local coordinates as

$$R = R_{jkl}^i \frac{\partial}{\partial x^i} \otimes dx^j \otimes dx^k \otimes dx^l,$$

where:

$$R_{jkl}^i = \partial_k \Gamma_{jl}^i - \partial_l \Gamma_{jk}^i + \Gamma_{sk}^i \Gamma_{jl}^s - \Gamma_{sl}^i \Gamma_{jk}^s. \quad (2.10)$$

**Theorem 2.10.** A Riemannian manifold  $(Q, \mathfrak{m})$  is locally euclidean if and only if its Riemann curvature tensor vanishes identically.

The theorem states that the Riemann tensor vanishes, i.e.  $R = 0$ , if and only if there exists a (local) *isometry* (i.e. a diffeomorphism  $\phi$  that preserves the Riemannian metric, i.e.  $\phi^* \mathfrak{m} = \delta$ ) between  $(Q, \mathfrak{m})$  and the Euclidean space  $(\mathbb{R}^n, \delta)$ . Such manifold is called locally *flat*. The above theorem can be generalized to any symmetric connection.

**Theorem 2.11.** *For any symmetric connection  $\nabla$  (not necessarily compatible with a metric) there exists a coordinate system such that Christoffel symbols vanish if and only if the Riemann curvature tensor  $R$  is zero.*

This theorem serves as a starting point in our later considerations about the problem of a mechanical linearization of mechanical control systems.

In Definition 2.6, we gave the covariant derivative of a vector field. More generally, an affine connection allows to compute the covariant derivative of any tensor field, for details see [22]. Below, we give formulae for the total covariant derivatives of some tensor fields, which will use later.

For a  $(0,0)$ -tensor, i.e. a scalar function  $\alpha \in C^\infty(Q)$ , the total covariant derivative  $\nabla\alpha$  is the exact differential  $d\alpha \in \Lambda(Q)$ , that is a  $(0,1)$ -tensor

$$\nabla\alpha = d\alpha = \frac{\partial\alpha}{\partial x^i} dx^i.$$

For a  $(1,0)$ -tensor field, i.e. a vector field  $Y$ , we have Definition 2.7, i.e.  $\nabla Y$  is a  $(1,1)$ -tensor field.

For a  $(0,1)$ -tensor field, i.e. a one-form  $\omega \in \Lambda(Q)$ ,  $\nabla\omega = \nabla_j \omega_i dx^i \otimes dx^j$ , i.e. a  $(0,2)$ -tensor field with

$$\nabla_j \omega_i = \frac{\partial\omega_i}{\partial x^j} - \Gamma_{ji}^k \omega_k.$$

For a  $(2,0)$ -tensor field  $\tau \in \mathcal{T}_0^2(Q)$ , we have  $\nabla\tau = \nabla_k \tau^{ij} \frac{\partial}{\partial x^i} \otimes \frac{\partial}{\partial x^j} \otimes dx^k$ , i.e. a  $(2,1)$ -tensor field with

$$\nabla_k \tau^{ij} = \frac{\partial\tau^{ij}}{\partial x^k} + \Gamma_{kl}^i \tau^{lj} + \Gamma_{kl}^j \tau^{il}.$$

For a  $(0,2)$ -tensor field  $\tau \in \mathcal{T}_2^0(Q)$ , we have  $\nabla\tau = \nabla_k \tau_{ij} dx^i \otimes dx^j \otimes dx^k$ , i.e. a  $(0,3)$ -tensor field with

$$\nabla_k \tau_{ij} = \frac{\partial\tau_{ij}}{\partial x^k} - \Gamma_{ki}^l \tau_{lj} - \Gamma_{kj}^l \tau_{il}.$$

For a  $(1,1)$ -tensor field  $\tau \in \mathcal{T}_1^1(Q)$ , we have  $\nabla\tau = \nabla_k \tau_j^i \frac{\partial}{\partial x^i} \otimes dx^j \otimes dx^k$ , i.e. a  $(1,2)$ -tensor field with

$$\nabla_k \tau_j^i = \frac{\partial\tau_j^i}{\partial x^k} + \Gamma_{kl}^i \tau_j^l - \Gamma_{kj}^l \tau_l^i.$$

In general, for  $(r,s)$ -tensor field  $\tau \in \mathcal{T}_s^r(Q)$ , the total covariant derivative  $\nabla\tau$  is a  $(r,s+1)$ -tensor field.

The second covariant derivative of a vector field is the derivative of its derivative with respect to another two vector fields

**Definition 2.12.** *The second covariant derivative of a vector field  $Z$  on  $Q$  in the directions  $(X, Y)$  is a mapping*

$$\begin{aligned} \nabla^2 : \mathfrak{X}(Q) \times \mathfrak{X}(Q) \times \mathfrak{X}(Q) &\rightarrow \mathfrak{X}(Q) \\ \nabla_{X,Y}^2 Z &= \nabla_X \nabla_Y Z - \nabla_{\nabla_X Y} Z \end{aligned}$$

satisfying the following properties:

(i) *linearity over  $C^\infty(Q)$  in  $X$  and  $Y$ :*

$$\begin{aligned}\nabla_{(\alpha_1 X_1 + \alpha_2 X_2), Y}^2 Z &= \alpha_1 \nabla_{X_1, Y}^2 Z + \alpha_2 \nabla_{X_2, Y}^2 Z \\ \nabla_{X, (\alpha_1 Y_1 + \alpha_2 Y_2)}^2 Z &= \alpha_1 \nabla_{X, Y_1}^2 Z + \alpha_2 \nabla_{X, Y_2}^2 Z\end{aligned}$$

(ii) *linearity over  $\mathbb{R}$  in  $Z$ :*

$$\nabla_{X, Y}^2 (aZ_1 + bZ_2) = a\nabla_{X, Y}^2 Z_1 + b\nabla_{X, Y}^2 Z_2$$

(iii) *the product rule:*

$$\nabla_{X, Y}^2 (\beta Z) = \beta \nabla_{X, Y}^2 Z + L_X \beta \nabla_Y Z + L_Y \beta \nabla_X Z + \left( \nabla_{X, Y}^2 \beta \right) Z,$$

where  $\nabla_{X, Y}^2 \beta = L_X L_Y \beta - L_{\nabla_X Y} \beta \in C^\infty(Q)$ ,  $X_i, Y_i, Z_i \in \mathfrak{X}(Q)$ ,  $\alpha_i, \beta \in C^\infty(Q)$ , and  $a, b \in \mathbb{R}$ .

**Definition 2.13.** *The second total covariant derivative of a vector field  $Z$  is a  $(1, 2)$ -tensor field*

$$\nabla^2 Z = \nabla(\nabla Z) = \nabla_k \nabla_j Z^i \frac{\partial}{\partial x^i} \otimes dx^j \otimes dx^k.$$

The following proposition gives an expression of  $\nabla^2 Z$  in terms of Christoffel symbols and a relation between the notion of the second covariant derivative  $\nabla_{X, Y}^2 Z$  and the total one  $\nabla^2 Z$ .

**Proposition 2.14.** *For any affine connection  $\nabla$ , we have*

$$\begin{aligned}(i) \quad \nabla_k \nabla_j Z^i &= \partial_k \partial_j Z^i + \partial_k \Gamma_{j_s}^i Z^s + \Gamma_{j_s}^i \partial_k Z^s + \Gamma_{kl}^i \partial_j Z^l + \Gamma_{kl}^i \Gamma_{j_s}^l Z^s - \Gamma_{kj}^l \partial_l Z^i - \Gamma_{kj}^l \Gamma_{ls}^i Z^s \\ (ii) \quad \nabla_k \nabla_j Z^i &= \nabla_{kj}^2 Z^i,\end{aligned}$$

where  $\nabla_{kj}^2 Z^i = \nabla_{\partial_k, \partial_j}^2 Z^i$  is the  $i$ -th component of the second covariant derivative of the vector field  $Z$  in the directions  $(\partial_k, \partial_j)$ .

*Proof.* (i). We will calculate the second total covariant derivative as the total covariant derivative of the total covariant derivative of  $Z$  (a  $(1, 1)$ -tensor field) in coordinates.

$$\begin{aligned}\nabla_k \nabla_j Z^i &= \partial_k \left( \nabla_j Z^i \right) + \Gamma_{kl}^i \left( \nabla_j Z^l \right) - \Gamma_{kj}^l \left( \nabla_l Z^i \right) = \\ &= \partial_k \left( \partial_j Z^i + \Gamma_{j_s}^i Z^s \right) + \Gamma_{kl}^i \left( \partial_j Z^l + \Gamma_{j_s}^l Z^s \right) - \Gamma_{kj}^l \left( \partial_l Z^i + \Gamma_{ls}^i Z^s \right) = \\ &= \partial_k \partial_j Z^i + \partial_k \left( \Gamma_{j_s}^i Z^s \right) + \Gamma_{kl}^i \partial_j Z^l + \Gamma_{kl}^i \Gamma_{j_s}^l Z^s - \Gamma_{kj}^l \partial_l Z^i - \Gamma_{kj}^l \Gamma_{ls}^i Z^s = \\ &= \partial_k \partial_j Z^i + \partial_k \Gamma_{j_s}^i Z^s + \Gamma_{j_s}^i \partial_k Z^s + \Gamma_{kl}^i \partial_j Z^l + \Gamma_{kl}^i \Gamma_{j_s}^l Z^s - \Gamma_{kj}^l \partial_l Z^i - \Gamma_{kj}^l \Gamma_{ls}^i Z^s.\end{aligned}$$

(ii). First, using Definition 2.12, properties of the covariant derivative, and formula (2.3), we calculate

$$\begin{aligned}\nabla_{kj}^2 \partial_s &= \nabla_{\partial_k, \partial_j}^2 \partial_s = \nabla_{\partial_k} \nabla_{\partial_j} \partial_s - \nabla_{\nabla_{\partial_k} \partial_j} \partial_s = \nabla_{\partial_k} \left( \Gamma_{j_s}^l \partial_l \right) - \nabla_{\left( \Gamma_{kj}^l \partial_l \right)} \partial_s = \\ &= \Gamma_{j_s}^l \left( \nabla_{\partial_k} \partial_l \right) + \left( L_{\partial_k} \Gamma_{j_s}^l \right) \partial_l - \Gamma_{kj}^l \left( \nabla_{\partial_l} \partial_s \right) = \\ &= \Gamma_{j_s}^l \Gamma_{kl}^i \partial_i + \left( \partial_k \Gamma_{j_s}^i \right) \partial_i - \Gamma_{kj}^l \Gamma_{ls}^i \partial_i = \left( \partial_k \Gamma_{j_s}^i + \Gamma_{j_s}^i \Gamma_{kl}^i - \Gamma_{kj}^l \Gamma_{ls}^i \right) \partial_i.\end{aligned}$$

Then, using properties of the second covariant derivative, we calculate

$$\begin{aligned}
\nabla_{kj}^2 Z &= \nabla_{kj}^2 Z^s \partial_s = \\
&= Z^s \nabla_{kj}^2 \partial_s + (L_{\partial_k} Z^s) \nabla_{\partial_j} \partial_s + (L_{\partial_j} Z^s) \nabla_{\partial_k} \partial_s + (L_{\partial_k} L_{\partial_j} Z^s - L_{(\nabla_{\partial_k} \partial_j)} Z^s) \partial_s = \\
&= Z^s \nabla_{kj}^2 \partial_s + (\partial_k Z^s) \Gamma_{js}^i \partial_i + (\partial_j Z^l) \Gamma_{kl}^i \partial_i + \partial_k \partial_j Z^i \partial_i - \Gamma_{kj}^l \partial_l Z^i \partial_i = \\
&= (\partial_k \partial_j Z^i + Z^s (\partial_k \Gamma_{js}^i + \Gamma_{js}^l \Gamma_{kl}^i - \Gamma_{kj}^l \Gamma_{ls}^i) + \Gamma_{js}^i \partial_k Z^s + \Gamma_{kl}^i \partial_j Z^l - \Gamma_{kj}^l \partial_l Z^i) \partial_i = \\
&= (\partial_k \partial_j Z^i + \partial_k \Gamma_{js}^i Z^s + \Gamma_{js}^i \partial_k Z^s + \Gamma_{kl}^i \partial_j Z^l + \Gamma_{kl}^i \Gamma_{js}^l Z^s - \Gamma_{kj}^l \partial_l Z^i - \Gamma_{kj}^l \Gamma_{ls}^i Z^s) \partial_i,
\end{aligned}$$

whose  $i$ -th component is equal to (i).  $\square$

## 2.3 Control-affine systems

In this section, we will define a class of control systems that we are studying, namely those with controls entering in an affine way.

**Definition 2.15.** A control-affine system  $\Sigma$  is a triple  $(M, \mathfrak{g}, f)$  where

- $M$  is an  $N$ -dimensional configuration manifold,
- $\mathfrak{g} = (g_1, \dots, g_m)$  is an  $m$ -tuple control vector fields, where  $g_i \in \mathfrak{X}(M)$ ,
- $f \in \mathfrak{X}(M)$  is a drift vector field on  $M$ .

**Definition 2.16.** A trajectory of  $\Sigma$  is a piecewise  $C^1$ -function of time  $z(t) : I \rightarrow M$ , where  $I$  is an open interval in  $\mathbb{R}$ , and that  $z(t)$  satisfies the following differential equation

$$\dot{z} = f(z) + \sum_{r=1}^m g_r(z) u_r, \quad (2.11)$$

where  $z \in M$  denotes the state of the system and  $u = (u_1, \dots, u_m) \in \mathcal{U} \subset \mathbb{R}^m$  are control inputs that belong to a class of admissible controls  $\mathcal{U}$  for the system. We choose  $\mathcal{U}$  to be the set of piecewise continuous functions of time  $t \in \mathbb{R}^+$ .

Among all control systems  $\Sigma$  we distinguish a particular class, namely linear control systems  $L\Sigma$  of the following form

$$\dot{\tilde{z}} = A\tilde{z} + Bu, \quad (2.12)$$

where the state  $\tilde{z} \in \mathbb{R}^N$ , the state matrix  $A$  is an  $N \times N$  constant real matrix, the input matrix  $B$  is an  $N \times m$  constant real matrix consisting of  $m$  constant input vector fields  $b_r$ , and  $u = (u_1, \dots, u_m)^T$ , that is  $Bu = \sum_{r=1}^m b_r u_r$ .

The motivation to distinguish the class of linear systems is that those are somewhat the simplest possible. For example, control problems (e.g. stabilization or trajectory tracking) are solvable for linear systems using systematic, algebraic methods. However, the property of a control system to be in the linear form (2.12) can be easily unnoticed by choosing improper<sup>2</sup> set of coordinates or control variables to

<sup>2</sup>By "improper" we mean nonlinear. In many cases, often dealing with mechanical systems, coordinates (states) and controls (inputs) have clear physical interpretation. However, as will be apparent latter, often those "physical" states and control variables lead to high nonlinearities in the dynamics (2.11) of a control system.

describe the system. Therefore, the premise that it is possible to transform the system into a linear one (and thus recover its linear behaviour) is "raison d'être" of a branch of control theory called linearization of control systems (as well as of this thesis). A potential of applications in the control engineering is straightforward, since the constructive solution of a linearization problem leads to extension of linear techniques to nonlinear systems. What is more, the linearization gives a geometrical (thus invariant) characterization of linear control systems by describing their equivalence classes.

In order to formulate the first problem of linearization of nonlinear systems  $\Sigma$  to the linear form  $L\Sigma$  using coordinates transformations, we have to define state-space equivalence of control systems. Consider two  $N$ -dimensional control-affine systems with the same control space  $\mathcal{U} \subset \mathbb{R}^m$

$$\Sigma : \quad \dot{z} = f(z) + \sum_{r=1}^m g_r(z)u_r, \quad \tilde{\Sigma} : \quad \dot{\tilde{z}} = \tilde{f}(\tilde{z}) + \sum_{r=1}^m \tilde{g}_r(\tilde{z})u_r,$$

we say that  $\Sigma$  and  $\tilde{\Sigma}$  are *state-space equivalent*, shortly S-equivalent, if there exists a diffeomorphism (a change of coordinates)  $\phi : M \rightarrow \tilde{M}$ , such that

$$\frac{\partial \phi}{\partial z}(z) f(z) = \tilde{f}(\phi(z)) \quad \text{and} \quad \frac{\partial \phi}{\partial z}(z) g_r(z) = \tilde{g}_r(\phi(z)),$$

for  $1 \leq r \leq m$ , that is, using compact notation of Section 2.1.1,  $\phi_* f = \tilde{f}$  and  $\phi_* g_r = \tilde{g}_r$ . The above definition is natural because a diffeomorphism  $\phi$  that establishes S-equivalence preserves trajectories corresponding to the same controls  $u \in \mathcal{U}$ , i.e.  $\phi(z(t, z^0, u)) = \tilde{z}(t, \tilde{z}^0, u)$ , where  $z^0$  and  $\tilde{z}^0 = \phi(z^0)$  denote initial points in  $M$  and  $\tilde{M}$  respectively.

We can formulate the linearization problem by asking that  $\Sigma$  is equivalent to the linear system (2.12).

**Definition 2.17.**  $\Sigma$  is *state-space linearizable* (shortly, *S-linearizable*) if it is S-equivalent to a linear control system  $L\Sigma$  of the form (2.12).

That is to say, there exists a local diffeomorphism  $\phi : M \rightarrow \mathbb{R}^N$  that simultaneously linearize the drift vector field  $f$  and maps the control vector fields  $g_r$  into constant ones  $b_r$ , i.e.

$$\frac{\partial \phi}{\partial z}(z) f(z) = A\tilde{z} \quad \text{and} \quad \frac{\partial \phi}{\partial z}(z) g_r(z) = b_r,$$

therefore the system in the new coordinates  $\tilde{z} = \phi(z)$  reads

$$\dot{\tilde{z}} = \phi_* f + \sum_{r=1}^m \phi_* g_r u_r = A\tilde{z} + \sum_{r=1}^m b_r u_r.$$

If  $\phi$  is a local diffeomorphisms between open neighbourhoods of  $z_0$  and  $\tilde{z}_0 = \phi(z_0)$ , respectively, then we speak about local S-equivalence.

**Remark 2.18.** All linearization results in this thesis are considered locally around a given  $z_0$ , moreover we will assume that the point  $z_0$ , around which the linearization is performed, is an equilibrium of the system  $f(z_0) = 0$  and  $\phi(z_0) = 0$ . Without these technical assumptions all results still hold however the resultant linear dynamics is modified by adding constant vector  $d$ , i.e.  $\dot{z} = Ax + Bu + d$ .

**Theorem 2.19.** [32], [42] *A nonlinear system  $\Sigma$  is locally S-linearizable into a controllable linear system if and only if the following conditions hold, around  $x_0$*

$$(S1) \dim \text{span} \left\{ ad_f^i g_r, 0 \leq i \leq n-1, 1 \leq r \leq m \right\} (z) = N$$

$$(S2) \left[ ad_f^i g_r, ad_f^j g_s \right] = 0, \text{ for } 0 \leq i, j \leq N, 1 \leq r, s \leq m.$$

One could deduce from the above theorem that the property of a system to be S-linearizable is rare since the conditions are very restrictive, i.e. we need all Lie brackets of condition (S2) to be identically zero.

In order to enlarge the class of systems that can be linearizable we can use a bigger class of transformations than just coordinate changes. This class is natural from the engineering point of view, namely to apply feedback. Therefore we allow for transformations in the state-space as well as in the control space of  $\Sigma$ . To formalize this concept, we define feedback equivalence of control systems. Consider two  $N$ -dimensional control-affine systems

$$\Sigma : \dot{z} = f(z) + \sum_{r=1}^m g_r(z) u_r, \quad \tilde{\Sigma} : \dot{\tilde{z}} = \tilde{f}(\tilde{z}) + \sum_{s=1}^m \tilde{g}_s(\tilde{z}) \tilde{u}_s,$$

where  $z \in M$ ,  $\tilde{z} \in \tilde{M}$ ,  $u, \tilde{u} \in \mathbb{R}^m$ . We say that  $\Sigma$  and  $\tilde{\Sigma}$  are *feedback equivalent*, shortly F-equivalent, if there exist a diffeomorphism  $\phi : M \rightarrow \tilde{M}$  and an invertible feedback of the form  $u_r = \alpha^r(z) + \sum_{s=1}^m \beta_s^r(z) \tilde{u}_s$ , such that

$$\frac{\partial \phi}{\partial z}(z) \left( f + \sum_{r=1}^m g_r \alpha^r \right) (z) = \tilde{f}(\phi(z)) \quad \text{and} \quad \frac{\partial \phi}{\partial z}(z) \left( \sum_{r=1}^m \beta_s^r g_r \right) (z) = \tilde{g}_s(\phi(z)).$$

In this case, the systems are related by a diffeomorphism and a feedback transformation that preserves the set of all trajectories, that is, the image of trajectory of  $\Sigma$  is a trajectory of  $\tilde{\Sigma}$  corresponding to a transformed control, i.e.  $\phi(z(t, z^0, u)) = \tilde{z}(t, \tilde{z}^0, \tilde{u})$ .

The feedback linearization problem that is considered in this thesis has been solved by Jakubczyk and Respondek [18], and independently, by Hunt and Su [16].

**Definition 2.20.**  *$\Sigma$  is feedback linearizable (F-linearizable) if it is F-equivalent to a linear control system of the form  $\dot{\tilde{z}} = A\tilde{z} + B\tilde{u}$ .*

In other words, there exist a diffeomorphism  $\phi : M \rightarrow \mathbb{R}^N$ , and an invertible feedback of the form  $u_r = \alpha^r(z) + \sum_{s=1}^m \beta_s^r(z) \tilde{u}_s$ , such that the control system (2.11), in the new coordinates  $\tilde{z} = \phi(z)$  with the new controls  $\tilde{u}$ , reads

$$\dot{\tilde{z}} = \phi_* \left( f + \sum_{r=1}^m g_r \alpha^r \right) + \sum_{s=1}^m \phi_* \left( \sum_{r=1}^m \beta_s^r g_r \right) \tilde{u}_s = A\tilde{z} + \sum_{s=1}^m b_s \tilde{u}_s.$$

In order to formulate the result, we associate with  $\Sigma$  the following sequence of *nested distributions*

$$\mathcal{D}^0 \subset \mathcal{D}^1 \subset \mathcal{D}^2 \subset \dots \subset \mathcal{D}^i \subset \dots \subset TM,$$

where

$$\mathcal{D}^0 = \text{span} \{ g_r, 1 \leq r \leq m \}$$

$$\mathcal{D}^i = \text{span} \left\{ ad_f^j g_r, 1 \leq r \leq m, 0 \leq j \leq i \right\}.$$

If the distributions  $\mathcal{D}^i$  are involutive, then they are invariant under feedback transformations of the form  $u_r = \alpha^r(z) + \sum_{s=1}^m \beta_s^r(z) \tilde{u}_s$ , i.e. they remain unchanged if we replaced  $f$  and  $g_r$  by, respectively,  $f + \sum_{r=1}^m g_r \alpha^r$  and  $\sum_{r=1}^m \beta_s^r g_r$ . For the proof of that property see [32].

If the dimensions of  $\mathcal{D}^i(z)$ , equivalently ranks of  $\mathcal{D}^i$ , are constant, we define integers  $r_i$  attributed to them

$$\begin{aligned} r_0 &= \text{rank } \mathcal{D}^0 \\ r_i &= \text{rank } \mathcal{D}^i - \text{rank } \mathcal{D}^{i-1} \end{aligned} \quad (2.13)$$

for  $1 \leq i \leq N - 1$  and integers

$$\rho_j = \text{card} (r_i \geq j : i \geq 0). \quad (2.14)$$

The integers  $\rho_j$  are called controllability (Brunovský, Kronecker) indices and form a complete set of invariants of feedback equivalence of control-affine systems.

**Theorem 2.21.** *A nonlinear system  $\Sigma$  is, locally around  $z_0$ , F-linearizable if and only if the following conditions hold*

$$(F1) \text{ rank } \mathcal{D}^{N-1} = N,$$

$$(F2) \mathcal{D}^i \text{ are involutive and of constant rank, for } 0 \leq i \leq N - 2.$$

A proof can be found in [18], [32] or [17]. Moreover, an important corollary follows. It is true both, locally and globally.

**Corollary 2.22.** *The following statements are equivalent:*

(i)  $\Sigma$  is F-linearizable to a controllable linear system  $L\Sigma$ ,

(ii)  $\Sigma$  is F-equivalent to the Brunovský canonical form, i.e.  $m$  chains of integrators of length  $\rho_j$ , for  $1 \leq j \leq m$ .

*Proof.* (i)  $\implies$  (ii). By Definition 2.20, the system  $\Sigma$  is feedback equivalent to a controllable linear system  $L\Sigma$  of the form (2.12). Then, by the Brunovský classification of controllable linear systems [5], we show that  $L\Sigma$  is (linear) feedback equivalent to the Brunovský canonical form. Therefore the composition of these two feedback transformations transforms  $\Sigma$  to the Brunovský canonical form. The inverse is trivial, since the Brunovský canonical form is, indeed, a controllable linear system, thus the feedback equivalence to the form, defines a linearizing diffeomorphism and feedback.  $\square$

Conditions (F1) – (F2) from the above theorem give an answer whether the control system  $\Sigma$  is F-linearizable. They do not, however, tell how to linearize such a system, that is, do not give linearizing transformations. The problem of feedback linearization of control systems can be rephrased as an *input-output linearization* of a control system with *artificial ("dummy")* outputs, whose relative degrees sum up to the dimension  $n$  of the system  $\Sigma$ . This point of view brings a new insight to the F-linearization problem and leads to a set of first order partial differential equations, whose solution defines the linearizing diffeomorphism and feedback.

For simplicity, we present this approach for a control system with scalar control, i.e.  $m = 1$ . The generalization to multi-input case is straightforward, yet it is more

complicated, since it involves the controllability indices. We formulate it later, at the end of this section.

Consider a control system with a scalar control

$$\dot{z} = f(z) + g(z)u \quad (2.15)$$

together with an (output) function  $h(z) \in C^\infty(M)$ .

**Definition 2.23.** *System (2.15) has relative degree  $\nu$  around  $z_0$  if*

$$\begin{aligned} L_g h &= 0 \\ L_g L_f h &= 0 \\ &\vdots \\ L_g L_f^{\nu-2} h &= 0 \\ L_g L_f^{\nu-1} h(z_0) &\neq 0. \end{aligned} \quad (2.16)$$

**Proposition 2.24.** *A scalar control system (2.15) is locally F-linearizable if and only if there exists a function  $h(z)$  whose relative degree  $\nu$  around  $z_0$  is equal to  $N$ .*

The linearizing diffeomorphism and feedback read

$$\phi(z) = \left( h, L_f h, L_f^2 h, \dots, L_f^{N-1} h \right)^T, \quad u = \alpha(z) + \beta(z)\tilde{u} = -\frac{L_f^N h}{L_g L_f^{N-1} h} + \frac{1}{L_g L_f^{N-1} h} \tilde{u}.$$

The relative degree  $\nu$  is equal to the number of times that one has to differentiate the function  $h(z)$  in order to the control  $u$  appears explicitly. By asking that  $\nu = N$ , we enforce the control to appear in the last equation only. What is more,  $N$ -functions  $\left( h, L_f h, \dots, L_f^{N-1} h \right) = \left( \tilde{z}^1, \dots, \tilde{z}^N \right)$  are of special importance, namely they define a local coordinate system  $\tilde{z}$ , in which  $N - 1$  first components of the drift  $\tilde{f}$  are linear and, moreover,  $N - 1$  first components of the control vector field  $g$  vanish, i.e.  $\tilde{g} = \tilde{g}^N(\tilde{z}) \frac{\partial}{\partial \tilde{z}^N}$ . Thus, by applying an appropriate feedback that normalizes  $\tilde{g}^N$  to 1 and compensates the last component of the drift, the system is linearized.

The multi-input case is the following straightforward generalization of the above result.

**Definition 2.25.** *Consider a control system of the form (2.11) with  $m$  (output) functions  $h_1(z), \dots, h_m(z) \in C^\infty(M)$ . The system has a vector relative degree  $(\nu_1, \dots, \nu_m)$  around  $z_0$  if*

$$(i) \quad L_{g_r} L_f^k h_i = 0$$

for  $1 \leq i, r \leq m$  and  $0 \leq k \leq \nu_i - 2$

(ii) the  $m \times m$  decoupling matrix

$$D(z) = \left( L_{g_r} L_f^{\nu_i-1} h_i \right) (z)$$

is of full rank equal to  $m$ .

**Theorem 2.26.** *Control system (2.11) is locally, around  $z_0$ , F-linearizable to a controllable linear system if and only if there exist  $m$  functions  $h_1(z), \dots, h_m(z)$  around  $z_0$  whose vector relative degree  $(\nu_1, \dots, \nu_m)$  satisfies  $\sum_{i=1}^m \nu_i = N$ .*

Proofs of the above results can be found in e.g. [17] and [32].





## Chapter 3

# Mechanical control systems and their structure

In this chapter we introduce the concept of *mechanical control systems* and their representations. We derive equations of a mechanical control system ( $\mathcal{MS}$ ) from geodesic equations (2.8) on a Riemannian manifold by introducing external actions (controlled or uncontrolled) on the system. Such mathematical approach lacks, however, a physical interpretation, therefore later we recall the classical Lagrangian formalism and draw the equivalence between these two methodologies. Henceforth, it will be apparent why we call such extended geodesic equation a mechanical control system, as well as we will connect two realms: Riemannian geometry and Lagrangian mechanics. The geometrical approach to mechanical control system has been intensively studied at the turn of the 21th century. For further introduction and topics beyond the interest of this thesis we refer to [1], [4], [6], [26], [36], and [38].

### 3.1 Mechanical Control Systems

We define a mechanical control system as an extension of the geodesic equation (2.8) on a Riemannian manifold, that is, the equations of motion are considered under an external action (controlled or not) added to the system.

**Definition 3.1.** *A mechanical control system  $(\mathcal{MS})_{(n,m)}$  with  $n$  degrees of freedom and  $m$  controls is defined by a 4-tuple  $(Q, \nabla, \mathbf{g}, e)$ , where:*

- $Q$  is an  $n$ -dimensional configuration manifold,
- $\nabla$  is a symmetric affine connection on  $Q$ ,
- $\mathbf{g} = \{g_1, \dots, g_m\}$  is an  $m$ -tuple of control vector fields on  $Q$ ,
- $e$  is an uncontrolled vector field on  $Q$ .

A mechanical system  $(\mathcal{MS})_{(n,m)}$  can be represented by the differential equation

$$\nabla_{\dot{x}} \dot{x} = e(x) + \sum_{r=1}^m g_r(x) u_r, \quad (3.1)$$

which can be viewed as an equation that balances accelerations of the system, where the left hand side represents geometric accelerations (i.e. accelerations caused by the geometry of the system) and the right hand side represents accelerations caused by external actions on the system (controlled or not). Equation (3.1) in local coordinates

$x = (x^1, \dots, x^n)$  on  $Q$  takes the form of a second-order system of differential equations:

$$\ddot{x}^i = -\Gamma_{jk}^i(x)\dot{x}^j\dot{x}^k + e^i(x) + \sum_{r=1}^m g_r^i(x)u_r, \quad 1 \leq i \leq n, \quad (3.2)$$

or, equivalently, a first-order system on the tangent bundle  $TQ$  with coordinates  $(x, y) = (x^1, \dots, x^n, y^1, \dots, y^n)$ :

$$\begin{aligned} \dot{x}^i &= y^i \\ \dot{y}^i &= -\Gamma_{jk}^i(x)y^jy^k + e^i(x) + \sum_{r=1}^m g_r^i(x)u_r, \quad 1 \leq i \leq n, \end{aligned} \quad (3.3)$$

or as a control system on the manifold  $M = TQ$  of dimension  $N = 2n$  with coordinates  $z = (x, y)$ :

$$\dot{z} = F(z) + \sum_{r=1}^m G_r(z)u_r, \quad (3.4)$$

with

$$\begin{aligned} F &= S + e^{vlift} = y^i \frac{\partial}{\partial x^i} + \left( -\Gamma_{jk}^i(x)y^jy^k + e^i(x) \right) \frac{\partial}{\partial y^i} \\ G_r &= g_r^{vlift} = g_r^i(x) \frac{\partial}{\partial y^i}, \end{aligned}$$

where  $S$  is the geodesic spray and  $e^{vlift}, g_r^{vlift}$  are the vertical lifts of  $e$  and  $g_r$  respectively.

Note that the state-space trajectories of (3.4) (equivalently (3.3)), denoted by  $z(t, z^0, u)$ , where  $z^0 = (x^0, y^0)$  is the initial point in  $TQ$ , are examples of phase space trajectories in classical mechanics. They can be projected on  $Q$  via the canonical projection  $\pi(z) = \pi(x, y) = x$ , such that

$$\pi(z(t, z^0, u)) = x(t, x^0, u),$$

where  $x^0$  is the corresponding initial point in  $Q$ . Those are configuration trajectories on  $Q$  and have a clear mechanical interpretation, being geometrical paths that a mechanical system follows in the configuration space as functions of time.

Notice that in (3.3) we deal with objects on  $Q$  (like  $e$  and  $g_r$ ) and, in (3.4), objects on  $TQ$  (like  $e^{vlift}$  and  $G_r$ ). To discuss relations of them observe that for the control system (3.4) on  $TQ$ , we can associate a sequence of nested distribution  $\mathcal{D}^i$  (see Section 2.3)

$$\begin{aligned} \mathcal{D}^0 &= \text{span} \{G_r, 1 \leq r \leq m\} \\ \mathcal{D}^i &= \text{span} \left\{ ad_F^j G_r, 1 \leq r \leq m, 0 \leq j \leq i \right\}. \end{aligned}$$

The state space of the system (3.4) is  $M = TQ$  and therefore the above distributions are subbundles of  $TM = TTQ$ , the double tangent bundle, and  $ad_F^j G_r$  is the Lie bracket of vector fields on  $TQ$ , i.e.  $F, G, ad_F^j G_r \in \mathfrak{X}(TQ)$ . We will also attach to  $(\mathcal{MS})$ , represented in any of the equivalent forms (3.1)-(3.4), distributions on  $Q$ , vector fields on  $Q$ , and their Lie brackets. Those are defined using equation (3.1), where  $e$  and  $g_r$  are "usual" vector fields on  $Q$ , therefore their Lie bracket  $ad_e^j g_r \in \mathfrak{X}(Q)$ , gives a vector field on  $Q$ . And this matches the standard definition given in Chapter

2. Hence, we can define another sequence of nested distributions  $\mathcal{E}^i$  as:

$$\begin{aligned}\mathcal{E}^0 &= \text{span} \{g_r, 1 \leq r \leq m\} \\ \mathcal{E}^i &= \text{span} \left\{ ad_e^j g_r, 1 \leq r \leq m, 0 \leq j \leq i \right\}.\end{aligned}$$

If the dimensions of  $\mathcal{E}^i(x)$ , equivalently ranks of  $\mathcal{E}^i$ , are constant we can associate the following coefficients

$$\begin{aligned}\bar{r}_0 &= \text{rank } \mathcal{E}^0, \\ \bar{r}_i &= \text{rank } \mathcal{E}^i - \text{rank } \mathcal{E}^{i-1},\end{aligned}$$

for  $1 \leq i \leq n-1$ . Now define indices

$$\bar{\rho}_j = \text{card} (\bar{r}_i \geq j : 0 \leq i \leq n-1) \quad \text{for } 1 \leq j \leq m.$$

We call these indices *mechanical half-indices*. They play analogous role to the controllability (Brunovský, Kronecker) indices. We will investigate them in detail in Chapter 4.

A natural question arises, namely: is there any relation between small and big objects? The full answer is quite elaborate, therefore we show this relation partially, where it is relevant in our study.

The simplest relation can be drawn between  $\mathcal{D}^0$  and  $\mathcal{E}^0$ . Indeed, the control vector fields  $G_r = g_r^i(x) \frac{\partial}{\partial y^i}$  that span  $\mathcal{D}^0$  are the vertical lifts of  $g_r \in \mathfrak{X}(Q)$  that span the distribution  $\mathcal{E}^0$ .

The next observation is the following,

$$g_r = -\pi_*(ad_F G_r),$$

where  $\pi : TQ \rightarrow Q$  is the canonical projection. To show it, calculate

$$\begin{aligned}ad_F G_r &= \left[ y^i \frac{\partial}{\partial x^i} + \left( -\Gamma_{jk}^i(x) y^j y^k + e^i(x) \right) \frac{\partial}{\partial y^i}, g_r^i(x) \frac{\partial}{\partial y^i} \right] = \\ &= -g_r^i(x) \frac{\partial}{\partial x^i} + \left( \frac{\partial g_r^i}{\partial x^j} y^j + 2\Gamma_{jk}^i y^j g_r^k \right) \frac{\partial}{\partial y^i},\end{aligned}$$

and thus

$$-\pi_*(ad_F G_r) = g_r^i(x) \frac{\partial}{\partial x^i}.$$

Therefore we can formulate the following relation between  $\mathcal{D}^1$  and  $\mathcal{E}^0$

$$\pi_*(\mathcal{D}^1) = \mathcal{E}^0.$$

## 3.2 Lagrange formalism

In this section, we present the classical Lagrangian formalism for deriving equations of motion, i.e. the Euler-Lagrange equations with external forces. Our purpose here is to show that formalism (commonly used among engineers) and to identify a class of Lagrangian mechanical systems which form a subclass of mechanical systems.

Consider a (local) coordinate system  $x = (x^1, \dots, x^n) \in Q$  describing configurations of the system and let  $\dot{x}(t) \in T_{x(t)}Q$  be its velocity. We define its Lagrangian

being equal to the kinetic minus the potential energy, i.e.  $\mathcal{L} := \frac{1}{2}\mathbf{m}_{ij}(x)\dot{x}^i\dot{x}^j - V(x)$ , where  $\mathbf{m}_{ij}$  are the elements of the inertia matrix (equivalently, elements of the metric tensor, see its geometric interpretation in Section 2.2) and  $V(x)$  is the potential energy of the system (e.g. gravitational, elastic, or electric). Furthermore, we assume that the system is subject to  $m$  external (control) forces that are positional (depend on configurations only). Geometrically, these are differential forms  $\mathbf{f}_i(x)$  on  $Q$ . The forced Euler-Lagrange equations of the system on the cotangent bundle  $T^*Q$  are:

$$\frac{d}{dt} \left( \frac{\partial \mathcal{L}}{\partial \dot{x}} \right) - \frac{\partial \mathcal{L}}{\partial x} = \sum_{r=1}^m \mathbf{f}_r(x) u_r, \quad (3.5)$$

where  $u_i$  are controls of the system. Direct calculations yield

$$\begin{aligned} \frac{\partial \mathcal{L}}{\partial x^i} &= \frac{1}{2} \frac{\partial \mathbf{m}_{jk}}{\partial x^i} \dot{x}^j \dot{x}^k - \frac{\partial V}{\partial x^i} \\ \frac{\partial \mathcal{L}}{\partial \dot{x}^i} &= \mathbf{m}_{ij} \dot{x}^j \\ \frac{d}{dt} \left( \frac{\partial \mathcal{L}}{\partial \dot{x}^i} \right) &= \mathbf{m}_{ij} \ddot{x}^j + \frac{\partial \mathbf{m}_{ij}}{\partial x^k} \dot{x}^j \dot{x}^k, \end{aligned}$$

and implies that the left hand side of (3.5) reads

$$\begin{aligned} \frac{d}{dt} \left( \frac{\partial \mathcal{L}}{\partial \dot{x}^i} \right) - \frac{\partial \mathcal{L}}{\partial x^i} &= \mathbf{m}_{ij} \ddot{x}^j + \frac{\partial \mathbf{m}_{ij}}{\partial x^k} \dot{x}^j \dot{x}^k - \frac{1}{2} \frac{\partial \mathbf{m}_{jk}}{\partial x^i} \dot{x}^j \dot{x}^k + \frac{\partial V}{\partial x^i} \\ &= \mathbf{m}_{ij} \ddot{x}^j + \Gamma_{ijk} \dot{x}^j \dot{x}^k + \frac{\partial V}{\partial x^i}, \end{aligned}$$

with  $\Gamma_{ijk} = \frac{\partial \mathbf{m}_{ij}}{\partial x^k} - \frac{1}{2} \frac{\partial \mathbf{m}_{jk}}{\partial x^i} = \frac{1}{2} \left( \frac{\partial \mathbf{m}_{ik}}{\partial x^j} + \frac{\partial \mathbf{m}_{ij}}{\partial x^k} - \frac{\partial \mathbf{m}_{jk}}{\partial x^i} \right)$ .

Therefore in the local coordinates equations (3.5) are

$$\mathbf{m}_{ij} \ddot{x}^j + \Gamma_{ijk} \dot{x}^j \dot{x}^k + \frac{\partial V}{\partial x^i} = \sum_{r=1}^m \mathbf{f}_{ir} u_r, \quad (3.6)$$

where:

- $\mathbf{m}_{ij}$  - elements of the inertia matrix (the metric tensor),
- $\Gamma_{ijk}$  - Christoffel symbols of the first kind representing centrifugal forces ( $j = k$ ) and Coriolis forces ( $j \neq k$ ) (see [28]),
- $\frac{\partial V}{\partial x^i}$  - the  $i$ -th component of the differential form representing the potential force in the system.

Note that, the above equations are also called *equations of motions*, *equation of robot dynamics* or *manipulator equation of dynamics*, depending on the context and are commonly written as

$$M(x)\ddot{x} + C(x, \dot{x})\dot{x} + G(x) = F(x)u \quad (3.7)$$

where  $M(x) = (\mathbf{m}_{ij}(x))$  is the inertia matrix,  $C(x, \dot{x}) = (\Gamma_{ijk}(x)\dot{x}^k)$  is the Coriolis matrix,  $G(x) = \left( \frac{\partial V}{\partial x^i} \right)$  is the gravity (potential) co-vector, and  $F(x) = (\mathbf{f}_{ir})$  is called the input matrix<sup>1</sup>.

<sup>1</sup>In the sequel, we will not use the notation of (3.7) and the symbols  $M, G, F$  will denote other objects.

Multiplying equation (3.6) by the inverse of  $\mathbf{m}$  yields

$$\begin{aligned} \mathbf{m}^{il}\mathbf{m}_{ij}\ddot{x}^j + \mathbf{m}^{il}\Gamma_{ijk}\dot{x}^j\dot{x}^k + \mathbf{m}^{il}\frac{\partial V}{\partial x^i} &= \mathbf{m}^{il}\sum_{r=1}^m \mathbf{f}_{ir}u_r \\ \dot{x}^l + \Gamma_{jk}^l\dot{x}^j\dot{x}^k + e^l &= \sum_{r=1}^m g_r^l u_r \end{aligned}$$

which can be seen as a mechanical system ( $\mathcal{MS}$ ) in local coordinates (see (3.2)), where  $\Gamma_{jk}^l = \frac{1}{2}\mathbf{m}^{li}\left(\frac{\partial\mathbf{m}_{ik}}{\partial x^j} + \frac{\partial\mathbf{m}_{ij}}{\partial x^k} - \frac{\partial\mathbf{m}_{jk}}{\partial x^i}\right)$  are the Christoffel symbols of the second kind for the Levi-Civita connection,  $e^l = \mathbf{m}^{il}\frac{\partial V}{\partial x^i}$ , and  $g_r^l = \mathbf{m}^{il}\mathbf{f}_{ir}$ .

Recall that the multiplication by the inverse of  $\mathbf{m}$ , converts differential forms into vector fields and can be written using musical isomorphism  $\sharp : T^*Q \rightarrow TQ$  (see Definition 2.5). So we have

$$e = dV^\sharp, \quad g_r = \mathbf{f}_r^\sharp, \quad \text{for } 1 \leq r \leq m.$$

It is apparent now what constitutes the Lagrangian subclass of ( $\mathcal{MS}$ ).

**Proposition 3.2.** *A Lagrangian mechanical control system with  $n$  degrees of freedom and  $m$  controls, called Lagrangian ( $\mathcal{MS}$ ) $_{(n,m)}$ , is defined by a 4-tuple  $(Q, \nabla, \mathbf{g}, e)$ , where:*

- $Q$  is an  $n$ -dimensional Riemannian manifold with a Riemannian metric  $\mathbf{m}$  (defined by the kinetic energy),
- $\nabla$  is the Levi-Civita connection of  $\mathbf{m}$ ,
- $\mathbf{g} = \left(\mathbf{f}_r^\sharp \text{ for } 1 \leq r \leq m\right)$  is an  $m$ -tuple of control vector fields arising from the controlled forces.
- $e = dV^\sharp$  is a vector field arising from the uncontrolled potential force of the system.

### 3.3 Examples of models of mechanical control systems

In this section, we introduce some examples of mechanical control systems. The process of derivation the equations of ( $\mathcal{MS}$ ), called modelling, is treated here briefly, without systematic approach. In some cases we use relations deduced using basic physics, otherwise we use Lagrangian formalism.

#### 3.3.1 Robotic manipulators

We start our considerations with an example of arguably the most common robotic system, namely a robotic manipulator, which is widely used in the industry, e.g. in automated factories for assembling, welding, palletizing and many other manipulations that require high accuracy and repeatability. Although, they vary in size, shape and even number of degrees of freedom, they share a distinctive feature, namely they are fully-actuated, i.e. the number of controls (actuators) is equal to the number of degrees of freedom. There are numerous books devoted to systematic modelling robotic manipulators including examples of industrial robots with 5, 6 or even 7 axes. The interested reader is referred to [9], [43], [28], to name a few examples. In our considerations, we will use the Lagrangian formalism, however since the modelling process is quite elaborate we just briefly sketch it.

The links of a robotic manipulator are connected by joints allowing rotational or translational displacement, each giving rise to one degree of freedom. Therefore configurations can be described by introducing  $n = r + t$  generalized coordinates,  $r$  of them are joint angles  $\theta^i$  (whenever a joint is rotational) and  $t$  are linear distances  $q^i$  (for translational joints). Hence,  $(x^1, \dots, x^n) := (\theta^1, \dots, \theta^r, q^1, \dots, q^t)$ . The configuration manifold is  $Q = \mathbb{S}^r \times \mathbb{R}^t$ . The kinetic energy is given by the inertia matrix  $\mathbf{m}$  (a metric tensor) and the  $m := n$  control forces act directly on the joints, i.e.  $\mathbf{f}_i = dx^i$ , for  $1 \leq i \leq n$ . Finally, the potential energy  $V$  is the sum of a gravitational energy of each link. Therefore the system in local coordinates reads, see (3.6),

$$\mathbf{m}_{ij}\ddot{x}^j + \Gamma_{ijk}\dot{x}^j\dot{x}^k + \frac{\partial V}{\partial x^i} = u_i. \quad (3.8)$$

We use the calculation presented in the previous section to derive equation of  $(\mathcal{MS})$

$$\begin{aligned} \dot{x}^l &= y^l \\ \dot{y}^l &= -\Gamma_{jk}^l(x)y^j y^k + \mathbf{m}^{il} \frac{\partial V}{\partial x^i} + \sum_{r=1}^n \mathbf{m}^{rl} u_r. \end{aligned}$$

### 3.3.2 The two-link manipulator

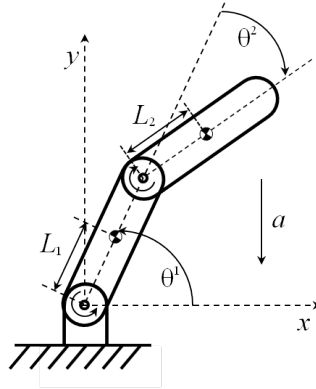

FIGURE 3.1: The two-link manipulator

An interesting (yet quite simple) example is a robotic manipulator with two rotational joints, as depicted in Figure 3.1. For  $i = 1, 2$ , let  $\theta^i$  denote the angle of the  $i$ -th joint,  $L_i$  - the distance from the  $i$ -th center of mass (which is also geometric center) to the axis,  $m_i$  - the mass of the  $i$ -th link,  $J_i$  - the moment of inertia of the  $i$ -th link about its center of mass. The gravitational acceleration is denoted  $a$ . The position of the center of mass of the  $i$ -th link in the global frame is denoted by  $(\bar{x}^i, \bar{y}^i)$  and can be calculated as follows

$$\begin{aligned} \bar{x}^1 &= L_1 \cos \theta^1, & \bar{x}^2 &= 2L_1 \cos \theta^1 + L_2 \cos (\theta^1 + \theta^2) \\ \bar{y}^1 &= L_1 \sin \theta^1, & \bar{y}^2 &= 2L_1 \sin \theta^1 + L_2 \sin (\theta^1 + \theta^2). \end{aligned}$$

The kinetic energy is  $T = T_1 + T_2$ , where  $T_i = \frac{1}{2}J_i \left( \sum_{j=1}^i \dot{\theta}^j \right)^2 + \frac{1}{2}m_i ((\dot{\bar{x}}^i)^2 + (\dot{\bar{y}}^i)^2)$  and the potential energy is  $V = V_1 + V_2$ , where  $V_i = m_i a \bar{y}^i$ . By a direct calculation

we obtain equations of the form (3.8) as

$$\begin{aligned} m_{11}\ddot{\theta}^1 + m_{12}\ddot{\theta}^2 + \Gamma_{1jk}\dot{\theta}^j\dot{\theta}^k + \frac{\partial V}{\partial \theta^1} &= u_1 \\ m_{21}\ddot{\theta}^1 + m_{22}\ddot{\theta}^2 + \Gamma_{2jk}\dot{\theta}^j\dot{\theta}^k + \frac{\partial V}{\partial \theta^2} &= u_2, \end{aligned} \quad (3.9)$$

where:

$$\begin{aligned} m_{11} &= \zeta_1 + \zeta_2 + 2\zeta_3 \cos \theta^2 \\ m_{12} &= m_{21} = \zeta_2 + \zeta_3 \cos \theta^2 \\ m_{22} &= \zeta_2 \\ \Gamma_{111} &= \Gamma_{212} = \Gamma_{221} = \Gamma_{222} = 0 \\ \Gamma_{112} &= \Gamma_{121} = \Gamma_{122} = -\Gamma_{211} = -\zeta_3 \sin \theta^2 \\ \frac{\partial V}{\partial \theta^1} &= \zeta_4 \cos \theta^1 + \zeta_5 \cos(\theta^1 + \theta^2) \\ \frac{\partial V}{\partial \theta^2} &= \zeta_5 \cos(\theta^1 + \theta^2). \end{aligned}$$

with constant parameters listed below

$$\begin{aligned} \zeta_1 &= J_1 + L_1^2 m_1 + 4L_1^2 m_2 & \zeta_4 &= (m_1 L_1 + 2m_2 L_1) a \\ \zeta_2 &= m_2 L_2^2 + J_2 & \zeta_5 &= m_2 L_2 a \\ \zeta_3 &= 2L_1 L_2 m_2 \end{aligned}$$

The equations of  $(\mathcal{MS})$  can be obtained by introducing coordinates  $(x^1, x^2) := (\theta^1, \theta^2)$

$$\begin{aligned} \dot{x}^1 &= y^1 \\ \dot{x}^2 &= y^2 \\ \dot{y}^1 &= -\Gamma_{jk}^1 y^j y^k + e^1 + g_1^1 u_1 + g_2^1 u_2 \\ \dot{y}^2 &= -\Gamma_{jk}^2 y^j y^k + e^2 + g_1^2 u_1 + g_2^2 u_2, \end{aligned}$$

where:

$$\begin{aligned} \Gamma_{11}^1 &= -\Gamma_{12}^2 = -\Gamma_{21}^1 = -\Gamma_{22}^2 = -\frac{\zeta_2 \zeta_3 \sin x^2 + \zeta_3^2 \sin x^2 \cos x^2}{\zeta_1 \zeta_2 - \zeta_3^2 \cos^2 x^2} \\ \Gamma_{12}^1 &= \Gamma_{21}^1 = \Gamma_{22}^1 = -\frac{\zeta_2 \zeta_3 \sin x^2}{\zeta_1 \zeta_2 - \zeta_3^2 \cos^2 x^2} \\ \Gamma_{11}^2 &= \frac{\zeta_3 \sin x^2 (\zeta_1 + \zeta_2 + 2\zeta_3 \cos x^2)}{\zeta_1 \zeta_2 - \zeta_3^2 \cos^2 x^2} \\ e^1 &= \frac{-\zeta_2 \zeta_4 \cos x^1 + \zeta_3 \zeta_5 \cos x^2 \cos(x^1 + x^2)}{\zeta_1 \zeta_2 - \zeta_3^2 \cos^2 x^2} \\ e^2 &= \frac{\zeta_2 \zeta_4 \cos x^1 - \zeta_1 \zeta_5 \cos(x^1 + x^2) + \zeta_3 \cos x^2 (\zeta_4 \cos x^1 - \zeta_5 \cos(x^1 + x^2))}{\zeta_1 \zeta_2 - \zeta_3^2 \cos^2 x^2} \\ g_1^1 &= \frac{\zeta_2}{\zeta_1 \zeta_2 - \zeta_3^2 \cos^2 x^2}, \quad g_2^1 = g_1^2 = -\frac{\zeta_2 + \zeta_3 \cos x^2}{\zeta_1 \zeta_2 - \zeta_3^2 \cos^2 x^2}, \quad g_2^2 = \frac{\zeta_1 + \zeta_2 + 2\zeta_3 \cos x^2}{\zeta_1 \zeta_2 - \zeta_3^2 \cos^2 x^2}. \end{aligned}$$

There are several interesting modifications of (3.9) that have been extensively studied in the literature. By setting  $u_1 \equiv 0$ , the equations describe the dynamics of the Acrobot (see e.g. [45], [46], [35]), while the dynamics of the Pendubot (e.g. [47],



[45]) can be obtained by  $u_2 \equiv 0$ . Another modification can be considered by eliminating the influence of the gravitation  $\frac{\partial V}{\partial x^i} \equiv 0$ , i.e. the manipulator lies on the horizontal plane. An underactuated version of this, i.e.  $u_2 \equiv 0$ , was considered in [37].

### 3.3.3 The Inertia Wheel Pendulum

Another example of a mechanical system with two degrees of freedom is the Inertia Wheel Pendulum [48], which is shown in Figure 3.2. It is an inverted pendulum with a rotating wheel attached. Let  $\theta^1$  denote the angle of the pendulum measured from the vertical position, and  $\theta^2$  is the angle of the wheel. The masses and the moments of inertia of the pendulum and the wheel are  $m_1, m_2$  and  $J_1, J_2$ , respectively. The distance to the center of the pendulum is denoted  $L_1$ . The only control applied to the system is a torque applied to the wheel so that the system is underactuated.

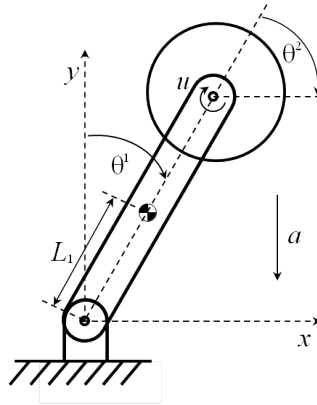

FIGURE 3.2: The inertia wheel pendulum

Similarly to the previous example we derive the equations of dynamics as

$$\begin{aligned} \mathbf{m}_{11}\ddot{\theta}^1 + \mathbf{m}_{12}\ddot{\theta}^2 + \frac{\partial V}{\partial \theta^1} &= 0 \\ \mathbf{m}_{21}\ddot{\theta}^1 + \mathbf{m}_{22}\ddot{\theta}^2 &= u, \end{aligned}$$

where:

$$\begin{aligned} \mathbf{m}_{11} &= m_d + J_2 \\ \mathbf{m}_{12} &= \mathbf{m}_{21} = \mathbf{m}_{22} = J_2 \\ m_d &= L_1^2(m_1 + 4m_2) + J_1 \\ m_0 &= aL_1(m_1 + 2m_2) \\ \frac{\partial V}{\partial \theta^1} &= -m_0 \sin \theta^1. \end{aligned}$$

The equations of  $(\mathcal{MS})$  can be obtained by introducing coordinates  $(x^1, x^2) := (\theta^1, \theta^2)$

$$\begin{aligned} \dot{x}^1 &= y^1 \\ \dot{x}^2 &= y^2 \\ \dot{y}^1 &= e^1 + g^1 u \\ \dot{y}^2 &= e^2 + g^2 u, \end{aligned}$$

where

$$\begin{aligned} e^1 &= \frac{m_0}{m_d} \sin x^1, & g^1 &= -\frac{1}{m_d}, \\ e^2 &= -\frac{m_0}{m_d} \sin x^1, & g^2 &= \frac{m_d + J_2}{J_2 m_d}. \end{aligned}$$

### 3.3.4 The TORA system

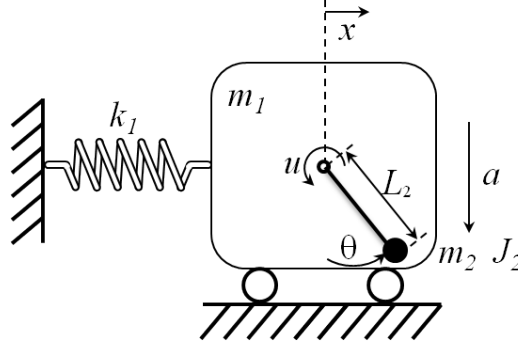

FIGURE 3.3: The TORA system

The TORA (Translational Oscillator with Rotational Actuator) system (see Figure 3.3) is a nonlinear benchmark system studied in the literature, e.g. [49]. It consists of a spring-mass system, with mass  $m_1$  and spring constant  $k_1$ , and a pendulum of length  $L_2$ , mass  $m_2$  and moment of inertia  $J_2$ . The linear displacement of the system is denoted  $x$  and the angle of the pendulum is  $\theta$ . The control  $u$  is the torque applied to the pendulum. The kinetic energy is

$$T = \frac{1}{2}(m_1 + m_2)\dot{x}^2 + \frac{1}{2}(J_2 + m_2 L_2^2)\dot{\theta}^2 + m_2 L_2 \cos \theta \dot{x} \dot{\theta}$$

and the potential energy is  $V = -m_2 L_2 a \cos \theta + \frac{1}{2} k_1 x^2$ . The equations of dynamics in  $(x, \theta)$  coordinates read

$$\begin{aligned} (m_1 + m_2)\ddot{x} + m_2 L_2 \cos \theta \ddot{\theta} - m_2 L_2 \sin \theta \dot{\theta}^2 + k_1 x &= 0 \\ m_2 L_2 \cos \theta \ddot{x} + (m_2 L_2^2 + J_2)\ddot{\theta} + m_2 L_2 a \sin \theta &= u. \end{aligned}$$

The equations of  $(\mathcal{MS})$  can be obtained by introducing coordinates  $(x^1, x^2) := (x, \theta)$

$$\begin{aligned} \dot{x}^1 &= y^1 \\ \dot{x}^2 &= y^2 \\ \dot{y}^1 &= -\Gamma_{22}^1 y^2 y^2 + e^1 + g^1 u \\ \dot{y}^2 &= -\Gamma_{22}^2 y^2 y^2 + e^2 + g^2 u, \end{aligned}$$

where

$$\begin{aligned} \Gamma_{22}^1 &= \frac{\zeta_0 \sin x^2}{\zeta_1 - \zeta_2 \cos^2 x^2}, & e^1 &= \frac{\zeta_4 \sin x^2 \cos x^2 - \zeta_3 x^1}{\zeta_1 - \zeta_2 \cos^2 x^2}, & g^1 &= \frac{-m_{12} \cos x^2}{\zeta_1 - \zeta_2 \cos^2 x^2}, \\ \Gamma_{22}^2 &= \frac{\zeta_2 \sin x^2 \cos x^2}{\zeta_1 - \zeta_2 \cos^2 x^2}, & e^2 &= \frac{-\zeta_5 \sin x^2 + \zeta_6 x^1 \cos x^2}{\zeta_1 - \zeta_2 \cos^2 x^2}, & g^2 &= \frac{m_{11}}{\zeta_1 - \zeta_2 \cos^2 x^2}, \end{aligned}$$

with some constant parameters listed below

$$\begin{aligned} m_{11} &= m_1 + m_2, & m_{12} &= m_2 L_2, & m_{22} &= m_2 L_2^2 + J_2, \\ \zeta_0 &= -m_{12} m_{22}, & \zeta_1 &= m_{11} m_{22}, & \zeta_2 &= m_{12}^2, \\ \zeta_3 &= k_1 (m_2 L_2^2 + J_2), & \zeta_4 &= m_2^2 L_2^2 a, & \zeta_5 &= m_2 L_2 (m_1 + m_2) a, \\ \zeta_6 &= k_1 m_2 L_2. \end{aligned}$$

### 3.3.5 The single link manipulator with joint elasticity

The single link manipulator with joint elasticity (see Figure 3.4 and [11]) consists of a revolute joint actuated by a motor with the elasticity modeled as a torsional spring with a linear characteristic  $k$ . Let  $\theta^1$  denote the link angle and  $\theta^2$  the motor shaft angle. The mass of the link is  $m$ , the distance from the joint to the center of mass of the link is  $L$ , the inertia of the motor shaft is  $J_1$  and  $J_2$  is the inertia of the link about the axis of rotation. The kinetic energy is  $T = \frac{1}{2} J_1 (\dot{\theta}^1)^2 + \frac{1}{2} J_2 (\dot{\theta}^2)^2$  and the potential energy  $V = \frac{1}{2} k (\theta^1 - \theta^2)^2 + maL (1 - \cos \theta^1)$ . The dynamics of the system reads

$$\begin{aligned} J_1 \ddot{\theta}^1 + maL \sin \theta^1 + k (\theta^1 - \theta^2) &= 0 \\ J_2 \ddot{\theta}^2 - k (\theta^1 - \theta^2) &= u. \end{aligned}$$

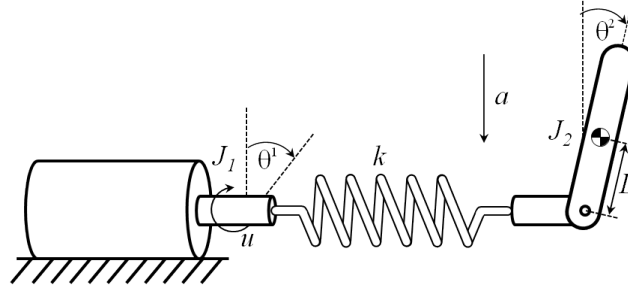

FIGURE 3.4: The single link manipulator with joint elasticity

The equations of  $(\mathcal{MS})$  can be obtained by introducing coordinates  $(x^1, x^2) := (\theta^1, \theta^2)$

$$\begin{aligned} \dot{x}^1 &= y^1 \\ \dot{x}^2 &= y^2 \\ \dot{y}^1 &= e^1 \\ \dot{y}^2 &= e^2 + \frac{1}{J_2} u, \end{aligned}$$

where

$$\begin{aligned} e^1 &= -\frac{maL}{J_1} \sin x^1 - \frac{k}{J_1} (x^1 - x^2), \\ e^2 &= \frac{k(x^1 - x^2)}{J_2}. \end{aligned}$$

## Chapter 4

# Linear mechanical control systems

In this chapter, we consider a particular subclass of mechanical control systems, namely linear control systems denoted  $(\mathcal{LMS})$ . The reason for investigating this class separately is threefold. Firstly, the class of  $(\mathcal{LMS})$  is the goal of linearization, in the sense that, by definition,  $(\mathcal{MS})$  after a linearization procedure is  $(\mathcal{LMS})$ . Therefore it is worth to gain some understanding of those systems. Secondly, the theory of  $(\mathcal{LMS})$  in many aspects reminds the theory of linear control systems  $LS$  and many results of classical linear control theory have their mechanical analogues. Finally, the matrix notation commonly used in the classical linear control theory is also convenient to use in the case of  $(\mathcal{LMS})$ . Similarly to Chapter 3, we define the class of  $(\mathcal{LMS})$  and then its subclass consisting of Lagrangian linear mechanical systems.

Most of the content of this chapter is based on classical results concerning linear systems. The controllability result for Lagrangian linear mechanical systems is known in the literature [15],[6], we just slightly generalize it and adopt it to  $(\mathcal{LMS})$ . The main result of this chapter namely the classification of controllable  $(\mathcal{LMS})$  and the introduction of invariants of  $(\mathcal{LMS})$  is analogous to the work of Brunovský [5]. We refer to the above-mentioned literature for further information on linear mechanical systems.

### 4.1 Linear Mechanical Control Systems $(\mathcal{LMS})$

We define the class of linear mechanical control systems by their differential equations, since  $(\mathcal{LMS})$  systems are distinguished among all nonlinear  $(\mathcal{MS})$  systems by a choice of coordinates in which differential equations describing the system are linear. Later on, we introduce a class transformations that preserve linearity and thus classify linear mechanical systems.

**Definition 4.1.** *A linear mechanical system  $(\mathcal{LMS})_{(n,m)}$  can be represented by a second-order differential equation of the following form*

$$\ddot{x} = Ex + Bu, \quad (4.1)$$

where  $x \in \mathbb{R}^n$ ,  $u \in \mathbb{R}^m$ , the matrix  $E$  is an  $n \times n$  real matrix, the input matrix  $B$  is an  $n \times m$  real matrix consisting of constant input vector fields  $b_r$ , and  $u = (u_1, \dots, u_m)^T$ , that is,  $Bu = \sum_{r=1}^m b_r u_r$ .

Equivalently,  $(\mathcal{LMS})_{(n,m)}$  can be represented as a first-order system on the tangent bundle  $\mathbb{T}\mathbb{R}^n = \mathbb{R}^n \times \mathbb{R}^n$  with coordinates  $(x, y)$

$$\begin{aligned}\dot{x} &= y \\ \dot{y} &= Ex + Bu,\end{aligned}\tag{4.2}$$

or as a linear control system of dimension  $2n$  with coordinates  $z = (x, y)$

$$\dot{z} = \hat{A}z + \hat{B}u,\tag{4.3}$$

where:

$$\hat{A} = \begin{pmatrix} 0 & I_n \\ E & 0 \end{pmatrix}, \quad \hat{B} = \begin{pmatrix} 0 \\ B \end{pmatrix}.\tag{4.4}$$

Notice that, similarly to the case of nonlinear mechanical control systems, we do not consider in (4.2) dissipative terms of the form  $Dy$ , linear in velocities. A linear mechanical control system  $(\mathcal{LMS})$  is *controllable* if for any  $t_0$ , any initial state  $(x_0, y_0) = (x(t_0), y(t_0))$  and any final state  $(x_f, y_f)$  there exist  $t_f > t_0$  and a control  $u : [t_0, t_f] \rightarrow \mathbb{R}^m$ , such that  $(x_f, y_f) = (x(t_f), y(t_f))$ . The following result is a straightforward generalization of [15].

**Lemma 4.2** (Controllability of  $(\mathcal{LMS})$ ). *For  $(\mathcal{LMS})$  the following statements are equivalent*

- (i)  $(\mathcal{LMS})$  is controllable
- (ii)  $\text{rank}(\hat{B}, \hat{A}\hat{B}, \dots, \hat{A}^{2n-1}\hat{B}) = 2n$  (Kalman Rank Condition)
- (iii)  $\text{rank}(\hat{A}^{2i}\hat{B} : 0 \leq i \leq n-1) = n$
- (iv)  $\text{rank}(B, EB, \dots, E^{n-1}B) = n$  (Mechanical Kalman Rank Condition)

*Proof.* From the Kalman controllability result we have (i)  $\iff$  (ii). The rest of the proof follows from a direct computation of the Kalman controllability matrix

$$\left(\hat{B}, \hat{A}\hat{B}, \dots, \hat{A}^{2n-1}\hat{B}\right) = \begin{pmatrix} 0 & B & 0 & EB & \dots & 0 & E^{n-1}B \\ B & 0 & EB & 0 & \dots & E^{n-1}B & 0 \end{pmatrix}.\tag{4.5}$$

Therefore we see that we can take only even powers  $\hat{A}^{2i}\hat{B}$  in (iii) or the lower part of the matrix (4.5) as in (iv).  $\square$

## 4.2 Classification of controllable $(\mathcal{LMS})$

A classification of general controllable linear systems under general linear transformations and general linear feedback has been solved in the celebrated Brunovský classification [5]. In this section, we consider the problem of classification of linear controllable mechanical systems, under linear extended point transformations and linear mechanical feedback.

A linear extended point transformation is given by a linear transformation of the following form

$$\begin{aligned}\tilde{x} &= Tx \\ \tilde{y} &= Ty,\end{aligned}\tag{4.6}$$

where  $T$  is an invertible  $n \times n$  real matrix. This transformation preserves configurations, i.e. it is a linear transformation from  $x$ -coordinates to  $\tilde{x}$ -coordinates. Moreover, since the derivatives of configurations are velocities, it induces the same linear transformations on velocities because we want to map the equation  $\dot{x} = y$  into  $\dot{\tilde{x}} = \tilde{y}$ .

The linear mechanical feedback is

$$u = Fx + G\tilde{u}, \quad (4.7)$$

where  $F$  is an  $n \times n$  matrix and  $G$  is an  $n \times m$  invertible matrix. The linear mechanical system ( $\mathcal{LMS}$ ) transformed by the transformations (4.6) and (4.7) reads

$$\begin{aligned} \dot{\tilde{x}} &= Ty = \tilde{y} \\ \dot{\tilde{y}} &= T(E + BF)T^{-1}\tilde{x} + TBG\tilde{u} = \tilde{E}\tilde{x} + \tilde{B}\tilde{u}. \end{aligned} \quad (4.8)$$

Systems (4.2) and (4.8) are called linear mechanical feedback equivalent, shortly LMF-equivalent.

For better readability, we start with the problem of classification of controllable linear mechanical control systems with a scalar control ( $\mathcal{LMS}$ ) $_{(n,1)}$  under a change of coordinates (4.6) only. Consider a class of systems of the form

$$\begin{aligned} \dot{x} &= y \\ \dot{y} &= Ex + bu, \end{aligned} \quad (4.9)$$

where  $x \in \mathbb{R}^n$ ,  $u \in \mathbb{R}$  and  $b$  is an input vector. The transformed system reads

$$\begin{aligned} \dot{\tilde{x}} &= Ty = \tilde{y} \\ \dot{\tilde{y}} &= TET^{-1}\tilde{x} + Tbu. \end{aligned}$$

We say that two controllable systems ( $\mathcal{LMS}$ ) $_{(n,1)}$ , represented by the pairs  $(E, b)$  and  $(\tilde{E}, \tilde{b})$ , respectively, are linear mechanical state-space equivalent, shortly *LMS*-equivalent, if there exists an invertible  $n \times n$  matrix  $T$  that transforms one system into the other by the change of coordinates (4.6). Since  $\tilde{E} = TET^{-1}$  and  $\tilde{b} = Tb$ , it is clear that the solution of the classification problem is equivalent to classify pairs  $(E, b)$  under the linear transformations  $T$  and we can adopt the classical result from linear control theory.

**Proposition 4.3.** *Two controllable systems ( $\mathcal{LMS}$ ) $_{(n,1)}$ , are *LMS*-equivalent if and only if the characteristic polynomials of  $E$  and  $\tilde{E}$  coincide.*

*Proof.* First we show that the characteristic polynomials are invariant under *LMS*-equivalence

$$\begin{aligned} \det(\lambda I_n - \tilde{E}) &= \det(T\lambda I_n T^{-1} - TET^{-1}) = \det\left(T(\lambda I_n - E)T^{-1}\right) = \\ &= \det(T) \det(\lambda I_n - E) \det(T^{-1}) = \det(\lambda I_n - E). \end{aligned}$$

Now, assume that the characteristic polynomials of  $E$  and  $\tilde{E}$  coincide. In order to construct a matrix  $T$  establishing transformation (4.6) that maps ( $\mathcal{LMS}$ ) $_{(n,1)}$  into  $(\widetilde{\mathcal{LMS}})_{(n,1)}$ , we bring both systems into their Frobenius normal form. First, we solve

the following system of linear equations for a nontrivial  $c \in \mathbb{R}^{1 \times n}$

$$\begin{aligned} cb = cEb = \dots = cE^{n-2}b = 0 \\ cE^{n-1}b = 1. \end{aligned}$$

In other words, we search for a co-vector  $c$  that is orthogonal to the subspace spanned by  $n-1$  independent vectors  $b, Eb, \dots, E^{n-2}b$ . By the controllability assumption, the above system is solvable. We introduce new linear coordinates  $(q, v)$ , where  $q = Sx$  and  $v = Sy$  are new configurations and velocities, where the transformation

$$S = \begin{pmatrix} c \\ cE \\ \vdots \\ cE^{n-1} \end{pmatrix}, \quad (4.10)$$

that is,

$$\begin{aligned} q^1 &= cx & v^1 &= cy \\ q^2 &= cEx & v^2 &= cEy \\ &\vdots & &\vdots \\ q^n &= cE^{n-1}x & v^n &= cE^{n-1}y. \end{aligned}$$

We have

$$\begin{aligned} \dot{q}^1 &= c\dot{x} &= cy &= v^1 \\ \dot{q}^2 &= cE\dot{x} &= cEy &= v^2 \\ &\vdots & &\vdots \\ \dot{q}^n &= cE^{n-1}\dot{x} &= cE^{n-1}y &= v^n \\ \dot{v}^1 &= c\dot{y} &= cEx + cbu &= q^2 \\ \dot{v}^2 &= cE\dot{y} &= cE^2x + cEbu &= q^3 \\ &\vdots & &\vdots \\ \dot{v}^{n-1} &= cE^{n-2}\dot{y} &= cE^{n-1}x + cE^{n-2}bu &= q^n \\ \dot{v}^n &= cE^{n-1}\dot{y} &= cE^n x + cE^{n-1}bu &= \sum_{i=1}^n e_i q^i + u. \end{aligned} \quad (4.11)$$

Therefore the pair  $(E_F, b_F) = (SES^{-1}, Sb)$  is now in the Frobenius form.

Now, we apply an analogous procedure to bring the second  $(\mathcal{LMS})$ , given by the pair  $(\tilde{E}, \tilde{b})$ , into its Frobenius form. That is, we solve

$$\begin{aligned} \tilde{c}\tilde{b} = \tilde{c}\tilde{E}\tilde{b} = \dots = \tilde{c}\tilde{E}^{n-2}\tilde{b} = 0 \\ \tilde{c}\tilde{E}^{n-1}\tilde{b} = 1. \end{aligned}$$

and construct the transformation

$$\tilde{S} = \begin{pmatrix} \tilde{c} \\ \tilde{c}\tilde{E} \\ \vdots \\ \tilde{c}\tilde{E}^{n-1} \end{pmatrix},$$

such that the pair  $(\tilde{E}_F, \tilde{b}_F) = (\tilde{S}\tilde{E}\tilde{S}^{-1}, \tilde{S}b)$  is in the Frobenius normal form (with the elements of the last row denoted  $\tilde{e}_i$ , compare (4.11)).

Now, we calculate the characteristic polynomials for both  $E_F$  and  $\tilde{E}_F$  which are

$$\begin{aligned} p(E_F) &= \lambda^n - e_n\lambda^{n-1} - \dots - e_2\lambda - e_1 \\ p(\tilde{E}_F) &= \lambda^n - \tilde{e}_n\lambda^{n-1} - \dots - \tilde{e}_2\lambda - \tilde{e}_1, \end{aligned}$$

and coincide by our assumption, implying  $e_i = \tilde{e}_i$ . Hence  $E_F = \tilde{E}_F$  and  $b_F = \tilde{b}_F$ . Therefore, the composition of the transformations  $S$  and  $\tilde{S}^{-1}$  maps one system into the other, i.e.

$$T = \tilde{S}^{-1}S$$

transforms system (4.9), defined by the pair  $(E, b)$ , into the system

$$\begin{aligned} \dot{\hat{x}} &= Ty = \tilde{y} \\ \dot{\hat{y}} &= \tilde{E}\tilde{x} + \tilde{b}u. \end{aligned}$$

with  $\tilde{E} = TET^{-1}$  and  $\tilde{b} = Tb$ . □

Due the above result and its proof we classify linear systems  $(\mathcal{LMS})_{(n,1)}$  under transformations (4.6). Hence, the coefficients of the characteristic polynomial fully characterize all systems. Now, apply to the system (4.11) a feedback of the form (4.7) given by

$$u = -\sum_{i=1}^n e_i q^i + \tilde{u}, \quad (4.12)$$

and we result in the *mechanical canonical form*, consisting of a chain of double integrators

$$\begin{aligned} \dot{\hat{x}}^1 &= \tilde{y}^1, & \dot{\hat{x}}^2 &= \tilde{y}^2, & \dots, & \dot{\hat{x}}^{n-1} &= \tilde{y}^{n-1}, & \dot{\hat{x}}^n &= \tilde{y}^n \\ \dot{\hat{y}}^1 &= \tilde{x}^2, & \dot{\hat{y}}^2 &= \tilde{x}^3, & \dots, & \dot{\hat{y}}^{n-1} &= \tilde{x}^n, & \dot{\hat{y}}^n &= \tilde{u}. \end{aligned} \quad (4.13)$$

By the presented construction, any controllable  $(\mathcal{LMS})_{(n,1)}$  is LMF-equivalent by an appropriate change of coordinates (4.10) and feedback (4.12), to the mechanical canonical form (4.13). Thus, there exists a unique mechanical canonical form, which we summarize in the following corollary.

**Corollary 4.4.** *For any two controllable  $(\mathcal{LMS})_{(n,1)}$  and  $(\widetilde{\mathcal{LMS}})_{(n,1)}$  the following holds:  $(\mathcal{LMS})_{(n,1)}$  is LMF-equivalent to  $(\widetilde{\mathcal{LMS}})_{(n,1)}$  and they are LMF-equivalent to the mechanical canonical form (4.13).*

The above observation can be generalized to multi-input systems  $(\mathcal{LMS})_{(n,m)}$ , which we will present below. To start with, attach to system (4.2) an  $n$ -tuple of indices  $\bar{r}_i$

$$\begin{aligned} \bar{r}_0 &= \text{rank}(B), \\ \bar{r}_i &= \text{rank}(B, EB, \dots, E^i B) - \text{rank}(B, EB, \dots, E^{i-1} B), \end{aligned} \quad (4.14)$$

for  $1 \leq i \leq n-1$ . Furthermore define the dual indices

$$\bar{\rho}_j = \text{card}(\bar{r}_i \geq j : 0 \leq i \leq n-1) \quad \text{for } 1 \leq j \leq m. \quad (4.15)$$



These integers are mechanical analogues of the controllability (Brunovský, Kronecker) indices  $\rho_i$  (cf. (2.14)), and we call them the *mechanical half-indices*. Note that the indices  $\bar{\rho}_i$  are invariant under (4.6) and (4.7), therefore form a set of invariants of  $(\mathcal{LMS})$ . Actually, they form a set of complete invariant, as we will show in Theorem 4.6 below. We denote the above sequences as  $\bar{\mathcal{R}}(E, B) = (\bar{r}_0, \dots, \bar{r}_{n-1})$  and  $\bar{\mathcal{P}}(E, B) = (\bar{\rho}_1, \dots, \bar{\rho}_m)$ .

**Proposition 4.5.** *Consider  $(\mathcal{LMS})$*

(i) *the sequence of indices  $\mathcal{R}(\hat{A}, \hat{B}) = (r_0, r_1, \dots, r_{2n-1})$  is the doubled sequence of  $\bar{\mathcal{R}}(E, B)$ , i.e.  $(r_0, r_1, \dots, r_{2n-1}) = (\bar{r}_0, \bar{r}_0, \bar{r}_1, \bar{r}_1, \dots, \bar{r}_{n-1}, \bar{r}_{n-1})$ ,*

(ii) *the mechanical half-indices are half of the controllability indices, i.e.  $\rho_j = 2\bar{\rho}_j$ .*

*Proof.* Let us invoke controllability matrix of  $(\mathcal{LMS})$  given by (4.5) and calculate  $r_i$  (using (2.13)) and compare them with  $\bar{r}_i$  given by (4.14). The crucial observation is that we can calculate the ranks of the lower and upper submatrices separately and then add them.

$$\begin{aligned}
r_0 &= \text{rank } \hat{B} = \text{rank } B = \bar{r}_0 \\
r_1 &= \text{rank} \begin{pmatrix} \hat{B} \\ \hat{A}\hat{B} \end{pmatrix} - \text{rank } \hat{B} = (\text{rank } B + \text{rank } B) - \text{rank } B = \bar{r}_0 \\
r_2 &= \text{rank} \begin{pmatrix} \hat{B} \\ \hat{A}\hat{B} \\ \hat{A}^2\hat{B} \end{pmatrix} - \text{rank} \begin{pmatrix} \hat{B} \\ \hat{A}\hat{B} \end{pmatrix} = \text{rank} (EB, B) + \text{rank } B - \\
&\quad - 2 \text{rank } B = \text{rank} (EB, B) - \text{rank } B = \bar{r}_1 \\
r_3 &= \text{rank} \begin{pmatrix} \hat{B} \\ \hat{A}\hat{B} \\ \hat{A}^2\hat{B} \\ \hat{A}^3\hat{B} \end{pmatrix} - \text{rank} \begin{pmatrix} \hat{B} \\ \hat{A}\hat{B} \\ \hat{A}^2\hat{B} \end{pmatrix} = 2 \text{rank} (EB, B) - \\
&\quad - (\text{rank} (EB, B) + \text{rank } B) = \bar{r}_1 \\
&\quad \vdots \\
r_{2n-2} &= \text{rank} (E^{n-1}B, \dots, B) + \text{rank} (E^{n-2}B, \dots, B) - \\
&\quad - 2 \text{rank} (E^{n-2}B, \dots, B) = \bar{r}_{n-1} \\
r_{2n-1} &= 2 \text{rank} (E^{n-1}B, \dots, B) - \\
&\quad - (\text{rank} (E^{n-1}B, \dots, B) + \text{rank} (E^{n-2}B, \dots, B)) = \bar{r}_{n-1}.
\end{aligned}$$

To summarize, we have the sequence of  $n$  integers

$$\bar{\mathcal{R}}(E, B) = (\bar{r}_0, \bar{r}_1, \dots, \bar{r}_{n-1})$$

and the sequence of  $2n$  integers  $r_i$

$$\mathcal{R}(\hat{A}, \hat{B}) = (\bar{r}_0, \bar{r}_0, \bar{r}_1, \bar{r}_1, \dots, \bar{r}_{n-1}, \bar{r}_{n-1}),$$

thus they satisfy the desired relation (i). Using (4.15) and (2.14), and (i), calculate

$$\bar{\rho}_j = \text{card}(\bar{r}_i \geq j : 0 \leq i \leq n-1),$$

and

$$\rho_j = \text{card}(r_i \geq j : 0 \leq i \leq 2n-1) = 2 \text{card}(\bar{r}_i \geq j : 0 \leq i \leq n-1) = 2\bar{\rho}_j,$$

thus we proved (ii).  $\square$

Now we can formulate the following theorem.

**Theorem 4.6.** *The following are equivalent:*

- (i) Two controllable systems ( $\mathcal{LMS}$ ) and  $(\widetilde{\mathcal{LMS}})$ , represented by pairs  $(E, B)$  and  $(\tilde{E}, \tilde{B})$ , respectively, are LMF-equivalent,
- (ii)  $\bar{\mathcal{R}}(E, B) = \bar{\mathcal{R}}(\tilde{E}, \tilde{B})$ ,
- (iii)  $\bar{\mathcal{P}}(E, B) = \bar{\mathcal{P}}(\tilde{E}, \tilde{B})$ , i.e. the mechanical half-indices coincide,
- (iv)  $\mathcal{P}(\hat{A}, \hat{B}) = \mathcal{P}(\hat{\tilde{A}}, \hat{\tilde{B}})$ , i.e. the controllability indices coincide,

where  $\hat{A}, \hat{B}$  and  $\hat{\tilde{A}}, \hat{\tilde{B}}$  are of the form (4.4).

*Proof.* Equivalence of (ii) and (iii) follows from the definition.

(i)  $\Leftrightarrow$  (iii). We associate with ( $\mathcal{LMS}$ ), given by the pair  $(E, B)$ , a virtual linear (first-order) control system  $L\Sigma$

$$\dot{x} = Ex + Bv, \quad (4.16)$$

and similarly with  $(\widetilde{\mathcal{LMS}})$ , given by  $(\tilde{E}, \tilde{B})$ , we associate  $L\tilde{\Sigma}$

$$\dot{\tilde{x}} = \tilde{E}\tilde{x} + \tilde{B}\tilde{v}. \quad (4.17)$$

Now we directly use the Brunovský classification theorem [5] to prove that (4.16) and (4.17) are equivalent under a transformation  $\tilde{x} = Tx$  and feedback  $v = Fx + G\tilde{v}$ , if and only if their controllability indices coincide. Note that the controllability indices of (4.16) (or (4.17)) coincide with the mechanical half-indices of associated ( $\mathcal{LMS}$ ) (or  $(\widetilde{\mathcal{LMS}})$ ). Now notice that  $\tilde{x} = Tx$  and  $v = Fx + G\tilde{v}$  establish feedback equivalence between (4.16) and (4.17) if and only if  $\tilde{x} = Tx$ ,  $\tilde{y} = Ty$  and  $u = Fx + G\tilde{u}$  establish LMF-equivalence between (4.2) and (4.8). Therefore (i) is equivalent to (iii). Equivalence of (iii) and (iv) follows immediately from Proposition 4.5.  $\square$

**Remark 4.7.** *Notice that the general feedback group acting on systems of the form (4.3) by  $\hat{A} \mapsto S(\hat{A} + \hat{B}\hat{F})S^{-1}$ ,  $\hat{B} \mapsto S\hat{B}\hat{G}$  is much bigger than the mechanical feedback group (4.6)-(4.7). Nevertheless both groups action have exactly the same invariants implying that if two linear mechanical systems are feedback equivalent they are also mechanical feedback equivalent.*

Similarly to the scalar control case, we can formulate the following important corollary. Define auxiliary indices

$$\mu_0 = 0 \quad \text{and} \quad \mu_j = \sum_{i=1}^j \bar{\rho}_i, \quad \text{for } 1 \leq j \leq m.$$

**Corollary 4.8.** *For any two controllable  $(\mathcal{LMS})_{(n,m)}$  and  $(\widetilde{\mathcal{LMS}})_{(n,m)}$  with  $\bar{\mathcal{R}}(E, B) = \bar{\mathcal{R}}(\tilde{E}, \tilde{B})$  (or  $\bar{\mathcal{P}}(E, B) = \bar{\mathcal{P}}(\tilde{E}, \tilde{B})$ ) the following statements hold*

- (i)  $(\mathcal{LMS})_{(n,m)}$  is LMF-equivalent to  $(\widetilde{\mathcal{LMS}})_{(n,m)}$

(ii) Both  $(\mathcal{LMS})_{(n,m)}$  and  $(\widetilde{\mathcal{LMS}})_{(n,m)}$  are LMF-equivalent to the mechanical canonical form

$$\begin{aligned} \dot{x}^i &= y^i & 1 \leq i \leq n \\ \dot{y}^i &= x^{i+1} & \mu_j + 1 \leq i \leq \mu_{j+1} - 1, \quad 0 \leq j \leq m - 1 \\ \dot{y}^{\mu_j} &= u_j. & 1 \leq j \leq m \end{aligned} \quad (4.18)$$

### 4.3 Lagrangian Linear Mechanical Systems

Consider a subclass of  $(\mathcal{LMS})$  whose configuration space is the real vector space  $Q = \mathbb{R}^n$  equipped with an inner product given by a real valued quadratic form  $\frac{1}{2}\dot{x}^T M \dot{x}$ , where  $M$  is a constant metric tensor ( $M^T = M > 0$ ). The tangent bundle is  $TQ = \mathbb{R}^n \times \mathbb{R}^n$ . Moreover, consider a potential energy given by a quadratic form  $V = \frac{1}{2}x^T N x$ , where  $N$  is a symmetric potential matrix ( $N^T = N$ ).

The corresponding linear Lagrangian reads  $\mathcal{L} = \frac{1}{2}\dot{x}^T M \dot{x} - \frac{1}{2}x^T N x$ . The derivation of  $(\mathcal{LMS})$  using the Euler-Lagrange formulation yields the second-order equation:

$$M\ddot{x} + N x = K u, \quad (4.19)$$

where  $K$  is  $n \times m$  real matrix whose columns are vectors corresponding to the external controlled forces. Denoting  $z = (x, y)^T$  it can be expressed in the form of a classical linear system:  $\dot{z} = \hat{A}z + \hat{B}u$ , where:

$$\hat{A} = \begin{pmatrix} 0 & I_n \\ -M^{-1}N & 0 \end{pmatrix}, \quad \hat{B} = \begin{pmatrix} 0 \\ M^{-1}K \end{pmatrix}. \quad (4.20)$$

Therefore for Lagrangian class of  $(\mathcal{LMS})$  the matrices  $E = -M^{-1}N$  and  $B = M^{-1}K$ .

Following [15], we establish a normal form for Lagrangian  $(\mathcal{LMS})$  systems and formulate an alternative controllability condition for these systems. In order to do that we need the following result

**Lemma 4.9.** *Consider Lagrangian  $(\mathcal{LMS})$  given by (4.19), with  $M^T = M > 0$  and  $N^T = N$ . Then there exists a transformation  $\tilde{x} = T x$  such that the system reads*

$$\ddot{\tilde{x}} + \tilde{N}\tilde{x} = \tilde{K}u, \quad (4.21)$$

where  $\tilde{N} = \text{diag}(\lambda_1, \dots, \lambda_n)$  and  $\tilde{K} = T K$ .

For a proof see [14], page 263.

Therefore, for Lagrangian  $(\mathcal{LMS})$  systems the metric tensor  $M$  can be transformed into an identity matrix and, simultaneously, the potential matrix  $N$  can be diagonalized. Now permute  $\tilde{x}^1, \dots, \tilde{x}^n$  such that the rows of matrices  $\tilde{N}$  and  $\tilde{K}$  are partitioned according to the multiplicity of  $\lambda_i$ 's, that is

$$\tilde{N} = \begin{pmatrix} \lambda_1 I_{d_1} & 0 & \cdots & 0 \\ 0 & \lambda_2 I_{d_2} & \cdots & 0 \\ \vdots & \vdots & \ddots & \vdots \\ 0 & 0 & \cdots & \lambda_l I_{d_l} \end{pmatrix} \quad \text{and} \quad \tilde{K} = \begin{pmatrix} \tilde{k}_1 \\ \tilde{k}_2 \\ \vdots \\ \tilde{k}_l \end{pmatrix} \quad \begin{array}{l} d_1 \text{ rows} \\ d_2 \text{ rows} \\ \vdots \\ d_l \text{ rows,} \end{array}$$

where  $\tilde{N}$  is block diagonal matrix, with  $i$ -th block  $\lambda_i I_{d_i}$  is diagonal matrix of dimension  $d_i$ , the multiplicity of  $\lambda_i$ , such that  $d_1 + \dots + d_l = n$ , where  $l$  is the number of distinct

eigenvalues. Using the partition given above, we calculate the Kalman mechanical rank condition for system (4.21)

$$\text{rank} \left( \tilde{K}, \tilde{N}\tilde{K}, \dots, \tilde{N}^{n-1}\tilde{K} \right) = \text{rank} \begin{pmatrix} \tilde{k}_1 & \lambda_1 \tilde{k}_1 & \lambda_1^2 \tilde{k}_1 & \dots & \lambda_1^{n-1} \tilde{k}_1 \\ \vdots & \vdots & \vdots & \ddots & \vdots \\ \tilde{k}_l & \lambda_l \tilde{k}_l & \lambda_l^2 \tilde{k}_l & \dots & \lambda_l^{n-1} \tilde{k}_l \end{pmatrix}$$

therefore it is clear that the above matrix is of rank  $n$  if and only if the following condition is satisfied.

**Lemma 4.10.** *The system (4.21) is controllable if and only if*

$$\text{rank } \tilde{k}_i = d_i \quad 1 \leq i \leq l.$$

It is worth to note that in order to check the condition, one has to bring the system into the form (4.21). This procedure could be hard in many cases or even nonconstructive.

## 4.4 Examples of Linear Mechanical Control System

Classical examples of linear mechanical control systems are spring-mass systems. We present the equations of motions of  $n$ -coupled spring-mass system, which consists of  $n$  bodies, where the position of  $i$ -th body is denoted  $x^i$ , and  $m_i$  is the mass of  $i$ -th body. The bodies are connected by  $n + 1$  springs with  $k_i$  being the spring constant of  $i$ -th spring, as depicted in Figure 4.1. The external forces (controls)  $u_i$  are applied to each body.

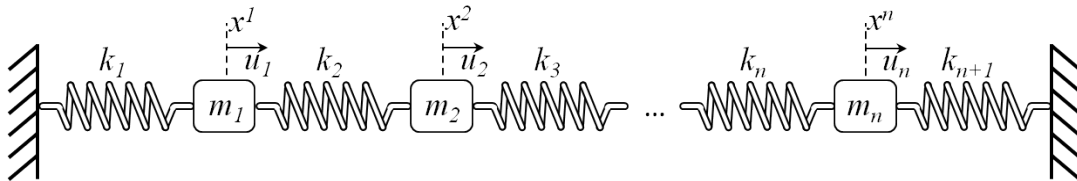

FIGURE 4.1: The  $n$ -coupled spring-mass system

The dynamics of  $i$ -th body is given by the balance of forces acting on the body

$$m_i \ddot{x}^i = -k_i (x^i - x^{i-1}) + k_{i+1} (x^{i+1} - x^i) + u_i, \quad (4.22)$$

where  $x^0 \equiv x^{n+1} \equiv 0$ . The equations can be formulated in the form of (4.19), where

$$M = \begin{pmatrix} m_1 & 0 & 0 & \dots & 0 \\ 0 & m_2 & 0 & \dots & 0 \\ 0 & 0 & m_3 & \dots & 0 \\ 0 & 0 & 0 & \ddots & 0 \\ 0 & 0 & 0 & \dots & m_n \end{pmatrix} \quad N = \begin{pmatrix} k_1 + k_2 & -k_2 & 0 & \dots & 0 \\ -k_2 & k_2 + k_3 & -k_3 & \dots & 0 \\ 0 & -k_3 & k_3 + k_4 & \dots & 0 \\ 0 & 0 & 0 & \ddots & -k_n \\ 0 & 0 & \dots & -k_n & k_n + k_{n+1} \end{pmatrix}$$

or as a ( $\mathcal{LMS}$ ) of the form (4.2), where

$$E = \begin{pmatrix} \frac{-k_1-k_2}{m_1} & \frac{k_2}{m_1} & 0 & \dots & 0 \\ \frac{k_2}{m_2} & \frac{-k_2-k_3}{m_2} & \frac{k_3}{m_2} & \dots & 0 \\ 0 & \frac{k_3}{m_3} & \frac{-k_3-k_4}{m_3} & \dots & 0 \\ \vdots & \vdots & \vdots & \ddots & \vdots \\ 0 & 0 & 0 & \dots & \frac{k_n}{m_n} \\ 0 & 0 & \dots & \frac{k_n}{m_n} & \frac{-k_n-k_{n+1}}{m_n} \end{pmatrix} \quad B = \begin{pmatrix} \frac{1}{m_1} & 0 & 0 & \dots & 0 \\ 0 & \frac{1}{m_2} & 0 & \dots & 0 \\ 0 & 0 & \frac{1}{m_3} & \dots & 0 \\ \vdots & \vdots & \vdots & \ddots & \vdots \\ 0 & 0 & 0 & \dots & \frac{1}{m_n} \end{pmatrix} \quad (4.23)$$

If all  $n$  controls are present the system is fully actuated. However, it is enough to apply one control  $u_n$  in order to the system be controllable.

**Example** *The spring-mass system with one control.* Consider the  $n$ -spring-mass system (4.22) with only one control  $u := u_n$ , i.e.  $u_i = 0$  for  $1 \leq i \leq n-1$ . The system reads

$$\begin{aligned} \dot{x} &= y \\ \dot{y} &= Ex + bu, \end{aligned}$$

where  $E$  is given by (4.23) and  $b = \left(0, \dots, \frac{1}{m_n}\right)^T$ . It is straightforward to show that  $\text{rank}(b, Eb, \dots, E^{n-1}b) = n$ . What is more, introduce

$$c = \left(\frac{\prod_{i=1}^n m_i}{\prod_{i=2}^n k_i}, 0, 0, \dots, 0\right)$$

and calculate the transformation  $T$  as in (4.10). The transformed system is in the Frobenius form (4.11), and by applying the feedback (4.12), we obtain the mechanical canonical form (4.13).

## Chapter 5

# Mechanical state-space linearization

In this chapter we introduce a problem of mechanical state-space linearization (MS-linearization) of mechanical control systems  $(\mathcal{MS})$ . That is, the problem whether  $(\mathcal{MS})$  is equivalent to  $(\mathcal{LMS})$  via a change of coordinates that preserves configurations and velocities. We consider that class of transformations since they are natural and have physical interpretation. In order to specify this problem, first, we describe MS-equivalence of two  $(\mathcal{MS})$  systems. Then, we state the problem of MS-linearization, i.e. MS-equivalence to a special form of  $(\mathcal{MS})$ , namely a linear mechanical control system  $(\mathcal{LMS})$ . This problem is a *mechanical* version of state-space linearization (S-linearization) of classical control systems  $\Sigma$ , that was mentioned in Chapter 2.

The problem of MS-equivalence and MS-linearization has been extensively studied by Respondek and Ricardo [39], [40], [41]. They considered a broader class of mechanical systems by including also dissipative forces acting on the system. They also studied several other variants of equivalence via diffeomorphisms. For linearization of mechanical systems along controlled trajectories see [7]. For a problem of quasi-linearization of mechanical systems see pioneering works of Bedrossian [2] and Spong [44], and also [8].

We present two new result in this field. The first one is a new set of conditions (equivalent to those in [40]) for MS-linearization to controllable  $(\mathcal{LMS})$ , however we formulate it entirely in terms of the objects on  $Q$ . The second one gives conditions for  $(\mathcal{MS})$  to be MS-linearizable without controllability assumption.

### 5.1 Mechanical state-space equivalence

Consider a mechanical control system as described in Chapter 3. Recall that it can be defined by a 4-tuple  $(\mathcal{MS})_{(n,m)} = (Q, \nabla, \mathbf{g}, e)$  yielding the control system on  $TQ$

$$\begin{aligned} \dot{x}^i &= y^i \\ \dot{y}^i &= -\Gamma_{jk}^i(x)y^j y^k + e^i(x) + \sum_{r=1}^m g_r^i(x)u_r \end{aligned} \quad (5.1)$$

or, equivalently, using coordinates  $z = (x, y)$

$$\dot{z} = F(z) + \sum_{r=1}^m G_r(z)u_r, \quad (5.2)$$

where:

$$F = S + e^{vlift} = y^i \frac{\partial}{\partial x^i} + \left( -\Gamma_{jk}^i(x) y^j y^k + e^i(x) \right) \frac{\partial}{\partial y^i}, \quad G_r = g_r^{vlift} = g_r^i(x) \frac{\partial}{\partial y^i},$$

with  $S = y^i \frac{\partial}{\partial x^i} - \Gamma_{jk}^i(x) y^j y^k \frac{\partial}{\partial y^i}$  being the geodesic spray, and  $e^{vlift} = e^i(x) \frac{\partial}{\partial y^i}$  and  $g_r^{vlift} = g_r^i(x) \frac{\partial}{\partial y^i}$  vertical lifts (see Chapter 3).

It is well known [1] (and straightforward to show) how Christoffel symbols of an affine connection transform under a change of coordinates. Consider a diffeomorphism  $\tilde{x} = \phi(x)$ , an affine connection  $\nabla$  on  $Q$  and its image under  $\phi$ , namely  $\phi(\nabla) = \tilde{\nabla}$ . The Christoffel symbols of  $\tilde{\nabla}$  are given by

$$\tilde{\Gamma}_{ps}^i(\tilde{x}) = \frac{\partial^2 x^j}{\partial \tilde{x}^p \partial \tilde{x}^s} \frac{\partial \tilde{x}^i}{\partial x^j} + \frac{\partial x^q}{\partial \tilde{x}^p} \frac{\partial x^l}{\partial \tilde{x}^s} \frac{\partial \tilde{x}^i}{\partial x^j} \Gamma_{ql}^j(x), \quad (5.3)$$

that is, they do not change tensor-like.

**Definition 5.1.** Two mechanical control systems  $(\mathcal{MS})_{(n,m)} = (Q, \nabla, \mathfrak{g}, e)$  and  $(\tilde{\mathcal{M}}\mathcal{S})_{(n,m)} = (\tilde{Q}, \tilde{\nabla}, \tilde{\mathfrak{g}}, \tilde{e})$  are mechanical state-space equivalent, shortly MS-equivalent, if there exists a diffeomorphism  $\phi : Q \rightarrow \tilde{Q}$  such that

$$\begin{aligned} \phi(x) &= \tilde{x} \\ \phi(\nabla) &= \tilde{\nabla} \\ \phi_* g_r &= \tilde{g}_r \quad \text{for } 1 \leq r \leq m \\ \phi_* e &= \tilde{e}, \end{aligned} \quad (5.4)$$

The diffeomorphism  $\phi$  maps the 4-tuple  $(Q, \nabla, \mathfrak{g}, e)$ , that defines  $(\mathcal{MS})$ , into the one that defines  $(\tilde{\mathcal{M}}\mathcal{S})$ . If  $(\mathcal{MS})$  and  $(\tilde{\mathcal{M}}\mathcal{S})$  are MS-equivalent, then their corresponding control systems (5.1) are equivalent via a mechanical diffeomorphism on tangent bundles induced by  $\phi$  namely

$$\begin{aligned} \Phi : \quad \text{T}Q &\rightarrow \text{T}\tilde{Q} \\ (x, y) &\mapsto (\phi(x), D\phi(x)y), \end{aligned}$$

which is called an extended point transformation. In other words,  $\Phi$  preserves the structure of mechanical equations (5.1). Computations of (5.1) transformed via  $\Phi$  are straightforward:

$$\begin{aligned} \hat{\tilde{x}}^i &= \frac{\partial \tilde{x}^i}{\partial x^j} y^j = \tilde{y}^i \\ \hat{\tilde{y}}^i &= \frac{\partial^2 \tilde{x}^i}{\partial x^j \partial x^k} y^j y^k + \frac{\partial \tilde{x}^i}{\partial x^j} \dot{y}^j = \\ &= \frac{\partial^2 \tilde{x}^i}{\partial x^j \partial x^k} y^j y^k + \frac{\partial \tilde{x}^i}{\partial x^j} \left( -\Gamma_{ql}^j y^q y^l + e^j + \sum_{r=1}^m g_r^j u_r \right) = \\ &= \frac{\partial^2 \tilde{x}^i}{\partial x^j \partial x^k} \frac{\partial x^j}{\partial \tilde{x}^p} \tilde{y}^p \frac{\partial x^k}{\partial \tilde{x}^s} \tilde{y}^s + \frac{\partial \tilde{x}^i}{\partial x^j} \left( -\Gamma_{ql}^j \frac{\partial x^q}{\partial \tilde{x}^p} \tilde{y}^p \frac{\partial x^l}{\partial \tilde{x}^s} \tilde{y}^s + e^j + \sum_{r=1}^m g_r^j u_r \right) = \\ &= -\tilde{\Gamma}_{ps}^i \tilde{y}^p \tilde{y}^s + \tilde{e}^i + \sum_{l=1}^m \tilde{g}_r^i u_r, \end{aligned}$$

where:

$$\begin{aligned}\tilde{\Gamma}_{ps}^i(\tilde{x}) &= -\frac{\partial^2 \tilde{x}^i}{\partial x^j \partial x^k} \frac{\partial x^j}{\partial \tilde{x}^p} \frac{\partial x^k}{\partial \tilde{x}^s} + \frac{\partial \tilde{x}^i}{\partial x^j} \frac{\partial x^q}{\partial \tilde{x}^p} \frac{\partial x^l}{\partial \tilde{x}^s} \Gamma_{ql}^j(x) \\ \tilde{e}^i(\tilde{x}) &= \frac{\partial \tilde{x}^i}{\partial x^j} e^j(x) \\ \tilde{g}_r^i(\tilde{x}) &= \frac{\partial \tilde{x}^i}{\partial x^j} g_r^j(x).\end{aligned}\tag{5.5}$$

Therefore we see that  $e, g_r$  transform accordingly to (5.4). In order to show that (5.5) agrees with (5.3), we need to consider the following identity

$$\frac{\partial \tilde{x}^i}{\partial x^j} \frac{\partial x^j}{\partial \tilde{x}^p} = \delta_p^i,$$

and we differentiate both sides with respect to  $\frac{\partial}{\partial x^k}$ , which yields

$$\frac{\partial^2 \tilde{x}^i}{\partial x^k \partial x^j} \frac{\partial x^j}{\partial \tilde{x}^p} + \frac{\partial \tilde{x}^i}{\partial x^j} \frac{\partial}{\partial x^k} \left( \frac{\partial x^j}{\partial \tilde{x}^p} \right) = 0,$$

hence

$$\frac{\partial^2 \tilde{x}^i}{\partial x^k \partial x^j} \frac{\partial x^j}{\partial \tilde{x}^p} = -\frac{\partial \tilde{x}^i}{\partial x^j} \frac{\partial^2 x^j}{\partial \tilde{x}^r \partial \tilde{x}^p} \frac{\partial \tilde{x}^r}{\partial x^k},$$

and we multiply both sides by  $\frac{\partial x^k}{\partial \tilde{x}^s}$

$$\frac{\partial^2 \tilde{x}^i}{\partial x^k \partial x^j} \frac{\partial x^j}{\partial \tilde{x}^p} \frac{\partial x^k}{\partial \tilde{x}^s} = -\frac{\partial \tilde{x}^i}{\partial x^j} \frac{\partial^2 x^j}{\partial \tilde{x}^r \partial \tilde{x}^p} \frac{\partial \tilde{x}^r}{\partial x^k} \frac{\partial x^k}{\partial \tilde{x}^s},$$

$$\frac{\partial^2 \tilde{x}^i}{\partial x^k \partial x^j} \frac{\partial x^j}{\partial \tilde{x}^p} \frac{\partial x^k}{\partial \tilde{x}^s} = -\frac{\partial \tilde{x}^i}{\partial x^j} \frac{\partial^2 x^j}{\partial \tilde{x}^r \partial \tilde{x}^p} \delta_s^r,$$

$$-\frac{\partial^2 \tilde{x}^i}{\partial x^j \partial x^k} \frac{\partial x^j}{\partial \tilde{x}^p} \frac{\partial x^k}{\partial \tilde{x}^s} = \frac{\partial \tilde{x}^i}{\partial x^j} \frac{\partial^2 x^j}{\partial \tilde{x}^p \partial \tilde{x}^s}.$$

Note that MS-equivalence, and thus the mechanical diffeomorphism  $\Phi$ , being a subclass of S-equivalence, preserves state-space trajectories of (5.2) (or (5.1)) corresponding to the same controls  $u$  (see Section 2.3), i.e.

$$\Phi \left( z(t, z^0, u) \right) = \tilde{z}(t, \tilde{z}^0, u),$$

where  $z^0 = (x^0, y^0)$  and  $\tilde{z}^0 = (\tilde{x}^0, \tilde{y}^0)$  are the initial points in  $TQ$  and  $T\tilde{Q}$ , respectively. Moreover, via  $\phi$ , it establishes the equivalence between trajectories in  $Q$  and  $\tilde{Q}$  (see Chapter 3), i.e.

$$\phi \left( x(t, z^0, u) \right) = \tilde{x}(t, \tilde{z}^0, u),\tag{5.6}$$

making the following diagram commutative (notice, however,  $\pi(z(t, z_0, u)) = x(t, z_0, u)$  depends on  $z_0 = (x_0, y_0)$  consisting of initial configurations *and* velocities):



$$\begin{array}{ccc}
z(t, z^0, u) & \xrightarrow{\Phi} & \tilde{z}(t, \tilde{z}^0, u) \\
\downarrow \pi & & \downarrow \pi \\
x(t, x^0, u) & \xrightarrow{\phi} & \tilde{x}(t, \tilde{x}^0, u)
\end{array}$$

## 5.2 MS-linearization of controllable mechanical systems

A natural question arises, namely when a mechanical system ( $\mathcal{MS}$ ) is MS-equivalent to a linear mechanical system ( $\mathcal{LMS}$ ). We formalize that question as follows.

**Definition 5.2.** A mechanical control systems  $(\mathcal{MS})_{(n,m)} = (Q, \nabla, \mathbf{g}, e)$  is called MS-linearizable if it is MS-equivalent to a linear mechanical system  $(\mathcal{LMS})_{(n,m)} = (\mathbb{R}^n, \bar{\nabla}, \mathbf{b}, E\tilde{x})$ , where  $\bar{\nabla}$  is an affine connection whose all Christoffel symbols are zero (that is,  $\bar{\nabla}$  is a flat connection), and  $\mathbf{b} = (b_1, \dots, b_m)$  is an  $m$ -tuple of constant vector fields. That is, there exists a linearizing diffeomorphism  $\phi : Q \rightarrow \mathbb{R}^n$  such that

$$\begin{aligned}
\phi(x) &= \tilde{x} \\
\phi(\nabla) &= \bar{\nabla} \\
\phi_* g_r &= b_r \quad \text{for } 1 \leq r \leq m \\
\phi_* e &= E\tilde{x}.
\end{aligned}$$

The linearizing diffeomorphism  $\phi$  that maps the 4-tuples, induces the mechanical diffeomorphism  $\Phi : \text{T}Q \rightarrow \text{T}\mathbb{R}^n$  that maps corresponding control system (5.1) (equivalently, (5.2)) into the linear control system of the form

$$\begin{aligned}
\dot{\tilde{x}} &= \tilde{y} \\
\dot{\tilde{y}} &= E\tilde{x} + \sum_{r=1}^m b_r u_r,
\end{aligned}$$

or equivalently (4.3). That is, the mechanical diffeomorphism  $\Phi = (\phi(x), D\phi(x)y)$  transforms  $\Phi_* F = (y, E\tilde{x})^T$ , (i.e.  $\bar{\Gamma}_{jk}^i = 0$ , and  $\tilde{e}(\tilde{x})$  is a linear vector field  $E\tilde{x}$ ), and  $\Phi_* G_r = (0, b_r)^T$ , for  $1 \leq r \leq m$ , are constant vector fields.

**Remark 5.3.** All mechanical linearization problems in this thesis (formulated in this and the next chapter) are considered locally around  $(x_0, y_0)$ . Moreover we assume that the point  $(x_0, y_0)$ , around which the linearization is performed, is an equilibrium of the system  $F(x_0, y_0) = 0$  and  $\phi(x_0) = 0$ . Without these technical assumptions all results still hold however the resultant linear mechanical system ( $\mathcal{LMS}$ ) is modified by adding a constant vector  $d$ , i.e.  $\ddot{x} = Ex + Bu + d$ .

An answer to the mechanical state-space linearization problem was formulated in [40] for mechanical systems with dissipative forces that are MS-linearizable to controllable mechanical systems. A natural slight modification for ( $\mathcal{MS}$ ) can be formulated as follows.

Recall that the vertical distribution of (5.1) is  $\mathcal{V} = \text{span} \left\{ \frac{\partial}{\partial y^1}, \dots, \frac{\partial}{\partial y^n} \right\}$ , see Section 2.2.

**Theorem 5.4.** A mechanical control system ( $\mathcal{MS}$ ) is, locally around  $(x_0, y_0) \in \text{T}Q$ , MS-linearizable to a linear controllable mechanical control system ( $\mathcal{LMS}$ ) if and only if it satisfies, in a neighbourhood of  $(x_0, y_0)$ , the following conditions

$$(MS1) \dim \text{span} \{ad_F^q G_r, 0 \leq q \leq 2n-1, 1 \leq r \leq m\} = 2n$$

$$(MS2) [ad_F^p G_r, ad_F^q G_s] = 0 \quad \text{for } 0 \leq p, q \leq 2n, 1 \leq r, s \leq m$$

$$(MS3) \mathcal{V} = \text{span} \{ad_F^{2i} G_r, 0 \leq i \leq n-1, 1 \leq r \leq m\}$$

The first two conditions describe S-linearizable control systems  $\Sigma$  (with no a priori mechanical structure). The third one is a compatibility condition that assures that, first, the linear equivalent system has a mechanical structure and, second, that the linearizing transformation is mechanical. Those conditions are expressed in terms of the second order vector fields on  $TQ$ , i.e.  $F, G, ad_F^i G_r \in \mathfrak{X}(TQ)$ . Moreover, in order to verify those conditions one needs to compute brackets up to  $2n$ . Therefore it would be convenient to use object on  $Q$  only, as suggested in Chapter 3.

Recall that given a connection  $\nabla$ , we denote by  $\langle X : Y \rangle$  the symmetric bracket of vector fields  $X, Y \in \mathfrak{X}(Q)$  given by  $\langle X : Y \rangle = \nabla_X Y + \nabla_Y X$ , see Section 2.2.

**Theorem 5.5.** *A mechanical control system  $(\mathcal{MS})$  is, locally around  $x_0 \in Q$ , MS-linearizable to a linear controllable mechanical control system  $(\mathcal{LMS})$  if and only if it satisfies, in a neighbourhood of  $x_0$ , the following conditions:*

$$(MS1)' \dim \text{span} \{ad_e^q g_r, 0 \leq q \leq n-1, 1 \leq r \leq m\} = n,$$

$$(MS2)' [ad_e^p g_r, ad_e^q g_s] = 0 \quad \text{for } 0 \leq p, q \leq n, 1 \leq r, s \leq m,$$

$$(MS3)' \langle ad_e^j g_r : ad_e^k g_s \rangle = 0 \quad \text{for } 0 \leq j, k \leq n, 1 \leq r, s \leq m.$$

*Proof.* Necessity. For any controllable  $(\mathcal{LMS})_{(n,m)}$ , with  $\tilde{e} = E\tilde{x}$  and  $\tilde{g}_r = b_r$ , we have  $(MS1)'$  is satisfied by Lemma 4.2. The vector fields are constant

$$ad_{\tilde{e}}^q \tilde{g}_r = (-1)^q E^q b_r,$$

and the Christoffel symbols are zero, therefore  $(MS2)'$  and  $(MS3)'$  are satisfied for the linear system  $(\mathcal{LMS})$ . Conditions are defined geometrically, thus are invariant by the diffeomorphism  $\phi$ , proving that  $(MS1)' - (MS3)'$  are necessary for MS-linearization.

Sufficiency. Consider the set of vector fields

$$ad_e^q g_r, 0 \leq q \leq n-1, 1 \leq r \leq m$$

By  $(MS1)'$  and  $(MS2)'$  we can select  $n$  vector fields  $v_1, \dots, v_n$  independent around  $x_0$ , that satisfy

$$[v_i, v_j] = 0.$$

Therefore we can locally simultaneously rectify them by a diffeomorphism  $\tilde{x} = \phi(x)$

$$\phi_* v_i = \frac{\partial}{\partial \tilde{x}^i} \quad \text{for } 1 \leq i \leq n,$$

and we calculate

$$\left[ \phi_* g_r, \frac{\partial}{\partial \tilde{x}^i} \right] = [\phi_* g_r, \phi_* v_i] = \phi_* [g_r, v_i] = 0,$$

therefore  $\phi_* g_r = b_r$  is constant.

$$\left[ \left[ \frac{\partial}{\partial \tilde{x}^i}, \phi_* e \right], \frac{\partial}{\partial \tilde{x}^j} \right] = [[\phi_* v_i, \phi_* e], \phi_* v_j] = \phi_* [[v_i, e], v_j] = 0,$$

so  $\phi_*e = E\tilde{x} + c$  is affine. Since  $F(x_0, y_0) = 0$  (see Remark 5.3) it follows that  $e(x_0) = 0$  and, by  $\phi(x_0) = 0$ , we have  $\phi_*e = E\tilde{x}$ .

Next, we calculate the symmetric product

$$\left\langle \frac{\partial}{\partial \tilde{x}^j} : \frac{\partial}{\partial \tilde{x}^k} \right\rangle = \tilde{\nabla}_{\frac{\partial}{\partial \tilde{x}^j}} \frac{\partial}{\partial \tilde{x}^k} + \tilde{\nabla}_{\frac{\partial}{\partial \tilde{x}^k}} \frac{\partial}{\partial \tilde{x}^j} = \left( \tilde{\Gamma}_{jk}^i + \tilde{\Gamma}_{kj}^i \right) \frac{\partial}{\partial \tilde{x}^i} = 0$$

therefore in  $\tilde{x}$ -coordinates the Christoffel symbols vanish (recall that  $\tilde{\nabla}$  is symmetric, i.e.  $\tilde{\Gamma}_{jk}^i = \tilde{\Gamma}_{kj}^i$ ). Hence, by Definition 5.1 we result with controllable  $(\mathcal{LMS})_{(n,m)}$ .  $\square$

### 5.3 MS-linearization of non-controllable mechanical systems

In this section, we present a new result concerning MS-linearization of  $(\mathcal{MS})$  without controllability assumption. We motivate our result by the following example

**Example Non-controllable  $(\mathcal{MS})$ .** Consider the following  $(\mathcal{MS})$  on  $\text{TQ} = \mathbb{R}^2 \times \mathbb{R}^2$

$$\begin{aligned} \dot{x}^1 &= y^1 \\ \dot{x}^2 &= y^2 \\ \dot{y}^1 &= -2y^1y^2 - x^1y^2y^2 + x^1 - x^1u \\ \dot{y}^2 &= u, \end{aligned} \tag{5.7}$$

where  $F = y^1 \frac{\partial}{\partial x^1} + y^2 \frac{\partial}{\partial x^2} + (-2y^1y^2 - x^1y^2y^2 + x^1) \frac{\partial}{\partial y^1}$  and  $G = -x^1 \frac{\partial}{\partial y^1} + \frac{\partial}{\partial y^2}$ . Calculate

$$\begin{aligned} ad_e g &= 0 \\ ad_F G &= x^1 \frac{\partial}{\partial x^1} - \frac{\partial}{\partial x^2} + y^1 \frac{\partial}{\partial y^1} \\ ad_F^2 G &= ad_F^3 G = 0. \end{aligned}$$

and therefore neither  $(MS1)$  of Theorem 5.4 nor  $(MS1)'$  of Theorem 5.5 is satisfied. Actually, the system (5.7) is not accessible (all reachable sets have empty interior) because the dimension of the accessibility Lie algebra evaluated at  $(x, y) \in \text{TQ}$  does not exceed 3 (see [17], [32]).

We can introduce, however, the following mechanical diffeomorphism

$$\begin{aligned} \tilde{x}^1 &= x^1 \exp(x^2) & \tilde{y}^1 &= \exp(x^2)y^1 + x^1 \exp(x^2)y^2 \\ \tilde{x}^2 &= x^2 & \tilde{y}^2 &= y^2 \end{aligned} \tag{5.8}$$

that transforms the system into the following  $(\mathcal{LMS})$

$$\begin{aligned} \dot{\tilde{x}}^1 &= \tilde{y}^1 \\ \dot{\tilde{x}}^2 &= \tilde{y}^2 \\ \dot{\tilde{y}}^1 &= \exp(x^2) \left[ 2y^1y^2 + \dot{y}^1 + x^1 (y^2y^2 + \dot{y}^2) \right] = x^1 \exp(x^2) = \tilde{x}^1 \\ \dot{\tilde{y}}^2 &= u. \end{aligned}$$

Note that the resultant  $(\mathcal{LMS})$  system is linear although clearly non-controllable.

It is somehow remarkable, that the problem of mechanical linearization can be solved with no controllability assumption, as formulated by the following theorem. As it turns out that the crucial operator is the total covariant derivative  $\nabla$ , the notion of parallel vector fields on  $Q$ , and the Riemann tensor  $R$ . The importance of vanishing of the Riemann tensor has been already noticed by Bedrossian and Spong [2], [3], [44]. However, in their version of the linearization problem, only Christoffel symbols  $\Gamma_{jk}^i$  are required to vanish (while  $e$  and  $g_r$  are arbitrary, possibly nonlinear). We present the conditions that result in linearization of the whole mechanical system ( $\mathcal{MS}$ ). In Section 7.1, we present examples that show the difference between these two approaches.

**Theorem 5.6.** *A mechanical control system ( $\mathcal{MS}$ ) is, locally around  $x_0 \in Q$ , MS-linearizable to a linear, possibly non-controllable, mechanical control system ( $\mathcal{LMS}$ ) if and only if it satisfies, around  $x_0$ , the following conditions:*

$$(MNS1) \quad R = 0,$$

$$(MNS2) \quad \nabla g_r = 0 \quad \text{for } 1 \leq r \leq m,$$

$$(MNS3) \quad \nabla^2 e = 0.$$

*Proof.* Necessity. Assume that there exist a diffeomorphism  $\tilde{x} = \phi(x)$  that maps ( $\mathcal{MS}$ ) into ( $\mathcal{LMS}$ ), that is  $\phi_* e = \tilde{e} = E\tilde{x}$ ,  $\phi_* g_r = \tilde{g}_r = b_r$  and the connection  $\tilde{\nabla} = \phi(\nabla)$  is flat, i.e.  $\tilde{\Gamma}_{jk}^i = 0$ . Therefore we have

$$\begin{aligned} \tilde{R} &= 0 \\ \tilde{\nabla} \tilde{g}_r &= \frac{\partial \tilde{g}_r^i}{\partial \tilde{x}^j} = \frac{\partial b_r^i}{\partial \tilde{x}^j} = 0 \\ \tilde{\nabla}^2 \tilde{e} &= \frac{\partial^2 \tilde{e}^i}{\partial \tilde{x}^j \partial \tilde{x}^k} = \frac{\partial^2 E^i \tilde{x}}{\partial \tilde{x}^j \partial \tilde{x}^k} = 0. \end{aligned}$$

All objects are defined geometrically therefore are invariant by the diffeomorphism  $\tilde{x} = \phi(x)$ . It follows that (MNS1) – (MNS3), being satisfied for ( $\mathcal{LMS}$ ), are also satisfied for ( $\mathcal{MS}$ ).

Sufficiency. By (MNS1) there exists a local coordinate system  $\bar{x} = \phi(x)$ , such that Christoffel symbols vanish, i.e.  $\bar{\Gamma}_{jk}^i = 0$ , see Theorem 2.11. In this coordinate system the total covariant derivative simplifies to the Jacobian matrix of partial derivatives. By (MNS2) and (MNS3) we thus have

$$\begin{aligned} \bar{\nabla} \bar{g}_r &= \frac{\partial \bar{g}_r^i}{\partial \bar{x}^j} = 0 \\ \bar{\nabla}^2 \bar{e} &= \frac{\partial^2 \bar{e}^i}{\partial \bar{x}^j \partial \bar{x}^k} = 0, \end{aligned}$$

therefore the control vector fields  $\bar{g}_r$  are constant and the uncontrolled vector field  $\bar{e}$  is linear. Hence, we obtain ( $\mathcal{LMS}$ )<sub>(n,m)</sub>.  $\square$

**Example Non-controllable ( $\mathcal{MS}$ ) cont'd.** *Using the formula for Riemannian tensor (2.10) we calculate  $R = 0$ . Then, using (2.6), we calculate  $\nabla g = 0$  and using formula from Definition 2.13, we calculate  $\nabla^2 e = 0$ . We thus conclude that the system is MS-linearizable which explains the existence of the mechanical linearizing transformation (5.8).*



## Chapter 6

# Mechanical Feedback linearization

### 6.1 MF-equivalence of Mechanical Systems

In this chapter, we formulate and solve the main problem considered in the thesis, i.e. when a mechanical control system can be brought into a linear mechanical form by a mechanical change of coordinates and mechanical feedback. We name this problem *mechanical feedback linearization*, shortly *MF-linearization*, of mechanical control systems ( $\mathcal{MS}$ ). In other words, we ask when the mechanical system ( $\mathcal{MS}$ ) is *mechanical feedback equivalent* (MF-equivalent) to the linear mechanical system ( $\mathcal{LMS}$ ) preserving the structure of the tangent bundle TQ.

Recall that, a mechanical control system ( $\mathcal{MS}$ )<sub>(m,n)</sub> in local coordinates reads

$$\begin{aligned}\dot{x}^i &= y^i \\ \dot{y}^i &= -\Gamma_{jk}^i(x)y^j y^k + e^i(x) + \sum_{r=1}^m g_r^i(x)u_r.\end{aligned}\tag{6.1}$$

or, equivalently, using coordinates  $z = (x, y)$

$$\dot{z} = F(z) + \sum_{r=1}^m G_r(z)u_r,\tag{6.2}$$

where:

$$F = S + e^{vlift} = y^i \frac{\partial}{\partial x^i} + \left(-\Gamma_{jk}^i(x)y^j y^k + e^i(x)\right) \frac{\partial}{\partial y^i}, \quad G_r = g_r^{vlift} = g_r^i(x) \frac{\partial}{\partial y^i},$$

where  $S = y^i \frac{\partial}{\partial x^i} - \Gamma_{jk}^i(x)y^j y^k \frac{\partial}{\partial y^i}$  is the geodesic spray, and  $e^{vlift} = e^i(x) \frac{\partial}{\partial y^i}$  and  $g_r^{vlift} = g_r^i(x) \frac{\partial}{\partial y^i}$  are vertical lifts (see Chapter 3).

**Definition 6.1.** Let *MF* be a group of transformations generated by:

(i) *changes of coordinates given by diffeomorphisms*

$$\begin{aligned}\phi: \quad Q &\rightarrow \tilde{Q} \\ x &\mapsto \tilde{x} = \phi(x),\end{aligned}\tag{6.3}$$

(ii) *mechanical feedback transformations, denoted  $(\alpha, \beta, \gamma)$ , of the form*

$$u_r = \gamma_{jk}^r(x)y^j y^k + \alpha^r(x) + \sum_{s=1}^m \beta_s^r(x)\tilde{u}_s,\tag{6.4}$$

where  $\gamma_{jk}^r = \gamma_{kj}^r$ .

Sometimes, whenever it is convenient, we use the vector notation  $u = y^T \gamma y + \alpha + \beta \tilde{u}$ , where  $u = (u_1, \dots, u_m)^T$ ,  $\tilde{u} = (\tilde{u}_1, \dots, \tilde{u}_m)^T$ ,  $y = (y^1, \dots, y^n)^T$ ,  $\alpha = (\alpha^1, \dots, \alpha^m)^T$ ,  $\beta = (\beta_s^r)$ , and  $\gamma = (\gamma_{jk}^r)$ .

**Proposition 6.2.** *Consider a feedback in form (6.4). Each term  $\gamma^r$  is a symmetric  $(0, 2)$ -tensor field.*

*Proof.* By definition,  $u_r$  is scalar and  $y \in T_x Q$ . It is immediate to see that

$$\gamma^r(x) : T_x Q \times T_x Q \rightarrow \mathbb{R}.$$

Now, take the diffeomorphism (6.3) that induces the following transformation on  $TQ$  and its inverse given by

$$\begin{aligned} \tilde{x} &= \phi(x) & \text{and} & & x &= \phi^{-1}(\tilde{x}) \\ \tilde{y}^i &= \frac{\partial \tilde{x}^i}{\partial x^j} y^j & & & y^j &= \frac{\partial x^j}{\partial \tilde{x}^i} \tilde{y}^i \end{aligned}$$

The feedback transformation (6.4) expressed in the new coordinates, given by transformations (6.3), reads as

$$\begin{aligned} u_r &= u_r(\tilde{x}, \tilde{u}) = \gamma_{jk}^r(\phi^{-1}(\tilde{x})) \frac{\partial x^j}{\partial \tilde{x}^i} \tilde{y}^i \frac{\partial x^k}{\partial \tilde{x}^l} \tilde{y}^l + \alpha^r(\phi^{-1}(\tilde{x})) + \sum_{s=1}^m \beta_s^r(\phi^{-1}(\tilde{x})) \tilde{u}_s = \\ &= \tilde{\gamma}_{il}^r(\tilde{x}) \tilde{y}^i \tilde{y}^l + \alpha^r(\tilde{x}) + \sum_{s=1}^m \beta_s^r(\tilde{x}) \tilde{u}_s. \end{aligned}$$

Hence

$$\tilde{\gamma}_{il}^r = \frac{\partial x^j}{\partial \tilde{x}^i} \frac{\partial x^k}{\partial \tilde{x}^l} \gamma_{jk}^r, \quad (6.5)$$

which is the transformation rule of a  $(0, 2)$ -tensor. The purpose of the term  $\gamma_{jk}^r(x) y^j y^k$  is to change Christoffel symbols which are symmetric, i.e.  $\Gamma_{jk}^i = \Gamma_{kj}^i$ , hence we assumed symmetric tensor  $\gamma_{jk}^r = \gamma_{kj}^r$ .  $\square$

Now we introduce a notion of the mechanical feedback equivalence (MF-equivalence) of two  $(\mathcal{MS})$  and their equations (6.1).

**Definition 6.3.** *Two mechanical control systems  $(\mathcal{MS})_{(n,m)} = (Q, \nabla, \mathfrak{g}, e)$  and  $(\widetilde{\mathcal{MS}})_{(n,m)} = (\tilde{Q}, \tilde{\nabla}, \tilde{\mathfrak{g}}, \tilde{e})$  are mechanical feedback equivalent, shortly MF-equivalent, if there exists a mechanical transformation  $(\phi, \alpha, \beta, \gamma) \in MF$  that maps  $(\mathcal{MS})$  into  $(\widetilde{\mathcal{MS}})$  according to the following transformations*

$$\begin{aligned} \phi : Q &\rightarrow \tilde{Q} & \phi(x) &= \tilde{x} \\ \phi\left(\nabla - \sum_{r=1}^m g_r \otimes \gamma^r\right) &= \tilde{\nabla} \\ \phi_*\left(\sum_{r=1}^m \beta_s^r g_r\right) &= \tilde{g}_s & \text{for } 1 \leq s \leq m \\ \phi_*\left(e + \sum_{r=1}^m g_r \alpha^r\right) &= \tilde{e}. \end{aligned} \quad (6.6)$$

The second transformation rule shows that the modified connection  $\nabla - \sum_{r=1}^m g_r \otimes \gamma^r$  is mapped via  $\phi$  into  $\tilde{\nabla}$ . Equivalently, the Christoffel symbols of the former are changed via (5.3) into those of latter, i.e.  $\phi \left( \Gamma_{jk}^i - \sum_{r=1}^m g_r^i \otimes \gamma_{jk}^r \right) = \tilde{\Gamma}_{jk}^i$ . Moreover, note that

$$\phi \left( \nabla - \sum_{r=1}^m g_r \otimes \gamma^r \right) = \phi(\nabla) - \sum_{r=1}^m \phi_* g_r \otimes \phi^* \gamma^r,$$

where  $\phi^* \gamma^r = \tilde{\gamma}_{il}^r d\tilde{x}^i \otimes d\tilde{x}^l$ , and  $\tilde{\gamma}_{il}^r$  are given by (6.5).

Notice that Definition 6.3 formalizes how a mechanical feedback transformations  $(\phi, \alpha, \beta, \gamma) \in MF$  acts on a 4-tuple  $(Q, \nabla, \mathbf{g}, e)$ . It is crucial to understand how this action prolongs to a transformation of the equations of the mechanical control system (6.1). Any transformation  $(\phi, \alpha, \beta, \gamma) \in MF$  induces the transformations on the equations (6.1) as follows:

$$\begin{aligned} \phi : Q &\rightarrow \tilde{Q} &\implies &\Phi = (\phi, D\phi y) : TQ \rightarrow T\tilde{Q} \\ \alpha : Q &\rightarrow \mathbb{R}^m &\implies &\alpha^{vlift} : TQ \rightarrow \mathbb{R}^m \\ \beta : Q &\rightarrow Gl(m, \mathbb{R}) &\implies &\beta^{vlift} : TQ \rightarrow Gl(m, \mathbb{R}) \\ \gamma : Q &\rightarrow T^*Q \times T^*Q &\implies &\gamma^{vlift} : TQ \rightarrow \mathbb{R}^m. \end{aligned}$$

In other words, the diffeomorphism on  $Q$  induces the mechanical diffeomorphism on  $TQ$  (the extended point transformation) given by  $(\tilde{x}, \tilde{y}) = (\phi(x), D\phi(x)y)$  and the mechanical feedback transformation  $(\alpha, \beta, \gamma)$  gives rise to a triple  $(\alpha^{vlift}, \beta^{vlift}, \gamma^{vlift})$  whose elements are defined using the pull-back of the canonical projection  $\pi(x, y) = x$  (see Chapter 2) for  $\alpha^{vlift}, \beta^{vlift}$  and using an evaluation at  $(y, y)$  for the tensor  $\gamma^r$

$$\begin{aligned} \alpha^{vlift}(x, y) &= \pi^* \alpha(x, y) = \alpha(x) \\ \beta^{vlift}(x, y) &= \pi^* \beta(x, y) = \beta(x) \\ \gamma^{vlift}(x, y) &= y^T \gamma(x) y. \end{aligned}$$

Therefore the drift  $F$  and the control vector fields  $G_r$  of system (6.1), equivalently (6.2), changes under the mechanical feedback as follows

$$\begin{aligned} F &\mapsto F + \sum_{r=1}^m G_r (\pi^* \alpha^r + \gamma^r(y, y)) \\ G_r &\mapsto \sum_{s=1}^m \pi^* \beta_r^s G_s, \end{aligned}$$

where  $\gamma^r(y, y) = y^T \gamma^r y$  is the symmetric  $(0, 2)$ -tensor applied to the pair of vectors  $(y, y)$ . Since we have just shown that, in coordinates,  $(\alpha^{vlift}, \beta^{vlift}, \gamma^{vlift})$  have the same components as  $(\alpha, \beta, \gamma)$ , doing calculations we drop the above notation and use  $(\alpha, \beta, \gamma)$  in both cases, namely applying  $(\alpha, \beta, \gamma)$  to the 4-tuple  $(Q, \nabla, \mathbf{g}, e)$  or to equations (6.1), depending on the context.

**Proposition 6.4.** *The action of the group  $MF$  preserves the mechanical structure of  $(\mathcal{MS})_{(n,m)}$*



*Proof.* We show how  $MF$  transforms a mechanical system of the form (6.1):

$$\begin{aligned}
\dot{\tilde{x}}^i &= \frac{\partial \tilde{x}^i}{\partial x^j} y^j = \tilde{y}^i \\
\dot{\tilde{y}}^i &= \frac{\partial^2 \tilde{x}^i}{\partial x^j \partial x^k} y^j y^k + \frac{\partial \tilde{x}^i}{\partial x^j} \dot{y}^j = \\
&= \frac{\partial^2 \tilde{x}^i}{\partial x^j \partial x^k} y^j y^k + \frac{\partial \tilde{x}^i}{\partial x^j} \left( -\Gamma_{qr}^j y^q y^r + e^j + \sum_{l=1}^m g_l^j u_l \right) = \\
&= \frac{\partial^2 \tilde{x}^i}{\partial x^j \partial x^k} \frac{\partial x^j}{\partial \tilde{x}^p} \tilde{y}^p \frac{\partial x^k}{\partial \tilde{x}^s} \tilde{y}^s + \frac{\partial \tilde{x}^i}{\partial x^j} \left( -\Gamma_{qr}^j \frac{\partial x^q}{\partial \tilde{x}^p} \tilde{y}^p \frac{\partial x^r}{\partial \tilde{x}^s} \tilde{y}^s + e^j + \sum_{l=1}^m g_l^j u_l \right) = \\
&= \frac{\partial^2 \tilde{x}^i}{\partial x^j \partial x^k} \frac{\partial x^j}{\partial \tilde{x}^p} \tilde{y}^p \frac{\partial x^k}{\partial \tilde{x}^s} \tilde{y}^s + \\
&+ \frac{\partial \tilde{x}^i}{\partial x^j} \left( -\Gamma_{qr}^j \frac{\partial x^q}{\partial \tilde{x}^p} \tilde{y}^p \frac{\partial x^r}{\partial \tilde{x}^s} \tilde{y}^s + e^j + \sum_{l=1}^m g_l^j \left( \gamma_{qr}^l \frac{\partial x^q}{\partial \tilde{x}^p} \tilde{y}^p \frac{\partial x^r}{\partial \tilde{x}^s} \tilde{y}^s + \alpha^l + \sum_{t=1}^m \beta_t^l \tilde{u}_t \right) \right) = \\
&= -\tilde{\Gamma}_{ps}^i \tilde{y}^p \tilde{y}^s + \tilde{e}^i + \sum_{t=1}^m \tilde{g}_t^i \tilde{u}_t,
\end{aligned}$$

where:

$$\begin{aligned}
\tilde{\Gamma}_{ps}^i(\tilde{x}) &= -\frac{\partial^2 \tilde{x}^i}{\partial x^j \partial x^k} \frac{\partial x^j}{\partial \tilde{x}^p} \frac{\partial x^k}{\partial \tilde{x}^s} + \frac{\partial \tilde{x}^i}{\partial x^j} \frac{\partial x^q}{\partial \tilde{x}^p} \frac{\partial x^r}{\partial \tilde{x}^s} \left( \Gamma_{qr}^j(x) - \sum_{l=1}^m g_l^j(x) \gamma_{qr}^l(x) \right) \\
\tilde{e}^i(\tilde{x}) &= \frac{\partial \tilde{x}^i}{\partial x^j} \left( e^j(x) + \sum_{l=1}^m g_l^j(x) \alpha^l(x) \right) \\
\tilde{g}_t^i(\tilde{x}) &= \frac{\partial \tilde{x}^i}{\partial x^j} \left( \sum_{l=1}^m g_l^j(x) \beta_t^l(x) \right).
\end{aligned} \tag{6.7}$$

Therefore we obtain a system in the mechanical form (6.1), defined in coordinates  $(\tilde{x}, \tilde{y})$  on  $T\tilde{Q}$ .  $\square$

We have just shown that the mechanical structure of  $(\mathcal{MS})$  is preserved under  $MF$ . Now we want to take a second look at that fact and investigate it further. From (6.6), we see that  $e$  and  $g_r$  change under  $MF$  as vector fields on  $Q$ . For the system (6.1) defined by  $(\mathcal{MS})$  they give rise to  $e^{vlift}, g_r^{vlift} \in \mathfrak{X}(TQ)$ , respectively (see Chapter 3). A natural question is: how are the lifts of MF-equivalent vector fields related? That is, What is the relation between  $e^{vlift}$  and  $\left( \phi_* \left( e + \sum_{r=1}^m g_r \alpha^r \right) \right)^{vlift}$ , as well as,  $g_r^{vlift}$  and  $\left( \phi_* \left( \sum_{s=1}^m \beta_r^s g_s \right) \right)^{vlift}$ .

**Proposition 6.5.** *We have*

(i) *Two control vector fields  $g_r$  and  $\tilde{g}_r$  are related by an MF-transformation, i.e.*

$$\tilde{g}_r = \phi_* \left( \sum_{s=1}^m \beta_r^s g_s \right)$$

*if and only if their vertical lifts  $G_r = g_r^{vlift}$  and  $\tilde{G}_r = \tilde{g}_r^{vlift}$  satisfy*

$$\tilde{G}_r = \tilde{g}_r^{vlift} = \Phi_* \left( \sum_{s=1}^m (\pi^* \beta_r^s) G_s \right),$$

that is, the following diagram commutes

$$\begin{array}{ccc} g_r & \xrightarrow{(\phi, \beta)} & \tilde{g}_r = \phi_* (\beta_r^s g_s) \\ \downarrow \text{vlift} & & \downarrow \text{vlift} \\ G_r = g_r^{\text{vlift}} & \xrightarrow{(\Phi, \pi^* \beta)} & \tilde{g}_r^{\text{vlift}} = \Phi_* (\pi^* \beta_r^s G_s) = \tilde{G}_r. \end{array}$$

(ii) Two uncontrolled vector fields  $e$  and  $\tilde{e}$  are related by an MF-transformation, i.e.

$$\tilde{e} = \phi_* \left( e + \sum_{r=1}^m g_r \alpha^r \right)$$

if and only if their vertical lifts  $e = e^{\text{vlift}}$  and  $\tilde{e} = \tilde{e}^{\text{vlift}}$  satisfy

$$\tilde{e}^{\text{vlift}} = \Phi_* \left( e^{\text{vlift}} + \sum_{r=1}^m g_r^{\text{vlift}} \pi^* \alpha^r \right),$$

that is the following diagram commutes

$$\begin{array}{ccc} e & \xrightarrow{(\phi, \alpha)} & \tilde{e} = \phi_* (e + g_r \alpha^r) \\ \downarrow \text{vlift} & & \downarrow \text{vlift} \\ e^{\text{vlift}} & \xrightarrow{(\Phi, \pi^* \alpha)} & \tilde{e}^{\text{vlift}} = \Phi_* (e^{\text{vlift}} + g_r^{\text{vlift}} \pi^* \alpha^r) \end{array}$$

(iii) Two connections  $\nabla$  and  $\tilde{\nabla}$  are related by an MF-transformation, i.e.

$$\tilde{\nabla} = \phi(\nabla - \sum_{r=1}^m g_r \otimes \gamma^r)$$

if and only if their geodesic sprays  $S$  and  $\tilde{S}$  satisfy

$$\tilde{S} = \Phi_* \left( y^i \frac{\partial}{\partial x^i} + (-\Gamma_{jk}^i + \sum_{r=1}^m G_r^i \gamma_{jk}^r) y^j y^k \right),$$

*Proof.* (i) By direct calculations in coordinates we have

$$\tilde{g}_r = \phi_* \left( \sum_{s=1}^m \beta_r^s g_s \right) = \sum_{s=1}^m \frac{\partial \tilde{x}^i}{\partial x^j} g_s^j \beta_r^s \frac{\partial}{\partial \tilde{x}^i}$$

and then

$$\tilde{g}_r^{\text{vlift}} = \sum_{s=1}^m \frac{\partial \tilde{x}^i}{\partial x^j} g_s^j \beta_r^s \frac{\partial}{\partial \tilde{y}^i}$$

On the other hand, for  $g_s = g_s^j \frac{\partial}{\partial x^j}$ , we have  $G_s = g_s^{vlift} = g_s^j(x) \frac{\partial}{\partial y^j}$ , and since  $(\pi^* \beta_r^s)(x, y) = \beta_r^s(x)$ , we conclude

$$\Phi_* \left( g_s^{vlift} \pi^* \beta_r^s \right) = \Phi_* \left( g_s^j(x) \beta_r^s(x) \frac{\partial}{\partial y^j} \right) = \frac{\partial \tilde{x}^i}{\partial x^j} g_s^j \beta_r^s \frac{\partial}{\partial y^i},$$

which is  $\tilde{g}_r^{vlift}$ .

Proofs of (ii) and (iii) follow exactly the same line.  $\square$

## 6.2 MF-equivalence of mechanical distributions

According to Definition 6.3, MF-transformations act on the vector fields  $g_r$  and  $e$  via the triple  $(\phi, \alpha, \beta)$  (the tensor  $\gamma$  does not act on them) and thus we can analyse how MF-transformations act on their iterative Lie brackets  $ad_e^i g_r$  and the distributions

$$\begin{aligned} \mathcal{E}^0 &= \text{span} \{g_r, 1 \leq r \leq m\} \\ \mathcal{E}^j &= \text{span} \left\{ ad_e^i g_r, 1 \leq r \leq m, 0 \leq i \leq j \right\}. \end{aligned} \quad (6.8)$$

In particular, we are interested in MF-invariant properties of these distributions. It turns out that involutivity is an MF-invariant property.

**Lemma 6.6.** *If the distributions  $\mathcal{E}^j$  are involutive, then they are invariant under any triple  $(\phi, \alpha, \beta) = (Id, \alpha, \beta)$ .*

*Proof.* The proof is analogous to the classical one that assures involutivity of linearizability distributions  $\mathcal{D}^j$  (see [32]) but for completeness of exposition we will present it below. The distributions  $\mathcal{E}^j$  are invariant under  $(Id, \alpha, \beta)$  if  $\mathcal{E}^j = \tilde{\mathcal{E}}^j$ , where  $\tilde{\mathcal{E}}^j = \text{span} \{ ad_{\tilde{e}}^i \tilde{g}_s, 1 \leq s \leq m, 0 \leq i \leq j \}$  and  $\tilde{e}, \tilde{g}_s$  are given by (6.6). The invariance under identity map is trivial. Therefore we need to prove that they are also invariant under the feedback  $(\alpha, \beta)$ . The equality  $\mathcal{E}^0 = \tilde{\mathcal{E}}^0$  is straightforward

$$\tilde{\mathcal{E}}^0 = \text{span} \{ \tilde{g}_s, 1 \leq s \leq m \} = \text{span} \left\{ \sum_{r=1}^m \beta_r^s g_r, 1 \leq r \leq m \right\} = \mathcal{E}^0.$$

To prove by the induction, assume that it holds for certain  $k$ , i.e.  $\mathcal{E}^k = \tilde{\mathcal{E}}^k$ . Then,

$$ad_{\tilde{e}}^{k+1} \tilde{g}_s = \left[ e + \sum_{r=1}^m g_r \alpha^r, ad_{\tilde{e}}^k \tilde{g}_s \right] = \left[ e, ad_{\tilde{e}}^k \tilde{g}_s \right] + \sum_{r=1}^m \alpha^r \left[ g_r, ad_{\tilde{e}}^k \tilde{g}_s \right] - \sum_{r=1}^m \left( L_{ad_{\tilde{e}}^k \tilde{g}_s} \alpha^r \right) g_r.$$

Since, by the induction assumption,  $ad_{\tilde{e}}^k \tilde{g}_s \in \mathcal{E}^k$ , the bracket  $\left[ e, ad_{\tilde{e}}^k \tilde{g}_s \right] \in \mathcal{E}^{k+1}$  by the definition of  $\mathcal{E}^{k+1}$ . Moreover, since  $\mathcal{E}^k = \tilde{\mathcal{E}}^k$  is assumed involutive,  $\alpha^r \left[ g_r, ad_{\tilde{e}}^k \tilde{g}_s \right] \in \mathcal{E}^k$  and  $\left( L_{ad_{\tilde{e}}^k \tilde{g}_s} \alpha^r \right) g_r \in \mathcal{E}^0 \subset \mathcal{E}^k$ . Therefore,  $ad_{\tilde{e}}^{k+1} \tilde{g}_s \in \mathcal{E}^{k+1}$ , thus  $\tilde{\mathcal{E}}^{k+1} \subset \mathcal{E}^{k+1}$ . To prove the converse inclusion, calculate

$$ad_e^{k+1} g_s = \left[ \tilde{e} - \sum_{r=1}^m g_r \alpha^r, ad_e^k g_s \right] = \left[ \tilde{e}, ad_e^k g_s \right] - \sum_{r=1}^m \alpha^r \left[ g_r, ad_e^k g_s \right] + \sum_{r=1}^m \left( L_{ad_e^k g_s} \alpha^r \right) g_r.$$

Again, by definition  $\left[ \tilde{e}, ad_e^k g_s \right] \in \tilde{\mathcal{E}}^{k+1}$ ,  $\alpha^r \left[ g_r, ad_e^k g_s \right] \in \mathcal{E}^k$ , and  $\sum_{r=1}^m \left( L_{ad_e^k g_s} \alpha^r \right) g_r \in \mathcal{E}^0$ . So we have,  $ad_e^{k+1} g_s \in \tilde{\mathcal{E}}^{k+1} = \mathcal{E}^{k+1}$ .  $\square$

**Corollary 6.7.** *The involutivity of  $\mathcal{E}^j$  is preserved under MF.*

*Proof.* The above Lemma shows that the involutivity of  $\mathcal{E}^j$  is preserved by  $(Id, \alpha, \beta)$ . The property is also preserved under any diffeomorphism  $\phi$  (and thus preserved by the whole transformation MF) since Lie brackets are compatible with diffeomorphisms (see Section 2.1.2).  $\square$

What directly follows from the above Lemma, is a formula that links generators of the involutive distribution  $\tilde{\mathcal{E}}^j$  with generators of  $\mathcal{E}^j$ , namely

$$ad_{\tilde{e}}^k \tilde{g}_r = \sum_{s=1}^m \sum_{i=0}^k \eta_{ri}^{ks} ad_e^i g_s, \quad (6.9)$$

i.e. they are linear combinations of  $ad_e^i g_s$ , for  $0 \leq i \leq k$  and  $1 \leq s \leq m$ , with structural functions  $\eta_{ri}^{ks} \in C^\infty(Q)$  satisfying  $\eta_{rk}^{ks} = \beta_r^s$ . In a compact form, we can formulate it as

$$ad_{\tilde{e}}^j \tilde{g}_r = \sum_{s=1}^m \beta_r^s ad_e^j g_s + d^{j-1}, \quad (6.10)$$

where  $d^{j-1} \in \mathcal{E}^{j-1}$  or, equivalently,  $ad_{\tilde{e}}^j \tilde{g}_r = \sum_{s=1}^m \beta_r^s ad_e^j g_s \pmod{\mathcal{E}^{j-1}}$ .

Finally, we formulate a result that describes simultaneous rectification of suitably chosen generators of the distribution  $\mathcal{E}^0$  and those of their lifts.

**Lemma 6.8.** *Let  $\mathcal{E}^0$  be an involutive distribution of constant rank on  $Q$ . There exists a (local) diffeomorphism  $\tilde{x} = \phi(x)$  and an invertible change of controls  $u = \beta \tilde{u}$ , such that  $\tilde{g}_r = \frac{\partial}{\partial \tilde{x}^r}$ , where  $\tilde{g}_r = \phi_* \left( \sum_{s=1}^m \beta_r^s g_s \right)$  and the corresponding extended point transformation  $\Phi : TQ \rightarrow T\tilde{Q}$  and the same change of controls  $u = \beta \tilde{u}$  yields  $\tilde{G}_r = \frac{\partial}{\partial \tilde{y}^r}$ , where  $\tilde{G}_r = \Phi_* \left( \sum_{s=1}^m \beta_r^s G_s \right)$  and  $G_r = g_r^{vlift}$ .*

*Proof.* By Rectification Procedure (see Chapter 2), there exist  $(\phi, \beta)$  that rectifies  $\mathcal{E}^0$ , i.e.  $\tilde{g}_r = \frac{\partial}{\partial \tilde{x}^r}$ . Then, by Proposition 6.5, the transformation  $(\Phi, \beta)$  is such that  $\tilde{G}_r = \frac{\partial}{\partial \tilde{y}^r}$ .  $\square$

## 6.3 MF-linearization of controllable Mechanical Systems

### 6.3.1 Normalization of $(\mathcal{MS})$

We start our considerations by establishing a normal form for mechanical control systems. We state conditions under which the system is MF-equivalent to a nonlinear system, where the  $(m+1)$ -tuple  $(e, g_r)$  is controllable, whose control vector fields  $G_r = g_r^{vlift}$  are constant,  $e^{vlift}$  is linear and the system is in the following special form

$$\begin{aligned} \dot{x}^{i,l} &= y^{i,l} \\ \dot{y}^{i,l} &= -\Gamma_{jk}^{i,l} y^j y^k + x^{i,l+1} \quad \text{for } 1 \leq l \leq \bar{\rho}_i - 1 \\ \dot{x}^{i,\bar{\rho}_i} &= y^{i,\bar{\rho}_i} \\ \dot{y}^{i,\bar{\rho}_i} &= u_i, \end{aligned} \quad (6.11)$$

for  $1 \leq i \leq m$ , where  $\bar{\rho}_1 \geq \dots \geq \bar{\rho}_m$  are mechanical half-indices.

The conditions under which  $(\mathcal{MS})$  is MF-equivalent to (6.11) are formulated in the following lemma.

**Lemma 6.9.** *A mechanical system  $(\mathcal{MS})_{(n,m)}$  is (locally) MF-equivalent to the normal form (6.11) if and only if*

$$(MN1) \dim \mathcal{E}^{n-1}(x_0) = n,$$

$$(MN2) \mathcal{E}^j(x) \text{ are involutive and of constant rank, for } 0 \leq j \leq n-2.$$

*Proof.* Consider a mechanical system  $(\mathcal{MS})$  and its corresponding equations (6.1). In order to transform it into normal form (6.11), we attach to  $(\mathcal{MS})$  the virtual control system  $\Sigma$

$$\dot{x} = e(x) + \sum_{r=1}^m g_r(x)v_r,$$

with  $x \in Q$ . Notice that by  $(MN1) - (MN2)$ , the virtual system is F-linearizable, see Theorem 2.21, and e.g. [32]. Therefore there exists a local diffeomorphism  $\phi : Q \rightarrow Q$  and feedback  $v_r = \alpha^r(x) + \sum_{s=1}^m \beta_s^r(x)\tilde{v}_s$  brings  $\Sigma$  into

$$\begin{aligned} \dot{x}^{i,l} &= x^{i,l+1} \\ \dot{x}^{i,\bar{\rho}_i} &= \tilde{v}_i, \end{aligned} \tag{6.12}$$

for  $1 \leq l \leq \bar{\rho}_i - 1$  and  $1 \leq i \leq m$ . Then the mechanical diffeomorphism  $\Phi = (\phi, D\phi y)$ , together with  $u_r = \alpha^r(x) + \sum_{s=1}^m \beta_s^r(x)\tilde{u}_s$  (with the same  $(\alpha, \beta)$  as above) bringing  $(\mathcal{MS})$  into

$$\begin{aligned} \dot{x}^{i,l} &= y^{i,l} \\ \dot{y}^{i,l} &= -\Gamma_{jk}^{i,l} y^j y^k + x^{i,l+1} \quad \text{for } 1 \leq l \leq \bar{\rho}_i - 1 \\ \dot{x}^{i,\bar{\rho}_i} &= y^{i,\bar{\rho}_i} \\ \dot{y}^{i,\bar{\rho}_i} &= -\Gamma_{jk}^{i,\bar{\rho}_i} y^j y^k + \tilde{u}_i, \end{aligned}$$

We use supplementary feedback  $\tilde{u}_i = u_i + \Gamma_{jk}^{i,\bar{\rho}_i} y^j y^k$  to get normal form (6.11). To show necessity of  $(MN1) - (MN2)$  consider the normal form (6.11). Its virtual system is given by (6.12), for which the distributions  $\mathcal{E}^j = \text{span} \left\{ \frac{\partial}{\partial x^{i,\bar{\rho}_i - k}} \right\}$  for  $0 \leq k \leq j$  and  $1 \leq i \leq m$ , satisfy  $(MN1) - (MN2)$  ( $\mathcal{E}^j$  are involutive and of constant rank because the system is linear and  $\dim \mathcal{E}^{n-1} = n$  since it is controllable). Since involutivity of  $\mathcal{E}^j$  is MF-invariant the conditions are necessary.  $\square$

Note that, in (6.11) the controls affect the last variables, i.e.  $\dot{y}^{i,\bar{\rho}_i} = u_i$ . However, by a simple transformation  $\tilde{x}^{i,1} = x^{i,\bar{\rho}_i}$  and  $\tilde{x}^{i,j+1} = x^{i,\bar{\rho}_i - j}$ , for  $1 \leq j \leq \bar{\rho}_i - 1$ , we can obtain an equivalent normal form where the controls affect the first variables, i.e.

$$\begin{aligned} g_i &= \frac{\partial}{\partial \tilde{x}^{i,1}} \\ ad_e^{j-1} g_i &= (-1)^{j-1} \frac{\partial}{\partial \tilde{x}^{i,j}}, \end{aligned}$$

which reads

$$\begin{aligned}
\dot{\tilde{x}}^{i,1} &= \tilde{y}^{i,1} \\
\dot{\tilde{y}}^{i,1} &= u_i \\
\dot{\tilde{x}}^{i,l} &= \tilde{y}^{i,l} \\
\dot{\tilde{y}}^{i,l} &= -\tilde{\Gamma}_{jk}^{i,l} \tilde{y}^j \tilde{y}^k + \tilde{x}^{i,l-1} \quad \text{for } 2 \leq l \leq \bar{\rho}_i - 1
\end{aligned} \tag{6.13}$$

for  $1 \leq i \leq m$ . We will use this last normal form in our considerations in the following sections.

### 6.3.2 MF-Linearization to controllable ( $\mathcal{LMS}$ )

Now, we define the problem of MF-linearization and formulate one of the main theorems of the thesis.

**Definition 6.10.** *A mechanical control system  $(\mathcal{MS})_{(n,m)} = (Q, \nabla, \mathbf{g}, e)$  is called MF-linearizable if it is MF-equivalent to a linear mechanical system  $(\mathcal{LMS})_{(n,m)} = (\mathbb{R}^n, \bar{\nabla}, \mathbf{b}, E\tilde{x})$ , where  $\bar{\nabla}$  is an affine connection whose all Christoffel symbols are zero (that is,  $\bar{\nabla}$  is a flat connection), and  $\mathbf{b} = \{b_1, \dots, b_m\}$  is an  $m$ -tuple of constant vector fields. That is, there exist  $(\phi, \alpha, \beta, \gamma) \in MF$  such that*

$$\begin{aligned}
\phi : Q &\rightarrow \mathbb{R}^n \quad \phi(x) = \tilde{x} \\
\phi(\nabla - \sum_{r=1}^m g_r \otimes \gamma^r) &= \bar{\nabla} \\
\phi_* \left( \sum_{r=1}^m \beta_s^r g_r \right) &= b_s \quad \text{for } 1 \leq s \leq m \\
\phi_* \left( e + \sum_{r=1}^m g_r \alpha^r \right) &= E\tilde{x}.
\end{aligned}$$

Equivalently, the corresponding mechanical control system (6.1) (or (6.2)) is transformed into a linear mechanical system  $(\mathcal{LMS})_{(n,m)}$  of the form

$$\begin{aligned}
\dot{\tilde{x}} &= \tilde{y} \\
\dot{\tilde{y}} &= E\tilde{x} + \sum_{s=1}^m b_s u_s.
\end{aligned}$$

That is, there exist a mechanical transformation  $(\Phi, \alpha, \beta, \gamma)$  such that

$\Phi_* \left( F + \sum_{r=1}^m G_r (y^T \gamma^r y + \alpha^r) \right) = (\tilde{y}, E\tilde{x})^T$  is linear, and  $\Phi_* \left( \sum_{r=1}^m G_r \beta_s^r \right) = (0, b_s)^T$ , for  $1 \leq s \leq m$ , are constant vector fields.

**Theorem 6.11.** *Assume  $n \geq 3$ . A mechanical control system  $(\mathcal{MS})_{(n,1)}$  is, locally around  $x_0 \in Q$ , MF-linearizable to a controllable  $(\mathcal{LMS})_{(n,1)}$  if and only if it satisfies, in a neighbourhood of  $x_0$ , the following conditions:*

$$(MC1) \quad \text{rank } \mathcal{E}^{n-1} = n,$$

$$(MC2) \quad \mathcal{E}^j \text{ is involutive and of constant rank, for } 0 \leq j \leq n-2,$$

$$(MC3) \quad \nabla_{ad_i^*} g \in \mathcal{E}^0 \quad \text{for } 0 \leq i \leq n-1,$$

$$(MC4) \quad \nabla_{ad_k^* g, ad_l^* g}^2 e \in \mathcal{E}^1 \quad \text{for } 0 \leq k, l \leq n-1,$$

*Proof.* Necessity.

For  $(\mathcal{LMS})_{(n,1)}$ , given by (4.9), we have  $\Gamma_{jk}^i = 0$ ,  $e = Ex$  and  $g = b$ . It follows that  $ad_e^i g = (-1)^i E^i b$  and therefore, using (2.4) and Definition 2.12, we calculate

$$\begin{aligned} \nabla_{ad_e^i g} ad_e^j g &= 0 \\ \nabla_{ad_e^k g, ad_e^j g}^2 e &= 0 \\ \nabla_g e &= Eb. \end{aligned} \tag{6.14}$$

All conditions  $(MC1) - (MC4)$  are expressed in a geometrical way, therefore they are invariant under diffeomorphisms.  $(MC1)$ ,  $(MC2)$  are mechanical feedback invariant by Lemma 6.6. It remains to show that  $(MC3)$  and  $(MC4)$  are invariant under the mechanical feedback  $u = \gamma_{jk}(x)y^j y^k + \alpha(x) + \beta(x)\tilde{u}$ . For the closed-loop system, we have

$$\begin{aligned} \tilde{\nabla} : \tilde{\Gamma}_{jk}^i &= \Gamma_{jk}^i - g^i \gamma_{jk} \\ \tilde{e} &= e + g\alpha \\ \tilde{g} &= g\beta, \end{aligned} \tag{6.15}$$

hence

$$\tilde{\nabla}_X Y = \nabla_X Y - \gamma(X, Y)g = \nabla_X Y \quad \text{mod } \mathcal{E}^0, \quad X, Y \in \mathfrak{X}(Q), \quad \gamma(X, Y) \in C^\infty(Q),$$

therefore

$$\tilde{\nabla}_{ad_{\tilde{e}}^i \tilde{g}} \tilde{g} = \nabla_{ad_{\tilde{e}}^i \tilde{g}} \tilde{g} - \gamma(ad_{\tilde{e}}^i \tilde{g}, \tilde{g})g = \nabla_{ad_{\tilde{e}}^i \tilde{g}} \tilde{g} \quad \text{mod } \mathcal{E}^0.$$

By

$$\nabla_X \tilde{g} = \nabla_X (g\beta) = \nabla_X g + (L_X \beta)g,$$

it follows that instead of calculating  $\nabla_{ad_{\tilde{e}}^i \tilde{g}} \tilde{g}$  it is enough to calculate  $\nabla_{ad_{\tilde{e}}^i \tilde{g}} g$ , since the second term  $(L_X \beta)g \in \mathcal{E}^0$ . By induction, for  $i=0$ ,

$$\nabla_{\tilde{g}} g = \nabla_{(g\beta)} g = \beta \nabla_g g \in \mathcal{E}^0.$$

Assume  $\nabla_{ad_{\tilde{e}}^l \tilde{g}} g \in \mathcal{E}^0$ , for  $0 \leq l \leq i-1$ . Then, by formula (6.10),

$$\nabla_{ad_{\tilde{e}}^i \tilde{g}} g = \nabla_{\beta ad_{\tilde{e}}^i g + d^{i-1} g} g = \beta \nabla_{ad_{\tilde{e}}^i g} g + \nabla_{d^{i-1} g} g \in \mathcal{E}^0,$$

where the first term is in  $\mathcal{E}^0$  by the  $(MC3)$  and the second by the induction assumption. We have thus proved necessity of  $(MC3)$ .

To show necessity of  $(MC4)$  calculate

$$\begin{aligned} \tilde{\nabla}_{X,Y}^2 Z &= \tilde{\nabla}_X \tilde{\nabla}_Y Z - \tilde{\nabla}_{\tilde{\nabla}_X Y} Z = \tilde{\nabla}_X (\nabla_Y Z - \gamma(Y, Z)g) - \tilde{\nabla}_{(\nabla_X Y - \gamma(X, Y)g)} Z = \\ &= \nabla_X \nabla_Y Z - \gamma(X, \nabla_Y Z)g - \left( \gamma(Y, Z) \tilde{\nabla}_X g + L_X \gamma(Y, Z) g \right) - \\ &= \nabla_{\nabla_X Y} Z + \gamma(\nabla_X Y, Z)g + \gamma(X, Y) \tilde{\nabla}_g Z = \\ &= \nabla_{X,Y}^2 Z - \gamma(Y, Z) \nabla_X g + \gamma(X, Y) \nabla_g Z \quad \text{mod } \mathcal{E}^0. \end{aligned} \tag{6.16}$$

Using the above formula, we get

$$\tilde{\nabla}_{ad_e^k \tilde{g}, ad_e^l \tilde{g}}^2 \tilde{e} = \nabla_{ad_e^k \tilde{g}, ad_e^l \tilde{g}}^2 \tilde{e} - \gamma(ad_e^j \tilde{g}, \tilde{e}) \nabla_{ad_e^k \tilde{g}} \tilde{g} + \gamma(ad_e^k \tilde{g}, ad_e^j \tilde{g}) \nabla_{\tilde{g}} \tilde{e} \quad \text{mod } \mathcal{E}^0.$$

The second term, on the right hand side, is a sum of elements in  $\mathcal{E}^0$  (by (MC3) and its invariance), while the third term is a smooth combination of

$$\begin{aligned} \nabla_{\tilde{g}} \tilde{e} &= \nabla_{(\beta g)} (e + g\alpha) = \beta \nabla_g e + \beta \nabla_g (g\alpha) = \\ &= \beta \nabla_g e + \beta (\alpha \nabla_g g + L_g \alpha g) \in \mathcal{E}^1, \end{aligned}$$

since for (LM) we have  $\nabla_g e = -ad_e g \in \mathcal{E}^1$ .

The first term  $\nabla_{ad_e^k \tilde{g}, ad_e^l \tilde{g}}^2 \tilde{e}$  is, by (6.9) and Definition 2.12 (i), a linear combination with smooth coefficients of  $\nabla_{ad_e^i g, ad_e^l g}^2 \tilde{e}$ , with  $0 \leq i \leq k$  and  $0 \leq l \leq j$ . Thus we calculate

$$\nabla_{ad_e^i g, ad_e^l g}^2 \tilde{e} = \nabla_{ad_e^i g, ad_e^l g}^2 e + \nabla_{ad_e^i g, ad_e^l g}^2 (g\alpha).$$

The first term vanishes since for (LM) we have (6.14). We calculate the second term using Definition 2.12 (iii)

$$\nabla_{ad_e^i g, ad_e^l g}^2 (g\alpha) = \alpha \nabla_{ad_e^i g, ad_e^l g}^2 g + L_{ad_e^i g} \alpha \nabla_{ad_e^l g} g + L_{ad_e^l g} \alpha \nabla_{ad_e^i g} g + \nabla_{ad_e^i g, ad_e^l g}^2 \alpha g \in \mathcal{E}^0.$$

Clearly, the first three terms vanish since (6.14), and the last one is in  $\mathcal{E}^0$ . Summarizing the above calculation, we conclude that

$$\tilde{\nabla}_{ad_e^k \tilde{g}, ad_e^l \tilde{g}}^2 \tilde{e} \in \mathcal{E}^1 = \tilde{\mathcal{E}}^1,$$

which proves necessity of (MC4).

Sufficiency.

By (MC1) – (MC2), see Lemma 6.9, the system (MS) is locally MF-equivalent to

$$\begin{aligned} \dot{x}^1 &= y^1 \\ \dot{y}^1 &= u \\ \dot{x}^i &= y^i \\ \dot{y}^i &= -\Gamma_{jk}^i y^j y^k + x^{i-1} \quad 2 \leq i \leq n, \end{aligned} \tag{6.17}$$

for which  $\Gamma_{jk}^1 = 0$  and  $ad_e^{k-1} g = (-1)^{k-1} \frac{\partial}{\partial x^k}$  and the distributions are

$$\begin{aligned} \mathcal{E}^0 &= \text{span} \{g\} = \text{span} \left\{ \frac{\partial}{\partial x^1} \right\} \\ \mathcal{E}^1 &= \text{span} \{g, ad_e g\} = \text{span} \left\{ \frac{\partial}{\partial x^1}, \frac{\partial}{\partial x^2} \right\}. \end{aligned}$$

Since  $ad_e^{k-1} g = (-1)^{k-1} \frac{\partial}{\partial x^k}$ , we will calculate conditions (MC3) – (MC4) using  $\nabla_k X := \nabla_{\frac{\partial}{\partial x^k}} X = (-1)^{k-1} \nabla_{ad_e^{k-1} g} X$ .

By (MC3) we have, for  $1 \leq k \leq n$ ,

$$\nabla_k g = \sum_{i=2}^n \left( \Gamma_{k1}^i \frac{\partial}{\partial x^i} \right) \in \mathcal{E}^0,$$



implying  $\Gamma_{1k}^i = \Gamma_{k1}^i = 0$  (since the connection defining  $(\mathcal{MS})$  is assumed symmetric).

Next we express  $(MC4)$  for the vector fields of (6.17), for which we have  $ad_e^{k-1}g = (-1)^{k-1} \frac{\partial}{\partial x^k}$  and  $e = e^i \frac{\partial}{\partial x^i} = x^{i-1} \frac{\partial}{\partial x^i}$  (by definition,  $x^0 \equiv 0$ ). It follows (recall the notation  $\partial_k e^i = \frac{\partial e^i}{\partial x^k}$ )

$$\partial_k e^i = \begin{cases} 1 & i = k + 1 \\ 0 & \text{otherwise} \end{cases}$$

and  $\partial_k \partial_j e^i = 0$ .

By Proposition 2.14 (ii), we have  $\nabla_{kj}^2 e^i = \nabla_k \nabla_j e^i$  and by  $(MC4)$  we conclude  $\nabla_{kj}^2 e^i \frac{\partial}{\partial x^i} = (-1)^{k+j} \nabla_{ad_e^{k-1}g, ad_e^{j-1}g}^2 e \in \mathcal{E}^1 = \text{span} \left\{ \frac{\partial}{\partial x^1}, \frac{\partial}{\partial x^2} \right\}$ , and finally, using Proposition 2.14 (i) the condition  $(MC4)$  reads

$$\nabla_{kj}^2 e^i = \left( \partial_k \Gamma_{js}^i \right) e^s + \Gamma_{jk+1}^i + \Gamma_{kj+1}^i + \left( \Gamma_{kl}^i \Gamma_{js}^l - \Gamma_{kj}^l \Gamma_{ls}^i \right) e^s - \Gamma_{kj}^{i-1} = 0, \quad (6.18)$$

for  $3 \leq i \leq n$ , and  $1 \leq j, k \leq n$ .

Now we will repeatedly use (6.18), successively, for  $j = 1, 2, \dots, n$ , and all  $1 \leq k \leq n$ .

For  $j = 1$ , we employ that from  $(MC3)$  we already concluded  $\Gamma_{1k}^i = \Gamma_{k1}^i = 0$ , and thus (6.18) gives

$$\nabla_{k1}^2 e^i = \Gamma_{k2}^i = 0$$

implying  $\Gamma_{2k}^i = \Gamma_{k2}^i = 0$ , for  $3 \leq i \leq n$ .

For  $j = 2$  and  $3 \leq i \leq n$  we conclude, using (6.18) and  $\Gamma_{2k}^i = \Gamma_{k2}^i = 0$ , for  $3 \leq i \leq n$

$$\nabla_{k2}^2 e^i = \Gamma_{k3}^i + \left( \Gamma_{k2}^i \Gamma_{2s}^2 - \Gamma_{k2}^2 \Gamma_{2s}^i \right) e^s - \Gamma_{k2}^{i-1} = \Gamma_{k3}^i - \Gamma_{k2}^{i-1} = 0$$

implying  $\Gamma_{k3}^i = \Gamma_{k2}^{i-1}$ , which yields

$$\begin{aligned} \Gamma_{k3}^3 &= \Gamma_{k2}^2 \\ \Gamma_{k3}^i &= 0 \quad 4 \leq i \leq n. \end{aligned}$$

To perform the induction step, assume that, for a fixed  $j$ ,

$$\begin{aligned} \Gamma_{kj+1}^{j+1} &= \Gamma_{kj}^j \\ \Gamma_{ks}^i &= 0 \quad j+2 \leq i \leq n, \quad 1 \leq s \leq j+1. \end{aligned} \quad (6.19)$$

For  $j$  replaced by  $j+1$ , equation (6.18) becomes (for all  $i$  satisfying  $j+2 \leq i \leq n$ )

$$\begin{aligned} \nabla_{kj+1}^2 e^i &= \left( \partial_k \Gamma_{j+1s}^i \right) e^s + \Gamma_{j+1k+1}^i + \Gamma_{kj+2}^i + \left( \Gamma_{kl}^i \Gamma_{j+1s}^l - \Gamma_{kj+1}^l \Gamma_{ls}^i \right) e^s - \Gamma_{kj+1}^{i-1} = \\ &= \Gamma_{kj+2}^i + \left( \sum_{l=1}^{j+1} \Gamma_{kl}^i \Gamma_{j+1s}^l - \sum_{l=1}^{j+1} \Gamma_{kj+1}^l \Gamma_{ls}^i \right) e^s - \Gamma_{kj+1}^{i-1} = \Gamma_{kj+2}^i - \Gamma_{kj+1}^{i-1} = 0. \end{aligned}$$

Therefore we have

$$\begin{aligned} \Gamma_{kj+2}^{j+2} - \Gamma_{kj+1}^{j+1} & \quad \text{for } i = j+2 \\ \Gamma_{kj+2}^i &= 0 \quad \text{for } j+3 \leq i \leq n \quad (\text{since } i-1 \geq j+2) \end{aligned}$$

and thus, by the induction assumption

$$\Gamma_{ks}^i = 0 \quad j+3 \leq i \leq n, \quad 1 \leq s \leq j+2.$$

Therefore by the induction argument, (6.19) holds for any  $2 \leq j \leq n-1$ . After performing the recurrence for  $2 \leq j \leq n-1$  we conclude that  $\Gamma_{kn}^n = \Gamma_{kn-1}^{n-1}$  and by previous steps we have

$$\begin{aligned} \Gamma_{nn}^n &= \Gamma_{nn-1}^{n-1} = \Gamma_{nn-2}^{n-2} = \dots = \Gamma_{n2}^2 =: \lambda(x), \\ \Gamma_{kn}^n &= \Gamma_{kn-1}^{n-1} = \Gamma_{kn-2}^{n-2} = \dots = \Gamma_{k2}^2 = 0 \quad 1 \leq k \leq n-1. \end{aligned}$$

It follows that for each  $1 \leq k \leq n-1$  the matrices of Christoffel symbols  $(C_k)^i_j = (\Gamma_{jk}^i)$ , for  $2 \leq i, j \leq n$  are strictly upper triangular, and the last one,  $k = n$ , is upper triangular with all diagonal elements equal to each other, which we denoted by  $\lambda(x)$ . The matrices read

$$(C_k)^i_j = \begin{pmatrix} 0 & \Gamma_{k3}^2 & \Gamma_{k4}^2 & \cdots & \Gamma_{kn-2}^2 & \Gamma_{kn-1}^2 & \Gamma_{kn}^2 \\ 0 & 0 & \Gamma_{k4}^3 & \cdots & \Gamma_{kn-2}^3 & \Gamma_{kn-1}^3 & \Gamma_{kn}^3 \\ & & \ddots & & & & \\ & & & \ddots & & & \\ 0 & 0 & 0 & \cdots & 0 & \Gamma_{kn-1}^{n-2} & \Gamma_{kn}^{n-2} \\ 0 & 0 & 0 & \cdots & 0 & 0 & \Gamma_{kn}^{n-1} \\ 0 & 0 & 0 & \cdots & 0 & 0 & 0 \end{pmatrix},$$

for  $1 \leq k \leq n-1$ , and

$$(C_n)^i_j = \begin{pmatrix} \lambda & \Gamma_{n3}^2 & \Gamma_{n4}^2 & \cdots & \Gamma_{nn-2}^2 & \Gamma_{nn-1}^2 & \Gamma_{nn}^2 \\ 0 & \lambda & \Gamma_{n4}^3 & \cdots & \Gamma_{nn-2}^3 & \Gamma_{nn-1}^3 & \Gamma_{nn}^3 \\ & & \ddots & & & & \\ & & & \ddots & & & \\ 0 & 0 & 0 & \cdots & \lambda & \Gamma_{nn-1}^{n-2} & \Gamma_{nn}^{n-2} \\ 0 & 0 & 0 & \cdots & 0 & \lambda & \Gamma_{nn}^{n-1} \\ 0 & 0 & 0 & \cdots & 0 & 0 & \lambda \end{pmatrix}.$$

Note that, in the above matrices we skip the first row  $\Gamma_{kj}^1$ , and the first column  $\Gamma_{k1}^i$ . This is due the fact that  $\Gamma_{jk}^1 = 0$  (which can always be achieved by a suitable feedback transformation, see Lemma 6.9) and  $\Gamma_{k1}^i = 0$  by (MC3).

Next, we calculate formula (6.18) for  $i = j = n$  only

$$\begin{aligned} \nabla_{kn}^2 e^n &= (\partial_k \Gamma_{ns}^n) e^s + \Gamma_{nk+1}^n + (\Gamma_{kl}^n \Gamma_{ns}^l - \Gamma_{kn}^l \Gamma_{ls}^n) e^s - \Gamma_{kn}^{n-1} = \\ &= (\partial_k \lambda) e^n + \Gamma_{nk+1}^n + (\Gamma_{kn}^n \Gamma_{ns}^n - \Gamma_{kn}^n \Gamma_{ns}^n) e^s - \Gamma_{kn}^{n-1} = \\ &= (\partial_k \lambda) x^{n-1} + \Gamma_{nk+1}^n - \Gamma_{kn}^{n-1} = 0, \end{aligned} \tag{6.20}$$

for which, we will further distinguish two cases. First, if  $1 \leq k \leq n-1$ , then

$$\nabla_{kn}^2 e^n = (\partial_k \lambda) x^{n-1} = 0$$

implying that  $\lambda$  is a function of the last variable  $x^n$  only, i.e.  $\lambda = \lambda(x^n)$ . Then, calculating (6.20) for  $k = n$  gives

$$\nabla_{nn}^2 e^n = (\partial_n \lambda) x^{n-1} - \Gamma_{nn}^{n-1} = 0,$$

implying that  $\Gamma_{nn}^{n-1} = L_e \lambda$ , since  $\frac{\partial \lambda(x^n)}{\partial x^n} x^{n-1} = L_e \lambda$ .

Transform system (6.17) via the local mechanical diffeomorphism  $\Phi : \text{T}Q \rightarrow \text{T}\tilde{Q}$

$$\begin{aligned} \tilde{x} &= \phi(x) \\ \tilde{y} &= D\phi(x)y \end{aligned} \quad \text{where} \quad \phi(x) = \begin{pmatrix} L_e^{n-1} h \\ \vdots \\ L_e h \\ h \end{pmatrix}, \quad (6.21)$$

with

$$\begin{aligned} h(x^n) &= \int_0^{x^n} \Lambda(s_2) ds_2 \\ \Lambda(s_2) &= \exp\left(\int_0^{s_2} \lambda(s_1) ds_1\right). \end{aligned} \quad (6.22)$$

Denote by  $\tilde{\Gamma}_{jk}^i, \tilde{e}, \tilde{g}$  objects of the system expressed in the coordinates  $\tilde{x} = \phi(x)$ . Applying feedback  $\tilde{u} = -\tilde{\Gamma}_{jk}^1 \tilde{y}^j \tilde{y}^k + L_e h + L_g L_e^{n-1} h u$  and thus transformed system becomes

$$\begin{aligned} \dot{\tilde{x}}^1 &= \tilde{y}^1 \\ \dot{\tilde{y}}^1 &= \tilde{u} \\ \dot{\tilde{x}}^i &= \tilde{y}^i \\ \dot{\tilde{y}}^i &= -\tilde{\Gamma}_{jk}^i \tilde{y}^j \tilde{y}^k + \tilde{x}^{i-1} \quad 2 \leq i \leq n, \end{aligned} \quad (6.23)$$

and it is in the normal form (6.11) with "tildas". That is, the vector fields are

$$\begin{aligned} \tilde{e} &= \tilde{x}^{i-1} \frac{\partial}{\partial \tilde{x}^i} \\ \tilde{g} &= \frac{\partial}{\partial \tilde{x}^1}. \end{aligned} \quad (6.24)$$

Now calculate explicitly the evolution of the pair of  $n$ -th transformed coordinates  $(\tilde{x}^n, \tilde{y}^n)$ , we get

$$\begin{aligned} \dot{\tilde{x}}^n &= \frac{d}{dt} h(x^n) = \Lambda(x^n) \dot{x}^n = \Lambda(x^n) y^n = \tilde{y}^n \\ \dot{\tilde{y}}^n &= \frac{d}{dt} (\Lambda(x^n) y^n) = \Lambda(x^n) \lambda(x^n) \dot{x}^n y^n + \Lambda(x^n) \dot{y}^n = \Lambda(x^n) \lambda(x^n) y^n y^n + \Lambda(x^n) \dot{y}^n = \\ &= \Lambda(x^n) \lambda(x^n) y^n y^n + \Lambda(x^n) \left(-\Gamma_{nn}^n(x^n) y^n y^n + x^{n-1}\right) = \Lambda(x^n) x^{n-1} = \tilde{x}^{n-1}, \end{aligned}$$

since  $\tilde{x}^{n-1} = L_e h = \Lambda(x^n) x^{n-1}$ . It follows that  $\tilde{\Gamma}_{jk}^n = 0$ , for all  $1 \leq k, j \leq n$ .

Since formula (6.18) applies to (6.17), we can adopt it to the system (6.23) (which is a special case of the normal form with  $\tilde{\Gamma}_{jk}^n = 0$ ) with  $e$  replaced by  $\tilde{e}$  and  $\Gamma_{jk}^i$  are replaced by  $\tilde{\Gamma}_{jk}^i$ , and  $\partial_i$  denoting now  $\frac{\partial}{\partial \tilde{x}^i}$ . Thus the formula (6.18) becomes

$$\nabla_{kj}^2 \tilde{e}^i = \left(\partial_k \tilde{\Gamma}_{js}^i\right) \tilde{e}^s + \tilde{\Gamma}_{jk+1}^i + \tilde{\Gamma}_{kj+1}^i + \left(\tilde{\Gamma}_{kl}^i \tilde{\Gamma}_{js}^l - \tilde{\Gamma}_{kj}^l \tilde{\Gamma}_{ls}^i\right) \tilde{e}^s - \tilde{\Gamma}_{kj}^{i-1} = 0, \quad (6.25)$$

for  $3 \leq i \leq n$ , and  $1 \leq j, k \leq n$ .

We will analyse (6.25) for  $i = n$  and  $1 \leq j, k \leq n$

$$\begin{aligned}\nabla_{kj}^2 \tilde{e}^n &= \left( \partial_k \tilde{\Gamma}_{js}^n \right) \tilde{e}^s + \tilde{\Gamma}_{jk+1}^n + \tilde{\Gamma}_{kj+1}^n + \left( \tilde{\Gamma}_{kl}^n \tilde{\Gamma}_{js}^l - \tilde{\Gamma}_{kj}^l \tilde{\Gamma}_{ls}^n \right) \tilde{e}^s - \tilde{\Gamma}_{kj}^{n-1} = \\ &= -\tilde{\Gamma}_{kj}^{n-1} = 0\end{aligned}$$

therefore  $\tilde{\Gamma}_{kj}^{n-1} = 0$ . Assume  $\tilde{\Gamma}_{jk}^i = 0$  for  $1 \leq j, k \leq n$ . Then (6.25) implies  $\tilde{\Gamma}_{jk}^{i-1} = 0$ . Therefore we prove that all Christoffel symbols of (6.23) vanish. Therefore the system is a linear controllable ( $\mathcal{LMS}$ ), since the vector field  $\tilde{e}$  is linear and  $\tilde{g}$  is constant and they are given by (6.24).  $\square$

The above theorem does not work in the planar case, i.e. for  $n=2$ . The reason for that is the fact that 2-dimensional case is "too narrow" for involutivity. That is to say, any two independent vector fields on  $\mathbb{R}^2$  span the involutive distribution  $\mathcal{D} = \text{TR}^2$  of rank 2. Therefore we state a proposition for MF-linearization of planar ( $\mathcal{MS}$ ). Also, see [34], for a classification of feedback linearizable ( $\mathcal{MS}$ )<sub>(2,1)</sub>.

**Proposition 6.12.** *A planar mechanical system ( $\mathcal{MS}$ )<sub>(2,1)</sub> is, locally at  $x_0 \in Q$ , MF-linearizable to a controllable linear ( $\mathcal{LMS}$ )<sub>(2,1)</sub> if and only if it satisfies, in a neighbourhood of  $x_0$ , the following conditions:*

(MD1)  $g, ad_e g$  are independent

(MD2)  $\nabla_g g \in \mathcal{E}^0$  and  $\nabla_{ad_e g} g \in \mathcal{E}^0$ ,

(MD3)  $\nabla_{g, ad_e g}^2 ad_e g - \nabla_{ad_e g, g}^2 ad_e g \in \mathcal{E}^0$ .

*Proof.* Necessity. Note that (MD1) is equivalent to (MC1) and (MD2) is (MC3) from Theorem 6.11. Since the necessity part of the proof of Theorem 6.11 works for any  $n \geq 2$ , it shows necessity of (MD1)–(MD2). Therefore we need to show necessity of (MD3). For a controllable ( $\mathcal{LMS}$ ) we have  $\Gamma_{jk}^i = 0$ ,  $g = b$  and  $ad_e g = -Eb$  are independent, and

$$\begin{aligned}\nabla_{ad_e^i g} ad_e^j g &= 0 \\ \nabla_{ad_e^j g, ad_e^k g}^2 ad_e^i g &= 0 \\ \left[ ad_e^j g, ad_e^k g \right] &= 0,\end{aligned}\tag{6.26}$$

for  $0 \leq i, j, k \leq 1$ . We will use formula (6.16) to show that (MD3) is invariant under mechanical feedback. Denote  $\tilde{\nabla}, \tilde{e}, \tilde{g}, \gamma$  as in (6.15). Then we calculate

$$\begin{aligned}\tilde{\nabla}_{\tilde{g}, ad_{\tilde{e}} \tilde{g}}^2 ad_{\tilde{e}} \tilde{g} &= \nabla_{\tilde{g}, ad_{\tilde{e}} \tilde{g}}^2 ad_{\tilde{e}} \tilde{g} - \gamma(ad_{\tilde{e}} \tilde{g}, ad_{\tilde{e}} \tilde{g}) \nabla_{\tilde{g}} \tilde{g} + \gamma(\tilde{g}, ad_{\tilde{e}} \tilde{g}) \nabla_{\tilde{g}} ad_{\tilde{e}} \tilde{g} \quad \text{mod } \mathcal{E}^0 \\ \tilde{\nabla}_{ad_{\tilde{e}} \tilde{g}, \tilde{g}}^2 ad_{\tilde{e}} \tilde{g} &= \nabla_{ad_{\tilde{e}} \tilde{g}, \tilde{g}}^2 ad_{\tilde{e}} \tilde{g} - \gamma(g, ad_{\tilde{e}} \tilde{g}) \nabla_{ad_{\tilde{e}} \tilde{g}} \tilde{g} + \gamma(ad_{\tilde{e}} \tilde{g}, \tilde{g}) \nabla_{\tilde{g}} ad_{\tilde{e}} \tilde{g} \quad \text{mod } \mathcal{E}^0\end{aligned}$$

The second terms of both equations are in  $\mathcal{E}^0$  due to the invariance of (MD2), while the third terms are equal since  $\gamma(X, Y) = \gamma(Y, X)$  is symmetric. Therefore we conclude

$$\tilde{\nabla}_{\tilde{g}, ad_{\tilde{e}} \tilde{g}}^2 ad_{\tilde{e}} \tilde{g} - \tilde{\nabla}_{ad_{\tilde{e}} \tilde{g}, \tilde{g}}^2 ad_{\tilde{e}} \tilde{g} = \nabla_{\tilde{g}, ad_{\tilde{e}} \tilde{g}}^2 ad_{\tilde{e}} \tilde{g} - \nabla_{ad_{\tilde{e}} \tilde{g}, \tilde{g}}^2 ad_{\tilde{e}} \tilde{g} \quad \text{mod } \mathcal{E}^0.$$

Denoting  $ad_{\tilde{e}}\tilde{g} = \beta ad_e g + \eta g$  (hereafter  $\eta := \eta_0^1$ , see (6.9)) and using Definition 2.12 (i), we have

$$\begin{aligned}\nabla_{\tilde{g}, ad_{\tilde{e}}\tilde{g}}^2 ad_{\tilde{e}}\tilde{g} &= \nabla_{\beta g, \beta ad_e g + d^0 g}^2 ad_{\tilde{e}}\tilde{g} = \beta^2 \nabla_{g, ad_e g}^2 ad_{\tilde{e}}\tilde{g} + \beta \eta \nabla_{g, g}^2 ad_{\tilde{e}}\tilde{g} \\ \nabla_{ad_{\tilde{e}}\tilde{g}, \tilde{g}}^2 ad_{\tilde{e}}\tilde{g} &= \nabla_{\beta ad_e g + d^0 g, \beta g}^2 ad_{\tilde{e}}\tilde{g} = \beta^2 \nabla_{ad_e g, g}^2 ad_{\tilde{e}}\tilde{g} + \beta \eta \nabla_{g, g}^2 ad_{\tilde{e}}\tilde{g},\end{aligned}$$

where the last terms are equal, implying

$$\nabla_{\tilde{g}, ad_{\tilde{e}}\tilde{g}}^2 ad_{\tilde{e}}\tilde{g} - \nabla_{ad_{\tilde{e}}\tilde{g}, \tilde{g}}^2 ad_{\tilde{e}}\tilde{g} = \beta^2 \left( \nabla_{g, ad_e g}^2 ad_{\tilde{e}}\tilde{g} - \nabla_{ad_e g, g}^2 ad_{\tilde{e}}\tilde{g} \right)$$

and it remains to prove that

$$\nabla_{g, ad_e g}^2 ad_{\tilde{e}}\tilde{g} - \nabla_{ad_e g, g}^2 ad_{\tilde{e}}\tilde{g} \in \mathcal{E}^0,$$

which we show using Definition 2.12 (iii), where  $X, Y$  stands for either  $g$  or  $ad_e g$

$$\begin{aligned}\nabla_{X, Y}^2 ad_{\tilde{e}}\tilde{g} &= \nabla_{X, Y}^2 (\beta ad_e g + \eta g) = \\ &\beta \nabla_{X, Y}^2 ad_e g + L_X \beta \nabla_Y ad_e g + L_Y \beta \nabla_X ad_e g + \left( \nabla_{X, Y}^2 \beta \right) ad_e g + \\ &+ \eta \nabla_{X, Y}^2 g + L_X \eta \nabla_Y g + L_Y \eta \nabla_X g + \left( \nabla_{X, Y}^2 \eta \right) g = \left( \nabla_{X, Y}^2 \beta \right) ad_e g \pmod{\mathcal{E}^0},\end{aligned}$$

since all  $\nabla_{X, Y}^2 X = 0$  and  $\nabla_X Y = 0$ , see (6.26). Therefore we have

$$\nabla_{g, ad_e g}^2 ad_{\tilde{e}}\tilde{g} - \nabla_{ad_e g, g}^2 ad_{\tilde{e}}\tilde{g} = \left( \nabla_{g, ad_e g}^2 \beta - \nabla_{ad_e g, g}^2 \beta \right) ad_e g \pmod{\mathcal{E}^0}.$$

Finally, we calculate

$$\nabla_{g, ad_e g}^2 \beta - \nabla_{ad_e g, g}^2 \beta = L_g L_{ad_e g} \beta - L_{\nabla_g ad_e g} \beta - \left( L_{ad_e g} L_g \beta - L_{\nabla_{ad_e g} g} \beta \right) = L_{[g, ad_e g]} \beta = 0,$$

which shows necessity of (MD3).

Sufficiency. By (MD1), i.e.  $\text{rank } \mathcal{E}^1 = 2$ , and  $\mathcal{E}^0 = \text{span}\{g\}$  is of constant rank 1 and thus always involutive, the system is locally MF-equivalent to the following form (see Lemma 6.9)

$$\begin{aligned}\dot{x}^1 &= y^1 \\ \dot{y}^1 &= -\Gamma_{jk}^1 y^j y^k + x^2 \\ \dot{x}^2 &= y^2 \\ \dot{y}^2 &= u.\end{aligned}$$

We have  $g = \frac{\partial}{\partial x^2}$ ,  $ad_e g = -\frac{\partial}{\partial x^1}$  and now we calculate

$$\begin{aligned}\nabla_g g &= \Gamma_{22}^1 \frac{\partial}{\partial x^1} \\ \nabla_{ad_e g} g &= \Gamma_{12}^1 \frac{\partial}{\partial x^1},\end{aligned}$$

which by (MD2) are in  $\mathcal{E}^0 = \text{span}\left\{\frac{\partial}{\partial x^2}\right\}$ , implying  $\Gamma_{22}^1 = \Gamma_{12}^1 = \Gamma_{21}^1 = 0$ . It follows

$$\begin{aligned}\nabla_g g &= \nabla_{ad_e g} g = \nabla_g ad_e g = 0 \\ \nabla_{ad_e g} ad_e g &= \Gamma_{11}^1 \frac{\partial}{\partial x^1},\end{aligned}$$

and thus

$$\begin{aligned}\nabla_{g,ad_e g}^2 ad_e g - \nabla_{ad_e g, g}^2 ad_e g &= \nabla_g \nabla_{ad_e g} ad_e g - \nabla_{\nabla_g ad_e g} ad_e g - \nabla_{ad_e g} \nabla_g ad_e g + \nabla_{\nabla_{ad_e g} g} ad_e g = \\ &= \nabla_g \nabla_{ad_e g} ad_e g = \nabla_{\frac{\partial}{\partial x^2}} \Gamma_{11}^1 \frac{\partial}{\partial x^1} = \frac{\partial \Gamma_{11}^1}{\partial x^2} \frac{\partial}{\partial x^1}\end{aligned}$$

implying, by (MD3),  $\frac{\partial \Gamma_{11}^1}{\partial x^2} = 0$ , i.e.  $\Gamma_{11}^1(x^1) = \lambda(x^1)$ .

Now, we transform the system via the local mechanical diffeomorphism  $\Phi : TQ \rightarrow T\tilde{Q}$  (compare (6.21) and (6.22))

$$\begin{aligned}\tilde{x} &= \phi(x) \\ \tilde{y} &= D\phi(x)y\end{aligned}\quad \text{where} \quad \phi(x) = \begin{pmatrix} h \\ L_e h \end{pmatrix},$$

with

$$\begin{aligned}h(x^1) &= \int_0^{x^1} \Lambda(s_2) ds_2 \\ \Lambda(s_2) &= \exp\left(\int_0^{s_2} \lambda(s_1) ds_1\right).\end{aligned}$$

We calculate the evolution of the pair of transformed coordinates  $(\tilde{x}^1, \tilde{y}^1)$ , using  $\frac{d}{dt} h(x^1(t)) = \Lambda(x^1(t)) \dot{x}^1(t)$  and  $\frac{d}{dt} \Lambda(x^1(t)) = \lambda(x^1(t)) \Lambda(x^1(t)) \dot{x}^1(t)$

$$\begin{aligned}\dot{\tilde{x}}^1 &= \frac{d}{dt} h(x^1) = \Lambda(x^1) y^1 = \tilde{y}^1 \\ \dot{\tilde{y}}^1 &= \Lambda(x^1) \lambda(x^1) y^1 y^1 + \Lambda(x^1) \dot{y}^1 = \Lambda(x^1) \lambda(x^1) y^1 y^1 + \Lambda(x^1) (-\lambda(x^1) y^1 y^1 + x^2) = \Lambda(x^1) x^2 = \tilde{x}^2 \\ \dot{\tilde{x}}^2 &= \tilde{y}^2 \\ \dot{\tilde{y}}^2 &= -\tilde{\Gamma}_{jk}^2 \tilde{y}^j \tilde{y}^k + L_e^2 h + L_g L_e h u,\end{aligned}$$

where we denote by  $\tilde{\Gamma}_{jk}^2$  the new Christoffel symbols in the second equation of the transformed system. Applying feedback  $\tilde{u} = -\tilde{\Gamma}_{jk}^2 \tilde{y}^j \tilde{y}^k + L_e^2 h + L_g L_e h u$ , we get a controllable linear mechanical system in the canonical form

$$\begin{aligned}\dot{\tilde{x}}^1 &= \tilde{y}^1 \\ \dot{\tilde{y}}^1 &= \tilde{x}^2 \\ \dot{\tilde{x}}^2 &= \tilde{y}^2 \\ \dot{\tilde{y}}^i &= \tilde{u}.\end{aligned}$$

□

### 6.3.3 Linearization outputs and Input-Output Linearization

As we explained in Section 2.3, the problem of feedback linearization of control systems can be rephrased as the input-output linearization of control systems with the relative degrees of virtual output functions that sum up to the dimension of the system. This point of view brings new insight to the problem and leads to the formulation of a set of partial differential equations, whose solutions define linearizing diffeomorphisms (see Section 2.3). In this section, we present a mechanical version of that problem.

For simplicity, we present this problem for  $(\mathcal{MS})_{(n,1)}$  with scalar controls, i.e.  $m = 1$ . Before we formulate results we need the following technical lemmata.

**Lemma 6.13.** *Let  $e, g \in \mathfrak{X}(Q)$  and  $h \in C^\infty(Q)$ . The following statements are equivalent, for a fixed  $j$ ,*

$$(i) \quad L_g L_e^k h = 0, \quad \text{for } 0 \leq k \leq j - 2.$$

$$(ii) \quad L_{ad_e^k g} h = 0, \quad \text{for } 0 \leq k \leq j - 2,$$

$$(iii) \quad L_{ad_e^p g} L_e^q h = 0, \quad \text{for } 0 \leq p + q \leq j - 2,$$

Moreover each of the above equivalent items implies

$$(iv) \quad L_{ad_e^{j-1} g} h = (-1)^k L_{ad_e^{j-1-k} g} L_e^k h, \quad \text{for } 0 \leq k \leq j - 1.$$

*Proof.* The above Lemma is analogous to Lemma 6.15 (p. 179) from [32], although for completeness sake we will prove it anyway.

For  $q = 0$ , (iii)  $\implies$  (ii) and, for  $p = 0$ , (iii)  $\implies$  (i).

(ii)  $\implies$  (iii). We adopt equation (2.1), for  $X, Y \in \mathfrak{X}(Q)$  and  $\varphi \in C^\infty(Q)$ ,

$$L_X L_Y \varphi = L_Y L_X \varphi + L_{ad_X Y} \varphi.$$

Therefore, for  $1 \leq k + 1 \leq j - 2$  we have  $L_{ad_e^k g} h = 0$  and thus

$$0 = L_e L_{ad_e^k g} h = L_{ad_e^k g} L_e h + L_{ad_e^{k+1} g} h.$$

The term  $L_{ad_e^{k+1} g} h = 0$  since  $k + 1 \leq j - 2$ , so it implies  $L_{ad_e^k g} L_e h = 0$ . Hence we showed that (ii)  $\implies$  (iii) for  $q = 1$ . Now assume that (iii) holds for  $0 \leq q \leq j - 3$  and we use induction to prove it for  $q + 1$ . Let  $2 \leq k + q + 1 \leq j - 2$ , then by induction assumption

$$L_{ad_e^k g} L_e^q h = 0 = L_{ad_e^{k+1} g} L_e^q h.$$

Therefore

$$0 = L_e L_{ad_e^k g} L_e^q h = L_{ad_e^k g} L_e^{q+1} h + L_{ad_e^{k+1} g} L_e^q h.$$

The term  $L_{ad_e^{k+1} g} L_e^q h = 0$  since  $2 \leq k + q + 1 \leq j - 2$ , so it implies  $L_{ad_e^k g} L_e^{q+1} h = 0$ . Therefore, indeed, (iii) holds for  $q + 1$ .

(i)  $\implies$  (iii). For  $p = 0$ , clearly (iii) holds. Now assume (iii) holds for  $0 \leq p \leq j - 3$ . Let  $1 \leq k + p + 1 \leq j - 2$ , then by the induction assumption

$$L_{ad_e^p g} L_e^k h = 0 = L_{ad_e^p g} L_e^{k+1} h.$$

Therefore

$$0 = L_e L_{ad_e^p g} L_e^k h = L_{ad_e^p g} L_e^{k+1} h + L_{ad_e^{p+1} g} L_e^k h.$$

The term  $L_{ad_e^{p+1} g} L_e^k h = 0$  since  $1 \leq k + p + 1 \leq j - 2$ , so it implies  $L_{ad_e^p g} L_e^{k+1} h = 0$ . Therefore, indeed, (iii) holds for  $p + 1$ .

Finally, we will prove that (iii)  $\implies$  (iv). For  $k = 0$ , the identity (iv) holds trivially. Assume that it holds for  $k - 1$ . Then, by (iii),  $L_{ad_e^{j-1-k} g} L_e^{k-1} h = 0$  and thus

$$0 = L_e L_{ad_e^{j-1-k} g} L_e^{k-1} h = L_{ad_e^{j-1-k} g} L_e^k h + L_{ad_e^{j-k} g} L_e^{k-1} h.$$

Hence  $L_{ad_e^{j-k-1} g} L_e^k h = -L_{ad_e^{j-k} g} L_e^{k-1} h = -(-1)^{k-1} L_{ad_e^{j-1} g} h$ , so we proved for  $k$ .  $\square$

**Lemma 6.14.** *Suppose there exists a function  $h(x) \in C^\infty(Q)$  such that*

$$\begin{aligned} L_g L_e^k h &= 0 & \text{for } 0 \leq k \leq n-2 \\ L_g L_e^{n-1} h(x_0) &\neq 0. \end{aligned} \quad (6.27)$$

*Then the functions  $h, L_e h, \dots, L_e^{n-1} h$  are independent around  $x_0$*

*Proof.* Consider the following product of two  $n \times n$  matrices

$$\begin{aligned} & \begin{pmatrix} dh \\ dL_e h \\ \vdots \\ dL_e^{n-1} h \end{pmatrix} \begin{pmatrix} g & ad_e g & \dots & ad_e^{n-2} g & ad_e^{n-1} g \end{pmatrix} (x_0) = \\ & = \begin{pmatrix} L_g h & \dots & L_{ad_e^{n-1} g} h \\ \vdots & & \vdots \\ L_g L_e^{n-1} h & \dots & L_{ad_e^{n-1} g} L_e^{n-1} h \end{pmatrix} (x_0) \end{aligned}$$

which by (6.27) and a repetitive application of Lemma 6.13 with  $j = n$  reads

$$\begin{pmatrix} 0 & 0 & \dots & 0 & \psi \\ 0 & 0 & \dots & -\psi & * \\ \vdots & & \ddots & \ddots & \vdots \\ (-1)^{n-1} \psi & * & \dots & * \end{pmatrix} (x_0),$$

where  $\psi = L_{ad_e^{n-1} g} h$ . Thus the matrix is lower triangular and of rank  $n$ , implying that  $dh, \dots, dL_e^{n-1} h$  are linearly independent and the functions  $h, L_e h, \dots, L_e^{n-1} h$  are independent around  $x_0$ .  $\square$

Consider a mechanical control system  $(\mathcal{MS})_{(n,1)}$  that reads

$$\begin{aligned} \dot{x}^i &= y^i \\ \dot{y}^i &= -\Gamma_{jk}^i(x) y^j y^k + e^i(x) + g^i(x) u. \end{aligned} \quad (6.28)$$

We introduce a concept of a *relative half-degree* of the above system. We say that, mechanical system (6.28) with an (output) function  $h(x) \in C^\infty(Q)$  has relative half-degree  $\bar{\nu}$  around  $x_0$  if

$$\begin{aligned} L_g L_e^k h &= 0 & \text{for } 0 \leq k \leq \bar{\nu} - 2 \\ L_g L_e^{\bar{\nu}-1} h(x_0) &\neq 0. \end{aligned}$$

That is to say, the relative half-degree of  $h$  with respect to the mechanical system (6.28) is equal to the (usual) relative degree of  $h$  with respect to the virtual system  $\dot{x} = e(x) + g(x)u$  (the latter, as well as the relative degree of its outputs, being well-defined Proposition 6.5).

**Proposition 6.15.** *The mechanical control system (6.28) is, locally around  $x_0$ , MF-linearizable to a linear controllable ( $\mathcal{LMS}$ ) if and only if there exists a function  $h(x) \in C^\infty(Q)$  that satisfies*



(MP1) the relative half-degree  $\bar{\nu}$ , around  $x_0$ , is equal to  $n$ , i.e.

$$\begin{aligned} L_g L_e^k h &= 0 & \text{for } 0 \leq k \leq n-2 \\ L_g L_e^{n-1} h(x_0) &\neq 0 \end{aligned}$$

(MP2) the differentials of the output function  $h$  and its successive  $n-2$  Lie derivatives with respect to  $e$  are covariantly constant, i.e.

$$\nabla(dL_e^k h) = 0 \quad \text{for } 0 \leq k \leq n-2.$$

*Proof.* Necessity. First we will prove that the conditions are invariant under mechanical diffeomorphisms and feedback, then we will show that they hold for MF-linearizable mechanical control system ( $\mathcal{MS}$ ). The invariance under diffeomorphism is obvious since both the Lie derivative and the covariant derivative are geometrical operations. Now, we prove the invariance under feedback

$$\begin{aligned} \tilde{g} &= \beta g \\ \tilde{e} &= e + g\alpha \\ \tilde{\nabla} : \quad \tilde{\Gamma}_{jk}^i &= \Gamma_{jk}^i - g^i \gamma_{jk}. \end{aligned}$$

Note that

$$\begin{aligned} L_{\tilde{g}} h &= L_{\beta g} h = \beta L_g h = 0 \\ L_{\tilde{e}} h &= L_{e+g\alpha} h = L_e h + \alpha L_g h = L_e h. \end{aligned}$$

Now assume that  $L_{\tilde{e}}^k h = L_e^k h$  is true for some  $0 \leq k \leq n-2$ . Then

$$L_{\tilde{e}}^{k+1} h = L_{e+g\alpha}^{k+1} h = L_{e+g\alpha} L_e^k h = L_e^{k+1} h + \alpha L_g L_e^k h = L_e^{k+1} h,$$

which implies  $L_{\tilde{e}}^k h = L_e^k h$ , for  $0 \leq k \leq n-1$ . Thus we calculate

$$L_{\tilde{g}} L_{\tilde{e}}^k h = L_{\beta g} L_e^k h = \beta L_g L_e^k h = 0,$$

for  $0 \leq k \leq n-2$ . Then

$$L_{\tilde{g}} L_{\tilde{e}}^{n-1} h = L_{\beta g} L_e^{n-1} h = \beta L_g L_e^{n-1} h \neq 0,$$

which proves the invariance of (MP1).

A direct calculation shows that the covariant derivative of a one-form changes under the mechanical feedback as follows

$$\tilde{\nabla}\omega = \nabla\omega + \omega(g) \cdot \gamma,$$

where  $\omega \in \Lambda(Q)$  and  $\gamma = (\gamma_{jk})$ . Thus, for  $\omega = dL_e^k h$ , we have

$$\tilde{\nabla} dL_e^k h = \nabla dL_e^k h + L_{\tilde{g}} L_e^k h \cdot \gamma = \nabla dL_e^k h,$$

for  $0 \leq k \leq n-2$ , since (MP1) is invariant. Now we calculate

$$\begin{aligned} \nabla dh &= 0 \\ \nabla dL_{e+g\alpha} h &= \nabla dL_e h + \nabla d(\alpha L_g h) = \nabla dL_e h, \end{aligned}$$

since  $L_g h = 0$  from (MP1). Assume that  $\nabla dL_{e+g\alpha}^k h = \nabla dL_e^k h$ , for  $0 \leq k \leq n-2$ . By induction we have

$$\nabla dL_{\tilde{e}}^{k+1} h = \nabla dL_{\tilde{e}} L_{\tilde{e}}^k h = \nabla dL_{e+g\alpha} L_e^k h = \nabla dL_e^{k+1} h + \nabla d(\alpha L_g L_e^k h) = \nabla dL_e^{k+1} h,$$

since (MP1). Therefore (MP2) is invariant.

Now, we have to show that conditions (MP1) – (MP2) hold for a linear controllable mechanical control system  $(\mathcal{LMS})_{(n,1)}$ . Since we just showed that the conditions are invariant under mechanical diffeomorphisms and feedback, without loss of generality, we can take any controllable linear mechanical system  $(\mathcal{LMS})_{(n,1)}$ , thus we choose the mechanical canonical form

$$\begin{aligned} \dot{x}^i &= y^i \\ \dot{y}^i &= x^{i+1} && \text{for } 1 \leq i \leq n-1 \\ \dot{x}^n &= y^n \\ \dot{y}^n &= u, \end{aligned}$$

and we set  $h(x) = x^1$ . A direct calculations show that

$$\begin{aligned} L_e^k h &= x^{k+1} \\ L_g L_e^k h &= 0 \\ L_g L_e^{n-1} h &= 1 \neq 0 \\ \nabla dL_e^k h &= 0 \end{aligned}$$

for  $0 \leq k \leq n-2$ .

Sufficiency. Consider a mechanical control system of the form (6.28) and take  $h(x)$  that satisfies (MP1) – (MP2) for it. For better readability we rewrite the Lie derivative and the covariant derivative involved in (MP1) – (MP2) in coordinates

$$\begin{aligned} L_e^k h &= \frac{\partial L_e^{k-1} h}{\partial x^i} e^i \\ L_g L_e^k h &= \frac{\partial L_e^k h}{\partial x^i} g^i \end{aligned}$$

and

$$\nabla dL_e^s h = \left( \frac{\partial^2 L_e^s h}{\partial x^j \partial x^k} - \frac{\partial L_e^s h}{\partial x^i} \Gamma_{jk}^i \right) dx^j \otimes dx^k.$$

Note that by Lemma 6.14, the map  $\tilde{x} = \phi(x) = (h, L_e h, \dots, L_e^{n-1} h)$  is a local diffeomorphism  $\phi : \mathcal{X} \subset \mathcal{Q} \rightarrow \tilde{\mathcal{X}} \subset \tilde{\mathcal{Q}}$ , where  $\mathcal{X}$  and  $\tilde{\mathcal{X}}$  are open neighbourhoods of  $x_0$  and  $0 \in \mathbb{R}^n$ , respectively. The diffeomorphism  $\phi$  on  $\mathcal{X}$  induces a diffeomorphism on  $T\mathcal{X}$ , i.e. the extended point transformation,  $\Phi : T\mathcal{X} \rightarrow T\tilde{\mathcal{X}}$  such that  $(\tilde{x}, \tilde{y}) = (\phi(x), D\phi(x)y)$ . Hence we have

$$\begin{aligned} \tilde{x}^1 &= h(x) && \tilde{y}^1 = dh \ y \\ \tilde{x}^2 &= L_e h && \tilde{y}^2 = dL_e h \ y \\ &\vdots && \vdots \\ \tilde{x}^n &= L_e^{n-1} h && \tilde{y}^n = dL_e^{n-1} h \ y. \end{aligned}$$

We represent the mechanical control system (6.28) in the new coordinates  $(\tilde{x}, \tilde{y})$ :

$$\begin{aligned}\dot{\tilde{x}}^1 &= \frac{\partial h}{\partial x^j} y^j = \tilde{y}^1 \\ \dot{\tilde{y}}^1 &= \frac{\partial^2 h}{\partial x^j \partial x^k} y^j y^k + \frac{\partial h}{\partial x^i} \dot{y}^i = \left( \frac{\partial^2 h}{\partial x^j \partial x^k} - \frac{\partial h}{\partial x^i} \Gamma_{jk}^i \right) y^j y^k + \frac{\partial h}{\partial x^i} e^i + \frac{\partial h}{\partial x^i} g^i u = L_e h = \tilde{x}^2,\end{aligned}$$

since, by (MP2),  $\frac{\partial^2 h}{\partial x^j \partial x^k} - \frac{\partial h}{\partial x^i} \Gamma_{jk}^i = 0$  and  $\frac{\partial h}{\partial x^i} g^i = 0$ , by (MP1). Now assume that for a certain  $1 \leq s \leq n-2$

$$\begin{aligned}\dot{\tilde{x}}^s &= \frac{\partial L_e^{s-1} h}{\partial x^j} y^j = \tilde{y}^s \\ \dot{\tilde{y}}^s &= L_e^s h = \tilde{x}^{s+1}\end{aligned}\tag{6.29}$$

Then we have

$$\begin{aligned}\dot{\tilde{x}}^{s+1} &= \frac{\partial L_e^s h}{\partial x^j} y^j = \tilde{y}^{s+1} \\ \dot{\tilde{y}}^{s+1} &= \frac{\partial^2 L_e^s h}{\partial x^j \partial x^k} y^j y^k + \frac{\partial L_e^s h}{\partial x^i} \dot{y}^i = \left( \frac{\partial^2 L_e^s h}{\partial x^j \partial x^k} - \frac{\partial L_e^s h}{\partial x^i} \Gamma_{jk}^i \right) y^j y^k + \frac{\partial L_e^s h}{\partial x^i} e^i + \frac{\partial L_e^s h}{\partial x^i} g^i u = \\ &= L_e^{s+1} h = \tilde{x}^{s+2}.\end{aligned}$$

Thus, by induction, (6.29) holds for any  $1 \leq s \leq n-1$ . Finally, we calculate

$$\begin{aligned}\dot{\tilde{x}}^n &= \frac{\partial L_e^{n-1} h}{\partial x^j} y^j = \tilde{y}^n \\ \dot{\tilde{y}}^n &= \frac{\partial^2 L_e^{n-1} h}{\partial x^j \partial x^k} y^j y^k + \frac{\partial L_e^{n-1} h}{\partial x^i} \dot{y}^i = \\ &= \left( \frac{\partial^2 L_e^{n-1} h}{\partial x^j \partial x^k} - \frac{\partial L_e^{n-1} h}{\partial x^i} \Gamma_{jk}^i \right) y^j y^k + \frac{\partial L_e^{n-1} h}{\partial x^i} e^i + \frac{\partial L_e^{n-1} h}{\partial x^i} g^i u = \tilde{u}.\end{aligned}$$

We result in the mechanical canonical form, i.e. a chain of double integrators, proving that the system is MF-linearizable.  $\square$

The linearizing mechanical diffeomorphism is  $\Phi = (\phi(x), D\phi(x)y)$ , with

$$\phi(x) = \left( h, L_e h, L_e^2 h, \dots, L_e^{n-1} h \right)^T.$$

The mechanical feedback reads

$$u = \gamma_{jk}(x) y^j y^k + \alpha(x) + \beta(x) \tilde{u},$$

where

$$\begin{aligned}\gamma_{jk}(x) &= -\frac{1}{L_g L_e^{n-1} h} \left( \frac{\partial^2 L_e^{n-1} h}{\partial x^j \partial x^k} - \frac{\partial L_e^{n-1} h}{\partial x^i} \Gamma_{jk}^i \right) \\ \alpha(x) &= -\frac{L_e^n h}{L_g L_e^{n-1} h} \\ \beta(x) &= \frac{1}{L_g L_e^{n-1} h}.\end{aligned}$$

It is worth to interpret the linearizability conditions. The first condition, (MP1) ensures that in the  $\tilde{x}$ -coordinates the control appears in the last equation only. The second condition ensures that by introducing the new coordinates we compensate the Christoffel symbols.

The generalization of the above result to the multi-input case is quite straightforward. In this case, one should find  $m$  linearizing functions  $h_i(x)$ , each of the relative half-degree  $\bar{\nu}_i$ , that sum up to the dimension of the configuration manifold  $n$ . Moreover the differentials  $dL_e^k h_i$ , for  $0 \leq k \leq \bar{\nu}_i - 2$ , have to be covariantly constant.

**Definition 6.16.** *The mechanical control system  $(\mathcal{MS})_{(n,m)}$  with  $m$  configuration (virtual output) functions  $h_1(x), \dots, h_m(x) \in C^\infty(Q)$  has a vector relative half-degree  $(\bar{\nu}_1, \dots, \bar{\nu}_m)$  around  $x_0$  if*

(i)

$$L_{g_r} L_e^k h_i = 0,$$

for  $1 \leq i, r \leq m$  and  $0 \leq k \leq \bar{\nu}_i - 2$ ,

(ii) the  $m \times m$  decoupling matrix

$$D(x) = \left( L_{g_r} L_e^{\bar{\nu}_i - 1} h_i \right) (x)$$

is of full rank equal to  $m$ , around  $x_0$ .

Before we formulate our theorem we need a lemma analogous to Lemma 6.14.

**Lemma 6.17.** *Suppose there exist  $m$  functions  $h_1(x), \dots, h_m(x) \in C^\infty(Q)$  has a vector relative half-degree  $(\bar{\nu}_1, \dots, \bar{\nu}_m)$  around  $x_0$ , with  $\sum_{i=1}^m \bar{\nu}_i = n$ . Then the functions*

$$\begin{aligned} &h_1, L_e h_1, \dots, L_e^{\bar{\nu}_1 - 1} h_1, \\ &h_2, L_e h_2, \dots, L_e^{\bar{\nu}_2 - 1} h_2, \\ &\vdots \\ &h_m, L_e h_m, \dots, L_e^{\bar{\nu}_m - 1} h_m \end{aligned} \tag{6.30}$$

are independent around  $x_0$

*Proof.* The proof is analogous to the proof of Lemma 6.14 and follows the proof of Lemma 5.1.1. from [17]. Reorder  $\bar{\nu}_i$  such that  $\bar{\nu}_1 \geq \bar{\nu}_2 \geq \dots \geq \bar{\nu}_m$

Consider the following product of two matrices

$$\begin{pmatrix} dh_1 \\ dL_e h_1 \\ \vdots \\ L_e^{\bar{\nu}_1 - 1} h_1 \\ \vdots \\ dh_m \\ dL_e h_m \\ \vdots \\ L_e^{\bar{\nu}_m - 1} h_m \end{pmatrix} \begin{pmatrix} g_1 & \dots & g_m & ad_e g_1 & \dots & ad_e g_m & \dots & ad_e^{\bar{\nu}_1 - 1} g_1 & \dots & ad_e^{\bar{\nu}_1 - 1} g_m \end{pmatrix} (x_0).$$

Using Lemma 6.13 with  $h$  replaced by  $h_i$ ,  $g$  replaced by  $g_r$  and  $j = \bar{\nu}_i$ , and Definition 6.16, it is easy to see that the product consists a block triangular structure in which the diagonal blocks are rows of the mechanical decoupling matrix  $D(x)$ , implying that the differentials (i.e. rows of the first matrix) are linearly independent and thus the functions (6.30) are independent around  $x_0$ .  $\square$

**Theorem 6.18.** *The mechanical control system  $(\mathcal{MS})_{(n,m)}$  given by (6.1) is, locally around  $x_0 \in Q$ , MF-linearizable if and only if there exist  $m$  functions  $h_1(x), \dots, h_m(x) \in C^\infty(Q)$  satisfying*

(MR1) *the vector relative half-degree  $(\bar{\nu}_1, \dots, \bar{\nu}_m)$  with  $\sum_{i=1}^m \bar{\nu}_i = n$ .*

(MR2) *the differentials of the output functions  $h_i$  and its successive  $\bar{\nu}_i - 2$  Lie derivatives with respect to  $e$  are covariantly constant, i.e.*

$$\nabla(dL_e^k h_i) = 0 \quad \text{for } 0 \leq k \leq \bar{\nu}_i - 2.$$

*Proof.* Necessity. First we will prove that the conditions are invariant under mechanical diffeomorphisms and feedback, then we will show that they hold for MF-linearizable mechanical control system  $(\mathcal{MS})$ . The invariance under diffeomorphism is obvious since both the Lie derivative and the covariant derivative are geometric operations. Now, we prove invariance under feedback

$$\begin{aligned} \tilde{\nabla} : \tilde{\Gamma}_{jk}^i &= \Gamma_{jk}^i - \sum_{r=1}^m g_r^i \gamma_{jk}^r \\ \tilde{e} &= e + \sum_{r=1}^m g_r \alpha^r \\ \tilde{g}_s &= \sum_{r=1}^m \beta_s^r g_r, \end{aligned}$$

Note that, for  $1 \leq i \leq m$

$$\begin{aligned} L_{\tilde{g}_s} h_i &= L \left( \sum_{r=1}^m \beta_s^r g_r \right) h_i = \sum_{r=1}^m \beta_s^r L_{g_r} h_i = 0 \\ L_{\tilde{e}} h_i &= L \left( e + \sum_{r=1}^m g_r \alpha^r \right) h_i = L_e h_i + \sum_{r=1}^m \alpha^r L_{g_r} h_i = L_e h_i. \end{aligned}$$

Now assume that  $L_{\tilde{e}}^k h_i = L_e^k h_i$  is true for some  $0 \leq k \leq \bar{\nu}_i - 2$ . Then

$$L_{\tilde{e}}^{k+1} h_i = L^{k+1} \left( e + \sum_{r=1}^m g_r \alpha^r \right) h_i = L \left( e + \sum_{r=1}^m g_r \alpha^r \right) L_e^k h_i = L_e^{k+1} h_i + \sum_{r=1}^m \alpha^r L_{g_r} L_e^k h_i = L_e^{k+1} h_i,$$

which implies  $L_{\tilde{e}}^k h_i = L_e^k h_i$ , for  $0 \leq k \leq \bar{\nu}_i - 1$ . Thus we calculate

$$L_{\tilde{g}_s} L_{\tilde{e}}^k h_i = L \left( \sum_{r=1}^m \beta_s^r g_r \right) L_e^k h_i = \sum_{r=1}^m \beta_s^r L_{g_r} L_e^k h_i = 0,$$

for  $0 \leq k \leq \bar{\nu}_i - 2$ . Then

$$L_{\tilde{g}_s} L_{\tilde{e}}^{\bar{\nu}_i - 1} h_i = L \left( \sum_{r=1}^m \beta_s^r g_r \right) L_e^{\bar{\nu}_i - 1} h_i = \sum_{r=1}^m \beta_s^r L_{g_r} L_e^{\bar{\nu}_i - 1} h_i,$$

thus the decoupling matrix  $D = \left( L_{\tilde{g}_s} L_{\tilde{e}}^{\bar{\nu}_i - 1} h_i \right)$  is of full rank, since matrix  $(\beta_s^r)$  is invertible, which proves invariance of  $(MR1)$ .

Direct calculations shows that the covariant derivative of a one-form changes under feedback as follows

$$\tilde{\nabla} \omega = \nabla \omega + \sum_{r=1}^m \omega(g_r) \cdot \gamma^r,$$

where  $\omega \in \Lambda(Q)$  and  $\gamma^r = \left( \gamma_{jk}^r \right)$ . Thus, for  $\omega = dL_{\tilde{e}} h_i$ , we have

$$\tilde{\nabla} dL_{\tilde{e}}^k h_i = \nabla dL_{\tilde{e}}^k h_i + \sum_{r=1}^m L_{\tilde{g}_r} L_{\tilde{e}}^k h_i \cdot \gamma^r = \nabla dL_{\tilde{e}}^k h_i,$$

for  $0 \leq k \leq \bar{\nu}_i - 2$ , since  $(MR1)$  is invariant. Now we calculate

$$\begin{aligned} \nabla d h_i &= 0 \\ \nabla d L_{\tilde{e}} h_i &= \nabla d L \left( e + \sum_{r=1}^m g_r \alpha^r \right) h_i = \nabla d L_e h_i + \nabla d \left( \sum_{r=1}^m \alpha^r L_{g_r} h_i \right) = \nabla d L_e h_i, \end{aligned}$$

since  $L_{g_r} h_i = 0$  from  $(MR1)$ . Assume that

$$\nabla d L_{\tilde{e}}^k h_i = \nabla d L^k \left( e + \sum_{r=1}^m g_r \alpha^r \right) h_i = \nabla d L_e^k h_i,$$

for a certain  $0 \leq k \leq \bar{\nu}_i - 2$ . By induction we have

$$\begin{aligned} \nabla d L_{\tilde{e}}^{k+1} h_i &= \nabla d L_{\tilde{e}} L_{\tilde{e}}^k h_i = \nabla d L \left( e + \sum_{r=1}^m g_r \alpha^r \right) L_e^k h_i = \\ &= \nabla d L_e^{k+1} h_i + \nabla d \left( \sum_{r=1}^m \alpha^r L_{g_r} L_e^k h_i \right) = \nabla d L_e^{k+1} h_i, \end{aligned}$$

since  $(MR1)$ . Therefore  $(MR2)$  is invariant.

Now, we will show that conditions  $(MR1) - (MR2)$  hold for the controllable linear mechanical control system  $(\mathcal{LMS})$ . Since we have just shown that the conditions are invariant under mechanical diffeomorphisms and feedback, without loss of generality, we can take any controllable linear mechanical system  $(\mathcal{LMS})$ , thus we choose the mechanical canonical form with the mechanical half-indices  $\bar{\rho}_1, \dots, \bar{\rho}_m$ . Denote

$$\begin{aligned} \mu_0 &= 0 \\ \mu_j &= \sum_{i=1}^j \bar{\rho}_i, \quad \text{for } 1 \leq j \leq m, \end{aligned}$$

and the system reads

$$\begin{aligned} \dot{x}^i &= y^i & 1 \leq i \leq n \\ \dot{y}^i &= x^{i+1} & \mu_j + 1 \leq i \leq \mu_{j+1} - 1, \quad 0 \leq j \leq m - 1 \\ \dot{y}^{\mu_j} &= u_j & 1 \leq j \leq m \end{aligned}$$

We set  $h_i(x) = x^{\mu_{i-1}+1}$ , for  $1 \leq i \leq m$ . A direct calculation shows that

$$\begin{aligned} L_e^k h_i &= x^{\mu_{i-1}+1+k} \\ L_{g_r} L_e^k h_i &= 0 \\ L_{g_r} L_e^{\bar{\rho}_i-1} h_i &= \begin{cases} 0 & r \neq i \\ 1 & r = i \end{cases} \end{aligned}$$

and

$$\nabla dL_e^k h_i = 0 \quad (6.31)$$

for  $0 \leq k \leq \bar{\rho}_i - 2$ . Therefore the relative half-degree  $\bar{\nu}_i$  of  $h_i$  is equal to the mechanical half-index  $\bar{\rho}_i$ . Since, by definition,  $\sum_{i=1}^m \bar{\rho}_i = n$ , the condition (MR1) holds. By (6.31) (MR2) holds as well.

Sufficiency. Fix a mechanical system (6.1) and take  $h_1(x), \dots, h_m(x) \in C^\infty(Q)$  that satisfy (MR1) – (MR2). Note that by Lemma 6.17, the map  $\tilde{x} = \phi(x) = (h_1, L_e h_1, \dots, L_e^{\bar{\nu}_1-1} h_1)$ , for  $1 \leq i \leq m$ , is a local diffeomorphism  $\phi : \mathcal{X} \subset Q \rightarrow \tilde{\mathcal{X}} \subset \tilde{Q}$ , where  $\mathcal{X}$  and  $\tilde{\mathcal{X}}$  are open neighbourhoods of  $x_0$  and  $0 \in \mathbb{R}^n$ , respectively. The diffeomorphism  $\phi$  on  $\mathcal{X}$  induces a diffeomorphism on  $T\mathcal{X}$ , i.e. the extended point transformation,  $\Phi : T\mathcal{X} \rightarrow T\tilde{\mathcal{X}}$  such that  $(\tilde{x}, \tilde{y}) = (\phi(x), D\phi(x)y)$ . Denote auxiliary integers

$$\mu_j = \sum_{i=1}^j \bar{\nu}_i, \quad \text{for } 1 \leq j \leq m,$$

and we have

$$\begin{aligned} \tilde{x}^1 &= h_1(x) & \tilde{y}^1 &= dh_1 \cdot y \\ \tilde{x}^2 &= L_e h_1 & \tilde{y}^2 &= dL_e h_1 \cdot y \\ & \vdots & & \vdots \\ \tilde{x}^{\mu_1} &= L_e^{\bar{\nu}_1-1} h_1 & \tilde{y}^{\mu_1} &= dL_e^{\bar{\nu}_1-1} h_1 \cdot y \\ \tilde{x}^{\mu_1+1} &= h_2(x) & \tilde{y}^{\mu_1+1} &= dh_2 \cdot y \\ & \vdots & & \vdots \\ \tilde{x}^{\mu_2} &= L_e^{\bar{\nu}_2-1} h_2 & \tilde{y}^{\mu_2} &= dL_e^{\bar{\nu}_2-1} h_2 \cdot y \\ & \vdots & & \vdots \\ \tilde{x}^{\mu_{m-1}+1} &= h_m & \tilde{y}^{\mu_{m-1}+1} &= dh_m \cdot y \\ & \vdots & & \vdots \\ \tilde{x}^{\mu_m} &= L_e^{\bar{\nu}_m-1} h_m & \tilde{y}^{\mu_m} &= dL_e^{\bar{\nu}_m-1} h_m \cdot y, \end{aligned}$$

where  $y = y^i \frac{\partial}{\partial x^i}$ . We represent the mechanical control system (6.1) in the new coordinates  $(\tilde{x}, \tilde{y})$

$$\begin{aligned}\dot{\tilde{x}}^1 &= \frac{\partial h_1}{\partial x^j} y^j = \tilde{y}^1 \\ \dot{\tilde{y}}^1 &= \frac{\partial^2 h_1}{\partial x^j \partial x^k} y^j y^k + \frac{\partial h_1}{\partial x^i} \dot{y}^i = \left( \frac{\partial^2 h_1}{\partial x^j \partial x^k} - \frac{\partial h_1}{\partial x^i} \Gamma_{jk}^i \right) y^j y^k + \frac{\partial h_1}{\partial x^i} e^i + \sum_{r=1}^m \frac{\partial h_1}{\partial x^i} g_r^i u_r = \\ &= L_e h_1 = \tilde{x}^2,\end{aligned}$$

since, by (MR2),  $\frac{\partial^2 h_1}{\partial x^j \partial x^k} - \frac{\partial h_1}{\partial x^i} \Gamma_{jk}^i = \nabla d h_1 = 0$  and  $\frac{\partial h_1}{\partial x^i} g_r^i = L_{g_r} h_1 = 0$ , by (MR1). Assume that for a certain  $1 \leq s \leq \bar{\nu}_1 - 2$

$$\begin{aligned}\dot{\tilde{x}}^s &= \frac{\partial L_e^{s-1} h_1}{\partial x^j} y^j = \tilde{y}^s \\ \dot{\tilde{y}}^s &= L_e^s h_1 = \tilde{x}^{s+1}\end{aligned}\tag{6.32}$$

Then we have

$$\begin{aligned}\dot{\tilde{x}}^{s+1} &= \frac{\partial L_e^s h_1}{\partial x^j} y^j = \tilde{y}^{s+1} \\ \dot{\tilde{y}}^{s+1} &= \frac{\partial^2 L_e^s h_1}{\partial x^j \partial x^k} y^j y^k + \frac{\partial L_e^s h_1}{\partial x^i} \dot{y}^i = \\ &= \left( \frac{\partial^2 L_e^s h_1}{\partial x^j \partial x^k} - \frac{\partial L_e^s h_1}{\partial x^i} \Gamma_{jk}^i \right) y^j y^k + \frac{\partial L_e^s h_1}{\partial x^i} e^i + \sum_{r=1}^m \frac{\partial L_e^s h_1}{\partial x^i} g_r^i u_r = L_e^{s+1} h_1 = \tilde{x}^{s+2},\end{aligned}$$

since, by (MR2),  $\frac{\partial^2 L_e^s h_1}{\partial x^j \partial x^k} - \frac{\partial L_e^s h_1}{\partial x^i} \Gamma_{jk}^i = \nabla d L_e^s h_1 = 0$  and  $\frac{\partial L_e^s h_1}{\partial x^i} g_r^i = L_{g_r} L_e^s h_1 = 0$ , by (MR1). Thus, by an induction argument, (6.32) holds for all  $1 \leq s \leq \bar{\nu}_1 - 1$ . Next, we calculate

$$\begin{aligned}\dot{\tilde{x}}^{\bar{\nu}_1} &= \frac{\partial L_e^{\bar{\nu}_1-1} h_1}{\partial x^j} y^j = \tilde{y}^{\bar{\nu}_1} \\ \dot{\tilde{y}}^{\bar{\nu}_1} &= \frac{\partial^2 L_e^{\bar{\nu}_1-1} h_1}{\partial x^j \partial x^k} y^j y^k + \frac{\partial L_e^{\bar{\nu}_1-1} h_1}{\partial x^i} \dot{y}^i = \left( \frac{\partial^2 L_e^{\bar{\nu}_1-1} h_1}{\partial x^j \partial x^k} - \frac{\partial L_e^{\bar{\nu}_1-1} h_1}{\partial x^i} \Gamma_{jk}^i \right) y^j y^k + \\ &+ \frac{\partial L_e^{\bar{\nu}_1-1} h_1}{\partial x^i} e^i + \sum_{r=1}^m \frac{\partial L_e^{\bar{\nu}_1-1} h_1}{\partial x^i} g_r^i u_r = \tilde{u}_1.\end{aligned}$$

Thus, the equations are linear for the first  $2\bar{\nu}_1$  state variables (i.e.  $\bar{\nu}_1$  positions  $\tilde{x}^i$  and  $\bar{\nu}_1$  velocities  $\tilde{y}^i$ , for  $1 \leq i \leq \bar{\nu}_1$ ) using the first function  $h_1$ . We repeat this procedure for the remaining  $m - 1$  positions and velocities. For  $2 \leq p \leq m$ ,

$$\begin{aligned}\dot{\tilde{x}}^{\mu_{p-1}+1} &= \frac{\partial h_p}{\partial x^j} y^j = \tilde{y}^{\mu_{p-1}+1} \\ \dot{\tilde{y}}^{\mu_{p-1}+1} &= \frac{\partial^2 h_p}{\partial x^j \partial x^k} y^j y^k + \frac{\partial h_p}{\partial x^i} \dot{y}^i = \\ &= \left( \frac{\partial^2 h_p}{\partial x^j \partial x^k} - \frac{\partial h_p}{\partial x^i} \Gamma_{jk}^i \right) y^j y^k + \frac{\partial h_p}{\partial x^i} e^i + \sum_{r=1}^m \frac{\partial h_p}{\partial x^i} g_r^i u_r = L_e h_p = \tilde{x}^{\mu_{p-1}+2},\end{aligned}$$

since  $\frac{\partial^2 h_p}{\partial x^j \partial x^k} - \frac{\partial h_p}{\partial x^i} \Gamma_{jk}^i = \nabla d h_p = 0$  and  $\frac{\partial h_p}{\partial x^i} g_r^i = L_{g_r} h_p = 0$ .



Assume that for a certain  $1 \leq s \leq \bar{\nu}_p - 2$

$$\begin{aligned}\dot{\tilde{x}}^{\mu_{p-1}+s} &= \frac{\partial L_e^{s-1} h_p}{\partial x^j} y^j = \tilde{y}^{\mu_{p-1}+s} \\ \dot{\tilde{y}}^{\mu_{p-1}+s} &= L_e^s h_p = \tilde{x}^{\mu_{p-1}+s+1}\end{aligned}\quad (6.33)$$

Then we have

$$\begin{aligned}\dot{\tilde{x}}^{\mu_{p-1}+s+1} &= \frac{\partial L_e^s h_p}{\partial x^j} y^j = \tilde{y}^{\mu_{p-1}+s+1} \\ \dot{\tilde{y}}^{\mu_{p-1}+s+1} &= \frac{\partial^2 L_e^s h_p}{\partial x^j \partial x^k} y^j y^k + \frac{\partial L_e^s h_p}{\partial x^i} \dot{y}^i = \\ &= \left( \frac{\partial^2 L_e^s h_p}{\partial x^j \partial x^k} - \frac{\partial L_e^s h_p}{\partial x^i} \Gamma_{jk}^i \right) y^j y^k + \frac{\partial L_e^s h_p}{\partial x^i} e^i + \sum_{r=1}^m \frac{\partial L_e^s h_p}{\partial x^i} g_r^i u_r = \\ &= L_e^{s+1} h_p = \tilde{x}^{\mu_{p-1}+s+2},\end{aligned}$$

since  $\frac{\partial^2 L_e^s h_p}{\partial x^j \partial x^k} - \frac{\partial L_e^s h_p}{\partial x^i} \Gamma_{jk}^i = \nabla dL_e^s h_p = 0$  and  $\frac{\partial L_e^s h_p}{\partial x^i} g_r^i = L_{g_r} L_e^s h_p = 0$ . Thus, by an induction argument, (6.33) holds for  $1 \leq s \leq \bar{\nu}_i - 1$ . Next, we calculate

$$\begin{aligned}\dot{\tilde{x}}^{\mu_p} &= \frac{\partial L_e^{\bar{\nu}_p-1} h_p}{\partial x^j} y^j = \tilde{y}^{\mu_p} \\ \dot{\tilde{y}}^{\mu_p} &= \frac{\partial^2 L_e^{\bar{\nu}_p-1} h_p}{\partial x^j \partial x^k} y^j y^k + \frac{\partial L_e^{\bar{\nu}_p-1} h_p}{\partial x^i} \dot{y}^i = \left( \frac{\partial^2 L_e^{\bar{\nu}_p-1} h_p}{\partial x^j \partial x^k} - \frac{\partial L_e^{\bar{\nu}_p-1} h_p}{\partial x^i} \Gamma_{jk}^i \right) y^j y^k + \\ &+ \frac{\partial L_e^{\bar{\nu}_p-1} h_p}{\partial x^i} e^i + \sum_{r=1}^m \frac{\partial L_e^{\bar{\nu}_p-1} h_p}{\partial x^i} g_r^i u_r = \tilde{u}_p.\end{aligned}$$

We result in the mechanical canonical form, i.e. a chains of double integrators, thus proving that the system is MF-linearizable.  $\square$

The linearizing mechanical diffeomorphism is given by

$$(\tilde{x}, \tilde{y}) = \Phi(x, y) = (\phi(x), D\phi(x)y) \quad \text{with} \quad (6.34)$$

$$\phi(x) = \left( h_1, L_e h_1, \dots, L_e^{\bar{\nu}_1-1} h_1, h_2, L_e h_2, \dots, L_e^{\bar{\nu}_2-1} h_2, \dots, h_m, L_e h_m, \dots, L_e^{\bar{\nu}_m-1} h_m \right)^T,$$

and the new control is

$$\tilde{u}_i = \left( \frac{\partial^2 L_e^{\bar{\nu}_i-1} h_i}{\partial x^j \partial x^k} - \frac{\partial L_e^{\bar{\nu}_i-1} h_i}{\partial x^i} \Gamma_{jk}^i \right) y^j y^k + L_e^{\bar{\nu}_i} h_i + \sum_{r=1}^m L_{g_r} L_e^{\bar{\nu}_i-1} h_i u_r,$$

or using matrix notation

$$\tilde{u} = \mathcal{C}(x, y) + \mathcal{A}(x) + \mathcal{B}(x)u,$$

where  $u = (u_1, \dots, u_m)^T$ ,  $\tilde{u} = (\tilde{u}_1, \dots, \tilde{u}_m)^T$ ,

$$\mathcal{A}(x) = \begin{pmatrix} L_e^{\bar{\nu}_1} h_1 \\ \dots \\ L_e^{\bar{\nu}_m} h_m \end{pmatrix}, \quad \mathcal{B}(x) = \begin{pmatrix} L_{g_1} L_e^{\bar{\nu}_1-1} h_1 & \dots & L_{g_m} L_e^{\bar{\nu}_1-1} h_1 \\ \vdots & \ddots & \vdots \\ L_{g_1} L_e^{\bar{\nu}_m-1} h_m & \dots & L_{g_m} L_e^{\bar{\nu}_m-1} h_m \end{pmatrix},$$

$$\mathcal{C}(x, y) = \begin{pmatrix} \left( \frac{\partial^2 L_e^{\bar{\nu}_1-1} h_1}{\partial x^j \partial x^k} - \frac{\partial L_e^{\bar{\nu}_1-1} h_1}{\partial x^i} \Gamma_{jk}^i \right) y^j y^k \\ \dots \\ \left( \frac{\partial^2 L_e^{\bar{\nu}_m-1} h_m}{\partial x^j \partial x^k} - \frac{\partial L_e^{\bar{\nu}_m-1} h_m}{\partial x^i} \Gamma_{jk}^i \right) y^j y^k \end{pmatrix},$$

hence the linearizing mechanical feedback reads

$$u = \mathcal{B}^{-1}(x) (-\mathcal{C}(x, y) - \mathcal{A}(x) + \tilde{u}). \quad (6.35)$$

**Corollary 6.19.** *If the mechanical control system  $(\mathcal{MS})_{(n,m)}$  given by (6.1) is, locally around  $x_0$ , MF-linearizable, that is, there exist  $m$  functions  $h_1(x), \dots, h_m(x) \in C^\infty(Q)$  satisfying conditions (MR1)–(MR2) of Theorem 6.18, then the states  $(x, y) = (x^1, \dots, x^n, y^1, \dots, y^n)$  and the controls  $u = (u_1, \dots, u_m)$  can be represented with the help of  $h = (h_1, \dots, h_m)$  and their derivatives*

$$\begin{aligned} x &= \zeta_0(h, \dot{h}, \dots, h^{(s)}) \\ y &= \zeta_1(h, \dot{h}, \dots, h^{(s)}) \\ u &= \zeta_2(h, \dot{h}, \dots, h^{(s)}), \end{aligned}$$

where  $s = (s_1, \dots, s_m) = (2\bar{\nu}_1, \dots, 2\bar{\nu}_m)$ , and  $s_i$  stand for the highest time-derivatives of  $h_i$ , thus  $h^{(s)} = (h_1^{(s_1)}, \dots, h_m^{(s_m)})$ , and  $(\bar{\nu}_1, \dots, \bar{\nu}_m)$  is the vector relative half-degree.

**Remark 6.20.** *Note that the linearizing outputs  $h_1(x), \dots, h_m(x)$  define a set of coordinates, for which the evolution of the state  $(x(t), y(t))$  can be determined using the minimal possible number (i.e.  $m+n$ ) of differentiations only (of  $h_i(x(t))$ ), instead of integrations. For mechanical systems  $(\mathcal{MS})$  such a choice of linearizing outputs is unique up to a linear transformations.*

The above corollary and remark refer to the property of the *differential flatness* [12], [23], [27], [33] and the *differential weight* [30], [31]. It is well known that all feedback linearizable control systems are differentially flat. We use that corollary in Chapter 7 to solve the motion planning problem.

## 6.4 MF-linearization of non-controllable Mechanical Systems

In this section we will formulate and prove one of our main result describing MF-linearizable mechanical control systems. Contrary to the previous section we will consider MF-equivalence to any linear mechanical system  $(\mathcal{LMS})$ , without assuming its controllability. We refer the reader to Chapter 2 for the definition of the Riemann tensor  $R$ , the total covariant derivative  $\nabla g_r$ , and the second total covariant derivative  $\nabla^2 e$ . For the definition of distributions  $\mathcal{E}^j$ , see Chapter 3 and Section 6.2 of this chapter. Moreover, we define annihilators of the following objects

- $\text{ann } \mathcal{E}^0 = \{\omega \in \Lambda(Q) : \omega(g_r) = 0, 1 \leq r \leq m\}$
- $\text{ann } R = \{\omega \in \Lambda(Q) : \omega(R) = 0\}$
- $\text{ann } \nabla g_r = \{\omega \in \Lambda(Q) : \omega(\nabla g_r) = 0, 1 \leq r \leq m\}$
- $\text{ann } \nabla^2 e = \{\omega \in \Lambda(Q) : \omega(\nabla^2 e) = 0\}$ .

Note that, while the above objects are tensors of different types, all have one contravariant component, i.e.  $g_r$  is a  $(1, 0)$ -tensor field,  $R$  is a  $(1, 3)$ -tensor field,  $\nabla g_r$  is a  $(1, 1)$ -tensor field, and  $\nabla^2 e$  is a  $(1, 2)$ -tensor field. Thus the definitions of the annihilators are unambiguous.

Now, we formulate a theorem describing MF-linearizability.

**Theorem 6.21.** *A mechanical system  $(\mathcal{MS})_{(n,m)}$ , is locally around  $x_0 \in Q$ , MF-linearizable if and only if it satisfies, in a neighbourhood of  $x_0$ , the following conditions:*

(ML0)  $\mathcal{E}^0$  and  $\mathcal{E}^1$  are of constant rank

(ML1)  $\mathcal{E}^0$  is involutive

(ML2)  $\text{ann } \mathcal{E}^0 \subset \text{ann } R$

(ML3)  $\text{ann } \mathcal{E}^0 \subset \text{ann } \nabla g_r$  for  $1 \leq r \leq m$

(ML4)  $\text{ann } \mathcal{E}^1 \subset \text{ann } \nabla^2 e$

*Proof.* Necessity. Consider a linear mechanical system  $(\mathcal{LMS})_{(n,m)}$  of the following form

$$\begin{aligned} \dot{x}^i &= y^i \\ \dot{y}^i &= E_j^i x^j + \sum_{r=1}^m b_r^i u_r. \end{aligned} \quad (6.36)$$

For system (6.36), we have  $\Gamma_{jk}^i = 0$ ,  $g_r = b_r$ ,  $e(x) = Ex$  and

$$[b_r, b_s] = 0.$$

It follows that  $\text{ann } R = \text{ann } \nabla g_r = \text{ann } \nabla^2 e = T^*\mathbb{R}^n$ . Compute the Lie bracket

$$ad_e g_r = [Ex, b_r] = -Eb_r \quad (6.37)$$

and thus

$$\mathcal{E}^1 = \text{span} \{b_1, \dots, b_m, Eb_1, \dots, Eb_m\}.$$

Therefore we conclude that (ML0)-(ML4) hold for  $(\mathcal{LMS})_{(n,m)}$ .

All objects involved in (ML0)-(ML4) are defined in a coordinate-free way (i.e. are defined geometrically), so the conditions are invariant under diffeomorphisms. Now, we will show that they are also invariant under  $(Id, \alpha, \beta, \gamma) \in MF$ .

Consider MF-feedback of the form (6.4). The transformed connection  $\tilde{\nabla}$ , and the components of vector fields  $\tilde{e}$  and  $\tilde{g}_r$  are given by

$$\begin{aligned} \tilde{\nabla} : \tilde{\Gamma}_{jk}^i &= \Gamma_{jk}^i - \sum_{r=1}^m g_r^i \gamma_{jk}^r \\ \tilde{e}^i &= e^i + \sum_{r=1}^m g_r^i \alpha^r \\ \tilde{g}_s^i &= \sum_{r=1}^m g_r^i \beta_s^r. \end{aligned} \quad (6.38)$$

The distribution  $\mathcal{E}^0$  is feedback invariant since the matrix  $(\beta_s^r)$  is invertible and thus

$$\tilde{\mathcal{E}}^0 = \text{span} \{\tilde{g}_1, \dots, \tilde{g}_m\} = \text{span} \{g_1, \dots, g_m\} = \mathcal{E}^0,$$

therefore it is involutive and of constant rank implying that condition  $(ML1)$  is MF-invariant.

Now, we calculate

$$ad_{\tilde{e}}\tilde{g}_r = \left[ e + \sum_{s=1}^m \alpha^s g_s, \sum_{p=1}^m \beta_r^p g_p \right] = \sum_{p=1}^m \beta_r^p ad_e g_p \quad \text{mod } \mathcal{E}^0.$$

Since the matrix  $(\beta_r^p)$  is invertible,  $\text{rank } \tilde{\mathcal{E}}^1 = \text{rank } \mathcal{E}^1$ . Therefore  $(ML0)$  is invariant.

The  $\gamma$ -part of the mechanical feedback transformation (6.4) modifies the Christoffel symbols according to first formula of (6.38) and thus the Riemann tensor of the closed loop system reads

$$\tilde{R}_{jkl}^i = \partial_k \tilde{\Gamma}_{jl}^i - \partial_l \tilde{\Gamma}_{jk}^i + \tilde{\Gamma}_{ks}^i \tilde{\Gamma}_{jl}^s - \tilde{\Gamma}_{ls}^i \tilde{\Gamma}_{jk}^s,$$

and we calculate its terms

$$\begin{aligned} \partial_k \tilde{\Gamma}_{jl}^i &= \partial_k \left( \Gamma_{jl}^i - \sum_{t=1}^m g_t^i \gamma_{jl}^t \right) = \partial_k \Gamma_{jl}^i - \sum_{t=1}^m \gamma_{jl}^t \partial_k g_t^i - \sum_{t=1}^m g_t^i \partial_k \gamma_{jl}^t \\ \partial_l \tilde{\Gamma}_{jk}^i &= \partial_l \left( \Gamma_{jk}^i - \sum_{t=1}^m g_t^i \gamma_{jk}^t \right) = \partial_l \Gamma_{jk}^i - \sum_{t=1}^m \gamma_{jk}^t \partial_l g_t^i - \sum_{t=1}^m g_t^i \partial_l \gamma_{jk}^t \end{aligned}$$

$$\begin{aligned} \tilde{\Gamma}_{ks}^i \tilde{\Gamma}_{jl}^s &= \left( \Gamma_{ks}^i - \sum_{t=1}^m g_t^i \gamma_{ks}^t \right) \left( \Gamma_{jl}^s - \sum_{r=1}^m g_r^s \gamma_{jl}^r \right) = \Gamma_{ks}^i \Gamma_{jl}^s - \Gamma_{ks}^i \sum_{r=1}^m g_r^s \gamma_{jl}^r - \\ &\quad - \sum_{t=1}^m g_t^i \gamma_{ks}^t \Gamma_{jl}^s + \sum_{t=1}^m \sum_{r=1}^m g_t^i g_r^s \gamma_{ks}^t \gamma_{jl}^r \\ \tilde{\Gamma}_{ls}^i \tilde{\Gamma}_{jk}^s &= \left( \Gamma_{ls}^i - \sum_{t=1}^m g_t^i \gamma_{ls}^t \right) \left( \Gamma_{jk}^s - \sum_{r=1}^m g_r^s \gamma_{jk}^r \right) = \Gamma_{ls}^i \Gamma_{jk}^s - \Gamma_{ls}^i \sum_{r=1}^m g_r^s \gamma_{jk}^r - \\ &\quad - \sum_{t=1}^m g_t^i \gamma_{ls}^t \Gamma_{jk}^s + \sum_{t=1}^m \sum_{r=1}^m g_t^i g_r^s \gamma_{ls}^t \gamma_{jk}^r. \end{aligned}$$

Therefore we have (below  $\nabla$  stands for the covariant derivative defined with the help of  $\Gamma_{jk}^i$  and  $\tilde{\nabla}$  for that defined via  $\tilde{\Gamma}_{jk}^i$ )

$$\begin{aligned} \tilde{R}_{jkl}^i &= R_{jkl}^i - \sum_{t=1}^m \gamma_{jl}^t \nabla_k g_t^i + \sum_{t=1}^m \gamma_{jk}^t \nabla_l g_t^i - \\ &\quad - \sum_{t=1}^m g_t^i \left( \partial_k \gamma_{jl}^t - \partial_l \gamma_{jk}^t + \gamma_{ks}^t \Gamma_{jl}^s - \gamma_{ls}^t \Gamma_{jk}^s - \gamma_{ks}^t \sum_{r=1}^m g_r^s \gamma_{jl}^r + \gamma_{ls}^t \sum_{r=1}^m g_r^s \gamma_{jk}^r \right). \end{aligned} \quad (6.39)$$

Clearly, for  $(\mathcal{LMS})_{(n,m)}$  we have  $R_{jkl}^i = 0$ , and  $\nabla_k g_t^i = \nabla_k b_t^i = 0$  and thus (6.39) reads

$$\tilde{R}_{jkl}^i = \sum_{t=1}^m g_t^i \zeta_{jkl}^t,$$

where  $\zeta_{jkl}^t = - \left( \partial_k \gamma_{jl}^t - \partial_l \gamma_{jk}^t - \gamma_{ks}^t \sum_{r=1}^m g_r^s \gamma_{jl}^r + \gamma_{ls}^t \sum_{r=1}^m g_r^s \gamma_{jk}^r \right)$  are functions. Since  $\text{ann } \mathcal{E}^0 = \text{ann } \tilde{\mathcal{E}}^0$ , it follows that

$$\text{ann } \tilde{\mathcal{E}}^0 \subset \text{ann } \tilde{R}$$

and  $(ML2)$  is, indeed,  $MF$ -invariant.

To prove that  $(ML3)$  is invariant we will calculate  $\tilde{\nabla}\tilde{g}_r$ , for  $1 \leq r \leq m$ . Since

$$\tilde{\nabla}_j g_r^i = \partial_j g_r^i + \tilde{\Gamma}_{jk}^i g_r^k = \partial_j g_r^i + \left( \Gamma_{jk}^i - \sum_{p=1}^m g_p^i \gamma_{jk}^p \right) g_r^k = \nabla_j g_r^i - \sum_{p=1}^m g_p^i \gamma_{jk}^p g_r^k,$$

and denoting  $\gamma^p(g_r) = \gamma_{jk}^p g_r^k$ , we have

$$\tilde{\nabla} g_r = \nabla g_r - \sum_{p=1}^m g_p \otimes \gamma^p(g_r),$$

and

$$\tilde{\nabla}\tilde{g}_r = \tilde{\nabla} \left( \sum_{s=1}^m \beta_r^s g_s \right) = \sum_{s=1}^m \beta_r^s \tilde{\nabla} g_s + \sum_{s=1}^m d\beta_r^s \otimes g_s.$$

Therefore we have:

$$\tilde{\nabla}\tilde{g}_r = \sum_{s=1}^m \beta_r^s \tilde{\nabla} g_s + \sum_{s=1}^m d\beta_r^s \otimes g_s = \sum_{s=1}^m \beta_r^s \nabla g_s - \sum_{s=1}^m \sum_{p=1}^m \beta_r^s g_p \otimes \gamma^p(g_s) + \sum_{s=1}^m d\beta_r^s \otimes g_s,$$

and since  $\nabla g_r = \nabla b_r = 0$ , it follows

$$\text{ann } \tilde{\mathcal{E}}^0 \subset \text{ann } \tilde{\nabla}\tilde{g}_r,$$

implying that  $(ML3)$  is  $MF$ -invariant.

The second total covariant derivative  $\tilde{\nabla}^2 \tilde{e}$ , see Definition 2.13, is given by

$$\tilde{\nabla}^2 \tilde{e} = \tilde{\nabla}^2 (e + \sum_{t=1}^m \alpha^t g_t) = \tilde{\nabla}^2 e + \sum_{t=1}^m \alpha^t \otimes \tilde{\nabla}^2 g_t + 2 \sum_{t=1}^m d\alpha^t \otimes \tilde{\nabla} g_t + \sum_{t=1}^m \tilde{\nabla} d\alpha^t \otimes g_t, \quad (6.40)$$

where  $\tilde{\nabla}^2 e = \tilde{\nabla}_{jk}^2 e^i \partial_i \otimes dx^j \otimes dx^k$  and

$$\begin{aligned} \tilde{\nabla}_{jk}^2 e^i &= \tilde{\nabla}_j (\tilde{\nabla}_k e^i) = \partial_j \tilde{\nabla}_k e^i + \left( \Gamma_{jl}^i - \sum_{t=1}^m g_t^i \gamma_{jl}^t \right) \tilde{\nabla}_k e^l - \left( \Gamma_{jk}^l - \sum_{r=1}^m g_r^l \gamma_{jk}^r \right) \tilde{\nabla}_l e^i = \\ &= \nabla_j (\tilde{\nabla}_k e^i) - \sum_{t=1}^m g_t^i \gamma_{jl}^t \tilde{\nabla}_k e^l + \sum_{r=1}^m g_r^l \gamma_{jk}^r \tilde{\nabla}_l e^i = \\ &= \nabla_{jk}^2 e^i - \nabla_j \left( \sum_{t=1}^m g_t^i \gamma_{ks}^t e^s \right) - \sum_{t=1}^m g_t^i \gamma_{jl}^t \nabla_k e^l + \sum_{t=1}^m \sum_{r=1}^m g_t^i \gamma_{jl}^t g_r^l \gamma_{ks}^r e^s + \\ &\quad + \sum_{r=1}^m g_r^l \gamma_{jk}^r \nabla_l e^i - \sum_{r=1}^m \sum_{t=1}^m g_r^l \gamma_{jk}^r g_t^i \gamma_{ls}^t e^s, \end{aligned}$$

where  $\nabla_j \left( \sum_{t=1}^m g_t^i \gamma_{ks}^t e^s \right) = \sum_{t=1}^m \gamma_{ks}^t e^s \nabla_j g_t^i + \sum_{t=1}^m g_t^i e^s \nabla_j \gamma_{ks}^t + \sum_{t=1}^m g_t^i \gamma_{ks}^t \nabla_j e^s$ .

A linear system satisfies:  $\Gamma_{jk}^i = 0$  (thus  $\nabla_j(\cdot) = \partial_j(\cdot)$ ),  $\nabla g = 0$  and  $\nabla^2 e = 0$ . Therefore we have

$$\tilde{\nabla}_{jk}^2 e^i = \sum_{t=1}^m g_t^i \left( -e^s \partial_j \gamma_{ks}^t - \gamma_{ks}^t \partial_j e^s - \gamma_{jl}^t \partial_k e^l + \sum_{r=1}^m \gamma_{jl}^t g_r^l \gamma_{ks}^r e^s - \sum_{r=1}^m g_r^l \gamma_{jk}^r \gamma_{ls}^t e^s \right) + \sum_{r=1}^m \gamma_{jk}^r g_r^l \partial_l e^i.$$

The last term is

$$\sum_{r=1}^m \gamma_{jk}^r g_r^l \partial_l e^i = \sum_{r=1}^m \gamma_{jk}^r g_r^l \partial_l (E_p^i x^p) = \sum_{r=1}^m \gamma_{jk}^r E_l^i b_r^l,$$

that is, the  $i$ -th component of  $ad_e g_r = -Eb_r$  multiplied by  $-\gamma_{jk}^r$ .

Therefore, we conclude that  $\text{ann } \tilde{\mathcal{E}}^1 \subset \text{ann } \tilde{\nabla}^2 \tilde{e}$ , where

$$\tilde{\mathcal{E}}^1 = \mathcal{E}^1 = \text{span} \{b_1, \dots, b_r, Eb_1, \dots, Eb_r\}$$

and therefore  $(ML_4)$  is invariant.

Sufficiency. By  $(ML_0)$ - $(ML_0)$  and Lemma 6.8, we may assume that after applying a preliminary diffeomorphism  $\phi : Q \rightarrow Q$  and  $u \mapsto \beta u$ , the vector fields  $g_r$  are rectified, that is,  $g_r = \frac{\partial}{\partial x^r}$ . Then we apply a feedback of the form (6.4) with  $\gamma_{jk}^r = \Gamma_{jk}^r$ ,  $\alpha^r = 0$ ,  $\beta_s^r = \delta_s^r$  (the Kronecker delta), for  $1 \leq r \leq m$ .

Using (6.39), we calculate the Riemann tensor  $\tilde{R}_{jkl}^i$  of the closed-loop system

$$\begin{aligned} \tilde{R}_{jkl}^i &= R_{jkl}^i - \sum_{r=1}^m \Gamma_{jl}^r \nabla_k g_r^i + \sum_{r=1}^m \Gamma_{jk}^r \nabla_l g_r^i - \\ &\quad - \sum_{r=1}^m g_r^i \left( \partial_k \Gamma_{jl}^r - \partial_l \Gamma_{jk}^r + \Gamma_{ks}^r \Gamma_{jl}^s - \Gamma_{ls}^r \Gamma_{jk}^s - \Gamma_{ks}^r \sum_{t=1}^m g_t^s \Gamma_{jl}^t + \Gamma_{ls}^r \sum_{t=1}^m g_t^s \Gamma_{jk}^t \right) = \\ &= R_{jkl}^i - \sum_{r=1}^m \Gamma_{jl}^r \nabla_k g_r^i + \sum_{r=1}^m \Gamma_{jk}^r \nabla_l g_r^i - \sum_{r=1}^m g_r^i \left( R_{jkl}^r - \Gamma_{ks}^r \sum_{t=1}^m g_t^s \Gamma_{jl}^t + \Gamma_{ls}^r \sum_{t=1}^m g_t^s \Gamma_{jk}^t \right). \end{aligned}$$

We will prove that  $\tilde{R}_{jkl}^i = 0$ . For  $m+1 \leq i \leq n$ , we have  $R_{jkl}^i = 0$  (by  $(ML_2)$ ) and  $g_r^i = 0$ , for  $1 \leq r \leq m$  (since  $g_r = \frac{\partial}{\partial x^r}$ ), implying that

$$\tilde{R}_{jkl}^i = R_{jkl}^i + 0 = 0 \quad \text{for } m+1 \leq i \leq n.$$

For  $1 \leq i \leq m$ , we have  $g_r^i = \delta_r^i$  and thus

$$\nabla_k g_r^i = \frac{\partial g_r^i}{\partial x^k} + \Gamma_{ks}^i g_r^s = \Gamma_{kr}^i,$$

for all  $1 \leq k \leq n$ . Therefore we have

$$\tilde{R}_{jkl}^i = R_{jkl}^i - \sum_{r=1}^m \Gamma_{jl}^r \Gamma_{kr}^i + \sum_{r=1}^m \Gamma_{jk}^r \Gamma_{lr}^i - \left( R_{jkl}^i - \sum_{s=1}^m \Gamma_{ks}^i \Gamma_{jl}^s + \sum_{s=1}^m \Gamma_{ls}^i \Gamma_{jk}^s \right) = 0,$$

for  $1 \leq i \leq m$ .

By Riemann theorem, see Theorem 2.11, ( $R = 0$  and  $\nabla$  is assumed symmetric), there exists a local change of coordinates  $\tilde{x} = \phi(x)$ , such that  $\tilde{\Gamma}_{jk}^i(\tilde{x}) = 0$ . Note that in this coordinate system, the control vector fields are not rectified any longer, i.e.  $\tilde{g}_r = \tilde{g}_r^i \frac{\partial}{\partial \tilde{x}^i}$ . Then we apply feedback  $u \mapsto \beta u$ , such that  $(\beta_j^i) = (\tilde{g}_j^i)^{-1}$ , for

$1 \leq i, j \leq m$ . To simplify notation we drop "tildas" and we thus have

$$\begin{aligned}\Gamma_{jk}^i &= 0, \\ g_r &= \frac{\partial}{\partial x^r} + \sum_{s=m+1}^n g_r^s(x) \frac{\partial}{\partial x^s}, \quad 1 \leq r \leq m, \\ e &= e^i(x) \frac{\partial}{\partial x^i}.\end{aligned}$$

The annihilator of  $\mathcal{E}^0 = \text{span}\{g_1, \dots, g_m\}$  is given by  $n - m$  one-forms

$$\omega^k = dx^k - \sum_{s=1}^m g_s^k dx^s, \quad \text{for } m+1 \leq k \leq n.$$

By (ML3), these forms annihilate the covariant derivative of  $g_r$  and thus, since  $\Gamma_{jk}^i = 0$ ,

$$\omega_i^k \nabla_j g_r^i = \omega_i^k \partial_j g_r^i = 0,$$

which forms sets of PDEs of the following form

$$\frac{\partial g_r^k}{\partial x^j} - \sum_{s=1}^m g_s^k \frac{\partial g_r^s}{\partial x^j} = 0 \quad \text{for } m+1 \leq k \leq n, \quad 1 \leq j \leq n, \quad 1 \leq r \leq m.$$

Since  $\frac{\partial g_r^s}{\partial x^j} = 0$ , for  $1 \leq s \leq m$ , it follows that

$$\frac{\partial g_r^k}{\partial x^j} = 0 \quad \text{for } m+1 \leq k \leq n, \quad 1 \leq j \leq n, \quad 1 \leq r \leq m.$$

and therefore  $g_r^k = b_r^k$  are constant. Thus the control vector fields are

$$g_r = \frac{\partial}{\partial x^r} + \sum_{k=m+1}^n b_r^k \frac{\partial}{\partial x^k}.$$

Now, consider a linear change of coordinates  $\tilde{x} = Tx$ , which is defined as follows

$$\begin{aligned}\tilde{x}^i &= x^i && \text{for } 1 \leq i \leq m \\ \tilde{x}^i &= x^i - \sum_{j=1}^m b_j^i x^j && \text{for } m+1 \leq i \leq n.\end{aligned}$$

Note that linear transformations do not produce new Christoffel symbols, since  $\frac{\partial^2 \tilde{x}^i}{\partial x^j \partial x^k} = 0$  (see (6.7)). Therefore we have

$$\begin{aligned}\tilde{\Gamma}_{jk}^i &= 0 \\ \tilde{g}_r &= \frac{\partial}{\partial \tilde{x}^r} \\ \tilde{e} &= \tilde{e}^i(\tilde{x}) \frac{\partial}{\partial \tilde{x}^i}.\end{aligned}$$

Using feedback  $\tilde{e} \mapsto \tilde{e} + \sum_{r=1}^m \alpha^r \tilde{g}_r$  we can reject the first  $m$  components of  $\tilde{e}$  to get

$$\tilde{e} = \sum_{i=m+1}^n \tilde{e}^i(\tilde{x}) \frac{\partial}{\partial \tilde{x}^i}.$$

Denote  $\text{rank } \tilde{\mathcal{E}}^1 = m + p$ , where  $0 \leq p \leq m$ . We have

$$\tilde{\mathcal{E}}^1 = \text{span} \{ \tilde{g}_1, \dots, \tilde{g}_m, \text{ad}_{\tilde{e}} \tilde{g}_1, \dots, \text{ad}_{\tilde{e}} \tilde{g}_m \},$$

where  $\tilde{g}_r = \frac{\partial}{\partial \tilde{x}^r}$  and  $\text{ad}_{\tilde{e}} \tilde{g}_r = - \sum_{i=m+1}^n \frac{\partial \tilde{e}^i}{\partial \tilde{x}^r} \frac{\partial}{\partial \tilde{x}^i}$ . It follows that, if  $\text{rank} \left( \frac{\partial \tilde{e}^i}{\partial \tilde{x}^r}(x) \right) = p$ , for  $m+1 \leq i \leq n$  and  $1 \leq r \leq m$  then there exists a permutation of coordinates  $\tilde{x}^1, \dots, \tilde{x}^n$  (i.e. a linear transformation preserving  $\tilde{\Gamma}_{jk}^i = 0$ ), such that

$$\text{rank} \left( \frac{\partial \tilde{e}^i}{\partial \tilde{x}^r}(x) \right) = p \quad \text{for } m+1 \leq i \leq m+p, 1 \leq r \leq p.$$

It follows that the following change of coordinates

$$\begin{aligned} \bar{x}^i &= \tilde{e}^i(\tilde{x}) && \text{for } 1 \leq i \leq p \\ \bar{x}^i &= \tilde{x}^i && \text{otherwise} \end{aligned}$$

is a local diffeomorphism  $\bar{\phi}$  in which  $\bar{e} = \bar{\phi}_* \tilde{e} = \tilde{e}^i \frac{\partial}{\partial \bar{x}^i}$ , where

$$\begin{aligned} \bar{e}^{m+i} &= \bar{x}^i && \text{for } m+1 \leq i \leq m+p. \\ \bar{e}^i &= \tilde{e}^i(\bar{x}) \quad (\text{any functions}) && \text{otherwise.} \end{aligned}$$

Again, we apply the mechanical feedback, such that

$$\begin{aligned} \bar{e} &\mapsto \bar{e} + \sum_{s=1}^m \bar{\alpha}^s \bar{g}_s \\ \bar{g}_r &\mapsto \sum_{s=1}^m \bar{\beta}_r^s \bar{g}_s \\ \bar{\Gamma}_{jk}^i &\mapsto \bar{\Gamma}_{jk}^i - \sum_{s=1}^m \bar{g}_s^i \gamma_{jk}^s \quad \text{for } 1 \leq i \leq p, \end{aligned}$$

since the diffeomorphism  $\bar{\phi}$  is nonlinear only in first  $p$  coordinates, it induces Christoffel symbols  $\bar{\Gamma}_{jk}^i(\bar{x})$ , for  $1 \leq i \leq p$ , that can be compensated by the above feedback. Moreover, the feedback compensate the first  $m$  components of  $\bar{e}$  and rectifies  $\bar{g}_r = \frac{\partial}{\partial \bar{x}^r}$ .

Finally, for notational sake, we drop "bars" and we obtain

$$\begin{aligned} e &= \sum_{i=m+1}^{m+p} x^{i-m} \frac{\partial}{\partial x^i} + \sum_{i=m+p+1}^n e^i(x) \frac{\partial}{\partial x^i} \\ g_r &= \frac{\partial}{\partial x^r} \\ \Gamma_{jk}^i &= 0 \end{aligned}$$

Now, we calculate

$$\text{ad}_e g_j = - \frac{\partial}{\partial x^{m+j}} - \sum_{i=m+p+1}^n \frac{\partial e^i}{\partial x^j} \frac{\partial}{\partial x^i},$$

for  $1 \leq j \leq p$ .



Annihilators of  $\mathcal{E}^1$  are given by

$$\nu^k = dx^k - \sum_{s=1}^p \frac{\partial e^k}{\partial x^s} dx^{m+s},$$

for  $m + p + 1 \leq k \leq n$ .

By (ML4), these forms annihilate the second total covariant derivative of  $e$

$$\nu_i^k \nabla_j^2 e^i = \nu_i^k \partial_j \partial_l e^i = 0,$$

which forms a set of PDEs

$$\frac{\partial e^k}{\partial x^j \partial x^l} - \sum_{s=1}^p \frac{\partial^2 e^{m+s}}{\partial x^j \partial x^l} \frac{\partial e^k}{\partial x^s} = 0$$

for  $m + p + 1 \leq k \leq n$ ,  $1 \leq j, l \leq n$ . The term  $\frac{\partial^2 e^{m+s}}{\partial x^j \partial x^l} = 0$ , since  $e^{m+s} = x^s$ , for  $1 \leq s \leq p$ . Therefore we have

$$\frac{\partial e^k}{\partial x^j \partial x^l} = 0, \quad \text{for } m + p + 1 \leq k \leq n,$$

implying that  $e^k = E_j^k x^j + c^k$  are linear components and  $e$  reads

$$e = \sum_{i=m+1}^{m+p} x^{i-m} \frac{\partial}{\partial x^i} + \sum_{i=m+p+1}^n \left( E_j^i x^j + c^i \right) \frac{\partial}{\partial x^i}.$$

Finally the linear mechanical system ( $\mathcal{LMS}$ ), possibly non-controllable, reads

$$\begin{aligned} \dot{x}^i &= y^i & 1 \leq i \leq n \\ \dot{y}^i &= u_i & 1 \leq i \leq m \\ \dot{y}^i &= x^{i-m} & m+1 \leq i \leq m+p \\ \dot{y}^i &= E_j^i x^j + c^i & m+p+1 \leq i \leq n. \end{aligned}$$

□

There are several remarks that can be concluded from the proof.

**Remark 6.22.** For ( $\mathcal{MS}$ ) with scalar control, i.e.  $m = 1$ , the distribution  $\mathcal{E}^0 = \text{span}\{g\}$  is always involutive, therefore (ML1) can be dropped out.

**Remark 6.23.** If a mechanical system ( $\mathcal{MS}$ )<sub>(n,m)</sub> is maximally non-controllable, i.e.  $\text{rank } \mathcal{E}^1 = \text{rank } \mathcal{E}^0 = m$ , or equivalently  $p = 0$ , condition (ML4) is more restrictive and reads

$$\text{ann } \mathcal{E}^0 \subset \text{ann } \nabla^2 e.$$

Moreover, for the two-dimensional case, the conditions can be simplified. If the mechanical system ( $\mathcal{MS}$ )<sub>(2,1)</sub> is maximally non-controllable then the above remark applies. In other cases, we have  $\mathcal{E}^1 = 2 = n$ , thus the condition (ML4) is always satisfied and can be dropped out. Therefore the three remaining conditions are

(ML0)'  $g, ad_e g$  are independent at  $x_0$

(ML2)'  $\text{ann } g \subset \text{ann } R$

(ML3)'  $\text{ann } g \subset \text{ann } \nabla g$

In this case  $g, ad_e g$  are independent and form a frame. Therefore we can express tensors  $R$  and  $\nabla g$  in this frame, as the covariant derivatives of  $g, ad_e g$  in the direction of  $g$  and  $ad_e g$ . Note that, this directly corresponds to Proposition 6.12.

#### 6.4.1 Potential-free ( $\mathcal{MS}$ )

Consider ( $\mathcal{MS}$ ) without uncontrolled vector field, i.e.  $e \equiv 0$ . This corresponds to the case, where the potential energy of the system is zero (or constant), for example, the gravity is non-existent (e.g. satellites) or the direction of the gravitational field is orthogonal to the plane of the motion (e.g. planar manipulators). What is more, there are no additional devices that store energy in the system (e.g. springs). Members of that class of mechanical control systems will be called the *potential-free* ( $\mathcal{MS}$ ). They are also known as *affine connection control systems* and has been studied by Lewis [25].

The equations of the potential-free ( $\mathcal{MS}$ ) read

$$\begin{aligned}\dot{x}^i &= y^i \\ \dot{y}^i &= -\Gamma_{jk}^i(x)y^j y^k + \sum_{r=1}^m g_r^i(x)u_r.\end{aligned}$$

In this section, we consider MF-linearization of such systems. First, we consider their linear form, i.e. a potential-free ( $\mathcal{LMS}$ ). For simplicity, we use the matrix notation, as introduced in Chapter 4. The system reads

$$\begin{aligned}\dot{x} &= y \\ \dot{y} &= Bu.\end{aligned}$$

By Lemma 4.2, the potential-free ( $\mathcal{LMS}$ ) is controllable if and only if  $\text{rank } B = m = n$ , i.e. the system is fully-actuated. Since for fully-actuated case, the conditions for MF-linearization are always satisfied, we call this situation trivial (e.g. for fully-actuated manipulators this is known as the *computed torques method*). On the other hand, the underactuated case can be summarized with the following corollary.

**Corollary 6.24.** *There are no controllable, underactuated (i.e.  $m < n$ ), potential-free ( $\mathcal{MS}$ ) that are MF-linearizable.*

Note that, this corresponds to the classical case of F-linearization of driftless systems, where there do not exist controllable, underactuated (i.e.  $m < n$ ) driftless control systems that are F-linearizable.

Now we can consider the non-controllable case. We invoke conditions (ML0) – (ML4) of Theorem 6.21 and investigate them in this case. Note that condition (ML0) is simplified and condition (ML4) is trivially satisfied, therefore can be omitted. The rest conditions remain. Thus we have

**Proposition 6.25.** *A potential-free mechanical control system  $(\mathcal{MS})_{(n,m)}$  is locally around  $x_0$  MF-linearizable if and only if it satisfies*

(MP0)  $\mathcal{E}^0$  is involutive and of constant rank

(MP1)  $\text{ann } \mathcal{E}^0 \subset \text{ann } R$

(MP2)  $\text{ann } \mathcal{E}^0 \subset \text{ann } \nabla g_r$  for  $1 \leq r \leq m$

The proof follows directly from the proof of Theorem 6.21.



## Chapter 7

# Examples and control problems solved using linearization

In this chapter, we present several examples of mechanical systems and investigate their linearizability. Then, we use our theory to solve some control problems in more involved cases.

### 7.1 Examples

**Example Robot cart propelled by a blower.** Consider a simplified model of a cart on rails (as considered in [19]) propelled by a horizontal blower whose angle of thrust (denoted  $x^1$ ) can be controlled and the thrust  $\tau$  is fixed (therefore it is a constant parameter). The system is depicted in Figure 7.1. The position of the cart is  $x^2$ . Denoting by  $m$  the mass of the cart and the moment of inertia of the blower by  $J$ , we can write simple dynamics of the system:

$$\begin{aligned} J\ddot{x}^1 &= u \\ m\ddot{x}^2 &= \tau \cos x^1, \end{aligned}$$

thus the corresponding equations of  $(\mathcal{MS})$  read (with  $b = \frac{1}{J}$  and  $a = \frac{\tau}{m}$ )

$$\begin{aligned} \dot{x}^1 &= y^1 \\ \dot{x}^2 &= y^2 \\ \dot{y}^1 &= bu \\ \dot{y}^2 &= a \cos x^1. \end{aligned} \tag{7.1}$$

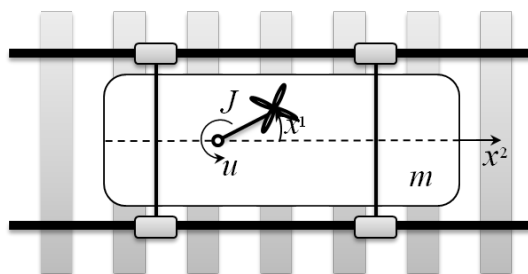

FIGURE 7.1: Robot cart propelled by a blower.

We will illustrate with this system several questions related to our results. Notice that all Christoffel symbols  $\Gamma_{jk}^i = 0$  and therefore the Riemann tensor  $R = 0$ ,

see (2.10). It is obvious because the mass matrix (the metric tensor)  $\mathbf{m} = (\mathbf{m}_{ij})$  is Euclidean, with  $\mathbf{m}_{11} = J$ ,  $\mathbf{m}_{22} = m$ ,  $\mathbf{m}_{12} = \mathbf{m}_{21} = 0$ .

The first question is whether (7.1) is MS-linearizable, that is, can we find a (local) diffeomorphism  $\phi$  that keeps  $\Gamma_{jk}^i = 0$  and  $g$  constant and simultaneously linearizes the drift  $a \cos x^1 \frac{\partial}{\partial y^2}$ . Theorem 5.6 gives a negative answer to that question. Indeed,  $R = 0$  (giving (MNS1)) and  $\nabla g = \left( \frac{\partial g^i}{\partial x^j} \right) = 0$  (giving (MNS2)) but (MNS3) fails since  $\nabla^2 e = \left( \frac{\partial^2 e^i}{\partial x^j \partial x^k} \right) \neq 0$  because  $\left( \frac{\partial^2 e^2}{\partial x^1 \partial x^1} \right) = -a \cos x^1$ .

The second natural question is whether allowing for MF-transformations (mechanical feedback) improves the situation. The positive answer is given by Theorem 6.21 (see also Remark 6.22). Indeed,  $\mathcal{E}^0 = \text{span}\{g\}$  is involutive, (ML2) and (ML3) are trivially satisfied since  $R = 0$ ,  $\nabla g = 0$  and, finally, (ML4) holds since  $\mathcal{E}^1 = \text{span}\{g, ad_e g\} = \text{TS} \times \text{T}\mathbb{R}$  and thus  $\text{ann } \mathcal{E}^1 = 0$ .

The third question is what are MF-linearizing functions (outputs) of system (7.1). The answer is given by Proposition 6.15. All functions  $h$  satisfying (MP1) are of the form  $h = h(x^2)$ ,  $h'(x^2) \neq 0$ . Since  $\Gamma_{jk}^i = 0$ , we see that for  $h = x^2$  we have  $\nabla(dx^2) = 0$  and thus it is, indeed, an MF-linearizing output. However, if we take an arbitrary  $h = h(x^2)$ , then  $dh = h'(x^2)dx^2$  and  $\nabla(h'(x^2)dx^2) = h''(x^2)dx^2 \otimes dx^2$ , which vanishes if and only if  $h'' \equiv 0$ . It follows that all MF-linearizing outputs (satisfying  $h(0) = 0$ ) are of the form  $h(x^2) = cx^2$ ,  $c \neq 0$ ,  $c \in \mathbb{R}$  and so they are very particular among all F-linearizing outputs that are of the form  $h = h(x^2)$ ,  $h'(x^2) \neq 0$ .

In the above example we discussed F-linearizable system that is MF-linearizable. One of the crucial questions for the whole thesis is the following: are there F-linearizable systems that are not MF-linearizable? An answer is given by the following example.

**Example *Linearization of the two-link manipulator with joint elasticity.*** Consider a two-link manipulator with joint elasticity. It can be viewed as a combination of the two-link manipulator (see 3.3.2) and the single link manipulator with joint elasticity (see 3.3.5). For a modelling and analysis see [20] (and equations (13-14) there). However, we neglect friction terms as irrelevant in our study. Moreover we assume unit gear ratios in both motors. We invoke equations of (MS) and do not focus on their physical interpretation as it has been done in the previous examples. All parameters below are constant for a given construction.

Let  $x^1, x^2$  denote the angles of the first and the second link respectively and  $x^3, x^4$  denote the angles of the first and the second motor shaft. It is a mechanical control system with 4 degrees of freedom,  $x = (x^1, x^2, x^3, x^4) \in Q = \mathbb{S} \times \mathbb{S} \times \mathbb{S} \times \mathbb{S} = \mathbb{T}^4$ , and two controls  $(u_1, u_2) \in \mathcal{U} \subset \mathbb{R}^2$ . The equation of (MS) on  $\text{T}Q$  read

$$\begin{aligned} \dot{x}^1 &= y^1 \\ \dot{x}^2 &= y^2 \\ \dot{x}^3 &= y^3 \\ \dot{x}^4 &= y^4 \\ \dot{y}^1 &= -\Gamma_{jk}^1 y^j y^k + e^1 \\ \dot{y}^2 &= -\Gamma_{jk}^2 y^j y^k + e^2 \\ \dot{y}^3 &= e^3 + \frac{1}{J_1} u_1 \\ \dot{y}^4 &= e^4 + \frac{1}{J_2} u_2 \end{aligned}$$

where only non-zero Christoffel symbols are:

$$\begin{aligned}\Gamma_{11}^1 &= -\Gamma_{12}^2 = -\Gamma_{21}^2 = -\Gamma_{22}^2 = -\frac{\zeta_2 \zeta_3 \sin x^2 + \zeta_3^2 \sin x^2 \cos x^2}{\zeta_1 \zeta_2 - \zeta_3^2 \cos^2 x^2} \\ \Gamma_{12}^1 &= \Gamma_{21}^1 = \Gamma_{22}^1 = -\frac{\zeta_2 \zeta_3 \sin x^2}{\zeta_1 \zeta_2 - \zeta_3^2 \cos^2 x^2} \\ \Gamma_{11}^2 &= \frac{\zeta_3 \sin x^2 (\zeta_1 + \zeta_2 + 2\zeta_3 \cos x^2)}{\zeta_1 \zeta_2 - \zeta_3^2 \cos^2 x^2},\end{aligned}$$

and components of the uncontrolled vector field  $e(x)$  are

$$\begin{aligned}e^1 &= \frac{-\zeta_2 k_1 (x^1 - x^3) + k_2 (x^2 - x^4) (\zeta_2 + \zeta_3 \cos x^2)}{\zeta_1 \zeta_2 - \zeta_3^2 \cos^2 x^2} \\ e^2 &= \frac{k_1 (x^1 - x^3) (\zeta_2 + \zeta_3 \cos x^2) - k_2 (x^2 - x^4) (\zeta_1 + \zeta_2 + 2\zeta_3 \cos x^2)}{\zeta_1 \zeta_2 - \zeta_3^2 \cos^2 x^2} \\ e^3 &= \frac{k_1 (x^1 - x^3)}{J_1} \\ e^4 &= \frac{k_2 (x^2 - x^4)}{J_2},\end{aligned}$$

and the control vector fields are  $g_1 = \frac{1}{J_1} \frac{\partial}{\partial x^3}$  and  $g_2 = \frac{1}{J_2} \frac{\partial}{\partial x^4}$ .

Equivalently, it is a control system on the manifold  $M = \mathbb{T}Q$  equipped with coordinates  $z = (x, y)$

$$\dot{z} = F(z) + G_1(z)u_1 + G_2(z)u_2$$

where  $F, G_1, G_2 \in \mathfrak{X}(M)$ ,

$$\begin{aligned}F &= \sum_{i=1}^4 y^i \frac{\partial}{\partial x^i} + \left(-\Gamma_{jk}^1 y^j y^k + e^1\right) \frac{\partial}{\partial y^1} + \left(-\Gamma_{jk}^2 y^j y^k + e^2\right) \frac{\partial}{\partial y^2} + e^3 \frac{\partial}{\partial y^3} + e^4 \frac{\partial}{\partial y^4} \\ G_1 &= \frac{1}{J_1} \frac{\partial}{\partial y^3} \quad \text{and} \quad G_2 = \frac{1}{J_2} \frac{\partial}{\partial y^4}.\end{aligned}$$

A direct calculation of the iterative Lie brackets gives

$$\begin{aligned}
ad_F G_1 &= -\frac{1}{J_1} \frac{\partial}{\partial x^3} \\
ad_F G_2 &= -\frac{1}{J_2} \frac{\partial}{\partial x^4} \\
ad_F^2 G_1 &= \left( \frac{k_1 \zeta_2}{J_1 (\zeta_1 \zeta_2 - \zeta_3^2 \cos^2 x^2)} \right) \frac{\partial}{\partial y^1} - \left( \frac{k_1 (\zeta_2 + \zeta_3 \cos x^2)}{J_1 (\zeta_1 \zeta_2 - \zeta_3^2 \cos^2 x^2)} \right) \frac{\partial}{\partial y^2} - \frac{k_1}{J_1^2} \frac{\partial}{\partial y^3} \\
ad_F^2 G_2 &= -\left( \frac{k_2 (\zeta_2 + \zeta_3 \cos x^2)}{J_2 (\zeta_1 \zeta_2 - \zeta_3^2 \cos^2 x^2)} \right) \frac{\partial}{\partial y^1} + \left( \frac{k_2 (\zeta_1 + \zeta_2 + 2\zeta_3 \cos x^2)}{J_2 (\zeta_1 \zeta_2 - \zeta_3^2 \cos^2 x^2)} \right) \frac{\partial}{\partial y^2} - \frac{k_2}{J_2^2} \frac{\partial}{\partial y^4} \\
ad_F^3 G_1 &= -\left( \frac{k_1 \zeta_2}{J_1 (\zeta_1 \zeta_2 - \zeta_3^2 \cos^2 x^2)} \right) \frac{\partial}{\partial x^1} + \left( \frac{k_1 (\zeta_2 + \zeta_3 \cos x^2)}{J_1 (\zeta_1 \zeta_2 - \zeta_3^2 \cos^2 x^2)} \right) \frac{\partial}{\partial x^2} + \frac{k_1}{J_1^2} \frac{\partial}{\partial x^3} \\
&\quad + a_1(z) \frac{\partial}{\partial y^1} + a_2(z) \frac{\partial}{\partial y^2} \\
ad_F^3 G_2 &= \left( \frac{k_2 (\zeta_2 + \zeta_3 \cos x^2)}{J_2 (\zeta_1 \zeta_2 - \zeta_3^2 \cos^2 x^2)} \right) \frac{\partial}{\partial x^1} - \left( \frac{k_2 (\zeta_1 + \zeta_2 + 2\zeta_3 \cos x^2)}{J_2 (\zeta_1 \zeta_2 - \zeta_3^2 \cos^2 x^2)} \right) \frac{\partial}{\partial x^2} + \frac{k_2}{J_2^2} \frac{\partial}{\partial x^4} \\
&\quad + a_3(z) \frac{\partial}{\partial y^1} + a_4(z) \frac{\partial}{\partial y^2},
\end{aligned}$$

where  $a_1(z), a_2(z), a_3(z), a_4(z)$  are functions whose explicit form is irrelevant here. What is more, all Lie brackets of the following form are zero, i.e.

$$\left[ ad_F^i G_r, ad_F^j G_s \right] = 0,$$

for  $r, s = 1, 2$ ,  $i = 0, 1, 2$ , and  $j = 0, 1, 2, 3$ . However, we calculate

$$\left[ ad_F^2 G_r, ad_F^3 G_s \right] \neq 0,$$

thus the system is not S-linearizable (see Theorem 2.19). The linearizability distributions  $\mathcal{D}^0, \mathcal{D}^1, \mathcal{D}^2$  are involutive and of constant rank 2, 4, and 6, respectively. Finally,  $\mathcal{D}^3$  is of rank 8. Therefore, by Theorem 2.21 the system is F-linearizable.

Set  $h_1 = x^1$  and  $h_2 = x^2$  and calculate the vector relative degree. For  $r, i = 1, 2$  and  $k = 0, 1, 2$  we have

$$L_{G_r} L_F^k h_i = 0,$$

and

$$\begin{aligned}
L_{G_1} L_F^3 h_1 &= \frac{k_1 \zeta_2}{J_1 (\zeta_1 \zeta_2 - \zeta_3^2 \cos^2 x^2)} \\
L_{G_1} L_F^3 h_2 &= -\frac{k_1 (\zeta_2 + \zeta_3 \cos x^2)}{J_1 (\zeta_1 \zeta_2 - \zeta_3^2 \cos^2 x^2)} \\
L_{G_2} L_F^3 h_1 &= -\frac{k_2 (\zeta_2 + \zeta_3 \cos x^2)}{J_2 (\zeta_1 \zeta_2 - \zeta_3^2 \cos^2 x^2)} \\
L_{G_2} L_F^3 h_2 &= \frac{k_2 (\zeta_1 + \zeta_2 + 2\zeta_3 \cos x^2)}{J_2 (\zeta_1 \zeta_2 - \zeta_3^2 \cos^2 x^2)}
\end{aligned}$$

thus the decoupling matrix  $D(z) = (L_{g_r} L_f^{\nu_i - 1} h_i)(z)$  is of full rank 2. Therefore we conclude that the vector relative degree is (4,4) and the system is F-linearizable with

the linearization outputs  $h_i = x^i$ , for  $i = 1, 2$  (see Theorem 2.26).

At this point, we could expect that, similarly to the cases presented before, the system is also MF-linearizable. However that is not the case here. Indeed, the linearizing diffeomorphism is not mechanical since  $L_F^2 h_i = \dot{y}^i$  do depend on velocities, which is an obstruction for MF-linearizability. To show that there are no MF-linearizing outputs defining a mechanical diffeomorphism, we will prove that the system does not satisfy the condition (ML2) of Theorem 6.21. Calculate the non-zero components of Riemann tensor

$$R_{112}^1 = -R_{121}^1 = -R_{212}^2 = R_{221}^2 = -\frac{(-\zeta_1 \zeta_2 + \zeta_3^2) \zeta_3 \cos x^2 (\zeta_2 + \zeta_3 \cos x^2)}{(\zeta_1 \zeta_2 - \zeta_3^2 \cos^2 x^2)^2}$$

$$R_{212}^1 = -R_{221}^1 = \frac{(\zeta_1 \zeta_2 - \zeta_3^2) \zeta_2 \zeta_3 \cos x^2}{(\zeta_1 \zeta_2 - \zeta_3^2 \cos^2 x^2)^2}$$

$$R_{112}^2 = \frac{(-\zeta_1 \zeta_2 + \zeta_3^2) \zeta_3 \cos x^2 (\zeta_1 + \zeta_2 + 2\zeta_3 \cos x^2)}{(\zeta_1 \zeta_2 - \zeta_3^2 \cos^2 x^2)^2} = -R_{121}^2$$

and

$$\det \begin{pmatrix} R_{112}^1 & R_{212}^1 \\ R_{112}^2 & R_{212}^2 \end{pmatrix} = \frac{(-\zeta_1 \zeta_2 + \zeta_3^2)^2 \zeta_3^2 \cos^2 x^2}{(\zeta_1 \zeta_2 - \zeta_3^2 \cos^2 x^2)^3}$$

is non-zero at regular points. We see that the system is not MF-linearizable since  $\mathcal{E}^0 = \text{span}\{g_1, g_2\} = \text{span}\left\{\frac{\partial}{\partial x^3}, \frac{\partial}{\partial x^4}\right\}$  and its annihilator  $\Omega = \text{span}\{dx^1, dx^2\}$  clearly is not contained in  $\text{ann } R = \text{span}\{dx^3, dx^4\}$ .

In conclusion, we showed that the system is F-linearizable and even the linearization outputs depend on the configurations only, i.e.  $h_i = x^i$ , for  $i = 1, 2$ . Although, the linearizing diffeomorphism is not mechanical, which results in the transformed system is linear but not mechanical. That shows the distinction between the MF-linearization and F-linearization.

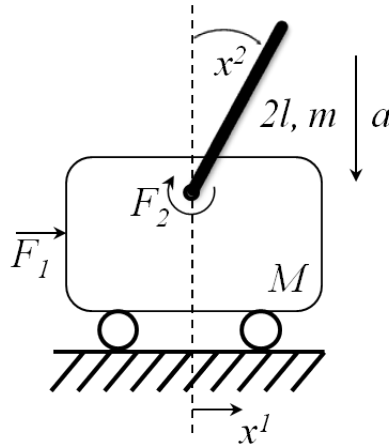

FIGURE 7.2: Cart-pole system.

**Example Cart-pole system.** Consider a pole on a cart (also known as a P-R manipulator or an inverted pendulum on a cart) as shown in Figure 7.2. The pole is a uniform density beam of length  $2l$  and mass  $m$  with center of mass at the pole center. The angle of the pole is denoted  $x^2$  and the position of the cart is  $x^1$ . The



mass of the cart is  $M$ . The kinetic energy of the system is

$$T = \frac{1}{2} (m + M) (\dot{x}^1)^2 + ml \cos x^2 \dot{x}^1 \dot{x}^2 + \frac{1}{2} \left( \frac{4}{3} ml^2 \right) (\dot{x}^2)^2,$$

and the potential energy is  $V = mal \cos x^2$ , thus the equations of dynamics read

$$\begin{aligned} (M + m) \ddot{x}^1 + ml \cos x^2 \ddot{x}^2 - m \sin x^2 (\dot{x}^2)^2 &= F_1 \\ ml \cos x^2 \ddot{x}^1 + \frac{4}{3} ml^2 \ddot{x}^1 - mal \sin x^2 &= F_2. \end{aligned}$$

We will consider two types of actuation, namely the only control force is applied to the cart, i.e.  $u := F_1$ ,  $F_2 \equiv 0$ , or the control torque is applied to the pole, i.e.  $u := F_2$ ,  $F_1 \equiv 0$ .

First, we will consider the case with the control force applied to the cart, i.e.  $u := F_1$ ,  $F_2 \equiv 0$ . By inverting the mass matrix, the equations of (MS) read

$$\begin{aligned} \dot{x}^1 &= y^1 \\ \dot{x}^2 &= y^2 \\ \dot{y}^1 &= -\Gamma_{22}^1 y^2 y^2 + e^1 + g^1 u \\ \dot{y}^2 &= -\Gamma_{22}^2 y^2 y^2 + e^2 + g^2 u, \end{aligned} \tag{7.2}$$

where, for  $\eta = 3 / (ml^2 (4(m + M) - 3m \cos^2 x^2))$ ,

$$\begin{aligned} \Gamma_{22}^1 &= \left( -\frac{4}{3} m^2 l^3 \sin x^2 \right) \eta, \quad e^1 = \left( -\frac{1}{2} m^2 l^2 a \sin(2x^2) \right) \eta, \quad g^1 = \left( \frac{4}{3} ml^2 \right) \eta, \\ \Gamma_{22}^2 &= \left( \frac{1}{2} m^2 l^2 \sin(2x^2) \right) \eta, \quad e^2 = \left( (M + m) mal \sin x^2 \right) \eta, \quad g^2 = \left( -ml \cos x^2 \right) \eta. \end{aligned}$$

By a direct calculation, see (2.10), the Riemann tensor is  $R = 0$ , so the system belongs to a class studied in a series of papers by Bedrossian and Spong, see [2], [3], [44]. In order to linearize this system, annihilating non-zero Christoffel symbols requires applying a non-trivial mechanical diffeomorphism, contrary to (7.1), where  $\Gamma_{jk}^i$  are zero in original coordinates. A natural question is whether the cart pole system (7.2) is MF-linearizable? By (2.7), we have  $\nabla g = \eta \nabla \bar{g} + d\eta \otimes \bar{g}$ , where  $\bar{g} = \left( \frac{4}{3} ml^2 \right) \frac{\partial}{\partial x^1} + (-ml \cos x^2) \frac{\partial}{\partial x^2}$ . Hence, we calculate

$$\nabla \bar{g} = \begin{pmatrix} \nabla_1 \bar{g}^1 & \nabla_2 \bar{g}^1 \\ \nabla_1 \bar{g}^2 & \nabla_2 \bar{g}^2 \end{pmatrix},$$

where, denoting  $c_1 = -\frac{4}{3} m^2 l^3 \sin x^2$  and  $c_2 = -\frac{4}{3} m^2 l^3 \sin x^2$ , we have

$$\begin{aligned} \nabla_1 \bar{g}^1 &= \nabla_{\frac{\partial}{\partial x^1}} \bar{g}^1 = 0 \\ \nabla_1 \bar{g}^2 &= \nabla_{\frac{\partial}{\partial x^1}} \bar{g}^2 = 0 \\ \nabla_2 \bar{g}^1 &= \nabla_{\frac{\partial}{\partial x^2}} \bar{g}^1 = \frac{\partial \bar{g}^1}{\partial x^2} + \Gamma_{22}^1 \bar{g}^2 = c_1 \eta \bar{g}^2 \\ \nabla_2 \bar{g}^2 &= \nabla_{\frac{\partial}{\partial x^2}} \bar{g}^2 = \frac{\partial \bar{g}^2}{\partial x^2} + \Gamma_{22}^2 \bar{g}^2 = \frac{\partial \bar{g}^2}{\partial x^2} + c_2 \eta \bar{g}^2. \end{aligned}$$

Since  $\frac{\partial \eta}{\partial x^1} = 0$ , we obtain

$$\begin{aligned}\nabla_1 g^1 &= \eta \nabla_{\frac{\partial}{\partial x^1}} \bar{g}^1 + \frac{\partial \eta}{\partial x^1} \bar{g}^1 = 0 \\ \nabla_1 g^2 &= \eta \nabla_{\frac{\partial}{\partial x^1}} \bar{g}^2 + \frac{\partial \eta}{\partial x^1} \bar{g}^2 = 0 \\ \nabla_2 g^1 &= \eta \nabla_{\frac{\partial}{\partial x^2}} \bar{g}^1 + \frac{\partial \eta}{\partial x^2} \bar{g}^1 = -\frac{2}{3} m^3 l^4 \sin(2x^2) \eta^2 \\ \nabla_2 g^2 &= \eta \nabla_{\frac{\partial}{\partial x^2}} \bar{g}^2 + \frac{\partial \eta}{\partial x^2} \bar{g}^2 = \frac{4}{3} m^2 l^3 (m + M) \sin x^2 \eta^2.\end{aligned}$$

Clearly  $\text{ann } g = \text{span } \{\omega\}$  where  $\omega = \cos x^2 dx^1 + \frac{4}{3} l dx^2$ , therefore

$$\begin{aligned}\omega_i \nabla_1 g^i &= 0 \\ \omega_i \nabla_2 g^i &= \cos x^2 \nabla_2 g^1 + \frac{4}{3} l \nabla_2 g^2 = -\frac{8 \sin x^2}{-5m - 8M + 3m \cos(2x^2)}\end{aligned}$$

so the condition (ML3) of Theorem 6.21 is not satisfied and therefore the system is not MF-linearizable. This example shows that the class of systems satisfying  $R = 0$  (the class of Bedrossian and Spong) does not coincide with the class of MF-linearizable systems.

**Example *Cart-pole with the control applied to the pole.*** Consider the cart-pole system of the previous example, but now the control torque is applied to the pole, i.e.  $u := F_2$ ,  $F_1 \equiv 0$ . The equations of (MS) are the same as in (7.2) except for  $g^1 = (-ml \cos x^2) \eta$  and  $g^2 = (M + m) \eta$ .

We perform analogous calculations, for  $\bar{g} = (-ml \cos x^2) \frac{\partial}{\partial x^1} + (M + m) \frac{\partial}{\partial x^2}$ ,

$$\begin{aligned}\nabla_1 \bar{g}^1 &= \nabla_{\frac{\partial}{\partial x^1}} \bar{g}^1 = 0 \\ \nabla_1 \bar{g}^2 &= \nabla_{\frac{\partial}{\partial x^1}} \bar{g}^2 = 0 \\ \nabla_2 \bar{g}^1 &= \nabla_{\frac{\partial}{\partial x^2}} \bar{g}^1 = \frac{\partial \bar{g}^1}{\partial x^2} + \Gamma_{22}^1 \bar{g}^2 = \frac{\partial \bar{g}^1}{\partial x^2} + c_1 \eta \bar{g}^2 \\ \nabla_2 \bar{g}^2 &= \nabla_{\frac{\partial}{\partial x^2}} \bar{g}^2 = \frac{\partial \bar{g}^2}{\partial x^2} + \Gamma_{22}^2 \bar{g}^2 = c_2 \eta \bar{g}^2.\end{aligned}$$

Again, since  $\frac{\partial \eta}{\partial x^1} = 0$  we have

$$\begin{aligned}\nabla_1 g^1 &= \eta \nabla_{\frac{\partial}{\partial x^1}} \bar{g}^1 + \frac{\partial \eta}{\partial x^1} \bar{g}^1 = 0 \\ \nabla_1 g^2 &= \eta \nabla_{\frac{\partial}{\partial x^1}} \bar{g}^2 + \frac{\partial \eta}{\partial x^1} \bar{g}^2 = 0 \\ \nabla_2 g^1 &= \eta \nabla_{\frac{\partial}{\partial x^2}} \bar{g}^1 + \frac{\partial \eta}{\partial x^2} \bar{g}^1 = \frac{1}{2} m^3 l^3 \cos x^2 \sin(2x^2) \eta^2 \\ \nabla_2 g^2 &= \eta \nabla_{\frac{\partial}{\partial x^2}} \bar{g}^2 + \frac{\partial \eta}{\partial x^2} \bar{g}^2 = -\frac{1}{2} m^2 l^2 (m + M) \sin(2x^2) \eta^2.\end{aligned}$$

The annihilator  $\text{ann } g = \text{span } \{\omega\}$ , where  $\omega = (m + M) dx^1 + ml \cos x^2 dx^2$ , therefore

$$\begin{aligned}\omega_i \nabla_1 g^i &= 0 \\ \omega_i \nabla_2 g^i &= \omega_1 \nabla_2 g^1 + \omega_2 \nabla_2 g^2 = 0\end{aligned}$$

and thus the condition  $(ML3)$  of Theorem 6.21 is satisfied. Since  $R = 0$  and  $\mathcal{E}^0 = \text{span}\{g\}$ , both  $(ML1)$  and  $(ML2)$  are satisfied. Now we calculate

$$ad_e g = \left( m^2 l^2 a(M+m) \cos^2 x^2 \eta^2 \right) \frac{\partial}{\partial x^1} - \left( m l a(M+m)^2 \cos x^2 \eta^2 \right) \frac{\partial}{\partial x^2}$$

and  $g$  and  $ad_e g$  are linearly dependent (in fact, so are  $g$  and  $e$ ). Therefore  $\mathcal{E}^0 = \mathcal{E}^1$  are of constant rank 1 ( $(ML0)$  is satisfied) and the system is maximally non-controllable. Thus, we apply Remark 6.23 and calculate more restrictive  $(ML4)$ , namely  $\text{ann } \mathcal{E}^0 \subset \text{ann } \nabla^2 e$ . We calculate the components of  $\nabla^2 e = \nabla_k \nabla_j e^i \frac{\partial}{\partial x^i} \otimes dx^j \otimes dx^k$

$$\nabla_1 \nabla_1 e^i = \nabla_1 \nabla_2 e^i = \nabla_2 \nabla_1 e^i = 0$$

for  $i = 1, 2$  and

$$\begin{aligned} \nabla_2 \nabla_2 e^1 &= \frac{1}{36} m^4 l^6 a(4M+m) \left( 17m + 8M + 9m \cos(2x^1) \right) \sin(2x^2) \eta^3 \\ \nabla_2 \nabla_2 e^2 &= -\frac{1}{18} m^3 l^5 a(m^2 + 5mM + 4M^2) \left( 17m + 8M + 9m \cos(2x^2) \right) \sin x^2 \eta^3 \end{aligned}$$

and we see that  $(ML4)$  is satisfied since, for  $j, k = 1, 2$ ,

$$\omega_1 \nabla_j \nabla_k e^1 + \omega_2 \nabla_j \nabla_k e^2 = 0.$$

To summarize, the system is MF-linearizable to a linear mechanical system  $(\mathcal{LMS})$ . Notice that, first, a nontrivial mechanical diffeomorphism and mechanical feedback are needed for linearization and, second, the linear system  $(\mathcal{LMS})$  is non-controllable (the controllable and non-controllable subsystems are decoupled by linearizing transformations).

Finally, assume that there is no gravitational force acting on the system, that is,  $a = 0$  implying  $e = 0$ . The same effect can be obtained by applying a suitable mechanical feedback to the previous example (since  $e$  and  $g$  linearly dependent). This is an example of a potential-free mechanical systems  $(\mathcal{MS})$ , the class that is considered in Section 6.4.1. As we have just seen, the system satisfies conditions  $(MP0)$ - $(MP2)$  of Proposition 6.25 and therefore the system is MF-linearizable to a linear mechanical system  $(\mathcal{LMS})$  that is non-controllable which is perfectly conform with Corollary 6.24 stating that there are no potential-free (recall  $e = 0$ ) underactuated systems that are MF-linearizable.

## 7.2 Control Problems

Now, we show several practical applications of the established theory, that is a direct utilization of MF-linearization in the control synthesis. Based on the considerations outlined in Chapter 6, we design a controller in systematic and relatively simple manner for any controllable  $(\mathcal{MS})$  that is MF-linearizable. The control scheme consists of a cascade control approach, where an inner controller is the linearization feedback, that brings the  $(\mathcal{MS})$  to  $(\mathcal{LMS})$  and then, an outer loop is designed to perform a particular control task. This approach is summarized with the following scheme.

The great advantage of this approach is the fact that the task controller is designed for a linear system. Therefore, the (simple) linear control techniques can be used,

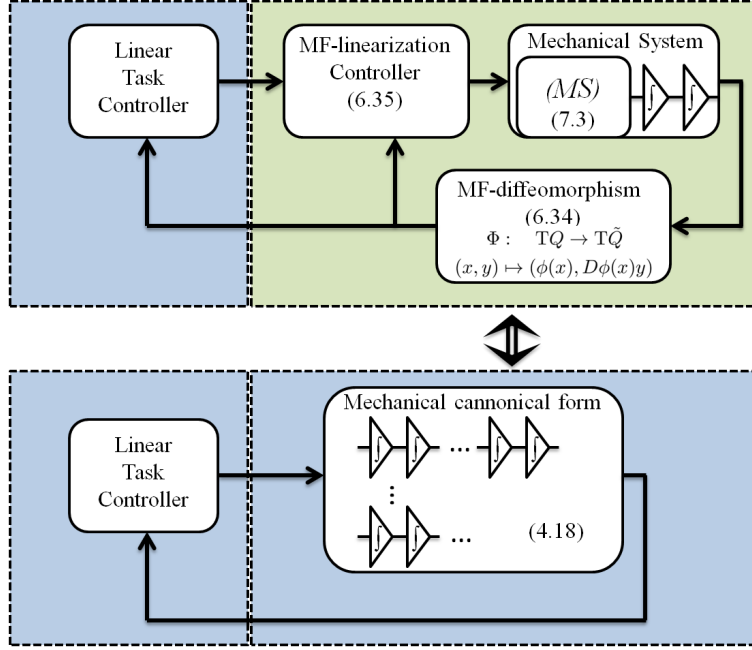
FIGURE 7.3: The cascade controller for MF-linearizable  $(\mathcal{MS})$ .

such as root locus or linear stability analysis (e.g. Hurwitz stability criterion), which is almost immediate in contrary to generally challenging nonlinear case.

We illustrate our considerations with numerical simulations for three mechanical control systems presented in Chapter 3, namely the Inertia Wheel Pendulum, the TORA system, and the single link manipulator with joint elasticity. Therefore we refer there for the modeling part and here, we invoke the final equations of these systems in the form of  $(\mathcal{MS})$ . The presented control tasks are arbitrary and focused on exemplifying a particular feature of the system that is discussed, rather than being of strict engineering practice. Our goal is to separate the impacts of various phenomena and investigate them one by one. Therefore, some assumptions that have been made might seem impractical (e.g. non-zero initial conditions or availability of the whole state). However, we claim that it is quite simple to satisfy them (e.g. observers design), even if the practical implementations of these solutions are beyond the scope of this thesis.

First, we define 3 types of control problems for which we present solutions using our results. We assume that the linearized system is controllable, i.e.  $\text{rank } \mathcal{E}^{n-1} = n$ . Moreover, we do not define the actual regularity class of the designed controllers, as it can be easily done in each particular implementation.

Consider a mechanical control system  $(\mathcal{MS})_{(2,1)}$ , with 2 degrees of freedom and one control, that is MF-linearizable

$$\begin{aligned} \dot{x}^i &= y^i \\ \dot{y}^i &= -\Gamma_{jk}^i(x)y^j y^k + e^i(x) + g^i(x)u. \end{aligned} \quad (7.3)$$

and the corresponding linear mechanical canonical form, obtained from (7.3) via  $(\tilde{x}, \tilde{y}) = (\phi(x), D\phi(x)y)$  and  $u = \gamma_{jk}(x)y^j y^k + \alpha(x) + \beta(x)\tilde{u}$ ,

$$\begin{aligned}\dot{\tilde{x}}^1 &= \tilde{y}^1 \\ \dot{\tilde{y}}^1 &= \tilde{x}^2 \\ \dot{\tilde{x}}^2 &= \tilde{y}^2 \\ \dot{\tilde{y}}^2 &= \tilde{u},\end{aligned}\tag{7.4}$$

for which the outer loop controller is designed.

As mentioned earlier and summarized in the Figure 7.3, each solution uses the cascade controller. The inner controller is a mechanical feedback controller (6.35) that linearizes the original system (7.3) by transforming it into the corresponding mechanical canonical form (4.18). The outer controller is a simple linear feedback that solves the control problem for the linearized system.

Since our simulation examples present systems that belong to the class of mechanical systems with 2 degrees of freedom and a single control, i.e.  $(\mathcal{MS})_{(2,1)}$ , we limit our considerations to that case. All problems and proposed solutions presented in this Chapter are defined for  $(\mathcal{MS})_{(2,1)}$ , however they can be simply generalized.

### 7.2.1 Stabilization

**Definition 7.1** (Stabilization problem (set-point control)). *For system (7.3), find a feedback control law of the form*

$$u = \psi(x, y, x_e, \kappa),$$

where  $\kappa$  is a set of constant parameters, such that the desired point  $x_e \in Q$  is an asymptotically stable equilibrium of the closed-loop system given by

$$\begin{aligned}\dot{x}^i &= y^i \\ \dot{y}^i &= -\Gamma_{jk}^i(x)y^j y^k + e^i(x) + g^i(x)\psi(x, y, x_e, \kappa).\end{aligned}$$

For the linearized system (i.e. equivalent to (7.4)) we propose a simple state feedback

$$\tilde{u} = -\kappa_1(\tilde{x}^1 - \tilde{x}_e^1) - \kappa_2\tilde{y}^1 - \kappa_3\tilde{x}^2 - \kappa_4\tilde{y}^2,\tag{7.5}$$

where  $(\tilde{x}_e^1, 0) = \phi(x_e^1, x_e^2)$  is the image of the desired point  $(x_e^1, x_e^2) \in Q$  under the linearizing diffeomorphism  $\tilde{x} = \phi(x)$  given by (6.34). The control gains  $\kappa_i$  are chosen so that the characteristic polynomial of the closed-loop  $p(\lambda) = \lambda^4 + \kappa_4\lambda^3 + \kappa_3\lambda^2 + \kappa_2\lambda + \kappa_1$  is a Hurwitz polynomial. By Definition 7.1, the problem is solvable at equilibria of the closed-loop system. In order to characterize them for the original mechanical system (7.3), i.e. to define a set of stabilizable points, we equate the right hand side of (7.3) to zero. The first equality  $y^i = 0$  restricts the state space to the zero section of the tangent bundle, i.e. the set of zero-velocity points  $(x, 0)$ , which can be further identified with the configuration manifold  $Q$ . Therefore the second equality can be simplified into  $e(x) + g(x)u = 0$ , or equivalently,  $e(x) = 0 \pmod{\mathcal{E}^0}$ . Thus, it is one dimensional submanifold of  $Q$  defined by  $\{x \in Q : L_e^j h = 0, 1 \leq j \leq n\}$ , that is, a curve which defines the set of all stabilizable points.

Note that for the linear system (7.4) the asymptotic stability implies the exponential stability. This implication also holds locally for the original system (7.3).

The global problem can be addressed if the configuration manifold  $Q$  is  $\mathbb{R}^n$  (or it is globally diffeomorphic to  $\mathbb{R}^n$ ) and moreover under two conditions:

- (i) Both the linearizing diffeomorphism  $\Phi = (\phi(x), D\phi(x)y)$  and the cascade feedback (consisting of (6.35) and (7.5)) are globally defined,
- (ii)  $\exists c \in \mathbb{R}$ , such that  $\|\phi(x)\| \leq c\|x\|$ , where  $\|\cdot\|$  denotes the norm.

Notice, that is not the case in our examples where at least one of configuration variables denotes an angle in  $\mathbb{S}$ .

### 7.2.2 Point-to-point controllability (a motion planning)

**Definition 7.2** (Point-to-point controllability (motion planning problem)). *For system (7.3), given initial conditions*

$$x^i(t_0), \quad y^i(t_0), \quad \text{and} \quad u(t_0), \quad (7.6)$$

where  $t_0$  is the initial time, and final conditions

$$x^i(t_f), \quad y^i(t_f), \quad \text{and} \quad u(t_f), \quad (7.7)$$

where  $t_f$  is the final time, find a trajectory  $t \mapsto (x^i(t), y^i(t), u_r(t))$ , for  $t \in [t_0, t_f]$  that satisfies (7.3) with (7.6) and (7.7), that is, a feasible phase space trajectory  $t \mapsto (x^i(t), y^i(t))$  and the control that generates it  $t \mapsto u(t)$ .

Taking into account a direct consequence of Corollary 6.19, a reference trajectory  $h_d(t)$  in the space of linearizing outputs can be designed. We state the problem of point-to-point controllability as that of generating a reference trajectory  $h_d(t)$  by finding a solution of the system

$$h_d^{(4)} = \tilde{u}_d,$$

which is a reference system for (7.4). In other words, we find the reference trajectory  $h_d(t)$  starting, at the initial time  $t_0$ , from a given value  $h(t_0)$ , together with given values of the successive time-derivatives  $\dot{h}_d(t_0), \ddot{h}_d(t_0), h_d^{(3)}(t_0)$  as well as that of the reference control  $\tilde{u}_d(t_0)$  and arriving, at the final time  $t_f$ , at a given final configuration  $h_d(t_f)$  (with given values  $\dot{h}_d(t_f), \ddot{h}_d(t_f), h_d^{(3)}(t_f)$ ), and  $\tilde{u}_d(t_f)$ . We thus, fix 5 initial conditions  $(h_d(t_0), \dot{h}_d(t_0), \ddot{h}_d(t_0), h_d^{(3)}(t_0), h_d^{(4)}(t_0))$  and 5 final conditions  $(h_d(t_f), \dot{h}_d(t_f), \ddot{h}_d(t_f), h_d^{(3)}(t_f), h_d^{(4)}(t_f))$ , where  $h_d^{(4)}(t_0) = \tilde{u}_d(t_0)$ ,  $h_d^{(4)}(t_f) = \tilde{u}_d(t_f)$ . We will design each reference trajectory  $h_d(t)$  in the space of polynomials of degree 9, with 10 coefficients  $a_k$  for  $0 \leq k \leq 9$  calculated based on the initial and final conditions.

The polynomial  $h_d(t)$  is chosen as

$$h_d(t) = \sum_{k=0}^9 a_k \left( \frac{t-t_0}{t_f-t_0} \right)^k, \quad (7.8)$$

and its derivatives are given by

$$h_d^{(k)}(t) = \frac{1}{(t_f-t_0)^k} \sum_{l=k}^9 \frac{l!}{(l-k)!} a_l \left( \frac{t-t_0}{t_f-t_0} \right)^{l-k}. \quad (7.9)$$

The coefficients  $a_k$  are computed by equating the successive derivatives of  $h_d$  at  $t_0$  and  $t_f$  with the initial and final conditions, respectively. In order to simplify these calculations, note that, the first 5 coefficients ( $a_0, \dots, a_4$ ) can be calculated directly

$$a_j = \frac{(t_f - t_0)^j}{j!} h_d^{(j)}(t_0), \text{ for } 0 \leq j \leq 4, \quad (7.10)$$

and the remaining  $a_5, \dots, a_9$  are given by the system of linear equation

$$h_d^{(k)}(t_f) = \frac{1}{(t_f - t_0)^k} \sum_{l=k}^9 \frac{l!}{(l-k)!} a_l, \text{ for } 0 \leq k \leq 4. \quad (7.11)$$

To summarize, there are 10 coefficients  $a_k$  in total, 5 to be calculated from (7.10) and the remaining 5 can be calculated by solving the linear systems given by (7.11). Now, putting the calculated reference control  $\tilde{u}(t) := \tilde{u}_d(t)$  into (6.35) results in the open-loop control that solves the point-to-point controllability problem.

### 7.2.3 Trajectory tracking

Given that the motion planning problem has been solved previously and consequently  $h_d(t)$  and their derivatives are known, the trajectory tracking problem can be tackled. In order to define tracking on manifolds, we fix a metric on the tangent bundle  $TQ$  and the most natural choice is the Sasaki metric  $\hat{m}$  [13], corresponding to the Riemannian metric  $\mathfrak{m}$  on  $Q$ , that preserves lifting vector fields both horizontally and vertically. Denote by  $\varrho_{\hat{m}}$  the Riemannian distance defined by  $\hat{m}$  on  $TQ$ .

**Definition 7.3** (Trajectory tracking). *For the system (7.3), find a feasible (reference) phase space trajectory  $t \mapsto (x_d(t), y_d(t))$  and find a control law  $u = \psi(x, y, t)$ , such that*

$$\lim_{t \rightarrow \infty} \varrho_{\hat{m}}\left((x_d(t), y_d(t)), (x(t), y(t))\right) = 0.$$

Choosing an arbitrary function of time  $h_d(t)$  being at least class  $C^{2n}$  we can create a phase space trajectory of (7.4) by setting

$$\begin{aligned} \tilde{x}_d^1 &= h_d(t) \\ \tilde{y}_d^1 &= \dot{h}_d(t) \\ \tilde{x}_d^2 &= \ddot{h}_d(t) \\ \tilde{y}_d^2 &= h_d^{(3)}(t) \end{aligned}$$

and the corresponding control  $\tilde{u}_d = h_d^{(4)}$ . Then  $(x_d(t), y_d(t)) = \Phi^{-1}(\tilde{x}_d(t), \tilde{y}_d(t))$  is a feasible trajectory of (7.3) corresponding to the control  $u = \gamma_{jk}(x)y^j y^k + \alpha(x) + \beta(x)\tilde{u}$ , where  $\tilde{u}$  is a trajectory tracking controller for (7.4) designed as follows

$$\tilde{u} = \kappa_1 (\tilde{x}_d^1 - \tilde{x}^1) + \kappa_2 (\tilde{y}_d^1 - \tilde{y}^1) + \kappa_3 (\tilde{x}_d^2 - \tilde{x}^2) + \kappa_4 (\tilde{y}_d^2 - \tilde{y}^2) + \tilde{u}_d \quad (7.12)$$

where  $\kappa_j$ , with  $j = 1, 2, 3, 4$ , are control gains. By plugging (7.12) into (7.4), the error dynamics of the closed-loop system is obtained as

$$e^{(4)} + \kappa_4 e^{(3)} + \kappa_2 \ddot{e} + \kappa_3 \dot{e} + \kappa_1 e = 0,$$

where  $e = \tilde{x}_d^1 - \tilde{x}^1$ . Appropriately chosen gains (for example using the pole placement method) ensure that the error dynamics is asymptotically stable.

Note that, if the reference trajectories are defined on a finite time interval  $[t_0, t_f]$  (as it is done in the point-to-point controllability) then the solution requires the system to start "sufficiently close" to the reference trajectories, in order to be able to almost approach them before the experiment ends, that is, before  $t_f$ . Although this assumption is theoretically limiting, we claim that from practical point of view, it is relatively easy to be satisfied.

## 7.3 The Inertia Wheel Pendulum

Recall the equation of the Inertia Wheel Pendulum, see Section 3.3.3,

$$\begin{aligned} \dot{x}^1 &= y^1 \\ \dot{x}^2 &= y^2 \\ \dot{y}^1 &= e^1 + g^1 u \\ \dot{y}^2 &= e^2 + g^2 u, \end{aligned} \tag{7.13}$$

where:

$$\begin{aligned} e^1 &= \frac{m_0}{m_d} \sin x^1, & g^1 &= -\frac{1}{m_d}, \\ e^2 &= -\frac{m_0}{m_d} \sin x^1, & g^2 &= \frac{m_d + J_2}{J_2 m_d}. \end{aligned}$$

We will consider control problems where the number of revolutions of the wheel are important therefore we will consider the configuration manifold to be  $Q = \mathbb{S} \times \mathbb{R}$ , that is,  $x^2 \in \mathbb{R}$ . In the subsequent simulations we use the following parameters taken from [48]:

$$\begin{aligned} L_1 &= 0.063 [m], \\ m_1 &= 0.02 [kg], \\ m_2 &= 0.3 [kg], \\ J_1 &= 47 \cdot 10^{-6} [kg \cdot m^2], \\ J_2 &= 32 \cdot 10^{-6} [kg \cdot m^2], \\ a &= 9.81 \left[ \frac{m}{s^2} \right], \\ m_0 &= a L_1 (m_1 + 2m_2) = 0.3832 \left[ \frac{kg \cdot m^2}{s^2} \right], \\ m_d &= L_1^2 (m_1 + 4m_2) + J_1 = 49 \cdot 10^{-4} [kg \cdot m^2]. \end{aligned} \tag{7.14}$$

### 7.3.1 MF-linearization

We will verify whether conditions (MD1) – (MD3) of Proposition 6.12 are satisfied. First, we calculate



$$ad_{e_g} = 0 - \begin{pmatrix} \frac{m_0}{m_d} \cos x^1 & 0 \\ -\frac{m_0}{m_d} \cos x^1 & 0 \end{pmatrix} \begin{pmatrix} -\frac{1}{m_d} \\ \frac{m_d + J_2}{J_2 m_d} \end{pmatrix} = \begin{pmatrix} \frac{m_0}{m_d^2} \cos x^1 \\ -\frac{m_0}{m_d^2} \cos x^1 \end{pmatrix}.$$

It can be checked that  $g$  and  $ad_{e_g}$  are independent for  $x^1 \neq \pm \frac{\pi}{2}$ , which denotes the horizontal position of the pendulum, therefore (MD1) is satisfied everywhere except  $x^1 = \pm \frac{\pi}{2}$ . Next, we need to verify condition (MD2).

$$\begin{aligned} \nabla_g g &= \left( \frac{\partial g^i}{\partial x^j} g^j + \Gamma_{jk}^i g^j g^k \right) \frac{\partial}{\partial x^i} = 0 \in \mathcal{E}^0 \\ \nabla_{ad_{e_g}} g &= 0 \in \mathcal{E}^0, \end{aligned}$$

hence (MD2) is satisfied. Finally we calculate

$$\begin{aligned} \nabla_g ad_{e_g} &= \begin{pmatrix} \frac{m_0}{m_d^3} \sin x^1 \\ -\frac{m_0}{m_d^3} \sin x^1 \end{pmatrix} \\ \nabla_{ad_{e_g}} ad_{e_g} &= \begin{pmatrix} -\frac{m_0^2}{m_d^4} \sin x^1 \cos x^1 \\ \frac{m_0^2}{m_d^4} \sin x^1 \cos x^1 \end{pmatrix} \\ \nabla_g \nabla_{ad_{e_g}} ad_{e_g} &= \begin{pmatrix} \frac{m_0^2}{m_d^5} \cos(2x^1) \\ -\frac{m_0^2}{m_d^5} \cos(2x^1) \end{pmatrix} \\ \nabla_{\nabla_g ad_{e_g}} ad_{e_g} &= \begin{pmatrix} -\frac{m_0^2}{m_d^5} \sin^2 x^1 \\ \frac{m_0^2}{m_d^5} \sin^2 x^1 \end{pmatrix} \\ \nabla_{ad_{e_g}} \nabla_g ad_{e_g} &= \begin{pmatrix} \frac{m_0^2}{m_d^5} \cos^2 x^1 \\ -\frac{m_0^2}{m_d^5} \cos^2 x^1 \end{pmatrix} \\ \nabla_{\nabla_{ad_{e_g}} g} ad_{e_g} &= 0 \end{aligned}$$

$$\nabla_{g, ad_{e_g}}^2 ad_{e_g} = \nabla_g \nabla_{ad_{e_g}} ad_{e_g} - \nabla_{\nabla_g ad_{e_g}} ad_{e_g} = \begin{pmatrix} \frac{m_0^2}{m_d^5} \cos^2 x^1 \\ -\frac{m_0^2}{m_d^5} \cos^2 x^1 \end{pmatrix}$$

$$\nabla_{ad_{e_g}, g}^2 ad_{e_g} = \nabla_{ad_{e_g}} \nabla_g ad_{e_g} - \nabla_{\nabla_{ad_{e_g}} g} ad_{e_g} = \begin{pmatrix} \frac{m_0^2}{m_d^5} \cos^2 x^1 \\ -\frac{m_0^2}{m_d^5} \cos^2 x^1 \end{pmatrix}$$

$$\nabla_{g, ad_{e_g}}^2 ad_{e_g} - \nabla_{ad_{e_g}, g}^2 ad_{e_g} = 0 \in \mathcal{E}^0.$$

Therefore (MD3) is satisfied. Since all conditions (MD1) – (MD3) are satisfied the system is MF-linearizable.

Next, in order to find a linearizing output  $h$ , we need to solve the following set of equations, see Proposition 6.15,

$$\begin{aligned} L_g h &= 0 \\ L_g L_e h &\neq 0 \\ \nabla(dh) &= 0, \end{aligned}$$

and a solution is  $h(x) = \frac{m_d + J_2}{J_2} x^1 + x^2$  (all other are of the form  $ch(x)$ , where  $c \neq 0$ ,  $c \in \mathbb{R}$ ). The linearizing diffeomorphism  $(\tilde{x}, \tilde{y})$  is  $\Phi(x, y) = (\phi(x), D\phi(x)y)$  with  $\phi(x) = (h, L_e h)^T$ . Therefore, the system in new coordinates reads

$$\begin{aligned} \dot{\tilde{x}}^1 &= \frac{m_d + J_2}{J_2} y^1 + y^2 = \tilde{y}^1 \\ \dot{\tilde{y}}^1 &= \frac{m_d + J_2}{J_2} \left( \frac{m_0}{m_d} \sin x^1 - \frac{1}{m_d} u \right) - \frac{m_0}{m_d} \sin x^1 + \frac{m_d + J_2}{m_2 J_2} u = \\ &= \frac{m_0}{J_2} \sin x^1 = L_e h = \tilde{x}^2 \\ \dot{\tilde{x}}^2 &= \frac{m_0}{J_2} \cos x^1 y^1 = \tilde{y}^2 \\ \dot{\tilde{y}}^2 &= -\frac{m_0}{J_2} \sin x^1 y^1 y^1 + \frac{m_0^2}{2m_d J_2} \sin(2x^1) - \frac{m_0}{m_d J_2} \cos x^1 u = \tilde{u}. \end{aligned} \tag{7.15}$$

### 7.3.2 Stabilization

The simulations concerning stabilization task were performed on the basis of the overall block diagram presented in Figure 7.4. All blocks are discussed briefly. The block **IWP** consists of the equation of dynamics of the Inertia Wheel Pendulum (7.13), the block **MF-feedback** is the linearization controller, calculated based on (7.15), which reads

$$u = m_0 \sin x^1 - \frac{m_d J_2}{m_0} \sec x^1 \tilde{u} - m_d \tan x^1 y^1 y^1. \tag{7.16}$$

The linear stabilization task controller (denoted as **Lin-controller** in Figure 7.4) is of the form (7.5), and finally the block **Diffeomorphism** contains the change of coordinates, i.e.

$$\begin{aligned} \tilde{x}^1 &= \frac{m_d + J_2}{J_2} x^1 + x^2 \\ \tilde{y}^1 &= \frac{m_d + J_2}{J_2} y^1 + y^2 \\ \tilde{x}^2 &= \frac{m_0}{J_2} \sin x^1 \\ \tilde{y}^2 &= \frac{m_0}{J_2} \cos x^1 y^1. \end{aligned} \tag{7.17}$$

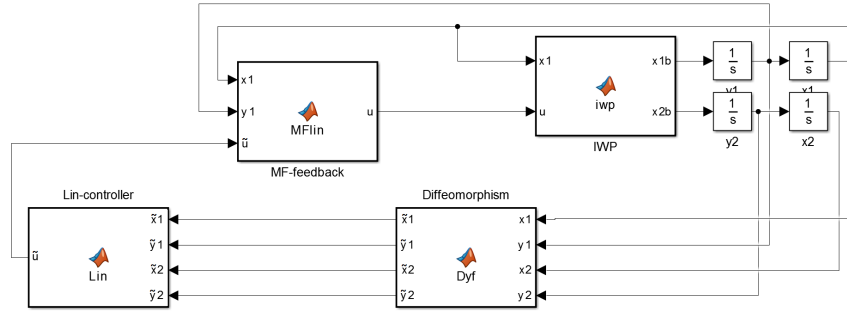

FIGURE 7.4: The simulation scheme for stabilization of the Inertia Wheel Pendulum.

**Scenario 1. Tuning** In this scenario we analyze the impact of the tuning of the gain parameters  $\kappa_i$  on the dynamics of the closed-loop system, and thus, the quality of the control. We compare three tuning methods, namely the natural frequency method, the pole placement method and the LQR optimal control.

In all simulations in this scenario the initial conditions are chosen to be equal to

$$x^1(0) = \frac{\pi}{4}, \quad x^2(0) = y^1(0) = y^2(0) = 0,$$

and the desired stabilization point is the origin, i.e.  $x_e^1 = x_e^2 = y_e^1 = y_e^2 = 0$ .

The first method of choosing gains of the characteristic polynomial is based on designing double critically damped (i.e.  $\zeta = 1$ ) oscillators with a natural frequency  $\omega_n$

$$p(\lambda) = (\lambda^2 + 2\zeta\omega_n\lambda + \omega_n^2)^2 = \lambda^4 + 4\omega_n\lambda^3 + 6\omega_n^2\lambda^2 + 4\omega_n^3\lambda + \omega_n^4,$$

which results in the following gains of the controller (7.5)

$$\kappa_1 = \omega_n^4, \quad \kappa_2 = 4\omega_n^3, \quad \kappa_3 = 6\omega_n^2, \quad \kappa_4 = 4\omega_n.$$

In the following simulations the natural frequency  $\omega_n = 2$  [s] is chosen to limit the gain values to a decent extent. Simulation results are shown in Figure 7.5.

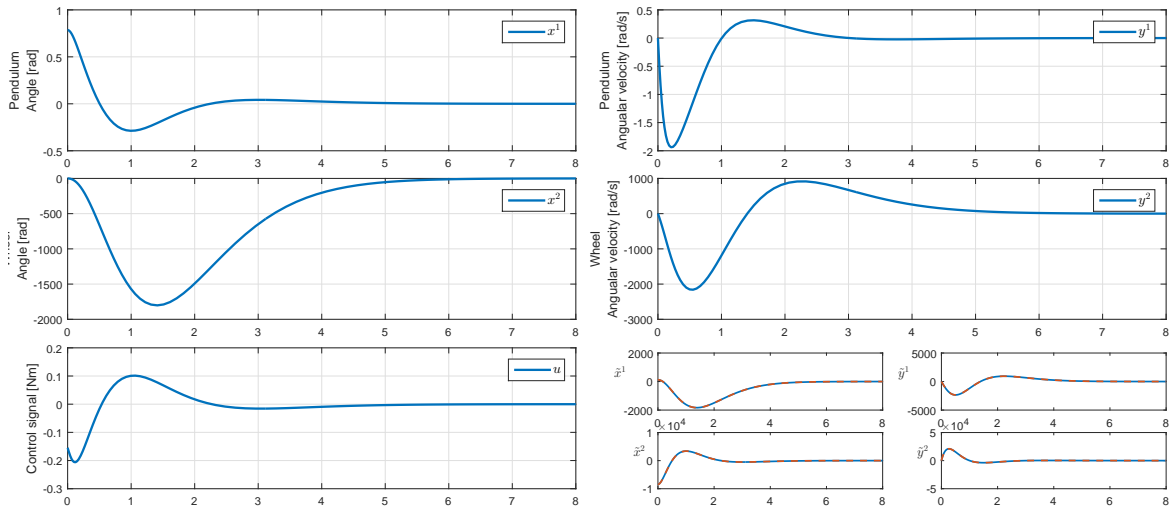

FIGURE 7.5: S1a. The simulation results for the Inertia Wheel Pendulum with the natural frequency tuning.

The second tuning method is the classical pole placement method. We choose to place the poles of the closed loop system to be equal to

$$\lambda_1 = -10, \quad \lambda_2 = -20, \quad \lambda_3 = -30, \quad \lambda_4 = -40.$$

We assume no overshoot in the linearized system, since the poles are chosen to be real. The corresponding gains are

$$\kappa_1 = 240000, \quad \kappa_2 = 50000, \quad \kappa_3 = 3500, \quad \kappa_4 = 100.$$

Simulation results for the pole placement tuning method are shown in Figure 7.6.

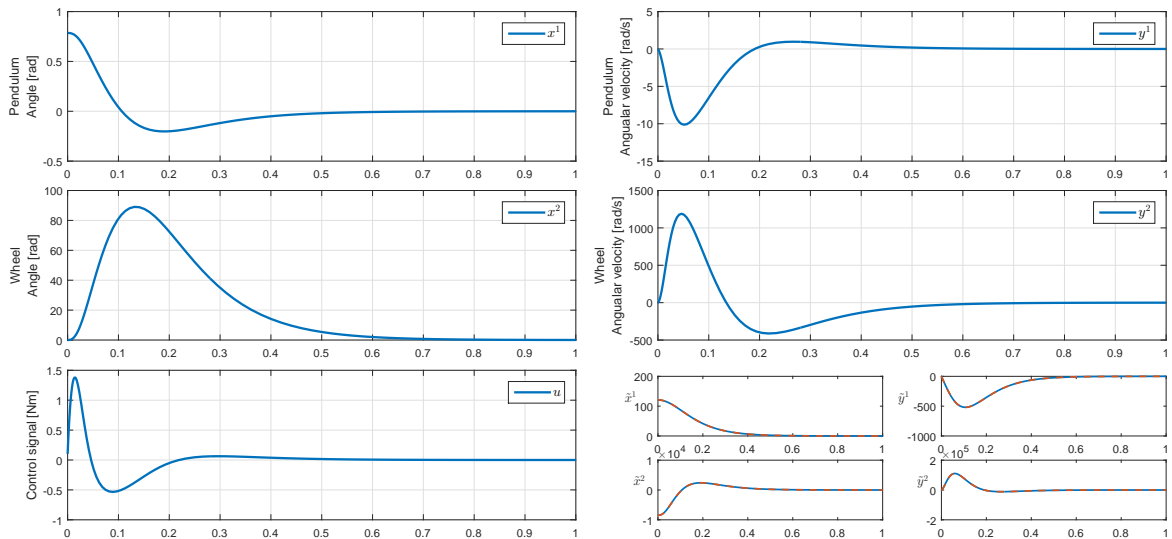

FIGURE 7.6: S1b. The simulation results for the Inertia Wheel Pendulum with pole placement tuning.

Finally, we use the linear–quadratic regulator (LQR) to solve an optimal control problem. We choose the following quadratic cost function

$$J(\tilde{u}) = \int_0^{\infty} (\tilde{z}^T R \tilde{z} + \tilde{u}^2) dt,$$

where  $\tilde{z} = (\tilde{x}, \tilde{y})^T$  and  $R = 10^3 \cdot I_4$  where  $I_4$  is an  $4 \times 4$  identity matrix. The gains that minimize the chosen cost are calculated as

$$\kappa_1 = 31.6228, \quad \kappa_2 = 77.3255, \quad \kappa_3 = 78.7287, \quad \kappa_4 = 34.0214.$$

Simulation results with LQR tuning are shown in Figure 7.7.

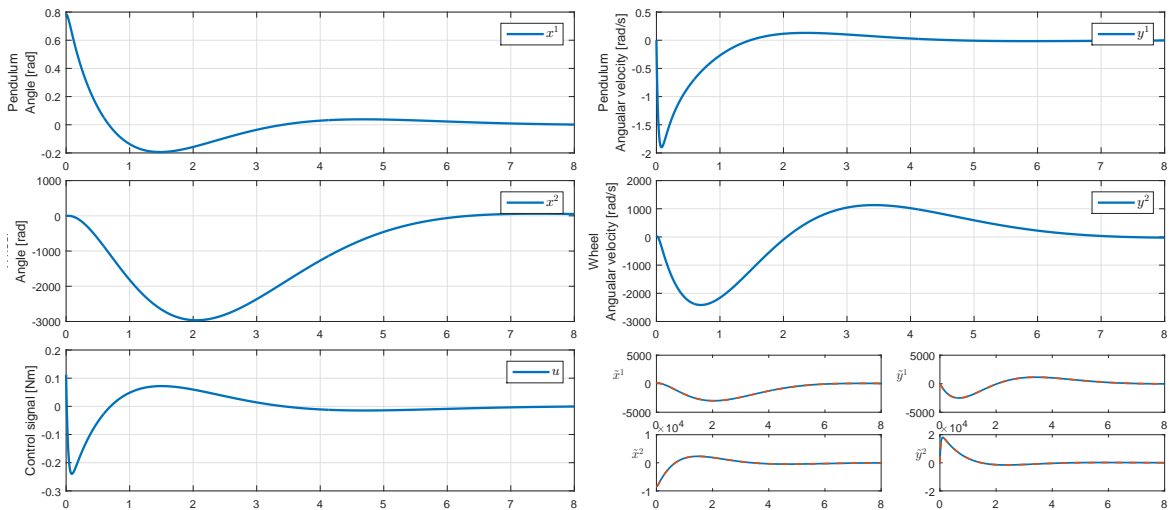

FIGURE 7.7: S1c. The simulation results for the Inertia Wheel Pendulum with LQR tuning.

All three tuning methods resulted in the exponential stabilization of the linearized system which implies local exponential stabilization of the Inertia Wheel Pendulum. This behavior is expected since we have assumed no uncertainties in the control system. The dynamic performance can be easily designed for the linearized system (e.g. setting all poles to be real ensures no overshoot). The performance propagates into the original system via the inverse of diffeomorphism  $\Phi$ , which is not highly nonlinear. We have examined the dynamic performance of the system in the case of choosing gains of different values, i.e. small for the natural frequency method in comparison to large of the pole placement method. What is worth mentioning, in the pole placement method, choosing the poles to be placed far from the imaginary axis results in high-gains which increases the speed of the convergence (under 1[s], see Figure 7.6) without unwanted effects (e.g. peaking phenomenon). The natural frequency method resulted in longer convergence time (approx. 6[s]) but with favourable control signal values and lower angular velocity of pendulum. It is worth noting that the optimal LQR method shows similar effect to the natural frequency method in terms of the overshoot in both angles, angular velocities, as well as in the control signal. Admittedly, several measures of controlled system performance could be used to quantify the performance for all three methods but this is beyond of the scope of this thesis. Our goal was to study the dynamic behaviour of the system for different tuning techniques and for large scale of gain values chosen.

**Scenario 2. Parametric robustness** In the following simulations we test the influence of parametric uncertainty to the overall performance of the proposed control system. In this scenario we assume that all of the system parameters are not precisely known for the control synthesis. Thus, we changed the parameters used to design control system in the block **MF-feedback** and **Diffeomorphism** (see Figure 7.4) to be

$$\begin{aligned}\tilde{L}_1 &= 10L_1 = 0.63 \text{ [m]} \\ \tilde{m}_1 &= 10m_1 = 0.2 \text{ [kg]} \\ \tilde{m}_2 &= 10m_2 = 3 \text{ [kg]} \\ \tilde{J}_1 &= 10J_1 = 47 \cdot 10^{-5} \text{ [kg} \cdot \text{m}^2\text{]} \\ \tilde{J}_2 &= 10J_2 = 32 \cdot 10^{-5} \text{ [kg} \cdot \text{m}^2\text{]} \\ \tilde{a} &= a = 9.81 \left[ \frac{\text{m}}{\text{s}^2} \right],\end{aligned}$$

Thus the level of uncertainty for all parameters (except the gravitational acceleration) is assumed to be as high as 1000%. We use the same initial conditions as previously, i.e.

$$x^1(0) = \frac{\pi}{4}, \quad x^2(0) = y^1(0) = y^2(0) = 0,$$

the desired stabilization point is again equal to  $x_e^1 = x_e^2 = y_e^1 = y_e^2 = 0$ . The control gains are the same as in the first simulation, i.e. for  $\omega_n = 2$  [s],

$$\kappa_1 = \omega_n^4 \quad \kappa_2 = 4\omega_n^3 \quad \kappa_3 = 6\omega_n^2 \quad \kappa_4 = 4\omega_n.$$

Simulation results are shown in Figure 7.8.

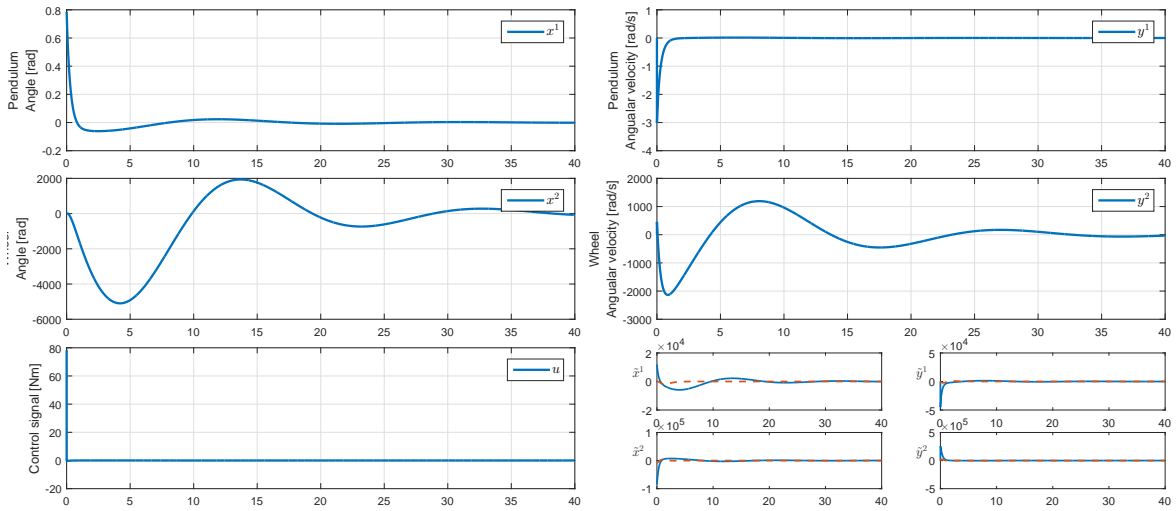

FIGURE 7.8: S2. The simulation results for the Inertia Wheel Pendulum with the parametric uncertainties of 1000%.

The stabilization problem is solved despite uncertainties. One could claim that conducted simulations show robustness of the control system. Note that in this scenario the evolution of the reference and the linearized systems differ since the linearization controller is imperfect. We observe that the convergence time is several times longer than in the nominal case (approx. 40[s] in comparison to approx. 6[s]).

This increase in time may seem overwhelming but considering the large parametric uncertainty introduced in this simulation, the decrease in performance could be considered acceptable. Moreover there is a significant peak in the control signal.

Note that, we do not develop analytic methods to calculate the bound of the uncertainties as well we do not analyze structural uncertainties, as it is beyond the scope of this thesis.

**Scenario 3. Stabilization outside the origin** In this scenario we examine the performance of the system in case of choosing the desired point  $x_e$  that is outside the origin. As pointed out in Section 7.2.1, the set of all stabilizable points is given by  $\tilde{x}^2 = \tilde{y}^1 = 0$  (implying  $y^1 = y^2 = 0$ ) and  $\frac{m_0}{J_2} \sin x^1 = 0$ . Thus the set of all stabilizable points is given by  $\{(0, x_e^2)\}$  and  $\{(\pi, x_e^2)\}$  which are the lines (in cylinder  $Q = \mathbb{R} \times \mathbb{S}$ )  $\{0\} \times \mathbb{R}$  and  $\{\pi\} \times \mathbb{R}$ , corresponding, respectively, to the upright (or downright) position of the pendulum with the freely chosen angle of the wheel. We chose the desired point  $x_e = (0, 100\pi)$ , which corresponds to 50 revolutions of the wheel. The initial conditions remain the same as in the previous scenario, i.e.  $x^1(0) = \frac{\pi}{4}$ ,  $x^2(0) = y^1(0) = y^2(0) = 0$ , as well as the gain parameters, for  $\omega_n = 2$  [s], i.e.

$$\kappa_1 = \omega_n^4 \quad \kappa_2 = 4\omega_n^3 \quad \kappa_3 = 6\omega_n^2 \quad \kappa_4 = 4\omega_n.$$

Simulation results with are shown in Figure 7.9.

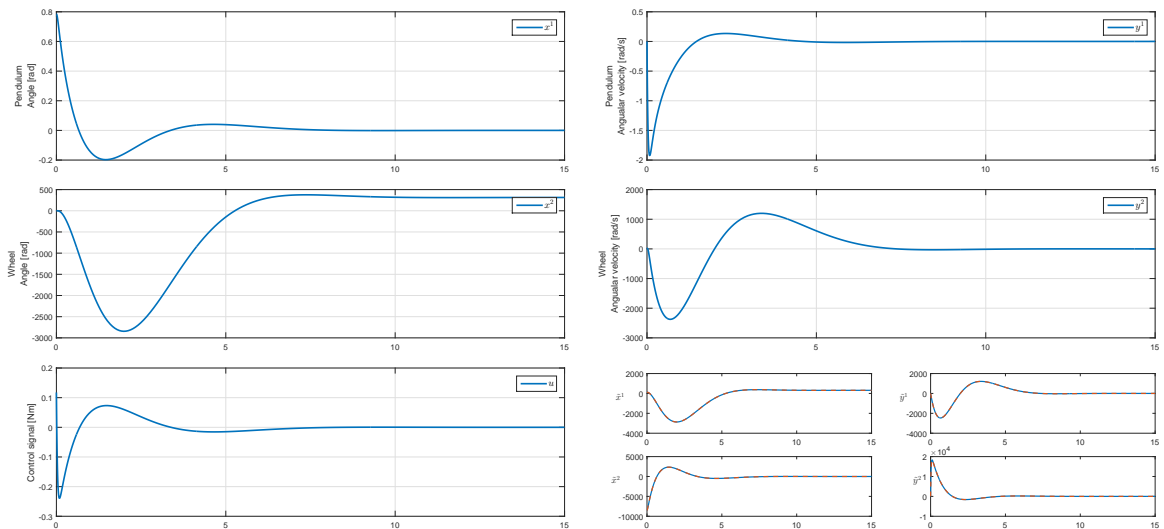

FIGURE 7.9: S3. The simulation results for the Inertia Wheel Pendulum outside the origin.

It can be concluded, that the proposed control system is able to stabilize the position of the Inertia Wheel Pendulum at a point outside the origin.

### 7.3.3 Motion planning and trajectory tracking

In this subsection we show combined simulations concerning the two remaining control problems that we stated previously, namely the motion planing and trajectory tracking. The reference trajectory, that is tracked by the system, is designed as a

polynomial of time  $h_d(t)$ , as stated in (7.8). The reason for this approach is to robustify the control loop that is influenced by numerical inaccuracies in the simulation environment. The simulation scheme is shown in Figure 7.10.

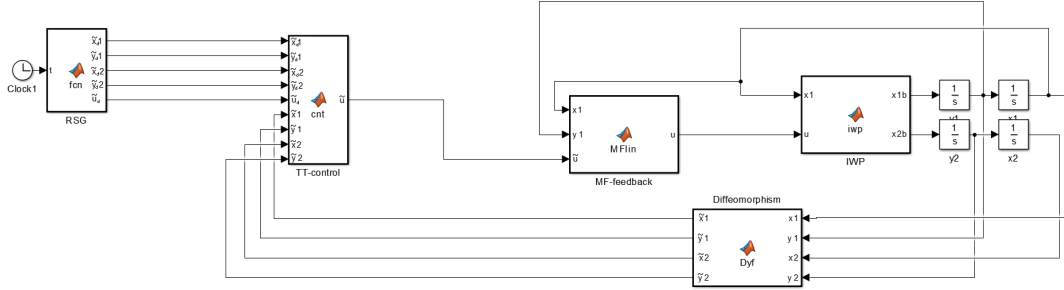

FIGURE 7.10: The simulation scheme for trajectory tracking of the Inertia Wheel Pendulum.

As previously, the block IWP consists of the equation of dynamics of the Inertia Wheel Pendulum, the block MF-feedback is the linearization controller (7.16). The block Diffeomorphism consist of the change of coordinates, as in (7.17). The linear trajectory tracking controller (denoted TT-control on the scheme) is of the form (7.12) and a reference signal generator (denoted RSG) is a block, where reference trajectories (and their derivatives) are generated according to (7.8) and (7.9). The actual parameters of the trajectory are calculated numerically using (7.10) and (7.11).

**Scenario 4. Rest-to-rest trajectory** In the following scenario we show simulation results of a reference trajectory tracking. The designed trajectory is a rest-to-rest trajectory, i.e. it starts and ends at the equilibria of the system. In all of the simulations presented in this scenario we use the same gains, as in Scenario 1 (pole placement method for  $\omega_n = 2$ )

$$\kappa_1 = \omega_n^4, \quad \kappa_2 = 4\omega_n^3, \quad \kappa_3 = 6\omega_n^2, \quad \kappa_4 = 4\omega_n.$$

For the desired trajectory, the initial conditions ( $t_0 = 0$ ) are

$$x^1(t_0) = 0, \quad y^1(t_0) = 0, \quad x^2(t_0) = 0, \quad y^2(t_0) = 0, \quad u(t_0) = 0,$$

and the final conditions  $t_f = 10$  are

$$x^1(t_f) = 0, \quad y^1(t_f) = 0, \quad x^2(t_f) = \pi, \quad y^2(t_f) = 0, \quad u(t_f) = 0.$$

The simulation results are presented in Figure 7.11. The evolution of the system (blue lines) overlaps with the reference trajectory (red dashed lines) transformed into  $(x, y)$ -coordinates as there are no uncertainties or disturbances in the control system.



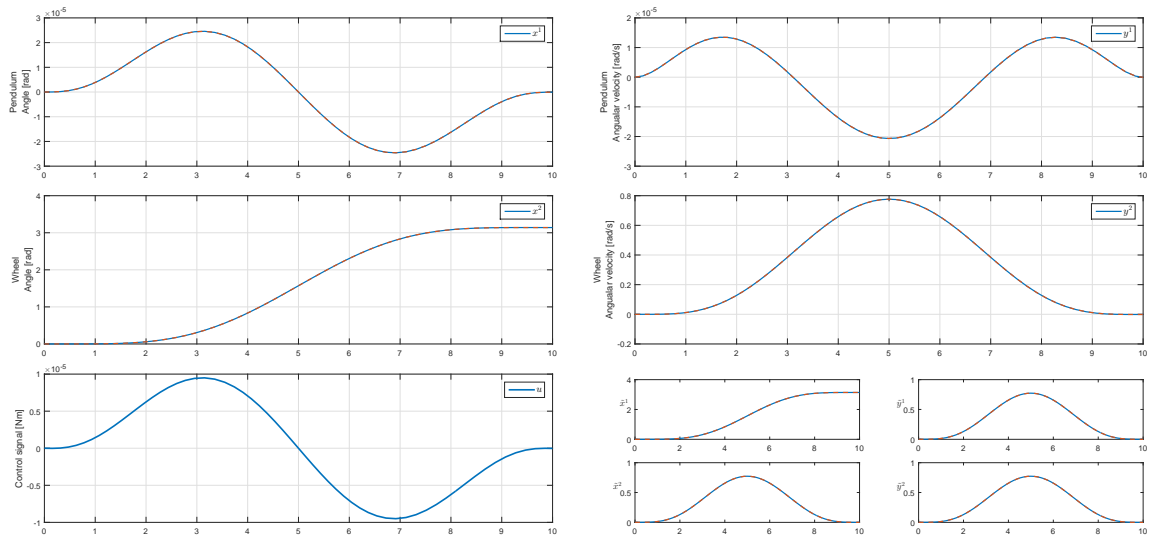

FIGURE 7.11: S4. Rest-to-rest trajectory tracking for Inertia Wheel Pendulum.

The simulation starts and finishes at rest, therefore, all velocities are equal to zero after reaching the final configuration. One can conclude, that the presented control scheme is a decent solution for trajectory tracking, given the start and final points are equilibrium points.

**Scenario 5. Mismatched initial conditions.** In the following simulations we analyze the influence of different initial conditions on the convergence and the dynamic performance. The desired trajectory starts at the initial condition ( $t_0 = 0$ ), given by

$$x^1(t_0) = \frac{\pi}{3} \quad y^1(t_0) = 0 \quad x^2(t_0) = 0 \quad y^2(t_0) = 0 \quad u(t_0) = 0$$

and ends at the final condition, for  $t_f = 10$ ,

$$x^1(t_f) = 0 \quad y^1(t_f) = 0 \quad x^2(t_f) = \pi \quad y^2(t_f) = 0 \quad u(t_f) = 0.$$

Note that in this scenario at the beginning of the simulation the pendulum is not at rest. Figure 7.12 shows results with matching initial conditions in the reference trajectory and the system, while Figure 7.13 presents results where the initial conditions of the system differ from the initial conditions of the reference trajectory, and they are  $x^1(t_0) = \frac{\pi}{3} + 0.5$ ,  $y^1(t_0) = 0.5$ ,  $x^2(t_0) = 0.5$ ,  $y^2(t_0) = 0.5$ . Setting different initial conditions does not influence the overall performance of the system. In the second case, the trajectory tracking controller is able to lead the system to the reference trajectory relatively fast. The presented scenario shows robustness of the control design to the mismatched initial conditions, as well as the convergence to the reference trajectory given by the asymptotically stable error dynamics.

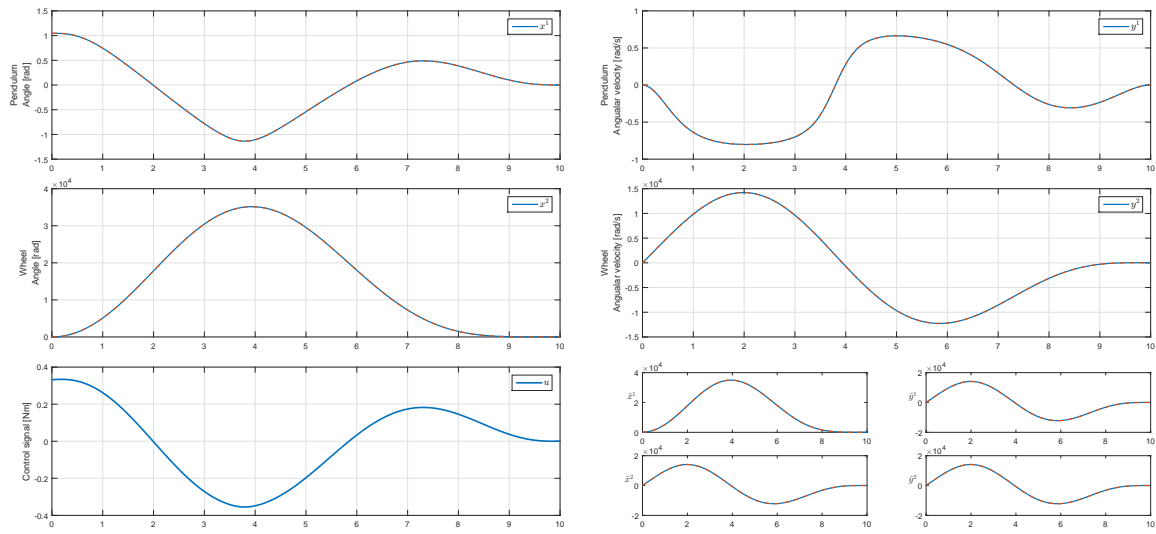

FIGURE 7.12: S5a. Trajectory tracking for matched initial conditions of the Inertia Wheel Pendulum.

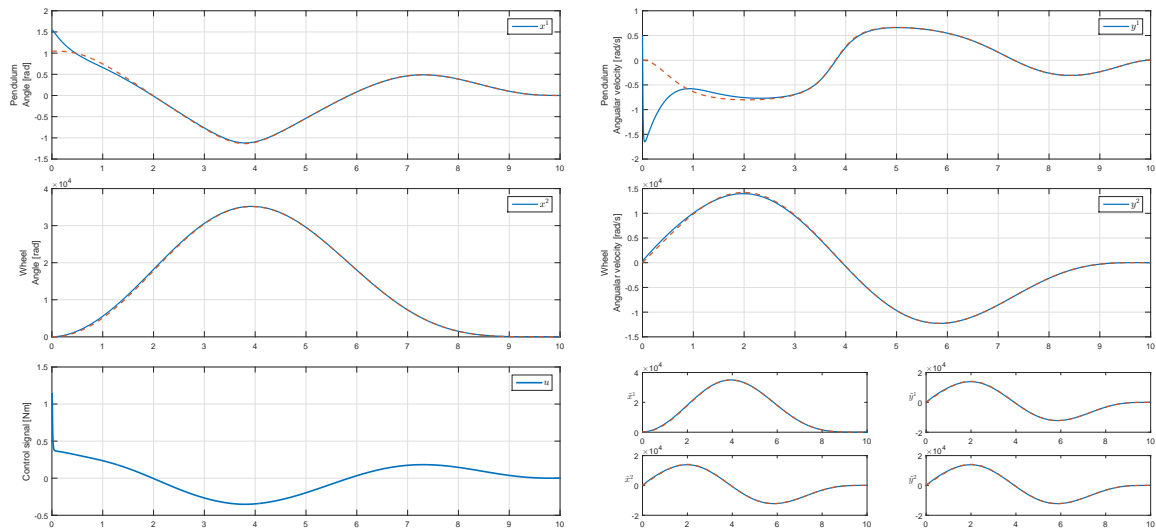

FIGURE 7.13: S5b. Trajectory tracking for mismatched initial conditions of the Inertia Wheel Pendulum.

**Scenario 6. Passing through the singular locus** The following scenario presents the solution to the problem of trajectory tracking which passes through the singularity in the control space. As we investigated in Section 7.3.1 the Inertia Wheel Pendulum is not first-order controllable at the point  $x^1 = \pm \frac{\pi}{2}$ . Therefore a rest-to-rest trajectory starting at the equilibrium given by  $x^1 = \pi$  (denoting the downright position of the pendulum) and ending at the equilibrium  $x^1 = 0$  (i.e. the upright position) has to pass through the singularity. The proposed solution consists of three steps. First, the system tracks a reference trajectory  $h_{1d}(t)$  that arrives close to the singularity with non-zero velocity. Then, the control signal is switched off as the system drifts through the singularity. Finally, at a calculated time, the control signal is switched

on and the system tracks a new trajectory  $h_{2d}(t)$  that ends at the upright position. Thus, we propose a discontinuous control law that can be summarized as follows

$$u(t) = \begin{cases} u_1(t) & 0 \leq t \leq 4 \\ 0 & 4 < t \leq 4.1 \\ u_2(t) & 4.1 < t \leq 8.1 \end{cases}$$

where  $u_1(t)$  is the control corresponding to the reference trajectory  $h_{1d}(t)$  from the initial conditions ( $t_0 = 0$ ) and ends at an intermediate final condition, for  $t_f = 4$ , close to the singular locus, and  $u_2(t)$  is the control corresponding to the reference trajectory  $h_{2d}(t)$  from the initial condition ( $t_0 = 4.1$ ), which has been reached (at  $t_0 = 4.1$ ) after having crossed the singular locus, and ends at the final condition, for  $t_f = 8.1$ . Therefore, the singularity is out of both trajectories  $h_{1d}(t)$  and  $h_{2d}(t)$ .

The initial and final conditions for  $h_{1d}(t)$  are given by

$$\begin{aligned} x^1(t_0) &= \pi & y^1(t_0) &= 0 & x^2(t_0) &= 0 & y^2(t_0) &= 0 & u(t_0) &= 0, \\ x^1(t_f) &= \frac{\pi}{1.9} & y^1(t_f) &= -10 & x^2(t_f) &= 0 & y^2(t_f) &= 0 & u(t_f) &= 0. \end{aligned}$$

and the initial and final conditions for  $h_{2d}(t)$  are given by

$$\begin{aligned} x^1(t_0) &= 0.9073 & y^1(t_0) &= -3.942 & x^2(t_0) &= 19.79 & y^2(t_0) &= 169 & u(t_0) &= 0, \\ x^1(t_f) &= \frac{\pi}{1.9} & y^1(t_f) &= 0 & x^2(t_f) &= 0 & y^2(t_f) &= 0 & u(t_f) &= 0. \end{aligned}$$

The results are presented in Figure 7.14.

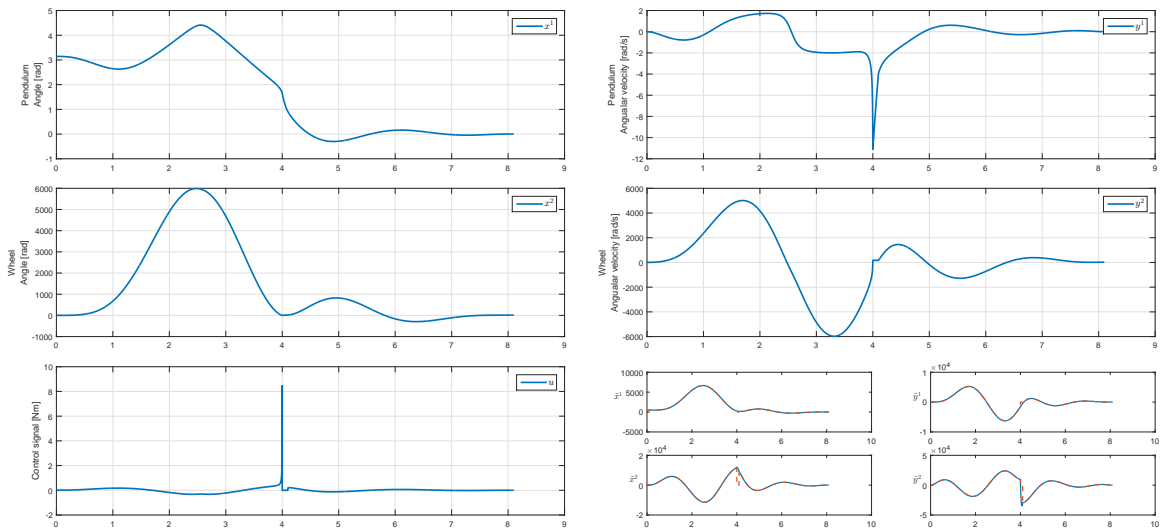

FIGURE 7.14: S6. Tracking the trajectory that passes through the singularity of the Inertia Wheel Pendulum.

It can be observed that there is a peak in the control signal. It is due to the rapid acceleration of the pendulum at the end of the trajectory  $h_{1d}(t)$ . One could limit this effect by generating a different, smoother trajectory.

**Scenario 7. Sinusoidal trajectory** The last scenario for the Inertia Wheel Pendulum presents tracking of a sinusoidal reference trajectory which is given by

$$\begin{aligned}\tilde{x}_d^1(t) &= A \sin(\omega t) \\ \tilde{y}_d^1(t) &= A\omega \cos(\omega t) \\ \tilde{x}_d^2(t) &= -A\omega^2 \sin(\omega t) \\ \tilde{y}_d^2(t) &= -A\omega^3 \cos(\omega t),\end{aligned}$$

where  $A = 7500$  and  $\omega = 1$ , and a reference control  $\tilde{u}_d(t) = A\omega^4 \sin(\omega t)$ . The initial conditions ( $t_0 = 0$ ) of the system are

$$x^1(t_0) = 0 \quad y^1(t_0) = 0 \quad x^2(t_0) = 0 \quad y^2(t_0) = 0 \quad u(t_0) = 0.$$

The simulation results are shown in Figure 7.15. Note that the initial condition of the system does not match the initial conditions of the reference trajectory. Despite that, the evolution of the system converges to the reference values after approx. 5 [s].

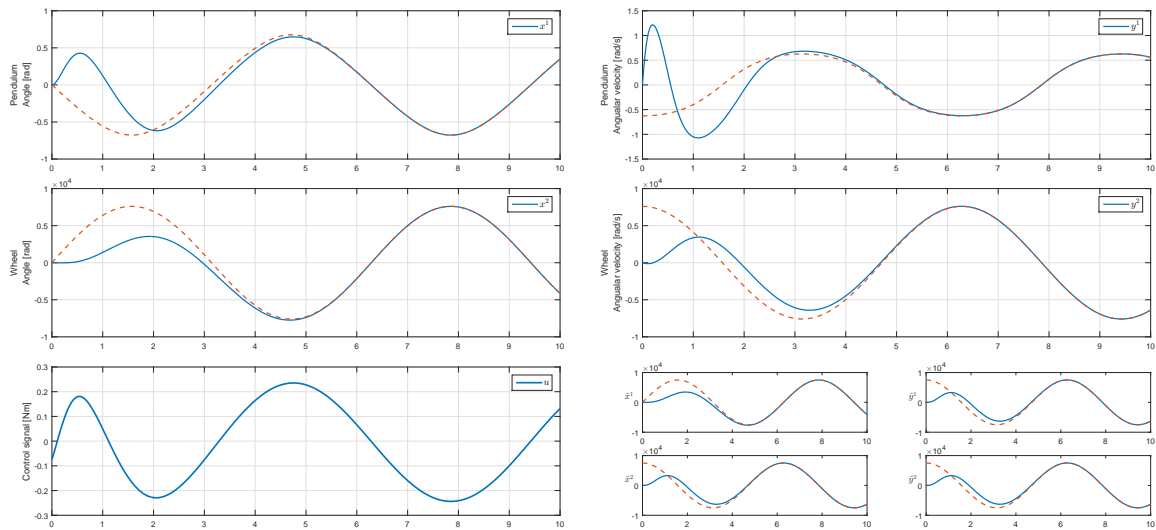

FIGURE 7.15: S7. Sinusoidal trajectory tracking of the Inertia Wheel Pendulum.

## 7.4 The TORA system

As derived in Section 3.3.4, the equations of the TORA system read

$$\begin{aligned}\dot{x}^1 &= y^1 \\ \dot{x}^2 &= y^2 \\ \dot{y}^1 &= -\Gamma_{22}^1 y^2 y^2 + e^1 + g^1 u \\ \dot{y}^2 &= -\Gamma_{22}^2 y^2 y^2 + e^2 + g^2 u,\end{aligned}$$

where:

$$\begin{aligned}\Gamma_{22}^1 &= \frac{\zeta_0 \sin x^2}{\zeta_1 - \zeta_2 \cos^2 x^2}, & e^1 &= \frac{\zeta_4 \sin x^2 \cos x^2 - \zeta_3 x^1}{\zeta_1 - \zeta_2 \cos^2 x^2}, & g^1 &= \frac{-m_{12} \cos x^2}{\zeta_1 - \zeta_2 \cos^2 x^2}, \\ \Gamma_{22}^2 &= \frac{\zeta_2 \sin x^2 \cos x^2}{\zeta_1 - \zeta_2 \cos^2 x^2}, & e^2 &= \frac{-\zeta_5 \sin x^2 + \zeta_6 x^1 \cos x^2}{\zeta_1 - \zeta_2 \cos^2 x^2}, & g^2 &= \frac{m_{11}}{\zeta_1 - \zeta_2 \cos^2 x^2},\end{aligned}$$

see Section 3.3.4, for definition of constants  $\zeta_i$ . We use the following parameters in simulations:

$$\begin{aligned}m_1 &= 2 \text{ [kg]}, & L_2 &= 0.5 \text{ [m]}, & a &= 9.81 \left[ \frac{m}{s^2} \right], \\ m_2 &= 0.5 \text{ [kg]}, & J_2 &= 0.1 \text{ [kg} \cdot \text{m}^2], & k_1 &= 3.\end{aligned}$$

### 7.4.1 MF-linearization

First, we need to verify if conditions  $(ML0)' - (ML3)'$  formulated in Chapter 6 are satisfied. In order to do it, we calculate  $ad_e g$  as follows

$$ad_e g = \left( \begin{array}{c} \frac{f(x^1, x^2)}{4(\zeta_1 - \zeta_2 \cos^2 x^2)^3} \\ \frac{\zeta_6 m_{12} \cos^2 x^2 + m_{11}(\zeta_5 \cos x^2 + \zeta_6 x^1 \sin x^2)}{(\zeta_1 - \zeta_2 \cos^2 x^2)^2} \end{array} \right),$$

where  $f(x^1, x^2) = \xi_0 + \xi_1 \cos^2 x^2 + \xi_2 \cos(2x^2) + \xi_3 \cos x^2 + \xi_4 \sin^2 x^2 + \xi_5 x^1 \sin(2x^2) + \xi_6 \cos(2x^2) \sin^2 x^2 + \xi_7 x^1 \sin(4x^2)$  and  $\xi_i$  are constant parameters listed below

$$\begin{aligned}\xi_0 &= 2\zeta_2 \zeta_4 m_{11}, & \xi_1 &= 4\zeta_2 \zeta_3 m_{12}, & \xi_2 &= 2\zeta_4 m_{11}(\zeta_2 - 2\zeta_1), \\ \xi_3 &= -4\zeta_1 \zeta_3 m_{12}, & \xi_4 &= -2\zeta_5 m_{12}(2\zeta_1 + \zeta_2), & \xi_5 &= \zeta_6 m_{12}(2\zeta_1 + \zeta_2) - 4\zeta_2 \zeta_3 m_{11}, \\ \xi_6 &= -2\zeta_2 \zeta_5 m_{12}, & \xi_7 &= \frac{1}{2} \zeta_2 \zeta_6 m_{12}.\end{aligned}$$

We can conclude that the vector fields  $g$  and  $ad_e g$  are independent everywhere, therefore  $(ML0)'$  is satisfied. Second, we need to examine condition  $(ML2)'$

$$\begin{aligned}\omega &= \text{ann } g = m_{11} dx^1 + m_{12} \cos x^2 dx^2, \\ \omega(g) &= \left( m_{11} \quad m_{12} \cos x^2 \right) \left( \begin{array}{c} \frac{-m_{12} \cos x^2}{\zeta_1 - \zeta_2 \cos^2 x^2} \\ \frac{m_{11}}{\zeta_1 - \zeta_2 \cos^2 x^2} \end{array} \right) = 0.\end{aligned}$$

The only non-trivial elements of the Riemann tensor are equal to zero, i.e.

$$\begin{aligned}R_{212}^1 &= \frac{\partial \Gamma_{22}^1}{\partial x^1} = -R_{221}^1 = 0 \\ R_{212}^2 &= \frac{\partial \Gamma_{22}^2}{\partial x^1} = -R_{221}^2 = 0,\end{aligned}$$

therefore  $R_{jkl}^i = 0$  and  $(ML2)'$  is satisfied. Next we calculate

$$\nabla g = \left( \begin{array}{cc} \nabla_1 g^1 & \nabla_2 g^1 \\ \nabla_1 g^2 & \nabla_2 g^2 \end{array} \right),$$

where

$$\begin{aligned}\nabla_1 g^1 &= \nabla_{\frac{\partial}{\partial x^1}} g^1 = 0 \\ \nabla_1 g^2 &= \nabla_{\frac{\partial}{\partial x^1}} g^2 = 0 \\ \nabla_2 g^1 &= \nabla_{\frac{\partial}{\partial x^2}} g^1 = \frac{\partial g^1}{\partial x^2} + \Gamma_{22}^1 g^2 = \frac{m_{12} \zeta_2 \cos^2 x^2 \sin x^2}{(\zeta_1 - \zeta_2 \cos^2 x^2)^2} \\ \nabla_2 g^2 &= \nabla_{\frac{\partial}{\partial x^2}} g^2 = \frac{\partial g^2}{\partial x^2} + \Gamma_{22}^2 g^2 = \frac{-m_{11} \zeta_2 \sin(2x^2)}{2(\zeta_1 - \zeta_2 \cos^2 x^2)^2}.\end{aligned}$$

Therefore

$$\begin{aligned}\omega \nabla_1 g^i &= 0 \\ \omega \nabla_2 g^i &= m_{11} \frac{m_{12} \zeta_2 \cos^2 x^2 \sin x^2}{(\zeta_1 - \zeta_2 \cos^2 x^2)^2} + m_{12} \cos x^2 \frac{-m_{11} \zeta_2 \sin(2x^2)}{2(\zeta_1 - \zeta_2 \cos^2 x^2)^2} = \\ &= \frac{m_{11} m_{12} \zeta_2 \left( \cos^2 x^2 \sin x^2 - \frac{1}{2} \cos x^2 \sin(2x^2) \right)}{(\zeta_1 - \zeta_2 \cos^2 x^2)^2} = 0\end{aligned}$$

and condition  $(ML3)'$  is satisfied. Since all conditions  $(ML0)'$  -  $(ML3)'$  are satisfied, we can conclude that the system is MF-linearizable.

We choose new coordinates of the system,  $\Phi(x, y) = (\phi(x), D\phi(x)y)$ , where  $\tilde{x} = \phi(x)$  is given by

$$\begin{aligned}\tilde{x}^1 &= m_{11}x^1 + m_{12} \sin x^2 \quad \text{for } x^2 \neq \pm \frac{\pi}{2} \\ \tilde{x}^2 &= -k_1 x^1.\end{aligned}$$

Thus, the system described in those coordinates is linear, i.e.

$$\begin{aligned}\dot{\tilde{x}}^1 &= m_{11}y^1 + m_{12} \cos x^2 y^2 = \tilde{y}^1 \\ \dot{\tilde{x}}^2 &= m_{11}\dot{y}^1 + m_{12} \left( -\sin x^2 y^2 y^2 + \cos x^2 \dot{y}^2 \right) = -k_1 x^1 = \tilde{x}^2 \\ \dot{\tilde{x}}^2 &= -k_1 y^1 = \tilde{y}^2 \\ \dot{\tilde{y}}^2 &= -k_1 \left( -\Gamma_{22}^1 y^2 y^2 + e^1 + g^1 u \right) = \tilde{u}.\end{aligned}$$

### 7.4.2 Stabilization

Similarly to the Inertia Wheel Pendulum we have performed simulations concerning the stabilization task of the TORA system. The simulation scheme is shown in Figure 7.16. The block **TORA** contains the equations of dynamics of the TORA system, the block **MF-feedback** is the linearization controller which reads

$$u = \frac{\Gamma_{22}^1}{g^1} y^2 y^2 - \frac{e^1}{g^1} - \frac{1}{k_1 g^1} \tilde{u}.$$

The linear stabilization task controller (denoted as **Lin-controller** on the scheme) is of the form (7.5), and finally the block **Diffeomorphism** consists of the change of

coordinates

$$\begin{aligned}\tilde{x}^1 &= m_{11}x^1 + m_{12}\sin x^2 \quad \text{for } x^2 \neq \pm\frac{\pi}{2} \\ \tilde{y}^1 &= m_{11}y^1 + m_{12}\cos x^2 y^2 \\ \tilde{x}^2 &= -k_1 x^1 \\ \tilde{y}^2 &= -k_1 y^1.\end{aligned}$$

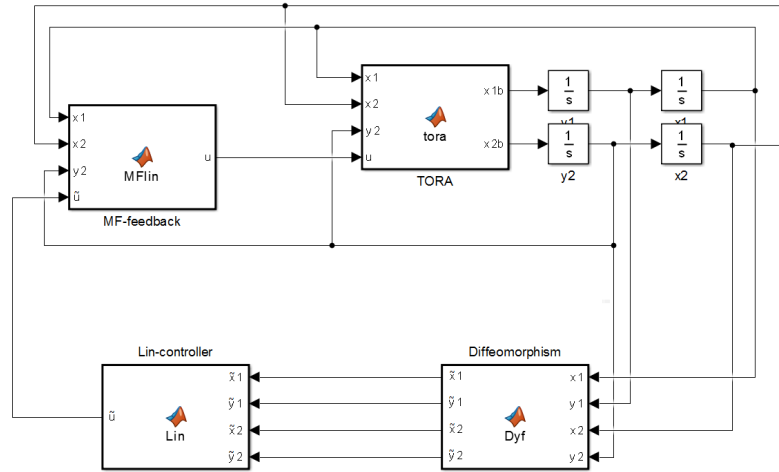

FIGURE 7.16: The simulation scheme for stabilization of the TORA system.

**Scenario 8. Tuning** We analyze the dynamics of the closed-loop system in case of different values of gain parameters  $\kappa_i$ . We choose two tuning methods, namely the natural frequency and the pole placement method.

In both methods we set the same initial conditions

$$x^1(0) = 0 \quad y^1(0) = 0 \quad x^2(0) = 0.7 \quad y^2(0) = 0,$$

and the task is to asymptotically stabilize the system around the origin, i.e.  $x_e^1 = x_e^2 = y_e^1 = y_e^2 = 0$ .

In the first method, we design the characteristic polynomial to be of double critically damped (i.e.  $\zeta = 1$ ) oscillators with a natural frequency  $\omega_n = 2$ , i.e.

$$p(\lambda) = (\lambda^2 + 2\zeta\omega_n\lambda + \omega_n^2)^2 = \lambda^4 + 4\omega_n\lambda^3 + 6\omega_n^2\lambda^2 + 4\omega_n^3\lambda + \omega_n^4$$

which results in the following gains  $\kappa_1 = \omega_n^4$ ,  $\kappa_2 = 4\omega_n^3$ ,  $\kappa_3 = 6\omega_n^2$ ,  $\kappa_4 = 4\omega_n$ . Simulation results with  $\omega_n = 2$  [s] are shown in Figure 7.17.

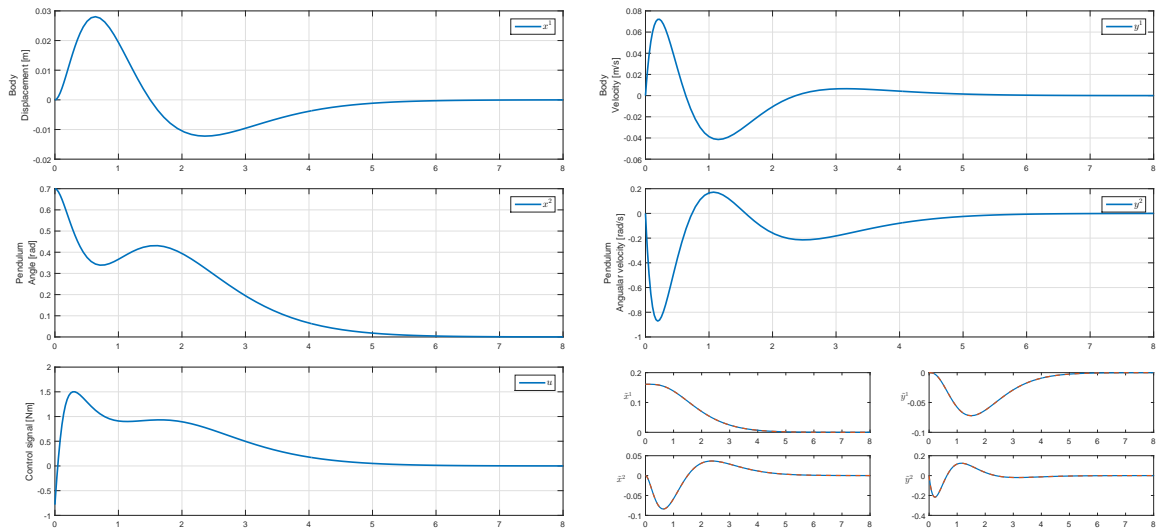

FIGURE 7.17: S8a. The simulation results for the TORA system with the natural frequency tuning.

In the second method, i.e. the pole placement, we place the poles to be equal to

$$\lambda_1 = -1 \quad \lambda_2 = -2 \quad \lambda_3 = -3 \quad \lambda_4 = -4$$

so the corresponding gains are  $\kappa_1 = 24$ ,  $\kappa_2 = 50$ ,  $\kappa_3 = 35$ ,  $\kappa_4 = 10$ .

Simulation results for the pole placement tuning method are shown in Figure 7.18.

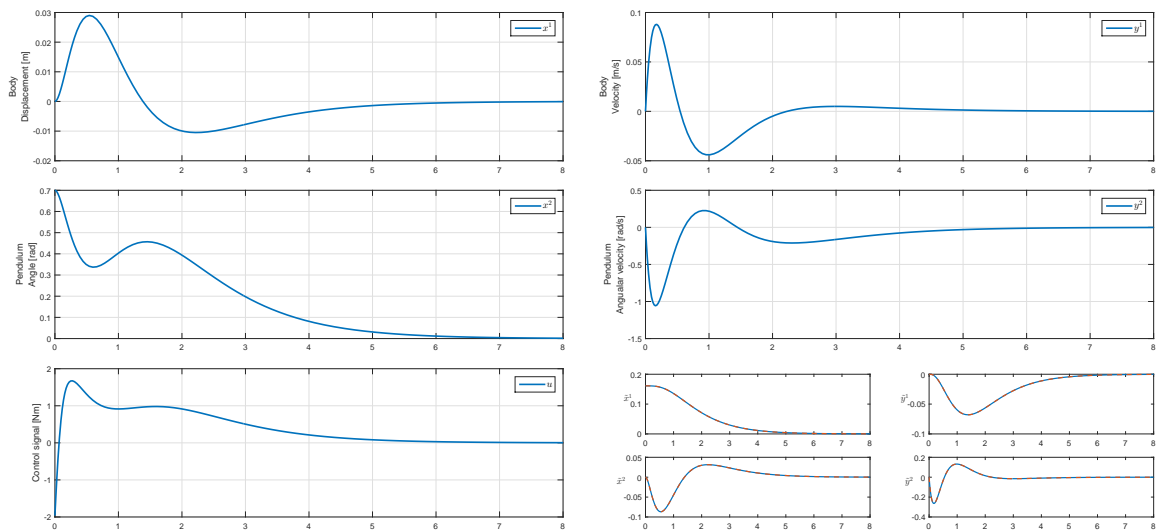

FIGURE 7.18: S8b. The simulation results for the TORA system with the pole placement tuning.

Both methods give comparable results in terms of convergence time, control signal value, velocities and positions of the pendulum and the body. The simulations conducted in this scenario showed that the nonlinear TORA system can be efficiently



controlled with a linear controller, while it is properly linearized. This feature simplifies the synthesis of the nonlinear control system to a basic linear control assuring the decent closed-loop dynamics of the overall system.

### 7.4.3 Motion planning and trajectory tracking

Here, we present simulations concerning the motion planing and the trajectory tracking. The simulation scheme is shown in Figure 7.19.

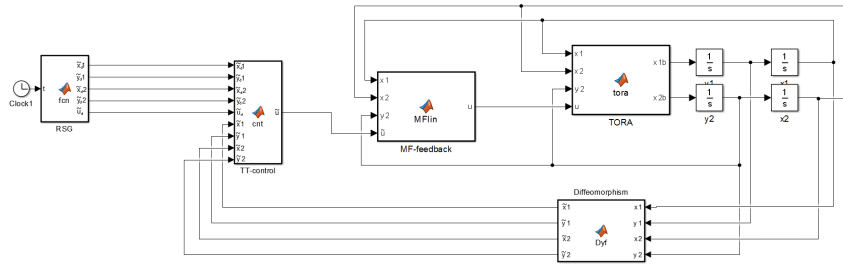

FIGURE 7.19: The simulation scheme for trajectory tracking of the TORA system.

The blocks TORA, MF-feedback, Lin-controller and Diffeomorphism are analogous to the ones in Figure 7.16. Additionally, two blocks are introduced, that are dedicated to trajectory tracking tasks, i.e. TT-control and RSG.

The block TT-control on the scheme is a linear controller of the form (7.12) whereas RSG is a reference signal generator.

**Scenario 9. Sinusoidal trajectory** Similarly to Scenario 7 we present the results for tracking of a sinusoidal reference trajectory with mismatching initial conditions. The reference trajectory is given by

$$\begin{aligned}\tilde{x}_d^1(t) &= A \sin(\omega t) \\ \tilde{y}_d^1(t) &= A\omega \cos(\omega t) \\ \tilde{x}_d^2(t) &= -A\omega^2 \sin(\omega t) \\ \tilde{y}_d^2(t) &= -A\omega^3 \cos(\omega t),\end{aligned}$$

where  $A = 0.5$  and  $\omega = 1$ . A reference control is equal to  $\tilde{u}_d(t) = A\omega^4 \sin(\omega t)$ . Importantly, the initial conditions ( $t_0 = 0$ ) of the system

$$x^1(t_0) = 0 \quad y^1(t_0) = 0 \quad x^2(t_0) = 0 \quad y^2(t_0) = 0 \quad u(t_0) = 0,$$

do not match the initial conditions of the reference trajectory.

We choose gains using the pole placement method. We place the poles to be equal to  $\lambda_1 = -3$ ,  $\lambda_2 = -1.5$ ,  $\lambda_3 = -3$ ,  $\lambda_4 = -1$  and the corresponding gains are  $\kappa_1 = 9$ ,  $\kappa_2 = 22.5$ ,  $\kappa_3 = 20$ ,  $\kappa_4 = 7.5$ .

Simulation results are shown in Figure 7.20. Notably, the evolution of the system converges to the reference values after approx. 8 [s]. Not only the proposed linear controller is able to track the sinusoidal trajectory, but handle the difference in the initial conditions of the reference trajectory and the TORA system.

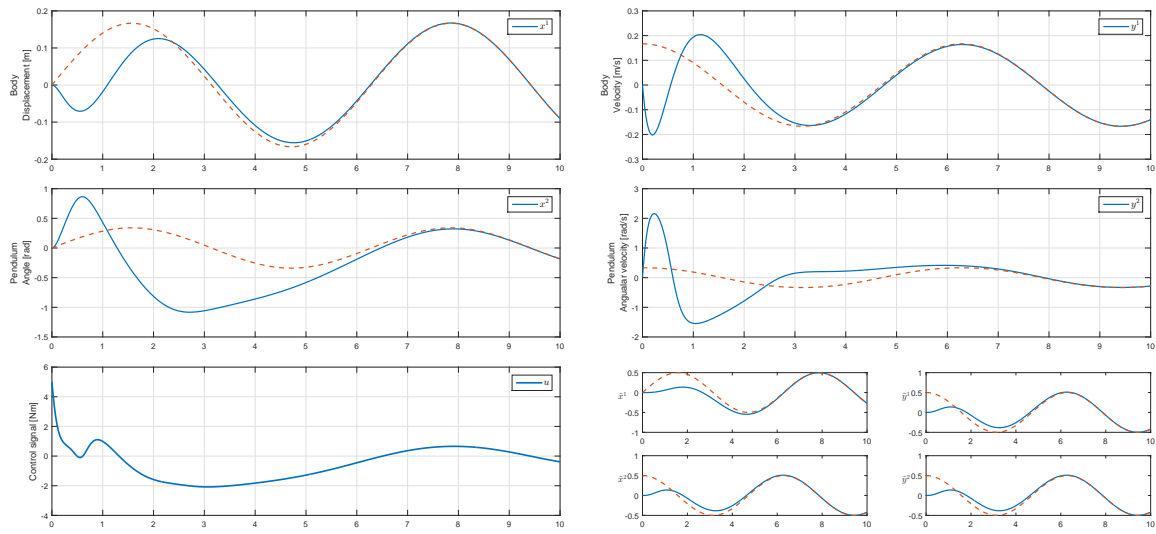

FIGURE 7.20: S9. Sinusoidal trajectory tracking of the TORA system.

We can observe that in the beginning of the simulation the displacement of the body occurs in the opposite direction to the reference signal. This feature is connected with the dynamics of original TORA system. Additionally, there is a peak in control signal equal to approx. 6 [Nm].

## 7.5 The single link manipulator with joint elasticity

Recall from Section 3.3.5, the equations of the single link manipulator with joint elasticity (hereafter called the FLEX system)

$$\begin{aligned}\dot{x}^1 &= y^1 \\ \dot{x}^2 &= y^2 \\ \dot{y}^1 &= e^1 \\ \dot{y}^2 &= e^2 + \frac{1}{J_2}u,\end{aligned}$$

where:

$$\begin{aligned}e^1 &= -\frac{maL}{J_1} \sin x^1 - \frac{k}{J_1} (x^1 - x^2), \\ e^2 &= \frac{k(x^1 - x^2)}{J_2}.\end{aligned}$$

In this subsection we assume the following parameters of the FLEX system:

$$\begin{aligned}m &= 0.5 \text{ [kg]}, & J_1 &= 4 \cdot 10^{-3} \text{ [kg} \cdot \text{m}^2], & a &= 9.81 \left[ \frac{\text{m}}{\text{s}^2} \right], \\ L &= 0.5 \text{ [m]}, & J_2 &= 3 \cdot 10^{-3} \text{ [kg} \cdot \text{m}^2], & k &= 3.\end{aligned}$$

### 7.5.1 MF-linearization

The first step of MF-linearization is to verify if conditions  $(ML0)' - (ML3)'$  formulated in Chapter 6 are satisfied. Once again we begin with calculating

$$ad_e g = 0 - \begin{pmatrix} -\frac{k}{J_1} - \frac{maL}{J_1} \cos x^1 & \frac{k}{J_1} \\ \frac{k}{J_2} & -\frac{k}{J_2} \end{pmatrix} \begin{pmatrix} 0 \\ \frac{1}{J_2} \end{pmatrix} = \begin{pmatrix} -\frac{k}{J_1 J_2} \\ \frac{k}{J_2^2} \end{pmatrix}.$$

We see that  $g$ ,  $ad_e g$  are independent everywhere, therefore  $(ML0)'$  is satisfied. The second condition  $(ML2)'$  can be verified by taking  $\omega = \text{ann } g = dx^1$ , i.e.

$$\omega(g) = (1 \ 0) \begin{pmatrix} 0 \\ \frac{1}{J_2} \end{pmatrix} = 0.$$

Since the Christoffel symbols are zero, the Riemann tensor is trivially zero, i.e.  $R_{jkl}^i = 0$ . We can conclude that  $(ML2)'$  is satisfied. Finally,

$$\nabla g = 0,$$

thus  $(ML3)'$  is satisfied. All three conditions  $(ML0)' - (ML3)'$  are fulfilled therefore it follows that the FLEX system is MF-linearizable.

Finally, we perform the linearization by choosing new coordinates,  $\Phi(x, y) = (\phi(x), D\phi(x)y)$ , where  $\tilde{x} = \phi(x)$  is given by

$$\begin{aligned} \tilde{x}^1 &= x^1 \\ \tilde{x}^2 &= e^1 = -\frac{maL}{J_1} \sin x^1 - \frac{k}{J_1} (x^1 - x^2) \end{aligned}$$

and calculate the linear representation of the system in new coordinates

$$\begin{aligned} \dot{\tilde{x}}^1 &= y^1 = \tilde{y}^1 \\ \dot{\tilde{x}}^2 &= e^1 = \tilde{x}^2 \\ \dot{\tilde{x}}^2 &= -\frac{maL}{J_1} \cos x^1 y^1 - \frac{k}{J_1} (y^1 - y^2) = \tilde{y}^2 \\ \dot{\tilde{y}}^2 &= \frac{1}{J_1^2} \left( (k + maL \cos x^1)(maL \sin x^1 + k(x^1 - x^2)) \right) + \frac{k^2}{J_1 J_2} (x^1 - x^2) + \\ &+ \frac{maL}{J_1} \sin x^1 y^1 y^1 + \frac{k}{J_1 J_2} u = \tilde{u}. \end{aligned}$$

In the following subsections we will describe the simulations showing the performance of the closed-loop linearized FLEX system with linear controller. Once again we will distinguish two main control problems, i.e. stabilization and jointly motion planing and trajectory tracking.

### 7.5.2 Stabilization

The simulation scheme, presented in Figure 7.21, consist of analogous blocks to the scheme used for simulations of two previous systems (see Figure 7.4 and 7.16). The block FLEX consists of the equation of dynamics of the FLEX system, whereas the

block **MF-feedback** is the linearization controller which reads

$$u = \frac{J_1 J_2}{k} \tilde{u} - \frac{J_2 m L a}{k} \sin x^1 y^1 y^1 - k (x^1 - x^2) + \\ - \frac{J_2}{k J_1} (k + m L a \cos x^1) (m L a \sin x^1 + k (x^1 - x^2)).$$

The linear stabilization task controller (denoted **Lin-controller** on the scheme) is of the form (7.5), and finally the block **Diffeomorphism** consist of the change of coordinates, as described previously, i.e.

$$\tilde{x}^1 = x^1 \\ \tilde{y}^1 = y^1 \\ \tilde{x}^2 = -\frac{m L a}{J_1} \sin x^1 - \frac{k}{J_1} (x^1 - x^2) \\ \tilde{y}^2 = -\frac{m L a}{J_1} \cos x^1 y^1 - \frac{k}{J_1} (y^1 - y^2).$$

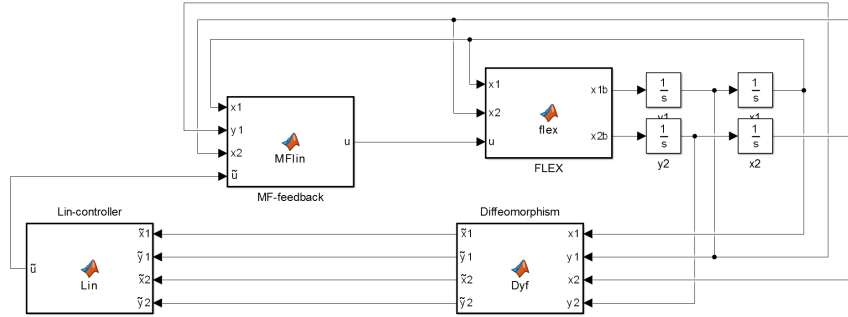

FIGURE 7.21: The simulation scheme for the FLEX system.

**Scenario 10. Tuning** Similarly to Scenario 8, we analyze the dynamic performance of the closed-loop system for various tuning methods. Once again, a linear controller parameters  $\kappa_i$  are tuned via the natural frequency or the pole placement methods. In both methods we set the same initial conditions

$$x^1(0) = \frac{\pi}{3} \quad y^1(0) = 0 \quad x^2(0) = \frac{\pi}{4} \quad y^2(0) = 0,$$

and the task is to asymptotically stabilize the system around the origin, i.e.  $x_e^1 = x_e^2 = y_e^1 = y_e^2 = 0$ .

We have chosen the natural frequency of double critically damped oscillators to be equal to  $\omega_n = 15$  [s], which imposed the following gain values:  $\kappa_1 = 50625$ ,  $\kappa_2 = 13500$ ,  $\kappa_3 = 1350$ ,  $\kappa_4 = 60$ .

Simulation results are shown in Figure 7.22.

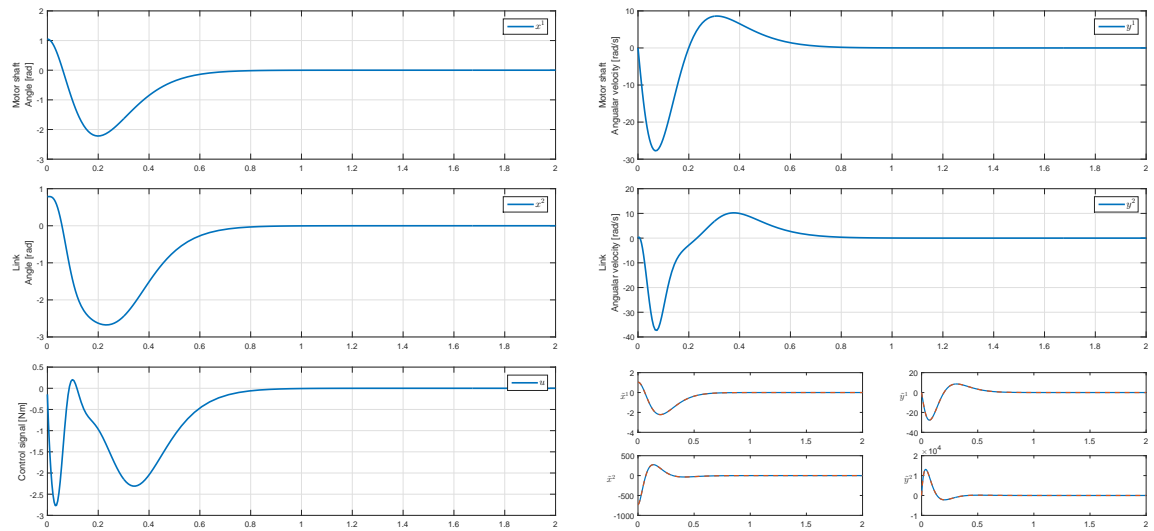

FIGURE 7.22: S10a. The simulation results for the FLEX system with the natural frequency tuning.

In the classical pole placement method, we place the poles to be  $\lambda_1 = -10$ ,  $\lambda_2 = -20$ ,  $\lambda_3 = -30$ ,  $\lambda_4 = -40$ , so the corresponding gains are  $\kappa_1 = 240000$ ,  $\kappa_2 = 50000$ ,  $\kappa_3 = 3500$ ,  $\kappa_4 = 100$ . Simulation results for pole placement tuning are shown in Figure 7.23.

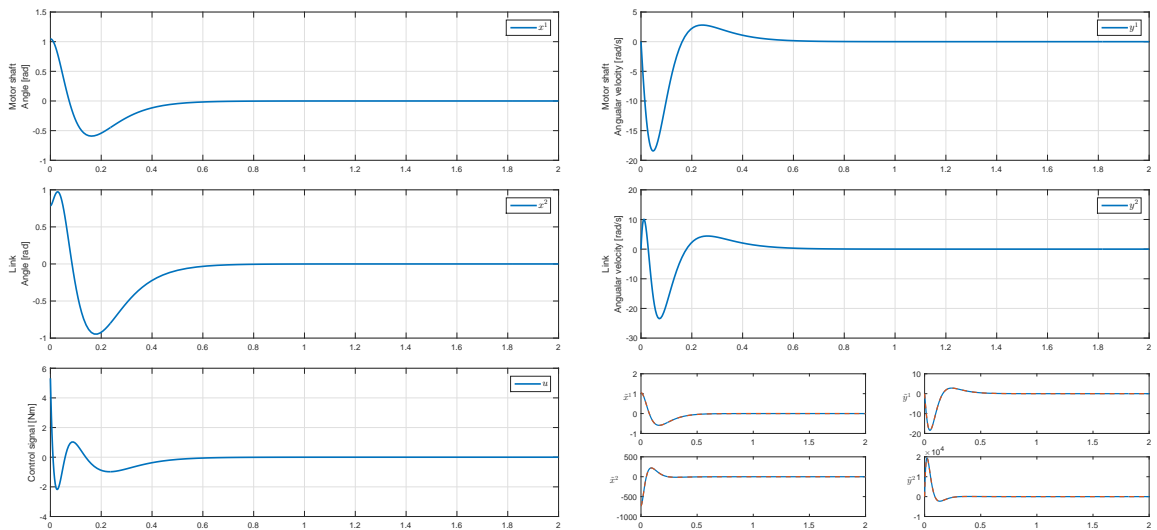

FIGURE 7.23: S10b. The simulation results for the FLEX system with pole placement tuning.

We can observe, that the pole placement method resulted in a lower overshoot in both, motor and shaft positions and velocities, but at the expense of higher controller gains. No matter which tuning method is concerned, in both cases, the motors shaft and link position passed through the reference stabilization value and exceeded it, before stabilizing at a zero error. Nevertheless, the stabilization task is accomplished in less than 1 [s], which is a satisfying result, considering highly oscillatory nature

of the FLEX system. Interestingly, we can observe the peek in the control signal value in the beginning of the simulation, for the pole placement method, which is a direct influence of high values of  $\kappa_i$ . From the engineering point of view, this feature may be considered unenforceable, due to the hardware limits. Nevertheless, as stated before, the goal of simulations conducted in the presented scenarios is to examine each feature independently, and saturation of control signal is beyond the scope of this particular scenario.

**Scenario 11. Stabilization outside the origin** Similarly to scenario 3, in this simulation he have examined the ability to stabilize the system at a point different that  $x_e = (0, 0)$ . The set of all stabilizable points is given by  $\tilde{x}^2 = \tilde{y}^1 = 0$  (implying  $y^1 = y^2 = 0$ ) and  $-\frac{maL}{J_1} \sin x^1 - \frac{k}{J_1} (x^1 - x^2) = 0$ . In summary, the set of all stabilizable points is given by  $(x_e^1, \frac{maL}{J_1} \sin x_e^1 + x_e^1)$ . We can conclude that the motor shaft angle can be freely chosen, whereas the link position is restricted. In this scenario, we chose the desired point  $x_e = (\frac{\pi}{2}, 2.3883)$ . The gains remain equal to those used in the pole placement method of Scenario 9, i.e.  $\kappa_1 = 240000$ ,  $\kappa_2 = 50000$ ,  $\kappa_3 = 3500$ ,  $\kappa_4 = 100$ . Additionally, we assume zero initial conditions for the given scenario, i.e.

$$x^1(0) = 0 \quad y^1(0) = 0 \quad x^2(0) = 0 \quad y^2(0) = 0.$$

Simulation results are shown in Figure 7.24.

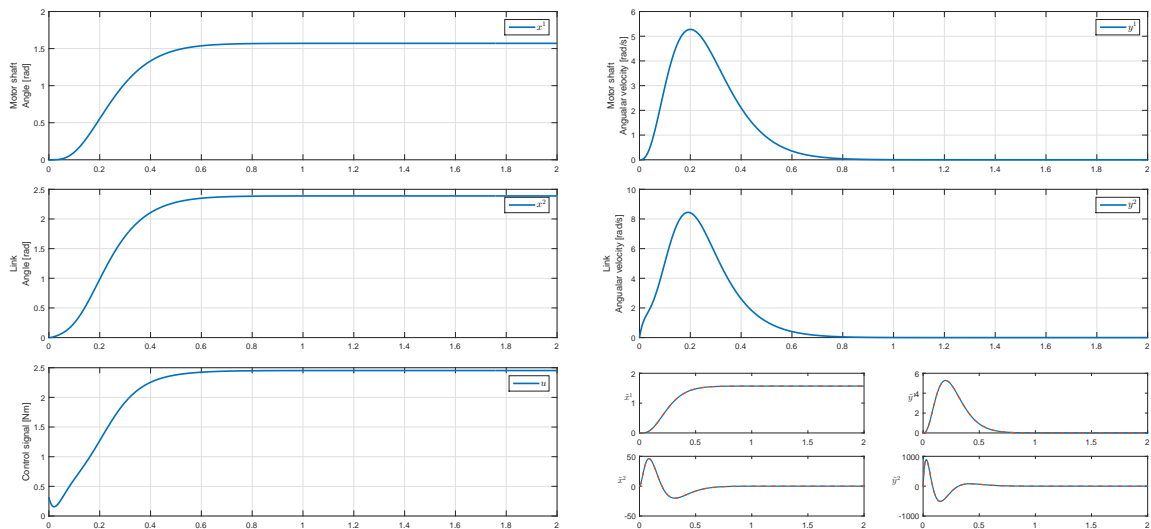

FIGURE 7.24: S11. The simulation results for the FLEX system outside the origin.

The convergence of the system is achieved in approx. 1 [s]. No overshoot is observed, in shaft as well as link position. Control signal is limited to an acceptable extent. The system is stabilized at the zero-velocity point, thus all velocities are approximately equal to zero after arriving close to  $x_e$ .

### 7.5.3 Motion planning and trajectory tracking

Here, we present simulations concerning the motion planing and trajectory tracking. The simulation scheme is shown in Figure 7.25.

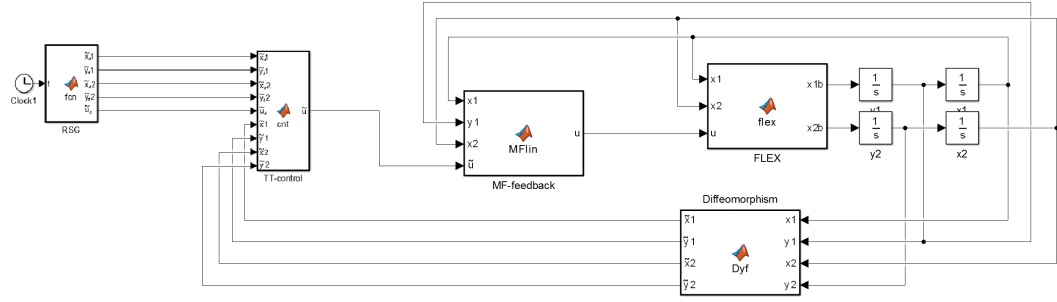

FIGURE 7.25: The simulation scheme for trajectory tracking for the FLEX system.

The block "FLEX" contains the equation of dynamics of the FLEX system, the block "MF-feedback" is the linearization controller that reads

$$u = \frac{J_1 J_2}{k} \tilde{u} - \frac{J_2 m L a}{k} \sin x^1 y^1 y^1 - k (x^1 - x^2) + \\ - \frac{J_2}{k J_1} (k + m L a \cos x^1) (m L a \sin x^1 + k (x^1 - x^2)).$$

The linear trajectory tracking controller (denoted "TT-control" on the scheme) is of the form (7.12), the block "Diffeomorphism" consist of the change of coordinates

$$\tilde{x}^1 = x^1 \\ \tilde{y}^1 = y^1 \\ \tilde{x}^2 = -\frac{m L a}{J_1} \sin x^1 - \frac{k}{J_1} (x^1 - x^2) \\ \tilde{y}^2 = -\frac{m L a}{J_1} \cos x^1 y^1 - \frac{k}{J_1} (y^1 - y^2).$$

and a reference signal generator (denoted "RSG") is a block, where reference trajectories (and their derivatives) are generated.

**Scenario 12. Rest-to-rest trajectory** In the following scenario we show simulations of the tracking of a reference trajectory that is a rest-to-rest trajectory, i.e. the trajectory that starts and ends at the equilibria of the system. In the following simulation we use the following gains, for  $\omega_n = 15$

$$\kappa_1 = \omega_n^4 \quad \kappa_2 = 4\omega_n^3 \quad \kappa_3 = 6\omega_n^2 \quad \kappa_4 = 4\omega_n.$$

For the desired trajectory, the initial conditions ( $t_0 = 0$ ) are

$$x^1(t_0) = \pi \quad y^1(t_0) = 0 \quad x^2(t_0) = \pi \quad y^2(t_0) = 0 \quad u(t_0) = 0$$

and the final conditions  $t_f = 5$  are

$$x^1(t_f) = 0 \quad y^1(t_f) = 0 \quad x^2(t_f) = 0 \quad y^2(t_f) = 0 \quad u(t_f) = 0.$$

The simulation results are presented in Figure 7.26. Plots of the evolution of the system (blue lines) overlap with the reference trajectory (red dashed lines) transformed into  $(x, y)$ -coordinates as there are no uncertainties or disturbances in the control system.

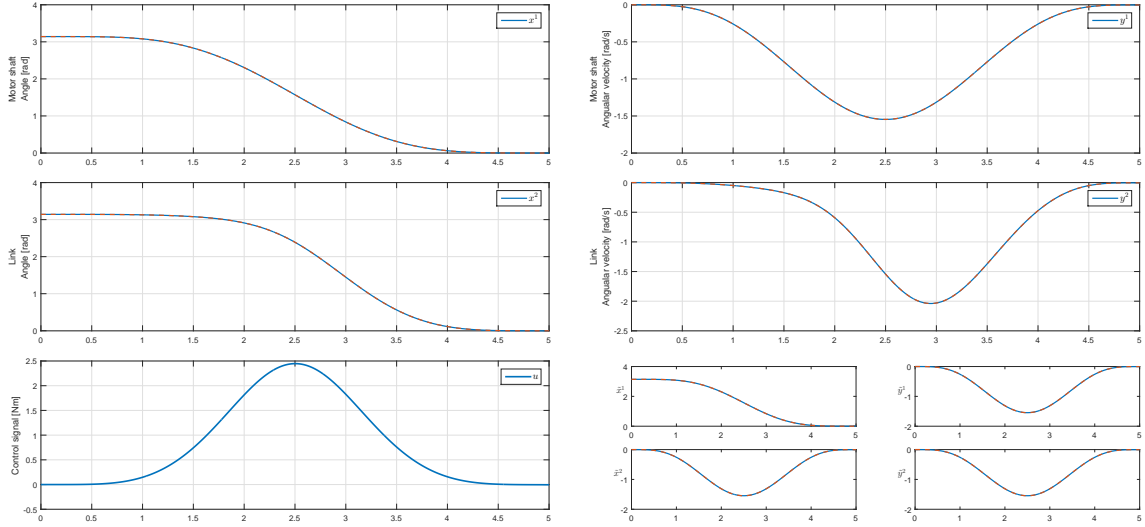

FIGURE 7.26: S12. Rest-to-rest trajectory tracking for the FLEX system.

**Scenario 13. Tracking sinusoidal trajectory** The second scenario presents tracking of a sinusoidal reference trajectory. It is given by, for  $A = \frac{\pi}{2}$  and  $\omega = 5$ ,

$$\begin{aligned}\tilde{x}_d^1(t) &= A \sin(\omega t) \\ \tilde{y}_d^1(t) &= A\omega \cos(\omega t) \\ \tilde{x}_d^2(t) &= -A\omega^2 \sin(\omega t) \\ \tilde{y}_d^2(t) &= -A\omega^3 \cos(\omega t)\end{aligned}$$

and a reference control  $\tilde{u}_d(t) = A\omega^4 \sin(\omega t)$ . The initial conditions ( $t_0 = 0$ ) of the system

$$x^1(t_0) = 0 \quad y^1(t_0) = 0 \quad x^2(t_0) = 0 \quad y^2(t_0) = 0 \quad u(t_0) = 0,$$

do not match the initial conditions of the reference trajectory. Despite that, the evolution of the system converges to the reference values after approx. 0.8 [s]. The control gains are, for  $\omega_n = 15$ ,

$$\kappa_1 = \omega_n^4 \quad \kappa_2 = 4\omega_n^3 \quad \kappa_3 = 6\omega_n^2 \quad \kappa_4 = 4\omega_n.$$

The simulation results are shown in Figure 7.27.



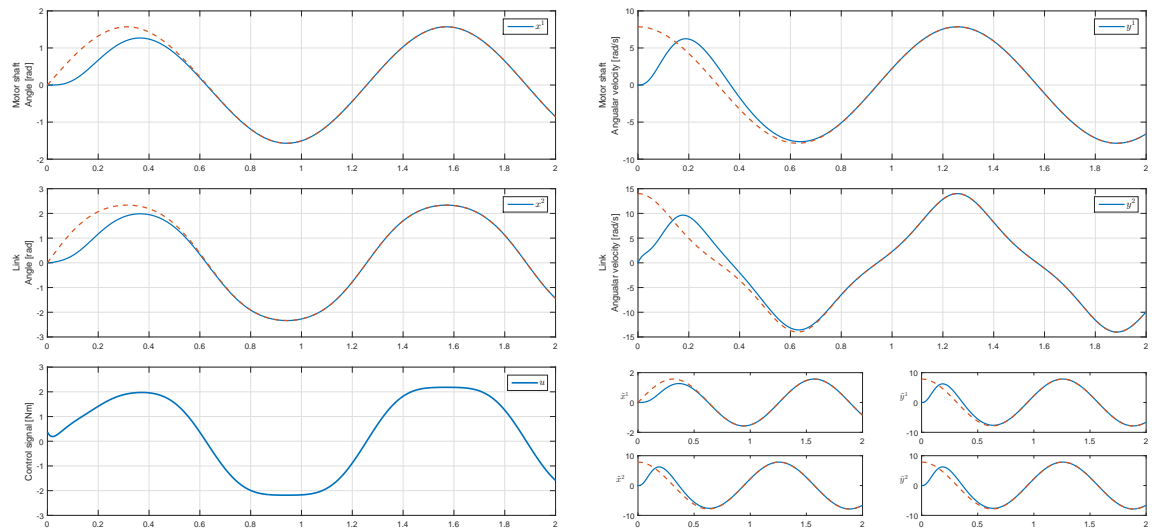

FIGURE 7.27: S13. Sinusoidal trajectory tracking of the FLEX system.

## 7.6 Construction the underactuated two-link manipulator

In the previous examples we show systems that are MF-linearizable. In the following one, we ask the question whenever we can design a system that can be MF-linearizable. We realized that the mechanical construction (moments of inertia, masses, lengths of the links, etc.) determine the inertia matrix of the system, which determines the Christoffel symbols in consequence. However by designing actuation on the system we are able to shape control vector fields  $g_r$ , and by designing the influence of gravitational field on the system and introducing elements that stores energy (like springs), we are able to shape uncontrolled vector field  $e$ . By this process, and using the conditions for  $(\mathcal{MS})$  to be MF-linearizable, we can answer whenever there exists a particular design of the  $(\mathcal{MS})$  that can be MF-linearizable.

It is well known[29], that arguably the most famous constructions of the underactuated two-link manipulator, namely the Acrobot and the Pendubot are not F-linearizable (hence not MF-linearizable). However there is an ongoing debate whenever there a is possibility to change the placement of the motor (e.g. using a transmission belt), change the influence of the gravitational field (e.g. by placing it on a horizontal plane as mentioned in Chapter 3) or introducing some springs to the system in order to make the system linearizable. By the following consideration we claim that the answer is negative (at least in case of MF-linearization) and we explore the reason why is that. The answer lies in the Riemannian tensor which is of full rank.

Consider a construction of the underactuated two-link manipulator, presented in Section 3.3.2.

The equations of  $(\mathcal{MS})$  can be obtain by introducing coordinates  $(x^1, x^2) := (\theta^1, \theta^2)$

$$\begin{aligned}\dot{x}^1 &= y^1 \\ \dot{x}^2 &= y^2 \\ \dot{y}^1 &= -\Gamma_{jk}^1 y^j y^k + e^1 + g_1^1 u \\ \dot{y}^2 &= -\Gamma_{jk}^2 y^j y^k + e^2 + g_1^2 u\end{aligned}$$

where:

$$\begin{aligned}\Gamma_{11}^1 &= -\Gamma_{12}^2 = -\Gamma_{21}^2 = -\Gamma_{22}^2 = -\frac{\zeta_2 \zeta_3 \sin x^2 + \zeta_3^2 \sin x^2 \cos x^2}{\zeta_1 \zeta_2 - \zeta_3^2 \cos^2 x^2} \\ \Gamma_{12}^1 &= \Gamma_{21}^1 = \Gamma_{22}^1 = -\frac{\zeta_2 \zeta_3 \sin x^2}{\zeta_1 \zeta_2 - \zeta_3^2 \cos^2 x^2} \\ \Gamma_{11}^2 &= \frac{\zeta_3 \sin x^2 (\zeta_1 + \zeta_2 + 2\zeta_3 \cos x^2)}{\zeta_1 \zeta_2 - \zeta_3^2 \cos^2 x^2}\end{aligned}$$

The components of Riemann tensor are

$$\begin{aligned}R_{jkk}^i &= 0 \\ R_{112}^1 &= -R_{121}^1 = -R_{212}^2 = R_{221}^2 = -\frac{(-\zeta_1 \zeta_2 + \zeta_3^2) \zeta_3 \cos x^2 (\zeta_2 + \zeta_3 \cos x^2)}{(\zeta_1 \zeta_2 - \zeta_3^2 \cos^2 x^2)^2} \\ R_{212}^1 &= -R_{221}^1 = \frac{(\zeta_1 \zeta_2 - \zeta_3^2) \zeta_2 \zeta_3 \cos x^2}{(\zeta_1 \zeta_2 - \zeta_3^2 \cos^2 x^2)^2} \\ R_{112}^2 &= \frac{(-\zeta_1 \zeta_2 + \zeta_3^2) \zeta_3 \cos x^2 (\zeta_1 + \zeta_2 + 2\zeta_3 \cos x^2)}{(\zeta_1 \zeta_2 - \zeta_3^2 \cos^2 x^2)^2} = -R_{121}^2\end{aligned}$$

Therefore we see that  $R_{112} = -R_{121}$  and  $R_{212} = -R_{221}$ . However  $R_{112}$  and  $R_{212}$  are independent since

$$\det \begin{pmatrix} R_{112}^1 & R_{212}^1 \\ R_{112}^2 & R_{212}^2 \end{pmatrix} = \frac{(-\zeta_1 \zeta_2 + \zeta_3^2)^2 \zeta_3^2 \cos^2 x^2}{(\zeta_1 \zeta_2 - \zeta_3^2 \cos^2 x^2)^3}$$

is non zero at regular points.

Therefore we conclude that  $\text{ann } R = 0$  so there exists no  $g$  satisfying  $(ML2)$  of Theorem 6.21. And we claim that there is no possible construction such that the system is MF-linearizable.



## Chapter 8

# Conclusions and further research

In this thesis we have studied a particular class of mechanical control systems and their various mechanical linearizations. Instead of defining a mechanical control system by its differential equations of motion, we define a mechanical control system  $(\mathcal{MS})$  as a 4-tuple  $(Q, \nabla, \mathbf{g}, e)$ , where  $Q$  is an  $n$ -dimensional configuration manifold,  $\nabla$  is a symmetric affine connection on  $Q$ ,  $\mathbf{g}$  is an  $m$ -tuple of control vector fields on  $Q$ , and  $e$  is an uncontrolled vector field on  $Q$  representing potential force in the system. Therefore our class of mechanical control systems can be physically interpreted as those that are not subjected to dissipative-type forces acting on the system (or they have been pre-compensated). We will undertake a short discussion of practicality of this assumption in a paragraph below, where we will outline future research directions.

We would like to emphasize that the purpose of the above abstract definition of  $(\mathcal{MS})$  (inspired by the founding fathers of geometric control theory of mechanical systems) is not to make this work intentionally cryptic and detached from the engineering practice. On the contrary, it has been shown numerous of times that this approach can bring a new insight into the problem and leads to fruitful theoretical results followed by practical engineering solutions. And it was our intention to embed our work into that trend.

In our work, we used tools that come from differential (especially Riemannian) geometry and tensor calculus to formulate a theory of linearization of  $(\mathcal{MS})$ . The geometric approach turned out to be profitable and gave rise to a mechanical linearization theory that is somehow analogous to the classical theory of a linearization of control systems. We want to underline that developing results that relate to classical ones was deeply intentional and a very challenging task. The purpose of this analogy was to increase the affordability and bring some systematization for the reader.

In Chapter 3, we have developed a geometric framework for mechanical control systems and presented a new sequence of nested distributions  $\mathcal{E}^j$  to study them. Also a connection to Lagrangian formalism has been drawn to establish a bridge between geometry and mechanics. This has been followed by several examples of models of  $(\mathcal{MS})$  that come from robotics.

Inspired by one of the most beautiful results of the classical linear control theory, namely the Brunovský classification, in Chapter 4, we have classified controllable linear mechanical systems  $(\mathcal{LMS})$ , established the mechanical canonical form, and found analogous invariants that we called mechanical half-indices. Later on we characterise Lagrangian linear mechanical systems and consider their canonical form.

In Chapter 5, we have investigated the mechanical state-space linearization (MS-linearization). We have formulated the problem of MS-equivalence (and MS-linearization) using transformations on the 4-tuple  $(Q, \nabla, \mathbf{g}, e)$  that defines  $(\mathcal{MS})$ . Later on, we have interpreted it by transformations on the corresponding differential equations of the mechanical control system. A new theorem of MS-linearization in the controllable case is presented, where the conditions are expressed entirely in terms of objects

on  $Q$ . Then, we solve the problem of MS-linearization of  $(\mathcal{MS})$  without controllability assumption, which opens a new area of research in the linearization techniques.

The Chapter 6 is the heart of the thesis. A problem of mechanical feedback linearization (MF-linearization) is stated and defined in terms of the 4-tuple  $(Q, \nabla, \mathbf{g}, e)$  and the corresponding equations of mechanical control system. Then, the role of distributions  $\mathcal{E}^j$  is explained. Finally, we have formulated three main theorems of this thesis. The first one solves the MF-linearization problem under the controllability assumption. The conditions that are stated make a connection with the classical result for F-linearization. Then, the problem of MF-linearization is rephrased using linearization outputs, and we have formulated mechanical input-output linearization with newly defined mechanical relative half-degree. Finally, similarly to the previous chapter, we have solved the problem of MF-linearization without the controllability assumption.

The role of Chapter 7 is invaluable. In the first part, we have illustrated results of Chapter 5 and 6 via examples of mechanical control systems that are subject (or not) to various forms of linearization. In the second part, we have stated several control problems with an application to robotic mechanical control systems. We have presented a systematic and relatively simple process of designing a control law, based on the established theory. Then, results of numerical simulations are presented to visualize usefulness and practicality of the presented solution.

Our study of linearization of mechanical control systems has opened many directions for a future research. As we mentioned, it was our intention to introduce a theory analogous to that of linearization in the case of classical control systems. Therefore, similarly to the classical case, our results give rise to a selection of problems that are related to the problem of linearization, i.e. partial linearization, input-output decoupling, decomposition of systems, disturbance decoupling and more. We have obtained preliminary results in some of these topics that did not fit in this thesis and will be published in the future.

Another set of problems comes from changing the class of used transformations by enlarging that of given by mechanical transformations. Here, a natural problem is to give a complete classification of feedback linearizable mechanical control systems under that larger class of transformations.

A natural (and most desired) extension of our work is by introducing dissipative-type terms in the system. Lacking them in our theory, however, could not be as limiting as can be seen at the first sight. From a practical point of view we propose two solutions: neglect them in the modelling, as one does with numerous phenomena that do not fit into the assumed description or precompasete them (if possible) by a preliminary feedback. From a theoretical viewpoint the problem is much complicated than it looks like. A linearization of controllable systems is connected with a classification of controllable linear systems. And this problem (including dissipative-terms) is known to be hard. In particular, an analogous to the mechanical Kalman rank condition (see Chapter 4) could be a good starting point. And even this is still an open problem (not due to lack of efforts).

We hope that new ideas will come up at the least expected moment, as they have done so far.

# Bibliography

- [1] R. Abraham and J.E. Marsden, *Foundations of Mechanics*, Addison-Wesley, 1978
- [2] N. S. Bedrossian, *Linearizing coordinate transformation and Riemannian curvature*, Proc. IEEE Conf. Dec. Control, pp. 80-85, 1992
- [3] N. S. Bedrossian and M. W. Spong, *Feedback Linearization of Robot Manipulators and Riemannian Curvature*, Journal of Robotic Systems, vol. 12, issue 8, pp. 541-552, 1995
- [4] A. M. Bloch, *Nonholonomic Mechanics and Control*, Springer, 2003
- [5] P. Brunovský, *A classification of linear controllable systems*, Kybernetika, vol. 6, issue: 3, pp. (173)-188, 1970
- [6] F. Bullo and A.D. Lewis, *Geometric Control of Mechanical Systems. Modeling, Analysis and Design for Simple Mechanical Control Systems*, Springer-Verlag, 2004
- [7] F. Bullo and A.D. Lewis, *Reduction, linearization, and stability of relative equilibria for mechanical systems on riemannian manifolds*, Acta Applicandae Mathematicae, 99 (1), pp. 53-95, 2007
- [8] D. E. Chang and R. G. McLenaghan, *Geometric Criteria for the Quasi-Linearization of the Equations of Motion of Mechanical Systems*, in IEEE Transactions on Automatic Control, vol. 58, no. 4, pp. 1046-1050, 2013.
- [9] J. J. Craig, *Introduction to Robotics: Mechanics and Control*, 2nd Ed., Addison-Wesley Publishing Company, 1989
- [10] P. E. Crouch, *Geometric structures in systems theory*, in IEE Proceedings D - Control Theory and Applications, vol. 128, no. 5, pp. 242-252, 1981
- [11] R. B. Doelman, *Feedback linearization control of a single link manipulator with joint elasticity*, DCT rapporten; Vol. 1991.068, Eindhoven: Technische Universiteit Eindhoven, 1991
- [12] M. Fliess, J. Lévine, P. Martin and P. Rouchon, *A Lie-Bäcklund approach to equivalence and flatness of nonlinear systems*, IEEE Trans. Automat. Control, 44(5), 922-937, 1999
- [13] S. Gudmundsson and E. Kappos, *On the geometry of tangent bundles*, Expositiones Mathematicae, Vol. 20, Issue 1, pp. 1-41, 2002
- [14] G. Hadley, *Linear Algebra*, Addison-Wesley, 1961.
- [15] P. C. Hughes, R. E. Skelton, *Controllability and Observability of Linear Matrix-Second-Order Systems*, Journal of Applied Mechanics, vol. 47, issue 2, pp. 415, 1980

- 
- [16] L. R. Hunt and R. Su, *Linear equivalents of nonlinear time varying systems*, Proc. of the MTNS, Santa Monica, 119-123, 1981
- [17] A. Isidori *Nonlinear Control Systems* (3rd ed.), Springer-Verlag, Berlin, Heidelberg, 1995
- [18] B. Jakubczyk and W. Respondek, *On Linearization of Control Systems*, Bull. Acad. Polonaise Sci., Ser. Sci. Math., 28, 517-522, 1980
- [19] L. Jaulin, *Mobile Robotics*, ISTE Press-Elsevier, 2015
- [20] K. Kozłowski, P. Sauer, *The Adaptive Control Algorithm for Manipulators with Joint Flexibility*, in Adaptive Control for Robotic Manipulators, eds. Zhang, Wei, CRC Press, 2016, pp. 264-297
- [21] J. M. Lee, *Introduction to smooth manifolds*, Graduate Texts in Mathematics, Springer New York, ISBN: 978-0-387-21752-9, 2000
- [22] J. M. Lee, *Riemannian Manifolds: An Introduction to Curvature*, Graduate Texts in Mathematics, Springer New York, ISBN: 978-0-387-22726-9, 1997
- [23] J. Lévine, *Analysis and Control of Nonlinear Systems: A Flatness-Based Approach*, Springer, 2009
- [24] A. D. Lewis, *Affine connections and distributions with applications to nonholonomic mechanics*, Rep. Math. Phys., 42, pp. 135–164, 1998
- [25] A. D. Lewis, *Affine Connection Control Systems*, IFAC Proceedings Volumes, 33(2), pp. 123–128, 2000
- [26] J.E. Marsden and T. Ratiu, *Introduction to Mechanics and Symmetry*, Springer-Verlag, 1994
- [27] P. Martin, P. Rouchon and R. M. Murray, *Flat systems, equivalence and trajectory generation*, CDS Tech. Report, Caltech, 2003
- [28] R. M. Murray, Z. X. Li, and S. S. Sastry, *A Mathematical Introduction to Robotic Manipulation*, CRC Press, 1994
- [29] R. M. Murray, and J. Hauser, *A Case Study in Approximate Linearization: The Acrobot Example*, Tech. Rep. UCB/ERL M91/46, Electronics Research Laboratory, College of Engineering, University of California, Berkeley, 1991
- [30] F. Nicolau and W. Respondek, *Flatness of Mechanical Systems with 3 Degrees of Freedom*, Proc. 5th IFAC Workshop on Lagrangian and Hamiltonian Methods for Nonlinear Control, Lyon, 2015
- [31] F. Nicolau and W. Respondek, *Flatness of multi-input control-affine systems linearizable via one-fold prolongation*, SIAM J. Control, 55, pp. 3171-3203, 2017
- [32] H. Nijmeijer and A. J. van der Schaft, *Nonlinear Dynamical Control Systems*, Springer-Verlag, New York, ISBN 978-0-387-97234-3, 1990
- [33] M. Nowicki, et al., *Geometry and flatness of m-crane systems*, Bulletin of the Polish Academy of Sciences: Technical Sciences, Vol. 67, nr 5, pp. 893-903, 2019

- [34] M. Nowicki and W. Respondek, *A Classification of Feedback Linearizable Mechanical Systems with 2 Degrees of Freedom*. In: Bartoszewicz A., Kabziński J., Kacprzyk J. (eds) *Advanced, Contemporary Control. Advances in Intelligent Systems and Computing*, vol 1196., pp 638-650. Springer, Cham., 2020
- [35] R. Olfati-Saber, *Normal forms for underactuated mechanical systems with symmetry*, *IEEE Trans. on Automatic Control*, 47:305–308, 2002
- [36] W.M. Oliva, *Geometric Mechanics*, *Lecture Notes in Mathematics*, Springer Science and Business Media, 2002
- [37] G. Oriolo, Y. Nakamura, *Control of mechanical systems with second-order non-holonomic constraints: Underactuated manipulators*, In *Proc. of the 30th IEEE Conf. on Decision and Control*, 2398–2403, 1991
- [38] S. Ricardo and W Respondek, *When is a control system mechanical?*, *Journal of Geometric Mechanics*, 2(3),265-302, 2010
- [39] W. Respondek and S. Ricardo, *Equivalence and equivariants of mechanical control systems*, 50th IEEE Conference on Decision and Control and European Control Conference, Orlando, FL, 2011, pp. 7129-7134, 2011
- [40] W. Respondek and S. Ricardo, *On Linearization of Mechanical Control Systems*, *IFAC Proceedings Volumes*, Vol. 45, Issue 19, pp. 102-107, 2012
- [41] W. Respondek and S. Ricardo, *Equivariants of Mechanical Control Systems*, *SIAM Journal on Control and Optimization* 51:4, 3027-3055, 2013
- [42] W. Respondek, *Introduction to geometric nonlinear control; linearization, observability and decoupling*. In *Mathematical Control Theory No.1*, *Lecture Notes Series of the Abdus Salam, ICTP*, vol. 8, Trieste, 2001
- [43] B. Siciliano, et al., *Robotics Modelling, Planning and Control*, Springer-Verlag London, 2009
- [44] M. W. Spong, *Remark on robot dynamics: Canonical transformations and Riemannian geometry*, *Proc. IEEE Int. Conf. Robot. Autom.*, pp. 554-559, 1992.
- [45] M.W. Spong, *Underactuated mechanical systems*, *Control Problems in Robotics and Automation. Lecture Notes in Control and Information Sciences*, vol 230, Springer, Berlin, Heidelberg, 1998
- [46] M.W. Spong, *The swing up control problem for the acrobot*, *IEEE Control Systems Magazine*, 15, Issue: 1:49–55, 1995
- [47] M. W. Spong and D. J. Block, *The Pendubot: a mechatronic system for control research and education*, *Proceedings of 1995 34th IEEE Conference on Decision and Control*, New Orleans, LA, USA, pp. 555-556, vol 1, 1995
- [48] M. W. Spong, P. Corke, R. Lozano, *Nonlinear control of the reaction wheel pendulum*, *Automatica*, vol. 37, no. 11, pp. 1845-1851, 2001
- [49] C. Wan, D. Bernstein, V. Coppola, *Global Stabilization of the Oscillating Eccentric Rotor*, *Nonlinear Dynamics*, 10: 49–62, 1995