



HAL
open science

Étalonnage du calorimètre électromagnétique ATLAS et mesure des propriétés du Boson W à $\sqrt{s} = 5$ et 13 TeV avec le détecteur ATLAS au LHC.

Hicham Atmani

► **To cite this version:**

Hicham Atmani. Étalonnage du calorimètre électromagnétique ATLAS et mesure des propriétés du Boson W à $\sqrt{s} = 5$ et 13 TeV avec le détecteur ATLAS au LHC.. Physique des Hautes Energies - Expérience [hep-ex]. Université Paris-Saclay, 2020. Français. NNT : 2020UPASP070 . tel-03224873

HAL Id: tel-03224873

<https://theses.hal.science/tel-03224873>

Submitted on 12 May 2021

HAL is a multi-disciplinary open access archive for the deposit and dissemination of scientific research documents, whether they are published or not. The documents may come from teaching and research institutions in France or abroad, or from public or private research centers.

L'archive ouverte pluridisciplinaire **HAL**, est destinée au dépôt et à la diffusion de documents scientifiques de niveau recherche, publiés ou non, émanant des établissements d'enseignement et de recherche français ou étrangers, des laboratoires publics ou privés.

Calibration of the ATLAS Electromagnetic
Calorimeter and Measurement of W Boson
Properties at $\sqrt{s} = 5$ and 13 TeV with the
ATLAS Detector at the LHC

Thèse de doctorat de l'Université Paris-Saclay

École doctorale n° 576, Particules, Hadrons, Énergie, Noyau,
Instrumentation, Imagerie, Cosmos, Simulation (PHENIICS)
Spécialité de doctorat: La physique des particules.
Unité de recherche: Université Paris-Saclay, CNRS, IJCLab,
91405, Orsay, France.
Réfèrent: Faculté des sciences d'Orsay.

Thèse présentée et soutenue à Orsay, le 03/12/2020, par

HICHAM ATMANI

Composition du jury:

Maire-Hélène Schune Directrice de recherche, Université Paris-Saclay (IJCLAB)	Présidente de jury
Alexandre Glazov Chercheur, Desy Laboratory	Rapporteur
Aram Apyan Research Associate, Fermi Laboratory	Rapporteur
Anne-Catherine Le Bihan Chargée de recherche, l'Université de Strasbourg (IPHC)	Examinatrice
Maarten Boonekamp Directeur de Recherche, CEA Saclay	Examinateur
Zhiqing ZHANG Directeur de recherche, Université Paris-Saclay (IJCLAB)	Directeur de thèse
Louis FAYARD Directeur de recherche, Université Paris-Saclay (IJCLAB)	Co-directeur de thèse

Titre: Étalonage du calorimètre électromagnétique ATLAS et mesure des propriétés du Boson W à $\sqrt{s} = 5$ et 13 TeV avec le détecteur ATLAS au LHC.

Mots clés: Masse, Mesure de précision, Boson W , ATLAS, LHC

Résumé: Cette thèse se compose de deux parties principales. La première partie correspond à un étalonage in-situ du calorimètre électromagnétique à l'aide d'électrons et de positrons provenant de désintégrations du boson Z sélectionnées parmi toutes les données nominales collectées par ATLAS lors du Run 2 entre 2015 et 2018, ainsi que pendant des runs spéciaux, caractérisés par un faible nombre d'interactions par croisement afin d'améliorer la résolution expérimentale de la mesure du recul des bosons Z et W et de la reconstruction des différentes variables cinématiques nécessaires à la détermination de la masse du boson W . Les

données nominales ont été collectées à une énergie dans le centre de masse de 13 TeV correspondant à une luminosité intégrée d'environ 140 fb^{-1} , alors que les runs spéciaux ont été collectés à 5 et 13 TeV, correspondant à 258 pb^{-1} et 340 pb^{-1} , respectivement. La deuxième partie porte sur la mesure des propriétés du boson W à l'aide des données des runs spéciaux, y compris une mesure de l'impulsion transverse du boson W , des mesures des sections efficaces fiducielles, simple et double différentielles, et une évaluation préliminaire des incertitudes statistiques et systématiques expérimentales sur la détermination de la masse du boson W .

Title: Calibration of the ATLAS Electromagnetic Calorimeter and Measurement of W Boson Properties at $\sqrt{s} = 5$ and 13 TeV with the ATLAS Detector at the LHC.

Keywords: Mass, Precision measurement, W boson, ATLAS, LHC

Abstract: This thesis consists of two main parts. The first part corresponds to an in-situ calibration of the electromagnetic calorimeter using electrons and positrons from Z boson decays selected from all nominal data samples taken by ATLAS during Run 2 between 2015 and 2018, as well as during special runs, characterised by a low number of interactions per bunch crossing in order to improve the experimental resolution of the recoil measurement of Z and W bosons and of the reconstruction of various kinematic variables needed for the W boson mass determination. The nominal data

samples were taken at a center of mass energy of 13 TeV corresponding to an integrated luminosity of about 140 fb^{-1} , whereas the special runs were taken at 5 and 13 TeV, corresponding to 258 pb^{-1} and 340 pb^{-1} , respectively. The second part is on the measurement of W boson properties using data from the special runs, including a measurement of the transverse momentum of the W boson, a measurement of fiducial, single and double differential cross sections, and a preliminary evaluation of the statistical and experimental uncertainties of the W mass determination.

1 Introduction

2 After the discovery of W and Z bosons at the Super Proton Synchrotron (SPS) at
3 CERN, particles responsible of weak interactions, the efforts have been geared to-
4 wards measuring their properties with high precision to test the consistency of the
5 Standard Model. The Standard Model has 25 free parameters to describe particles
6 and their interactions, some of them are measured directly, sometimes with great
7 precision, the other parameters are constrained by the measurement of physical
8 quantities related by the theory. For example, the W boson mass M_W , by includ-
9 ing radiative corrections, is related to the masses of the Z boson, Higgs boson and
10 quark top. The Z boson mass is measured with high precision at LEP experiments,
11 and after the discovery of the Higgs boson in 2012 at the LHC, the W boson mass
12 can be predicted theoretically and the comparison between the predicted and mea-
13 sured values is considered as a solid test for the consistency of the Standard Model.

14
15 This thesis describes the measurement of the W boson properties using data
16 collected with the ATLAS detector at the LHC at a center-of-mass energy of 5 and
17 13 TeV, corresponding to an integrated luminosity of 258 pb^{-1} at $\sqrt{s} = 5 \text{ TeV}$ and
18 340 pb^{-1} at $\sqrt{s} = 13 \text{ TeV}$. The data used are collected using special runs, with low
19 number of interactions per bunch crossing, in order to improve the experimental
20 resolution of the recoil measurement and the reconstruction of the missing trans-
21 verse momentum and of the transverse mass. In this work, we are interested in the
22 leptonic decays of the W boson, and the charged products of this decay, electron or
23 muon, are accompanied by a neutrino. The neutrino can not be measured directly
24 in the detector but can be measured indirectly using the lepton and the hadronic
25 system which recoils against the W boson.

26
27 Chapter 1 describes the Standard Model with a brief review of the spontaneous
28 symmetry breaking mechanism. Also the W boson production in pp collisions at
29 the LHC is described. Finally, a brief history of W boson mass measurements is
30 given, focusing on last results published by the ATLAS collaboration, with a de-
31 scription of all the dominant sources of uncertainties.

32
33 Chapter 2 briefly describes the LHC machine, gives a review of the LHC ac-
34 celeration chain and describes the machine performance. Then, the ATLAS de-
35 tector is described with its different parts focusing mainly on the electromagnetic
36 calorimeter, an important element of this thesis.

37
38 Chapter 3 gives a detailed explanation of the calibration procedure of electro-
39 magnetic particles, electrons and photons, in the ATLAS detector. To reach a high
40 precision in our measurement, a precise calibration of electron energy is required.
41 My personal contribution is basically the extraction of the energy scale factors, re-
42 sponsible of the correction of the mis-calibration of the electromagnetic calorime-
43 ter, for the nominal runs collected during Run 2, and for special runs collected
44 with low number of interactions per bunch crossing, to be used in a precise mea-
45 surement of the W mass. For the special runs, and because of the low statistics, we

46 proposed a new approach for the extraction of the energy scale factors.

47

48 Chapter 4 presents a theoretical description of the unfolding problem, focusing
49 on the iterative Bayesian unfolding method used in the high energy physics to cor-
50 rect undesired detector effects. The unfolding is used in the measurement of the
51 transverse momentum of the W boson, the measurement of the differential cross
52 sections and the measurement of the W boson mass.

53

54 Chapter 5 gives a detailed study on the measurement of the W -boson trans-
55 verse momentum distribution at 5 and 13 TeV. A precise measurement of p_T^W will
56 provide a direct comparison with predictions, and a direct measurement may re-
57 duce the QCD modeling uncertainties by a factor of two. My personal contribu-
58 tion concerns the unfolding of distributions at the detector level, the propagation
59 of uncertainties through the unfolding, the estimation of the unfolding bias (a bias
60 introduced with the unfolding procedure), and finally an optimisation study of
61 one of the unfolding parameters.

62

63 Chapter 6 reports results for the measurement of the W boson fiducial cross
64 sections using the unfolded distributions of p_T^W .

65

66 Chapter 7 presents detailed studies of the measurement of differential and dou-
67 ble differential cross section of the W boson at 5 and 13 TeV. The measurements are
68 based on the unfolded distributions of p_T^ℓ and η_ℓ . My personal contribution is the
69 unfolding of p_T^ℓ and η_ℓ distributions at the detector level and the estimation of the
70 corresponding uncertainties.

71

72 Chapter 8 gives preliminary results for the uncertainties of the W boson mass
73 determination, using the template method introduced in Run 1, focusing on the
74 statistical and systematic experimental uncertainties.

0.1 Résumé

Motivation. Au 20^e siècle, les physiciens ont commencé à construire un modèle qui décrit toutes les particules de la nature et leurs interactions, à l'exception de celles dues à la gravité, que l'on appelle le modèle standard. Ce modèle est la combinaison de deux théories qui décrivent les particules et leurs interactions dans un cadre unique. Les deux composantes du modèle standard sont la théorie électrofaible, qui décrit les interactions via les forces électromagnétiques et faibles, et la chromodynamique quantique (QCD), la théorie de la force nucléaire forte. Ces deux théories sont des théories de champ de jauge, qui décrivent les interactions entre particules en termes d'échange de particules intermédiaires «messagères». Avec le développement technologique au début des années 1970, des expériences ont été construites pour étudier les particules du modèle standard et leurs interactions.

Après la découverte des bosons W et Z au Super Synchrotron à Protons du CERN, particules responsables d'interactions faibles, les efforts ont été orientés vers la mesure de leurs propriétés avec une grande précision pour tester la cohérence du modèle standard. Le modèle standard dispose de 25 paramètres libres pour décrire les particules et leurs interactions, certains d'entre eux sont mesurés directement, parfois avec une grande précision, les autres paramètres sont contraints par la mesure des grandeurs physiques liées par la théorie. Par exemple, la masse M_W du boson W , en incluant des corrections radiatives, est liée aux masses du boson Z , du boson de Higgs et du quark top. La masse du boson Z est mesurée avec une grande précision par les expériences LEP, et après la découverte du boson de Higgs en 2012 au LHC, la masse du boson W peut être prédite théoriquement et la comparaison entre les valeurs prédites et mesurées est considérée comme un test solide pour la cohérence du modèle standard.

Cette thèse décrit la mesure des propriétés du boson W à partir de données collectées avec le détecteur ATLAS au LHC à deux énergies dans le centre de masse de 5 et 13 TeV, correspondant à une luminosité intégrée de 258 pb⁻¹ à $\sqrt{s} = 5$ TeV et 340 pb⁻¹ à $\sqrt{s} = 13$ TeV. Les données utilisées sont collectées à l'aide des runs spéciaux, avec un faible nombre d'interactions par croisement, afin d'améliorer la résolution expérimentale de la mesure du recul et la reconstruction de l'impulsion transverse manquante et de la masse transverse. Dans ce travail, nous nous intéressons aux désintégrations leptoniques du boson W , et les produits chargés de cette désintégration, électron ou muon, sont accompagnés d'un neutrino. Le neutrino ne peut pas être mesuré directement dans le détecteur mais peut être mesuré indirectement à l'aide du lepton et du système hadronique qui recule contre le boson W . Cette thèse est divisée en deux parties, la première partie étudie la calibration du calorimètre électromagnétique du détecteur ATLAS, utilisé pour déterminer l'énergie des électrons et des photons avec une grande précision. La

117 deuxième partie est consacrée à la mesure des propriétés du boson W .

118

119 **Le calorimètre électromagnétique du détecteur ATLAS au LHC.** Le LHC est
120 un collisionneur de particules à haute énergie, approuvé en 1996, avec les premiers
121 faisceaux en 2008 à l'organisation européenne pour la recherche nucléaire (CERN)
122 à la frontière entre la France et la Suisse. Avec une circonférence de 27 km et qua-
123 tre points d'interaction pour quatre grandes expériences (ATLAS, CMS, ALICE
124 et LHCb), le LHC est actuellement le plus grand et le plus puissant accélérateur
125 de la planète. Le LHC est conçu pour accélérer deux faisceaux de protons à plus
126 de 99,99% de la vitesse de la lumière, qui se déplacent dans des directions op-
127 posées autour de l'accélérateur et entrent en collision aux emplacements des qua-
128 tre expériences principales. ATLAS (A Toroidal LHC ApparatuS) est un détecteur
129 polyvalent développé pour étudier différents programmes de physique : interac-
130 tions électrofaible, production du boson de Higgs, QCD et signatures possibles
131 de la physique au-delà du modèle standard. Le détecteur ATLAS est situé à 100
132 mètres sous terre au premier point d'interaction du LHC, d'environ 44 mètres de
133 long et 25 mètres de diamètre, pesant environ 7 000 tonnes. Le détecteur ATLAS
134 est composé de différents sous-détecteurs qui présentent une couverture uniforme
135 autour du tube de faisceau et mesurent différentes propriétés des particules dans
136 les collisions proton-proton au LHC. Près du centre, nous commençons par les
137 détecteurs de trace internes, qui mesurent les trajectoires des particules chargées
138 à proximité du point d'interaction. Les calorimètres électromagnétiques (EM) et
139 hadroniques, qui mesurent l'énergie déposée par les électrons, les photons et les
140 jets hadroniques. Les calorimètres sont entourés par le spectromètre à muons, la
141 couche la plus externe, qui est conçu pour mesurer la trajectoire des muons.

142

143 Les particules électromagnétiques, électrons et photons, sont utilisées essen-
144 tiellement dans toutes les analyses notamment dans les études des propriétés du
145 boson de Higgs et dans la mesure de précision des paramètres électrofaible tels que
146 la masse du boson W , permettant un test de cohérence pour le modèle standard.
147 Les particules électromagnétiques sont arrêtées et mesurées dans le calorimètre
148 EM. Pour atteindre une bonne précision dans nos mesures, un étalonnage précis
149 de l'énergie des électrons et des photons est nécessaire. La procédure d'étalonnage
150 est basée sur des échantillons $Z \rightarrow ee$, en raison des statistiques élevées et de
151 l'état final propre qui caractérise ce canal. Dans cette thèse, nous discuterons de
152 l'étalonnage de l'énergie des électrons et des photons pour les données nominales
153 en utilisant un étalonnage "in-situ" du calorimètre EM. L'idée principale de cette
154 méthode est de comparer les distributions de la masse invariante m_{ee} des données
155 et de la simulation, et en utilisant cette comparaison nous pouvons déduire deux
156 facteurs de correction que nous appliquons aux données et aux simulations pour
157 la calibration du calorimètre électromagnétique. En plus des runs appelés runs
158 nominaux, on discute aussi de la calibration des runs spéciaux, utilisé pour des
159 mesures de précision, caractérisés par un faible nombre d'interactions par croise-
160 ment ($\mu \approx 2$). Pour ces runs, nous proposons deux approches différentes pour
161 l'étalonnage des énergies des électrons, la première est similaire à ce que nous
162 faisons pour les runs nominaux, la seconde consiste à faire une extrapolation des
163 résultats des runs nominaux, ce qui permet de réduire les incertitudes statistiques.

164

165 **La mesure de la distribution d'impulsion transverse du boson W .** L'une des
 166 sources d'incertitudes théoriques la plus importante dans la mesure de la masse
 167 du boson W est l'extrapolation de la distribution en p_T du boson Z au boson W (\approx
 168 6 MeV), où les prédictions d'ordre supérieur de la QCD ne sont pas suffisamment
 169 précises pour décrire les données. Une mesure précise du p_T^W fournira une com-
 170 paraison directe avec les prédictions QCD, cela revient à dire que le remplacement
 171 de l'extrapolation théorique de p_T^Z par une telle mesure directe de la distribution
 172 p_T^W améliorera la précision de la mesure de M_W . La mesure de la distribution du
 173 p_T^W dans la région du p_T^W faible ($p_T^W < 30$ GeV) avec une incertitude $\sim 1\%$ dans un
 174 bin de 5 GeV réduira l'incertitude de modélisation QCD dans la mesure de M_W
 175 d'un facteur deux. La distribution de p_T^W est reconstruite à l'aide d'événements
 176 $W \rightarrow \ell\nu$, où les leptons chargés sont mesurés dans les différents détecteurs de
 177 trace ou dans le calorimètre EM, tandis que le neutrino quitte le détecteur sans
 178 être directement mesuré. C'est la raison pour laquelle, la distribution p_T^W est re-
 179 construite par le recul hadronique, u_T , défini comme la somme vectorielle de tous
 180 les dépôts d'énergie à l'exclusion de l'énergie du lepton. L'impulsion transverse
 181 du boson W est définie par:

$$\vec{p}_T^W = -\vec{u}_T. \quad (1)$$

182

183 Dans la plupart des cas, les distributions des observables physiques sont affectées
 184 par des effets de détecteur: efficacité limitée, migration entre les bins etc. Dans
 185 cette thèse on discute de la mesure de la distribution d'impulsion transverse du
 186 boson W et de la correction des effets indésirables du détecteur avec la méthode
 187 d'unfolding. L'utilisation de la technique d'unfolding en physique des hautes én-
 188 ergies permet d'obtenir des résultats indépendants des effets de détection et de
 189 reconstruction. Par conséquent, les résultats d'unfolding peuvent être comparés
 190 directement à des prédictions théoriques ou à d'autres expériences.

190

191 L'idée principale de l'unfolding consiste à construire une matrice à partir de la
 192 simulation, appelée matrice de migration, qui contient des informations au niveau
 193 de la vérité et de la reconstruction. L'application de l'inverse de la matrice de
 194 migration à la distribution des données permet de passer au niveau de la vérité
 195 correspondant aux données, qui ne contient aucun effet de détecteur. Aussi cette
 196 thèse discute la propagation des différents sources d'incertitude par l'unfolding,
 197 en utilisant des techniques de bootstrapping, fit, etc. Au final, les résultats pour
 198 la mesure du p_T^W après l'unfolding sont comparés aux différentes prédictions
 199 théoriques.

200

201 Les distributions d'impulsion transverse du boson W , p_T^W , sont utilisées aussi
 202 pour la mesure des sections efficaces fiducielles, ce qui permet de comparer nos ré-
 203 sultats avec les prédictions disponibles, incluant les corrections de QCD (NNLO)
 204 et EW (NLO). Les sections efficaces sont mesurées en utilisant deux méthodes :
 205 une avec la correction bin-par-bin qui consiste à appliquer un factor C_i , déduit
 206 de la comparaison des niveaux vérité et reconstruit de la simulation. Alors que la
 207 deuxième consiste à utiliser les distributions d'unfolding.

208

209 **Mesure des sections efficaces simple et double différentielles.** Les sections

210 efficaces différentielles sont mesurées en fonction de différentes variables (η_ℓ, p_T^ℓ)
 211 en utilisant les distributions après l'unfolding. La mesure des sections efficaces
 212 différentielles dans ce processus fournit des tests rigoureux de la théorie QCD,
 213 cruciaux pour une compréhension approfondie et la modélisation des interactions
 214 QCD. De plus, la dépendance en fonction de la rapidité de la production de boson
 215 W dans le processus Drell–Yan fournit des contraintes sur les fonctions de distribu-
 216 tion des partons (PDFs), qui sont actuellement la source d'incertitude dominante
 217 dans la mesure de la masse W ($\approx 9,2$ MeV).

218 En parallèle, un unfolding à 2 dimensions est réalisé pour mesurer les sections
 219 efficaces double différentielles dans les bins de $(\eta_\ell - p_T^\ell)$. Une technique est util-
 220 isée pour transférer l'unfolding bidimensionnel à un unfolding unidimensionnel
 221 tel qu'utilisé pour les sections efficaces différentielles de η_ℓ et p_T^ℓ séparément. Dans
 222 les deux cas, les différentes sources d'incertitudes (statistiques, systématiques et bi-
 223 ais) sont propagées par l'unfolding en utilisant la même approche que celle de
 224 l'analyse de p_T^W .

225
 226 **La mesure de la masse du boson W .** Le boson W est une particule instable qui
 227 se désintègre en un lepton chargé et un neutrino. La masse du boson W est déter-
 228 minée en utilisant les distributions de la masse transverse du boson W (m_T^W) et de
 229 l'impulsion transverse du lepton (p_T^ℓ). L'idée de base de la méthode, appelée "tem-
 230 plates" (utilisée pour le Run 1), consiste à calculer les distributions simulées par
 231 Monte Carlo (MC) de p_T^ℓ et m_T^W pour différentes valeurs supposées de M_W ("tem-
 232 plates"), et la comparaison entre les "templates" et les données donne la meilleure
 233 valeur de la masse du boson W . En plus de la méthode des "templates", il existe
 234 une approche différente consistant à utiliser les distributions au niveau unfolded
 235 au lieu des distributions au niveau reconstruit. L'idée principale est d'utiliser
 236 des distributions déjà corrigées par la procédure d'unfolding et ne contera pas
 237 d'effets de détecteur indésirables. La masse du boson W et les différentes sources
 238 d'incertitudes (statistiques et systématiques) sont calculées en utilisant les distri-
 239 butions de p_T^ℓ et m_T^W séparément puis combinées pour le résultat final. Puisque
 240 nos distributions d'intérêt sont générées à partir des mêmes événements, nous de-
 241 vons prendre en compte la corrélation entre ces deux variables. La corrélation est
 242 calculée à l'aide des "Toys" de MC, générés en faisant varier les distributions p_T^ℓ
 243 et m_T^W simultanément avec une variation aléatoire de Poisson. Cette thèse, donne
 244 des résultats préliminaires pour la mesure de la masse du boson W avec les in-
 245 certitudes statistiques et expérimentales correspondantes, en utilisant les données
 246 des runs spéciaux collectés avec un faible nombre d'interactions par croisement (μ
 247 ≈ 2).

248 Contents

249	0.1	Résumé	5
250	1	Theoretical overview	1
251	1.1	Introduction	1
252	1.2	The Standard Model	1
253	1.2.1	Elementary particles	1
254	1.2.1.1	Fermions	1
255	1.2.1.2	Gauge bosons	2
256	1.2.2	Fields and interactions	3
257	1.2.2.1	Lagrangian formalism and symmetries	3
258	1.2.2.2	Quantum chromodynamics	4
259	1.2.2.3	Electroweak interaction	5
260	1.3	W boson production in pp collision	6
261	1.4	Properties of the W boson	10
262	1.4.1	W boson mass	10
263	1.4.2	Experimental determinations of W boson mass	11
264	2	Experimental Setup: The ATLAS experiment at the LHC	15
265	2.1	The large hadron collider	15
266	2.1.1	The LHC acceleration chain	15
267	2.1.2	LHC performance	16
268	2.2	The ATLAS detector	17
269	2.2.1	Coordinate system	18
270	2.2.2	Inner tracking detectors	19
271	2.2.3	Electromagnetic and hadronic calorimeters	20
272	2.2.3.1	The electromagnetic calorimeter	21
273	2.2.3.2	The ATLAS tile hadronic calorimeter	25
274	2.2.4	Muon spectrometer and toroidal magnets	25
275	2.2.5	ATLAS trigger and data acquisition system	26
276	2.3	Reconstruction of physics objects	27
277	2.3.1	Electron reconstruction	27
278	2.3.2	Electron identification	31
279	3	Calibration of the electromagnetic calorimeter	33
280	3.1	Introduction	33
281	3.2	Overview of the calibration procedure	33
282	3.3	Energy scale and resolution determination with electrons from $Z \rightarrow ee$ decays	34
284	3.3.1	Overview	34
285	3.3.2	Definition of the correction factors	35
286	3.3.3	Effect of the scale factors (α, c') on the di-electrons mass m_{ee}	36

287	3.4	Template method for the energy scale factors	37
288	3.4.1	Methodology of the template method	37
289	3.4.2	Inversion procedure	38
290	3.5	Selections and corrections	39
291	3.5.1	Binning	41
292	3.6	Results	41
293	3.6.1	Extraction of the correction factors (α, ϵ')	41
294	3.6.2	Systematic uncertainties	44
295	3.6.3	Data to simulation comparison	46
296	3.7	Calibration for low pile-up runs	47
297	3.7.1	Introduction	47
298	3.7.2	Energy scale factors for low pile-up runs	47
299	3.7.3	Extrapolation method	50
300	3.7.4	Extrapolation results	53
301	3.7.5	Uncertainties for the extrapolation method	55
302	3.7.6	Data to simulation comparison for low pile-up runs	56
303	3.8	Future of the calibration	57
304	4	Statistical overview: Unfolding	59
305	4.1	Introduction	59
306	4.2	Unfolding in high energy physics	59
307	4.3	Iterative Bayesian unfolding	61
308	4.3.1	Migration matrix	62
309	4.4	Uncertainties with unfolding	63
310	4.4.1	Propagation of the statistical uncertainty	64
311	4.4.2	Propagation of systematic uncertainties	65
312	4.4.3	Bias uncertainty with unfolding	65
313	4.5	Optimisation of the number of iterations	67
314	4.6	Bin-by-bin unfolding	67
315	5	Measurement of the W-boson transverse momentum distribution	71
316	5.1	Introduction	71
317	5.2	Data and simulated distributions	72
318	5.2.1	Selections	72
319	5.2.2	Control plots for the p_T^W distribution	72
320	5.3	Data unfolding	77
321	5.3.1	Unfolding description	77
322	5.3.2	Experimental systematic uncertainties	79
323	5.3.3	Propagation of statistical uncertainties	81
324	5.3.4	Propagation of systematic uncertainties	81
325	5.3.5	Comparison of the uncertainties	84
326	5.3.6	Unfolding bias	87
327	5.4	Results of p_T^W measurement	88
328	6	W boson production cross sections	91
329	6.1	Introduction	91
330	6.2	Fiducial cross-section methodology	91
331	6.2.1	The bin-by-bin method	91

332	6.2.2	The Bayesian unfolding method	92
333	6.2.3	Results	94
334	6.2.4	Comparison with theoretical predictions	94
335	7	Measurement of single and double differential cross sections	97
336	7.1	Introduction	97
337	7.2	Data and simulation distributions	98
338	7.2.1	Fiducial phase space	98
339	7.2.2	Experimental systematic uncertainties	98
340	7.2.3	Data and MC comparison	99
341	7.2.4	Unfolding of data distributions	99
342	7.2.5	Propagation of the statistical and systematic uncertainties	102
343	7.2.6	Unfolding bias	103
344	7.2.7	Optimisation of the number of iterations in iterative Bayesian unfolding	103
346	7.3	Differential cross sections	106
347	7.4	Comparison of electron and muon channels	119
348	7.5	Comparison with theoretical predictions	121
349	7.6	Double differential cross sections in p_T^ℓ and η_ℓ bins	122
350	7.6.1	Introduction	122
351	7.6.2	Migration matrix	123
352	7.6.3	Statistical uncertainty	123
353	7.6.4	Unfolding bias	123
354	7.6.5	Double differential cross sections	126
355	8	Measurement of the W-boson mass	131
356	8.1	Introduction	131
357	8.2	Template fit method methodology	131
358	8.3	W boson mass using the unfolded distribution	132
359	8.4	Statistical uncertainty	134
360	8.5	Systematic uncertainties	135
361	8.6	Statistical uncertainty with the unfolded distribution	139
362	9	Conclusion	143
363	A	Control plots	145
364	B	Breakdown of uncertainties	151
365	C	Uncertainties for the differential cross sections	159

Chapter 1

Theoretical overview

1.1 Introduction

For a long time, understand the nature of the matter that surrounds us was one of the most interesting questions of philosophers. The first idea to explain the nature of matter is due to ancient Greek philosophers in the 6th century B.C., who introduced the term "atom" to describe the small and indivisible object we can find in nature. The next huge step in the understanding of the matter came in the 18th century, where the chemists started to classify the materials on observed properties and also proposed predictions. However, near the end of the 19th century, physicists discovered that atoms are not the fundamental particles of nature, but conglomerates of even smaller particles.

In the 20th century, physicists started to build a model that describes all the particles in nature and their interactions except those due to gravity, which is so called the Standard Model (SM). This model is the combination of two theories that describe particles and their interactions into a single framework. The two components of the SM are the electroweak theory, which describes interactions via the electromagnetic and weak forces, and quantum chromodynamics, the theory of the strong nuclear force. Both these theories are gauge field theories, which describe the interactions between particles in terms of exchange of intermediary "messenger" particles. This chapter gives an overview of the particles and their interactions in the SM.

1.2 The Standard Model

1.2.1 Elementary particles

The particles in the SM, are divided in two groups called fermions and bosons, and are interacting with each other through three known interactions. The classification of particles is based on their physical properties.

1.2.1.1 Fermions

The fermions [118] in the SM are separated into two groups, leptons and quarks. Leptons are assumed to be elementary with no inner structure, while the quarks are constituent of other particles, hadrons, combined by the strong interaction [154].

397 The SM fermion sector is organised in three generations as shown in Table 1.1. Ac-
 398 cording to the predictions of relativistic quantum mechanics [80], each fermion has
 399 a corresponding anti-particle.

400 **Leptons:** They are one of the three classes of particles in the SM. There are six
 401 known leptons and they occur in pairs called generations. The three charged
 402 leptons (e^- , μ^- , τ^-) are: electron, mu-lepton or muon and the tau-lepton or
 403 tau. The three charged leptons have the same charge $Q = -e$. In addition
 404 to charged leptons, there are three neutral leptons-neutrinos (ν_{e^-} , ν_{μ^-} , ν_{τ^-})
 405 called the electron neutrino, muon neutrino and tau neutrino respectively,
 406 having very small masses.

407 **Quarks:** Considered as elementary particles and without inner structure, quarks
 408 are combined by the strong interactions to form the hadrons. Quarks can
 409 not be isolated because of the “color confinement” (Sec. 1.2.2.2). The strong
 410 interaction regroups quarks with different charges and color charges, to form
 411 hadrons. The most well known and stable hadrons are protons and neutrons.

TABLE 1.1: Generations of quarks and leptons with their masses and charges [63].

	1 st Generation	2 nd Generation	3 rd Generation	Charge[e]
Quarks	Up (u) $m = 2.3$ MeV	Charm (c) $m = 1.275$ GeV	Top (t) $m = 173.2$ GeV	+2/3
	Down (d) $m = 4.8$ MeV	Strange (s) $m = 95$ MeV	Bottom (b) $m = 4.18$ GeV	-1/3
Leptons	Electron (e^-) $m = 511$ keV	Muons (μ^-) $m = 105.7$ MeV	Tau (τ^-) $m = 1.8$ GeV	-1
	Electron neutrino (ν_e) $m < 2$ eV	Muon neutrino (ν_μ) $m < 0.19$ MeV	Tau neutrino (ν_τ) $m < 18.2$ MeV	0

412 1.2.1.2 Gauge bosons

413 Called also messenger particles or intermediate particles, the gauge bosons (Ta-
 414 ble 1.2) give rise to the interactions between particles. Photons are the intermediate
 415 particles of electromagnetic interactions, which bond the electrons to the nucleus
 416 to form the atoms, and which also bond the atoms together to form the molecules.
 417 The W and Z bosons, discovered at CERN in 1983 by the UA1 and UA2 collabora-
 418 tions [90], are the weak interaction messengers. Unlike photons, these particles are
 419 characterised by a non-zero mass, and their masses were found to be about 80 GeV
 420 and 91 GeV, respectively [71]. Exchange of gluons, the intermediate particles for
 421 strong interactions are analogous to the exchange of photons in the electromag-
 422 netic force between two charged particles, but for strong interactions, they “glue”
 423 quarks together, forming hadrons such as protons and neutrons. The Higgs boson
 424 has, contrary to the gauge bosons, a spin 0 and has been discovered at CERN in
 425 2012 by the ATLAS and CMS collaborations [4, 126].

TABLE 1.2: The SM bosons with their masses and charges, and corresponding interaction types [130].

Boson	Mass	Charge	Spin	Interaction	Range	Act on
Photon	0	0	1	Electromagnetism	Infinite	Charge
8 gluons	0	0	1	Strong	10^{-15} m	Colour
W^{\pm}	80.4 GeV	\pm	1	Weak	10^{-18} m	Weak isospin
Z	91.2 GeV	0	1	Weak	10^{-18} m	Weak isospin and hypercharge
Higgs	125 GeV	0	0			

1.2.2 Fields and interactions

In the SM, there are quantum fields associated to the bosons that are responsible of the interactions between particles. The SM is a theory describing the electromagnetic, weak, and strong interactions by a class of quantum field theories constrained by various symmetry principles.

1.2.2.1 Lagrangian formalism and symmetries

The Lagrangian formalism is an efficient method used to describe variety of physical systems including systems with finite (particles) and an infinite number of degrees of freedom (fields). In the SM, we describe all the interactions with the notion of field, and they are built using the Lagrangian formalism.

The easiest way to understand this formalism, is to take an example of an isolated system in classical physics, where the Lagrangian can be written as:

$$\mathcal{L}(x, \dot{x}, t) = T - V, \quad (1.1)$$

where T and V are the kinetic and potential energy, respectively. In the simple case of a system of a particle of mass m moving along a dimension x in a potential $V(x)$, the Lagrangian can be written as:

$$\mathcal{L}(x, \dot{x}, t) = \frac{1}{2}m\dot{x}^2 - V(x). \quad (1.2)$$

On the other hand, the principle of least action [35] tells us that the action:

$$S = \int_{t_1}^{t_2} \mathcal{L}(x, \dot{x}, t) dt, \quad (1.3)$$

must be minimised or maximised [35], which implies that:

$$\delta S = \int_{t_1}^{t_2} \left(\frac{\partial \mathcal{L}}{\partial q} \delta q + \frac{\partial \mathcal{L}}{\partial \dot{q}} \delta \dot{q} \right) dt = 0, \quad (1.4)$$

leading finally to the Lagrangian equation which describes the movement of the system:

$$\frac{\partial}{\partial t} \frac{\partial \mathcal{L}}{\partial \dot{q}} - \frac{\partial \mathcal{L}}{\partial q} = 0. \quad (1.5)$$

445 For the example introduced in equation (1.2), by injecting equation (1.2) in (1.5) we
446 find:

$$m\ddot{q} = -\frac{\partial V}{\partial q}, \quad (1.6)$$

447 which is none other than Newton's first law. On the other hand and from the
448 equation (1.5) we find that

$$\frac{d}{dt} \left[\frac{\partial \mathcal{L}}{\partial \dot{q}} \dot{q} - \mathcal{L} \right] = 0, \quad (1.7)$$

449 which leads us to another important theorem, Noether theorem [88], which means
450 that for any continuous symmetry of a system, there is a constant associated to the
451 movement (in our case here temporal). This notion of symmetry, or invariance, is
452 a key element in the construction of the SM as a gauge theory.

453 1.2.2.2 Quantum chromodynamics

454 Quantum chromodynamics (QCD) [84] is the gauge field theory which describes
455 the strong interactions. The QCD is a local gauge symmetry under the $SU(3)_c$
456 group [84]. This symmetry generates eight gluons, massless gauge bosons consid-
457 ered as intermediate particle for strong interactions. Gluons are characterised by a
458 conserved quantum number called the color charge (there are eight color states of
459 gluons, composed by the three colors: red, green or blue, and the three anti-colors).
460 The associated Lagrangian of QCD is:

$$\mathcal{L}_{\text{QCD}} = \bar{\psi}_{q,a} (i\gamma^\mu \partial_\mu \delta_{ab} - g_s \gamma^\mu t_{ab}^c A_\mu^c - m_q \delta_{ab}) \psi_{q,a} - \frac{1}{4} F_{\mu\nu}^A F^{A\mu\nu}. \quad (1.8)$$

461 The γ^μ are the Dirac γ -matrices, the $\psi_{q,a}$ represent the field of quark of flavor q [84]
462 and a is the color index (quarks come in three colors). The A_μ^c correspond to gluon
463 fields, with c running from 1 to $N_c^2 - 1 = 8$ representing the number of existing
464 gluons. The g_s is the strong coupling constant and is universal for all gluons. The
465 constant g_s ($g_s^2 = 4\pi\alpha_s$) is a fundamental parameter of QCD and can be written as
466 a function of the energy scale Q as:

$$\alpha_s(Q^2) \approx \frac{1}{\beta_0 \ln(Q^2/\Lambda^2)}, \quad (1.9)$$

467 where β_0 is a constant term related to the number of quark flavors and Λ is the scale
468 of the QCD. The dependence of α_s as a function of the energy scale Q , plotted in
469 Figure 1.1, defines the characteristic properties of QCD interactions:

- 470 • Asymptotic freedom: it means that at large Q^2 (small distance) the coupling
471 between quarks becomes weak.
- 472 • Quark confinement: it means that at small Q^2 (large distance) the coupling
473 between quarks becomes strong and we cannot find a quark as an isolated
474 particle.

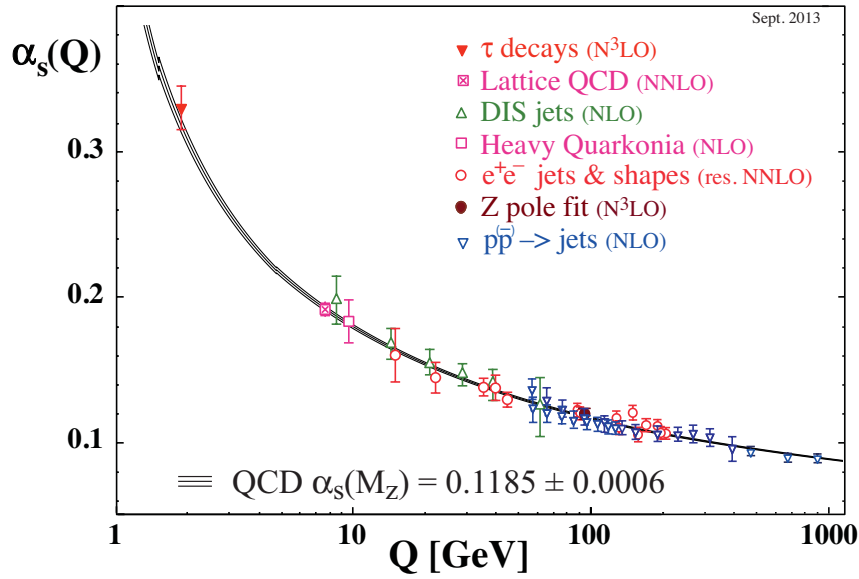


FIGURE 1.1: Evolution of the strong coupling constant as a function of the energy scale measured by various experiments [61].

475 1.2.2.3 Electroweak interaction

476 In the SM, the electromagnetic and weak interactions are considered as two dif-
 477 ferent low-energy aspects of a single electroweak (EW) interaction, this theory de-
 478 veloped by Glashow, Weinberg, and Salam being known as “GWS theory” [133].
 479 This theory is described by an $SU(2)_L \otimes U(1)_Y$ gauge group, with the exchange of
 480 four mediator bosons: photon, Z , W^+ and W^- . The Lagrangian of the EW theory
 481 is described as:

$$\mathcal{L}_{EW} = \sum_{\Psi} \bar{\Psi} [i\gamma^{\mu} D_{\mu}] \Psi - \frac{1}{4} W_{\mu\nu}^a W_a^{\mu\nu} - \frac{1}{4} B_{\mu\nu} B^{\mu\nu}, \quad (1.10)$$

$$D_{\mu} = \partial_{\mu} + igT^a W_{\mu}^a + ig' \frac{1}{2} T_Y B_{\mu}, \quad (1.11)$$

482 where T^a and T_Y are the generators of $SU(2)_L$ and $U(1)_Y$, g and g' are the weak and
 483 electromagnetic couplings. B_{μ} and W_{μ}^a are gauge fields which give rise to the four
 484 mediator bosons. The bosons photon, Z , W^+ and W^- can be written as:

$$A_{\mu} = B_{\mu} \cos \theta_W + W_{\mu}^3 \sin \theta_W, \quad (1.12)$$

$$Z_{\mu} = -B_{\mu} \sin \theta_W + W_{\mu}^3 \cos \theta_W, \quad (1.13)$$

$$W_{\mu}^{\pm} = \frac{1}{\sqrt{2}} (W_{\mu}^1 \mp W_{\mu}^2), \quad (1.14)$$

485 where θ_W is a mixing parameter called the weak mixing (Weinberg) angle which
 486 is precisely measured by experiments: $\sin^2(\theta_W) = 0.23153 \pm 0.00006$, in the scheme
 487 where θ_W is the effective leptonic weak mixing angle [89], and can be expressed in

488 terms of the coupling constants as:

$$\cos \theta_W = \frac{g}{\sqrt{g^2 + g'^2}}, \quad (1.15)$$

$$\sin \theta_W = \frac{g'}{\sqrt{g^2 + g'^2}}, \quad (1.16)$$

489 according to the EW Lagrangian (1.11). The fermionic and bosonic fields must be
 490 massless to preserve the $SU(2)_L \otimes U(1)_Y$ gauge symmetry. On the other hand, the
 491 experimental observations show the existence of massive bosons and fermions. In
 492 1964, the Brout-Englert-Higgs mechanism [32] proposed a solution to solve this
 493 conflict with experiments by adding an additional scalar boson called the (Brout-
 494 Englert-) Higgs boson and generating a ‘‘Higgs field’’ which interacts with all the
 495 particles. This mechanism is called ‘‘spontaneous symmetry breaking’’. The La-
 496 grangian of the Higgs field can be written as:

$$\mathcal{L}_{\text{Higgs}} = -\frac{1}{4}F^{\mu\nu}F_{\mu\nu} + (D^\mu\Phi)^\dagger(D_\mu\Phi) - V(\Phi), \quad (1.17)$$

$$V(\Phi) = -\mu^2|\Phi|^2 + \lambda(|\phi|^2)^2, \quad (1.18)$$

497 where $(D^\mu\Phi)^\dagger(D_\mu\Phi)$ contains the interaction between Higgs and gauge bosons.
 498 The Higgs boson mass term is expressed as: $m_H^2 = 2|\mu|^2 = 2\lambda v^2$, while the gauge
 499 bosons masses are written as:

$$m_W^2 = \frac{1}{4}g^2v^2, \quad m_Z^2 = \frac{1}{4}(g^2 + g'^2)v^2. \quad (1.19)$$

500 1.3 W boson production in pp collision

501 At the LHC [148], the electroweak gauge bosons W and Z are produced from
 502 proton–proton collisions (at Tevatron they were produced by proton–antiproton
 503 collisions). Each proton is composed of two quarks up (u) and one quark
 504 down (d) which interact through strong interactions by exchange of gluons.
 505 Quarks u and d , containing valence quarks, determine the quantum numbers of
 506 proton. The production of W and Z bosons at leading order is dominated by
 507 quark–antiquark annihilation processes, as seen in Figure 1.2, with $q\bar{q}' \rightarrow W$,
 508 $q\bar{q} \rightarrow Z$ with no momentum in the plane transverse to the beam [132]. However,
 509 high order corrections can include radiation of gluons or quarks, where the glu-
 510 ons can self-interact and produce more gluons, and each gluon can also produce a
 511 quark and anti-quark pairs, called *sea* quarks, also shown in Figure 1.2.

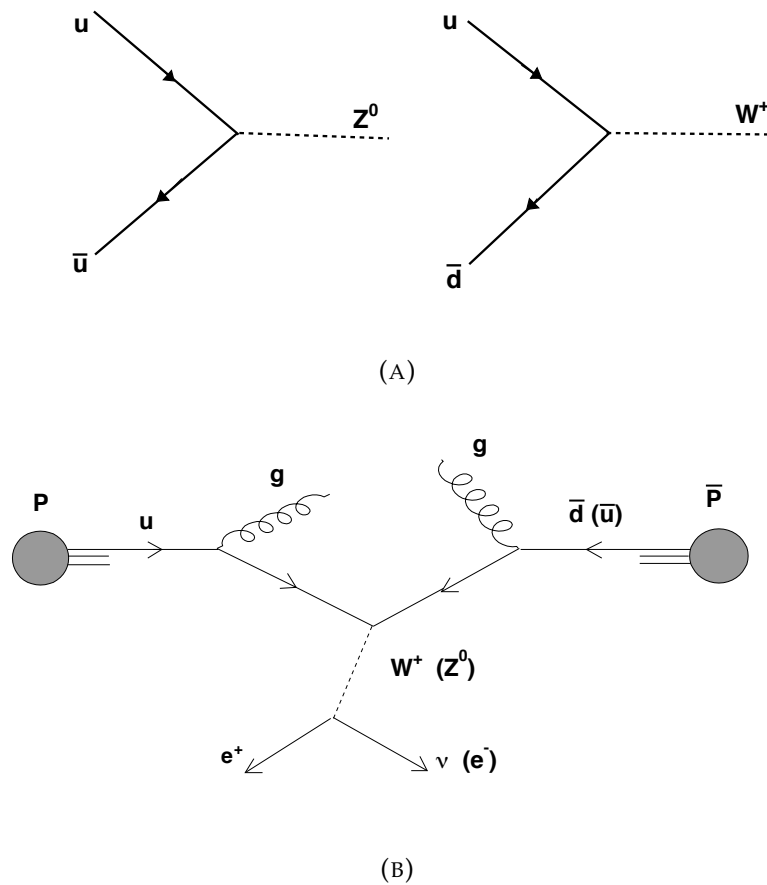


FIGURE 1.2: (A) First-order production diagrams for the W and Z boson. (B) Basic production and leptonic decay for W/Z bosons with radiated gluons.

512 Eventually, the production of the EW gauge bosons in proton–proton collisions with high order of QCD corrections, is mainly related to the distributions of
 513 partons inside each proton. The partonic structure is studied in particular in scattering processes like Deep Inelastic Scattering (DIS) [76], and the resulting Parton
 514 Distribution Functions (PDFs) [75] represent the probability density to find partons (quarks and gluons) carrying a momentum fraction x at an energy scale Q .
 515 PDF sets cannot be calculated analytically but are obtained by fits to a large number of cross section data points from many experiments [76]. Figure 1.3 shows
 516 examples of parton distributions in the proton at two energy scales $Q = 2$ GeV
 517 and $Q = 100$ GeV.
 518
 519
 520
 521

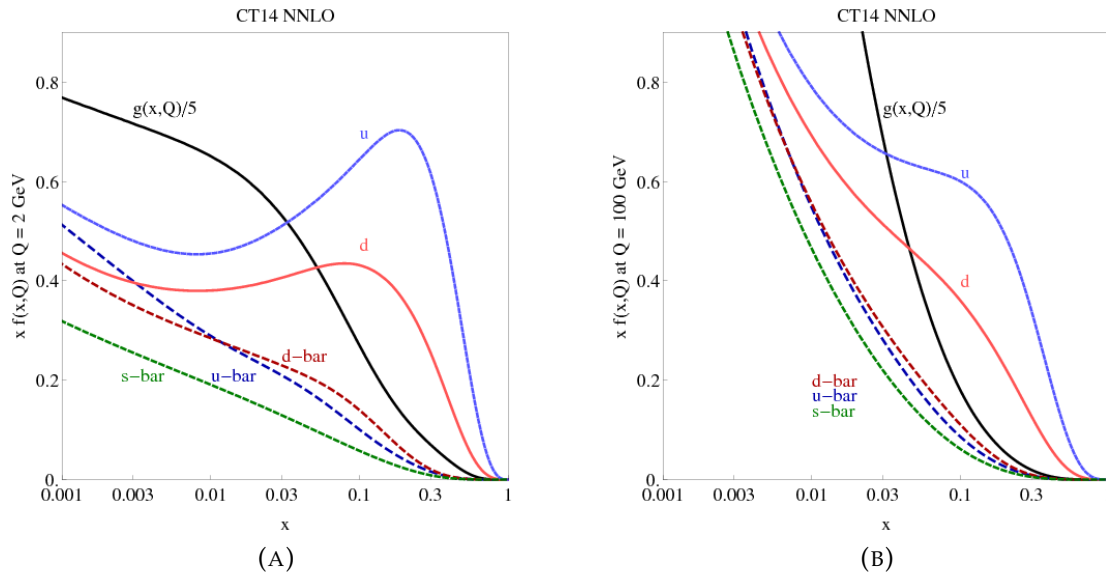


FIGURE 1.3: The CT14 parton distribution functions at $Q = 2$ GeV (A) and $Q = 100$ GeV (B) for $u, \bar{u}, d, \bar{d}, s = \bar{s}$ and g [65]

522 In proton–proton collisions, the hadrons interactions can be separated in two
 523 types, hard QCD and soft QCD. The hard QCD process for the W boson produc-
 524 tion corresponds to a production with large momentum transfer Q , and the W
 525 boson production cross-section ($p_1 + p_2 \rightarrow V + X$) can be determined using the
 526 *Factorization Theorem* [66] and the PDFs $f_i(x, Q)$:

$$\sigma_V(h_1(p_1), h_2(p_2)) = \sum_{a,b} \int_0^1 dx_a dx_b f_{a/h_1}(x_a, \mu_F^2) f_{b/h_2}(x_b, \mu_F^2) \times \sigma_{ab \rightarrow V}(x_a p_1, x_b p_2, \mu_F^2). \quad (1.20)$$

527 where $x_{1,2}$ are the fractions of the momenta of the hadrons and $f_{i,j}$ are the corre-
 528 sponding distributions of quark and anti-quark (a, b), μ_F is the factorization scale
 529 that separates hard and soft QCD regimes. The generalisation of equation (1.20)
 530 for higher order corrections that can contribute to the W boson production is writ-
 531 ten as:

$$\sigma_{ab \rightarrow V} = \sigma_0 + \alpha_s(\mu_R^2) \sigma_1 + \alpha_s^2(\mu_R^2) \sigma_2 + \dots \quad (1.21)$$

532 where μ_R is the renormalisation scale of the QCD running coupling constant, and
 533 σ_0 corresponds to the cross section at Leading Order (LO). The terms $\alpha_s(\mu_R^2)\sigma_1$ and
 534 $\alpha_s^2(\mu_R^2)\sigma_2$ correspond to the cross-sections at Next-Leading Order (NLO) and Next-
 535 to-Next-Leading Order (NNLO). For Drell-Yan processes, the scale parameters μ_F
 536 and μ_R are chosen as $\mu_F = \mu_R = M$ [46]. The predictions at NLO order for some
 537 important SM cross sections in proton–proton and proton–antiproton collisions
 538 are shown in Figure 1.4.

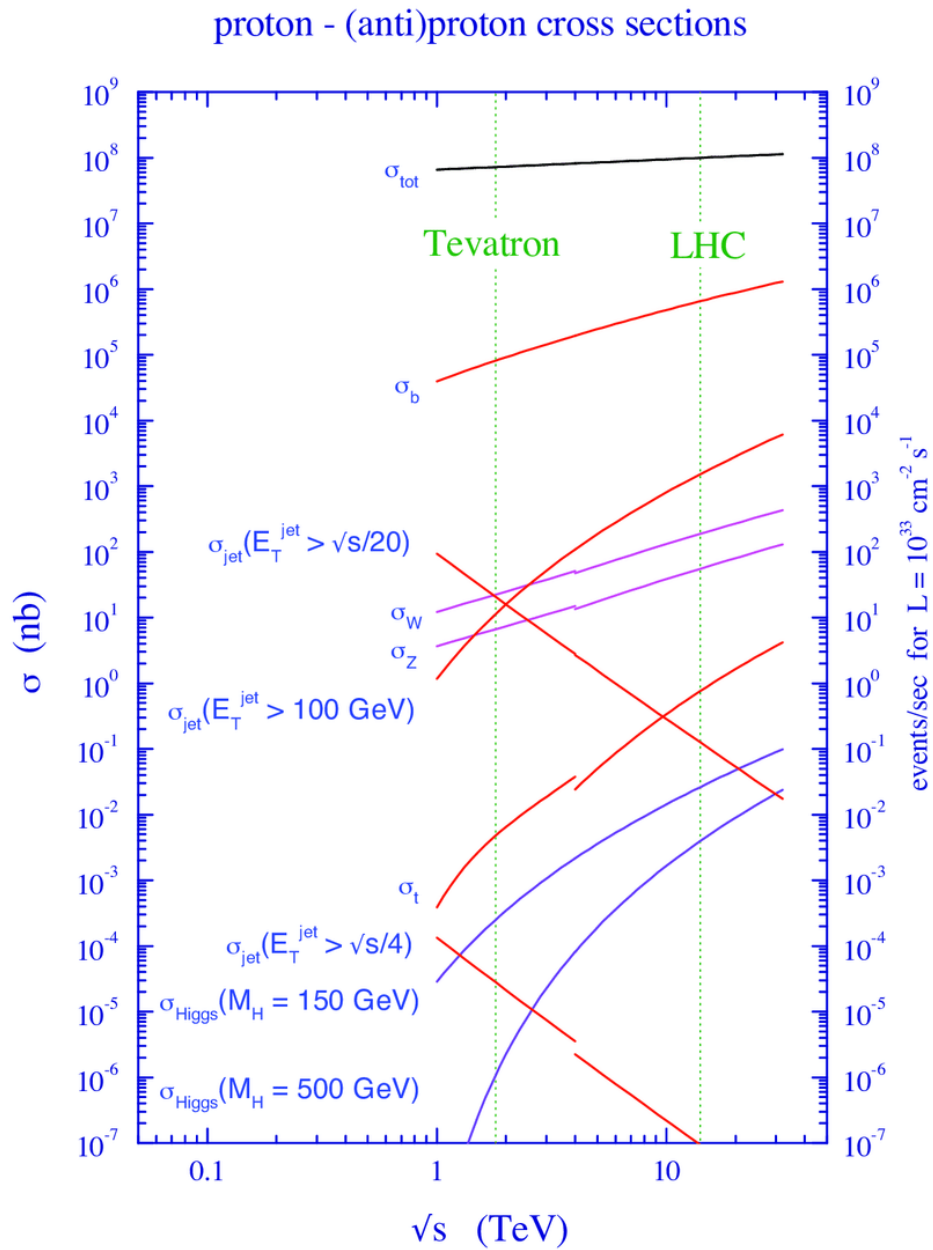


FIGURE 1.4: Standard Model cross sections at the Tevatron and LHC colliders, calculated at next-to-leading order in perturbation theory [141].

539 1.4 Properties of the W boson

540 1.4.1 W boson mass

541 As described in Sec. 1.2.2.3 for the spontaneous symmetry breaking, the funda-
 542 mental parameters of the electroweak interactions are: the mass of the Higgs bo-
 543 son, the weak mixing angle θ_W , and the coupling constants (g, g'). At lowest order
 544 in the EW theory, the W boson mass can be expressed as a function of the fine-
 545 structure constant $\alpha(= e^2/4\pi)$, the Fermi constant G_F and the mass of the Z boson.
 546 The Fermi constant G_F is a function of the the coupling constant g and calculated
 547 using the Fermi model [144]. The Z boson mass is determined with high precision
 548 from the Z lineshape scan at LEP1 [138]:

$$\alpha^{-1} = 137.035999074(44), \quad (1.22)$$

$$G_F = 1.1663787(6) \times 10^{-5} \text{ GeV}^{-2}, \quad (1.23)$$

$$M_Z = 91.1876(21) \text{ GeV}. \quad (1.24)$$

549 At this level, the W boson mass can be expressed as:

$$M_W^2 = M_Z^2 \left(\frac{1}{2} + \sqrt{\frac{1}{4} - \frac{\alpha\pi}{\sqrt{2}G_F M_Z^2}} \right). \quad (1.25)$$

550 It predicts a W mass value of $M_W = 80.939 \pm 0.0026 \text{ GeV}$. However, higher-order
 551 EW corrections introduce an additional dependence on the gauge couplings and
 552 the mass of heavy particles of the SM. The W mass boson can be expressed with
 553 an additional parameter Δr containing all the high-order corrections:

$$M_W^2 = M_Z^2 \left(\frac{1}{2} + \sqrt{\frac{1}{4} - \frac{\alpha\pi}{\sqrt{2}G_F M_Z^2(1 - \Delta r)}} \right). \quad (1.26)$$

554 In summary, the additional parameter Δr depends on the vacuum polarisation
 555 contribution of leptons and light quarks, as well as the top-quark and Higgs boson
 556 masses and may be sensitive to additional particles and interactions beyond the
 557 SM. All those effects make the W mass boson an extremely important parameter of
 558 the SM. Producing a W mass measurement with excellent accuracy is accordingly
 559 of high importance for testing the overall consistency of the SM, by comparing the
 560 experimental measurement of M_W to the theoretical predictions. The determina-
 561 tion of the W boson mass at the NLO order (2-loop EW), with some leading NNLO
 562 and few N³LO QCD contributions, is performed with a global fit [28, 89] (see also
 563 Refs. [146, 39]) of electroweak parameters. The resulting W mass value is:

$$M_W = 80.359 \pm 0.006 \text{ GeV}. \quad (1.27)$$

1.4.2 Experimental determinations of W boson mass

After the first detection of the W boson by the UA1 [21] and UA2 [29] collaborations [90] in proton–antiproton collisions at the SPS collider in 1983, the obtained M_W value was 81 ± 5 GeV [72] and it was difficult to determine it precisely at this accelerator [60]. However, UA2 produced finally a determination $M_W = 80.35 \pm 0.37$ GeV in 1991 [11]. Later, the W mass was determined [137] in Large Electron-Positron (LEP) collider at CERN [1995-2000] [83]. LEP was accelerating electrons and positrons to reach a center-of-mass energy up to 209 GeV. The direct measurement of the W boson mass at LEP experiments (ALEPH, DELPHI, L3 and OPAL) gives the following result:

$$M_W^{\text{LEP}} = 80.376 \pm 0.025_{\text{stat}} \pm 0.022_{\text{syst}} \text{ GeV}. \quad (1.28)$$

Later, a new determination of M_W was performed in Tevatron experiments (CDF and D0) at Fermilab [2002-2011] [59]. The Tevatron collider was a proton–antiproton collider, where the center of mass energy can reach 1.96 TeV [125]. The M_W was determined from the comparison of kinematical distributions of $W \rightarrow l\nu$ with simulated distributions characterised with different M_W values. The direct determination of the W boson mass by the Tevatron experiments (CDF and D0) gives the following result [5]:

$$M_W^{\text{Tevatron}} = 80.387 \pm 0.016 \text{ GeV}, \quad (1.29)$$

The Tevatron and LEP combined results lead to the world average value:

$$M_W = 80.385 \pm 0.015 \text{ GeV}, \quad (1.30)$$

The latest M_W determination is carried out with the ATLAS detector at the LHC [115, 17], using proton–proton collision at a center of mass energy of 7 TeV collected during Run 1 in 2011. The M_W is determined using the lepton transverse momentum (p_T^ℓ) and transverse mass (m_T^W) distributions from $W \rightarrow l\nu$ with the template approach [115]. The W boson transverse mass, m_T^W , is derived from the missing transverse momentum (p_T^{miss}) and from p_T^ℓ as follows:

$$m_T^W = \sqrt{2p_T^\ell p_T^{\text{miss}}(1 - \cos \Delta\phi)}, \quad (1.31)$$

where $\Delta\phi$ is the azimuthal opening angle between the charged lepton and the missing transverse momentum. The different sources of uncertainties are described in the Table 1.3, and the dominant systematic uncertainties are:

Lepton calibration: The measurement of lepton momentum and energy is derived using information from the Z decay due to its very clean final state. The Run 1 corrections for the leptons with their uncertainties are described in [23, 41, 67] and are studied in detail for this analysis in [158, 152]. Electron energy calibration will be discussed in Chapter 3.

Hadronic recoil uncertainty: It is defined as the uncertainty from the hadronic recoil (HR) calibration [48]. The study for the Run 1 analysis is shown in [140].

598 The uncertainties in HR calibration are mainly driven by data statistics in the
599 resolution and response corrections [155, 101].

600 **Backgrounds in the W boson sample:** The W boson background contributions
601 are estimated using simulation, except for the multijet background using
602 data-driven techniques [155, 157]. The study for the Run 1 analysis is shown
603 in [17].

604 **QCD corrections:** The NNLO is used to describe the differential cross-section as
605 a function of boson rapidity and angular coefficient [143, 16]. The QCD un-
606 certainties are coming from the uncertainties in the fixed-order predictions,
607 parton-shower predictions and angular coefficients [115].

608 **Electroweak corrections:** Dominated by QED final-state radiation (FSR) [33], the
609 uncertainties are evaluated by comparing the distributions with different
610 computations.

611 **PDF uncertainties:** Uncertainties in the PDFs are the dominant source of physics-
612 modelling uncertainty, due to our imperfect knowledge of the PDFs affecting
613 the differential cross section as a function of boson rapidity, the angular co-
614 efficients, and the W boson transverse momentum distribution.

615 The ATLAS experiment gives the following results:

$$M_W^{\text{ATLAS}} = 80.370 \pm 0.019 \text{ GeV.} \quad (1.32)$$

616 The W boson mass results of ATLAS in comparison with other determinations are
617 shown in Figure 1.5.

TABLE 1.3: The ATLAS M_W result with statistical and systematic uncertainties [115].

Combined categories	Value MeV	Stat. Unc.	Muon Unc.	Elec. Unc.	Recoil Unc.	Bckg. Unc.	QCD Unc.	EW Unc.	PDF Unc.	Total Unc.
m_T^W, p_T^ℓ	80369.5	6.8	6.6	6.4	2.9	4.5	8.3	5.5	9.2	18.5

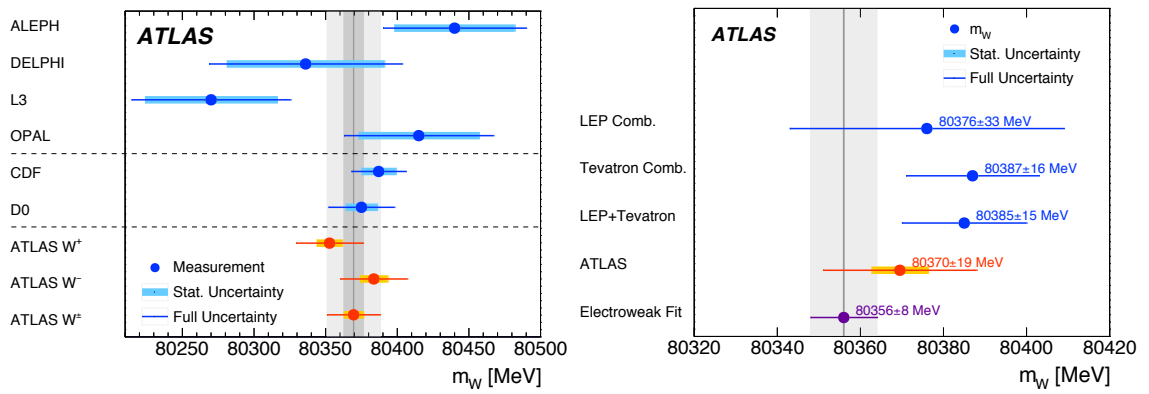


FIGURE 1.5: Left: The M_W results of ATLAS [115] in comparison with other published results from the LEP experiments ALEPH, DELPHI, L3 and OPAL, and from the Tevatron collider experiments CDF and D0. The vertical bands show the statistical and total uncertainties of the ATLAS determination, and the horizontal bands and lines show the statistical and total uncertainties of the other published results. Right: The ATLAS result compared to the SM prediction from the global electroweak fit, and to the combined values determined at LEP and at Tevatron.

Chapter 2

Experimental Setup: The ATLAS experiment at the LHC

The results presented in this thesis are based on data collected during Run 2 by the ATLAS experiment at the Large Hadron Collider (LHC). This chapter provides an overview of the LHC [81] and of the ATLAS experiment [102], with a description focused on the components relevant for the analysis.

2.1 The large hadron collider

The LHC is a high-energy particle collider, approved in 1996, with the first beams in 2008 at the European Organization for Nuclear Research (CERN) [30] at the border of France and Switzerland. With a circumference of 27 km and with four interaction points for four large experiments (ATLAS, CMS, ALICE and LHCb [122]), the LHC is currently the largest and most powerful accelerator on Earth. The LHC is designed to accelerate two beams of protons to more than 99.99% the speed of light, which travel in opposite directions around the accelerator and collide at the locations of the four major experiments. In the LHC, the particles are grouped together in about 2000 bunches in each beam, which can contain 10^{11} particles per bunch [92], and reach an energy up to 6.5 TeV per beam. The beams are therefore at a center of mass energy up to 13 TeV [92] and collide every 25 nanoseconds.

2.1.1 The LHC acceleration chain

Before being injected in the LHC, particles are accelerated through a series of lower energy accelerators that successively increase the energy of the colliding beams [145]. The starting point is a cylinder of hydrogen gas, where the electrons are stripped from hydrogen atoms before injecting the protons in the linear accelerator LINAC2 to begin the first phase of acceleration up to an energy of 50 MeV [81]. Afterwards, the beam of protons is injected into the Proton Synchrotron Booster (PSB) which accelerates them to an energy of 1.4 GeV. The proton bunches are then injected into the Proton Synchrotron (PS) in which they are accelerated to an energy of 26 GeV. After the PS, the 7 km long Super Proton Synchrotron (SPS) accelerates them to reach an energy of 450 GeV. In the last step, the proton beams are injected in the LHC where they are accelerated to their current maximal energy 6.5 TeV [81].

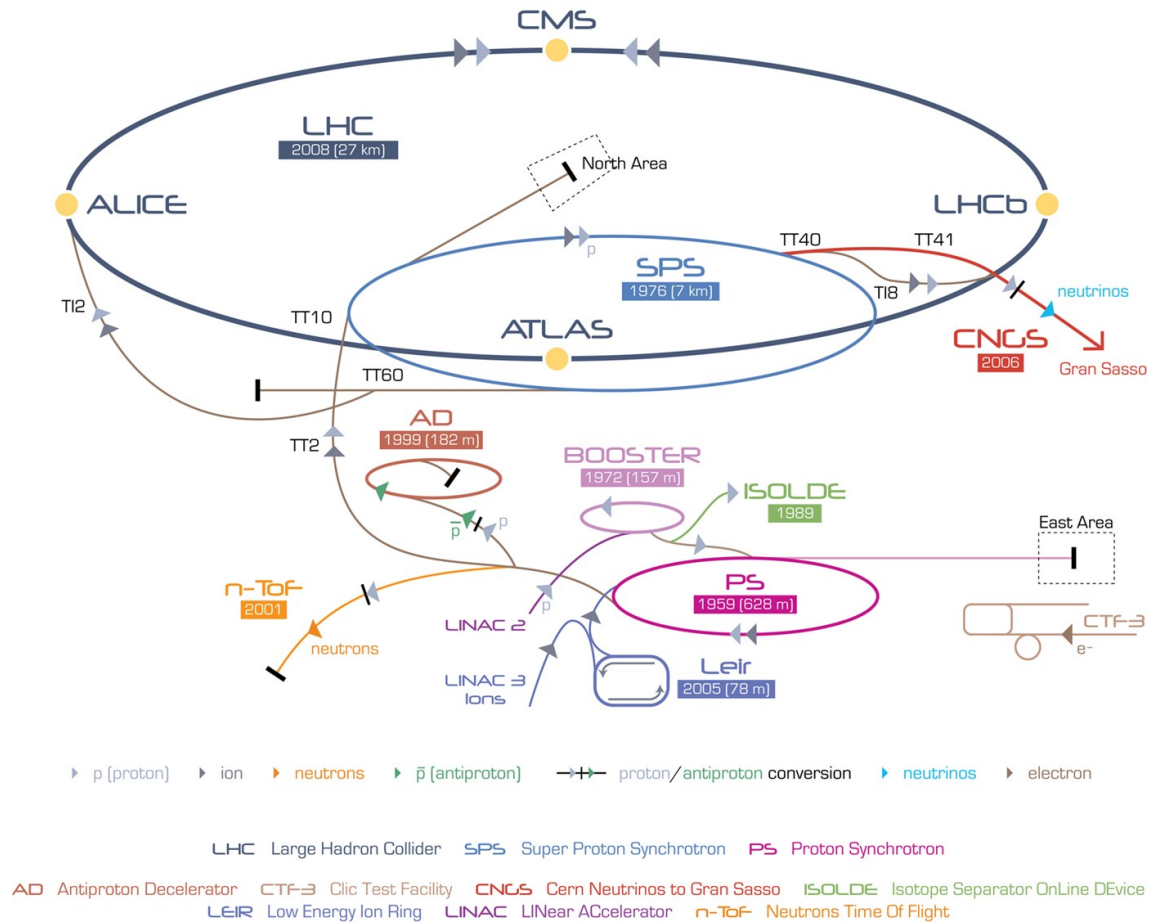


FIGURE 2.1: An overview of the LHC acceleration chain at CERN [119]

2.1.2 LHC performance

The performance of the LHC can be parameterised with two factors, the center of mass-energy which allows to estimate the energy available for the production of new processes, and the instantaneous luminosity [105] (expressed in units $\text{cm}^{-2}\text{s}^{-1}$) which represents the rate of physics process a collider is able to produce. The instantaneous luminosity (in the limit of no crossing angle between the beams) is defined as:

$$L_{\text{inst}} = \frac{N_1 N_2 f_r n_b}{4\pi \sigma_x \sigma_y}, \quad (2.1)$$

where n_b is the number of bunches in a beam, f_r is the bunch revolution frequency in the LHC, N_1 and N_2 are the number of protons per colliding bunch, σ_x and σ_y are the horizontal and vertical beam size (about $7 \mu\text{m}$ for the Run 2 in the standard working point). The integrated luminosity is the integral over the data taking time of the instantaneous luminosity:

$$L_{\text{int}} = \int L_{\text{inst}}(t) d(t), \quad (2.2)$$

662 and it is directly connecting the number of events to the cross-section by:

$$L_{\text{int}} \times \sigma_{\text{process}} = N_{\text{process}}. \quad (2.3)$$

663 Another significant parameter for our analysis is the pileup, which is the number
 664 of inelastic proton–proton interactions per bunch crossing. The average number
 665 of proton–proton collisions per bunch crossing is named as $\langle\mu\rangle$ [124]. The dataset
 666 used in our analysis is a special dataset characterised with low pileup ($\langle\mu\rangle = 2$)
 667 taken in 2017 and 2018 during Run 2.

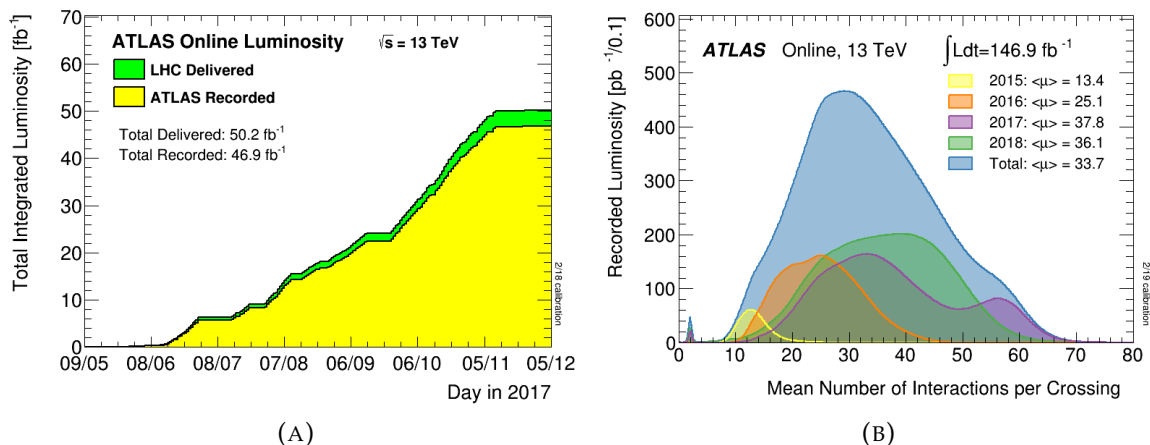


FIGURE 2.2: (A) Integrated luminosity versus time delivered (green) and recorded (yellow) by ATLAS during stable beams for pp collisions at 13 TeV center of mass energy. (B) Mean number of interactions per crossing $\langle\mu\rangle$ per year in Run 2 [106]

668 2.2 The ATLAS detector

669 ATLAS (A Toroidal LHC ApparatuS) [52] is a general-purpose detector developed
 670 to study different physics programs: SM electroweak interactions, Higgs boson
 671 production, hard QCD and possible signatures of BSM physics. An overview of
 672 the ATLAS detector components can be seen in Figure 2.3. The ATLAS detector is
 673 located 100 meters underground at the LHC first interaction point, approximately
 674 44 meters long and 25 meters in diameter, weighing around 7000 tons [50]. The
 675 ATLAS detector is composed of different sub-detectors [52] which give uniform
 676 coverage around the beam pipe and measure different properties of particles in
 677 proton–proton collisions at the LHC [24]. Near the center, we start by the inner
 678 tracker detectors, which measure the trajectories of charged particles close to the
 679 interaction point. The electromagnetic and hadronic calorimeters, which measure
 680 the energy deposited by electrons, photons and hadronic jets. The calorimeters are
 681 surrounded by the muon spectrometer, the outermost layer, which is designed to
 682 measure the trajectory of muons.

The ATLAS Experiment

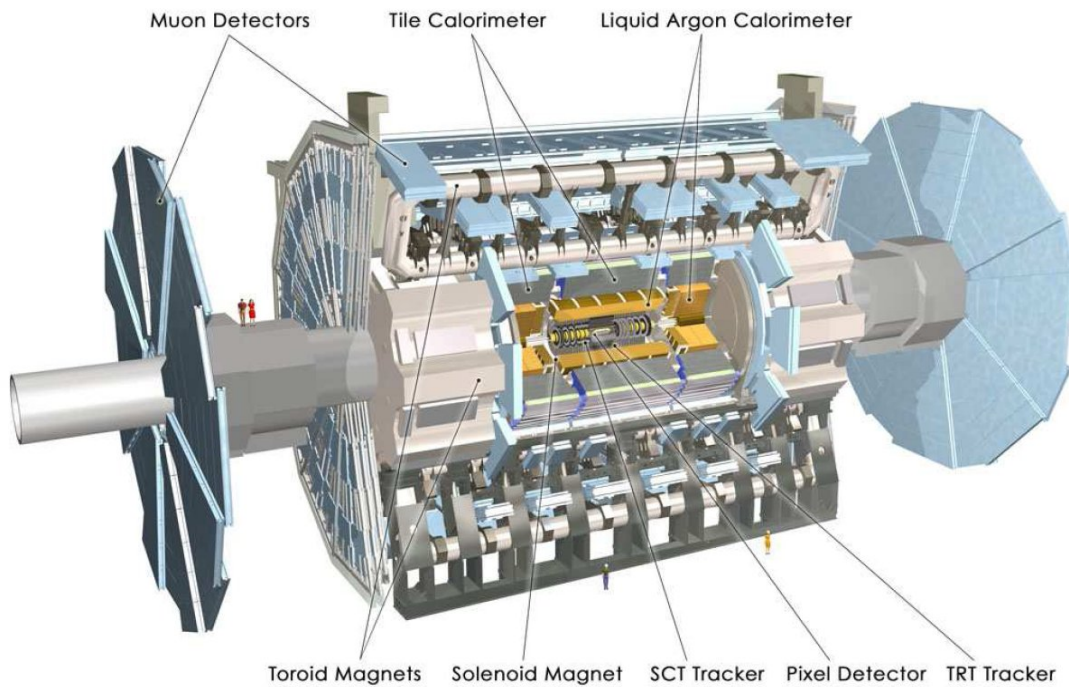


FIGURE 2.3: An overview of the ATLAS detector at CERN [42].

2.2.1 Coordinate system

683 The nominal interaction point of pp collisions is defined as the origin of the ATLAS
 684 coordinate system. The beam direction defines the z -axis where the positive direc-
 685 tion is defined as oriented counter clockwise to the LHC ring, while the x is hori-
 686 zontal, orthogonal to the beam pipe and pointing towards the center of the LHC .
 687 The y direction is defined as orthogonal to the beam pipe and pointing upwards.
 688 The (x, y, z) frame is a right handed frame. Because of the symmetry of the AT-
 689 LAS detector, a polar coordinate system (ϕ, θ, z) is used, with ϕ being defined with
 690 respect to the x -axis and θ with respect to the z -axis, as shown in Figure 2.4. The
 691 angle $\theta = 0$ is parallel to the z -axis while $\theta = \pi/2$ is in the xy -plane. In most cases,
 692 the pseudo-rapidity η is used to instead of θ and is defined as $\eta = -\ln[\tan(\theta/2)]$,
 693 where $\Delta\eta$ is invariant under boosts along the z -axis. Another important variable
 694 ΔR is used to calculate the distances between two particles in the $\theta - \eta$ space and
 695 is defined as $\Delta R = \sqrt{(\Delta\theta)^2 + (\Delta\eta)^2}$.

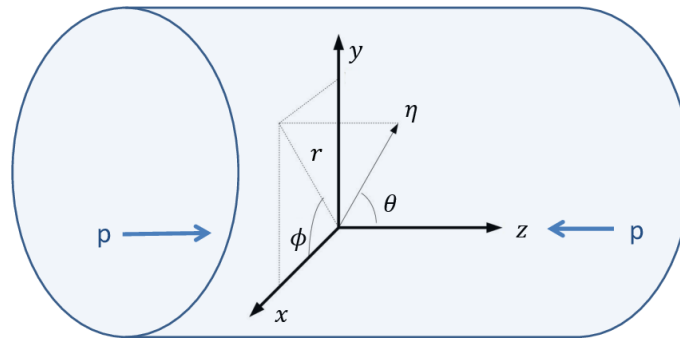


FIGURE 2.4: An overview of the ATLAS coordinate system [128].

697 2.2.2 Inner tracking detectors

698 The ATLAS Inner Detector (ID) [149] is the closest detector to the collision point,
 699 and it is responsible for the reconstruction of the tracks of charged particles emitted
 700 in pp collisions. In the normal (high) pileup mode one has approximately 1000
 701 particles produced in a bunch crossing within the acceptance of the ID (each 25 ns).
 702 The inner detector contributes also with the calorimeter and muons spectrometer
 703 to the identification of electron, photon and muon. As shown in Figure 2.5, the
 704 ID consists of three sub-detectors: the silicon pixel detector, the Semiconductor
 705 Tracker (SCT) and Transition Radiation Tracker (TRT):

706 **Silicon pixel detector [150]:** It is built with four concentric cylindrical layers
 707 around the beampipe (in the barrel). The most-inner layer is called the In-
 708 sertable B-Layer (IBL) and was installed between Run 1 and Run 2. The pixel
 709 detector is reconstructed with a pixel size of $50\mu\text{m} \times 400\mu\text{m}$ ($50\mu\text{m} \times 250\mu\text{m}$
 710 for the IBL). The pixel detector is used for b -tagging and track reconstruction.

711 **Semi-conductor tracker [147]:** It is the second part of the inner detector, with four
 712 layers of silicon microstrips (in the barrel). The SCT is used for the measure-
 713 ment of momentum and to identify the vertex of charged particles.

714 **Transition Radiation Tracker [129]:** This sub-detector surrounds the SCT sub-
 715 detector, and consists of multiple layers of straw tubes with a diameter of
 716 4 mm. The TRT is used for momentum measurement and provides discrim-
 717 ination between electrons and hadrons.

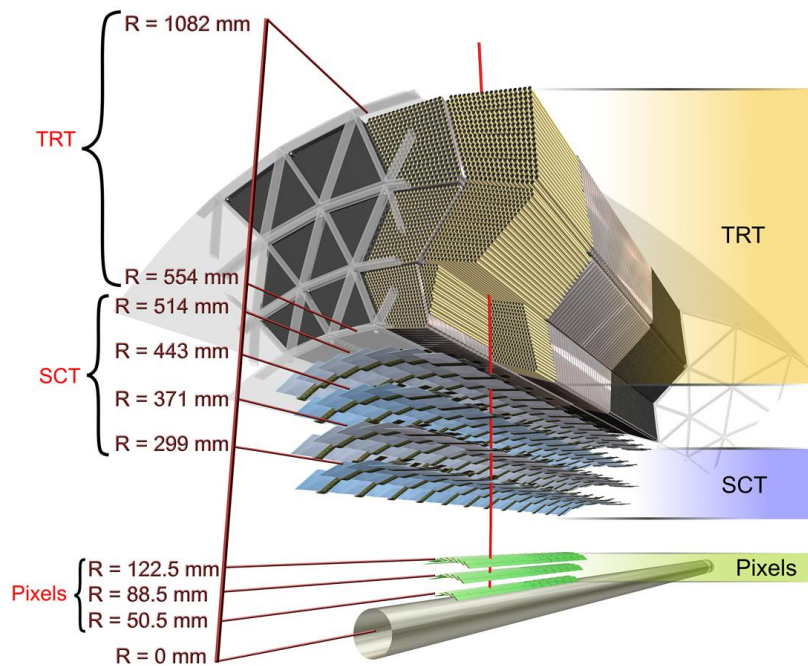


FIGURE 2.5: Schematic showing the ATLAS inner detector [134].

718 2.2.3 Electromagnetic and hadronic calorimeters

719 The ATLAS calorimeters system is composed of two main sub-detectors: the elec-
 720 tromagnetic (EM) [10] and hadronic [79] calorimeters. The two calorimeters are
 721 designed to stop and measure the energy of particles coming from pp collisions
 722 (or other processes) and sensitive to electromagnetic or strong interactions: the
 723 EM calorimeter, which targets EM showers and measures the energies of electrons
 724 and photons, and the hadronic calorimeter, which targets hadronic showers and
 725 measures the energy of hadrons. The inner sub-detector is the EM calorimeter, sur-
 726 rounded by the hadronic calorimeter. Both calorimeters are composed of the barrel
 727 and two symmetric end-caps, as shown in Figure 2.6, and cover the acceptance up
 728 to $|\eta| = 4.9$.

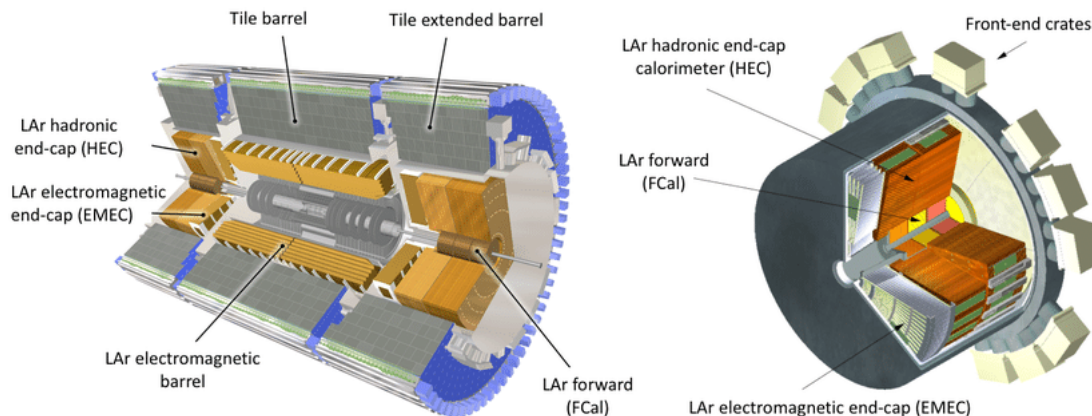


FIGURE 2.6: An overview of ATLAS calorimeter system [142].

729 2.2.3.1 The electromagnetic calorimeter

730 The ATLAS EM calorimeter is the most relevant sub-detector for this thesis. In
 731 this paragraph, the EM showers and the different components of the ATLAS EM
 732 calorimeter are described:

733 **EM shower:** An EM shower begins when a high-energy particle (electron,
 734 positron or photon) enters a material. Depending on their properties (charge,
 735 mass ...), particles interact differently with matter. In our case we are inter-
 736 ested in high-energy electrons and photons interactions. Figure 2.7 shows
 737 the fraction of energy loss by electrons in lead (used as an absorber in the
 738 ATLAS EM calorimeter) and the photon interaction cross-section as a func-
 739 tion of their energies. **Electrons** with low energies lose their energy mainly
 740 through ionisation and excitation (collisions with the atoms and molecules
 741 of the material and the transferred energy is enough to unbind an electron
 742 from this atom), while electrons with energies larger than $\simeq 10$ MeV, lose
 743 their energy with bremsstrahlung (interaction of the incoming particle in the
 744 electric field of an atom and emission of a high energy photon). **Photons**
 745 with low energies, lose their energy through Compton scattering (photons
 746 mainly scatter on the electrons of the atoms constituting the medium) and
 747 photoelectric effect (emission of electrons). For photons with energies larger
 748 than $\simeq 10$ MeV, interactions result in conversion, produce electron–positron
 749 pairs. **Electrons and photons** with high energy (≥ 1 GeV) interact with mat-
 750 ter to produce secondary photons by bremsstrahlung and electron–positron
 751 by pair-production with lower energy. These in turn will interact with the
 752 matter with the same mechanisms as described before until they lose their
 753 energy. This avalanche of produced electrons, positrons, and photons is
 754 known as an **EM shower**.

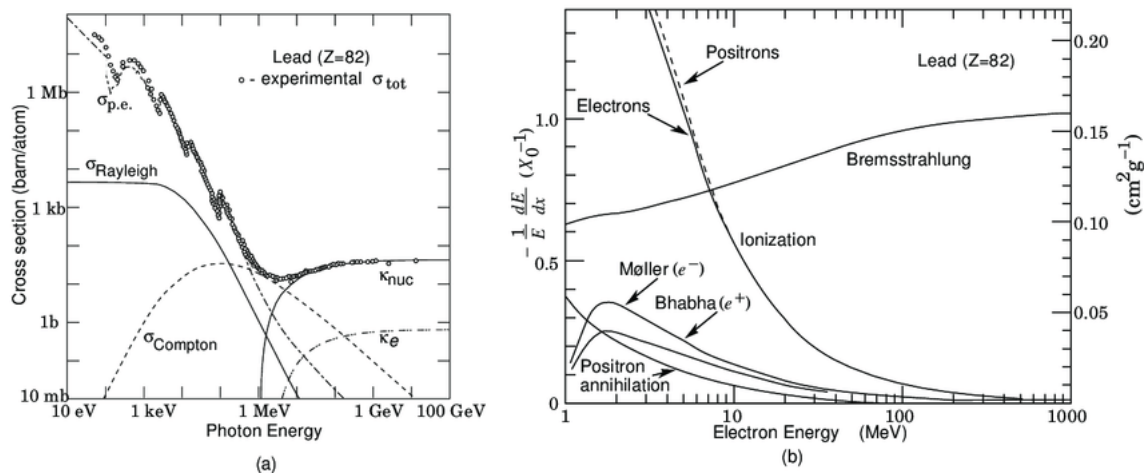


FIGURE 2.7: (a) Photon energy loss in lead as a function of its energy. (b) Electron energy loss in lead as a function of its energy [98].

755 **Energy resolution of an EM calorimeter:** The energy resolution of an EM
756 calorimeter can be described by [70]:

$$\left(\frac{\sigma}{E}\right)^2 = \left(\frac{S}{\sqrt{E}}\right)^2 + \left(\frac{N}{E}\right)^2 + C^2 \quad (2.4)$$

757 where the first term on the right side is the stochastic (S) term, being due
758 to the fluctuations related to the physical development of the shower [73],
759 the second term is a noise (N) term, coming from the electronic noise of the
760 signal readout chain and the pileup noise, the last term is a constant (C) term,
761 coming from instrumental defects that cause variations of the calorimeter
762 response [73], and is independent of the particle energy.

763 The ATLAS EM calorimeter is a lead liquid Argon (LAr) sampling calorimeter.
764 It is designed with an accordion geometry, an original idea of D. Fournier [78], in
765 order to avoid azimuthal cracks in the detector (ϕ symmetry) [26]. The EM shower
766 is generated when particles interact with the absorber (lead). Secondary particles
767 produced by these interaction ionise the argon and produce ionisation electrons.
768 These ionisation electrons drift towards the anode following the electric field lines
769 produced by the high voltage connected to the electrodes. During their drift, these
770 ionisation electrons induce on the electrodes (see Figure 2.8) an electric current
771 proportional to the number of electrons drifting in the medium, and at the end
772 proportional to the energy deposited.

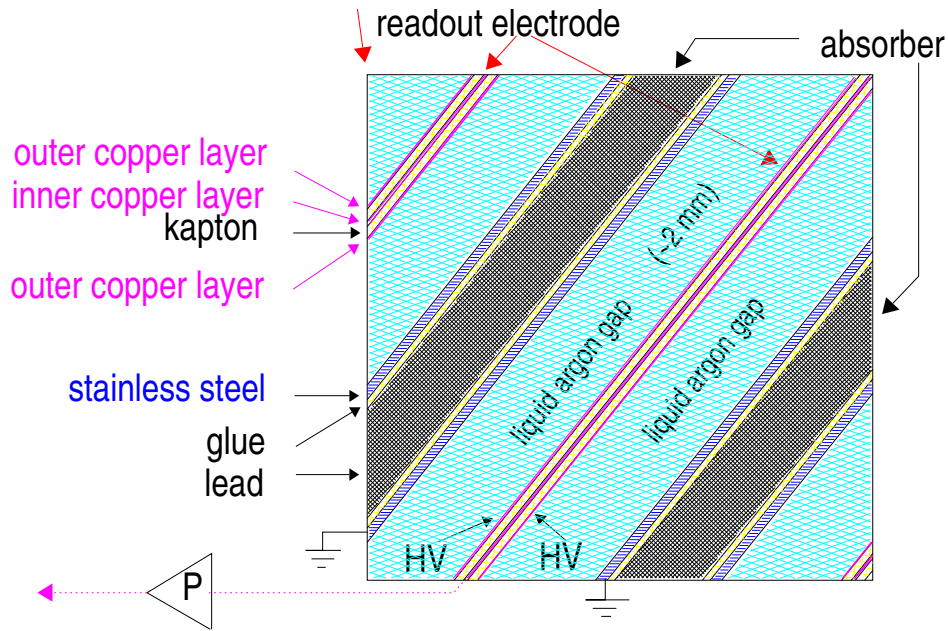


FIGURE 2.8: A sketch of the LAr EM calorimeter [123].

773 The EM calorimeter [26] has two main parts: the **Barrel** which consists of two
 774 half-barrels separated with a gap of 4mm and covers the regions $|\eta| < 1.37$, and two
 775 **end-caps** placed at each end of the barrel which cover the regions $1.52 < |\eta| < 3.2$.
 776 The part of the end-cap used for precise measurements stops at $|\eta| \approx 2.4$. The
 777 region between the barrel and the end-cap is called the transition region and cor-
 778 responds to $1.37 < \eta < 1.52$, characterised by the presence of a large amount of
 779 dead material and is not used in precision measurements like the decay of the
 780 Higgs boson into two photons. For the Run 1 W mass analysis [14] a larger part of
 781 the detector, corresponding to $1.2 < \eta < 1.82$ was excluded, due to the higher qual-
 782 ity wanted and small mismodeling in this region [96]. More details about the EM
 783 calorimeter can be found in different theses [6, 13, 141, 31, 82]. The EM calorimeter
 784 is divided in three layers: front, middle and back (as shown in Figure 2.9):

- 785 • Front layer (L1): It has a very fine segmentation along η : $\Delta\eta \times \Delta\phi = 0.0031 \times$
 786 0.1 in the barrel and $\Delta\eta \times \Delta\phi$ varying between 0.0031×0.1 and 0.0062×0.1
 787 in the end-cap. The fine granularity in η allows to separate a single photon
 788 from photons coming from: $\pi^0 \rightarrow \gamma\gamma$.
- 789 • Middle layer (L2): it is where the particles deposit most of their energy. The
 790 cells in the middle layer are of size η : $\Delta\eta \times \Delta\phi = 0.025 \times 0.025$ in the barrel
 791 and in the end-cap.
- 792 • Back layer (L3): it is where part of the shower leaking after L2 is measured.
 793 The cells in the middle layer are of size η : $\Delta\eta \times \Delta\phi = 0.05 \times 0.025$ in the barrel
 794 and the end-cap.

795 In front of the LAr EM calorimeter, there is for $0 < |\eta| < 1.8$ a presampler, which
 796 is also based on LAr technology. A detailed description of the LAr EM calorimeter
 797 and of the presampler can be found in Table 2.1.

TABLE 2.1: Description of the composition of the LAr calorimeter [25].

	Barrel		End-cap	
EM calorimeter				
Number of layers and $ \eta $ coverage				
Presampler	1	$ \eta < 1.52$	1	$1.5 < \eta < 1.8$
Calorimeter	3	$ \eta < 1.35$	2	$1.375 < \eta < 1.5$
	2	$1.35 < \eta < 1.475$	3	$1.5 < \eta < 2.5$
			2	$2.5 < \eta < 3.2$
Granularity $\Delta\eta \times \Delta\phi$ versus $ \eta $				
Presampler	0.025×0.1	$ \eta < 1.52$	0.025×0.1	$1.5 < \eta < 1.8$
Calorimeter 1st layer	$0.025/8 \times 0.1$	$ \eta < 1.40$	0.050×0.1	$1.375 < \eta < 1.425$
	0.025×0.025	$1.40 < \eta < 1.475$	0.025×0.1	$1.425 < \eta < 1.5$
			$0.025/8 \times 0.1$	$1.5 < \eta < 1.8$
			$0.025/6 \times 0.1$	$1.8 < \eta < 2.0$
			$0.025/4 \times 0.1$	$2.0 < \eta < 2.4$
			0.025×0.1	$2.4 < \eta < 2.5$
			0.1×0.1	$2.5 < \eta < 3.2$
Calorimeter 2nd layer	0.025×0.025	$ \eta < 1.40$	0.050×0.025	$1.375 < \eta < 1.425$
	0.075×0.025	$1.40 < \eta < 1.475$	0.025×0.025	$1.425 < \eta < 2.5$
			0.1×0.1	$2.5 < \eta < 3.2$
Calorimeter 3rd layer	0.050×0.025	$ \eta < 1.35$	0.050×0.025	$1.5 < \eta < 2.5$
Number of readout channels				
Presampler	7808		1536 (both sides)	
Calorimeter	101760		62208 (both sides)	
LAr hadronic end-cap				
$ \eta $ coverage			$1.5 < \eta < 3.2$	
Number of layers			4	
Granularity $\Delta\eta \times \Delta\phi$			0.1×0.1	$1.5 < \eta < 2.5$
			0.2×0.2	$2.5 < \eta < 3.2$
Readout channels			5632 (both sides)	
LAr forward calorimeter				
$ \eta $ coverage			$3.1 < \eta < 4.9$	
Number of layers			3	
Granularity $\Delta x \times \Delta y$ (cm)			FCal1: 3.0×2.6	$3.15 < \eta < 4.30$
			FCal1: \sim four times finer	$3.10 < \eta < 3.15,$ $4.30 < \eta < 4.83$
			FCal2: 3.3×4.2	$3.24 < \eta < 4.50$
			FCal2: \sim four times finer	$3.20 < \eta < 3.24,$ $4.50 < \eta < 4.81$
			FCal3: 5.4×4.7	$3.32 < \eta < 4.60$
			FCal3: \sim four times finer	$3.29 < \eta < 3.32,$ $4.60 < \eta < 4.75$
Readout channels			3524 (both sides)	
Scintillator tile calorimeter				
	Barrel		Extended barrel	
$ \eta $ coverage	$ \eta < 1.0$		$0.8 < \eta < 1.7$	
Number of layers	3		3	
Granularity $\Delta\eta \times \Delta\phi$	0.1×0.1		0.1×0.1	
	Last layer 0.2×0.1		0.2×0.1	
Readout channels	5760		4092 (both sides)	

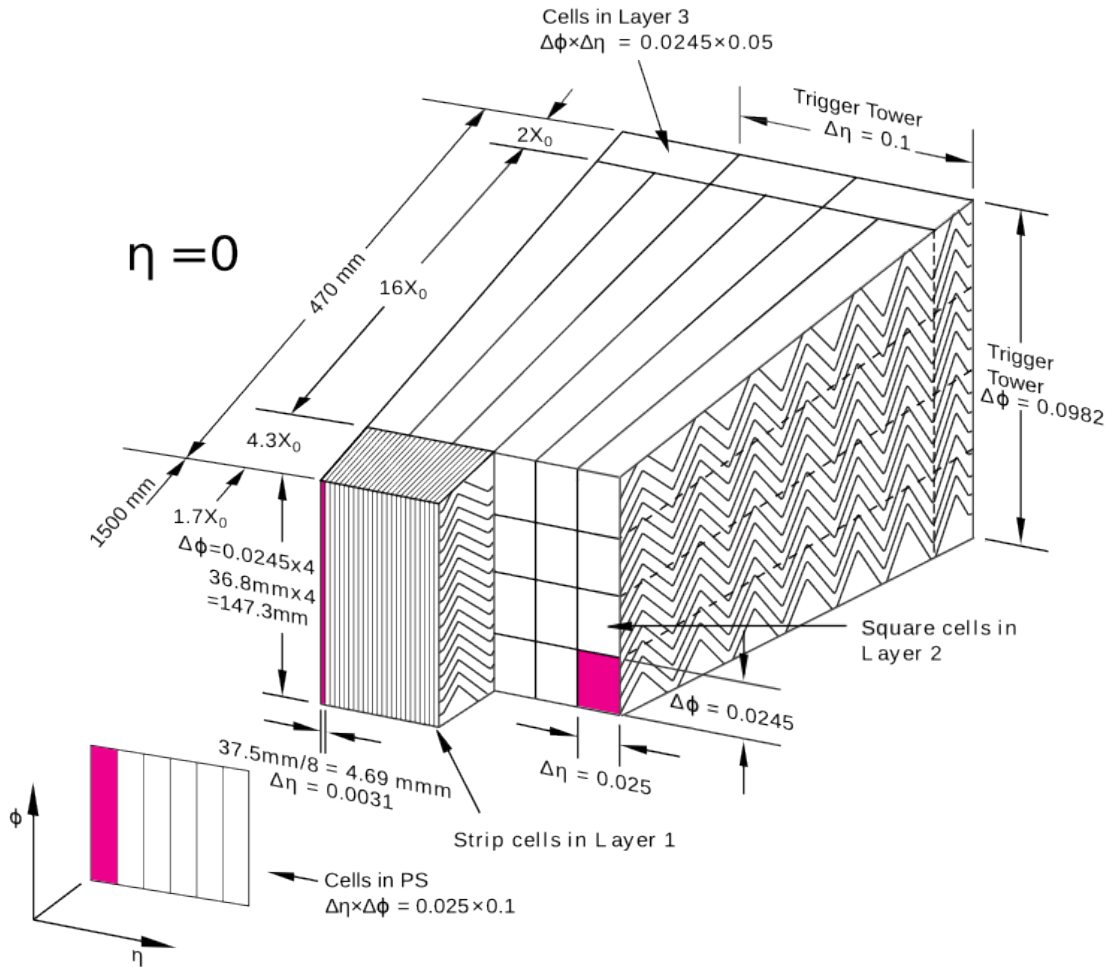


FIGURE 2.9: A sketch of the LAr EM calorimeter layers [135].

798 2.2.3.2 The ATLAS tile hadronic calorimeter

799 The tile hadronic calorimeter is located behind the EM calorimeter and operates in
 800 a similar way but uses iron as an absorber and scintillating tiles as active material.
 801 The tile hadronic calorimeter is composed of three layers covering the range $|\eta| <$
 802 1.7 . The first two layers have the same granularity $\Delta\eta \times \Delta\phi = 0.1 \times 0.1$ while
 803 $\Delta\eta \times \Delta\phi = 0.2 \times 0.1$ is the granularity of the last layer. The tile hadronic calorimeter
 804 is used to measure the position and energy of the jets.

805 2.2.4 Muon spectrometer and toroidal magnets

806 The ATLAS muon spectrometer, shown in Figure 2.10, is the outermost part of
 807 the ATLAS detector and is designed to measure the position and the energy of
 808 particles that are able to pass through the inner detectors [86]. Since the muons
 809 pass through the calorimeter system with little interaction and therefore conserv-
 810 ing most of their initial energy, they are detected with high efficiency in the Muon
 811 Spectrometer (MS). It consists of four main types of detectors:

812 **Monitor Drift Tubes (MDTs):** They are used for the precision measurement of
 813 muon momentum and cover the entire MS detection region $|\eta| < 2.7$. They

814 are built with straw aluminum tubes with 30 mm diameter and each tube is
 815 filled with an Ar/CO₂ mixture (93% and 7%). The muons ionise the gas and
 816 signals of the ionisation electrons are measured.

817 **Cathode Strip Chambers (CSCs):** Because of the radiation level in $2.0 < |\eta| <$
 818 2.7 [19], the CSCs replace the MDTs in the most inner layer and provide a
 819 precise track measurement.

820 **Resistive Plate Chambers (RPCs):** In the RPCs two parallel plates are separated
 821 by a thin layer of gas filled with C₂H₂F₄ and SF₆. The RPCs provide a track
 822 identification and trigger measurements in the barrel region $|\eta| < 1.05$.

823 **Thin Gap Chambers (TGCs):** TGCs are multi-wire proportional chambers filled
 824 with n-C₅H₁₂. The purpose of the TGCs is to replace RPCs in the end-cap
 825 regions, $1.05 < |\eta| < 2.4$.

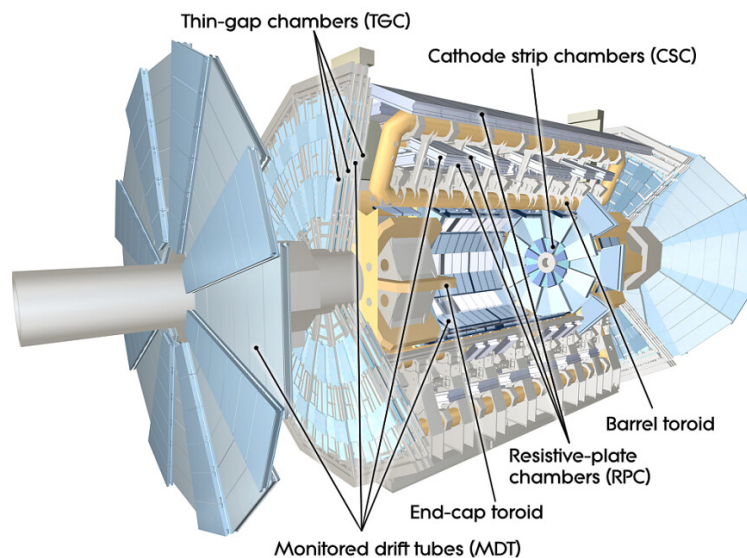


FIGURE 2.10: An overview of ATLAS muon system [3].

826 2.2.5 ATLAS trigger and data acquisition system

827 Within the ATLAS detector the proton bunches collide every 25 ns, and can pro-
 828 duce nearly 600 terabytes of raw data every second [128]. Because of the limited
 829 storage (each event is characterised with a size of the order of 1 Mb) it is impossi-
 830 ble to record all these interactions. The aim of the trigger system is to select events
 831 having desired signatures. The trigger system selects between 100 and 1000 events
 832 per second out of 1000 million in total [128]. During Run 2, the trigger system [136],
 833 was divided in two parts (as shown in Figure 2.11):

834 **The L1 trigger:** It is a hardware trigger and performs the first stage of the trig-
 835 ger. The L1 trigger uses inputs from the muon spectrometer and the
 836 calorimeter systems and searches for signatures from high- p_T muons, elec-
 837 trons/photons, jet and τ -lepton decays in order to choose desired events. The

838 L1 trigger reduces the event rate from the LHC bunch crossing of 40 MHz to
 839 about > 100 kHz.

840 **The High Level Trigger (HLT):** The events that have been triggered by the L1 are
 841 then filtered by the HLT in order to reduce the rate to 1 kHz. The HLT recon-
 842 structs events using a finer granularity of the data with ID tracks to remove
 843 most of the pre-selected events.

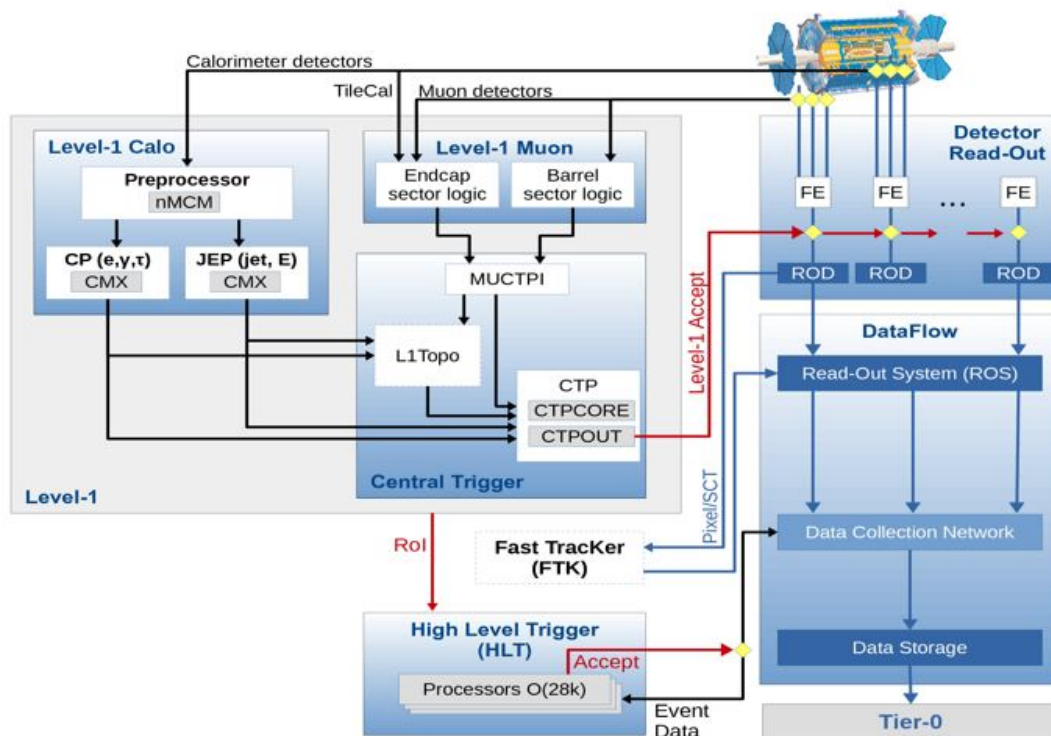


FIGURE 2.11: An overview of ATLAS trigger system [136].

844 2.3 Reconstruction of physics objects

845 This section gives an overview of the identification of the electrons and their re-
 846 construction by the ATLAS detector. The electrons will be used for the calibration
 847 of the ATLAS EM calorimeter as discussed in Chapter 3.

848 2.3.1 Electron reconstruction

849 Electrons and photons are reconstructed in the EM calorimeter (see Chapter 3).
 850 When electrons and photons enter to the EM calorimeter, they interact with the
 851 lead absorbers and create the EM showers. The EM showers ionise the liquid
 852 argon and the ionisation electrons will drift thanks to a high voltage which pro-
 853 duces an electric field between the electrodes. During their drift, these ionisation
 854 electrons induce on the electrode an electric current. The charge collection time

855 in the electrode is $t_d \approx 450$ ns and the induced signal has a triangular shape as
 856 shown in Figure 2.12. Since the charge collection time (450 ns) is longer than the
 857 time difference between two bunch crossings at the LHC (25 ns), we will integrate
 858 in the charge collection time several bunch crossings and include a lot of pileup
 859 events. In order to reduce this effect, the signals are passed through a bipolar filter
 860 which shape the signals as shown in Figure 2.12 in order to be more peaked and
 861 therefore to have a smaller contribution from pileup.

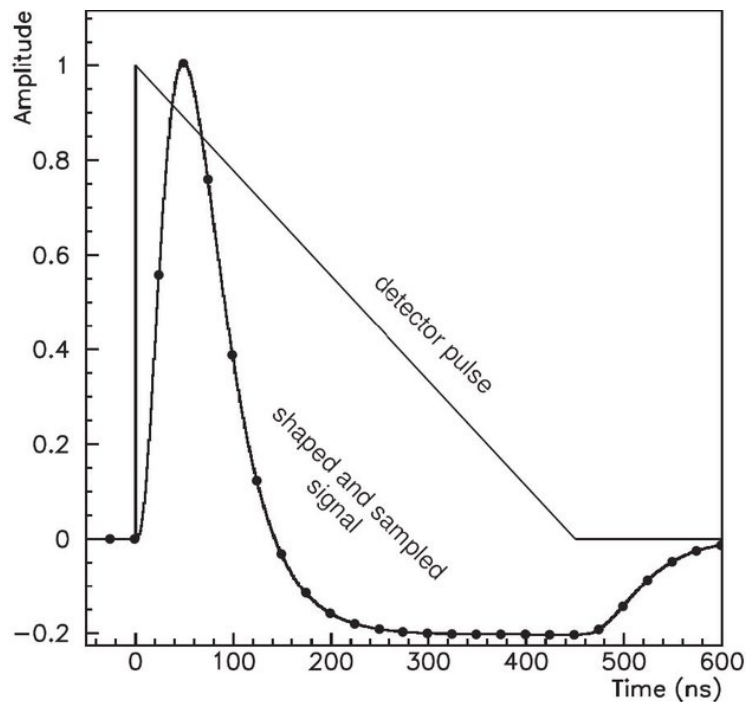


FIGURE 2.12: The pulse shape in the ATLAS LAr calorimeters. The triangular shape is the current pulse generated in the liquid argon by ionisation electrons. The dots shows the positions of the samples separated by 25 ns [127].

862 The pulses recorded for a cell are used to reconstruct the cell energy in MeV
 863 with the formula:

$$E_{\text{cell}} = F_{\mu A \rightarrow \text{MeV}} \times F_{\text{DAC} \rightarrow \mu A} \times \frac{1}{\frac{M_{\text{phys}}}{M_{\text{cali}}}} \times G \times A \quad (2.5)$$

864 where:

- 865 • $F_{\mu A \rightarrow \text{MeV}}$: relates the current from ionisation electrons to the energy de-
 866 posited in the EM cell [116].
- 867 • $F_{\text{DAC} \rightarrow \mu A}$: is a conversion factor related to the digital-to-analog converter
 868 (DAC).
- 869 • $\frac{M_{\text{phys}}}{M_{\text{cali}}}$: is used to correct the gain to take into account the fact that the injected
 870 calibration signal is exponential while the physics signal is triangular (see
 871 Figure 2.12), and have therefore slightly different maximum amplitudes after
 872 the bipolar shaping. It can be obtained from delayed calibration runs, as it is
 873 described in [54].

- 874 • G : represents the cell gain, measured during the calibration runs (expressed
875 in ADC \rightarrow DAC).
- 876 • A : is the signal amplitude extracted using the optimal filtering method [51,
877 13].

878 The procedure to reconstruct electrons starts by building a cluster using the
879 measured cell energies in the EM calorimeter, these energies being obtained by
880 equation (2.5). At the beginning of Run 2, a sliding-window clustering algorithm
881 was used, but since 2017, a new algorithm called “dynamical topological cell clus-
882 tering algorithm” is used. This new algorithm improves the measurement of the
883 electron and photon energy, specially when an electron is emitting a photon by
884 bremsstrahlung [69]. The main difference between the “sliding-window cluster-
885 ing” and the “topological clustering” algorithms, is that the first one is charac-
886 terised by a fixed-size window, unlike the topological clustering where the selec-
887 tion of cells in a cluster depends on a parameter, $\varsigma_{\text{cell}}^{\text{EM}}$, called cell significance, and
888 computed as:

$$\varsigma_{\text{cell}}^{\text{EM}} = \left| \frac{E_{\text{cell}}^{\text{EM}}}{\sigma_{\text{noise,cell}}^{\text{EM}}} \right| \quad (2.6)$$

889 where $E_{\text{cell}}^{\text{EM}}$ is the absolute cell energy at the EM scale [69] and $\sigma_{\text{noise,cell}}^{\text{EM}}$ is the ex-
890 pected cell noise (electronic and pileup noise). This algorithm starts by building
891 clusters of EM cells, called *topo-cluster*. Each *topo-cluster* is built using the same
892 procedure:

- 893 • A *topo-cluster* includes cells characterised by $\varsigma > 4$.
- 894 • The neighboring cells with $\varsigma > 2$ are added to the *topo-cluster*.
- 895 • All neighboring cells with $\varsigma > 0$ are added to the *topo-cluster*.

896 The procedure of grouping cells in *topo-cluster* is called also 4 – 2 – 0 which
897 refers to the values of the thresholds on ς . Figure 2.13 shows an overview of the
898 *topo-cluster* construction.

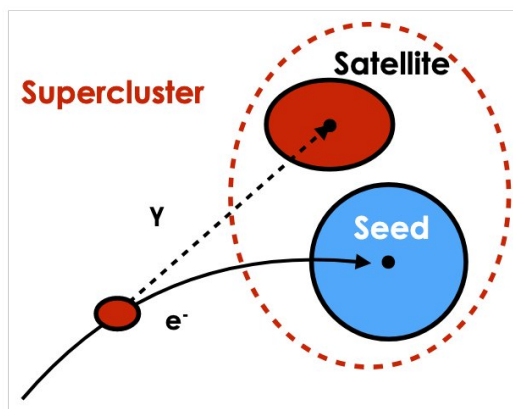


FIGURE 2.13: Illustration of a *topo-cluster* construction [69].

899 In addition to the procedure described above, there are other selections applied
900 to a *topo-cluster* to ensure a large rejection of pileup, and to isolate clusters that

901 are primarily from showers in the EM calorimeter. Those selections are based on
 902 the factor f_{EM} computed as:

$$f_{\text{EM}} = \frac{E_{\text{L1}} + E_{\text{L2}} + E_{\text{L3}}}{E_{\text{Cluster}}} \quad (2.7)$$

903 where E_{L1} , E_{L2} and E_{L3} are the energies deposited in the first, second and last
 904 layers, E_{Cluster} is the energy in the cluster. At the end, only topo-clusters with
 905 $f_{\text{EM}} > 0.5$ and $E_{\text{Cluster}} > 400$ MeV are kept. As shown in Figure 2.14, the selection
 906 $f_{\text{EM}} > 0.5$ allows to reject over than $\approx 60\%$ of pileup clusters without changing the
 907 reconstruction efficiency of true electron topo-clusters [69].

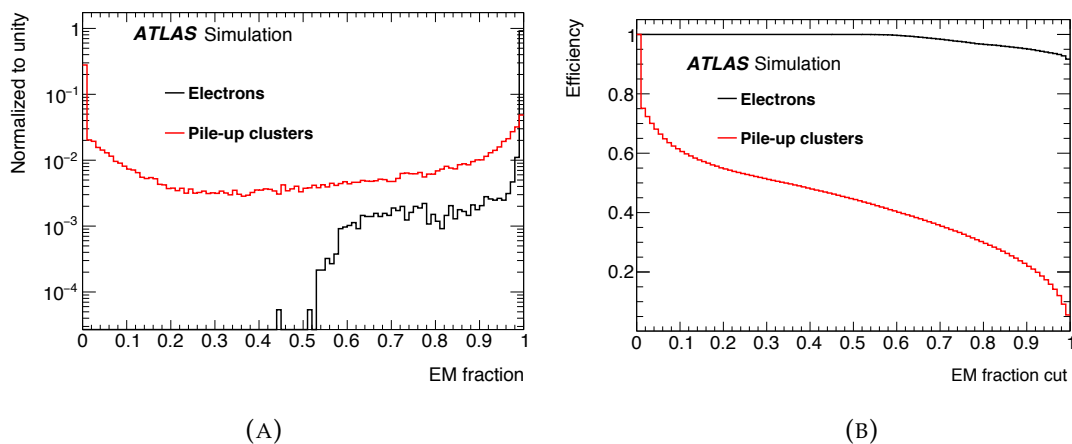


FIGURE 2.14: (A) Distribution of f_{EM} . (B) Reconstruction efficiency as a function of f_{EM} [69].

2.3.2 Electron identification

In fact, not all of the electrons reconstructed by the “topological clustering” algorithms are prompt electrons. In order to reject background objects, an identification algorithm is used to select prompt electrons and photons from the backgrounds coming from hadronic jets, prompt electrons from photon conversions, and QCD jets. The identification algorithm is based on a likelihood-based (LH) identification, where we use information from the tracking system and the calorimeter system. The discriminant variables are based on the EM shower information, and are shown in Table 2.2.

TABLE 2.2: List of the discrimination variables used in the electron and photon identification [68].

Category	Description	Name	Usage
Hadronic leakage	Ratio of E_T in the first layer of the hadronic calorimeter to E_T of the EM cluster (used over the ranges $ \eta < 0.8$ and $ \eta > 1.37$)	R_{had_1}	e/γ
	Ratio of E_T in the hadronic calorimeter to E_T of the EM cluster (used over the range $0.8 < \eta < 1.37$)	R_{had}	e/γ
EM third layer	Ratio of the energy in the third layer to the total energy in the EM calorimeter	f_3	e
EM second layer	Ratio of the sum of the energies of the cells contained in a $3 \times 7 \eta \times \phi$ rectangle (measured in cell units) to the sum of the cell energies in a 7×7 rectangle, both centred around the most energetic cell	R_η	e/γ
	Lateral shower width, $\sqrt{(\sum E_i \eta_i^2)/(\sum E_i) - ((\sum E_i \eta_i)/(\sum E_i))^2}$, where E_i is the energy and η_i is the pseudorapidity of cell i and the sum is calculated within a window of 3×5 cells	w_{η_2}	e/γ
EM first layer	Ratio of the sum of the energies of the cells contained in a $3 \times 3 \eta \times \phi$ rectangle (measured in cell units) to the sum of the cell energies in a 3×7 rectangle, both centred around the most energetic cell	R_ϕ	e/γ
	Total lateral shower width, $\sqrt{(\sum E_i (i - i_{\text{max}})^2)/(\sum E_i)}$, where i runs over all cells in a window of $\Delta\eta \approx 0.0625$ and i_{max} is the index of the highest-energy cell	$w_s \text{ tot}$	e/γ
	Lateral shower width, $\sqrt{(\sum E_i (i - i_{\text{max}})^2)/(\sum E_i)}$, where i runs over all cells in a window of 3 cells around the highest-energy cell	$w_s 3$	γ
	Energy fraction outside core of three central cells, within seven cells	f_{side}	γ
	Difference between the energy of the cell associated with the second maximum, and the energy reconstructed in the cell with the smallest value found between the first and second maxima	ΔE_s	γ
	Ratio of the energy difference between the maximum energy deposit and the energy deposit in a secondary maximum in the cluster to the sum of these energies	E_{ratio}	e/γ
	Ratio of the energy measured in the first layer of the electromagnetic calorimeter to the total energy of the EM cluster	f_1	e/γ
Track conditions	Number of hits in the innermost pixel layer	$n_{\text{innermost}}$	e
	Number of hits in the pixel detector	n_{pixel}	e
	Total number of hits in the pixel and SCT detectors	n_{Si}	e
	Transverse impact parameter relative to the beam-line	d_0	e
	Significance of transverse impact parameter defined as the ratio of d_0 to its uncertainty	$ d_0/\sigma(d_0) $	e
	Momentum lost by the track between the perigee and the last measurement point divided by the momentum at perigee	$\Delta p/p$	e
Track-cluster matching	Likelihood probability based on transition radiation in the TRT	eProbabilityHT	e
	$\Delta\eta$ between the cluster position in the first layer of the EM calorimeter and the extrapolated track	$\Delta\eta_1$	e
	$\Delta\phi$ between the cluster position in the second layer of the EM calorimeter and the momentum-rescaled track, extrapolated from the perigee, times the charge q	$\Delta\phi_{\text{res}}$	e
	Ratio of the cluster energy to the measured track momentum	E/p	e

917 Chapter 3

918 Calibration of the electromagnetic 919 calorimeter

920 3.1 Introduction

921 Electromagnetic particles, electrons and photons, are used essentially in all analy-
922 ses in particular in the studies of the Higgs boson properties and in the precision
923 measurement of electroweak parameters such as the W boson mass, allowing for
924 a consistency test for the Standard Model. As described in Chapter 2, electromag-
925 netic particles are stopped and measured in the EM calorimeter. To reach a good
926 precision in our measurements, a precise electron and photon energy calibration
927 is required. The calibration procedure is based on $Z \rightarrow ee$ samples, because of the
928 high statistics and clean final state which characterises this channel. In this chap-
929 ter, we will discuss the electron and photon energy calibration for the nominal and
930 low pile-up data collected during Run 2 with the ATLAS detector.

931 3.2 Overview of the calibration procedure

932 The calibration of the EM calorimeter is a complex procedure and was established
933 during Run 1 [67]. The aim of the calibration procedure, summarised in Figure 3.1,
934 is to measure the energy of electrons and photons with the best precision and reso-
935 lution. In order to estimate the signal and background contribution, the generated
936 events are passed through a full simulation of the ATLAS detector using GEANT4
937 [8].

938 The calibration procedure starts with the energy in EM calorimeter clusters (see
939 Chapter 2), and can be described as follows:

940 **Step 1:** based on a MultiVariate Algorithm (MVA) [107], it allows to determine
941 the energy of electrons and photons using the calorimeter cluster properties,
942 measured by the EM calorimeter. The MVA is performed separately for elec-
943 trons, converted and unconverted photons [67, 100, 151].

944 **Step 2:** this step is related to the EM calorimeter design. In fact, the energy of
945 electrons and photons is obtained using the energy deposit in different layers
946 of the EM calorimeter. This step equalises the energy scales of the different
947 longitudinal layers between data and simulation [67].

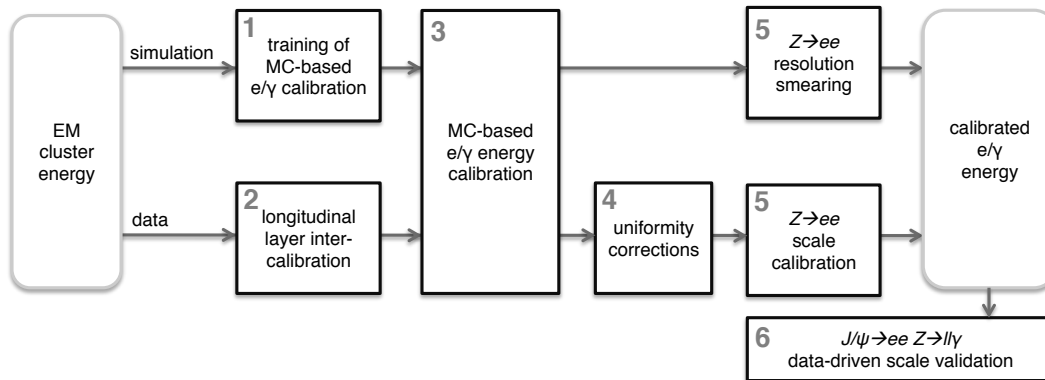


FIGURE 3.1: Schematic overview of the procedure used to calibrate the energy response of electrons and photons in ATLAS [67].

948 **Step 3:** the MC-based calibration determined in previous steps is applied to the
 949 energy of the clusters in data and simulation.

950 **Step 4:** the aim of this step is to include corrections which take into account the
 951 uniformity of the calorimeter energy reconstruction as: high-voltage inho-
 952 mogeneities [18], (where a perfect correction is taken into account in the de-
 953 tector simulation for the zones where there is a "stable" problem) geometric
 954 effects such as the inter-module widening (IMW) [113] which are not taken
 955 into account in the detector simulation, or biases related to the EM in the
 956 detecteectronic calibration [18].

957 **Step 5:** at this step of the calibration procedure, the electron response in data is
 958 calibrated to match the expected value in simulation. Also, an additional
 959 correction factor aiming to correct the resolution is applied to the simulation,
 960 in order to match the data. This step is an important part of this thesis and
 961 will be discussed in Sec. 3.3.

962 **Step 6:** is the last step, and it does the validation of the scale extracted in step 5
 963 using $J/\psi \rightarrow ee$ and $Z \rightarrow \ell\ell\gamma$ processes.

964 In this thesis we will focus on the extraction of the energy scale factors showed
 965 in step 5 of Figure 3.1, for the nominal runs and low pile-up runs used for the
 966 precise measurement of M_W . As the Z boson mass is precisely measured in LEP
 967 experiments [58] and there is a large statistics of Z bosons in ATLAS, the Z boson
 968 decay channel ($Z \rightarrow ee$) is used for the extraction of the energy scale factors.

969 3.3 Energy scale and resolution determination with 970 electrons from $Z \rightarrow ee$ decays

971 3.3.1 Overview

972 After applying the first steps of the calibration procedure (steps 1 to 4 described in
 973 Figure 3.1), we still observe an important difference between data and simulation.
 974 The sources of the difference are not precisely known. This difference between

975 data and simulation can be seen in the Figure 3.2, which shows the di-electron in-
 976 variant mass m_{ee} at the step 4 of the calibration procedure, as defined in Figure 3.1,
 977 and computed as:

$$m_{ee} = \sqrt{2E_1E_2(1 - \cos\theta_{12})}, \quad (3.1)$$

978 where θ_{12} is the angle between the two electrons measured by the track, and E_1, E_2
 are their energies. The discrepancies showed in Figure 3.2 affect the central value

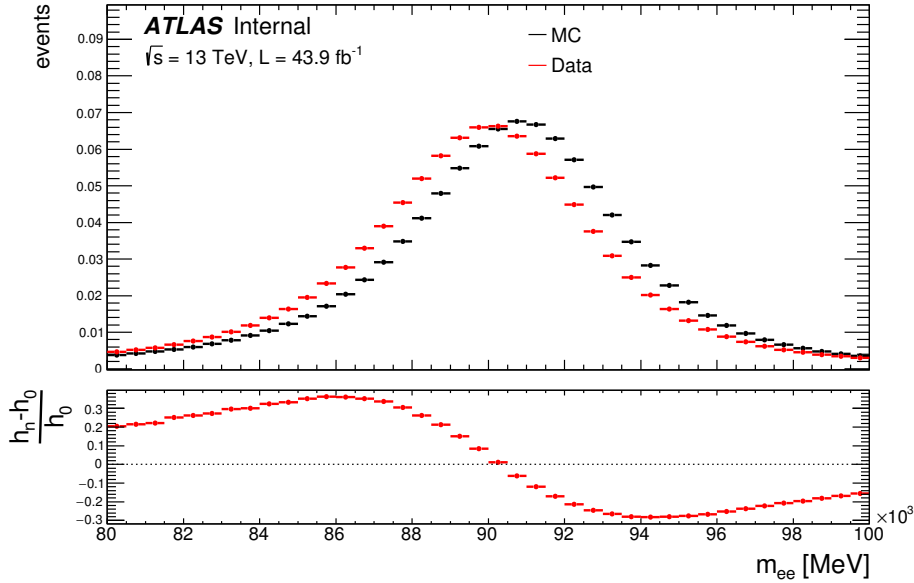


FIGURE 3.2: The di-electron invariant mass m_{ee} after step 4 of the calibration procedure, Figure 3.1, for data and simulation.

979 of the energy response and the energy resolution. To correct for this difference
 980 between data and simulation, two correction factors are extracted. The next para-
 981 graph will discuss the methodology used to extract those correction factors.
 982

983 3.3.2 Definition of the correction factors

984 As discussed in the previous paragraph, two correction factors are extracted from
 985 the $Z \rightarrow ee$ channel. The correction factors are called the energy scale factors α
 986 and the additional constant term c' . The factors (α, c') will be expressed in η bin i ,
 987 defined in sec. 3.5.1, as (α_i, c'_i) :

- 988 • The energy scale factor α : it is applied to the data in order to match the
 989 energy response of the simulation:

$$E_i^{\text{corr}} = \frac{E_i^{\text{data}}}{1 + \alpha_i} \quad (3.2)$$

990 where E^{data} is the measured energy and E^{corr} is the corrected energy.

- 991 • The additional constant term c' : it is applied to the simulation to be in agree-
992 ment with the energy resolution of the data:

$$\left(\frac{\sigma(E)}{E}\right)_i^{\text{corr}} = \left(\frac{\sigma(E)}{E}\right)_i^{\text{MC}} \oplus c'_i \quad (3.3)$$

993 where $\sigma(E)^{\text{corr}}$ is the resolution of the simulation after applying c' , supposed
994 to be equal to $\sigma(E)^{\text{data}}$, which is the resolution of the data, and $\sigma(E)^{\text{MC}}$ is the
995 resolution of the simulation before applying c' .

996 3.3.3 Effect of the scale factors (α, c') on the di-electrons mass m_{ee}

997 The scale factors (α, c') are computed using the comparison of the di-electrons
998 invariant mass between data and simulation. Before discussing the method used
999 for the extraction of the scale factors, we will discuss in this part the effect of the
1000 scale factors (α, c') on the invariant mass m_{ee} :

$$m_{ee}^{\text{MC}} = \sqrt{2E_1^{\text{MC}}E_2^{\text{MC}}(1 - \cos\theta_{12})}, \quad (3.4)$$

1001 by replacing E_1^{MC} and E_2^{MC} with their expressions as shown in equation (3.2). The
1002 effect of the scale factor α on m_{ee} is expressed as:

$$m_{ee}^{\text{data}} = m_{ee}^{\text{MC}} \sqrt{(1 + \alpha_i)(1 + \alpha_j)}, \quad (3.5)$$

1003 where i and j are η_{calo} bins where each electron falls in. By neglecting the term of
1004 the second order ($\alpha_i \times \alpha_j$) the invariant mass is expressed as:

$$m_{ee}^{\text{data}} = m_{ee}^{\text{MC}}(1 + \alpha_{i,j}), \quad (3.6)$$

1005 and $\alpha_{i,j}$ is written as:

$$\alpha_{i,j} = \frac{\alpha_i + \alpha_j}{2}. \quad (3.7)$$

1006 Contrary to the scale factor α , we can not relate directly the additional constant
1007 term c' and the resolution on the invariant mass. Instead, the di-electron invariant
1008 mass resolution is expressed in term of the relative energy resolution as:

$$\begin{aligned} \left(\frac{\sigma(m)}{m}\right)_{\text{data}}^2 &\simeq \frac{1}{4} \left(\left(\frac{\sigma(E_1)}{E_1}\right)_{\text{data}}^2 + \left(\frac{\sigma(E_2)}{E_2}\right)_{\text{data}}^2 \right) \\ &= \frac{1}{4} \left(\left(\frac{\sigma(E_1)}{E_1}\right)_{\text{MC}}^2 + c_i'^2 + \left(\frac{\sigma(E_2)}{E_2}\right)_{\text{MC}}^2 + c_j'^2 \right) \\ &= \left(\frac{\sigma(m)}{m}\right)_{\text{MC}}^2 + \frac{c_i'^2 + c_j'^2}{4}. \end{aligned} \quad (3.8)$$

1009 What is done is to apply to both electrons (with independent random numbers) an
1010 effective correction $c'_{i,j}$ and the resolution is therefore expressed as:

$$\left(\frac{\sigma(m)}{m}\right)_{\text{data}}^2 = \left(\frac{\sigma(m)}{m}\right)_{\text{MC}}^2 + \frac{c_i'^2 + c_j'^2}{4} = \left(\frac{\sigma(m)}{m}\right)_{\text{MC}}^2 + \frac{c_{ij}'^2}{2}, \quad (3.9)$$

1011 and $c'_{i,j}$ is written as:

$$c_{ij}'^2 \equiv \frac{c_i'^2 + c_j'^2}{2}. \quad (3.10)$$

1012 Finally, the calibration of the EM calorimeter is simplified to the extraction of the
1013 correction factors $\alpha_{i,j}$ and $c'_{i,j}$. To extract these correction factors, the template
1014 method in [36, 38] is used for the early Run 2 analysis with a sliding window
1015 clustering algorithm, and in [15] for the final Run 2 algorithm with the dynamical
1016 topo-cell clustering algorithm (see Chapter 2). The next paragraph will give a
1017 detailed explanation of this method.

1018 3.4 Template method for the energy scale factors

1019 3.4.1 Methodology of the template method

1020 The template method described in [82] was established during Run 1 for the ex-
1021 traction of the correction factors $\alpha_{i,j}$ and $c'_{i,j}$. The corrections are determined inde-
1022 pendently in each $(\eta_{\text{calo}}^i, \eta_{\text{calo}}^j)$ configuration. The idea of the template method is to
1023 apply hypothesized values of the scale factors to simulation. For each MC event,
1024 the di-electron invariant mass is modified and expressed as:

$$m_{ee}^{\text{template}} = m_{ee}^{\text{MC}} \sqrt{\left((1 + c'_{i,j} \times N_i(0, 1)) (1 + c'_{i,j} \times N_j(0, 1)) (1 + \alpha_{i,j}) (1 + \alpha_{i,j})\right)}. \quad (3.11)$$

1025 For each couple $(\alpha_{i,j}, c'_{i,j})$, the new mass distribution is called a template. The
1026 comparison between the template and data distributions is done using a χ^2 test,
1027 by default for mass values between 80 and 100 GeV:

$$\chi^2 = \sum_{k=1}^{N_{\text{bins}}} \frac{\left(m_{ee,k}^{\text{template}} - m_{ee,k}^{\text{data}}\right)^2}{\left(\sigma_k^{\text{template}}\right)^2 + \left(\sigma_k^{\text{data}}\right)^2}, \quad (3.12)$$

1028 where N_{bins} is the number of mass bins used, $m_{ee,k}^{\text{template}}$ and $m_{ee,k}^{\text{data}}$ are the bin con-
1029 tents of the invariant mass distributions in bin k and $\sigma_k^{\text{template}}$ and σ_k^{data} are the
1030 corresponding uncertainties in the bin. By repeating this procedure for all the tem-
1031 plates, we can plot a 2D scan of the χ^2 as shown in the Figure 3.3. The minimum of
1032 the distribution gives the final correction factors $(\hat{\alpha}_{i,j}, \hat{c}'_{i,j})$, which correspond to the
1033 best agreement between data and simulation. The determination of the correction
1034 factors is related to the determination of the minimum of χ^2 .

1035 There is in Figure 3.3 a small correlation between α and c' and the minimum
1036 of this 2D distributions is obtained using several 1D fits. The minimisation proce-
1037 dure [82] is shown in Figure 3.4 and can be summarised in the steps below:

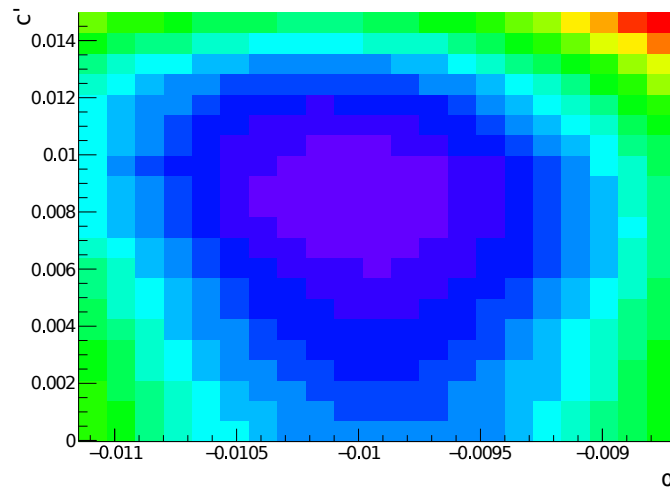


FIGURE 3.3: Distribution of χ^2 test between data and templates, as a function of the energy scale factor and the resolution factor.

- 1038 • For a fixed value of c'_{ij} , we look at the χ^2 distribution as a function of α_{ij} ,
 1039 as can be seen as a line in Figure 3.3, and the resulting χ^2 is fitted using a
 1040 parabolic shape function:

$$\chi^2(\alpha_{ij}, c'_{ij}) = a_0(c'_{ij}) + \frac{(\alpha_{ij} - \alpha_{ij,\min}(c'_{ij}))^2}{(\delta\alpha_{ij}(c'_{ij}))^2} \quad (3.13)$$

1041 where $\delta\alpha_{ij}(c'_{ij})$ is the uncertainty on $\alpha_{ij,\min}(c'_{ij})$ determined by $\Delta\chi^2 = 1$
 1042 around the minimum.

- 1043 • All the c'_{ij} lines of Figure 3.3 are scanned, and the $\chi^2_{\min}(c'_{ij})$ is plotted as a
 1044 function of c'_{ij} and fitted using a 3rd polynomial function characterised with
 1045 the parameters (b_0, b_1, b_2) :

$$\chi^2_{\min}(c'_{ij}) = b_0 + \frac{(c'_{ij} - \hat{c}'_{ij})^2}{b_2^2} + b_1 \frac{(c'_{ij} - \hat{c}'_{ij})^3}{b_2^3}. \quad (3.14)$$

1046 The minimum of this distribution \hat{c}'_{ij} is the most probable value (MPV) for
 1047 the additional constant term in the configuration (η_1, η_2) . The uncertainty on
 1048 \hat{c}'_{ij} is determined by $\Delta\chi^2 = 1$.

- 1049 • Finally, $\alpha_{ij,\min}(\hat{c}'_{ij})$ is plotted as a function of \hat{c}'_{ij} and a linear fit is performed
 1050 around \hat{c}'_{ij} . The most probable value $\hat{\alpha}'_{ij}$ is defined as the value corresponding
 1051 to \hat{c}'_{ij} .

1052 3.4.2 Inversion procedure

1053 As the values of α_{ij} and c'_{ij} are computed for each configuration (η_1, η_2) as de-
 1054 scribed above, the correction factors α_i and c'_i must then be computed. For the

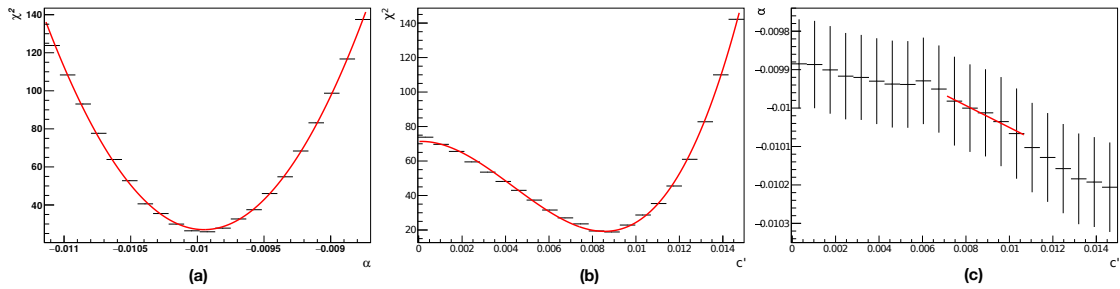


FIGURE 3.4: (a): χ^2 as a function of $\alpha_{i,j}$ for a given value of c'_{ij} . (b): $\chi^2_{\min}(c'_{ij})$ as a function of c'_{ij} . (c): $\alpha_{ij,\min}(c'_{ij})$ as a function of c'_{ij} .

1055 energy scale factor, and because of the linear equation (3.7), α_i can be computed
 1056 by the minimisation of a χ^2_α described as:

$$\chi^2_\alpha = \sum_{i,j \leq i} \frac{(\alpha_i + \alpha_j - 2\alpha_{ij})^2}{(\Delta\alpha_{ij})^2}. \quad (3.15)$$

1057 On the other hand, the extraction of the additional constant term c'_i is more com-
 1058 plicated because of the non-linearity of equation (3.10) describing the relation be-
 1059 tween $c'_{i,j}$ and (c'_i, c'_j) . The extraction of the constant c'_i is based on the likelihood
 1060 minimisation [83, 108] using the formula:

$$\chi^2_{c'} = \sum_{i,j \leq i} \frac{\left(\sqrt{\frac{c'^2_i + c'^2_j}{2}} - c'_{ij} \right)^2}{(\delta c'_{ij})^2}. \quad (3.16)$$

1061 3.5 Selections and corrections

1062 The results presented in this thesis are based on data collected during Run 2 with
 1063 the ATLAS detector, corresponding to an integrated luminosity of 139 fb^{-1} col-
 1064 lected in 2015, 2016, 2017 and 2018. The data samples are detailed in [156]. To
 1065 select $Z \rightarrow ee$ events, electrons candidates must pass the triggers shown in Table
 1066 3.1.

TABLE 3.1: Triggers used for data collected during Run 2.

Year	Trigger
2015	HLT_2e12_lhloose_L12EM10VH
2016	HLT_2e17_lhvloose_nod0
2017	HLT_2e24_lhvloose_nod0
2018	HLT_2e24_lhvloose_nod0 HLT_2e17_lhvloose_nod0_L12EM15VHI

1067 In addition, electron events must pass the MediumLH identification (ID) and
 1068 loose isolation criteria in order to reduce mis-identified electrons and to suppress
 1069 the QCD background [82]. Also, electrons are required to have $p_T^\ell > 27 \text{ GeV}$ and

1070 $|\eta_{\text{track}}| < 2.47$. Finally, events which pass all the selections mentioned above and
 1071 with opposite charge are selected in the range $0 < m_{ee} < 180$ GeV. The number of
 1072 selected events is shown in Table 3.2.

TABLE 3.2: Number of selected events which passes the selections used for the $Z \rightarrow ee$ analysis.

	2015	2016	2017	2018
Data	1.62 M	15.6 M	19.2 M	25.4 M
Simulation	6.53 M (MC16a)	18.5 M (MC16a)	20.2 M (MC16d)	28.8 M (MC16e)

1073 In Table 3.2, MC16a, MC16d and MC16e indicate the tag of simulation samples.
 1074 Additional corrections in terms of weights to match the data need to be applied to
 1075 the simulation. One of the corrections is the pile-up reweighting, used to repro-
 1076 duce the distribution of the number of pp collisions per bunch crossing in the data.
 1077 Figure 3.5 shows an example of the actual number of interactions per bunch cross-
 1078 ing in data compared to simulation after the pile-up reweighting.

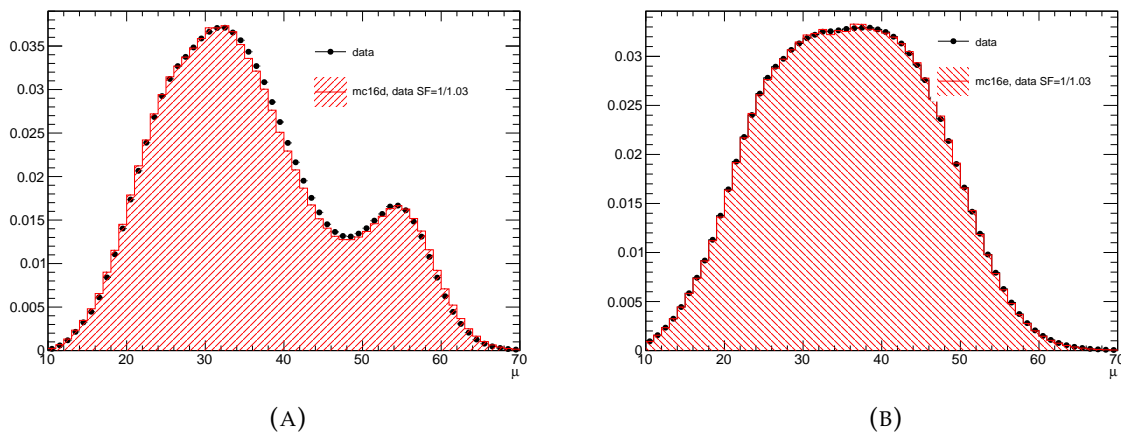


FIGURE 3.5: The actual number of interactions per bunch crossing of data which is re-scaled by a factor $1/1.03$ and simulation for 2017 (A) and 2018 (B), after the pile-up reweighting procedure.

1079 Also, the difference between data and simulation for the reconstruction, iden-
 1080 tification, isolation and trigger efficiencies is taken into account by applying cor-
 1081 responding scale factors to the simulation. As shown in Figure 3.6, the changes
 1082 in the invariant mass distribution of the MC before and after applying the pile-
 1083 up reweighting correction and the different scale factors is typically small. In the
 1084 current analysis, the electroweak background has been neglected. It is included in
 1085 the systematic uncertainty (Table 3.4) and its contribution is smaller than 0.05% for
 1086 invariant mass m_{ee} between 75 and 97 GeV.

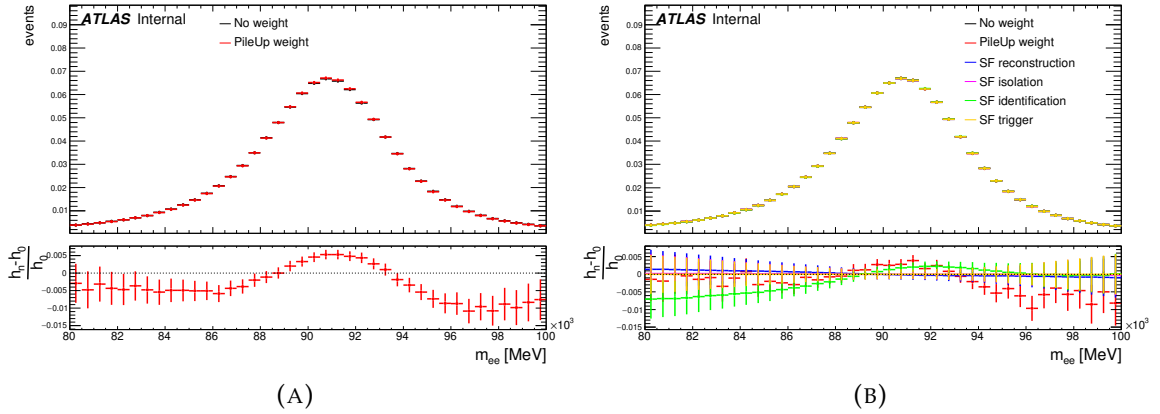


FIGURE 3.6: Effect of the pile-up reweighting (A) and different efficiency scale factors (B) corrections on the normalized $Z \rightarrow ee$ mass distribution in simulation. The bottom plot shows the fractional differences of the invariant mass distribution without any scale factors (labelled h_0) and with the application of different efficiency scale factors or reweightings (labelled h_n) separately.

1087 3.5.1 Binning

1088 During Run 1, the energy scale factor α was extracted in 34 bins along η . For
 1089 Run 2 and because of the high statistics of the data collected, the energy scale
 1090 factors α are extracted using 68 bins, which correspond to Run 1 binning splitted
 1091 by two. The small binning allows a better correction of data. For the additional
 1092 constant term, the Run 1 binning is kept in order to maximise the statistics in each
 1093 configuration. Table 3.3 shows the new binning used for α and c' in the barrel and
 end-cap regions.

TABLE 3.3: Absolute values of η_{calo} bin boundaries for energy scale factors α and resolution constant terms c' used in the calibration of electromagnetic calorimeter during Run 2.

		Barrel															
α_i	0	0.1	0.2	0.3	0.4	0.5	0.6	0.7	0.8	0.9	1	1.1	1.2	1.285	1.37		
c'_i	0		0.2		0.4		0.6		0.8		1		1.2		1.37		
		End-cap															
α_i	1.55	1.59	1.63	1.6775	1.725	1.7625	1.8	1.9	2	2.05	2.1	2.2	2.3	2.35	2.4	2.435	2.47
c'_i	1.55						1.8		2				2.3				2.47

1094

1095 3.6 Results

1096 3.6.1 Extraction of the correction factors (α , c')

1097 The results of the energy scale factors α for Run 2 data sets are presented in Fig-
 1098 ure 3.7. The results are extracted separately for each year to take into account the

1099 data taking conditions. The observed differences (up to ± 0.005) in the end-cap
1100 region between the different years are related to two effects [2]:

1101 **Change of luminosity:** at high luminosity, a larger current I is induced on HV
1102 lines due to a larger amount of energy deposited in the liquid argon gaps.
1103 The HV in the detector is reduced by $R \times I$, where R is the resistance between
1104 the power supply where the voltage is set to a constant value and the LAr
1105 gap. This effect is called high voltage drop and is dominated by luminosity
1106 effects.

1107 **Change of LAr temperature:** this effect is related to the change of liquid argon
1108 temperature between the different data taking periods. Studies [97, 31] show
1109 that the energy response change by $-2\%/K^0$.

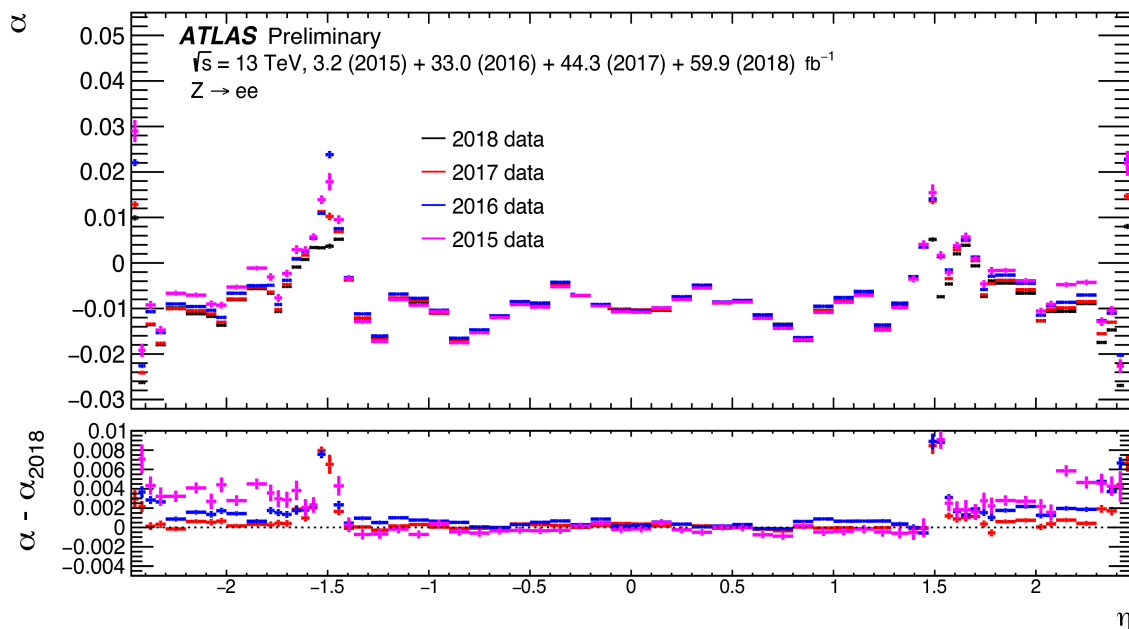


FIGURE 3.7: Energy scale factors extracted for 2015, 2016, 2017 and 2018 data taking during Run 2 as a function of η_{calo} . The bottom panel shows the differences between 2015, 2016 and 2017 to the 2018 data measurements.

1110 For the additional constant term c' , the results are shown in the same way for
1111 different years of Run 2 in Figure 3.8. Ideally, the additional constant term is inde-
1112 pendent of luminosity, but, as shown in Figure 3.8, the constant c' decreases as a
1113 function of the year. Studies [15] show that this effect is related to mis-modelling
1114 of the pile-up noise in simulation: the pile-up noise in the calorimeter increases
1115 with $\langle \mu \rangle$ in data and this effect is not well modelled in simulation, and therefore is
1116 absorbed by the additional constant c' .

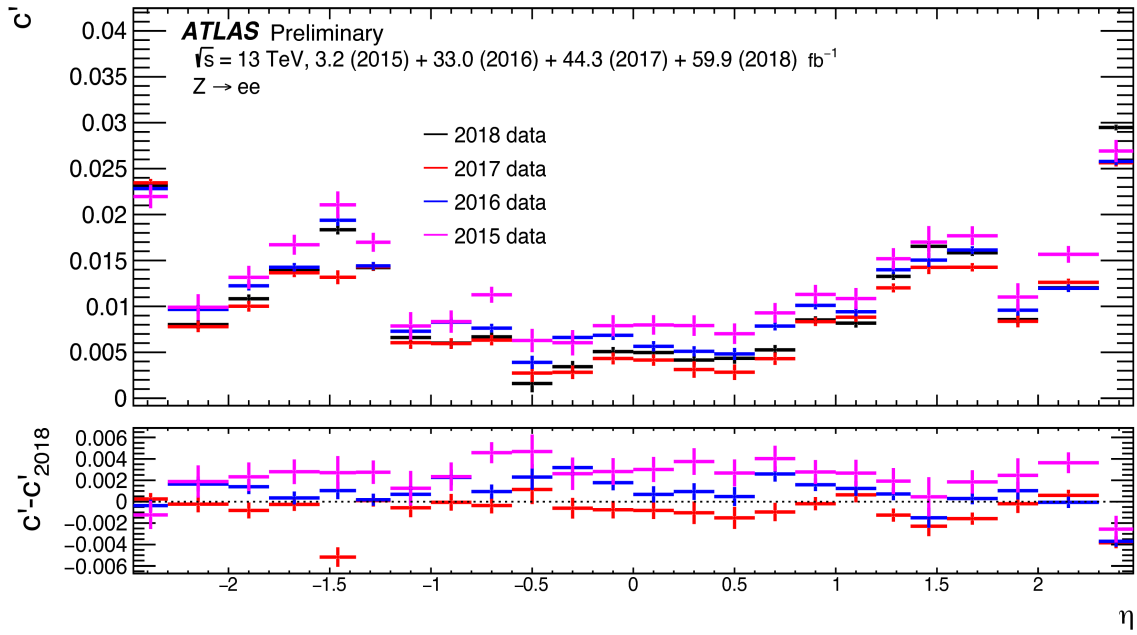


FIGURE 3.8: Additional constant term c' extracted for 2015, 2016, 2017 and 2018 data taking during Run 2 as a function of η_{calo} . The bottom panel shows the differences between 2015, 2016 and 2017 to the 2018 data measurements.

1117 This effect is due to the fact that, in order to simulate the charged distribution and
 1118 the calorimeter distribution of the data, different tunings of the pile-up reweight-
 1119 ing are needed [99]. This is also dependent on the beam crossing configuration at
 1120 LHC [153] as seen for instance in [121]. The official ATLAS pile-up reweighting
 1121 correction factor of 1.03 (see figure 3.5) can be changed to 1.2 or 1.3, depending
 1122 of the beam crossing configuration and the additional constant terms of different
 1123 years are much more similar [131].

3.6.2 Systematic uncertainties

Different sources of systematic uncertainties of the correction factors (α and c') are evaluated using 64 bins for the energy scale factor α and 24 bins for the additional constant term c' described in Table 3.3, then symmetrised in bins of η_{calo} to reduce the statistical fluctuations. The systematic sources can be summarised in:

Mass window: the energy scale factors depend on the invariant mass window of the fit, due to the fact that the distribution tails are not well modelled in simulation [96]. The impact of the mass window is estimated by changing the window from [80, 100] to [87, 94.5] GeV, and the difference is taken as a systematic uncertainty.

Mass threshold: in the template method, we use only configurations with $m_{ee}^{\text{th}} > 70$ GeV. This threshold mass is computed [82] based on the fact that the mass of the Z boson, when both electrons have the same E_T and are at opposite ϕ , is equal to $M_Z = E_T \sqrt{2 \cdot \cosh(\eta_j - \eta_i)}$. Since the selection requires electrons to have at least $E_T = 27$ GeV, the threshold mass for an (i, j) configuration is defined as $m_{ee}^{\text{th}} = 27 \cdot \sqrt{2 \cdot \cosh(\eta_j - \eta_i)}$. This choice is arbitrary and a systematic uncertainty, defined by comparing the scale factors using $m_{ee}^{\text{th}} > 70$ and $m_{ee}^{\text{th}} > 77$ GeV, is added to take into account the impact of the selection.

Background: in the template method, the electroweak background has been neglected. This systematic uncertainty is computed by comparing the scale factors with and without the background.

Electron reconstruction efficiencies: this uncertainty is added to take into account the scale factors (reconstruction, isolation, identification and trigger) applied to MC in order to match data. These efficiency factors are characterised by uncertainties propagated by the template method and considered as systematic uncertainties in α and c' .

Electron reconstruction quality: as shown in Sec. 3.5, electrons must pass medium ID requirement. A systematic uncertainty is evaluated by comparing medium and tight ID electrons. In addition, another systematic uncertainty is added to take into account the uncertainty on the emission of photon by bremsstrahlung in the calorimeter.

Method comparison: in addition to the template method used on this thesis, there is another method called the “lineshape method” [74]. A systematic uncertainty is defined by the difference between the two methods.

Method accuracy: this uncertainty is used to take into account the intrinsic bias of the template method. It is evaluated by injecting known values in a MC sample and try to measure these values using the template method. The difference between the measured and injected values is defined as the systematic uncertainty.

The systematic uncertainties in the scale factors are listed in Table 3.4. The total uncertainty is calculated by the quadratic sum of all the effects described above.

TABLE 3.4: Ranges of systematic uncertainties in α and c' for different η ranges [74].

$ \eta $ range	Uncertainty in $\alpha_i \times 10^3$				Uncertainty in $c_i \times 10^3$			
	0 – 1.2	1.2 – 1.8	1.8 – 2.4	1.8 – 2.4	0 – 1.2	1.2 – 1.8	1.8 – 2.4	1.8 – 2.4
Uncertainty source								
Method accuracy	(0.01 – 0.04)	(0.04 – 0.10)	(0.02 – 0.08)	(0.02 – 0.08)	(0.1 – 0.7)	(0.2 – 0.4)	(0.1 – 0.2)	(0.1 – 0.2)
Method comparison	(0.1 – 0.3)	(0.3 – 1.2)	(0.1 – 0.4)	(0.1 – 0.4)	(0.1 – 0.5)	(0.7 – 2.0)	(0.2 – 0.5)	(0.2 – 0.5)
Mass range	(0.1 – 0.5)	(0.2 – 4.0)	(0.2 – 1.0)	(0.2 – 1.0)	(0.2 – 0.8)	(1.0 – 3.5)	1.0	1.0
Region selection	(0.02 – 0.08)	(0.02 – 0.2)	(0.02 – 0.2)	(0.02 – 0.2)	(0 – 0.1)	0.1	(0.2 – 1.0)	(0.2 – 1.0)
Bkg. with prompt electrons	(0 – 0.05)	(0 – 0.1)	(0 – 0.5)	(0 – 0.5)	(0.1 – 0.4)	0.2	(0.1 – 0.2)	(0.1 – 0.2)
Electron isolation requirement	(0 – 0.02)	(0.02 – 5.0)	(0.02 – 0.20)	(0.02 – 0.20)	(0.1 – 0.9)	(0.1 – 1.5)	(0.5 – 1.5)	(0.5 – 1.5)
Electron identification criteria	(0 – 0.30)	(0.20 – 2.0)	(0.20 – 0.70)	(0.20 – 0.70)	(0 – 0.5)	0.3	0.0	0.0
Electron bremsstrahlung removal	(0 – 0.30)	(0.05 – 0.7)	(0.20 – 1.0)	(0.20 – 1.0)	(0.2 – 0.3)	(0.1 – 0.8)	(0.2 – 1.0)	(0.2 – 1.0)
Electron efficiency corrections	0.10	(0.1 – 5.0)	(0.10 – 0.20)	(0.10 – 0.20)	(0 – 0.3)	(0.1 – 3.0)	(0.1 – 0.2)	(0.1 – 0.2)
Total uncertainty	(0.2 – 0.7)	(0.5 – 10)	(0.6 – 2.0)	(0.6 – 2.0)	(0.3 – 1.2)	(1.0 – 6.0)	(2.0 – 3.0)	(2.0 – 3.0)

3.6.3 Data to simulation comparison

After deriving the energy correction factors, they are applied to data and MC events and the final distributions are compared in Figure 3.9. The energy scale factors α are applied to data in order to match the energy response of the simulation and MC events are smeared according to c' factors in order to match the slightly worse resolution in data. The lower panel shows the data to simulation ratio and the total systematic uncertainty on the energy scale and resolution corrections from [36]. The deviations are largest in the tails where they can reach 3% and are mostly covered by uncertainties.

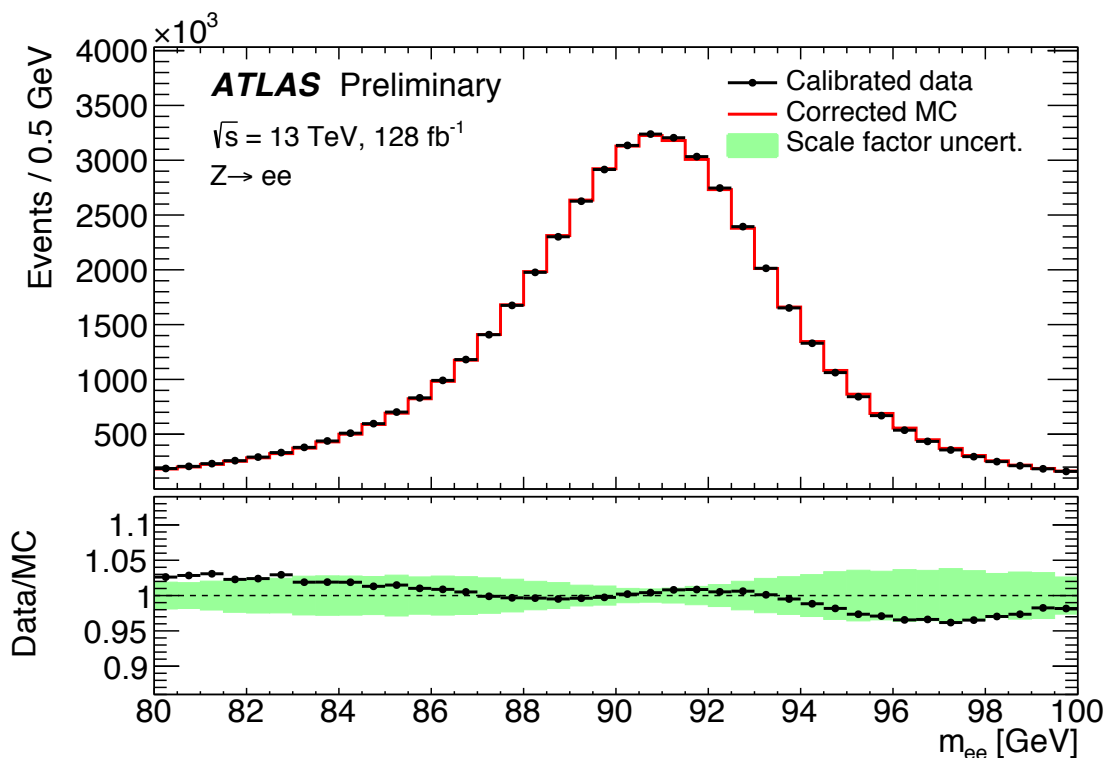


FIGURE 3.9: Inclusive di-electron invariant mass distribution from $Z \rightarrow ee$ decays in data compared to MC after applying the full calibration. The simulation is normalized to data. The lower panel shows the data to simulation ratio, together with the uncertainty from the energy scale and resolution corrections.

The systematic uncertainties (see Table 3.4) are dominated by the electron identification, the method comparison, the mass range and the electron Bremsstrahlung removal. However, for the W -mass measurement [115] some improvements [41] were achieved with respect to the Run 1 calibration [67]: in particular restricting the η range by excluding $1.2 < |\eta| < 1.8$, using broader η bins in order to compute the systematic uncertainties and neglecting some uncertainties when we apply the calibration to electrons, like in $W \rightarrow e\nu$, for instance the uncertainty related to the electron ID as well as the uncertainty related to Bremsstrahlung emission since the analysis is inclusive in Bremsstrahlung.

1183 3.7 Calibration for low pile-up runs

1184 3.7.1 Introduction

1185 In addition to the data collected for the nominal Run 2 analyses, called nominal
 1186 runs, there are other runs dedicated to special studies. For the measurement of
 1187 the W boson mass, we use low pile-up runs characterised with low number of
 1188 interactions per crossing ($\langle\mu\rangle \approx 2$), as shown in Figure 3.10. These data sets were
 1189 collected by ATLAS in autumn 2017 (258 pb⁻¹ at $\sqrt{s} = 5$ TeV and 148 pb⁻¹ at $\sqrt{s} = 13$
 1190 TeV) and in summer 2018 (an additional 193 pb⁻¹ at $\sqrt{s} = 13$ TeV). The low pile-up
 1191 samples are detailed in [95]. For low pile-up runs, we use the the same selections
 1192 as for the nominal runs described in Sec. 3.5, except for the trigger where we use
 1193 $HLT_e15_lhloose_nod0_L1EM12$ for 2017 and 2018 data. The number of selected
 events for low pile-up runs is shown in Table 3.5.

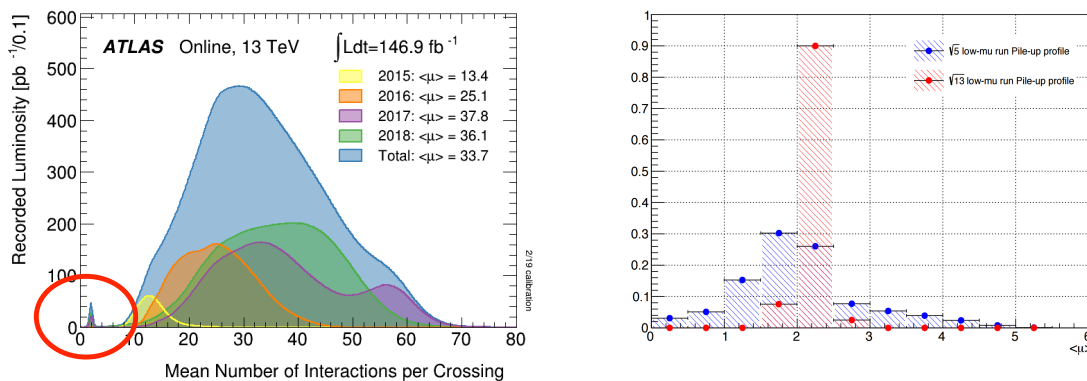


FIGURE 3.10: **left:** low pile-up runs at $\langle\mu\rangle \approx 2$ showed in the red circle. **right:** the pile-up distribution of simulated low pile-up data at $\sqrt{s} = 5$ and 13 TeV.

1194

TABLE 3.5: The number of $Z \rightarrow ee$ candidate events selected after applying all the selections for low pile-up runs at $\sqrt{s} = 5$ and 13 TeV.

	5 TeV(2017)	13 TeV(2017)	13 TeV(2018)
Data	58.7 k	79.9 k	107.2 k
Simulation	2.14 M	1.38 M	1.41 M

1195 The correction factors related to the reconstruction, identification, isolation and
 1196 trigger efficiencies are applied also for the low pile-up runs. All these correction
 1197 factors are obtained from the low pile-up runs except for the reconstruction effi-
 1198 ciencies. In the same way, the pile-up reweighting is applied to MC in order to
 1199 reproduce the distribution of the number of pp collisions per bunch crossing in
 1200 data. Figure 3.11 shows the distribution of $\langle\mu\rangle$ in data and MC.

1201 3.7.2 Energy scale factors for low pile-up runs

1202 For the low pile-up runs, the same procedure described above is used to derive α
 1203 and c' correction factors to equalise the response and resolution of data and MC.

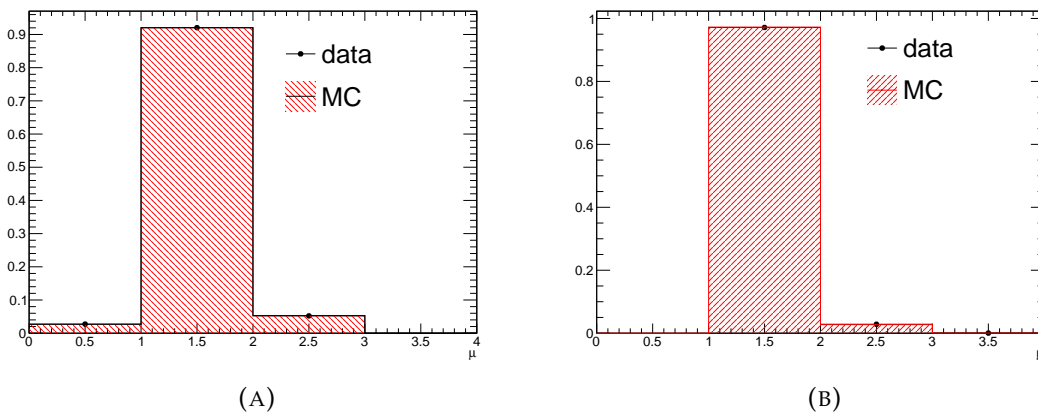


FIGURE 3.11: The average number of interaction per bunch crossing of data and simulation with low pile-up $\sqrt{s} = 13$ TeV runs for 2017 (A), 2018 (B) after the pile-up reweighting procedure.

1204 For the nominal high pile-up data, the energy scale factors corrections are derived
 1205 in 68 η_{calo} bins. Because of the smaller number of $Z \rightarrow ee$ events in the low pile-up
 1206 runs, the scale factors extracted with the same 68 bins result have large statistical
 1207 fluctuation and systematic bias, especially in the end-cap region, as shown in the
 1208 Figure 3.12. To avoid this problem, two binnings were studied combining some
 1209 bins of the 68 η_{calo} bins:

- 1210 • either 48 bins in total with bins of larger size only in the end-cap
- 1211 • or 24 bins in total with bins of larger size in both the barrel and the end-cap
- 1212 regions, as shown in Figure 3.12 and Table 3.6.

TABLE 3.6: Values of η_{calo} bin boundaries for energy scale α for 24 bins.

-2.47	-2.4	-2.1	-1.8	-1.55	-1.37	-1.2	-1	-0.8	-0.6	-0.4	-0.2	0	0.2	0.4	0.6	0.8	1	1.2	1.37	1.55	1.8	2.1	2.4	2.47
-------	------	------	------	-------	-------	------	----	------	------	------	------	---	-----	-----	-----	-----	---	-----	------	------	-----	-----	-----	------

1213 The results obtained from these binnings are shown in Figure 3.12. As can be
 1214 seen, the instability for the end-cap bins disappears. As the α factors do not vary
 1215 strongly between the 48 and 24 bins versions, the baseline chosen is 24 bins. The
 1216 additional constant term c'_i applied to MC to account for the worse resolution in
 1217 data is shown in Figure 3.13. As the c'_i values were previously observed to be de-
 1218 pendent on the pile-up and data taking conditions, it is best to extract and use the
 1219 constants from the respective data set under study. This is further discussed in
 1220 Sec. 3 of Ref. [15]. The physics analyses currently use directly the in-situ calibra-
 1221 tions as derived in this section. The main uncertainties are given by the statistical
 1222 uncertainties of the α_i and c'_i factors. As these are significantly larger than other
 1223 uncertainties, another approach is used to extract the energy scale factor α_i and
 1224 explained in Sec. 3.7.3.

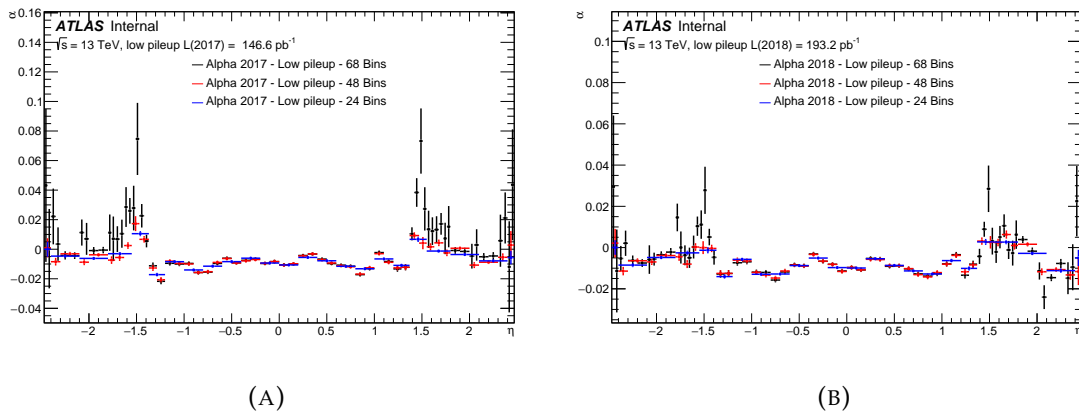


FIGURE 3.12: Energy scale factors α for low pile-up runs of 2017 (A) and 2018 (B) using 68, 48 and 24 η bins. It can be seen, that the extraction is unstable in case of 68 bins, resulting in α factors with very large uncertainties.

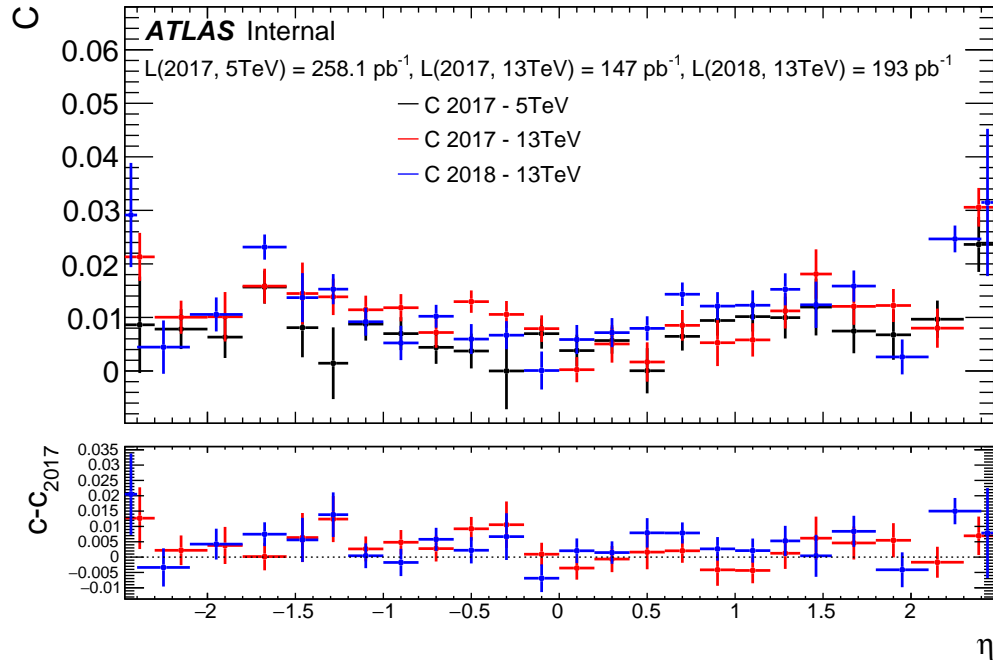


FIGURE 3.13: Additional constant term c_i' for low pile-up runs of 2017 (13 TeV), 2018 (13 TeV) and 2017 (5 TeV) using 24 bins. The lower panel shows the difference of c_i' to 2017 (5 TeV) results.

1225 3.7.3 Extrapolation method

1226 An alternative method to derive the energy correction scale factors for the low
 1227 pile-up data is to study the dependence of the factor α for high pile-up data sets
 1228 and to perform an extrapolation to $\langle\mu\rangle \approx 2$. This method exploits the large sample
 1229 of the high pile-up data, but requires additional work to ensure the extrapolation
 1230 is under control. The extrapolation proceeds by separating the high pile-up data
 1231 into intervals of $\langle\mu\rangle$ and applying the template method to extract the energy scale
 1232 factors as a function of $\langle\mu\rangle$, i.e. $\alpha(\langle\mu\rangle)$. Using a (linear) fit $\alpha(\langle\mu\rangle)$ can be extrapolated
 1233 to $\langle\mu\rangle \approx 2$. The $\langle\mu\rangle$ intervals are defined in Table 3.7. The extrapolation
 1234 for two example η bins is shown in Figure 3.14. Figures 3.15 and 3.16 show the
 1235 extrapolation from high pile-up to low pile-up data for all η bins comparing the
 1236 negative and positive η bins in a same plot. The asymmetric effect observed be-
 1237 tween the negative and positive η bins could be due mainly to temperature effects
 1238 which may not be symmetric. Over the $\langle\mu\rangle$ range samples in the high pile-up data
 1239 a linear fit is found to be sufficient. In many bins the slope of $\alpha(\langle\mu\rangle)$ is found to be
 1240 small, but in particularly in the end-cap region the slopes are often significant.

TABLE 3.7: The μ intervals used for extrapolation study.

[0 : 26]	[26 : 33]	[33 : 40]	[40 : 50]	[50 : 80]
------------	-------------	-------------	-------------	-------------

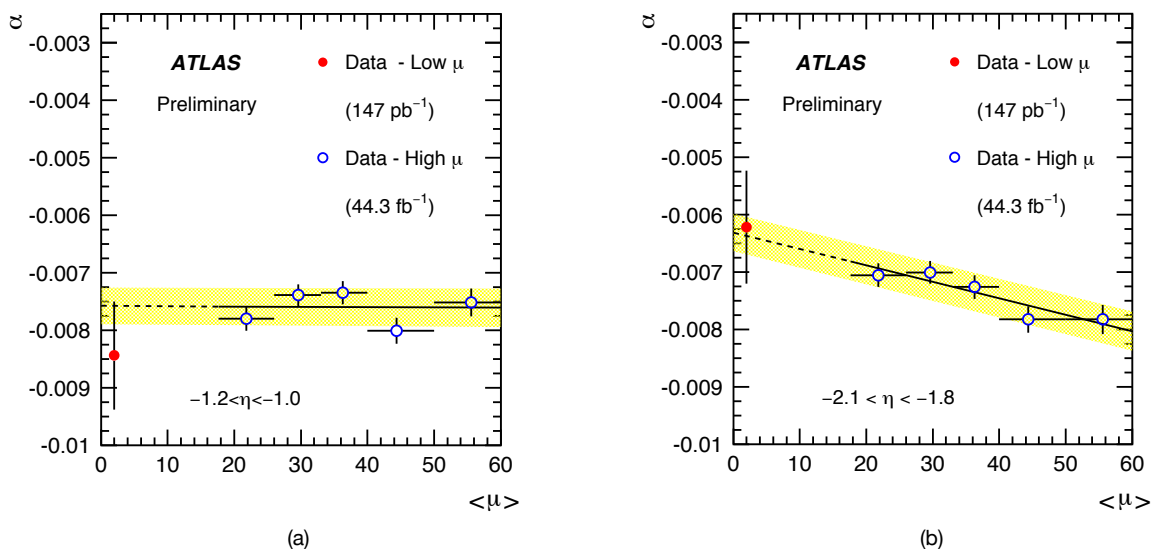


FIGURE 3.14: Examples of the energy scale extrapolation from high pile-up to low pile-up in the barrel (a) and end-cap (b). The blue points show the energy scale factors α for the high pile-up data set as a function of $\langle\mu\rangle$, the black lines show the extrapolation to $\langle\mu\rangle \approx 2$ using a linear function and 5 intervals of $\langle\mu\rangle$, the band represents the uncertainty in the extrapolation. The extrapolation results are compared to the energy scale factors α extracted from the low pile-up data set, represented by the red point.

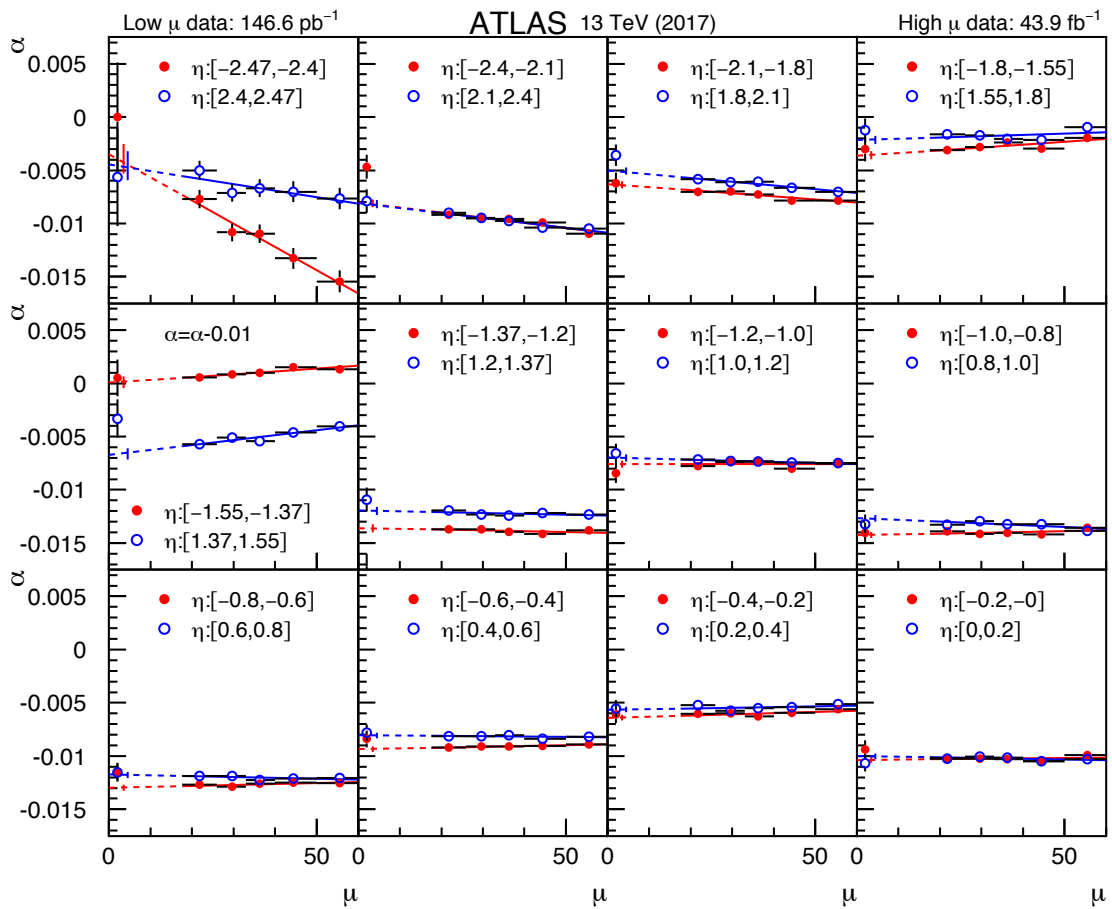


FIGURE 3.15: Energy scale extrapolation from 2017 high pile-up to low pile-up for 2017 (at 13 TeV) low pile-up data. The blue and red points show the energy scale factors α for the high pile-up data set as a function of $\langle\mu\rangle$ for different η regions, the dotted lines show the extrapolation to $\langle\mu\rangle \approx 2$ using a linear function and 5 intervals of $\langle\mu\rangle$. The values of α determined using the low $\langle\mu\rangle$ data sets are also shown at $\langle\mu\rangle \approx 2$. The size of the vertical lines near the low α points represents the uncertainty of the extrapolation.

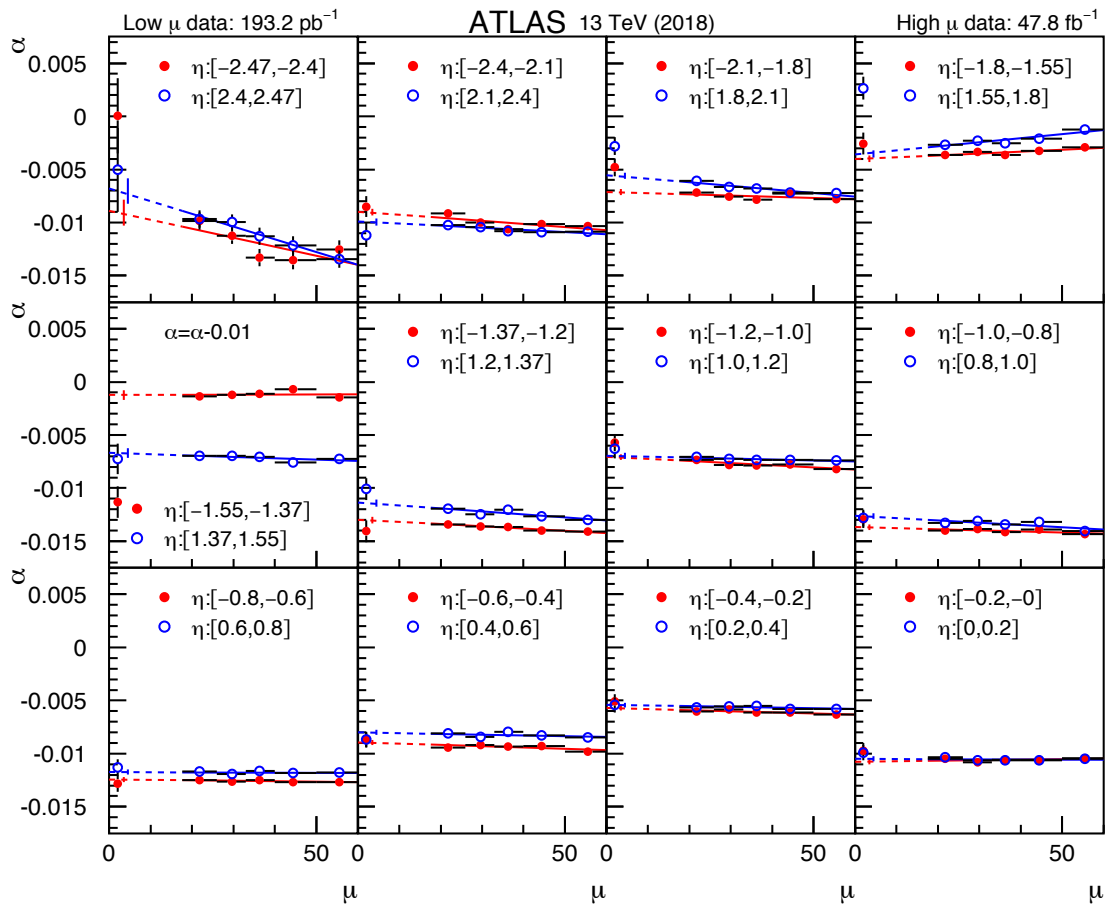


FIGURE 3.16: Energy scale extrapolation from 2018 high pile-up to low pile-up for 2018 (13 TeV) low pile-up data. The blue and red points show the energy scale factors α for the high pile-up data set as a function of $\langle\mu\rangle$ for different η regions, the dotted lines show the extrapolation to $\langle\mu\rangle \approx 2$ using a linear function and 5 intervals of $\langle\mu\rangle$. The values of α determined using the low $\langle\mu\rangle$ data sets are also shown at $\langle\mu\rangle \approx 2$. The size of the vertical lines near the low α points represents the uncertainty of the extrapolation.

1241 3.7.4 Extrapolation results

1242 After extrapolating the results to $\langle\mu\rangle \approx 2$, it could be expected that the energy scale
 1243 factors coincide with those extracted directly using the low pile-up data within
 1244 uncertainties. However, this is not always the case as it is shown in Figure 3.17,
 1245 where it is observed that the extrapolation results are in fact closer to the high
 pile-up results without extrapolation than to the low pile-up results.

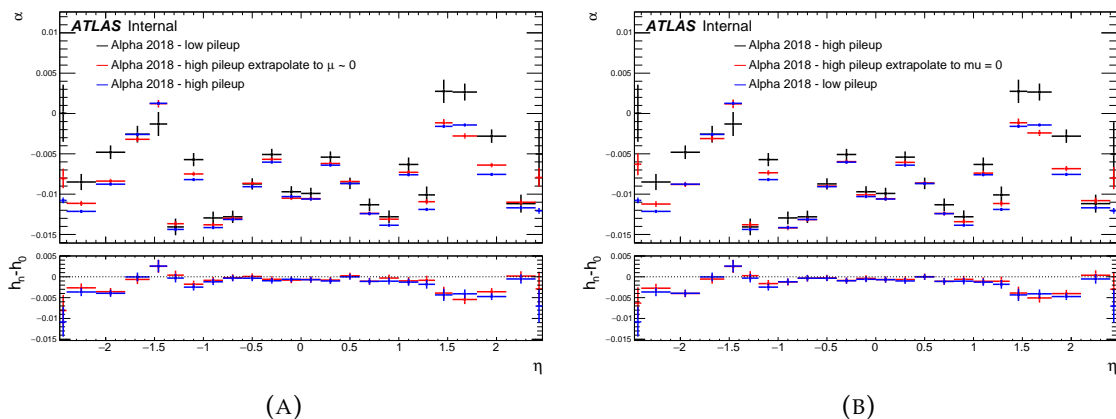


FIGURE 3.17: The energy scale factors α for 2017 (A) and 2018 (B) data, respectively. The results are shown using directly the low (black) and high (blue) pile-up data and extrapolating the high pile-up results to $\langle\mu\rangle \approx 2$ (red). The bottom panels show the absolute differences between the high-pile-up α factors with and without extrapolation correction (labelled h_n) to the in-situ low pile-up derived α factors (labelled h_0).

1246 This behavior of the extrapolated results was understood to be due to the dif-
 1247 ferent settings of the topo-cluster noise thresholds at reconstruction level: for the
 1248 low pile-up data these were set to correspond to $\langle\mu\rangle = 0$ (to improve the hadronic
 1249 recoil reconstruction), while the nominal high pile-up data is reconstructed with a
 1250 threshold corresponding to $\langle\mu\rangle = 40$. The lower noise threshold used for the low
 1251 pile-up data leads to more cells added to the topo-clusters and thus to a higher en-
 1252 ergy as shown in Figure 3.18. The effect of different noise thresholds on the energy
 1253 scale factors α is studied with a dedicated processing of the data and MC (as de-
 1254 scribed in Sec. 3.3) where the noise thresholds are set to the nominal high pile-up
 1255 values.
 1256

1257 Using the template method, the energy scale factors for the low pile-up data
 1258 are extracted separately for low and high noise thresholds and compared in Fig-
 1259 ure 3.19 (A). As an alternative method, the difference of the average energy re-
 1260 sponse $(E^{\text{low-threshold}} - E^{\text{high-threshold}})/E^{\text{low-threshold}}$ electron-by-electron reconstructed
 1261 with low and high noise thresholds can be compared between data and simula-
 1262 tion, as shown in Figure 3.19 (B). This second method is chosen because it reduces
 1263 the statistical fluctuations. After correcting the threshold effect by applying the
 1264 correction from Figure 3.19 (B), the extrapolation results in 24 bins of η are closer
 1265 to the low pile-up results extracted directly with the template method, as shown
 1266 in Figure 3.20. As can be seen from this figure, the difference between the extrap-
 1267 olated and low pile-up results is of the order of 0.1% (absolute difference in α of
 1268 0.001) in the barrel region, but increases to 0.5% (absolute difference in α of 0.005)

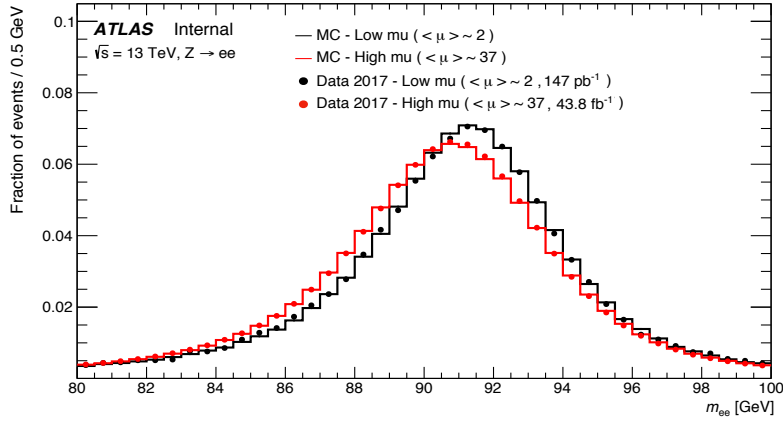
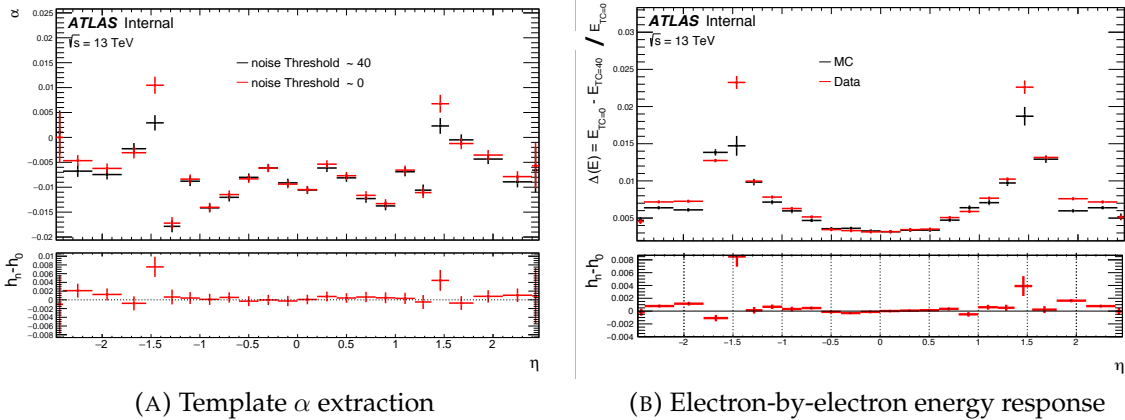


FIGURE 3.18: Comparison of the di-electron invariant mass distribution m_{ee} for data and simulation between high and low pile-up runs.



(A) Template α extraction

(B) Electron-by-electron energy response

FIGURE 3.19: (A): The effect of the noise threshold corresponding to $\mu = 0$ (red) or $\mu = 40$ (black) on the energy scale factors α using the template extraction. The bottom panel shows the absolute differences of α -factors obtained with high pile-up (labelled h_n) to those obtained with the low pile-up (labelled h_0) topo-cluster thresholds. (B): The difference in the energy response from the noise threshold settings extracted electron-by-electron on MC (black) and data (red). The bottom panel shows the absolute differences between data (labelled h_n) to MC (labelled h_0).

1269 in the end-cap region (excluding the “crack” region). The additional constant term
 1270 c' in any case will be taken from the direct results from the template method using
 1271 low pile-up samples without extrapolation from high pile-up data, as the calibration
 uncertainties are dominated by the scale factors α_i corrections.

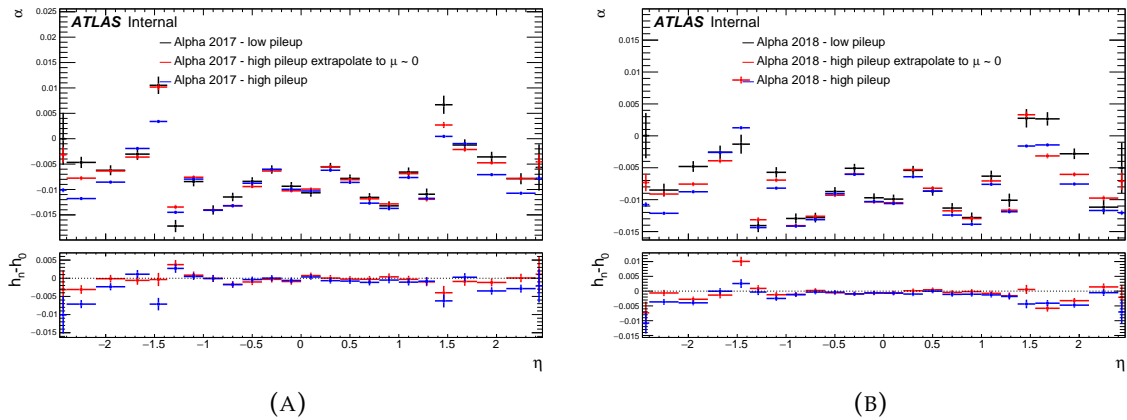


FIGURE 3.20: The extrapolation results for the energy correction factors α before (blue) and after (red) correcting the effects of the difference of the noise threshold for 2017 (A) and 2018 (B). The results are compared to the in-situ low pile-up results (black). The bottom panels show the absolute differences between the extrapolated results (labelled h_n) to the in-situ results (labelled h_0).

1272

1273 3.7.5 Uncertainties for the extrapolation method

1274 As the high pile-up results are used in the extrapolation procedure, the systematic
 1275 uncertainties of high pile-up samples evaluated in Sec.3.6.2 are relevant also at
 1276 low pile-up. In addition to high pile-up systematic uncertainties, there are other
 1277 uncertainties mainly related to the difference between high and low pile-up runs
 1278 and to the extrapolation procedure:

1279 **Threshold correction:** for low pile-up data set a different topo-cluster noise
 1280 threshold for the energy reconstruction is used, and a systematic uncertainty
 1281 is evaluated to take into account this difference. This systematic uncertainty
 1282 is defined as the statistical error on the difference of threshold, shown in the
 1283 bottom plot panel in Figure 3.19 (B).

1284 **Extrapolation systematic uncertainties:** The extrapolation uncertainty is consid-
 1285 ered as the quadratic sum of the following two effects:

- 1286 1. The choice of the polynomial functions used in the extrapolation: the
 1287 baseline extrapolation is performed with a polynomial of order 1. The
 1288 difference between using a first or a second order polynomial function
 1289 is included as discussed in [15].
- 1290 2. The number of $\langle\mu\rangle$ intervals used in the extrapolation: for the baseline
 1291 extrapolation, we used five intervals in $\langle\mu\rangle$. The effect of using three
 1292 intervals is considered [15].

1293 **Temperature uncertainty:** for nominal runs, there is a systematic uncertainty
 1294 which includes the changes of LAr calorimeter response with temperature,
 1295 but this effect is not linear with μ . Indeed, since it takes some time (few
 1296 hours) for the liquid argon calorimeter to heat, there is a rough delay be-
 1297 tween the increase or decrease of luminosity and the corresponding increase
 1298 or decrease of temperature. This introduces [99] a systematic uncertainty of
 1299 0.03% in the barrel and 0.1% in the end-cap region for low pile-up runs.

1300 Figure 3.21 shows an overview of all the sources on the energy scale factor α for
 the 2017 low pile-up run at $\sqrt{s} = 13$ TeV while using the extrapolation method.

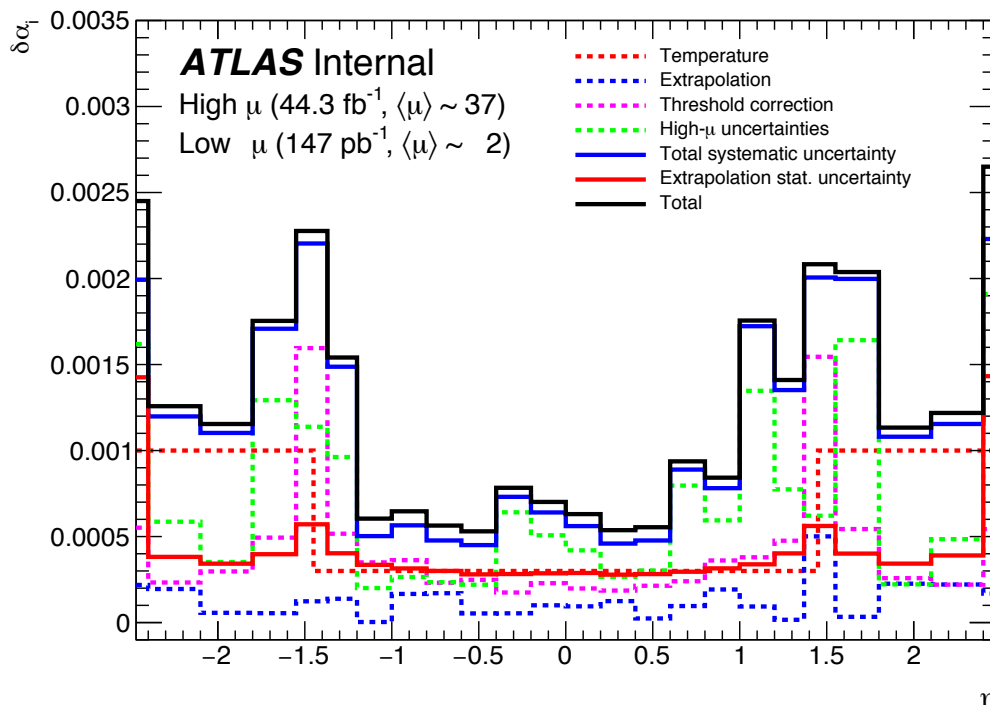


FIGURE 3.21: Uncertainties on the energy scale corrections as a function of η for the 2017 low pile-up runs at $\sqrt{s} = 13$ TeV.

1301

1302 3.7.6 Data to simulation comparison for low pile-up runs

1303 After having calculated the energy correction factor α , we apply them to data and
 1304 MC events and the final distributions are compared in Figure 3.22. The lower panel
 1305 shows the data to simulation ratio with the statistical uncertainty in the energy
 1306 scale.

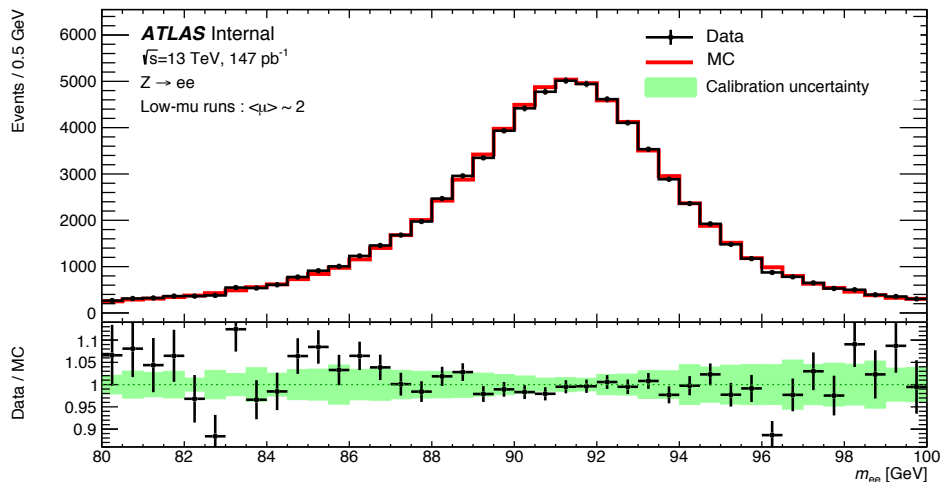


FIGURE 3.22: Inclusive di-electron invariant mass distribution for low pile-up runs from $Z \rightarrow ee$ decays in data compared to MC after applying the full calibration. The simulation is normalized to data. The lower panel shows the data to simulation ratio, together with the statistical uncertainty from the energy scale corrections.

3.8 Future of the calibration

1307

1308 A lot of efforts have been made on the e/γ calibration, in Run 1 and Run 2, however
 1309 there remain several problems. In particular there a small mismodeling of the
 1310 lineshape by the Monte Carlo as seen in Figure 3.9. Several ideas have been studied
 1311 (or will be studied) to understand and solve this problem:

- 1312 • It was noticed [41, 97, 115] that excluding the $1.2 < |\eta| < 1.8$ region gives a
 1313 better agreement. This was confirmed and scrutinized with more in depth in
 1314 recent analysis [131, 85].
- 1315 • Non linearity [57, 85] checks have been performed using a method [38] sim-
 1316 ilar to the template method described in Sec 3.4. The non linearity has been
 1317 computed but the improvement in the mismodeing is marginal. Additional
 1318 test of non linearity will be test using E/p as a measure.
- 1319 • Additional non Gaussian tails could be at the origin of this effect. However
 1320 simple tests using additional material in front of the calorimeter did not show
 1321 any significant improvement of the mismodeling [85]. Following work on
 1322 the forward calorimeter [44], a study as started [94] in order to study these
 1323 non Gaussian tails in the EM calorimeter.

Chapter 4

Statistical overview: Unfolding

4.1 Introduction

In this chapter we will discuss the theoretical part of the unfolding problem [139], used in chapter 7, to calculate the fiducial and differential cross sections, and in chapter 5 for the measurement of the boson transverse momentum and in the chapter 8 for the measurement of W mass. The need for unfolding stems from the fact that any quantity measured at the LHC detectors is affected by the not completely well known detector effects (like acceptance and resolution). The goal of the unfolding is to correct data distributions and estimate the true physical distributions of the observables of interest without detector effects [40]. In high energy physics, several unfolding methods are used [49], and in our analysis, the iterative Bayesian unfolding [55] is used.

4.2 Unfolding in high energy physics

In high energy physics, we are interested in distributions of the observables of interest. In most of the cases, different distributions are affected by detector effects with different sizes. For example, the transverse mass of the W boson is more affected by detector effects than the transverse momentum of the lepton in $W \rightarrow \ell + \nu$. Figure 4.1 shows the comparison between simulated distributions without detector effects (particle level), with detector effects (reconstructed level) and after the unfolding for m_T^W and p_T^ℓ .

The reconstructed distributions are different from truth distributions because of two effects:

- Limited acceptance: it reflects the fact that not all events are observed by the detector, it is called the detector acceptance and it is smaller than 1 [120].
- Migration: due to limited detector resolution, an event originating from bin i can be measured in another bin j . This effect is taken into account with the migration matrix explained in Sec. 4.3.1.

For a mathematical presentation of the unfolding problem, let's consider that we have just MC simulation vector x (y) of dimension N_x (N_y), where the elements x_i (y_i) represent the number of events in bin i in our distribution at the truth (reconstructed) level. Both vectors x and y are related with a matrix R , called response matrix:

$$R \times x = y. \quad (4.1)$$

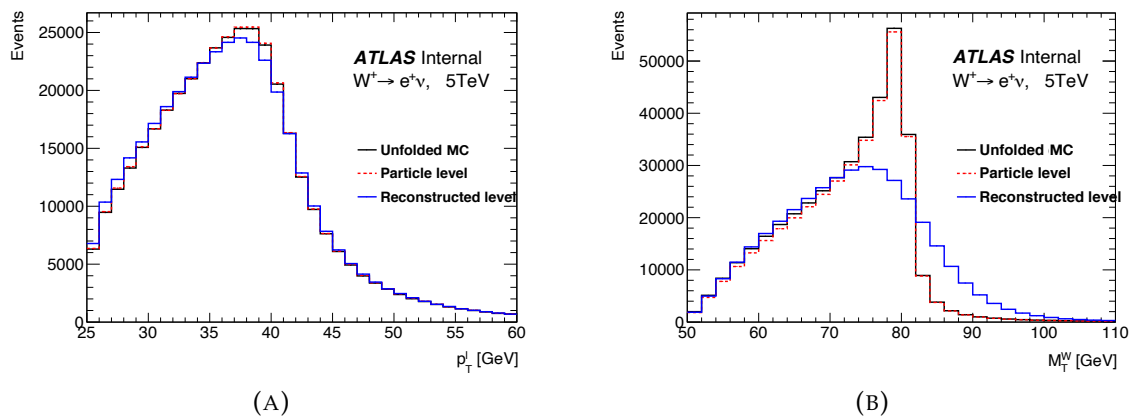


FIGURE 4.1: p_T^ℓ (A) and m_T^W (B) distributions before and after detector effects, with the unfolded distributions.

1357 The elements $R_{i,j}$ of the response matrix R represent the probability that an event
 1358 generated in bin j is measured in bin i . The number of background events must be
 1359 removed from the vector y . In a real case, the response matrix R is calculated from
 1360 the migration matrix M , where the $M_{i,j}$ are estimated using information from MC
 1361 simulation:

$$M_{i,j} = N_{i,j}^{\text{rec}\wedge\text{gen}}, \quad (4.2)$$

1362 where $N_{i,j}^{\text{rec}\wedge\text{gen}}$ represents the number of event generated in truth bin j and recon-
 1363 structed in bin i . If N_j^{gen} represents the number of event generated in truth bin j ,
 1364 the response matrix is then defined as:

$$R_{i,j} = \frac{M_{i,j}}{N_j^{\text{gen}}}. \quad (4.3)$$

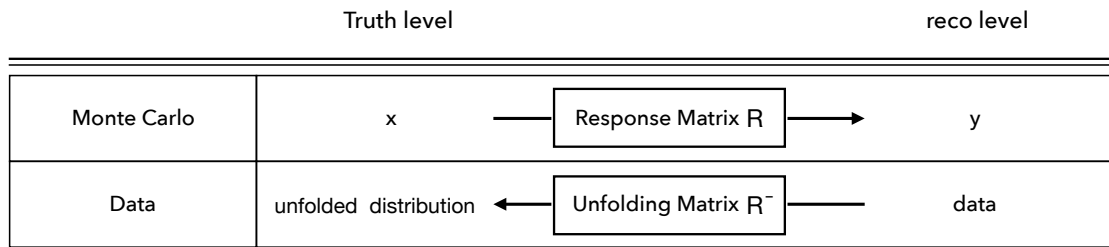
1365 In our case, we are using a slightly modified response matrix $R'_{i,j}$ defined as

$$R'_{i,j} = \frac{M_{i,j}}{N_j^{\text{rec}\wedge\text{gen}}} \quad (4.4)$$

1366 where $N_j^{\text{rec}\wedge\text{gen}}$ is the number of events generated and reconstructed in bin j . The
 1367 ratio of R by R' is a function of the truth bin j and is equal to the acceptance
 1368 correction (Sec. 4.3.1)

$$A_j = \frac{N_j^{\text{rec}\wedge\text{gen}}}{N_j^{\text{gen}}}. \quad (4.5)$$

1369 Now let's take the case of real data, where we don't have any information about
 1370 distributions at the truth level, the idea of unfolding is to apply the inverse of the
 1371 response matrix calculated using MC simulation to real data to estimate the true
 1372 physical distributions. At this moment, the unfolding problem is an inversion
 1373 problem of the response matrix:



1374 The use of the unfolding technique in high energy physics allows to obtain
 1375 results which are independent from detector and reconstruction effects. Conse-
 1376 quently, the unfolding results can be compared directly to theoretical predictions
 1377 or to other experiments. They also can be used for the precision measurements
 1378 as the W boson mass M_W measurement. On the other hand, there are some cases
 1379 where the unfolding is not needed. Mainly, the unfolding is used for observables
 1380 characterised by a large migration between truth and reconstruction distributions.
 1381 In other words, for the observables with small migration between the truth and
 1382 reco level, a bin-by-bin correction is sufficient to determine the true physical dis-
 1383 tributions of the observables of interest. Applying the inverse of the migration
 1384 matrix to the reconstructed simulation distribution is considered as a closure test
 1385 for the unfolding.

1386 4.3 Iterative Bayesian unfolding

1387 In this thesis, the iterative Bayesian unfolding [56] is used for the unfolding of our
 1388 variables of interest with RooUnfold [7]. This paragraph will give an overview of
 1389 the method, with a detailed description of the propagation of the source uncer-
 1390 tainties through the unfolding. The iterative Bayesian unfolding is based on Bayes
 1391 theorem, which describes the probability of an effect based on prior knowledge
 1392 of causes related to the effect. Let us consider a list of causes and effects (C, E),
 1393 where causes (C) correspond to the true values and effects (E) to the values after
 1394 smearing. Each effect (E) results from several causes. The unfolding problem can
 1395 be summarised in the estimation of $P(C_i|E_j)$ which corresponds to the probability
 to observe a cause C_i responsible of observed effects E_j .

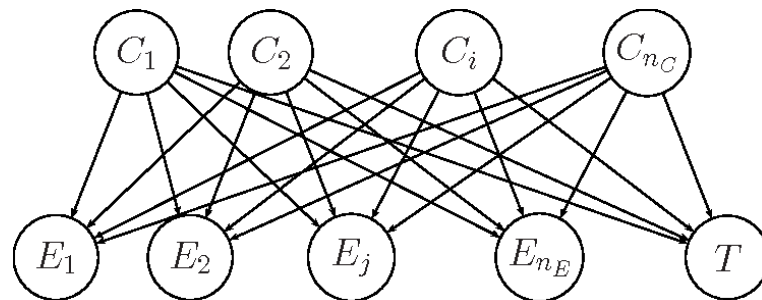


FIGURE 4.2: Probabilistic links from causes to effects. The node T corresponds to unde-
 tected events [56].

1397 In the Bayes theorem, the probability $P(C_i|E_j)$ can be calculated as:

$$P(C_i|E_j) = \frac{P(E_j|C_i) \cdot P(C_i)}{\sum_{l=1}^{n_C} P(E_j|C_l) \cdot P(C_l)}, \quad (4.6)$$

1398 n_C corresponds to the number of possible causes, $P(E_j|C_i)$ represents the probability to observe the effect E_j knowing C_i and $P(C_i)$ is the probability to observe the cause (i). Finally the number of events in the cause bin (i) can be expressed as:

$$\hat{n}(C_i) = \frac{1}{\epsilon_i} \sum_{j=1}^{n_E} n(E_j) \cdot P(C_i|E_j), \quad \epsilon_i \neq 0, \quad (4.7)$$

1401 $n(E_j)$ corresponds to the number of events in the effect bin (j) and $P(C_i|E_j)$ is calculated with formula (4.6) which is using $P(E_j|C_i)$ based on simulation. The iterative Bayesian unfolding is characterised by a bias [139] that we introduce with the unfolding procedure. To reduce the unfolding bias, a regularization parameter is used. The regularization consists in repeating the unfolded procedure several times, as will be discussed later in Sec. 4.4.3. The migration matrix can be determined from simulation by filling a two-dimensional histogram for all selected events with a common matching of truth and reconstructed values (TR) [20].

1409 4.3.1 Migration matrix

1410 The migration matrix is a matrix containing information from the truth and reconstructed level, with e.g. the x -axis corresponding to reconstructed bins and the y -axis to truth bins. The example in Figure 4.3 shows the migration matrix for two variables, p_T^ℓ and m_T^W . Comparing m_T^W to p_T^ℓ matrix, the transverse mass is characterised with a larger migration between the truth and reconstructed level because of the detector effects which affect more the transverse mass m_T^W .

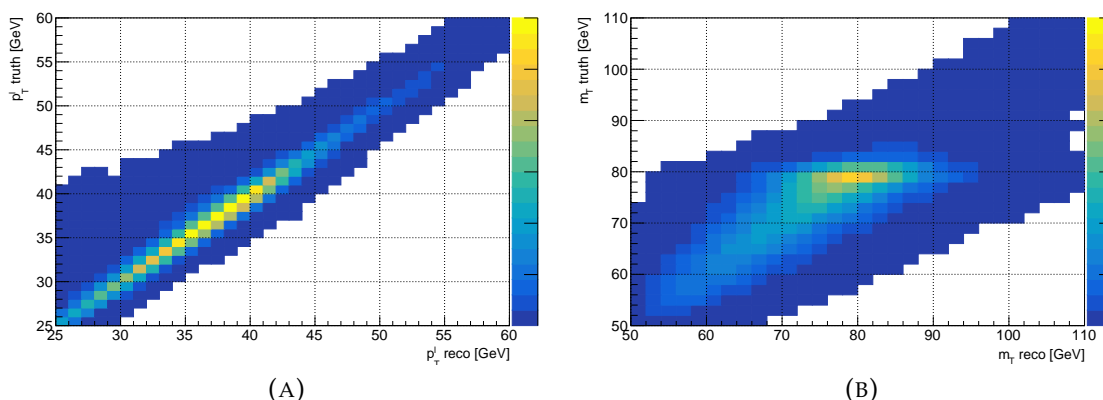


FIGURE 4.3: Example of the migration matrix for p_T^ℓ (A) and m_T^W (B).

1415 In addition to the migration and response matrix, there are two important factors, as shown in Figure 4.4, that we apply before and after the unfolding, and will be used later especially for the measurement of the differential cross sections:

1419 **The efficiency correction:** It is defined as the fraction of events passing recon-
 1420 structed and truth level selections ($N^{\text{reco,truth}}$) to the number of events that
 1421 meet the selection criteria at reconstruction level (N^{reco}):

$$\epsilon_i = \frac{N^{\text{reco,truth}}}{N^{\text{reco}}}. \quad (4.8)$$

1422 It is defined as a function of the reconstructed bin number i . The efficiency
 1423 correction is applied before unfolding to correct data distributions since the
 1424 data events pass reconstructed selections only.

1425 **The acceptance correction:** It is defined as the fraction of events that passing re-
 1426 constructed and truth level selections ($N^{\text{reco,truth}}$) to the number of events that
 1427 meet the selection criteria at truth level (N^{truth}):

$$A_i = \frac{N^{\text{reco,truth}}}{N^{\text{truth}}}. \quad (4.9)$$

1428 It is defined as a function of the truth bin number i . The inverse of the ac-
 1429 ceptance is applied to the unfolded distribution in order to extrapolate to
 1430 the truth fiducial phase space. This has to be done because the unfolding is
 1431 done with a response matrix R' obtained with events satisfying both truth
 1432 and reconstructed criteria.

1433 It is worth to note that the events passing $N^{\text{reco,truth}}$ and N^{reco} selections receive
 1434 both reconstructed and truth weights i.e. SF efficiency, hadronic recoil, calibration,
 1435 polarisation, generator weights, while the events passing N^{truth} have only truth
 weights applied.

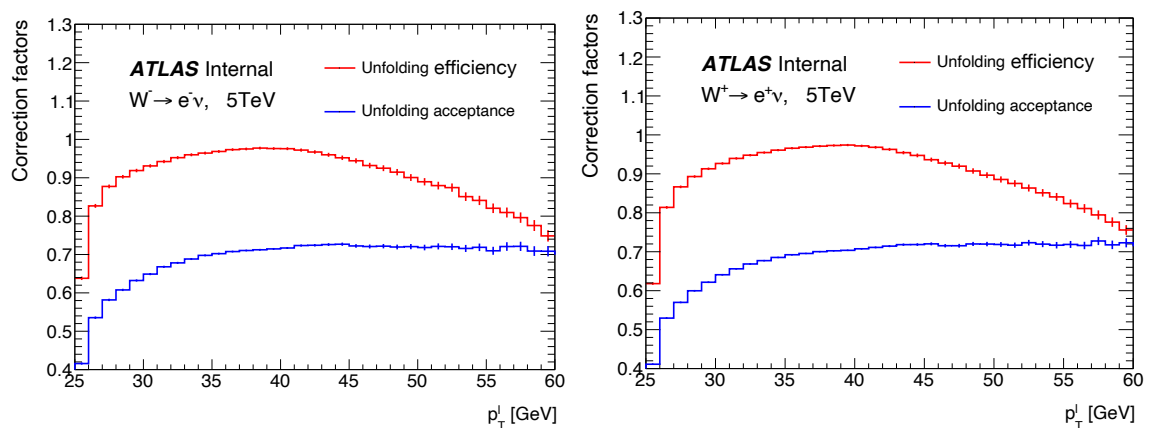


FIGURE 4.4: Example of the acceptance and efficiency factors for p_T^l .

1436

1437 4.4 Uncertainties with unfolding

1438 The propagation of the statistical and systematic uncertainties through unfolding
 1439 is a crucial technical aspect when the unfolding is applied to an analysis. In this

part, we discuss the propagation of the uncertainties in the iterative Bayesian unfolding.

4.4.1 Propagation of the statistical uncertainty

The propagation of the statistical uncertainties through the unfolding is done using pseudo-data (toys). Basically, the idea is to fluctuate the unfolding inputs (data distributions) with Poisson variations [37] to generate toys. Then, for each toy we redo the unfolding procedure using the nominal (not modified) migration matrix. The covariance matrix for the statistical uncertainty is calculated by comparing the unfolded distributions for each toy using:

$$\text{Cov}(i, j) = \frac{1}{n-1} \sum_{k=1}^n (X_i^k - \bar{X}_i) (X_j^k - \bar{X}_j)^T, \quad (4.10)$$

where X_i^k (X_j^k) corresponds to the content of bin i (j) of the unfolded toy k , \bar{X}_i (\bar{X}_j) corresponds to the content of bin i (j) of the average of all toys. The correlation matrix between bins for the statistical uncertainty is calculated using the covariance matrix by the formula:

$$\text{Corr}(i, j) = \frac{\text{Cov}(i, j)}{\sqrt{\text{Cov}(i, i)} \times \sqrt{\text{Cov}(j, j)}}. \quad (4.11)$$

Propagation of the statistical uncertainty for MC simulation is treated differently from data. In fact, the statistical uncertainty for simulation is treated as a systematic uncertainty, and the unfolding for simulation toys is done with a modified migration matrix instead of the nominal migration matrix. Figure 4.5 shows an example of the statistical uncertainty with the correlation matrix for the unfolded distribution.

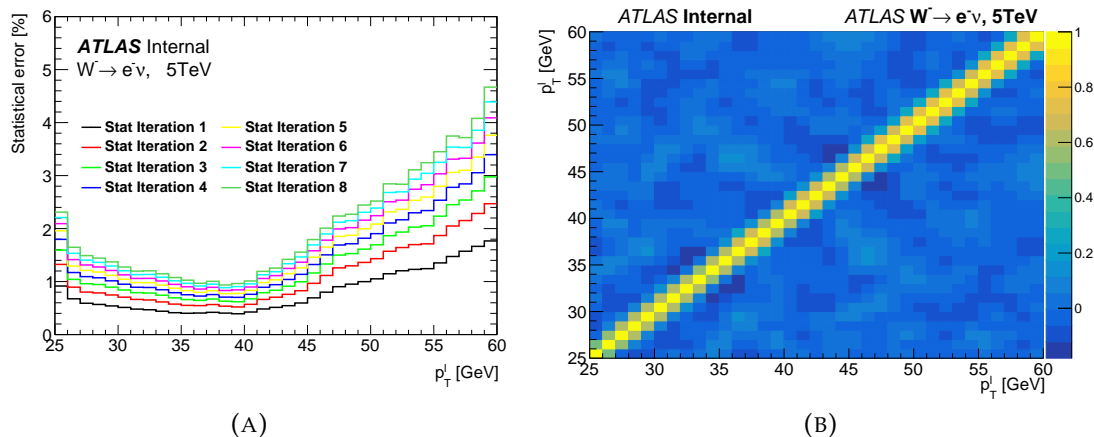


FIGURE 4.5: (A) Example of the statistical uncertainty for different iterations. (B) Example of the correlation matrix for the the statistical uncertainty of the unfolding distribution.

1458

1459 Because of the correlation between truth and reconstruction level for our vari-
 1460 ables of interest, the statistical uncertainty increases with the number of iterations,

1461 as shown in Figure 4.5. Along with the increase of uncertainty with the number of
 1462 iterations, the anti-correlation between bins increases also to ensure that the sta-
 1463 tistical uncertainty is independent of the number of iterations when we integrate
 1464 over all the bins.

1465 4.4.2 Propagation of systematic uncertainties

1466 The estimation of systematic uncertainties at the unfolded level is based on simu-
 1467 lated distributions. For a given systematic uncertainty, we varied the inputs distri-
 1468 butions (reconstructed distributions and migration matrix) according to this sys-
 1469 tematic uncertainty. The propagation of the systematic uncertainty through un-
 1470 folding is estimated as the the difference between the unfolding of the nominal
 1471 distribution and the unfolding of the modified distribution. For the same reason
 1472 of migration between bins, the systematic uncertainties increase with the number
 1473 of iterations as seen in Sec. 4.6. After the unfolding, all the systematic uncertainties
 1474 are assumed to be fully correlated between the bins, and the covariance matrix (V)
 1475 is calculated as:

$$V_{i,j} = \sigma_i \times \sigma_j, \quad (4.12)$$

1476 where σ_i (σ_j) is the systematic uncertainty in bin i (j). Figure 4.6 shows as an
 1477 example the calibration systematic uncertainty as a function of iteration and the
 1478 corresponding correlation matrix. In fact, the systematic uncertainties must be
 1479 independent of the number of iterations, and the variation with the number of it-
 1480 erations is related to statistical fluctuations in the systematic variations. For the
 1481 choice of the number of iterations, the systematic uncertainties are not included in
 the optimisation study described in Sec. 4.5.

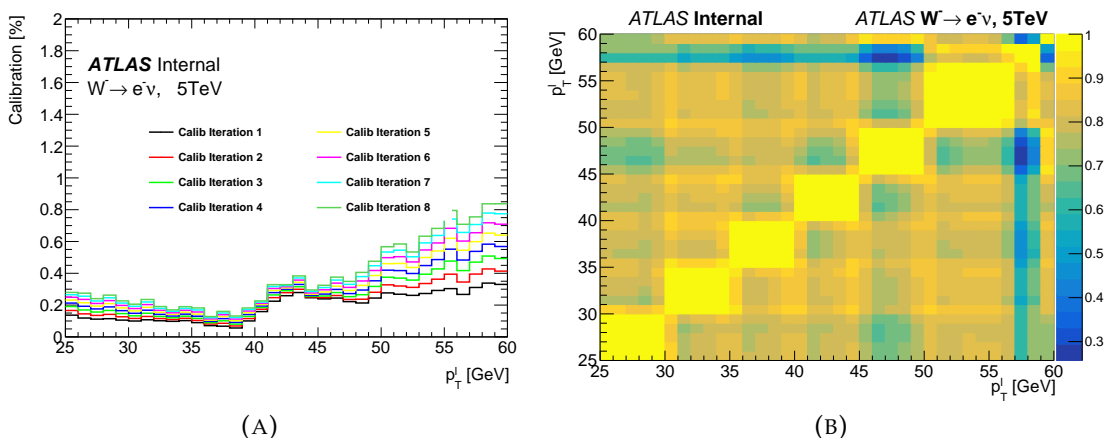


FIGURE 4.6: (A) Example of the systematic uncertainty for different iterations. (B) Exam-
 ple of the correlation matrix. The calibration uncertainty is defined as the sum of several
 variations.

1482

1483 4.4.3 Bias uncertainty with unfolding

1484 In addition to the statistical and systematic uncertainties, there is the unfolding
 1485 bias that we have to take into account. This bias is related mainly to the unfolding

1486 method and can be estimated with different approaches. The approach used in this
 1487 chapter is a simple one used for the unfolding of a variable with small migration
 1488 between reconstruction and truth level, like for p_T^ℓ and η_ℓ . For the unfolding of
 1489 a variable with larger migration like p_T^W , a more involved approach is used and
 1490 will be described later. The procedure to estimate the bias, through a "data-driven
 1491 closure test" using the data/MC shape differences for the unfolded observable, can
 1492 be summarised in two steps: (Figure 4.7) [111]:

- 1493 • Reweight the MC distribution at truth level with the fitted ratio of data
 1494 over simulation, in such a way that the reconstructed distribution after the
 1495 reweighting matches the data in which the background has been subtracted.
 1496 As shown in Figure 4.8, as we expect, the ratio data/MC is closer to 1 for the
 1497 reconstruction-weighted distribution.
- 1498 • The bias is estimated as the difference between the unfolding of the
 1499 reconstruction-weighted distribution and the truth-weighted distribution.

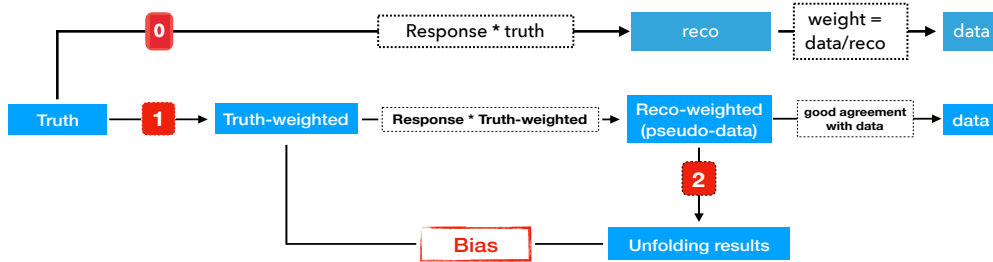


FIGURE 4.7: An overview of the procedure used to estimate the unfolding bias.

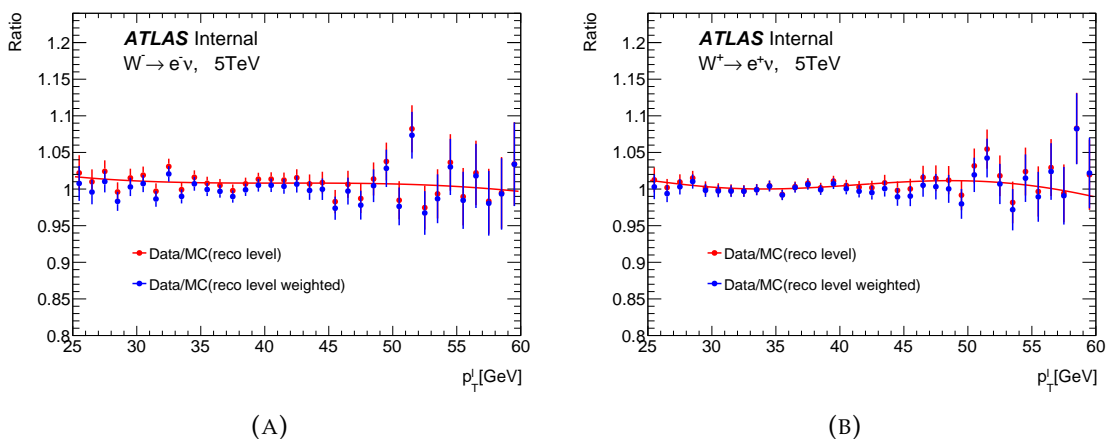


FIGURE 4.8: Comparison of the ratio data/MC using the reconstruction and weighted reconstruction-distributions, for W^- (A) and W^+ (B) at 5 TeV.

1500 In general, the unfolding bias decreases with the number of iterations, as
 1501 shown in Figure 4.9. Also, as the unfolding does not change the normalisation of

1502 the input distributions, the total integrated unfolding bias when we take the corre-
 1503 lation (anti-correlation) between bins into account must be equal to 0. Contrary to
 1504 other source of uncertainties, the bias decreases with the number of iterations and
 1505 the anti-correlation between bins increases with the number of iterations to ensure
 that the integrated bias is zero.

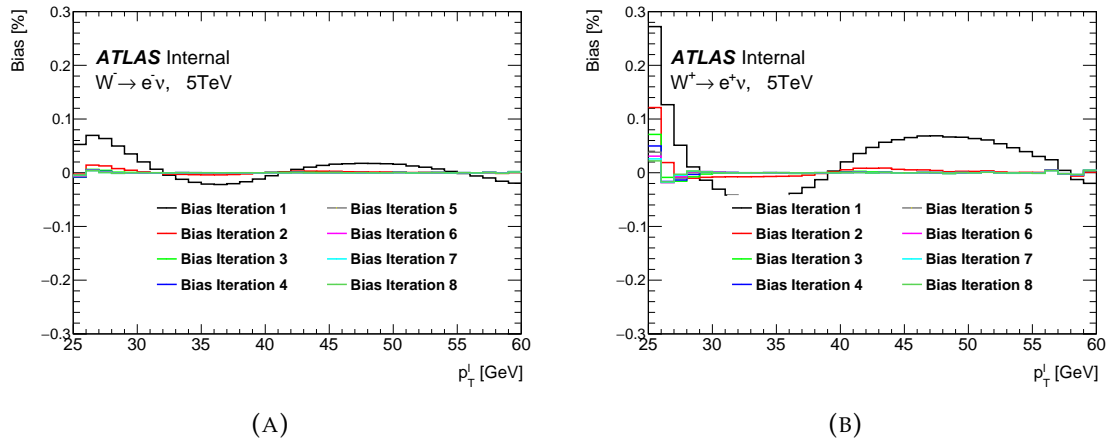


FIGURE 4.9: Comparison of the unfolding bias for different iterations, for W^- (A) and W^+ (B) at 5 TeV.

1506

1507 4.5 Optimisation of the number of iterations

1508 As discussed above, the statistical uncertainty increases with the number of itera-
 1509 tions, whereas the unfolding bias, considered as a source of uncertainty, decreases
 1510 with the number of iterations, as seen in Figure 4.10. Therefore, it is possible to
 1511 optimise the number of iterations by minimising the combined statistical and bias
 1512 uncertainties. The other systematic uncertainties are not included in the optimi-
 1513 sation as they should be independent of the number of iterations as mentioned
 1514 earlier. Also, the optimisation should be performed for a selected region of the
 1515 unfolded distribution since we can not use the whole range of the unfolded dis-
 1516 tribution (the bias is zero). The example in Figure 4.10 shows the information that
 1517 can be used for the bin-by-bin optimisation around the peak region:

1518 For our example shown in Figure 4.11, as the bias is very small comparing to other
 1519 source of uncertainties, the best choice is to use the first iteration. But to avoid
 1520 the fluctuation/bias in the first iteration, see Figure 4.9, the 2nd iteration is chosen
 1521 instead.

1522 4.6 Bin-by-bin unfolding

1523 The bin-by-bin unfolding consists in applying a correction factor that we extract di-
 1524 rectly from simulation. This unfolding method is used basically in the case where
 1525 the variable of interest is characterised with a small migration between truth and
 1526 reconstructed level and when the number of bins is the same between the truth

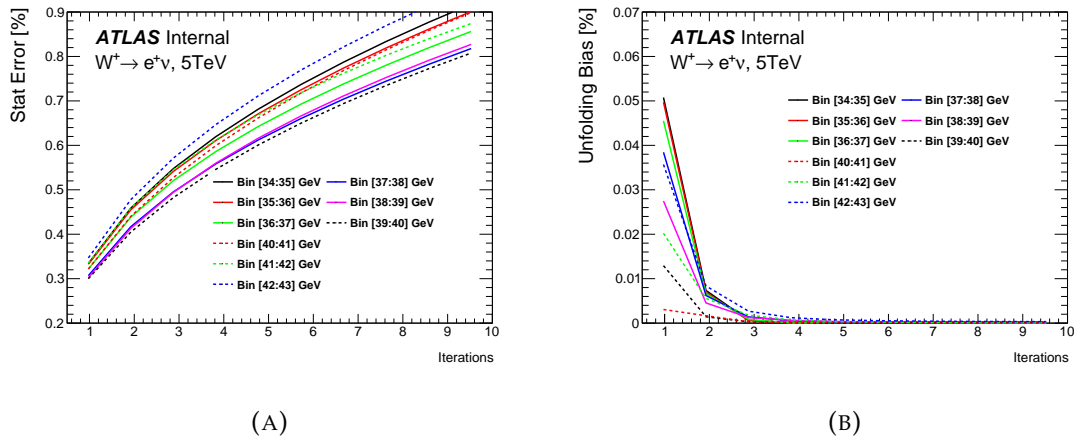


FIGURE 4.10: Statistical (A) and unfolding bias (B) uncertainties as a function of the number of iterations for different bins of p_T^l , around the peak region in our distribution of interest.

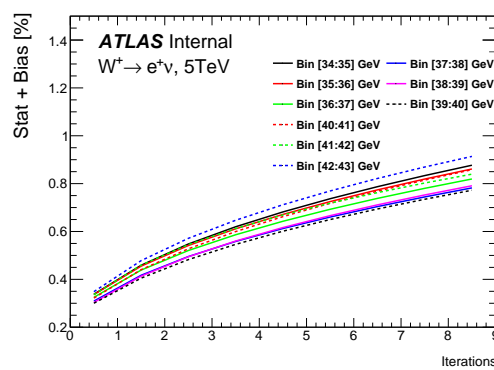


FIGURE 4.11: Sum of the statistical and unfolding bias uncertainties as a function of the number of iterations for different bins of p_T^l , around the peak region in our distribution of interest.

1527 and reconstructed distributions. Let us consider a MC truth distribution x_i^{gen} and
1528 a MC reconstructed distribution y_i^{rec} . The correction factor is calculated as:

$$C_i = \frac{x_i^{\text{gen}}}{y_i^{\text{rec}}}. \quad (4.13)$$

1529 The unfolded data using the bin-by-bin method is calculated as:

$$\text{Unfolded}_i = C_i \times \text{data}_i. \quad (4.14)$$

1530 The bin-by-bin is used only in the case where the detector effects are very small,
1531 otherwise this method will introduce a large bias [110]. This method can be used
1532 mainly for the unfolding of p_{T}^{ℓ} and η_{ℓ} .

Chapter 5

Measurement of the W -boson transverse momentum distribution

5.1 Introduction

One of the most important theoretical sources of uncertainties in the measurement of the W -boson mass, is the extrapolation of the boson p_T distribution from Z -boson to W -boson (≈ 6 MeV [155]), where the QCD high order predictions are not sufficiently precise to describe the data. A precise direct measurement of p_T^W will provide a direct comparison with QCD predictions, this is equivalent to saying that replacing the theoretical extrapolation from p_T^Z by such a direct measurement of the p_T^W distribution will improve the precision of the measurement of M_W . Measuring the p_T^W distribution in low p_T^W region ($p_T^W < 30$ GeV) with an uncertainty $\approx 1\%$ in bin of 5 GeV will reduce the QCD modelling uncertainty [115] in the measurement of M_W by a factor of two [132]. The p_T^W distribution is reconstructed using $W \rightarrow \ell\nu$ events, where the charged leptons are measured in the different tracking detectors or in the EM calorimeter, as discussed in Chapter 2, while the neutrino leaves the detector unseen. Because of the neutrino, the p_T^W distribution is reconstructed through the hadronic recoil, u_T , defined as the vector sum of all energy deposits excluding the energy of the lepton. The transverse momentum of the W boson is defined by:

$$\vec{p}_T^W = -\vec{u}_T, \quad (5.1)$$

and the transverse momentum of the decay neutrino \vec{p}_T^ν is inferred from the vector of the missing transverse momentum \vec{p}_T^{miss} which corresponds to the momentum imbalance in the transverse plan:

$$\vec{p}_T^{\text{miss}} = -(\vec{p}_T^\ell + \vec{u}_T). \quad (5.2)$$

For the reconstruction of p_T^W , a good understanding of \vec{u}_T is needed. The reconstruction of the hadronic recoil is described in [101]. The measurement of p_T^W is based on low number of interactions per bunch crossing data (low pile-up μ) to ensure a reasonable resolution on the hadronic recoil, as shown in Figure 5.1, which shows the comparison of the resolution on the hadronic recoil between high pile-up runs (black circles) and low pile-up runs (red points). In this chapter, we will describe the measurement of the W -boson transverse momentum through the unfolding of the p_T^W distributions at the detector level, using the unfolding method described in Chapter 4, with low pile-up data sets collected during Run 2 at \sqrt{s}

1565 = 5 and 13 TeV. Also, a different approach is used to estimate the unfolding bias
 1566 for the p_T^W analysis, in order to improve our evaluation of the unfolding bias. The
 1567 new approach, described in [114], consists of using a different reweighing method
 1568 to get the best data/MC agreement. The main signal events for W and Z boson
 1569 productions are described in [95]. They generated using the POWHEG event gener-
 1570 ator using the CT10 PDF interfaced to PYTHIA8 using the AZ NLO tune, and
 being interfaced to PHOTOS++ to simulate the effect of final state QED radiation.

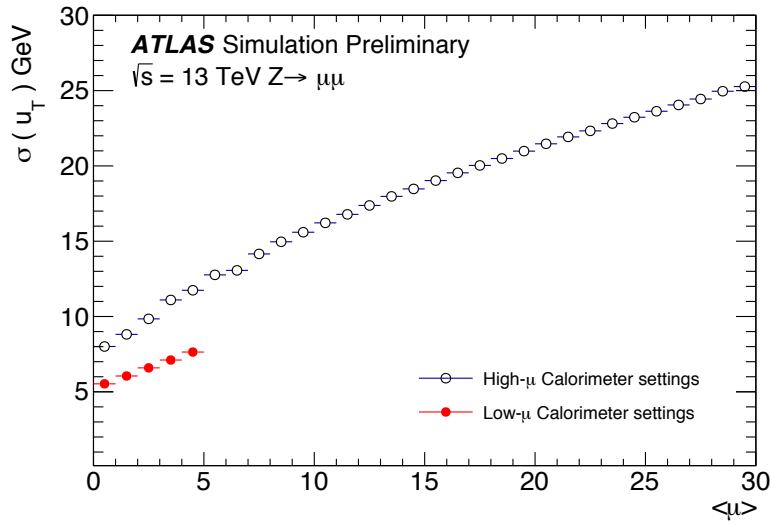


FIGURE 5.1: Hadronic recoil resolution as a function of $\langle\mu\rangle$ for simulated $Z \rightarrow \mu\mu$ events with two different calorimeter settings [132], see Chapter 3 for a discussion of the calorimeter settings.

1571

1572 5.2 Data and simulated distributions

1573 5.2.1 Selections

1574 The selections of $W \rightarrow \ell\nu$ events for the p_T^W distribution are based on the follow-
 1575 ing two triggers $HLT_e15_lhloose_nod0_L1EM12$ and HLT_mu14 , for electrons and
 1576 muons, respectively. In addition, events are required to contain one lepton with
 1577 $p_T^\ell > 25$ GeV and $E_T^{\text{miss}} > 25$ GeV to reduce background effects. In addition, the W
 1578 boson transverse mass defined as $m_T^W = \sqrt{2p_T^\ell p_T^{\text{miss}}(1 - \cos(\Delta\phi))}$, with $\Delta\phi$ being
 1579 the azimuthal opening angle between the charged lepton and the missing trans-
 1580 verse momentum, is chosen to be $m_T^W > 50$ GeV. A detailed description of the
 1581 selections, with the final number of events which pass all the selections, is given
 1582 for 5 and 13 TeV samples separately in [114].

1583 5.2.2 Control plots for the p_T^W distribution

1584 Once all the events pass the selections described above, we show the distribu-
 1585 tions of the W -boson transverse momentum for data compared to MC simulation

TABLE 5.1: Analysis cut flow for $W^+ \rightarrow e^+ \nu_e$ 5 TeV signal selection.

Cut	Data	Signal	$W^\pm \rightarrow \ell^\pm \nu$ BG	$Z \rightarrow \ell\ell$	Top	Diboson	Multijet
One electron	1993720	643610 \pm 260	32940 \pm 190	44338 \pm 71	1754.4 \pm 3.9	772.2 \pm 3.7	-
Electron trig matched	1907724	612940 \pm 250	30790 \pm 190	42100 \pm 69	1698.5 \pm 3.8	741.1 \pm 3.6	-
Isolation	1438941	610320 \pm 250	30590 \pm 190	41923 \pm 69	1663.6 \pm 3.8	722.5 \pm 3.6	-
$p_T^e > 25$ GeV	720284	482240 \pm 220	14790 \pm 130	31955 \pm 53	1464.5 \pm 3.5	592.1 \pm 3.2	-
$E_T^{\text{miss}} > 25$ GeV	440605	421510 \pm 210	9650 \pm 100	1336 \pm 20	1223 \pm 3.2	420.8 \pm 2.4	-
$m_T^W > 50$ GeV	430620	417430 \pm 210	8800 \pm 96	1047 \pm 16	944.3 \pm 2.9	373.5 \pm 2.2	3030 \pm 550

TABLE 5.2: Analysis cut flow for $W^+ \rightarrow e^+ \nu_e$ 13 TeV signal selection.

Cut	Data	Signal	$W^\pm \rightarrow \ell^\pm \nu$ BG	$Z \rightarrow \ell\ell$	Top	Diboson	Multijet
One electron	7915023	1797340 \pm 390	92520 \pm 270	147490 \pm 140	63207 \pm 89	3069 \pm 63	-
Electron trig matched	7840239	1709140 \pm 380	86370 \pm 260	139760 \pm 140	61110 \pm 88	2967 \pm 62	-
Isolation	5413483	1698430 \pm 380	85560 \pm 260	138890 \pm 140	59834 \pm 87	2939 \pm 61	-
$p_T^e > 25$ GeV	2452868	1342200 \pm 330	44450 \pm 190	106270 \pm 110	53811 \pm 82	2565 \pm 58	-
$E_T^{\text{miss}} > 25$ GeV	1275513	1136520 \pm 310	28580 \pm 150	8313 \pm 46	45707 \pm 75	1990 \pm 53	-
$m_T^W > 50$ GeV	1207776	1117560 \pm 310	24760 \pm 130	6443 \pm 36	34580 \pm 65	1718 \pm 50	28000 \pm 1800

TABLE 5.3: Analysis cut flow for $W^+ \rightarrow \mu^+ \nu_\mu$ 5 TeV signal selection.

Cut	Data	Signal	$W^\pm \rightarrow \ell^\pm \nu$ BG	$Z \rightarrow \ell\ell$	Top	Diboson	Multijet
One muon	2434459	760980 \pm 280	35090 \pm 200	37015 \pm 82	2025.3 \pm 4.1	864.7 \pm 3.7	-
Muon trig matched	2353403	664100 \pm 260	30610 \pm 190	32554 \pm 76	1725.6 \pm 3.8	746.6 \pm 3.4	-
Isolation	1186616	659200 \pm 260	30400 \pm 190	32303 \pm 76	1574.6 \pm 3.7	710.1 \pm 3.3	-
$p_T^\mu > 25$ GeV	632016	508270 \pm 230	13900 \pm 130	22556 \pm 57	1335.3 \pm 3.4	568.2 \pm 2.9	-
$E_T^{\text{miss}} > 25$ GeV	470856	442600 \pm 210	8700 \pm 100	9959 \pm 31	1111.8 \pm 3	424.5 \pm 2.5	-
$m_T^W > 50$ GeV	457053	438280 \pm 210	7879 \pm 97	9649 \pm 27	879.7 \pm 2.8	381.7 \pm 2.3	720 \pm 190

TABLE 5.4: Analysis cut flow for $W^+ \rightarrow \mu^+ \nu_\mu$ 13 TeV signal selection.

Cut	Data	Signal	$W^\pm \rightarrow \ell^\pm \nu$ BG	$Z \rightarrow \ell\ell$	Top	Diboson	Multijet
One muon	9570104	2100770 \pm 410	83110 \pm 270	2019400 \pm 2200	71602 \pm 94	3442 \pm 63	-
Muon trig matched	9382783	1840550 \pm 390	72820 \pm 250	1750400 \pm 2000	61519 \pm 87	2956 \pm 59	-
Isolation	3905612	1821750 \pm 380	71780 \pm 250	595700 \pm 1100	56849 \pm 84	2916 \pm 59	-
$p_T^\mu > 25$ GeV	1930655	1393330 \pm 340	34470 \pm 170	170840 \pm 490	49338 \pm 78	2471 \pm 54	-
$E_T^{\text{miss}} > 25$ GeV	1321407	1173860 \pm 310	21450 \pm 140	51090 \pm 180	41956 \pm 72	1930 \pm 49	-
$m_T^W > 50$ GeV	1244892	1153800 \pm 310	18270 \pm 130	38304 \pm 81	32375 \pm 63	1705 \pm 44	9040 \pm 800

TABLE 5.5: Analysis cut flow for $W^- \rightarrow e^- \bar{\nu}_e$ 5 TeV signal selection.

Cut	Data	Signal	$W^\pm \rightarrow \ell^\pm \nu$ BG	$Z \rightarrow \ell\ell$	Top	Diboson	Multijet
One electron	1724472	374900 \pm 200	24150 \pm 160	41995 \pm 70	1590.5 \pm 2.9	684.8 \pm 4	-
Electron trig matched	1645694	359010 \pm 200	22070 \pm 160	39854 \pm 68	1539.9 \pm 2.9	655.7 \pm 3.9	-
Isolation	1176976	357660 \pm 200	21920 \pm 160	39686 \pm 68	1504.6 \pm 2.8	640.7 \pm 3.8	-
$p_T^e > 25$ GeV	529183	302070 \pm 180	11920 \pm 110	30214 \pm 52	1330.8 \pm 2.6	532.9 \pm 3.5	-
$E_T^{\text{miss}} > 25$ GeV	281957	266750 \pm 170	8084 \pm 90	1293 \pm 20	1112.5 \pm 2.4	380 \pm 3	-
$m_T^W > 50$ GeV	274329	264540 \pm 170	7317 \pm 84	994 \pm 16	855.2 \pm 2.1	338.1 \pm 2.9	2400 \pm 500

TABLE 5.6: Analysis cut flow for $W^- \rightarrow e^- \bar{\nu}_e$ 13 TeV signal selection.

Cut	Data	Signal	$W^\pm \rightarrow \ell^\pm \nu$ BG	$Z \rightarrow \ell\ell$	Top	Diboson	Multijet
One electron	7471742	1323710 \pm 330	78230 \pm 230	140980 \pm 140	61951 \pm 86	3059 \pm 58	-
Electron trig matched	7402574	1267710 \pm 330	72240 \pm 230	133580 \pm 140	59950 \pm 85	2968 \pm 57	-
Isolation	4949352	1260540 \pm 330	71550 \pm 230	132740 \pm 140	58689 \pm 84	2937 \pm 57	-
$p_T^e > 25$ GeV	2113364	1053510 \pm 300	39660 \pm 160	101350 \pm 110	52923 \pm 79	2544 \pm 53	-
$E_T^{\text{miss}} > 25$ GeV	1008915	900640 \pm 280	25900 \pm 130	7954 \pm 45	45065 \pm 73	1962 \pm 48	-
$m_T^W > 50$ GeV	949362	887810 \pm 270	22400 \pm 120	6052 \pm 35	34177 \pm 64	1695 \pm 44	27400 \pm 2000

TABLE 5.7: Analysis cut flow for $W^- \rightarrow \mu^- \bar{\nu}_\mu$ 5 TeV signal selection.

Cut	Data	Signal	$W^\pm \rightarrow \ell^\pm \nu$ BG	$Z \rightarrow \ell\ell$	Top	Diboson	Multijet
One muon	2075709	440560 \pm 220	22510 \pm 170	34440 \pm 80	1835.6 \pm 3.1	751.5 \pm 3.3	-
Muon trig matched	2002955	383720 \pm 200	19640 \pm 160	30277 \pm 75	1561.6 \pm 2.9	648 \pm 3.1	-
Isolation	883078	381010 \pm 200	19450 \pm 160	30046 \pm 74	1411 \pm 2.7	616.9 \pm 2.9	-
$p_T^\mu > 25$ GeV	426119	314370 \pm 180	9370 \pm 110	20749 \pm 56	1202.1 \pm 2.5	505 \pm 2.5	-
$E_T^{\text{miss}} > 25$ GeV	298992	276060 \pm 170	5893 \pm 89	8716 \pm 29	1004.2 \pm 2.3	372.6 \pm 2	-
$m_T^W > 50$ GeV	287870	273710 \pm 170	5158 \pm 82	8408 \pm 26	788.2 \pm 2	335.6 \pm 1.9	760 \pm 160

TABLE 5.8: Analysis cut flow for $W^- \rightarrow \mu^- \bar{\nu}_\mu$ 13 TeV signal selection.

Cut	Data	Signal	$W^\pm \rightarrow \ell^\pm \nu$ BG	$Z \rightarrow \ell\ell$	Top	Diboson	Multijet
One muon	8773414	1518070 \pm 360	64930 \pm 230	2019900 \pm 2200	70580 \pm 90	3230 \pm 60	-
Muon trig matched	8597493	1322980 \pm 330	56520 \pm 210	1750300 \pm 2000	60579 \pm 84	2806 \pm 56	-
Isolation	3298569	1310310 \pm 330	55680 \pm 210	593700 \pm 1100	55949 \pm 80	2751 \pm 55	-
$p_T^\mu > 25$ GeV	1561721	1069770 \pm 300	28230 \pm 150	166810 \pm 490	48544 \pm 75	2362 \pm 52	-
$E_T^{\text{miss}} > 25$ GeV	1030406	910150 \pm 280	17380 \pm 120	47370 \pm 180	41259 \pm 69	1842 \pm 46	-
$m_T^W > 50$ GeV	963568	896850 \pm 270	14710 \pm 110	34572 \pm 80	31772 \pm 61	1598 \pm 43	9050 \pm 620

1586 (signal and background) for 5 TeV, in Figure 5.2 and 13 TeV in Figure 5.3 separately.
1587 The bottom panels show the ratio data to simulation, with the green band
1588 corresponding to the total uncertainty with the statistical and systematic uncer-
1589 tainties added in quadrature. In general, one finds good agreement between the
1590 data and the predicted number of events within the uncertainty except for some
1591 of the 13 TeV cases.

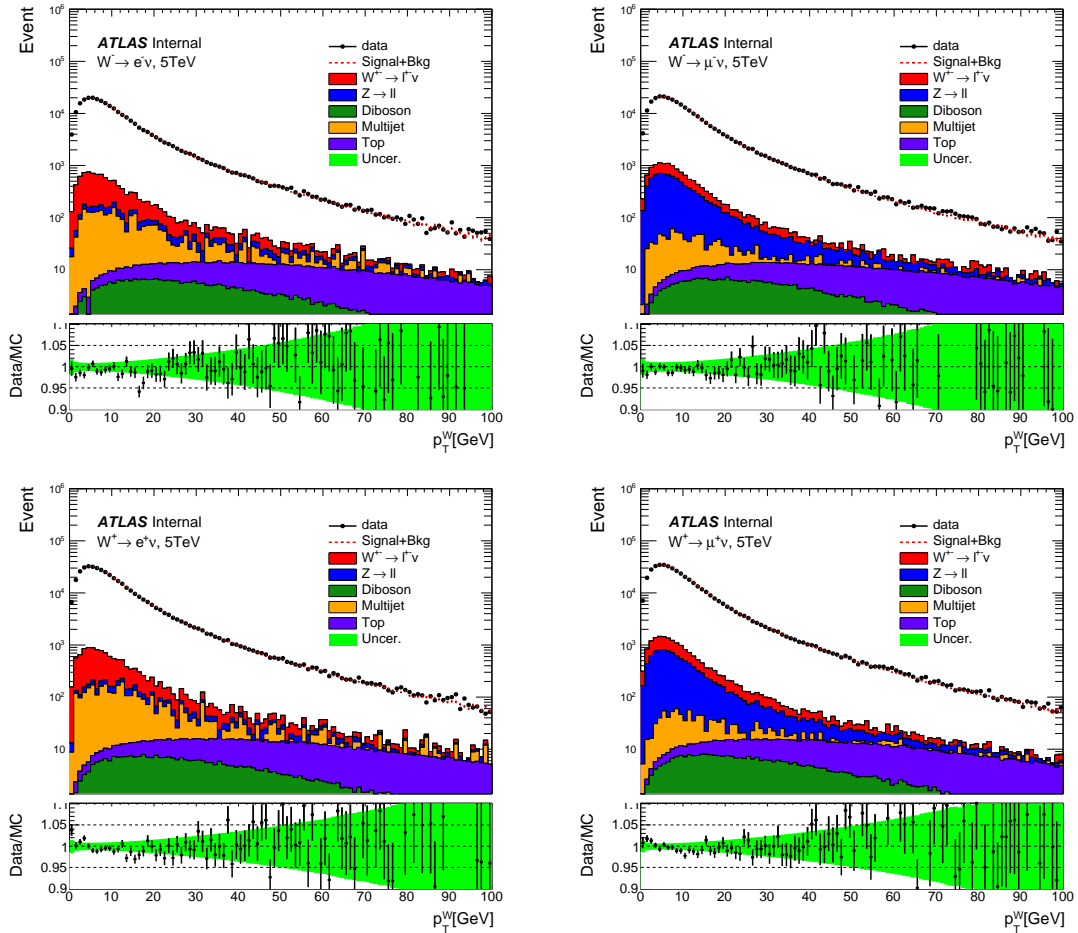


FIGURE 5.2: Reconstructed p_T^W distributions in data compared to MC (signal and background) in the electron (left) and muon (right) channels for negative (top) and positive (bottom) charges for the $\sqrt{s} = 5$ TeV data set. The lower panel of each plot shows the data to simulation ratio, together with the total uncertainty at the detector level. The green band is dominated by the uncertainty due to the calibration of the hadronic recoil and the statistical uncertainty. The different sources of uncertainties at the detector level are shown in Appendix B.

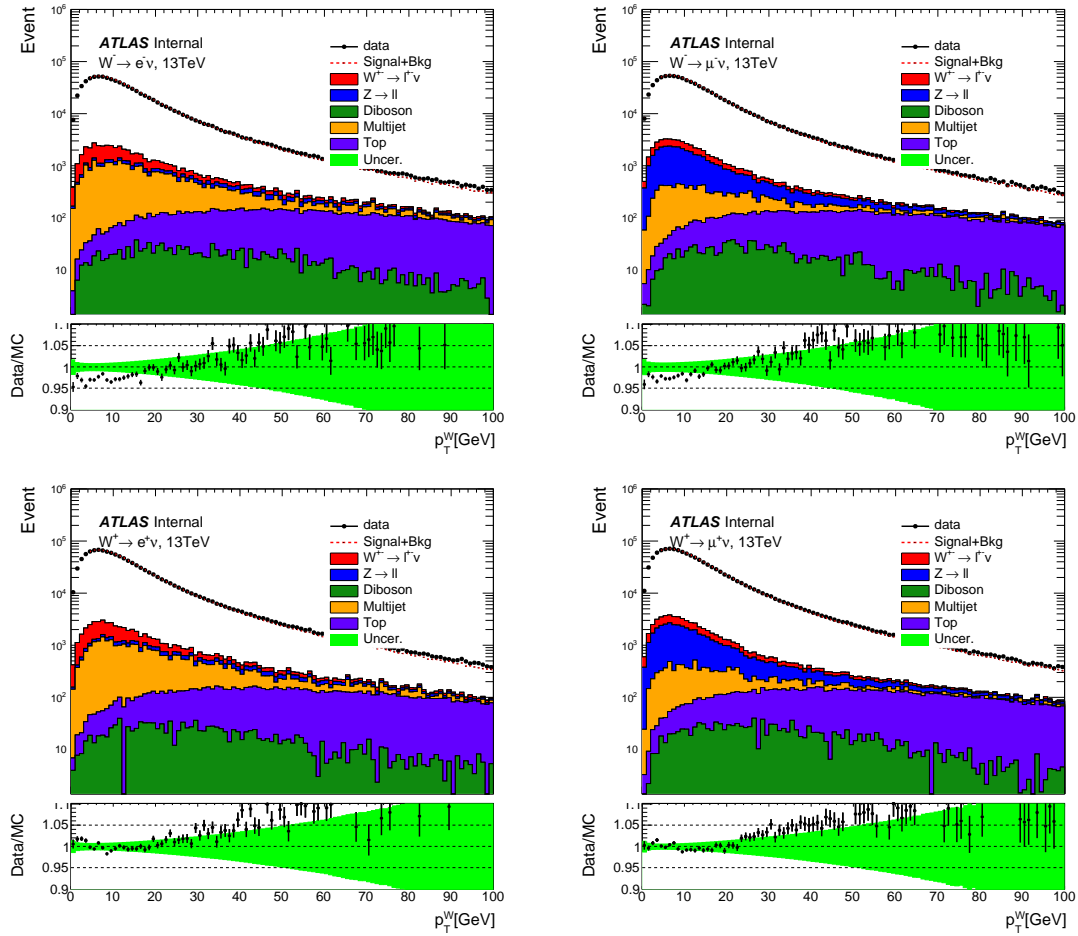


FIGURE 5.3: Same as Figure 5.2 but for the $\sqrt{s} = 13$ TeV data set. The agreement is generally worse at 13 TeV compared to 5 TeV, because for simulation we use the the same tuning, AZ tuned at 7 TeV, which gives a better agreement between data and simulation for 5 than 13 TeV.

5.3 Data unfolding

5.3.1 Unfolding description

As described in Chapter 4, the Bayesian unfolding method is used to unfold data distributions. The unfolding procedure starts by subtracting the background effects from data distributions. The background contribution is based on simulation samples, and their effect on the data is estimated using the formula:

$$\text{data}_i^{\text{corrected}} = \text{data}_i \times \left(1 - \frac{N_i^{\text{Bkgr}}}{N_i^{\text{Sig}} + N_i^{\text{Bkgr}}} \right), \quad (5.3)$$

where N_i^{Bkgr} is the sum of all the background contributions in bin i , showed in Figures 5.2 and 5.3, N_i^{Sig} is the number of events in signal in bin i . Then, the efficiency correction factor, defined in Chapter 4, is applied to data. Figure 5.4 shows an example of such efficiency correction factors. Once the data distributions are corrected, it can be unfolded as described in Chapter 4 using the migration matrix. Figure 5.5 shows an example of the migration matrix used for the p_T^W unfolding. The migration matrix is characterised by a large migration between truth and detector variables, which makes the unfolding more involved than that of p_T^ℓ and η_ℓ . The migration matrix is determined using the simulation samples,

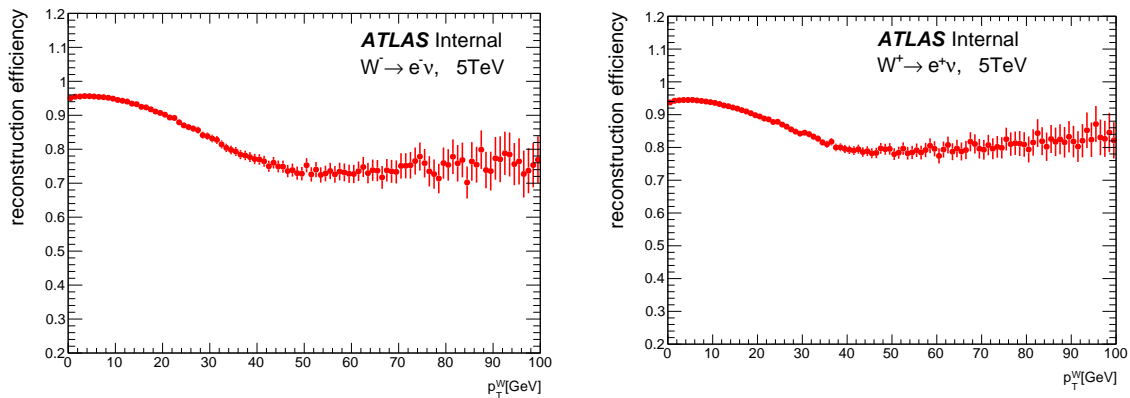


FIGURE 5.4: Example of the unfolding efficiency factor, defined as the ratio of the number of events at the reconstruction level with correspond to a truth level selection divided by the total number of events at the reconstruction level. This efficiency is applied to correct data distributions before unfolding, for electron channels at $\sqrt{s} = 5$ TeV.

Powheg+Pythia8 [43] in our analysis, where the x -axis corresponds to the reconstructed bins and the y -axis to true bins. The migration matrix is constructed in such a way that each event passes both truth and reconstructed selections. The migration between the truth and the reconstructed levels depends on detector effects (such as the finite resolution of the detector and the limited reconstruction efficiency). After the unfolding, the unfolded distribution can not be compared directly to the truth distribution, since this unfolded distribution corresponds to the truth distribution with both truth and reconstructed selections. For a direct

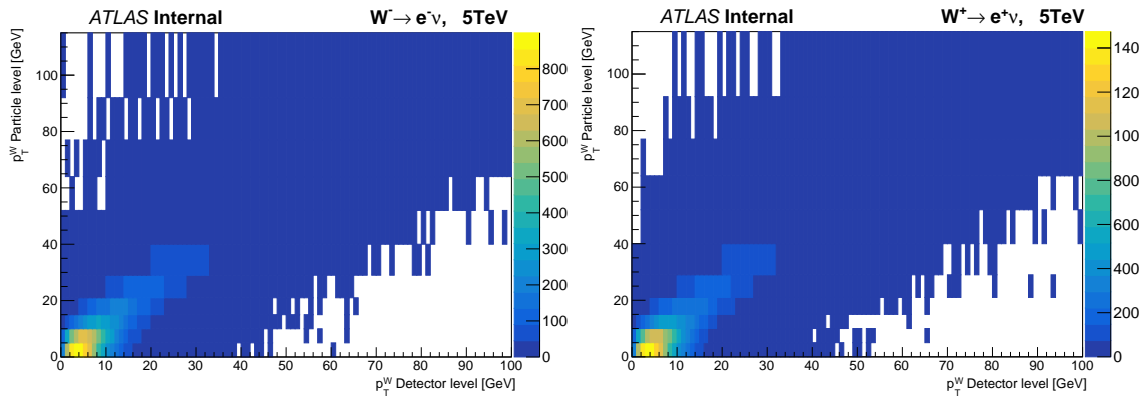


FIGURE 5.5: Example of the migration matrix of p_T^W for electron channels at $\sqrt{s} = 5$ TeV. The correlation between bins is more important in the low p_T^W region ($p_T^W < 30$ GeV).

1615 comparison, the unfolded distribution needs the acceptance correction, discussed
 1616 in Chapter 4. After all the corrections, Figure 5.6 shows an example of the compar-
 1617 ison between the truth, reconstructed data and the unfolded data distributions. As
 1618 described in Chapter 4, the Bayesian unfolding method is characterised by a regu-
 1619 larisation parameter, used to reduce the bias that we introduce with the unfolding
 1620 procedure. This parameter is optimised using statistical and bias uncertainties in
 Sec. 5.3.6.

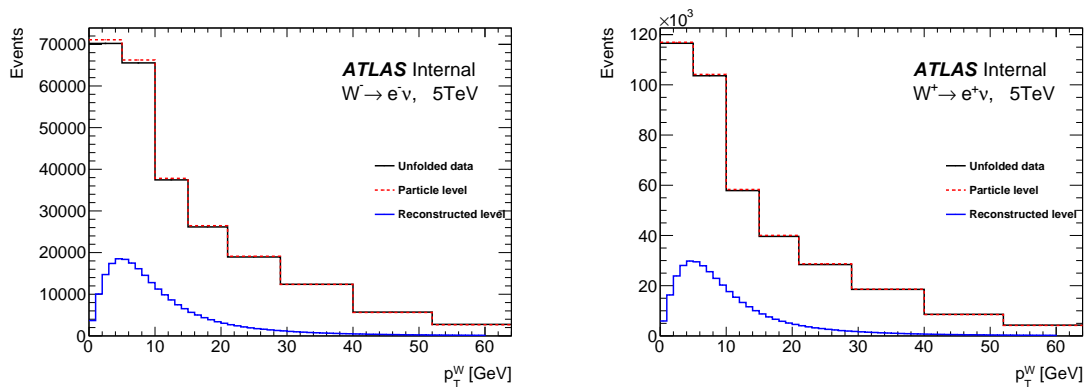


FIGURE 5.6: Example of the unfolded data distribution compared to reconstructed data events and the truth distributions for electron channels at $\sqrt{s} = 5$ TeV. The acceptance correction is applied to the unfolded distribution to take into account events at the truth level which are not reconstructed.

5.3.2 Experimental systematic uncertainties

In this section, we review different sources of systematic uncertainties affecting the measurement of p_T^W distributions and the measurement of the differential cross sections in Chapter 7:

Lepton scale factors: As described in Chapter 3, two factors (energy scale and resolution) are applied to data and MC respectively to correct the residual difference observed between data and simulation. The combined effect of all scale and resolution uncertainties on the distributions of p_T^W is shown in Figures 5.7 and 5.8. The effect on p_T^W is up to 0.2% in low p_T^W region.

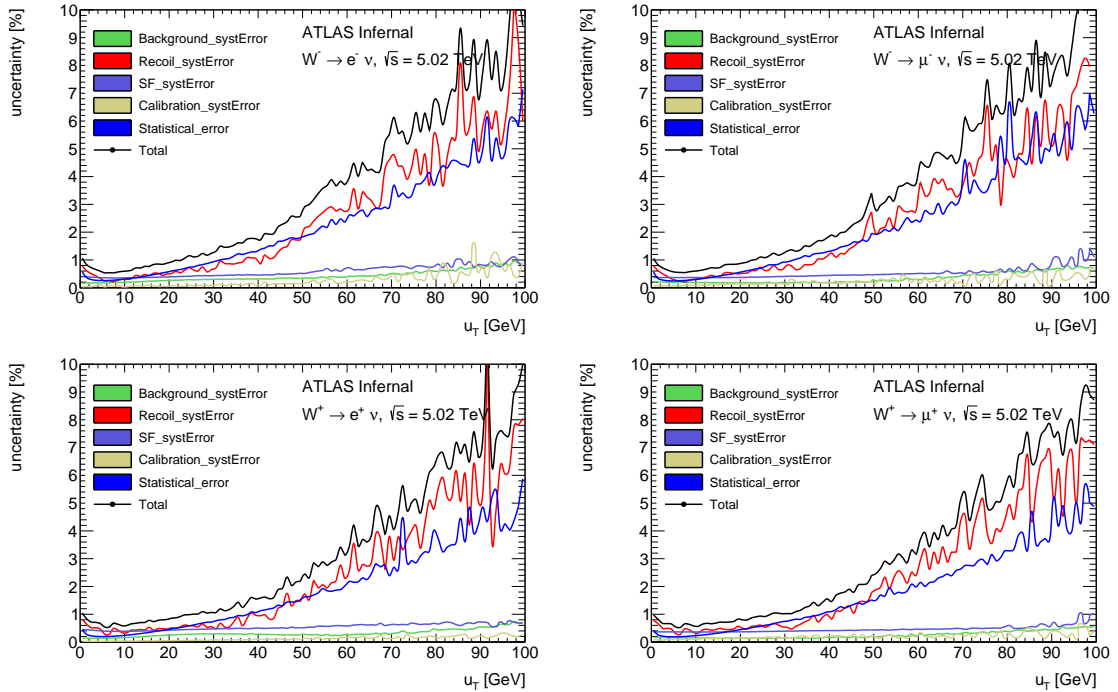


FIGURE 5.7: Different sources of uncertainties on the measurement of p_T^W distributions at the detector level for the $\sqrt{s} = 5$ TeV data set. The total uncertainty is less than 1% in the low p_T^W region ($p_T^W < 30$ GeV) and around 5% in the high p_T^W region ($p_T^W \approx 100$ GeV). The total uncertainty is dominated by the hadronic recoil calibration uncertainty and the statistical uncertainty of the data.

Lepton selection efficiency: As detailed in Sec. 7.2, selected leptons are required to pass specific criteria. The efficiency of the selections in the simulation is normalised to that in data and applied to the simulation as product of different scale factors (SFs):

$$W_{\text{event}} = \text{SF}_{\text{reco}} \cdot \text{SF}_{\text{ID}} \cdot \text{SF}_{\text{isolation}} \cdot \text{SF}_{\text{trigger}}, \quad (5.4)$$

which correspond to the reconstruction, identification, isolation and trigger scale factors. The SFs are calculated using a “tag-and-probe” method detailed in [22].

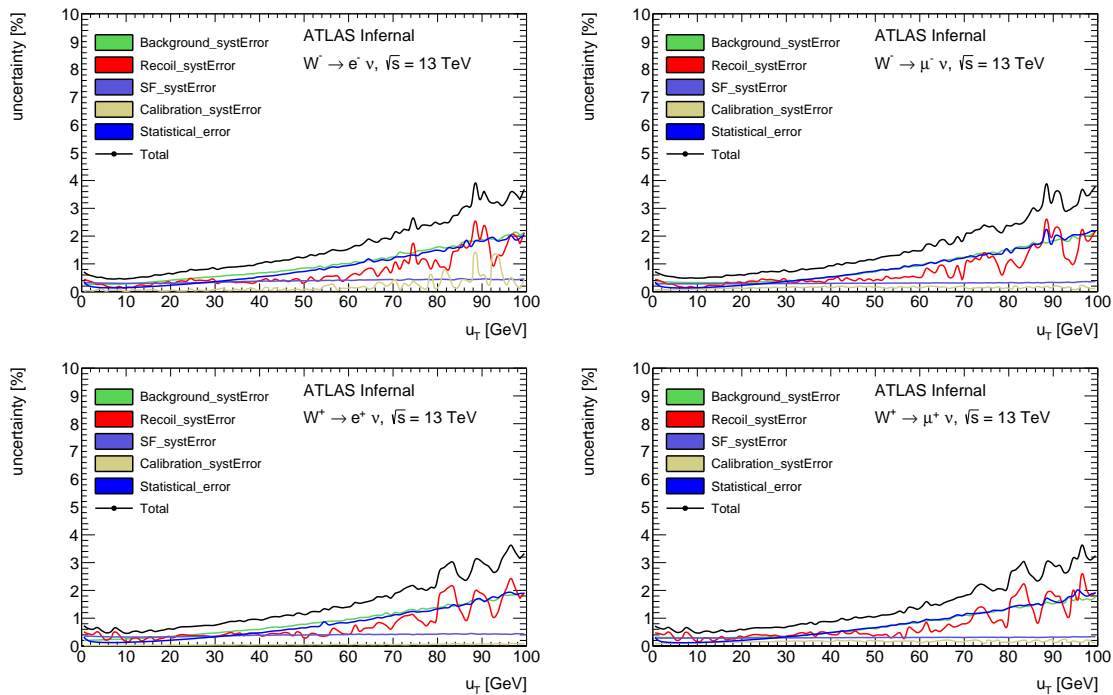


FIGURE 5.8: Different sources of uncertainties on the measurement of p_T^W distributions at the detector level for the $\sqrt{s} = 13$ TeV data set. The total uncertainty is less than 1% in the low p_T^W region ($p_T^W < 30$ GeV) and around 5% in the high p_T^W region ($p_T^W \approx 100$ GeV). The total uncertainty is dominated by the hadronic recoil calibration uncertainty and the background uncertainty (because of the large background contributions of gauge-boson pair production and top quark production).

1638 **Hadronic recoil calibration:** Because the neutrino can not be measured in the AT-
1639 LAS detector, the hadronic recoil, defined as the vector sum of all energy
1640 deposits excluding energy of lepton, is used in the W boson analysis to deter-
1641 mine p_T^ν and p_T^W . The uncertainty coming from the calibration of the hadronic
1642 recoil is dominated mainly by data statistics, specially at low p_T^W . The uncer-
1643 tainty on the hadronic recoil calibration is the dominant systematic uncer-
1644 tainty compared to other source of uncertainties.

1645 **Background uncertainty:** It is related to the background estimation, in particular
1646 to the multi-jet contribution [155], and varies between channels and center-
1647 of-mass energies. In general, the background uncertainty is below 0.5% for
1648 our regions of interest.

1649 **Luminosity:** The luminosity uncertainty for 13 TeV low pile-up runs is 1.5 % for
1650 the combination of 2017+2018 data (2.1% for 2017, 1.5% for 2018). The lumi-
1651 nosity uncertainty is 1.6% for 5 TeV 2017 low pile-up runs [104].

1652 5.3.3 Propagation of statistical uncertainties

1653 The propagation of the statistical uncertainties of the data through the unfolding
1654 is done using pseudo-data, constructed by fluctuating the data distribution with
1655 Poisson variations, and the covariance matrix of the statistical uncertainties at the
1656 unfolded level is built using the unfolding results for each pseudo-data distribu-
1657 tion, as described in Chapter 4. There is also another approach to calculate the
1658 covariance matrix at the unfolded level, by using internal toys generated by the
1659 *RooUnfoldBayes* class. Figure 5.9 shows an example of the statistical uncertainties
1660 at the unfolded level, bin-by-bin, for different iterations. The statistical uncer-
1661 tainties are smaller than 1% in low p_T^W region ($p_T^W < 30$ GeV) and larger than 2 % at
1662 $p_T^W = 100$ GeV. Because of the correlation between truth and reconstructed levels
1663 (Figure 5.10), the statistical uncertainties increase with the number of iterations as
1664 shown in Figure 5.9. In fact, the diagonal elements of the covariance matrix in-
1665 crease with the number of iterations, on the other hand, the correlation between
1666 bins (non-diagonal elements) decrease to ensure that the total statistical uncer-
1667 tainties are independent of the number of iterations when we integrate over all bins.
1668

1669 5.3.4 Propagation of systematic uncertainties

1670 The systematic uncertainties are propagated through the unfolding in the same
1671 way as described in Chapter 4. In general the propagation of systematic uncer-
1672 tainties is based on simulation samples, where the reconstructed distribution and
1673 the migration matrix are modified by their uncertainties. The difference between
1674 the unfolding of the modified distribution and the unfolding of the nominal dis-
1675 tribution is considered as the systematic uncertainty. The systematic uncertainties
1676 increase also with the number of iterations, but contrary to the statistical uncer-
1677 tainties, the increase for the experimental systematic uncertainties is due to fluc-
1678 tuations related to the low statistics. Figure 5.11 shows an example of the recoil
1679 systematic uncertainty, the dominant one, as a function of the number of iterations

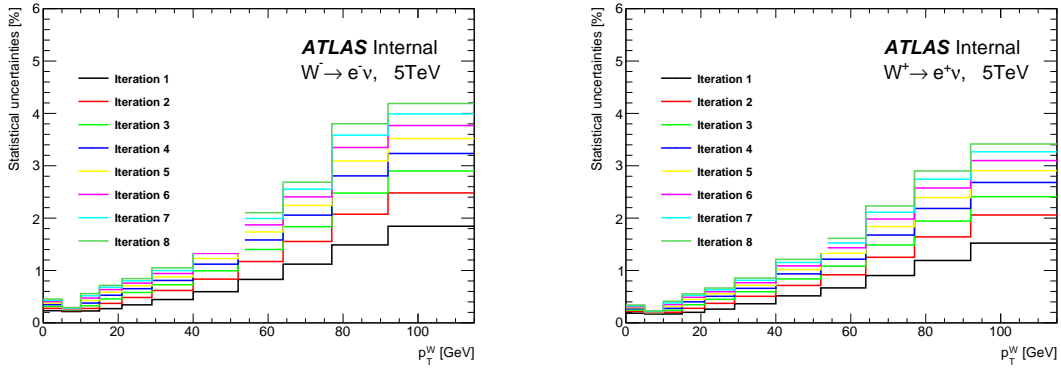


FIGURE 5.9: Statistical uncertainties on the unfolded distribution as a function of the number of iterations, bin-by-bin, for electron channels at $\sqrt{s} = 5$ TeV.

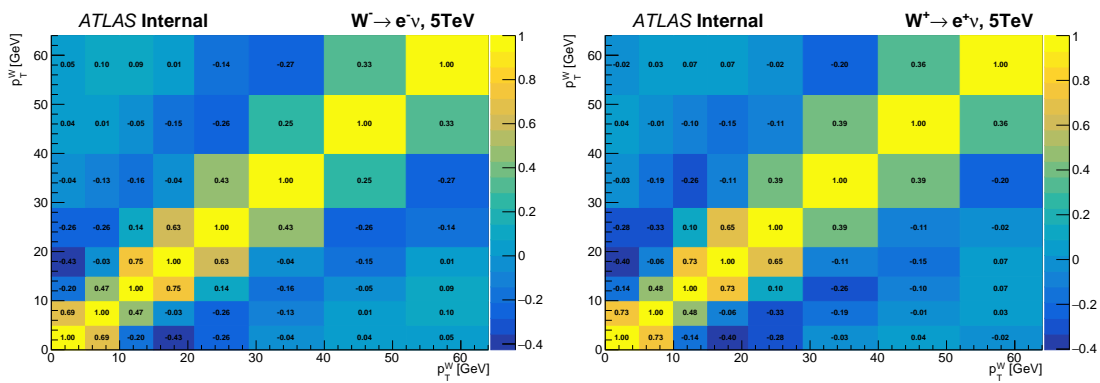


FIGURE 5.10: Correlation matrix of the statistical uncertainties, for electron channels at $\sqrt{s} = 5$ TeV, corresponding to the iteration 4.

1680 for different bins. As for the statistical uncertainties, the correlation between bins
 1681 (Figure 5.12) decreases with the number of iterations to ensure that the total uncertainty
 1682 is independent of the number of iterations. All the sources of uncertainties
 1683 are shown as a function of the number of iterations in Ref. [114]. The different
 sources of uncertainties at the detector level are shown in Appendix B.

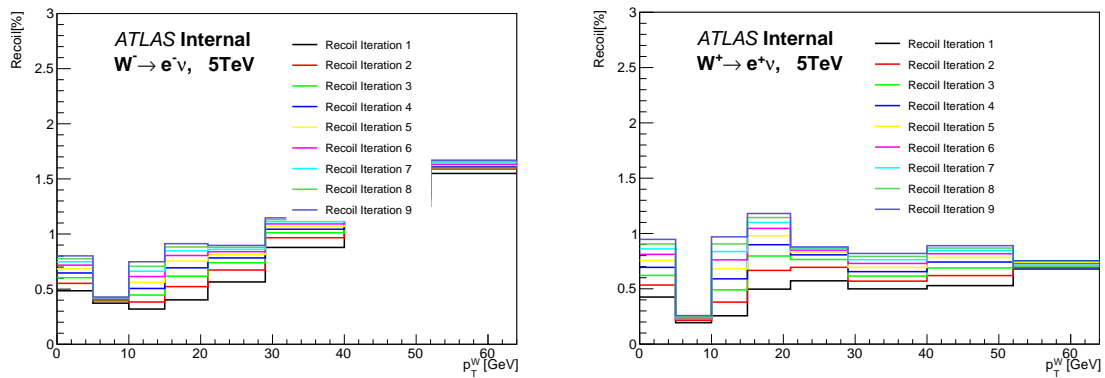


FIGURE 5.11: Example of the recoil systematic uncertainties on the unfolded distribution as a function of the number of iterations, bin-by-bin, for electron channels at $\sqrt{s} = 5$ TeV.

1684

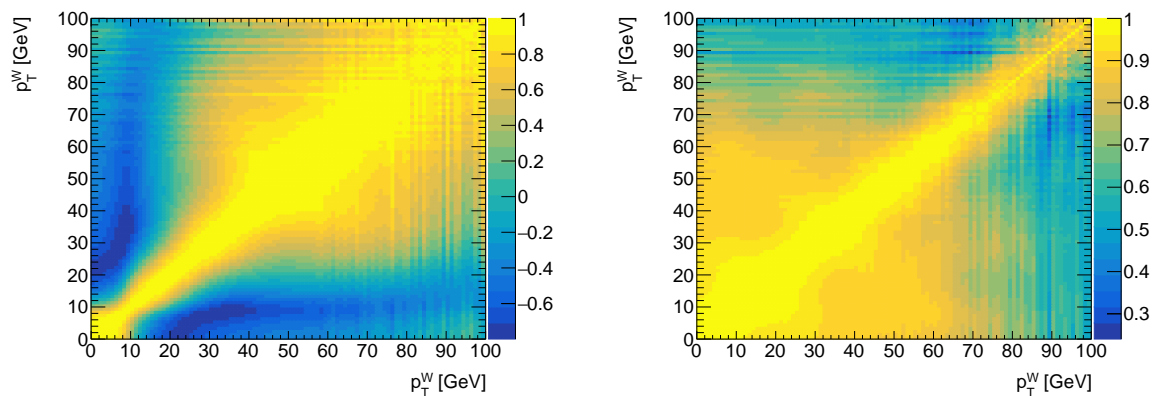


FIGURE 5.12: Correlation matrix for the hadronic recoil calibration uncertainty (left) and lepton calibration uncertainty (right), at 5 TeV, corresponding to iteration 4.

1685 5.3.5 Comparison of the uncertainties

1686 The breakdown of the systematic uncertainties is shown in Figure 5.13 at the un-
1687 folded level. The total experimental measurement uncertainty remains below 1%
1688 up to $p_T^W = 25$ GeV at 5 TeV, and below 2% up to 50 GeV at 13 TeV, for each of
1689 the $W^+ \rightarrow e^+\nu_e$ and $W^- \rightarrow e^-\bar{\nu}_e$ channels. The same results are observed also for
1690 muon channels [114]. In this range, the statistical uncertainties and recoil calibra-
1691 tion uncertainties dominate compared to other sources of uncertainty as shown in
1692 Figure 5.13. At 13 TeV the background uncertainty is more important comparing
1693 to 5 TeV because of the large contributions of gauge-boson pair production and
1694 top-quark production [114]. At 100 GeV, the total uncertainties reach 9% and 3%
1695 for 5 and 13 TeV, respectively. The scale and hierarchy of uncertainties are pre-
1696 served at the unfolded level. The breakdown of the uncertainties for the electron
1697 and the muon channels at the detector level are shown in [114]. The uncertain-
1698 ties are calculated using 3 iterations as a parameter of the Bayesian unfolding. The
1699 number of iterations is optimised for the measurement of the p_T^W spectrum in [114].

1700

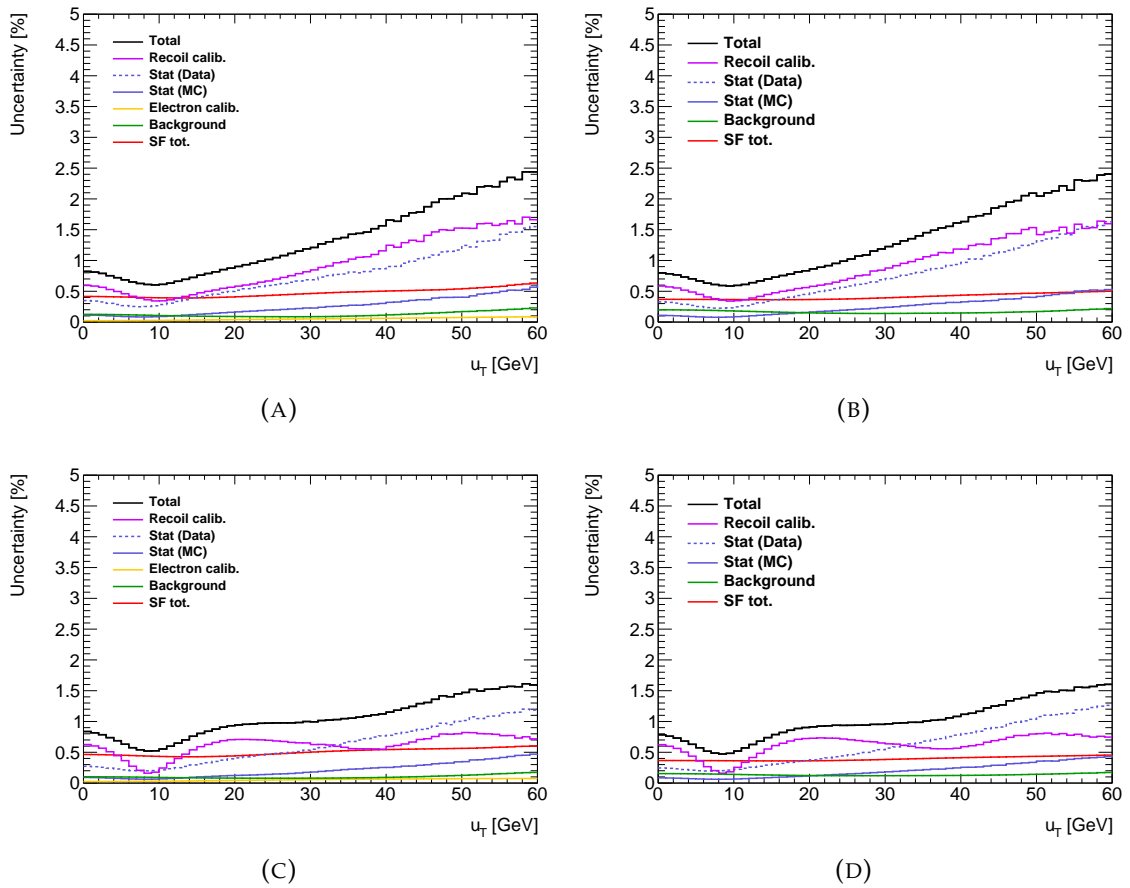


FIGURE 5.13: Different sources of uncertainties on the measurement of p_T^W distributions at the unfolded level for the $\sqrt{s} = 5$ TeV data set, for electron channels W^- (A), W^+ (B) and muon channels W^- (C), and W^+ (D). The total uncertainty is less than 1% in the low p_T^W region ($p_T^W < 30$ GeV) and around 2% in the high p_T^W region ($p_T^W \approx 60$ GeV). The total uncertainty is dominated by the hadronic recoil calibration uncertainty and the statistical uncertainty of data.

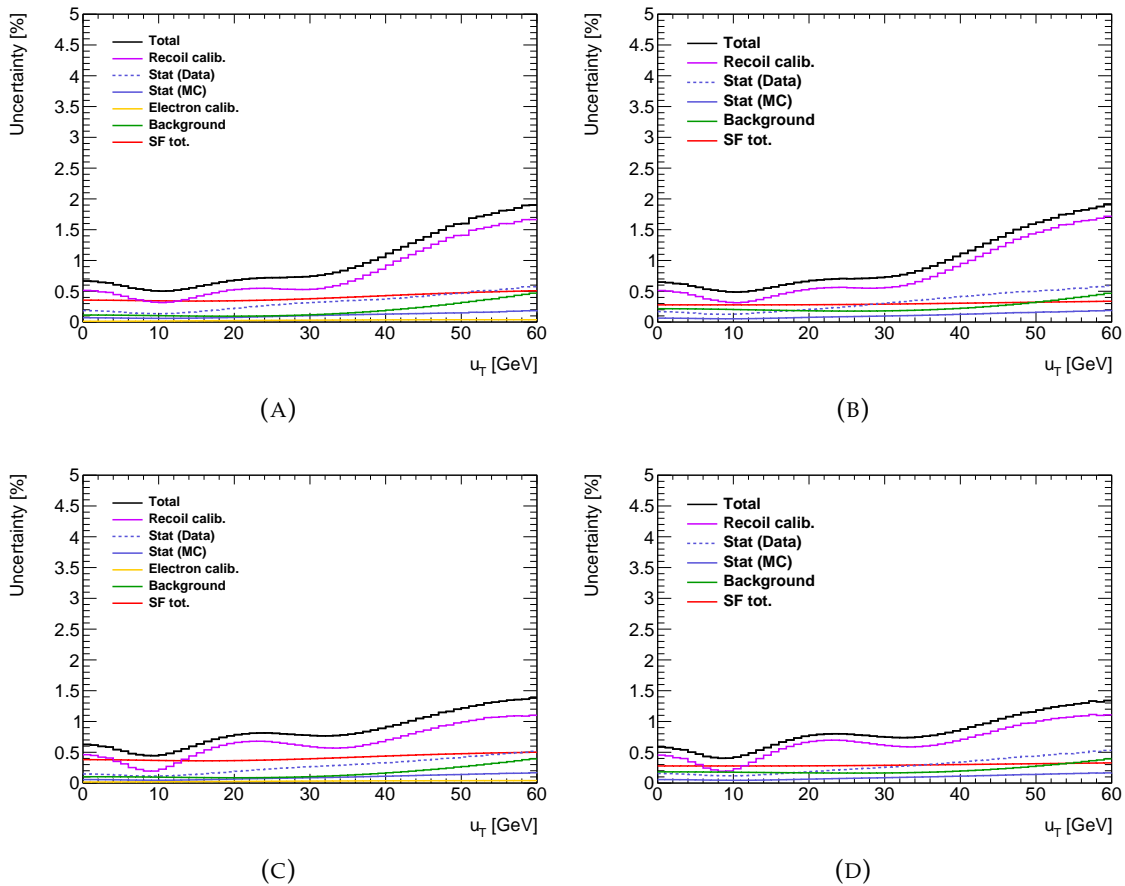


FIGURE 5.14: Different sources of uncertainties on the measurement of p_T^W distributions at the unfolded level for the $\sqrt{s} = 13$ TeV data set, for the electron channels W^- (A), W^+ (B) and the muon channels W^- (C), and W^+ (D). The total uncertainty is smaller than 1% in the low p_T^W region ($p_T^W < 30$ GeV) and around 1.5% for the high p_T^W region ($p_T^W \approx 60$ GeV). The total uncertainty is dominated by the hadronic recoil calibration uncertainty and the background uncertainty.

1701 5.3.6 Unfolding bias

1702 In the p_T^W analysis, the unfolding bias estimation is the major concern, because
 1703 of the large migration between truth and detector levels variables, as shown in
 1704 Figure 5.5. Contrary to the method used to estimate the bias described in Chap-
 1705 ter 4, another more involved approach is used for the p_T^W analysis. As described in
 1706 Chapter 4, the unfolding bias can be estimated by:

- 1707 1. The MC events are reweighted at the truth level to get the best agreement to
 1708 the data (reconstruction level).
- 1709 2. The corresponding reconstruction-level distribution is unfolded (as pseudo-
 1710 data) using the original migration matrix (used for data unfolding).
- 1711 3. The unfolded result is compared to the reweighted truth distribution, thus
 1712 providing an estimate of the bias uncertainty.

1713 The new approach is to change the truth level reweighting method. In fact we
 1714 usually reweight the truth distribution by the data/MC, as discussed in Chap-
 1715 ter 4, but for the new approach, we define several reweighting functions at the
 1716 truth level and we minimise the χ^2 value in order to get the best agreement at
 1717 the reconstruction-level with data. Figure 5.15 shows an example of the bias un-
 1718 certainty for 5 TeV. Contrary to the statistical uncertainty, the bias uncertainty de-
 1719 creases with the number of iterations. The bias is important for the first bins, and
 1720 starts to decrease after 40 GeV because of the large bins size. The bias uncertainty
 1721 is considered fully correlated, and the correlation between bins increases in or-
 1722 der to ensure that the bias is zero when we add all the bins together, as seen in
 Figure 5.15.

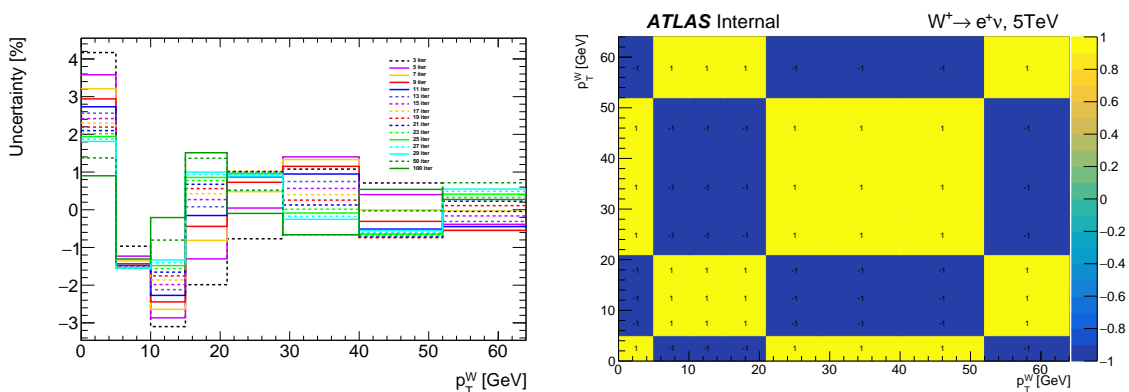


FIGURE 5.15: Relative bias uncertainty for $W^+ \rightarrow e^+ \nu_e$ at $\sqrt{s} = 5$ TeV for large bins. The truth reweighting is defined based on the new method. Different number of iterations is shown.

1724 **5.4 Results of p_T^W measurement**

1725 The results for the unfolded p_T^W distributions compared to the different predic-
 1726 tions are shown in Figures 5.16 and 5.17 for the electron and muon channels, re-
 1727 spectively. Excluding luminosity, the experimental uncertainties range from less
 1728 than 1% at low p_T^W to about 5% (2%) at $p_T^W=100$ GeV, at 5 TeV (13 TeV). These
 1729 numbers are smaller than those quoted in Appendix B due to the large size of the
 1730 binning used. The luminosity uncertainty contributes in addition to 1.6% at 5 TeV,
 1731 and 1.5% at 13 TeV. The predictions include Powheg AZNLO, Pythia AZ, Sherpa
 1732 and DYRES. An approximately equal level of agreement with data is visible for
 1733 Powheg and Pythia. Sherpa predicts a softer spectrum, while DYRES is harder
 1734 than the data. These features are consistently observed in the electron and muon
 channels, for both W boson charges, and at both energies.

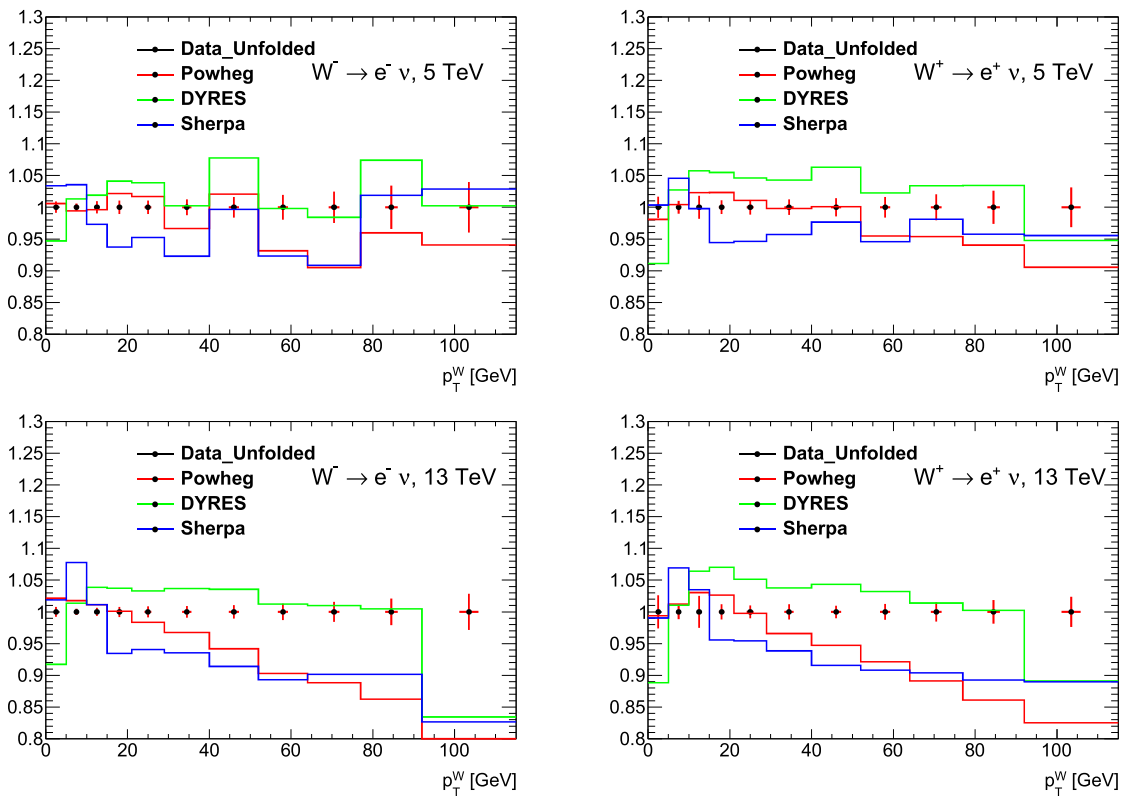


FIGURE 5.16: Unfolded p_T^W distribution in comparison with various predictions in the W^- (left) and W^+ (right) electron channels, at 5 TeV (top) and 13 TeV (bottom).

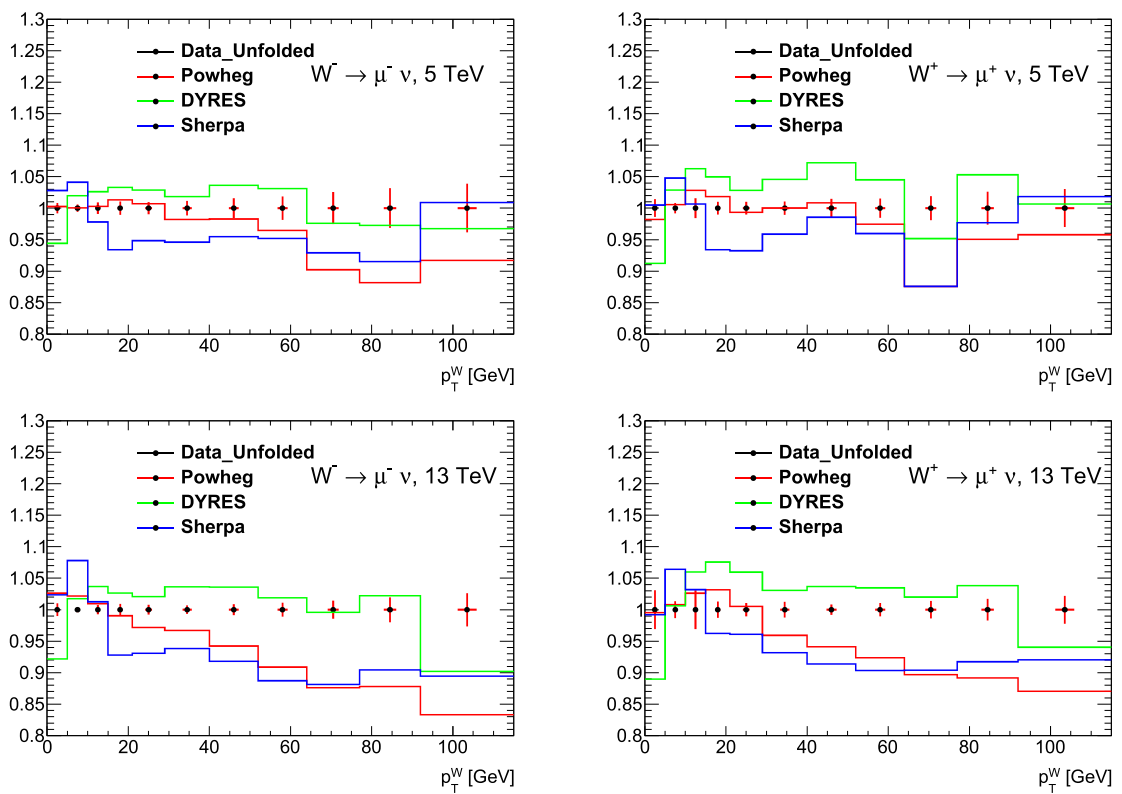


FIGURE 5.17: Unfolded P_T^W distribution in comparison with various predictions in the W^- (left) and W^+ (right) muon channels, at 5 TeV (top) and 13 TeV (bottom).

Chapter 6

W boson production cross sections

6.1 Introduction

The W boson production cross section predictions are available including corrections from QCD (at NNLO in the differential case) and EW (at NLO also in the differential case) [12]. Recently an N3LO computation was performed [64], and a mixed QCD-EW differential computation was also done in [34], see also [62] for an almost complete calculation. Therefore, the measurement of W boson production cross section at the LHC will provide an important test of the SM. Figure 6.1 shows the comparison between the theoretical predictions and measurements from different experiments. The production cross sections are based on p_T^W distributions described in Chapter 5 with the same selections and corrections, and calculated using two methods: using bin-by-bin correction and using the unfolded distributions. This chapter describes the measurement of the inclusive production cross sections of $W^\pm \rightarrow \ell^\pm \nu$. The data used correspond to low pile-up runs ($\mu \approx 2$) collected during 2017 and 2018 using proton–proton collisions at $\sqrt{s} = 5$ TeV and 13 TeV. The bin-by-bin correction is based on a correction factor C extracted from simulation by comparing the truth and reconstruction level, whereas the second method consists of using the unfolded distribution already corrected by the unfolding procedure described in Chapter 4.

6.2 Fiducial cross-section methodology

The fiducial cross section is calculated using the bin-by-bin correction method and compared to the unfolding method, and a brief comparison of the two approaches is shown below.

6.2.1 The bin-by-bin method

The fiducial cross section is calculated from the observed number of events selected in a fiducial phase space after subtracting background contributions and taking into account the detector efficiencies. The resulting fiducial cross section of W^\pm for a given channel ($W^\pm \rightarrow \ell^\pm \nu$) can be expressed with the formula:

$$\sigma_{\text{fid}} = \frac{N^{\text{data}} - N^{\text{bg}}}{\mathcal{L} \cdot C_v} \quad (6.1)$$

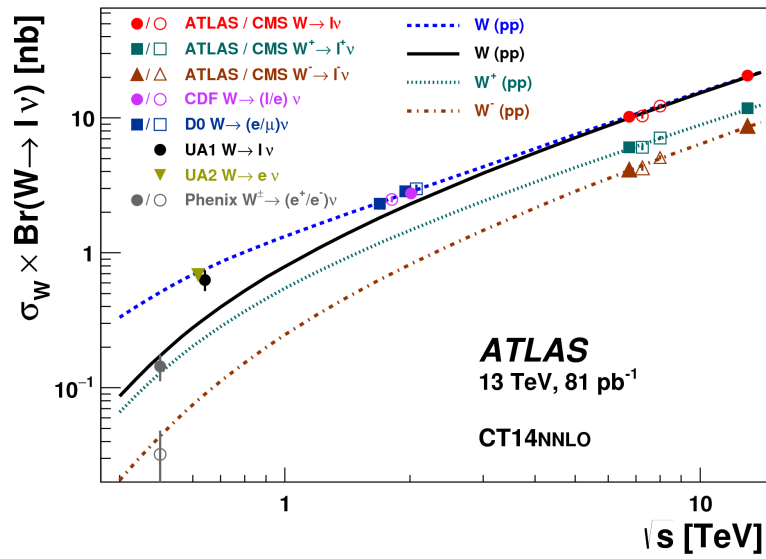


FIGURE 6.1: The measured values of $\sigma_W \times \text{Br}(W \rightarrow \ell)$ for W boson compared to the theoretical predictions based on NNLO QCD calculations [117].

1765 where

- 1766 • for a given channel, N^{data} and N^{bg} represent the number of events of data in the phase space defined in the section, and the expected number of background events.
- 1767
- 1768
- 1769 • C_v is a correction factor calculated using simulation, corresponding to the ratio of the number of selected events at the detector level and the number of events at the particle level in the fiducial phase space. This correction factor allows to correct the observed difference between data and simulation (due to e.g. reconstruction, identification, isolation, and trigger).
- 1770
- 1771
- 1772
- 1773
- 1774 • \mathcal{L} is the integrated luminosity of data.

1775 6.2.2 The Bayesian unfolding method

1776 The second option is to use the unfolding method (the Bayesian unfolding method) defined in the Chapter 4. In general, the idea behind the unfolding is to correct all the detector effects in data distributions, and the total and differential cross sections can be calculated using the unfolded distributions.

1779 For the unfolding approach, the cross section is calculated via the formula:

$$1780 \quad \sigma_{\text{fid}} = \frac{N^{\text{Unfolded}}}{\mathcal{L}} \times \frac{N^{\text{truth\&reco}}}{N^{\text{truth}}} = \frac{N^{\text{Unfolded}}}{\mathcal{L}} \cdot A_{\text{unf}} \quad (6.2)$$

1781 where

- 1782 • N_{Unfolded} represents the number of events in the unfolded distribution.
- 1783 • A_{unf} is a correction factor related to the unfolding procedure, defined in the Chapter 4. This factor represents the fraction of events passing reconstructed
- 1784

1785 and truth selections to the number of events that meet the selection criteria
 1786 at truth level.

1787 • \mathcal{L} is the integrated luminosity of data.

1788 The unfolding method used in this thesis depends on a regularisation parameter
 1789 related to the number of iterations (Chapter 4). However as the unfolding does
 1790 not change the normalisation of the input distributions, the fiducial cross section is
 1791 independent of the number of iterations. For the different sources of uncertainties
 1792 (statistical and systematic), the uncertainties are independent of the number of
 1793 iterations when we take the correlation between bins into account. Also, as the
 1794 unfolding bias (Chapter 4) depends mainly on the shape of a distribution, when
 1795 we integer aver all the bins we find no bias. Figure 6.2 shows the fiducial cross
 sections for different iterations.

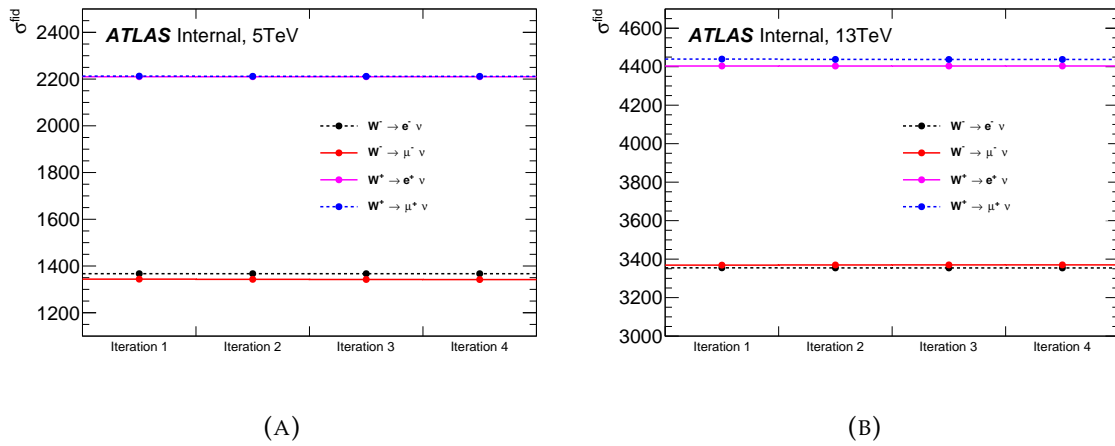


FIGURE 6.2: Fiducial cross section as a function of the number of iterations at 5 TeV (A) and 13 TeV (B).

1796

1797 The propagation of systematic uncertainties using bin-by-bin correction is
 1798 based on the comparison between the fiducial cross section σ_{fid} and the modified
 1799 fiducial cross section $\sigma_{\text{fid}}^{\text{var}}$, where:

$$\sigma_{\text{fid}} = \frac{N^{\text{data}} - N^{\text{bg}}}{\mathcal{L}} \times \frac{N^{\text{truth}}}{N^{\text{reco}}}, \quad (6.3)$$

$$\sigma_{\text{fid}}^{\text{var}} = \frac{N^{\text{data}} - (N^{\text{bg}} + \text{var})}{\mathcal{L}} \times \frac{N^{\text{truth}}}{N^{\text{reco}} + \text{var}}. \quad (6.4)$$

1800 The systematic uncertainty can be written as:

$$\text{Systematic} = \frac{\sigma_{\text{fid}}^{\text{var}} - \sigma_{\text{fid}}}{\sigma_{\text{fid}}}. \quad (6.5)$$

1801 For the unfolding procedure, the propagation of systematic uncertainty is done as
 1802 described in Chapter 5, and the total uncertainty is taken as the sum of all the el-
 1803 ements of the unfolding covariance matrix. Good agreement is observed between
 1804 the two approaches as shown in table 6.1 as example for the $W^+ \rightarrow e^+ \nu_e$ at 5 TeV.

TABLE 6.1: An example comparison the $W^+ \rightarrow e^+\nu_e$ channel at 5 TeV between systematic uncertainties using bin-by-bin correction and the Bayesian unfolding.

	$W^+ \rightarrow e^+\nu_e$					
Syst. uncer	Reco SF	Id SF	Iso SF	Trigger SF	e^+ calib	HR calib
Unfolding	0.30%	0.31%	0.33%	0.23%	0.012%	0.08%
Bin-by-bin	0.30%	0.30%	0.33%	0.22%	0.013%	0.08%

1805 6.2.3 Results

1806 The measured fiducial cross sections σ_{fid} for $W^\pm \rightarrow \ell^\pm\nu$ are shown in the tables 6.2 and 6.3 with the different sources of uncertainties.

TABLE 6.2: Fiducial cross section with different sources of uncertainties using the bin-by-bin correction and the unfolding approach using 5 TeV samples.

	$W^- \rightarrow e^-\bar{\nu}_e, 5 \text{ TeV, (value } \pm \text{ stat } \pm \text{ syst } \pm \text{ lum) [pb]}$
σ_{fid} (Unfolding)	$1379 \pm 2.7 \pm 6.4 \pm 22$
σ_{fid} (Bin-by-bin)	$1380 \pm 2.6 \pm 6.3 \pm 22$
	$W^+ \rightarrow e^+\nu_e, 5 \text{ TeV, (value } \pm \text{ stat } \pm \text{ syst } \pm \text{ lum) [pb]}$
σ_{fid} (Unfolding)	$2227 \pm 3.3 \pm 10 \pm 36$
σ_{fid} (Bin-by-bin)	$2228 \pm 3.4 \pm 10 \pm 36$
	$W^- \rightarrow \mu^-\bar{\nu}_\mu, 5 \text{ TeV, (value } \pm \text{ stat } \pm \text{ syst } \pm \text{ lum) [pb]}$
σ_{fid} (Unfolding)	$1377 \pm 2.5 \pm 5.6 \pm 22$
σ_{fid} (Bin-by-bin)	$1376 \pm 2.6 \pm 5.5 \pm 22$
	$W^+ \rightarrow \mu^+\nu_\mu, 5 \text{ TeV, (value } \pm \text{ stat } \pm \text{ syst } \pm \text{ lum) [pb]}$
σ_{fid} (Unfolding)	$2224 \pm 3.3 \pm 8.2 \pm 36$
σ_{fid} (Bin-by-bin)	$2225 \pm 3.3 \pm 8.1 \pm 36$

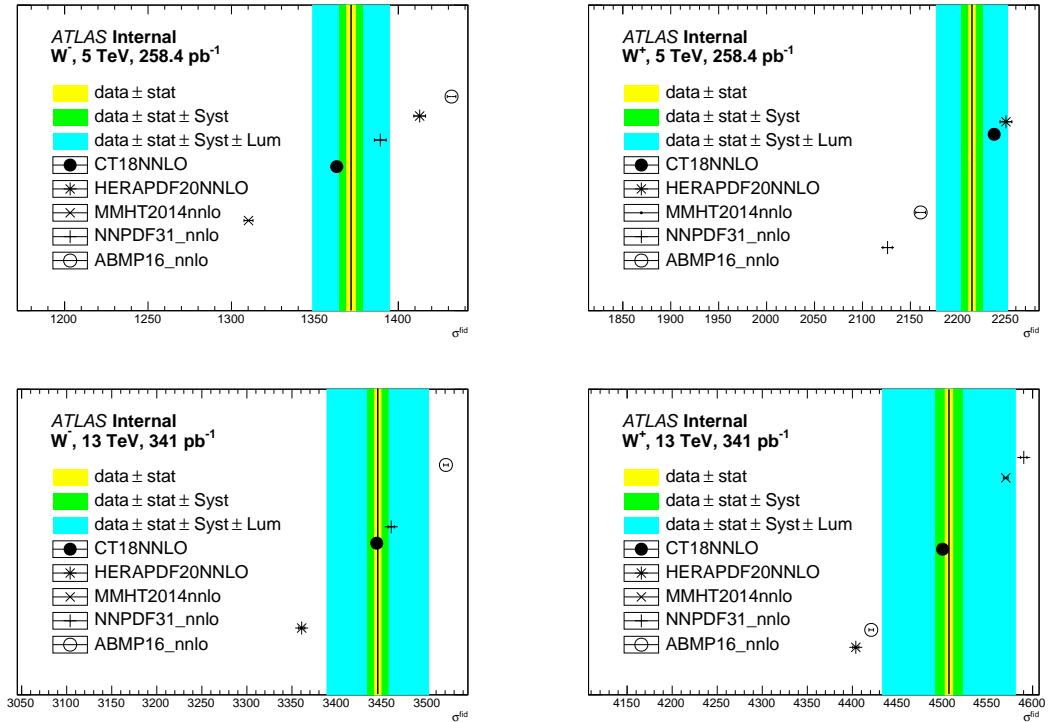
1807

1808 6.2.4 Comparison with theoretical predictions

1809 Theoretical predictions are calculated for the fiducial cross-sections σ_{fid} using DY-
 1810 TURBO [45] at NNLO QCD, with different PDF sets: CT18 [93], HERAPDF20 [87],
 1811 MMHT2014 [91], NNPDF31 [53], ABMP16 [9]. The comparison between measured
 1812 fiducial cross section and theoretical predictions is shown in Figure 6.3. The un-
 1813 certainties on the measured σ_{fid} is dominated by the uncertainty on the luminosity,
 1814 estimated to 1.6% and 1.5% for 5 TeV and 13 TeV, respectively. The CT18 PDF set
 1815 describes the data best, while the rest of PDFs shows deviation for at least one data
 1816 set.

TABLE 6.3: Fiducial cross section with different sources of uncertainties using the bin-by-bin correction and the unfolding approach using 13 TeV samples.

	$W^- \rightarrow e^- \bar{\nu}_e$, 13 TeV, (value \pm stat \pm syst \pm lum) [pb]
σ_{fid} (Unfolding)	$3445 \pm 3.8 \pm 21 \pm 50$
σ_{fid} (Bin-by-bin)	$3445 \pm 3.8 \pm 20 \pm 50$
	$W^+ \rightarrow e^+ \nu_e$, 13 TeV, (value \pm stat \pm syst \pm lum) [pb]
σ_{fid} (Unfolding)	$4507 \pm 4.3 \pm 22 \pm 66$
σ_{fid} (Bin-by-bin)	$4505 \pm 4.4 \pm 22 \pm 66$
	$W^- \rightarrow \mu^- \bar{\nu}_\mu$, 13 TeV, (value \pm stat \pm syst \pm lum) [pb]
σ_{fid} (Unfolding)	$3444 \pm 3.7 \pm 24 \pm 50$
σ_{fid} (Bin-by-bin)	$3445 \pm 3.8 \pm 25 \pm 50$
	$W^+ \rightarrow \mu^+ \nu_\mu$, 13 TeV, (value \pm stat \pm syst \pm lum) [pb]
σ_{fid} (Unfolding)	$4504 \pm 4.3 \pm 28 \pm 66$
σ_{fid} (Bin-by-bin)	$4505 \pm 4.3 \pm 28 \pm 66$

FIGURE 6.3: Measured fiducial cross sections (σ_{fid}) compared to different PDFs set using QCD (NNLO) predictions. The yellow band corresponds to the statistical uncertainty, the middle band to the statistical and experimental systematic uncertainties added in quadrature, while the outer band shows the total uncertainty, including the luminosity uncertainty.

Chapter 7

Measurement of single and double differential cross sections

7.1 Introduction

In this chapter we present detailed studies of the measurement of the differential cross sections of the W^\pm boson using the low pile-up runs at $\sqrt{s} = 5$ and 13 TeV, taken in Fall 2017 and July 2018 with the ATLAS detector, corresponding to an integrated luminosity of data of 258 pb^{-1} for $\sqrt{s} = 5$ TeV and 340 pb^{-1} for $\sqrt{s} = 13$ TeV. The data, simulation and all the corrections used in this study are described in Ref. [95]. The differential cross sections are measured in fiducial phase spaces, described in section 4 of Ref. [27], as functions of different variables ($\eta_\ell, p_{\text{T}}^\ell, \eta_\ell - p_{\text{T}}^\ell$) using the unfolded distributions. Different sources of statistical and systematic uncertainties, described in the section 8 of Ref. [27], are propagated via the unfolding procedure. In addition to these sources of uncertainties, there is a bias related to the unfolding procedure, but as the migrations between bins are low for η_ℓ and p_{T}^ℓ , the bias in this case is negligible comparing to other sources of uncertainties. The unfolding of data distributions and the propagation of different sources of uncertainties (statistical, systematic and bias) through unfolding, including an optimisation study for the number of iterations needed for the unfolding, are described in Sec. ???. Section 7.3 shows the results of the differential cross-section measurements and the different sources of uncertainties using the unfolded distributions. In Sec. 7.6, a two dimensional unfolding is used to measure the double differential cross sections in bins of η_ℓ and p_{T}^ℓ . A technique is used to transfer the two dimensional unfolding to a one dimensional unfolding as used for differential cross sections of η_ℓ and p_{T}^ℓ , separately. All the sources of uncertainties, discussed in Ref. [27], are propagated through unfolding as described in Sec. ???.

The measurement of differential cross sections in this process provides stringent tests of the QCD theory, and is crucial for a deep understanding and modelling of QCD interactions. Also, the rapidity dependence of the W boson production in the Drell–Yan process provides constraints on the parton distribution functions (PDFs), which are currently the dominant uncertainty source in the W mass measurement (9.2 MeV) [115].

7.2 Data and simulation distributions

7.2.1 Fiducial phase space

The selection of the W candidate events follows the p_T^W measurement described in Chapter 5. The analysis requires lepton candidates satisfying medium identification criteria based on the EM showers shapes (defined in Rif. [103]). In addition, medium likelihood identification, “ptvarcone20/ $p_T < 0.1$ ” isolation and trigger requirements are applied, trigger requiring the online reconstruction and identification of one lepton passing a p_T^ℓ threshold of 15 GeV, definitions are shown in Ref. [103]. Candidates within the barrel-end-cap crack ($1.37 < |\eta_\ell| < 1.52$) are rejected. Also, the selections: $E_T^{\text{miss}} > 25$ GeV and $m_T^W > 50$ GeV are applied in order to remove most of the Z -boson and multi-jet backgrounds in the signal phase space.

7.2.2 Experimental systematic uncertainties

In this section, we review the different sources of systematic uncertainty affecting the measurement of the differential cross sections:

Lepton scale factors: As described in Chapter 3, two factors (energy scale and resolution) are applied to data and MC respectively to correct residual difference observed between data and simulation. The energy scale and resolution factors determined from low pile-up runs are applied. The combined effect of all scale and resolution uncertainties on the distributions of η_ℓ , p_T^ℓ are shown in Figure 7.1. The effect on p_T^ℓ is up to 2% for large value of p_T^ℓ , but it’s negligible for η_ℓ .

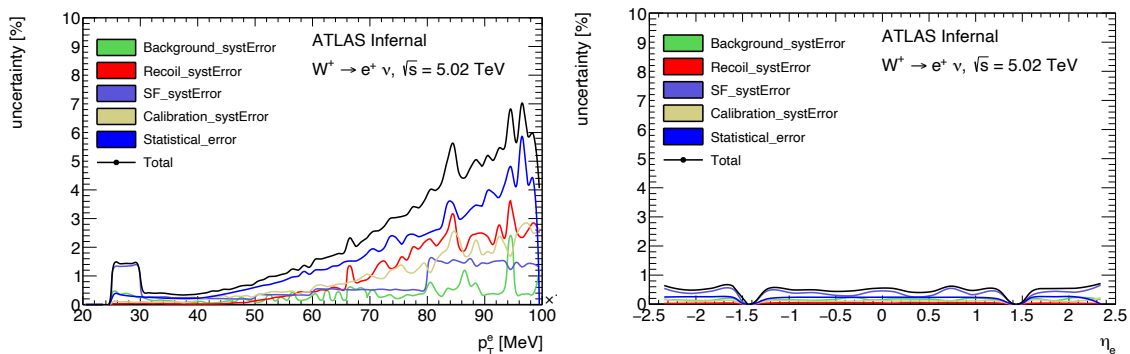


FIGURE 7.1: Uncertainties effect on the distributions of η_ℓ , p_T^ℓ for $W^+ \rightarrow e^+ \nu_e$ at 5 TeV. Uncertainties for 5 and 13 TeV data sets are described in Appendix B.

Lepton selection efficiency: As detailed in Sec. 7.2, selected leptons are required to pass specific criteria. Small differences between data and simulation on the efficiencies of the selections are applied to the simulation as:

$$W_{\text{event}} = \text{SF}_{\text{reco}} \cdot \text{SF}_{\text{ID}} \cdot \text{SF}_{\text{isolation}} \cdot \text{SF}_{\text{trigger}} , \quad (7.1)$$

1874 which correspond to the reconstruction, identification, isolation and trigger
 1875 scale factors (SFs). The SFs are calculated using “tag-and-probe” method
 1876 detailed in Ref. [22]. The uncertainty on the selection efficiency is found to
 1877 be the dominant systematic comparing to other source of uncertainties.

1878 **Hadronic recoil calibration:** Because of the neutrino which can not be measured
 1879 in the ATLAS detector, the hadronic recoil, defined as the vector sum of all
 1880 energy deposits excluding energy of lepton, is used in W boson analysis to
 1881 determine p_T^{ν} , p_T^W , etc. The uncertainty coming from the calibration of the
 1882 hadronic recoil is related principally to data statistics. This systematic is more
 1883 important for p_T^{ℓ} and is of the order of 2% for large value of p_T^{ℓ} , see Figure 7.1.

1884 **Background uncertainty:** It is related to the background estimation, in particular
 1885 to the multi-jet contribution [155], and varies between channels and center-
 1886 of-mass energies. In general, the background uncertainty is below 0.5% for
 1887 our regions of interest.

1888 **Luminosity:** The luminosity uncertainty for 13 TeV low pile-up runs is 1.5% for
 1889 the combination of 2017+2018 data (2.1% for 2017, 1.5% for 2018). It is 1.6 %
 1890 for 5 TeV low pile-up runs.

1891 7.2.3 Data and MC comparison

1892 The corrections applied during the unfolding are extracted basically from the mi-
 1893 gration matrix, determined using MC simulation, which connects the particle and
 1894 detector levels. The idea is that in order to unfold data distribution, the simulation
 1895 must describe data perfectly. Otherwise, the unfolded data can not be precisely
 1896 compared to distributions at truth level. More information about objects defini-
 1897 tions and all the corrections are described in Section 3 of Ref [27]. Figure 7.2 show
 1898 the relevant data and MC distributions used for the cross-section measurement.

1899 7.2.4 Unfolding of data distributions

1900 The idea of unfolding is to use a migration matrix built from MC which contains
 1901 all detector effects and allows us to pass from reconstruction to truth level. As
 1902 detailed in Section 4, the unfolding is done to correct all detector effects. Contrary
 1903 to the p_T^W unfolding described in Ref [27], the η_{ℓ} or p_T^{ℓ} unfolding is easier because of
 1904 the small migration between bins, due to a negligible difference between truth and
 1905 reconstructed levels (less detector effects), which means that the migration matrix
 1906 is more diagonal, see Figure 7.3.

1907 The same unfolding method used for p_T^W is used also for η_{ℓ} , p_T^{ℓ} unfolding, the itera-
 1908 tive Bayesian unfolding method [55]. Figure 7.4 shows an example of distributions
 1909 at the unfolding and reconstructed level using 3 iterations. Because of the small
 1910 migration between bins, the unfolded level distribution is identical to the truth
 1911 level distribution.

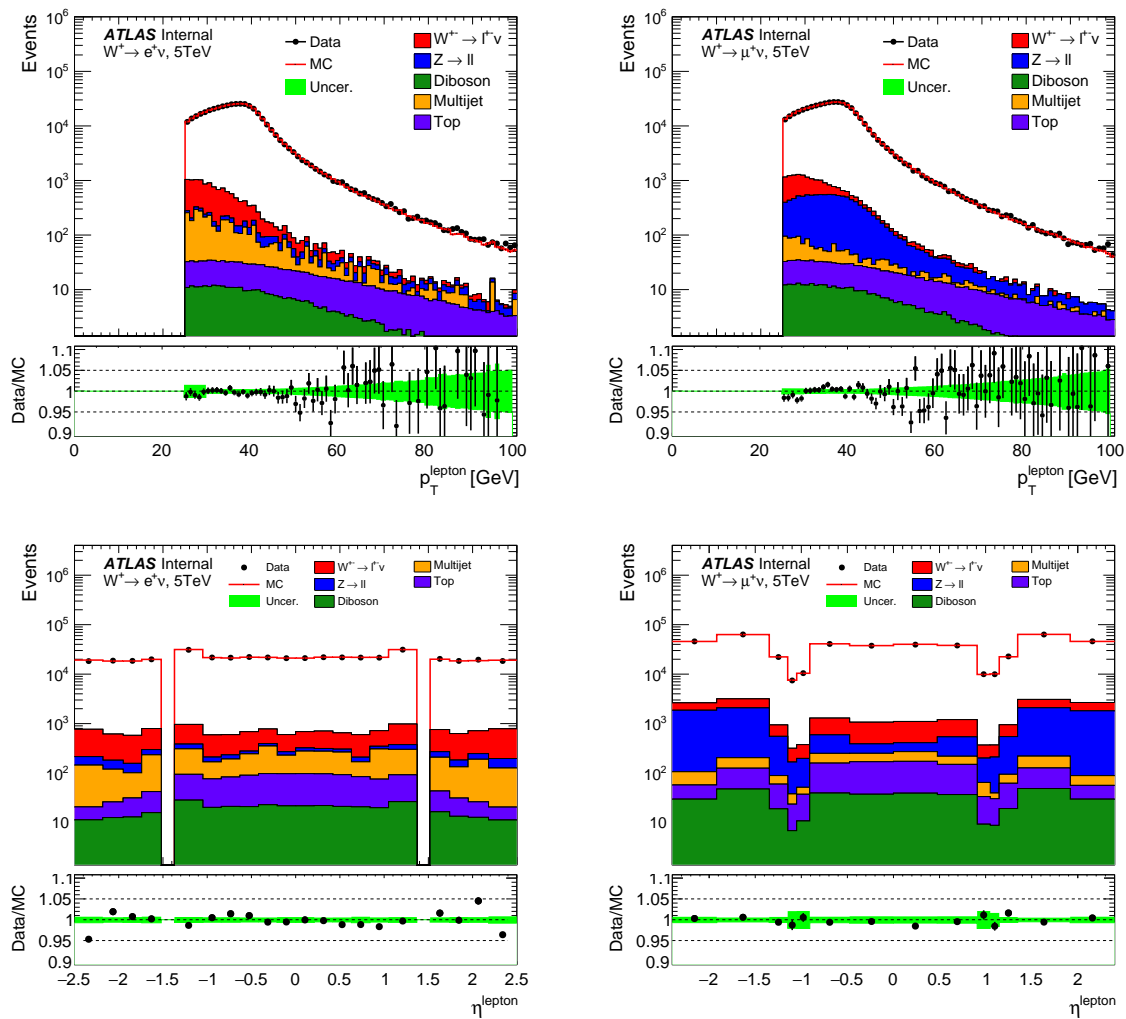


FIGURE 7.2: Example distributions of the observables p_T^{ℓ} (top) and η_{ℓ} (bottom) chosen to be unfolded for W^+ in the electron (left) and muon (right) channels at 5 TeV in the fiducial phase space. The signal and background are normalised to data. The low panel gives the ratio Data/MC in each bin. The green band shows the statistical and systematic uncertainties. Control plots for other channels are shown in Appendix A.

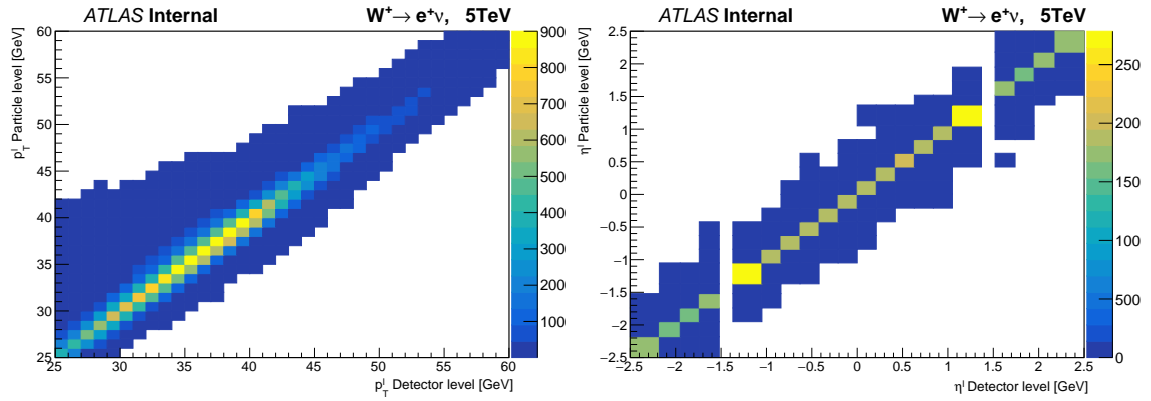


FIGURE 7.3: Example of the migration matrix used in the unfolding of p_T^l (left) and η_ℓ (right) for $W^+ \rightarrow e^+\nu_e$ at 5 TeV, the migration matrix is quasi diagonal because of the small difference between particle and detector levels.

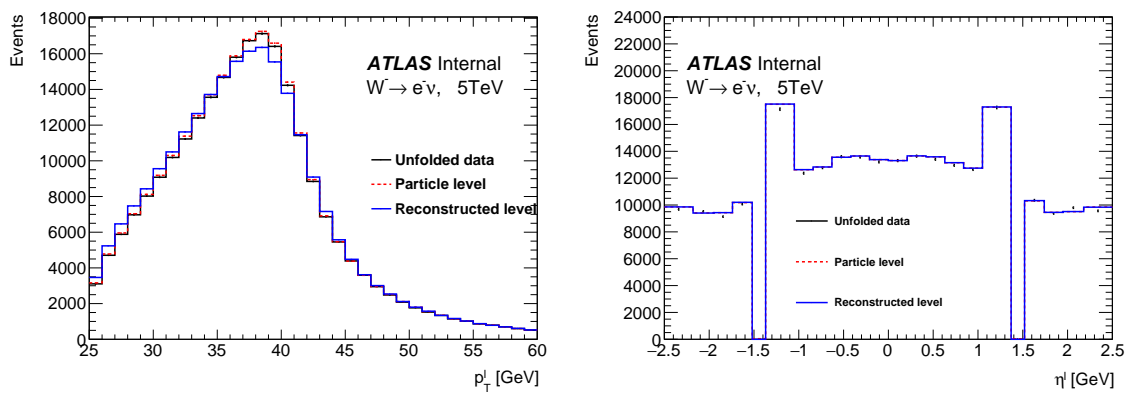


FIGURE 7.4: Example of the unfolded distributions for p_T^l (left) and η_ℓ (right) for $W^- \rightarrow e^-\bar{\nu}_e$ at 5 TeV at detector level, particle level and unfolded level.

7.2.5 Propagation of the statistical and systematic uncertainties

The propagation of uncertainties through the unfolding is done in the same way as for p_T^W , as detailed in Chapter 4. The main difference comes from the degree of migration between bins. Figure 7.5 shows an example of statistical uncertainty at the unfolding level, comparing to η_ℓ , p_T^ℓ is characterised with slightly larger migration between bins which explains the increase in the statistical error with the number of iterations.

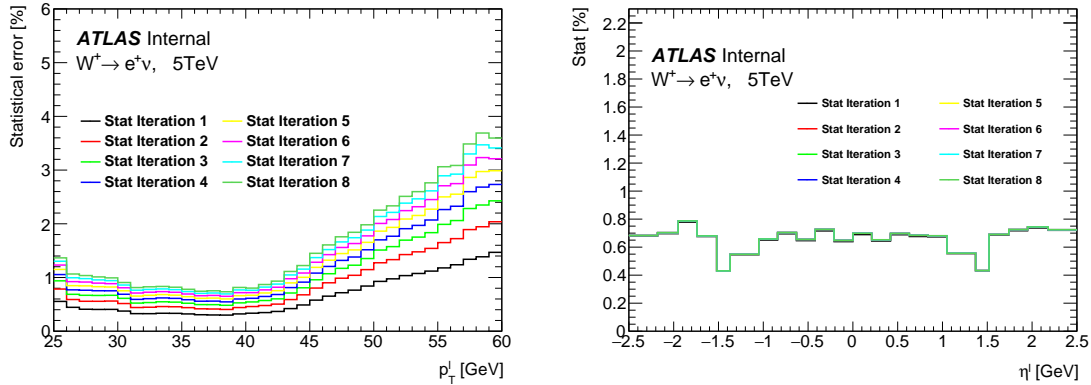


FIGURE 7.5: Example of the statistical uncertainties for p_T^ℓ (left) and η_ℓ (right), for $W^+ \rightarrow e^+ \nu_e$ at 5 TeV. Statistical error increases with the number of iterations because of the migration between bins. Statistical uncertainties with their correlation matrices are described in Appendix B.

Contrary to the statistical uncertainty, the systematic uncertainties are more stable with the number of iterations, Figure 7.6 shows an example of the dominant systematic uncertainty at the unfolded level as a function of the number of iterations. For η_ℓ and p_T^ℓ , the total uncertainty is dominated by the uncertainty from the efficiency scale factors.

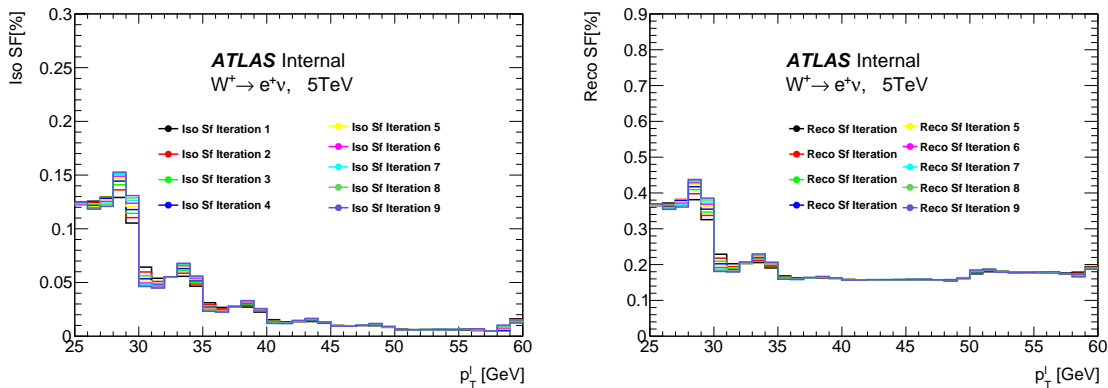


FIGURE 7.6: Example of the systematic uncertainties (isolation (left) and reconstruction (right) SFs) for p_T^ℓ for $W^+ \rightarrow e^+ \nu_e$ at 5 TeV.

7.2.6 Unfolding bias

As detailed in Chapter 4, the unfolding method used in this thesis introduces a bias that should not be dominant. The bias is calculated as explained in Chapter 4. The procedure to estimate the bias can be summarised in two steps (Ref [111]):

- Reweight the MC distribution at truth level with the fitted ratio data/MC, in such a way that the corresponding reconstructed distribution, obtained by the truth level reweighted distribution, matches better the data distribution after the background subtraction.
- The bias is estimated as the difference between the unfolded distribution of the reconstruction-weighted distribution and the truth-weighted distribution.

The procedure used to calculate the bias of unfolding is illustrated in Fig. ?? . The reconstruction-weighted distribution must be closer to data compared to the original reconstructed distribution (Fig. 7.7).

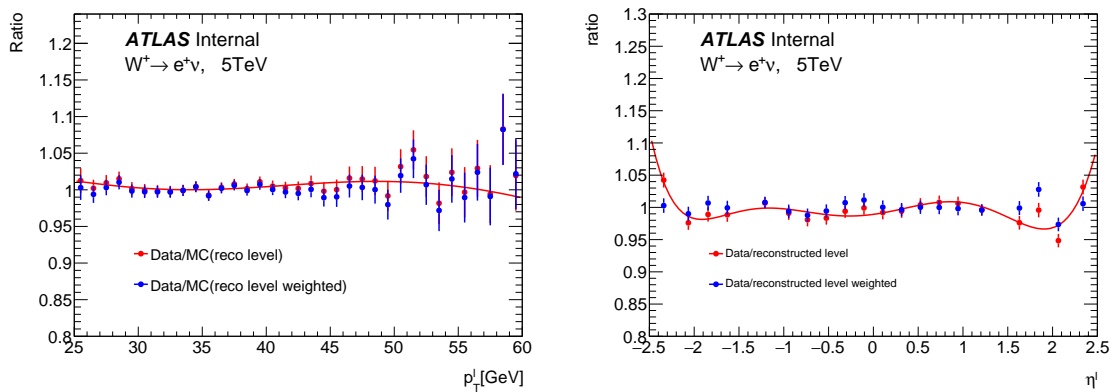


FIGURE 7.7: The ratio of data over the original reconstructed MC distributions for p_T^ℓ (left) and η_ℓ (right) compared to the ratio of data over the weighted one. The latter is in better agreement with data (background subtracted).

As the unfolding does not change the normalisation of input distributions, the total unfolding bias when we take the correlation (anti-correlation) between bins into account must be equal to 0. Contrary to other sources of uncertainties, the bias decreases with the number of iterations and the anti-correlation between bins increases with the number of iterations to ensure that the bias integrated in all bins is zero (Fig. 7.8).

7.2.7 Optimisation of the number of iterations in iterative Bayesian unfolding

As discussed above, the statistical uncertainty increases with the number of iterations, while the unfolding bias decreases with them. Therefore it is possible to minimise the total uncertainty by optimising the number of iterations. As the bias

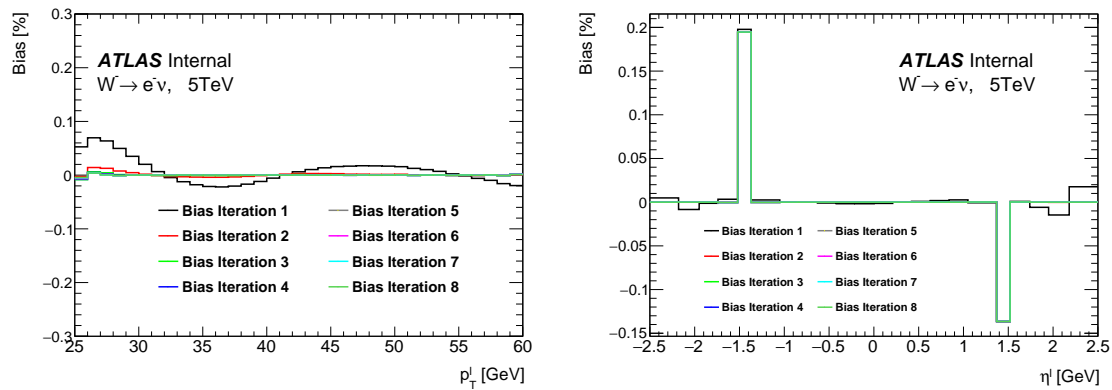


FIGURE 7.8: Example of the unfolding bias of p_T^ℓ (left) and η_ℓ (right) as a function of the number of iterations used in the unfolding for W^- at 5 TeV. After the second iteration, the bias is negligible compared to other sources of uncertainty. The unfolding bias for other channels is shown in Appendix B.

1949 is very small comparing to other sources of uncertainties, the best choice is to use
 1950 the first iteration. However to avoid the fluctuations in the bias as shown in Fig-
 1951 ure 7.9, the second iteration is used. As we are interested in the differential cross
 1952 sections, the optimisation study is done for each bin separately around the peak
 1953 region.

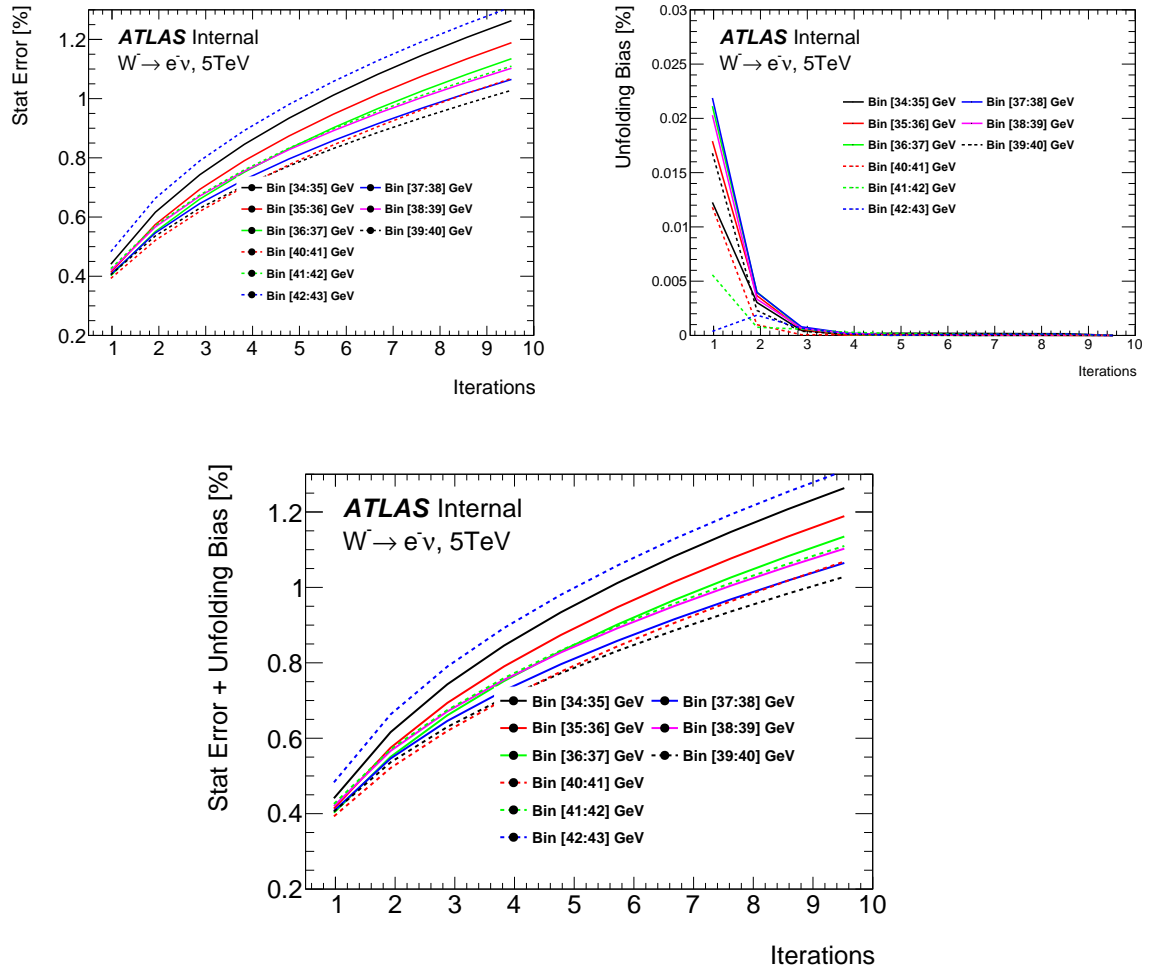


FIGURE 7.9: Example of the statistical uncertainty (top left) and the unfolding bias uncertainty (top right) and their combined uncertainty (bottom) for a few selected bins in p_T^ℓ as a function of the number of iterations used in the unfolding.

7.3 Differential cross sections

The differential cross sections can be estimated using a correction factor calculated from simulation, the bin-by-bin unfolding, where the differential cross-section formula can be expressed as:

$$\frac{d\sigma_i}{dx^i} = \frac{N_{\text{data}}^i}{\Delta x^i \mathcal{L}} \cdot C_i = \frac{N_{\text{data}}^i}{\Delta x^i \mathcal{L}} \cdot \frac{N_{\text{truth}}^i}{N_{\text{reco}}^i}, \quad (7.2)$$

where Δx^i is the bin width, and N^i is the number of events in bin i . On the other hand, there is another option to calculate the differential cross section, replacing the correction bin-by-bin factor C_i , by the unfolding of the data distribution using the inverse of the migration matrix M_{ij} . The new formula using the unfolded distribution of data is expressed as:

$$\frac{d\sigma_i}{dx^i} = \frac{N_{\text{Unf}}^i}{\Delta x^i \mathcal{L}} \cdot \frac{1}{A_c} = \frac{1}{\Delta x^i \mathcal{L}} \cdot \sum_j M_{ij}^{-1} (N_{\text{reco}}^j - N_{\text{reco,bkg}}^j) \cdot \frac{1}{A_c}, \quad (7.3)$$

where Δx^i is the bin width, N_{Unf}^i is the number of events in the unfolded distribution, A_c is the acceptance correction, used to correct the unfolded distribution and take into account the events that pass the detector-level selection but fail the particle-level selection. Figure 7.10 shows an example of the acceptance correction for p_{T}^ℓ and η_ℓ at 5 TeV.

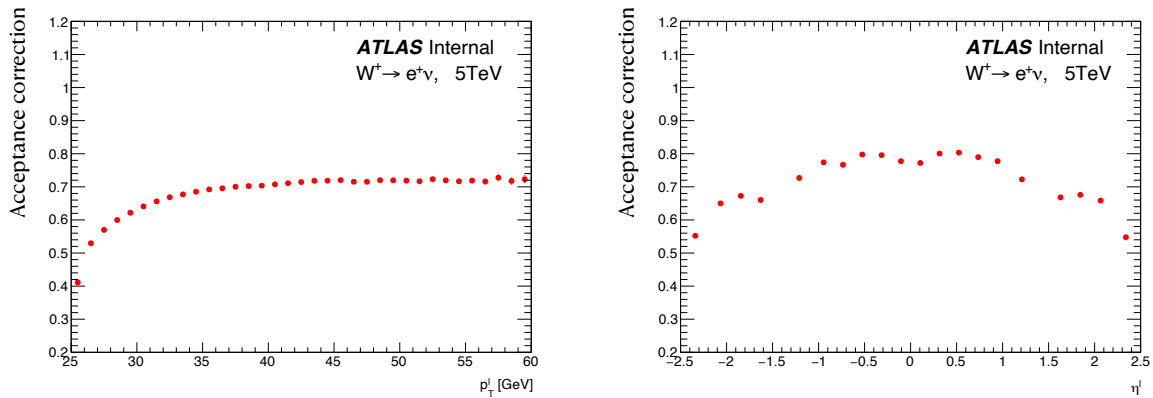


FIGURE 7.10: Fraction of events that pass the detector-level selection but fail the particle-level selection bin-by-bin for p_{T}^ℓ (left) and η_ℓ (right).

1968 **Differential cross sections in the e channel versus p_T^e at 5 TeV**

TABLE 7.1: Differential cross sections versus p_T^e for 5 TeV (W^- , e^-). The columns show the bin range, the measured cross section and the corresponding relative uncertainties.

$W^- \rightarrow e^- \bar{\nu}_e$, 5 TeV, uncertainties in (%)				
Range	$d\sigma/dp_T^e$ [pb/GeV]	Stat uncertainty	Unfolding bias	Syst uncertainty
[26, 27]	18.300	0.895	0.014	1.583
[27, 28]	22.885	0.802	0.013	1.674
[28, 29]	27.240	0.786	0.008	1.783
[29, 30]	31.219	0.747	0.005	1.344
[30, 31]	35.345	0.706	0.002	0.425
[31, 32]	39.692	0.663	0.001	0.310
[32, 33]	43.592	0.653	0.003	0.315
[33, 34]	48.299	0.616	0.003	0.323
[34, 35]	52.746	0.575	0.004	0.313
[35, 36]	57.124	0.551	0.004	0.286
[36, 37]	61.673	0.546	0.004	0.276
[37, 38]	65.344	0.567	0.003	0.280
[38, 39]	66.728	0.536	0.002	0.275
[39, 40]	63.810	0.521	0.001	0.276
[40, 41]	55.319	0.571	0.001	0.292
[41, 42]	44.373	0.663	0.002	0.344
[42, 43]	34.381	0.705	0.003	0.379
[43, 44]	26.705	0.759	0.003	0.408
[44, 45]	21.292	0.828	0.003	0.385

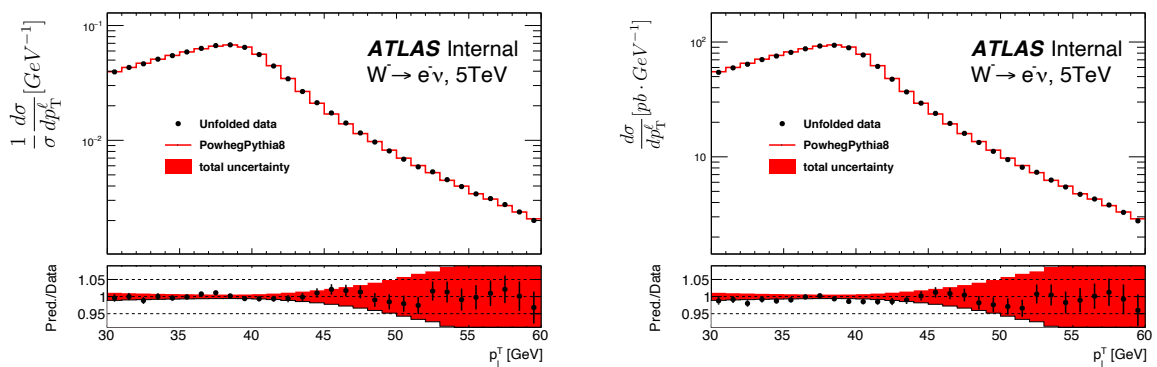


FIGURE 7.11: Differential cross sections (left) and normalised differential cross sections (right) as a function of p_T^e for 5 TeV (W^- , e^-). The bottom panel shows the ratio data to MC (Powheg+Pethia8) together with the red band showing the total uncertainty.

TABLE 7.2: Differential cross sections versus p_T^e for 5 TeV (W^+ , e^+). The columns show the bin range, the measured cross section and the corresponding relative uncertainties.

$W^+ \rightarrow e^+ \nu_e$, 5 TeV, uncertainties in (%)				
Range	$d\sigma/dp_T^e$ [pb/GeV]	Stat uncertainty	Unfolding bias	Syst uncertainty
[26, 27]	36.907	0.590	0.019	1.536
[27, 28]	44.556	0.557	0.008	1.644
[28, 29]	51.628	0.557	0.010	1.768
[29, 30]	58.724	0.561	0.009	1.308
[30, 31]	65.036	0.515	0.008	0.389
[31, 32]	71.340	0.441	0.007	0.275
[32, 33]	76.950	0.446	0.008	0.281
[33, 34]	81.804	0.459	0.007	0.297
[34, 35]	87.183	0.455	0.007	0.284
[35, 36]	92.366	0.439	0.007	0.261
[36, 37]	95.698	0.417	0.006	0.258
[37, 38]	98.590	0.413	0.005	0.261
[38, 39]	98.572	0.405	0.001	0.260
[39, 40]	92.989	0.440	0.002	0.253
[40, 41]	79.972	0.459	0.006	0.249
[41, 42]	63.485	0.478	0.008	0.275
[42, 43]	48.760	0.504	0.008	0.294
[43, 44]	37.878	0.589	0.009	0.309
[44, 45]	29.757	0.677	0.006	0.287

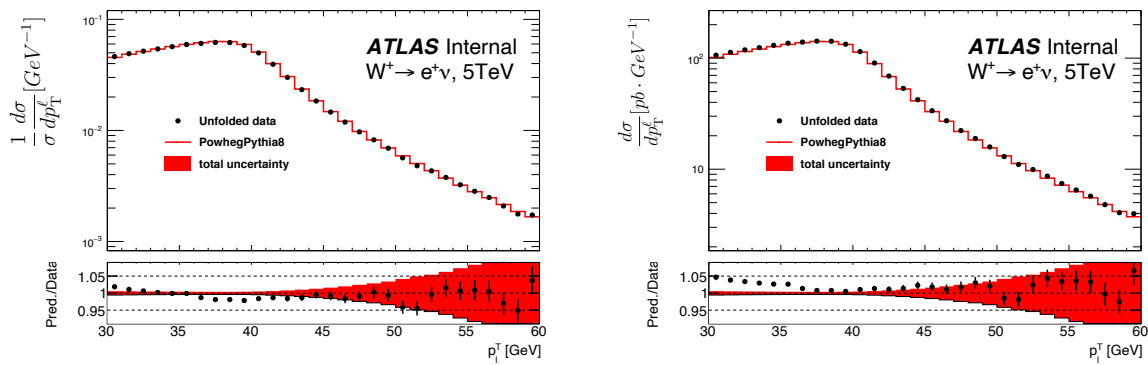


FIGURE 7.12: Differential cross sections (right) and normalised differential cross sections (left) as a function of p_T^e for 5 TeV (W^+ , e^+). The bottom panel shows the ratio data to MC (Powheg+Pethia8) together with the red band showing the total uncertainty.

1969 **Differential cross sections of the μ channel versus p_T^μ at 5 TeV**

TABLE 7.3: Differential cross sections versus p_T^μ for 5 TeV (W^- , μ^-). The columns show the bin range, the measured cross section and the corresponding relative uncertainties.

$W^- \rightarrow \mu^- \bar{\nu}_\mu$, 5 TeV, uncertainties in (%)				
Range	$d\sigma/dp_T^\mu$ [pb/GeV]	Stat uncertainty	Unfolding bias	Syst uncertainty
[26, 27]	20.256	0.928	0.010	0.732
[27, 28]	24.586	0.850	0.023	0.764
[28, 29]	28.525	0.770	0.015	0.846
[29, 30]	32.915	0.782	0.011	0.752
[30, 31]	36.989	0.696	0.007	0.542
[31, 32]	41.858	0.638	0.006	0.650
[32, 33]	46.520	0.645	0.004	0.644
[33, 34]	50.704	0.592	0.002	0.676
[34, 35]	55.074	0.557	0.000	0.586
[35, 36]	59.439	0.559	0.001	0.469
[36, 37]	63.851	0.503	0.001	0.564
[37, 38]	67.492	0.499	0.002	0.580
[38, 39]	69.177	0.508	0.002	0.579
[39, 40]	66.828	0.510	0.000	0.498
[40, 41]	58.303	0.531	0.002	0.467
[41, 42]	46.584	0.562	0.005	0.550
[42, 43]	35.949	0.629	0.005	0.563
[43, 44]	27.695	0.736	0.004	0.548
[44, 45]	22.101	0.809	0.004	0.494

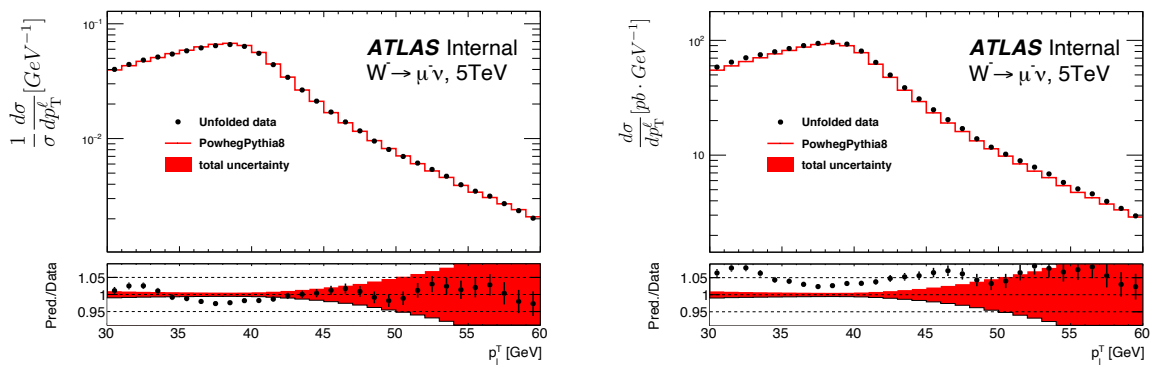


FIGURE 7.13: Differential cross sections (right) and normalised differential cross sections (left) as a function of p_T^μ for 5 TeV (W^- , μ^-). The bottom panel shows the ratio data to MC (Powheg+Pethia8) together with the red band showing the total uncertainty.

TABLE 7.4: Differential cross sections versus p_T^μ for 5 TeV (W^+ , μ^+). The columns show the bin range, the measured cross section and the corresponding relative uncertainties.

$W^+ \rightarrow \mu^+ \nu_\mu$, 5 TeV, uncertainties in (%)				
Range	$d\sigma/dp_T^\mu$ [pb/GeV]	Stat uncertainty	Unfolding bias	Syst uncertainty
[26, 27]	40.943	0.613	0.025	0.707
[27, 28]	49.223	0.592	0.014	0.734
[28, 29]	56.081	0.572	0.013	0.814
[29, 30]	62.909	0.555	0.006	0.713
[30, 31]	69.407	0.518	0.001	0.521
[31, 32]	75.895	0.483	0.001	0.632
[32, 33]	81.579	0.458	0.006	0.634
[33, 34]	87.212	0.439	0.009	0.660
[34, 35]	92.731	0.435	0.013	0.562
[35, 36]	98.205	0.420	0.014	0.457
[36, 37]	102.257	0.414	0.017	0.547
[37, 38]	104.721	0.411	0.017	0.565
[38, 39]	104.533	0.405	0.014	0.567
[39, 40]	97.729	0.432	0.008	0.493
[40, 41]	83.991	0.457	0.002	0.464
[41, 42]	66.658	0.479	0.012	0.539
[42, 43]	51.638	0.534	0.018	0.546
[43, 44]	39.754	0.619	0.020	0.526
[44, 45]	30.943	0.718	0.017	0.476

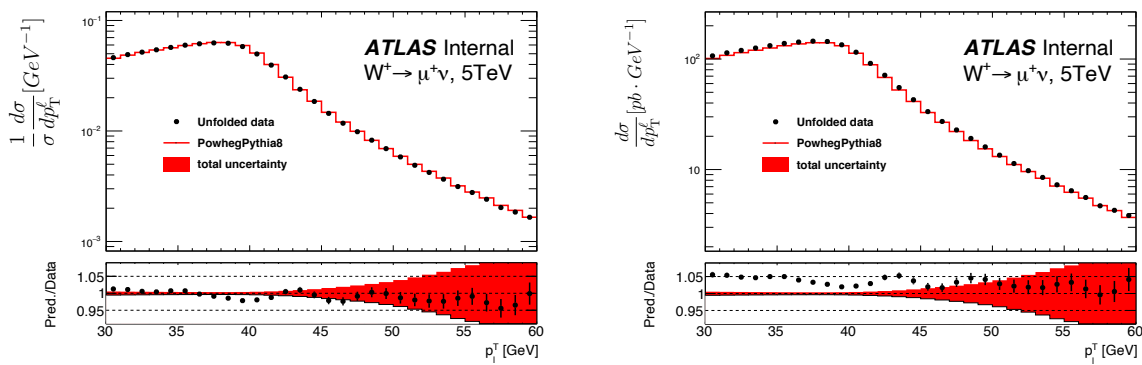


FIGURE 7.14: Differential cross sections (right) and normalised differential cross sections (left) as a function of p_T^μ for 5 TeV (W^+ , μ^+). The bottom panel shows the ratio data to MC (Powheg+Pethia8) together with the red band showing the total uncertainty.

1970 **Differential cross sections of the e channel versus p_T^e at 13 TeV**TABLE 7.5: Differential cross sections versus p_T^e for 13 TeV (W^- , e^-). The columns show the bin range, the measured cross section and the corresponding relative uncertainties.

$W^- \rightarrow e^- \bar{\nu}_e$, 13 TeV, uncertainties in (%)				
Range	$d\sigma/dp_T^e$ [pb/GeV]	Stat uncertainty	Unfolding bias	Syst uncertainty
[26, 27]	48.398	0.448	0.058	0.888
[27, 28]	59.710	0.442	0.026	0.942
[28, 29]	69.166	0.406	0.012	0.997
[29, 30]	78.766	0.376	0.034	0.758
[30, 31]	88.430	0.371	0.041	0.468
[31, 32]	97.272	0.370	0.039	0.501
[32, 33]	106.339	0.360	0.031	0.523
[33, 34]	115.313	0.331	0.019	0.538
[34, 35]	124.252	0.317	0.006	0.418
[35, 36]	133.374	0.312	0.007	0.258
[36, 37]	141.726	0.294	0.020	0.251
[37, 38]	146.909	0.280	0.029	0.256
[38, 39]	148.526	0.273	0.033	0.259
[39, 40]	141.766	0.283	0.030	0.246
[40, 41]	125.030	0.305	0.021	0.230
[41, 42]	104.001	0.351	0.007	0.237
[42, 43]	83.848	0.375	0.006	0.252
[43, 44]	67.814	0.394	0.015	0.263
[44, 45]	55.272	0.458	0.023	0.273

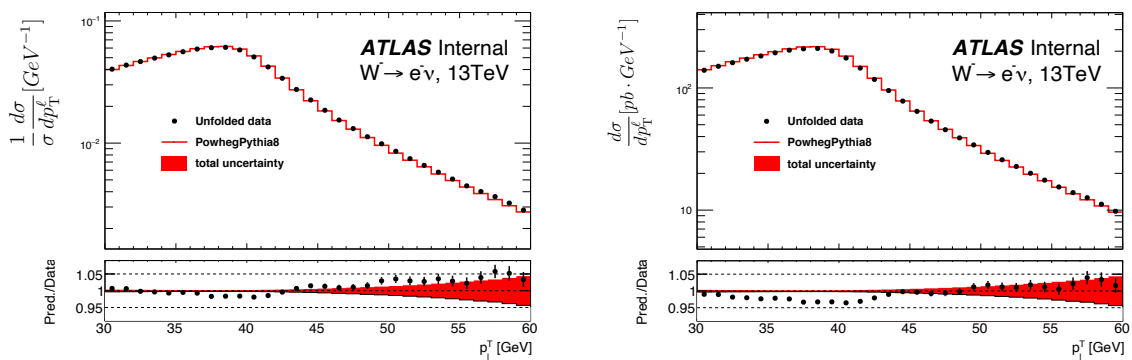
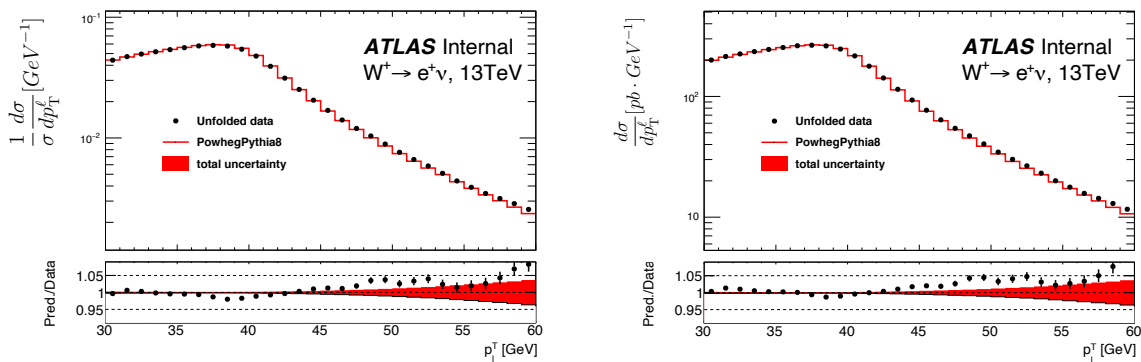
FIGURE 7.15: Differential cross sections (right) and normalised differential cross sections (left) as a function of p_T^e for 13 TeV (W^- , e^-). The bottom panel shows the ratio data to MC (Powheg+Pethia8) together with the red band showing the total uncertainty.

TABLE 7.6: Differential cross sections versus p_{T}^e for 13 TeV (W^+ , e^+). The columns show the bin ranges, the measured cross section and the corresponding relative uncertainties.

W ⁺ → e ⁺ ν _e , 13 TeV, uncertainties in (%)				
Range	$d\sigma/dp_{\text{T}}^e$ [pb/GeV]	Stat uncertainty	Unfolding bias	Syst uncertainty
[26, 27]	73.773	0.372	0.106	0.879
[27, 28]	89.046	0.354	0.123	0.932
[28, 29]	101.290	0.328	0.051	0.988
[29, 30]	112.455	0.316	0.006	0.750
[30, 31]	124.343	0.326	0.035	0.453
[31, 32]	135.555	0.296	0.044	0.481
[32, 33]	145.498	0.293	0.040	0.499
[33, 34]	154.658	0.292	0.029	0.510
[34, 35]	163.823	0.281	0.016	0.398
[35, 36]	172.351	0.276	0.001	0.254
[36, 37]	179.925	0.268	0.016	0.248
[37, 38]	183.698	0.265	0.028	0.252
[38, 39]	182.920	0.270	0.036	0.256
[39, 40]	172.858	0.268	0.034	0.243
[40, 41]	151.985	0.297	0.025	0.226
[41, 42]	125.704	0.317	0.011	0.230
[42, 43]	100.523	0.308	0.002	0.240
[43, 44]	81.060	0.339	0.015	0.251
[44, 45]	65.895	0.395	0.024	0.253

FIGURE 7.16: Differential cross sections (right) and normalised differential cross sections (left) as a function of p_{T}^e for 13 TeV (W^+ , e^+). The bottom panel shows the ratio data to MC (Powheg+Pethia8) together with the red band showing the total uncertainty.

1971 **Differential cross sections of the μ channel versus p_T^μ at 13 TeV**TABLE 7.7: Differential cross sections versus p_T^μ for 13 TeV (W^- , μ^-). The columns show the bin range, the measured cross section and the corresponding relative uncertainties.

$W^- \rightarrow \mu^- \bar{\nu}_\mu$, 13 TeV, uncertainties in (%)				
Range	$d\sigma/dp_T^\mu$ [pb/GeV]	Stat uncertainty	Unfolding bias	Syst uncertainty
[26, 27]	52.018	0.476	0.066	0.392
[27, 28]	62.789	0.464	0.085	0.400
[28, 29]	72.624	0.450	0.056	0.431
[29, 30]	81.235	0.390	0.037	0.393
[30, 31]	90.532	0.395	0.023	0.317
[31, 32]	100.091	0.373	0.011	0.360
[32, 33]	109.480	0.328	0.001	0.361
[33, 34]	119.185	0.314	0.009	0.372
[34, 35]	127.754	0.306	0.017	0.340
[35, 36]	136.933	0.291	0.024	0.305
[36, 37]	144.898	0.272	0.029	0.340
[37, 38]	150.402	0.273	0.030	0.347
[38, 39]	152.265	0.289	0.024	0.347
[39, 40]	146.020	0.295	0.011	0.320
[40, 41]	128.869	0.307	0.004	0.311
[41, 42]	107.394	0.334	0.020	0.341
[42, 43]	86.287	0.370	0.026	0.348
[43, 44]	69.418	0.384	0.033	0.346
[44, 45]	56.634	0.403	0.032	0.334

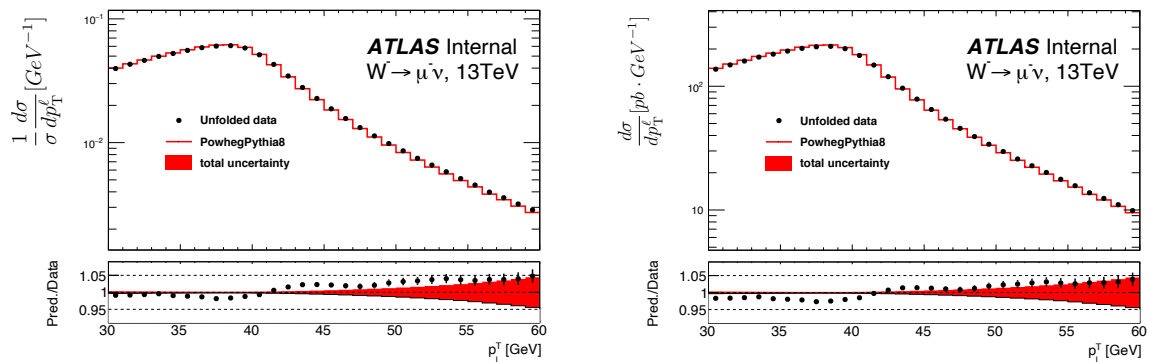
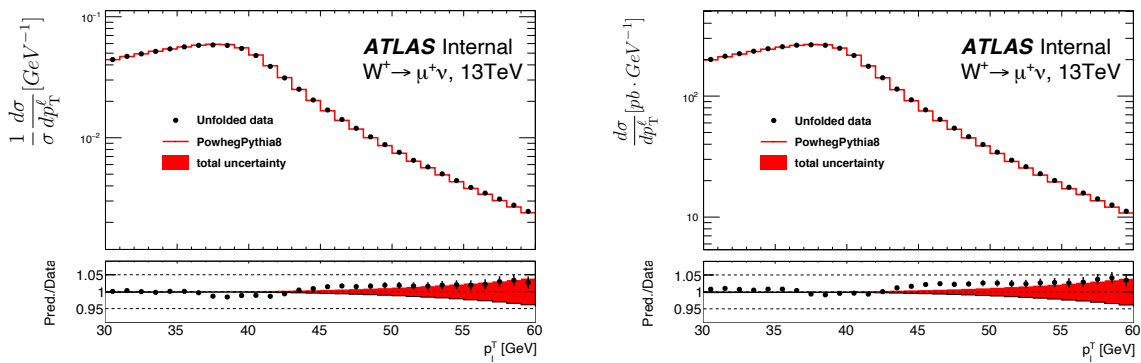
FIGURE 7.17: Differential cross sections (right) and normalised differential cross sections (left) as a function of p_T^μ for 13 TeV (W^- , μ^-). The bottom panel shows the ratio data to MC (Powheg+Pethia8) together with the red band showing the total uncertainty.

TABLE 7.8: Differential cross sections versus p_T^μ for 13 TeV (W^+ , μ^+). The columns show the bin range, the measured cross sections and the corresponding relative uncertainties.

$W^+ \rightarrow \mu^+ \nu_{\mu}$, 13 TeV, uncertainties in (%)				
Range	$d\sigma/dp_T^\mu$ [pb/GeV]	Stat uncertainty	Unfolding bias	Syst uncertainty
[26, 27]	80.886	0.359	0.030	0.374
[27, 28]	96.188	0.390	0.007	0.383
[28, 29]	108.856	0.382	0.010	0.411
[29, 30]	120.804	0.352	0.020	0.373
[30, 31]	131.932	0.317	0.024	0.305
[31, 32]	142.772	0.310	0.023	0.345
[32, 33]	152.768	0.294	0.020	0.348
[33, 34]	162.641	0.287	0.014	0.359
[34, 35]	172.353	0.269	0.006	0.325
[35, 36]	180.673	0.265	0.002	0.294
[36, 37]	187.665	0.265	0.011	0.327
[37, 38]	190.965	0.257	0.020	0.336
[38, 39]	190.346	0.262	0.026	0.337
[39, 40]	179.390	0.260	0.025	0.311
[40, 41]	157.157	0.278	0.020	0.305
[41, 42]	128.185	0.303	0.010	0.335
[42, 43]	102.682	0.326	0.000	0.341
[43, 44]	82.328	0.367	0.008	0.335
[44, 45]	66.918	0.413	0.015	0.318

FIGURE 7.18: Differential cross sections (right) and normalised differential cross sections (left) as a function of p_T^μ for 13 TeV (W^+ , μ^+). The bottom panel shows the ratio data to MC (Powheg+Pethia8) together with the red band showing the total uncertainty.

1972 **Differential cross sections of the e channel versus η_e** TABLE 7.9: Differential cross sections versus η_e at 5 TeV (W^+ , e^+). The columns show the bin range, measured cross section, relative uncertainties.

W ⁺ → e ⁺ ν _e , 5 TeV, uncertainties in (%)				
Range	$d\sigma/d\eta_e$	Stat uncertainty	Unfolding bias	Syst uncertainty
[-2.50, -2.18]	367.836	0.678	0.000	0.642
[-1.95, -1.74]	461.329	0.775	0.000	0.525
[-1.74, -1.52]	469.095	0.667	0.000	0.641
[-1.52, -1.37]	468.811	0.427	0.146	0.587
[-1.37, -1.05]	464.068	0.543	0.000	0.568
[-1.05, -0.84]	465.592	0.643	0.000	0.492
[-0.84, -0.63]	464.723	0.683	0.000	0.433
[-0.63, -0.42]	460.784	0.637	0.000	0.380
[-0.42, -0.21]	452.088	0.705	0.000	0.375
[-0.21, 0.00]	449.530	0.637	0.000	0.537
[0.00, 0.21]	453.114	0.681	0.000	0.495
[0.21, 0.42]	456.250	0.643	0.000	0.325
[0.42, 0.63]	452.126	0.683	0.000	0.370
[0.63, 0.84]	454.408	0.662	0.000	0.645
[0.84, 1.05]	459.436	0.666	0.000	0.432
[1.05, 1.37]	469.338	0.537	0.000	0.555
[1.37, 1.52]	472.773	0.413	0.030	0.490
[1.52, 1.74]	474.614	0.670	0.000	0.467
[1.74, 1.95]	457.307	0.715	0.000	0.511
[2.18, 2.50]	371.495	0.694	0.000	0.797

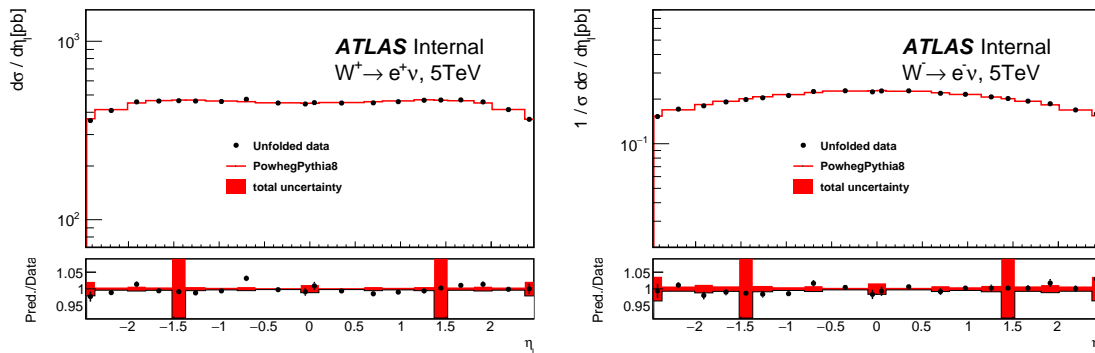
FIGURE 7.19: Differential cross sections (left) and normalised differential cross sections (right) as a function of p_T^e for 13 TeV (W^+ , e^+). The bottom panel shows the ratio data to MC (Powheg+Pethia8) together with the red band showing the total uncertainty.

TABLE 7.10: Differential cross sections versus η_e at 5 TeV (W^- , e^-). The columns show the bin range, measured cross section, relative uncertainties.

$W^- \rightarrow e^- \bar{\nu}_e$, 5 TeV, uncertainties in (%)				
Range	$d\sigma/d\eta_e$	Stat uncertainty	Unfolding bias	Syst uncertainty
[-2.50, -2.18]	216.082	0.935	0.944	0.688
[-2.18, -1.95]	249.183	0.929	0.491	0.450
[-1.95, -1.74]	250.450	0.972	0.067	0.531
[-1.74, -1.52]	268.866	0.997	0.578	0.617
[-1.52, -1.37]	275.843	0.602	0.948	0.550
[-1.37, -1.05]	284.339	0.720	0.999	0.519
[-1.05, -0.84]	293.295	0.888	0.591	0.463
[-0.84, -0.63]	305.781	0.838	0.119	0.421
[-0.63, -0.42]	312.623	0.853	0.303	0.353
[-0.42, -0.21]	315.281	0.818	0.569	0.344
[-0.21, 0.00]	311.796	0.802	0.623	0.486
[0.00, 0.21]	317.227	0.796	0.457	0.448
[0.21, 0.42]	314.936	0.842	0.165	0.304
[0.42, 0.63]	308.392	0.770	0.150	0.343
[0.63, 0.84]	302.388	0.800	0.361	0.581
[0.84, 1.05]	298.429	0.797	0.345	0.389
[1.05, 1.37]	289.149	0.712	0.084	0.501
[1.37, 1.52]	280.873	0.552	0.762	0.467
[1.52, 1.74]	272.492	0.908	1.314	0.447
[1.74, 1.95]	256.505	0.972	1.667	0.493
[1.95, 2.18]	250.888	0.912	1.039	0.481
[2.18, 2.50]	215.071	0.924	2.373	0.858

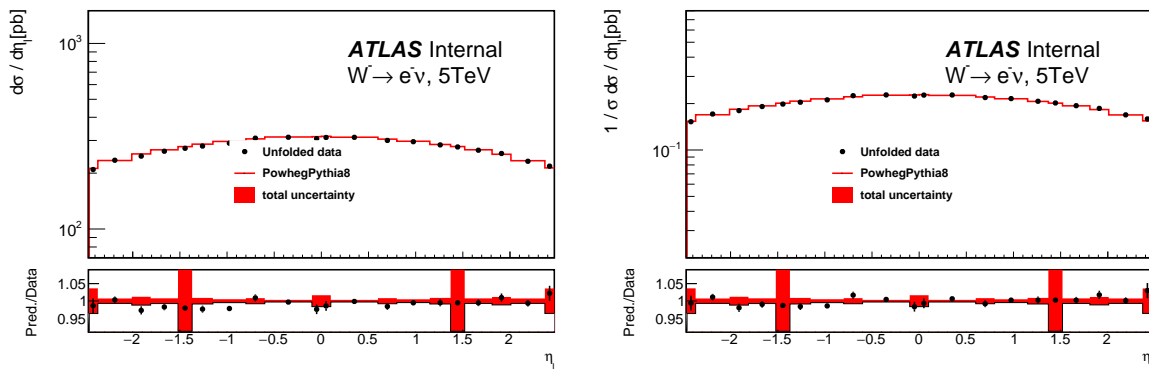


FIGURE 7.20: Differential cross sections (left) and normalised differential cross sections (right) as a function of p_T^e for 13 TeV (W^- , e^-). The bottom panel shows the ratio data to MC (Powheg+Pethia8) together with the red band showing the total uncertainty.

1973 **Differential cross sections of the μ channel versus η_μ** TABLE 7.11: Differential cross-sections versus η^μ at 5 TeV (W^+, μ^+). The columns show the bin range, measured cross section, relative uncertainties.

$W^+ \rightarrow \mu^+ \nu_{\mu^+}$ 5 TeV, uncertainties in (%)				
Range	$d\sigma/d\eta_\mu$	Stat uncertainty	Unfolding bias	Syst uncertainty
[-2.40, -1.92]	417.143	0.470	0.000	0.761
[-1.92, -1.35]	464.547	0.411	0.000	0.571
[-1.35, -1.15]	462.196	0.670	0.000	0.697
[-1.15, -1.05]	458.964	1.183	0.000	2.246
[-1.05, -0.91]	461.993	0.987	0.000	2.243
[-0.91, -0.48]	453.411	0.504	0.000	0.782
[-0.48, 0.00]	446.514	0.529	0.000	0.896
[0.00, 0.48]	443.203	0.493	0.000	0.886
[0.48, 0.91]	454.335	0.489	0.000	0.893
[0.91, 1.05]	466.137	1.020	0.000	2.233
[1.05, 1.15]	455.781	1.055	0.000	1.775
[1.15, 1.35]	474.952	0.689	0.000	0.664
[1.35, 1.92]	459.009	0.412	0.000	0.543
[1.92, 2.40]	417.343	0.470	0.000	0.769

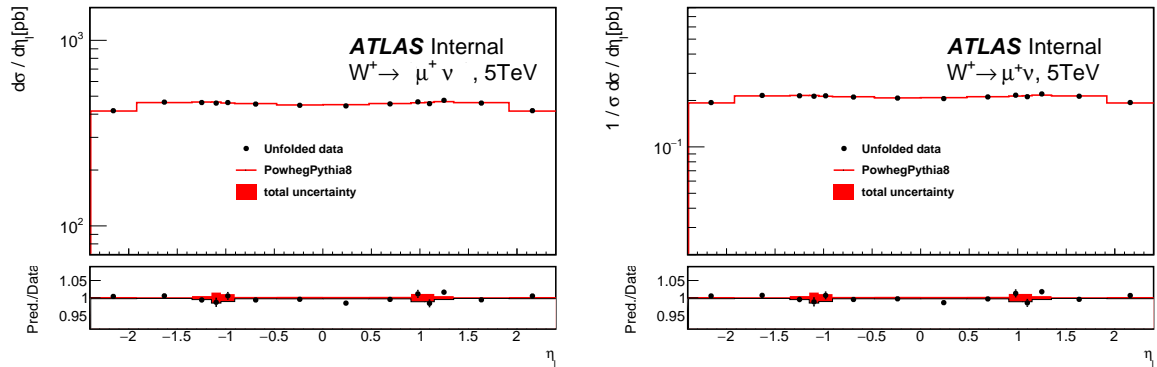
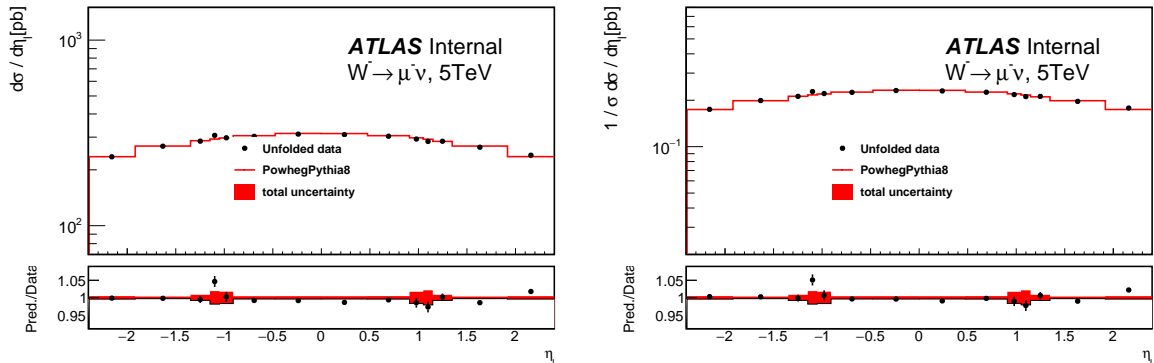
FIGURE 7.21: Differential cross sections (left) and normalised differential cross sections (right) as a function of p_T^μ for 13 TeV (W^+, μ^+). The bottom panel shows the ratio data to MC (Powheg+Pethia8) together with the red band showing the total uncertainty

TABLE 7.12: Differential cross-sections versus η^μ at 5 TeV (W^- , μ^-). The columns show the bin range, measured cross section, relative uncertainties.

$W^- \rightarrow \mu^- \bar{\nu}_\mu$, 5 TeV, uncertainties in (%)				
Range	$d\sigma/d\eta_\mu$	Stat uncertainty	Unfolding bias	Syst uncertainty
[-2.40, -1.92]	234.738	0.621	0.000	0.752
[-1.92, -1.35]	268.060	0.508	0.000	0.501
[-1.35, -1.15]	285.380	0.881	0.000	1.307
[-1.15, -1.05]	306.520	1.296	0.000	3.090
[-1.05, -0.91]	297.537	1.314	0.000	0.024
[-0.91, -0.48]	302.886	0.607	0.000	1.061
[-0.48, 0.00]	311.382	0.569	0.000	0.738
[0.00, 0.48]	309.306	0.633	0.000	0.707
[0.48, 0.91]	303.490	0.635	0.000	0.778
[0.91, 1.05]	293.061	1.202	0.000	2.989
[1.05, 1.15]	284.430	1.390	0.000	3.657
[1.15, 1.35]	285.125	0.837	0.000	1.393
[1.35, 1.92]	264.657	0.512	0.000	0.550
[1.92, 2.40]	239.405	0.592	0.000	0.775


 FIGURE 7.22: Differential cross sections (left) and normalised differential cross sections (right) as a function of p_T^μ for 13 TeV (W^- , μ^-). The bottom panel shows the ratio data to MC (Powheg+Pethia8) together with the red band showing the total uncertainty

1974 7.4 Comparison of electron and muon channels

1975 The differential cross sections for electron and muon are calculated using different
 1976 binning in η direction. The choose of η binning is related mainly to the scale factor
 1977 (SF) binning (reconstruction, trigger, isolation and identification SFs) that we apply
 1978 to simulation in order to correct the difference between data and simulation. The
 1979 electron SFs are calculated in the same binning, Table 7.13, while for muon, the SFs
 are calculated using different binning, Table 7.14.

TABLE 7.13: Values of η bin boundaries for electron SFs.

-2.47	-2.37	-2.01	-1.81	-1.37	-1.15	-0.8	-0.6	-0.1	0	0.1	0.6	0.8	1.15	1.37	1.52	1.81	2.01	2.37	2.47
-------	-------	-------	-------	-------	-------	------	------	------	---	-----	-----	-----	------	------	------	------	------	------	------

TABLE 7.14: Values of η bin boundaries for muon trigger SF.

-2.4	-1.918	-1.348	-1.1479	-1.05	-0.908	-0.476	0	0.476	0.908	1.05	1.1479	1.348	1.918	2.4
------	--------	--------	---------	-------	--------	--------	---	-------	-------	------	--------	-------	-------	-----

1980
 1981 The idea to compare the differential cross sections in the electron and muon
 1982 channels, is to keep the binning at the reconstruction level unchanged, to conserve
 1983 the SFs effects, and change the binning at the unfolded level to a common binning
 1984 for the two channels. The new binning is chosen in a such a way that we conserve
 1985 the bin boundaries similar to the SFs binning at the reconstructed level, Table 7.15.
 1986 Figure 7.23 shows the comparison between the different SFs for electron and muon
 and the proposed binning at the unfolded level.

TABLE 7.15: Values of η bin boundaries for new binning at the unfolded level.

-2.5	-1.85	-1.36	-1.05	-0.85	-0.5	0	0.5	0.85	1.05	1.36	1.85	2.5
------	-------	-------	-------	-------	------	---	-----	------	------	------	------	-----

1987
 1988 The distributions of η for electron and muon are unfolded to a common un-
 1989 folded level, Figure 7.24 shows the comparison between distributions at the re-
 1990 construction and unfolded level, together with differential cross sections for elec-
 1991 tron and muon. The comparison of the cross sections shows in a good agreement
 1992 for electrons and muons, excepting for the around $\eta \approx 1.2$, where the difference
 1993 is related mainly to the variation of trigger SF for muon, shown in Figure 7.23.
 1994 The difference observed is around 1.8% and included in the uncertainty. For the
 1995 comparison with theoretical predictions, the binning defined in the Tables 7.13 and
 1996 7.14 are used in order to conserve the effect of scale factors.

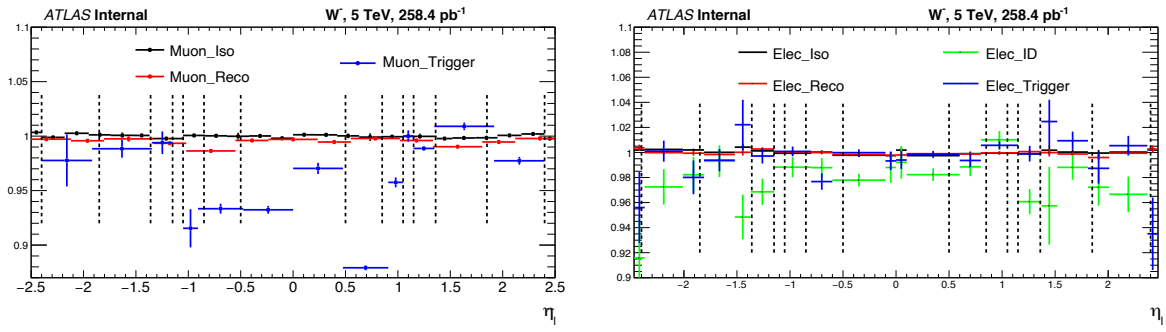


FIGURE 7.23: Muon (left) and electron (right) scale factors (SFs) used to correct simulation. The muons SFs are calculated using different binning, while the electron SFs are calculated in the same binning. The dotted vertical line shows the boundaries for proposed common binning at the unfolded level.

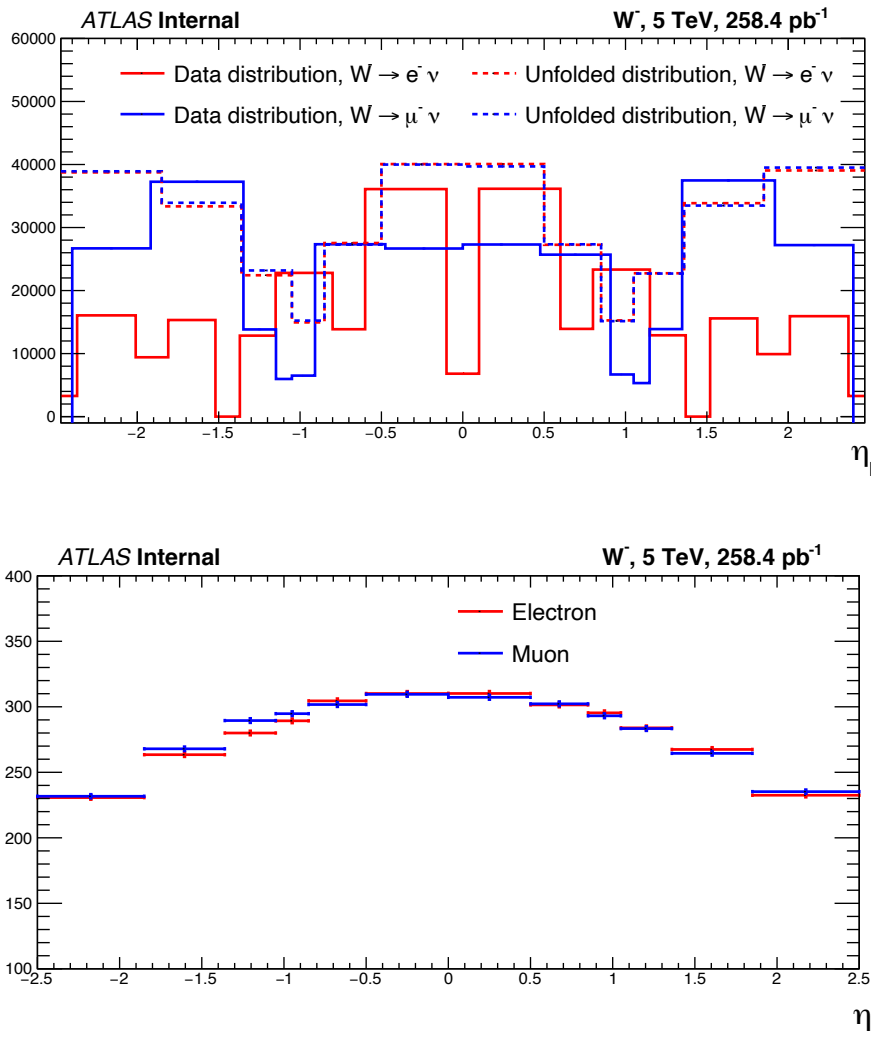


FIGURE 7.24: (Top) Distributions of data as a function of η_l for electron and muon at the reconstructed and the unfolded levels using the new common binning at the unfolded level. (Bottom) Comparison of the differential cross sections as a function of η_l for electron and muon.

1997 7.5 Comparison with theoretical predictions

1998 The measured differential cross sections for $W^\pm \rightarrow \ell^\pm \nu$ are compared to theoretical
 1999 predictions using DYTURBO [45] at NNLO QCD and LO in the EW theory, with
 2000 different PDF sets: CT18 [93], HERAPDF20 [87], MMHT2014 [91], in the fiducial
 2001 phase space defined in Section 7.2. The differential cross sections are compared
 2002 separately for electron and muon without combination. The uncertainties of the
 2003 theoretical predictions arise from the limited knowledge of proton PDFs. The DY-
 2004 TURBO uses input parameters (G_F , M_W , M_Z) for the theoretical predictions. The
 2005 PDF sets used were extracted from analyses of various experimental data sets us-
 ing the corresponding predictions at NNLO in QCD.

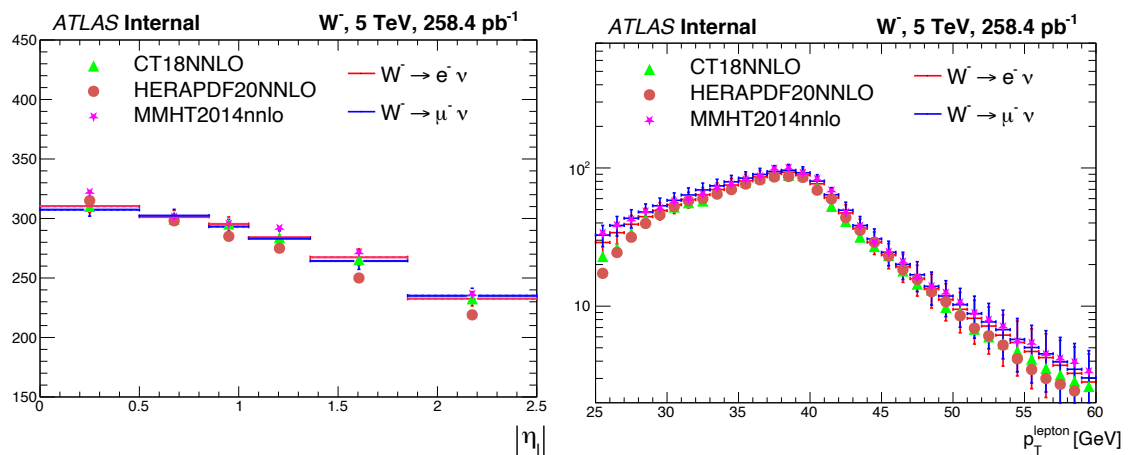


FIGURE 7.25: (left) Differential cross sections as a function of η_ℓ for electron and muon compared to different PDF sets. (right) Differential cross sections as a function of p_T^ℓ for electron and muon compared to different PDF sets.

2006 The PDF uncertainty on the M_W measurement, the dominant source of physics
 2007 modelling uncertainty ≈ 9.2 MeV, arises from our imperfect knowledge of the
 2008 PDFs affecting the differential cross section as a function of boson rapidity, the
 2009 angular coefficients, and the W boson transverse momentum distribution. The
 2010 measurements of the differential cross sections of the W boson, as a function of η_ℓ ,
 2011 are used to validate and constrain the PDF uncertainty on the measurement of W
 2012 boson, by comparing the uncertainties on the measured level and the uncertainties
 2013 on the PDF predictions.
 2014

2015 7.6 Double differential cross sections in p_T^ℓ and η_ℓ bins

2016 7.6.1 Introduction

2017 Double differential cross sections in p_T^ℓ and η_ℓ bins are measured using a two di-
 2018 mensional (2d) unfolding of data distributions. The two dimensional unfolding
 2019 can be transferred to a one dimensional (1d) unfolding by splitting the data dis-
 2020 tributions of η_ℓ , in different ranges of p_T^ℓ as shown in Fig. 7.26. The statistical and
 2021 systematic uncertainties are evaluated in the same way as we did for one dimen-
 2022 sional unfolding described in Sec. 7.6.2. The bin-by-bin correction method can not
 2023 be used because of the large migration between bins (Fig. 7.27).

2024 The double differential cross sections can be expressed as:

$$\frac{d\sigma}{dp_T^\ell d\eta_j^\ell} = \frac{N_{i,j}^{\text{Unfolded}}}{\mathcal{L} \Delta p_T^\ell \Delta \eta_j^\ell} \cdot \frac{1}{A_{\text{unf}}} \quad (7.4)$$

2025 where N_{Unfolded} represents the number of events in the unfolded distribution, and
 2026 A_{unf} is a correction factor related to the unfolding procedure. This factor represents
 2027 the fraction of the entries in a truth bin that are in the same bin at reconstruction
 level, \mathcal{L} is the integrated luminosity of data, and Δp_T^ℓ , $\Delta \eta_\ell$ are the bin widths.

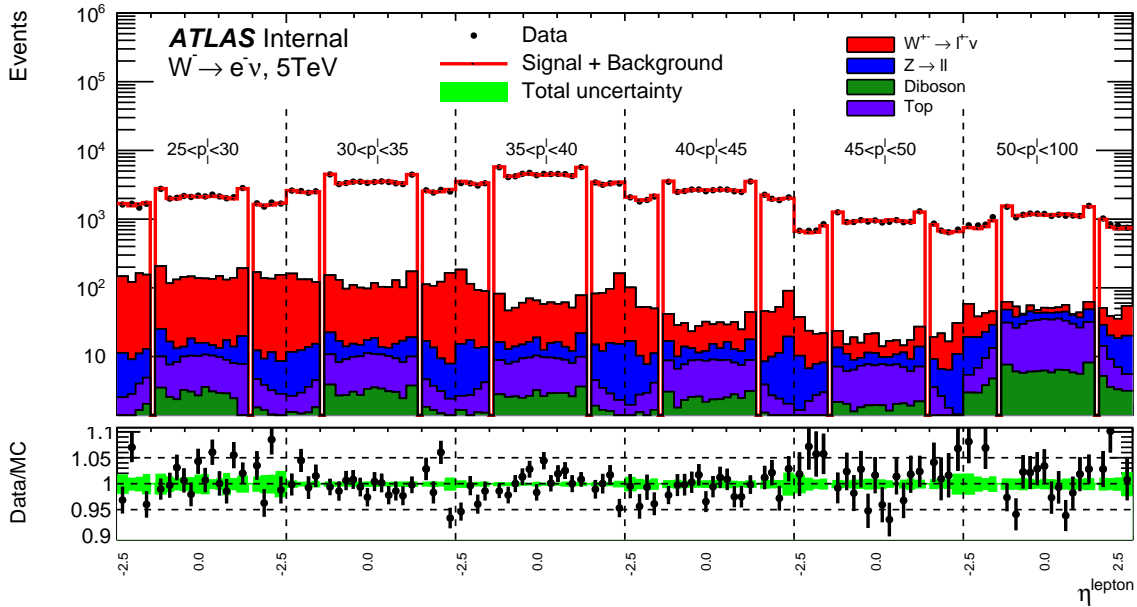


FIGURE 7.26: Distributions of the observables chosen to be unfolded η_ℓ in bins of p_T^ℓ for 5 TeV in the fiducial phase space. The signal and backgrounds are normalised to data. The low panel gives the ratio of the numbers of observed events to the total prediction in each bin. The green band shows the total statistical and systematic uncertainties. All the comparisons data/MC for 5 and 13 TeV are shown in Appendix B.

2029 7.6.2 Migration matrix

2030 In a migration matrix, one axis, e.g. the x -axis corresponds to reconstructed bins,
 2031 the y -axis to true bins. For the double differential cross sections, the migration ma-
 2032 trix is constructed in the same way but we take into account the different ranges of
 2033 p_T^ℓ . The x -axis, corresponds to reconstructed η_ℓ in different ranges of reconstructed
 p_T^ℓ . The y -axis, corresponds to true η_ℓ in different ranges of true p_T^ℓ .

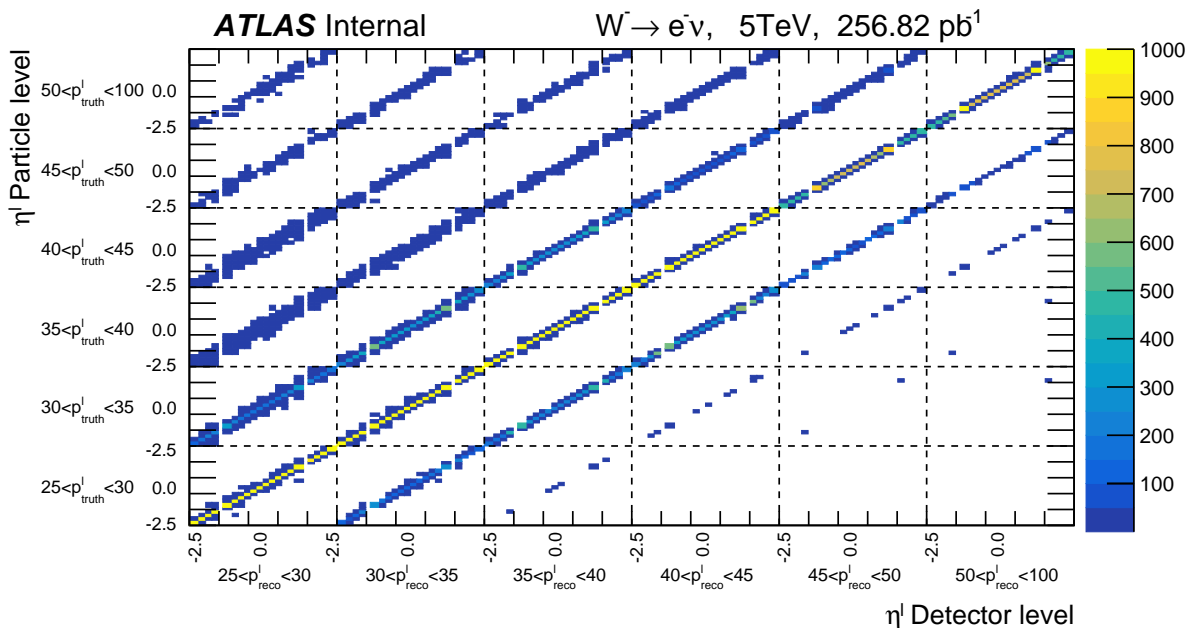


FIGURE 7.27: Example of the migration matrix used to unfold the data distribution for the measurement of the double differential cross sections, for $W^- \rightarrow e^- \nu$ at 5 TeV.

2034

2035 7.6.3 Statistical uncertainty

2036 As the 2d unfolding problem is transformed into 1d unfolding, the statistical and
 2037 systematic uncertainties are calculated as described in Sec. 7.6.2. As shown in
 2038 Fig. 7.27, the 2d unfolding is characterised with a large migration between bins
 2039 which explains the variation of statistical uncertainty with the number of iterations
 2040 (Fig. 7.28).

2041 7.6.4 Unfolding bias

2042 The bias is calculated as described for 1d unfolding (Sec. 7.6.2). The only differ-
 2043 ence is that we fit the ratio data/MC separately for each range of p_T^ℓ as shown in
 2044 Fig. 7.29.

2045 Because of the migration in the 2 dimensional unfolding, the bias is in the order
 2046 of 1% for the first iteration and decreases with the number of iterations. For the
 2047 double differential cross-sections results, 4 iterations are used in the final results to
 2048 ensure that bias contribution is negligible comparing to other source of uncertain-
 2049 ties. There are some bins where the bias is in the order 1.5% and does not change

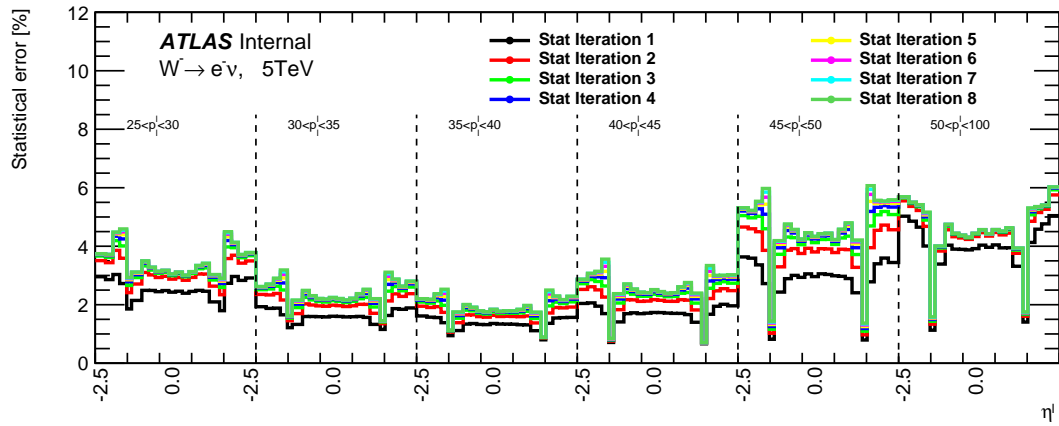


FIGURE 7.28: Example of the statistical uncertainty of unfolded distribution of η_ℓ in different ranges of p_T^ℓ

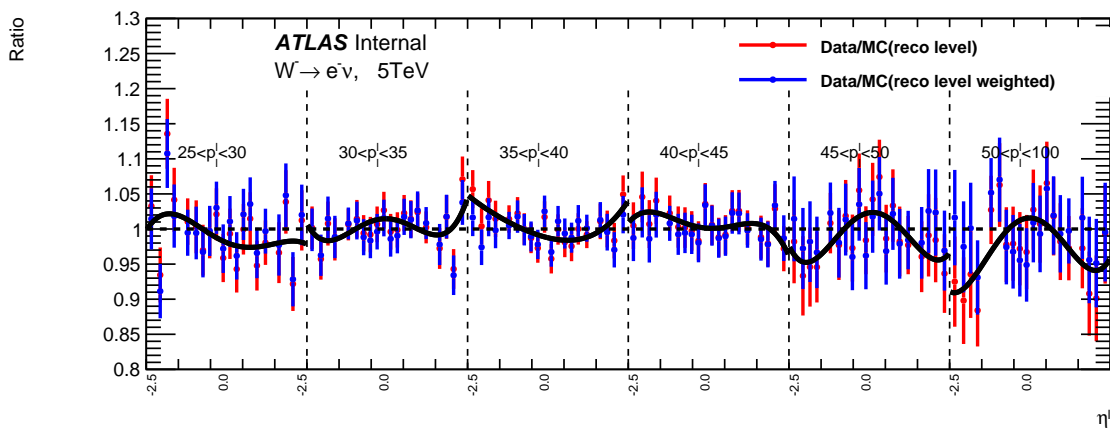


FIGURE 7.29: Example of the fitted ratio data/MC of η_ℓ in different ranges of p_T^ℓ

2050 with iterations. Basically, the bias values in these bins have no significance as bins correspond to empty bin [1.52, 1.37] (Fig. 7.30).

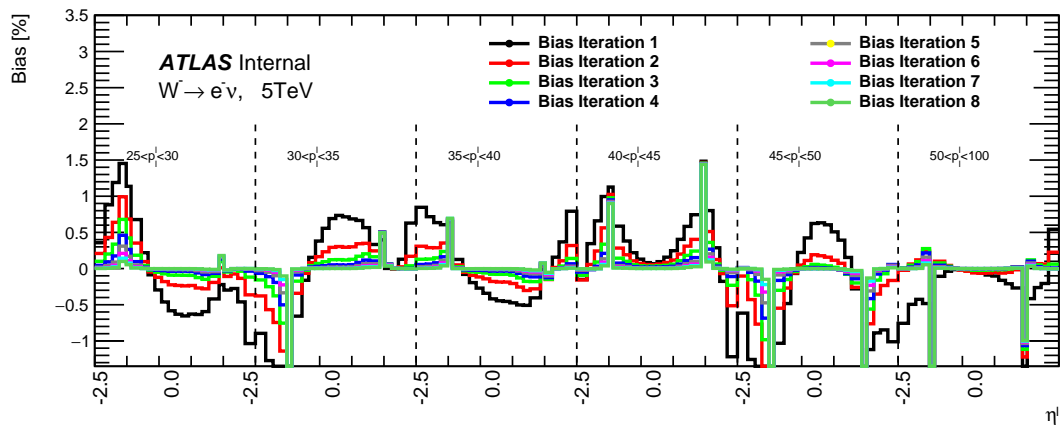


FIGURE 7.30: Example of the bias uncertainty as a function of η_ℓ in different ranges of p_T^ℓ .

2051

2052 7.6.5 Double differential cross sections

2053 The double differential cross section results, together with the statistical, experi-
 2054 mental systematic and unfolding bias uncertainties, are shown in Figures 7.31 and
 2055 7.32 for 5 TeV and Figures 7.33 and 7.34 for 13 TeV.

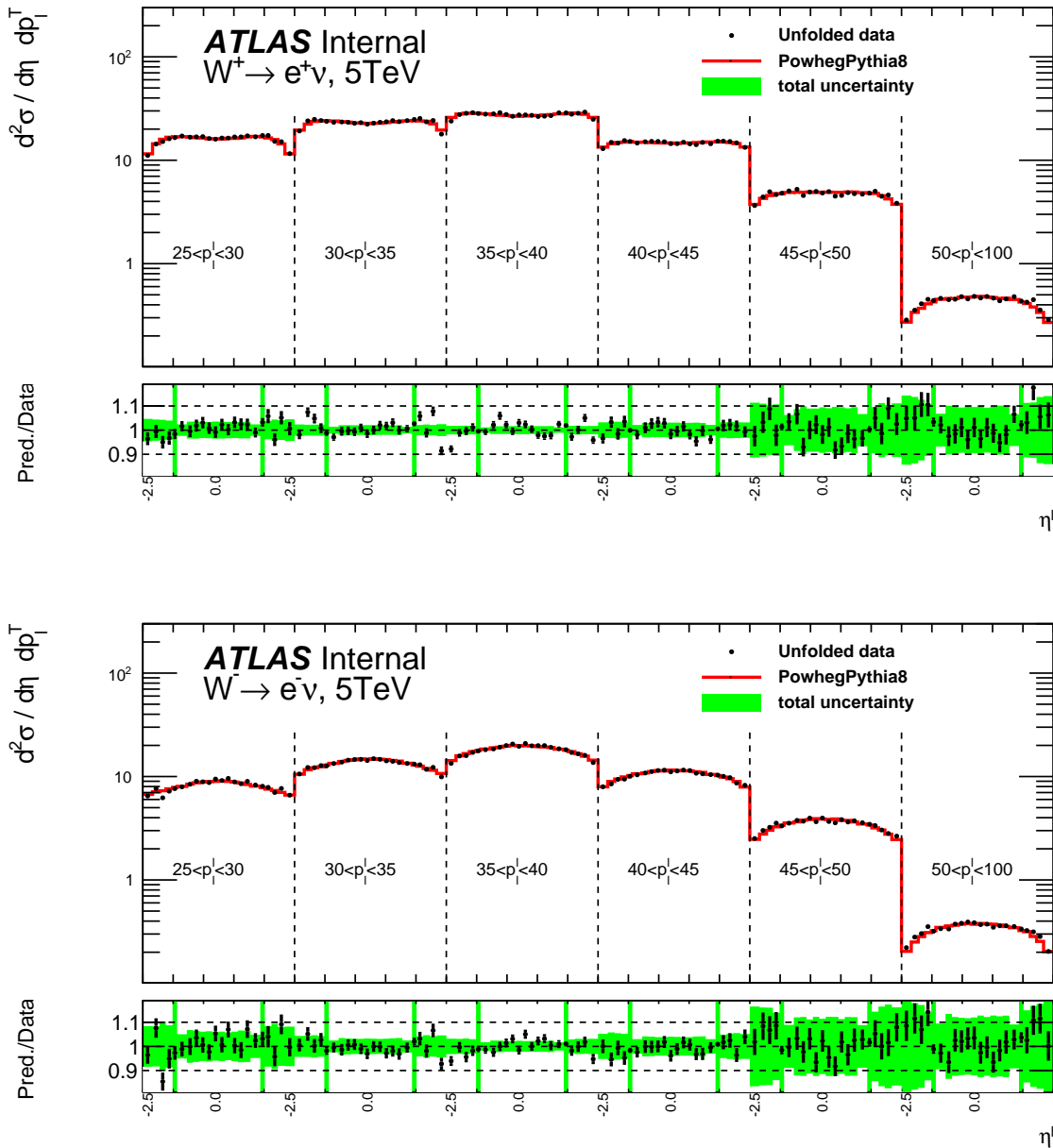


FIGURE 7.31: Double differential cross sections in bins of η_ℓ and p_T^ℓ compared to Powheg+Pythia8 for $W^+ \rightarrow e^+\nu$ and $W^- \rightarrow e^-\nu$ at 5 TeV. The low panel shows the ratio data/MC and the green band represents the statistical and systematic uncertainties added in quadrature.

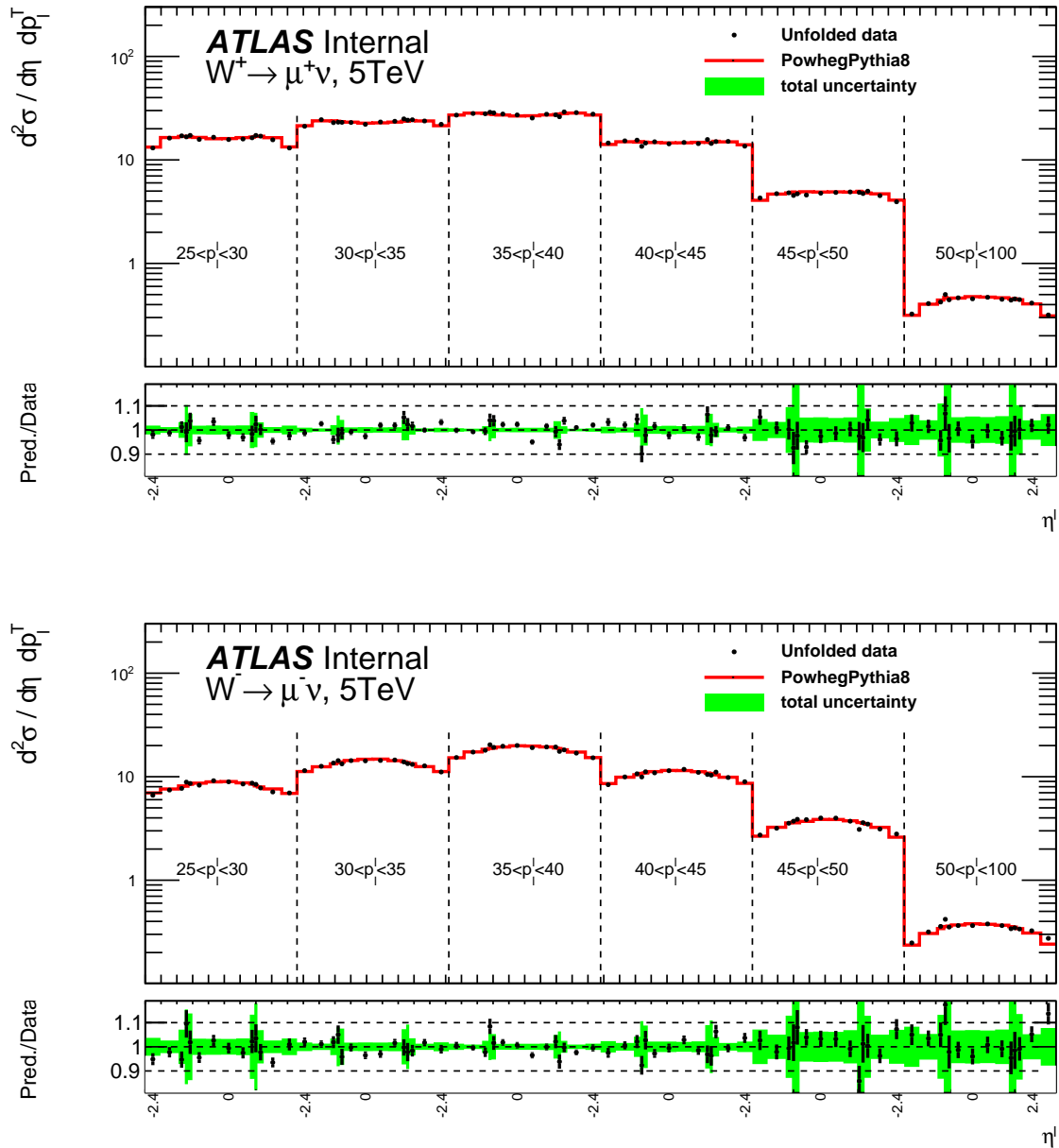


FIGURE 7.32: Double differential cross sections in bins of η_ℓ and p_T^ℓ compared to Powheg+Pythia8 for $W^+ \rightarrow \mu^+ \nu$ and $W^- \rightarrow \mu^- \nu$ at 5 TeV. The low panel shows the ratio data/MC and the green band represents the statistical and systematic uncertainties added in quadrature.

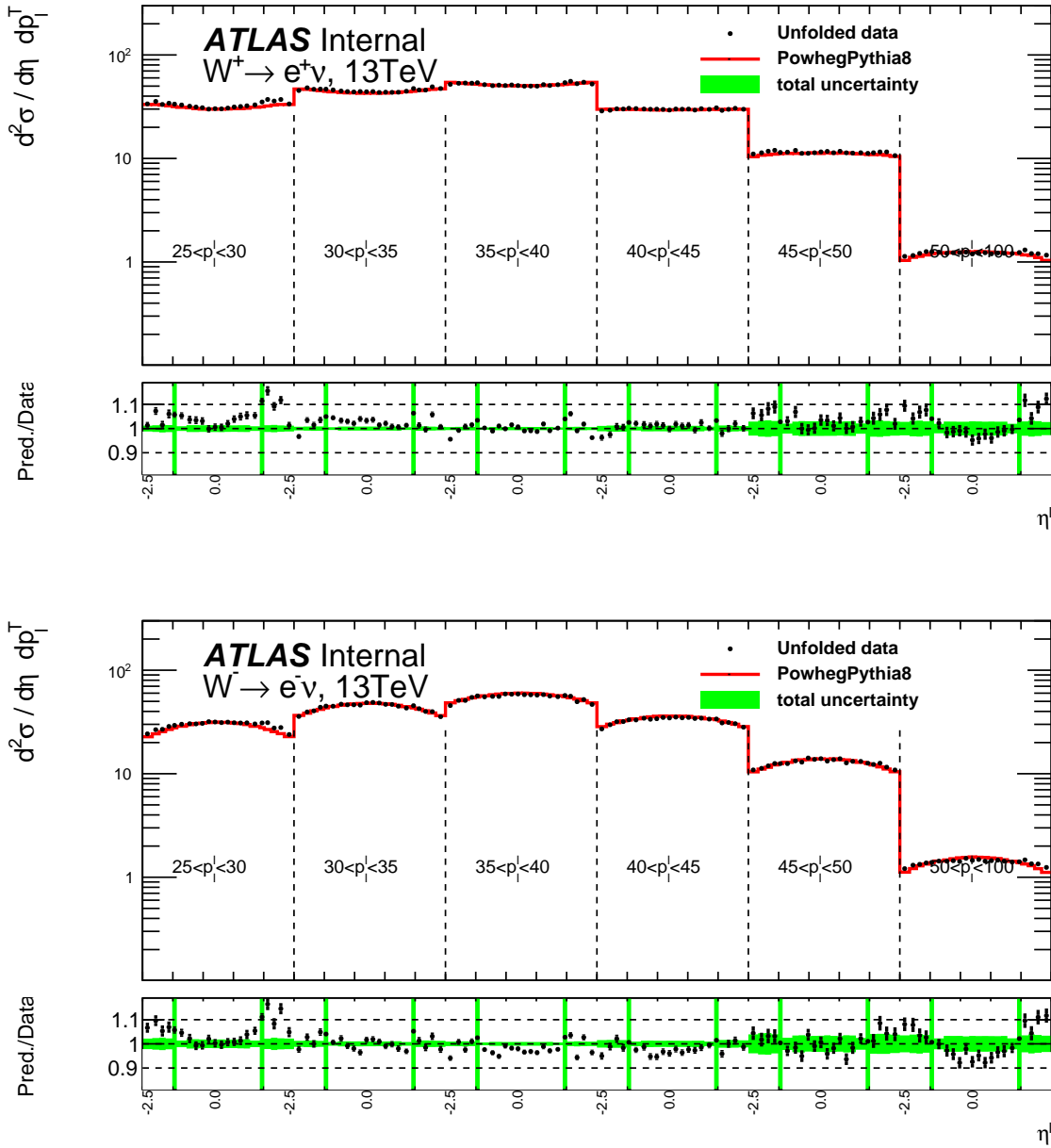


FIGURE 7.33: Double differential cross sections in bins of η_ℓ and p_T^ℓ compared to Powheg+Pythia8 for $W^+ \rightarrow e^+ \nu$ and $W^- \rightarrow e^- \nu$ at 13 TeV. The low panel shows the ratio data/MC and the green band represents the statistical and systematic uncertainties added in quadrature.

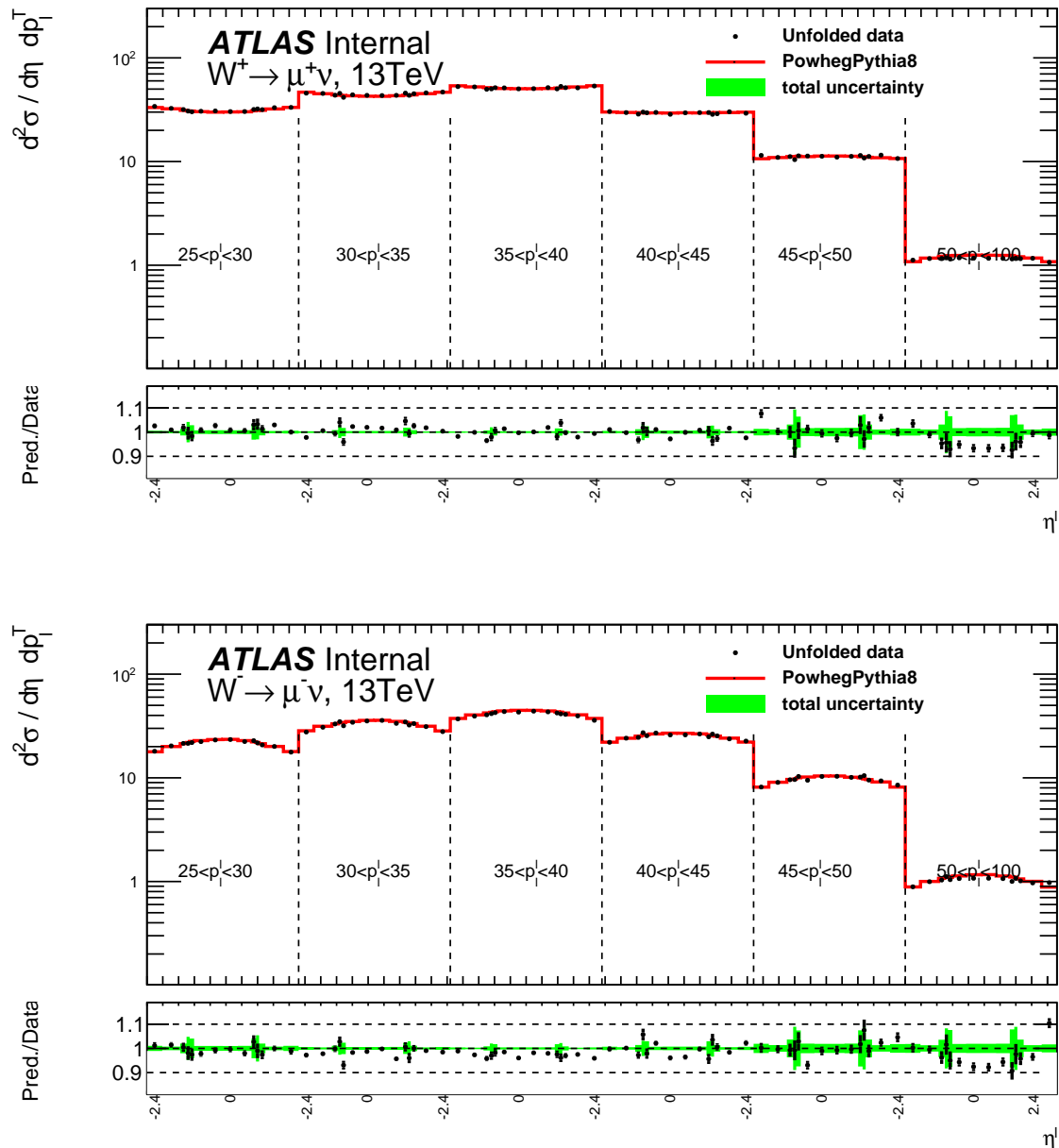


FIGURE 7.34: Double differential cross sections in bins of η_ℓ and p_T^ℓ compared to Powheg+Pythia8 for $W^+ \rightarrow \mu^+ \nu$ and $W^- \rightarrow \mu^- \nu$ at 13 TeV. The low panel shows the ratio data/MC and the green band represents the stat and systematic uncertainties added in quadrature.

Chapter 8

Measurement of the W -boson mass

8.1 Introduction

This chapter will show preliminary results of the measurement of W boson mass using low pile-up data set at $\sqrt{s} = 5$ TeV and 13 TeV with two approaches: using the templates method [17], developed before for Run 1 analysis, and using the unfolded distributions of our variables of interest. The methodology of using the unfolded distributions for W boson mass is described in Sec. 8.3. In parallel of those methods, there is another approach, using a new fitting algorithm in global W mass, with the profile likelihood approach [77], which treats the correlation between uncertainties differently from the template method. However, in this chapter, we will focus on the evaluation of statistical uncertainty on the W boson mass measurement using the two approaches described above, and the dominated experimental uncertainties: lepton efficiency, lepton calibration and hadronic recoil calibration.

8.2 Template fit method methodology

The W boson is an unstable particle which decays to a charged lepton and a neutrino. The mass of the W boson is determined using the distributions of the transverse mass of W (m_T^W) and of the transverse momentum of lepton (p_T^ℓ), where the p_T^ℓ distribution has a Jacobian peak at $M_W/2$, while the transverse mass peak at M_W , Figure 8.1 shows the distributions of p_T^ℓ and m_T^W at the Jacobian peaks. The basic idea of the template method consists in computing the p_T^ℓ and m_T^W distributions for different assumed values of M_W , called the templates, and the comparison between templates and data gives the best fit value.

To generate templates with different W masses, the truth level distributions are reweighted using the Breit-Wigner equation:

$$f(m_W) = \frac{d\sigma}{dm} \propto \frac{m^2}{(m^2 - m_W^2)^2 + m^4 \Gamma_W^2 / m_W^2}, \quad (8.1)$$

where m_W is the W boson mass, and the weight applied to truth distributions is considered as:

$$\text{weight} = \frac{f(m'_W)}{f(m_W)}, \quad (8.2)$$

where m'_W is the modified mass.

2085 Figure 8.6 shows an example of p_T^ℓ and m_T^W distributions compared to the tem-
 2086 plates generated with different mass values. Then, the comparison between tem-
 2087 plates and data is based on χ^2 defined as:

$$\chi^2 = \sum_{i=1}^N \frac{(n_i^{\text{data}} - n_i^{\text{template}})^2}{(\sigma_{n_i^{\text{data}}}^2 + (\sigma_{n_i^{\text{template}}})^2)}, \quad (8.3)$$

2088 where n_i^{data} (n_i^{template}) is the number of entries in bin i of data (template), and $\sigma_{n_i^{\text{data}}}$
 2089 ($\sigma_{n_i^{\text{template}}}$) is the uncertainty in bin i of data (template). The background is sub-
 tracted from the number of entries in data n_i^{data} .

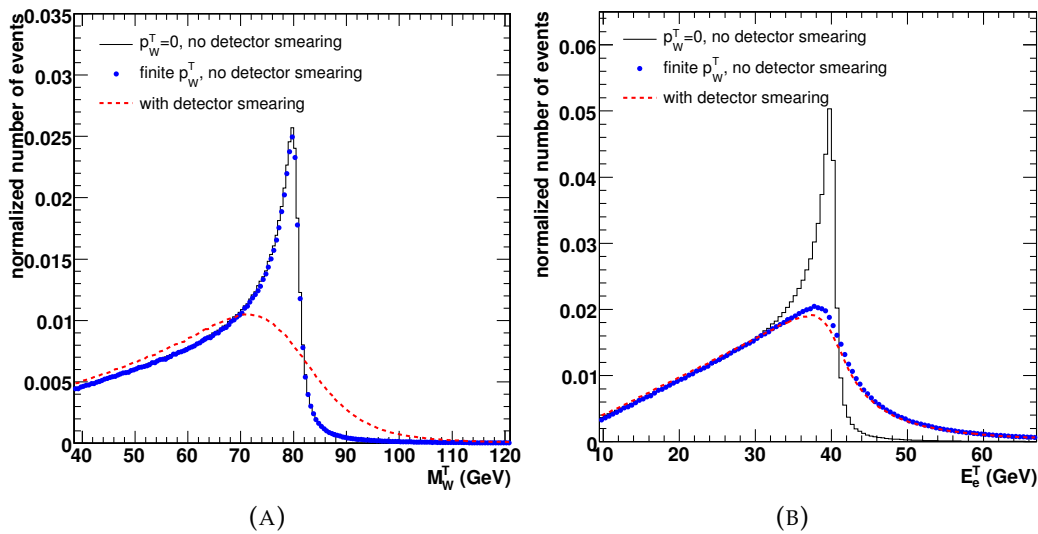


FIGURE 8.1: Transverse mass of W (A) and lepton transverse momentum (B) distributions in W decays. The distributions at the generator level with $p_T^W = 0$ (blackline), with finite W boson p_T^W (blue dots) and including the experimental resolution in the low luminosity phase (red dashed line) are shown [112].

2090 The χ^2 is calculated between data and each template separately, then the com-
 2091 puted χ^2 values are fitted using a polynomial function. The minimum of χ^2 distri-
 2092 bution gives the best M_W value. Figure 8.3 shows an example of the fitted χ^2
 2093 distribution. The templates used in the W -mass fit are signal MC samples reweighted
 2094 to $M_W \pm [0, 25, 50, 100, 150, 200]$ MeV.

2095 This method has been used in previous experiments (CDF and DO) for the W
 2096 mass measurement. In parallel to the template method, there is a new method [77]
 2097 being developed called “profile likelihood” approach, which allows to deal with
 2098 systematic uncertainties and their correlations in a different way.
 2099

2100 8.3 W boson mass using the unfolded distribution

2101 In addition to the method described above, there is a different approach consist-
 2102 ing in using the distributions at the unfolded level instead of the distributions at
 2103 the reconstructed level. The main idea is to use distributions which are already

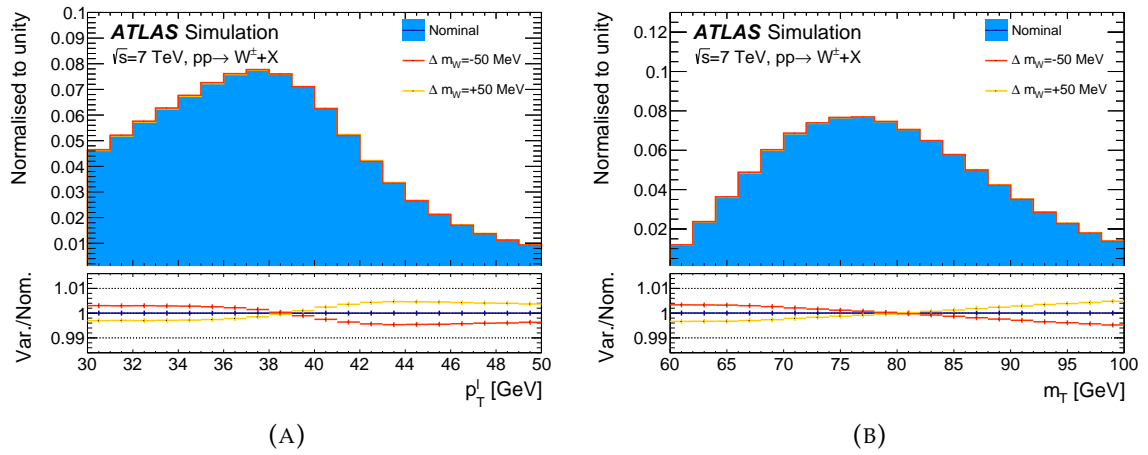


FIGURE 8.2: Kinematic distributions of p_T^ℓ (A) and m_T^W (B) in simulated events for the W -boson mass nominal value $M_W = 80370$ MeV and the shifted values $M_W = 80320$ MeV and $M_W = 80420$ MeV [115].

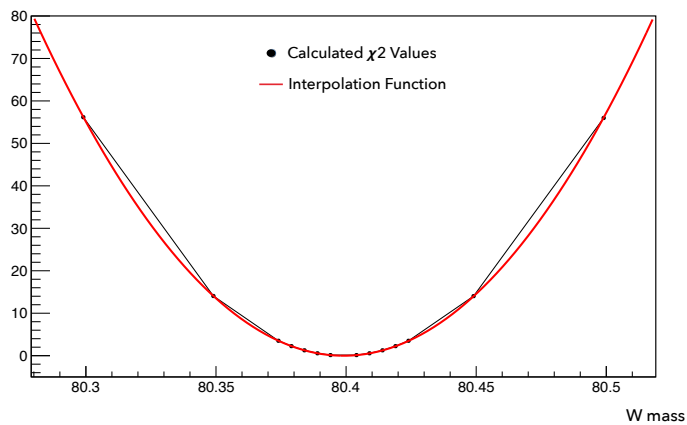


FIGURE 8.3: Fit to χ^2 distribution at different template mass values.

2104 corrected by the unfolding procedure and does not contain undesirable detector
 2105 effects. The extraction of the M_W boson is the same as described with the template
 2106 method, except for the χ^2 formula which have to be changed to take into account
 2107 the correlation between bins at the unfolded level, introduced by the unfolding
 2108 procedure. The new χ^2 formula is expressed as:

$$\chi^2 = (n_{\text{data}}^{\text{Unf}} - n_{\text{template}}^{\text{Unf}})^T \cdot (V_{\text{data}} + V_{\text{template}})^{-1} \cdot (n_{\text{data}}^{\text{Unf}} - n_{\text{template}}^{\text{Unf}}), \quad (8.4)$$

2109 where $n_{\text{data}}^{\text{Unf}}$ is the unfolded distribution of data, $n_{\text{template}}^{\text{Unf}}$ is the unfolded distribu-
 2110 tion of template, V_{data} (V_{template}) represents the covariance matrix of the statistical
 2111 uncertainty for the unfolded distribution of data (template) calculated as described
 2112 in Chapter 4. Once the χ^2 is calculated for all the unfolded templates, the proce-
 2113 dure is the same as described for the template method. Ideally for both meth-
 2114 ods, we expect to have the same results but with an additional bias for the second
 2115 method due to the unfolding of the variables of interest.

2116 8.4 Statistical uncertainty

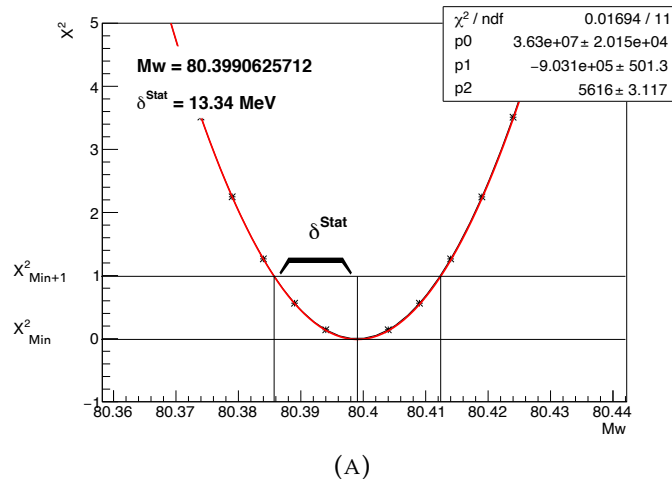
2117 The evaluation of statistical uncertainty is based on data distributions and MC
 2118 templates, calculated from the χ^2 fit using a parabola function and estimated as
 2119 the deviation from the measured value of M_W and M'_W correspond to $\chi^2_{\text{min}} + 1$.
 2120 Figure 8.4 shows an example of the statistical uncertainty estimation. The statisti-
 2121 cal uncertainties are calculated using distributions of p_T^ℓ and m_T^W separately and
 2122 then combined. Since our distributions of interest are generated using the same
 2123 events, we have to take into account the correlation between this two variables.
 2124 The correlation is calculated using toys of MC (400 toys), generated by varying the
 2125 p_T^ℓ and m_T^W distributions simultaneous with a random Poisson variation, and for
 2126 each toy the W mass is calculated. Then the correlation factor is calculated as:

$$r = \frac{\sum_{i=1}^N (X_i - \bar{X}) (Y_i - \bar{Y})}{\sqrt{\sum_{i=1}^N (X_i - \bar{X})^2} \sqrt{\sum_{i=1}^N (Y_i - \bar{Y})^2}}, \quad (8.5)$$

2127 where N is the number of toys, X_i (Y_i) represent the W mass results for toy i of p_T^ℓ
 2128 (m_T^W), \bar{X} (\bar{Y}) is the average of all the measured values X_i (Y_i). The final measured
 2129 value of the W -boson statistical uncertainty is obtained from the combination of
 2130 various measurements performed in the electron and muon channels, and in $|\eta|$ -
 2131 dependent categories, as defined in Table 8.1. The boundaries of the $|\eta|$ categories
 2132 were defined as for Run 1 analysis, driven mainly by experimental and statisti-
 2133 cal constraints [115]. Figure B.8 shows an example of the correlation between p_T^ℓ
 2134 and m_T^W with the corresponding correlation factor for different ranges of $|\eta|$. The

TABLE 8.1: Summary of categories and kinematic distributions used in the W mass analysis for the electron and muon decay channels [115].

Decay channel	$W \rightarrow e\nu$	$W \rightarrow \mu\nu$
Kinematic distributions	p_T^ℓ, m_T	p_T^ℓ, m_T
Charge categories	W^+, W^-	W^+, W^-
$ \eta_\ell $ categories	[0,0.6], [0.6,1.2], [1.8,2.4]	[0,0.8], [0.8,1.4], [1.4,2.0], [2.0,2.4]

FIGURE 8.4: Statistical uncertainty calculation from χ^2 distribution.

2135 average is done using BLUE [109].

2136 8.5 Systematic uncertainties

2137 In this section, we will describe the propagation of systematic uncertainties for
 2138 the W boson mass measurement, focusing on the dominant uncertainties: lepton
 2139 efficiency corrections, lepton calibration and hadronic recoil calibration. The mod-
 2140 eling uncertainties: QCD, Electroweak and PDF's uncertainties are not included in
 2141 the work described in this thesis. The propagation of uncertainties is based on the
 2142 templates method introduced in Sec.8.2, where for each uncertainty source, a new
 2143 set of MC templates is produced. The fitting is then performed separately for the
 2144 modified and nominal MC templates, and the difference between the fitted values
 2145 is considered as a systematic uncertainty. The resulting uncertainty for each error
 2146 source is combined quadratically in order to have for the total uncertainty. The
 2147 advantage of the template fit method is that it allows a detailed study of the im-
 2148 pact of different experimental uncertainties independently, contrary to the profile
 2149 likelihood approach [77] which gives a total uncertainty.

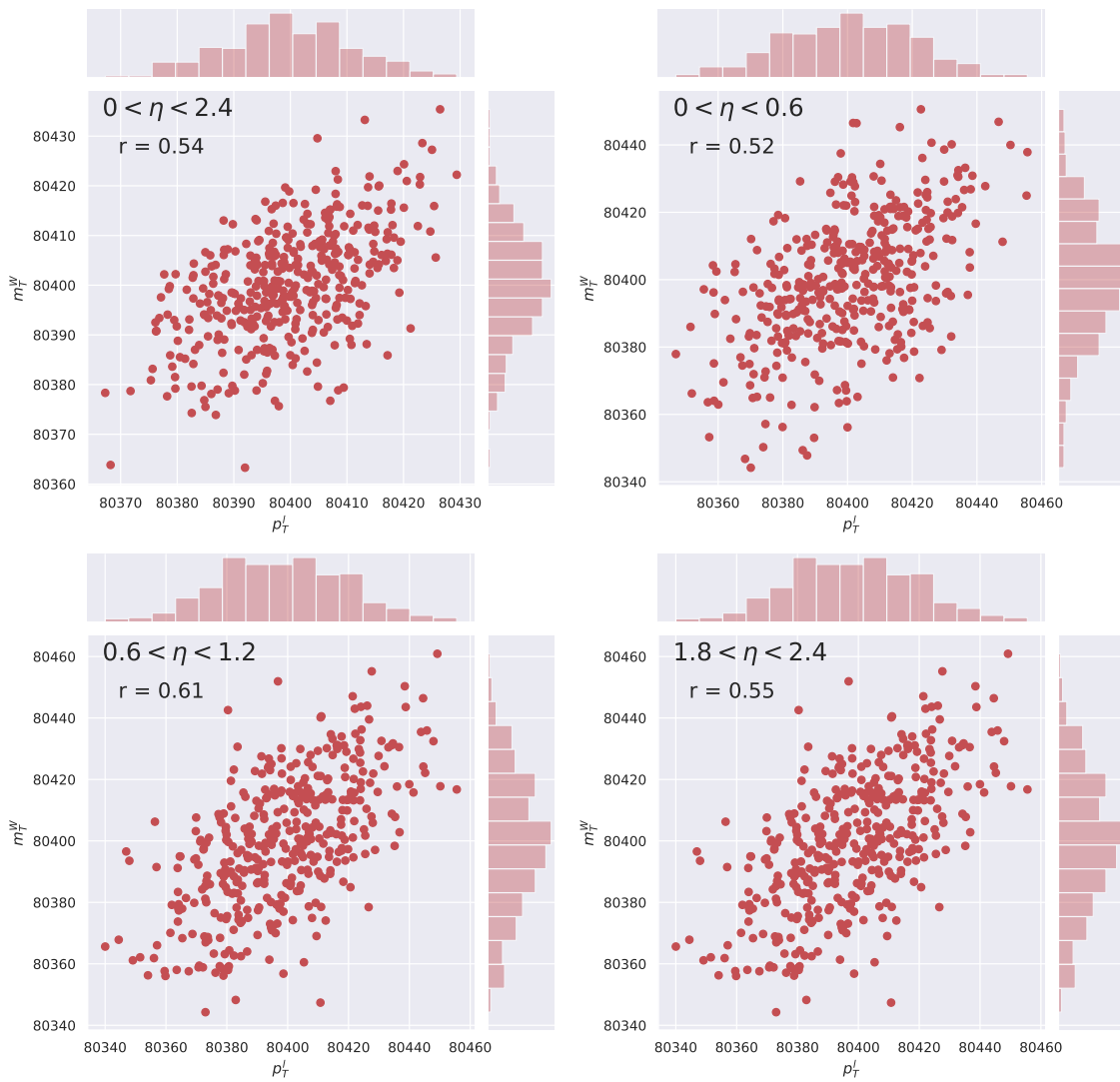


FIGURE 8.5: Correlation between p_T^l and m_W^W with the corresponding correlation factor for different ranges of $|\eta_l|$.

TABLE 8.2: Statistical uncertainties in the M_W measurement for the different kinematic distributions and their combination in $|\eta_\ell|$ regions using data sets of 5 TeV.

η_ℓ range	[0, 0.6]		[0.6, 1.2]		[1.2, 1.8]		[1.8, 2.4]		[0, 2.4]	
Kinematic distribution	p_T^ℓ	m_T^W	p_T^ℓ	m_T^W	p_T^ℓ	m_T^W	p_T^ℓ	m_T^W	p_T^ℓ	m_T^W
Channel	$W^- \rightarrow e^- \bar{\nu}_e, 5 \text{ TeV}$									
Stat[MeV]	55	49	58	53	78	70	61	71	32	29
Correlation	0.52		0.61		0.44		0.55		0.54	
Combined	45		50		63		58		27	
Channel	$W^+ \rightarrow e^+ \nu_e, 5 \text{ TeV}$									
Stat[MeV]	54	48	55	49	64	59	53	48	28	25
Correlation	0.57		0.60		0.59		0.57		0.56	
Combined	45		46		55		45		23	
Channel	$W^- \rightarrow \mu^- \bar{\nu}_\mu, 5 \text{ TeV}$									
Stat[MeV]	55	48	59	53	58	55	78	73	31	28
Correlation	0.50		0.52		0.55		0.52		0.53	
Combined	44		49		50		66		26	
Channel	$W^+ \rightarrow \mu^+ \nu_\mu, 5 \text{ TeV}$									
Stat[MeV]	51	46	56	50	50	46	54	50	27	25
Correlation	0.51		0.59		0.60		0.50		0.56	
Combined	42		48		43		45		23	

TABLE 8.3: Statistical uncertainties in the M_W measurement for the different kinematic distributions and their combination in $|\eta_\ell|$ regions using data sets of 13 TeV.

η_ℓ range	[0, 0.6]		[0.6, 1.2]		[1.2, 1.8]		[1.8, 2.4]		[0, 2.4]	
Kinematic distribution	p_T^ℓ	m_T^W	p_T^ℓ	m_T^W	p_T^ℓ	m_T^W	p_T^ℓ	m_T^W	p_T^ℓ	m_T^W
Channel	$W^- \rightarrow e^- \bar{\nu}_e, 13 \text{ TeV}$									
Stat[MeV]	37	35	39	36	51	49	44	42	21	20
Correlation	0.56		0.57		0.60		0.61		0.54	
Combined	32		33		45		39		18	
Channel	$W^+ \rightarrow e^+ \nu_e, 13 \text{ TeV}$									
Stat[MeV]	36	34	37	36	48	45	40	38	20	19
Correlation	0.59		0.63		0.60		0.67		0.59	
Combined	31		33		41		36		17	
Channel	$W^- \rightarrow \mu^- \bar{\nu}_\mu, 13 \text{ TeV}$									
Stat[MeV]	35	33	39	38	39	37	48	47	20	19
Correlation	0.55		0.60		0.58		0.60		0.63	
Combined	30		31		34		42		18	
Channel	$W^+ \rightarrow \mu^+ \nu_\mu, 13 \text{ TeV}$									
Stat[MeV]	35	34	39	37	36	35	46	44	19	18
Correlation	0.57		0.60		0.64		0.64		0.62	
Combined	31		34		32		41		17	

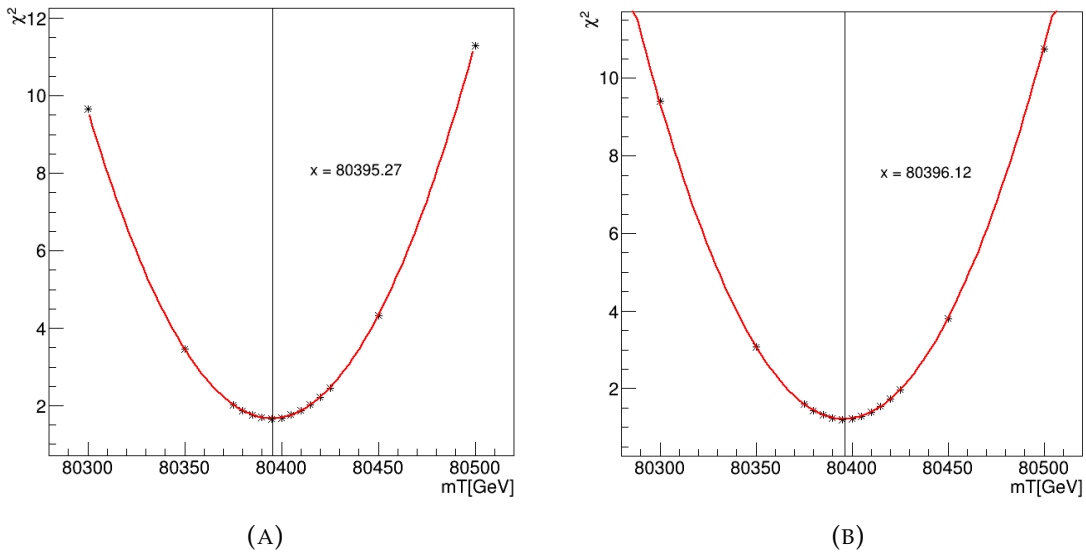


FIGURE 8.6: Example of M_W fitting results using the nominal MC templates (A) and varied MC templates (B) [155], the difference between the fitted values is considered as the propagated uncertainty on the M_W mass measurement.

- Lepton selection efficiency: lepton efficiency corrections are determined using tag-and-prob [1], and measured separately for electron reconstruction, identification and trigger efficiencies [47], using p_T^ℓ and m_T^W separately for different range of $|\eta_\ell|$. For p_T^ℓ and m_T^W ranges, and without including the extracted crack region ($1.2 < \eta_\ell < 1.8$), the reconstruction and identification efficiency corrections have an uncertainty of ≈ 4.5 MeV in the barrel region, and around 4 MeV in the end-cap region. The isolation and trigger efficiency corrections are smaller and have an uncertainty of 1 to 2 MeV in the barrel and end-cap.

TABLE 8.4: Lepton selection efficiency uncertainties (in MeV) on the measurement of W -boson mass, for $W^- \rightarrow e^- \bar{\nu}_e$ at 5 TeV.

η_ℓ range	[0, 0.6]		[0.6, 1.2]		[1.2, 1.8]		[1.8, 2.4]		[0, 2.4]	
Kinematic distribution	p_T^ℓ	m_T^W	p_T^ℓ	m_T^W	p_T^ℓ	m_T^W	p_T^ℓ	m_T^W	p_T^ℓ	m_T^W
Channel	$W^- \rightarrow e^- \bar{\nu}_e, 5 \text{ TeV}$									
Identification efficiency	4.6	4.7	3.9	3.9	6.8	5.9	4.9	4.2	4.3	4.5
Isolation efficiency	2.1	1.3	2.3	1.3	3.6	2.2	2.3	1.4	2.1	1.2
Reconstruction efficiency	4.7	2.4	5.7	2.9	6.7	3.3	4.5	1.6	5.1	2.2
Trigger efficiency	1.9	1.7	1.3	1.2	2.4	1.9	7.1	4.9	1.4	0.9

2158

- Lepton energy calibration: as shown in Ref. [152] for muons and in Chapter 3 for electrons, lepton energies are calibrated in order to correct the difference between data and simulation. For electrons, the uncertainty related to the lepton energy calibration is in particular due to the limited size of the $Z \rightarrow ee$ sample, used in the calibration procedure, while for muons, the uncertainty

2159

2160

2161

2162

2163

2164 is related mainly to the limited knowledge of the detector alignment and res-
 2165 olution [155]. The uncertainty for electron channel is in the order of 18 MeV,
 and larger when we split bins of η_l because of statistical fluctuations.

TABLE 8.5: Lepton energy calibration uncertainties (in MeV) on the measurement of W -
 boson mass, for $W^- \rightarrow e^- \bar{\nu}_e$ at 5 TeV.

η_l range	[0, 0.6]		[0.6, 1.2]		[1.2, 1.8]		[1.8, 2.4]		[0, 2.4]	
Kinematic distribution	p_T^ℓ	m_T^W	p_T^ℓ	m_T^W	p_T^ℓ	m_T^W	p_T^ℓ	m_T^W	p_T^ℓ	m_T^W
Channel	$W^- \rightarrow e^- \bar{\nu}_e, 5 \text{ TeV}$									
Energy scale	27	28	30	33	44	48	44	48	19	20
Energy resolution	1.3	2.3	2.8	4.1	4.1	7.2	3.2	7.7	1.4	2.5

2166

- Hadronic recoil calibration:

TABLE 8.6: Hadronic recoil calibration uncertainties (in MeV) on the measurement of W -
 boson mass, for $W^- \rightarrow e^- \bar{\nu}_e$ at 5 TeV.

η_l range	[0, 0.6]		[0.6, 1.2]		[1.2, 1.8]		[1.8, 2.4]		[0, 2.4]	
Kinematic distribution	p_T^ℓ	m_T^W	p_T^ℓ	m_T^W	p_T^ℓ	m_T^W	p_T^ℓ	m_T^W	p_T^ℓ	m_T^W
channel	$W^- \rightarrow e^- \bar{\nu}_e, 5 \text{ TeV}$									
$\sum E_T$ reweighting	4.1	6.2	3.9	6.5	6.5	11.2	4.3	7.9	3.8	6.7
Resolution correction	1.9	2.7	2.0	3.4	5.3	8.6	2.3	3.2	2.0	2.9
Response correction	2.9	3.3	3.9	3.2	4.1	7.2	3.5	3.5	3.2	3.3

2167

2168 8.6 Statistical uncertainty with the unfolded distribu- 2169 tion

2170 As described in Sec. 8.3, unfolded distributions are already corrected by the un-
 2171 folding procedure and do not include detector effects. The m_T^W and p_T^ℓ distribu-
 2172 tions with the corresponding templates are unfolded using the iterative Bayesian
 2173 unfolding. The comparison between the modified templates and the nominal dis-
 2174 tributions at the reconstructed and unfolded levels is shown in Figure 8.7.

2175 The main particularity of the unfolded distributions is that the unfolding pro-
 2176 cedure introduces a correlation between bins that we have to take into account
 2177 in the χ^2 formula, while the statistical uncertainties of the different bins of the
 2178 reconstructed distributions are fully uncorrelated. The correlation matrix for the
 2179 statistical uncertainty of the unfolded distribution is calculated with the RooUn-
 2180 fold framework [7]. Figure 8.8 shows an example of the correlation matrix at the
 2181 reconstructed and unfolded levels for the transverse mass m_T^W . Then, the tem-
 2182 plate distributions are also unfolded using the corresponding migration matrix.
 2183 As shown in Sec 8.3, the χ^2 is calculated as:

$$\chi^2 = (n_{\text{data}}^{\text{Unf}} - n_{\text{template}}^{\text{Unf}})^T \cdot (V)^{-1} \cdot (n_{\text{data}}^{\text{Unf}} - n_{\text{template}}^{\text{Unf}}), \quad (8.6)$$

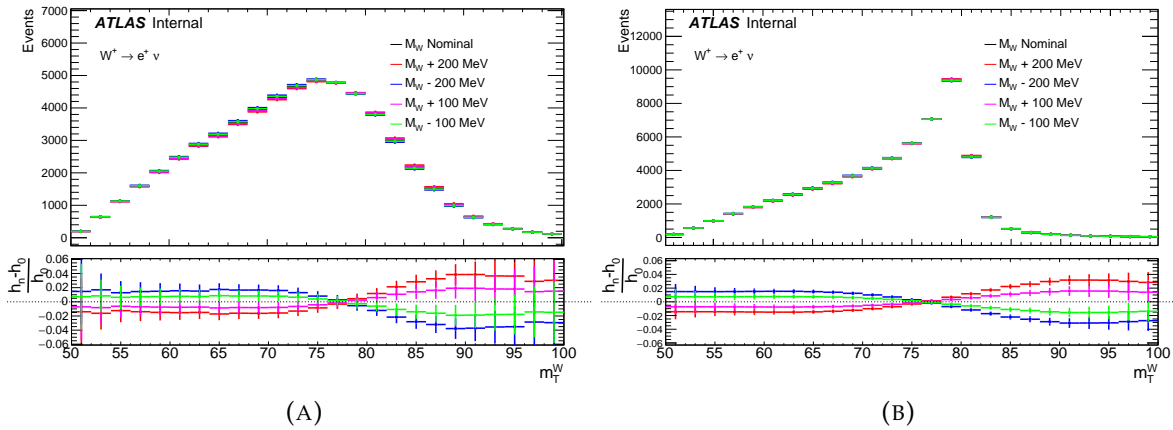


FIGURE 8.7: Distributions of m_T^W with the corresponding templates at the reconstructed level (A) and at the unfolded level (B).

2184 where the total covariance matrix V is considered as the sum of the covariance
 2185 matrix of the unfolded data and the unfolded templates, $V = V_{\text{data}} + V_{\text{template}}$. The
 same procedure is applied also separately for p_T^ℓ distributions.

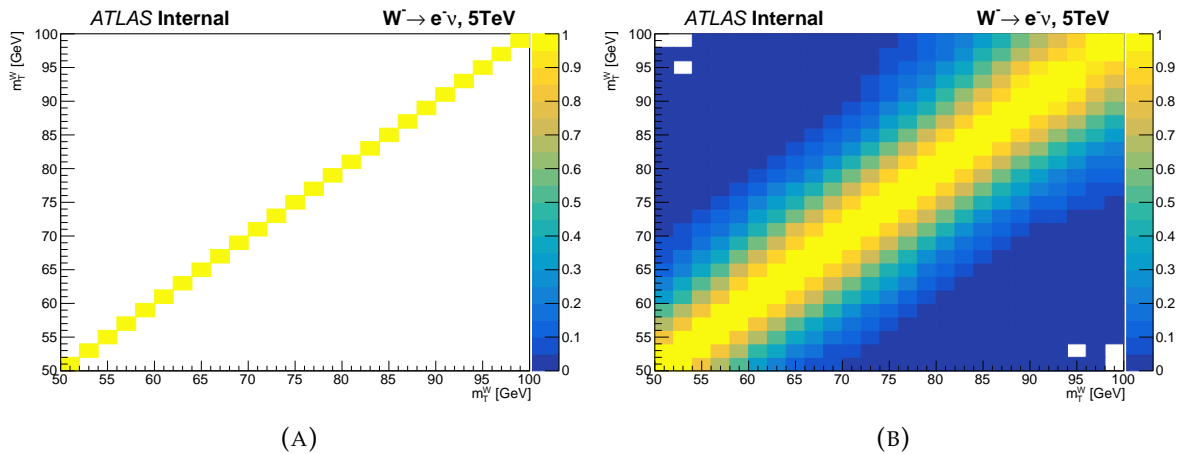


FIGURE 8.8: Correlation matrix for the statistical uncertainty for m_T^W distribution at the reconstructed level (A) and at the unfolded level (B), the correlation between bins is introduced by the unfolding procedure.

2186 Table 8.7 shows an example of the statistical uncertainties calculated using the
 2187 unfolded and the reconstructed distributions, for different regions of η . In general,
 2188 the results are similar for the statistical uncertainty for both methods. Then, the
 2189 correlation between p_T^ℓ and m_T^W is evaluated using the unfolded toys as described
 2190 for the templates method in Sec. 8.4. In general, using the unfolded distribution
 2191 does not change the results for the statistical uncertainties, but it is not the case
 2192 when we treat the systematic uncertainties because of the statistical fluctuations
 2193 in p_T^ℓ and m_T^W and also because of the bias that we introduce with the unfolding
 2194 procedure.
 2195

TABLE 8.7: Statistical uncertainties (in MeV) on the M_W measurement using the unfolded and reconstructed distributions, for p_T^ℓ and m_T^W separately, using different regions of η_ℓ at 5 TeV.

η_ℓ range	[0, 0.6]		[0.6, 1.2]		[1.2, 1.8]		[1.8, 2.4]		[0, 2.4]	
Kinematic distribution	p_T^ℓ	m_T^W	p_T^ℓ	m_T^W	p_T^ℓ	m_T^W	p_T^ℓ	m_T^W	p_T^ℓ	m_T^W
Channel	$W^- \rightarrow e^- \bar{\nu}_e, 5 \text{ TeV}$									
Stat [Unfolded]	55	49	58	53	78	70	61	71	32	29
Stat [Reconstructed]	54	49	57	53	76	71	62	71	31	29

2196 Chapter 9

2197 Conclusion

2198 This thesis describes mainly my personal work on the in-situ calibration of the
2199 electromagnetic calorimeter of the ATLAS detector, and on the measurement
2200 of W boson properties using low pile-up data set collected by ATLAS in 2017
2201 and 2018 during Run 2 corresponding to an integrated luminosity of 258 pb^{-1} at
2202 $\sqrt{s} = 5 \text{ TeV}$ and 340 pb^{-1} at $\sqrt{s} = 13 \text{ TeV}$.

2203
2204 The in-situ calibration is the last step in the calibration procedure. It is based
2205 on the $Z \rightarrow e^+e^-$ event samples and aims for correcting for residual difference in
2206 the energy scale and resolution between data and MC simulation. The calibration
2207 using the template method developed for Run 1 analysis has been performed
2208 for all nominal data samples taken in Run 2 in 2015, 2016, 2017 and 2018 under
2209 different running conditions. The number of interactions per bunch crossing μ of
2210 these nominal data samples varies typically between 10 and 70, being lower in
2211 2015 and 2016 and higher in 2017 and 2018. Year dependence of the calibration
2212 corrections has been studied. The same procedure has also been applied to the
2213 low pile-up data showing larger uncertainties due to the limited statistics of the
2214 samples. The low pile-up data have a μ value around 2. We have thus developed
2215 a new approach by studying the μ dependence of the energy scale correction
2216 of the nominal data samples and extrapolating the correction of the nominal
2217 samples to $\mu \sim 2$ to be compared with that obtained directly from the low pile-up
2218 data samples. It is found that the two sets of the corrections are consistent and
2219 the extrapolated correction has better precision even when the extrapolation
2220 uncertainties are taken into account.

2221
2222 The measurement of the W boson properties includes three parts. The first
2223 part corresponds to a measurement of the transverse momentum of the W boson,
2224 p_{T}^W . The modelling uncertainty of p_{T}^W by a theoretical extrapolation from Z -boson
2225 measurements has been one of the dominant systematic uncertainties of the pre-
2226 vious mass determination of the W boson by ATLAS. A direct measurement of
2227 p_{T}^W would avoid such an extrapolation and the corresponding theoretical mod-
2228 elling uncertainty. The second part is on the measurement of the fiducial, single
2229 and double differential cross sections of the W boson production in the electron
2230 and muon decay channels at 5 and 13 TeV. The measurement has been compared
2231 with a NNLO QCD prediction using different PDF sets, showing its potential in
2232 constraining the uncertainty of the PDFs which was the dominant source for the
2233 determination of the W boson mass. The third part represents preliminary results

2234 for the W boson mass determination using the templates method and a new ap-
2235 proach which relies on unfolded distributions. In this thesis, we focused on the
2236 measurement of the dominant experimental uncertainties. The final result for the
2237 W boson mass must take into account the theoretical and modeling uncertainties
2238 that are not studied in this thesis.

2239 Appendix A

2240 Control plots

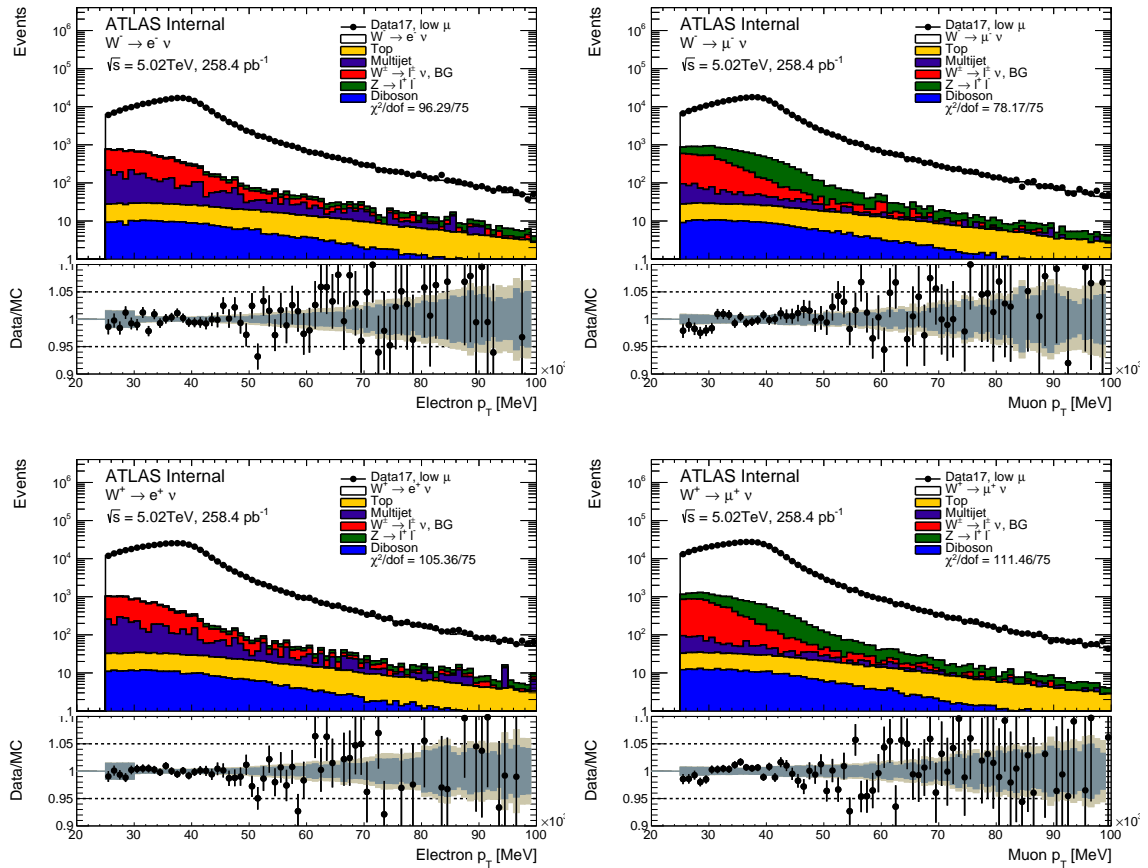
2241 Comparison data/simulation for p_T^ℓ 

FIGURE A.1: Reconstructed p_T^ℓ distributions at detector level for $\sqrt{s} = 5$ TeV data set in the fiducial phase space. The signal and backgrounds are normalised to data. The low panel gives the ratio data/MC in each bin. The green band shows the statistical and systematic uncertainties added in quadrature. The total uncertainty is dominated by the uncertainty in the efficiency corrections applied to lepton.

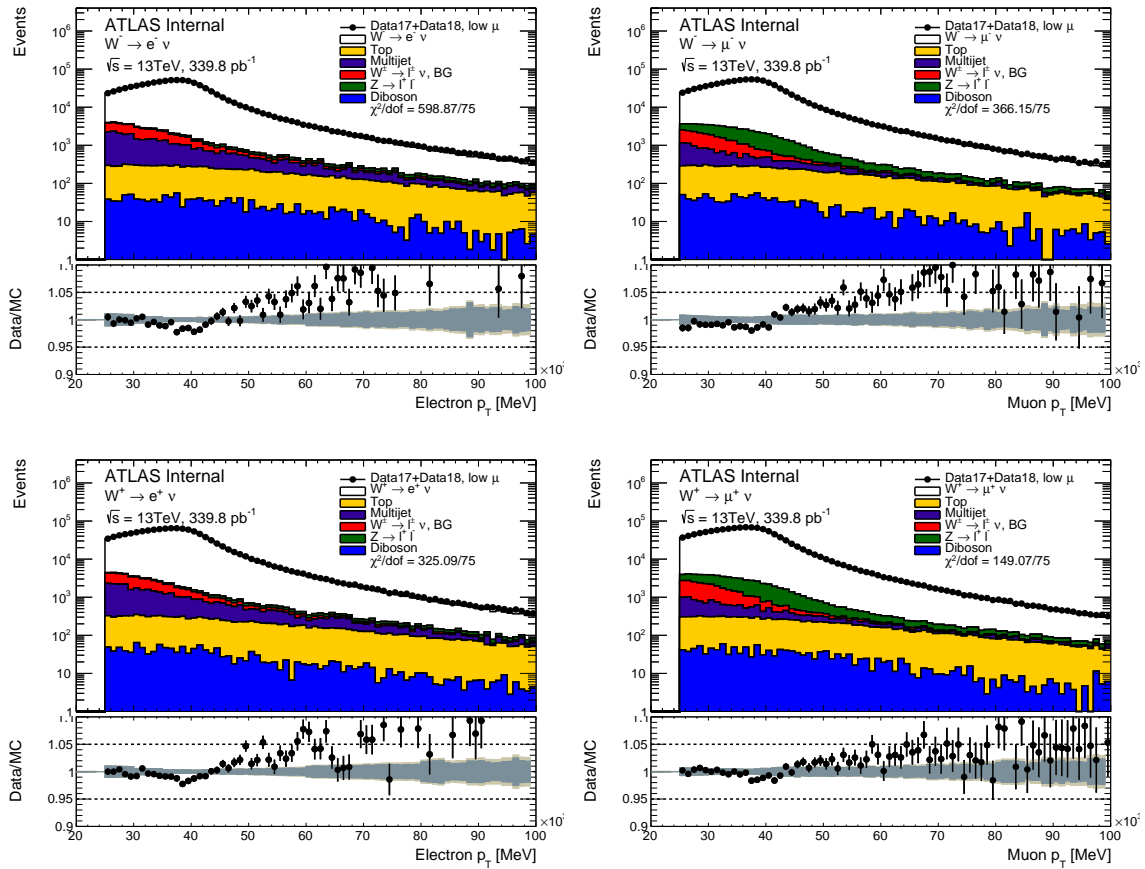


FIGURE A.2: Reconstructed p_T^ℓ distributions at the detector level for $\sqrt{s} = 13$ TeV data set in the fiducial phase space. The signal and backgrounds are normalised to data. The low panel gives the ratio data/MC in each bin. The green band shows the statistical and systematic uncertainties added in quadrature. The total uncertainty is dominated by the uncertainty on the efficiency corrections applied to lepton.

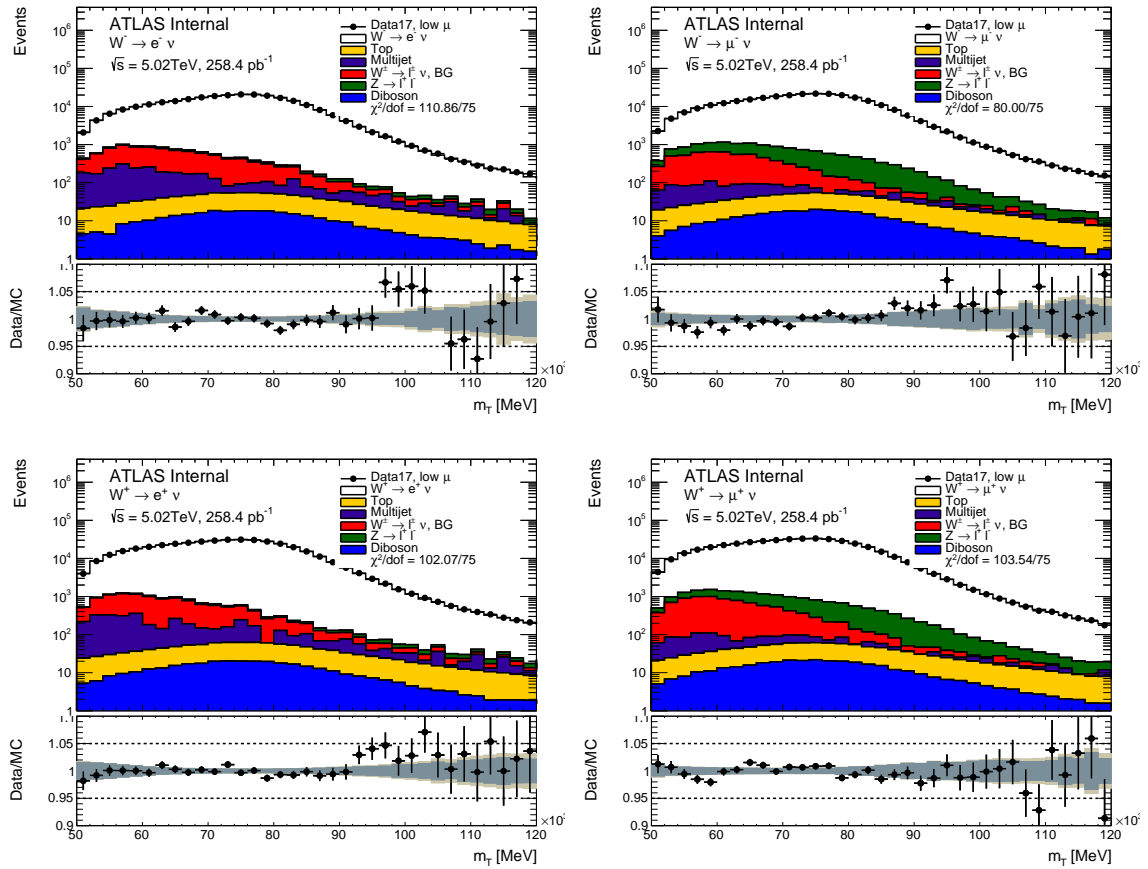
2242 Comparison data/simulation for m_T^W 

FIGURE A.3: Reconstructed m_T^W distributions at detector level for $\sqrt{s} = 5$ TeV data set in the fiducial phase space. The signal and backgrounds are normalised to data. The low panel gives the ratio data/MC in each bin. The green band shows the statistical and systematic uncertainties added in quadrature. The total uncertainty is dominated by the uncertainty on the efficiency corrections applied to lepton.

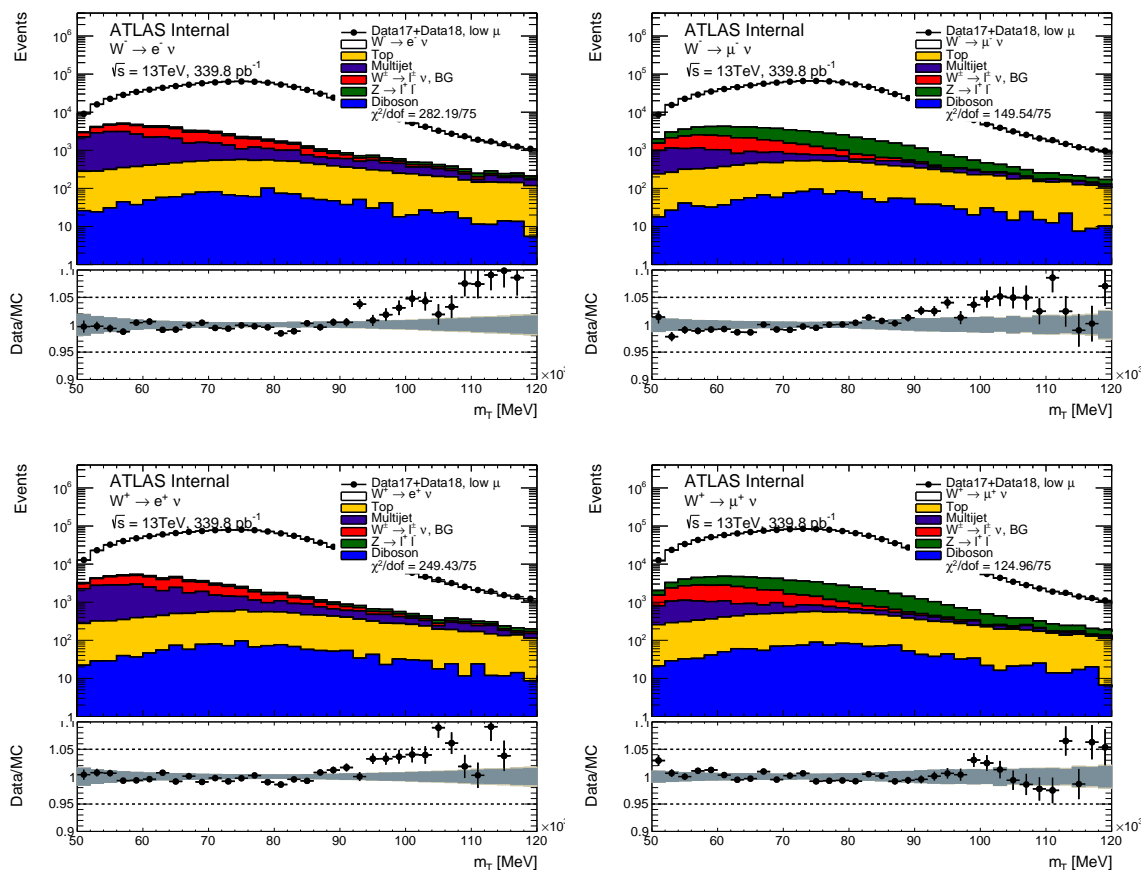


FIGURE A.4: Reconstructed m_T^W distributions at detector level for $\sqrt{s} = 13$ TeV data set in the fiducial phase space. The signal and backgrounds are normalised to data. The low panel gives the ratio data/MC in each bin. The green band shows the statistical and systematic uncertainties added in quadrature. The total uncertainty is dominated by the uncertainty on the efficiency corrections applied to lepton.

2243 Comparison data/simulation for η_ℓ

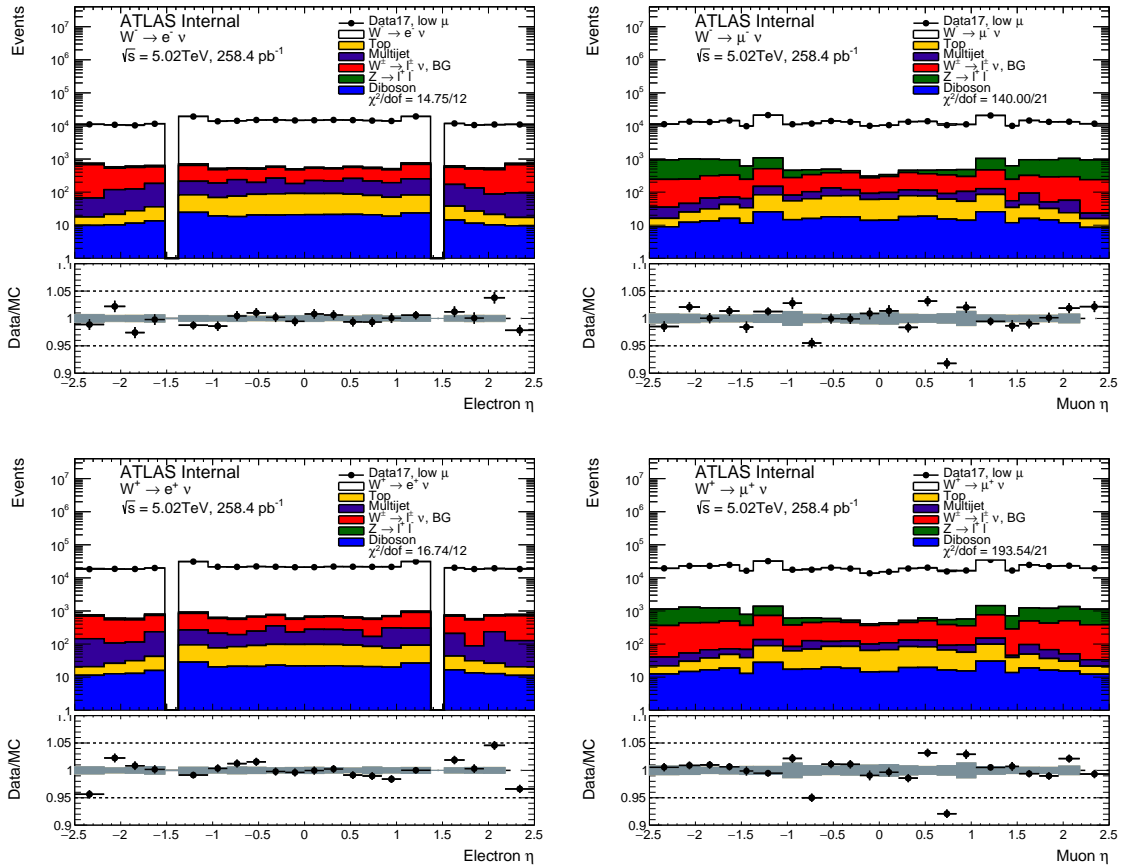


FIGURE A.5: Reconstructed η_ℓ distributions at detector level for $\sqrt{s} = 5$ TeV data set in the fiducial phase space. The signal and backgrounds are normalised to data. The low panel gives the ratio data/MC in each bin. The green band shows the statistical and systematic uncertainties added in quadrature. The total uncertainty is dominated by the uncertainty on the efficiency corrections applied to lepton.

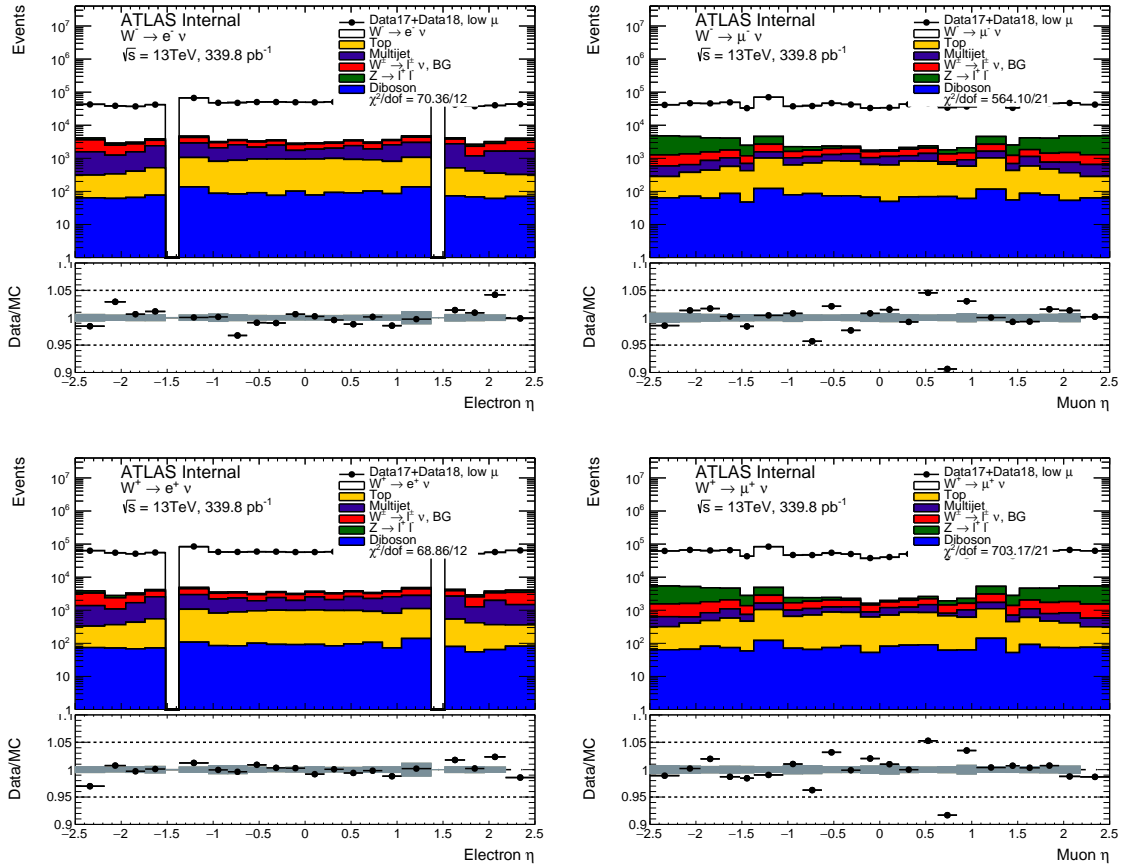


FIGURE A.6: Reconstructed η_ℓ distributions at detector level for $\sqrt{s} = 13$ TeV data set in the fiducial phase space. The signal and backgrounds are normalised to data. The low panel gives the ratio data/MC in each bin. The green band shows the statistical and systematic uncertainties added in quadrature. The total uncertainty is dominated by the uncertainty on the efficiency corrections applied to lepton.

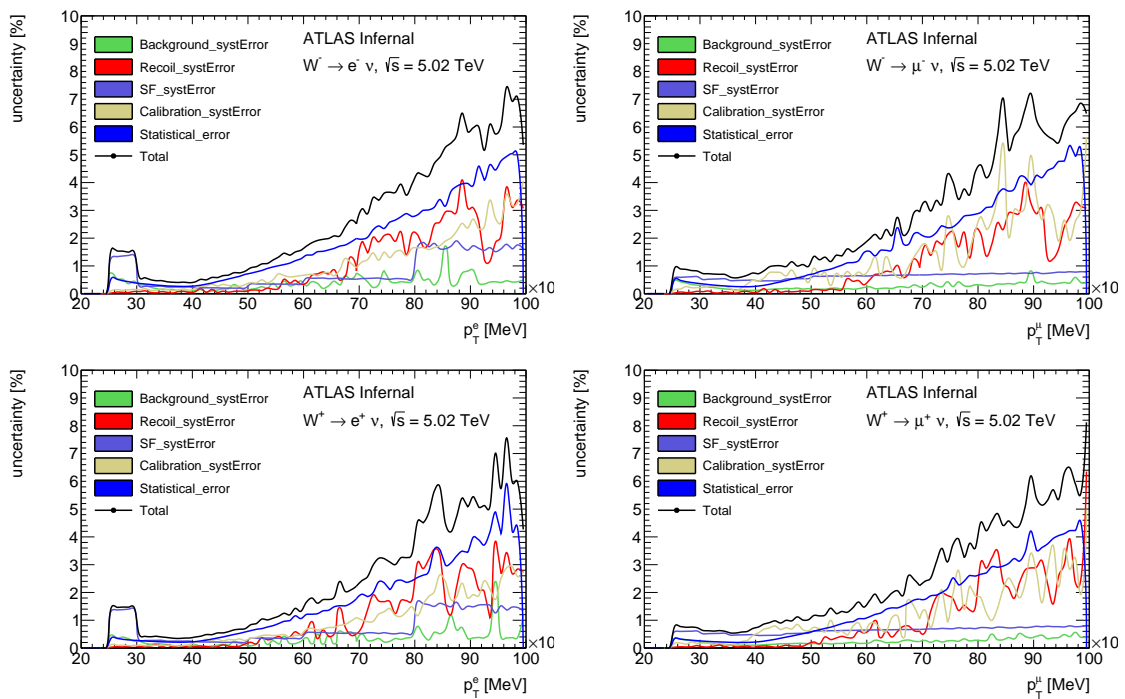
2244 **Appendix B**2245 **Breakdown of uncertainties**2246 **Uncertainties in the measurement of p_T^ℓ at detector level**

FIGURE B.1: Different sources of uncertainties on the measurement of p_T^ℓ distributions at detector level for the $\sqrt{s} = 5$ TeV data set. The total uncertainty is less than 2% at low p_T^ℓ region ($p_T^\ell < 50$ GeV) and around 6% for high p_T^ℓ region ($p_T^\ell \approx 100$ GeV). The total uncertainty is dominated by SF systematic uncertainty and the statistical uncertainty of data.

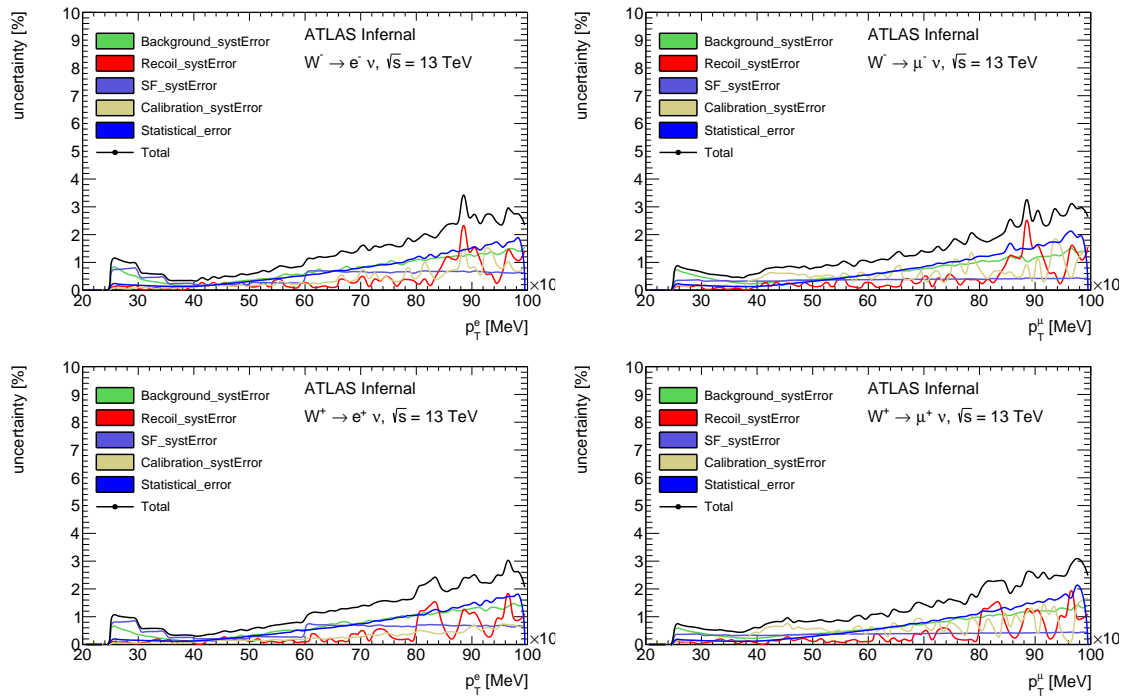


FIGURE B.2: Different sources of uncertainties on the measurement of p_T^l distributions at detector level for the $\sqrt{s} = 13$ TeV data set. The total uncertainty is less than 1% at low p_T^l region ($p_T^l < 50$ GeV) and around 3% for high p_T^l region ($p_T^l \approx 100$ GeV). The total uncertainty is dominated by SF systematic uncertainty and the statistical uncertainty of data.

2247

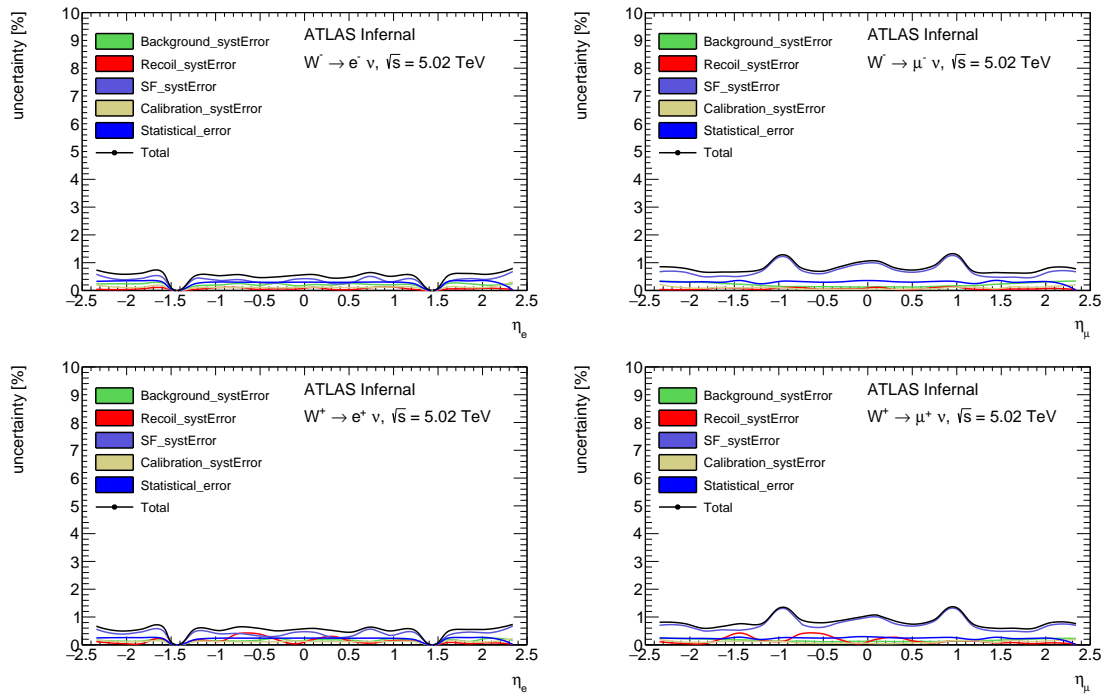
Uncertainties in the measurement of η_ℓ at detector level

FIGURE B.3: Different sources of uncertainties on the measurement of η_ℓ distributions at detector level for the $\sqrt{s} = 5$ TeV data set. The total uncertainty is less than 1% and dominated by SF systematic uncertainty and the statistical uncertainty of data.

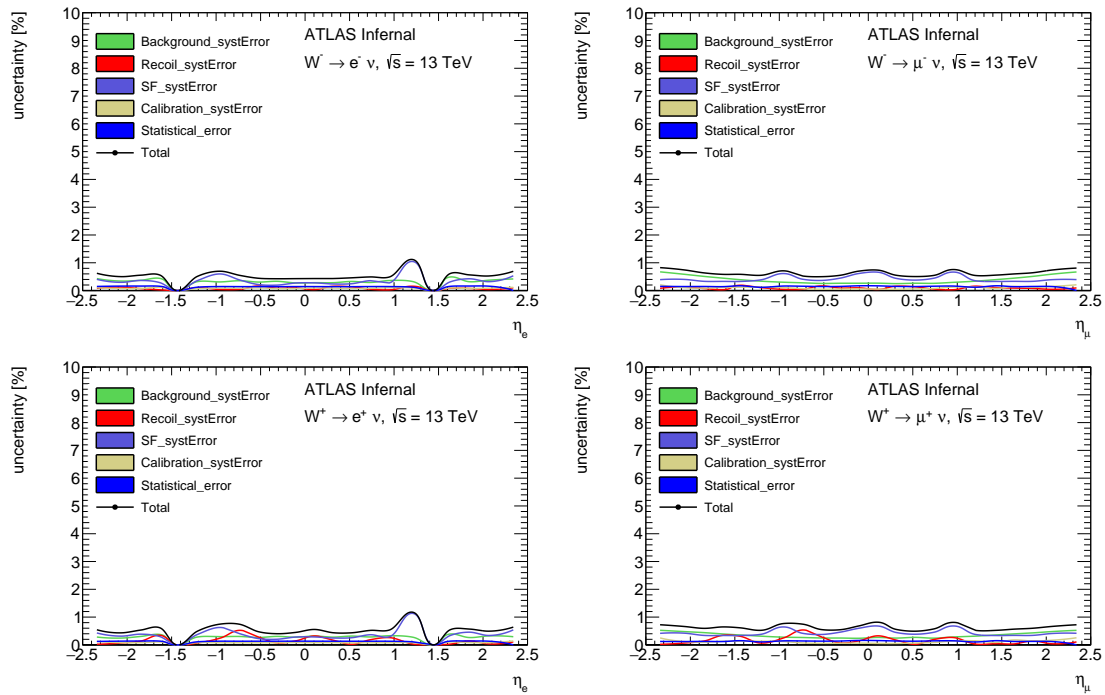


FIGURE B.4: Different sources of uncertainties on the measurement of η_ℓ distributions at the detector level for the $\sqrt{s} = 13$ TeV data set. The total uncertainty is less than 1% and dominated by SF systematic uncertainty and the statistical uncertainty of data.

2248 **Uncertainties in the measurement of p_T^W at detector**
 2249 **level**

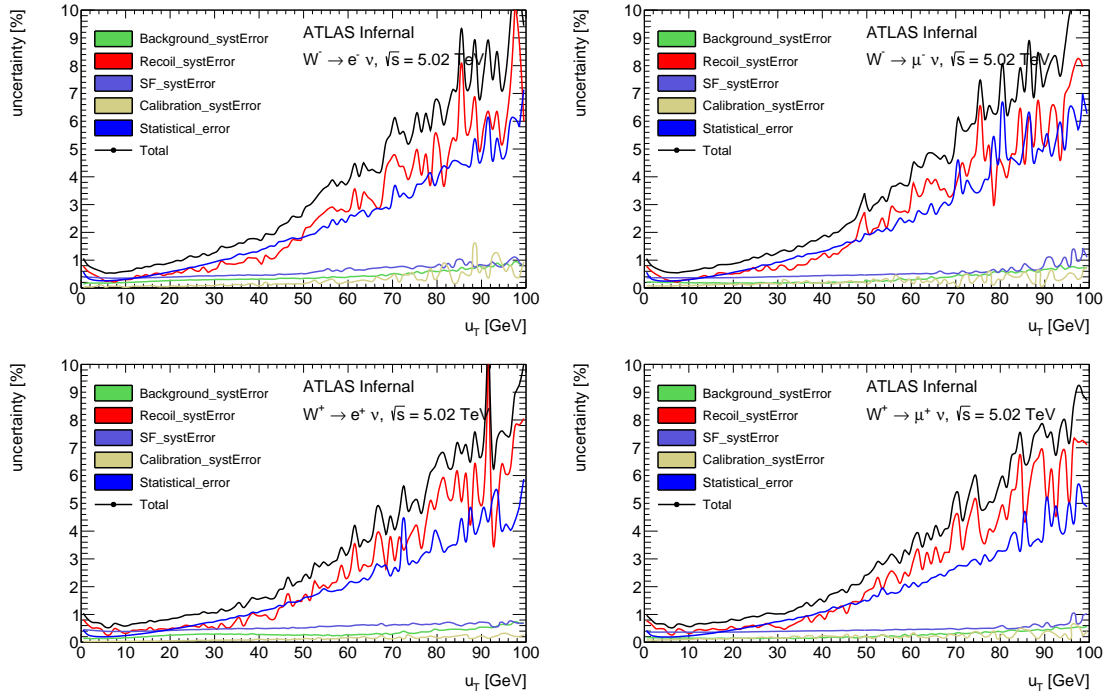


FIGURE B.5: Different sources of uncertainties in the measurement of p_T^W distributions at detector level for the $\sqrt{s} = 5$ TeV data set. The total uncertainty is less than 1% at low p_T^W region ($p_T^W < 30$ GeV) and around 5% for high p_T^W region ($p_T^W \approx 100$ GeV). The total uncertainty is dominated by hadronic recoil calibration uncertainty and the statistical uncertainty of data.

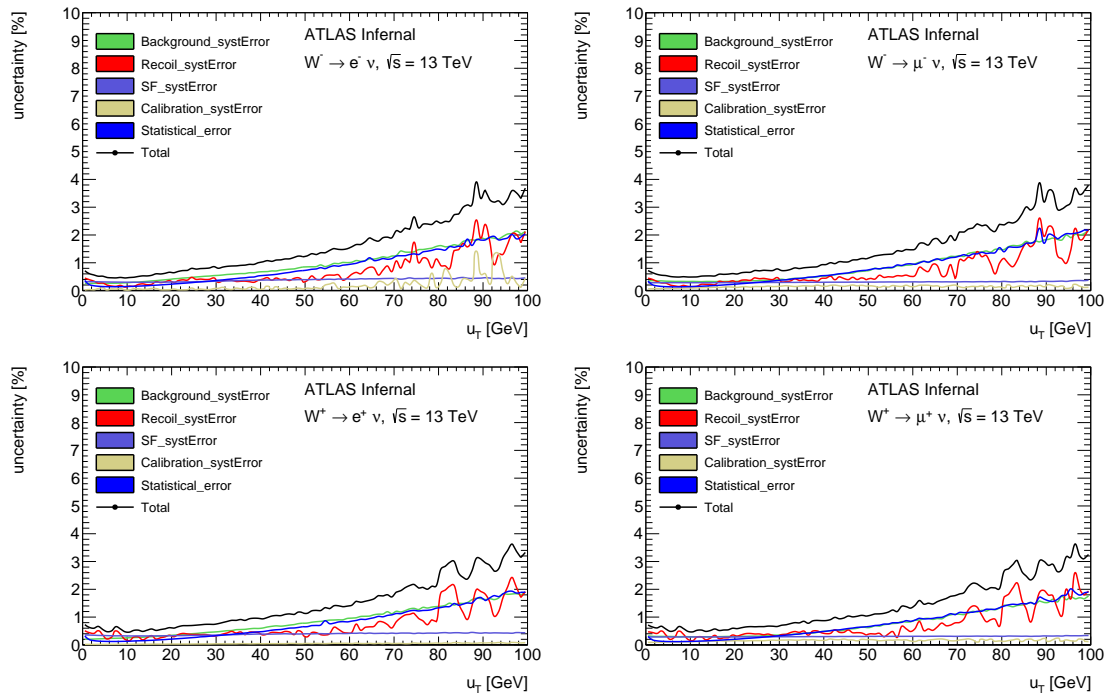


FIGURE B.6: Different sources of uncertainties on the measurement of p_T^W distributions at detector level for the $\sqrt{s} = 13$ TeV data set. The total uncertainty is less than 1% at low p_T^W region ($p_T^W < 30$ GeV) and around 3% for high p_T^W region ($p_T^W \approx 100$ GeV). The total uncertainty is dominated by hadronic recoil calibration uncertainty and background uncertainty (because of the large contributions of gauge-boson pair production and top-quark production in background).

2250 **Uncertainties in the measurement of p_T^W at unfolded**
 2251 **level**

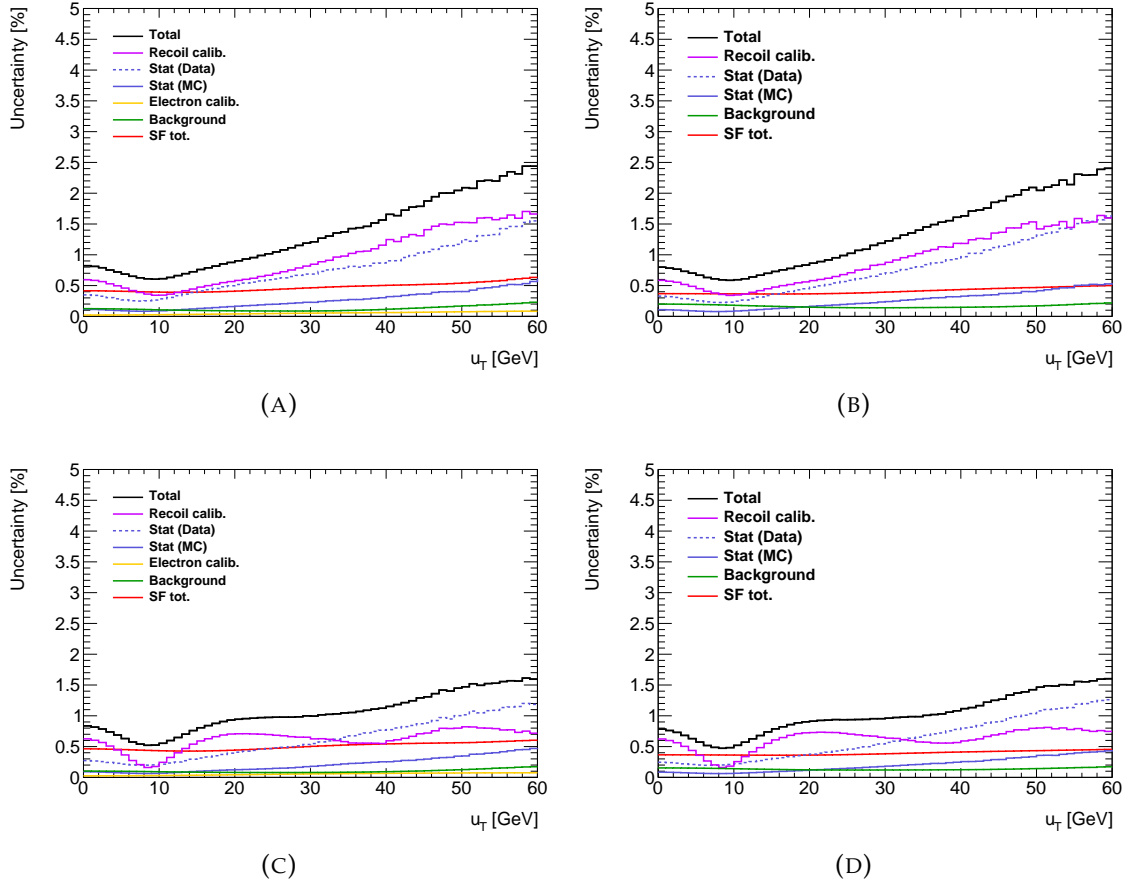


FIGURE B.7: Different sources of uncertainties on the measurement of unfolded p_T^W distributions for the $\sqrt{s} = 5$ TeV data set, for the electron (A, B) and muon (C, D) channels. The total uncertainty is less than 1% at low p_T^W region ($p_T^W < 30$ GeV) and around 2% for high p_T^W region ($p_T^W \approx 60$ GeV). The total uncertainty is dominated by hadronic recoil calibration uncertainty and the statistical uncertainty of data.

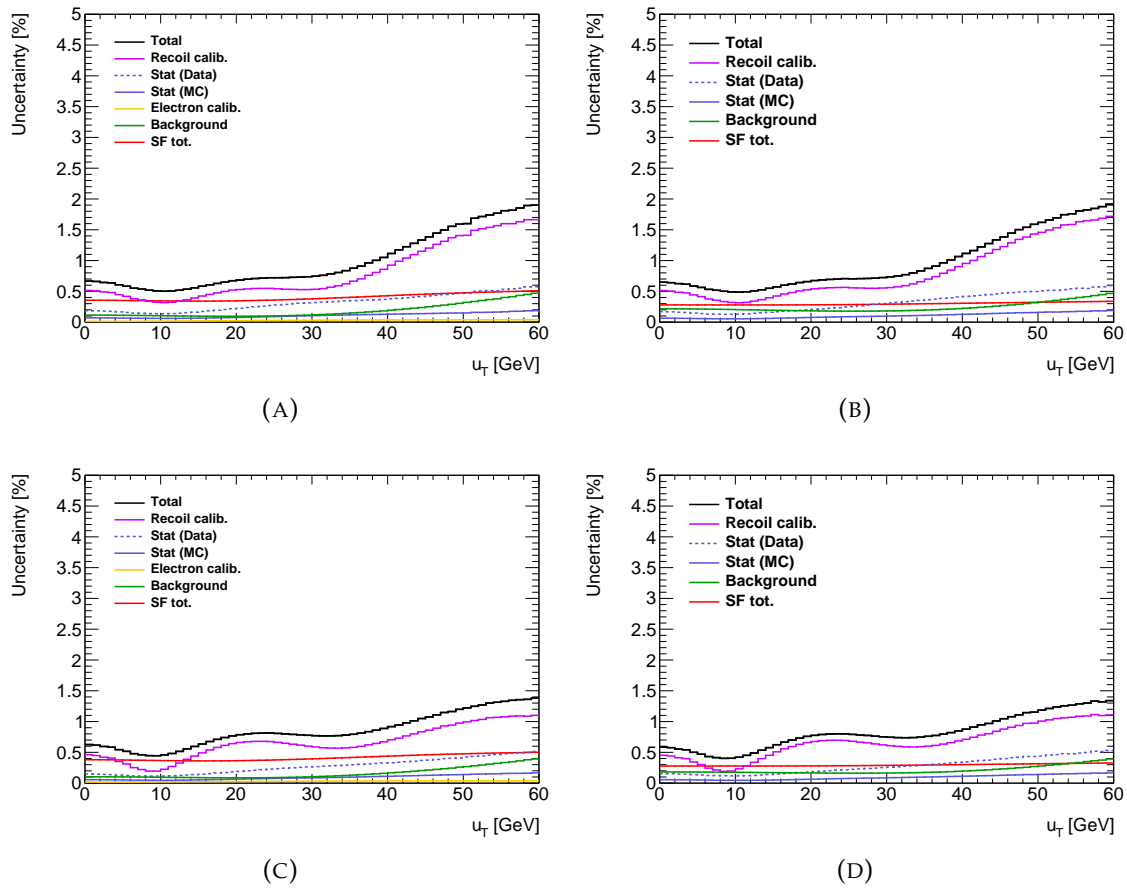
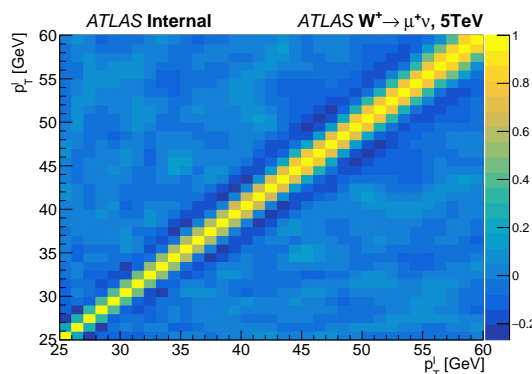
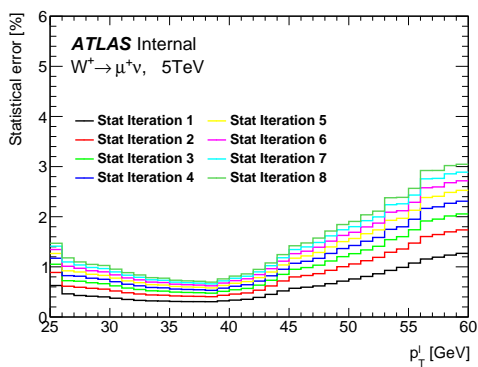
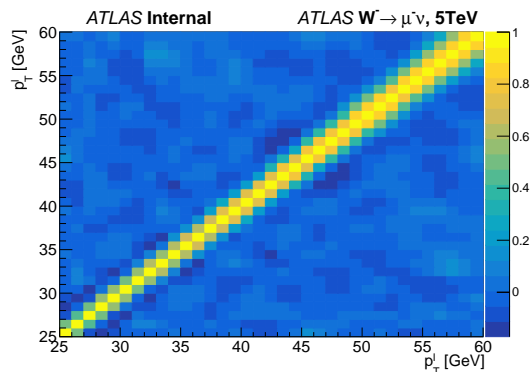
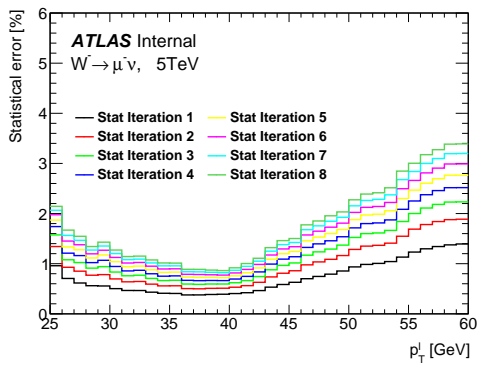
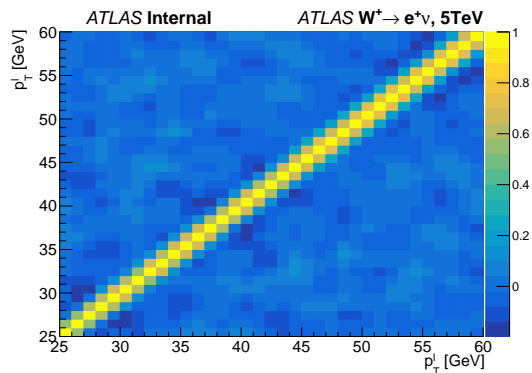
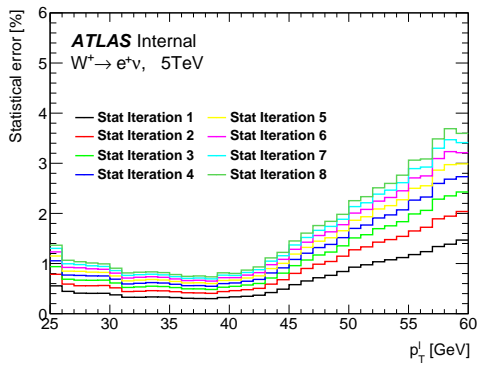
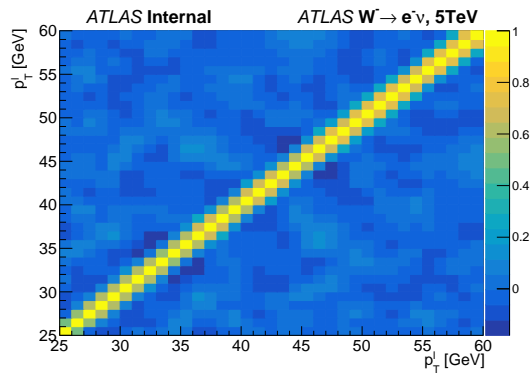
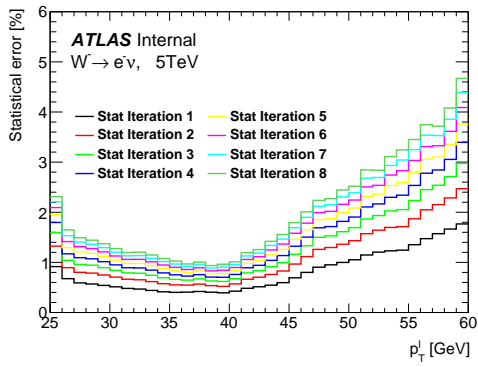


FIGURE B.8: Different sources of uncertainties on the measurement of unfolded p_T^W distributions at for the $\sqrt{s} = 13$ TeV data set, for the electron (A, B) and muon (C, D) channels. The total uncertainty is less than 1% at low p_T^W region ($p_T^W < 30$ GeV) and around 1.5% for high p_T^W region ($p_T^W \approx 60$ GeV). The total uncertainty is dominated by hadronic recoil calibration uncertainty and the background uncertainty.

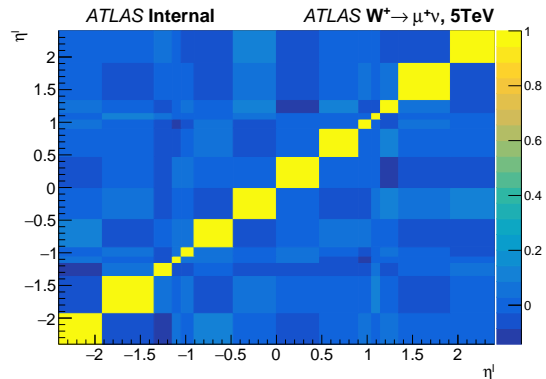
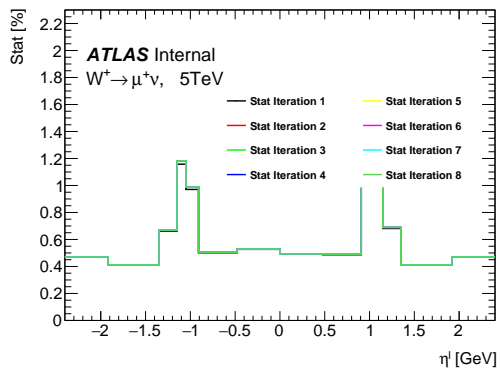
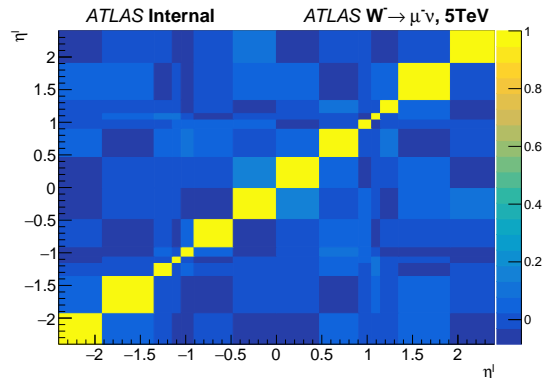
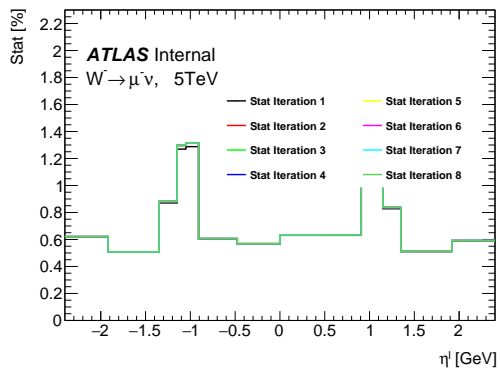
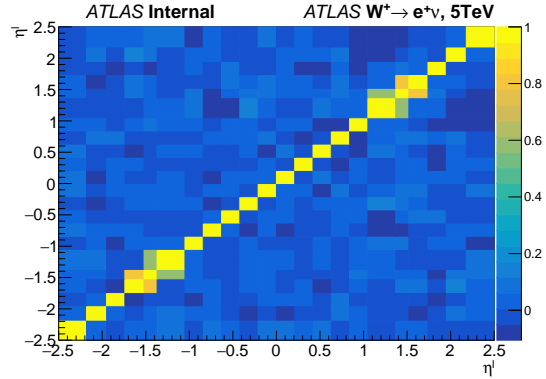
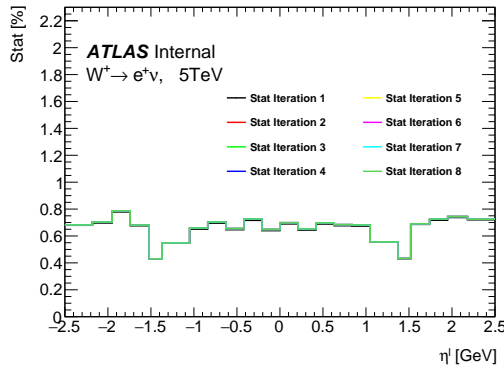
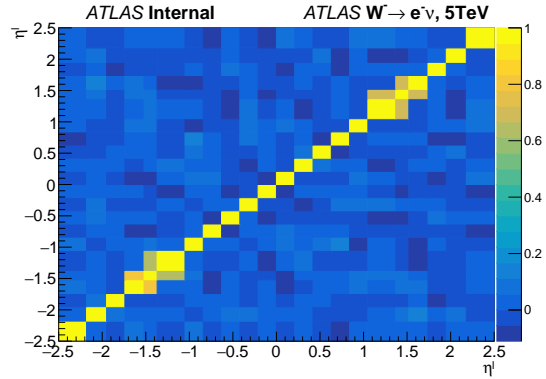
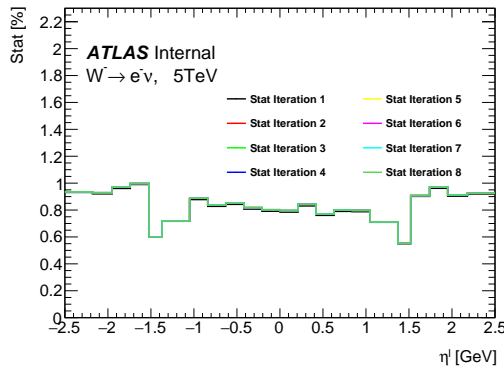
2252 **Appendix C**

2253 **Uncertainties for the differential cross**
2254 **sections**

2255 **Statistical uncertainties with their correlation matrix of**
 2256 **p_T^l at 5 TeV**



2257 **Statistical uncertainties with their correlation matrix of**
 2258 **η_l at 5 TeV**

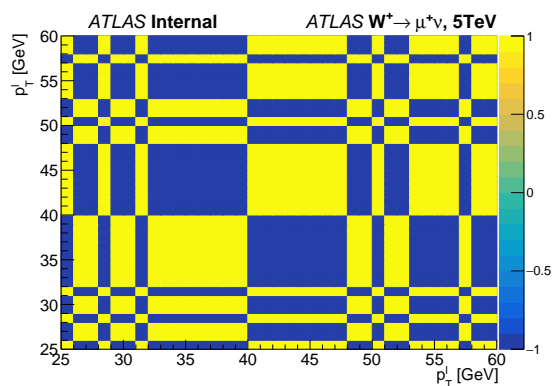
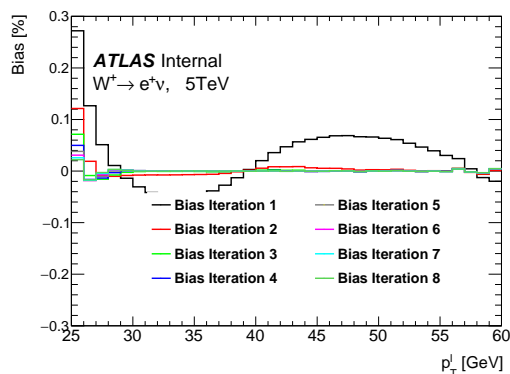
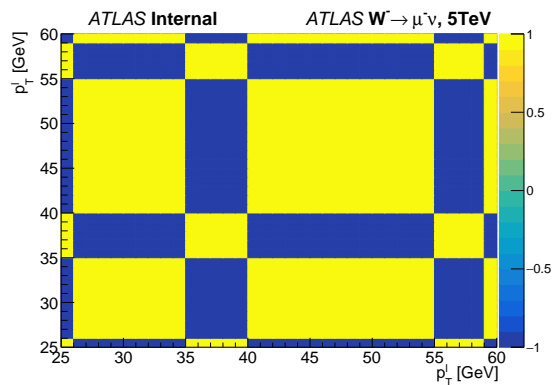
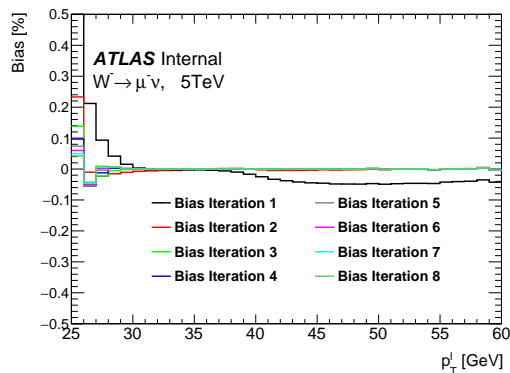
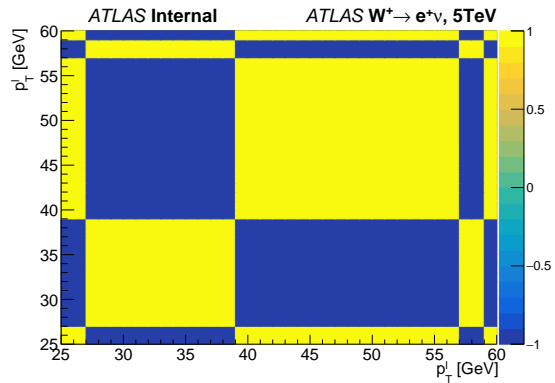
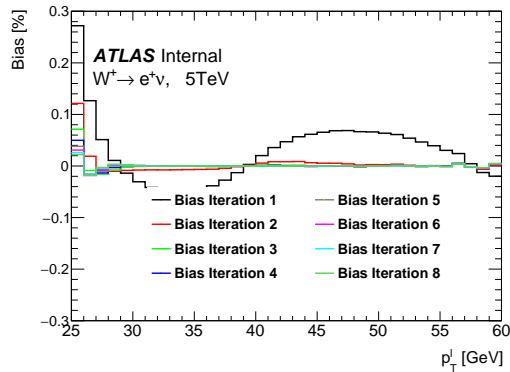
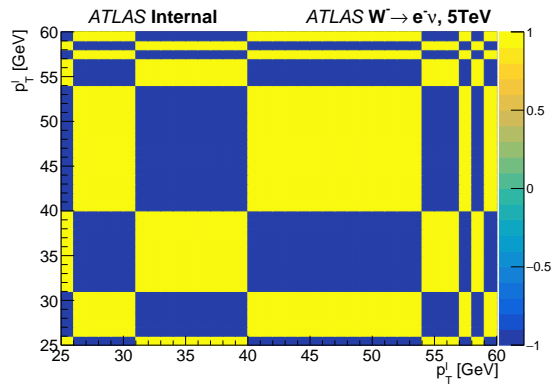
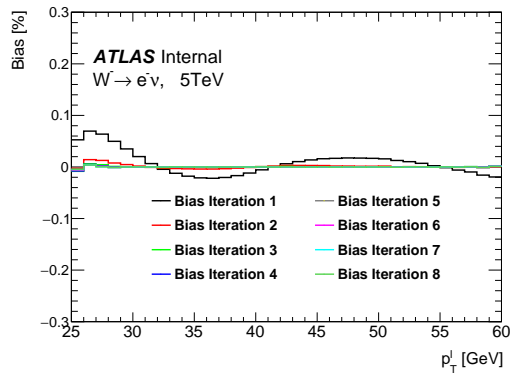


2259

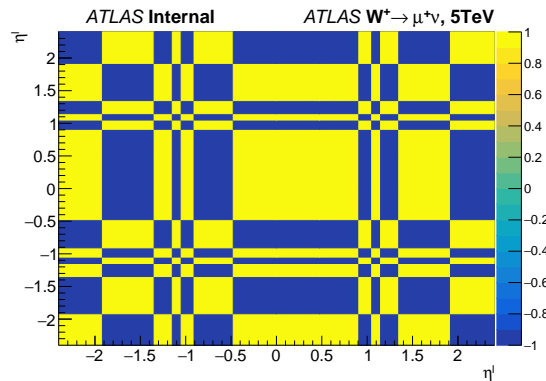
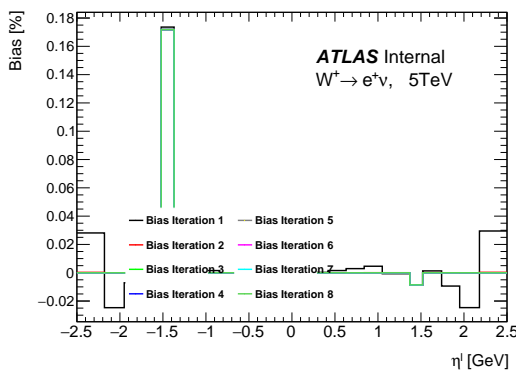
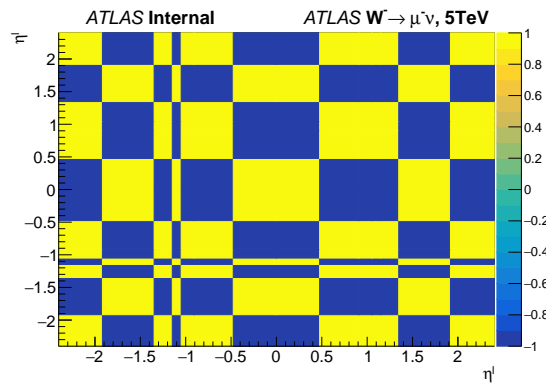
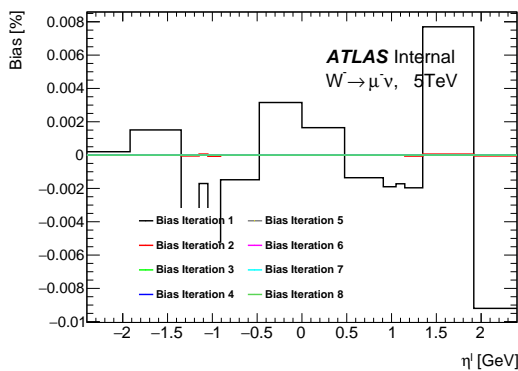
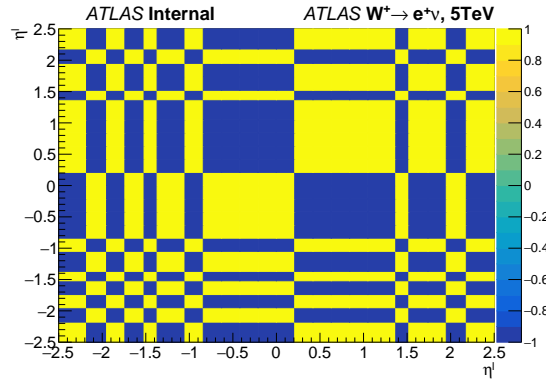
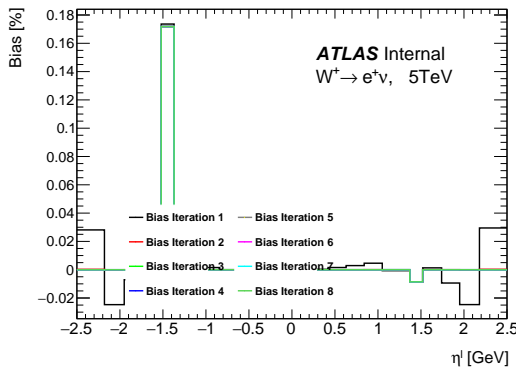
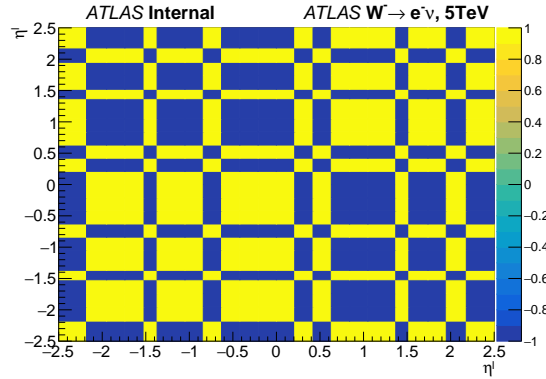
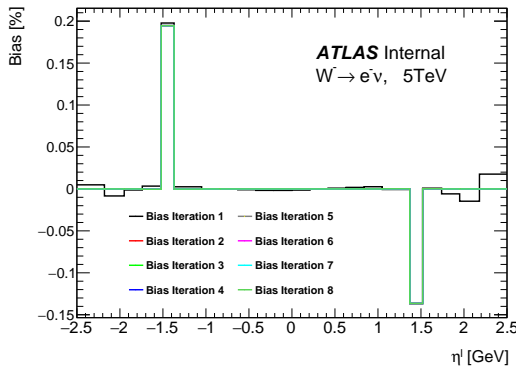
Unfolding bias with their correlation matrix of p_T^l at

2260

5 TeV



2261 **Unfolding bias with their correlation matrix of η_ℓ at**
 2262 **5 TeV**



2263 **Statistical uncertainties for double differential cross**
 2264 **sections at 5 TeV**

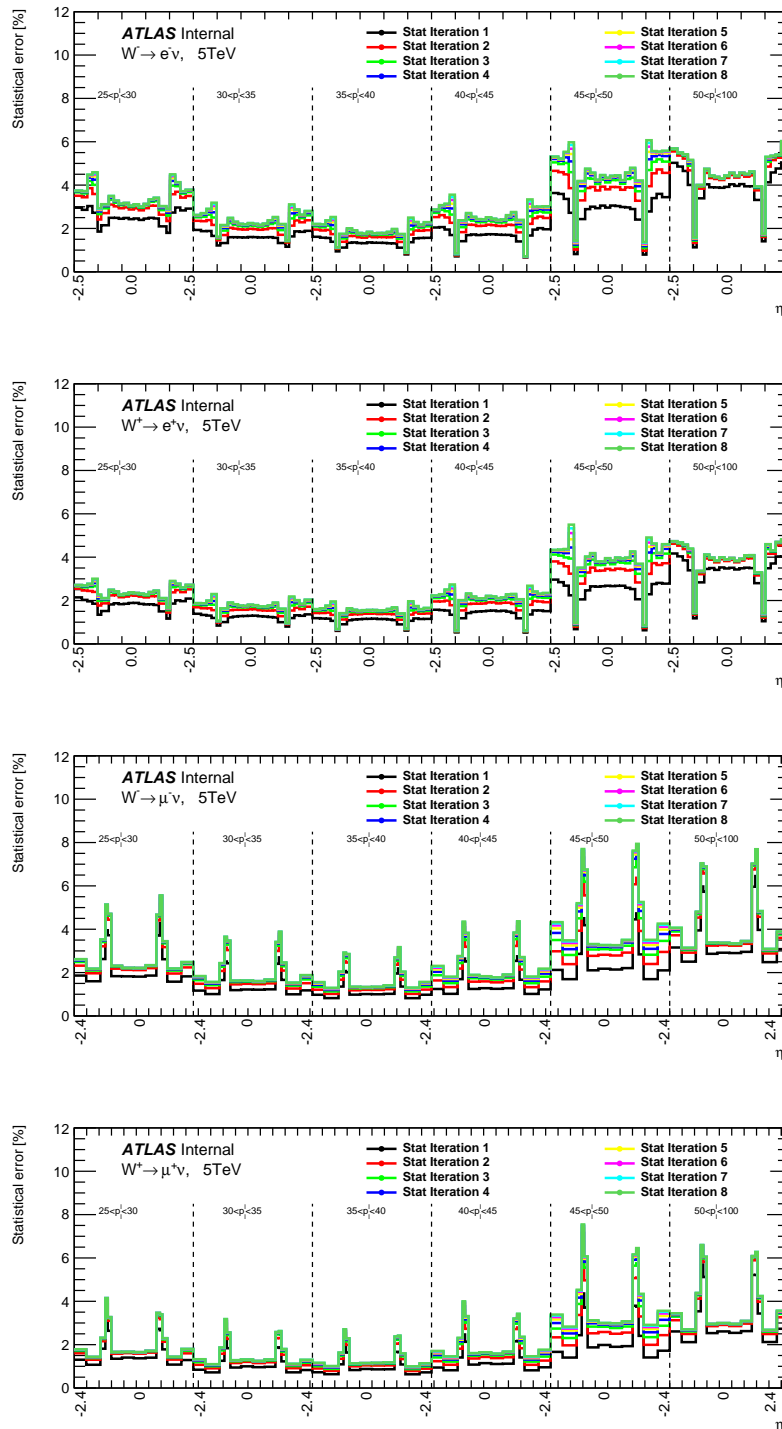


FIGURE C.1: Statistical uncertainties of unfolded distributions used for double differential cross sections at 5 TeV

2265 **Statistical uncertainties for double differential cross**
 2266 **sections at 13 TeV**

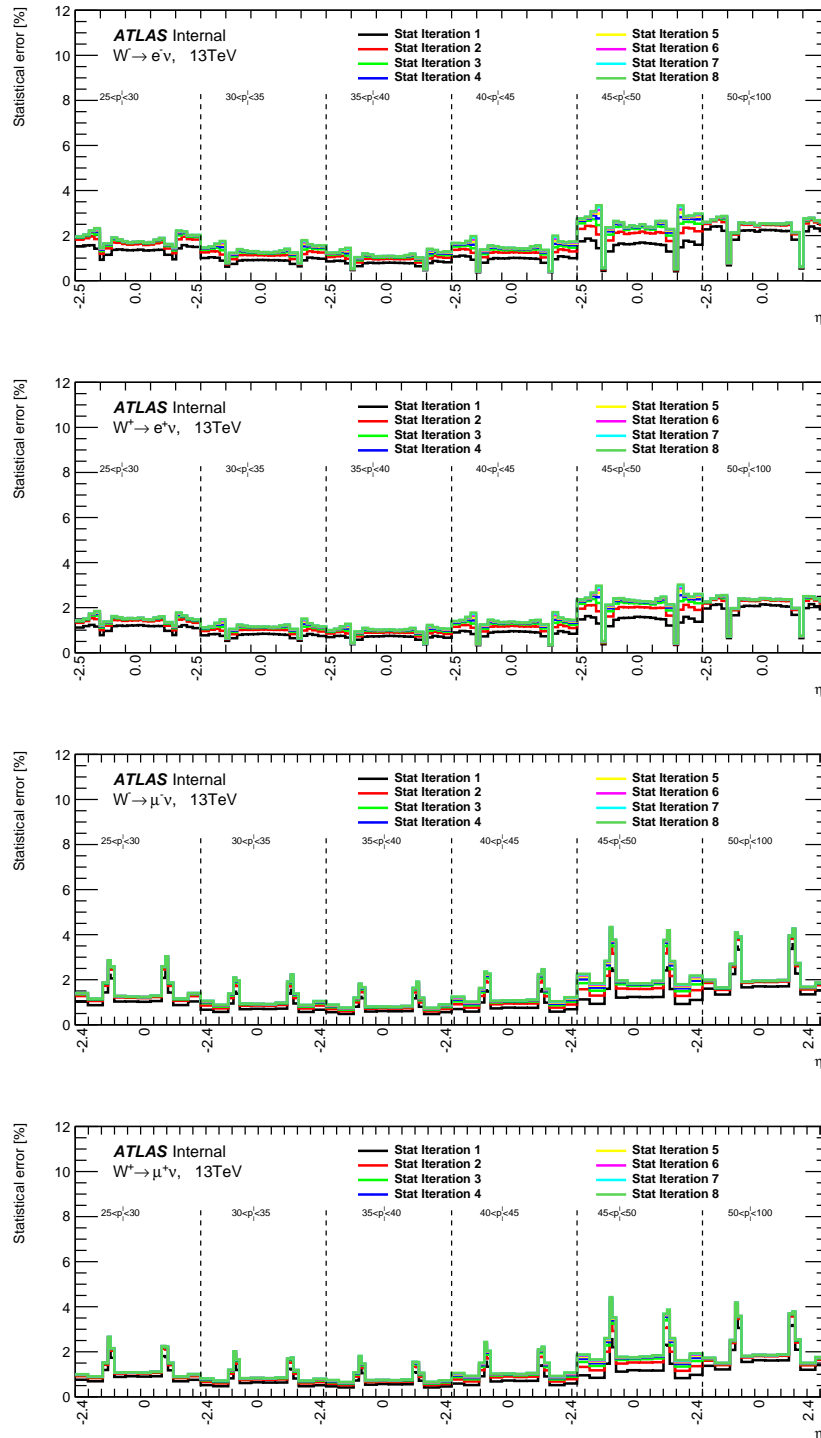


FIGURE C.2: Statistical uncertainties of unfolded distributions used for double differential cross sections at 13 TeV

2267 **Unfolding bias for double differential cross sections at**
 2268 **5 TeV**

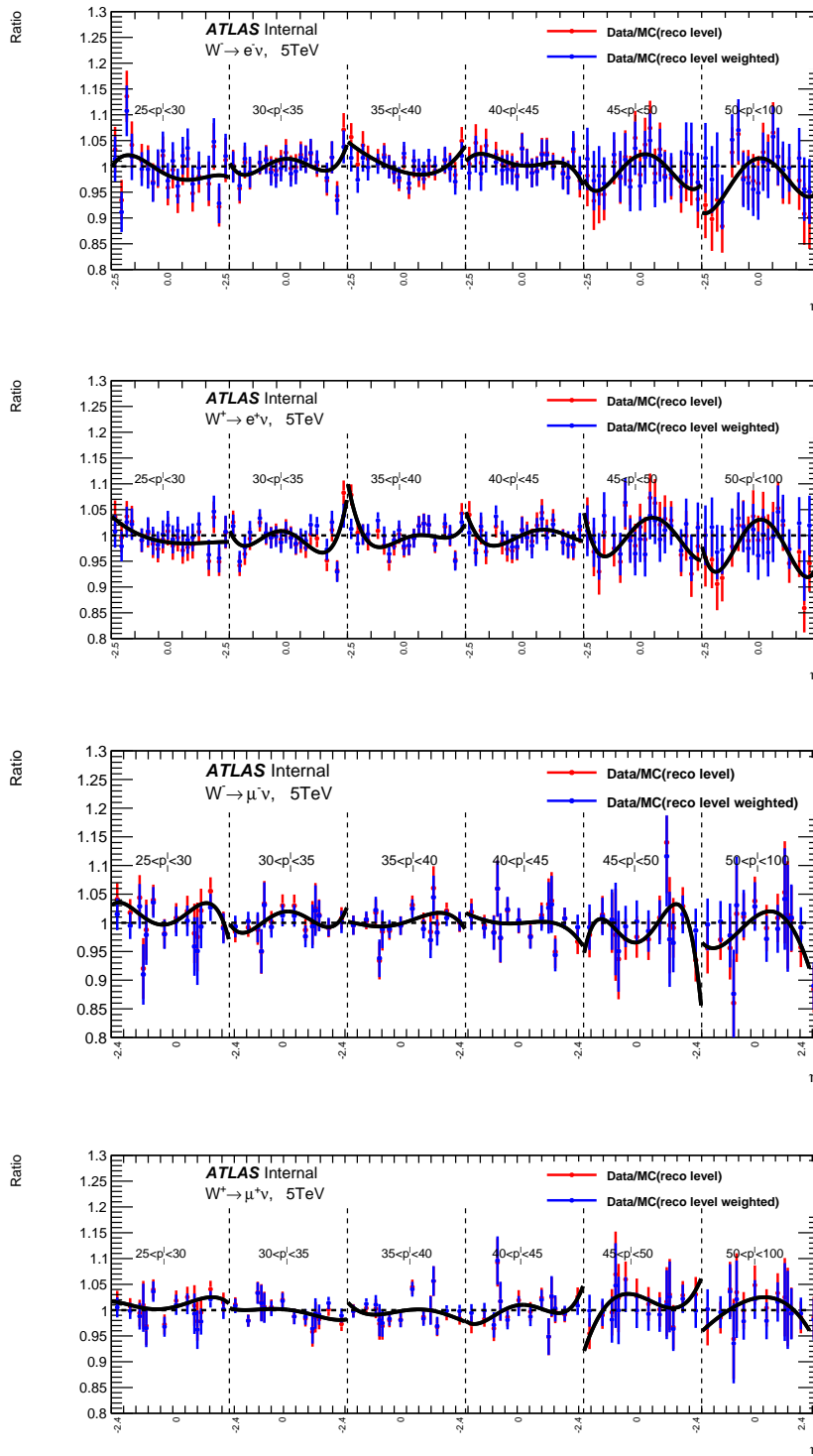


FIGURE C.3: Ratio data/MC used to calculate the unfolding bias for double differential cross sections at 5 TeV

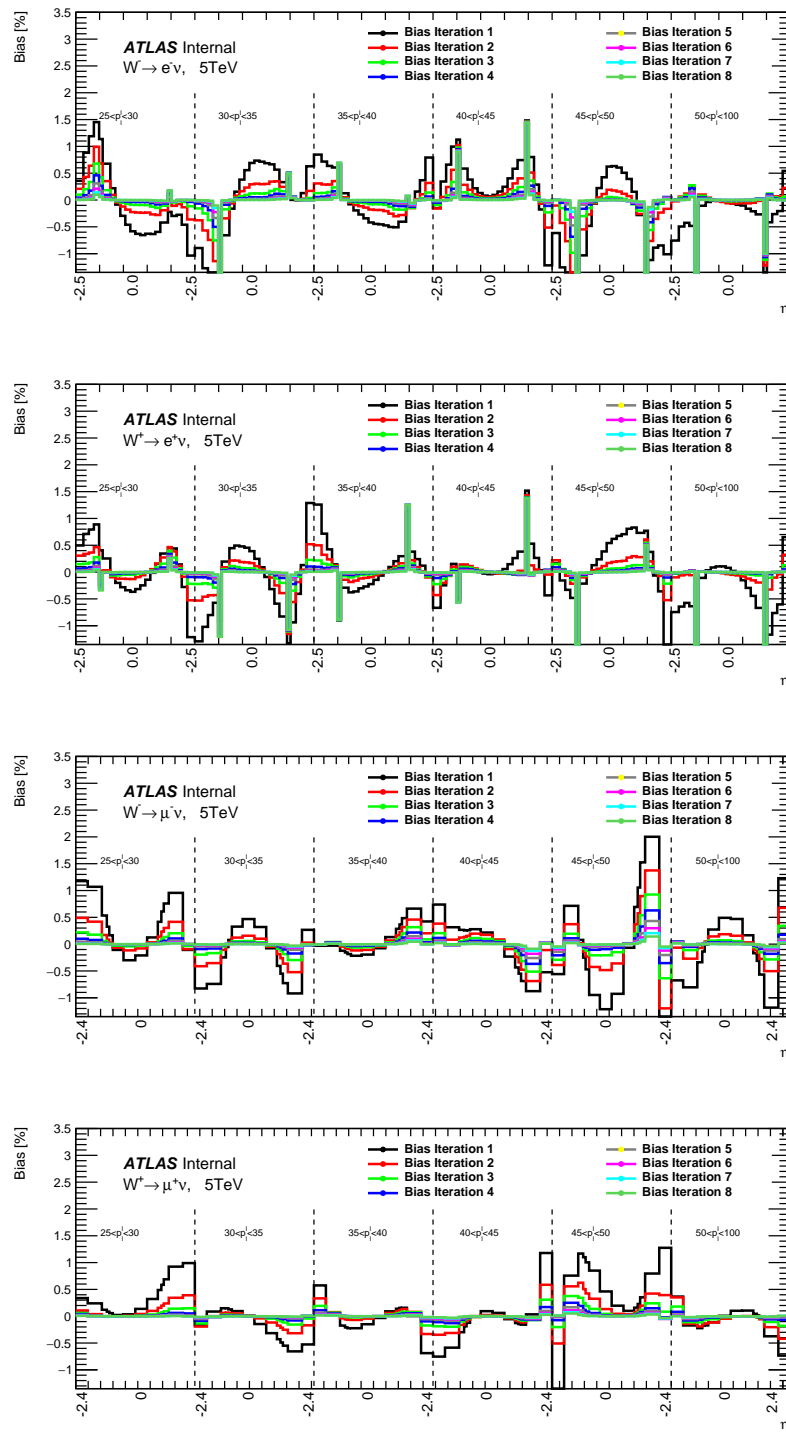


FIGURE C.4: Unfolding bias for double differential cross sections at 5 TeV

2269 **Unfolding bias for double differential cross sections at**
 2270 **13 TeV**

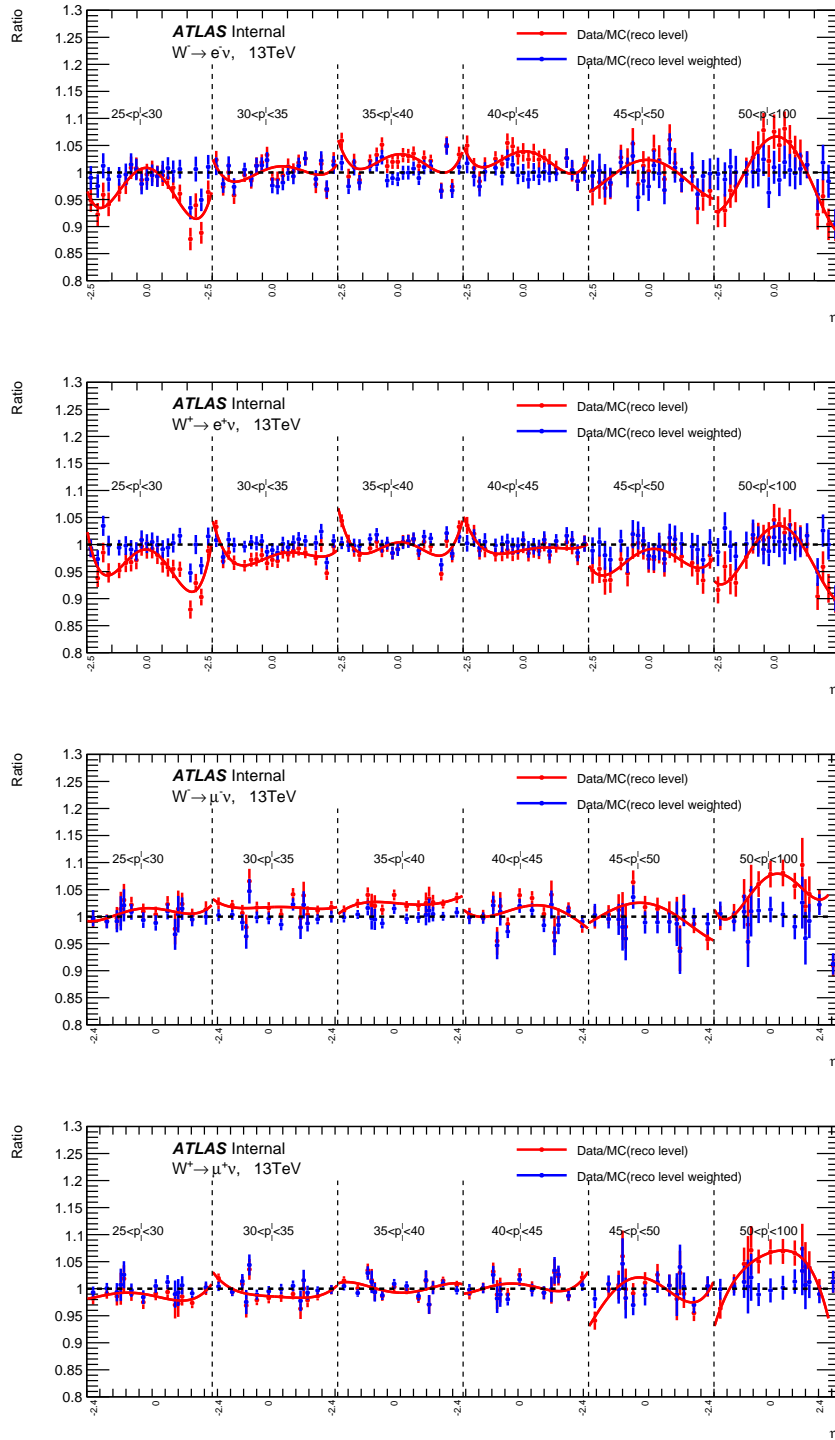


FIGURE C.5: Ratio data/MC used to calculate the unfolding bias for double differential cross sections at 13 TeV

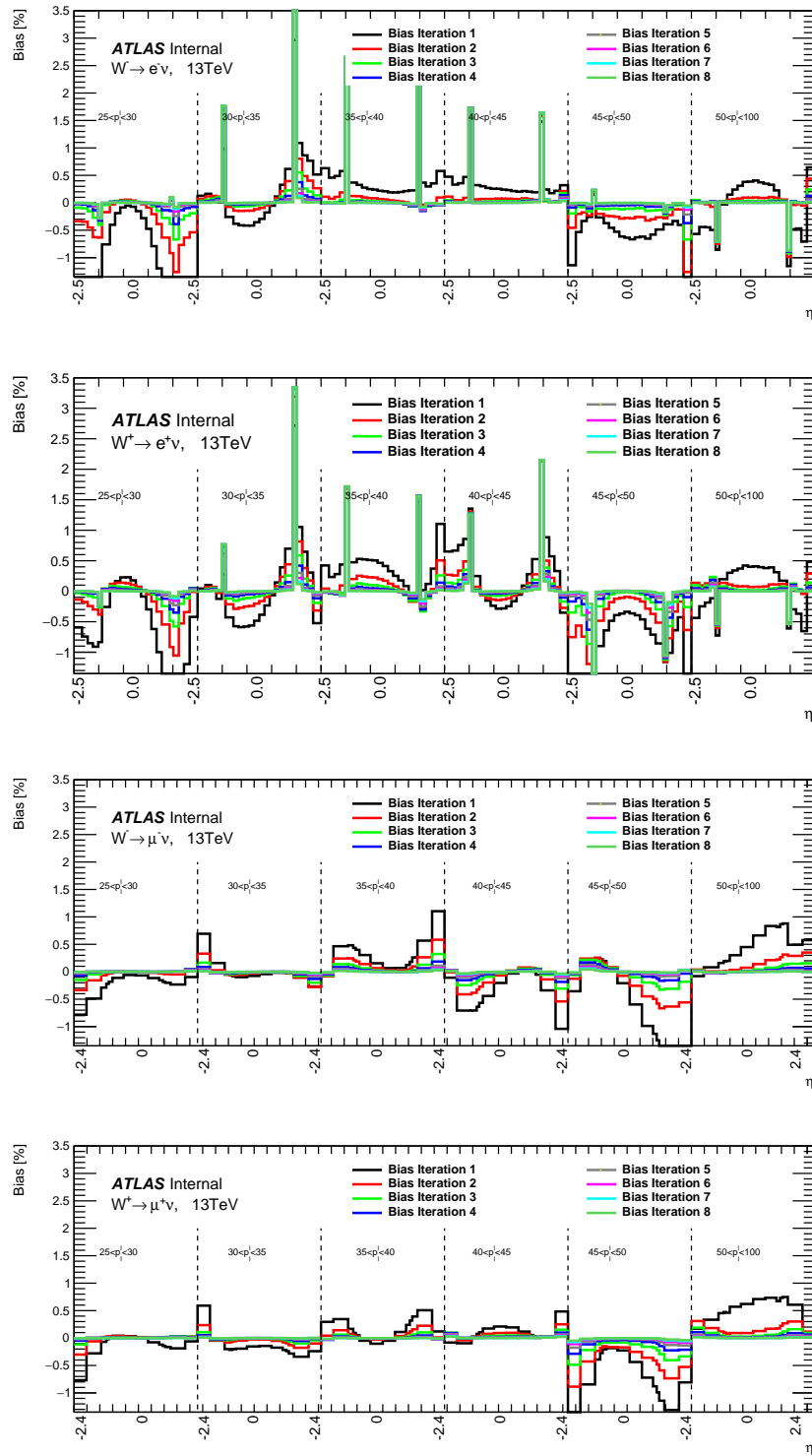


FIGURE C.6: Unfolding bias for double differential cross sections at 13 TeV

2272 Bibliography

- 2273 [1] M. Aaboud et al. “Electron efficiency measurements with the ATLAS detec-
2274 tor using 2012 LHC proton–proton collision data”. In: *The European Physical*
2275 *Journal C* 77.3 (Mar. 2017). ISSN: 1434-6052. DOI: [10.1140/epjc/s10052-](https://doi.org/10.1140/epjc/s10052-017-4756-2)
2276 [017-4756-2](https://doi.org/10.1140/epjc/s10052-017-4756-2). URL: [http://dx.doi.org/10.1140/epjc/s10052-](http://dx.doi.org/10.1140/epjc/s10052-017-4756-2)
2277 [017-4756-2](http://dx.doi.org/10.1140/epjc/s10052-017-4756-2) (cit. on p. 138).
- 2278 [2] Morad Aaboud et al. “Electron and photon energy calibration with the AT-
2279 LAS detector using 2015–2016 LHC proton-proton collision data”. In: *JINST*
2280 14.03 (2019), P03017. DOI: [10.1088/1748-0221/14/03/P03017](https://doi.org/10.1088/1748-0221/14/03/P03017). arXiv:
2281 [1812.03848](https://arxiv.org/abs/1812.03848) [hep-ex] (cit. on p. 42).
- 2282 [3] G. Aad et al. “The ATLAS Experiment at the CERN Large Hadron Col-
2283 lider”. In: *JINST* 3 (2008), S08003. DOI: [10.1088/1748-0221/3/08/](https://doi.org/10.1088/1748-0221/3/08/S08003)
2284 [S08003](https://doi.org/10.1088/1748-0221/3/08/S08003) (cit. on p. 26).
- 2285 [4] G. Aad et al. “Observation of a new particle in the search for the Standard
2286 Model Higgs boson with the ATLAS detector at the LHC”. In: *Physics Letters*
2287 *B* 716.1 (Sept. 2012), pp. 1–29. DOI: [10.1016/j.physletb.2012.08.](https://doi.org/10.1016/j.physletb.2012.08.020)
2288 [020](https://doi.org/10.1016/j.physletb.2012.08.020). arXiv: [1207.7214](https://arxiv.org/abs/1207.7214) [hep-ex] (cit. on p. 2).
- 2289 [5] Timo Antero Aaltonen et al. “Combination of CDF and D0 *W*-Boson Mass
2290 Measurements”. In: *Phys. Rev. D* 88.5 (2013), p. 052018. DOI: [10.1103/](https://doi.org/10.1103/PhysRevD.88.052018)
2291 [PhysRevD.88.052018](https://doi.org/10.1103/PhysRevD.88.052018). arXiv: [1307.7627](https://arxiv.org/abs/1307.7627) [hep-ex] (cit. on p. 11).
- 2292 [6] Henso Abreu. “Measurement of the inclusive prompt photon cross section
2293 and preparation of the search of the Higgs boson decaying into two pho-
2294 tons with the ATLAS detector at the LHC”. PhD thesis. Orsay, 2011 (cit. on
2295 p. 23).
- 2296 [7] Tim Adye. “Unfolding algorithms and tests using RooUnfold”. In: *arXiv*
2297 *e-prints*, arXiv:1105.1160 (May 2011), arXiv:1105.1160. arXiv: [1105.1160](https://arxiv.org/abs/1105.1160)
2298 [[physics.data-an](https://arxiv.org/abs/1105.1160)] (cit. on pp. 61, 139).
- 2299 [8] S. Agostinelli et al. “GEANT4—a simulation toolkit”. In: *Nucl. Instrum. Meth.*
2300 *A* 506 (2003), pp. 250–303. DOI: [10.1016/S0168-9002\(03\)01368-8](https://doi.org/10.1016/S0168-9002(03)01368-8) (cit.
2301 on p. 33).
- 2302 [9] S. Alekhin, J. Blümlein, and S. Moch. “NLO PDFs from the ABMP16 fit”.
2303 In: *The European Physical Journal C* 78.6 (June 2018). ISSN: 1434-6052. DOI:
2304 [10.1140/epjc/s10052-018-5947-1](https://doi.org/10.1140/epjc/s10052-018-5947-1). URL: [http://dx.doi.org/](http://dx.doi.org/10.1140/epjc/s10052-018-5947-1)
2305 [10.1140/epjc/s10052-018-5947-1](http://dx.doi.org/10.1140/epjc/s10052-018-5947-1) (cit. on p. 94).
- 2306 [10] M Aleksa and M Diemoz. *Discussion on the electromagnetic calorimeters of*
2307 *ATLAS and CMS*. Tech. rep. ATL-LARG-PROC-2013-002. Geneva: CERN,
2308 May 2013. URL: <https://cds.cern.ch/record/1547314> (cit. on
2309 p. 20).

- 2310 [11] J. Alitti et al. “An Improved determination of the ratio of W and Z masses
2311 at the CERN $\bar{p}p$ collider”. In: *Phys. Lett. B* 276 (1992), pp. 354–364. DOI: [10 .
2312 1016/0370-2693 \(92\) 90332-X](https://doi.org/10.1016/0370-2693(92)90332-X) (cit. on p. 11).
- 2313 [12] Charalampos Anastasiou et al. “High-precision QCD at hadron colliders:
2314 Electroweak gauge boson rapidity distributions at next-to-next-to leading
2315 order”. In: 69.9, 094008 (May 2004), p. 094008. DOI: [10 .1103/PhysRevD .
2316 69.094008](https://doi.org/10.1103/PhysRevD.69.094008). arXiv: [hep-ph/0312266](https://arxiv.org/abs/hep-ph/0312266) [hep-ph] (cit. on p. 91).
- 2317 [13] Nansi Andari. “Observation of a BEH-like boson decaying into two pho-
2318 tons with the ATLAS detector at the LHC”. PhD thesis. Orsay, LAL, Sept.
2319 2012 (cit. on pp. 23, 29).
- 2320 [14] Nansi Andari. *W mass measurement*. Tech. rep. ATL-PHYS-PROC-2017-051.
2321 Geneva: CERN, May 2017. DOI: [oai : cds . cern . ch : 2264497](https://doi.org/10.264497). URL:
2322 <https://cds.cern.ch/record/2264497> (cit. on p. 23).
- 2323 [15] Nansi Andari et al. *Electron and photon energy calibration with the ATLAS de-*
2324 *tor using 2015-2017 LHC proton-proton collision data*. Tech. rep. ATL-COM-
2325 PHYS-2018-1720. Geneva: CERN, Dec. 2018. URL: [https://cds.cern .
2326 ch/record/2651890](https://cds.cern.ch/record/2651890) (cit. on pp. 37, 42, 48, 55).
- 2327 [16] Nansi Andari et al. *Measurement of m_W at 7 TeV: Physics modeling*. Tech. rep.
2328 ATL-COM-PHYS-2014-1436. Geneva: CERN, Nov. 2014. URL: [https://
2329 cds.cern.ch/record/1966965](https://cds.cern.ch/record/1966965) (cit. on p. 12).
- 2330 [17] Nansi Andari et al. *Measurement of m_W with 7 TeV data: W boson mass mea-*
2331 *surement*. Tech. rep. ATL-COM-PHYS-2014-1569. Geneva: CERN, Dec. 2014.
2332 URL: <https://cds.cern.ch/record/1976186> (cit. on pp. 11, 12, 131).
- 2333 [18] Samir. S. Arfaoui. “The ATLAS liquid argon calorimeter high-voltage sys-
2334 tem: commissioning, optimisation, and LHC relative luminosity measure-
2335 ment”. Theses. Université de la Méditerranée - Aix-Marseille II, Oct. 2011.
2336 URL: <https://tel.archives-ouvertes.fr/tel-00658194> (cit. on
2337 p. 34).
- 2338 [19] Theodoros Argyropoulos et al. “Cathode strip chambers in ATLAS: Instal-
2339 lation, commissioning and in situ performance”. In: *IEEE Trans. Nucl. Sci.*
2340 56 (2009), pp. 1568–1574. DOI: [10 .1109/TNS .2009 .2020861](https://doi.org/10.1109/TNS.2009.2020861) (cit. on
2341 p. 26).
- 2342 [20] A Armbruster et al. *Practical considerations for unfolding*. Tech. rep. ATL-
2343 COM-PHYS-2014-277. Geneva: CERN, Apr. 2014. URL: [https://cds .
2344 cern.ch/record/1694351](https://cds.cern.ch/record/1694351) (cit. on p. 62).
- 2345 [21] G. Arnison et al. “Experimental Observation of Isolated Large Transverse
2346 Energy Electrons with Associated Missing Energy at $s^{1/2} = 540\text{-GeV}$ ”.
2347 In: *Phys. Lett. B* 122 (1983), pp. 103–116. DOI: [10 .1016/0370-2693 \(83\)
2348 91177-2](https://doi.org/10.1016/0370-2693(83)91177-2) (cit. on p. 11).
- 2349 [22] ATLAS Collaboration. “Electron efficiency measurements with the AT-
2350 LAS detector using 2012 LHC proton-proton collision data”. In: *arXiv e-*
2351 *prints*, arXiv:1612.01456 (Dec. 2016), arXiv:1612.01456. arXiv: [1612 .01456
2352 \[hep-ex\]](https://arxiv.org/abs/1612.01456) (cit. on pp. 79, 99).

- 2353 [23] ATLAS Collaboration. “Measurement of the muon reconstruction perfor-
2354 mance of the ATLAS detector using 2011 and 2012 LHC proton-proton col-
2355 lision data”. In: *arXiv e-prints*, arXiv:1407.3935 (July 2014), arXiv:1407.3935.
2356 arXiv: 1407.3935 [hep-ex] (cit. on p. 11).
- 2357 [24] *ATLAS detector and physics performance: Technical Design Report, 1*. Technical
2358 Design Report ATLAS. Geneva: CERN, 1999. URL: [https://cds.cern.
2359 ch/record/391176](https://cds.cern.ch/record/391176) (cit. on p. 17).
- 2360 [25] *ATLAS Liquid Argon Calorimeter Phase-I Upgrade Technical Design Report*.
2361 Tech. rep. CERN-LHCC-2013-017. ATLAS-TDR-022. Final version pre-
2362 sented to December 2013 LHCC. Sept. 2013. URL: [https://cds.cern.
2363 ch/record/1602230](https://cds.cern.ch/record/1602230) (cit. on p. 24).
- 2364 [26] *ATLAS liquid-argon calorimeter: Technical Design Report*. Technical Design Re-
2365 port ATLAS. Geneva: CERN, 1996. URL: [https://cds.cern.ch/
2366 record/331061](https://cds.cern.ch/record/331061) (cit. on pp. 22, 23).
- 2367 [27] Hicham Atmani et al. *Measurement of the p_T spectrum of W - and Z -bosons
2368 produced in pp collisions at $\sqrt{s} = 5$ TeV and 13 TeV in low-pileup runs*. Tech.
2369 rep. ATL-COM-PHYS-2018-1084. Geneva: CERN, July 2018. URL: [https:
2370 //cds.cern.ch/record/2632159](https://cds.cern.ch/record/2632159) (cit. on pp. 97, 99).
- 2371 [28] M. Baak et al. “The global electroweak fit at NNLO and prospects for the
2372 LHC and ILC”. In: *European Physical Journal C* 74, 3046 (Sept. 2014), p. 3046.
2373 DOI: 10.1140/epjc/s10052-014-3046-5. arXiv: 1407.3792
2374 [hep-ph] (cit. on p. 10).
- 2375 [29] M. Banner et al. “Observation of Single Isolated Electrons of High Trans-
2376 verse Momentum in Events with Missing Transverse Energy at the CERN
2377 anti-p p Collider”. In: *Phys. Lett. B* 122 (1983), pp. 476–485. DOI: 10.1016/
2378 0370-2693(83)91605-2 (cit. on p. 11).
- 2379 [30] J Beacham et al. “Physics beyond colliders at CERN: beyond the Standard
2380 Model working group report”. In: *Journal of Physics G: Nuclear and Particle
2381 Physics* 47.1 (Dec. 2019), p. 010501. ISSN: 1361-6471. DOI: 10.1088/1361-
2382 6471/ab4cd2. URL: [http://dx.doi.org/10.1088/1361-6471/
2383 ab4cd2](http://dx.doi.org/10.1088/1361-6471/ab4cd2) (cit. on p. 15).
- 2384 [31] Cyril Pascal Becot. “Diphoton lineshape of the BEH boson using the AT-
2385 LAS detector at the LHC: calibration, mass, width and interferences”. PhD
2386 thesis. Diderot U., Paris, Sept. 2015 (cit. on pp. 23, 42).
- 2387 [32] V. A. Bednyakov, N. D. Giokaris, and A. V. Bednyakov. “On the Higgs mass
2388 generation mechanism in the Standard Model”. In: *Physics of Particles and
2389 Nuclei* 39.1 (Jan. 2008), pp. 13–36. DOI: 10.1007/s11496-008-1002-9.
2390 arXiv: hep-ph/0703280 [hep-ph] (cit. on p. 6).
- 2391 [33] W. Beenakker, F. A. Berends, and A. P. Chapovsky. “Final-state radiation
2392 and line-shape distortion in resonance pair production”. In: *Physics Letters
2393 B* 435.1-2 (Sept. 1998), pp. 233–239. DOI: 10.1016/S0370-2693(98)
2394 00760-6. arXiv: hep-ph/9805327 [hep-ph] (cit. on p. 12).

- 2395 [34] Arnd Behring et al. “Mixed QCD-electroweak corrections to W-boson
2396 production in hadron collisions”. In: (Sept. 2020). arXiv: 2009.10386
2397 [hep-ph] (cit. on p. 91).
- 2398 [35] Jacob D. Bekenstein and Bibhas Ranjan Majhi. “Is the principle of least ac-
2399 tion a must?” In: *Nuclear Physics B* 892 (Mar. 2015), pp. 337–352. DOI: 10.
2400 1016/j.nuclphysb.2015.01.015. arXiv: 1411.2424 [hep-th] (cit.
2401 on p. 3).
- 2402 [36] Carsten Bittrich et al. *In-situ scale factors from Zee events*. Tech. rep. ATL-
2403 COM-PHYS-2017-757. Geneva: CERN, June 2017. URL: <https://cds.cern.ch/record/2268800> (cit. on pp. 37, 46).
- 2405 [37] Serguei I. Bityukov. “Signal Significance in the Presence of Systematic and
2406 Statistical Uncertainties”. In: *Journal of High Energy Physics* 2002.9, 060 (Sept.
2407 2002), p. 060. DOI: 10.1088/1126-6708/2002/09/060. arXiv: hep-
2408 ph/0207130 [hep-ph] (cit. on p. 64).
- 2409 [38] J-B Blanchard, J-B de Vivie, and P Mastrandrea. *In situ scales and smear-
2410 ings from Z and J/Ψ events*. Tech. rep. ATL-COM-PHYS-2013-1653. Geneva:
2411 CERN, Dec. 2013. URL: <https://cds.cern.ch/record/1637533> (cit.
2412 on pp. 37, 57).
- 2413 [39] Jorge de Blas et al. “The Global Electroweak and Higgs Fits in the LHC
2414 era”. In: *PoS EPS-HEP2017* (2017). Ed. by Paolo Checchia et al., p. 467. DOI:
2415 10.22323/1.314.0467. arXiv: 1710.05402 [hep-ph] (cit. on p. 10).
- 2416 [40] Volker Blobel. “Unfolding Methods in Particle Physics”. In: (Jan. 2011), 240–
2417 251. 12 p. DOI: 10.5170/CERN-2011-006.240. URL: <https://cds.cern.ch/record/2203257> (cit. on p. 59).
- 2419 [41] Maarten Boonekamp and Jean-Baptiste Blanchard. *Measurement of m_W at 7
2420 TeV: Electron performance corrections and uncertainties*. Tech. rep. ATL-COM-
2421 PHYS-2014-1434. Geneva: CERN, Nov. 2014. URL: <https://cds.cern.ch/record/1966963> (cit. on pp. 11, 46, 57).
- 2423 [42] Maximilien Brice and Claudia Marcelloni. “View of the Detector ATLAS
2424 open.” Feb. 2007. URL: <https://cds.cern.ch/record/1206860> (cit.
2425 on p. 18).
- 2426 [43] Andrew Buckley. *ATLAS Pythia 8 tunes to 7 TeV data*. Tech. rep. Dec. 2014,
2427 p. 29 (cit. on p. 77).
- 2428 [44] C.Wang. “presentation at the egamma calibration meeting”. In: (Sept.
2429 2020). URL: [https://indico.cern.ch/event/957069/
2430 contributions/4031631/attachments/2108689/3546663/
2431 ElectronCalibration.pdf](https://indico.cern.ch/event/957069/contributions/4031631/attachments/2108689/3546663/ElectronCalibration.pdf) (cit. on p. 57).
- 2432 [45] Stefano Camarda et al. “DYTurbo: fast predictions for Drell–Yan processes”.
2433 In: *The European Physical Journal C* 80.3 (Mar. 2020). ISSN: 1434-6052. DOI:
2434 10.1140/epjc/s10052-020-7757-5. URL: [http://dx.doi.org/
2435 10.1140/epjc/s10052-020-7757-5](http://dx.doi.org/10.1140/epjc/s10052-020-7757-5) (cit. on pp. 94, 121).

- 2436 [46] John M. Campbell, J.W. Huston, and W.J. Stirling. “Hard Interactions of
2437 Quarks and Gluons: A Primer for LHC Physics”. In: *Rept. Prog. Phys.* 70
2438 (2007), p. 89. DOI: [10.1088/0034-4885/70/1/R02](https://doi.org/10.1088/0034-4885/70/1/R02). arXiv: [hep-ph/
2439 0611148](https://arxiv.org/abs/hep-ph/0611148) (cit. on p. 8).
- 2440 [47] Leonor Cerda Alberich. *Photon and electron identification with the ATLAS de-*
2441 *tor*. Tech. rep. ATL-PHYS-PROC-2016-230. Geneva: CERN, Nov. 2016.
2442 DOI: [10.22323/1.282.1235](https://doi.org/10.22323/1.282.1235). URL: [https://cds.cern.ch/record/
2443 2233097](https://cds.cern.ch/record/2233097) (cit. on p. 138).
- 2444 [48] Olmo Cerri. “Hadronic recoil in the W boson production at LHC for a
2445 W mass measurement with the CMS experiment”. Presented 20 Sep 2017.
2446 2017. URL: <https://cds.cern.ch/record/2285935> (cit. on p. 11).
- 2447 [49] Georgios Choudalakis. “Fully Bayesian Unfolding”. In: 2012 (cit. on p. 59).
- 2448 [50] P.J. Clark. “The ATLAS Detector Simulation”. In: *Nuclear Physics B - Pro-*
2449 *ceedings Supplements* 215.1 (2011). Proceedings of the 12th Topical Seminar
2450 on Innovative Particle and Radiation Detectors (IPRD10), pp. 85–88. ISSN:
2451 0920-5632. DOI: [https://doi.org/10.1016/j.nuclphysbps.
2452 2011.03.142](https://doi.org/10.1016/j.nuclphysbps.2011.03.142). URL: [http://www.sciencedirect.com/science/
2453 article/pii/S092056321100212X](http://www.sciencedirect.com/science/article/pii/S092056321100212X) (cit. on p. 17).
- 2454 [51] W.E. Cleland and E.G. Stern. “Signal processing considerations for liquid
2455 ionization calorimeters in a high rate environment”. In: *Nuclear Instruments*
2456 *and Methods in Physics Research Section A: Accelerators, Spectrometers, Detec-*
2457 *tors and Associated Equipment* 338.2 (1994), pp. 467–497. ISSN: 0168-9002.
2458 DOI: [https://doi.org/10.1016/0168-9002\(94\)91332-3](https://doi.org/10.1016/0168-9002(94)91332-3).
2459 URL: [http://www.sciencedirect.com/science/article/pii/
2460 0168900294913323](http://www.sciencedirect.com/science/article/pii/S0168900294913323) (cit. on p. 29).
- 2461 [52] The ATLAS Collaboration. “The ATLAS Experiment at the CERN Large
2462 Hadron Collider”. In: *Journal of Instrumentation* 3.08 (Aug. 2008), S08003–
2463 S08003. DOI: [10.1088/1748-0221/3/08/S08003](https://doi.org/10.1088/1748-0221/3/08/S08003). URL: [https://
2464 doi.org/10.1088/1748-0221/3/08/S08003](https://doi.org/10.1088/1748-0221/3/08/S08003) (cit. on
2465 p. 17).
- 2466 [53] The NNPDF Collaboration et al. *Parton distributions from high-precision col-*
2467 *lider data*. 2017. arXiv: [1706.00428](https://arxiv.org/abs/1706.00428) [hep-ph] (cit. on p. 94).
- 2468 [54] *Computation and validation of the electronic calibration constants for the ATLAS*
2469 *Liquid Argon Calorimeters*. Tech. rep. ATL-LARG-INT-2010-007. Geneva:
2470 CERN, July 2010. URL: <https://cds.cern.ch/record/1278462>
2471 (cit. on p. 28).
- 2472 [55] G. D’Agostini. *Improved iterative Bayesian unfolding*. 2010. arXiv: [1010.
2473 0632](https://arxiv.org/abs/1010.0632) [physics.data-an] (cit. on pp. 59, 99).
- 2474 [56] G. D’Agostini. “Improved iterative Bayesian unfolding”. In: *arXiv e-*
2475 *prints*, arXiv:1010.0632 (Oct. 2010), arXiv:1010.0632. arXiv: [1010.
2476 0632](https://arxiv.org/abs/1010.0632) [physics.data-an] (cit. on p. 61).

- 2477 [57] Delgove David. “presentation at the egamma calibration meeting”. In:
2478 (Mar. 2019). URL: [https://indico.cern.ch/event/804207/
2479 contributions/3353868/attachments/1811758/2959326/
2480 Linearity.pdf](https://indico.cern.ch/event/804207/contributions/3353868/attachments/1811758/2959326/Linearity.pdf) (cit. on p. 57).
- 2481 [58] W. de Boer. “Precision Experiments at LEP”. In: *60 YEARS OF CERN EX-
2482 PERIMENTS AND DISCOVERIES. Edited by SCHOPPER HERWIG ET AL.
2483 Published by World Scientific Publishing Co. Pte. Ltd* 23 (July 2015), pp. 107–
2484 136. DOI: [10 . 1142 / 9789814644150 _ 0005](https://doi.org/10.1142/9789814644150_0005). arXiv: [1509 . 06050](https://arxiv.org/abs/1509.06050)
2485 [[hep-ex](https://arxiv.org/abs/1509.06050)] (cit. on p. 34).
- 2486 [59] *Design Report Tevatron 1 project*. Tech. rep. FERMILAB-DESIGN-1984-01.
2487 1984. URL: <https://cds.cern.ch/record/1478620> (cit. on p. 11).
- 2488 [60] Luigi Di Lella and Carlo Rubbia. “The Discovery of the W and Z Parti-
2489 cles”. In: *Adv. Ser. Dir. High Energy Phys.* 23 (2015), pp. 137–163. DOI: [10 .
2490 1142/9789814644150_0006](https://doi.org/10.1142/9789814644150_0006). URL: [https://cds.cern.ch/record/
2491 2103277](https://cds.cern.ch/record/2103277) (cit. on p. 11).
- 2492 [61] Günther Dissertori. “The Determination of the Strong Coupling Constant”.
2493 In: *The Standard Theory of Particle Physics: Essays to Celebrate CERN’s 60th
2494 Anniversary*. Ed. by Luciano Maiani and et al. Oct. 2016, pp. 113–128. DOI:
2495 [10 . 1142 / 9789814733519 _ 0006](https://doi.org/10.1142/9789814733519_0006). arXiv: [1506 . 05407](https://arxiv.org/abs/1506.05407) [[hep-ex](https://arxiv.org/abs/1506.05407)] (cit.
2496 on p. 5).
- 2497 [62] Stefan Dittmaier, Timo Schmidt, and Jan Schwarz. “Mixed NNLO QCD
2498 x electroweak corrections of $\mathcal{O}(N_f \alpha_s \alpha)$ to single-W/Z production at the
2499 LHC”. In: (Sept. 2020). arXiv: [2009.02229](https://arxiv.org/abs/2009.02229) [[hep-ph](https://arxiv.org/abs/2009.02229)] (cit. on p. 91).
- 2500 [63] Daniel Dominguez. “Standard Model. Le modèle standard”. In: (Mar.
2501 2015). General Photo. URL: <https://cds.cern.ch/record/2002395>
2502 (cit. on p. 2).
- 2503 [64] Claude Duhr, Falko Dulat, and Bernhard Mistlberger. “Charged Current
2504 Drell-Yan Production at N³LO”. In: (July 2020). arXiv: [2007 . 13313](https://arxiv.org/abs/2007.13313)
2505 [[hep-ph](https://arxiv.org/abs/2007.13313)] (cit. on p. 91).
- 2506 [65] Sayipjamal Dulat et al. “New parton distribution functions from a global
2507 analysis of quantum chromodynamics”. In: *Phys. Rev. D* 93.3 (2016),
2508 p. 033006. DOI: [10 . 1103 / PhysRevD . 93 . 033006](https://doi.org/10.1103/PhysRevD.93.033006). arXiv: [1506 . 07443](https://arxiv.org/abs/1506.07443)
2509 [[hep-ph](https://arxiv.org/abs/1506.07443)] (cit. on p. 8).
- 2510 [66] Miguel G. Echevarria, Ahmad Idilbi, and Ignazio Scimemi. “Factorization
2511 Theorem For Drell-Yan At Low q_T And Transverse Momentum Distri-
2512 butions On-The-Light-Cone”. In: *JHEP* 07 (2012), p. 002. DOI: [10 . 1007 /
2513 JHEP07\(2012\)002](https://doi.org/10.1007/JHEP07(2012)002). arXiv: [1111 . 4996](https://arxiv.org/abs/1111.4996) [[hep-ph](https://arxiv.org/abs/1111.4996)] (cit. on p. 8).
- 2514 [67] “Electron and photon energy calibration with the ATLAS detector using
2515 LHC Run 1 data”. In: *European Physical Journal C* 74, 3071 (Oct. 2014),
2516 p. 3071. DOI: [10 . 1140 / epjc / s10052 - 014 - 3071 - 4](https://doi.org/10.1140/epjc/s10052-014-3071-4). arXiv: [1407 . 5063](https://arxiv.org/abs/1407.5063)
2517 [[hep-ex](https://arxiv.org/abs/1407.5063)] (cit. on pp. 11, 33, 34, 46).

- 2518 [68] “Electron and photon performance measurements with the ATLAS detector
2519 using the 20152017 LHC proton-proton collision data”. In: *Journal of Instru-*
2520 *mentation* 14.12 (Dec. 2019), P12006. DOI: [10.1088/1748-0221/14/12/](https://doi.org/10.1088/1748-0221/14/12/P12006)
2521 [P12006](https://doi.org/10.1088/1748-0221/14/12/P12006). arXiv: [1908.00005](https://arxiv.org/abs/1908.00005) [hep-ex] (cit. on p. 31).
- 2522 [69] *Electron and photon reconstruction and performance in ATLAS using a dynamical, topological cell clustering-based approach*. Tech. rep. ATL-PHYS-PUB-2017-022. Geneva: CERN, Dec. 2017. URL: <https://cds.cern.ch/record/2298955> (cit. on pp. 29, 30).
- 2526 [70] *Energy Resolution of the Barrel of the CMS Electromagnetic Calorimeter*. Tech. rep. CMS-NOTE-2006-148. Geneva: CERN, Nov. 2006. DOI: [10.1088/1748-0221/2/04/P04004](https://doi.org/10.1088/1748-0221/2/04/P04004). URL: <https://cds.cern.ch/record/1009081> (cit. on p. 22).
- 2530 [71] Jens Erler and Matthias Schott. “Electroweak precision tests of the Standard Model after the discovery of the Higgs boson”. In: *Progress in Particle and Nuclear Physics* 106 (May 2019), pp. 68–119. DOI: [10.1016/j.pnpnp.2019.02.007](https://doi.org/10.1016/j.pnpnp.2019.02.007). arXiv: [1902.05142](https://arxiv.org/abs/1902.05142) [hep-ph] (cit. on p. 2).
- 2534 [72] “Experimental observation of isolated large transverse energy electrons with associated missing energy at $\sqrt{s} = 540\text{GeV}$ ”. In: *Phys. Lett. B* 122.CERN-EP-83-13 (Jan. 1983), 103–116. 31 p. DOI: [10.5170/CERN-1983-004.123](https://doi.org/10.5170/CERN-1983-004.123). URL: <https://cds.cern.ch/record/142059> (cit. on p. 11).
- 2539 [73] Christian Wolfgang Fabjan and F Gianotti. “Calorimetry for Particle Physics”. In: *Rev. Mod. Phys.* 75.CERN-EP-2003-075 (Oct. 2003), 1243–1286. 96 p. DOI: [10.1103/RevModPhys.75.1243](https://doi.org/10.1103/RevModPhys.75.1243). URL: <https://cds.cern.ch/record/692252> (cit. on p. 22).
- 2543 [74] Saskia Falke. “Measurement of the Higgs boson properties with Run 2 data collected by the ATLAS experiment. Mesure des propriétés du boson de Higgs avec les données du Run 2 collectées par l’expérience ATLAS”. Presented 17 Sep 2019. 2019. URL: <https://cds.cern.ch/record/2691944> (cit. on pp. 44, 45).
- 2548 [75] J. Feltesse. “Introduction to Parton Distribution Functions”. In: *Scholarpedia* 5.11 (2010). revision #186761, p. 10160. DOI: [10.4249/scholarpedia.10160](https://doi.org/10.4249/scholarpedia.10160) (cit. on p. 7).
- 2551 [76] Joel Feltesse. “Introduction to deep inelastic scattering: Past and present”. In: *20th International Workshop on Deep-Inelastic Scattering and Related Subjects*. 2012, pp. 3–12. DOI: [10.3204/DESY-PROC-2012-02/6](https://doi.org/10.3204/DESY-PROC-2012-02/6) (cit. on p. 7).
- 2555 [77] “Fits for W mass analysis”. In: (). $\sin^2\theta$ and low mu run analyses workshop 2019. URL: https://indico.cern.ch/event/776453/contributions/3284036/attachments/1792310/2920446/PeregoMarta_2019-02-07-workshopOrsay.pdf (cit. on pp. 131, 132, 135).

- 2560 [78] D. Fournier. “Liquid argon calorimetry”. In: *ECFA Large Hadron Collider*
2561 *(LHC) Workshop: Physics and Instrumentation*. Oct. 1990, pp. 356–359 (cit. on
2562 p. 22).
- 2563 [79] Paolo Francavilla. “The ATLAS Tile Hadronic Calorimeter performance at
2564 the LHC”. In: *Journal of Physics: Conference Series* 404 (Dec. 2012), p. 012007.
2565 DOI: [10.1088/1742-6596/404/1/012007](https://doi.org/10.1088/1742-6596/404/1/012007). URL: [https://doi.org/
2566 10.1088%2F1742-6596%2F404%2F1%2F012007](https://doi.org/10.1088%2F1742-6596%2F404%2F1%2F012007) (cit. on p. 20).
- 2567 [80] Juerg Froehlich. “Relativistic Quantum Theory”. In: *arXiv e-prints*,
2568 arXiv:1912.00726 (Dec. 2019), arXiv:1912.00726. arXiv: [1912 . 00726](https://arxiv.org/abs/1912.00726)
2569 [[quant-ph](https://arxiv.org/abs/1912.00726)] (cit. on p. 2).
- 2570 [81] Cecilia E. Gerber. *LHC Highlights and Prospects*. Sept. 2019. arXiv: [1909 .
2571 10919](https://arxiv.org/abs/1909.10919) [[hep-ex](https://arxiv.org/abs/1909.10919)] (cit. on p. 15).
- 2572 [82] Christophe Goudet. “Etalonnage du calorimètre électromagnétique de
2573 l’expérience ATLAS et application à la mesure des couplages du boson de
2574 (Brout-Englert)-Higgs dans le canal diphoton dans le cadre du Run 2 du
2575 LHC.” PhD thesis. Saclay, 2017 (cit. on pp. 23, 37, 39, 44).
- 2576 [83] “Grand collisionneur électron-positon (LEP)”. In: (Jan. 2013). URL: [https :
2577 //cds.cern.ch/record/1997707](https://cds.cern.ch/record/1997707) (cit. on pp. 11, 39).
- 2578 [84] Andrey Grozin. “Quantum Chromodynamics”. In: *arXiv e-prints*,
2579 arXiv:1205.1815 (May 2012), arXiv:1205.1815. arXiv: [1205 . 1815](https://arxiv.org/abs/1205.1815)
2580 [[hep-ph](https://arxiv.org/abs/1205.1815)] (cit. on p. 4).
- 2581 [85] Linghua Guo. *Electron energy in-situ calibration and linearity measurements*
2582 *from Z-gt;ee events*. Tech. rep. ATL-COM-PHYS-2020-757. Geneva: CERN,
2583 Oct. 2020. URL: [https : // cds . cern . ch / record / 2742791](https://cds.cern.ch/record/2742791) (cit. on
2584 p. 57).
- 2585 [86] Manuel Guth. “Signal Region Optimisation Studies Based on BDT and
2586 Multi-Bin Approaches in the Context of Supersymmetry Searches in
2587 Hadronic Final States with the ATLAS Detector”. Presented 27 Mar 2018.
2588 Mar. 2018. URL: [https : // cds . cern . ch / record / 2308793](https://cds.cern.ch/record/2308793) (cit. on
2589 p. 25).
- 2590 [87] H1 and ZEUS collaborations. *Combination and QCD analysis of charm and*
2591 *beauty production cross-section measurements in deep inelastic ep scattering at*
2592 *HERA*. 2018. arXiv: [1804.01019](https://arxiv.org/abs/1804.01019) [[hep-ex](https://arxiv.org/abs/1804.01019)] (cit. on pp. 94, 121).
- 2593 [88] A. K. Halder, Andronikos Paliathanasis, and P. G. L. Leach. “Noether’s
2594 Theorem and Symmetry”. In: *arXiv e-prints*, arXiv:1812.03682 (Dec. 2018),
2595 arXiv:1812.03682. arXiv: [1812.03682](https://arxiv.org/abs/1812.03682) [[math-ph](https://arxiv.org/abs/1812.03682)] (cit. on p. 4).
- 2596 [89] Johannes Haller et al. “Update of the global electroweak fit and constraints
2597 on two-Higgs-doublet models”. In: *Eur. Phys. J. C* 78.8 (2018), p. 675. DOI:
2598 [10.1140/epjc/s10052-018-6131-3](https://doi.org/10.1140/epjc/s10052-018-6131-3). arXiv: [1803.01853](https://arxiv.org/abs/1803.01853) [[hep-ph](https://arxiv.org/abs/1803.01853)]
2599 (cit. on pp. 5, 10).
- 2600 [90] P. Hansen. “Results from the UA1 and UA2 Experiments”. In: *International*
2601 *School of Physics Enrico Fermi: Elementary Particles*. June 1984, pp. 1–18 (cit.
2602 on pp. 2, 11).

- 2603 [91] L. A. Harland-Lang et al. “Parton distributions in the LHC era: MMHT 2014
2604 PDFs”. In: *The European Physical Journal C* 75.5 (May 2015). ISSN: 1434-6052.
2605 DOI: [10.1140/epjc/s10052-015-3397-6](https://doi.org/10.1140/epjc/s10052-015-3397-6). URL: <http://dx.doi.org/10.1140/epjc/s10052-015-3397-6> (cit. on pp. 94, 121).
2606
- 2607 [92] B J Holzer. “Introduction to Particle Accelerators and their Limitations”. In:
2608 *arXiv e-prints*, arXiv:1705.09601 (May 2017), arXiv:1705.09601. arXiv: 1705.
2609 09601 [physics.acc-ph] (cit. on p. 15).
- 2610 [93] Tie-Jiun Hou et al. “New CTEQ global analysis of quantum chromodynam-
2611 ics with high-precision data from the LHC”. In: (Dec. 2019). arXiv: 1912.
2612 10053 [hep-ph] (cit. on pp. 94, 121).
- 2613 [94] Tafoya Juan. “presentation at the egamma calibration meeting”. In: (Nov.
2614 2020). URL: [https://indico.cern.ch/event/973758/
2615 contributions/4100232/attachments/2141733/3609191/
2616 calibration_Egamma.pdf](https://indico.cern.ch/event/973758/contributions/4100232/attachments/2141733/3609191/calibration_Egamma.pdf) (cit. on p. 57).
- 2617 [95] Jan Kretzschmar. *Samples and Physics modelling for low pile-up runs taken in
2618 2017 and 2018*. Tech. rep. ATL-COM-PHYS-2019-075. Geneva: CERN, Feb.
2619 2019. URL: <https://cds.cern.ch/record/2657141> (cit. on pp. 47,
2620 72, 97).
- 2621 [96] L. Iconomidou-Fayard. “Status of the E1/E2 investigations with electrons”.
2622 In: (cit. on pp. 23, 44).
- 2623 [97] C de La Taille and L Serin. *Temperature dependance of the ATLAS electromag-
2624 netic calorimeter signal. Preliminary drift time measurement*. Tech. rep. ATL-
2625 LARG-95-029. ATL-A-PN-29. Geneva: CERN, Nov. 1995. URL: [https://
2626 cds.cern.ch/record/686091](https://cds.cern.ch/record/686091) (cit. on pp. 42, 57).
- 2627 [98] W. Lampl, Christian Fabjan, and M. Aleksa. “Optimizing the Energy Mea-
2628 surement of the ATLAS Electromagnetic Calorimeter”. In: (Jan. 2006) (cit.
2629 on p. 22).
- 2630 [99] “LAr temperature vs luminosity and impact on energy calibration”. In: ().
2631 URL: [https://indico.cern.ch/event/748648/contributions/
2632 3222929/subcontributions/273194/attachments/1785880/
2633 2907510/temperature-2017-ws.pdf](https://indico.cern.ch/event/748648/contributions/3222929/subcontributions/273194/attachments/1785880/2907510/temperature-2017-ws.pdf) (cit. on pp. 43, 56).
- 2634 [100] B Lenzi and R Turra. *Monte Carlo calibration update for electrons and pho-
2635 tons using multivariate techniques*. Tech. rep. ATL-COM-PHYS-2013-1426.
2636 Geneva: CERN, Oct. 2013. URL: [https://cds.cern.ch/record/
2637 1609589](https://cds.cern.ch/record/1609589) (cit. on p. 33).
- 2638 [101] Mengran Li et al. *Hadronic recoil reconstruction and calibration for low pile-up
2639 runs taken in 2017 and 2018*. Tech. rep. ATL-COM-PHYS-2019-078. Geneva:
2640 CERN, Feb. 2019. URL: <https://cds.cern.ch/record/2657182> (cit.
2641 on pp. 12, 71).
- 2642 [102] Peilian Liu. “Expected performance of the upgrade ATLAS experi-
2643 ment for HL-LHC”. In: *arXiv e-prints*, arXiv:1809.02181 (Sept. 2018),
2644 arXiv:1809.02181. arXiv: 1809.02181 [physics.ins-det] (cit. on
2645 p. 15).

- 2646 [103] “Low Mu W Z Analyses”. In: (). URL: <https://twiki.cern.ch/twiki/bin/viewauth/AtlasProtected/LowMuWZAnalyses> (cit. on
2647 p. 98).
2648
- 2649 [104] “Luminosity determination for low-pileup datasets at $\sqrt{s} = 5$ and 13 TeV
2650 using the ATLAS detector at the LHC”. In: (July 2020) (cit. on p. 81).
- 2651 [105] *Luminosity determination in pp collisions at $\sqrt{s} = 13$ TeV using the ATLAS
2652 detector at the LHC*. Tech. rep. ATLAS-CONF-2019-021. Geneva: CERN, June
2653 2019. URL: <https://cds.cern.ch/record/2677054> (cit. on p. 16).
- 2654 [106] “Luminosity determination in pp collisions at $\sqrt{s} = 7$ TeV using the AT-
2655 LAS detector at the LHC”. In: *European Physical Journal C* 71, 1630 (Apr.
2656 2011), p. 1630. DOI: [10.1140/epjc/s10052-011-1630-5](https://doi.org/10.1140/epjc/s10052-011-1630-5). arXiv:
2657 [1101.2185](https://arxiv.org/abs/1101.2185) [hep-ex] (cit. on p. 17).
- 2658 [107] Melina Luthi. “Multivariate analysis techniques for Particle Flow-based
2659 neutral pileup suppression at the ATLAS experiment”. In: (Jan. 2019). URL:
2660 <https://cds.cern.ch/record/2655145> (cit. on p. 33).
- 2661 [108] Simon Lyddon, Chris Holmes, and Stephen Walker. “General Bayesian
2662 Updating and the Loss-Likelihood Bootstrap”. In: *arXiv e-prints*,
2663 arXiv:1709.07616 (Sept. 2017), arXiv:1709.07616. arXiv: [1709.07616](https://arxiv.org/abs/1709.07616)
2664 [stat.ME] (cit. on p. 39).
- 2665 [109] Louis Lyons, Duncan Gibaut, and Peter Clifford. “How to Combine Cor-
2666 related Estimates of a Single Physical Quantity”. In: *Nucl. Instrum. Meth.*
2667 *A* 270 (1988), p. 110. DOI: [10.1016/0168-9002\(88\)90018-6](https://doi.org/10.1016/0168-9002(88)90018-6) (cit. on
2668 p. 135).
- 2669 [110] Bogdan Malaescu. *Discussions on unfolding problems, methods and solutions*.
2670 Tech. rep. 2016. URL: [http://dpnc.unige.ch/~sfyrla/teaching/
2671 Statistics/lectures/Unfolding_Lecture_UGE_Malaescu.pdf](http://dpnc.unige.ch/~sfyrla/teaching/Statistics/lectures/Unfolding_Lecture_UGE_Malaescu.pdf)
2672 (cit. on p. 69).
- 2673 [111] Bogdan Malaescu. *Standard Model Unfolding twiki-page*. Tech. rep. 2016.
2674 URL: [https://twiki.cern.ch/twiki/bin/viewauth/
2675 AtlasProtected/StandardModelUnfoldingNew](https://twiki.cern.ch/twiki/bin/viewauth/AtlasProtected/StandardModelUnfoldingNew) (cit. on pp. 66, 103).
- 2676 [112] Martina Malberti. “Prospects for the precision determination of the W bo-
2677 son mass with the CMS detector at the LHC”. PhD thesis. Milan Bicocca U.,
2678 2007 (cit. on p. 132).
- 2679 [113] Neil Fraser Mcblane. “Energy Dependence of the Intermodule Widening
2680 Correction”. In: (Aug. 2017). URL: [https://cds.cern.ch/record/
2681 2281006](https://cds.cern.ch/record/2281006) (cit. on p. 34).
- 2682 [114] *Measurement of the p_T spectrum of W- and Z-bosons produced in pp collisions at
2683 $\sqrt{s} = 5$ TeV and 13 TeV in low-pileup runs*. Tech. rep. ATL-COM-PHYS-2018-
2684 1084. Geneva: CERN, July 2018. URL: [https://cds.cern.ch/record/
2685 2632159](https://cds.cern.ch/record/2632159) (cit. on pp. 72, 83, 84).
- 2686 [115] “Measurement of the W-boson mass in pp collisions at $\sqrt{s} = 7$ TeV with
2687 the ATLAS detector”. In: *Eur. Phys. J. C* 78.2, 110 (Feb. 2018), p. 110. DOI:
2688 [10.1140/epjc/s10052-017-5475-4](https://doi.org/10.1140/epjc/s10052-017-5475-4). arXiv: [1701.07240](https://arxiv.org/abs/1701.07240) [hep-ex]
2689 (cit. on pp. 11, 12, 13, 46, 57, 71, 97, 133, 134, 135).

- 2690 [116] “Measurement of the response of the ATLAS liquid argon barrel calorimeter
2691 to electrons at the 2004 combined test-beam”. In: *Nucl. Instrum. Methods*
2692 *Phys. Res., A* 614 (2010), 400–432. 33 p. DOI: [10.1016/j.nima.2009.12.](https://doi.org/10.1016/j.nima.2009.12.055)
2693 [055](https://doi.org/10.1016/j.nima.2009.12.055). URL: <https://cds.cern.ch/record/1273537> (cit. on p. 28).
- 2694 [117] “Measurement of W^\pm and Z-boson production cross sections in pp collisions at $\sqrt{s} = 13$ TeV with the ATLAS detector”. In: *Physics Letters B* 759
2695 (Aug. 2016), pp. 601–621. DOI: [10.1016/j.physletb.2016.06.023](https://doi.org/10.1016/j.physletb.2016.06.023).
2696 arXiv: [1603.09222](https://arxiv.org/abs/1603.09222) [hep-ex] (cit. on p. 92).
2697
- 2698 [118] Krzysztof A. Meissner and Hermann Nicolai. “Standard Model Fermions
2699 and Infinite-Dimensional R Symmetries”. In: 121.9, 091601 (Aug. 2018),
2700 p. 091601. DOI: [10.1103/PhysRevLett.121.091601](https://doi.org/10.1103/PhysRevLett.121.091601). arXiv: [1804.](https://arxiv.org/abs/1804.09606)
2701 [09606](https://arxiv.org/abs/1804.09606) [hep-th] (cit. on p. 1).
- 2702 [119] Esma Mobs. “The CERN accelerator complex - 2019. Complexe des ac-
2703 célérateurs du CERN - 2019”. In: (July 2019). General Photo. URL: [https://](https://cds.cern.ch/record/2684277)
2704 cds.cern.ch/record/2684277 (cit. on p. 16).
- 2705 [120] J.W. Monk and C. Oropeza-Barrera. “The HBOM method for unfolding de-
2706 tector effects”. In: *Nuclear Instruments and Methods in Physics Research Section*
2707 *A: Accelerators, Spectrometers, Detectors and Associated Equipment* 701 (Feb.
2708 2013), pp. 17–24. ISSN: 0168-9002. DOI: [10.1016/j.nima.2012.09.045](https://doi.org/10.1016/j.nima.2012.09.045).
2709 URL: <http://dx.doi.org/10.1016/j.nima.2012.09.045> (cit. on
2710 p. 59).
- 2711 [121] N.Andari. “presentation at the ATLAS W precision analyses informal meet-
2712 ing 27Th October 2020”. In: (Sept. 2020). URL: [https://indico.cern.](https://indico.cern.ch/event/969042/contributions/4078527/attachments/2130404/3587822/presentation_271020_andari.pdf)
2713 [ch/event/969042/contributions/4078527/attachments/](https://indico.cern.ch/event/969042/contributions/4078527/attachments/2130404/3587822/presentation_271020_andari.pdf)
2714 [2130404/3587822/presentation_271020_andari.pdf](https://indico.cern.ch/event/969042/contributions/4078527/attachments/2130404/3587822/presentation_271020_andari.pdf) (cit. on
2715 p. 43).
- 2716 [122] Jason Nielsen. “Fundamentals of LHC Experiments”. In: *String Theory and*
2717 *its Applications - TASI 2010, From meV to the Planck Scale*. Ed. by Michael
2718 Dine, Thomas Banks, and Subir Sachdev. Nov. 2012, pp. 127–152. DOI:
2719 [10.1142/9789814350525_0003](https://doi.org/10.1142/9789814350525_0003). arXiv: [1106.2516](https://arxiv.org/abs/1106.2516) [hep-ex] (cit.
2720 on p. 15).
- 2721 [123] Nikiforos Nikiforou. *Performance of the ATLAS Liquid Argon Calorimeter af-*
2722 *ter three years of LHC operation and plans for a future upgrade*. Tech. rep.
2723 arXiv:1306.6756. June 2013. DOI: [10.1109/ANIMMA.2013.6728060](https://doi.org/10.1109/ANIMMA.2013.6728060). URL:
2724 <http://cds.cern.ch/record/1558820> (cit. on p. 23).
- 2725 [124] Tadej Novak. “ATLAS Pile-up and Overlay Simulation”. In: (June 2017).
2726 URL: <https://cds.cern.ch/record/2270396> (cit. on p. 17).
- 2727 [125] J Nowell. “A Measurement of the W Boson Mass with the ALEPH De-
2728 tector”. Presented on Nov 2000. 2000. URL: [https://cds.cern.ch/](https://cds.cern.ch/record/537297)
2729 [record/537297](https://cds.cern.ch/record/537297) (cit. on p. 11).

- 2730 [126] “Observation of a new boson at a mass of 125 GeV with the CMS experi-
2731 ment at the LHC”. In: *Physics Letters B* 716.1 (2012), pp. 30–61. ISSN: 0370-
2732 2693. DOI: <https://doi.org/10.1016/j.physletb.2012.08.021>.
2733 URL: [http://www.sciencedirect.com/science/article/pii/
2734 S0370269312008581](http://www.sciencedirect.com/science/article/pii/S0370269312008581) (cit. on p. 2).
- 2735 [127] D Oliveira Damazio. *Signal Processing for the ATLAS Liquid Argon Calorimeter : studies and implementation*. Tech. rep. ATL-LARG-PROC-2013-015. Geneva: CERN, Nov. 2013. URL: [https://cds.cern.ch/record/
2736 1630826](https://cds.cern.ch/record/1630826) (cit. on p. 28).
- 2737 [128] ATLAS Outreach. “ATLAS Fact Sheet : To raise awareness of the ATLAS
2738 detector and collaboration on the LHC”. 2010. URL: [https://cds.cern.
2739 ch/record/1457044](https://cds.cern.ch/record/1457044) (cit. on pp. 19, 26).
- 2740 [129] “Performance of the ATLAS Transition Radiation Tracker in Run 1 of the
2741 LHC: tracker properties”. In: *Journal of Instrumentation* 12.5 (May 2017),
2742 P05002. DOI: 10.1088/1748-0221/12/05/P05002. arXiv: 1702.
2743 06473 [hep-ex] (cit. on p. 19).
- 2744 [130] Antonio Pich. “The Standard Model of Electroweak Interactions; rev. ver-
2745 sion”. In: hep-ph/0502010. FTUV-2005-0201. IFIC-2005-13 (Feb. 2005), 48 p.
2746 DOI: 10.5170/CERN-2006-003.1. URL: [https://cds.cern.ch/
2747 record/819632](https://cds.cern.ch/record/819632) (cit. on p. 3).
- 2748 [131] “presnetation at the egamma calibration meeting”. In: (July 2019). URL:
2749 [https://indico.cern.ch/event/827055/contributions/
2750 3506176/attachments/1885454/3110615/Slide_ES.pdf](https://indico.cern.ch/event/827055/contributions/3506176/attachments/1885454/3110615/Slide_ES.pdf) (cit. on
2751 pp. 43, 57).
- 2752 [132] *Prospects for the measurement of the W-boson transverse momentum with a low
2753 pileup data sample at $\sqrt{s} = 13$ TeV with the ATLAS detector*. Tech. rep. ATL-
2754 PHYS-PUB-2017-021. Geneva: CERN, Dec. 2017. URL: [https://cds.
2755 cern.ch/record/2298152](https://cds.cern.ch/record/2298152) (cit. on pp. 6, 71, 72).
- 2756 [133] Chris Quigg. “The Electroweak Theory”. In: *arXiv e-prints*, hep-ph/0204104
2757 (Apr. 2002), hep-ph/0204104. arXiv: [hep-ph/0204104](https://arxiv.org/abs/hep-ph/0204104) [hep-ph] (cit. on
2758 p. 5).
- 2759 [134] Giulia Ripellino. *The alignment of the ATLAS Inner Detector in Run 2*. Tech.
2760 rep. ATL-INDET-PROC-2016-003. Geneva: CERN, Sept. 2016. DOI: 10.
2761 22323/1.276.0196. URL: [https://cds.cern.ch/record/2213441
2762 22323/1.276.0196](https://cds.cern.ch/record/2213441) (cit. on p. 20).
- 2763 [135] Valerio Rossetti. “Performance of the ATLAS Calorimeters and Commis-
2764 sioning for LHC Run-2”. In: (July 2015). URL: [https://cds.cern.ch/
2765 record/2037117](https://cds.cern.ch/record/2037117) (cit. on p. 25).
- 2766 [136] Aranzazu Ruiz-Martinez and ATLAS Collaboration. *The Run-2 ATLAS Trig-
2767 ger System*. Tech. rep. ATL-DAQ-PROC-2016-003. Geneva: CERN, Feb. 2016.
2768 DOI: 10.1088/1742-6596/762/1/012003. URL: [https://cds.
2769 cern.ch/record/2133909](https://cds.cern.ch/record/2133909) (cit. on pp. 26, 27).
- 2770
2771

- 2772 [137] S. Schael et al. “Electroweak Measurements in Electron-Positron Collisions
2773 at W-Boson-Pair Energies at LEP”. In: *Phys. Rept.* 532 (2013), pp. 119–
2774 244. DOI: [10.1016/j.physrep.2013.07.004](https://doi.org/10.1016/j.physrep.2013.07.004). arXiv: [1302.3415](https://arxiv.org/abs/1302.3415)
2775 [[hep-ex](#)] (cit. on p. 11).
- 2776 [138] Christoph Schäfer. “The Z lineshape at LEP”. In: *Nuclear Physics B - Proceed-*
2777 *ings Supplements* 65.1 (1998). The Irresistible Rise of the Standard Model,
2778 pp. 93–97. ISSN: 0920-5632. DOI: [https://doi.org/10.1016/S0920-](https://doi.org/10.1016/S0920-5632(97)00982-1)
2779 [5632\(97\)00982-1](https://doi.org/10.1016/S0920-5632(97)00982-1). URL: [http://www.sciencedirect.com/](http://www.sciencedirect.com/science/article/pii/S0920563297009821)
2780 [science/article/pii/S0920563297009821](http://www.sciencedirect.com/science/article/pii/S0920563297009821) (cit. on p. 10).
- 2781 [139] Stefan Schmitt. “Data Unfolding Methods in High Energy Physics”. In:
2782 *EPJ Web of Conferences* 137 (2017). Ed. by Y. Foka, N. Brambilla, and
2783 V.Editors Kovalenko, p. 11008. ISSN: 2100-014X. DOI: [10.1051/epjconf/](https://doi.org/10.1051/epjconf/201713711008)
2784 [201713711008](https://doi.org/10.1051/epjconf/201713711008). URL: [http://dx.doi.org/10.1051/epjconf/](http://dx.doi.org/10.1051/epjconf/201713711008)
2785 [201713711008](http://dx.doi.org/10.1051/epjconf/201713711008) (cit. on pp. 59, 62).
- 2786 [140] Matthias Schott et al. *Measurement of m_W at 7 TeV: Reconstruction of the*
2787 *hadronic recoil*. Tech. rep. ATL-COM-PHYS-2014-1435. Geneva: CERN, Nov.
2788 2014. URL: <https://cds.cern.ch/record/1966964> (cit. on p. 11).
- 2789 [141] Estelle Scifo. “Measurement of the Brout-Englert-Higgs boson couplings
2790 in its diphoton decay channel with the ATLAS detector at the LHC”. PhD
2791 thesis. Orsay, LAL, July 2014 (cit. on pp. 9, 23).
- 2792 [142] Steffen Starz. “ATLAS Calorimeter system: Run-2 performance, Phase-1
2793 and Phase-2 upgrades”. In: (July 2018). URL: [https://cds.cern.ch/](https://cds.cern.ch/record/2628123)
2794 [record/2628123](https://cds.cern.ch/record/2628123) (cit. on p. 21).
- 2795 [143] John Strologas and Steven Errede. “Study of the angular coefficients and
2796 corresponding helicity cross sections of the W boson in hadron collisions”.
2797 In: 73.5, 052001 (Mar. 2006), p. 052001. DOI: [10.1103/PhysRevD.73.](https://doi.org/10.1103/PhysRevD.73.052001)
2798 [052001](https://doi.org/10.1103/PhysRevD.73.052001). arXiv: [hep-ph/0503291](https://arxiv.org/abs/hep-ph/0503291) [[hep-ph](#)] (cit. on p. 12).
- 2799 [144] Robin G. Stuart. “An Improved Determination of the Fermi Coupling
2800 Constant, G_F ”. In: *arXiv e-prints*, hep-ph/9902257 (Feb. 1999), hep-
2801 [ph/9902257](https://arxiv.org/abs/hep-ph/9902257). arXiv: [hep-ph/9902257](https://arxiv.org/abs/hep-ph/9902257) [[hep-ph](#)] (cit. on p. 10).
- 2802 [145] “Summary Report of Physics Beyond Colliders at CERN”. In: *arXiv e-*
2803 *prints*, arXiv:1902.00260 (Feb. 2019), arXiv:1902.00260. arXiv: [1902.00260](https://arxiv.org/abs/1902.00260)
2804 [[hep-ex](#)] (cit. on p. 15).
- 2805 [146] M. Tanabashi et al. “Review of Particle Physics”. In: *Phys. Rev. D* 98.3 (2018),
2806 p. 030001. DOI: [10.1103/PhysRevD.98.030001](https://doi.org/10.1103/PhysRevD.98.030001) (cit. on p. 10).
- 2807 [147] The ATLAS Collaboration. “Operation and performance of the ATLAS
2808 semiconductor tracker”. In: *Journal of Instrumentation* 9.8, P08009 (Aug.
2809 2014), P08009. DOI: [10.1088/1748-0221/9/08/P08009](https://doi.org/10.1088/1748-0221/9/08/P08009). arXiv: [1404.](https://arxiv.org/abs/1404.7473)
2810 [7473](https://arxiv.org/abs/1404.7473) [[hep-ex](#)] (cit. on p. 19).
- 2811 [148] “The ATLAS Experiment at the CERN Large Hadron Collider”. In: *JINST* 3
2812 (2008). Also published by CERN Geneva in 2010, S08003. 437 p. DOI: [10.](https://doi.org/10.1088/1748-0221/3/08/S08003)
2813 [1088/1748-0221/3/08/S08003](https://doi.org/10.1088/1748-0221/3/08/S08003). URL: [https://cds.cern.ch/](https://cds.cern.ch/record/1129811)
2814 [record/1129811](https://cds.cern.ch/record/1129811) (cit. on p. 6).

- 2815 [149] “The ATLAS Inner Detector commissioning and calibration”. In: *European*
2816 *Physical Journal C* 70.3 (Dec. 2010), pp. 787–821. DOI: [10.1140/epjc/](https://doi.org/10.1140/epjc/s10052-010-1366-7)
2817 [s10052-010-1366-7](https://doi.org/10.1140/epjc/s10052-010-1366-7). arXiv: 1004.5293 [physics.ins-det] (cit. on
2818 p. 19).
- 2819 [150] “The ATLAS silicon pixel sensors”. In: *Nuclear Instruments and Methods in*
2820 *Physics Research Section A: Accelerators, Spectrometers, Detectors and Associ-*
2821 *ated Equipment* 456.3 (2001), pp. 217–232. ISSN: 0168-9002. DOI: [https :](https://doi.org/10.1016/S0168-9002(00)00574-X)
2822 [/ / doi . org / 10 . 1016 / S0168 - 9002 \(00 \) 00574 - X](https://doi.org/10.1016/S0168-9002(00)00574-X). URL:
2823 [http : / / www . sciencedirect . com / science / article / pii /](http://www.sciencedirect.com/science/article/pii/S016890020000574X)
2824 [S016890020000574X](http://www.sciencedirect.com/science/article/pii/S016890020000574X) (cit. on p. 19).
- 2825 [151] Ruggero Turra, Stefano Manzoni, and Archil Durglishvili. *Monte Carlo en-*
2826 *ergy calibration of electrons and photons for release 20.7*. Tech. rep. ATL-COM-
2827 PHYS-2017-761. Geneva: CERN, June 2017. URL: [https : / / cds . cern .](https://cds.cern.ch/record/2268813)
2828 [ch/record/2268813](https://cds.cern.ch/record/2268813) (cit. on p. 33).
- 2829 [152] Nenad Vranjes, Troels Petersen, and Mikhail Karnevskiy. *Measurement of*
2830 *m_W at 7 TeV: Muon momentum corrections and uncertainties*. Tech. rep. ATL-
2831 COM-PHYS-2014-1433. Geneva: CERN, Nov. 2014. URL: [https : / / cds .](https://cds.cern.ch/record/1966962)
2832 [cern.ch/record/1966962](https://cds.cern.ch/record/1966962) (cit. on pp. 11, 138).
- 2833 [153] Jorg Wenninger. “Operation and Configuration of the LHC in Run 2”. In:
2834 (Mar. 2019). URL: [https : / / cds . cern . ch / record / 2668326](https://cds.cern.ch/record/2668326) (cit. on
2835 p. 43).
- 2836 [154] Scott Willenbrock. “Hadron Colliders, the Standard Model, and Beyond”.
2837 In: *arXiv e-prints*, hep-ph/0212032 (Dec. 2002), hep-ph/0212032. arXiv:
2838 [hep-ph/0212032](https://arxiv.org/abs/hep-ph/0212032) [hep-ph] (cit. on p. 1).
- 2839 [155] Tairan Xu. “Measurements of W boson properties at $\sqrt{s} = 5$ and 13 TeV
2840 with the ATLAS detector at the LHC”. Presented 25 Sep 2019. 2019. URL:
2841 [https : / / cds . cern . ch / record / 2689846](https://cds.cern.ch/record/2689846) (cit. on pp. 12, 71, 81, 99,
2842 138, 139).
- 2843 [156] Tairan Xu, Hicham Atmani, and Ludovica Aperio Bella. *Electron corrections*
2844 *for low pile-up runs taken in 2017 and 2018*. Tech. rep. ATL-COM-PHYS-2019-
2845 077. Geneva: CERN, Feb. 2019. URL: [https : / / cds . cern . ch / record /](https://cds.cern.ch/record/2657152)
2846 [2657152](https://cds.cern.ch/record/2657152) (cit. on p. 39).
- 2847 [157] Tairan Xu and Maarten Boonekamp. *Multi-jet background in low-pile-up*
2848 *runs taken in 2017 and 2018*. Tech. rep. ATL-COM-PHYS-2019-076. Geneva:
2849 CERN, July 2019. URL: [https : / / cds . cern . ch / record / 2657146](https://cds.cern.ch/record/2657146) (cit.
2850 on p. 12).
- 2851 [158] Christoph Zimmermann, Matthias Schott, and Mikhail Karnevskiy. *Mea-*
2852 *surement of m_W at 7 TeV : Muon efficiency corrections and uncertainties*. Tech.
2853 rep. ATL-COM-PHYS-2015-073. Geneva: CERN, Feb. 2015. URL: [https :](https://cds.cern.ch/record/1987497)
2854 [/ / cds . cern . ch / record / 1987497](https://cds.cern.ch/record/1987497) (cit. on p. 11).