



HAL
open science

Rogers-Ramanujan type identities : bijective proofs and Lie-theoretic approach

Isaac Konan

► **To cite this version:**

Isaac Konan. Rogers-Ramanujan type identities : bijective proofs and Lie-theoretic approach. Combinatorics [math.CO]. Université Paris Cité, 2020. English. NNT : 2020UNIP7087 . tel-03226154

HAL Id: tel-03226154

<https://theses.hal.science/tel-03226154>

Submitted on 14 May 2021

HAL is a multi-disciplinary open access archive for the deposit and dissemination of scientific research documents, whether they are published or not. The documents may come from teaching and research institutions in France or abroad, or from public or private research centers.

L'archive ouverte pluridisciplinaire **HAL**, est destinée au dépôt et à la diffusion de documents scientifiques de niveau recherche, publiés ou non, émanant des établissements d'enseignement et de recherche français ou étrangers, des laboratoires publics ou privés.



Université
de Paris

UNIVERSITÉ DE PARIS

ÉCOLE DOCTORALE SCIENCES MATHÉMATIQUES DE PARIS CENTRE ED 386

INSTITUT DE RECHERCHE EN INFORMATIQUE FONDAMENTALE

*Thèse en vue d'obtenir le titre de
Docteur en Mathématiques*

Identités de type Rogers-Ramanujan: preuves bijectives et approche à la théorie de Lie

Par
Isaac KONAN

Dirigé par
Jeremy LOVEJOY

Présentée et soutenue publiquement
le 04 Décembre 2020

Devant un jury composé de

Rapporteurs:

Ole Warnaar, Professeur
The University of Queensland
Jiang Zeng, Professeur
Université Claude Bernard Lyon-I

Examineurs:

Frederic Jouhet, MC HDR
Université Claude Bernard Lyon-I
Eric Fusy, DR
Université Gustave Eiffel
Hussein Mourta, MC HDR
Université de Paris
Frédéric Bassino, PR
Université Paris 13
(Présidente du jury)



Except where otherwise noted, this is work licensed under <https://creativecommons.org/licenses/by-nc-nd/3.0/fr/>

"...I delight in weaknesses, in insults, in hardships, in persecutions, in difficulties. For when I am weak, then I am strong."

A wise man.

"Mon plus grand succès est d'avoir connu beaucoup d'échecs."

Un homme sage.

Identités de type Rogers-Ramanujan: preuves bijectives et approche à la théorie de Lie

Mots clefs: Théorie des partitions d'entiers, identités de type Rogers-Ramanujan, Théorie des représentation des algèbres de Lie affine

Résumé

Cette thèse relève de la théorie des partitions d'entiers, à l'intersection de la combinatoire et de la théorie de nombres. En particulier, nous étudions les identités de type Rogers-Ramanujan sous le spectre de la méthode des mots pondérés. Une révision de cette méthode nous permet d'introduire de nouveaux objets combinatoires au delà de la notion classique de partitions d'entiers: partitions colorées généralisées. À l'aide de ces nouveaux éléments, nous établissons de nouvelles identités de type Rogers-Ramanujan via deux approches différentes.

La première approche consiste en une preuve combinatoire, essentiellement bijective, des identités étudiées. Cette approche nous a ainsi permis d'établir des identités généralisant plusieurs identités importantes de la théorie: l'identité de Schur et l'identité Göllnitz, l'identité de Glaisher généralisant l'identité d'Euler, les identités de Siladić, de Primc et de Capparelli issues de la théorie des représentations de algèbres de Lie affines.

La deuxième approche fait appel à la théorie des cristaux parfaits, issue de la théorie des représentations des algèbres de Lie affines. Nous interprétons ainsi le caractère des représentations standards comme des identités de partitions d'entiers colorées généralisées. En particulier, cette approche permet d'établir des formules assez simplifiées du caractère pour toutes les représentations standards de niveau 1 des types affines $A_{n-1}^{(1)}, A_{2n}^{(2)}, D_{n+1}^{(2)}, A_{2n-1}^{(2)}, B_n^{(1)}, D_n^{(1)}$.

Rogers-Ramanujan type identities: bijective proofs and Lie-theoretic approach

Keywords: Integer partition theory, Rogers-Ramanujan type identity, Representation theory of affine Lie algebra

Abstract

The topic of this thesis belongs to the theory of integer partitions, at the intersection of combinatorics and number theory. In particular, we study Rogers-Ramanujan type identities in the framework of the method of weighted words. This method revisited allows us to introduce new combinatorial objects beyond the classical notion of integer partitions: the generalized colored partitions. Using these combinatorial objects, we establish new Rogers-Ramanujan identities via two different approaches.

The first approach consists of a combinatorial proof, essentially bijective, of the studied identities. This approach allowed us to establish some identities generalizing many important identities of the theory of integer partitions: Schur's identity and Göllnitz' identity, Glaisher's identity generalizing Euler's identity, the identities of Siladić, of Primc and of Capparelli coming from the representation theory of affine Lie algebras.

The second approach uses the theory of perfect crystals, coming from the representation theory of affine Lie algebras. We view the characters of standard representations as some identities on the generalized colored partitions. In particular, this approach allows us to establish simple formulas for the characters of all the level one standard representations of type $A_{n-1}^{(1)}, A_{2n}^{(2)}, D_{n+1}^{(2)}, A_{2n-1}^{(2)}, B_n^{(1)}, D_n^{(1)}$.

Remerciements

Je ne saurais commencer ce mémoire sans adresser mes profonds remerciements à mon directeur de thèse, *Jeremy Lovejoy*. Merci de m'avoir fait découvrir ce champ de recherche passionnant qu'est la théorie des partitions d'entiers, de m'avoir proposé des problèmes ouverts qui ont su susciter mon intérêt, de m'avoir accordé une liberté d'action dans mes choix de résolution tout en étant disponible pour me donner les sources et documentations qui ont aidé à la résolution de ces problèmes. Il a su faire preuve de patience pour pouvoir digérer mes présentations de solutions par moment bien trop abstraites, et m'a permis d'y apporter un peu plus de simplicité.

Merci également à *Sylvie* pour les invitations à Berkeley, qui m'ont permis de peaufiner mes différents articles, mais aussi de partager des moments conviviaux en dehors du cadre mathématique, entre autres la fameuse traversée aller-retour du *Golden Gate bridge*, les déjeuners chez Picente, le concert de *Sisseline*, les défaites au basket infligées par *Vigo*...

Je voudrais aussi remercier *Ole Warnaar* et *Jiang Zeng* d'avoir accepté de rapporter ma thèse. Special thanks to Ole for helping me to get rid of the excessive amount of "we" in my thesis. I hope this will help me to improve the writing of my future papers.

Je remercie également *Frédérique Bassino*, *Éric Fusy*, *Frédéric Jouhet* et *Hussein Mourtada* d'avoir accepté d'être membres de mon jury de soutenance.

Ces trois années de thèse passées à l'IRIF ont indéniablement été les plus agréables des dix dernières à cotoyer le milieu universitaire depuis mon arrivée en France. Ce laboratoire est certes de renommée mondiale tant par la qualité des recherches qui y sont effectuées, que par l'excellence des permanents et non-permanents s'y trouvant. Mais je pense surtout que ce qui fait la force de l'IRIF, ce sont les rapports humains. Je voudrais remercier les membres de l'équipe combinatoire avec lesquels j'ai beaucoup appris au cours des différents séminaires et groupes de travail, en particulier à *Enrica*, *Guillaume*, *Matthieu* et *Vlady* pour les discussions sur certains aspects de combinatoire énumérative. Merci à mes collègues de bureau passés ou toujours présents, *Alex*, *Alessandro*, *Anupa*, *Jonas*, *Valia* et *Zeinab*, pour les discussions diverses et variées tant sur les mathématiques et l'informatique que sur des sujets de société. Un merci à la communauté des doctorants, aters et postdocs. Aussi, il ne me serait possible de faire cette séquence de remerciements sans penser à la dynamique et chaleureuse équipe administrative, toujours disponible et sans laquelle le laboratoire ne saurait fonctionner.

À mon ainée *Jehanne* que j'appelle affectueusement sœur, avec laquelle j'ai collaboré et que je continue à collaborer sur bons nombres d'articles, je ne peux qu'exprimer mon immense gratitude. À l'instar de *Jeremy*, elle a su faire preuve de patience lors de nos échanges et m'a beaucoup appris sur l'art de la synthèse et la simplicité dans l'argumentation mathématique.

Je voudrais également adresser mes remerciements à *Frédéric Bourgeois*, *Florent Jouve* et *Rémi Nicolai*, qui m'ont apporté conseils et recommandations à des moments importants de mon parcours universitaire et sans lesquels je n'en serais très certainement pas là.

Mon amour des mathématiques est né de ma rencontre avec le monde des Olympiades, et je tiens ici à remercier sincèrement la fondation des *Amis de l'Excellence* qui me l'a fait découvrir. Une pensée particulière aux acteurs clés de cette fondation, *Isaac Tapé*, *Sylvestre Konin* et feu le Ministre *Bohoun Bouabré*, qui ont ouvert la voie à de nombreux jeunes ivoiriens qui font aujourd'hui la fierté de notre pays. J'ai la chance de pouvoir encore cotoyer certains de ces brillants ivoiriens, et j'espère que ces liens d'amitiés perdureront sur de très nombreuses années. Je pense en particulier à *Cédric*, *Edgar*, *Fabrice*, *Ibrahim*, *Jaurès*, *Julien*, *Maméry* de la team "famille en retard", avec lesquels j'espère pouvoir fêter comme il se doit mon titre nouvellement acquis.

À *Jean-Pierre* et *Audrey*, ces amis qui m'ont toujours été de bon conseil,

À *Blé Patrice*, que j'appelle affectueusement "Papa Blé" et que je considère comme tel,

À mon père *François*, l'une des personnes les plus brillantes qu'il m'ait été donné de connaître,

À ma mère *Christine*, mes sœurs *Rébecca* et *Hannielle*, mon frère *Othniel*, qui pour moi constituent une force et un soutien inestimable,

x

À toutes ces personnes qui me portent dans leur coeur et que j'oublie de citer,

Au pays qui m'a vu naître, *la Côte d'Ivoire*, et celui qui m'a accueilli, *la France*,

Merci...

Contents

Résumé	v
Abstract	vii
Remerciements	ix
I Introduction	1
1 State of the art	3
1.1 Integer Partitions	3
1.2 Partition identities	5
1.2.1 Glaisher's identity	5
1.2.2 Rogers-Ramanujan type identities	7
1.3 Weighted words	8
1.3.1 From the Alladi-Gordon identity to the Alladi-Andrews-Berkovich identity	8
1.3.2 On Siladić's partition theorem	10
1.4 Partition identities and Representation theory of affine Lie algebras	11
1.4.1 Lie-theoretic proof of the Rogers-Ramanujan identities	12
1.4.2 Capparelli's identity	12
1.4.3 Primc's identities	13
1.4.4 Character formula as series with positive coefficients	15
2 Contribution of the thesis	17
2.1 Weighted words revisited	17
2.1.1 Generalized colored partitions	17
2.1.2 Generalized colored Frobenius partitions	22
2.2 Rogers-Ramanujan type identities via bijective approaches	23
2.2.1 Beyond Göllnitz theorem: a generalization of Bressoud's algorithm	23
2.2.2 Beyond Siladić's theorem: weighted words in the framework of statistical mechanics	26
2.2.3 Beyond Glaisher's theorem: a duality between flat and regular partitions	31
2.2.4 Beyond the Durfee square: a duality between colored partitions and colored Frobenius partitions	35
2.2.5 Beyond Capparelli's theorem: regularity over Primc's theorem	39
2.3 Rogers-Ramanujan type identities via representations of affine Lie algebras	44
2.3.1 Perfect crystals and multi-grounded partitions	44
2.3.2 Level one standard modules of $A_{n-1}^{(1)}$: a Lie-theoretic interpretation of Primc's theorem	45
2.3.3 Level one standard modules of $A_{2n}^{(2)}, D_{n+1}^{(2)}, A_{2n-1}^{(2)}, B_n^{(1)}, D_n^{(1)}$	47
II Rogers-Ramanujan type identities via bijections	49
3 Beyond Göllnitz' theorem	51
3.1 Preliminaries	51
3.1.1 The setup	51
3.1.2 Technical lemmas	52
3.2 Bressoud's algorithm	52
3.2.1 Machine Φ : from \mathcal{O} to \mathcal{E}	52
3.2.2 Machine Ψ : on \mathcal{E}	53
3.3 Proof of Theorem 2.2.7	54
3.4 Description of $\mathcal{E}_1 = \Phi(\mathcal{O})$ and proof of Theorem 2.2.9	55

3.4.1	Enumeration of parts	55
3.4.2	Definition and properties of the Bridge	56
3.4.3	Proof of Theorem 3.4.2	58
3.5	Forbidden patterns of \mathcal{E}_1	61
3.5.1	Properties of optimal forbidden patterns	62
3.5.2	Optimal forbidden patterns of \mathcal{E}_1 for four primary colors	63
3.5.3	Optimal forbidden patterns of \mathcal{E}_1 for more than four primary colors	64
3.6	Bijjective proof of Theorem 1.3.3	69
3.6.1	From \mathcal{E}_1 to quaternary partitions	69
3.6.2	From quaternary partitions to \mathcal{E}_1	71
3.7	Bressoud's algorithm, Motzkin paths and oriented rooted forests	72
4	Beyond Siladić's theorem	75
4.1	Energy transfer	75
4.2	Bijjective maps for Theorem 2.2.15	76
4.2.1	From \mathcal{O}_ϵ to \mathcal{E}_ϵ	76
4.2.2	From \mathcal{E}_ϵ to \mathcal{O}_ϵ	77
4.3	Proof of Theorem 2.2.15	78
4.3.1	Well-definedness of Φ	78
4.3.2	Well-definedness of Ψ	80
4.3.3	Reciprocity between Φ and Ψ	82
4.4	Closing remarks	83
5	Beyond Glaisher's theorem	85
5.1	Bijjective proof of Theorem 2.2.24	85
5.1.1	The setup	85
5.1.2	The map Ω from $\mathcal{F}_1^{\epsilon, c_g}(C)$ to $\mathcal{R}_1^{\epsilon, c_g}(C)$	87
5.1.3	The map Ω^{-1} from $\mathcal{R}_1^{\epsilon, c_g}(C)$ to $\mathcal{F}_1^{\epsilon, c_g}(C)$	89
5.1.4	Inversion of the maps	91
5.2	Bijjective proof of Theorem 2.2.31	91
5.2.1	Bijection between $\mathcal{F}_2^{\epsilon, c_g}(C, n)$ and $\mathcal{F}_1^{\epsilon, c_g}(C, n)$	91
5.2.2	Bijection between $\mathcal{R}_1^{\epsilon, c_g}(C, n)$ and $\mathcal{R}_2^{\epsilon, c_g}(C, n)$	92
5.3	Beyond Glaisher's theorem at degree $k \geq 3$	95
6	Beyond the Durfee square	99
6.1	Reduced color sequences and minimal partitions	99
6.1.1	Minimal partitions	99
6.1.2	Combinatorial description of reduced color sequences	100
6.1.3	Influence of the insertions on the minimal partition	101
6.1.4	Generating function for partitions with a given kernel	105
6.2	Generalized colored Frobenius partitions	106
6.2.1	The difference conditions corresponding to minimal colored Frobenius partitions	106
6.2.2	The generating function for the generalized colored Frobenius partitions in $\mathcal{F}_{\epsilon_1, \epsilon_2}^{c_\infty}$ with a given kernel	107
6.2.3	Proof of Theorem 2.2.39	108
6.3	Proof of Theorem 6.1.28	109
6.4	Proof of Theorem 2.2.45	111
7	Beyond Capparelli's theorem: a regularity over Primc's theorem	115
7.1	The setup	115
7.1.1	Insertion of parts with free colors	115
7.1.2	Insertion in a pair of parts	116
7.1.3	Insertion at the extremities	117
7.2	Bijjective proof of Theorem 2.2.51	117
7.2.1	The map Φ	117
7.2.2	The map Φ^{-1}	118
7.3	Duality between Capparelli's and Primc's identities	120
7.3.1	Well-definedness according to the decomposition	120
7.3.2	Forbidden patterns	122
7.3.3	Proof of Theorem 2.2.59	123

7.3.4	The case of Capparelli's and Meurman-Primc's identities	124
-------	---	-----

III Rogers-Ramanujan type identities via representations of affine Lie algebras 125

8	Perfect crystals and multi-grounded partitions	127
8.1	Basics on Crystals	127
8.1.1	Cartan datum and quantum affine algebras	127
8.1.2	Integrable modules, highest weight modules and character formula	129
8.1.3	Crystal bases	130
8.1.4	Perfect crystals	132
8.2	Perfect crystals and grounded partitions	134
8.3	Multi-grounded partitions	135
9	Level one standard modules of type $A_{n-1}^{(n)}$	139
9.1	Perfect crystal of type $A_{n-1}^{(1)}$: tensor product of the vector representation and its dual	139
9.2	Proof of the character formulas	142
9.2.1	Proof of Theorem 2.3.3	142
9.2.2	Proof of Theorem 2.3.4	142
9.3	Proof of Theorem 2.3.2	143
9.3.1	Symmetry in the crystal graph of $\mathbb{B} \otimes \mathbb{B}$	143
9.3.2	Redefining the minimal differences Δ	146
9.3.3	Construction of the paths in $\mathcal{B} \otimes \mathcal{B}$	146
10	Level one standard modules of $A_{2n}^{(2)}, D_{n+1}^{(2)}, A_{2n-1}^{(2)}, B_n^{(1)}, D_n^{(1)}$	153
10.1	Case of affine type $A_{2n}^{(2)}$ ($n \geq 2$)	153
10.2	Case of affine type $D_{n+1}^{(2)}$ ($n \geq 2$)	155
10.2.1	Character for Λ_0	156
10.2.2	Character for Λ_n	157
10.3	Case of affine type $A_{2n-1}^{(1)}$ ($n \geq 3$)	157
10.3.1	Character for Λ_0	158
10.3.2	Character for Λ_1	159
10.4	Case of affine type $B_n^{(1)}$ ($n \geq 3$)	160
10.4.1	Character for Λ_n	160
10.4.2	Character for Λ_0	161
10.4.3	Character for Λ_1	162
10.5	Case of affine type $D_n^{(1)}$ ($n \geq 4$)	162
10.5.1	Character for Λ_0	163
10.5.2	Character for Λ_1	164
10.5.3	Character for Λ_n	164
10.5.4	Character for Λ_{n-1}	164

IV Appendices 165

A	Proofs of technical lemmas and propositions	167
A.1	Beyond Göllnitz's theorem	167
A.1.1	Proof of Lemma 3.1.4	167
A.1.2	Proof of Lemma 3.1.5	167
A.1.3	Proof of Lemma 3.1.6	168
A.1.4	Proof of Lemma 3.4.5	168
A.1.5	Proof of Lemma 3.4.8	169
A.1.6	Proof of Lemma 3.4.9	169
A.1.7	Proof of Lemma 3.5.8	170
A.1.8	Proof of Proposition 3.3.2	171
A.1.9	Proof of Proposition 3.3.4	173
A.1.10	Proof of Proposition 3.3.6	174
A.1.11	Proof of Proposition 3.4.6	175
A.1.12	Proof of Proposition 3.4.7	175

- A.1.13 Proof of Proposition 3.5.5 177
- A.1.14 Proof of Proposition 3.7.2 177
- A.1.15 Proof of Proposition 3.7.3 178
- A.2 Beyond Siladić’s theorem 180
 - A.2.1 Proof of Lemma 4.3.5 180
 - A.2.2 Proof of Lemma 4.3.6 180
 - A.2.3 Proof of Lemma 4.3.7 180
 - A.2.4 Proof of Proposition 4.1.3 181
 - A.2.5 Proof of Proposition 4.3.2 182
 - A.2.6 Proof of Proposition 4.3.3 183
 - A.2.7 Proof of Proposition 4.3.4 183
 - A.2.8 Proof of Proposition 4.3.8 183
 - A.2.9 Proof of Proposition 4.3.9 184
 - A.2.10 Proof of Proposition 4.3.10 185
- A.3 Beyond the Durfee square 187
 - A.3.1 Proof of Lemma 6.1.24 187
 - A.3.2 Proof of Lemma 6.1.26 187
 - A.3.3 Proof of Lemma 6.2.4 187
 - A.3.4 Proof of Lemma 6.2.7 188
 - A.3.5 Proof of Lemma 6.3.1 188
 - A.3.6 Proof of Lemma 6.3.2 189
 - A.3.7 Proof of Lemma 6.3.3 190
 - A.3.8 Proof of Lemma 6.3.5 190
 - A.3.9 Proof of Lemma 6.3.7 191
 - A.3.10 Proof of Lemma 6.4.1 192
 - A.3.11 Proof of Proposition 6.2.3 193
 - A.3.12 Proof of Proposition 6.2.5 194
 - A.3.13 Proof of Proposition 6.3.4 195
 - A.3.14 Proof of Proposition 6.3.6 195
- A.4 Perfect crystal and multi-grounded partitions 196
 - A.4.1 Proof of Lemma 8.3.1 196
 - A.4.2 Proof of Proposition 8.2.2 196
 - A.4.3 Proof of Proposition 8.2.3 197
 - A.4.4 Proof of Proposition 8.3.2 197
 - A.4.5 Proof of Proposition 8.3.3 198

Bibliography **201**

List of Figures

1.1	Ferrers diagram of $(5, 3, 1, 1)$ and its conjugate $(4, 2, 2, 1, 1)$	5
2.1	$s = 4, \lambda = (9, 7, 3, 0)$ and $\mu = (5, 4, 2, 0)$	22
9.1	Vector representation \mathcal{B} of for type $A_{n-1}^{(1)} (n \geq 3)$	139
9.2	Local i -arrows of \mathcal{B}	139
9.3	Dual \mathcal{B}^\vee of the vector representation for type $A_{n-1}^{(1)} (n \geq 3)$	140
9.4	tensor product $\mathcal{B} \otimes \mathcal{B}^\vee$ for type $A_{n-1}^{(1)} (n \geq 3)$	141
9.5	Subgraph with i -arrows	141
9.6	Local configurations	142
10.1	Crystal graph \mathcal{B} of the vector representation for type $A_{2n}^{(2)} (n \geq 2)$	153
10.2	Crystal graph of $\mathcal{B} \otimes \mathcal{B}$ for type $A_{2n}^{(2)} (n \geq 2)$	154
10.3	Crystal graph \mathcal{B} of the vector representation for type $D_{n+1}^{(2)} (n \geq 2)$	155
10.4	Crystal graph of $\mathcal{B} \otimes \mathcal{B}$ for type $D_{n+1}^{(2)} (n \geq 2)$	155
10.5	Crystal graph \mathcal{B} of the vector representation for type $A_{2n-1}^{(2)} (n \geq 3)$	157
10.6	Crystal graph of $\mathcal{B} \otimes \mathcal{B}$ for type $A_{2n-1}^{(2)} (n \geq 3)$	158
10.7	Crystal graph \mathcal{B} of the vector representation for type $B_n^{(1)} (n \geq 3)$	160
10.8	Crystal graph of $\mathcal{B} \otimes \mathcal{B}$ for type $B_n^{(1)} (n \geq 3)$	160
10.9	Crystal graph \mathcal{B} of the vector representation for type $D_n^{(1)} (n \geq 4)$	162
10.10	Crystal graph of $\mathcal{B} \otimes \mathcal{B}$ for type $D_n^{(1)} (n \geq 4)$	163
A.1	Durfee-like decomposition	188
A.2	Decomposition of the Ferrers board.	189
A.3	A partition as a path.	190
A.4	Decomposition of the Ferrers board.	190

*Dedicated to people who believed in me since the very beginning of my
mathematical journey.*

Part I

Introduction

Chapter 1

State of the art

1.1 Integer Partitions

By all accounts, the history of integer partitions started in 1674 with a letter of Leibniz to Bernoulli, in which he asked for the number of ways to decompose a positive integer into a sum of smaller positive integers. To uniquely identify such sums of integers, we sort the terms in a non-increasing order.

Definition 1.1.1. A partition of a positive integer n is then defined as a non-increasing sequence of positive integers, called the parts of the partition, whose sum is equal to n .

The problem raised by Leibniz is then equivalent to the following: for a fixed positive integer n , what is the exact cardinality $p(n)$ of the set $\mathcal{P}(n)$ of partitions of n ?

Example 1.1.2. For example, here we give the list of the partitions of $n \leq 5$.

n	$p(n)$	$\mathcal{P}(n)$
1	1	(1)
2	2	(2), (1, 1)
3	3	(3), (2, 1), (1, 1, 1)
4	5	(4), (3, 1), (2, 2), (2, 1, 1), (1, 1, 1, 1)
5	7	(5), (4, 1), (3, 2), (3, 1, 1), (2, 2, 1), (2, 1, 1, 1), (1, 1, 1, 1, 1)

While these combinatorial objects are simple to visualize, the study of integer partitions remained difficult for Leibniz and his contemporaries. The actual significant study started with the works of Euler in (Euler, 1741-43, 1751; Euler, 1748).

To compute $p(n)$ the number of partitions of a positive integer n , Euler formally introduced one of the most useful tools of the combinatorial theory: *generating functions*.

Definition 1.1.3. Let \mathcal{A} be a countable family of combinatorial objects, and let (a_k) be a countable family of functions from \mathcal{A} to \mathbb{Z} , called *statistics* of the objects. Suppose that for each $\pi \in \mathcal{A}$, all but finitely many of the $a_k(\pi)$ are equal to 0. The generating function of \mathcal{A} with respect to the statistics $(a_k)_k$ is then the series in $\mathbb{Z}_{\geq 0}[[x_k, x_k^{-1}]]$ defined by

$$GF_{\mathcal{A},(a_k)}((x_k)) = \sum_{\pi \in \mathcal{A}} \prod_k x_k^{a_k(\pi)}. \quad (1.1.1)$$

Using this definition, the method presented by Euler is the following.

Let us formally define an integer partition λ as a finite non-increasing sequence of positive integers $(\lambda_1, \dots, \lambda_s)$. The positive integers $\lambda_1, \dots, \lambda_s$ are referred to as the parts of the partitions λ . By convention, the empty sequence is set to be the empty partition \emptyset . We now define the following statistics.

1. The size of λ , denoted $|\lambda|$, is the sum $\lambda_1 + \dots + \lambda_s$.
2. The length of λ , denoted $\ell(\lambda)$, is the number of parts of λ , namely the value s .
3. For each $k \in \mathbb{Z}_{>0}$, $n_k(\lambda)$ denotes the number of occurrences of k in λ , i.e $n_k(\lambda) = \{i \in \{1, \dots, s\} : \lambda_i = k\}$.

We take by convention $|\emptyset| = \ell(\emptyset) = n_k(\emptyset) = 0$. A partition of n is then an integer partition having size n . We remark that the empty partition is the only partition having size 0. We also note that the partition

λ is uniquely determined by the statistics $(n_k)_{k>0}$, and we obtain the following relations:

$$\begin{aligned}\ell(\lambda) &= \sum_{k>0} n_k(\lambda), \\ |\lambda| &= \sum_{k>0} kn_k(\lambda).\end{aligned}$$

The latter relations are indeed well-defined, as the partition λ is a finite sequence, and then all but finitely many of the terms of sequence $(n_k(\lambda))_{k>0}$ are equal to 0. Let us now compute the generating function according to the occurrences $(n_k)_{k>0}$. Since the number of occurrences determined the partitions, We then have the equality

$$\sum_{\lambda} \prod_{k=1}^{\infty} x_k^{n_k(\lambda)} = \prod_{k=1}^{\infty} \left(\sum_{m_k=0}^{\infty} x_k^{m_k} \right) = \prod_{k=1}^{\infty} \frac{1}{1-x_k}. \quad (1.1.2)$$

Using a change of variables $x_k \mapsto xq^k$ for all positive integer k , we are able to compute the generating function with respect to the size and the length of the partitions:

$$\sum_{\lambda} x^{\ell(\lambda)} q^{|\lambda|} = \prod_{k=1}^{\infty} \frac{1}{1-xq^k}.$$

In particular, the number $p(n)$ Leibniz was looking for is the coefficient of n in the above series with $x = 1$, namely

$$\sum_{n=0}^{\infty} p(n)q^n = \prod_{k=1}^{\infty} \frac{1}{1-q^k}. \quad (1.1.3)$$

With the same reasoning, Euler succeeded in computing the generating function of partitions into distinct parts. This condition is equivalent to saying that $n_k(\lambda) \in \{0,1\}$ for all $k > 0$. By setting $\mathcal{D}(n), d(n)$ to be respectively the set and the number of such partitions of n , with the convention that $\emptyset \in \mathcal{D}(0)$ (so that $d(0) = 1$), we then obtain

$$\sum_{n=0}^{\infty} d(n)q^n = \prod_{k=1}^{\infty} (1+q^k). \quad (1.1.4)$$

Using the same method on the set of partitions into odd parts, i.e $n_{2k}(\lambda) = 0$ for all $k > 0$, and setting $\mathcal{O}(n), o(n)$ to be the set and the number of such partitions of n , with the convention that $\emptyset \in \mathcal{O}(0)$ (so that $o(0) = 1$), we obtain the corresponding generating function

$$\sum_{n=0}^{\infty} o(n)q^n = \prod_{k=1}^{\infty} \frac{1}{1-q^{2k-1}}. \quad (1.1.5)$$

By observing that

$$\prod_{k=1}^{\infty} (1+q^k) = \prod_{k=1}^{\infty} \frac{(1-q^{2k})}{1-q^k} = \prod_{k=1}^{\infty} \frac{1}{1-q^{2k-1}},$$

Euler stated the first relation that links different sets of partitions, known as the Euler distinct-odd identity.

Theorem 1.1.4 (Euler). *For any non-negative integer n , the set of partitions of n into distinct parts and the set of partitions of n into odd parts are equinumerous.*

Example 1.1.5. *For example, here we give the list of the partitions of $\mathcal{D}(n)$ and $\mathcal{O}(n)$ for $n \leq 5$.*

n	$\mathcal{D}(n)$	$\mathcal{O}(n)$
1	(1)	(1)
2	(2)	(1, 1)
3	(3), (2, 1)	(3), (1, 1, 1)
4	(4), (3, 1)	(3, 1), (1, 1, 1, 1)
5	(5), (4, 1), (3, 2)	(5), (3, 1, 1), (1, 1, 1, 1, 1, 1)

We end this section by presenting a graphical representation of integer partitions, namely the Ferrers diagram, as well as a key transformation on integer partitions, the conjugacy.

Definition 1.1.6. Let $\lambda = (\lambda_1, \dots, \lambda_s)$ be an integer partition. The *Ferrers diagram* of the partition λ is the subset of the plane \mathbb{R}^2 defined by

$$\{(i, j) : 0 < i < s, 0 < j < \lambda_{[i]}\}.$$

The conjugate of the partition λ is the partition $\lambda' = (\lambda'_1, \dots, \lambda'_r)$, where $r = \lambda_1$, and for all $j \in \{1, \dots, r\}$,

$$\lambda'_j = |\{i \in \{1, \dots, s\} : \lambda_i \geq j\}|,$$

where $|set|$ is the cardinality of the set set .

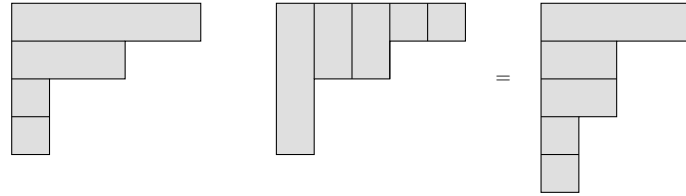

FIGURE 1.1: Ferrers diagram of $(5,3,1,1)$ and its conjugate $(4,2,2,1,1)$

The area of the Ferrers diagram of λ is exactly $|\lambda|$, and the conjugacy is an involution of the set of integer partitions that preserves the size of the partitions, and maps the length of the partitions to the first (greatest) part of their image.

1.2 Partition identities

In the spirit of Euler's distinct-odd identity, we define the general notion of partition identity.

Definition 1.2.1. A partition identity is a combinatorial identity that links two or several sets of integer partitions.

We now introduce an important tool for the computation of partition generating functions.

Definition 1.2.2. The q -Pochhammer symbol is defined by $(x; q)_m = \prod_{k=0}^{m-1} (1 - xq^k)$ for any integer $m \in \mathbb{Z}_{m \geq 0} \cup \{\infty\}$ and any complex numbers x, q such that $|q| < 1$. More generally, we define for any complex numbers x_1, \dots, x_s the expression $(x_1, \dots, x_s; q)_m = (x_1; q)_m \cdots (x_s; q)_m$. A q -series is a series whose coefficients can be expressed in terms of the symbols $(x_1, \dots, x_s; q)_m$.

Using this notation, the generation function given in (1.1.3) is $1/(q; q)_\infty$ and the Euler distinct-odd identity becomes $(-q; q)_\infty = 1/(q; q^2)_\infty$. In this section, we focus on two such identities, the Glaisher identity and the Rogers-Ramanujan identities.

1.2.1 Glaisher's identity

While the Euler identity is not difficult to prove by computing the generating function of both sets of partitions, finding a bijection that links these sets is not a trivial task. In (Glaisher, 1883; Sylvester, 1973), Glaisher and Sylvester gave two different bijections.

In (Glaisher, 1883), Glaisher bijectively proved the first broad generalization of the Euler identity. Here we present the machinery of Glaisher's bijection.

Let us take a partition into odd parts. Then, as long as two parts are equal, sum them up to obtain a new part corresponding to their double. Since the partition has a finite number of parts, the algorithm then necessarily ends, and this when all the parts in the sequence are distinct.

The inverse bijection then consists in starting from a partition into distinct parts and splitting, as long as it is possible, any even part into two parts both equal to its half. The process then ends when all the parts are odd, and this because of the fact that any positive integer has a maximal divisor which is a power of 2.

Example 1.2.3. Apply this algorithm on the partition $(9, 9, 7, 5, 5, 3, 1, 1, 1, 1, 1)$, and we obtain

$$\begin{array}{c}
 (9, 9, 7, 5, 5, 5, 3, 1, 1, 1, 1, 1, 1) \\
 \downarrow \\
 (18, 7, 10, 5, 3, 2, 2, 2, 1) \\
 \downarrow \\
 (18, 7, 10, 5, 3, 4, 2, 1)
 \end{array}$$

By sorting the final sequence, the corresponding image is then $(18, 10, 7, 5, 4, 3, 2, 1)$. Reciprocally, by applying the inverse bijection on $(18, 10, 7, 5, 4, 3, 2, 1)$, we have

$$\begin{array}{c}
 (18, 10, 7, 5, 4, 3, 2, 1) \\
 \downarrow \\
 (9, 9, 5, 5, 7, 5, 2, 2, 3, 1, 1, 1) \\
 \downarrow \\
 (9, 9, 5, 5, 7, 5, 1, 1, 1, 1, 3, 1, 1, 1)
 \end{array}$$

and by sorting the parts, we obtain as image the original partition into odd parts $(9, 9, 7, 5, 5, 5, 3, 1, 1, 1, 1, 1, 1)$.

One can observe that the order in which we sum the parts does not matter, and the final image only depends on the binary decomposition of the numbers of occurrences $n_{2k-1}(\lambda)$ for $k > 0$. In the example above with $\lambda = (9, 9, 7, 5, 5, 5, 3, 1, 1, 1, 1, 1, 1)$, we respectively have

$$(n_1(\lambda), n_3(\lambda), n_5(\lambda), n_7(\lambda), n_9(\lambda)) = (7, 1, 3, 1, 2) = (4 + 2 + 1, 1, 2 + 1, 1, 2)$$

and then the image is obtained after sorting the sequence

$$(4 \times 1, 2 \times 1, 1 \times 1, 1 \times 3, 2 \times 5, 1 \times 5, 1 \times 7, 2 \times 9) = (4, 2, 1, 3, 10, 5, 7, 18).$$

The well-definedness of the inverse bijection relies on the fact that any positive integer can be uniquely written as a product of a odd number and a power of 2. At the end of the process, the part $(2k - 1) \times 2^n$ will then result in 2^n parts equal to $2k - 1$.

Glaisher observed that the above machinery behind the bijection only depends on the binary decomposition. Then, using a similar approach in base m for any positive $m > 1$, he stated the first broad result beyond the Euler identity.

Definition 1.2.4. Let m be a positive integer. We define an m -flat partition to be a partition where the differences between two consecutive parts, as well the smallest part, are less than m , and an m -regular partition to be a partition with parts not divisible by m .

The generalization of Euler's identity given by Glaisher, and which makes the connection between m -flat and m -regular partitions, is stated in the following theorem.

Theorem 1.2.5 (Glaisher). For a fixed positive integer n , the following sets of partitions are equinumerous:

1. the m -regular partitions of n ,
2. the partitions of n with fewer than m occurrences for each positive integer,
3. the m -flat partitions of n .

In terms of q -series, they can be stated

$$\prod_{n \geq 1} (1 + q^n + q^{2n} + \dots + q^{n(m-1)}) = \frac{(q^m; q^m)_\infty}{(q; q)_\infty} = \prod_{\substack{n \geq 1 \\ m \nmid n}} \frac{1}{(1 - q^n)}. \quad (1.2.1)$$

The conjugacy allows us to link the m -flat partitions to the partitions with fewer than m occurrences for each integer. The Glaisher bijection analogous to the one given for Euler's distinct-odd identity, that links the m -regular partitions and the partitions with fewer than m occurrences for each integer, is the following: for any m -regular partition, as long as a part appears m times, we sum then up to the part which is the m times the repeated part.

The bijective proof of the Euler identity, given by Sylvester (Sylvester, 1973), is more subtle and will be presented in Chapter 5. It was an open problem to find a suitable generalization of Sylvester's bijection for the Glaisher identity. This problem was solved, a century after the paper of Sylvester, by Stockhofe in his Ph.D thesis (Stockhofe, 1982). In the 90's, seminal works of Bessenrodt (Bessenrodt, 1994), and Pak and Postnikov (Pak and Postnikov, 1998), related the Sylvester algorithm to the alternating sign sum of integer partitions. They then gave new refinements of the Euler identity.

In this thesis, we especially focus on a broad refinement of Glaisher's identity given by Keith and Xiong (Keith and Xiong, 2019).

Theorem 1.2.6 (Keith-Xiong). *Let $m \geq 2$, u_1, \dots, u_{m-1}, n be non-negative integers. Then, the number of m -flat partitions of n with u_i parts congruent to $i \pmod{m}$ is equal to the number of m -regular partitions of n into u_i parts congruent to $i \pmod{m}$.*

Their proof used a variant of the Sylvester-style bijection given by Stockhofe. In Chapter 5, we adapt this bijection to give a result beyond their refinement.

1.2.2 Rogers-Ramanujan type identities

The most famous partition identities are probably the Rogers-Ramanujan identities (Rogers and Ramanujan, 1919). They can be stated as follows.

Theorem 1.2.7 (Rogers 1894, Ramanujan 1913). *Let $i = 0$ or 1 . Then*

$$\sum_{n \geq 0} \frac{q^{n^2 + (1-i)n}}{(q; q)_n} = \frac{1}{(q^{2-i}; q^5)_\infty (q^{3+i}; q^5)_\infty}. \quad (1.2.2)$$

By interpreting both sides of (1.2.2) as generating functions for partitions, MacMahon (MacMahon, 1916) gave the following combinatorial version of the identities. This very interpretation was independently given by Schur.

Theorem 1.2.8 (Rogers-Ramanujan identities, partition version). *Let $a = 0$ or 1 . For every natural number n , the number of partitions of n such that the difference between two consecutive parts is at least 2 and the part 1 appears at most $1 - a$ times is equal to the number of partitions of n into parts congruent to $\pm(1 + a) \pmod{5}$.*

In this spirit, we define the notion of Rogers-Ramanujan type identity.

Definition 1.2.9. A partition identity of the Rogers-Ramanujan type is a theorem stating that for all n , the number of partitions of n satisfying some difference conditions equals the number of partitions of n satisfying some congruence conditions.

Dozens of proofs of these identities have been given, using different techniques, see for example (Andrews, 1984b; Bressoud, 1983; Watson, 1929). Especially, in (Garsia and Milne, 1981), Garsia and Milne gave the first bijective proof for these identities, laying the foundations of the *involution principle*. One can also observe that the Glaisher identity is of Rogers-Ramanujan type.

Following in the track of the Rogers-Ramanujan identities, Schur gave in (Schur, 1926) one of the most important identities in the theory of partitions, probably the most studied after the Rogers-Ramanujan identities.

Theorem 1.2.10 (Schur 1926). *For any positive integer n , the number of partitions of n into distinct parts congruent to $\pm 1 \pmod{3}$ is equal to the number of partitions of n where parts differ by at least three and multiples of three differ by at least six.*

There have been a number of proofs of Schur's result over the years, including a q -difference equation proof of Andrews (Andrews, 1968) and a simple bijective proof of Bressoud (Bressoud, 1980).

Another important identity is Göllnitz' theorem Göllnitz, 1967.

Theorem 1.2.11 (Göllnitz 1967). *For any positive integer n , the number of partitions of n into distinct parts congruent to $2, 4, 5 \pmod{6}$ is equal to the number of partitions of n into parts different from 1 and 3, and where parts differ by at least six with equality only if parts are congruent to $2, 4, 5 \pmod{6}$.*

Like Schur's theorem, Göllnitz' identity can be proved using q -difference equations (Andrews, 1969b) and elegant Bressoud-style bijections (Padmavathamma and Sudarshan, 2004; Zhao, 2015).

The Rogers-Ramanujan type identities have a rich history, and the study of such identities allowed mathematicians to develop several key methods for the theory of integer partitions. In this thesis we investigate two such methods: a combinatorial method, the weighted words, and a Lie-theoretic method, the $(KMN)^2$ character formula.

1.3 Weighted words

The *weighted words* were introduced by Alladi and Gordon to understand the combinatorial machinery behind the Schur identity. They consist in associating to the part of a classical partition some colors. In this section we present major works using weighted words.

1.3.1 From the Alladi-Gordon identity to the Alladi-Andrews-Berkovich identity

Seminal work of Alladi, Andrews, and Gordon in the 90's showed how the theorems of Schur and Göllnitz emerge from more general results on colored partitions (Alladi and Gordon, 1993; Alladi, Andrews, and Gordon, 1995).

In the case of Schur's theorem, we consider parts in three colors $\{a, b, ab\}$ and order them as follows:

$$1_{ab} < 1_a < 1_b < 2_{ab} < 2_a < 2_b < 3_{ab} < \dots \quad (1.3.1)$$

We then consider the partitions with colored parts different from 1_{ab} and satisfying the minimal difference conditions in the table

$\lambda_i \setminus \lambda_{i+1}$	ab	b	a
ab	2	2	2
a	1	1	2
b	1	1	1

(1.3.2)

Here, the part λ_i with color in the row and the part λ_{i+1} with color in the column differ by at least the corresponding entry in the table. An example of such a partition is $(7_{ab}, 5_b, 4_a, 3_{ab}, 1_b)$. The Alladi-Gordon refinement of Schur's partition theorem (Alladi and Gordon, 1993) is stated as follows:

Theorem 1.3.1. *Let u, v, n be non-negative integers. Denote by $A(u, v, n)$ the number of partitions of n into u distinct parts with color a and v distinct parts with color b , and denote by $B(u, v, n)$ the number of partitions of n satisfying the conditions above, with u parts with color a or ab , and v parts with color b or ab . We then have $A(u, v, n) = B(u, v, n)$ and the identity*

$$\sum_{u, v, n \geq 0} B(u, v, n) a^u b^v q^n = \sum_{u, v, n \geq 0} A(u, v, n) a^u b^v q^n = (-aq; q)_\infty (-bq; q)_\infty. \quad (1.3.3)$$

Note that a transformation implies Schur's theorem :

$$\begin{cases} \text{dilation :} & q \mapsto q^3 \\ \text{translations :} & a, b \mapsto q^{-2}, q^{-1} \end{cases} \quad (1.3.4)$$

In fact, the minimal difference conditions given in (1.3.2) give after these transformations the minimal differences in Schur's theorem. Moreover, finding such refinements and non-dilated versions of partition identities can be helpful to find bijective proofs of them.

In the case of Göllnitz' theorem, we consider parts that occur in six colors $\{a, b, c, ab, bc, ac\}$ with the order

$$1_{ab} < 1_{ac} < 1_a < 1_{bc} < 1_b < 1_c < 2_{ab} < 2_{ac} < 2_a < 2_{bc} < 2_b < 2_c < 3_{ab} < \dots, \quad (1.3.5)$$

and the partitions with colored parts different from $1_{ab}, 1_{ac}, 1_{bc}$ and satisfying the minimal difference conditions in

$\lambda_i \setminus \lambda_{i+1}$	ab	ac	a	bc	b	c
ab	2	2	2	2	2	2
ac	1	2	2	2	2	2
a	1	1	1	2	2	2
bc	1	1	1	2	2	2
b	1	1	1	1	1	2
c	1	1	1	1	1	1

(1.3.6)

The Alladi-Andrews-Gordon refinement of Göllnitz's partition theorem can be stated as follows:

Theorem 1.3.2. *Let u, v, w, n be non-negative integers. Denote by $A(u, v, w, n)$ the number of partitions of n into u distinct parts with color a , v distinct parts with color b and w distinct parts with color c , and denote by $B(u, v, w, n)$ the number of partitions of n satisfying the conditions above, with u parts with color a, ab or ac , v parts with color b, ab or bc and w parts with color c, ac or bc . We then have $A(u, v, w, n) = B(u, v, w, n)$ and the identity*

$$\sum_{u,v,w,n \geq 0} B(u, v, w, n) a^u b^v c^w q^n = \sum_{u,v,w,n \geq 0} A(u, v, w, n) a^u b^v c^w q^n = (-aq; q)_\infty (-bq; q)_\infty (-cq; q)_\infty. \tag{1.3.7}$$

Note that a transformation implies Göllnitz' theorem :

$$\begin{cases} \text{dilation :} & q \mapsto q^6 \\ \text{translations :} & a, b, c \mapsto q^{-4}, q^{-2}, q^{-1} \end{cases}. \tag{1.3.8}$$

Observe that while Schur's theorem is not a direct corollary of Göllnitz' theorem, Theorem 1.3.1 is implied by Theorem 1.3.2 by setting $c = 0$. Therefore Göllnitz' theorem may be viewed as a level higher than Schur's theorem, since it requires three primary colors instead of two.

Following the work of Alladi, Andrews, and Gordon, it was an open problem to find a partition identity beyond Göllnitz' theorem, in the sense that it would arise from four primary colors. This was famously solved by Alladi, Andrews, and Berkovich (Alladi, Andrews, and Berkovich, 2003). To describe their result, we consider parts that occur in eleven colors $\{a, b, c, d, ab, ab, ad, bc, bd, cd, abcd\}$ and ordered as follows:

$$1_{abcd} < 1_{ab} < 1_{ac} < 1_{ad} < 1_a < 1_{bc} < 1_{bd} < 1_b < 1_{cd} < 1_c < 1_d < 2_{abcd} < \dots \tag{1.3.9}$$

Let us consider the partitions with the length of the secondary parts greater than one and satisfying the minimal difference conditions in

$\lambda_i \setminus \lambda_{i+1}$	ab	ac	ad	a	bc	bd	b	cd	c	d
ab	2	2	2	2	2	2	2	2	2	2
ac	1	2	2	2	2	2	2	2	2	2
ad	1	1	2	2	2	2	2	2	2	2
a	1	1	1	1	2	2	2	2	2	2
bc	1	1	1	1	2	2	2	2	2	2
bd	1	1	1	1	1	2	2	2	2	2
b	1	1	1	1	1	1	1	2	2	2
cd	1	1	1	1	1	1	1	2	2	2
c	1	1	1	1	1	1	1	1	1	2
d	1	1	1	1	1	1	1	1	1	1

(1.3.10)

and such that parts with color $abcd$ differ by at least 4, and the smallest part with color $abcd$ is at least equal to $4 + 2\tau - \chi(1_a \text{ is a part})$, where τ is the number of primary and secondary parts in the partition. The theorem is then stated as follows.

Theorem 1.3.3. *Let u, v, w, t, n be non-negative integers. Denote by $A(u, v, w, t, n)$ the number of partitions of n into u distinct parts with color a , v distinct parts with color b , w distinct parts with color c and t distinct parts with color d , and denote by $B(u, v, w, t, n)$ the number of partitions of n satisfying the conditions above, with u parts with color a, ab, ac, ad or $abcd$, v parts with color b, ab, bc, bd or $abcd$, w parts with color c, ac, bc, cd or $abcd$ and t parts with color d, ad, bd, cd or $abcd$. We then have $A(u, v, w, t, n) = B(u, v, w, t, n)$ and the identity*

$$\sum_{u,v,w,t,n \geq 0} B(u, v, w, t, n) a^u b^v c^w d^t q^n = (-aq; q)_\infty (-bq; q)_\infty (-cq; q)_\infty (-dq; q)_\infty. \tag{1.3.11}$$

Note that the result of Alladi-Andrews-Berkovich uses four primary colors, the full set of secondary colors, along with one quaternary color $abcd$. When $d = 0$, we recover Theorem 1.3.2. Their main tool was a difficult q -series identity:

$$\sum_{i,j,k,l \text{ -constraints}} \frac{q^{T_\tau + T_{AB} + T_{AC} + T_{AD} + T_{CB} + T_{BD} + T_{CD} - BC - BD - CD + 4T_{Q-1} + 3Q + 2Q\tau}}{(q)_A (q)_B (q)_C (q)_D (q)_{AB} (q)_{AC} (q)_{AD} (q)_{BC} (q)_{BD} (q)_{CD} (q)_Q}$$

$$\begin{aligned} & \cdot \{(1 - q^A) + q^{A+BC+BD+Q}(1 - q^B) + q^{A+BC+BD+Q+B+CD}\} \\ & = \sum_{i,j,k,l-\text{constraints}} \frac{q^{T_i+T_j+T_k+T_l}}{(q)_i(q)_j(q)_k(q)_l} \end{aligned} \quad (1.3.12)$$

where $A, B, C, D, AB, AC, AD, BC, BD, CD, Q$ are variables which count the number of parts with respectively color $a, b, c, d, ab, ab, ad, bc, bd, cd, abcd$,

$$\begin{cases} i = A + AB + AC + AD + Q \\ j = B + AB + BC + BD + Q \\ k = C + AC + BC + CD + Q \\ l = D + AD + BD + CD + Q \\ \tau = A + B + C + D + AB + AC + AD + BC + BD + CD + Q \end{cases},$$

$T_n = \frac{n(n+1)}{2}$ is the n^{th} triangular number and $(q)_n = (q; q)_n$. While this identity is difficult to prove, it is relatively straightforward to show that it is equivalent to the statement in Theorem 1.3.3.

One of the contribution of this thesis consists in using a bijective approach to show, not only the Alladi-Andrews-Gordon theorem, but a more general result beyond Göllnitz' theorem for an arbitrary number of primary colors.

1.3.2 On Siladić's partition theorem

Another rich source of Rogers-Ramanujan type identities is the representation theory of Lie algebras. This has its origins in work of Lepowsky and Wilson (Lepowsky and Wilson, 1984), who proved the Rogers-Ramanujan identities by using representations of the affine Lie algebra $\mathfrak{sl}(2, \mathbb{C})^\sim$. Subsequently, Capparelli (Capparelli, 1993), Meurman and Primc (Meurman and Primc, 1987) and others examined related standard modules and affine Lie algebras and found many new Rogers-Ramanujan type identities. We present some of these identities in the next section.

Here, we shall be concerned by one such identity given by Siladić (Siladić, 2017) in his study of representations of the twisted affine Lie algebra $A_2^{(2)}$.

Theorem 1.3.4 (Siladić). *The number of partitions $\lambda_1 + \dots + \lambda_s$ of an integer n into distinct odd parts is equal to the number of partitions of n , into parts different from 2, such that $\lambda_i - \lambda_{i+1} \geq 5$ and*

$$\begin{aligned} \lambda_i - \lambda_{i+1} = 5 &\Rightarrow \lambda_i + \lambda_{i+1} \equiv \pm 3 \pmod{16}, \\ \lambda_i - \lambda_{i+1} = 6 &\Rightarrow \lambda_i + \lambda_{i+1} \equiv 0, \pm 4, 8 \pmod{16}, \\ \lambda_i - \lambda_{i+1} = 7 &\Rightarrow \lambda_i + \lambda_{i+1} \equiv \pm 1, \pm 5, \pm 7 \pmod{16}, \\ \lambda_i - \lambda_{i+1} = 8 &\Rightarrow \lambda_i + \lambda_{i+1} \equiv 0, \pm 2, \pm 6, 8 \pmod{16}. \end{aligned}$$

Rephrased, we obtain the following equivalent formulation.

Theorem 1.3.5 (Siladić, rephrased by Dousse). *The number of partitions $\lambda_1 + \dots + \lambda_s$ of an integer n into distinct odd parts is equal to the number of partitions of n into parts different from 2 such that $\lambda_i - \lambda_{i+1} \geq 5$ and*

$$\begin{aligned} \lambda_i - \lambda_{i+1} = 5 &\Rightarrow \lambda_i \equiv 1, 4 \pmod{8}, \\ \lambda_i - \lambda_{i+1} = 6 &\Rightarrow \lambda_i \equiv 1, 3, 5, 7 \pmod{8}, \\ \lambda_i - \lambda_{i+1} = 7 &\Rightarrow \lambda_i \equiv \pm 0, 1, 3, 4, 6, 7 \pmod{8}, \\ \lambda_i - \lambda_{i+1} = 8 &\Rightarrow \lambda_i \equiv 0, 1, 3, 4, 5, 7 \pmod{8}. \end{aligned}$$

For example, for $n = 16$, the partitions into distinct odd parts are

$$15 + 1, 13 + 3, 11 + 5, 9 + 7 \text{ and } 7 + 5 + 3 + 1,$$

while the partitions of the second kind are

$$15 + 1, 13 + 3, 11 + 5, 16 \text{ and } 12 + 4.$$

Siladić's theorem has recently been refined by Dousse (Dousse, 2017b) via weighted words. Her framework is as follows: we consider parts colored by two primary colors a, b and three secondary colors

a^2, b^2, ab , with the colored parts ordered as follows:

$$1_{ab} < 1_a < 1_{b^2} < 1_b < 2_{ab} < 2_a < 3_{a^2} < 2_b < 3_{ab} < 3_a < 3_{b^2} < 3_b < \dots \quad (1.3.13)$$

Note that only odd parts can be colored by a^2, b^2 . The transformations

$$q \rightarrow q^4, a \rightarrow aq^{-3}, b \rightarrow bq^{-1}, \quad (1.3.14)$$

leads to the natural order

$$0_{ab} < 1_a < 2_{b^2} < 3_b < 4_{ab} < 5_a < 6_{a^2} < 7_b < 8_{ab} < 9_a < 10_{b^2} < 11_b < \dots \quad (1.3.15)$$

We then impose the minimal differences according the following table

$\lambda_i \setminus \lambda_{i+1}$	a^2_{odd}	a_{odd}	a_{even}	b^2_{odd}	b_{odd}	b_{even}	ab_{odd}	ab_{even}
a^2_{odd}	4	4	3	4	4	3	4	3
a_{odd}	2	2	3	2	2	3	2	1
a_{even}	3	3	2	3	3	2	3	2
b^2_{odd}	2	2	3	4	4	3	2	3
b_{odd}	2	2	1	2	2	3	2	1
b_{even}	1	1	2	3	3	2	1	2
ab_{odd}	2	2	3	4	4	3	2	3
ab_{even}	3	3	2	3	3	2	3	2

(1.3.16)

which can be reduced to the table :

$\lambda_i \setminus \lambda_{i+1}$	a^2_{odd}	a	b^2_{odd}	b	ab_{odd}	ab_{even}
a^2_{odd}	4	3	4	3	4	3
a	2	2	2	2	2	1
b^2_{odd}	2	2	4	3	2	3
b	1	1	2	2	1	1
ab_{odd}	2	2	4	3	2	3
ab_{even}	3	2	3	2	3	2

(1.3.17)

One can check that these minimal differences define a partial strict order on the set of parts colored by primary and secondary colors. With this coloring, Dousse refined the Siladić theorem as follows:

Theorem 1.3.6 (Dousse). *Let $(u, v, n) \in \mathbb{N}^3$. Denote by $\mathcal{D}(u, v, n)$ the set of all the partitions of n , such that no part is equal to $1_{ab}, 1_{a^2}$ or 1_{b^2} , with the difference between two consecutive parts following the minimal conditions in (1.3.16), and with u equal to the number of parts with color a or ab plus twice the number of parts colored by a^2 , and v equal to the number of parts with color b or ab plus twice the number of parts colored by b^2 . Denote by $\mathcal{C}(u, v, n)$ the set of all the partitions of n with u distinct parts colored by a and v distinct parts colored by b . We then have $\#\mathcal{D}(u, v, n) = \#\mathcal{C}(u, v, n)$.*

In terms of q -series, we have the equation

$$\sum_{u,v,n \geq 0} \#\mathcal{D}(u, v, n) a^u b^v q^n = \sum_{u,v,n \geq 0} \#\mathcal{C}(u, v, n) a^u b^v q^n = (-aq; q)_\infty (-bq; q)_\infty \quad (1.3.18)$$

Dilating (1.3.16) by (1.3.14) gives exactly the minimal difference conditions in Siladić's theorem and (1.3.18) becomes the generating function for partitions into distinct odd parts, so that Theorem 1.3.5 is a corollary of Theorem 1.3.6.

In this thesis, we bijectively prove a broad generalization of the refinement of Siladić's theorem for an arbitrary number of primary colors.

1.4 Partition identities and Representation theory of affine Lie algebras

In the representation theory of Lie algebras, the character is a statistic of representations whose expression can be seen as a generating function in terms of simple roots. The starting point of our discussion is

the Weyl-Kac character formula (Kac, 1978; Kac, 1990), whose principal specialization gives an expression of the character as an infinite q -product. This provides good candidates for Rogers-Ramanujan type identities, whose expressions consist of an equality between a sum (partitions satisfying some difference conditions) and a product (partitions satisfying some congruence conditions). Seminal works of representation theorists allowed to develop techniques to build the sum-side for the character. In this section, we discuss two such tools: the vertex operator theory and the theory perfect crystals.

1.4.1 Lie-theoretic proof of the Rogers-Ramanujan identities

First, Lepowsky and Milne (Lepowsky and Milne, 1978a; Lepowsky and Milne, 1978b) noticed that the product side of the Rogers-Ramanujan identities (1.2.2) multiplied by the “fudge factor” $1/(q; q^2)_\infty$ is equal to the principal specialisation of the Weyl-Kac character formula for level 3 standard modules of the affine Lie algebra $A_1^{(1)}$. Then, Lepowsky and Wilson (Lepowsky and Wilson, 1984; Lepowsky and Wilson, 1985) gave an interpretation of the sum side by constructing a basis of these standard modules using vertex operators. Very roughly, they proceed as follows. They start with a spanning set of the module V , indexed by monomials of the form $Z_1^{f_1} \dots Z_s^{f_s}$ for $s, f_1, \dots, f_s \in \mathbb{N}$. Then by the theory of vertex operators, there are some relations between these monomials, which allows them to reduce the spanning set by removing the monomials containing Z_j^2 and $Z_j Z_{j+1}$. The last step is then to prove that this reduced family of monomials is actually free, and therefore a basis of the representation. The connection to Theorem 1.2.7 is then done by noting that monomials $Z_1^{f_1} \dots Z_s^{f_s}$ which do not contain Z_j^2 or $Z_j Z_{j+1}$ for any j are in bijection with partitions which do not contain twice the part j or both the part j and $j + 1$ for any j , i.e. partitions with difference at least 2 between consecutive parts.

The theory of vertex operator algebras developed by Lepowsky and Wilson turned out to be very influential: for example, it was used by Frenkel, Lepowsky, and Meurman to construct a natural representation of the Monster finite simple group (Frenkel, Lepowsky, and Meurman, 1988), and was key in the work of Borcherds on vertex algebras and his resolution of the Conway-Norton monstrous moonshine conjecture (Borcherds, 1992).

1.4.2 Capparelli’s identity

Following Lepowsky and Wilson’s discovery, several other representation theorists studied other Lie algebras or representations at other levels, and discovered new interesting and intricate partition identities, that were previously unknown to the combinatorics community, see for example (Capparelli, 1993; Meurman and Primc, 1987; Meurman and Primc, 1999; Meurman and Primc, 2001; Nandi, 2014; Primc, 1994; Primc and Šikić, 2016; Siladić, 2017),

After Lepowsky and Wilson’s work, Capparelli (Capparelli, 1993) was the first to conjecture a new identity, by studying the level 3 standard modules of the twisted affine Lie algebra $A_2^{(2)}$. It was first proved combinatorially by Andrews in (Andrews, 1992), then refined by Alladi, Andrews and Gordon in (Alladi, Andrews, and Gordon, 1995) using the method of weighted words, and finally proved by Capparelli (Capparelli, 1996) and Tamba and Xie (Tamba and Xie, 1995) via representation theoretic techniques. Later, Meurman and Primc (Meurman and Primc, 1999) showed that Capparelli’s identity can also be obtained by studying the $(1, 2)$ -specialisation of the character formula for the level 1 modules of $A_1^{(1)}$. Capparelli’s original identity can be stated as follows.

Theorem 1.4.1 (Capparelli’s identity (Andrews 1992)). *Let $C(n)$ denote the number of partitions of n into parts > 1 such that parts differ by at least 2, and at least 4 unless consecutive parts add up to a multiple of 3. Let $D(n)$ denote the number of partitions of n into distinct parts not congruent to $\pm 1 \pmod{6}$. Then for every positive integer n , $C(n) = D(n)$.*

In this thesis, we will mostly be interested in the weighted words version of Theorem 1.4.1. We now describe Alladi, Andrews, and Gordon’s refinement of Capparelli’s identity (slightly reformulated by Dousse in (Dousse, 2020)).

Consider partitions into natural numbers in three colours, a , c , and d (the absence of the color b will be made clear in a few paragraphs, when we will mention the connection with Primc’s identity), with the order

$$1_a < 1_c < 1_d < 2_a < 2_c < 2_d < \dots, \quad (1.4.1)$$

satisfying the difference conditions in the matrix

$$C_2 = \begin{matrix} & a & c & d \\ a & \begin{pmatrix} 2 & 2 & 2 \\ 1 & 1 & 2 \\ 0 & 1 & 2 \end{pmatrix} \\ c & \\ d & \end{matrix}. \quad (1.4.2)$$

The non-dilated version of Capparelli's identity can be stated as follows.

Theorem 1.4.2 (Alladi–Andrews–Gordon 1995). *Let $C_2(n; i, j)$ denote the number of partitions of n into colored parts satisfying the difference conditions in matrix C_2 , having i parts colored a and j parts colored d . We have*

$$\sum_{n, i, j \geq 0} C(n; i, j) a^i d^j q^n = (-q)_\infty (-aq; q^2)_\infty (-dq; q^2)_\infty.$$

Performing the dilations

$$q \rightarrow q^3, \quad a \rightarrow aq^{-1}, \quad d \rightarrow dq,$$

which correspond to the following transformations on the parts of the partitions

$$k_a \rightarrow (3k-1)_a, \quad k_b \rightarrow 3k, \quad k_d \rightarrow (3k+1)_d,$$

we obtain a refinement of Capparelli's original identity. Other dilations can lead to infinitely many other (but related) partition identities.

1.4.3 Primc's identities

Another way to obtain Rogers-Ramanujan type partition identities using representation theory is the theory of perfect crystals of affine Lie algebras. Much more detail on crystals is given in Chapter 8, but the rough idea is the following. The generating function for partitions with congruence conditions, which is always an infinite product, is still obtained via a specialisation of the Weyl-Kac character formula. The equality with the generating function for partitions with difference conditions is established through the crystal base character formula of Kang, Kashiwara, Misra, Miwa, Nakashima, and Nakayashiki (Kang et al., 1992c). This formula expresses, under certain specialisations, the character as the generating function for partitions satisfying difference conditions given by energy matrices of perfect crystals.

The identity which we study in this section, due to Primc (Primc, 1999), was obtained that way by studying crystal bases of $A_1^{(1)}$. The energy matrix of the perfect crystal coming from the tensor product of the vector representation and its dual is given by

$$P_2 = \begin{matrix} & a & b & c & d \\ a & \begin{pmatrix} 2 & 1 & 2 & 2 \\ 1 & 0 & 1 & 1 \\ 0 & 1 & 0 & 2 \\ 0 & 1 & 0 & 2 \end{pmatrix} \\ b & \\ c & \\ d & \end{matrix}. \quad (1.4.3)$$

Let $P(n; i, j, k, \ell)$ denote the number of partitions of n into four colors a, b, c, d , with i (resp. j, k, ℓ) parts colored a (resp. b, c, d), satisfying the difference conditions of the matrix P_2 . Then the crystal base character formula and the Weyl-Kac character formula imply that under the dilations

$$k_a \rightarrow 2k-1, \quad k_b \rightarrow 2k, \quad k_c \rightarrow 2k, \quad k_d \rightarrow 2k+1, \quad (1.4.4)$$

the generating function for these colored partitions becomes $1/(q; q)_\infty$.

Theorem 1.4.3 (Primc 1999). *We have*

$$\sum_{n, i, j, k, \ell} P(n; i, j, k, \ell) q^{2n-i+\ell} = \frac{1}{(q; q)_\infty}.$$

By taking the same approach for the affine Lie algebra $A_2^{(1)}$, Primc also gave the following energy matrix (where the naming of the colors comes from our generalization):

$$P_3 = \begin{matrix} & a_2b_0 & a_2b_1 & a_1b_0 & a_0b_0 & a_2b_2 & a_1b_1 & a_0b_1 & a_1b_2 & a_0b_2 \\ \begin{matrix} a_2b_0 \\ a_2b_1 \\ a_1b_0 \\ a_0b_0 \\ a_2b_2 \\ a_1b_1 \\ a_0b_1 \\ a_1b_2 \\ a_0b_2 \end{matrix} & \begin{pmatrix} 2 & 2 & 2 & 1 & 2 & 2 & 2 & 2 & 2 \\ 1 & 2 & 1 & 1 & 2 & 1 & 2 & 2 & 2 \\ 1 & 1 & 2 & 1 & 1 & 2 & 2 & 2 & 2 \\ 1 & 1 & 1 & 0 & 1 & 1 & 1 & 1 & 1 \\ 0 & 0 & 1 & 1 & 0 & 1 & 1 & 2 & 2 \\ 0 & 1 & 0 & 1 & 1 & 0 & 2 & 1 & 2 \\ 0 & 1 & 0 & 1 & 1 & 0 & 2 & 1 & 2 \\ 0 & 0 & 1 & 1 & 0 & 1 & 1 & 2 & 2 \\ 0 & 0 & 0 & 1 & 0 & 0 & 1 & 1 & 2 \end{pmatrix} \end{matrix}. \quad (1.4.5)$$

Theorem 1.4.4 (Primc 1999). *Under the dilations*

$$\begin{aligned} k_{a_2b_0} &\rightarrow 3k - 2, & k_{a_2b_1} &\rightarrow 3k - 1, & k_{a_1b_0} &\rightarrow 3k - 1, \\ k_{a_0b_0} &\rightarrow 3k, & k_{a_1b_1} &\rightarrow 3k, & k_{a_2b_2} &\rightarrow 3k, \\ k_{a_0b_1} &\rightarrow 3k + 1, & k_{a_1b_2} &\rightarrow 3k + 1, & k_{a_0b_2} &\rightarrow 3k + 2, \end{aligned} \quad (1.4.6)$$

the generating function for 9-colored partitions satisfying the difference conditions of (1.4.5) becomes $1/(q; q)_\infty$.

When seeing these two theorems of Primc, one might find it surprising that the generating function for partitions with such intricate difference conditions simply becomes $1/(q; q)_\infty$, the generating function for unrestricted partitions. However recently, Dousse and Lovejoy (Dousse and Lovejoy, 2018) gave a weighted words version of Theorem 1.4.3.

Theorem 1.4.5 (Dousse-Lovejoy 2018, non-dilated version of Primc's identity). *Let $P(n; i, j, k, \ell)$ be defined as above. We have*

$$\sum_{n, i, j, k, \ell} P(n; i, j, k, \ell) q^n a^i c^k d^\ell = \frac{(-aq; q^2)_\infty (-dq; q^2)_\infty}{(q; q)_\infty (cq; q^2)_\infty}.$$

Performing the dilations of (1.4.4) indeed transforms the infinite product above into $1/(q; q)_\infty$. But the theorem above shows that keeping track of all colors except b leads to a much more intricate infinite product as well, and that the extremely simple expression $1/(q; q)_\infty$ appears only because of the particular dilation that Primc considered. Later, Dousse (Dousse, 2020) even gave an expression for the generating function for $P(n; i, j, k, \ell)$ keeping track of all the colors, but it can be written as an infinite product only if we do not keep track of the color b .

Thus it is interesting from a combinatorial point of view to see whether a similar phenomenon happens with Theorem 1.4.4 as well. To do so, we would like to compute the generating function for colored partitions satisfying the difference conditions (1.4.5), at the non-dilated level, keeping track of as many colors as possible. In a joint-work with Dousse (Dousse and Konan, 2019a; Dousse and Konan, 2019b), not only do we succeed in doing this, but we embed both of Primc's theorems into an infinite family of identities about partitions satisfying difference conditions given by $n^2 \times n^2$ matrices.

Apart from the fact that they can be obtained from the same Lie algebra $A_1^{(1)}$, Capparelli's and Primc's identities didn't seem related from the representation theoretic point of view, as they were obtained in completely different ways, and Capparelli's identity did not seem related to perfect crystals. However, recently, Dousse (Dousse, 2020) gave a bijection between colored partitions satisfying the difference conditions (1.4.3) and pairs of partitions (λ, μ) , where λ is a colored partition satisfying the difference conditions (1.4.2), and μ is a partition colored b . This bijection preserves the total weight, the number of parts, the size of the parts, and the number of parts colored a and d . Therefore, combinatorially, these two identities are very closely related. We generalized this bijection to our new generalization of Primc's identity and obtain two families of partition identities with difference conditions given by $(n^2 - 1) \times (n^2 - 1)$ matrices, which generalize Capparelli's identity.

In this thesis, we present a broad result beyond the generalizations of both Capparelli's and Primc's identities for more general families of colored partitions.

1.4.4 Character formula as series with positive coefficients

Finding an explicit expression of the character as a series with positive coefficients is an important problem. While the principal specialisation of the Weyl-Kac character formula is a product of q -series with obvious positive coefficients, the original formula expresses the character as a product with a factor which has negative coefficient according to the parity of the elements of the Weyl group. In (Kac and Peterson, 1984), using modular forms and string functions, Kac and Peterson gave a formula for $e^{-\Lambda} \text{ch}(L(\Lambda))$ for all the irreducible highest weight level 1 modules Λ of all classical types as a series in $\mathbb{Z}[[e^{-\alpha_0}, e^{-\alpha_1}, \dots, e^{-\alpha_{n-1}}]]$ with obviously positive coefficients. This built on earlier work of Kac (Kac, 1978), in which he proved the particular case where $M = L(\Lambda_0)$ in $A_n^{(1)}$, $D_n^{(1)}$, and $E_n^{(1)}$.

In (Bartlett and Warnaar, 2015), Bartlett and Warnaar used Hall-Littlewood polynomials to give explicitly positive formulas for the characters of certain highest weight modules of the affine Lie algebras $C_n^{(1)}$, $A_{2n}^{(2)}$, and $D_{n+1}^{(2)}$, which also led to generalisations for the Macdonald identities in types $B_n^{(1)}$, $C_n^{(1)}$, $A_{2n-1}^{(2)}$, $A_{2n}^{(2)}$, and $D_{n+1}^{(2)}$. However their approach failed to give a formula for the case $A_n^{(1)}$. Using Macdonald-Koornwinder theory, Rains and Warnaar ("**Bounded Littlewood identities**") later found additional character formulas for these types, together with new Rogers-Ramanujan type identities. In (Griffin, Ono, and Warnaar, 2016), Griffin, Ono, and Warnaar obtained a limiting Rogers-Ramanujan type identity for the principal specialisation of the character of some particular weights $(m-k)\Lambda_0 + k\Lambda_1$ in $A_n^{(1)}$. On the other hand, Meurman and Primc Meurman and Primc, 1999 treated the case of all levels of $A_1^{(1)}$ via vertex operator algebras.

In the paper dealing with the Lie-theoretic interpretation of the generalization of Capparelli's and Primc's identities (Dousse and Konan, 2019b), we introduced a tool which allowed us to compute the precise formulas of all the level one standard modules of type $A_n^{(1)}$. In this thesis, we present the generalization of this tool, which allows us to compute the character of level one standard module for other types $A_{2n}^{(2)}$, $D_{n+1}^{(2)}$, $A_{2n-1}^{(2)}$, $B_n^{(1)}$, $D_n^{(1)}$.

Chapter 2

Contribution of the thesis

Here we present an exhaustive list of the works that comprise this thesis. We start with a new notion of weighted words, the foundation of all the remaining results. We present all these results as generalizations, which, from our viewpoint, are easier to prove when they are well-formalized. In addition, for each generalization, we give explicit results as particular cases of the generalization.

2.1 Weighted words revisited

We present in this section our weighted words in a more general and formal way than the original method given by Alladi and Gordon. The purpose of this exposition is to set the major tools that will enable us to generalize the identities presented in Chapter 1.

2.1.1 Generalized colored partitions

Let \mathcal{C} be a set of colors, and let $\mathbb{Z}_{\mathcal{C}} = \{k_c : k \in \mathbb{Z}, c \in \mathcal{C}\}$ be the set of colored integers. First, we relax the condition that parts of colored partitions have to be in non-increasing order.

Definition 2.1.1. Let \gg be a binary relation defined on $\mathbb{Z}_{\mathcal{C}}$. A *generalized colored partition* with relation \gg is a finite sequence (π_1, \dots, π_s) of colored integers, where for all $i \in \{1, \dots, s-1\}$, $\pi_i \gg \pi_{i+1}$.

In the following, $c(\pi_i) \in \mathcal{C}$ denotes the color of the part π_i . The quantity $|\pi| = \pi_1 + \dots + \pi_s$ is the size of π , and $C(\pi) = c(\pi_1) \dots c(\pi_s)$ is its color sequence.

Remark 2.1.2. The binary relation is not necessarily an order. When \gg is a strict order, we can easily check that every finite set of colored parts defines a classical colored partition, by ordering the parts. In the same way, for an order, the generalized colored partitions are finite multi-sets of colored integers.

Definition 2.1.3. An *energy* ϵ on \mathcal{C} is a function from \mathcal{C}^2 to \mathbb{Z} . Note that when $\mathcal{C} = \{c_1, \dots, c_n\}$ is a finite color set, the data given by ϵ is equivalent to a matrix $M_{\epsilon} = (\epsilon(c_i, c_j))_{i,j=1}^n$, called *energy matrix*. The binary relation \gg_{ϵ} on $\mathbb{Z}_{\mathcal{C}}$, associated to an energy ϵ , is defined by

$$k_c \gg_{\epsilon} l_d \iff k - l \geq \epsilon(c, d).$$

We then call the relation \gg_{ϵ} the *minimal difference condition* given by energy ϵ , and denote by \mathcal{P}_{ϵ} the set of generalized colored partitions with relation \gg_{ϵ} .

An energy ϵ is said to be *minimal* if it has value in $\{0, 1\}$. For such an energy, we refer respectively to \succ_{ϵ} and \mathcal{O}_{ϵ} instead of \gg_{ϵ} and \mathcal{P}_{ϵ} .

Example 2.1.4. For the set of classical integer partitions $\pi = (\pi_1, \dots, \pi_s)$, where parts satisfy $\pi_1 \geq \dots \geq \pi_s > 0$, the empty partition is such that $s = 0$. This set is in bijection with the set of generalized colored partitions of \mathcal{P}_{ϵ} with $\mathcal{C} = \{c\}$ and the minimal energy ϵ satisfying $\epsilon(c, c) = 0$, and such that the last part size is at least equal to 1. The bijection is given by

$$(\pi_1, \dots, \pi_s) \mapsto ((\pi_1)_c, \dots, (\pi_s)_c).$$

Example 2.1.5. The weighted words used by Alladi-Gordon in Theorem 1.3.1 consist of two color sets $\mathcal{C}_1 = \{a, b\}$ and $\mathcal{C}_2 = \{ab, a, b\}$, the energies ϵ_1 and ϵ_2 represented by the energy matrices

$$M_{\epsilon_1} = \begin{pmatrix} 1 & 1 \\ 0 & 1 \end{pmatrix} \quad \text{and} \quad M_{\epsilon_2} = \begin{pmatrix} 2 & 2 & 2 \\ 1 & 1 & 2 \\ 1 & 1 & 1 \end{pmatrix},$$

and the sets of colored partitions counted by $A(u, v, n)$ and $B(u, v, n)$ correspond to some subsets of generalized colored partitions of \mathcal{P}_{ϵ_1} and \mathcal{P}_{ϵ_2} with some restrictions on the minimal part sizes.

Examples 2.1.6. Let $\mathcal{C} = \{c_1, \dots, c_n\}$ be a set of colors.

1. For the minimal energy $\epsilon(c_i, c_j) = \chi(i < j)$, where $\chi(\text{prop})$ equals 1 if the proposition prop is true and 0 otherwise, we can set an order $c_1 < \dots < c_n$ on \mathcal{C} and the energy relation \succ_ϵ becomes the lexicographic order on $\mathbb{Z}_{\mathcal{C}}$:

$$\dots \succ_\epsilon (k+1)_{c_1} \succ_\epsilon k_{c_n} \succ_\epsilon k_{c_n} \succ_\epsilon k_{c_{n-1}} \succ_\epsilon k_{c_{n-1}} \succ_\epsilon \dots \succ_\epsilon k_{c_2} \succ_\epsilon k_{c_2} \succ_\epsilon k_{c_1} \succ_\epsilon k_{c_1} \succ_\epsilon \dots$$

The corresponding energy matrix is given by

$$M_\epsilon = \begin{matrix} & c_1 & c_2 & \dots & c_{n-1} & c_n \\ \begin{matrix} c_1 \\ c_2 \\ \vdots \\ c_{n-1} \\ c_n \end{matrix} & \begin{pmatrix} 0 & 1 & \dots & 1 & 1 \\ 0 & 0 & \ddots & 1 & 1 \\ \vdots & \vdots & \ddots & \ddots & \vdots \\ 0 & 0 & \dots & 0 & 1 \\ 0 & 0 & \dots & 0 & 0 \end{pmatrix} \end{matrix}.$$

2. For the minimal energy $\epsilon(c_i, c_j) = \chi(i \leq j)$, we can set an order $c_1 < \dots < c_n$ on \mathcal{C} and the energy relation \succ_ϵ is the strict lexicographic order on $\mathbb{Z}_{\mathcal{C}}$:

$$\dots \succ_\epsilon (k+1)_{c_1} \succ_\epsilon k_{c_n} \succ_\epsilon k_{c_{n-1}} \succ_\epsilon \dots \succ_\epsilon k_{c_2} \succ_\epsilon k_{c_1} \succ_\epsilon \dots$$

The corresponding energy matrix is given by

$$M_\epsilon = \begin{matrix} & c_1 & c_2 & \dots & c_{n-1} & c_n \\ \begin{matrix} c_1 \\ c_2 \\ \vdots \\ c_{n-1} \\ c_n \end{matrix} & \begin{pmatrix} 1 & 1 & \dots & 1 & 1 \\ 0 & 1 & \dots & 1 & 1 \\ \vdots & \ddots & \ddots & \vdots & \vdots \\ 0 & 0 & \dots & 1 & 1 \\ 0 & 0 & \dots & 0 & 1 \end{pmatrix} \end{matrix}.$$

Example 2.1.7. Let $\mathcal{C}' = \{c_1, \dots, c_n\}$ be a set of colors. If we set $\bar{\mathcal{C}}' = \{\bar{c} : c \in \mathcal{C}'\}$ and $\mathcal{C} = \mathcal{C}' \sqcup \bar{\mathcal{C}}'$ we can then define ϵ on \mathcal{C} , for any $i, j \in \{1, \dots, n\}$, by the following:

1. $\epsilon(c_i, c_j) = \chi(i < j)$,
2. $\epsilon(c_i, \bar{c}_j) = 0$, $\epsilon(\bar{c}_i, c_j) = 1$,
3. $\epsilon(\bar{c}_i, \bar{c}_j) = \chi(i \geq j)$.

The relation \succ_ϵ is then an order on $\mathbb{Z}_{\mathcal{C}}$, where over-lined colored particles can occur at most once in any ordered chain:

$$\dots \succ_\epsilon (k+1)_{\bar{c}_n} \succ_\epsilon k_{c_n} \succ_\epsilon k_{c_n} \succ_\epsilon k_{c_{n-1}} \succ_\epsilon \dots \succ_\epsilon k_{c_2} \succ_\epsilon k_{c_1} \succ_\epsilon k_{c_1} \succ_\epsilon k_{\bar{c}_1} \succ_\epsilon k_{\bar{c}_2} \succ_\epsilon \dots k_{\bar{c}_{n-1}} \succ_\epsilon k_{\bar{c}_n} \succ_\epsilon \dots$$

The latter inequalities give some generalized colored partitions that can be identified as overpartitions (Corteel and Lovejoy, 2004). The corresponding energy matrix is given by

$$M_\epsilon = \begin{matrix} & \bar{c}_n & \dots & \bar{c}_1 & c_1 & \dots & c_n \\ \begin{matrix} \bar{c}_n \\ \vdots \\ \bar{c}_1 \\ c_1 \\ \dots \\ c_n \end{matrix} & \begin{pmatrix} 1 & \dots & 1 & 1 & \dots & 1 \\ \vdots & \ddots & \vdots & \vdots & 1^* & \vdots \\ 0 & \dots & 1 & 1 & \dots & 1 \\ 0 & \dots & 0 & 0 & \dots & 1 \\ \vdots & 0^* & \vdots & \vdots & \ddots & \vdots \\ 0 & \dots & 0 & 0 & \dots & 0 \end{pmatrix} \end{matrix}.$$

Note that Examples 2.1.6 respectively correspond to the restriction to $\{c_1, \dots, c_n\}$ in the first case, and the restriction to $\{\bar{c}_n, \dots, \bar{c}_1\}$, with $\bar{c}_i \equiv c_{n+1-i}$ in the second case.

Example 2.1.8. Let us consider $\mathcal{C} = \{a, b\}$, and the minimal energy ϵ given by the following energy matrix:

$$M_\epsilon = \begin{matrix} & a & b \\ \begin{matrix} a \\ b \end{matrix} & \begin{pmatrix} 1 & 0 \\ 0 & 1 \end{pmatrix} \end{matrix}.$$

The well-ordered sequences of particles with the same potential have the form

$$\cdots \succ_\epsilon k_a \succ_\epsilon k_b \succ_\epsilon k_a \succ_\epsilon k_b \succ_\epsilon \cdots$$

Degree of the coloring

We now define the notion of degree of the coloring.

Definition 2.1.9. For a fixed set of colors \mathcal{C} , referred to as *primary* colors, we define the set of secondary colors by $\mathcal{C}_2 = \{cc' : c, c' \in \mathcal{C}\}$, and we note that the secondary colors are non-commutative products of two primary colors, i.e $cc' \neq c'c$ for $c \neq c' \in \mathcal{C}$. We extend this definition to degree d for any $d \geq 1$. The set \mathcal{C}_d of colors with degree d is the set of all the non-commutative products of d primary colors. We then have $\mathcal{C}_1 = \mathcal{C}$, and we use the term "secondary" for degree 2. We finally set for any integer $d \geq 1$

$$\langle \mathcal{C} \rangle_d = \bigsqcup_{k=1}^d \mathcal{C}_k \quad (2.1.1)$$

the set of colors of degree at most d , and

$$\langle \mathcal{C} \rangle = \bigsqcup_{k \geq 1} \mathcal{C}_k \quad (2.1.2)$$

the set of all the colors without restriction of the degree. The weighted words method is said to be *at degree d* if it only involves colors with degree at most d , i.e if the set of colors is a subset of $\langle \mathcal{C} \rangle_d$.

Remark 2.1.10. Note that whatever the degree of the weighted words, the color sequence of a non-empty generalized colored partition can always be seen as a finite non-commutative product of primary colors. In the following, we then consider that the color sequence belongs to $\langle \mathcal{C} \rangle$. Conversely, any color in $\langle \mathcal{C} \rangle$ can be seen as the color sequence of a partition equal to a sequence of parts with the corresponding sequence of primary colors.

The first two theorems of this thesis will then have the following formulations.

Theorem 2.1.11. Let \mathcal{C}_1 be a set of primary colors. Then, for some suitable energies ϵ_1 on \mathcal{C}_1 and ϵ_2 on $\mathcal{C}_1 \sqcup \mathcal{C}_2$, there exists a bijection between **a certain** subset of \mathcal{P}_{ϵ_1} and **a certain** subset of \mathcal{P}_{ϵ_2} .

Grounded partitions

As in the subsequent example 2.1.5, all the colored partitions of the theorems of Chapter 1 satisfy some restrictions on the minimal part size. Contrary to these colored partitions, for a given energy ϵ on \mathcal{C} , the generalized colored partitions of \mathcal{P}_ϵ do not have any restriction on last part size. To deal with that problem, we introduce the notion of ground partitions. Let us choose a particular color c_g in \mathcal{C} . We then define the notion of grounded partitions as follows.

Definition 2.1.12. A *grounded partition* with ground c_g and relation \gg is a non-empty generalized colored partition $\pi = (\pi_0, \dots, \pi_s)$ with relation \gg , such that $\pi_s = 0_{c_g}$, and when $s > 0$, $\pi_{s-1} \neq 0_{c_g}$. Let $\mathcal{P}_{c_g}^{\gg}$ denote the set of such partitions.

In the following, we explicitly write $\pi = (\pi_0, \dots, \pi_{s-1}, 0_{c_g})$. The trivial partition in $\mathcal{P}_{c_g}^{\gg}$ is then (0_{c_g}) .

Example 2.1.13. For example, the set of classical partitions is in bijection with the set \mathcal{P}_c of the grounded partitions, with ground $c_g = c$ and relation \gg_ϵ , where $\mathcal{C} = \{c\}$ and the energy ϵ satisfies $\epsilon(c, c) = 0$. The bijection is given by

$$(\pi_1, \dots, \pi_s) \mapsto ((\pi_1)_c, \dots, (\pi_s)_c, 0_c),$$

where the empty partition \emptyset corresponds to the grounded partition (0_c) .

In the following, most of the chosen grounds c_g will satisfy the condition $0_{c_g} \gg 0_{c_g}$. The condition " $\pi_{s-1} \neq 0_{c_g}$ " is then to avoid repeated part 0_{c_g} at the end of the generalized colored partitions. However, in general, especially when the conditions on the minimal part sizes are rather difficult to express in

terms of the colors in \mathcal{C} and an energy ϵ that defines the relation, we add a “fictitious” color c_∞ as the ending color. In that case, we extend the energy ϵ to $\mathcal{C} \cup \{c_\infty\}$ in such a way that $\epsilon(c(\pi_{s-1}), c_\infty)$ is the minimal part size for any color c .

Remark 2.1.14. Note that in the case where the ground is an existing color c_g in \mathcal{C} , we can still replace it by a fictitious color c_∞ satisfying $\epsilon(c, c_g) = \epsilon(c, c_\infty)$ and $\epsilon(c_g, c) = \epsilon(c_\infty, c)$ for all $c \neq c_g$, and $\epsilon(c_g, c_\infty) = \max\{\epsilon(c_g, c_g), 1\}$.

Regularity

Let us now generalize the notion of regularity defined for the m -regular partitions.

Definition 2.1.15 (Regularity in c). Let c be a color in \mathcal{C} . A c -regular partition with ground c_g and relation \gg is a grounded partition $\pi = (\pi_0, \dots, \pi_{s-1}, 0_{c_g})$ with ground c_g and relation \gg , such that $c(\pi_k) \neq c$ for all $k \in \{0, \dots, s-1\}$.

Example 2.1.16. Examples of such partitions are the m -regular partitions. It suffices to consider the set of colors $\mathcal{C} = \{c_0, \dots, c_{m-1}\}$, $c = c_g = c_0$ and define the relation \gg by

$$k_{c_i} \gg l_{c_j} \iff k \geq l \quad \text{and} \quad k - l \equiv i - j \pmod{m},$$

so that, in any regular partition, the size of parts with color c_i is necessarily congruent to i modulo m . We then associate to any m -regular partition $\lambda = (\lambda_1, \dots, \lambda_s)$ the regular partition $\pi = (\pi_0, \dots, \pi_{s-1}, 0_{c_0})$ such that, for all $k \in \{0, \dots, s-1\}$,

$$\pi_k = \lambda_{k+1} \quad \text{and} \quad c(\pi_k) = c_{[\lambda_{k+1}]_m},$$

where $[\lambda_{k+1}]_m = \lambda_{k+1} \pmod{m}$.

In the following, unless otherwise stated, we generally choose $c = c_g$.

Definition 2.1.17. In the case we add a fictitious color c_∞ to define the minimal conditions on part sizes, we then consider the generalized colored partitions c_∞ -regular with ground c_∞ and the extended relation \gg_ϵ . We denote the set of such partitions $\mathcal{P}_\epsilon^{c_\infty}$.

Flatness

We now extend the notion of flatness defined for the m -flat partitions to the grounded partitions.

Definition 2.1.18. A flat partition with ground c_g and energy ϵ is a grounded partition with ground c_g and relation \succ_ϵ defined by

$$k_c \succ_\epsilon l_d \iff k - l = \epsilon(c, d).$$

We call the relation \succ_ϵ the flat difference condition defined by the energy ϵ .

These partitions are determined by their color sequence as well as the energy ϵ . This comes from the fact that for such a partition $\pi = (\pi_0, \dots, \pi_{s-1}, 0_{c_g})$, the computation of the size of π_k gives the following relation:

$$\pi_k = \sum_{l=k}^{s-1} \epsilon(c(\pi_l), c(\pi_{l+1})).$$

Remark 2.1.19. In the case where $\epsilon(c_g, c_g) = 0$, the condition $\pi_{s-1} \neq 0_{c_g}$ on the grounded partitions implies that $c(\pi_{s-1}) \neq c_g$ for any flat partition with ground c_g and energy ϵ .

Example 2.1.20. A good example of flat partitions are the m -flat partitions. It suffices to consider the set of colors $\mathcal{C} = \{c_0, \dots, c_{m-1}\}$, $c_g = c_0$ and define the energy ϵ by

$$\epsilon(c_i, c_j) = \begin{cases} i - j & \text{if } i \geq j \\ m + i - j & \text{if } i < j \end{cases}.$$

With these definitions, for any flat partition, its parts with color c_i necessarily have a size congruent to i modulo m . We also observe that ϵ has values in $\{0, \dots, m-1\}$. We then associate to any m -flat partition $\lambda = (\lambda_1, \dots, \lambda_s)$ the flat partition $\pi = (\pi_0, \dots, \pi_{s-1}, 0_{c_0})$ such that, for all $k \in \{0, \dots, s-1\}$,

$$\pi_k = \lambda_{k+1} \quad \text{and} \quad c(\pi_k) = c_{[\lambda_{k+1}]_m}.$$

Considering the set of colors and the energy ϵ given in Example 2.1.20, by Theorem 1.2.6, there exists a bijection between the corresponding flat partitions with ground c_0 and energy ϵ and the c_0 -regular partitions with ground c_0 and minimal difference condition defined by ϵ , such that the parts with color c_i have sizes congruent to $i \pmod m$. The latter c_0 -regular partitions are those described in Example 2.1.16. Furthermore, the bijection occurs between the partitions of both kinds with a fixed total size and numbers of occurrences of the colors different from the ground c_0 .

In this thesis, we give three theorems having the same formulation.

Theorem 2.1.21 (Duality between flatness and regularity). *Let \mathcal{C} be a set of colors and let $c_g \in \mathcal{C}$ be the ground. Then, for some suitable energies ϵ' and ϵ , there exists a bijection between **a certain** set of flat partitions with ground c_g and energy ϵ and **a certain** set of c -regular partitions with ground c_g and with the minimal difference condition defined by energy ϵ' .*

The duality between flat and regular partitions naturally arises from representation theory via vertex operators and crystal theory. The first theory permits to describe a basis of standard modules as a set of partitions that satisfy minimal difference conditions (Meurman and Primc, 1987), while the $(KMN)^2$ character formula builds a basis of standard modules as a set of partitions satisfying flat difference conditions (see Chapter 8).

Multi-grounded partitions

One of the theorems that we present in this thesis, with the form of Theorem 2.1.21, will allow us to compute the character of certain standard modules using the perfect crystals and the $(KMN)^2$ character formula. However, in general, the partitions that we define for a perfect crystal have conditions on minimal parts which depend not only on one but several colors. To deal with these conditions, we define, in the spirit of the grounded partitions, the notion of the multi-grounded partitions.

Definition 2.1.22. Let \mathcal{C} be a set of colors, $\mathbb{Z}_{\mathcal{C}}$ the set of colored integers, and \gg a binary relation defined on $\mathbb{Z}_{\mathcal{C}}$. Suppose that there exist some colors $c_{g_0}, \dots, c_{g_{t-1}}$ in \mathcal{C} and **unique** colored integers $u_{c_{g_0}}^{(0)}, \dots, u_{c_{g_{t-1}}}^{(t-1)}$ such that

$$u^{(0)} + \dots + u^{(t-1)} = 0, \quad (2.1.3)$$

$$u_{c_{g_0}}^{(0)} \gg u_{c_{g_1}}^{(1)} \gg \dots \gg u_{c_{g_{t-1}}}^{(t-1)} \gg u_{c_{g_0}}^{(0)}. \quad (2.1.4)$$

Then, the multi-grounded partitions with grounds $c_{g_0}, \dots, c_{g_{t-1}}$ and relation \gg are the generalized colored partitions $\pi = (\pi_0, \dots, \pi_{s-1}, u_{c_{g_0}}^{(0)}, \dots, u_{c_{g_{t-1}}}^{(t-1)})$ with relation \gg and such that $(\pi_{s-t}, \dots, \pi_{s-1}) \neq (u_{c_{g_0}}^{(0)}, \dots, u_{c_{g_{t-1}}}^{(t-1)})$ in terms of colored integers.

Example 2.1.23. Let us consider the set of color $\mathcal{C} = \{c_1, c_2, c_3\}$, and the energy matrix

$$M_{\epsilon} = \begin{pmatrix} 2 & 2 & 2 \\ 0 & 0 & 2 \\ -2 & 0 & 2 \end{pmatrix}.$$

If we choose $(g_0, g_1) = (1, 3)$, and we then have the unique pair $(u^{(0)}, u^{(1)}) = (1, -1)$. Therefore, the generalized colored partitions

$$(3_{c_3}, 3_{c_2}, 3_{c_1}, -1_{c_3}, 1_{c_1}, -1_{c_3}), (1_{c_3}, 3_{c_1}, 1_{c_3}, 3_{c_1}, -1_{c_3}, 1_{c_1}, -1_{c_3})$$

are multi-grounded with grounds c_3, c_1 and energy ϵ , while the generalized colored partition

$$(1_{c_1}, -1_{c_3}, 1_{c_1}, -1_{c_3})$$

is not.

In Definition 2.1.22, we note that for fixed grounds $c_{g_0}, \dots, c_{g_{t-1}}$ and colored integers $u_{c_{g_0}}^{(0)}, \dots, u_{c_{g_{t-1}}}^{(t-1)}$, the condition (2.1.4) implies the definition of multi-grounded partitions for any cyclic permutation of $0, \dots, t-1$, with the ground sequences having the form $c_{g_i}, \dots, c_{g_{t-1}}, c_{g_0}, \dots, c_{g_{i-1}}$. This has a direct connection with the notion of *ground state path* defined for the perfect crystals. In particular, using the $(KMN)^2$ character formula, we compute the character of standard modules as generating function of certain multi-grounded partitions.

2.1.2 Generalized colored Frobenius partitions

Following Andrews (Andrews, 1984a), a generalized Frobenius partition is a two-rowed array

$$\begin{pmatrix} \lambda_1 & \lambda_2 & \cdots & \lambda_s \\ \mu_1 & \mu_2 & \cdots & \mu_s \end{pmatrix},$$

where s is a non-negative integer and $\lambda := \lambda_1 + \lambda_2 + \cdots + \lambda_s$ and $\mu := \mu_1 + \mu_2 + \cdots + \mu_s$ are two partitions into s non-negative parts. The Frobenius partitions are then the special cases where λ and μ consist of distinct parts. Frobenius partitions of length s and size $m = s + \sum_{i=1}^s \lambda_i + \sum_{i=1}^s \mu_i$ are in bijection with the partitions of m whose Durfee square (the largest square fitting in the top-left corner of the Ferrers board of the partition) is of side s . A formal expression of the Durfee square's length side for a classical partition $\pi = (\pi_1, \dots, \pi_t)$ is

$$\max\{i \in \{1, \dots, t\} : \pi_i \geq i\}.$$

Example 2.1.24. We give an example for the Ferrers diagram corresponding to the partitions $(10, 9, 6, 4, 3, 2)$

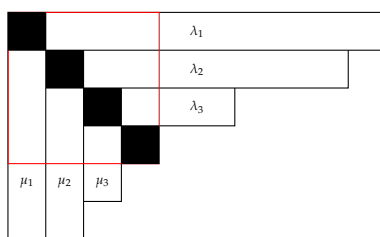

FIGURE 2.1: $s = 4$, $\lambda = (9, 7, 3, 0)$ and $\mu = (5, 4, 2, 0)$.

The bijection through the Durfee square implies the following combinatorial identity:

$$\sum_{s \geq 0} \frac{q^{s^2}}{(q; q)_s^2} = \frac{1}{(q; q)_\infty}. \quad (2.1.5)$$

The generating function for the number $F(m)$ of Frobenius partitions of m is given by

$$\sum_{m \geq 0} F(m)q^m = [x^0](-xq; q)_\infty(-x^{-1}; q)_\infty.$$

Indeed, the product $(-xq; q)_\infty$ generates the partition λ together with the boxes on the diagonal where the power of x counts the number of parts, $(-x^{-1}; q)_\infty$ generates the partition μ where the power of x^{-1} counts the number of parts, and taking the coefficient of x^0 in the above ensures that λ and μ have the same number of parts. Using Jacobi's triple product identity (see, e.g., Andrews, 1984b),

$$(-xq; q)_\infty(-x^{-1}; q)_\infty(q; q)_\infty = \sum_{k \in \mathbb{Z}} x^k q^{\frac{k(k+1)}{2}}, \quad (2.1.6)$$

we see that the generating function for Frobenius partitions equals $1/(q; q)_\infty$, the generating function for partitions.

We now extend the notion of generalized Frobenius partitions to the framework of weighted words. Let \mathcal{C} be a set of colors, and

$$\mathbb{Z}_{\mathcal{C}}^2 = \{(z, z')_c : z, z' \in \mathbb{Z}, c \in \mathcal{C}\}$$

be the set of colored pair of integers.

Definition 2.1.25. Let \gg be a binary relation defined on $\mathbb{Z}_{\mathcal{C}}^2$. A *generalized colored partition* with relation \gg is a finite sequence (π_1, \dots, π_s) of colored integers, where for all $i \in \{1, \dots, s-1\}$, $\pi_i \gg \pi_{i+1}$.

As we defined before for the generalized colored partitions, we set $c(\pi_i) \in \mathcal{C}$ to be the color of the part π_i . By setting $\pi_i = (\lambda_i, \mu_i)$, the quantity $|\pi_i| = \lambda_i + \mu_i$ is called the size of the part π . We then define the size $|\pi|$ of π to be the sum $|\pi_1| + \cdots + |\pi_s|$, and $C(\pi) = c(\pi_1) \cdots c(\pi_s)$ is its color sequence.

Example 2.1.26. Let us set $\mathcal{C} = \{c\}$, and let us consider the relation \gg on \mathbb{Z}_c^2 defined by

$$(k, l)_c \gg (k', l')_c \iff k \geq k' \text{ and } l \geq l'.$$

The map

$$((\lambda_1, \mu_1)_c, \dots, (\lambda_s, \mu_s)_c) \mapsto \begin{pmatrix} \lambda_1 - 1 & \cdots & \lambda_s - 1 \\ \mu_1 & \cdots & \mu_s \end{pmatrix}$$

implies a bijection between the generalized colored Frobenius partitions, whose last part $(\lambda_s, \mu_s)_c$ is well related to $(1, 0)_c$ in terms of \gg , and the generalized Frobenius partitions. Moreover, this bijection preserves the size of the generalized Frobenius partitions.

In the following, we consider the relation $\gg_{\epsilon_1, \epsilon_2}$ defined by two energies ϵ_1 and ϵ_2 on \mathcal{C} as follows:

$$(k, l)_c \gg_{\epsilon_1, \epsilon_2} (k', l')_{c'} \iff \begin{cases} k - k' \geq \epsilon_1(c, c') \text{ and} \\ l - l' \geq \epsilon_2(c, c') \end{cases}. \quad (2.1.7)$$

We then define the set $\mathcal{F}_{\epsilon_1, \epsilon_2}$ of generalized colored Frobenius partition with relation $\gg_{\epsilon_1, \epsilon_2}$. This definition yields to a natural correspondence between $\mathcal{F}_{\epsilon_1, \epsilon_2}$ and the subset of $\mathcal{P}_{\epsilon_1} \times \mathcal{P}_{\epsilon_2}$ of pairs (λ, μ) of generalized colored partitions having the same number of parts.

We finally extend the notion of ground to the generalized colored Frobenius partitions.

Definition 2.1.27. A *grounded Frobenius partition* with ground c_g and relation \gg is a non-empty generalized colored Frobenius partition $\pi = (\pi_0, \dots, \pi_s)$ with relation \gg , such that $\pi_s = (0, 0)_{c_g}$, and when $s > 0$, $\pi_{s-1} \neq (0, 0)_{c_g}$.

In the same way, one can extend the notion of flatness and regularity to the generalized colored Frobenius Partitions, as well as the addition of a fictitious color at the end of the color sequence.

In this thesis, we will present a generalization of the identity (2.1.5) which has the following formulation.

Theorem 2.1.28. Let \mathcal{C} be a set of colors. Then, for some suitable energies ϵ and ϵ_1, ϵ_2 , there exists a bijection between a **certain** set of generalized colored partitions in \mathcal{P}_ϵ and a **certain** set of generalized colored Frobenius partitions in $\mathcal{F}_{\epsilon_1, \epsilon_2}$.

The correspondence between the classical partitions and the Frobenius partitions is the case where $\mathcal{C} = \{c\}$, $\epsilon(c, c) = 0$ with a positive size for the last part, and $\epsilon_1(c, c) = \epsilon_2(c, c) = 1$ with a positive size for the last pair of integer.

2.2 Rogers-Ramanujan type identities via bijective approaches

Throughout history, most of the Rogers-Ramanujan type identities were primarily discovered via the computation of q -series. Then, a combinatorial interpretation of these identities led to an equality between the cardinalities of the corresponding partition sets. A subsequent problem then consisted in building a suitable bijection to link these sets of partitions. However, in general, this still remains a difficult problem to deal with. For example, the Rogers-Ramanujan identities were proved bijectively by Garsia and Milne (Garsia and Milne, 1981) via the involution principle, and their bijection does not establish a direct correspondence between the partitions of the sets involved. A bijective proof without a sign-reversing involution is yet to be found for these identities.

In this thesis we present several identities established via bijections. We start from the identities presented in Chapter 1, formalize via our weighted words the corresponding partitions and then outline the general rules followed by these partitions. These formal rules not only allow us to build an adequate bijection for the original identities, but also allow us to discover identities which generalize them. This process succeeded for the four following identities: Göllnitz' identity, Siladić's identity, Glaisher's identity and Capparelli's identity. A fifth result on a generalization of the duality between partitions and Frobenius partitions is given in this section, but contrary to the four other generalizations, the proof is partially bijective, and the last part of the proof rests on the computation of the generation functions.

2.2.1 Beyond Göllnitz theorem: a generalization of Bressoud's algorithm

In a pair of papers (Konan, 2019a; Konan, 2019b), we gave a result beyond the Göllnitz theorem for an arbitrary number of primary colors.

Refinement and bijective proof of Theorem 1.3.3

In paper one (Konan, 2019a), we showed an equivalent version of Theorem 1.3.3. We supposed that the parts occur in only primary colors a, b, c, d and secondary colors ab, ac, ad, bc, bd, cd , and are ordered as in (1.3.9) by omitting quaternary parts:

$$1_{ab} < 1_{ac} < 1_{ad} < 1_a < 1_{bc} < 1_{bd} < 1_b < 1_{cd} < 1_c < 1_d < 2_{ab} < \dots \quad (2.2.1)$$

We then considered the partitions with the size of the secondary parts greater than one and satisfying the minimal difference conditions in

$\lambda_i \setminus \lambda_{i+1}$	ab	ac	ad	a	bc	bd	b	cd	c	d
ab	2	2	2	2	2	2	2	2	2	2
ac	1	2	2	2	2	2	2	2	2	2
ad	1	1	2	2	1	2	2	2	2	2
a	1	1	1	1	2	2	2	2	2	2
bc	1	1	1	1	2	2	2	2	2	2
bd	1	1	1	1	1	2	2	2	2	2
b	1	1	1	1	1	1	1	2	2	2
cd	0	1	1	1	1	1	1	2	2	2
c	1	1	1	1	1	1	1	1	1	2
d	1	1	1	1	1	1	1	1	1	1

(2.2.2)

and which avoid the forbidden patterns

$$((k+2)_{cd}, (k+2)_{ab}, k_c), ((k+2)_{cd}, (k+2)_{ab}, k_d), ((k+2)_{ad}, (k+1)_{bc}, k_a), \quad (2.2.3)$$

except the pattern $(3_{ad}, 2_{bc}, 1_a)$ which is allowed. We then obtained the following theorem:

Theorem 2.2.1. *Let u, v, w, t, n be non-negative integers. Denote by $A(u, v, w, t, n)$ the number of partitions of n into u distinct parts with color a , v distinct parts with color b , w distinct parts with color c and t distinct parts with color d , and denote by $B(u, v, w, t, n)$ the number of partitions of n satisfying the conditions above, with u parts with color a, ab, ac or ad , v parts with color b, ab, bc or bd , w parts with color c, ac, bc or cd and t parts with color d, ad, bd or cd . We then have $A(u, v, w, t, n) = B(u, v, w, t, n)$, and the corresponding q -series identity is given by*

$$\sum_{u, v, w, t, n \in \mathbb{N}} B(u, v, w, t, n) a^u b^v c^w d^t q^n = (-aq; q)_\infty (-bq; q)_\infty (-cq; q)_\infty (-dq; q)_\infty. \quad (2.2.4)$$

The proof of Theorem 2.2.1 consisted of a bijection established between the two sets of partitions. We also used a second bijection to show that Theorem 2.2.1 is equivalent to Theorem 1.3.3.

By specializing the variables in Theorem 2.2.1, one can deduce many partition identities. For example, by considering the following transformation in (2.2.4)

$$\begin{cases} \text{dilation :} & q \mapsto q^{12} \\ \text{translations :} & a, b, c, d \mapsto q^{-8}, q^{-4}, q^{-2}, q^{-1} \end{cases} \quad (2.2.5)$$

we obtain a corollary of Theorem 2.2.1.

Corollary 2.2.2. *For any positive integer n , the number of partitions of n into distinct parts congruent to $-2^3, -2^2, -2^1, -2^0 \pmod{12}$ is equal to the number of partitions of n into parts not congruent to $1, 5 \pmod{12}$ and different from $2, 3, 6, 7, 9$, such that the difference between two consecutive parts is greater than 12 up to the following exceptions:*

- $\lambda_i - \lambda_{i+1} = 9 \implies \lambda_i \equiv \pm 3 \pmod{12}$ and $\lambda_i - \lambda_{i+2} \geq 24$,
- $\lambda_i - \lambda_{i+1} = 12 \implies \lambda_i \equiv -2^3, -2^2, -2^1, -2^0 \pmod{12}$,

except that the pattern $(27, 18, 4)$ is allowed.

Example 2.2.3. *For example, with $n = 49$, the partitions of the first kind are*

$$(35, 10, 4), (34, 11, 4), (28, 11, 10), (23, 22, 4), \\ (23, 16, 10), (22, 16, 11) \text{ and } (16, 11, 10, 8, 4)$$

and the partitions of the second kind are

$$(35, 14), (34, 15), (33, 16), (45, 4), (39, 10), (38, 11) \text{ and } (27, 18, 4).$$

Generalization to an arbitrary number of primary colors

We now give a general result beyond Göllnitz' theorem, by proving a generalization of Theorem 2.2.1 for an arbitrary finite set of primary colors. Let $\mathcal{C} = \{a_1, \dots, a_n\}$ be an ordered set of primary colors, with $a_1 < \dots < a_n$ and let us set $\mathcal{C}_\times = \{a_i a_j : 1 \leq i < j \leq n\}$. Note that $\mathcal{C}_\times \neq \mathcal{C}_2$ as we do not have color $a_i a_j$ for $i \geq j$.

We can naturally extend the order from \mathcal{C} to $\mathcal{C} \sqcup \mathcal{C}_\times$ with

$$\begin{aligned} a_1 a_2 < \dots < a_1 a_n < a_1 < a_2 a_3 < \dots < a_2 a_n < a_2 < \dots < a_{i-1} \\ < a_i a_{i+1} < \dots < a_i a_n < a_i < \dots < a_{n-1} a_n < a_{n-1} < a_n. \end{aligned} \quad (2.2.6)$$

We also set

$$\mathcal{SP}_\times = \{(a_k a_l, a_i a_j) \in \mathcal{C}_\times^2 : i < j < k < l \text{ or } k < i < j < l\} \quad (2.2.7)$$

to be the set of the *special pairs* of secondary colors. Note that the pairs of \mathcal{SP}_\times use four different primary colors.

Definition 2.2.4. The lexicographic order \succ on the set of colored parts is defined by the following relation:

$$k_p \succ l_q \iff k - l \geq \chi(p \leq q). \quad (2.2.8)$$

Explicitly, this relation implies an order on colored parts

$$1_{a_1 a_2} \prec \dots \prec 1_{a_n} \prec 2_{a_1 a_2} \prec \dots \prec 2_{a_n} \prec 3_{a_1 a_2} \prec \dots \quad (2.2.9)$$

We remark that the relation \succ on $\mathbb{Z}_{\mathcal{C} \sqcup \mathcal{C}_\times}$ is implied by the energy ϵ defined by

$$\epsilon(c, c') = \chi(c \leq c'), \quad (2.2.10)$$

where we consider the order on the colors set in (2.2.6).

Definition 2.2.5. Let \mathcal{P} be the set of the positive parts with primary color, and let \mathcal{S} be the set of the parts with secondary color in \mathcal{C}_\times and size greater than one. We then define two relations \triangleright and \gg on $\mathcal{P} \sqcup \mathcal{S}$ as follows :

$$k_p \triangleright l_q \iff \begin{cases} k_p \succeq (l+1)_q & \text{if } p \text{ or } q \in \mathcal{C} \\ k_p \succ (l+1)_q & \text{if } p \text{ and } q \in \mathcal{C}_\times \end{cases} \quad (2.2.11)$$

and

$$k_p \gg l_q \iff \begin{cases} k_p \succeq (l+1)_q & \text{if } p \text{ or } q \in \mathcal{C} \\ k_p \succ (l+1)_q & \text{if } (p, q) \in \mathcal{C}_\times^2 \setminus \mathcal{SP}_\times \\ k_p \succ l_q & \text{if } (p, q) \in \mathcal{SP}_\times \end{cases} \quad (2.2.12)$$

We observe that the relation \triangleright is the minimal difference condition with respect to the energy ϵ_2 defined by

$$\epsilon_2(c, c') = 1 + \chi(c \leq c') - \chi(c = c' \in \mathcal{C}), \quad (2.2.13)$$

and the relation \gg is related to the energy ϵ_1 defined by

$$\epsilon_1(c, c') = 1 + \chi(c \leq c') - \chi(c = c' \in \mathcal{C}) - \chi((c, c') \in \mathcal{SP}_\times). \quad (2.2.14)$$

Note that $k_p \triangleright l_q$ implies $k_p \gg l_q$. We can easily check that in the case $n = 4$ and $\mathcal{C} = \{a < b < c < d\}$, the energies ϵ_2 and ϵ_1 correspond respectively to the minimal differences $\lambda_i - \lambda_{i+1}$ in (1.3.10) and (2.2.2). We also remark that these differences constitute an exhaustive list of all the minimal differences for our relations, since at most four primary colors occur in any pair of colors in $\mathcal{C} \sqcup \mathcal{C}_\times$.

Definition 2.2.6. A secondary color is just a product of two primary colors. For any type of partition λ , its size $|\lambda|$ is the sum of its part sizes.

1. We denote by \mathcal{O} the set of generalized colored partitions with parts in \mathcal{P} and relation by \succ . We recall that $c(\lambda_i)$ in \mathcal{C} is the color of λ_i , and the color sequence is $C(\lambda) = c(\lambda_1) \cdots c(\lambda_t)$, here viewed as a **commutative** product of primary colors in \mathcal{C} .

2. We denote by \mathcal{E} the set of generalized colored partitions with parts in $\mathcal{P} \sqcup \mathcal{S}$ and relation \gg defined in (2.2.12). We then have the colors $c(v_i) \in \mathcal{C} \sqcup \mathcal{C}_\times$ depending on whether v_i is in \mathcal{P} or \mathcal{S} , and we view the color sequence $C(v) = c(v_1) \cdots c(v_i)$ as a **commutative** product of colors in \mathcal{C} .
3. We finally denote by \mathcal{E}_2 the subset of partitions of \mathcal{E} with relation \triangleright .

We can now state the first theorem that stand for the basement of our result beyond Göllnitz' theorem.

Theorem 2.2.7. *Let m be a non-negative integer and C a commutative product of primary colors in \mathcal{C} . Denote by $U(C, m)$ the number of partitions λ in \mathcal{O} with $(C(\lambda), |\lambda|) = (C, m)$, and denote by $V(C, m)$ the number of partitions v in \mathcal{E} with $(C(v), |v|) = (C, m)$. We then have the following inequality :*

$$U(C, m) \leq V(C, m). \quad (2.2.15)$$

The previous theorem implies that \mathcal{O} can be associated to a set \mathcal{E}_1 such that $\mathcal{E}_1 \subset \mathcal{E}$. We define this set \mathcal{E}_1 using two technical tools : the **different-distance** and the **bridge**. The definition of the different-distance is stated here, while the definition of the bridge, which is more intricate, will be given in 3.

Definition 2.2.8. Let $\lambda = (\lambda_1, \dots, \lambda_s)$ be a sequence, where the elements λ_i belong to a set of colored numbers ordered by a relation \succeq , and let d be a positive number. For any $i, j \in \{1, \dots, s\}$, we say that λ_i is d -different-distant from λ_j if we have the following relation:

$$\lambda_i \succeq \lambda_j + d(j - i). \quad (2.2.16)$$

Note that the relation "being d -different-distant from" is transitive, as λ_i is d -different-distant from λ_j and λ_j is d -different-distant from λ_k implies that λ_i is d -different-distant from λ_k .

A good example of a partition having such a property is a partition $v = (v_1, \dots, v_s) \in \mathcal{E}_2$. In fact, by (2.2.11), we recursively obtain for any $i \leq j \in \{1, \dots, s\}$ that v_i is 1-different-distant from v_j . This is not true in general when $v \in \mathcal{E}$, as by (2.2.11) and (2.2.12), a part v_i not well-ordered with v_{i+1} in terms of \triangleright is also not 1-different-distant from v_{i+1} .

The generalization of Theorem 2.2.1 can be stated as follows.

Theorem 2.2.9. *Let \mathcal{E}_1 be the set of partitions $v = (v_1, \dots, v_s) \in \mathcal{E}$ such that, for all $i \in \{1, \dots, s - 1\}$ with*

$$v_{i-1} \triangleright v_i \not\triangleright v_{i+1}, \quad (2.2.17)$$

*the part v_i is 1-different-distant from its **bridge**. Then, for any non-negative integer m and any commutative product of primary colors C in \mathcal{C} , by setting $U(C, m)$ as before in Theorem 2.2.7, and by setting $W(C, m)$ to be the number of partitions v in \mathcal{E}_1 with $(C(v), |v|) = (C, m)$, we then have that $U(C, m) = W(C, m)$ and the identity*

$$\sum_{m, \mu_1, \dots, \mu_n \geq 0} W\left(\prod_{i=1}^n a_i^{\mu_i}, m\right) \prod_{i=1}^n a_i^{\mu_i} q^{\mu_i} = \sum_{m, \mu_1, \dots, \mu_n \geq 0} U\left(\prod_{i=1}^n a_i^{\mu_i}, m\right) \prod_{i=1}^n a_i^{\mu_i} q^{\mu_i} = (-a_1 q; q)_\infty \cdots (-a_n q; q)_\infty. \quad (2.2.18)$$

Another identity, discovered by Corteel and Lovejoy, 2006, relates the same set of partitions, with primary colored parts, to a set of partitions with parts having some colors as products of at most n different primary colors, giving $2^n - 1$ colors in total.

Note that by definition, a partition in \mathcal{E}_2 never satisfies (2.2.17), so that the definition of \mathcal{E}_1 still holds for this partition. We thus have $\mathcal{E}_2 \subset \mathcal{E}_1 \subset \mathcal{E}$. We also remark that \mathcal{SP}_\times is empty for \mathcal{C} with fewer than four primary colors, so that in that case, $\mathcal{E}_2 = \mathcal{E}$. Therefore, Theorem 2.2.9 implies the Alladi-Andrews-Gordon refinement of Göllnitz' identity. For $n \geq 4$, the set \mathcal{E}_1 can be seen as a subset of \mathcal{E} that avoids some patterns. When $n = 4$, we show that the forbidden patterns are the ones described in Theorem 2.2.1. For $n > 4$, the enumeration of forbidden patterns becomes more intricate. Chapter 3 is dedicated to the discussion on the result beyond Göllnitz' theorem.

2.2.2 Beyond Siladić's theorem: weighted words in the framework of statistical mechanics

In papers (Konan, 2020a; Konan, 2020b), we gave a result beyond the Dousse refinement of Siladić's theorem for an arbitrary number of primary colors. In this section, we view the weighted words in the framework of statistical mechanics.

Integer partitions in statistical mechanics

The connection between integer partitions and physics was first pointed out by Bohr and Kalckar (Bohr and Kalckar, 1937). In the same year, Van Lier and Uhlenbeck noted links between the problem of counting microstates of the systems obeying Bose or Fermi statistics and some problems related to integer partitions (Lier and Uhlenbeck, 1937).

Since then, a current approach in statistical mechanics consists in considering a partition of a given integer into parts with certain restrictions as a sharing of a fixed amount of energy among the different possible states of an assembly. This approach can be found in the seminal works of Auluck and Kothari (Auluck and Kothari, 1946), Temperley (Temperley, 1949) and Nanda (Nanda, 1951).

We now refer to the colors as *states*, and the sizes of parts as *potentials*. The main goal will consist in using a new variant of Bressoud's algorithm as a process in which we operate energy transfers according to the states involved in the generalized colored partition. Recall that the allowable differences between the potentials of consecutive particles in Siladić's identity are defined by a certain energy. By taking a larger family of allowable energies, we generate an infinite family of identities generalizing the Siladić theorem for a arbitrary number of primary states.

Let \mathcal{C} be a set of states, countable or not, and let $\mathcal{P} = \mathbb{Z}_{\mathcal{C}}$ be the corresponding set of particles. We recall that the *energetic particle* k_c is identified by its potential k and its state c . In the remainder of this section, such a particle is called a *primary* particle. We consider a relation \succ_{ϵ} on $\mathbb{Z}_{\mathcal{C}}$ related to a minimal energy, and we recall that \mathcal{O}_{ϵ} is the set of generalized colored partitions with relation \succ_{ϵ} . Here, we recall that

$$k_p \succ_{\epsilon} l_q \implies k - l \geq \epsilon(p, q). \quad (2.2.19)$$

The sequence of colors is now referred to as the *State* of the partition.

Suitable secondary particles and generalization of Dousse's refinement

We recall that a secondary state is the product of two primary states. The key idea is to build secondary particles starting from the primary particles. The following definition permits a suitable construction for these secondary particles.

Definition 2.2.10. We define the *secondary particles* as sums of two consecutive primary particles in terms of \succ_{ϵ} . We denote by $\mathcal{S} = \mathbb{Z} \times \mathcal{C}^2$ the set of secondary particles, in such a way that the particle

$$(k, c, c') = (k + \epsilon(c, c'), c) + (k, c') \quad (2.2.20)$$

has potential $2k + \epsilon(c, c')$ and state cc' . In fact, $(k + \epsilon(c, c'), c)$ is exactly the primary particle of state c with smallest potential, which is well-related to (k, c') in terms of \succ_{ϵ} . We then set the functions γ and μ on \mathcal{S} , defined by

$$\gamma(k, c, c') = (k + \epsilon(c, c'), c) \text{ and } \mu(k, c, c') = (k, c'), \quad (2.2.21)$$

to be respectively the *upper* and *lower* halves of (k, c, c') . In the following, we identify a secondary particle as (k, c, c') or $(2k + \epsilon(c, c'))_{cc'}$.

Example 2.2.11. Let us take $\mathcal{C} = \{a, \bar{a}\}$ in Example 2.1.7. We then have

$$\begin{array}{cc} \bar{a} & a \\ \bar{a} & \begin{pmatrix} 1 & 1 \\ 0 & 0 \end{pmatrix} \\ a & \end{array}$$

and we obtain with Definition 2.2.10 and (2.2.35) the following secondary particles:

$$\begin{cases} (k, a, a) = 2k_{a^2}, \\ (k, a, \bar{a}) = 2k_{\bar{a}\bar{a}} \equiv \overline{2k}_{a^2}, \\ (k, \bar{a}, a) = 2k + 1_{\bar{a}a} \equiv \overline{2k + 1}_{a^2}, \\ (k, \bar{a}, \bar{a}) = 2k + 1_{\bar{a}^2} \equiv \overline{2k + 1}_{\bar{a}^2}. \end{cases}$$

We now build a relation on the set $\mathcal{P} \sqcup \mathcal{S}$ of primary and secondary particles.

Definition 2.2.12. We define the relation \gg_{ϵ} on $\mathcal{P} \sqcup \mathcal{S}$ as follows:

1. Two primary particles of \mathcal{P} are well-ordered by \gg_ϵ if and only if they are well-ordered but not consecutive in terms of \succ_ϵ :

$$(k, c) \gg_\epsilon (k', c') \iff k - k' > \epsilon(c, c'). \quad (2.2.22)$$

2. A primary particle of \mathcal{P} is well-ordered with a secondary particle of \mathcal{S} if and only if their potentials' difference is at least equal to the energy of transfer from the first to the last primary states:

$$(k, c) \gg_\epsilon (k', c', c'') \iff k - (2k' + \epsilon(c', c'')) \geq \epsilon(c, c') + \epsilon(c', c''). \quad (2.2.23)$$

3. A secondary particle of \mathcal{S} is well-ordered with a primary particle of \mathcal{P} if and only if their potentials' difference is greater than the transfer energy (from first to last state):

$$(k, c, c') \gg_\epsilon (k', c'') \iff (2k + \epsilon(c, c')) - k' > \epsilon(c, c') + \epsilon(c', c''). \quad (2.2.24)$$

4. Two secondary particles of \mathcal{S} are well-ordered by \gg_ϵ if and only if the lower half of the first one is greater than the upper half of the second in terms of \succ_ϵ :

$$(k, c, c') \gg_\epsilon (k', c'', c''') \iff \mu(k, c, c') \succ_\epsilon \gamma(k', c'', c'''). \quad (2.2.25)$$

This is equivalent to saying that the potentials' difference $k - k'$ is at least equal to the energy of transfer $\epsilon(c', c'') + \epsilon(c'', c''')$.

One can check that for $C' = \{a < b\}$ and the minimal energy ϵ described in Example 2.1.7, the relations in the latter definition exactly give the minimal difference conditions presented in (2.2.34).

Remark 2.2.13. We notice that

$$(k, c) \succ_\epsilon (k', c') \text{ and } (k, c) \not\gg_\epsilon (k', c') \iff k - k' = \epsilon(c, c'). \quad (2.2.26)$$

Such pair of primary particles is called a troublesome pair.

Definition 2.2.14. We define \mathcal{O}_ϵ (respectively \mathcal{E}_ϵ) to be the set of all generalized colored partitions with particles in \mathcal{P} (respectively $\mathcal{P} \sqcup \mathcal{S}$) and relation \succ_ϵ (respectively \gg_ϵ).

For $\rho \in \{0, 1\}$, we consider the following sets:

- $\mathcal{P}^{\rho+} = \mathbb{Z}_{\geq \rho} \times \mathcal{C}$ and $\mathcal{S}^{\rho+} = \mathbb{Z}_{\geq \rho} \times \mathcal{C}^2 = \{(k, c, c') \in \mathcal{S} : k \geq \rho\}$,
- $\mathcal{P}^{\rho-} = \mathbb{Z}_{\leq \rho} \times \mathcal{C}$ and $\mathcal{S}^{\rho-} = \{(k, c, c') \in \mathcal{S} : k + \epsilon(c, c') \leq \rho\}$.

We then denote by $\mathcal{O}_\epsilon^{\rho+}$ (respectively $\mathcal{O}_\epsilon^{\rho-}$) the subset of \mathcal{O}_ϵ of generalized colored partitions with particles in $\mathcal{P}^{\rho+}$ (respectively $\mathcal{P}^{\rho-}$), and by $\mathcal{E}_\epsilon^{\rho+}$ (respectively $\mathcal{E}_\epsilon^{\rho-}$) the subset of \mathcal{E}_ϵ of generalized colored partitions with particles in $\mathcal{P}^{\rho+} \sqcup \mathcal{S}^{\rho+}$ (respectively $\mathcal{P}^{\rho-} \sqcup \mathcal{S}^{\rho-}$).

Since the secondary states are products of two primary states, the States of partitions in \mathcal{O}_ϵ and \mathcal{E}_ϵ are then seen as a finite *non-commutative* product of primary states in \mathcal{C} .

We now state the main result of this part.

Theorem 2.2.15. For any integer n and any State C as a finite non-commutative product of states in \mathcal{C} , there exists a bijection between $\{\lambda \in \mathcal{O}_\epsilon : (C(\lambda), |\lambda|) = (C, n)\}$ and $\{v \in \mathcal{E}_\epsilon : (C(v), |v|) = (C, n)\}$. In particular, for $\rho \in \{0, 1\}$, we have the identities

$$|\{v \in \mathcal{E}_\epsilon^{\rho+} : (C(v), |v|) = (C, n)\}| = |\{\lambda \in \mathcal{O}_\epsilon^{\rho+} : (C(\lambda), |\lambda|) = (C, n)\}|, \quad (2.2.27)$$

$$|\{v \in \mathcal{E}_\epsilon^{\rho-} : (C(v), |v|) = (C, n)\}| = |\{\lambda \in \mathcal{O}_\epsilon^{\rho-} : (C(\lambda), |\lambda|) = (C, n)\}|. \quad (2.2.28)$$

One can observe that, for any integer n and any State C with at least two primary states, the sets $\{\lambda \in \mathcal{O}_\epsilon : (C(\lambda), |\lambda|) = (C, n)\}$ and $\{v \in \mathcal{E}_\epsilon : (C(v), |v|) = (C, n)\}$ are infinite. However, as soon as we give an upper or a lower bound on the particles' potentials, the corresponding subsets are finite.

Example 2.2.16. Let us consider $C' = \{a < b\}$ in Example 2.1.7 and the corresponding minimal energy. We then have for $n = 10$ and $C = \bar{b}a\bar{b}a$ the relation $\{\lambda \in \mathcal{O}_\epsilon^{1-} : (C(\lambda), |\lambda|) = (\bar{b}a\bar{b}a, 10)\} = \{\lambda \in \mathcal{E}_\epsilon^{1-} :$

$(C(\lambda), |\lambda|) = (\bar{b}\bar{a}b\bar{a}, 10) \} = \emptyset$ and the corresponding partitions for ρ_+ are given in the following table:

$\mathcal{O}_\epsilon^{0+}$	$\mathcal{O}_\epsilon^{1+}$	$\mathcal{E}_\epsilon^{0+}$	$\mathcal{E}_\epsilon^{1+}$
$(9_{\bar{b}}, 1_{\bar{a}}, 0_b, 0_a)$		$(9_{\bar{b}}, 1_{\bar{a}}, 0_{ba})$	
$(8_{\bar{b}}, 2_{\bar{a}}, 0_b, 0_a)$		$(8_{\bar{b}}, 2_{\bar{a}}, 0_{ba})$	
$(7_{\bar{b}}, 3_{\bar{a}}, 0_b, 0_a)$		$(7_{\bar{b}}, 3_{\bar{a}}, 0_{ba})$	
$(7_{\bar{b}}, 2_{\bar{a}}, 1_b, 0_a)$		$(7_{\bar{b}}, 3_{\bar{a}b}, 0_a)$	
$(6_{\bar{b}}, 4_{\bar{a}}, 0_b, 0_a)$		$(6_{\bar{b}}, 4_{\bar{a}}, 0_{ba})$	
$(6_{\bar{b}}, 3_{\bar{a}}, 1_b, 0_a)$		$(6_{\bar{b}}, 3_{\bar{a}}, 1_b, 0_a)$	
$(6_{\bar{b}}, 2_{\bar{a}}, 1_b, 1_a)$	$(6_{\bar{b}}, 2_{\bar{a}}, 1_b, 1_a)$	$(6_{\bar{b}}, 3_{\bar{a}b}, 1_a)$	$(6_{\bar{b}}, 3_{\bar{a}b}, 1_a)$
$(5_{\bar{b}}, 4_{\bar{a}}, 1_b, 0_a)$		$(9_{\bar{b}\bar{a}}, 1_b, 0_a)$	
$(5_{\bar{b}}, 3_{\bar{a}}, 2_b, 0_a)$		$(7_{\bar{b}\bar{a}}, 3_b, 0_a)$	
$(5_{\bar{b}}, 3_{\bar{a}}, 1_b, 1_a)$	$(5_{\bar{b}}, 3_{\bar{a}}, 1_b, 1_a)$	$(5_{\bar{b}}, 3_{\bar{a}}, 2_{ba})$	$(5_{\bar{b}}, 3_{\bar{a}}, 2_{ba})$
$(4_{\bar{b}}, 3_{\bar{a}}, 2_b, 1_a)$	$(4_{\bar{b}}, 3_{\bar{a}}, 2_b, 1_a)$	$(7_{\bar{b}\bar{a}}, 2_b, 1_a)$	$(7_{\bar{b}\bar{a}}, 2_b, 1_a)$

We have for $n = -8$ and $C = \bar{b}\bar{a}b\bar{a}$ the relation $\{\lambda \in \mathcal{O}_\epsilon^{0+} : (C(\lambda), |\lambda|) = (\bar{b}\bar{a}b\bar{a}, -8)\} = \{\lambda \in \mathcal{E}_\epsilon^{0+} : (C(\lambda), |\lambda|) = (\bar{b}\bar{a}b\bar{a}, -8)\} = \emptyset$ and the corresponding partitions for ρ_- are given in the following table:

$\mathcal{O}_\epsilon^{1-}$	$\mathcal{O}_\epsilon^{0-}$	$\mathcal{E}_\epsilon^{1-}$	$\mathcal{E}_\epsilon^{0-}$
$(1_{\bar{b}}, 0_{\bar{a}}, -1_b, -8_a)$		$(1_{\bar{b}}, -1_{\bar{a}b}, -8_a)$	
$(1_{\bar{b}}, 0_{\bar{a}}, -2_b, -7_a)$		$(1_{\bar{b}\bar{a}}, -2_b, -7_a)$	
$(1_{\bar{b}}, 0_{\bar{a}}, -3_b, -6_a)$		$(1_{\bar{b}\bar{a}}, -3_b, -6_a)$	
$(1_{\bar{b}}, -1_{\bar{a}}, -2_b, -6_a)$		$(1_{\bar{b}}, -3_{\bar{a}b}, -8_a)$	
$(1_{\bar{b}}, 0_{\bar{a}}, -4_b, -5_a)$		$(1_{\bar{b}\bar{a}}, -4_b, -5_a)$	
$(1_{\bar{b}}, -1_{\bar{a}}, -3_b, -5_a)$		$(1_{\bar{b}}, -1_{\bar{a}}, -3_b, -5_a)$	
$(0_{\bar{b}}, -1_{\bar{a}}, -2_b, -5_a)$	$(0_{\bar{b}}, -1_{\bar{a}}, -2_b, -5_a)$	$(0_{\bar{b}}, -3_{\bar{a}b}, -5_a)$	$(0_{\bar{b}}, -3_{\bar{a}b}, -5_a)$
$(1_{\bar{b}}, -1_{\bar{a}}, -4_b, -4_a)$		$(1_{\bar{b}}, -1_{\bar{a}}, -8_{ba})$	
$(1_{\bar{b}}, -2_{\bar{a}}, -3_b, -4_a)$		$(1_{\bar{b}}, -3_{\bar{a}}, -6_{ba})$	
$(0_{\bar{b}}, -1_{\bar{a}}, -3_b, -4_a)$	$(0_{\bar{b}}, -1_{\bar{a}}, -3_b, -4_a)$	$(-1_{\bar{b}}, -3_{\bar{a}}, -4_{ba})$	$(-1_{\bar{b}}, -3_{\bar{a}}, -4_{ba})$
$(0_{\bar{b}}, -2_{\bar{a}}, -3_b, -3_a)$	$(0_{\bar{b}}, -2_{\bar{a}}, -3_b, -3_a)$	$(0_{\bar{b}}, -2_{\bar{a}}, -6_{ba})$	$(0_{\bar{b}}, -2_{\bar{a}}, -6_{ba})$

We obtain the following corollary of Theorem 2.2.15.

Corollary 2.2.17. For any set \mathcal{C} of primary states and any minimal energy ϵ on \mathcal{C}^2 , we have

$$\sum_{\substack{n \geq 0 \\ C \in \langle \mathcal{C} \rangle}} |\{v \in \mathcal{E}_\epsilon^{0+} : (C(v), |v|) = (C, n)\}| \underline{C} q^n = \sum_{\substack{n \geq 0 \\ C \in \langle \mathcal{C} \rangle}} |\{\lambda \in \mathcal{O}_\epsilon^{0+} : (C(\lambda), |\lambda|) = (C, n)\}| \underline{C} q^n = \prod_{m \geq 0} F_C(\epsilon; q^m) \quad (2.2.29)$$

where $\langle \mathcal{C} \rangle$ is the non-commutative group generated by the primary states of \mathcal{C} , and $F_C(\epsilon, x)$ is a series in the commutative algebra $\mathbb{Z}[[C, x]]$, and \underline{C} is the commutative product corresponding to C in $\mathbb{Z}[[C, x]]$. In particular, we have the following explicit expressions for $F_C(\epsilon, x)$:

1. For $\mathcal{C} = \{c_1, \dots, c_n\}$, we have

$\epsilon(c_i, c_j)$	$F_C(\epsilon, x)$
0	$\frac{1}{1 - (c_1 + \dots + c_n)x}$
1	$\frac{1}{1 + (c_1 + \dots + c_n)x}$
$\chi(i \neq j)$	$1 + \sum_{i=1}^n \frac{c_i x}{1 - c_i x}$
$\chi(i < j)$	$\prod_{i=1}^n \frac{1}{1 - c_i x}$
$\chi(i \leq j)$	$\prod_{i=1}^n (1 + c_i x)$

(2.2.30)

2. For $\mathcal{C}' = \{c_1, \dots, c_n\}$ and ϵ as described in Example 2.1.7,

$$F_C(\epsilon, x) = \prod_{i=1}^n \frac{1 + \bar{c}_i x}{1 - c_i x}. \quad (2.2.31)$$

3. For $\mathcal{C} = \{a, b\}$ and ϵ as described in Example 2.1.8,

$$F_{\mathcal{C}}(\epsilon, x) = \frac{(1+ax)(1+bx)}{(1-abx^2)}. \quad (2.2.32)$$

Application to overpartitions

We now give an example that will generalize Siladić's theorem to overpartitions. Recall that an overpartition is a partition where we can over-line at most one occurrence of each positive integer (Cortee and Lovejoy, 2004). It has been a recurrent problem in partition theory to extend some partition identities to overpartitions (Dousse, 2014; Dousse, 2017a; Lovejoy, 2003; Lovejoy, 2004).

Consider the set of colors $\mathcal{C} = \{\bar{b} < \bar{a} < a < b\}$ and the relation \succ_{ϵ} defined by the minimal difference conditions in the following energy matrix

$$D := \begin{matrix} & \bar{b} & \bar{a} & a & b \\ \begin{matrix} \bar{b} \\ \bar{a} \\ a \\ b \end{matrix} & \begin{pmatrix} 1 & 1 & 1 & 1 \\ 0 & 1 & 1 & 1 \\ 0 & 0 & 0 & 1 \\ 0 & 0 & 0 & 0 \end{pmatrix} \end{matrix}. \quad (2.2.33)$$

These differences correspond to the energy of Example 2.1.7 for $(c_1, c_2) = (a, b)$. They imply that a partition in \mathcal{O}_{ϵ} can have any number of primary particles with a fixed potential and a non over-lined state, while there is at most one primary particle with a fixed potential and an over-lined state. The partitions of \mathcal{O}_{ϵ} are then identified as the *generalized overpartitions* whose definition is given by the following.

Definition 2.2.18. Let us fix a set of states \mathcal{C} . A generalized overpartition is a generalized partition where we are allowed to over-line at most one particle with a fixed potential and state.

Example 2.2.19. The generalized partition $(1_a, 1_{\bar{a}}, 1_{\bar{b}}, 0_b, 0_b, 0_a, 0_a, 0_{\bar{a}}, 0_{\bar{b}}, -1_b, -1_{\bar{a}})$ belongs to \mathcal{O} , and corresponds to the generalized overpartition $(1_a, \bar{1}_a, \bar{1}_b, 0_b, 0_b, 0_a, 0_a, \bar{0}_a, \bar{0}_b, -1_b, \bar{-1}_a)$.

We then call the partitions in \mathcal{O}_{ϵ} the colored overpartitions, and this means that we can have any number of particles with a fixed potential and state, with at most one such particle over-lined. We observe that once a particle is over-lined, by the difference conditions in D , it no longer has the same order with respect to the other particles. For example, we have $1_b \succ 1_a$ but $\bar{1}_b \prec 1_a$. This is different from the usual convention, but the way we defined these relative orders plays a major role in the definition of the corresponding secondary particles.

The relation \gg_{ϵ} then corresponds the minimal difference conditions in the following table

$$D' := \begin{matrix} & \bar{b} & \bar{a} & a & b & \bar{b}^2 & \bar{b}\bar{a} & \bar{b}a & \bar{b}b & \bar{a}\bar{b} & \bar{a}^2 & \bar{a}a & \bar{a}b & a\bar{b} & a\bar{a} & a^2 & ab & \bar{b}\bar{b} & \bar{b}\bar{a} & \bar{b}a & b^2 \\ \begin{matrix} \bar{b} \\ \bar{a} \\ a \\ b \\ \bar{b}\bar{b} \\ \bar{b}\bar{a} \\ \bar{b}a \\ \bar{b}b \\ \bar{a}\bar{b} \\ \bar{a}^2 \\ \bar{a}a \\ \bar{a}b \\ a\bar{b} \\ a\bar{a} \\ a^2 \\ ab \\ \bar{b}\bar{b} \\ \bar{b}\bar{a} \\ \bar{b}a \\ b^2 \end{matrix} & \begin{pmatrix} 2 & 2 & 2 & 2 & 2 & 2 & 2 & 2 & 1 & 2 & 2 & 2 & 1 & 1 & 1 & 1 & 1 & 1 & 1 & 1 & 1 \\ 1 & 2 & 2 & 2 & 1 & 1 & 1 & 1 & 1 & 2 & 2 & 2 & 1 & 1 & 1 & 1 & 2 & 1 & 1 & 1 & 1 \\ 1 & 1 & 1 & 2 & 1 & 1 & 1 & 1 & 0 & 1 & 1 & 1 & 0 & 0 & 0 & 1 & 1 & 1 & 1 & 1 & 1 \\ 1 & 1 & 1 & 1 & 1 & 1 & 1 & 1 & 0 & 1 & 1 & 1 & 0 & 0 & 0 & 1 & 0 & 0 & 0 & 0 & 0 \\ 3 & 3 & 3 & 3 & 4 & 4 & 4 & 4 & 3 & 4 & 4 & 4 & 3 & 3 & 3 & 4 & 3 & 3 & 3 & 3 & 3 \\ 2 & 3 & 3 & 3 & 2 & 2 & 2 & 2 & 3 & 4 & 4 & 4 & 3 & 3 & 3 & 4 & 3 & 3 & 3 & 3 & 3 \\ 2 & 2 & 2 & 3 & 2 & 2 & 2 & 2 & 1 & 2 & 2 & 2 & 1 & 1 & 1 & 2 & 3 & 3 & 3 & 3 & 3 \\ 2 & 2 & 2 & 2 & 2 & 2 & 2 & 2 & 1 & 2 & 2 & 2 & 1 & 1 & 1 & 2 & 1 & 1 & 1 & 1 & 1 \\ 1 & 1 & 1 & 1 & 3 & 3 & 3 & 3 & 2 & 3 & 3 & 3 & 2 & 2 & 2 & 3 & 2 & 2 & 2 & 2 & 2 \\ 1 & 2 & 2 & 2 & 1 & 1 & 1 & 1 & 2 & 3 & 3 & 3 & 2 & 2 & 2 & 3 & 2 & 2 & 2 & 2 & 2 \\ 1 & 1 & 1 & 2 & 1 & 1 & 1 & 1 & 0 & 1 & 1 & 1 & 0 & 0 & 0 & 1 & 2 & 2 & 2 & 2 & 2 \\ 2 & 2 & 2 & 2 & 2 & 2 & 2 & 2 & 1 & 2 & 2 & 2 & 1 & 1 & 1 & 2 & 1 & 1 & 1 & 1 & 1 \\ 1 & 1 & 1 & 1 & 3 & 3 & 3 & 3 & 2 & 3 & 3 & 3 & 2 & 2 & 2 & 3 & 2 & 2 & 2 & 2 & 2 \\ 1 & 2 & 2 & 2 & 1 & 1 & 1 & 1 & 2 & 3 & 3 & 3 & 2 & 2 & 2 & 3 & 2 & 2 & 2 & 2 & 2 \\ 1 & 1 & 1 & 2 & 1 & 1 & 1 & 1 & 0 & 1 & 1 & 1 & 0 & 0 & 0 & 1 & 2 & 2 & 2 & 2 & 2 \\ 1 & 1 & 1 & 1 & 1 & 1 & 1 & 1 & 0 & 1 & 1 & 1 & 0 & 0 & 0 & 1 & 0 & 0 & 0 & 0 & 0 \end{pmatrix} \end{matrix}. \quad (2.2.34)$$

By definition, the secondary particles with state cc' then have a potential with the same parity as the entry of D corresponding to the row c and the column c' . Therefore, we have the following correspondence

for secondary states:

$$\begin{matrix} \bar{b} & \bar{a} & a & b \\ \bar{b} & \begin{pmatrix} b_{odd}^2 & ba_{odd} & \bar{b}a_{odd} & \bar{b}_{odd}^2 \\ ab_{even} & a_{odd}^2 & \bar{a}_{odd}^2 & \bar{a}b_{odd} \\ \bar{a}b_{even} & \bar{a}_{even}^2 & a_{even}^2 & ab_{odd} \\ \bar{b}_{even}^2 & \bar{b}a_{even} & ba_{even} & b_{even}^2 \end{pmatrix} & \end{matrix}, \quad (2.2.35)$$

where c_{parity} refers to a particle with state c and potential with the same parity as the index. Here again, the generalized partitions in \mathcal{E}_ϵ can be identified as some generalized overpartitions for the set of colors $\{a, b, a^2, ab, ba, b^2\}$. We now state the corresponding corollary of Theorem 2.2.15. To simplify the formulation of the corollary, we assume that the symbols a, b and c commute in the generating functions.

Corollary 2.2.20. *Let u, v, w and n be non-negative integers. Let us denote by $A(n; u, v, w)$ the number of colored overpartitions of size n with positive potentials and colors in $\{a, b\}$, with u particles with color a , v particles with color b and w over-lined particles. Let us denote by $B(n; u, v, w)$ the number of colored overpartitions of size n with colors in $\{a, b, a^2, ab, ba, b^2\}$, with positive potential for the primary particles and potential greater than one for the secondary particles, satisfying the minimal difference conditions given D' , with u occurrences of the symbol a , v occurrences of the symbol b , and such that w equals the number of over-lined particles plus twice the number of even particles with color ab and odd particles with color a^2, ba or b^2 . We then have $A(n; u, v, w) = B(n; u, v, w)$ and the identity*

$$\sum_{n,u,v,w \geq 0} B(n; u, v, w) a^u b^v c^w d^{u+v-w} q^n = \sum_{n,u,v,w \geq 0} A(n; u, v, w) a^u b^v c^w d^{u+v-w} q^n = \frac{(-acq; q)_\infty (-bcq; q)_\infty}{(adq; q)_\infty (bdq; q)_\infty}. \quad (2.2.36)$$

In the previous corollary, if we restrict the partitions in \mathcal{O}_ϵ to those with only over-lined particles, i.e $u + v = w$, and by applying the transformations $(q, a, b, c, d) \mapsto (q^4, q^{-1}, q^{-3}, 1, 0)$, we recover the identity given by Siladić and corresponding to Theorem 1.3.4.

On the other hand, by restricting the partitions in \mathcal{O}_ϵ to those with only non over-lined particles, i.e $w = 0$, and by applying the transformations $(q, a, b, c, d) \mapsto (q^4, q^{-3}, q^{-1}, 0, 1)$, we obtain the following analogue of Siladić's theorem.

Theorem 2.2.21. *The number of partitions $\lambda_1 + \dots + \lambda_s$ of an integer n into odd parts is equal to the number of partitions of n such that*

$$\begin{aligned} \lambda_i - \lambda_{i+1} = 0 &\Rightarrow \lambda_i + \lambda_{i+1} \equiv \pm 4 \pmod{16}, \\ \lambda_i - \lambda_{i+1} = 1 &\Rightarrow \lambda_i + \lambda_{i+1} \equiv \pm 3 \pmod{16}, \\ \lambda_i - \lambda_{i+1} = 2 &\Rightarrow \lambda_i + \lambda_{i+1} \equiv \pm 2, \pm 6 \pmod{16}, \\ \lambda_i - \lambda_{i+1} = 3 &\Rightarrow \lambda_i + \lambda_{i+1} \equiv \pm 1, \pm 5, \pm 7 \pmod{16}. \end{aligned}$$

Example 2.2.22. *For $n = 10$, the partitions of n into odd parts are*

$$(9, 1), (7, 3), (7, 1, 1, 1), (5, 5), (5, 3, 1, 1), (5, 1, 1, 1, 1, 1), (3, 3, 3, 1), (3, 3, 1, 1, 1, 1), (3, 1, 1, 1, 1, 1, 1, 1, 1, 1) \text{ and } (1, 1, 1, 1, 1, 1, 1, 1, 1, 1)$$

and the partitions of given by Theorem 2.2.21 are

$$(10), (9, 1), (8, 2), (7, 3), (7, 2, 1), (6, 4), (6, 2, 2), (5, 2, 2, 1), (4, 2, 2, 2) \text{ and } (2, 2, 2, 2, 2).$$

Remark 2.2.23. *For Siladić's theorem, since we have $\bar{b} < \bar{a}$, we carry out the transformation $(a, b) \mapsto (q^{-1}, q^{-3})$ to keep the order, while for its analogue, we have $a < b$ and we then apply $(a, b) \mapsto (q^{-3}, q^{-1})$.*

The proof of Theorem 2.2.15 will be given in Chapter 4.

2.2.3 Beyond Glaisher's theorem: a duality between flat and regular partitions

In paper (Konan, 2020c), we gave a result beyond the refinement of Keith-Xiong, that links our general definition of flat partitions and regular partitions given in terms of weighted words. Here again, we see the weighted words in the framework of statistical mechanics.

Weighted words at degree one

Let \mathcal{C} be a set of primary states, and let ϵ be a **minimal energy**. We set $\mathcal{F}_1^{\epsilon, c_g}$ to be the set of *primary* flat partitions, which are the flat partitions with ground c_g and energy ϵ . Recall that the energy ϵ defines a relation \succ_ϵ as follows,

$$k_c \succ_\epsilon k_{c'} \iff k - k' = \epsilon(c, c'). \quad (2.2.37)$$

Let us also recall the energy relation \succ_ϵ defined by

$$k_c \succ_\epsilon k_{c'} \iff k - k' \geq \epsilon(c, c'), \quad (2.2.38)$$

and let $\mathcal{R}_1^{\epsilon, c_g}$ be the set of *primary* c_g -regular partitions, which are the c_g -regular partitions with ground c_g and relation \succ_ϵ .

Assuming that $c_g = 1$, one can see, for both flat or regular partitions, the state sequence as a product of states in $\mathcal{C} \setminus \{c_g\}$. Let us set $\mathcal{C}' = \mathcal{C} \setminus \{c_g\}$. Depending on certain properties of ϵ , we can build a bijection between $\mathcal{R}_1^{\epsilon, c_g}$ and $\mathcal{F}_1^{\epsilon, c_g}$ which preserves both the Energy and the State of partitions.

Theorem 2.2.24 (degree one). *Let us assume that $\epsilon(c_g, c_g) = 0$, and that for all $c, c' \neq 0$,*

$$\epsilon(c', c_g) = \epsilon(c, c_g) = 1 - \epsilon(c_g, c). \quad (2.2.39)$$

There then exists a bijection Ω between $\mathcal{F}_1^{\epsilon, c_g}$ and $\mathcal{R}_1^{\epsilon, c_g}$ which preserves the total energy and the sequence of states different from c_g .

This theorem is a generalization of Theorem 1.2.6. To see that Theorem 2.2.24 implies Theorem 1.2.6, we take the set $\mathcal{C} = \{c_0, \dots, c_{m-1}\}$, and set $c_g = c_0$. Theorem 1.2.6 then corresponds to the energy $\epsilon(c_i, c_j) = \chi(i < j)$, followed by the transformation

$$(q, c_0, c_1, \dots, c_{m-1}) \mapsto (q^m, 1, q, \dots, q^{m-1}).$$

The latter operation means that the particle is k_{c_i} is transformed into the part $mk + i$, and the relations in (2.2.37) and (2.2.38) induced by ϵ then become

$$mk + i \succ_\epsilon mk' + i' \iff (mk + i) - (mk' + i') = \begin{cases} i - i' & \text{if } i \geq i' \\ m + i - i' & \text{if } i < i' \end{cases} \quad ,$$

$$mk + i \succ_\epsilon mk' + i' \iff (mk + i) - (mk' + i') \geq \begin{cases} i - i' & \text{if } i \geq i' \\ m + i - i' & \text{if } i < i' \end{cases} \quad .$$

Note that the last part corresponds to 0 for both flat and regular partitions after this transformation. We then retrieve the flat partitions of Example 2.1.20 and the regular partitions in Example 2.1.16, except that we implicitly assimilate the congruence modulo m of the part size to the unique corresponding state in \mathcal{C} .

Similarly, Theorem 1.2.6 is also implied by Theorem 2.2.24 with the energy $\epsilon(c_i, c_j) = \chi(i > j)$ followed by the transformation $(q, c_0, c_1, \dots, c_{m-1}) \mapsto (q^m, 1, q^{-1}, \dots, q^{1-m})$, in which case the particle k_{c_i} is assimilated to the part $km - i$.

In the same way, we obtain the analogue of Glaisher, stated in Corollary 2.2.25, by considering the same set of states $\mathcal{C} = \{c_0, \dots, c_{m-1}\}$, the ground $c_g = c_0$, the transformation $(q, c_0, c_1, \dots, c_{m-1}) \mapsto (q^m, 1, q, \dots, q^{m-1})$, but a slightly different energy ϵ defined by

$$\epsilon(c_i, c_j) = \begin{cases} \chi(i < j) & \text{if } i \neq j \\ 0 & \text{if } i = j = 0 \\ 1 & \text{if } i = j \neq 0 \end{cases} \quad .$$

Note that the restriction of ϵ to $\mathcal{C} \setminus \{c_0\} = \mathcal{C}'$ then gives $\epsilon(c_i, c_j) = \chi(i \leq j)$.

Here we give a corollary of Theorem 2.2.24 as the following analogue of Glaisher's theorem for m -regular partitions into distinct parts.

Corollary 2.2.25. *Let m and n be positive integers. Then, the number of m -regular partitions of n into **distinct** parts is equal to the number of $(m + 1)$ -flat partitions of n , such that*

- the smallest part is less than m ,
- two consecutive parts divisible by m are necessarily equal,
- two consecutive parts not divisible by m and with the same congruence modulo m are necessarily distinct.

Example 2.2.26. Here we take $m = 3$ and $n = 16$, and the 3-regular partition of 16 into distinct parts are

$$(16), (14, 2), (13, 2, 1), (11, 5), (11, 4, 1), (10, 5, 1), (10, 4, 2), (8, 7, 1), (8, 5, 2, 1), \text{ and } (7, 5, 4)$$

and the 4-flat partitions of 16 of the second kind are

$$(8, 5, 2, 1), (7, 5, 3, 1), (7, 4, 3, 2), (6, 5, 4, 1), (6, 5, 3, 2), (6, 4, 3, 2, 1), (5, 4, 3, 3, 1), (5, 3, 3, 3, 2), (4, 3, 3, 3, 2, 1),$$

$$\text{and } (3, 3, 3, 3, 3, 1).$$

Another consequence of Theorem 2.2.24 consists in easing the computation of characters of the representations of some affine Lie algebras.

Weighted words at degree two

The second result, Theorem 2.2.31 below, concerns weighted words at degree two, and energies satisfying $\epsilon = \epsilon'$ up to some exceptions. This second theorem uses Theorem 2.2.24 and Theorem 2.2.15. In the particular case of representations of affine Lie algebras we study here, Theorem 2.2.31 allows us to connect the difference conditions of Theorem 2.2.15 and the energy function of the square, in terms of tensor product, of the vector representation. Let us now assume that ϵ satisfies the conditions of Theorem 2.2.24 and consider the set of secondary particles \mathcal{S} defined in Definition 2.2.10. We set δ_g to be the common value of $\epsilon(c_g, c)$ for all $c \in \mathcal{C}'$.

Definition 2.2.27. We define $\mathcal{F}_2^{\epsilon, c_g}$ to be the set of *secondary flat partitions*, which are the flat partitions into secondary particles in \mathcal{S} , with ground c_g^2 and energy ϵ_2 defined by

$$\epsilon_2(cc', dd') = \epsilon(c, c') + 2\epsilon(c', d) + \epsilon(d, d'). \quad (2.2.40)$$

Remark 2.2.28. The definition of ϵ_2 is equivalent to defining a relation \succ_{ϵ_2} on secondary particles which satisfies the following:

$$(2k + \epsilon(c, c'))_{cc'} \succ_{\epsilon_2} (2l + \epsilon(d, d'))_{dd'} \iff (2k + \epsilon(c, c')) - (2l + \epsilon(d, d')) = \epsilon(c, c') + 2\epsilon(c', d) + \epsilon(d, d').$$

$$\iff k - (l + \epsilon(d, d')) = \epsilon(c', d)$$

$$\iff \mu((2k + \epsilon(c, c'))_{cc'}) \succ_{\epsilon} \gamma((2l + \epsilon(d, d'))_{dd'}). \quad (2.2.41)$$

Definition 2.2.29. We set $\mathcal{R}_2^{\epsilon, c_g}$ to be the set of *secondary regular partitions*, which are the regular partitions into secondary particles in \mathcal{S} , with ground c_g^2 and the energy ϵ' defined by

$$\epsilon'_2(cc', dd') = \epsilon_2(cc', dd') + 2\delta^\epsilon(cc', dd'), \quad (2.2.42)$$

where $\delta^\epsilon(cc', dd') = 0$ apart from

$$\delta^\epsilon(cc_g, c_g d') = \epsilon(c, d') \quad \text{for all } c, d' \in \mathcal{C}', \quad (2.2.43)$$

and the additional exceptions when $\delta_g = 1$:

$$\delta^\epsilon(cc', dd') = -1 \quad \text{if } \begin{cases} c = c_g, c', d, d' \in \mathcal{C}' \text{ and } \epsilon(c', d) = 1 \\ c' = c_g, c, d, d' \in \mathcal{C}' \text{ and } \epsilon(c, d) = 0 \end{cases} \quad (2.2.44)$$

$$\delta^\epsilon(cc', dd') = 1 \quad \text{if } \begin{cases} d' = c_g, c', d \in \mathcal{C}' \text{ and } \epsilon(c', d) = 0 \\ d = c_g, c, c', d' \in \mathcal{C}' \text{ and } \epsilon(c', d') = 1 \end{cases}. \quad (2.2.45)$$

Remark 2.2.30. Note that the energy ϵ'_2 defines a binary relation \ggg^ϵ on secondary particles of \mathcal{S} as follows,

$$(2k + \epsilon(c, c'))_{cc'} \ggg^\epsilon (2l + \epsilon(d, d'))_{dd'} \iff k - l - \epsilon(c', d) - \epsilon(d, d') \geq \delta^\epsilon(cc', dd'). \quad (2.2.46)$$

The level above Theorem 2.2.24 can be stated as follows.

Theorem 2.2.31 (degree two). *Assuming that $c_g = 1$, there exists a bijection between $\mathcal{R}_2^{\epsilon, c_g}$ and $\mathcal{F}_2^{\epsilon, c_g}$ which preserves the total energy and the sequence of states different from c_g .*

Let us give an example of such an identity. Consider the set $\mathcal{C} = \{a, b\}$, $c_g = b$ and the energy matrix

$$M_\epsilon = \begin{matrix} & a & b \\ a & \begin{pmatrix} 1 & 1 \\ 0 & 0 \end{pmatrix} \\ b & \end{matrix}.$$

We then obtain the energy matrix for ϵ_2

$$M_{\epsilon_2} = \begin{matrix} & a^2 & ab & ba & b^2 \\ a^2 & \begin{pmatrix} 4 & 4 & 3 & 3 \\ 2 & 2 & 1 & 1 \\ 3 & 3 & 2 & 2 \\ 1 & 1 & 0 & 0 \end{pmatrix} \\ ab & \\ ba & \\ b^2 & \end{matrix},$$

and the energy matrix for ϵ'_2

$$M_{\epsilon'_2} = \begin{matrix} & a^2 & ab & ba & b^2 \\ a^2 & \begin{pmatrix} 4 & 4 & 3 & 3 \\ 2 & 2 & 3 & 1 \\ 3 & 3 & 2 & 2 \\ 1 & 1 & 0 & 0 \end{pmatrix} \\ ab & \\ ba & \\ b^2 & \end{matrix}.$$

Since in the regular partitions we never have a state b^2 except for the last part 0_{b^2} , one can consider these partitions as partitions into particles with state in $\{a^2, ab, ba\}$, satisfying the minimal difference condition in

$$M_{\epsilon'_2} = \begin{matrix} & a^2 & ab & ba \\ a^2 & \begin{pmatrix} 4 & 4 & 3 \\ 2 & 2 & 3 \\ 3 & 3 & 2 \end{pmatrix} \\ ab & \\ ba & \end{matrix}$$

and such that the minimal potentials for the particle with state a^2, ab and ba are respectively 3, 1 and 2. By applying the transformation $(q, a, b) \mapsto (q^3, q^{-2}, 1)$, we obtain the following corollary of Theorem 2.2.31.

Corollary 2.2.32. *Let n be a non-negative integer. Let $A(n)$ be the number of partitions of n into distinct parts congruent to 1, 4, 5 modulo 6 such that two consecutive parts differ by at least 6 with equality only if they are not congruent to 5. Let $B(n)$ be the number of 13-flat partitions into parts congruent to 0, 1, 4, 5 modulo 6, the smallest part less than 6, and such that:*

- *two consecutive parts congruent to 1, 4, 5 modulo 6 differ by at least 6 with equality only if they are not congruent to 5 mod 6, with the exception that they differ by 3 if the greater is congruent to 1 and the smaller to 4 modulo 6,*
- *two consecutive parts, with at least one divisible by 6, differ by less than 6, except that they differ by 7 when the larger part is divisible by 6 and the smaller part is congruent to 5 modulo 6.*

We then have that $A(n) = B(n)$, and the corresponding identity is

$$\sum_{n \geq 0} B(n)q^n = \sum_{n \geq 0} A(n)q^n = (-q; q^3)_\infty. \quad (2.2.47)$$

Example 2.2.33. *As examples, the partitions of 30 of the first kind are*

$$(29, 1), (25, 5), (23, 7), (22, 7, 1), (19, 11), (19, 10, 1) \text{ and } (16, 10, 4),$$

and the partitions of 30 of the second kind are

$$(18, 11, 1), (16, 10, 4), (16, 7, 6, 1), (13, 12, 5), (13, 10, 6, 1), (13, 7, 6, 1) \text{ and } (11, 6, 6, 6, 1).$$

We then have $A(30) = B(30) = 7$.

2.2.4 Beyond the Durfee square: a duality between colored partitions and colored Frobenius partitions

In this section we present a result generalizing the identity that links partitions to Frobenius partitions. For a particular case, we retrieve the generalization of Primc's identities given in (Dousse and Konan, 2019a). Chapter 6 is dedicated to the proof of the duality theorem.

Color reduction and duality

Let \mathcal{C} be a set of colors, and $\mathcal{C}_{\text{free}} \sqcup \mathcal{C}_{\text{bound}}$ a set-partition of \mathcal{C} . We called $\mathcal{C}_{\text{free}}$ the set of *free* colors, and $\mathcal{C}_{\text{bound}}$ the set of *bound* colors. Let a and b be two functions from $\mathcal{C}_{\text{bound}}$ to $\mathcal{C}_{\text{free}}$. We now define the first notion needed for the duality theorem.

Definition 2.2.34. Let c_1, \dots, c_s be a finite sequence of colors in \mathcal{C} . We then define the *reduced* color sequence of c_1, \dots, c_s with respect to a and b , as the unique maximal subsequence $\text{red}_{a,b}(c_1, \dots, c_s)$ of c_1, \dots, c_s which satisfies the following:

1. all the colors in $\mathcal{C}_{\text{bound}}$ are preserved,
2. for all $c \in \mathcal{C}_{\text{free}}$, we do not have the pattern c, c ,
3. for all $c \in \mathcal{C}_{\text{bound}}$, we do not have the patterns $a(c), c$ or $c, b(c)$.

A sequence of colors c_1, \dots, c_s is said to be *reduced* if $\text{red}_{a,b}(c_1, \dots, c_s) = c_1, \dots, c_s$, which is equivalent to saying that the sequence of colors c_1, \dots, c_s does not have the forbidden patterns defined above.

Given a sequence c_1, \dots, c_s of colors taken from \mathcal{C} , the reduced color sequence $\text{red}_{a,b}(c_1, \dots, c_s)$ is then obtained after applying the following operations:

- if there is some i such that $c_i \in \mathcal{C}_{\text{free}}$ and $c_{i+1} = c_i$, then remove c_{i+1} from the color sequence,
- if there is some i such that $c_i \in \mathcal{C}_{\text{bound}}$ and $c_{i+1} = b(c_i)$, then remove c_{i+1} from the color sequence,
- if there is some i such that $c_i \in \mathcal{C}_{\text{bound}}$ and $c_i = a(c_{i+1})$, then remove c_i from the color sequence.

The reduction operation only removes free colors and the order in which removals are done does not have any influence on the final result.

Example 2.2.35. Let us consider the set of colors $\mathcal{C} = \{a_i b_j : i, j \in \mathbb{N}\}$ for two sequences of symbols $(a_n)_{n \geq 0}$ and $(b_n)_{n \geq 0}$. Let us set $\mathcal{C}_{\text{free}} = \{a_i b_i : i \in \mathbb{N}\}$ and the function a and b such that for all $i \neq j \in \mathbb{N}$,

$$a(a_i b_j) = a_i b_i \quad \text{and} \quad b(a_i b_j) = a_j b_j.$$

The reduction of

$$a_1 b_1, a_1 b_2, a_2 b_2, a_3 b_3, a_3 b_1, a_1 b_3, a_3 b_3, a_3 b_3, a_3 b_2, a_1 b_1$$

is

$$a_1 b_2, a_3 b_1, a_1 b_3, a_3 b_2, a_1 b_1.$$

Definition 2.2.36. Let $\pi = (\pi_1, \dots, \pi_s)$ be a generalized colored (Frobenius) partition such that $c(\pi_1) = c_1, \dots, c(\pi_s) = c_s \in \mathcal{C}$. The *kernel* of π with respect to the function a and b , denoted by $\ker_{a,b}(\pi)$, is the reduced color sequence $\text{red}_{a,b}(c_1, \dots, c_s)$.

Definition 2.2.37. In the following, we consider a fictitious color c_∞ , and an energy ϵ defined on $\mathcal{C} \sqcup \{c_\infty\}$ satisfying the following,

1. for any $c, c' \in \mathcal{C}_{\text{free}} \sqcup \{c_\infty\}$,
- $$\epsilon(c, c') = \chi(c \neq c'), \tag{2.2.48}$$

2. for any $c \in \mathcal{C}_{\text{bound}}$,
- $$\epsilon(a(c), c) + \epsilon(c, b(c)) = 1, \tag{2.2.49}$$

and for any $c' \in (\mathcal{C}_{\text{free}} \sqcup \{c_\infty\}) \setminus \{a(c)\}$,

$$\epsilon(c', c) \in \{\epsilon(a(c), c), \epsilon(a(c), c) + 1\}, \tag{2.2.50}$$

and for any $c' \in (\mathcal{C}_{\text{free}} \sqcup \{c_\infty\}) \setminus \{b(c)\}$,

$$\epsilon(c, c') \in \{\epsilon(c, b(c)), \epsilon(c, b(c)) + 1\}, \tag{2.2.51}$$

3. for any $c, c' \in \mathcal{C}_{\text{bound}}$,

$$\epsilon(c, c') = \epsilon(c, a(c')) + \epsilon(b(c), c') - \chi(b(c) \neq a(c')). \quad (2.2.52)$$

Such an energy ϵ is said to be *well-defined* according to the reduction with respect to a and b .

Let us now consider weighted words on $\mathcal{C} \sqcup \{c_\infty\}$, and denote by $\mathcal{P}_\epsilon^{c_\infty}$ the set of generalized colored partitions c_∞ -regular with ground c_∞ and relation \gg_ϵ as defined in Definition 2.1.3. It is then equivalent to consider weighted words on \mathcal{C} and the generalized colored partitions in \mathcal{P}_ϵ with ϵ restricted to \mathcal{C} , and such that the minimal size for the last part with color c is $\epsilon(c, c_\infty)$.

Example 2.2.38. For the set of colors as in Example 2.2.35, as well as the free and bound colors, and function a and b , one can check that the energy ϵ defined by

$$\begin{aligned} \epsilon(a_i b_j, a_k b_l) &= \chi(i \geq k) - \chi(i = j = k) + \chi(j \leq l) - \chi(j = k = l), \\ \epsilon(c_\infty, a_i b_j) &= 1 \quad \text{and} \quad \epsilon(a_i b_j, c_\infty) = 1 \end{aligned}$$

is well-defined according to the reduction with respect to a and b .

Let us now consider two energies ϵ_1 and ϵ_2 on $\mathcal{C} \sqcup \{c_\infty\}$ such that

$$\epsilon_1(c, c') + \epsilon_2(c, c') = \begin{cases} 2 & \text{if } c = c' \in \mathcal{C}_{\text{free}} \sqcup \{c_\infty\} \\ \epsilon(c, c') + 1 & \text{if } c' \in \mathcal{C}_{\text{bound}} \text{ and } c = a(c') \\ \epsilon(c, c') + 1 & \text{if } c \in \mathcal{C}_{\text{bound}} \text{ and } c' = b(c) \\ \epsilon(c, c') & \text{otherwise.} \end{cases} \quad (2.2.53)$$

Denote by $\mathcal{F}_{\epsilon_1, \epsilon_2}^{c_\infty}$ the set of generalized colored Frobenius partitions c_∞ -regular with ground c_∞ and relation $\gg_{\epsilon_1, \epsilon_2}$ as defined in (2.1.7).

We are now ready to state the duality theorem. Unlike most classical Rogers-Ramanujan type identities, we relate the generalized colored partitions to the generalized colored Frobenius partitions.

Theorem 2.2.39. Let ϵ be an energy well-defined according to the reduction with respect to a and b , and ϵ_1, ϵ_2 defined as in (2.2.53). There exists a bijection between $\mathcal{P}_\epsilon^{c_\infty}$ and $\mathcal{F}_{\epsilon_1, \epsilon_2}^{c_\infty}$ which preserves the size and the kernel of the generalized colored partitions and Frobenius partitions.

We retrieve the correspondence between the classical partitions and Frobenius partitions by setting $\mathcal{C} = \mathcal{C}_{\text{free}} = \{c\}$, $\epsilon_1(c, c_\infty) = 1$ and $\epsilon_2(c, c_\infty) = 0$.

Generalized n^2 -colored Primc's partitions and n^2 -colored Frobenius partitions

Here, we consider the set of colors defined in Example 2.2.35. Recall that $\mathcal{C} = \{a_i b_j : i, j \in \mathbb{N}\}$. The *free colors* are the elements of the set $\mathcal{C}_{\text{free}} = \{a_i b_i : i \in \mathbb{N}\}$, and the *bound colors* are the elements of the set $\mathcal{C}_{\text{bound}} = \{a_i b_k : i \neq k, i, k \in \mathbb{N}\}$. We now define the difference conditions, which generalize those of matrices (1.4.3) and (1.4.5) in the two identities of Primc.

Definition 2.2.40. For all $i, k, i', k' \in \mathbb{N}$, we define the minimal difference Δ between a part colored $a_i b_k$ and a part colored $a_{i'} b_{k'}$ in the following way:

$$\Delta(a_i b_k, a_{i'} b_{k'}) = \chi(i \geq i') - \chi(i = k = i') + \chi(k \leq k') - \chi(k = i' = k'), \quad (2.2.54)$$

For non-negative integers $\ell < n$, we define $\mathcal{P}_{\ell, n}$ to be the set of grounded partitions $\lambda = (\lambda_1, \dots, \lambda_s, 0_{a_\ell b_\ell})$ with ground $a_\ell b_\ell$ and relation \gg_Δ . To simplify some calculations throughout the thesis, we adopt the following convention: if c_1, \dots, c_s , is the color sequence of the partition $\lambda_1, \dots, \lambda_s$, we remove the last color $a_\ell b_\ell$ and add fictitious colors $c_0 = c_{s+1} = c_\infty$ to both extremities of the color sequence. The difference conditions are, for all $i, k \in \mathbb{N}$,

$$\Delta(c_\infty, a_i b_k) = 1 \quad \text{and} \quad \Delta(a_i b_k, c_\infty) = \chi(i \geq \ell) + \chi(j < \ell).$$

In particular, when $\ell = 0$, we have $\Delta(a_i b_k, c_\infty) = 1$ for all $i, j \in \mathbb{N}$. The difference conditions defining $\mathcal{P}_{0, n}$ generalized Primc's difference conditions matrices P_2 and P_3 in (1.4.3) and (1.4.5), as we shall see in the next two examples.

Example 2.2.41. If we set $a = a_1b_0, b = a_0b_0, c = a_1b_1, d = a_0b_1$, as shown in Table (2.2.55), then $\mathcal{P}_{0,2}$ is exactly the set of partitions with difference conditions (1.4.3) of Primc's 4-colored theorem.

$b_i \backslash a_i$	0	1
0	b	a
1	d	c

(2.2.55)

For example,

$$\begin{aligned} \Delta(a, b) &= \Delta(a_1b_0, a_0b_0) \\ &= \chi(1 \geq 0) - \chi(1 = 0 = 0) + \chi(0 \leq 0) - \chi(0 = 0 = 0) \\ &= 1 - 0 + 1 - 1 \\ &= 1. \end{aligned}$$

This is exactly the entry in row a and column b in (1.4.3).

Example 2.2.42. The set $\mathcal{P}_{0,3}$ is exactly the set of partitions with difference conditions (1.4.5) of Primc's 9-colored theorem. For example,

$$\begin{aligned} \Delta(a_2b_0, a_2b_1) &= \chi(2 \geq 2) - \chi(2 = 0 = 2) + \chi(0 \leq 1) - \chi(0 = 2 = 1) \\ &= 1 - 0 + 1 - 0 \\ &= 2. \end{aligned}$$

This is exactly the entry in row a_2b_0 and column a_2b_1 in (1.4.5).

Recall the functions a and b defined from $\mathcal{C}_{\text{bound}}$ to $\mathcal{C}_{\text{free}}$ by

$$a(a_i b_j) = a_i b_i \quad \text{and} \quad b(a_i b_j) = a_j b_j.$$

By setting $\Delta(c_\infty, c_\infty) = 0$, one can check that Δ is an energy well-defined according to the reduction with respect to a and b , and the set $\mathcal{P}_{\ell, n}$ then corresponds to the set $\mathcal{P}_\Delta^{c_\infty}$. Let us now set energies Δ_1 and Δ_2 on $\mathcal{C} \sqcup \{c_\infty\}$ as follows:

$$\left\{ \begin{array}{l} \Delta_1(a_i b_j, a_k b_l) = \chi(i \geq k), \\ \Delta_1(c_\infty, a_i b_j) = 1, \\ \Delta_1(a_i b_j, c_\infty) = \chi(i \geq \ell), \\ \Delta_1(c_\infty, c_\infty) = 0 \end{array} \right. \quad \text{and} \quad \left\{ \begin{array}{l} \Delta_2(a_i b_j, a_k b_l) = \chi(j \leq k), \\ \Delta_2(c_\infty, a_i b_j) = 1, \\ \Delta_2(a_i b_j, c_\infty) = \chi(j < \ell), \\ \Delta_2(c_\infty, c_\infty) = 0. \end{array} \right. \quad (2.2.56)$$

This allows us to define the set $\mathcal{F}_{\epsilon_1, \epsilon_2}^{c_\infty}$ the set of generalized colored Frobenius partitions c_∞ -regular with ground c_∞ and relation $\gg_{\epsilon_1, \epsilon_2}$. This set is in bijection with the set of the pairs of generalized colored partitions in (λ, μ) having the same numbers of parts, for any λ being a finite subsequence of

$$\cdots > 2_{a_{n-1}} > 1_{a_0} > \cdots > 1_{a_{n-1}} > 0_{a_0} > \cdots > 0_{a_{\ell-2}} > 0_{a_{\ell-1}}$$

and any μ being a finite subsequence of

$$\cdots > 2_{a_0} > 1_{a_n} > \cdots > 1_{a_0} > 0_{a_{n-1}} > \cdots > 0_{a_{\ell+1}} > 0_{b_\ell}.$$

We denote by $\mathcal{F}_{\ell, n}$ the latter set of pairs of generalized colored partitions.

This allows us to find simple and elegant formulations for the generating functions. Following the same reasoning as for classical Frobenius partitions, the generating function for the number $F_{\ell, n}(m; u_0, \dots, u_{n-1}; v_0, \dots, v_{n-1})$ of n^2 -colored Frobenius partitions of m where for $i \in \{0, \dots, n-1\}$, the symbol a_i (resp. b_i) appears u_i (resp. v_i) times, is

$$\sum_{m, u_0, \dots, u_{n-1}, v_0, \dots, v_{n-1} \geq 0} F_n(m; u_0, \dots, u_{n-1}; v_0, \dots, v_{n-1}) q^m a_0^{u_0} \cdots a_{n-1}^{u_{n-1}} b_1^{v_1} \cdots b_{n-1}^{v_{n-1}} \quad (2.2.57)$$

$$= [x^0] \prod_{i=0}^{n-1} (-x a_i q^{\chi(i \geq \ell)}; q)_\infty (-x^{-1} b_i q^{\chi(i < \ell)}; q)_\infty. \quad (2.2.58)$$

This refines the following expression due to Andrews (Andrews, 1984a, (5.14)):

$$\mathbf{C}\Phi_n(q) = [x^0](-xq; q)_\infty^n (-x^{-1}; q)_\infty^n,$$

for the case $\ell = 0$, and where the colors were not taken into account in the generating function. Note that the generating function (2.2.57) only depends on the condition “all parts are distinct” in λ and μ . In (Andrews, 1984a, (4.8)), Andrews defined a generalization of Frobenius partitions where λ and μ are partitions into distinct parts chosen from $\{k_j : k \in \mathbb{N}, 1 \leq j \leq n\}$, where $k_j = k'_j$ if and only if $k = k'$ and $j = j'$. Their generating function $\mathbf{C}\Phi_n(q)$ has been widely studied from the point of view of modular forms and congruences, see for example (Chan, Wang, and Yang, 2019; Lovejoy, 2000; Sellers, 1994).

The n^2 -colored Frobenius partitions are very natural objects to consider when studying our generalizations of Primc’s identity. In fact, one can check that the energies defined in (2.2.56) satisfy the conditions in (2.2.53) with $\epsilon = \Delta, \epsilon_1 = \Delta_1$ and $\epsilon_2 = \Delta_2$. Indeed, by Theorem 2.2.39 and the fact that the reduced color sequence conserves the bound colors, it suffices to consider in our enumeration only the bound colors. Moreover, when we set for all $i, b_i = a_i^{-1}$, then all free colors vanish and we have an elegant expression for our generating functions as the constant term in an infinite product.

Theorem 2.2.43 (Generalisation of Primc’s identity). *Let $\ell < n$ be non-negative integers.*

*Let $P_{\ell,n}(m; u_0, \dots, u_{n-1}; v_0, \dots, v_{n-1})$ be the number of generalized colored partitions in $\mathcal{P}_{\ell,n}$ with size m , where for $i \in \{0, \dots, n-1\}$, the symbol a_i (resp. b_i) appears u_i (resp. v_i) times **in their bound colors**.*

*Let $F_{\ell,n}(m; u_0, \dots, u_{n-1}; v_0, \dots, v_{n-1})$ be the number of n^2 -colored Frobenius partitions $\mathcal{F}_{\ell,n}$ with size m , in where for $i \in \{0, \dots, n-1\}$, the symbol a_i (resp. b_i) appears u_i (resp. v_i) times **in their bound colors**. Then*

$$P_{\ell,n}(m; u_0, \dots, u_{n-1}; v_0, \dots, v_{n-1}) = F_{\ell,n}(m; u_0, \dots, u_{n-1}; v_0, \dots, v_{n-1}),$$

and we have

$$\begin{aligned} & \sum_{m, u_0, \dots, u_{n-1}, v_0, \dots, v_{n-1} \geq 0} P_{\ell,n}(m; u_0, \dots, u_{n-1}; v_0, \dots, v_{n-1}) q^m a_0^{u_0 - v_0} \dots a_{n-1}^{u_{n-1} - v_{n-1}} \\ &= \sum_{m, u_0, \dots, u_{n-1}, v_0, \dots, v_{n-1} \geq 0} F_{\ell,n}(m; u_0, \dots, u_{n-1}; v_0, \dots, v_{n-1}) q^m a_0^{u_0 - v_0} \dots a_{n-1}^{u_{n-1} - v_{n-1}} \\ &= [x^0] \prod_{i=0}^{n-1} (-x a_i q^{\chi(i \geq \ell)}; q)_\infty (-x^{-1} a_i^{-1} q^{\chi(i < \ell)}; q)_\infty. \end{aligned}$$

Let us set

$$G_n^P(q; b_0, \dots, b_{n-1}) = [x^0] \prod_{i=0}^{n-1} (-x b_i^{-1} q; q)_\infty (-x^{-1} b_i; q)_\infty.$$

We then obtain that

$$G_n^P(q; q b_0, \dots, q^{\ell-1} b_\ell, b_\ell, \dots, b_{n-1}) = [x^0] \prod_{i=0}^{n-1} (-x b_i^{-1} q^{\chi(i \geq \ell)}; q)_\infty (-x^{-1} b_i q^{\chi(i < \ell)}; q)_\infty. \quad (2.2.59)$$

From this theorem, it is easy to deduce a corollary, corresponding to the principal specialization, which generalizes both of Primc’s original identities. By performing the dilations $q \rightarrow q^n$, and for all $i \in \{0, \dots, n-1\}$, $a_i \rightarrow q^{-i}$, the generating function above becomes $[x^0](-xq^{1-\ell}; q)_\infty (-x^{-1}q^\ell; q)_\infty$, which is also equal to $1/(q; q)_\infty$.

Corollary 2.2.44 (Principal specialization). *Let n be a positive integer. We have*

$$\sum_{m, u_0, \dots, u_{n-1}, v_0, \dots, v_{n-1} \geq 0} P_{\ell,n}(m; u_0, \dots, u_{n-1}; v_0, \dots, v_{n-1}) q^{nm - \sum_{i=0}^{n-1} i(v_i - u_i)} = \frac{1}{(q; q)_\infty}.$$

Moreover, by using Jacobi’s triple product repeatedly, we are able to give an expression of the generating function for colored Frobenius partitions as a sum of infinite products, which gives yet another expression for the generating function for $\mathcal{P}_{0,n}$.

Theorem 2.2.45. *Let n be a positive integer. Then*

$$\sum_{m, u_0, \dots, u_{n-1}, v_0, \dots, v_{n-1} \geq 0} P_{0,n}(m; u_0, \dots, u_{n-1}; v_0, \dots, v_{n-1}) q^m a_0^{u_0 - v_0} \dots a_{n-1}^{u_{n-1} - v_{n-1}}$$

$$= \frac{1}{(q; q)_\infty^n} \sum_{\substack{s_1, \dots, s_{n-1} \in \mathbb{Z} \\ s_n = 0}} a_0^{-s_1} \prod_{i=1}^{n-1} a_i^{s_i - s_{i+1}} q^{s_i(s_i - s_{i+1})} \quad (2.2.60)$$

$$= \frac{1}{(q; q)_\infty} \left(\prod_{i=1}^{n-1} \frac{(q^{i(i+1)}; q^{i(i+1)})_\infty}{(q; q)_\infty} \right) \sum_{\substack{r_1, \dots, r_{n-1} \\ 0 \leq r_j \leq j-1 \\ r_n = 0}} \prod_{i=1}^{n-1} a_i^{r_i - r_{i+1}} q^{r_i(r_i - r_{i+1})} \\ \times \left(- \left(\prod_{\ell=0}^{i-1} a_\ell a_\ell^{-1} \right) q^{\frac{i(i+1)}{2} + (i+1)r_i - ir_{i+1}}; q^{i(i+1)} \right)_\infty \\ \times \left(- \left(\prod_{\ell=0}^{i-1} a_\ell a_\ell^{-1} \right) q^{\frac{i(i+1)}{2} - (i+1)r_i + ir_{i+1}}; q^{i(i+1)} \right)_\infty. \quad (2.2.61)$$

The formula (2.2.61) gives an expression for Andrews' function $C\Phi_n(q)$ as a sum of infinite products, which makes it easy to express this function as a sum of modular forms. An expression for $C\Phi_n(q)$ as a sum of infinite products was already given by Andrews (Andrews, 1984a) (without the colors) in the cases $n = 1, 2, 3$. This is the first time that the case of general k is treated and that a refinement with color variables is introduced.

2.2.5 Beyond Capparelli's theorem: regularity over Primc's theorem

This section is dedicated to the exposition of the main result that generalizes the Capparelli theorem. We start by presenting the formal tools as well as the formal result beyond Capparelli, and then discuss in the second part an explicit generalization of Capparelli's theorem by using the generalization of Primc's theorem. The proof of the main theorem is postponed till Chapter 7.

Another duality theorem between flat and regular partitions

Let \mathcal{C} be a set of colors, and let $\mathcal{C}_{\text{sup}} \sqcup \mathcal{C}_{\text{free}} \sqcup \mathcal{C}_{\text{inf}}$ be a set-partition of \mathcal{C} . Consider now an energy ϵ on \mathcal{C}^2 with values in $\{0, 1, 2\}$.

Definition 2.2.46. The energy ϵ is said to be *well-defined* according to the decomposition $\mathcal{C}_{\text{sup}} \sqcup \mathcal{C}_{\text{free}} \sqcup \mathcal{C}_{\text{inf}}$ if it satisfies the following.

1. For all $c, c' \in \mathcal{C}_{\text{free}}$, we have

$$\epsilon(c, c') = \chi(c \neq c'). \quad (2.2.62)$$

2. For all $(c, c') \in \mathcal{C}_{\text{sup}} \times \mathcal{C}_{\text{free}}$, we have

$$\epsilon(c, c') \in \{0, 1\} \quad \text{and} \quad \epsilon(c', c) \in \{1, 2\}, \quad (2.2.63)$$

and in particular, for all $c \in \mathcal{C}_{\text{sup}}$, there exists $c' \in \mathcal{C}_{\text{free}}$ such that $\epsilon(c, c') = 0$.

3. For all $(c, c') \in \mathcal{C}_{\text{free}} \times \mathcal{C}_{\text{inf}}$, we have

$$\epsilon(c, c') \in \{0, 1\} \quad \text{and} \quad \epsilon(c', c) \in \{1, 2\}, \quad (2.2.64)$$

and in particular, for all $c' \in \mathcal{C}_{\text{inf}}$, there exists $c \in \mathcal{C}_{\text{free}}$ such that $\epsilon(c, c') = 0$.

4. For all $(c, c') \in \mathcal{C}_{\text{sup}} \times \mathcal{C}_{\text{inf}}$, we have

$$\epsilon(c, c') \in \{0, 1\} \quad \text{and} \quad \epsilon(c', c) \in \{1, 2\} \quad (2.2.65)$$

and in particular, if $\epsilon(c, c') = 0$, there then exists $c'' \in \mathcal{C}_{\text{free}}$ such that

$$\epsilon(c, c'') = 0 \quad \text{and} \quad \epsilon(c'', c') = 0. \quad (2.2.66)$$

5. For all $c, c' \in \mathcal{C}_{\text{sup}}$, if $\epsilon(c, c') \in \{0, 1\}$, there then exists $c'' \in \mathcal{C}_{\text{free}}$ such that

$$\epsilon(c, c'') = 0 \quad \text{and} \quad \epsilon(c'', c') = 1. \quad (2.2.67)$$

6. For all $c, c' \in \mathcal{C}_{\text{inf}}$, if $\epsilon(c, c') \in \{0, 1\}$, there then exists $c'' \in \mathcal{C}_{\text{free}}$ such that

$$\epsilon(c, c'') = 1 \quad \text{and} \quad \epsilon(c'', c') = 0. \quad (2.2.68)$$

Example 2.2.47. Let us consider $\mathcal{C} = \{a_i b_j : i, j \in \mathbb{N}\}$, and set

$$\begin{aligned} \mathcal{C}_{\text{sup}} &= \{a_i b_j : i < j \in \mathbb{N}\}, \\ \mathcal{C}_{\text{free}} &= \{a_i b_j : i \in \mathbb{N}\}, \\ \mathcal{C}_{\text{inf}} &= \{a_i b_j : i > j \in \mathbb{N}\}. \end{aligned}$$

Then, the energy Δ defined in (2.2.54) is well-defined according to the above decomposition.

Definition 2.2.48. Let δ be a function from $\mathcal{C}_{\text{sup}} \sqcup \mathcal{C}_{\text{inf}}$ to $\mathcal{C}_{\text{free}}$, and let γ be a function from the set

$$\{(c, c') \in \mathcal{C}_{\text{sup}} \times \mathcal{C}_{\text{inf}} : \epsilon(c, c') = 0\} \sqcup \{(c, c') \in \mathcal{C}_{\text{sup}}^2 : \epsilon(c, c') \in \{0, 1\}\} \sqcup \{(c, c') \in \mathcal{C}_{\text{inf}}^2 : \epsilon(c, c') \in \{0, 1\}\} \quad (2.2.69)$$

to $\mathcal{C}_{\text{free}}$. We say that δ is well-defined according to ϵ if

- for all $c \in \mathcal{C}_{\text{sup}}$, we have $\epsilon(c, \delta(c)) = 0$, and
- for all $c \in \mathcal{C}_{\text{inf}}$, we have $\epsilon(\delta(c), c) = 0$.

Similarly, we say that γ is well-defined according to ϵ if

- for all $(c, c') \in \mathcal{C}_{\text{sup}} \times \mathcal{C}_{\text{inf}}$ such that $\epsilon(c, c') = 0$, we have $\epsilon(c, \gamma(c, c')) = \epsilon(\gamma(c, c'), c') = 0$,
- for all $(c, c') \in \mathcal{C}_{\text{sup}}^2$ such that $\epsilon(c, c') \in \{0, 1\}$, we have $\epsilon(c, \gamma(c, c')) = 0$ and $\epsilon(\gamma(c, c'), c') = 1$,
- for all $(c, c') \in \mathcal{C}_{\text{inf}}^2$ such that $\epsilon(c, c') \in \{0, 1\}$, we have $\epsilon(c, \gamma(c, c')) = 1$ and $\epsilon(\gamma(c, c'), c') = 0$.

For any energy well-defined according to the decomposition $\mathcal{C}_{\text{sup}} \sqcup \mathcal{C}_{\text{free}} \sqcup \mathcal{C}_{\text{inf}}$, the conditions (2.2.63) and (2.2.64) imply the existence of some function δ well-defined according to ϵ , and by (2.2.66), (2.2.67) and (2.2.68), there exists some function γ well-defined according to ϵ .

We finally add a fictitious color c_∞ , and extend the energy ϵ such that

$$\epsilon(\mathcal{C}_{\text{free}}, c_\infty) = \{1\}, \quad (2.2.70)$$

$$\epsilon(\mathcal{C}_{\text{sup}}, c_\infty) \subset \{1, 2\}, \quad (2.2.71)$$

$$\epsilon(\mathcal{C}_{\text{inf}}, c_\infty) \subset \{0, 1\}. \quad (2.2.72)$$

Recall that $\mathcal{P}_\epsilon^{c_\infty}$ is the set of c_∞ -regular partitions with ground c_∞ and relation \gg_ϵ . We now define a subset of $\mathcal{P}_\epsilon^{c_\infty}$ of partitions avoiding forbidden pattern according to δ and γ .

Definition 2.2.49. We denote by ${}_{\delta, \gamma}^{c_0} \mathcal{P}_\epsilon^{c_\infty}$ the set of generalized colored partitions of $\mathcal{P}_\epsilon^{c_\infty}$, c_0 -regular, and which avoid the following forbidden patterns:

1. for all $c \in \mathcal{C}_{\text{free}} \setminus \{c_0\}$, the pattern

$$p_c, p_c \quad (2.2.73)$$

2. for all $(c, c') \in \mathcal{C}_{\text{sup}} \times \mathcal{C}_{\text{inf}}$ such that $\epsilon(c, c') = 0$, the pattern

$$p_c, p_{\gamma(c, c')}, p_{c'} \quad (2.2.74)$$

3. for all $(c, c') \in \mathcal{C}_{\text{sup}}^2$ such that $\epsilon(c, c') \in \{0, 1\}$, the pattern

$$p_c, p_{\gamma(c, c')}, (p-1)_{c'} \quad (2.2.75)$$

4. for all $(c, c') \in \mathcal{C}_{\text{inf}}^2$ such that $\epsilon(c, c') \in \{0, 1\}$, the pattern

$$(p+1)_c, p_{\gamma(c, c')}, p_{c'} \quad (2.2.76)$$

5. for all $c \in \mathcal{C}_{\text{sup}}$,

(a) for all $c' \in (\mathcal{C}_{\text{free}} \setminus \{c_0\}) \sqcup \mathcal{C}_{\text{inf}} \sqcup \{c_\infty\}$, the pattern

$$p_{c'}, p_{\delta(c)'}, (p-1)_{c'} \quad (2.2.77)$$

(b) for all $c' \in (\mathcal{C} \setminus \{c_0\}) \sqcup \{c_\infty\}$, and for all positive integers $u \geq 2$, the pattern

$$p_{c'}, p_{\delta(c)'}, (p-u)_{c'} \quad (2.2.78)$$

6. for all $c' \in \mathcal{C}_{\text{inf}}$,

(a) at the head of the partition, the pattern

$$p_{\delta(c)'}, p_{c'} \quad (2.2.79)$$

(b) for all $c \in (\mathcal{C}_{\text{free}} \setminus \{c_0\}) \sqcup \mathcal{C}_{\text{sup}}$, the pattern

$$(p+1)_c, p_{\delta(c)'}, p_{c'} \quad (2.2.80)$$

(c) for all $c \in \mathcal{C} \setminus \{c_0\}$, and for all positive integers $u \geq 2$, the pattern

$$(p+u)_c, p_{\delta(c)'}, p_{c'} \quad (2.2.81)$$

Remark 2.2.50. One can observe that the forbidden patterns, apart from (2.2.73) and (2.2.79), have the form

$$p_{c_1}^{(1)}, p_f, p_{c_2}^{(2)}$$

with the allowed pattern $p_{c_1}^{(1)}, p_{c_2}^{(2)}$ and f a unique free color depending on c_1, c_2, δ and γ . Also, we remark that either c_1 or c_2 is not a free color. We extend the above notation to the forbidden pattern (2.2.79), by setting $p^{(1)} = \infty$. We will show in Chapter 7 that the above cases form the exhausted list of all the insertions, between two consecutive parts $p_{c_1}^{(1)}, p_{c_2}^{(2)}$, of a part p_f with a color $f \in \mathcal{C}_{\text{free}}$ and with the same size as one of the two parts.

We are now ready to state the main theorem of this section.

Theorem 2.2.51. Assume that there exists a color c_0 in $\mathcal{C}_{\text{free}}$ such that for all $c \neq c_0$, $\epsilon(c_0, c) = \epsilon(c, c_0) = 1$. Then, for the functions δ and γ defined above, there exist a bijection Φ between $\mathcal{P}_{\epsilon}^{c_0, \infty}$ and the product set $\mathcal{P}_{\delta, \gamma}^{c_0, \infty} \times \mathcal{P}$, where \mathcal{P} is the set of classical integer partitions. Furthermore, for $\Phi(\lambda) = (\mu, \nu)$, we have that $|\lambda| = |\mu| + |\nu|$, the number of parts of π is equal to the number of parts of μ plus the number of parts of ν , and the color sequence of λ , restricted to the colors in $\mathcal{C}_{\text{sup}} \sqcup \mathcal{C}_{\text{inf}}$, is the same as the color sequence of μ restricted to the colors in $\mathcal{C}_{\text{sup}} \sqcup \mathcal{C}_{\text{inf}}$.

Duality between Capparelli's identity and Primc's identity

Since its discovery, Capparelli's identity has been one of the most studied partition identities in the literature, see for example (Bringmann and Mahlburg, 2015; Berkovich and Uncu, 2015; Berkovich and Uncu, 2019; Dousse and Lovejoy, 2019; Fu and Zeng, 2018; Kanade and Russell, 2018; Kursungoz, 2018; Sills, 2004) for articles from the combinatorial point of view. While the other most important partition identities, such as the Rogers-Ramanujan identities (Rogers and Ramanujan, 1919) and Schur's theorem (Schur, 1926) have been successfully embedded in large families of identities, such as the Andrews-Gordon identities for Rogers-Ramanujan (Andrews, 1974; Gordon, 1965) and Andrews' theorems for Schur's theorem (Andrews, 1969a; Andrews, 1968), finding such a broad generalization of Capparelli's identity was still an open problem. Here, we solve this problem by giving two different families of identities which generalize Capparelli.

In the previous section, we gave difference conditions which generalize those of Primc's identities (1.4.3) and (1.4.5). In this section, we define two other families of difference conditions which generalise those of Capparelli's identity (1.4.2). For these two generalizations, we refer to the set $\mathcal{C} = \{a_i b_j : i, j \in \mathbb{N}\}$ and the energy Δ as defined in (2.2.54). Let us start with the first energy.

Definition 2.2.52. Let us define the energy Δ_1 on $\mathcal{C} = \{a_i b_j : i, j \in \mathbb{N}\}$ in the following way:

$$\begin{aligned} \Delta_1(a_k b_k, a_k b_k) &= 1 \text{ for all } k \in \mathbb{N}^*, \\ \Delta_1(a_k b_k, a_k b_\ell) &= 1 \text{ for all } \ell < k, \\ \Delta_1(a_\ell b_k, a_k b_k) &= 1 \text{ for all } \ell < k, \\ \Delta_1(a_i b_k, a_{i'} b_{k'}) &= \Delta(a_i b_k, a_{i'} b_{k'}) \text{ in all the other cases.} \end{aligned} \tag{2.2.82}$$

Remark 2.2.53. By (2.2.54), in all the cases where $\Delta_1 \neq \Delta$, we have $\Delta_1 = 1$ and $\Delta = 0$.

For any non-negative integers $\ell < n$, we restrict the set of colors to $\{a_i b_j : i, j \leq n-1\}$, and we define a fictitious color c_∞ and extend Δ_1 with the following:

$$\begin{aligned} \Delta_1(c_\infty, c_\infty) &= 0, \\ \Delta_1(c_\infty, a_i a_j) &= 1, \\ \Delta_1(a_i a_j, c_\infty) &= \chi(i \geq \ell) + \chi(j < \ell). \end{aligned}$$

Recall that these definitions are the same as the case where we set c_∞ instead of $a_\ell b_\ell$ for the generalized Primc's partitions of $\mathcal{P}_{\ell, n}$. We now define $\mathcal{C}_{\ell, n}$ to be the set of $a_0 b_0$ -regular and c_∞ -regular partitions with ground c_∞ and relation \gg_{Δ_1} , and which avoid the following forbidden patterns:

- for all $n-1 \geq k \geq k' > l > l' \geq 0$, the forbidden pattern

$$(p+1)_{a_k b_l}, p_{a_{l+1} b_{l+1}}, p_{a_{k'} b_{l'}} \tag{2.2.83}$$

- for all $0 \leq k < k' < l \leq l' \leq n-1$, the forbidden pattern

$$(p+1)_{a_k b_{l'}}, (p+1)_{a_{k+1} b_{k+1}}, p_{a_{k'} b_{l'}} \tag{2.2.84}$$

The difference conditions implied by the energy Δ_1 generalize those of Capparelli's identity stated in (1.4.2).

Example 2.2.54. If we define a, c, d (omitting $b = a_0 b_0$) as previously in Table (2.2.55), then \mathcal{C}_2 is exactly the set of partitions with difference conditions (1.4.2) of Capparelli's identity. For example,

$$\Delta_1(c, a) = \delta(a_1 b_1, a_1 b_0) = 1.$$

Example 2.2.55. The set \mathcal{C}_3 is the set of partitions with difference conditions shown in the following matrix:

$$\mathcal{C}_3 = \begin{matrix} & a_2 b_0 & a_2 b_1 & a_1 b_0 & a_2 b_2 & a_1 b_1 & a_0 b_1 & a_1 b_2 & a_0 b_2 \\ \begin{matrix} a_2 b_0 \\ a_2 b_1 \\ a_1 b_0 \\ a_2 b_2 \\ a_1 b_1 \\ a_0 b_1 \\ a_1 b_2 \\ a_0 b_2 \end{matrix} & \begin{pmatrix} 2 & 2 & 2 & 2 & 2 & 2 & 2 & 2 \\ 1 & 2 & 1 & 2 & 1 & 2 & 2 & 2 \\ 1 & 1 & 2 & 1 & 2 & 2 & 2 & 2 \\ 1 & 1 & 1 & 1 & 1 & 1 & 2 & 2 \\ 0 & 1 & 1 & 1 & 1 & 2 & 1 & 2 \\ 0 & 1 & 0 & 1 & 1 & 2 & 1 & 2 \\ 0 & 0 & 1 & 1 & 1 & 1 & 2 & 2 \\ 0 & 0 & 0 & 1 & 0 & 1 & 1 & 2 \end{pmatrix} \end{matrix} \tag{2.2.85}$$

Let us now turn to the second energy.

Definition 2.2.56. Let us define the energy Δ_2 on $\mathcal{C} = \{a_i b_j : i, j \in \mathbb{N}\}$ in the following way:

$$\begin{aligned} \Delta_2(a_k b_k, a_k b_k) &= 1 \text{ for all } k \in \mathbb{N}^*, \\ \Delta_2(a_k b_k, a_\ell b_{k-1}) &= 1 \text{ for all } \ell \geq k \geq 1, \\ \Delta_2(a_{k-1} b_\ell, a_k b_k) &= 1 \text{ for all } \ell \geq k \geq 1, \\ \Delta_2(a_i b_k, a_{i'} b_{k'}) &= \Delta(a_i b_k, a_{i'} b_{k'}) \text{ in all the other cases.} \end{aligned} \tag{2.2.86}$$

For any non-negative integers $\ell < n$, we restrict the set of colors to $\{a_i b_j : i, j \leq n-1\}$, and we define a fictitious color c_∞ and extend Δ_1 with the following:

$$\Delta_2(c_\infty, c_\infty) = 0,$$

$$\begin{aligned} \Delta_2(c_\infty, a_i a_j) &= 1, \\ \Delta_2(a_i a_j, c_\infty) &= \chi(i \geq \ell) + \chi(j < \ell). \end{aligned}$$

We now define $\mathcal{C}_{\ell, n}$ to be the set of $a_0 b_0$ -regular and c_∞ -regular partitions with ground c_∞ and relation \gg_{Δ_2} , which avoid the following forbidden patterns:

- for all $n - 1 \geq k' > k > l' \geq l \geq 0$, the forbidden pattern

$$(p + 1)_{a_k b_l}, p_{a_{k'} b_{k'}}, p_{a_{k'} b_{l'}} \tag{2.2.87}$$

- for all $0 \leq k' \leq k < l' < l \leq n - 1$, the forbidden pattern

$$(p + 1)_{a_k b_{l'}}, (p + 1)_{a_{l'} b_{l'}}, p_{a_{k'} b_{l'}} \tag{2.2.88}$$

The difference conditions implied by Δ_2 also generalize those of Capparelli’s identity (1.4.2), as well as those of another partition identity mentioned in Primc’s paper (Primc, 1999).

Example 2.2.57. Defining the colors a, c, d as before in Table (2.2.55), \mathcal{C}'_2 is again exactly the set of partitions with difference conditions of Capparelli’s identity.

Example 2.2.58. The set \mathcal{C}'_3 is the set of partitions with difference conditions shown in the following matrix, which appeared in Primc’s paper (Primc, 1999).

$$C'_3 = \begin{matrix} & a_2 b_0 & a_2 b_1 & a_1 b_0 & a_2 b_2 & a_1 b_1 & a_0 b_1 & a_1 b_2 & a_0 b_2 \\ \begin{matrix} a_2 b_0 \\ a_2 b_1 \\ a_1 b_0 \\ a_2 b_2 \\ a_1 b_1 \\ a_0 b_1 \\ a_1 b_2 \\ a_0 b_2 \end{matrix} & \begin{pmatrix} 2 & 2 & 2 & 2 & 2 & 2 & 2 & 2 & 2 \\ 1 & 2 & 1 & 2 & 1 & 2 & 2 & 2 & 2 \\ 1 & 1 & 2 & 1 & 2 & 2 & 2 & 2 & 2 \\ 0 & 1 & 1 & 1 & 1 & 1 & 1 & 2 & 2 \\ 1 & 1 & 1 & 1 & 1 & 2 & 1 & 2 & 2 \\ 0 & 1 & 0 & 1 & 1 & 2 & 1 & 2 & 2 \\ 0 & 0 & 1 & 1 & 1 & 1 & 2 & 2 & 2 \\ 0 & 0 & 0 & 0 & 1 & 1 & 1 & 1 & 2 \end{pmatrix} \end{matrix} \tag{2.2.89}$$

It was proved by Meurman and Primc in (Meurman and Primc, 2001), using basic $A_2^{(1)}$ modules, that after performing the dilations (1.4.6), the generating function for these partitions becomes $(q; q^3)_\infty^{-1} (q^2; q^3)_\infty^{-1}$.

Recently in (Dousse, 2020), Dousse built a bijection between Primc’s partitions \mathcal{P}_2 and pairs (λ, μ) where $\lambda \in \mathcal{C}_2$ is a Capparelli partition and μ is a classical partition. This bijection only modifies some free colors, so it preserves the size, the number of parts, the size of the parts, and the number of appearances of colors a and d . In this way, she showed that Capparelli’s identity is very closely related to Primc’s identity and can be deduced from it, even though until then, these two identities seemed unrelated from a representation theoretic point of view. The proof of Theorem 2.2.51 uses a broad generalization of the Dousse bijection. Here we give a generalization of the Dousse result.

Theorem 2.2.59. For any non-negative integers $\ell < n$, let $\mathcal{CC}_{\ell, n}$ (resp. $\mathcal{CC}'_{\ell, n}$) denote partition pairs (λ, μ) , where $\lambda \in \mathcal{C}_{\ell, n}$ (resp. $\mathcal{C}'_{\ell, n}$) and μ is a classical partition. There is a bijection between:

- colored partitions in $\mathcal{P}_{\ell, n}$,
- colored partition pairs in $\mathcal{CC}_{\ell, n}$,
- colored partition pairs in $\mathcal{CC}'_{\ell, n}$

This bijection preserves the total size, the number of parts, the size of the parts, and the color subsequence of bound colors.

The result stated in (Dousse and Konan, 2019a) is the particular case where $\ell = 0$. We note that both Capparelli’s identity and Meurman and Primc’s identity with difference conditions (2.2.89) did not have any apparent connection to the theory of perfect crystals. The bijection between $\mathcal{P}_{0,2}$ and $\mathcal{CC}_{0,2}$ in (Dousse, 2020) gave an unexpected connection with Primc’s identity and the theory of perfect crystals. The present theorem shows that Meurman and Primc’s identity with difference conditions (2.2.89) can actually be deduced from Primc’s Theorem 1.4.4. More generally, through the bijection with the $\mathcal{P}_{\ell, n}$ ’s, we related both families of generalisations of Capparelli’s identity to the theory of perfect crystals.

2.3 Rogers-Ramanujan type identities via representations of affine Lie algebras

We will define all the necessary notions from crystal base theory in Chapter 8. For now, let us define a few notations which will allow us to state our main theorems.

Let n be a non-negative integer, and consider the Cartan datum $(A, \Pi, \Pi^\vee, P, P^\vee)$ for a generalized Cartan matrix A of affine type and rank n . Here Π is the set of the simple roots $\alpha_i (i \in \{0, \dots, n\})$, and we denote by $\bar{P} = \mathbb{Z}\Lambda_0 \oplus \dots \oplus \mathbb{Z}\Lambda_n$ the lattice of the classical weights, where the elements $\Lambda_\ell (\ell \in \{0, \dots, n\})$ are the fundamental weights. We denote by δ the null root. $L(\Lambda)$ denotes the irreducible module of highest weight Λ , also called the standard module.

In this section, we present the connection between the theory of perfect crystals and our notion of weighted words. In particular, we compute via our method explicit formulas for the character of level one standard module for several classical affine types.

2.3.1 Perfect crystals and multi-grounded partitions

Let \mathcal{B} be a perfect crystal of level ℓ , and let $\Lambda \in \bar{P}_\ell^+$ be a level ℓ dominant classical weight such that the corresponding ground state path is $\mathfrak{p}_\Lambda = (g_k)_{k \geq 0}$. The finiteness of the set P_ℓ implies the periodicity of the sequence $(g_i)_{i \geq 0}$ (see (8.1.10)). We then set t to the smallest non-negative integer k such that $g_k = g_0$. Let H be an energy function on $\mathcal{B} \otimes \mathcal{B}$. Since $\mathcal{B} \otimes \mathcal{B}$ is connected, H is then unique up to a constant. We then define the function H_Λ on $\mathcal{B} \otimes \mathcal{B}$ satisfying

$$H_\Lambda(b \otimes b') = H(b \otimes b') - \frac{1}{t} \sum_{k=0}^{t-1} H(g_{k+1} \otimes g_k). \quad (2.3.1)$$

Note that for any energy function H , we always have

$$\sum_{k=0}^{t-1} (k+1)H_\Lambda(g_{k+1} \otimes g_k) = \sum_{k=0}^{t-1} (k+1)H(g_{k+1} \otimes g_k) - \frac{t+1}{2} \sum_{k=0}^{t-1} H(g_{k+1} \otimes g_k) \in \frac{1}{2}\mathbb{Z}.$$

The above number is an integer when t is odd, and is equal to 0 when $t = 1$. We can then choose a suitable divisor D of $2\chi^{(t \text{ even})}t$ such that $DH_\Lambda(\mathcal{B} \otimes \mathcal{B}) \subset \mathbb{Z}$ and $\frac{1}{t} \sum_{k=0}^{t-1} (k+1)DH_\Lambda(g_{k+1} \otimes g_k) \in \mathbb{Z}$. For the particular case $t = 1$, we can choose $D = 1$. Let us now consider the set of colors $\mathcal{C}_\mathcal{B}$ with indices in \mathcal{B} , and let us define the relation \succ on $\mathbb{Z}_{\mathcal{C}_\mathcal{B}}$ by

$$k_{c_b} \succ k'_{c_{b'}} \iff k - l = DH_\Lambda(b' \otimes b). \quad (2.3.2)$$

We also define the relation $\succ\succ$ on $\mathbb{Z}_{\mathcal{C}_\mathcal{B}}$ by

$$k_{c_b} \succ\succ k'_{c_{b'}} \iff k - l \geq DH_\Lambda(b' \otimes b). \quad (2.3.3)$$

By taking

$$u^{(k)} = -\frac{1}{t} \sum_{l=0}^{t-1} (l+1)DH_\Lambda(g_{l+1} \otimes g_l) + \sum_{l=k}^{t-1} DH_\Lambda(g_{l+1} \otimes g_l), \quad (2.3.4)$$

the colors $c_{g_0}, \dots, c_{g_{t-1}}$ and the colored integers $u_{c_{g_0}}^{(0)}, \dots, u_{c_{g_{t-1}}}^{(t-1)}$ satisfy the conditions in Definition 2.1.22 for both relations \succ and $\succ\succ$. We can then define the multi-grounded partition with grounds $c_{g_0}, \dots, c_{g_{t-1}}$ and relation \succ . We denote by $\mathcal{P}_{c_{g_0} \dots c_{g_{t-1}}}^\succ$ the set of all such partitions. We also define the set $\mathcal{P}_{c_{g_0} \dots c_{g_{t-1}}}^{\succ\succ}$ of the multi-grounded partitions with grounds g_0, \dots, g_{t-1} and the relation $\succ\succ$ defined in (2.3.3). In particular for any positive integer d , we denote by ${}^d\mathcal{P}_{c_{g_0} \dots c_{g_{t-1}}}^{\succ\succ}$ the set of the partitions

$$\pi = (\pi_0, \dots, \pi_{s-1}, u_{c_{g_0}}^{(0)}, \dots, u_{c_{g_{t-1}}}^{(t-1)})$$

of $\mathcal{P}_{c_{g_0} \dots c_{g_{t-1}}}^{\succ\succ}$ with $c(\pi_k) = c_{p_k}$ for all $k \in \{0, \dots, s-1\}$, such that

$$\pi_k - \pi_{k+1} - DH_\Lambda(g_{k+1} \otimes g_k) \in d\mathbb{Z}_{\geq 0}, \quad (2.3.5)$$

where we set π_s to be $u_{c_{g_0}}^{(0)}$. We finally set ${}^d\mathcal{P}_{c_{g_0}\cdots c_{g_{t-1}}}^{\gg}$ to be the set of partitions of ${}^d\mathcal{P}_{c_{g_0}\cdots c_{g_{t-1}}}^{\gg}$ with a number of parts divisible by t . The main theorem that connects the perfect crystals and the multi-grounded partitions is the following.

Theorem 2.3.1. *Setting $q = e^{-\delta/d_0D}$ and $c_b = e^{\overline{wt}b}$ for all $b \in \mathcal{B}$, we have $c_{g_0} \cdots c_{g_{t-1}} = 1$, and the character of the irreducible highest weight $U_q(\widehat{\mathfrak{g}})$ -module $L(\Lambda)$ is given by the following expressions:*

$$\sum_{\mu \in {}^d\mathcal{P}_{c_{g_0}\cdots c_{g_{t-1}}}^{\gg}} C(\pi)q^{|\pi|} = e^{-\Lambda} \text{ch}(L(\Lambda)), \quad (2.3.6)$$

$$\sum_{\pi \in {}^d\mathcal{P}_{c_{g_0}\cdots c_{g_{t-1}}}^{\gg}} C(\pi)q^{|\pi|} = \frac{e^{-\Lambda} \text{ch}(L(\Lambda))}{(q^d; q^d)_{\infty}}. \quad (2.3.7)$$

In Chapter 8, we present the crystal base theory and the proof of Theorem 2.3.1

2.3.2 Level one standard modules of $A_{n-1}^{(1)}$: a Lie-theoretic interpretation of Primc's theorem

We present in this section the main results of (Dousse and Konan, 2019b) which make the connection between the generalization of Primc's identity and the representations of the affine type $A_{n-1}^{(1)}$.

Let n be a positive integer, and consider the Cartan datum for the generalized Cartan matrix of affine type $A_{n-1}^{(1)}$. We denote by $\bar{P} = \mathbb{Z}\Lambda_0 \oplus \cdots \oplus \mathbb{Z}\Lambda_{n-1}$ the lattice of the classical weights, where the elements Λ_{ℓ} ($\ell \in \{0, \dots, n-1\}$) are the fundamental weights. The set of all the level 1 classical weights is given by $\bar{P}_1^+ = \{\Lambda_{\ell} : \ell \in \{0, \dots, n-1\}\}$. The null root is denoted by δ , and the simple roots by α_i , $i \in \{0, \dots, n-1\}$. Let $\mathcal{B} = \{v_i : i \in \{0, \dots, n-1\}\}$ be the crystal of the vector representation of $A_{n-1}^{(1)}$ and let $\mathcal{B}^{\vee} = \{v_i^{\vee} : i \in \{0, \dots, n-1\}\}$ be its dual. For all $v_i \in \mathcal{B}$, we denote by $\overline{wt}v_i \in \bar{P}$ the classical weight of v_i . We finally set \mathbb{B} to be the tensor product $\mathcal{B} \otimes \mathcal{B}^{\vee}$.

Given that (1.4.3) and (1.4.5) are energy matrices for perfect crystals coming from the tensor product of the vector representation and its dual in $A_1^{(1)}$ and $A_2^{(1)}$, respectively, it is natural to wonder whether our generalized difference conditions Δ define in (2.2.54) are also energy functions for certain perfect crystals. We answer this question in the affirmative by showing the following.

Theorem 2.3.2. *Let n be a positive integer, and let \mathcal{B} denote the crystal of the vector representation of $A_{n-1}^{(1)}$. The crystal $\mathbb{B} = \mathcal{B} \otimes \mathcal{B}^{\vee}$ is a perfect crystal of level 1. Furthermore, the energy function on $\mathbb{B} \otimes \mathbb{B}$ such that $H((v_0 \otimes v_0^{\vee}) \otimes (v_0 \otimes v_0^{\vee})) = 0$ satisfies for all $k, \ell, k', \ell' \in \{0, \dots, n-1\}$,*

$$H((v_{\ell'} \otimes v_{k'}^{\vee}) \otimes (v_{\ell} \otimes v_k^{\vee})) = \Delta(a_k b_{\ell}; a_{k'} b_{\ell'}), \quad (2.3.8)$$

where Δ is the minimal difference for Primc generalized partitions defined in (2.2.54).

Primc showed Theorem 2.3.2 in the cases $n = 2$ and $n = 3$. The theorem is still true when $n = 1$, in which case the crystal \mathcal{B} has a single vertex and a loop 0, and the corresponding partitions are simply the classical partitions.

In (Benkart et al., 2006), Benkart, Frenkel, Kang, and Lee gave another formulation of the energy function of certain level 1 perfect crystals of classical types, including the $A_{n-1}^{(1)}$ -crystal studied in Theorem 2.3.2. However, they did not give a closed expression valid for all $k, \ell, k', \ell' \in \{0, \dots, n-1\}$ as we have done in Theorem 2.3.2 and (2.2.54). They used the fact that, when removing the 0-arrows from the crystal graph on Figure 9.4, the energy function H is constant on each connected component, and gave a table with the value of H for a representative of each connected component. The value of H for the other vertices can then be obtained by determining to which connected component they belong. Both their and our energy functions satisfy $H((v_0 \otimes v_0^{\vee}) \otimes (v_0 \otimes v_0^{\vee})) = 0$, so they must be the same, even though their expressions differ. In this sense, Theorem 2.3.2 gives a simpler, more explicit and unified formula for the $A_{n-1}^{(1)}$ energy function in (Benkart et al., 2006).

Our proof of Theorem 2.3.2 in Chapter 9 relies on explicitly building paths in the crystal graph. We only treat the case $n \geq 3$, as $n = 1$ and $n = 2$ give crystals with a slightly different shape, and we already know that the theorem is true in these cases.

Theorem 2.3.2 gives a simple explicit expression for the energy function. Using the (KMN)² crystal base character formula of (Kang et al., 1992a), it allows us to relate the generating function $G_n^P(q; b_0, \dots, b_{n-1})$ of generalized Primc partitions with the character of the irreducible highest weight module $L(\Lambda_0)$. This result gives an evaluation of the character of the irreducible highest weight module for the particular weight Λ_0 , but we can extend our techniques to retrieve the characters for the other level 1 weights of \bar{P}_1^+ .

Theorem 2.3.3. *Let n be a positive integer, and let $\Lambda_0, \dots, \Lambda_{n-1}$ be the fundamental weights of $A_{n-1}^{(1)}$. By setting $e^{\text{wt}v_i} = b_i$ and $e^{-\delta} = q$, we have the following identities for any $\ell \in \{0, \dots, n-1\}$:*

$$G_n^P(q; b_0q, \dots, b_{\ell-1}q, b_\ell, \dots, b_{n-1}) = \frac{e^{-\Lambda_\ell} \text{ch}(L(\Lambda_\ell))}{(q; q)_\infty},$$

$$G_n^C(q; b_0q, \dots, b_{\ell-1}q, b_\ell, \dots, b_{n-1}) = G_n^C(q; b_0q, \dots, b_{\ell-1}q, b_\ell, \dots, b_{n-1}) = e^{-\Lambda_\ell} \text{ch}(L(\Lambda_\ell)).$$

Unlike previous connections between character formulas and partition generating functions, where a specific specialization (often the principal specialization) was needed, here we give a **non-dilated character formula**.

Theorem 2.3.4. *Let n be a positive integer, and let $\Lambda_0, \dots, \Lambda_{n-1}$ be the fundamental weights of $A_{n-1}^{(1)}$. For all $\ell \in \{0, \dots, n-1\}$, we have*

$$\begin{aligned} & e^{-\Lambda_\ell} \text{ch}(L(\Lambda_\ell)) \\ &= \frac{1}{(e^{-\delta}; e^{-\delta})_\infty^{n-1}} \sum_{\substack{s_1, \dots, s_{n-1} \in \mathbb{Z} \\ s_0 = s_n = 0}} e^{-s_\ell \delta} \prod_{i=1}^{n-1} e^{s_i \alpha_i} e^{s_i(s_{i+1} - s_i)\delta} \quad (2.3.9) \\ &= \left(\prod_{i=1}^{n-1} \frac{(e^{-i(i+1)\delta}; e^{-i(i+1)\delta})_\infty}{(e^{-\delta}; e^{-\delta})_\infty} \right) \sum_{\substack{r_1, \dots, r_{n-1}: \\ 0 \leq r_j \leq j-1 \\ r_n = 0}} e^{-r_\ell \delta} \prod_{i=1}^{n-1} e^{r_i \alpha_i} e^{r_i(r_{i+1} - r_i)\delta} \\ & \quad \times \left(-e^{(ir_{i+1} - (i+1)r_i - \frac{i(i+1)}{2})\delta - \ell \chi(i \geq \ell > 0)} e^{\sum_{j=1}^i j \alpha_j}; e^{-i(i+1)\delta} \right)_\infty \quad (2.3.10) \\ & \quad \times \left(-e^{((i+1)r_i - ir_{i+1} - \frac{i(i+1)}{2})\delta + \ell \chi(i \geq \ell > 0)} e^{-\sum_{j=1}^i j \alpha_j}; e^{-i(i+1)\delta} \right)_\infty, \end{aligned}$$

where $\delta = \alpha_0 + \dots + \alpha_{n-1}$ is the null root.

The character formula (2.3.9) is, up to a change of variables, a reformulation of the Kac-Peterson character formula for the type $A_{n-1}^{(1)}$ given in (Kac and Peterson, 1984, p. 217). Thus, our partition identity Theorem 2.2.45 combined with theorem 2.3.1, makes the connection between the (KMN)² crystal base character formula and the Kac-Peterson character formula.

The *principal specialization* (Kac, 1990, Chapter 10) for the affine type $A_{n-1}^{(1)}$ consists in transforming the generators with

$$e^{-\alpha_i} \mapsto q \quad \text{for all } i \in \{1, \dots, n-1\}.$$

In that case, we have a natural transformation $b_i := q^i b_0$ and a dilated version of the character formula can be deduced from Theorems 2.2.43 and 2.3.4.

Corollary 2.3.5. *Let n be a positive integer, and let $\Lambda_0, \dots, \Lambda_{n-1}$ be the fundamental weights of $A_{n-1}^{(1)}$. For all $\ell \in \{0, \dots, n-1\}$, the principal specialization of $e^{-\Lambda_\ell} \text{ch}(L(\Lambda_\ell))$, denoted by $\mathbb{F}_\perp(e^{-\Lambda_\ell} \text{ch}(L(\Lambda_\ell)))$, is the generating function of the classical integer partitions with no parts divisible by n :*

$$\begin{aligned} \mathbb{F}_\perp(e^{-\Lambda_\ell} \text{ch}(L(\Lambda_\ell))) &= (q^n; q^n) \times G_n^P(q^n; q^n b_0, \dots, q^{n+\ell-1} b_0, q^\ell, \dots, q^{n-1} b_0) \\ &= (q^n; q^n) \times [x^0] \left(\prod_{i=0}^{\ell-1} (-q^{-i} b_0^{-1} x; q^n)_\infty (-q^{n+i} b_0 x^{-1}; q^n)_\infty \right. \\ & \quad \left. \times \prod_{i=\ell}^{n-1} (-q^{n-i} b_0^{-1} x; q^n)_\infty (-q^i b_0 x^{-1}; q^n)_\infty \right) \\ &= (q^n; q^n) \times [x^0] (-q^{1-\ell} b_0^{-1} x; q)_\infty (q^\ell b_0 x^{-1}; q)_\infty \end{aligned}$$

$$= \frac{(q^n; q^n)}{(q; q)_\infty}.$$

In this particular case, we recover the principal specialization of the Weyl-Kac character formula (Kac, 1990).

2.3.3 Level one standard modules of $A_{2n}^{(2)}, D_{n+1}^{(2)}, A_{2n-1}^{(2)}, B_n^{(1)}, D_n^{(1)}$

We compute the following characters $\text{ch}(L(\Lambda))$.

Theorem 2.3.6. *Let $n \geq 2$, and let $\Lambda_0, \dots, \Lambda_n$ be the fundamental weights and let $\alpha_0, \dots, \alpha_n$ be the simple roots of $A_{2n}^{(2)}$. We have in $\mathbb{Z}[[e^{-\alpha_0}, e^{-\alpha_1}, \dots, e^{-\alpha_n}]]$ that*

$$e^{-\Lambda_0} \text{ch}(L(\Lambda_0)) = \prod_{u=1}^n (-e^{-\delta' - \frac{1}{2}\alpha_n - \sum_{i=u}^{n-1} \alpha_i}, -e^{-\delta' + \frac{1}{2}\alpha_n + \sum_{i=u}^{n-1} \alpha_i}; e^{-2\delta'})_\infty, \quad (2.3.11)$$

where $2\delta' = \delta = 2\alpha_0 + \dots + 2\alpha_{n-1} + \alpha_n$ is the null root.

Theorem 2.3.7. *Let $n \geq 2$, and let $\Lambda_0, \dots, \Lambda_n$ be the fundamental weights and let $\alpha_0, \dots, \alpha_n$ be the simple roots of $D_{n+1}^{(2)}$. We have in $\mathbb{Z}[[e^{-\alpha_0}, e^{-\alpha_1}, \dots, e^{-\alpha_n}]]$ that*

$$e^{-\Lambda_0} \text{ch}(L(\Lambda_0)) = \frac{1}{(e^{-\delta}; e^{-2\delta})_\infty} \cdot \prod_{u=1}^n (-e^{-\delta - \sum_{i=u}^n \alpha_i}, -e^{-\delta + \sum_{i=u}^n \alpha_i}; e^{-2\delta})_\infty, \quad (2.3.12)$$

$$e^{-\Lambda_n} \text{ch}(L(\Lambda_n)) = \frac{1}{(e^{-\delta}; e^{-2\delta})_\infty} \cdot \prod_{u=1}^n (-e^{-\sum_{i=u}^n \alpha_i}, -e^{-2\delta + \sum_{i=u}^n \alpha_i}; e^{-2\delta})_\infty, \quad (2.3.13)$$

where $\delta = \alpha_0 + \dots + \alpha_n$ is the null root.

Theorem 2.3.8. *Let $n \geq 3$, and let $\Lambda_0, \dots, \Lambda_n$ be the fundamental weights and let $\alpha_0, \dots, \alpha_n$ be the simple roots of $A_{2n-1}^{(2)}$. We have in $\mathbb{Z}[[e^{-\alpha_0}, e^{-\alpha_1}, \dots, e^{-\alpha_n}]]$ that*

$$e^{-\Lambda_0} \text{ch}(L(\Lambda_0)) = \frac{(e^{-\delta}; e^{-2\delta})}{2} \cdot \left(\prod_{u=1}^n (-e^{-\frac{\delta}{2} - \frac{\alpha_n}{2} - \sum_{i=u}^{n-1} \alpha_i}, -e^{-\frac{\delta}{2} + \frac{\alpha_n}{2} + \sum_{i=u}^{n-1} \alpha_i}; e^{-\delta})_\infty \right. \\ \left. + \prod_{u=1}^n (e^{-\frac{\delta}{2} - \frac{\alpha_n}{2} - \sum_{i=u}^{n-1} \alpha_i}, e^{-\frac{\delta}{2} + \frac{\alpha_n}{2} + \sum_{i=u}^{n-1} \alpha_i}; e^{-\delta})_\infty \right), \quad (2.3.14)$$

$$e^{-\Lambda_1} \text{ch}(L(\Lambda_1)) = \frac{(e^{-\delta}; e^{-2\delta})}{2} \cdot \left(\prod_{u=1}^n (-e^{-\frac{1-2\chi(u=1)}{2}\delta - \frac{\alpha_n}{2} - \sum_{i=u}^{n-1} \alpha_i}, -e^{-\frac{1+2\chi(u=1)}{2}\delta + \frac{\alpha_n}{2} + \sum_{i=u}^{n-1} \alpha_i}; e^{-\delta})_\infty \right. \\ \left. + \prod_{u=1}^n (e^{-\frac{1-2\chi(u=1)}{2}\delta - \frac{\alpha_n}{2} - \sum_{i=u}^{n-1} \alpha_i}, e^{-\frac{1+2\chi(u=1)}{2}\delta + \frac{\alpha_n}{2} + \sum_{i=u}^{n-1} \alpha_i}; e^{-\delta})_\infty \right), \quad (2.3.15)$$

where $\delta = \alpha_0 + \alpha_1 + 2\alpha_2 + \dots + 2\alpha_{n-1} + \alpha_n$ is the null root.

Theorem 2.3.9. *Let $n \geq 3$, and let $\Lambda_0, \dots, \Lambda_n$ be the fundamental weights and let $\alpha_0, \dots, \alpha_n$ be the simple roots of $B_n^{(1)}$. We have in $\mathbb{Z}[[e^{-\alpha_0}, e^{-\alpha_1}, \dots, e^{-\alpha_n}]]$ that*

$$e^{-\Lambda_n} \text{ch}(L(\Lambda_n)) = \frac{1}{(e^{-\delta}; e^{-2\delta})_\infty} \cdot \prod_{u=1}^n (-e^{-\sum_{i=u}^n \alpha_i}, -e^{-\delta + \sum_{i=u}^n \alpha_i}; e^{-\delta})_\infty \quad (2.3.16)$$

$$e^{-\Lambda_0} \text{ch}(L(\Lambda_0)) = \frac{(e^{-\frac{\delta}{2}}; e^{-\delta})}{2} \cdot \prod_{u=1}^n (-e^{-\frac{\delta}{2} - \sum_{i=u}^n \alpha_i}, -e^{-\frac{\delta}{2} + \sum_{i=u}^n \alpha_i}; e^{-\delta})_\infty \\ + \frac{(e^{-\frac{\delta}{2}}; e^{-\delta})}{2} \cdot \prod_{u=1}^n (e^{-\frac{\delta}{2} - \sum_{i=u}^n \alpha_i}, e^{-\frac{\delta}{2} + \sum_{i=u}^n \alpha_i}; e^{-\delta})_\infty, \quad (2.3.17)$$

$$e^{-\Lambda_1} \text{ch}(L(\Lambda_1)) = \frac{(e^{-\frac{\delta}{2}}; e^{-\delta})}{2} \cdot \prod_{u=1}^n (-e^{-\frac{1-2\chi(u=1)}{2}\delta - \sum_{i=u}^n \alpha_i}, -e^{-\frac{1+2\chi(u=1)}{2}\delta + \sum_{i=u}^n \alpha_i}; e^{-\delta})_\infty \\ + \frac{(e^{-\frac{\delta}{2}}; e^{-\delta})}{2} \cdot \prod_{u=1}^n (e^{-\frac{1-2\chi(u=1)}{2}\delta - \sum_{i=u}^n \alpha_i}, e^{-\frac{1+2\chi(u=1)}{2}\delta + \sum_{i=u}^n \alpha_i}; e^{-\delta})_\infty, \quad (2.3.18)$$

where $\delta = \alpha_0 + \alpha_1 + 2\alpha_2 \cdots + 2\alpha_n$ is the null root.

Theorem 2.3.10. Let $n \geq 4$, and let $\Lambda_0, \dots, \Lambda_n$ be the fundamental weights and let $\alpha_0, \dots, \alpha_n$ be the simple roots of $D_n^{(1)}$. We have in $\mathbb{Z}[[e^{-\alpha_0}, e^{-\alpha_1}, \dots, e^{-\alpha_n}]]$ that

$$\begin{aligned} e^{-\Lambda_0} \text{ch}(L(\Lambda_0)) &= \frac{1}{2} \prod_{u=1}^n \left(-e^{-\frac{\delta}{2} - \frac{\alpha_n - \alpha_{n-1}}{2} - \sum_{i=u}^{n-1} \alpha_i}, -e^{-\frac{\delta}{2} + \frac{\alpha_n - \alpha_{n-1}}{2} + \sum_{i=u}^{n-1} \alpha_i}; e^{-\delta} \right)_{\infty} \\ &+ \frac{1}{2} \prod_{u=1}^n \left(e^{-\frac{\delta}{2} - \frac{\alpha_n - \alpha_{n-1}}{2} - \sum_{i=u}^{n-1} \alpha_i}, e^{-\frac{\delta}{2} + \frac{\alpha_n - \alpha_{n-1}}{2} + \sum_{i=u}^n \alpha_i}; e^{-\delta} \right)_{\infty}, \end{aligned} \quad (2.3.19)$$

$$\begin{aligned} e^{-\Lambda_1} \text{ch}(L(\Lambda_1)) &= \frac{1}{2} \prod_{u=1}^n \left(-e^{-\frac{1-2\chi(u=1)}{2} \delta - \frac{\alpha_n - \alpha_{n-1}}{2} - \sum_{i=u}^{n-1} \alpha_i}, -e^{-\frac{1+2\chi(u=1)}{2} \delta + \frac{\alpha_n - \alpha_{n-1}}{2} + \sum_{i=u}^{n-1} \alpha_i}; e^{-\delta} \right)_{\infty} \\ &+ \frac{1}{2} \prod_{u=1}^n \left(e^{-\frac{1-2\chi(u=1)}{2} \delta - \frac{\alpha_n - \alpha_{n-1}}{2} - \sum_{i=u}^{n-1} \alpha_i}, e^{-\frac{1+2\chi(u=1)}{2} \delta + \frac{\alpha_n - \alpha_{n-1}}{2} + \sum_{i=u}^{n-1} \alpha_i}; e^{-\delta} \right)_{\infty}, \end{aligned} \quad (2.3.20)$$

$$\begin{aligned} e^{-\Lambda_{n-1}} \text{ch}(L(\Lambda_{n-1})) &= \frac{1}{2} \prod_{u=1}^n \left(-e^{-\chi(u=n)\delta - \frac{\alpha_n - \alpha_{n-1}}{2} - \sum_{i=u}^{n-1} \alpha_i}, -e^{-\chi(u \neq n)\delta + \frac{\alpha_n - \alpha_{n-1}}{2} + \sum_{i=u}^{n-1} \alpha_i}; e^{-\delta} \right)_{\infty} \\ &+ \frac{1}{2} \prod_{u=1}^n \left(e^{-\chi(u=n)\delta - \frac{\alpha_n - \alpha_{n-1}}{2} - \sum_{i=u}^{n-1} \alpha_i}, e^{-\chi(u \neq n)\delta + \frac{\alpha_n - \alpha_{n-1}}{2} + \sum_{i=u}^n \alpha_i}; e^{-\delta} \right)_{\infty}, \end{aligned} \quad (2.3.21)$$

$$\begin{aligned} e^{-\Lambda_n} \text{ch}(L(\Lambda_n)) &= \frac{1}{2} \prod_{u=1}^n \left(-e^{-\frac{\alpha_n - \alpha_{n-1}}{2} - \sum_{i=u}^{n-1} \alpha_i}, -e^{-\delta + \frac{\alpha_n - \alpha_{n-1}}{2} + \sum_{i=u}^{n-1} \alpha_i}; e^{-\delta} \right)_{\infty} \\ &+ \frac{1}{2} \prod_{u=1}^n \left(e^{-\frac{\alpha_n - \alpha_{n-1}}{2} - \sum_{i=u}^{n-1} \alpha_i}, e^{-\delta + \frac{\alpha_n - \alpha_{n-1}}{2} + \sum_{i=u}^n \alpha_i}; e^{-\delta} \right)_{\infty}, \end{aligned} \quad (2.3.22)$$

where $\delta = \alpha_0 + \alpha_1 + 2\alpha_2 \cdots + 2\alpha_{n-2} + \alpha_{n-1} + \alpha_n$ is the null root.

An analogous computation for the type $C_n^{(1)}$ is part of a work in progress.

Part II

Rogers-Ramanujan type identities via bijections

Chapter 3

Beyond Göllnitz' theorem

In this chapter, we discuss the results beyond Göllnitz' theorem presented in Section 2.2.1.

In Section 3.1, we will present some tools that will be useful for the proof of Theorem 2.2.7 and Theorem 2.2.9. After that, in Section 3.2, we will give two mappings Φ and Ψ for Theorem 2.2.7 that preserve the size and the color product of partitions. Then, in Section 3.3, we will prove Theorem 2.2.7 by showing that $\Phi(\mathcal{O}) \subset \mathcal{E}$ and $\Psi \circ \Phi|_{\mathcal{O}} = Id|_{\mathcal{O}}$. In Section 3.4, we will set $\mathcal{E}_1 = \Phi(\mathcal{O})$, describe the notion of bridge, and prove Theorem 2.2.9. In Section 3.5, we explain how to generate the forbidden patterns of Theorem 2.2.9, and we especially retrieve in the case of four primary colors the three forbidden patterns as enumerated in Theorem 2.2.1, and we prove that, for more than four primary colors, there is an infinite set of forbidden patterns. In Section 3.6, we give the bijective proof of Theorem 1.3.3. Finally, in Section 3.7, we relate the mapping Ψ to *Motzkin paths* and *oriented rooted forests*, giving new perspectives for the study of the forbidden patterns.

We postpone the proof of the technical lemmas and propositions to Appendix A.1.

3.1 Preliminaries

3.1.1 The setup

Let us first analyze the secondary parts in \mathcal{S} . For any $1 \leq i < j \leq n$, and any positive integer k , we have

$$\begin{aligned} (2k)_{a_i a_j} &= k_{a_j} + k_{a_i} \\ (2k+1)_{a_i a_j} &= (k+1)_{a_i} + k_{a_j}. \end{aligned} \quad (3.1.1)$$

Recall that the sum of two colored parts consists of the part whose size and color are respectively the sum of the sizes and the product (here, commutative) of the colors of the added parts. In fact, any secondary part in \mathcal{S} with color $a_i a_j$ can be uniquely written as the sum of two consecutive parts in \mathcal{P} with colors a_i and a_j in terms of \succ .

Definition 3.1.1. For any $1 \leq i < j \leq n$, we define the functions α and β on \mathcal{S} by

$$\alpha : \begin{cases} 2k_{a_i a_j} & \mapsto k_{a_j} \\ (2k+1)_{a_i a_j} & \mapsto (k+1)_{a_i} \end{cases} \quad \text{and} \quad \beta : \begin{cases} 2k_{a_i a_j} & \mapsto k_{a_i} \\ (2k+1)_{a_i a_j} & \mapsto k_{a_j} \end{cases}, \quad (3.1.2)$$

respectively named *upper* and *lower halves*.

One can check that for any $k_{a_i a_j} \in \mathcal{S}$,

$$\alpha((k+1)_{a_i a_j}) = \beta(k_{a_i a_j}) + 1 \quad \text{and} \quad \beta((k+1)_{a_i a_j}) = \alpha(k_{a_i a_j}). \quad (3.1.3)$$

In the previous sum, adding an integer to a part only changes its size but does not change its color. We can then deduce by induction that for any $m \geq 0$,

$$\alpha((k+m)_{a_i a_j}) \leq \alpha(k_{a_i a_j}) + m \quad \text{and} \quad \beta((k+m)_{a_i a_j}) \leq \beta(k_{a_i a_j}) + m. \quad (3.1.4)$$

Remark 3.1.2. In fact, we have

$$\alpha((k+2m)_{a_i a_j}) = \alpha(k_{a_i a_j}) + m \quad \text{and} \quad \beta((k+2m)_{a_i a_j}) = \beta(k_{a_i a_j}) + m. \quad (3.1.5)$$

Remark 3.1.3. Let us consider a partition λ in \mathcal{O} . By definition (2.2.6), it does not belong to \mathcal{E} if and only if it has two consecutive parts λ_i, λ_{i+1} such that $\lambda_i \not\gg \lambda_{i+1}$. We then have by (2.2.12) that

$$\lambda_i \succ \lambda_{i+1} \quad \text{and} \quad \lambda_i \not\gg \lambda_{i+1} \quad \iff \quad \lambda_{i+1} + 1 \succ \lambda_i \succ \lambda_{i+1}. \quad (3.1.6)$$

An equivalent reformulation consists in saying that λ_i and λ_{i+1} are two primary parts with distinct colors, consecutive in terms of \succ . Then, by (3.1.2), $\lambda_i + \lambda_{i+1}$ can be seen as the unique secondary part with respectively λ_i and λ_{i+1} as its upper and lower halves.

3.1.2 Technical lemmas

We will state some important lemmas for the proof of Theorem 2.2.7 and Theorem 2.2.9. The proofs can be found in Appendices A.1.1, A.1.2 and A.1.3.

Lemma 3.1.4 (Ordering primary and secondary parts). For any $(l_p, k_q) \in \mathcal{P} \times \mathcal{S}$, we have the following equivalences:

$$l_p \not\gg k_q \iff (k+1)_q \gg (l-1)_p, \quad (3.1.7)$$

$$l_p \gg \alpha(k_q) \iff \beta((k+1)_q) \not\prec (l-1)_p. \quad (3.1.8)$$

Lemma 3.1.5 (Ordering secondary parts). Let us consider the table Δ in (2.2.2). Then, for any secondary colors $p, q \in \mathcal{C}_\times$,

$$\Delta(p, q) = \min\{k - l : \beta(k_p) \succ \alpha(l_q)\}. \quad (3.1.9)$$

Moreover, if the secondary parts k_p, l_q are such that $\beta(k_p) \succ \beta(l_q)$, then

$$(k+1)_p \gg l_q. \quad (3.1.10)$$

Furthermore, if $k - l \geq \Delta(p, q)$, we then have either $\beta(k_p) \succ \alpha(l_q)$ or

$$\alpha(l_q) + 1 \gg \alpha((k-1)_p) \succ \beta((k-1)_p) \succ \beta(l_q). \quad (3.1.11)$$

In the case of equality $k - l = \Delta(p, q)$, we necessarily have

$$\beta(l_q) + 1 \succeq \beta(k_p), \quad (3.1.12)$$

and in the other case, we necessarily have that $\beta(k_p) \succ \alpha(l_q)$.

Lemma 3.1.6 (1-different-distance on \mathcal{E}_2). Let us consider a partition $v = (v_1, \dots, v_t) \in \mathcal{E}_2$. Then, for any $1 \leq i < j \leq t$, we have

$$v_i \triangleright v_j + j - i - 1. \quad (3.1.13)$$

3.2 Bressoud's algorithm

Here we adapt the algorithm given by Bressoud in his bijective proof of Schur's partition theorem (Bressoud, 1980). The mappings are easy to describe and execute, but their justifications are more subtle and are given in the next section.

3.2.1 Machine Φ : from \mathcal{O} to \mathcal{E}

Let us consider the following machine Φ :

Step 1: For a sequence $\lambda = \lambda_1, \dots, \lambda_t$, take the smallest $i < t$ such that $\lambda_i, \lambda_{i+1} \in \mathcal{P}$ and $\lambda_i \succ \lambda_{i+1}$ but $\lambda_i \not\gg \lambda_{i+1}$, if it exists, and replace

$$\begin{array}{ll} \lambda_i & \leftarrow \lambda_i + \lambda_{i+1} \quad \text{as a part in } \mathcal{S} \\ \lambda_j & \leftarrow \lambda_{j+1} \quad \text{for all } i < j < t \end{array} \quad (3.2.1)$$

and move to **Step 2**. We call such a pair of parts a *troublesome pair*. We observe that λ loses two parts in \mathcal{P} and gains one part in \mathcal{S} . The new sequence is $\lambda = \lambda_1, \dots, \lambda_{t-1}$. Otherwise, exit from the machine.

Step 2: For $\lambda = \lambda_1, \dots, \lambda_t$, take the smallest $i < t$ such that $(\lambda_i, \lambda_{i+1}) \in \mathcal{P} \times \mathcal{S}$ and $\lambda_i \not\gg \lambda_{i+1}$ if it exists, and replace

$$(\lambda_i, \lambda_{i+1}) \rightsquigarrow (\lambda_{i+1} + 1, \lambda_i - 1) \in \mathcal{S} \times \mathcal{P} \quad (3.2.2)$$

and redo **Step 2**. We say that the parts λ_i, λ_{i+1} are *crossed*. Otherwise, move to **Step 1**.

Let $\Phi(\lambda)$ be the resulting sequence after putting any $\lambda = (\lambda_1, \dots, \lambda_t) \in \mathcal{O}$ in Φ . This transformation preserves the size and the commutative product of primary colors of partitions.

Example 3.2.1. For $\mathcal{C} = \{a < b < c < d\}$, let us apply this machine on the partition $(5_b, 3_d, 2_a, 1_d, 1_c, 1_b, 1_a)$:

$$\begin{array}{ccccccc} \begin{array}{c} 5_b \\ 3_d \\ 2_a \\ 1_d \\ 1_c \\ 1_b \\ 1_a \end{array} & \rightsquigarrow & \begin{array}{c} 5_b \\ 3_d \\ 3_{ad} \\ 1_c \\ 1_b \\ 1_a \end{array} & \rightsquigarrow & \begin{array}{c} 5_b \\ 4_{ad} \\ 2_d \\ 1_c \\ 1_b \\ 1_a \end{array} & \rightsquigarrow & \begin{array}{c} 5_b \\ 4_{ad} \\ 2_d \\ 2_{bc} \\ 1_a \end{array} & \rightsquigarrow & \begin{array}{c} 5_b \\ 4_{ad} \\ 3_{bc} \\ 1_d \\ 1_a \end{array} & \rightsquigarrow & \begin{array}{c} 5_b \\ 4_{ad} \\ 3_{bc} \\ 2_{ad} \end{array} \end{array} \quad (3.2.3)$$

This example shows that $\Phi(\mathcal{O}) \not\subseteq \mathcal{E}_2$.

3.2.2 Machine Ψ : on \mathcal{E}

Let us consider the following machine Ψ :

Step 1: For a sequence $v = v_1, \dots, v_t$, take the greatest $i \leq t$ such that $v_i \in \mathcal{S}$ if it exists. If $v_{i+1} \in \mathcal{P}$ and $\beta(v_i) \not\prec v_{i+1}$, then replace

$$(v_i, v_{i+1}) \rightsquigarrow (v_{i+1} + 1, v_i - 1) \in \mathcal{P} \times \mathcal{S} \quad (3.2.4)$$

and redo **Step 1**. We say that the parts v_i, v_{i+1} are *crossed*. Otherwise, move to **Step 2**. If there are no more parts in \mathcal{S} , exit from the machine.

Step 2: For $v = v_1, \dots, v_t$, take the the greatest $i \leq t$ such that $v_i \in \mathcal{S}$. By **Step 1**, it satisfies $\beta(v_i) \succ v_{i+1}$. Then replace

$$\begin{array}{l} v_{j+1} \leftarrow v_j \\ (v_i) \Rightarrow (\alpha(v_i), \beta(v_i)) \end{array} \quad \begin{array}{l} \text{for all } t \geq j > i \\ \text{as a pair of parts in } \mathcal{P}, \end{array} \quad (3.2.5)$$

and move to **Step 1**. We say that the part v_i *splits*. We observe that v gains two parts in \mathcal{P} and loses one part in \mathcal{S} . The new sequence is $v = v_1, \dots, v_{t+1}$.

Let $\Psi(v)$ be the resulting sequence after putting any $v = (v_1, \dots, v_t) \in \mathcal{E}$ in Ψ . This transformation preserves the size and the product of primary colors of partitions.

Examples 3.2.2. For example, we choose $\mathcal{C} = \{a < b < c < d < e < f\}$ and we apply the machine Ψ respectively on $(4_{ae}, 3_{cd}, 3_{ab})$, $(4_a, 3_{ae}, 2_{cd}, 1_b)$ and $(4_e, 3_{ef}, 3_{cd}, 3_{ab}, 1_f)$, and we obtain

$$\begin{array}{ccccccc} \begin{array}{c} 4_{ae} \\ 3_{cd} \\ 2_a + 1_b \end{array} & \Rightarrow & \begin{array}{c} 4_{ae} \\ 2_c + 1_d \\ 2_a \\ 1_b \end{array} & \rightsquigarrow & \begin{array}{c} 4_{ae} \\ 3_a \\ 1_d + 1_c \\ 1_b \end{array} & \Rightarrow & \begin{array}{c} 2_e + 2_a \\ 3_a \\ 1_d \\ 1_c \\ 1_b \end{array} & \rightsquigarrow & \begin{array}{c} 4_a \\ 2_a + 1_e \\ 1_d \\ 1_c \\ 1_b \end{array} & \Rightarrow & \begin{array}{c} 4_a \\ 2_a \\ 1_e \\ 1_d \\ 1_c \\ 1_b \end{array} \end{array} ,$$

$$\begin{array}{ccc} \begin{array}{c} 4_a \\ 3_{ae} \\ 1_d + 1_c \\ 1_b \end{array} & \Rightarrow & \begin{array}{c} 4_a \\ 2_a + 1_e \\ 1_d \\ 1_c \\ 1_b \end{array} & \Rightarrow & \begin{array}{c} 4_a \\ 2_a \\ 1_e \\ 1_d \\ 1_c \\ 1_b \end{array} \end{array} ,$$

$$\begin{array}{ccccccc}
\begin{array}{c} 4_e \\ 3_{ef} \\ 3_{cd} \\ 2_a + 1_b \\ 1_f \end{array} & \rightsquigarrow & \begin{array}{c} 4_e \\ 3_{ef} \\ 3_{cd} \\ 2_f \\ 1_b + 1_a \end{array} & \Rightarrow & \begin{array}{c} 4_e \\ 3_{ef} \\ 2_c + 1_d \\ 2_f \\ 1_b \\ 1_a \end{array} & \rightsquigarrow & \begin{array}{c} 4_e \\ 3_{ef} \\ 3_f \\ 1_d + 1_c \\ 1_b \\ 1_a \end{array} & \Rightarrow & \begin{array}{c} 4_e \\ 2_e + 1_f \\ 3_f \\ 1_d \\ 1_c \\ 1_b \\ 1_a \end{array} & \rightsquigarrow & \begin{array}{c} 4_e \\ 4_f \\ 1_f + 1_e \\ 1_d \\ 1_c \\ 1_b \\ 1_a \end{array} & \Rightarrow & \begin{array}{c} 4_e \\ 4_f \\ 1_f \\ 1_e \\ 1_d \\ 1_c \\ 1_b \\ 1_a \end{array} .
\end{array}$$

With these examples, we can see that Ψ is not injective on \mathcal{E} and $\Psi(\mathcal{E}) \not\subseteq \mathcal{O}$.

3.3 Proof of Theorem 2.2.7

In this section, we prove Theorem 2.2.7 by showing the following theorem.

Theorem 3.3.1. *The transformation Φ describes an injection from \mathcal{O} into \mathcal{E} such that $\Psi \circ \Phi|_{\mathcal{O}} = Id|_{\mathcal{O}}$.*

Theorem 3.3.1 follows from the next three propositions whose proofs can be found in Appendices A.1.8, A.1.9 and A.1.10.

In the following for any sequence $\mathcal{U} = u_1, \dots, u_t$, we set $g(\mathcal{U}) = u_1$ and $s(\mathcal{U}) = u_t$ respectively the first and the last terms of \mathcal{U} .

Proposition 3.3.2. *Let us consider any $\lambda = (\lambda_1, \dots, \lambda_t) \in \mathcal{O}$. Then, in the process Φ on λ , before the u^{th} application of **Step 1**, there exists a triplet of partitions $(\delta^u, \gamma^u, \mu^u) \in \mathcal{E} \times (\mathcal{E} \cap \mathcal{O}) \times \mathcal{O}$ such that the sequence obtained is $\delta^u, \gamma^u, \mu^u$. Moreover, the triplet $(\delta^u, \gamma^u, \mu^u)$ satisfies the following conditions:*

1. The u^{th} application of **Step 1** occurs in the pairs $(s(\gamma^u), g(\mu^u))$,
2. $s(\delta^u)$ is the $(u - 1)^{\text{th}}$ secondary part of δ^u and satisfies $s(\delta^u) \gg g(\gamma^u)$,
3. μ^{u+1} is the tail of the partition μ^u and has at least one less part than μ^u ,
4. δ^u is the head of δ^{u+1} .

Note that the first triplet for $u = 1$ has the form $(\emptyset, \gamma^1, \mu^1)$ with $(\gamma^1, \mu^1) \in (\mathcal{E} \cap \mathcal{O}) \times \mathcal{O}$ and $(s(\gamma^1), g(\mu^1))$ the first troublesome pair of λ . The fact that $\Phi(\mathcal{O}) \subset \mathcal{E}$ follows from Proposition 3.3.2 since μ^u strictly decreases in terms of number of parts and the process stops as soon as $\mu^u = \emptyset$. In fact, if $\mu^u \neq \emptyset$, then $g(\mu^u)$ exists and we can still apply **Step 1** on the pair $(s(\gamma^u), g(\mu^u))$. The last triplet then has the form $(\delta^{S+1}, \gamma^{S+1}, \emptyset)$ with $(\delta^{S+1}, \gamma^{S+1}) \in \mathcal{E} \times (\mathcal{E} \cap \mathcal{O})$, $s(\delta^{S+1})$ the S^{th} and last secondary part of $\Phi(\lambda)$ and $s(\delta^{S+1}) \gg g(\gamma^{S+1})$ if $\gamma^{S+1} \neq \emptyset$.

Example 3.3.3. *We again take the example $\lambda = (5_b, 3_d, 2_a, 1_d, 1_c, 1_b, 1_a)$ given in (3.2.3). We summarize the triplets of Proposition 3.3.2 in the following table:*

u	δ^u	γ^u	μ^u
1	\emptyset	$5_b, 3_d, 2_a$	$1_d, 1_c, 1_b, 1_a$
2	$5_b, 4_{ad}$	$2_d, 1_c$	$1_b, 1_a$
3	$5_b, 4_{ad}, 3_{bc}$	1_d	1_a
4	$5_b, 4_{ad}, 3_{bc}, 2_{ad}$	\emptyset	\emptyset

Proposition 3.3.4. *Let us consider any $v = v_1, \dots, v_t \in \mathcal{E}$. Then, in the process Ψ on v , after the $(v - 1)^{\text{th}}$ application of **Step 2**, there exists a triplet of partitions $(\delta^v, \gamma^v, \mu^v)$ with $\delta^v \in \mathcal{E}$ and γ^v, μ^v some sequences of primary parts, such that the sequence obtained is $\delta^v, \gamma^v, \mu^v$. Moreover, the triplet $(\delta^v, \gamma^v, \mu^v)$ satisfies the following conditions:*

1. $(s(\gamma^v), g(\mu^v))$ is the troublesome pair resulting from the $(v - 1)^{\text{th}}$ splitting in **Step 2**,
2. $s(\delta^v) \in \mathcal{S}$ so that the next iterations of **Step 1** after the $(v - 1)^{\text{th}}$ **Step 2** occur on this part,
3. μ^v is the tail of the sequence μ^{v+1} and has at least one less part than μ^{v+1} ,
4. δ^{v+1} is the head of δ^v .

The process stops as soon as $\delta^v = \emptyset$, which means that we have split every secondary part of v . If we set S to be the number of secondary parts of v , the last triplet then has the form $(\emptyset, \gamma^{S+1}, \mu^{S+1})$ with $(s(\gamma^{S+1}), g(\mu^{S+1}))$ being a troublesome pair of primary parts. Also, we remark that the first triplet for $v = 1$ is such that $(\delta^1, \gamma^1, \emptyset)$ with δ^1 equal to the head of v up to the last secondary part, and with γ^1 equal to the tail of v after this last part, so that $(\delta^1, \gamma^1) \in \mathcal{E} \times (\mathcal{E} \cap \mathcal{O})$ with $s(\delta^1) \gg g(\gamma^1)$ if $\gamma^1 \neq \emptyset$.

Example 3.3.5. We take the example $v = \Phi(\lambda) = 5_b, 4_{ad}, 3_{bc}, 2_{ad}$ in (3.2.3). We summarize the triplets of Proposition 3.3.4 in the following table:

v	δ^v	γ^v	μ^v
1	$5_b, 4_{ad}, 3_{bc}, 2_{ad}$	\emptyset	\emptyset
2	$5_b, 4_{ad}, 3_{bc}$	1_d	1_a
3	$5_b, 4_{ad}$	$2_d, 1_c$	$1_b, 1_a$
4	\emptyset	$5_b, 3_d, 2_a$	$1_d, 1_c, 1_b, 1_a$

We now show that $\Psi \circ \Phi|_{\mathcal{O}} = Id|_{\mathcal{O}}$ using the following proposition.

Proposition 3.3.6. For any $\lambda \in \mathcal{O}$, if we set $v = \Phi(\lambda)$ and S to be the number of secondary parts of v , then for any $v \in [1, S + 1]$, the triplet of Proposition 3.3.4 is equal to the triplet of Proposition 3.3.2 for $u = S + 2 - v$.

3.4 Description of $\mathcal{E}_1 = \Phi(\mathcal{O})$ and proof of Theorem 2.2.9

In this section, we set $\mathcal{E}_1 = \Phi(\mathcal{O})$, and we give an explicit definition of the bridge for a partition $v \in \mathcal{E}$ in order to fit with the condition given in Theorem 2.2.9. Note that, by setting $\mathcal{E}_1 = \Phi(\mathcal{O})$, the mapping Φ then describes a bijection between \mathcal{O} and \mathcal{E}_1 , and $\Psi = \Phi^{-1}$, so that the identity (2.2.18) holds and this implies Theorem 2.2.9.

3.4.1 Enumeration of parts

Let us consider a partition $v = (v'_1, \dots, v'_{p+s})$ with p primary parts and s secondary parts. We can thus consider the $p + 2s$ primary parts that occur in v by counting both the upper and lower halves of the secondary parts. We then set

$$v = (v_1, \dots, v_{p+2s}) \quad (3.4.1)$$

with J, I and $I + 1$ defined to be respectively the sets of indices of the primary parts, the upper and lower halves of secondary parts. The secondary parts of v are indeed the parts $v_i + v_{i+1}$ for $i \in I$. We can then retrieve the corresponding indices for the parts v'_k with

$$\begin{aligned} v_j &= v'_{j-|I \cap [1,j]|} \quad \text{for all } j \in J, \\ v_i + v_{i+1} &= v'_{i-|I \cap [1,i]|} \quad \text{for all } i \in I. \end{aligned}$$

For ease of notation, we set $I = \{i_1 < \dots < i_s\}$ and $J = \{j_1 < \dots < j_p\}$. We then consider the index set of the *troublesome secondary parts* as defined in (2.2.16),

$$\mathcal{TS}(v) = \{i \in I : v^-(i) \triangleright v_i + v_{i+1} \not\leq v_{i+2} + v_{i+3}\}, \quad (3.4.2)$$

where $v^-(i) = v'_{i-|I \cap [1,i]|}$ is the (primary or secondary) part to the left of $v_i + v_{i+1}$. We recall that, by (2.2.11) and (2.2.12), we do not have $v_i + v_{i+1} \triangleright v_{i+2} + v_{i+3}$ only if the pair of consecutive secondary parts has a pair of colors in \mathcal{SP}_\times .

Example 3.4.1. We take $v = (14_{bd}, 11_a, 10_{ad}, 9_{bc}, 8_{ac}, 3_c, 2_{cd}, 2_{ab}) \in \mathcal{E}$ with $(p, s) = (2, 6)$. Our enumeration gives

$$v = (\underbrace{7_d, 7_d}_{14_{bd}}, 11_a, \underbrace{5_d, 5_a}_{10_{ad}}, \underbrace{5_b, 4_c}_{9_{bc}}, \underbrace{4_c, 4_a}_{8_{ac}}, 3_c, \underbrace{1_d, 1_c}_{2_{cd}}, \underbrace{1_b, 1_a}_{2_{ab}})$$

$$J = \{3, 10\}, \quad I = \{1, 4, 6, 8, 11, 13\}, \quad I + 1 = \{2, 5, 7, 9, 12, 14\},$$

and $\mathcal{TS}(v) = \{4, 11\}$.

We will then define, in the first part of this section, for any $i \in I$, the *Bridge* $\mathbf{Br}_v(i) \geq i$ as an index in $I \cup J$, and the *bridge* as the part $v_{\mathbf{Br}_v(i)}$ corresponding to this index. This definition will fit with the definition of \mathcal{E}_1 given in Theorem 2.2.9, that we can explicitly state in the following theorem.

Theorem 3.4.2 (Explicit definition of \mathcal{E}_1). *The following are equivalent:*

- (1) $\nu \in \mathcal{E}_1 = \Phi(\mathcal{O})$,
- (2) For any $i \in I$ such that $\mathbf{Br}_\nu(i) > i$, we have

$$\nu^-(i) \gg \nu_{\mathbf{Br}_\nu(i)} + \frac{\mathbf{Br}_\nu(i) - i}{2} \not\asymp \nu_i + \nu_{i+1},$$

- (3) (Necessary and sufficient checks) For all $i \in \mathcal{TS}(\nu)$ such that $\mathbf{Br}_\nu(i) > i$, we have

$$\nu_i + \nu_{i+1} \succ \nu_{\mathbf{Br}_\nu(i)} + \frac{\mathbf{Br}_\nu(i) - i}{2}. \quad (3.4.3)$$

Recall that if $\nu \in \mathcal{E}_2$, then $\mathcal{TS}(\nu) = \emptyset$ so that (3) is true. We thus recover the fact that $\mathcal{E}_2 \subset \mathcal{E}_1$.

In the remainder of this section, we will first give an explicit definition of the bridge, describe its properties and show how to easily compute it. Then, we prove Theorem 3.4.2 by proceeding as follows. We first prove that (1) implies (2). After that, we show that (2) implies (1). Finally, we give a proof of the equivalence between (2) and (3).

3.4.2 Definition and properties of the Bridge

For any $i \in I$, let us consider $j = \min(i, p + 2s] \cap J$, if it exists, which is the index of the greatest primary part to the right of the secondary part $\nu_i + \nu_{i+1}$. Otherwise, there is no primary part to its right, and we set $j = p + 2s + 1$. Note that $j - i$ is twice the number of secondary parts ($\nu_i + \nu_{i+1}$ included) between $\nu_i + \nu_{i+1}$ and ν_j , even if we set $\nu_{p+2s+1} = 0_{a_n}$. In all cases, we can set $j = \min(i, p + 2s + 1] \cap (J \cup \{p + 2s + 1\})$.

Definition 3.4.3. We define the *Bridge* $\mathbf{Br}_\nu(i)$ to be as follows :

- If j satisfies

$$\nu_{i'+1} \not\asymp \nu_j + \frac{j - i'}{2} - 1 \quad (3.4.4)$$

for all $i' \in [i, j] \cap I$, we set $\mathbf{Br}_\nu(i) = j$. Note that for $j = p + 2s + 1$, the relation (3.4.4) is never satisfied for the last secondary part, since its upper and lower halves have size greater than 0.

- Otherwise, we define

$$\mathcal{S}_i = \{u \in (i, j) \cap I : \nu_{i'+1} \not\asymp \nu_u + \frac{u - i'}{2} - 1 \quad \forall i' \in [i, u) \cap I\}. \quad (3.4.5)$$

If $\mathcal{S}_i \neq \emptyset$, we then set

$$\mathbf{Br}_\nu(i) = \max \mathcal{S}_i. \quad (3.4.6)$$

Otherwise, we set $\mathbf{Br}_\nu(i) = i$.

Here, we observe that $\mathbf{Br}_\nu(i) \geq i$, and for $\mathbf{Br}_\nu(i) > i$, we have the relation

$$\nu_{i'+1} \not\asymp \nu_{\mathbf{Br}_\nu(i)} + \frac{\mathbf{Br}_\nu(i) - i'}{2} - 1 \quad (3.4.7)$$

for all $i' \in [i, \mathbf{Br}_\nu(i)) \cap I$. Also note that the function \mathbf{Br}_ν is *local*, as it only depends on the maximal sequence of secondary parts and not on the entire partition ν .

Remark 3.4.4. The value $\frac{\mathbf{Br}_\nu(i) - i'}{2}$ indeed corresponds to the difference between the index of the secondary part $\nu'_{i' - |I \cap [1, i')|}$ and the index of the primary or secondary part $\nu'_{\mathbf{Br}_\nu(i) - |I \cap [1, \mathbf{Br}_\nu(i))|}$, so that the relation (3.4.7) can be formulated as follows: the lower half $\nu_{i'+1}$ is not 1-distant-different from $\nu_{\mathbf{Br}_\nu(i)} - 1$.

The definition of bridge as stated above has the sole purpose to make our results simpler to prove.

Hint for the computation of the Bridge

It may seem difficult to compute, but the calculation of the bridge is indeed quite simple as it can be done recursively. In fact, the first hint for the computational method is given by the following lemma, whose proof is postponed to Appendix A.1.4.

Lemma 3.4.5. *The function \mathbf{Br}_v is non-decreasing on I , and for any i such that $\mathbf{Br}_v(i) \in I$, we have*

$$\mathbf{Br}_v(\mathbf{Br}_v(i)) = \mathbf{Br}_v(i).$$

Lemma 3.4.5 allows us to state that for any $i \in I$, $\mathbf{Br}_v(i)$ is either the index of the greatest primary part to the right of $v_i + v_{i+1}$, or the smallest fixed point (by \mathbf{Br}_v) to its right. This fact leads to the following proposition, which gives us the second and final hint for the computation of \mathbf{Br}_v .

Proposition 3.4.6 (Crossing rules for Ψ). *By applying Ψ on $v = (v_1, \dots, v_{p+2s})$, we have that the secondary part $v_i + v_{i+1}$:*

- *does not cross any primary part if and only if $\mathbf{Br}_v(i) = i$,*
- *otherwise, for $i_u = i < \mathbf{Br}_v(i)$, it first crosses the primary part that comes from $v_{\mathbf{Br}_v(i)}$:*

$$g(\gamma^{s+1-u}) = v_{\mathbf{Br}_v(i_u)} + \frac{\mathbf{Br}_v(i_u) - i_u}{2} - 1. \quad (3.4.8)$$

The proof is given in Appendix A.1.11. The relevance of this proposition consists in saying that, during Ψ , the fixed points are the indices of the secondary parts which split directly with no application of **Step 1**, and if a fixed point $i = \mathbf{Br}_v(i)$ is found, then the next fixed point to its left is the index of the smallest secondary part which is not crossed by the upper half v_i during iterations of **Step 1**.

Note that, by definition, the *bridges* are exactly the parts v_i for the fixed points i , along with the primary parts v_j after the tail of a sequence of secondary parts. The key idea to compute the bridge is then to retrieve the fixed points by performing iterations of **Step 1** with the bridges v_j and v_i .

Method to compute the Bridge

The function \mathbf{Br}_v being local, we then consider a maximal sequence of secondary parts, with the ending primary part to its right. The reasoning will be the same when we do not have a primary part at the tail of the sequence. Without loss of generality, we can restrict the partition v to such sequence: $v = (v_1, \dots, v_{2s+1})$ with

$$v_1 + v_2 \gg v_3 + v_4 \gg \dots \gg v_{2s-1} + v_{2s} \gg v_{2s+1}.$$

For simplicity, we show the computation on the following example. We take the set of primary colors $\mathcal{C} = \{a < b < c < d < e < f\}$ and the partition

$$v = (20_{ef}, 20_{ad}, 19_{bc}, 16_{de}, 14_{af}, 11_{ad}, 6_c),$$

or rewritten with our enumeration

$$v = \left(\underbrace{10_f, 10_e}_{i=1}, \underbrace{10_d, 10_a}_{i=3}, \underbrace{10_b, 9_c}_{i=5}, \underbrace{8_e, 8_d}_{i=7}, \underbrace{7_f, 7_a}_{i=9}, \underbrace{6_a, 5_d}_{i=11}, \underbrace{6_c}_{j=13} \right).$$

Recall that to perform **Step 1** of Ψ , we always compare a primary part to the lower half of a secondary part. We then proceed as follows:

1. We start with the sequence

$$(\beta_1, \beta_2, \dots, \beta_s, \alpha_{s+1}) = (v_2, v_4, \dots, v_{2s}, v_{2s+1})$$

consisting of the lower halves and the primary part. Our example gives the sequence

$$\left(\underbrace{10_e, 10_a, 9_c, 8_d, 7_a, 5_d}_{\beta_u, u=1, \dots, 6}, \underbrace{6_c}_{\alpha_7} \right).$$

The first fixed point (starting from the right) corresponds to the first β_u which is 1-different-distant from $\alpha_{s+1} - 1$ in the order \succ . We then have $i_1 = 2u_1 - 1$ if such u_1 exists. If there is no such u_1 , it means that j is the Bridge of all $i \in 2\{1, \dots, s\} - 1$. With our example, we just have to compare the two sequences

$$\begin{aligned} &(10_e, 10_a, 9_c, \underline{8_d}, 7_a, 5_d) \\ &(11_c, 10_c, 9_c, 8_c, 7_c, 6_c) \end{aligned}$$

starting from the right, and we identify the first fixed point, $i_1 = 2u_1 - 1 = 7$, corresponding to the underlined lower half.

2. We redo the same process for the sequence

$$(\beta_1, \beta_2, \dots, \beta_{u_1-1}, \alpha_{u_1}) = (v_2, v_4, \dots, v_{i_1-1}, v_{i_1}),$$

where β_u are the lower halves of the $(u_1 - 1)$ first secondary parts, and α_{u_1} is the upper half the u_1^{th} secondary part, which corresponds to the first Bridge. Our example gives the sequence $(\underbrace{10_e, 10_a, 9_c}_{\beta_{1,2,3}}, 8_e)$ and the sequence comparison

$$\begin{array}{c} (10_e, 10_a, \underline{9_c}) \\ (10_e, 9_e, 8_e) \end{array}$$

and the second fixed point is $i_2 = 2u_2 - 1 = 5$.

3. Following the same process, we apply the comparisons for the sequence

$$(\beta_1, \beta_2, \dots, \beta_{u_k-1}, \alpha_{u_k}) = (v_2, v_4, \dots, v_{i_k-1}, v_{i_k}),$$

in order to retrieve the $(k+1)^{\text{th}}$ fixed point. Here again, we have $i_k = 2u_k - 1$. If there is no β_u which is 1-different-distant from $\alpha_{u_k} - 1$ in the order \succ , we stop the process, as i_k is the last fixed point and becomes the Bridge of the remaining $i < i_k$. In our example the last fixed point is indeed i_2 , since we have the sequence $(\underbrace{10_e, 10_a}_{\beta_{1,2}}, 10_b)$ and the sequence comparison

$$\begin{array}{c} (10_e, 10_a) \\ (11_b, 10_b) \end{array}$$

Note that applying this computation requires in fact s comparisons, starting from the right to the left, to retrieve all of the fixed points, but computing the precise bridge for an i will require as many comparisons as the number of secondary parts to its right. For our example, we summarize the computation of the Bridge with the following table.

i	1	3	5	7	9	11
$\mathbf{Br}_v(i)$	5	5	5	7	13	13

(3.4.9)

By condition (3) of Theorem 3.4.2, to see if $v \in \mathcal{E}_1$, we only need to check the secondary part 20_{ef} , whose bridge corresponds to 10_b , and we have $20_{ef} \succ 10_b + 2$. We then have $v \in \mathcal{E}_1$. One can check that

$$\Psi(v) = (12_b, 11_a, 9_f, 9_e, 9_d, 9_c, 8_e, 8_d, 8_c, 7_a, 6_f, 5_d, 5_a),$$

and that $\Phi(\Psi(v)) = v$.

For the case where the sequence $v = (v_1, \dots, v_{2s})$ does not end by a primary part, the first splitting occurs at the right most secondary part, and we set the first fixed point $i_1 = 2u_1 - 1 = 2s - 1$. We then start the process at step (2) and the remainder of the computation of the bridges is the same.

3.4.3 Proof of Theorem 3.4.2

Proof that (1) implies (2)

We suppose that $i = i_{s+1-v}$ for some $v \in [1, s]$. Then by the Proposition 3.4.6 and Proposition 3.3.4, $v_i + v_{i+1} = s(\delta^v)$ and $g(\gamma^v) = v_{\mathbf{Br}_v(i)} + \frac{\mathbf{Br}_v(i) - i}{2} - 1$. After crossing, the primary part becomes $v_{\mathbf{Br}_v(i)} + \frac{\mathbf{Br}_v(i) - i}{2}$ and the secondary part becomes $v_i + v_{i+1} - 1$. But, by Proposition 3.3.6, the crossing is the reverse crossing of **Step 2** in process Φ , so that we have

$$v_{\mathbf{Br}_v(i)} + \frac{\mathbf{Br}_v(i) - i}{2} \not\geq v_i + v_{i+1} - 1 \iff v_{\mathbf{Br}_v(i)} + \frac{\mathbf{Br}_v(i) - i}{2} \not\leq v_i + v_{i+1}.$$

Also, note that the sequence

$$\delta^v \setminus \{v_i + v_{i+1}\} \quad , \quad v_{\mathbf{Br}_v(i)} + \frac{\mathbf{Br}_v(i) - i}{2}$$

is indeed the head of the sequence $\delta^{v+1}, \gamma^{v+1}$, which is a partition in \mathcal{E} by Proposition 3.3.6. In fact, this pair of sequences corresponds to the same pair in Proposition 3.3.2 for $u = s - v$, and is a pair in $\mathcal{E} \times (\mathcal{E} \cap \mathcal{O})$ satisfying $s(\delta^u) \gg g(\gamma^u)$. We then deduce that the part $v^-(i)$ to the left $v_i + v_{i+1}$ is well-ordered with $v_{\mathbf{Br}_v(i)} + \frac{\mathbf{Br}_v(i) - i}{2}$ in terms of \gg , so that

$$v^-(i) \gg v_{\mathbf{Br}_v(i)} + \frac{\mathbf{Br}_v(i) - i}{2}.$$

With this, we have proved that (1) implies (2) in Theorem 3.4.2.

Proof that (2) implies (1)

We prove that (2) implies (1) with the following proposition whose proof is given in Appendix A.1.12.

Proposition 3.4.7. *If v satisfies condition (2) in Theorem 3.4.2, then in Proposition 3.3.4, the triplet $(\delta^v, \gamma^v, \mu^v)$ satisfies the following properties:*

1. $(\gamma^v, \mu^v) \in (\mathcal{E} \cap \mathcal{O}) \times \mathcal{O}$,
2. $s(\delta^v) \gg g(\gamma^v)$.
3. *If we apply Step 1 once and some iterations of Step 2 of the process Φ on the sequence $\delta^{v+1}, \gamma^{v+1}, \mu^{v+1}$, we obtain the sequence $\delta^v, \gamma^v, \mu^v$.*

Proposition 3.4.7 says that, for any $v \in \mathcal{E}$ that satisfies (2) of Theorem 3.4.2, we have that $\Psi(v) \in \mathcal{O}$, since the last sequence $\delta^{s+1}, \gamma^{s+1}, \mu^{s+1}$ is such that $\delta^{s+1} = \emptyset$ and $(s(\gamma^v), g(\mu^v))$ is a troublesome pair so that $s(\gamma^v) \succ g(\mu^v)$. The fact that all the crossings and the splitting of Ψ are invertible by Φ means that the process Ψ on v is invertible by Φ , and we then have $\mathcal{E}_1 \ni \Phi(\Psi(v)) = v$.

Proof of the equivalence between (2) and (3)

In this part, we will show that it is sufficient to satisfy the condition (2) only on $\mathcal{TS}(v)$. In fact, condition (2) of Theorem 3.4.2 implies that (3.4.3) is true on $\mathcal{TS}(v)$, so that (2) implies (3). To prove that (3) implies (2), we will use the following lemmas (for the proof, see Appendices A.1.5 and A.1.6).

Lemma 3.4.8. *For consecutive secondary parts $v_i + v_{i+1} \gg \dots \gg v_{i'} + v_{i'+1}$ such that*

$$v_i + v_{i+1} \not\prec \dots \not\prec v_{i'} + v_{i'+1},$$

the following holds:

$$v_{i'} + v_{i'+1} + \frac{i' - i}{2} \succ v_i + v_{i+1}. \quad (3.4.10)$$

Lemma 3.4.9. *For consecutive secondary parts $v_i + v_{i+1} \gg \dots \gg v_{i'} + v_{i'+1}$ such that the size differences between consecutive parts are minimal, the following holds: if $\mathbf{Br}_v(i') > i'$, then $\mathbf{Br}_v(i) = \mathbf{Br}_v(i')$.*

Proof that (3) implies (2). Let us consider a maximal sequence of consecutive secondary parts $v_i + v_{i+1} \gg \dots \gg v_{i'} + v_{i'+1}$ with

$$v_i + v_{i+1} \not\prec \dots \not\prec v_{i'} + v_{i'+1}.$$

We then have that the leftmost and rightmost parts are well-ordered in terms of \triangleright with the parts to the left and to the right of the sequence, and we have the inequality

$$\dots \triangleright v_i + v_{i+1} \not\prec \dots \not\prec v_{i'} + v_{i'+1} \triangleright \dots \quad (3.4.11)$$

In particular, $i \in \mathcal{TS}(v)$. Now, let us consider the set

$$\{u \in [i, i'] \cap I : \mathbf{Br}_v(u) > u\}.$$

If it is empty, then any $u \in [i, i'] \cap I$ is a fixed-point of \mathbf{Br}_v . Otherwise, by Lemma 3.4.9, it has the form $[i, u] \cap I$ and \mathbf{Br}_v is the identity on $(u, i'] \cap I$. Furthermore, $\mathbf{Br}_v(i) = \mathbf{Br}_v(u') > u'$ for all $u' \in [i, u] \cap I$.

If we assume that

$$v_i + v_{i+1} \succ v_{\mathbf{Br}_v(i)} + \frac{\mathbf{Br}_v(i) - i}{2},$$

by (3.4.10), we then have for all $u' \in [i, u] \cap I$

$$v_{u'} + v_{u'+1} \succ v_{\mathbf{Br}_v(u')} + \frac{\mathbf{Br}_v(u') - u'}{2} \iff v_{\mathbf{Br}_v(u')} + \frac{\mathbf{Br}_v(u') - u'}{2} \not\succeq v_{u'} + v_{u'+1}.$$

In addition, by (2.2.12), we obtain, for all $u' \in (i, u] \cap I$, that $u' - 2 \in [i, u] \cap I$. We thus have $\mathbf{Br}_v(u' - 2) = \mathbf{Br}_v(u')$, and

$$v_{u'-2} + v_{u'-1} \succ v_{\mathbf{Br}_v(u'-2)} + \frac{\mathbf{Br}_v(u' - 2) - u' + 2}{2} \iff v_{u'-2} + v_{u'-1} \gg v_{\mathbf{Br}_v(u')} + \frac{\mathbf{Br}_v(u') - u'}{2},$$

so that the condition (2) is also satisfied. Note that condition (2) is also satisfied in i , since we have by definition (2.2.11)

$$\begin{aligned} v^-(i) \triangleright v_i + v_{i+1} \succ v_{\mathbf{Br}_v(i)} + \frac{\mathbf{Br}_v(i) - i}{2} &\implies v^-(i) \triangleright v_{\mathbf{Br}_v(i)} + \frac{\mathbf{Br}_v(i) - i}{2} \not\succeq v_i + v_{i+1} \\ &\implies v^-(i) \gg v_{\mathbf{Br}_v(i)} + \frac{\mathbf{Br}_v(i) - i}{2} \not\succeq v_i + v_{i+1}. \end{aligned}$$

It thus follows that the condition (2) is satisfied for any element of I in a sequence of the form (3.4.11).

Now let us take $i \in I$ such that i is not in a sequence of the form (3.4.11). This is equivalent to saying that $v_i + v_{i+1}$ is well-ordered to its left and to its right in terms of \triangleright , so that

$$\cdots \triangleright v_i + v_{i+1} \triangleright \cdots$$

We can then see by (2.2.11) that, for $\mathbf{Br}_v(i) > i$,

$$\begin{aligned} v^-(i) \triangleright v_i + v_{i+1} \succ v_{\mathbf{Br}_v(i)} + \frac{\mathbf{Br}_v(i) - i}{2} &\implies v^-(i) \triangleright v_{\mathbf{Br}_v(i)} + \frac{\mathbf{Br}_v(i) - i}{2} \not\succeq v_i + v_{i+1} \\ &\implies v^-(i) \gg v_{\mathbf{Br}_v(i)} + \frac{\mathbf{Br}_v(i) - i}{2} \not\succeq v_i + v_{i+1}. \end{aligned}$$

This means that we only need to prove that $v_i + v_{i+1} \succ v_{\mathbf{Br}_v(i)} + \frac{\mathbf{Br}_v(i) - i}{2}$ in order to satisfy the condition (2).

- Suppose first that there exists $i' \in \mathcal{TS}(v)$ such that $i' \in (i, \mathbf{Br}_v(i))$. We then have by Lemma 3.4.5 that $\mathbf{Br}_v(i') = \mathbf{Br}_v(i)$. By taking i' to be the minimum of all such elements, we obtain the sequence

$$v_i + v_{i+1} \triangleright \cdots \triangleright v_{i'} + v_{i'+1}$$

so that, by (2.2.11) and the fact that the parts between these two are in \mathcal{S} , we obtain

$$v_i + v_{i+1} \succ v_{i'} + v_{i'+1} + \frac{i' - i}{2}.$$

Since i' satisfies condition (3), we then have

$$v_{i'} + v_{i'+1} \succ v_{\mathbf{Br}_v(i')} + \frac{\mathbf{Br}_v(i') - i'}{2},$$

and thus,

$$v_i + v_{i+1} \succ v_{\mathbf{Br}_v(i)} + \frac{\mathbf{Br}_v(i) - i}{2}.$$

- If $(i, \mathbf{Br}_v(i)) \cap \mathcal{TS}(v) = \emptyset$, we then have the sequence

$$v_i + v_{i+1} \triangleright \cdots \triangleright v_{\mathbf{Br}_v(i)-2} + v_{\mathbf{Br}_v(i)-1} \triangleright v_{\mathbf{Br}_v(i)}$$

if $\mathbf{Br}_v(i) \in J$, and otherwise,

$$v_i + v_{i+1} \triangleright \cdots \triangleright v_{\mathbf{Br}_v(i)-2} + v_{\mathbf{Br}_v(i)-1} \triangleright v_{\mathbf{Br}_v(i)} + v_{\mathbf{Br}_v(i)+1}.$$

By (2.2.11), in the first case, we directly have

$$v_i + v_{i+1} \succ v_{\mathbf{Br}_v(i)} + \frac{\mathbf{Br}_v(i) - i}{2},$$

while in the second case, we obtain

$$v_i + v_{i+1} \succ v_{\mathbf{Br}_v(i)} + v_{\mathbf{Br}_v(i)+1} + \frac{\mathbf{Br}_v(i) - i}{2}.$$

But, in terms of part sizes for the second case, we have by definition (2.2.9) that

$$v_i + v_{i+1} - \left(v_{\mathbf{Br}_v(i)} + \frac{\mathbf{Br}_v(i) - i}{2} \right) \geq v_{\mathbf{Br}_v(i)+1} \geq 1,$$

so that, again by (2.2.9),

$$v_i + v_{i+1} \succ v_{\mathbf{Br}_v(i)} + \frac{\mathbf{Br}_v(i) - i}{2}. \quad \square$$

3.5 Forbidden patterns of \mathcal{E}_1

In this section, we study the forbidden patterns that a partition in \mathcal{E} has to avoid to be in \mathcal{E}_1 .

By the definition of *bridge* and Theorem 3.4.2, we can see that the invertibility of Ψ by Φ is a local problem. In fact, for any secondary part in a partition $\nu \in \mathcal{E}$, the invertibility only depends on the sequence starting from this part up to either the greatest primary part to its right if it exists, or the last part of ν if there is no primary part to its right. Furthermore, by condition (3) of Theorem 3.4.2, we only have to consider the sequences whose head is a sequence which is not well-ordered by \triangleright . Then, it suffices to restrict the forbidden patterns to those such that the first part does not satisfy (3.4.3):

$$\nu = \nu_1 + \nu_2 \not\succeq \nu_3 + \nu_4 \gg \cdots \gg \nu_{2s+1} \quad \text{or} \quad \nu_{2s+1} + \nu_{2s+2}, \quad (3.5.1)$$

such that $\mathbf{Br}_\nu(1) = 2s + 1$ and $\nu_{2s+1} + s \succ \nu_1 + \nu_2$.

Remark 3.5.1. *It is sufficient to consider the last part to be a primary part. In fact, a sequence that ends by a secondary part can be viewed as the same sequence with this last part replaced by its upper half, as by (2.2.8) and (2.2.12),*

$$\begin{aligned} \nu_{2s-1} + \nu_{2s} \gg \nu_{2s+1} + \nu_{2s+2} &\implies \nu_{2s-1} + \nu_{2s} \succ \nu_{2s+1} + \nu_{2s+2} \\ &\implies \nu_{2s-1} + \nu_{2s} \succ \nu_{2s+1} + 1 \\ &\implies \nu_{2s-1} + \nu_{2s} \gg \nu_{2s+1}. \end{aligned}$$

Note that, if a pattern ν is forbidden, then any pattern η whose head or tail is ν is also forbidden. This is obvious when the tail of η is ν since the troublesome crossing will not change. When ν is the head of η , we have that $\mathbf{Br}_\eta(1) = \mathbf{Br}_\eta(\mathbf{Br}_\nu(1))$ and we use the same reasoning as in the proof of Lemma 3.1.6 given in Appendix A.1.3 to show that

$$v_{\mathbf{Br}_\nu(1)} + \frac{\mathbf{Br}_\nu(1) - 1}{2} \succ \nu_1 + \nu_2 \implies \eta_{\mathbf{Br}_\eta(1)} + \frac{\mathbf{Br}_\eta(1) - 1}{2} \succ \eta_1 + \eta_2.$$

Therefore, the *optimal* forbidden patterns are the ones that are allowed after removing either the first part or the last part. Furthermore, these forbidden patterns satisfy the fact that the Bridge of the first part is the position of the last part, so that all along the transformation Ψ , every secondary part is crossed by the last part if it is a primary part, or by its upper half. The optimization also implies that all these crossings are invertible by Φ , except the last one which occurs with the first part of the pattern.

In the next subsections, we first give some particular properties of the optimal forbidden patterns, and after that, we aim at retrieving the optimal forbidden patterns for four primary colors. Finally, we enumerate the optimal forbidden patterns, with some restrictions, for five primary colors, showing that there is an infinitude of optimal forbidden patterns for more than four primary colors.

3.5.1 Properties of optimal forbidden patterns

We first define a tool that will lead to a better understanding of the optimal forbidden patterns.

Definition 3.5.2. We say that two secondary colors p and q are *primary equivalent* if and only if their orders according to the primary colors are the same, which means that $p = a_i a_u$ and $q = a_i a_v$ for some $u, v \in (i, n]$. If p and q are primarily equivalent, we write $k_p \equiv k_q$ and write the corresponding equivalence class of primarily equivalent colored parts by $\overline{k_p}$. This matters in the sense that for any primary color c , we have the equivalence between $k_p \equiv k_q$ and

$$k_p \succ l_c \iff k_q \succ l_c. \quad (3.5.2)$$

We can then write $\overline{k_p} \succ l_c$. For two secondary colors p and q , we say that $\overline{k_p} \succ \overline{h_q}$ if and only if we can find a primary part l_c such that $\overline{k_p} \succ l_c \succ \overline{h_q}$. This is equivalent to saying that $k > h$ or $k = h$ and $(p, q) = (a_i a_u, a_j a_v)$ with $i > j$.

Let us now consider an optimal forbidden pattern

$$v = v_1 + v_2 \not\prec v_3 + v_4 \gg \cdots \gg v_{2s+1} \quad (3.5.3)$$

where the secondary parts are $v_{2i-1} + v_{2i}$ and the last part v_{2s+1} is a primary part. In the remainder of the section, we consider the different-distance with respect to the order \succ . We thus have the following properties:

1. For all $i \in [1, s]$, we have $\mathbf{Br}_v(2i - 1) = 2s + 1$.

2. The part v_{2s+1} is 1-different-distant from $\overline{v_1 + v_2}$:

$$v_{2s+1} + s \succ \overline{v_1 + v_2}. \quad (3.5.4)$$

3. The fact that the pattern $v_3 + v_4 \gg \cdots \gg v_{2s-1} + v_{2s} \gg v_{2s+1}$ is allowed implies by Theorem 3.4.2, for all $i \in [2, s]$, that $v_{2i-1} + v_{2i}$ is 1-different-distant from v_{2s+1} ,

$$\overline{v_{2i-1} + v_{2i}} \succ v_{2s+1} + s + 1 - i, \quad (3.5.5)$$

and by transitivity, this implies that $\overline{v_{2i-1} + v_{2i}}$ is 1-different-distant from $\overline{v_1 + v_2 - i + 1}$,

$$\overline{v_{2i-1} + v_{2i}} \succ \overline{v_1 + v_2 - i + 1}. \quad (3.5.6)$$

4. We obtain the following inequality

$$\overline{v_3 + v_4 + 1} \succ v_{2s+1} + s \succ \overline{v_1 + v_2}. \quad (3.5.7)$$

5. If we replace the primary part v_{2s+1} by another v'_{2s+1} satisfying $v_1 + v_2 \succ v'_{2s+1} + s$, we then obtain the following allowed pattern

$$v' = v_1 + v_2 \not\prec v_3 + v_4 \gg \cdots \gg v_{2s-1} + v_{2s} \gg v'_{2s+1}.$$

Remark 3.5.3. By (3.5.1), a pattern $v_1 + v_2 \gg \cdots \gg v_{2s-1} + v_{2s} \gg v_{2s+1} + v_{2s+2}$ only consisting of secondary parts is optimal and forbidden if and only if $v_1 + v_2 \gg \cdots \gg v_{2s-1} + v_{2s} \gg v_{2s+1}$ is an optimal forbidden pattern. Note that in this case, (3.5.6) is also satisfied for $i = s + 1$.

We now define a special kind of pattern, that we call a *shortcut*.

Definition 3.5.4. A pattern $v_1 + v_2 \gg \cdots \gg v_{2s+1} + v_{2s+2}$ is said to be a shortcut if

$$\overline{v_{2s+1} + v_{2s+2}} \succ \overline{v_1 + v_2 - s + 1}. \quad (3.5.8)$$

One can check that a shortcut has at least three secondary parts, and that the relation (3.5.8) is stronger than (3.5.6). The following property makes the enumeration of optimal forbidden patterns which contain shortcuts quite difficult (see Appendix A.1.13 for the proof).

Proposition 3.5.5. We can always build a forbidden pattern starting from any allowed pattern and iterating of a shortcut (iterate here means use consecutively the same pattern several times).

By considering the optimal forbidden pattern $v = v_1 + v_2 \not\prec v_3 + v_4 \gg \cdots \gg v_{2s+1}$ which does not contain any shortcut, we then have by (3.5.4), (3.5.5) and (3.5.8) the following relation for all $i \in \{1, \dots, s-1\}$:

$$\overline{v_1 + v_2 - i + 1} \succ \overline{v_{2i+1} + v_{2i+2}} \succ v_{2s+1} + s - i \succ \overline{v_1 + v_2 - i}. \quad (3.5.9)$$

The latter implies the following properties:

1. By definition of the head and (2.2.12), $v_1 + v_2$ and $v_3 + v_4$ are consecutive for \succ .
2. For all $i \in \{2, \dots, s-1\}$, two consecutive parts $v_{2i-1} + v_{2i}$ and $v_{2i+1} + v_{2i+2}$ are either consecutive in terms of \succ (or equivalently not well-ordered by \triangleright), or consecutive in terms of \triangleright . In fact, by (3.5.9), we necessarily have

$$\overline{v_{2i+1} + v_{2i+2} + 2} \succ \overline{v_{2i-1} + v_{2i}} \implies v_{2i-1} + v_{2i} \not\prec v_{2i+1} + v_{2i+2} + 2.$$

3. By (3.5.9), we have

$$v_{2s+1} + 2 \succ \overline{v_1 + v_2 - s + 2} \succeq \overline{v_{2s-1} + v_{2s}} \succ v_{2s+1} + 1,$$

so that, by (2.2.11), $v_{2s-1} + v_{2s}$ and v_{2s+1} are consecutive for \triangleright .

We see that the optimal forbidden patterns with no shortcut have their parts either consecutive in the order \succ or in the order \triangleright . Let us then consider the following moves:

- The arrow $p \rightarrow q$ means that (p, q) is a special pair and it represents a pattern of the form

$$(k + \chi(p \leq q))_{p, k_q}.$$

- The two-headed arrow $p \rightarrow q$ represents a move from a part with color p to the greatest secondary part with color q smaller than the first part in terms of \triangleright . In fact, it indeed represents the pattern

$$k + 1 + \chi(p \leq q))_{p, k_q}.$$

Therefore, the optimal forbidden patterns with no shortcut have the form

$$c_1 \circ \cdots \circ c_m \quad , \quad k \quad (3.5.10)$$

where c_1, \dots, c_m are some colors, \circ is either \rightarrow or \rightarrow , and k is the size of the smallest part, so that the last part is k_{c_m} .

Example 3.5.6. For $\mathcal{C} = \{a < b < c < d\}$, the pattern

$$ad \rightarrow bc \rightarrow cd \rightarrow b \quad , \quad 5$$

will represent the pattern $9_{ad}, 8_{bc}, 6_{cd}, 5_b$.

Since an optimal forbidden pattern is allowed after removing the last part, we will consider the following form

$$c_1 \circ \cdots \circ c_{m-1} | \circ c_m \quad , \quad k \quad (3.5.11)$$

If we refer to an optimal pattern into another one (see Proposition 3.5.10), then it means that we only use the allowed pattern obtained after removing the last part.

3.5.2 Optimal forbidden patterns of \mathcal{E}_1 for four primary colors

For four primary colors $a < b < c < d$, recall (2.2.6), the total order on primary and secondary colors

$$ab < ac < ad < a < bc < bd < b < cd < c < d \quad (3.5.12)$$

and the set of special pairs $\mathcal{SP}_\times = \{(ad, bc), (cd, ab)\}$.

Theorem 3.5.7. The optimal forbidden patterns are the following:

$$cd \rightarrow ab | \rightarrow c, d \quad , \quad k \geq 1 \quad (3.5.13)$$

$$ad \rightarrow bc | \rightarrow a \quad , \quad k \geq 2 \quad . \quad (3.5.14)$$

Proof. Let us consider the following diagram:

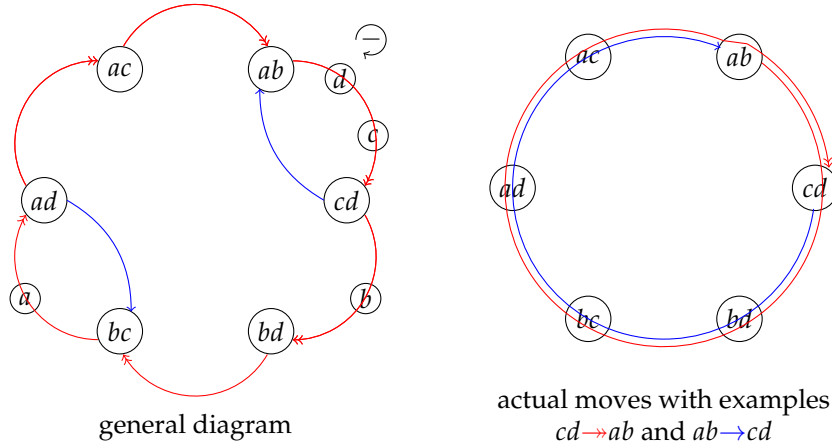

We can see that the main nodes are the secondary colors, and we remark that a move $p \rightarrow q$ is indeed between p and the color q of the greatest secondary part smaller, in terms of \triangleright , than a part with color p . Thus, any move $p \rightarrow q'$ with another secondary color q' will be *greater* than the move $p \rightarrow q$ represented in the first diagram. As we notice on the second diagram, proceeding clockwise, we need more than one loop for a move $p \rightarrow q$, while a move $p \rightarrow q$ requires less than one loop.

Since a forbidden pattern must necessarily begin with a sequence of secondary parts not well-ordered by \triangleright , we then have as the head of the pattern either $cd \rightarrow ab$ or $ad \rightarrow bc$.

- Suppose that the pattern begins by $cd \rightarrow ab$. By (3.5.7), if it ends with a primary part k_{c_s} , by setting $\nu_1 + \nu_2 = h_{cd}$ we then have

$$h_{ab} + 1 \succ k_{c_s} + s \succ h_{cd}$$

so that $c_m \in \{c, d\}$. Another interpretation is that, in the diagram, the color c_m is in the clockwise arc (ab, cd) , and it leads to the same result. Suppose now that $s \geq 3$, which means that the third part is secondary. Since the next move can be at least $ab \rightarrow cd$, we then obtain that

$$h_{cd} - 2 \succeq \nu_5 + \nu_6 \implies \overline{h_{cd} - 2} \succeq \overline{\nu_5 + \nu_6}.$$

This contradicts (3.5.6). Therefore, $s = 2$ and, by (3.5.7), we obtain the pattern $cd \rightarrow ab \rightarrow c, d$. It actually corresponds to the pattern $(k+2)_{cd}, (k+2)_{ab}, k_{c,d}$. Here $k_{c,d}$ means k_c or k_d . Since we must necessarily have that

$$\beta((k+2)_{ab}) \not\succeq k_{c,d}$$

and a quick check according to the parity of k shows that is always the case for $k \geq 1$.

- The same reasoning occurs when the pattern begins by $ad \rightarrow bc$. We obtain the pattern $ad \rightarrow bc \rightarrow a$ which corresponds to $(k+2)_{ad}, (k+1)_{bc}, k_a$. We then look for k such that

$$\beta((k+1)_{bc}) \not\succeq k_a$$

and a quick check according to the parity of k shows that is always the case for $k \geq 2$.

Note that we cannot have a optimal forbidden pattern consisting of three secondary parts, since whatever the head is, the third secondary part does not respect the relation (3.5.6). \square

Theorem 3.5.7 and Proposition 3.5.5 imply that, for four primary colors, we do not have any shortcut. This is not the case for more than four primary colors, as we now see in the next subsection.

3.5.3 Optimal forbidden patterns of \mathcal{E}_1 for more than four primary colors

We can restrict the study to five colors, as the set of colored partitions generated by five primary colors is embedded in any set of colored partitions generated by more than four primary colors. We then consider the set of primary colors $\mathcal{C} = \{a < b < c < d < e\}$. The corresponding diagram with the primary equivalence classes for the secondary colors gives

where **pattern** $\in \langle \rightarrow (3.5.16) \rangle$

$$(3.5.22)(\rightarrow be)(\rightarrow bd)(\rightarrow bc) \mid \rightarrow a \quad , \quad k \geq 2 \quad (3.5.23)$$

head: $de \rightarrow bc$

$$de \rightarrow bc \mid \rightarrow a \quad , \quad k \geq 2 \quad (3.5.24)$$

$$de \rightarrow bc \quad (\mathbf{pattern}) \mid \rightarrow e \quad , \quad k \geq 1 \quad (3.5.25)$$

where **pattern** $\in \langle \rightarrow (3.5.23), \rightarrow (3.5.20), \rightarrow (3.5.19), (\rightarrow ae) \rightarrow (3.5.15) \rangle$

$$(3.5.25)(\rightarrow ae)(\rightarrow ad)(\rightarrow ac)(\rightarrow ab) \mid \rightarrow e \quad , \quad k \geq 1 \quad (3.5.26)$$

$$(3.5.26) \mid \rightarrow d \quad , \quad k \geq 2 \quad (3.5.27)$$

$$(3.5.26) \mid \rightarrow d \quad , \quad 1 \quad (3.5.28)$$

with (3.5.26) not ending by ae, be

$$(3.5.25) \rightarrow (3.5.22) \mid \rightarrow be, bd \quad , \quad 2 \quad (3.5.29)$$

$$(3.5.25) \rightarrow (3.5.23) \mid \rightarrow ae \quad , \quad 2 \quad (3.5.30)$$

$$(3.5.30) \mid \rightarrow ad \quad , \quad 2 \quad (3.5.31)$$

with (3.5.30) not ending by be

head: $cd, ce \rightarrow ab$

$$cd, ce \rightarrow ab \mid \rightarrow d, e \quad , \quad k \geq 1 \quad (3.5.32)$$

$$cd, ce \rightarrow ab(\mathbf{pattern}) \mid \rightarrow c \quad , \quad k \geq 2 \quad (3.5.33)$$

where **pattern** $\in \langle \rightarrow (3.5.17), \rightarrow (3.5.18), \rightarrow (3.5.26) \rangle$

$$(3.5.33) \rightarrow de \mid \rightarrow c \quad , \quad k \geq 2 \quad (3.5.34)$$

$$(3.5.33) \mid \rightarrow c \quad , \quad 1 \quad (3.5.35)$$

with (3.5.33) ending by ac, ab, bc

$$(3.5.33) \rightarrow (3.5.29) \rightarrow be \mid \rightarrow cd \quad , \quad 3 \quad (3.5.36)$$

$$(3.5.33) \rightarrow (3.5.30) \rightarrow ae \mid \rightarrow cd \quad , \quad 3 \quad (3.5.37)$$

$$(3.5.33) \rightarrow (3.5.25)(\rightarrow ae) \rightarrow ad \mid \rightarrow ac \quad , \quad 2 \quad (3.5.38)$$

$$(3.5.33) \rightarrow (3.5.25) \mid \rightarrow ac \quad , \quad 2 \quad (3.5.39)$$

with (3.5.25) ending by bc

Proof of Theorem 3.5.10. We recall that the optimal forddiden patterns

$$v = v_1 + v_2 \not\prec v_3 + v_4 \gg \cdots \gg v_{2s+1}$$

with no shortcut have the form described in (3.5.11):

$$c_1 \circ \cdots \circ c_s \mid \circ c_{s+1} \quad , \quad k \quad .$$

The part $v_{2i-1} + v_{2i}$ has the secondary color c_i for all $i \in [1, s]$, and the primary part v_{2s+1} has the color c_{s+1} .

Rule 1 : For all $i \in [2, s]$, c_{s+1} belongs to the clockwise arc (\bar{c}_i, \bar{c}_1) . In fact, by (3.5.9), we have that

$$v_{2s+1} + s - i + 2 \succ \overline{v_1 + v_2 - i + 2} \succeq \overline{v_{2i-1} + v_{2i}} \succ v_{2s+1} + s - i + 1,$$

so that by starting a clockwise loop in the diagram from \bar{c}_i , we respectively meet c_{s+1}, \bar{c}_1 and \bar{c}_i .

Rule 2 : If we have a move $c_i \rightarrow c_{i+1}$, then c_{i+1} strictly belongs to the clockwise arc (c_i, c_{s+1}) . In fact, we have by the primary equivalence definition and (3.5.9) that

$$v_{2s+1} + s + 2 - i \succ v_{2i-1} + v_{2i} \succ v_{2s+1} + s + 1 - i \succ v_{2i+1} + v_{2i+2} \succ v_{2s+1} + s - i$$

and the move $c_i \rightarrow c_{i+1}$ implies that

$$v_{2i-1} + v_{2i} \triangleright v_{2i+1} + v_{2i+2} \iff v_{2i-1} + v_{2i} - 1 \succ v_{2i+1} + v_{2i+2}.$$

We thus obtain the following inequality

$$v_{2s+1} + s + 1 - i \succ v_{2i-1} + v_{2i} - 1 \succ v_{2i+1} + v_{2i+2} \succ v_{2s+1} + s - i.$$

With these two rules, we can retrieve all the optimal forbidden patterns. In our construction, we will see that our moves are indeed minimal with respect to \gg . This means that, in the case where $(c_i, c_{i+1}) \in \mathcal{SP}_{\times}$, we necessarily make the move $c_i \rightarrow c_{i+1}$. By Lemma 3.4.9, with the minimality of the consecutive size differences, once the part ν_{2s+1} crosses the parts $\nu_{2s-1} + \nu_{2s}$, it then crosses all the parts up to $\nu_1 + \nu_2$. Therefore, the choice of the size k is such that the part $k_{c_{s+1}}$ crosses the last secondary part $(k + 1 + \chi(c_s \leq c_{s+1}))_{c_s}$. We thus have

$$k_{c_{s+1}} \geq \beta((k + 1 + \chi(c_s \leq c_{s+1}))_{c_s}). \tag{3.5.40}$$

We then proceed as follows.

1. We select a head $c_1 \rightarrow c_2$, and c_{s+1} a primary color in the clockwise arc (c_2, c_1) . Let us begin with those with the shortest arc.
2. The next move must necessarily be of the form $c_2 \rightarrow c_3$.
 - (a) With Rule 2, the patterns (3.5.15),(3.5.16),(3.5.17) and (3.5.19) follow immediately. In fact, in these cases, the only primary colors in the arc (c_1, c_2) directly follow c_2 in the clockwise sense before all the secondary colors.

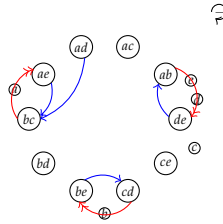

- (b) We also obtain the patterns (3.5.21),(3.5.24), and (3.5.32) since the chosen primary color is directly after c_2 .

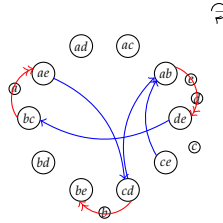

- (c) In the case (3.5.18) and (3.5.20), there is only one secondary color in the arc which occurs before the chosen primary color, and we can see that from this color we only have moves of the form \rightarrow . The only possibility if we choose c_3 to be this secondary color will be then to directly reach the primary color at c_4 . We can also decide to choose c_3 as the primary color. We recall that

$$c_1 \rightarrow c_2(\rightarrow c_3) \rightarrow c_4$$

means that the choice of the secondary color in between c_2 and the primary color c_4 is optional.

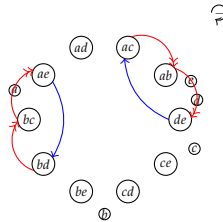

For all these cases, one can check that it is not possible to build from them some forbidden pattern with only secondary parts.

3. The remaining case is where c_3 is in the arc (c_2, c_{s+1}) and such that we can have a move $c_3 \rightarrow c_4$. We then use the following property of our optimal forbidden pattern due to (3.5.9): *when we do m moves from the first color to another secondary color, in the diagram, we do around the first color fewer than m but at least $m - 1$ primary loops*. This means that, by taking the allowed pattern resulting from the removal of the last part in an optimal forbidden pattern beginning by $c_3 \rightarrow c_4$, we will always satisfy (3.5.9). For this reason, we begin with $c_1 \rightarrow c_2 = ae \rightarrow cd$ and $c_{s+1} = a$.

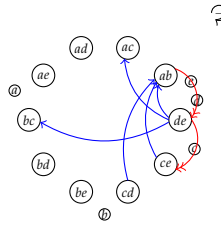

We use the same reasoning to show that the only moves that can leave the arc (ab, c) are (3.5.26), (3.5.18), (3.5.17). As before, in the composition of these moves, we remark that we do not make a move $cd \rightarrow$ and the secondary colors stay in the clockwise arc (cd, c) . Once we do not make these moves, we can only go to c by optionally passing by de through \rightarrow . For these patterns, the passage from $de = c_1$ to c_s requires more than $s - 1$ primary loops, so that the pattern

$$cd, ce \cdots c_s \rightarrow ce, cd$$

requires $s + 1$ primary loops. We obtain the optimal forbidden patterns consisting of only secondary parts, always by choosing those corresponding to optimal forbidden patterns ending primary colors and such that the upper half of the last part corresponds to the primary color and is at least equal to the lower half of the previous secondary part.

□

To conclude, we see that for more than four colors, there exist some shortcuts. However, even for five colors, the set of optimal forbidden patterns without shortcut is infinite, as a consequence of Theorem 3.5.10, since some patterns use as many iterations of others. The enumeration of the forbidden patterns then becomes intricate for more than four primary colors.

3.6 Bijective proof of Theorem 1.3.3

In this section, we will describe a bijection for proving Theorem 1.3.3. For brevity, we refer to the partitions in Theorem 1.3.3 as quaternary partitions. We first observe the following major fact. Looking at the forbidden patterns in Theorem 3.5.7, one can check by (2.2.6) that if we have in ν , the pattern

$$k_{cd}, k_{ab}, l_p$$

we then necessarily have $(k - 2)_{cd} \geq l_p$, and if we have the pattern

$$(k + 1)_{ad}, k_{bc}, l_p \neq 3_{ad}, 2_{bc}, 1_a,$$

we then necessarily have $(k - 1)_{ad} \geq l_p$. In all cases, if we have in a partition of \mathcal{E}_1 a pattern

$$M, m, l_p$$

with $(M, m) \in \{(k_{cd}, k_{ab}), ((k + 1)_{ad}, k_{bc})\}$ such that $M, m, l_p \neq 3_{ad}, 2_{bc}, 1_a$, then

$$M - 2 \geq l_p. \tag{3.6.1}$$

3.6.1 From \mathcal{E}_1 to quaternary partitions

We consider the patterns $((k + 1)_{ad}, k_{bc}), (k_{cd}, k_{ab})$ and sum them as follows :

$$\begin{aligned} (k + 1)_{ad} + k_{bc} &= (2k + 1)_{abcd} \\ k_{cd} + k_{ab} &= 2k_{abcd}. \end{aligned} \tag{3.6.2}$$

Let us now take a partition ν in \mathcal{E}_1 . We then identify all the patterns $(M^i, m^i) \in \{((k + 1)_{ad}, k_{bc}), (k_{cd}, k_{ab})\}$ and assume that

$$\nu = (\nu_1, \dots, \nu_x, M^1, m^1, \nu_{x+1}, \dots, \nu_y, M^2, m^2, \nu_{y+1}, \dots, M^t, m^t, \dots, \nu_s).$$

As long as we have a pattern ν_j, M^i, m^i , we cross the parts by replacing them using

$$\nu_j, M^i, m^i \mapsto M^i + 1, m^i + 1, \nu_j - 2. \tag{3.6.3}$$

At the end of the process, we obtain a final sequence

$$N^1, n^1, N^2, n^2, \dots, N^t, n^t, v'_1, \dots, v'_s.$$

Finally, the associated pair of partitions is set to be $(K^1, \dots, K^t), v' = (v'_1, \dots, v'_t)$, where $K^i = N^i + n^i$ according to (3.6.2).

We remark that, for each quaternary part K^i obtained by summing of the original pattern M^i, m^i , we add twice the number of the remaining primary and secondary parts in v to the left of the pattern that gave K^i , while we subtract from these parts two times the number of quaternary parts obtained by patterns that occur to their right.

Example 3.6.1. With the example $11_c, 10_{cd}, 10_{ab}, 6_d, 5_{ab}, 3_{ad}, 2_{bc}, 1_a$,

$$\begin{array}{ccccccc}
 \begin{array}{l} 11_c \\ 10_{cd} \\ 10_{ab} \\ 6_d \\ 5_{ab} \\ 3_{ad} \\ 2_{bc} \\ 1_a \end{array} & \mapsto & \begin{array}{l} 11_c \\ 10_{cd}, 10_{ab} \\ 6_d \\ 5_{ab} \\ 3_{ad}, 2_{bc} \\ 1_a \end{array} & \mapsto & \begin{array}{l} 11_{cd}, 11_{ab} \\ 9_c \\ 6_d \\ 5_{ab} \\ 3_{ad}, 2_{bc} \\ 1_a \end{array} & \mapsto & \begin{array}{l} 11_{cd}, 11_{ab} \\ 9_c \\ 6_d \\ 4_{ad}, 3_{bc} \\ 3_{ab} \\ 1_a \end{array} & \mapsto & \begin{array}{l} 11_{cd}, 11_{ab} \\ 9_c \\ 5_{ad}, 4_{bc} \\ 4_d \\ 3_{ab} \\ 1_a \end{array} & \mapsto & \begin{array}{l} 11_{cd}, 11_{ab} \\ 6_{ad}, 5_{bc} \\ 7_c \\ 4_d \\ 3_{ab} \\ 1_a \end{array} .
 \end{array}$$

we obtain $[(22_{abcd}, 11_{abcd}), (7_c, 4_d, 3_{ab}, 1_a)]$.

We now proceed to show that the image of this mapping is indeed a quaternary partition. The inverse mapping will be presented in the next subsection.

1. **Quaternary parts are well-ordered.** Let us consider two consecutive patterns $(M^j, m^j) = (k_p, l_q)$ and $(M^{j+1}, m^{j+1}) = (k'_{p'}, l'_{q'})$. Since v is well-ordered by \gg , we have by (2.2.12) and (2.2.11) that

$$l_q \triangleright l_{p_1}^1 \triangleright \dots \triangleright l_{p_i}^i \triangleright k'_{p'} . \quad (3.6.4)$$

By (2.2.11), we then have that $l_q \succ k'_{p'} + i + 1$ so that $l - k' \geq i + 1 + \chi(q \leq p')$. Since by (2.2.12), $k - l = \chi(p \leq q)$ and $k' - l' = \chi(p' \leq q')$, we then have that

$$\begin{aligned}
 k + l - (k' + l') &= \chi(p \leq q) + \chi(p' \leq q') + 2(l - k') \\
 &\geq \chi(p \leq q) + \chi(p' \leq q') + 2\chi(q \leq p') + 2i + 2
 \end{aligned}$$

and we obtain that

$$\begin{aligned}
 \chi(cd \leq ab) + \chi(cd \leq ab) + 2\chi(ab \leq cd) &= 2 \\
 \chi(cd \leq ab) + \chi(ad \leq bc) + 2\chi(ab \leq ad) &= 3 \\
 \chi(ad \leq bc) + \chi(cd \leq ab) + 2\chi(bc \leq cd) &= 3 \\
 \chi(ad \leq bc) + \chi(ad \leq bc) + 2\chi(bc \leq ad) &= 2,
 \end{aligned}$$

so that $k + l - (k' + l') \geq 4 + 2i$. We will then have, after adding twice the remaining primary and secondary elements to their left, that the difference between two consecutive quaternary parts will be at least 4.

2. **The partition v' is in \mathcal{E}_2 .** Let us consider two consecutive elements $v_x = k_p, v_{x+1} = l_q$. We then have for consecutive patterns M^u, m^u in between k_p and l_q that

$$k_p \triangleright M^i \gg m^i \gg \dots \gg M^j \gg m^j \triangleright l_q . \quad (3.6.5)$$

Then, in the case that $(M^j, m^j, l_p) \neq (3_{ad}, 2_{bc}, 1_a)$, we necessarily have by (3.6.1) that $M^u \succeq M^{u+1} + 2$, $M^j \succeq l_q + 2$, and by (2.2.12), we have that $k_p \succ M^i + 1$, and then

$$k_p \succ 1 + 2(j - i + 1) + l_q \implies k_p \triangleright 2(j - i + 1) + l_q . \quad (3.6.6)$$

For the case $(M^j, m^j, l_p) = (3_{ad}, 2_{bc}, 1_a)$, we obtain by (3.6.1) that

$$k_p - 2(j - i + 1) + 1 \succ 3_{ad} \quad (3.6.7)$$

and this means that $k_p - 2(j - i + 1) + 1 \succeq 3_a$ so that $k_p - 2(j - i + 1) \succeq 2_a \triangleright 1_a$.

In any case, $k_p \triangleright 2(j - i + 1) + l_p$, and this implies that after the subtraction of twice the number of the quaternary parts obtained to their right, these parts will be well-ordered by \triangleright .

3. **The minimal quaternary part is well-bounded.** Let us first suppose that the tail of ν consists only of patterns M^u, m^u . We then have that

$$\nu_s \triangleright M^i \gg m^i \gg \dots \gg M^t \gg m^t$$

and, then by (3.6.1), $\nu_s - 2(t - i + 1) + 1 \succeq M^t \succeq 2_{cd}$, so that $\nu'_s = \nu_s - 2(t - i + 1) \succeq 1_{cd} \succ 1_a$. This means that $1_a \notin \nu'$. We also obtain that $K^t = M^t + m^t + 2s \geq 2s + 4$.

Now suppose that the tail of ν has the form

$$l_q \triangleright \nu_u \triangleright \dots \triangleright \nu_s, \quad (3.6.8)$$

with $M^t, m^t = k_p, l_q$. By (2.2.11), we obtain that $l_q \succ \nu_s + s - u + 1$.

- If $\nu_s = 1_a$, we then have

$$\begin{aligned} k + l &= \chi(p \leq q) + 2l \\ &\geq \chi(p \leq q) + 2(s - u + 2 + \chi(q \leq a)) \\ &= 2(s - u + 1) + 2 + \chi(p \leq q) + 2\chi(q \leq a), \end{aligned}$$

and with $(p, q) \in \{(ad, bc), (cd, ab)\}$ we have

$$\begin{aligned} \chi(ad \leq bc) + 2\chi(bc \leq a) &= 1 \\ \chi(cd \leq ab) + 2\chi(ab \leq a) &= 2 \end{aligned}$$

so that $k + l \geq 2(s - u + 1) + 3$. Then after the addition of $2(u - 1)$ for the remaining primary and secondary parts of ν to the left of the pattern (M^t, m^t) , we obtain that the smallest quaternary part is at least $2s + 3$. Note that $\nu'_s = \nu_s = 1_a$.

- When $\nu_s = h_r \neq 1_a$, we obtain that

$$\begin{aligned} k + l &\geq \chi(p \leq q) + 2(s - u + 1 + h + \chi(q \leq r)) \\ &= 2(s - u + 1) + 2h + \chi(p \leq q) + 2\chi(q \leq r), \end{aligned}$$

so that if $h \geq 2$, then $k + l \geq 2(s - u + 1) + 4$. If not, $h = 1$, and since there is no secondary part of length 1, we necessary have that $r \geq b$, so that $\chi(q \leq r) = 1$ whenever $q \in \{ab, bc\}$. We thus obtain $k + l \geq 2(s - u + 1) + 4$. We then conclude that for $\nu_s \neq 1_a$, the smallest quaternary part is at least $2s + 4$.

In any case, we have that the smallest quaternary part is at least $2s + 4 - \chi(1_a \in \nu')$.

3.6.2 From quaternary partitions to \mathcal{E}_1

Recall by (3.6.2) that K_{abcd} splits as follows :

$$\begin{aligned} (k + 1)_{ad} + k_{bc} &= (2k + 1)_{abcd} \\ k_{cd} + k_{ab} &= 2k_{abcd} \end{aligned}$$

Let us consider partitions (K^1, \dots, K^t) and $\nu = (\nu_1, \dots, \nu_s) \in \mathcal{E}_2$, with quaternary part K^u such that $K^t \geq 4 + 2s - \chi(1_a \in \nu)$ and $K^u - K^{u+1} \geq 4$. We also set $K^u = (k^u, l^u)$, the decomposition according to (3.6.2). We then proceed as follows by beginning with K^t and ν_1 ,

Step 1: If we do not encounter $K^{u+1} = (k^{u+1}, l^{u+1})$ and $\nu_i \neq 1_a$ and $\nu_i + 2 \triangleright k^u - 1$, then replace

$$\begin{aligned} \nu_i &\longmapsto \nu_i + 2 \\ (k^u, l^u) &\longmapsto (k^u - 1, l^u - 1) \end{aligned}$$

and move to $i + 1$ and redo **Step 1**. Otherwise, move to **Step 2**.

Step 2 If we encounter $K^{u+1} = k^{u+1} \gg l^{u+1}$, then split (k^u, l^u) into $k^u \gg l^u$. If not, it means that we have met v_i such that $v_i + 2 \not\prec k^u - 1$. Then we split $k^u \gg l^u$. Since we have $v_i + 2 \not\prec k^u - 1$, which is equivalent by (2.2.11) to $k^u \succeq v_i + 2$, by (3.6.1), this is exactly the condition to avoid the forbidden patterns, with $k^u \gg l^u \triangleright v_i$.

We can now move to **Step 1** with $u - 1$ and $i = 1$.

With the example $[(22_{abcd}, 11_{abcd}), (7_c, 4_d, 3_{ab}, 1_a)]$, we obtain

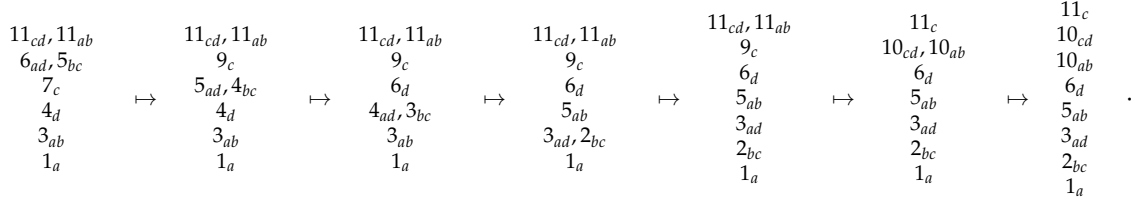

It is easy to check that when two quaternary parts meet in **Step 2**, we will always have $l^u \gg k^{u+1}$, since this is exactly the condition for the minimal difference $K^u - K^{u+1} \geq 4$ and they crossed the same number of v_i . We can also check that even if the minimal part crossed $v_1, \dots, v_s \neq 1_a$, we will still have at the end $K^t \geq 4$ and for $v_s = 1_a, K^t \geq 5$. We see with (3.6.2) that the length of m^t is at least equal to 2, and for the case $v_s = 1_a, m^t$ is at least equal to $2_{bc} \gg 1_a$. The partition obtained is then in \mathcal{E}_1 .

3.7 Bressoud's algorithm, Motzkin paths and oriented rooted forests

In this section, we relate the partitions in \mathcal{E} to oriented rooted forests, and give a new potential approach to deal with the enumeration of the forbidden patterns.

Let us take a partition $\nu \in \mathcal{E}$ and write it as

$$\nu = (v_1, \dots, v_{p+2s}), \tag{3.7.1}$$

where as before, p is the number of primary parts and s is the number of secondary parts. We recall that the set J is the set of indices that correspond to the primary parts, and I corresponds to the upper halves, so that $I + 1$ is associated to the lower halves.

We observe that the sequence $\lambda = \Psi(\nu)$ has also $p + 2s$ primary parts. We then have $\lambda = \lambda_1, \dots, \lambda_{p+s}$. For any $x \in [1, p + 2s]$, we set θ_x to be the index in λ of the primary part that comes from v_x .

Example 3.7.1. As an example, we apply Φ to the partition $\lambda = (12_a, 7_b, 6_d, 6_c, 5_a, 4_d, 4_c, 4_b, 4_a, 3_c, 1_d, 1_c, 1_b, 1_a)$ and take $\nu = \Phi(\lambda)$:

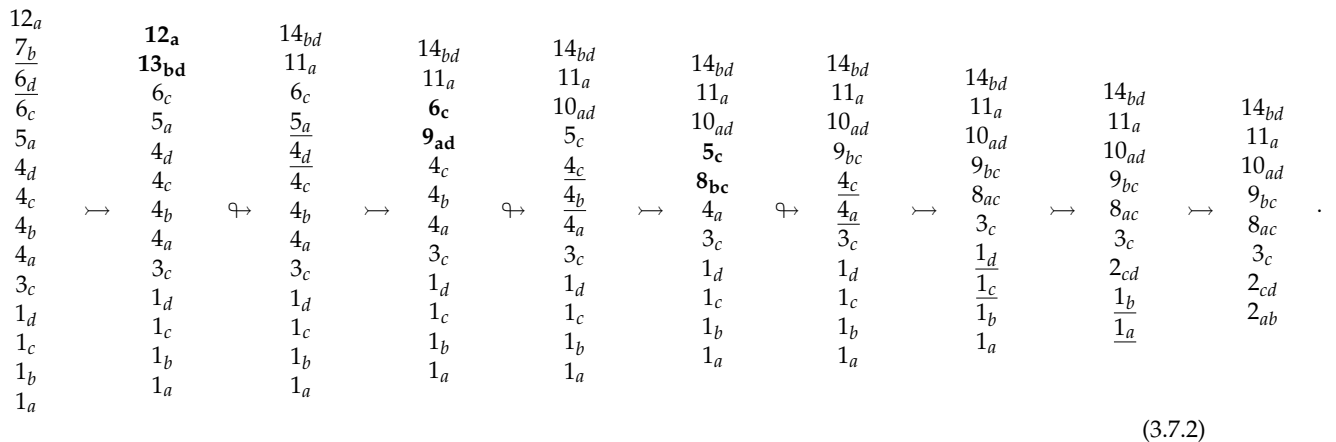

$$\tag{3.7.2}$$

We retrieve the partition ν of Example 3.4.1. By considering the occurrences of the primary parts, we obtain the following diagram:

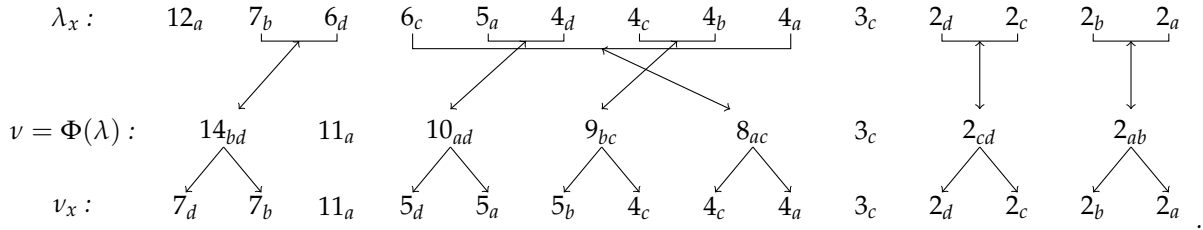

We recall that

$$(p, s) = (2, 6), \quad J = \{3, 10\}, \quad I = \{1, 4, 6, 8, 11, 13\}, \quad I + 1 = \{2, 5, 7, 9, 12, 14\}$$

and we have

x	1	2	3	4	5	6	7	8	9	10	11	12	13	14
θ_x	2	3	1	5	6	7	8	4	9	10	11	12	13	14

(3.7.3)

We also compute \mathbf{Br}_v for $v = \Phi(\lambda)$ and we obtain

i	1	4	6	8	11	13
$\mathbf{Br}_v(i)$	3	8	8	8	11	13

(3.7.4)

The most important results of this part are the following (proofs in Appendices A.1.14 and A.1.15).

Proposition 3.7.2 (Motzkin path behavior of the final positions). For any $(i, i', j, j') \in I^2 \times J^2$, we have the following relations:

$$\text{If } i < i', \text{ then either } \theta_i < \theta_{i+1} < \theta_{i'} < \theta_{i'+1} \text{ or } \theta_{i'} < \theta_i < \theta_{i+1} < \theta_{i'+1}. \quad (3.7.5)$$

$$\text{If } j < j', \text{ then } \theta_j < \theta_{j'}. \quad (3.7.6)$$

$$i + 1 \leq \theta_{i+1} \text{ and } \theta_j \leq j. \quad (3.7.7)$$

$$\text{Either } \theta_j < \theta_i \text{ or } \theta_{i+1} < \theta_j. \quad (3.7.8)$$

Proposition 3.7.3 (Bridge according to the final positions). For any $i \in I$, we have the following:

- If there exists $i < j \in J$ such that $\theta_j < \theta_i$, then

$$\mathbf{Br}_v(i) = \min\{j \in J : j > i \text{ and } \theta_j < \theta_i\}. \quad (3.7.9)$$

- Otherwise,

$$\mathbf{Br}_v(i) = \max\{i' \in I : i' \geq i \text{ and } \theta_{i'} \leq \theta_i\}. \quad (3.7.10)$$

Remark 3.7.4. We indeed have by Proposition 3.7.2 for all $i \in I$ that

$$\theta_{i+1} - (i + 1) = |\{u \in I \sqcup J : u > i \text{ and } \theta_u < \theta_i\}|,$$

and Proposition 3.7.3 gives the following equivalence:

$$\mathbf{Br}_v(i) = i \iff \theta_{i+1} = i + 1.$$

Let us set $I = \{i_1 < \dots < i_s\}$ and $J^+ = J \sqcup \{0, p + 2s + 1\} = \{j_0 < j_1 < \dots < j_p < j_{p+1}\}$ and $(\theta_0, \theta_{p+2s+1}) = (0, p + 2s + 1)$. Then, by (3.7.6) and (3.7.8) of Proposition 3.7.2, for any consecutive $j, j' \in J^+$, there exists a unique $V \subset \{1, \dots, s\}$ such that

$$\{\theta_j + 1, \dots, \theta_{j'} - 1\} = \{\theta_x : x \in \{i_v, i_v + 1 : v \in V\}\}.$$

This means that the final positions between those of consecutive primary parts consist of those of the upper and lower halves of some secondary parts. By (3.7.5), we can check that those secondary parts are consecutive, and V is indeed an interval. Since the positions θ_{i+1} form an increasing sequence, we then have a unique decomposition

$$\{1, \dots, s\} = V_0 \sqcup V_1 \sqcup \dots \sqcup V_p$$

where the V_y are consecutive intervals.

We refer the reader to the book of R. Stanley (Stanley, 1997) for the definition of the combinatorial terms we use in the following. In each interval, the positions behave like a *Dyck path*. In fact, the positions θ_i of the upper halves occur as the moves $(1, 1)$ and the positions θ_{i+1} of the lower halves as the moves $(1, -1)$. We also draw the positions θ_j of the primary parts as the moves $(1, 0)$, and we obtain what is called a *Motzkin path* (also see Donaghey and Shapiro, 1977). With the bijection between *Dyck paths* of length $2l$ and the oriented rooted trees with l edges, one can then see the initial positions as an oriented rooted forest with exactly $p + 1$ trees and s edges.

Example 3.7.5. We take the corresponding representations for the example (3.7.2). We then have that

$$(i_1, i_2, i_3, i_4, i_5, i_6) = (1, 4, 6, 8, 11, 13), \quad (j_0, j_1, j_2, j_3) = (0, 3, 10, 15)$$

and

$$0, \dots, 15 = \theta_{j_0}, \theta_{j_1}, \theta_{i_1}, \theta_{i_1+1}, \theta_{i_4}, \theta_{i_2}, \theta_{i_2+1}, \theta_{i_3}, \theta_{i_3+1}, \theta_{i_4+1}, \theta_{j_2}, \theta_{i_5}, \theta_{i_5+1}, \theta_{i_6}, \theta_{i_6+1}, \theta_{j_3}$$

and the representations correspond to the following diagrams:

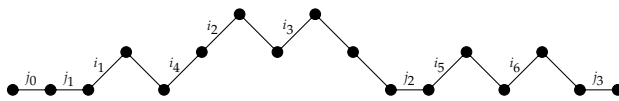

Motzkin path representation

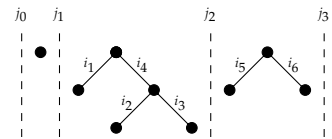

Forest representation

Note that while we still keep track of the primary parts as the horizontal moves in Motzkin paths, they *vanish* in oriented rooted forests. However, we can manage to record all information of the partition ν in the oriented rooted forest by weighting the edges with the corresponding secondary part, while recording each primary part on the root to its right. The optimal forbidden pattern ending by a primary part will then be represented by a weighted oriented rooted tree.

Let us now consider the edges of the roots. In terms of *Motzkin paths*, they exactly correspond to the meeting points with the horizontal axis. For the final positions, they correspond to the elements $i \in I$ that satisfy $\theta_{i+1} < \theta_{i'}$ for all $i' > i$. By Proposition 3.7.3, in the case where the Bridge is not a element of J , it then corresponds to some root's edge. This means that the study of optimal forbidden patterns not ending by a primary part can be reduced to the study of *planted trees* weighted by the secondary parts. The planted trees are indeed in bijection with the oriented trees with one fewer edge, and the problem then becomes the same as the previous case.

To conclude, we see that we can reduce the study of the optimal forbidden patterns to the study of weighted oriented rooted trees, and this give a new perspective to investigate the precise enumeration of these patterns.

Chapter 4

Beyond Siladić's theorem

In this chapter, we discuss the result beyond Siladić's theorem.

We first present in Section 4.1 the main operator for our bijection, which acts as an energy transfer on the particles. Then, in Section 4.2, we explicitly give the bijective maps for Theorem 2.2.15, whose well-definedness is proved in Section 4.3. Finally, in Section 4.4, we conclude with some remarks related to the theory of perfect crystals.

4.1 Energy transfer

In this section, we define an operator on the pairs of particles of different degree (primary and secondary), presented as an energy transfer. This operator is a variant of the crossing operator used in Chapter 3 for the generalization of Göllnitz' theorem.

The proof of the technical lemmas and propositions are postponed to Appendix A.2.

Definition 4.1.1. We define a mapping Λ on $\mathcal{P} \times \mathcal{S} \sqcup \mathcal{S} \times \mathcal{P}$ by the following:

$$\begin{array}{ccc} \mathcal{P} \times \mathcal{S} & \longrightarrow & \mathcal{S} \times \mathcal{P} \\ (k, c), (k', c', c'') & \longmapsto & (k' + \epsilon(c', c''), c, c'), (k - \epsilon(c, c') - \epsilon(c', c''), c'') \end{array} \quad (4.1.1)$$

$$\begin{array}{ccc} \mathcal{S} \times \mathcal{P} & \longrightarrow & \mathcal{P} \times \mathcal{S} \\ (k, c, c'), (k', c'') & \longmapsto & (k' + \epsilon(c, c') + \epsilon(c', c''), c), (k - \epsilon(c', c''), c', c'') \end{array} \quad (4.1.2)$$

What does Λ do to the particles? Let us consider the following diagrams according to the occurrences of primary states:

$$\begin{array}{ccc} \mathcal{P} \times \mathcal{S} \longrightarrow \mathcal{S} \times \mathcal{P} : & \begin{array}{ccc} & \xrightarrow{-\epsilon(c, c') - \epsilon(c', c'')} & \\ c & \xleftarrow{+\epsilon(c, c')} c' & \xleftarrow{+\epsilon(c', c'')} c'' \\ & & \end{array} \\ \mathcal{S} \times \mathcal{P} \longrightarrow \mathcal{P} \times \mathcal{S} : & \begin{array}{ccc} & \xrightarrow{+\epsilon(c, c') + \epsilon(c', c'')} & \\ c & \xrightarrow{-\epsilon(c, c')} c' & \xrightarrow{-\epsilon(c', c'')} c'' \\ & & \end{array} \end{array}$$

These diagrams encode the transfer of energies that occurs during the application of Λ . For example, one can understand the process on the first diagram as follows:

1. The lower half (k', c'') moves from state c'' to c' and gains the minimal energy $\epsilon(c', c'')$:

$$\begin{array}{ccc} & c' & \longleftarrow c'' \\ k' + \epsilon(c', c'') & \longleftarrow & k' \end{array} \quad .$$

2. The upper half $(k' + \epsilon(c', c''), c')$ moves from state c' to c and gains the minimal energy $\epsilon(c, c')$:

$$\begin{array}{ccc} & c & \longleftarrow c' \\ k' + \epsilon(c, c') + \epsilon(c', c'') & \longleftarrow & k' + \epsilon(c', c'') \end{array} \quad .$$

3. The primary particle (k, c) moves from state c to state c'' , through state c' , and loses the energy of transfer $\epsilon(c, c') + \epsilon(c', c'')$:

$$\begin{array}{ccccc} c & \longrightarrow & c' & \longrightarrow & c'' \\ k & \longrightarrow & k - \epsilon(c, c') & \longrightarrow & k - \epsilon(c, c') - \epsilon(c', c'') \end{array} .$$

The second diagram follows exactly the same transfer of energies. We can then see Λ as a *energy transfer* that conserves the sequence of states but switches particles with the minimal loss or gain of energies. One can check that the operator Λ is an involution, i.e. $\Lambda^2 = Id$.

In the following, if we apply Λ to a pair of particles (x, y) in $\mathcal{P} \times \mathcal{S} \sqcup \mathcal{S} \times \mathcal{P}$, we say that we *cross* the particles x and y .

Example 4.1.2. We take $\mathcal{C}' = \{a < b\}$ in Example 2.1.7. We then have that $\Lambda(3_{ab}, -10_{\bar{a}}) = (-9_a, 2_{b\bar{a}})$. The energy transfer that occurs can be summarized by the following diagram

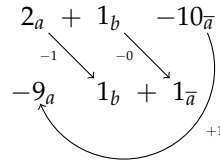

The main proposition that follows from the definition of Λ is the following.

Proposition 4.1.3. For any $(p, s) \in \mathcal{P} \times \mathcal{S}$, let $(s', p') = \Lambda(p, s)$. We then have the following:

$$p \not\gg_{\epsilon} s \iff s' \gg_{\epsilon} p', \quad (4.1.3)$$

$$p \not\prec_{\epsilon} \gamma(s) \iff \mu(s') \gg_{\epsilon} p'. \quad (4.1.4)$$

The proof is given in Appendix A.2.4. The relation (4.1.3) means that the operator Λ allows us to order, in terms of \gg_{ϵ} , two particles of different degree which are not well-related. This property stands as the key result that will allow us to construct the mapping Φ from \mathcal{O}_{ϵ} to \mathcal{E}_{ϵ} . On the other hand, the relation (4.1.4), more subtle to explain, will play a major role in the inverse Ψ of Φ .

4.2 Bijective maps for Theorem 2.2.15

We present in this section the bijective proof of Theorem 2.2.15. This bijection rests on the energy transfer defined in the previous section.

4.2.1 From \mathcal{O}_{ϵ} to \mathcal{E}_{ϵ}

We now present the map Φ from \mathcal{O}_{ϵ} to \mathcal{E}_{ϵ} .

Let us take any $\lambda \in \mathcal{O}_{\epsilon}$. We set $\lambda = (\lambda_1, \dots, \lambda_s)$ with $\lambda_k \succ_{\epsilon} \lambda_{k+1}$ for any $k \in \{1, \dots, s-1\}$. We illustrate this map on an example with $\mathcal{C}' = \{a < b\}$ and ϵ as described in Example 2.1.7:

$$\lambda = (11_{\bar{b}}, 5_b, 5_a, 5_a, 4_{\bar{a}}, 2_a, 1_b, 1_{\bar{a}}, 0_a, 0_{\bar{b}}, -1_b, -2_b).$$

Step 1: First identify the consecutive disjoint troublesome pairs of particles $(\lambda_k, \lambda_{k+1})$ such that $\lambda_k \not\gg_{\epsilon} \lambda_{k+1}$, by beginning by those with the **smallest** potentials (from the right to the left). Then, sum up these troublesome pairs $(\lambda_k, \lambda_{k+1})$ to have the secondary particles corresponding to $\lambda_k + \lambda_{k+1}$, without changing the order of the particles. We then obtain a new sequence of particles (where particles are not necessarily well-related in terms of \gg_{ϵ}) $\lambda' = (\lambda'_1, \dots, \lambda'_t)$, with particles λ'_k in \mathcal{O}_{ϵ} and \mathcal{E}_{ϵ} . With our example, we have the troublesome pairs

$$\lambda = (11_{\bar{b}}, 5_b, \underbrace{5_a, 5_a}_{10_{a^2}}, \underbrace{4_{\bar{a}}, 2_a}_{3_{ab}}, \underbrace{1_b, 1_{\bar{a}}}_{1_{\bar{a}b}}, \underbrace{0_a, 0_{\bar{b}}}_{-1_{\bar{b}b}}, -1_b, -2_b)$$

and we obtain

$$\lambda' = (11_{\bar{b}}, 5_b, \underbrace{10_{a^2}}, 4_{\bar{a}}, \underbrace{3_{ab}}, \underbrace{1_{\bar{a}b}}, \underbrace{-1_{\bar{b}b}}, -2_b).$$

Step 2: As long as there is a pair $(\lambda'_k, \lambda'_{k+1}) \in (\mathcal{P} \times \mathcal{S}) \sqcup (\mathcal{S} \times \mathcal{P})$ such that $\lambda'_k \not\gg_\epsilon \lambda'_{k+1}$, cross the particles in the pair with the operator Λ :

$$(\lambda'_k, \lambda'_{k+1}) \longrightarrow \Lambda(\lambda'_k, \lambda'_{k+1}).$$

The order in which we operate the crossings is not specified here. Let us then apply this process on our example according to whether we choose the particles with the greatest or the smallest potentials for each application of Λ . We then have the following diagrams:

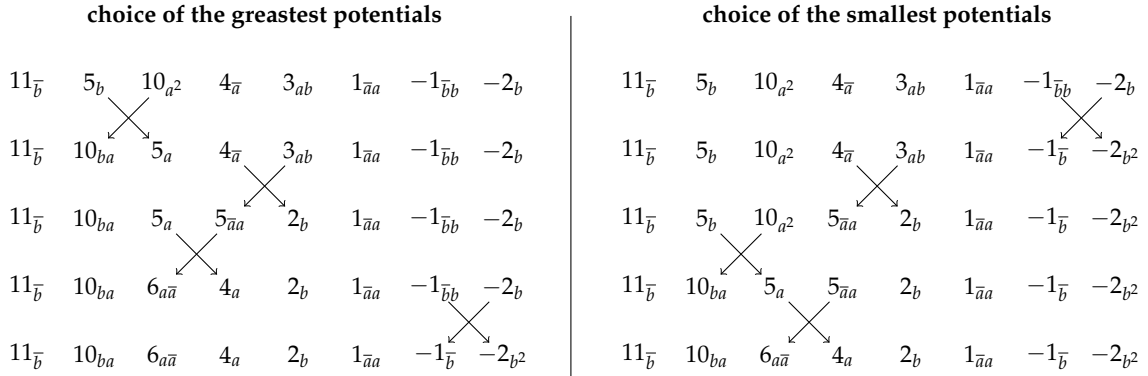

One can observe with our example that the final result is the same in both choices. This is indeed the case in general, whatever the choice of the applications of Λ .

We claim that **Step 2** always ends, and that the final result λ'' is unique and belongs to \mathcal{E}_ϵ (two consecutive particles are always well-related by \gg_ϵ). We then set $\Phi(\lambda)$ to be the final partition λ'' obtained at the end of **Step 2**. Our example gives

$$\Phi(11_{\bar{b}}, 5_b, 5_a, 5_a, 4_{\bar{a}}, 2_a, 1_b, 1_{\bar{a}}, 0_a, 0_{\bar{b}}, -1_b, -2_b) = (11_{\bar{b}}, 10_{ba}, 6_{a\bar{a}}, 4_a, 2_b, 1_{\bar{a}a}, -1_{\bar{b}}, -2_{b^2}).$$

4.2.2 From \mathcal{E}_ϵ to \mathcal{O}_ϵ

Here we present the inverse map Ψ of Φ . Let us take any $\nu = (\nu_1, \dots, \nu_t) \in \mathcal{E}_\epsilon$. We illustrate Ψ on the example $\nu = (11_{\bar{b}}, 10_{ba}, 6_{a\bar{a}}, 4_a, 2_b, 1_{\bar{a}a}, -1_{\bar{b}}, -2_{b^2})$, the final result obtained before for the map Φ .

Step 1: As long as there is a pair $(\nu_k, \nu_{k+1}) \in \mathcal{P} \times \mathcal{S}$ such that $\nu_k \not\prec_\epsilon \nu_{k+1}$ or $(\nu_k, \nu_{k+1}) \in \mathcal{S} \times \mathcal{P}$ such that $\mu(\nu_k) \not\gg_\epsilon \nu_{k+1}$, cross the particles in the pair with Λ :

$$(\nu_k, \nu_{k+1}) \longrightarrow \Lambda(\nu_k, \nu_{k+1}).$$

Here again, the order in which the applications of Λ occur is not specified. We proceed, as before, according to whether we choose the smallest or the greatest potentials.

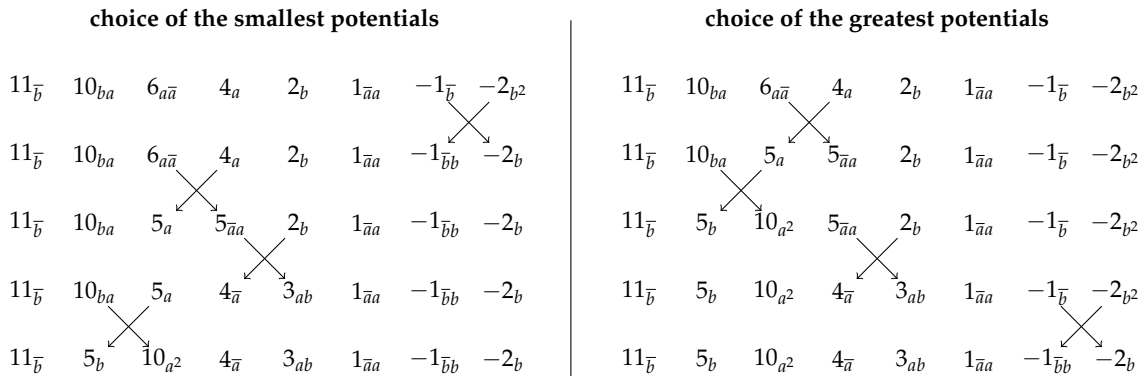

We observe that the process by choosing the smallest potentials is the exact reverse process of **Step 2** of Φ by selecting the greatest potentials. The same occurs between the choice of the greatest potentials, that gives the reverse process of **Step 2** of Φ by choosing the smallest potentials. We again have the same final result at the end of **Step 1** for both choices. Let us set $\nu' = (\nu'_1, \dots, \nu'_t)$ as the final sequence.

Step 2: Split all the secondary particles v'_k of v' into their upper and lower halves:

$$v'_k \longrightarrow \gamma(v'_k), \mu(v'_k).$$

We then obtain v'' . With our example, we have that

$$v'' = (11_{\bar{b}}, 5_b, 5_a, 5_a, 4_{\bar{a}}, 2_a, 1_b, 1_{\bar{a}}, 0_a, 0_{\bar{b}}, -1_b, -2_b).$$

We claim that **Step 1** always ends in a unique result, whatever the choice of the applications of Λ , and that the final result v'' after **Step 2** belongs to \mathcal{O}_ϵ (the primary particles are well-related in terms of \succ_ϵ). We finally set $\Psi(v) = v''$. Our example gives

$$\Psi(11_{\bar{b}}, 10_{ba}, 6_{\bar{a}\bar{a}}, 4_a, 2_b, 1_{\bar{a}a}, -1_{\bar{b}}, -2_{b^2}) = (11_{\bar{b}}, 5_b, 5_a, 5_a, 4_{\bar{a}}, 2_a, 1_b, 1_{\bar{a}}, 0_a, 0_{\bar{b}}, -1_b, -2_b).$$

4.3 Proof of Theorem 2.2.15

In this section, we prove that the maps Φ and Ψ given in Section 4.2 are well-defined and $\Phi^{-1} = \Psi$.

4.3.1 Well-definedness of Φ

Let us take any $\lambda = (\lambda_1, \dots, \lambda_s) \in \mathcal{O}_\epsilon$, and set $\lambda_k = (l_k, c_k) \in \mathcal{P}$ for all $k \in \{1, \dots, s\}$. Here we take the example from Section 4.2.1,

$$\lambda = (11_{\bar{b}}, 5_b, 5_a, 5_a, 4_{\bar{a}}, 2_a, 1_b, 1_{\bar{a}}, 0_a, 0_{\bar{b}}, -1_b, -2_b).$$

We then have $s = 12$ and the following table:

k	1	2	3	4	5	6	7	8	9	10	11	12
c_k	\bar{b}	b	a	a	\bar{a}	a	b	\bar{a}	a	\bar{b}	b	b
l_k	11	5	5	5	4	2	1	1	0	0	-1	-2

(4.3.1)

In the following, we first define some functions related to the partition λ , that will be useful for the second part which concerns the proof of the well-definedness of Φ . We explicitly compute all the functions defined in the following for our example.

The setup

We first define the function Δ on $\{1, \dots, s\}^2$ as follows,

$$\Delta : (k, k') \mapsto \sum_{u=k}^{s-1} \epsilon(c_u, c_{u+1}) - \sum_{u=k'}^{s-1} \epsilon(c_u, c_{u+1}). \quad (4.3.2)$$

We remark that, for any $k \leq k'$,

$$0 \leq \Delta(k, k') \leq k' - k, \quad \Delta(k, k') = -\Delta(k', k), \quad (4.3.3)$$

and for all $k \in \{1, \dots, s-1\}$, we have by (4.3.2) that

$$l_k - l_{k+1} \geq \epsilon(c_k, c_{k+1}) = \Delta(k, k+1).$$

Moreover, the function Δ satisfies *Chasles' relation*:

$$\Delta(k, k') + \Delta(k', k'') = \Delta(k, k'')$$

for all $k, k', k'' \in \{1, \dots, s\}$. We then identify $\Delta(k, k')$ as the *formal energy* of transfer from the primary state c_k to the primary state c'_k . Using (4.3.1), we obtain the following table in our example

k	1	2	3	4	5	6	7	8	9	10	11
$\Delta(k, k+1)$	1	0	0	0	1	1	0	1	0	1	0

(4.3.4)

We now formalize the choice of troublesome pairs of primary particles in **Step 1**. In order to select the pairs with smallest potentials, from the right to the left, we proceed as follows:

- i_1 is the greatest $k \in \{1, \dots, s-1\}$ such that $l_k - l_{k+1} = \Delta(k, k+1)$,
- if i_{t-1} is selected, then, whenever it is still possible, i_t is the greatest $k \in \{1, \dots, i_{t-1} - 2\}$ such that $l_k - l_{k+1} = \Delta(k, k+1)$.

We then set $I = \{i_t\}$ and $J = \{1, \dots, s\} \setminus (I \sqcup (I+1))$. In our example, we have by (4.3.1) and (4.3.4) that

$$i_1 = 10, i_2 = 8, i_3 = 6, i_4 = 3,$$

and then

$$I = \{3, 6, 8, 10\} \quad \text{and} \quad J = \{1, 2, 5, 12\}.$$

Remark 4.3.1. *The sets I and J are the unique sets satisfying the following relations:*

1. $I', I'+1, J'$ form a set-partition of $\{1, \dots, s\}$,
2. for all $i \in I', l_i - l_{i+1} = \Delta(i, i+1)$,
3. for all $j \in \{2, \dots, s\} \cap J', l_{j-1} - l_j > \Delta(j-1, j)$.

We now define the function α on $\{1, \dots, s\}^2$ to be such that

$$\alpha : (k, k') \mapsto \begin{cases} |(k, k'] \cap J| & \text{if } k \leq k' \\ -\alpha(k', k) & \text{if } k > k' \end{cases}, \quad (4.3.5)$$

we then have that α satisfies *Chasles' relation*. One can also observe that $\alpha(k, k) = 0$ for all $k \in \{1, \dots, s\}$. Therefore, using Remark 4.3.1, we obtain for all $k \leq k' \in \{1, \dots, s\}$ that

$$l_k - l_{k'} \geq \alpha(k, k') + \Delta(k, k'). \quad (4.3.6)$$

We finally define the function β on $\{1, \dots, s\}^2$ by

$$\beta : (k, k') \mapsto \begin{cases} |[k, k') \cap J| & \text{if } k \leq k' \\ -\beta(k', k) & \text{if } k > k' \end{cases}, \quad (4.3.7)$$

and we have that β satisfies *Chasles' relation*. Our example gives the table

k	1	2	3	4	5	6	7	8	9	10	11
$\alpha(k, k+1)$	1	0	0	1	0	0	0	0	0	1	0
$\beta(k, k+1)$	1	1	0	0	1	0	0	0	0	0	0

(4.3.8)

Using this table, *Chasles' relation* then allows us to compute all the values for α and β . For example,

$$\alpha(2, 4) = \alpha(2, 3) + \alpha(3, 4) = 0 \quad \text{and} \quad \beta(4, 2) = \beta(4, 3) + \beta(3, 2) = -0 - 1 = -1.$$

To conclude, we observe that, at the end of **Step 1**, the particles in \mathcal{S} are $\lambda_i + \lambda_{i+1}$ for $i \in I$. The set I then corresponds to the index set of the upper halves, the set $I+1$ to the index set of the lower halves, and J represents the index set of the particles λ_j that stay in \mathcal{P} .

Proof of the well-definedness of Φ

During **Step 2**, the positions of particles change by the actions of Λ . Here we see the secondary particles in \mathcal{S} as the corresponding pair of two consecutive particles in \mathcal{P} . We can then consider the permutation σ of $\{1, \dots, s\}$ which determines the new positions of these primary particles, and σ satisfies the following properties:

- $\sigma(i+1) = \sigma(i) + 1$ for all $i \in I$, since we move the upper and lower halves together,
- σ is increasing on I and J , since Λ never crosses the particles of the same degree.

We can now state the main results that will ensure the well-definedness of the map Φ .

Proposition 4.3.2 (Final positions). *Let ϕ be the function on $J \times I$ defined by*

$$\phi : (j, i) \mapsto l_j - 2l_{i+1} - \Delta(j, i+1) - \Delta(i+1 - \beta(j, i), i+1). \quad (4.3.9)$$

*Then the final position σ after **Step 2** is such that for any $(j, i) \in J \times I$,*

$$\sigma(j) < \sigma(i) \iff \phi(j, i) \geq 0. \quad (4.3.10)$$

*Furthermore, **Step 2** comes to an end after exactly*

$$|\{(j, i) \in J \times I : j > i \text{ and } \phi(j, i) \geq 0, \text{ or } j < i \text{ and } \phi(j, i) < 0\}| \quad (4.3.11)$$

applications of Λ .

The above proposition ensures that the process **Step 2** always ends. Using (4.3.1), (4.3.4) and (4.3.8), we obtain with our example the following table corresponding to ϕ :

$j \setminus i$	3	6	8	10
1	0	4	5	6
2	-5	-1	1	2
5	-6	-1	0	1
12	-8	-2	-1	0

By the proposition, we have exactly four crossings which occur in the pairs (j, i) in $\{(2, 3), (2, 6), (5, 6), (12, 10)\}$, and this corresponds to the illustration of **Step 2** in Section 4.2.1.

The well-belonging of the final partition is given by the next two propositions.

Proposition 4.3.3. *The partition obtained after **Step 2** belongs to \mathcal{E}_ϵ .*

Proposition 4.3.4. *For any $\rho \in \{0, 1\}$, we have $\Phi(\mathcal{O}_\epsilon^{\rho\pm}) \subset \mathcal{E}_\epsilon^{\rho\pm}$.*

The proofs of the above propositions can be found in Appendices A.2.5, A.2.9 and A.2.10. Here we state two lemmas that will be useful for these proofs.

Lemma 4.3.5. *If a primary particle (l_k, c_k) originally at position k moves to position $\sigma(k)$, then it becomes energetic particle $(l_k + \Delta(\sigma(k), k), c_{\sigma(k)})$.*

Lemma 4.3.6. *The function ϕ is non-increasing on J and non-decreasing on I .*

For the proofs the lemmas, see Appendices A.2.1 and A.2.2.

Lemma 4.3.5 plays a central role in the understanding of the operator Λ . Rephrased, it can be stated as follows: a primary particle that moves from a state c_k to a state $c_{k'}$ gains the **formal** energy of transfer from c_k to $c_{k'}$. By (4.3.3), this energy is non-negative if $k \leq k'$, and non-positive if $k \geq k'$.

4.3.2 Well-definedness of Ψ

Let us consider $\nu \in \mathcal{E}_\epsilon$ with $\nu = (\nu_1, \dots, \nu_t)$. We rename the indices by enumerating all primary particles that occur in ν . This means that we count the secondary particles as a pair of consecutive primary particles. We take the example in Section 4.2.2

$$\nu = (11_{\bar{b}}, 10_{ba}, 6_{a\bar{a}}, 4_a, 2_b, 1_{\bar{a}a}, -1_{\bar{b}}, -2_{b^2}),$$

and the rewriting gives

$$\nu = (11_{\bar{b}}, \underbrace{5_b, 5_a}_{}, \underbrace{3_a, 3_{\bar{a}}}_{}, 4_a, 2_b, \underbrace{1_{\bar{a}}, 0_a}_{}, -1_{\bar{b}}, \underbrace{-1_b, -1_b}_{}).$$

As we did before for the process Φ , we first give some functions related to ν , and then prove the well-definedness of Ψ . We explicitly compute the value of these functions for our example.

The setup

We consider $\nu = (\nu'_1, \dots, \nu'_s)$ written according to the primary particles that occur in ν . There then exist unique sets I, J such that $\{1, \dots, s\} = J \sqcup I \sqcup (I+1)$, where J is the index set of the particles in \mathcal{P} , and

I and $I + 1$ are respectively the index sets of upper and lower halves of the particles in \mathcal{S} . In the case of our example

$$I = \{2, 4, 8, 11\} \quad \text{and} \quad J = \{1, 6, 7, 10\}.$$

Also set

$$v'_k = (l_k, c_k) \text{ for all } k \in \{1, \dots, s\},$$

and define the function Δ on $\{1, \dots, s\}^2$ in a similar manner as in (4.3.2). Finally define the function η on $\{1, \dots, s\}^2$ to be as

$$\eta : (k, k') \mapsto \begin{cases} |(k, k') \cap J| & \text{if } k \leq k' \\ -\eta(k', k) & \text{if } k > k' \end{cases}. \quad (4.3.12)$$

Note that η satisfies *Chasles' relation*. In our example, we obtain the following table:

k	1	2	3	4	5	6	7	8	9	10	11	12
c_k	\bar{b}	b	a	a	\bar{a}	a	b	\bar{a}	a	\bar{b}	b	b
l_k	11	5	5	3	3	4	2	1	0	-1	-1	-1
$\Delta(k, k+1)$	1	0	0	0	1	1	0	1	0	1	0	
$\eta(k, k+1)$	0	0	0	0	1	1	0	0	1	0	0	

(4.3.13)

We now give in the following lemma the relations that link the particles' potentials. The proof is given in Appendix A.2.3.

Lemma 4.3.7. *Let us set*

$$l'_k = \begin{cases} l_k & \text{if } k \in J \\ 2l_k & \text{if } k \in I \sqcup (I + 1) \end{cases}.$$

Then for all $k \leq k' \in \{1, \dots, s\}$, we have

$$l'_k - l'_{k'} \geq \eta(k, k') + \Delta(k, k'). \quad (4.3.14)$$

In particular, for all $i \leq i' \in I \sqcup (I + 1)$, we have

$$l_i - l_{i'} \geq \Delta(i, i'). \quad (4.3.15)$$

Proof of the well-definedness of Ψ

We can now focus on the position σ of the particles during **Step 1** of Ψ . Note that Lemma 4.3.5 still holds here, as well as the fact that $\sigma(i + 1) = \sigma(i) + 1$ for all $i \in I$ and σ is increasing on $I \sqcup (I + 1)$ and J .

We now give the analogues of Proposition 4.3.2, Proposition 4.3.3 and Proposition 4.3.10 that ensure the well-definedness of Ψ . The proof of the following propositions are given in Appendices A.2.8, A.2.6 and A.2.7.

Proposition 4.3.8 (Final position). *Let ψ be a function on $J \times I$ defined by :*

$$\psi : (j, i) \mapsto l_j - l_i - \Delta(j, i). \quad (4.3.16)$$

Then, the final position σ of Ψ after **Step 1** is such that, for all $(j, i) \in J \times I$,

$$\sigma(j) < \sigma(i) \iff \psi(j, i) \geq 0, \quad (4.3.17)$$

and **Step 1** comes to an end after exactly

$$|\{(j, i) \in J \times I : j > i \text{ and } \psi(j, i) \geq 0, \text{ or } j < i \text{ and } \psi(j, i) < 0\}| \quad (4.3.18)$$

applications of Λ .

Proposition 4.3.9. *The resulting partition after **Step 2** belongs to \mathcal{O}_ϵ .*

Proposition 4.3.10. *For any $\rho \in \{0, 1\}$, we have $\Psi(\mathcal{E}_\epsilon^{\rho\pm}) \subset \mathcal{O}_\epsilon^{\rho\pm}$.*

In our example, the following table for Ψ is obtained:

$j \setminus i$	2	4	8	11
1	5	7	7	7
6	0	2	2	2
7	-1	1	1	1
10	-3	-1	-1	-1

By Proposition 4.3.8, there are four crossings that occur in the pairs (j, i) in $\{(6, 2), (6, 4), (7, 4), (10, 11)\}$.

Remark 4.3.11. One can check that the sets $\sigma(I), \sigma(I) + 1$ and $\sigma(J)$ form the unique set-partition of $\{1, \dots, s\}$ such that

1. For all $i \in \sigma(I)$, $v''_i - v''_{i+1} = \Delta(i, i + 1)$,
2. for any $j \in \sigma(J) \cap \{2, \dots, s\}$, $v''_{j-1} \gg_\epsilon v''_j$.

4.3.3 Reciprocity between Φ and Ψ

The relation $\Psi \circ \Phi = Id_{\mathcal{O}_\epsilon}$

For any $\lambda = (\lambda_1, \dots, \lambda_s) \in \mathcal{O}_\epsilon$, we choose unique sets I, J such that

1. $I, I + 1, J$ form a set-partition of $\{1, \dots, s\}$,
2. for all $i \in I$, $l_i - l_{i+1} = \Delta(i, i + 1)$,
3. for all $j \in \{2, \dots, s\} \cap J$, $l_{j-1} - l_j > \Delta(j - 1, j)$.

Let σ be the final position after application of Φ . Since by Lemma 4.3.5

$$\lambda''_{\sigma(k)} - \lambda''_{\sigma(k')} - \Delta(\sigma(k), \sigma(k')) = l_k - l_{k'} - \Delta(k, k'),$$

by considering the function ψ in Proposition 4.3.8, we obtain, for all $(j, i) \in J \times I$, that

$$\begin{aligned} j < i &\iff \psi(\sigma(j), \sigma(i)) = l_j - l_i - \Delta(j, i) \\ &\geq \alpha(j, i) \\ &= |(j, i] \cap J| \\ &\geq 0 \end{aligned}$$

and

$$\begin{aligned} j > i &\iff \psi(\sigma(j), \sigma(i)) = l_j - l_i - \Delta(j, i) \\ &\leq -\alpha(i, j) \\ &= -|(i, j] \cap J| \\ &\leq -1, \end{aligned}$$

so that I, J are exactly the final positions of $\sigma(I), \sigma(J)$ after applying Ψ . Thus $\Psi(\Phi(\lambda)) = \lambda$.

The relation $\Phi \circ \Psi = Id_{\mathcal{E}_\epsilon}$

Let us now take any $\nu \in \mathcal{E}_\epsilon$, and let σ be the final position after Ψ , and $\Psi(\nu) = \nu'' = (v''_1, \dots, v''_s)$ with the enumeration of primary particles. We saw Remark 4.3.11 that, $\sigma(I), \sigma(I) + 1$ and $\sigma(J)$ form the unique set-partition of $\{1, \dots, s\}$, such that

- for all $\sigma(i) \in \sigma(I)$, $v''_{\sigma(i)} - v''_{\sigma(i)+1} = \Delta(\sigma(i), \sigma(i) + 1)$,
- for all $\sigma(j) \in \sigma(J) \cap \{2, \dots, s\}$, $v''_{\sigma(j)-1} \gg_\epsilon v''_{\sigma(j)}$.

The sets $\sigma(I)$ and $\sigma(J)$ then are the unique sets obtained after **Step 1** in the process of Φ on ν'' . Let us recall β . For $k \leq k'$

$$\beta(k, k') = |[k, k'] \cap \sigma(J)| \text{ and } \beta(k, k') = -\beta(k', k).$$

Then, since σ is increasing on J and $I \sqcup (I+1)$, for any $(j, i) \in J \times I$,

$$\begin{aligned} \beta(\sigma(j), \sigma(i)) &= |[1, \sigma(i)] \cap \sigma(J)| - |[1, \sigma(j)] \cap \sigma(J)| \\ &= \sigma(i) - 1 - |[1, \sigma(i)] \cap \sigma(I \cap (I+1))| - |[1, j] \cap J| \\ &= \sigma(i) - 1 - |[1, i] \cap (I \cap (I+1))| - |[1, j] \cap J| \\ &= \sigma(i) - i + |[1, i] \cap J| - |[1, j] \cap J|. \end{aligned}$$

We then obtain in Proposition 4.3.2, by the fact that $l_i = l_{i+1} + \Delta(i, i+1)$,

$$\begin{aligned} \phi(\sigma(j), \sigma(i)) &= (l_j + \Delta(\sigma(j), j) - 2(l_{i+1} + \Delta(\sigma(i+1), i+1)) - \Delta(\sigma(j), \sigma(i+1))) \\ &\quad - \Delta(\sigma(i+1) - \beta(\sigma(j), \sigma(i)), \sigma(i+1))) \\ &= l_j - 2l_{i+1} - \Delta(j, i+1) - \Delta(i+1 - |[1, i] \cap J| + |[1, j] \cap J|, i+1) \\ &= l_j - 2l_i - \Delta(j, i) - \Delta(i+1 - |[1, i] \cap J| + |[1, j] \cap J|, i). \end{aligned}$$

By (4.3.3) and (4.3.14), we obtain

$$\begin{aligned} j < i &\iff \phi(\sigma(j), \sigma(i)) \geq \eta(j, i) - \Delta(i - |(j, i) \cap J|, i) \\ &\geq |(j, i] \cap J| - |(j, i) \cap J| \\ &= 0 \end{aligned}$$

and

$$\begin{aligned} j > i &\iff \phi(\sigma(j), \sigma(i)) \leq -\eta(i+1, j) - \Delta(i+1 + |[i+1, j] \cap J|, i+1) \\ &\leq -|[i+1, j] \cap J| + |[i+1, j] \cap J| \\ &= -1. \end{aligned}$$

The final positions for $\sigma(I), \sigma(J)$ after applying Φ on v'' are then exactly I, J . Thus $\Phi(\Psi(v)) = v$.

4.4 Closing remarks

We end this paper with three remarks.

First, we consider another relation \gg^ϵ on $\mathcal{P} \sqcup \mathcal{S}$, which is the same as \gg_ϵ for (2.2.22) and (2.2.25), but slightly different for other comparisons :

$$(k, c) \gg^\epsilon (k'', c', c'') \iff k - (2k'' + \epsilon(c', c'')) > \epsilon(c, c') + \epsilon(c', c'') \quad (4.4.1)$$

$$(k', c, c') \gg^\epsilon (k'', c'') \iff (2k' + \epsilon(c, c')) - k'' \geq \epsilon(c, c') + \epsilon(c', c''). \quad (4.4.2)$$

One can easily check that, for $\epsilon^*(c', c) = \epsilon(c, c')$:

$$\begin{aligned} (k, c) \gg^\epsilon (k', c') &\iff (-k', c') \gg_{\epsilon^*} (-k, c), \\ (k, c) \gg^\epsilon (k', c', c'') &\iff (-k' - \epsilon^*(c'', c'), c'', c') \gg_{\epsilon^*} (-k, c), \\ (k, c, c') \gg^\epsilon (k', c'') &\iff (-k', c'') \gg_{\epsilon^*} (-k - \epsilon^*(c', c), c', c), \\ (k, c, c') \gg^\epsilon (k', c'', c''') &\iff (-k' - \epsilon^*(c''', c''), c''', c'') \gg_{\epsilon^*} (-k - \epsilon^*(c', c), c', c). \end{aligned}$$

If we define \mathcal{E}_ϵ to be the set of all generalized colored partitions with particles in $\mathcal{P} \sqcup \mathcal{S}$ and with relation \gg^ϵ , we obtain the following corollary of Theorem 1.1.

Corollary 4.4.1. *For any integer n and any finite non-commutative product C of colors in \mathcal{C} , there exists a bijection between $\{\lambda \in \mathcal{O}_\epsilon : (C(\lambda), |\lambda|) = (C, n)\}$ and $\{v \in \mathcal{E}_\epsilon : (C(v), |v|) = (C, n)\}$.*

While the relation \gg^ϵ differs from \gg_ϵ , they both give similar difference conditions. A good example of the similarity between these relations is the fact that we can retrieve Siladić's theorem by taking $\mathcal{C} = \{a < b\}$, $\epsilon(i, j) = \chi(i \leq j)$ with non-negative primary part size, followed by the transformation $(q, a, b) \mapsto (q^4, q, q^3)$, in Corollary 4.4.1.

Second, we point out that another major result, the Euler distinct-odd identity, can be retrieved from Corollary 2.2.20. Let us consider the restriction of \mathcal{C} to the singleton $\{a\}$. The corresponding difference

condition gives the matrix

$$a \begin{pmatrix} a \\ 0 \end{pmatrix}$$

and the corresponding generalized partitions in Corollary 2.2.20 are the classical partitions where all the parts have state a . The restriction of D' to the states a, a^2 gives the matrix

$$\begin{matrix} & a & a^2 \\ a & \begin{pmatrix} 1 & 0 \\ 1 & 0 \end{pmatrix} \\ a^2 & \end{matrix}$$

One can view the corresponding partitions in \mathcal{E} as the generalized partitions into distinct positive particles with state a , along with some particles with states a^2 having positive even potentials. In other words, we have a pair of partitions, the first partition into distinct positive particles with state a , and the second into particles with positive even potential and state a^2 .

We then redo the process with the following rules. At step k , we apply the transformation $(q, a) \mapsto (q^{2^{k-1}}, a^{2^{k-1}})$ to the identity given by the step 1. This leads to the following identity: the number of partitions of n into particles with state $a^{2^{k-1}}$ and potential divisible by 2^{k-1} is equal to the number of partitions of n into distinct particles with state $a^{2^{k-1}}$ and potential divisible by 2^{k-1} , and particles with state a^{2^k} and potential divisible by 2^k .

By considering the initial step 1, and iterating the steps k , we then have the following identity: the number of partitions of n into positive particles with state a is equal to the number of partitions of n into distinct particles, with the particles with states a^{2^k} ($k \in \mathbb{Z}_{\geq 0}$) having a potential divisible by 2^k . We finally recover the Euler distinct-odd identity by applying the transformation $(q, a) \mapsto (q^2, q^{-1})$.

Finally, we remark that the maps given in Section 4.2.1 and Section 4.2.2 differ from the variant of Bressoud's algorithm in (Konan, 2020a) for the generalization of Siladić's theorem. In **Step 1** of Φ , instead of choosing the troublesome pairs of primary particles from the right to the left, we started in (Konan, 2020a) from the left to the right by first choosing the greatest potentials. This choice could have been made here. The major observation by proceeding this way is that the map Φ remains the same. This comes from the fact that the choice of troublesome pairs only depends on the maximal sub-sequences of λ of the form $\lambda_k, \dots, \lambda_{k'}$, which satisfy $l_i - l_{i+1} = \Delta(i, i+1)$ for all $i \in \{k, \dots, k'\}$, with notation as in Section 4.3.1. For such a sub-sequence with an even length, whatever the choice made, we always take the primary particles pairwise. When the length is odd, our choice implies that we take the particles pairwise from the right to the left so that there still remains a primary particle to the left of the sequence. By crossing this primary particle with the secondary particles obtained after summing the pairs in the sequence, by Lemma 4.3.5, we exactly obtain the pairs resulting from the choice of the troublesome pairs starting from the left to the right, and the primary particle then becomes the rightmost particle of the sequence.

This observation unveils a strong property that links the generalized partitions of \mathcal{O}_ϵ and \mathcal{E}_ϵ , both kinds of partitions seen as sequences of primary particles: their major attribute are the maximal sequences of consecutive primary particles. In the next chapter, we will see how this attribute allows us to define the particles of degree k for a positive $k \geq 3$, and how this definition is closely related to the notion of crystal and energy function in the quantum mechanics.

Chapter 5

Beyond Glaisher's theorem

In this chapter, bijective proofs of the results beyond Glaisher's theorem are presented.

5.1 Bijective proof of Theorem 2.2.24

In this section we construct a bijection Ω_1 between the set $\mathcal{F}_1^{\epsilon, c_g}$ and $\mathcal{R}_1^{\epsilon, c_g}$ of Theorem 2.2.24. In the following, we illustrate Ω_1 with the set of states $\mathcal{C} = \{a, b, c\}$, the ground c , and the energy ϵ defined by the energy matrix

$$M_\epsilon = \begin{matrix} & \begin{matrix} a & b & c \end{matrix} \\ \begin{matrix} a \\ b \\ c \end{matrix} & \begin{pmatrix} 1 & 0 & 1 \\ 0 & 0 & 1 \\ 0 & 0 & 0 \end{pmatrix} \end{matrix}.$$

5.1.1 The setup

Let δ_g be the common value of $\epsilon(c_g, c)$ for $c \neq c_g$ given by (2.2.39). Note that for any $c \neq c_g$, for any $k, l \in \mathbb{Z}$

$$\begin{aligned} k_c \not\prec_\epsilon l_{c_g} &\iff k - l \leq \epsilon(c, c_g) - 1 \\ &\iff l - k \geq 1 - \epsilon(c, c_g) \\ &\iff l - k \geq \epsilon(c_g, c) \\ &\iff l_{c_g} \succ_\epsilon k_c \end{aligned} \tag{5.1.1}$$

$$\tag{5.1.2}$$

so that *the particles with state c_g can be always related in terms of \gg with the particles with state different from c_g .*

Here we can see the classical integer partitions as the non-increasing sequences of non-negative integers, with all but a finite number of parts equal to 0.

Let us recall the conjugate of classical partitions. The partitions $\nu = (\nu_i)_{i=0}^\infty$ and $\nu' = (\nu'_i)_{i=0}^\infty$ are conjugate if and only if their part sizes satisfy

$$\nu_i = |\{\nu'_j \geq i + 1\}| \tag{5.1.3}$$

The transformation $\nu \mapsto \nu'$ is an involution, and we then have $\nu'_i = |\{\nu_j \geq i + 1\}|$.

The set $\mathcal{R}_1^{\epsilon, c_g}$

We identify a partition $\pi = (\pi_0, \dots, \pi_{s-1}, 0_{c_g})$ of $\mathcal{R}_1^{\epsilon, c_g}$ as the unique pair of partitions

$$(\mu, \nu) = [(\mu_0, \dots, \mu_{s-1}, 0_{c_0}), (\nu_0, \dots, \nu_{s-1})],$$

such that $C(\pi) = C(\mu) = c_0 \cdots c_{s-1} c_g$, and for all $k \in \{1, \dots, s-1\}$, we have $c_k \neq c_g$,

$$\mu_k = \left(\sum_{l=k}^{s-1} \epsilon(c_k, c_{k+1}) \right)_{c_k}$$

and

$$\nu_k = \pi_k - \sum_{l=k}^{s-1} \epsilon(c_l, c_{l+1}).$$

The partition μ is then the unique element in $\mathcal{F}_1^{\epsilon, c_g} \cap \mathcal{R}_1^{\epsilon, c_g}$ satisfying $C(\pi) = C(\mu) = c_0 \cdots c_{s-1} c_g$, and ν is the *residual* partition with s parts, possibly ending with some parts equal to 0. The partition ν then corresponds to a unique classical partition, with at most s parts.

Example 5.1.1. *The partition*

$$\pi = (10_a, 8_a, 8_b, 7_b, 5_a, 4_a, 3_a, 2_b, 1_a, 1_b, 1_b, 0_c)$$

is identified with the pair (μ, ν) with

$$\mu = (4_a, 3_a, 3_b, 3_b, 3_a, 2_a, 1_a, 1_b, 1_a, 1_b, 1_b, 0_c)$$

and

$$\nu = (6, 5, 5, 4, 2, 2, 2, 1, 0, 0, 0).$$

Let us now fix $C = c_0 \cdots c_{s-1}$. The partition μ in the pair then becomes fixed. By considering the set of regular partitions in $\mathcal{R}_1^{\epsilon, c_g}$ with State Cc_g , we have the bijection

$$\mathcal{R}_1^{\epsilon, c_g}(C) = \{\pi \in \mathcal{R}_1^{\epsilon, c_g} : C(\pi) = Cc_g\} \approx \{\mu\} \times \{(v_0, \dots, v_{s-1}) \in \mathbb{Z}_{\geq 0} : v_0 \geq \dots \geq v_{s-1}\}. \quad (5.1.4)$$

The set $\mathcal{R}_1^{\epsilon, c_g}(C)$ is then isomorphic to the set of classical partitions with at most s positive parts.

We now consider the set of the *descents*

$$D = \{k : \{1, \dots, s\} : \epsilon(c_{k-1}, c_k) = 0\} = \{k_0 < \dots < k_{|D|-1}\} \quad \text{and} \quad \bar{D} = \{1, \dots, s-1\} \setminus D. \quad (5.1.5)$$

Note that, since $\epsilon(c_{s-1}, c_g) = 1 - \delta_g$, we recursively have for all $k \in \{1, \dots, s-1\}$ that

$$\mu_k = \sum_{l=k}^{s-1} \epsilon(c_l, c_{l+1}) = 1 - \delta_g + |\{k+1, \dots, s-1\} \cap \bar{D}| \leq s - k - \delta_g. \quad (5.1.6)$$

We obtain with Example 5.1.1 that $C = aabbaaababb$, $s = 11$, $D = \{2, 3, 4, 7, 8, 9, 10\}$ and $\bar{D} = \{0, 1, 5, 6\}$.

For a fixed non-negative n , we construct Ω in such a way that the partitions π in $\mathcal{R}_1^{\epsilon, c_g}$ satisfying $(|\pi|, C(\pi)) = (n, Cc_g)$ correspond to the partitions π in $\mathcal{F}_1^{\epsilon, c_g}$ which satisfy $(n, C) = (|\pi|, C(\pi)|_{c_g=1})$. This means that the sequence of states different from c_g is equal to C .

The set $\mathcal{F}_1^{\epsilon, c_g}$

We now consider the set $\mathcal{F}_1^{\epsilon, c_g}(C)$ of flat partitions π in $\mathcal{F}_1^{\epsilon, c_g}$ such that $C(\pi)|_{c_0=1} = C$. For such a partition π , there exists a unique set $S = \{u_0 < \dots < u_{s-1}\} \subset \mathbb{Z}_{\geq 0}$ such that

$$\begin{aligned} \pi &= (\pi_0, \dots, \pi_{u_{s-1}}, 0_{c_0}), \\ c(\pi_{u_k}) &= c_k \quad \forall k \in \{0, \dots, s-1\}, \\ c\pi_k &= c_g \quad \forall k \in \{0, \dots, u_{s-1}\} \setminus S. \end{aligned} \quad (5.1.7)$$

In fact, we cannot have $c(\pi_{u_{s-1}}) = c_g$, otherwise $\pi_{u_{s-1}} = \epsilon(c_g, c_g) = 0$, so that $\pi_{u_{s-1}} = 0_{c_g}$, which contradicts the definition of grounded partitions. Let us set

$$\begin{aligned} s' &= u_{s-1} + 1 - s \\ W &= \{0 \leq v < |D| : u_{k_v} - u_{k_{v-1}} > 1\} = \{v_0 < \dots < v_{|W|-1}\}, \\ D_W &= \{k_v : v \in W\}, \\ D_{\bar{W}} &= D \setminus D_W. \end{aligned} \quad (5.1.8)$$

If there are particles with state c_g between u_k and u_{k+1} (which means that $k+1 \notin D$), their potentials' differences gives

$$\begin{aligned} \epsilon(c_k, c_g) + \underbrace{0 + \dots + 0}_{\# \text{parts inserted} - 1} + \epsilon(c_g, c_{k+1}) &= \epsilon(c_k, c_g) + \epsilon(c_g, c_{k+1}) \\ &= 1 - \delta_g + \delta_g \\ &= 1 \end{aligned}$$

which differs from $\epsilon(c_k, c_{k+1})$ if and only if $k+1 \in D$. Then

$$\pi_{u_k} = \mu_k + |\{k+1, \dots, s-1\} \cap D_W|,$$

so that by (5.1.6). Since $\pi_{u_{s-1}} = 1 - \delta_g$, we obtain recursively that for all $k \in \{0, \dots, s-2\}$,

$$\pi_{u_k} = 1 - \delta_g + |\{k+1, \dots, s-1\} \cap (\overline{D} \sqcup D_W)|. \quad (5.1.9)$$

Note that by (5.1.9), for all $u_{k-1} < u < u_k$, we necessarily have that $k \in \overline{D} \sqcup D_W$, and then

$$\pi_u = \delta_g + \pi_{u_k} = |\{k, \dots, s-1\} \cap (\overline{D} \sqcup D_W)|.$$

We now construct the bijection between $\mathcal{F}_1^{\epsilon, c_g}(C)$ and $\mathcal{R}_1^{\epsilon, c_g}(C)$.

5.1.2 The map Ω from $\mathcal{F}_1^{\epsilon, c_g}(C)$ to $\mathcal{R}_1^{\epsilon, c_g}(C)$.

For any partition $\pi \in \mathcal{F}_1^{\epsilon, c_g}(C)$ described above, let ν' be the classical partition whose parts are the following:

1. for $k \notin D$, the $u_k - u_{k-1} - 1$ particles between u_{k-1} and u_k with potential

$$\pi_u = |\{k, \dots, s-1\} \cap (\overline{D} \sqcup D_W)|,$$

with the convention $u_{-1} = -1$.

2. For $k \in D_W$, we take $u_k - u_{k-1} - 2$ particles between u_{k-1} and u_k with potential

$$\pi_u = |\{k, \dots, s-1\} \cap (\overline{D} \sqcup D_W)|,$$

and one particle (called the *weighted* particle) with potential

$$\pi_u + k = |\{k, \dots, s-1\} \cap (\overline{D} \sqcup D_W)| + k. \quad (5.1.10)$$

We then set $\Omega(\pi) = (\mu, \nu)$ where ν is the conjugate of ν' .

Example 5.1.2. For example, we illustrate these transformations with $C = aabbaaababb$ and

$$\pi = (6_a, 5_a, 5_b, 4_c, 4_c, 4_c, 4_b, 4_a, 3_c, 3_a, 2_a, 1_c, 1_c, 1_b, 1_a, 1_b, 1_b, 0_c).$$

Recall that $\mu = (4_a, 3_a, 3_b, 3_b, 3_a, 2_a, 1_a, 1_b, 1_a, 1_b, 1_b, 0_c)$, $D = \{2, 3, 4, 7, 8, 9, 10\}$ and $\overline{D} = \{0, 1, 5, 6\}$. Here

k	0	1	2	3	4	5	6	7	8	9	10
u_k	0	1	2	6	7	9	10	13	14	15	16

and thus $D_W = \{3, 7\}$. We thus obtain that ν' is the classical partition with parts 3, 4, 4, 7 and 1, 8. We thus have $\nu = (8, 7, 4, 4, 3, 1)$ and the conjugation then gives the following partition with 11 parts

$$\nu = (6, 5, 5, 4, 2, 2, 2, 1, 0, 0, 0).$$

By adding the parts of ν to the corresponding particles of μ , we finally obtain

$$\Omega(6_a, 5_a, 5_b, 4_c, 4_c, 4_c, 4_b, 4_a, 3_c, 3_a, 2_a, 1_c, 1_c, 1_b, 1_a, 1_b, 1_b, 0_c) = (10_a, 8_a, 8_b, 7_b, 5_a, 4_a, 3_a, 2_b, 1_a, 1_b, 1_b, 0_c).$$

We first note that the total energy is conserved by these transformations, since

$$\begin{aligned} \sum_{k=0}^{s-1} |\{k+1, \dots, s-1\} \cap D_W| &= \#\{(k, l) : l \in \{k+1, \dots, s-1\} : l \in D_W\} \\ &= \sum_{l \in D_W} \#\{0 \leq k < l\} \\ &= \sum_{l \in D_W} l \end{aligned}$$

and thus

$$\begin{aligned} \sum_{u=0}^{u_{s-1}} \pi_u &= \sum_{k=0}^{s-1} \pi_{u_k} + \sum_{\substack{k \\ 1 < u_k - u_{k-1}}} (u_k - u_{k-1} - 1) \pi_{u_{k-1}} \\ &= \sum_{u \notin S} \pi_u + \sum_{k=0}^{s-1} \mu_k + \sum_{l \in D_W} l \\ &= |\mu| + \sum_{l \in D_W} l + \pi_{u_{l-1}} + (u_l - u_{l-1} - 2) \pi_{u_{l-1}} \\ &\quad + \sum_{l \notin D} (u_l - u_{l-1} - 1) \pi_{u_{l-1}}. \end{aligned}$$

The *unweighted* particles are those which are not weighted. We then remark that for all $k \in \{1, \dots, s-1\}$,

$$\begin{aligned} |\{k, \dots, s-1\} \cap (\overline{D} \sqcup D_W)| + k &= |\overline{D} \sqcup D_W| + |\{0, \dots, k-1\} \cap D_{\overline{W}}| \\ &= \pi_{u_0} + \delta_g + |\{0, \dots, k-1\} \cap D_{\overline{W}}| \end{aligned}$$

so that the weighted particles all have potentials greater than or equal to the potentials of the unweighted particles. We also notice that unweighted particles coming from different k are distinct, since the potentials' difference gives

$$|\{k, \dots, s-1\} \cap (\overline{D} \sqcup D_W)| - |\{k+1, \dots, s-1\} \cap (\overline{D} \sqcup D_W)| = \chi(k \in \overline{D} \sqcup D_W)$$

and this is exactly the condition required to *insert* a particle in v' . Also when we take two consecutive weighted particles in $k_{v_j} < k_{v_{j+1}} \in D_W$, we obtain the difference of potential

$$k_{v_i} - k_{v_{i+1}} + |\{k_{v_i}, \dots, k_{v_{i+1}} - 1\} \cap (\overline{D} \sqcup D_W)| = -|\{k_{v_i}, \dots, k_{v_{i+1}} - 1\} \cap D_{\overline{W}}|$$

so that the weighted particles appear in a non-decreasing order according to the indices i in $\{0, |W| - 1\}$. We then obtain $v' = (v'_0, \dots, v'_{s'-1})$, where for all $i \in \{0, \dots, |W| - 1\}$

$$\begin{aligned} v'_{|W|-1-i} &= |\{k_{v_i}, s-1\} \cap (\overline{D} \sqcup D_W)| + k_{v_i} \\ &= s - |D_{\overline{W}} \cap \{k_{v_i}, \dots, s-1\}| \\ &= s - |\{v_i \leq p < |D| : p \notin W\}| \quad \text{by (5.1.8)} \\ &= s + |W| - |D| + v_i - i \\ &\leq s, \end{aligned}$$

and the rest of the particles consists of $u_k - u_{k-1} - 1 - \chi(k \in D_W)$ particles for $k \in \overline{D} \sqcup D_W$, each of them with potential

$$|\{k, s-1\} \cap (\overline{D} \sqcup D_W)| \geq 1.$$

Note that v' viewed as a classical partition has s' parts, all with size at most equal to s , and by (5.1.3), the partition v then has at most s positive parts and satisfies $v_0 = s'$. Our map from $\mathcal{F}_1^{\epsilon, \mathcal{L}^g}(C)$ to $\mathcal{R}_1^{\epsilon, \mathcal{L}^g}(C)$ is then well-defined.

We conclude by observing the following equality: for all $i \in \{0, \dots, |W| - 1\}$ we have

$$\begin{aligned} v'_{|W|-1-i} - |W| + i &= s - |D| + v_i \\ &= |\{0, \dots, k_{v_i} - 1\}| + |\{k_{v_i}, s-1\} \cap \overline{D}| \end{aligned}$$

$$= \delta_g + \mu_{k_{v_i}} + k_{v_i}, \quad (5.1.11)$$

and for all $u \in \{|W|, \dots, s' - 1\}$,

$$v'_u - u - 1 \leq v'_{|W|} - |W| - 1 < \delta_g + \mu_0. \quad (5.1.12)$$

5.1.3 The map Ω^{-1} from $\mathcal{R}_1^{\epsilon, c_g}(C)$ to $\mathcal{F}_1^{\epsilon, c_g}(C)$

Let consider a partition π in $\mathcal{R}_1^{\epsilon, c_g}(C)$, and the corresponding pair (μ, ν) . The partition ν then corresponds to a classical partition with at most s positive parts. The partitions ν' then has ν_0 positive parts, whose sizes are at most equal to s . Let us set $s' = \nu_0$ and write $\nu' = (\nu'_0, \dots, \nu'_{s'-1})$. We then apply the following transformations:

1. For each $k \in \{1, \dots, s - 1\}$, change the part μ_k into μ'_k with the relations

$$\begin{cases} c(\mu'_k) = c(\mu_k) = c_k \\ \mu'_k = \mu_k + |\{0 \leq u < s' : \delta_g + \mu_k + k \leq v'_u - u - 1\}| \end{cases}. \quad (5.1.13)$$

2. For each $u \in \{0, \dots, s' - 1\}$, change the part ν'_u into ν''_u with the relations

$$\begin{cases} c(\nu''_u) = c_g \\ \nu''_u = \nu'_u - |\{0 \leq k < s : \delta_g + \mu_k + k \leq v'_u - u - 1\}| \end{cases}. \quad (5.1.14)$$

The final partition $\Omega^{-1}(\pi)$ is obtained by inserting the particles ν''_u into the sequence of particles μ'_k according \succ_{ϵ} , and adding the ground 0_{c_g} . The partition $\Omega^{-1}(\pi)$ then has $s + s'$ particles different from 0_{c_g} and by double counting, it follows that $|\Omega^{-1}(\pi)| = |\mu| + |\nu| = |\pi|$.

Example 5.1.3. For example, we illustrate these transformations with $C = aabbaaababb$ and

$$\pi = (10_a, 8_a, 8_b, 7_b, 5_a, 4_a, 3_a, 2_b, 1_a, 1_b, 1_b, 0_c),$$

corresponding to

$$\mu = (4_a, 3_a, 3_b, 3_b, 3_a, 2_a, 1_a, 1_b, 1_a, 1_b, 1_b, 0_c),$$

and

$$\nu = (6, 5, 5, 4, 2, 2, 2, 1, 0, 0, 0).$$

By conjugation,

$$\nu' = (8, 7, 4, 4, 3, 1)$$

Recall that $\delta_g = 0$. Using the following tables

k	0	1	2	3	4	5	6	7	8	9	10
$\mu_k + k$	4	4	5	6	7	7	7	8	9	10	11

u	0	1	2	3	4	5
$\nu'_u - u - 1$	7	5	1	0	-2	-5

it follows that

$$\mu' = (6_a, 5_a, 5_b, 4_b, 4_a, 3_a, 2_a, 1_b, 1_a, 1_b, 1_b, 0_c) \quad , \quad \nu'' = (1_c, 4_c, 4_c, 4_c, 3_c, 1_c)$$

and the insertion then gives

$$\Omega^{-1}(\pi) = (6_a, 5_a, 5_b, 4_c, 4_c, 4_c, 4_b, 4_a, 3_c, 3_a, 2_a, 1_c, 1_c, 1_b, 1_a, 1_b, 1_b, 0_c).$$

Let us now show that $\pi \in \mathcal{F}_1^{\epsilon, c_g}$. First note that

$$\delta_g + \mu_{s-1} + s - 1 = s,$$

and since $\nu'_u \leq s$ for all $u \in \{0, \dots, s' - 1\}$, it follows that $\mu'_{s-1} = \mu_{s-1} = 1 - \delta_g$. Moreover, for all the $k \in \{0, \dots, s - 1\}$,

$$(\delta_g + \mu_k + k) - (\delta_g + \mu_{k-1} + k - 1) = 1 + \mu_k - \mu_{k-1}$$

$$= 1 - \epsilon(c_{k-1}, c_k) \in \{0, 1\}.$$

This means that the sequence $(\delta_g + \mu_k + k)_{k=0}^{s-1}$ is non-decreasing, and with the difference between consecutive terms at most equal to 1, with equality if and only if $k \in D$.

On the other hand, for $u \in \{1, \dots, s-1\}$, we have for all $u \in \{0, \dots, s'-1\}$ that

$$v'_{u-1} - u - (v'_u - u - 1) = 1 + v'_{u-1} - v'_u \geq 1.$$

The sequence $(v'_u - u - 1)_{u=0}^{s'-1}$ is then decreasing.

Let us now set

$$D_V = \{k \in \{1, \dots, s\} : \mu'_{k-1} - \mu'_k \neq \mu_{k-1} - \mu_k\}.$$

Since $\epsilon(c_{k-1}, c_k) \in \{0, 1\}$, the set D_V then contains all the $k \in \{1, \dots, s-1\}$ such that

$$0 < |\{0 \leq u < s' : \delta_g + \mu_{k-1} + k - 1 \leq v'_u - u - 1 < \delta_g + \mu_k + k\}| \leq 1 - \epsilon(c_{k-1}, c_k),$$

so that we necessarily have $D_V \subset D$. For such k , there exists a unique u such that

$$\delta_g + \mu_{k-1} + k - 1 \leq v'_u - u - 1 < \delta_g + \mu_k + k. \quad (5.1.15)$$

In fact, the sequence $(v'_u - u - 1)_{u=0}^{s'-1}$ being decreasing, and the interval $[\delta_g + \mu_{k-1} + k - 1, \delta_g + \mu_k + k)$, which is a singleton for $k \in D_V$, contains at at most one element of the latter sequence. Also,

$$\begin{aligned} |\{0 \leq l < s : \delta_g + \mu_l + l \leq v'_u - u - 1\}| &= |\{0, \dots, k-1\}| = k \\ |\{0 \leq v < s' : \delta_g + \mu_{k-1} + k - 1 \leq v'_v - v - 1\}| &= |\{0, \dots, u\}| = u + 1. \end{aligned}$$

Therefore,

$$\begin{aligned} v'_u &= v''_u + k, \\ \mu'_k &= \mu_k + u \\ \mu'_{k-1} &= \mu_{k-1} + u + 1, \end{aligned} \quad (5.1.16)$$

and by (5.1.1) and (5.1.15), we necessarily have

$$\mu'_{k-1} \succ_{\epsilon} v''_u \succ_{\epsilon} \mu'_k. \quad (5.1.17)$$

The particle v''_u is then inserted between μ'_{k-1} and μ'_k . Note that this insertion occurs once for all u such that

$$|\overline{D}| = \delta_g + \mu_0 \leq v'_u - u - 1,$$

so that

$$|D_V| = |\{0 \leq k < s : \delta_g + \mu_0 \leq v'_u - u - 1\}|.$$

Then, for all $u \geq |D_V|$, we have

$$v'_u - u - 1 < \delta_g + \mu_0,$$

so that $v''_u = v'_u$. In particular, we have

$$v''_{|D_V|} - |D_V| - 1 < \delta_g + \mu_0 \iff v''_{|D_V|} \leq \delta_g + \mu_0 + |D_V| = \delta_g + \mu'_0. \quad (5.1.18)$$

We remark that for all $k \in D \setminus D_V$, since $\mu'_{k-1} - \mu'_k = \mu_{k-1} - \mu_k = 0$, the parts μ'_{k-1}, μ'_k have the same size, and then the same relation with all particles with state c_g . This means that, after inserting of the particles v''_u into μ' , there is no particle between the parts μ'_{k-1} and μ'_k . Note that, for all $k \in \overline{D} \sqcup D_V$, $\mu'_{k-1} - \mu'_k = 1$, so that we can insert any number of particles with state c_g and potential $\delta_g + \mu'_k$, and since $\epsilon(c_g, c_g) = 0$, these particle with the same potential and state c_g are well-related by \succ_{ϵ} .

These facts, together with (5.1.17) and (5.1.18), imply that π belongs to $\mathcal{F}_1^{\epsilon, c_g}$.

We conclude by observing that, by (5.1.17), D_V can be also defined as the unique subset of D with satisfies the following: $k \in D$ belongs to D_V if and only if there exists $u \in \{0, \dots, s'\}$ such that $\mu'_{k-1} \succ_{\epsilon} v''_u \succ_{\epsilon} \mu'_k$.

5.1.4 Inversion of the maps

Using (5.1.11) and (5.1.12), we straightforward to observe by the definition of Ω^{-1} that $\Omega^{-1} \circ \Omega = Id_{\mathcal{F}_1^{\epsilon, c_g}(C)}$. On the other hand, the fact that $\Omega \circ \Omega^{-1} = Id_{\mathcal{R}_1^{\epsilon, c_g}(C)}$ comes from the correspondence between D_W and D_V . In fact, this correspondence is deduced from the equivalence between the definition of W and the above definition of D_V . We also observe that the only particles whose potential changes from one set of partitions to another are those related to the set D_W and D_V . We finally conclude by observing the reciprocity between the definition of the weighted particles related to D_W given in (5.1.10), and the definition of the particles related to D_V given by the formula (5.1.16).

Remark 5.1.4. *The maps described here give a more refined property that the bijection between the sets $\mathcal{F}_1^{\epsilon, c_g}(C)$ and $\mathcal{R}_1^{\epsilon, c_g}(C)$, as for a fixed State C product of s states different from c_g , it leads to the correspondence between the partitions ν with at most s parts such that the greatest part has size s' and the flat partitions having s' additional particles with states c_g different from 0_{c_g} .*

5.2 Bijective proof of Theorem 2.2.31

In this section, we prove the following.

Theorem 5.2.1. *For a fixed State C as product of colors different from c_g and a fixed non-negative integer n , the following sets of generalized partitions are equinumerous:*

1. $\mathcal{F}_2^{\epsilon, c_g}(C, n) = \{\pi \in \mathcal{F}_2^{\epsilon, c_g} : C(\pi)|_{c_g=1} = C, |\pi| = n\}$,
2. $\mathcal{F}_1^{\epsilon, c_g}(C, n) = \{\pi \in \mathcal{F}_1^{\epsilon, c_g} : C(\pi)|_{c_g=1} = C, |\pi| = n\}$,
3. $\mathcal{R}_1^{\epsilon, c_g}(C, n) = \{\pi \in \mathcal{R}_1^{\epsilon, c_g} : C(\pi)|_{c_g=1} = C, |\pi| = n\}$,
4. $\mathcal{R}_2^{\epsilon, c_g}(C, n) = \{\pi \in \mathcal{R}_2^{\epsilon, c_g} : C(\pi)|_{c_g=1} = C, |\pi| = n\}$.

In the previous section, we have shown in the proof of Theorem 2.2.24 that $|\mathcal{F}_1^{\epsilon, c_g}(C, n)| = |\mathcal{R}_1^{\epsilon, c_g}(C, n)|$. In the following, we first show that there is a bijection between $\mathcal{F}_2^{\epsilon, c_g}(C, n)$ and $\mathcal{F}_1^{\epsilon, c_g}(C, n)$, and after that we describe a bijection between $\mathcal{R}_1^{\epsilon, c_g}(C, n)$ and $\mathcal{R}_2^{\epsilon, c_g}(C, n)$.

5.2.1 Bijection between $\mathcal{F}_2^{\epsilon, c_g}(C, n)$ and $\mathcal{F}_1^{\epsilon, c_g}(C, n)$

Here recall that, by Definition 2.2.27, the partitions of $\mathcal{F}_2^{\epsilon, c_g}$ have the form $(\pi_0, \dots, \pi_{s-1}, 0_{c_g^2})$, such that for all $k \in \{0, \dots, s-1\}$, $\pi_k \in \mathcal{S}$, and by setting $c(\pi_k) = c_{2k}c_{2k+1} \in \mathcal{C}^2$, we have by (2.2.41) that

$$\mu(\pi_k) \geq \epsilon \gamma(\pi_{k+1}). \quad (5.2.1)$$

We also observe that $c_{2s-2}c_{2s-1} \neq c_g^2$, otherwise the above equation gives that $\pi_{s-1} - 0_{c_g^2} = 4\epsilon(c_g, c_g) = 0$, and then $\pi_{s-1} = 0_{c_g^2}$, which contradicts the definition of grounded partitions. Furthermore, note that $\mu(\pi_{s-1}) = 0_{c_g}$ if and only if $c_{2s-1} = c_g$.

Consider the map \mathcal{F} from $\mathcal{F}_2^{\epsilon, c_g}$ to $\mathcal{F}_1^{\epsilon, c_g}$ defined by

$$(\pi_0, \dots, \pi_{s-1}, 0_{c_g^2}) \mapsto \begin{cases} (\gamma(\pi_0), \mu(\pi_0), \gamma(\pi_1), \mu(\pi_1), \dots, \gamma(\pi_{s-2}), \mu(\pi_{s-2}), \gamma(\pi_{s-1}), 0_{c_g}) & \text{if } c_{2s-1} = c_g \\ (\gamma(\pi_0), \mu(\pi_0), \gamma(\pi_1), \mu(\pi_1), \dots, \gamma(\pi_{s-2}), \mu(\pi_{s-2}), \gamma(\pi_{s-1}), \mu(\pi_{s-1}), 0_{c_g}) & \text{if } c_{2s-1} \neq c_g \end{cases} \quad (5.2.2)$$

It is easy to check that both the total energy and the sequence of primary states are preserved. To show that $\mathcal{F}(\pi_0, \dots, \pi_{s-1}, 0_{c_g^2}) \in \mathcal{F}_1^{\epsilon, c_g}$, we proceed according to whether $c_{2s-1} = c_g$ or $c_{2s-1} \neq c_g$. Note that by definition of the secondary particles, for all $k \in \{0, \dots, s-1\}$,

$$\gamma(\pi_k) - \mu(\pi_k) = \epsilon(c_{2k}, c_{2k+1}) \iff \gamma(\pi_k) \geq \epsilon \mu(\pi_k).$$

- If $c_{2s-1} = c_g$, then the above equation and (5.2.1) give that $\mathcal{F}(\pi_0, \dots, \pi_{s-1}, 0_{c_g^2})$ is well-defined up to $\mu(\pi_{s-1})$, and with the fact that $c_{2s-2} \neq c_g$ and $\mu(\pi_{s-1}) = 0_{c_g}$, we obtain that $\mathcal{F}(\pi_0, \dots, \pi_{s-1}, 0_{c_g^2}) \in \mathcal{F}_1^{\epsilon, c_g}$.
- If $c_{2s-1} \neq c_g$, then the above equation and (5.2.1) give that $\mathcal{F}(\pi_0, \dots, \pi_{s-1}, 0_{c_g^2})$ is well-defined up to $\mu(\pi_{s-1})$, with the fact that $c_{2s-1} \neq c_g$ and $\mu(\pi_{s-1}) = \epsilon(c_{2s-1}, c_g)$, we obtain that $\mathcal{F}(\pi_0, \dots, \pi_{s-1}, 0_{c_g^2}) \in \mathcal{F}_1^{\epsilon, c_g}$.

The inverse map \mathcal{F}^{-1} is even easier to build. We simply proceed as follows:

$$(\pi_0, \dots, \pi_{s-1}, 0_{c_g}) \mapsto \begin{cases} (\pi_0 + \pi_1, \dots, \pi_{s-1} + 0_{c_g}, 0_{c_g^2}) & \text{if } s \equiv 1 \pmod{2} \\ (\pi_0 + \pi_1, \dots, \pi_{s-2} + \pi_{s-1}, 0_{c_g^2}) & \text{if } s \equiv 0 \pmod{2} \end{cases}. \quad (5.2.3)$$

The primary particles being consecutive in terms of \succ_ϵ , the map \mathcal{F}^{-1} is well-defined, and one can check that the first case of \mathcal{F}^{-1} is the inverse of the first case of \mathcal{F} , so as the second case of \mathcal{F}^{-1} is the inverse of the second case of \mathcal{F} .

5.2.2 Bijection between $\mathcal{R}_1^{\epsilon, c_g}(C, n)$ and $\mathcal{R}_2^{\epsilon, c_g}(C, n)$

Let us recall that $\mathcal{C}' = \mathcal{C} \setminus \{c_g\}$, and set $\mathcal{C}'_x = \{cc' : c, c' \in \mathcal{C}'\}$. We now set $\rho = 1 - \delta_g$ the common value of $\epsilon(c, c_g)$ for all $c \in \mathcal{C}'$. Here we refer to \mathcal{O}_ϵ and \mathcal{E} as the sets corresponding to the set \mathcal{C}' in Chapter 4. We now show the following proposition.

Theorem 5.2.2. *For a fixed State C as product of states in \mathcal{C}' and a fixed non-negative integer n , the following sets of generalized partitions are equinumerous:*

1. $\mathcal{R}_1^{\epsilon, c_g}(C, n) = \{\pi \in \mathcal{F}_2^{\epsilon, c_g} : C(\pi)|_{c_g=1} = C, |\pi| = n\}$,
2. $\mathcal{O}_\epsilon^{\rho+}(C, n) = \{\pi \in \mathcal{O}_\epsilon^{\rho+} : C(\pi) = C, |\pi| = n\}$,
3. $\mathcal{E}^{\rho+}(C, n) = \{\pi \in \mathcal{E}^{\rho+} : C(\pi) = C, |\pi| = n\}$,
4. $\mathcal{R}_2^{\epsilon, c_g}(C, n) = \{\pi \in \mathcal{R}_2^{\epsilon, c_g} : C(\pi)|_{c_g=1} = C, |\pi| = n\}$.

By Theorem 2.2.15, we already have that $|\mathcal{O}_\epsilon^{\rho+}(C, n)| = |\mathcal{E}^{\rho+}(C, n)|$. We show in the remainder of this section that $\mathcal{R}_1^{\epsilon, c_g}(C, n)$ and $\mathcal{O}_\epsilon^{\rho+}(C, n)$ are in bijection, as are $\mathcal{E}^{\rho+}(C, n)$ and $\mathcal{R}_2^{\epsilon, c_g}(C, n)$.

Bijection between $\mathcal{R}_1^{\epsilon, c_g}(C, n)$ and $\mathcal{O}_\epsilon^{\rho+}(C, n)$

This is straightforward by considering the following map from $\mathcal{R}_1^{\epsilon, c_g}(C, n)$ to $\mathcal{O}_\epsilon^{\rho+}(C, n)$:

$$(\pi_0, \dots, \pi_{s-1}, 0_{c_g}) \mapsto (\pi_0, \dots, \pi_{s-1}). \quad (5.2.4)$$

In fact, we have that $c(\pi_k) \in \mathcal{C}'$ for all $k \in \{0, \dots, s-1\}$, and by (2.2.38), that

$$\pi_k - \pi_{k+1} \geq \epsilon(c(\pi_k), c(\pi_{k+1})),$$

so that $\pi_{s-1} \geq \epsilon(c(\pi_{k+1}), c_g) = 1 - \delta_g = \rho$. By Definition 2.1.3 and Definition 2.2.14, we then have that the partition $(\pi_0, \dots, \pi_{s-1})$ belongs to $\mathcal{O}_\epsilon^{\rho+}(C, n)$.

The inverse map is obtained by adding a 0_{c_g} to the right to a partition in $\mathcal{O}_\epsilon^{\rho+}(C, n)$, and the above relations imply that the resulting partition indeed belongs to $\mathcal{R}_1^{\epsilon, c_g}(C, n)$.

Bijection between $\mathcal{E}^{\rho+}(C, n)$ and $\mathcal{R}_2^{\epsilon, c_g}(C, n)$

It may seem intricate to construct a bijection between these two sets, as a partition in the first set can have primary particles while a partition in the second set cannot. The regularity in c_g^2 allows us to overcome this obstacle. For simplicity, we write $\mathcal{S}(\mathcal{C})$, $\mathcal{S}(\mathcal{C}')$ and $\mathcal{P}(\mathcal{C}')$ respectively the sets of the secondary particles with states as a product of two primary states in \mathcal{C} , the secondary particles with states as a product of two primary states in \mathcal{C}' and the primary particles with state in \mathcal{C}' . We observe that we have a natural embedding $\mathcal{S}(\mathcal{C}') \hookrightarrow \mathcal{S}(\mathcal{C})$.

By definition, for any $c \in \mathcal{C}'$, the potential of the secondary particle with state cc_g has the same parity as $\epsilon(c, c_g) = \rho$, while the potential of the secondary particle with color $c_g c$ has the same parity as $\epsilon(c_g, c) = 1 - \rho$. The embedding $\mathcal{P}(\mathcal{C}') \hookrightarrow \mathcal{S}(\mathcal{C})$ can then be described as follows:

$$k_c \mapsto \begin{cases} k_{cc_g} & \text{if } k \equiv \rho \pmod{2} \\ k_{c_g c} & \text{if } k \equiv 1 - \rho \pmod{2} \end{cases}.$$

Therefore, we obtain a natural bijection \mathcal{R} between $\mathcal{P}(\mathcal{C}') \sqcup \mathcal{S}(\mathcal{C}')$ and $\mathcal{S}(\mathcal{C}) \setminus \{(2\mathbb{Z})_{c_g^2}\}$ with the relations

$$\mathcal{S}(\mathcal{C}') \ni (2k + \epsilon(c, c'))_{cc'} \mapsto (2k + \epsilon(c, c'))_{cc'} \quad (5.2.5)$$

$$\mathcal{P}(\mathcal{C}') \ni k_c \mapsto \begin{cases} k_{cc_g} & \text{if } k \equiv \rho \pmod{2} \\ k_{c_g c} & \text{if } k \equiv 1 - \rho \pmod{2} \end{cases}. \quad (5.2.6)$$

Note that the inverse \mathcal{R}^{-1} is also the identity on $\mathcal{S}(\mathcal{C}')$, and for a particle with state cc_g or $c_g c$, we associate the particle in $\mathcal{P}(\mathcal{C}')$ with the same potential and state c .

The map \mathcal{R} can now be extended to the partitions in $\mathcal{E}^{\rho+}$ with

$$\mathcal{R} : (\pi_0, \dots, \pi_{s-1}) \mapsto (\mathcal{R}(\pi_0), \dots, \mathcal{R}(\pi_{s-1}), 0_{c_g^2}), \quad (5.2.7)$$

resulting in the following proposition.

Proposition 5.2.3. *The map \mathcal{R} defines a bijection between $\mathcal{E}^{\rho+}(C, n)$ and $\mathcal{R}_2^{\epsilon, c_g}(C, n)$.*

Recall that \ggg_{ϵ} in Definition 2.2.10 is the relation that relates the particles of a partition in $\mathcal{E}^{\rho+}$, and the relation \ggg^{ϵ} defined in (2.2.46) relates the particles of a partition in $\mathcal{R}_2^{\epsilon, c_g}$.

Note that the map \mathcal{R} from $\mathcal{P}(\mathcal{C}') \sqcup \mathcal{S}(\mathcal{C}')$ to $\mathcal{S}(\mathcal{C}) \setminus \{(2\mathbb{Z})_{c_g^2}\}$ conserves the potential and the sequence of states different from c_g , so that extended to $\mathcal{E}^{\rho+}$, it also preserves the total energy and the sequence of states different from c_g . The proof of Proposition 5.2.3 is straightforward using the two next lemmas.

Lemma 5.2.4. *Let $c \in \mathcal{C}' \sqcup \mathcal{C}'_{\times}$ and $c = c(\pi_{s-1})$. Then the minimal potential of $\pi_{s-1} \in \mathcal{P}^{\rho+} \sqcup \mathcal{S}^{\rho+}$ is the minimal potential of $\mathcal{R}(\pi_{s-1})$ satisfying $\mathcal{R}(\pi_{s-1}) \ggg 0_{c_g^2}$.*

Lemma 5.2.5. *For all particles $k_p, l_q \in \mathcal{P}(\mathcal{C}') \sqcup \mathcal{S}(\mathcal{C}')$, we have the following :*

$$k_p \ggg_{\epsilon} l_q \iff \mathcal{R}(k_p) \ggg^{\epsilon} \mathcal{R}(l_q). \quad (5.2.8)$$

Lemma 5.2.4 gives the equivalence of the minimal potential condition for the last particle, while Lemma 5.2.5 states that the difference conditions are equivalent for both sets of partitions, and we directly obtain Proposition 5.2.3.

Proof of Lemma 5.2.4. We reason on whether $c \in \mathcal{C}'_{\times}$, or $c \in \mathcal{C}'$ and π_{s-1} has a potential with the same parity as ρ or $1 - \rho$.

- If $c \in \mathcal{C}'_{\times}$, write $c = c_0 c_1$. Then,

$$\begin{aligned} \pi_{s-1} \in \mathcal{S}^{\rho+} &\iff \mu(\pi_{s-1}) \geq \rho && \text{by Definition 2.2.14} \\ &\iff \mu(\pi_{s-1}) \geq \epsilon(c_1, c_g) \\ &\iff \mathcal{R}(\pi_{s-1}) = \pi_{s-1} \ggg^{\epsilon} 0_{c_g^2}. && (2.2.46) \end{aligned}$$

- If $c \in \mathcal{C}'$ and $\pi_{s-1} \equiv \rho \pmod{2}$,

$$\begin{aligned} \pi_{s-1} \in \mathcal{P}^{\rho+} &\iff \pi_{s-1} \geq \rho \quad \text{and} \quad \pi \equiv \rho \pmod{2} && \text{by Definition 2.2.14} \\ &\iff \pi_{s-1} \in 2\mathbb{Z}_{\geq 0} + \rho \\ &\iff c(\mu(\mathcal{R}(\pi_{s-1}))) = c_g \quad \text{and} \quad \mu(\mathcal{R}(\pi_{s-1})) \geq 0 && (1.2.2) \\ &\iff \mu(\mathcal{R}(\pi_{s-1})) \geq \epsilon(c_g, c_g) \\ &\iff \mathcal{R}(\pi_{s-1}) \ggg^{\epsilon} 0_{c_g^2}. && (2.2.46) \end{aligned}$$

- If $c \in \mathcal{C}'$ and $\pi_{s-1} \equiv 1 - \rho \pmod{2}$,

$$\begin{aligned} \pi_{s-1} \in \mathcal{P}^{\rho+} &\iff \pi_{s-1} \geq \rho \quad \text{and} \quad \pi \equiv 1 + \rho \pmod{2} && \text{by Definition 2.2.14} \\ &\iff \pi_{s-1} \in 2\mathbb{Z}_{\geq 0} + 1 + \rho \\ &\iff \mu(\mathcal{R}(\pi_{s-1})) \geq \rho \quad \text{and} \quad c(\mu(\mathcal{R}(\pi_{s-1}))) = c && (1.2.2) \end{aligned}$$

$$\begin{aligned} &\iff \mu(\mathcal{R}(\pi_{s-1})) \geq \epsilon(c, c_g) \\ &\iff \mathcal{R}(\pi_{s-1}) \gg^\epsilon 0_{c_g^2}. && (2.2.46) \end{aligned}$$

To conclude, one can observe that we always have the equivalence

$$\pi_{s-1} \in \mathcal{P}^{\rho+} \sqcup \mathcal{S}^{\rho+} \iff \mathcal{R}(\pi_{s-1}) \gg^\epsilon 0_{c_g^2}$$

and this concludes the proof of the lemma. \square

Proof of Lemma 5.2.5. Let us first state an obvious fact: for all integer a, b , we have the following,

1. if $b \in \{-1, 0, 1\}$, then

$$2a \geq b \iff a \geq \chi(b = 1), \quad (5.2.9)$$

2. if $b \in \{-2, -1, 0\}$, then

$$2a \geq b \iff a \geq -\chi(b = -2). \quad (5.2.10)$$

As before, we reason on whether particles k_p and l_q are primary or secondary.

- If $k_p \in \mathcal{S}$, write $k_p = (2u + \epsilon(c_0, c_1))_{c_0 c_1}$.

- If $l_q \in \mathcal{S}$, write $l_q = (2v + \epsilon(c_2, c_3))_{c_2 c_3}$.

$$k_p \gg^\epsilon l_q \iff u - v - \epsilon(c_1, c_2) - \epsilon(c_2, c_3) \geq 0 \quad (2.2.25)$$

$$\iff \mathcal{R}(k_p) \gg^\epsilon \mathcal{R}(l_q). \quad (2.2.46)$$

- If $q \in \mathcal{C}'$ and $l \equiv \rho \pmod{2}$, write $l_q = (2v + \epsilon(q, c_g))_q$. Then,

$$k_p \gg^\epsilon l_q \iff (2u + \epsilon(c_0, c_1)) - (2v + \epsilon(q, c_g)) \geq 1 + \epsilon(c_0, c_1) + \epsilon(c_1, q) \quad (2.2.24)$$

$$\iff 2(u - v - \epsilon(q, c_g) - \epsilon(c_1, q)) \geq \epsilon(c_g, q) - \epsilon(c_1, q)$$

$$\iff u - v - \epsilon(q, c_g) - \epsilon(c_1, q) \geq \epsilon(c_g, q)(1 - \epsilon(c_1, q)) \quad (5.2.9)$$

$$\iff \mathcal{R}(k_p) \gg^\epsilon \mathcal{R}(l_q). \quad (2.2.45)$$

- If $q \in \mathcal{C}'$ and $l \equiv 1 - \rho \pmod{2}$, write $l_q = (2v + \epsilon(c_g, q))_q$.

$$k_p \gg^\epsilon l_q \iff (2u + \epsilon(c_0, c_1)) - (2v + \epsilon(c_g, q)) \geq 1 + \epsilon(c_0, c_1) + \epsilon(c_1, q) \quad (2.2.24)$$

$$\iff 2(u - v - \epsilon(c_1, c_g) - \epsilon(c_g, q)) \geq \epsilon(c_1, q) + \epsilon(c_g, q) - 1$$

$$\iff 2(u - v - \epsilon(c_1, c_g) - \epsilon(c_g, q)) \geq \epsilon(c_1, q) - \epsilon(q, c_g)$$

$$\iff u - v - \epsilon(c_1, c_g) - \epsilon(c_g, q) \geq \epsilon(c_1, q)\epsilon(c_g, q) \quad (5.2.9)$$

$$\iff \mathcal{R}(k_p) \gg^\epsilon \mathcal{R}(l_q). \quad (2.2.45)$$

- If $p \in \mathcal{C}'$ and $k \equiv \rho \pmod{2}$, write $k_p = (2u + \epsilon(p, c_g))_p$

- If $l_q \in \mathcal{S}$, write $l_q = (2v + \epsilon(c_2, c_3))_{c_2 c_3}$. Then

$$k_p \gg^\epsilon l_q \iff (2u + \epsilon(p, c_g)) - (2v + \epsilon(c_2, c_3)) \geq \epsilon(p, c_2) + \epsilon(c_2, c_3) \quad (2.2.23)$$

$$\iff 2(u - v - \epsilon(c_g, c_2) - \epsilon(c_2, c_3)) \geq \epsilon(p, c_2) - \epsilon(p, c_g) - 2\epsilon(c_g, c_2)$$

$$\iff 2(u - v - \epsilon(c_g, c_2) - \epsilon(c_2, c_3)) \geq (\epsilon(p, c_2) - 1) - \epsilon(c_g, p)$$

$$\iff u - v - \epsilon(c_g, c_2) - \epsilon(c_2, c_3) \geq -(1 - \epsilon(p, c_2))\epsilon(c_g, p) \quad (5.2.10)$$

$$\iff \mathcal{R}(k_p) \gg^\epsilon \mathcal{R}(l_q). \quad (2.2.44)$$

- If $q \in \mathcal{C}'$ and $l \equiv \rho \pmod{2}$, write $l_q = (2v + \epsilon(q, c_g))_q$. Then

$$k_p \gg^\epsilon l_q \iff (2u + \epsilon(p, c_g)) - (2v + \epsilon(q, c_g)) \geq 1 + \epsilon(p, q) \quad (2.2.22)$$

$$\begin{aligned}
&\iff 2(u - v - \epsilon(c_g, q) - \epsilon(q, c_g)) \geq \epsilon(p, q) - 1 \\
&\iff u - v - \epsilon(c_g, q) - \epsilon(q, c_g) \geq 0 & (5.2.9) \\
&\iff \mathcal{R}(k_p) \gg^\epsilon \mathcal{R}(l_q). & (2.2.46)
\end{aligned}$$

- If $q \in \mathcal{C}'$ and $l \equiv 1 - \rho \pmod{2}$, write $l_q = (2v + \epsilon(c_g, q))_q$. Then

$$\begin{aligned}
k_p \gg_\epsilon l_q &\iff (2u + \epsilon(p, c_g)) - (2v + \epsilon(c_g, q)) \geq 1 + \epsilon(p, q) & (2.2.22) \\
&\iff 2(u - v - \epsilon(c_g, c_g) - \epsilon(c_g, q)) \geq \epsilon(p, q) + \epsilon(c_g, p) - \epsilon(c_g, q) \\
&\iff 2(u - v - \epsilon(c_g, c_g) - \epsilon(c_g, q)) \geq \epsilon(p, q) \\
&\iff u - v - \epsilon(c_g, c_g) - \epsilon(c_g, q) \geq \epsilon(p, q) & (5.2.9) \\
&\iff \mathcal{R}(k_p) \gg^\epsilon \mathcal{R}(l_q). & (2.2.43)
\end{aligned}$$

• If $p \in \mathcal{C}'$ and $k \equiv 1 - \rho \pmod{2}$, write $k_p = (2u + \epsilon(c_g, p))_p$.

- If $l_q \in \mathcal{S}$, write $l_q = (2v + \epsilon(c_2, c_3))_{c_2 c_3}$. Then

$$\begin{aligned}
k_p \gg_\epsilon l_q &\iff (2u + \epsilon(c_g, p)) - (2v + \epsilon(c_2, c_3)) \geq \epsilon(p, c_2) + \epsilon(c_2, c_3) & (2.2.23) \\
&\iff 2(u - v - \epsilon(p, c_2) - \epsilon(c_2, c_3)) \geq -\epsilon(p, c_2) - \epsilon(c_g, p) \\
&\iff u - v - \epsilon(p, c_2) - \epsilon(c_2, c_3) \geq -\epsilon(p, c_2)\epsilon(c_g, p) & (5.2.10) \\
&\iff \mathcal{R}(k_p) \gg^\epsilon \mathcal{R}(l_q). & (2.2.44)
\end{aligned}$$

- If $q \in \mathcal{C}'$ and $l \equiv \rho \pmod{2}$, write $l_q = (2v + \epsilon(q, c_g))_q$. Then

$$\begin{aligned}
k_p \gg_\epsilon l_q &\iff (2u + \epsilon(c_g, p)) - (2v + \epsilon(q, c_g)) \geq 1 + \epsilon(p, q) & (2.2.22) \\
&\iff 2(u - v - \epsilon(p, q) - \epsilon(q, c_g)) \geq \epsilon(c_g, q) - \epsilon(p, q) \\
&\iff u - v - \epsilon(p, q) - \epsilon(q, c_g) \geq \epsilon(c_g, q)(1 - \epsilon(p, q)) & (5.2.9) \\
&\iff \mathcal{R}(k_p) \gg^\epsilon \mathcal{R}(l_q). & (2.2.45)
\end{aligned}$$

- If $q \in \mathcal{C}'$ and $l \equiv 1 - \rho \pmod{2}$, write $l_q = (2v + \epsilon(c_g, q))_q$. Then

$$\begin{aligned}
k_p \gg_\epsilon l_q &\iff (2u + \epsilon(c_g, p)) - (2v + \epsilon(c_g, q)) \geq 1 + \epsilon(p, q) & (2.2.22) \\
&\iff 2(u - v - \epsilon(p, c_g) - \epsilon(c_g, q)) \geq \epsilon(p, q) - 1 \\
&\iff u - v - \epsilon(p, c_g) - \epsilon(c_g, q) \geq 0 & (5.2.9) \\
&\iff \mathcal{R}(k_p) \gg^\epsilon \mathcal{R}(l_q). & (2.2.46)
\end{aligned}$$

□

5.3 Beyond Glaisher's theorem at degree $k \geq 3$

We begin this section by defining a particle of degree k .

Definition 5.3.1. Let \mathcal{C} be a set of primary states. For any $k \in \mathbb{Z}_{\geq 1}$, define the set of states of degree k as the set of the products of k primary states:

$$\mathcal{C}^k = \{c_1 \cdots c_k : c_1, \dots, c_k \in \mathcal{C}\}.$$

For an energy ϵ and the corresponding flat relation \gg_ϵ defined on the set of primary particles, define the set $\mathcal{P}^k = \mathbb{Z} \times \mathcal{C}^k$ of particles of degree k as the sum of k primary particles well-related by \gg_ϵ :

$$(p, c_1 \cdots c_k) = \sum_{u=1}^k \left(p + \sum_{v=u}^{k-1} \epsilon(c_v, c_{v+1}) \right)_{c_u} = \left(kp + \sum_{u=1}^{k-1} u\epsilon(c_u, c_{u+1}) \right)_{c_1 \cdots c_k}. \quad (5.3.1)$$

We set the function $\gamma_1, \dots, \gamma_k$ on \mathcal{P}^k such that

$$\gamma_i(p, c_1 \cdots c_k) = \left(p + \sum_{u=i}^{k-1} \epsilon(c_i, c_{i+1}) \right)_{c_i}. \quad (5.3.2)$$

Then

$$(p, c_1 \cdots c_k) = \sum_{i=1}^k \gamma_i(p, c_1 \cdots c_k), \quad (5.3.3)$$

$$\gamma_1(p, c_1 \cdots c_k) \succ_{\epsilon} \gamma_2(p, c_1 \cdots c_k) \succ_{\epsilon} \cdots \succ_{\epsilon} \gamma_k(p, c_1 \cdots c_k). \quad (5.3.4)$$

We can then naturally define a flat relation \succ^k on \mathcal{P}^k as follows:

$$\begin{aligned} (p, c_1 \cdots c_k) \succ^k (q, d_1 \cdots d_k) &\iff p - q = \epsilon(c_k, d_1) + \sum_{u=1}^{k-1} \epsilon(d_u, d_{u+1}) \\ &\iff \gamma_k(p, c_1 \cdots c_k) \succ_{\epsilon} \gamma_1(q, d_1 \cdots d_k). \end{aligned} \quad (5.3.5)$$

The latter is equivalent to saying that the smallest primary particle of $(p, c_1 \cdots c_k)$ is greater than the greatest primary particle of $(q, d_1 \cdots d_k)$ in terms of \succ_{ϵ} .

One can check that the relation \succ^k is indeed the flat relation linked to the energy ϵ^k defined on $\mathcal{C}^k \times \mathcal{C}^k$ by

$$\epsilon^k : (c_1 \cdots c_k, d_1 \cdots d_k) \mapsto \sum_{u=1}^{k-1} u \epsilon(c_u, c_{u+1}) + n \epsilon(c_k, d_1) + \sum_{u=1}^{k-1} (k-u) \epsilon(d_u, d_{u+1}). \quad (5.3.6)$$

In fact, by using (5.3.1) and (5.3.5), the difference of potentials of the particles $(p, c_1 \cdots c_k)$ and $(q, d_1 \cdots d_k)$ is exactly equal to $\epsilon^k(c_1 \cdots c_k, d_1 \cdots d_k)$.

This extension of the flatness to degree k has a strong connection with crystal base theory via the following proposition.

Proposition 5.3.2. *Let \mathcal{B} be a crystal and suppose that there exists an energy function H on $\mathcal{B} \otimes \mathcal{B}$. Then, the function H^k on $\mathcal{B}^{\otimes k} \otimes \mathcal{B}^{\otimes k}$ defined by*

$$b_1 \otimes \cdots \otimes b_k \otimes b_{k+1} \otimes \cdots \otimes b_{2k} \mapsto \sum_{i=1}^{2k-1} \min\{i, 2k-i\} H(b_i \otimes b_{i+1}) \quad (5.3.7)$$

is also an energy function on $\mathcal{B}^{\otimes k} \otimes \mathcal{B}^{\otimes k}$.

Proof. Since the tensor product is associative, for all $i \in \{0, \dots, n\}$ and for all $j \in \{1, \dots, 2k\}$, that

$$\tilde{\epsilon}_i(b_1 \otimes \cdots \otimes b_{2k}) = b_1 \otimes \cdots \otimes \tilde{\epsilon}_i(b_j) \otimes \cdots \otimes b_{2k} \implies \begin{cases} \tilde{\epsilon}_i(b_{j-1} \otimes b_j) = b_{j-1} \otimes \tilde{\epsilon}_i(b_j) \\ \tilde{\epsilon}_i(b_j \otimes b_{j+1}) = \tilde{\epsilon}_i(b_j) \otimes b_{j+1} \end{cases}.$$

We thus obtain by (8.1.7) that, for $j \leq k$, (the following still holds for $j = 1$)

$$\begin{aligned} H^k(\tilde{\epsilon}_i(b_1 \otimes \cdots \otimes b_{2k})) - H^k(b_1 \otimes \cdots \otimes b_{2k}) &= (j-1) (H(b_{j-1} \otimes \tilde{\epsilon}_i(b_j)) - H(b_{j-1} \otimes b_j)) + \\ &\quad j (H(\tilde{\epsilon}_i(b_j) \otimes b_{j-1}) - H(b_j \otimes b_{j+1})) \\ &= -(j-1)\chi(i=0) + j\chi(i=0) \\ &= \chi(i=0). \end{aligned}$$

On the other hand by (8.1.7), for $j > k$ (the following still holds for $j = 2k$)

$$\begin{aligned} H^k(\tilde{\epsilon}_i(b_1 \otimes \cdots \otimes b_{2k})) - H^k(b_1 \otimes \cdots \otimes b_{2k}) &= (2k-j+1) (H(b_{j-1} \otimes \tilde{\epsilon}_i(b_j)) - H(b_{j-1} \otimes b_j)) + \\ &\quad (2k-j) (H(\tilde{\epsilon}_i(b_j) \otimes b_{j-1}) - H(b_j \otimes b_{j+1})) \\ &= -(2k-j+1)\chi(i=0) + (2k-j)\chi(i=0) \\ &= -\chi(i=0). \quad \square \end{aligned}$$

The tensor product of level ℓ perfect crystals being a level ℓ perfect crystal as well (Kang et al., 1992c), we then obtain that $\mathcal{B}^{\otimes k}$ is a perfect crystal if \mathcal{B} is.

We note that the energy function of the perfect crystal \mathcal{B} studied in Chapter 7 can be obtained by carrying out a transformation, which preserves the ground, on a certain minimal energy satisfying the condition in Theorem 2.2.24 and such that $\delta_g = 0$. Therefore, we can define both secondary flat and

regular partitions corresponding to this energy function. In particular, since the corresponding minimal energy satisfies $\delta_g = 0$, the energies related to these flat and regular partitions are almost equal by (2.2.41) and (2.2.46). By Proposition 5.2.3, this means that the partitions, corresponding to those in \mathcal{E}^{1+} after applying the transformation on the minimal energy, satisfy some difference condition equal to the difference implied by the corresponding energy function of \mathcal{B}^2 . In particular, one can view the case $A_{2n}^{(2)}$ as a result that links the generalization of the Siladić theorem for $2n$ primary colors to the unique level one standard module $L(\Lambda_0)$. This fits with the original work of Siladić (Siladić, 2017), where he stated his identity after describing a basis of the unique level one standard module of $A_2^{(2)}$ through vertex operators. A suitable subsequent work is then to build the vertex operators, for the level one standard module of $A_{2n}^{(2)}$ ($n \geq 2$), which will allow us to describe a basis corresponding to the difference conditions given by the generalization of Siladić's theorem.

We now define the degree k flat partitions.

Definition 5.3.3. The set $\mathcal{F}_k^{\epsilon, c_g}$, of degree k flat partitions, is defined as the set of the flat partitions into degree k particles in \mathcal{P}^k , with ground c_g^k and energy ϵ^k defined in (5.3.6).

In particular, when $\epsilon(c_g, c_g) = 0$, the bijection of Section 5.2.1 can be generalized.

Proposition 5.3.4. For any $k \geq 1$, there is a bijection \mathcal{F}_k between $\mathcal{F}_k^{\epsilon, c_g}$ and $\mathcal{F}_1^{\epsilon, c_g}$ that preserves the total energy and the sequence of states different from c_g of the flat partitions.

Proof. For any flat partition $\pi = (\pi_0, \dots, \pi_{s-1}, 0_{c_g^k})$ in $\mathcal{F}_k^{\epsilon, c_g}$, we associate the partition $\mathcal{F}_k(\pi)$ defined by the sequence

$$(\gamma_1(\pi_0), \dots, \gamma_k(\pi_0), \gamma_1(\pi_1), \dots, \gamma_k(\pi_1), \dots, \gamma_1(\pi_{s-2}), \dots, \gamma_k(\pi_{s-2}), \gamma_1(\pi_{s-1}), \dots, \gamma_i(\pi_{s-1}), 0_{c_g}),$$

where $i = \max\{j \in \{1, \dots, k\} : \gamma_j(\pi_{s-1}) \neq 0_{c_g^k}\}$. The existence of such index i is ensured by the fact that $\pi_{s-1} \neq 0_{c_g^k}$. It suffices to assume by contradiction that for all $j \in \{1, \dots, k\}$ we have $\gamma_j(\pi_{s-1}) = 0_{c_g^k}$. Since $\epsilon(c_g, c_g) = 0$, we then have $0_{c_g^k} \succ_{\epsilon} 0_{c_g}$, and by (5.3.3),

$$0_{c_g^k} \neq \pi_{s-1} = \sum_{j=1}^k \gamma_j(\pi_{s-1}) = \sum_{j=1}^k 0_{c_g} = 0_{c_g^k}.$$

To prove that $\mathcal{F}_k(\pi)$ belongs to $\mathcal{F}_1^{\epsilon, c_g}$, we use (5.3.4) along with (5.3.5) to see that $\mathcal{F}_k(\pi)$ is well related up to $\gamma_i(\pi_{s-1})$, and to show that $\gamma_i(\pi_{s-1}) \succ_{\epsilon} 0_{c_g}$, we distinguish two cases.

- If $i < k$, then $\gamma_{i+1}(\pi_{s-1}) = 0_{c_g}$, so that (5.3.4) follows.
- If $i = k$, then by (5.3.5) $\gamma_k(\pi_{s-1}) \succ_{\epsilon} \gamma_1(0_{c_g^k})$, and we are done.

Next we describe the inverse map \mathcal{F}_k^{-1} . For any $\pi = (\pi_0, \dots, \pi_{s-1}, 0_{c_0})$, we write the decomposition $s = km - s'$ with the unique non-negative integers m, s' such that $s' \in \{0, \dots, k-1\}$. We then set

$$\mathcal{F}_k^{-1}(\pi) = (\underbrace{\pi_0 + \dots + \pi_{k-1}}_{\pi_k}, \underbrace{\pi_k + \dots + \pi_{2k-1}}_{\pi_{2k}}, \dots, \underbrace{\pi_{(m-2)k} + \dots + \pi_{mk-k-1}}_{\pi_{(m-1)k}}, \underbrace{\pi_{(m-1)k} + \dots + \pi_{s-1} + s' \times 0_{c_g}}_{\pi_{(m-1)k} + \dots + \pi_{s-1} + s' \times 0_{c_g}}, 0_{c_g^k}).$$

Here we see by (5.3.3), (5.3.4) and (5.3.5), this sequence is well-defined up to the particle $\pi_{(m-1)k} + \dots + \pi_{s-1} + s' \times 0_{c_g}$. Note that since $\pi_{s-1} \neq 0_{c_g}$, we necessarily have that $\pi_{(m-1)k} + \dots + \pi_{s-1} + s' \times 0_{c_g} \neq 0_{c_g^k}$. We distinguish two cases.

- If $s' > 0$, since $\pi_{s-1} \succ_{\epsilon} 0_{c_g} \succ_{\epsilon} 0_{c_g}$, then by (5.3.3), $\pi_{(m-1)k} + \dots + \pi_{s-1} + s' \times 0_{c_g}$ is in \mathcal{P}^k , and by (5.3.5), $\pi_{(m-1)k} + \dots + \pi_{s-1} + s' \times 0_{c_g} \gg^k 0_{c_g^k}$.
- If $s' = 0$, then by (5.3.3), $\pi_{(m-1)k} + \dots + \pi_{s-1}$ is in \mathcal{P}^k , and since $\pi_{s-1} \succ_{\epsilon} 0_{c_g}$, by (5.3.5), $\pi_{(m-1)k} + \dots + \pi_{s-1} \gg^k 0_{c_g^k}$.

The inversion comes from the correspondence between the case $s' = 0$ for \mathcal{F}_k^{-1} and $i = k$ for \mathcal{F}_k . \square

Proposition 5.3.4 implies the following correspondences

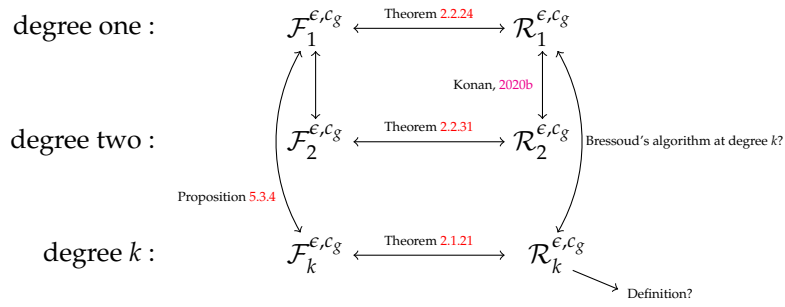

A major subsequent work would be to find a suitable energy to define regular partitions for degree k which would allow us to state an analogue of Theorem 2.1.21 at degree k . This problem appears to be closely related to the problem of finding a generalization to weighted words at degree k of the result stated in Theorem 2.2.15.

Chapter 6

Beyond the Durfee square

This chapter is dedicated to the proof of Theorem 2.2.39 and organized as followed. In Section 6.1, we give a precise characterization of the set of partitions in $\mathcal{P}_\epsilon^{c_\infty}$ with a fixed kernel as in Definition 2.2.36, compute their generating function, and state the main theorem, Theorem 6.1.28. After that, in Section 6.2, assuming Theorem 6.1.28 is true, we carry out the same steps and compute the generating function for the generalized colored Frobenius partitions in $\mathcal{F}_{\epsilon_1, \epsilon_2}^{c_\infty}$ with the same fixed kernel, and prove Theorem 2.2.39. Then, in Section 6.3, we prove Theorem 6.1.28. Finally, in Section 6.4, we prove the identity given in Theorem 2.2.45 for the n^2 -colored Frobenius partitions.

6.1 Reduced color sequences and minimal partitions

During this section, we illustrate different results on Example 2.2.35. In that case, we have

$$\begin{aligned}\mathcal{C} &= \{a_i b_j : i, j \in \mathbb{N}\}, \\ \mathcal{C}_{\text{free}} &= \{a_i b_i : i \in \mathbb{N}\}, \\ \mathcal{C}_{\text{bound}} &= \{a_i b_j : i \neq j \in \mathbb{N}\}, \\ a &: a_i b_j \rightarrow a_i b_i, \\ b &: a_i b_j \rightarrow a_j b_j.\end{aligned}$$

6.1.1 Minimal partitions

The original method of weighted words of Alladi and Gordon (Alladi and Gordon, 1993; Alladi, Andrews, and Gordon, 1995) relies on the idea, which can be tracked back to Schur and MacMahon that any partition with m parts satisfying difference conditions can be obtained from the minimal partition satisfying difference conditions and adding a partition with at most m parts to it. For example, all Rogers-Ramanujan partitions into m parts, satisfying difference at least 2 between consecutive parts, can be obtained by starting with the minimal partition $(2m - 1) + (2m - 3) + \cdots + 3 + 1$, and adding some partition into at most m parts to it.

Here, to compute the generating function for generalized colored partitions in $\mathcal{P}_\epsilon^{c_\infty}$, we also use minimal partitions. But while Alladi, Andrews, and Gordon computed minimal partitions with a certain number of parts, here we compute minimal partitions with a certain *kernel*.

Definition 6.1.1. Let c_1, \dots, c_s be a sequence of colors taken from \mathcal{C} . The *minimal partition* in $\mathcal{P}_\epsilon^{c_\infty}$ associated to c_1, \dots, c_s is the colored partition $\lambda = (\lambda_1, \dots, \lambda_s, 0_{c_\infty})$ with minimal size such that for all $i \in \{1, \dots, s\}$, $c(\lambda_i) = c_i$. We denote this partition by $\min_\epsilon(c_1, \dots, c_s)$. The size of $\min_\epsilon(c_1, \dots, c_s)$ is then equal to

$$|\min_\epsilon(c_1, \dots, c_s)| = \sum_{k=1}^s k\epsilon(c_k, c_{k+1}),$$

where $c_{s+1} = c_\infty$.

Example 6.1.2. Considering the energy ϵ from matrix P_3 in (1.4.5), the minimal partition with color sequence $a_1 b_0, a_0 b_0, a_2 b_2, a_1 b_1, a_1 b_1, a_0 b_1, a_1 b_2, a_0 b_2$ in $\mathcal{P}_{1,3}$ is

$$\min_\epsilon(a_1 b_0, a_0 b_0, a_2 b_2, a_1 b_1, a_1 b_1, a_0 b_1, a_1 b_2, a_0 b_2) = 8_{a_1 b_0} + 7_{a_0 b_0} + 6_{a_2 b_2} + 5_{a_1 b_1} + 5_{a_1 b_1} + 3_{a_0 b_1} + 2_{a_1 b_2} + 0_{a_0 b_2}.$$

It has size 52.

6.1.2 Combinatorial description of reduced color sequences

We want to study the partitions in $\mathcal{P}_\epsilon^{\infty}$ with a given kernel. To do so, we need to understand combinatorially the set of color sequences having a certain reduction. Recall that a sequence of colors in \mathcal{C} is reduced if and only if it does not contains the patterns

$$\begin{aligned} c \cdot c & \quad \text{for all } c \in \mathcal{C}_{\text{free}}, \\ c \cdot b(c) & \quad \text{for all } c \in \mathcal{C}_{\text{bound}}, \\ a(c) \cdot c & \quad \text{for all } c \in \mathcal{C}_{\text{bound}}. \end{aligned}$$

The above definition of reduced color sequences along with Definition 2.2.34 immediately yield the following proposition.

Proposition 6.1.3. *Let S be a reduced color sequence. Any color sequence C such that $\text{red}_{a,b}(C) = S$ can be obtained by performing a certain number of insertions of the following types in S :*

1. if there is a free color c in S , insert the same color c arbitrarily many times to its right,
2. if there is a bound color c in S , insert the free color $a(c)$ arbitrarily many times to its left,
3. if there is a bound color c in S , insert the free color $b(c)$ arbitrarily many times to its right.

Example 6.1.4.

$$S = a_1b_2, a_3b_1, a_2b_2, a_4b_3, a_3b_2.$$

The sequence

$$C = a_1b_1, a_1b_1, a_1b_2, a_2b_2, a_3b_3, a_3b_3, a_3b_3, a_3b_1, a_2b_2, a_2b_2, a_4b_3, a_3b_2$$

is obtained from S by inserting a_1b_1 twice to the left of a_1b_2 (insertion (2)), a_2b_2 once to the right of a_1b_2 (insertion (3)), a_3b_3 three times to the left of a_3b_1 (insertion (2)), and a_2b_2 once to the right of a_2b_2 (insertion (1)).

Remark 6.1.5. *The way one obtains C from S via the insertions above is not unique (even up to the order in which we perform the insertions). Indeed, it could be that in $S = c_1, \dots, c_s$, the color that can be inserted to the right of some c_j is the same as the one that can be inserted to the left of c_{j+1} . For example a_1b_2, a_2b_2, a_2b_3 can be obtained from a_1b_2, a_2b_3 either by inserting a_2b_2 to the right of a_1b_2 (insertion (3)) or to the left of a_2b_3 (insertion (2)).*

To understand reduced color sequences and insertions combinatorially, and make sure that we count our partitions in an unique way, we need some definitions.

Definition 6.1.6. A *primary pair* is a pair (c, c') of bound colors such that in the insertion rules of Proposition 6.1.3, the free color that can be inserted to the right of c is the same as the one that can be inserted to the left of c' . This is equivalent to saying that (c, c') is such that $b(c) = a(c')$.

We will be interested in maximal sequences of primary pairs in S .

Definition 6.1.7. Let $S = c_1, \dots, c_s$ be a reduced color sequence. The *maximal primary subsequences* of S are subsequences c_i, c_{i+1}, \dots, c_j of S such that

- for all $k \in \{i, \dots, j-1\}$, (c_k, c_{k+1}) is a primary pair,
- (c_{i-1}, c_i) and (c_j, c_{j+1}) are not primary pairs.

We denote by $t(S)$ the number of maximal primary subsequences of S , and by $S_1, \dots, S_{t(S)}$ these maximal primary subsequences.

Example 6.1.8. *Let*

$$S = a_1b_2, a_2b_3, a_2b_2, a_1b_4, a_3b_2, a_2b_1, a_3b_3, a_2b_2.$$

Here $t(S) = 3$ and the maximal primary subsequences of S are, from left to right,

$$\begin{aligned} S_1 & := a_1b_2, a_2b_3, \\ S_2 & := a_1b_4, \\ S_3 & := a_3b_2, a_2b_1. \end{aligned}$$

Let us now define secondary pairs of colors, inside which two different colors can be inserted.

Definition 6.1.9. A *secondary pair* is a pair (c, c') of colors satisfying one of the following assertions:

1. The colors c and c' are both bound, and the free color that can be inserted to the right of c is different from the one that can be inserted to the left of c' . These are the pairs of bound colors are such that $b(c) \neq a(c')$.
2. The color c is free, c' is bound, and the color that can be inserted to the left of c' is different from c . These are the pairs such that $c \neq a(c')$.
3. The color c is bound, c' is free, and the color which can be inserted to the right of c is different from c' . These are the pairs such that $b(c) \neq c'$.

Remark 6.1.10. *In the above, the colors c or c' can be equal to c_∞ , considered here as a free color. This allows us to avoid treating the case of insertions at one of the ends of the color sequence $C = c_1, \dots, c_s$ separately, with the convention that $c_0 = c_{s+1} = c_\infty$. Indeed, by our convention, inserting $a(c_1)$ to the left of c_1 is the same as inserting $a(c_1)$ inside the pair $(c_0, c_1) = (c_\infty, c_1)$. This is included in Case (2). Similarly, inserting $b(c_s)$ to the right of c_s is the same as inserting $b(c_s)$ inside the pair $(c_s, c_{s+1}) = (c_s, c_\infty)$, which is included in Case (3).*

With the definitions and propositions above, we can now uniquely determine the places where insertions can occur in a reduced color sequence.

Let $S = c_1, \dots, c_s$ be a reduced color sequence of length s . Then S can be written uniquely in the form

$$S = T_1 S_1 T_2 S_2 \dots T_t S_t T_{t+1},$$

where S_1, \dots, S_t are the maximal primary subsequences of S , and T_1, \dots, T_{t+1} are (possibly empty) sequences of consecutively distinct free colors.

For all $u \in \{1, \dots, t\}$, let i_{2u-1} (resp. i_{2u}) be the index of the first (resp. last) color of S_u , i.e.

$$S_u = c_{i_{2u-1}}, \dots, c_{i_{2u}}.$$

We have $i_{2u-1} \leq i_{2u}$, with equality when S_u is a singleton. By the definition of maximal primary subsequences, for all u , the pairs $(c_{i_{2u-1}-1}, c_{i_{2u-1}})$ and $(c_{i_{2u}}, c_{i_{2u}+1})$ are secondary pairs. We can now state the following.

Proposition 6.1.11. *Using the notation above, the insertions of free colors in S can occur exactly in the following $s + t$ places (possibly multiple times in the same place):*

- to the right of c_i , for all $i \in \{1, \dots, s\}$,
- to the left of $c_{i_{2u-1}}$, for all $u \in \{1, \dots, t\}$.

Let f_1, \dots, f_{s+t} be the $s + t$ free colors that can be inserted in S (in order). Let n_1, \dots, n_{s+t} be non-negative integers. We denote by $S(n_1, \dots, n_{s+t})$ the color sequence obtained from S by inserting n_i times the color b_i in S , for all i . Using this notation, we finally have the uniqueness of the insertions.

Proposition 6.1.12. *For each color sequence C such that $\text{red}(C) = S$, there exist a unique $(s + t)$ -tuple of non-negative integers (n_1, \dots, n_{s+t}) such that $C = S(n_1, \dots, n_{s+t})$.*

Example 6.1.13. *In Example 6.1.4, we have $s = 5, t = 3$,*

$$S_1 = a_1 b_2, \quad S_2 = a_3 b_1, \quad S_3 = a_4 b_3, a_3 b_2$$

$$T_1 = \emptyset, \quad T_2 = \emptyset, \quad T_3 = a_2 b_2, \quad T_4 = \emptyset,$$

and

$$C = S(2, 1, 3, 0, 1, 0, 0, 0).$$

6.1.3 Influence of the insertions on the minimal partition

Recall the well-definedness according to the reduction as stated in (2.2.48), (2.2.49), (2.2.50), (2.2.51) and (2.2.52). An energy ϵ well-defined according to reduction with respect to a and b if

1. for any $c, c' \in C_{\text{free}} \sqcup \{c_\infty\}$,
- $$\epsilon(c, c') = \chi(c \neq c'),$$

2. for any $c \in \mathcal{C}_{\text{bound}}$,

$$\epsilon(a(c), c) + \epsilon(c, b(c)) = 1,$$

and for any $c' \in (\mathcal{C}_{\text{free}} \sqcup \{c_\infty\}) \setminus \{a(c)\}$,

$$\epsilon(c', c) \in \{\epsilon(a(c), c), \epsilon(a(c), c) + 1\},$$

and for any $c' \in (\mathcal{C}_{\text{free}} \sqcup \{c_\infty\}) \setminus \{b(c)\}$,

$$\epsilon(c, c') \in \{\epsilon(c, b(c)), \epsilon(c, b(c)) + 1\},$$

3. for any $c, c' \in \mathcal{C}_{\text{bound}}$,

$$\epsilon(c, c') = \epsilon(c, a(c')) + \epsilon(b(c), c') - \chi(b(c) \neq a(c')).$$

Example 6.1.14. With our example of color set and a and b , and an non-negative integer l , the energy ϵ_ℓ is defined by

$$\begin{cases} \epsilon_\ell(a_i b_j, a_k b_l) = \chi(i \geq k) - \chi(i = j = k) + \chi(j \leq l) - \chi(j = k = l) \\ \epsilon_\ell(c_\infty, a_i b_j) = 1 \\ \epsilon_\ell(a_i b_j, c_\infty) = \chi(i \geq l) + \chi(j < l) \\ \epsilon_\ell(c_\infty, c_\infty) = 0 \end{cases}$$

is well-defined according to the reduction with respect to a and b . In fact, we have

1. for any $i, j \in \mathbb{N}$,

$$\begin{aligned} \epsilon_\ell(a_i b_i, a_j b_j) &= \chi(i > j) + \chi(j < i) \\ &= \chi(i \neq j), \\ \epsilon_\ell(c_\infty, a_i b_i) &= 1, \\ \epsilon_\ell(a_i b_i, c_\infty) &= \chi(i \geq \ell) + \chi(i < \ell) \\ &= 1 \\ \epsilon_\ell(c_\infty, c_\infty) &= 0, \end{aligned}$$

2. for any $i \neq j \in \mathbb{N}$,

$$\begin{aligned} \epsilon_\ell(a_i b_i, a_j b_j) + \epsilon_\ell(a_i b_j, a_j b_i) &= \chi(i < j) + \chi(i > j) \\ &= 1, \end{aligned}$$

and for any $k \neq i \in \mathbb{N}$,

$$\begin{aligned} \epsilon_\ell(a_k b_k, a_i b_j) &= \chi(k > i) + \chi(k \leq j) \\ &\in \{\chi(i < j), \chi(i < j) + 1\}, \\ \epsilon_\ell(c_\infty, a_i b_j) &= 1 \\ &\in \{\chi(i < j), \chi(i < j) + 1\}, \end{aligned}$$

and for any $k \neq j \in \mathbb{N}$,

$$\begin{aligned} \epsilon_\ell(a_i b_j, a_k b_k) &= \chi(i \geq k) + \chi(j < k) \\ &\in \{\chi(i > j), \epsilon_\ell(i > j) + 1\}, \\ \epsilon_\ell(a_i b_i, c_\infty) &= \chi(i \geq \ell) + \chi(j < \ell) \\ &\in \{\chi(i > j), \chi(i > j) + 1\}, \end{aligned}$$

3. for any $i \neq j, k \neq l \in \mathbb{N}$,

$$\begin{aligned} \epsilon_\ell(a_i b_j, a_k b_l) &= \chi(i \geq k) + \chi(j \leq l) \\ &= (\chi(i \geq k) + \chi(j < k)) + ((j \leq l) + \chi(j > k)) - (\chi(j < k) + \chi(j > k)) \\ &= \epsilon_\ell(a_i b_j, a_k b_k) + \epsilon_\ell(a_j b_j, a_k b_l) - \chi(j \neq k). \end{aligned}$$

We now study how insertions inside a color sequence affect the corresponding minimal partition. If S is a reduced color sequence, we want to see how the insertion of some free color in S affects the minimal partition, or equivalently the minimal differences between successive parts.

Let us start with an observation. Because for all free colors c , $\epsilon(c, c) = 0$, inserting a free color c once or multiple times inside a given pair has exactly the same effect on the rest of the minimal partition. Therefore we only need to study the case where we insert a single free color inside a primary or secondary pair. First, let us see what happens to the minimal differences if we insert a free color inside a primary pair.

Proposition 6.1.15. *Let $C = c_1, \dots, c_s$ be a color sequence, and let $\min_\epsilon(C) = (\lambda_1, \dots, \lambda_s, 0_{c_\infty})$ be the corresponding minimal partition. Inserting a free color $c' = b(c_i) = b(c_{i+1})$ inside a primary pair (c_i, c_{i+1}) doesn't disrupt the minimal differences. The minimal partition after insertion will be $\min_\epsilon(c_1, \dots, c_i, c', c_{i+1}, \dots, c_s) = (\lambda_1, \dots, \lambda_i, \lambda', \lambda_{i+1}, \dots, \lambda_s, 0_{c_\infty})$, with $\lambda' = \lambda_{i+1} + \epsilon(c', c_{i+1})$.*

This follows immediately from (2.2.52), as we have $b(c_i) = a(c_{i+1})$ and then

$$\epsilon(c_i, c_{i+1}) = \epsilon(c_i, a(c_{i+1})) + \epsilon(b(c_i), c_{i+1}).$$

We now turn to insertions inside secondary pairs. In certain cases, it will disrupt the minimal differences.

We first study the case where we insert a free color to the left of c' in a secondary pair (c, c') . This means that c' is necessarily bound, and either c is a free color (possibly equal to c_∞) different from $a(c')$, or c is also bound with $b(c) \neq a(c')$.

1. When c is free, we then have that

$$\begin{aligned} \epsilon(c, a(c')) + \epsilon(a(c'), c') - \epsilon(c, c') &= 1 + \epsilon(a(c'), c') - \epsilon(c, c') && \text{by (2.2.48)} \\ &\in \{0, 1\} && \text{by (2.2.50)} \end{aligned}$$

2. When c is bound, we have

$$\begin{aligned} \epsilon(c, a(c')) + \epsilon(a(c'), c') - \epsilon(c, c') &= \chi(b(c) \neq a(c')) + \epsilon(a(c'), c') - \epsilon(b(c), c') && \text{by (2.2.52)} \\ &\in \{0, 1\} \end{aligned}$$

by what precedes. In both cases, we always have $\epsilon(c, a(c')) + \epsilon(a(c'), c') - \epsilon(c, c') \in \{0, 1\}$.

Definition 6.1.16. When the above is 0 (resp. 1), we call (c, c') a *type 0 (resp. type 1) left pair* for ϵ , and the corresponding insertion a *type 0 (resp. type 1) left insertion* for ϵ .

Remark 6.1.17. *The type of the left pair (c, c') for c bound is the same as the type of $(b(c), c')$.*

Similarly, we study the case where we insert a free color to the right of c in a secondary pair (c, c') . This happens when c is a bound color and either c' is free (possibly equals to c_∞) such that $b(c) \neq c'$, or c' is bound such that $b(c) \neq a(c')$, and this essentially works in the same way as left insertions.

1. When c' is free, we then have that

$$\begin{aligned} \epsilon(c, b(c)) + \epsilon(b(c), c') - \epsilon(c, c') &= \epsilon(c, b(c)) + 1 - \epsilon(c, c') && \text{by (2.2.48)} \\ &\in \{0, 1\} && \text{by (2.2.51)} \end{aligned}$$

2. When c is bound, we have

$$\begin{aligned} \epsilon(c, b(c)) + \epsilon(b(c), c') - \epsilon(c, c') &= \epsilon(c, b(c)) + \chi(b(c) \neq a(c')) - \epsilon(c, a(c')) && \text{by (2.2.52)} \\ &\in \{0, 1\} \end{aligned}$$

by what precedes. In both cases, we always have $\epsilon(c, b(c)) + \epsilon(b(c), c') - \epsilon(c, c') \in \{0, 1\}$. As before, we define type 0 and type 1.

Definition 6.1.18. When the difference above is 0 (resp. 1), we call (c, c') a *type 0 (resp. type 1) right pair* for ϵ , and the corresponding insertion a *type 0 (resp. type 1) right insertion* for ϵ .

Remark 6.1.19. *The type of the right pair (c, c') for c' bound is the same as the type of $(c, a(c'))$.*

We now understand the effect that an insertion inside a secondary pair has on the minimal partition, depending on the type of this insertion.

Proposition 6.1.20 (Type 0 insertion). *Let $C = c_1, \dots, c_s$ be a color sequence, and let $\min_\epsilon(C) = (\lambda_1, \dots, \lambda_s, 0_{c_\infty})$ be the corresponding minimal partition. For any $i \in \{0, \dots, s\}$, the type 0 insertion of a free color c' inside a secondary pair (c_i, c_{i+1}) doesn't disrupt the minimal differences. The minimal partition after insertion will be $\min_\epsilon(c_1, \dots, c_i, c', c_{i+1}, \dots, c_s) = (\lambda_1, \dots, \lambda_i, \lambda', \lambda_{i+1}, \dots, \lambda_s, 0_{c_\infty})$, with $\lambda' = \lambda_{i+1} + \epsilon(c', c_{i+1})$.*

Example 6.1.21. *The minimal partition with color sequence*

$$C = a_2b_2, a_1b_0, a_0b_2, a_1b_0, a_2b_1$$

is

$$\min_\epsilon(C) = 5_{a_2b_2} + 4_{a_1b_0} + 2_{a_0b_2} + 2_{a_1b_0} + 1_{a_2b_1}.$$

We insert a_1b_1 inside (a_0b_2, a_1b_0) . The minimal partition with color sequence

$$C' = a_2b_2, a_1b_0, a_0b_2, a_1b_1, a_1b_0, a_2b_1$$

is

$$\min_\epsilon(C') = 5_{a_2b_2} + 4_{a_1b_0} + 2_{a_0b_2} + 2_{a_1b_1} + 2_{a_1b_0} + 1_{a_2b_1}.$$

The part $2_{a_1b_1}$ was inserted, but all the other parts stay the same.

Proposition 6.1.22 (Type 1 insertion). *Let $C = c_1, \dots, c_s$ be a color sequence, and let $\min_\epsilon(C) = (\lambda_1, \dots, \lambda_s, 0_{c_\infty})$ be the corresponding minimal partition. For any $i \in \{0, \dots, s\}$, the type 1 insertion of a free color c' inside a secondary pair (c_i, c_{i+1}) adds 1 to the minimal difference between c_i and c_{i+1} . This forces us to add 1 to each part to the left of the newly inserted part in the minimal partition, which becomes $\min_\epsilon(c_1, \dots, c_i, c', c_{i+1}, \dots, c_s) = (\lambda_1 + 1, \dots, \lambda_i + 1, \lambda', \lambda_{i+1}, \dots, \lambda_s, 0_{c_\infty})$, with $\lambda' = \lambda_{i+1} + \epsilon(c', c_{i+1})$.*

Example 6.1.23. *In the color sequence C of the previous example, we insert a_2b_2 inside (a_0b_2, a_1b_0) . The minimal partition with color sequence*

$$C'' = a_2b_2, a_1b_0, a_0b_2, a_2b_2, a_1b_0, a_2b_1$$

is

$$\min_\epsilon(C'') = 6_{a_2b_2} + 5_{a_1b_0} + 3_{a_0b_2} + 3_{a_2b_2} + 2_{a_1b_0} + 1_{a_2b_1}.$$

All the parts to the left of the newly inserted part are increased by one compared to $\min_\epsilon(C)$.

So far we have only studied the case of a single insertion (either left or right) inside a secondary pair. We still need to understand what happens to the minimal differences if, inside a secondary pair (c, c') for c, c' are bound colors such that $b(c) \neq a(c')$, when we insert both free colors $b(c)$ and $a(c')$.

Lemma 6.1.24 (Left and right insertion). *Let (c, c') , with c, c' bound colors such that $b(c) \neq a(c')$. We have*

$$\begin{aligned} & \epsilon(c, b(c)) + \epsilon(b(c), a(c')) + \epsilon(a(c'), c') - \epsilon(c, c') \\ &= \begin{cases} 0 & \text{if both the right and left insertions inside } (c, c') \text{ are of type 0,} \\ 1 & \text{if exactly one of the insertions inside } (c, c') \text{ is of type 1,} \\ 2 & \text{if both the right and left insertions inside } (c, c') \text{ are of type 1.} \end{cases} \end{aligned}$$

The proof can be found in Appendix A.3.1. Thus performing both a left and right insertion inside a secondary pair is the same as performing the two insertions separately. We conclude this section by summarizing the influence of all the possible insertions on the minimal partition.

Proposition 6.1.25 (Summary of the different types of insertion). *Let $C = c_1, \dots, c_s$ be a color sequence, and let $\min_\epsilon(C) = (\lambda_1, \dots, \lambda_s, 0_{c_\infty})$ be the corresponding minimal partition. When we insert a free color c' inside a pair (c_i, c_{i+1}) , the minimal partition transforms as follows:*

- if c_i is a free color and $c' = c_i$, the minimal partition becomes $(\lambda_1, \dots, \lambda_i, \lambda_i, \lambda_{i+1}, \dots, \lambda_s, 0_{c_\infty})$ (i.e. the part λ_i repeats, and the rest of the partition remains unchanged);
- if (c_i, c_{i+1}) is a primary pair, the minimal partition becomes $(\lambda_1, \dots, \lambda_i, \lambda', \lambda_{i+1}, \dots, \lambda_s, 0_{c_\infty})$, with $\lambda' = \lambda_{i+1} + \epsilon(c', c_{i+1})$;
- if (c_i, c_{i+1}) is a secondary pair and the insertion of c' is of type 0, the minimal partition becomes $(\lambda_1, \dots, \lambda_i, \lambda', \lambda_{i+1}, \dots, \lambda_s, 0_{c_\infty})$, with $\lambda' = \lambda_{i+1} + \epsilon(c', c_{i+1})$;

- if (c_i, c_{i+1}) is a secondary pair and the insertion of c' is of type 1, the minimal partition becomes $(\lambda_1 + 1, \dots, \lambda_i + 1, \lambda', \lambda_{i+1}, \dots, \lambda_s, 0_{c_\infty})$, with $\lambda' = \lambda_{i+1} + \epsilon(c', c_{i+1})$ (i.e. we add 1 to all the parts to the left of the newly inserted part λ').

We call the first two types of insertions above *neutral insertions*.

6.1.4 Generating function for partitions with a given kernel

Our goal is to count partitions of $\mathcal{P}_\epsilon^{c_\infty}$ with a given kernel. The results from the previous section will help us do so.

Let $S = c_1, \dots, c_s$ be a reduced color sequence of length s , having t maximal primary subsequences. Let f_1, \dots, f_{s+t} be the free colors that can be inserted in S . In the following, we denote by \mathcal{N} (resp. $\mathcal{T}_0, \mathcal{T}_1$) the set of indices i such that the insertion of f_i is neutral (resp. of type 0, of type 1). We have $\mathcal{N} \sqcup \mathcal{T}_0 \sqcup \mathcal{T}_1 = \{1, \dots, s+t\}$. Moreover, the secondary pairs in S are exactly $(c_{i_{2u-1}-1}, c_{i_{2u-1}})$ and $(c_{i_{2u}}, c_{i_{2u}+1})$, for $u \in \{1, \dots, t\}$, where $S_u = c_{i_{2u-1}}, \dots, c_{i_{2u}}$. So we can write

$$\mathcal{T}_0 = \bigsqcup_{u=1}^t \mathcal{T}_0^u, \quad \mathcal{T}_1 = \bigsqcup_{u=1}^t \mathcal{T}_1^u,$$

where \mathcal{T}_0^u (resp. \mathcal{T}_1^u) is the set of indices j such that f_j can be inserted inside $(c_{i_{2u-1}-1}, c_{i_{2u-1}})$ or $(c_{i_{2u}}, c_{i_{2u}+1})$ and is of type 0 (resp. 1). For all $u \in \{1, \dots, t\}$, we have $|\mathcal{T}_0^u| = 2 - |\mathcal{T}_1^u|$.

We want to study the minimal partition of the color sequence $S(n_1, \dots, n_{s+t})$. Denote by \mathcal{S}_1^u (resp. \mathcal{S}_1) the indices j of \mathcal{T}_1^u (resp. \mathcal{T}_1) such that $n_j > 0$. We start with the following lemma whose proof is given in Appendix A.3.2.

Lemma 6.1.26. *For all $j \in \{1, \dots, s+t\}$, if $n_j > 0$, i.e. the color f_j is actually inserted, then the corresponding part $\lambda(f_j)$ in the minimal partition of $S(n_1, \dots, n_{s+t})$ is equal to*

$$\lambda(f_j) = \#(\{j, \dots, s+t\} \cap (\mathcal{N} \sqcup \mathcal{T}_0 \sqcup \mathcal{S}_1)). \quad (6.1.1)$$

We can now give a formula for the weight of the minimal partition with color sequence $S(n_1, \dots, n_{s+t})$. We start with the minimal partition $\min_\epsilon(S)$ with color sequence S . It has weight $|\min_\epsilon(S)|$. Then we insert the parts corresponding to colors of type 1. Let $j \in \mathcal{S}_1$. By Proposition 6.1.25, inserting f_j adds 1 to all the parts of $\min_\epsilon(S)$ which are to the left of $\lambda(f_j)$. So this adds $P(j)$ to the total weight. Moreover, by Lemma 6.1.26, the part $\lambda(f_j)$ is of size $\#(\{j, \dots, s+t\} \cap (\mathcal{N} \cup \mathcal{T}_0 \cup \mathcal{S}_1))$, and we insert it n_j times. Summing over all $j \in \mathcal{S}_1$ gives the first sum. Finally, the insertion of parts corresponding to colors f_j with $j \in \mathcal{N} \cup \mathcal{T}_0$ yields the following proposition.

Proposition 6.1.27. *With the notation above, the size of the minimal partition with color sequence $S(n_1, \dots, n_{s+t})$ is*

$$\begin{aligned} |\min_\epsilon(S(n_1, \dots, n_{s+t}))| &= |\min_\epsilon(S)| \\ &+ \sum_{j \in \mathcal{S}_1} (P(j) + n_j \times \#(\{j, \dots, s+t\} \cap (\mathcal{N} \sqcup \mathcal{T}_0 \sqcup \mathcal{S}_1))) \\ &+ \sum_{j \in \mathcal{N} \cup \mathcal{T}_0} n_j \times \#(\{j, \dots, s+t\} \cap (\mathcal{N} \sqcup \mathcal{T}_0 \sqcup \mathcal{S}_1)), \end{aligned} \quad (6.1.2)$$

where $P(j)$ is the number of colors of S that are to the left of f_j .

Starting from Proposition 6.1.27, we will show a key theorem, which will be very useful to establish the connection with generalized colored Frobenius partitions. Recall that the q -binomial coefficient is defined as follows:

$$\begin{bmatrix} n \\ k \end{bmatrix}_q := \frac{(q; q)_n}{(q; q)_k (q; q)_{n-k}},$$

and we assume that $\begin{bmatrix} n \\ k \end{bmatrix}_q = 0$ if $k < 0$ or $k > n$.

Theorem 6.1.28. *Let n be a positive integer and m a non-negative integer. Let $S = c_1, \dots, c_s$ be a reduced color sequence of length s , having t maximal primary subsequences. The generating function for minimal partitions in $\mathcal{P}_\epsilon^{c_\infty}$ with kernel S , having $s+m$ parts (apart from 0_{c_∞}), is the following:*

$$\sum_{\substack{\text{Ccolor sequence of length } s+m \\ \text{such that } \text{red}_{a,b}(\text{C})=S}} q^{|\min_\epsilon(\text{C})|} = q^{|\min_\epsilon(S)|+m} \sum_{u=0}^t q^{u(s-t)} g_{u,t}(q; |\mathcal{T}_0^1|, \dots, |\mathcal{T}_0^t|) \begin{bmatrix} s+m-1 \\ m-u \end{bmatrix}_q, \quad (6.1.3)$$

where $g_{0,0} = 1$, and for $u \leq v$,

$$g_{u,v}(q; x_1, \dots, x_v) = \sum_{\substack{\theta_1, \dots, \theta_v \in \{0,1\}: \\ \theta_1 + \dots + \theta_v = u}} q^{uv + \binom{u}{2}} \prod_{k=1}^v q^{(x_k - 1) \sum_{i=1}^{k-1} \theta_i}.$$

By observing that all partitions of $\mathcal{P}_\epsilon^{c_\infty}$ with a given color sequence C of length $s + m$ can be obtained in a unique way by adding a partition with at most $s + m$ parts to the minimal partition $\min_\epsilon(C)$, Theorem 6.1.28 is actually equivalent to the following generating function for all partitions of $\mathcal{P}_\epsilon^{c_\infty}$ with a given kernel.

Proposition 6.1.29. *Let n be a positive integer and m a non-negative integer. Let $S = c_1, \dots, c_s$ be a reduced color sequence of length s , having t maximal primary subsequences. The generating function for partitions in $\mathcal{P}_\epsilon^{c_\infty}$ with kernel S , having $s + m$ parts, is the following:*

$$\sum_{\substack{\lambda \in \mathcal{P}_\epsilon^{c_\infty}: \\ \ell(\lambda) = s+m \\ \ker_{a,b}(\lambda) = S}} q^{|\lambda|} = \frac{q^{|\min_\epsilon(S)|+m}}{(q; q)_{s+m}} \sum_{u=0}^t q^{u(s-t)} g_{u,t}(q; |\mathcal{T}_0^1|, \dots, |\mathcal{T}_0^t|) \begin{bmatrix} s+m-1 \\ m-u \end{bmatrix}_q. \quad (6.1.4)$$

The proof of Theorem 6.1.28 from Proposition 6.1.27, quite technical, is postponed to Section 6.3. Its reading is not necessary to understand the connection between $\mathcal{P}_\epsilon^{c_\infty}$ and $\mathcal{F}_{\epsilon_1, \epsilon_2}^{c_\infty}$, which we will study in the next section.

6.2 Generalized colored Frobenius partitions

In this section, we compute the generating function for generalized colored Frobenius in $\mathcal{F}_{\epsilon_1, \epsilon_2}^{c_\infty}$ with a given kernel and show that it is the same as the generating function (6.1.4) for generalized colored partitions in $\mathcal{P}_\epsilon^{c_\infty}$ with the same kernel.

6.2.1 The difference conditions corresponding to minimal colored Frobenius partitions

We start by observing that minimal generalized colored Frobenius in $\mathcal{F}_{\epsilon_1, \epsilon_2}^{c_\infty}$ are in bijection with minimal generalized colored partitions in $\mathcal{P}_{\epsilon_1 + \epsilon_2}^{c_\infty}$.

Definition 6.2.1. Let c_1, \dots, c_s be a sequence of colors taken from \mathcal{C} . The *minimal colored Frobenius partition* in $\mathcal{F}_{\epsilon_1, \epsilon_2}^{c_\infty}$ associated to c_1, \dots, c_s is the generalized colored Frobenius partition $\pi = ((\lambda_1, \mu_1), \dots, (\lambda_s, \mu_s), (0, 0)_{c_\infty})$ with minimal size such that for all $i \in \{1, \dots, s\}$, $c(\lambda_i, \mu_i) = c_i$. We denote this partition by $\min_{\epsilon_1, \epsilon_2}(c_1, \dots, c_s)$. This is equivalent to saying that

$$(\lambda_1, \dots, \lambda_s, 0_{c_\infty}) = \min_{\epsilon_1}(c_1, \dots, c_s)$$

and

$$(\mu_1, \dots, \mu_s, 0_{c_\infty}) = \min_{\epsilon_2}(c_1, \dots, c_s).$$

The size of $\min_{\epsilon_1, \epsilon_2}(c_1, \dots, c_s)$ is then equal to

$$\begin{aligned} |\min_{\epsilon_1, \epsilon_2}(c_1, \dots, c_s)| &= \sum_{k=1}^s k(\epsilon_1(c_k, c_{k+1}) + \epsilon_2(c_k, c_{k+1})) \\ &= |\min_{\epsilon_1 + \epsilon_2}(c_1, \dots, c_s)| \end{aligned}$$

Recall that

$$\epsilon_1(c, c') + \epsilon_2(c, c') = \begin{cases} 2 & \text{if } c = c' \in \mathcal{C}_{\text{free}} \sqcup \{c_\infty\} \\ \epsilon(c, c') + 1 & \text{if } c' \in \mathcal{C}_{\text{bound}} \text{ and } c = a(c') \\ \epsilon(c, c') + 1 & \text{if } c \in \mathcal{C}_{\text{bound}} \text{ and } c' = b(c) \\ \epsilon(c, c') & \text{otherwise.} \end{cases}$$

Using the fact that reduced color sequences do not contain any pair (c, c') of the three first above cases, we then have the following proposition.

Proposition 6.2.2. *Let S be a reduced color sequence. Then*

$$\min_{\epsilon}(S) = \min_{\epsilon_1 + \epsilon_2}(S).$$

When C is a colored sequence which is not reduced, we do not have $\min_{\epsilon}(C) = \min_{\epsilon_1 + \epsilon_2}(C)$ in general. So to compute the generating function for the generalized colored Frobenius partitions, we define one last difference condition

$$\epsilon' := 2 - \epsilon_1 - \epsilon_2,$$

which shares many properties with ϵ . The proof of the following proposition can be found in Appendix A.3.11.

Proposition 6.2.3. *The energy ϵ' is well-defined according to the reduction with respect to a and b . Furthermore, the type of insertion in a secondary pair for ϵ' is 0 if and only if the type of insertion in a secondary pair for ϵ is 1.*

In other words, using the notation at the beginning of Section 6.1.4, given a reduced color sequence $S = c_1, \dots, c_s$ and f_1, \dots, f_{s+t} the free colors that can be inserted in S , \mathcal{N} (resp. $\mathcal{T}_0, \mathcal{T}_1$) is exactly the set of indices i such that the insertion of f_i is neutral (resp. of type 1, of type 0) for ϵ' .

6.2.2 The generating function for the generalized colored Frobenius partitions in $\mathcal{F}_{\epsilon_1, \epsilon_2}^{c_{\infty}}$ with a given kernel

Now that we understand the orders $\epsilon_1 + \epsilon_2$ and ϵ' , we will use them to compute the generating function for generalized colored Frobenius partitions in $\mathcal{F}_{\epsilon_1, \epsilon_2}^{c_{\infty}}$ with a given kernel.

Before doing this, we need a technical lemma about the function $g_{u,v}$ defined in Theorem 6.1.28, which will appear again in this section (proof in Appendix A.3.3).

Lemma 6.2.4. *Let $g_{u,v}$ be the function defined in Theorem 6.1.28. Then*

$$g_{u,v}(q^{-1}; 2 - x_1, \dots, 2 - x_v) = q^{-u(2v+u-1)} g_{u,v}(q; x_1, \dots, x_v).$$

We now give the generating function for minimal generalized colored partitions in $\mathcal{P}_{\epsilon_1 + \epsilon_2}^{c_{\infty}}$ and a given kernel (see proof in Appendix A.3.12).

Proposition 6.2.5. *Let n be a positive integer and m a non-negative integer. Let $S = c_1, \dots, c_s$ be a reduced color sequence of length s , having t maximal primary subsequences. Using the notation of Section 6.1.4, the generating function for minimal partitions in*

$$\mathcal{P}_{\epsilon_1 + \epsilon_2}^{c_{\infty}}$$

with kernel S , having $s + m$ parts, is given by:

$$\sum_{\substack{\text{Color sequence} \\ \text{of length } s+m \\ \text{such that } \text{red}_{a,b}(C)=S}} q^{|\min_{\epsilon_1 + \epsilon_2}(C)|} = q^{|\min_{\epsilon}(S)| + m(s+m+1)} \sum_{u=0}^t q^{-u(t+m)} g_{u,t}(q; |\mathcal{T}_0^1|, \dots, |\mathcal{T}_0^t|) \begin{bmatrix} s+m-1 \\ m-u \end{bmatrix}_q. \quad (6.2.1)$$

By Definition 6.2.1, the generating function in (6.2.1) is also the generating function for minimal generalized colored Frobenius partitions in $\mathcal{F}_{\epsilon_1, \epsilon_2}^{c_{\infty}}$ with kernel S . Finally, using the fact that any generalized colored Frobenius partitions with color sequence C of length $s + m$ (apart from c_{∞}) can be obtained in a unique way by adding a partition into at most $s + m$ parts to λ and another partition into at most $s + m$ parts to μ in the minimal colored Frobenius partition, we obtain the following key expression for the generating function.

Proposition 6.2.6. *Let n be a positive integer and m a non-negative integer. Let $S = c_1, \dots, c_s$ be a reduced color sequence of length s , having t maximal primary subsequences. Using the notation of Section 6.1.4, the generating function for n^2 -colored Frobenius partitions with kernel S , having length $s + m$, is the following:*

$$\sum_{\substack{F \in \mathcal{F}_{\epsilon_1, \epsilon_2}^{c_{\infty}}: \\ \ell(F)=s+m \\ \ker(F)=S}} q^{|F|} = \frac{q^{|\min_{\epsilon}(S)| + m(s+m+1)}}{(q; q)_{s+m}^2} \sum_{u=0}^t q^{-u(t+m)} g_{u,t}(q; |\mathcal{T}_0^1|, \dots, |\mathcal{T}_0^t|) \begin{bmatrix} s+m-1 \\ m-u \end{bmatrix}_q. \quad (6.2.2)$$

6.2.3 Proof of Theorem 2.2.39

Proposition 6.1.29 gives the generating function for colored partitions of $\mathcal{P}_\epsilon^{\infty}$ with kernel S , and Proposition 6.2.6 gives the generating function for colored Frobenius partitions of $\mathcal{F}_{\epsilon_1, \epsilon_2}^{\infty}$ with the same kernel S . In this section, we show that these two generating functions are actually equal and then obtain Theorem 2.2.39. But before doing so, we need a lemma about q -binomial coefficients. For the proof, see Appendix A.3.4.

Lemma 6.2.7. *Let s be a positive integer and m, u two non-negative integers. Then*

$$\frac{1}{(q; q)_{s+m}} = \sum_{m' \geq 0} \frac{q^{(m'-u)(s+m')}}{(q; q)_{s+m'}} \begin{bmatrix} m-u \\ m'-u \end{bmatrix}_q.$$

We are now ready to prove Theorem 2.2.39.

By Proposition 6.1.29,

$$\begin{aligned} \sum_{\substack{\lambda \in \mathcal{P}_\epsilon^{\infty}: \\ \ker(\lambda) = S}} q^{|\lambda|} &= \sum_{m \geq 0} \frac{q^{|\min_\epsilon(S)|+m}}{(q; q)_{s+m}} \sum_{u=0}^t q^{u(s-t)} g_{u,t}(q; |\mathcal{T}_0^1|, \dots, |\mathcal{T}_0^t|) \begin{bmatrix} s+m-1 \\ m-u \end{bmatrix}_q \\ &= \sum_{u=0}^t q^{|\min_\epsilon(S)|+u(s-t)} g_{u,t}(q; |\mathcal{T}_0^1|, \dots, |\mathcal{T}_0^t|) \sum_{m \geq 0} \frac{q^m}{(q; q)_{s+m}} \begin{bmatrix} s+m-1 \\ m-u \end{bmatrix}_q, \end{aligned}$$

and by Proposition 6.2.6,

$$\begin{aligned} \sum_{\substack{F \in \mathcal{F}_{\epsilon_1, \epsilon_2}^{\infty}: \\ \ker(F) = S}} q^{|F|} &= \sum_{m \geq 0} \frac{q^{|\min_\epsilon(S)|+m(s+m+1)}}{(q; q)_{s+m}^2} \sum_{u=0}^t q^{-u(t+m)} g_{u,t}(q; |\mathcal{T}_0^1|, \dots, |\mathcal{T}_0^t|) \begin{bmatrix} s+m-1 \\ m-u \end{bmatrix}_q \\ &= \sum_{u=0}^t q^{|\min_\epsilon(S)|+u(s-t)} g_{u,t}(q; |\mathcal{T}_0^1|, \dots, |\mathcal{T}_0^t|) \sum_{m \geq 0} \frac{q^{(m-u)(s+m)+m}}{(q; q)_{s+m}^2} \begin{bmatrix} s+m-1 \\ m-u \end{bmatrix}_q \end{aligned}$$

Thus, to prove the theorem, it is sufficient to show that for $u \in \{0, \dots, t\}$,

$$\sum_{m \geq 0} \frac{q^m}{(q; q)_{s+m}} \begin{bmatrix} s+m-1 \\ m-u \end{bmatrix}_q = \sum_{m \geq 0} \frac{q^{(m-u)(s+m)+m}}{(q; q)_{s+m}^2} \begin{bmatrix} s+m-1 \\ m-u \end{bmatrix}_q. \quad (6.2.3)$$

By Lemma 6.2.7,

$$\begin{aligned} \frac{1}{(q; q)_{s+m}} \begin{bmatrix} s+m-1 \\ m-u \end{bmatrix}_q &= \sum_{m' \geq 0} \frac{q^{(m'-u)(s+m')}}{(q; q)_{s+m'}} \begin{bmatrix} m-u \\ m'-u \end{bmatrix}_q \begin{bmatrix} s+m-1 \\ m-u \end{bmatrix}_q \\ &= \sum_{m' \geq 0} \frac{q^{(m'-u)(s+m')}}{(q; q)_{s+m'}} \begin{bmatrix} s+m'-1 \\ m'-u \end{bmatrix}_q \begin{bmatrix} s+m-1 \\ s+m'-1 \end{bmatrix}_q. \end{aligned}$$

Thus

$$\begin{aligned} \sum_{m \geq 0} \frac{q^m}{(q; q)_{s+m}} \begin{bmatrix} s+m-1 \\ m-u \end{bmatrix}_q &= \sum_{m \geq 0} \sum_{m' \geq 0} \frac{q^{(m'-u)(s+m')+m}}{(q; q)_{s+m'}} \begin{bmatrix} s+m'-1 \\ m'-u \end{bmatrix}_q \begin{bmatrix} s+m-1 \\ s+m'-1 \end{bmatrix}_q \\ &= \sum_{m' \geq 0} \frac{q^{(m'-u)(s+m')+m'}}{(q; q)_{s+m'}} \begin{bmatrix} s+m'-1 \\ m'-u \end{bmatrix}_q \sum_{m \geq 0} q^{m-m'} \begin{bmatrix} s+m-1 \\ s+m'-1 \end{bmatrix}_q. \end{aligned}$$

The last thing to show is that

$$\sum_{m \geq 0} q^{m-m'} \begin{bmatrix} s+m-1 \\ s+m'-1 \end{bmatrix}_q = \frac{1}{(q; q)_{s+m'}},$$

which is true by separating the partitions into at most $s+m'$ parts counted by $\frac{1}{(q; q)_{s+m'}}$ according to the length $m-m'$ of their largest part.

6.3 Proof of Theorem 6.1.28

In this section, we give a proof of Theorem 6.1.28. Let $S = c_1, \dots, c_s$ be a reduced colour sequence of length s , having t maximal primary subsequences. We use the same notation as in Section 6.1.4. In addition, we define for all $u \in \{1, \dots, t\}$, j_{2u-1} (resp. j_{2u}) to be the index of the free colour which can be inserted to the left (resp. right) of S_u . Thus we have $\mathcal{T}_0^u = \{j_{2u-1}, j_{2u}\} \cap \mathcal{T}_0$ and $\mathcal{T}_1^u = \{j_{2u-1}, j_{2u}\} \cap \mathcal{T}_1$.

For brevity, from now we denote on the set of all integers between i and j by $\llbracket i; j \rrbracket$. Our starting point is the equality

$$G_{S,m}(q) := \sum_{\substack{\text{C colour sequence of length } s+m \\ \text{such that } \text{red}(C)=S}} q^{|\min_\epsilon(C)|} = \sum_{\substack{n_1, \dots, n_{s+t}: \\ n_1 + \dots + n_{s+t} = m}} q^{|\min_\epsilon(S(n_1, \dots, n_{s+t}))|}, \quad (6.3.1)$$

which simply follows from the definition of reduced color sequences. Proposition 6.1.27 gives us an expression for $|\min_\epsilon(S(n_1, \dots, n_{s+t}))|$, which we will use to derive Theorem 6.1.28. Let us start with a lemma which evaluates a sum appearing in the formula for $|\min_\epsilon(S(n_1, \dots, n_{s+t}))|$.

Lemma 6.3.1 (Proof in Appendix A.3.5). *Let*

$$\Sigma_1 := \sum_{j \in \mathcal{S}_1} (P(j) + \#(\llbracket j; s+t \rrbracket \cap (\mathcal{N} \sqcup \mathcal{T}_0 \sqcup \mathcal{S}_1))),$$

where $P(j)$ is the number of colours of S that are to the left of f_j . Then

$$\Sigma_1 = \sum_{u=1}^t \left(\left(|\mathcal{N}| + u - 1 + \sum_{v=u}^t (|\mathcal{T}_0^v| + |\mathcal{S}_1^v|) \right) |\mathcal{S}_1^u| + \sum_{j \in \mathcal{S}_1^u} \#\{j' < j : j' \in \overline{\mathcal{S}_1^u}\} \right),$$

where $\overline{\mathcal{S}_1^u} := \mathcal{T}_1^u \setminus \mathcal{S}_1^u$ is the set of indices j of \mathcal{T}_1^u such that the free color f_j is not inserted.

We can now give a formula for the generating function for minimal partitions $\min_\epsilon(S(n_1, \dots, n_{s+t}))$ for a fixed set \mathcal{S}_1 . The desired generating function $G_{S,m}(q)$ of (6.3.1) will then be obtained by summing over all possible sets \mathcal{S}_1 .

Lemma 6.3.2 (Proof in Appendix A.3.6). *Let \mathcal{S}_1 be fixed. Define*

$$H_{S,\mathcal{S}_1}(q) := \sum_{\substack{n_1, \dots, n_{s+t}: \\ n_1 + \dots + n_{s+t} = m, \\ \{j \in \mathcal{T}_1 : n_j > 0\} = \mathcal{S}_1}} q^{|\min_\epsilon(S(n_1, \dots, n_{s+t}))|}.$$

We have

$$H_{S,\mathcal{S}_1}(q) = q^{|\min_\epsilon(S)| + \Sigma_1 + m - |\mathcal{S}_1|} \begin{bmatrix} m - 1 + |\mathcal{N}| + |\mathcal{T}_0| \\ m - |\mathcal{S}_1| \end{bmatrix}_q. \quad (6.3.2)$$

Before we compute $G_{S,m}(q)$, one more lemma about q -binomial coefficients is needed.

Lemma 6.3.3 (Proof in Appendix A.3.7). *Let a and b be non-negative integers. We have*

$$\sum_{\substack{A \subseteq \llbracket 1; a+b \rrbracket \\ |A|=a}} q^{\sum_{j \in A} \#\{j' < j : j' \in \llbracket 1; a+b \rrbracket \setminus A\}} = \begin{bmatrix} a+b \\ a \end{bmatrix}_q.$$

We are now ready to sum $H_{S,\mathcal{S}_1}(q)$ over all possible sets \mathcal{S}_1 to obtain a formula for $G_{S,m}(q)$.

Proposition 6.3.4 (Proof in Appendix A.3.13). *Let S be a reduced colour sequence, and m a non-negative integer. We have*

$$G_{S,m}(q) = \sum_{\substack{k_1, \dots, k_t: \\ k_u \leq |\mathcal{T}_1^u|}} q^{|\min_\epsilon(S)| + \sum_{u=1}^t k_u (|\mathcal{N}| + u - 1 + \sum_{v=u}^t (|\mathcal{T}_0^v| + k_v))} q^{m - \sum_{u=1}^t k_u} \begin{bmatrix} m - 1 + |\mathcal{N}| + |\mathcal{T}_0| \\ m - \sum_{u=1}^t k_u \end{bmatrix}_q \prod_{u=1}^t \begin{bmatrix} |\mathcal{T}_1^u| \\ k_u \end{bmatrix}_q.$$

What remains to be done is show that the expression for $G_{S,m}(q)$ in Proposition 6.3.4 is actually the same as (6.1.3). First, let us give yet another lemma about q -binomial coefficients.

Lemma 6.3.5 (Proof in Appendix A.3.8). *Let m, ℓ_1, \dots, ℓ_t be non-negative integers. We have*

$$q^m \begin{bmatrix} m + \ell_1 + \dots + \ell_t - 1 \\ m \end{bmatrix}_q = q^m \sum_{0=x_0 \leq x_1 \leq \dots \leq x_t = m} \prod_{r=1}^t q^{\ell_r x_{r-1}} \begin{bmatrix} x_r - x_{r-1} + \ell_r - 1 \\ x_r - x_{r-1} \end{bmatrix}_q.$$

In the above, we use the convention that $\begin{bmatrix} -1 \\ 0 \end{bmatrix} = 1$.

We use the lemma above to rewrite a part of the expression in Proposition 6.3.4.

Proposition 6.3.6 (Proof in Appendix A.3.14). *We have:*

$$q^{m - \sum_{u=1}^t k_u} \begin{bmatrix} m - 1 + |\mathcal{N}| + |\mathcal{T}_0| \\ m - \sum_{u=1}^t k_u \end{bmatrix}_q = q^{m - \sum_{u=1}^t k_u (1 + |\mathcal{N}| + \sum_{v=u+1}^t (k_v + |\mathcal{T}_0^v|))} \\ \times \sum_{0=m_0 \leq m_1 \leq \dots \leq m_t \leq m} \left(\prod_{u=1}^t q^{(k_u + |\mathcal{T}_0^u|)m_{u-1}} \begin{bmatrix} m_u - m_{u-1} + |\mathcal{T}_0^u| - 1 \\ m_u - m_{u-1} - k_u \end{bmatrix}_q \right) q^{|\mathcal{N}|m_t} \begin{bmatrix} m - m_t + |\mathcal{N}| - 1 \\ m - m_t \end{bmatrix}_q.$$

Substituting Proposition 6.3.6 in Proposition 6.3.4 leads to

$$G_{S,m}(q) = q^{|\min_\epsilon(S)|+m} \sum_{\substack{k_1, \dots, k_t: \\ k_u \leq |\mathcal{T}_1^u|}} \prod_{u=1}^t q^{k_u(u-2+k_u+|\mathcal{T}_0^u|)} \begin{bmatrix} |\mathcal{T}_1^u| \\ k_u \end{bmatrix}_q \\ \times \sum_{0=m_0 \leq m_1 \leq \dots \leq m_t \leq m} \left(\prod_{u=1}^t q^{(k_u + |\mathcal{T}_0^u|)m_{u-1}} \begin{bmatrix} m_u - m_{u-1} + |\mathcal{T}_0^u| - 1 \\ m_u - m_{u-1} - k_u \end{bmatrix}_q \right) q^{|\mathcal{N}|m_t} \begin{bmatrix} m - m_t + |\mathcal{N}| - 1 \\ m - m_t \end{bmatrix}_q.$$

Interchanging the order of the two multisums, we obtain:

$$G_{S,m}(q) = q^{|\min_\epsilon(S)|+m} \sum_{0=m_0 \leq m_1 \leq \dots \leq m_t \leq m} \left(\sum_{\substack{k_1, \dots, k_t: \\ k_u \leq |\mathcal{T}_1^u|}} \prod_{u=1}^t q^{k_u(u-2+k_u+|\mathcal{T}_0^u|) + (k_u + |\mathcal{T}_0^u|)m_{u-1}} \right. \\ \left. \times \begin{bmatrix} |\mathcal{T}_1^u| \\ k_u \end{bmatrix}_q \begin{bmatrix} m_u - m_{u-1} + |\mathcal{T}_0^u| - 1 \\ m_u - m_{u-1} - k_u \end{bmatrix}_q \right) q^{|\mathcal{N}|m_t} \begin{bmatrix} m - m_t + |\mathcal{N}| - 1 \\ m - m_t \end{bmatrix}_q. \quad (6.3.3)$$

We need one last lemma to complete our proof of Theorem 6.1.28.

Lemma 6.3.7 (Proof in Appendix A.3.9). *We have*

$$\sum_{0=m_0 \leq m_1 \leq \dots \leq m_t} \sum_{\substack{k_1, \dots, k_t: \\ k_u \leq |\mathcal{T}_1^u|}} \prod_{u=1}^t q^{k_u(u-2+k_u+|\mathcal{T}_0^u|) + (k_u + |\mathcal{T}_0^u|)m_{u-1}} \begin{bmatrix} |\mathcal{T}_1^u| \\ k_u \end{bmatrix}_q \begin{bmatrix} m_u - m_{u-1} + |\mathcal{T}_0^u| - 1 \\ m_u - m_{u-1} - k_u \end{bmatrix}_q \\ = \sum_{v=0}^t g_{v,t}(q; |\mathcal{T}_0^1|, \dots, |\mathcal{T}_0^t|) \begin{bmatrix} m_t + t - 1 \\ m_t - v \end{bmatrix}_q,$$

where $g_{v,t}$ was defined in Theorem 6.1.28.

We can now write

$$G_{S,m}(q) = q^{|\min_\epsilon(S)|+m} \sum_{v=0}^t g_{v,t}(q; |\mathcal{T}_0^1|, \dots, |\mathcal{T}_0^t|) \sum_{0 \leq m'_t \leq m} q^{|\mathcal{N}|m'_t} \begin{bmatrix} m - m_t + |\mathcal{N}| - 1 \\ m - m_t \end{bmatrix}_q \begin{bmatrix} m_t + t - 1 \\ m_t - v \end{bmatrix}_q \\ = q^{|\min_\epsilon(S)|+m} \sum_{v=0}^t g_{v,t}(q; |\mathcal{T}_0^1|, \dots, |\mathcal{T}_0^t|) \sum_{0 \leq m'_t \leq m-v} q^{|\mathcal{N}|(m'_t+v)} \begin{bmatrix} m - m'_t - v + |\mathcal{N}| - 1 \\ m - m'_t - v \end{bmatrix}_q \begin{bmatrix} m'_t + v + t - 1 \\ m'_t \end{bmatrix}_q,$$

where the second equality follows from the change of variables $m'_t = m_t - v$. Using Lemma 6.3.5 with $t = 2$, $m = m - v$, $\ell_1 = v + t$, and $\ell_2 = |\mathcal{N}|$, this becomes

$$G_{S,m}(q) = q^{|\min_\epsilon(S)|+m} \sum_{v=0}^t q^{v|\mathcal{N}|} g_{v,t}(q; |\mathcal{T}_0^1|, \dots, |\mathcal{T}_0^t|) \begin{bmatrix} m + t + |\mathcal{N}| - 1 \\ m - v \end{bmatrix}_q.$$

Observing that $|\mathcal{N}| = s - t$ concludes the proof of Theorem 6.1.28.

6.4 Proof of Theorem 2.2.45

By Theorem 2.2.39, Theorem 2.2.43 relates the generating function for generalized Primc partitions to the generating function for colored Frobenius partitions. In this section, we study the particular case $b_i = a_i^{-1}$ for all $i \in \{0, \dots, n\}$. All the free colors vanish, and the generating function can now be written as a sum of infinite products.

Let n be a positive integer. By Theorem 2.2.43 with $b_i = a_i^{-1}$ for all i , it follows that

$$\begin{aligned} P_n &:= \sum_{m, u_0, \dots, u_{n-1}, v_0, \dots, v_{n-1} \geq 0} P_{0,n}(m; u_0, \dots, u_{n-1}; v_0, \dots, v_{n-1}) q^m a_0^{u_0 - v_0} \dots a_{n-1}^{u_{n-1} - v_{n-1}} \\ &= [x^0] \prod_{i=0}^{n-1} (-x a_i q; q)_\infty (-x^{-1} a_i^{-1}; q)_\infty. \end{aligned}$$

Using the Jacobi triple product (2.1.6) in each term of this product, we obtain

$$\begin{aligned} P_n &= \frac{1}{(q; q)_\infty^n} [x^0] \prod_{i=0}^{n-1} \left(\sum_{m_i \in \mathbb{Z}} x^{m_i} a_i^{m_i} q^{\frac{m_i(m_i+1)}{2}} \right) \\ &= \frac{1}{(q; q)_\infty^n} \sum_{\substack{m_0, \dots, m_{n-1} \in \mathbb{Z} \\ m_0 + \dots + m_{n-1} = 0}} \left(\prod_{i=0}^{n-1} a_i^{m_i} \right) q^{\sum_{i=0}^{n-1} \frac{m_i(m_i+1)}{2}}. \end{aligned}$$

Now replacing m_0 by $-m_1 - \dots - m_{n-1}$ and using that

$$\frac{m_0(m_0+1)}{2} = \frac{\sum_{i=1}^{n-1} m_i^2 - \sum_{i=1}^{n-1} m_i}{2} + \sum_{1 \leq i < j \leq n-1} m_i m_j,$$

we get

$$P_n = \frac{1}{(q; q)_\infty^n} \sum_{m_1, \dots, m_{n-1} \in \mathbb{Z}} \left(\prod_{i=1}^{n-1} (a_i a_0^{-1})^{m_i} \right) q^{\sum_{i=1}^{n-1} m_i^2 + \sum_{1 \leq i < j \leq n-1} m_i m_j}. \quad (6.4.1)$$

We want to apply the Jacobi triple product again inside the $n-1$ -parameters sum, in order to obtain a sum of infinite products. To do so, we carry out a change of variables. We first need the following lemma whose proof is given in Appendix A.3.10.

Lemma 6.4.1. *Let*

$$M(n) := \sum_{i=1}^{n-1} m_i^2 + \sum_{1 \leq i < j \leq n-1} m_i m_j.$$

Let $s_n = 0$ and for all $i \in \{1, \dots, n-1\}$,

$$s_i := \sum_{j=i}^{n-1} m_j.$$

Then,

$$M(n) = \sum_{i=1}^{n-1} s_i(s_i - s_{i+1}) = \sum_{i=1}^{n-1} \frac{((i+1)s_i - i s_{i+1})^2}{2i(i+1)}.$$

By Lemma 6.4.1 and (6.4.1), we obtain

$$\begin{aligned} P_n &= \frac{1}{(q; q)_\infty^n} \sum_{\substack{s_1, \dots, s_{n-1} \in \mathbb{Z} \\ s_n = 0}} \left(\prod_{i=1}^{n-1} (a_i a_0^{-1})^{s_i - s_{i+1}} \right) q^{\sum_{i=1}^{n-1} s_i(s_i - s_{i+1})} \\ &= \frac{1}{(q; q)_\infty^n} \sum_{\substack{s_1, \dots, s_{n-1} \in \mathbb{Z} \\ s_n = 0}} a_0^{-s_1} \prod_{i=1}^{n-1} a_i^{s_i - s_{i+1}} q^{s_i(s_i - s_{i+1})}. \end{aligned}$$

This is (2.2.60). Let us do perform a few more changes of variables to obtain (2.2.61).

For all $i \in \{1, \dots, n-1\}$, let us write $s_i = i \times d_i + r_i$, with $r_i \in \{0, \dots, i-1\}$. This is the euclidian division by i , so this expression is unique, and for r_1, \dots, r_{n-1} fixed, there is a bijection between $\{(s_1, \dots, s_{n-1}) \in \mathbb{Z}^{n-1} : s_i \equiv r_i \pmod{i}\}$ and $\{(d_1, \dots, d_{n-1}) \in \mathbb{Z}^{n-1}\}$. Moreover our choice $s_n = 0$ corresponds to $d_n = r_n = 0$. We obtain

$$M(n) = \sum_{i=1}^{n-1} \left(\frac{i(i+1)}{2} (d_i - d_{i+1})^2 + \frac{((i+1)r_i - ir_{i+1})^2}{2i(i+1)} + (d_i - d_{i+1})((i+1)r_i - ir_{i+1}) \right).$$

By a last change of variables $p_i = d_i - d_{i+1}$, equivalent to $d_i = \sum_{j=i}^{n-1} p_j$, $\{(d_1, \dots, d_{n-1}) \in \mathbb{Z}^{n-1}\}$ is in bijection with $\{(p_1, \dots, p_{n-1}) \in \mathbb{Z}^{n-1}\}$. This yields

$$\begin{aligned} M(n) &= \sum_{i=1}^{n-1} \left(\frac{i(i+1)}{2} p_i^2 + \frac{((i+1)r_i - ir_{i+1})^2}{2i(i+1)} + p_i((i+1)r_i - ir_{i+1}) \right) \\ &= \sum_{i=1}^{n-1} r_i(r_i - r_{i+1}) + \sum_{i=1}^{n-1} \left(\frac{i(i+1)}{2} p_i^2 + p_i((i+1)r_i - ir_{i+1}) \right). \end{aligned}$$

Backtracking all these changes of variables, we have for all $i \in \{1, \dots, n-1\}$,

$$\begin{aligned} m_i &= s_i - s_{i+1} && \text{(with } s_n = 0\text{)} \\ &= id_i + r_i - (i+1)d_{i+1} - r_{i+1} && \text{(with } d_n = r_n = 0\text{)} \\ &= i \sum_{j=i}^{n-1} p_j + r_i - (i+1) \sum_{j=i+1}^{n-1} p_j - r_{i+1} \\ &= ip_i - \sum_{j=i+1}^{n-1} p_j + r_i - r_{i+1}. \end{aligned}$$

Thus, by the above and Lemma 6.4.1, the generating function in (6.4.1) becomes

$$\begin{aligned} P_n &= \frac{1}{(q; q)_\infty^n} \sum_{\substack{r_1, \dots, r_{n-1} \\ 0 \leq r_j \leq j-1}} \sum_{p_1, \dots, p_{n-1} \in \mathbb{Z}} \left(\prod_{i=1}^{n-1} (a_i a_0^{-1})^{ip_i - \sum_{j=i+1}^{n-1} p_j + r_i - r_{i+1}} \right) \\ &\quad \times q^{\sum_{i=1}^{n-1} r_i(r_i - r_{i+1}) + \sum_{i=1}^{n-1} \left(\frac{i(i+1)}{2} p_i^2 + p_i((i+1)r_i - ir_{i+1}) \right)}. \end{aligned} \quad (6.4.2)$$

It can be shown by induction on n that

$$\prod_{i=1}^{n-1} (a_i a_0^{-1})^{ip_i - \sum_{j=i+1}^{n-1} p_j} = \prod_{i=1}^{n-1} \left(\prod_{\ell=0}^{i-1} a_i a_\ell^{-1} \right)^{p_i}.$$

Therefore reorganizing (6.4.2) leads to

$$\begin{aligned} P_n &= \frac{1}{(q; q)_\infty^n} \sum_{\substack{r_1, \dots, r_{n-1} \\ 0 \leq r_j \leq j-1}} \left(\prod_{i=1}^{n-1} (a_i a_0^{-1})^{r_i - r_{i+1}} q^{r_i(r_i - r_{i+1})} \right) \\ &\quad \times \sum_{p_1, \dots, p_{n-1} \in \mathbb{Z}} \prod_{i=1}^{n-1} \left(\left(\prod_{\ell=0}^{i-1} a_i a_\ell^{-1} \right) q^{(i+1)r_i - ir_{i+1}} \right)^{p_i} q^{\frac{i(i+1)}{2} p_i^2} \\ &= \frac{1}{(q; q)_\infty^n} \sum_{\substack{r_1, \dots, r_{n-1} \\ 0 \leq r_j \leq j-1}} \left(\prod_{i=1}^{n-1} a_i^{r_i - r_{i+1}} q^{r_i(r_i - r_{i+1})} \right) \\ &\quad \times \prod_{i=1}^{n-1} \sum_{p_1, \dots, p_{n-1} \in \mathbb{Z}} \left(\left(\prod_{\ell=0}^{i-1} a_i a_\ell^{-1} \right) q^{-\frac{i(i+1)}{2} + (i+1)r_i - ir_{i+1}} \right)^{p_i} q^{i(i+1) \frac{p_i(p_i+1)}{2}} \\ &= \frac{1}{(q; q)_\infty^n} \sum_{\substack{r_1, \dots, r_{n-1} \\ 0 \leq r_j \leq j-1}} \prod_{i=1}^{n-1} a_i^{r_i - r_{i+1}} q^{r_i(r_i - r_{i+1})} \\ &\quad \times \left(q^{i(i+1)}; q^{i(i+1)} \right)_\infty \left(- \left(\prod_{\ell=0}^{i-1} a_i a_\ell^{-1} \right) q^{\frac{i(i+1)}{2} + (i+1)r_i - ir_{i+1}}; q^{i(i+1)} \right)_\infty \end{aligned}$$

$$\times \left(- \left(\prod_{\ell=0}^{i-1} a_{\ell} a_i^{-1} \right) q^{\frac{i(i+1)}{2} - (i+1)r_i + ir_{i+1}}; q^{i(i+1)} \right)_{\infty},$$

where over the last equality, we used Jacobi's triple product identity in each of the sums in the p_i 's. Theorem 2.2.45 is proved.

Remark 6.4.2. Andrews (Andrews, 1984a) gave the particular cases $n = 1, 2, 3$ of this formula, but without keeping track of the colors. Our result is more general, as it keeps track of the colors and is valid for all n .

Chapter 7

Beyond Capparelli's theorem: a regularity over Primc's theorem

In this chapter, we discuss another duality between flatness and regularity which is presented in Theorem 2.2.51. The chapter is organized as follows. In Section 7.1, the necessary tools for our bijective proof of Theorem 2.2.51 are given. Then, in Section 7.2, we describe our bijection and prove its well-definedness. Finally, in Section 7.3, it is proved that Theorem 2.2.51 implies Theorem 2.2.59.

7.1 The setup

Before proving Theorem 2.2.51, we first need to understand the properties of the energy ϵ with values in $\{0, 1, 2\}$ as described in Definition 2.2.46.

7.1.1 Insertion of parts with free colors

Let us consider the partial order defined on \mathcal{C} with

$$\mathcal{C}_{\text{sup}} > \mathcal{C}_{\text{free}} > \mathcal{C}_{\text{inf}}.$$

This means that $c_1 > c_2 > c_3$ for any $(c_1, c_2, c_3) \in \mathcal{C}_{\text{sup}} \times \mathcal{C}_{\text{free}} \times \mathcal{C}_{\text{inf}}$. The relations in (2.2.63), (2.2.64) and (2.2.65) can be summarized in a single relation: for any c_1 and c_2 not belonging to the same set of colors,

$$\epsilon(c_1, c_2) \in \{\chi(c_1 < c_2), \chi(c_1 < c_2) + 1\}. \quad (7.1.1)$$

One can deduce from the above relation the following property: in $\mathcal{P}_\epsilon^{c_\infty}$, for c_1 and c_2 not belonging to the same set of colors, the pattern

$$p_{c_1}, p_{c_2}$$

is allowed if and only if $\epsilon(c_1, c_2) = 0$, and this implies that $c_1 > c_2$. Another key property of ϵ is the relation (2.2.62). This means that for any c_1, c_2 in $\mathcal{C}_{\text{free}}$, the pattern

$$p_{c_1}, p_{c_2}$$

is allowed if and only if $c_1 = c_2$. These properties on the allowed patterns having parts with the same size imply the following proposition.

Proposition 7.1.1. *Let $C = c_1 \cdots c_s$ be a sequence of colors such that for all $i \in \{1, \dots, s-1\}$, $\epsilon(c_i, c_{i+1}) = 0$. Then, there exist unique integers $1 \leq u \leq v \leq s+1$ such that*

$$\begin{aligned} \{c_1, \dots, c_{u-1}\} &\subset \mathcal{C}_{\text{sup}}, \\ c_u = \dots = c_{v-1} &\in \mathcal{C}_{\text{free}}, \\ \{c_v, \dots, c_s\} &\subset \mathcal{C}_{\text{inf}}, \end{aligned} \quad (7.1.2)$$

with the convention that $\{c_a, \dots, c_b\} = \emptyset$ if $a > b$.

The above proposition then implies the following insertion rules:

1. if there is a part p_f with $f \in \mathcal{C}_{\text{free}}$, then for any $f' \in \mathcal{C}_{\text{free}}$, insert a part $p_{f'}$ next to the part p_f if and only if $f = f'$,

2. if there is a part p_c with $c \in \mathcal{C}_{\text{sup}}$, then for any $f \in \mathcal{C}_{\text{free}}$, since the part p_f cannot be inserted to its left, then insert p_f to its right if and only if $\epsilon(c, f) = 0$,
3. if there is a part p_c with $c \in \mathcal{C}_{\text{inf}}$, then for any $f \in \mathcal{C}_{\text{free}}$, since the part p_f cannot be inserted to its right, then insert p_f to its left if and only if $\epsilon(f, c) = 0$.

7.1.2 Insertion in a pair of parts

We now study the case when a part p_f with a color $f \in \mathcal{C}_{\text{free}}$ is inserted between two consecutive parts $p_{c_1}^{(1)}, p_{c_2}^{(2)}$, and has the same size as one of the two parts, i.e $p \in \{p^{(1)}, p^{(2)}\}$. Observe that when a part p_f with the same size as a part with a free color is inserted, this necessarily means that f equals this free color. In the following, we then study the case when the insertion is such that the color of the part with the same size as the inserted part belongs to $\mathcal{C}_{\text{sup}} \sqcup \mathcal{C}_{\text{inf}}$.

By the two last insertion rules, we only need to investigate the insertions of the type $p = p^{(1)}$ and $c_1 \in \mathcal{C}_{\text{sup}}$, and the insertions of the type $p = p^{(2)}$ and $c_2 \in \mathcal{C}_{\text{inf}}$.

We start with the case where the two parts have the same size, which gives a pattern of the form p_{c_1}, p_{c_2} . By the insertion rules, such a insertion is not possible when both colors c_1 and c_2 are either in \mathcal{C}_{sup} or in \mathcal{C}_{inf} . Also, as soon as one of the color belongs to $\mathcal{C}_{\text{free}}$, the first insertion rule implies that only a part p_f with f equal to this free color can be inserted. The following lemma deals with the last case.

Lemma 7.1.2. *For any pair $(c_1, c_2) \in \mathcal{C}_{\text{sup}} \times \mathcal{C}_{\text{inf}}$ such that $\epsilon(c_1, c_2) = 0$, we can insert a part p_f with $f \in \mathcal{C}_{\text{free}}$ between the parts of the pattern p_{c_1}, p_{c_2} to obtain*

$$p_{c_1}, p_f, p_{c_2}$$

if and only if $\epsilon(c_1, f) = \epsilon(f, c_2) = 0$.

We now study the case where $p^{(1)} \neq p^{(2)}$. This necessarily means that $p^{(1)} > p^{(2)}$. We first start with the insertion of p_f to the right of p_{c_1} with $c_1 \in \mathcal{C}_{\text{sup}}$.

Lemma 7.1.3. *For any colors $(c_1, f) \in \mathcal{C}_{\text{sup}} \times \mathcal{C}_{\text{free}}$ and , we have the following:*

1. for any color c_2 in $\mathcal{C} \sqcup \{c_\infty\}$, and any integer $u \geq 2$, we can insert a part p_f between the parts of the pattern $p_{c_1}, (p - u)_{c_2}$ to obtain

$$p_{c_1}, p_f, (p - u)_{c_2}$$

if and only if $\epsilon(c_1, f) = 0$,

2. for any color $c_2 \in \mathcal{C}_{\text{free}} \sqcup \mathcal{C}_{\text{inf}}$, we can insert a part p_f between the parts of the pattern $p_{c_1}, (p - 1)_{c_2}$ to obtain

$$p_{c_1}, p_f, (p - 1)_{c_2}$$

if and only if $\epsilon(c_1, f) = 0$,

3. for any color $c_2 \in \mathcal{C}_{\text{sup}}$ such that $\epsilon(c_1, c_2) \in \{0, 1\}$, we can insert a part p_f between the parts of the pattern $p_{c_1}, (p - 1)_{c_2}$ to obtain

$$p_{c_1}, p_f, (p - 1)_{c_2}$$

if and only if $\epsilon(c_1, f) = 0$ and $\epsilon(f, c_2) = 1$.

The second case concerns the insertion of p_f to the left of p_{c_2} with $c_2 \in \mathcal{C}_{\text{sup}}$.

Lemma 7.1.4. *For any color $(c_2, f) \in \mathcal{C}_{\text{inf}} \times \mathcal{C}_{\text{free}}$, we have the following:*

1. for any color c_1 in \mathcal{C} , and any integer $u \geq 2$, we can insert a part p_f between the parts of the pattern $(p + u)_{c_1}, p_{c_2}$ to obtain

$$(p + u)_{c_1}, p_f, p_{c_2}$$

if and only if $\epsilon(c_1, f) = 0$,

2. for any color $c_1 \in \mathcal{C}_{\text{sup}} \sqcup \mathcal{C}_{\text{free}}$, we can insert a part p_f between the parts of the pattern $(p + 1)_{c_1}, p_{c_2}$ to obtain

$$(p + 1)_{c_1}, p_f, p_{c_2}$$

if and only if $\epsilon(f, c_2) = 0$,

3. for any color $c_1 \in \mathcal{C}_{\text{inf}}$ such that $\epsilon(c_1, c_2) \in \{0, 1\}$, we can insert a part p_f between the parts of the pattern $(p+1)_{c_1}, p_{c_2}$ to obtain

$$(p+1)_{c_1}, p_f, p_{c_2}$$

if and only if $\epsilon(c_1, f) = 1$ and $\epsilon(f, c_2) = 0$.

The color f of the possible inserted part depends on both colors c_1 and c_2 only if (c_1, c_2) belongs to $\{(c, c') \in \mathcal{C}_{\text{sup}} \times \mathcal{C}_{\text{inf}} : \epsilon(c, c') = 0\} \sqcup \{(c, c') \in \mathcal{C}_{\text{sup}}^2 : \epsilon(c, c') \in \{0, 1\}\} \sqcup \{(c, c') \in \mathcal{C}_{\text{inf}}^2 : \epsilon(c, c') \in \{0, 1\}\}$.

The existence of such a color f is rendered possible by the relations (2.2.66), (2.2.67) and (2.2.68). When the color f only depends on the color of the part with the same size as p_f , the existence of such a color f is ensured by (2.2.64) and (2.2.63).

The definition of the functions δ and γ in Definition 2.2.48 then allows us to forbid in ${}_{\delta, \gamma}^c \mathcal{P}_\epsilon^{c_\infty}$ a unique insertion in all the corresponding pairs $p_{c_1}^{(1)}, p_{c_2}^{(2)}$ of consecutive parts.

Remark 7.1.5. For any $(c_1, c_2) \in \mathcal{C}_{\text{sup}} \times \mathcal{C}_{\text{inf}}$, we can insert in the pair $(p+1)_{c_1}, p_{c_2}$ two parts $(p+1)_{f_1}$ and p_{f_2} with f_1, f_2 in \mathcal{C}_{sup} if only if $\epsilon(c_1, f_1) = \epsilon(f_2, c_2) = 0$. The choice of the color f_1 only depends on c_1 , as well as the choice of f_2 only depends on c_2 .

7.1.3 Insertion at the extremities

Recall that

$$\begin{aligned} \epsilon(\mathcal{C}_{\text{free}}, c_\infty) &= \{1\}, \\ \epsilon(\mathcal{C}_{\text{sup}}, c_\infty) &\subset \{1, 2\}, \\ \epsilon(\mathcal{C}_{\text{inf}}, c_\infty) &\subset \{0, 1\}. \end{aligned}$$

Then, by Proposition 7.1.1, the only possible tail for a partition in $\mathcal{P}_\epsilon^{c_\infty}$, consisting of parts of size 0, has the form

$$0_{c_1}, \dots, 0_{c_s}, 0_{c_\infty}$$

with $c_1, \dots, c_s \in \mathcal{C}_{\text{sup}}$. This means that we cannot insert a part 0_f for any $f \in \mathcal{C}_{\text{free}}$. We now study the insertion of at 1_f the tail of the partitions.

- When the tail has the form $1_c, 0_{c_\infty}$ with $c \in \mathcal{C}_{\text{sup}}$, for any free color f , one can insert a part 1_f to the right to 1_c as long as $\epsilon(c, f) = 0$.
- When the tail has the form $1_c, 0_{c_\infty}$ with $c \in \mathcal{C}_{\text{inf}}$, for any free color f , the only possible insertion of a part 1_f next to the 1_c occurs its left. The part 1_c then remains the last part before 0_{c_∞} .

We finally study the case of insertion at the head of the partition.

- When the first part is p_c with $c \in \mathcal{C}_{\text{sup}}$, for any free color f , the only possible insertion of a part p_f next to the p_c occurs its right. The part 1_c then remains the first part of the partitions.
- When the first part is p_c with $c \in \mathcal{C}_{\text{inf}}$, for any free color f , for any free color f , one can insert a part p_f to the right to p_c as long as $\epsilon(f, c) = 0$.

The above insertion properties at the extremities allow us to extend the insertion into the pair $p_{c_1}^{(1)}, p_{c_2}^{(2)}$ for the following cases,

1. the insertion of p_f in the pair $p_{c_1}, 0_{c_\infty}$ with $c_1 \in c \in \mathcal{C}_{\text{sup}}$ and $p \geq 1$,
2. the insertion of p_f in the pair ∞_{c_1}, p_{c_2} with $c_2 \in c \in \mathcal{C}_{\text{inf}}$ and $u \geq 1$, which means that p_{c_2} is at the head of the partitions.

7.2 Bijective proof of Theorem 2.2.51

7.2.1 The map Φ

Let us consider a partition $\lambda \in \mathcal{P}_\epsilon^{c_\infty}$. We want to build $\Phi(\lambda) = (\mu, \nu) \in {}_{\delta, \gamma}^c \mathcal{P}_\epsilon^{c_\infty} \times \mathcal{P}$. First, note that $\epsilon(c, c_0) = \epsilon(c, c_0) = \chi(c \neq c_0)$ for any color $c \in \mathcal{C}$. This is equivalent to saying that, in λ , the parts

colored by c_0 have a size different from the parts with color different from c_0 . We first consider ν to be the empty partition. We then proceed by transforming some parts p_f for free colors f into parts p and insert them into ν as follows.

1. We take all the parts of λ with color c_0 and add them to ν , while removing their color c_0 .

Since the parts to the left and to the right of a maximal sequence of the form

$$p_{c_0}, \dots, p_{c_0}$$

have respectively a size greater and less than p , this means that their sizes differ by at least 2. The fact that $\epsilon(\mathcal{C}, \mathcal{C} \sqcup \{c_\infty\}) \subset \{0, 1, 2\}$ implies that, by removing the parts with color c_0 from λ , we obtain a partition λ' that is still in $\mathcal{P}_\epsilon^{c_\infty}$. Furthermore, the parts of λ' have sizes different from the sizes of the parts of ν .

2. For all the parts p_f in λ' with $f \in \mathcal{C}_{\text{free}} \setminus \{c_0\}$ which appear more than twice, we transform all the parts p_f but one into p and move them to ν .

Since there is still one occurrence for all such parts, we obtain a partition λ'' that is still in $\mathcal{P}_\epsilon^{c_\infty}$, and has no repeated parts p_f with free colors, and no part colored by c_0 . Also, the only parts of λ'' having the same size as some part of ν are those with the same size as a certain part p_f with a free color.

3. For all the parts p_f that appear in patterns $p_{c_1}^{(1)}, p_f, p_{c_2}^{(2)}$ of λ'' which are forbidden in ${}_{\delta, \gamma}^{c_0} \mathcal{P}_\epsilon^{c_\infty}$, we then transform the parts p_f into p and add these parts to ν .

Note that such parts p_f may have been repeated in the previous step, and can only appear in forbidden patterns with $p = p^{(1)}$ and $c_1 \in \mathcal{C}_{\text{sup}}$, or $p = p^{(2)}$ and $c_2 \in \mathcal{C}_{\text{inf}}$. One can also observe that, by removing p_f from such patterns, the patterns $p_{c_1}^{(1)}, p_{c_2}^{(2)}$ are always allowed in ${}_{\delta, \gamma}^{c_0} \mathcal{P}_\epsilon^{c_\infty}$. At the end of this step, the partition obtained does not have any forbidden pattern or any part with color c_0 , and the part with free color p_f cannot be repeated. We then set this partition to be μ .

We then obtain at the end a pair of partitions $(\mu, \nu) \in {}_{\delta, \gamma}^{c_0} \mathcal{P}_\epsilon^{c_\infty} \times \mathcal{P}$.

Remark 7.2.1. We remark that the only parts in ν which do not have the same size as the parts in μ are those coming from the parts of λ with color c_0 .

7.2.2 The map Φ^{-1}

We will now describe the inverse map Φ^{-1} . For any $(\mu, \nu) \in {}_{\delta, \gamma}^{c_0} \mathcal{P}_\epsilon^{c_\infty} \times \mathcal{P}$, we proceed by inserting the parts p of ν in the partition μ as follows.

1. Suppose that there is no part p_f with $f \in \mathcal{C}_{\text{free}} \setminus \{c_0\}$, but there is a part p_c with $c \in \mathcal{C}_{\text{sup}} \sqcup \mathcal{C}_{\text{inf}}$. We then proceed as follows.
 - If there exists a pair of colors $(c_1, c_2) \in \mathcal{C}_{\text{sup}} \times \mathcal{C}_{\text{inf}}$ such that the pattern p_{c_1}, p_{c_2} is in μ , we then necessarily have that $\epsilon(c_1, c_2) = 0$, and $\gamma(c_1, c_2)$ is defined. By Proposition 7.1.1, the existence of such a pair is unique in the maximal sequence of parts with size p . Then set $f = \gamma(c_1, c_2)$, transform the part p into p_f and we insert p_f between p_{c_1} and p_{c_2} , to obtain the pattern

$$p_{c_1}, p_{\gamma(c_1, c_2)}, p_{c_2}$$

which is forbidden in ${}_{\delta, \gamma}^{c_0} \mathcal{P}_\epsilon^{c_\infty}$.

Note that this is the only suitable insertion in the maximal sequence of parts with size p .

- (a) We cannot insert a part p_f with a free color in the sequence to the left of p_{c_1} , as it consists of parts with color in \mathcal{C}_{sup} , and the second insertion rule forbids such insertion.
- (b) Similarly, we cannot insert a part p_f with a free color in the sequence to the right of p_{c_2} , as it consists of parts with color in \mathcal{C}_{inf} , and the third insertion rule forbids such insertion.

- (c) Finally, inserting a part p_f into the pair p_{c_1}, p_{c_2} for any free color $f \neq \gamma(c_1, c_2)$ such that $\epsilon(c_1, f) = \epsilon(f, c_2) = 0$ is useless and troublesome, as the pattern

$$p_{c_1}, p_f, p_{c_2}$$

is allowed in ${}^{c_0}_{\delta, \gamma} \mathcal{P}_\epsilon^{c_\infty}$, and this insertion renders the map Φ^{-1} not injective.

- If all the parts p_c have colors in \mathcal{C}_{sup} , we denote by c_1 the color of the rightmost part. With the same reasoning as above, we cannot insert a part p_f with a free color in the sequence to the left of p_{c_1} . Remark that the part to its right has necessarily a size less than p .
 - (a) If the part to the right of p_{c_1} has size less than $p - 1$, then transform p into $p_{\delta(c_1)}$, and insert $p_{\delta(c_1)}$ to the right of p_{c_1} , to obtain for an integer $2 \leq u$ the pattern

$$p_{c_1}, p_{\delta(c_1)}, (p - u)_{c_2}$$

which is forbidden in ${}^{c_0}_{\delta, \gamma} \mathcal{P}_\epsilon^{c_\infty}$.

- (b) If the part to the right of p_{c_1} has size $p - 1$ and a color $c_1 \in (\mathcal{C}_{\text{free}} \setminus \{c_0\}) \sqcup \mathcal{C}_{\text{inf}} \sqcup \{c_\infty\}$, then transform p into $p_{\delta(c_1)}$, and we insert $p_{\delta(c_1)}$ to the right of p_{c_2} , to obtain the pattern

$$p_{c_1}, p_{\delta(c_1)}, (p - 1)_{c_2}$$

which is forbidden in ${}^{c_0}_{\delta, \gamma} \mathcal{P}_\epsilon^{c_\infty}$.

- (c) If the part to the right of p_{c_1} has size than $p - 1$ and a color $c_2 \in \mathcal{C}_{\text{sup}}$, we necessarily have that $\epsilon(c_1, c_2) \in \{0, 1\}$. In that case, define $\gamma(c_1, c_2)$, and then transform p into $p_{\gamma(c_1, c_2)}$, and insert $p_{\gamma(c_1, c_2)}$ to the right of p_{c_1} , to we obtain the pattern

$$p_{c_1}, p_{\gamma(c_1, c_2)}, (p - 1)_{c_2}$$

which is forbidden in ${}^{c_0}_{\delta, \gamma} \mathcal{P}_\epsilon^{c_\infty}$.

- There now remains the case where all the parts p_c are such that $c \in \mathcal{C}_{\text{sup}}$. We then take the color of the leftmost part, denoted c_2 . We remark that we cannot insert a part p_f with a free color in the sequence to the right of p_{c_1} . Also, the part to its left, if such a part exists, has necessarily a size greater than p .
 - (a) If there is no part to the left of p_{c_2} , then transform the part p into $p_{\delta(c_2)}$ and insert $p_{\delta(c_2)}$ to the left of p_{c_2} , to obtain the pattern

$$p_{\delta(c_2)}, p_{c_2}$$

which is forbidden in ${}^{c_0}_{\delta, \gamma} \mathcal{P}_\epsilon^{c_\infty}$.

- (b) If the part to the left of p_{c_2} has a size greater than $p + 1$, then transform the part p into $p_{\delta(c_2)}$ and insert $p_{\delta(c_2)}$ to the left of p_{c_2} , to obtain for some integer $2 \leq u$ the pattern

$$(p + u)_{c_1}, p_{\delta(c_2)}, p_{c_2}$$

which is forbidden in ${}^{c_0}_{\delta, \gamma} \mathcal{P}_\epsilon^{c_\infty}$.

- (c) If the part to the left of p_{c_2} has size $p + 1$ and a color $c_1 \in (\mathcal{C}_{\text{free}} \setminus \{c_0\}) \sqcup \mathcal{C}_{\text{sup}}$, then transform the part p into $p_{\delta(c_2)}$ and insert $p_{\delta(c_2)}$ to the left of p_{c_2} , to obtain the pattern

$$(p + 1)_{c_1}, p_{\delta(c_2)}, p_{c_2}$$

which is forbidden in ${}^{c_0}_{\delta, \gamma} \mathcal{P}_\epsilon^{c_\infty}$.

- (d) If the part to the left of p_{c_2} has size $p + 1$ and a color $c_1 \in \mathcal{C}_{\text{inf}}$, we necessarily have that $\epsilon(c_1, c_2) \in \{0, 1\}$. Then transform the part p into $p_{\gamma(c_1, c_2)}$ and insert $p_{\gamma(c_1, c_2)}$ to the left of p_{c_2} , to obtain the pattern

$$(p + 1)_{c_1}, p_{\gamma(c_1, c_2)}, p_{c_2}$$

which is forbidden in ${}^{c_0}_{\delta, \gamma} \mathcal{P}_\epsilon^{c_\infty}$.

The order in which we insert the parts p_f does not matter, as the only case where the color of the inserted part depends on both colors c_1 and c_2 are the only insertion for which the value of

p is unique for the pair $p_{c_1}^{(1)}, p_{c_2}^{(2)}$. Moreover, for the above cases, which form an exhaustive list of insertions p_f into a pair $p_{c_1}^{(1)}, p_{c_2}^{(2)}$ with $p = p^{(1)}$ and $c_1 \in \mathcal{C}_{\text{sup}}$, or $p = p^{(2)}$ and $c_2 \in \mathcal{C}_{\text{inf}}$, the choice of the color f to render the obtained pattern $p_{c_1}^{(1)}, p_f, p_{c_2}^{(2)}$ forbidden in ${}^{c_0}_{\delta, \gamma} \mathcal{P}_{\epsilon}^{c_\infty}$ is unique.

At the end of this process, we obtain a partition μ' with some forbidden patterns of ${}^{c_0}_{\delta, \gamma} \mathcal{P}_{\epsilon}^{c_\infty}$, with no repeated part p_f with a free color f and no part colored by c_0 . This is then the exact reverse step of the third step of Φ .

2. If there is a part p_f in μ' with $f \in \mathcal{C}_{\text{free}} \setminus \{c_0\}$, then transform all the parts p into p_f and insert them in μ' . We then obtain a partition μ'' with some forbidden patterns of ${}^{c_0}_{\delta, \gamma} \mathcal{P}_{\epsilon}^{c_\infty}$ and repeated parts p_f , but no part colored by c_0 .

This is the reverse step of the second step of Φ , and allows us to have repeated parts with free color.

3. There now remains the parts p in ν such that there is no in μ'' with the same size. We transform these parts into p_{c_0} and insert them into μ'' . The partition obtained has some forbidden patterns of ${}^{c_0}_{\delta, \gamma} \mathcal{P}_{\epsilon}^{c_\infty}$, repeated parts p_f with free color f , and parts colored by c_0 . We then set this partition to be λ .

This is the exact reverse step of the first step of Φ .

The partition λ then obtained is a partition of $\mathcal{P}_{\epsilon}^{c_\infty}$, and we set $\Phi^{-1}(\mu, \nu) = \lambda$.

The inversion between the maps Φ and Φ^{-1} comes from the fact that the steps in their respective process are inverse and lead exactly to the same subsets of partitions.

7.3 Duality between Capparelli's and Primc's identities

Let us consider the set $\mathcal{C} = \{a_i b_j : i, j \in \mathbb{N}\}$, and the set-partition

$$\begin{aligned} \mathcal{C}_{\text{sup}} &= \{a_i b_j : i < j \in \mathbb{N}\}, \\ \mathcal{C}_{\text{free}} &= \{a_i b_j : i \in \mathbb{N}\}, \\ \mathcal{C}_{\text{inf}} &= \{a_i b_j : i > j \in \mathbb{N}\}. \end{aligned}$$

7.3.1 Well-definedness according to the decomposition

Recall that for all $i, j, k, l \in \{0, \dots, n-1\}$, we have the energy Δ in (2.2.54) defined by

$$\Delta(a_i b_j, a_k b_l) = \chi(i \geq k) - \chi(i = j = k) + \chi(j \leq l) - \chi(j = k = l).$$

We then have the following.

1. By comparing the free colors, for all $i, k \in \mathbb{N}$

$$\Delta(a_i b_i, a_k b_k) = \chi(i \neq k). \quad (7.3.1)$$

2. For all $i, j, k \in \mathbb{N}$ with $i < j$, we have

$$\Delta(a_i b_j, a_k b_k) = 1 - \chi(i < k \leq j) \quad (7.3.2)$$

$$\Delta(a_k b_k, a_i b_j) = 1 + \chi(i < k \leq j), \quad (7.3.3)$$

and the conditions (2.2.63) are satisfied. Furthermore, for all $i < j$,

$$\{k \in \mathbb{N} : \Delta(a_i b_j, a_k b_k) = 0\} = \{k \in \mathbb{N} : \Delta(a_k b_k, a_i b_j) = 2\} = \{i+1, \dots, j\} \neq \emptyset.$$

3. For all $i, j, k \in \mathbb{N}$ with $i > j \in \mathbb{N}$, we have

$$\Delta(a_i b_j, a_k b_k) = 1 + \chi(i \geq k > j) \quad (7.3.4)$$

$$\Delta(a_k b_k, a_i b_j) = 1 - \chi(i \geq k > j), \quad (7.3.5)$$

and the conditions (2.2.64) are satisfied. Furthermore, for all $i > j \in \mathbb{N}$,

$$\{k \in \mathbb{N} : \Delta(a_i b_j, a_k b_k) = 2\} = \{k \in \mathbb{N} : \Delta(a_k b_k, a_i b_j) = 0\} = \{j+1, \dots, i\} \neq \emptyset.$$

4. For all $i, j, k, l \in \mathbb{N}$ such that $i \neq j$ and $k \neq l$,

$$\Delta(a_i b_j, a_k b_l) = \chi(i \geq k) + \chi(j \leq l). \quad (7.3.6)$$

In particular, we have the following

$$\begin{aligned} \Delta(a_i b_j, a_k b_l) = 2 &\iff i \geq k \quad \text{and} \quad i \leq l \\ \Delta(a_i b_j, a_k b_l) = 0 &\iff i < k \quad \text{and} \quad i > l \end{aligned}$$

The above equation implies the following relations.

(a) If $i < j$ and $k > l$, then

$$\Delta(a_i b_j, a_k b_l) = 1 - \chi(i < k)\chi(j > l) \quad (7.3.7)$$

$$\Delta(a_k b_l, a_i b_j) = 1 + \chi(i \leq k)\chi(j \geq i), \quad (7.3.8)$$

and the conditions (2.2.65) are satisfied. Also, when $\Delta(a_i b_j, a_k b_l) = 0$, we then have that $i < k$ and $j > l$, so that

$$\begin{aligned} \{u \in \mathbb{N} : \Delta(a_i b_j, a_u b_u) = 0\} \cap \{u \in \mathbb{N} : \Delta(a_u b_u, a_k b_l) = 0\} &= \{i+1, \dots, j\} \cap \{l+1, \dots, k\} \\ &= \{\max\{i, l\} + 1, \dots, \min\{k, j\}\} \\ &\neq \emptyset, \end{aligned}$$

and the conditions (2.2.66) are satisfied.

(b) If $i < j$ and $k < l$ then

$$\begin{aligned} \Delta(a_i b_j, a_k b_l) = 2 &\iff i \geq k \quad \text{and} \quad j \leq l \\ &\iff \{i+1, \dots, j\} \subset \{k+1, \dots, l\} \\ &\iff \{i+1, \dots, j\} \setminus \{k+1, \dots, l\} = \emptyset \\ &\iff \{u \in \mathbb{N} : \Delta(a_i b_j, a_u b_u) = 0\} \cap \{u \in \mathbb{N} : \Delta(a_u b_u, a_k b_l) = 1\} = \emptyset. \end{aligned}$$

We then have equivalently

$$\Delta(a_i b_j, a_k b_l) \in \{0, 1\} \iff \{u \in \mathbb{N} : \Delta(a_i b_j, a_u b_u) = 0\} \cap \{u \in \mathbb{N} : \Delta(a_u b_u, a_k b_l) = 1\} \neq \emptyset,$$

and the conditions (2.2.67) are satisfied.

(c) If $i > j$ and $k > l$, then

$$\begin{aligned} \Delta(a_i b_j, a_k b_l) = 2 &\iff i \geq k \quad \text{and} \quad j \leq l \\ &\iff \{l+1, \dots, k\} \subset \{j+1, \dots, i\} \\ &\iff \{l+1, \dots, k\} \setminus \{j+1, \dots, i\} = \emptyset \\ &\iff \{u \in \mathbb{N} : \Delta(a_i b_j, a_u b_u) = 1\} \cap \{u \in \mathbb{N} : \Delta(a_u b_u, a_k b_l) = 0\} = \emptyset. \end{aligned}$$

We then have equivalently

$$\Delta(a_i b_j, a_k b_l) \in \{0, 1\} \iff \{u \in \mathbb{N} : \Delta(a_i b_j, a_u b_u) = 1\} \cap \{u \in \mathbb{N} : \Delta(a_u b_u, a_k b_l) = 0\} \neq \emptyset,$$

and the conditions (2.2.68) are satisfied.

Then, by Definition 2.2.46, the energy Δ is well-defined according to the decomposition $\mathcal{C}_{\text{sup}} \sqcup \mathcal{C}_{\text{free}} \sqcup \mathcal{C}_{\text{inf}}$. We now fix $\ell \in \mathbb{N}$, and introduce the fictitious color c_∞ and extend Δ with the relations

$$\begin{aligned} \Delta(c_\infty, c_\infty) &= 0, \\ \Delta(c_\infty, a_i a_j) &= 1, \\ \Delta(a_i a_j, c_\infty) &= \chi(i \geq \ell) + \chi(j < \ell). \end{aligned}$$

7.3.2 Forbidden patterns

By Definition 2.2.48, the functions δ and γ satisfy the following properties:

1. for all $a_k b_l (k \neq l)$,

$$\delta(a_k b_l) \in \{a_i b_i : i \in \{\min\{k, l\} + 1, \dots, \max\{k, l\}\}\}, \quad (7.3.9)$$

2. For the pairs of bound colors $(c_1, c_2) = (a_{k_1} b_{l_1}, a_{k_2} b_{l_2})$,
 - if $k_1 < l_1$ and $k_2 > l_2$ such that $\max\{k_1, l_2\} < \min\{k_2, l_1\}$, then

$$\gamma(c_1, c_2) \in \{a_i b_i : i \in \{\max\{k_1, l_2\} + 1, \dots, \min\{k_2, l_1\}\}\}. \quad (7.3.10)$$

- if $k_1 > l_1$ and $k_2 > l_2$ such that we do not have $k_1 \geq k_2 > l_2 \geq l_1$, then

$$\gamma(c_1, c_2) \in \{a_i b_i : i \in \{l_2 + 1, \dots, k_2\} \setminus \{l_1 + 1, \dots, k_1\}\}, \quad (7.3.11)$$

- if $k_1 < l_1$ and $k_2 < l_2$ such that we do not have $k_2 \leq k_1 < l_1 \leq l_2$, then

$$\gamma(c_1, c_2) \in \{a_i b_i : i \in \{k_1 + 1, \dots, l_1\} \setminus \{k_2 + 1, \dots, l_2\}\}. \quad (7.3.12)$$

Definition 7.3.1. For all non-negative integers $\ell < n$, the set $\mathcal{C}_{\ell, n}(\delta, \gamma)$ of the Capparelli partitions related to δ and γ is the set of generalized Primc partitions of $\mathcal{P}_{\ell, n}$, with no parts colored by $a_0 b_0$, and which avoid the following forbidden patterns (we here set $(c_1, c_2) = (a_{k_1} b_{l_1}, a_{k_2} b_{l_2})$)

- For all integer $i > 0$,

$$p_{a_i b_i} p_{a_i b_i}.$$

- For all $\max\{k_1, l_2\} < \min\{k_2, l_1\}$ and $f = a_i b_i$ with $i = \gamma(c_1, c_2)$,

$$p_{c_1} p_f p_{c_2}.$$

- For all integers $k_1 < l_1$:

- For all integers $2 \leq u$, the pattern (with c_2 possibly equal to c_∞)

$$p_{c_1} p_{\delta(c_1)} (p - u)_{c_2}.$$

- For all integers $k_2 \geq l_2$ or for c_2 equal to c_∞ , the pattern

$$p_{c_1} p_{\delta(c_1)} (p - 1)_{c_2}.$$

- For all $k_1 < l_1, k_2 < l_2$ such that we do not have $k_2 \leq k_1 < l_1 \leq l_2$, the pattern

$$p_{c_1} p_{\gamma(c_1, c_2)} (p - 1)_{c_2}.$$

- For all integers $k_2 > l_2$:

- For all integers $2 \leq u \leq \infty$, the pattern

$$(p + u)_{c_1} p_{\delta(c_2)} p_{c_2}.$$

Here the part ∞_{c_1} means that the pattern $p_{\delta(c_2)} p_{c_2}$ is at the head of the partition.

- For all integers $k_1 \leq l_1$, the pattern,

$$(p + 1)_{c_1} p_{\delta(c_2)} p_{c_2}.$$

- For all integers $k_1 > l_1$ such that we do not have $k_1 \geq k_2 > l_2 \geq l_1$, the pattern

$$(p + 1)_{c_1} p_{\gamma(c_1, c_2)} p_{c_2}.$$

Then the following corollary of Theorem 2.2.51 holds.

Corollary 7.3.2. *There is a bijection Φ between the set $\mathcal{P}_{\ell, n}$ of generalized Primc partitions and the product set $\mathcal{C}_{\ell, n}(\delta, \gamma) \times \mathcal{P}$, where $\mathcal{C}_{\ell, n}(\delta, \gamma)$ is the set of the Capparelli partitions related to δ and γ , and \mathcal{P} is the set of the classical partitions.*

7.3.3 Proof of Theorem 2.2.59

We now define the suitable functions δ and γ to retrieve the sets $\mathcal{C}_{\ell,n}$ and $\mathcal{C}'_{\ell,n}$.

Functions δ_1 and γ_1 for $\mathcal{C}'_{\ell,n}$

We define δ_1 and γ_1 as follows: for $k \neq l$,

$$\delta_1(a_k b_l) = a_i b_i \quad \text{with } i = 1 + \min\{k, l\}, \quad (7.3.13)$$

and for $(c_1, c_2) = (a_{k_1} b_{l_1}, a_{k_2} b_{l_2})$,

1. if $\max\{k_1, l_2\} < \min\{k_2, l_1\}$, we set

$$\gamma_1(c_1, c_2) = a_i b_i \quad \text{with } i = 1 + \max\{k_1, l_2\}, \quad (7.3.14)$$

2. if $k_1 > l_1$ and $k_2 > l_2$ such that we do not have $k_1 \geq k_2 > l_2 \geq l_1$, then

• if $l_2 < l_1$, then

$$\gamma_1(c_1, c_2) = a_{l_2+1} b_{l_2+1} \quad (7.3.15)$$

• if $l_2 \geq k_1$, then

$$\gamma_1(c_1, c_2) = a_{l_2+1} b_{l_2+1} \quad (7.3.16)$$

• if $k_2 > k_1 > l_2 \geq l_1$, then

$$\gamma_1(c_1, c_2) = a_{k_2} b_{k_2}, \quad (7.3.17)$$

3. if $k_1 < l_1$ and $k_2 < l_2$ such that we do not have $l_2 \geq l_1 > k_1 \leq k_2$, then

• if $k_2 > k_1$, then

$$\gamma_1(c_1, c_2) = a_{k_1+1} b_{k_1+1} \quad (7.3.18)$$

• if $k_1 \geq l_2$, then

$$\gamma_1(c_1, c_2) = a_{k_1+1} b_{k_1+1} \quad (7.3.19)$$

• if $l_1 > l_2 > k_1 \geq k_2$, then

$$\gamma_1(c_1, c_2) = a_{l_1} b_{l_1}. \quad (7.3.20)$$

We then have the corresponding proposition

Proposition 7.3.3. *We have $\mathcal{C}_{\ell,n}(\delta_1, \gamma_1) = \mathcal{C}'_{\ell,n}$.*

Functions δ_2 and γ_2 for $\mathcal{C}_{\ell,n}$

We define δ_2 and γ_2 as follows: for $k \neq l$,

$$\delta_2(a_k b_l) = a_i b_i \quad \text{with } i = \max\{k, l\}, \quad (7.3.21)$$

and for $(c_1, c_2) = (a_{k_1} b_{l_1}, a_{k_2} b_{l_2})$,

1. if $\max\{k_1, l_2\} < \min\{k_2, l_1\}$, we set

$$\gamma_2(c_1, c_2) = a_i b_i \quad \text{with } i = \min\{k_2, l_1\}, \quad (7.3.22)$$

2. if $k_1 > l_1$ and $k_2 > l_2$ such that we do not have $k_1 \geq k_2 > l_2 \geq l_1$, then

• if $k_2 > k_1$, then

$$\gamma_2(c_1, c_2) = a_{k_2} b_{k_2} \quad (7.3.23)$$

• if $l_1 \geq k_2$, then

$$\gamma_2(c_1, c_2) = a_{k_2} b_{k_2} \quad (7.3.24)$$

• if $k_1 \geq k_2 > l_1 > l_2$, then

$$\gamma_2(c_1, c_2) = a_{l_2+1} b_{l_2+1}, \quad (7.3.25)$$

3. if $k_1 < l_1$ and $k_2 < l_2$ such that we do not have $l_2 \geq l_1 > k_1 \geq k_2$, then

- if $l_1 > l_2$, then

$$\gamma_2(c_1, c_2) = a_{l_1} b_{l_1} \quad (7.3.26)$$

- if $k_2 \geq l_1$, then

$$\gamma_2(c_1, c_2) = a_{l_1} b_{l_1} \quad (7.3.27)$$

- if $l_2 \geq l_1 > k_2 > k_1$, then

$$\gamma_2(c_1, c_2) = a_{k_1+1} b_{k_1+1}. \quad (7.3.28)$$

We then have the corresponding proposition

Proposition 7.3.4. *We have $\mathcal{C}_{\ell,n}(\delta_2, \gamma_2) = \mathcal{C}_{\ell,n}$.*

7.3.4 The case of Capparelli's and Meurman-Primc's identities

For $n = 2$, there is only one possibility for the functions δ and γ , having both values in $\{a_1 b_1\}$. Also, the only possible pair in the preimage of γ is $(a_0 b_1, a_1 b_0)$. The Propositions 7.3.3 and 7.3.4 are equivalent and give the identity of Capparelli.

For $n = 3$, there are possibilities for δ and γ .

- We have

$$\begin{aligned} \delta(a_0 b_1) &= \delta(a_1 b_0) = a_1 b_1 \\ \delta(a_1 b_2) &= \delta(a_2 b_1) = a_2 b_2 \\ \delta(a_0 b_2), \delta(a_2 b_0) &\in \{a_1 b_1, a_2 b_2\}. \end{aligned}$$

- We have

$$\begin{aligned} \gamma(a_0 b_1, a_1 b_0) &= \gamma(a_0 b_1, a_2 b_0) = \gamma(a_0 b_2, a_1 b_0) = a_1 b_1 \\ \gamma(a_1 b_2, a_2 b_1) &= \gamma(a_1 b_2, a_2 b_0) = \gamma(a_0 b_2, a_2 b_1) = a_2 b_2 \\ \gamma(a_0 b_2, a_2 b_0) &\in \{a_1 b_1, a_2 b_2\} \end{aligned}$$

and

$$\begin{aligned} \gamma(a_1 b_0, a_2 b_0) &= \gamma(a_1 b_0, a_2 b_1) = a_2 b_2 \\ \gamma(a_2 b_1, a_2 b_0) &= \gamma(a_2 b_1, a_1 b_0) = a_1 b_1 \\ \gamma(a_1 b_2, a_0 b_1) &= \gamma(a_0 b_2, a_0 b_1) = a_2 b_2 \\ \gamma(a_0 b_1, a_1 b_2) &= \gamma(a_0 b_2, a_1 b_2) = a_1 b_1. \end{aligned}$$

The functions δ_1 and γ_1 then correspond to the choice

$$\delta(a_0 b_2) = \delta(a_2 b_0) = \gamma(a_0 b_2, a_2 b_0) = a_1 b_1$$

and we obtain the forbidden pattern

$$(p+1)_{a_1 b_0}, p_{a_2 b_2}, p_{a_2 b_0} \text{ and } (p+1)_{a_0 b_2} (p+1)_{a_2 b_2} p_{a_0 b_1}.$$

This is the case 8×8 given by Meurman-Primc.

The functions δ_2 and γ_2 then correspond to the choice

$$\delta(a_0 b_2) = \delta(a_2 b_0) = \gamma(a_0 b_2, a_2 b_0) = a_2 b_2$$

and we obtain the forbidden pattern

$$(p+1)_{a_2 b_1}, p_{a_1 b_1}, p_{a_2 b_0} \text{ and } (p+1)_{a_0 b_2} (p+1)_{a_1 b_1} p_{a_1 b_2}.$$

Part III

Rogers-Ramanujan type identities via representations of affine Lie algebras

Chapter 8

Perfect crystals and multi-grounded partitions

In this chapter, we present the connection between the theory of perfect crystals and the notion of multi-grounded partitions.

In Section 8.1, we first introduce the fundamentals of crystal base theory, and present the main tool that allows us to make a connection with the theory of integer partitions, namely the $(KMN)^2$ character formula. Then, in Section 8.2, we discuss a special case of the connection, related to the grounded partitions. Finally, in Section 8.3, we give the general results that link the perfect crystals to the multi-grounded partitions.

8.1 Basics on Crystals

In this section, we recall the definitions and basic theorems from crystal base theory which are necessary for our purpose. We refer to the book (Hong and Kang, 2002), which we consider to be a good summary of the basic theory of Kac-Moody algebras (Hong and Kang, 2002, Chapter 2), quantum groups (Hong and Kang, 2002, Chapter 3) and crystal bases (Hong and Kang, 2002, Chapters 4, 10). For a more combinatorial approach and more emphasis on the finite dimensional case, we refer the reader to (Bump and Schilling, 2017).

Throughout this section, n is a fixed positive integer.

8.1.1 Cartan datum and quantum affine algebras

A square matrix $A = (a_{i,j})_{i,j \in \mathcal{N}}$ is said to be a generalised Cartan matrix if A has the following properties:

- for all $i \in \mathcal{N}$, $a_{i,i} = 2$,
- for all $i \neq j$ in \mathcal{N} , $a_{i,j} \in \mathbb{Z}_{\leq 0}$,
- $a_{i,j} = 0$ if and only if $a_{j,i} = 0$.

Moreover, if there exists a diagonal matrix D with positive integer coefficients such that DA is symmetric, then A is said to be symmetrisable. In addition, if the rank of the matrix A is $n - 1$, then A is said to be of affine type. In this paper, we always assume that this is the case.

Let us consider such a matrix A . Let P^\vee be a free abelian group of rank $n + 1$ with \mathbb{Z} -basis $\{h_0, \dots, h_{n-1}, d\}$:

$$P^\vee = \mathbb{Z}h_0 \oplus \mathbb{Z}h_1 \oplus \dots \oplus \mathbb{Z}h_{n-1} \oplus \mathbb{Z}d.$$

We call P^\vee the *dual weight lattice*. The complexification $\mathfrak{h} = \mathbb{C} \otimes_{\mathbb{Z}} P^\vee$ is called the *Cartan subalgebra*. The linear functions α_i and Λ_i ($i \in \mathcal{N}$) on \mathfrak{h} given by

$$\begin{aligned} \langle h_j, \alpha_i \rangle &:= \alpha_i(h_j) = a_{j,i} & \langle d, \alpha_i \rangle &:= \alpha_i(d) = \delta_{i,0} \\ \langle h_j, \Lambda_i \rangle &:= \Lambda_i(h_j) = \delta_{i,j} & \langle d, \Lambda_i \rangle &:= \Lambda_i(d) = 0 \end{aligned} \quad (i, j \in \mathcal{N}) \quad (8.1.1)$$

are respectively the *simple roots* and *fundamental weights*. Let \mathfrak{h}^* be the dual space of \mathfrak{h} . We denote by $\Pi = \{\alpha_i \mid i \in \mathcal{N}\} \subset \mathfrak{h}^*$ the set of simple roots, and define $\Pi^\vee = \{\Lambda_i \mid i \in \mathcal{N}\} \subset \mathfrak{h}$ to be the set of *simple coroots*. We also set

$$P = \{\lambda \in \mathfrak{h}^* \mid \lambda(P^\vee) \subset \mathbb{Z}\}$$

to be the *weight lattice*. It contains the set of *dominant integral weights*

$$P^+ = \{\lambda \in P \mid \lambda(h_i) \in \mathbb{Z}_{\geq 0} \text{ for all } i \in \mathcal{N}\}.$$

The quintuple $(A, \Pi, \Pi^\vee, P, P^\vee)$ is said to be a *Cartan datum* for the Cartan matrix A . The *affine Kac-Moody Lie algebra* $\widehat{\mathfrak{g}}$ attached to this datum is the Lie algebra with generators e_i, f_i ($i \in \mathcal{N}$) and $h \in P^\vee$, with the following defining relations (Hong and Kang, 2002, Definition 2.1.3):

1. $[h, h'] = 0$ for all $h, h' \in P^\vee$,
2. $[e_i, f_j] = \delta_{ij} h_j$,
3. $[h, e_i] = \alpha_i(h) e_i$ for all $h \in P^\vee$,
4. $[h, f_i] = -\alpha_i(h) f_i$ for all $h \in P^\vee$,
5. $(\text{ad } e_i)^{1-a_{ij}} e_j = (\text{ad } f_i)^{1-a_{ij}} f_j = 0$ for $i \neq j$,

where $\text{ad } x : y \mapsto [x, y]$.

We also define the *coroot lattice*

$$\bar{P}^\vee = \mathbb{Z}h_0 \oplus \mathbb{Z}h_1 \oplus \cdots \oplus \mathbb{Z}h_{n-1},$$

and its complexification $\bar{\mathfrak{h}} = \mathbb{C} \otimes_{\mathbb{Z}} \bar{P}^\vee$. The restriction of the \mathbb{Z} -submodule

$$\mathbb{Z}\Lambda_0 \oplus \mathbb{Z}\Lambda_1 \oplus \cdots \oplus \mathbb{Z}\Lambda_{n-1}$$

of P to \bar{P}^\vee is called the lattice of *classical weights* and is denoted by \bar{P} .

Remark 8.1.1. By (8.1.1), for all $j \neq 0$, we have

$$\alpha_j = \sum_{i=0}^{n-1} a_{i,j} \Lambda_i \in \bar{P}.$$

We will denote by $\bar{\alpha}_0$ the restriction of α_0 to \bar{P} .

Let $\bar{P}^+ := \sum_{i=0}^n \mathbb{Z}_{\geq 0} \Lambda_i$ denote the corresponding set of dominant weights.

The center

$$\mathbb{Z}c = \{h \in P^\vee : \langle h, \alpha_i \rangle = 0 \text{ for all } i \in \mathcal{N}\}$$

of the affine Lie algebra $\widehat{\mathfrak{g}}$ is one-dimensional and generated by the *canonical central element* c , where

$$c = c_0 h_0 + \cdots + c_{n-1} h_{n-1}.$$

The space of imaginary roots

$$\mathbb{Z}\delta = \{\lambda \in P : \langle h_i, \lambda \rangle = 0 \text{ for all } i \in \mathcal{N}\}$$

of $\widehat{\mathfrak{g}}$ is also one-dimensional, generated by the *null root* δ , where

$$\delta = d_0 \alpha_0 + d_1 \alpha_1 + \cdots + d_{n-1} \alpha_{n-1},$$

and the vector ${}^t(d_0, d_1, \dots, d_{n-1}) \in \mathbb{C}^n$ spans the kernel of the Cartan matrix A . The *level* ℓ of a dominant weight $\lambda \in P^+$ is given by the expression $\langle c, \lambda \rangle := \lambda(c) = \ell$.

For any $k \in \mathbb{Z}$ and an indeterminate q , let us set

$$[k]_q = \frac{q^k - q^{-k}}{q - q^{-1}}.$$

We also set $[0]_q! = 1$ and for $k \geq 1$, $[k]_q! = [k]_q [k-1]_q \cdots [1]_q$. For $m \geq k \geq 0$, define

$$\left\langle \begin{matrix} m \\ k \end{matrix} \right\rangle_q = \frac{[m]_q!}{[k]_q! [m-k]_q!}.$$

We now have all the definitions necessary to introduce quantum affine Lie algebras.

Definition 8.1.2. (Hong and Kang, 2002, Definition 3.1.1) The *quantum affine algebra* $U_q(\widehat{\mathfrak{g}})$ associated with the Cartan datum $(A, \Pi, \Pi^\vee, P, P^\vee)$ is the associative algebra with unit element over $\mathbb{C}(q)$ (where q is an indeterminate) with generators e_i, f_i ($i \in \mathcal{N}$) and q^h ($h \in P^\vee$), satisfying the defining relations:

- (1) $q^0 = 1, q^h q^{h'} = q^{h+h'}$ for $h, h' \in P^\vee$,
- (2) $q^h e_i q^{-h} = q^{\alpha_i(h)} e_i$ for $h \in P^\vee, i \in \mathcal{N}$,
- (3) $q^h f_i q^{-h} = q^{-\alpha_i(h)} f_i$ for $h \in P^\vee, i \in \mathcal{N}$,
- (4) $e_i f_j - f_j e_i = \delta_{i,j} \frac{K_i - K_i^{-1}}{q_i - q_i^{-1}}$ for $i, j \in \mathcal{N}$,
- (5) $\sum_{k=0}^{1-a_{i,j}} \left\langle \begin{matrix} 1-a_{i,j} \\ k \end{matrix} \right\rangle_{q_i} e_i^{1-a_{i,j}-k} e_j^k = 0$ for $i \neq j$,
- (6) $\sum_{k=0}^{1-a_{i,j}} \left\langle \begin{matrix} 1-a_{i,j} \\ k \end{matrix} \right\rangle_{q_i} f_i^{1-a_{i,j}-k} f_j^k = 0$ for $i \neq j$.

Here $q_i = q^{s_i}$ and $K_i = q^{s_i h_i}$, where $D = \text{diag}(s_i : i \in \{0, \dots, n-1\})$ is a symmetrising matrix of A .

Definition 8.1.3. The *quantum affine algebra* $U'_q(\widehat{\mathfrak{g}})$ is the subalgebra of $U_q(\widehat{\mathfrak{g}})$ generated by $e_i, f_i, K_i^{\pm 1}$ ($i \in \mathcal{N}$).

Contrary to $U_q(\widehat{\mathfrak{g}})$, the quantum affine algebra $U'_q(\widehat{\mathfrak{g}})$ admits some non-trivial finite-dimensional irreducible modules.

8.1.2 Integrable modules, highest weight modules and character formula

We are now ready to define irreducible highest weight modules and characters.

Definition 8.1.4. Let \mathfrak{g} be a Lie algebra with bracket $[\cdot, \cdot]$, and let V be a vector space. Then V is a \mathfrak{g} -module if there is a bilinear map $\mathfrak{g} \times V \rightarrow V$, denoted by $(x, v) \mapsto x \cdot v$, satisfying for all $x, y \in \mathfrak{g}$ and all $v \in V$:

$$[x, y] \cdot v = x \cdot (y \cdot v) - y \cdot (x \cdot v).$$

A subspace W of a \mathfrak{g} -module V is called a *submodule* of V if for all $x \in \mathfrak{g}, x \cdot W \subseteq W$.

A \mathfrak{g} -module V is said to be *irreducible* if its only submodules are V and 0 .

The notion of modules extends naturally from an affine Lie algebra $\widehat{\mathfrak{g}}$ to its quantum affine algebra $U_q(\widehat{\mathfrak{g}})$.

Definition 8.1.5. A $U_q(\widehat{\mathfrak{g}})$ -module M is said to be *integrable* if it satisfies the following properties:

- (a) M has a weight space decomposition: $M = \bigoplus_{\lambda \in P} M_\lambda$, where $M_\lambda = \{v \in M \mid q^h \cdot v = q^{\lambda(h)} v \text{ for all } h \in P^\vee\}$;
- (b) there are finitely many $\lambda_1, \dots, \lambda_k \in P$ such that $\text{wt}(M) \subseteq \Omega(\lambda_1) \cup \dots \cup \Omega(\lambda_k)$, where $\text{wt}(M) = \{\lambda \in P \mid M_\lambda \neq 0\}$ and $\Omega(\lambda_j) = \{\mu \in P \mid \mu \in \lambda_j + \sum_{i \in \mathcal{N}} \mathbb{Z}_{\leq 0} \alpha_i\}$;
- (c) the elements e_i and f_i act locally nilpotently on M for all $i \in \mathcal{N}$.

We denote by $\mathcal{O}_{\text{int}}^q$ the category of integrable $U_q(\widehat{\mathfrak{g}})$ -modules.

For all $\lambda \in P$, a module of *highest weight* λ is an integrable module such that:

- (a) $\text{wt}(M) \subseteq \Omega(\lambda)$;
- (b) $\dim M_\lambda = 1$;
- (b) $M = U_q(\widehat{\mathfrak{g}})M_\lambda$.

For all $\lambda \in P$, up to isomorphism, there exists a unique highest weight module which is *irreducible*. We denote by $L(\lambda)$ the *irreducible highest weight* $U_q(\widehat{\mathfrak{g}})$ -module of highest weight λ .

Definition 8.1.6. Let M be an integrable module such that $\dim M_\lambda < \infty$ for all $\lambda \in \text{wt}(M)$. The *character* of M is defined by

$$\text{ch}(M) = \sum_{\lambda \in \text{wt}(M)} \dim M_\lambda \cdot e^\lambda, \quad (8.1.2)$$

where the e^λ 's are formal basis elements of the group algebra $\mathbb{C}[\mathfrak{h}^*]$, with the multiplication defined by $e^\lambda e^\mu = e^{\lambda+\mu}$.

When M is a highest weight module of highest weight λ , its character satisfies

$$e^{-\lambda} \text{ch}(M) = \sum_{\mu \in \text{wt}(M)} \dim M_\mu \cdot e^{\mu-\lambda} \in \mathbb{Z}_{\geq 0}[[e^{-\alpha_i}, i \in \mathcal{N}]].$$

All these definitions on modules also hold in the case of the $\widehat{\mathfrak{g}}$ -modules M' , where the weight spaces are given by $M'_\lambda = \{v \in M' \mid h \cdot v = \lambda(h)v \text{ for all } h \in P^\vee\}$. Thus, looking at the generators of the weight spaces, for a fixed weight $\lambda \in P$, the *irreducible highest weight* $\widehat{\mathfrak{g}}$ -module can be identified with the *irreducible highest weight* $U_q(\widehat{\mathfrak{g}})$ -module, and we have equality of characters.

8.1.3 Crystal bases

Crystal base theory was developed independently by Kashiwara (Kashiwara, 1990) and Lusztig (Lusztig, 1990) to study the category $\mathcal{O}_{\text{int}}^q$ of integrable $U_q(\widehat{\mathfrak{g}})$ -modules. If M is a module in the category $\mathcal{O}_{\text{int}}^q$, then for each $i \in \mathcal{N}$, a weight vector $u \in M_\lambda$ can be written uniquely in the form $u = \sum_{k=0}^N f_i^{(k)} u_k$, for some $N \geq 0$ and $u_k \in M_{\lambda+k\alpha_i} \cap \ker e_i$ for all $k = 0, 1, \dots, N$, with $f_i^{(k)} = f_i^k / ([k]_{q_i}!)$. The *Kashiwara operators* \tilde{e}_i and \tilde{f}_i , for $i \in \mathcal{N}$, are then defined as follows:

$$\tilde{e}_i u = \sum_{k=1}^N f_i^{(k-1)} u_k, \quad \tilde{f}_i u = \sum_{k=0}^N f_i^{(k+1)} u_k. \quad (8.1.3)$$

Crystal bases will be seen as bases at $q = 0$. To do so, let us define the *localisation* of $\mathbb{C}[q]$ at $q = 0$ by $\mathbb{A}_0 = \{f = g/h \mid g, h \in \mathbb{C}[q], h(0) \neq 0\}$.

Definition 8.1.7. (Hong and Kang, 2002, Definition 4.2.2) Assume that M is a $U_q(\widehat{\mathfrak{g}})$ -module in the category $\mathcal{O}_{\text{int}}^q$. A free \mathbb{A}_0 -submodule \mathcal{L} of M is a *crystal lattice* if

- (i) \mathcal{L} generates M as a vector space over $\mathbb{C}(q)$;
- (ii) $\mathcal{L} = \bigoplus_{\lambda \in P} \mathcal{L}_\lambda$ where $\mathcal{L}_\lambda = M_\lambda \cap \mathcal{L}$;
- (iii) $\tilde{e}_i \mathcal{L} \subset \mathcal{L}$ and $\tilde{f}_i \mathcal{L} \subset \mathcal{L}$, for all $i \in \mathcal{N}$.

Since the operators \tilde{e}_i and \tilde{f}_i preserve the lattice \mathcal{L} , they also define operators on the quotient $\mathcal{L}/q\mathcal{L}$.

Definition 8.1.8. (Hong and Kang, 2002, Definition 4.2.3) A *crystal base* for a $U_q(\widehat{\mathfrak{g}})$ -module $M \in \mathcal{O}_{\text{int}}^q$ is a pair $(\mathcal{L}, \mathcal{B})$ such that

- (1) \mathcal{L} is a crystal lattice of M ;
- (2) \mathcal{B} is a \mathbb{C} -basis of $\mathcal{L}/q\mathcal{L} \cong \mathbb{C} \otimes_{\mathbb{A}_0} \mathcal{L}$;
- (3) $\mathcal{B} = \sqcup_{\lambda \in P} \mathcal{B}_\lambda$, where $\mathcal{B}_\lambda = \mathcal{B} \cap (\mathcal{L}_\lambda / q\mathcal{L}_\lambda)$;
- (4) $\tilde{e}_i \mathcal{B}_\lambda \subset \mathcal{B}_{\lambda+\alpha_i} \cup \{0\}$ and $\tilde{f}_i \mathcal{B}_\lambda \subset \mathcal{B}_{\lambda-\alpha_i} \cup \{0\}$ for all $i \in \mathcal{N}$;
- (5) $\tilde{f}_i b = b'$ if and only if $b = \tilde{e}_i b'$, for $b, b' \in \mathcal{B}$ and $i \in \mathcal{N}$.

To each module $M \in \mathcal{O}_{\text{int}}^q$, we can associate a corresponding crystal base $(\mathcal{L}, \mathcal{B})$. Furthermore, the *crystal graph* associated to $(\mathcal{L}, \mathcal{B})$ can be defined as follows. The set of vertices is \mathcal{B} , and the oriented edges are built as follows:

$$b \xrightarrow{i} b' \quad \text{if and only if} \quad \tilde{f}_i b = b' \quad (\text{or equivalently } \tilde{e}_i b' = b).$$

Remark 8.1.9. When $\tilde{f}_i b = 0$ (resp. $\tilde{e}_i b = 0$), then there is no edge labelled i coming out of b (resp. arriving in b).

The crystal graph can be viewed as combinatorial data of the module M .

For $i \in \mathcal{N}$, let us define functions $\varepsilon_i, \varphi_i : \mathcal{B} \rightarrow \mathbb{Z}$ as follows:

$$\begin{aligned}\varepsilon_i(b) &= \max\{k \geq 0 \mid \tilde{e}_i^k b \in \mathcal{B}\}, \\ \varphi_i(b) &= \max\{k \geq 0 \mid \tilde{f}_i^k b \in \mathcal{B}\}.\end{aligned}$$

In other words, $\varepsilon_i(b)$ is the length of the longest chain of i -arrows ending at b in the crystal graph, and $\varphi_i(b)$ is the length of the longest chain of i -arrows starting from b . Furthermore, we have $\varphi_i(b) - \varepsilon_i(b) = \lambda(h_i)$ for all $b \in \mathcal{B}_\lambda$. Thus, by setting $\text{wt}b = \lambda$,

$$\varepsilon(b) = \sum_{i=0}^{n-1} \varepsilon_i(b) \Lambda_i, \quad \text{and} \quad \varphi(b) = \sum_{i=0}^{n-1} \varphi_i(b) \Lambda_i, \quad (8.1.4)$$

we then have $\overline{\text{wt}}b = \varphi(b) - \varepsilon(b)$ for all $b \in \mathcal{B}_\lambda$, where $\overline{\text{wt}}b$ is the projection of $\text{wt}b$ on \overline{P} . Also, by the definition of the weight vectors u_k in the Kashiwara operators (8.1.3), we have for all $b \in \mathcal{B}$ such that $\tilde{e}_i b \neq 0$,

$$\text{wt}\tilde{e}_i b - \text{wt}b = \alpha_i. \quad (8.1.5)$$

Let us now introduce the notion of a crystal.

Definition 8.1.10. (Hong and Kang, 2002, Definition 4.5.1) Let $A = (a_{i,j})_{0 \leq i,j \leq n-1}$ be a Cartan matrix with associated *Cartan datum* $(A, \Pi, \Pi^\vee, P, P^\vee)$. A *crystal* associated with $(A, \Pi, \Pi^\vee, P, P^\vee)$ is a set \mathcal{B} together with maps

$$\begin{aligned}\text{wt} : \mathcal{B} &\longrightarrow P, \\ \tilde{e}_i, \tilde{f}_i : \mathcal{B} &\longrightarrow \mathcal{B} \cup \{0\} \quad (i \in \mathcal{N}), \\ \varepsilon_i, \varphi_i : \mathcal{B} &\longrightarrow \mathbb{Z} \cup \{-\infty\} \quad (i \in \mathcal{N}),\end{aligned}$$

satisfying the following properties for all $i \in \mathcal{N}$:

1. $\varphi_i(b) = \varepsilon_i(b) + \langle h_i, \text{wt}(b) \rangle$,
2. $\text{wt}(\tilde{e}_i b) = \text{wt}b + \alpha_i$ if $\tilde{e}_i b \in \mathcal{B}$,
3. $\text{wt}(\tilde{f}_i b) = \text{wt}b - \alpha_i$ if $\tilde{f}_i b \in \mathcal{B}$,
4. $\varepsilon_i(\tilde{e}_i b) = \varepsilon_i(b) - 1$ if $\tilde{e}_i b \in \mathcal{B}$,
5. $\varphi_i(\tilde{e}_i b) = \varphi_i(b) + 1$ if $\tilde{e}_i b \in \mathcal{B}$,
6. $\varepsilon_i(\tilde{f}_i b) = \varepsilon_i(b) + 1$ if $\tilde{f}_i b \in \mathcal{B}$,
7. $\varphi_i(\tilde{f}_i b) = \varphi_i(b) - 1$ if $\tilde{f}_i b \in \mathcal{B}$,
8. $\tilde{f}_i b = b'$ if and only if $b = \tilde{e}_i b'$ for $b, b' \in \mathcal{B}$,
9. if $\varphi_i(b) = -\infty$ for $b \in \mathcal{B}$, then $\tilde{e}_i b = \tilde{f}_i b = 0$.

In particular, if $(\mathcal{L}, \mathcal{B})$ is a crystal base, then \mathcal{B} is a crystal.

Let \mathcal{B}_1 and \mathcal{B}_2 be two crystals. A *crystal morphism* between \mathcal{B}_1 and \mathcal{B}_2 is a map $\Psi : \mathcal{B}_1 \cup \{0\} \rightarrow \mathcal{B}_2 \cup \{0\}$ such that

- $\Psi(0) = 0$;
- Ψ commutes with $\text{wt}, \varepsilon_i, \varphi_i$ for all $i \in \mathcal{N}$;
- for $b, b' \in \mathcal{B}_1$ such that $\tilde{f}_i b = b'$ and $\Psi(b), \Psi(b') \in \mathcal{B}_2$, we have $\tilde{f}_i \Psi(b) = \Psi(b')$, $\tilde{e}_i \Psi(b') = \Psi(b)$.

A morphism Ψ is said to be *strict* if it commutes with \tilde{e}_i, \tilde{f}_i for all $i \in \mathcal{N}$.

The theory of crystal bases behaves very nicely with respect to the tensor product of $\mathcal{O}_{\text{int}}^q$ -modules, as can be seen in the next theorem.

All the theorems in this section are due to Kang, Kashiwara, Misra, Miwa, Nakashima, and Nakayashiki, but we give references to the book (Hong and Kang, 2002) for the reader's convenience. Let us start by defining perfect crystals.

Definition 8.1.13. (Hong and Kang, 2002, Definition 10.5.1) For a positive integer ℓ , a finite classical crystal \mathcal{B} is said to be a *perfect crystal of level ℓ* for the quantum affine algebra $U_q(\widehat{\mathfrak{g}})$ if

- (1) there is a finite-dimensional $U'_q(\widehat{\mathfrak{g}})$ -module with a crystal base whose crystal graph is isomorphic to \mathcal{B} (when the 0-arrows are removed);
- (2) $\mathcal{B} \otimes \mathcal{B}$ is connected;
- (3) there exists a classical weight λ_0 such that

$$\text{wt}(\mathcal{B}) \subset \lambda_0 + \frac{1}{d_0} \sum_{i \neq 0} \mathbb{Z}_{\leq 0} \alpha_i \quad \text{and} \quad |\mathcal{B}_{\lambda_0}| = 1;$$

- (4) for any $b \in \mathcal{B}$, we have

$$\langle c, \varepsilon(b) \rangle = \sum_{i=0}^{n-1} \varepsilon_i(b) \Lambda_i(c) \geq \ell;$$

- (5) for each $\lambda \in \bar{P}_\ell^+ := \{\mu \in \bar{P}^+ \mid \langle c, \mu \rangle = \ell\}$, there exist unique vectors b^λ and b_λ in \mathcal{B} such that $\varepsilon(b^\lambda) = \lambda$ and $\varphi(b_\lambda) = \lambda$.

In the remainder of this section, we fix a perfect crystal \mathcal{B} .

The maps $\lambda \mapsto \varepsilon(b_\lambda)$ and $\lambda \mapsto \varphi(b^\lambda)$ then define two bijections on \bar{P}_ℓ^+ .

As a consequence of the last condition, for any $\lambda \in \bar{P}_\ell^+$, the vertex operator theory (Hong and Kang, 2002, (10.4.4)) leads to a natural crystal isomorphism

$$\begin{aligned} \mathcal{B}(\lambda) &\xrightarrow{\sim} \mathcal{B}(\varepsilon(b_\lambda)) \otimes \mathcal{B} \\ u_\lambda &\mapsto u_{\varepsilon(b_\lambda)} \otimes b_\lambda. \end{aligned} \tag{8.1.9}$$

Definition 8.1.14. For $\lambda \in \bar{P}_\ell^+$, the *ground state path of weight λ* is the tensor product

$$\mathfrak{p}_\lambda = (g_k)_{k=0}^\infty = \cdots \otimes g_{k+1} \otimes g_k \otimes \cdots \otimes g_1 \otimes g_0,$$

where the elements $g_k \in \mathcal{B}$ are such that

$$\begin{aligned} \lambda_0 &= \lambda & g_0 &= b_\lambda \\ \lambda_{k+1} &= \varepsilon(b_{\lambda_k}) & g_{k+1} &= b_{\lambda_{k+1}} \end{aligned} \quad \text{for all } k \geq 0. \tag{8.1.10}$$

A tensor product $\mathfrak{p} = (p_k)_{k=0}^\infty = \cdots \otimes p_{k+1} \otimes p_k \otimes \cdots \otimes p_1 \otimes p_0$ of elements $p_k \in \mathcal{B}$ is said to be a λ -*path* if $p_k = g_k$ for k large enough.

Iterating the isomorphism (8.1.9), we obtain

$$\begin{aligned} \mathcal{B}(\lambda) &\xrightarrow{\sim} \mathcal{B}(\lambda_1) \otimes \mathcal{B} \xrightarrow{\sim} \mathcal{B}(\lambda_2) \otimes \mathcal{B} \otimes \mathcal{B} \xrightarrow{\sim} \cdots \\ u_\lambda &\mapsto u_{\lambda_1} \otimes g_0 \mapsto u_{\lambda_2} \otimes g_1 \otimes g_0 \mapsto \cdots, \end{aligned}$$

and this gives a natural bijection, stated in the next theorem.

Theorem 8.1.15. (Hong and Kang, 2002, Theorem 10.6.4) Let $\lambda \in \bar{P}_\ell^+$. Then there is a crystal isomorphism

$$\begin{aligned} \mathcal{B}(\lambda) &\xrightarrow{\sim} \mathcal{P}(\lambda) \\ u_\lambda &\mapsto \mathfrak{p}_\lambda \end{aligned}$$

between the crystal base $\mathcal{B}(\lambda)$ of $L(\lambda)$ and the set $\mathcal{P}(\lambda)$ of λ -paths.

We describe the crystal structure of $\mathcal{P}(\lambda)$ as follows (Hong and Kang, 2002, (10.48)). For any $\mathfrak{p} = (p_k)_{k=0}^\infty \in \mathcal{P}(\lambda)$, let $N \geq 0$ be the smallest integer such that $p_k = g_k$ for all $k \geq N$. We then set

$$\overline{\text{wtp}} = \lambda_N + \sum_{k=0}^{N-1} \overline{\text{wtp}}_k,$$

$$\begin{aligned}
\tilde{e}_i \mathbf{p} &= \cdots \otimes g_{N+1} \otimes \tilde{e}_i (g_N \otimes \cdots \otimes p_0), \\
\tilde{f}_i \mathbf{p} &= \cdots \otimes g_{N+1} \otimes \tilde{f}_i (g_N \otimes \cdots \otimes p_0), \\
\varepsilon_i(\mathbf{p}) &= \max(\varepsilon_i(\mathbf{p}') - \varphi_i(g_N), 0), \\
\varphi_i(\mathbf{p}) &= \varphi_i(\mathbf{p}') + \max(\varphi_i(g_N) - \varepsilon_i(\mathbf{p}'), 0),
\end{aligned}$$

where $\mathbf{p}' := p_{N-1} \otimes \cdots \otimes p_1 \otimes p_0$, and $\overline{\text{wt}}$ is viewed as the classical weight of an element of \mathcal{B} or $\mathcal{P}(\lambda)$.

The explicit expression for the affine weight $\text{wt} \mathbf{p}$ in P is given in the following theorem, which is known as the (KMN)² crystal base character formula, and plays a key role in connecting characters with partition generating functions.

Theorem 8.1.16. (Hong and Kang, 2002, Theorem 10.6.7) Let $\lambda \in \bar{P}_\ell^+$, let H be an energy function on $\mathcal{B} \otimes \mathcal{B}$, and let $\mathbf{p} = (p_k)_{k=0}^\infty \in \mathcal{P}(\lambda)$. Then the weight of \mathbf{p} and the character of the irreducible highest weight $U_q(\widehat{\mathfrak{g}})$ -module $L(\lambda)$ are given by the following expressions:

$$\begin{aligned}
\text{wt} \mathbf{p} &= \lambda + \sum_{k=0}^{\infty} (\overline{\text{wt}} p_k - \overline{\text{wt}} g_k) - \left(\sum_{k=0}^{\infty} (k+1) (H(p_{k+1} \otimes p_k) - H(g_{k+1} \otimes g_k)) \right) \frac{\delta}{d_0}, \\
&= \lambda + \sum_{k=0}^{\infty} (\overline{\text{wt}} p_k - \overline{\text{wt}} g_k) - \left(\sum_{l=k}^{\infty} (H(p_{l+1} \otimes p_l) - H(g_{l+1} \otimes g_l)) \right) \delta, \tag{8.1.11}
\end{aligned}$$

$$\text{ch}(L(\lambda)) = \sum_{\mathbf{p} \in \mathcal{P}(\lambda)} e^{\overline{\text{wt}} \mathbf{p}}. \tag{8.1.12}$$

8.2 Perfect crystals and grounded partitions

Let \mathcal{B} be a perfect crystal of level ℓ . A specialisation of Theorem 8.1.16 gives the following corollary.

Corollary 8.2.1. Suppose that Λ is such that $b_\Lambda = b^\Lambda = g$, and set $H(g \otimes g) = 0$. Then $\overline{\text{wt}} g = 0$, $g_k = g$ for all $k \in \mathbb{Z}_{\geq 0}$, and we have

$$\text{wt} \mathbf{p} = \lambda + \sum_{k=0}^{\infty} \overline{\text{wt}} p_k - \left(\sum_{l=k}^{\infty} H(p_{l+1} \otimes p_l) \right) \frac{\delta}{d_0}. \tag{8.2.1}$$

In the remainder of this section, we make the connection between grounded partitions and crystal base theory. Let us fix a weight $\Lambda \in \bar{P}_\ell^+$ such that $b_\Lambda = b^\Lambda = g$, and assume that $H(g \otimes g) = 0$. Let $\mathcal{C}_\mathcal{B} = \{c_b : b \in \mathcal{B}\}$ be the set of colours indexed by \mathcal{B} . We define the binary relation \succ on $\mathbb{Z}_{\mathcal{C}_\mathcal{B}}$ by

$$k_{c_b} \succ k'_{c_{b'}} \text{ if and only if } k - k' = H(b' \otimes b). \tag{8.2.2}$$

This relation leads to the following.

Proposition 8.2.2. Let ϕ be the map between λ -paths and grounded partitions defined as follows:

$$\phi : \mathbf{p} \mapsto (\pi_0, \dots, \pi_{s-1}, 0_{c_g}),$$

where $\mathbf{p} = (p_k)_{k \geq 0}$ is a Λ -path in $\mathcal{P}(\Lambda)$, $s \geq 0$ is the unique non-negative integer such that $p_{s-1} \neq g$ and $p_k = g$ for all $k \geq s$, and for all $k \in \{1, \dots, s-1\}$, the part π_k has colour c_{p_k} and size

$$\sum_{l=k}^{s-1} H(p_{l+1} \otimes p_l).$$

Then ϕ is a bijection between $\mathcal{P}(\Lambda)$ and $\mathcal{P}_{c_g}^{\succ}$. Furthermore, by taking $c_b = e^{\overline{\text{wt}} b}$, we have for all $\pi \in \mathcal{P}_{c_g}^{\succ}$,

$$e^{-\Lambda + \overline{\text{wt}}(\phi^{-1}(\pi))} = C(\pi) e^{-\frac{\delta |\pi|}{d_0}}. \tag{8.2.3}$$

The bijective proof of the above proposition is given in Appendix A.4.2.

The next proposition allows us to describe the set $\mathcal{P}_{c_g}^{\succ\succ}$ of grounded partitions for the relation $\succ\supseteq$ defined by

$$k_{c_b} \succ\supseteq k'_{c_{b'}} \text{ if and only if } k - k' \geq H(b' \otimes b). \tag{8.2.4}$$

We refer to this relation as the *minimal difference conditions*. One can view the partitions of $\mathcal{P}_{c_g}^{\gg}$ as the partitions of $\mathcal{P}_{c_g}^{\gg\gg}$ such that the differences between consecutive parts are minimal. Note that contrarily to $\mathcal{P}_{c_g}^{\gg}$, the set $\mathcal{P}_{c_g}^{\gg\gg}$ has some partitions $\pi = (\pi_0, \dots, \pi_{s-1}, 0_{c_g})$ such that $c(\pi_{s-1}) = c_g$. For this reason, the set $\mathcal{P}_{c_g}^{\gg}$ is not exactly the set of all minimal partitions of $\mathcal{P}_{c_g}^{\gg\gg}$, but is related to it.

Proposition 8.2.3. *Recall that \mathcal{P}_{c_g} is the set of grounded partitions where all parts have colour c_g . There is a bijection Φ between $\mathcal{P}_{c_g}^{\gg\gg}$ and $\mathcal{P}_{c_g}^{\gg} \times \mathcal{P}_{c_g}$, such that if $\Phi(\pi) = (\mu, \nu)$, then $|\pi| = |\mu| + |\nu|$, and by setting $c_g = 1$, we have $C(\pi) = C(\mu)$.*

A proof of the above proposition can be found in Appendix A.4.3.

We are now able to give a character formula in terms of generating functions for grounded partitions.

Theorem 8.2.4. *Setting $q = e^{-\delta/d_0}$ and $c_b = e^{\overline{\text{wt}}b}$ for all $b \in \mathcal{B}$, we have $c_g = 1$, and the character of the irreducible highest weight $U_q(\widehat{\mathfrak{g}})$ -module $L(\Lambda)$ is given by the following expressions:*

$$\begin{aligned} \sum_{\pi \in \mathcal{P}_{c_g}^{\gg\gg}} C(\pi)q^{|\pi|} &= e^{-\Lambda} \text{ch}(L(\Lambda)), \\ \sum_{\pi \in \mathcal{P}_{c_g}^{\gg\gg}} C(\pi)q^{|\pi|} &= \frac{e^{-\Lambda} \text{ch}(L(\Lambda))}{(q; q)_{\infty}}. \end{aligned}$$

Proof. By Proposition 8.2.2 and (8.2.1),

$$\sum_{\pi \in \mathcal{P}_{c_g}^{\gg\gg}} C(\pi)q^{|\pi|} = \sum_{\mathfrak{p} \in \mathcal{P}(\lambda)} e^{-\Lambda} e^{\text{wt}\mathfrak{p}} = e^{-\Lambda} \text{ch}(L(\Lambda)).$$

By Corollary 8.2.1, $\overline{\text{wt}}g = 0$. Thus $c_g = e^0 = 1$, and Proposition 8.2.3 yields

$$\sum_{\pi \in \mathcal{P}_{c_g}^{\gg\gg}} C(\pi)q^{|\pi|} = \frac{1}{(q; q)_{\infty}} \sum_{\pi \in \mathcal{P}_{c_g}^{\gg\gg}} C(\pi)q^{|\pi|} = \frac{e^{-\Lambda} \text{ch}(L(\Lambda))}{(q; q)_{\infty}}. \quad \square$$

By this theorem, the characters of some irreducible highest weight modules of level ℓ can be computed as the generating functions of some grounded partitions, in the very special case where the ground state path of Λ is reduced to a constant sequence. In general, we can always reach this case by considering, for any perfect crystal \mathcal{B} , the tensor product of $\mathbb{B} = \mathcal{B} \otimes \mathcal{B}^{\vee}$, where \mathcal{B}^{\vee} is the dual of \mathcal{B} . However, it is not always easy to compute an energy function for $\mathbb{B} \otimes \mathbb{B}$ knowing an energy function of $\mathcal{B} \otimes \mathcal{B}$. We then use in the next section the notion of multi-grounded partitions, that will allow us to deal with the case where the ground state path is not a constant sequence.

8.3 Multi-grounded partitions

Let \mathcal{B} be a perfect crystal of level ℓ , and let $\Lambda \in \bar{P}_{\ell}^+$ be a level ℓ dominant classical weight such that the corresponding ground state path is $\mathfrak{p}_{\Lambda} = (g_k)_{k \geq 0}$. By (8.1.10), since P_{ℓ} has a finite cardinality, the sequence $(g_i)_{i \geq 0}$ is then periodic. We then set t to be the smallest non-negative integer k such that $g_k = g_0$. This yields the following:

$$\begin{aligned} \sum_{k=0}^{t-1} \overline{\text{wt}}(g_k) &= \sum_{k=0}^{t-1} \varphi(g_k) - \varepsilon(g_k) \\ &= \sum_{k=0}^{t-1} \varphi(g_k) - \varphi(g_{k+1}) && \text{by (8.1.10)} \\ &= \varphi(g_0) - \varphi(g_t) \\ &= 0 \end{aligned} \tag{8.3.1}$$

Let H be an energy function on $\mathcal{B} \otimes \mathcal{B}$. Since $\mathcal{B} \otimes \mathcal{B}$ is connected, H is then unique up to a constant. We then define the function H_{Λ} on $\mathcal{B} \otimes \mathcal{B}$ satisfying

$$H_{\Lambda}(b \otimes b') = H(b \otimes b') - \frac{1}{t} \sum_{k=0}^{t-1} H(g_{k+1} \otimes g_k) \tag{8.3.2}$$

for all $b, b' \in \mathcal{B}$, which does not depend of the choice of H . We observe that H_Λ is the unique function on $\mathcal{B} \otimes \mathcal{B}$ which satisfies (8.1.8) the conditions of energy functions and such that

$$\sum_{k=0}^{t-1} H_\Lambda(g_{k+1} \otimes g_k) = 0. \quad (8.3.3)$$

However, the function H_Λ is not an energy function unless t divides $\sum_{k=0}^{t-1} H(g_{k+1} \otimes g_k)$ for any energy function H . Besides, we always have that $H_\Lambda(\mathcal{B} \otimes \mathcal{B}) \subset \mathbb{Z} \in \frac{1}{t}\mathbb{Z}$. In the particular case when $t = 1$, H_Λ is then the unique energy function that satisfies $H_\Lambda(g_0 \otimes g_0) = 0$.

Let us now take any Λ -path $\mathfrak{p} = (p_k)_{k \geq 0}$ in $\mathcal{P}(\Lambda)$ different from the ground state path \mathfrak{p}_Λ . There then exists a unique positive integer m such that

$$\begin{aligned} (p_{(m-1)t}, \dots, p_{mt-1}) &= (g_0, \dots, g_{t-1}) \\ (p_{m't}, \dots, p_{m't+t-1}) &\neq (g_0, \dots, g_{t-1}) \end{aligned} \quad \text{for all } m' \geq m.$$

Lemma 8.3.1. *The weight $\overline{\text{wt}}(\mathfrak{p})$ of \mathfrak{p} is given by the following formula:*

$$\overline{\text{wt}}(\mathfrak{p}) = \Lambda + \sum_{k=0}^{mt-1} \overline{\text{wt}}(p_k) - \frac{\delta}{d_0} \left(-\frac{1}{t} \sum_{l=0}^{t-1} (l+1) H_\Lambda(g_{l+1} \otimes g_l) + \sum_{l=k}^{mt-1} H_\Lambda(p_{l+1} \otimes p_l) \right). \quad (8.3.4)$$

A proof of the above lemma can be found in Appendix A.4.1. Note that for any energy function H , we always have

$$\sum_{k=0}^{t-1} (k+1) H_\Lambda(g_{k+1} \otimes g_k) = \sum_{k=0}^{t-1} (k+1) H(g_{k+1} \otimes g_k) - \frac{t+1}{2} \sum_{k=0}^{t-1} H(g_{k+1} \otimes g_k) \in \frac{1}{2}\mathbb{Z}.$$

The above number is an integer as soon as t is odd, and is equal to 0 when $t = 1$. We can then choose a suitable divisor D of $2^{\chi(t \text{ even})} t$ such that $DH_\Lambda(\mathcal{B} \otimes \mathcal{B}) \subset \mathbb{Z}$ and $\frac{1}{t} \sum_{k=0}^{t-1} (k+1) DH_\Lambda(g_{k+1} \otimes g_k) \in \mathbb{Z}$. For the particular case $t = 1$, we can choose $D = 1$.

Let us consider the set of color $\mathcal{C}_\mathcal{B}$ with indices in \mathcal{B} , and let us define the relation \succ on $\mathbb{Z}_{\mathcal{C}_\mathcal{B}}$ by

$$k_{c_b} \succ k'_{c_{b'}} \iff k - l = DH_\Lambda(b' \otimes b). \quad (8.3.5)$$

By taking

$$u^{(k)} = -\frac{1}{t} \sum_{l=0}^{t-1} (l+1) DH_\Lambda(g_{l+1} \otimes g_l) + \sum_{l=k}^{t-1} DH_\Lambda(g_{l+1} \otimes g_l), \quad (8.3.6)$$

the colors $c_{g_0}, \dots, c_{g_{t-1}}$ and the colored integers $u_{c_{g_0}}^{(0)}, \dots, u_{c_{g_{t-1}}}^{(t-1)}$ satisfy the condition in Definition 2.1.22. We can then define the multi-grounded partition with grounds $c_{g_0}, \dots, c_{g_{t-1}}$ and relation \succ . We denote by $\mathcal{P}_{c_{g_0} \dots c_{g_{t-1}}}^\succ$ the set of all such partitions. We then obtain the following proposition, whose proof is given in Appendix A.4.4.

Proposition 8.3.2. *Let us define the map ϕ from $\mathcal{P}(\Lambda)$ to $\mathcal{P}_{c_{g_0} \dots c_{g_{t-1}}}^\succ$, such that $\phi(\mathfrak{p}_\Lambda) = (u_{c_{g_0}}^{(0)}, \dots, u_{c_{g_{t-1}}}^{(t-1)})$, and for all $\mathfrak{p}_\Lambda \neq \mathfrak{p} \in \mathcal{P}(\Lambda)$ and m defined above,*

$$\mathfrak{p} \mapsto (\pi_0, \dots, \pi_{mt-1}, u_{c_{g_0}}^{(0)}, \dots, u_{c_{g_{t-1}}}^{(t-1)})$$

with $c(\pi_k) = c_{p_k}$ and

$$\pi_k = -\frac{1}{t} \sum_{l=0}^{t-1} (l+1) DH_\Lambda(g_{l+1} \otimes g_l) + \sum_{l=k}^{mt-1} DH_\Lambda(p_{k+1} \otimes p_k),$$

for all $k \in \{0, \dots, mt-1\}$. Then, ϕ defines a bijection between $\mathcal{P}(\Lambda)$ and the set ${}_t\mathcal{P}_{c_{g_0} \dots c_{g_{t-1}}}^\succ$ of partitions of $\mathcal{P}_{c_{g_0} \dots c_{g_{t-1}}}^\succ$ with the number of parts divisible t . Furthermore, by setting $c_b = e^{\overline{\text{wt}}(b)}$ for all $b \in \mathcal{B}$, we have for all $\pi \in {}_t\mathcal{P}_{c_{g_0} \dots c_{g_{t-1}}}^\succ$

$$e^{-\Lambda + \overline{\text{wt}}(\phi^{-1}(\pi))} = C(\pi) e^{-\frac{\delta|\pi|}{d_0 D}}. \quad (8.3.7)$$

We now define another set of multi-grounded partitions. Let \gg be the relation of $\mathcal{Z}_{\mathcal{C}_B}$ defined by

$$k_{c_b} \gg k'_{c_{b'}} \iff k - l \geq DH_{\Lambda}(b' \otimes b). \quad (8.3.8)$$

Here again, for

$$u^{(k)} = -\frac{1}{t} \sum_{l=0}^{t-1} (l+1) DH_{\Lambda}(g_{l+1} \otimes g_l) + \sum_{l=k}^{t-1} DH_{\Lambda}(g_{l+1} \otimes g_l),$$

the colors $c_{g_0}, \dots, c_{g_{t-1}}$ and the colored integers $u_{c_{g_0}}^{(0)}, \dots, u_{c_{g_{t-1}}}^{(t-1)}$ satisfy the condition in Definition 2.1.22. In fact, the choice of the integers $u^{(0)}, \dots, u^{(t-1)}$ is unique, as they must satisfy both conditions

$$\begin{aligned} 0 &= u^{(0)} - u^{(1)} + u^{(1)} - u^{(2)} + \dots + u^{(t-2)} - u^{(t-1)} + u^{(t-1)} - u^{(0)} \\ &\geq DH_{\Lambda}(g_1 \otimes g_0) + DH_{\Lambda}(g_2 \otimes g_1) + \dots + DH_{\Lambda}(g_{t-1} \otimes g_{t-2}) + DH_{\Lambda}(g_t \otimes g_{t-1}) \\ &= 0 \end{aligned}$$

and

$$\begin{aligned} 0 &= u^{(0)} + \dots + u^{(t-1)} \\ &= u^{(0)} - u^{(1)} + 2(u^{(1)} - u^{(2)}) + \dots + t(u^{(t-1)} - u^{(0)}) + tu^{(0)}. \end{aligned}$$

This implies that $u^{(k)} - u^{(k+1)} = DH_{\Lambda}(g_{k+1} \otimes g_k)$ for all $k \in \{0, \dots, t-1\}$ (with the convention $u^{(0)} = u^{(t)}$) and that

$$u^{(0)} = -\frac{1}{t} \sum_{l=0}^{t-1} (l+1) DH_{\Lambda}(g_{l+1} \otimes g_l).$$

We then define the set $\mathcal{P}_{c_{g_0} \dots c_{g_{t-1}}}^{\gg}$ of the multi-grounded partitions with grounds g_0, \dots, g_{t-1} and the relation \gg defined in (2.3.3). In particular for any positive integer d , we denote by ${}^d\mathcal{P}_{c_{g_0} \dots c_{g_{t-1}}}^{\gg}$ the set of the partitions $\pi = (\pi_0, \dots, \pi_{s-1}, u_{c_{g_0}}^{(0)}, \dots, u_{c_{g_{t-1}}}^{(t-1)})$ of $\mathcal{P}_{c_{g_0} \dots c_{g_{t-1}}}^{\gg}$ with $c(\pi_k) = c_{p_k}$ for all $k \in \{0, \dots, s-1\}$, such that

$$\pi_k - \pi_{k+1} - DH_{\Lambda}(g_{k+1} \otimes g_k) \in d\mathbb{Z}_{\geq 0}, \quad (8.3.9)$$

where we set π_s to be $u_{c_{g_0}}^{(0)}$. We finally set ${}^d\mathcal{P}_{c_{g_0} \dots c_{g_{t-1}}}^{\gg}$ to be the set of partitions of ${}^d\mathcal{P}_{c_{g_0} \dots c_{g_{t-1}}}^{\gg}$ with the number of parts divisible by t . We then obtain the following proposition.

Proposition 8.3.3. *Let ${}^d\mathcal{P}$ be the set of classical partitions where all parts are divisible by d . There is a bijection Φ_d between ${}^d\mathcal{P}_{c_{g_0} \dots c_{g_{t-1}}}^{\gg}$ and ${}^d\mathcal{P}_{c_{g_0} \dots c_{g_{t-1}}}^{\gg} \times {}^d\mathcal{P}$, such that if $\Phi_d(\pi) = (\mu, \nu)$, then $|\pi| = |\mu| + |\nu|$, and by setting $c_{g_0} \dots c_{g_{t-1}} = 1$, we have $C(\pi) = C(\mu)$.*

The proof of the above proposition is given in Appendix A.4.5. This proposition, along with Theorem 8.1.16, yields Theorem 2.3.1.

We remark that we can choose $D = 1$ when $t = 1$, and Theorem 8.2.4 is then implied by Theorem 2.3.1. The use of a parameter d allows us to have a finer equality, and appears especially practical when $DH_{\Lambda}(\mathcal{B} \otimes \mathcal{B}) \in d\mathbb{Z}$, in which case the parts of our partitions have the same congruence modulo d .

Chapter 9

Level one standard modules of type

$$A_{n-1}^{(n)}$$

9.1 Perfect crystal of type $A_{n-1}^{(1)}$: tensor product of the vector representation and its dual

We now describe the perfect crystal \mathbb{B} used in Theorem 2.3.2. Throughout this section, we fix an integer $n \geq 3$.

Consider the Cartan datum for the matrix $A = (a_{ij})_{i,j \in \mathcal{N}}$ where for all $i, j \in \mathcal{N}$,

$$a_{ij} = 2\delta_{i,j} - \chi(i - j \equiv \pm 1 \pmod{n}). \tag{9.1.1}$$

It corresponds to the affine type $A_{n-1}^{(1)}$ (Hong and Kang, 2002, p. 10.1.1). We then have the corresponding canonical central element c and null root δ , which are expressed in the following way:

$$\begin{aligned} c &= h_0 + h_1 + \cdots + h_{n-1}, \\ \delta &= \alpha_0 + \alpha_1 + \cdots + \alpha_{n-1}. \end{aligned} \tag{9.1.2}$$

Any dominant integral weight $\lambda = k_0\Lambda_0 + \cdots + k_{n-1}\Lambda_{n-1} \in \bar{P}^+$ has level

$$\langle c, \lambda \rangle = k_0 + \cdots + k_{n-1}.$$

Thus, the set of classical weights of level 1 is exactly $\bar{P}_1^+ = \{\Lambda_i : i \in \mathcal{N}\}$, the set of fundamental weights.

A perfect crystal of level 1 is given by the crystal graph in Figure 9.1 (Hong and Kang, 2002, p. 11.1.1).

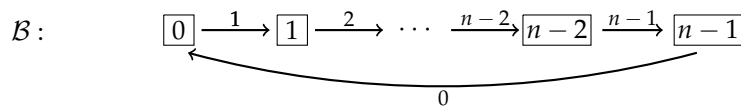

FIGURE 9.1: Vector representation \mathcal{B} of for type $A_{n-1}^{(1)} (n \geq 3)$

The $U'_q(\hat{\mathfrak{g}})$ -module corresponding to this crystal is called the *vector representation* of $A_{n-1}^{(1)}$. The most important property of this crystal is the order in which the arrows occur. The only purpose of labelling the vertices is to ease the calculations in the remainder of this paper. Noting that this crystal graph is cyclic, we identify \mathcal{N} with the group $(\mathbb{Z}/n\mathbb{Z}, +)$. In this way, the crystal graph of \mathcal{B} can be defined locally around each arrow i as shown on Figure 9.2.

$$\mathcal{B}(\overset{i}{\rightarrow}) : \quad \boxed{i-1} \xrightarrow{i} \boxed{i}$$

FIGURE 9.2: Local i -arrows of \mathcal{B}

Remark 9.1.1. For the type $A_1^{(1)}$, the Cartan matrix A is defined differently and is given by

$$\begin{pmatrix} 2 & -2 \\ -2 & 2 \end{pmatrix}.$$

Nonetheless, the crystal graph of the vector representation behaves in the same way as in the case $n \geq 3$.

For all $i \in \mathcal{N}$, let v_i be the element of \mathcal{B} corresponding to the vertex labelled i . The functions of this crystal are given by the following relations:

$$\overline{\text{wt}}v_i = \Lambda_{i+1} - \Lambda_i \quad \text{for all } i \in \mathcal{N}, \quad (9.1.3)$$

$$\begin{cases} \tilde{f}_i v_{i-1} = v_i \\ \varphi_i v_{i-1} = 1 \\ \tilde{f}_i v_j = \varphi_i v_j = 0 \quad \text{if } j \neq i-1, \end{cases} \quad (9.1.4)$$

$$\begin{cases} \tilde{e}_i v_i = v_{i-1} \\ \varepsilon_i v_i = 1 \\ \tilde{e}_i v_j = \varepsilon_i v_j = 0 \quad \text{if } j \neq i. \end{cases} \quad (9.1.5)$$

We note that for this crystal, the unique *maximal weight* λ_0 , as defined in Condition (3) of Definition 8.1.13, is attained in v_0 (i.e. $\lambda_0 = \overline{\text{wt}}v_0$). For all $i \in \mathcal{N}$, we have

$$\begin{aligned} \overline{\text{wt}}v_0 - \overline{\text{wt}}v_i &= \sum_{j=1}^i \overline{\text{wt}}v_{j-1} - \overline{\text{wt}}v_j \\ &= \sum_{j=1}^i \alpha_j \quad \text{by (8.1.5)}. \end{aligned}$$

The fact that the null root vanishes on $\bar{\mathfrak{h}}$ implies that in \bar{P} , $\bar{\alpha}_0 = -(\alpha_1 + \cdots + \alpha_{n-1})$. We also remark that the crystal \mathcal{B} has a unique *minimal weight*, attained in v_{n-1} :

$$\begin{aligned} \overline{\text{wt}}v_i - \overline{\text{wt}}v_{n-1} &= \sum_{j=i+1}^{n-1} \overline{\text{wt}}v_{j-1} - \overline{\text{wt}}v_j \\ &= \sum_{j=i+1}^{n-1} \alpha_j \quad \text{by (8.1.5)}. \end{aligned}$$

Let us consider the dual \mathcal{B}^\vee of \mathcal{B} , which is the crystal obtained from \mathcal{B} by reversing the edges in its graph, as shown on Figure 9.3.

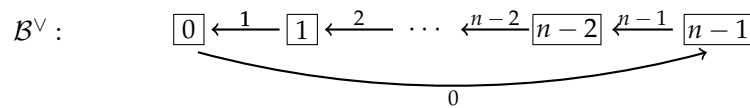

FIGURE 9.3: Dual \mathcal{B}^\vee of the vector representation for type $A_{n-1}^{(1)}$ ($n \geq 3$)

Let v^\vee denote the element of \mathcal{B}^\vee corresponding to v in \mathcal{B} . We then have the relations

$$\overline{\text{wt}}v^\vee = -\overline{\text{wt}}v, \quad \tilde{f}_i v^\vee = (\tilde{e}_i v)^\vee, \quad \varphi_i v^\vee = \varepsilon_i v, \quad \tilde{e}_i v^\vee = (\tilde{f}_i v)^\vee \quad \text{and} \quad \varepsilon_i v^\vee = \varphi_i v. \quad (9.1.6)$$

Recall that the duality is an involution, since by the previous equalities, we have

$$(\tilde{f}_i[(v^\vee)^\vee], \tilde{e}_i[(v^\vee)^\vee], \varphi_i[(v^\vee)^\vee], \varepsilon_i[(v^\vee)^\vee]) = (\tilde{f}_i[(v)^\vee], \tilde{e}_i[(v)^\vee], \varphi_i v, \varepsilon_i v), \quad (9.1.7)$$

and the map $v \mapsto (v^\vee)^\vee$ is an isomorphism between \mathcal{B} and $(\mathcal{B}^\vee)^\vee$. Thus $(\mathcal{B}^\vee)^\vee$ can be identified with \mathcal{B} .

The dual \mathcal{B}^\vee is also a perfect crystal of level 1, as its maximal weight is attained in the dual v_{n-1}^\vee of the minimal vertex v_{n-1} of \mathcal{B} .

By Theorem 8.1.11, $\mathcal{B} \otimes \mathcal{B}^\vee$ is a crystal for the tensor product of the vector representation of $A_{n-1}^{(1)}$ and its dual, and the tensor rules (8.1.6) on $\mathcal{B} \otimes \mathcal{B}^\vee$ become

$$\begin{aligned} \tilde{e}_i(v_k \otimes v_l^\vee) &= \begin{cases} \tilde{e}_i v_k \otimes v_l^\vee & \text{if } \varphi_i(v_k) \geq \varphi_i(v_l) \\ v_k \otimes \tilde{e}_i v_l^\vee & \text{if } \varphi_i(v_k) < \varphi_i(v_l) \end{cases}, \\ \tilde{f}_i(v_k \otimes v_l^\vee) &= \begin{cases} \tilde{f}_i v_k \otimes v_l^\vee & \text{if } \varphi_i(v_k) > \varphi_i(v_l) \\ v_k \otimes \tilde{f}_i v_l^\vee & \text{if } \varphi_i(v_k) \leq \varphi_i(v_l) \end{cases}. \end{aligned}$$

Using (9.1.4) and (9.1.5), we can draw the corresponding crystal graph, given in Figure 9.4.

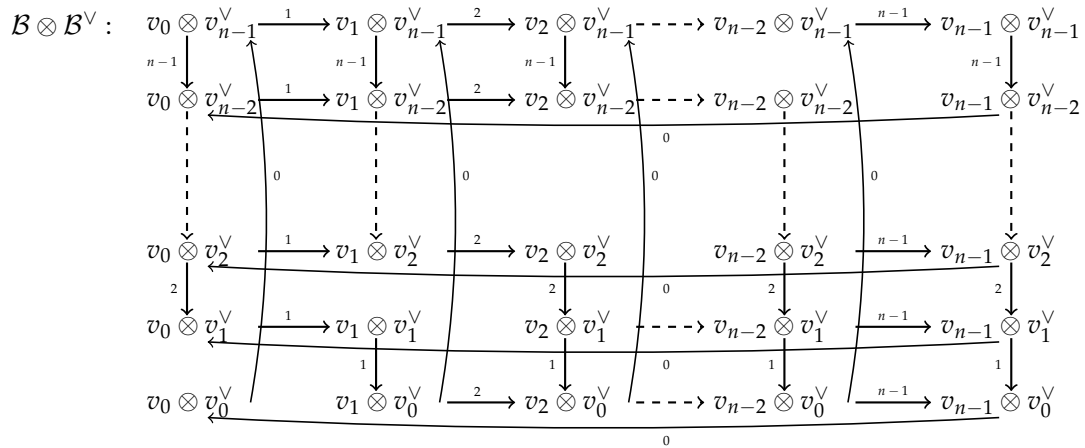

FIGURE 9.4: tensor product $\mathcal{B} \otimes \mathcal{B}^\vee$ for type $A_{n-1}^{(1)}$ ($n \geq 3$)

Again, the crystal graph of $\mathcal{B} \otimes \mathcal{B}^\vee$ can be defined locally by giving the vertices adjacent to the edges labelled i , as shown on Figure 9.5.

$$\begin{array}{ccc} \mathcal{B} \otimes \mathcal{B}^\vee (\overset{i}{\rightarrow}) : & v_k \otimes v_i^\vee & v_{i-1} \otimes v_i^\vee \xrightarrow{i} v_i \otimes v_i^\vee \\ & \downarrow i & \downarrow i \\ & v_k \otimes v_{i-1}^\vee & v_i \otimes v_{i-1}^\vee \\ & & \\ & & v_{i-1} \otimes v_k^\vee \xrightarrow{i} v_i \otimes v_k^\vee \end{array}$$

FIGURE 9.5: Subgraph with i -arrows

We obtain, for all i , the relations

$$\begin{cases} \varphi_i(v_{i-1} \otimes v_i^\vee) = \varepsilon_i(v_i \otimes v_{i-1}^\vee) = 2 \\ \varphi_i(v_i \otimes v_{i-1}^\vee) = \varepsilon_i(v_{i-1} \otimes v_i^\vee) = 0 \\ \varphi_i(v_i \otimes v_i^\vee) = \varepsilon_i(v_i \otimes v_i^\vee) = 1 \\ \varphi_i(v_{i-1} \otimes v_{i-1}^\vee) = \varepsilon_i(v_{i-1} \otimes v_{i-1}^\vee) = 0 \end{cases}, \quad (9.1.8)$$

$$\begin{cases} \varphi_i(v_k \otimes v_i^\vee) = \varepsilon_i(v_i \otimes v_k^\vee) = 1 \\ \varphi_i(v_{i-1} \otimes v_k^\vee) = \varepsilon_i(v_k \otimes v_{i-1}^\vee) = 1 \\ \varphi_i(v_k \otimes v_l^\vee) = \varepsilon_i(v_l \otimes v_k^\vee) = 0 \end{cases}, \quad \forall l, k \notin \{i, i-1\}.$$

The local configurations for the vertices are given in Figure 9.6.

$$\begin{array}{ccc}
& & \begin{array}{c} i+1 \downarrow \\ v_{i-1} \otimes v_i^\vee \end{array} \\
\begin{array}{c} l+1 \downarrow \\ v_k \otimes v_l^\vee \end{array} & \xrightarrow{k} & \xrightarrow{i-1} \\
& & \begin{array}{c} v_i \otimes v_i^\vee \\ \downarrow i \\ v_i \otimes v_{i-1}^\vee \\ \downarrow i-1 \end{array} \\
& & \xrightarrow{i+1}
\end{array}$$

FIGURE 9.6: Local configurations

The values of the functions ε, φ defined in (8.1.4) are

$$\begin{cases} \varphi(v_{i-1} \otimes v_i^\vee) = \varepsilon(v_i \otimes v_{i-1}^\vee) = 2\Lambda_i \\ \varepsilon(v_{i-1} \otimes v_i^\vee) = \varphi(v_i \otimes v_{i-1}^\vee) = \Lambda_{i-1} + \Lambda_{i+1} \\ \varphi(v_i \otimes v_i^\vee) = \varepsilon(v_i \otimes v_i^\vee) = \Lambda_i \end{cases}, \quad (9.1.9)$$

$$\begin{cases} \varphi(v_k \otimes v_l^\vee) = \Lambda_{k+1} + \Lambda_l \\ \varepsilon(v_k \otimes v_l^\vee) = \Lambda_{l+1} + \Lambda_k \end{cases},$$

where $k-l \notin \{0, \pm 1\}$. For all $k, l \in \mathcal{N}$, the weight of $v_k \otimes v_l^\vee$ is given by

$$\overline{\text{wt}}(v_k \otimes v_l^\vee) = \Lambda_{k+1} - \Lambda_k + \Lambda_l - \Lambda_{l+1}. \quad (9.1.10)$$

We then observe that

$$\langle c; \varepsilon(v_k \otimes v_l^\vee) \rangle = 1 + \chi(k \neq l). \quad (9.1.11)$$

By (Kang et al., 1992a, Lemma 4.6.2), since \mathcal{B} and \mathcal{B}^\vee are perfect crystals of level 1, their tensor product \mathbb{B} is also a perfect crystal of level 1. We observe that the potential grounds of \mathbb{B} are the vertices $v_i \otimes v_i^\vee$, since by (9.1.9), for all $i \in \mathcal{N}$, we have that

$$\varepsilon(b^{\Lambda_i}) = \Lambda_i \text{ if and only if } b^{\Lambda_i} = v_i \otimes v_i^\vee \quad \text{and} \quad \varphi(b_{\Lambda_i}) = \Lambda_i \text{ if and only if } b_{\Lambda_i} = v_i \otimes v_i^\vee.$$

9.2 Proof of the character formulas

In this section, we prove our character formulas given in Theorems 2.3.3, and 2.3.4, under the assumption that Theorem 2.3.2 is true. We will then prove Theorem 2.3.2 in the last two sections.

9.2.1 Proof of Theorem 2.3.3

By definition, the generalized colored partitions in $\mathcal{P}_{\ell, n}$ are the grounded partitions with ground $a_\ell b_\ell$ with energy Δ . This exactly corresponds to the grounded partitions $\mathcal{P}_{c_g}^{\gg}$ with ground c_g and the color correspondence $c_{v_i \otimes v_k^\vee} \leftrightarrow a_k b_l$. Thus their generating functions are the same with the correspondence $e^{\overline{\text{wt}}v_i} = b_i$, since by (9.1.10),

$$e^{\overline{\text{wt}}(v_i \otimes v_k^\vee)} = e^{\overline{\text{wt}}(l) - \overline{\text{wt}}(k)} = b_k^{-1} b_l.$$

Using the character formula of Theorem 8.2.4, this gives the desired result. \square

9.2.2 Proof of Theorem 2.3.4

Finally, we turn to the proof of Theorem 2.3.4, which gives the expression of the character for $L(\Lambda_\ell)$ as a sum of series with positive coefficients.

By the definition of characters, $e^{-\Lambda_\ell} \text{ch}(L(\Lambda_\ell))$ can be expressed as a power series in $e^{-\alpha_i}$ for $i \in \mathcal{N}$, or, by a change of variables, as a power series in $e^{-\delta}$ and e^{α_i} for $i \neq 0$. By definition of the crystal graph \mathcal{B} , we have $f_i v_{i-1} = v_i$, so that by (8.1.5), we have $\overline{\text{wt}}v_{i-1} - \overline{\text{wt}}v_i = \alpha_i$ for $i \in \{1, \dots, n-1\}$ and $\overline{\text{wt}}v_{n-1} - \overline{\text{wt}}v_0 = \bar{\alpha}_0$. The change of variables $e^{\overline{\text{wt}}v_i} = b_i$ then gives $e^{\alpha_i} = b_{i-1} b_i^{-1}$ for $i \in \{1, \dots, n-1\}$ and then

$$e^{\bar{\alpha}_0} = b_{n-1} b_0^{-1} = \prod_{i=1}^{n-1} b_i b_{i-1}^{-1} = \prod_{i=1}^{n-1} e^{-\alpha_i}.$$

The changes of variables are then natural, since for all $i \neq 0$, the weight α_i in P is indeed a classical weight in \bar{P} . In addition, the series $G_n^P(b_0q, \dots, b_{\ell-1}q, b_\ell, \dots, b_{n-1})$ can be expressed in terms of summands of the form

$$\left(\prod_{i=0}^{n-1} b_i^{r_i} \right) q^m \quad \text{with} \quad \sum_{i=0}^{n-1} r_i = 0,$$

so that we can always retrieve the exponent of $b_{i-1}b_i^{-1}$, for all $i \in \{1, \dots, n-1\}$, which corresponds to $\sum_{j=0}^{i-1} r_j$. Thus the identification

$$\begin{aligned} e^{-\delta} &\longleftrightarrow q \\ e^{\alpha_i} &\longleftrightarrow b_{i-1}b_i^{-1} \end{aligned}$$

is unique, and our generalization of Primc's identity allows us to retrieve the non-dilated version of the characters for all the irreducible highest weight modules with classical weight of level 1 for the type $A_{n-1}^{(1)}$.

Looking at Formula (2.2.61), we obtain the following correspondences (recall that $r_1 = 0 = r_n$)

$$\begin{aligned} \prod_{i=1}^{n-1} b_i^{-r_i+r_{i+1}} &= \prod_{i=1}^{n-1} (b_{i-1}b_i^{-1})^{r_i} = \prod_{i=1}^{n-1} e^{r_i\alpha_i} \\ \prod_{j=0}^{i-1} b_j b_i^{-1} &= \prod_{j=1}^i (b_{j-1}b_j^{-1})^j = e^{\sum_{j=1}^i j\alpha_j} \end{aligned}$$

By carrying out these transformations in (2.2.61), we then obtain by Theorem 2.2.43 that

$$\begin{aligned} e^{-\Lambda_0} \text{ch}(L(\Lambda_0)) &= \frac{1}{(e^{-\delta}; e^{-\delta})_{\infty}^{n-1}} \sum_{\substack{s_1, \dots, s_{n-1} \in \mathbb{Z} \\ s_n = 0}} \prod_{i=1}^{n-1} e^{s_i\alpha_i} e^{s_i(s_{i+1}-s_i)\delta} \\ &= \frac{1}{(e^{-\delta}; e^{-\delta})_{\infty}^{n-1}} \sum_{\substack{r_1, \dots, r_{n-1} \\ 0 \leq r_j \leq j-1 \\ r_n = 0}} \prod_{i=1}^{n-1} e^{r_i\alpha_i} e^{r_i(r_{i+1}-r_i)\delta} \left(e^{-i(i+1)\delta}, e^{-i(i+1)\delta} \right)_{\infty} \\ &\quad \times \left(-e^{(ir_{i+1}-(i+1)r_i-\frac{i(i+1)}{2})\delta + \sum_{j=1}^i j\alpha_j}, e^{-i(i+1)\delta} \right)_{\infty} \\ &\quad \times \left(-e^{((i+1)r_i-ir_{i+1}-\frac{i(i+1)}{2})\delta - \sum_{j=1}^i j\alpha_j}, e^{-i(i+1)\delta} \right)_{\infty}. \end{aligned}$$

Note that for all $\ell \in \{0, \dots, n-1\}$ and $j \in \{1, \dots, n-1\}$, the transformation $b_j \mapsto b_j q^{\chi(j < \ell)}$ is equivalent to $b_{j-1}b_j^{-1} \mapsto q^{\chi(j=\ell)} b_{j-1}b_j^{-1}$. This corresponds to the transformations $e^{\alpha_j} \mapsto e^{-\chi(j=\ell)\delta + \alpha_j}$ for all $j \in \{1, \dots, n-1\}$, and Theorem 2.3.4 follows. \square

9.3 Proof of Theorem 2.3.2

We already know that the crystal graph of $\mathbb{B} \otimes \mathbb{B}$ is connected, as \mathbb{B} is a perfect crystal. However, here we reprove this by constructing the paths in this graph, as these paths will allow us to compute the energy function. First, let us define some tools that will help us simplify the construction of the paths.

9.3.1 Symmetry in the crystal graph of $\mathbb{B} \otimes \mathbb{B}$

First, we observe a symmetry in the crystal graph of $\mathbb{B} \otimes \mathbb{B}$.

Proposition 9.3.1. *Let \mathcal{B} be a crystal, let \mathcal{B}^\vee be the dual of \mathcal{B} , and let us set $\mathbb{B} = \mathcal{B} \otimes \mathcal{B}^\vee$. Denote by σ^\vee the element in \mathcal{B}^\vee corresponding to $\sigma \in \mathcal{B}$. Then for any $\sigma_1, \sigma_2, \sigma_3, \sigma_4, \tau_1, \tau_2, \tau_3, \tau_4 \in \mathcal{B}$, we have the following*

equivalence in the crystal $\mathbb{B} \otimes \mathbb{B}$:

$$\tilde{f}_i[(\sigma_1 \otimes \sigma_2^\vee) \otimes (\sigma_3 \otimes \sigma_4^\vee)] = (\tau_1 \otimes \tau_2^\vee) \otimes (\tau_3 \otimes \tau_4^\vee) \iff \tilde{e}_i[(\sigma_4 \otimes \sigma_3^\vee) \otimes (\sigma_2 \otimes \sigma_1^\vee)] = (\tau_4 \otimes \tau_3^\vee) \otimes (\tau_2 \otimes \tau_1^\vee), \quad (9.3.1)$$

and an energy function H on $\mathbb{B} \otimes \mathbb{B}$ satisfies

$$H[(\sigma_1 \otimes \sigma_2^\vee) \otimes (\sigma_3 \otimes \sigma_4^\vee)] - H[\tilde{f}_i((\sigma_1 \otimes \sigma_2^\vee) \otimes (\sigma_3 \otimes \sigma_4^\vee))] = H[(\sigma_4 \otimes \sigma_3^\vee) \otimes (\sigma_2 \otimes \sigma_1^\vee)] - H[\tilde{e}_i((\sigma_4 \otimes \sigma_3^\vee) \otimes (\sigma_2 \otimes \sigma_1^\vee))]. \quad (9.3.2)$$

Furthermore, there exists a path between $(\sigma_1 \otimes \sigma_2^\vee) \otimes (\sigma_3 \otimes \sigma_4^\vee)$ and $(\tau_1 \otimes \tau_2^\vee) \otimes (\tau_3 \otimes \tau_4^\vee)$ if and only if there exists a path between $(\sigma_4 \otimes \sigma_3^\vee) \otimes (\sigma_2 \otimes \sigma_1^\vee)$ and $(\tau_4 \otimes \tau_3^\vee) \otimes (\tau_2 \otimes \tau_1^\vee)$. Moreover, in the case where $\tau_4 = \tau_1$ and $\tau_3 = \tau_2$, we have

$$H[(\sigma_1 \otimes \sigma_2^\vee) \otimes (\sigma_3 \otimes \sigma_4^\vee)] = H[(\sigma_4 \otimes \sigma_3^\vee) \otimes (\sigma_2 \otimes \sigma_1^\vee)]. \quad (9.3.3)$$

The relevance of this proposition lies in the fact that if we find a path from $(v_0 \otimes v_0^\vee) \otimes (v_0 \otimes v_0^\vee)$ to $(v_{l'} \otimes v_{k'}^\vee) \otimes (v_l \otimes v_k^\vee)$, then we immediately have a path from $(v_0 \otimes v_0^\vee) \otimes (v_0 \otimes v_0^\vee)$ to $(v_k \otimes v_l^\vee) \otimes (v_{k'} \otimes v_{l'}^\vee)$ as well, by reversing the edges and taking the symmetric of the vertices in the path. By (9.3.3), this gives the following symmetry on the energy function:

$$H[(v_{l'} \otimes v_{k'}^\vee) \otimes (v_l \otimes v_k^\vee)] = H[(v_k \otimes v_l^\vee) \otimes (v_{k'} \otimes v_{l'}^\vee)].$$

Besides, by (2.2.54), we have

$$\begin{aligned} \Delta(a_k b_l; a_{k'} b_{l'}) &= \chi(k \geq k') - \chi(k = l = k') + \chi(l \leq l') - \chi(l = k' = l') \\ &= \begin{cases} \chi(k > k') + \chi(l < l') & \text{if } l = k' \\ \chi(k \geq k') + \chi(l \leq l') & \text{if } l \neq k' \end{cases} \end{aligned} \quad (9.3.4)$$

and then

$$\Delta(a_k b_l; a_{k'} b_{l'}) = \Delta(a_{l'} b_{k'}; a_l b_k).$$

Therefore, if we prove that $H[(v_{l'} \otimes v_{k'}^\vee) \otimes (v_l \otimes v_k^\vee)] = \Delta(a_k b_l; a_{k'} b_{l'})$, we equivalently have $H[(v_k \otimes v_l^\vee) \otimes (v_{k'} \otimes v_{l'}^\vee)] = \Delta(a_{l'} b_{k'}; a_l b_k)$. Thus, to prove Theorem 2.3.2 in Section 9.3.3, we will distinguish several cases according to some relations between k, k', l, l' , and by interchanging $k \equiv l'$ and $k' \equiv l$, the symmetry will then imply the remaining cases.

Proof of Proposition 9.3.1. First, let us recall (9.1.6). For all $v \in \mathcal{B}$ and $i \in \mathcal{N}$, we have:

$$(\tilde{f}_i v^\vee, \tilde{e}_i v^\vee, \varphi_i v^\vee, \varepsilon_i v^\vee) = ((\tilde{e}_i v)^\vee, (\tilde{f}_i v)^\vee, \varepsilon_i v, \varphi_i v),$$

so that $\overline{w} t v^\vee = -\overline{w} t v$.

The tensor rules on \mathbb{B} are given by:

$$\begin{aligned} \tilde{e}_i(\sigma_1 \otimes \sigma_2^\vee) &= \begin{cases} \tilde{e}_i \sigma_1 \otimes \sigma_2^\vee & \text{if } \varphi_i(\sigma_1) \geq \varphi_i(\sigma_2) \\ \sigma_1 \otimes \tilde{e}_i \sigma_2^\vee & \text{if } \varphi_i(\sigma_1) < \varphi_i(\sigma_2), \end{cases} \\ \tilde{f}_i(\sigma_1 \otimes \sigma_2^\vee) &= \begin{cases} \tilde{f}_i \sigma_1 \otimes \sigma_2^\vee & \text{if } \varphi_i(\sigma_1) > \varphi_i(\sigma_2) \\ \sigma_1 \otimes \tilde{f}_i \sigma_2^\vee & \text{if } \varphi_i(\sigma_1) \leq \varphi_i(\sigma_2), \end{cases} \end{aligned}$$

or equivalently,

$$\begin{aligned} \tilde{f}_i(\sigma_2 \otimes \sigma_1^\vee) &= \begin{cases} \tilde{f}_i \sigma_2 \otimes \sigma_1^\vee & \text{if } \varphi_i(\sigma_2) > \varphi_i(\sigma_1) \\ \sigma_2 \otimes (\tilde{e}_i \sigma_1)^\vee & \text{if } \varphi_i(\sigma_2) \leq \varphi_i(\sigma_1), \end{cases} \\ \tilde{e}_i(\sigma_2 \otimes \sigma_1^\vee) &= \begin{cases} \tilde{e}_i \sigma_2 \otimes \sigma_1^\vee & \text{if } \varphi_i(\sigma_2) \geq \varphi_i(\sigma_1) \\ \sigma_2 \otimes (\tilde{f}_i \sigma_1)^\vee & \text{if } \varphi_i(\sigma_2) < \varphi_i(\sigma_1). \end{cases} \end{aligned}$$

Consider the involution η defined by

$$\eta : \begin{array}{ccc} \mathbb{B} \sqcup \{0\} & \longrightarrow & \mathbb{B} \sqcup \{0\} \\ 0 & \longmapsto & 0 \\ \sigma_1 \otimes \sigma_2^\vee & \longmapsto & \sigma_2 \otimes \sigma_1^\vee \end{array}.$$

The tensor rules on \mathbb{B} give, for all $i \in \mathcal{N}$,

$$(\eta \circ \tilde{e}_i, \eta \circ \tilde{f}_i) = (\tilde{f}_i \circ \eta, \tilde{e}_i \circ \eta),$$

so that

$$(\varphi_i \circ \eta, \varepsilon_i \circ \eta) = (\varepsilon_i, \varphi_i).$$

By (8.1.8), we obtain, for all $\sigma_1, \sigma_2, \sigma_3, \sigma_4 \in \mathcal{B}$,

$$\varphi_i(\sigma_1 \otimes \sigma_2^\vee) > \varepsilon_i(\sigma_3 \otimes \sigma_4^\vee) \iff \tilde{f}_i((\sigma_1 \otimes \sigma_2^\vee) \otimes (\sigma_3 \otimes \sigma_4^\vee)) = \tilde{f}_i(\sigma_1 \otimes \sigma_2^\vee) \otimes (\sigma_3 \otimes \sigma_4^\vee).$$

By symmetry of the action of η , we deduce

$$\begin{aligned} \varphi_i(\sigma_1 \otimes \sigma_2^\vee) > \varepsilon_i(\sigma_3 \otimes \sigma_4^\vee) &\iff \varphi_i(\eta(\sigma_3 \otimes \sigma_4^\vee)) < \varepsilon_i(\eta(\sigma_1 \otimes \sigma_2^\vee)) \\ &\iff \tilde{e}_i(\eta(\sigma_3 \otimes \sigma_4^\vee) \otimes \eta(\sigma_1 \otimes \sigma_2^\vee)) = \eta(\sigma_3 \otimes \sigma_4^\vee) \otimes \tilde{e}_i \circ \eta(\sigma_1 \otimes \sigma_2^\vee) \\ &\iff \tilde{e}_i(\eta(\sigma_3 \otimes \sigma_4^\vee) \otimes \eta(\sigma_1 \otimes \sigma_2^\vee)) = \eta(\sigma_3 \otimes \sigma_4^\vee) \otimes \eta \circ \tilde{f}_i(\sigma_1 \otimes \sigma_2^\vee). \end{aligned}$$

We also obtain that

$$\begin{aligned} \varphi_i(\sigma_1 \otimes \sigma_2^\vee) > \varepsilon_i(\sigma_3 \otimes \sigma_4^\vee) \quad \text{and} \quad \tilde{f}_i(\sigma_1 \otimes \sigma_2^\vee) \neq 0 \\ \iff H[(\sigma_1 \otimes \sigma_2^\vee) \otimes (\sigma_3 \otimes \sigma_4^\vee)] - H[\tilde{f}_i(\sigma_1 \otimes \sigma_2^\vee) \otimes (\sigma_3 \otimes \sigma_4^\vee)] = \chi(i = 0) \\ \iff H[\eta(\sigma_3 \otimes \sigma_4^\vee) \otimes \eta(\sigma_1 \otimes \sigma_2^\vee)] - H[\tilde{e}_i(\eta(\sigma_3 \otimes \sigma_4^\vee) \otimes \eta(\sigma_1 \otimes \sigma_2^\vee))] = \chi(i = 0). \end{aligned}$$

In the other case we have

$$\begin{aligned} \varphi_i(\sigma_1 \otimes \sigma_2^\vee) \leq \varepsilon_i(\sigma_3 \otimes \sigma_4^\vee) &\iff \tilde{f}_i((\sigma_1 \otimes \sigma_2^\vee) \otimes (\sigma_3 \otimes \sigma_4^\vee)) = (\sigma_1 \otimes \sigma_2^\vee) \otimes \tilde{f}_i(\sigma_3 \otimes \sigma_4^\vee) \\ &\iff \tilde{e}_i(\eta(\sigma_3 \otimes \sigma_4^\vee) \otimes \eta(\sigma_1 \otimes \sigma_2^\vee)) = \eta \circ \tilde{f}_i(\sigma_3 \otimes \sigma_4^\vee) \otimes \eta(\sigma_1 \otimes \sigma_2^\vee), \end{aligned}$$

and

$$\begin{aligned} \varphi_i(\sigma_1 \otimes \sigma_2^\vee) \leq \varepsilon_i(\sigma_3 \otimes \sigma_4^\vee) \quad \text{and} \quad \tilde{f}_i(\sigma_3 \otimes \sigma_4^\vee) \neq 0 \\ \iff H[(\sigma_1 \otimes \sigma_2^\vee) \otimes (\sigma_3 \otimes \sigma_4^\vee)] - H[\tilde{f}_i((\sigma_1 \otimes \sigma_2^\vee) \otimes (\sigma_3 \otimes \sigma_4^\vee))] = -\chi(i = 0) \\ \iff H[\eta(\sigma_3 \otimes \sigma_4^\vee) \otimes \eta(\sigma_1 \otimes \sigma_2^\vee)] - H[\tilde{e}_i(\eta(\sigma_3 \otimes \sigma_4^\vee) \otimes \eta(\sigma_1 \otimes \sigma_2^\vee))] = -\chi(i = 0), \end{aligned}$$

and we obtain (9.3.1) and (9.3.2).

Let us now define the involution

$$\begin{aligned} \zeta : \quad \mathbb{B} \otimes \mathbb{B} \sqcup \{0\} &\longrightarrow \mathbb{B} \otimes \mathbb{B} \sqcup \{0\} \\ 0 &\longmapsto 0 \\ (\sigma_1 \otimes \sigma_2^\vee) \otimes (\sigma_3 \otimes \sigma_4^\vee) &\longmapsto (\sigma_4 \otimes \sigma_3^\vee) \otimes (\sigma_2 \otimes \sigma_1^\vee). \end{aligned}$$

By (9.3.1), we see that $\tilde{e}_i \circ \zeta = \zeta \circ \tilde{f}_i$ and $\tilde{f}_i \circ \zeta = \zeta \circ \tilde{e}_i$. Thus for all $g_1, \dots, g_s \in \{\tilde{e}_i, \tilde{f}_i : i \in \mathcal{N}\}$, we have

$$\zeta \circ g_1 \circ \dots \circ g_s = \overline{g_1} \circ \dots \circ \overline{g_s} \circ \zeta,$$

where $\overline{\tilde{f}_i} = \tilde{e}_i$ and $\overline{\tilde{e}_i} = \tilde{f}_i$. Therefore, for $b, b' \in \mathbb{B} \otimes \mathbb{B}$, we have

$$g_1 \circ \dots \circ g_s(b) = b' \iff \overline{g_1} \circ \dots \circ \overline{g_s}(\zeta(b)) = \zeta(b'),$$

so that there is a path between two vertices if and only if there is a path between their images by ζ . By (9.3.2), we also observe that

$$\begin{aligned} H(b) - H(b') &= H(b) - H(g_s(b)) + H(g_s(b)) - H(g_{s-1} \circ g_s(b)) + \dots + H(g_2 \circ \dots \circ g_s(b)) - H(b') \\ &= H(\zeta(b)) - H(\overline{g_s}(\zeta(b))) + H(\overline{g_s}(\zeta(b))) - H(\overline{g_{s-1}} \circ \overline{g_s}(b)) + \dots \\ &\quad + H(\overline{g_2} \circ \dots \circ \overline{g_s}(\zeta(b)) - H(\zeta(b'))) \\ &= H(\zeta(b)) - H(\zeta(b')). \end{aligned} \tag{9.3.5}$$

Choosing any b' such that $b' = \zeta(b')$ gives (9.3.3). \square

9.3.2 Redefining the minimal differences Δ

To construct a path from $(v_0 \otimes v_0^\vee) \otimes (v_0 \otimes v_0^\vee)$ to $(v_{l'} \otimes v_{k'}^\vee) \otimes (v_l \otimes v_k^\vee)$ and show that

$$H[(v_{l'} \otimes v_{k'}^\vee) \otimes (v_l \otimes v_k^\vee)] = \Delta(a_k b_l; a_{k'} b_{l'}),$$

we will distinguish the cases $k' = l$ and $k' \neq l$. But first, let us define a tool which will make our problem easier to solve.

Definition 9.3.2. Identify \mathcal{N} with $\mathbb{Z}/n\mathbb{Z}$, and consider the natural order on \mathcal{N} ,

$$0 < 1 < \dots < n-2 < n-1.$$

We also define, for all $i, j \in \mathcal{N}$, the intervals

$$\text{int}(i, j) := \{i+1, i+2, \dots, j-1, j\}.$$

Lemma 9.3.3. For all $i \in \mathcal{N}$, we have the following:

$$\begin{aligned} i < i-1 & \iff i = 0, \\ \text{int}(i, i) & = \mathcal{N}, \\ I \setminus \text{int}(i, j) = \text{int}(i, j) & \iff i \neq j, \\ 0 \notin \text{int}(j, i) & \iff j < i, \\ 0 \in \text{int}(i, j) & \iff j \leq i. \end{aligned}$$

The aim of this lemma is to rewrite the difference conditions Δ according to the fact that 0 belongs to some interval or not. By (9.3.4), Δ can be reformulated as follows:

$$\Delta(a_k b_l; a_{k'} b_{l'}) = \begin{cases} \chi(0 \notin \text{int}(k', k)) + \chi(0 \notin \text{int}(l, l')) & \text{if } l = k' \\ \chi(0 \in \text{int}(k, k')) + \chi(0 \in \text{int}(l', l)) & \text{if } l \neq k' \end{cases}. \quad (9.3.6)$$

Proof of Lemma 9.3.3. The first equivalence is straightforward, since $i > i-1$ if and only if $i \neq 0$, and $0 < n-1 = -1$. The second equality follows from the definition of int , since we go around \mathcal{N} . Note that

$$\text{int}(i, j) = \{i+1, i+2, \dots, j-1, j\},$$

while

$$\text{int}(j, i) = \{j+1, j+2, \dots, i-1, i\},$$

and if $i \neq j$, these two sets are complementary in \mathcal{N} . Moreover, when $i \neq j$, we have $i \in \text{int}(j, i)$ and $j \in \text{int}(i, j)$, so that both sets never equal \emptyset or \mathcal{N} . Otherwise, when $i = j$, they both equal \mathcal{N} . This gives the third equivalence.

For the fourth equivalence, the fact that $0 \in \mathcal{N}$ gives

$$\begin{aligned} 0 \notin \text{int}(j, i) & \iff 0 \notin \{j+1, i+2, \dots, j-1, i\}, \\ & \iff i \neq j \text{ and } \emptyset \neq \{j+1, j+2, \dots, i-1, i\} \subseteq \{1, \dots, n-1\} \\ & \iff j < j+1 \leq i. \end{aligned}$$

Finally, for the last equivalence, we note that

$$\begin{aligned} \chi(j \leq i) & = \chi(j < i) + \chi(j = i) \\ & = \chi(j < i)\chi(j \neq i) + \chi(j = i) \\ & = \chi(0 \notin \text{int}(j, i))\chi(i \neq j) + \chi(i = j) \\ & = \chi(0 \in \text{int}(i, j))\chi(i \neq j) + \chi(i = j)\chi(0 \in \text{int}(i, i)). \end{aligned}$$

This concludes the proof. \square

9.3.3 Construction of the paths in $\mathcal{B} \otimes \mathcal{B}$

We are now ready to construct the paths in $\mathbb{B} \otimes \mathbb{B}$, and use them to compute the energy function $H[(v_{l'} \otimes v_{k'}^\vee) \otimes (v_l \otimes v_k^\vee)]$. We will use the relations in (9.1.8) and the local configurations of the vertices as defined in (9.6). The symmetric of $(v_{l'} \otimes v_{k'}^\vee) \otimes (v_l \otimes v_k^\vee)$ is $(v_k \otimes v_{l'}^\vee) \otimes (v_{k'} \otimes v_l^\vee)$, obtained by interchanging $k' \equiv l, l' \equiv k$. We distinguish several cases:

1. $k' = l'$ and $l = k$,
2. $k' = l \neq k = l'$,
3. $k' = l$ and $k \neq l'$,
4. $k' \neq k = l = l'$ (Symmetric: $l \neq k = k' = l'$),
5. $l' \neq k' = k \neq l$ (Symmetric: $k \neq l = l' \neq k'$),
6. $k \neq k', k' \neq l$ and $l \neq l'$
 - (a) $k + 1, k' \notin \text{int}(l, l')$ (Symmetric: $l' + 1, l \notin \text{int}(k', k)$),
 - (b) $k + 1 \in \text{int}(l, l')$ and $k' \notin \text{int}(l, l')$ (Symmetric: $l' + 1 \in \text{int}(k', k)$ and $l \notin \text{int}(k', k)$)
 - (c) $k + 1 \notin \text{int}(l, l')$ and $k' \in \text{int}(l, l')$ (Symmetric: $l' + 1 \notin \text{int}(k', k)$ and $l \in \text{int}(k', k)$)
 - (d) $k + 1, k' \in \text{int}(l, l')$ and $l' + 1, l \in \text{int}(k', k)$.

The case $k' = l'$ and $l = k$

We construct a path from $(v_{k'} \otimes v_{k'}^\vee) \otimes (v_k' \otimes v_{k'}^\vee)$ to $(v_{k'} \otimes v_{k'}^\vee) \otimes (v_l \otimes v_l^\vee)$. We consider the case $k' \neq l$, as otherwise the two elements are the same. By (9.1.9), we have

$$\varphi_i(v_{k'} \otimes v_{k'}^\vee) = \varepsilon_i(v_{k'} \otimes v_{k'}^\vee) = \chi(i = k').$$

By the tensor rules (8.1.6), we then obtain the path

$$\begin{aligned} (v_{k'} \otimes v_{k'}^\vee) \otimes (v_{k'} \otimes v_{k'}^\vee) &\xrightarrow{k'} \underbrace{(v_{k'} \otimes v_{k'}^\vee) \otimes (v_{k'} \otimes v_{k'-1}^\vee)}_{\text{empty if } k'=l+1} \xrightarrow{k'-1} \dots \xrightarrow{l+1} (v_{k'} \otimes v_{k'}^\vee) \otimes (v_{k'} \otimes v_l^\vee) \\ &\qquad\qquad\qquad \downarrow k'+1 \\ (v_{k'} \otimes v_{k'}^\vee) \otimes (v_l \otimes v_l^\vee) &\xleftarrow{l} \underbrace{(v_{k'} \otimes v_{k'}^\vee) \otimes (v_{l-1} \otimes v_l^\vee)}_{\text{empty if } k'+1=l} \xleftarrow{l-1} \dots \xleftarrow{k'+2} (v_{k'} \otimes v_{k'}^\vee) \otimes (v_{k'+1} \otimes v_l^\vee) \end{aligned}$$

This path is only made of forward moves \tilde{f}_i , with $i \in \text{int}(l, k') \sqcup \text{int}(k', l)$ appearing once, where we change the right side of the tensor products. By (8.1.8), we then have

$$H[(v_{k'} \otimes v_{k'}^\vee) \otimes (v_l \otimes v_l^\vee)] - H[(v_{k'} \otimes v_{k'}^\vee) \otimes (v_{k'} \otimes v_{k'}^\vee)] = \chi(0 \in \text{int}(l, k')) + \chi(0 \in \text{int}(k', l)) = 1. \quad (9.3.7)$$

By (9.3.3), we have the symmetry

$$H[(v_l \otimes v_l^\vee) \otimes (v_{k'} \otimes v_{k'}^\vee)] = H[(v_{k'} \otimes v_{k'}^\vee) \otimes (v_l \otimes v_l^\vee)].$$

Here we need to compute $H((v_{k'} \otimes v_{k'}^\vee) \otimes (v_{k'} \otimes v_{k'}^\vee))$. By interchanging k' and l , we obtain a path between $(v_{k'} \otimes v_{k'}^\vee) \otimes (v_l \otimes v_l^\vee)$ and $(v_l \otimes v_l^\vee) \otimes (v_{k'} \otimes v_{k'}^\vee)$, and

$$H[(v_{k'} \otimes v_{k'}^\vee) \otimes (v_l \otimes v_l^\vee)] - H[(v_l \otimes v_l^\vee) \otimes (v_{k'} \otimes v_{k'}^\vee)] = 1.$$

We have a path from $(v_{k'} \otimes v_{k'}^\vee) \otimes (v_{k'} \otimes v_{k'}^\vee)$ to $(v_l \otimes v_l^\vee) \otimes (v_l \otimes v_l^\vee)$ and

$$H[(v_{k'} \otimes v_{k'}^\vee) \otimes (v_{k'} \otimes v_{k'}^\vee)] = H[(v_l \otimes v_l^\vee) \otimes (v_l \otimes v_l^\vee)].$$

Recall that by definition, $H[(v_0 \otimes v_0^\vee) \otimes (v_0 \otimes v_0^\vee)] = 0$. Thus setting $k' = 0$ yields by (9.3.6) that for all $l \in \mathcal{N}$,

$$H[(v_l \otimes v_l^\vee) \otimes (v_l \otimes v_l^\vee)] = 0 = 2\chi(0 \notin \text{int}(l, l)) = \Delta(a_l b_l; a_l b_l). \quad (9.3.8)$$

Plugging this into (9.3.7) gives, for all $k' \neq l$,

$$H[(v_{k'} \otimes v_{k'}^\vee) \otimes (v_l \otimes v_l^\vee)] = 1 = \chi(0 \in \text{int}(l, k')) + \chi(0 \in \text{int}(k', l)) = \Delta(a_l b_l; a_{k'} b_{k'}). \quad (9.3.9)$$

The case $k' = l \neq k = l'$

We now construct a path from $(v_l \otimes v_l^\vee) \otimes (v_k \otimes v_k^\vee)$ to $(v_l \otimes v_k^\vee) \otimes (v_k \otimes v_l^\vee)$. By (9.1.9), we know that $\varepsilon_i(v_k \otimes v_k^\vee) = \chi(i = k)$ and $\varepsilon_i(v_k \otimes v_l^\vee) = 0$ if $i \notin \{l+1, k\}$. Since $k \neq l$, we have for all $i \in \text{int}(k, l)$ that $(v_l \otimes v_i^\vee) \neq (v_l \otimes v_{i+1}^\vee)$, and then $(v_l \otimes v_i^\vee) \xrightarrow{i} (v_l \otimes v_{i-1}^\vee)$. We obtain the path

$$\begin{array}{c} (v_l \otimes v_l^\vee) \otimes (v_k \otimes v_k^\vee) \xrightarrow{k} \underbrace{(v_l \otimes v_l^\vee) \otimes (v_k \otimes v_{k-1}^\vee) \xrightarrow{k-1} \dots \xrightarrow{l+1} (v_l \otimes v_l^\vee) \otimes (v_k \otimes v_l^\vee)}_{\text{empty if } l+1=k} \\ \downarrow l \\ (v_l \otimes v_k^\vee) \otimes (v_k \otimes v_l^\vee) \xleftarrow{k+1} (v_l \otimes v_{k+1}^\vee) \otimes (v_k \otimes v_l^\vee) \xleftarrow{k+2} \dots \xleftarrow{l-1} \underbrace{(v_l \otimes v_{l-1}^\vee) \otimes (v_k \otimes v_l^\vee)}_{\text{empty if } l=k+1} \end{array} \cdot$$

In the upper part of the path, we moved forward (by some \tilde{f}_i) by modifying the right side of the tensor product with arrows in $\text{int}(l, k)$ appearing once. Then, in the lower part of the path, we moved forward by modifying the left side of the tensor product with arrows in $\text{int}(k, l)$ appearing once. Using that $k \neq l$, the energy function satisfies:

$$\begin{aligned} H[(v_l \otimes v_k^\vee) \otimes (v_k \otimes v_l^\vee)] &= H[(v_l \otimes v_l^\vee) \otimes (v_k \otimes v_k^\vee)] + \chi(0 \in \text{int}(l, k)) - \chi(0 \in \text{int}(k, l)) && \text{by (8.1.8)} \\ &= 1 + 2\chi(0 \in \text{int}(l, k)) - 1 && \text{by (9.3.9)} \\ &= \Delta(a_l b_k; a_k b_l) && \text{by (9.3.6).} \end{aligned}$$

The case $k' = l$ and $k \neq l'$

The vertices $(v_{l'} \otimes v_l^\vee) \otimes (v_l \otimes v_k^\vee)$ and $(v_k \otimes v_l^\vee) \otimes (v_l \otimes v_{l'}^\vee)$ are symmetric.

Since $k \neq l'$, we have that $\text{int}(k, l) \neq \text{int}(l', l)$. By symmetry, we can assume that $\text{int}(l', l) \not\subset \text{int}(k, l) \subset \text{int}(l', l)$, so that $l' + 1 \notin \text{int}(k, l)$. In that case, we necessarily have $k \neq l$. Then, $\varphi_l(v_{l'} \otimes v_l^\vee) = 1 = \varepsilon_l(v_l \otimes v_l^\vee)$ and $\varphi_i(v_{l'} \otimes v_l^\vee) = 0$ for all $i \in \text{int}(k, l) \setminus \{l\}$, and we have the path

$$\begin{array}{c} \underbrace{(v_l \otimes v_l^\vee) \otimes (v_l \otimes v_l^\vee) \xleftarrow{l} (v_{l-1} \otimes v_l^\vee) \otimes (v_l \otimes v_l^\vee) \xleftarrow{l-1} \dots \xleftarrow{l'+1} (v_{l'} \otimes v_l^\vee) \otimes (v_l \otimes v_l^\vee)}_{\text{empty if } l=l'} \\ \downarrow l \\ (v_{l'} \otimes v_l^\vee) \otimes (v_l \otimes v_k^\vee) \xleftarrow{k+1} \dots \xleftarrow{l+1} (v_{l'} \otimes v_l^\vee) \otimes (v_l \otimes v_{l-1}^\vee) \end{array}$$

and the energy function is given by

$$\begin{aligned} H[(v_{l'} \otimes v_l^\vee) \otimes (v_l \otimes v_k^\vee)] &= \chi(l' \neq l)\chi(0 \in \text{int}(l', l)) + \chi(0 \in \text{int}(k, l)) && \text{by (8.1.8)} \\ &= \chi(0 \notin \text{int}(l', l)) + \chi(0 \notin \text{int}(l, k)) && \text{by Lemma 9.3.3} \\ &= \Delta(a_k b_l; a_l b_{l'}) && \text{by (9.3.6).} \end{aligned}$$

This was the last case where $k' = l$. Also, we have already studied a special case where $k' \neq l$, which was the case $l' = k' \neq l = k$. We now study the other cases where $k' \neq l$.

The case $k' \neq k = l = l'$ (Symmetric case: $l \neq k = k' = l'$)

Since $l \notin \text{int}(l, k')$, we have the path

$$(v_{l+1} \otimes v_{l+1}^\vee) \otimes (v_l \otimes v_l^\vee) \xleftarrow{l+1} \underbrace{(v_l \otimes v_{l+1}^\vee) \otimes (v_l \otimes v_l^\vee) \xleftarrow{l+2} \dots \xleftarrow{k'} (v_l \otimes v_k^\vee) \otimes (v_l \otimes v_l^\vee)}_{\text{empty if } k'=l+1}.$$

Thus the energy function satisfies

$$\begin{aligned} H[(v_l \otimes v_k^\vee) \otimes (v_l \otimes v_l^\vee)] &= 1 + \chi(0 \in \text{int}(l, k')) && \text{by (8.1.8) and (9.3.9)} \\ &= \chi(0 \in \text{int}(l, l)) + \chi(0 \in \text{int}(l, k')) && \text{by Lemma 9.3.3} \\ &= \Delta(a_l b_l; a_{k'} b_l) && \text{by (9.3.6).} \end{aligned}$$

The case $l' \neq k' = k \neq l$ (Symmetric case: $k \neq l = l' \neq k'$)

We first assume that $l' + 1 \notin \text{int}(k', l)$. Since $l' \neq k'$, it means that

$$\text{int}(l', k') \sqcup \text{int}(k', l) = \text{int}(l', l).$$

Since $l' + 1$ and k' do not belong to $\text{int}(k', l)$, we have by (9.1.9) that $\varphi_i(v_{l'} \otimes v_{k'}^\vee) = 0$ for all $i \in \text{int}(k', l)$. This gives the path

$$\begin{aligned} (v_{l'+1} \otimes v_{l'+1}^\vee) \otimes (v_{k'+1} \otimes v_{k'+1}^\vee) &\xleftarrow{l'+1} \underbrace{(v_{l'} \otimes v_{l'+1}^\vee) \otimes (v_{k'+1} \otimes v_{k'+1}^\vee)}_{\text{empty if } k'=l'+1} \xleftarrow{l'+2} \cdots \xleftarrow{k'} (v_{l'} \otimes v_{k'}^\vee) \otimes (v_{k'+1} \otimes v_{k'+1}^\vee) \\ &\qquad\qquad\qquad \downarrow k'+1 \\ &\qquad\qquad\qquad (v_{l'} \otimes v_{k'}^\vee) \otimes (v_l \otimes v_{k'}^\vee) \xleftarrow{l} \cdots \xleftarrow{k'+2} (v_{l'} \otimes v_{k'}^\vee) \otimes (v_{k'+1} \otimes v_{k'+1}^\vee) \cdot \\ &\qquad\qquad\qquad \underbrace{\hspace{10em}}_{\text{empty if } k'+1=l} \end{aligned}$$

We deduce the following formula for the energy function:

$$\begin{aligned} H[(v_{l'} \otimes v_{k'}^\vee) \otimes (v_l \otimes v_{k'}^\vee)] &= 1 + \chi(0 \in \text{int}(l', k')) + \chi(0 \in \text{int}(k', l)) && \text{by (8.1.8) and (9.3.9)} \\ &= \chi(0 \in \text{int}(k', k')) + \chi(0 \in \text{int}(l', l)) && \text{by Lemma 9.3.3} \\ &= \Delta(a_{k'} b_l; a_{k'} b_{l'}) && \text{by (9.3.6).} \end{aligned}$$

Let us now assume that $l' + 1 \in \text{int}(k', l)$. Since $\text{int}(k', l) \neq \emptyset$ and $l' \neq k'$, we necessarily have that $k' + 1 \neq l$ and $\text{int}(k', l') \subset \text{int}(k', l - 1)$, so that $l' \neq l$. Note also that, by (9.1.9),

$$\varphi_{k'}(v_{l'} \otimes v_{k'-1}^\vee) = 0 = \varepsilon_{k'}(v_{k'-1} \otimes v_{k'}^\vee),$$

since $k' \neq l' + 1$, and $\varphi_i(v_{l'} \otimes v_{k'}^\vee) = 0$ for all $i \in \text{int}(l, k') \setminus \{k'\}$. We then have the path

$$\begin{aligned} (v_{k'} \otimes v_{k'-1}^\vee) \otimes (v_{k'} \otimes v_{k'-1}^\vee) &\xleftarrow{\bullet, k'} \underbrace{(v_{k'} \otimes v_{k'-1}^\vee) \otimes (v_{k'} \otimes v_{k'}^\vee)}_{\text{nonempty since } k' \neq l'+1} \xrightarrow{k'+1} \cdots \xrightarrow{l'} (v_{l'} \otimes v_{k'-1}^\vee) \otimes (v_{k'} \otimes v_{k'}^\vee) \\ &\qquad\qquad\qquad \downarrow k' \\ &\qquad\qquad\qquad \star \\ \underbrace{(v_{l'} \otimes v_{k'}^\vee) \otimes (v_l \otimes v_{k'}^\vee)}_{\bullet} &\xrightarrow{l+1} \cdots \xrightarrow{k'-1} (v_{l'} \otimes v_{k'}^\vee) \otimes (v_{k'-1} \otimes v_{k'}^\vee) \xrightarrow{\star, k'} (v_{l'} \otimes v_{k'-1}^\vee) \otimes (v_{k'-1} \otimes v_{k'}^\vee) \cdot \end{aligned}$$

By the previous case ($l' \neq k' = k \neq l$), we obtain the energy function

$$H[(v_{k'} \otimes v_{k'-1}^\vee) \otimes (v_{k'} \otimes v_{k'-1}^\vee)] = \chi(0 \in \text{int}(k', k')) + \chi(0 \in \text{int}(k' - 1, k' - 1)) = 2\chi(0 \in \text{int}(k', k')). \quad (9.3.10)$$

In the computation of H , by (8.1.8), the moves marked by \star cancel each other, since it is the same arrow that operates backward consecutively on the right and on the left side of the tensor product. Besides, the moves marked by \bullet give $\text{int}(l, k')$ and operate backward on the right side of the tensor product. As a consequence,

$$\begin{aligned} H[(v_{l'} \otimes v_{k'}^\vee) \otimes (v_l \otimes v_{k'}^\vee)] &= H[(v_{k'} \otimes v_{k'-1}^\vee) \otimes (v_{k'} \otimes v_{k'-1}^\vee)] - \chi(0 \in \text{int}(k', l')) - \chi(0 \in \text{int}(l, k')) && \text{by (8.1.8)} \\ &= 2\chi(0 \in \text{int}(k', k')) - \chi(0 \in \text{int}(k', l')) - \chi(0 \in \text{int}(l, k')) && \text{by (9.3.10)} \\ &= \chi(0 \in \text{int}(k', k')) + \chi(0 \in \text{int}(k', l)) - \chi(0 \in \text{int}(k', l')) \\ &= \chi(0 \in \text{int}(k', k')) + \chi(0 \in \text{int}(l', l)) && \text{by Lemma 9.3.3} \\ &= \Delta(a_{k'} b_l; a_{k'} b_{l'}) && \text{by (9.3.6).} \end{aligned}$$

The case $k \neq k', k' \neq l$ and $l \neq l'$

The sub-case $k + 1, k' \notin \text{int}(l, l')$ (Symmetric case : $l' + 1, l \notin \text{int}(k', k)$) We have $l' + 1, k' \notin \text{int}(l, l')$, so that $\varphi_i(v_{l'} \otimes v_{k'}^\vee) = 0$ for all $i \in \text{int}(l, l')$. Besides, $k + 1 \notin \text{int}(l, l')$, so that $\tilde{\varepsilon}_i(v_i \otimes v_k^\vee) = (v_{i-1} \otimes v_k^\vee)$. We obtain the path

$$(v_{l'} \otimes v_{k'}^\vee) \otimes (v_{l'} \otimes v_k^\vee) \xleftarrow{l'} \cdots \xleftarrow{l+1} (v_{l'} \otimes v_{k'}^\vee) \otimes (v_l \otimes v_k^\vee).$$

and the fact that $l \in \text{int}(k', k)$ and $l \neq k$ implies that

$$\text{int}(l, k') = \text{int}(l, k) \sqcup \text{int}(k, k').$$

Thus the computation of H gives

$$\begin{aligned} H[(v_{l'} \otimes v_{k'}^\vee) \otimes (v_l \otimes v_k^\vee)] &= 1 - \chi(k' \neq l')\chi(0 \in \text{int}(k', l')) - \chi(0 \in \text{int}(l, k)) && \text{by (8.1.8) and (9.3.9)} \\ &= 1 - \chi(0 \notin \text{int}(l', k')) - \chi(0 \in \text{int}(l, k)) && \text{by Lemma 9.3.3} \\ &= \chi(0 \in \text{int}(l', k')) - \chi(0 \in \text{int}(l, k)) \\ &= \chi(0 \in \text{int}(l', l)) + \chi(0 \in \text{int}(l, k')) - \chi(0 \in \text{int}(l, k)) \\ &= \chi(0 \in \text{int}(l', l)) + \chi(0 \in \text{int}(k, k')) \\ &= \Delta(a_k b_l; a_{k'} b_{l'}) && \text{by (9.3.6).} \end{aligned}$$

We have checked all the possible choices of k, l, k', l' . Our proof of Theorem 2.3.2 is thus complete.

Chapter 10

Level one standard modules of $A_{2n}^{(2)}, D_{n+1}^{(2)}, A_{2n-1}^{(2)}, B_n^{(1)}, D_n^{(1)}$

In this chapter, we compute the character formula corresponding to the following level one weights:

- Λ_0 for the affine type $A_{2n}^{(2)} (n \geq 2)$,
- Λ_0 and Λ_n for the affine type $D_{n+1}^{(2)} (n \geq 2)$,
- Λ_0, Λ_1 for the affine type $A_{2n-1}^{(1)} (n \geq 3)$,
- $\Lambda_0, \Lambda_1, \Lambda_n$ for the affine type $B_n^{(1)} (n \geq 3)$,
- $\Lambda_0, \Lambda_1, \Lambda_{n-1}, \Lambda_n$ for the affine type $D_n^{(1)} (n \geq 4)$.

10.1 Case of affine type $A_{2n}^{(2)} (n \geq 2)$

The crystal \mathcal{B} of the vector representation of $A_{2n}^{(2)} (n \geq 2)$ is given by the crystal graph below

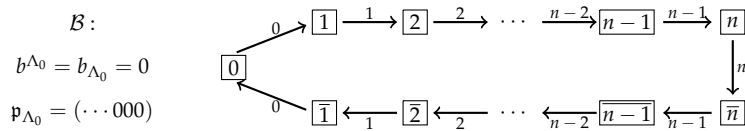

FIGURE 10.1: Crystal graph \mathcal{B} of the vector representation for type $A_{2n}^{(2)} (n \geq 2)$

with $\overline{\text{wt}}(0) = 0$ and for all $u \in \{1, \dots, n\}$,

$$-\overline{\text{wt}}(\bar{u}) = \overline{\text{wt}}u = \frac{1}{2}\alpha_n + \sum_{i=u}^{n-1} \alpha_i. \tag{10.1.1}$$

Here, we have $\delta = \alpha_n + 2\sum_{i=0}^{n-1} \alpha_i$. We thus obtain the following crystal graph for $\mathcal{B} \otimes \mathcal{B}$

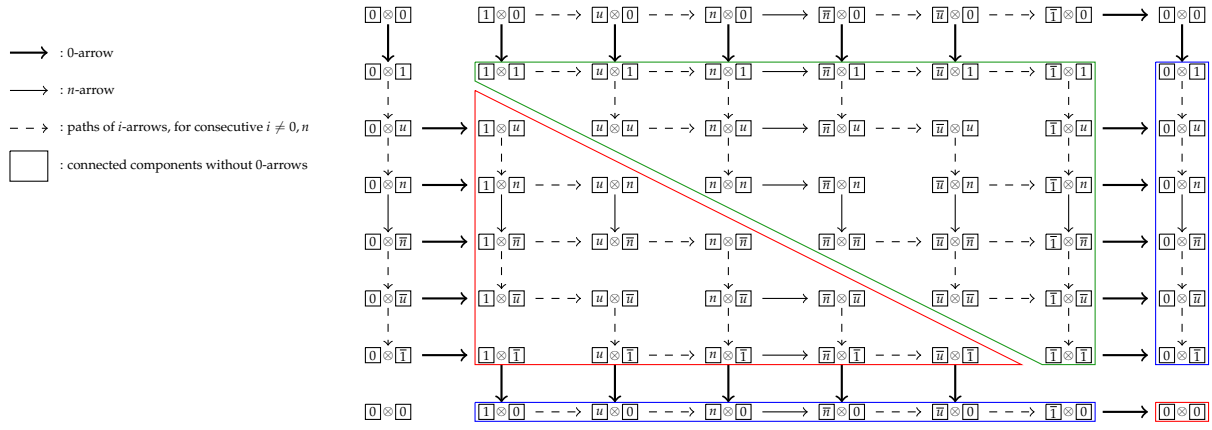

FIGURE 10.2: Crystal graph of $\mathcal{B} \otimes \mathcal{B}$ for type $A_{2n}^{(2)}$ ($n \geq 2$)

We then consider the set of states $\mathcal{C} = \{c_1, \dots, c_n, c_{\bar{n}}, \dots, c_{\bar{1}}, c_0\}$, $c_g = c_0$, and by setting $\epsilon'(c_u, c_v) = H(v \otimes u)$ and $H(0 \otimes 0) = 0$, we obtain the following energy matrix for ϵ' :

$$\begin{matrix}
 & c_1 & \cdots & c_{\bar{1}} & c_0 \\
 c_1 & \begin{pmatrix} 2 & \cdots & 2 & 1 \\ \vdots & \ddots & \vdots & \vdots \\ 0 & \cdots & 2 & 1 \\ 1 & \cdots & 1 & 0 \end{pmatrix} & & & \\
 \vdots & & & & \\
 c_{\bar{1}} & & & & \\
 c_0 & & & &
 \end{matrix}$$

This energy matrix can be obtain by taking the energy matrix of ϵ defined by

$$\begin{matrix}
 & c_1 & \cdots & c_{\bar{1}} & c_0 \\
 c_1 & \begin{pmatrix} 1 & \cdots & 1 & 1 \\ \vdots & \ddots & \vdots & \vdots \\ 0 & \cdots & 1 & 1 \\ 0 & \cdots & 0 & 0 \end{pmatrix} & & & \\
 \vdots & & & & \\
 c_{\bar{1}} & & & & \\
 c_0 & & & &
 \end{matrix}$$

followed by the transformation

$$(q, c_1, c_{\bar{1}}, \dots, c_n, c_{\bar{n}}) \mapsto (q^2, c_1 q^{-1}, c_{\bar{1}} q^{-1}, \dots, c_n q^{-1}, c_{\bar{n}} q^{-1}). \tag{10.1.2}$$

This means that, for $c \neq c_0$, the particle k_c for the energy ϵ is identified as the particle $(2k - 1)_c$ for the energy ϵ' , and since we do not modify the ground c_0 , the particle k_{c_0} for ϵ is identified as $(2k)_{c_0}$ for ϵ' , so that the last particle still remains 0_{c_0} .

By setting $c_0 = 1$, we can apply Theorem 2.2.24 to the flat partitions with ground c_0 and with energy ϵ to obtain the generation function

$$\sum_{\pi \in \mathcal{F}_1^{\epsilon, c_g}} C(\pi) q^{|\pi|} = \sum_{\pi \in \mathcal{R}_1^{\epsilon, c_g}} C(\pi) q^{|\pi|} = (-c_1 q, -c_{\bar{1}} q, \dots, -c_n q, -c_{\bar{n}} q; q)_\infty.$$

In fact, by the definition of the energy ϵ , one can view the partitions of $\mathcal{R}_1^{\epsilon, c_g}$ as the finite sub-sequences, ending with 0_{c_0} , of the infinite sequence

$$\cdots \succ_\epsilon 3_{c_1} \succ_\epsilon 2_{c_{\bar{1}}} \succ_\epsilon \cdots \succ_\epsilon 2_{c_1} \succ_\epsilon 1_{c_{\bar{1}}} \succ_\epsilon \cdots \succ_\epsilon 1_{c_{\bar{n}}} \succ_\epsilon 1_{c_n} \succ_\epsilon \cdots \succ_\epsilon 1_{c_1} \succ_\epsilon 0_{c_0}.$$

Using (10.1.2), the flat partitions with ground c_g and energy ϵ' are generated by the function

$$(-c_1 q, -c_{\bar{1}} q, \dots, -c_n q, -c_{\bar{n}} q; q^2)_\infty.$$

Using Theorem 8.2.4 and (10.1.1), we obtain the formula for the character for Λ_0 given in Theorem 2.3.6.

Another way to retrieve Theorem 2.3.6 is to consider in Theorem 2.3.1 the set ${}^2_1\mathcal{P}_{c_0}^{\gg}$, with $D = 1$. This set consists of the partitions grounded in c_0 , and which are finite subsequences of

$$\cdots \succ_{\epsilon} 5_{c_1} \succ_{\epsilon} 4_{c_0} \succ_{\epsilon} 3_{c_{\bar{1}}} \succ_{\epsilon} \cdots \succ_{\epsilon} 3_{c_1} \succ_{\epsilon} 2_{c_0} \succ_{\epsilon} 1_{c_{\bar{1}}} \succ_{\epsilon} \cdots \succ_{\epsilon} 1_{c_{\bar{n}}} \succ_{\epsilon} 1_{c_n} \succ_{\epsilon} \cdots \succ_{\epsilon} 1_{c_1} \succ_{\epsilon} 0_{c_0},$$

with possible repeated parts $2k_{c_0}$ for $k > 0$. It suffices to observe that, by definition of ${}^2_1\mathcal{P}_{c_0}^{\gg}$, the size difference between the two consecutive parts with colors c_b and $c_{b'}$ has the same parity as $H_{\Lambda_0}(b' \otimes b) = H(b' \otimes b)$. This implies that all the parts with colors $c_1, c_{\bar{1}}, \dots, c_n, c_{\bar{n}}$ have the same parity, different from the parity of the parts with color c_0 . Since the ground have size 0 and color c_0 , we obtain the sequence above.

By setting $c_0 = 1$, we then obtain

$$\sum_{\pi \in {}^2_1\mathcal{P}_{c_0}^{\gg} \cdots c_{g_{t-1}}} C(\pi)q^{|\pi|} = \frac{(-c_1q, -c_{\bar{1}}q, \dots, -c_nq, -c_{\bar{n}}q; q^2)_{\infty}}{(q^2; q^2)_{\infty}}.$$

Using (2.3.7) yields Theorem 2.3.6.

10.2 Case of affine type $D_{n+1}^{(2)}$ ($n \geq 2$)

The crystal graph of the vector representation \mathcal{B} of $D_{n+1}^{(1)}$ ($n \geq 2$) is the following,

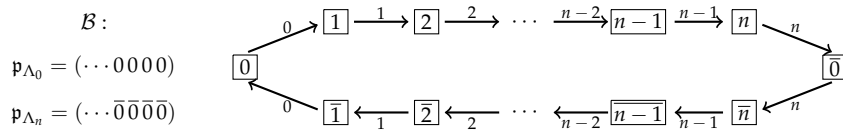

FIGURE 10.3: Crystal graph \mathcal{B} of the vector representation for type $D_{n+1}^{(2)}$ ($n \geq 2$)

with $\overline{\text{wt}}(0) = \overline{\text{wt}}(\bar{0}) = 0$ and for all $u \in \{1, \dots, n\}$,

$$-\overline{\text{wt}}(\bar{u}) = \overline{\text{wt}}u = \sum_{i=u}^n \alpha_i. \tag{10.2.1}$$

Here, we have $\delta = \sum_{i=0}^n \alpha_i$. We thus obtain the following crystal graph for $\mathcal{B} \otimes \mathcal{B}$

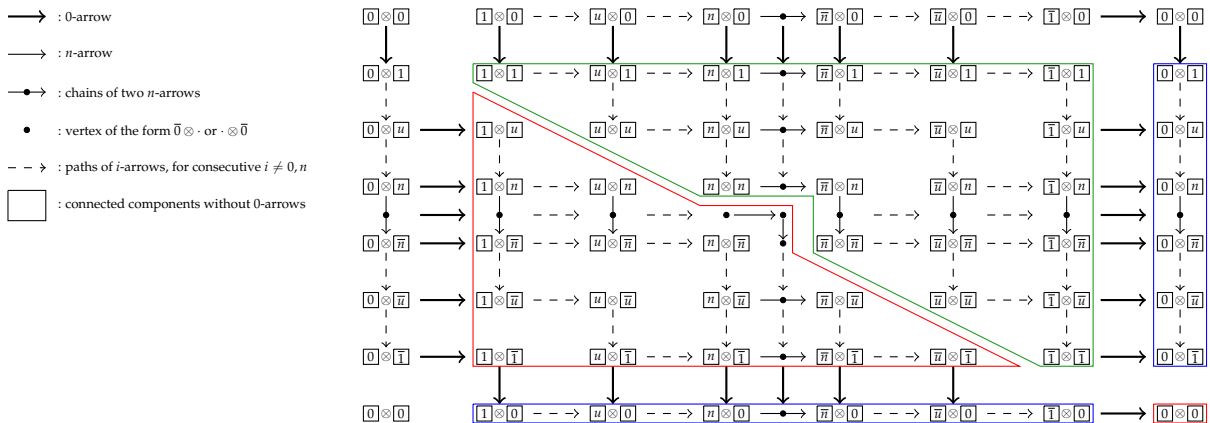

FIGURE 10.4: Crystal graph of $\mathcal{B} \otimes \mathcal{B}$ for type $D_{n+1}^{(2)}$ ($n \geq 2$)

Consider the set of states $\mathcal{C} = \{c_1, \dots, c_n, c_{\bar{0}}, c_{\bar{n}}, \dots, c_{\bar{1}}, c_0\}$. By setting $\epsilon'(c_u, c_v) = H(v \otimes u)$ and $H(0 \otimes 0) = 0$, this yields the following energy matrix for ϵ' :

$$\begin{matrix} & c_1 & \cdots & c_n & c_{\bar{0}} & c_{\bar{n}} & \cdots & c_{\bar{1}} & c_0 \\ \begin{matrix} c_1 \\ \vdots \\ c_n \\ c_{\bar{0}} \\ c_{\bar{n}} \\ \vdots \\ c_{\bar{1}} \\ c_0 \end{matrix} & \begin{pmatrix} 2 & \cdots & 2 & 2 & 2 & \cdots & 2 & 1 \\ \vdots & \ddots & \vdots & \vdots & \vdots & 2^* & \vdots & \vdots \\ 0 & \cdots & 2 & 2 & 2 & \cdots & 2 & 1 \\ 0 & \cdots & 0 & 0 & 2 & \cdots & 2 & 1 \\ 0 & \cdots & 0 & 0 & 2 & \cdots & 2 & 1 \\ \vdots & 0^* & \vdots & \vdots & \vdots & \ddots & \vdots & \vdots \\ 0 & \cdots & 0 & 0 & 0 & \cdots & 2 & 1 \\ 1 & \cdots & 1 & 1 & 1 & \cdots & 1 & 0 \end{pmatrix} \end{matrix}. \quad (10.2.2)$$

10.2.1 Character for Λ_0

In the following, the ground is set to be $c_g = c_0 = 1$. We obtain the energy matrix in (10.2.2) by considering the energy matrix for ϵ

$$\begin{matrix} & c_1 & \cdots & c_n & c_{\bar{0}} & c_{\bar{n}} & \cdots & c_{\bar{1}} & c_0 \\ \begin{matrix} c_1 \\ \vdots \\ c_n \\ c_{\bar{0}} \\ c_{\bar{n}} \\ \vdots \\ c_{\bar{1}} \\ c_0 \end{matrix} & \begin{pmatrix} 1 & \cdots & 1 & 1 & 1 & \cdots & 1 & 1 \\ \vdots & \ddots & \vdots & \vdots & \vdots & 1^* & \vdots & \vdots \\ 0 & \cdots & 1 & 1 & 1 & \cdots & 1 & 1 \\ 0 & \cdots & 0 & 0 & 1 & \cdots & 1 & 1 \\ 0 & \cdots & 0 & 0 & 1 & \cdots & 1 & 1 \\ \vdots & 0^* & \vdots & \vdots & \vdots & \ddots & \vdots & \vdots \\ 0 & \cdots & 0 & 0 & 0 & \cdots & 1 & 1 \\ 0 & \cdots & 0 & 0 & 0 & \cdots & 0 & 0 \end{pmatrix} \end{matrix}$$

followed by the transformation

$$(q, c_{\bar{0}}, c_1, c_{\bar{1}}, \dots, c_n, c_{\bar{n}}) \mapsto (q^2, c_{\bar{0}}q^{-1}, c_1q^{-1}, c_{\bar{1}}q^{-1}, \dots, c_nq^{-1}, c_{\bar{n}}q^{-1}). \quad (10.2.3)$$

By applying Theorem 2.2.24 to the corresponding flat partitions with ground c_0 and energy ϵ , this leads to the generation function

$$\sum_{\pi \in \mathcal{F}_1^{\epsilon, c_g}} C(\pi)q^{|\pi|} = \sum_{\pi \in \mathcal{R}_1^{\epsilon, c_g}} C(\pi)q^{|\pi|} = \frac{(-c_1q, -c_{\bar{1}}q, \dots, -c_nq, -c_{\bar{n}}q; q)_\infty}{(c_{\bar{0}}q; q)_\infty}.$$

In fact, by the definition of the energy ϵ , one can view the partitions of $\mathcal{R}_1^{\epsilon, c_g}$ as the finite sub-sequences, ending with 0_{c_0} , of the infinite sequence

$$\cdots \succ_\epsilon 3_{c_1} \succ_\epsilon 2_{c_{\bar{1}}} \succ_\epsilon \cdots \succ_\epsilon 2_{c_1} \succ_\epsilon 1_{c_{\bar{1}}} \succ_\epsilon \cdots \succ_\epsilon 1_{c_{\bar{n}}} \succ_\epsilon 1_{c_{\bar{0}}} \succ_\epsilon 1_{c_n} \succ_\epsilon \cdots \succ_\epsilon 1_{c_1} \succ_\epsilon 0_{c_0}.$$

with the particles $k_{c_{\bar{0}}}$ possibly repeated. Using (10.2.3), we then have that the flat partitions with ground c_0 and energy ϵ' are generated by the function

$$\frac{(-c_1q, -c_{\bar{1}}q, \dots, -c_nq, -c_{\bar{n}}q; q^2)_\infty}{(c_{\bar{0}}q; q^2)_\infty}.$$

By Theorem 8.2.4, (10.2.1) and the fact that $c_{\bar{0}} = 1$ with the convention of Theorem 8.2.4, we finally obtain the formula for the character in Theorem 2.3.7 corresponding to Λ_0 . As for the case $A_{2n}^{(2)}$ ($n \geq 2$), the character formula can be obtained by (2.3.7) with $t = D = 1$ and $d = 2$ and ground c_0 .

10.2.2 Character for Λ_n

Here we set the ground to be $c_g = c_{\bar{0}} = 1$. The energy matrix in (10.2.2) is obtained by considering the energy matrix of ϵ

$$\begin{matrix} & c_1 & \cdots & c_n & c_{\bar{0}} & c_{\bar{n}} & \cdots & c_{\bar{1}} & c_0 \\ c_1 & \left(\begin{array}{ccccccc} 1 & \cdots & 1 & 1 & 0 & \cdots & 0 & 0 \\ \vdots & \ddots & \vdots & \vdots & \vdots & 0^* & \vdots & \vdots \\ 0 & \cdots & 1 & 1 & 0 & \cdots & 0 & 0 \\ 0 & \cdots & 0 & 0 & 0 & \cdots & 0 & 0 \\ 1 & \cdots & 1 & 1 & 1 & \cdots & 1 & 1 \\ \vdots & \vdots & 1^* & \vdots & \vdots & \ddots & \vdots & \vdots \\ 1 & \cdots & 1 & 1 & 0 & \cdots & 1 & 1 \\ 1 & \cdots & 1 & 1 & 0 & \cdots & 0 & 0 \end{array} \right) & \equiv & \begin{matrix} c_{\bar{n}} & \cdots & c_{\bar{1}} & c_0 & c_1 & \cdots & c_n & c_{\bar{0}} \\ c_{\bar{n}} & \left(\begin{array}{ccccccc} 1 & \cdots & 1 & 1 & 1 & \cdots & 1 & 1 \\ \vdots & \ddots & \vdots & \vdots & \vdots & 1^* & \vdots & \vdots \\ 0 & \cdots & 1 & 1 & 1 & \cdots & 1 & 1 \\ 0 & \cdots & 0 & 0 & 1 & \cdots & 1 & 1 \\ 0 & \cdots & 0 & 0 & 1 & \cdots & 1 & 1 \\ \vdots & \vdots & 0^* & \vdots & \vdots & \ddots & \vdots & \vdots \\ 0 & \cdots & 0 & 0 & 0 & \cdots & 1 & 1 \\ 0 & \cdots & 0 & 0 & 0 & \cdots & 0 & 0 \end{array} \right) & , & \end{matrix} \end{matrix}$$

followed by the transformation

$$(q, c_0, c_{\bar{1}}, \dots, c_{\bar{n}}) \mapsto (q^2, c_0 q^{-1}, c_{\bar{1}} q^{-2}, \dots, c_{\bar{n}} q^{-2}). \tag{10.2.4}$$

Here the particle k_{c_0} for ϵ is transformed into $(2k-1)_{c_0}$ for ϵ' , and the particle $k_{c_{\bar{i}}}$ into $(2k-2)_{c_{\bar{i}}}$. Since $c_{\bar{0}}$ and c_i are not modified, the particle k_c then becomes $(2k)_c$ for any $c \in \{c_{\bar{0}}, c_i : i \in \{1, \dots, n\}\}$.

Applying Theorem 2.2.24 to the flat partitions with ground $c_{\bar{0}}$ and energy ϵ , this leads to the generating function

$$\sum_{\pi \in \mathcal{F}_1^{\epsilon, c_g}} C(\pi) q^{|\pi|} = \sum_{\pi \in \mathcal{R}_1^{\epsilon, c_g}} C(\pi) q^{|\pi|} = \frac{(-c_1 q, -c_{\bar{1}} q, \dots, -c_n q, -c_{\bar{n}} q; q)_\infty}{(c_0 q; q)_\infty}.$$

In fact, by the definition of the energy ϵ , one can view the partitions of $\mathcal{R}_1^{\epsilon, c_g}$ as the finite sub-sequences, ending with $0_{c_{\bar{0}}}$, of the infinite sequence

$$\cdots \succ_\epsilon 3_{c_{\bar{n}}} \succ_\epsilon 2_{c_n} \succ_\epsilon \cdots \succ_\epsilon 2_{c_{\bar{n}}} \succ_\epsilon 1_{c_n} \succ_\epsilon \cdots \succ_\epsilon 1_{c_1} \succ_\epsilon 1_{c_0} \succ_\epsilon 1_{c_{\bar{1}}} \succ_\epsilon \cdots \succ_\epsilon 1_{c_{\bar{n}}} \succ_\epsilon 0_{c_{\bar{0}}},$$

with the particles k_{c_0} possibly repeated. Using (10.2.4), the flat partitions with ground $c_{\bar{0}}$ and energy ϵ' are generated by the function

$$\frac{(-c_1 q^2, -c_{\bar{1}}, \dots, -c_n q^2, -c_{\bar{n}}; q^2)_\infty}{(c_0 q; q^2)_\infty}.$$

By Theorem 8.2.4, (10.2.1) and the fact that $c_0 = 1$ with the convention of Theorem 8.2.4, the formula for the character in Theorem 2.3.7 corresponding to Λ_n holds. This character formula can also be obtained by (2.3.7) with $t = D = 1$ and $d = 2$ and ground $c_{\bar{0}}$.

10.3 Case of affine type $A_{2n-1}^{(1)}$ ($n \geq 3$)

The crystal graph of the vector representation \mathcal{B} of $A_{2n-1}^{(2)}$ ($n \geq 3$) is the following,



FIGURE 10.5: Crystal graph \mathcal{B} of the vector representation for type $A_{2n-1}^{(2)}$ ($n \geq 3$)

and for all $u \in \{1, \dots, n\}$,

$$-\overline{\text{wt}}(\bar{u}) = \overline{\text{wt}}u = \frac{1}{2} \alpha_n + \sum_{i=u}^{n-1} \alpha_i. \tag{10.3.1}$$

1. When the sequences begin and end with $(2k-1)_{c_{\bar{1}}}$, there are an odd number of parts, and by gathering the pairs $(2k+1)_{c_1} \ll (2k-1)_{c_{\bar{1}}}$ after the first element (eventually no pairs), we obtain the series

$$\frac{c_{\bar{1}}q^{2k-1}}{(1 - c_{\bar{1}}c_1q^{4k})}.$$

2. In the same way, when the sequences begin and end with $(2k+1)_{c_1}$, then

$$\frac{c_1q^{2k+1}}{(1 - c_{\bar{1}}c_1q^{4k})}.$$

3. When the sequences have an even non zero number of parts, by taking pairwise and considering whether the sequences begin by either $(2k-1)_{c_{\bar{1}}}$ or $(2k+1)_{c_1}$, we obtain

$$\frac{2c_{\bar{1}}c_1q^{4k}}{(1 - c_{\bar{1}}c_1q^{4k})}.$$

4. Finally, in absence of both $(2k-1)_{c_{\bar{1}}}$ and $(2k+1)_{c_1}$, the generating function is 1.

Gathering these 4 cases, the generating function of such sequences (possibly empty or having one element) for a fixed positive integer k is

$$\frac{(1 + c_{\bar{1}}q^{2k-1})(1 + c_1q^{2k+1})}{(1 - c_{\bar{1}}c_1q^{4k})}. \quad (10.3.4)$$

Note that, for $k = 0$, only the sequence $(1_{c_1}, (-1)_{c_{\bar{1}}}, 1_{c_1})$ can occur at the tail of the partitions grounded in $c_{\bar{1}}, c_1$, but not the sequence $((-1)_{c_{\bar{1}}}, 1_{c_1}, (-1)_{c_{\bar{1}}}, 1_{c_1})$. We then obtain, without the condition on the even number of parts, that the generation function is

$$(1 + c_1q) \cdot \frac{(-c_1q^3, -c_{\bar{1}}q, -c_2q, -c_{\bar{2}}q, \dots, -c_nq, -c_{\bar{n}}q; q^2)}{(c_{\bar{1}}c_1q^4; q^4)} = \frac{(-c_1q, -c_{\bar{1}}q, \dots, -c_nq, -c_{\bar{n}}q; q^2)}{(c_{\bar{1}}c_1q^4; q^4)}.$$

The partitions in ${}^2\mathcal{P}_{c_{\bar{1}}c_1}^{\gg}$ having an even number of parts, so that

$$\sum_{{}^2\mathcal{P}_{c_{\bar{1}}c_1}^{\gg}} C(\pi)q^{|\pi|} = \frac{(-c_1q, -c_{\bar{1}}q, \dots, -c_nq, -c_{\bar{n}}q; q^2) + (c_1q, c_{\bar{1}}q, \dots, c_nq, c_{\bar{n}}q; q^2)}{2(c_{\bar{1}}c_1q^4; q^4)}. \quad (10.3.5)$$

We obtain $e^{-\Lambda_0} \text{ch}(L(\Lambda_0))$ by using (2.3.7) and setting $q = e^{-\frac{\delta}{2}}$ and $c_b = e^{\overline{wt}b}$.

10.3.2 Character for Λ_1

We follows the same reasoning as before. Recall that the ground state path of Λ_1 is $(g_k)_{k=0}^{\infty}$ with $g_{2k+1} = \bar{1}$ and $g_{2k} = 1$ for all $k \geq 0$. Hence, $H_{\Lambda_1} = H$, and by setting $D = 2$, we have by (2.3.4) that $u^0 = 1$ and $u^{(1)} = -1$. Here we consider the set of multi-grounded partitions with ground $c_1, c_{\bar{1}}$ corresponding to ${}^2\mathcal{P}_{c_1c_{\bar{1}}}^{\gg}$. We have almost the set of partitions as in ${}^2\mathcal{P}_{c_{\bar{1}}c_1}^{\gg}$, except that the tail is always $1_{c_1}, (-1)_{\bar{1}}$, and we can have the sequence $((-1)_{\bar{1}}, 1_{c_1}, (-1)_{\bar{1}})$ at the tail, but not $(1_{c_1}, (-1)_{\bar{1}}, 1_{c_1}, (-1)_{\bar{1}})$.

The generating function without the parity of the number of parts is given by

$$(1 + c_{\bar{1}}q^{-1}) \cdot \frac{(-c_1q^3, -c_{\bar{1}}q, -c_2q, -c_{\bar{2}}q, \dots, -c_nq, -c_{\bar{n}}q; q^2)}{(c_{\bar{1}}c_1q^4; q^4)} = \frac{(-c_1q^3, -c_{\bar{1}}q^{-1}, -c_2q, -c_{\bar{2}}q, \dots, -c_nq, -c_{\bar{n}}q; q^2)}{(c_{\bar{1}}c_1q^4; q^4)}.$$

The partitions in ${}^2\mathcal{P}_{c_1c_{\bar{1}}}^{\gg}$ having an even number of parts leads to the identity

$$\sum_{{}^2\mathcal{P}_{c_1c_{\bar{1}}}^{\gg}} C(\pi)q^{|\pi|} = \frac{(-c_1q^3, -c_{\bar{1}}q^{-1}, -c_2q, -c_{\bar{2}}q, \dots, -c_nq, -c_{\bar{n}}q; q^2) + (c_1q^3, c_{\bar{1}}q^{-1}, c_2q, c_{\bar{2}}q, \dots, c_nq, c_{\bar{n}}q; q^2)}{2(c_{\bar{1}}c_1q^4; q^4)}. \quad (10.3.6)$$

We obtain $e^{-\Lambda_1} \text{ch}(L(\Lambda_1))$ by using (2.3.7) and setting $q = e^{-\frac{\delta}{2}}$ and $c_b = e^{\overline{wt}b}$.

10.4 Case of affine type $B_n^{(1)} (n \geq 3)$

The crystal graph of the vector representation \mathcal{B} of $B_n^{(1)} (n \geq 3)$ is the following,

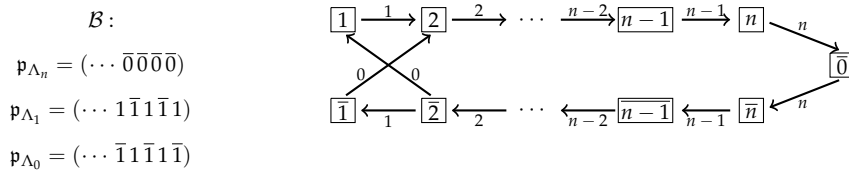

FIGURE 10.7: Crystal graph \mathcal{B} of the vector representation for type $B_n^{(1)} (n \geq 3)$

with $\overline{\text{wt}}(\bar{0}) = 0$ and for all $u \in \{1, \dots, n\}$,

$$-\overline{\text{wt}}(\bar{u}) = \overline{\text{wt}}u = \sum_{i=u}^n \alpha_i. \tag{10.4.1}$$

Here $\delta = \alpha_0 + \alpha_1 + 2\sum_{i=2}^n \alpha_i$. We thus obtain the following crystal graph for $\mathcal{B} \otimes \mathcal{B}$

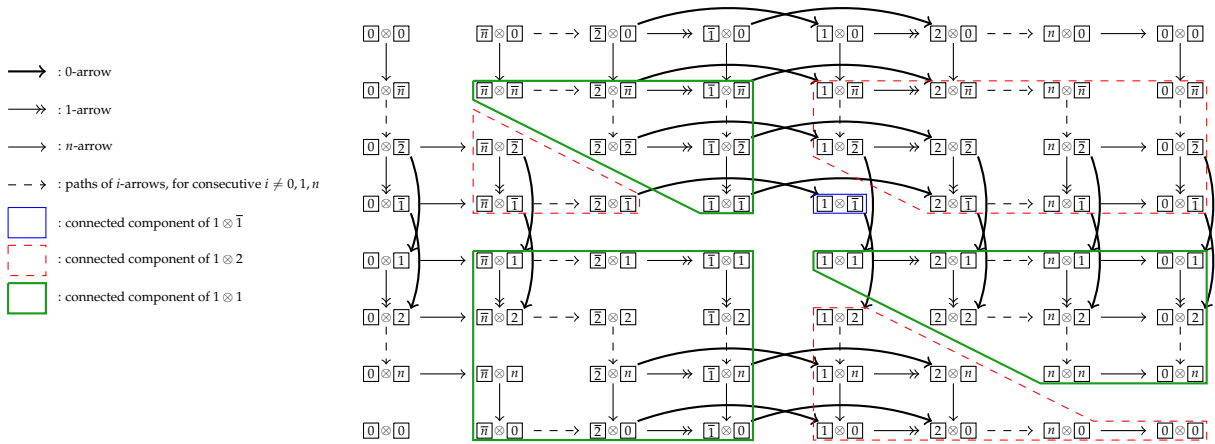

FIGURE 10.8: Crystal graph of $\mathcal{B} \otimes \mathcal{B}$ for type $B_n^{(1)} (n \geq 3)$

10.4.1 Character for Λ_n

Here, the only suitable ground to apply Theorem 8.2.4 is $c_{\bar{0}}$. Consider $\mathcal{C} = \{c_1, \dots, c_n, c_{\bar{n}}, \dots, c_{\bar{1}}, c_{\bar{0}}\}$. By setting $\epsilon'(c_u, c_v) = H(v \otimes u)$ and $H(\bar{0} \otimes \bar{0}) = 0$, we obtain the following energy matrix for ϵ' :

$$\begin{matrix} & c_{\bar{n}} & \cdots & c_{\bar{2}} & c_{\bar{1}} & c_1 & c_2 & \cdots & c_n & c_{\bar{0}} \\ c_{\bar{n}} & \left(\begin{array}{cccccccccc} 1 & \cdots & 1 & 1 & 0 & 0 & \cdots & 0 & 0 \\ \vdots & & \vdots & \vdots & \vdots & \vdots & 0^* & \vdots & \vdots \\ 0 & \cdots & 1 & 1 & 0 & 0 & \cdots & 0 & 0 \\ 0 & \cdots & 0 & 1 & -1 & 0 & \cdots & 0 & 0 \\ 1 & \cdots & 1 & 1 & 1 & 1 & \cdots & 1 & 1 \\ 1 & \cdots & 1 & 1 & 0 & 1 & \cdots & 1 & 1 \\ \vdots & & \vdots & \vdots & \vdots & \vdots & \ddots & \vdots & \vdots \\ c_n & \left(\begin{array}{cccccccccc} 1 & \cdots & 1 & 1 & 0 & 0 & \cdots & 1 & 1 \\ c_{\bar{0}} & \left(\begin{array}{cccccccccc} 1 & \cdots & 1 & 1 & 0 & 0 & \cdots & 0 & 0 \end{array} \right) \end{array} \right) \end{matrix} \cdot$$

This energy matrix can be obtained by taking the energy matrix of ϵ defined by

$$\begin{matrix} c_{\bar{n}} & \cdots & c_{\bar{2}} & c_{\bar{1}} & c_1 & c_2 & \cdots & c_n & c_{\bar{0}} \\ c_{\bar{n}} & \left(\begin{array}{cccccccc} 1 & \cdots & 1 & 1 & 1 & 1 & \cdots & 1 & 1 \\ \vdots & & \vdots & \vdots & \vdots & \vdots & 1^* & \vdots & \vdots \\ c_{\bar{2}} & 0 & \cdots & 1 & 1 & 1 & \cdots & 1 & 1 \\ c_{\bar{1}} & 0 & \cdots & 0 & 1 & 0 & \cdots & 1 & 1 \\ c_1 & 0 & \cdots & 0 & 0 & 1 & \cdots & 1 & 1 \\ c_2 & 0 & \cdots & 0 & 0 & 0 & \cdots & 1 & 1 \\ \vdots & \vdots & 0^* & \vdots & \vdots & \vdots & \ddots & \vdots & \vdots \\ c_n & 0 & \cdots & 0 & 0 & 0 & \cdots & 1 & 1 \\ c_{\bar{0}} & 0 & \cdots & 0 & 0 & 0 & \cdots & 0 & 0 \end{array} \right) , \end{matrix}$$

followed by the transformation

$$(q, c_{\bar{1}}, \dots, c_{\bar{n}}) \mapsto (q, c_{\bar{1}}q^{-1}, \dots, c_{\bar{n}}q^{-1}). \quad (10.4.2)$$

Here the particle $k_{c_{\bar{i}}}$ for ϵ is transformed into $(k-1)_{c_{\bar{i}}}$ for ϵ' . The other particles k_c remain unchanged. By setting the ground $c_g = c_{\bar{0}} = 1$, we can apply Theorem 2.2.24 to the flat partitions generated by ϵ . This results in the generation function

$$\sum_{\pi \in \mathcal{F}_1^{\epsilon, c_g}} C(\pi)q^{|\pi|} = \sum_{\pi \in \mathcal{R}_1^{\epsilon, c_g}} C(\pi)q^{|\pi|} = \frac{(-c_1q, -c_{\bar{1}}q, \dots, -c_nq, -c_{\bar{n}}q; q)_\infty}{(c_1c_{\bar{1}}q^2; q^2)_\infty}.$$

In fact, by the definition of the energy ϵ , one can view the partitions of $\mathcal{R}_1^{\epsilon, c_g}$ as the finite sub-sequences, ending with $0_{c_{\bar{0}}}$, of the infinite sequence

$$\cdots \succ_\epsilon 3_{c_{\bar{n}}} \succ_\epsilon 2_{c_n} \succ_\epsilon \cdots \succ_\epsilon 2_{c_{\bar{n}}} \succ_\epsilon 1_{c_n} \succ_\epsilon \cdots \succ_\epsilon 1_{c_2} \succ_\epsilon 1_{c_{\bar{1}}} \succ_\epsilon 1_{c_1} \succ_\epsilon 1_{c_{\bar{1}}} \succ_\epsilon 1_{c_2} \succ_\epsilon \cdots \succ_\epsilon 1_{c_{\bar{n}}} \succ_\epsilon 0_{c_{\bar{0}}},$$

with the additional condition that we have possibly alternating sub-sequences of the form

$$\cdots \succ_\epsilon k_{c_1} \succ_\epsilon k_{c_{\bar{1}}} \succ_\epsilon k_{c_1} \succ_\epsilon k_{c_{\bar{1}}} \succ_\epsilon \cdots$$

By reasoning on the parity of the length and the first element, the generating function of such alternating sequences for a fixed potential k , possibly empty or reduced to one element, is equal to

$$\frac{(1 + c_1q^k)(1 + c_{\bar{1}}q^k)}{1 - c_1c_{\bar{1}}q^{2k}}.$$

Using (10.4.2), we then have that the flat partitions with ground c_g and energy ϵ' are generated by the function

$$\frac{(-c_1q, -c_{\bar{1}}, \dots, -c_nq, -c_{\bar{n}}; q)_\infty}{(c_1c_{\bar{1}}q; q^2)_\infty}.$$

Using Theorem 8.2.4 and (10.4.1), we obtain the formula for the character corresponding to Λ_n in Theorem 2.3.9.

10.4.2 Character for Λ_0

We proceed exactly as we did for the type $A_{2n-1}^{(1)}$ ($n \geq 3$), all the combinatorial elements are defined in the same way. Here, we only add the color c_0 , the part colored by c_0 being odd, and with the fact that the the part $(2k+1)_{c_0}$ can appear several times, and $\overline{\text{wt}}0 = 0$, we obtain

$$\sum_{\pi \in \frac{1}{2}\mathcal{P}_{c_1}^{\geq c_1}} C(\pi)q^{|\pi|} = \frac{1}{2(c_{\bar{1}}c_1q^4; q^4)} \left(\frac{(-c_1q, -c_{\bar{1}}q, \dots, -c_nq, -c_{\bar{n}}q; q^2)}{(c_0q; q^2)} + \frac{(c_1q, c_{\bar{1}}q, \dots, c_nq, c_{\bar{n}}q; q^2)}{(-c_0q; q^2)} \right).$$

By taking $c_1 c_{\bar{1}} = c_0 = 1$, we then obtain

$$\sum_{\pi \in {}_2\mathcal{P}_{\bar{1}c_1}^{\geq}} C(\pi)q^{|\pi|} = \frac{1}{2} \left((-q, -c_1q, -c_{\bar{1}}q, \dots, -c_nq, -c_{\bar{n}}q; q^2) + (q, c_1q, c_{\bar{1}}q, \dots, c_nq, c_{\bar{n}}q; q^2) \right) \quad (10.4.3)$$

and we conclude with Theorem 2.3.1.

10.4.3 Character for Λ_1

We reason as before and by taking $c_1 c_{\bar{1}} = c_0 = 1$, this yields

$$\sum_{\pi \in {}_2\mathcal{P}_{\bar{1}c_1}^{\geq}} C(\pi)q^{|\pi|} = \frac{1}{2} \left((-q, -c_1q^3, -c_{\bar{1}}q^{-1}, -c_2q, -c_{\bar{2}}q, \dots, -c_nq, -c_{\bar{n}}q; q^2) + (q, c_1q^3, c_{\bar{1}}q^{-1}, c_2q, c_{\bar{2}}q, \dots, c_nq, c_{\bar{n}}q; q^2) \right) \quad (10.4.4)$$

resulting in Theorem 2.3.1.

10.5 Case of affine type $D_n^{(1)} (n \geq 4)$

The crystal graph of the vector representation \mathcal{B} of $D_n^{(1)} (n \geq 4)$ is the following,

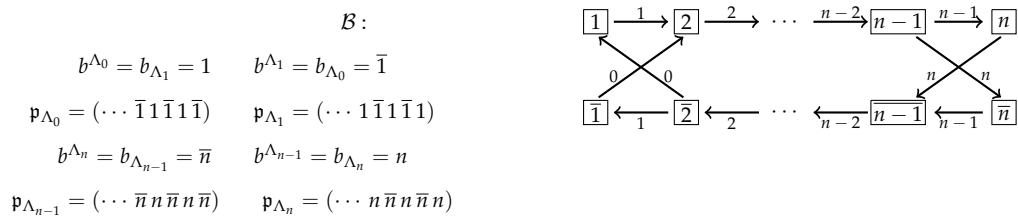

FIGURE 10.9: Crystal graph \mathcal{B} of the vector representation for type $D_n^{(1)} (n \geq 4)$

and for all $u \in \{1, \dots, n\}$,

$$-\overline{\text{wt}}(\bar{u}) = \overline{\text{wt}}u = \frac{1}{2}(\alpha_n - \alpha_{n-1}) + \sum_{i=u}^{n-1} \alpha_i. \quad (10.5.1)$$

Here,

$$\delta = \alpha_0 + \alpha_1 + \alpha_{n-1} + \alpha_n + 2 \sum_{i=2}^{n-2} \alpha_i.$$

With the convention $n - 1 \equiv -1$ this gives the crystal graph

By taking $c_1 c_{\bar{1}} = c_n c_{\bar{n}} = 1$, this yields

$$\sum_{\pi \in {}_2\mathcal{P}_{c_{\bar{1}}c_1}^{\gg}} C(\pi)q^{|\pi|} = \frac{1}{2} \left((-c_1q, -c_{\bar{1}}q, \dots, -c_nq, -c_{\bar{n}}q; q^2) + (c_1q, c_{\bar{1}}q, \dots, c_nq, c_{\bar{n}}q; q^2) \right) \quad (10.5.2)$$

resulting in Theorem 2.3.1.

10.5.2 Character for Λ_1

Here

$$\sum_{\pi \in {}_2\mathcal{P}_{c_{\bar{1}}c_1}^{\gg}} C(\pi)q^{|\pi|} = \frac{1}{2} \left((-c_1q^3, -c_{\bar{1}}q^{-1}, -c_2q, -c_{\bar{2}}q, \dots, -c_nq, -c_{\bar{n}}q; q^2) + (c_1q^3, c_{\bar{1}}q^{-1}, c_2q, c_{\bar{2}}q, \dots, c_nq, c_{\bar{n}}q; q^2) \right) \quad (10.5.3)$$

and Theorem 2.3.1 follows.

10.5.3 Character for Λ_n

Since $H(\bar{0} \otimes 0) = H(0 \otimes \bar{0}) = 0$, $H_{\Lambda_n} = H$, and $u^{(0)} = u^{(1)} = 0$ irrespective of the choice of D . In particular, by choosing $D = d = 1$ and reasoning on the tail of the multi-grounded partitions in ${}_2\mathcal{P}_{c_n c_{\bar{n}}}^{\gg}$ as for the case of $A_{2n-1}^{(2)}$, it follows that

$$\begin{aligned} \sum_{\pi \in {}_2\mathcal{P}_{c_n c_{\bar{n}}}^{\gg}} C(\pi)q^{|\pi|} &= \frac{1}{2(c_1 c_{\bar{1}} q; q^2)(c_n c_{\bar{n}} q^2; q^2)} \left((-c_1q, -c_{\bar{1}}q, \dots, -c_{-1}q, -c_{\bar{-1}}q, -c_nq, -c_{\bar{n}}q) \right. \\ &\quad \left. + (c_1q, c_{\bar{1}}q, \dots, c_{-1}q, c_{\bar{-1}}q, c_nq, c_{\bar{n}}q; q) \right) \end{aligned} \quad (10.5.4)$$

and Theorem 2.3.1, with the convention $c_b = e^{\overline{wt}b}$ which gives $c_1 c_{\bar{1}} = c_n c_{\bar{n}} = 1$, together with (2.3.7), result in the expected generating function.

10.5.4 Character for Λ_{n-1}

As before, it follows that

$$\begin{aligned} \sum_{\pi \in {}_2\mathcal{P}_{c_{\bar{n}}c_n}^{\gg}} C(\pi)q^{|\pi|} &= \frac{1}{2(c_1 c_{\bar{1}} q; q^2)(c_n c_{\bar{n}} q^2; q^2)} \left((-c_1q, -c_{\bar{1}}q, \dots, -c_{-1}q, -c_{\bar{-1}}q, -c_n, -c_{\bar{n}}q; q) \right. \\ &\quad \left. + (c_1q, c_{\bar{1}}q, \dots, c_{-1}q, c_{\bar{-1}}q, c_n, c_{\bar{n}}q; q) \right) \end{aligned} \quad (10.5.5)$$

and we conclude with (2.3.7).

Part IV

Appendices

Appendix A

Proofs of technical lemmas and propositions

A.1 Beyond Göllnitz's theorem

A.1.1 Proof of Lemma 3.1.4

To prove (3.1.7), we observe that, for any $(l_p, k_q) \in \mathcal{P} \times \mathcal{S}$, by (2.2.12),

$$l_p \not\triangleright k_q \iff l_p \not\triangleleft (k+1)_q,$$

and

$$\begin{aligned} (k+1)_q \gg (l-1)_p &\iff (k+1)_q \succ l_p \\ &\iff (k+1)_q \not\triangleleft l_p. \end{aligned}$$

To prove (3.1.8), we first remark that, by (3.1.3), $\alpha(k_q) = \beta((k+1)_q)$. We then obtain by (2.2.12) that

$$l_p \gg \alpha(k_q) \iff (l-1)_p \succeq \alpha(k_q)$$

and

$$\begin{aligned} \beta((k+1)_q) \not\triangleleft (l-1)_p &\iff \alpha(k_q) \not\triangleleft (l-1)_p \\ &\iff \alpha(k_q) \preceq (l-1)_p. \end{aligned}$$

A.1.2 Proof of Lemma 3.1.5

Let us consider $\min\{k-l : \beta(k_p) \succ \alpha(l_q)\}$. An abstract way to show (3.1.9) is to use the explicit formula

$$\Delta(p, q) = \chi(r \leq y) + \chi(r \leq x)\chi(s \leq y)$$

with $q = a_x a_y$ and $p = a_r a_s$. Recall that $x < y$ and $r < s$. In fact, by considering (2.2.6) and the lexicographic order \succ , one can check that the minimal difference between the secondary colors p and q for the relation \triangleright is

$$1 + \chi(p \leq q) = 1 + \chi(r < x) + \chi(r = x)\chi(s \leq y).$$

By definition (2.2.7),

$$\chi((p, q) \in \mathcal{SP}_\times) = \chi(r > y) + \chi(r < x)\chi(s > y)$$

so that, by (2.2.12), the minimal difference between the secondary colors p and q for the relation \gg is given by

$$1 + \chi(r < x) + \chi(r = x)\chi(s \leq y) - \chi((p, q) \in \mathcal{SP}_\times) = \chi(r \leq y) + \chi(r \leq x)\chi(s \leq y).$$

Now, we reason first according to the parity of k . For $k = 2u$, we have by (3.1.2) that $\alpha(k_p) = u_{a_s}$ and $\beta(k_p) = u_{a_r}$. In order to minimize $k-l$, $\alpha(l_q)$ and $\beta(l_q)$ have to be the greatest primary parts with color a_x and a_y smaller than u_{a_r} , in terms of \succ , so that, by (2.2.8), they must necessarily be the parts $(u - \chi(r \leq x))_{a_x}$ and $(u - \chi(r \leq y))_{a_y}$. We then obtain the difference

$$\chi(r \leq x) + \chi(r \leq y).$$

With the same reasoning for $k = 2u + 1$, since $\alpha(k_p) = (u + 1)_{a_r}$ and $\beta(k_p) = u_{a_s}$, we then reach the difference

$$1 + \chi(s \leq x) + \chi(s \leq y) \geq \chi(r \leq y) + \chi(s \leq y).$$

Since the minimum is reached either for k even or k odd, we then have that

$$\min\{k - l : \beta(k_p) \succ \alpha(l_q)\} \geq \min\{\chi(r \leq y) + \chi(s \leq y), \chi(r \leq x) + \chi(r \leq y)\}.$$

We finally consider the case $l = 2v$, so that $\alpha(l_q) = v_{a_y}$ and $\beta(l_q) = v_{a_x}$, and to minimize $k - l$, $\alpha(k_p)$ and $\beta(k_p)$ have to be the smallest primary parts with color a_r and a_s greater than v_{a_y} in terms of \succ , so that they must necessarily be the parts $(v + \chi(r \leq y))_{a_r}$ and $(v + \chi(s \leq y))_{a_s}$. We obtain the difference $\chi(r \leq y) + \chi(s \leq y)$ and then the inequality

$$\min\{k - l : \beta(k_p) \succ \alpha(l_q)\} \leq \min\{\chi(r \leq y) + \chi(s \leq y), \chi(r \leq x) + \chi(r \leq y)\}.$$

Since $\min\{\chi(r \leq y) + \chi(s \leq y), \chi(r \leq x) + \chi(r \leq y)\} = \chi(r \leq y) + \chi(r \leq x)\chi(s \leq y)$, we then have (3.1.9).

To prove (3.1.10), we have by (3.1.3) that $\alpha((l - 1)_q) = \beta(l_q)$. Since $\beta(k_p) \succ \beta(l_q) = \alpha((l - 1)_q)$, this then implies by (3.1.9) that $k_p \gg (l - 1)_q$, and this is equivalent to $(k + 1)_p \gg l_q$.

Let us now suppose that $k - l \geq \Delta(p, q)$. We just saw that this minimum value was reached at k or $k - 1$. Then if we do not have $\beta(k_p) \succ \alpha(l_q)$, we necessarily have $\beta((k - 1)_p) \succ \alpha((l - 1)_q) = \beta(l_q)$ by (3.1.3). Moreover, by (2.2.12), we have

$$\beta(k_p) \not\succeq \alpha(l_q) \iff \alpha(l_q) + 1 \gg \alpha((k - 1)_p),$$

so that we obtain (3.1.11). Suppose now that we have $k - l = \Delta(p, q)$. If $\beta(k_p) \succ \alpha(l_q)$ then we necessarily have

$$\beta(k_p) \succ \alpha(l_q) \succ \beta(l_q) \succeq \beta(k_p) - 1.$$

In fact, we saw that the minimal difference is obtained when the primary parts $\alpha(l_q)$ and $\beta(l_q)$ are the closest possible to $\beta(k_p)$ with the primary colors of q . If $\beta(k_p) \not\succeq \alpha(l_q)$, since we have $\beta(l_q) + 1 \succ \alpha(l_q)$, we also have

$$\beta(l_q) + 1 \succ \alpha(l_q) \succeq \beta(k_p).$$

In both cases, the relation (3.1.12) holds. If we have that $k - l - 1 \geq \Delta(p, q)$, then we necessarily have by (3.1.3) that

$$\beta(k_q) \succ \beta(l + 1)_q = \alpha(l_q).$$

A.1.3 Proof of Lemma 3.1.6

For any $v = (v_1, \dots, v_t) \in \mathcal{E}_2$ and any $i \in [1, t - 2]$, we have

$$v_i \triangleright \dots \triangleright v_j.$$

By (2.2.11), we have

$$v_i \succeq v_{i+1} + 1 \succeq \dots \succeq v_j + j - i \Rightarrow v_i \succeq v_j + j - i,$$

with a strict inequality as soon as we have v_i or v_j in \mathcal{S} , and we thus obtain (3.1.13).

A.1.4 Proof of Lemma 3.4.5

By definition, for all $i \in I$, $\mathbf{Br}_v(i) \in ([i, j] \cap I) \cup \{j\}$, for $j = \min(i, p + 2s + 1) \cap J$. This means that, for any $I \ni i' > j$,

$$\mathbf{Br}_v(i') \geq i' > j \geq \mathbf{Br}_v(i).$$

Let us now consider the function \mathbf{Br}_v on $[i, j] \cap I$. It is obvious that, for all $i' \in [i, j] \cap I$, we have $j = \min(i', p + 2s + 1) \cap J$.

- If $\mathbf{Br}_v(i) = i$, then

$$\mathbf{Br}_v(i') \geq i' \geq i = \mathbf{Br}_v(i).$$

- If we have $\mathbf{Br}_v(i) = j$, then by (3.4.4)

$$v_{u+1} \not\asymp v_j + \frac{j-u}{2} - 1$$

for all $u \in [i, j) \cap I$, and since $[i', j) \subset [i, j)$, we also obtain that $\mathbf{Br}_v(i') = j$.

- Finally, if $\mathbf{Br}_v(i) \in (i, j) \cap I$, then we have either $j > i' \geq \mathbf{Br}_v(i)$, or $i \leq i' < \mathbf{Br}_v(i)$. In the first case, we obtain

$$\mathbf{Br}_v(i') \geq i' \geq \mathbf{Br}_v(i).$$

In the second case, we observe that, by (3.4.5) and (3.4.6),

$$v_{u+1} \not\asymp v_{\mathbf{Br}_v(i)} + \frac{\mathbf{Br}_v(i) - u}{2} - 1$$

for all $u \in [i, \mathbf{Br}_v(i)) \cap I$, and in particular for all $u \in [i', \mathbf{Br}_v(i)) \cap I$. Thus, if $\mathbf{Br}_v(i') \neq j$, we necessarily have by (3.4.6) that $\mathbf{Br}_v(i') \geq \mathbf{Br}_v(i)$.

In any case, we have that $\mathbf{Br}_v(i') \geq \mathbf{Br}_v(i)$.

Let us now suppose that $\mathbf{Br}_v(i) \in I$. If $\mathbf{Br}_v(i) = i$, then $\mathbf{Br}_v(\mathbf{Br}_v(i)) = i = \mathbf{Br}_v(i)$. Otherwise, let us assume that $\mathbf{Br}_v(\mathbf{Br}_v(i)) > \mathbf{Br}_v(i)$.

- If $\mathbf{Br}_v(\mathbf{Br}_v(i)) = j$, this means that

$$v_{u+1} \not\asymp v_j + \frac{j-u}{2} - 1 \iff v_j + \frac{j-u}{2} - 1 \succeq v_{u+1}$$

for all $u \in [\mathbf{Br}_v(i), j) \cap I$. Since $v_{\mathbf{Br}_v(i)}$ and $v_{\mathbf{Br}_v(i)+1}$ have different primary colors and are consecutive with respect to \succ , we then obtain that $v_{\mathbf{Br}_v(i)+1} + 1 \succ v_{\mathbf{Br}_v(i)}$, so that

$$v_j + \frac{j - \mathbf{Br}_v(i)}{2} \succeq v_{\mathbf{Br}_v(i)}.$$

We also have by (3.4.5) and (3.4.6) that

$$v_{u+1} \not\asymp v_{\mathbf{Br}_v(i)} + \frac{\mathbf{Br}_v(i) - u}{2} - 1 \iff v_{\mathbf{Br}_v(i)} + \frac{\mathbf{Br}_v(i) - u}{2} - 1 \succeq v_{u+1}$$

for all $u \in [i, \mathbf{Br}_v(i)) \cap I$, so that

$$v_j + \frac{j-u}{2} - 1 \succeq v_{u+1} \iff v_{u+1} \not\asymp v_j + \frac{j-u}{2} - 1.$$

We then conclude by (3.4.4) that $\mathbf{Br}_v(i) = j$, which contradicts the fact that $\mathbf{Br}_v(i) \notin J$.

- For $\mathbf{Br}_v(\mathbf{Br}_v(i)) > \mathbf{Br}_v(i)$, we reason exactly in the same way, by replacing j by $\mathbf{Br}_v(\mathbf{Br}_v(i))$, and we obtain by (3.4.6) that $\mathbf{Br}_v(i) \geq \mathbf{Br}_v(\mathbf{Br}_v(i)) > \mathbf{Br}_v(i)$.

To conclude, we necessarily have that $\mathbf{Br}_v(\mathbf{Br}_v(i)) = \mathbf{Br}_v(i)$ for $\mathbf{Br}_v(i) \in I$.

A.1.5 Proof of Lemma 3.4.8

By (2.2.11), (2.2.12) and the fact that all the pairs in \mathcal{SP}_\times have distinct secondary colors, we have that for any $u \in [i, i') \cap I$

$$v_{u+2} + v_{u+3} + 1 \succ v_u + v_{u+1} \succ v_{u+2} + v_{u+3},$$

so that we obtain (3.4.10) recursively.

A.1.6 Proof of Lemma 3.4.9

By (3.1.12) of Lemma 3.1.5, we have for any $u \in [i, i') \cap I$ that

$$v_{u+3} + 1 \succeq v_{u+1},$$

so that we recursively have

$$v_{i'+1} + \frac{i' - u}{2} \succeq v_{u+1}.$$

By (3.4.7), if we suppose that $\mathbf{Br}_v(i') > i'$, we then have

$$v_{i'+1} \not\succeq v_{\mathbf{Br}_v(i')} + \frac{\mathbf{Br}_v(i') - i'}{2} - 1 \iff v_{\mathbf{Br}_v(i')} + \frac{\mathbf{Br}_v(i') - i'}{2} - 1 \succeq v_{i'+1},$$

and we obtain that

$$v_{\mathbf{Br}_v(i')} + \frac{\mathbf{Br}_v(i') - u}{2} - 1 \succeq v_{u+1} \iff v_{u+1} \not\succeq v_{\mathbf{Br}_v(i')} + \frac{\mathbf{Br}_v(i') - u}{2} - 1$$

for all $u \in [i, i'] \cap I$. Since the previous relation is also true for for all $u \in [i', \mathbf{Br}_v(i')] \cap I$, by (3.4.5) and (3.4.6), we have that $\mathbf{Br}_v(i') \leq \mathbf{Br}_v(i)$. Finally, by Lemma 3.4.5, the fact that \mathbf{Br}_v is non-decreasing on I gives that $\mathbf{Br}_v(i') = \mathbf{Br}_v(i)$.

A.1.7 Proof of Lemma 3.5.8

We can notice that for any pair (k_p, l_q) of secondary parts different from a pattern $cd \rightarrow ab$ and that satisfies $k_p \gg l_q$, we can always find an integer h such

$$k_p \succ h_{cd} \succeq l_q. \quad (\text{A.1.1})$$

This is obvious when $(p, q) \notin \mathcal{SP}_\times$. In fact,

$$k_p \gg l_q \iff k_p \succ (l+1)_q \succ l_q$$

and we can find a unique h_{cd} satisfying $(l+1)_q \succ h_{cd} \succeq l_q$. Note that if $q = cd$, we then have at least two possible integers $h = l, l+1$. Suppose now that $(p, q) \in \mathcal{SP}_\times$. Recall that here, we set $\{a_1 < a_2 < a_3 < a_4 < a_5\} = \{a < b < c < d < e\}$. We then have two kinds of pairs.

- First, we have the pairs $(a_i a_j, a_k a_l)$ with $5 \geq j > i > l > k \geq 1$, so that $i \geq 3$ and $l \leq 3$. Thus, $a_i a_j \geq cd$, while $a_k a_l \leq bc < cd$. If $a_i a_j \neq cd$, we have that $a_i a_j > cd$, and then

$$k_{a_i a_j} \succ k_{cd} \succ k_{a_k a_l}$$

and the property (A.1.1) is true for $(k_p, l_q) = (k_{a_i a_j}, k_{a_k a_l})$.

- The second kind of pair is of the form $(a_i a_j, a_k a_l)$ with $5 \geq j > l > k > i \geq 1$, so that $l \leq 4$ and $i \leq 2$. Thus, $a_i a_j \leq be < cd$, while $a_k a_l \leq cd$. We have that $a_i a_j > cd$, and then

$$(l+1)_{a_i a_j} \succ l_{cd} \succeq l_{a_k a_l}$$

and the property (A.1.1) is true for $(k_p, l_q) = ((l+1)_{a_i a_j}, l_{a_k a_l})$.

Let us now consider a pattern of secondary parts $(v_1, v_2, \dots, v_{2s-1}, v_{2s}, v_{2s+1}, v_{2s+2})$ with no moves $\rightarrow cd \rightarrow$.

If $v_1 + v_2, v_3 + v_4 \neq cd \rightarrow ab$, we recursively show on $1 \leq i \leq s$ that there exists h such that

$$v_1 + v_2 \succ (h+i-1)_{cd} \succ h_{cd} \succeq v_{2i+1} + v_{2i+2}. \quad (\text{A.1.2})$$

In fact, by (A.1.1), the previous statement holds for $i = 1$. Suppose now it holds by induction up to i . If $v_{2i+1} + v_{2i+2}, v_{2i+3} + v_{2i+4} \neq cd \rightarrow ab$, then by (A.1.1), we have h' such that

$$h_{cd} \succeq v_{2i+1} + v_{2i+2} \succ h'_{cd} \succeq v_{2i+3} + v_{2i+4}.$$

We thus have $h > h'$, and by choosing h' , we obtain

$$v_1 + v_2 \succ (h' + i)_{cd} \succ h'_{cd} \succeq v_{2i+3} + v_{2i+4}.$$

If $v_{2i+1} + v_{2i+2}, v_{2i+3} + v_{2i+4} = cd \rightarrow ab$, we then necessarily have that $v_{2i-1} + v_{2i} \triangleright v_{2i+1} + v_{2i+2}$ not to have the moves $\rightarrow cd \rightarrow$. Therefore, by setting $h_{cd} = v_{2i+1} + v_{2i+2}$, we have that $v_{2i-1} + v_{2i} \succ (h+1)_{cd}$.

Since the statement (A.1.2) also holds for $i - 1$, there exists h' such that

$$v_1 + v_2 \succ (h' + i - 2)_{cd} \succ h'_{cd} \succeq v_{2i-1} + v_{2i}.$$

We can then remark that $h' \geq h + 2$, and we conclude that

$$v_1 + v_2 \succ (h + i)_{cd} \succ h_{cd} \succeq v_{2i+3} + v_{2i+4}.$$

We have thus proved the statement (A.1.2) when the head is different from $cd \rightarrow ab$.

If the head is equal to $cd \rightarrow ab$, we then apply (A.1.2) on the pattern $(v_3, v_4, \dots, v_{2s-1}, v_{2s}, v_{2s+1}, v_{2s+2})$, and we obtain that there exists h such that

$$v_1 + v_2 \succ v_2 + v_3 \succ (h + i - 2)_{cd} \succ h_{cd} \succeq v_{2i+1} + v_{2i+2}$$

so that $v_1 + v_2 \succeq (h + i - 1)_{cd}$. In both cases, we always have that $v_1 + v_2 - s + 1 \succeq v_{2s+1} + v_{2s+2}$ so that

$$\overline{v_1 + v_2 - s + 1} \succeq \overline{v_{2s+1} + v_{2s+2}}.$$

By definition (3.5.8), $(v_1, v_2, \dots, v_{2s-1}, v_{2s}, v_{2s+1}, v_{2s+2})$ cannot be a shortcut. Since a pattern that does not contain the moves $\rightarrow cd \rightarrow$ does not have any subpattern that contains these moves, we then obtain our lemma.

A.1.8 Proof of Proposition 3.3.2

Let $\lambda = (\lambda_1, \dots, \lambda_t)$ be a partition in \mathcal{O} . Let us set c_1, \dots, c_t to be the primary colors of the parts $\lambda_1, \dots, \lambda_t$.

First Step 1 Now consider the first troublesome pair $(\lambda_i, \lambda_{i+1})$ at **Step 1** in Φ . We then set

$$\begin{aligned} \delta^1 &= \emptyset \\ \gamma^1 &= \lambda_1 \gg \dots \gg \lambda_i, \\ \mu^1 &= \lambda_{i+1} \succ \dots \succ \lambda_t. \end{aligned}$$

The first resulting secondary part is $\lambda_i + \lambda_{i+1}$.

First iterations of Step 2

- If there is a part λ_{i+2} after λ_{i+1} , we have that

$$\begin{aligned} \lambda_i + \lambda_{i+1} - \lambda_{i+2} &= \chi(c_i < c_{i+1}) + 2\lambda_{i+1} - \lambda_{i+2} && \text{by (3.1.6)} \\ &\geq \chi(c_i < c_{i+1}) + 2\chi(c_{i+1} \leq c_{i+2}) + \lambda_{i+2} && \text{by (2.2.8)} \\ &\geq 1 + \chi(c_i \leq c_{i+2}) + \chi(c_{i+1} \leq c_{i+2}). \end{aligned}$$

Since by (2.2.6), we have that $c_i > c_{i+2}$ and $c_{i+1} > c_{i+2}$ implies $c_i c_{i+1} > c_{i+2}$, we then have that $\lambda_i + \lambda_{i+1} - \lambda_{i+2} \geq 1 + \chi(c_i c_{i+1} \leq c_{i+2})$, and we conclude that $\lambda_i + \lambda_{i+1} \gg \lambda_{i+2}$. This means that if there is no iteration of **Step 2** (which happens if $i = 1$ or $\lambda_{i+1} \gg \lambda_i + \lambda_{i+1}$), then the secondary part is well-ordered with the primary part to its right.

- The primary parts of γ^1 are well-ordered by \gg . By (2.2.12) and (3.1.4), we have that for any $j < i$, if $\lambda_i + \lambda_{i+1}$ crosses λ_j after $i - j$ iterations of **Step 2**, we then have by (3.1.7) that

$$(\lambda_i + \lambda_{i+1} + i - j) \gg (\lambda_j - 1) \gg \dots \gg \lambda_{i-1} - 1.$$

- We also have by (2.2.12) that

$$\begin{aligned} \lambda_{i-1} \gg \lambda_i \succ \lambda_{i+1} \succ \lambda_{i+2} &\implies \lambda_{i-1} - 1 \succeq \lambda_i \succ \lambda_{i+1} \succ \lambda_{i+2} \\ &\implies \lambda_{i-1} - 1 \succ \lambda_{i+2}. \end{aligned}$$

If we can no longer apply **Step 2** after $i - j$ iterations, we then obtain (even when there is no crossing which means that $j = i$)

$$\lambda_1 \gg \cdots \gg \lambda_{j-1} \gg (\lambda_i + \lambda_{i+1} + i - j) \gg (\lambda_j - 1) \gg \cdots \gg \lambda_{i-1} - 1 \succ \lambda_{i+2} \succ \cdots \succ \lambda_t.$$

Second Step 1 Now, by applying **Step 1** for the second time, we see that the next troublesome pair is either $\lambda_{i-1} - 1, \lambda_{i+2}$, or $\lambda_{i+2+x}, \lambda_{i+3+x}$ for some $x \geq 0$.

- If $\lambda_{i-1} - 1 \not\gg \lambda_{i+2}$, this means that $(\lambda_{i-1} - 1, \lambda_{i+2})$ is a troublesome pair, and **Step 1** occurs there. We then set

$$\begin{aligned} \delta^2 &= \lambda_1 \gg \cdots \gg \lambda_{j-1} \gg (\lambda_i + \lambda_{i+1} + i - j) \\ \gamma^2 &= (\lambda_j - 1) \gg \cdots \gg \lambda_{i-1} - 1 \\ \mu^2 &= \lambda_{i+2} \succ \cdots \succ \lambda_t. \end{aligned}$$

By (3.1.10), we have that $(\lambda_i + \lambda_{i+1} + 1) \gg (\lambda_{i-1} + \lambda_{i+2} - 1)$. Then, even if $(\lambda_{i-1} + \lambda_{i+2} - 1)$ crosses the primary parts $(\lambda_j - 1) \gg \cdots \gg \lambda_{i-2} - 1$ after $i - j - 1$ iterations of **Step 2**, by (2.2.12), we will still have that

$$(\lambda_i + \lambda_{i+1} + i - j) \gg (\lambda_{i-1} + \lambda_{i+2} + i - j - 2).$$

We have before the third application of **Step 1** that

$$\begin{aligned} \delta^3 &= \lambda_1 \gg \cdots \gg (\lambda_i + \lambda_{i+1} + i - j) \gg \lambda_j - 1 \gg \cdots \gg \lambda_{j'-1} - 1 \gg (\lambda_{i-1} + \lambda_{i+2} - 2 + i - j') \\ \gamma^3, \mu^3 &= \lambda_{j'} - 2 \gg \cdots \gg \lambda_{i-2} - 2 \gg \lambda_{i+3} \succ \cdots \succ \lambda_t, \end{aligned}$$

for some $i - 1 \geq j' \geq j$. Observe that μ^3 is the tail of the partition $\lambda_{i+3} \succ \cdots \succ \lambda_t$.

- If $\lambda_{i-1} - 1 \gg \lambda_{i+2}$, then the next troublesome pair appears at $\lambda_{i+2+x}, \lambda_{i+3+x}$ for some $x \geq 0$, and it forms the secondary part $\lambda_{i+2+x} + \lambda_{i+3+x}$. We then set

$$\begin{aligned} \delta^2 &= \lambda_1 \gg \cdots \gg \lambda_{j-1} \gg (\lambda_i + \lambda_{i+1} + i - j) \\ \gamma^2 &= (\lambda_j - 1) \gg \cdots \gg \lambda_{i-1} - 1 \gg \lambda_{i+2} \gg \cdots \gg \lambda_{i+2+x} \\ \mu^2 &= \lambda_{i+x+3} \succ \cdots \succ \lambda_t. \end{aligned}$$

We also have

$$\lambda_i \succ \lambda_{i+1} \succ \lambda_{i+2} \gg \cdots \gg \lambda_{i+2+x} \succ \lambda_{i+3+x}.$$

By (2.2.12), we can easily check that

$$\lambda_i \succ \lambda_{i+1} \succ \lambda_{i+2} \succeq \lambda_{i+2+x} + x \succ \lambda_{i+3+x} + x$$

so that, by (3.1.9),

$$(\lambda_i + \lambda_{i+1}) \gg (\lambda_{i+2+x} + \lambda_{i+3+x} + 2x).$$

This means by (2.2.12) that,

$$(\lambda_i + \lambda_{i+1}) \gg (\lambda_{i+2+x} + \lambda_{i+3+x} + x)$$

and, as soon as $x \geq 1$, by (2.2.11)

$$(\lambda_i + \lambda_{i+1}) \triangleright (\lambda_{i+2+x} + \lambda_{i+3+x} + x).$$

We then obtain that, even if the secondary part $\lambda_{i+2+x} + \lambda_{i+3+x}$ crosses, after $x + i - j$ iterations of **Step 2**, the primary parts

$$\lambda_j - 1 \gg \cdots \gg (\lambda_{i-1} - 1) \gg \lambda_{i+2} \gg \cdots \gg \lambda_{i+1+x},$$

we still have

$$(\lambda_i + \lambda_{i+1} + i - j) \gg (\lambda_{i+2+x} + \lambda_{i+3+x} + x + i - j).$$

However, as soon as $x \geq 1$, we directly have

$$(\lambda_i + \lambda_{i+1} + i - j) \triangleright (\lambda_{i+2+x} + \lambda_{i+3+x} + x + i - j).$$

We thus obtain before the third application of **Step 1** that,

$$\begin{aligned} \delta^3 &= \lambda_1 \gg \cdots \gg (\lambda_i + \lambda_{i+1} + i - j) \gg \cdots \gg (\lambda_{i+2+x} + \lambda_{i+3+x} + x + i - j) \\ \gamma^3, \mu^3 &= \cdots \succ \lambda_{i+4+x} \succ \cdots \succ \lambda_t, \end{aligned}$$

for some $i + x \geq j' \geq j$. Observe that μ^3 is the tail of the partition $\lambda_{i+x+3} \succ \cdots \succ \lambda_t$. Moreover, we have the following inequalities

$$\begin{aligned} - \lambda_{j'-1} - 1 &\gg (\lambda_{i+2+x} + \lambda_{i+3+x} + x + i - j') \gg \lambda_{j'} - 2 \text{ for } x - 1 \geq j' \geq j, \\ - \lambda_{i-1} - 1 &\gg (\lambda_{i+2+x} + \lambda_{i+3+x} + x) \gg \lambda_{i+2} - 1 \text{ for } j' = i, \\ - \lambda_{j'+1} &\gg (\lambda_{i+2+x} + \lambda_{i+3+x} + x + i - j') \gg \lambda_{j'+2} - 1 \text{ for } x + i \geq j' \geq i + 1. \end{aligned}$$

Observe that the partition to the left of λ_{i+x+4} is well-ordered by \gg , so that μ^3 is the tail of the partition $\lambda_{i+x+4} \succ \cdots \succ \lambda_t$.

In both cases, the conditions in the proposition are satisfied. In fact, the partition δ^2 belongs to \mathcal{E} and is the head of the partition δ^3 that also belongs to \mathcal{E} , and the fourth statement is true. By comparing μ^1, μ^2 (and μ^3), the third statement is true since μ^2 is a strict tail of μ^1 . The two first statements directly come from the way we established the sequences, and the fact that $s(\delta^u) \gg g(\gamma^u)$ is true for $u = 2, 3$.

By induction, we only apply **Step 1** once to the troublesome pair $(s(\gamma^u), g(\mu^u))$ in the partition $\emptyset, \gamma^u, \mu^u \in \mathcal{O}$ and then some iterations of **Step 2**. We then obtain some sequence $\delta^{u+1}, \gamma^{u+1}, \mu^{u+1}$ with the same form as $(\delta^2, \gamma^2, \mu^2)$, and we set the triplet $(\delta^{u+1}, \gamma^{u+1}, \mu^{u+1}) = ((\delta^u, \delta^u), \gamma^u, \mu^u)$. Note that the sequence δ^u, δ^u is indeed a partition in \mathcal{E} by considering the process from the $(u-1)^{\text{th}}$ **Step 1**. Then, the sequence $(\delta^u, \gamma^u, \mu^u)$ becomes the sequence $(\delta^{u+1}, \gamma^{u+1}, \mu^{u+1})$ after applying **Step 1** once to the troublesome pair $(s(\gamma^u), g(\mu^u))$, and some iterations of **Step 2** by crossing the secondary part $s(\gamma^u) + g(\mu^u)$ with some primary parts of $\gamma^u \setminus \{s(\gamma^u)\}$. Proposition 3.3.2 follows naturally.

A.1.9 Proof of Proposition 3.3.4

Let us consider $\mathcal{E} \ni v = (v_1, \dots, v_t)$. If we suppose that the secondary parts of v are v_{i_1}, \dots, v_{i_S} for $i_1 < \cdots < i_S$, we can then set for all $v \in [1, S]$

$$\delta^v = v_1 \gg \cdots \gg v_{i_{S+1-v}}$$

and $\delta^{S+1} = \emptyset$. By setting $i = i_S$, we also have that

$$\begin{aligned} \delta^1 &= v_1 \gg \cdots \gg v_i \\ \gamma^1 &= v_{i+1} \gg \cdots \gg v_t \\ \mu^1 &= \emptyset. \end{aligned}$$

- If v_i crosses all the primary parts up to v_t after iterating **Step 1**, we have that

$$\beta(v_i - t + i + 1) \not\succeq v_t.$$

But, we also have that

$$v_i \triangleright \cdots \triangleright v_t$$

since v_{i+1}, \dots, v_t are all primary parts. We thus have by Lemma 3.1.6 that

$$v_i - t + i \succ v_t,$$

so that, if $v_i - t + i$ has size 1, then v_t has also size 1 and a color smaller than the color of v_i . But by (3.1.1) and (2.2.6), we necessarily have that $\beta(v_i - t + i + 1)$ has size 1 and a color greater than the color of v_i . We then obtain by (2.2.9) that

$$\beta(v_i - t + i + 1) \succ v_i - t + i \succ v_t,$$

and we do not cross $v_i - t + i + 1$ and v_t , which is absurd by assumption. This means that in any case after crossing, we still have that the secondary part size is greater than 1, so that after splitting, its upper and lower halves stay in \mathcal{P} .

- if v_i crosses all the primary parts up to v_j after iterating **Step 1** and stops before v_{j+1} , we then set

$$\begin{aligned}\delta^2 &= v_1 \gg \cdots \gg v_{i_{S-1}} \\ \gamma^2 &= v_{i_{S-1}+1}, \dots, v_{i_{S-1}}, v_{i_{S+1}} + 1, \dots, v_j + 1, \alpha(v_{i_S} + i_S - j) \\ \mu^2 &= \beta(v_{i_S} + i_S - j), v_{j+1}, \dots, v_t.\end{aligned}$$

The statements of Proposition 3.3.4 are then satisfied.

- Suppose now that $(\delta^v, \gamma^v, \mu^v)$ satisfies the conditions in Proposition 3.3.4. Note that $s(\gamma^v), g(\mu^v)$ are respectively the upper and the lower halves after the splitting of the secondary part coming from $v_{i_{S+2-v}}$. We also have by (2.2.12) that

$$v_{i_{S+1-v}} \gg v_{i_{S+1-v}} \gg \cdots \gg v_{i_{S+2-v}} \gg v_{i_{S+2-v}} \implies v_{i_{S+1-v}} + i_{S+1-v} - i_{S+2-v} + 1 \gg v_{i_{S+2-v}}$$

since the parts between these secondary parts are primary parts. By Lemma 3.1.5, even if these secondary parts meet after crossing the primary parts, the splitting of the part coming from $v_{i_{S+1-v}}$ will then occur either before the upper half or between the upper and the lower halves obtained after the splitting of $v_{i_{S+2-v}}$. Thus the splitting of $s(\delta^v) = v_{i_{S+1-v}}$ occurs before $g(\mu^v)$. By taking $s(\gamma^{v+1}), g(\mu^{v+1})$ as the upper and the lower halves of the split secondary part coming from $v_{i_{S+2-v}}$, we thus obtain a sequence $(\delta^{v+1}, \gamma^{v+1}, \mu^{v+1})$ such that μ^v is the strict tail of μ^{v+1} . Note that these sequences also satisfy the other statements.

A.1.10 Proof of Proposition 3.3.6

Note that **Step 1** of Φ is reversible by the splitting in **Step 2** of Ψ . Let us now show that iterations of **Step 2** of Φ are also reversible by iterations of **Step 1** in Ψ .

We saw in the proof of Proposition 3.3.2 in Appendix 3.3.2 that for any $u \geq 1$, the sequence $(\delta^u, \gamma^u, \mu^u)$ becomes the sequence $(\delta^{u+1}, \gamma^{u+1}, \mu^{u+1})$ after applying **Step 1** once to the troublesome pair $(s(\gamma^u), g(\mu^u))$, and some iterations of **Step 2** by crossing the secondary part $s(\gamma^u) + g(\mu^u)$ with some primary parts of $\gamma^u \setminus \{s(\gamma^u)\}$. Without loss of generality, let us set

$$\begin{aligned}\gamma^u &= \pi_1 \gg \cdots \gg \pi_i \\ \mu^u &= \pi_{i+1} \succ \cdots \succ \pi_r\end{aligned}$$

and suppose that the secondary parts $\pi_i + \pi_{i+1}$ crossed the primary parts $\pi_j \gg \cdots \gg \pi_{i-1}$. Since $\gamma^u \in \mathcal{E} \cap \mathcal{O} \subset \mathcal{E}_2$, by Lemma 3.1.6 and (3.1.4), we have that

$$\pi_j \gg \pi_i + i - j - 1 \succeq \alpha(\pi_i + \pi_{i+1} + i - j - 1).$$

Using (3.1.8) of Lemma 3.1.4, this is equivalent to saying that

$$\alpha(\pi_i + \pi_{i+1} + i - j) \not\prec \pi_j - 1. \quad (\text{A.1.3})$$

If the iteration of **Step 2** ceases before π_{k-1} , we then have that

$$\begin{aligned}\delta^{u+1} &= \pi_1 \gg \cdots \gg \pi_i + \pi_{i+1} + i - k \\ \gamma^{u+1}, \mu^{u+1} &= \pi_j - 1 \gg \cdots \gg \pi_{i-1} - 1 \succ \pi_{i+2} \succ \cdots \succ \pi_r\end{aligned}$$

so that $(\delta^{u+1}, \gamma^{u+1}, \mu^{u+1}) = ((\delta^u, \delta^{u+1}), \gamma^u, \mu^u)$. But the inequality (A.1.3) holds for all $k \leq j \leq i - 1$, so that by applying Ψ on $(\delta^{u+1}, \gamma^{u+1}, \mu^{u+1})$, the secondary part $s(\delta^{u+1}) = \pi_i + \pi_{i+1} + i - k$ will recursively cross by **Step 1** the parts $\pi_j - 1$. The iteration of **Step 1** stops before the part π_{i+2} since

$$\pi_{i+2} \prec \pi_{j+1} = \beta(\pi_i + \pi_{i+1})$$

and we split by **Step 2** the secondary part $\pi_i + \pi_{i+1}$ into π_i and π_{i+1} . We then retrieve the sequence $(\delta^u, \gamma^u, \mu^u)$.

To conclude, we observe that if $\Phi(\lambda) \in \mathcal{E}$ has S secondary parts, then the last sequence in the process Φ is $(\delta^{S+1}, \gamma^{S+1}, \mu^{S+1})$ with $\mu^{S+1} = \emptyset$, δ^{S+1} the partition $\Phi(\lambda)$ up to the S^{th} secondary part and γ^{S+1} the tail to the right of this last secondary part. But this triplet is equal to the triplet $(\delta^v, \gamma^v, \mu^v)$ of Proposition 3.3.4 for $v = 1$. We then recursively obtain the result of Proposition 3.3.6 in the decreasing order according to u .

A.1.11 Proof of Proposition 3.4.6

Let us take any $i \in I = \{i_1 < \dots < i_s\}$, let us consider $j = \min(i, p + 2s + 1) \cap J$. Since in the process of Ψ , the primary parts never cross, and the secondary parts can only move forward before splitting, the part v_j will not be affected by Ψ operating on any secondary part to its right.

- Suppose that $\mathbf{Br}_v(i) = j$. By definition (3.4.4), this means that

$$v_{i'+1} \neq v_j + \frac{j - i'}{2} - 1$$

for all $i' \in [i, j) \cap I$, so that, by the crossing condition of **Step 2** of Ψ , $v_j + \frac{j - i'}{2} - 1$ will recursively be the first primary part that crosses all the secondary parts $v_{i'} + v_{i'+1}$ up to $v_i + v_{i+1}$. Thus, for $i = i_u$

$$s(\delta^{s+1-u}) = v_{i_u} + v_{i_u+1}, \quad g(\gamma^{s+1-u}) = v_j + \frac{j - i_u}{2} - 1.$$

- Suppose that $\mathbf{Br}_v(i) < j$. Let us set $\mathbf{Br}_v(i) = i'_1$ and let $i'_1 < \dots < i'_t < j$ be all the fixed points by \mathbf{Br}_v in $[i, j)$. By Lemma 3.4.5, have that

$$\mathbf{Br}_v([i, i'_1]) = \{i'_1\}, \quad \mathbf{Br}_v((i'_{s-1}, i'_s]) = \{i'_s\} \quad \text{and for } (i'_t, j) \neq \emptyset, \quad \mathbf{Br}_v((i'_t, j)) = \{j\}.$$

We then have during the process of Ψ that v_j crosses all the secondary parts up to $v_{i'_t+2} + v_{i'_t+3}$, but does not cross $v_{i'_t} + v_{i'_t+1}$. Thus, $v_{i'_t} + v_{i'_t+1}$ directly splits into $v_{i'_t}$ and $v_{i'_t+1}$, and by (3.4.5) and the crossing condition of **Step 1**, $v_{i'_t}$ crosses all the secondary parts up to $v_{i'_{t-1}} + v_{i'_{t-1}+1}$, which is not crossed.

The process then continues and we reach $v_{i'_1} + v_{i'_1+1}$ which directly splits into $v_{i'_1}$ and $v_{i'_1+1}$. If $i = i_1$, we have the first statement of Proposition 3.4.6. Otherwise, $v_{i'_1}$ crosses all the secondary parts up to $v_i + v_{i+1}$. We then obtain for for $i = i_u$

$$s(\delta^{s+1-u}) = v_{i_u} + v_{i_u+1}, \quad g(\gamma^{s+1-u}) = v_{i'_1} + \frac{i'_1 - i_u}{2} - 1.$$

In any case, if $i = \mathbf{Br}_v(i)$, then $v_i + v_{i+1}$ directly splits, otherwise, we have that for $i = i_u$

$$g(\gamma^{s+1-u}) = v_{\mathbf{Br}_v(i_u)} + \frac{\mathbf{Br}_v(i_u) - i_u}{2} - 1,$$

and the part $v_{i_u} + v_{i_u+1}$ first crosses the primary part $g(\gamma^{s+1-u})$.

A.1.12 Proof of Proposition 3.4.7

Let us take $v = (v_1, \dots, v_{p+2s})$, and $I = \{i_1 < \dots < i_s\}$. Note that the triplet $(\delta^1, \gamma^1, \mu^1)$ is such that $\mu^1 = \emptyset$, δ^1 is the partition v up to $v_{i_s} + v_{i_s+1}$ and γ^1 is the tail to the right of this part. We then have that $\gamma^1, \mu^1 \in (\mathcal{E} \cap \mathcal{O}) \times \mathcal{O}$ and $v_{i_s} + v_{i_s+1} = s(\delta^1) \gg g(\gamma^1)$.

- If we have that $\mathbf{Br}_v(i_u) > i_u$, by Proposition 3.4.6, we necessarily have that

$$g(\gamma^{s+1-u}) = v_{\mathbf{Br}_v(i_u)} + \frac{\mathbf{Br}_v(i_u) - i_u}{2} - 1.$$

But with the condition (2), we have by (2.2.12) and (3.1.7) that

$$v_{\mathbf{Br}_v(i_u)} + \frac{\mathbf{Br}_v(i_u) - i_u}{2} \not\asymp v_{i_u} + v_{i_u+1} \iff v_{i_u} + v_{i_u+1} \gg v_{\mathbf{Br}_v(i_u)} + \frac{\mathbf{Br}_v(i_u) - i_u}{2} - 1.$$

If $\gamma^{s+1-u} \in \mathcal{E} \cap \mathcal{O} \subset \mathcal{E}_1$, we then obtain that the partition $s(\delta^{s+1-u}), \gamma^{s+1-u}$ belongs to \mathcal{E}_2 , so that, by Lemma 3.1.6 and (3.1.7) of Lemma 3.1.4, all the crossings in **Step 1** of Ψ are reversible by **Step 2** of Φ . We set

$$\gamma^{s+1-u} = \pi_1 \gg \dots \gg \pi_r$$

and if $v_{i_u} + v_{i_u+1} = s(\delta^{s+1-u})$ crosses all the primary parts up to π_j , we then have by (3.1.8) of Lemma 3.1.4

$$\begin{aligned} \delta^{s+2-u}, \gamma^{s+2-u} &= \delta^{s+1-u} \setminus v_{i_u} + v_{i_u+1}, \pi_1 + 1 \gg \dots \gg \pi_j + 1 \gg \alpha(v_{i_u} + v_{i_u+1} - j) \\ \mu^{s+2-u} &= \beta(v_{i_u} + v_{i_u+1} - j) \succ \pi_{j+1} \succ \dots \succ \pi_r, \mu_{s+1-u}. \end{aligned}$$

Furthermore, always by condition (2), we have that

$$s(\delta^{s+1-u} \setminus v_{i_u} + v_{i_u+1}) = v^-(i_u) \gg v_{\mathbf{Br}_v(i_u)} + \frac{\mathbf{Br}_v(i_u) - i_u}{2} = \pi_1 + 1$$

so that $\delta^{s+2-u}, \gamma^{s+2-u} \in \mathcal{E}$ and we obtain that $\gamma^{s+2-u} \in \mathcal{E} \cap \mathcal{O}$ and $s(\delta^{s+2-u}) \gg g(\gamma^{s+2-u})$.

Moreover, if $\mu_{s+1-u} \in \mathcal{O}$ and $j < r$, we then have that $(\pi_r, g(\mu_{s+1-u}))$ is the troublesome pair coming from the splitting of $v_{i_u+1} + v_{i_u+1+1}$ and satisfies $\pi_r \succ g(\mu_{s+1-u})$, so that $\mu^{s+2-u} \in \mathcal{O}$. If $\mu_{s+1-u} \in \mathcal{O}$ and $j = r$, this means that the splitting of $v_{i_u} + v_{i_u+1}$ occurs in between those of $v_{i_u+1} + v_{i_u+1+1}$ and the lower halves are still well-ordered in terms of \succ , so that $\mu^{s+2-u} \in \mathcal{O}$. In any case, if $\mu_{s+1-u} \in \mathcal{O}$ (with the previous assumption that $\gamma^{s+1-u} \in \mathcal{E} \cap \mathcal{O}$), then $\mu^{s+2-u} \in \mathcal{O}$.

- If we have that $\mathbf{Br}_v(i_u) = i_u$, then by Proposition 3.4.6, the splitting occurs directly and we have

$$v_{i_u+1} \succ g(\gamma^{s+1-u}).$$

Then we have that

$$\begin{aligned} \delta^{s+2-u}, \gamma^{s+2-u} &= \delta^{s+1-u} \setminus v_{i_u} + v_{i_u+1}, v_{i_u} \\ \mu^{s+2-u} &= v_{i_u+1}, \gamma^{s+1-u}, \mu^{s+1-u}. \end{aligned}$$

so that, if γ^{s+1-u} and μ^{s+1-u} are in \mathcal{O} , since $s(\gamma^{s+1-u}) \succ g(\mu^{s+1-u})$, we then have that μ^{s+2-u} is also in \mathcal{O} . Note that $s(\delta^{s+1-u} \setminus v_{i_u} + v_{i_u+1}) = v^-(i_u)$.

- If $v^-(i_u) \triangleright v_{i_u} + v_{i_u+1}$, then we obtain that

$$\begin{aligned} v^-(i_u) - v_{i_u} &= v^-(i_u) - (v_{i_u} + v_{i_u+1}) + v_{i_u+1} \\ &\geq 2 \quad (\text{by (2.2.11) and the fact that } v_{i_u+1} \geq 1), \end{aligned}$$

so that, by (2.2.9) and (2.2.11), $v^-(i_s) \gg v_{i_u}$.

- In the case that $v^-(i_s) \not\triangleright v_{i_u} + v_{i_u+1}$, this means by (2.2.12) that we have the case of a pair of secondary parts with colors in \mathcal{SP}_{\times} , and which are consecutive for \succ . Then the pair $(v^-(i_s), v_{i_u} + v_{i_u+1})$ has the form (k_{cd}, k_{ab}) or $((k+1)_{ad}, k_{bc})$ for some primary colors $a < b < c < d$. We check the different cases according to the parity of k :

$$(2k)_{cd} \gg k_b, \quad (2k+1)_{cd} \gg (k+1)_a \quad (2k+1)_{ad} \gg k_c \quad (2k+2)_{ad} \gg (k+1)_b.$$

We then conclude that $v^-(i_s) \gg v_{i_u}$.

In any case, we always have that v_{i_u} is well-ordered with the part to its left in terms of \gg , so that $\delta^{s+2-u}, \gamma^{s+2-u} \in \mathcal{E}$, and then $\gamma^{s+2-u} \in \mathcal{E} \cap \mathcal{O}$ and $s(\delta^{s+2-u}) \gg g(\gamma^{s+2-u})$.

Note that the process Ψ is reversible by Φ since the crossings are reversible and so is the splitting. We then obtain Proposition 3.4.7 recursively on u in decreasing order.

A.1.13 Proof of Proposition 3.5.5

Let us take a shortcut $\zeta = \zeta_1 + \zeta_2 \gg \cdots \gg \zeta_{2s+1} + \zeta_{2s+2}$, and an allowed pattern $\eta = \eta_1 + \eta_2 \gg \cdots \gg \eta_{2t-1} + \eta_{2t} \gg \eta_{2t+1}$ such that $\mathbf{Br}_\eta(1) = 2t + 1$. Without loss of generality, by adding a constant k to the part $v_{2i-1} + v_{2i}$, we can suppose that $\zeta_{2s+1} + \zeta_{2s+2} \gg \eta_1 + \eta_2$. If we consider the sequence

$$\nu^{(0)} = \zeta_1 + \zeta_2 \gg \cdots \gg \zeta_{2s+1} + \zeta_{2s+2} \gg \eta_1 + \eta_2 \gg \cdots \gg \eta_{2t-1} + \eta_{2t} \gg \eta_{2t+1},$$

by adding a large constant k to the parts of the sequence $\nu^{(0)}$, we can say η_{2t+1} is the bridge in ν of all

$$i \in 2\{0, \dots, s+t\} + 1.$$

In fact, by Remark 2.1, we have that the lower halves grow according to $k/2$, so that for some k large enough, $\eta_{2t+1} + k - 1$ will be 1-distant-different from all the lower halves in the sequence ν in terms of \succeq . We finally consider the sequences of the form

$$\begin{aligned} \nu^{(u)} = & \zeta_1 + \zeta_2 + su \gg \cdots \gg \zeta_{2s+1} + \zeta_{2s+2} + su \gg \zeta_1 + \zeta_2 + s(u-1) \gg \cdots \gg \zeta_{2s+1} + \zeta_{2s+2} + s(u-1) \gg \\ & \cdots \gg \zeta_1 + \zeta_2 + s \gg \cdots \gg \zeta_{2s+1} + \zeta_{2s+2} + s \gg \zeta_1 + \zeta_2 \gg \cdots \gg \zeta_{2s+1} + \zeta_{2s+2} \gg \\ & \eta_1 + \eta_2 \gg \cdots \gg \eta_{2t-1} + \eta_{2t} \gg \eta_{2t+1}. \end{aligned}$$

The sequence ν is well defined, since ζ is a shortcut, we then have by (2.2.11) and (2.2.12) that

$$\begin{aligned} \overline{\zeta_{2s+1} + \zeta_{2s+2}} \succ \overline{\zeta_1 + \zeta_2 + 1 - s} & \implies \zeta_{2s+1} + \zeta_{2s+2} \succ \zeta_1 + \zeta_2 + 1 - s \\ & \implies \zeta_{2s+1} + \zeta_{2s+2} \triangleright \zeta_1 + \zeta_2 - s \\ & \implies \zeta_{2s+1} + \zeta_{2s+2} + s \gg \zeta_1 + \zeta_2, \end{aligned}$$

so that $\zeta_{2s+1} + \zeta_{2s+2} + su' \gg \zeta_1 + \zeta_2 + s(u' - 1)$ for all $u' \geq 1$. We also have that η_{2t+1} is the bridge of all the indices of the secondary parts in $\nu^{(u)}$. In fact, we have by (3.1.4) that

$$\beta(\zeta_{2s+1} + \zeta_{2s+2} + s) \preceq s + \beta(\zeta_{2s+1} + \zeta_{2s+2}) \preceq s + t + \eta_{2t+1} \prec s + t + 1 + \eta_{2t+1},$$

and we obtain in the same way, that for all $i \in \{0, \dots, s-1\}$

$$\beta(\zeta_{2i+1} + \zeta_{2i+2} + s) \prec s - i + s + t + 1 + \eta_{2t+1},$$

so that η_{2t+1} is the bridge of all the indices (in the corresponding set I) of the parts in $\nu^{(1)}$. Using (3.1.4) recursively on u , we proved that η_{2t+1} is indeed the bridge of all indices of the secondary parts in the sequence $\nu^{(u)}$.

To conclude, we see that there are $(u+1)(s+1) + t$ secondary parts in $\nu^{(u)}$ (the head included) between $\zeta_1 + \zeta_2 + su$ and η_{2t+1} , and we then have

$$\eta_{2t+1} + (u+1)(s+1) + t - (\zeta_1 + \zeta_2 + su) = \eta_{2t+1} - (\zeta_1 + \zeta_2) + t + u + s + 1.$$

There then exists some u_0 such that,

$$\eta_{2t+1} + (u_0 + 1)(s+1) + t \succ (\zeta_1 + \zeta_2 + su_0),$$

so that condition (2) in Theorem 3.4.2 is not true. The sequence $\nu^{(u_0)}$ is then a forbidden pattern, and this concludes the proof.

A.1.14 Proof of Proposition 3.7.2

Let us take $\nu = (v_1, \dots, v_{p+2s})$, with $I = \{i_1 < \dots < i_s\}$ and $J = \{j_1 < \dots < j_p\}$.

We observe that, in Proposition 3.3.4, the sequence $(\delta^v, \gamma^v, \mu^v)$ becomes the sequence $(\delta^{v+1}, \gamma^{v+1}, \mu^{v+1})$ after applying **Step 1** once to the secondary part $s(\delta^v)$, and some iterations of **Step 2** by crossing the secondary part with some primary parts of γ^v . This means that once we obtain the sequence μ^v , it is no longer affected by the process Ψ .

- Since we never cross two primary parts in the process, once we have the splitting $s(\gamma^v), g(\mu^v)$, their relative position in the remainder of the process Ψ is unchanged. We then obtain that the

upper and the lower halves' positions satisfy $\theta_{i_{s-v+2}} < \theta_{i_{s-v+2}+1}$.

- The passage from the secondary part $s(\delta^v)$ to its splitting to become $s(\gamma^{v+1}), g(\mu^{v+1})$ implies that the position of the lower part increases during the crossings, and then is fixed after the splitting. We thus obtain that $\theta_{i_{s+1-v}+1}$ is the position of the $g(\mu^{v+1})$. With the fact that the sequence $g(\mu^v)$ is the strict tail of $g(\mu^{v+1})$, we reach the inequality $\theta_{i_{s-v+2}+1} > \theta_{i_{s+1-v}+1} \geq i_{s+1-v} + 1$. This gives the first inequality of (3.7.7).
- If the splitting of $s(\delta^v)$ occurs before $g(\gamma^v)$, it means that $g(\gamma^v)$ belongs to μ^{v+1} , and the position of the corresponding upper half is fixed in the rest of the process. We then have that $\theta_{i_{s-v+2}} > \theta_{i_{s+1-v}+1}$. Otherwise, the splitting of $s(\delta^v)$ occurs between $g(\gamma^v)$ and $g(\mu^v)$, and the relative position of the corresponding upper halves will not change until the end of the process. We thus have that $\theta_{i_{s+1-v}+1} > \theta_{i_{s+1-v}} > \theta_{i_{s-v+2}}$, and this leads (recursively on v) to the proof of (3.7.5).
- Recall that we never cross two primary parts in the process, and this naturally leads to $\theta_{j_v} < \theta_{j_{v+1}}$, for $j_v < j_{v+1}$ and we have (3.7.6). Moreover, the primary parts can only move backward, since they can only cross some secondary parts to their left. We then obtain the second inequality of (3.7.7) $\theta_{j_v} \leq j_v$.
- Since the crossing only occurs between the secondary and primary parts, if the secondary part corresponding to i does not cross in the primary part corresponding to j , then we have that $\theta_{i+1} < \theta_j$, and if they crossed, then both the upper and the lower halves move together, and in the remainder of the process, their relative positions stay unchanged, so that $\theta_j < \theta_i$, and we obtain (3.7.8).

A.1.15 Proof of Proposition 3.7.3

We saw in the previous proof that, since the positions of the lower halves are increasing, for any $i_u \in I$, the crossings can occur with primary parts coming from some indices J or in I . We then look for $x \in J \cup I$ such that $x > i_u$ and $\theta_x < \theta_{i_u}$. Let us then set $\{x_1, \dots, x_v\} = \{x \in J \cup I : x > i_u, \theta_x < \theta_{i_u}\}$ such that

$$\theta_{x_1} < \dots < \theta_{x_v}.$$

Note that if $\{x \in J \cup I : x > i_u, \theta_x < \theta_{i_u}\} = \emptyset$, then the splitting occurs directly and

$$\mathbf{Br}_v(i_u) = i_u = \max_{x \in I} \{x \geq i_u, \theta_x \leq \theta_{i_u}\}.$$

Recall that if $\{x \in J \cup I : x > i_u, \theta_x < \theta_{i_u}\} \neq \emptyset$, we then have

$$\theta_{x_v} < \theta_{i_u} < \theta_{i_u+1} \quad \text{and} \quad x_1, \dots, x_v > i_u.$$

- If $\{x_1, \dots, x_v\} \cap J \neq \emptyset$, then we necessarily have that $x_1 \in J$. In fact, suppose that $x_1 \in I$ and $x_1 < x \in \{x_1, \dots, x_v\} \cap J$. Since $x_1 > i_u$, by (3.7.5), we have $\theta_{i_u+1} < \theta_{x_1+1}$ and then

$$\theta_{x_1} < \theta_x < \theta_{i_u} < \theta_{i_u+1} < \theta_{x_1+1},$$

and this contradicts (3.7.8). Furthermore, by (3.7.6), we have that

$$x_1 = \min\{x_1, \dots, x_v\} \cap J = \min_{x \in J} \{x > i_u, \theta_x < \theta_{i_u}\}.$$

- Otherwise, we have $\{x_1, \dots, x_v\} \cap J = \emptyset$. In that case, $\{x_1, \dots, x_v\} \subset I$. We then have that $x_1 > \dots > x_v$. In fact, for any $x < x' \in \{x_1, \dots, x_v\}$, by (3.7.5), we have

$$\theta_{i_u+1} < \theta_{x+1} < \theta_{x'+1},$$

and if we suppose that $\theta_x < \theta_{x'}$, we then obtain the inequality

$$\theta_x < \theta_{x'} < \theta_{i_u} < \theta_{i_u+1} < \theta_{x+1} < \theta_{x'+1},$$

and this contradicts (3.7.5). Furthermore, this leads to the following relation

$$x_1 = \max\{x_1, \dots, x_v\} = \max_{x \in I} \{x \geq i_u, \theta_x \leq \theta_{i_u}\}.$$

In any case, by Proposition 3.4.6, we have that $x_1 = \mathbf{Br}_v(i)$. In fact, x_1 is the index of the first crossed part.

A.2 Beyond Siladić's theorem

A.2.1 Proof of Lemma 4.3.5

We prove it recursively on successive applications of Λ . The energy transfer Λ conserves the State of the partition, so that the sequence of states is fixed. On the other hand, the particles gain or lose exactly the minimal energy needed for the transfer, and by definition, this is exactly what Δ evaluates. As an example, if we do the transformation Λ , at position k , on a pair of particles in $\mathcal{P} \times \mathcal{S}$, we obtain

initial positions	j	$i + 1$	$i + 2$
positions before Λ	k	$k + 1$	$k + 2$
states before Λ	c_k	c_{k+1}	c_{k+2}
potentials before Λ	l'_k	l'_{k+1}	l'_{k+2}
positions after Λ	$k + 2$	k	$k + 1$
states after Λ	c_{k+2}	c_k	c_{k+1}
potentials after Λ	$\Delta(k + 2, k) + l'_k$	$\Delta(k, k + 1) + l'_{k+1}$	$\Delta(k + 1, k + 2) + l'_{k+2}$

Here we recall that $l'_{k+1} - l'_{k+2} = \Delta(k + 1, k + 2)$. The same calculation occurs when we consider the application of Λ on a pair in $\mathcal{S} \times \mathcal{P}$.

A.2.2 Proof of Lemma 4.3.6

We first prove that ϕ is non-increasing according to J , and then that ϕ is non-decreasing according to I .

- For any $j < j' \in J$ and $i \in I$, we have by *Chasles' relation* and (4.3.6) that

$$\begin{aligned} \phi(j, i) - \phi(j', i) &= l_j - l_{j'} - \Delta(j, j') - \Delta(i + 1 - \beta(j, i), i + 1 - \beta(j', i)) \\ &\geq \alpha(j, j') - \Delta(i + 1 - \beta(j, i), i + 1 - \beta(j', i)). \end{aligned}$$

But *Chasles' relation* and (4.3.3) give that

$$i + 1 - \beta(j', i) - (i + 1 - \beta(j, i)) = \beta(j, j') \geq 0,$$

so that by (4.3.3) again, we obtain that $\phi(j, i) - \phi(j', i) \geq \alpha(j, j') - \beta(j, j')$. Since $j, j' \in J$, we have that

$$\alpha(j, j') = |(j, j'] \cap J| = 1 + |(j, j') \cap J| = |[j, j') \cap J| = \beta(j, j').$$

Therefore, we always have for any $j < j' \in J$ and $i \in I$ that $\phi(j, i) - \phi(j', i) \geq 0$.

- For any $j \in J$ and $i < i' \in I$, we have by *Chasles' relation* and (4.3.6)

$$\begin{aligned} \phi(j, i') - \phi(j, i) &= 2(l_{i+1} - l_{i'+1}) - \Delta(i + 1, i' + 1) + \Delta(i + 1 - \beta(j, i), i + 1) \\ &\quad + \Delta(i' + 1, i' + 1 - \beta(j, i')) \\ &= 2(l_{i+1} - l_{i'+1} - \Delta(i + 1, i' + 1)) \\ &\quad + \Delta(i + 1 - \beta(j, i), i' + 1 - \beta(j, i')) \\ &\geq 2\alpha(i + 1, i' + 1) + \Delta(i + 1 - \beta(j, i), i' + 1 - \beta(j, i')) \end{aligned}$$

Since we have by (4.3.3) that

$$\begin{aligned} i' + 1 - \beta(j, i') - (i + 1 - \beta(j, i)) &= i' - i - \beta(i, i') \\ &= |[i, i') \cap (I \sqcup (I + 1))| \\ &\geq 0, \end{aligned}$$

we then obtain that $\phi(j, i') - \phi(j, i) \geq 0$.

A.2.3 Proof of Lemma 4.3.7

Since the functions η and Δ satisfy *Chasles' relation*, in order to show (4.3.14), it suffices to prove that for all $k \in \{1, \dots, s - 1\}$,

$$l'_k - l'_{k+1} \geq \beta(k, k + 1) + \Delta(k, k + 1).$$

- If $k \in I$, then $k + 1 \in I + 1$ and

$$\begin{aligned} l'_k - l'_{k+1} &= 2\Delta(k, k+1) \\ &\geq \Delta(k, k+1) \\ &= \beta(k, k+1) + \Delta(k, k+1). \end{aligned}$$

- If $k \in I + 1$ and $k + 1 \in I$, then by (2.2.25), $(l_k, c_{k-1}, c_k) \gg (l_{k+2}, c_{k+1}, c_{k+2})$ is equivalent to

$$\begin{aligned} l'_k - l'_{k+1} &\geq 2\Delta(k, k+1) \\ &\geq \eta(k, k+1) + \Delta(k, k+1). \end{aligned}$$

- If $k \in I + 1$ and $k + 1 \in J$, then by (2.2.24), $(l_k, c_{k-1}, c_k) \gg (l_{k+1}, c_{k+1})$ is equivalent to

$$\begin{aligned} l'_k - l'_{k+1} &\geq 1 + \Delta(k, k+1) \\ &= \eta(k, k+1) + \Delta(k, k+1). \end{aligned}$$

- If $k \in J$ and $k + 1 \in I$, then by (2.2.23), $(l_k, c_k) \gg (l_{k+2}, c_{k+1}, c_{k+2})$ is equivalent to

$$\begin{aligned} l'_k - l'_{k+1} &\geq \Delta(k, k+1) \\ &= \eta(k, k+1) + \Delta(k, k+1). \end{aligned}$$

- If $k, k + 1 \in J$, then by (2.2.22), $(l_k, c_k) \gg (l_{k+1}, c_{k+1})$ is equivalent to

$$\begin{aligned} l'_k - l'_{k+1} &\geq 1 + \Delta(k, k+1) \\ &= \eta(k, k+1) + \Delta(k, k+1). \end{aligned}$$

To show (4.3.15), we only need to prove the relation for two consecutive $i, i' \in I \sqcup I + 1$. This is obvious for $i \in I$, since the following index is $i + 1 \in I + 1$, and $l_i - l_{i+1} = \Delta(i, i + 1)$. Now let us take $i \in I + 1$. The next i' (if it exists) must necessarily be in I , and by (4.3.14), we obtain by the definition of η and (4.3.3) that

$$\begin{aligned} 2(l_i - l_{i'}) &= l'_i - l'_{i'} \\ &\geq \eta(i, i') + \Delta(i, i') \\ &= i' - i - 1 + \Delta(i, i') \\ &\geq 2\Delta(i, i') - 1 \\ \implies l_i - l_{i'} &\geq \Delta(i, i') - \frac{1}{2} \\ \implies l_i - l_{i'} &\geq \Delta(i, i'). \end{aligned}$$

A.2.4 Proof of Proposition 4.1.3

Let us set $p = (k, c)$ and $s = (k', c', c'')$. We then obtain that $s' = (k' + \epsilon(c', c''), c, c')$ and $p' = (k - \epsilon(c, c') - \epsilon(c', c''), c'')$. We also observe that $\mu(s') = \gamma(s)$. We then have the following equivalences:

$$\begin{aligned} p \not\gg_{\epsilon} s &\iff k - (2k' + \epsilon(c', c'')) < \epsilon(c, c') + \epsilon(c', c'') && \text{by (2.2.23)} \\ &\iff [2(k' + \epsilon(c', c'')) + \epsilon(c, c')] - (k - \epsilon(c, c') - \epsilon(c', c'')) > \epsilon(c, c') + \epsilon(c', c''), \\ &\iff s' \gg_{\epsilon} p' && \text{by (2.2.24)}. \end{aligned}$$

$$\begin{aligned} p \not\prec_{\epsilon} \gamma(s) &\iff k - (k' + \epsilon(c', c'')) < \epsilon(c, c') && \text{by (2.2.19)} \\ &\iff k - k' \leq 1 + \epsilon(c, c') + \epsilon(c', c''), \\ &\iff (k' + \epsilon(c', c'')) - (k - \epsilon(c, c') - \epsilon(c', c'')) \geq 1 + \epsilon(c', c'') \\ &\iff \mu(s') \gg_{\epsilon} p' && \text{by (2.2.22)}. \end{aligned}$$

A.2.5 Proof of Proposition 4.3.2

Let σ be the final position.

- Let us suppose that there exists $(j, i) \in J \times I$ such that $\sigma(j) < \sigma(i)$ and $\phi(j, i) < 0$. By Lemma 4.3.6 we have that $\phi(j', i') < 0$ for all $j < j' \in J$, $i' < i \in I$. Also since σ is increasing on J and I , and $\sigma(J) + 1 \setminus \sigma(J) \subset \sigma(I)$, we necessarily have some $j < j' \in J$, $i' < i \in I$ such that $\sigma(j') + 1 = \sigma(i')$. We then obtain by Lemma 4.3.5 the following difference of potentials:

$$\begin{aligned} D &= \lambda'_{\sigma(j')} - (\lambda'_{\sigma(j')+1} + \lambda'_{\sigma(j')+2}) - \Delta(\sigma(j'), \sigma(j') + 2) \\ &= l_{j'} + \Delta(\sigma(j'), j') - [2(l_{i'+1} + \Delta(\sigma(i') + 1, i' + 1)) + \Delta(\sigma(i'), \sigma(i' + 1))] \\ &\quad - \Delta(\sigma(j'), \sigma(i' + 1)) \\ &= l_{j'} - 2l_{i'+1} - \Delta(j', i' + 1) - \Delta(\sigma(i'), i' + 1). \end{aligned}$$

We now compute $\sigma(i')$. Since σ is increasing on $I \sqcup (I + 1)$ and on J , we have that

$$\begin{aligned} \sigma(i') - 1 &= \sigma(j') \\ &= |[1, j'] \cap J| + |[1, i'] \cap (I \sqcup (I + 1))| \\ &= 1 + \beta(j') + i' - 1 - \beta(i') \\ &= i' - \beta(j, i'). \end{aligned}$$

Finally, we obtain by definition that $D = \phi(j', i') < 0$. Since the potential difference is negative, by (2.2.23), we have that $\lambda'_{\sigma(j')} \not\geq_{\epsilon} \lambda'_{\sigma(j')+1} + \lambda'_{\sigma(j')+2}$ and σ is no longer the final position.

- Let us now suppose that there exists $(j, i) \in J \times I$ such that $\sigma(j) > \sigma(i)$ and $\phi(j, i) \geq 0$. By Lemma 4.3.6, we have that $\phi(j', i') \geq 0$ for all $j > j' \in J$, $i' > i \in I$. Also since σ is increasing on J and I , and $\sigma(J) - 1 \setminus \sigma(J) \subset \sigma(I) + 1$, we necessarily have some $j > j' \in J$, $i' > i \in I$ such that $\sigma(j') - 1 = \sigma(i') + 1$. We then obtain by Lemma 4.3.5 the following difference of potentials:

$$\begin{aligned} D &= (\lambda'_{\sigma(j')-2} + \lambda'_{\sigma(j')-1}) - \lambda'_{\sigma(j')} - \Delta(\sigma(j') - 2, \sigma(j')) \\ &= [2(l_{i'+1} + \Delta(\sigma(i') + 1, i' + 1)) + \Delta(\sigma(i'), \sigma(i' + 1))] - l_{j'} - \Delta(\sigma(j'), j') \\ &\quad - \Delta(\sigma(i'), \sigma(j')) \\ &= 2l_{i'+1} - l_{j'} - \Delta(i' + 1, j') - \Delta(i' + 1, \sigma(i' + 1)). \end{aligned}$$

We now compute $\sigma(i' + 1)$. Since σ is increasing on $I \sqcup (I + 1)$ and on J ,

$$\begin{aligned} \sigma(i' + 1) + 1 &= \sigma(j') \\ &= |[1, j'] \cap J| + |[1, i' + 1] \cap (I \sqcup (I + 1))| \\ &= 1 + |[1, j'] \cap J| + 2 + |[1, i'] \cap (I \sqcup (I + 1))| \\ &= 2 + \beta(j') + i' - \beta(i') \\ &= 2 + i' - \beta(j, i'). \end{aligned}$$

Finally, we obtain by definition that $D = -\phi(j', i') \leq 0$. Since the potential difference is non-positive, by (2.2.24), we have that $\lambda'_{\sigma(j')-2} + \lambda'_{\sigma(j')-1} \not\geq_{\epsilon} \lambda'_{\sigma(j')}$ and σ is no longer the final position.

To conclude, for σ being the last position, the first part of the reasoning gives that $\sigma(j) < \sigma(i) \implies \phi(j, i) \geq 0$ and the second part gives that $\sigma(j) < \sigma(i) \iff \phi(j, i) \geq 0$, so that we obtain the equivalence

$$\sigma(j) < \sigma(i) \iff \phi(j, i) \geq 0.$$

One can see in the previous reasoning that for any $(j, i) \in J \times I$, whatever the choice of **Step 2**, once they meet for some position σ' (particles have consecutive positions), we then have that the corresponding difference D between the potential of the particle to the left and the potential of the particle to the right does not depend on σ' :

- if $\sigma'(j) + 1 = \sigma'(i)$, then $D = \phi(j, i)$,
- if $\sigma'(j) - 1 = \sigma'(i + 1)$, then $D = -\phi(j, i)$.

By (2.2.24) and (2.2.23), this means that once the particles coming from i and j cross by Λ in **Step 2**, they cannot cross back. Also, by the fact that the position function σ' is increasing on J and $I \sqcup (I + 1)$, the crossings only occur, once, for $j < i$ such that $\phi(j, i) < 0$ or $j > i$ such that $\phi(j, i) \leq 0$, and this gives (4.3.11).

A.2.6 Proof of Proposition 4.3.3

By (4.1.3) of Proposition 4.1.3, we obtain, by crossing two particles with different degrees which are not well-related in terms of \gg_ϵ , that the resulting particles become well-related in terms of \gg_ϵ . **Step 2** then consists in ordering consecutive particles with different degrees, as the process stops as soon as this is the case.

Let us show that two consecutive primary particles are well related in terms of \gg_ϵ . Since σ is increasing on J , we then have, by *Chasles' relation*, that for any $j < j' \in J$

$$(l_j + \Delta(\sigma(j), j)) - (l_{j'} + \Delta(\sigma(j'), j')) = l_j - l_{j'} - \Delta(j, j') + \Delta(\sigma(j), \sigma(j')),$$

In particular, if $\sigma(j') = \sigma(j) + 1$, we then obtain by (4.3.6) and the definition of α that

$$\begin{aligned} (l_j + \Delta(\sigma(j), j)) - (l_{j'} + \Delta(\sigma(j'), j')) &\geq \alpha(j, j') + \Delta(\sigma(j), \sigma(j')) \\ &= |(j, j'] \cap J| + \epsilon(c_{\sigma(j)}, c_{\sigma(j')}) \\ &\geq 1 + \epsilon(c_{\sigma(j)}, c_{\sigma(j')}). \end{aligned}$$

This means, by (2.2.22), that two consecutive primary particles are always well-ordered in terms of \gg_ϵ in the final result.

Finally, with the same reasoning as before, since σ is increasing on $I \sqcup (I + 1)$, we have for $i < i' \in I$ such that $\sigma(i) + 2 = \sigma(i')$ that

$$\begin{aligned} (l_{i+1} + \Delta(\sigma(i+1), i)) - (l_{i'} + \Delta(\sigma(i'), i')) &\geq \alpha(i+1, i') + \Delta(\sigma(i+1), \sigma(i')) \\ &= |(i+1, i'] \cap J| + \epsilon(c_{\sigma(i)}, c_{\sigma(i')}) \\ &\geq \epsilon(c_{\sigma(i)}, c_{\sigma(i')}), \end{aligned}$$

so that by (2.2.19), we have $\lambda'_{\sigma(i+1)} \succ_\epsilon \lambda'_{\sigma(i')}$. We then obtain, by (2.2.25), that two consecutive secondary particles are always well-ordered in terms of \gg_ϵ in the final result.

A.2.7 Proof of Proposition 4.3.4

It suffices to show that all primary particles stay in the interval corresponding to ρ_\pm . By using (4.3.3), (4.3.6), and Lemma 4.3.5, we obtain for any $k \in \{1, \dots, s\}$ that

$$l_k + \Delta(\sigma(k), k) \leq l_1 - \alpha(1, k) - \Delta(1, \sigma(k)) \leq l_1$$

and

$$l_k + \Delta(\sigma(k), k) \geq l_s + \alpha(k, s) + \Delta(\sigma(k), s) \geq l_s.$$

Therefore, the potentials of the primary particles in the final partition stay in $[l_s, l_1]$. If $\lambda_k \in \mathcal{O}_\epsilon^{\rho_\pm}$ for all $k \in \{1, \dots, s\}$, then $\lambda'_{\sigma(k)} \in \mathcal{O}_\epsilon^{\rho_\pm}$ and then $\lambda'_{\sigma(j)} \in \mathcal{O}_\epsilon^{\rho_\pm}$ and $\lambda'_{\sigma(i)} + \lambda'_{\sigma(i+1)} \in \mathcal{E}_\epsilon^{\rho_\pm}$ for all $(j, i) \in J \times I$.

A.2.8 Proof of Proposition 4.3.8

By using Lemma 4.3.7, one can easily show that ψ is decreasing according to J (using (4.3.14)) and non-decreasing according to I (using (4.3.15)). Let σ be the final position **Step 1** of Ψ .

- Let us suppose that there exists $(j, i) \in J \times I$ such that $\sigma(j) < \sigma(i)$ but $\psi(j, i) < 0$. Since σ is increasing on J and I , and $\sigma(J) + 1 \setminus \sigma(J) \subset \sigma(I)$, there exist $(j', i') \in J \times I$ such that $j < j', i' < i$ and $\sigma(j') + 1 = \sigma(i')$. We also have that

$$\psi(j', i') \leq \psi(j', i) \leq \psi(j, i) < 0.$$

By evaluating the potential difference at $\sigma(j')$, we obtain that

$$\begin{aligned} D &= v''_{\sigma(j')} - v''_{\sigma(j')+1} - \Delta(\sigma(j'), \sigma(j') + 1) \\ &= (l_{j'} + \Delta(\sigma(j'), j')) - (l_{j'} + \Delta(\sigma(i'), i')) - \Delta(\sigma(j'), \sigma(i')) \\ &= l_{j'} - l_{i'} - \Delta(j', i') \\ &= \psi(j', i') < 0. \end{aligned}$$

This means by (2.2.19) that $v''_{\sigma(j')} \not\prec_{\epsilon} v''_{\sigma(j')+1}$. Since $\gamma(v''_{\sigma(i')} + v''_{\sigma(i'+1)}) = v''_{\sigma(j')+1}$, we can apply Λ , so that σ is no longer the final position.

- Let us now assume that there exists $(j, i) \in J \times I$ such that $\sigma(j) > \sigma(i)$ but $\psi(j, i) \geq 0$. Since σ is increasing on J and $I \sqcup (I + 1)$, and $\sigma(J) - 1 \setminus \sigma(J) \subset \sigma(I + 1)$, there exist $(j', i') \in J \times I$ such that $j > j', i' > i$ and $\sigma(j') - 1 = \sigma(i' + 1) = \sigma(i') + 1$. We also have that

$$\psi(j', i') \geq \psi(j', i) \geq \psi(j, i) \geq 0.$$

By evaluating the potential difference at $\sigma(j')$, we obtain

$$\begin{aligned} D &= v''_{\sigma(j')-1} - v''_{\sigma(j')} - \Delta(\sigma(j') - 1, \sigma(j')) \\ &= (l_{i'+1} + \Delta(\sigma(i' + 1), i' + 1)) - (l_{j'} + \Delta(\sigma(j'), j')) - \Delta(\sigma(i' + 1), \sigma(j')) \\ &= l_{i'+1} - l_{j'} - \Delta(i' + 1, j') \\ &= l_{i'} - l_{j'} - \Delta(i', j') \leq 0. \end{aligned}$$

This means by (2.2.22) that $v''_{\sigma(j')-1} \not\gg_{\epsilon} v''_{\sigma(j')}$. Since $\mu(v''_{\sigma(i')} + v''_{\sigma(i'+1)}) = v''_{\sigma(j')-1}$, we can apply Λ , so that σ is no longer the final position.

To conclude, we observe that the first part gives that $\sigma(j) < \sigma(i) \implies \psi(j, i) \geq 0$ and the second part $\sigma(j) < \sigma(i) \iff \psi(j, i) \geq 0$, so that we obtain the first result in Proposition 4.3.8.

We obtain (4.3.18) with the same reasoning as in the proof of Proposition 4.3.8, by observing that the difference of potential when two particles meet does not depend on the choice in which we apply Λ , and once particles cross by Λ , they cannot cross back.

A.2.9 Proof of Proposition 4.3.9

Since for all $k, k' \in \{1, \dots, s\}$, we obtain by Lemma 4.3.5 that

$$v''_{\sigma(k)} - v''_{\sigma(k')} - \Delta(\sigma(k), \sigma(k')) = l_k - l_{k'} - \Delta(k, k').$$

Let us now consider any k, k' such that $\sigma(k) + 1 = \sigma(k')$.

- If $(k, k') \in J^2$, we have then by (4.3.14) that

$$\begin{aligned} v''_{\sigma(k)} - v''_{\sigma(k')} &\geq \eta(k, k') \\ &= |(k, k') \cap J| \\ &\geq 1, \end{aligned}$$

so that by (2.2.22), $v''_{\sigma(k)} \succ_{\epsilon} v''_{\sigma(k')}$.

- If $(k, k') \in J \times I$, then since **Step 1** ended, we necessarily have

$$v''_{\sigma(k)} \succ_{\epsilon} v''_{\sigma(k')}.$$

- If $(k, k') \in I \times I + 1$, then we have

$$v''_{\sigma(k)} - v''_{\sigma(k')} = 0$$

so that by (2.2.19), $v''_{\sigma(k)} \succ_{\epsilon} v''_{\sigma(k')}$.

- If $(k, k') \in I + 1 \times J$, then since **Step 1** ended, we necessarily have

$$v''_{\sigma(k)} \gg_{\epsilon} v''_{\sigma(k')}.$$

- If $(k, k') \in I + 1 \times I$, we then have by (4.3.15) that

$$v''_{\sigma(k)} - v''_{\sigma(k')} \geq 0$$

so that by (2.2.19), $v''_{\sigma(k)} \succ_{\epsilon} v''_{\sigma(k')}$.

We then obtain that $v'' = (v''_1, \dots, v''_s)$ is well-ordered by \succ_{ϵ} so that it belongs to \mathcal{O}_{ϵ} .

A.2.10 Proof of Proposition 4.3.10

For $\rho \in \{0, 1\}$, it suffices to show that $v''_{\sigma(k)} \geq \rho$ in the case ρ_+ and $v''_{\sigma(k)} \leq \rho$ in the case ρ_- .

- If $v \in \mathcal{E}_{\epsilon}^{\rho_+}$, then, by Lemma 4.3.7, this implies that $l'_s \geq \rho$. For the last $j \in J$, it is easy to see by (4.3.14) that

$$\begin{aligned} v''_{\sigma(j)} &= l'_j + \Delta(\sigma(j), j) \\ &\geq l'_s + \eta(j, s) + \Delta(\sigma(j), s) \geq \rho. \end{aligned}$$

For the last $i + 1 \in I + 1$, we have by (4.3.14) that

$$\begin{aligned} 2v''_{\sigma(i+1)} &= 2(l_{i+1} + \Delta(\sigma(i+1), i+1)) \\ &\geq l'_s + \eta(i+1, s) + \Delta(i+1, s) + 2\Delta(\sigma(i+1), i+1) \end{aligned}$$

but we have by definition and (4.3.3) that $\eta(i+1, s) = s - i - 1 \geq \Delta(i+1, s)$, so that

$$\begin{aligned} 2v''_{\sigma(i+1)} &\geq l'_s + 2\Delta(\sigma(i+1), s) \\ &\geq l'_s \\ \implies v''_{\sigma(i+1)} &\geq \frac{1}{2}\rho. \end{aligned}$$

Since $\rho \in \{0, 1\}$ and $v''_{\sigma(i+1)} \in \mathbb{Z}$, we necessarily have that $v''_{\sigma(i+1)} \geq \rho$. Then for any $k \in \{1, \dots, s\}$, $v''_{\sigma(k)} \geq \rho$.

- For $v \in \mathcal{E}_{\epsilon}^{\rho_-}$, we have the following.
 - If $1 \in I$, since σ is increasing on $I \sqcup I + 1$, we obtain by (4.3.15) that for all $i \in I \sqcup (I + 1)$,

$$\begin{aligned} v''_{\sigma(i)} &= l_i + \Delta(\sigma(i), i) \\ &\leq l_1 - \Delta(1, \sigma(i)) \\ &\leq l_1 \leq \rho. \end{aligned}$$

For the first $j \in J$, we have by (4.3.14) that

$$\begin{aligned} v''_{\sigma(j)} &= l_j + \Delta(\sigma(j), j) \\ &\leq 2l_1 - \eta(1, j) - \Delta(1, \sigma(j)) \\ &\leq 2l_1 - \eta(1, j) \\ &\leq 2\rho - 1. \end{aligned}$$

Since $\rho \in \{0, 1\}$, we then have that $v''_{\sigma(k)} \leq \rho$ for all $k \in \{1, \dots, s\}$.

- If $1 \in J$, we can easily see as before that by (4.3.14), $v''_{\sigma(j)} \leq \rho$ for all $j \in J$. Now let us consider the first $i \in I$. We have by (4.3.14) that

$$2v''_{\sigma(i)} = 2(l_i + \Delta(\sigma(i), i))$$

$$\begin{aligned} &\leq 2(l_i + \Delta(1, i)) \\ &\leq l_1 - \eta(1, i) + \Delta(1, i) \\ &= l_1 - i + 2 + \Delta(1, i). \end{aligned}$$

By using (4.3.3), we obtain that

$$\begin{aligned} 2v''_{\sigma(i)} &\leq \rho + 1 \\ \implies v''_{\sigma(i)} &\leq \frac{\rho + 1}{2}, \end{aligned}$$

so that, since $\rho \in \{0, 1\}$ and $v''_{\sigma(i)} \in \mathbb{Z}$, we then always have $v''_{\sigma(i)} \leq \rho$.

A.3 Beyond the Durfee square

A.3.1 Proof of Lemma 6.1.24

This immediately comes from Remark 6.1.17, Remark 6.1.19, and the fact that we have by (2.2.48) and (2.2.52)

$$\begin{aligned} \epsilon(c, b(c)) + \epsilon(b(c), a(c')) + \epsilon(a(c'), c') - \epsilon(c, c') &= \epsilon(c, b(c)) + \epsilon(b(c), a(c')) - \epsilon(c, a(c')) \\ &\quad + \epsilon(b(c), a(c')) + \epsilon(a(c'), c') - \epsilon(b(c), c'). \end{aligned}$$

A.3.2 Proof of Lemma 6.1.26

We proceed via backward induction on j .

- If $j = s + t$, $\lambda(f_{s+t})$ is the last part of the minimal partition and therefore has size 1. Equation (6.1.1) is correct, as $s + t \in \mathcal{N} \sqcup \mathcal{T}_0 \sqcup \mathcal{S}_1$.
- Now assume that (6.1.1) holds for f_{j+1} , and prove it for f_j . Let k and ℓ be such that $f_j = a_k b_k$ and $f_{j+1} = a_\ell b_\ell$. We always have $k \neq \ell$.

1. For now, let us assume that $n_{j+1} > 0$, i.e. that f_{j+1} was actually inserted in the color sequence.
 - If $j \in \mathcal{N}$ or j is a left secondary insertion, then the subsequence between f_j and f_{j+1} in $S(n_1, \dots, n_{s+t})$ is $f_j, a_k b_\ell, f_{j+1}$ or $f_j, a_\ell b_\ell, f_{j+1}$. In the first case, we have

$$\begin{aligned} \lambda(f_j) &= \Delta(a_k b_k, a_k b_\ell) + \Delta(a_k b_\ell, a_\ell b_\ell) + \lambda(f_{j+1}) \\ &= 1 + \lambda(f_{j+1}), \end{aligned}$$

In the second case, we have also

$$\begin{aligned} \lambda(f_j) &= \Delta(a_k b_k, a_\ell b_\ell) + \Delta(a_\ell b_\ell, a_\ell b_\ell) + \lambda(f_{j+1}) \\ &= 1 + \lambda(f_{j+1}), \end{aligned}$$

By the induction hypothesis, we have

$$\begin{aligned} \lambda(f_j) &= 1 + \#(\{j+1, \dots, s+t\} \cap (\mathcal{N} \sqcup \mathcal{T}_0 \sqcup \mathcal{S}_1)) \\ &= \#(\{j, \dots, s+t\} \cap (\mathcal{N} \sqcup \mathcal{T}_0 \sqcup \mathcal{S}_1)), \end{aligned}$$

because $j \in \mathcal{N} \sqcup \mathcal{T}_0 \sqcup \mathcal{S}_1$.

- If j is a right secondary insertion, then f_j appears directly before f_{j+1} in $S(n_1, \dots, n_{s+t})$. Thus we have

$$\begin{aligned} \lambda(f_j) &= \Delta(f_j, f_{j+1}) + \lambda(f_{j+1}) \\ &= 1 + \lambda(f_{j+1}), \end{aligned}$$

and we can deduce (6.1.1) in the exact same way as before.

2. Now we treat the case where f_{j+1} was not inserted in the color sequence. By Proposition 6.1.25, if $j+1 \in \mathcal{N} \sqcup \mathcal{T}_0$, it does not change anything to the other parts in the minimal partition, so $\lambda(f_j)$ stays the same as in case (1).

If $j+1 \in \mathcal{T}_1$ and b_{j+1} was not inserted, then by Proposition 6.1.25, the part $\lambda(f_j)$ decreases by one compared to the previous case. But in this case, $\#(\{j, \dots, s+t\} \cap (\mathcal{N} \sqcup \mathcal{T}_0 \sqcup \mathcal{S}_1))$ also decreases by one compared to case (1), so Equation (6.1.1) is still correct.

A.3.3 Proof of Lemma 6.2.4

When $u = v = 0$, this is trivially true. Otherwise, we have by definition:

$$g_{u,v}(q^{-1}; 2 - x_1, \dots, 2 - x_v) = \sum_{\substack{\theta_1, \dots, \theta_v \in \{0,1\}: \\ \theta_1 + \dots + \theta_v = u}} q^{-(uv + \binom{u}{2})} \prod_{k=1}^v q^{-(2-x_k-1)\sum_{i=1}^{k-1} \theta_i}$$

$$\begin{aligned}
&= q^{-u(2v+u-1)} \sum_{\substack{\theta_1, \dots, \theta_v \in \{0,1\}: \\ \theta_1 + \dots + \theta_v = u}} q^{(uv + \binom{u}{2})} \prod_{k=1}^v q^{(x_k - 1) \sum_{i=1}^{k-1} \theta_i} \\
&= q^{-u(2v+u-1)} g_{u,v}(q; x_1, \dots, x_v).
\end{aligned}$$

A.3.4 Proof of Lemma 6.2.7

Let us consider a partition into parts at most $s + m$, generated by $\frac{1}{(q; q)_{s+m}}$.

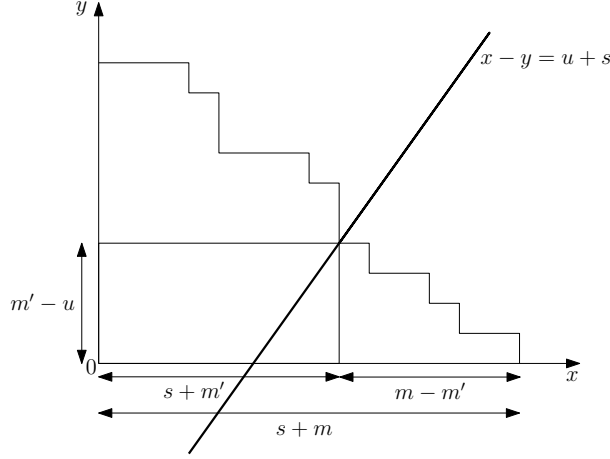

FIGURE A.1: Durfee-like decomposition

Draw its Ferrers diagram on the plane as shown in Figure A.1, and draw the line of equation $x - y = u + s$. This line intersects the boundary of the Ferrers board in a point with coordinates $(s + m', m' - u)$ for some integer $m' \in \{u, \dots, m\}$. (we take the convention that the x -axis always belongs to the boundary of the Ferrers board). It defines three zones in the Ferrers diagram:

- a rectangle of size $(m' - u) \times (s + m')$ on the bottom-left of the intersection, generated by $q^{(m' - u)(s + m')}$,
- a partition into parts at most $s + m'$ on top on the rectangle, generated by $\frac{1}{(q; q)_{s + m'}}$,
- a partition with at most $m' - u$ parts, each of size at most $m - m'$, generated by $\left[\begin{smallmatrix} m - u \\ m' - u \end{smallmatrix} \right]_q$.

Summing over all possible values of m' gives the desired result.

A.3.5 Proof of Lemma 6.3.1

First, writing $\mathcal{S}_1 = \bigsqcup_{u=1}^t \mathcal{S}_1^u$, we have

$$\Sigma_1 = \sum_{u=1}^t \sum_{j \in \mathcal{S}_1^u} (P(j) + \#(\llbracket j; s + t \rrbracket \cap (\mathcal{N} \sqcup \mathcal{T}_0 \sqcup \mathcal{S}_1))).$$

Now, noticing that for $j \in \mathcal{S}_1^u$, $P(j) = j - u$, we can write

$$\Sigma_1 = \sum_{u=1}^t \sum_{j \in \mathcal{S}_1^u} (j_{2u-1} - u + j - j_{2u-1} + \#(\llbracket j; s + t \rrbracket \cap (\mathcal{N} \sqcup \mathcal{T}_0 \sqcup \mathcal{S}_1))). \quad (\text{A.3.1})$$

We first note that

$$\begin{aligned}
j_{2u-1} - u &= 1 - u + j_{2u-1} - 1 \\
&= 1 - u + \#(\llbracket 1; j_{2u-1} - 1 \rrbracket \cap \mathcal{N}) + \#(\llbracket 1; j_{2u-1} - 1 \rrbracket \cap (\mathcal{T}_0 \sqcup \mathcal{T}_1)) && \text{because } \llbracket 1; s + t \rrbracket = \mathcal{N} \sqcup \mathcal{T}_0 \sqcup \mathcal{T}_1 \\
&= 1 - u + \#(\llbracket 1; j_{2u-1} - 1 \rrbracket \cap \mathcal{N}) + 2u - 2 && \text{by definition of } j_{2u-1} \\
&= \#(\llbracket 1; j_{2u-1} - 1 \rrbracket \cap \mathcal{N}) + u - 1.
\end{aligned}$$

We also rewrite $j - j_{2u-1}$ as

$$j - j_{2u-1} = \#(\llbracket j_{2u-1}; j-1 \rrbracket \cap \mathcal{T}_0^u) + \#(\llbracket j_{2u-1}; j-1 \rrbracket \cap \mathcal{S}_1^u) + \#(\llbracket j_{2u-1}; j-1 \rrbracket \cap \overline{\mathcal{S}_1^u}) + \#(\llbracket j_{2u-1}; j-1 \rrbracket \cap \mathcal{N}).$$

Finally, we have

$$\begin{aligned} \#(\llbracket j; s+t \rrbracket \cap (\mathcal{N} \sqcup \mathcal{T}_0 \sqcup \mathcal{S}_1)) &= \#(\llbracket j; s+t \rrbracket \cap \mathcal{N}) + \#(\llbracket j; j_{2u} \rrbracket \cap (\mathcal{T}_0^u \sqcup \mathcal{S}_1^u)) + \#(\llbracket j_{2u}+1; s+t \rrbracket \cap (\mathcal{T}_0 \sqcup \mathcal{S}_1)) \\ &= \#(\llbracket j; s+t \rrbracket \cap \mathcal{N}) + \#(\llbracket j; j_{2u} \rrbracket \cap (\mathcal{T}_0^u \sqcup \mathcal{S}_1^u)) + \sum_{v=u+1}^t (|\mathcal{T}_0^v| + |\mathcal{S}_1^v|). \end{aligned}$$

Combining the three observations above, (A.3.1) becomes

$$\Sigma_1 = \sum_{u=1}^t \sum_{j \in \mathcal{S}_1^u} \left(|\mathcal{N}| + u - 1 + \sum_{v=u}^t (|\mathcal{T}_0^v| + |\mathcal{S}_1^v|) + \#(\llbracket j_{2u-1}; j-1 \rrbracket \cap \overline{\mathcal{S}_1^u}) \right).$$

Noticing that $|\mathcal{N}| + u - 1 + \sum_{v=u}^t (|\mathcal{T}_0^v| + |\mathcal{S}_1^v|)$ does not depend on j , and that $\#(\llbracket j_{2u-1}; j-1 \rrbracket \cap \overline{\mathcal{S}_1^u}) = \#\{j' < j : j' \in \overline{\mathcal{S}_1^u}\}$ yields the desired formula.

A.3.6 Proof of Lemma 6.3.2

By Proposition 6.1.27 and Lemma 6.3.1, we have

$$H_{S, \mathcal{S}_1}(q) = \sum_{\substack{n_1, \dots, n_{s+t}: \\ n_1 + \dots + n_{s+t} = m, \\ \{j \in \mathcal{T}_1 : n_j > 0\} = \mathcal{S}_1}} q^{|\min_\epsilon(S)| + \Sigma_1 + \sum_{j \in \mathcal{S}_1} (n_j - 1) \#(\llbracket j; s+t \rrbracket \cap (\mathcal{N} \sqcup \mathcal{T}_0 \sqcup \mathcal{S}_1)) + \sum_{j \in \mathcal{N} \sqcup \mathcal{T}_0} n_j \#(\llbracket j; s+t \rrbracket \cap (\mathcal{N} \sqcup \mathcal{T}_0 \sqcup \mathcal{S}_1))}.$$

Thus by the changes of variables

$$n'_j = \begin{cases} n_j & \text{if } j \in \mathcal{N} \sqcup \mathcal{T}_0 \\ n_j - 1 & \text{if } j \in \mathcal{S}_1 \end{cases},$$

and noticing that $|\min_\epsilon(S)|$ and Σ_1 do not depend on the n'_j 's, we obtain

$$H_{S, \mathcal{S}_1}(q) = q^{|\min_\epsilon(S)| + \Sigma_1} \sum_{\substack{(n'_j)_{j \in \mathcal{N} \sqcup \mathcal{T}_0 \sqcup \mathcal{S}_1}: \\ \sum_j n'_j = m - |\mathcal{S}_1|}} q^{\sum_{j \in \mathcal{N} \sqcup \mathcal{T}_0 \sqcup \mathcal{S}_1} n'_j \#(\llbracket j; s+t \rrbracket \cap (\mathcal{N} \sqcup \mathcal{T}_0 \sqcup \mathcal{S}_1))} \quad (\text{A.3.2})$$

Moreover, we can interpret the sum above as the generating function for partitions into exactly $m - |\mathcal{S}_1|$ parts, each part being at most $|\mathcal{N}| + |\mathcal{T}_0| + |\mathcal{S}_1|$. Indeed, for all $j \in \mathcal{N} \sqcup \mathcal{T}_0 \sqcup \mathcal{S}_1$, n'_j can be interpreted as the number of parts of size $\#(\llbracket j; s+t \rrbracket \cap (\mathcal{N} \sqcup \mathcal{T}_0 \sqcup \mathcal{S}_1))$ (see Figure A.2 below).

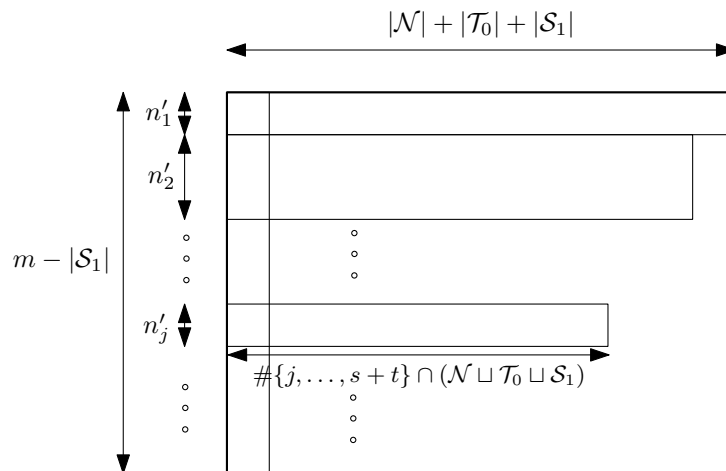

FIGURE A.2: Decomposition of the Ferrers board.

The generating function for such partitions is given by $q^{m-|S_1|} \left[\begin{matrix} m-1+|\mathcal{N}|+|\mathcal{T}_0| \\ m-|S_1| \end{matrix} \right]_q$, which yields the desired formula (6.3.2) for $H_{S,S_1}(q)$.

A.3.7 Proof of Lemma 6.3.3

Partitions whose Ferrers diagram fits inside a $a \times b$ box, generated by $\left[\begin{matrix} a+b \\ a \end{matrix} \right]_q$, are in bijection with walks on the plane going from $(0,0)$ to (b,a) , having b right steps and a up steps. The partition can be seen on top of the path, as shown in Figure A.3.

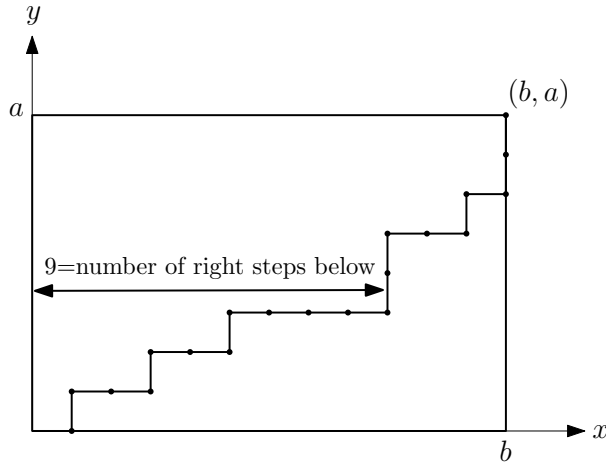

FIGURE A.3: A partition as a path.

If $A \subseteq \llbracket 1; a+b \rrbracket, |A| = a$ is the set of up steps, then for each position $j \in A$, the part of the partition corresponding to this up step has its size equal to the number of right steps that have been done before, i.e. $\#\{j' < j : j' \in \llbracket 1; a+b \rrbracket \setminus A\}$.

A.3.8 Proof of Lemma 6.3.5

The left-hand side is the generating function for partitions fitting inside a $m \times (\ell_1 + \dots + \ell_t)$ box, such that the largest part is equal to m . Take the Ferrers board of such a partition, and draw it in the plane as shown on Figure A.4 (where the partition is above the path).

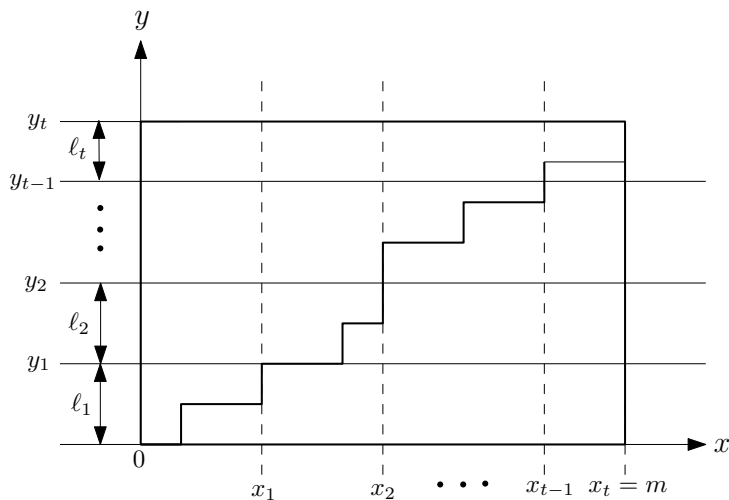

FIGURE A.4: Decomposition of the Ferrers board.

For all $i \in \{1, \dots, t\}$, let x_i be the size of the $\sum_{k=i+1}^t \ell_k + 1$ -th part (with $x_i = 0$ if there are less than $\ell_1 + \dots + \ell_t - y_i + 1$ parts).

For all $i \in \{1, \dots, t\}$, let $y_i := \sum_{k=1}^i \ell_k$. For fixed $0 \leq x_1 \leq \dots \leq x_t = m$, these partitions are generated by

$$\prod_{r=1}^t q^{\ell_r x_{r-1}} \times q^{x_r - x_{r-1}} \begin{bmatrix} x_r - x_{r-1} + \ell_r - 1 \\ x_r - x_{r-1} \end{bmatrix}_q,$$

where $q^{\ell_r x_{r-1}}$ generates the rectangle between the y -axis, the lines $y = y_r$ and $y = y_{r-1}$, and the line $x = x_{r-1}$, and the second term generates partitions fitting inside a $(x_r - x_{r-1}) \times \ell_r$ box, such that the largest part is equal to $x_r - x_{r-1}$. The above is equal to

$$q^m \prod_{r=1}^t q^{\ell_r x_{r-1}} \begin{bmatrix} x_r - x_{r-1} + \ell_r - 1 \\ x_r - x_{r-1} \end{bmatrix}_q,$$

and summing over all possible values for x_1, \dots, x_{t-1} gives the desired result.

A.3.9 Proof of Lemma 6.3.7

Let us define $G_0(q; m) = \chi(m = 0)$, and for $v \geq 1$,

$$G_v(q; x_1, \dots, x_v; m) := \sum_{0=m_0 \leq m_1 \leq \dots \leq m_v = m} \sum_{\substack{k_1, \dots, k_v: \\ k_u \in \llbracket 0; 2-x_u \rrbracket}} \prod_{u=1}^v q^{k_u(u-2+k_u+x_u) + (k_u+x_u)m_{u-1}} \begin{bmatrix} 2-x_u \\ k_u \end{bmatrix}_q \begin{bmatrix} m_u - m_{u-1} + x_u - 1 \\ m_u - m_{u-1} - k_u \end{bmatrix}_q,$$

So that the function in Lemma 6.3.7 is $G_t(q; |\mathcal{T}_0^1|, \dots, |\mathcal{T}_0^t|; m_t)$.

We show by induction on v that

$$G_v(q; x_1, \dots, x_v; m) = \sum_{u=0}^v g_{u,v}(q; x_1, \dots, x_v) \begin{bmatrix} m+v-1 \\ m-u \end{bmatrix}_q. \quad (\text{A.3.3})$$

Recall from Andrews, 1984b, p. 37, (3.3.10) that

$$\begin{bmatrix} a+b \\ c \end{bmatrix}_q = \sum_{a' \geq 0} \begin{bmatrix} a \\ a' \end{bmatrix}_q \begin{bmatrix} b \\ c-a' \end{bmatrix}_q q^{a'(b-c+a')}. \quad (\text{A.3.4})$$

By (A.3.4) with $a = 2 - x_1$, $b = m + x_1 - 1$, and $c = m$, we have

$$\begin{aligned} G_1(q; x_1; m) &= \begin{bmatrix} m+1 \\ m \end{bmatrix}_q \\ &= \begin{bmatrix} m \\ m \end{bmatrix}_q + q \begin{bmatrix} m \\ m-1 \end{bmatrix}_q \\ &= g_{0,1}(q; x_1) \begin{bmatrix} m \\ m \end{bmatrix}_q + g_{1,1}(q; x_1) \begin{bmatrix} m \\ m-1 \end{bmatrix}_q. \end{aligned}$$

So (A.3.3) is true for $v = 1$. Now assume that it is true for $v - 1 \geq 1$ and prove it for v . We have

$$\begin{aligned} G_v(q; x_1, \dots, x_v; m) &= \sum_{0=m_0 \leq m_1 \leq \dots \leq m_v = m} \prod_{u=1}^v \left(\sum_{k_u=0}^{2-x_u} q^{k_u(u-2+k_u+x_u) + (k_u+x_u)m_{u-1}} \begin{bmatrix} 2-x_u \\ k_u \end{bmatrix}_q \begin{bmatrix} m_u - m_{u-1} + x_u - 1 \\ m_u - m_{u-1} - k_u \end{bmatrix}_q \right) \\ &= \sum_{m_{v-1}=0}^m \left(\sum_{0=m_0 \leq m_1 \leq \dots \leq m_{v-1}} \prod_{u=1}^{v-1} \left(\sum_{k_u=0}^{2-x_u} q^{k_u(u-2+k_u+x_u) + (k_u+x_u)m_{u-1}} \begin{bmatrix} 2-x_u \\ k_u \end{bmatrix}_q \begin{bmatrix} m_u - m_{u-1} + x_u - 1 \\ m_u - m_{u-1} - k_u \end{bmatrix}_q \right) \right) \\ &\quad \times \sum_{k_v=0}^{2-x_v} q^{k_v(v-2+k_v+x_v) + (k_v+x_v)m_{v-1}} \begin{bmatrix} 2-x_v \\ k_v \end{bmatrix}_q \begin{bmatrix} m - m_{v-1} + x_v - 1 \\ m - m_{v-1} - k_v \end{bmatrix}_q \\ &= \sum_{m_{v-1}=0}^m G_{v-1}(q; x_1, \dots, x_{v-1}; m_{v-1}) \sum_{k_v=0}^{2-x_v} q^{k_v(v-2+k_v+x_v) + (k_v+x_v)m_{v-1}} \begin{bmatrix} 2-x_v \\ k_v \end{bmatrix}_q \begin{bmatrix} m - m_{v-1} + x_v - 1 \\ m - m_{v-1} - k_v \end{bmatrix}_q \end{aligned}$$

$$\begin{aligned}
&= \sum_{m_{v-1}=0}^m \sum_{u=0}^{v-1} g_{u,v-1}(q; x_1, \dots, x_{v-1}) \begin{bmatrix} m_{v-1} + v - 2 \\ m_{v-1} - u \end{bmatrix}_q \\
&\quad \times \sum_{k_v=0}^{2-x_v} q^{k_v(v-2+k_v+x_v)+(k_v+x_v)m_{v-1}} \begin{bmatrix} 2-x_v \\ k_v \end{bmatrix}_q \begin{bmatrix} m - m_{v-1} + x_v - 1 \\ m - m_{v-1} - k_v \end{bmatrix}_q,
\end{aligned}$$

where we used the induction hypothesis in the last equality. Rearranging the order of summation leads to

$$\begin{aligned}
G_v(q; x_1, \dots, x_v; m) &= \sum_{u=0}^{v-1} q^{ux_v} g_{u,v-1}(q; x_1, \dots, x_{v-1}) \sum_{k_v=0}^{2-x_v} q^{k_v(v-2+u+k_v+x_v)} \begin{bmatrix} 2-x_v \\ k_v \end{bmatrix}_q \\
&\quad \times \sum_{m_{v-1}=0}^m q^{(k_v+x_v)(m_{v-1}-u)} \begin{bmatrix} m_{v-1} + v - 2 \\ m_{v-1} - u \end{bmatrix}_q \begin{bmatrix} m - m_{v-1} + x_v - 1 \\ m - m_{v-1} - k_v \end{bmatrix}_q.
\end{aligned}$$

Using Lemma 6.3.5 with $t = 2$, $m = m - u - k_v$, $\ell_1 = v - 1 + u$, and $\ell_2 = k_v + x_v$, and the change of variable $x_1 = m_{v-1} - u$, this yields:

$$\begin{aligned}
G_v(q; x_1, \dots, x_v; m) &= \sum_{u=0}^{v-1} q^{ux_v} g_{u,v-1}(q; x_1, \dots, x_{v-1}) \sum_{k_v=0}^{2-x_v} q^{k_v(v-2+u+k_v+x_v)} \begin{bmatrix} 2-x_v \\ k_v \end{bmatrix}_q \\
&\quad \times \begin{bmatrix} m + v + x_v - 2 \\ m - u - k_v \end{bmatrix}_q.
\end{aligned}$$

Using (A.3.4) again with $a = 2 - x_v$, $b = m + v + x_v - 2$, $c = m - u$, and $a' = k_v$, we obtain

$$G_v(q; x_1, \dots, x_v; m) = \sum_{u=0}^{v-1} q^{ux_v} g_{u,v-1}(q; x_1, \dots, x_{v-1}) \begin{bmatrix} m + v \\ m - u \end{bmatrix}_q.$$

By the q -analogue of Pascal's triangle, this becomes

$$\begin{aligned}
&G_v(q; x_1, \dots, x_v; m) \\
&= \sum_{u=0}^{v-1} q^{ux_v} g_{u,v-1}(q; x_1, \dots, x_{v-1}) \begin{bmatrix} m + v - 1 \\ m - u \end{bmatrix}_q + \sum_{u=0}^{v-1} q^{ux_v+u+v} g_{u,v-1}(q; x_1, \dots, x_{v-1}) \begin{bmatrix} m + v - 1 \\ m - u - 1 \end{bmatrix}_q \\
&= \sum_{u=0}^{v-1} \left(q^{ux_v} g_{u,v-1}(q; x_1, \dots, x_{v-1}) + q^{(u-1)x_v+u+v-1} g_{u-1,v-1}(q; x_1, \dots, x_{v-1}) \right) \begin{bmatrix} m + v - 1 \\ m - u \end{bmatrix}_q \quad (\text{A.3.5})
\end{aligned}$$

Recall that

$$g_{u,v}(q; x_1, \dots, x_v) = \sum_{\substack{\epsilon_1, \dots, \epsilon_v \in \{0,1\}: \\ \epsilon_1 + \dots + \epsilon_v = u}} q^{uv + \binom{u}{2}} \prod_{k=1}^v q^{(x_k-1) \sum_{i=1}^{k-1} \epsilon_i}.$$

So, separating the case where $\epsilon_v = 0$ from the case where $\epsilon_v = 1$, we have

$$\begin{aligned}
g_{u,v}(q; x_1, \dots, x_v) &= \sum_{\substack{\epsilon_1, \dots, \epsilon_{v-1} \in \{0,1\}: \\ \epsilon_1 + \dots + \epsilon_{v-1} = u}} q^{uv + \binom{u}{2}} \left(\prod_{k=1}^{v-1} q^{(x_k-1) \sum_{i=1}^{k-1} \epsilon_i} \right) q^{(x_v-1)u} \\
&\quad + \sum_{\substack{\epsilon_1, \dots, \epsilon_{v-1} \in \{0,1\}: \\ \epsilon_1 + \dots + \epsilon_{v-1} = u-1}} q^{uv + \binom{u}{2}} \left(\prod_{k=1}^{v-1} q^{(x_k-1) \sum_{i=1}^{k-1} \epsilon_i} \right) q^{(x_v-1)(u-1)}.
\end{aligned}$$

After simplification, this is exactly (A.3.5).

A.3.10 Proof of Lemma 6.4.1

The first equality follows directly from the definition of the s_i 's.

Let us now prove the second equality. We have

$$\begin{aligned}
\sum_{i=1}^{n-1} \frac{((i+1)s_i - is_{i+1})^2}{2i(i+1)} &= \sum_{i=1}^{n-1} \left(\frac{i+1}{2i} s_i^2 - s_i s_{i+1} + \frac{i}{2(i+1)} s_{i+1}^2 \right) \\
&= - \sum_{i=1}^{n-1} s_i s_{i+1} + s_1^2 + \sum_{i=2}^{n-1} \left(\frac{i+1}{2i} s_i^2 + \frac{i-1}{2i} s_i^2 \right) \\
&= \sum_{i=1}^{n-1} s_i (s_i - s_{i+1}),
\end{aligned}$$

where the second equality followed from the change of variable $i \rightarrow i-1$ in the last sum.

A.3.11 Proof of Proposition 6.2.3

We first prove that the relations in Definition 2.2.37 are satisfied by ϵ' . We have the following.

1. for any $c, c' \in \mathcal{C}_{\text{free}} \sqcup \{c_\infty\}$,

$$\epsilon'(c, c) = 2 - (\epsilon_1 + \epsilon_2)(c, c) = 0$$

and for $c \neq c'$

$$\epsilon'(c, c') = 2 - (\epsilon_1 + \epsilon_2)(c, c') = 2 - 1 = 1.$$

Then, relation (2.2.48) is satisfied by ϵ' .

2. For any $c \in \mathcal{C}_{\text{bound}}$,

$$\begin{aligned}
\epsilon'(a(c), c) + \epsilon'(c, b(c)) &= 4 - (\epsilon_1 + \epsilon_2)(a(c), c) - (\epsilon_1 + \epsilon_2)(c, b(c)) \\
&= 4 - (1 + \epsilon(a(c), c)) - (1 + \epsilon(c, b(c))) \\
&= 2 - (\epsilon(a(c), c) + \epsilon(c, b(c))) \\
&= 1
\end{aligned}$$

and relation (2.2.49) is satisfied. For any $c' \in (\mathcal{C}_{\text{free}} \sqcup \{c_\infty\}) \setminus \{a(c)\}$,

$$\epsilon'(c', c) = 2 - (\epsilon_1 + \epsilon_2)(c', c) = 2 - \epsilon(c', c)$$

By (2.2.50), we obtain

$$\epsilon(c', c) \in \{\epsilon(a(c), c), \epsilon(a(c), c) + 1\} \iff \epsilon'(c', c) \in \{2 - \epsilon(a(c), c), 1 - \epsilon(a(c), c)\}$$

and since $\epsilon'(a(c), c) = 1 - \epsilon(a(c), c)$, we then have that ϵ' satisfies relation (2.2.50). By the same reasoning, we show that ϵ' satisfies relation (2.2.51).

3. For any $c, c' \in \mathcal{C}_{\text{bound}}$ with $b(c) = a(c')$, we have

$$\begin{aligned}
\epsilon'(c, c') &= 2 - (\epsilon_1 + \epsilon_2)(c, c') \\
&= 2 - \epsilon(c, c') \\
&= 2 - (\epsilon(c, a(c')) + \epsilon(b(c), c')) && \text{by (2.2.52)} \\
&= (1 - (\epsilon(c, b(c)))) + (1 - \epsilon(a(c'), c')) \\
&= \epsilon'(c, b(c)) + \epsilon(a(c'), c').
\end{aligned}$$

For any $c, c' \in \mathcal{C}_{\text{bound}}$ with $b(c) \neq a(c')$, we have

$$\begin{aligned}
\epsilon'(c, c') &= 2 - (\epsilon_1 + \epsilon_2)(c, c') \\
&= 2 - \epsilon(c, c') \\
&= 3 - (\epsilon(c, a(c')) + \epsilon(b(c), c')) && \text{by (2.2.52)} \\
&= (2 - (\epsilon(c, a(c')))) + (2 - \epsilon(b(c), c')) - 1 \\
&= \epsilon'(c, b(c)) + \epsilon(a(c'), c') - 1.
\end{aligned}$$

In both case, relation (2.2.52) is satisfied by ϵ' .

We now consider the left insertion of $a(c')$ in a secondary pair (c, c') with a bound color c' . Without loss of generality, since for a bound color c , the type of the insertion of $a(c')$ in the pair $(b(c), c')$ is the same as in the pair (c, c') , we can assume that c is a free color (then different from $a(c')$). The type of insertion is then given by the value of $\epsilon'(c, a(c')) + \epsilon'(a(c'), c') - \epsilon'(c, c')$. We then have

$$\begin{aligned} \epsilon'(c, a(c')) + \epsilon'(a(c'), c') - \epsilon'(c, c') &= 1 + (1 - \epsilon(a(c'), c')) - (2 - \epsilon(c, c')) \\ &= 1 - (1 + \epsilon(a(c'), c') - \epsilon(c, c')) \\ &= 1 - (\epsilon(c, a(c')) + \epsilon(a(c'), c') - \epsilon(c, c')). \end{aligned}$$

The type of insertion is then exchanged, as a type 0 with ϵ becomes a type 1 with ϵ' and reversely, a type 0 with ϵ becomes a type 0 with ϵ . We use the same reasoning for the right insertion and we obtain the same reversibility of the types.

A.3.12 Proof of Proposition 6.2.5

Let $C = c_1, \dots, c_{s+m}$ be a color sequence whose reduction is S . The weight of the corresponding minimal partition in $\mathcal{P}_{\epsilon_1 + \epsilon_2}^{c_\infty}$ is

$$|\min_{\epsilon_1 + \epsilon_2}(C)| = \sum_{i=1}^{s+m} i(\epsilon_1 + \epsilon_2)(c_i, c_{i+1}) = (s+m)(s+m+1) - |\min_{\epsilon'}(C)|, \quad (\text{A.3.6})$$

where the second equality follows from the definition of ϵ' . On the other hand, by Proposition 6.2.3 and (A.3.6), we have

$$|\min_{\epsilon}(S)| = |\min_{\epsilon_1 + \epsilon_2}(S)| = s(s+1) - |\min_{\epsilon'}(S)|. \quad (\text{A.3.7})$$

Given that, by Proposition 6.2.3, ϵ and ϵ' have exactly the same insertion properties up to exchanging the type 0 and 1 insertions, Proposition 6.1.29 immediately gives us that

$$\sum_{\substack{\text{Ccolor sequence of length } s+m \\ \text{such that } \text{red}(C)=S}} q^{|\min_{\Delta''}(C)|} = q^{|\min_{\epsilon'}(S)|+m} \sum_{u=0}^t q^{u(s-t)} g_{u,t}(q; |\mathcal{T}_1^1|, \dots, |\mathcal{T}_1^t|) \begin{bmatrix} s+m-1 \\ m-u \end{bmatrix}_q.$$

Combining this with (A.3.6), we get that the generating function for minimal partitions in $\mathcal{P}_{\epsilon_1 + \epsilon_2}^{c_\infty}$ is

$$\begin{aligned} G &:= \sum_{\substack{\text{Ccolor sequence} \\ \text{of length } s+m \\ \text{such that } \text{red}(C)=S}} q^{|\min_{\epsilon_1 + \epsilon_2}(C)|} \\ &= q^{(s+m)(s+m+1) - |\min_{\epsilon'}(S)| - m} \sum_{u=0}^t q^{-u(s-t)} g_{u,t}(q^{-1}; |\mathcal{T}_1^1|, \dots, |\mathcal{T}_1^t|) \begin{bmatrix} s+m-1 \\ m-u \end{bmatrix}_{q^{-1}}. \end{aligned}$$

By Lemma 6.2.4 and the fact that for all $k \in \{1, \dots, t\}$, $|\mathcal{T}_1^k| = 2 - |\mathcal{T}_0^k|$, the above becomes

$$G = q^{(s+m)(s+m+1) - |\min_{\Delta''}(S)| - m} \sum_{u=0}^t q^{-u(s+t+u-1)} g_{u,t}(q; |\mathcal{T}_0^1|, \dots, |\mathcal{T}_0^t|) \begin{bmatrix} s+m-1 \\ m-u \end{bmatrix}_{q^{-1}}.$$

Now using the fact that

$$\begin{bmatrix} s+m-1 \\ m-u \end{bmatrix}_{q^{-1}} = q^{-(s+u-1)(m-u)} \begin{bmatrix} s+m-1 \\ m-u \end{bmatrix}_q,$$

we obtain

$$\begin{aligned} G &= q^{(s+m)(s+m+1) - |\min_{\epsilon'}(S)| - ms} \sum_{u=0}^t q^{-u(t+m)} g_{u,t}(q; |\mathcal{T}_0^1|, \dots, |\mathcal{T}_0^t|) \begin{bmatrix} s+m-1 \\ m-u \end{bmatrix}_q \\ &= q^{|\min_{\epsilon}(S)| + m(s+m+1)} \sum_{u=0}^t q^{-u(t+m)} g_{u,t}(q; |\mathcal{T}_0^1|, \dots, |\mathcal{T}_0^t|) \begin{bmatrix} s+m-1 \\ m-u \end{bmatrix}_q, \end{aligned}$$

where we used (A.3.7) in the last equality. This completes the proof.

A.3.13 Proof of Proposition 6.3.4

By Lemma 6.3.2, we have:

$$G_{S,m}(q) = \sum_{\substack{k_1, \dots, k_t: \\ k_u \leq |\mathcal{T}_1^u|}} \sum_{\substack{S_1: \\ \forall u, S_1^u \subseteq \mathcal{T}_1^u \\ \text{and } |S_1^u| = k_u}} H_{S, S_1}(q) = \sum_{\substack{k_1, \dots, k_t: \\ k_u \leq |\mathcal{T}_1^u|}} \sum_{\substack{S_1: \\ \forall u, S_1^u \subseteq \mathcal{T}_1^u \\ \text{and } |S_1^u| = k_u}} q^{|\min_\epsilon(S)| + \Sigma_1 + m - |S_1|} \begin{bmatrix} m - 1 + |\mathcal{N}| + |\mathcal{T}_0| \\ m - |S_1| \end{bmatrix}_q.$$

By Lemma 6.3.1, this becomes

$$G_{S,m}(q) = \sum_{\substack{k_1, \dots, k_t: \\ k_u \leq |\mathcal{T}_1^u|}} q^{|\min_\epsilon(S)| + \Sigma_{u=1}^t k_u (|\mathcal{N}| + u - 1 + \Sigma_{v=u}^t (|\mathcal{T}_0^v| + k_v))} q^{m - \Sigma_{u=1}^t k_u} \begin{bmatrix} m - 1 + |\mathcal{N}| + |\mathcal{T}_0| \\ m - \Sigma_{u=1}^t k_u \end{bmatrix}_q \\ \times \sum_{\substack{S_1: \\ \forall u, S_1^u \subseteq \mathcal{T}_1^u \\ \text{and } |S_1^u| = k_u}} \prod_{u=1}^t q^{\sum_{j \in S_1^u} \#\{j' < j: j' \in \overline{S_1^u}\}}.$$

Exchanging the final sum and product, and then using Lemma 6.3.3 for each $u \in \{1, \dots, t\}$ with $a = k_u$ and $b = |\mathcal{T}_1^u| - k_u$ gives the desired formula.

A.3.14 Proof of Proposition 6.3.6

Let us start by applying Lemma 6.3.5 with $t = t + 1$, $m = m - \sum_{u=1}^t k_u$, $\ell_u = k_u + |\mathcal{T}_0^u|$ for all $u \in \{1, \dots, t\}$, and $\ell_{t+1} = |\mathcal{N}|$. We have

$$X := q^{m - \sum_{u=1}^t k_u} \begin{bmatrix} m + |\mathcal{T}_0| + |\mathcal{N}| - 1 \\ m - \sum_{u=1}^t k_u \end{bmatrix}_q \\ = q^{m - \sum_{u=1}^t k_u} \sum_{0 = x_0 \leq x_1 \leq \dots \leq x_{t+1} = m - \sum_{u=1}^t k_u} \left(\prod_{u=1}^t q^{(k_u + |\mathcal{T}_0^u|)x_{u-1}} \begin{bmatrix} x_u - x_{u-1} + k_u + |\mathcal{T}_0^u| - 1 \\ x_u - x_{u-1} \end{bmatrix}_q \right) \\ \times q^{|\mathcal{N}|x_t} \begin{bmatrix} m - \sum_{u=1}^t k_u - x_t + |\mathcal{N}| - 1 \\ m - \sum_{u=1}^t k_u - x_t \end{bmatrix}_q.$$

By the changes of variables $x_u = m_u - \sum_{v=1}^u k_v$, we obtain

$$X = q^{m - \sum_{u=1}^t k_u} \sum_{0 = m_0 \leq m_1 \leq \dots \leq m_{t+1} = m} \left(\prod_{u=1}^t q^{(k_u + |\mathcal{T}_0^u|)(m_{u-1} - \sum_{v=1}^{u-1} k_v)} \begin{bmatrix} m_u - m_{u-1} + |\mathcal{T}_0^u| - 1 \\ m_u - m_{u-1} - k_u \end{bmatrix}_q \right) \\ \times q^{|\mathcal{N}|(m_t - \sum_{v=1}^t k_v)} \begin{bmatrix} m - m_t + |\mathcal{N}| - 1 \\ m - m_t \end{bmatrix}_q \\ = q^{m - \sum_{u=1}^t k_u (1 + |\mathcal{N}|) - \sum_{u=1}^t (k_u + |\mathcal{T}_0^u|) \sum_{v=1}^{u-1} k_v} \\ \times \sum_{0 = m_0 \leq m_1 \leq \dots \leq m_t \leq m} \left(\prod_{u=1}^t q^{(k_u + |\mathcal{T}_0^u|)m_{u-1}} \begin{bmatrix} m_u - m_{u-1} + |\mathcal{T}_0^u| - 1 \\ m_u - m_{u-1} - k_u \end{bmatrix}_q \right) q^{|\mathcal{N}|m_t} \begin{bmatrix} m - m_t + |\mathcal{N}| - 1 \\ m - m_t \end{bmatrix}_q.$$

We deduce the final formula by using that

$$\sum_{u=1}^t (k_u + |\mathcal{T}_0^u|) \sum_{v=1}^{u-1} k_v = \sum_{v=1}^t k_v \sum_{u=v+1}^t (k_u + |\mathcal{T}_0^u|).$$

A.4 Perfect crystal and multi-grounded partitions

A.4.1 Proof of Lemma 8.3.1

We have the following formula for any positive integer m ,

$$\begin{aligned}
\sum_{k=0}^{mt-1} (k+1)H(g_{k+1} \otimes g_k) &= \frac{m(mt+1)}{2} \sum_{k=0}^{t-1} H(g_{k+1} \otimes g_k) + \sum_{k=0}^{mt-1} (k+1)H_{\Lambda}(g_{k+1} \otimes g_k) && \text{by (2.3.1)} \\
&= \frac{m(mt+1)}{2} \sum_{k=0}^{t-1} H(g_{k+1} \otimes g_k) \\
&\quad + \sum_{l=0}^{m-1} \left[\sum_{k=0}^{t-1} (k+1)H_{\Lambda}(g_{k+1} \otimes g_k) \right] + lt \left[\sum_{k=0}^{t-1} H_{\Lambda}(g_{k+1} \otimes g_k) \right] \\
&= \frac{m(mt+1)}{2} \sum_{k=0}^{t-1} H(g_{k+1} \otimes g_k) + m \sum_{k=0}^{t-1} (k+1)H_{\Lambda}(g_{k+1} \otimes g_k) && \text{by (8.3.3)} \cdot \\
&&& \text{(A.4.1)}
\end{aligned}$$

Therefore, but computing the weight $\overline{\text{wt}}(\mathfrak{p})$ given by (8.1.11), we obtain

$$\begin{aligned}
\overline{\text{wt}}(\mathfrak{p}) &= \Lambda + \sum_{k=0}^{\infty} (\overline{\text{wt}}(p_k) - \overline{\text{wt}}(g_k)) - \left(\sum_{k=0}^{\infty} (k+1) (H(p_{k+1} \otimes p_k) - H(g_{k+1} \otimes g_k)) \right) \frac{\delta}{d_0} \\
&= \Lambda + \sum_{k=0}^{mt-1} (\overline{\text{wt}}(p_k) - \overline{\text{wt}}(g_k)) - \left(\sum_{k=0}^{mt-1} (k+1) (H(p_{k+1} \otimes p_k) - H(g_{k+1} \otimes g_k)) \right) \frac{\delta}{d_0} \\
&= \Lambda + \sum_{k=0}^{mt-1} \overline{\text{wt}}(p_k) - \frac{\delta}{d_0} \sum_{k=0}^{mt-1} (k+1)H_{\Lambda}(p_{k+1} \otimes p_k) \\
&\quad + \frac{m\delta}{d_0} \sum_{k=0}^{t-1} (k+1)H_{\Lambda}(g_{k+1} \otimes g_k) && \text{by (8.3.1), (2.3.1)}
\end{aligned}$$

A.4.2 Proof of Proposition 8.2.2

It is easy to see that $\phi(\mathfrak{p})$ belongs to $\mathcal{P}_{c_g}^{\geq}$, since by (8.2.2) we have $\pi_k \geq \pi_{k+1}$ for $k \in \{1, \dots, s-1\}$, and $p_{s-1} \neq g$ implies that $\pi_{s-1} \neq 0_{c_g}$. Note that the ground state path $\cdots \otimes g \otimes g \otimes g$ is associated to (0_{c_g}) .

Let us now give the inverse bijection. Start with $\pi \in (\pi_0, \dots, \pi_{s-1}, 0_{c_g}) \in \mathcal{P}_{c_g}^{\geq}$, different from (0_{c_g}) , with colour sequence $c_{p'_0} \cdots c_{p'_{s-1}} c_g$. Recall that $\pi_s = 0_{c_g}$. We set $\phi^{-1}(\pi) = (p_k)_{k \geq 0}$, where $p_k = g$ for all $k \geq s$ and $p_k = p'_k$ for all $k \in \{1, \dots, s-1\}$.

- We first show that $p_{s-1} \neq g$. Assume for the purpose of contradiction that $p_{s-1} = g$. By (8.2.2), we know that $\pi_{s-1} > 0_{c_g}$ if and only if

$$\pi_{s-1} - 0_{c_g} = H(p_s \otimes p_{s-1}) = H(g \otimes g) = 0,$$

i.e. if and only if $\pi_{s-1} = 0_{c_g}$. This contradicts the fact that $\pi_{s-1} \neq 0_{c_g}$.

- By (8.2.2), we also have, for all $k \in \{1, \dots, s-1\}$, $\pi_k - \pi_{k+1} = H(p_{k+1} \otimes p_k)$. Therefore

$$\pi_k = \pi_k - 0_{c_g} = \sum_{l=k}^{s-1} \pi_l - \pi_{l+1} = \sum_{l=k}^{s-1} H(p_{l+1} \otimes p_l).$$

With what precedes, we have $\phi(\phi^{-1}(\pi)) = \pi$ and $\phi^{-1}(\phi(\mathfrak{p})) = \mathfrak{p}$. We obtain (8.2.3) by Corollary 8.2.1 and by observing that

$$\pi_k = \sum_{l=k}^{s-1} H(p_{l+1} \otimes p_l) = \sum_{l=k}^{\infty} H(p_{l+1} \otimes p_l),$$

since $H(p_{l+1} \otimes p_l) = H(g \otimes g) = 0$ for all $l \geq s$.

A.4.3 Proof of Proposition 8.2.3

We set $\Phi(0_{c_g}) = ((0_{c_g}), (0_{c_g}))$. Let us now consider any $\pi = (\pi_0, \dots, \pi_{s-1}, 0_{c_g}) \in \mathcal{P}_{c_g}^{\ggg}$, different from (0_{c_g}) , with colour sequence $c_{p'_0} \cdots c_{p'_{s-1}} c_g$, and build $\Phi(\pi) = (\mu, \nu)$. Recall that $\pi_{s-1} \neq \pi_s = 0_{c_g}$. Let us set $\mathfrak{p} = (p_k)_{k \geq 0}$, with $p_k = g$ for all $k \geq s$ and $p_k = p'_k$ for all $k \in \{1, \dots, s-1\}$, and set

$$r = \max\{k \in \{0, \dots, s\} : p_{k-1} \neq g\}.$$

Since $p_k = g$ for all $k \geq r$, with the convention $c_g = 1$, we obtain that $C(\pi) = c_{p_0} \cdots c_{p_{s-1}} = c_{p_0} \cdots c_{p_{r-1}}$. Note that $r = 0$ if and only if all the parts of π have colour c_g . We set $\mu = (\mu_0, \dots, \mu_{r-1}, 0_{c_g}) = \phi(\mathfrak{p})$. By Proposition 8.2.2, for all $k \in \{0, \dots, r-1\}$, the part μ_k is coloured by c_{p_k} and has size

$$\sum_{l=k}^{r-1} H(p_{l+1} \otimes p_l).$$

Let us now build $\nu = (\nu_0, \dots, \nu_{t-1}, 0_{c_g}) \in \mathcal{P}_{c_g}$, where $c(\nu_k) = c_g$ and $\nu_k > 0$ for all $k \in \{0, \dots, t-1\}$. We distinguish two different cases.

- If $r < s$, then we set $t = s$ and $\nu = (\nu_0, \dots, \nu_{s-1}, 0_{c_g})$, where

$$\begin{cases} \nu_k = \pi_k - \mu_k & \text{for } k \in \{0, \dots, r-1\}, \\ \nu_k = \pi_k & \text{for } k \in \{r, \dots, s-1\}. \end{cases}$$

By (8.2.4), the sequence $(\nu_k)_{k=0}^{r-1}$ is non-increasing. Moreover the fact that $H(g \otimes g) = 0$ and $\pi_{s-1} \neq 0_{c_g}$ implies that $\nu_{s-1} > 0$, and $(\nu_k)_{k=r}^{s-1}$ is a non-increasing sequence of positive integers. Finally, let us check that $\nu_{r-1} \geq \nu_r$. We have

$$\begin{aligned} \nu_{r-1} - \nu_r &= \pi_{r-1} - \pi_r - \mu_{r-1} \\ &\geq H(p_r \otimes p_{r-1}) - H(p_r \otimes p_{r-1}) && \text{by (8.2.4)} \\ &\geq 0. \end{aligned}$$

Thus $(\nu_k)_{k=0}^{s-1}$ is indeed a non-increasing sequence of positive integers.

- By definition, $r \leq s$, so the only other possible case is $r = s$. As before, $(\pi_k - \mu_k)_{k=0}^s$ is a non-increasing sequence of non-negative integers, now with $\pi_s - \mu_s = 0 - 0 = 0$. We then set

$$t = \min\{k \in \{0, \dots, s\} : \pi_k = \mu_k\},$$

and $\nu_k = \pi_k - \mu_k$ for all $k \in \{0, \dots, t-1\}$.

Observe that for $\Phi(\pi) = (\mu, \nu)$, with $\pi = (\pi_0, \dots, \pi_{s-1}, 0_{c_g})$, $\mu = (\mu_0, \dots, \mu_{r-1}, 0_{c_g})$ and $\nu = (\nu_0, \dots, \nu_{t-1}, 0_{c_g})$, we always have $s = \max\{r, t\}$, and by adding $s - \min\{r, t\}$ parts 0_{c_g} at the end of the shorter partition, we have $\pi_k = \mu_k + \nu_k$ and $c(\pi_k) = c(\mu_k)$ for all $k \in \{0, \dots, s-1\}$.

The map Φ^{-1} from $\mathcal{P}_{c_g}^{\gg} \times \mathcal{P}_{c_g}$ to $\mathcal{P}_{c_g}^{\ggg}$ simply consists in adding the parts of $\mu = (\mu_0, \dots, \mu_{r-1}, 0_{c_g}) \in \mathcal{P}_{c_g}^{\gg}$ to those of $\nu = (\nu_0, \dots, \nu_{t-1}, 0_{c_g}) \in \mathcal{P}_{c_g}$ to obtain a grounded partition $\pi \in \mathcal{P}_{c_g}^{\ggg}$ in the following way:

- if $t \leq r$, then π_k has size $\mu_k + \nu_k$ and colour $c(\mu_k)$, where we set $\nu_k = 0$ for all $k \in \{t, \dots, r-1\}$, and we obtain the partition

$$\pi = (\pi_0, \dots, \pi_{r-1}, 0_{c_g}),$$

- if $t > r$, the first r parts are defined as in the case $t \leq r$, and the remaining parts are $\pi_k = \nu_k$ for all $k \in \{r, \dots, t-1\}$ with colour c_g , and we obtain the partition

$$\pi = (\pi_0, \dots, \pi_{t-1}, 0_{c_g}).$$

A.4.4 Proof of Proposition 8.3.2

Here, we use the same reasoning as in the proof of Proposition 8.2.2. It is easy to check that π belongs to ${}_t\mathcal{P}_{c_{g_0} \cdots c_{g_{t-1}}}^{\gg}$. In fact, π has $(m+1)t$ parts, $\pi_k \geq \pi_{k+1}$ for all $k \in \{0, mt-2\}$, and by observing that

$u^{(0)} = -\frac{1}{t} \sum_{l=0}^{t-1} (k+1) DH_{\Lambda}(g_{k+1} \otimes g_k)$ we obtain that

$$\pi_{mt-1} = -\frac{1}{t} \sum_{l=0}^{t-1} (k+1) DH_{\Lambda}(g_{k+1} \otimes g_k) + DH_{\Lambda}(p_{mt} \otimes p_{mt-1}),$$

and then $\pi_{mt-1} \succ u_{c_{g_0}}^{(0)}$. Also, since $(p_{(m-1)t}, \dots, p_{mt-1}) \neq (g_0, \dots, g_{t-1})$, we necessarily have that $(\pi_{(m-1)t}, \dots, \pi_{mt-1}) \neq (u_{c_{g_0}}^{(0)}, \dots, u_{c_{g_{t-1}}}^{(t-1)})$ in terms of colored integers.

Let us now give the inverse bijection. Start with $\pi \in (\pi_0, \dots, \pi_{mt-1}, u_{c_{g_0}}^{(0)}, \dots, u_{c_{g_{t-1}}}^{(t-1)})$ in ${}^t\mathcal{P}_{c_{g_0} \dots c_{g_{t-1}}}^{\succ}$, with $m > 0$ and color sequence $c_{p'_0} \dots c_{p'_{mt-1}} c_{g_0} \dots c_{g_{t-1}}$. We set $\phi^{-1}(\pi) = (p_k)_{k \geq 0}$, where $p_{m't+i} = g_i$ for all $m' \geq m$ and $i \in \{0, \dots, t-1\}$, and $p_k = p'_k$ for all $k \in \{0, \dots, mt-1\}$.

- We first show that $(p_{mt-m}, \dots, p_{mt-1}) \neq (g_0, \dots, g_{t-1})$. Assume for the purpose of contradiction that $(p_{mt-m}, \dots, p_{mt-1}) = (g_0, \dots, g_{t-1})$. We then obtain by (2.3.2) that

$$\pi_{(m-1)t+k} = -\frac{1}{t} \sum_{l=0}^{t-1} (l+1) DH_{\Lambda}(g_{l+1} \otimes g_l) + \sum_{l=k}^{t-1} DH_{\Lambda}(g_{l+1} \otimes g_l) = u_{c_{g_k}}^{(k)}.$$

This contradicts the fact that $(\pi_{(m-1)t}, \dots, \pi_{mt-1}) \neq (u_{c_{g_0}}^{(0)}, \dots, u_{c_{g_{t-1}}}^{(t-1)})$ in terms of colored integers.

- By (2.3.2), we also have, for all $k \in \{0, \dots, mt-1\}$, $\pi_k - \pi_{k+1} = DH_{\Lambda}(p_{k+1} \otimes p_k)$. Therefore

$$\pi_k = \pi_k - u_{c_{g_0}} = \sum_{l=k}^{mt-1} \pi_l - \pi_{l+1} = \sum_{l=k}^{mt-1} DH_{\Lambda}(p_{l+1} \otimes p_l).$$

With what precedes, we have $\phi(\phi^{-1}(\pi)) = \pi$ and $\phi^{-1}(\phi(\mathfrak{p})) = \mathfrak{p}$. We obtain (8.3.7) by Lemma 8.3.1.

A.4.5 Proof of Proposition 8.3.3

The main trick here consists in considering a classical partition as a partition with always a number of parts divisible by t . It suffices to add the minimal number of parts equal to 0 at the end the partition to have a total number of parts divisible by t . Then, a partition $\pi \in {}^d\mathcal{P}$ different from \emptyset can be uniquely written in a non-increasing sequence of non-negative multiples of d with $\pi = (d\pi_0, \dots, d\pi_{st-1})$, with $\pi_{(s-1)t} > 0$.

We set $\Phi_d(u_{c_{g_0}}^{(0)}, \dots, u_{c_{g_{t-1}}}^{(t-1)}) = ((u_{c_{g_0}}^{(0)}, \dots, u_{c_{g_{t-1}}}^{(t-1)}), \emptyset)$. Let us consider any $\pi = (\pi_0, \dots, \pi_{ts-1}, u_{c_{g_0}}^{(0)}, \dots, u_{c_{g_{t-1}}}^{(t-1)})$ in ${}^d\mathcal{P}_{c_{g_0} \dots c_{g_{t-1}}}^{\succ}$, different from $(u_{c_{g_0}}^{(0)}, \dots, u_{c_{g_{t-1}}}^{(t-1)})$, with color sequence $c_{p'_0} \dots c_{p'_{ts-1}} c_{g_0} \dots c_{g_{t-1}}$. We now build $\Phi_d(\pi) = (\mu, \nu)$. Let us set $\mathfrak{p} = (p_k)_{k \geq 0}$, with $p_{s't+i} = g_i$ for all $s' \geq s$ and $i \in \{0, \dots, t-1\}$, and $p_k = p'_k$ for all $k \in \{0, \dots, st-1\}$, and set

$$m = \max\{k \in \{0, \dots, s\} : (p_{(k-1)t}, \dots, p_{kt-1}) \neq (g_0, \dots, g_{t-1})\}.$$

Since $(p_{kt}, \dots, p_{kt+t-1}) = (g_0, \dots, g_{t-1})$ for all $k \geq m$, with the convention $c_{g_0} \dots c_{g_{t-1}} = 1$, we obtain that $C(\pi) = c_{p_0} \dots c_{p_{st-1}} = c_{p_0} \dots c_{p_{mt-1}}$. Note that $m = 0$ if and only if $\mathfrak{p} = \mathfrak{p}_{\Lambda_0}$. We set

$$\mu = (\mu_0, \dots, \mu_{mt-1}, u_{c_{g_0}}^{(0)}, \dots, u_{c_{g_{t-1}}}^{(t-1)}) = \phi(\mathfrak{p}).$$

By Proposition 8.2.2, for all $k \in \{0, \dots, mt-1\}$, the part μ_k is colored by c_{p_k} and has size

$$u^{(0)} + \sum_{l=k}^{mt-1} DH_{\Lambda}(p_{l+1} \otimes p_l).$$

We then have $C(\pi) = C(\mu)$.

Let us now build $\nu = (\nu_0, \dots, \nu_{rt-1})$ in ${}^d\mathcal{P}$, where we write ν in a number divisible by t of parts divisible by d . We distinguish two different cases.

1. If $m < s$, then we set $r = s$ and $v = (v_0, \dots, v_{st-1})$, where

$$\begin{cases} v_k &= \pi_k - \mu_k & \text{for } k \in \{0, \dots, mt-1\}, \\ v_{kt+i} &= \pi_k - u^{(i)} & \text{for } k \in \{m, \dots, s-1\} \text{ and } i \in \{0, \dots, t-1\}. \end{cases}$$

We then for all $k \in \{0, \dots, mt-2\}$

$$\begin{aligned} v_k - v_{k+1} &= \pi_k - \pi_{k+1} - \mu_k + \mu_{k+1} \\ &= \pi_k - \pi_{k+1} - DH_\Lambda(p_{k+1} \otimes p_k) \\ &\in d\mathbb{Z}_{\geq 0} \end{aligned}$$

and

$$\begin{aligned} v_{mt-1} - v_{mt} &= \pi_{mt-1} - \pi_{mt} - \mu_{mt-1} + u^{(0)} \\ &= \pi_k - \pi_{k+1} - DH_\Lambda(p_{mt} \otimes p_{mt-1}) \\ &\in d\mathbb{Z}_{\geq 0} \end{aligned}$$

We also have for all $k \in \{m, \dots, s-1\}$ and all $i \in \{0, \dots, t-1\}$ that

$$\begin{aligned} v_{kt+i} - v_{kt+i+1} &= \pi_{kt+i} - \pi_{kt+i+1} - u^{(i)} + u^{(i+1)} \\ &= \pi_{kt+i} - \pi_{kt+i+1} - DH_\Lambda(p_{kt+i+1} \otimes p_{kt+i}) \\ &\in d\mathbb{Z}_{\geq 0}, \end{aligned}$$

and, for all $k \in \{m+1, s-1\}$

$$\begin{aligned} v_{kt-1} - v_{kt} &= \pi_{kt-1} - \pi_{kt} - u^{(t-1)} + u^{(0)} \\ &= \pi_{kt-1} - \pi_{kt} - DH_\Lambda(p_{kt} \otimes p_{kt-1}) \\ &\in d\mathbb{Z}_{\geq 0}. \end{aligned}$$

We finally observe that

$$\begin{aligned} v_{st-1} &= \pi_{st-1} - u^{(t-1)} \\ &= \pi_{st-1} - u^{(0)} + u^{(0)} - u^{(t-1)} \\ &= \pi_{st-1} - u^{(0)} - DH_\Lambda(p_{st} \otimes p_{st-1}) \\ &\in d\mathbb{Z}_{\geq 0}. \end{aligned}$$

The sequence $(v_k)_{k=0}^{st-1}$ is then a non-increasing sequence of multiples of d . Moreover, $\pi_{(s-1)t} > u^{(0)}$, otherwise by the inequalities above, we obtain that $(\pi_{(s-1)t}, \dots, \pi_{st-1}) = (u_{c_{s_0}}^{(0)}, \dots, u_{c_{s_{t-1}}}^{(t-1)})$. We then have that $v_{(s-1)t} = \pi_{(s-1)t} > 0$.

2. By definition, $m \leq s$, so the only other possible case is $m = s$. As before, we obtain $(\pi_k - \mu_k)_{k=0}^{mt-1}$ is a non-increasing sequence of non-negative multiple of d . We then set

$$r = \min\{k \in \{0, \dots, s\} : \pi_{kt} = \mu_{kt}\},$$

and $v_k = \pi_k - \mu_k$ for all $k \in \{0, \dots, rt-1\}$.

The map Φ_d^{-1} from ${}^t\mathcal{P}_{c_{s_0} \dots c_{s_{t-1}}}^{\gg} \times {}^d\mathcal{P}$ to ${}^d\mathcal{P}_{c_{s_0} \dots c_{s_{t-1}}}^{\gg}$ simply consists in adding the parts of $\mu = (\mu_0, \dots, \mu_{mt-1}, u_{c_{s_0}}^{(0)}, \dots, u_{c_{s_{t-1}}}^{(t-1)})$ in ${}^t\mathcal{P}_{c_{s_0} \dots c_{s_{t-1}}}^{\gg}$ to those of $v = (v_0, \dots, v_{rt-1}) \in {}^d\mathcal{P}$ to obtain a multi-grounded partition π in ${}^d\mathcal{P}_{c_{s_0} \dots c_{s_{t-1}}}^{\gg}$ in the following way:

1. if $m \geq r$, then π_k has size $\mu_k + v_k$ and colour $c(\mu_k)$, where we set $v_k = 0$ for all $k \in \{rt, \dots, mt - 1\}$, and we obtain the partition

$$\pi = (\pi_0, \dots, \pi_{mt-1}, u_{c_{g_0}}^{(0)}, \dots, u_{c_{g_{t-1}}}^{(t-1)}),$$

2. if $m < r$, the first mt parts are defined as in the case $m \geq r$, and the remaining parts are $\pi_{kt+i} = v_{kt+i} + u^{(i)}$ with color c_{g_i} for all $k \in \{m, \dots, r - 1\}$ and $i \in \{0, \dots, t - 1\}$, and we obtain the partition

$$\pi = (\pi_0, \dots, \pi_{rt-1}, u_{c_{g_0}}^{(0)}, \dots, u_{c_{g_{t-1}}}^{(t-1)}).$$

It easy to see that these two processes are recipocal, the first case of Φ_d being recipocal to the second case of Φ_d^{-1} , as well as the second case of Φ_d is recipocal to the first case of Φ_d^{-1} .

Bibliography

- Alladi, K., G. E. Andrews, and A. Berkovich (2003). “An new four parameter q -series identity and its partitions implications”. In: *Invent. Math.* 153, pp. 231–260.
- Alladi, K., G. E. Andrews, and B. Gordon (1995). “Refinements and Generalizations of Capparelli’s Conjecture on Partitions”. In: *J. Algebra* 174, pp. 636–658.
- Alladi, K. and B. Gordon (1993). “Generalizations of Schur’s partition theorem”. In: *Manuscripta Math.* 79, pp. 113–126.
- Andrews, G. E. (1968). “A new generalization of Schur’s second partition theorem”. In: *Acta Arith.* 14, pp. 429–434.
- (1969a). “A general theorem on partitions with difference conditions”. In: *Amer. J. Math.* 91, pp. 18–24.
- (1969b). “On a partition theorem of Göllnitz and related formula”. In: *J. Reine Angew. Math.* 236, pp. 37–42.
- (1974). “An analytic generalization of the Rogers-Ramanujan identities for odd moduli”. In: *Proc. Nat. Acad. Sci. USA* 71, pp. 4082–4085.
- (1984a). “Generalized Frobenius Partitions”. In: *Mem. Amer. Math. Soc.* 49.301.
- (1984b). *The Theory of Partitions*. Cambridge University Press.
- (1992). “Schur’s theorem, Capparelli’s conjecture and q -trinomial coefficients”. In: *Contemp. Math.* 166, pp. 141–154.
- Auluck, F. C. and D. S. Kothari (1946). “Statistical mechanics and the partitions of numbers”. In: *Proc. Camb. Phil. Soc.* 42, pp. 272–277.
- Bartlett, N. and S. O. Warnaar (Nov. 2015). “Hall-Littlewood polynomials and characters of affine Lie algebras”. In: *Adv. Math.* 285, 1066–1105. DOI: [10.1016/j.aim.2015.08.011](https://doi.org/10.1016/j.aim.2015.08.011).
- Benkart, G. et al. (2006). “Level 1 Perfect Crystals and Path Realizations of Basic Representations at $q = 0$ ”. In: *Int. Math. Res. Not. IMRN* 2006, pp. 1–28.
- Berkovich, A. and A. K. Uncu (2015). “A new companion to Capparelli’s identities”. In: *Adv. in Appl. Math.* 71, pp. 125–137.
- (2019). “Polynomial Identities Implying Capparelli’s Partition Theorems”. In: *J. Number Theory* 201, pp. 77–107.
- Bessenrodt, C. (1994). “A bijection for Lebesgue’s partition identity in the spirit of Sylvester”. In: *Discrete Math.* 132, pp. 1–10.
- Bohr, N. and F. Kalckar (1937). “The Unreasonable Effectiveness of Number Theory”. In: *Kgl. Danske Vid. Selskab. Math. Phys. Medd.* 14.10.
- Borcherds, R. E. (1992). “Monstrous moonshine and monstrous Lie superalgebras”. In: *Invent. Math.* 109, pp. 405–444.
- Bressoud, D. M. (1980). “A combinatorial proof of Schur’s 1926 partition theorem”. In: *Proc. Amer. Math. Soc.* 79, pp. 338–340.
- (1983). “An easy proof of the Rogers-Ramanujan identities”. In: *J. Number Th.* 16, pp. 335–241.
- Bringmann, K. and K. Mahlburg (2015). “False theta functions and companions to Capparelli’s identities”. In: *Adv. Math.* 278, pp. 121–136.
- Bump, D. and A. Schilling (2017). *Crystal Bases: Representations and Combinatorics*. World Scientific Publishing Company.
- Capparelli, S. (1993). “On some representations of twisted affine Lie algebras and combinatorial identities”. In: *J. Algebra* 154, pp. 335–355.
- (1996). “A construction of the level 3 modules for the affine Lie algebra $A_2^{(2)}$ and a new combinatorial identity of the Rogers-Ramanujan type”. In: *Trans. Amer. Math. Soc.* 348, pp. 481–501.
- Chan, H. H., L. Wang, and Y. Yang (2019). “Modular forms and k -colored generalized Frobenius partitions”. In: *Trans. Amer. Math. Soc.* 371.3, pp. 2159–2205.
- Corteel, S. and J. Lovejoy (2004). “Overpartitions”. In: *Trans. Amer. Math. Soc.* 356, pp. 1623–1635.
- (2006). “An iterative-bijective approach to generalizations of Schur’s theorem”. In: *European J. Combin.* 27, pp. 496–512.

- Donaghey, R. and L. W. Shapiro (1977). "Motzkin numbers". In: *J. Combin. Theory Ser. A* 23.3, pp. 291–301.
- Dousse, J. (2014). "On generalizations of partition theorems of Schur and Andrews to overpartitions". In: *Ramanujan J.* 35.3, pp. 339–360.
- (2017a). "A generalisation of a second partition theorem of Andrews to overpartitions". In: *J. Combin. Theory Ser. A* 145, pp. 101–128.
- (2017b). "Siladić's theorem: weighted words, refinement and companion". In: *Proc. Amer. Math. Soc.* 145, pp. 1997–2009.
- (2020). "On partition identities of Capparelli and Primc". In: *Adv. Math.* 370, p. 107245.
- Dousse, J. and I. Konan (2019a). "Generalisations of Capparelli's and Primc's identities, I: Coloured Frobenius partitions and combinatorial proofs". arXiv:1911.13191.
- (2019b). "Generalisations of Capparelli's and Primc's identities, II: Perfect $A_{n-1}^{(1)}$ crystals and explicit character formulas". arXiv:1911.13189.
- Dousse, J. and J. Lovejoy (2018). "On a Rogers-Ramanujan type identity from crystal base theory". In: *Proc. Amer. Math. Soc.* 146.1, pp. 55–67.
- (2019). "Generalizations of Capparelli's identity". In: *Bull. Lond. Math. Soc.* 51, pp. 193–206.
- Euler, L. (1741-43, 1751). "Observationes analyticae variae de combinationibus". In: *Comm. Acad. Petrop.* 13, pp. 64–93.
- (1748). *Introductio in Analysin Infinitorum*. English translation: *Introduction to Analysis of the Infinite*, trad. J. Blanton, Springer, New York, 2005. Lausanne: Marcun-Michaelem Bousquet.
- Frenkel, I., J. Lepowsky, and A. Meurman (1988). *Vertex Operator Algebras and the Monster*. Academic Press.
- Fu, S. and J. Zeng (2018). "A unifying combinatorial approach to refined little Göllnitz and Capparelli's companion identities". In: *Adv. in Appl. Math.* 98, pp. 127–154.
- Garsia, A. M. and S. C. Milne (1981). "A Rogers-Ramanujan bijection". In: *J. Combin. Theory Ser. A* 31, pp. 289–339.
- Glaisher, J.W.L. (1883). "A theorem in partitions". In: *Messenger of Math.* 12, pp. 158–170.
- Göllnitz, H. (1967). "Partitionen mit Differenzenbedingungen". In: *J. Reine Angew. Math.* 225, pp. 154–190.
- Gordon, B. (1965). "Some continued fractions of the Rogers-Ramanujan type". In: *Duke Math. J.* 31, pp. 741–748.
- Griffin, M. J., K. Ono, and S. O. Warnaar (2016). "A framework of Rogers–Ramanujan identities and their arithmetic properties". In: *Duke Math. J.* 8, pp. 1475–1527.
- Hong, J. and S. Kang (Feb. 2002). *Introduction to Quantum Groups and Crystal Bases*. Vol. 42. Graduate Studies in Mathematics. American Mathematical Society. ISBN: 978-0821828748.
- Kac, V. (1978). "Infinite-dimensional algebras, Dedekind's η -function, classical Möbius function and the very strange formula". In: *Adv. Math.* 30, pp. 85–136.
- (1990). *Infinite dimensional Lie algebras*. 3rd edition. Cambridge University Press.
- Kac, V. and D. Peterson (1984). "Infinite-dimensional Lie algebras, theta functions and modular forms". In: *Adv. Math.* 53, pp. 125–264.
- Kanade, S. and M. C. Russell (2018). "Staircases to analytic sum-sides for many new integer partition identities of Rogers-Ramanujan type". arXiv:1803.02515.
- Kang, S. et al. (Apr. 1992a). "Affine Crystals and Vertex Models". In: *Int. Journ. Mod. Phys. A* 7, pp. 449–484. DOI: [10.1142/S0217751X92003896](https://doi.org/10.1142/S0217751X92003896).
- (Dec. 1992b). "Perfect crystals of quantum affine Lie algebras". In: *Duke Math.* 68.3, pp. 499–607. DOI: [10.1215/S0012-7094-92-06821-9](https://doi.org/10.1215/S0012-7094-92-06821-9).
- Kang, S.-J. et al. (1992c). "Affine crystals and vertex models". In: *Infinite analysis, Part A, B (Kyoto, 1991)*. Vol. 16. Adv. Ser. Math. Phys. World Sci. Publ., River Edge, NJ, pp. 449–484.
- Kashiwara, M. (Jan. 1990). "Crystalizing the q -analogue of universal enveloping algebras". In: *Com. Math. Phys.* 133, pp. 249–260. DOI: [10.1007/BF02097367](https://doi.org/10.1007/BF02097367).
- Keith, W.J. and X. Xiong (2019). "Euler's partition theorem for all moduli and new companions to Rogers-Ramanujan-Andrews-Gordon identities". In: *Ramanujan J.* 49.3, pp. 555–565.
- Konan, I. (2019a). "Beyond Göllnitz' Theorem I: A Bijective Approach". arXiv:1909.00364.
- (2019b). "Beyond Göllnitz' Theorem II: arbitrarily many primary colors". arXiv:1912.06702.
- (2020a). "A bijective proof and generalization of Siladić's Theorem". In: *Eur. Journ. of Comb.* 87, 103101.
- (2020b). "Weighted words at degree two, I: Bressoud's algorithm as an energy transfer". arXiv:2001.10927.
- (2020c). "Weighted words at degree two, II: flat partitions, regular partitions, and application to level one perfect crystals". arXiv:2002.00300.

- Kursungoz, K. (2018). "Andrews-Gordon Type Series for Capparelli's and Göllnitz-Gordon Identities". arXiv:1807.11189.
- Lepowsky, J. and S. Milne (1978a). "Lie algebraic approaches to classical partition identities". In: *Adv. in Math.* 29.1, pp. 15–59.
- (1978b). "Lie algebras and classical partition identities". In: *Proc. Natl. Acad. Sci. USA* 75.2, pp. 578–579.
- Lepowsky, J. and R. L. Wilson (1984). "The structure of standard modules, I: Universal algebras and the Rogers-Ramanujan identities". In: *Invent. Math.* 77, pp. 199–290.
- (1985). "The structure of standard modules, II: The case $A_1^{(1)}$, principal gradation". In: *Invent. Math.* 79, pp. 417–442.
- Lier, C. Van and G. E. Uhlenbeck (1937). "On the statistical calculation of the density of the energy levels of the nuclei". In: *Physica* 4, pp. 531–542.
- Lovejoy, J. (2000). "Ramanujan type congruences for three-colored Frobenius partitions". In: *J. Number Theory* 85, pp. 283–290.
- (2003). "Gordon's theorem for overpartitions". In: *J. Combin. Theory Ser. A* 103, pp. 393–401.
- (2004). "Overpartition theorems of the Rogers-Ramanujan type". In: *J. London Math. Soc.* 69, pp. 562–574.
- Lusztig, G. (Apr. 1990). "Canonical bases arising from quantized enveloping algebras". In: *Journ. Amer. Math. Soc.* 3, pp. 447–498.
- MacMahon, P. A. (1916). *Combinatory Analysis*. Vol. 2. New York, NY, USA: Cambridge University Press.
- Meurman, A. and M. Primc (1987). "Annihilating ideals of standard modules of $sl(2, \mathbb{C})^{\sim}$ and combinatorial identities". In: *Adv. Math.* 64, pp. 177–240.
- (1999). "Annihilating fields of standard modules of $sl(2, \mathbb{C})^{\sim}$ and combinatorial identities". In: *Mem. Amer. Math. Soc.* 137, viii + 89 pp.
- (2001). "A basis of the basic $sl(3, \mathbb{C})^{\sim}$ -module". In: *Commun. Contemp. Math.* 3, pp. 593–614.
- Nanda, V. S. (1951). "Partition theory and thermodynamics of multidimensional oscillator assemblies". In: *Proc. Camb. Phil. Soc.* 47, pp. 591–601.
- Nandi, D. (2014). "Partition Identities Arising from Standard $A_2^{(2)}$ -modules of Level 4". PhD thesis. Rutgers University.
- Padmavathamma, M. Rudy Salestina and S. R. Sudarshan (2004). "Combinatorial proof of the Göllnitz theorem on partitions". In: *Adv. Stud. Contemp. Math.* 8.1, pp. 47–54.
- Pak, I. and A. Postnikov (1998). "A generalization of Sylvester's Identity". In: *Discrete Math.* 178, pp. 277–281.
- Primc, M. (1994). "Vertex operator construction of standard modules for $A_n^{(1)}$ ". In: *Pacific J. Math.* 162, pp. 143–187.
- (1999). "Some crystal Rogers-Ramanujan type identities". In: *Glas. Math. Ser. III* 34, pp. 73–86.
- Primc, M. and T. Šikić (2016). "Combinatorial bases of basic modules for affine Lie algebras $C_n^{(1)}$ ". In: *Journal of Mathematical Physics* 57.9, p. 091701.
- Rains, E. M. and S. O. Warnaar. "Bounded Littlewood identities". to appear in *Memoirs of the AMS*.
- Rogers, L. J. and S. Ramanujan (1919). "Proof of certain identities in combinatory analysis". In: *Cambr. Phil. Soc. Proc.* 19, pp. 211–216.
- Schur, I. (1926). "Zur additiven Zahlentheorie". In: *Sitzungsberichte der Preussischen Akademie der Wissenschaften*, pp. 488–495.
- Sellers, J. A. (1994). "New congruences for generalized Frobenius partitions with 2 or 3 colors". In: *Discrete Math.* 131, pp. 367–374.
- Siladić, I. (2017). "Twisted $sl(3, \mathbb{C})^{\sim}$ -modules and combinatorial identities". In: *Glasnik Matematički*, 52.1, pp. 53–77.
- Sills, A. V. (2004). "On series expansions of Capparelli's infinite product". In: *Adv. in Appl. Math.* 33.2, pp. 397–408.
- Stanley, R.P. (1997). *Enumerative Combinatorics*: Cambridge Studies in Advanced Mathematics. Cambridge University Press. ISBN: 9780521663519. URL: <https://books.google.fr/books?id=EvJg1VjIGyMC>.
- Stockhofe, D. (1982). "Bijektive Abbildungen auf der Menge der Partitionen einer natürlichen Zahl". PhD thesis. Bayreuth. Math. Schr.
- Sylvester, J. J. (1973). "A constructive theory of partitions, arranged in three acts, an interact, and an exodion". In: *The Collected Papers of J. J. Sylvester*. Vol. 3. London, reprinted by Chelsea, New York: Cambridge University Press, pp. 1–83.
- Tamba, M. and C. Xie (1995). "Level three standard modules for $A_2^{(2)}$ and combinatorial identities". In: *J. Pure Applied Algebra* 105, pp. 53–92.

- Temperley, H. N. V. (1949). "Statistical mechanics and the partition of numbers. I. The transition of liquid helium". In: *Proc. R. Soc. London A* 199, pp. 361–375.
- Watson, G. N. (1929). "A new proof of the Rogers-Ramanujan identities". In: *J. London Math. Soc.* 4, pp. 4–9.
- Zhao, J.Y.J (2015). "A bijective proof of the Alladi-Andrews-Gordon partition theorem". In: *Electron. J. Combin.* 22.1.