



HAL
open science

Large deviations in interacting particle systems : out of equilibrium correlations and interface dynamics

Benoît Dagallier

► **To cite this version:**

Benoît Dagallier. Large deviations in interacting particle systems : out of equilibrium correlations and interface dynamics. Mathematical Physics [math-ph]. Institut Polytechnique de Paris, 2021. English. NNT : 2021IPPAX054 . tel-03378239

HAL Id: tel-03378239

<https://theses.hal.science/tel-03378239v1>

Submitted on 14 Oct 2021

HAL is a multi-disciplinary open access archive for the deposit and dissemination of scientific research documents, whether they are published or not. The documents may come from teaching and research institutions in France or abroad, or from public or private research centers.

L'archive ouverte pluridisciplinaire **HAL**, est destinée au dépôt et à la diffusion de documents scientifiques de niveau recherche, publiés ou non, émanant des établissements d'enseignement et de recherche français ou étrangers, des laboratoires publics ou privés.



INSTITUT
POLYTECHNIQUE
DE PARIS

NNT : 2021IPPAX054

Thèse de doctorat



Large deviations in interacting particle systems: out of equilibrium correlations and interface dynamics

Thèse de doctorat de l'Institut Polytechnique de Paris
préparée à Ecole Polytechnique

École doctorale n°574 Ecole Doctorale de Mathématiques Hadamard (EDMH)
Spécialité de doctorat : Mathématiques appliquées

Thèse présentée et soutenue à Palaiseau, le 13/09/2021, par

M. BENOÎT DAGALLIER

Composition du Jury :

Giambattista Giacomini Professeur, Université de Paris	Président du jury
Stefano Olla Professeur, Université Paris Dauphine	Rapporteur
Fabio Toninelli Professeur, Technische Universität Wien	Rapporteur
Giovanni Conforti Professeur associé, Ecole Polytechnique	Examineur
Marielle Simon Chargée de recherche, Inria Lille	Examinatrice
Thierry Bodineau Directeur de recherche, Ecole Polytechnique (CMAP)	Directeur de thèse

Remerciements

A l'issue de ces trois ans de thèse, je tiens tout d'abord à exprimer ma gratitude à mon directeur, Thierry Bodineau. Thierry a toujours trouvé du temps pour nos rendez-vous, malgré le covid et un emploi du temps de plus en plus chargé. Sur le plan mathématique, j'ai beaucoup appris de sa manière de revenir aux choses simples, de chercher le sens derrière la technique. Je le remercie aussi pour sa patience et ses encouragements tout au long de ces trois ans, que ce soit lors de nos discussions ou au cours des multiples relectures d'article.

I would also like to thank Milton Jara, Stefano Olla and Fabio Toninelli, who accepted and took time to review this manuscript. Un grand merci également à Giovanni Conforti, Giambattista Giacomini, Marielle Simon d'avoir accepté de faire partie de mon jury de thèse.

Je souhaite remercier aussi mes maîtres de stage Kirone Mallick et Jean-René Chazottes, qui m'ont donné un avant-goût, et parfois un goût tout court, d'un certain nombre de questions, mathématiques ou non. Merci en particulier, Kirone, pour les multiples discussions et rencontres pendant le stage et dans les années suivantes, qui n'ont pas peu contribué à mon choix d'orientation.

Je suis très reconnaissant envers les membres de l'équipe administrative du CMAP, et tout particulièrement Alexandra et Nasséra. Leur gentillesse, leur serviabilité, leur disponibilité ont aplani quantité d'obstacles, et ont pour moi contribué pour beaucoup à faire du laboratoire un lieu de vie et de travail agréable. En ce sens, j'aimerais également remercier Pierre et Sylvain, toujours disponibles et d'une grande aide.

J'ai beaucoup appris au cours de mes monitorats au laboratoire, grâce notamment à Giovanni, Sylvie et Teddy, que je souhaite remercier. Merci en particulier, Giovanni, pour l'enthousiasme et la constance avec lequel tu m'as fait part de ces nombreuses questions sur lesquelles tu me proposais de réfléchir en commun, tout au long de la thèse. Merci aussi à Lucas et Aline pour le travail qu'ils fournissent (ou fournissaient) chaque année pour répartir les cours entre moniteurs. Et merci encore aux membres du groupe Peips qui, au laboratoire puis à distance, ont toujours su proposer un cadre où il soit possible aux membres du groupe de discuter et d'échanger.

Merci enfin aux nombreux doctorants du laboratoire que j'ai eu l'occasion et le plaisir de côtoyer, en particulier Alejandro, Clément, Josué, Fedor et Paul, et encore bien d'autres. Merci pour toutes ces pauses et discussions sur des sujets variés, qui ponctuaient les journées au laboratoire.

Résumé

Cette thèse est consacrée à l'étude d'événements dynamiques rares dans des systèmes de particules en interaction. Deux modèles sont considérés : le processus d'exclusion simple symétrique unidimensionnel interagissant avec des réservoirs, et un modèle de dynamiques d'interfaces se rapprochant de la dynamique de Glauber du modèle d'Ising bidimensionnel à température nulle.

Dans le cadre du modèle d'exclusion simple, les travaux présentés visent à l'étude des corrélations à deux points hors équilibre. Plus précisément, le but est d'estimer la probabilité d'obtenir une valeur atypique des corrélations à deux points moyennées en temps dans la limite hydrodynamique et en temps long. Pour étudier les corrélations à deux points avec le niveau de précision requis, il est nécessaire d'améliorer les techniques existantes. En raffinant la méthode d'entropie relative initialement développée par Yau, un principe de grandes déviations pour les corrélations à deux points est obtenu.

La dynamique d'interface modélise l'évolution d'une goutte de spins $-$ d'Ising immergés dans une mer de spins $+$ sur un réseau carré. Dans le cas de la dynamique d'Ising à température nulle, la frontière de cette goutte évolue selon un mouvement à courbure moyenne anisotrope, comme a été rigoureusement établi par Lacoïn, Simenhaus et Toninelli il y a quelques années. Dans la thèse, c'est la structure des trajectoires atypiques que l'on cherche à comprendre. Pour ce faire, une dynamique d'interface, appelée dynamique de contour et très similaire à la dynamique d'Ising à température nulle est introduite. La seule dissemblance vient de la présence d'un paramètre supplémentaire, jouant le rôle d'une (faible) température agissant localement sur l'interface. En particulier, les dynamiques d'Ising et de contour coïncident quand ce paramètre est nul. Il est montré que la trajectoire typique d'une interface sous la dynamique de contour évolue également par mouvement par courbure moyenne anisotrope, avec une influence du paramètre de température. Un principe de grandes déviations est alors obtenu pour la dynamique de contour, permettant de relier les trajectoires atypiques à des perturbations d'un mouvement à courbure moyenne anisotrope, toujours avec une influence du paramètre de température.

Abstract

The objective of this thesis is the study of rare dynamical events in some interacting particle systems. Two models are considered : the one dimensional symmetric simple exclusion process interacting with reservoirs, and an interface dynamics related to the zero temperature Glauber dynamics for the two dimensional Ising model.

In the case of the simple exclusion process, the work presented in the manuscript concerns the study of the out of equilibrium two-point correlation field. More precisely, the objective of the work is to estimate the probability of observing anomalous time-averaged two-point correlations, in the hydrodynamics scaling and the long time limit simultaneously. Studying two-point correlations at a suitable level of precision requires improving existing techniques. A refinement of the relative entropy method initially due to Yau provides a sufficient toolbox, thanks to which a large deviation principle for time-averaged two-point correlations is obtained.

The interface dynamics aims at modelling the evolution of the interface separating a droplet of $-$ Ising spins in a sea of $+$ spins in the zero temperature Ising model. In the zero temperature Ising case, the boundary of this droplet has been shown to follow an anisotropic motion by curvature by Lacoïn, Simenhaus and Toninelli a few years ago, rigorously establishing a long standing conjecture. In the manuscript, we aim to investigate the structure of atypical interface trajectories. To do so, another interface dynamics, called the contour dynamics, is introduced. Very similar to the zero temperature Ising dynamics, it differs by the presence of an additional parameter, which plays the role of a (small) temperature acting locally on the interface. In particular, Ising and contour dynamics coincide when this parameter vanishes. We show that the typical interface trajectory in the contour dynamics is still given by an anisotropic motion by curvature, with an influence of the temperature-like parameter. A large deviation principle is also established, characterising atypical trajectories as perturbations of the anisotropic motion by curvature, again with an influence of the temperature-like parameter.

Contents

1	Introduction	7
1	General context	7
2	A prototype of interacting particle system: the symmetric simple exclusion process	8
2.1	The model	8
2.2	Dynamical large deviations and invariant measures	9
2.3	Large deviations and invariant measures	14
2.4	Summary and objectives of the thesis	16
3	Anomalous correlations in the open symmetric simple exclusion process	17
3.1	Invariant measures and Donsker-Varadhan formula in the scaling limit	17
3.2	Scaling of correlations at equilibrium in the long-time, large N limit	18
3.3	Contribution of the thesis	22
3.4	Perspectives	29
4	Ising interfaces at zero temperature	33
4.1	The Ising and stochastic Ising models	33
4.2	Contribution of the thesis	39
4.3	Conclusion and perspectives	47
2	Résumé	49
1	Cadre et objectif de la thèse	49
2	Corrélations atypiques dans l'exclusion simple symétrique avec réservoirs	49
3	Interfaces d'Ising et dynamique de contour	51
3	Anomalous correlations in the open symmetric simple exclusion process	53
1	Introduction	54
2	Notations and results	58
2.1	Notations and definition of the microscopic model	58
2.2	The topology	60
2.3	Large deviations for time-averaged correlations	61
2.4	The relative entropy method	64
2.5	Conclusion and perspectives	66
3	Main ingredient: the entropic estimate	67
3.1	The relative entropy method and Feynman-Kac inequality	67
3.2	Estimates on $L_h^* \mathbf{1}$	71
3.3	Adjoint at the boundary	73
3.4	Adjoint in the bulk	75

3.5	Conclusion	86
3.6	The Radon-Nikodym derivative	87
4	Long-time behaviour: upper bound	88
4.1	Upper bound for open and compact sets	89
4.2	An \mathbb{L}^2 estimate and a first Poisson equation	95
4.3	Energy estimate	98
5	Lower bound for smooth trajectories	103
5.1	Estimate of the cost of changing initial condition	103
5.2	Law of large numbers and Poisson equation	104
5.3	Estimating the dynamical part	109
5.4	Conclusion of the lower bound for smooth trajectories and accessible correlations	111
A	Correlations and concentration under discrete Gaussian measures	112
A.1	Bound on the partition function and correlations	112
A.2	Exponential moments of higher order correlations	120
A.3	Gaussian behaviour of the invariant measures and computation of the partition function \mathcal{Z}_g^N	125
B	Integration by parts formulae	129
B.1	Integration by parts in the bulk	129
B.2	Integration by parts at the boundary and boundary correlations	131
C	Control of the error terms	133
C.1	Estimate of X_2	134
C.2	Proof of Proposition C.2 and Corollary C.3	137
D	The Neumann condition on the diagonal	140
E	Sobolev spaces	145
F	Poisson equations	146
F.1	Existence and uniqueness	147
F.2	Regularity estimates	150
4	Ising interfaces and contour dynamics	153
1	Introduction	154
2	Model and results	157
2.1	The contour model	157
2.2	Heuristics	164
2.3	Results	167
2.4	Comments on metastability	172
2.5	Structure of the proof of large deviations	173
3	Some relevant martingales	174
3.1	Motivations	174
3.2	Computation of $N^2 \mathcal{L}_{r,\beta,H} \langle \Gamma, G \rangle$	174
4	Large deviation upper-bound and properties of the rate functions	188
4.1	The upper bound	189
4.2	Properties of the rate function	193
5	Lower bound large deviations and hydrodynamic limits	196
5.1	Large deviation lower-bound	196

5.2	The droplet moves on a diffusive scale	198
5.3	Characterisation of limit points	203
6	Behaviour of the poles and $\mathbf{1}_{p_k=2}$ terms	205
6.1	Size of the poles and local equilibrium	205
6.2	Convergence of the $\mathbf{1}_{p=2}$ term at fixed β and slope around the poles	210
A	Replacement lemma and projection of the dynamics	227
A.1	Replacement lemma	227
A.2	Projection of the contour dynamics in the good state space	231
A.3	Equilibrium estimates at the pole	233
B	Topology results	236
B.1	Definition of \mathcal{E}_r and topological properties	236
B.2	The set $E([0, T_0], \mathcal{E}_r(d))$	241
B.3	Proof of the sufficient condition for exponential tightness	245

Bibliography

250

Chapter 1

Introduction

1 General context

The central premise of statistical physics can be stated as follows: the behaviour of matter at a large, or macroscopic scale can be described in terms of the interaction of a very large number of small, or microscopic elementary components. For simplicity, there should be as few different types of elementary components as possible. Over the past one and a half century, this premise has not been fundamentally called into question. To the contrary, statistical physics has enjoyed many successes, such as modelling phase transitions or, more recently, the modelling of fluid dynamics, with which this thesis is concerned.

As the name indicates, a statistical physics description of fluid dynamics involves a notion of randomness. The microscopic components in the description, that we shall call particles for convenience, are assigned evolution and interaction rules. The resulting description is then called an *interacting particle system*. The randomness in such a description may either concern the initial configuration of particles, their evolution rule, the interactions, or a mixture of all three. Given an interacting particle system, the objective is then to estimate the probability that macroscopic observables take certain values. Informally, an observable is a quantity of physical interest, for instance the local density of particles, the density of particles of a certain type if not all particles are identical, etc. It is represented by a real-valued function F , which takes as argument a description $X_1(t), \dots, X_N(t)$ of the N particles at time $t \geq 0$. One is then led to estimate objects of the form:

$$\mathbb{P}(F(X_1(t), \dots, X_N(t)) \approx F_0(t)), \quad F_0(t) \in \mathbb{R}, \quad (1.1)$$

where \mathbb{P} is a probability accounting for the aforementioned randomness. The integer N is the number of particles in the model, assumed to be large, X_1, \dots, X_N are labels denoting the N particles which move around in a space Ω , and $t \geq 0$ is a time. Finally, the notation \approx indicates that the observable F at time t should be close to the real number $F_0(t)$.

If the modelling is accurate, the probability in (1.1) should be close to 1 when $F_0(t)$ corresponds to the value of the observable F predicted by the macroscopic equations of fluid dynamics. One may then ask about the probability that the observable F takes atypical values when N is large, try to quantify the probability of such occurrences, and understand how particles must behave to

create a given atypical macroscopic dynamical evolution. The study of all these questions falls under the general topic of large deviations, which is at the heart of this thesis. Large deviations are introduced on a prototypical interacting particle system in the next section: the symmetric simple exclusion process.

2 A prototype of interacting particle system: the symmetric simple exclusion process

2.1 The model

The symmetric simple exclusion process (henceforth SSEP), presented here in one dimension, is a simple interacting particle system defined as follows. For a scaling parameter $N \in \mathbb{N}^*$, particles evolve on a domain $\Lambda_N = \{-(N-1), \dots, N-1\}$ with $2N-1$ sites (i.e. space is discretised). There can be at most one particle per site, and the evolution is random: at each time $t \geq 0$, independently of all other particles, a particle at site $i \in \Lambda_N$ has a probability $dt/2$ of jumping to a neighbouring site between times t and $t+dt$, with $dt \ll 1$. The only interaction between particles arises when a particle jumps on an already occupied neighbouring site. In this case, the jump is cancelled. At the boundary sites $\pm(N-1)$ of the domain Λ_N , one can connect reservoirs of particles at respective density $\rho_{\pm} \in [0, 1]$, which pump particles in and out of Λ_N . The SSEP with boundary reservoirs will be called the open SSEP (see Figure 1.1).

The open SSEP is a model of dynamics for a high temperature gas of particles with hard-core exclusion. The "high temperature" part is related to the fact that particles do not interact except when they collide, see also some more context in [Spo83]. By definition, particles evolve on a discrete lattice, are identical, and have no memory. These simplifying assumptions make mathematical analysis much easier. For this reason, the open SSEP and more or less close variants (with non nearest-neighbour hopping, asymmetric hopping rates, in higher dimension, with more than one particle per site...) have been studied at length in the past fifty years, be it their invariant measures and the required time to reach stationarity; or hydrodynamics, the behaviour of a tracer particle, fluctuations or large deviations. The literature on these topics is extensive, both in the mathematics and physics community, and here we only wish to indicate the books [Lig05], [Spo12] and [KL99], in which the interested reader will find much material and more references.

The open SSEP will serve as a reference example for the rest of this introduction. All models studied in this manuscript are related to the open SSEP by some choice of boundary dynamics. Let us first give a rigorous definition of the model. Formally, the open SSEP on $\Lambda_N = \{-(N-1), \dots, N-1\}$ is a Markov process on the state space $\Omega_N = \{0, 1\}^{\Lambda_N}$. Elements $\eta \in \Omega_N$ are called *configurations*, and η_i is the *occupation number* at site $i \in \Lambda_N$, with $\eta_i = 1$ if and only if there is a particle. The generator $L = L_0 + L_- + L_+$ of the open SSEP can be split into two parts: the bulk dynamics L_0 , and the boundary dynamics L_-, L_+ . Several choices of boundary dynamics can be considered. To fix ideas, we shall consider L as the operator acting on functions $f : \Omega_N \rightarrow \mathbb{R}$ as

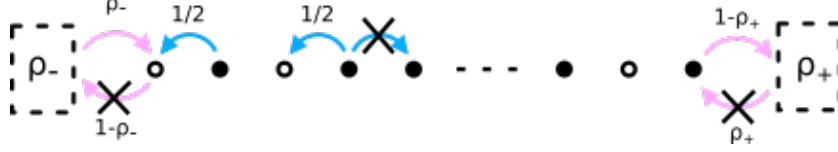

Figure 1.1 – The one dimensional symmetric simple exclusion process interacting with reservoirs of particles at densities $\rho_{\pm} \in [0, 1]$ (open SSEP for short). Possible dynamical updates are represented by arrows. A particle can jump to either neighbouring site at rate $1/2$. The jump is cancelled if the site is already occupied. Particles can hop in and out of the reservoirs, at respective rates $\rho_{\pm}, 1 - \rho_{\pm}$ with the choice (2.1). If the site closest to a reservoir is already filled, the exclusion rule prevents a new particle from entering the system at that site.

follows: for each $\eta \in \Omega_N$,

$$L f(\eta) = L_0 f(\eta) + L_- f(\eta) + L_+ f(\eta), \quad L_0 f(\eta) = \frac{1}{2} \sum_{i < N-1} c(\eta, i, i+1) [f(\eta^{i, i+1}) - f(\eta)],$$

$$L_{\pm} f(\eta) = \frac{1}{2} c(\eta, \pm(N-1)) [f(\eta^{\pm(N-1)}) - f(\eta)]. \quad (2.1)$$

In (2.1), the jump rates c are defined, for each $\eta \in \Omega_N$, by:

$$c(\eta, i, i+1) = \eta_{i+1}(1 - \eta_i) + \eta_i(1 - \eta_{i+1}), \quad i < N-1,$$

$$c(\eta, \varepsilon(N-1)) = \eta_{\varepsilon(N-1)}(1 - \rho_{\varepsilon}) + (1 - \eta_{\varepsilon(N-1)})\rho_{\varepsilon}, \quad \varepsilon \in \{-, +\}. \quad (2.2)$$

In addition, for $i, j \in \Lambda_N$ and $\eta \in \Omega_N$, the configurations $\eta^{i, j}$ and η^i are defined as:

$$\eta_k^{i, j} = \begin{cases} \eta_k & \text{if } k \notin \{i, j\}, \\ \eta_j & \text{if } k = i, \\ \eta_i & \text{if } k = j, \end{cases} \quad \eta^i(k) = \begin{cases} \eta_k & \text{if } k \neq i, \\ 1 - \eta_i & \text{if } k = i. \end{cases} \quad (2.3)$$

The open SSEP can equivalently be considered as a process on the discretisation $N^{-1}\Lambda_N$ of the interval $(-1, 1)$.

2.2 Dynamical large deviations and invariant measures

2.2.1 The general method

Recall that the goal is to study (1.1). As all particles are identical in the SSEP, one can only measure local numbers of particles, and variations of these numbers. As a consequence, the natural macroscopic observables associated with the SSEP are the density $\rho = (\rho(t, x))_{t \geq 0, x \in (-1, 1)}$ and its variations, such as the current $j = (j(t, x))_{t, x}$. The goal is then, starting from the microscopic dynamics (2.1), to characterise the time evolution of the density of particles in the scaling limit. This is usually referred to as proving *hydrodynamics* for the density.

Let us do so in an informal manner. For a configuration $\eta \in \Omega_N$, $\varepsilon > 0$ and a point $i \in \Lambda_N$ in the bulk ($N(-1 + \varepsilon) < i < N(1 - \varepsilon)$), denote by $\eta_i^{\varepsilon N}$ the density of particles in the box

$\frac{i}{N} + [-\varepsilon, \varepsilon] \subset (-1, 1)$:

$$\eta_i^{\varepsilon N} = \frac{1}{2\varepsilon N + 1} \sum_{|j-i| \leq \varepsilon N} \eta_j.$$

Let $C^\infty([-1, 1])$ be the set of smooth functions on $[-1, 1]$. Assume that $\rho_0 \in C^\infty([-1, 1])$ is given, and the microscopic dynamics start from configurations that are macroscopically close to ρ_0 , so that:

$$\forall x \in (-1, 1), \quad \mathbb{E} \left[\left| \eta_{[xN]}^{\varepsilon N}(0) - \rho_0(x) \right| \right] \rightarrow 0 \quad \text{when } N \rightarrow \infty, \text{ then } \varepsilon \rightarrow 0. \quad (2.4)$$

Above, $[xN]$ is the integer part of xN . Then, for each $x \in (-1, 1)$ and each $t \geq 0$, one has (see [ELS90]):

$$\forall t \geq 0, \quad \mathbb{E} \left[\left| \eta_{[xN]}^{\varepsilon N}(tN^2) - \rho(t, x) \right| \right] \rightarrow 0 \quad \text{when } N \rightarrow \infty, \text{ then } \varepsilon \rightarrow 0, \quad (2.5)$$

where $\rho = (\rho(t, x))_{t \geq 0, x \in (-1, 1)}$ is the solution of the heat equation on $(-1, 1)$ starting from ρ_0 , with boundary conditions prescribed by the reservoirs:

$$\begin{cases} \partial_t \rho = \frac{1}{2} \Delta \rho & \text{for } t > 0, x \in (-1, 1), \\ \rho(0, \cdot) = \rho_0(\cdot), & \\ \rho(t, \pm 1) = \rho_\pm, & \text{for } t > 0. \end{cases} \quad (2.6)$$

Note the N^2 rescaling of time in (2.5): since particles do not preferentially move in a single direction, it typically takes a diffusive amount of time to obtain a macroscopic change in the density of particles. Using standard hydrodynamics argument, see e.g. Chapter 4 in [KL99], one can in fact prove that, for times $T_N \ll N^2$, the macroscopic density of particles has not changed; while for times $T_N \gg N^2$, it has already reached a stable profile, which in the case of (2.6) is the solution of $\Delta \rho = 0$ with $\rho(\pm 1) = \rho_\pm$. In particular, all interesting dynamical effects for the density at the macroscopic scale occur on the N^2 , diffusive time-scale, on which we focus on for now.

Remarkably, the macroscopic evolution (2.6) of the density for the SSEP is the same as for independent symmetric random walkers on Λ_N . Intuitively, if one starts from a density profile ρ_0 with a lot of particles around the same position, one could expect that the exclusion rule of the microscopic dynamics is going to play a role. Equations (2.5)-(2.6) tell us that this intuition is not correct as far as the typical evolution of the density is concerned. To understand better the effect of the exclusion interaction and the detailed structure of the dynamics is a first motivation for studying dynamical large deviations, as we now explain.

The question is now the following. Consider a trajectory $\tilde{\rho} \in C^\infty(\mathbb{R}_+ \times (-1, 1))$, assumed to be smooth for simplicity, and such that $0 < \tilde{\rho} < 1$. For a time $T \geq 0$, can one find a functional I on trajectories such that, when N is large and ε, δ are small, one has informally:

$$\mathbb{P} \left(\forall t \in [0, T], \forall x \in (-1, 1), \left| \eta_{[xN]}^{\varepsilon N}(tN^2) - \tilde{\rho}(t, x) \right| \leq \delta \right) \asymp e^{-N[I(\tilde{\rho}) + o_{\varepsilon, \delta}(1)]}, \quad (2.7)$$

with $o_{\varepsilon, \delta}(1)$ a quantity that vanishes when ε, δ become small, and \asymp indicating logarithmic equivalence when N is large.

The now standard method to find such a functional for interacting particle systems was pioneered

on the SSEP, in a paper by Kipnis, Olla and Varadhan [KOV89]. They treat the case of the SSEP on a torus, but the method was used in [Ber+03] to obtain the result for the open SSEP (2.2). Rather than using average occupation numbers in small macroscopic boxes, it is convenient to work with the *empirical measure* π^N , defined as an element of the set $\mathcal{M}_{\leq 1}((-1, 1))$ of positive measures with mass at most 1 on $(-1, 1)$ as follows:

$$\forall \eta \in \Omega_N, \quad \pi^N(\eta) = \frac{1}{N} \sum_{i \in \Lambda_N} \eta_i \delta_{i/N}. \quad (2.8)$$

In this case, the event in (2.7) can be written $\{(\pi_t^N)_{t \leq T} \approx (\tilde{\rho}(t, x) dx)_{t \leq T}\}$, where \approx means proximity in a suitable topology. The answer to (2.7) then takes the following form: on the set $D(\mathbb{R}_+, \mathcal{M}_{\leq 1}((-1, 1)))$ of càdlàg trajectories with values in $\mathcal{M}_{\leq 1}((-1, 1))$, there is a functional I , taking values in $\mathbb{R}_+ \cup \{+\infty\}$, with the following property. The probability of observing a trajectory $\tilde{\rho}$ of density profiles has "weight" $I((\tilde{\rho}(t, x) dx)_{t \leq T})$, in the sense:

$$\forall T > 0, \quad \frac{1}{N} \log \mathbb{P}\left((\pi_{t/N^2}^N)_{t \leq T} \approx (\tilde{\rho}(t, x) dx)_{t \leq T}\right) \stackrel{N \gg 1}{\approx} -I((\tilde{\rho}(t, x) dx)_{t \leq T}). \quad (2.9)$$

To prove (2.9), the main idea of [KOV89] is the following. To force the microscopic density to stay close to a trajectory $\tilde{\rho}$, more precisely to enforce that π^N stay close to $(\tilde{\rho}(t, x) dx)_t$ in an appropriate topology, one modifies the jump rates (2.2) of the open SSEP by means of a time-dependent function $h \in C^\infty(\mathbb{R}_+ \times [-1, 1])$ with $h(\cdot, \pm 1) = 0$; setting, for each time $t \geq 0$ and each $\eta \in \Omega_N$:

$$\begin{aligned} c^{h_t}(\eta, i, i+1) &= \eta_i(1 - \eta_{i+1}) \exp \left[h\left(\frac{t}{N^2}, \frac{i+1}{N}\right) - h\left(\frac{t}{N^2}, \frac{i}{N}\right) \right] \\ &\quad + \eta_{i+1}(1 - \eta_i) \exp \left[-h\left(\frac{t}{N^2}, \frac{i+1}{N}\right) + h\left(\frac{t}{N^2}, \frac{i}{N}\right) \right], \quad i < N-1, \end{aligned} \quad (2.10)$$

$$c^{h_t}(\eta, \pm(N-1)) = c(\eta, \pm(N-1)) \exp \left[(1 - 2\eta_i) h\left(\frac{t}{N^2}, \frac{\pm(N-1)}{N}\right) \right]. \quad (2.11)$$

Above, $h_t := h(t, \cdot)$ for $t \geq 0$. Such an h is called a *bias*, and the resulting dynamics is referred to as the dynamics *tilted by h*. One can again determine the typical evolution ρ^h of the density under this dynamics. It satisfies:

$$\partial_t \rho^h = \frac{1}{2} \Delta \rho^h - \nabla \cdot (\sigma(\rho^h) \nabla h), \quad (2.12)$$

where $\sigma(r) = r(1-r)$ for $r \in [0, 1]$. σ is called the mobility, and its structure depends on the choice of the microscopic jump rates. Equation (2.12) gives a way to choose h such that $\tilde{\rho} = \rho^h$ (since we assumed $0 < \tilde{\rho} < 1$ so that $\sigma(\tilde{\rho})^{-1}$ is well defined). The cost of observing $\tilde{\rho}$ then corresponds to the cost of changing dynamics, from the open SSEP to the inhomogeneous Markov process (2.10). This change of dynamics can be computed explicitly through Feynman-Kac formula, see Appendix A1.7 in [KL99]. In the large N limit and assuming one starts from an initial configuration $\eta^N \in \Omega_N$ satisfying (2.4), one then obtains for each $T > 0$:

$$\begin{aligned} \frac{1}{N} \log \mathbb{P}(\pi^N \approx (\tilde{\rho}(t, x) dx)_{t \leq T} | \pi_0^N \approx \tilde{\rho}_0 dx) &\stackrel{N \gg 1}{\approx} -\frac{1}{2} \int_0^T \int_{(-1, 1)} [\nabla h(t, x)]^2 \sigma(\tilde{\rho}(t, x)) dx dt \\ &=: -I((\tilde{\rho}(t, x) dx)_{t \leq T} | \tilde{\rho}_0), \end{aligned} \quad (2.13)$$

where h is the bias chosen according to (2.12), when $\rho^h = \tilde{\rho}$.

The above sketch of the method of [KOV89] omits a crucial part of the argument, required to change scales from microscopic to macroscopic. Indeed, the Radon-Nikodym derivative between the open SSEP and the dynamics (2.10), at each fixed value $N \in \mathbb{N}^*$ of the scaling parameter, cannot directly be written in terms of the functional I . This is because I depends only on the empirical measures π_t^N , $t \geq 0$ (defined in (2.8)). Due to the exclusion interaction between particles, the Radon-Nikodym derivative however does not have a closed expression in terms of the empirical measure.

A key step in establishing large deviations for the open SSEP (and more generally for interacting particle systems) is to derive what is known as *local equilibrium*. Mathematically, this is achieved by the so called Replacement Lemma, that turns the Radon-Nikodym derivative into a function of the empirical measure. Such a result, first proven by Guo, Papanicolaou and Varadhan in [GPV88], states that, inside a small macroscopic box around $x \in (-1, 1)$, the time it takes for the SSEP to approach equilibrium is much smaller than the time, of order N^2 , required to change the density macroscopically at x .

In the proof of large deviations for the SSEP, this statement takes the more formal expression: for each $T \geq 0$, each $\delta > 0$ and each bias $h \in C^\infty(\mathbb{R}_+ \times [-1, 1])$,

$$\frac{1}{N} \log \mathbb{P} \left(\left| \int_0^{TN^2} \frac{1}{N} \sum_{i < N-1} \left[\eta_i(t)(1 - \eta_{i+1}(t)) - \sigma(\eta_i^{\varepsilon N}(t)) \right] \left| \nabla h \left(\frac{t}{N^2}, \frac{i}{N} \right) \right|^2 dt \right| > \delta \right) \rightarrow -\infty,$$

when $N \rightarrow \infty$ then $\varepsilon \rightarrow 0$. (2.14)

The function $\sigma(r) = r(1-r)$, $r \in [0, 1]$, appearing in (2.14), is the same as the one in the expression (2.13) of the functional $I(\cdot | \tilde{\rho}_0)$. Since $\eta_i^{\varepsilon N}$ is a function of the empirical measure, the replacement (2.14) turns the Radon-Nikodym derivative into a function of the empirical measure as desired.

To summarise, [KOV89] provides a general method to establish dynamical large deviations for a large class of interacting particle systems evolving on a diffusive time-scale, provided one knows enough information on their invariant measure. It has been used successfully in the Ginzburg-Landau model, where the occupation number at each site is replaced by a real parameter [DV89], in the zero-range process [BKL95], in the SSEP with more general jump rates [QRV99], in the SSEP and WASEP connected with reservoirs [Ber+03]-[BLM09] and for more general exclusion processes [FLM11], for reaction diffusion models [JLV93]-[BL12], and more. All these models possess the so-called gradient property, which makes microscopic computations much easier. Non-gradient large deviations have been studied in [Qua95], [BFG13].

2.2.2 Equilibrium and non-equilibrium steady states

As mentioned at the end Section 2, the method of [KOV89] relies on the knowledge of the invariant measure. In many models mentioned at the end of the previous section, the invariant measures of the microscopic dynamics are well known. In particular, for the open SSEP defined in (2.1), when both reservoirs have the same density $\rho_- = \rho_+ = \rho \in [0, 1]$, the Bernoulli product measure ν_ρ^N on Ω_N is invariant. This measure is defined as follows:

$$\nu_\rho^N := \bigotimes_{i \in \Lambda_N} \text{Ber}(\rho), \tag{2.15}$$

where $\text{Ber}(\rho)$ is the Bernoulli measure on $\{0, 1\}$ giving probability ρ to 1. Recall that a measure μ^N on Ω_N is invariant for the open SSEP if, for all test functions $\phi : \Omega_N \rightarrow \mathbb{R}$,

$$\mu^N(L\phi) = 0,$$

where $\mu^N(\cdot)$ denotes expectation under μ^N , and L is the generator of the open SSEP defined in (2.1).

In contrast, as soon as the reservoirs in the open SSEP impose different densities $\rho_- \neq \rho_+$, a macroscopic flow of particles is maintained by the dynamics in the steady state. Following [Ber+15], an invariant measure with a macroscopic flow of particles is called a *non-equilibrium steady state*. When instead $\rho_- = \rho_+ = \rho \in [0, 1]$, i.e. both reservoirs impose the same density at the boundaries, no such macroscopic flow exists. The corresponding invariant measure ν_ρ^N , defined in (2.15), is then called an *equilibrium state*.

Compared to the product structure of the equilibrium state of the open SSEP with both reservoirs at the same density $\rho_- = \rho_+ = \rho \in [0, 1]$, when $\rho_- \neq \rho_+$ the steady state of the SSEP is a considerably more complicated object: it does not have an explicit expression, and exhibits long range correlations [Spo83][DLS02]. The proofs of large deviations in models with a non-equilibrium steady state (corresponding to [Ber+03][BLM09][FLM11][BL12] above) then rely on the fact that, to control the density, one does not have to know the whole invariant measure: the knowledge of the macroscopic density profile prescribed by the invariant measure is enough.

To better understand this last claim, let us change our starting point and assume that, instead of a microscopic model, we are given the expression (2.13) of the large deviation functional I . One can then heuristically deduce what the steady state density profile of an associated microscopic model should be. Indeed, I is minimal when no bias is applied to the open SSEP, corresponding to the following equation on the density ρ :

$$\partial_t \rho = \Delta \rho.$$

Due to the two reservoirs imposing densities ρ_-, ρ_+ at the boundaries $-1, 1$ respectively, one must additionally have $\rho(t, -1) = \rho_-, \rho(t, 1) = \rho_+$ for each time $t \geq 0$ [Ber+03]. This equation has only one stationary solution $\bar{\rho}$, which solves:

$$\Delta \bar{\rho} = 0, \quad \bar{\rho}(-1) = \rho_-, \quad \bar{\rho}(1) = \rho_+.$$

The stationary measure of the open SSEP should thus have density given by $\bar{\rho}$ in the scaling limit, a fact rigorously established e.g. in [ELS90]. A rigorous microscopic application of these heuristics, comparing the steady state measure at each N with a product measure with the correct macroscopic densities, is used to obtain the large deviations in [Ber+03].

In Chapter 3 of this thesis, we will investigate large deviations not for the density, but for correlations. In this case, the knowledge of the macroscopic density of the invariant measure is not enough any more, and more information on the invariant measure is required. In Section 2.3, we explain how to obtain more information on the invariant measure through the study of large deviations for dynamical quantities, in particular through the rate function (2.13).

2.3 Large deviations and invariant measures

Besides dynamical large deviations as in Section 2.2.1, a second, related topic of investigation concerns large deviations for the invariant measure of the microscopic dynamics. When it is an equilibrium state i.e., for the open SSEP, when both reservoirs have the same density, it is well-known that there is a functional \mathcal{F} , called the free energy, such that, for any smooth density profile $\rho : (-1, 1) \rightarrow [0, 1]$ (see e.g. Chapter 11 in [KL99])

$$\frac{1}{N} \lim_{N \rightarrow \infty} \pi_{inv}^N(\pi^N \approx \rho(x)dx) = -\mathcal{F}(\rho). \quad (2.16)$$

Recall that π^N is the empirical measure defined in (2.8). Out of equilibrium, the functional \mathcal{F} satisfying (2.16) is referred to as the out of equilibrium free energy. Finding a candidate for such a functional out of equilibrium is a more difficult problem. In particular, the presence of a macroscopic current of particles in the steady state is reflected in a non-local structure of this functional [Der07][Ber+15]. The next two sections present two approaches to investigate the invariant measure through two different types of large deviations.

2.3.1 Steady state large deviations: the quasi-potential

In the previous section, we saw how to formally determine the density profile in the steady state from the rate function. Obtaining more information, such as the structure of correlations, is a difficult problem for dynamics with a non-equilibrium steady state. For general diffusive models, a systematic argument, as part of the more general macroscopic fluctuation theory, is put forward in [Ber+02], then in the review [Ber+15] in a more comprehensive form. Asymptotic probabilities under the steady state measure π_{inv}^N are characterised in terms of a functional $V : \mathcal{M}_{\leq 1}((-1, 1)) \rightarrow \mathbb{R}_+ \cup \{+\infty\}$, called the quasi-potential. The quasi-potential V is defined in terms of a variational problem involving the dynamical rate function (2.13). This variational problem can be solved for equilibrium systems, but is in general very complicated in non-equilibrium situations. The functional V then plays the role of an out of equilibrium free energy for the steady state measure π_{inv}^N , in the sense that, for each smooth density profile $\rho : (-1, 1) \rightarrow [0, 1]$:

$$\lim_{N \rightarrow \infty} \frac{1}{N} \log \pi_{inv}^N(\pi^N \approx \rho(x)dx) = -V(\rho), \quad (2.17)$$

where π^N is the empirical measure defined in (2.8). For the open SSEP in one dimension with reservoirs at different densities (i.e. with a non-equilibrium steady state), the functional satisfying (2.17) has been obtained through a static approach in [DLS02]. Formally, the knowledge of the quasi-potential gives access to the moment generating function of density correlations [Der07], through a Taylor expansion.

2.3.2 Long-time large deviations: the Donsker Varadhan formula

So far in this introduction, the focus was on the diffusive time-scale, on which interesting dynamical effects arise in the open SSEP. Obtaining information about the steady state of a model can then be done, at least at the heuristics level, through the computation of the quasi-potential (2.17). In terms of scaling limits, this procedure corresponds to looking at the microscopic model at time TN^2 when N is taken large, then T as well.

One can however adopt another point of view. For an irreducible Markov chain on a finite state space Ω_N , the steady state π_{inv}^N at each value $N \in \mathbb{N}^*$ of the scaling parameter satisfies:

$$\forall \eta \in \Omega_N, \quad \lim_{T \rightarrow \infty} \mathbb{P}[\eta_t = \eta' | \eta_0 = \eta] = \pi_{inv}^N(\eta'), \quad \eta' \in \Omega_N.$$

The Donsker-Varadhan formula [DV75] then gives a framework to estimate the probability of observing statistics that differ from the steady state π_{inv}^N . To state this formula, introduce, for $T > 0$ and a trajectory $(\eta_{tN^2})_{t \leq T} \subset \Omega_N$, the time empirical measure $\tilde{\pi}^T$ on Ω_N as follows:

$$\forall \eta \in \Omega_N, \quad \tilde{\pi}^T(\eta) := \frac{1}{T} \int_0^T \delta_{\eta_{tN^2} = \eta} dt. \quad (2.18)$$

Note the diffusive scaling, kept for convenience. In words, $\tilde{\pi}^T$ associates, with each trajectory $(\eta_{tN^2})_{t \leq T}$ of configurations, a measure given by T^{-1} times the local time on each configuration. The Donsker-Varadhan formula then establishes large deviations for $\tilde{\pi}^T$, seen as an element of the set $\mathcal{M}_1(\Omega_N)$ of probability measures on Ω_N . In our context, this formula reads:

$$\forall \mu \in \mathcal{M}_1(\Omega_N), \quad \lim_{T \rightarrow \infty} \frac{1}{T} \log \mathbb{P}(\tilde{\pi}^T \approx \mu) = -I_{DV}^N(\mu), \quad (2.19)$$

where \approx means proximity in the weak topology of measures, and the functional I_{DV}^N is defined by the variational principle (recall the definition (2.1) of the generator L):

$$I_{DV}^N(\mu) := \sup_{f: \Omega_N \rightarrow \mathbb{R}_+^*} \mu \left(\frac{(-N^2 L f)}{f} \right). \quad (2.20)$$

From this large-time result, one of the goal of this thesis, corresponding to Chapter 3, is to take the large N limit and recover explicit information on the scaling limit of the interacting particle system.

However, the variational problem defining I_{DV}^N is difficult to work with in general, and obtaining information on its large N limit is a hard problem. The notable exception concerns systems with reversible dynamics, that is a dynamics with jump rates $(c(\eta, \eta'))_{\eta, \eta' \in \Omega_N}$ satisfying:

$$\forall (\eta, \eta') \in \Omega_N^2, \quad c(\eta, \eta') \pi_{inv}^N(\eta) = c(\eta', \eta) \pi_{inv}^N(\eta').$$

This is the case for the open SSEP with reservoirs at the same density $\rho_- = \rho_+ = \rho \in [0, 1]$. For this model, the invariant measure $\pi_{inv}^N = \nu_\rho^N$ is given in (2.15), and I_{DV}^N reads:

$$\forall \mu \in \mathcal{M}_1(\Omega_N), \quad I_{DV}^N(\mu) = N^2 D_{SSEP}^N(f_\mu^{1/2}), \quad (2.21)$$

where $f_\mu = \mu / \nu_\rho^N$, and D_{SSEP}^N is the Dirichlet form of the open SSEP dynamics on Ω_N , acting on $f: \Omega_N \rightarrow \mathbb{R}_+$ according to:

$$D_{SSEP}^N(f^{1/2}) = \nu_\rho^N(-f^{1/2} L f^{1/2}) = \frac{1}{4} \nu_\rho^N \left(\sum_{i < N-1} c(\eta, i, i+1) [f^{1/2}(\eta^{i, i+1}) - f^{1/2}(\eta)]^2 + \sum_{i \in \{\pm(N-1)\}} c(\eta, i) [f^{1/2}(\eta^i) - f^{1/2}(\eta)]^2 \right). \quad (2.22)$$

Reversibility does not hold, however, as soon as the reservoir densities are different: $\rho_- \neq \rho_+$. This is intuitively understandable: reversibility would mean an equilibrium steady state, whereas one expects, on the basis of Fick's law, that imposing different densities at the extremities of the system will create a macroscopic current of particles proportional to the difference in density (this is actually proven rigorously in [FLM11]).

For the open SSEP with reservoirs at different densities, the functional I_{DV}^N is very complicated, as expected from the previous discussion. In Section 3, we present heuristics to argue that, at least at equilibrium, one can still obtain information about the large N limit of the invariant measure π_{inv}^N from Donsker-Varadhan's formula. These heuristics serve as intuition for the content of Chapter 3 of this thesis, where the probability of observing anomalous correlations in the out of equilibrium open SSEP is investigated in the long, diffusive time scale (i.e. at times TN^2 with N large, then T large).

2.4 Summary and objectives of the thesis

In Section 2, dynamical large deviations were introduced on the SSEP. Two motivations for the study of large deviations were highlighted.

- Large deviations give information on the kind of anomalous trajectories that the microscopic dynamics can follow at the macroscopic level. These trajectories typically look like solutions of:

$$\partial_t \rho = \frac{1}{2} \Delta \rho - \nabla \cdot (\sigma(\rho) \nabla h),$$

where h is an applied external field.

- Large deviations give information on the invariant measure, either through a large deviation functional for the steady state which can be interpreted as a quasi-potential; or indirectly, through a study of the deviations of the time empirical measure, via the Donsker-Varadhan formula.

In this thesis, we shall consider two models, which can both be seen as limit cases of the framework of dynamical large deviations introduced in Section 2.2.1. In both cases, reservoirs play a key role. The first model is the one-dimensional open SSEP, in Section 3. We do not study the density, which is well-known, but the two-point correlations. We address the problem of estimating the probability to observe time-averaged correlations very different from the ones of the steady state π_{inv}^N , in the long, diffusive time scale, i.e. at times TN^2 when N , then T are large.

The second model is introduced in Section 4. It is an interface model on the square lattice \mathbb{Z}^2 , related to the zero temperature Ising model. The dynamics on these interfaces can be understood as one-dimensional interacting particle systems which enter into the framework presented in Section 2. However, the domain on which these interacting particle systems are defined - previously, $\{-(N-1), \dots, N-1\}$ - is now itself modified by the dynamics.

3 Anomalous correlations in the open symmetric simple exclusion process

In this section, we introduce the results of Chapter 3. Unless mentioned otherwise, notations in the section agree with those of Chapter 3. When they do not, modified notations are indicated in the following by a $\tilde{\cdot}$ symbol.

3.1 Invariant measures and Donsker-Varadhan formula in the scaling limit

In Sections 2.3.1-2.3.2, the general question of how to gain explicit information on the scaling limit of a non-equilibrium steady state was raised. Recall that such a state is characterised by the fact that, in the scaling limit, the average current does not vanish [Ber+15]. Understanding the structure of the steady state is motivated by the profound differences between equilibrium- and non-equilibrium situations. Let us again illustrate these differences through the open SSEP (2.1) on $\Lambda_N = \{-(N-1), \dots, N-1\}$, with reservoirs at densities $0 < \rho_- \leq \rho_+ < 1$.

- Assume both reservoirs impose the same density of particle $0 < \rho_- = \rho_+ =: \rho < 1$. The SSEP then admits the Bernoulli product measure $\nu_\rho^N = \bigotimes_{\Lambda_N} \text{Ber}(\rho)$ as its invariant measure, where $\text{Ber}(\rho)$ is the probability measure on $\{0, 1\}$, with $\text{Ber}(\rho)(\{\eta = 1\}) = \rho$. In particular, the dynamics is reversible with respect to ν_ρ^N , there is no macroscopic current and particles are uncorrelated. In particular, the quasi-potential (2.17) is known explicitly [Ber+15], and is a local function of the density. The Donsker-Varadhan rate function at each $N \in \mathbb{N}^*$ has an explicit expression (2.21), and can be used to compute various dynamical quantities in the large N limit, see Sections 3.2.1-3.2.2.
- Assume now that $0 < \rho_- < \rho_+ < 1$. The non-equilibrium steady state π_{inv}^N is then not known explicitly. It has long-range correlations, in particular n -point cumulants of the density decay like N^{-n+1} [DLS07]. In one dimension, the quasi-potential can be computed [DLS02][Ber+03][BG04]. It is a non-local function of the density. This property is conjectured to be generic in dynamics with a non-equilibrium steady state [Spo83][Gar+90][BLM09]. The Donsker-Varadhan rate function is not explicit in general.

As already mentioned, Donsker-Varadhan formula (2.19) quantifies the probability that the time empirical measure $\tilde{\pi}^T$ (recall (2.18)) have statistics different from the steady state π_{inv}^N . The resulting rate function I_{DV}^N (2.20) is defined at each value of the scaling parameter $N \in \mathbb{N}^*$ through a variational principle. When π_{inv}^N is an out of equilibrium steady state, this variational principle is hard to work with. However, one may hope that it simplifies in the large N limit, so that one could identify a sequence $a_N, N \in \mathbb{N}^*$ increasing to infinity and a limiting rate function I_{DV} such that, for any measure μ on a suitable limit of the configuration space Ω_N :

$$\lim_{N \rightarrow \infty} \lim_{T \rightarrow \infty} \frac{1}{a_N T} \log \mathbb{P}(\tilde{\pi}^T \approx \mu) = -I_{DV}(\mu). \quad (3.1)$$

In particular, this rate function should vanish only on the large N limit of the invariant measure π_{inv}^N , so that one could hope to extract information on this limiting measure from (3.1).

Before even attempting to prove (3.1), one has to find a suitable space for the large N limit of measures on Ω_N . This is in fact a major difficulty because, informally, not all information in the measure $\tilde{\pi}^T$ is stored at the same scale in N . We substantiate this claim in Section 3.2 in the case of the open SSEP with reservoirs at the same density, for which the dynamics is reversible and the Donsker-Varadhan rate function I_{DV}^N is known explicitly at each $N \in \mathbb{N}^*$. We estimate the cost of changing the macroscopic density on the one hand, and the cost of keeping the same density but changing the macroscopic two-point correlations on the other hand. We find that these two costs do not scale with N in the same way. Indeed, changing the density occurs with probability of order e^{-TN} when T , then N are large. In contrast, changing only the two-point correlations is possible with probability of order e^{-T} , again when T , then N are large.

3.2 Scaling of correlations at equilibrium in the long-time, large N limit

Consider the open SSEP as given in (2.1) with two reservoirs at equal densities $\rho_- = \rho_+ = \rho \in (0, 1)$. In this setting, the dynamics is reversible with respect to ν_ρ^N as defined in (2.15), and the Donsker-Varadhan rate function at each $N \in \mathbb{N}^*$ is given by the Dirichlet form (2.22).

In the next two sections, we show that there is little chance of establishing a formula such as (3.1) at the level of the time empirical measure. This is done by computing the cost of observing an anomalous macroscopic density, in Section 3.2.1, and the cost of an anomalous macroscopic two-point correlations, in Section 3.2.2.

3.2.1 Changing the macroscopic density

Consider a smooth density profile $\hat{\rho} : [-1, 1] \rightarrow (0, 1)$. For simplicity, assume that the density close to the boundaries is unchanged, i.e. that $\hat{\rho}(x) = \rho$ for x in an open neighbourhood of ± 1 . Define then:

$$\mu^N = \bigotimes_{i \in \Lambda_N} \text{Ber}(\hat{\rho}(i/N)).$$

For a function $q : (-1, 1) \rightarrow \mathbb{R}$, write for short $q_i := q(i/N)$ for $i \in \Lambda_N$. Introduce the chemical potential λ and its discrete derivative $\partial^N \lambda_i$, defined by:

$$\forall x \in (-1, 1), \quad \lambda(x) := \log \left(\frac{\hat{\rho}(x)}{1 - \hat{\rho}(x)} \right), \quad \partial^N \lambda_i = N[\lambda_{i+1} - \lambda_i], \quad i < N - 1. \quad (3.2)$$

Recall that $\mu^N[\cdot]$ (or $\mu^N(\cdot)$) denotes expectation under the measure μ^N , and the definition (2.18) of the time empirical measure $\tilde{\pi}^T$. Elementary computations using (2.21) then give, for each $N \in \mathbb{N}^*$:

$$\lim_{T \rightarrow \infty} \frac{1}{T} \log \mathbb{P}(\tilde{\pi}^T \approx \mu^N) = -\frac{N^2}{4} \mu^N \left[\sum_{i < N-1} c(\eta, i, i+1) \left(\exp \left[-\frac{(\eta_{i+1} - \eta_i)}{2N} \partial^N \lambda_i \right] - 1 \right)^2 \right]. \quad (3.3)$$

Note that there is no contribution from the boundary dynamics, since $\hat{\rho}$ is constant and equal to ρ close to ± 1 by assumption. Expanding the right-hand side of (3.3), one finds, recalling

$\sigma(r) = r(1 - r)$ for $r \in [0, 1]$:

$$\begin{aligned} \lim_{T \rightarrow \infty} \frac{1}{T} \log \mathbb{P}(\tilde{\pi}^T \approx \mu^N) &= -\frac{1}{16} \mu^N \left[\sum_{|i| < N-1} c(\eta, i, i+1) [\partial^N \lambda_i]^2 \right] + O_N(1) \\ &= -\frac{N}{8} \int_{(-1,1)} \sigma(\hat{\rho}(x)) |\nabla \lambda(x)|^2 dx + O_N(1), \end{aligned} \quad (3.4)$$

where we used the smoothness of $\hat{\rho}$, and $\mu^N(c(\eta, i, i+1)) = 2\sigma(\hat{\rho}_i) + O(N^{-1})$ for each $i < N-1$, with the $O(N^{-1})$ uniform on i . It follows that a macroscopic change of density is observed with probability of order e^{-TN} in the large T , then large N limit.

For future reference, notice that, up to factors of N, T , the right-hand side of (3.4) is the same as the one given by the dynamical rate function (2.13). To see it, recall that the rate function I_{SSEP} evaluated at the constant profile $\hat{\rho}$ on the time interval $[0, T]$ for $T > 0$ is given by:

$$I_{SSEP}((\hat{\rho}(x)dx)_{t \leq T} | \hat{\rho}) = \frac{1}{2} \int_0^T \int_{(-1,1)} |\nabla h(t, x)|^2 \sigma(\hat{\rho}(x)) dx dt,$$

where h is the bias such that $h(t, \pm 1) = 0$ for each $t \in [0, T]$, and:

$$\partial_t \hat{\rho} = 0 = \frac{1}{2} \Delta \hat{\rho} - \nabla \cdot (\sigma(\hat{\rho}) \nabla h).$$

In particular, integrating the divergence operator, there is a divergence-free function j on $(-1, 1)$ (the current), i.e. a constant in our one-dimensional setting, such that:

$$\nabla h = \frac{(1/2) \nabla \hat{\rho} + j}{\sigma(\hat{\rho})} \quad \Rightarrow \quad I_{SSEP}((\hat{\rho}(x)dx)_{t \leq T} | \hat{\rho}) = \frac{T}{2} \int_{(-1,1)} \frac{((1/2) \nabla \hat{\rho} + j)^2}{\sigma(\hat{\rho}(x))} dx.$$

In the present case, $h(\cdot, \pm 1) = 0$ and $\nabla \lambda = \nabla \hat{\rho} / \sigma(\hat{\rho})$ implies that $j = 0$, with λ defined in (3.2). As a result:

$$\forall t \geq 0, x \in (-1, 1), \quad \nabla h(t, x) = \nabla \lambda(x) / 2.$$

The right-hand side above divided by T thus reduces to N^{-1} times (3.4) in the large N limit, and we find:

$$\lim_{N \rightarrow \infty} \lim_{T \rightarrow \infty} \frac{1}{NT} \log \mathbb{P}(\tilde{\pi}^T \approx \mu^N) = \lim_{T \rightarrow \infty} \lim_{N \rightarrow \infty} \frac{1}{NT} \log \mathbb{P}((\pi_t^N)_{t \leq T} \approx (\hat{\rho}(x)dx)_{t \leq T}). \quad (3.5)$$

In other words, the long time, large N limit and the long diffusive time limits coincide.

3.2.2 Changing the macroscopic correlations

Consider again the open SSEP at equilibrium at density $\rho \in (0, 1)$. For simplicity, set $\rho = 1/2$. For a bounded function $\psi : [-1, 1] \rightarrow \mathbb{R}$, define the fluctuation field $Y^N(\psi)$ by:

$$\forall \eta \in \Omega_N, \quad Y^N(\psi) = \frac{1}{\sqrt{N}} \sum_{i \in \Lambda_N} \bar{\eta}_i \psi(i/N), \quad \text{with } \bar{\eta}_i = \eta_i - 1/2.$$

Under the invariant measure $\nu_{1/2}^N$, $Y^N(\psi)$ vanishes. However, at each time t , the fluctuation field $Y_{tN^2}^N(\psi)$ can be proven to converge to a Gaussian random variable, and is in particular typically of order 1 in N (see Chapter 11 in [KL99], or [Der+05][LMO06] when $\rho_- \neq \rho_+$). The two-point correlations $Y(\psi_1)Y(\psi_2)$ are thus also of order 1 in N for bounded functions ψ_1, ψ_2 (see e.g. [GJ19] for the reversible SSEP on the torus, and [Spo93] for correlations in the steady state when $\rho_- \neq \rho_+$). Define more generally the (off diagonal) correlation field Π^N , acting on a bounded function $\phi : [-1, 1]^2 \rightarrow \mathbb{R}$ according to:

$$\forall \eta \in \Omega_N, \quad \Pi^N(\phi) = \frac{1}{4N} \sum_{i \neq j \in \Lambda_N} \bar{\eta}_i \bar{\eta}_j \phi\left(\frac{i}{N}, \frac{j}{N}\right). \quad (3.6)$$

In view of the above discussion, to find a measure that is close to ν_{ρ}^N but with a different correlation structure, it is reasonable to look at:

$$\mu^N = \nu_{1/2, \phi}^N := \frac{1}{\mathcal{Z}_{1/2, \phi}^N} e^{2\Pi^N(\phi)} \nu_{1/2}^N, \quad \mathcal{Z}_{1/2, \phi}^N \text{ a normalisation factor.}$$

Assume $\|\phi\|_{\infty}$ is sufficiently small and ϕ is smooth, symmetric, i.e.:

$$\forall (x, y) \in [-1, 1]^2, \quad \phi(x, y) = \phi(y, x).$$

Assume also that $\phi(x, \cdot) = 0$ for x in an open neighbourhood of ± 1 . n -point correlations under the measure μ^N can then be estimated for each $n \in \mathbb{N}^*$. Let U_{ϕ}^N be the matrix:

$$\forall (i, j) \in \Lambda_N^2, \quad U_{\phi}^N(i, j) = \sigma(1/2)^{-1} \mathbf{1}_{i=j} + \frac{1}{N} \phi\left(\frac{i}{N}, \frac{j}{N}\right) \mathbf{1}_{i \neq j}.$$

One can then prove (see Appendix A of Chapter 3) that the inverse $(U_{\phi}^N)^{-1}$ has diagonal coefficients bounded with N , off-diagonal coefficients of order N^{-1} , and:

$$\sup_{i \in \Lambda_N} |\mu^N(\bar{\eta}_i)| = O(N^{-1}), \quad \sup_{i \neq j \in \Lambda_N} |\mu^N(\bar{\eta}_i \bar{\eta}_j) - [(U_{\phi}^N)^{-1}](i, j)| = o(N^{-1}). \quad (3.7)$$

In other words, the macroscopic density is still given by $\rho = 1/2$, but there are now long-range correlations parametrised by ϕ . Let us again compute the Donsker-Varadhan rate function at each fixed N .

Lemma 3.1. *For ϕ and μ^N as above, one has:*

$$\lim_{T \rightarrow \infty} \frac{1}{T} \log \mathbb{P}(\tilde{\pi}^T \approx \mu^N) = -C_N, \quad 0 \leq C_N \leq \sup_N C_N < \infty.$$

Proof. Write:

$$\phi_{i,j} := \phi\left(\frac{i}{N}, \frac{j}{N}\right), \quad \partial_1^N \phi_{i,j} = N[\phi_{i+1,j} - \phi_{i,j}], \quad (i, j) \in \Lambda_N^2.$$

Notice then that, for each $\eta \in \Omega_N$:

$$\forall i < N - 1, \quad \Pi^N(\phi)(\eta^{i,i+1}) - \Pi^N(\phi)(\eta) = -\frac{(\eta_{i+1} - \eta_i)}{2N^2} \sum_{j \notin \{i, i+1\}} \bar{\eta}_j \partial_1^N \phi_{i,j}.$$

In particular, as ϕ is smooth, the above difference is bounded by $O(N^{-1})$ uniformly in $i < N - 1$. By definition, the Donsker-Varadhan rate function reads:

$$I_{DV}^N(\mu^N) = \frac{N^2}{4} \mu^N \left[\sum_{i < N-1} c(\eta, i, i+1) \left(\exp [2\Pi^N(\phi)(\eta^{i,i+1}) - 2\Pi^N(\phi)(\eta)]^{1/2} - 1 \right)^2 \right]. \quad (3.8)$$

To compute this quantity, we need a bound on correlations under μ^N . In Appendix A of Chapter 3, we prove that, for each $n \geq 2$:

$$\sup_{\substack{I \subset \Lambda_N \\ |I| \in \{n-1, n\}}} \left| \mu^N \left(\prod_{i \in I} \bar{\eta}_i \right) \right| = O(N^{-n/2}). \quad (3.9)$$

Expanding the exponential in (3.8) using $|e^x - 1 - x| \leq Cx^2$ for some $C > 0$ and all $|x| \leq 2\|\phi\|_\infty$, (3.8) reads:

$$I_{DV}^N(\mu^N) = \frac{1}{4} \mu^N \left[\sum_{i < N-1} c(\eta, i, i+1) \left(\frac{1}{2N} \sum_{j \notin \{i, i+1\}} \bar{\eta}_j \partial_1^N \phi_{i,j} \right)^2 \right] + O(N^{-2}). \quad (3.10)$$

Recall that $\bar{\eta}_i = \eta_i - 1/2$ at density $\rho = 1/2$ for each $i \in \Lambda_N$, and notice:

$$\forall i < N - 1, \quad c(\eta, i, i+1) := \eta_i(1 - \eta_{i+1}) + \eta_{i+1}(1 - \eta_i) = 2\sigma(1/2) - 2\bar{\eta}_i\bar{\eta}_{i+1}.$$

Moreover, $(\bar{\eta}_i)^2 = \sigma(1/2)$ for each $i \in \Lambda_N$. Separating diagonal and off-diagonal terms in (3.10), Donsker-Varadhan's formula (2.19) yields:

$$\begin{aligned} \lim_{T \rightarrow \infty} \frac{1}{T} \log \mathbb{P}(\tilde{\pi}^T \approx \mu^N) &= -\frac{1}{2N^2} \mu^N \left[\sum_{i < N-1} \sigma(1/2) \sum_{j \neq \ell \notin \{i, i+1\}} \bar{\eta}_j \bar{\eta}_\ell \partial_1^N \phi_{i,j} \partial_1^N \phi_{i,\ell} \right] \\ &\quad - \frac{1}{2N^2} \sum_{i < N-1} \sum_{j \notin \{i, i+1\}} \sigma(1/2)^2 [\partial_1^N \phi_{i,j}]^2 + O(N^{-2}). \end{aligned}$$

Using (3.7), the first line is bounded with N :

$$\begin{aligned} \lim_{T \rightarrow \infty} \frac{1}{T} \log \mathbb{P}(\tilde{\pi}^T \approx \mu^N) &= -\frac{\sigma(1/2)}{2N^2} \sum_{i < N-1} \sum_{j \neq \ell \notin \{i, i+1\}} [(U_\phi^N)^{-1}](j, \ell) \partial_1^N \phi_{i,j} \partial_1^N \phi_{i,\ell} \\ &\quad - \frac{1}{2N^2} \sum_{i < N-1} \sum_{j \notin \{i, i+1\}} \sigma(1/2)^2 [\partial_1^N \phi_{i,j}]^2 + O(N^{-2}). \end{aligned} \quad (3.11)$$

The right-hand side above is consequently bounded with N . The probability of observing the measure μ^N with the same density but correlations macroscopically different from those of $\nu_{1/2}^N$ thus scales like e^T in the large T , then large N limit. \square

The large N limit of the expression (3.11) reads:

$$\lim_{N \rightarrow \infty} \lim_{T \rightarrow \infty} \frac{1}{T} \log \mathbb{P}(\tilde{\pi}^T \approx \mu^N) = -\frac{1}{8} \int_{(-1,1)} \sigma(1/2) \langle \partial_1 \phi(z, \cdot), (U_\phi)^{-1} \partial_1 \phi(z, \cdot) \rangle dz, \quad (3.12)$$

where $\langle \cdot, \cdot \rangle$ is the scalar product in $\mathbb{L}^2((-1, 1))$, and U_ϕ^{-1} is the inverse of the operator U_ϕ , acting on $\psi \in \mathbb{L}^2((-1, 1))$ according to:

$$\forall x \in (-1, 1), \quad U_\phi \psi(x) := \sigma(1/2)^{-1} \psi(x) - \int_{(-1,1)} \phi(x, y) \psi(y) dy.$$

The formula (3.12) will be generalised below to a non-equilibrium situation, in Theorem 3.2. As was the case for the density (3.5), we will see that the formula (3.12) again agrees with the one that can be obtained in the long diffusive time limit. In other words, the observation (3.5) that the time and scaling limits can be exchanged in the case of the density is also valid for correlations.

3.3 Contribution of the thesis

In view of Section 3.2, rather than obtaining a global formula such as (3.1), it seems relevant to split the study of the time empirical measure in the large N to separately study the different scales in N . In Chapter 3, we make a first step in that direction in the case of the open SSEP with reservoirs at different densities $\rho_- \neq \rho_+$. We study the probability to observe anomalous values of the time average of the two-point correlation field Π^N , i.e. of the quantity;

$$\frac{1}{T} \int_0^T \Pi_{tN^2}^N dt, \quad T > 0, N \in \mathbb{N}^*. \quad (3.13)$$

3.3.1 Results

When $\rho_- \neq \rho_+$, the correlation field Π^N is defined as in (3.6), but with $\bar{\eta} := \eta - \bar{\rho}$, and $\bar{\rho}$ stands for the steady state profile in the large N limit:

$$\Delta \bar{\rho} = 0, \quad \bar{\rho}(\pm 1) = \rho_\pm. \quad (3.14)$$

The method used to study Π^N is not specific to the SSEP, and applies to a large class of interacting particle systems, see Section 3.3.2. Let us present our results. In the following, we simply say correlations for two-point correlations.

In the spirit of Donsker-Varadhan's formula, one would like to prove a large deviation result in large time, then investigate its scaling limit, i.e. establish an estimate of the form:

$$\lim_{N \rightarrow \infty} \lim_{T \rightarrow \infty} \frac{1}{T} \log \mathbb{P} \left(\frac{1}{T} \int_0^T \Pi_{tN^2}^N dt \approx \Pi \right) = -\mathcal{I}(\Pi), \quad (3.15)$$

with \mathbb{P} the probability associated with the open SSEP dynamics, and for a rate function \mathcal{I} acting on a correlation field Π defined in a suitable space. Taking the long-time limit at fixed value of the scaling parameter as in (3.15) turns out to be out of reach. The reason is that, at each N , the candidate for a rate function is not a closed functional of the correlation field, but instead also involves n -point correlations with $n \geq 3$. We have no way to estimate these correlations in the long-time limit.

Instead, we look at the field (3.13) in the long diffusive time-scale, i.e. times TN^2 with N large, then T large. From the heuristics presented in (3.5) and at the end of Section 3.2.2, we can

expect that these limits coincide with the large T , then large N limits of (3.15). A variety of tools to study hydrodynamics are available on time windows of the form $[0, TN^2]$ with T fixed and N large, such as the relative entropy method of Yau [Yau91]. By a refinement of this method (see Section 3.3.2), we obtain uniform estimates in T when N is large. We manage to quantify, for a large class of correlation fields, the quantity:

$$\lim_{T \rightarrow \infty} \lim_{N \rightarrow \infty} \frac{1}{T} \log \mathbb{P} \left(\frac{1}{T} \int_0^T \Pi_{tN^2}^N dt \approx \Pi \right). \quad (3.16)$$

In the rest of this section, we give a precise large deviation statement, before explaining, in Section 3.3.2, the ideas of proof and the difficulties. Let us first fix some notations. The correlation kernel k_0 in the steady state π_{inv}^N of the open SSEP with reservoirs at density $\rho_- \neq \rho_+$ is known explicitly [Spo83][DLS02]:

$$k_0 = (\bar{\rho}')^2 \Delta_{1d}^{-1}, \quad (3.17)$$

where Δ_{1d}^{-1} is the inverse of the Dirichlet Laplacian on $(-1, 1)$ with 0 boundary conditions.

Denote by \square the open set $(-1, 1)^2$, by $D = \{(x, x) : x \in (-1, 1)\}$ its diagonal, and let $\boxminus := \square \setminus D$. Let also $\triangleright := \{(x, y) \in \square : x < y\}$ and $\triangleleft = \boxminus \setminus \triangleright$. For the open SSEP with reservoirs at density (ρ_-, ρ_+) , we estimate the cost of observing a given correlation field Π , seen as an element of $\tilde{\mathcal{T}}'$, the set of continuous linear forms on $\tilde{\mathcal{T}}$, with:

$$\tilde{\mathcal{T}} := \{ \phi \in C^0(\bar{\square}) : \phi_{|\triangleright} \in C^2(\bar{\triangleright}), \phi_{|\triangleleft} \in C^2(\bar{\triangleleft}), \phi_{|\partial \square} = 0 \}.$$

Note that, if $\langle \cdot, \cdot \rangle$ denotes the standard scalar product on $\mathbb{L}^2(\boxminus)$ and duality pairing between elements of $\tilde{\mathcal{T}}$ and $\tilde{\mathcal{T}}'$, one can always represent $\Pi \in \tilde{\mathcal{T}}'$ by a distribution k_Π such that:

$$\forall \phi \in \tilde{\mathcal{T}}, \quad \Pi(\phi) := \frac{1}{4} \langle k_\Pi, \phi \rangle = \frac{1}{4} \int_{(-1, 1)^2} k_\Pi(x, y) \phi(x, y) dx dy, \quad (3.18)$$

where the last equality makes sense as soon as $k_\Pi \in \mathbb{L}^2(\boxminus)$. In such a case, define also the operator $C_\Pi := \sigma(\bar{\rho}) + k_\Pi$ on $\mathbb{L}^2((-1, 1))$ as follows:

$$\forall f \in \mathbb{L}^2((-1, 1)), \quad C_\Pi f(x) = \sigma(\bar{\rho}(x))f(x) + \int_{(-1, 1)} k_\Pi(x, y) f(y) dy, \quad x \in (-1, 1). \quad (3.19)$$

Theorem 3.2. *Assume $\rho_-, \rho_+ \in (1/2 - \varepsilon, 1/2 + \varepsilon)$ for a sufficiently small $\varepsilon > 0$. For a suitable family of measures $(\mu^N)_N$ which serve as initial condition, there is a functional \mathcal{I} with values in $\mathbb{R} \cup \{+\infty\}$ such that, for any compact set \mathcal{K} in the weak* topology of $\tilde{\mathcal{T}}'$,*

$$\limsup_{T \rightarrow \infty} \limsup_{N \rightarrow \infty} \frac{1}{T} \log \mathbb{P}^{\mu^N} \left(\frac{1}{T} \int_0^T \Pi_{tN^2}^N dt \in \mathcal{K} \right) \leq - \inf_{\Pi' \in \mathcal{K}} \mathcal{I}(\Pi'). \quad (3.20)$$

If the kernel k_Π associated with $\Pi \in \tilde{\mathcal{T}}'$ via (3.18) is both sufficiently smooth and close to k_0 (defined in (3.17)), then, for any weak open neighbourhood \mathcal{O} of Π :*

$$\limsup_{T \rightarrow \infty} \limsup_{N \rightarrow \infty} \frac{1}{T} \log \mathbb{P}^{\mu^N} \left(\frac{1}{T} \int_0^T \Pi_{tN^2}^N dt \in \mathcal{O} \right) \geq -\mathcal{I}(\Pi), \quad (3.21)$$

where the correlations C_Π are defined in (3.19). Moreover, in this case, there is a smooth function $h_\Pi \in \tilde{\mathcal{T}}$, such that the rate function \mathcal{I} reads:

$$\mathcal{I}(\Pi) = \frac{1}{8} \int_{(-1,1)} \sigma(\bar{\rho}(z)) \langle \partial_1 h_\Pi(z, \cdot), C_\Pi \partial_1 h_\Pi(z, \cdot) \rangle dz. \quad (3.22)$$

The initial condition will be the measures $\nu_{g_0}^N$, defined in (3.31) and Theorem 3.3 below, which have both the same macroscopic density and the same macroscopic correlations as the invariant measure π_{inv}^N of the open SSEP.

Let us give a very informal justification for the formula (3.22). Consider a density profile $\rho(t, x) = \bar{\rho}(x) + \phi(t, x)$ with a time-dependent fluctuation profile ϕ of order $N^{-1/2}$, and take a bias $H : (-1, 1) \rightarrow \mathbb{R}$ of the form:

$$\forall x \in (-1, 1), \quad \nabla H(x) := \frac{1}{2} \int_{(-1,1)} \partial_1 h(x, y) \phi(y) dy, \quad (3.23)$$

Contrary to (2.12), the bias H is now non-local. Then, to lowest order in ϕ , the rate function (2.13) at each fixed time $T > 0$ becomes, at a strictly formal level:

$$I((\rho(t, x) dx)_{t \leq T} | \rho_0) = \frac{1}{8} \int_0^T \int_{(-1,1)} \sigma(\bar{\rho}(z)) \left[\int_{(-1,1)^2} \partial_1 h(z, x) \partial_1 h(z, y) \phi(t, x) \phi(t, y) dx dy \right] dz. \quad (3.24)$$

Under an assumption of ergodicity and sufficiently fast time decorrelation, the "correlations" $(\frac{1}{T} \int_0^T \phi(t, x) \phi(t, y) dt)_{(x,y) \in \square}$ in (3.24) can be expected to average to C_h , the macroscopic correlations in the invariant measure of the open SSEP dynamics biased by H . Dividing (3.24) by T and taking the large T limit, the formula (3.22) can be recovered:

$$\lim_{T \rightarrow \infty} \frac{1}{T} I((\rho(t, x) dx)_{t \leq T} | \rho_0) = \frac{1}{8} \int_{(-1,1)} \sigma(\bar{\rho}(z)) \langle \partial_1 h(z, \cdot), C_h \partial_1 h(z, \cdot) \rangle dz = \mathcal{I}(\Pi_h).$$

3.3.2 The method and context

Let us now explain how to prove Theorem 3.2. The framework is still the one of Section 2: the dynamics is tilted by suitable biases, and the cost of the tilt must be estimated. The difficulty, however, lies in the fact that correlations are objects that live on a much finer scale than the density. This means that Replacement Lemma-type results (recall (2.14)), known in this context as Boltzmann-Gibbs principles, are much more difficult to prove. In the context of the open SSEP, one would typically need the following estimate to study correlations:

$$\limsup_{T \rightarrow \infty} \limsup_{N \rightarrow \infty} \frac{1}{T} \log \mathbb{P} \left(\left| \frac{1}{T} \int_0^T \frac{1}{N} \sum_{\substack{i_1 < N-1 \\ i_2 \notin \{i_1, i_1+1\}}} A_{i_1, i_2} \bar{\eta}_{i_1}(t) \bar{\eta}_{i_1+1}(t) \bar{\eta}_{i_2}(t) dt \right| > \varepsilon \right) = -\infty, \quad (3.25)$$

for each $\varepsilon > 0$ and each tensor $(A_{i_1, i_2})_{(i_1, i_2) \in (\Lambda_N)^2}$ with entries uniformly bounded with N . Estimates such as (3.25) have not been established before, be it at, or out of equilibrium. Existing

results on correlations are restricted to a finite time window, and concern either correlations at equilibrium [Ass07][GJ19], or rely on certain duality property of the underlying models [ACR21][CS20].

In fact, let alone correlations, even studying out of equilibrium fluctuations is difficult. Studies are often model-dependent, in particular much work has been carried out on the SSEP [LMO06] and WASEP [Der+05][Gon+20], and earlier on the zero range process [FPV88], see also the book [KLO12]. Earlier, specific model could be studied using duality techniques, see e.g. [DFL86] for an example, and Sections II.3 and III.4 of the book [Lig05] for a presentation. Though obtaining an estimate such as (3.25) would be easier at the level of fluctuations (one would only need to estimate (3.25) with the sum replaced with $N^{-1/2} \sum_{i < N-1} \bar{\eta}_i \bar{\eta}_{i+1} B_i$ for some bounded $B : \Lambda_N \rightarrow \mathbb{R}$), existing methods are still insufficient.

To summarise, there are thus two issues: first, there are no known general methods to study correlations out of equilibrium. Secondly, existing methods to study long time asymptotics only apply at the level of the density, and do not easily carry over to fluctuations, much less correlations. In the following, we first present the method used to obtain (3.25), then explain how it is applied to derive Theorem 3.2.

The relative entropy method for correlations.

A recent breakthrough by Jara and Menezes [JM18b][JM18a] paves the way towards a solution of the first problem, i.e. a general approach to studying correlations out of equilibrium. They propose a general method to study out of equilibrium fluctuations for a large class of interacting particle systems which evolve in diffusive time, relying on the relative entropy method of Yau [Yau91]. The idea in [Yau91] is that, at each time, one should compare the actual law of the dynamics with a reference measure, supposed to mimic the large-scale behaviour of the dynamics. The distance between these two measures is controlled in terms of the relative entropy: if $\mu^N, \pi^N \in \mathcal{M}_1(\Omega_N)$ with $\inf_{\eta \in \Omega_N} \pi^N(\eta) > 0$,

$$H(\mu^N | \pi^N) := \pi^N \left[\frac{\mu^N}{\pi^N} \log \left(\frac{\mu^N}{\pi^N} \right) \right] = \mu^N \left[\log \left(\frac{\mu^N}{\pi^N} \right) \right].$$

Above, $\pi^N[\cdot]$ (or $\pi^N(\cdot)$) denotes expectation under π^N . The law $f_t \pi^N$ of the dynamics at time $t \geq 0$ can then be controlled in terms of $H(f_t \pi^N | \pi^N)$ using the entropy inequality: for each $V : \Omega_N \rightarrow \mathbb{R}$,

$$\pi^N(f_t V) \leq H(f_t \pi^N | \pi^N) + \log \pi^N[e^V]. \quad (3.26)$$

The relative entropy method of Yau [Yau91] then consists in bounding the quantity $\partial_t H(f_t \pi^N | \pi^N)$, known as the entropy dissipation. In [JM18b], the entropy dissipation is shown to satisfy:

$$\forall t \geq 0, \quad \partial_t H(f_t \pi^N | \pi^N) \leq -\pi^N \left(\Gamma(\sqrt{f_t}) \right) + \pi^N(L^* \mathbf{1} f_t), \quad (3.27)$$

where $L^* \mathbf{1}$ is the adjoint of the generator L in the space $\{f : \Omega_N \rightarrow \mathbb{R} : \int f^2 d\pi^N < \infty\}$, and Γ is the carré du champ operator associated with the dynamics, acting on $f : \Omega_N \rightarrow \mathbb{R}_+$ according to:

$$\begin{aligned} \forall \eta \in \Omega_N, \quad \Gamma(\sqrt{f}) &= \frac{1}{2} \sum_{i < N-1} c(\eta, i, i+1) [\sqrt{f(\eta^{i,i+1})} - \sqrt{f(\eta)}]^2 \\ &\quad + \frac{1}{2} \sum_{i \in \{\pm(N-1)\}} c(\eta, i) [\sqrt{f(\eta^i)} - \sqrt{f(\eta)}]^2. \end{aligned}$$

When $\pi^N = \pi_{inv}^N$ is the invariant measure, $L^*\mathbf{1} = 0$ and the right-hand side of (3.27) is negative. If $\pi^N \neq \pi_{inv}^N$, the term $\pi^N(f_t L^*\mathbf{1})$ can be understood as way to quantify the proximity of π^N to the invariant measure. The goal of the relative entropy method is then to find a measure π^N for which good bounds on $\pi^N(f_t L^*\mathbf{1})$ can be obtained via the entropy inequality (3.26), and computation of exponential moments under π^N . In practice, π^N must be chosen simple enough to compute exponential moments, and yet close to the invariant measure. The usual choice consists in taking a product measure, in our set-up the product measure with densities given by the invariant profile $\bar{\rho}$ at each site:

$$\bar{\nu}^N = \bigotimes_{i \in \Lambda_N} \text{Ber}(\bar{\rho}_i), \quad (3.28)$$

with $\text{Ber}(\rho)$ the Bernoulli measure on $\{0, 1\}$ such that $\text{Ber}(\rho)(\{\eta = 1\}) = \rho$, $\rho \in [0, 1]$. Informally, if one considers an interacting particle system in dimension d , the relative entropy method allows for the study of hydrodynamics for the density provided one has an upper bound of the form:

$$\forall t \geq 0, \quad H(f_{tN^2} \pi^N | \pi^N) \leq C_d(t) \varepsilon_N, \quad C_d(t) > 0, \quad \varepsilon_N = o(N^d).$$

Comparing the law of the dynamics at each time with a reference measure π^N given by a product measure, the relative entropy method has been successfully used to determine the hydrodynamics of the density in many models. Starting with the seminal paper [Yau91] on the Ginzburg-Landau model, many results have been obtained in the 90's, a list of which can be found in Section 2 of Chapter 6 of [KL99]. More recent works include the hydrodynamics of an interface appearing in a superposition of Glauber and Kawasaki dynamics [FT19], or Glauber and zero-range dynamics [Ket+20].

When one is interested in a finer scale than the density, such as the scales of dynamical fluctuations; much sharper bounds on the relative entropy are required:

$$\forall t \geq 0, \quad H(f_{tN^2} \pi^N | \pi^N) \leq C'_d(t) \varepsilon_N, \quad C'_d(t) > 0, \quad \varepsilon_N = o(N^{d/2}). \quad (3.29)$$

If one still takes a product measure for π^N , say $\pi^N = \bar{\nu}^N$ as in (3.28), it may not be possible to prove (3.29) simply by using the entropy inequality to estimate $\bar{\nu}^N(f_t L^*\mathbf{1})$. Indeed, some quantities arising in the computation of $L^*\mathbf{1}$ may be very singular, with the consequence that their exponential moments are too big [JM18b]. The improvement on the relative entropy method in [JM18b] is a general procedure to renormalise such singular terms. The idea is to make use of the dissipative carré du champ term in (3.27) to turn singular terms into functions for which the entropy inequality is effective. This method enabled Jara and Menezes in [JM18b] to considerably improve existing relative entropy bounds. They obtain bounds of the form:

$$\forall t \geq 0, \quad H(f_{tN^2} \bar{\nu}^N | \bar{\nu}^N) \leq C''_d(t) g_d(N) N^{d-2}, \quad C''_d(t) > 0, \quad g_d(N) = \begin{cases} N & \text{if } d = 1, \\ \log N & \text{if } d = 2, \\ 1 & \text{if } d \geq 3. \end{cases}$$

In view of (3.29), the above bounds are good enough to allow for the study of out of equilibrium fluctuations in dimension $d < 4$, for a large class of models (see in particular Section 8 of [JM18b]). Here, we build on the idea of Jara and Menezes to improve relative entropy bounds in order to study correlations as in (3.6), which are objects that live on a still finer scale than fluctuations. To

do so, informally, the bounds on the relative entropy one would need are, in an interacting particle system in dimension d :

$$\forall t \geq 0, \quad H(f_{tN^2} \pi^N | \pi^N) \leq K_d(t) \varepsilon_N, \quad K_d(t) > 0, \quad \varepsilon_N = o_N(1), \quad (3.30)$$

for a suitable reference measure π^N . To establish (3.30) in order to study correlations, it is not possible to take $\pi^N = \bar{\nu}^N$ to be a measure without correlations as before. In the context of the one-dimensional open SSEP, as defined in (2.1), we propose instead to consider discrete Gaussian measures of the form:

$$\nu_g^N = (\mathcal{Z}_g^N)^{-1} e^{2\Pi^N(g)} \bar{\nu}^N, \quad \mathcal{Z}_g^N \text{ a normalising factor}, \quad (3.31)$$

where $g : \square \rightarrow \mathbb{R}$ is a bounded function to be determined, and Π^N is defined in (3.6). Recall that $\square = \square \setminus D$ is the open square without its diagonal $D = \{(x, x) : x \in (-1, 1)\}$.

The function g is supposed to encode the correlation structure of the dynamics. For a large choice of g , the measure ν_g^N has the same macroscopic density $\bar{\rho}_i$ at each site $i \in \Lambda_N$ as the invariant measure π_{inv}^N , and its two-point correlations depend on g . Exponential moments under ν_g^N of either Π^N or the three-point correlations appearing in (3.25) can be computed for sufficiently smooth and small g ; this is done in Appendix A.2 of Chapter 3, following the method of [G+19][SS20]. The entropy inequality (3.26) can therefore still be used, with $\pi^N = \nu_g^N$ as a reference measure. Let us illustrate the role of the function g in the particular case of the unbiased dynamics, where ν_g^N is supposed to approximate the invariant measure π_{inv}^N . Write $g = g_0$ in this case. The invariant measure π_{inv}^N has correlation kernel k_0 in the scaling limit (recall (3.17)). The function g_0 is given in terms of the macroscopic correlations (3.17) of the invariant measure in the following sense: if C_0 is the operator $\sigma(\bar{\rho}) + k_0$, acting on $f \in \mathbb{L}^2((-1, 1))$ according to:

$$\forall x \in (-1, 1), \quad C_0 f(x) = \sigma(\bar{\rho}(x)) f(x) + \int_{(-1, 1)} k_0(x, y) f(y) dy,$$

Then:

$$C_0^{-1} := \sigma(\bar{\rho})^{-1} - g_0. \quad (3.32)$$

One can then check that the measure $\nu_{g_0}^N$, defined through (3.31), has macroscopic density profile given by $\bar{\rho}$ (recall (3.14)). Moreover, $\nu_{g_0}^N$ satisfies, for each bounded test function $\phi : (-1, 1)^2 \rightarrow \mathbb{R}$:

$$\lim_{N \rightarrow \infty} \nu_{g_0}^N(\Pi^N(\phi)) = \frac{1}{4} \int_{\square} k_0(x, y) \phi(x, y) dx dy = \lim_{N \rightarrow \infty} \pi_{inv}^N(\Pi^N(\phi)). \quad (3.33)$$

In other words, the measure $\nu_{g_0}^N$ approximates π_{inv}^N at the level of two-point correlations. A similar function g is built for the tilted processes used to prove large deviations, as we will now see.

The large deviations.

Let us now explain how one obtains the large deviation results of Theorem 3.2. The method is still the one of [KOV89] presented in Section 2, in which the dynamics is tilted by suitable biases to explore all possible correlations. In view of the heuristics (3.23), we consider biases of the form $\Pi^N(h)$ for suitable functions $h : \square \rightarrow \mathbb{R}$, so that the new jump rates read:

$$\begin{aligned} \forall \eta \in \Omega_N, \forall i \in \{\pm(N-1)\}, \quad c_h(\eta, i) &= c(\eta, i) \exp[\Pi^N(h)(\eta^i) - \Pi^N(h)(\eta)], \\ \forall j < N-1, \quad c_h(\eta, j, j+1) &= c(\eta, j, j+1) \exp[\Pi^N(h)(\eta^{j, j+1}) - \Pi^N(h)(\eta)]. \end{aligned} \quad (3.34)$$

The aim is then to compute the Radon-Nikodym derivative between the dynamics with jump rates $c_h(\eta, i, i+1), c_h(\eta, j)$, call it \mathbb{P}_h , and the open SSEP dynamics \mathbb{P} with jump rates $c(\eta, i, i+1), c(\eta, j)$, for $\eta \in \Omega_N, i < N-1$ and $j \in \{\pm(N-1)\}$. This Radon-Nikodym derivative is given by Feynman-Kac formula (Appendix A.7 in [KL99]), and reads, for a time $T > 0$ and trajectory $(\eta_{tN^2})_{t \leq T}$:

$$\log \frac{d\mathbb{P}_h}{d\mathbb{P}}(\eta_{tN^2})_{t \leq T} = \Pi_T^N(h) - \Pi_0^N(h) - N^2 \int_0^T e^{-\Pi_t^N(h)} L e^{\Pi_t^N(h)} dt, \quad (3.35)$$

with L the generator (2.1) of the open SSEP. The right-hand side (3.35) involves, on the one hand, the field Π^N applied to h and its derivatives. On the other hand, it also involves time integrals of three-point and four-point correlations, such as the one appearing inside the probability in (3.25). The challenge is then to control the size of these objects, when N , then T are large, under the tilted dynamics \mathbb{P}_h . This is achieved through our main result on the relative entropy, stated next and corresponding to Theorem 2.5 of Chapter 3.

Theorem 3.3. *Let $\rho_- < \rho_+ \in (0, 1)$ be sufficiently close to $1/2$, and let $h \in \mathcal{T}$ be a smooth bias with $\|h\|_\infty, \|\nabla h\|_\infty$ sufficiently small. There is a function $g = g_h : \square \rightarrow \mathbb{R}$, the unique classical solution of:*

$$\left\{ \begin{array}{l} \Delta(g-h)(x, y) + \frac{\bar{\rho}'\sigma'(\bar{\rho}(x))}{\sigma(\bar{\rho}(x))} \partial_1(2g-h)(x, y) + \frac{\bar{\rho}'\sigma'(\bar{\rho}(y))}{\sigma(\bar{\rho}(y))} \partial_2(2g-h)(x, y) \quad \text{for } (x, y) \in \square \\ \quad + \int_{(-1,1)} \sigma(\bar{\rho}(z)) [\partial_1(g-h)(z, x) \partial_1 g(z, y) + \partial_1 g(z, x) \partial_1(g-h)(z, y)] = 0, \\ g = 0 \quad \text{on } \partial \square, \\ (\partial_2 - \partial_1)(g-h)(x_+, x) = (\partial_1 - \partial_2)(g-h)(x_-, x) = \frac{(\bar{\rho}')^2}{\sigma(\bar{\rho}(x))^2} \quad \text{for } x \in (-1, 1). \end{array} \right. \quad (3.36)$$

In addition, there is $C > 0$ such that, for each $T \geq 0$, the relative entropy $H(f_{tN^2} \nu_{g_h}^N | \nu_{g_h}^N)$ for $t \in [0, T]$ satisfies:

$$\forall N \in \mathbb{N}^*, \quad \sup_{t \in [0, T]} H(f_{tN^2} \nu_{g_h}^N | \nu_{g_h}^N) \leq \frac{C e^{CT}}{N^{1/2}}. \quad (3.37)$$

It is then possible to use Theorem 3.3 in order to prove that (3.25) holds, as well as a similar statement for four-point correlations. Thanks to these Replacement lemma-type estimates, it becomes possible to obtain a closed expression of the Radon-Nikodym derivative in (3.35) in terms of the correlation field, up to well-controlled errors. From this closed expression, the resulting rate function \mathcal{I} of Theorem 3.2 is built.

Let us explain the role of the function g appearing in Theorem 3.3, and make a connection with the heuristics at equilibrium of Section 3.2. Recall from Theorem 3.2 that the objective is to observe a given correlation kernel k . The function g in (3.36) is in fact the correlation kernel of the inverse of the correlation operator $C_k := \bar{\sigma} + k$. Precisely, assume that k is such that $C_k := \sigma(\bar{\rho}) + k$ is invertible. One can then define a function g by:

$$C_k := \sigma(\bar{\rho}) + k = (\sigma(\bar{\rho})^{-1} - g)^{-1}. \quad (3.38)$$

If the kernel k is sufficiently smooth and close to the steady state correlation kernel k_0 (3.17), then we can show that there is a bias h_k such that k is the typical correlation kernel, in the long diffusive time scale, under the dynamics \mathbb{P}_h . The resulting $g = g_k$ built through (3.38) then solves (3.36). Moreover, Theorem 3.2 then states that the rate function at the correlation field $\Pi_k := (1/4)\langle k, \cdot \rangle$ is given by:

$$\begin{aligned} \mathcal{I}(\Pi_k) &= \frac{1}{8} \int_{(-1,1)} \sigma(\bar{\rho}(z)) \langle \partial_1 h_k(z, \cdot), C_k \partial_1 h_k(z, \cdot) \rangle dz \\ &= \frac{1}{8} \int_{(-1,1)} \sigma(\bar{\rho}(z)) \langle \partial_1 h_k(z, \cdot), (\sigma(\bar{\rho})^{-1} - g_k)^{-1} \partial_1 h_k(z, \cdot) \rangle dz. \end{aligned} \quad (3.39)$$

Compare the last expression with the equilibrium setting (3.12): at equilibrium, tilting the dynamics by $\Pi^N(h)$ modifies the steady state from the Bernoulli product measure ν_ρ^N to $e^{2\Pi^N(h)}\nu_\rho^N$ up to a normalisation factor. The resulting correlation matrix then reads $(\sigma(\rho)^{-1} - h)^{-1}$, so that the equilibrium g_{eq} satisfies $g_{eq} = h$, and the formula (3.12) coincides with (3.39).

Out of equilibrium, however, the invariant measure $\pi_{inv,h}^N$ of the dynamics tilted by h is not simply given by a constant times $e^{2\Pi^N(h)}\pi_{inv}^N$, so that its inverse correlation kernel g in the scaling limit is different from h . This is reflected in the partial differential equation (3.36) through the fact that $g = h$ is not a solution, due to the term involving the first derivatives of $2g - h$, which is proportional to $\bar{\rho}'$.

3.4 Perspectives

In this section, we mention several directions in which the results of Theorem 3.2 could be improved (Section 3.4.1), and those of Theorem 3.3 could be applied to other situations (Sections 3.4.2-3.4.3)

3.4.1 The large deviations

Initial condition.

In Theorem 3.2, the large deviation result is stated for the dynamics starting for a sequence of measures $(\mu^N)_N$, later identified with the measures $(\nu_{g_0}^N)_N$ defined in (3.31); with g_0 related to correlations in the steady state via (3.32).

A natural question is to ask whether the dynamics could start from the invariant measure π_{inv}^N rather than from $\nu_{g_0}^N$. Derrida, Lebowitz and Speer [DLS07] present heuristics on the behaviour of the entropy of the steady state which in particular imply $\|\pi_{inv}^N - \nu_{g_0}^N\|_{TV} = o_N(1)$, where the total variation $\|\cdot\|_{TV}$ is defined as:

$$\|\pi_{inv}^N - \nu_{g_0}^N\|_{TV} := \frac{1}{2} \sum_{\eta \in \Omega_N} |\pi_{inv}^N(\eta) - \nu_{g_0}^N(\eta)|.$$

These heuristics immediately imply that $\|\mathbb{P}^{\pi_{inv}^N}(\cdot) - \mathbb{P}^{\nu_{g_0}^N}(\cdot)\|_{TV} = o_N(1)$, and Theorem 3.2 would hold also starting from π_{inv}^N . Further discussion on this topic can be found in Appendix A.3 of Chapter 3.

It is also possible to start from a measure ν_g^N with a function $g \neq g_0$, which does not have the same correlations as the invariant measure. To treat such a case, one would need to adapt the relative entropy estimates of Theorem 3.3 to a time-dependent setting, where the initial condition is g . From the point of view of microscopic computations, this does not change anything. Additional work would however be required to check that the solution $(g_t)_{t \geq 0}$ of a time-dependent version of the partial differential equation of Theorem 3.3 is sufficiently well-behaved.

The Neumann condition on the diagonal for correlations.

The strength of correlations in the steady state of the open SSEP is proportional to $(\bar{\rho}')^2$, with $\bar{\rho}' = (\rho_+ - \rho_-)/2$. In fact, the macroscopic correlation kernel k_0 in the steady state solves the following partial differential equation. Recall that $\square = (-1, 1)^2$ is the open square, with diagonal $D = \{(x, x) : x \in (-1, 1)\}$.

$$\begin{cases} \Delta k_0 = 0 & \text{on } \square = \square \setminus D, \\ k_0 = 0 & \text{on } \partial \square, \\ (\partial_1 - \partial_2)k_0(x_{\pm}, x) = \pm(\bar{\rho}')^2 & \text{for } x \in (-1, 1). \end{cases} \quad (3.40)$$

When $\bar{\rho}' = 0$, $k_0 = 0$ and there are no macroscopic correlations. The Neumann condition the diagonal in (3.40) is therefore central, and it is interesting to try to observe correlation profiles which have a normal derivative on the diagonal that differs from the one in (3.40).

The Neumann condition is a boundary condition. Estimating the cost of changing boundary conditions is difficult in general. For large deviations of the density in the open SSEP, the probability of observing a density profile with different boundary conditions is not of order e^{-TN} in the long diffusive time limit, but in fact smaller. In our context, observing correlations that do not vanish at the reservoirs similarly has a probability much smaller than e^{-T} in the long diffusive time limit. However, we manage to tune the Neumann boundary condition to a large extent, basically allowing for $(\bar{\rho}')^2$ to be replaced with $(\bar{\rho}')^2 + q$, where q is any smooth function which vanishes at the two extremities of the diagonal. It is not clear whether this restriction is only technical (it arises in the study of regularity of solutions of the partial differential equation (3.36)), or more essential in nature. In particular, we would like to estimate the probability of observing no correlations at all:

$$\mathbb{P}\left(\frac{1}{T} \int_0^T \Pi_{tN^2}^N dt \approx 0\right). \quad (3.41)$$

The estimate of this probability is not part of the result of Theorem 3.2. Understanding whether our framework can be extended to study (3.41) without essential change as well as the structure of the bias one should apply to the dynamics to not see any correlation will be the object of future work.

3.4.2 The relative entropy method

Out of equilibrium correlations.

The relative entropy method was initially introduced in a time-dependent context [Yau91]. In this case, the macroscopic density of particles, rather than equal to $\bar{\rho}$ at each time, is given by a trajectory $0 \leq \rho_t(x) \leq 1$, $x \in (-1, 1), t \geq 0$. If one defines the correlation field in terms of the

variables $\tilde{\eta} = \eta - \rho(t, \cdot/N)$ instead of the $\bar{\eta}$. as in (3.6), the result of Theorem 3.2 carries over with minimal change. This is in particular the case for a large class of one-dimensional diffusive systems satisfying the technical gradient condition, such as the models mentioned in Section 8 of [JM18b].

Higher dimensions.

The comparison of the dynamics with reference measures of the form (3.31) is not restricted to dimension 1. In dimension d on a lattice $\Lambda_N^d = \{-N-1, \dots, N-1\}^d$, the correlation field around a density profile $\rho : [-1, 1]^d \rightarrow [0, 1]$ would act on functions $g : [-1, 1]^d \rightarrow \mathbb{R}$ as:

$$\Pi^N(g) = \frac{1}{N^d} \sum_{i \neq j \in \Lambda_N^d} \bar{\eta}_i \bar{\eta}_j g_{i,j}, \quad \bar{\eta} = \eta - \rho, \quad \eta \in \Omega_N,$$

The corresponding d -dimensional discrete Gaussian measure $\nu_{g,d}^N$ is then defined as in (3.31). A result similar to Theorem 3.3 can then informally be stated in any dimension in the following form. Consider any nice gradient interacting particle systems, such as the ones mentioned in Section 8 of [JM18b]. For $d \geq 2$, if there is a sufficiently nice function g_d solution of a d -dimensional analogue of the partial differential equation (3.36) in Theorem 3.3, then the relative entropy, with respect to $\nu_{g_d,d}^N$, of the law of the dynamics at time tN^2 , is bounded by $C(T)(1 + N^{d-4})$ uniformly in $t \leq T$. Such a bound can be used to study out of equilibrium fluctuations as in [JM18b]. The maximal dimension d in which this study can be carried out is improved, from $d < 4$ there, to $d < 8$.

3.4.3 Fluctuations and correlations for the SSEP conditioned to an atypical current

In this section, we present an ongoing work done in a different perspective. Consider the one-dimensional SSEP on a ring conditioned to having a strong current on average. Precisely, let \mathbb{P} denote the SSEP dynamics on the torus, with associated expectation \mathbb{E} , and define, for $\lambda \in \mathbb{R}$ and a time $T > 0$, the dynamics $\mathbb{P}_{\lambda,T}$ conditioned to having an atypical current with strength tuned by λ on $[0, T]$ as follows:

$$\mathbb{P}_{\lambda,T}(\cdot) := \frac{\mathbb{E} \left[\cdot e^{\lambda N Q_{TN^2}} \right]}{\mathbb{E} \left[e^{\lambda N Q_{TN^2}} \right]}, \quad (3.42)$$

where, for $t \geq 0$,

$$Q_t = \frac{1}{N^2} \sum_{i \in \mathbb{T}_N} Q_t^{i,i+1}, \quad \mathbb{T}_N := \mathbb{Z}/N\mathbb{Z}.$$

Above, for $i \in \mathbb{T}_N$, $Q_t^{i,i+1} \in \mathbb{Z}$ is the signed number of particles having jumped across the edge $(i, i+1)$ up to time t , counting $+1$ for each particle jumping from site i to site $i+1$, and -1 from site $i+1$ to site i . The additional factor of $1/N$ in the definition of Q_t is related to the diffusive scaling: a macroscopic current of particles means that Q_{tN^2} is of order 1 in N .

At equilibrium under, observing a macroscopic current is a rare dynamical event. The probability of such an event has been investigated for a large class of interacting particle systems in [Ber+07], and shown to scale like e^{-NT} when N is large, up to sub-exponential corrections. Under the dynamics $\mathbb{P}_{\lambda,T}$, one can thus prove that there is typically a macroscopic current with

strength tuned by the parameter λ . The dynamics induced by $\mathbb{P}_{\lambda,T}$, however, is a complicated, time-inhomogeneous Markov process. The presence of the current is known to create a rich correlation structure [Bod+08]. An expression of these correlations in the long time limit has also been conjectured in [Bod+08]. Due to the complexity of the dynamics, however, an analysis of these correlations or even of the structure of fluctuations has so far remained out of grasp.

The relative entropy estimate presented in Theorem 3.2 offers a powerful tool to study this dynamics. The idea is to find a time-homogeneous Markov process, sometimes referred to as the *driven process*, a notion introduced in [CT15a][CT15b] and built on ideas originating in [Doo57], see also Chapter X of Part 2 in the book [Doo01]. This driven process mimics the dynamics $\mathbb{P}_{\lambda,T}$ at least for times $1 \ll t \ll T$ assuming T large. This process can be characterised in terms of spectral quantities involving the dynamics and the current [CT15a], which are in general hard to access. However, one can look for an approximate driven process, in the sense that it only approximates $\mathbb{P}_{\lambda,T}$ at some given level of precision. In our case, we would like this approximate driven process \mathbb{P}^{driv} to have the same macroscopic current and macroscopic correlation structure, so that, informally, for each set χ of trajectories for the correlations:

$$\mathbb{P}_{\lambda,T} \left((\Pi_{tN^2}^N)_{1 \ll t \ll T} \in \chi \right) = \mathbb{P}^{driv} \left((\Pi_{tN^2}^N)_{1 \ll t \ll T} \in \chi \right) + \varepsilon_{N,T}(\chi), \quad (3.43)$$

with:

$$\limsup_{T \rightarrow \infty} \limsup_{N \rightarrow \infty} |\varepsilon_{N,T}(\chi)| = 0$$

To look for \mathbb{P}^{driv} , we first enforce the correct current, by modifying the jump rates of the SSEP as follows:

$$c(\eta, i, i+1) \rightarrow c_\lambda(\eta, i, i+1) := \eta_i(1 - \eta_{i+1})e^{\lambda/N} + \eta_{i+1}(1 - \eta_i)e^{-\lambda/N}, \quad i \in \mathbb{T}_N, \eta \in \{0, 1\}^{\mathbb{T}_N}.$$

We then implement the large deviation ideas leading to Theorem 3.2 on the dynamics with jump rates c_λ , call it \mathbb{P}_λ , looking for a function $h_\lambda : \mathbb{T}^2 \rightarrow \mathbb{R}$ (\mathbb{T} is the unit torus) such that the dynamics \mathbb{P}_λ biased by $\Pi^N(h_\lambda)$ as in (3.34) satisfies (3.43). This step is at present not carried out in a fully rigorous manner. One of the main issue is the possibility to control the error terms arising in such a change of dynamics, about which the relative entropy estimates of Theorem 3.3 play a crucial role. If these error terms can be controlled (work in progress), we find that, for a statement such as (3.43) to hold, say for the SSEP at density $1/2$, the bias h_λ must satisfy a certain partial differential equation. This partial differential equation is similar to (3.36), and the parameter λ tuning the strength of the current again enters as a Neumann boundary condition:

$$\begin{cases} \Delta h_\lambda(x, y) + \sigma(1/2) \int_{\mathbb{T}} \partial_1 h_\lambda(z, x) \partial_1 h_\lambda(z, y) dz = 0 & \text{for } (x, y) \in \mathbb{T}^2 \setminus \{(x, x) : x \in \mathbb{T}\}, \\ (\partial_1 - \partial_2) h_\lambda(x_\pm, x) = \pm \lambda^2 & \text{for } x \in \mathbb{T}, \end{cases} \quad (3.44)$$

where we recall $\sigma(r) := r(1 - r)$ for $r \in [0, 1]$. The macroscopic correlations under the conditioned measure $\mathbb{P}_{\lambda,T}$ in the long time limit would then be given by $(\sigma(1/2) - h_\lambda)^{-1}$, at least for sufficiently small λ . The fluctuation process under $\mathbb{P}_{\lambda,T}$ at times tN^2 with $1 \ll t \ll T$ can also be characterised.

To make fully rigorous the arguments leading to (3.44) and to better understand the resulting correlations is the subject of ongoing work.

4 Ising interfaces at zero temperature

In this section, we introduce the contour dynamics, a family of interface dynamics on \mathbb{Z}^2 related to the zero temperature Ising model. This dynamics has deep links with the open SSEP. The notations in this section coincide with the ones of Chapter 4 except when mentioned otherwise. In this case, modified notations are indicated by the $\tilde{\cdot}$ symbol.

4.1 The Ising and stochastic Ising models

Here, we introduce the Ising model and associated dynamics on \mathbb{Z}^2 . The proof of all statements in this section can be found in [Mar99] or [BIV99].

4.1.1 The model

The Ising model, here on the graph \mathbb{Z}^2 , is a toy model for modelling magnetism in solids, in which an arrow, either upwards (or $+1$) or downwards (or -1), is associated with each face of the graph \mathbb{Z}^2 . Each arrow is called a spin, and each spin interacts with its neighbours in a way that promotes alignment with them. The interaction strength is parametrised by the temperature: the lower the temperature, the higher the interaction. More precisely, consider the box $B_N = (1/2, 1/2) + \mathbb{Z}^2 \cap [-N, N]^2$, and let $\Sigma_N = \{-1, +1\}^{B_N}$ be the set of all configurations of arrows on B_N (elements of B_N are centres of faces of \mathbb{Z}^2). For $\beta > 0$, define then the Ising measure at inverse temperature β on Σ_N as follows:

$$\mu_\beta^N(\sigma) = \frac{1}{\mathcal{Z}_\beta^N} \exp \left[\frac{\beta}{4} \sum_{\substack{(i,j) \in B_N^2 \\ |j-i|=1}} \sigma_i \sigma_j \right], \quad \sigma \in \Sigma_N,$$

where the distance above is in 1-norm, and the partition function \mathcal{Z}_β^N is a normalisation factor. A vertex $i \in B_N$ is the center of the square $C_i = i + [-1/2, 1/2]^2$. The vertex i and the corresponding square C_i are associated, so that two spins are neighbours if and only if their corresponding squares have an edge in common.

The stochastic Ising model then corresponds to a "single flip" dynamics, reversible with respect to the Ising measure, i.e. a dynamics with jump rates $(c(\sigma, \sigma'))$ satisfying:

$$\forall \sigma \in \Sigma_N, \quad c(\sigma, \sigma') \neq 0 \quad \Leftrightarrow \quad \exists i \in B_N, \quad \sigma' = \sigma^i, \quad \text{with } \sigma^i(j) := \begin{cases} \sigma(j) & \text{if } j \neq i, \\ -\sigma(i) & \text{if } j = i. \end{cases}$$

The configuration σ^i then corresponds to σ in which the spin at $i \in B_N$ has been flipped. Moreover, the reversibility condition on the jump rates reads:

$$\forall (\sigma, \sigma') \in \Sigma_N^2, \quad c(\sigma, \sigma') \mu_\beta^N(\sigma) = c(\sigma', \sigma) \mu_\beta^N(\sigma'). \quad (4.1)$$

Define then the empirical magnetisation m^N as follows:

$$m^N(\sigma) = \frac{1}{|B_N|} \sum_{i \in B_N} \sigma_i, \quad \sigma \in \Sigma_N.$$

When the temperature is low enough, i.e. for $\beta > \beta_c$ for some $\beta_c \in \mathbb{R}_+^*$, in the large N limit, the Ising model has a phase transition: for each $\beta > \beta_c$, each limit point of the sequence $(\mu_\beta^N)_N$ is a convex combination of two ergodic, translation-invariant measures $\mu_{\pm, \beta}$ on \mathbb{Z}^2 , characterised by their magnetisation:

$$\mu_{\pm, \beta}(\sigma_0) := \pm m_\beta, \quad m_\beta > 0.$$

Above, $\mu_{\pm, \beta}(\cdot)$ denotes the expectation with respect to $\mu_{\pm, \beta}(\cdot)$.

At each fixed $N \in \mathbb{N}^*$, however, the measure μ_β^N is symmetric and does not select an orientation for the spins, i.e. a configuration σ with predominant $+$ spins has exactly the same weight as the configuration $-\sigma$. This has very interesting dynamical consequences. For instance, the stochastic Ising dynamics takes an extremely large time to approach the equilibrium measure μ_β^N . Precisely, this time diverges as the $e^{Nc(\beta)}$ for a parameter $c(\beta) > 0$ that can be made explicit.

One can however decide to favour an orientation, either by adding a small magnetic field $h \neq 0$ to the measure μ_β^N or, as we consider here, by setting boundary conditions. Precisely, to each i at distance 1 from B_N in 1 norm, associate a $+$ spin. The modified measure $\mu_{+, \beta}^N$ reads:

$$\mu_{+, \beta}^N(\sigma) = \frac{1}{\mathcal{Z}_{+, \beta}^N} \exp \left[\frac{\beta}{4} \sum_{\substack{(i, j) \in B_N^2 \\ |j-i|=1}} \sigma_i \sigma_j + \frac{\beta}{2} \sum_{\substack{i \in B_N, j \notin B_N \\ |i-j|=1}} \sigma_i \right], \quad \sigma \in \Sigma_N.$$

Consider the stochastic Ising dynamics, defined with respect to $\mu_{+, \beta}^N$ rather than μ_β^N . In [Lif62], Lifshitz formulated a conjecture which, in the present setting, amounts to the following. Start the dynamics from the configuration $\sigma = -1$. Then, in a diffusive time-scale, when N is large, the spin configuration is close to a configuration with a well defined interface between two regions, one with magnetisation m_β , the other one with magnetisation $-m_\beta$. This interface evolves locally with a speed that is proportional to the curvature. In particular, the area with magnetisation $-m_\beta$ disappears after a time of order N^2 . This is conjectured to be true in any dimension $d \geq 2$.

The conjecture is very hard to prove for $\beta \in (\beta_c, \infty)$. So far, the only known proof is in dimension $d = 2$ at zero temperature, i.e. $\beta = +\infty$, where $m_\beta = 1$. Heuristics and exact results for special initial configurations were given in [Spo93]. A similar dynamics was analysed in [CSS95], for which the $-$ region is shown to disappear in diffusive time. The conjecture was fully proven in [LST14b]-[LST14a]. In dimension $d \geq 3$ (still at zero temperature), the precise motion of the interface is not known. However, a region of $-$ spins of side-length N is known to disappear in a time of order N^2 up to logarithmic corrections [Cap+11][Lac13]. In dimension $d = 2$, at any inverse temperature $\beta > \beta_c$, the best known bounds provide a quasi-polynomial disappearance time of the region of $-$ spins in the following sense: the mixing time of the stochastic Ising dynamics with $+$ boundary conditions is bounded by $N^{c(\beta) \log N}$ for some $c(\beta) > 0$ [Lub+13]. In the following, we focus on the $d = 2$, $\beta = +\infty$, i.e. zero temperature case.

Before defining the zero temperature dynamics, let us introduce a standard one-to-one mapping between spin configurations in the Ising model, and contour configurations, where a contour configuration is a union of contours. A contour is defined as a non self-intersecting closed lattice paths in \mathbb{Z}^2 , through the following rule.

For $\sigma \in \Omega_N$, the contour configuration $\gamma(\sigma)$ is defined as the boundary of the set of $-$ spins:

$$\gamma(\sigma) = \partial \left(\bigcup_{i \in B_N: \sigma_i = -1} C_i \right), \quad C_i = i + [-1/2, 1/2]^2, \quad i \in B_N. \quad (4.2)$$

Through the mapping (4.2), the measure $\mu_{+, \beta}^N$ has the expression:

$$\mu_{+, \beta}^N(\sigma) = \frac{1}{\mathcal{Z}_{+, \beta}^N} \exp[-\beta |\gamma(\sigma)|], \quad \sigma \in \Sigma_N, \quad (4.3)$$

where $|\gamma(\sigma)|$ is the length of the boundary $\gamma(\sigma)$. We will later focus on the case in which the contour configuration $\gamma(\sigma)$ contains a single contour, in which case $\gamma(\sigma)$ is simply called a contour.

At zero temperature, the measure $\mu_{+, \infty}^N$ is degenerate, and equal to δ_+ , the Dirac measure on the configuration with only $+$ spins. The zero temperature stochastic Ising dynamics is then defined through the following jump rates (see Figure 1.2 for an illustration on a special case):

$$\forall i \in \Lambda_N, \quad c(\sigma, \sigma^i) = \begin{cases} 0 & \text{if } \sigma_i \text{ and at least three neighbours have the same sign,} \\ 1/2 & \text{if } \sigma_i \text{ has two neighbours of each sign,} \\ +\infty & \text{if } \sigma_i \text{ has at least three neighbours with opposite sign.} \end{cases} \quad (4.4)$$

The choice (4.4) differs from those in [LST14b] and [Spo93], but has useful implications. Moreover, the results of [LST14b] are also valid for this choice of rates.

In (4.4) A jump rate equal to $+\infty$ must be understood as follows. Suppose that flipping spin $i \in B_N$ creates a configuration in which a spin at position $i' \in B_N$ has at least three neighbours of opposite sign. In this case, the spin at i' is flipped instantaneously, and the procedure is iterated until no spin has three or more neighbours of opposite sign.

The resulting dynamics is not reversible any more, and admits δ_+ as its invariant measure. It has many nice properties. For instance, it is monotonous in the following sense. For two configurations σ, σ' , write $\sigma \leq \sigma'$ if $\sigma_i \leq \sigma'_i$ for each $i \in B_N$. Then:

$$\forall (\sigma, \sigma') \in \Sigma_N^2, \quad \sigma \leq \sigma' \quad \Rightarrow \quad \forall t \geq 0, \quad \sigma(t) \leq \sigma'(t). \quad (4.5)$$

Another nice property is the following. Let γ be a continuous, closed, non self-intersecting curve in \mathbb{R}^2 . By Jordan's theorem, the curve γ splits \mathbb{R}^2 into two regions. We henceforth say that γ is a *Jordan curve*, and let Γ denote the closed, bounded region with boundary γ .

For a Jordan curve γ delimiting a convex Γ , assume that the zero temperature stochastic Ising model starts from the configuration with $-$ spins in $\mathbb{Z}^2 \cap N\Gamma$, $+$ outside. Such a configuration is called a *droplet* associated with γ (or with Γ). In the following, we will only consider the dynamics on droplets, as illustrated on Figure 1.2. A useful property, established in [LST14b] in the case of the Ising dynamics, then states that the interface $\gamma(\sigma(t))$ associated with configuration $\sigma(t)$ at time t through (4.2) is still a Jordan curve for sufficiently short times. As we will see, this property also holds starting from more general configurations than convex droplets.

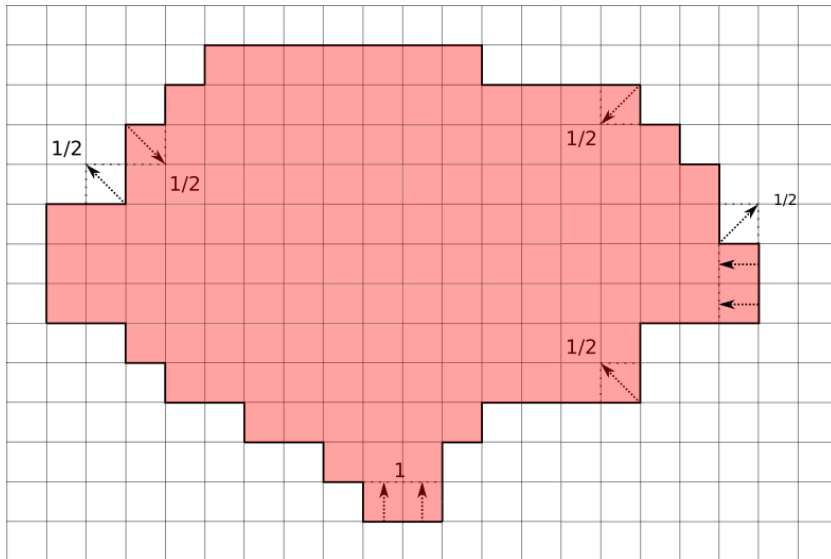

Figure 1.2 – The Ising dynamics starting from a droplet. The red zone corresponds to a region where all spins are $-$, the white zone to $+$ spins. Examples of dynamically allowed moves are indicated by arrows, with the corresponding rate. If there are only two spins left on a line (e.g. at the bottom) or a column (on the right), when either of the two spins disappears, which occurs at rate $1/2$, then so does the other, instantaneously. Such groups of two spins are thus flipped at rate one.

4.1.2 Typical interface motion in the scaling limit

In [LST14b]-[LST14a], the authors establish the Lifshitz law as follows. Let γ_0 be a C^∞ , closed, non self-intersecting curve with a finite number of inflection points. For $t \geq 0$, let Γ_t be the droplet associated with the family $(\gamma_t)_{t \geq 0} = (\partial\Gamma_t)_{t \geq 0}$ of curves satisfying the following *anisotropic motion by curvature*:

$$v := \partial_t \gamma_t \cdot \mathbf{N} = a(\theta)k, \quad (4.6)$$

where \mathbf{N} is the inwards normal vector, v is the inwards normal speed, each γ_t , $t \leq T$ is parametrised as $(\gamma_t(u))_{u \in \mathbb{T}}$ on the torus \mathbb{T} and the time-derivative is taken at fixed $u \in \mathbb{T}$. The function $\theta = \theta(\gamma_t(u))$, $t \leq T$ is the angle between the tangent vector \mathbf{T} at $\gamma_t(u)$ and the first basis vector e_1 , so that $\mathbf{T}(\theta) = \cos(\theta)e_1 + \sin(\theta)e_2$. Finally, k is the curvature, and a is the anisotropy, defined as:

$$a(\theta) := \frac{1}{2[|\cos \theta| + |\sin(\theta)|]^2}, \quad \theta \in [0, 2\pi]. \quad (4.7)$$

The existence of the family $(\gamma_t)_{t \geq 0}$ is part of the results of [LST14b]-[LST14a]. After a time $T_f = \text{area}(\Gamma_0)/2$, γ_t and Γ_t are reduced to a point for $t \geq T_f$.

Assume the zero temperature stochastic Ising model starts from the droplet configuration associated with γ_0 . Define then $\gamma^N(t)$ as the curve separating $+$ and $-$ spins at time $t \geq 0$, and $\Gamma^N(t)$ as the associated droplet. Finally, for a set $A \subset \mathbb{R}^2$, define respectively the ε -fattening and ε -thinning of A as follows:

$$A^{(\varepsilon)} := \bigcup_{x \in A} B(x, \varepsilon), \quad A^{(-\varepsilon)} := \left(\bigcup_{x \notin A} B(x, \varepsilon) \right)^c, \quad \varepsilon > 0, \quad (4.8)$$

where $B(x, \varepsilon)$ is the ball of center $x \in \mathbb{R}^2$ and radius $\varepsilon > 0$, e.g. in 2-norm. The results of [LST14b]-[LST14a] establish the convergence in probability of the microscopic droplet to the solution (4.6) in the following sense.

Theorem 4.1 ([LST14b]-[LST14a]). *Let $(\gamma_t)_{t \geq 0}$ solve (4.6) starting from a Jordan curve γ_0 with a continuous curvature and a finite number of inflection points. Let $(\Gamma_t)_{t \geq 0}$ be the associated droplets, and let T_f be the first time $t \geq 0$ at which Γ_t is reduced to a point. Then, for each $\varepsilon > 0$,*

$$\lim_{N \rightarrow \infty} \mathbb{P} \left(\forall t \geq 0, \quad \Gamma_t^{(-\varepsilon)} \subset N^{-1} \Gamma^N(tN^2) \subset \Gamma_t^{(\varepsilon)} \right) = 1, \quad (4.9)$$

and:

$$\lim_{N \rightarrow \infty} \mathbb{P} \left(\forall t \geq T_f + \varepsilon, \quad \Gamma^N(tN^2) = \emptyset \right) = 1.$$

The proof in [LST14b]-[LST14a] relies on two key ingredients: the fact that the interface dynamics can locally be mapped onto a version of the SSEP, and the monotonicity property (4.5).

- The monotonicity (4.5) of the dynamics allows one to prove that the Ising interface for the full droplet stays sandwiched between interfaces corresponding to droplets in which some spins are frozen to their initial value, with probability close to 1. This reduces the global control in the probability in (4.9) to a finite number of local controls on portions of the interface.
- In [LST14b], the authors note that, if one freezes suitable portions of the Ising interface, then the Ising dynamics on the non-frozen part can be mapped either to the one dimensional SSEP (see Figure 1.4 below), or to a variant of the zero-range process (on small portions of the boundary). In both cases, the interface dynamics is compared with one dimensional interacting particle systems for which the scaling limit can be established, and, informally, the evolution of the interface can be deduced from the hydrodynamics for the SSEP. The heat equation satisfied by the SSEP corresponds to the anisotropic motion by curvature (4.6) in a suitable reference frame.

4.1.3 The mapping to the SSEP

The mapping of portions of an interface undergoing Ising dynamics to the SSEP is central in the argument of [LST14b]-[LST14a], and we now rigorously define it in the following case. Let γ be a Lipschitz convex Jordan curve, the boundary of a bounded, convex set Γ . The curve γ is oriented clockwise by convention.

Let \mathbf{T} be the tangent vector at γ , defined almost everywhere:

$$\mathbf{T} = \cos(\theta)e_1 + \sin(\theta)e_2, \quad \theta \in [0, 2\pi]. \quad (4.10)$$

At a point of γ where \mathbf{T} is well defined, the corresponding angle θ is referred to as the *tangent angle*.

By convexity, γ can be split into four connected regions of maximal length, such that the tangent angle θ is in $[0, \pi/2] - k\pi/2$ in region $1 \leq k \leq 4$. In fact, region 1 corresponds to the portion of the boundary between points with the highest ordinate, and points with the highest abscissa; while

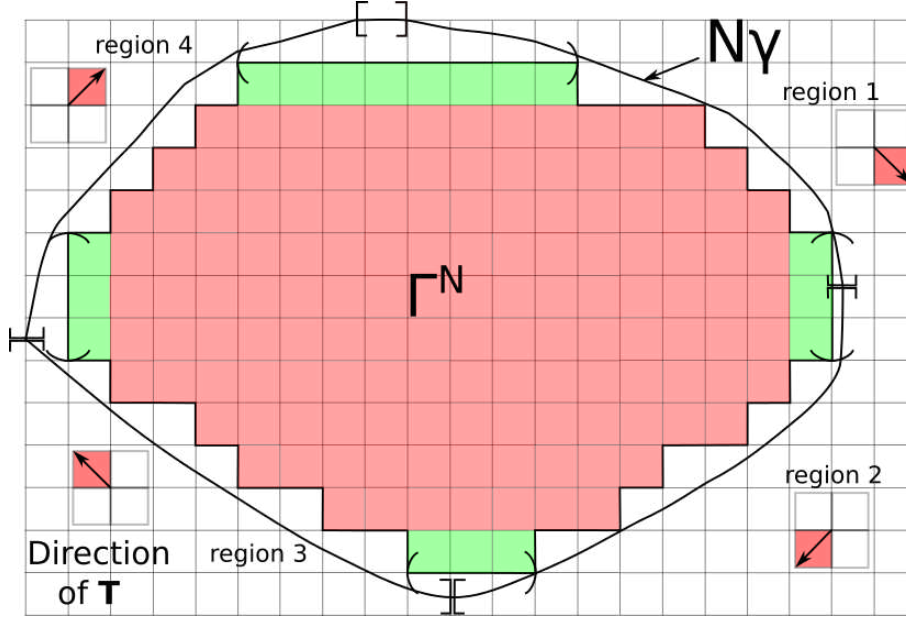

Figure 1.3 – The Lipschitz convex curve γ rescaled by a factor N , and the droplet Γ^N . On $N\gamma$, the four regions in which the tangent vector points towards the same quarter plane are delimited by brackets, with the corresponding direction of the tangent vector indicated by arrows pointing in a red square. On the boundary γ^N of Γ^N , there are still four regions, different from those of $N\gamma$, delimited by parentheses. These regions intersect on portions of the interface with extremal ordinate or abscissa. Such portions will be called poles in Section 4.2 and play an important role. The $-$ spins in Γ^N that are closer to each pole are represented in green (lighter colour).

region 2 is the portion between points with highest abscissa and those with lowest ordinate, etc. (see Figure 1.3).

Consider the droplet configuration Γ^N associated with Γ :

$$\Gamma^N = \bigcup_{\substack{i \in (1/2, 1/2) + \mathbb{Z}^2 \\ C_i \subset \Gamma^N}} C_i, \quad C_x := x + [-1/2, 1/2]^2, \quad x \in \mathbb{R}^2.$$

Then Γ^N has Lipschitz boundary γ^N , and its tangent vector is parallel to e_1 or e_2 at every point where it is defined. Although Γ^N is not convex, there are still four connected regions of the boundary γ^N of maximal length such that, in region $1 \leq k \leq 4$, the tangent angle θ is in $[0, \pi/2] - k\pi/2$ whenever it is well defined (see Figure 1.3).

Fix $1 \leq k \leq 4$. Rotating the axis (e_1, e_2) by $\pi/4 + (k-1)\pi/2$, region k of the boundary is turned into the graph of a 1-Lipschitz function f^k , which has slope ± 1 . The $k = 1$ case is illustrated on Figure 1.4. With each edge in the original region, associate a site. Put a particle in the site if the corresponding edge corresponds to a position in which f^k has slope -1 , and no particle if f^k has slope 1 . By this procedure, region k is mapped onto a particle configuration with at most one particle per site.

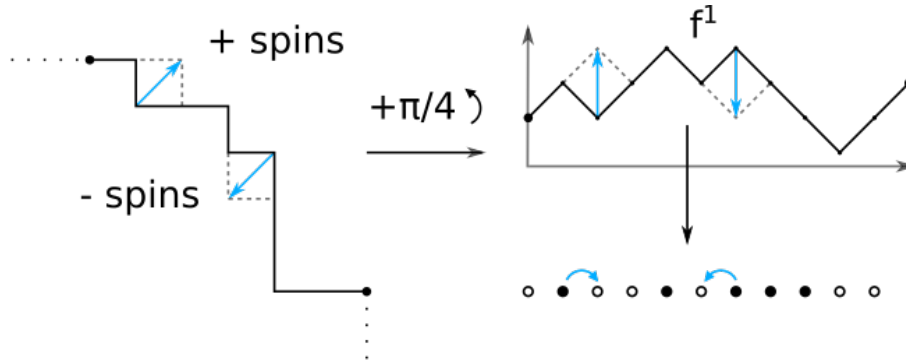

Figure 1.4 – The mapping from a portion of region 1, delimited by the two big black dots, to the graph of a Lipschitz function f^1 in the reference frame materialised by the two gray arrows. This Lipschitz function is then mapped to a particle configuration. Each edge of the initial interface corresponds to a possible site for particles. In the region delimited by the black dots, no dynamical update can modify the length of the region. Allowed dynamical moves, which are single spin flips, correspond to allowed moves in the SSEP dynamics (2.1) with no boundary interaction, i.e. setting the boundary generators L_{\pm} in (2.1) to 0.

Consider now the dynamics. Assume that all updates of the Ising dynamics that change the length of region k are cancelled, see Figure 1.4. Fix $k = 1$ for clarity. The remaining updates can happen only when two consecutive edges of the original interface are perpendicular, e.g. the first edge is parallel to e_2 , the second to e_1 (see Figure 1.2). In the graph of f^1 , this corresponds to a change in monotonicity, in the present example from decreasing to increasing. The corresponding particle configuration then has two neighbouring sites, with the first one filled and the second one empty. An Ising update, which occurs at rate $1/2$ (recall (4.4)), then changes this order (look e.g. at the jump indicated by the first blue arrow): the new first edge is now parallel to e_1 , the second to e_2 , corresponding to a jump of the particle to the empty site.

4.2 Contribution of the thesis

The statement (4.9) characterises the typical motion of the interface. To analyse more closely the stochastic structure of the dynamics, the next step is to study the probability of observing a trajectory that is not given by (4.6), i.e. to investigate the large deviations for the zero temperature stochastic Ising dynamics.

Assume that the Ising interface has Gaussian fluctuations around its typical trajectory (4.6) in some sense. For a trajectory $(\gamma_t)_{t \leq T}$ of smooth Jordan curves, if s denotes the arclength coordinate on γ_t for $t \leq T$, one would have:

$$I((\gamma_t)_{t \leq T}) = \frac{1}{2} \int_0^T \int_{\gamma_t} \frac{(v - ak)^2}{2\mu} ds dt. \quad (4.11)$$

In (4.11), recall that $v = v(\gamma_t(s))$ is the inwards normal speed at the point $\gamma_t(s)$, and $k = k(\gamma_t(s))$ the curvature for $t \leq T$. The quantity $a(\theta(s)) = a(\theta(\gamma_t(s)))$ is the anisotropy (4.7), and the function $\mu(\theta(s)) = \mu(\theta(\gamma_t(s)))$ is the mobility of the model, defined later in (4.18). Both depend only

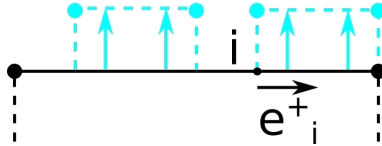

Figure 1.5 – The north pole of an interface, delimited by black dots, and in cyan, two positions at which a growth at rate $e^{-2\beta}$ is possible. In this case, two contiguous blocks are added on top of the pole. A point $i \in \mathbb{Z}^2$ in the north pole is at a position where growth can occur if it is at distance at least 2 from the right extremity of the north pole. This corresponds to asking that $[i, i + 2e_i^+]$ be a subset of the pole, with e_i^+ the vector indicating the direction of the edge starting at i in clockwise orientation. If a growth takes place, the new interface is materialized by the cyan dashed lines, and the new north pole is delimited by the two cyan dots.

on the tangent angle $\theta(\gamma_t(s))$ (recall (4.10)) at the point $\gamma_t(s)$, $t \leq T$.

Studying large deviations and proving that I is indeed the correct rate function cannot easily be done through the program outlined at the end of the previous section. Indeed, the comparison of the Ising interface to macroscopic ones using the monotonicity (4.5) is not valid when the Ising interface follows an atypical trajectory.

This is not the only difficulty. The large deviation techniques presented in Section 4, particularly the Replacement Lemma in Equation (2.14), require the invariant measure of the dynamics to be "smooth" in the following sense: the law of the dynamics at each time needs at least to be absolutely continuous with respect to the invariant measure. Here, the invariant measure δ_+ is too degenerate.

In Chapter 4 of this thesis, both difficulties are solved by introducing the *contour dynamics*, a dynamics on closed, non self-intersecting lattice paths on \mathbb{Z}^2 (recall (4.2)). This dynamics, defined in Section 4.2.1, is nearly identical with the stochastic Ising dynamics (recall (4.4)).

The main ideas, difficulties and results of Chapter 4 are then presented in Sections 4.2.2-4.2.3.

4.2.1 The contour dynamics

The contour dynamics is a dynamics on interfaces parametrised by a parameter β , which plays the role of an inverse temperature acting on small portions of the interface. This parameter β makes the contour dynamics reversible with respect to a nice invariant measure, namely the measure ν_β^N in (4.3) conditioned on a suitable set of interfaces (see Definition 4.2 for a complete description):

$$\tilde{\nu}_\beta^N(\gamma) \propto e^{-\beta|\gamma|}, \quad \text{for admissible } \gamma.$$

The admissible interfaces will correspond to all curves that can be split into four regions as in Figure 1.3. The parameter β will only influence the dynamics on small portions of the interface (those mapped to a zero-range process in [LST14b]), so that practically every dynamical update follows the same rules as the zero temperature stochastic Ising dynamics (4.4). These portions where β acts are called *poles*. They correspond to the portions of a curve with extremal abscissa or ordinate, see Figure 1.3. We call north pole the portion with highest ordinate, east pole the one with highest abscissa, and so on. In addition, the dynamics is stopped before a curve disappears; and we can restrict to curves with poles containing at least two edges of \mathbb{Z}^2 . Indeed, a pole with

only one edge corresponds to a spin with three neighbours of opposite sign, which must disappear instantaneously according to the Ising rules (4.4).

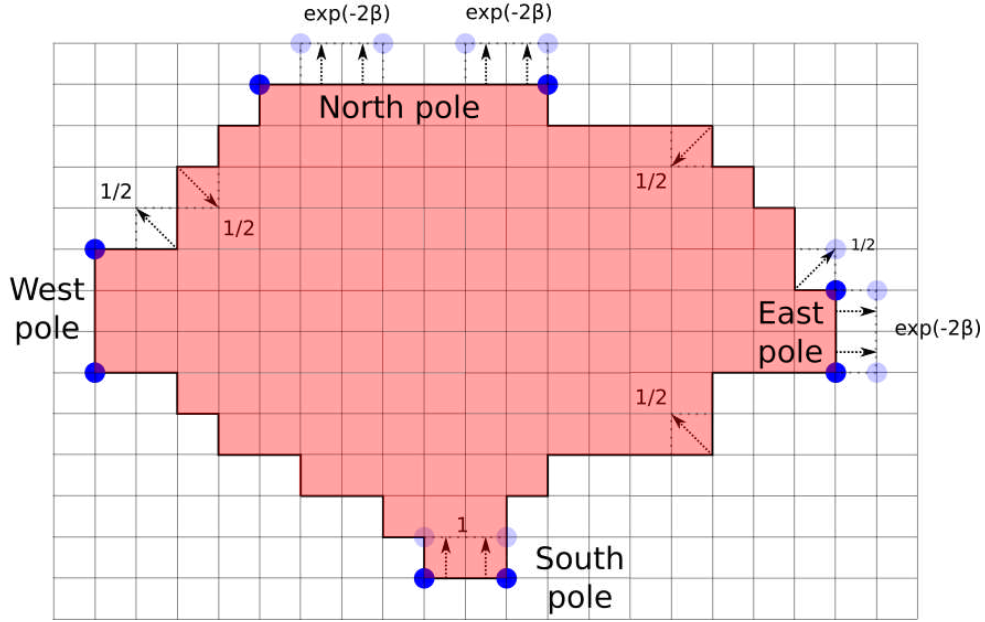

Figure 1.6 – Summary of dynamical moves in the contour dynamics at $\beta > 0$, with associated rates. The only jumps added compared to the zero temperature stochastic Ising dynamics occur at the poles, and make the droplet grow.

The additional updates in the contour dynamics compared to the Ising case can then be described as follows (see Figure 1.5). Let $i \in \mathbb{Z}^2$ be a point of an interface $\gamma^N = \partial\Gamma^N$, and denote by e_i^+ the vector which indicates the direction of the edge of which i is the first extremity, with γ^N oriented clockwise.

Assume that i is in a pole of γ^N , and is at distance at least 2 from the right extremity of the pole. Then, with rate $e^{-2\beta}$, independently of all the rest, add to Γ^N the two blocks, corresponding to + spins, which respectively have $i, i + e_i^+$ as their lower left corner.

Examples of all possible updates are represented in Figure 1.6. Note that, in the $\beta \rightarrow \infty$ limit, the contour dynamics on non-empty curves has the same updates as the stochastic Ising dynamics (4.4). We stress that, due to the pole updates, the contour dynamics at each $\beta > 0$ however does not have the monotonicity property (4.5).

In the rest of this introduction, we restrict all contours we consider to those that lie in the neighbourhood of a nice reference curve. A more general situation is considered in Chapter 4, see Section 2.1. The state space $\tilde{\mathcal{E}}_r^N$, $r > 0$ of the microscopic interfaces is then defined as follows.

Definition 4.2. Let γ_{ref} be a Lipschitz convex Jordan curve, delimiting a bounded, convex domain Γ_{ref} . For $r > 0$, recall from (4.8) the definition of $\Gamma_{\text{ref}}^{(-r)}$, and take $r > 0$ such that $\Gamma_{\text{ref}}^{(-2r)} \neq \emptyset$. Define then a set $\tilde{\mathcal{E}}_r = \tilde{\mathcal{E}}_r(\gamma_{\text{ref}})$ containing all Lipschitz Jordan $\gamma \subset \mathbb{R}^2$ such that:

- The curve γ can be split into four regions of maximal length with the following property. For every point in region $1 \leq k \leq 4$ for which the tangent vector $\mathbf{T} = \cos(\theta)e_1 + \sin(\theta)e_2$ is well defined, the tangent angle θ is in $[0, \pi/2] - k\pi/2$.
- If Γ is the bounded set with boundary γ , then:

$$\Gamma_{ref}^{(-r)} \subset \Gamma \subset \Gamma_{ref}^{(r)}.$$

The set $\tilde{\mathcal{E}}_r^N$ is then defined as the set of all curves in $N\tilde{\mathcal{E}}_r \cap \mathbb{Z}^2$, with all four poles having length at least 2.

The jump rates of the contour dynamics are modified to ensure that any update that breaks one of the above conditions is cancelled. As a result, the measure $\tilde{\nu}_\beta^N$ is reversible for the contour dynamics on $\tilde{\mathcal{E}}_r^N$, with:

$$\tilde{\nu}_{r,\beta}^N := \left(\tilde{\mathcal{Z}}_{r,\beta}^N\right)^{-1} e^{-\beta|\gamma|}, \quad \gamma \in \tilde{\mathcal{E}}_r^N, \quad \tilde{\mathcal{Z}}_{r,\beta}^N \text{ a normalising factor.} \quad (4.12)$$

The probability associated with the contour dynamics is denoted by $\tilde{\mathbb{P}}_{r,\beta}^N$.

4.2.2 Mapping to one dimensional interacting particle systems and moving reservoirs

Fix $\beta > 0$. In the spirit of [LST14b], it is still possible to map portions of interfaces following the contour dynamics onto one-dimensional interacting particle process. In fact, the contour dynamics can be mapped on a collection of SSEP defined on varying domains, see Figure 1.7. These SSEP interact through very complicated dynamical mechanisms depending on β at the poles (part of the pole dynamics consists in changing the size of the domains on which the SSEP are defined). In fact, recalling the mapping to the SSEP in Figure 1.4, the pole dynamics have the following effect, e.g. on the north pole for concreteness.

- Assume the north pole has length 2, corresponding to two isolated $-$ spins atop a droplet (as in Figure 1.7). Both $-$ spins can then disappear, i.e. the north pole goes down. Regions 1 and 4 (recall Figure 1.3) are consequently modified. Through the mapping to the SSEP as in Figure 1.4, this means that the number of sites in each region changes. In addition, e.g. for region 1, the disappearance of the $-$ spins means that the associated particle configuration has one less particle.
- The north pole can also go up through one of the moves with rate $e^{-2\beta}$ of Figure 1.5. Again, regions 1 and 4 are modified, which amounts to a change of the number of sites in the SSEPs associated via the mapping of Figure 1.4. E.g. in region 1, the north pole going up means that the SSEP contains one more particle.

These effects are illustrated on Figure 1.7, in the particular case where an update at the north pole only modifies the ordinate of the north pole, but not its lateral position.

Understanding the effect of the pole dynamics is a central ingredient in the study of the contour dynamics. We prove that, for large enough β , the pole dynamics produce the same effect as reservoirs in the open SSEP: they fix the average number of particles in their vicinity to a density that depends on β . This amounts to fixing the slope at the interface on either side of each pole.

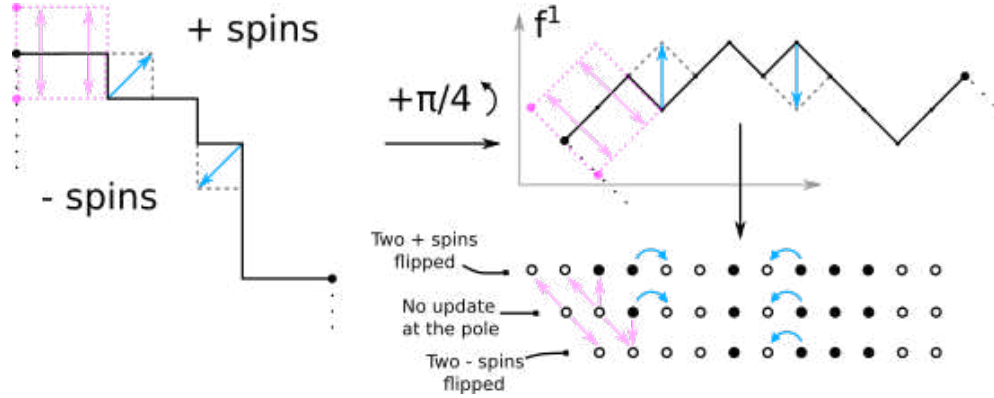

Figure 1.7 – *Left figure*: a portion of interface delimited by the two black dots, corresponding to the graph of a function f^1 ; with some dynamically allowed updates represented by arrows. The left dot is at the left extremity of the north pole. The single flips (i.e. the updates that flip a single spin, corresponding to single arrows) do not modify the ordinate of the pole. The double flips either reduce, or increase it by 1, and the new position of the left extremity of the pole is indicated by the magenta dot.

Right figure: a $\pi/4$ rotation turns the portion of the interface between the black dots into a path that is the graph of a 1-Lipschitz function. This path is mapped to a particle configuration as follows. Each edge on the path corresponds to a site. A site contains a particle if the associated edge points downwards, and no particle if it points upwards.

If one only considers single flips on the contour dynamics of the left figure, the corresponding dynamics on particles is the SSEP (middle line). However, flipping two + spins (upper line) or two – spins (lower line) at the pole changes the number of sites, and adds/deletes a particle respectively.

This density can be explicitly computed. Let $[L_k, R_k]$ be the segment composing pole k , $1 \leq k \leq 4$. Fix $1 \leq k \leq 4$. At the left extremity of the domain of the k^{th} SSEP, corresponding to L_k , it is equal to $e^{-\beta}$. At the right extremity, corresponding to R_{k+1} , it is equal to $1 - e^{-\beta}$.

By the mapping of Figure 1.4, the average number of particles determines the average slope at the poles, i.e. the macroscopic tangent vector $\mathbf{T} = \cos(\theta)e_1 + \sin(\theta)e_2$. E.g. at the north pole, a slope $e^{-\beta}$ translates into a tangent angle $\theta((L_1)_\pm)$ of the macroscopic curve on either side of L_1 satisfying:

$$\tan(\theta((L_1)_\pm)) = \mp \frac{e^{-\beta}}{1 - e^{-\beta}}. \quad (4.13)$$

For all four poles $1 \leq k \leq 4$, the condition (4.13) reads:

$$\tan\left(\theta((L_k)_-) + \frac{(k-1)\pi}{2}\right) = \frac{e^\beta}{1 - e^{-\beta}} = -\tan\left(\theta((L_k)_+) + \frac{(k-1)\pi}{2}\right). \quad (4.14)$$

The derivation of the reservoir-like behaviour of the dynamics at the poles is the main difficulty of the paper at the microscopic level. The analysis of the behaviour of the poles relies on three ingredients. First, a priori estimates to ensure that the contour dynamics cannot maintain long, thin filaments atop a pole for a positive time. Secondly, a very precise microscopic control of the contour dynamics around a pole, rewriting it as a zero-range process in a moving domain, the definition of which is one of the difficulties. The first point then can be understood as proving that the zero-range process does not exhibit condensation. Thirdly, equilibrium computations in the

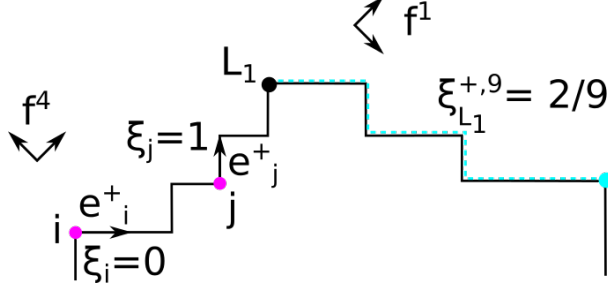

Figure 1.8 – A neighbourhood of the north pole including portions of regions 1 and 4, i.e. portions of the graphs of functions f^1, f^4 in the indicated reference frames. The left extremity L_1 or the north pole is materialised by the black dot. Examples of points i, j with associated edge labels ξ_i, ξ_j and vectors e_i^+, e_j^+ are given. The portion of the interface between L_1 and the cyan dot, materialised by the cyan dashes contains 9 points in $\gamma^N \cap \mathbb{Z}^2$. The associated $\xi_{L_1}^{+,9}$ is equal to $2/9$.

resulting model to identify the dependence of the "density" that is imposed by the reservoir-like pole dynamics in terms of β . The corresponding results are stated in the next proposition.

For $\gamma^N \in \tilde{\mathcal{E}}_r^N$, and $i, j \in \gamma^N$, write $i \leq j$ if j is encountered after i when travelling from i to j clockwise on γ^N . Let $i \in \gamma^N \cap \mathbb{Z}^2$, and recall that $j = i + e_i^+ \in \gamma^N \cap \mathbb{Z}^2$ is the first point after i . Define then $\xi_i \in \{0, 1\}$ as follows (see Figure 1.8):

$$\xi_i = 1 \quad \text{if} \quad e_i^+ \parallel e_2, \quad \xi_i = 0 \quad \text{if} \quad e_i^+ \parallel e_1.$$

Finally, denote by L_k the left extremity of pole k of a curve and, for $\varepsilon > 0$, denote by $\xi_{L_k}^{\pm, \varepsilon N}$ the quantity:

$$\xi_{L_k}^{+, \varepsilon N} := \frac{1}{\varepsilon N} \sum_{\substack{i \in \mathbb{Z}^2 \cap \gamma^N \cap B_1(L_k, \varepsilon N) \\ L_k \leq i}} \xi_i, \quad \xi_{L_k}^{-, \varepsilon N} := \frac{1}{\varepsilon N} \sum_{\substack{i \in \mathbb{Z}^2 \cap \gamma^N \cap B_1(L_k, \varepsilon N) \\ i \leq L_k}} \xi_i,$$

where $B_1(L_k, \varepsilon N) := \{j \in \mathbb{Z}^2 : \|j - L_k\|_1 \leq \varepsilon N\}$. The following proposition states that the slope at the poles have a fixed value in terms of β .

Proposition 4.3. *Let $\beta > 0$ be large enough and take a time $T > 0$. Then:*

$$\forall \delta > 0, \quad \limsup_{\varepsilon \rightarrow 0} \limsup_{N \rightarrow \infty} \frac{1}{N} \log \tilde{\mathbb{P}}_{r, \beta}^N \left(\forall t \in [0, T], \gamma_t^N \in \tilde{\mathcal{E}}_{r/2}^N; \right. \\ \left. \left| \frac{1}{T} \int_0^T \xi_{L_k(t)}^{\pm, \varepsilon N} dt - \mathbf{1}_{k \in \{1,3\}} e^{-\beta} - \mathbf{1}_{k \in \{2,4\}} (1 - e^{-\beta}) \right| > \delta \right) = -\infty.$$

Let us use Proposition 4.3 to propose a conjecture for the rate function of the contour dynamics. Considering the contour dynamics as four SSEP connected by reservoirs, we can express the rate function of the contour dynamics in terms of the rate functions of the four SSEP. Consider a trajectory $(\gamma_t)_{t \leq T}$ with values in $\tilde{\mathcal{E}}_{r/2}$ (recall Definition 4.2). Let $[L_k(t), R_k(t)]$ be the k^{th} pole of γ_t , $1 \leq k \leq 4$, so that $L_k(t)$ and $R_{k+1}(t)$ are the two extremities of region $1 \leq k \leq 4$, with $k+1 := 1$

if $k = 4$ (see Figure 1.3). Associate with $(\gamma_t)_{t \leq T}$ the trajectories $(\rho_t^k)_{t \leq T}$ of the four SSEP. If we believe in the analogy of the poles with reservoirs, one can check that the SSEP should satisfy:

$$\forall t \leq T, \quad \rho^k(t, L_k(t)) = e^{-\beta} = 1 - \rho(t, R_{k+1}(t)), \quad 1 \leq k \leq 4. \quad (4.15)$$

The rate function of the contour dynamics would then be given by:

$$I_\beta^{\text{heur}}((\gamma_t)_{t \leq T} | \gamma_0) = \sum_{k=1}^4 I_{\text{SSEP},k}((\rho_t^k)_{t \leq T} | \rho_0^k). \quad (4.16)$$

The precise comparison of the pole dynamics to reservoirs is complicated, since the position of the reservoirs also changes, and the conjecture (4.16) is not completely accurate. To obtain large deviations for the contour dynamics, we therefore do not exclusively rely on the SSEP picture, but instead use a more direct approach, as presented in the next section.

4.2.3 The large deviations

We do not directly use the mapping with the SSEP to compute the rate function at the microscopic level (although it constantly serves as a guideline, and at the macroscopic level). To apply the method of [KOV89] presented in Section 2, we need to find a suitable way to tilt the contour dynamics. Recall that this dynamics originates from a two dimensional dynamics for the Ising model. It is thus natural to tilt the contour dynamics with a time-dependent magnetic field $H : \mathbb{R}_+ \times \mathbb{R}^2 \rightarrow \mathbb{R}$. We find that, for a large class of trajectories $(\gamma_t)_{t \leq T}$, one can construct a magnetic field H such that the rate function is given, for large enough $\beta > 0$, by:

$$I_\beta((\gamma_t)_{t \leq T} | \gamma_0) = \begin{cases} \frac{1}{2} \int_0^T \int_{\gamma_t} \mu(\theta(s)) H(\gamma_t(s))^2 ds dt & \text{if } (\gamma_t)_{t \leq T} \text{ satisfies (4.14) for} \\ & \text{almost every time, and } \gamma_{t=0} = \gamma_0; \\ +\infty & \text{otherwise.} \end{cases} \quad (4.17)$$

In (4.17), s is the arclength coordinate on the curve γ_t , $t \leq T$. The angle $\theta(s) = \theta(\gamma_t(s))$ is the tangent angle at $\gamma_t(s)$, i.e. the tangent vector \mathbf{T} satisfies:

$$\mathbf{T}(\gamma_t(s)) = \cos(\theta(s))e_1 + \sin(\theta(s))e_2.$$

The function μ in (4.17) is the mobility of the model:

$$\mu(\theta) = \frac{|\sin(2\theta)|}{2[|\sin(\theta)| + |\cos(\theta)|]}, \quad \theta \in [0, 2\pi]. \quad (4.18)$$

The mobility agrees with the formula obtained by Spohn for the stochastic Ising model in the zero temperature limit, using linear response arguments [Spo93].

To obtain the formula (4.17) directly from the microscopic model turns out to be quite technical. Indeed, one has to pass from discrete sums to line integrals, and to find a way to express the tangent angle θ in terms of microscopic quantities.

The central result of Chapter 4, the large deviations, is stated in the next two theorems. The first one gives an upper bound.

Theorem 4.4. *Assume that $\beta > 0$ is large enough, take a time $T > 0$ and let F be a closed set of trajectories in a suitable topology, containing only trajectories with values in $\tilde{\mathcal{E}}_{r/2}$ and starting from $\gamma_0 \in \tilde{\mathcal{E}}_{r/2}$. Then:*

$$\frac{1}{N} \limsup_{N \rightarrow \infty} \log \tilde{\mathbb{P}}_{r,\beta}^N \left((\gamma_{tN^2}^N)_{t \leq T} \in F \right) \leq - \inf_{(\gamma_t)_{t \leq T} \in F} I_\beta((\gamma_t)_{t \leq T} | \gamma_0).$$

The precise topology in which Theorem 4.4 must be understood is very complicated, so we chose not to state it in this introduction. It is defined below (2.30) and in Appendix B.2 in Chapter 4. The reason is the peculiar nature of the β -dependent part of the contour dynamics. Basically, its local nature makes it tremendously difficult to control exponential moments involving the poles, and we have to forego any point-wise control of their trajectories. Trajectories of points in the poles are in fact treated as elements of $L^1([0, T], \mathbb{R}^2)$, even though they are càdlàg at the microscopic level. We can then only prove that, at almost every time, the poles are indeed point-like and (4.14) holds.

The magnetic field $H : \mathbb{R}_+ \times \mathbb{R}^2 \rightarrow \mathbb{R}$ appearing in (4.17) is the bias one has to apply to the dynamics to create the trajectory $(\gamma_t)_{t \leq T}$. For a smooth bias H , the representation enables us to characterise atypical trajectories as solutions of an anisotropic motion by curvature with a drift term (recall the notations of (4.6)):

$$\begin{cases} v := \partial_t \gamma \cdot \mathbf{N} = ak - \mu H(t, \gamma_t) & \text{away from the poles,} \\ \text{the tangent angles } \theta((L_k(t))_\pm) & \text{on either side of each junction almost always satisfy (4.14).} \end{cases} \quad (4.19)$$

More precisely, we obtain a weak formulation of (4.19), in terms of integrals on the droplets $(\Gamma_t)_{t \leq T}$ against test functions, see Proposition 2.5 in Chapter 4. Under a uniqueness assumption for weak solutions to (4.19), we obtain a lower bound on the cost of observing a trajectory associated with a smooth magnetic field, as stated in the next theorem.

Theorem 4.5. *Let $H \in C^\infty(\mathbb{R}_+ \times \mathbb{R}^2, \mathbb{R})$, and assume that there is a unique weak solution γ^H to (4.19) in a suitable sense, that is almost always in $\tilde{\mathcal{E}}_{r/2}$ until a time T . Then:*

$$\liminf_{N \rightarrow \infty} \frac{1}{N} \log \tilde{\mathbb{P}}_{r,\beta}^N \left((\gamma_{tN^2}^N)_{t \leq T} \approx \gamma^H \right) \geq -I_\beta((\gamma^H)_{t \leq T} | \gamma_0).$$

Above, \approx must be understood as proximity in the same topology as in Theorem 4.4.

In the above theorem, the only assumption concerns the uniqueness of solutions to (4.19), since we can prove that trajectories with a drift typically stay in the set $\tilde{\mathcal{E}}_{r/2}$ until some time. This does not particularly require new ideas. It relies on the one hand on the form of the invariant measure (4.12) to control that the poles do not rise too high. On the other hand, one has to make sure the droplet does not shrink too fast, which can be done using estimates similar to the Ising case in the spirit of Section 8 in [Cap+11].

Let us conclude this section by comments on the rate function (4.17) of the contour dynamics. At the formal level, (4.19) means that $H = (v - ak)/\mu$, where v is the inwards normal speed $\partial_t \gamma \cdot \mathbf{N}$. The expression of the rate function (4.17) thus formally agrees with the one in (4.11). Consider now the $\beta \rightarrow \infty$ case. If one formally takes the limit $\beta \rightarrow \infty$ in the rate function (4.17),

the conditions (4.15) can be shown to be satisfied for curves with a tangent vector that is continuous at the junctions between SSEP. In particular, a trajectory $(\gamma_t)_{t \leq T}$ that is both continuous in time and has curvature defined everywhere will correspondingly satisfy equation (4.19) at each time $t \leq T$ and every point of γ_t (i.e. even at the junctions between SSEP). The connection between anisotropic motion by curvature with drift and fluctuations in the zero-temperature stochastic Ising model (i.e., formally, when $\beta \rightarrow \infty$) was made by Spohn [Spo93], who showed that the response of the Ising interface to a small magnetic field in the large temperature limit is described by anisotropic motion by curvature with drift.

4.3 Conclusion and perspectives

In the previous section, the conjecture (4.11) was established on a large class of trajectories, under a uniqueness assumption on weak solutions of anisotropic motion by curvature with a smooth drift (4.19). Let us summarise the key ingredients of the proof:

- First and foremost, an understanding of the behaviour of the contour dynamics at the poles is crucial, i.e. Proposition 4.3. It is the main difficulty of the paper at the microscopic level. It relies on finding an appropriate reference frame in which the dynamics at the poles is mapped onto variants of one dimensional zero range processes; then on a priori estimates to prove that these particle systems are well-behaved (i.e. no condensation occurs); finally on equilibrium computations.
- To quantify the difference between the contour dynamics with or without a bias $H : \mathbb{R}_+ \times \mathbb{R}^2 \rightarrow \mathbb{R}$, very technical microscopic computations are required. Indeed, it is for instance not easy to make sense of the tangent angle to a macroscopic curve in terms of microscopic quantities.
- The upper bound of Theorem 4.4 then follows from the large deviation techniques of [KOV89], as presented in Section 2 for the SSEP. Two additional difficulties arise. On the one hand, the functionals under consideration do not have good continuity property (an intrinsic problem, unrelated to our special choice of topology). On the other hand, the lack of point-like control of the motion of the poles forces us to work in a weaker, but unconventional topology. The proof of exponential tightness in this weaker topology is nonetheless still difficult.
- The lower bound of Theorem 4.5 in fact relies on a generalisation of the upper bound to the contour dynamics tilted by a bias H , and on the uniqueness assumption of solutions to (4.19).

The above few point outline several perspectives that could be investigated.

1. From a technical viewpoint, a substantial part of the proofs could be simplified with a point-wise control of the trajectory of the poles. At present, this is difficult to obtain, because exponential moments of the size of a pole are hard to estimate, as a pole could theoretically have size of order N .
2. Uniqueness of weak solutions to (4.19) has to be looked into. If one fixes the trajectory of the poles and assumes that it is sufficiently regular in time, then uniqueness boils down to

proving uniqueness for SSEP in domains that vary with time. This can be done using results of [Can84]. The problem is therefore to understand how the interface motion influences the motion of the poles. In this sense, the equation (4.19) can be viewed as four one-dimensional Stefan problems (one for each SSEP), coupled by their boundary conditions. Stefan problems have been studied as limits of interacting particle systems in several contexts, see e.g. [CS96][CK08][CKG12] and [Lac14]. However, the methods devised in these papers apply only to a single Stefan problem at a time, and it is not clear whether they could be used for four coupled Stefan problems.

3. The large deviations give some insights on the nature of the stochastic corrections to the anisotropic motion by curvature (4.6). It would be interesting to investigate the fluctuations around the typical trajectory. Using the analogy with the SSEP, it may be possible to say something about the structure of the fluctuations at least away from the poles.

Chapter 2

Résumé

Ce chapitre de présentation de la thèse est un abrégé du Chapitre 1.

1 Cadre et objectif de la thèse

Cette thèse est consacrée à l'étude d'événements dynamiques rares dans des systèmes de particules en interaction. Le cadre théorique est celui de la physique statistique : la matière est modélisée, à l'échelle microscopique, par le biais d'un grand nombre de composants fondamentaux, appelés particules dans la suite, et interagissant entre eux de manière aléatoire. Un modèle est adapté si, dans la limite d'échelle (grand nombre de particules, grand volume du modèle...), ou échelle macroscopique, le comportement typique d'observables telle que la densité locale de particules correspond à celui prédit par ailleurs par les lois de la physique.

Dans cette thèse, nous nous intéressons plus spécifiquement à des modèles de dynamique des fluides. Notre objectif : étudier les comportements atypiques du système de particules microscopiques, afin de mieux comprendre la structure du modèle. Cet objectif rentre dans le cadre général de la théorie des grandes déviations. Pour notre étude, nous utilisons de manière centrale la méthode de Kipnis, Olla et Varadhan [KOV89] d'études des grandes déviations. Cette méthode procède de l'idée suivante, bien connue dans la théorie des grandes déviations : pour quantifier la probabilité d'obtenir un événement dynamique rare, il est possible de perturber la dynamique microscopique de telle sorte que l'événement rare devienne typique sous la dynamique perturbée.

Deux modèles sont considérés dans la thèse : le processus d'exclusion simple symétrique unidimensionnel en contact avec des réservoirs, et un modèle de dynamiques d'interfaces se rapprochant de la dynamique de Glauber du modèle d'Ising bidimensionnel à température nulle.

2 Corrélations atypiques dans l'exclusion simple symétrique avec réservoirs

Le modèle d'exclusion simple symétrique avec réservoirs (abrégé en SSEP ouvert), ici unidimensionnel, (cf Figure 2.1) est un système de particules prototypique. Dans ce modèle, des particules



Figure 2.1 – Le SSEP ouvert unidimensionnel avec réservoirs de particules à densité $\rho_{\pm} \in [0, 1]$. Certains mouvements permis par la dynamique sont représentés par des flèches. Une particule peut sauter vers un de ses voisins à taux $1/2$. Le saut n’a pas lieu si le site de destination est déjà occupé. Les réservoirs fournissent des particules au système et en absorbent, avec un taux lié à la densité ρ_{\pm} du réservoir. Si le site voisin d’un réservoir est déjà plein, la règle d’exclusion empêche une nouvelle particule de rentrer dans le système à cet endroit.

suivent une marche aléatoire symétrique indépendamment les unes des autres, sautant à taux $1/2$ sur un site voisin. La seule interaction survient lorsqu’une particule tente de sauter vers un site déjà occupé, auquel cas le saut est annulé. Des réservoirs, connectés à chaque extrémité du système, imposent une certaine densité de particules dans leur voisinage en échangeant des particules avec le système à un certain taux.

Malgré sa simplicité apparente, le SSEP ouvert est un modèle très riche, qui a été considérablement étudié, cf. [KL99][Lig05] et références ci-incluses. Dans le cadre de cette thèse, l’aspect qui nous intéresse est le suivant. Lorsque les deux réservoirs (voir Figure 2.1) imposent des densités $\rho_{\pm} \in [0, 1]$ différentes, le SSEP ouvert se stabilise en temps long dans un état stationnaire hors équilibre, caractérisé par la présence d’un courant macroscopique de particules induisant des corrélations à longue portée [Spo83][DLS02]. Ces corrélations sont des objets difficiles à étudier, car évoluant à une échelle bien plus fine que, par exemple, celle de la densité de particules. Le but du travail présenté au Chapitre 3 est précisément l’étude des corrélations à deux points, dans le but de quantifier la probabilité d’observer, en temps long, des corrélations dont la valeur ne correspond pas à celle de la mesure invariante.

Pour étudier les corrélations à deux points avec le niveau de précision requis, l’outil de base reste la méthode de grandes déviations de Kipnis, Olla et Varadhan [KOV89]. Il est nécessaire d’améliorer substantiellement la précision des estimations existantes, usuellement formulées au niveau de la densité de particules. Cette amélioration est obtenue en raffinant la méthode d’entropie relative initialement développée par Yau. La méthode d’entropie relative consiste à estimer, à chaque temps, la proximité de la loi de la dynamique à une mesure de référence à choisir. La distance entre ces deux mesures est quantifiée par leur entropie relative. L’idée sous-jacente à cette méthode est liée à la notion d’équilibre local, et peut être illustrée comme suit dans le cas du SSEP ouvert. La dynamique dans une petite portion du système s’équilibre beaucoup plus vite que la dynamique globale. Localement, la loi de la dynamique devrait donc ressembler à la mesure invariante d’un SSEP, avec un nombre de particules correspondant à celui présent dans la petite portion. En pratique, cette méthode a été utilisée dans de nombreux systèmes de particules en interaction (voir [KL99], Chapitre 6 et références ci-incluses) afin de déterminer l’évolution typique de la densité de particules dans le système. Pour étudier cette évolution, il suffit de considérer une mesure de référence produit, imposant seulement la bonne densité macroscopique.

La méthode d'entropie relative a récemment été considérablement améliorée par Jara et Menezes [JM18b][JM18a]. En analysant finement l'effet de la composante dissipative de la variation de l'entropie relative en fonction du temps, ils parviennent à obtenir des bornes sur l'entropie relative suffisamment précises pour étudier les fluctuations hors équilibre d'une large classe de systèmes de particules en interaction, évoluant à une échelle diffusivité en temps (comme le SSEP ouvert), en dimension $d \leq 3$. Dans leur méthode, les mesures de référence sont toujours produit.

Dans cette thèse, la méthode de Jara et Menezes est raffinée en dimension 1, en incorporant des informations sur la structure des corrélations hors équilibre d'un système de particules en interaction. En comparant la loi de la dynamique en chaque temps avec une mesure imposant non seulement la bonne densité macroscopique, mais aussi les bonnes corrélations à deux points ; nous obtenons des bornes suffisamment précises sur l'entropie relative pour étudier les corrélations hors équilibre et en temps long. Bien que présenté dans le cadre du SSEP ouvert, ce raffinement de la méthode d'entropie relative, intéressant en lui même, s'applique à une large classe de systèmes de particules en interaction.

3 Interfaces d'Ising et dynamique de contour

Une deuxième direction de la thèse concerne l'étude d'une dynamique d'interface. Cette dynamique d'interface modélise l'évolution d'une goutte de spins $-$, immergés dans une mer de spins $+$, sur un réseau carré. Il est conjecturé de longue date que, pour une large classe de telles dynamiques d'interface, la frontière de la goutte de spins $-$ dans la limite d'échelle devrait évoluer typiquement selon un mouvement par courbure moyenne anisotrope [Lif62][Spo93]. Dans le cas de la dynamique d'Ising à température nulle, Lacoïn, Simenhaus et Toninelli [LST14b][LST14a], ce fait a été établi rigoureusement, confirmant des résultats partiels et heuristiques [Spo93][CSS95].

La preuve du comportement typique de l'interface des articles [LST14b][LST14a] utilise de manière centrale la monotonie de la dynamique d'Ising, qui peut informellement se définir comme suit : si une goutte de spins $-$ est initialement incluse dans une autre, alors cette inclusion est préservée par la dynamique. Dans [LST14b][LST14a], cette propriété est utilisée pour encadrer, avec une probabilité proche de 1, la goutte microscopique par une goutte dont la frontière suit un mouvement par courbure moyenne anisotrope.

Dans la thèse, on cherche à comprendre la structure des trajectoires atypiques. Les estimations utilisant la monotonie dans le cas d'Ising dans [LST14b][LST14a] ne s'appliquent pas aisément à l'étude d'événements rares. Pour étudier la structure des trajectoires atypiques, une dynamique d'interface est introduite dans la thèse, appelée dynamique de contour et très similaire à la dynamique d'Ising à température nulle. La seule dissemblance vient de la présence d'un paramètre supplémentaire, jouant le rôle d'une (faible) température agissant localement sur l'interface. En particulier, les dynamiques d'Ising et de contour coïncident quand ce paramètre est nul.

On montre que la trajectoire typique d'une interface sous cette dynamique de contour évolue également selon un mouvement par courbure moyenne anisotrope, avec une influence du paramètre de température. A l'aide de la méthode de Kipnis, Olla et Varadhan [KOV89], un principe de grandes déviations est alors obtenu pour la dynamique de contour, permettant de relier les tra-

jectoires atypiques à des perturbations d'un mouvement à courbure moyenne anisotrope, toujours avec une influence du paramètre de température.

L'intuition dirigeant la preuve repose sur une comparaison microscopique de la dynamique de contour avec des processus d'exclusion simple symétrique. Ces SSEP ouverts sont reliés par une dynamique de bord complexe, qui agit notamment comme un réservoir mobile de densité. L'analyse de cette dynamique de bord est la difficulté majeure de la preuve.

Chapter 3

Anomalous correlations in the open symmetric simple exclusion process

In this chapter, we investigate the probability to observe anomalous two-point correlations in the one dimensional symmetric simple exclusion process connected with reservoirs.

Contents

1	Introduction	54
2	Notations and results	58
2.1	Notations and definition of the microscopic model	58
2.2	The topology	60
2.3	Large deviations for time-averaged correlations	61
2.4	The relative entropy method	64
2.5	Conclusion and perspectives	66
3	Main ingredient: the entropic estimate	67
3.1	The relative entropy method and Feynman-Kac inequality	67
3.2	Estimates on $L_h^* \mathbf{1}$	71
3.3	Adjoint at the boundary	73
3.4	Adjoint in the bulk	75
3.5	Conclusion	86
3.6	The Radon-Nikodym derivative	87
4	Long-time behaviour: upper bound	88
4.1	Upper bound for open and compact sets	89
4.2	An \mathbb{L}^2 estimate and a first Poisson equation	95
4.3	Energy estimate	98
5	Lower bound for smooth trajectories	103
5.1	Estimate of the cost of changing initial condition	103
5.2	Law of large numbers and Poisson equation	104

5.3	Estimating the dynamical part	109
5.4	Conclusion of the lower bound for smooth trajectories and accessible correlations	111
A	Correlations and concentration under discrete Gaussian measures . .	112
A.1	Bound on the partition function and correlations	112
A.2	Exponential moments of higher order correlations	120
A.3	Gaussian behaviour of the invariant measures and computation of the partition function \mathcal{Z}_g^N	125
B	Integration by parts formulae	129
B.1	Integration by parts in the bulk	129
B.2	Integration by parts at the boundary and boundary correlations	131
C	Control of the error terms	133
C.1	Estimate of X_2	134
C.2	Proof of Proposition C.2 and Corollary C.3	137
D	The Neumann condition on the diagonal	140
E	Sobolev spaces	145
F	Poisson equations	146
F.1	Existence and uniqueness	147
F.2	Regularity estimates	150

1 Introduction

Correlations in a fluid in thermal equilibrium have been well-understood for decades. They decay exponentially, except in the vicinity of a phase transition. In particular, each macroscopic portion of the fluid is basically independent from the rest. For fluids driven out of equilibrium, e.g. by contact with reservoirs at two different temperatures, this picture breaks down. The fluid settles in a steady state where heat and/or matter are transported at a macroscopic level. This transport induces long-range correlations, which can be modelled by a variety of approaches at different scales and that have been observed experimentally, see [Spo83][Gar+90] and references therein.

The derivation, from a microscopic model, of such correlations of a genuinely dynamical nature, is usually a difficult problem. Rigorous results are mostly obtained for certain simple interacting particle systems on a lattice. The Symmetric Simple Exclusion Process connected with reservoirs (henceforth open SSEP) is a paradigmatic example for which this correlation structure can be analysed. In the open SSEP, defined in Section 2, identical particles follow independent symmetric random walks on vertices (or *sites*) of an underlying lattice, which in the following will always be a subset Λ_N of \mathbb{Z} , where N is the scaling parameter. The only interaction between particles is an exclusion rule: no two particles may occupy the same site. Reservoirs pump particles in and out of the system, at rates that fix a certain density of particles in their vicinity. When reservoirs are at the same density, the open SSEP dynamics is reversible. However, when connected with

reservoirs which enforce a different density of particles, this dynamics settles in long time in a non-equilibrium steady state, characterised by a macroscopic current of particles. The strength of this current is proportional to the density difference between the reservoirs [ELS90][FLM11]. Two-point correlations in the steady state are known exactly [Spo83], as well as all higher cumulants [DLS07][Der07][DR13] in dimension one. The correlation structure of the steady state of the open SSEP is conjectured to be representative of a large class of out of equilibrium systems [Spo83]. However, much less is known rigorously about steady state correlations for general lattice gases.

In this paper, the broad objective is to study the long-time behaviour of a large class of interacting particle systems in the scaling limit $N \rightarrow \infty$. The main question we wish to address is to estimate the asymptotic probability of observing a correlation structure that is different from the one of the steady state, thereby also gaining information on this invariant measure. When the value N of the scaling parameter is fixed, this question has already received a comprehensive answer by Donsker and Varadhan [DV75]. For a general, irreducible Markovian dynamics on a finite state space Ω_N , they study the time empirical measure $\tilde{\pi}_T$, defined for each $T > 0$ as a probability measure on the configuration space Ω_N by:

$$\forall \eta \in \Omega_N, \quad \tilde{\pi}^T = \frac{1}{T} \int_0^T \mathbf{1}_{\eta_t = \eta} dt.$$

The quantity $\tilde{\pi}^T(\eta)$ then corresponds to the proportion of time spent at a configuration $\eta \in \Omega_N$. A full large deviation principle with speed T and rate function I_{DV}^N is then provided in [DV75] for the time empirical measure $\tilde{\pi}_T$, in the sense that, if μ^N is a probability measure on Ω_N and \mathbb{P} denotes the probability associated with the dynamics:

$$\lim_{T \rightarrow \infty} \frac{1}{T} \log \mathbb{P}(\tilde{\pi}^T \approx \mu^N) = -I_{DV}^N(\mu^N), \quad (1.1)$$

where \approx means proximity in the weak topology of measures. The rate function I_{DV}^N vanishes only at the invariant measure π_{inv}^N of the dynamics, and is defined through a complicated variational problem. When the underlying dynamics is reversible, however, this variational problem can be solved, and I_{DV}^N is expressed in terms of the Dirichlet form of the dynamics.

The question is then how to study the scaling limit (i.e. the large N limit) of the probability in (1.1). The key observation is that one cannot naively take the large N limit in (1.1) without losing information, because not all the information contained in a measure μ^N is stored at the same scale in N . Let us explain this claim in the case of the one dimensional open SSEP, assuming that the dynamics is reversible (i.e. with reservoirs at the same density). The method we propose in the article however applies to the non-equilibrium situation, as well as to a wide range of diffusive one-dimensional interacting particle systems.

In the one dimensional SSEP, the scaling parameter N is the order of magnitude of the number of sites in the model. In the reversible case, where the explicit expression of I_{DV}^N allows for computations, one can prove that observing a macroscopic density profile different from the one of the invariant measure has a probability that scales like $e^{-TN^{-2} \cdot N}$ in the large T , then large N limit, up to sub-exponential corrections. In contrast, changing the two-point correlation structure only requires a cost of order $e^{-TN^{-2}}$ (see the heuristics presented in Section 3.2 of Chapter 1 where T

is replaced by TN^2).

To study the scaling limit of (1.1), one therefore has to choose a scale. Out of equilibrium, the rate function I_{DV}^N is not known explicitly, and the above equilibrium heuristics cannot be used. A different approach to study the scaling limit of the formula (1.1) is therefore needed.

In this article, we focus on the two-point correlation scale, and quantify the probability of observing anomalous two-point correlations in the one dimensional, out of equilibrium open SSEP in the large N, T limits. We establish a large deviation principle for the time-averaged two-point correlation field, in Theorem 2.2 below. The technique employed to prove large deviations has two main features. The first is a variant of the standard large deviation argument introduced in [KOV89] (see also Chapter 10 of [KL99] for a review). It consists in estimating the probability of rare events by considering tilted dynamics, under which this rare event becomes typical. The second feature is the introduction of appropriate Poisson equations to study the long-time behaviour of macroscopic correlations.

The difficulty in establishing large deviations lies in the fact that two-point correlations are objects that live on a much finer scale than the density, which makes precise controls difficult to obtain. As a consequence, the limit we consider is not the long time, then large N limit in the spirit of Donsker-Varadhan's formula (1.1), but the long, diffusive time scale TN^2 where N is taken large before T also, for reasons explained in the next paragraph. Let us note however that, for the open SSEP, the two ways to take limits coincide at least when the dynamics is reversible, see again the heuristics of Section 3.2 in Chapter 1.

The two-point correlation field, defined below in (2.6), is also called quadratic field, or quadratic fluctuation field in the literature [Ass07][GJ19]. Both of these works are concerned with two-point correlations at equilibrium. The difficulty when trying to estimate its long-time behaviour is hinted at by the structure of the invariant measure: two-point correlations in the steady state of the open SSEP are long range, and scale like $O(N^{-1})$, compared to $O_N(1)$ for the density of particle at a given site. For this reason, and while model-dependent estimates on correlations have been obtained e.g. in [Spo83][Der+05][LMO06][Gon+20], to our knowledge there is no general method to study the out of equilibrium behaviour of the two-point correlation field in the long-time, large N limits.

On the other hand, on the diffusive time scale TN^2 with N large and $T > 0$ fixed, there are well-established, general methods to study the density of particles (see e.g. Chapters 4-6 in [KL99]) and its fluctuations (Chapter 11 of [KOV89] at equilibrium, or [JM18b] out of equilibrium). Based on entropy considerations originating in [GPV88] and [Yau91], these methods allow for obtaining closed equations on the density or fluctuation field, through so-called Replacement Lemmas. Such estimates, crucial in our case as well, do not hold in the literature with the level of precision required to study correlations on a diffusive time scale TN^2 with N large. A fortiori, nothing is known in the long diffusive time limit where T also becomes large after N . As explained in the next paragraphs, our approach consists in building on the improvement to the relative entropy method obtained in [JM18b], in order to obtain results valid at the levels of correlations on the one hand, and on the other hand results that are sufficiently precise to investigate the long time limit.

The relative entropy method dates back to Yau [Yau91] (see also Chapter 6 in [KL99] for a re-

view), and has recently been considerably improved upon by Jara and Menezes in [JM18b]-[JM18a]. It consists in quantifying, at each time and in terms of the relative entropy, the proximity of the law of the Markovian dynamics in an interacting particle system with a known reference measure. The idea behind the method is that, locally, the dynamics in large microscopic boxes equilibrates much faster than the typical time-scale at which the system evolves macroscopically. If one has a proposal for the evolution of macroscopic variables of interest, say, henceforth, the density in a lattice gas; one can then expect to prove that the corresponding microscopic variables, when averaged over a large microscopic box, are close to their macroscopic counterpart. This property is known as local equilibrium.

If one is interested only in the density or its fluctuations, then only the knowledge of the macroscopic evolution of the density is required to construct a suitable reference measure to which to compare the microscopic dynamics, see Chapter 6 in [KL99] and references therein. In particular, the reference measure does not need to contain any information on correlations. To study two-point correlations, however, the knowledge of only the density is not enough any more. Thus, our key argument introduces a correlation term in the reference measure. In the case of the open SSEP, since density fluctuations around the typical density profile at each time (and in the steady state [LMO06]) are known to be Gaussian [JM18b], our candidates for reference measures are discrete Gaussian measures, see (2.21). One expects that a good choice of discrete Gaussian measure will contain all leading-order information about the two-point correlation field. This statement is made precise in Theorem 2.5 where we obtain, for each suitably tilted dynamics, a characterisation of the correlations in the long diffusive time limit as the solution of a certain partial differential equation (see also Appendix A.3 for a discussion).

The approach used in this paper can be used for a large class of one-dimensional diffusive interacting particle systems (see Section 8 in [JM18b]). In this sense, it allows for what we believe is the first quite general method to study two-point correlations out of equilibrium. Let us however mention that, at equilibrium, the behaviour of n -point correlation fields has come under much scrutiny in the past few years. In [Ass07], the two-point correlation field around the diagonal is studied in the SSEP on \mathbb{Z} . In [GJ19], this study is carried out on the one-dimensional torus using a different approach, and as a means to defining squares of distributions arising in certain ill-posed stochastic partial differential equations. In [ACR21] and [CS20], interacting particle systems enjoying a self-duality property are investigated in all dimensions. In that context, fluctuation fields involving n -point functions are investigated for any n .

The rest of the article is structured as follows. In Section 2, we present the model and results. Section 3 gives the main microscopic tool for the study of two-point correlations: the relative entropy estimate when the reference measure is a certain discrete Gaussian measure. Properties of these measures are established in Appendix A. Together with Appendices B, C and D, sharp relative entropy bounds are derived. These in particular allow for the computation of the Radon-Nikodym derivative between the open SSEP and the tilted processes introduced to estimate rare events.

The large deviations are then established, in Section 4 for the upper bound, and 5 for the lower bound. Control of the open SSEP dynamics in long-time is obtained via the study of certain Poisson equations. Well-posedness of these equations is investigated in Appendix F, while Appendix E gathers useful topological facts.

2 Notations and results

2.1 Notations and definition of the microscopic model

The model. For $N \in \mathbb{N}^*$, let $\Lambda_N := \{-N + 1, \dots, N - 1\}$ and $\Omega_N = \{0, 1\}^{2N-1}$. Elements of Ω_N , denoted by the letter η , will be called configurations. We say that there is a particle at site $i \in \Lambda_N$ if $\eta_i = 1$, and no particle if $\eta_i = 0$. The variable η_i is called the occupation number (of site i). On Ω_N , we consider the dynamics given by the Symmetric Simple Exclusion Process connected to reservoirs at position $\pm N$ (henceforth open SSEP), which we now describe.

Let $\rho_- < \rho_+ \in (0, 1)$ be the densities of the left (for ρ_-) and the right (ρ_+) reservoirs. The open SSEP is defined through its generator $N^2L := N^2(L_0 + L_- + L_+)$. It is made up of two parts, the bulk and boundary dynamics, corresponding to L_0 and L_\pm respectively. The operators L_0 and L_\pm act on $f : \Omega_N \rightarrow \mathbb{R}$ as follows:

$$\forall \eta \in \Omega_N, \quad N^2L_0f(\eta) = \frac{N^2}{2} \sum_{i < N-1} c(\eta, i, i+1) [f(\eta^{i, i+1}) - f(\eta)], \quad (2.1)$$

$$N^2L_\pm f(\eta) = \frac{N^2}{2} c(\eta, \pm(N-1)) [f(\eta^{\pm(N-1)}) - f(\eta)]. \quad (2.2)$$

Above, the jump rates c are defined, for each $\eta \in \Omega_N$, by:

$$\begin{aligned} c(\eta, i, i+1) &= \eta_{i+1}(1 - \eta_i) + \eta_i(1 - \eta_{i+1}), & i < N - 1, \\ c(\eta, \pm(N-1)) &= (1 - \rho_\pm)\eta_{\pm(N-1)} + \rho_\pm(1 - \eta_{\pm(N-1)}), \end{aligned} \quad (2.3)$$

and for $i, j \in \Lambda_N$ and $\eta \in \Omega_N$, the configurations η^i and $\eta^{i,j}$ read:

$$\eta_\ell^i = \begin{cases} \eta_\ell & \text{if } \ell \neq i, \\ 1 - \eta_i & \text{if } \ell = i; \end{cases}, \quad \eta_\ell^{i,j} = \begin{cases} \eta_\ell & \text{if } \ell \notin \{i, j\}, \\ \eta_j & \text{if } \ell = i, \\ \eta_i & \text{if } \ell = j. \end{cases} \quad (2.4)$$

We write $\mathbb{P}^\eta, \mathbb{E}^\eta$ be the probability/expectation under this dynamics starting from $\eta \in \Omega_N$.

The invariant measure and the correlation field. For each $N \in \mathbb{N}^*$, let π_{inv}^N denote the unique invariant measure of the open SSEP. If $\rho_+ = \rho_- = \rho \in (0, 1)$, π_{inv}^N is simply the Bernoulli product measure on Λ_N with parameter ρ . If $\rho_- < \rho_+$, however, the measure π_{inv}^N is not product. The average occupation number at each site was computed in [Spo83]: it is given in terms of an affine function $\bar{\rho}$, with:

$$\forall i \in \Lambda_N, \quad \pi_{inv}^N(\eta_i) := \bar{\rho}(i/N) = \left(1 - \frac{i}{N}\right) \frac{\rho_-}{2} + \left(1 + \frac{i}{N}\right) \frac{\rho_+}{2}. \quad (2.5)$$

Note that, as $\bar{\rho}$ is affine, $\bar{\rho}' = (\rho_+ - \rho_-)/2$ is a constant. As π_{inv}^N is invariant, one has, for $F : \Omega_N \Rightarrow \mathbb{R}$:

$$\forall t \geq 0, \quad \pi_{inv}^N(F) := \sum_{\eta \in \Omega_N} \pi_{inv}^N(\eta) F(\eta) = \mathbb{E}^{\pi_{inv}^N} [F(\eta_t)].$$

The measure π_{inv}^N exhibits long-range correlations. To make this statement precise, let us first define the main object of interest in this article, the *correlation field* Π^N . It is a distribution, acting on test functions $\phi : (-1, 1)^2 \rightarrow \mathbb{R}$ according to:

$$\forall \eta \in \Omega_N, \quad \Pi^N(\phi) = \Pi^N(\phi)(\eta) = \frac{1}{4N} \sum_{i \neq j \in \Lambda_N} \bar{\eta}_i \bar{\eta}_j \phi(i/N, j/N), \quad \bar{\eta}_i := \eta_i - \bar{\rho}(\cdot/N). \quad (2.6)$$

Notations. Throughout, we write $\bar{\rho}_i := \bar{\rho}(i/N)$ for $i \in \Lambda_N$. More generally, for a function $\phi : [-1, 1]^p \rightarrow \mathbb{R}$, $p \in \mathbb{N}^*$, we write ϕ_{i_1, \dots, i_p} for $\phi(i_1/N, \dots, i_p/N)$, $(i_1, \dots, i_p) \in \Lambda_N^p$. The letters i, j, ℓ, \dots , when used as indices, index elements of Λ_N ; while x, y, z are used for continuous variables. More generally, when we speak of n -point correlations, $n \in \mathbb{N}^*$ in the text, it will always mean products of centred variables, the $\bar{\eta}$'s, of the form $\bar{\eta}_{i_1} \dots \bar{\eta}_{i_n}$ for some $(i_1, \dots, i_n) \in \Lambda_N^n$ that are all different. When considering a trajectory $\eta_t \in \Omega_N, t \geq 0$, we write Π_t^N for $\Pi^N(\cdot)(\eta_t)$.

Note the scaling of (2.6) with N : the sum contains N^2 terms, and the normalisation is only proportional to N^{-1} . This is related to the following fact. The variable $\bar{\eta}_i$, which measures the difference of the density at a given site compared to $\bar{\rho}(\cdot/N)$, is a trivial quantity when looking at a single site, and bounded away from 0 independently of N . However, when averaged over many sites as in (2.6) the scaling changes and, informally, $\Pi^N(f)$ is typically bounded with N under π_{inv}^N . More precisely, let $\sigma(\rho) = \rho(1 - \rho)$, $\rho \in [0, 1]$, and define:

$$\forall x \in [-1, 1], \quad \bar{\sigma}(x) := \sigma(\bar{\rho}(x)). \quad (2.7)$$

The average value of the correlation field under the invariant measure was obtained in [Spo83], and again in [DLS02] in the large N limit. If $D = \{(x, x) : x \in (-1, 1)\}$ denotes the diagonal of the open square, then, for each $f \in C^0([-1, 1]^2)$:

$$\lim_{N \rightarrow \infty} \pi_{inv}^N(\Pi^N(f)) = \frac{1}{4} \int_{(-1, 1)^2} f(x, y) k_0(x, y) dx dy. \quad (2.8)$$

In the remainder of this section, we collect some properties of the correlations under π_{inv}^N in the large N limit, which may be skipped on a first reading.

The kernel k_0 is a symmetric function, equal to $(\bar{\rho}')^2 \Delta_{1d}^{-1}$, where Δ_{1d}^{-1} denotes the inverse of the one-dimensional Dirichlet Laplacian on $(-1, 1)$ with 0 boundary conditions:

$$\forall (x, y) \in (-1, 1)^2, \quad k_0(x, y) = -\frac{(\bar{\rho}')^2}{2} \left[(1+x)(1-y) \mathbf{1}_{x \leq y} + (1+y)(1-x) \mathbf{1}_{x \geq y} \right]. \quad (2.9)$$

It follows that k_0 is continuous on $[-1, 1]^2$, and that its restriction to the triangle $\{(x, y) \in [-1, 1]^2 : x \leq y\}$ is C^∞ , idem for the other triangle. Moreover, the difference $\bar{\rho}' = (\rho_+ - \rho_-)/2$ in the reservoir densities determines the size of the correlations. This is reflected in the jumps of the normal derivative of k_0 on the diagonal $D = \{(x, x) : x \in (-1, 1)\}$:

$$\forall x \in (-1, 1), \quad (\partial_1 - \partial_2) k_0(x_\pm, x) = \pm (\bar{\rho}')^2.$$

Above $x_\pm = \lim_{h \downarrow 0} (x \pm h)$. From the explicit expression for k_0 and $\bar{\rho}$, one has, for $\bar{\rho}'$ sufficiently small:

$$\int_{(-1, 1)^2} \bar{\sigma}^{-1}(x) k_0(x, y)^2 \bar{\sigma}^{-1}(y) dx dy < 1. \quad (2.10)$$

We will always work under the assumption that (2.10) holds. In the large N limit, by (2.8), the correlations under the steady state are therefore given by the operator $C_0 = \bar{\sigma} + k_0$, where $\bar{\sigma}$ is identified with the operator mapping $f \in \mathbb{L}^2((-1, 1)^2)$ to $\bar{\sigma}f$, and k_0 with the kernel operator $k_0f(x) = \int_{(-1, 1)} k_0(x, y)f(y)dy$, $x \in [-1, 1]$. It follows in particular from (2.10) that the inverse C_0^{-1} of C_0 can be expressed as a series:

$$C_0^{-1} := \bar{\sigma}^{-1} - g_0, \quad g_0 = \bar{\sigma}^{-1} - (\bar{\sigma} + k_0)^{-1} = -\bar{\sigma}^{-1/2} \sum_{n=1}^{\infty} (-1)^n (\bar{\sigma}^{-1/2} k_0 \bar{\sigma}^{-1/2})^n \bar{\sigma}^{-1/2}, \quad (2.11)$$

where A^n denotes the n -times composition of an operator A for $n \in \mathbb{N}^*$. The inverse correlation kernel g_0 inherits the regularity of k_0 . This kernel g_0 will play an important role throughout the chapter. Note that both k_0 and g_0 are negative operators on $\mathbb{L}^2((-1, 1)^2)$:

$$\forall f \in \mathbb{L}^2((-1, 1)^2), \quad \int_{(-1, 1)^2} f(x)k_0(x, y)f(y)dxdy \leq 0, \\ \int_{(-1, 1)^2} f(x)g_0(x, y)f(y)dxdy \leq 0. \quad (2.12)$$

For k_0 , this follows from the negativity of Δ_{1d}^{-1} . On the other hand, g_0 is negative as (-1) times a limit of sums of compositions of positive kernels, see [Ber74].

2.2 The topology

To study the field Π^N , we need to choose a space to which Π^N belongs, and equip it with a topology. Let us start with a few observations. By definition (2.6), Π^N can be seen as a bounded linear form on several function spaces. Let $\square = (-1, 1)^2$ and notice:

$$\forall f : \square \rightarrow \mathbb{R}, \quad \Pi^N(\phi) = \Pi^N(\phi_s), \quad \phi_s(x, y) = f(x, y)/2 + f(y, x)/2, \quad (x, y) \in \square. \quad (2.13)$$

Note also that any function $\phi \in C^1(\square)$ which is symmetric, i.e. $\phi = \phi_s$, is such that:

$$\forall (x, y) \in \square, \quad \partial_1 \phi(x, y) = \partial_2 \phi(y, x) \quad \Rightarrow \quad \forall x \in (-1, 1), \quad (\partial_1 - \partial_2) \phi(x_{\pm}, x) = 0.$$

In view of (2.9), it seems important to be able to evaluate Π^N on functions with non-vanishing normal derivative on the diagonal D of \square , defined by:

$$D := \{(x, x) : x \in (-1, 1)\}. \quad (2.14)$$

We therefore cannot only consider symmetric ϕ that are smooth on the whole of \square . Finally, to account for the reservoirs, we require $\phi|_{\partial \square} = 0$.

With the above discussion, let us now define the test functions Π^N will act on. Split \square as follows:

$$\square = \triangleright \cup D \cup \triangleleft = \boxplus \cup D, \quad \triangleright = \{(x, y) \in \square : x < y\}, \quad \triangleleft = \{(x, y) \in \square : x > y\}, \quad \boxplus = \triangleright \cup \triangleleft.$$

For $n \in \mathbb{N}$ and $p \geq 1$, let $\mathbb{W}^{n,p}(\boxplus)$ be the Sobolev space of functions with distributional derivatives up to order n in $\mathbb{L}^p(\boxplus)$. By definition of \boxplus , those are exactly the functions with restriction to $\triangleright, \triangleleft$ in $\mathbb{W}^{n,p}(\triangleright), \mathbb{W}^{n,p}(\triangleleft)$ respectively. Properties of these spaces are recalled in Appendix E. Note

that $\mathbb{L}^p(\square) = \mathbb{L}^p(\boxminus)$ since the diagonal has vanishing two-dimensional Lebesgue measure. The difference between functions on \square and \boxminus arises in the integration by parts formula defining their weak derivatives. If $p = 2$, we simply write $\mathbb{H}^n(\triangleright) := \mathbb{W}^{n,2}(\triangleright)$. Define then the set \mathcal{T} as follows:

$$\mathcal{T} = \{\phi \in \mathbb{H}^2(\boxminus) : \phi|_{\partial\square} = 0\}. \quad (2.15)$$

The set \mathcal{T} is a separable Hilbert space, and elements of $\mathcal{T} \subset C^0(\bar{\triangleright}) \cap C^0(\bar{\triangleleft})$ by Sobolev embedding, see Appendix E, so the above definition is meaningful. Denote then by \mathcal{T}' the set of bounded linear forms on \mathcal{T} , and by $\mathcal{T}'_s \subset \mathcal{T}'$ the subset of those forms that are symmetric (recall (2.13))

$$\mathcal{T}'_s = \{\Pi \in \mathcal{T}' : \forall \phi \in \mathcal{T}, \quad \Pi(\phi_s) = \Pi(\phi)\}. \quad (2.16)$$

To keep topology-related issues as simple as possible, we equip \mathcal{T}'_s with the weak* topology, i.e. $(\Pi_n)_n \subset \mathcal{T}'_s$ converges to $\Pi \in \mathcal{T}'_s$ if and only if $\lim_{n \rightarrow \infty} \Pi_n(f) = \Pi(f)$ for each $f \in \mathcal{T}$ (or, equivalently, each $f \in \mathcal{T}_\triangleright$). To avoid ambiguities, we write $(\mathcal{T}'_s, *)$ when we explicitly refer to the weak* topology.

As a bounded linear form on (a closed subset of) the Hilbert space $\mathbb{H}^2(\boxminus)$, the Riesz representation theorem allows each $\Pi \in \mathcal{T}'_s$ to be written as:

$$\forall f \in \mathcal{T}, \quad \Pi(f) = \frac{1}{4} \langle k_\Pi, f \rangle. \quad (2.17)$$

Above, $\langle \cdot, \cdot \rangle$ denotes the standard scalar product on $\mathbb{L}^2(\boxminus)$ and duality pairing between elements of $\mathbb{H}^n(\boxminus)$ and $(\mathbb{H}^n(\boxminus))'$, $n \in \mathbb{N}$. The norm on $\mathbb{L}^2(\square) = \mathbb{L}^2(\boxminus)$ is denoted by $\|\cdot\|_2$. We use both Π and k_Π indifferently in the following.

2.3 Large deviations for time-averaged correlations

As explained in the introduction, we study the following problem: for a given $\Pi \in \mathcal{T}'_s$ and an initial measure μ^N on Ω_N , estimate:

$$\mathbb{P}^{\mu^N} \left(\frac{1}{T} \int_0^T \Pi_t^N dt \approx \Pi \right) \quad \text{when } N \text{ and } T \text{ are large.} \quad (2.18)$$

The symbol \approx is to be understood in the sense of the weak* topology described in the previous section. To study (2.18), we use large deviation techniques (see e.g. chapter 10 in [KL99]), modifying the jump rates of the open SSEP dynamics in such a way that, loosely speaking, the event in (2.18) becomes typical when N, T are large. The corresponding modified dynamics have generator L_h parametrised by a function $h : [-1, 1]^2 \rightarrow \mathbb{R}$ that we call a *bias*. The modified jump rates c_h read:

$$\begin{aligned} \forall \eta \in \Omega_N, \forall i \in \{\pm(N-1)\}, \quad c_h(\eta, i) &= c(\eta, i) \exp [\Pi^N(h)(\eta^i) - \Pi^N(h)(\eta)], \\ \forall j < N-1, \quad c_h(\eta, j, j+1) &= c(\eta, j, j+1) \exp [\Pi^N(h)(\eta^{j,j+1}) - \Pi^N(h)(\eta)]. \end{aligned} \quad (2.19)$$

We write $\mathbb{P}_h, \mathbb{E}_h$ for the probability/expectation under this dynamics, and $\mathbb{P}_h^{\mu^N}, \mathbb{E}_h^{\mu^N}$ when starting from the measure μ^N on Ω_N . Once the correct bias h has been found, one has to prove that:

$$\mathbb{P}_h^{\mu^N} \left(\frac{1}{T} \int_0^T \Pi_t^N dt \approx \Pi \right) \approx 1. \quad (2.20)$$

Via (2.20), to each bias h will correspond a correlation kernel $k_h : \square \rightarrow \mathbb{R}$, in a sense made precise in Section 2.4. Let $\mathcal{C}_B = \{k_h : h \text{ is a bias}\}$ be the set of these correlation kernels, defined precisely in (2.32). \mathcal{C}_B is viewed as a subset of \mathcal{T}'_s through (2.17).

Our main result concerns the large deviation behaviour of the probability (2.18), when the large N limit is taken *before* the large T limit. To state it, we need more notations. The method of proof is discussed later, in Section 2.4.

The initial condition. The dynamics are started from a discrete approximation $\nu_{g_0}^N$ of the invariant measure π_{inv}^N . It reads:

$$\forall \eta \in \Omega_N, \quad \nu_{g_0}^N(\eta) = (\mathcal{Z}_{g_0}^N)^{-1} \exp [2\Pi^N(g_0)] \bar{\nu}^N(\eta), \quad \text{with} \quad \bar{\nu}^N(\eta) := \bigotimes_{i \in \Lambda_N} \text{Ber}(\bar{\rho}_i). \quad (2.21)$$

Above, for $\rho \in [0, 1]$, $\text{Ber}(\rho)$ is the Bernoulli measure on $\{0, 1\}$ with parameter ρ . The partition function $\mathcal{Z}_{g_0}^N$ is a normalisation factor, and g_0 , defined in (2.11), is the inverse correlation kernel of the large N limit of the steady state π_{inv}^N . Motivations for the definition of this measure are given in Section 2.4.

Main assumption and characterisation of the biases. In theory, one could define the open SSEP dynamics with any value of the reservoir densities ρ_-, ρ_+ , and consider any sufficiently regular $h \in \mathcal{T}$ and any $k \in \mathcal{T}'_s$ in (2.18). In practice, for technical reasons, we have to restrict the range of ρ_-, ρ_+ , as well as the size of the biases h , in a sense made precise in (2.22). This limits the choice of k in (2.18) to kernels close to k_0 , the large N limit of correlations in the steady state, defined in (2.9). The restriction, that we call the *size assumption*, is given next.

Let $\pm 1_{\triangleright}$ denote the two corners of the triangle \triangleright corresponding to extremities of the diagonal D (defined in (2.14)):

$$1_{\triangleright} = (1_-, 1), \quad -1_{\triangleright} = (-1, -1_+).$$

For $\varepsilon \in (0, 1/2)$, define:

$$\mathcal{S}(\varepsilon) = \left\{ h \in \mathcal{T} : \exists p > 2, h \in \mathbb{W}^{4,p}(\square), h \text{ is symmetric,} \right. \\ \left. \|h\|_2, \|\nabla h\|_2 \leq \varepsilon, (\partial_1 - \partial_2)h(\pm 1_{\triangleright}) = 0 \right\}. \quad (2.22)$$

The size assumption then reads:

Assumption 2.1 (Size Assumption). *There are sufficiently small $\varepsilon_{res}, \varepsilon_B \in (0, 1/2)$ such that $\rho_-, \rho_+ \in [1/2 - \varepsilon_{res}, 1/2 + \varepsilon_{res}]$, and each bias h belongs to $\mathcal{S}(\varepsilon_B)$.*

The quantity ε_{res} is in particular chosen to ensure that (2.10) holds.

The rate function. Introduce the bilinear mapping I from $\mathbb{L}^2(\square)^2$ to $\mathbb{L}^2(\square)$, defined for $(u, v) \in \mathbb{L}^2(\square)^2$ by:

$$\forall (x, y) \in \square, \quad I(u, v)(x, y) = \int_{(-1, 1)} u(z, x) \bar{\sigma}(z) v(z, y) dz, \quad (2.23)$$

where $\bar{\sigma}$ was defined in (2.7). Let h be a bias in the set $\mathcal{S}(\varepsilon_B)$ as in Assumption 2.1. Introduce the functional J_h , defined for $\Pi \in \mathcal{T}'_s \cap \mathbb{H}^1(\square)$ by:

$$J_h(\Pi) = -\frac{1}{2}\Pi(\Delta h + I(\partial_1 h, \partial_1 h)) + \frac{1}{4} \int_{(-1,1)} \text{tr}_D(k_\Pi)(x)(\partial_2 - \partial_1)h(x_+, x)dx \\ + \frac{(\bar{\rho}')^2}{4} \int_{(-1,1)} h(x, x)dx - \frac{1}{8} \int_{\square} \bar{\sigma}(x)\bar{\sigma}(y) [\partial_1 h(x, y)]^2 dx dy, \quad (2.24)$$

and such that $J_h(\Pi) = +\infty$ if $\Pi \notin \mathcal{T}'_s \cap \mathbb{H}^1(\square)$. In (2.24), $\text{tr}_D(k_\Pi)$ is the trace of k_Π on the diagonal D (defined in (2.14)), with k_Π related to Π via (2.17). It is well defined for elements of $\mathbb{H}^1(\square)$, see Theorem 1.5.1.3 in [Gri11]. Moreover, $\Pi \in \mathcal{T}'_s \cap \mathbb{H}^1(\square)$ implies that k_Π is symmetric, thus its trace on either side of the diagonal is the same and the notation $\text{tr}_D(k_\Pi)$ is not ambiguous.

Define then a functional $\mathcal{I} : (\mathcal{T}'_s, *) \rightarrow \mathbb{R}_+$ as follows:

$$\mathcal{I} = \sup_{h \in \mathcal{S}(\varepsilon_B)} J_h. \quad (2.25)$$

For each $T > 0$, let $\mathbb{Q}_T^{\nu_{g_0}^N}$ denote the law of $\frac{1}{T} \int_0^T \Pi_t^N dt$ starting from $\nu_{g_0}^N$, defined as in (2.21):

$$\mathbb{Q}_T^{\nu_{g_0}^N}(O) := \mathbb{P}^{\nu_{g_0}^N} \left(\frac{1}{T} \int_0^T \Pi_t^N dt \in O \right), \quad O \text{ a Borel set in } (\mathcal{T}'_s, *). \quad (2.26)$$

The next theorem gives a large deviation result for the family $(\mathbb{Q}_T^{\nu_{g_0}^N})_{N,T}$

Theorem 2.2. *Let $O, \mathcal{K} \subset (\mathcal{T}'_s, *)$ respectively be an open, compact set. Then:*

$$\limsup_{T \rightarrow \infty} \limsup_{N \rightarrow \infty} \frac{1}{T} \log \mathbb{Q}_T^{\nu_{g_0}^N}(\mathcal{K}) \leq - \inf_{\mathcal{K}} \mathcal{I}. \quad (2.27)$$

A lower bound also holds for smooth correlations. Recall that $\mathcal{C}_B \subset \mathcal{T}'_s$ is the set of all correlation kernels associated with biases $h \in \mathcal{S}(\varepsilon_B)$, defined in (2.32) below. Then:

$$\liminf_{T \rightarrow \infty} \liminf_{N \rightarrow \infty} \frac{1}{T} \log \mathbb{Q}_T^{\nu_{g_0}^N}(O) \geq - \inf_{O \cap \mathcal{C}_B} \mathcal{I}. \quad (2.28)$$

Remark 2.3. Recall that the kernel k_0 of the steady state π_{inv}^N of the open SSEP in the large N limit, defined in (2.9), was observed to be smooth away from the diagonal. As Theorem 2.2 shows, it is in fact a general property that the time-average of Π_t^N is much more regular than an element of \mathcal{T}'_s when N, T are large: it belongs to $\mathcal{T}'_s \cap \mathbb{H}^1(\square)$. ■

Remark 2.4. Due to the restriction on the size of biases in $\mathcal{S}(\varepsilon_B)$, the rate function \mathcal{I} is correct only for kernels sufficiently close to k_0 . This point is further discussed in Section 2.5. The restriction on the smoothness of the kernels one can approximate is not essential, and could likely be lifted with more work on \mathcal{I} . ■

2.4 The relative entropy method

In this section, we explain the method used to establish Theorem 2.2. To establish the theorem, we wish to study, i.e. to study, for some $\Pi \in \mathcal{T}_s$, the probability:

$$\mathbb{P}^{\nu_{g_0}^N} \left(\frac{1}{T} \int_0^T \Pi_t^N dt \approx \Pi \right) \quad \text{when } N, \text{ then } T \text{ are large,} \quad (2.29)$$

with $\nu_{g_0}^N$ the measure defined in (2.21). Understanding correlations out of equilibrium is notoriously difficult. Existing results in the literature deal either with the equilibrium case $\rho_- = \rho_+$, see e.g. [GJ19] for the $h = 0$ case, or use methods particular to the $h = 0$ case, which cannot easily be generalised to $h \neq 0$ [Gon+20]. The methods rely on explicit knowledge of the invariant measure of the dynamics. However, for $h \neq 0$, the invariant measure $\pi_{inv,h}^N$ of \mathbb{P}_h (recall (2.19)) is not known explicitly. Even for $h = 0$, where the invariant measure π_{inv}^N is well understood [DLS02], its complexity makes the study of the probability in (2.29) difficult. To study (2.29) in full generality, we therefore need a different approach.

We will use the generalisation by Jara and Menezes [JM18b] of the relative entropy method of Yau [Yau91]. This method is presented in detail in Section 3.1, and here we only say a few words about it. In our context, the relative entropy method consists in finding a measure μ^N on the state space Ω_N , that is both sufficiently simple to perform explicit computations, and as close as possible to the invariant measure $\pi_{inv,h}^N$. This closeness to the invariant measure aims at ensuring that, if the dynamics \mathbb{P}_h starts from μ^N then, at time $t \geq 0$, the law $f_t \mu^N$ of the dynamics is still close to μ^N . The proximity to the invariant measure is quantified by the relative entropy $H(f_t \mu^N | \mu^N)$. The level of precision needed on this relative entropy depends both on the quantity to study - e.g. the density, the density fluctuations, or in our case the correlations; and on the time range one wishes to probe.

Here, we improve on the estimates of Jara and Menezes [JM18b], obtaining sufficiently precise estimates to study (2.29) in the diffusive time-scale TN^2 with N , then T large. To do so, for each bias h in the set $\mathcal{S}(\varepsilon_B)$, defined in (2.22), we compare the law of the dynamics at each time with a discrete measure $\mu^N = \nu_{g_h}^N$ of the form already encountered in (2.21):

$$\forall \eta \in \Omega_N, \quad \nu_{g_h}^N(\eta) = (\mathcal{Z}_{g_h}^N)^{-1} \exp [2\Pi^N(g_h)] \bar{\nu}^N(\eta), \quad \text{with} \quad \bar{\nu}^N(\eta) := \bigotimes_{i \in \Lambda_N} \text{Ber}(\bar{\rho}_i). \quad (2.30)$$

The partition function $\mathcal{Z}_{g_h}^N$ is a normalisation factor.

The function $g_h : \square \rightarrow \mathbb{R}$, which solves a partial differential equation depending on h , is the function that allows us to minimise the entropy production $\partial_t H(f_t \nu_{g_h}^N | \nu_{g_h}^N)$, as stated in Theorem 2.5 below. When $h = 0$, $g_{h=0} = g_0$, the inverse correlation kernel of the invariant measure π_{inv}^N of the open SSEP in the large N limit, introduced in (2.11). The measure $\nu_{g_0}^N$ is an approximation of the invariant measure π_{inv}^N : we prove in Appendix A that it has both the same occupation numbers at each site, and the same two-point correlations in the large N limit.

Theorem 2.5. *Under Assumption 2.1, there is $\varepsilon_G \in (0, 1/2)$ such that the following holds. Take a bias $h \in \mathcal{S}(\varepsilon_B)$ and consider the following problem with unknown g , referred to as the main*

equation:

$$\left\{ \begin{array}{l} \Delta(g-h)(x,y) + \frac{\bar{\sigma}'(x)}{\bar{\sigma}(x)} \partial_1(2g-h)(x,y) + \frac{\bar{\sigma}'(y)}{\bar{\sigma}(y)} \partial_2(2g-h)(x,y) \quad \text{for } (x,y) \in \square \\ + \int_{(-1,1)} \bar{\sigma}(z) [\partial_1 g(z,x) \partial_1(g-h)(z,y) + \partial_1 g(z,y) \partial_1(g-h)(z,x)] dz = 0, \\ g = 0 \quad \text{on } \partial \square, \\ (\partial_2 - \partial_1)(h-g)(x_+, x) = (\partial_1 - \partial_2)(h-g)(x_-, x) = \frac{(\bar{\rho}')^2}{\bar{\sigma}(x)^2} \quad \text{for } x \in (-1, 1). \end{array} \right. \quad (2.31)$$

Then (2.31) has a unique solution $g_h \in g_0 + \mathcal{S}(\varepsilon_G)$. Let $f_t \nu_{g_h}^N$ denote the law of \mathbb{P}_h at time $t \geq 0$. For each $T > 0$, there is then $C = C(h, \rho_{\pm}) > 0$ such that:

$$\forall t \leq T, \quad H(f_t \nu_{g_h}^N | \nu_{g_h}^N) \leq C e^{CT} \left(H(f_0 \nu_{g_h}^N | \nu_{g_h}^N) + \frac{1}{N^{1/2}} \right).$$

Remark 2.6. The main equation (2.31) is really an equation on the triangle \triangleright . It is written on the whole of \square to have a compact expression for the integral term. \blacksquare

It is now possible to state precisely the definition of the set \mathcal{C}_B of correlation kernels associated with a bias h . For each $h \in \mathcal{S}(\varepsilon_B)$, let $g_h \in g_0 + \mathcal{S}(\varepsilon_G)$ be given by Theorem 2.2, and notice that $\bar{\sigma}^{-1} - g_h = \bar{\sigma}^{-1}(I - \bar{\sigma}g_h)$ is invertible, since $\|\bar{\sigma}g_h\|_2 \leq \varepsilon_G/4 \leq 1/8$ by hypothesis on ε_G . Define then:

$$\mathcal{C}_B = \{k_h := -\bar{\sigma} + (\bar{\sigma}^{-1} - g_h)^{-1} : h \in \mathcal{S}(\varepsilon_B)\}. \quad (2.32)$$

Note that k_h is indeed a kernel operator for $h \in \mathcal{S}(\varepsilon_B)$, in the sense that there is a function $\tilde{k}_h \in \mathbb{L}^2(\square)$ such that:

$$\forall f \in \mathbb{L}^2((-1, 1)), \forall x \in (-1, 1) \quad k_h f(x) = \int_{(-1,1)} k_h(x, y) f(y) dy.$$

This follows from the fact that $k_h(\bar{\sigma}^{-1} - g_h) = \bar{\sigma}g_h$ is a kernel operator, see the first Theorem in section 4.6.1 in [BKM96].

Remark 2.7. If $h = 0$, the explicit expression of k_0 allows one to check, after long and tedious computations, that g_0 indeed satisfies (2.31). The g_0 minimising the entropy production is therefore related to the invariant measure, as one expects.

When $h \neq 0$, in analogy with the $h = 0$ case in (2.11), it is tempting to think that the kernel k_h , defined in (2.32), is the correlation kernel, in the large N limit, of the invariant measure $\pi_{inv,h}^N$ of the dynamics biased by h . We can prove such a statement only in a very indirect way, with additional hypotheses on $\pi_{inv,h}^N$, so we do not state a precise result and rather refer to Appendix A.3 for a discussion. \blacksquare

We conclude this section with a discussion of the consequence of the Size Assumption 2.1 on the large deviation result of Theorem 2.2. The functionals J_h for $h \in \mathcal{S}(\varepsilon_B)$, defined in (2.24), determine the kind of anomalous correlations one expects to observe. Due to the Size Assumption 2.1, we focus on small biases $h \in \mathcal{S}(\varepsilon_B)$, for which it is reasonable to expect that the corresponding correlation kernels are close to k_0 (recall (2.8)). This is however a priori not obvious: one could

imagine that, for some reason, tilting the dynamics with a small h result in correlations far from k_0 . Conversely, some correlations very close to k_0 may be accessible only by imposing a very large bias h . In Proposition 2.8, we argue that this pathological situation indeed does not happen, at least for a class of correlation kernels with good properties.

Proposition 2.8 (Accessible kernels). *Assume the Size Assumption 2.1 holds. There is $\varepsilon > 0$ depending only on ρ_{\pm} such that, if $k \in k_0 + \mathcal{S}(\varepsilon)$, one can find $h \in \mathcal{S}(\varepsilon_B)$ and a corresponding $g_h \in g_0 + \mathcal{S}(\varepsilon_G)$ given by Theorem 2.5 such that $g_h = \bar{\sigma}^{-1} - (\bar{\sigma} + k)^{-1}$, and the rate function $\mathcal{I}(\Pi)$ reads:*

$$\mathcal{I}((1/4)\langle k, \cdot \rangle) = J_h((1/4)\langle k, \cdot \rangle) = \frac{1}{8} \int_{(-1,1)} \bar{\sigma}(z) \langle \partial_1 h(z, \cdot), (\bar{\sigma} + k)(\partial_1 h(z, \cdot)) \rangle dz. \quad (2.33)$$

2.5 Conclusion and perspectives

The large deviations. The large deviation result of Theorem 2.2 is stated starting from the measure $\nu_{g_0}^N$. One could hope to have the same result starting from the invariant measure π_{inv}^N of the open SSEP. We can in fact prove such a result if we admit heuristics of Derrida et al. [DLS07] on the behaviour of the entropy of the steady state, see the discussion in Appendix A.3. More generally, assume that one starts from a probability $\mu^N = e^Q \nu_{g_0}^N$ with $\nu_{g_0}^N(Q) = o_N(1)$. Then:

$$|\mathbb{P}^{\mu^N}(\cdot) - \mathbb{P}^{\nu_{g_0}^N}(\cdot)| \leq \sum_{\eta \in \Omega_N} |\mu^N(\eta) - \nu_{g_0}^N(\eta)| = o_N(1),$$

since the hypothesis $\nu_{g_0}^N(Q) = o_N(1)$ implies $H(\nu_{g_0}^N | \mu^N) = o_N(1)$, and the total variation distance between $\nu_{g_0}^N$ and μ^N is bounded by $\sqrt{2H(\nu_{g_0}^N | \mu^N)}$ (see the proof of Corollary 3.4).

The Size Assumption 2.1 has two components: one assumption on the possible reservoir densities ρ_-, ρ_+ , and another on the size of biases. The assumption on the reservoir densities is only needed in the method we use to prove the existence of solutions to the main equation (2.31), so it should be possible to remove it with more work on the main equation (2.31).

The assumption on the size of the biases means that the rate function \mathcal{I} , defined in (2.25), only correctly approximates the cost of correlation kernels close to the steady state kernel k_0 . It should in contrast be at least partly essential.

Indeed, if the bias h is too large, one can expect that the correlation structure, and even the density of the corresponding biased dynamics changes. On the other hand, the precise restrictions in (2.22) is most likely too strong. Indeed, consider a correlation kernel $k = k_- + k_+$ with a negative part k_- and positive part k_+ . The restriction in (2.22) on the possible biases implies that k can be reached by a bias $h \in \mathcal{S}(\varepsilon_B)$ only if k_+ is sufficiently small, and k_- sufficiently close to k_0 . However, one may wish to observe a correlation kernel k for which the positive part k_+ is not close to 0. For such kernels, the correlation operator $\bar{\sigma} + k$ is still well behaved, in particular one can define an inverse correlation kernel g , and the result of Theorem 2.5 may still hold.

The relative entropy method. In dimension 1, the relative entropy approach used to obtain large deviations can be applied to study the following, still in dimension 1:

1. Two-point correlations as a time-dependent distribution-valued process. One can prove that it solves an appropriate martingale problem in the spirit of [GJ19].
2. Correlations and long-time fluctuations around a density profile evolving in a diffusive time-scale.
3. Other diffusive gradient systems, see the discussion in Section 8.1. in [JM18b].

One could also try to study fluctuations in a system conditioned to a rare dynamical event. For instance, the SSEP on the one-dimensional discrete torus, conditioned to a macroscopic current on average on the time interval $[0, T]$, is known to develop correlations. An expression of these correlations in the long time limit has been conjectured in [Bod+08]. The rigorous derivation of the correlation and fluctuation processes for this system is the subject of ongoing work.

Another direction of inquiry concerns the extension of the relative entropy results to higher dimensions. Extending the entropy estimates of the paper to higher dimensions is possible, but at present our bounds worsen. Fix a dimension $d \geq 1$, take the interacting particle systems of Jara and Menezes in [JM18b], and assume that one can find a regular, small enough function g solving the equivalent of the main equation (2.31) in dimension d . We claim that, using only concentration bounds, we can prove:

$$\exists K > 0, \forall T \geq 0, \quad H(f_t^\mu \nu_g^N | \nu_g^N) \leq K e^{KT} (H(\mu | \nu_g^N) + 1 + N^{d-4}). \quad (2.34)$$

This is a sizeable improvement on existing bounds as soon as $d \geq 2$, see the discussion at the beginning of Section 3.1. The condition $d \leq 4$ is actually an intrinsic limitation, that has nothing to do with the correlation structure of an interacting particle systems. It comes from the error that one makes when approximating a macroscopic PDE on a non-equilibrium density profile by a discrete difference equation. This error does not scale with dimension.

3 Main ingredient: the entropic estimate

In this section, we provide the key microscopic estimates to study the long-time behaviour of the process $(\Pi_t^N)_{t \geq 0}$, i.e. we prove Theorem 2.5. We do so by a careful use of the relative entropy method of Jara and Menezes [JM18b]-[JM18a]. The same kind of computations give the expression of the Radon-Nikodym derivative $D_h = d\mathbb{P}_h/d\mathbb{P}$ for $h \in \mathcal{S}(\varepsilon_B)$, stated in Proposition 3.10 at the end of the section.

3.1 The relative entropy method and Feynman-Kac inequality

The relative entropy method, introduced by Yau [Yau91], has been used extensively to derive hydrodynamic limit-type results. The method is used in the following context. Let $(\omega_t)_{t \geq 0}$ be a Markov chain on a state space Ω , assumed to be finite for simplicity. Let \mathbb{P}, \mathbb{E} denote the associated probability and expectation. Let $V : \Omega \rightarrow \mathbb{R}$. One would like to estimate quantities of the form:

$$\mathbb{E}[V(\omega_t)], \quad t > 0. \quad (3.1)$$

The entropy inequality provides a tool to estimate (3.1). Let μ be any probability measure on Ω and $f_t\mu$ be the law of ω_t , $t \geq 0$. Then, for any $\gamma > 0$:

$$\forall t \geq 0, \quad \mathbb{E}[V(\omega_t)] \leq \gamma^{-1}H(f_t\mu|\mu) + \gamma^{-1} \log \mu(\exp[\gamma V]).$$

Remark 3.1. The symbol $\mathbb{E}[\cdot]$ (or $\mathbb{E}(\cdot)$) always denotes dynamical expectations with respect to a dynamics. In contrast, static expectations with respect to a measure μ are denoted by $\mu[\cdot]$ (or $\mu(\cdot)$). ■

In this way, the dynamical problem (3.1) is reduced to a static problem: a relative entropy estimate, and a concentration-of-measure result under μ . The relative entropy method aims at finding a measure μ which satisfies the following two criteria: exponential moments must be under control, and the relative entropy $H(f_t\mu|\mu)$, $t \geq 0$ must be sufficiently small, the size depending on the kind of observables V one is interested in.

It is therefore crucial to estimate $H(f_t\mu|\mu)$, $t \geq 0$. Recently, in [JM18b]-[JM18a], Jara and Menezes managed to use the relative entropy method to study out of equilibrium fluctuations around hydrodynamic limits in diffusive systems. Their analysis greatly improves the existing method to control $H(f_t\mu|\mu)$, $t \geq 0$. As a starting point, they revisit Yau's entropy bounds in the following form.

Lemma 3.2 (Lemma A.1 in [JM18b]). *Let $(\omega_t)_{t \geq 0}$ be a Markov chain on a finite state space Ω , with jump rates $(c(\omega, \omega'))_{(\omega, \omega') \in \Omega^2}$. Denote by L its generator and by Γ the corresponding carré du champ operator:*

$$\forall \omega \in \Omega, \forall f : \Omega \rightarrow \mathbb{R}, \quad \Gamma f(\omega) = \sum_{\omega' \in \Omega} c(\omega, \omega') [f(\omega') - f(\omega)]^2. \quad (3.2)$$

Let μ be a probability measure on Ω satisfying $\inf_{\Omega} \mu > 0$. Let $f_t\mu$ be the law of ω_t at time $t \geq 0$. Then:

$$\forall t \geq 0, \quad \partial_t H(f_t\mu|\mu) \leq -\mu(\Gamma(\sqrt{f_t})) + \mu(f_t L^* \mathbf{1}), \quad (3.3)$$

where L^* is the adjoint of L in $\mathbb{L}^2(\mu) = \{f : \Omega \rightarrow \mathbb{R} : \mu(f^2) < \infty\}$. It acts on $f : \Omega \rightarrow \mathbb{R}$ according to:

$$\forall \omega \in \Omega, \quad L^* f(\omega) = \sum_{\omega' \in \Omega} \left[c(\omega', \omega) f(\omega') \frac{\mu(\omega')}{\mu(\omega)} - c(\omega, \omega') f(\omega) \right]. \quad (3.4)$$

For future reference, we also state the Feynman-Kac inequality (Lemma A.2. in [JM18b]): for any function $V : \Omega \rightarrow \mathbb{R}$ and time $T \geq 0$,

$$\log \mathbb{E}^\mu \left[\exp \int_0^T V(\omega_t) dt \right] \leq T \sup_{f \geq 0: \mu(f)=1} \left\{ \mu(fV) - \frac{1}{2} \mu(\Gamma(\sqrt{f})) + \frac{1}{2} \mu(f L^* \mathbf{1}) \right\}. \quad (3.5)$$

Since the adjoint L^* is known explicitly in terms of μ , (3.3) provides a way to estimate $\partial_t H(f_t\mu|\mu)$, $t \geq 0$. An estimate of $H(f_t\mu|\mu)$ follows by applying the entropy and Gronwall inequalities.

Note that the carré du champ is always positive. Moreover, $L^* \mathbf{1} = 0$ if and only if $\mu = \pi$ is the

invariant measure. The quantity $L^* \mathbf{1}$ thus appears as a way to quantify the proximity of μ to the invariant measure π . This serves as an informal guiding principle for the choice of μ :

$$\text{for each } f \geq 0 \text{ with } \mu(f) = 1, \quad \mu(fL^* \mathbf{1}) \text{ must be small.} \quad (3.6)$$

We are going to apply Lemma 3.2 to the dynamics \mathbb{P}_h , defined in (2.19), for $h \in \mathcal{S}(\varepsilon_B)$. Let us emphasize again that "small" must always be understood in comparison with the size of the V 's one wishes to estimate as in (3.1). Typically, if one wants to study the hydrodynamic limit of the density of particles in a d -dimensional open SSEP on a lattice of side-length N , then $o(N^d)$ bounds on the relative entropy are sufficient. These can be achieved if μ is a product measure with the same densities as those of the invariant measure at each site, i.e:

$$\mu = \bar{\nu}^N = \bigotimes_{i \in \Lambda_N} \text{Ber}(\bar{\rho}_i), \quad (3.7)$$

with $\text{Ber}(\rho)$ the Bernoulli measure on $\{0, 1\}$ with parameter $\rho \in (0, 1)$, and $\bar{\rho}$ the steady state density profile in the large N limit, see (2.5) In contrast, consider the fluctuation field:

$$\forall \phi : (-1, 1) \rightarrow \mathbb{R}, \quad Y_t^N(\phi) = \frac{1}{N^{1/2}} \sum_{i \in \Lambda_N} \bar{\eta}_i(t) \phi(i/N),$$

To study Y_t^N , one needs $o(N^{1/2})$ bounds on the relative entropy (in fact $o(N^{d/2})$ bounds in dimension d). Remarkably, while one could expect that some information on the correlation structure of the invariant state should be necessary to study Y^N , Jara and Menezes [JM18b] managed to obtain such bounds on the relative entropy by still taking μ product as in (3.7). To do so, they set up a general renormalisation scheme to bound $\mu(fL^* \mathbf{1})$, for a μ -density f , in terms of the carré du champ, and objects that can be estimated by the entropy inequality. Precisely, they manage to prove $g_d(N)N^{d-2}$ relative entropy bounds, with $g_1(N) = N$, $g_2(N) = \log N$ and $g_d(N) = 1$ for $d \geq 3$; where the factor $g_d(N)$ arises from the renormalisation scheme. This is enough to study fluctuations in dimension $d < 4$. They also argue that these bounds are the best possible when μ is product.

Let us come back to the study of the correlation process Π^N in the (one-dimensional) open SSEP. We need $o_N(1)$ bounds on the relative entropy at each time. The measure μ therefore cannot be taken product. With (3.6) in mind, we look for μ that has both the same density at each site, and the same correlations as the invariant measure - which are in general not known - when N is large. We therefore look for them in an indirect way, taking a smooth function $g : \square \rightarrow \mathbb{R}$, and looking for the optimal choice of g such that the measure $\mu = \nu_g^N$ satisfies (3.6), with:

$$\nu_g^N := \frac{1}{\mathcal{Z}_g^N} \exp [2\Pi^N(g)] \bar{\nu}^N, \quad \mathcal{Z}_g^N \text{ a normalisation factor,} \quad (3.8)$$

For each bias $h \in \mathcal{S}(\varepsilon_B)$, the optimal $g = g_h$ arises as the solution of a certain partial differential equation, the main equation (2.31). For this g_h , the method of [JM18b], adapted to this context, yields the bound of Theorem 2.5:

$$\exists C > 0, \forall t \geq 0, \quad H(f_t \nu_{g_h}^N | \nu_{g_h}^N) \leq C e^{Ct} (H(f_0 \nu_g^N | \nu_g^N) + N^{-1/2}). \quad (3.9)$$

The exponent $-1/2$ is related to the size of exponential moments of three-point and four-point correlation functions for product measures (see Section A.2), and thus cannot be improved without adding a correction to ν_g^N . The proof of (3.9) is the main technical result of the article. Its precise statement is the content of the next lemma, a more comprehensive reformulation of Theorem 2.5. For $h \in \mathcal{S}(\varepsilon_B)$ and $f : \Omega_N \rightarrow \mathbb{R}_+$, let $\Gamma_h(\sqrt{f})$ be the carré du champ operator associated with the generator L_h biased by h , with jump rates c_h defined in (2.19):

$$\begin{aligned} \forall \eta \in \Omega_N, \quad \Gamma_h(\sqrt{f})(\eta) &= \frac{1}{4} \sum_{i < N-1} c_h(\eta, i, i+1) [\sqrt{f}(\eta^{i, i+1}) - \sqrt{f}(\eta)]^2 \\ &\quad + \frac{1}{4} \sum_{i \in \{\pm(N-1)\}} c_h(\eta, i) [\sqrt{f}(\eta^i) - \sqrt{f}(\eta)]^2. \end{aligned} \quad (3.10)$$

Lemma 3.3. *Let $h \in \mathcal{S}(\varepsilon_B)$, and denote by $g_h \in g_0 + \mathcal{S}(\varepsilon_G)$ the solution of the main equation (2.31). The set $\mathcal{S}(\varepsilon)$ for $\varepsilon > 0$ is defined in (2.22). For $N \in \mathbb{N}^*$, let $\nu_{g_h}^N$ be the associated measure via (3.8). Then, for any $N \in \mathbb{N}^*$, there is a function $\mathcal{E} : \Omega_N \rightarrow \mathbb{R}$ such that, for any $\nu_{g_h}^N$ -density f , the adjoint L_h^* of L_h in $\mathbb{L}^2(\nu_{g_h}^N)$ satisfies:*

$$\nu_{g_h}^N(f L_h^* \mathbf{1}) \leq \nu_{g_h}^N(f \mathcal{E}) + \frac{N^2}{2} \nu_{g_h}^N(\Gamma_h(\sqrt{f})). \quad (3.11)$$

Moreover, there are constants $\gamma, C = C(g_h, h) > 0$ such that:

$$\forall N \in \mathbb{N}^*, \quad \gamma^{-1} \log \nu_{g_h}^N \left(\exp[\gamma |\mathcal{E}|] \right) \leq \frac{C}{N^{1/2}}. \quad (3.12)$$

As a consequence, if $f_t \nu_{g_h}^N$ denotes the law of the dynamics at time t , then for the constants γ, C of (3.12):

$$\forall t \geq 0, \forall N \in \mathbb{N}^*, \quad \partial_t H(f_t \nu_{g_h}^N | \nu_{g_h}^N) \leq \frac{H(f_t \nu_{g_h}^N | \nu_{g_h}^N)}{\gamma} + \frac{C}{N^{1/2}} - \frac{N^2}{2} \nu_{g_h}^N(\Gamma_h(\sqrt{f_t})). \quad (3.13)$$

Applying Gronwall inequality to $H(f_t \nu_{g_h}^N | \nu_{g_h}^N)$, $t \geq 0$ in (3.13) yields:

$$\forall t \geq 0, \quad H(f_t \nu_{g_h}^N | \nu_{g_h}^N) \leq e^{t/\gamma} \left(H(f_0 \nu_{g_h}^N | \nu_{g_h}^N) + \frac{\gamma C}{N^{1/2}} \right),$$

which implies the statement of Theorem 2.5. We will often use the following corollary.

Corollary 3.4. *Let $h \in \mathcal{S}(\varepsilon_B)$, let g_h solve the main equation (2.31) with bias h , and let $\nu_{g_h}^N$ be the associated measure. There is $K > 0$, such that for any $F_N : \Omega_N \rightarrow \mathbb{R}$ and each $T \geq 0$:*

$$\sup_{t \in [0, T]} \left| \mathbb{E}_h^{\nu_{g_h}^N} [F_N(\eta_t)] - \nu_{g_h}^N(F_N) \right| \leq \frac{K \|F_N\|_\infty e^{KT}}{N^{1/4}}. \quad (3.14)$$

Proof. The corollary follows immediately from Theorem 2.5 and the following inequality, known as Pinsker's inequality in the literature for the second part: for any two measures μ_1^N, μ_2^N on Ω_N ,

$$\|\mu_1^N - \mu_2^N\|_{TV} = \frac{1}{2} \sum_{\eta \in \Omega_N} |\mu_1^N(\eta) - \mu_2^N(\eta)| \leq \sqrt{2H(\mu_1^N | \mu_2^N)}.$$

□

Lemma 3.3 is derived in the next four subsections. Functions $h \in \mathcal{S}(\varepsilon_B)$ and $g \in g_0 + \mathcal{S}(\varepsilon_G)$ (these sets are defined in Assumption 2.1 and Theorem 2.5) are fixed throughout the rest of the section. Recall in particular that h, g are symmetric functions, and that their restriction to \triangleright is in $C^3(\bar{\triangleright})$. We do not assume a priori that g solve the main equation (2.31).

3.2 Estimates on $L_h^* \mathbf{1}$

To prove Lemma 3.3, we need to compute $L_h^* \mathbf{1}$. Before doing so in the next subsections, we introduce some notations and discuss how to identify whether terms arising in the computation of $L_h^* \mathbf{1}$ are "big" or "small". Consider a density f for ν_g^N , and a function $X_N : \Omega_N \rightarrow \mathbb{R}$. Our main tool to estimate the scaling of X_N with N is the entropy inequality, which states:

$$\forall \gamma > 0, \quad \nu_g^N(f X_N) \leq \gamma^{-1} H(f \nu_g^N | \nu_g^N) + \gamma^{-1} \log \nu_g^N \left(\exp [\gamma |X_N|] \right). \quad (3.15)$$

Informally, X_N will be small if its moment generating function under ν_g^N vanishes with N in an N -independent neighbourhood of 0: this is the kind of characterisation of smallness that is used to estimate the size of the function \mathcal{E} in Lemma 3.3. In some cases, typically when dealing with the effect of the reservoirs, we will encounter an X_N that is not small, but can be transformed into some Y_N that indeed is, up to a cost estimated by the carré du champ operator. The next definition formalises these considerations.

Definition 3.5. *Let $a_N \in \mathbb{R}_+^*$, $N \in \mathbb{N}^*$. A family $X_N : \Omega_N \rightarrow \mathbb{R}$, $N \in \mathbb{N}^*$ is said to be:*

- Controllable with size a_N if there is γ independent of N , and $K > 0$ independent of N, a_N , such that:

$$\forall N \in \mathbb{N}^*, \quad \gamma^{-1} \log \nu_g^N \left(\exp [\gamma |X_N|] \right) \leq K a_N. \quad (3.16)$$

By K independent of N, a_N , we mean that if $a_N = a_N(p)$ is a function of N and a parameter p , then K depends neither on N nor on p .

By the entropy inequality (3.15), (3.16) implies, for each density f for ν_g^N :

$$\forall N \in \mathbb{N}^*, \quad \nu_g^N(f |X_N|) \leq \gamma^{-1} H(f \nu_g^N | \nu_g^N) + K a_N.$$

- Γ -controllable with size a_N if one can transform X_N , using the carré du champ Γ_h , into a controllable function with size a_N . More precisely: X_N is Γ -controllable with size a_N if, for each $\delta > 0$, there are controllable functions $Y_{N,\pm}^\delta$ with size a_N such that, for each $N \in \mathbb{N}^*$ and each density f for ν_g^N :

$$\nu_g^N(f(\pm X_N)) \leq \delta N^2 \nu_g^N(\Gamma_h(f^{1/2})) + \nu_g^N(f Y_{N,\pm}^\delta),$$

in which case there are $\gamma_\delta > 0$ independent of N , and $K_\delta > 0$ independent of N, a_N ; such that:

$$\nu_g^N(f(\pm X_N)) \leq \delta N^2 \nu_g^N(\Gamma_h(f^{1/2})) + \gamma_\delta^{-1} H(f \nu_g^N | \nu_g^N) + K_\delta a_N.$$

- An error term with size a_N , or error term for short, if it is either controllable or Γ -controllable with size a_N , and $a_N = o_N(1)$.

To illustrate the notion of controllability, the following corollary states its consequence on the dynamical behaviour of observables. A more general result is proven in Proposition C.2.

Corollary 3.6. *Let $h \in \mathcal{S}(\varepsilon_B)$, and let g_h be the associated solution of the main equation (2.31) as in Lemma 3.3. Let $E^N : \Omega_N \rightarrow \mathbb{R}$ be an error term, and let F^N be controllable with size 1 and associated constant K . There are then $C(h), C(K) > 0$ such that, for each $T > 0$:*

$$\limsup_{N \rightarrow \infty} \mathbb{E}^{\nu_{g_h}^N} \left[\left| \int_0^T E^N(\eta_t) dt \right| \right] = 0, \quad \text{and} \quad \mathbb{E}^{\nu_{g_h}^N} \left[\left| \int_0^T F^N(\eta_t) dt \right| \right] \leq C(K)T \left(1 + \frac{C(h)e^{C(h)T}}{N^{1/2}} \right).$$

Let $\phi : \Lambda_N \rightarrow \mathbb{R}$. To determine whether a field is an error term or not, one must keep in mind the following heuristics: the ν_g^N are discrete Gaussian measures, in the sense that the fluctuation field $Y^N(\phi)$, which reads:

$$Y^N(\phi) := \frac{1}{N^{1/2}} \sum_{i \in \Lambda_N} \bar{\eta}_i \phi(i), \quad (3.17)$$

is close to a Gaussian random variable when N is large, provided $N^{-1/2} \|\phi\|_\infty < \infty$. In particular, $\lambda \mapsto \nu_g^N(\exp[\lambda Y^N(\phi)])$ is bounded uniformly in N in a neighbourhood $[0, \gamma)$ of 0 for some $\gamma > 0$. By (3.16), this means that $Y^N(\phi)$ is controllable with size 1. In analogy with Gaussian random variables, one can prove that $Y^N(\phi)^2$ is controllable with size 1, but $Y^N(\phi)^n$ for $n \geq 3$ is not. Similarly, the quantity:

$$Z^N(\phi) := \frac{1}{N^{1/2}} \sum_{i < N-1} \bar{\eta}_i \bar{\eta}_{i+1} \phi(i) \quad (3.18)$$

should have the same concentration properties as $Y^N(\phi)$. In contrast with a genuine Gaussian random variable, however, $Y^N(\phi)$ and $Z^N(\phi)$ are bounded by $C \|\phi\|_\infty N^{1/2}$ for some $C > 0$. As a result, it is always possible to find a_N small enough such that $a_N (Y^N(\phi))^n$ is controllable with size 1. This discussion is summarised in the next lemma.

Lemma 3.7. *For $n \in \mathbb{N}^*$, let $\phi_n : \Lambda_N^n \rightarrow \mathbb{R}$ satisfy $\sup_N \|\phi_n\|_\infty < \infty$. Define, for $N \in \mathbb{N}^*$ and either $J = \{0\}$ or $J = \{0, 1\}$, the functions (an empty sum is by convention equal to 0):*

$$\begin{aligned} \forall \eta \in \Omega_N, \quad X_{n,J}^{\phi_n}(\eta) &= \sum_{i_0 < N-1} \sum_{i_1, \dots, i_{n-1} \in \Lambda_N} \prod_{j \in J} \phi_n(i_0, \dots, i_{n-1}) \bar{\eta}_{i_0+j} \left(\prod_{a=1}^{n-1} \bar{\eta}_{i_a} \right), \\ U_0^\varepsilon(\eta) &= \bar{\eta}_{\varepsilon(N-1)}, \quad U_1^\varepsilon(\eta) = \bar{\eta}_{\varepsilon(N-1)} \sum_{i \neq \varepsilon(N-1)} \bar{\eta}_i \phi_1(i), \quad \varepsilon \in \{-, +\}. \end{aligned} \quad (3.19)$$

- The function U_0^\pm is Γ -controllable with size N^{-2} , and U_1^\pm is Γ -controllable with size $\|\phi_1\|_\infty N^{-1}$. Moreover, $N^{-1/2} X_{1,J}^{\phi_1}$ is controllable with size $\|\phi_1\|_\infty^2$.
- For $n \in \{2, \dots, 4\}$, $N^{-(n-1)} X_{n,J}^{\phi_n}$ is controllable with size $\|\phi_n\|_\infty N^{-(n-2)/2}$.

Remark 3.8. Note that, for $n \in \mathbb{N}^*$, if $\phi_n(i_1, \dots, i_n) = \prod_{i=1}^n \phi_1(i)$, then:

$$X_{n,J}^{\phi_n} = (Y^N(\phi_1))^{n+1-|J|} Z^N(\phi_1)^{|J|-1},$$

with $Y^N(\phi)$, $Z^N(\phi)$ defined in (3.17)-(3.18). Moreover, $X_{2,\{0\}}^{\phi_2} = \Pi^N(\phi_2)$ if $\phi_2(i, i) = 0$ for each $i \in \Lambda_N$. The estimate of Lemma 3.7, however, does not require ϕ_2 to vanish on the diagonal. ■

Lemma 3.7 is proven in Appendix A.2 for the variables $X_{n,J}^{\phi_n}$. The statement for U_0^\pm, U_1^\pm is proven in Appendix B.2.

We now turn to computing $L_h^* \mathbf{1}$, in the next two subsections. We split L_h^* into $L_h^* = L_{h,0}^* + L_{h,\pm}^*$, the adjoint dynamics respectively in the bulk and at the boundaries, and study each contribution separately.

3.3 Adjoint at the boundary

In this section, we compute $L_{h,\pm}^* \mathbf{1}$, the part of the adjoint $L_h^* \mathbf{1}$ of L_h corresponding to the dynamics at the boundary. By (3.4), it reads:

$$\begin{aligned} N^2 L_{h,\pm}^* \mathbf{1}(\eta) &= \frac{N^2}{2} \sum_{i \in \{\pm(N-1)\}} \left[c_h(\eta^i, i) \frac{\nu_g^N(\eta^i)}{\nu_g^N(\eta)} - c_h(\eta, i) \right] \\ &= \frac{N^2}{2} \sum_{i \in \{\pm(N-1)\}} \left[c(\eta^i, i) \left(\frac{\bar{\rho}_i}{1 - \bar{\rho}_i} \right)^{1-2\eta_i} \exp \left[\frac{(1-2\eta_i)}{2N} \sum_{j \neq i} \bar{\eta}_j (2g - h)_{i,j} \right] \right. \\ &\quad \left. - c(\eta, i) \exp \left[\frac{(1-2\eta_i)}{2N} \sum_{j \neq i} \bar{\eta}_j h_{i,j} \right] \right]. \end{aligned} \quad (3.20)$$

The jump rates $c(\eta, i)$, $i \in \{\pm(N-1)\}$ are defined in (2.3). To compute (3.20), recall that both h, g satisfy $h(\pm 1, \cdot) = 0 = g(\pm 1, \cdot)$ by hypothesis. It follows that the arguments of the exponentials in (3.20) are bounded by $O(N^{-1})$. Moreover, introduce:

$$\forall i \in \Lambda_N, \quad \lambda_i := \log \left(\frac{\bar{\rho}_i}{1 - \bar{\rho}_i} \right), \quad \lambda_{\pm N} = \log \left(\frac{\rho_\pm}{1 - \rho_\pm} \right). \quad (3.21)$$

With this notation and by reversibility, one has for $i \in \{\pm(N-1)\}$:

$$c(\eta^i, i) = c(\eta, i) \left(\frac{\rho_{\text{sign}(i)}}{1 - \rho_{\text{sign}(i)}} \right)^{2\eta_i - 1}.$$

As a result:

$$c(\eta^i, i) \left(\frac{\bar{\rho}_i}{1 - \bar{\rho}_i} \right)^{1-2\eta_i} = c(\eta, i) \exp \left[\frac{(1-2\eta_i)}{N} (\mathbf{1}_{i=-(N-1)} \partial^N \lambda_{-N} - \mathbf{1}_{i=N-1} \partial^N \lambda_{N-1}) \right]. \quad (3.22)$$

Write for short:

$$\Lambda_i := \mathbf{1}_{i=-(N-1)} \partial^N \lambda_{-N} - \mathbf{1}_{i=N-1} \partial^N \lambda_{N-1}.$$

Using (3.22) and the existence of $C_{h,g,\bar{\rho}} = C(\|h\|_\infty, \|g\|_\infty, \|\bar{\rho}\|_\infty) > 0$ such that $|e^x - 1 - x^2/2| \leq C_{h,g,\bar{\rho}} |x|^3$ for $|x| \leq 2(\|h\|_\infty + 2\|g\|_\infty + \|\lambda\|_\infty)$, (3.20) becomes:

$$\begin{aligned} N^2 L_{h,\pm}^* \mathbf{1}(\eta) &- \frac{N}{2} \sum_{i \in \{\pm(N-1)\}} c(\eta, i) (1-2\eta_i) \left[\frac{1}{N} \sum_{j \neq i} \bar{\eta}_j N (g - h)_{i,j} + \Lambda_i \right] \\ &- \frac{1}{4} \sum_{i \in \{\pm(N-1)\}} c(\eta, i) \left[\left(\frac{1}{N} \sum_{j \neq i} \bar{\eta}_j N (2g - h)_{i,j} + \Lambda_i \right)^2 - \left(\frac{1}{N} \sum_{j \neq i} \bar{\eta}_j N h_{i,j} \right)^2 \right] := \delta_{\pm}^{N,1}(\eta), \end{aligned} \quad (3.23)$$

with $|\delta_{\pm}^{N,1}| \leq C_{h,g,\bar{\rho}}/N$. To compute the two terms in the left-hand side of (3.23), let $i \in \{\pm(N-1)\}$ and let us first rewrite the jump rate in terms of $\bar{\eta}_i$ in two different ways. One has:

$$c(\eta, i) := (1 - \eta_i)\rho_{\text{sign}(i)} + (1 - \rho_{\text{sign}(i)})\eta_i = a_{\text{sign}(i)} + \bar{\eta}_i(1 - 2\rho_{\text{sign}(i)}), \quad (3.24)$$

with:

$$a_{\text{sign}(i)} := (1 - \bar{\rho}_i)\rho_{\text{sign}(i)} + (1 - \rho_{\text{sign}(i)})\bar{\rho}_i. \quad (3.25)$$

Moreover, it also holds that:

$$\begin{aligned} (1 - 2\eta_i)c(\eta, i) &= -(\eta_i - \rho_{\text{sign}(i)}) = -\bar{\eta}_i + (\rho_{\text{sign}(i)} - \bar{\rho}_i) \\ &= -\bar{\eta}_i - \frac{1}{N} [\mathbf{1}_{i=-(N-1)}\partial^N \bar{\rho}_{-N} - \mathbf{1}_{i=N-1}\partial^N \bar{\rho}_{N-1}]. \end{aligned} \quad (3.26)$$

Using (3.26) in the first sum in (3.23), one finds:

$$\begin{aligned} \frac{N}{2} \sum_{i \in \{\pm(N-1)\}} c(\eta, i)(1 - 2\eta_i) &\left[\frac{1}{N} \sum_{j \neq i} \bar{\eta}_j N(g - h)_{i,j} + (\mathbf{1}_{i=-(N-1)}\partial^N \lambda_{-N} - \mathbf{1}_{i=N-1}\partial^N \lambda_{N-1}) \right] \\ &= -\frac{N\partial^N \lambda_{-N}}{2} \left[\bar{\eta}_{-(N-1)} + \frac{\partial^N \bar{\rho}_{-N}}{N} \right] + \frac{N\partial^N \lambda_{N-1}}{2} \left[\bar{\eta}_{N-1} - \frac{\partial^N \bar{\rho}_{N-1}}{N} \right] + \delta_{\pm}^{N,2}(\eta), \end{aligned} \quad (3.27)$$

where $\delta_{\pm}^{N,2}$ is an error term that reads:

$$\delta_{\pm}^{N,2}(\eta) = -\frac{1}{2} \sum_{i \in \{\pm(N-1)\}} \left(\bar{\eta}_i + \frac{1}{N} [\mathbf{1}_{i=-(N-1)}\partial^N \bar{\rho}_{-N} - \mathbf{1}_{i=N-1}\partial^N \bar{\rho}_{N-1}] \right) \sum_{j \neq i} \bar{\eta}_j N(g - h)_{i,j}.$$

The term involving $\bar{\eta}_i$ above is of the same form as U_1^{\pm} in Lemma 3.7, thus Γ -controllable with size N^{-1} . The other term is of the form $N^{-1/2}Y^N(\phi)$ for a bounded ϕ (recall (3.17)), and therefore controllable with size N^{-1} . It follows that $\delta_{\pm}^{N,2}$ is Γ -controllable with size N^{-1} .

Consider now the second sum in (3.23). Using (3.24) and recalling the definition (3.25) of a_{\pm} , it reads:

$$\begin{aligned} \frac{1}{4} \sum_{i \in \{\pm(N-1)\}} c(\eta, i) &\left[\left(\frac{1}{N} \sum_{j \neq i} \bar{\eta}_j N(2g - h)_{i,j} + (\mathbf{1}_{i=-(N-1)}\partial^N \lambda_{-N} - \mathbf{1}_{i=N-1}\partial^N \lambda_{N-1}) \right)^2 \right. \\ &\left. - \left(\frac{1}{N} \sum_{j \neq i} \bar{\eta}_j N h_{i,j} \right)^2 \right] = \frac{a_{-}(\partial^N \lambda_{-N})^2}{4} + \frac{a_{+}(\partial^N \lambda_{N-1})^2}{4} + \delta_{\pm}^{N,3}(\eta), \end{aligned} \quad (3.28)$$

where $\delta_{\pm}^{N,3}$ is an error term that contains all other contributions:

$$\begin{aligned} \delta_{\pm}^{N,3}(\eta) &= \frac{1}{4} \sum_{i \in \{\pm(N-1)\}} c(\eta, i) \left[\left(\frac{1}{N} \sum_{j \neq i} \bar{\eta}_j N(2g - h)_{i,j} \right)^2 - \left(\frac{1}{N} \sum_{j \neq i} \bar{\eta}_j N h_{i,j} \right)^2 \right] \\ &+ \frac{1}{2N} \sum_{i \in \{\pm(N-1)\}} c(\eta, i) \left[(\mathbf{1}_{i=-(N-1)}\partial^N \lambda_{-N} - \mathbf{1}_{i=N-1}\partial^N \lambda_{N-1}) \sum_{j \neq i} \bar{\eta}_j N(2g - h)_{i,j} \right] \\ &+ \bar{\eta}_{-(N-1)}(1 - 2\rho_{-}) \frac{(\partial^N \lambda_{-N})^2}{4} + \bar{\eta}_{N-1}(1 - 2\rho_{+}) \frac{(\partial^N \lambda_{N-1})^2}{4}. \end{aligned}$$

With the notations of Lemma 3.7 and bounding $c(\eta, \cdot)$ by $C(\bar{\rho})$, the first line of $\delta_{\pm}^{N,3}$ is bounded by a term of the form $N^{-2}X_{2,\{0\}}^{\phi_2}$, thus controllable with size N^{-1} . Similarly, the second line is bounded by a term of the form $N^{-1/2}|Y^N(\phi)|$ (recall (3.17)) for bounded ϕ , and therefore also controllable with size N^{-1} . Finally, the third line is of the form U_0^{\pm} , therefore Γ -controllable with size N^{-2} . It follows that $\delta_{\pm}^{N,3}$ is Γ -controllable with size N^{-1} .

Putting together (3.27) and (3.28), we have obtained the following expression of the adjoint at the boundary:

$$\begin{aligned} N^2 L_{h,\pm}^* \mathbf{1}(\eta) &= -\frac{N\partial^N \lambda_{-N}}{2} \left[\bar{\eta}_{-(N-1)} + \frac{\partial^N \bar{\rho}_{-N}}{N} \right] + \frac{N\partial^N \lambda_{N-1}}{2} \left[\bar{\eta}_{N-1} - \frac{\partial^N \bar{\rho}_{N-1}}{N} \right] \\ &\quad + \frac{a_-(\partial^N \lambda_{-N})^2}{4} + \frac{a_+(\partial^N \lambda_{N-1})^2}{4} + \sum_{q=1}^3 \delta_{\pm}^{N,q}(\eta). \end{aligned}$$

It remains to notice that the constant terms in the last equation compensate each other to obtain the final expression for $N^2 L_{h,\pm}^* \mathbf{1}(\eta)$. Indeed, for each $i \in \{\pm(N-1)\}$, a Taylor expansion yields:

$$a_{\text{sign}(i)} = 2\bar{\sigma}_i + O(N^{-1}), \quad \partial^N \lambda_i = \frac{\partial^N \bar{\rho}_i}{\bar{\sigma}_i} + O(N^{-1}). \quad (3.29)$$

It follows that there is a configuration-independent $\delta^{N,4}$ with $\delta^{N,4} = O(N^{-1})$, such that:

$$N^2 L_{h,\pm}^* \mathbf{1}(\eta) = -\frac{N\partial^N \lambda_{-N}}{2} \bar{\eta}_{-(N-1)} + \frac{N\partial^N \lambda_{N-1}}{2} \bar{\eta}_{N-1} + \delta_{\pm}^N(\eta), \quad \delta_{\pm}^N := \sum_{q=1}^4 \delta_{\pm}^{N,q}(\eta). \quad (3.30)$$

The quantity δ_{\pm}^N is, by definition, Γ -controllable with size N^{-1} .

3.4 Adjoint in the bulk

We now compute $L_{h,0}^* \mathbf{1}$. For each $i < N-1$, define B_i^h, C_i^h, D_i^h as follows:

$$B_i^h(\eta) = \frac{1}{2N} \sum_{j \notin \{i, i+1\}} \bar{\eta}_j \partial_1^N h_{i,j}, \quad D_i^h(\eta) = \frac{\partial^N \bar{\rho}_i h_{i,i+1}}{2N}, \quad C_i^h = B_i^h + D_i^h, \quad (3.31)$$

where, for $u : \mathbb{Z}^2 \rightarrow \mathbb{R}$:

$$\forall (i, j) \in \mathbb{Z}^2, \quad \partial_1^N u(i, j) = N[u(i+1, j) - u(i, j)].$$

With these definitions,

$$\forall i < N-1, \quad \Pi^N(h)(\eta^{i,i+1}) - \Pi^N(h)(\eta) = -\frac{(\eta_{i+1} - \eta_i)}{N} C_i^h(\eta).$$

Define similarly C^g , and notice that, since h, g are regular:

$$\sup_{N \in \mathbb{N}^*} \sup_{\eta \in \Omega_N} \sup_{i < N-1} (|C_i^h(\eta)| + |C_i^g(\eta)|) < \infty. \quad (3.32)$$

By (3.4), the adjoint $L_{h,0}^*$ in the bulk reads, by definition:

$$N^2 L_{h,0}^* \mathbf{1}(\eta) = \frac{N^2}{2} \sum_{i < N-1} \left[c_h(\eta^{i,i+1}, i, i+1) \frac{\nu_g^N(\eta^{i,i+1})}{\nu_g^N(\eta)} - c_h(\eta, i, i+1) \right].$$

With the above notations, this becomes:

$$N^2 L_{h,0}^* \mathbf{1}(\eta) = \frac{N^2}{2} \sum_{i < N-1} c(\eta, i, i+1) \left[\exp \left[\frac{(\eta_{i+1} - \eta_i)}{N} (C_i^h - 2C_i^g) \right] \left[\frac{\bar{\rho}_i(1 - \bar{\rho}_{i+1})}{\bar{\rho}_{i+1}(1 - \bar{\rho}_i)} \right]^{\eta_{i+1} - \eta_i} - \exp \left[- \frac{(\eta_{i+1} - \eta_i)}{N} C_i^h \right] \right]. \quad (3.33)$$

To compute (3.33), recall the definition of λ :

$$\forall i \in \Lambda_N, \quad \lambda_i := \log \left(\frac{\bar{\rho}_i}{1 - \bar{\rho}_i} \right).$$

Notice that $C_i^h - 2C_i^g = C_i^{h-2g}$. Moreover, $c(\eta, i, i+1) = (\eta_{i+1} - \eta_i)^2$ for each $i < N-1$. With these notations, (3.33) reads:

$$N^2 L_{h,0}^* \mathbf{1}(\eta) = \frac{N^2}{2} \sum_{i < N-1} (\eta_{i+1} - \eta_i)^2 \left[\exp \left[\frac{(\eta_{i+1} - \eta_i)}{N} (C_i^{h-2g} - \partial^N \lambda_i) \right] - \exp \left[- \frac{(\eta_{i+1} - \eta_i)}{N} C_i^h \right] \right]. \quad (3.34)$$

To compute (3.34), we expand the above exponentials. Write $(N^2 L_{h,0}^* \mathbf{1})_{\text{order } p}$ for the term of order $p \in \mathbb{N}$. From the existence of $C_{h,g} = C(\|h\|_\infty, \|g\|_\infty) > 0$ such that $|e^x - 1 - x - x^2/2 - x^3/6| \leq C_{h,g} x^4$ when $|x| \leq 2(\|h\|_\infty + 2\|g\|_\infty)$, one has $|\delta_{0, \text{order} \geq 4}^N(\eta)| \leq 2C_{h,g}/N$, with:

$$N^2 L_{h,0}^* \mathbf{1}(\eta) = \frac{N}{2} \sum_{i < N-1} (\eta_{i+1} - \eta_i) \left[2C_i^{h-g} - \partial^N \lambda_i \right] \quad (3.35)$$

$$+ \frac{1}{4} \sum_{i < N-1} (\eta_{i+1} - \eta_i)^2 \left[(C_i^{h-2g} - \partial^N \lambda_i)^2 - (C_i^h)^2 \right] \quad (3.36)$$

$$+ \frac{1}{12N} \sum_{i < N-1} (\eta_{i+1} - \eta_i) \left[[C_i^{h-2g} - \partial^N \lambda_i]^3 + (C_i^h)^3 \right] + \delta_{0, \text{order} \geq 4}^N(\eta). \quad (3.37)$$

The sum in the last line (3.37) will later be found to be an error term, in Section 3.4.3. The important terms are therefore the sums in (3.35)-(3.36), which we will see impose conditions on the choice of g .

To highlight the structure of $L_h^* \mathbf{1}$, let us rewrite the sums in (3.35)-(3.36) by grouping together terms involving n -point correlations, $n \in \mathbb{N}^*$. By (3.31), C is the sum of B , which involves one-point correlations (i.e. one $\bar{\eta}$); and of D , which is configuration-independent, like λ . Moreover, the sum in (3.35) will have to be integrated by parts to remove the N factor. To do so, write:

$$\forall i < N-1, \quad \eta_{i+1} - \eta_i = \bar{\eta}_{i+1} - \bar{\eta}_i + \bar{\rho}_{i+1} - \bar{\rho}_i = \bar{\eta}_{i+1} - \bar{\eta}_i + N^{-1} \partial^N \bar{\rho}_i. \quad (3.38)$$

The sum in (3.35) therefore contains constant terms, fluctuations and two-point correlations. Let us similarly analyse the second line (3.36). The jump rate $(\eta_{i+1} - \eta_i)^2$, $i < N - 1$ can be expressed in terms of $\bar{\eta}_i$ and $\bar{\eta}_{i+1}$ as follows:

$$\forall i < N - 1, \quad (\eta_{i+1} - \eta_i)^2 = a_i + \sigma'(\bar{\rho}_i)\bar{\eta}_{i+1} + \sigma'(\bar{\rho}_{i+1})\bar{\eta}_i - 2\bar{\eta}_i\bar{\eta}_{i+1}, \quad (3.39)$$

where $a_i = \bar{\rho}_{i+1}(1 - \bar{\rho}_i) + \bar{\rho}_i(1 - \bar{\rho}_{i+1})$, $i < N - 1$. The sum in (3.36) therefore involves constant terms and n -point correlations for each $1 \leq n \leq 4$. In Section 3.4.3, we prove that three-point and four-point correlations lead to an error term $\delta_{0,3-4}^N$, while the sum in the third line (3.37) is an error term $\delta_{0,\text{order } 3}^N$. The adjoint in the bulk thus reads:

$$N^2 L_{h,0}^* \mathbf{1} = \text{Const} + \text{Fluct} + \text{Corr} + \delta_{0,3-4}^N + \delta_{0,\text{order } 3}^N + \delta_{0,\text{order} \geq 4}^N, \quad (3.40)$$

where Const, Fluct, Corr respectively denote the constant terms, the fluctuations and the correlations. The expression of these terms is given in the next three sections. Informally, these are small only when ν_g^N satisfies specific conditions. Namely, the fluctuations term Fluct is small because, by definition, ν_g^N has the same average occupation number as the invariant measure in the large N limit, see Section 3.4.1. On the other hand, the correlations Corr are small provided g solves the partial differential equation (2.31), as shown in Section 3.4.2. Finally, the constant Const is small provided all other terms are, as established in Section 3.4.4. We will repeatedly use the following estimates (recall the definition (3.31) of D):

$$\sup_{i < N-1} |D_i| = O(N^{-1}), \quad \sup_{i < N-1} \left| \frac{a_i \partial^N \lambda_i}{2} - \partial^N \bar{\rho}_i \right| = O(N^{-1}) = \sup_{i < N-1} \left| \partial^N \lambda_i - \frac{\partial^N \bar{\rho}_i}{\bar{\sigma}_i} \right|. \quad (3.41)$$

3.4.1 The fluctuations

Here, we estimate the fluctuations term Fluct in (3.40), which we recall accounts for all terms with a single $\bar{\eta}$ in the two sums (3.35)-(3.36). Recalling (3.39), it reads:

$$\begin{aligned} \text{Fluct} &= \frac{1}{2} \sum_{i < N-1} \left[N(\bar{\eta}_{i+1} - \bar{\eta}_i)(2D_i^{h-g} - \partial^N \lambda_i) + 2\partial^N \bar{\rho}_i B_i^{h-g} \right. \\ &\quad \left. + \frac{a_i}{2} [2B_i^{h-2g}(D_i^{h-2g} - \partial^N \lambda_i) - 2B_i^g D_i^g] \right. \\ &\quad \left. + \frac{1}{2} [\sigma'(\bar{\rho}_i)\bar{\eta}_{i+1} + \sigma'(\bar{\rho}_{i+1})\bar{\eta}_i] [(D_i^{h-2g} - \partial^N \lambda_i)^2 - (D_i^g)^2] \right]. \end{aligned} \quad (3.42)$$

To estimate the size of each term above, recall from Lemma 3.7 that a term of the form $Y^N(\phi)$ (defined in (3.17)), with $\phi : (-1, 1) \rightarrow \mathbb{R}$ bounded, is controllable with size 1. Anything of the form $\varepsilon_N Y^N(\phi)$, with $\varepsilon_N = o_N(1)$, is therefore an error term with size ε_N^2 . Using (3.41), (3.42) thus turns into:

$$\begin{aligned} \text{Fluct} &= \frac{1}{2} \sum_{i < N-1} \left[N(\bar{\eta}_{i+1} - \bar{\eta}_i)(2D_i^{h-g} - \partial^N \lambda_i) + 2\partial^N \bar{\rho}_i B_i^{h-g} - a_i \partial^N \lambda_i B_i^{h-2g} \right. \\ &\quad \left. + \frac{(\partial^N \lambda_i)^2}{2} [\sigma'(\bar{\rho}_i)\bar{\eta}_{i+1} + \sigma'(\bar{\rho}_{i+1})\bar{\eta}_i] \right] + \delta_{0,1}^{N,1}(\eta), \end{aligned} \quad (3.43)$$

where $\delta_{0,1}^{N,1}(\eta)$ reads:

$$\begin{aligned} \delta_{0,1}^{N,1}(\eta) := & \frac{1}{2} \sum_{i < N-1} \left[a_i [B_i^{h-2g} D_i^{h-2g} - B_i^g D_i^g] + [\bar{\sigma}'(\bar{\rho}_i) \bar{\eta}_{i+1} + \sigma'(\bar{\rho}_{i+1}) \bar{\eta}_i] \right. \\ & \left. \times [(D_i^{h-2g})^2 - 2D_i^{h-2g} \partial^N \lambda_i - (D_i^g)^2] \right]. \end{aligned}$$

Recall from (3.31) that each B_i for $i < N-1$ is of the form $N^{-1/2} Y^N(\phi)$ for a bounded function ϕ , and that $\sup_i |D_i| = O(N^{-1})$. As a result, all terms composing $\delta_{0,1}^{N,1}$ are of the form $N^{-1/2} Y^N(\psi)$ or $N^{-3/2} Y^N(\psi)$ for a bounded ψ , thus controllable with size at most N^{-1} by Lemma 3.7. It follows that $\delta_{0,1}^{N,1}$ is controllable with size N^{-1} .

Let us compute (3.43). From (3.31) and the regularity of h, g , one draws, for each $i < N-1$:

$$D_{i-1}^{h-g} - D_i^{h-g} = -\frac{1}{2N^2} \left[(h-g)_{i,i+1} \Delta^N \bar{\rho}_i + N [(h-g)_{i,i+1} - (h-g)_{i-1,i}] \partial^N \bar{\rho}_{i-1} \right], \quad (3.44)$$

where $\Delta^N \bar{\rho}_i = \partial^N (\partial^N \bar{\rho}_{i-1}) = N^2 [\bar{\rho}_{i+1} + \bar{\rho}_{i-1} - 2\bar{\rho}_i]$. As a result, $\sup_i |D_{i-1}^{h-g} - D_i^{h-g}| = O(N^{-2})$. Moreover, $g(\pm 1, \cdot) = 0 = h(\pm 1, \cdot)$, which implies that $D_{-(N-1)}^{h-g} = O(N^{-2}) = D_{N-2}^{h-g}$. An integration by parts therefore turns (3.43) into:

$$\begin{aligned} \text{Fluct} = & \frac{1}{2} \sum_{|i| < N-1} \bar{\eta}_i \Delta^N \lambda_i - \frac{N}{2} \bar{\eta}_{N-1} \partial^N \lambda_{N-2} + \frac{N}{2} \bar{\eta}_{-(N-1)} \partial^N \lambda_{-(N-1)} \\ & + \sum_{i < N-1} \left[\partial^N \bar{\rho}_i B_i^{h-g} - \frac{a_i \partial^N \lambda_i}{2} B_i^{h-2g} + \frac{(\partial^N \lambda_i)^2}{4} [\sigma'(\bar{\rho}_i) \bar{\eta}_{i+1} + \sigma'(\bar{\rho}_{i+1}) \bar{\eta}_i] \right] + \sum_{q=1}^2 \delta_{0,1}^{N,q}(\eta), \end{aligned} \quad (3.45)$$

where $\delta_{0,1}^{N,2}$ is a controllable error term with size N^{-1} , as it reads:

$$\delta_{0,1}^{N,2}(\eta) = \frac{1}{N} \sum_{|i| < N-1} \bar{\eta}_i N^2 [D_{i-1}^{h-g} - D_i^{h-g}] + \bar{\eta}_{N-1} D_{N-2}^{h-g} - \bar{\eta}_{-(N-1)} D_{-(N-1)}^{h-g}.$$

Using (3.41) to express $a \cdot \partial^N \lambda$ in terms of $\partial^N \bar{\rho}$ in the terms involving B in the second line, (3.45) becomes:

$$\begin{aligned} \text{Fluct} = & \frac{1}{2} \sum_{|i| < N-1} \bar{\eta}_i \Delta^N \lambda_i - \frac{N}{2} \bar{\eta}_{N-1} \partial^N \lambda_{N-2} + \frac{N}{2} \bar{\eta}_{-(N-1)} \partial^N \lambda_{-(N-1)} \\ & + \sum_{i < N-1} \left[\partial^N \bar{\rho}_i B_i^g + \frac{(\partial^N \lambda_i)^2}{4} [\sigma'(\bar{\rho}_i) \bar{\eta}_{i+1} + \sigma'(\bar{\rho}_{i+1}) \bar{\eta}_i] \right] + \sum_{q=1}^3 \delta_{0,1}^{N,q}(\eta), \end{aligned} \quad (3.46)$$

with $\delta_{0,1}^{N,3}(\eta)$ of the form $N^{-1/2} Y^N(\phi)$ (recall (3.17)) with ϕ bounded, thus controllable with size N^{-1} . Indeed, recalling the estimates (3.41) and the definition (3.31) of B , it reads:

$$\delta_{0,1}^{N,3}(\eta) = -\frac{1}{2N} \sum_{j \in \Lambda_N} \bar{\eta}_j \left(\frac{1}{N} \sum_{i \notin \{j-1, j, N-1\}} N \left[\frac{a_i \partial^N \lambda_i}{2} - \partial^N \bar{\rho}_i \right] \partial_1^N (h-2g)_{i,j} \right),$$

and the term between parenthesis is bounded uniformly in $j \in \Lambda_N$ and $N \in \mathbb{N}^*$. Let us now compute the term involving B in (3.46). Recall that $g \in C^3(\bar{\square})$ and is symmetric, thus $\sup_{|j| < N-1} N|g_{j-1,j} - g_{j+1,j}|$ is bounded uniformly in N . Integrating by parts and using $g(\pm 1, \cdot) = 0$, and the symmetry of g in the last line below; we find:

$$\begin{aligned}
\sum_{i < N-1} \partial^N \bar{\rho}_i B_i^g &= \frac{1}{2N} \sum_{i < N-1} \partial^N \bar{\rho}_i \sum_{j \notin \{i, i+1\}} \bar{\eta}_j \partial_1^N g_{i,j} = \frac{1}{2N} \sum_{j \in \Lambda_N} \bar{\eta}_j \sum_{i \notin \{j-1, j, N-1\}} \partial^N \bar{\rho}_i \partial_1^N g_{i,j} \\
&= -\frac{1}{2N} \sum_{j \in \Lambda_N} \bar{\eta}_j \left[\sum_{\substack{|i| < N-1 \\ |j-i| > 1}} \Delta^N \bar{\rho}_i g_{i,j} + \partial^N \bar{\rho}_{j-2} (N g_{j-1,j}) - \partial^N \bar{\rho}_{j+1} (N g_{j+1,j}) \right. \\
&\quad \left. + \partial^N \bar{\rho}_{N-2} (N g_{N-1,j}) - \partial^N \bar{\rho}_{-N+1} (N g_{-N+1,j}) \right] \\
&=: -\frac{1}{2N} \sum_{j \in \Lambda_N} \bar{\eta}_j \sum_{\substack{|i| < N-1 \\ |j-i| > 1}} \Delta^N \bar{\rho}_i g_{i,j} + \delta_{0,1}^{N,4}(\eta) \\
&=: -\frac{1}{2} \sum_{j \in \Lambda_N} \bar{\eta}_j (N^{-1} M_g)(\Delta \bar{\rho})(j) + \delta_{0,1}^{N,5}(\eta), \tag{3.47}
\end{aligned}$$

where $\delta_{0,1}^{N,4}, \delta_{0,1}^{N,5}$ are of the form $N^{-1/2} Y^N(\phi)$ ($Y^N(\phi)$ is defined in (3.17)) for bounded ϕ , and therefore controllable error terms with size N^{-1} . M_g is the matrix $(g_{i,j})_{(i,j) \in \Lambda_N^2}$ and $(\Delta \bar{\rho})$ the vector $(\Delta \bar{\rho}_i)_{i \in \Lambda_N}$, so that $\delta_{0,1}^{N,5}$ accounts for the replacement of $\Delta^N \bar{\rho}$ by $\Delta \bar{\rho}$ (this cost vanishes in our case since $\bar{\rho}$ is linear, but we do not use this fact at this point), as well as the addition of missing terms in the sum on i :

$$\delta_{0,1}^{N,5}(\eta) = -\frac{1}{2N} \sum_{j \in \Lambda_N} \bar{\eta}_j \sum_{\substack{-N+1 < i < N-1 \\ |j-i| > 1}} [\Delta^N \bar{\rho}_i - \Delta \bar{\rho}_i] g_{i,j} - \frac{1}{2N} \sum_{j \in \Lambda_N} \bar{\eta}_j \sum_{i \in \{\pm(N-1), j, j \pm 1\}} \Delta \bar{\rho}_i g_{i,j}.$$

Consider now the sums involving λ . in (3.46). Elementary computations give, for each $i < N-1$:

$$\Delta^N \lambda_i = N[\partial^N \lambda_i - \partial^N \lambda_{i-1}] = \frac{\Delta^N \bar{\rho}_i}{\bar{\sigma}_i} - \frac{(\partial^N \bar{\rho}_i)^2 \sigma'(\bar{\rho}_i)}{(\bar{\sigma}_i)^2} + \varepsilon_i^N, \quad \sup_{|i| < N-1} |\varepsilon_i^N| = O(N^{-1}).$$

By (3.41), we also know $\sup_i |\partial^N \lambda_i - \partial^N \bar{\rho}_i / \bar{\sigma}_i| = O(N^{-1})$. As a result:

$$\begin{aligned}
\frac{1}{2} \sum_{|i| < N-1} \bar{\eta}_i \Delta^N \lambda_i &+ \sum_{i < N-1} \frac{(\partial^N \lambda_i)^2}{4} [\sigma'(\bar{\rho}_i) \bar{\eta}_{i+1} + \sigma'(\bar{\rho}_{i+1}) \bar{\eta}_i] \\
&\quad - \frac{N}{2} \bar{\eta}_{N-1} \partial^N \lambda_{N-2} + \frac{N}{2} \bar{\eta}_{-(N-1)} \partial^N \lambda_{-(N-1)} \\
&= \frac{1}{2} \sum_{i \in \Lambda_N} \bar{\eta}_i \frac{\Delta \bar{\rho}_i}{\bar{\sigma}_i} - \frac{N}{2} \bar{\eta}_{N-1} \partial^N \lambda_{N-2} + \frac{N}{2} \bar{\eta}_{-(N-1)} \partial^N \lambda_{-(N-1)} + \delta_{0,1}^{N,6}(\eta), \tag{3.48}
\end{aligned}$$

where $\delta_{0,1}^{N,6}$ reads:

$$\begin{aligned} \delta_{0,1}^{N,6}(\eta) &:= \frac{1}{2} \sum_{|i| < N-1} \bar{\eta}_i \left[\Delta^N \lambda_i + \frac{1}{4} [(\partial^N \lambda_{i-1})^2 \sigma'(\bar{\rho}_{i-1}) + (\partial^N \lambda_i)^2 \sigma'(\bar{\rho}_{i+1})] - \frac{\Delta \bar{\rho}_i}{\bar{\sigma}_i} \right] \\ &\quad + \frac{\bar{\eta}_{N-1} (\partial^N \lambda_{N-2})^2 \sigma'(\bar{\rho}_{N-2})}{4} + \frac{\bar{\eta}_{-(N-1)} (\partial^N \lambda_{-(N-1)})^2 \sigma'(\bar{\rho}_{-(N-2)})}{4} \\ &\quad - \bar{\eta}_{N-1} \frac{\Delta \bar{\rho}_{N-1}}{\bar{\sigma}_{N-1}} - \bar{\eta}_{-(N-1)} \frac{\Delta \bar{\rho}_{-(N-1)}}{\bar{\sigma}_{-(N-1)}}. \end{aligned}$$

The function $\delta_{0,1}^{N,6}$ involves terms of the form $\bar{\eta}_{\pm(N-1)} u(\pm(N-1))$ with u bounded (the last two lines), and $N^{-1/2} Y^N(\phi)$ for bounded $\phi : (-1, 1) \rightarrow \mathbb{R}$ (the first line). It is therefore Γ -controllable with size N^{-1} by Lemma 3.7. Note that the last line actually vanishes since $\Delta \bar{\rho} = 0$. We do not need this fact at this point.

Putting (3.46), (3.47) and (3.48) together, we have computed the fluctuations term (3.42) in $N^2 L_{h,0}^* \mathbf{1}$:

$$\begin{aligned} \text{Fluct} &= \frac{1}{2} \sum_{i \in \Lambda_N} \bar{\eta}_i (\bar{\sigma}^{-1} - N^{-1} M_g) (\Delta \bar{\rho})(i) - \frac{N}{2} \bar{\eta}_{N-1} \partial^N \lambda_{N-2} \\ &\quad + \frac{N}{2} \bar{\eta}_{-(N-1)} \partial^N \lambda_{-(N-1)} + \sum_{q=1}^6 \delta_{0,1}^{N,q}(\eta). \end{aligned}$$

Since $\Delta \bar{\rho} = 0$, the first sum vanishes, and:

$$\text{Fluct} = -\frac{N}{2} \bar{\eta}_{N-1} \partial^N \lambda_{N-2} + \frac{N}{2} \bar{\eta}_{-(N-1)} \partial^N \lambda_{-(N-1)} + \delta_{0,1}^N(\eta), \quad \delta_{0,1}^N := \sum_{q=1}^6 \delta_{0,1}^{N,q}. \quad (3.49)$$

By definition of error terms, see Definition 3.5, we have proven the following: for any $\theta > 0$, there are $\gamma_\theta, C_\theta > 0$ such that, for any density f for ν_g^N :

$$\begin{aligned} \nu_g^N(f \cdot \text{Fluct}) &\leq \frac{N}{2} \nu_g^N(f[-\bar{\eta}_{N-1} \partial^N \lambda_{N-2} + \bar{\eta}_{-(N-1)} \partial^N \lambda_{-(N-1)}]) \\ &\quad + \theta N^2 \nu_g^N(\Gamma_h(\sqrt{f})) + \frac{H(f \nu_g^N | \nu_g^N)}{\gamma_\theta} + \frac{C_\theta}{N}. \end{aligned} \quad (3.50)$$

3.4.2 The correlations

In this section, we compute the Corr term in (3.40) and obtain the partial differential equation that an optimal g must solve. Recall that Corr corresponds to all terms in (3.35)-(3.36) that involve products of two $\bar{\eta}$'s. It reads:

$$\begin{aligned} \text{Corr} &= \sum_{i < N-1} \left[N(\bar{\eta}_{i+1} - \bar{\eta}_i) B_i^{h-g} - a_i B_i^g B_i^{h-g} - \frac{1}{2} \bar{\eta}_i \bar{\eta}_{i+1} [(D_i^{h-2g} - \partial^N \lambda_i)^2 - (D_i^h)^2] \right. \\ &\quad \left. + \frac{1}{2} [\sigma'(\bar{\rho}_i) \bar{\eta}_{i+1} + \sigma'(\bar{\rho}_{i+1}) \bar{\eta}_i] [B_i^{h-2g} (D_i^{h-2g} - \partial^N \lambda_i) - B_i^h D_i^h] \right] \end{aligned} \quad (3.51)$$

Recall from Lemma 3.7 that terms of the form $\Pi^N(u)$, or $N^{-1/2}X_{1,\{0,1\}}^v = N^{-1/2}\sum_{i < N-1} \bar{\eta}_i \bar{\eta}_{i+1} v_i$, are controllable with size 1 as soon as the test functions u, v are bounded. Multiplying them by ε_N with $\varepsilon_N = o_N(1)$ therefore turns them into controllable error terms with size $\varepsilon_N, \varepsilon_N^2$ respectively. As in Section 3.4.1, we first use the estimate (3.41) on the size of D to remove some terms from (3.51):

$$\begin{aligned} \text{Corr} = \sum_{i < N-1} & \left[N(\bar{\eta}_{i+1} - \bar{\eta}_i) B_i^{h-g} - a_i B_i^g B_i^{h-g} - \frac{1}{2} \bar{\eta}_i \bar{\eta}_{i+1} (\partial^N \lambda_i)^2 \right. \\ & \left. - \frac{1}{2} [\sigma'(\bar{\rho}_i) \bar{\eta}_{i+1} + \sigma'(\bar{\rho}_{i+1}) \bar{\eta}_i] \partial^N \lambda_i B_i^{h-2g} \right] + \delta_{0,2}^{N,1}(\eta), \end{aligned} \quad (3.52)$$

with $\delta_{0,2}^{N,1}$ controllable with size N^{-1} , that reads:

$$\begin{aligned} \delta_{0,2}^{N,1}(\eta) := & -\frac{1}{2N} \sum_{i < N-1} \bar{\eta}_i \bar{\eta}_{i+1} N [(D_i^{h-2g})^2 - 2D_i^{h-2g} \partial^N \lambda_i - (D_i^h)^2] \\ & + \frac{1}{2N} \sum_{i < N-1} [\sigma'(\bar{\rho}_i) \bar{\eta}_{i+1} + \sigma'(\bar{\rho}_{i+1}) \bar{\eta}_i] N [B_i^{h-2g} D_i^{h-2g} - B_i^h D_i^h]. \end{aligned}$$

Let us integrate by parts the term involving $\bar{\eta}_{i+1} - \bar{\eta}_i$ in (3.52), $i < N - 1$. To do so, notice first that, for each i with $|i| < N - 1$:

$$\begin{aligned} N[B_{i-1}^{h-g} - B_i^{h-g}] = N[B_i^{g-h} - B_{i-1}^{g-h}] & = \frac{1}{2N} \sum_{j:|j-i|>1} \bar{\eta}_j \Delta_1^N (g-h)_{i,j} \\ & + \frac{1}{2} [\bar{\eta}_{i-1} \partial_1^N (g-h)_{i,i-1} - \bar{\eta}_{i+1} \partial_1^N (g-h)_{i-1,i+1}], \end{aligned}$$

with $\Delta_1^N u(i, j) = \partial_1^N (\partial_1^N u(i-1, j))$ for $u : \mathbb{Z}^2 \rightarrow \mathbb{R}$ and $(i, j) \in \mathbb{Z}^2$. As a result:

$$\begin{aligned} \sum_{i < N-1} N(\bar{\eta}_{i+1} - \bar{\eta}_i) B_i^{h-g} & = N\bar{\eta}_{N-1} B_{N-2}^{h-g} - N\bar{\eta}_{-(N-1)} B_{-(N-1)}^{h-g} + \sum_{|i| < N-1} \bar{\eta}_i N [B_{i-1}^{h-g} - B_i^{h-g}] \\ & = \delta_{0,2}^{N,2}(\eta) + \frac{1}{2N} \sum_{|i| < N-1} \sum_{j:|j-i|>1} \bar{\eta}_i \bar{\eta}_j \Delta_1^N (g-h)_{i,j} \\ & + \frac{1}{2} \sum_{|i| < N-1} \bar{\eta}_i [\bar{\eta}_{i-1} \partial_1^N (g-h)_{i,i-1} - \bar{\eta}_{i+1} \partial_1^N (g-h)_{i-1,i+1}], \end{aligned} \quad (3.53)$$

where $\delta_{0,2}^{N,2}(\eta) := N\bar{\eta}_{N-1} B_{N-2}^{h-g} - N\bar{\eta}_{-(N-1)} B_{-(N-1)}^{h-g}$. $\delta_{0,2}^{N,2}$ involves correlations between the reservoir and the bulk, of the same form as the function U_1^\pm defined in Lemma 3.7. $\delta_{0,2}^{N,2}$ is thus Γ -controllable with size N^{-1} . On the other hand, the last line of (3.53) can be integrated by parts once again:

$$\begin{aligned} & \sum_{|i| < N-1} \bar{\eta}_i [\bar{\eta}_{i-1} \partial_1^N (g-h)_{i,i-1} - \bar{\eta}_{i+1} \partial_1^N (g-h)_{i-1,i+1}] \\ & = \sum_{-(N-1) < i < N-2} \bar{\eta}_i \bar{\eta}_{i+1} [\partial_1^N (g-h)_{i+1,i} - \partial_1^N (g-h)_{i-1,i+1}] + \delta_{0,2}^{N,3}(\eta), \end{aligned}$$

with:

$$\delta_{0,2}^{N,3}(\eta) := \bar{\eta}_{-(N-1)}\bar{\eta}_{-(N-2)}\partial_1^N(g-h)_{-(N-2),-(N-1)} - \bar{\eta}_{N-2}\bar{\eta}_{N-1}\partial_1^N(g-h)_{N-3,N-1}.$$

$\delta_{0,2}^{N,3}$ is again a Γ -controllable error term with size N^{-1} (in fact N^{-2}), as it is of the same form as the function U_1^\pm of Lemma 3.7. Equation (3.53) thus reads:

$$\begin{aligned} \sum_{i < N-1} N(\bar{\eta}_{i+1} - \bar{\eta}_i)B_i^{h-g} &= \frac{1}{2N} \sum_{|i| < N-1} \sum_{j: |j-i| > 1} \bar{\eta}_i \bar{\eta}_j \Delta_1^N(g-h)_{i,j} \\ &+ \frac{1}{2} \sum_{-(N-1) < i < N-2} \bar{\eta}_i \bar{\eta}_{i+1} [\partial_1^N(g-h)_{i+1,i} - \partial_1^N(g-h)_{i-1,i+1}] + \sum_{q=2}^3 \delta_{0,2}^{N,q}(\eta). \end{aligned} \quad (3.54)$$

The other terms in (3.52) are simpler. Indeed, recall that:

$$\sup_{i < N-1} |a_i - 2\bar{\sigma}_i| = O(N^{-1}), \quad \sup_{i < N-1} \left| \partial^N \lambda_i - \frac{\partial^N \bar{\rho}_i}{\bar{\sigma}_i} \right| = O(N^{-1}).$$

Using these estimates in (3.52), Corr becomes:

$$\begin{aligned} \text{Corr} &= \frac{1}{2N} \sum_{|i| < N-1} \sum_{j: |j-i| > 1} \bar{\eta}_i \bar{\eta}_j \Delta_1^N(g-h)_{i,j} \\ &+ \frac{1}{2} \sum_{-(N-1) < i < N-2} \bar{\eta}_i \bar{\eta}_{i+1} \left[\partial_1^N(g-h)_{i+1,i} - \partial_1^N(g-h)_{i-1,i+1} - \frac{(\partial^N \bar{\rho}_i)^2}{(\bar{\sigma}_i)^2} \right] \\ &- \sum_{i < N-1} \left[[\sigma'(\bar{\rho}_i)\bar{\eta}_{i+1} + \sigma'(\bar{\rho}_{i+1})\bar{\eta}_i] \frac{\partial^N \bar{\rho}_i}{2\bar{\sigma}_i} B_i^{h-2g} + 2\bar{\sigma}_i B_i^g B_i^{h-g} \right] + \sum_{q=1}^4 \delta_{0,2}^{N,q}(\eta), \end{aligned} \quad (3.55)$$

where $\delta_{0,2}^{N,4}$ is an error term with size N^{-1} , that reads:

$$\begin{aligned} \delta_{0,2}^{N,4}(\eta) &= -\frac{1}{2N} \sum_{i < N-1} [\sigma'(\bar{\rho}_i)\bar{\eta}_{i+1} + \sigma'(\bar{\rho}_{i+1})\bar{\eta}_i] \left[\partial^N \lambda_i - \frac{\partial^N \bar{\rho}_i}{\bar{\sigma}_i} \right] B_i^{h-2g} - \frac{1}{N} \sum_{i < N-1} N[a_i - 2\bar{\sigma}_i] B_i^g B_i^{h-g} \\ &- \frac{1}{2N} \sum_{-(N-1) < i < N-2} \bar{\eta}_i \bar{\eta}_{i+1} N \left[(\partial^N \lambda_i)^2 - \frac{(\partial^N \bar{\rho}_i)^2}{\bar{\sigma}_i^2} \right] \\ &- \frac{1}{2} \left[\bar{\eta}_{-(N-1)} \bar{\eta}_{-(N-2)} (\partial^N \lambda_{-(N-1)})^2 + \bar{\eta}_{N-2} \bar{\eta}_{N-1} (\partial^N \lambda_{N-2})^2 \right]. \end{aligned}$$

The last line comes from the fact that the sum involving $\bar{\eta}_i \bar{\eta}_{i+1}$ in (3.52) and in (3.54) do not have the same range. It is of the same form as U_1^+ in Lemma 3.7, thus is Γ -controllable with size N^{-1} (in fact N^{-2}). The first line above is of the form $N^{-2} X_{2,\{0\}}^{\phi_2}$, while the second line reads $N^{-1/2} X_{1,\{0,1\}}^{\phi_1}$; for bounded tensors ϕ_1, ϕ_2 . As a result, $\delta_{0,2}^{N,4}$ is Γ -controllable with size N^{-1} by Lemma 3.7.

To conclude on the expression of the correlations, it remains to take care of the two terms involving B in (3.55). Recalling the definition (3.31) of B , using the regularity of h, g and $\bar{\rho}$ and changing

indices, one can write:

$$\begin{aligned} \frac{1}{2} \sum_{i < N-1} [\sigma'(\bar{\rho}_i) \bar{\eta}_{i+1} + \sigma'(\bar{\rho}_{i+1}) \bar{\eta}_i] \frac{\partial^N \bar{\rho}_i}{\bar{\sigma}_i} B_i^{2g-h} \\ = \frac{1}{2N} \sum_{|i| < N-1} \frac{\sigma'(\bar{\rho}_i) \partial^N \bar{\rho}_i}{\bar{\sigma}_i} \bar{\eta}_i \sum_{j \notin \{i, i+1\}} \bar{\eta}_j \partial_1^N (2g-h)_{i,j} + \delta_{0,2}^{N,5}(\eta), \end{aligned}$$

where $\delta_{0,2}^{N,5}$ is an error term that reads:

$$\begin{aligned} \delta_{0,2}^{N,5}(\eta) &= \frac{1}{2N} \sum_{|i| < N-1} \bar{\eta}_i N [\sigma'(\bar{\rho}_{i+1}) - \sigma'(\bar{\rho}_i)] \frac{\partial^N \bar{\rho}_i}{\bar{\sigma}_i} B_i^{2g-h} \\ &+ \frac{1}{2N} \sum_{|i| < N-1} \bar{\eta}_i N \left[\sigma'(\bar{\rho}_{i-1}) \frac{\partial^N \bar{\rho}_{i-1}}{\bar{\sigma}_{i-1}} B_{i-1}^{2g-h} - \sigma'(\bar{\rho}_i) \frac{\partial^N \bar{\rho}_i}{\bar{\sigma}_i} B_i^{2g-h} \right] \\ &+ \bar{\eta}_{N-1} \frac{\sigma'(\bar{\rho}_{N-2}) \partial^N \bar{\rho}_{N-2}}{2\bar{\sigma}_{N-2}} B_{N-2}^{2g-h} + \bar{\eta}_{-(N-1)} \frac{\sigma'(\bar{\rho}_{-(N-2)}) \partial^N \bar{\rho}_{-(N-1)}}{2\bar{\sigma}_{-(N-1)}} B_{-(N-1)}^{2g-h}. \end{aligned}$$

$\delta_{0,2}^{N,5}$ is of the form $N^{-1} X_{2,\{0\}}^{\phi_2}$ for a bounded ϕ_2 for the first two lines, and $N^{-1} U_1^\pm$ for the third line. By Lemma 3.7, it is therefore Γ -controllable with size N^{-1} . Finally, recall that $(\bar{\eta})^2 = \bar{\sigma} + \sigma'(\bar{\rho}) \bar{\eta}$. Separating diagonal and off-diagonal contributions, the term involving $B^g B^{h-g}$ in (3.55) reads:

$$\begin{aligned} -2 \sum_{i < N-1} \bar{\sigma}_i B_i^g B_i^{h-g} &= \frac{1}{2N^2} \sum_{i < N-1} \bar{\sigma}_i \sum_{j, \ell \notin \{i, i+1\}} \bar{\eta}_j \bar{\eta}_\ell \partial_1^N g_{i,j} \partial_1^N (g-h)_{i,\ell} \\ &= \frac{1}{2N} \sum_{\substack{|j| < N-1 \\ \ell \neq j}} \bar{\eta}_j \bar{\eta}_\ell \left(\frac{2}{2N} \sum_{i \notin \{j-1, j, \ell-1, \ell, N-1\}} \bar{\sigma}_i \partial_1^N g_{i,j} \partial_1^N (g-h)_{i,\ell} \right) \\ &+ \frac{1}{2N^2} \sum_{i < N-1} \sum_{j \notin \{i, i+1\}} \bar{\sigma}_i \bar{\sigma}_j \partial_1^N g_{i,j} \partial_1^N (g-h)_{i,j} + \delta_{0,2}^{N,6}(\eta), \end{aligned}$$

where $\delta_{0,2}^{N,6}$ is an error term of the form $N^{-1/2} Y^N(\phi) + U_1^\pm$ (recall (3.17)), thus Γ -controllable with size N^{-1} by Lemma 3.7, which reads:

$$\begin{aligned} \delta_{0,2}^{N,6}(\eta) &= \frac{1}{2N^2} \sum_{i < N-1} \sum_{j \notin \{i, i+1\}} \bar{\sigma}_i \sigma'(\bar{\rho}_j) \bar{\eta}_j \partial_1^N g_{i,j} \partial_1^N (g-h)_{i,j} \\ &+ \sum_{j \in \{\pm(N-1)\}} \sum_{\ell \neq j} \bar{\eta}_j \bar{\eta}_\ell \left(\frac{2}{2N} \sum_{i \notin \{j-1, j, \ell-1, \ell, N-1\}} \bar{\sigma}_i \partial_1^N g_{i,j} \partial_1^N (g-h)_{i,\ell} \right). \end{aligned}$$

The correlations (3.51) have so far been rewritten as follows:

$$\text{Corr} = \sum_{\substack{|i| < N-1 \\ j \neq i}} \bar{\eta}_i \bar{\eta}_j \left\{ \frac{1}{2N} \left[\mathbf{1}_{|i-j| > 1} \Delta_1^N (g-h)_{i,j} + \mathbf{1}_{j \neq i+1} \partial_1^N \bar{\rho}_i \frac{\sigma'(\bar{\rho}_i)}{\bar{\sigma}_i} \partial_1^N (2g-h)_{i,j} \right. \right. \quad (3.56)$$

$$\left. + \frac{1}{N} \sum_{\ell \notin \{i-1, i, j-1, j, N-1\}} \bar{\sigma}_\ell \partial_1^N g_{\ell,i} \partial_1^N (g-h)_{\ell,j} \right] \\ + \mathbf{1}_{j=i+1 < N-1} \frac{1}{2} \left[\partial_1^N (g-h)_{i+1,i} - \partial_1^N (g-h)_{i-1,i+1} - \frac{\partial_1^N \bar{\rho}_i}{(\bar{\sigma}_i)^2} \right] \left. \right\} \quad (3.57)$$

$$+ \frac{1}{2N^2} \sum_{i < N-1} \sum_{j \notin \{i, i+1\}} \bar{\sigma}_i \bar{\sigma}_j \partial_1^N g_{i,j} \partial_1^N (g-h)_{i,j} + \sum_{q=1}^6 \delta_{0,2}^{N,q}(\eta). \quad (3.58)$$

We claim that the curly bracket is a discrete version of the partial differential equation (2.31). To see it, first use the symmetry of g, h and exchange i, j . Recall then that, by assumption, $h, g \in W^{4,s}(\square)$ for some $s > 2$. By Sobolev embedding, $W^{4,s}(\square) \subset C^3(\bar{\square}) \cap C^3(\bar{\square})$, see Appendix E. As a result, approximating discrete derivatives by continuous ones and the Riemann sum in the second line of (3.57) by an integral, there is a controllable error term $\delta_{0,2}^{N,7}$ with size N^{-1} , of the form $N^{-1} \Pi^N(u) + N^{-1} X_{1,\{0,1\}}^v$ for bounded u, v , such that:

$$(3.56) + (3.57) = \Pi^N \left(\Delta(g-h) + \frac{(\bar{\sigma})'}{\bar{\sigma}} \partial_1 (2g-h) + \partial_2 (2g-h) \frac{(\bar{\sigma})'}{\bar{\sigma}} \right) \\ + \Pi^N \left(I(\partial_1 g, \partial_1 (g-h)) + I(\partial_1 (g-h), \partial_1 g) \right) \\ + \sum_{i < N-1} \bar{\eta}_i \bar{\eta}_{i+1} \left[\partial_1 (g-h)_{i+,i} - \partial_1 (g-h)_{i-,i} - \frac{(\bar{\rho}')^2}{\bar{\sigma}_i^2} \right] + \delta_{0,2}^{N,7}(\eta), \quad (3.59)$$

with I the integral operator defined in (2.23) and the convention $w\phi(x, y) = w(x)\phi(x, y)$, $\phi w(x, y) = \phi(x, y)w(y)$ if $\phi : \square \rightarrow \mathbb{R}$, $w : (-1, 1) \rightarrow \mathbb{R}$ and $(x, y) \in \square$. If g is chosen as the solution g_h of the main equation (2.31), then the right-hand side of (3.59) reduces to $\delta_{0,2}^{N,7}(\eta)$, whence:

$$\text{Corr} = \frac{1}{2N^2} \sum_{i < N-1} \sum_{j \notin \{i, i+1\}} \bar{\sigma}_i \bar{\sigma}_j \partial_1^N (g_h)_{i,j} \partial_1^N (g_h - h)_{i,j} + \delta_{0,2}^N(\eta), \quad \delta_{0,2}^N = \sum_{q=1}^7 \delta_{0,2}^{N,q}. \quad (3.60)$$

By definition of error terms (see Definition 3.5), for any $\theta > 0$, there are thus $\gamma_\theta, C_\theta > 0$ such that, for any density f for $\nu_g^N = \nu_{g_h}^N$:

$$\nu_{g_h}^N(f \cdot \text{Corr}) \leq \frac{1}{2N^2} \sum_{i < N-1} \sum_{j \notin \{i, i+1\}} \bar{\sigma}_i \bar{\sigma}_j \partial_1^N (g_h)_{i,j} \partial_1^N (g_h - h)_{i,j} + \theta N^2 \nu_{g_h}^N(\Gamma_h(\sqrt{f})) \\ + \frac{H(f \nu_{g_h}^N | \nu_{g_h}^N)}{\gamma_\theta} + \frac{C_\theta}{N}. \quad (3.61)$$

Remark 3.9. The choice of $g = g_h$ cancelling (3.56)+(3.57) is optimal in the following sense: for another g , the first two terms in the right-hand side of (3.59) are not even error terms, but only controllable with size 1. As a result, for $g \neq g_h$, (3.61) can only be true with C_θ replacing C_θ/N in the right-hand side, which breaks the $o_N(1)$ bound on the entropy obtained in Section 3.5. ■

3.4.3 Higher-order correlations

In this section, we need not assume that $g = g_h$, and we estimate the third order term $(N^2 L_h^* \mathbf{1})_{\text{order } 3}$ in the development (3.37) of the exponentials making up the adjoint in the bulk, as well as three-point and four-point correlations arising in (3.36).

From (3.37)-(3.38)-(3.39), the latter read:

$$\delta_{0,3-4}^N(\eta) := \sum_{i < N-1} \left[- [\sigma'(\bar{\rho}_i) \bar{\eta}_{i+1} + \sigma'(\bar{\rho}_{i+1}) \bar{\eta}_i] B_i^g B_i^{h-g} + \bar{\eta}_i \bar{\eta}_{i+1} B_i^g (D_i^{2h-2g} - \partial^N \lambda_i) \right] \quad (3.62)$$

$$+ \bar{\eta}_i \bar{\eta}_{i+1} (D_i^{2g} + \partial^N \lambda_i) B_i^{h-g} \Big] + 2 \sum_{i < N-1} \bar{\eta}_i \bar{\eta}_{i+1} B_i^g B_i^{h-g}. \quad (3.63)$$

The first sum (3.62) involves three-point correlations, albeit of the form $\bar{\eta}_i \bar{\eta}_{i+1} \bar{\eta}_j$ for the second term. Lemma 3.7 only yields that it is controllable with size 1. However, using the renormalisation scheme of Jara and Menezes, we prove that it is Γ -controllable with size $N^{-1/2}$ for all $g \in g_0 + \mathcal{S}(\varepsilon_G)$, in Appendix C. The last sum in (3.63) involves four-point correlation, suitably rescaled with N . By Lemma 3.7, it is controllable with size N^{-1} , again for all $g \in g_0 + \mathcal{S}(\varepsilon_G)$. It follows that $\delta_{0,3-4}^N$ is Γ -controllable with size $N^{-1/2}$.

Consider now $(N^2 L_h^* \mathbf{1})_{\text{order } 3}$, which by (3.37) reads:

$$(N^2 L_h^* \mathbf{1}(\eta))_{\text{order } 3} = \frac{1}{12N} \sum_{i < N-1} (\eta_{i+1} - \eta_i) \left[[C_i^{h-2g} - \partial^N \lambda_i]^3 + [C_i^h]^3 \right].$$

For $i < N-1$, write $\eta_{i+1} - \eta_i = \bar{\eta}_{i+1} - \bar{\eta}_i + N^{-1} \partial^N \bar{\rho}_i$ as before, and recall from (3.32) that C_i^{h-2g} , C_i^h are bounded with N . As a result:

$$\left| (N^2 L_h^* \mathbf{1}(\eta))_{\text{order } 3} - \frac{1}{12N} \sum_{i < N-1} (\bar{\eta}_{i+1} - \bar{\eta}_i) \left[[C_i^{h-2g} - \partial^N \lambda_i]^3 + [C_i^h]^3 \right] \right| \leq \frac{C(h, g)}{N}. \quad (3.64)$$

One need not even integrate by parts to find that the sum in (3.64) is small. Indeed, developing the cubes and recalling that $C = B + D$ (see (3.31)) with ND bounded, one finds:

$$\frac{1}{12N} \sum_{i < N-1} (\bar{\eta}_{i+1} - \bar{\eta}_i) \left[[C_i^{h-2g} - \partial^N \lambda_i]^3 + [C_i^h]^3 \right] = \sum_{n=1}^4 N^{-n} X_{n, \{0\}}^{\phi_n}(\eta),$$

for bounded ϕ_n , $1 \leq n \leq 4$, depending on h, g, λ . By Lemma 3.7, $N^{-n} X_{n, \{0\}}^{\phi_n}$ is controllable with size N^{-1} at most for $1 \leq n \leq 4$. This observation and (3.64) yield:

$$\left| (N^2 L_h^* \mathbf{1}(\eta))_{\text{order } 3} \right| \leq \delta_{0, \text{order } 3}^N(\eta) := \frac{C(h, g)}{N} + \left| \sum_{n=1}^4 N^{-n} X_{n, \{0\}}^{\phi_n}(\eta) \right|, \quad (3.65)$$

and $\delta_{0, \text{order } 3}^N$ is controllable with size N^{-1} .

3.4.4 The constant terms

Here, we prove that the configuration-independent terms appearing in the full adjoint $L_h^* \mathbf{1}$ are small when $g = g_h$, with g_h the solution of the main equation (2.31). The terms in question correspond to various constant terms bounded by $O(N^{-1})$ encountered in the previous subsections and the computation of $L_{h,\pm}^* \mathbf{1}$, which already are error terms; and the sum of the constant term in (3.60), as well as the Const term of (3.40), which reads:

$$\text{Const} := \sum_{i < N-1} \left[\partial^N \bar{\rho}_i \left(D_i^{h-g} - \frac{\partial^N \lambda_i}{2} \right) + \frac{a_i}{4} \left[(D_i^{h-2g} - \partial^N \lambda_i)^2 - (D_i^h)^2 \right] \right]. \quad (3.66)$$

By definition of $L_h^* \mathbf{1}$, one has:

$$\nu_{g_h}^N(L_h^* \mathbf{1}) = \nu_{g_h}^N(L_h \mathbf{1}) = 0.$$

We can also estimate $\nu_{g_h}^N(L_h^* \mathbf{1})$ through the expression (3.30) of the adjoint at the boundary and the expansion (3.37) of the adjoint in the bulk. Indeed, Lemmas A.1-A.3 and Proposition A.5 tell us:

$$\begin{aligned} \forall n \geq 1, \quad & \sup_{\substack{J \subset \Lambda_N \\ |J| \in \{2n-1, 2n\}}} \nu_{g_h}^N \left(\prod_{j \in J} \bar{\eta}_j \right) = O(N^{-n}), \\ \forall j \notin \{\pm(N-1)\}, \quad & \nu_{g_h}^N(\bar{\eta}_{\pm(N-1)} \bar{\eta}_j) = O(N^{-2}) = \nu_{g_h}^N(\bar{\eta}_{\pm(N-1)}). \end{aligned}$$

These bounds can be used on the adjoint at the boundary (3.30), the error term $\delta_{\text{order} \geq 3,0}^N$ defined in (3.65), the error term $\delta_{3-4,0}^N$ accounting for three and four point correlations defined in (3.62)-(3.63), the estimate (3.49) of the fluctuations, and (3.60) of the correlations. They yield:

$$\begin{aligned} \nu_{g_h}^N(N^2 L_h^* \mathbf{1}) = 0 &= \text{Const} + \frac{1}{2N^2} \sum_{i < N-1} \sum_{j \notin \{i, i+1\}} \bar{\sigma}_i \bar{\sigma}_j \partial_1^N g_{i,j} \partial_1^N (g-h)_{i,j} + O(N^{-1}) \\ &=: \delta_{0,0}^N + O(N^{-1}). \end{aligned}$$

The configuration-independent terms $\delta_{0,0}^N$ arising in $L_{h,0}^* \mathbf{1}$ are thus bounded by $O(N^{-1})$.

3.5 Conclusion

Let us put together the estimates obtained so far to conclude the proof of Lemma 3.3. The expression of the adjoint at the boundary was obtained in (3.30), while the adjoint in the bulk has been estimated in the last three sections, provided one takes $g = g_h$, with g_h the solution of the main equation (2.31). One has therefore:

$$\begin{aligned} N^2 L_h^* \mathbf{1}(\eta) &= N^2 L_{h,\pm}^* \mathbf{1}(\eta) + N^2 L_{h,0}^* \mathbf{1}(\eta) \\ &= \frac{N}{2} \bar{\eta}_{-(N-1)} \left(\partial^N \lambda_{-N} - \partial^N \lambda_{-(N-1)} \right) - \frac{N}{2} \bar{\eta}_{N-1} \left(\partial^N \lambda_{N-1} - \partial^N \lambda_{N-2} \right) + \delta^N(\eta) \\ &= \frac{\bar{\eta}_{-(N-1)}}{2} \Delta^N \lambda_{-(N-1)} - \frac{\bar{\eta}_{N-1}}{2} \Delta^N \lambda_{N-1} + \delta^N(\eta), \end{aligned}$$

with δ^N a Γ -controllable error term with size $N^{-1/2}$, given by:

$$\delta^N(\eta) = \delta_{\pm}^N(\eta) + \delta_{0,0}^N + \delta_{0,1}^N(\eta) + \delta_{0,2}^N(\eta) + \delta_{0,3-4}^N(\eta) + \delta_{0,\text{order } 3}^N(\eta) + \delta_{0,\text{order} \geq 4}^N(\eta).$$

Since $\sup_N |\Delta^N \lambda_{\pm(N-1)}| < \infty$, the quantity:

$$\frac{\bar{\eta}_{-(N-1)}}{2} \Delta^N \lambda_{-(N-1)} - \frac{\bar{\eta}_{N-1}}{2} \Delta^N \lambda_{N-1}$$

is Γ -controllable with size N^{-1} by Lemma B.3. It follows that $N^2 L_h^* \mathbf{1}$ is Γ -controllable with size $N^{-1/2}$. Thus, by Definition 3.5 of controllability, for any $\theta > 0$, there is a controllable random variable \mathcal{E}_θ with size $N^{-1/2}$ and $\gamma_\theta, C_\theta > 0$ such that, for any density f for $\nu_{g_h}^N$:

$$\begin{aligned} \nu_{g_h}^N(f N^2 L_h^* \mathbf{1}) &= \nu_{g_h}^N(f \delta^N) \leq \nu_{g_h}^N(f \mathcal{E}_\theta) + \theta N^2 \nu_{g_h}^N(\Gamma_h(\sqrt{f})) \\ &\leq \frac{H(f \nu_{g_h}^N | \nu_{g_h}^N)}{\gamma_\theta} + \theta N^2 \nu_{g_h}^N(\Gamma_h(\sqrt{f})) + \frac{C_\theta}{N^{1/2}}. \end{aligned}$$

This concludes the proof of Lemma 3.3. \square

3.6 The Radon-Nikodym derivative

Coming back to the time-independent case with $\bar{\eta}_\cdot = \eta_\cdot - \bar{\rho}_\cdot$, the computations in the previous subsections can be used to obtain an expression of the Radon-Nikodym derivative $D_h = d\mathbb{P}_h/d\mathbb{P}$, $h \in \mathcal{S}$. By definition, D_h reads (see Appendix A.7 in [KL99]):

$$\log D_h((\eta_t)_{t \leq T}) = \Pi_T^N(h) - \Pi_0^N(h) - N^2 \int_0^T e^{-\Pi_t^N(h)} L e^{\Pi_t^N(h)} dt. \quad (3.67)$$

The field Π^N is defined in (2.6).

Proposition 3.10. *Let $h \in \mathcal{S}(\varepsilon_B)$, and recall that $I(u, v)(x, y) = \int_{(-1,1)} u(z, x) \bar{\sigma}(z) u(z, y) dz$ for $u, v \in \mathbb{L}^2(\mathbb{Z})$ and $(x, y) \in \mathbb{Z}$. Then, for each $\eta \in \Omega_N$:*

$$\begin{aligned} N^2 e^{-\Pi^N(h)} L e^{\Pi^N(h)}(\eta) &= \frac{1}{2} \Pi^N(\Delta h + I(\partial_1 h, \partial_1 h)) - \frac{(\bar{\rho}')^2}{4} \int_{(-1,1)} h(x, x) dx \\ &\quad + \frac{1}{4} \sum_{i < N-1} \bar{\eta}_i \bar{\eta}_{i+1} (\partial_1 h_{i+,i} - \partial_1 h_{i-,i}) + \frac{1}{8} \int_{\mathbb{Z}} \bar{\sigma}(x) \bar{\sigma}(y) [\partial_1 h(x, y)]^2 dx dy + \varepsilon^N(h), \end{aligned} \quad (3.68)$$

where $\varepsilon^N(h)$ is a Γ -controllable error term with size $N^{-1/2}$.

Remark 3.11. A bias $h \in \mathcal{S}(\varepsilon_B)$ is a symmetric function by definition. As a result, for each $(x, y) \in \mathbb{Z}$:

$$\partial_1 h(x, y) = \partial_2 h(y, x) \quad \Rightarrow \quad \partial_1 h(x_+, x) - \partial_1 h(x_-, x) = (\partial_1 - \partial_2) h(x_+, x).$$

The first term in the second line of (3.68) thus corresponds to a contribution of the derivative of h normal to the diagonal. \blacksquare

The following corollary will be useful in the proof of lower bound large deviations.

Corollary 3.12. Consider the \mathbb{P}_h -martingale $M^{N,\phi}$, defined for $T \geq 0$ and $\phi \in \mathcal{T}$ (\mathcal{T} is defined in (2.15)) by:

$$M_T^{N,\phi} = \Pi_T^N(\phi) - \Pi_0^N(\phi) - \int_0^T N^2 L_h \Pi_t^N(\phi) dt. \quad (3.69)$$

If additionally ϕ is a symmetric function in $C^3(\mathbb{S})$, there is a Γ -controllable error term $\hat{\varepsilon}^N(h, \phi)$ with size $N^{-1/2}$ such that, for any $T \geq 0$:

$$\begin{aligned} M_T^{N,\phi} &= \Pi_T^N(\phi) - \Pi_0^N(\phi) - \frac{1}{2} \int_0^T \Pi_t^N \left(\Delta \phi + I(\partial_1 \phi, \partial_1 h) + I(\partial_1 h, \partial_1 \phi) \right) dt \\ &\quad + \frac{1}{4} \int_0^T \sum_{i < N-1} \bar{\eta}_i(t) \bar{\eta}_{i+1}(t) (\partial_1 \phi_{i+,i} - \partial_1 \phi_{i-,i}) dt + \frac{(\bar{\rho}')^2 T}{4} \int_{(-1,1)} \phi(x, x) dx \\ &\quad - \frac{T}{4} \int_{\mathbb{Z}} \bar{\sigma}(x) \bar{\sigma}(y) \partial_1 \phi(x, y) \partial_1 h(x, y) dx dy + \int_0^T \hat{\varepsilon}_t^N(h, \phi) dt. \end{aligned}$$

When $\phi = h$, one has in particular:

$$\begin{aligned} M_T^{N,h} - \log D_h &= -\frac{1}{2} \int_0^T \Pi_t^N (I(\partial_1 h, \partial_1 h)) dt - \frac{T}{8} \int_{\mathbb{Z}} \bar{\sigma}(x) \bar{\sigma}(y) [\partial_1 h(x, y)]^2 dx dy \\ &\quad + \int_0^T \hat{\varepsilon}_t^N(h) dt, \end{aligned}$$

for a Γ -controllable error term $\hat{\varepsilon}^N(h)$ with size $N^{-1/2}$.

4 Long-time behaviour: upper bound

In this section, we establish the upper bound in Theorem 2.2, i.e. the following result. Recall that, for $N \in \mathbb{N}^*$, $\nu_{g_0}^N$ is the discrete Gaussian measure (2.21) built from the inverse correlation kernel g_0 of the steady state of the open SSEP. We prove that, for any compact set \mathcal{K} in $(\mathcal{T}'_s, *)$,

$$\limsup_{T \rightarrow \infty} \limsup_{N \rightarrow \infty} \frac{1}{T} \log \mathbb{Q}_T^{\nu_{g_0}^N}(\mathcal{K}) \leq - \inf_{\Pi \in \mathcal{K}} \mathcal{I}(\Pi), \quad (4.1)$$

with \mathcal{I} the functional defined in (2.25). This result is established in Section 4.1, relying on a regularity estimate in the space $\mathbb{H}^1(\mathbb{Z})$, proven in Section 4.3. The proof of this regularity estimate makes use of an $\mathbb{L}^2(\mathbb{Z})$ estimate, obtained in Section 4.2.

Before we start, let us make some remarks and fix notations. For $T > 0$ and O a Borel set in $(\mathcal{T}'_s, *)$, we use the notation O^T for the set:

$$O^T := \left\{ \frac{1}{T} \int_0^T \Pi_t dt \in O \right\} \quad \Rightarrow \quad \mathbb{P}(O^T) := \mathbb{Q}_T(O).$$

We will repeatedly use the following bound: if $O \subset (\mathcal{T}'_s, *)$ and $X \subset D([0, T], \Omega_N)$ are Borel sets,

$$\limsup_{N \rightarrow \infty} \log \mathbb{Q}_T^{\nu_{g_0}^N}(O) \leq \log 2 + \max \left\{ \limsup_{N \rightarrow \infty} \log \mathbb{P}^{\nu_{g_0}^N}(O^T \cap X), \limsup_{N \rightarrow \infty} \log \mathbb{P}^{\nu_{g_0}^N}(X^c) \right\}. \quad (4.2)$$

4.1 Upper bound for open and compact sets

Fix an open set $O \subset (\mathcal{T}'_s, *)$. We wish to estimate $\mathbb{Q}_T^{\nu_{g_0}^N}(O)$ as in (4.1). We do so by the martingale method presented in Chapter 10 of [KL99], which relies on the computation of the Radon-Nikodym derivatives $D_h = d\mathbb{P}_h/d\mathbb{P}$, $h \in \mathcal{S}(\varepsilon_B)$. In Section 4.1.1, a first upper bound on compact sets with a rate function $\tilde{\mathcal{I}} \leq \mathcal{I}$ is established. The bound is then improved to \mathcal{I} in Section 4.1.2.

4.1.1 A first upper bound

Here, we build a functional $\tilde{\mathcal{I}} : (\mathcal{T}'_s, *) \rightarrow \mathbb{R}_+$ such that, if $\mathcal{K} \subset (\mathcal{T}'_s, *)$ is a compact set,

$$\limsup_{T \rightarrow \infty} \limsup_{N \rightarrow \infty} \frac{1}{T} \log \mathbb{Q}_T^{\nu_{g_0}^N}(\mathcal{K}) \leq -\inf_{\mathcal{K}} \tilde{\mathcal{I}}. \quad (4.3)$$

Let $h \in \mathcal{S}(\varepsilon_B)$. In Proposition 3.10, we proved that, for any $T > 0$ and any trajectory $(\eta(t))_{t \leq T}$:

$$\begin{aligned} \log D_h((\eta(t))_{t \leq T}) &= \Pi_T^N(h) - \Pi_0^N(h) - \frac{1}{2} \int_0^T \Pi_t^N \left(\Delta h + I(\partial_1 h, \partial_1 h) \right) dt \\ &\quad - \frac{1}{4} \int_0^T \sum_{i < N-1} \bar{\eta}_i(t) \bar{\eta}_{i+1}(t) (\partial_1 h_{i+,i} - \partial_1 h_{i-,i}) + \frac{(\bar{\rho}')^2 T}{4} \int_{(-1,1)} h(x, x) dx \\ &\quad - \frac{T}{8} \int_{\square} \bar{\sigma}(x) \bar{\sigma}(y) [\partial_1 h(x, y)]^2 dx dy - \int_0^T \varepsilon_t^N(h) dt, \end{aligned} \quad (4.4)$$

with $\varepsilon^N(h)$ a Γ -controllable error term with size $N^{-1/2}$ (see Definition 3.5 for the definition of error terms). As a consequence of (4.2), one can write, for any set X :

$$\begin{aligned} \limsup_{N \rightarrow \infty} \frac{1}{T} \log \mathbb{Q}_T^{\nu_{g_0}^N}(O) &\leq \frac{\log 2}{T} + \max \left\{ \limsup_{N \rightarrow \infty} \frac{1}{T} \log \mathbb{E}_h^{\nu_{g_0}^N} \left[\mathbf{1}_{O^T \cap X} (D_h)^{-1} \right], \right. \\ &\quad \left. \limsup_{N \rightarrow \infty} \frac{1}{T} \log \mathbb{P}^{\nu_{g_0}^N}(X^c) \right\}. \end{aligned} \quad (4.5)$$

To obtain (4.1), we rewrite D_h as a closed expression in terms of $\frac{1}{T} \int_0^T \Pi_t^N dt$. This requires taking care of ε^N , $\Pi_T(h)$, $\Pi_0(h)$ and the sum involving $\bar{\eta}_i \bar{\eta}_{i+1}$, $i < N-1$. We do so by choosing the set X in a suitable manner. The set X will be a union of sets, described below, which control the error terms.

The error term ε^N . For $\delta > 0$, introduce the set:

$$A_T(\delta, h) = \left\{ (\eta_t)_{t \leq T} : \left| \frac{1}{T} \int_0^T \varepsilon_t^N(h) dt \right| \leq \delta \right\}. \quad (4.6)$$

The function ε^N is an error term (recall Proposition 3.10), so the event $A_T(\delta, h)^c$ is unlikely according to Corollary 3.6:

$$\limsup_{N \rightarrow \infty} \mathbb{P}^{\nu_{g_0}^N}(A_T(\delta, h)^c) = 0. \quad (4.7)$$

The diagonal term. In Appendix D, we estimate the cost of rewriting the sum on $\bar{\eta}_i \bar{\eta}_{i+1}$, $i < N-1$ in (4.4) in terms of the correlation field Π^N . Consider a function $\chi^\varepsilon \in C^\infty(\bar{\square})$ with $\chi^\varepsilon = 0$ on $\partial \square$, $0 \leq \chi^\varepsilon \leq 2/\varepsilon$, such that $\chi^\varepsilon(x, \cdot)$ is supported on $(x, x + \varepsilon) \cap (-1, 1)$ for each $x \in (-1, 1)$, and:

$$\forall x < 1 - \varepsilon, \quad \int_{(x, x+\varepsilon)} \chi^\varepsilon(x, y) dy = 1, \quad \forall x \geq 1 - \varepsilon, \quad \int_{(x, x+\varepsilon)} \chi^\varepsilon(x, y) dy \leq 1. \quad (4.8)$$

Define then $\mathcal{N}_h^\varepsilon(x, y)$ for $(x, y) \in \square$ as follows:

$$\mathcal{N}_h^\varepsilon(x, y) = \frac{\bar{\sigma}(x)}{\bar{\sigma}(y)} \chi^\varepsilon(x, y) (\partial_1 - \partial_2) h(x_+, x). \quad (4.9)$$

Then $\mathcal{N}_h^\varepsilon \in \mathcal{T}$, and we prove the following in Proposition D.1. For $T > 0$, define:

$$R_T(\varepsilon, \delta, h) = \left\{ \left| \frac{1}{T} \int_0^T \left[\frac{1}{4} \sum_{i < N-1} \bar{\eta}_i(t) \bar{\eta}_{i+1}(t) (\partial_1^N h_{i_+, i} - \partial_1^N h_{i_-, i}) - \Pi_t^N(\mathcal{N}_h^\varepsilon) \right] dt \right| \leq \delta \right\}. \quad (4.10)$$

There is then $c'(h) > 0$ and $\varepsilon(\delta, h) \in (0, 1)$ such that, for each $T > 0$ and each $\varepsilon < \varepsilon(\delta, h)$:

$$D_T^\infty(\varepsilon, \delta, h) \leq c e^{-c'(h)\varepsilon^{-1/2}\delta T}, \quad \text{with} \quad D_T^\infty(\varepsilon, \delta, h) := \limsup_{N \rightarrow \infty} \mathbb{P}^{\nu_{g_0}^N} (R_T(\varepsilon, \delta, h)^c). \quad (4.11)$$

The time boundaries $\Pi_0^N(h), \Pi_T^N(h)$. We are now going to introduce a set in order to control the large values of $\Pi_T^N(h)$. Within this set, we will show in Lemma 4.1 below that $\Pi_0^N(h), \Pi_T^N(h)$ do not contribute to the right-hand side of (4.1) when N, T are large. We prove it by estimating exponential moments of these quantities independently of N, T . For $\Pi_0^N(h)$, this follows from the fact that the initial measure is $\nu_{g_0}^N$. At time T , we make use of Corollary 3.4 to reduce our claim to a static estimate.

Lemma 4.1. *Let $T > 0$, and define:*

$$B_T(h) = \left\{ |\Pi_T^N(h)| \leq T^2 \right\}. \quad (4.12)$$

Then, for any $h \in \mathcal{S}(\varepsilon_B)$, one has:

$$\limsup_{N \rightarrow \infty} \mathbb{P}^{\nu_{g_0}^N} (B_T(h)^c) \leq c(h) e^{-T^2}. \quad (4.13)$$

In addition, there is $C(h) > 0$ such that:

$$\limsup_{N \rightarrow \infty} \log \mathbb{E}_h^{\nu_{g_0}^N} \left[\exp \left[-\Pi_T^N(h) + \Pi_0^N(h) \right] \mathbf{1}_{B_T(T^2, h)} \right] \leq C(h). \quad (4.14)$$

Proof. Let $h \in \mathcal{S}(\varepsilon_B)$. We first prove (4.13). By Corollary 3.4, one has:

$$\limsup_{N \rightarrow \infty} \left| \mathbb{P}^{\nu_{g_0}^N} (B_T(h)^c) - \nu_{g_0}^N (|\Pi^N(h)| > T^2) \right| = 0. \quad (4.15)$$

Moreover, since $\|h\|_2 \leq 1/2$ for $h \in \mathcal{S}(\varepsilon_B)$, Lemma A.1 yields the existence of $c(h) > 0$ with:

$$\forall \lambda > 0, \quad \sup_N \nu_{g_0}^N (|\Pi^N(h)| > \lambda) \leq c(h) e^{-\lambda}, \quad (4.16)$$

and (4.13) follows.

We now prove (4.14). To estimate the exponential moment of $\Pi_T^N(h)$ under \mathbb{E}_h , we need the

starting measure to be $\nu_{g_h}^N$. Write thus, using Cauchy-Schwarz inequality:

$$\begin{aligned} \log \mathbb{E}_h^{\nu_{g_0}^N} \left[\exp \left[-\Pi_T^N(h) + \Pi_0^N(h) \right] \mathbf{1}_{B_T(h)} \right] &= \log \mathbb{E}_h^{\nu_{g_h}^N} \left[\mathbf{1}_{B_T(h)} \exp \left[-\Pi_T^N(h) + \Pi_0^N(h) \right] \frac{d\nu_{g_0}^N}{d\nu_{g_h}^N} \right] \\ &\leq \frac{1}{2} \log \mathbb{E}_h^{\nu_{g_h}^N} \left[\mathbf{1}_{B_T(h)} \exp \left[-2\Pi_T^N(h) \right] \right] \\ &\quad + \frac{1}{2} \log \nu_{g_0}^N \left[\exp \left[2\Pi^N(h + g_0 - g_h) \right] \right] + \frac{1}{2} \log \left(\frac{\mathcal{Z}_{g_h}^N}{\mathcal{Z}_{g_0}^N} \right). \end{aligned} \quad (4.17)$$

As $g_h \in g_0 + \mathcal{S}(\varepsilon_G)$ and $h \in \mathcal{S}(\varepsilon_B)$ with $\varepsilon_B, \varepsilon_G \in (0, 1/2)$, thus $\sup_N \mathcal{Z}_{g_h}^N / \mathcal{Z}_{g_0}^N =: C_1(h) < \infty$, where the partition function $\mathcal{Z}_{g_h}^N$ is defined in (2.30). The constants $\varepsilon_B, \varepsilon_G$ are chosen to ensure $\|h + g_0 - g_h\|_2 < 1/2$, which by Lemma A.1 means that the expectation under $\nu_{g_0}^N$ in (4.17) is bounded by some $C_2(h) > 0$. Finally, Corollary 3.4 applied to the first expectation in (4.17) yields the existence of $C_3(h) > 0$, such that:

$$\mathbb{E}_h^{\nu_{g_h}^N} \left[\mathbf{1}_{B_T(h)} \exp \left[-2\Pi_T^N(h) \right] \right] \leq \frac{C_3(h) e^{C_3(h)T} e^{2T^2}}{N^{1/2}} + \nu_{g_h}^N \left[\exp \left[-2\Pi^N(h) \right] \right].$$

Taking the large N limit and again writing $g_h - h = g_h - g_0 - h + g_0$ concludes the proof:

$$\begin{aligned} \limsup_{N \rightarrow \infty} \log \mathbb{E}_h^{\nu_{g_h}^N} \left[\mathbf{1}_{B_T(h)} \exp \left[-2\Pi_T^N(h) \right] \right] &\leq \limsup_{N \rightarrow \infty} \log \nu_{g_h}^N \left[\exp \left[-2\Pi^N(h) \right] \right] \\ &= \limsup_{N \rightarrow \infty} \log \left[\frac{\mathcal{Z}_{g_0}^N}{\mathcal{Z}_{g_h}^N} \nu_{g_0}^N \left[\exp \left[2\Pi^N(g_h - g_0 - h) \right] \right] \right] \leq C_4(h). \end{aligned}$$

□

In view of the last three points, let $\varepsilon \in (0, 1)$, $\delta > 0$ and define:

$$X = A_T(\delta, h) \cap R_T(\varepsilon, \delta, h) \cap B_T(h). \quad (4.18)$$

Let also J_h^ε be the following continuous functional on $(\mathcal{T}'_s, *)$:

$$\begin{aligned} \forall \Pi \in \mathcal{T}'_s, \quad J_h^\varepsilon(\Pi) &= -\frac{1}{2} \Pi \left(\Delta h + I(\partial_1 h, \partial_1 h) \right) + \Pi(\mathcal{N}_h^\varepsilon) \\ &\quad + \frac{(\bar{\rho}')^2}{4} \int_{(-1,1)} h(x, x) dx - \frac{1}{8} \int_{\mathbb{Z}} \bar{\sigma}(x) \bar{\sigma}(y) [\partial_1 h(x, y)]^2 dx dy. \end{aligned} \quad (4.19)$$

With these notations, (4.5) becomes:

$$\begin{aligned} \limsup_{N \rightarrow \infty} \mathbb{Q}_T^{\nu_{g_0}^N}(O) &\leq \limsup_{N \rightarrow \infty} \mathbb{E}_h^{\nu_{g_0}^N} \left[\mathbf{1}_X \exp \left[-\Pi_T^N(h) + \Pi_0^N(h) - \int_0^T \varepsilon_t^N(h) dt \right] \right] \exp \left[\sup_{\Pi \in O} (-J_h^\varepsilon(\Pi)) \right] \\ &\quad + \limsup_{N \rightarrow \infty} \mathbb{P}^{\nu_{g_0}^N}(X^c) \\ &\leq \exp \left[\delta T + C(h) + T \sup_{\Pi \in O} (-J_h^\varepsilon(\Pi)) \right] + \limsup_{N \rightarrow \infty} \mathbb{P}^{\nu_{g_0}^N}(X^c), \end{aligned} \quad (4.20)$$

with, using (4.7) to estimate the probability of $A_T(\delta, h)$ and (4.11) for $D_T^\infty(\varepsilon, h, \delta)$:

$$\begin{aligned} \limsup_{N \rightarrow \infty} \mathbb{P}^{\nu_{g_0}^N}(X^c) &\leq \limsup_{N \rightarrow \infty} \mathbb{P}^{\nu_{g_0}^N}(A_T(h, \delta)) + D_T^\infty(\varepsilon, h, \delta) + e^{c(h)-T^2} \\ &= ce^{-c'(h)\varepsilon^{-1/2}\delta T} + e^{c(h)-T^2}. \end{aligned} \quad (4.21)$$

Take now the logarithm of (4.20), divide by T and take the large T limit to find, using (4.2) and the definition (4.11) of $D_T^\infty(h, \varepsilon, \delta)$:

$$\limsup_{T \rightarrow \infty} \limsup_{N \rightarrow \infty} \frac{1}{T} \log \mathbb{Q}_T^{\nu_{g_0}^N}(O) \leq \sup_O \tilde{J}_{h,\delta}^\varepsilon, \quad \tilde{J}_{h,\delta}^\varepsilon := \max \left\{ \delta - J_h^\varepsilon, -c'(h)\varepsilon^{-1/2}\delta \right\}. \quad (4.22)$$

Let $\varepsilon_0 \in (0, \varepsilon(\delta, h))$, where $\varepsilon(\delta, h)$ is defined in (4.11). Taking the infimum on $\varepsilon \in (0, \varepsilon_0)$, $\delta > 0$ and $h \in \mathcal{S}(\varepsilon_B)$ yields a first bound on open sets:

$$\limsup_{T \rightarrow \infty} \limsup_{N \rightarrow \infty} \frac{1}{T} \log \mathbb{Q}_T^{\nu_{g_0}^N}(O) \leq \inf_{h \in \mathcal{S}(\varepsilon_B)} \inf_{\delta > 0} \inf_{\varepsilon \in (0, \varepsilon_0)} \sup_O \tilde{J}_{h,\delta}^\varepsilon. \quad (4.23)$$

We now extend the bound (4.23) to compact sets. The argument is standard and relies on Lemmas 3.2 and 3.3 in Appendix 2 of [KL99]. Let $\mathcal{K} \subset (\mathcal{T}', *)$ be compact. We wish to prove:

$$\limsup_{T \rightarrow \infty} \limsup_{N \rightarrow \infty} \frac{1}{T} \log \mathbb{Q}_T^{\nu_{g_0}^N}(\mathcal{K}) \leq \sup_{\mathcal{K}} \inf_{h \in \mathcal{S}(\varepsilon_B)} \liminf_{\varepsilon \rightarrow 0} (-J_h^\varepsilon). \quad (4.24)$$

Since $(\tilde{J}_{h,\delta}^\varepsilon)_{h,\varepsilon,\delta}$ is a family of continuous functionals on $(\mathcal{T}'_s, *)$, Lemmas 3.2 and 3.3 in Appendix 2 of [KL99] allow for the exchange of the infima on h, δ, ε and the supremum on (open covers of) \mathcal{K} :

$$\limsup_{N \rightarrow \infty} \frac{1}{T} \log \mathbb{Q}_T^{\nu_{g_0}^N}(\mathcal{K}) \leq \sup_{\mathcal{K}} \inf_{h \in \mathcal{S}(\varepsilon_B)} \inf_{\delta > 0} \inf_{\varepsilon \in (0, \varepsilon_0)} \tilde{J}_{h,\delta}^\varepsilon. \quad (4.25)$$

Owing to the bound (4.11), for each $\Pi \in \mathcal{K}$ and h, δ , there is $\varepsilon_0(\Pi, h, \delta) < \varepsilon(\delta, h)$ below which the maximum in $\tilde{J}_{h,\delta}^\varepsilon$ (defined in (4.22)), is achieved by the first member. Since $\varepsilon_0 \mapsto \inf_{\varepsilon < \varepsilon_0}$ increases when ε_0 shrinks, (4.25) becomes:

$$\begin{aligned} \limsup_{N \rightarrow \infty} \frac{1}{T} \log \mathbb{Q}_T^{\nu_{g_0}^N}(\mathcal{K}) &\leq \sup_{\Pi \in \mathcal{K}} \inf_{h \in \mathcal{S}(\varepsilon_B)} \inf_{\delta > 0} \inf_{\varepsilon \in (0, \varepsilon_0(\Pi, h, \delta))} \left[\delta - J_h^\varepsilon(\Pi) \right] \\ &\leq \sup_{\Pi \in \mathcal{K}} \inf_{h \in \mathcal{S}(\varepsilon_B)} \liminf_{\varepsilon \rightarrow 0} (-J_h^\varepsilon(\Pi)). \end{aligned}$$

This yields a first bound on compact sets and proves (4.3):

$$\limsup_{T \rightarrow \infty} \limsup_{N \rightarrow \infty} \frac{1}{T} \log \mathbb{Q}_T^{\nu_{g_0}^N}(\mathcal{K}) \leq -\inf_{\mathcal{K}} \tilde{\mathcal{I}}, \quad \tilde{\mathcal{I}} = \sup_{h \in \mathcal{S}(\varepsilon_B)} \limsup_{\varepsilon \rightarrow 0} J_h^\varepsilon. \quad (4.26)$$

4.1.2 Refinement of the upper bound to more regular correlations

Let $\Pi = \frac{1}{4} \langle k_\Pi, \cdot \rangle \in \mathcal{T}'_s$. If $k_\Pi \in \mathbb{H}^1(\square)$, then k_Π has well-defined trace on either side of the diagonal $D = \{(x, x) : x \in (-1, 1)\}$. As $\Pi \in \mathcal{T}'_s \cap \mathbb{H}^1(\square)$, k_Π is a symmetric function, and the traces on both sides coincide. We thus write $\text{tr}_D(k_\Pi)$ for the trace of k_Π on the diagonal. One has then:

$$\lim_{\varepsilon \rightarrow 0} \Pi(\mathcal{N}_h^\varepsilon) = \lim_{\varepsilon \rightarrow 0} \frac{1}{4} \langle k_\Pi, \mathcal{N}_h^\varepsilon \rangle = \frac{1}{4} \int_{(-1,1)} \text{tr}(k_\Pi)(x, x) (\partial_2 - \partial_1) h(x_+, x) dx. \quad (4.27)$$

For such $\Pi \in \mathcal{T}'_s \cap \mathbb{H}^1(\square)$, $\limsup_{\varepsilon \rightarrow 0} |J_h^\varepsilon(\Pi) - J_h(\Pi)| = 0$, with J_h the functional equal to $+\infty$ outside of $\mathcal{T}'_s \cap \mathbb{H}^1(\square)$, and:

$$\begin{aligned} \forall \Pi \in \mathcal{T}'_s \cap \mathbb{H}^1(\square), \quad J_h(\Pi) &= -\frac{1}{2}\Pi\left(\Delta h + I(\partial_1 h, \partial_1 h)\right) + \frac{1}{4} \int_{(-1,1)} \text{tr}_D(k_\Pi)(\partial_2 - \partial_1)h(x_+, x) dx \\ &\quad + \frac{(\bar{\rho}')^2}{4} \int_{(-1,1)} h(x, x) dx - \frac{1}{8} \int_{\square} \bar{\sigma}(x)\bar{\sigma}(y) [\partial_1 h(x, y)]^2 dx dy. \end{aligned} \quad (4.28)$$

As a result, for $\Pi \in \mathcal{T}'_s \cap \mathbb{H}^1(\square)$, $\mathcal{I}(\Pi) = \tilde{\mathcal{I}}(\Pi)$, with $\tilde{\mathcal{I}}$ defined in (4.26), and \mathcal{I} the rate function defined in (2.25). For general $\Pi \in \mathcal{T}'_s$, however, k_Π is not regular enough to make sense of the small ε limit of $\mathcal{N}_h^\varepsilon(\Pi)$. We shall introduce another set $U \subset \mathcal{T}'_s$ to restrict the upper bound to Π 's with enough regularity in the large N limit, and prove the following result.

Lemma 4.2. *Let $\mathcal{K} \subset (\mathcal{T}'_s, *)$ be a compact set. Then:*

$$\limsup_{T \rightarrow \infty} \limsup_{N \rightarrow \infty} \frac{1}{T} \log \mathbb{Q}_T^{\nu_{g_0}^N}(\mathcal{K}) \leq -\inf_{\mathcal{K}} \mathcal{I}. \quad (4.29)$$

To prove Lemma 4.2, consider the functionals \mathcal{Q} and \mathcal{Q}_f , defined for each $f \neq 0$ in $C_c^\infty(\square)$, the set of compactly supported, C^∞ functions on \square , by:

$$\forall \Pi \in \mathcal{T}'_s, \quad \mathcal{Q}_f(\Pi) = \frac{\Pi(\partial_1 f)}{\|f\|_2}, \quad \mathcal{Q} = \sup_{f \in C_c^\infty(\square) \setminus \{0\}} \mathcal{Q}_f, \quad (4.30)$$

In the following lemma, we argue that \mathcal{Q} controls the regularity of elements of \mathcal{T}'_s .

Lemma 4.3. *For $\Pi \in \mathcal{T}'_s$, $\Pi \in \mathbb{H}^1(\square)$ if and only if $\mathcal{Q}(\Pi) < \infty$. Moreover, \mathcal{Q} is weak* lower semi-continuous on $(\mathcal{T}'_s, *)$.*

Proof. We first prove the equivalence. Let $\Pi \in \mathcal{T}'_s$. If $\Pi \in \mathbb{H}^1(\square)$, then $\Pi(\partial_1 f) = -\frac{1}{4} \langle \partial_1 k_\Pi, f \rangle$ for each $f \in C_c^\infty(\square)$, and Cauchy-Schwarz inequality gives:

$$\mathcal{Q}(\Pi) = \sup_{f \in C_c^\infty(\square) \setminus \{0\}} \frac{1}{4} \frac{\langle \partial_1 k_\Pi, -f \rangle}{\|f\|_2} \leq \frac{\|\partial_1 k_\Pi\|_2}{4}.$$

Conversely, assume $\mathcal{Q}(\Pi) < \infty$. Notice that, if $f \in C_c^\infty(\square)$, then $\Pi(\partial_1 f) = \Pi(\partial_2 \check{f})$ as $\Pi \in \mathcal{T}'_s$, with $\check{f} \in C_c^\infty(\square)$ defined by $\check{f}(x, y) := f(y, x)$ for $(x, y) \in \square$. It is therefore enough to prove that k_Π admits a weak first derivative. As $\mathcal{Q}(\Pi) < \infty$, one has:

$$\forall f \in C_c^\infty(\square), \quad |\ell_\Pi(f)| \leq \mathcal{Q}(\Pi) \|f\|_2, \quad \ell_\Pi(f) := \Pi(\partial_1 f).$$

By density of C_c^∞ in $\mathbb{L}^2(\square)$, $\ell_\Pi(\cdot)$ can be extended to a bounded linear form on $\mathbb{L}^2(\square)$. By Riesz representation theorem, there is $\partial_1 k_\Pi \in \mathbb{L}^2(\square)$ with $\ell_\Pi(\cdot) = -\frac{1}{4} \langle \partial_1 k_\Pi, \cdot \rangle$, which concludes the proof of the equivalence.

For the weak* lower semi-continuity of \mathcal{Q} on $(\mathcal{T}'_s, *)$, simply notice that it is a supremum over the \mathcal{Q}_f for $f \in C_c^\infty(\square) \setminus \{0\}$; each \mathcal{Q}_f being weak* continuous, since $\|f\|_2 \mathcal{Q}_f(\Pi)$ is the evaluation of Π at $\partial_1 f \in \mathcal{T}$ for $\Pi \in \mathcal{T}'_s$. \square

Proof of Lemma 4.2. We now begin the proof of the large deviation bound (4.29). Consider a sequence $f_j \in C_c^\infty(\square) \setminus \{0\}, j \in \mathbb{N}^*$, dense in $\{f \in \mathbb{H}^3(\square) : \text{tr}_{\partial \square}(f) = 0\}$. Introduce then, for each $\ell \in \mathbb{N}^*$ and each $A > 0$:

$$U(\ell, A) = \left\{ \max_{1 \leq j \leq \ell} \mathcal{Q}_{f_j} \leq A \right\}. \quad (4.31)$$

In Lemma 4.6, we prove the existence of $C, C' > 0$ such that, for A larger than some $A_0 > 0$ and each $\ell \in \mathbb{N}^*$:

$$\limsup_{N \rightarrow \infty} \mathbb{Q}_T^{\nu_{g_0}^N} \left((U(\ell, A))^c \right) \leq C \ell e^{-C' A T}. \quad (4.32)$$

Notice also that, for $\Pi \in \mathcal{T}'_s$, if (f_{j_n}) converges to $f \in C_c^\infty(\square)$ in the norm of $\mathbb{H}^3(\square)$, then $\partial_1 f_{j_n}$ converges to $\partial_1 f$ in \mathcal{T} , so that $\lim_n \mathcal{Q}_{f_{j_n}}(\Pi) = \mathcal{Q}_f(\Pi)$, and:

$$\mathcal{Q}(\Pi) = \sup_{j \in \mathbb{N}^*} \mathcal{Q}_{f_j}(\Pi). \quad (4.33)$$

Let $\ell \in \mathbb{N}^*$ and $A > A_0$. Recall the notation:

$$U(\ell, A)^T := \left\{ \frac{1}{T} \int_0^T \Pi_t dt \in U(\ell, A) \right\},$$

so that $\mathbb{P}(U(\ell, A)^T) = \mathbb{Q}_T(U(\ell, A))$, and let $O \subset (\mathcal{T}'_s, *)$ be an open set. We again estimate $\mathbb{Q}_T^{\nu_{g_0}^N}(O)$, starting from (4.20), but considering $X \cap U(\ell, A)^T$ instead of X (X is defined in (4.18)). Equation (4.20) consequently becomes:

$$\limsup_{N \rightarrow \infty} \mathbb{Q}_T^{\nu_{g_0}^N}(O) \leq \exp \left[\delta T + C(h) + T \sup_{O \cap U(\ell, A)} (-J_h^\varepsilon) \right] + \limsup_{N \rightarrow \infty} \mathbb{P}^{\nu_{g_0}^N} \left((X \cap U^T(\ell, A))^c \right), \quad (4.34)$$

with:

$$\limsup_{N \rightarrow \infty} \mathbb{P}^{\nu_{g_0}^N} \left((X \cap U^T(\ell, A))^c \right) \leq c e^{-c'(h)\varepsilon^{-1/2}\delta T} + e^{c(h)-T^2} + C \ell e^{-C' A T}. \quad (4.35)$$

For each h, ε, ℓ, A , let $J_{h,\ell,A}^\varepsilon$ be equal to J_h^ε on $U(\ell, A)$, to $+\infty$ outside. Proceeding as in (4.22) and using (4.2), one finds:

$$\limsup_{T \rightarrow \infty} \limsup_{N \rightarrow \infty} \frac{1}{T} \log \mathbb{Q}_T^{\nu_{g_0}^N}(O) \leq \sup_O \bar{J}_{h,\delta,\ell,A}^\varepsilon, \quad (4.36)$$

with:

$$\bar{J}_{h,\delta,\ell,A}^\varepsilon := \max \left\{ \delta - J_{h,\ell,A}^\varepsilon, -C' A, -c'(h)\delta\varepsilon^{-1/2} \right\}. \quad (4.37)$$

Let $\varepsilon_0 \in (0, \varepsilon(\delta, h))$, where $\varepsilon(\delta, h)$ is defined in (4.11), and recall the definition of A_0 from above (4.32). Equation (4.36) yields a second bound on open sets:

$$\limsup_{T \rightarrow \infty} \limsup_{N \rightarrow \infty} \frac{1}{T} \log \mathbb{Q}_T^{\nu_{g_0}^N}(O) \leq \inf_{h \in \mathcal{S}(\varepsilon_B)} \inf_{\delta, \ell, A, \varepsilon} \sup_O \bar{J}_{h,\delta,\ell,A}^\varepsilon, \quad (4.38)$$

where the infimum is taken on $\ell \in \mathbb{N}^*, A > A_0, \delta > 0$ and $\varepsilon \in (0, \varepsilon_0)$.

Let us obtain a bound on compact sets from (4.38). Let $\mathcal{K} \subset (\mathcal{T}'_s, *)$ be compact. Since $U(\ell, A)$

is weak* closed by continuity of \mathcal{Q}_{f_j} , $1 \leq j \leq \ell$, $(\bar{J}_{h,\delta,\ell,A}^\varepsilon)_{h,\varepsilon,\ell,A}$ is a family of weak* upper semi-continuous functionals. Lemmas A.2.3.2 and A.2.3.3 in [KL99] thus give as before:

$$\limsup_{T \rightarrow \infty} \limsup_{N \rightarrow \infty} \frac{1}{T} \log \mathbb{Q}_T^{\nu_{g_0}^N}(\mathcal{K}) \leq \sup_{\mathcal{K}} \inf_{h \in \mathcal{S}(\varepsilon_B)} \inf_{\delta, \ell, A, \varepsilon} \bar{J}_{h,\delta,\ell,A}^\varepsilon, \quad (4.39)$$

with the infimum again taken on $\ell \in \mathbb{N}^*$, $A > A_0$, $\delta > 0$ and $\varepsilon \in (0, \varepsilon_0)$.

Proceeding as in (4.25) to (4.26), one can take the infimum on ε, δ and turn (4.39) into:

$$\limsup_{T \rightarrow \infty} \limsup_{N \rightarrow \infty} \frac{1}{T} \log \mathbb{Q}_T^{\nu_{g_0}^N}(\mathcal{K}) \leq \sup_{\mathcal{K}} \inf_{h \in \mathcal{S}(\varepsilon_B)} \inf_{\ell, A} \max \left\{ \liminf_{\varepsilon \rightarrow 0} (-J_{h,\ell,A}^\varepsilon), -C'A \right\}. \quad (4.40)$$

Let $A > A_0$. As $U(\ell, A) \subset U(\ell', A)$ if $\ell \leq \ell'$, the argument of the supremum on \mathcal{K} in (4.40) is equal to $-\infty$ when evaluated at any $\Pi \notin \bigcap_{\ell \in \mathbb{N}^*} U(\ell, A)$. By definition of $U(\ell, A)$ in (4.31) and using (4.33), one has:

$$\bigcap_{\ell \in \mathbb{N}^*} U(\ell, A) = \{\mathcal{Q} \leq A\}.$$

Equation (4.40) thus becomes:

$$\limsup_{T \rightarrow \infty} \limsup_{N \rightarrow \infty} \frac{1}{T} \log \mathbb{Q}_T^{\nu_{g_0}^N}(\mathcal{K}) \leq \sup_{\mathcal{K}} \inf_{h \in \mathcal{S}(\varepsilon_B)} \inf_{A > A_0} \max \left\{ \liminf_{\varepsilon \rightarrow 0} (-J_{h,A}^\varepsilon), -C'A \right\}, \quad (4.41)$$

with, for each h, ε, A , $J_{h,A}^\varepsilon = +\infty$ on $\{\mathcal{Q} > A\}$, and $J_{h,A}^\varepsilon = J_h^\varepsilon$ on $\{\mathcal{Q} \leq A\}$. Consider again $A > A_0$. For each $\Pi \in \{\mathcal{Q} \leq A\}$, the associated k_Π via the Riesz representation theorem can be taken in $\mathbb{H}^1(\square)$. In particular, by (4.27), if $h \in \mathcal{S}(\varepsilon_B)$ and $\Pi \in \{\mathcal{Q} \leq A\}$,

$$\liminf_{\varepsilon \rightarrow 0} (-J_{h,A}^\varepsilon(\Pi)) = -J_{h,A}(\Pi).$$

Above, $J_{h,A} = J_h$ on $\{\mathcal{Q} \leq A\}$, $J_{h,A} = +\infty$ outside, and J_h is defined in (4.28). Equation (4.41) thus becomes:

$$\limsup_{T \rightarrow \infty} \limsup_{N \rightarrow \infty} \frac{1}{T} \log \mathbb{Q}_T^{\nu_{g_0}^N}(\mathcal{K}) \leq \sup_{\mathcal{K}} \inf_{h \in \mathcal{S}(\varepsilon_B)} \inf_{A > A_0} \max \left\{ -J_{h,A}, -C'A \right\}.$$

Finally, note that $J_{h,A} \geq J_h$ for $A > A_0$, since J_h may be finite on $\{\mathcal{Q} > A\}$ while $J_{h,A}$ may not. Lemma 4.2 is proven:

$$\limsup_{T \rightarrow \infty} \limsup_{N \rightarrow \infty} \frac{1}{T} \log \mathbb{Q}_T^{\nu_{g_0}^N}(O) \leq -\inf_{\mathcal{K}} \mathcal{I}, \quad \mathcal{I} := \sup_{h \in \mathcal{S}(\varepsilon_B)} J_h. \quad (4.42)$$

□

4.2 An \mathbb{L}^2 estimate and a first Poisson equation

In this section, we begin the proof of the energy estimate (4.32). We first argue that, in the large N , then large T limits, the time-averaged correlation field behaves like a bounded linear form on $\mathbb{L}^2(\square)$. The following proposition gives the main ingredient.

Proposition 4.4. *There are constants $C, C' > 0$ such that, for any large enough $A > 0$, any $T > 0$, and any $\phi \in \mathcal{T} \cap C^2(\bar{\triangleright}) \cap C^2(\bar{\triangleleft})$ with $\|\phi\|_2 \leq 1$, one can find $C(T, \phi) > 0$ satisfying:*

$$\forall N \in \mathbb{N}^*, \quad \mathbb{P}^{\nu_{g_0}^N} \left(\left| \frac{1}{T} \int_0^T \Pi_t^N(\phi) dt \right| \geq A \right) \leq C \exp[-C'AT] + \frac{C(T, \phi)}{AN^{1/2}}. \quad (4.43)$$

Proof. To prove (4.43), we need to estimate exponential moments of $\frac{1}{T} \left| \int_0^T \Pi_t^N(\phi) dt \right|$. Up to considering ϕ and $-\phi$, we may remove the absolute value in the probability in (4.43). Moreover, as $\Pi^N(\phi) = \Pi^N(\check{\phi})$, with $\check{\phi}(x, y) = \phi(y, x)$ for $x, y \in \square$; we may assume without loss of generality that ϕ is symmetric. The next lemma provides the desired estimates by means of a certain Poisson equation.

Lemma 4.5. *For symmetric $\phi \in \mathcal{T} \cap C^2(\bar{\triangleright}) \cap C^2(\bar{\triangleleft})$ with $\|\phi\|_2 \leq 1$ (recall that $\phi \in \mathcal{T}$ implies $\phi|_{\partial\square} = 0$), denote by $f_\phi \in C^3(\bar{\triangleright}) \cap C^3(\bar{\triangleleft})$ a symmetric function, the classical solution of:*

$$\begin{cases} \frac{1}{2}\Delta f(x, y) + \frac{1}{2} \int_{(-1,1)} \partial_1 f(z, x) \bar{\sigma}(z) \partial_1 f(z, y) dz = -\frac{\phi(x, y)}{2} & \text{for } (x, y) \in \square, \\ f = 0 & \text{on } \partial\square, \\ (\partial_1 - \partial_2)f(x_\pm, x) = 0 & \text{for } x \in (-1, 1). \end{cases} \quad (4.44)$$

Then:

$$\begin{aligned} \frac{1}{2}\Pi^N(\phi) &= -e^{-\Pi^N(f_\phi)} N^2 L e^{\Pi^N(f_\phi)} + \varepsilon^N(f_\phi) - \frac{(\bar{\rho}')^2}{4} \int_{(-1,1)} f_\phi(x, x) dx \\ &\quad + \frac{1}{8} \int_{\square} \bar{\sigma}(x) \bar{\sigma}(y) [\partial_1 f_\phi(x, y)]^2 dx dy, \end{aligned} \quad (4.45)$$

where $\varepsilon^N(f_\phi)$ is the error term with of Proposition 3.10. There is $C(T, f_\phi) > 0$ such that it satisfies:

$$\mathbb{E}^{\nu_{g_0}^N} \left[\left| \int_0^T \varepsilon_t^N(f_\phi) dt \right| \right] \leq C(T, f_\phi) N^{-1/4}. \quad (4.46)$$

Equation (4.45) is proven in Proposition 3.10, while the estimate (4.46) is established in Corollary C.3. Using Lemma 4.5, let us conclude the proof of Proposition 4.4. From (4.45), one has for any $A, T > 0$:

$$\begin{aligned} \mathbb{P}^{\nu_{g_0}^N} \left(\frac{1}{T} \int_0^T \Pi_t^N(\phi) dt > A \right) &= \mathbb{P}^{\nu_{g_0}^N} \left(-\frac{1}{T} \int_0^T e^{-\Pi_t^N(f_\phi)} N^2 L e^{\Pi_t^N(f_\phi)} dt + \frac{1}{T} \int_0^T \varepsilon_t^N(f_\phi) dt \right. \\ &\quad \left. - \frac{(\bar{\rho}')^2}{4} \int_{(-1,1)} f_\phi(x, x) dx + \frac{1}{8} \int_{\square} \bar{\sigma}(x) \bar{\sigma}(y) [\partial_1 f_\phi(x, y)]^2 > \frac{A}{2} \right). \end{aligned} \quad (4.47)$$

By Proposition F.2, $\|f_\phi\|_{\mathbb{H}^1(\square)} \leq 3$, which bounds the last two terms in (4.47) by continuity of the trace mapping $\text{tr}_D : \mathbb{H}^1(\square) \rightarrow \mathbb{L}^2(D)$, see Theorem 1.5.2.1 in [Gri11]. As a result, as soon as $A/4 > 6$, one has using (4.46):

$$\begin{aligned} \mathbb{P}^{\nu_{g_0}^N} \left(\frac{1}{T} \int_0^T \Pi_t^N(\phi) dt > A \right) &\leq \mathbb{P}^{\nu_{g_0}^N} \left(-\frac{1}{T} \int_0^T e^{-\Pi_t^N(f_\phi)} N^2 L e^{\Pi_t^N(f_\phi)} dt > A/8 \right) \\ &\quad + \frac{8C(T, f_\phi)}{AN^{1/4}}. \end{aligned} \quad (4.48)$$

Note that the object inside the probability in (4.48) satisfies:

$$-\frac{1}{T} \int_0^T e^{-\Pi_t^N(f_\phi)} N^2 L e^{\Pi_t^N(f_\phi)} dt = \frac{1}{T} \log D_{f_\phi} - \Pi_T^N(f_\phi)/T + \Pi_0^N(f_\phi)/T, \quad (4.49)$$

where the Radon-Nikodym derivative D_{f_ϕ} was computed in Proposition 3.10. We estimate these three terms separately. For $\Pi_0^N(f_\phi)$, the fact that the starting measure is $\nu_{g_0}^N$, that $\|f_\phi\|_2 \leq 3$ and Corollary A.9 yield the existence of $c > 0$ such that:

$$\mathbb{P}^{\nu_{g_0}^N} \left(\Pi_0^N(f_\phi)/T > A/24 \right) = \nu_{g_0}^N \left(\Pi^N(f_\phi)/T > A/24 \right) \leq c e^{-cAT}. \quad (4.50)$$

Consider now $\Pi_T^N(f_\phi)$, which requires more care. Directly using Corollary 3.4 would yield, for some $C_0 > 0$:

$$\mathbb{P}^{\nu_{g_0}^N} \left(\Pi_T^N(f_\phi)/T > A/24 \right) \leq \frac{C_0 e^{C_0 T}}{N^{1/2}} + \nu_{g_0}^N \left(\Pi^N(f_\phi)/T > A/24 \right). \quad (4.51)$$

In the bound (4.51), the first term is independent of A , which is not what we want. To remedy this situation, we will make use of a moment bound on $\Pi_T(f_\phi)$. In Lemma 5.5, we prove that there is $C_1(\|f_\phi\|_\infty) > 0$ such that:

$$\sup_{N \in \mathbb{N}^*} \mathbb{E}^{\nu_{g_0}^N} [|\Pi_T(f_\phi)|^{3/2}]^{2/3} \leq C_1(\|f_\phi\|_\infty) e^{C_3(\|f_\phi\|_\infty)T} = C_2 e^{C_2 T}, \quad (4.52)$$

where we used the fact that $\|f_\phi\|_\infty$ is bounded independently of ϕ , as proven in Proposition F.2. Using this bound and (4.51), one can write:

$$\begin{aligned} \mathbb{P}^{\nu_{g_0}^N} \left(\Pi_T^N(f_\phi)/T > A/24 \right) &\leq \frac{24}{AT} \mathbb{E}^{\nu_{g_0}^N} \left[|\Pi_T^N(f_\phi)| \mathbf{1}_{|\Pi_T^N(f_\phi)| > AT/24} \right] \\ &\leq \frac{24}{AT} \mathbb{E}^{\nu_{g_0}^N} \left[|\Pi_T^N(f_\phi)|^{3/2} \right]^{2/3} \mathbb{P}^{\nu_{g_0}^N} \left(|\Pi_T^N(f_\phi)| > AT/24 \right)^{1/3} \\ &\leq \frac{C_3(T)}{AT N^{1/6}} + \frac{24 C_2 c^{1/3}}{AT} e^{-cAT/3 + C_2 T}. \end{aligned} \quad (4.53)$$

This bound now depends on A , as in the statement of the Proposition.

Finally, the last term to estimate in (4.49) is D_{f_ϕ} . It is a mean 1 martingale, thus:

$$\mathbb{P}^{\nu_{g_0}^N} \left(\frac{1}{T} \log D_{f_\phi} > A/24 \right) \leq e^{-AT/24}. \quad (4.54)$$

Putting (4.48), (4.50), (4.53) and (4.54) concludes the proof of (4.43): there are $C, C' > 0$ such that, for any $T > 1$, any large enough $A > 0$ (precisely: $A > 3C_2/c$), there is $C(T, \phi) > 0$ such that:

$$\mathbb{P}^{\nu_{g_0}^N} \left(\frac{1}{T} \int_0^T \Pi_t^N(\phi) dt > A \right) \leq C e^{-C'AT} + \frac{C(T, \phi)}{AN^{1/6}}. \quad (4.55)$$

□

4.3 Energy estimate

In this section, we prove the energy estimate (4.32). The key argument is the following lemma.

Lemma 4.6. *Let $A > 0$ be larger than some $A_0 > 0$ and let $\phi \in C_c^2(\mathbb{Z})$, where the subscript c stands for compactly supported. There are constants C, C' independent of ϕ such that:*

$$\limsup_{N \rightarrow \infty} \mathbb{P}^{\nu_{g_0}^N} \left(\left| \frac{1}{T} \int_0^T \Pi_t^N(\partial_1 \phi) dt \right| > A \|\phi\|_2 \right) \leq C e^{-C' AT}. \quad (4.56)$$

Assuming the lemma, (4.32) immediately follows by a union bound.

Proof of Lemma 4.6. Up to considering $-\phi$, it is enough to prove the result without the absolute value. Without loss of generality, we assume that the support of ϕ is contained in $\{z \in \mathbb{Z} : d(z, \partial \mathbb{Z}) > 2/N\}$, so that $\phi_{i,i+1} = 0 = \partial_1 \phi_{i,i+1}$ for each $i < N - 1$. As was done in the proof of Proposition 4.4, we may assume without loss of generality that ϕ is symmetric owing to the identity $\Pi^N(\phi) = \Pi^N(\check{\phi})$, with $\check{\phi}(x, y) = \phi(y, x)$ for $x, y \in \mathbb{Z}$. Starting from $\nu_{g_0}^N$, we use Feynman-Kac inequality to rewrite $\int_0^T \Pi_t^N(\partial_1 \phi) dt$ as $\int_0^T \Pi_t^N(F(\phi)) dt$, where $F(\phi)$ is a function in which only ϕ appears, and not its first partial derivative. This involves a microscopic integration by parts, which is controlled by Lemma B.2. We then use the $\mathbb{L}^2(\mathbb{Z})$ estimate of Proposition 4.4 to control the resulting $\int_0^T \Pi_t^N(F(\phi)) dt$ in terms of $\|\phi\|_2$.

Let $A > 0$, and let $V : \Omega_N \rightarrow \mathbb{R}$ be a function to be made explicit later. By Feynman-Kac inequality (3.5), one has:

$$\begin{aligned} \limsup_{N \rightarrow \infty} \log \mathbb{P}^{\nu_{g_0}^N} \left(\frac{1}{T} \int_0^T [\|\phi\|_2^{-1} \Pi^N(\partial_1 \phi) - V](\eta_t) dt > A/2 \right) \\ \leq -\frac{AT}{2} + T \sup_{f \geq 0: \nu_{g_0}^N(f)=1} \left\{ \nu_{g_0}^N(f(\|\phi\|_2^{-1} \Pi^N(\partial_1 \phi) - V)) + \frac{1}{2} \nu_{g_0}^N(f N^2 L^* \mathbf{1}) - \frac{N^2}{2} \nu_{g_0}^N(\Gamma(f^{1/2})) \right\}, \end{aligned} \quad (4.57)$$

where L^* is the adjoint of L in $\mathbb{L}^2(\nu_{g_0}^N)$. The function X will later on be chosen such that the above supremum vanishes, and also controllable with size $o_N(1)$, so that $\int_0^T V(\eta_t) dt$ vanishes in probability.

Recall first that, according to Lemma 3.3, there is a Γ -controllable random variable \mathcal{E} with size $N^{-1/2}$ such that, for each density f for $\nu_{g_0}^N$:

$$\nu_{g_0}^N(f N^2 L^* \mathbf{1}) - N^2 \nu_{g_0}^N(\Gamma(\sqrt{f})) \leq \nu_{g_0}^N(f \mathcal{E}) - \frac{N^2}{2} \nu_{g_0}^N(\Gamma(\sqrt{f})).$$

Set therefore $V := \mathcal{E}/2 + V'$, and look for a controllable error term V' such that the supremum in (4.57) vanishes. To see how, fix $\eta \in \Omega_N$ and write out $\|\phi\|_2^{-1} \Pi^N(\partial_1 \phi)$:

$$\|\phi\|_2^{-1} \Pi^N(\partial_1 \phi) = \frac{1}{4 \|\phi\|_2 N} \sum_{i < N-1} \left[\sum_{j \notin \{i, i+1\}} \bar{\eta}_i \bar{\eta}_j \partial_1^N \phi_{i,j} + \bar{\eta}_i \bar{\eta}_{i+1} \partial_1 \phi_{i,i+1} \right] + \frac{1}{N \|\phi\|_2} \Pi^N(b), \quad (4.58)$$

where $b = N[\partial_1\phi - \partial_1^N\phi]$ is the discretisation error, which is bounded with N . By assumption on the compact support of ϕ in \square , $\partial_1\phi_{i,i+1} = 0$ for each $i < N - 1$, and (4.58) becomes:

$$\|\phi\|_2^{-1}\Pi^N(\partial_1\phi) = \frac{1}{4\|\phi\|_2N} \sum_{i < N-1} \sum_{j \notin \{i, i+1\}} \bar{\eta}_i \bar{\eta}_j \partial_1^N \phi_{i,j} + \frac{1}{N\|\phi\|_2} \Pi^N(b).$$

By Lemma 3.7, as b is bounded, the last term above is controllable with size N^{-1} . Let us rewrite the first term through an integration by parts:

$$\begin{aligned} \frac{1}{4\|\phi\|_2} \sum_{i < N-1} \sum_{j \notin \{i, i+1\}} \bar{\eta}_i \bar{\eta}_j (\phi_{i+1,j} - \phi_{i,j}) &= \frac{1}{4\|\phi\|_2} \sum_{|i| < N-1} \sum_{j: |j-i| > 1} (\bar{\eta}_{i-1} - \bar{\eta}_i) \bar{\eta}_j \phi_{i,j} \\ &\quad + \frac{1}{4\|\phi\|_2} \sum_{|i| < N-1} \bar{\eta}_{i-1} (\bar{\eta}_{i+1} \phi_{i,i+1} - \bar{\eta}_i \phi_{i,i-1}) \\ &= \frac{1}{4\|\phi\|_2} \sum_{|i| < N-1} \sum_{j: |j-i| > 1} (\bar{\eta}_{i-1} - \bar{\eta}_i) \bar{\eta}_j \phi_{i,j} =: S, \end{aligned} \quad (4.59)$$

where the first equality makes use of $\phi_{\pm(N-1),\cdot} = 0$, while the second equality follows from $\phi_{i,i\pm 1} = 0$ for each $|i| < N - 1$. To choose V' in the supremum in (4.57), we have to estimate $\nu_{g_0}^N(fS)$. This is done through the integration by parts Lemma B.2. This lemma is formulated with the variables $\omega_i = \bar{\eta}_i/\bar{\sigma}_i$ for $i \in \Lambda_N$, so we need to rewrite (4.59). For $|i| < N - 1$, using the identity:

$$\begin{aligned} \bar{\eta}_{i-1} - \bar{\eta}_i &= \bar{\sigma}_{i-1}(\omega_{i-1} - \omega_i) - (\bar{\sigma}_i - \bar{\sigma}_{i-1})\omega_i \\ &= \bar{\sigma}_i(\omega_{i-1} - \omega_i) - \frac{\bar{\rho}'}{N} \left(\sigma'(\bar{\rho}) + \frac{\bar{\rho}'}{N} \right) \omega_i, \end{aligned}$$

S can be rewritten as follows:

$$\begin{aligned} S &= \frac{1}{4\|\phi\|_2} \sum_{|i| < N-1} \sum_{j: |j-i| > 1} \bar{\sigma}_{i-1}(\omega_{i-1} - \omega_i) \bar{\eta}_j \phi_{i,j} - \frac{1}{\|\phi\|_2} \Pi^N \left(\frac{\bar{\rho}'}{\bar{\sigma}} \left(\sigma'(\bar{\rho}) + \frac{\bar{\rho}'}{N} \right) \phi \right) \\ &=: S' + \Pi^N(Y^{(0)}), \quad Y^{(0)} = -\frac{1}{\|\phi\|_2} \frac{\bar{\rho}'}{\bar{\sigma}} \left(\sigma'(\bar{\rho}) + \frac{\bar{\rho}'}{N} \right) \phi, \end{aligned} \quad (4.60)$$

with the convention that $q\phi(x, y) = q(x)\phi(x, y)$ when $q : (-1, 1) \rightarrow \mathbb{R}$ and $(x, y) \in \square$. The last term is already of the form $\|\phi\|_2^{-1}\Pi^N(q\phi)$ with q bounded independently of ϕ , so it remains to estimate S' . Define, for $|i| < N - 1$, a function v_i on Ω_N as follows:

$$\forall \eta \in \Omega_N, \quad v_i(\eta) = \frac{1}{4} \sum_{j: |j-i| > 1} \bar{\eta}_j \bar{\sigma}_{i-1} \frac{\phi_{i,j}}{\|\phi\|_2}. \quad (4.61)$$

Recall also the notation C^{g_0} defined in (3.31):

$$\forall \eta \in \Omega_N, \forall i < N - 1, \quad \Pi^N(g_0)(\eta^{i,i+1}) - \Pi^N(g_0)(\eta) =: -\frac{(\eta_{i+1} - \eta_i)}{N} C_i^{g_0}.$$

With these notations, we can apply the integration by parts Lemma B.2 to each $|i| < N - 1$ with $u = v_i$, and obtain the existence of $C > 0$ such that, for each $\delta > 0$ and each density f for $\nu_{g_0}^N$:

$$\begin{aligned} \nu_{g_0}^N(fS') &\leq \delta N^2 \nu_{g_0}^N(\Gamma(f^{1/2})) + \frac{C}{\delta N^2} \sum_{|i| < N-1} \nu_{g_0}^N(f(v_i)^2) \\ &\quad + \sum_{|i| < N-1} (\bar{\rho}_i - \bar{\rho}_{i-1}) \nu_{g_0}^N(\omega_{i-1} \omega_i f e^{-(\eta_i - \eta_{i-1})C_{i-1}^{g_0}/N} v_i) \\ &\quad - \sum_{|i| < N-1} \nu_{g_0}^N\left((\omega_i - \omega_{i-1})(1 - e^{-(\eta_i - \eta_{i-1})C_{i-1}^{g_0}/N}) f v_i\right). \end{aligned} \quad (4.62)$$

We express each term appearing in (4.62) as $\Pi^N(F(\phi))$ plus error terms, for an explicit F . Consider first the second term on the first line. By definition (4.61) of v and using $(\bar{\eta})^2 = \bar{\sigma} + \sigma'(\bar{\rho})\bar{\eta}$, it reads:

$$\begin{aligned} &\frac{C}{16\delta N} \nu_{g_0}^N\left(f \sum_{j, \ell \in \Lambda_N} \frac{\bar{\eta}_j \bar{\eta}_\ell}{N} \sum_{\substack{|i| < N-1: \\ |i-j| > 1, |i-\ell| > 1}} \bar{\sigma}_i^2 \frac{\phi_{i,j} \phi_{i,\ell}}{\|\phi\|_2^2}\right) \\ &= \nu_{g_0}^N(f \Pi^N(Y^{(1)})) + \frac{C}{16\delta} \int_{\square} \bar{\sigma}(x) \bar{\sigma}(y)^2 \frac{\phi(x, y)^2}{\|\phi\|_2^2} dx dy + \nu_{g_0}^N(f \theta^{N,1}(\phi)), \end{aligned} \quad (4.63)$$

with $Y^{(1)}$ the function recording the off-diagonal, $\ell \neq j$ contribution:

$$\forall (x, y) \in \square, \quad Y^{(1)}(x, y) = \frac{C}{4\delta} \int_{(-1,1)} \bar{\sigma}(z)^2 \frac{\phi(z, x) \phi(z, y)}{\|\phi\|_2^2} dz. \quad (4.64)$$

The error term $\theta^{N,1}(\phi)$ in (4.63) involves discretisation errors and the diagonal, $\ell = j$ contributions. It is given for $\eta \in \Omega_N$ by:

$$\begin{aligned} \theta^{N,1}(\phi)(\eta) &= \frac{C}{16\delta} \int_{\square} \bar{\sigma}(x) \bar{\sigma}(y)^2 \frac{\phi(x, y)^2}{\|\phi\|_2^2} dx dy - \frac{C}{16\delta N^2} \sum_{\substack{|i| < N-1 \\ |j-i| > 1}} \bar{\sigma}_i \bar{\sigma}_j^2 \frac{\phi_{i,j}^2}{\|\phi\|_2^2} \\ &\quad + \frac{C}{16\delta N^2} \nu_{g_0}^N\left(f \sum_{\substack{|i| < N-1 \\ |j-i| > 1}} \bar{\eta}_i \bar{\sigma}_j^2 \frac{\phi_{i,j}^2}{\|\phi\|_2^2}\right) + \frac{1}{N} \Pi^N(c), \end{aligned}$$

where c is a discretisation error arising in the replacement of (4.63) by $Y^{(1)}$. The first line of $\theta^{N,1}(\phi)$ is configuration-independent, and bounded by $C(\phi)/N$. The first sum on the second line is of the form $N^{-1/2} Y^N(u)$ for $u : (-1, 1) \rightarrow \mathbb{R}$ bounded, with $Y^N(u)$ the fluctuations defined in (3.17). $\theta^{N,1}(\phi)$ is therefore controllable with size N^{-1} by Lemma 3.7. For later use, note that the middle term in (4.63) is bounded by $C/(2^{10}\delta)$ for all large enough N , as $\bar{\sigma} \leq 1/4$.

Consider now line 2 of (4.62). Using the identity $e^x = 1 + \int_0^1 x e^{tx} dt$ for $x \in \mathbb{R}$, there is $C(\rho_{\pm}) > 0$ such that:

$$\begin{aligned} \sum_{|i| < N-1} (\bar{\rho}_i - \bar{\rho}_{i-1}) \nu_{g_0}^N(\omega_{i-1} \omega_i f e^{-(\eta_i - \eta_{i-1})C_{i-1}^{g_0}/N} v_i) &\leq \frac{\bar{\rho}'}{N} \sum_{|i| < N-1} \nu_{g_0}^N(\omega_{i-1} \omega_i f v_i) \\ &\quad + \frac{C(\rho_{\pm})}{N^2} \sum_{|i| < N-1} \nu_{g_0}^N(f |v_i C_{i-1}^{g_0}|) =: \nu_{g_0}^N(f \theta^{N,2}(\phi)). \end{aligned}$$

The first term in $\theta^{N,2}(\phi)$ already involves three point correlations. It is shown to be Γ -controllable with size $N^{-1/2}$ in Proposition C.1. The second term is of the form $N^{-1}X_{2,\{0\}}^{v_2}$ in the notations of Lemma 3.7, and therefore controllable with size N^{-1} . As a result, $\theta^{N,2}(\phi)$ is Γ -controllable with size $N^{-1/2}$.

Consider finally line 3 of (4.63). Let $C(\bar{\rho}) > 0$ be such that:

$$\forall |i| < N - 1, \quad |\omega_i - \omega_{i-1}| \leq C(\bar{\rho}).$$

Using this time the existence of $K(g_0) > 0$ such that $|e^x - 1 - x| \leq K(g_0)x^2$ for all $|x| \leq 2\|g_0\|_\infty$, one can write, for each $\eta \in \Omega_N$:

$$\begin{aligned} - \sum_{|i| < N-1} (\omega_i - \omega_{i-1})(1 - e^{-(\eta_i - \eta_{i-1})C_{i-1}^{g_0}/N})v_i &\leq -\frac{1}{N} \sum_{|i| < N-1} (\omega_i - \omega_{i-1})(\eta_i - \eta_{i-1})C_{i-1}^{g_0}v_i \\ &\quad + \frac{K(g_0)C(\bar{\rho})}{N^2} \sum_{|i| < N-1} |v_i|(C_{i-1}^{g_0})^2. \end{aligned} \quad (4.65)$$

The last term is an average over i of terms of the form $N^{-3}|X_{3,\{0\}}^{w_3^i}|$ with the notations of Lemma 3.7, where the w_3^i satisfy $\sup_{N,i} \sup_{\Lambda_N^3} |w_3^i| < \infty$. It is therefore controllable with size $N^{-3/2}$. To estimate the first sum in the right-hand side of (4.65), we use the following elementary identity, valid for each $|i| < N - 1$:

$$(\omega_i - \omega_{i-1})(\eta_i - \eta_{i-1}) = \left[2 + (1 - \bar{\rho}_i - \bar{\rho}_{i-1})[\omega_i + \omega_{i-1}] - (\bar{\sigma}_{i-1} + \bar{\sigma}_i)\omega_{i-1}\omega_i \right]. \quad (4.66)$$

This identity can be obtained by making the following observation:

$$\forall i \in \Lambda_N, \quad \eta_i \omega_i := \eta_i \frac{(\eta_i - \bar{\rho}_i)}{\bar{\sigma}_i} = \frac{\eta_i}{\bar{\sigma}_i} (1 - \bar{\rho}_i) = \frac{\bar{\eta}_i}{\bar{\rho}_i} + 1.$$

Looking at (4.65), we see that the term $C_{i-1}^{g_0}v_i$ already contains two-point correlations for each $|i| < N - 1$. We therefore claim that only the constant term in the identity (4.66) will give something that is not an error term in (4.65). More precisely, we claim that one can obtain the following bound for line 3 of (4.63):

$$\begin{aligned} - \sum_{|i| < N-1} \nu_{g_0}^N \left((\omega_i - \omega_{i-1})(1 - e^{-(\eta_i - \eta_{i-1})C_{i-1}^g/N}) f v_i \right) \\ \leq \nu_{g_0}^N (f \Pi^N(Y^{(2)})) - \frac{1}{4} \int_{\square} \bar{\sigma}(x)\bar{\sigma}(y) \frac{\phi(x,y)}{\|\phi\|_2} \partial_1 g(x,y) dx dy + \nu_{g_0}^N (f \theta^{N,3}(\phi)), \end{aligned}$$

where $\theta^{N,3}(\phi)$ is controllable with size $N^{-1/2}$. There is $C(g_0) > 0$ independent of ϕ bounding the middle term above, and $Y^{(2)}$ is defined as:

$$\forall (x,y) \in \square, \quad Y^{(2)}(x,y) = -4 \int_{(-1,1)} \bar{\sigma}(z) \partial_1 g_0(z,x) \frac{\phi(z,y)}{\|\phi\|_2} dz. \quad (4.67)$$

We may now define the function V of (4.57):

$$V = \Pi^N(Y^{(0)} + Y^{(1)} + Y^{(2)}) + C'(g_0) + \zeta^N(\phi) + \mathcal{E}/2,$$

where \mathcal{E} is the error term of Lemma 3.3, $\zeta^N(\phi) := \sum_{k=1}^3 \theta^{N,k}(\phi) + (N\|\phi\|_2)^{-1}\Pi^N(b)$, and $C'(g_0) = (C(g_0) + C/(2^{10}\delta))$. The Feynman-Kac inequality in (4.57) then yields:

$$\limsup_{N \rightarrow \infty} \mathbb{P}^{\nu_{g_0}^N} \left(\frac{1}{T} \int_0^T \left[\|\phi\|_2^{-1} \Pi_t^N(\partial_1 \phi) - \Pi_t^N \left(\sum_{k=0}^2 Y^{(k)} \right) - C'(g_0) - \zeta_t^N(\phi) - \frac{\mathcal{E}_t}{2} \right] dt > A/2 \right) \leq e^{-AT/2}.$$

Moreover, by Corollary 3.6, the error term $\zeta^N(\phi) + \mathcal{E}/2$ satisfies:

$$\forall T > 0, \forall \varepsilon > 0, \quad \limsup_{N \rightarrow \infty} \mathbb{P}^{\nu_{g_0}^N} \left(\left| \frac{1}{T} \int_0^T \left[\zeta_t^N(\phi) + \frac{\mathcal{E}_t}{2} \right] dt \right| > \varepsilon \right) = 0,$$

and we have established:

$$\begin{aligned} & \limsup_{N \rightarrow \infty} \log \mathbb{P}^{\nu_{g_0}^N} \left(\frac{1}{T} \int_0^T \|\phi\|_2^{-1} \Pi_t^N(\partial_1 \phi) dt > A \right) \\ & \leq \max \left\{ -\frac{AT}{2}, \limsup_{N \rightarrow \infty} \log \mathbb{P}^{\nu_{g_0}^N} \left(\frac{1}{T} \int_0^T \left[\Pi_t^N \left(\sum_{k=0}^2 Y^{(k)} \right) + C'(g_0) \right] dt > A/4 \right) \right\}. \end{aligned}$$

To conclude the proof of the lemma, it remains to prove that there are constants $c, c' > 0$, independent of ϕ , such that:

$$\limsup_{N \rightarrow \infty} \mathbb{P}^{\nu_{g_0}^N} \left(\frac{1}{T} \int_0^T \left[\Pi_t^N \left(\sum_{k=0}^2 Y^{(k)} \right) + C'(g_0) \right] dt > A/4 \right) \leq ce^{-c'AT}. \quad (4.68)$$

If $A > 8C'(g_0)$, $A/4 - C'(g_0) > A/8$, and (4.68) satisfies:

$$\begin{aligned} & \limsup_{N \rightarrow \infty} \mathbb{P}^{\nu_{g_0}^N} \left(\frac{1}{T} \int_0^T \left[\Pi_t^N \left(\sum_{k=0}^2 Y^{(k)} \right) + C'(g_0) \right] dt > A/4 \right) \\ & \leq \limsup_{N \rightarrow \infty} \mathbb{P}^{\nu_{g_0}^N} \left(\frac{1}{T} \int_0^T \Pi_t^N \left(\sum_{k=0}^2 Y^{(k)} \right) dt > A/8 \right). \end{aligned} \quad (4.69)$$

Recall moreover that $Y^{(0)}$ has 2-norm bounded by 4 and, by Cauchy-Schwarz inequality, $Y^{(1)}$ has 2-norm bounded by $2^{-6}\delta^{-1}C$, and $Y^{(2)}$ by $\sqrt{2}\|\nabla g_0\|_2/8$. If $K(g_0)$ denotes the sum of these three norms, (4.69) becomes:

$$\begin{aligned} & \limsup_{N \rightarrow \infty} \mathbb{P}^{\nu_{g_0}^N} \left(\frac{1}{T} \int_0^T \Pi_t^N \left(\sum_{k=0}^2 Y^{(k)} \right) dt > A/4 \right) \\ & \leq \limsup_{N \rightarrow \infty} \mathbb{P}^{\nu_{g_0}^N} \left(\frac{1}{T} \int_0^T \Pi_t^N \left(\sum_{k=0}^2 Y^{(k)} \right) dt > \frac{A \|\sum_{k=0}^2 Y^{(k)}\|_2}{8K(g_0)} \right). \end{aligned} \quad (4.70)$$

To estimate the last line (4.70), let us use the exponential control in $\mathbb{L}^2(\square)$ stated in Proposition 4.4. To do so, we need to check that $Y_{\partial \square}^{(i)} = 0$ for $1 \leq i \leq 3$. This follows from the definition for $i \in \{1, 2\}$, and for $i = 3$ (recall (4.67)) it follows from the fact that $\partial_1 g(z, \pm 1) = 0$ for $z \in (-1, 1)$. Moreover, each $Y^{(i)}$ is in $C^2(\overline{\square}) \cap C^2(\overline{\square})$ for $1 \leq i \leq 3$. Proposition 4.4 thus applies to (4.70) to yield (4.68), which concludes the proof. \square

5 Lower bound for smooth trajectories

In this section, we give a lower bound on (2.26) when O is an open subset of $(\mathcal{T}'_s, *)$, in terms of the kernels $k_h, h \in \mathcal{S}(\varepsilon_B)$. As for standard large deviations (see Chapter 10 in [KL99]), we consider the tilted dynamics $\mathbb{P}_h, h \in \mathcal{S}(\varepsilon_B)$ such that $\frac{1}{4}\langle k_h, \cdot \rangle \in O$, and obtain a lower bound by proving that the measure \mathbb{P}_h concentrates on O . In the following, let $\mathbb{Q}_{T,h}$ denote the law of $\frac{1}{T} \int_0^T \Pi_t^N dt$ under \mathbb{P}_h .

Using Jensen inequality to obtain the last line below, one finds, with $D_h = d\mathbb{P}_h/d\mathbb{P}$ (see (3.67)):

$$\begin{aligned} \log \mathbb{Q}_T^{\nu_{g_0}^N}(O) &= \log \mathbb{E}_h^{\nu_{g_h}^N} \left[\mathbf{1}_O \frac{\nu_{g_0}^N(\eta_0)}{\nu_{g_h}^N(\eta_0)} (D_h)^{-1} \right] \\ &= \log \mathbb{E}_{h,O}^{\nu_{g_h}^N} \left[\frac{\nu_{g_0}^N(\eta_0)}{\nu_{g_h}^N(\eta_0)} (D_h)^{-1} \right] + \log \mathbb{Q}_{T,h}^{\nu_{g_h}^N}(O) \\ &\geq \mathbb{E}_{h,O}^{\nu_{g_h}^N} \left[-\log D_h \right] + \mathbb{E}_{h,O}^{\nu_{g_h}^N} \left[\log \left(\frac{\nu_{g_0}^N(\eta_0)}{\nu_{g_h}^N(\eta_0)} \right) \right] + \log \mathbb{Q}_{T,h}^{\nu_{g_h}^N}(O). \end{aligned} \quad (5.1)$$

Above, $\mathbb{P}_{h,O}^{\nu_{g_h}^N}$ is the probability $\mathbb{P}_h^{\nu_{g_h}^N}$ conditional to $\left\{ \frac{1}{T} \int_0^T \Pi_t^N dt \in O \right\}$:

$$\mathbb{P}_{h,O}^{\nu_{g_h}^N}(\cdot) = \frac{\mathbb{P}_h^{\nu_{g_h}^N} \left(\cdot \cap \left\{ \frac{1}{T} \int_0^T \Pi_t^N dt \in O \right\} \right)}{\mathbb{Q}_{T,h}^{\nu_{g_h}^N}(O)}, \quad \mathbb{E}_{h,O}^{\nu_{g_h}^N}[\cdot] = \int \cdot d\mathbb{P}_{h,O}^{\nu_{g_h}^N}.$$

The terms appearing in (5.1) are of three types: the change of initial condition corresponding to $\nu_{g_0}^N/\nu_{g_h}^N$, the dynamical part with $\log D_h$, and the term $\mathbb{Q}_{T,h}^{\nu_{g_h}^N}(O)$. The latter is well controlled only if h is such that, under $\mathbb{Q}_{T,h}^{\nu_{g_h}^N}$, correlations are typically in O when N, T are large. For such h 's, upon dividing by T and taking the large T limit, only the dynamical part will contribute. This is proven in the next subsections, where the above terms are estimated one by one.

5.1 Estimate of the cost of changing initial condition

Here we prove that changing the initial condition does not affect the long-time behaviour.

Lemma 5.1. *Let $h \in \mathcal{S}(\varepsilon_B)$. If:*

$$\liminf_{T \rightarrow \infty} \liminf_{N \rightarrow \infty} \mathbb{Q}_{T,h}^{\nu_{g_h}^N}(O) > 0, \quad (5.2)$$

then the lower bound (5.1) becomes:

$$\liminf_{T \rightarrow \infty} \liminf_{N \rightarrow \infty} \frac{1}{T} \log \mathbb{Q}_T^{\nu_{g_0}^N}(O) \geq \liminf_{T \rightarrow \infty} \liminf_{N \rightarrow \infty} \frac{1}{T} \mathbb{E}_{h,O}^{\nu_{g_h}^N} \left[-\log D_h \right]. \quad (5.3)$$

Proof. By assumption (5.2),

$$\liminf_{T \rightarrow \infty} \liminf_{N \rightarrow \infty} \frac{1}{T} \log \mathbb{Q}_{T,h}^{\nu_{g_h}^N}(O) = 0, \quad (5.4)$$

and it is sufficient to estimate the middle term in the right-hand side of (5.1). It reads:

$$\mathbb{E}_{h,O}^{\nu_{g_h}^N} \left[\log \left(\frac{\nu_{g_0}^N(\eta_0)}{\nu_{g_h}^N(\eta_0)} \right) \right] = \sum_{\eta \in \Omega_N} \nu_{g_h}^N(\eta) \log \left(\frac{\nu_{g_0}^N(\eta)}{\nu_{g_h}^N(\eta)} \right) \frac{\mathbb{Q}_{T,h}^\eta(O)}{\mathbb{Q}_{T,h}^{\nu_{g_h}^N}(O)}. \quad (5.5)$$

To bound this term, we would like to express it in terms of the relative entropy $H(\nu_{g_h}^N | \nu_{g_0}^N)$, which can be bounded explicitly. Due to conditioning on the set O , this is however not directly possible. Instead, write $O = \mathcal{T}' \setminus O^c$ to obtain:

$$\begin{aligned} \mathbb{E}_{h,O}^{\nu_{g_h}^N} \left[\log \left(\frac{\nu_{g_0}^N(\eta_0)}{\nu_{g_h}^N(\eta_0)} \right) \right] &\geq \mathbb{Q}_{T,h}^{\nu_{g_h}^N}(O)^{-1} \left[\sum_{\eta \in \Omega_N} \nu_{g_h}^N(\eta) \log \left(\frac{\nu_{g_0}^N(\eta)}{\nu_{g_h}^N(\eta)} \right) \right. \\ &\quad \left. - \sum_{\eta \in \Omega_N} \nu_{g_h}^N(\eta) \log \left(\frac{\nu_{g_0}^N(\eta)}{\nu_{g_h}^N(\eta)} \right) \mathbb{Q}_{T,h}^\eta(O^c) \right] \\ &= \mathbb{Q}_{T,h}^{\nu_{g_h}^N}(O)^{-1} \left[-H(\nu_{g_h}^N | \nu_{g_0}^N) + \nu_{g_0}^N \left[\frac{d\nu_{g_h}^N}{d\nu_{g_0}^N} \log \left(\frac{d\nu_{g_h}^N}{d\nu_{g_0}^N} \right) \mathbb{Q}_{T,h}(O^c) \right] \right]. \end{aligned}$$

Since $x \mapsto x \log x$ is bounded below by $-1/e$ on \mathbb{R}_+^* and $\mathbb{Q}_{T,h}(O^c) \in [0, 1]$, we obtain:

$$\mathbb{E}_{h,O}^{\nu_{g_h}^N} \left[\log \left(\frac{\nu_{g_0}^N(\eta_0)}{\nu_{g_h}^N(\eta_0)} \right) \right] \geq \mathbb{Q}_{T,h}^{\nu_{g_h}^N}(O)^{-1} \left[-H(\nu_{g_h}^N | \nu_{g_0}^N) - \frac{1}{e} \right].$$

Let us now estimate $H(\nu_{g_h}^N | \nu_{g_0}^N)$. It reads:

$$H(\nu_{g_h}^N | \nu_{g_0}^N) = 2 \sum_{\eta \in \Omega_N} \nu_{g_h}^N(\eta) \Pi^N(g_h - g_0)(\eta) - \log \mathcal{Z}_{g_h}^N + \log \mathcal{Z}_{g_0}^N.$$

Since $g_h \in g_0 + \mathcal{S}(\varepsilon_G)$, defined in (2.22), and g_0 is a negative kernel, $\mathcal{Z}_{g_h}^N$ and $\mathcal{Z}_{g_0}^N$ are bounded with N by Lemma A.1. The first sum is moreover bounded with N by Proposition A.5, which states:

$$\sup_{i \neq j \in \Lambda_N} |\nu_{g_h}^N(\bar{\eta}_i \bar{\eta}_j)| = O(N^{-1}) \quad \Rightarrow \quad \sup_N \left| \nu_{g_h}^N \left(\Pi^N(g_h - g_0) \right) \right| < \infty.$$

Under assumption (5.2), dividing by T and taking the large N , large T limits as in (5.3) thus yields:

$$\liminf_{T \rightarrow \infty} \liminf_{N \rightarrow \infty} \frac{1}{T} \mathbb{E}_{h,O}^{\nu_{g_h}^N} \left[\log \left(\frac{\nu_{g_0}^N(\eta_0)}{\nu_{g_h}^N(\eta_0)} \right) \right] = 0.$$

Together with (5.4), this concludes the proof. \square

In the next section, the assumption (5.2) on the limit of $\mathbb{Q}_{T,h}^{\nu_{g_h}^N}(O)$ is established.

5.2 Law of large numbers and Poisson equation

In this section, we establish (5.2).

Proposition 5.2. *Let $h \in \mathcal{S}(\varepsilon_B)$, and let k_h be the large N limit of the correlations under $\nu_{g_h}^N$, where g_h solves the main equation (2.31). If $O \subset (\mathcal{T}'_s, *)$ is an open set containing $\frac{1}{4}\langle k_h, \cdot \rangle$, then:*

$$\liminf_{T \rightarrow \infty} \liminf_{N \rightarrow \infty} \mathbb{Q}_{T,h}^{\nu_{g_h}^N}(O) = 1. \quad (5.6)$$

An open set in $(\mathcal{T}'_s, *)$ is a (possibly uncountable) union of finite intersections of sets of the form $\left\{ \left| \frac{1}{T} \int_0^T \Pi_t^N(\phi) dt - \frac{1}{4} \langle k_h, \phi \rangle \right| \in U \right\}$, for an open set $U \subset \mathbb{R}$ and $\phi \in \mathcal{T}$. It is therefore enough to prove (5.6) for those sets, with $U = (-\varepsilon, \varepsilon)$ for $\varepsilon > 0$. This is done in the next proposition, by means of a Poisson problem associated with the large N limit of the generator $N^2 L_h$.

Proposition 5.3. *Let $\phi \in \mathcal{T} \cap C^2(\bar{\square})$ be a symmetric function, with \mathcal{T} defined in (2.15), and let $h \in \mathcal{S}(\varepsilon_B)$. Then, for any $\varepsilon \in (0, 1)$ and any $T > 0$, there are positive constants $C(h, T)$, $C'(h, T, \phi)$ such that:*

$$\mathbb{P}_h^{\nu_{g_h}^N} \left(\left| \frac{1}{T} \int_0^T \Pi_t^N(\phi) dt - \frac{1}{4} \langle k_h, \phi \rangle \right| \geq \varepsilon \|\phi\|_2 \right) \leq \frac{C(h, \phi)}{\varepsilon^2 T} + \frac{C'(h, \phi, T)}{\varepsilon^2 N^{1/4}}. \quad (5.7)$$

Proof. Fix a symmetric $\phi \in \mathcal{T} \cap C^2(\bar{\square})$. To prove Proposition 5.3, we express the difference appearing in the probability in (5.7) as a time integral involving the generator $N^2 L_h$, plus a martingale term. The martingale term is then proven to fluctuate like \sqrt{T} when N is large. It thus vanishes in the large T limit upon dividing by T . Recall that $I(u, v)(x, y) = \int_{(-1,1)} u(z, x) \bar{\sigma}(z) v(z, y) dz$ for any $u, v \in \mathbb{L}^2(\square)$. The key ingredient is the following Poisson equation:

$$\begin{cases} \frac{1}{2} \Delta f(x, y) + \frac{1}{2} I(\partial_1 f, \partial_1 h) + \frac{1}{2} I(\partial_1 h, \partial_1 f) = \frac{\phi(x, y)}{\|\phi\|_2} & \text{for } (x, y) \in \square, \\ f = 0 & \text{on } \partial \square, \\ (\partial_1 - \partial_2) f(x_{\pm}, x) = 0 & \text{for } x \in (-1, 1). \end{cases} \quad (5.8)$$

In Appendix F, (5.8) is proven to have a unique solution $f_{\phi} \in \mathcal{T} \cap C^3(\bar{\square})$, a symmetric function on \square . For this f_{ϕ} , the martingale decomposition of Corollary 3.12 gives:

$$\forall T \geq 0, \quad \Pi_T^N(f_{\phi}) = \Pi_0^N(f_{\phi}) + \int_0^T N^2 L_h \Pi_t^N(f_{\phi}) dt + M_t^{N, f_{\phi}}. \quad (5.9)$$

Let us first use the Poisson equation (5.8) to express $N^2 L_h \Pi^N(f_{\phi})$ in terms of $\Pi^N(\phi)$. We prove:

Lemma 5.4.

$$N^2 L_h \Pi^N(f_{\phi}) = \frac{1}{\|\phi\|_2} \left(\Pi^N(\phi) - \frac{1}{4} \langle k_h, \phi \rangle \right) + \theta^N(f_{\phi}), \quad (5.10)$$

where $\theta^N(f_{\phi})$ is an error term (recall Definition 3.5 of error terms) satisfying, for each $T \geq 0$ and some $C(h, T, \phi) > 0$:

$$\mathbb{E}_h^{\nu_{g_h}^N} \left[\left| \int_0^T \tilde{\theta}_t^N(f_{\phi}) dt \right| \right] \leq C(h, T, \phi) N^{-1/4}. \quad (5.11)$$

Assuming Lemma 5.4 for the moment, let us prove Proposition 5.3. For each $T > 0$ and $\varepsilon > 0$, integrate (5.10) between 0 and T and use the martingale decomposition (5.9) to find:

$$\begin{aligned} & \mathbb{P}_h^{\nu_{g_h}^N} \left(\left| \frac{1}{T} \int_0^T \Pi_t^N(\phi) dt - \frac{1}{4} \langle k_h, \phi \rangle \right| \geq \varepsilon \|\phi\|_2 \right) \\ & \leq \mathbb{P}_h^{\nu_{g_h}^N} \left(\frac{1}{T} \left| \Pi_T^N(f_\phi) - \Pi_0^N(f_\phi) - M_T^{N,f_\phi} - \int_0^T \theta_t^N(f_\phi) dt \right| > \varepsilon \right). \end{aligned}$$

Let us estimate each of the terms appearing in the last probability. Equation (5.11) takes care of $\theta^N(f_\phi)$. By Markov- and Chebychev inequalities:

$$\begin{aligned} & \mathbb{P}_h^{\nu_{g_h}^N} \left(\left| \frac{1}{T} \int_0^T \Pi_t^N(\phi) dt - \frac{1}{4} \langle k_h, \phi \rangle \right| \geq \varepsilon \|\phi\|_2 \right) \\ & \leq \frac{3C(h, T, \phi)}{\varepsilon N^{1/4} T} + \frac{3}{T\varepsilon} \mathbb{E}_h^{\nu_{g_h}^N} \left[\left| \Pi_T^N(f_\phi) - \Pi_0^N(f_\phi) \right| \right] + \frac{9}{\varepsilon^2 T^2} \mathbb{E}_h^{\nu_{g_h}^N} \left[\langle M^{N,f_\phi} \rangle_T \right]. \end{aligned} \quad (5.12)$$

Consider first the terms $\Pi_T^N(f_\phi)$, $\Pi_0^N(f_\phi)$. As f_ϕ is bounded, one can use the $C(h)e^{C(h)T}N^{-1/2}$ relative entropy bound of Theorem 2.5 and estimate moments of $\Pi^N(f_\phi)$ under $\nu_{g_h}^N$ by Lemma 3.7 to find that there are $c(f_\phi), c'(f_\phi) > 0$ such that:

$$\begin{aligned} & \frac{3}{T\varepsilon} \mathbb{E}_h^{\nu_{g_h}^N} \left[\left| \Pi_T^N(f_\phi) - \Pi_0^N(f_\phi) \right| \right] \leq \frac{3}{T\varepsilon} \mathbb{E}_h^{\nu_{g_h}^N} \left[\left| \Pi_T^N(f_\phi) \right| \right] + \frac{3}{T\varepsilon} \nu_{g_h}^N \left[\left| \Pi^N(f_\phi) \right| \right] \\ & \leq \frac{3c(\phi)}{T\varepsilon} \left[H(f_T \nu_{g_h}^N | \nu_{g_h}^N) + \log \nu_{g_h}^N \left[\exp \left[c(f_\phi)^{-1} \Pi^N(f_\phi) \right] \right] \right] + \frac{3}{T\varepsilon} \nu_{g_h}^N \left[\left| \Pi^N(f_\phi) \right| \right] \\ & \leq \frac{3c'(f_\phi)}{T\varepsilon} \left[1 + \frac{C(h)e^{C(h)T}}{N^{1/2}} \right]. \end{aligned} \quad (5.13)$$

Let us prove that the quadratic variation of M^{N,f_ϕ} has average bounded linearly in time in the large N limit, which will be enough to conclude the proof of Proposition 5.3. The quadratic variation is given for each $t \geq 0$ by:

$$\langle M^{N,f_\phi} \rangle_t = \frac{1}{2} \int_0^t \sum_{i < N-1} c_h(\eta(s), i, i+1) \left[\frac{\bar{\rho}'}{4N} (f_\phi)_{i,i+1} + \frac{1}{2N} \sum_{j \notin \{i, i+1\}} \bar{\eta}_j(s) \partial_1^N (f_\phi)_{i,j} \right]^2 ds. \quad (5.14)$$

Recall from the definition (2.19) of c_h that $\sup_{N, \Omega_N} c_h \leq c(h)$. Using the inequality $(a+b)^2 \leq 2a^2 + 2b^2$ for $a, b \in \mathbb{R}$ as well as the fact that f_ϕ is bounded, one has:

$$\mathbb{E}_h^{\nu_{g_h}^N} \left[\langle M^{N,f_\phi} \rangle_T \right] \leq c(h) \mathbb{E}_h^{\nu_{g_h}^N} \left[\int_0^T \sum_{i < N-1} \left(\frac{1}{2N} \sum_{j \notin \{i, i+1\}} \bar{\eta}_j(t) \partial_1^N (f_\phi)_{i,j} \right)^2 dt \right] + \frac{Tc(h) \|f_\phi\|_\infty}{N}.$$

The integrand at each time $t \leq T$ is of the form $N^{-1} X_{2, \{0\}}^u$ in the notations of Lemma 3.7, with $u = (u_{i,j})_{i,j \in \Lambda_N}$ given by:

$$u_{i,j} = \frac{1}{N} \sum_{k \notin \{i-1, i, j-1, j, N-1\}} \partial_1^N (f_\phi)_{k,i} \partial_1^N (f_\phi)_{k,j} = \int_{(-1,1)} \partial_1 f_\phi(z, i/N) \partial_1 f_\phi(z, j/N) dz + \frac{v_{i,j}^N}{N},$$

where v^N is a discretisation error bounded by $C(\phi) > 0$. It is thus controllable with size 1, and Corollary 3.6 concludes the proof: there are $C(h, \phi) > 0$, $C'(h, \phi, T) > 0$ such that:

$$\frac{9}{\varepsilon^2 T^2} \mathbb{E}_h^{\nu_{g_h}^N} \left[\langle M^{N, f_\phi} \rangle_T \right] \leq \frac{1}{\varepsilon^2} \left(\frac{C(h, \phi)}{T} + \frac{C(h, \phi, T)}{N^{1/2}} \right).$$

This estimate and (5.12)-(5.13) conclude the proof of Proposition 5.3 assuming Lemma 5.4, that we now prove. \square

Proof of Lemma 5.4. To prove Lemma 5.4, the starting point is the expression of $N^2 L_h \Pi^N(f_\phi)$ worked out in Corollary 3.12: there is an error term $\tilde{\varepsilon}^N(h, f_\phi)$ such that:

$$\begin{aligned} N^2 L_h \Pi^N(f_\phi) &= \frac{1}{2} \Pi^N \left(\Delta f_\phi + I(\partial_1 f_\phi, \partial_1 h) + I(\partial_1 h, \partial_1 f_\phi) \right) - \frac{(\bar{\rho}')^2}{4} \int_{(-1,1)} f_\phi(x, x) dx \\ &\quad + \frac{1}{4} \int_{\square} \bar{\sigma}(x) \bar{\sigma}(y) [\partial_1 f_\phi(x, y) \partial_1 h(x, y)] dx dy + \tilde{\varepsilon}^N(h, f_\phi). \end{aligned} \quad (5.15)$$

Note the absence of the diagonal term $\sum_{i < N-1} \bar{\eta}_i \bar{\eta}_{i+1} (\partial_1(f_\phi)_{i+,i} - \partial_1(f_\phi)_{i-,i})$. Recall from Remark 3.11 that this term corresponds to the derivative of f_ϕ in the normal direction to the diagonal, which vanishes according to (5.8). By Corollary C.3, there is $C(h, T, \phi) > 0$ with:

$$\mathbb{E}_h^{\nu_{g_h}^N} \left[\left| \int_0^T \tilde{\varepsilon}_t^N(h, f_\phi) dt \right| \right] \leq C(h, T, \phi) N^{-1/4}. \quad (5.16)$$

As f_ϕ solves (5.8), (5.15) can be written as:

$$\begin{aligned} N^2 L_h \Pi^N(f_\phi) &= \frac{1}{\|\phi\|_2} \Pi^N(\phi) - \frac{(\bar{\rho}')^2}{4} \int_{(-1,1)} f_\phi(x, x) dx \\ &\quad + \frac{1}{4} \int_{\square} \bar{\sigma}(x) \bar{\sigma}(y) [\partial_1 f_\phi(x, y) \partial_1 h(x, y)] dx dy + \tilde{\varepsilon}^N(h, f_\phi). \end{aligned} \quad (5.17)$$

Equation (5.17) will correspond to (5.10) with $\theta^N(f_\phi) = \tilde{\varepsilon}^N(h, f_\phi)$, if we can prove:

$$- \frac{1}{4\|\phi\|_2} \langle k_h, \phi \rangle = - \frac{(\bar{\rho}')^2}{4} \int_{(-1,1)} f_\phi(x, x) dx + \frac{1}{4} \int_{\square} \bar{\sigma}(x) \bar{\sigma}(y) [\partial_1 f_\phi(x, y) \partial_1 h(x, y)] dx dy. \quad (5.18)$$

There is no clear visible link between k_h that is obtained as a function of g_h in Proposition A.5, and the constant terms in (5.17). We prove (5.18) in an indirect way, starting from the martingale decomposition of $\Pi^N(f_\phi)$ given in (5.9):

$$\forall T \geq 0, \quad \Pi_T^N(f_\phi) = \Pi_0^N(f_\phi) + \int_0^T N^2 L_h \Pi_s^N(f_\phi) ds + M_t^{N, f_\phi}. \quad (5.19)$$

Assume we can prove that, for symmetric $\tilde{f} \in C^2(\square)$:

$$\limsup_{N \rightarrow \infty} \sup_{t \leq T} \left| \int_0^t \mathbb{E}_h^{\nu_{g_h}^N} \left[N^2 L_h \Pi_s^N(\tilde{f}) \right] ds \right| = 0. \quad (5.20)$$

Since $\nu_{g_h}^N(\Pi^N(f_\phi)) = (1/4)\langle k_h, \phi \rangle + o_N(1)$, (5.20) is equivalent, using (5.19) with \tilde{f} instead of f_ϕ , to:

$$\limsup_{N \rightarrow \infty} \sup_{t \leq T} \left| \mathbb{E}_h^{\nu_{g_h}^N} [\Pi_t^N(\tilde{f})] - \frac{1}{4} \langle k_h, \tilde{f} \rangle \right| = 0. \quad (5.21)$$

Taking expectations in (5.17) and estimating $\tilde{\varepsilon}^N(h, f_\phi)$ through (5.16), we find, using (5.20) with $\tilde{f} = f_\phi$ in the first line, and (5.21) with $\tilde{f} = \phi$ to obtain the last equality:

$$\begin{aligned} 0 &= \limsup_{N \rightarrow \infty} \int_0^T \mathbb{E}_h^{\nu_{g_h}^N} \left[N^2 L_h \Pi_t^N(f_\phi) \right] dt \\ &= \limsup_{N \rightarrow \infty} \int_0^T \left[\mathbb{E}_h^{\nu_{g_h}^N} \left[\frac{\Pi_t^N(\phi)}{\|\phi\|_2} \right] - \frac{(\bar{\rho}')^2}{4} \int_{(-1,1)} f_\phi(x, x) dx \right. \\ &\quad \left. + \frac{1}{4} \int_{\square} \bar{\sigma}(x) \bar{\sigma}(y) [\partial_1 f_\phi(x, y) \partial_1 h(x, y)] dx dy \right] dt \\ &= \frac{T}{4\|\phi\|_2} \langle k_h, \phi \rangle - \frac{T(\bar{\rho}')^2}{4} \int_{(-1,1)} f_\phi(x, x) dx + \frac{T}{4} \int_{\square} \bar{\sigma}(x) \bar{\sigma}(y) [\partial_1 f_\phi(x, y) \partial_1 h(x, y)] dx dy. \end{aligned}$$

It follows that (5.20) implies the thesis of Lemma 5.4 with $\theta^N(f_\phi) = \tilde{\varepsilon}^N(h, f_\phi)$. Equation (5.20) is proven next in Lemma 5.5. \square

Lemma 5.5. *For any $T > 0$ and any continuous and bounded $F : \square \rightarrow \mathbb{R}$, there is $C(h, \|F\|_\infty) > 0$ such that:*

$$\sup_{N \in \mathbb{N}^*} \sup_{t \leq T} \mathbb{E}_h^{\nu_{g_h}^N} [|\Pi_t^N(F)|^{3/2}] \leq C(h, \|F\|_\infty) e^{C(h, \|F\|_\infty)T}, \quad (5.22)$$

and, for each $\varepsilon \in (0, 1/2)$:

$$\limsup_{N \rightarrow \infty} \sup_{t \leq T} \mathbb{E}_h^{\nu_{g_h}^N} [|\Pi_t^N(F)|^{1+\varepsilon}] \leq C(h, \|F\|_\infty). \quad (5.23)$$

As a result, (5.20)-(5.21) hold.

Remark 5.6. Here, we do not use the specific form of the bound in (5.22). It is however used in the proof of the $\mathbb{L}^2(\square)$ estimate of Proposition 4.4 (see (4.52)), and (5.23) is useful in the next section. \blacksquare

Proof. Let ϕ, f_ϕ be as in the proof of Proposition 5.3. One could prove (5.21) through a direct application of the entropy inequality. However, the moment bounds (5.22)-(5.23) have other uses, so we obtain (5.21) as a consequence of these bounds.

Assume first that (5.22)-(5.23) hold and let us explain how they give (5.21), which will then imply (5.20) as noticed below (5.20). Fix $F \in C^0(\triangleright) \cap C^0(\triangleleft)$ and assume the moment bound (5.22) holds. For $t \leq T$, write:

$$\mathbb{E}_h^{\nu_{g_h}^N} [\Pi_t^N(F)] = \mathbb{E}_h^{\nu_{g_h}^N} [\Pi_t^N(F) \mathbf{1}_{|\Pi_t^N(F)| < \log N}] + \mathbb{E}_h^{\nu_{g_h}^N} [\Pi_t^N(F) \mathbf{1}_{|\Pi_t^N(F)| \geq \log N}]. \quad (5.24)$$

By Hölder inequality with exponents $(3/2, 3)$, the second expectation is bounded by $C_1(\log N)^{-1/3}$, $C_1 = C_1(T, F) > 0$, uniformly in $t \in [0, T]$. On the other hand, Corollary 3.4 can be used on the

first expectation to obtain:

$$\begin{aligned} \sup_{t \leq T} \left| \mathbb{E}_h^{\nu_{g_h}^N} [\Pi_t^N(F)] - \nu_{g_h}^N [\Pi^N(F)] \right| &\leq \nu_{g_h}^N [\Pi^N(F) \mathbf{1}_{|\Pi^N(F)| \geq \log N}] + C_2(T) N^{-1/2} \log N \\ &+ C_1(\log N)^{-1/3}, \end{aligned}$$

with $C_2(T) > 0$. As $\Pi^N(F)$ has bounded moments of all orders under $\nu_{g_h}^N$, as also $\nu_{g_h}^N(\Pi^N(F))$ converges to $\frac{1}{4} \langle k_h, F \rangle$, (5.20)-(5.21) are proven:

$$\limsup_{N \rightarrow \infty} \sup_{t \in [0, T]} \left| \mathbb{E}_h^{\nu_{g_h}^N} [\Pi_t^N(F)] - \frac{1}{4} \langle k_h, F \rangle \right| = 0. \quad (5.25)$$

We now prove the moment bounds (5.22)-(5.23). Fix $t \in [0, T]$ and let $\varepsilon > 0$ to be chosen later. We estimate the moment of order $1 + \varepsilon$ of $\Pi_t^N(F)$. The moment bound is obtained by a careful application of the entropy inequality, putting to good use the $O(N^{-1/2})$ estimate on the size of the entropy of Theorem 2.5. Note that $|\Pi_t^N(F)| \leq \|F\|_\infty N$. As a result, fixing $c > 0$ to be chosen later and applying the entropy inequality to $c\lambda \mathbf{1}_{|\Pi^N(F)| > \lambda}$ for each $\lambda > 1$ in the second line below:

$$\begin{aligned} \mathbb{E}_h^{\nu_{g_h}^N} [|\Pi_t^N(F)|^{1+\varepsilon}] &\leq 1 + (1 + \varepsilon) \int_1^{\|F\|_\infty N} \lambda^\varepsilon \mathbb{P}^{\nu_{g_h}^N} (|\Pi_t^N(F)| > \lambda) d\lambda \\ &\leq 1 + (1 + \varepsilon) \int_1^{\|F\|_\infty N} c^{-1} \lambda^{-1+\varepsilon} \left[H(f_t \nu_{g_h}^N | \nu_{g_h}^N) + \log \left(1 + (e^{c\lambda} - 1) \nu_{g_h}^N (|\Pi^N(F)| > \lambda) \right) \right] d\lambda. \end{aligned}$$

By Theorem 2.5, $H(f_t \nu_{g_h}^N | \nu_{g_h}^N) \leq C(h) e^{C(h)T} N^{-1/2}$ for some $C(h) > 0$. Moreover, by Corollary A.9, the probability involving $\nu_{g_h}^N$ above is bounded by $C(h, \|F\|_\infty) e^{-c(h, \|F\|_\infty)\lambda}$ for some $C(h, \|F\|_\infty), c(h, \|F\|_\infty) > 0$. Choosing $c = c(h, \|F\|_\infty)/2$, one obtains the existence of $C'(h, \|F\|_\infty) > 0$ such that:

$$\begin{aligned} \sup_{t \leq T} \mathbb{E}_h^{\nu_{g_h}^N} [|\Pi_t^N(F)|^{1+\varepsilon}] &\leq 1 + \frac{(1 + \varepsilon) C'(h, \|F\|_\infty) e^{C(h, \|F\|_\infty)T}}{\varepsilon N^{1/2-\varepsilon}} \\ &+ \frac{2(1 + \varepsilon)}{c(h, \|F\|_\infty)} \int_1^{\|F\|_\infty N} \lambda^{-1+\varepsilon} e^{-c(h, \|F\|_\infty)\lambda/2} d\lambda. \end{aligned}$$

The integral is bounded with N whatever ε . Overall, the right-hand side above is therefore bounded with N as soon as $\varepsilon \in (0, 1/2]$, which yields (5.22). This bound is independent of T in the large N limit if $\varepsilon \in (0, 1/2)$, hence (5.23). This concludes the proof of the Lemma. \square

5.3 Estimating the dynamical part

In this section, we estimate the term $\mathbb{E}_{h,O}^{\nu_{g_h}^N} [-\log D_h]$ arising in (5.1). Recall from Corollary 3.12 the definition of the martingale $M_T^{N,h}$. Then $\mathbb{E}_{h,O}^{\nu_{g_h}^N} [-\log D_h]$ reads:

$$\begin{aligned} \mathbb{E}_{h,O}^{\nu_{g_h}^N} [-\log D_h] &= \left(\mathbb{Q}_{T,h}^{\nu_{g_h}^N}(O) \right)^{-1} \mathbb{E}_h^{\nu_{g_h}^N} \left[\mathbf{1}_O \left(-M_T^{N,h} - \frac{1}{2} \int_0^T \Pi_t^N(I(\partial_1 h, \partial_1 h)) dt \right) \right] \\ &- \frac{T}{8} \int_{\mathbb{Q}} \bar{\sigma}(x) \bar{\sigma}(y) [\partial_1 h(x, y)]^2 dx dy + \frac{\mathbb{E}_h^{\nu_{g_h}^N} \left[\mathbf{1}_O \int_0^T \hat{\varepsilon}^N(h)(\eta_t) dt \right]}{\mathbb{Q}_{T,h}^{\nu_{g_h}^N}(O)}, \quad (5.26) \end{aligned}$$

with $\hat{\varepsilon}^N(h)$ the error term defined in Corollary 3.12. As such, the expectation in (5.26) vanishes in the large N limit by Proposition C.2. Moreover, Proposition 5.2 establishes the convergence of $\mathbb{Q}_{T,h}^{\nu_{g_h}^N}(O)$ to 1 as N , then T become large. In particular, this quantity is bounded from below, and:

$$\limsup_{N \rightarrow \infty} \left| \frac{\mathbb{E}_h^{\nu_{g_h}^N} \left[\mathbf{1}_O \int_0^T \hat{\varepsilon}^N(h)(\eta_t) dt \right]}{\mathbb{Q}_{T,h}^{\nu_{g_h}^N}(O)} \right| = 0. \quad (5.27)$$

Consider now the expectation in the first line of (5.26). By Cauchy-Schwarz inequality and the fact that $\langle M^{N,h} \rangle_T$ grows at most linearly in time when N is large (see the proof of Proposition 5.3), the contribution of the martingale term scales like \sqrt{T} , thus will vanish upon dividing by T in the large T limit.

Consider now the term involving $\Pi_t^N(I(\partial_1 h, \partial_1 h))$. With $\mathbf{1}_O = 1 - \mathbf{1}_{O^c}$ and recalling (5.21), one has:

$$\begin{aligned} \limsup_{N \rightarrow \infty} \left| \int_0^T \mathbb{E}_h^{\nu_{g_h}^N} [\mathbf{1}_O \Pi_t^N(I(\partial_1 h, \partial_1 h))] dt - \frac{T}{4} \langle k_h, I(\partial_1 h, \partial_1 h) \rangle \right| \\ \leq \limsup_{N \rightarrow \infty} \left| \int_0^T \mathbb{E}_h^{\nu_{g_h}^N} [\mathbf{1}_{O^c} \Pi_t^N(I(\partial_1 h, \partial_1 h))] dt \right|. \end{aligned}$$

To compute the last expectation, use the moment bound (5.23) of Lemma 5.5 and Hölder inequality to find, for any $\theta \in (0, 1/2)$:

$$\limsup_{N \rightarrow \infty} \sup_{t \leq T} \mathbb{E}_h^{\nu_{g_h}^N} [\mathbf{1}_{O^c} \Pi_t^N(I(\partial_1 h, \partial_1 h))] \leq C(h, \theta) \limsup_{N \rightarrow \infty} \mathbb{Q}_{T,h}^{\nu_{g_h}^N}(O^c)^{\theta/(1+\theta)} = o_T(1). \quad (5.28)$$

From (5.27) to (5.28), we obtain:

$$\begin{aligned} \liminf_{T \rightarrow \infty} \liminf_{N \rightarrow \infty} \frac{1}{T} \mathbb{E}_{h,O}^{\nu_{g_h}^N} [-\log D_h] &= -\frac{1}{8} \int_{\mathbb{Z}} dx dy \bar{\sigma}(x) \bar{\sigma}(y) [\partial_1 h(x, y)]^2 - \frac{1}{8} \langle k_h, I(\partial_1 h, \partial_1 h) \rangle \\ &= -\frac{1}{8} \int_{(-1,1)} dz \bar{\sigma}(z) \langle \partial_1 h(z, \cdot), (\bar{\sigma} + k_h) \partial_1 h(z, \cdot) \rangle. \end{aligned} \quad (5.29)$$

Adapting the method of Lemma 5.3 in Chapter 10 of [KL99], it is not difficult to prove:

$$J_h(k_h) = \mathcal{I}(k_h) = \frac{1}{8} \int_{(-1,1)} dz \bar{\sigma}(z) \langle \partial_1 h(z, \cdot), (\bar{\sigma} + k_h) \partial_1 h(z, \cdot) \rangle. \quad (5.30)$$

Equations (5.29)-(5.30) enable us to recover the expected large deviation functional:

$$\liminf_{T \rightarrow \infty} \liminf_{N \rightarrow \infty} \frac{1}{T} \mathbb{E}_{h,O}^{\nu_{g_h}^N} [-\log D_h] \geq -\frac{1}{8} \int_{(-1,1)} dz \bar{\sigma}(z) \langle \partial_1 h(z, \cdot), (\bar{\sigma} + k_h) \partial_1 h(z, \cdot) \rangle = -\mathcal{I}(k_h).$$

Above, we write $J_h(k_h)$ as short for $J_h(\frac{1}{4} \langle k_h, \cdot \rangle)$. ■

5.4 Conclusion of the lower bound for smooth trajectories and accessible correlations

The previous three sections provide the following bound: for each open set $O \subset (\mathcal{T}'_s, *)$,

$$\liminf_{T \rightarrow \infty} \liminf_{N \rightarrow \infty} \frac{1}{T} \log \mathbb{Q}_T^{\nu_{g_0}^N}(O) = - \inf_{h \in \mathcal{S}(\varepsilon_B): k_h \in O} \mathcal{I}(k_h). \quad (5.31)$$

This concludes the proof of the lower bound in Theorem 2.2.

Yet, so far, we have only proven that the rate function \mathcal{I} properly estimates the cost of observing smooth kernels k_h corresponding to some $h \in \mathcal{S}(\varepsilon_B)$, i.e. to h 's which are sufficiently small in the sense that $h \in \mathcal{S}(\varepsilon_B)$ (recall (2.22)). For the rate function to be useful, we need to make sure that any kernel k close to the typical kernel k_0 (recall (2.8)), at least sufficiently smooth, will actually look like one of the $k_h, h \in \mathcal{S}(\varepsilon_B)$. This is the claim of Proposition 2.8, that we now prove.

Proof. Let $\varepsilon > 0$ and let $k \in k_0 + \mathcal{S}(\varepsilon)$, where k_0 is the correlation kernel of the steady state defined in (2.9). If ε is small enough, $g := \bar{\sigma}^{-1} - (\bar{\sigma} + k)^{-1}$ is a well-defined kernel operator. Indeed, writing $k = k - k_0 + k_0$:

$$\begin{aligned} g - g_0 &= (\bar{\sigma} + k_0)^{-1} - (\bar{\sigma} + k)^{-1} = (\bar{\sigma} + k_0)^{-1} \left(I - ((\bar{\sigma} + k_0 + k - k_0)(\bar{\sigma} + k_0)^{-1})^{-1} \right) \\ &= (\bar{\sigma} + k_0)^{-1} \left(I - (I + (k - k_0)(\bar{\sigma} + k_0)^{-1})^{-1} \right) \\ &= (\bar{\sigma} + k_0)^{-1} \left(I - \sum_{p=0}^{\infty} \left(- (k - k_0)(\bar{\sigma} + k_0)^{-1} \right)^p \right) \\ &= -(\bar{\sigma} + k_0)^{-1} \sum_{p=1}^{\infty} \left(- (k - k_0)(\bar{\sigma} + k_0)^{-1} \right)^p. \end{aligned} \quad (5.32)$$

The series expansion is legitimate for ε small enough, since $(\bar{\sigma} + k_0)^{-1} = C_0^{-1} = \bar{\sigma}^{-1} - g_0$ with $\|g_0\|_2$ bounded, and if ε is small enough:

$$\|(k - k_0)(\bar{\sigma} + k_0)^{-1}\|_2 = \|(k - k_0)\bar{\sigma}^{-1} - (k - k_0)g_0\|_2 \leq (\sqrt{2}\|\bar{\sigma}^{-1}\|_{\mathbb{L}^2((-1,1))} + \|g_0\|_2)\varepsilon < 1.$$

Since it starts at $p = 1$, the series is a kernel operator, thus g as well. Moreover, g is in $W^{4,p}(\square)$ for some $p > 2$ and, differentiating inside the sum in (5.32), $(\partial_1 - \partial_2)(g - g_0)$ vanishes at the extremities of the diagonal D . The function g is thus in $g_0 + \mathcal{S}(\varepsilon')$ for some $\varepsilon' > 0$. In Appendix F, the main equation (2.31), seen as an equation with data $g \in g_0 + \mathcal{S}(\varepsilon')$ and unknown h , is shown to have a unique solution $h \in \mathcal{S}(\varepsilon'')$, and $\mathcal{S}(\varepsilon'') \subset \mathcal{S}(\varepsilon_B)$ as soon as $\varepsilon'' \leq \varepsilon_B$. The associated correlation kernel k_h is given by $k_h = -\bar{\sigma} + (\bar{\sigma}^{-1} - g)^{-1} = k$. The expression 2.33 of the rate function at k then follows from (5.30):

$$\mathcal{I}(k) = J_h(k) = \frac{1}{8} \int_{(-1,1)} \bar{\sigma}(z) \langle \partial_1 h(z, \cdot), (\bar{\sigma} + k) \partial_1 h(z, \cdot) \rangle dz.$$

□

A Correlations and concentration under discrete Gaussian measures

In this section, we investigate the measures ν_g^N , defined for $g : \square \rightarrow \mathbb{R}$ as follows:

$$\bar{\nu}^N = \bigotimes_{i \in \Lambda_N} \text{Ber}(\bar{\rho}_i), \quad \forall \eta \in \Omega_N, \quad \nu_g^N(\eta) = \frac{1}{\mathcal{Z}_g^N} \exp \left[\frac{1}{2N} \sum_{i \neq j \in \Lambda_N} g_{i,j} \bar{\eta}_i \bar{\eta}_j \right] \bar{\nu}^N(\eta), \quad (\text{A.1})$$

where the partition function \mathcal{Z}_g^N is a normalising constant.

A.1 Bound on the partition function and correlations

Lemma A.1 (Bound on the partition function). *Let $g : \square \rightarrow \mathbb{R}$ be a continuous, bounded and symmetric function, and suppose that $g = g_- + g_+$, where g_+ (resp.: g_-) is a continuous positive (negative) kernel on $\mathbb{L}^2(\square)$, i.e. $\pm \int_{\square} f(x) g_{\pm}(x, y) f(y) dx dy \geq 0$ for any $f \in \mathbb{L}^2((-1, 1))$. Assume also that the positive part satisfies:*

$$\int_{\square} \bar{\sigma}(x) g_+(x, y)^2 \bar{\sigma}(y) dx dy < 1/16 \quad \text{or, more simply, as } \bar{\sigma} \leq 1/4 : \quad \int_{\square} g_+(x, y)^2 dx dy < 1. \quad (\text{A.2})$$

Then, there is $\alpha_g > 0$ such that:

$$\sup_{N \geq 1} \bar{\nu}^N \left[\exp \left[\frac{(1 + \alpha_g)}{2N} \sum_{i \neq j \in \Lambda_N} \bar{\eta}_i \bar{\eta}_j g_{i,j} \right] \right] < \infty. \quad (\text{A.3})$$

In particular, as the inverse correlation kernel g_0 of the steady state of the open SSEP is a negative kernel, such an α_g exists for each g in the set $g_0 + \mathcal{S}(\varepsilon_G)$ defined in (2.22) and Theorem 2.5.

Proof. Since $((g_-)_{i,j})_{(i,j) \in \Lambda_N^2}$ is a negative quadratic form, one has:

$$\begin{aligned} \mathcal{Z}_g^N &:= \bar{\nu}^N [e^{2\Pi^N(g_- + g_+)}] = \bar{\nu}^N \left[e^{2\Pi^N(g_+)} \exp \left[\frac{1}{2N} \sum_{(i,j) \in \Lambda_N^2} \bar{\eta}_i \bar{\eta}_j (g_-)_{i,j} - \frac{1}{2N} \sum_{i \in \Lambda_N} (\bar{\eta}_i)^2 (g_-)_{i,j}^2 \right] \right] \\ &\leq \mathcal{Z}_{g_+}^N e^{\|g\|_{\infty}}. \end{aligned}$$

The result then follows from the so-called Hanson-Wright inequality. Proofs of this inequality for independent sub-Gaussian random variables and $\|g_+\|_2$ smaller than a non-explicit constant abound in the literature, see e.g. [RV13] and references therein. The sufficiency of (A.2) follows from the proof of Lemma F.13 in [JM18b]. \square

Remark A.2. The boundedness of g in Lemma A.1 is used only for the diagonal terms. The continuity of g_+ implies that it is Riemann integrable, so that (A.2) in particular implies:

$$\text{for all large enough } N, \quad \frac{1}{N^2} \sum_{i \neq j \in \Lambda_N} \bar{\sigma}_i (g_+)_{i,j}^2 \bar{\sigma}_j < 1/8.$$

The sum above is the trace norm of the matrix $(N^{-1} \bar{\sigma}_i^{-1/2} (g_+)_{i,j} \bar{\sigma}_j^{-1/2} \mathbf{1}_{i \neq j})_{(i,j) \in \Lambda_N^2}$. Note, for future reference, that assumption (A.2) therefore implies that the matrix $(\bar{\sigma}_i^{-1} \mathbf{1}_{i=j} - N^{-1} g_{i,j} \mathbf{1}_{i \neq j})_{i,j}$ is invertible for all large enough N . \blacksquare

Lemma A.3. *Let $g : \square \rightarrow \mathbb{R}$ satisfy the hypotheses of Lemma A.1. Then:*

$$\forall n \in \mathbb{N}^*, \quad \sup_{I \subset \Lambda_N : |I|=n} \left| \nu_g^N \left(\prod_{a \in I} \bar{\eta}_a \right) \right| = O(N^{-n/2}). \quad (\text{A.4})$$

Moreover, if $g \in C^1(\bar{\triangleright}) \cap C^1(\bar{\triangleleft})$ with $g(\pm 1, \cdot) = 0$, then:

$$\forall n \in \mathbb{N}^*, \forall \varepsilon \in \{+, -\}, \quad \sup_{\substack{I \subset \Lambda_N \\ \varepsilon(N-1) \in I \text{ and } |I|=n}} \left| \nu_g^N \left(\bar{\eta}_{\varepsilon(N-1)} \prod_{a \in I \setminus \{\varepsilon(N-1)\}} \bar{\eta}_a \right) \right| = O(N^{-n/2-1}). \quad (\text{A.5})$$

Proof. Let $I \subset \Lambda_N$ with $|I| = n \in \mathbb{N}^*$. A proof for general n is very cumbersome, so we focus on the $n \in \{1, 2\}$ case that contains the important ideas. Define:

$$\forall \eta_I \in \{0, 1\}^{\Lambda_N \setminus I}, \quad G_{I^c}(\eta_{I^c}) = \frac{1}{4N} \sum_{i \neq j \in \Lambda_N \setminus \{I\}} \bar{\eta}_i \bar{\eta}_j g_{i,j}. \quad (\text{A.6})$$

Let also ν_I^N be the Bernoulli product measure $\bigotimes_{a \in I} \text{Ber}(\bar{\rho}_i)$. Consider first a single site $a \in \Lambda_N$, in which case (A.4) says that ν_g^N and $\bar{\nu}^N$ have practically the same average occupation number. For each $\eta = (\eta_a, \eta_{\{a\}^c}) \in \Omega_N$, one has:

$$2\Pi^N(g) = 2G_{\{a\}^c}(\eta_{\{a\}^c}) + \frac{1}{N} \sum_{i \neq a} \bar{\eta}_a \bar{\eta}_i g_{a,i}. \quad (\text{A.7})$$

As a result:

$$\mathcal{Z}_g^N \nu_g^N[\bar{\eta}_a] = \sum_{\eta_{\{a\}^c}} \bar{\nu}_{\{a\}^c}(\eta_{\{a\}^c}) e^{2G_{\{a\}^c}(\eta_{\{a\}^c})} \bar{\nu}_{\{a\}} \left[\bar{\eta}_a \exp \left[\frac{1}{N} \sum_{i \neq a} \bar{\eta}_a \bar{\eta}_i g_{a,i} \right] \right]. \quad (\text{A.8})$$

Fix $\eta_{\{a\}^c} \in \{0, 1\}^{\Lambda_N \setminus \{a\}}$, and use $e^x = 1 + x \int_0^1 e^{tx} dt$ for $x \in \mathbb{R}$ to obtain:

$$\bar{\nu}_{\{a\}} \left[\bar{\eta}_a \exp \left[\frac{1}{N} \sum_{i \neq a} \bar{\eta}_a \bar{\eta}_i g_{a,i} \right] \right] = \frac{1}{N} \sum_{i \neq a} (\bar{\eta}_a)^2 \bar{\eta}_i g_{a,i} \int_0^1 \exp \left[\frac{t}{N} \sum_{i \neq a} \bar{\eta}_a \bar{\eta}_i g_{a,i} \right] dt. \quad (\text{A.9})$$

Recalling the identity (A.7), it follows that $\nu_g^N(\bar{\eta}_a)$ reads:

$$\begin{aligned} \nu_g^N(\bar{\eta}_a) &= \int_0^1 \nu_g^N \left[\frac{(\bar{\eta}_a)^2}{N} \sum_{i \neq a} \bar{\eta}_i g_{a,i} \exp \left[\frac{(t-1)}{N} \sum_{i \neq a} \bar{\eta}_a \bar{\eta}_i g_{a,i} \right] \right] \\ &\leq e^{2\|g\|_\infty} \nu_g^N \left[\left| \frac{1}{N} \sum_{i \neq a} \bar{\eta}_i g_{a,i} \right| \right], \end{aligned} \quad (\text{A.10})$$

where in the second line we used $|\bar{\eta}_a| \leq 1$. To estimate this last expectation, let α_g be as in Lemma A.1, and let $p \in \mathbb{N}^*$ be odd and such that $1/p < \alpha_g$. By Hölder inequality with exponents $(1 + 1/p, p + 1)$, $\nu_g^N(\bar{\eta}_a)$ can be bounded as follows:

$$|\nu_g^N(\bar{\eta}_a)| \leq (\mathcal{Z}_g^N)^{-1} \bar{\nu}^N \left[e^{2(1+1/p)\Pi^N(g)} \right]^{p/(p+1)} \bar{\nu}^N \left[\left(\frac{1}{N} \sum_{i \neq a} \bar{\eta}_i g_{a,i} \right)^{p+1} \right]^{1/(p+1)}. \quad (\text{A.11})$$

The exponential moment of $2(1+1/p)\Pi^N(g)$ is bounded by Lemma A.1. On the other hand, there is $C_{p+1} > 0$ such that:

$$\bar{\nu}^N \left[\left(\frac{1}{N} \sum_{i \neq a} \bar{\eta}_i g_{a,i} \right)^{p+1} \right] \leq C_{p+1} \|g_{a,\cdot}\|_\infty^{p+1} N^{-(p+1)/2}. \quad (\text{A.12})$$

Since $\bar{\nu}^N$ is product and $\bar{\nu}^N(\bar{\eta}_i) = 0$, $i \in \Lambda_N$, the last equality follows either from a combinatorial argument (developing the sum, a product $\bar{\eta}_{i_1} \dots \bar{\eta}_{i_{p+1}}$ contributes to the average if and only if each site $j \in \{i_1, \dots, i_{p+1}\}$ appears at least twice); or from the computation of the moment generating function of $\sum_{i \neq a} \bar{\eta}_i g_{a,i}$ in a neighbourhood of 0, and elementary computations to bound its $(p+1)$ -times derivative:

$$\forall t \in \mathbb{R}, \quad \bar{\nu}^N \left[\exp \left[t \sum_{i \neq a} \bar{\eta}_i g_{a,i} \right] \right] = \exp \left[\sum_{i \neq a} \left[-t \bar{\rho}_i g_{a,i} + \log \left(\bar{\rho}_i (e^{t g_{a,i}} - 1) + 1 \right) \right] \right].$$

Since \mathcal{Z}_g^N is also bounded by Lemma A.1, we have proven:

$$\sup_{a \in \Lambda_N} |\nu_g^N(\bar{\eta}_a)| = O(N^{-1/2}).$$

Suppose now that $a \in \{\pm(N-1)\}$ and g is C^1 with $g(\pm 1, \cdot) = 0$. As a result, $Ng_{a,\cdot}$ is bounded uniformly in a, N , and (A.12) can be written:

$$\bar{\nu}^N \left[\left(\frac{1}{N} \sum_{i \neq a} \bar{\eta}_i g_{a,i} \right)^{p+1} \right] \leq C_{p+1} \|Ng_{a,\cdot}\|_\infty^{p+1} N^{-(p+1)} N^{-(p+1)/2}.$$

Using this bound in (A.11) yields (A.5) when $|I| = 1$.

Consider now the case of two-point correlations: $I = \{a, b\} \subset \Lambda_N$ with $a \neq b$. The idea is the same, starting with: for each $\eta \in \Omega_N$,

$$\begin{aligned} 2\Pi_g^N &= 2G_{\{a\}^c}(\eta_{\{a\}^c}) + \frac{1}{N} \sum_{i \neq a} \bar{\eta}_a \bar{\eta}_i g_{a,i} \\ &= 2G_{I^c}(\eta_{I^c}) + \frac{1}{N} \sum_{i \neq a} \bar{\eta}_a \bar{\eta}_i g_{a,i} + \frac{1}{N} \sum_{j \notin I} \bar{\eta}_b \bar{\eta}_j g_{b,j}. \end{aligned} \quad (\text{A.13})$$

We proceed as in (A.9) and first develop the exponential involving $\bar{\eta}_a$ to find:

$$\mathcal{Z}_g^N \nu_g^N(\bar{\eta}_a \bar{\eta}_b) = \int_0^1 \bar{\nu}^N \left[\bar{\eta}_b e^{2G_{\{a\}^c}} \frac{(\bar{\eta}_a)^2}{N} \sum_{i \neq a} \bar{\eta}_i g_{a,i} \exp \left[\frac{t_a}{N} \sum_{i \neq a} \bar{\eta}_a \bar{\eta}_i g_{a,i} \right] \right] dt_a. \quad (\text{A.14})$$

Use then (A.13) and the identity $e^x = 1 + \int_0^1 e^{tx} dt$ for $x \in \mathbb{R}$ to obtain:

$$\begin{aligned} \mathcal{Z}_g^N \nu_g^N(\bar{\eta}_a \bar{\eta}_b) &= \int_0^1 \bar{\nu}^N \left[e^{2G_{I^c}} \bar{\eta}_b \left(1 + \int_0^1 \sum_{j \neq a, b} \frac{\bar{\eta}_b \bar{\eta}_j g_{b,j}}{N} \exp \left[\frac{t_b}{N} \sum_{j \neq a, b} \bar{\eta}_b \bar{\eta}_j g_{b,j} \right] dt_b \right) \right. \\ &\quad \left. \frac{(\bar{\eta}_a)^2}{N} \sum_{i \neq a} \bar{\eta}_i g_{a,i} \exp \left[\frac{t_a}{N} \sum_{i \neq a} \bar{\eta}_a \bar{\eta}_i g_{a,i} \right] \right] dt_a. \end{aligned} \quad (\text{A.15})$$

In the one-point case, the 1 in the parenthesis above vanished because the average of $\bar{\eta}$ under $\bar{\nu}^N$ is exactly zero. Here, because of the exponential of the sum $\frac{t_a}{N} \sum_{i \neq a} \bar{\eta}_a \bar{\eta}_i g_{a,i}$ that involves $\bar{\eta}_b$, the average does not vanish. It is instead shifted by an amount bounded by $O(N^{-1})$, as we shall see. Developing the parenthesis in the first line above and isolating the index $i = b$ in the sums, one finds:

$$\nu_g^N(\bar{\eta}_a \bar{\eta}_b) = (\mathcal{Z}_g^N)^{-1} \int_0^1 dt_a \bar{\nu}^N \left[e^{2G_{I^c}} \bar{\eta}_b (\bar{\eta}_a)^2 \left(\frac{\bar{\eta}_b g_{a,b}}{N} + \frac{1}{N} \sum_{i \neq a,b} \bar{\eta}_i g_{a,i} \right) \right. \quad (\text{A.16})$$

$$\begin{aligned} & \times \exp \left[\frac{t_a}{N} \sum_{i \neq a,b} \bar{\eta}_a \bar{\eta}_i g_{a,i} + \frac{t_a \bar{\eta}_a \bar{\eta}_b g_{a,b}}{N} \right] dt_a \\ & + \int_{[0,1]^2} dt_a dt_b \nu_g^N \left[\left[\frac{(\bar{\eta}_a \bar{\eta}_b)^2}{N^2} \sum_{i \neq a} \bar{\eta}_i g_{a,i} \sum_{j \neq a,b} \bar{\eta}_j g_{b,j} \right] \right. \quad (\text{A.17}) \\ & \left. \times \exp \left[\frac{(t_a - 1)}{N} \sum_{i \neq a} \bar{\eta}_a \bar{\eta}_i g_{a,i} + \frac{(t_b - 1)}{N} \sum_{j \neq a,b} \bar{\eta}_b \bar{\eta}_j g_{b,j} \right] \right]. \end{aligned}$$

Bounding $(\bar{\eta}_a \bar{\eta}_b)^2$ by 1 and the exponential by $e^{4\|g\|_\infty}$, the expectation (A.17) spanning the last two lines is shown to be bounded by $O(N^{-1})$ as in the one-point case (respectively: $O(N^{-2})$ if either a or b is in $\{\pm(N-1)\}$). Let us now check that the first term (A.16) in the right-hand side is also bounded by $O(N^{-1})$ (resp. $O(N^{-2})$). Taking expectations with respect to $\eta_b \in \{0, 1\}$, it can be written as:

$$\begin{aligned} & \int_0^1 dt_a \bar{\nu}^N \left[e^{2G_{I^c}} \exp \left[\frac{t_a}{N} \sum_{i \neq a,b} \bar{\eta}_a \bar{\eta}_i g_{a,i} \right] (\bar{\eta}_a)^2 \left\{ \bar{\nu}_{\{b\}}^N \left[\frac{(\bar{\eta}_b)^2 g_{a,b}}{N} \exp \left[\frac{t_a \bar{\eta}_a \bar{\eta}_b g_{a,b}}{N} \right] \right] \right. \right. \\ & \left. \left. + \bar{\nu}_{\{b\}}^N \left[\bar{\eta}_b \exp \left[\frac{t_a \bar{\eta}_a \bar{\eta}_b g_{a,b}}{N} \right] \right] \left(\frac{1}{N} \sum_{i \neq a,b} \bar{\eta}_i g_{a,i} \right) \right\} \right] dt_a. \end{aligned}$$

The first expectation under $\bar{\nu}_{\{b\}}^N$ is bounded by $O(N^{-1})$ (resp: $O(N^{-2})$) as desired, due to the factor $g_{a,b}/N$. The identity $e^x = 1 + \int_0^1 x e^{tx} dt$ shows that the second expectation has the same scaling. Putting together the estimates of (A.16)-(A.17) yields the claim of Lemma A.3 for $|I| = 2$.

The general case follows by a cumbersome iteration of the above procedure. If $I \subset \Lambda_N$ and a new point is added to the set I , then the starting point is again the identity:

$$2G_{I^c} = 2G_{(I \cup \{a\})^c} + \frac{1}{N} \sum_{i \notin I \cup \{a\}} \bar{\eta}_a \bar{\eta}_i g_{a,i}.$$

One then successively expands all exponentials using $e^x = 1 + \int_0^1 x e^{tx} dt$, $x \in \mathbb{R}$. If $I = \{i_1, \dots, i_n\}$ and $i_0 := a$, this procedure yields:

$$\begin{aligned} \mathcal{Z}_g^N \nu_g^N \left(\bar{\eta}_a \prod_{i \in I} \bar{\eta}_i \right) &= \int_{[0,1]^{n+1}} \bar{\nu}^N \left[e^{2G_{(I \cup \{i_0\})^c}} (\bar{\eta}_{i_0}^2) \left(\prod_{\ell=1}^n \bar{\eta}_{i_\ell} \right) \exp \left[\frac{t_0 \bar{\eta}_{i_0}}{N} \sum_{i \neq i_0} \bar{\eta}_i g_{i_0,i} \right] \right. \\ & \left. \times \prod_{\ell=1}^n \left(1 + \frac{\bar{\eta}_{i_\ell}}{N} \sum_{\substack{i \in \Lambda_N \\ i \neq i_0, \dots, i_{\ell-1}}} \bar{\eta}_i g_{i_\ell,i} \exp \left[\frac{t_\ell \bar{\eta}_{i_\ell}}{N} \sum_{\substack{i \in \Lambda_N \\ i \neq i_0, \dots, i_{\ell-1}}} \bar{\eta}_i g_{i_\ell,i} \right] \right) \right] \prod_{i=0}^n dt_i. \end{aligned}$$

Averages of the resulting sums and exponentials under $\bar{\nu}_{\{i\}}^N$ for each $i \in I \cup \{a\} = \{i_0, \dots, i_n\}$ are then performed iteratively. Each successive average shifts the average occupation numbers of remaining sites by $O(N^{-1})$ as in (A.16). As long as $|I|$ is independent from N , these $O(N^{-1})$ shifts do not change the scaling of correlations. \square

Remark A.4. Note that, if g is a negative kernel, then one can simply write:

$$\forall \lambda \in \mathbb{R}, \quad \nu_g^N [e^{\lambda \bar{\eta}_a}] \leq (\mathcal{Z}_g^N)^{-1} \bar{\nu}^N [e^{\lambda \bar{\eta}_a}] \leq (\mathcal{Z}_g^N)^{-1} e^{\lambda^2/8}, \quad (\text{A.18})$$

where the last inequality comes from the fact that, by Hoeffding's lemma, $\bar{\eta}_a$ is sub-Gaussian under $\bar{\nu}^N$, with variance $1/4$ (it takes values $1 - \bar{\rho}_a, -\bar{\rho}_a$ with average 0). Equation (A.18) implies that $\bar{\eta}_a$ is sub-Gaussian under ν_g^N , hence has vanishing expectation (see Appendix F of [JM18b] for properties of sub-Gaussian random variables in the present context). \blacksquare

We now exactly compute two-point correlations under ν_g^N . In the following, denote by $\bar{\sigma}$ the diagonal matrix with entries $\bar{\sigma}_i \mathbf{1}_{i=j}$. Define also the matrix M_g^N by:

$$\forall (i, j) \in \Lambda_N^2, \quad M_g^N(i, j) = g_{i,j}, \quad M_g^N(i, i) = 0. \quad (\text{A.19})$$

The two point correlations under ν_g^N are denoted by the matrix C_g^N :

$$\forall (i, j) \in (\Lambda_N)^2, \quad C_g^N(i, j) = \nu_g^N(\bar{\eta}_i \bar{\eta}_j) - \nu_g^N(\bar{\eta}_i) \nu_g^N(\bar{\eta}_j). \quad (\text{A.20})$$

Proposition A.5. *Let $g : \square \rightarrow \mathbb{R}$ satisfy the hypotheses of Lemma A.1. Then:*

$$\sup_{a \in \Lambda_N} |\nu_g^N(\bar{\eta}_a)| = O(N^{-1}). \quad (\text{A.21})$$

Moreover, the correlations under ν_g^N are given by:

$$C_g^N = \left(\bar{\sigma}^{-1} - N^{-1} M_g^N \right)^{-1} + e_N, \quad M_g^N = N(\bar{\sigma}^{-1} - (C_g^N)^{-1}) + N e'_N,$$

with e_N a matrix satisfying $\sup_i |e_N(i, i)| = O(N^{-1})$, $\sup_{i \neq j} |e_N(i, j)| = O(N^{-3/2})$, idem for e'_N .

Proof. The method of proof is the same as for Lemma A.1, except that bounds on higher order correlations can now be used to get exact results. Consider first $a \in \Lambda_N$. From (A.10), one has:

$$\nu_g^N(\bar{\eta}_a) = \int_0^1 \nu_g^N \left[\frac{(\bar{\eta}_a)^2}{N} \sum_{i \neq a} \bar{\eta}_i g_{a,i} \exp \left[\frac{t-1}{N} \sum_{i \neq a} \bar{\eta}_a \bar{\eta}_i g_{a,i} \right] \right] dt. \quad (\text{A.22})$$

Recall the identity:

$$(\bar{\eta})^2 = \bar{\sigma} + \sigma'(\bar{\rho}) \bar{\eta}, \quad \bar{\sigma} := \bar{\rho} \cdot (1 - \bar{\rho}).$$

Using this identity and expanding the exponential in (A.22) using $e^x \leq 1 + C|x|$ if $|x| \leq 2\|g\|_\infty$, we find:

$$\left| \nu_g^N(\bar{\eta}_a) - \frac{\bar{\sigma}_a}{N} \sum_{i \neq a} g_{a,i} \bar{\nu}_g^N(\bar{\eta}_i) - \frac{\sigma'(\bar{\rho}_a)}{N} \sum_{i \neq a} g_{a,i} \nu_g^N(\bar{\eta}_a \bar{\eta}_i) \right| \leq 2C \nu_g^N \left[|\bar{\eta}_a|^3 \left(\frac{1}{N} \sum_{i \neq a} \bar{\eta}_i g_{a,i} \right)^2 \right].$$

Bounding $|\bar{\eta}_a|$ by 1, the right-hand side involves two-point correlations, thus is bounded by $O(N^{-1})$ uniformly on $a \in \Lambda_N$ by Lemma A.1. The same can be said for the term involving $\sigma'(\bar{\rho}_a)$ in the left-hand side. As a result:

$$\nu_g^N(\bar{\eta}_a) = \frac{\bar{\sigma}_a}{N} \sum_{i \neq a} g_{a,i} \bar{\nu}_g^N(\bar{\eta}_i) + \varepsilon_N(a), \quad \sup_{b \in \Lambda_N} \varepsilon_N(b) = O(N^{-1}).$$

Let $\nu_g^N(\bar{\eta}.)$ be the vector $(\nu_g^N(\bar{\eta}_a))_{a \in \Lambda_N}$, and ε_N the vector $(\varepsilon_N(a))_a$. We have just proven:

$$(\bar{\sigma}^{-1} - N^{-1}M_g^N)\nu_g^N(\bar{\eta}.) = \varepsilon_N.$$

To obtain the claim (A.21), it is enough to prove that the matrix on the left-hand side is invertible, and has a sufficiently nice inverse, as we now explain. The structure of the inverse is the content of the following lemma.

Lemma A.6. *Let \mathcal{M} be the set of sequences of matrices on Λ_N^2 , $N \in \mathbb{N}^*$ defined as follows. $(A_N)_N \in \mathcal{M}$ if and only if there are sequences $(D_N)_N, (R_N)_N$ of matrices and $c > 0$ such that, for each large enough $N \in \mathbb{N}^*$, D_N is diagonal, $R_N(i, i) = 0$ for $i \in \Lambda_N$, $A_N = D_N + N^{-1}R_N$. Moreover, $(D_N)_N, (R_N)_N$ must satisfy:*

$$\text{for all large enough } N, \quad \inf_{i \in \Lambda_N} |D_N(i, i)| \geq c, \quad \sup_{(i,j) \in \Lambda_N^2} |R_N(i, j)| \leq c^{-1}.$$

If $(A_N)_N \in \mathcal{M}$ is symmetric and invertible, then $(A_N^{-1})_N \in \mathcal{M}$.

Momentarily admitting Lemma A.6, one can apply Lemma A.6 to $A_N := \bar{\sigma}^{-1} - N^{-1}M_g^N$, $N \in \mathbb{N}^*$, which is invertible for large enough N as a consequence of Remark A.2. Equation (A.21) follows:

$$\nu_g^N(\bar{\eta}.) = A_N^{-1}\varepsilon, \quad \sup_{b \in \Lambda_N} |(A_N^{-1}\varepsilon_N)(b)| = O(N^{-1}).$$

Let us now compute two-point correlations. The idea is the same: we build on the computation in Lemma A.3 to obtain that, for $b \in \Lambda_N$, A_N applied to the vector $(\nu_g^N(\bar{\eta}_a \bar{\eta}_b))_a$ is small away from the diagonal $a = b$. On the diagonal, the identity $(\bar{\eta}.)^2 = \bar{\sigma} + \sigma'(\bar{\rho}.)\bar{\eta}.$ and (A.21) give:

$$\sup_{a \in \Lambda_N} |\nu_g^N((\bar{\eta}_a)^2) - \bar{\sigma}_a| = O(N^{-1}). \quad (\text{A.23})$$

Fix now $a \neq b \in \Lambda_N$. Recall the identity:

$$2\Pi^N(g) = 2G_{\{a\}^c} + \frac{1}{N} \sum_{i \neq a} \bar{\eta}_i \bar{\eta}_a g_{a,i}, \quad \eta \in \Omega_N.$$

The starting point is (A.14), on which we use the last identity as well as $e^x = 1 + x + \int_0^1 tx^2 e^{tx} dt$,

$x \in \mathbb{R}$, to obtain:

$$\begin{aligned} \mathcal{Z}_g^N \nu_g^N(\bar{\eta}_a \bar{\eta}_b) &= \int_0^1 \bar{\nu}^N \left[\bar{\eta}_b e^{2G_{\{a\}^c}} \frac{(\bar{\eta}_a)^2}{N} \sum_{i \neq a} \bar{\eta}_i g_{a,i} \exp \left[\frac{t}{N} \sum_{i \neq a} \bar{\eta}_a \bar{\eta}_i g_{a,i} \right] \right] dt \\ &= \mathcal{Z}_g^N \int_0^1 \bar{\nu}_g^N \left[\bar{\eta}_b \frac{(\bar{\eta}_a)^2}{N} \sum_{i \neq a} \bar{\eta}_i g_{a,i} \left\{ 1 \right. \right. \end{aligned} \quad (\text{A.24})$$

$$\left. + \frac{(1-t)\bar{\eta}_a}{N} \sum_{i \neq a} \bar{\eta}_i g_{a,i} \right. \quad (\text{A.25})$$

$$\left. + \int_0^1 \left(\frac{(1-t)\bar{\eta}_a}{N} \sum_{i \neq a} \bar{\eta}_i g_{a,i} \right)^2 \exp \left[\frac{(1-t)s}{N} \sum_{i \neq a} \bar{\eta}_a \bar{\eta}_i g_{a,i} \right] ds \right\} dt. \quad (\text{A.26})$$

Let us separately compute the contribution of each of the terms in the curly bracket, corresponding to (A.24)-(A.25)-(A.26). We will repeatedly make use of the following two identities:

$$(\bar{\eta}_\cdot)^2 = \bar{\sigma}_\cdot + \sigma'(\bar{\rho}_\cdot) \bar{\eta}_\cdot. \quad (\text{A.27})$$

Moreover, let $(q_j^N)_{j \in \Lambda_N}$ satisfy $\sup_{N,j} |q_j^N| < \infty$ and let $I \subset \Lambda_N$ with $|I| = n \in \mathbb{N}^*$ and $p \in \mathbb{N}^*$. Then, by Lemma A.3:

$$\nu_g^N \left(\prod_{i \in I} \bar{\eta}_i \left(\frac{1}{N} \sum_{j \in \Lambda_N} \bar{\eta}_j q_j^N \right)^p \right) = O(N^{-(n+p)/2}). \quad (\text{A.28})$$

In other words, the above correlation has average under ν_g^N that scales like $(n+p)$ -points correlations, even though the sums contain elements of I .

Consider first (A.24). Using (A.27), the first line (A.24) reads:

$$\begin{aligned} (\text{A.24}) &= \frac{\bar{\sigma}_a}{N} \mathcal{Z}_g^N \nu_g^N \left[\bar{\eta}_b \sum_{i \neq a} \bar{\eta}_i g_{a,i} \right] + \frac{\sigma'(\bar{\rho}_a)}{N} \mathcal{Z}_g^N \nu_g^N \left[\bar{\eta}_b \bar{\eta}_a \sum_{i \neq a} \bar{\eta}_i g_{a,i} \right] \\ &=: \mathcal{Z}_g^N (\bar{\sigma} N^{-1} M_g^N) \nu_g^N(\bar{\eta}_\cdot \bar{\eta}_b)(a) + \delta_N^1(a, b), \quad \sup_{i \neq j \in \Lambda_N^2} |\delta_N^1(i, j)| = O(N^{-3/2}), \end{aligned}$$

where $\nu_g^N(\bar{\eta}_\cdot \bar{\eta}_b)$ is the vector $(\nu_g^N(\bar{\eta}_i \bar{\eta}_b))_{i \in \Lambda_N}$, and we used (A.28) with $I = \{a, b\}$ and $p = 1$ to estimate δ_N^1 .

Consider now the contribution of the second line (A.25). Recalling (A.27), one has:

$$\begin{aligned} &\int_0^1 \nu_g^N \left[\bar{\eta}_b \frac{(1-t)(\bar{\eta}_a)^3}{N^2} \left(\sum_{i \neq a} \bar{\eta}_i g_{a,i} \right)^2 \right] dt \\ &= \int_0^1 (1-t) \nu_g^N \left[\bar{\eta}_b [\bar{\sigma}_a (1 + \sigma'(\bar{\rho}_a)) + \bar{\eta}_a \sigma'(\bar{\rho}_a)^2] \left(\frac{1}{N} \sum_{i \neq a} \bar{\eta}_i g_{a,i} \right)^2 \right] dt =: \delta_N^2(a, b). \end{aligned}$$

Using (A.28) with $I = \{b\}$ and $p = 2$ for the term involving $\bar{\sigma}_a (1 + \sigma'(\bar{\rho}_a))$, and $I = \{a, b\}$ and $p = 2$ for the other one, we find:

$$\sup_{i \neq j \in \Lambda_N} |\delta_N^2(i, j)| = O(N^{-3/2}).$$

Finally, the third line (A.26) is bounded by:

$$\mathcal{Z}_g^N e^{2\|g\|_\infty} \nu_g^N \left[\left| \frac{1}{N} \sum_{i \neq a} \bar{\eta}_i g_{a,i} \right|^3 \right] =: \delta_N^3(a, b), \quad \sup_{i \neq j \in \Lambda_N} |\delta_N^3(i, j)| = O(N^{-3/2}),$$

Due to the absolute value, this bound is not a consequence of (A.28), but is instead obtained as in (A.11)-(A.12). We have obtained:

$$\nu_g^N(\bar{\eta}_a \bar{\eta}_b) = (\bar{\sigma} N^{-1} M_g^N) \nu_g^N(\bar{\eta}, \bar{\eta}_b)(a) + \sum_{k=1}^3 \sup_{a \neq b \in \Lambda_N} |\delta_N^k(a, b)|, \quad \sum_{k=1}^3 \delta_N^k(a, b) = O(N^{-3/2}).$$

Multiplying by the diagonal matrix $\bar{\sigma}^{-1}$ from the left and recalling the estimate (A.23) of the diagonal correlations, we have obtained, for each $b \in \Lambda_N$:

$$(\bar{\sigma}^{-1} - N^{-1} M_g^N) \nu_g^N(\bar{\eta}, \bar{\eta}_b) = (1 + O(N^{-1})) I_N + \sum_{k=1}^3 (\bar{\sigma}_a^{-1} \delta_N^k(a, b))_{a \neq b \in \Lambda_N},$$

with I_N the identity matrix. Using Lemma A.6 and the identity:

$$C_g^N(a, b) := \nu_g^N(\bar{\eta}_a \bar{\eta}_b) - \nu_g^N(\bar{\eta}_a) \nu_g^N(\bar{\eta}_b), \quad \sup_{(a,b) \in \Lambda_N^2} |\nu_g^N(\bar{\eta}_a) \nu_g^N(\bar{\eta}_b)| = O(N^{-2}), \quad (\text{A.29})$$

we obtain the existence of matrices e_N, e'_N as in Proposition A.5 such that:

$$C_g^N = (\bar{\sigma}^{-1} - N^{-1} M_g^N)^{-1} + e_N, \quad M_g^N = N(\bar{\sigma}^{-1} - (C_g^N)^{-1}) + N e'_N. \quad (\text{A.30})$$

□

Remark A.7. As in the proof of Proposition A.5, it is possible to exactly compute the leading order term of all n -point correlations, $n \in \mathbb{N}^*$. One can in fact prove that the leading order in N of the $2n$ -point correlations under ν_g^N satisfies Wick theorem. On the other hand, $2n + 1$ -point correlations in fact decay faster than $O(N^{-n-1/2})$. More precisely, one can prove:

$$\forall n \in \mathbb{N}^*, \quad \sup_{I \subset \Lambda_N: |I|=n} \left| \nu_g^N \left(\prod_{i \in I} \bar{\eta}_i \right) \right| = \begin{cases} O(N^{-n/2}) & \text{as before if } n \text{ is even,} \\ O(N^{-(n+1)/2}) & \text{if } n \text{ is odd.} \end{cases} \quad (\text{A.31})$$

■

Proof of Lemma A.6. Let $N_0 \in \mathbb{N}^*$ and $(A_N)_{N \geq N_0} \in \mathcal{M}$ be a family of symmetric and invertible matrices. Then $(A_N(i, j))_{1 \leq i, j \leq n}$ is also invertible for each $n \leq 2N - 1$ (this is the only place where the symmetry assumption on A_N is used). This implies (see Theorem 4.3.1 in [Cia89]) that, for each $N \geq N_0$, there is a lower triangular matrix L_N with diagonal equal to 1, and an upper triangular matrix U_N such that:

$$\forall N \in \mathbb{N}^*, \quad A_N = L_N U_N.$$

L_N is invertible by assumption, thus U_N is invertible by invertibility of A_N . The claim of Lemma A.6 thus boils down to proving that $(U_N^{-1}L_N^{-1})_N \in \mathcal{M}$. Let us first prove that $(L_N)_N, (U_N)_N \in \mathcal{M}$. The coefficients of these matrices can be computed explicitly: for each $N \geq N_0$,

$$\begin{aligned} \forall 1 \leq i \leq 2N-1, \quad U_N(i, j) &= A_N(i, j) - \sum_{\ell=1}^{i-1} L_N(i, \ell)U_N(\ell, j) \quad \text{for } j \geq i, \\ L_N(j, i) &= \frac{1}{U_N(i, i)} \left(A_N(j, i) - \sum_{\ell=1}^{i-1} L_N(j, \ell)U_N(\ell, i) \right) \quad \text{for } j > i. \end{aligned}$$

In particular, $(L_N)_N, (U_N)_N$ indeed belong to \mathcal{M} . In fact, so do their inverses. Indeed, the inverse L_N^{-1} of L_N is also lower triangular, and can be computed straightforwardly: for $N \geq N_0$,

$$\forall i \geq j, \quad [L_N^{-1}](i, j) = \frac{1}{A_N(i, i)} \left(\delta_{i,j} - \sum_{\ell=1}^{i-1} L_N(i, \ell)[L_N^{-1}](\ell, j) \right), \quad \delta_{i,j} := \begin{cases} 1 & \text{if } i = j, \\ 0 & \text{otherwise.} \end{cases}$$

The same result holds for the upper-triangular U_N . Thus, $(L_N^{-1})_N, (U_N^{-1})_N \in \mathcal{M}$. It remains to notice that \mathcal{M} is stable by multiplication: $(B_N)_N, (C_N)_N \in \mathcal{M}$ implies $(B_N C_N)_N \in \mathcal{M}$. This concludes the proof of Lemma A.6. \square

A.2 Exponential moments of higher order correlations

Let $g \in g_0 + \mathcal{S}(\varepsilon_G)$ be fixed throughout, where this set is defined in (2.22) and Theorem 2.5. In this section, we give bounds on the size of exponential moments, under ν_g^N , of random variables involving n -point correlations, $n \geq 1$. These are useful when applying the entropy inequality. Such concentration results are established in the literature by means of a logarithmic Sobolev inequality, see [G+19]-[SS20]. Such an inequality could be shown to hold for ν_g^N by [BB19]. However, $g \in g_0 + \mathcal{S}(\varepsilon_G)$ means that it is enough to only obtain concentration bounds under the product measure $\bar{\nu}^N$. Indeed, by Lemma A.1, there is $\alpha_g > 0$ such that, by Hölder inequality, for any $F : \Omega_N \rightarrow \mathbb{R}$:

$$\nu_g^N(\exp[F]) \leq (\mathcal{Z}_g^N)^{-1} \bar{\nu}^N \left[\exp[\alpha_g^{-1}(1 + \alpha_g)F] \right]^{\frac{\alpha_g}{1+\alpha_g}} \bar{\nu}^N \left[\exp[2(1 + \alpha_g)\Pi^N(g)] \right]^{\frac{1}{1+\alpha_g}}, \quad (\text{A.32})$$

and both exponential moments are bounded with N . For $d \in \mathbb{N}$, let $A : \Lambda_N^d \rightarrow \mathbb{R}$ be a tensor. Define its Hilbert-Schmidt norm by:

$$\|A\|_{HS} = \left(\sum_{(i_0, \dots, i_{d-1}) \in \Lambda_N^d} (A(i_0, \dots, i_{d-1}))^2 \right)^{1/2}. \quad (\text{A.33})$$

For $J \subset \mathbb{Z}$ containing 0, let $X_{d,J}^A$ be defined as:

$$\forall \eta \in \Omega_N, \quad X_{d,J}^A(\eta) = \sum_{\substack{(i_0, \dots, i_{d-1}) \in \Lambda_N^d \\ i_0 + J \subset \Lambda_N}} A(i_0, \dots, i_{d-1}) \bar{\eta}_{i_0+J} \prod_{p=1}^{d-1} \bar{\eta}_{i_p}, \quad \bar{\eta}_{i_0+J} := \prod_{j \in J} \bar{\eta}_{i_0+j}. \quad (\text{A.34})$$

The next theorem gives concentration estimates of $X_{d,J}^A$ under $\bar{\nu}^N$ for $J \subset \mathbb{Z}$ and $d \in \mathbb{N}^*$. The case $J = \{0\}$, $d \leq 4$ corresponds to Theorem 1.4. in [G+19], but their proof extends to any $d \in \mathbb{N}^*$. However, we use in the article the case $J = \{0, 1\}$, for which a proof is needed.

Theorem A.8. Let $J \subset \mathbb{Z}$ contain 0 and $d \in \mathbb{N}^*$. Assume that A is such that $A(i_0, \dots, i_{d-1})$ vanishes whenever the same site appears twice in $\bar{\eta}_{i_0+J} \prod_{p=1}^{d-1} \bar{\eta}_{i_p}$ for $\eta \in \Omega_N$, i.e. assume:

$$\forall (i_0, \dots, i_{d-1}) \in \Lambda_N^d, \quad \left(\exists j \in J, |\{i_0 + j, i_1, \dots, i_{d-1}\}| < d \right) \Rightarrow A(i_0, \dots, i_{d-1}) = 0. \quad (\text{A.35})$$

There are then constants $c_d > 0$ depending only on d such that, for any $c \in (0, c_d)$ and any N with $J \subset \Lambda_N$:

$$\bar{\nu}^N \left(\exp \left[\frac{(c|X_{d,J}^A|)^{2/d}}{\|A\|_{HS}^{2/d}} \right] \right) \leq 2. \quad (\text{A.36})$$

Proof. The proof for general J and the $J = \{0\}$ case in [G+19] are very similar, so we only give a sketch. Without loss of generality, A can be assumed to be invariant under permutation of its last $d-1$ indices. The idea is to proceed by recursion on d , noticing that, for each $\ell \in \Lambda_N$ and $\eta \in \Omega_N$:

$$\begin{aligned} \nabla_\ell X_{d,J}^A(\eta) &:= X_{d,J}^A(\eta^\ell) - X_{d,J}^A(\eta) \\ &= (1 - 2\eta_\ell) \left[\sum_{i_0: i_0+J \ni \ell} A(i_0, \dots, i_{d-1}) \bar{\eta}_{(i_0+J) \setminus \{\ell\}} \prod_{a=1}^{d-1} \bar{\eta}_{i_a} \right. \\ &\quad \left. + (d-1)A(i_0, \dots, i_{d-2}, \ell) \bar{\eta}_{i_0+J} \prod_{a=1}^{d-2} \bar{\eta}_{i_a} \right]. \end{aligned} \quad (\text{A.37})$$

Fix $d \in \mathbb{N}$, $J \subset \mathbb{Z}$ with $0 \in J$, and N with $J \subset \Lambda_N$. For brevity, simply write X_d for $X_{d,J}^A$.

Step 1: reduction to moment bound. To prove (A.36), it is enough to prove the existence of $C_d > 0$ such that:

$$\forall p \in \mathbb{N}^*, \quad M_p(X_d) := \bar{\nu}^N [|X_d|^p]^{1/p} \leq C_d \|A\|_{HS} p^{\frac{d}{2}}. \quad (\text{A.38})$$

Indeed, assuming such a bound, one has, for each $c > 0$, using Jensen inequality when $d \geq 2$ for the convex function $f(x) = x^{d/2}$, $x \in \mathbb{R}$:

$$\bar{\nu}^N [\exp(c|X_d|^{2/d})] = 1 + \sum_{p=1}^{\infty} \frac{c^p}{p!} \bar{\nu}^N (|X_d|^{2p/d}) \leq 1 + \sum_{p=1}^{\infty} \frac{(cC_d p \|A\|_{HS}^{2/d})^p}{p!}.$$

As $p^p \leq p!e^p$ for each $p \geq 1$, taking $c \leq c_d := (2C_d e)^{-1}$ yields (A.36).

Step 2: moment estimate. It is enough to prove (A.38) for $p \geq 2$, since the first moment can be estimated by Cauchy-Schwarz inequality. We will restrict to $p \geq 2$ at some point in the computation. For now, we treat p as a continuous variable in \mathbb{R}_+^* and differentiate $M_p(X_d)$. For each $p > 0$, one has:

$$\begin{aligned} \frac{dM_p(X_d)}{dp} &= \frac{d}{dp} \left(\exp \left[\frac{1}{p} \log \bar{\nu}^N (|X_d|^p) \right] \right) \\ &= -\frac{\log \bar{\nu}^N (|X_d|^p)}{p^2} M_p(X_d) + \frac{1}{p} \frac{\bar{\nu}^N (|X_d|^p \log |X_d|)}{\bar{\nu}^N (|X_d|^p)} M_p(X_d), \end{aligned}$$

which can be written as:

$$\forall p > 0, \quad \frac{dM_p(X_d)}{dp} = \frac{M_p(X_d)^{1-p}}{p^2} \text{Ent}(|X_d|^p), \quad (\text{A.39})$$

with $\text{Ent}(F^2)$ the entropy of F^2 against $\bar{\nu}^N$, given by:

$$\forall F : \Omega_N \rightarrow \mathbb{R}, \quad \text{Ent}(F^2) = \bar{\nu}^N(F^2 \log F^2) - \bar{\nu}^N(F^2) \log \bar{\nu}^N(F^2).$$

The entropy on the right-hand side of (A.39) is estimated by means of a logarithmic Sobolev inequality, satisfied by $\bar{\nu}^N$ for the Glauber dynamics on Ω_N (see e.g. Theorem A.1. in [DS96]): there is $C_{LS} > 0$, independent of N , such that:

$$\forall F : \Omega_N \rightarrow \mathbb{R}_+, \quad \text{Ent}(F^2) \leq C_{LS} \bar{\nu}^N \left(\sum_{i \in \Lambda_N} [\nabla_i F]^2 \right), \quad (\text{A.40})$$

where, for $i \in \Lambda_N$ and $\eta \in \Omega_N$, $\nabla_i F(\eta) = F(\eta^i) - F(\eta)$ for each $F : \Omega_N \rightarrow \mathbb{R}$. Similarly, a Poincare inequality holds with constant $C_{LS}/2$:

$$\forall F : \Omega_N \rightarrow \mathbb{R}_+, \quad \bar{\nu}^N(F^2) - \bar{\nu}^N(F)^2 \leq \frac{C_{LS}}{2} \bar{\nu}^N \left(\sum_{i \in \Lambda_N} [\nabla_i F]^2 \right). \quad (\text{A.41})$$

Injecting (A.40) in (A.39) and proceeding as in [G+19], one successively obtains, restricting to $p > 2$:

$$\begin{aligned} \forall p > 2, \quad \frac{dM_p(X_d)^2}{dp} &\leq \frac{2C_{LS}M_p(X_d)^{2-p}}{p^2} \bar{\nu}^N \left(\sum_{i \in \Lambda_N} [\nabla_i (|X_d|^{p/2})]^2 \right) \\ &\leq C_{LS}M_p(X_d)^{2-p} \bar{\nu}^N \left(|X_d|^{p-2} \sum_{i \in \Lambda_N} [\nabla_i |X_d|]^2 \right). \end{aligned}$$

Applying Hölder inequality with exponents $(p/(p-2), p/2)$ then yields, for each $p > 2$:

$$\frac{dM_p(X_d)^2}{dp} \leq C_{LS}M_{p/2} \left(\sum_{i \in \Lambda_N} [\nabla_i |X_d|]^2 \right) \leq C_{LS}M_{p/2} \left(\sum_{i \in \Lambda_N} [\nabla_i X_d]^2 \right).$$

The function $M_p(X_d)$ is increasing for $p > 0$ by (A.39). As a result, integrating between 2 and p and using the Poincare inequality (A.41) to estimate $M_2(X_d)$ yields:

$$\begin{aligned} \forall p \geq 2, \quad M_p(X_d)^2 &\leq M_2(X_d)^2 + C_{LS}(p-2)M_{p/2} \left(\sum_{i \in \Lambda_N} [\nabla_i X_d]^2 \right) \\ &\leq C_{LS} p M_{p/2} \left(\sum_{i \in \Lambda_N} [\nabla_i X_d]^2 \right). \end{aligned} \quad (\text{A.42})$$

Step 3: recursion on d . Let $p \geq 2$. For $j \in \Lambda_N$ and $0 \leq a \leq d-1$, define $A^{(i_a=j)}$ as the $d-1$ -tensor $(A(i_0, \dots, i_{a-1}, j, i_{a+1}, \dots, i_{d-1}))_{(i_q)_{q \neq a}}$, and note that $A^{(i_a=j)}$ also satisfies the assumption (A.35). Recall that X_d was short for $X_{d,J}^A$. Let us prove by recursion on d :

$$\forall p \geq 2, \quad M_p(X_{d,J}^A)^2 \leq 2^{d-1} (C_{LS} p)^d (d!)^2 |J|^2 \|A\|_{HS}^2. \quad (\text{A.43})$$

Proving such a result would conclude the proof. In the $d = 1$ case, (A.42) yields, for each $p \geq 2$:

$$M_p(X_{1,J}^A)^2 \leq C_{LS} p M_{p/2} \left(\sum_{i \in \Lambda_N} [\nabla_i X_{1,J}^A]^2 \right) \leq C_{LS} p \sum_{i \in \Lambda_N} M_p(\nabla_i X_{1,J}^A)^2.$$

By (A.37), bounding $\bar{\eta}$ by 1, the result for $d = 1$ is proven:

$$\forall p \geq 2, \quad M_p(X_{1,J}^A)^2 \leq C_{LS} p \sum_{\ell \in \Lambda_N} \left[\sum_{i_0 + J \ni \ell} A(i_0) \right]^2 \leq C_{LS} p |J|^2 \|A\|_{HS}^2.$$

For $d \geq 2$, (A.42) similarly gives, bounding $\bar{\eta}$ by 1:

$$\begin{aligned} M_{p/2} \left(\sum_{\ell \in \Lambda_N} [\nabla_\ell X_{d,J}^A]^2 \right) &\leq \sum_{\ell \in \Lambda_N} M_p(\nabla_\ell X_{d,J}^A)^2 \\ &\leq \sum_{\ell \in \Lambda_N} \left[(d-1) M_p(X_{d-1,J}^{A^{(i_{d-1}=\ell)}}) + \sum_{i: i+J \ni \ell} M_p(X_{d-1,\{0\}}^{A^{(i_0=i)}}) \right]^2. \end{aligned}$$

For each $\ell \in \Lambda_N^d$, the recursion hypothesis at rank $d-1$ applied to $X_{d-1,J}^{A^{(i_{d-1}=\ell)}}$, and to $X_{d-1,\{0\}}^{A^{(i_0=i)}}$ for each $i + J \ni \ell$, yields:

$$\begin{aligned} M_{p/2} \left(\sum_{\ell \in \Lambda_N} [\nabla_\ell X_{d,J}^A]^2 \right) &\leq 2^{d-2} (C_{LS} p)^{d-1} ((d-1)!)^2 \sum_{\ell \in \Lambda_N} \left[|J|(d-1) \|A^{(i_{d-1}=\ell)}\|_{HS} + \sum_{i: i+J \ni \ell} \|A^{(i_0=i)}\|_{HS} \right]^2 \\ &\leq 2^{d-1} (C_{LS} p)^{d-1} ((d-1)!)^2 d^2 |J|^2 \|A\|_{HS}^2 = 2^{d-1} (C_{LS} p)^{d-1} (d!)^2 |J|^2 \|A\|_{HS}^2, \end{aligned}$$

where we used $(a+b)^2 \leq 2a^2 + 2b^2$ for $a, b \in \mathbb{R}$ and bounded $(d-1)^2 + 1$ by d^2 to obtain the second inequality. Injecting this bound in (A.42) yields (A.43) at rank d , concluding the proof. \square

In the next corollary, we use Theorem A.8 to establish the controllability results of Lemma 3.7 on the variables $X_{d,J}^A$.

Corollary A.9. *Let $J \subset \mathbb{Z}$ contain 0 and, for $N \in \mathbb{N}^*$ and $d \in \mathbb{N}^*$, let $A = A(d, N)$ be a d tensor. We do not assume that A satisfy (A.35), but instead that $\sup_{N \in \mathbb{N}^*} \sup_{\Lambda_N^d} |A| < \infty$. Recall the definition of α_g from (A.32). There are constants $\gamma_d = \gamma_d(\alpha_g) > 0$, $C_d > 0$ that are independent of A , with $\gamma_1 = +\infty$, such that, for each $\gamma < \gamma_d(\sup_{\Lambda_N^d} |A|)^{-1}$:*

$$\text{for each } N \in \mathbb{N}^* \text{ with } J \subset \Lambda_N, \quad \begin{cases} \log \nu_g^N(\exp[\gamma N^{-1/2} X_{0,J}^A]) \leq C_0 \gamma^2 \sup_{\Lambda_N^d} |A|^2 & \text{if } d = 1, \\ \log \nu_g^N(\exp[\gamma N^{-(d-1)} X_{d,J}^A]) \leq \frac{C_d \gamma \sup_{\Lambda_N^d} |A|}{N^{\frac{d-2}{2}}} & \text{if } d \geq 2. \end{cases} \quad (\text{A.44})$$

Proof. Fix $J \subset \mathbb{Z}$ with $0 \in J$, and N such that $J \subset \Lambda_N$. We will use Theorem A.8 to obtain (A.44). Let us first explain why it is not necessary to assume the condition (A.35) on the tensor A if it is bounded. Without this condition, $N^{-(d-1)} X_{d,J}^A$ contains products of terms of the form $(\bar{\eta})^p$

for $p \geq 2$. Let us explain why these terms are not a problem through an example: take $d = 3$ and $J = 0$. Using $(\bar{\eta}_i)^2 = \sigma'(\bar{\rho}_i)\bar{\eta}_i + \bar{\sigma}_i$, one has:

$$\begin{aligned} \frac{1}{N^2} X_{3,\{0\}}^A &= \frac{1}{N^2} \sum_{(i_0, i_1, i_2) \in \Lambda_N^3} \bar{\eta}_{i_0} \bar{\eta}_{i_1} \bar{\eta}_{i_2} A(i_0, i_1, i_2) = \frac{1}{N^2} \sum_{(i_0, i_1, i_2) \text{ all different}} \bar{\eta}_{i_0} \bar{\eta}_{i_1} \bar{\eta}_{i_2} A(i_0, i_1, i_2) \\ &+ \frac{1}{N^2} \sum_{i_0 \neq i_1} [\sigma'(\bar{\rho}_{i_0}) \bar{\eta}_{i_0} \bar{\eta}_{i_1} + \bar{\sigma}_{i_0} \bar{\eta}_{i_1}] [A(i_0, i_0, i_1) + A(i_0, i_1, i_0) + A(i_1, i_0, i_0)] \\ &+ \frac{1}{N^2} \sum_{i_0} [\sigma'(\bar{\rho}_{i_0})^2 \bar{\eta}_{i_0} + \sigma'(\bar{\rho}_{i_0}) \bar{\sigma}_{i_0}] A(i_0, i_0, i_0). \end{aligned}$$

The first term is $N^{-2} X_{3,\{0\}}^{A'}$, for a bounded tensor A' that satisfies (A.35). All other terms are either of the form $N^{-2} X_{d',\{0\}}^B$ for B a bounded d' -tensor, $1 \leq d' \leq 2$ that satisfies (A.35); or constant and bounded by $N^{-2} \|A\|_\infty N$. If one proves the corollary by recursion on d , then the $N^{-1} N^{-1} X_{d',\{0\}}^B$ are already known to concentrate nicely, thanks to the extra factor of N^{-1} . The constant term is bounded by $O(N^{-1})$, and $O(N^{-1}) = o(N^{\frac{d-2}{d}})$ for any $d \geq 2$. The case where A satisfies (A.35) therefore reduces to the case where it does not in this example. For $J \neq \{0\}$ and higher d , the argument is similar. The general case $N^{-(d-1)} X_{d,J}^A$ for A bounded therefore follows from the case of tensors satisfying (A.35), and a recursion on d . A is henceforth assumed to satisfy (A.35). We first obtain estimates of tail probabilities of $X_d = X_{d,J}^A$ under ν_g^N . These are then used to obtain (A.44). Fix $\alpha_g > 0$ as in (A.32), and let $\zeta > 0$ satisfy $\zeta(1 + \alpha_g)^{d/2} \alpha_g^{-d/2} < c_d$. Then, by Theorem A.8,

$$\nu_g^N \left(\exp \left[\frac{(\zeta |X_d|)^{2/d}}{\|A\|_{HS}^{2/d}} \right] \right) \leq \frac{\mathcal{Z}_g^{1+\alpha_g}}{\mathcal{Z}_g^N} \bar{\nu}^N \left(\exp \left[\frac{(1 + \alpha_g)(\zeta |X_d|)^{2/d}}{\alpha_g \|A\|_{HS}^{2/d}} \right] \right)^{\frac{\alpha_g}{1+\alpha_g}} \leq 2(\mathcal{Z}_g^N)^{-1},$$

It follows that there is $\zeta = \zeta_d(c_d, g) > 0$ such that, for each $t \geq 0$,

$$\nu_g^N (|X_d| > t) \leq 2(\mathcal{Z}_g^N)^{-1} \exp \left[- \frac{\zeta t^{2/d}}{\|A\|_{HS}^{2/d}} \right]. \quad (\text{A.45})$$

At this point the proof is the same for each $d \geq 1$. We focus on the $d \geq 2$ case. Let $\gamma > 0$ and write:

$$\nu_g^N [\exp(\gamma N^{-(d-1)} |X_d|)] = 1 + \int_0^\infty e^t \nu_g^N (\gamma N^{-(d-1)} |X_d| > t) dt. \quad (\text{A.46})$$

By assumption on A ,

$$\sup_{N \in \mathbb{N}^*} \|N^{-d/2} A\|_{HS} < \infty.$$

Note that $\gamma N^{-(d-1)} |X_d|$ is bounded by $\gamma C \|N^{-d/2} A\|_{HS} N$ for some numerical constant $C > 0$ and each $N \in \mathbb{N}^*$. Define $\tilde{A} := N^{-d/2} A$. Then, with ζ given by (A.45):

$$\begin{aligned} \nu_g^N [\exp[\gamma N^{-(d-1)} |X_d|]] &\leq 1 + 2(\mathcal{Z}_g^N)^{-1} \int_0^{\gamma C \|\tilde{A}\|_{HS} N} \exp \left[t - \frac{\zeta t^{2/d} N^{(d-2)/d}}{\gamma^{2/d} \|\tilde{A}\|_{HS}^{2/d}} \right] dt \\ &=: 1 + 2(\mathcal{Z}_g^N)^{-1} \int_0^{\gamma C \|\tilde{A}\|_{HS} N} q_\gamma(t) dt. \end{aligned}$$

If γ is small enough, we claim that the negative part of the exponential is dominant. Indeed, one has:

$$\begin{aligned} \forall t \leq \gamma C \|\tilde{A}\|_{HS} N, \quad q_\gamma(t) &\leq \exp \left[-\frac{\zeta t^{2/d} N^{(d-2)/d}}{2\gamma^{2/d} \|\tilde{A}\|_{HS}^{2/d}} \right] \\ &\Leftrightarrow \quad \gamma \leq \frac{\gamma_0}{\|\tilde{A}\|_{HS}}, \quad \gamma_0 = \gamma_0(d, \zeta) := \frac{C^{(2-d)/d} \zeta}{2}. \end{aligned}$$

For any $\gamma < \gamma_0 / \|\tilde{A}\|_{HS}$, one has then:

$$\nu_g^N \left[\exp[\gamma N^{-(d-1)} |X_d|] \right] \leq 1 + 2(\mathcal{Z}_g^N)^{-1} \int_0^\infty \exp \left[-\frac{\zeta t^{2/d} N^{(d-2)/d}}{2\gamma^{2/d} \|\tilde{A}\|_{HS}^{2/d}} \right] dt.$$

The change of variable $u = t\zeta^{d/2} \|\tilde{A}\|_{HS}^{-1} \gamma^{-1} N^{(d-2)/2}$, the boundedness of $(\mathcal{Z}_g^N)_N$ by Lemma A.1 and the inequality $\|\tilde{A}\|_{HS} \leq \|A\|_\infty$ conclude the proof: for each $\gamma < \gamma_0 / \|\tilde{A}\|_{HS} \leq \gamma_0 / \sup_{\Lambda_N^d} |A|$,

$$\nu_g^N \left[\exp[\gamma N^{-(d-1)} |X_d|] \right] \leq 1 + \frac{2\gamma \sup_{\Lambda_N^d} |A| \zeta^{2/d}}{N^{(d-2)/2}} (\mathcal{Z}_g^N)^{-1} \int_0^\infty \exp \left[-\frac{u^{2/d}}{2} \right] dt.$$

□

A.3 Gaussian behaviour of the invariant measures and computation of the partition function \mathcal{Z}_g^N

In this section, we discuss the relation between ν_g^N for $g \in g_0 + \mathcal{S}(\varepsilon_G)$ and the invariant measure of a dynamics \mathbb{P}_h , $h \in \mathcal{S}(\varepsilon_B)$. These sets are defined in Assumption 2.1, (2.22) and Theorem 2.5. In the $h = 0$ case corresponding to the open SSEP, we have an explicit expression for g_0 , and in particular we know that π_{inv}^N and $\nu_{g_0}^N$ have the same average at each site and two-point correlations to leading order in N . It is therefore natural to expect these measures to be close in some sense. This is the statement of our first result, which is conditional to heuristic computations on the entropy of π_{inv}^N in [DLS07], described afterwards.

Lemma A.10. *Assume the heuristic entropy computations of [DLS07] hold, i.e., if C_0^N is the correlation matrix of the steady state π_{inv}^N at each $N \in \mathbb{N}^*$, assume:*

$$\limsup_{N \rightarrow \infty} \left| H(\pi_{inv}^N | \bar{\nu}^N) + \frac{1}{2} \log \det \left(\frac{1}{\sqrt{\sigma}} C_0^N \frac{1}{\sqrt{\sigma}} \right) \right| = 0. \quad (\text{A.47})$$

Then $\lim_{N \rightarrow \infty} H(\pi_{inv}^N | \nu_{g_0}^N) = 0$.

Remark A.11. Assuming Lemma A.10 holds, the large deviation results of Theorem 2.2 are also valid with the invariant measure π_{inv}^N as initial condition by Pinsker's inequality, see Corollary 3.4. ■

Observe that the relative entropy $H(\pi_{inv}^N | \nu_{g_0}^N)$ is given by:

$$H(\pi_{inv}^N | \nu_{g_0}^N) = \sum_{\eta \in \Omega_N} \pi_{inv}^N(\eta) \log \left(\frac{\pi_{inv}^N(\eta)}{\bar{\nu}^N(\eta)} \right) - \log \mathcal{Z}_{g_0}^N + \frac{1}{2N} \sum_{(i,j) \in \Lambda_N^2} C_0^N(i,j) M_{g_0}^N(i,j).$$

The last sum is the trace of $M_{g_0}^N C_0^N$ (recall that $M_{g_0}^N(i, i) = 0$ for each $i \in \Lambda_N$ by construction. By Proposition A.5, one has:

$$\frac{1}{2N} \text{Tr}(C_0^N M_{g_0}^N) = \frac{1}{2N} \text{Tr}\left(C_0^N \bar{\sigma}^{-1} - I_N + C_0^N e'_N\right) = O(N^{-1/2}).$$

Proving Lemma A.10 therefore boils down to proving:

$$\limsup_{N \rightarrow \infty} \left| \log \mathcal{Z}_{g_0}^N - \frac{1}{2} \log \det \left(\frac{1}{\sqrt{\bar{\sigma}}} C_0^N \frac{1}{\sqrt{\bar{\sigma}}} \right) \right| = 0.$$

The partition function \mathcal{Z}_g^N is computed for general g in Lemma A.12 below.

Lemma A.12. *Assume that $g : \square \rightarrow \mathbb{R}$ satisfies the hypotheses of Lemma A.1, as well as:*

$$\int_{\square} \bar{\sigma}(x) g(x, y)^2 \bar{\sigma}(y) dx dy < 1/16. \quad (\text{A.48})$$

Compare with (3.6), which requires the same bound only of g_+ , not g . Then:

$$\log \mathcal{Z}_g^N = \frac{1}{2} \log \det \left(\frac{1}{\sqrt{\bar{\sigma}}} C_g^N \frac{1}{\sqrt{\bar{\sigma}}} \right) + o_N(1). \quad (\text{A.49})$$

Proof. Fix g satisfying (A.48). We construct a path $(g_t)_{t \in [0,1]}$ between g and 0, composed of functions satisfying the hypotheses of Lemma A.1, and compute the partition function by differentiating along this path. Define:

$$\forall t \in [0, 1], \quad g_t = t g, \quad M_t^N := M_{g_t}^N, \quad M_t^{N,\sigma} = \bar{\sigma}^{1/2} M_t^N \bar{\sigma}^{1/2}, \quad \tilde{C}_t^N := (\nu_{g_t}^N(\bar{\eta}_i \bar{\eta}_j))_{(i,j) \in \Lambda_N^2}$$

Note that each $g_t, t \geq 0$ satisfies (A.48). In particular, Proposition A.5 holds, and gives (see (A.29)(A.30)):

$$\forall t \in [0, 1], \quad \tilde{C}_t^N = \left(\bar{\sigma}^{-1} - N^{-1} M_t^N \right)^{-1} + e_N(t),$$

where diagonal terms of $\sup_{t \in [0,1]} e_N(t)$ are uniformly bounded by $O(N^{-1})$, and off-diagonal ones by $O(N^{-2})$ by Remark A.7. One then has, for each $t \in (0, 1)$, recalling $\partial_t M_t^N = M_g^N$:

$$\begin{aligned} \partial_t \log \mathcal{Z}_{g_t}^N &= \nu_{g_t}^N(\partial_t 2\Pi^N(g_t)) = \frac{1}{2N} \sum_{i \neq j} \tilde{C}_t^N(i, j) \partial_t M_t^N(i, j) \\ &= \frac{1}{2N} \text{Tr} \left[\left(\bar{\sigma}^{-1} - N^{-1} M_t^N \right)^{-1} \partial_t M_t^N \right] + \frac{1}{2N} \text{Tr} \left[e_N(t) M_g^N \right], \end{aligned}$$

where we used $M_g^N(i, i) = 0$ for each $i \in \Lambda_N$. By definition of $e_N(t)$, this yields:

$$\forall t \in (0, 1), \quad \partial_t \log \mathcal{Z}_{g_t}^N = \text{Tr} \left[\left(I_N - N^{-1} M_t^{N,\sigma} \right)^{-1} \left(\frac{1}{2N} \partial_t M_t^{N,\sigma} \right) \right] + O(N^{-1}). \quad (\text{A.50})$$

We could directly diagonalise this expression to obtain the claim of Lemma A.12 up to replacing $\bar{\sigma}^{-1/2} C_g^N \bar{\sigma}^{-1/2}$ by $\bar{\sigma}^{-1/2} ((C_g^N)^{-1} - e_N)^{-1} \bar{\sigma}^{-1/2}$. As we lack sufficient control on e_N to relate the determinant of these two quantities, we proceed differently. By assumption (A.48), the inverse of

$I_N - N^{-1}M_t^{N,\sigma}$ exists and can be expressed as a series. More precisely, (A.50) becomes, for each $t \in (0, 1)$:

$$\begin{aligned}\partial_t \log \mathcal{Z}_{gt}^N &= \frac{1}{2} \sum_{n=0}^{\infty} \text{Tr} \left[N^{-1} \partial_t M_t^{N,\sigma} \left(N^{-1} M_t^{N,\sigma} \right)^n \right] + O(N^{-1}) \\ &= \frac{1}{2} \sum_{n=0}^{\infty} \frac{1}{n+1} \text{Tr} \left[\partial_t \left(N^{-1} M_t^{N,\sigma} \right)^{n+1} \right] + O(N^{-1}).\end{aligned}\tag{A.51}$$

Integrate (A.51) between 0 and 1 and exchange \int and \sum , which is legitimate by (A.48), to find:

$$\log \mathcal{Z}_g^N - O(N^{-1}) = \frac{1}{2} \sum_{n=0}^{\infty} \frac{1}{n+1} \text{Tr} \left[\left(N^{-1} M_g^{N,\sigma} \right)^{n+1} \right].$$

To obtain (A.49), recall from Proposition A.5 that $N^{-1}M_g^N = (\bar{\sigma}^{-1} - C_g^N)^{-1} + e'_N$, with $\|e'_N\|_{HS} = O(N^{-1/2})$. The series $\sum_n (N^{-1}M^{N,\sigma} - \bar{\sigma}^{1/2}/e'_N \bar{\sigma}^{1/2})^n$ thus converges for large enough N , and the mean value inequality applied to the function $t \mapsto A + tB$ for $A = N^{-1}M^{N,\sigma}$, $B = \text{bar} \sigma^{1/2}/e'_N \bar{\sigma}^{1/2}$ gives:

$$\begin{aligned}\sum_{n=0}^{\infty} \frac{1}{n+1} \text{Tr} \left[\left(\bar{\sigma}^{1/2} [(\bar{\sigma}^{-1} - C_g^N)^{-1} + e'_N] \bar{\sigma}^{1/2} \right)^{n+1} \right] \\ = \sum_{n=0}^{\infty} \frac{1}{n+1} \text{Tr} \left[\left((I_N - \bar{\sigma}^{-1/2} C_g^N \bar{\sigma}^{-1/2})^{-1} \right)^{n+1} \right] + O(N^{-1}).\end{aligned}$$

To conclude the proof, let $\text{sp} \subset (-1, 1)$ denote the spectrum of $\bar{\sigma}^{-1/2} C_g^N \bar{\sigma}^{-1/2}$. Then:

$$\begin{aligned}\log \mathcal{Z}_g^N - O(N^{-1}) &= \frac{1}{2} \sum_{n=0}^{\infty} \frac{1}{n+1} \text{Tr} \left[\left(I_N - \left(\bar{\sigma}^{-1/2} C_g^N \bar{\sigma}^{-1/2} \right)^{-1} \right)^{n+1} \right] \\ &= \frac{1}{2} \sum_{n=1}^{\infty} \frac{1}{n} \sum_{\lambda \in \text{sp}} (1 - \lambda^{-1})^n = -\frac{1}{2} \sum_{\lambda \in \text{sp}} \log (1 - (1 - \lambda^{-1})) \\ &= \frac{1}{2} \log \left(\prod_{\lambda \in \text{sp}} \lambda \right) = \frac{1}{2} \log \det (\bar{\sigma}^{-1/2} C_g^N \bar{\sigma}^{-1/2}).\end{aligned}$$

□

Let us now discuss the results of [DLS07] in more details. The formula (A.47) in [DLS07] is actually given in the form:

$$\limsup_{N \rightarrow \infty} \left| H(\pi_{inv}^N) - H(\bar{\nu}^N) - \frac{1}{2} \log \det \left(\frac{1}{\sqrt{\sigma}} C_0^N \frac{1}{\sqrt{\sigma}} \right) \right| = 0,\tag{A.52}$$

where the entropy $H(\mu^N)$ of a measure μ^N on Ω_N reads:

$$H(\mu^N) := - \sum_{\eta \in \Omega_N} \mu^N(\eta) \log \mu^N(\eta).$$

The equivalence between (A.47) and (A.52) follows from the observation that, since $\bar{\nu}^N(\eta_i) = \bar{\rho}_i = \pi_{inv}^N(\eta_i)$ for each $i \in \Lambda_N$ by definition:

$$\begin{aligned} H(\pi_{inv}^N | \bar{\nu}^N) &= \sum_{\eta \in \Omega_N} \pi_{inv}^N(\eta) \log \left(\frac{\pi_{inv}^N(\eta)}{\bar{\nu}^N(\eta)} \right) = -H(\pi_{inv}^N) - \sum_{\eta \in \Omega_N} [\pi_{inv}^N(\eta) - \bar{\nu}^N(\eta)] \log \bar{\nu}^N(\eta) + H(\bar{\nu}^N) \\ &= -H(\pi_{inv}^N) + H(\bar{\nu}^N). \end{aligned}$$

The computation of $H(\pi_{inv}^N)$ in [DLS07] relies on the representation of a measure in terms of its truncated correlation functions. π_{inv}^N is written as $\bar{\nu}^N(\eta)(1+x^N(\eta))$, with x^N that can be expressed as a function F of two-point correlations, plus a correction term, that should be of sub-leading order in N . The study of F relies on clever combinatorial arguments. Rigorously establishing that the correction term is indeed small, however, appears to be very complicated, and only a conjecture is offered in [DLS07].

Let us comment on the expression (A.47) of $H(\pi_{inv}^N | \bar{\nu}^N)$. First, it is one whole order of magnitude lower than the entropy $H(\pi_{inv}^N)$ or $H(\bar{\nu}^N)$. Estimates on the relative entropy of the invariant state π_{inv}^N with respect to a product measure with the correct averages have been obtained for a large class of dynamics by Bahadoran [Bah07]. However, only an $o_N(1)$ estimate on this relative entropy is available.

Secondly, the relative entropy $H(\pi_{inv}^N | \bar{\nu}^N)$ involves only two-point correlations at leading order.

Both points are related to the fact that cumulants of the occupation numbers $(\eta_i)_{i \in \Lambda_N}$ under π_{inv}^N have a very particular scaling: any cumulant built from η at $k \in \mathbb{N}^*$ different sites is bounded by $O(N^{-k+1})$. A similar bound for the entropy $H(\pi_{inv}^N | \bar{\nu}^N)$ is therefore expected to hold for any dynamics with invariant measure featuring such a scaling behaviour for cumulants. In particular, such a bound on the entropy may be used to prove that, for a bias $h \in \mathcal{S}(\varepsilon_B)$ (defined in (2.22)), the scaling limit $\bar{\sigma} + k_h$ of correlations under the measure $\nu_{g_h}^N$ indeed coincides with the scaling limit of correlations under the invariant measure $\pi_{inv,h}^N$ of the dynamics \mathbb{P}_h (although in a weaker sense than (2.8)). Recall that g_h is the function obtained through the relative entropy method of Theorem 2.5.

Let us explain how. Assume that the following relative entropy bound holds:

$$\limsup_{N \rightarrow \infty} H(\pi_{inv,h}^N | \bar{\nu}^N) < \infty, \tag{A.53}$$

To study the scaling limit of correlations under $\pi_{inv,h}^N$, we proceed indirectly. First, the relative entropy method presented in Section 3.1 can be applied to the study of the distribution-valued process Π^N starting from $\nu_{g_h}^N$, in the large N limit. This process can be characterised as the solution of a certain martingale problem, and one can study its stationary measures. It is possible to prove that there is but one: the large N limit of the law $\nu_{g_h}^N \circ (\Pi^N)^{-1}$ of correlations under $\nu_{g_h}^N$. This limit can be described explicitly: the law of the fluctuation field $Y^N = N^{-1/2} \sum_{i \in \Lambda_N} \bar{\eta}_i \delta_{i/N}$ under $\nu_{g_h}^N$ converges to a Gaussian field with covariance $(\bar{\sigma}^{-1} - g_h)^{-1}$. Now, under assumption (A.53), the law of Π_0^N starting from $\pi_{inv,h}^N$ is tight. Any of its weak limit points is naturally invariant for the limiting correlation process. Since there is only one invariant measure for the limiting correlation process, the limit of $\nu_{g_h}^N \circ (\Pi^N)^{-1}$, $\pi_{inv}^N \circ (\Pi^N)^{-1}$ converges weakly to this measure, which characterises the correlations under $\pi_{inv,h}^N$ in terms of k_h .

B Integration by parts formulae

Fix $h \in \mathcal{S}(\varepsilon_B)$ and $g \in g_0 + \mathcal{S}(\varepsilon_G)$ (the set $\mathcal{S}(\varepsilon)$ is defined in (2.22) for each $\varepsilon > 0$). In this section, we provide an integration by parts formula under the measure ν_g^N , both in the bulk and close to the reservoirs. The formula close to the reservoirs proves the Γ -controllability of the variables U_0^\pm, U_1^\pm encountered in Lemma 3.7.

B.1 Integration by parts in the bulk

Before stating the result, let us give some notations and explain what we mean by an integration by parts formula. Fix a density $f : \Omega_N \rightarrow \mathbb{R}$ for ν_g^N . For $i < N - 1$, let $\Gamma_h^{i,i+1}$ be defined as:

$$\forall \eta \in \Omega_N, \quad \Gamma_h^{i,i+1}(\sqrt{f})(\eta) = \frac{1}{2} c_h(\eta, i, i+1) [\nabla_{i,i+1} \sqrt{f}(\eta)]^2, \quad (\text{B.1})$$

with, for any $u : \Omega_N \rightarrow \mathbb{R}$ and any $i < N - 1$:

$$\forall \eta \in \Omega_N, \quad \nabla_{i,i+1} u(\eta) = u(\eta^{i,i+1}) - u(\eta).$$

The jump rates c_h are defined in (2.19).

Consider a family $(\omega_i)_{i \in \Lambda_N}$ of functions on Ω_N . By an integration by parts formula under ν_g^N , we mean:

$$\sum_{\eta \in \Omega_N} (\omega_{i+1} - \omega_i) f(\eta) \nu_g^N(\eta) = \sum_{\eta \in \Omega_N} q(\eta) [f(\eta^{i,i+1}) - f(\eta)] \nu_g^N(\eta) + \nu_g^N(fX), \quad (\text{B.2})$$

where q, X are explicit functions, and X hopefully has good concentration properties under ν_g^N . The point of such a formula is that the first term in the right-hand side above can be expressed in terms of $\Gamma_h^{i,i+1}(\sqrt{f})$. The equality (B.2) amounts to turning a discrete *spatial* gradient (here $\omega_{i+1} - \omega_i$) into a gradient *on the dynamics*, along an edge $\eta \rightarrow \eta^{i,i+1}$. The natural choice for ω in our case is $\omega = \bar{\eta}$, however a simpler formula (B.2) is obtained, following [JM18b], through the choice:

$$\forall i \in \Lambda_N, \quad \omega_i = \frac{\bar{\eta}_i}{\bar{\sigma}_i}, \quad \bar{\eta}_i = \eta_i - \bar{\rho}_i, \quad \bar{\sigma}_i = \bar{\rho}_i(1 - \bar{\rho}_i). \quad (\text{B.3})$$

We are now ready to state the integration by parts formula.

Lemma B.1. *Let f be a ν_g^N -density. Fix $i < N - 1$ and let $u : \Omega_N \rightarrow \mathbb{R}$ be such that $\nabla_{i,i+1} u = 0$. Then:*

$$\begin{aligned} \nu_g^N [u(\omega_{i+1} - \omega_i) f] &= \nu_g^N (uq \nabla_{i,i+1} f) \\ &\quad - (\bar{\rho}_{i+1} - \bar{\rho}_i) \nu_g^N \left[\omega_i \omega_{i+1} e^{-(\eta_{i+1} - \eta_i) C_i^g / N} u f \right] \\ &\quad + \nu_g^N \left[(\omega_{i+1} - \omega_i) \left(1 - e^{-(\eta_{i+1} - \eta_i) C_i^g / N} \right) u f \right], \end{aligned} \quad (\text{B.4})$$

where the function q also depends on i :

$$\forall \eta \in \Omega_N, \quad q(\eta) = \frac{\eta_i(1 - \eta_{i+1})}{\bar{\rho}_i(1 - \bar{\rho}_{i+1})} e^{-(\eta_{i+1} - \eta_i) C_i^g / N}. \quad (\text{B.5})$$

Recall that, for each $i < N - 1$, $N^{-1}(\eta_i - \eta_{i+1}) C_i^g = \nabla_{i,i+1} \Pi^N(g)$ is defined in (3.31), and satisfies $\|C^g\| \leq 2\|g\|_\infty$.

Proof. Let $i < N - 1$ and $q : \Omega_N \rightarrow \mathbb{R}$. Notice that, by definition of $\nabla_{i,i+1}$:

$$\nu_g^N [uq \nabla_{i,i+1} f] = \sum_{\Omega_N} uq \nabla_{i,i+1} f \nu_g^N = \sum_{\Omega_N} f \frac{\nabla_{i,i+1}(uq \nu_g^N)}{\nu_g^N} \nu_g^N = \nu_g^N \left[u f \frac{\nabla_{i,i+1}(q \nu_g^N)}{\nu_g^N} \right], \quad (\text{B.6})$$

where we used $\nabla_{i,i+1} u = 0$ to obtain the second equality. The gradient in the right-hand side reads:

$$\forall \eta \in \Omega_N, \quad \frac{\nabla_{i,i+1}(q \nu_g^N)(\eta)}{\nu_g^N(\eta)} = q(\eta^{i,i+1}) \exp \left[-\frac{(\eta_{i+1} - \eta_i)}{N} (2C_i^g + \partial^N \lambda_i) \right] - q(\eta),$$

where $\lambda_i = \log(\bar{\rho}_i / (1 - \bar{\rho}_i))$. We need to choose a suitable q in order to have a difference $\omega_{i+1} - \omega_i$ arise above. In the $g = 0$ case, corresponding to [JM18b], one can take:

$$\tilde{q}(\eta) := \frac{\eta_i(1 - \eta_{i+1})}{\bar{\rho}_i(1 - \bar{\rho}_{i+1})}.$$

When $g \neq 0$, the exponential of C_i^g does not change things much, and if q is taken as in (B.5), then:

$$\frac{\nabla_{i,i+1}(q \nu_g^N)}{\nu_g^N}(\eta) = \left[\frac{\eta_{i+1}(1 - \eta_i)}{\bar{\rho}_{i+1}(1 - \bar{\rho}_i)} - \frac{\eta_i(1 - \eta_{i+1})}{\bar{\rho}_i(1 - \bar{\rho}_{i+1})} \right] e^{-(\eta_{i+1} - \eta_i)C_i^g/N}. \quad (\text{B.7})$$

The variables ω . (see (B.3)) are tailored to give the above bracket a nice expression (see (A.3) in [JM18b]):

$$\left[\frac{\eta_{i+1}(1 - \eta_i)}{\bar{\rho}_{i+1}(1 - \bar{\rho}_i)} - \frac{\eta_i(1 - \eta_{i+1})}{\bar{\rho}_i(1 - \bar{\rho}_{i+1})} \right] = \omega_{i+1} - \omega_i + (\bar{\rho}_{i+1} - \bar{\rho}_i)\omega_i\omega_{i+1}.$$

This formula can be checked by looking for the left-hand side as a polynomial in ω_i, ω_{i+1} , of the form $a + b\omega_i + c\omega_{i+1} + d\omega_i\omega_{i+1}$ for real numbers a, b, c, d . Equation (B.7) then becomes:

$$\begin{aligned} \frac{\nabla_{i,i+1}(q \nu_g^N)}{\nu_g^N}(\eta) &= \omega_{i+1} - \omega_i + (\omega_{i+1} - \omega_i) \left(e^{-(\eta_{i+1} - \eta_i)C_i^g/N} - 1 \right) \\ &\quad + (\bar{\rho}_{i+1} - \bar{\rho}_i)\omega_i\omega_{i+1} e^{-(\eta_{i+1} - \eta_i)C_i^g/N}, \end{aligned}$$

which proves the lemma when plugged into (B.6). \square

The next lemma rewrites the result of Lemma B.1 in terms of the carré du champ operator.

Lemma B.2. *Let $i < N - 1$ and let $u : \Omega_N \rightarrow \mathbb{R}$ be such that $\nabla_{i,i+1} u = 0$. There is then a constant $C = C(h, g, \bar{\rho}) > 0$ such that, for any $\delta > 0$:*

$$\begin{aligned} \nu_g^N [u(\omega_{i+1} - \omega_i)f] &\leq \delta N^2 \nu_g^N [\Gamma_h^{i,i+1}(f^{1/2})] + \frac{C}{\delta N^2} \nu_g^N [fu^2] \\ &\quad - (\bar{\rho}_{i+1} - \bar{\rho}_i) \nu_g^N \left[\omega_i \omega_{i+1} e^{-(\eta_{i+1} - \eta_i)C_i^g/N} u f \right] \\ &\quad + \nu_g^N \left[(\omega_{i+1} - \omega_i) \left(1 - e^{-(\eta_{i+1} - \eta_i)C_i^g/N} \right) u f \right]. \end{aligned} \quad (\text{B.8})$$

Proof. Let $i < N - 1$ and $\beta > 0$. In (B.4), write, for each $\eta \in \Omega_N$:

$$\nabla_{i,i+1} f(\eta) u(\eta) q(\eta) = \beta^{1/2} [f^{1/2}(\eta^{i,i+1}) - f^{1/2}(\eta)] \cdot \beta^{-1/2} u(\eta) q(\eta) [f^{1/2}(\eta^{i,i+1}) + f^{1/2}(\eta)].$$

Apply then Cauchy-Schwarz inequality to obtain:

$$\begin{aligned} \nu_g^N [u(\omega_{i+1} - \omega_i) f] &\leq \frac{\beta}{2} \nu_g^N [(\nabla_{i,i+1} f^{1/2})^2] + \frac{1}{\beta} \nu_g^N [(f(\eta) + f(\eta^{i,i+1})) u^2 q^2] \\ &\quad - (\bar{\rho}_{i+1} - \bar{\rho}_i) \nu_g^N [\omega_i \omega_{i+1} e^{-(\eta_{i+1} - \eta_i) C_i^g / N} u f] + \nu_g^N \left[(\omega_{i+1} - \omega_i) \left(1 - e^{-(\eta_{i+1} - \eta_i) C_i^g / N} \right) u f \right]. \end{aligned} \quad (\text{B.9})$$

Changing variables $\eta \leftarrow \eta^{i,i+1}$, since $\bar{\rho}_i \in [\rho_-, \rho_+] \subset (0, 1)$, the second expectation in (B.9) reads:

$$\begin{aligned} \frac{1}{\beta} \nu_g^N [(f(\eta) + f(\eta^{i,i+1})) u^2 q^2] &= \frac{1}{\beta} \sum_{\eta \in \Omega_N} f(\eta) u^2(\eta) \left[q^2(\eta) + q^2(\eta^{i,i+1}) \frac{\nu_g^N(\eta^{i,i+1})}{\nu_g^N(\eta)} \right] \nu_g^N(\eta) \\ &\leq \frac{e^{4\|g\|_\infty} M}{\beta} \nu_g^N [f u^2], \end{aligned}$$

where $M = \max\{(\bar{\rho}_j(1 - \bar{\rho}_{j+1}))^{-2}, (\bar{\sigma}_j \bar{\sigma}_{j+1})^{-1} : j < N - 1\}$ depends only on ρ_\pm .

Consider now the first term in the right-hand side of (B.9). Since $c_h(\eta, i, i+1) \geq c(\eta, i, i+1) e^{-2\|h\|_\infty}$ for each $\eta \in \Omega_N$, it reads:

$$\frac{\beta}{2} \int [\nabla_{i,i+1} f^{1/2}]^2 d\nu_g^N \leq \beta e^{2\|h\|_\infty} \nu_g^N (\Gamma_h^{i,i+1}(\sqrt{f})).$$

Taking $\beta = \delta N^2 e^{2\|h\|_\infty}$ concludes the proof. \square

B.2 Integration by parts at the boundary and boundary correlations

Here, we estimate dynamical correlations involving sites close the reservoirs, i.e. correlations of the form $\bar{\eta}_{\pm(N-1)} X_N$ for a function $X_N : \Omega_N \rightarrow \mathbb{R}$. Recall that $h \in \mathcal{S}(\varepsilon_B)$, $g \in g_0 + \mathcal{S}(\varepsilon_G)$ are fixed, and the definition (2.2) of the jump rates at the boundary. Define, for $f : \Omega_N \rightarrow \mathbb{R}$:

$$\forall \eta \in \Omega_N, \quad \Gamma_h^\pm(f) = \frac{c_h(\eta, \pm(N-1))}{2} [f(\eta^{\pm(N-1)}) - f(\eta)]^2, \quad (\text{B.10})$$

and observe:

$$c_h(\eta, \pm(N-1)) \geq e^{-2\|h\|_\infty} \min\{\rho_{\varepsilon_1}, (1 - \rho_{\varepsilon_2}) : \varepsilon_1, \varepsilon_2 \in \{-, +\}\}. \quad (\text{B.11})$$

Lemma B.3. *Fix $n \in \mathbb{N}^*$ and, for each $N \in \mathbb{N}^*$, let $\phi_n : \Lambda_N^r \rightarrow \mathbb{R}$ satisfy:*

$$\sup_{N \in \mathbb{N}^*} \sup_{\Lambda_N^r} |\phi_n| < \infty.$$

For $\varepsilon \in \{+, -\}$, define $U_0^\varepsilon(\eta) = \bar{\eta}_{\varepsilon(N-1)}$ for $\eta \in \Omega_N$, and:

$$\forall \eta \in \Omega_N, \quad U_n^\varepsilon(\eta) = \bar{\eta}_{\varepsilon(N-1)} V_n^\varepsilon(\eta), \quad V_n^\varepsilon(\eta) = \frac{1}{N^{n-1}} \sum_{i_1, \dots, i_n \neq \varepsilon(N-1)} \bar{\eta}_{i_1} \dots \bar{\eta}_{i_n} \phi_n(i_1, \dots, i_n).$$

Then, for each $n \in \mathbb{N}$, U_n^ε is Γ -controllable with size N^{-1} in the sense of Lemma 3.7. More precisely, there is $C > 0$ such that, for any ν_g^N -density f and any $\delta \in (0, 1)$:

$$\nu_g^N(fU_n^\varepsilon) \leq \delta N^2 \nu_g^N(\Gamma_h^\varepsilon(\sqrt{f})) + \nu_g^N \left(f \frac{C}{N^2} \left(\frac{(V_n^\varepsilon)^2}{\delta} + \left| V_n^\varepsilon \sum_{j \neq \varepsilon(N-1)} \bar{\eta}_j (Ng_{\varepsilon(N-1),j}) \right| \right) \right) + \alpha_n^N, \quad (\text{B.12})$$

setting $V_0^\varepsilon := 1$ by convention and with $\alpha_n^N = O(N^{-1})$ if $n \geq 1$ and $\alpha_0^N = O(N^{-2})$.

Remark B.4. The estimate on the size of U_n^ε is optimal only if $n \leq 1$. U_n^ε with $n \leq 1$ are used in the computation of the adjoint in Section 3.2, while U_2^ε is useful in Section C. \blacksquare

Proof. Let $n \in \mathbb{N}^*$. Using the notations of Corollary A.9, the term in the expectation in the right-hand side of (B.12) is of the form $N^{-1} \cdot (N^{-(2n-1)} X_{2n, \{0\}}^{\psi_{2n}} + N^{-n} X_{n+1, \{0\}}^{\psi_{n+1}})$ with $\sup_{N \in \mathbb{N}^*} \|N^{-q} \psi_q\|_{HS} < \infty$, $q \in \{n, 2n\}$. It is thus controllable with size (at most) N^{-1} as claimed, and it is enough to prove (B.12). We do so for the left boundary $\varepsilon = -$, the proof for the right boundary being identical. The goal is to create a gradient of f of the form (B.10). We use the shorthand notation $b = -(N-1)$. Notice that $V_n^-(\eta^b) = V_n^-(\eta)$ for any η . The mapping $\eta \mapsto \eta^b$ is bijective on Ω_N , thus:

$$\nu_g^N(f\bar{\eta}_b V_n^-) = \frac{1}{2} \sum_{\eta \in \Omega_N} \nu_g^N(\eta) V_n^-(\eta) \left[f(\eta)(\eta_b - \bar{\rho}_b) + f(\eta^b)(1 - \eta_b - \bar{\rho}_b) \frac{\nu_g^N(\eta^b)}{\nu_g^N(\eta)} \right]. \quad (\text{B.13})$$

For $\eta \in \Omega_N$, let us compute the ratio $\nu_g^N(\eta^b)/\nu_g^N(\eta)$:

$$\begin{aligned} \frac{\nu_g^N(\eta^b)}{\nu_g^N(\eta)} &= \frac{(1 - \eta_b)\bar{\rho}_b + \eta_b(1 - \bar{\rho}_b)}{\eta_b\bar{\rho}_b + (1 - \eta_b)(1 - \bar{\rho}_b)} e^{2\Pi^N(g)(\eta^b) - 2\Pi^N(g)(\eta)} \\ &= \left(\frac{\bar{\rho}_b}{1 - \bar{\rho}_b} \right)^{1-2\eta_b} \exp \left[\frac{(1 - 2\eta_b)}{N} \sum_{j \neq b} \bar{\eta}_j g_{b,j} \right]. \end{aligned} \quad (\text{B.14})$$

For future reference, notice that (B.14) is bounded by $C(\rho_\pm) e^{2\|g\|_\infty}$ for some $C(\rho_\pm) > 0$. Forgetting g for a second in (B.13), notice also that, for each $\eta \in \Omega_N$:

$$\begin{aligned} &f(\eta)(\eta_b - \bar{\rho}_b) + f(\eta^b)(1 - \eta_b - \bar{\rho}_b) \left(\frac{\bar{\rho}_b}{1 - \bar{\rho}_b} \right)^{1-2\eta_b} \\ &= \eta_b(1 - \bar{\rho}_b) [f(\eta) - f(\eta^b)] - (1 - \eta_b)\bar{\rho}_b [f(\eta) - f(\eta^b)] \\ &= \bar{\eta}_b (f(\eta) - f(\eta^b)), \end{aligned} \quad (\text{B.15})$$

which involves a gradient of f as desired. Coming back to (B.14), note that, since $g(\pm 1, \cdot) = 0$, the argument of the exponential in (B.14) is bounded by $O(N^{-1})$. Equation (B.15) and the existence of $C(g) > 0$ such that $|e^x - 1 - x| \leq C(g)x^2$ holds for $x \leq 2\|g\|_\infty$ therefore yield the bound:

$$\begin{aligned} &\left| \nu_g^N(f\bar{\eta}_b V_n^-) - \frac{1}{2} \sum_{\eta \in \Omega_N} \nu_g^N(\eta) V_n^-(\eta) \bar{\eta}_b [f(\eta) - f(\eta^b)] - \frac{1}{2N^2} \sum_{\eta \in \Omega_N} \nu_g^N(\eta) V_n^-(\eta) f(\eta^b) \right. \\ &\quad \left. \times (1 - \eta_b - \bar{\rho}_b) \left(\frac{\bar{\rho}_b}{1 - \bar{\rho}_b} \right)^{1-2\eta_b} (1 - 2\eta_b) \sum_{j \neq b} \bar{\eta}_j (Ng_{b,j}) \right| \leq \frac{C(g) \|V_n^-\|_\infty}{N^2} =: \alpha_n^n. \end{aligned} \quad (\text{B.16})$$

It remains to estimate the second and third terms in the left-hand side. Consider first the third term. Using the bijection $\eta \mapsto \eta^b$ to turn $f(\eta^b)$ into $f(\eta)$, recalling that $V_n^-(\eta^b) = V_n^-(\eta)$ for each $\eta \in \Omega_N$, and bounding the ratio (B.14) by $C(\rho_\pm)e^{2\|g\|_\infty}$, one finds:

$$\begin{aligned} & \left| \frac{1}{2N^2} \sum_{\eta \in \Omega_N} \nu_g^N(\eta) V_n^-(\eta) f(\eta^b) (1 - \eta_b - \bar{\rho}_b) \left(\frac{\bar{\rho}_b}{1 - \bar{\rho}_b} \right)^{1-2\eta_b} \sum_{j \neq b} \bar{\eta}_j(Ng_{b,j}) \right| \\ & \leq \frac{C(\rho_\pm)e^{2\|g\|_\infty}}{N^2} \nu_g^N \left(f \left| V_n^- \sum_{j \neq b} \bar{\eta}_j(Ng_{b,j}) \right| \right), \end{aligned} \quad (\text{B.17})$$

which is one of the terms appearing in (B.12). Consider now the second term in the left-hand side of (B.16). For $\beta > 0$ and $\eta \in \Omega_N$, split $[f(\eta) - f(\eta^b)]$ into $\beta[f^{1/2}(\eta) - f^{1/2}(\eta^b)]\beta^{-1}[f^{1/2}(\eta) + f^{1/2}(\eta^b)]$ and apply Cauchy-Schwarz inequality twice to find, bounding $(\bar{\eta}_b)^2$ by 1:

$$\frac{1}{2} \sum_{\eta \in \Omega_N} V_n^-(\eta) \bar{\eta}_b [f(\eta) - f(\eta^b)] \leq \frac{\beta}{4} \sum_{\eta \in \Omega_N} [f^{1/2}(\eta) - f^{1/2}(\eta^b)]^2 + \frac{1}{2\beta} \sum_{\eta \in \Omega_N} \nu_g^N(\eta) [f(\eta) + f(\eta^b)] (V_n^-)^2(\eta).$$

As for (B.17), the last expectation is bounded by $\beta^{-1}C(g)\nu_g^N(f(V_n^-)^2)$. To conclude the proof, recall from (B.10) the expression of Γ_h^- and from (B.11) the lower bound $C(\rho_\pm)e^{-\|h\|_\infty}$ on the jump rates. Choose $\beta = 2C(\rho_\pm)e^{-2\|h\|_\infty}\delta N^2$ for $\delta > 0$. Then:

$$\frac{1}{2} \sum_{\eta \in \Omega_N} V_n^-(\eta) \bar{\eta}_b [f(\eta) - f(\eta^b)] \leq \delta N^2 \nu_g^N(\Gamma_h^-(\sqrt{f})) + \frac{C(g)C(\rho_\pm)e^{2\|h\|_\infty}}{2\delta N^2} \nu_g^N(f(V_n^-)^2),$$

which together with (B.16) and (B.17) is precisely the right-hand side of (B.12). \square

C Control of the error terms

Fix $h \in \mathcal{S}(\varepsilon_B)$ and an associated $g_h \in g_0 + \mathcal{S}(\varepsilon_G)$, solution of the main equation (2.31). Recall that the set $\mathcal{S}(\varepsilon)$, $\varepsilon > 0$ is defined in (2.22). In this section we estimate, for each density f for $\nu_{g_h}^N$, the average against $f\nu_{g_h}^N$ of the function $X_{2,\{0,1\}}^\phi$, $\phi : \Lambda_N^2 \rightarrow \mathbb{R}$, defined below in (C.1). This proves the claim on the size of (3.62) in the proof of Lemma 3.3. We also estimate the expectation of the time average of any error term encountered in the text.

Proposition C.1. *Let $\phi \in \Lambda_N^2 \rightarrow \mathbb{R}$ satisfy $\sup_{N \in \mathbb{N}^*} \|\phi_2\|_\infty < \infty$. Recall that $X_{2,\{0,1\}}^\phi$, abbreviated as X_2 , was defined in (A.34) by:*

$$\forall \eta \in \Omega_N, \quad X_2(\eta) = \sum_{i < N-1} \sum_{j \notin \{i, i+1\}} \bar{\eta}_i \bar{\eta}_{i+1} \bar{\eta}_j \phi(i, j). \quad (\text{C.1})$$

Then $N^{-1}X_2$ is Γ -controllable with size $N^{-1/2}$ (recall Definition 3.5).

The next proposition controls in particular the size of error terms.

Proposition C.2. *Let E^N be an error term, and let F^N be either controllable or Γ -controllable with size 1 (recall Definition 3.5). There is then $C > 0$ such that:*

$$\begin{aligned} \forall T > 0, \quad \limsup_{N \rightarrow \infty} \mathbb{E}_h^{\nu_{gh}^N} \left[\left| \int_0^T E^N(\eta_t) dt \right| \right] &= 0, \\ \mathbb{E}_h^{\nu_{gh}^N} \left[\left| \int_0^T F^N(\eta_t) dt \right| \right] &\leq C(1+T) + CT \frac{C(h)e^{C(h)T}}{N^{1/2}}, \end{aligned} \quad (\text{C.2})$$

If the error term is known explicitly, the estimate (C.2) can be made quantitative.

Corollary C.3. *For $p \in \mathbb{N}^*$, let $\phi_p : \Lambda_N^p \rightarrow \mathbb{R}$ satisfy $\sup_N \|\phi_p\|_\infty < \infty$. Let $J = \{0\}$ or $\{0, 1\}$, and recall the definition of $X_{p,J}^{\phi_p}$ from Theorem A.8 and of U_p^\pm from Lemma B.3.*

If E^N is either $E_1^N = N^{-1}X_{1,J}^{\phi_1}$, $N^{-2}X_{2,J}^{\phi_2}$ or $E_p^N \in \{N^{-(p-1)}X_{p,J}^{\phi_p}, U_{p-1}^\pm\}$ if $p \geq 3$, then for any $T > 0$, there is $C(T, h) > 0$ such that:

$$\forall p \in \mathbb{N}^*, \quad \mathbb{E}_h^{\nu_{gh}^N} \left[\left| \int_0^T E_p^N(\eta_t) dt \right| \right] \leq C(T, h)(1 + \|\phi_p\|_\infty)N^{-1/4}. \quad (\text{C.3})$$

Propositions C.1-C.2 and Corollary C.3 are proven in the next two sections.

C.1 Estimate of X_2

In this section, we prove Proposition C.1. Fix $\phi : \Lambda_N^2 \rightarrow \mathbb{R}$, $N \in \mathbb{N}^*$ as in the proposition. Fix also a density f for ν_{gh}^N once and for all. The proof of Proposition C.1 being very technical, we first present its general structure.

The idea is to smoothen the product $\bar{\eta}_i \bar{\eta}_{i+1}$ into a quantity that depends on all $\bar{\eta}$'s in a box of size ℓ with ℓ sufficiently large, then use the entropic inequality to estimate the resulting term. The cost of this replacement will be estimated by an integration by parts formula, see Section B.

We need room between the indices $i, i+1$ and j in the definition (C.1) of X_2 to take averages in a box. Let I_ℓ be the segment $\{0, \dots, \ell-1\}$ and split the sum on j in (C.1) as follows:

$$\forall \eta \in \Omega_N, \quad \frac{1}{N} X_2(\eta) = \overrightarrow{X}_2^\ell + \overleftarrow{X}_2^\ell, \quad \overrightarrow{X}_2^\ell = \frac{1}{N} \sum_{i < N-1} \sum_{\substack{j \in \Lambda_N \\ j \notin i+1+I_\ell}} \bar{\eta}_i \bar{\eta}_{i+1} \bar{\eta}_j \phi(i, j) \quad (\text{C.4})$$

$$\overleftarrow{X}_2^\ell = \frac{1}{N} \sum_{i < N-1} \sum_{\substack{j \in \Lambda_N \setminus \{i, i+1\} \\ j \in i+1+I_\ell}} \bar{\eta}_i \bar{\eta}_{i+1} \bar{\eta}_j \phi(i, j) \quad (\text{C.5})$$

The direction of the arrow indicates the direction in which the replacement of $\bar{\eta}_i$ (\leftarrow) or $\bar{\eta}_{i+1}$ (\rightarrow) by averages on sites to the left of i (\leftarrow) or to the right of $i+1$ (\rightarrow) is going to be performed. Estimates for \overleftarrow{X}_2^ℓ and $\overrightarrow{X}_2^\ell$ are identical, so we only estimate the latter. In practice, the replacement is made thanks to the integration by parts Lemma B.2, which uses $\omega = \bar{\eta}/\bar{\sigma}$ as main variable. Write:

$$A(i, j) := \bar{\sigma}_{i+1} \phi(i, j), \quad i < N-1, j \in \Lambda_N.$$

Then:

$$\forall \eta \in \Omega_N, \quad \overrightarrow{X}_2^\ell(\eta) = \sum_{-(N-1) \leq i < N-1} \sum_{\substack{j \in \Lambda_N \\ j \notin i+1+I_\ell}} \bar{\eta}_i \omega_{i+1} \bar{\eta}_j A(i, j), \quad (\text{C.6})$$

and we replace ω_{i+1} by $\frac{1}{\ell} \sum_{a \in i+1+I_\ell} \omega_a$. If $i+1$ is too close to the reservoirs, i.e. if $i+1+\ell > N-1$, then this replacement does not make sense. In this case, we spread the unit mass at $i+1$ to $1/\ell$ at each site in $i+1+I_\ell \cap \Lambda_N$, and leave the remaining $1 - \frac{N-(i+1)}{\ell}$ mass at the boundary. This is summarised in the following definition:

$$\forall i < N-1, \quad \vec{\omega}_{i+1}^\ell = \frac{1}{\ell} \sum_{a=i+1}^{\min\{i+\ell, N-1\}} \omega_a + \mathbf{1}_{i+1+\ell > N-1} \left(1 - \frac{N-(i+1)}{\ell}\right) \omega_{N-1}.$$

Choice of ℓ . Let \vec{Y}_2^ℓ denote the averaged version of \vec{X}_2^ℓ :

$$\begin{aligned} \forall \eta \in \Omega_N, \quad \vec{Y}_2^\ell(\eta) &= \vec{Z}_2^\ell(\eta) \\ &+ \frac{1}{N} \sum_{-(N-1) \leq i < N-1} \sum_{\substack{j \in \Lambda_N \\ j \notin i+1+I_\ell}} \bar{\eta}_i \bar{\eta}_j \mathbf{1}_{i+\ell > N-1} \left(1 - \frac{N-(i+1)}{\ell}\right) \omega_{N-1} A(i, j), \end{aligned} \quad (\text{C.7})$$

with:

$$\forall \eta \in \Omega_N, \quad \vec{Z}_2^\ell(\eta) = \frac{1}{N} \sum_{-(N-1) \leq i < N-1} \sum_{\substack{j \in \Lambda_N \\ j \notin i+1+I_\ell}} \bar{\eta}_i \bar{\eta}_j \left(\frac{1}{\ell} \sum_{a=i+1}^{\min\{i+1+\ell, N-1\}} \omega_a \right) A(i, j).$$

The last term in (C.7) is Γ -controllable with size N^{-1} by Lemma B.3. For the replacement of \vec{X}_2^ℓ by \vec{Y}_2^ℓ to be useful, \vec{Z}_2^ℓ should be controllable with size $o_N(1)$. This requirement will fix the choice of ℓ . Looking at Corollary A.9, we see that any ℓ such that $\ell = o(N)$ fails, so we take:

$$\ell := N. \quad (\text{C.8})$$

The entropy inequality is then effective on \vec{Z}_2^N . Indeed, it is of the form:

$$\forall \eta \in \Omega_N, \quad \vec{Z}_2^N(\eta) = \frac{1}{N^2} \sum_{\substack{(i,j,a) \in \Lambda_N^3 \\ |\{(i,j,a)\}|=3}} \bar{\eta}_i \bar{\eta}_j \bar{\eta}_a \tilde{A}(i, j, a),$$

for some function \tilde{A} satisfying $|\tilde{A}(i, j, a)| \leq |A(i, j)|$ for each $(i, j, a) \in \Lambda_N^3$. By Corollary A.9, \vec{Z}_2^N is therefore controllable with size $N^{-1/2}$: there are $\gamma, C > 0$ such that:

$$\nu_{g_h}^N(f \vec{Z}_2^N) \leq \frac{H(f \nu_g^N | \nu_g^N)}{\gamma} + \frac{1}{\gamma} \log \nu_g^N \left[\exp(\gamma \vec{Z}_2^N) \right] \leq \frac{H(f \nu_g^N | \nu_g^N)}{\gamma} + \frac{C}{N^{1/2}}.$$

Cost of the replacement. Let us estimate the cost of replacing \vec{X}_2^N by \vec{Y}_2^N , defined in (C.7). To do so, we use of the following integration by parts identity, which explicitly describes how to spread the unit mass at $i+1$, $i < N-1$, to $1/N$ on every site up to the boundary, where the remaining mass is then left. One has:

$$\omega_{i+1} - \vec{\omega}_{i+1}^N = \sum_{a=i+1}^{\min\{i+N, N-1\}-1} \phi_N(a - (i+1)) (\omega_a - \omega_{a+1}), \quad \phi_N(b) = \frac{N-1-b}{N} \mathbf{1}_{0 \leq b < N}, \quad b \in \mathbb{Z}.$$

For brevity, for $a \in \Lambda_N$, let u_a denote the quantity:

$$\forall \eta \in \Omega_N, \quad u_a(\eta) = \frac{1}{N} \sum_{\substack{i < N-1 \\ a-N \leq i < a}} \phi_N(a - (i+1)) \bar{\eta}_i \sum_{\substack{j \in \Lambda_N \\ j \notin i+1+I_N}} \bar{\eta}_j A(i, j). \quad (\text{C.9})$$

Then, for each $\eta \in \Omega_N$:

$$\vec{X}_2^N - \vec{Y}_2^N = \sum_{a < N-1} (\omega_a - \omega_{a+1}) u_a(\eta),$$

To estimate the expectation of the right-hand side above under $f\nu_g^N$, apply, for each $a < N-1$, the integration by parts formula of Lemma B.2, with $u = -u_a$. There is thus a constant $C > 0$ such that, for each $\delta > 0$:

$$\sum_{a < N-1} \nu_{g_h}^N(f(\omega_a - \omega_{a+1})u_a) \leq \frac{\delta N^2}{4} \nu_{g_h}^N(\Gamma_h(\sqrt{f})) + \frac{C}{\delta N^2} \sum_{a < N-1} \nu_{g_h}^N(u_a^2 f) \quad (:= \nu_{g_h}^N(fR_1)) \quad (\text{C.10})$$

$$+ \sum_{a < N-1} (\rho_{a+1} - \rho_a) \nu_{g_h}^N(\omega_a \omega_{a+1} e^{-(\eta_{a+1} - \eta_a) C_a^{g_h}/N} u_a f) \quad (:= \nu_{g_h}^N(fR_2)) \quad (\text{C.11})$$

$$- \sum_{a < N-1} \nu_{g_h}^N\left((\omega_{a+1} - \omega_a) \left(1 - e^{-(\eta_{a+1} - \eta_a) C_a^{g_h}/N}\right) u_a f\right) \quad (:= \nu_{g_h}^N(fR_3)). \quad (\text{C.12})$$

Let us estimate one by one each of (C.10)-(C.11)-(C.12). Consider first $\nu_{g_h}^N(fR_3)$, and note that:

$$\sup_N \sup_{a \in \Lambda_N} |(\omega_{a+1} - \omega_a)(\eta_{a+1} - \eta_a)| \leq C(\rho_{\pm}).$$

As a result, using the identity $e^x = 1 + \int_0^1 x e^{tx} dt$ for $x \in \mathbb{R}$ and the fact that $|C^{g_h}| \leq 2\|g_h\|_{\infty}$, $\nu_{g_h}^N(fR_3)$ can be bounded as follows:

$$|\nu_{g_h}^N(fR_3)| \leq C(\rho_{\pm}) e^{2\|g\|_{\infty}} \nu_{g_h}^N\left(\frac{1}{N} \sum_{a < N-1} f |C_a^{g_h} u_a|\right).$$

By definition of C^{g_h} (see e.g. Lemma B.1) and of u in (C.9), the product $C^{g_h} u$ is of the form:

$$\forall a \in \Lambda_N, \quad C_a^{g_h} u_a = \frac{1}{N^2} \sum_{(i,j,b) \in \Lambda_N^3} \bar{\eta}_i \bar{\eta}_j \bar{\eta}_b \psi_{i,j,b}^a + \frac{1}{N^3} \sum_{(i,j) \in \Lambda_N^2} \bar{\eta}_i \bar{\eta}_j \tilde{\psi}_{i,j}^a,$$

where the functions $\psi^a, \tilde{\psi}^a : (-1, 1)^3 \rightarrow \mathbb{R}$ are bounded uniformly in a . It follows by Corollary A.9 that R_3 is controllable with size $N^{-1/2}$.

Consider now R_2 , defined in (C.11). Again using $e^x = 1 + \int_0^1 x e^{tx} dt$ for $x \in \mathbb{R}$, we can bound $\nu_{g_h}^N(fR_2)$ as follows:

$$\nu_{g_h}^N(fR_2) \leq \frac{\bar{\rho}'}{N} \sum_{a < N-1} \nu_{g_h}^N(f\omega_a \omega_{a+1} u_a) + \frac{\bar{\rho}' e^{2\|g_h\|_{\infty}}}{N^2} \sum_{a < N-1} \frac{1}{\bar{\sigma}_a \bar{\sigma}_{a+1}} \nu_{g_h}^N\left(f |C_a^{g_h} u_a|\right). \quad (\text{C.13})$$

Recalling the definition of u from (C.9), the first term in (C.13) is of the form $N^{-2} X_{3,\{0,1\}}^B$ in the notations of Theorem A.8, i.e. of the form $N^{-2} \sum_{i,j,b} \bar{\eta}_i \bar{\eta}_{i+1} \bar{\eta}_j \bar{\eta}_b B(i, j, b)$, with B bounded. Corollary A.9 tells us that this function does not behave worse than a sum of three-point correlations,

and is therefore controllable with size $N^{-1/2}$. In addition, the second term in (C.13) has the same structure as $N^{-1}R_3$, and is therefore controllable with size $N^{-3/2}$.

Consider finally R_1 in (C.12). It reads:

$$\nu_{g_h}^N(fR_1) = \frac{C}{\delta N^4} \sum_{a < N-1} \sum_{\substack{i, j < N-1 \\ a-N \leq i, j < a}} \phi_N(a - (i+1)) \phi_N(a - (j+1)) \bar{\eta}_i \bar{\eta}_j \sum_{\substack{(b, c) \in \Lambda_N^2 \\ b \notin i+1+I_N \\ c \notin j+1+I_N}} \bar{\eta}_b \bar{\eta}_c A(i, b) A(j, c).$$

In particular, it is of the form $N^{-3}X_{4, \{0\}}^{v_4}$ for a $v_4 : \Lambda_N^4 \rightarrow \mathbb{R}$ satisfying $\sup_N \sup_{\Lambda_N^4} |v_4| < \infty$, and therefore controllable with size N^{-1} by Corollary A.9. For each $\delta > 0$, we have proven the existence of a controllable function $R_\delta : \Omega_N \rightarrow \mathbb{R}$ such that:

$$\left| \nu_{g_h}^N(\vec{X}_2^N) \right| \leq \frac{\delta N^2}{2} \nu_{g_h}^N(\Gamma_h(\sqrt{f})) + \nu_{g_h}^N(f(\vec{Y}_2^N + R_\delta)), \quad R_\delta := R_1^\delta + R_2 + R_3.$$

The arguments above do not depend on the sign of A in the definition (C.5) of \vec{X}_2^N . This implies that \vec{X}_2^N is Γ controllable with size $N^{-1/2}$ in the sense of Definition 3.5. Since the same arguments also apply to \overleftarrow{X}_2^N , Proposition C.1 is proven.

C.2 Proof of Proposition C.2 and Corollary C.3

We now have all we need to prove Proposition C.2 and Corollary C.3.

Proof of Proposition C.2. Fix a time $T > 0$. Write G^N for either E^N or F^N . The proof of Proposition C.2 for a controllable function G^N with size $s_N = O_N(1)$ ($s_N = o_N(1)$ corresponding to a controllable error term, recall Definition 3.5) follows immediately from the entropy inequality: by Theorem 2.5, there is $C(h) > 0$ such that, applying the entropy inequality at each time:

$$\begin{aligned} \mathbb{E}_h^{\nu_{g_h}^N} \left[\left| \int_0^T G^N(\eta_t) dt \right| \right] &\leq \mathbb{E}_h^{\nu_{g_h}^N} \left[\int_0^T |G^N(\eta_t)| dt \right] \\ &\leq \frac{T}{\gamma} \left(\frac{C(h)e^{C(h)T}}{N^{1/2}} + \log \nu_{g_h}^N \left(\exp(\gamma |G^N|) \right) \right). \end{aligned} \quad (\text{C.14})$$

By definition of controllability, there are $\gamma(G), C(G) > 0$ independent of N such that the exponential moment above is bounded by $\gamma(G)C(G)s_N$. As a result:

$$\mathbb{E}_h^{\nu_{g_h}^N} \left[\left| \int_0^T G^N(\eta_t) dt \right| \right] \leq \frac{TC(h)e^{C(h)T}}{\gamma(G)N^{1/2}} + TC(G)s_N. \quad (\text{C.15})$$

If G^N is controllable with size 1, s_N is bounded. If instead G^N is a controllable error term, $s_N = o_N(1)$ and (C.15) becomes:

$$\limsup_{N \rightarrow \infty} \mathbb{E}_h^{\nu_{g_h}^N} \left[\left| \int_0^T G^N(\eta_t) dt \right| \right] = 0.$$

Assume now that G^N be Γ -controllable with size $s_N = O_N(1)$. The important observation is that aG is then also Γ -controllable with size $c(a)s_N$ for some $c(a) > 0$. Indeed, for each $\delta' > 0$, by definition of Γ -controllability, there are functions $\tilde{Y}_{G^N, \pm}^{\delta'}$ such that, for each density f for $\nu_{g_h}^N$:

$$\nu_{g_h}^N(f(\pm G^N)) \leq \delta' N^2 \nu_{g_h}^N(\Gamma_h(\sqrt{f})) + \nu_{g_h}^N(f \tilde{Y}_{G^N, \pm}^{\delta'}).$$

For each $a > 0$ and each $\delta > 0$, the above equation with $\delta' = \delta/a$ yields:

$$\nu_{g_h}^N(f(\pm aG^N)) \leq \delta N^2 \nu_{g_h}^N(\Gamma_h(\sqrt{f})) + \nu_{g_h}^N(f Y_{G^N, \pm}^{a, \delta}), \quad Y_{G^N, \pm}^{a, \delta} := a \tilde{Y}_{G^N, \pm}^{\delta/a}, \quad (\text{C.16})$$

and $Y_{G^N, \pm}^{a, \delta}$ is indeed controllable with size $c(a)s_N$ for some $c(a) > 0$.

Let $a > 0$ to be chosen later. In the following, we set:

$$\delta := \frac{1}{4}, \quad Y_{G^N, \pm}^a := Y_{G^N, \pm}^{a, 1/4}.$$

To estimate $\mathbb{E}_h^{\nu_{g_h}^N} [|\int_0^T G^N(\eta_t) dt|]$, recall from Lemma 3.3 the existence of a controllable function \mathcal{E} with size $N^{-1/2}$ such that, for any $\bar{\nu}_{g_h}$ -density f ,

$$\nu_{g_h}^N(f L_h^* \mathbf{1}) \leq \frac{N^2}{2} \nu_{g_h}^N(\Gamma_h(\sqrt{f})) + \nu_{g_h}^N(f \mathcal{E}). \quad (\text{C.17})$$

Write then:

$$\begin{aligned} \mathbb{E}_h^{\nu_{g_h}^N} \left[\left| \frac{1}{T} \int_0^T G^N(\eta_t) dt \right| \right] &= \int_0^\infty \mathbb{P}_h^{\nu_{g_h}^N} \left(\left| \int_0^T G^N(\eta_t) dt \right| > \lambda T \right) d\lambda \\ &\leq \int_0^\infty \mathbb{P}_h^{\nu_{g_h}^N} \left(\int_0^T a G^N(\eta_t) dt > a \lambda T \right) + \int_0^\infty \mathbb{P}_h^{\nu_{g_h}^N} \left(- \int_0^T a G^N(\eta_t) dt > a \lambda T \right) d\lambda. \end{aligned} \quad (\text{C.18})$$

Recall the definition of \mathcal{E} from (C.17). Add and subtract $Y_{G^N, +}^a + \mathcal{E}/2$ to the argument of the integral in the first probability, $Y_{G^N, -}^a + \mathcal{E}/2$ to the argument of the second to find that (C.18) is bounded from above by:

$$\int_0^\infty \mathbb{P}_h^{\nu_{g_h}^N} \left(\int_0^T \left[a G^N - Y_{G^N, +}^a - \frac{\mathcal{E}}{2} \right] (\eta_t) dt > a \lambda T / 2 \right) d\lambda \quad (\text{C.19})$$

$$\begin{aligned} &+ \frac{2}{aT} \mathbb{E}_h^{\nu_{g_h}^N} \left[\left| \int_0^T \left[Y_{G^N, +}^a + \frac{\mathcal{E}}{2} \right] (\eta_t) dt \right| \right] \\ &+ \int_0^\infty \mathbb{P}_h^{\nu_{g_h}^N} \left(\int_0^T \left[-a G^N - Y_{G^N, -}^a - \frac{\mathcal{E}}{2} \right] (\eta_t) dt > a \lambda T / 2 \right) d\lambda \quad (\text{C.20}) \\ &+ \frac{2}{aT} \mathbb{E}_h^{\nu_{g_h}^N} \left[\left| \int_0^T \left[Y_{G^N, -}^a + \frac{\mathcal{E}}{2} \right] (\eta_t) dt \right| \right]. \end{aligned}$$

The functions $Y_{G^N, \pm}^a, \mathcal{E}$ have been defined in (C.16)-(C.17) in such a way that, applying Feynman-Kac inequality (3.5) to each of the probabilities in (C.19)-(C.20) yields, for each $\lambda > 0$:

$$\begin{aligned} &\log \mathbb{P}_h^{\nu_{g_h}^N} \left(\int_0^T \left[\pm a G^N - Y_{G^N, \pm}^a - \frac{\mathcal{E}}{2} \right] (\eta_t) dt > a \lambda T / 2 \right) \\ &\leq -a \lambda T / 2 + T \sup_{f \geq 0: \nu_{g_h}^N(f)=1} \left\{ \nu_{g_h}^N \left(f \left[\pm a G^N - Y_{G^N, \pm}^a - \frac{\mathcal{E}}{2} + \frac{L_h^* \mathbf{1}}{2} \right] \right) - \frac{N^2}{2} \nu_{g_h}^N(\Gamma_h(\sqrt{f})) \right\}. \end{aligned}$$

Recalling (C.16) and (C.17), the above supremum is negative and one finds, for each $\lambda > 0$:

$$\mathbb{P}_h^{\nu_h^N} \left(\int_0^T \left[\pm aG^N - Y_{G^N, \pm}^a - \frac{\mathcal{E}}{2} \right] (\eta_t) dt > a\lambda T/2 \right) \leq e^{-a\lambda T/2}.$$

As a result, putting together the last equation and the estimate (C.15), which holds for some constants $C(e), C(a) > 0$ for $\mathcal{E}, Y_{G^N, \pm}^a$ instead of $C(G)$:

$$\begin{aligned} \mathbb{E}_h^{\nu_h^N} \left[\left| \int_0^T G^N(\eta_t) dt \right| \right] &\leq 2 \int_0^\infty e^{-a\lambda/2} d\lambda + \frac{TC(h)e^{C(h)T}[C(e) + C(a)]}{aN^{1/2}} + \frac{TC(e)}{aN^{1/2}} + \frac{TC(a)s_N}{a} \\ &= \frac{4}{a} + \frac{TC(h)e^{C(h)T}[C(e) + C(a)]}{aN^{1/2}} + \frac{TC(e)}{aN^{1/2}} + \frac{TC(a)s_N}{a}. \end{aligned} \quad (\text{C.21})$$

If $s_n = o_N(1)$, corresponding to an error term, then taking N large followed by a large concludes the proof of Proposition C.2. Otherwise, if $s_N = O_N(1)$, taking any $a > 0$ independent of N yields the claim. \square

Proof of Corollary C.3. Let E^N be one of the error term amongst $N^{-1}X_{1,J}^{\phi_1}$, $N^{-2}X_{2,J}^{\phi_2}$ or $N^{-(p-1)}X_{p,J}^{\phi_p}$ for $p \geq 3$ and bounded $\phi_p : \Lambda_N^p \rightarrow \mathbb{R}$, $p \geq 1$, as in Corollary C.3. Write $E^N = E_p^N$ for the corresponding $p \in \mathbb{N}^*$. Then E_p^N is a controllable error term with size at most $N^{-1/2}$. The estimate (C.15) thus applies to $G^N = E_p^N$ and yields the claim.

Assume now that E_p^N is either U_p^\pm for $p \in \mathbb{N}$, or $X_{2,\{0,1\}}^{\phi_2}$. Then E_p^N is a Γ -controllable error term with size at most $N^{-1/2}$ by Lemma B.3 and Proposition C.1. It can then be seen from (B.12) and the proof of Proposition C.1 (see Equations (C.10) to (C.12)) that the $Y_{E_p^N, \pm}^a$ associated with E_p^N in fact read:

$$Y_{E_p^N, \pm}^a = aY_{E_p^N, \pm} + a^2Z_{E_p^N, \pm},$$

where $Y_{E_p^N, \pm}, Z_{E_p^N, \pm}$ are independent of a , and controllable with size $N^{-1/2}$. Indeed, the a^2 factor arises due to the integration by parts formulae of Appendix B, as a consequence of the use of Cauchy-Schwarz inequality to have the Dirichlet form appear. On the other hand, $aY_{E_p^N, \pm}$ is the sum of the other terms that appear when using the integration by parts formula.

From this observation, one can see that both $Y_{E_p^N, \pm}$ and $Z_{E_p^N, \pm}$ are of the form $X_{q,J}^{\psi_q}$ or U_q^\pm for some $q \in \mathbb{N}^*$. The tensor ψ_q has entries bounded by $C\|\phi_p\|_\infty$ for $Y_{E_p^N, \pm}$, and by $C'\|\phi_p\|_\infty^2$ for $Z_{E_p^N, \pm}$ for some C, C' independent of ϕ_p . The constant $C(a)$ in (C.21) thus satisfies:

$$C(a) \leq aC''\|\phi_p\|_\infty(1 + a\|\phi_p\|_\infty),$$

for some $C'' > 0$ independent of ϕ_p , where from (C.21) becomes:

$$\mathbb{E}_h^{\nu_h^N} \left[\left| \int_0^T E_p^N(\eta_t) dt \right| \right] \leq \frac{4}{a} + \left[TC(h)e^{C(h)T} + T \right] \left[\frac{C(e)}{aN^{1/2}} + \frac{C''\|\phi_p\|_\infty(1 + a\|\phi_p\|_\infty)}{N^{1/2}} \right].$$

Taking $a = \min\{1, \|\phi_p\|_\infty^{-1}\}N^{1/4}$ then yields the claim (C.3). \square

D The Neumann condition on the diagonal

Let $h \in \mathcal{S}(\varepsilon_B)$ and let $g_h \in g_0 + \mathcal{S}(\varepsilon_G)$ be the associated solution of the main equation (2.31), where the set $\mathcal{S}(\varepsilon)$, $\varepsilon > 0$ is defined in (2.22). In this section, we rewrite the term:

$$\frac{1}{4} \sum_{i < N-1} \bar{\eta}_i \bar{\eta}_{i+1} (\partial_1 h_{i+,i} - \partial_1 h_{i-,i}) \quad (\text{D.1})$$

as a function of the two-point correlations field Π^N , defined in (2.6). This is necessary in the proof of the upper-bound large deviations, in order to obtain a closed expression of the Radon-Nikodym derivative in terms of the field Π^N . It is done through the integration by parts Lemma B.1. As $h \in \mathcal{S}(\varepsilon_B)$, the function $q(x) = \partial_1 h_{x+,x} - \partial_1 h_{x-,x}$, $x \in (-1, 1)$ can be extended into an element of $C^2([-1, 1])$, still denoted by q , which satisfies $q(\pm 1) = 0$ (by hypothesis on $\mathcal{S}(\varepsilon_B)$, see (2.22)).

Let $\varepsilon \in (0, 1) \in \mathbb{N}^*$ and $I_{N\varepsilon} := \{0, \dots, N\varepsilon - 1\}$, writing $N\varepsilon$ for $\lfloor N\varepsilon \rfloor$. As the correlation field Π^N is defined on \mathcal{T} , which contains sufficiently smooth functions only, we cannot simply replace ω_{i+1} by a uniform average of ω . on $i + 1 + I_{N\varepsilon}$. Consider instead a function $\chi^\varepsilon \in C^\infty(\bar{\square})$ with $\chi^\varepsilon = 0$ on $\partial\square$, $0 \leq \chi^\varepsilon \leq 2/\varepsilon$, such that $\chi^\varepsilon(x, \cdot)$ is supported on $(x, x + \varepsilon) \cap (-1, 1)$ for each $x \in (-1, 1)$, and:

$$\forall x < 1 - \varepsilon, \quad \int_{(x, x+\varepsilon)} \chi^\varepsilon(x, y) dy = 1, \quad \forall x \geq 1 - \varepsilon, \quad \int_{(x, x+\varepsilon)} \chi^\varepsilon(x, y) dy \leq 1. \quad (\text{D.2})$$

For $i < N - 1$, write then $\omega_{i+1}^{\chi^\varepsilon}$ for the average of ω . on $i + 1 + I_{N\varepsilon}$ with weights given in terms of χ^ε as follows:

$$\begin{aligned} \forall \eta \in \Omega_N, \quad \omega_{i+1}^{\chi^\varepsilon}(\eta) &= \frac{1}{N} \sum_{j=i+1}^{\min\{i+\varepsilon N, N-1\}} \omega_j \int_0^1 \chi^\varepsilon\left(\frac{i+1}{N}, \frac{j}{N} + \frac{r}{N}\right) dr \\ &\quad + \mathbf{1}_{i+\varepsilon N > N-1} \omega_{N-1} \left[1 - \int_{\frac{i+1}{N}}^1 \chi^\varepsilon\left(\frac{i+1}{N}, y\right) dy\right]. \end{aligned} \quad (\text{D.3})$$

In other words, the mass is spread according to χ^ε up to the reservoir, where the remaining mass is piled up on ω_{N-1} . Define then, recalling that $\bar{\sigma}(x) = \bar{\rho}(x)(1 - \bar{\rho}(x))$ for $x \in [-1, 1]$:

$$\forall (x, y) \in \square, \quad \mathcal{N}_\varepsilon^q(x, y) = \frac{\bar{\sigma}(x)}{\bar{\sigma}(y)} q(x) \chi^\varepsilon(x, y),$$

and note that $\mathcal{N}_\varepsilon^q$ belongs to \mathcal{T} , defined in (2.15), since it is a regular function which vanishes on $\partial\square$.

Proposition D.1. *Let $q \in C^2([-1, 1])$ satisfy $q(\pm 1) = 0$. Define, for $\eta \in \Omega_N$:*

$$W_q(\eta) = \frac{1}{4} \sum_{i < N-1} \bar{\eta}_i \bar{\eta}_{i+1} q_i.$$

There are then $c > 0$, $c'(h, q) > 0$ independent of χ^ε such that, for each $T > 0$ and each $\theta > 0$, there is $\varepsilon(\theta, h, q) \in (0, 1)$ independent of T , χ^ε satisfying:

$$\forall \varepsilon < \varepsilon(\theta, h, q), \quad \limsup_{N \rightarrow \infty} \mathbb{P}_h^{\nu_h^N} \left(\left| \frac{1}{T} \int_0^T [W_q(\eta_t) - \Pi_t^N(\mathcal{N}_\varepsilon^q)] dt \right| > \theta \right) \leq ce^{-c'(h, q)\theta\varepsilon^{-1/2}T}. \quad (\text{D.4})$$

Proof. Let $\varepsilon \in (0, 1), \theta > 0$. Up to considering q and $-q$ in the definition of W_q , the absolute value inside the probability can be removed. The proof follows the same line as that of Proposition C.2, but estimates on the dependence of $W_q - \Pi^N(\mathcal{N}_\varepsilon^q)$ in ε are required, so we give the full argument. The idea is again to decompose, for each $\lambda > 0$, $\lambda W_q - \lambda \Pi^N(\mathcal{N}_\varepsilon^q) = \lambda W_q - \lambda \Pi^N(\mathcal{N}_\varepsilon^q) - \lambda \mathcal{E}_\lambda + \lambda \mathcal{E}_\lambda$ for a suitable function $\mathcal{E}_\lambda : \Omega_N \rightarrow \mathbb{R}$. The function \mathcal{E}_λ is built to ensure that $\lambda W_q - \lambda \Pi^N(\mathcal{N}_\varepsilon^q) - \lambda \mathcal{E}_\lambda$ can be shown to be small by Feynman-Kac inequality. This time, however, the function \mathcal{E}_λ is not an error term and Proposition C.2 is not sufficient to obtain (D.4). A suitable bound on the time average of \mathcal{E}_λ can instead be obtained through Proposition 4.4.

By Feynman-Kac inequality, for any $\lambda > 0$ and any function $\mathcal{E}_\lambda : \Omega_N \rightarrow \mathbb{R}$, one has:

$$\begin{aligned} & \log \mathbb{P}_h^{\nu_{gh}^N} \left(\frac{1}{T} \int_0^T [W_q - \Pi^N(\mathcal{N}_\varepsilon^q) - \mathcal{E}_\lambda](\eta_t) dt > \theta \right) \\ & \leq -\lambda \theta T + \log \mathbb{E}_h^{\nu_{gh}^N} \left[\exp \left[\lambda \int_0^T [W_q - \Pi^N(\mathcal{N}_\varepsilon^q) - \mathcal{E}_\lambda](\eta_t) dt \right] \right] \\ & \leq -\lambda \theta T + \int_0^T \sup_{f \geq 0: \nu_{gh}^N(f)=1} \left\{ \lambda \nu_{gh}^N \left(f [W_q - \Pi^N(\mathcal{N}_\varepsilon^q) - \mathcal{E}_\lambda] \right) - \frac{N^2}{2} \nu_{gh}^N(\Gamma_h(\sqrt{f})) + \frac{1}{2} \nu_{gh}^N(f L^* \mathbf{1}) \right\}. \end{aligned}$$

To estimate the expectation of $W_q - \Pi^N(\mathcal{N}_\varepsilon^q)$, we will use the integration by parts Lemma B.1. It is formulated with the variables $\omega_i = \bar{\eta}_i / \bar{\sigma}_i$, $i \in \Lambda_N$, for which W_q becomes:

$$\forall \eta \in \Omega_N, \quad W_q(\eta) = \frac{1}{4} \sum_{i < N-1} \omega_i \omega_{i+1} \bar{\sigma}_i \bar{\sigma}_{i+1} q_i = \frac{1}{4} \sum_{i < N-1} \omega_i \omega_{i+1} (\bar{\sigma}_i)^2 q_i + \theta^{N,0}(\eta),$$

where $\theta^{N,0}$ is the error term:

$$\forall \eta \in \Omega_N, \quad \theta^{N,0}(\eta) = \frac{1}{4N} \sum_{i < N-1} \omega_i \omega_{i+1} N \bar{\sigma}_i [\bar{\sigma}_{i+1} - \bar{\sigma}_i] q_i.$$

It is of the form $N^{-1} X_{1,\{0,1\}}^v$ with the notations of Theorem A.8, thus controllable with size N^{-1} . In addition, in (D.3), χ^ε appears inside an integral, rather than directly being evaluated at lattice points. One thus also has:

$$\forall \eta \in \Omega_N, \quad \Pi^N(\mathcal{N}_\varepsilon^q) = \frac{1}{4N} \sum_{i < j} \omega_i \omega_j (\bar{\sigma}_i)^2 q_i \int_0^1 \chi^\varepsilon \left(\frac{i+1}{N}, \frac{j}{N} + \frac{r}{N} \right) dr - \tilde{\theta}^{N,0}(\eta),$$

where $\tilde{\theta}^{N,0}$ is of the form $N^{-1} X_{2,\{0\}}^v$ for a bounded v , thus controllable with size N^{-1} :

$$\tilde{\theta}^{N,0}(\eta) := -\frac{1}{4N^2} \sum_{i < j} \bar{\eta}_i \bar{\eta}_j \frac{q_i \bar{\sigma}_i}{\bar{\sigma}_j} N \left[\chi_{i,j}^\varepsilon - \int_0^1 \chi^\varepsilon \left(\frac{i+1}{N}, \frac{j}{N} + \frac{r}{N} \right) dr \right].$$

Introduce, for each $x \in (-1, 1)$ and $z \in \mathbb{R}$, the remaining mass $\phi_{\chi^\varepsilon}(x, z)$ after spreading the unit mass at x between x and $x + \mathbf{1}_{z \geq 0}(z + 1/N)$ according to $\chi^\varepsilon(x, \cdot)$:

$$\phi_{\chi^\varepsilon}(x, z) = \left[1 - \int_x^{x+z+\frac{1}{N}} \chi^\varepsilon(x, y) dy \right] \mathbf{1}_{0 \leq z < \varepsilon}, \quad z \in \mathbb{R}.$$

For future use, recall that $\chi^\varepsilon(x, \cdot)$ is supported in an interval of length ε at most for each $x \in (-1, 1)$. As a result, bounding χ^ε by 1 when it does not vanish and using the definition (D.2) of χ^ε , there is $K > 0$ that depends neither on ε , nor on the precise choice of χ^ε , such that:

$$\begin{aligned} \sum_{a \in \mathbb{N}} |\phi_{\chi^\varepsilon}(i/N, a)| &\leq KN\varepsilon, & \sum_{a \in \mathbb{N}} |\phi_{\chi^\varepsilon}(i/N, a)|^2 &\leq KN\varepsilon, & i < N - \varepsilon N, \\ \|\phi_{\chi^\varepsilon}\|_2 &\leq K\varepsilon^{1/2}. \end{aligned} \quad (\text{D.5})$$

For each $i < N - 1$, one can then write:

$$\omega_{i+1} - \omega_{i+1}^{\chi^\varepsilon} = \sum_{j=i+1}^{\min\{N-1, i+\varepsilon N\}-1} \phi_{\chi^\varepsilon}\left(\frac{i+1}{N}, \frac{j-(i+1)}{N}\right) (\omega_j - \omega_{j+1}).$$

Define then $u_j : \Omega_N \rightarrow \mathbb{R}$ for $j > -(N-1)$ as follows:

$$\forall \eta \in \Omega_N, \quad u_j(\eta) = \sum_{i < j} \bar{\sigma}_i^2 q_i \omega_i \phi_{\chi^\varepsilon}\left(\frac{i+1}{N}, \frac{j-(i+1)}{N}\right). \quad (\text{D.6})$$

With this definition, the quantity $\lambda W_q - \lambda \Pi^N(\mathcal{N}_\varepsilon^q)$ reads, for each $\eta \in \Omega_N$:

$$\begin{aligned} \lambda[W_q(\eta) - \Pi^N(\mathcal{N}_\varepsilon^q)] &= \lambda \sum_{j > -(N-1)} (\omega_j - \omega_{j+1}) u_j(\eta) \\ &\quad + \lambda \omega_{N-1} \sum_{i < N-1} (\bar{\sigma}_i)^2 q_i \omega_i \phi_{\chi^\varepsilon}\left(\frac{i+1}{N}, 1 - \frac{i+1}{N}\right) + \lambda[\theta^{N,0}(\eta) + \tilde{\theta}^{N,0}(\eta)]. \end{aligned} \quad (\text{D.7})$$

Fix a density f for $\nu_{g_h}^N$. As it involves boundary correlations, the first term in the second line is Γ -controllable with size N^{-1} : by Lemma B.3, for each $\delta > 0$, there is a function $\mathcal{D}_{\delta,\lambda}$, controllable with size N^{-1} such that:

$$\lambda \nu_{g_h}^N \left(f \omega_{N-1} \sum_{i < N-1} (\bar{\sigma}_i)^2 q_i \omega_i \phi_{\chi^\varepsilon}\left(\frac{i+1}{N}, 1 - \frac{i+1}{N}\right) \right) \leq \delta \nu_{g_h}^N(\Gamma_h(\sqrt{f})) + \nu_{g_h}^N(f \mathcal{D}_{\delta,\lambda}). \quad (\text{D.8})$$

It therefore remains to estimate the other term in the right-hand side of (D.7). By the integration by parts Lemma B.2 applied to u_j for each $j < N - 1$, there is a constant $C > 0$ such that, for any $\delta > 0$:

$$\begin{aligned} \lambda \nu_{g_h}^N \left(f \sum_{j < N-1} (\omega_j - \omega_{j+1}) u_j \right) &\leq \delta N^2 \nu_{g_h}^N(\Gamma_h(\sqrt{f})) + \frac{C\lambda^2}{\delta N^2} \sum_{j < N-1} \int f |u_j|^2 d\nu_{g_h}^N \quad (:= \frac{\lambda^2}{\delta} \nu_{g_h}^N(f \mathcal{N}_1)) \\ &\quad + \lambda \sum_{j < N-1} (\bar{\rho}_{j+1} - \bar{\rho}_j) \int \omega_j \omega_{j+1} f u_j d\nu_{g_h}^N \quad (:= \lambda \nu_{g_h}^N(f \mathcal{N}_2)) \\ &\quad - \lambda \sum_{j < N-1} \int [\omega_{j+1} - \omega_j] \left(1 - e^{-(\eta_{j+1} - \eta_j) C_j^{g_h}/N} \right) f u_j d\nu_{g_h}^N \quad (:= \lambda \nu_{g_h}^N(f \mathcal{N}_3)). \end{aligned} \quad (\text{D.9})$$

The function \mathcal{N}_2 is of the form $N^{-1} X_{2,\{0,1\}}^{v_2}$, and is therefore a Γ -controllable error term with size $N^{-1/2}$ by Proposition C.1. Define:

$$\theta^{N,2} := \mathcal{N}_2.$$

Consider now \mathcal{N}_1 . For each $\eta \in \Omega_N$, it reads:

$$\mathcal{N}_1(\eta) := \frac{C}{N^2} \sum_{j < N-1} |u_j|^2.$$

Recall the identity $(\bar{\eta})^2 = \bar{\sigma} + \sigma'(\bar{\rho})\bar{\eta}$ and the definition (D.6) of u_j , $j < N-1$. Developing $|u_j|^2$, then separating diagonal and off-diagonal contributions, one finds:

$$\begin{aligned} \mathcal{N}_1(\eta) &= \frac{C}{N^2} \sum_{i_1, i_2 < N-1} \bar{\eta}_{i_1} \bar{\eta}_{i_2} \bar{\sigma}_{i_1} q_{i_1} \bar{\sigma}_{i_2} q_{i_2} \left[\sum_{j < N-1} \phi_{\chi^\varepsilon} \left(\frac{i_1+1}{N}, \frac{j-(i_1-1)}{N} \right) \phi_{\chi^\varepsilon} \left(\frac{i_2+1}{N}, \frac{j-(i_2-1)}{N} \right) \right] \\ &=: \Pi^N(Y^{(1)}) + \frac{C}{N^2} \sum_{i < N-1} \bar{\sigma}_i^3 q_i^2 \sum_{j < N-1} \phi_{\chi^\varepsilon} \left(\frac{i}{N}, \frac{j-(i-1)}{N} \right)^2 + \theta^{N,1}(\eta). \end{aligned}$$

In the last line, the middle term is bounded by $KC(q)\varepsilon$ using (D.5). The function $Y_\varepsilon^{(1)}$ reads:

$$\forall (x, y) \in \square, \quad Y_\varepsilon^{(1)}(x, y) := 4Cq(x)q(y)\bar{\sigma}(x)\bar{\sigma}(y) \int_{(-1,1)} \phi_{\chi^\varepsilon}(x, z-x)\phi_{\chi^\varepsilon}(y, z-y)dz, \quad (\text{D.10})$$

and $\theta^{N,1}$ is a controllable error term with size N^{-1} that reads, for each $\eta \in \Omega_N$:

$$\begin{aligned} \theta^{N,1}(\eta) &= \frac{1}{N^2} \sum_{i_1 \neq i_2 < N-1} \bar{\eta}_{i_1} \bar{\eta}_{i_2} N \left[-\frac{(Y_\varepsilon^{(1)})_{i_1, i_2}}{4} + \frac{C\bar{\sigma}_{i_1} q_{i_1} \bar{\sigma}_{i_2} q_{i_2}}{N} \right. \\ &\quad \left. \times \sum_{j < N-1} \phi_{\chi^\varepsilon} \left(\frac{i_1+1}{N}, \frac{j-(i_1-1)}{N} \right) \phi_{\chi^\varepsilon} \left(\frac{i_2+1}{N}, \frac{j-(i_2-1)}{N} \right) \right] \\ &\quad + \frac{C}{N^2} \sum_{i < N-1} \bar{\eta}_i \bar{\sigma}_i^2 \sigma'(\bar{\rho}_i) q_i^2 \sum_{j < N-1} \phi_{\chi^\varepsilon} \left(\frac{i}{N}, \frac{j-(i-1)}{N} \right)^2, \end{aligned}$$

where the last line corresponds to the error terms coming from the diagonal.

Consider finally \mathcal{N}_3 , defined in (D.9). Using $|e^x - 1 - x| \leq C(\|g_h\|_\infty)x^2$ for $x \leq \|g_h\|_\infty$ and bounding $\omega_j - \omega_{j+1}$ by $C(\bar{\rho}) > 0$ for each $j < N-1$, we may write, for each $\eta \in \Omega_N$:

$$\mathcal{N}_3(\eta) \leq -\frac{\lambda}{N} \sum_{j < N-1} [\omega_{j+1} - \omega_j](\eta_{j+1} - \eta_j) C_j^{g_h} u_j + \frac{\lambda C(\bar{\rho})C(g_h)}{N^2} \sum_{j < N-1} |u_j (C_j^{g_h})^2|. \quad (\text{D.11})$$

Bounding C^2 by $2B^2 + 2D^2$ (defined in (3.31)) with D bounded by $O(N^{-1})$, the last term in (D.11) satisfies:

$$\frac{\lambda C(\bar{\rho})C(g_h)}{N^2} \sum_{j < N-1} |u_j (C_j^{g_h})^2| \leq \frac{\lambda C(\bar{\rho})C(g_h)}{N^2} \sum_{j < N-1} |u_j (B_j^{g_h})^2| + \frac{\lambda C'(\bar{\rho}, g_h)}{N^2}.$$

The term involving B above is an average over $j < N-1$ of terms of the form $N^{-3}|X^{v_3^j}|_{3, \{0\}}$ with the notation of Corollary A.9, for tensors v_3^j satisfying $\sup_{N,j} \sup_{\Lambda_N^3} |v_3^j| < \infty$. It is therefore controllable with size $N^{-3/2}$. Proceeding as in the proof of Lemma 4.6 (see between (4.65) and (4.67))

to estimate the first sum in (D.11), we conclude that there is a function $Y_\varepsilon^{(3)}$ and a controllable error term $\theta^{N,3}$ with size $N^{-1/2}$ such that, for each $\eta \in \Omega_N$:

$$\mathcal{N}_3(\eta) \leq \Pi^N(Y_\varepsilon^{(3)}) - \frac{1}{N^2} \sum_{j < N-1} \sum_{i \notin \{j, j+1\}} \bar{\sigma}_i^2 q_i \partial_1^N(g_h)_{j,i} \phi_{\chi^\varepsilon} \left(\frac{i+1}{N}, \frac{j-(i+1)}{N} \right) + \theta^{N,3}(\eta).$$

By (D.5), the middle term is bounded by $KC(h)\|q\|_\infty \varepsilon$ for some $C(h) = C(g_h) > 0$. The function $Y_\varepsilon^{(3)}$ is defined as:

$$\forall (x, y) \in \square, \quad Y_\varepsilon^{(3)}(x, y) = -4 \int_{(-1,1)} \partial_1 g_h(z, y) \phi_{\chi^\varepsilon}(x, z-x) q(x) \frac{\bar{\sigma}(x)}{\bar{\sigma}(y)} dz. \quad (\text{D.12})$$

To summarise, we have established the following. Take $\delta = 1/6$, recall that $\mathcal{D}_{1/6, \lambda}$ is given in (D.8), recall the definition (D.10)-(D.12) of $Y_\varepsilon^{(1)}, Y_\varepsilon^{(2)}$ and define:

$$\lambda Z_{\lambda, \varepsilon} := \frac{\lambda^2}{6} Y_\varepsilon^{(1)} + \lambda Y_\varepsilon^{(3)}, \quad (\text{D.13})$$

and:

$$\lambda \mathcal{E}_\lambda := \Pi^N(\lambda Z_{\lambda, \varepsilon}) + \mathcal{D}_{1/6, \lambda} + \frac{\mathcal{E}}{2} + \lambda[\theta^{N,0} + \tilde{\theta}^{N,0}] + \frac{\lambda^2}{6} \theta^{N,1} + \lambda \sum_{p=2}^3 \theta^{N,p},$$

where \mathcal{E} is the random variable of Lemma 3.3. There is then $c(h) > 0$ such that, by Feynman-Kac inequality, for each $\lambda > 0$:

$$\limsup_{N \rightarrow \infty} \mathbb{P}_h^{\nu_h^N} \left(\frac{1}{T} \int_0^T \left[[W_q - \Pi^N(\mathcal{N}_\varepsilon^q) - \mathcal{E}_\lambda](\eta_t) - c(h)K(\lambda+1)\varepsilon \right] dt > \theta \right) \leq e^{-\lambda \theta T}. \quad (\text{D.14})$$

As $\mathcal{D}_{1/6, \lambda}, \mathcal{E}, \tilde{\theta}^{N,0}, \theta^{N,i}$ are error terms for $i \in \{0, \dots, 3\}$, thus have time average vanishing with N according to Proposition C.2, we have proven:

$$\begin{aligned} \limsup_{N \rightarrow \infty} \mathbb{P}_h^{\nu_h^N} \left(\frac{1}{T} \int_0^T [W_q - \Pi^N(\mathcal{N}_\varepsilon^q)](\eta_t) > \theta \right) &\leq e^{-\lambda \theta T/2} \\ &+ \limsup_{N \rightarrow \infty} \mathbb{P}_h^{\nu_h^N} \left(\frac{1}{T} \int_0^T Z_{\lambda, \varepsilon}(\eta_t) dt + c(h, q)K(\lambda+1)\varepsilon > \theta/2 \right). \end{aligned} \quad (\text{D.15})$$

Taking $\lambda = \varepsilon^{-1/2}$, we see that it remains to evaluate the probability in the right-hand side. We do so through Lemma 4.4. Assume that ε is smaller than some $\varepsilon(\theta, h, q) \in (0, 1)$, chosen such that:

$$\forall \varepsilon < \varepsilon(\theta, h, q), \quad c(h, q)K(\varepsilon^{-1/2} + 1)\varepsilon < \theta/4.$$

Then, for any $\varepsilon < \varepsilon(\theta, h, q)$:

$$\begin{aligned} \limsup_{N \rightarrow \infty} \mathbb{P}_h^{\nu_h^N} \left(\frac{1}{T} \int_0^T Z_{\varepsilon^{-1/2}, \varepsilon}(\eta_t) dt + c(h, q)K(\varepsilon^{-1/2} + 1)\varepsilon > \theta/2 \right) \\ \leq \limsup_{N \rightarrow \infty} \mathbb{P}_h^{\nu_h^N} \left(\frac{1}{T} \int_0^T Z_{\varepsilon^{-1/2}, \varepsilon}(\eta_t) dt > \theta/4 \right). \end{aligned}$$

The function $Z_{\varepsilon^{-1/2}, \varepsilon}$, defined in (D.13), is in $C^2(\bar{\triangleright}) \cap C^2(\bar{\triangleleft})$, and $\lim_{x \rightarrow \pm 1} q(x) = 0$, $\partial_1 g(\cdot, \pm 1) = 0$ implies that $Z_{\varepsilon^{-1/2}, \varepsilon}$ vanishes on $\partial \square$. Moreover, from (D.10)-(D.12) and (D.5), we find:

$$\|Z_{\varepsilon^{-1/2}, \varepsilon}\|_2 \leq C(h, q)\varepsilon^{1/2}.$$

Proposition 4.4 thus applies and gives the existence of $c, c' > 0$ such that, for each $\varepsilon < \varepsilon(\theta, h, q)$:

$$\limsup_{N \rightarrow \infty} \mathbb{P}_h^{\nu_{gh}^N} \left(\frac{1}{T} \int_0^T Z_{\varepsilon^{-1/2}, \varepsilon}(\eta_t) dt > \theta/4 \right) \leq c \exp \left[- \frac{c'\theta T}{4\|Z_{\varepsilon^{-1/2}, \varepsilon}\|_2} \right] \leq c \left[- \frac{c'\theta T}{4C(h, q)\varepsilon^{1/2}} \right]. \quad (\text{D.16})$$

Putting (D.15) and (D.16) together concludes the proof of Proposition D.1. \square

E Sobolev spaces

Definition E.1. Let $U \subset \mathbb{R}^2$ be a bounded open set with Lipschitz boundary. For $n \in \mathbb{N}$ and $p \geq 1$, let $\mathbb{W}^{n,p}(U)$ be the following space. If $n = 0$, it is simply $\mathbb{L}^p(U)$. If $n \geq 1$, $\mathbb{W}^{n,p}(U)$ is the set of functions $f \in \mathbb{L}^p(U)$ such that, for any $(n_1, n_2) \in \mathbb{N}^2$ with $n_1 + n_2 \leq n$, there is $f^{n_1, n_2} \in \mathbb{L}^p(U)$ satisfying:

$$\forall u \in C_c^\infty(U), \quad \int_U f(x, y) \partial_1^{n_1} \partial_2^{n_2} u(x, y) dx dy = (-1)^{n_1+n_2} \int_U f^{n_1, n_2}(x, y) u(x, y) dx dy.$$

$\mathbb{W}^{n,p}(U)$ is a separable Banach space for the norm:

$$\forall f \in \mathbb{W}^{n,p}(U), \quad \|f\|_{\mathbb{W}^{n,p}(U)} = \left[\sum_{\substack{(n_1, n_2) \in \mathbb{N}^2 \\ n_1 + n_2 \leq n}} \|f^{n_1, n_2}\|_{\mathbb{L}^p(U)}^2 \right]^{1/2}.$$

Moreover, the set $C^\infty(\bar{U})$ of restrictions of elements of $C^\infty(\mathbb{R}^2)$ to \bar{U} is dense in $\mathbb{W}^{n,p}(U)$ for $\|\cdot\|_{\mathbb{W}^{n,p}(U)}$. In the special case $p = 2$, define $\mathbb{H}^n(U) := \mathbb{W}^{n,2}(U)$. This is a Hilbert space.

Along the text, we make use of the following Sobolev embedding results (see Theorem 4.12 in [AF03] and Theorem 1.4.4.1 in [Gri11]).

Proposition E.2. Let $U \subset \mathbb{R}^2$ be a bounded set with Lipschitz boundary. The following embeddings hold.

- Let $p > 2$ and $n \in \mathbb{N}^*$, then $\mathbb{W}^{n,p}(U) \subset C^n(\bar{U})$.
- Let $p \geq 2$ and $n \in \mathbb{N}^*$, then $\mathbb{W}^{n,p}(U) \subset \mathbb{W}^{\ell, q}(U)$ for any $\ell \leq n - 1$ and any $q \geq 1$.

In our case, $U = \square = \triangleleft \cup \triangleright$, where we recall that $\square = (-1, 1)^2$, $\triangleleft = \square \setminus D$ and $\triangleright = \{(x, y) \in \square : x < y\} = \square \setminus \{\triangleleft\}$. We are interested in the subset \mathcal{T}'_s , defined in (2.16), of the topological dual \mathcal{T}' of \mathcal{T} .

Definition E.3. If $(X, \|\cdot\|_X)$ is a Banach space, let X' be its topological dual, equipped with the norm:

$$\forall \phi \in X', \quad N_X(\phi) = \sup_{x \in X \setminus \{0\}} \frac{|\phi(x)|}{\|x\|_X}. \quad (\text{E.1})$$

If $f : \square \rightarrow \mathbb{R}$, let $f_s(x, y) = [f(x, y) + f(y, x)]/2$ denote its symmetric part, and let $\mathcal{T}' \subset \mathcal{T}$ be the subset of elements Π satisfying $\Pi(f) = \Pi(f_s)$ for any $f \in \mathcal{T}$. Then:

$$\forall \Pi \in \mathcal{T}', \quad \mathcal{N}_{\mathcal{T}}(\Pi) := \sup_{f \in \mathcal{T} \setminus \{0\}} \frac{|\Pi(f)|}{\|f\|_{\mathbb{H}^2(\square)}} = \sup_{f \in \mathcal{T} \setminus \{0\}} \frac{|\Pi(f_s)|}{\|f_s\|_{\mathbb{H}^2(\square)}} = \sup_{f \in \mathcal{T} \setminus \{0\}} \frac{|\Pi(f_{|\triangleright})|}{\|f_{|\triangleright}\|_{\mathbb{H}^2(\triangleright)}}, \quad (\text{E.2})$$

where $f_{|\triangleright}$ is the restriction of f to \triangleright . \mathcal{T}' is closed for the norm (E.2).

The weak* topology on \mathcal{T}' is the topology of simple convergence: a sequence $(\Pi_n) \in (\mathcal{T}')^{\mathbb{N}}$ weak* converges to $\Pi \in \mathcal{T}'$ if and only if:

$$\forall f \in \mathcal{T}, \quad \lim_{n \rightarrow \infty} \Pi_n(f) = \Pi(f) \quad \Leftrightarrow \quad \forall f \in \mathcal{T}_{\triangleright}, \quad \lim_{n \rightarrow \infty} \Pi_n(f_{|\triangleright}) = \Pi(f_{|\triangleright})$$

The set \mathcal{T}' is also closed for the weak* topology. We write $(\mathcal{T}'_s, *)$ when explicitly referring to this topology.

F Poisson equations

In this section, we give conditions for the existence and uniqueness of solutions of the various Poisson equations - among which the main equation (2.31) - encountered along the text. We rewrite them all in a common framework, for which we need to introduce some notations.

Recall that $\square := (-1, 1)^2$, $\square \setminus D$ and $\triangleright = \{(x, y) \in \square : x < y\}$, $\triangleleft = \square \setminus \triangleright$. The Poisson equations encountered in the text are formulated as equations on \square involving symmetric functions. To solve them, it is therefore enough to look at the equation in a single triangle, say \triangleright . For $u, v : \mathbb{H}^1(\triangleright) \rightarrow \mathbb{R}$, define a function $I_{\triangleright}(u, v)$ as follows:

$$\begin{aligned} \forall (x, y) \in \triangleright, \quad I_{\triangleright}(u, v)(x, y) &= \int_{-1}^x \partial_1 \phi(z, x) \bar{\sigma}(z) \partial_1 \psi(z, y) dz + \int_x^y \partial_2 \phi(x, z) \bar{\sigma}(z) \partial_1 \psi(z, y) dz \\ &+ \int_y^1 \partial_2 \phi(x, z) \bar{\sigma}(z) \partial_2 \psi(y, z) dz. \end{aligned} \quad (\text{F.1})$$

Finally, let ν_{\triangleright} denote the outwards normal from \triangleright to the diagonal. Given symmetric $\phi, \psi : \square \rightarrow \mathbb{R}$ and $a \in \{0, 1, 2\}$, $\eta_1 \in \{0, 1\}$, $\eta_2 \in \{0, 1, 2\}$, we say that $f : \square \rightarrow \mathbb{R}$ solves the Poisson problem $(P) = (P_{\phi, \psi, a, \eta_1, \eta_2})$ if f is symmetric, and $f_{|\triangleright}$ is a classical solution of (P_{\triangleright}) , where:

$$(P_{\triangleright}) : \begin{cases} \Delta f(x, y) + \frac{a\bar{\sigma}'(x)}{\bar{\sigma}(x)} \partial_1 f(x, y) + \frac{a\bar{\sigma}'(y)}{\bar{\sigma}(y)} \partial_2 f(x, y) + \eta_2 I_{\triangleright}(f, f) \\ \quad + \eta_1 I_{\triangleright}(f, \psi) + \eta_1 I_{\triangleright}(\psi, f) = \phi(x, y) \quad \text{for } (x, y) \in \triangleright, \\ \partial_{\nu_{\triangleright}} f = 0 \quad \text{on } D, \\ f = 0 \quad \text{on } (\partial \triangleright) \setminus D. \end{cases} \quad (\text{F.2})$$

Remark F.1. • When u, v are defined on \square and symmetric, $I_{\triangleright}(u, v)$ is simply:

$$\forall (x, y) \in \triangleright, \quad I_{\triangleright}(u, v)(x, y) = \int_{(-1, 1)} \partial_1 \phi(z, x) \bar{\sigma}(\rho_z) \partial_1 \psi(z, y) dz = I(\partial_1 \phi, \partial_1 \psi)(x, y),$$

with $I(u, v) = \int_{(-1, 1)} u(z, x) \bar{\sigma}(z) v(z, y) dz$.

- If $a = 0$, $\psi = h \in \mathcal{S}(\varepsilon_B)$, $\eta_1, \eta_2 \in \{0, 1\}$ and $\phi \in C_{c,s}^2(\square)$ has norm 1, then (P) corresponds to the Poisson problems encountered in the proof of large deviations, in (4.44) and (5.8) respectively.

If $a \in \{1, 2\}$, (P) is a rewriting of the main equation (2.31) with unknown $f = g - g_0 - h$, where g_0 is the inverse correlation kernel of the steady state of the open SSEP in the large N limit. If $h \in \mathcal{S}(\varepsilon_B)$ is known and one seeks to find a solution $g \in g_0 + \mathcal{S}(\varepsilon_G)$, then this amounts to solving (P_{\triangleright}) with $\eta_1 = 1$, $\eta_2 = 2$, $a = 2$, $\psi = h + 2g_0$ and:

$$\begin{aligned} \forall(x, y) \in \triangleright, \quad \phi(x, y) = & -I_{\triangleright}(g_0, h)(x, y) - I_{\triangleright}(h, g_0)(x, y) - \frac{\bar{\sigma}'(x)}{\bar{\sigma}(x)} \partial_1 h(x, y) \\ & - \frac{\bar{\sigma}'(y)}{\bar{\sigma}(y)} \partial_2 h(x, y). \end{aligned} \quad (\text{F.3})$$

If instead $g \in g_0 + \mathcal{S}(\varepsilon_G)$ is known and one seeks $h \in \mathcal{S}(\varepsilon_B)$, then $\eta_1 = 1$, $\eta_2 = 0$, $a = 1$, $\psi = g$ and:

$$\begin{aligned} \forall(x, y) \in \triangleright, \quad \phi(x, y) = & -I_{\triangleright}(g_0, g - g_0)(x, y) - I_{\triangleright}(g - g_0, g_0)(x, y) \\ & - \frac{\bar{\sigma}'(x)}{\bar{\sigma}(x)} \partial_1 (g - g_0)(x, y) - \frac{\bar{\sigma}'(y)}{\bar{\sigma}(y)} \partial_2 (g - g_0)(x, y). \end{aligned} \quad (\text{F.4})$$

■

In the remainder of the section, we study existence, uniqueness and regularity of solutions of (P) . For $\star \in \{\triangleright, \triangleleft\}$, we write $\langle \cdot, \cdot \rangle_{\star}$ for the usual scalar product on $\mathbb{L}^2(\star)$, and simply $\langle \cdot, \cdot \rangle$ as before for the scalar product on $\mathbb{L}^2(\square) = \mathbb{L}^2(\square)$. The norm on $\mathbb{L}^2(\square)$ is denoted by $\|\cdot\|_2$. Let also tr denote the trace operator on the boundary of \square . When interested only in a portion Γ of the boundary, we may write tr_{Γ} .

We will use the fact that the Laplacian with 0 Dirichlet boundary condition on $(\partial \triangleright) \setminus D$ and 0 Neumann boundary condition on the diagonal D has a gap $\alpha > \pi^2/4 > 0$, see e.g. Equation 5 in Section 3.3. of [Siu16]. This means that, for any symmetric $f \in \mathcal{T}$ satisfying the boundary conditions of (P_{\triangleright}) , one has:

$$\|f|_{\triangleright}\|_{\triangleright}^2 \leq \alpha^{-1} \|\nabla f|_{\triangleright}\|_{\triangleright}^2 \quad \Rightarrow \quad \|f\|_2^2 \leq \alpha^{-1} \|\nabla f\|_2^2. \quad (\text{F.5})$$

F.1 Existence and uniqueness

We first obtain existence and uniqueness of solutions of (P) in the set $\mathcal{T}_{(P)} \subset \mathcal{T}$ of functions satisfying the boundary conditions of (P) by a fixed point argument. The set $\mathcal{T}_{(P)}$ and its counterpart $\mathcal{T}_{(P_{\triangleright})}$ for functions on \triangleright are defined as follows:

$$\begin{aligned} \mathcal{T}_{(P)} &= \mathcal{T} \cap \{f : \text{tr}_D(\partial_{\nu_{\triangleright}} f) = 0\}, \\ \mathcal{T}_{(P_{\triangleright})} &= \mathbb{H}^2(\triangleright) \cap \{f : \text{tr}(f) = 0 \text{ on } \partial(\triangleright) \setminus \bar{D}, \text{tr}_D(\partial_{\nu_{\triangleright}} f) = 0\} = \{f|_{\triangleright} : f \in \mathcal{T}_{(P)}\}. \end{aligned} \quad (\text{F.6})$$

Proposition F.2 (Solving (P)). *Let $\phi \in \mathbb{L}^2(\square)$, $\psi \in \mathcal{T}$ be symmetric functions. Let $a \in \{0, 1, 2\}$ and $\eta \in \{0, 1\}$. For $f \in \mathcal{T}_{(P)}$, define Sf as the symmetric function such that, for $(x, y) \in \triangleright$,*

$$\begin{aligned} Sf(x, y) = & -\Delta_{\triangleright}^{-1} \left[-\phi(x, y) + \frac{a\bar{\sigma}'(x)}{\bar{\sigma}(x)} \partial_1 f(x, y) + \frac{a\bar{\sigma}'(y)}{\bar{\sigma}(y)} \partial_2 f(x, y) + \eta_2 I_{\triangleright}(f, f) \right. \\ & \left. + \eta_1 I_{\triangleright}(f, \psi) + \eta_1 I_{\triangleright}(\psi, f) \right]. \end{aligned} \quad (\text{F.7})$$

Above, $\Delta_{\triangleright}^{-1}$ is the inverse of the Laplacian on \triangleright with 0 Dirichlet condition on $(\partial\triangleright) \setminus D$, and 0 Neumann conditions on the diagonal D .

Then $Sf \in \mathcal{T}_{(P)}$. Moreover, if $a = 0$ and $\|\nabla\psi\|_2 \leq 1$, $\|\phi\|_2 \leq 1$, then S has a unique fixed point $f_{\phi,\psi} \in \mathcal{T}_{(P)}$ with $\|f_{\phi,\psi}\|_{\mathbb{H}^1(\square)} \leq \sqrt{2}$ and $\|f_{\phi,\psi}\|_{\infty} \leq C$, for a numerical constant $C > 0$.

If $a \in \{1, 2\}$, there are $\varepsilon_a, \varepsilon'_a > 0$ such that, whenever $(\rho_-, \rho_+) \in (1/2 - \varepsilon_a, 1/2 + \varepsilon_a)$ and $\|\phi\|_2, \|\nabla\psi\|_2 \leq \varepsilon'_a$, there is $\delta(\varepsilon_a) > 0$ such that S has a unique fixed point $f_{\phi,\psi} \in \mathcal{T}_{(P)}$, with $\|f_{\phi,\psi}\|_{\mathbb{H}^1(\square)} \leq \delta_a(\varepsilon_a, \varepsilon'_a)$ and $\lim_{(x,y) \downarrow 0} \delta(x, y) = 0$.

Proof. We prove that S is a contraction on $\mathcal{T}_{(P)}$ for the norm $\|\nabla \cdot\|_2$. Let us start by showing that S is well defined. The inverse operator $\Delta_{\triangleright}^{-1}$ exists by Lemma 4.4.3.1 in [Gri11] and, by Theorem 4.4.3.7 in [Gri11], maps $\mathbb{L}^2(\triangleright)$ onto $\mathcal{T}_{(P_{\triangleright})}$. It follows that $S(\mathcal{T}_{(P)}) \subset \mathcal{T}_{(P)}$.

We now prove that S is a contraction. For $f \in \mathcal{T}_{(P)}$, one has:

$$\|\nabla Sf\|_2^2 = \langle (\nabla Sf)_{|\triangleright}, (\nabla Sf)_{|\triangleright} \rangle_{\triangleright} + \langle (\nabla Sf)_{|\triangleleft}, (\nabla Sf)_{|\triangleleft} \rangle_{\triangleleft} \quad (\text{F.8})$$

$$= -\langle (Sf)_{|\triangleright}, (\Delta Sf)_{|\triangleright} \rangle_{\triangleright} - \langle (Sf)_{|\triangleleft}, (\Delta Sf)_{|\triangleleft} \rangle_{\triangleleft} = -\langle Sf, \Delta f \rangle \quad (\text{F.9})$$

The integration by parts is legitimate by Theorem 1.5.3.1 in [Gri11]. Let us compute the right-hand side. For $f \in \mathcal{T}_{(P)}$, write $\bar{\sigma}'$ for $\rho'\sigma'(\bar{\rho})$. By convention, if $q : (-1, 1) \rightarrow \mathbb{R}$, we write $qf(x, y) := q(x)f(x, y)$, $fq(x, y) := f(x, y)q(y)$ for $(x, y) \in \square$. The symmetry of f, ψ enables one to extend $I_{\triangleright}(f, \psi)$, $I_{\triangleright}(\psi, f)$ and $I_{\triangleright}(f, f)$ to \square with a nicer expression, e.g. for $I_{\triangleright}(f, \psi)$:

$$\begin{aligned} \forall (x, y) \in \square, \quad I_{\triangleright}(f, \psi)(x, y) &= I(\partial_1 f, \partial_1 \psi)(x, y) = \int_{(-1,1)} \partial_1 f(z, x) \bar{\sigma}(z) \partial_1 \psi(z, y) dz \\ &\leq \left(\int_{(-1,1)} \bar{\sigma}(z) \partial_1 f(z, x)^2 dz \right)^{1/2} \left(\int_{(-1,1)} \bar{\sigma}(z) \partial_1 \psi(z, y)^2 dz \right)^{1/2} \end{aligned}$$

As a result, by Cauchy-Schwarz inequality and using $\|\partial_1 f\|_2 = 2^{-1/2} \|\nabla f\|_2$ as implied by the symmetry of f , one has:

$$\left| \langle Sf, I(f, \psi) \rangle \right| \leq \|Sf\|_2 \|\partial_1 f\|_2 \|\bar{\sigma} \partial_1 \psi\|_2 \leq 2^{-1/2} \|Sf\|_2 \|\nabla f\|_2 \|\bar{\sigma} \partial_1 \psi\|_2.$$

Recalling the expression of Sf from (F.7) and using $\bar{\sigma} \leq 1/4$, (F.9) is therefore bounded as follows:

$$\|\nabla Sf\|_2^2 \leq \|Sf\|_2 \left(\|\phi\|_2 + a \|\bar{\sigma}^{-1} \bar{\sigma}' \partial_1 f\|_2 + \frac{\|\nabla f\|_2}{8} \left[\eta_2 \|\nabla f\|_2 + 8\sqrt{2} \eta_1 \|\bar{\sigma} \partial_1 \psi\|_2 \right] \right).$$

Since $Sf \in \mathcal{T}_{(P)}$, the Poincaré inequality F.5 can be applied to Sf and yields:

$$\|\nabla Sf\|_2 \leq \alpha^{-1/2} \left(\|\phi\|_2 + a \|\bar{\sigma}^{-1} \bar{\sigma}' \partial_1 f\|_2 + \frac{\|\nabla f\|_2}{8} \left[\eta_2 \|\nabla f\|_2 + 8\sqrt{2} \eta_1 \|\bar{\sigma} \partial_1 \psi\|_2 \right] \right). \quad (\text{F.10})$$

By similar computations, if $f_1, f_2 \in \mathcal{T}_{(P)}$, one obtains:

$$\begin{aligned} \|\nabla(Sf_1 - Sf_2)\|_2 &\leq \alpha^{-1/2} \left(a \|\bar{\sigma}^{-1} \bar{\sigma}' \partial_1(f_1 - f_2)\|_2 \right. \\ &\quad \left. + \frac{\|\nabla(f_1 - f_2)\|_2}{8} \left[\eta_2 \|\nabla f_1\|_2 + \eta_2 \|\nabla f_2\|_2 + 8\sqrt{2} \eta_1 \|\bar{\sigma} \partial_1 \psi\|_2 \right] \right). \quad (\text{F.11}) \end{aligned}$$

To prove that S is a contraction, due to the quadratic term in (F.10), we first look for $c > 0$ such that the ball $B(0, c) = \{u \in \mathbb{H}^1(\square) : \text{tr}(u) = 0 \text{ on } \partial\square, \|\nabla u\|_2 \leq c\}$ is stable under S . Let us separately treat the different values of a, η_1, η_2 .

Consider first $a = 0$ and $\eta_1, \eta_2 \in \{0, 1\}$. Bounding $\bar{\sigma}$ by $1/4$ in $\|\bar{\sigma}\partial_1\psi\|_2$ turns (F.10) into:

$$\|\nabla Sf\|_2 \leq \alpha^{-1/2} \left(\|\phi\|_2 + \frac{\|\nabla f\|_2}{8} [\|\nabla f\|_2 + 2\|\nabla\psi\|_2] \right).$$

Recall that $\alpha > \pi^2/4$. Taking $\|\phi\|_2 \leq 1$, we see that e.g. $B(0, 1)$ is stable under S as soon as $\|\nabla\psi\|_2 \leq 2\pi - 9/2$, in particular $2\pi - 9/2 \geq 1$. This value of $\|\nabla\psi\|_2$ also ensures that S is a contraction, as (F.11) becomes, since $\sqrt{2}\|\bar{\sigma}\partial_1\psi\|_2 \leq 4\|\nabla\psi\|_2$:

$$\|\nabla(Sf_1 - Sf_2)\|_2 \leq \left(1 - \frac{7}{4\pi}\right) \|\nabla(f_1 - f_2)\|_2 \leq \frac{1}{2} \|\nabla(f_1 - f_2)\|_2.$$

There is thus a unique fixed point $f_{\phi, \psi} \in \mathcal{T}_{(P)} \cap B(0, c)$ with $c = 1$. Poincaré inequality (F.5) yields $\|f_{\phi, \psi}\|_{\mathbb{H}^1(\square)} \leq (1 + 4/\pi^2)^{1/2} \leq \sqrt{2}$, and Theorem 4.3.1.4 in [Gri11] yields $\|f_{\phi, \psi}\|_{\mathbb{H}^2(\square)} \leq C$ for some universal $C > 0$. The Sobolev embedding $\mathbb{H}^2(\square) \subset C^0(\bar{\square}) \cap C^0(\bar{\square})$ implies $\|f_{\phi, \psi}\|_\infty \leq C'$ for a universal $C' > 0$ as claimed.

Consider now the case $a \in \{1, 2\}$. Letting $A := 2^{-1/2} \sup_x |\bar{\sigma}'(x)/\bar{\sigma}(x)|$, (F.9) becomes:

$$\|\nabla Sf\|_2 \leq \alpha^{-1/2} \left(\|\phi\|_2 + (aA + \sqrt{2}\|\bar{\sigma}\partial_1\psi\|_2)c + \frac{c^2}{4} \right).$$

$B(0, c)$ is stable under S as soon as:

$$\frac{c^2}{4} + c \left(aA - \alpha^{1/2} + \sqrt{2}\|\bar{\sigma}\partial_1\psi\|_2 \right) + \|\phi\|_2 \leq 0. \quad (\text{F.12})$$

There are $\varepsilon_a, \varepsilon'_a > 0$ such that, for any $\varepsilon \in (0, \varepsilon_a]$, $\varepsilon' \in (0, \varepsilon'_a]$, whenever $(\rho_-, \rho_+) \in (1/2 - \varepsilon, 1/2 + \varepsilon)$ and $\|\phi\|_2, \|\bar{\sigma}\partial_1\psi\|_2 \leq \varepsilon'_a$, the above polynomial has at least one real root $c_a(\varepsilon, \varepsilon') > 0$. This ensures that $B(0, c_a(\varepsilon, \varepsilon'))$ is stable under S . Using (F.12), (F.11) then becomes:

$$\|\nabla(Sf_1 - Sf_2)\|_2 \leq \alpha^{-1/2} \left[\frac{c_a(\varepsilon, \varepsilon')^2}{4} + c_a(\varepsilon, \varepsilon')\alpha^{1/2} - \|\phi\|_2 \right] \|\nabla(f_1 - f_2)\|_2.$$

Choosing $\varepsilon = \varepsilon_a, \varepsilon' = \varepsilon'_a$ small enough ensures that S is a contraction, thus has a unique fixed point $f_{\phi, \psi} \in \mathcal{T}_{(P)} \cap B(0, c_a(\varepsilon_a, \varepsilon'_a))$. By Poincaré inequality (F.5), $\|f_{\phi, \psi}\|_{\mathbb{H}^1(\square)} \leq c_a(\varepsilon_a, \varepsilon'_a)(1 + \alpha^{-1/2}) =: \delta_a(\varepsilon_a, \varepsilon'_a)$, with $\lim_{\mathbb{R}^2 \ni x \downarrow 0} \delta_a(x) = 0$. This concludes the proof. \square

To define the quantities $\varepsilon_B, \varepsilon_G$ arising in Assumption 2.1 and Theorem 2.5. For $h \in \mathcal{S}(\alpha)$ for some $\alpha > 0$, let $\phi = \phi(h, \rho_+, \rho_-), \psi = \psi(h, \rho_+, \rho_-)$ be given in and above (F.3). Then:

$$\|\phi\|_2, \|\nabla\psi\|_2 \leq \omega(\rho_+, \rho_-) + C(\rho_\pm)\|\nabla h\|_2, \quad (\text{F.13})$$

for a constant $C(\rho_\pm) > 0$, and a positive continuous function ω which vanishes when $|\rho_+ - 1/2|, |\rho_- - 1/2|$ are small. With the notations of the proof of Proposition F.2, the solution g_h of the main equation is then given by:

$$g_h = f_{\phi, \psi} + g_0 + h \quad \Rightarrow \quad \|\nabla(g_h - g_0)\|_2 \leq c_2(\varepsilon_2, \varepsilon'_2) + \|\nabla h\|_2, \quad (\text{F.14})$$

and we can now define the $\varepsilon_B, \varepsilon_G$ arising in Assumption 2.1 and Theorem 2.5.

Definition F.3. Consider the $a = 2$ case, corresponding to the main equation (2.31) with data $h \in \mathcal{S}(\varepsilon_B)$ for some $\varepsilon_B > 0$ to be chosen below, the corresponding ϕ, ψ being given in and above (F.3). Recall that $h \in \mathcal{S}(\varepsilon_B)$ implies $\|h\|_2, \|\nabla h\|_2 \leq \varepsilon_B$. For any $\varepsilon_2 > 0$ such that $\rho_+, \rho_- \in [1/2 - \varepsilon_2, 1/2 + \varepsilon_2]$, choose $\varepsilon_B \in (0, 1/2)$ such that:

- The contraction S has a fixed point $f_{\phi, \psi}$.
- $\alpha^{-1/2}(c_2(\varepsilon_2, \varepsilon'_2) + \varepsilon_B) + \varepsilon_B < 1/2$, $\varepsilon'_2 := \omega(\rho_+, \rho_-) + C(\rho_{\pm})\varepsilon_B$.

Such an ε_B exists for small enough ε_2 by the proof of Proposition F.2 and (F.13). To define ε_G , recall that $\alpha > \pi^2/4$ is the spectral gap of $-\Delta$ on the triangle \triangleright , and define:

$$\varepsilon_G := \alpha^{-1/2}(c_2(\varepsilon_2, \varepsilon'_2) + \varepsilon_B) + \varepsilon_B < 1/2.$$

The definition is meant to ensure the following: by (F.14), Poincaré inequality and the fact that the fixed point $f_{\phi, \psi} = g_h - g_0 - h$ in the $a = 2$ case lies in $B(0, \varepsilon_G)$,

$$\|\nabla(g_h - g_0)\|_2 \leq c_2(\varepsilon_2, \varepsilon'_2) + \varepsilon_B \leq \varepsilon_G,$$

and:

$$\begin{aligned} \|g_h - g_0\|_2 &\leq \|h\|_2 + \|g_h - g_0 - h\|_2 \leq \varepsilon_B + \alpha^{-1/2}(c_2(\varepsilon_2, \varepsilon'_2) + \|\nabla h\|_2) \\ &\leq \alpha^{-1/2}(c_2(\varepsilon_2, \varepsilon'_2) + \varepsilon_B) + \varepsilon_B = \varepsilon_G. \end{aligned}$$

F.2 Regularity estimates

In Proposition F.2, the solution of (P) has been shown to be in a certain \mathbb{H}^2 space. In this section, we use results of [Gri11] to argue that the solution of (P) is more regular if the data ϕ, ψ are regular. The study of regularity is made very complicated by the presence of corners.

Proposition F.4 (Theorem 5.1.3.1. in [Gri11]). *Let $b \in \mathbb{N}$ and let $q \in \mathbb{W}^{b,p}(\triangleright)$. Let S_1, S_2, S_3 denote the corners of \triangleright numbered in a counter-clockwise fashion, with S_1 the upper left corner. Consider on \triangleright the problem $\Delta f = q$, with the boundary conditions of (P_{\triangleright}) . If $b = 0$, then $f \in \mathbb{W}^{2,p}(\triangleright)$. If $b \leq 3$, $f \in \mathbb{W}^{b+2,p}(\triangleright)$ provided q vanishes at the corners, i.e. provided:*

$$\forall j \in \{1, 2, 3\}, \quad q(S_j) = 0. \tag{F.15}$$

Remark F.5. Though the statement of Proposition F.4 makes no mention of them, we recall notations from [Gri11] so that the reader may check that Theorem 5.1.3.1 applies to our case. Label by $j \in \{1, \dots, 3\}$ the line segments composing $\partial\triangleright$ in a counter clockwise fashion, with the convention that $j = 1$ for the $y = -1$ segment. S_j is then the point joining segments $j, j + 1$ in $\partial\triangleright$. Let ω_j be the counter-clockwise measure of the inwards angle at S_j :

$$\omega_j = \begin{cases} \pi/2 & \text{if } j = 1, \\ \pi/4 & \text{if } j \in \{2, 3\}. \end{cases}$$

Let $\nu_j = \mu_j$ denote the unit outwards normal and τ_j be the (counter clockwise) unit tangent vector on the line segment j . Define also $\Phi_j = \pi/2$ if $j \in \{1, 2\}$, $\Phi_j = 0$ if $j = 3$ and $\Phi_{3+1} := \Phi_1$. Finally, for $m \in \mathbb{Z}$ and each j , define:

$$\lambda_{j,m} = \frac{\Phi_j - \Phi_{j+1} + m\pi}{\omega_j} = \begin{cases} 2m & \text{if } j = 1, \\ 2 + 4m & \text{if } j = 2, \\ -2 + 4m & \text{if } j = 3. \end{cases} \quad (\text{F.16})$$

■

In our context, Proposition F.4 translates to the following result.

Proposition F.6 (Regularity of solutions of (P_Δ)). *Let ϕ, ψ be such that the solution $f_{\phi, \psi}$ given by Proposition F.2 exists.*

1. *Assume $a = 0$, let $\phi \in C^2(\bar{\triangleright}) \cap C^2(\bar{\triangleleft})$ be symmetric, and let $\psi \in \mathcal{S}(\varepsilon_B)$. If $\phi|_{\partial\Box} = 0$, then $f_{\phi, \psi} \in \mathbb{W}^{4,p}(\Box)$ for any $p > 2$.*
2. *If $a = 1$ and $r > 0$ is small enough, let $g \in g_0 + \mathcal{S}(r)$ and define $h := f_{\phi, \psi} - g_0 + g$ with the choice of ϕ, ψ given in and above (F.4). Then $f_{\phi, \psi} \in \mathbb{W}^{4,p}(\Box)$ for any $p > 2$, and $h \in \mathcal{S}(r')$ for some $r' > 0$.*
3. *If $a = 2$ and $h \in \mathcal{S}(\varepsilon_B)$, define $g_h := f_{\phi, \psi} + g_0 + h$, with the ϕ, ψ given in and above (F.3). Then $f_{\phi, \psi} \in \mathbb{W}^{4,p}(\Box)$ for any $p > 2$, and $g_h \in g_0 + \mathcal{S}(\varepsilon_G)$.*

Proof. Since $f_{\phi, \psi}$ is symmetric, we work only on \triangleright . Let us first treat all claims of items 2 and 3 that do not have to do with the regularity of $f_{\phi, \psi}$.

Recall the definition (2.22) of $\mathcal{S}(\varepsilon)$ for $\varepsilon > 0$. E.g. for item 3, the estimates on $\|\nabla f_{\phi, \psi}\|_2$ in Proposition F.2 already prove that, if $h \in \mathcal{S}(\varepsilon_B)$ and ϕ, ψ are chosen as in and above (F.3), then $g_h = f_{\phi, \psi} + g_0 + h$ satisfies $\|g_h - g_0\|_2, \|\nabla(g_h - g_0)\| \leq \varepsilon_G$. Let us check that $g_h - g_0$ satisfies the boundary conditions in $\mathcal{S}(\varepsilon_G)$. By definition, of g_0 and $\mathcal{S}(\varepsilon_B)$, $(g_0)_{\partial\Box} = 0 = h|_{\partial\Box}$. $g_h = f_{\phi, \psi} + g_0 + h$ already gives $(g_h)_{|\partial\Box} = 0$. Moreover, using $\partial_{\nu_\triangleright} f_{\phi, \psi} = 0$ ($\partial_{\nu_\triangleright} f_{\phi, \psi} \in \mathbb{H}^1(\triangleright)$ has a well defined trace on $\partial\triangleright$), one has:

$$\partial_{\nu_\triangleright}(g - g_0)(S_j) = \partial_{\nu_\triangleright}(f_{\phi, \psi} + h)(S_j) = 0.$$

It follows that $g_h \in g_0 + \mathcal{S}(\varepsilon_G)$. Similar statements hold for item 2.

Let us now focus on establishing that $f_{\phi, \psi}$ is regular. For short, write $f = f_{\phi, \psi}$, and q_f for the bracket in the right-hand side of (F.7); so that $\Delta f = q_f$ in \triangleright . Let $p > 2$. The idea is classical: if $f \in \mathbb{W}^{2+n,p}(\Box)$, $n \in \mathbb{N}$, we want to prove that $q_f \in \mathbb{W}^{1+n,p}(\Box)$, from which $f \in \mathbb{W}^{3+n,p}(\Box)$ by Proposition F.4 provided q_f satisfies suitable boundary conditions. To implement this recursion scheme, we first prove that $q_f \in \mathbb{L}^p(\Box)$. By assumption on ϕ, ψ in the $a = 0$ case (using $C^2(\bar{\triangleright}) \subset \mathbb{W}^{2,s}(\triangleright)$ for any $s > 2$), and from (F.3)-(F.4) if $a \in \{1, 2\}$, we see that it is the regularity of f only that limits the regularity of q_f . The fact that $q_f \in \mathbb{L}^p(\Box)$ then follows from the embedding $\mathbb{H}^1(\Box) \subset \mathbb{L}^s(\Box)$, valid for any $s > 2$, see Proposition E.2. It follows that $f \in \mathbb{W}^{2,p}(\Box)$ by Proposition F.4.

To obtain further regularity on f , we need to check that q_f is in $\mathbb{W}^{b-1,p}(\Box)$ whenever $f \in \mathbb{W}^{b,p}(\Box)$ for $b \in \mathbb{N}^*$, and also that q_f satisfies the condition (F.15) in Proposition F.4.

The regularity of q_f boils down to proving that $I_{\triangleright}(u, v)$, defined in (F.1), is in $\mathbb{W}^{b,p}(\triangleright)$, $b \in \mathbb{N}^*$, whenever $u, v \in \mathbb{W}^{b,p}(\triangleright)$. This is the claim of the following lemma.

Lemma F.7. *Let $p \geq 2$ and $1 \leq b \leq 4$. Let $u, v \in \mathbb{W}^{b,p}(\triangleright)$, and recall from (F.1) the definition of I_{\triangleright} . Then $I_{\triangleright}(u, v) \in \mathbb{W}^{b,p}(\triangleright)$.*

Lemma F.7 is easily proven by approximating u, v in $\mathbb{W}^{b,p}(\triangleright)$ by sequences in $C^\infty(\bar{\triangleright})$, and integrating by parts.

It remains to prove that q_f satisfies the condition of Proposition F.4, i.e. that $q_f(S_j) = 0$ for $j \in \{1, 2, 3\}$. By assumption in the $a = 0$ case, and from (F.3)-(F.4) if $a \in \{1, 2\}$, one has $\phi = 0$ on $\partial\Box$. Integrating by parts, $I_{\triangleright}(f, f)$ and $I_{\triangleright}(f, \psi), I_{\triangleright}(\psi, f)$ also vanish on $\partial\Box$. It follows that $q_f(S_j) = 0$ for $j \in \{1, 2, 3\}$, thus $f \in \mathbb{W}^{4,p}(\Box)$. Since $p > 2$ was arbitrary, this concludes the proof. \square

Chapter 4

Ising interfaces and contour dynamics

This chapter contains an article that was first put up on the Arxiv in May 2020. Compared to the online version, some notations have been modified and some mistakes fixed.

Abstract: We study large deviations for a Markov process on curves in \mathbb{Z}^2 mimicking the motion of an interface. Our dynamics can be tuned with a parameter β , which plays the role of an inverse temperature, and coincides at $\beta = \infty$ with the zero-temperature Ising model with Glauber dynamics, where curves correspond to the boundaries of droplets of one phase immersed in a sea of the other one. We prove that contours typically follow a motion by curvature with an influence of the parameter β , and establish large deviations bounds at all large enough $\beta < \infty$. The diffusion coefficient and mobility of the model are identified and correspond to those predicted in the literature.

Contents

1	Introduction	154
2	Model and results	157
2.1	The contour model	157
2.2	Heuristics	164
2.3	Results	167
2.4	Comments on metastability	172
2.5	Structure of the proof of large deviations	173
3	Some relevant martingales	174
3.1	Motivations	174
3.2	Computation of $N^2 \mathcal{L}_{r,\beta,H} \langle \Gamma, G \rangle$	174
4	Large deviation upper-bound and properties of the rate functions	188
4.1	The upper bound	189
4.2	Properties of the rate function	193
5	Lower bound large deviations and hydrodynamic limits	196
5.1	Large deviation lower-bound	196

5.2	The droplet moves on a diffusive scale	198
5.3	Characterisation of limit points	203
6	Behaviour of the poles and $\mathbf{1}_{p_k=2}$ terms	205
6.1	Size of the poles and local equilibrium	205
6.2	Convergence of the $\mathbf{1}_{p=2}$ term at fixed β and slope around the poles . . .	210
A	Replacement lemma and projection of the dynamics	227
A.1	Replacement lemma	227
A.2	Projection of the contour dynamics in the good state space	231
A.3	Equilibrium estimates at the pole	233
B	Topology results	236
B.1	Definition of \mathcal{E}_r and topological properties	236
B.2	The set $E([0, T_0], \mathcal{E}_r(d))$	241
B.3	Proof of the sufficient condition for exponential tightness	245

1 Introduction

A basic paradigm in non-equilibrium statistical mechanics is the following. Consider a system with two coexisting pure phases separated by an interface, and undergoing a first-order phase transition with non-conserved order parameter. Then, macroscopically, the interface should evolve in time to reduce its surface tension, according to a motion by curvature. For microscopic models on a lattice, some trace of the lattice symmetries should remain at the macroscopic scale, and the resulting motion by curvature should be anisotropic. The following general behaviour, known as the Lifshitz law, is expected: if a droplet of linear size $N \gg 1$ of one phase is immersed in a sea of the other phase, then it should disappear in a time of order N^2 . (Anisotropic) motion by curvature should correspond to the limiting dynamics, when N is large, under diffusive rescaling of space and time. Phenomenological arguments in favour of this picture go back to Lifshitz [Lif62], and can be summarised as follows. Consider a model with surface tension $\mathbf{t} = \mathbf{t}(\mathbf{N})$, which depends on the local inwards normal \mathbf{N} to an interface. We work in two dimensions to keep things simple. The surface energy associated with a curve γ separating two phases reads

$$F(\gamma) = \int_{\gamma} \mathbf{t}(\mathbf{N}(s)) ds,$$

where s is the arclength coordinate on γ . The postulate, on phenomenological grounds, is that the local inwards normal speed v to the interface reads

$$v = \mu \frac{\delta F}{\delta \gamma}. \tag{1.1}$$

The quantity $\mu = \mu(\mathbf{N})$ is the mobility of the model, computed by Spohn in [Spo93] using linear response arguments. Let us relate (1.1) and motion by curvature. The change in energy induced

by the motion of a length ds in the normal direction \mathbf{N} is equal to $(\mathbf{t}(\mathbf{N})/R(\mathbf{N}))ds$, with $R(\mathbf{N})$ the radius of curvature at \mathbf{N} . As such,

$$v = \mu tk =: ak, \quad \text{with} \quad a(\mathbf{N}) = \mu(\mathbf{N})\mathbf{t}(\mathbf{N}) \text{ the anisotropy and } k = 1/R \text{ the curvature.} \quad (1.2)$$

A closed curve satisfying (1.2) is said to evolve according to anisotropic motion by curvature. A set with boundary following this equation is known to shrink to a point in finite time for a wide range of anisotropies a , see e.g. [LST14a] and references therein.

Ideally, one would like to start from a microscopic model with short-range interactions, with at least two different phases initially segregated on a macroscopic scale, and derive motion by curvature (1.2) of the boundaries between the phases in the diffusive scaling. To this day however, results on microscopic models are scarce. Let us provide a (non-exhaustive) account of works on the subject.

The paper [Spo93], already cited, is a landmark in the rigorous study of interface motion starting from microscopic models. A major difficulty is to understand how to decouple, from the comparatively slower motion of the interface, the fast relaxation inside the bulk of each phase. Indeed, in a diffusive time scale and at least for models with local interactions, one expects the bulk to behave as if at equilibrium.

In one dimension, motion by curvature has been proven for a number of interacting particle systems. It usually boils down to the heat equation in this case, and the Lifshitz law is related to freezing/melting problems, see [CS96][CK08][CKG12], as well as [Lac14] and the monograph [Car+16].

In two dimensions, a landmark is the proof of anisotropic motion by curvature for the zero temperature Ising model with Glauber dynamics (or zero-temperature stochastic Ising model). The drift at time 0 was computed in [CL07] before the full motion by curvature (1.2) was proven in [LST14b]-[LST14a]. Their proof crucially relies on monotonicity of the Glauber dynamics.

More is known on another type of microscopic models for which some sort of a mean-field mesoscopic description can be achieved. This comprises the so-called Glauber+Kawasaki process [DFL86] (see also [BBP18] for an account of works on the model), which has local evolution rules, and models with long range interactions such as the Ising model with Kac potentials [Com87][De+93][De+94][KS94]. For these models, studied in any dimension, the derivation takes place in two steps: first deriving a mean-field description of the dynamics, then rescaling space-time to derive motion by curvature. As a result, lattice symmetries are blurred and the resulting motion by curvature is isotropic. Note however the recent works [FT19][Ket+20], where a Glauber+Kawasaki dynamics is considered (respectively Glauber+Zero-range), in dimension two and above. In these works, the existence of an interface between regions at high-and low-density is established, and motion by curvature for this interface is obtained directly from the microscopic model, in a suitable scaling of the Glauber part of the dynamics.

A last category of models comprises the so-called effective interface models. By definition, the bulk of each phase is disregarded. One associates an "interfacial" cost to the graph of a given function, seen as an interface between phases. These comprise the so Ginzburg-Landau model in any dimension, see [FS97], and more recently Lozenge-tiling dynamics in dimension three [LT18].

Another related line of investigation concerns large deviations of the interface dynamics around motion by curvature. Assuming Gaussian-like fluctuations around the mean behaviour (1.2), the

rate function describing the cost of observing an abnormal trajectory $\gamma. = (\gamma_t)_{t \leq T}$ should read

$$I(\gamma.) = \int_0^T dt \int_{\gamma_t} \frac{(v - ak)^2}{2\mu} ds, \quad (1.3)$$

with s the arclength coordinate on γ_t . In the assumption of Gaussian fluctuations leading to (1.3), one of the difficulties is that it is not even clear how the noise should be incorporated into the deterministic equations describing the interface motion. Extensive work on this question has been carried out for some of the models listed above in recent years, notably in [BBP17a]-[BBP18] (see also the references there). In [BBP17a], the stochastic Allen-Cahn equation is considered. It is known that, in the diffusive (or sharp interface) limit, solutions to the Allen-Cahn equation satisfy motion by mean curvature in some sense, see [Ilm93] [ESS92] [BSS93]. In [BBP17b], regularity of solutions to the stochastic Allen-Cahn equation depending on how the noise is added are studied, and a large deviation upper-bound in the joint diffusive, small noise and vanishing regularisation limits is established in [BBP17a]. The associated rate function coincides with (1.3) in simple cases, e.g. for a droplet trajectory with smooth boundary. The authors however use tools from geometric measure theory, which enable them to consider very general trajectories that may feature nucleation events.

In [BBP18], upper bound large deviations for both Glauber+Kawasaki process and Ising model with Kac potentials are investigated. They prove that (1.3) is the correct rate function for smooth trajectories and discuss how to extend it to more general paths.

To the best of our knowledge however, no large deviations result for microscopic dynamics with local interactions have yet been published. In particular the question of large deviations for the zero temperature stochastic Ising model is still open.

In this work, we make a contribution in that direction. To do so, we study a microscopic modification of the zero-temperature Ising dynamics in terms of a parameter $\beta > 0$. At each $\beta > 0$, we consider contours evolving according to zero-temperature Ising rules, except for the parameter β , which plays the role of an inverse temperature acting on local portions of the contours. The model at each $\beta > 0$ has reversible dynamics and, contrary to the zero-temperature Ising case, the dynamics is not monotonous. The $\beta = \infty$ case corresponds to the zero-temperature Ising dynamics.

We implement in our framework the large deviation method initiated by Kipnis, Olla and Varadhan in [KOV89] (see also [KL99]). There are substantial difficulties as we are dealing with curves, i.e. one-dimensional objects, evolving in two-dimensional space. One of the advantages of the method is that we no longer rely on monotonicity of the dynamics as in [LST14a]. Monotonicity appears difficult to use for large deviations in any case, as atypical events, such as closeness to some atypical trajectory, are in general not monotonous. At each large enough $\beta > 0$, we prove that the dynamics approaches anisotropic motion by curvature in the large size limit, with a dependence on the parameter β . At the formal level, the $\beta = \infty$ case indeed corresponds to anisotropic motion by curvature in the sense of [LST14b]. We also obtain large deviations for the model. The large deviations results give upper- and lower-bounds, which coincide for smooth trajectories.

As opposed to the zero-temperature stochastic Ising model, an interesting feature of our model at finite β is that its dynamics is reversible. This enables us to connect our results with metastability for the Ising model initially at equilibrium in one phase, forced out of equilibrium with a

small magnetic field of opposite sign [SS98]. We briefly discuss in Section 2.4 the existence of a threshold value of the volume of a droplet, depending on the strength of the magnetic field, below which droplets typically do not grow and above which they typically do. The speed at which the droplet grows is also easily estimated thanks to the large deviation results. The interested reader will find an up to date account of results on metastability in the Ising model in [GMV20], and may refer to the books [OV05]-[BD16].

The rest of this article is structured as follows. In Section 2, we introduce the microscopic model and fix notations. The dynamics is introduced in details, while useful topological facts are collected in Appendix B. The main results of the paper are listed in Section 2.

In Section 3, we investigate some martingales used to obtain large deviations, and show how motion by curvature emerges from the microscopic dynamics. Though computationally intensive, we have tried to use this section to showcase the main differences between dealing with a one-dimensional interface in two dimensions, and a purely one-dimensional system. A number of technical results and sub-exponential estimates are postponed to Section 6 and Appendices A-B. Section 6 is a collection of estimates that are genuinely particular to our model, concerning the dynamical behaviour of the poles, i.e. the sections of the contours on which the parameter β acts. Albeit very technical, the estimates on the poles are essential. We also explain there the connection between our dynamics and suitable one-dimensional exclusion and zero range processes as in [LST14b]. This connection is again used in Appendix A to prove an adaptation of the so-called replacement lemma to our model. An important estimate allowing the restriction of the contour dynamics to a nicer state space is also proven there, as well as some equilibrium estimates around the pole. Appendix B gathers useful topological properties and the proof of exponential tightness.

In Section 4, we obtain upper-bound large deviations for large enough $\beta > 0$. Finally, Section 5 deals with lower-bound large deviations, i.e. with hydrodynamic limits for tilted processes.

2 Model and results

2.1 The contour model

Consider the zero temperature, two-dimensional stochastic Ising model on $(\mathbb{Z}^*)^2$, that we now define, with \mathbb{Z}^* the dual graph of \mathbb{Z} . On configurations, i.e. elements σ of $\{-1, 1\}^{(\mathbb{Z}^*)^2}$, one defines a dynamics as follows: at rate 1, each vertex $x \in (\mathbb{Z}^*)^2$ is updated independently, and $\sigma(x)$ takes the same value as the majority of its neighbours. If it has exactly two neighbours of each sign, then with probability 1/2 it remains unchanged, and with probability 1/2 it is flipped. This dynamics is well defined for all time on any subset of $(\mathbb{Z}^*)^2$, and the so-called graphical construction of the dynamics (see Section 3.3 in [Mar99]) enables one to couple the dynamics starting from any initial configurations and with any boundary conditions. It is also monotonous in the following sense. Write $\sigma \leq \eta$ when $\sigma(x) \leq \eta(x)$ for each $x \in (\mathbb{Z}^*)^2$. Then $\sigma_t \leq \eta_t$ for all $t \geq 0$, with probability 1. The dynamics is however not reversible.

The hydrodynamical behaviour of this dynamics is proven in [LST14b]-[LST14a]. Let us provide an informal description of their results. Start from a configuration with $+$ everywhere except in

an area of linear size N (a "droplet" of $-$ spins), corresponding to the discretisation on $(\mathbb{Z}^*)^2$ of ND_0 , where $D_0 \subset [-1, 1]^2$ is a nice enough domain, say with smooth, simple boundary with a finite number of inflection points. Rescale space by $1/N$ and time by N^2 . Then, in the large N limit, with probability going to one, the rescaled droplet converges uniformly in time and in Hausdorff distance to the unique solution of an anisotropic motion by curvature starting from D_0 . This flow of sets $(D_t)_{t \geq 0}$ is defined as follows. It starts from D_0 and, until a time T_f after which $D_t = \emptyset, t \geq T_f$, the boundaries $(\gamma_t)_{t \geq 0}$ of the D_t satisfy (1.2):

$$\forall u \in \mathbb{T}, \forall t < T_f, \quad \partial_t \gamma(t, u) = a(\theta_t(u)) \partial_s^2 \gamma(t, u) = a(\theta_t(u)) k(t, u) \mathbf{N}_t(u), \quad (2.1)$$

where $u \in \mathbb{T} \mapsto \gamma_t(u)$ is a parametrisation on the torus $\mathbb{T} = [0, 1)$ of each of the $\gamma_t, t < T_f$; k is the curvature, $\theta(u) = \theta_t(u)$ is the angle between the tangent vector at point $\gamma_t(u)$ and $e_1 = (1, 0)$, $\mathbf{N} = \mathbf{N}_t(u)$ is the inwards normal vector at $\gamma_t(u)$. The $\pi/2$ -periodic anisotropy a is a factor reflecting the symmetries of the square lattice:

$$a(\theta) := \frac{1}{2(|\sin(\theta)| + |\cos(\theta)|)^2}, \quad \theta \in [0, 2\pi]. \quad (2.2)$$

Existence and uniqueness of such a flow is part of the results in [LST14b]-[LST14a]. The proof of the hydrodynamic limit relies strongly on monotonicity properties of the dynamics, which allow local comparison of the dynamics with nicer ones.

The contour dynamics

Take a spin configuration σ such that $\sigma_x = +$ for x outside a finite subset Λ^* of $(\mathbb{Z}^*)^2$. The boundaries between $-$ and $+$ spins form closed contours on edges of \mathbb{Z}^2 . In this picture, a spin $x \in \Lambda^*$ is identified with the square $x + [-1/2, 1/2]^2$, which we call a "block", and spin-flips correspond to adding or deleting blocks. At strictly positive temperature $\beta^{-1} > 0$, a contour of length L should occur with probability roughly proportional to $\exp[-\beta L]$. Let ν_β denote the associated probability measure:

$$\nu_\beta(\gamma) \propto e^{-\beta|\gamma|}.$$

At zero temperature however, in a fixed volume with e.g. all $+$ boundary conditions, the only possible configuration contains only $+$ spins.

We consider a model on closed paths on edges of $\Lambda_N = [-N, N]^2 \cap \mathbb{Z}^2$ for $N \in \mathbb{N}^*$. For simplicity, we only allow configurations with a single contour. We want to build a dynamics that is as close as possible to the zero-temperature Ising dynamics, but has ν_β as an invariant measure. One way to do this is to take the dynamical moves allowed in the stochastic Ising model, and add regrowth, β -dependent moves to obtain a reversible dynamics with respect to ν_β . Proximity to the zero-temperature Ising dynamics is ensured by allowing droplet regrowth only at small zones on the droplet (see Figure 4.2). We call this dynamics the contour dynamics. Importantly, and contrary to the stochastic Ising model, the contour dynamics is not monotonous. This is illustrated on Figure 4.3 below.

Additional constraints, e.g. boundary effects, will be placed on the dynamics and on the state space. We also restrict the study to specific droplet shapes for simplicity. We need however more notations to state these conditions. Let us now precisely define the contour model and dynamics; further heuristics can be found in Section 2.2. Take $N \in \mathbb{N}^*$, recall that $\Lambda_N = \mathbb{Z}^2 \cap [-N, N]^2$ and let $E_N = \{(x, y) : x, y \in \Lambda_N, \|x - y\|_1 = 1\}$ be the corresponding set of edges. Define first the

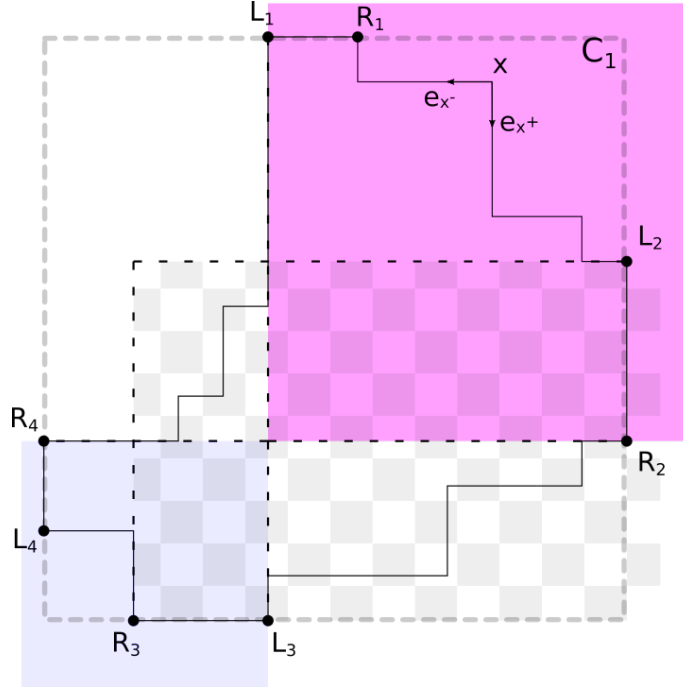

Figure 4.1 – Example of a curve in X_r^N . The thick pale dashed line delimits the rectangle \mathfrak{R} . The quadrants are quarterplanes which depend on the curve. Here (part of) the first three quadrants are represented: C_1 is the dark shaded area, C_2 the checkered area and C_3 the light-shaded one. In this example, C_1 and C_3 have the same origin; this is not true in general. Note that C_1 and C_2 intersect. The vectors e_x^\pm are represented for a vertex x .

state space X_r^N of the dynamics (see Figure 4.1), which depends on an additional parameter $r > 0$, independent of N .

- Elements of X_r^N , denoted by γ , are closed paths on edges in E_N .
- (*Four poles*). Each γ in X_r^N is contained in a unique rectangle of least area, call it \mathfrak{R} , which contains the extremal faces of γ , i.e. edges (x, y) where x, y are vertices of γ with one coordinate that is extremal. We impose that each extremal face of γ be connected. For $k \in \{N, E, S, W\} = \{1, 2, 3, 4\}$, we call P_k the pole number k , corresponding to the vertices of γ on face k of \mathfrak{R} . We also impose that the number $p_k = |P_k| - 1$ of edges with both extremities inside P_k be always greater than 2. Equivalently, p_k is the number of blocks with two corners in P_k .
- (*Monotonicity condition*). Denote by $L_1, R_1, \dots, L_4, R_4 \in \Lambda_N$ the leftmost and rightmost extremities of the poles P_1, \dots, P_4 when γ is travelled on clockwise. We impose that the part of γ between L_1 and R_2 is a south-east path, the part between L_2 and R_3 is a south-west path, the part between L_3 and R_4 is a north-west path and, finally, the part between L_4 and R_4 is a north-east path.
- (*Macroscopic droplet condition*). Further impose that if $\gamma \in X_r^N$, then $y_{\max} - y_{\min} \geq \lceil Nr \rceil$, $x_{\max} - x_{\min} \geq \lceil Nr \rceil$, where y_{\max} is the maximum ordinate of a point in γ , etc.

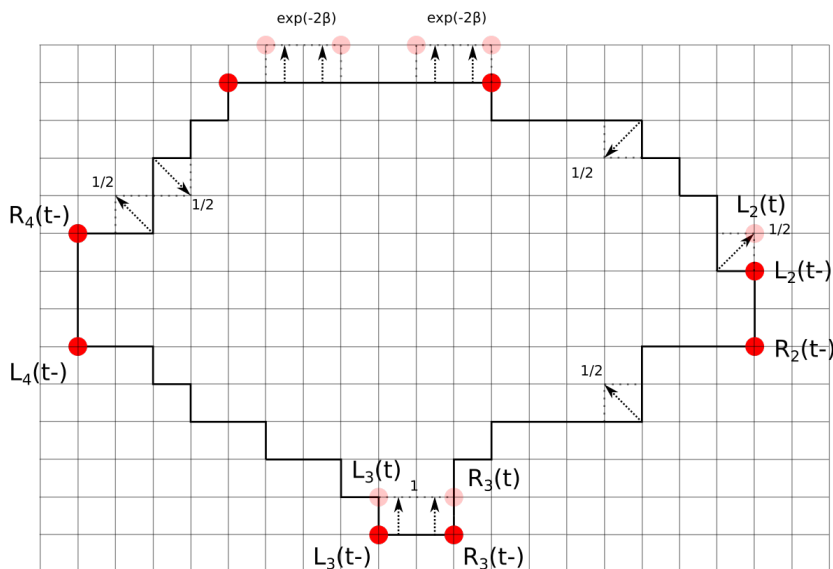

Figure 4.2 – Some moves and associated jump rates for a typical contour configuration. Positions of $L_k, R_k, k \in \{1, \dots, 4\}$, the points that delimit the poles, i.e. the zones where regrowth can occur, are represented at time t_- in dark dots. Possible pole positions after a jump at time t are represented by light dots. L_1, R_1 are omitted for legibility. Dynamical moves amount to adding or deleting squares of side-length 1 (“blocks”). Just before the jump, at t_- , the pole $P_3(t_-)$ had length $p_3 = 2$ and both blocks are removed at the same time.

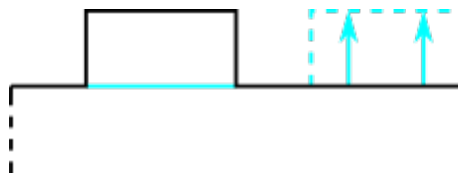

Figure 4.3 – Two configurations equal everywhere except at the pole: the configuration represented by the black line has a pole of size 2. Initially, the droplet delimited by the black line contains the droplet in light colour. A possible update after which the inclusion does not hold is represented in dashed lines: the contour dynamics is not monotonous.

The last condition ensures that contours delimit macroscopic droplets. It is useful for technical reasons, see e.g. the proof of the Replacement lemma in Appendix A. We will always consider droplets larger than what this condition allows for, so that the parameter r will play no role at the macroscopic level.

For $\gamma \in X_r^N$, call quadrants C_1, \dots, C_4 the quarter-planes delimited by portions of γ between consecutive (clockwise) poles. More precisely, define C_1 as the quarter plane delimited by the vertical line going through L_1 and the horizontal one going through R_2 . We similarly define C_2, C_3, C_4 , which may intersect (see Figure 4.1).

Let also $V(\gamma) \subset \Lambda_N$ be the set of all points encountered when travelling on γ . For $x \in V(\gamma)$,

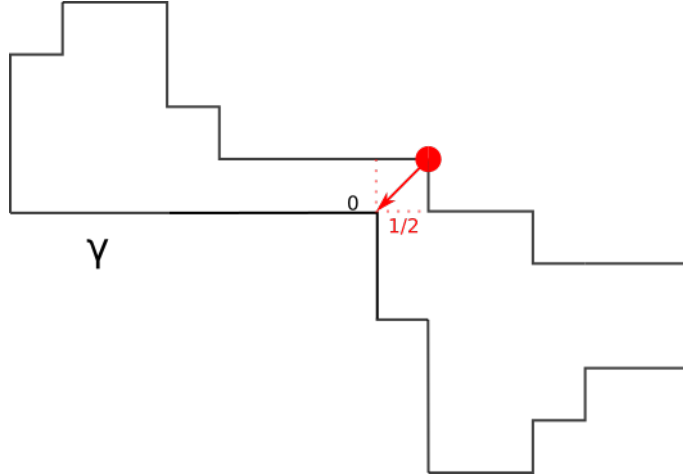

Figure 4.4 – A configuration γ in X_r^N with a forbidden single-flip: the dot denotes a point that, if flipped, makes γ non-simple. The jump rate for such flips is a non-local function of the curve. Rescaled by N , γ converges in Hausdorff distance to a curve with self-intersections at points inside quadrants 1 and 3.

define an edge label $\xi_x \in \{0, 1\}$ to be 1 if the edge exiting from x when travelling clockwise on γ is vertical, and 0 if it is horizontal. Let e_x^+, e_x^- be the unitary vectors with origin x such that e_x^+ gives the direction of the edge exiting from x , and e_x^- points towards the vertex before x (see Figure 4.1).

We can now precisely define the contour dynamics. For each curve γ , the following moves are allowed, summed up in Figure 4.2.

- (*Single spin flips*). Suppose $x \in V(\gamma)$ is not in a pole of size 2, and the curve at x has a corner, i.e. e_{+x} and e_{-x} are orthogonal. Then, independently of the other vertices, add/remove a block of extremity x at rate $1/2$ whenever possible (i.e. when the curve after the flip remains simple, or equivalently the event described in Figure 4.4 does not occur).
- (*Shrinking the droplet*). Assume the pole P_k is made of only two blocks. Suppose e.g. that $k = 1$, the others are the same. If $y(P_1) - y(P_3) \geq \lceil Nr \rceil + 1$, then, with rate 1 and independently from the rest, delete both blocks with vertices in P_1 .
- (*Added regrowth term*). Suppose that $x \in V(\gamma)$ is in one of the poles, and such that $x + 2e_x^+$ is in the same pole (this is simply a way of enumerating elements of a given pole). If $x \notin \partial\Lambda_N$, then with rate $e^{-2\beta}$, independently from the rest, add two blocks on top of the segment $[x, x + 2e_x^+]$.

The set X_r^N is stable under the dynamics. Moreover, the dynamics was built to be reversible with respect to the measure $\nu_{r,\beta}^N$ on X_r^N , with:

$$\forall \gamma \in X_r^N, \quad \nu(\gamma) = \nu_{r,\beta}^N(\gamma) := e^{-\beta|\gamma|} / \mathcal{Z}_{r,\beta}^N, \quad (2.3)$$

where $|\gamma|$ is the length of γ in 1-norm. When ambiguities may arise, $|\gamma|_1$ will denote the length in 1 norm and $|\gamma|_2$ the length in 2-norm. Note that the two coincide for $\gamma \in X_r^N$. The dynamics described above is not monotonous because of the regrowth part. The parameter $\beta > 0$ plays

the role of an inverse temperature, but only at the pole. The quantity $\mathcal{Z} = \mathcal{Z}_{r,\beta}^N$ is the partition function on X_r^N :

$$\mathcal{Z} = \mathcal{Z}_{r,\beta}^N = \sum_{\gamma \in X_r^N} e^{-\beta|\gamma|}. \quad (2.4)$$

In the following, we always assume that β is large enough to ensure that Z is bounded with N . In practice, $\beta > 3$ is enough except in Lemma 5.2, where we use $\beta > 64 \log 3$ for convenience (it is a technical condition that could be relaxed by considering curves in a larger square than $[-1, 1]^2$).

Let us write out the jump rates $c(\gamma, \gamma')$ associated with the contour dynamics, $\gamma, \gamma' \in X_r^N$. Reversibility with respect to $\nu_{r,\beta}^N$ means:

$$c(\gamma, \gamma')e^{-\beta|\gamma|} = c(\gamma', \gamma)e^{-\beta|\gamma'|}.$$

Single spin flips. Let $x \in V(\gamma)$. It is convenient to express the jump rate in terms of edges, and thus draw a parallel with the Symmetric Simple Exclusion Process (SSEP). Assume x is a corner of γ , i.e. a point where e_x^- and e_x^+ are orthogonal. Define a curve γ^x in which the block of diagonal $[x, x + e_x^- + e_x^+]$ is added/removed compared to γ . In terms of edges, this corresponds to exchanging $(x + e_x^-, x)$ and $(x, x + e_x^+)$, which leads to a change in γ whenever:

$$\xi_{x+e_x^-}(1 - \xi_x) + \xi_x(1 - \xi_{x+e_x^+}) = 1. \quad (2.5)$$

Note that if x is not a corner, $\gamma^x = \gamma$. If the case of Figure 4.4 occurs or x is in a pole of size 2, the flip is impossible and $\gamma^x \notin X_r^N$, otherwise $\gamma^x \in X_r^N$. Note also that the left-hand side in (2.5) is exactly the jump rate on an edge connecting two neighbouring sites in a SSEP. Define:

$$c(\gamma, \gamma^x) := \mathbf{1}_{\gamma^x \in X_r^N} c_x(\gamma), \quad c_x(\gamma) := \frac{1}{2} [\xi_{x+e_x^-}(1 - \xi_x) + \xi_x(1 - \xi_{x+e_x^+})]. \quad (2.6)$$

Double flips at the poles: if x is a point of pole P_{k_x} , $k_x \in \{1, \dots, 4\}$ such that $x + 2e_x^+ \in P_{k_x}$, and $x \notin \partial\Lambda_N$, let $\gamma^{+,x}$ be the curve γ on which two blocks with basis $[x, x + 2e_x^+]$ are added (see Figure 4.2). Then $|\gamma^{+,x}| = |\gamma| + 2$, and we set:

$$c(\gamma, \gamma^{+,x}) = \mathbf{1}_{\substack{x, x+2e_x^+ \in P_{k_x} \\ x \notin \partial\Lambda_N}} e^{-2\beta}. \quad (2.7)$$

Finally, if the pole P_k of γ has size 2 and $x \in P_k$, we let $\gamma^{-,x}$ or $\gamma^{-,k}$ be the curve γ with this pole deleted and define the corresponding jump rate:

$$c(\gamma, \gamma^{-,x}) = \mathbf{1}_{p_k=2, \gamma^{-,x} \in X_r^N}. \quad (2.8)$$

Let V_r, H_r be the sets enforcing that poles can be shrunk, i.e. that opposite poles are at least at vertical or horizontal distance $\lceil Nr \rceil + 1$ (1 more than the minimum value for curves in X_r^N):

$$V_r = \{\gamma \in X_r : y(P_1) - y(P_3) \geq \lceil Nr \rceil + 1\} \quad (2.9)$$

$$H_r = \{\gamma \in X_r : x(P_2) - x(P_4) \geq \lceil Nr \rceil + 1\}. \quad (2.10)$$

Let also DP_r^k denote H_r or V_r depending on $k \in \{1, \dots, 4\}$.

The generator $\mathcal{L}_{r,\beta}$ corresponding to the contour dynamics acts on bounded function $f : X_r^N \mapsto \mathbb{R}$ as:

$$\begin{aligned} \mathcal{L}_{r,\beta} f(\gamma) &= \sum_{x \in V(\gamma)} c(\gamma, \gamma^x) [f(\gamma^x) - f(\gamma)] \\ &+ \sum_{k=1}^4 \sum_{x \in P_k(\gamma): x+2e_x^+ \in P_k(\gamma)} \left[\mathbf{1}_{DP_r^k, p_k=2} [f(\gamma^{x,-}) - f(\gamma)] + e^{-2\beta} \mathbf{1}_{x \notin \partial \Lambda_N} [f(\gamma^{x,+}) - f(\gamma)] \right]. \end{aligned} \quad (2.11)$$

Recall that writing $x, x + 2e_x^+ \in P_k$ is just a way of enumerating vertices in P_k such that $\gamma^{+,x}$ can exist, and that $p_k = |P_k| - 1$ is the number of blocks in the pole P_k . It will be convenient later on to transform the first line a bit, and allow for fictitious single flips of a block of a pole of size 2. The first line is then recast as (recall (2.6)):

$$\sum_{x \in V(\gamma)} c_x(\gamma) [f(\gamma^x) - f(\gamma)] - \frac{1}{2} \sum_{k=1}^4 \mathbf{1}_{p_k=2} \sum_{x \in \{R_k, L_k\}} [f(\gamma^x) - f(\gamma)]. \quad (2.12)$$

Define the set \mathcal{C} of test functions:

$$\mathcal{C} = \{G \in C_c(\mathbb{R}_+ \times [-1, 1]^2) : \partial_t G, \partial_i G, \partial_i \partial_j G \in C(\mathbb{R}_+ \times [-1, 1]^2), (i, j) \in \{1, 2\}^2\}, \quad (2.13)$$

where the c subscript means compactly supported. Then $(\mathcal{C}, \|\cdot\|_\infty)$ is separable.

We shall later need to consider a larger class of dynamics. For $H \in \mathcal{C}$, define another (time-inhomogeneous) Markov chain with generator $\mathcal{L}_{r,\beta,H}$ by modifying the jump rates as follows (recall that Γ is the set with boundary γ):

$$\forall t \geq 0, \quad c^{H_t}(\gamma, \gamma') := c(\gamma, \gamma') \exp \left[\frac{1}{N} \int_{\Gamma'} H_{t/N^2} - \frac{1}{N} \int_{\Gamma/N} H_t \right]. \quad (2.14)$$

The probability measure associated with the speeded-up generator $N^2 \mathcal{L}_{r,\beta,H}$ will be denoted by $\mathbb{P}_{r,\beta,H}^N$, or simply $\mathbb{P}_{r,\beta}^N$ when $H \equiv 0$. The corresponding expectations are denoted by $\mathbb{E}_{r,\beta,H}^N, \mathbb{E}_{r,\beta}^N$ respectively, and the law of the process induced by $\mathbb{P}_{r,\beta,H}^N, \mathbb{P}_{r,\beta}^N$ is denoted by $Q_{r,\beta,H}^N, Q_{r,\beta}^N$.

Macroscopic and effective macroscopic state spaces. We define here the space of macroscopic curves. All microscopic curves, rescaled by N^{-1} , are elements of the set X of non-empty, connected compact subsets of $[-1, 1]^2$ with perimeter bounded by 8. This set is compact for the topology associated with the Hausdorff distance $d_{\mathcal{H}}$. It is of course much too large, and we work instead with an effective state space \mathcal{E}_r , which contains only curves with four poles satisfying a monotonicity condition similar to the one for X_r^N . In addition, we shall define \mathcal{E}_r to ensure that the constraints V_r, H_r defined in (2.9)-(2.10) are satisfied, and that any pathological curve, like the one of Figure 4.4, is discarded. Informally, one should think of \mathcal{E}_r as follows:

$$\mathcal{E}_r = X \cap \left\{ \Gamma \subset [-1, 1]^2 : \Gamma \text{ has four non-intersecting poles, satisfies a monotonicity condition and } \partial \Gamma \text{ is a simple curve} \right\}. \quad (2.15)$$

In practice, the definition of \mathcal{E}_r is more subtle, as we want it to be closed for the Hausdorff distance and we need to allow droplets with non-simple boundaries, corresponding to curves with poles standing atop vertical or horizontal lines. It is detailed in Appendix B.

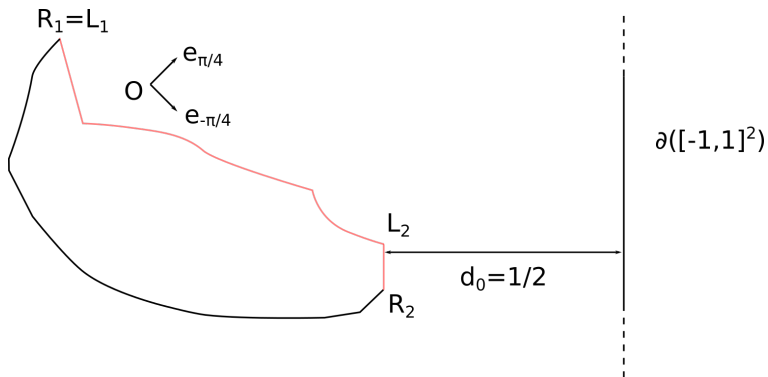

Figure 4.5 – A possible initial condition Γ_0 . The reference frame $\mathcal{R}_1 = (O, e_{-\pi/4}, e_{\pi/4})$ is represented, and the graph of f^1 appears in light colour. The position of the origin O is not relevant.

Definition 2.1 (Initial condition and notations). *In the rest of this article, unless explicitly stated otherwise, parameters $r > 0$, $\beta > \log 3$, $H \in \mathcal{C}$ are fixed once and for all (or $\beta > 64 \log 3$ in Lemma 5.2, see (2.4)). A parameter $r_0 > r$ is also fixed and we consider, for $N \in \mathbb{N}^*$, the dynamics given by $\mathbb{P}_{r,\beta,H}^N$ that starts from some $\Gamma_0^N \in N\mathcal{E}_{r_0}$ satisfying:*

- *$(N^{-1}\Gamma_0^N)_N$ converges in Hausdorff distance to a set $\Gamma_0 \in \mathcal{E}_{r_0}$, and each $N^{-1}\Gamma_0^N$ and Γ_0 are at a distance at least $d_0 = 1/2$ in 1-norm from the boundary of $[-1, 1]^2$. We call $\mathcal{E}_{r_0}(1/2) \subset \mathcal{E}_{r_0}$ the subset of such curves, and in general $\mathcal{E}_r(d) \subset \mathcal{E}_r$ is the set of droplets at 1-distance at least $d > 0$ from the domain boundaries.*
- *The boundary γ_0 of Γ_0 is a Jordan curve, nowhere flat or vertical, i.e. there is no point $x \in \gamma_0$ admitting an open neighbourhood inside γ on which the curvature vanishes.*

Unless otherwise said, d is a fixed number in $(0, 1/4)$. Travelling on a curve in X_r^N is always done clockwise. Moreover, we set $P_5 := P_1$, $P_6 := P_2$. In this article, $O_G(\delta)$ always means: bounded by a constant depending on an object G times δ for $\delta > 0$ sufficiently small. The letter C is used to denote a constant that may change from line to line, and $C(G, \delta)$ means that the constant depends only on G, δ and a numerical factor.

Importantly, if $\gamma^N \in X_r^N$, we unambiguously write $\gamma^N \in N\mathcal{E}_r$ instead of $\Gamma^N \in N\mathcal{E}_r$, when $\gamma^N = \partial\Gamma^N$. We also sometimes treat $\mathbb{P}_{r,\beta}^N$ as a measure on trajectories taking values in $N^{-1}X_r^N$ instead of X_r^N . The letter Γ will always denote a "droplet", i.e. a compact subset of \mathbb{R}^2 , or a trajectory or droplets; and the letter γ its boundary, or the trajectory of the boundaries.

2.2 Heuristics

Before stating the results, let us give an idea of what the contour dynamics does, and describe how it relates to the Symmetric Simple Exclusion Process (SSEP). One should always have in mind this connection, which serves as a guideline for many intuitions and computations presented in this article.

Microscopic curves, i.e. elements of X_r^N , can by definition be split in four quadrants C^1, \dots, C^4 . Inside quadrant k , consider the reference frame \mathcal{R}_k obtained by rotating the canonical frame by $\pi/4$ plus a multiple of $\pi/2$:

$$\mathcal{R}_k = (O, e_{\pi/4 - k\pi/2}, e_{\pi/4 - (k-1)\pi/2}) \quad \text{for } k \in \{1, \dots, 4\}. \quad (2.16)$$

In quadrant $k \in \{1, \dots, 4\}$, the curve is given by the graph $\{(x^k, f^k(x^k))_{\mathcal{R}_k} : x^k \in I^k\}$ of a function $f^k : I^k \subset \mathbb{R} \rightarrow \mathbb{R}$, see Figure 4.5. Assimilate each vertical edge to a particle, each horizontal edge to an empty site. Away from the poles, adding or removing a block is then possible whenever a corresponding particle can jump according to the exclusion rule (i.e. at most one particle per site), and the "occupation number" at a point $y = (x^k, f^k(x^k)) \in V(\gamma)$ reads

$$\xi_y = \frac{1 + (-1)^k (f^k(x^k + 2^{-1/2}) - f^k(x^k))}{2}. \quad (2.17)$$

This correspondence is detailed in the proof of Lemma 6.5, see Figure 4.9.

Consider now the macroscopic counterparts of elements of X_r^N : denote again by $(f^k(t, \cdot))_{t \geq 0}$ the family of functions representing quadrant $k \in \{1, \dots, 4\}$ of a macroscopic trajectory $(\gamma_t)_{t \geq 0}$ of curves taking values in \mathcal{E}_r (defined in Appendix B). Consider a parametrisation of each $\gamma_t, t \geq 0$ on the unit torus \mathbb{T} . Recall from (2.1) that the family $(\gamma_t)_{t \geq 0}$ is said to satisfy anisotropic motion by curvature until a time $T > 0$ if it solves:

$$\forall t < T, \forall u \in \mathbb{T}, \quad \partial_t \gamma(t, u) = a(\theta_t(u)) k(t, u) \mathbf{N}_t(u). \quad (2.18)$$

In this equation, the time derivative is taken at fixed values of the parameter u , and $k(t, u)$ is the curvature of γ_t at $\gamma_t(u)$. The vector $\mathbf{N}_t(u)$ is the inwards normal vector at $\gamma_t(u)$, $\theta_t(u)$ is the angle between the tangent vector \mathbf{T} and e_1 and, finally, a is the anisotropy:

$$a(\theta) := \frac{1}{2(|\sin(\theta)| + |\cos(\theta)|)^2} = \frac{1}{2\|\mathbf{T}(\theta)\|_1^2}, \quad \theta \in [0, 2\pi]. \quad (2.19)$$

One can check that, for each $x \in \mathbb{R}$ and $k \in \mathbb{Z}$, $a(\arctan(x) + \pi/4 + k\pi/2) = (1 + x^2)/2$. Elementary computations on a formal level then yield that, away from each pole, equation (2.18) translates into the heat equation on each quadrant:

$$\partial_t f^k = \frac{1}{4} \partial_{x^k}^2 f^k,$$

where the time derivative is taken at fixed value of the parameter x^k . This observation was already made by Spohn in [Spo93], and is used in the proof of the hydrodynamic limit in [LST14b]-[LST14a].

Assume that the poles of (γ_t) are fixed in time. Its four quadrants are then also fixed in time, hence each interval of definition I^k of f^k as well for $k \in \{1, \dots, 4\}$. Define $\rho^k = 1/2 + (-1)^k \partial_{x^k} f^k / 2$. The function $\rho^k : I^1 \rightarrow [0, 1]$ is the density of the equivalent SSEP on the first quadrant (compare with (2.17)). Forgetting about boundary conditions for now, recall e.g. from [KL99] large deviations results for the density of a SSEP: trajectories occurring with probability of order e^{-N} are solutions, in a suitable sense, of:

$$\partial_t \rho^k = \frac{1}{4} \partial_{x^k}^2 \rho^k - (1/2) \partial_{x^k} (\sigma(\rho^k) \partial_{x^k} H_k), \quad (2.20)$$

for some (possibly irregular) function $H_k : I^k \rightarrow \mathbb{R}$, and with $\sigma(\rho^k) = \rho^k(1 - \rho^k)$. By analogy with (2.20), interfaces occurring with probability of order e^{-N} should be solutions, inside each quadrant, to:

$$\partial_t f^k = \frac{1}{4} \partial_{x^k}^2 f^k + \sigma(f^k) \partial_{x^k} H_k, \quad (2.21)$$

with $\sigma(f^k) = \rho^k(1 - \rho^k) = (1 - (\partial_{x^k} f^k)^2)/4$. Recall that (2.21) is written under the assumption that I^k does not change with time. However, in the contour dynamics, poles move, as they are coupled together by the dynamics on each quadrant. Thus each interval $I^k, k \in \{1, \dots, 4\}$ depends on time, and it is not possible to define a single function H depending only on x^k , simultaneously in the four quadrants and for each time. This leads one to replace each of the $\partial_{x^k} H_k, k \in \{1, \dots, 4\}$ by a single function $H : \mathbb{R}^2 \rightarrow \mathbb{R}$. As a consequence, H now also depends on $f^k(x^k)$ inside each quadrant, and not just on x^k . The behaviour of (2.21) is still expected to be valid away from the poles, i.e. in the interior of $I^k(t)$ for each time, thus we expect that interfaces occurring with probability of order e^{-N} should satisfy:

$$\forall t > 0, \forall x \in \mathring{I}^k(t), \quad \partial_t f^k = \frac{1}{4} \partial_{x^k}^2 f^k + \sqrt{2} \sigma(f^k) H((\cdot, f^k(\cdot))_{\mathcal{R}_k}). \quad (2.22)$$

The additional $\sqrt{2}$ factor compared to (2.21) comes from the derivative $\partial_{x^k} H$ that was removed. Let us obtain from (2.22) a parametrisation independent equation on the family (γ_t) . To do so, write for the tangent vector:

$$\mathbf{T}(\theta) = \cos(\theta)e_1 + \sin(\theta)e_2 = [1 + (\partial_{x^k} f^k)^2]^{-1/2} (1, \partial_{x^k} f^k)_{\mathcal{R}_k}, \quad \theta = \theta(x^k) \in [0, 2\pi]. \quad (2.23)$$

If $v = (\|\mathbf{T}\|_1)^{-1}$ and a is the anisotropy (2.19), then

$$a(\theta^k) = a(\pi/4 - k\pi/2 + \arctan(\partial_{x^k} f^k)) = \frac{1 + (\partial_{x^k} f^k)^2}{4}, \quad \frac{v(\theta^k)^2}{2} = a(\theta^k). \quad (2.24)$$

After some elementary computations, one finds that trajectories $(\gamma_t)_{t \geq 0}$ at scale e^{-N} , away from their poles, should look like solutions of an anisotropic motion by curvature with drift:

$$\partial_t \gamma \cdot \mathbf{N} = ak - \mu H. \quad (2.25)$$

Recall that \mathbf{N} is the inwards normal vector, a is the anisotropy defined in (2.19), and μ is the mobility of the model, defined as:

$$\mu(\theta) := \frac{|\sin(2\theta)|}{2(|\sin(\theta)| + |\cos(\theta)|)} = \frac{|\mathbf{T}(\theta) \cdot e_1| |\mathbf{T}(\theta) \cdot e_2|}{\|\mathbf{T}(\theta)\|_1}, \quad \theta \in [0, 2\pi]. \quad (2.26)$$

Indeed, e.g. in the first quadrant at time $t_0 \geq 0$, one has for each $x^1 \in I^1(t_0)$:

$$\mu(\theta(x^1)) = \sqrt{2} [1 + (\partial_{x^1} f^1)^2]^{1/2} \sigma(f^1(x^1)).$$

From (2.25), we see that the function H , that we introduced from considerations on the SSEP on each quadrant, plays the role of a magnetic field applied to \pm Ising spins (see [Spo93]), separated by an interface corresponding to our contours γ .

It remains to somehow add in the contribution of the poles to that picture. It turns out (see

Proposition 2.2) that due to the regrowth, β -dependent part of the microscopic dynamics, poles act as moving reservoirs which, at each time $t \geq 0$, fix the value of $\partial_{x^k} f^k(t, \cdot)$ in terms of β at the extremities of its interval of definition $I^k(t)$. We shall loosely refer to $\partial_{x^k} f^k$ as *the slope*. Equation (2.25) can then be interpreted as the coupling of four equations of the type (2.22) via Stefan-like boundary conditions at the poles, each of these equations being written in a domain $I^k(t)$, $k \in \{1, \dots, 4\}$ that depends on time. Understanding how this coupling works and how to deal with the motion of the poles without any monotonicity in the dynamics is the main challenge of this work.

2.3 Results

We now state our results, starting with the behaviour of the slope at the poles, in Proposition 2.2. This result is the most important specificity of our model. Define the microscopic averaged slope on either side of a pole as follows. For $\gamma \in N\mathcal{E}_r$, $k \in \mathbb{N}^*$ and $x \in V(\gamma)$, denote by $\xi_x^{+,k}$ the quantity:

$$\xi_x^{+,k} = \frac{1}{k+1} \sum_{\substack{y \in V(\gamma), y \geq x \\ \|x-y\|_1 \leq k}} \xi_y.$$

By $y \geq x$ we mean that y is encountered after x when travelling on γ clockwise ($N \gg k$). We define the other slope $\xi_x^{-,k}$ similarly by averaging over points that are before x on γ .

Proposition 2.2. *For $d > 0$, recall that $\mathcal{E}_r(d)$ is the subset of \mathcal{E}_r of curves at 1-distance at least d from the domain boundary $\partial([-1, 1]^2)$. For a trajectory $(\gamma_t)_{t \geq 0}$ of curves, let $(L_k(t))_{t \geq 0}$ denote the trajectories of the left extremities of pole k , $1 \leq k \leq 4$. Let $T_0 > 0$. Then, for any test function $G \in \mathcal{C}$ and $\delta > 0$, if $k \in \{1, 3\}$:*

$$\limsup_{\varepsilon \rightarrow 0} \limsup_{N \rightarrow \infty} \frac{1}{N} \log \mathbb{P}_{r,\beta}^N \left(\text{for a.e. } t \in [0, T_0], \gamma(t) \in N\mathcal{E}_r(d); \right. \\ \left. \left| \int_0^{T_0} G(t, N^{-1}L_k(t)) (\xi_{L_k(t)}^{\pm, \varepsilon N} - e^{-\beta}) dt \right| \geq \delta \right) = -\infty.$$

If on the other hand $k \in \{2, 4\}$:

$$\limsup_{\varepsilon \rightarrow 0} \limsup_{N \rightarrow \infty} \frac{1}{N} \log \mathbb{P}_{r,\beta}^N \left(\text{for a.e. } t \in [0, T_0], \gamma(t) \in N\mathcal{E}_r(d); \right. \\ \left. \left| \int_0^{T_0} G(t, N^{-1}L_k(t)) (1 - \xi_{L_k(t)}^{\pm, \varepsilon N} - e^{-\beta}) dt \right| \geq \delta \right) = -\infty.$$

Remark 2.3. The result of Proposition 2.2 is stated only for trajectories with values in $N\mathcal{E}_r(d)$ for almost every time. Whether a trajectory stays in $N\mathcal{E}_r(d)$ on a time interval $[0, T_0]$, $T_0 > 0$ is a separate question, addressed in Proposition 2.4. ■

This proposition shows that the time average of the slopes at the poles are fixed and form a cusp. This is reminiscent of the SSEP in contact with reservoirs which fix the density at the points of contact [ELS90]. In our case, the exclusion dynamics on each quadrant are coupled by the fixed value of the slope.

Take a sequence $\gamma^N \in X_r^N \cap N\mathcal{E}_r(d)$, $N \in \mathbb{N}^*$, and assume $N^{-1}\gamma^N$ converges to some $\gamma \in \mathcal{E}_r(d)$ in Hausdorff distance. For future reference, assume that the condition on the slope at the pole of Proposition 2.2 holds for γ^N , in the sense that:

$$\forall 1 \leq k \leq 4, \quad \limsup_{\varepsilon \rightarrow 0} \limsup_{N \rightarrow \infty} \left| \xi_{L_k(\gamma^N)}^{\pm, \varepsilon N} - \mathbf{1}_{k \in \{1,3\}} e^{-\beta} - \mathbf{1}_{k \in \{2,4\}} (1 - e^{-\beta}) \right| = 0.$$

One can then prove that γ has point-like poles (this is done in a different context in Appendix B.3), and the above condition can be translated into a condition on the angle $\theta(L_k(\gamma)_\pm)$ between the tangent vector \mathbf{T} approaching $L_k(\gamma)$ from the left ($-$) or the right ($+$), and the vector e_1 :

$$\tan \left(\theta(L_k(\gamma)_-) + \frac{(k-1)\pi}{2} \right) = \frac{e^{-\beta}}{1 - e^{-\beta}} = -\tan \left(\theta(L_k(\gamma)_+) + \frac{(k-1)\pi}{2} \right), \quad 1 \leq k \leq 4. \quad (2.27)$$

Our second result justifies the definition of the "effective" state space \mathcal{E}_r : first, configurations starting inside the restricted configuration space $N\mathcal{E}_{r_0}$ take a time of order N^2 to exit this set. The arguments for this point are inspired by [Cap+11]. Second, any trajectory that starts from Γ_0 , which is at distance $1/2$ from the domain boundary $\partial([-1, 1]^2)$, takes at least a diffusive time to first reach $\partial([-1, 1]^2)$. As in the proof of the large N behaviour for the zero-temperature stochastic Ising model in [LST14b], this proposition is crucial to be able to say anything about the typical behaviour of the contour process, meaning also about lower-bound large deviations.

Proposition 2.4. *Recall that $r, \beta, H, r_0, d_0 = 1/2$ are fixed as in Definition 2.1.*

1. *Let $r_1 \in (r, r_0)$ and define $\tau = \tau_{r_1, \beta, H}^N$ as the time for which the dynamics induced by $\mathbb{P}_{r, \beta, H}^N$ first leaves $N\mathcal{E}_{r_1}$. There are constants c_0, α that depend only on Γ_0, H, r_0, r_1 (but not on r, β) such that:*

$$\mathbb{P}_{r, \beta, H}^N(\tau < c_0) \leq \exp[-\alpha N]. \quad (2.28)$$

2. *Assume $\beta > 64 \log 3$. For each $d < 1/4$, there is a time $T_0 = T_0(\Gamma_0, d, d_0, \beta, H) \in (0, c_0]$, with c_0 as in (2.28), such that:*

$$\mathbb{P}_{r, \beta, H}^N \left(\forall t \in [0, T_0], \gamma_t \in \mathcal{E}_r; \int_0^{T_0} \mathbf{1}_{\text{dist}(\gamma_t, \partial([-1, 1]^2)) < d} dt > 0 \right) = o_N(1). \quad (2.29)$$

Hydrodynamic limit

Next, we investigate the hydrodynamic limit of the contour process. This requires choosing a suitable topology on trajectories. In the proof of the hydrodynamic limit for the zero temperature stochastic Ising model in [LST14b]-[LST14a], the authors prove uniform convergence in time for the Hausdorff topology. The Hausdorff distance between sets appears as a natural distance to put on the state space: inside each quadrant, it is equivalent to weak convergence of the slopes, a topology in which hydrodynamics are known for the SSEP.

In the case of the contour model, the Skorokhod topology associated with the Hausdorff distance seems like a suitable choice. However, the regrowth part of the dynamics at the poles makes it very complicated to estimate the position of the poles at each time. We thus equip the set $D_{\mathcal{H}}([0, T_0], \mathcal{E}_r)$ of càdlàg functions in Hausdorff distance with a weaker topology, without any point-like control at the pole, induced by the distance (2.30).

Let $T_0 > 0$ be a time given by Proposition 2.4. Recall that $X \supset N^{-1}X_r^N$ is the macroscopic state space and consider the distance:

$$\forall \Gamma, \Gamma' \in X^{[0, T_0]}, \quad d_E(\Gamma, \Gamma') = d_S^{L^1}(\Gamma, \Gamma') + \int_0^{T_0} d_{\mathcal{H}}(\Gamma_t, \Gamma'_t) dt. \quad (2.30)$$

Above, $d_S^{L^1}$ is the Skorokhod distance associated with $L^1([-1, 1]^2)$ topology, and $d_{\mathcal{H}}$ is the Hausdorff distance on X . More is said on these objects in Appendix B.

For $d \in (0, d_0/2) = (0, 1/4)$, recall that $\mathcal{E}_r(d)$ is defined in Definition 2.1 as the subset of the effective state space \mathcal{E}_r with curves at 1-distance at least d from the domain boundary. A suitable set of trajectories for the contour dynamics will be $E([0, T_0], \mathcal{E}_r(d))$, defined as the completion of $D_{\mathcal{H}}([0, T_0], \mathcal{E}_r(d))$ for the distance d_E . An explicit characterisation of elements in $E([0, T_0], \mathcal{E}_r(d))$ and topological properties are given in Appendix B.2.

The hydrodynamic limit result is the following: $\{Q_{r, \beta, H}^N : N \in \mathbb{N}^*\}$ has weak limit points supported on $E([0, T_0], \mathcal{E}_r(d))$, and any weak limit point concentrates onto weak solutions, in the sense defined below in (2.32), of (recall (2.27)):

$$\begin{cases} \partial_t \gamma \cdot \mathbf{N} = a \partial_s^2 \gamma \cdot \mathbf{N} - \mu H = ak - \mu H & \text{away from the poles,} \\ (\gamma_t)_{t \leq T_0} \text{ satisfies (2.27) at almost every } t \in [0, T_0]. \end{cases} \quad (2.31)$$

with \mathbf{N} the inwards normal vector, a the anisotropy (2.19), k the curvature, μ the mobility (2.26), and s the arclength coordinate.

Proposition 2.5. *Let $\beta > 64 \log 3$. The set $\{Q_{r, \beta, H}^N : N \in \mathbb{N}^*\}$ is relatively compact in the set $\mathcal{M}_1(E([0, T_0], X))$ equipped with the weak topology associated with d_E . Moreover, if $Q_{r, \beta, H}^*$ is one of its weak limit points, then it is concentrated on trajectories in $E([0, T_0], \mathcal{E}_r(d))$ satisfying the following. These trajectories have almost always point-like poles, i.e. for a.e. $\tau \in [0, T_0]$, each $P_k(\gamma_\tau) := [L_k(\tau), R_k(\tau)]$ is reduced to the point $L_k(\tau)$, $1 \leq k \leq 4$. Moreover, for any test function G in the set \mathcal{C} defined in (2.13),*

$$\begin{aligned} \int_{\Gamma_{T_0}} G_{T_0} - \int_{\Gamma_0} G_0 - \int_0^{T_0} \int_{\Gamma_\tau} \partial_\tau G_\tau d\tau &= \int_0^{T_0} \int_{\gamma_\tau \setminus P(\gamma_\tau)} \alpha(\theta(s)) \partial_s G(\tau, \gamma_\tau(s)) ds d\tau \\ &\quad - \sum_{k=1}^4 \int_0^{T_0} \left(\frac{1}{2} - e^{-\beta} \right) G(\tau, L_k(\tau)) d\tau \\ &\quad + \int_0^{T_0} \int_{\gamma_\tau} \mu(\theta(s)) (HG)(\tau, \gamma_\tau(s)) ds d\tau. \end{aligned} \quad (2.32)$$

Above, μ is the mobility of the model, defined in (2.26), and s is the arclength coordinate on γ_τ , $\tau \in [0, T_0]$. For each $\theta \in [0, 2\pi] \setminus (\pi/2)\mathbb{Z}$, α is related to the anisotropy a by $\alpha'(\theta) = -a(\theta)$. One has:

$$\alpha(\theta) = \frac{a(\theta) \sin(2\theta) \cos(2\theta)}{2 |\sin(2\theta)|} = \frac{\mathbf{T}(\theta) \cdot e_1 \mathbf{T}(\theta) \cdot e_2}{4 \|\mathbf{T}(\theta)\|_1} \left[\frac{1}{|\mathbf{T}(\theta) \cdot e_2|} - \frac{1}{|\mathbf{T}(\theta) \cdot e_1|} \right], \quad (2.33)$$

where $\mathbf{T}(\theta) = \cos(\theta)e_1 + \sin(\theta)e_2$.

The proof relies on well-known martingale methods [KL99]. However, the fact that configurations are one-dimensional objects moving in a two-dimensional space introduces major difficulties. At the microscopic level, the main issue is that the vertices or edges of a curve cannot be labelled in a fixed reference frame.

Remark 2.6. The value of the slope at the pole of curves satisfying (2.32) is fixed as in Proposition 2.2 by the term on the second line of (2.32). Indeed, assume the curvature k_τ on a solution $(\gamma_\tau)_{\tau \leq T_0}$ of (2.32) is, say, continuous away from each pole. By definition, the tangent angle $s \mapsto \theta(s) = \theta(\gamma_\tau(s))$ then satisfies $\partial_s \theta(s) = -k_\tau(s)$, with the $-$ sign due to the clockwise parametrisation of γ_τ . Let $G \in \mathcal{C}$. Integrating $\alpha \partial_s G(\tau, \cdot)$ by parts on each quadrant in (2.32) for a fixed $\tau \in [0, T_0]$, one then finds, by definition (2.33) of α :

$$\begin{aligned} \int_{\gamma_\tau \setminus P(\gamma_\tau)} \alpha(\theta(s)) \partial_s G(\tau, \gamma_\tau(s)) ds \\ = \sum_{k=1}^4 [\alpha((L_{k+1}(\tau))_-) G(\tau, L_{k+1}(\tau)) - \alpha((R_k(\tau))_+) G(\tau, R_k(\tau))] \\ - \int_{\gamma_\tau \setminus P(\gamma_\tau)} a(\theta(s)) k_\tau(s) G(\tau, \gamma_\tau(s)) ds. \end{aligned}$$

Since $L_k(\tau) = R_k(\tau)$ for each k and almost every $\tau \in [0, T_0]$, the first sum compensates the second line of (2.32) provided $\alpha((L_{k+1}(\tau))_-) = 1/4 - e^{-\beta}/2 = -\alpha((L_k(\tau))_+)$. This means that the tangent angle on either side of each pole satisfying (2.27). \blacksquare

Large deviations

We obtain upper-bound large deviations for the contour dynamics at finite $\beta > \log 3$. Assuming solutions of (2.32) to be unique, lower-bound large deviations also follow. Upper and lower bounds match for smooth trajectories. Specific to our model is, again, the control of the poles of the curves.

Let $T_0 > 0$ and consider r, β, H, d as in Definition 2.1. Given a trajectory $\Gamma \in E([0, T_0], \mathcal{E}_r(d))$ with boundaries $\gamma_t = \partial \Gamma_t$, $t \leq T_0$, define, recalling that L_k, R_k are the extremities of the pole P_k :

$$\begin{aligned} \ell_H^\beta(\Gamma) = \langle \Gamma_{T_0}, H_{T_0} \rangle - \langle \Gamma_0, H_0 \rangle - \int_0^{T_0} \langle \Gamma_\tau, \partial_\tau H_\tau \rangle d\tau - \int_0^{T_0} d\tau \int_{\gamma_\tau \setminus P(\gamma_\tau)} \alpha(\theta(s)) \partial_s H(\tau, \gamma_\tau(s)) ds \\ + \left(\frac{1}{4} - \frac{e^{-\beta}}{2} \right) \int_0^{T_0} \sum_{k=1}^4 [H(\tau, L_k(\tau)) + H(\tau, R_k(\tau))] d\tau. \end{aligned} \quad (2.34)$$

Define also:

$$J_H^\beta(\Gamma) = \ell_H^\beta(\Gamma) - \frac{1}{2} \int_0^{T_0} \int_{\gamma_\tau} \mu(\theta(s)) H^2(\tau, \gamma_\tau(s)) ds d\tau, \quad \Gamma \in E([0, T_0], \mathcal{E}_r(d)) \quad (2.35)$$

where the mobility μ is defined in (2.26).

To build the rate function, we will have to restrict the state space to control the behaviour of the

poles. Introduce thus the subset $E_{pp}([0, T_0], \mathcal{E}_r(d)) \subset E([0, T_0], \mathcal{E}_r(d))$ of trajectories with almost always point-like poles:

$$E_{pp}([0, T_0], \mathcal{E}_r(d)) = \left\{ \Gamma \in E([0, T_0], \mathcal{E}_r(d)) : \sum_{k=1}^4 \int_0^{T_0} |L_k(t) - R_k(t)| dt = 0 \right\}. \quad (2.36)$$

Recall that R_k (L_k) is the right (left) extremity of pole $k \in \{1, \dots, 4\}$. Let us now define the rate function $I_\beta(\cdot | \Gamma_0)$:

$$I_\beta(\Gamma | \Gamma_0) = \begin{cases} \sup_{H \in \mathcal{C}} J_H^\beta(\Gamma) & \text{if } \Gamma \in E_{pp}([0, T_0], \mathcal{E}_r(d)), \\ +\infty & \text{otherwise,} \end{cases} \quad (2.37)$$

Remark 2.7. • Note that it is possible by Proposition 2.2 to enforce that only trajectories with slope $e^{-\beta}$ at the poles have finite rate function. One would expect this condition to already be present in (2.37), but the very weak topology at the poles makes it more complicated to see than e.g. for a SSEP with reservoirs, see [BLM09].

- If $\beta = \infty$ and Γ is a smooth trajectory in $C([0, T_0], \mathcal{E}_r(d))$ starting from Γ_0 (i.e. it has well defined, continuous normal speed and curvature at each time $t \in (0, T_0]$), then setting $\beta = \infty$ in (2.37) one obtains:

$$I_\infty(\Gamma | \Gamma_0) = \frac{1}{2} \int_0^{T_0} \int_{\gamma_t} \frac{(v - ak)^2}{\mu} ds dt.$$

As conjectured in (1.3), the rate function $I_\infty(\cdot | \Gamma_0)$ thus measures the quadratic cost of deviations from anisotropic mean-curvature motion. At $\beta < \infty$, the same picture holds except that trajectories with finite rate function are not smooth: they have kinks at the poles in the sense of Proposition 2.2. ■

In the proof of large deviations, trajectories associated with a smooth bias $H \in \mathcal{C}$ play a special role. Define the set of trajectories $\mathcal{A}_{T_0, r, \beta}^{\mathcal{C}} \subset E([0, T_0], \mathcal{E}_r)$ as follows:

$$\mathcal{A}_{T_0, r, \beta}^{\mathcal{C}} = \left\{ \Gamma \in E([0, T_0], \mathcal{E}_r(d)) : \text{there is a bias } H \in \mathcal{C} \text{ such that (2.32) has a unique solution in } E([0, T_0], \mathcal{E}_r(d)), \text{ which is continuous in time in Hausdorff topology, and this solution is } \Gamma \right\}. \quad (2.38)$$

Theorem 2.8. *Let $r < r_0$. For any $d \in (0, 1 - r)$, any closed set $F \subset E([0, T_0], \mathcal{E}_r(d))$ and any $\beta > \log 3$:*

$$\limsup_{N \rightarrow \infty} \frac{1}{N} \log Q_{r, \beta}^N(F) \leq - \inf_F I_\beta(\cdot | \Gamma_0). \quad (2.39)$$

For any open set $O \subset E([0, T_0], \mathcal{E}_r(d))$ with $d \in [1/2, 1 - r)$ and any $\beta > 64 \log 3$,

$$\liminf_{N \rightarrow \infty} \frac{1}{N} \log Q_{r, \beta}^N(O) \geq - \inf_{O \cap \mathcal{A}_{T_0, r, \beta}^{\mathcal{C}}} I_\beta(\cdot | \Gamma_0). \quad (2.40)$$

Remark 2.9. • The restriction to $d > 1/2$ and $\beta > 64 \log 3$ for the lower bound is purely technical. It is a consequence of item 2 in Proposition 2.4, and smaller d 's or smaller β 's could be considered, without change to the proofs, by enlarging the state space to droplets in $[-A, A]^2$, $A > 1$.

- We consider large deviation events on trajectories avoiding the domain boundary $\partial([-1, 1]^2)$ to avoid additional boundary conditions in (2.32).
- The choice of initial condition is for convenience only. We could also consider large deviations on the initial condition, with minor changes.
- One expects that the set $\mathcal{A}_{T_0, r, \beta}^{\mathcal{C}}$ contain all sufficiently regular trajectories which satisfy the angle constraint (2.27) at each time at the poles. Typically, classical solutions of (2.31) for each $H \in \mathcal{C}$ should belong to $\mathcal{A}_{T_0, r, \beta}^{\mathcal{C}}$ until some time T_0 . Existence and uniqueness of classical solutions of (2.31) could be studied at $\beta = \infty$ by the methods of [LST14b][LST14a]. When $\beta < \infty$ however, the study of uniqueness of classical solutions to (2.31), let alone of (2.32), appears to be very complicated. \blacksquare

2.4 Comments on metastability

Before starting our study, we make some comments about metastability properties of the contour model. The reversibility introduced in the microscopic dynamics and the large deviation results of Theorem 2.8 give us a lot of information, as illustrated below.

Nucleation with a small magnetic field:

At equilibrium under $\nu_{r, \beta}^N$ (defined in (2.3)) with r small, contours are typically small as well. If a small magnetic field h/N , $h > 0$ is added to the dynamics as in (2.14) with $H \equiv \beta h$, it remains reversible with respect to the measure ν_h defined by:

$$\forall \gamma \in X_r^N, \quad \nu_h(\gamma) = \nu_{r, \beta, h}^N(\gamma) = (\mathcal{Z}_{r, \beta, h})^{-1} \exp[-\beta|\gamma| + 2\beta h \text{Vol}(\gamma)/N],$$

where $\mathcal{Z}_{r, \beta, h} = \sum_{\gamma \in X_r^N} \exp[-\beta|\gamma| + \beta h \text{Vol}(\gamma)/N]$ is the associated partition function, and $\text{Vol}(\gamma)$ is the volume of the droplet that γ delimits. We can use the large deviations result (Theorem 2.8 above) to inquire about the typical volume above which a nucleated droplet can grow, as well as the shape that a droplet has while it grows or shrinks, depending on its size.

The surface tension $\mathfrak{t}_\beta = \mathfrak{t}_\beta(\theta)$, $\theta \in [0, 2\pi]$ of the contour model plays a key role in the nucleation. Away from the pole, it is equal, for each tangent angle $\theta \notin (\pi/2)\mathbb{Z}$ and inverse temperature β , to the surface tension for the Ising model at first order in the large β limit, as given in [Spo93]:

$$\begin{aligned} \mathfrak{t}_\beta(\theta) = |\cos(\theta)| + |\sin(\theta)| + \beta^{-1} & \left[|\sin(\theta)| \log \left[\frac{|\sin(\theta)|}{|\cos(\theta)| + |\sin(\theta)|} \right] \right. \\ & \left. + |\cos(\theta)| \log \left[\frac{|\cos(\theta)|}{|\cos(\theta)| + |\sin(\theta)|} \right] \right]. \end{aligned}$$

The results of Section 6, Proposition A.3 yield the value of the surface tension at the poles, i.e. for a tangent angle $\theta \in (\pi/2)\mathbb{Z}$. It reads:

$$\forall k \in \mathbb{Z}, \quad \mathfrak{t}_\beta(k\pi/2) = 1 + \frac{1}{\beta} \log(1 - e^{-\beta}) < 1. \quad (2.41)$$

The parameter β introduces a discontinuity at the poles: for $k \in \mathbb{Z}$, $\lim_{\theta \rightarrow k\pi/2} \mathfrak{t}_\beta(\theta) = 1 \neq \mathfrak{t}_\beta(k\pi/2)$.

Speed of growth:

Another question of interest is the magnitude of the typical speed at which a big enough droplet grows to cover the whole space. The conjecture is that the microscopic speed V_{micro} reads

$$V_{\text{micro}} \sim CH, \tag{2.42}$$

see [SS98] for details, with H the amplitude of the magnetic field. This conjecture is easily verified in our case, where $H = h/N$ with a fixed $h > 0$. Indeed, we establish in Section 5, see particularly Lemma 5.5, that away from the poles droplets grow in volume with (inwards, macroscopic) normal speed:

$$v = ak - \mu h, \tag{2.43}$$

and the curvature should reasonably stay bounded as the droplet grows. The quantity a is the anisotropy defined in (2.19) and μ the mobility, see (2.26). As space is rescaled by $1/N$ and time by N^2 , one can relate microscopic and macroscopic speed by

$$v \sim (1/N) \times N^2 V_{\text{micro}} \quad \Rightarrow \quad V_{\text{micro}} \sim N^{-1} \sim H,$$

and (2.42) holds for the contour dynamics. The typical growth trajectory will satisfy (2.32).

2.5 Structure of the proof of large deviations

The proof of Theorem 2.8 takes up nearly whole of the paper.

- Before looking at rare events specifically, an understanding of the dynamics at the poles is required. This is the object of the very technical Section 6, where in particular a proof that poles behave like reservoirs in the sense of Proposition 2.2 is carried out.
- The proof of large deviations starts in Section 3. Following the standard techniques of [KOV89] (see also Chapter 11 in [KL99]), we introduce dynamics tilted by a bias $H \in \mathcal{C}$, where \mathcal{C} is defined in (2.13), and compute the Radon-Nikodym derivative between the contour and tilted dynamics. To avoid pathological issues with the contour dynamics, the computation is carried out for trajectories with values in $N\mathcal{E}_r$, with \mathcal{E}_r the nice set of droplets, defined heuristically in (2.15), and precisely in Appendix B. There are then two difficulties. The first one is the understanding of the contribution of the poles, which is made possible through Section 6. The second one is related to the fact that, at the microscopic level, we obtain discrete sums on points in a contour, on objects that do not directly make sense at the macroscopic level. These discrete objects have to be interpreted in terms of line integrals and tangent angles to obtain the functionals ℓ_H, J_H for $H \in \mathcal{C}$, defined in (2.34)-(2.35), from which the rate function (2.37) is built.
- Section 4 contains upper bound large deviations. The proof mirrors that of Chapter 10 in [KL99]. The added difficulty comes from the fact that the functional J_H does not have nice continuity property, so the state space needs to be further restricted. This involves a lot of work on the functional J_H itself, as well as a refinement of the estimates of Section 6 on the dynamics at the poles, which is carried out in Appendix B.3.

- Section 5 contains the lower bound, which amounts to laws of large numbers for the tilted processes, i.e. Proposition 2.5. As a first step, we need to make sure that the tilted contour dynamics takes a diffusive time to exit a nice subset of the state space, i.e. we prove Proposition 2.4. Due to the lack of suitable continuity of the functional J_H , $H \in \mathcal{C}$, it is difficult to directly obtain the lower bound, and thus Proposition 2.5; through a standard hydrodynamic limit approach (see e.g. Chapters 4-5 in [KL99]). Instead, the lower bound of Theorem 2.8 is obtained through upper bound large deviations for the tilted processes.

3 Some relevant martingales

3.1 Motivations

To investigate rare events, we are going to consider a tilted probability measure, as in Chapter 10 of [KL99]. Fix a time $T_0 > 0$ throughout the rest of Section 3, and introduce a magnetic field $H \in \mathcal{C}$ (defined in (2.13)), so that for any Borel set $B \subset D_{\mathcal{H}}([0, T_0], N^{-1}X_r^N)$ (the set of Hausdorff-càdlàg trajectories with values in $N^{-1}X_r^N$):

$$Q_{r,\beta}^N(B) = \mathbb{E}_{r,\beta}^N[\mathbf{1}_{\gamma \in B}] = \mathbb{E}_{r,\beta,H}^N[(D_{r,\beta,H}^N)^{-1}\mathbf{1}_{\gamma \in B}],$$

where $D_{r,\beta,H}^N = d\mathbb{P}_{r,\beta,H}^N/d\mathbb{P}_{r,\beta}^N$ is the Radon-Nikodym derivative until time T_0 , defined by:

$$N^{-1} \log D_{r,\beta,H}^N = \langle \Gamma_{T_0}, H_{T_0} \rangle - \langle \Gamma_0, H_0 \rangle - \int_0^{T_0} e^{-N\langle \Gamma_\tau, H_\tau \rangle} (\partial_\tau + N^2 \mathcal{L}_{r,\beta}) e^{N\langle \Gamma_\tau, H_\tau \rangle} d\tau. \quad (3.1)$$

In (3.1), for a domain $\Gamma \in N^{-1}X_r^N$ and $G : [-1, 1]^2 \rightarrow \mathbb{R}$, we write $\langle \Gamma, G \rangle := \int_\Gamma G$.

Obtaining lower-bound large deviations from that method requires computing hydrodynamic limits for all sequences of laws $(Q_{r,\beta,H}^N)_N$ with bias $H \in \mathcal{C}$. To do so, we investigate the behaviour of the projected processes $\langle \Gamma, G \rangle$, $\Gamma \in D_{\mathcal{H}}([0, T_0], N^{-1}X_r^N)$, for a large class of test functions G (here, $G \in \mathcal{C}$), for which Ito's formula reads:

$$\forall t \leq T_0, \quad \langle \Gamma_t, H_t \rangle = \langle \Gamma_0, H_0 \rangle + \int_0^t (\partial_\tau + N^2 \mathcal{L}_{r,\beta,H}) \langle \Gamma_\tau, H_\tau \rangle d\tau + M_t^G, \quad (3.2)$$

where $(M_t^G)_{t \in [0, T_0]}$ is a martingale. It turns out that the computations of the action of the generator in (3.1) and in (3.2) are similar. Moreover, for the specific choice $G = H$, (3.2) is nearly identical to (3.1) to highest order in N . For this reason, as (3.2) is slightly more general, we detail the computation of M_t^G rather than that of $D_{r,\beta,H}^N$. The only non-trivial part is the computation of $N^2 \mathcal{L}_{r,\beta,H} \langle \Gamma, G \rangle$, which we now perform. For the rest of Section 3, we fix a test function $G \in \mathcal{C}$.

3.2 Computation of $N^2 \mathcal{L}_{r,\beta,H} \langle \Gamma, G \rangle$

We rewrite $N^2 \mathcal{L}_{r,\beta,H} \langle \Gamma, G \rangle$ as a term depending on the pole dynamics, plus another term that corresponds to the exclusion process on each quadrant of Γ . With particles corresponding to

vertical edges, the exclusion term is rewritten in terms of local averages $\xi_x^{\varepsilon N}$ of the ξ 's, where for $\gamma \in X_r^N$ and $x \in V(\gamma)$, $\varepsilon > 0$ and $N \in \mathbb{N}^*$, the local density of vertical edges $\xi_x^{\varepsilon N}$ is defined as:

$$\xi_x^{\varepsilon N} = \frac{1}{2\varepsilon N + 1} \sum_{y \in B(x, \varepsilon N) \cap V(\gamma)} \xi_y. \quad (3.3)$$

The ball is taken with respect to $\|\cdot\|_1$, and we omit integer parts for ease of notation. In our case, it will be convenient to write $\xi_x^{\varepsilon N}$ as a function of the tangent vector at x . Recall that we always enumerate elements of $V(\gamma)$ *clockwise*, and define $\mathbf{t}_x = e_x^+$ as the vector tangent to γ between x and $x + e_x^+$. In this case, the average tangent vector $\mathbf{t}_x^{\varepsilon N}$ reads:

$$\mathbf{t}_x^{\varepsilon N} = \frac{1}{2\varepsilon N + 1} \sum_{y \in B(x, \varepsilon N) \cap V(\gamma)} e_y^+ = \pm(1 - \xi_x^{\varepsilon N})e_1 + \pm\xi_x^{\varepsilon N}e_2. \quad (3.4)$$

In the following, we shall consider rescaled microscopic curves $\gamma \in N^{-1}X_r^N$, and we write $\xi_x, \mathbf{t}_x^{\varepsilon N}$ for $x \in \gamma$ to denote $\xi_y, \mathbf{t}_y^{\varepsilon N}$ with $y \in N\gamma \in X_r^N$, $y = Nx$.

The signs in (3.4) depend on the quadrant x belongs to. For instance, if $B(x, \varepsilon N)$ is included in the first quadrant,

$$\mathbf{t}_x = (1 - \xi_x)e_1 - \xi_x e_2 \Rightarrow \mathbf{t}_x^{\varepsilon N} = (1 - \xi_x^{\varepsilon N})e_1 - \xi_x^{\varepsilon N}e_2.$$

We stress the fact that due to the lattice structure, $\|\mathbf{t}_x^{\varepsilon N}\|_1 = 1 \neq \|\mathbf{t}_x^{\varepsilon N}\|_2$. This is where the anisotropy (2.2) in the macroscopic motion by curvature (2.18) comes from. Define consequently the norm and normalised tangent vector:

$$\forall x \in V(\gamma), \quad v_x^{\varepsilon N} := \|\mathbf{t}_x^{\varepsilon N}\|_2, \quad \mathbf{T}_x^{\varepsilon N} = \mathbf{t}_x^{\varepsilon N} / v_x^{\varepsilon N}. \quad (3.5)$$

As $\|\mathbf{t}_x^{\varepsilon N}\|_1 = 1$, we get:

$$v_x^{\varepsilon N} = \|\mathbf{t}_x^{\varepsilon N}\|_2 = (\|\mathbf{T}_x^{\varepsilon N}\|_1)^{-1}. \quad (3.6)$$

For $d \in (0, 1/4)$, recall from Definition 2.1 the definition of $N^{-1}X_r^N \cap \mathcal{E}_r(d)$, the set of (rescaled) microscopic curves in the effective state space \mathcal{E}_r which, in addition, are at distance at least d from $\partial([-1, 1]^2)$. Take a contour γ in that set and let $J \in C^2([-1, 1]^2)$. We are going to prove:

$$N^2 \mathcal{L}_{r, \beta, H} \langle \Gamma, J \rangle = \left[\text{line integral on } \gamma \text{ of a function of } \mathbf{t}^{\varepsilon N} \text{ and } J, H \right] + o(1), \quad (3.7)$$

where $o(1)$ is shorthand for error terms in N, ε , and other parameters that will appear along the proof, whose time integral is small. The precise statement of (3.7) is given later on in Proposition 3.9; for now we give a microscopic expression of $N^2 \mathcal{L}_{r, \beta, H} \langle \Gamma, G \rangle$.

Proposition 3.1. *Fix a time $T_0 > 0$. For any $\delta > 0$, there is $\varepsilon_0(\delta) \in (0, 1)$ such that, for any $\varepsilon \in (0, \varepsilon_0(\delta))$ smaller than some $\varepsilon(\delta)$ and any $d \in (0, 1/4)$, there is a set $Z = Z(\delta, \varepsilon, d) \subset E([0, T_0], X)$ such that, for trajectories in Z :*

$$\begin{aligned} \int_0^{T_0} N^2 \mathcal{L}_{r, \beta, H} \langle \Gamma_\tau, G_\tau \rangle d\tau &= -\left(\frac{1}{4} - \frac{e^{-\beta}}{2}\right) \int_0^{T_0} \sum_{k=1}^4 [G(\tau, L_k(\tau)) + G(\tau, R_k(\tau))] d\tau + C(G, H) o_\delta(1) \\ &+ O_{G, H} \left(\int_0^{T_0} d\tau \sum_{k=1}^4 \frac{p_k(\tau)}{N} \right) + \frac{1}{4N} \int_0^{T_0} d\tau \sum_{x \in V^\varepsilon(\gamma_\tau)} (v_x^{\varepsilon N})^2 [\mathbf{T}_x^{\varepsilon N} \cdot m(x)] \mathbf{T}_x^{\varepsilon N} \cdot \nabla G(\tau, x) d\tau \\ &+ \frac{1}{N} \int_0^{T_0} d\tau \sum_{x \in V(\gamma_\tau)} (v_x^{\varepsilon N})^2 |\mathbf{T}_x^{\varepsilon N} \cdot e_1| |\mathbf{T}_x^{\varepsilon N} \cdot e_2| (GH)(\tau, x). \end{aligned} \quad (3.8)$$

Recall that p_k is the number of edges in Pole $k \in \{1, \dots, 4\}$. The vector $\mathbf{T}^{\varepsilon N}$ is defined in (3.5), and the quantity $m = (\pm 1, \pm 1)$ is a sign vector with value determined only by the quadrant, see Definition 3.6. For $\gamma \in X_r^N$, $V^\varepsilon(\gamma) \subset V(\gamma)$ is the subset of vertices at 1-distance at least εN from the poles.

Moreover, $Z^c \cap E([0, T_0], \mathcal{E}_r(d))$ satisfies:

$$\limsup_{\varepsilon \rightarrow 0} \limsup_{N \rightarrow \infty} \frac{1}{N} \log \mathbb{P}_{r, \beta, H}^N(Z^c \cap E([0, T_0], \mathcal{E}_r(d))) = -\infty.$$

The set $E([0, T_0], \mathcal{E}_r(d))$ is defined in Appendix B.2.

The rest of Section 3 is devoted to the proof of Proposition 3.1 (and its statement in the continuous limit, Proposition 3.9). We write the different terms in (3.8) for fixed time whenever possible, in which case the time dependence on G and H is omitted.

Notation: in the rest of Section 3, we consider only rescaled microscopic curves in $N^{-1}X_r^N$, and fix $\gamma \in N^{-1}X_r^N \cap \mathcal{E}_r$. $\Gamma \subset [-1, 1]^2$ is the corresponding droplet: $\gamma = \partial\Gamma$. We still denote by $V(\gamma)$ the points of $N^{-1}\mathbb{Z}^2$ that γ passes through, and by $P_k(\gamma)$, $k \in \{1, \dots, 4\}$ the poles of γ . We write abusively $x, x + 2e_x^+ \in P_k(\gamma)$ for $x \in V(\gamma)$, instead of $x, x + 2e_x^+/N \in P_k(\gamma)$.

Proof of Proposition 3.1.

Recall from (2.14) the definition of the jump rates under the dynamics with bias H . We claim that, to highest order in N , the bias does not change the jump rate at the pole. Indeed, if x is in a pole of γ and $t \in [0, T_0]$,

$$c^{Ht}(\gamma, \gamma^{\pm, x}) = c(\gamma, \gamma^{\pm, x})(1 + O_H(N^{-1})), \quad (3.9)$$

so that the bias changes the jump rate at pole $P_k(t)$, $k \in \{1, \dots, 4\}$ by at most $O_H(p_k(t)/N)$, with $p_k(t) = |P_k(t)|$. As proven later (in Section 6), the time integral of this quantity is of order $1/N$. To highest order in N , $N^2 \mathcal{L}_{r, \beta, H} \langle \Gamma, G \rangle$ thus reads, omitting the time dependence:

$$N^2 \mathcal{L}_{r, \beta, H} \langle \Gamma, G \rangle = \text{Bulk term} + \text{Pole terms},$$

with (recall (2.14) for the definition of the jump rates):

$$\text{Bulk term} = N^2 \sum_{x \in V(\gamma)} c_x^{Ht}(\gamma) [\langle \Gamma^x, G \rangle - \langle \Gamma, G \rangle], \quad (3.10)$$

and, by (2.11)-(2.12):

$$\begin{aligned} \text{Pole terms} &= N^2 \sum_{k=1}^4 \sum_{\substack{x \in P_k(\gamma) \\ x+2e_x^+ \in P_k(\gamma)}} \left[\mathbf{1}_{D_{P_r^k, P_k=2}} [\langle \Gamma^{x, -}, G \rangle - \langle \Gamma, G \rangle] + e^{-2\beta} \mathbf{1}_{x \notin \partial([-1, 1]^2)} [\langle \Gamma^{x, +}, G \rangle - \langle \Gamma, G \rangle] \right] \\ &\quad - \frac{N^2}{2} \sum_{k=1}^4 \mathbf{1}_{p_k=2} \sum_{x \in \{R_k, L_k\}} [\langle \Gamma^x, G \rangle - \langle \Gamma, G \rangle] + O_H \left(\sum_{k=1}^4 \frac{p_k}{N} \right). \end{aligned} \quad (3.11)$$

DP_r^k is the set V_r or H_r , defined in (2.9)-(2.10), depending on the value of $k \in \{1, \dots, 4\}$. The second line in (3.11) corresponds to the rate $1/2$ jumps that delete only one of two blocks of a pole of size 2, that are forbidden by the dynamics. However, it is convenient to incorporate them in the Bulk term (3.10), hence the need to subtract them.

The notation $\sum_{x, x+2e_x^+ \in P_k}$ is a way of enumerating all $p_k - 1$ vertices in the pole P_k , $k \in \{1, \dots, 4\}$ such that two blocks can be placed atop $[x, x + 2e_x^+]$ or removed below $[x, x + 2e_x^+]$. Finally, the error term $O_H(\sum_{k=1}^4 p_k/N)$ is a consequence of (3.9); its time integral is of order $O_H(1/N)$ as proven in Section 6.

To prove Proposition 3.1, we treat the Bulk and Pole terms separately.

- Section 3.2.1 deals with the Pole terms (3.11), which are a specificity of the contour dynamics. We state all useful results; proofs are postponed to Section 6.
- Section 3.2.2 contains all results on the Bulk term (3.10). We explain how to express them in terms of local averages of the tangent vector $\mathbf{t}_x^{\varepsilon N}$, by tweaking the usual methods used e.g. for the exclusion process. This concludes the proof of Proposition 3.1. The Bulk term (3.10), which will correspond to the last two terms in (3.8), is then recast in terms of N -independent line-integrals. This is the content of Proposition 3.9, stated at the end of the section.

3.2.1 Pole terms

Fix $d \in (0, 1/4)$ and recall notations and the definition of $\mathcal{E}_r(d)$ from Definition 2.1; of $E([0, T_0], \mathcal{E}_r(d))$ from Appendix B.2. In this section, we compute the Pole terms (3.11), and obtain the following result:

Lemma 3.2. *For each $\delta > 0$, there is a set $Z_P = Z_P(d, \delta) \subset E([0, T_0], X)$ such that, for trajectories in Z_P :*

$$\int_0^{T_0} d\tau [\text{Pole terms for } \gamma_\tau] = C(G)O_N(1) + O_G(\delta) + \frac{e^{-\beta}}{2} \int_0^{T_0} [G(\tau, R_k(\tau)) + G(\tau, L_k(\tau))] d\tau. \quad (3.12)$$

Moreover:

$$\limsup_{N \rightarrow \infty} \frac{1}{N} \log \mathbb{P}_{r, \beta, H}^N((Z_P)^c \cap E([0, T_0], \mathcal{E}_r(d))) = -\infty.$$

Proof. Notice first that deleting a single block with extremity x means subtracting to $\langle \Gamma, G \rangle$ the contribution of G on a block of side-length $1/N$, i.e. $N^{-2}G(x/N) + O_G(N^{-3})$. Similarly, adding one block contributes $N^{-2}G(x/N) + O_G(N^{-3})$. As a result, $N^2 \sum_{x \in \{R_k, L_k\}} \langle \Gamma^x, G \rangle$ contributes $-G(L_k/N) - G(R_k/N)$ to highest order in N for each $k \in \{1, \dots, 4\}$, so that (3.11) reads:

$$\text{Pole terms} = \frac{1}{2} \sum_{k=1}^4 \mathbf{1}_{p_k=2} [G(L_k/N) + G(R_k/N)] \quad (3.13)$$

$$+ 2 \sum_{k=1}^4 \sum_{\substack{x \in P_k(\gamma) \\ x+2e_x^+ \in P_k(\gamma)}} [e^{-2\beta} \mathbf{1}_{x \notin \partial([-1, 1]^2)} - \mathbf{1}_{DP_r^k, p_k=2}] G(x/N) + O_{G, H} \left(N^{-1} \sum_{k=1}^4 p_k \right) \quad (3.14)$$

The claim of Lemma 3.2 is then a simple consequence of the following three lemmas, the proofs of which, postponed to Section 6, are one of the major technical difficulties of this article. In each of the lemmas, the condition $\{\forall \tau \in [0, T_0], \gamma_\tau \in \mathcal{E}_r\}$ (or $\mathcal{E}_r(d)$) is enforced to control the change of probability between $\mathbb{P}_{r,\beta,H}^N$ and $\mathbb{P}_{r,\beta}^N$, as will be seen in the computations of Section 3.2.2. Parameters r, β are chosen as in Definition 2.1.

Lemma 3.3. *For each pole $k \in \{1, \dots, 4\}$ and each $A > 1$,*

$$\limsup_{N \rightarrow \infty} \frac{1}{N} \log \mathbb{P}_{r,\beta,H}^N \left(\forall \tau \in [0, T_0], \gamma_\tau \in \mathcal{E}_r; \right. \\ \left. \frac{1}{T_0} \int_0^{T_0} \mathbf{1}_{P_k(\gamma_\tau) \cap \partial([-1,1]^2) = \emptyset} e^{-2\beta} (p_k(\tau) - 1) d\tau > A \right) = -\infty.$$

For trajectories taking values in $\mathcal{E}_r(d) \subset \mathcal{E}_r$, this lemma implies that the time integral of the $\sum_{k=1}^4 p_k/N$ error term in (3.14) is of order $1/N$, hence vanishes to leading order in N as previously claimed.

Lemma 3.4. *Let $G \in C^{0,1}(\mathbb{R}_+ \times [-1, 1]^2)$ be compactly supported in time, recall the definition of DP_r^k from (2.9)-(2.10) and let W_t^G be defined, for $t \geq 0$, as:*

$$W_t^G = \sum_{k=1}^4 \sum_{\substack{x \in P_k(t) \\ x+2e_x^\pm \in P_k(t)}} [\mathbf{1}_{P_k(t)=2, DP_r^k} - \mathbf{1}_{P_k(t) \cap \partial([-1,1]^2) = \emptyset} e^{-2\beta}] G(t, x). \quad (3.15)$$

We write $G(t, x)$ instead of $G(t, x/N)$ as we work on rescaled microscopic curves. Then:

$$\forall \delta > 0, \quad \limsup_{N \rightarrow \infty} \frac{1}{N} \log \mathbb{P}_{r,\beta,H}^N \left(\forall \tau \in [0, T_0], \gamma_\tau \in \mathcal{E}_r; \left| \int_0^{T_0} W_\tau^G d\tau \right| > \delta \right) = -\infty. \quad (3.16)$$

Thanks to Lemma 3.4, the time integral of the first term in (3.14) vanishes to leading order in N . It remains to compute (3.13), i.e. the $\mathbf{1}_{p_k=2} \sum_{x \in \{R_k, L_k\}}$ term. Its value is in fact fixed by the dynamics in terms of β , and can be computed.

Lemma 3.5. *For each pole $k \in \{1, \dots, 4\}$, each $\delta > 0$ and each $G \in \mathcal{C}$,*

$$\limsup_{N \rightarrow \infty} \frac{1}{N} \log \mathbb{P}_{r,\beta,H}^N \left(\text{for a.e. } \tau \in [0, T_0], \gamma_\tau \in \mathcal{E}_r(d); \right. \\ \left. \left| \int_0^{T_0} G(\tau, L_k(\tau)) (\mathbf{1}_{p_k(\tau)=2} - e^{-\beta}) d\tau \right| > \delta \right) = -\infty.$$

We now define the set Z_P mentioned in Lemma 3.2. For $A > 1$, define the set of trajectories with poles of size less than $Ae^{2\beta}$:

$$B_p^N = B_p^N(A, \beta) := \bigcap_{k=1}^4 \left\{ (\gamma_\tau^N)_{\tau \in [0, T_0]} \in E([0, T_0], N^{-1} X_r^N) : \right. \\ \left. \frac{1}{T_0} \int_0^{T_0} (p_k(\tau) - 1) e^{-2\beta} \mathbf{1}_{P_k(\gamma_\tau^N) \cap \partial([-1,1]^2) = \emptyset} d\tau \leq A \right\}. \quad (3.17)$$

On this set, the error term $\int_0^{T_0} d\tau \sum_k p_k(\tau)/N$ is of order N^{-1} as claimed below (3.11). By Lemma 3.3, $(B_p^N)^c \cap E([0, T_0], \mathcal{E}_r)$ has probability super-exponentially small under $\mathbb{P}_{r, \beta, H}^N$. Define then $Z_P = Z_P(A = 2, \beta, \delta)$ as:

$$Z_P = B_p^N(2, \beta) \cap \left\{ \left| \int_0^{T_0} W_\tau^G d\tau \right| \leq \delta \right\} \cap \left\{ \sum_{k=1}^4 \left| \int_0^{T_0} G(t, L_k(t)) (\mathbf{1}_{p_k(\tau)=2} - e^{-\beta}) d\tau \right| \leq \delta \right\}. \quad (3.18)$$

On the subset of trajectories taking values in $N^{-1}X_r^N \cap \mathcal{E}_r(d)$ for almost every time, $(Z_P)^c$ has indeed probability super-exponentially small under $\mathbb{P}_{r, \beta, H}^N$. This completes the proof of Lemma 3.2. \square

3.2.2 Bulk terms

In this section, we focus on the Bulk term. The proof of Proposition 3.1 is completed, and discrete sums recast in terms of line integrals in Proposition 3.9. As the time dependence of H, G plays no role in the detail of the computations, we consider H, G as functions in $C^2([-1, 1]^2)$. We proceed in several steps.

Step 1: discrete Bulk terms.

Recall from (3.4) that the microscopic tangent vector $\mathbf{t}_x^{\varepsilon N}$ has coordinates $\pm \xi_x^{\varepsilon N}$, $\pm(1 - \xi_x^{\varepsilon N})$ with signs that vary depending on the quadrant. It is useful to define a function m that contains information on how these signs vary.

Definition 3.6. Recall that γ is a curve in $N^{-1}X_r^N \cap \mathcal{E}_r$, and define a function $m(\gamma) : \gamma \setminus P(\gamma) \rightarrow \mathbb{R}^2$ as follows:

$$\forall x \in \gamma \setminus P(\gamma), \quad m(x) := m(\gamma, x) = -\sqrt{2}e_{\pi/4 - (k(x)-1)\pi/2}, \quad (3.19)$$

where $P(\gamma) = \cup_k P_k(\gamma)$ is the union of the poles of γ . In (3.19), $k(x) \in \{1, \dots, 4\}$ is the index of the quadrant of γ the point x belongs to. This means that $m(x) = (-1, -1)$ for x in the first quadrant, $m(x) = (-1, 1)$ in the second quadrant, etc.

Lemma 3.7. For fixed $\delta > 0$, there is $\varepsilon_0(\delta) \in (0, 1)$ such that, for each $\varepsilon \in (0, \varepsilon_0(\delta))$, there is a set $Z_B = Z_B(\delta, \varepsilon) \subset E([0, T_0], X)$, on which:

$$\begin{aligned} \int_0^{T_0} d\tau [\text{Bulk term for } \gamma_\tau] &= -\frac{1}{4} \int_0^{T_0} d\tau \sum_{k=1}^4 [G(\tau, L_k(\gamma_\tau)) + G(\tau, R_k(\gamma_\tau))] + C_{G,H}(o_\delta(1) + o_N(1)) \\ &+ \frac{1}{N} \int_0^{T_0} d\tau \sum_{x \in V(\gamma_\tau)} |\mathbf{t}_1 \mathbf{t}_2| H(\tau, x) G(\tau, x) + \frac{1}{4N} \int_0^{T_0} d\tau \sum_{x \in V^\varepsilon(\gamma_\tau)} [\mathbf{t} \cdot m(x)] \mathbf{t} \cdot \nabla G(\tau, x). \end{aligned} \quad (3.20)$$

In this formula, \mathbf{t}, \mathbf{t}_i are short for $\mathbf{t}_x^{\varepsilon N}, \mathbf{t}_x^{\varepsilon N} \cdot e_i$, $i \in \{1, 2\}$, with $\mathbf{t}_x^{\varepsilon N}$ defined in (3.4). For $\gamma \in N^{-1}X_r^N$, the set $V^\varepsilon(\gamma) \subset V(\gamma)$ contains all points at 1-distance at least ε from the poles of γ .

In addition, the set $Z_B = Z_B(\delta, \varepsilon)$ satisfies:

$$\limsup_{\varepsilon \rightarrow 0} \limsup_{N \rightarrow \infty} \frac{1}{N} \log \mathbb{P}_{r, \beta, H}^N (Z_B^c \cap E([0, T_0], \mathcal{E}_r)) = -\infty.$$

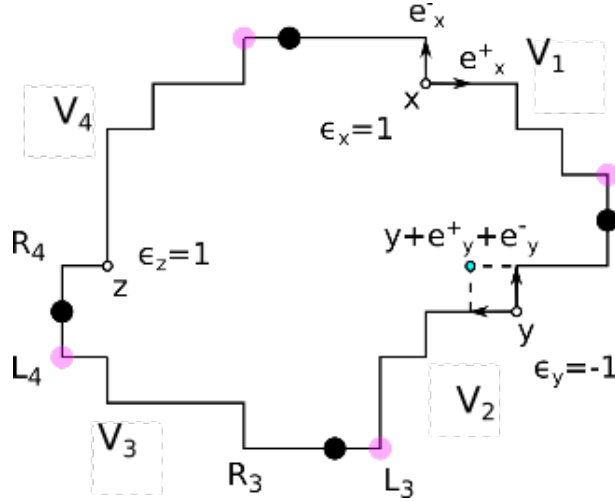

Figure 4.6 – Definition of the V^k , $k \in \{1, \dots, 4\}$, represented for a curve in X_r^N (i.e. non rescaled by N^{-1}) for legibility. The black dots are the first vertices and the light dots the last vertices of each V^k . Three points are marked by empty circles, with the corresponding value of $\varepsilon(\gamma)$. The block that is deleted if y is flipped is represented, the two arrows correspond to e_y^+ and e_y^- .

Proof of Lemma 3.7. As for the Pole terms in Section 3.2.1, we work at fixed time and omit the time dependence. The letter γ still denotes a curve in $N^{-1}X_r^N \cap \mathcal{E}_r$. Let $x \in V(\gamma)$ not be in a pole of size 2. Recall that e_x^+, e_x^- are the unit vectors with origin x , pointing respectively towards the next and the previous point of $V(\gamma)$ when travelling clockwise. If x is flipped, then:

$$\begin{aligned} \int_{\Gamma^x} G - \int_{\Gamma} G &= \varepsilon_x(\gamma) \int_{[x, x+e_x^-/N] \times [x, x+e_x^+/N]} G = \frac{\varepsilon_x(\gamma)}{N^2} \int_{[0,1]^2} G\left(x + \frac{u}{N}e_x^- + \frac{v}{N}e_x^+\right) dudv \\ &= \frac{\varepsilon_x(\gamma)}{N^2} \left(G(x) + \frac{1}{2N} (\partial_{e_x^-} + \partial_{e_x^+}) G(x) \right) + O(N^{-4}), \end{aligned}$$

which is the contribution of the integral of G over the block that is added or removed when flipping x . Above, $\varepsilon_x(\gamma)$ is 1 if flipping x means adding one block, and -1 if it means deleting one (see Figure 4.6). Recall from (2.6)-(2.14) that for $x \in V(\gamma)$ and $t \in [0, T_0]$,

$$c_x^{H_t}(\gamma) = c_x(\gamma) (1 + N \langle \Gamma^x, H_t \rangle - N \langle \Gamma, H_t \rangle) + O_H(N^{-2}). \quad (3.21)$$

Since $\gamma \in \mathcal{E}_r$, the jump rate $c^{H_t}(\gamma, \gamma^x)$ is equal to $c_x^{H_t}(\gamma)$, i.e. it is local, see (2.6). The Bulk term (3.10) thus reads:

$$\begin{aligned} \text{Bulk term} &= \frac{1}{N} \sum_{x \in V(\gamma)} c_x(\gamma) (HG)(x) + \sum_{x \in V(\gamma)} c_x(\gamma) \varepsilon_x(\gamma) G(x) \\ &\quad + \frac{1}{2N} \sum_{x \in V(\gamma)} c_x(\gamma) \varepsilon_x(\gamma) (\partial_{e_x^-} + \partial_{e_x^+}) G(x) + O_G(N^{-1}). \end{aligned} \quad (3.22)$$

At first sight, the second sum is of order N since $|V(\gamma)| \approx N$, whereas we want something of order 1. We split it along each quadrant and show that we can perform another integration by

parts. To decompose the curves on each quadrant $C_k(\gamma)$, $k \in \{1, \dots, 4\}$, consider the subset V_k of $V(\gamma) \cap C_k(\gamma)$ composed of all vertices starting from the first vertex of P_k after L_k , and ending at L_{k+1} ($L_5 := L_1$), see Figure 4.6. In that way, on each of the V_k , the computation of (3.22) is the same as for a SSEP. Indeed, with this definition of the V_k , for each k and $x \in V_k$, $\varepsilon_x(\gamma)$ and $c_x(\gamma)$ can be expressed in terms of the local "occupation numbers" ξ_y , $\|y - x\|_1 \leq N^{-1}$ only. For instance for $x \in V_1$:

$$2c_x(\gamma)\varepsilon_x(\gamma) = \xi_{x+e_x^-} - \xi_x. \quad (3.23)$$

With that splitting along the V_k , (3.22) becomes:

$$\text{Bulk term} := \frac{1}{N} \sum_{x \in V(\gamma)} c_x(\gamma)(HG)(x) + \sum_{k=1}^4 B_k + \sum_{k=1}^4 B'_k + O_G(N^{-1}), \quad (3.24)$$

where:

$$B_k = \sum_{x \in V_k} c_x(\gamma)\varepsilon_x(\gamma)G(x), \quad B'_k = \frac{1}{2N} \sum_{x \in V_k} c_x(\gamma)\varepsilon_x(\gamma)(\partial_{e_x^-} + \partial_{e_x^+})G(x). \quad (3.25)$$

1) B_k **terms**: using equation (3.23), B_1 reads:

$$\begin{aligned} B_1 &= \sum_{x \in V_1} c_x(\gamma)\varepsilon_x(\gamma)G(x) = \frac{1}{2} \sum_{x \in V_1} G(x)(\xi_{x+e_x^-} - \xi_x) \\ &= \frac{1}{4} \sum_{x \in V_1} G(x) [\xi_{x+e_x^-} - \xi_x + (1 - \xi_x) - (1 - \xi_{x+e_x^-})]. \end{aligned} \quad (3.26)$$

The passage from first to second line aims at making the expression symmetrical with respect to the transformation $\xi \leftarrow 1 - \xi$. The reason is that the contour model is symmetrical with respect to a global $\pi/2$ rotation, whereas the notation ξ_x is not: in terms of SSEP, ξ_x is one if there is a particle in quadrants 1 and 3, but is 1 if there is a hole instead in quadrants 2 and 4.

By definition, the first edge in V_1 , write it $(R_1 + 1, R_1 + 2)$, is always horizontal: $1 - \xi_{R_1+1} = 1$. On the other hand, V_1 ends at L_2 and $\xi_{L_2} = 1$ by definition of L_2 . Integrating (3.26) by parts, some of the boundary term thus vanish, whence:

$$B_1 = -\frac{1}{4}(G(L_1) + G(L_2)) + \frac{1}{4N} \sum_{x \in V_1} [\xi_x \partial_{e_x^+} G(x) - (1 - \xi_x) \partial_{e_x^+} G(x)] + O_G(N^{-1}). \quad (3.27)$$

On V_1 , $\xi_x e_x^+$ is either 0 if $\xi_x = 0$, or $-e_2$ if $\xi_x = 1$. Similarly, $(1 - \xi_x) e_x^+$ is either 0 or e_1 . In any case, the sign of $e_x^+ \cdot e_i$ is fixed in a given quadrant whenever $e_x^+ \cdot e_i \neq 0$. Thus, to obtain an expression for the B_k that does not explicitly depend on the quadrant, we keep in mind Figure 4.6 and define signs σ_1, σ_2 constant on a given quadrant:

$$\sigma_1 := \begin{cases} 1 & \text{if } x \in V_4 \cup V_1 \\ -1 & \text{if } x \in V_2 \cup V_3 \end{cases}, \quad \sigma_2 := \begin{cases} 1 & \text{if } x \in V_3 \cup V_4 \\ -1 & \text{if } x \in V_1 \cup V_2 \end{cases}. \quad (3.28)$$

The idea behind (3.28) is that (σ_1, σ_2) is "the direction of the tangent vector to a curve" in each quadrant. For instance, in the first quadrants, curves are south-east paths and $(\sigma_1, \sigma_2) = (1, -1)$,

in quadrant 2 curves are south-west paths and $(\sigma_1, \sigma_2) = (-1, -1)$, etc. Compare with m in Definition 3.6, which gives "the direction of the inwards normal":

$$m = -(-\sigma_2, \sigma_1) = (\sigma_2, -\sigma_1). \quad (3.29)$$

Repeating the computations leading to (3.27) on the other quadrants V^k , one finds for the B_k :

$$\begin{aligned} \sum_{k=1}^4 B_k &= -\frac{1}{4} \sum_{k=1}^4 [G(L_k) + G(R_k)] + O_G \left(N^{-1} \sum_{k=1}^4 p_k \right) \\ &+ \frac{1}{4N} \sum_{x \in V(\gamma) \setminus P(\gamma)} \left(-\xi_x \sigma_1 \partial_2 + (1 - \xi_x) \sigma_2 \partial_1 \right) G(x). \end{aligned} \quad (3.30)$$

Equation (3.30) is now clearly composed of terms of order at most 1 in N . The error term is comprised of two contributions. On the one hand, summing the B_k yields a term $-(1/2) \sum_k G(L_k)$. It is more convenient to symmetrise this term and write it as $-(1/4) \sum_k [G(R_k) + G(L_k)]$, which creates an error bounded by $\|\nabla G\|_\infty \sum_k p_k / N$. On the other hand, the sum in (3.27) bore on the entirety of $V(\gamma)$, while in (3.30) all points in $P(\gamma)$ are removed. There are $\sum_k p_k$ such points, which are responsible for an error term bounded by $N^{-1} \sum_k p_k \|G\|_\infty$.

2) B'_k terms (defined in (3.25)): Notice that if $c_x(\gamma) \neq 0$, then $\varepsilon_x(\gamma)(\partial_{e_x^+} + \partial_{e_x^-})$ is the same whether a block is added or deleted at x . Moreover, it depends only on the value of $k \in \{1, \dots, 4\}$ with $x \in V_k$, thus:

$$\sum_{k=1}^4 B'_k = \frac{1}{2N} \sum_{x \in V(\gamma)} c_x(\gamma) \left(-\sigma_2 \partial_1 + \sigma_1 \partial_2 \right) G(x). \quad (3.31)$$

To conclude the proof of Lemma 3.7 from (3.24)-(3.30)-(3.31), it remains to replace ξ_x and $c_x(\gamma)$ by local averages on small macroscopic boxes. It is simple for ξ_x , and requires only an integration by parts and the smoothness of G . For $c_x(\gamma)$, this is the content of the so-called Replacement lemma, stated below and proven in Appendix A.

Lemma 3.8 (Replacement lemma). *Consider a function ϕ on $N^{-1}X_r^N$ defined as follows:*

$$\forall \gamma' \in N^{-1}X_r^N, \forall x \in V(\gamma'), \quad \phi(\gamma', x) := c_x(\gamma').$$

For $\varepsilon > 0$, recall from (3.3) the definition of $\xi_x^{\varepsilon N}$ and define:

$$\tilde{\phi}(\rho) = \rho(1 - \rho), \quad \rho \in [0, 1].$$

For and $F : \mathbb{R}_+ \times [-1, 1]^2$ bounded, define $W_{\varepsilon N}^{\phi, F}$ on $(\tau, \gamma') \in [0, T_0] \times N^{-1}X_r^N$ by:

$$W_{\varepsilon N}^{\phi, F}(\tau, \gamma') = \frac{1}{N} \sum_{x \in V(\gamma')} F(\tau, x) \left[\phi(\gamma', x) - \tilde{\phi}(\xi_x^{\varepsilon N}) \right]. \quad (3.32)$$

Then, for each $\delta > 0$,

$$\limsup_{\varepsilon \rightarrow 0} \limsup_{N \rightarrow \infty} \frac{1}{N} \log \mathbb{P}_{r, \beta, H}^N \left(\forall \tau \in [0, T_0], \gamma_\tau \in \mathcal{E}_r; \left| \int_0^{T_0} W_{\varepsilon N}^{\phi, F}(\tau, \gamma_\tau) d\tau \right| > \delta \right) = -\infty.$$

Using Lemma 3.8, we conclude the proof of Lemma 3.7. Define:

$$B_F(\delta, \varepsilon) = \left\{ (\gamma_\tau)_{\tau \in [0, T_0]} \in E([0, T_0], \mathcal{E}_r) : \left| \int_0^{T_0} W_{\varepsilon N}^{\phi, F}(\tau, \gamma_\tau) d\tau \right| \leq \delta \right\}. \quad (3.33)$$

By Lemma 3.8, for each $\delta > 0$, $(B_F(\delta, \varepsilon)^c \cap E([0, T_0], \mathcal{E}_r))$ satisfies:

$$\limsup_{\varepsilon \rightarrow 0} \limsup_{N \rightarrow \infty} \frac{1}{N} \log \mathbb{P}_{r, \beta, H}^N((B_F(\delta, \varepsilon)^c \cap E([0, T_0], \mathcal{E}_r))) = -\infty.$$

has probability super-exponentially small under $\mathbb{P}_{r, \beta, H}^N$ when N is large and ε small. Define then

$$\tilde{Z}_B := (\tilde{Z}_B)_{H, G}^N(\delta, \varepsilon) = B_{\nabla G}(\delta, \varepsilon) \cap B_{HG}(\delta, \varepsilon). \quad (3.34)$$

The computations leading to (3.24)-(3.30)-(3.31) are valid at each time for a trajectory γ . taking values in $N^{-1}X_r^N \cap \mathcal{E}_r$. Recall from Lemma 3.7 that we are interested in time integrals of (3.24)-(3.30)-(3.31). By Lemma 3.8, for trajectories in \tilde{Z}_B , replacement of local quantities by averages in these equations yields an error term with time integral bounded by δ . To not burden the notations with a time dependence however, we continue to work with a curve $\gamma \in N^{-1}X_r^N \cap \mathcal{E}_r$ and formally replace local functions $\xi_x, e_x^+, c_x(\gamma)$ by their averages on an εN -neighbourhood, knowing by Lemma 3.8 that the procedure is legitimate when integrating in time, up to an error δ .

We start by applying Lemma 3.8 to the first term in (3.24). Recalling that $|\mathbf{t}_x^{\varepsilon N} \cdot e_2| = \xi_x^{\varepsilon N} = 1 - |\mathbf{t}_x^{\varepsilon N} \cdot e_1|$, we find:

$$\frac{1}{N} \sum_{x \in V(\gamma)} c_x(\gamma)(HG)(x) =: \frac{1}{N} \sum_{x \in V(\gamma)} |\mathbf{t}_x^{\varepsilon N} \cdot e_1| |\mathbf{t}_x^{\varepsilon N} \cdot e_2| (HG)(x) + \omega_\varepsilon^{HG}(\gamma). \quad (3.35)$$

Let us now turn to the B_k terms (3.30) and the B'_k terms (3.31). Removing portions of length ε on either side of each pole of γ and replacing $\mathbf{t}_1, \mathbf{t}_2$ by local averages, the sum in the second line of the B_k terms (3.30) is equal to:

$$\frac{1}{4N} \sum_{x \in V^\varepsilon(\gamma) \setminus P(\gamma)} \left[-|\mathbf{t}_x^{\varepsilon N} \cdot e_2| \sigma_1 \partial_2 + |\mathbf{t}_x^{\varepsilon N} \cdot e_1| \sigma_2 \partial_1 \right] G(x) + \omega_\varepsilon^{\nabla G, 1}(\gamma). \quad (3.36)$$

Similarly, the sum in the B'_k terms (3.31) is equal to:

$$\frac{1}{2N} \sum_{x \in V^\varepsilon(\gamma)} |\mathbf{t}_x^{\varepsilon N} \cdot e_2| |\mathbf{t}_x^{\varepsilon N} \cdot e_1| \left(-\sigma_2 \partial_1 + \sigma_1 \partial_2 \right) G(x) + \omega_\varepsilon^{\nabla G, 2}(\gamma). \quad (3.37)$$

By Lemma 3.8, we know that, if $\omega_\varepsilon \in \{\omega_\varepsilon^{HG}, \omega_\varepsilon^{\nabla G, 1}, \omega_\varepsilon^{\nabla G, 2}\}$:

$$\forall \delta > 0, \quad \limsup_{\varepsilon \rightarrow 0} \limsup_{N \rightarrow \infty} \frac{1}{N} \log \mathbb{P}_{r, \beta, H}^N \left(\forall \tau \in [0, T_0], \gamma_\tau \in \mathcal{E}_r \mid \left| \int_0^{T_0} \omega_\varepsilon(\gamma'_\tau) d\tau \right| > \delta \right) = -\infty. \quad (3.38)$$

To conclude the proof of Lemma 3.7, it remains to prove that there is a function $\omega_\varepsilon^{\nabla G}$ of γ , also satisfying (3.38), and such that the contribution of (3.36) and (3.37) is given by:

$$(3.36) + (3.37) = \frac{1}{4N} \sum_{x \in V^\varepsilon(\gamma)} [\mathbf{t} \cdot m(x)] \mathbf{t} \cdot \nabla G(x) + \omega_\varepsilon^{\nabla G}(\gamma), \quad (3.39)$$

where the vector m is defined in Definition 3.6, and \mathbf{t} is short for $\mathbf{t}_x^{\varepsilon N}$; write also $\mathbf{t}_1, \mathbf{t}_2$ for $\mathbf{t}_x^{\varepsilon N} \cdot e_1, \mathbf{t}_x^{\varepsilon N} \cdot e_2$, $x \in V^\varepsilon(\gamma)$. To prove (3.39), write, not explicitly mentioning the error terms:

$$\begin{aligned} (3.36) + (3.37) - \omega'_\varepsilon(\gamma) &= \frac{1}{4N} \sum_{x \in V^\varepsilon(\gamma)} \left[(-|\mathbf{t}_2|\sigma_1 + 2|\mathbf{t}_1||\mathbf{t}_2|\sigma_1)\partial_2 + (|\mathbf{t}_1|\sigma_2 - 2|\mathbf{t}_1||\mathbf{t}_2|\sigma_2)\partial_1 \right] G(x) \\ &= \frac{1}{4N} \sum_{x \in V^\varepsilon(\gamma)} \left[\sigma_1|\mathbf{t}_2|(|\mathbf{t}_1| - |\mathbf{t}_2|)\partial_2 + \sigma_2|\mathbf{t}_1|(|\mathbf{t}_1| - |\mathbf{t}_2|)\partial_1 \right] G(x). \end{aligned} \quad (3.40)$$

To obtain the second line, we used $|\mathbf{t}_1| + |\mathbf{t}_2| = 1$ by definition of \mathbf{t} , see (3.4).

Recall from (3.28) the definition of (σ_1, σ_2) , and by the ensuing discussion and (3.29) the fact that $m = (\sigma_2, -\sigma_1)$, with m as in Definition 3.6. Recall moreover that $V^\varepsilon(\gamma) \subset V(\gamma)$ is the set of points at 1-distance more than ε to the poles to obtain:

$$\forall x \in V^\varepsilon(\gamma), \quad |\mathbf{t}_1| := |\mathbf{t}_x^{\varepsilon N} \cdot e_1| = \sigma_1 \mathbf{t}_1, \quad |\mathbf{t}_2| := |\mathbf{t}_x^{\varepsilon N} \cdot e_2| = \sigma_2 \mathbf{t}_2.$$

This is because all points in $B_1(x, \varepsilon)$ are in the same quadrant for $x \in V^\varepsilon(\gamma)$, thus σ_1, σ_2 are constant on $B_1(x, \varepsilon)$. As a result, (3.40) becomes:

$$\begin{aligned} (3.36) + (3.37) - \omega'_\varepsilon(\gamma) &= \frac{1}{4N} \sum_{x \in V^\varepsilon(\gamma)} \left[\sigma_1 \sigma_2 \mathbf{t}_2 (\sigma_1 \mathbf{t}_1 - \sigma_2 \mathbf{t}_2) \partial_2 + \sigma_2 \sigma_1 \mathbf{t}_1 (\sigma_1 \mathbf{t}_1 - \sigma_2 \mathbf{t}_2) \partial_1 \right] G(x) \\ &= \frac{1}{4N} \sum_{x \in V^\varepsilon(\gamma)} [\sigma_2 \mathbf{t}_1 - \sigma_1 \mathbf{t}_2] [\mathbf{t}_1 \partial_1 + \mathbf{t}_2 \partial_2] G(x) \\ &= \frac{1}{4N} \sum_{x \in V^\varepsilon(\gamma)} [\mathbf{t} \cdot m(x)] \mathbf{t} \cdot \nabla G(x). \end{aligned} \quad (3.41)$$

Now properly integrating (3.24) in time and including all error terms in (3.30)-(3.35)-(3.39), one obtains that, on \tilde{Z}_B , (defined in (3.34)),

$$\left| \int_0^{T_0} \omega_\varepsilon(\gamma_\tau) d\tau \right| \leq 2\delta + C(G, H)\varepsilon T_0 = O_{G,H}(\delta), \quad \omega_\varepsilon := \omega_\varepsilon^{HG} + \omega_\varepsilon^{\nabla G},$$

and:

$$\begin{aligned} \int_0^{T_0} [\text{Bulk term evaluated at } \gamma_\tau] d\tau &= C(G, H)o_\delta(1) + O_{G,H} \left(\int_0^{T_0} d\tau \sum_{k=1}^4 \frac{p_k(\tau)}{N} \right) \\ &+ \frac{1}{4N} \int_0^{T_0} d\tau \sum_{x \in V^\varepsilon(\gamma_\tau)} [\mathbf{t}_x^{\varepsilon N} \cdot m(x)] \mathbf{t}_x^{\varepsilon N} \cdot \nabla G(\tau, x) d\tau \\ &- \frac{1}{4} \int_0^{T_0} \sum_{k=1}^4 [G(\tau, L_k(\tau)) + G(\tau, R_k(\tau))] d\tau + \frac{1}{N} \int_0^{T_0} d\tau \sum_{x \in V(\gamma_\tau)} |\mathbf{t}_x^{\varepsilon N} \cdot e_1| |\mathbf{t}_x^{\varepsilon N} \cdot e_2| (GH)(\tau, x). \end{aligned} \quad (3.42)$$

This is equation (3.20) in Lemma 3.7, up to the error term $\int_0^{T_0} \sum_k p_k/N$. We defined in (3.17) the set $B_p^N(2, \beta)$ in which it is of order N^{-1} , so that if the set Z_B in Lemma 3.7 is defined as:

$$Z_B := (\tilde{Z}_B)_{H,G}^N(\delta, \varepsilon) \cap B_p^N(2, \beta), \quad (3.43)$$

then, on this set, $\int_0^{T_0} p_k(t)/N = O(N^{-1})$, and Z_B satisfies

$$\limsup_{\varepsilon \rightarrow 0} \limsup_{N \rightarrow \infty} \frac{1}{N} \log \mathbb{P}_{r,\beta,H}^N (\forall \tau \in [0, T_0], \gamma_\tau \in \mathcal{E}_r; \gamma \notin Z_B) = -\infty.$$

This concludes the proof of Lemma 3.7. \square

Let us summarise our results and conclude the proof of Proposition 3.1. We have shown the existence of two sets Z_P, Z_B of trajectories in (3.18)-(3.43), with $(Z_P)^c \cup (Z_B)^c \cap E([0, T], \mathcal{E}_r(d))$ having super-exponentially small probability under $\mathbb{P}_{r,\beta,H}^N$. This yields the set Z in Proposition 3.1, setting:

$$Z = Z_{H,G}^N(A = 2, \beta, \delta, \varepsilon) := Z_P(2, \beta, \delta) \cap (Z_B)_{H,G}^N(2, \beta, \delta, \varepsilon). \quad (3.44)$$

In Section 3.2.1, all Pole terms (3.13)-(3.14) were computed, and shown to yield the $e^{-\beta}$ term contribution of the last line of (3.53). In Section 3.2.2, the other terms in (3.53) have been identified. Proposition 3.1 is thus proven, once one recalls the definitions (3.5) of $v^{\varepsilon N}, T^{\varepsilon N}$ and replaces $t^{\varepsilon N}$ by $v^{\varepsilon N} T^{\varepsilon N}$ in (3.42).

\square
Proposition 3.1.

Step 2: Replacement of the discrete sums by line integrals

In Proposition 3.1, discrete sums on all vertices of a contour in $N^{-1}X_r^N$ appear. In the large N limit for element of \mathcal{E}_r , the corresponding N -independent object should be some sort of line integral, thus depends on the contour. In comparison, in the exclusion process the domain on which configurations live is fixed. Correspondingly, only integrals on a fixed interval arise in the large N limit.

If $\gamma \in N^{-1}X_r^N \cap \mathcal{E}_r$ and s is the arclength coordinate on γ , for any continuous mapping $f : \gamma \rightarrow \mathbb{R}$:

$$\frac{1}{N} \sum_{x \in V(\gamma)} f(x) = \sum_{x \in V(\gamma)} f(x) [s(x + e_x^+/N) - s(x)] = \int_\gamma f ds. \quad (3.45)$$

In writing (3.45), information about the lattice structure was omitted, and the resulting functional on the right-hand side of (3.45) is not continuous on \mathcal{E}_r , not even if $f \equiv 1$. Indeed, take a sequence $\gamma_N \in N^{-1}X_r^N \cap \mathcal{E}_r$ converging to some $\gamma_\infty \in \mathcal{E}_r$. The left-hand side of (3.45) converges, for $f \equiv 1$, to the length of γ_∞ in 1-norm, whereas the right-hand side evaluated at γ_∞ is equal to the length in 2-norm, which is in general not the same.

The correct way to write the left-hand side of (3.45), that retains sufficient information on the lattice structure to yield a continuous functional on (a nice subset of) \mathcal{E}_r , is the following:

$$\frac{1}{N} \sum_{x \in V(\gamma)} f(x) = \frac{1}{N} \sum_{x \in V(\gamma)} f(x) \|\mathbf{T}_x\|_1 = \int_\gamma f v^{-1} ds, \quad (3.46)$$

where \mathbf{T} is the tangent vector normed by $\|\mathbf{T}\|_2 = 1$ and $v^{-1} = \|\mathbf{T}\|_1$ is almost everywhere equal to 1 on $\gamma \in N^{-1}X_r^N \cap \mathcal{E}_r$, hence the equalities in (3.46). The proof of the continuity of the right-hand side of (3.46) in Hausdorff distance is not related to microscopic computations, so we postpone it to Proposition 4.3.

Let us however motivate the factor v^{-1} in (3.46), when e.g. v^{-2} would a priori also work. Take $\gamma^N \in N^{-1}X_r^N$ and $x \in V^\varepsilon(\gamma^N)$, i.e. x is at 1-distance at least ε from the poles. For definiteness take x in the first quadrant. By definition of X_r^N , see Figure 4.1, in the reference frame $\mathcal{R}_1 = (O, e_{-\pi/4}, e_{\pi/4})$, the curve $\gamma^N \cap B_1(x, \varepsilon)$ is the graph of a 1-Lipschitz function f^1 :

$$\gamma^N \cap B_1(x, \varepsilon) = \{(y, f^1(y))_{\mathcal{R}_1} : y \in u + [-\varepsilon/\sqrt{2}, \varepsilon/\sqrt{2}]\}, \quad u := x \cdot e_{-\pi/4}.$$

As a result, $\mathbf{t}_x^{\varepsilon N}$ reads:

$$\mathbf{t}_x^{\varepsilon N} = \frac{1}{\sqrt{2}\varepsilon} \int_{u-\varepsilon/\sqrt{2}}^{u+\varepsilon/\sqrt{2}} \mathbf{t}(y) dy, \quad \mathbf{t}(y) = \frac{\sqrt{2}}{2} (1, \partial_y f^1(y))_{\mathcal{R}_1} \quad (3.47)$$

where \mathbf{t} is the tangent vector normed by $\|\mathbf{t}\|_1 = 1$, defined almost everywhere for a Lipschitz curve. Since $\gamma^N \in N^{-1}X_r^N$, $\|\mathbf{t}\|_2 = 1$ almost everywhere, but this is not the case in general for Lipschitz curves. Recall that, by definition:

$$\mathbf{t} = v\mathbf{T}, \quad \|\mathbf{t}\|_1 = 1, \quad \|\mathbf{T}\|_2 = 1, \quad v = \|\mathbf{t}\|_2 = (\|\mathbf{T}\|_1)^{-1}. \quad (3.48)$$

Expression (3.47) does not explicitly depend on N any more, thus can also be written for a curve $\gamma \in \mathcal{E}_r$. Define the set $\gamma(\varepsilon) \subset \gamma$ of points at 1-distance ε or more to the poles, and similarly write:

$$\forall k \in \{1, \dots, 4\}, \forall x \in \gamma(\varepsilon) \cap C_k(\gamma), \quad \mathbf{t}^\varepsilon(x) = \frac{1}{\sqrt{2}\varepsilon} \int_{x \cdot e_{\pi/4 - k\pi/2} - \varepsilon/\sqrt{2}}^{x \cdot e_{\pi/4 - k\pi/2} + \varepsilon/\sqrt{2}} \mathbf{t}(y) dy. \quad (3.49)$$

Recall that $C_k(\gamma)$ is quadrant k of γ , defined in Figure 4.1 or in Appendix B. The vector $\mathbf{t}^\varepsilon(x)$ indeed satisfies $\|\mathbf{t}^\varepsilon(x)\|_1 = 1$, and coincides with $\mathbf{t}_x^{\varepsilon N}$ if $\gamma \in N^{-1}X_r^N$ and $x \in V(\gamma)$. Let us now change variables to obtain a line integral in (3.49). To do so, define $d_\varepsilon^\pm(\cdot) \geq 0$ as the functions of the arclength coordinate s on γ that satisfy:

$$\forall s \leq |\gamma|_2, \quad \|\gamma(s \pm d_\varepsilon^\pm(s)) - \gamma(s)\|_1 = \varepsilon. \quad (3.50)$$

The quantity $|\gamma|_2$ is the usual Euclidean length of γ . Recall the notations $(x^k, f^k)_{\mathcal{R}_k}$ of Section 2.2 to write the portion in quadrant k of γ as the graph of the function f^k in the reference frame \mathcal{R}_k , $k \in \{1, \dots, 4\}$. With $x^k = x \cdot e_{\pi/4 - k\pi/2}$ if $x \in C_k(\gamma)$ and $dx^k = [1 + (\partial_{x^k} f^k)^2]^{-1/2} d\sigma$, (3.49) becomes, if $s(x)$ denotes the value of the arclength coordinate associated with x , $d\sigma$ denotes an integration with respect to arclength coordinate, and d_ε^\pm is short for $d_\varepsilon^\pm(s(x))$:

$$\forall k \in \{1, \dots, 4\}, \forall x \in \gamma(\varepsilon) \cap C_k(\gamma),$$

$$\mathbf{t}^\varepsilon(x) = \frac{1}{\sqrt{2}\varepsilon} \int_{s(x)-d_\varepsilon^-}^{s(x)+d_\varepsilon^+} \frac{\mathbf{t}(\sigma) d\sigma}{\sqrt{1 + (\partial_{x^k} f^k)^2}} = \frac{1}{2\varepsilon} \int_{s(x)-d_\varepsilon^-}^{s(x)+d_\varepsilon^+} \mathbf{T}(\sigma) d\sigma, \quad (3.51)$$

where we used $\mathbf{t} = v\mathbf{T}$, which implies $\|\mathbf{t}\|_2 = v$. In other words, the factor v^{-1} in (3.46) is exactly what is needed to pass from the parametrisation by 1-Lipschitz curves on each quadrants, inherited from the lattice structure, to a line integral formulation. Define now \mathbf{T}^ε and v^ε from \mathbf{t}^ε :

$$\forall s \leq |\gamma|_2, \quad \mathbf{T}^\varepsilon(s) := \mathbf{t}^\varepsilon(s) / \|\mathbf{t}^\varepsilon(s)\|_2, \quad v^\varepsilon(s) := \|\mathbf{t}^\varepsilon(s)\|_2 = \frac{1}{\|\mathbf{T}^\varepsilon(s)\|_1}. \quad (3.52)$$

Using (3.51)-(3.52), it is straightforward to transform Proposition 3.1 into the following.

Proposition 3.9. *With the notations and the set Z defined in Proposition 3.1, trajectories in Z satisfy:*

$$\begin{aligned}
\int_0^{T_0} N^2 \mathcal{L}_{r,\beta,H} \langle \Gamma_\tau, G_\tau \rangle d\tau &= \frac{1}{4} \int_0^{T_0} d\tau \int_{\gamma_\tau(\varepsilon)} \frac{(v^\varepsilon)^2}{v} [\mathbf{T}^\varepsilon \cdot m(\gamma_\tau(s))] \mathbf{T}^\varepsilon \cdot \nabla G(\tau, \gamma(s)) ds \\
&+ \frac{1}{2} \int_0^{T_0} d\tau \int_{\gamma_\tau(\varepsilon)} \frac{(v^\varepsilon)^2}{v} |\mathbf{T}_1^\varepsilon| |\mathbf{T}_2^\varepsilon| (HG)(\tau, \gamma_\tau(s)) ds + C(G, H)(o_\delta(1) + o_N(1)) \\
&- \frac{1}{2} \int_0^{T_0} \sum_{k=1}^4 (1/2 - e^{-\beta}) [G(\tau, L_k(\Gamma_\tau)) + G(\tau, R_k(\Gamma_\tau))] d\tau, \tag{3.53}
\end{aligned}$$

where s is the arclength coordinate on γ_τ , $\gamma_\tau(\varepsilon)$ is the set of points in γ_τ at 1-distance at least ε from the poles and $m = (\pm 1, \pm 1)$ is the sign vector in Definition 3.6. The $\mathbf{T}_i^\varepsilon, i \in \{1, 2\}$ stand for the components of \mathbf{T}^ε defined in (3.52). Note that both v and v^ε appear in (3.53). There is a $v^\varepsilon \mathbf{T}^\varepsilon$ for each \mathbf{t}^ε in Lemma 3.7, while the v comes from the change of variable (3.46) to get a line integral from discrete sums.

Remark 3.10. • Note that the line integral on the second line of (3.53) bears on $\gamma_\tau(\varepsilon)$, whereas the corresponding sum in Proposition 3.1 bore on the whole of $V(\gamma_\tau)$. This change is purely for convenience and induces an error $O_{G,H}(\varepsilon) = C(G, H)o_\delta(1)$ independent of the curve.

- To connect (3.53) to the weak formulation (2.32) of anisotropic motion by curvature with drift, notice from (3.49) that $\lim_{\varepsilon \rightarrow 0} \mathbf{t}^\varepsilon(x) = t(x)$ for almost every point x of a curve that is at 1-distance ε or more to the poles. As a result, $\mathbf{T}^\varepsilon, v^\varepsilon$, defined in (3.52), converge a.e. to \mathbf{T}, v on such portions of a curve, and:

$$\lim_{\varepsilon \rightarrow 0} \left[\frac{(v^\varepsilon)^2}{v} |\mathbf{T}_1^\varepsilon \mathbf{T}_2^\varepsilon| \right] (\theta) = (v |\mathbf{T}_1 \mathbf{T}_2|) (\theta) = \frac{|\sin(2\theta)|}{2(|\sin(\theta)| + |\cos(\theta)|)} \quad \text{for } \theta \in [0, 2\pi].$$

This quantity is precisely $\mu(\theta)$, see (2.26). In the same way, if $\theta \in [0, 2\pi] \setminus \frac{\pi}{2}\mathbb{Z}$:

$$\lim_{\varepsilon \rightarrow 0} \left[\frac{(v^\varepsilon)^2}{v} [\mathbf{T}^\varepsilon \cdot m] \right] (\theta) \mathbf{T}^\varepsilon(\theta) \cdot \nabla = [v[\mathbf{T} \cdot m]] (\theta) \mathbf{T}(\theta) \cdot \nabla = \alpha(\theta) \partial_s,$$

where α is defined in (2.33) and $\partial_s = \partial_{\mathbf{T}}$ is the derivative with respect to the arclength coordinate, almost everywhere well defined.

- In (3.53), the tangent vector at each point is averaged on a portion of 1-length ε of the curve. Away from the poles, this is a natural choice, well adapted to the underlying SSEP structure, see Section 2.2.

At the poles however, this requires the knowledge of the position of the pole, that is the position of a *point* whereas the droplets are *volumic* objects. Even more, the line integrals bear on $\gamma_\tau(\varepsilon), \tau \in [0, T_0]$, the set of points at 1-distance ε from the poles of γ_τ , and the last line of (3.53) explicitly requires the knowledge of the $L_k, R_k, k \in \{1, \dots, 4\}$. If the droplet boundaries were less regular, such a requirement would not be reasonable.

Instead, as in the BV setting (see e.g. [EG15]), it would make sense to define a weaker notion of neighbourhood of the pole in terms of volume, replacing e.g. L_k, R_k by an average over all points of the droplet in an area of volume ε around pole $k \in \{1, \dots, 4\}$. This definition would then be relevant even with less regular droplets, and we use it in Section 4 to control the poles.

However, the formulation of Proposition 3.9 for $N^2 \mathcal{L}_{r,\beta,H} \langle \Gamma, G \rangle$ is useful for the following reason. When integrating by parts the α term in (2.32) assuming the corresponding curves to be smooth, the position of the pole actually arises as a boundary term. This fact is retained in our microscopic computations, where the L_k, R_k terms naturally come out. \blacksquare

4 Large deviation upper-bound and properties of the rate functions

In this section, we prove upper bound large deviations, i.e. the upper bound in Theorem 2.8. Many results presented below are well-known, so we only detail model-specific results. A time $T_0 > 0$ is fixed throughout the section. Parameters r, β are fixed according to Definition 2.1. The parameter r is omitted in the notations.

For $H \in \mathcal{C}$, the Radon-Nikodym derivative $D_{\beta,H}^N = d\mathbb{P}_{\beta,H}^N / d\mathbb{P}_\beta^N$ until time T_0 reads:

$$N^{-1} \log D_{\beta,H}^N((\Gamma_\tau)_{\tau \leq T_0}) = \langle \Gamma_{T_0}, H_{T_0} \rangle - \langle \Gamma_0, H_0 \rangle - \int_0^{T_0} e^{-N \langle \Gamma_\tau, H_\tau \rangle} (\partial_\tau + N^2 \mathcal{L}_\beta) e^{N \langle \Gamma_\tau, H_\tau \rangle} d\tau. \quad (4.1)$$

Recall from (3.44) the definition of $Z_{H,H}^N(A=2, \beta, \delta, \varepsilon) =: Z$, the set of trajectories in which the computations of Section 3 can be performed, and from Definition 3.6 that of m . Refer to Appendix B.2 for properties of $E([0, T_0], \mathcal{E}_r(d))$, $d \in (0, 1)$. For a trajectory $(\Gamma_\tau)_{\tau \in [0, T_0]}$ in $Z \cap E([0, T_0], \mathcal{E}_r(d))$, the results of Proposition 3.9 apply with next to no change to (4.1), so that on Z , $D_{\beta,H}^N$ satisfies:

$$N^{-1} \log D_{\beta,H}^N(\Gamma) = J_{H,\varepsilon}^\beta(\Gamma) + C(H)(o_\delta(1) + o_N(1)), \quad (4.2)$$

where $J_{H,\varepsilon}^\beta$ is the functional defined on $E([0, T_0], \mathcal{E}_r)$ by $(\gamma_\tau = \partial \Gamma_\tau, \tau \in [0, T_0])$:

$$\forall \Gamma \in E([0, T_0], \mathcal{E}_r), \quad J_{H,\varepsilon}^\beta(\Gamma) := \ell_{H,\varepsilon}^\beta(\Gamma) - \frac{1}{2} \int_0^{T_0} \int_{\gamma_\tau(\varepsilon)} |\mathbf{T}_1^\varepsilon \mathbf{T}_2^\varepsilon| \frac{(v^\varepsilon)^2}{v} H^2(\tau, \gamma_\tau(s)) ds d\tau. \quad (4.3)$$

The functional $\ell_{H,\varepsilon}^\beta$ is defined as:

$$\begin{aligned} \forall \Gamma \in E([0, T_0], \mathcal{E}_r), \quad \ell_{H,\varepsilon}^\beta(\Gamma) &:= \langle \Gamma_{T_0}, H_{T_0} \rangle - \langle \Gamma_0, H_0 \rangle - \int_0^{T_0} \langle \Gamma_\tau, \partial_\tau H_\tau \rangle d\tau \\ &\quad - \frac{1}{4} \int_0^{T_0} d\tau \int_{\gamma_\tau(\varepsilon)} \frac{(v^\varepsilon)^2}{v} [\mathbf{T}^\varepsilon \cdot m(\gamma_\tau(s))] \mathbf{T}^\varepsilon \cdot \nabla H(\tau, \gamma(s)) ds \\ &\quad + \left(\frac{1}{4} - \frac{e^{-\beta}}{2} \right) \int_0^{T_0} \sum_{k=1}^4 [H(\tau, L_k(\tau)) + H(\tau, R_k(\tau))] d\tau. \end{aligned} \quad (4.4)$$

Recall that, for $\tau \in [0, T_0]$, $\gamma_\tau(\varepsilon)$ is the set of points in γ_τ at 1-distance at least ε from the poles, and s is the arclength coordinate.

Formally taking the limit $\varepsilon \downarrow 0$, we claim that $J_{H,\varepsilon}^\beta, \ell_{H,\varepsilon}^\beta$ converge point-wise to J_H^β, ℓ_H^β respectively, defined in (2.35)-(2.34). Furthermore, the functionals $J_{H,\varepsilon}^\beta, \ell_{H,\varepsilon}^\beta$ are continuous on $E_{pp}([0, T_0], \mathcal{E}_r)$, the subset of $E([0, T_0], \mathcal{E}_r)$ with trajectories with almost always point-like poles. These claims, assumed for the moment, are established in Section 4.2.

4.1 The upper bound

Fix $d, T_0 > 0$. In this section, we establish the upper bounds in Theorem 2.8 for open and compact sets in $(E([0, T_0], \mathcal{E}_r(d)), d_E)$ (see Appendix B.2), with d_E the distance defined in (B.4). To do so, we temporarily admit the continuity of the functionals $(J_{H,\varepsilon}^\beta)_{\varepsilon}$ and their point-wise convergence to J_H^β on $E_{pp}([0, T_0], \mathcal{E}_r(d))$ (defined in (2.36)). These properties are established in Section 4.2.

4.1.1 Restriction of the dynamics to good sets and behaviour of the poles

Let us start by listing the several sets with sub-exponential probability on which the dynamics will be restricted to obtain the upper bound of Theorem 2.8. These include both the sets occurring in the computation of the Radon-Nikodym derivative in Proposition 3.1, and additional sets used to better control the pole dynamics.

Let $\mathcal{O} \subset E([0, T_0], \mathcal{E}_r(d))$ be a measurable set of trajectories. Recall that $\mathcal{E}_r(d)$ is the set of droplets at distance at least $d > 0$ from $\partial([-1, 1])^2$. Recall also from (3.44) the definition of the set Z , on which the pole size is microscopic and the Replacement lemma 3.8 holds, and define:

$$U^N = U^N(H, A = 2, \beta, \delta, \varepsilon) := \frac{1}{N} \log \mathbb{E}_{\beta, H}^N [(D_{\beta, H}^N)^{-1} \mathbf{1}_{\mathcal{O}} \mathbf{1}_{Z^c}] = \frac{1}{N} \log \mathbb{E}_{\beta}^N [\mathbf{1}_{\mathcal{O}} \mathbf{1}_{Z^c}]. \quad (4.5)$$

We argue in the proof of the Replacement lemma in Appendix A that, for any $\delta > 0$,

$$\limsup_{\varepsilon > 0} \limsup_{N \rightarrow \infty} U^N = -\infty.$$

In particular, for each $\delta > 0$, there is $\varepsilon_0(\delta) > 0$ such that:

$$\limsup_{0 < \varepsilon < \varepsilon_0(\delta)} \limsup_{N \rightarrow \infty} U^N = -\delta^{-1}. \quad (4.6)$$

Let us now turn to the behaviour of the poles. It is proven in Section 6.2.4 that the time integrated slope around the pole is $e^{-\beta}$ up to a small error, with probability super-exponentially close to 1 (see Corollary 6.11). This is better stated in terms of volume below the pole (see the last item of Remark 3.10): for $\eta > 0$, define V_η as the volume of points with ordinate at most η below the north pole:

$$\forall \Gamma \in \mathcal{E}_r, \quad V_\eta(\Gamma) = |\{x \in \Gamma : y_{\max}(\Gamma) - x \cdot e_2 \geq \eta\}|. \quad (4.7)$$

Compared to the slope, the volume V_η is more robust to changes in the position of the pole: V_η is continuous on \mathcal{E}_r equipped with the Hausdorff distance $d_{\mathcal{H}}$, since y_{\max} , the ordinate of the highest

point of an element of \mathcal{E}_r , also is (and similarly for the volumes beneath the other three poles). By Lemma B.14, for each $q, n \in \mathbb{N}^*$, there is $\eta(q, n) > 0$ such that, for any $\eta \leq \eta(q, n)$:

$$\limsup_{N \rightarrow \infty} \frac{1}{N} \log \mathbb{P}_{r, \beta, H}^N \left(\text{for a.e. } t \in [0, T_0], \Gamma_t \in \mathcal{E}_r(d); \right. \\ \left. \frac{1}{T_0} \int_0^{T_0} \mathbf{1} \left\{ \left| \eta^{-2} V_\eta(\Gamma_t) - (e^\beta - 1) \right| > \frac{1}{n} \right\} dt \right) > \frac{1}{n} \Big) \leq -q. \quad (4.8)$$

Simply by inclusion between the sets in the above probability, $n \mapsto \eta(q, n)$ can be taken to be decreasing. Define then a set $D_{q, n}$ as follows to control the poles:

$$D_{q, n} := \left\{ \forall 1 \leq m \leq n, \frac{1}{T_0} \int_0^{T_0} \mathbf{1} \left\{ \left| \left(\frac{\eta(q, m)}{m} \right)^{-2} V_{\eta(q, m)/m}(\Gamma_t) - (e^\beta - 1) \right| > \frac{1}{m} \right\} dt \leq \frac{1}{m} \right\} \\ \cap \{ \text{similar event for the other three poles} \} \cap E([0, T_0], \mathcal{E}_r(d)). \quad (4.9)$$

Since V_η is continuous on \mathcal{E}_r for the Hausdorff distance and the indicator function of an open set is lower semi-continuous, the set $D_{q, n}$ is closed in $E([0, T_0], \mathcal{E}_r(d))$ for each $q, n \in \mathbb{N}^*$. Moreover, by (4.8):

$$\limsup_{N \rightarrow \infty} P_{q, n}^N := \limsup_{N \rightarrow \infty} \frac{1}{N} \log \mathbb{P}_{\beta, H}^N (D_{q, n}^c \cap E([0, T_0], \mathcal{E}_r(d))) \leq -q. \quad (4.10)$$

By construction, for $q \in \mathbb{N}^*$, $D_{q, n} \subset D_{q, n'}$ if $n \leq n'$. For $q \in \mathbb{N}^*$, define then D_q as:

$$D_q := \bigcap_{n \geq 1} D_{q, n}. \quad (4.11)$$

We claim that trajectories in a D_q , $q \in \mathbb{N}^*$ have almost always point-like poles, with kinks at each pole with slope $e^{-\beta}$. This claim is proven in the following lemma.

Lemma 4.1. *Fix $q \in \mathbb{N}^*$, and let $(\Gamma_t)_{t \leq T_0} \in D_q$. Then:*

$$\text{for a.e. } t \in [0, T_0], \quad \liminf_{\eta \rightarrow 0} \left| \eta^{-2} V_\eta(\Gamma_t) - (e^\beta - 1) \right| = 0.$$

This in particular implies that $(\Gamma_t)_{t \leq t_0}$ has almost always point-like poles.

Proof. We consider the north pole, the others are similar. Due to the monotonicity condition in the definition of \mathcal{E}_r , a droplet $\Gamma' \in \mathcal{E}_r$ does not have point-like north pole if and only if there is $c > 0$ (the width of the north pole) such that, for any $\eta > 0$ smaller than some η_0 which only depends on Γ' ,

$$V_\eta(\Gamma') \geq \eta c.$$

In particular, Γ' has point-like north pole as soon as:

$$\liminf_{\eta \rightarrow 0} \eta^{-1} V_\eta(\Gamma') = 0. \quad (4.12)$$

Fix a trajectory $(\Gamma_t)_{t \leq T_0} \in D_q$ and let $\varepsilon > 0$. For each integer $n \geq 1/\varepsilon$, one has by definition of D_q :

$$\frac{1}{T_0} \int_0^{T_0} \mathbf{1} \left\{ \left| \left(\frac{\eta(q, n)}{n} \right)^{-2} V_{\eta(q, n)/n}(\Gamma_t) - (e^\beta - 1) \right| > \varepsilon \right\} dt \leq \frac{1}{n}.$$

Since n can be chosen to make $\eta(q, n)/n$ arbitrarily small as $n \mapsto \eta(q, n)$ is decreasing, thus bounded, this implies:

$$\liminf_{\eta \rightarrow 0} \int_0^{T_0} \mathbf{1}\{|\eta^{-2}V_\eta(\Gamma_t) - (e^\beta - 1)| > \varepsilon\} dt = 0.$$

Using Fatou inequality, we find:

$$\begin{aligned} \int_0^{T_0} \liminf_{\eta \rightarrow 0} \mathbf{1}\{|\eta^{-2}V_\eta(\Gamma_t) - (e^\beta - 1)| > \varepsilon\} dt &= 0 \\ \Rightarrow \liminf_{\eta \rightarrow 0} \mathbf{1}\{|\eta^{-2}V_\eta(\Gamma_t) - (e^\beta - 1)| > \varepsilon\} &= 0 \quad \text{for a.e } t \in [0, T_0] \\ \Rightarrow \liminf_{\eta \rightarrow 0} |\eta^{-2}V_\eta(\Gamma_t) - (e^\beta - 1)| &\leq \varepsilon \quad \text{for a.e } t \in [0, T_0]. \end{aligned}$$

Since ε is arbitrary, the lemma is proven recalling (4.12). \square

4.1.2 Upper bound large deviations

We are now ready to obtain the upper bound large deviations. Recalling the expression (4.2) of the Radon-Nikodym derivative, one has, for any Borel set $\mathcal{O} \subset E([0, T_0], \mathcal{E}_r(d))$:

$$\begin{aligned} \frac{1}{N} \log Q_\beta^N(\mathcal{O}) &\leq \max \left\{ \frac{1}{N} \log \mathbb{E}_{\beta, H}^N [(D_{\beta, H}^N)^{-1} \mathbf{1}_{\mathcal{O}} \mathbf{1}_Z \mathbf{1}_{D_{q, n}}], U^N, P_{q, n}^N \right\} + \frac{\log 3}{N} \\ &\leq \max \left\{ C(H)(o_\delta(1) + o_N(1)) + \sup_{\Gamma \in \mathcal{O} \cap D_{q, n}} (-J_{H, \varepsilon}^\beta(\Gamma)), U^N, P_{q, n}^N \right\} + \frac{\log 3}{N}. \end{aligned}$$

Taking the limit in N yields, recalling the estimates (4.6)-(4.10) of $U^N, P_{q, n}^N$:

$$\limsup_{N \rightarrow \infty} \frac{1}{N} \log Q_\beta^N(\mathcal{O}) \leq \max \left\{ C(H)o_\delta(1) + \sup_{\Gamma \in \mathcal{O} \cap D_{q, n}} (-J_{H, \varepsilon}^\beta(\Gamma)), -\delta^{-1}U^N, -q \right\}.$$

Take the liminf in $n \in \mathbb{N}^*$, then minimise over $\varepsilon \in (0, \varepsilon_0(\delta))$ (recall (4.6)), then over $\delta > 0, H \in \mathcal{C}$ and $q \geq 1$ to obtain a first upper bound for general \mathcal{O} :

$$\limsup_{N \rightarrow \infty} \frac{1}{N} \log Q_\beta^N(\mathcal{O}) \leq \inf_{q \geq 1} \inf_{H \in \mathcal{C}} \inf_{\delta, \varepsilon} \max \left\{ \liminf_{n \rightarrow \infty} \sup_{\Gamma \in \mathcal{O} \cap D_{q, n}} (-J_{H, \varepsilon}^\beta(\Gamma)) + C(H)o_\delta(1), -\delta^{-1}, -q \right\}. \quad (4.13)$$

Upper bound for compact sets. We now extend the bound (4.13) to a bound on compact sets. Let \mathcal{K} be a compact set in $E([0, T_0], \mathcal{E}_r(d))$. Were $J_{H, \varepsilon}^\beta$ a continuous functional on $E([0, T_0], \mathcal{E}_r(d))$ for each H, ε , one could remove $D_{q, n}$ in the maximum in the right-hand side of (4.13), which would then also be continuous. Lemmas A.2.3.2 and A.2.3.3 in [KL99] could consequently be used to exchange inf and sup in (4.13), yielding an upper bound on compact sets.

Unfortunately, $J_{H, \varepsilon}^\beta$ is not a continuous functional on $E([0, T_0], \mathcal{E}_r(d))$ for $H \in \mathcal{C}, \varepsilon > 0$. However, in Proposition 4.3, we prove the following. Let $E_{pp}([0, T_0], \mathcal{E}_r(d)) \subset E([0, T_0], \mathcal{E}_r(d))$ be the set of trajectories with almost always point-like poles. Then any trajectory in $E_{pp}([0, T_0], \mathcal{E}_r(d))$ is a point of continuity of each functional $J_{H, \varepsilon}^\beta$ for $H \in \mathcal{C}$ and $\varepsilon > 0$. The introduction of the sets $D_{q, n}$ for $(q, n) \in (\mathbb{N}^*)^2$, defined in (4.9), aims at restricting to trajectories with almost always point-like poles, as explained in the next lemma.

Lemma 4.2. *Let $H \in \mathcal{C}$, $\varepsilon > 0$ and $q \geq 1$. Let $\mathcal{O} \subset E([0, T_0], \mathcal{E}_r(d))$ be an open set. Then:*

$$\liminf_{n \rightarrow \infty} \sup_{\mathcal{O} \cap \mathcal{K} \cap D_{q,n}} (-J_{H,\varepsilon}^\beta) = \sup_{\mathcal{O} \cap \mathcal{K} \cap D_q} (-J_{H,\varepsilon}^\beta).$$

Proof. Since $D_q \subset D_{q,n}$ for each $n \in \mathbb{N}^*$, we need only prove that the left-hand side is smaller than the right-hand side, and we may assume without loss of generality that, for each $n \in \mathbb{N}^*$, $\mathcal{O} \cap \mathcal{K} \cap D_{q,n}$ is not empty. Assume by contradiction that there is $n_0 \in \mathbb{N}^*$, $\eta > 0$ and a sequence $\Gamma^n \in \mathcal{O} \cap \mathcal{K} \cap D_{q,n}$, $n \geq n_0$ such that:

$$-J_{H,\varepsilon}^\beta(\Gamma^n) \geq \eta + \sup_{\mathcal{O} \cap \mathcal{K} \cap D_q} (-J_{H,\varepsilon}^\beta).$$

Since \mathcal{K} is compact, $(\Gamma^n)_n$ converges to some $\Gamma \in \bar{\mathcal{O}} \cap \mathcal{K}$ up to a subsequence. Since each $D_{q,n}$, $n \in \mathbb{N}^*$ is closed and $D_{q,n} \subset D_{q,n'}$ for $n \leq n'$, Γ is in D_q . As $D_q \subset E_{pp}([0, T_0], \mathcal{E}_r(d))$ by Lemma 4.1, Γ is a point of continuity of $J_{H,\varepsilon}^\beta$ by Proposition 4.3, thus:

$$-J_{H,\varepsilon}^\beta(\Gamma) \geq \eta + \sup_{\mathcal{O} \cap \mathcal{K} \cap D_q} (-J_{H,\varepsilon}^\beta).$$

Since $-J_{H,\varepsilon}^\beta$ has the same supremum on $\mathcal{O} \cap \mathcal{K} \cap D_q$ and $\bar{\mathcal{O}} \cap \mathcal{K} \cap D_q$, as it is continuous on both sets due to $D_q \subset E_{pp}([0, T_0], \mathcal{E}_r(d))$, we obtain a contradiction:

$$-J_{H,\varepsilon}^\beta(\Gamma) \leq \sup_{\bar{\mathcal{O}} \cap \mathcal{K} \cap D_q} (-J_{H,\varepsilon}^\beta) = \sup_{\mathcal{O} \cap \mathcal{K} \cap D_q} (-J_{H,\varepsilon}^\beta) \leq -J_{H,\varepsilon}^\beta(\Gamma) - \eta.$$

□

Let $\mathcal{O} \subset E([0, T_0], \mathcal{E}_r(d))$ be an open set. Using Lemma 4.2, the general upper bound (4.13) applied to $\mathcal{O} \cap \mathcal{K}$ becomes:

$$\begin{aligned} \limsup_{N \rightarrow \infty} \frac{1}{N} \log Q_\beta^N(\mathcal{O} \cap \mathcal{K}) &\leq \inf_{q \geq 1} \inf_{H \in \mathcal{C}} \inf_{\delta, \varepsilon} \max \left\{ \sup_{\Gamma \in \mathcal{O} \cap \mathcal{K} \cap D_q} (-J_{H,\varepsilon}^\beta(\Gamma)) + C(H)o_\delta(1), -\delta^{-1}, -q \right\} \\ &= \inf_{q \geq 1} \inf_{H \in \mathcal{C}} \inf_{\delta, \varepsilon} \sup_{\mathcal{O} \cap \mathcal{K}} \tilde{J}_{H,\varepsilon,\delta,q}^\beta, \end{aligned}$$

where:

$$\tilde{J}_{H,\varepsilon,\delta,q}^\beta := \max \left\{ (-J_{H,\varepsilon}^\beta) + C(H)o_\delta(1), -\delta^{-1}, -q \right\}. \quad (4.14)$$

This time, for each fixed $q \geq 1$ and each admissible H, ε, δ , $\tilde{J}_{H,\varepsilon,\delta,q}^\beta$ is a continuous functional on D_q . Taking finite open covers of \mathcal{K} , Lemmas A.2.3.2 and A.2.3.3 in [KL99] apply for each $q \geq 1$ to the family $(\tilde{J}_{H,\varepsilon,\delta,q}^\beta)_{H,\varepsilon,\delta}$ on the compact set $\mathcal{K} \cap D_q$, and we obtain:

$$\limsup_{N \rightarrow \infty} \frac{1}{N} \log Q_\beta^N(\mathcal{K}) \leq \inf_{q \geq 1} \sup_{\Gamma \in \mathcal{K} \cap D_q} \inf_{H \in \mathcal{C}} \inf_{\delta, \varepsilon} \tilde{J}_{H,\varepsilon,\delta,q}^\beta. \quad (4.15)$$

Recall the definition (4.14). For each $H \in \mathcal{C}$ and each $\Gamma \in D_q$, by Proposition 4.3,

$$-J_{H,\varepsilon}^\beta(\Gamma) = -J_H^\beta(\Gamma) + C(\Gamma, H)o_\varepsilon(1) \quad \text{where} \quad C(\Gamma, H)o_\varepsilon(1) \quad \text{can be taken positive.}$$

Bounding the infimum on $\varepsilon \in (0, \varepsilon_0(\delta))$ in (4.15) by $\liminf_{\varepsilon \rightarrow 0}$, (4.15) thus becomes:

$$\limsup_{N \rightarrow \infty} \frac{1}{N} \log Q_\beta^N(\mathcal{K}) \leq \inf_{q \geq 1} \sup_{\Gamma \in \mathcal{K} \cap D_q} \inf_{H \in \mathcal{C}} \max \{ -J_H^\beta(\Gamma), -q \} \leq -\inf_{\mathcal{K}} I_\beta(\cdot | \Gamma_0). \quad (4.16)$$

The last bound comes from the fact that $D_q \subset E_{pp}([0, T_0], \mathcal{E}_r(d))$ for each q by Lemma 4.1, and from the definition (2.37) of $I_\beta(\cdot | \Gamma_0)$. This is the desired upper bound for compact sets.

Upper bound for closed sets. Upper bound large deviations for closed sets follow from the exponential tightness of $(Q_{r,\beta}^N(\cdot, E([0, T_0], \mathcal{E}_r(d))))_N$ in $\mathcal{M}_1(E([0, T_0], \mathcal{E}_r(d)))$. Establishing exponential tightness is quite technical, so we postpone it to Appendix B.3 and conclude here the proof of the upper bound in Theorem (2.8).

4.2 Properties of the rate function

In this section, continuity of the functional $J_{H,\varepsilon}^\beta$ is established on the set $E_{pp}([0, T_0], \mathcal{E}_r(d))$ of trajectories with almost always point-like poles (see (2.36)). A parameter $d > 0$ is fixed throughout the section. The functional $J_{H,\varepsilon}^\beta$ is defined in (4.3)-(4.4).

Proposition 4.3. *Let $H \in \mathcal{C}$ and $\varepsilon > 0$. Recall the definition (4.3) of the functional $J_{H,\varepsilon}^\beta$. Then each element of the set $E_{pp}([0, T_0], \mathcal{E}_r(d))$ of trajectories with almost always point-like poles, equipped with the distance d_E (see (2.30)), is a point of continuity of $J_{H,\varepsilon}^\beta$. Moreover,*

$$\lim_{\varepsilon \rightarrow 0} J_{H,\varepsilon}^\beta(\Gamma) = J_H^\beta(\Gamma) \quad \text{pointwise on } E_{pp}([0, T_0], \mathcal{E}_r(d)). \quad (4.17)$$

The same holds for $J_{H,\varepsilon}$.

Before proving Proposition 4.3, let us state an intermediate result which explains the advantage of dealing with trajectories in $E_{pp}([0, T_0], \mathcal{E}_r(d))$ rather than in $E([0, T_0], \mathcal{E}_r(d))$.

Lemma 4.4 (Convergence of the poles). *For $n \in \mathbb{N}$, let $\Gamma^n \in E([0, T_0], \mathcal{E}_r(d))$ and assume that (Γ^n) converges to $\Gamma \in E_{pp}([0, T_0], \mathcal{E}_r(d))$ for the distance $\int_0^{T_0} d_{\mathcal{H}}(\cdot, \cdot) dt \leq d_E$. Then $L_k(\Gamma_t) = R_k(\Gamma_t)$ for each $k \in \{1, \dots, 4\}$ and almost every time since Γ has almost always point-like poles, and:*

$$\forall k \in \{1, \dots, 4\}, \quad \lim_{n \rightarrow \infty} \int_0^{T_0} dt \|L_k(\Gamma_t^n) - L_k(\Gamma_t)\|_1 \vee \|R_k(\Gamma_t^n) - R_k(\Gamma_t)\|_1 dt = 0. \quad (4.18)$$

Proof. We deal with the north pole, the others are the same. For $\tilde{\Gamma} \in \mathcal{E}_r$, let $y_{\max}(\tilde{\Gamma})$ be the ordinate of its north pole. Notice that y_{\max} is 1-Lipschitz in Hausdorff distance. Since $L_1 \cdot e_2 = R_1 \cdot e_2 = y_{\max}$, we find:

$$\begin{aligned} & \int_0^{T_0} dt |L_1(\Gamma_t^n) \cdot e_2 - y_{\max}(\Gamma_t)| \vee |R_1(\Gamma_t^n) \cdot e_2 - y_{\max}(\Gamma_t)| dt \\ &= \int_0^{T_0} dt |y_{\max}(\Gamma_t^n) - y_{\max}(\Gamma_t)| dt \leq \int_0^{T_0} d_{\mathcal{H}}(\Gamma_t^n, \Gamma_t) dt \xrightarrow{n \rightarrow \infty} 0. \end{aligned}$$

As for the second component of $L_1(\Gamma^n)$, $R_1(\Gamma^n)$, the two functionals $R_1 \cdot e_1$ and $L_1 \cdot e_1$ are respectively upper and lower semi-continuous on \mathcal{E}_r . In particular, let $t \in [0, T_0]$ such that the droplet Γ_t has point-like poles, and $d_{\mathcal{H}}(\Gamma_t^n, \Gamma_t) = o_N(1)$ vanishes. Then:

$$L_1(\Gamma_t) \cdot e_1 \leq \liminf_{n \rightarrow \infty} L_1(\Gamma_t^n) \cdot e_1 \leq \limsup_{n \rightarrow \infty} R_1(\Gamma_t^n) \cdot e_1 \leq R_1(\Gamma_t) \cdot e_1 = L_1(\Gamma_t) \cdot e_1.$$

Since almost every $t \in [0, T_0]$ satisfies this condition, we find:

$$\lim_{n \rightarrow \infty} \int_0^{T_0} |L_1(\Gamma_\tau^n) \cdot e_1 - L_1(\Gamma_\tau) \cdot e_1| \vee |R_1(\Gamma_\tau^n) \cdot e_1 - R_1(\Gamma_\tau) \cdot e_1| d\tau = 0.$$

□

Proof of Proposition 4.3. In view of the expression (4.3)-(4.4) of $J_{H,\varepsilon}^\beta$, we need to prove that elements of $E_{pp}([0, T_0], \mathcal{E}_r(d))$ are points of continuity of the two terms:

$$\left(\frac{1}{4} - \frac{e^{-\beta}}{2}\right) \sum_{k=1}^4 \int_0^{T_0} [H(\tau, R_k(\tau)) + H(\tau, L_k(\tau))] d\tau, \quad (4.19)$$

$$- \int_0^{T_0} \int_{\gamma_\tau(\varepsilon)} \frac{(v^\varepsilon)^2}{4v} [\mathbf{T}^\varepsilon \cdot m] \mathbf{T}^\varepsilon \cdot \nabla H ds d\tau - \frac{1}{2} \int_0^{T_0} \int_{\gamma_\tau(\varepsilon)} \frac{(v^\varepsilon)^2}{v} |\mathbf{T}_1^\varepsilon \mathbf{T}_2^\varepsilon| H^2 dd\tau. \quad (4.20)$$

The functional in (4.19) has already been treated in Lemma 4.4: any trajectory in $E_{pp}([0, T_0], \mathcal{E}_r(d))$ is one of its points of continuity for $\int_0^{T_0} d_{\mathcal{H}} dt \leq d_E$, hence for d_E .

Consider now (4.20). Clearly, to prove that elements of $E_{pp}([0, T_0], \mathcal{E}_r(d))$ are points of continuity of this functional, it is enough to prove that each $\Gamma \in \mathcal{E}_r^{pp} \subset \mathcal{E}_r$, the set $\mathcal{E}_r^{pp} \subset \mathcal{E}_r$ of droplets with point-like poles, is a point of continuity of the integrand at each fixed time, seen as a functional on $(\mathcal{E}_r, d_{\mathcal{H}})$.

We prove it for the first term in (4.20), the second one is similar. For $H \in C^2([-1, 1]^2)$, consider the functional:

$$\forall \Gamma \in \mathcal{E}_r, \quad F_{H,\varepsilon}(\Gamma) = \int_{\gamma(\varepsilon)} \frac{(v^\varepsilon)^2}{4v} [\mathbf{T}^\varepsilon \cdot m] \mathbf{T}^\varepsilon \cdot \nabla H ds. \quad (4.21)$$

The definition of $\mathbf{T}^\varepsilon, v^\varepsilon$ is given in (3.52), $v = \|\mathbf{T}\|_1^{-1}$ with \mathbf{T} the tangent vector normed by $\|\mathbf{T}\|_2 = 1$, and m is the sign vector in Definition 3.6.

Let $\Gamma^n \in \mathcal{E}_r$, $n \in \mathbb{N}$ converge in Hausdorff distance to $\Gamma \in \mathcal{E}_r^{pp}$. The idea is to split the integral in (4.21) between each quadrant of Γ . On each quadrant, the integrand, expressed in terms of the equivalent SSEP, is easily shown to be continuous.

Let us first prove that we can consider the integrand on each quadrant of Γ separately. Recall from Section 2.2 the definition of the functions $f^k : I^k \rightarrow \mathbb{R}$, whose graph at each time in the reference frame \mathcal{R}_k , defined in (2.16), is the portion of γ in its quadrant k . Define similarly f_n^k for the $\gamma^n = \partial\Gamma^n$, $n \in \mathbb{N}$. For brevity, we write $\mathbf{T}^{n,\varepsilon} = \mathbf{T}^\varepsilon(\Gamma^n)$ and similarly $v^{n,\varepsilon}, m^n$ for $v^\varepsilon(\Gamma^n), m(\Gamma^n)$. Let $I_n^k = [a_n^k, b_n^k]$, $I^k = [a^k, b^k]$ be the intervals of definition of the functions $f_n^k(\cdot), f^k(\cdot)$ respectively,

for $k \in \{1, \dots, 4\}$. As $\Gamma \in \mathcal{E}_r^{pp}$, $(L_k(\Gamma^n))$, $(R_k(\Gamma^n))$ converge to $L_k(\Gamma)$ as n is large by (the proof of) Lemma 4.4. As a result, $\lim_n \gamma_n(\varepsilon) = \gamma(\varepsilon)$ in Hausdorff distance, and:

$$\forall k \in \{1, \dots, 4\}, \quad \lim_{n \rightarrow \infty} a_n^k = a^k, \quad \lim_{n \rightarrow \infty} b_n^k = b^k. \quad (4.22)$$

Equation (4.22) enables us to consider the integrand in (4.21) on each quadrant of Γ separately. Indeed, fix $\eta \in (0, \varepsilon/\sqrt{2})$. For all n large enough and each k , (4.22) tells us that f_n^k is well defined on $[a^k + \eta, b^k - \eta]$, and in particular in the portion of $\gamma(\varepsilon)$ in quadrant k of Γ , i.e. for $x^k \in [a^k + \varepsilon/\sqrt{2}, b^k - \varepsilon/\sqrt{2}]$. As a result, $F_{H,\varepsilon}$ can be recast as follows: for each $\tilde{\Gamma} \in \mathcal{E}_r$,

$$F_{H,\varepsilon}(\tilde{\Gamma}) = \sum_{k=1}^4 \int_{a^k + \varepsilon/\sqrt{2}}^{b^k + \varepsilon/\sqrt{2}} \frac{(v^\varepsilon(x^k))^2}{2\sqrt{2}} [\mathbf{T}^\varepsilon(x^k) \cdot m(x^k)] \mathbf{T}^\varepsilon(x^k) \cdot \nabla H(\tau, (x^k, \tilde{f}^k(x^k)))_{\mathcal{R}_k} dx^k. \quad (4.23)$$

To write (4.24), we used the relation:

$$ds(x^k) = (1 + (\partial_{x^k} \tilde{f}^k)^2)^{1/2} dx^k = \sqrt{2} v dx^k,$$

where the last equality comes from Section 2.2, see (2.24). As a consequence of (4.23), continuity of $F_{H,\varepsilon}$ is proven as soon as, for each $k \in \{1, \dots, 4\}$:

$$\begin{aligned} \lim_{n \rightarrow \infty} \int_{a^k + \varepsilon/\sqrt{2}}^{b^k - \varepsilon/\sqrt{2}} \frac{(v^{n,\varepsilon}(x^k))^2}{2\sqrt{2}} [\mathbf{T}^{n,\varepsilon}(x^k) \cdot m^n(x^k)] \mathbf{T}^{n,\varepsilon}(x^k) \cdot \nabla H((x^k, f_n^k(x^k)))_{\mathcal{R}_k} dx^k \\ = \int_{a^k + \varepsilon/\sqrt{2}}^{b^k - \varepsilon/\sqrt{2}} \frac{(v^\varepsilon(x^k))^2}{2\sqrt{2}} [\mathbf{T}^\varepsilon(x^k) \cdot m(x^k)] \mathbf{T}^\varepsilon(x^k) \cdot \nabla H((x^k, f^k(x^k)))_{\mathcal{R}_k} dx^k. \end{aligned} \quad (4.24)$$

Note the replacement of a_n^k, b_n^k by a^k, b^k in the first line of (4.24), thanks to (4.22) and the fact that the integrand in (4.24) is bounded.

Fix $k \in \{1, \dots, 4\}$. On quadrant k , the integral in (4.24) has a much simpler expression in terms of the tangent vector $\mathbf{t}^{n,\varepsilon}$ with 1-norm equal to 1, defined in (3.49). Indeed, recall from (3.52) that, for each $x^k \in I^k$,

$$\begin{aligned} v^{n,\varepsilon}(x^k) \mathbf{T}^{n,\varepsilon}(x^k) &= \mathbf{t}^{n,\varepsilon}(x^k) = \left(\frac{\sqrt{2}}{2}, \frac{f_n^k(x^k + \varepsilon/\sqrt{2}) - f_n^k(x^k - \varepsilon/\sqrt{2})}{2\varepsilon/\sqrt{2}} \right)_{\mathcal{R}_k} \\ &=: \frac{\sqrt{2}}{2} (1, \Delta_\varepsilon f_n^k(x^k))_{\mathcal{R}_k}. \end{aligned} \quad (4.25)$$

Moreover, the function m , defined in Definition 3.6 is equal to a sign vector, determined only by the index of the quadrant. As a result, for n large enough, $m^n = m$ for each $x^k \in [a^k + \varepsilon/\sqrt{2}, b^k - \varepsilon/\sqrt{2}]$, $k \in \{1, \dots, 4\}$, and $v^{n,\varepsilon} [\mathbf{T}^{n,\varepsilon} \cdot m^n](\theta^k)$ reads:

$$v^{n,\varepsilon} [\mathbf{T}^{n,\varepsilon} \cdot m^n](\theta^k) = \mathbf{t}^{n,\varepsilon}(x^k) \cdot m(x^k) = -\frac{f_n^k(x^k + \varepsilon/\sqrt{2}) - f_n^k(x^k - \varepsilon/\sqrt{2})}{2\varepsilon} = -\Delta_\varepsilon f_n^k(x^k).$$

The integral in (4.24) then becomes, for n large enough and with $\partial_{y^k} = \partial_{e_{\pi/4 - (k-1)\pi/2}}$ the partial derivative with respect to the second basis vector in \mathcal{R}_k :

$$-\frac{1}{4} \int_{a^k + \varepsilon/\sqrt{2}}^{b^k - \varepsilon/\sqrt{2}} \Delta_\varepsilon f_n^k(x^k) [\partial_{x^k} + \Delta_\varepsilon f_n^k(x^k) \partial_{y^k}] H((x^k, f_n^k(x^k)))_{\mathcal{R}_k} dx^k. \quad (4.26)$$

Observe that $x^k \mapsto \partial_{y^k} H((x^k, f_n^k(x^k)))$ is continuous, and that $\Delta_\varepsilon f_n^k(x^k)$ converges point-wise to $\Delta_\varepsilon f^k(x^k)$, defined as in (4.25). As the integrand in (4.26) is bounded, the dominated convergence theorem yields (4.24), hence the Hausdorff continuity of $F_{H,\varepsilon}$ and the d_E -continuity of the first term in (4.20). The second term in (4.21) is treated similarly.

We now turn to the point-wise convergence of $J_{H,\varepsilon}^\beta$ to J_H^β as $\varepsilon \downarrow 0$, i.e. the proof of (4.17). The fact that $\mathbf{T}^\varepsilon \rightarrow \mathbf{T}$ for almost every point of a curve and the dominated convergence theorem immediately give the result. This concludes the proof of Proposition 4.3. \square

5 Lower bound large deviations and hydrodynamic limits

In this section, we prove lower bound large deviations for the measures $\{Q_{r,\beta}^N : N \in \mathbb{N}^*\}$, i.e. the lower bound in Theorem 2.8. The method is expounded in [KL99]. It consists in first proving hydrodynamic limits for all the $\{Q_{r,\beta,H}^N : N \in \mathbb{N}^*\}$, $H \in \mathcal{C}$, which are shown to concentrate on solutions to anisotropic motion by curvature with drift in the sense of (2.32). This yields a lower-bound, that matches the upper-bound of Section 4 for smooth trajectories. In this article, we will not consider more general trajectories, as the analysis of solutions to (2.32) proves to be very difficult due to the motion of the poles.

5.1 Large deviation lower-bound

In this section, we explain how to obtain lower bound large deviations assuming the following points:

1. trajectories typically remain in the effective state space $\mathcal{E}_r(d)$ for some $d \in (0, 1/4]$, which is Proposition 2.4;
2. the hydrodynamic limit of the measures $\{Q_{r,\beta,H}^N : N \in \mathbb{N}^*\}$ can be characterised for each $H \in \mathcal{C}$ (this is Proposition 2.5), and we consider only those $H \in \mathcal{C}$ for which the weak formulation (2.32) of the anisotropic motion by curvature with drift has a unique solution, which is additionally continuous in time in Hausdorff topology.

With these two assumptions, one concludes on a lower-bound in the same way as in [KL99], Chapter 10, Section 5.

More precisely, let $H \in \mathcal{C}$, and let $\Gamma^H \in E([0, T_H], \bigcup_{r,d>0} \mathcal{E}_r(d))$ be a solution of (2.32). Assume that H is chosen such that Γ^H is the only solution, and is continuous in time in Hausdorff topology. Γ^H exists until a maximal time T_H , which is the first time Γ^H reaches $\partial([-1, 1]^2)$, or has either opposite quadrants touching each other, or two consecutive poles collapsing into a segment. For any $r \in (0, r_0)$, there is a time $T_r < T_H$ such that:

- Γ^H takes values in $\mathcal{E}_r(1/2)$ on $[0, T_r]$. This is a technical point related to the proof of item 2 of Proposition 2.4 in Section 5.2.
- For any $T_0 \leq T_r$, the measures $Q_{r,\beta,H}^N$, $N \in \mathbb{N}^*$ concentrate in the large N limit on $\delta_{(\Gamma^H)_{t \leq T_0}}$.

For each $T_0 \leq T_r$, recall from (2.38) the definition of the set $\mathcal{A}_{T_0, r, \beta}^{\mathcal{C}}$. Let $\mathcal{O} \subset E([0, T_0], \mathcal{E}_r(1/2))$ be an open set. Assume there is $H \in \mathcal{C}$ such that $\Gamma_{[0, T_0]}^H \in \mathcal{O} \cap \mathcal{A}_{T_0, r, \beta}^{\mathcal{C}}$. Then:

$$\begin{aligned} \liminf_{N \rightarrow \infty} N^{-1} \log Q_{r, \beta}^N(\mathcal{O}) &\geq -I_{\beta}((\Gamma^H)_{t \leq T_0} | \Gamma_0) \\ &\Rightarrow \liminf_{N \rightarrow \infty} N^{-1} \log Q_{r, \beta}^N(\mathcal{O}) \geq - \inf_{\mathcal{O} \cap \mathcal{A}_{T_0, r, \beta}^{\mathcal{C}}} I_{\beta}(\cdot | \Gamma_0). \end{aligned} \quad (5.1)$$

We now prove (5.1) under the assumptions listed at the beginning of this section. As in [KL99], the proof consists in a change of probability from $\mathbb{P}_{r, \beta}^N$ to a tilted measure $\mathbb{P}_{r, \beta, H}^N$, and in using Jensen inequality to bound from below $\log Q_{r, \beta, H}^N(\mathcal{O})$ by the entropy $\mathbb{E}_{r, \beta, H}^N[\log d\mathbb{P}_{r, \beta}^N/d\mathbb{P}_{r, \beta, H}^N]$. The only difference in our case comes from the fact that the quantity $N^{-1}(\log d\mathbb{P}_{r, \beta}^N/d\mathbb{P}_{r, \beta, H}^N)$ is not bounded on $E([0, T_0], N^{-1}X_r^N)$. Indeed, from the proof of Proposition 3.1 (see in particular (3.14)) which, although stated for $\mathcal{L}_{r, \beta, H}\langle \Gamma, G \rangle$ for $G \in \mathcal{C}$, is easily adapted to $d\mathbb{P}_{r, \beta}^N/d\mathbb{P}_{r, \beta, H}^N(\Gamma)$, it must satisfy:

$$\begin{aligned} N^{-1}(\log d\mathbb{P}_{r, \beta}^N/d\mathbb{P}_{r, \beta, H}^N)(\Gamma) &= \sum_{k=1}^4 \int_0^{T_0} [(p_k(\gamma_t) - 1)e^{-2\beta} \mathbf{1}_{P_k \cap \partial([-1, 1])^2} - \mathbf{1}_{p_k=2, DP_r^k}] dt \\ &\quad + C(H)O_N(1), \end{aligned}$$

and p_k can be of order N for each $k \in \{1, \dots, 4\}$. Above, DP_r^k is either V_r or H_r , defined in (2.9)-(2.10), depending on the value of $k \in \{1, \dots, 4\}$. This unbounded term is however easily controlled as we shall see. Proceeding as in [KL99], one obtains, for each H such that $(\Gamma^H)_{t \leq T_0} \in \mathcal{O}$ and each $\delta > 0$, each ε small enough as a function of δ :

$$\begin{aligned} N^{-1} \log Q_{r, \beta}^N(\mathcal{O}) &\geq \mathbb{E}_{r, \beta, H}^N[-J_{H, \varepsilon}^{\beta} \mathbf{1}_{Z \cap \mathcal{O}}] + O_H(\delta) + o_N(1) \\ &\quad + \mathbb{E}_{r, \beta, H}^N \left[\mathbf{1}_{\mathcal{O}} \mathbf{1}_{Z^c} 2 \sum_{k=1}^4 \int_0^{T_0} [(p_k(\gamma_t) - 1)e^{-2\beta} \mathbf{1}_{P_k \cap \partial([-1, 1])^2} - \mathbf{1}_{p_k(\gamma_t)=2, DP_r^k}] dt \right]. \end{aligned} \quad (5.2)$$

Recall that $J_{H, \varepsilon}^{\beta}$ is defined in (4.3), and Z is the set of (3.44), on which the Replacement lemma applies with error δ and the pole terms are controlled. The set $Z^c \cap \mathcal{O}$ has probability super-exponentially small in the large N , small ε limit. In particular, it has probability bounded by $e^{-c(\varepsilon)N}$ for some $c(\varepsilon) > 0$ under $\mathbb{P}_{r, \beta, H}^N$, for ε small enough uniformly on N large enough. This accounts for the $o_N(1)$ term in the first line, and shows that the expectation on the second line is $o_N(1)$ as well.

We now study the expectation in the first line of (5.2), and show that it is equal to $-J_{H, \varepsilon}^{\beta}(\Gamma^H)$. As an element (in fact, the only one by hypothesis) in the support of the hydrodynamic limit of $(Q_{r, \beta, H}^N)_N$, Γ^H must have almost always point-like poles on $[0, T_0]$. It is thus a point of continuity of $J_{H, \varepsilon}^{\beta}$ by Proposition 4.3. As such, for a fixed $\eta > 0$, one has:

$$\sup_{\Gamma \in B_{d_E}(\Gamma^H, \eta)} |J_{H, \varepsilon}^{\beta}(\Gamma) - J_{H, \varepsilon}^{\beta}(\Gamma^H)| = \omega_{\Gamma^H, H, \varepsilon}(\eta).$$

Above, $B_{d_E}(\Gamma^H, \eta)$ is the open ball with radius η centred on Γ^H , and $\omega_{\Gamma^H, H, \varepsilon}(\cdot)$ is the modulus of continuity of $J_{H, \varepsilon}^\beta$ at Γ^H , in which we stress the dependence on both Γ^H and H , and which vanishes at 0. The first expectation in (5.2) is then recast as follows:

$$\begin{aligned} \mathbb{E}_{r, \beta, H}^N [-J_{H, \varepsilon}^\beta \mathbf{1}_{Z \cap \mathcal{O}}] &= -J_{H, \varepsilon}^\beta(\Gamma^H) \mathbb{E}_{r, \beta, H}^N [\mathbf{1}_{Z \cap \mathcal{O} \cap B_{d_E}(\Gamma^H, \eta)}] + O_\eta(\omega_{\Gamma^H, H, \varepsilon}(\eta)) \\ &\quad + \mathbb{E}_{r, \beta, H}^N [\mathbf{1}_{Z \cap \mathcal{O} \cap B_{d_E}(\Gamma^H, \eta)^c} (-J_{H, \varepsilon}^\beta)]. \end{aligned}$$

The expectation in the first term converges to 1 for N large, while the last one vanishes as $J_{H, \varepsilon}^\beta$ is bounded and $Q_{r, \beta, H}^N(B_{d_E}(\Gamma^H, \eta)^c)$ vanishes. It remains to let η , then ε go down to 0 to obtain the left-hand side of (5.1). Taking the supremum of the resulting expression on all H such that Γ^H belongs to \mathcal{O} then yields the right-hand side of (5.1).

To conclude the proof of lower-bound large deviations, it remains to prove the two assumptions presented at the beginning of this section. This is the content of the next two sections. In Section 5.2, we prove that trajectories typically do not leave the good state space $\mathcal{E}_r(d)$ on $[0, \eta]$ for some $\eta > 0$ and $d \leq 1/4$. In Section 5.3, we prove that $(Q_{r, \beta, H}^N)_N$ concentrates on $[0, \eta]$ on δ_{Γ^H} . The trajectory Γ^H , defined at the beginning of this section, is the solution of (2.32), and assumed to be unique as well as continuous in time in Hausdorff topology. Since Γ^H is almost always in $\mathcal{E}_r(1/2)$ before time $T_r \geq T_0$, it is in $\mathcal{E}_r(1/2)$ on $[0, T_r]$ by continuity. If $T_0 \leq \eta$, then the lower bound is proven. Otherwise, the result until time T_0 follows by recursion, re-starting the dynamics at $\Gamma_\eta^H \in \mathcal{E}_r(1/2)$.

5.2 The droplet moves on a diffusive scale

In this section, we prove Proposition 2.4. First, we show that a configuration in \mathcal{E}_{r_0} cannot have left \mathcal{E}_{r_1} , for some $r_1 \in (r, r_0)$, before a time of order N^2 . The set \mathcal{E}_{r_0} is defined in (2.15). The techniques employed have the following two nice properties.

1. First, we obtain estimates depending only on the initial point and parameters of the model.
2. Second, we get quantitative estimates for all N large enough, in e^{-cN} for some parameter c . This is the best possible decay rate, as large deviations around the hydrodynamic limit occur at the e^{-N} scale.

Recall from Definition 2.1 the properties of the initial condition of the dynamics. Recall also that, for $r_1 \in (r, r_0)$ and $\beta > 0$, $\tau = \tau_{r_1, \beta, H}^N$ is the first time at which the dynamics with generator $N^2 \mathcal{L}_{r, \beta, H}^N$ starting from Γ_0^N leaves $N\mathcal{E}_{r_1}$. We prove the following.

Lemma 5.1 (Item 1 of Proposition 2.4). *For each $r_1 \in (r, r_0)$, there are constants $c_0, \alpha > 0$ which depend only on H, Γ_0, r_0, r_1 (and in particular not on r, β), and a numerical constant C such that:*

$$\mathbb{P}_{r, \beta, H}^N(\tau \leq c_0) \leq C e^{-\alpha N}. \quad (5.3)$$

Proof. We adapt the method used in [Cap+11]. The idea is to show that exiting $N\mathcal{E}_{r_1}$, $r_1 < r_0$ from $N\mathcal{E}_{r_0}$ requires moving a deterministic volume of blocks of order N^2 , which must take a time

of order N^2 when N is large.

Consider the first point, i.e. that for $r_1 \in (r, r_0)$, leaving $N\mathcal{E}_{r_1}$ when starting from $N\mathcal{E}_{r_0}$ requires moving at least ψN^2 blocks, for $\psi = \psi(\Gamma_0, r_0, r_1) > 0$. Recall that if $\gamma \in X_r^N$, Γ is the droplet it delimits. There are three ways of leaving the set $N\mathcal{E}_{r_1}$, defined in Appendix B:

- a) breaking V_{r_1} or H_{r_1} (defined in (2.9)-(2.10));
- b) having the difference in abscissa or in ordinate between two consecutive poles less than Nr_1 .
- c) having two points in opposite quadrants become closer than r_1 in 1-distance;

Notice that condition a) is necessarily realised after condition b), so we focus on conditions b) and c). The set \mathcal{E}_{r_1} is defined to contain pathological limits of elements of $N^{-1}X_r^N$ when N is large. However, the dynamics starts from a nice initial condition, i.e. with simple boundary, see Definition 2.1. The hitting time τ of conditions b) and c) is thus larger than the hitting time of the following simpler conditions (see Figure 4.7):

1. At τ^1 , the droplet first fails to contain the set $D := N^{-1}\{x \in \Gamma_0^N : d(x, \gamma_0^N) \geq N\varepsilon\}$; where $\varepsilon = \varepsilon(\Gamma_0, r_0, r_1)$ is small enough to ensure that the heights (north and south poles) and abscissas (west and east poles) of the poles of D differ from those of $N^{-1}\Gamma_0^N$ by at most $(r_0 - r_1)/10$.
2. At τ^2 , one of the poles has first moved sideways by at least $N(r_0 - r_1)/2$ compared to Γ_0^N .

Write \mathbb{P}_k for the probability associated with the dynamics that stops upon reaching τ^k , $k \in \{1, 2\}$. This (inhomogeneous) Markov chain has generator $N^2\mathcal{L}_k$ equal to $N^2\mathcal{L}_{r,\beta,H}$ (defined in (2.11)-(2.14)) for times below τ^k , and 0 strictly after. With the lower bound for τ provided by $\tau^1 \wedge \tau^2$ in conditions 1, 2 and Figure 4.7, we claim that there must be $\psi = \psi(\Gamma_0, r_0, r_1) > 0$ and functions G_1, G_2 , corresponding to indicator functions of suitable sets, such that, for $k \in \{1, 2\}$ and for the dynamics induced by \mathbb{P}_k :

$$\{\tau^k \leq t\} \subset \left\{ \int_{N^{-1}\Gamma_0^N} G_k - \int_{\Gamma_t^N} G_k \geq \psi \right\}. \quad (5.4)$$

The probability of the event on the right in (5.4) is estimated by the computations of Section 3 as long as G_1, G_2 are replaced by smooth approximations, as we now explain.

Estimating τ^1 :

Define G_1 as the indicator function of the ring between the two droplets on the left Figure of 4.7. For $\zeta > 0$ sufficiently small, let $G_1^\zeta \in [0, 1]$ be a C^2 approximation of G_1 equal to 0 when $G_1 = 0$, to 1 at 1-distance ζ or more to $\{G_1 = 0\}$, and going down smoothly to 0 as a function of the distance otherwise. Take then $\psi_1 = \psi_1(\Gamma_0, r_0, r_1)$ as the smallest volume to delete in order to reach D from $N^{-1}\Gamma_0^N$. Then for $t \geq 0$, up to dividing ψ_1 by 2, for all ζ small enough:

$$\mathbb{P}_{r,\beta,H}^N(\tau^1 \leq t) = \mathbb{P}_1(\tau^1 \leq t) \leq \mathbb{P}_1\left(\int_{N^{-1}\Gamma_0^N} G_1^\zeta - \int_{N^{-1}\Gamma_t^N} G_1^\zeta \geq \psi_1\right). \quad (5.5)$$

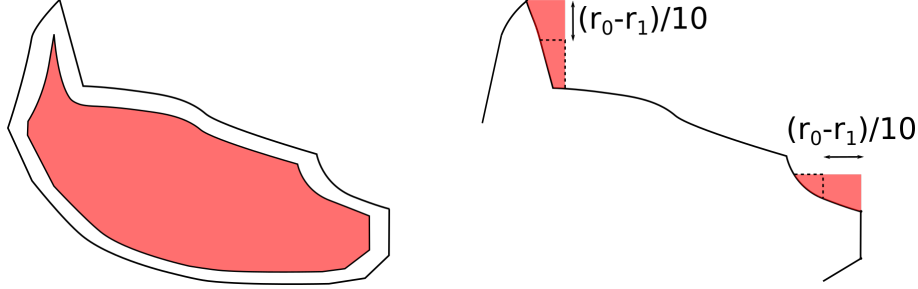

Figure 4.7 – Initial condition/portion of the initial condition of the dynamics. Left figure: the shaded area is the set of points of Γ_0 at distance more than a suitable $\varepsilon > 0$ from the boundary (see item 1 for the choice of ε). τ^1 is the first time at which the boundary of the droplet touches the shaded area. Right figure: The shaded areas, of smaller side of length $(r_0 - r_1)/2$, have to be filled for either the north or east pole to have moved sideways by $(r_0 - r_1)/2$. The dashed lines delimit areas which always stay below the poles before time τ^1 .

Note that this "volume" difference is always negative. By Chebychev exponential inequality, it is sufficient to estimate, for $t > 0$, the quantity $M_t^{1,\zeta} e^{A_t}$, where $(M_t^{1,\zeta})_{t \geq 0}$ is the \mathbb{P}_1 -martingale defined for an X_r^N -valued trajectory $\Gamma = (\Gamma_t^N)_{t \geq 0}$ by:

$$\forall t \geq 0, \quad M_t^{G_1^\zeta} = \exp \left[-N \int_{N^{-1}\Gamma_t^N} G_1^\zeta + N \int_{N^{-1}\Gamma_0^N} G_1^\zeta - A_t \right], \quad (5.6)$$

and $(A_t)_{t \geq 0}$ is the process:

$$\forall t \geq 0, \quad A_t = N^2 \int_0^t e^{N \int_{N^{-1}\Gamma_u^N} G_1^\zeta} \mathcal{L}_1 e^{-N \int_{N^{-1}\Gamma_u^N} G_1^\zeta} du. \quad (5.7)$$

Since $A_t = A_{t \wedge \tau^1}$ for $t \geq 0$, the droplets entering in the definition of (A_t) are all in $N\mathcal{E}_r$. The computations of Section 3 thus apply: recall the notation $\varepsilon_x = 1$ if a block is added corresponding to a vertex x , $\varepsilon_x = -1$ if it is removed. Then for each $t \geq 0$, with $\gamma^N = \partial\Gamma^N$:

$$\begin{aligned} A_t &\leq \int_0^{t \wedge \tau^1} \left[NC(H) + N \sum_{x \in V(\gamma_u^N)} \varepsilon_x c_x(\Gamma_u^N) G_1^\zeta(x/N) \right. \\ &\quad \left. - 2N \sum_{k=1}^4 \sum_{\substack{x \in P_k(u) \\ x+2e_x^+ \in P_k(u)}} [e^{-2\beta} \mathbf{1}_{P_k(u) \cap \partial\Lambda_N = \emptyset} - \mathbf{1}_{p_k(u)=2, DP_r^k}] G_1^\zeta(x/N) \right] du \\ &\leq N(C(G_1^\zeta) + C(H))t. \end{aligned} \quad (5.8)$$

To obtain the first inequality in (5.8), p_k was bounded by N for $k \in \{1, \dots, 4\}$. To obtain the second line, the crucial point is that the contribution of the sum on P_k , which may be of order N^2 , is negative ($G_1^\zeta \geq 0$), since it makes the droplet grow. Moreover, $\mathbf{1}_{p_k(u)=2, DP_r^k}$ was bounded by 1. For $\zeta = (r_0 - r_1)/100$, $C(G_1^\zeta)$ depends only on Γ_0 and r_1 . The event DP_r^k corresponds to V_r or H_r , defined in (2.9)-(2.10), depending on the value of $k \in \{1, \dots, 4\}$. Equation (5.8) concludes the bound on τ^1 :

$$\mathbb{P}_{r,\beta,H}^N(\tau^1 \leq t) \leq e^{-\psi_1 N} e^{(C(H)+C(\Gamma_0,r_1))Nt} \mathbb{E}_1[M_t^{1,\zeta}] = e^{-\psi_1 N} e^{(C(H)+C(\Gamma_0,r_1))Nt}, \quad (5.9)$$

which decays exponentially fast to 0 as long as $t < \psi_1/(C(H) + C(\Gamma_0, r_1))$.

Estimating $\tau^1 \wedge \tau^2$:

Equation (5.8) cannot be used to estimate τ^2 directly. Indeed, τ^2 occurs only after the initial droplet has grown somewhere, which means that the poles may contribute. Define however G_2 as the indicator function of the zones delimited by the dashed lines in Figure 4.7 (in all quadrants, not just the first one as represented). Take then ψ_2 as the smallest volume of one of these dashed area. Then as stated in (5.4), for $t \geq 0$, under \mathbb{P}_2 , the dynamics stopped at τ_2 :

$$\{\tau^1 \wedge \tau^2 \leq t\} \subset \left\{ \tau^1 \geq t, \int_{N^{-1}\Gamma_0^N} G_2 - \int_{N^{-1}\Gamma_t^N} G_2 \geq \psi_2 \right\} \cup \{\tau^1 \leq t\}.$$

The argument is then the same as for the estimate of τ^1 , and we again obtain an exponential decay for sufficiently short time. Since $\tau \geq \tau^1 \wedge \tau^2$, this concludes the proof. \square

Let us now prove the second item in Proposition 2.4.

Lemma 5.2 (Item 2 in Proposition 2.4). *Let $c_0 > 0$ be given by Lemma 5.1. For this lemma only, take $\beta > 64 \log 3$. Then, for each $d \in (0, 1/4)$ and each $H \in \mathcal{C}$, there is a time $T_0 = T_0(\Gamma_0, d_0, d, \beta, H)$, $T_0 \leq c_0$ such that:*

$$\mathbb{P}_{r,\beta,H}^N \left(\int_0^{T_0} \mathbf{1}_{\text{dist}(\Gamma_t, \partial([-1,1]^2)) < d} dt = 0 \right) \xrightarrow[N \rightarrow \infty]{} 1. \quad (5.10)$$

Proof. The idea is to use the structure of the invariant measure ν to estimate the cost of having one pole come close to the boundary. Let $\eta \leq c_0$, with c_0 given by Lemma 5.1. For short, let $(z_1, \dots, z_4) = (y_{\max}, x_{\max}, y_{\min}, x_{\min})$ be the extremal abscissas/ordinates of a droplet, and denote by z_k^0 , $k \in \{1, \dots, 4\}$ the corresponding values for the initial condition $N^{-1}\Gamma_0^N$ of Definition 2.1. Let also ℓ_0^N be the length in 1-norm of the boundary of $N^{-1}\Gamma_0^N$. Recall that $N^{-1}\Gamma_0^N$ is at distance $d_0 \geq 1/2$ from $\partial([-1, 1]^2)$ for each N .

If $x \in \mathbb{R}$, define $x_+ = \max(x, 0)$ and notice that e.g. $(z_1(\Gamma) - z_1^0)_+$ represents how much closer to the boundary the highest point in a droplet $\Gamma \in \mathcal{E}_r$ is compared to $N^{-1}\Gamma_0^N$. The lemma thus holds if we can prove that there is $\eta > 0$ with:

$$\mathbb{P}_{r,\beta,H}^N \left(\sup_{t \leq \eta} \max_{1 \leq k \leq 4} (z_k - z_k^0)_+ > d_0 - d \right) = o_N(1). \quad (5.11)$$

Let us rewrite the event in (5.11) in terms of the length of the interface. By definition, an interface $\gamma \in X_r^N$ has length:

$$|\gamma| = 2(z_1(\gamma) - z_3(\gamma)) + 2(z_2(\gamma) - z_4(\gamma)). \quad (5.12)$$

For each $\zeta > 0$, let τ^ζ be the first time at which one of the pole has gone down by at least ζ , defined as follows:

$$\tau^\zeta = \inf \{ t \geq 0 : \min_{1 \leq k \leq 4} [z_k(t) - z_k^0] \leq -\zeta \}.$$

As a consequence of Lemma 5.1, there are $c(\zeta), C(\zeta) > 0$ such that:

$$\mathbb{P}_{r,\beta,H}^N (\tau^\zeta \leq c(\zeta)) \leq C(\zeta) e^{-C(\zeta)N}.$$

Fix $\zeta > 0$ to be chosen below. Equation (5.11) is proven if we can establish the existence of $\eta \in (0, c(\zeta))$ with:

$$\mathbb{P}_{r,\beta,H}^N \left(\tau^\zeta > c(\zeta), \sup_{t \leq \eta} \max_{1 \leq k \leq 4} (z_k - z_k^0)_+ > d_0 - d \right) = o_N(1). \quad (5.13)$$

Recall (5.12). Since the length changes by $2/N$ when z_k changes by $1/N$ for $1 \leq k \leq 4$, the event in (5.13) is included in:

$$\left\{ \sup_{t \leq \eta} [|\gamma(t)| - \ell_0^N] > 2(d_0 - d) - 6\zeta \right\}.$$

Take $\zeta = (d_0 - d)/3$, and let us estimate the probability of the above event. As η is chosen to satisfy $\eta \leq c_0$ with the c_0 of Lemma 5.1, we need only do so under $\mathbb{P}_{r,\beta}^N$. Indeed, by Lemma 5.1:

$$\begin{aligned} & \mathbb{P}_{r,\beta,H}^N \left(\sup_{t \leq \eta} [|\gamma(t)| - \ell_0^N] > d_0 - d \right) \\ &= \mathbb{P}_{r,\beta,H}^N \left(\forall t \in [0, \eta], \gamma_t \in \mathcal{E}_r; \sup_{t \leq \eta} [|\gamma(t)| - \ell_0^N] > d_0 - d \right) + o_N(1) \\ &\leq e^{C(H)\eta N} \mathbb{P}_{r,\beta}^N \left(\sup_{t \leq \eta} [|\gamma(t)| - \ell_0^N] > d_0 - d \right)^{1/2} + o_N(1). \end{aligned} \quad (5.14)$$

The second line comes from Cauchy-Schwarz inequality and the fact that, by (4.2)-(4.3)-(4.4):

$$\mathbb{E}_{r,\beta}^N \left[\mathbf{1}_{\{\forall t \in [0, \eta], \gamma_t \in \mathcal{E}_r\}} (d\mathbb{P}_{r,\beta,H}^N / d\mathbb{P}_{r,\beta}^N)_{[0, \eta]}^2 \right]^{1/2} \leq e^{C(H)\eta N}.$$

Change initial condition in (5.14) to obtain a probability starting from the invariant measure ν :

$$\mathbb{P}_{r,\beta}^N \left(\sup_{t \leq \eta} [|\gamma(t)| - \ell_0^N] > d_0 - d \right) \leq \nu(\gamma_0^N)^{-1} \mathbb{P}_\nu \left(\sup_{t \leq \eta} [|\gamma(t)| - \ell_0^N] > d_0 - d \right). \quad (5.15)$$

Let \mathcal{N}_t be the number of updates in the dynamics \mathbb{P}_ν up to time t . $(\mathcal{N}_t)_{t \geq 0}$ is a Poisson process with rate bounded by $20N^3$, which is a rough bound for the update rate of a curve under the contour dynamics. To use the fact that ν is invariant under the dynamics, split $[0, \eta]$ in, say, N^4 intervals of length ηN^{-4} . $\mathcal{N}_{\eta N^{-4}}$ is thus a Poisson random variable with rate bounded by $20\eta N^{-1}$, and for N large enough:

$$\mathbb{P}_\nu \left(\mathcal{N}_{\eta N^{-4}} \geq \frac{10\beta N}{\log N} \right) \leq \exp [-10\beta N]. \quad (5.16)$$

Since γ_0^N has length smaller than $4N$ and the partition function \mathcal{Z} is bounded, one has $\nu(\gamma_0^N)^{-1} \leq C e^{-6\beta N}$ for some $C > 0$, and (5.16) applied to (5.15) yields:

$$\begin{aligned} & \mathbb{P}_{r,\beta}^N \left(\sup_{t \leq \eta} [|\gamma(t)| - \ell_0^N] > d_0 - d \right) \leq \nu(\Gamma_0^N)^{-1} N^4 \mathbb{P}_\nu \left(\sup_{t \leq N^{-4}\eta} [|\gamma(t)| - \ell_0^N] > d_0 - d \right) \\ &= \nu(\Gamma_0^N)^{-1} N^4 \mathbb{P}_\nu \left(\sup_{t \leq N^{-4}\eta} [|\gamma(t)| - \ell_0^N] > d_0 - d, \mathcal{N}_{\eta N^{-4}} \leq \frac{10\beta N}{\log N} \right) + O(e^{-6\beta N}). \\ &= \nu(\Gamma_0^N)^{-1} N^4 \nu \left(|\gamma| - \ell_0^N > (d_0 - d)/2 \right) + O(e^{-6\beta N}). \end{aligned}$$

To obtain the last equation, we assumed that N was large enough to have $(d_0 - d)/2 > 2 \cdot 10\beta N/\log N$. Recalling (5.14), one obtains by definition of ν , for $\eta < c/C(H)$:

$$\mathbb{P}_{r,\beta,H}^N \left(\sup_{t \leq \eta} [|\gamma(t)| - \ell_0^N] > d_0 - d \right) \leq e^{C(H)\eta N} N^4 e^{-\beta N(d_0-d)/2} 3^{8N} + o_N(1),$$

where 3^{8N} is a rough upper bound for the number of curves with length larger than $|\ell_0^N| + (d_0 - d)/2$. As $d < 1/4$, $d_0 \geq 1/2$ and $\beta \geq 64 \log 3 > 16 \log 3/(d_0 - d)$, there is $\eta = T_0 \leq c_0$ small enough satisfying the claim of the lemma. \square

Corollary 5.3 (Relative compactness of the sequence $\{Q_{r,\beta,H}^N : N \in \mathbb{N}^*\}$). *Let T_0 be chosen according to the previous lemma. Then $\{Q_{r,\beta,H}^N : N \in \mathbb{N}^*\}$ is relatively compact in $\mathcal{M}_1(E([0, T_0], X))$, and its weak limit points are supported in $E([0, T_0], \mathcal{E}_r(d))$.*

Proof. By Lemmas 5.1- 5.2, the first hypothesis of Corollary B.10 is satisfied. The second one proceeds from Appendix B.3. \square

5.3 Characterisation of limit points

Fix $H \in \mathcal{C}$ and let $T_0 > 0$ be a time given by Lemma 5.2. In this section, we prove Proposition 2.5, i.e. we prove that any weak limit point $Q_{r,\beta,H}^*$ of $(Q_{r,\beta,H}^N)_N$ in $\mathcal{M}_1(E([0, T_0], X))$ is concentrated on weak solutions (2.32) of anisotropic motion by curvature with drift in $E_{pp}([0, T_0], \mathcal{E}_r(d))$ (defined in (2.36)). We start by extending upper-bound large deviations to the sequence $(Q_{r,\beta,H}^N)_N$.

Lemma 5.4. *For the sequence $(Q_{r,\beta,H}^N)$, for any closed set $C \subset E([0, T_0], \mathcal{E}_r(d))$:*

$$\limsup_{N \rightarrow \infty} \frac{1}{N} \log Q_{r,\beta,H}^N(C) \leq - \sup_{q \geq 1} \inf_{C \cap D_q} \sup_{G,\varepsilon} [J_{G,\varepsilon} - J_{H,\varepsilon}] \leq - \inf_C I_{\beta,H}. \quad (5.17)$$

The set $D_q = \bigcap_{n \geq 1} D_{q,n}$ controls the neighbourhood of the poles, as defined in (4.9). The functional $I_{\beta,H}$ is $+\infty$ outside of $E_{pp}([0, T_0], \mathcal{E}_r(d))$, and is defined for $\Gamma \in E_{pp}([0, T_0], \mathcal{E}_r(d))$ as:

$$I_{\beta,H}(\Gamma) = \sup_{G \in \mathcal{C}} \{J_G^\beta(\Gamma) - J_H^\beta(\Gamma)\} = \sup_{F \in \mathcal{C}} \left\{ J_F^\beta(\Gamma) - \int_0^{T_0} d\tau \int_{\gamma_\tau} \mu F H ds \right\}. \quad (5.18)$$

Recall that μ is the mobility defined in (2.26), and that $E_{pp}([0, T_0], \mathcal{E}_r(d))$ is defined in (2.36).

Proof. Simply write:

$$Q_{r,\beta,H}^N(C) = \mathbb{E}_{r,\beta}^N \left[\frac{d\mathbb{P}_{r,\beta,H}^N}{d\mathbb{P}_{r,\beta}^N} \mathbf{1}_C \right],$$

and repeat the computations of Section 4 to obtain the large deviation upper bound (5.18) as well as the first expression of $I_{\beta,H}$. The second expression (5.18) is obtained by the change of functions $F = G - H$ and elementary computations. \square

It is a well-known fact that the only trajectories for which the rate function $I_{\beta,H}$ vanishes are solutions of (2.32), which corresponds to its first variation. Let us provide a quick proof. Consider

$\Gamma \in E([0, T_0], \mathcal{E}_r(d))$ such that $I_{\beta, H}(\Gamma) = 0$, and take $\varepsilon > 0$ and $G \in \mathcal{C}$. Then $\Gamma \in E_{pp}([0, T_0], \mathcal{E}_r(d))$, and:

$$0 \geq J_{\pm\varepsilon G}^\beta - \pm\varepsilon \int_0^{T_0} d\tau \int_{\gamma_\tau} \mu H G ds = \pm\varepsilon \left(\ell_G^\beta - \int_0^{T_0} d\tau \int_{\gamma_\tau} \mu H G ds \right) - \frac{\varepsilon^2}{2} \int_0^{T_0} d\tau \int_{\gamma_\tau} \mu G^2 ds.$$

Taking ε small with G fixed, the term of order ε must vanish, and it is precisely (2.32) with test function G . As this is true for all $G \in \mathcal{C}$, Γ is a solution of (2.32). The converse is clearly true, since if Γ satisfies (2.32), then:

$$I_{\beta, H}(\Gamma) = \sup_{G \in \mathcal{C}} \left\{ -\frac{1}{2} \int_0^{T_0} d\tau \int_{\gamma_\tau} \mu G^2 ds \right\} = 0.$$

We now conclude on the proof of Proposition 2.5 through the following Lemma.

Lemma 5.5. *Recall from Section 5.1 the definition of $\Gamma_{[[0, T_0]]}^H \in E([0, T_0], \mathcal{E}_r(d))$, still denoted by Γ^H , assumed to be the unique solution to (2.32) on $[0, T_0]$. Then $Q_{r, \beta, H}^*$ is supported on $\{I_{\beta, H} = 0\}$, thus:*

$$Q_{r, \beta, H}^* = \delta_{\Gamma^H}.$$

Proof. For ease of notation, we still denote by $(Q_{r, \beta, H}^N)_N$ a subsequence converging weakly to some limit point $Q_{r, \beta, H}^*$. The idea is to use the large deviation upper-bound of Lemma 5.4 to obtain the hydrodynamics limit. Although classical, this is made difficult in our case by the lack of lower semi-continuity of the functional $I_{\beta, H}$ defined in (5.18) and, in a related manner, by the fact that the set $E_{pp}([0, T_0], \mathcal{E}_r(d))$ on which it can be finite is not closed.

This justifies the introduction of the functional $\chi_{\cap_{n \geq 1} D_{q, n}} \sup_{G, \varepsilon} [J_{G, \varepsilon} - J_{H, \varepsilon}]$ in the middle term in (5.17), where $\chi_A(x) = 1$ if $x \in A$, $\chi_A(x) = +\infty$ if $x \notin A$. This functional is infinite outside the closed set $D_p = \cap_{n \geq 1} D_{q, n} \subset E_{pp}([0, T_0], \mathcal{E}_r(d))$ (defined in (4.9)), and lower semi-continuous by continuity of $J_{G, \varepsilon}(\cdot)$ on $E_{pp}([0, T_0], \mathcal{E}_r(d))$ for $G \in \mathcal{C}$.

Let $(K_\eta)_{\eta > 0}$ be a family of compact sets in $E([0, T_0], \mathcal{E}_r(d))$, which exists by Corollary 5.3, such that:

$$\forall N \geq 1, \quad Q_{r, \beta, H}^N(K_\eta) \geq 1 - \eta.$$

Then $Q_{r, \beta, H}^*(K_\eta) \geq 1 - \eta$. Let $\varepsilon > 0$ and consider the open set $B(\varepsilon) := \{\Gamma : d_E(\Gamma, \{I_{\beta, H} = 0\}) < \varepsilon\}$. Let $B_c(\varepsilon)$ be its closure. The complementary of $B_c(\varepsilon)$ is open, thus:

$$Q_{r, \beta, H}^*(B_c(\varepsilon)^c) \leq \liminf_{N \rightarrow \infty} Q_{r, \beta, H}^N(B_c(\varepsilon)^c).$$

As $B_c(\varepsilon)^c \subset B(\varepsilon)^c$,

$$Q_{r, \beta, H}^N(B_c(\varepsilon)^c) \leq Q_{r, \beta, H}^N(B(\varepsilon)^c) \leq \eta + Q_{r, \beta, H}^N(B(\varepsilon)^c \cap K_\eta).$$

The set $K_\eta \cap B(\varepsilon)^c$ is compact, thus by Lemma 5.4:

$$\limsup_{N \rightarrow \infty} \frac{1}{N} \log Q_{r, \beta, H}^N(B(\varepsilon)^c \cap K_\eta) \leq -\sup_{q \geq 1} \inf_{K_\eta \cap B(\varepsilon)^c \cap D_q} \sup_{G, \varepsilon} [J_{G, \varepsilon} - J_{H, \varepsilon}] < 0. \quad (5.19)$$

Let us explain the strict inequality in (5.19). Suppose by contradiction that the right-hand side in (5.19) vanishes. The supremum on q can then be removed, so take $q = 1$ and let $\Gamma^n \in D_1 \cap K_\eta \cap B(\varepsilon)^c$, $n \in \mathbb{N}$ be a sequence such that:

$$\lim_{n \rightarrow \infty} \sup_{G, \varepsilon} [J_{G, \varepsilon} - J_{H, \varepsilon}](\Gamma^n) = 0.$$

As $D_1 \cap K_\eta \cap B(\varepsilon)^c$ is compact, (Γ^n) has a subsequence that converges to some Γ . By lower semi-continuity of $\sup_{G, \varepsilon} [J_{G, \varepsilon} - J_{H, \varepsilon}]$ on D_1 ,

$$\forall \varepsilon > 0, \forall G \in \mathcal{C}, \quad J_{G, \varepsilon}(\Gamma) - J_{H, \varepsilon}(\Gamma) \leq 0. \quad (5.20)$$

In particular, Γ is a solution of (2.32), thus it is in $\{I_{\beta, H} = 0\} \subset B(\varepsilon)$ by the discussion preceding the lemma, which is absurd. It follows that, for N large enough:

$$Q_{r, \beta, H}^N(B_c(\varepsilon)^c) \leq \eta + Q_{r, \beta, H}^N(B(\varepsilon)^c \cap K_\eta) \leq 2\eta \quad \Rightarrow \quad Q_{r, \beta, H}^*(B_c(\varepsilon)^c) \leq 3\eta.$$

As this holds for all $\eta > 0$, $Q_{r, \beta, H}^*$ is concentrated on $\{I_{\beta, H} = 0\}$, which by hypothesis is simply $\{\Gamma^H\}$. \square

6 Behaviour of the poles and $1_{p_k=2}$ terms

In this section, we focus on the specificity of the contour dynamics: the behaviour of the poles. The main result is the proof of Proposition 2.2, which states that the regrowth, $e^{-2\beta}$ term in the generator (2.11) acts as a reservoir, injecting particles into the SSEP on each quadrant. This fixes the particle density around the poles, i.e. the tangent vector. It is shown to be discontinuous across the pole, and depends only on the value of β . The proof of these statements is carried out in Subsection 6.2. It makes crucial use of the irreducibility of the dynamics around the poles, which is the single added feature in the contour dynamics compared to the zero temperature stochastic Ising model.

Subsection 6.1 presents a useful bijection argument which yields an estimate of the pole size as well as local equilibrium at the poles. These two statements were used in Sections 3-4. Parameters $r < r_0$, $\beta > 0$, $H \in \mathcal{C}$ are fixed throughout the section according to Definition 2.1, as well as a time $T_0 > 0$. All proofs are done for the north pole $P := P_1$ with size $p := p_1 = |P_1| - 1$, the other poles are similar. We work with elements of X_r^N , rather than rescaled microscopic curves in $N^{-1}X_r^N$ as in Section 3.

Throughout the section, $T_0 > 0$ is a fixed time.

6.1 Size of the poles and local equilibrium

In this section, we estimate (3.14), i.e. we estimate the pole size and the term

$$W_t^G(\gamma) := \sum_{\substack{x \in P \\ x + 2e_x^+ \in P}} (\mathbf{1}_{p=2, V_r} - e^{-2\beta} \mathbf{1}_{x \notin \partial \Lambda_N}) G(t, x/N), \quad \gamma \in X_r^N, t \geq 0 \quad (6.1)$$

for any test function $G \in \mathcal{C}$. The condition V_r , defined in (2.9), states that the north pole of a curve is allowed to go down by the contour dynamics. Summing on $x \in P$ such that $x + 2e_x^+ \in P$ is just a way of enumerating the different positions at which one can add two blocks atop the pole. We prove:

Lemma 6.1. Write P for the north pole of a curve in X_r^N . For each $A > 1$,

$$\limsup_{N \rightarrow \infty} \frac{1}{N} \log \mathbb{P}_{r,\beta}^N \left(\frac{1}{T_0} \int_0^{T_0} \mathbf{1}_{P(\gamma_t) \cap \partial \Lambda_N = \emptyset} e^{-2\beta} (p_t - 1) dt \geq A \right) = -\infty. \quad (6.2)$$

Moreover, for each $\delta > 0$ and $G \in \mathcal{C}$,

$$\limsup_{N \rightarrow \infty} \frac{1}{N} \log \mathbb{P}_{r,\beta}^N \left(\left| \frac{1}{T_0} \int_0^{T_0} W_t^G dt \right| > \delta \right) = -\infty. \quad (6.3)$$

Equations (6.2)-(6.3) hold also under $\mathbb{P}_{r,\beta,H}^N$, with the additional condition $\{\forall t \in [0, T_0], \gamma_t \in N\mathcal{E}_r\}$.

The proof of Lemma 6.1 relies on a bijection argument to estimate the expectation of the terms between parentheses in (6.1) one in terms of the other and the Dirichlet form. It is stated in the following lemma.

Lemma 6.2. Let f be a density with respect to the contour measure $\nu = \nu_{r,\beta}^N$, defined in (2.3), and denote by \mathbb{E}_{ν_f} the expectation under $f d\nu$. Then, for any $A \geq 2$,

$$\left(\nu_f(p = 2, V_r, p' \geq A)^{1/2} - \mathbb{E}_{\nu_f}[(p-1)e^{-2\beta} \mathbf{1}_{x \notin \partial \Lambda_N} \mathbf{1}_{p \geq A}]^{1/2} \right)^2 \leq 2D_N(f), \quad (6.4)$$

where $D_N(f) = -\mathbb{E}_{\nu}[f^{1/2} \mathcal{L}_{r,\beta} f^{1/2}]$ is the Dirichlet form of the contour dynamics, and $p' = p'(\gamma)$ for $\gamma \in X_r^N$ is the number of blocks one level below the pole in the droplet Γ such that $\gamma = \partial \Gamma$. Equation (6.4) also holds with $p' \leq A, p \leq A$ instead of $p' \geq A, p \geq A$ respectively in the probability and in the expectation.

Proof. We prove the result with $A = 2$ (i.e. without constraint), the general case is similar. Fix a density f and define the two sets $I_r, V_r(2)$ as:

$$I_r = \{\gamma \in X_r^N : P(\gamma) \cap \partial \Lambda_N = \emptyset\}, \quad V_r(2) = V_r \cap \{p = 2\}, \quad (6.5)$$

with V_r defined in (2.9). Define U on X_r^N as follows:

$$\forall \gamma \in X_r^N, \quad U(\gamma) = \mathbf{1}_{I_r}(\gamma) e^{-2\beta} (p(\gamma) - 1). \quad (6.6)$$

Let us prove that $\nu_f(V_r(2))$ and $\mathbb{E}_{\nu_f}[U]$ are comparable, up to an error that can be expressed in terms of the Dirichlet form $D_N(f)$.

To each $\gamma \in I_r$ (defined in (6.5)), it is dynamically allowed to add two blocks above the north pole. Denote by $\gamma^{(1)}, \dots, \gamma^{(p-1)}$ the $p(\gamma) - 1$ corresponding curves, where $\gamma^{(k)}$ is identical to γ except that two blocks sitting on the edges $k, k+1$ are added, counting the edges from the left extremity of the pole (see Figure 4.8). Note that the $\gamma^{(k)}$ correspond to the $\gamma^{+,x}$ with $x, x+2e_x^+ \in P$ defined above (2.7).

Conversely, the size 2 pole of each curve $\gamma' \in V_r(2)$ can be deleted, to obtain a curve $\gamma = (\gamma')^{-,1} \in I_r$ with the notations of Section 2. The curve γ has length $|\gamma| = |\gamma'| - 2$. The same curve $\gamma \in I_r$ occurs $p-1 := p(\gamma) - 1$ times when enumerating elements of $V_r(2)$ and deleting their pole, thus:

$$\begin{aligned} \nu_f(V_r(2)) &= \sum_{\gamma' \in V_r(2)} \nu(\gamma') f(\gamma') = \sum_{\gamma' \in V_r(2)} \sum_{\gamma \in I_r} \mathbf{1}_{\{\exists k \leq p-1: \gamma' = \gamma^{(k)}\}} \nu(\gamma) e^{-2\beta} f(\gamma^{(k)}) \\ &= \sum_{\gamma \in I_r} \nu(\gamma) e^{-2\beta} \sum_{k=1}^{p-1} f(\gamma^{(k)}). \end{aligned}$$

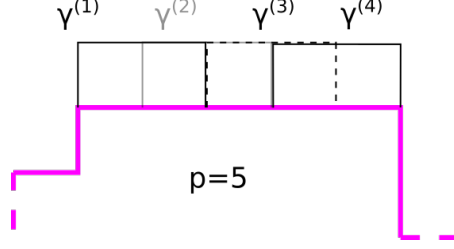

Figure 4.8 – Neighbourhood of the north pole of a curve $\gamma \in I_r$ (thick line) and the $\gamma^{(k)}$, $k \leq p - 1 = 4$. $\gamma^{(3)}$ is the curve γ to which the two blocks delimited by dashed lines are added. Conversely, any of the $\gamma^{(k)}$, $k \leq 4$ is in $V_r(2)$, and deleting the two blocks constituting their poles yields γ .

Add and subtract the quantities needed to bound the second line by the Dirichlet form $D_N(f)$:

$$\begin{aligned} \nu_f(V_r(2)) &= \sum_{\gamma \in I_r} \nu(\gamma) e^{-2\beta} \sum_{k=1}^{p-1} [f(\gamma^{(k)}) + f(\gamma) - 2f^{1/2}(\gamma)f^{1/2}(\gamma^{(k)})] \\ &\quad - \sum_{\gamma \in I_r} \nu(\gamma) e^{-2\beta} \left[(p-1)f(\gamma) - 2 \sum_{k=1}^{p-1} f^{1/2}(\gamma)f^{1/2}(\gamma^{(k)}) \right]. \end{aligned} \quad (6.7)$$

To estimate the second line of (6.7), apply Cauchy-Schwarz inequality to the sum $\sum_{k=1}^{p-1}$ to obtain:

$$\nu_f(V_r(2)) \leq 2D_N(f) - \mathbb{E}_{\nu_f}[e^{-2\beta}(p-1)\mathbf{1}_{I_r}] + 2 \sum_{\gamma \in I_r} \nu(\gamma) e^{-2\beta} (p-1)^{1/2} f^{1/2}(\gamma) \left[\sum_{k=1}^{p-1} f(\gamma^{(k)}) \right]^{1/2}.$$

Recall the definition of U from (6.6) and again use Cauchy-Schwarz on the sum on the curves in I_r to find:

$$\begin{aligned} \nu_f(V_r(2)) &\leq 2D_N(f) - \mathbb{E}_{\nu_f}[U] + 2 \left[\sum_{\gamma \in I_r} \nu(\gamma) e^{-2\beta} (p-1)f(\gamma) \right]^{1/2} \left[\sum_{\gamma \in I_r} \nu(\gamma) e^{-2\beta} \sum_{k=1}^{p-1} f(\gamma^{(k)}) \right]^{1/2} \\ &= 2D_N(f) - \mathbb{E}_{\nu_f}[U] + 2\mathbb{E}_{\nu_f}[U]^{1/2} \nu_f(V_r(2))^{1/2}. \end{aligned}$$

Putting things together yields the claim of the lemma:

$$\left[\nu_f(V_r(2))^{1/2} - \mathbb{E}_{\nu_f}[U]^{1/2} \right]^2 \leq 2D_N(f). \quad (6.8)$$

□

Proof of Lemma 6.1. We now explain how to obtain Lemma 6.1 from (6.4). We need to do three things:

1. bound from above the probabilities appearing in the claim by an expression involving (6.4);
2. prove that (6.3) holds for W^G , with $G \in \mathcal{C}$. The first point only gives the result for $\mathbf{1}_{p=2, V_r} - U$, which corresponds to W^1 ;

3. and prove the result under $\mathbb{P}_{r,\beta,H}^N$ up to adding the condition $\{\forall t \leq T_0, \gamma_t \in N\mathcal{E}_r\}$.

The first and third points are classical and easily adapted to the present case. Since they are used repeatedly in the article, we present them here once and for all. The second point requires some care because the function $G \in \mathcal{C}$ may change sign, which breaks the upper-bounds in the proof of Lemma 6.2.

Let us explain the general idea for the first point using (6.2) as an example. We wish to estimate:

$$\mathbb{P}_{r,\beta}^N \left(\frac{1}{T_0} \int_0^{T_0} e^{-2\beta} \mathbf{1}_{I_r}(\gamma_t)(p(\gamma_t) - 1) dt \geq A \right),$$

where I_r is defined in (6.5). We do so using Feynman-Kac formula. Let $a > 0$, and apply the exponential Chebychev inequality to obtain

$$\begin{aligned} \frac{1}{N} \log \mathbb{P}_{r,\beta}^N \left(\frac{1}{T_0} \int_0^{T_0} e^{-2\beta} \mathbf{1}_{I_r}(\gamma_t)(p(\gamma_t) - 1) dt \geq A \right) \\ \leq -aAT_0 + \frac{1}{N} \log \mathbb{E}_{r,\beta}^N \left[\exp \left[aN \int_0^{T_0} \mathbf{1}_{\gamma_t \in I_r} e^{-2\beta} (p_t - 1) dt \right] \right]. \end{aligned} \quad (6.9)$$

Consider the generator $N^2 \mathcal{L}_{r,\beta} + aNU$, with U defined in (6.6). This generator is self-adjoint for the contour measure $\nu = \nu_{r,\beta}^N$ (2.3), and Feynman-Kac inequality plus a representation theorem for the largest eigenvalue of a symmetric operator yield that, at equilibrium:

$$\mathbb{E}_\nu \left[\exp \left[aN \int_0^{T_0} U(\gamma_t) dt \right] \right] \leq \exp \int_0^{T_0} dt \sup_{f \geq 0: \mathbb{E}_\nu[f]=1} \left\{ aN \mathbb{E}_{\nu_f}[U] - N^2 D_N(f) \right\}. \quad (6.10)$$

One can bound $\mathbb{P}_{r,\beta}^N$ from above by the probability \mathbb{P}_ν starting under the equilibrium measure ν :

$$\mathbb{P}_{r,\beta}^N(\cdot) \leq \mathcal{Z}_{r,\beta} e^{\beta|\gamma_0|} \mathbb{P}_\nu(\cdot) \leq e^{C\beta N} \mathbb{P}_\nu(\cdot), \quad (6.11)$$

for some constant $C \leq 8$. Using (6.10)-(6.11), (6.9) becomes:

$$\frac{1}{N} \log \mathbb{P}_{r,\beta}^N \left(\frac{1}{T_0} \int_0^{T_0} U(\gamma_t) dt \geq A \right) \leq -aAT_0 + C\beta + T_0 \sup_{\substack{f \geq 0, \\ \int f d\nu = 1}} \left\{ a \mathbb{E}_{\nu_f}[U] - N D_N(f) \right\}. \quad (6.12)$$

At this point, we can use Lemma 6.2 to estimate the supremum in the right-hand side of (6.12). U may be unbounded as a function of N , but the bound $\mathbb{E}_{\nu_f}[U] \leq 1 + (2D_N(f))^{1/2}$ provided by Lemma 6.2 and elementary computations show that the supremum is positive only for densities f with $D_N(f) \leq C(a)/N$. For such densities, (6.4) yields:

$$\mathbb{E}_{\nu_f}[U] \leq \nu_f(V_r(2)) + C(a)O(N^{-1/2}) \leq 1 + C(a)O(N^{-1/2}).$$

Inject this result in (6.12), take the lim sup in N , then have a increase to infinity to conclude the proof of (6.2). Equation (6.3) in the $G \equiv 1$ case follows similarly, using the identity $x - y =$

$(\sqrt{x} - \sqrt{y})(\sqrt{x} + \sqrt{y})$ valid for $x, y \geq 0$. Indeed, for W^1 , the quantity in the supremum in (6.12) is now $a\mathbb{E}_{\nu_f}[W^1] - ND_N(f)$, where by definition:

$$W^1 = \sum_{\substack{x \in P \\ x+2e_x^+ \in P}} [\mathbf{1}_{p=2, V_r} - e^{-2\beta} \mathbf{1}_{I_r}] = \mathbf{1}_{p=2, V_r} - (p-1)e^{-2\beta} \mathbf{1}_{I_r} = \mathbf{1}_{V_r(2)} - U.$$

As a result, $\mathbb{E}_{\nu_f}[W^1]$ can be bounded from above as follows:

$$\begin{aligned} |\mathbb{E}_{\nu_f}[W^1]| &= \left| \nu_f(V_r(2))^{1/2} - \mathbb{E}_{\nu_f}[U]^{1/2} \right| \left[\nu_f(V_r(2))^{1/2} + \mathbb{E}_{\nu_f}[U]^{1/2} \right] \\ &\leq (2D_N(f))^{1/2} [2 + (2D_N(f))^{1/2}]. \end{aligned} \quad (6.13)$$

Elementary computations again yield that the supremum in (6.12) with W^1 instead of U is positive only for $D_N(f) \leq C(a)/N^2$. This concludes the proof of the first point.

Let us now deal with the second point, i.e. proving (6.3) for any G and not just $G \equiv 1$. As G may not have constant sign, one cannot directly use the bounds in the proof of Lemma 6.2. However, if G is positive, it is not complicated to repeat the bijection argument of Lemma 6.2 to obtain, for each $t \leq T_0$:

$$\begin{aligned} \left[\mathbb{E}_{\nu_f} \left[e^{-2\beta} \mathbf{1}_{I_r} \sum_{\substack{x \in P \\ x+2e_x^+ \in P}} G(t, x/N) \right]^{1/2} - \mathbb{E}_{\nu_f} \left[\mathbf{1}_{V_r(2)} \sum_{\substack{x \in P \\ x+2e_x^+ \in P}} G(t, x/N) \right]^{1/2} \right]^2 \\ \leq C(G)D_N(f) + O_G(N^{-1}). \end{aligned} \quad (6.14)$$

Recall that the summation on $x \in P$ such that $x + 2e_x^+ \in P$ is just a way of enumerating all places where two blocks can appear atop the pole. For general $G \in \mathcal{C}$, the result follows by splitting G into its positive and negative parts $G = G^+ - G^-$, and estimating the contribution of G^+, G^- by (6.14).

We now prove the third point, i.e. establish (6.2) and (6.3) under $\mathbb{P}_{r,\beta,H}^N$ assuming trajectories take values in $N\mathcal{E}_r$. The point of this additional condition is the following. According to Section 3 (see (3.14) for the first term and (3.22)-(3.30) for the second one), for each $N\mathcal{E}_r$ -valued trajectory $\gamma = (\gamma_t)_{t \leq T_0}$,

$$\frac{1}{N} \log D_{r,\beta,H}^N(\gamma) = \sum_{k=1}^4 \int_0^{T_0} [(p_k(\gamma_t) - 1)e^{-2\beta} \mathbf{1}_{P_k \cap \partial \Lambda_N = \emptyset} - \mathbf{1}_{p_k=2, DP_r^k}] dt + C(H)T_0 O_N(1), \quad (6.15)$$

where $D_{r,\beta,H}^N = d\mathbb{P}_{r,\beta,H}^N / d\mathbb{P}_{r,\beta}^N$ until time T_0 , and DP_r^k is defined in (2.9)-(2.10). Let χ denote any of the two events appearing in (6.2)-(6.3). In the proof of the first point, we saw for the north pole:

$$\mathbb{E}_{r,\beta}^N \left[\exp \left[NC(H) \int_0^{T_0} (p(\gamma_t) - 1)e^{-2\beta} \mathbf{1}_{I_r}(\gamma_t) dt \right] \right] \leq T_0 + T_0 O_H(N^{-1/2}).$$

This immediately generalises to the other three poles. As a result, using (6.15):

$$\begin{aligned} \frac{1}{N} \log \mathbb{P}_{r,\beta,H}^N(\forall t \in [0, T_0], \gamma_t \in N\mathcal{E}_r; \chi) &= \frac{1}{N} \log \mathbb{E}_{r,\beta}^N [\mathbf{1}_{\forall t \in [0, T_0], \gamma_t \in N\mathcal{E}_r} \mathbf{1}_\chi D_{r,\beta,H}^N] \\ &\leq \frac{1}{2N} \log \mathbb{P}_{r,\beta}^N(\chi) + C(H)T_0 + \frac{1}{2N} \log \mathbb{E}_{r,\beta}^N \left[\exp \left[2NC(H) \int_0^{T_0} (p(\gamma_t) - 1)e^{-2\beta} \mathbf{1}_{I_r}(\gamma_t) dt \right] \right]. \end{aligned}$$

The last term is bounded: taking N to infinity proves item 3. \square

6.2 Convergence of the $\mathbf{1}_{p=2}$ term at fixed β and slope around the poles

This section is devoted to the proof of Proposition 2.2: poles act as reservoirs that fix to $e^{-\beta}$ the averaged slopes $\xi_{L_1}^{\pm, \varepsilon N}, 1 - \xi_{L_1}^{\pm, \varepsilon N}$ at the poles. We prove this statement in several steps. First, we explain how to use the effective state space \mathcal{E}_r (or $\mathcal{E}_r(d)$) to obtain a local dynamics from the contour dynamics, which is non-local due to boundary conditions in the definition of X_r^N , see Section 6.2.1. This is a key technical argument to be able to compare the contour dynamics to simpler 1-dimensional ones.

We then prove that the $\mathbf{1}_{p=2}$ term fixes the slope around the poles, in the sense that the time integrals of $\mathbf{1}_{p=2}$ and $\xi_{L_1}^{\pm, \varepsilon N}$ are close, see Section 6.2.2. This should not come as a surprise if one remembers that, in a Symmetric Simple Exclusion Process (SSEP) with reservoirs, the density close to the reservoirs is fixed. The time average of $\mathbf{1}_{p=2}$ is then proven to be equal to $e^{-\beta}$ in Section 6.2.4. Preliminary microscopic estimates, crucial to Section 6.2 and thereby of central importance to the paper, are carried out in Section 6.2.3.

6.2.1 Turning the contour dynamics into a local dynamics

To compare the non-local (due to boundary effects in the definition of X_r^N) 2-dimensional contour dynamics to a local, 1-dimensional dynamics (in the present case the SSEP and a kind of zero range process introduced in Section 6.2.4), we need to explain how to remove the non-local constraints. For moves away from the poles (addition/deletion of a single block), the only non-local constraint is that opposite quadrants of an element of X_r^N cannot cross. For deletion or regrowth at the poles, one has to make sure neither to touch $\partial\Lambda_N$ nor to shrink droplets too much, see the definition of X_r^N in Section 2.1.

In the "good" state space $N\mathcal{E}_r(d)$, all dynamical moves are local; this is why we introduced it in the first place. The idea is then to prove that, under the condition $\{\forall t \in [0, T_0], \gamma_t \in N\mathcal{E}_r(d)\}$, for $d > 0$ henceforth fixed, one can turn the contour dynamics into a local dynamics inside $N\mathcal{E}_r(d)$. This is the content of the following lemma. Since the proof is quite general, we postpone it to Appendix A.2.

Lemma 6.3 (Projection onto a local dynamics in the effective state space $N\mathcal{E}_r(d)$). *Let $\psi : [0, T_0] \times X_r^N \rightarrow \mathbb{R}$ be bounded. Then, for some $C > 0$:*

$$\begin{aligned} & \frac{1}{N} \log \mathbb{E}_{r, \beta}^N \left[\mathbf{1}_{\{\forall t \in [0, T_0], \gamma_t \in N\mathcal{E}_r(d)\}} \exp \left[N \int_0^{T_0} \psi(t, \gamma_t) dt \right] \right] \\ & \leq C\beta + \int_0^{T_0} \sup_{f \geq 0: \nu_f(N\mathcal{E}_r(d))=1} \left\{ \mathbb{E}_{\nu_f} [\psi(t, \cdot)] - ND_N(f) \right\} dt. \end{aligned} \quad (6.16)$$

The result is also valid with the weaker condition $\{\forall t \in [0, T_0], \gamma_t \in N\mathcal{E}_r\}$ provided D_N is replaced by D_N^S , the Dirichlet form of all SSEP jumps, i.e. D_N without the regrowth/deletion jumps at the poles corresponding to line 2 of (2.11).

Remark 6.4. Equation (6.16) looks like a standard Feynman-Kac estimate. Note however that the supremum in (6.16) is on densities with full support in $N\mathcal{E}_r(d)$. In general, if f is a ν -density,

there is no way to control $D_N(f)$ by $D_N(f\mathbf{1}_{N\mathcal{E}_r(d)})$. Indeed, if $\tilde{f} = f\mathbf{1}_{N\mathcal{E}_r(d)}$, $D_N(\tilde{f})$ contains terms of the form:

$$\sum_{\substack{\gamma \in N\mathcal{E}_r(d) \\ \gamma' \notin N\mathcal{E}_r(d)}} [\nu(\gamma)c(\gamma, \gamma')f(\gamma) + \nu(\gamma')c(\gamma', \gamma)f(\gamma)],$$

which have a priori no reason to be comparable to differences $[f(\gamma)^{1/2} - f(\gamma')^{1/2}]^2$.

Note also that Lemma 6.3 is not a statement about the contour dynamics conditioned to stay inside $N\mathcal{E}_r(d)$, but about the full dynamics. This is an important point: the jump rates of a conditioned dynamics would be non-local, whereas we really need locality to later project the dynamics onto 1-dimensional particle dynamics. \blacksquare

6.2.2 The $\mathbf{1}_{p=2}$ term coincides with the slope around the pole

The argument presented here is the same as for a SSEP with a reservoir. Indeed, informally, one can think of the contour dynamics as four SSEP connected by four point-like reservoirs, as explained in the proof of Lemma 6.5 below. As poles move, the lengths of these SSEP change; however this does not change the average density around the pole much. The key observation is the fact that $\mathbf{1}_{p=2}$ coincides with the occupation number of the closest site to the reservoir in these SSEP.

Lemma 6.5. *Recall the notations of Proposition 2.2. For each $\delta > 0$ and each $G \in \mathcal{C}$, the slope on each side of the pole satisfies a one block estimate:*

$$\limsup_{k \rightarrow \infty} \limsup_{N \rightarrow \infty} \frac{1}{N} \log \mathbb{P}_{r,\beta}^N \left(\forall t \in [0, T_0], \gamma_t \in N\mathcal{E}_r; \left| \frac{1}{T_0} \int_0^{T_0} G(t, L_1(t)/N) (\mathbf{1}_{p=2} - \xi_{L_1+2e_1}^{\pm, k}) dt \right| \geq \delta \right) = -\infty, \quad (6.17)$$

and a two block estimate:

$$\limsup_{\varepsilon \rightarrow 0} \limsup_{N \rightarrow \infty} \frac{1}{N} \log \mathbb{P}_{r,\beta}^N \left(\forall t \in [0, T_0], \gamma_t \in N\mathcal{E}_r; \left| \frac{1}{T_0} \int_0^{T_0} G(t, L_1(t)/N) (\mathbf{1}_{p=2} - \xi_{L_1+2e_1}^{\pm, \varepsilon N}) dt \right| \geq \delta \right) = -\infty. \quad (6.18)$$

Both estimates are valid under $\mathbb{P}_{r,\beta,H}^N$, with the same proof as for Lemma 6.1.

The proof of Lemma 6.5 is used to showcase the connection between the contour dynamics and the SSEP at the microscopic level, that is used numerous times in this article.

Proof. The proof relies on the key observation that the quantity $\mathbf{1}_{p=2}$ can be controlled by the edges of the poles:

$$\mathbf{1}_{p=2} = \xi_{L_1+2e_1} = \xi_{R_1-3}, \quad (6.19)$$

where we abuse notations and denote by $R_1 - 3$ the vertex at distance three from R_1 anticlockwise. In other words, $\mathbf{1}_{p=2}$ can be thought of as the occupation number of the closest site to a reservoir in

a SSEP, in which case (6.17)-(6.18) are well-known (see [ELS90]). We first prove (6.17). Building on the observation (6.19), define ϕ as the function:

$$\forall \gamma \in X_r^N, \quad \phi(\gamma) = \xi_{L_1+2e_1} - \xi_{L_1+2e_1}^{+,k}. \quad (6.20)$$

Let us slightly rewrite the probability in (6.17): it is enough to estimate, for each $a > 0$, the quantity:

$$\begin{aligned} & \mathbb{P}_{r,\beta}^N \left(\forall t \in [0, T_0], \gamma_t \in N\mathcal{E}_r; \exp \left[aN \int_0^{T_0} G(t, L_1(t)/N) \phi(\gamma_t) dt \right] \geq \exp[aNT_0\delta] \right) \\ & \leq e^{-aN T_0 \delta} \mathbb{E}_{r,\beta}^N \left[\mathbf{1}_{\{\forall t \in [0, T_0], \gamma_t \in N\mathcal{E}_r\}} \exp \left[aN \int_0^{T_0} \mathbf{1}_{N\mathcal{E}_r} G(t, L_1(t)/N) \phi(\gamma_t) dt \right] \right]. \end{aligned} \quad (6.21)$$

Let $D_N^S \leq D_N$ be the Dirichlet form of the contour dynamics without the regrowth/deletion terms, i.e. without the jumps of line 2 of (2.11). Apply Lemma 6.3 to $\psi = aG\phi$ to obtain that (6.21) is bounded from above by:

$$-a\delta T_0 + C\beta + \left| \int_0^{T_0} dt \sup_{f \geq 0: \nu_f(N\mathcal{E}_r)=1} \left\{ a\mathbb{E}_{\nu_f}[G(t, L_1/N)\phi] - ND_N^S(f) \right\} \right|. \quad (6.22)$$

Let us now compare the contour dynamics around the north pole to a SSEP. Fix $t \in [0, T_0]$ and a ν -density f with support in $N\mathcal{E}_r$. Denote by (E_f) the expectation in the supremum in (6.22). We first take care of the dependence on L_1 in G , by splitting (E_f) depending on where L_1 lies in Λ_N . Let $M(x) \subset X_r^N$ be all curves with $L_1 + 2e_1 = x \in \Lambda_N$. Then, up to an error $O_G(N^{-1})$ uniform in f :

$$\mathbb{E}_{\nu_f}[G(t, L_1/N)\phi] = \sum_{x \in \Lambda_N} G(t, x/N) \left[\sum_{\gamma \in M(x)} \nu(\gamma) f(\gamma) \phi(\gamma) \right]. \quad (6.23)$$

In the following, for $\gamma \in M(x)$, we refer to the edge $(x, x + e_x^+)$ as edge 1, to the one following it as edge 2, etc, up to edge k , and write $\xi_1(\gamma), \dots, \xi_k(\gamma)$ for the corresponding values of the edge labels (as usual, curves are travelled on clockwise). Notice that all these edges are in the same quadrant (in fact quadrant 1), as we work with curves in $N\mathcal{E}_r$. Indeed, all four quadrants of curves in $N\mathcal{E}_r$ are macroscopic, thus contain much more than k edges, see the definition of \mathcal{E}_r in Appendix B. Configurations in $\{0, 1\}^k =: \Omega_k$, are denoted by the letter ξ . ϕ depends only on the k first edges, so that the expectation in (6.23) reads:

$$\mathbb{E}_{\nu_f}[G(t, L_1/N)\phi] = \sum_{x \in \Lambda_N} \nu_f(M(x)) G(t, x) \frac{1}{|\Omega_k|} \sum_{\xi \in \Omega_k} f_{k,x}(\xi) \phi(\xi), \quad (6.24)$$

where $|\Omega_k| = 2^k$ and if $\xi(\gamma)$ denotes the collection $\xi_1(\gamma), \dots, \xi_k(\gamma)$ for a given $\gamma \in X_r^N$,

$$\forall \xi \in \Omega_k, \quad f_{k,x}(\xi) = \frac{1}{\nu_f(M(x))} \sum_{\gamma \in M(x): \xi(\gamma)=\xi} |\Omega_k| \nu(\gamma) f(\gamma). \quad (6.25)$$

Note that we need only consider points x and densities f with $\nu_f(M(x)) > 0$. This ensures that $f_{k,x}$ is unambiguously defined. Moreover, $f_{k,x}$ is a density for the uniform measure on Ω_k .

Let us do the same operations on the Dirichlet form D_N^S , in order to bound it from below by that of the SSEP on configurations with k sites. Recall the definition of the bulk jump rates of the contour dynamics in (2.6). The mapping to go from part of a curve $\gamma \in N\mathcal{E}_r$ to an associated SSEP configuration $\xi(\gamma) \in \Omega_k$ is represented on Figure 4.9 for the first quadrant. The idea is to take the portion of γ in quadrant k , turn it clockwise by $k\pi/4$, and put a particle at site j whenever the resulting path goes down between $j\sqrt{2}$ and $(j+1)\sqrt{2}$, or no particle if it goes up.

Define thus D_k^S , the Dirichlet form associated with the SSEP on Ω_k : for any density g for the

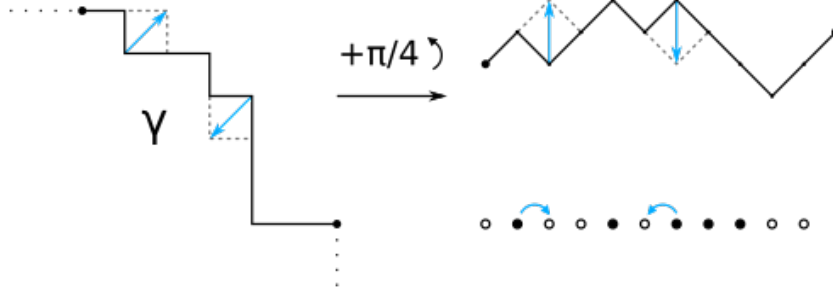

Figure 4.9 – On the left, a portion of the interface delimited by the two black dots. On the right, the corresponding path and simple exclusion particle configuration. The mapping is possible if the left-extremity of the interface as well as its length are fixed.

uniform measure U_k on $\Omega_k = \{0, 1\}^k$,

$$D_k^S(g) = \frac{1}{2|\Omega_k|} \sum_{\xi \in \Omega_k} \sum_{\substack{1 \leq u \leq v \leq k \\ |u-v|=1}} \frac{1}{2} [\xi_u(1 - \xi_v) + \xi_v(1 - \xi_u)] [g^{1/2}(\xi^{u,v}) - g^{1/2}(\xi)]^2.$$

Recalling the definition of $D_N^S(g)$ from Lemma 6.3, a simple upper-bound and convexity yield:

$$\begin{aligned} D_N^S(f) &\geq \frac{1}{2} \sum_{x \in \Lambda_N} \sum_{\gamma \in M(x)} \nu(\gamma) \sum_{y \in V(\gamma): (y, y+e_y^+) \in \{1, \dots, k\}} c(\gamma, \gamma^{y+e_y^+}) [f^{1/2}(\gamma^{y+e_y^+}) - f^{1/2}(\gamma)]^{1/2} \\ &\geq \sum_{x \in \Lambda_N} \nu_f(M(x)) D_k^S(f_{k,x}). \end{aligned} \quad (6.26)$$

The reason, as emphasised in Lemma 6.3, is that the jump rate $c(\gamma, \gamma')$ for all non-vanishing terms in $D_N^S(f)$ is local, in particular all $\gamma^x, x \in V(\gamma)$ are well-defined (i.e. elements of X_r^N) for these jumps. As a result of (6.24)-(6.26), at time $t \in [0, T_0]$ the supremum in (6.22) can be bounded from above by:

$$\begin{aligned} &\sup_{f \geq 0: \nu_f(N\mathcal{E}_r)=1} \left\{ \sum_{x \in \Lambda_N} \nu_f(M(x)) \left[aG(t, x/N) \mathbb{E}_{U_k} [f_{k,x} \phi] - ND_k^S(f_{k,x}) \right] \right\} \\ &\leq \sup_{f \geq 0: \nu_f(N\mathcal{E}_r)=1} \left\{ \sum_{x \in \Lambda_N} \nu_f(M(x)) \sup_{g \geq 0: \mathbb{E}_{U_k}[g]=1} \left\{ aG(t, x/N) \mathbb{E}_{U_k} [g\phi] - ND_k^S(g) \right\} \right\} \\ &\leq \sup_{f \geq 0: \nu_f(N\mathcal{E}_r)=1} \left\{ \sum_{x \in \Lambda_N} \nu_f(M(x)) a|G(t, x/N)| \right\} \sup_{\substack{g \geq 0: \mathbb{E}_{U_k}[g]=1 \\ D_k^S(g) \leq C(a)/N}} |\mathbb{E}_{U_k} [g\phi]|. \end{aligned} \quad (6.27)$$

The conclusion of the proof then follows, since the problem is reduced to a one-block estimate for a SSEP of size k (see [KL99], Chapter 5): the expectation in (6.27) satisfies

$$\limsup_{N \rightarrow \infty} \sup_{\substack{g \geq 0: \mathbb{E}_{U_k}[g]=1 \\ D_k^S(g) \leq C(a)/N}} |\mathbb{E}_{U_k}[g\phi]| = O(k^{-1}).$$

As the first term in the right-hand side of (6.27) is bounded by $a\|G\|_\infty$, the proof of the one block estimate (6.17) is concluded. The two block estimate (6.18) is proven similarly. \square

Now that we know that the time integral of $\mathbf{1}_{p=2}$ and of the slope at the poles are close, it remains to compute their common value. This is the goal of the next two sections.

6.2.3 A compactness result

This section presents microscopic estimates used to control the pole terms. Although technical, this estimate is crucial to prove that the contour dynamics does not behave too strangely around the pole, leading to a control of the $\mathbf{1}_{p=2}$ term in the next section.

To compute the time integral of $\mathbf{1}_{p=2}$, we need to zoom in on the dynamics around the pole. As used in the proof of the hydrodynamic limit in [LST14a], in a suitable frame around the pole (the definition of which is one of the difficulties), the height-function describing the interface in time can be interpreted as a kind of two-species zero-range process, in our case with a moving reservoir in the middle. Leaving for later a detailed description of the mapping to the zero-range process and the frame around the pole (see Figure 4.12), we will have to estimate expectations of the form:

$$\mathbb{E}_{\nu_f}[\mathbf{1}_{p=2}] = \mathbb{E}_\mu[\tilde{f}\mathbf{1}_{\eta_{L_1+2e_1} \neq 0}],$$

where f is a density for ν , \tilde{f} its marginal against μ . The measure μ is the marginal of ν on a well-chosen portion of the curve around the pole, in which the interface is described in terms of a particle number η taking values in \mathbb{Z} , corresponding to the height difference between two consecutive columns. \tilde{f} is the marginal of f in this proper frame. To show that the expectation of the right-hand side reduces to an estimate at equilibrium under μ up to a small error term, a compactness argument is typically used to prove that particles do not condensate macroscopically at a single site, as in [KL99], Chapter 5. In our cases, this compactness argument is provided by the following lemmas.

The first estimate concerns the $\mathbf{1}_{p=2}$ term, which as shown in Section 6.2.2 coincides with the slope around each pole. We prove that poles are typically not flat.

Lemma 6.6 (Upper bound on the slope). *For $\gamma \in X_r^N$, $\gamma = \partial\Gamma$, let $p'(\gamma)$ be the number of blocks in Γ composing the level below the north pole. If $C > 0$ and $A \geq 2$ is an integer:*

$$\limsup_{N \rightarrow \infty} \sup_{f: D_N(f) \leq C/N} \nu_f(V_r(2), p' \geq A) \leq \frac{1}{\log A}, \quad (6.28)$$

with $V_r(2) = \{p = 2, V_r\}$, and V_r defined in (2.9). In particular:

$$\limsup_{N \rightarrow \infty} \sup_{f: D_N(f) \leq C/N} \nu_f(V_r(2)) \leq \frac{2}{\beta}. \quad (6.29)$$

Proof. Fix a density f with $D_N(f) \leq C/N$. Notice that $p' \geq p$, the number of blocks in the pole, by definition of X_r^N . The idea is to estimate $\nu_f(p = 2, V_r, p' \geq A)$ for $A \geq 2$ in terms of $\nu_f(p = A, V_r)$, using the fact that:

$$\sum_{B \geq 2} \nu_f(p = B, V_r) \leq 1. \quad (6.30)$$

To do so, we use a bijection argument similar to the one in Lemma 6.2. Fix $A \geq 2$, take γ in $\{p = 2, V_r, p' \geq A\}$, and turn it into an element $F(\gamma)$ of $\{p = A, V_r\}$ as follows. Add as many blocks as possible to the left of the north pole of γ at the height of the pole. If $A - 2$ such blocks can be added, an element of $\{p = A, V_r\}$ has been created. If $B < A - 2$ blocks only can fit to the left of the pole, add the remaining $A - 2 - B$ blocks to the right of the pole.

This procedure is nearly bijective in the following sense. Label the columns corresponding to blocks of the level below the pole from 1 to p' , starting from the left.

- If the pole of $\gamma \in \{p = 2, V_r, p' \geq A\}$ is above the blocks with labels $k, k + 1$ with $1 \leq k \leq A - 1$, which we write $P = \{k, k + 1\}$, then the procedure described above yields the same $F(\gamma) \in \{p = A, V_r\}$ for each k , and this $F(\gamma)$ is the curve with a pole composed of the blocks $1, \dots, A$. Let $\{P = \{1, \dots, A\}\}$ refer to the set of such $F(\gamma)$.
- If instead the pole of γ starts at column $k \geq A$, which we write $P \geq A$, then the resulting curve $F(\gamma)$ has a pole starting at $k - (A - 2) > 1$, and it is bijectively mapped into γ by inverting the above procedure.

In terms of the mapping F , the previous two cases can be rewritten as:

$$\forall k \leq A - 1, \quad F(\{p = 2, V_r, p' \geq A, P = \{k, k + 1\}\}) = \{V_r, p = A, P = \{1, \dots, A\}\}$$

and:

$$F(\{p = 2, V_r, p' \geq A, P \geq A\}) = \{P \geq 2, V_r, p = A\}.$$

Notice moreover that the mapping F leaves the equilibrium measure ν invariant, since the length of $\gamma \in X_r^N$ and $F(\gamma)$ are the same. Overall, writing also $\{P \leq k\}$ for the event that the pole starts at or before column k , we obtain for the equilibrium measure ν :

$$\begin{aligned} \nu(V_r(2), p' \geq A) &= \nu(P \leq A - 1, p = 2, V_r, p' \geq A) + \nu(P \geq A, p = 2, V_r, p' \geq A) \\ &= (A - 1)\nu(P = \{1, \dots, A\}, V_r) + \nu(P \geq 2, p = A, V_r) \\ &\leq (A - 1)\nu(p = A, V_r). \end{aligned} \quad (6.31)$$

Let us prove that, up to an error that vanishes for N large, (6.31) holds also under ν_f for any ν -density f with $D_N(f) \leq C/N$. The idea is that the mapping F described above for $\gamma \in \{V_r(2), p' \geq A\}$ requires a number of moves that is independent of N , so $f(\gamma)$ and $f(F(\gamma))$ are close.

We prove it for the $\{P = \{1, \dots, A\}, V_r\}$ term in (6.31), the $P \geq 2$ term is similar. We proceed as in Lemma 6.2.

$$\begin{aligned} (A - 1)\nu_f(P = \{1, \dots, A\}, V_r) &= (A - 1) \sum_{\gamma' \in F(\{P \leq A - 1, p = 2, V_r, p' \geq A\})} \nu(\gamma') f(\gamma') \\ &= \sum_{\gamma' \in F(\{P \leq A - 1, p = 2, V_r, p' \geq A\})} \nu(\gamma') f(\gamma') \sum_{\gamma \in V_r(2), P \leq A - 1, p' \geq A} \mathbf{1}_{F(\gamma) = \gamma'} \\ &= \sum_{\gamma \in V_r(2), P \leq A - 1, p' \geq A} \nu(\gamma) f(F(\gamma)). \end{aligned} \quad (6.32)$$

The second line comes from the fact that F maps exactly $A - 1$ elements of $\{P \leq A - 1, p = 2, V_r, p' \geq A\}$ onto the same curve in $\{P = \{1, \dots, A\}, V_r\}$. The third line uses the fact that F does not change the measure ν . The notation $V_r(2)$ stands for $V_r \cap \{p = 2\}$. One has then:

$$(6.32) = \sum_{\gamma \in V_r(2), P \leq A-1, p' \geq A} \nu(\gamma) [f^{1/2}(F(\gamma)) - f^{1/2}(\gamma)]^2 - \sum_{\gamma \in V_r(2), P \leq A-1, p' \geq A} \nu_f(\gamma) \\ + 2 \sum_{\gamma \in V_r(2), P \leq A-1, p' \geq A} \nu(\gamma) f^{1/2}(\gamma) f^{1/2}(F(\gamma)).$$

Applying Cauchy-Schwarz inequality yields:

$$[(A - 1)^{1/2} \nu_f(P = \{1, \dots, A\}, V_r)^{1/2} - \nu_f(P \leq A - 1, V_r(2), p' \geq A)^{1/2}]^2 \\ \leq \sum_{\gamma \in V_r(2), P \leq A-1, p' \geq A} \nu(\gamma) [f^{1/2}(F(\gamma)) - f^{1/2}(\gamma)]^2. \quad (6.33)$$

It remains to bound the right-hand side of (6.33) from above in terms of the Dirichlet form. Decompose the passage from γ to $F(\gamma)$ in single-block flips: $\gamma = \gamma_0 \rightarrow \gamma_1 \rightarrow \dots \rightarrow \gamma_{A-2} = F(\gamma)$, and apply Cauchy-Schwarz inequality to find:

$$\sum_{\gamma \in V_r(2), P \leq A-1, p' \geq A} \nu(\gamma) [f^{1/2}(F(\gamma)) - f^{1/2}(\gamma)]^2 \\ \leq (A - 2) \sum_{\gamma \in V_r(2), P \leq A-1, p' \geq A} \nu(\gamma) \sum_{k=1}^{A-2} [f^{1/2}(\gamma_{k+1}) - f^{1/2}(\gamma_k)]^2.$$

Each move above is authorised in the contour dynamics, at rate $1/2$. A given curve corresponding to one of the γ_k can occur at most $A - 1$ times in all paths $\gamma \rightarrow F(\gamma)$ for $\gamma \in \{V_r(2), P \leq A - 1\}$. As a result, and since $\nu(\gamma_k) = \nu(\gamma)$ for all $k \leq A - 2$:

$$[(A - 1)^{1/2} \nu_f(P = \{1, \dots, A\}, V_r)^{1/2} - \nu_f(P \leq A - 1, V_r(2), p' \geq A)^{1/2}]^2 \leq 4(A - 1)^2 D_N(f). \quad (6.34)$$

Similar computations give the same kind of bound for the second term in (6.31) under ν_f :

$$[\nu_f(1 \notin P, p = A, V_r)^{1/2} - \nu_f(P \geq A, V_r(2))^{1/2}]^2 \leq 4(A - 1) D_N(f). \quad (6.35)$$

Let us use (6.34)-(6.35), to prove that (6.31) still holds under ν_f with a small error in N (recall that $D_N(f) \leq C/N$). Equation (6.34) yields:

$$\nu_f(V_r(2), P \leq A - 1, p' \geq A) \leq (A - 1) \nu_f(P = \{1, \dots, A\}, V_r) + C(A) [D_N(f)^{1/2} + D_N(f)] \\ \leq (A - 1) \nu_f(P = \{1, \dots, A\}, V_r) + C(A) N^{-1/2},$$

where the constant $C(A) > 0$ changes between inequalities. Similarly, (6.35) yields:

$$\nu_f(P \geq A, V_r(2)) \leq \nu_f(P \geq 2, p = A, V_r) + C(A) N^{-1/2} \\ \leq (A - 1) \nu_f(P \geq 2, p = A, V_r) + C(A) N^{-1/2},$$

whence the following counterpart of (6.31) for ν_f :

$$\begin{aligned}\nu_f(V_r(2), p' \geq A) &= \nu_f(V_r(2), P \leq A-1) + \nu_f(P \geq A, V_r(2)) \\ &\leq (A-1)\nu_f(p = A, V_r) + C(A)N^{-1/2}.\end{aligned}\tag{6.36}$$

Equation (6.36) is sufficient to conclude the proof of the upper bound in (6.29). Indeed, fix $B \geq 2$ and apply (6.36) to each $A \in \{2, \dots, B\}$ to obtain (recall that $V_r(2) = V_r \cap \{p = 2\}$):

$$1 \geq \sum_{A=2}^B \nu_f(p = A, V_r) \geq \sum_{A=2}^B \frac{1}{A-1} \nu_f(V_r(2), p' \geq A) + O(N^{-1/2}).\tag{6.37}$$

For $\ell \geq 2$, let $H_\ell = \sum_{k=2}^\ell (k-1)^{-1}$, $H_1 := 0$ and integrate the right-hand side of (6.37) by parts to find:

$$1 \geq \nu_f(p = 2, V_r, p' \geq B)H_B + \sum_{A=2}^{B-1} H_A \nu_f(V_r(2), p' = A) + O(N^{-1/2}).$$

Equation (6.28) follows:

$$\limsup_{N \rightarrow \infty} \nu_f(p = 2, V_r, p' \geq B) \leq H_B^{-1} \leq \frac{1}{\log B}.\tag{6.38}$$

From (6.38) we conclude the proof of Lemma 6.6 using again the correspondence of Lemma 6.2:

$$\begin{aligned}\nu_f(V_r(2)) &= \nu_f(p = 2, V_r) = \nu_f(p = 2, V_r, p' \geq e^\beta) + \nu_f(p = 2, V_r, p' \leq e^\beta - 1) \\ &\leq \frac{1}{\beta} + \mathbb{E}_{\nu_f}[e^{-2\beta}(p-1)\mathbf{1}_{I_r, p \leq e^\beta - 1}] + O(N^{-1/2}) \\ &\leq \frac{1}{\beta} + e^{-\beta}(1 - e^{-\beta} + O(N^{-1/2})) \leq \frac{2}{\beta} + O(N^{-1/2}),\end{aligned}$$

with I_r defined in (6.5). □

Next, we use Lemma 6.6 to bound the width of the droplet at a given depth below the pole, and its depth at a given width to either side of the pole.

For $\gamma \in X_r^N \cap N\mathcal{E}_r$ and $k \geq 1$, the line $y = y_{\max}(\gamma) - k$ contains a certain number of horizontal edges in γ , where y_{\max} is the ordinate of the highest points in γ . Let $\ell(k)$ be the number of these edges to the right of L_1 , and $\ell(-k)$ the number to the left of L_1 . Define also $\ell(0) = p(\gamma) - 2$. For N large enough, because $\gamma \in N\mathcal{E}_r$ each of the $\ell(i)$, $|i| \leq k$ are well defined and the corresponding edges are in quadrant 4 ($i \leq 0$) or quadrant 1 ($i \geq 0$) (see Figure 4.10).

Lemma 6.7 (Width of a curve at depth k below the north pole). *For $k \in \mathbb{N}^*$, $C > 0$, $A \geq 2$,*

$$\forall |i| \leq k, \quad \limsup_{N \rightarrow \infty} \sup_{f: D_N(f) \leq C/N} \nu_f(N\mathcal{E}_r(d), \ell(i) \geq A) \leq \frac{e^{2\beta}}{(A+1)\log(A+2)}.\tag{6.39}$$

As a result, the numbers $w_k^+ = 2 + \sum_{i=0}^k \ell(i)$ and $w_k^- = \sum_{i=1}^k \ell(-i)$ of blocks with centres at height $y_{\max}(\gamma) - k - 1/2$ in a droplet $\Gamma \in N\mathcal{E}_r$, respectively to the right/to the left of L_1 , satisfy:

$$\limsup_{N \rightarrow \infty} \sup_{f: D_N(f) \leq C/N} \nu_f(N\mathcal{E}_r(d), w_k^\pm \geq k^2) \leq \frac{3e^{2\beta}}{\log k}.\tag{6.40}$$

Proof. Equation (6.40) follows from (6.39) by a union bound. Let us prove (6.40) by recursion on $|i| \leq k$. For $\ell(0)$, recall from Lemma 6.2 that, uniformly on ν -densities f with $D_N(f) \leq C/N$:

$$\begin{aligned} \nu_f(p = 2, V_r, p' \geq A + 2) &= \mathbb{E}_{\nu_f}[(p - 1)\mathbf{1}_{I_r} e^{-2\beta} \mathbf{1}_{p \geq A+2}] + o_N(1) \\ &= \mathbb{E}_{\nu_f}[(\ell(0) + 1)\mathbf{1}_{I_r} e^{-2\beta} \mathbf{1}_{\ell(0) \geq A}] + o_N(1), \end{aligned} \quad (6.41)$$

V_r is defined in (2.9) and I_r in (6.5). In view of the following:

$$(A + 1)\nu_f(N\mathcal{E}_r(d), \ell(0) \geq A) \leq e^{2\beta} \mathbb{E}_{\nu_f}[(\ell(0) + 1)\mathbf{1}_{I_r} e^{-2\beta} \mathbf{1}_{\ell(0) \geq A}],$$

Equation (6.39) follows for $i = 0$ via (6.41):

$$(A + 1)\nu_f(N\mathcal{E}_r(d), \ell(0) \geq A) \stackrel{(6.39)}{\leq} e^{2\beta} \nu_f(p = 2, V_r, p' \geq A + 2) + o_N(1) \stackrel{(6.38)}{\leq} \frac{e^{2\beta}}{\log(A + 2)} + o_N(1).$$

Now assume the result holds for $|i| < k$. To show it for e.g. $i + 1$, we are going to prove:

$$\nu_f(N\mathcal{E}_r(d), \ell(i + 1) \geq A) = \nu_f(N\mathcal{E}_r(d), \ell(i + 1) \geq 0, \ell(i) \geq A) + O(D_N(f)^{1/2} + D_N(f)). \quad (6.42)$$

The argument is very similar to the one used in the proof of Lemma 6.6. Consider the event $\{\ell(i + 1) \geq A\}$ and a curve γ in this event. This time, instead of adding blocks to the pole, we add A blocks to line i below the pole of γ (see Figure 4.10 for a representation of $\ell(i)$) to obtain a curve $F(\gamma)$. By this procedure, $\{\ell(i + 1) \geq A\}$ is sent onto $\{\ell(i) \geq A\}$, and both γ and $F(\gamma)$ have the same ν -measure.

The procedure $\gamma \rightarrow F(\gamma)$ requires A SSEP moves, corresponding to flipping blocks of line i one after the other. None of these break any constraints involved in the definition of $N\mathcal{E}_r(d)$, so that in fact:

$$F(\{N\mathcal{E}_r(d), \ell(i + 1) \geq A\}) = \{N\mathcal{E}_r(d), \ell(i) \geq A\}.$$

Moreover, each curve in the chain $\gamma_1 = \gamma \rightarrow \dots \rightarrow \gamma_f = F(\gamma)$ appears at most $A + 1$ times when effecting the procedure for all curves in $\{N\mathcal{E}_r(d), \ell(i + 1) \geq A\}$. The difference of the square roots of the two probabilities appearing in (6.42) is thus bounded by $C(A)D_N(f)$, which completes the proof of (6.42), thus of Lemma 6.7. \square

Lemma 6.7 gives a bound on the width of a curve below its pole. Let us now show that, at distance $k \geq 1$ to the right or to the left of the north pole, the height cannot be too big as a function of k . To do so, for $k \in \mathbb{N}^*$ and $|i| \leq k$, define $\delta(i)$ as the absolute value of the height difference between columns i and $i + 1$, fixing $\delta_0 = 0$ to be the height difference of the columns with left extremities L_1 and $L_1 + e_1$ respectively (see Figure 4.10). Note the different choice in labels of the δ 's compared to the ℓ 's to mark the symmetry between quadrants 1 and 4.

Lemma 6.8 (Height of a column at fixed distance to the pole). *For $k \in \mathbb{N}^*$ and each $C > 0, A \geq 1$,*

$$\forall 1 \leq i, j \leq k, \quad \limsup_{N \rightarrow \infty} \sup_{f: D_N(f) \leq C/N} \nu_f(N\mathcal{E}_r(d), \delta(i) \geq A, \delta(-j) \geq A) \leq e^{-2\beta(A-1)}. \quad (6.43)$$

Let $\Delta_k^\pm = \sum_{i=1}^k \delta(\pm i)$ be the heights that a curve has gone down after k horizontal steps on either side of L_1 . Then ($\beta > 1$):

$$\limsup_{N \rightarrow \infty} \sup_{f: D_N(f) \leq C/N} \nu_f(N\mathcal{E}_r(d), \Delta_k^+ \geq k(1 + \log k), \Delta_k^- \geq k(1 + \log k)) \leq \frac{1}{k^{2\beta-2}} = o_k(1). \quad (6.44)$$

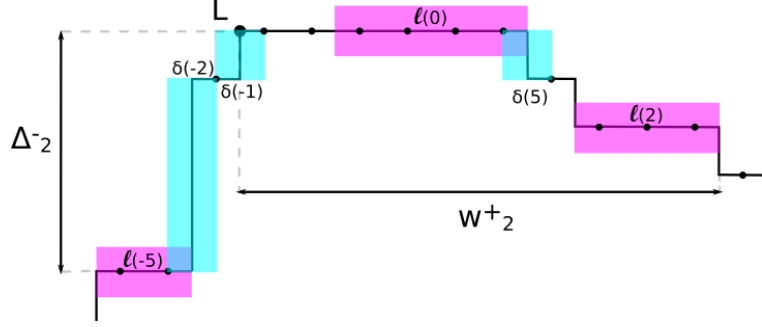

Figure 4.10 – Definition of the $\delta(\pm i), \ell(\pm i), \Delta_k^\pm, w_k^\pm$. The small black dots mark the centre of each column, the shaded areas are blocks in columns/lines constituting one of the pictured $\ell(\pm i), \delta(\pm i)$. Here, $\ell(-2) = \delta(-3) = 0$.

Proof. Equation (6.44) follows from (6.43) by a union bound. To prove (6.43), we first treat the case $i = j = 1$. $\{\delta(1) \geq A, \delta(-1) \geq A\}$ is the event that the north pole is atop a column of width 2 and height at least A . With $\gamma \in \{\delta(1) \geq A, \delta(-1) \geq A\}$ associate a curve $G(\gamma) \in \{\delta(1) \geq 1, \delta(-1) \geq 1\}$ in which the north pole has been shrunk $A - 1$ times. $G(\gamma)$ has length $|\gamma| - 2(A - 1)$, thus has higher equilibrium probability. In fact, up to boundary effects in the definition of X_r^N , G is a bijection between the above sets, and:

$$\nu(\delta(1) \geq A, \delta(-1) \geq A) \simeq e^{-2\beta(A-1)} \nu(\delta(1) \geq 1, \delta(-1) \geq 1). \quad (6.45)$$

Equation 6.45 is not an equality because of boundary conditions. Indeed, elements of X_r^N must satisfy $y_{\max} - y_{\min} \geq \lceil Nr \rceil$, with y_{\min} the ordinate of the south pole of a curve, and be subsets of Λ_N . As a result, G is a mapping from X_r^N onto itself provided we write:

$$\{\delta(\pm 1) \geq A, y_{\max} - y_{\min} \geq \lceil Nr \rceil + A - 1\} \xrightarrow{G} \{\delta(\pm 1) \geq 1, y_{\max} \leq N - (A - 1)\}. \quad (6.46)$$

The condition on the first set ensures that deleting $A - 1$ levels of the north pole of one of its element γ still yields a curve $G(\gamma) \in X_r^N$. Conversely, the height of the north pole of $G(\gamma)$ cannot be higher than $N - (A - 1)$, otherwise the original curve γ would have a north pole outside of Λ_N . The mapping G written as in (6.46) is bijective, and one has:

$$\nu(\delta(\pm 1) \geq A, y_{\max} - y_{\min} \geq \lceil Nr \rceil + A - 1) = e^{-2\beta(A-1)} \nu(\delta(\pm 1) \geq 1, y_{\max} \leq N - (A - 1)). \quad (6.47)$$

In the same way as in Lemma 6.6, (6.47) holds under ν_f for any ν -density f up to a term bounded by $C(A)(D_N(f)^{1/2} + D_N(f))$, quantifying the cost of deleting $A - 1$ lines of the pole of a curve one by one. As a result, if f is a ν -density with $D_N(f) \leq C/N$:

$$\nu_f(\delta(\pm 1) \geq A, y_{\max} - y_{\min} \geq \lceil Nr \rceil + A - 1) \leq e^{-2\beta(A-1)} + O(N^{-1/2}). \quad (6.48)$$

The dependence in A in the error term is not kept, as we choose it independent of N . Each curve involved in these strings of dynamical moves appears at most A times in all the strings of all the curves, hence an error bounded by $C(A)D_N(f)^{1/2}$. As curves in $N\mathcal{E}_r(d)$ satisfy $y_{\min} - y_{\max} \geq 2Nr \geq \lceil Nr \rceil + A - 1$ (opposite poles must be at distance at least $2Nr$), (6.43) holds for $i = j = 1$.

To prove (6.43) for each $(i, j) \in \{1, \dots, k\}$, let us first prove it for $j = 1, i > 1$. One has:

$$\nu_f(N\mathcal{E}_r(d), \delta(i) \geq A, \delta(-1) \geq A) = \nu_f(N\mathcal{E}_r(d), \delta(i-1) \geq A, \delta(-1) \geq A) + o_N(1). \quad (6.49)$$

Indeed, as in Lemma 6.7, a curve with $\delta(i) \geq A$ is transformed into one with $\delta(i-1) \geq A$ by deleting A blocks in column $i-1$. These SSEP moves do not change the length of the curve, nor do they affect whether a curve is in $N\mathcal{E}_r(d)$ for N large enough, since all blocks involved in the moves are at distance of order Nr to the other quadrants or any pole other than the north pole. Iterating (6.49) from i to 1 and using (6.48) yields (6.43) for the couple $(i, -1)$. Now if $j \neq 1$, the same argument applies to go from $-j$ to -1 . This concludes the proof of (6.43). \square

6.2.4 Value of the slope at the pole

We now have all prerequisites to prove that the motion of the north pole imposes a particle density of $e^{-\beta}$ on each side, as stated in Lemma 6.9. Its proof crucially makes use of the fact that the contour dynamics around the pole is irreducible. This is due to the $e^{-2\beta}$ regrowth jumps allowed in the contour dynamics which means, in particular, that it is not true for the zero temperature stochastic Ising model.

Lemma 6.9. *For each $\delta > 0$ and test function $G \in \mathcal{C}$,*

$$\limsup_{N \rightarrow \infty} \frac{1}{N} \log \mathbb{P}_{r,\beta}^N \left(\text{for a.e. } t \in [0, T_0], \gamma_t \in N\mathcal{E}_r(d); \left| \frac{1}{T_0} \int_0^{T_0} G(t, L_1(t)/N) (\mathbf{1}_{p=2} - e^{-\beta}) dt \right| \geq \delta \right) = -\infty. \quad (6.50)$$

The claim is also valid under $\mathbb{P}_{r,\beta,H}^N$.

Proof. The proof only deals with $G \equiv 1$ and $H \equiv 0$. Generalisations to $\mathbb{P}_{r,\beta,H}^N$ follow as in the proof of Lemma 6.5, and we explain how to include a test function G in Remark 6.10. Integer parts are systematically omitted.

The proof is structured as follows. We first use Lemma 6.3 to project the dynamics inside $N\mathcal{E}_r(d)$. The compactness results provided by Section 6.2.3 are then incorporated to the probability in (6.50). This enables us to define a proper frame around the pole. After conditioning to this frame, the quantity to estimate in (6.50) can be retrieved from an equilibrium computation, which is the last step of the proof.

Let $\phi = \mathbf{1}_{p=2} - e^{-\beta}$. By Markov inequality and Lemma 6.3, the left-hand side of (6.50) without the limits is bounded from above, for each $a > 0$ by:

$$-a\delta T_0 + C\beta + T_0 \left| \sup_{f \geq 0: \nu_f(N\mathcal{E}_r(d))=1} \left\{ a\mathbb{E}_{\nu_f}[\phi] - ND_N(f) \right\} \right|. \quad (6.51)$$

Step 1: definition of a suitable frame around the pole.

The first step consists in writing the expectation in (6.51) as a quantity that depends only on the dynamics around the pole. The idea is to compare the contour dynamics to a zero-range process with two species of particles. The number of particles is given by the height difference between

consecutive columns around the pole. The type of particle is determined by the sign of the height difference. This process is irreducible and its invariant measure can be made explicit. More is said on this dynamics below, see also Figure 4.12. To make such a comparison, we define a frame around the pole without fixing its position, contrary to what was done e.g. in Lemma 6.5. This is done as follows.

Fix an integer k , which will be the typical size of the frame around the pole, and consider the following partition of $X_r^N \cap N\mathcal{E}_r(d)$. For any curve γ , let $h_k(\gamma)$ be the smallest integer such that the number of blocks in Γ (the droplet delimited by γ) with centre at height $y = y_{\max} - h_k(\gamma) - 1/2$ is strictly larger than k (see Figure 4.11):

$$h_k(\gamma) = \min \{y \in \mathbb{N} : N_y(\gamma) > k\}, \quad (6.52)$$

where:

$$N_y(\gamma) = \#\{\text{blocks in } \Gamma \text{ with centre at height } y_{\max}(\gamma) - y - 1/2\}.$$

Let $x_k(\gamma), y_k(\gamma)$ denote the extremal vertices of the last level of Γ with width smaller than k , and

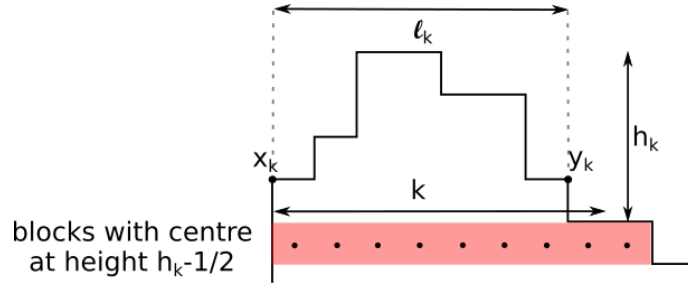

Figure 4.11 – Definition of h_k, ℓ_k and x_k, y_k for a given curve. The first level of blocks with width strictly larger than k corresponds to the filled area, unchanged by the ZRP dynamics. In this case there are $k + 1$ such blocks, with centres indicated by black dots. The width ℓ_k of the last level of width smaller than k is equal here to $k - 1$. The portion of the curve affected by the ZRP dynamics is delimited by dashed lines and the segment $[x_k, y_k]$.

let

$$\ell_k(\gamma) := \|y_k(\gamma) - x_k(\gamma)\|_1 \quad (6.53)$$

be this width, see Figure 4.11. For fixed $k \in \mathbb{N}^*$ and $2 \leq \ell \leq k$, consider the set:

$$M_\ell = \{\gamma \in X_r^N : \ell_k(\gamma) = \ell\}. \quad (6.54)$$

Then $(M_\ell)_{2 \leq \ell \leq k}$ is a disjoint family, which partitions $X_r^N \cap N\mathcal{E}_r(d)$. This second point comes from the fact that curves in $N\mathcal{E}_r(d)$ have width at least $Nr \geq k$ at some level on each side of L_1 for N large enough. The expectation in (6.51) thus reads, for each ν -density f supported on $N\mathcal{E}_r(d)$:

$$\mathbb{E}_{\nu_f}[\phi] = \sum_{2 \leq \ell \leq k} \mathbb{E}_{\nu_f}[\mathbf{1}_{M_\ell} \phi]. \quad (6.55)$$

At this point, the splitting of curves in the different M_ℓ in (6.55) suffers from two flaws. On the one hand, the width ℓ , which will correspond to the number of sites in a ZRP, may not be large.

This makes a local equilibrium argument impossible to apply. On the other hand, the pole may be macroscopically higher than the points $x_k(\gamma), y_k(\gamma)$. In other words, we must control both the height $h_k(\gamma)$ below the pole and the width $\ell_k(\gamma)$ in terms of k . Lemmas 6.7-6.8 enable such a control, as we now explain.

Consider first the height $h_k(\gamma)$, defined in (6.52). Then either $h_k(\gamma) = 0$, which corresponds to having a pole size $p(\gamma) \geq k$, or $h_k(\gamma) > 1$ and the level at height $h_k(\gamma) - 1$ below the pole has width strictly smaller than k , thus has width smaller than k on both sides of L_1 . Recalling from Lemma 6.8 that $\Delta_k^\pm(\gamma)$ is the depth at horizontal distance k on either side of the pole, we find:

$$h_k(\gamma) \leq \min \{ \Delta_k^+(\gamma), \Delta_k^-(\gamma) \}.$$

Lemma 6.8 then yields, for each $C > 0$:

$$\limsup_{N \rightarrow \infty} \sup_{f: D_N(f) \leq C/N} \nu_f(N\mathcal{E}_r(d), h_k \geq k(1 + \log k)) = o_k(1). \quad (6.56)$$

We now turn to the width $\ell_k = \ell_k(\gamma)$ of the level at height h_k below the pole. Recalling the definition of the widths w^\pm from Lemma 6.7, notice first the identity:

$$\forall \gamma \in X_r^N \cap N\mathcal{E}_r(d), \quad \ell_k(\gamma) = w_{h_k(\gamma)-1}^+ + w_{h_k(\gamma)-1}^-. \quad (6.57)$$

Let $a_k > 0$ to be chosen later, fix $C > 0$ and a ν -density f with $D_N(f) \leq C/N$. According to (6.57), one has for instance:

$$\nu_f(N\mathcal{E}_r(d), \ell_k \leq a_k) \leq \nu_f(N\mathcal{E}_r(d), w_{h_k-1}^- \leq a_k). \quad (6.58)$$

If at level $h_k - 1$ below the pole one has gone left less than a_k times, then one must be below $h_k - 1$ once reaching a distance a_k to the left of the pole, i.e.:

$$w_{h_k-1}^- \leq a_k \quad \Rightarrow \quad \Delta_{a_k}^- \geq h_k - 1. \quad (6.59)$$

Let us provide a lower bound on h_k , then choose a_k in terms of this upper bound such that (6.59) with imply that the probability of the right-hand side of (6.58) is small. For $b_k > 0$ to be chosen, analogously to (6.59), one has:

$$h_k \leq b_k \quad \Rightarrow \quad w_{b_k}^- + w_{b_k}^+ > k.$$

By Lemma 6.7, for $b_k = \lfloor \sqrt{k/2} \rfloor$:

$$\begin{aligned} \limsup_{N \rightarrow \infty} \sup_{f \geq 0: D_N(f) \leq C/N} \nu_f(N\mathcal{E}_r(d), h_k \leq b_k) \\ \leq 2 \limsup_{N \rightarrow \infty} \max_{\varepsilon \in \{-, +\}} \sup_{f \geq 0: D_N(f) \leq C/N} \nu_f(N\mathcal{E}_r(d), w_{b_k}^\varepsilon \geq k/2) = o_k(1). \end{aligned} \quad (6.60)$$

Using (6.60), the bound (6.58) then implies the following bound for ℓ_k :

$$\begin{aligned} \limsup_{N \rightarrow \infty} \sup_{f \geq 0: D_N(f) \leq C/N} \nu_f(N\mathcal{E}_r(d), \ell_k \leq a_k) \\ \leq \limsup_{N \rightarrow \infty} \sup_{f \geq 0: D_N(f) \leq C/N} \nu_f(N\mathcal{E}_r(d), \Delta_{a_k}^- \geq h_k \geq b_k + 1) + o_k(1), \end{aligned} \quad (6.61)$$

where the error term is bounded from above by (6.60). It remains to choose a_k as a function of $b_k + 1 = \lfloor \sqrt{k/2} \rfloor + 1$ such that the right-hand side of (6.61) vanishes for large k . By Lemma 6.8, it suffices to take a_k such that $a_k(1 + \log(a_k)) \leq b_k + 1$, e.g. for large enough k :

$$a_k = (1/2)k^{1/2}/\log k =: \ell_{\min}(k). \quad (6.62)$$

With this choice of $a_k = \ell_{\min}(k)$, (6.61) yields the desired control on ℓ_k :

$$\limsup_{N \rightarrow \infty} \sup_{f \geq 0: D_N(f) \leq C/N} \nu_f(N\mathcal{E}_r(d), \ell_k \leq \ell_{\min}(k)) = o_k(1). \quad (6.63)$$

We now use equations (6.56)-(6.63) to restrict admissible configurations around the pole, thus concluding the definition of the frame around the pole. Define $h_{\max}(k) := k(1 + \log k)$ and recall that $\ell_{\min}(k) := (1/4)k^{1/2}/\log k$. By the discussion of the previous paragraph, and as $\phi = \mathbf{1}_{p=2} - e^{-\beta}$ is bounded, (6.51) is bounded from above by:

$$-a\delta T_0 + C\beta + T_0 \left| \sup_{f \geq 0: \nu_f(N\mathcal{E}_r(d))=1} \left\{ a \sum_{\ell_{\min}(k) \leq \ell \leq k} \mathbb{E}_{\nu_f} [\mathbf{1}_{M_\ell} \mathbf{1}_{h_k \leq h_{\max}(k)} \phi] - \frac{N}{2} D_N(f) \right\} \right| + \omega_{N,k}, \quad (6.64)$$

where $\omega_{N,k}$ satisfies by (6.56)-(6.63):

$$\limsup_{N \rightarrow \infty} \omega_{N,k} \leq a \|\phi\|_\infty \limsup_{N \rightarrow \infty} \sup_{f: D_N(f) \leq 2\|\phi\|_\infty a/N} \nu_f(N\mathcal{E}_r(d), h_k > h_{\max}(k) \text{ or } \ell_k < \ell_{\min}(k)) = o_k(1).$$

It is thus sufficient to estimate the supremum in (6.64).

Step 2: conditioning and mapping to a two-species zero-range process.

We now study the expectation in (6.64) in detail on M_ℓ , defined in (6.54), for a given $\ell_{\min}(k) \leq \ell \leq k$, and obtain a local description of the contour dynamics around the pole. We claim that to configurations in M_ℓ corresponds a unique particle configuration in $\Omega_\ell = \mathbb{Z}^{\ell+1}$. The mapping goes as follows. If $\gamma \in M_\ell$, define, for $0 \leq j \leq \ell$, a particle number η_j corresponding to the height increment at column j , with column 0 the one centred on $x_k(\gamma)$, as:

$$\eta_j = \varepsilon_j \sum_{\substack{z \in \Lambda_N: z \cdot e_1 = x(\gamma) \cdot e_1 + j \\ z \cdot e_2 \geq y_{\max}(\gamma) - h_k(\gamma)}} \xi_z, \quad \varepsilon_j = \begin{cases} 1 & \text{if } j \leq L_1 \cdot e_1, \\ -1 & \text{if } j > L_1 \cdot e_1. \end{cases}$$

If $\eta_j < 0$ for some j , we say that there are $|\eta_j|$ antiparticles at site j . The constraint $z \cdot e_2 \geq y_{\max}(\gamma) - h(\gamma)$ guarantees that only the vertical edges above the level of $x_k(\gamma), y_k(\gamma)$ are counted as particles. We let $\eta(\gamma)$ denote the unique particle configuration in Ω_ℓ associated with $\gamma \in M_\ell$ (see Figure 4.12).

In the particle language, h_k corresponds to the number of particles or antiparticles. The event $\{h_k \leq h_{\max}(k)\}$ can thus be recast, for each ℓ , as the event:

$$W^\ell = \{\rho^\ell \leq C_\ell\}, \quad \text{where} \quad \rho^\ell = \frac{1}{\ell+1} \sum_{j=0}^{\ell} |\eta_j|, \quad C_\ell = C_{\ell,k} = \frac{2}{\ell+1} h_{\max}(k) = \frac{2k(1 + \log k)}{\ell+1}. \quad (6.65)$$

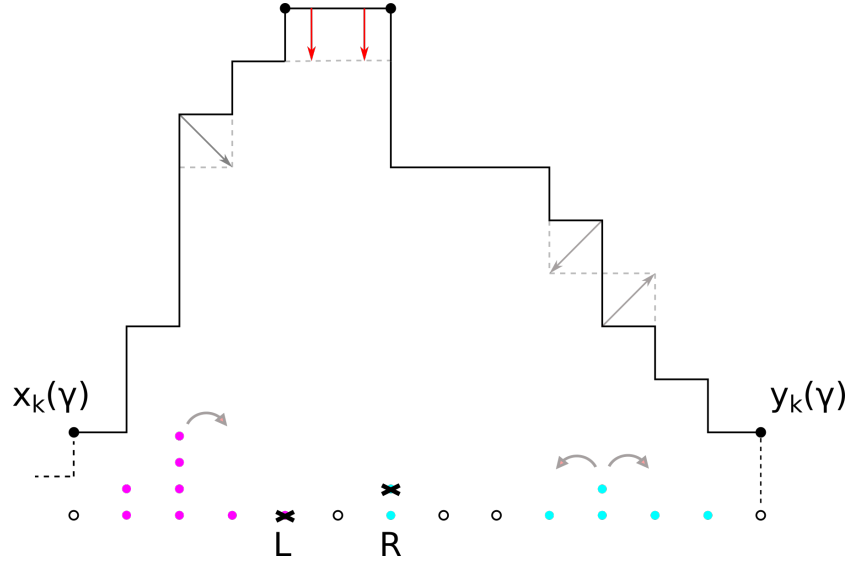

Figure 4.12 – Portion of the interface of a curve around the north pole, and associated path and particle configurations. Particles are in dark dots, antiparticles in light dots, and empty sites are white with a dark contour. The grey arrows on the particle configuration correspond to jumps allowed by the contour dynamics that conserve the particle number. A move reducing the length of the curve, materialised on the curve by the vertical arrows, corresponds to a particle-antiparticle pair annihilation, represented by the black crosses. No particle creation is represented here.

Let $\ell \in \{\ell_{\min}(k), \dots, k\}$, f be a ν -density supported on $N\mathcal{E}_r(d)$ with $\nu_f(M_\ell) > 0$, and define:

$$\forall \eta \in \Omega_\ell, \quad \bar{f}_\ell(\eta) = \frac{1}{\nu_f(M_\ell)} \sum_{\gamma \in M_\ell: \eta = \eta(\gamma)} \mathcal{Z}_{r,\beta}^{-1} f(\gamma) e^{-\beta|\gamma| + \beta|\eta| + \beta\ell}. \quad (6.66)$$

Define also the probability measure $\bar{\mu}_\ell$:

$$\forall \eta \in \Omega_\ell, \quad \bar{\mu}_\ell(\eta) = \bar{\mathcal{Z}}_\ell^{-1} \exp \left[-\beta\ell - \beta \sum_{j=0}^{\ell} |\eta_j| \right], \quad (6.67)$$

where $\bar{\mathcal{Z}}_\ell$ is a normalisation factor, and $\sum_{j=0}^{\ell} |\eta_j| + \ell$ is the length of the path which corresponds to the particle configuration η . Though we could factor it out as it is common to all η , the $e^{-\beta\ell}$ factor in the definition of $\bar{\mu}_\ell$ will be convenient later on. The expectation in (6.64) is recast in terms of particle configurations as follows:

$$\mathbb{E}_{\nu_f} [\mathbf{1}_{M_\ell} \mathbf{1}_{h_k \leq h_{\max}(k)} \phi] = \nu_f(M_\ell) \mathbb{E}_{\bar{\mu}_\ell} [\bar{f}_\ell \mathbf{1}_{W_\ell} \phi], \quad (6.68)$$

so that we know how to estimate the supremum in (6.51) as soon as we can estimate (recall the definition (6.62) of $\ell_{\min}(k)$):

$$\sup_{f \geq 0: \nu_f(N\mathcal{E}_r(d))=1} \left\{ \sum_{\ell=\ell_{\min}(k)}^k a \nu_f(M_\ell) \mathbb{E}_{\bar{\mu}_\ell} [\bar{f}_\ell \mathbf{1}_{W_\ell} \phi] - \frac{N}{2} D_N(f) \right\}, \quad \phi = \mathbf{1}_{p=2} - e^{-\beta}. \quad (6.69)$$

Step 3: local equilibrium.

We now prove that estimating the supremum in (6.69) reduces to an equilibrium computation. At this stage, the technique is the same as in [KL99]. Denote by \bar{D}_ℓ the reduced Dirichlet form on Ω_ℓ , defined as follows. For $\eta \in \Omega_\ell$, let $P(\eta)$ denote the pole of η , that is the subset $\{L, \dots, R\}$ of $\{0, \dots, \ell\}$ such that η_L is the last η_j that is strictly positive or $L = 0$ if there are none, η_R the first to be strictly negative or $R = \ell$ if none exist. Let also $p = |P(\eta)| - 1$. For any $\bar{\mu}_\ell$ -density g , define:

$$\bar{D}_\ell(g) = \frac{1}{2} \sum_{\eta, \eta' \in \Omega_\ell} \bar{\mu}_\ell(\eta) c(\eta, \eta') [g^{1/2}(\eta') - g^{1/2}(\eta)]^2. \quad (6.70)$$

Importantly, the positions of the extremal sites $0, \ell$ (corresponding for curves γ compatible with a given configuration to the points $x_k(\gamma), y_k(\gamma)$) are unchanged by the dynamics. This is because the ZRP dynamics only acts on the portion of γ above $x_k(\gamma), y_k(\gamma)$. In particular, the first level of γ with width strictly larger than k , which defines the position of $x_k(\gamma), y_k(\gamma)$, is never modified. In (6.70), we abuse notations and still write $c(\cdot, \cdot)$ for the jump rates of the ZRP moves corresponding to moves on the contour dynamics. This is legitimate, since if f is a ν -density supported on $N\mathcal{E}_r(d)$, any jump featured in $\bar{D}_\ell(\bar{f}_\ell)$ is an allowed jump for D_N with the same rate by definition of $N\mathcal{E}_r(d)$. Convexity then yields, recalling that $\ell_{\min}(k)$ is defined in (6.62):

$$D_N(f) \geq \sum_{\ell=\ell_{\min}(k)}^k \nu_f(M_\ell) \bar{D}_\ell(\bar{f}_\ell). \quad (6.71)$$

Reinjecting (6.71) into the supremum in (6.69), we see that it is enough to estimate:

$$\sup_{f \geq 0: \nu_f(N\mathcal{E}_r(d))=1} \left\{ \sum_{\ell=\ell_{\min}(k)}^k \nu_f(M_\ell) \left[a \mathbb{E}_{\bar{\mu}_\ell} [\bar{f}_\ell \mathbf{1}_{W_\ell} \phi] - \frac{N}{2} \bar{D}_\ell(\bar{f}_\ell) \right] \right\}. \quad (6.72)$$

We are nearly done with conditioning to a frame where we can compute the expectation in (6.72). The remaining step is to reduce the state space $\Omega_\ell = \mathbb{Z}^{\ell+1}$ to something that is compact. By definition of $\bar{f}_\ell, \bar{\mu}_\ell, \bar{D}_\ell$ in (6.66)-(6.67)-(6.70) respectively, the process is painless: it is enough to delete all jumps that increase the number of particles above what is authorised by W_ℓ (defined in (6.73)). Indeed, define μ_ℓ as a measure on W_ℓ as follows:

$$\forall \eta \in W_\ell = \left\{ \rho^\ell \leq C_\ell =: \frac{2h_{\max}(k)}{\ell+1} \right\}, \quad \mu_\ell(\eta) := \mathcal{Z}_\ell^{-1} \exp \left[-\beta \ell - \beta \sum_{j=0}^{\ell} |\eta_j| \right] = \frac{\bar{\mathcal{Z}}_\ell}{\mathcal{Z}_\ell} \bar{\mu}_\ell(\eta), \quad (6.73)$$

where \mathcal{Z}_ℓ is a normalisation factor on W_ℓ . The marginal \bar{f}_ℓ is correspondingly modified into a μ_ℓ -density f_ℓ :

$$\forall \eta \in W_\ell, \quad f_\ell(\eta) := \frac{\mathcal{Z}_\ell}{\bar{\mathcal{Z}}_\ell} \frac{1}{\mathbb{E}_{\bar{\mu}_\ell} [\bar{f}_\ell \mathbf{1}_{W_\ell}]} \bar{f}_\ell(\eta).$$

Finally, the Dirichlet form D_ℓ for the reduced dynamics (written here in compact form) reads, for any μ_ℓ -density g :

$$D_\ell(g) = \sum_{\eta, \eta' \in W_\ell} c(\eta, \eta') [g^{1/2}(\eta') - g^{1/2}(\eta)]^2. \quad (6.74)$$

Since we simply restricted allowed jumps, one has $\bar{D}_\ell(\bar{f}_\ell) \geq D_\ell(f_\ell)\mathbb{E}_{\bar{\mu}_\ell}[\bar{f}_\ell\mathbf{1}_{W_\ell}]$. Under μ_ℓ , the quantity (6.72) to estimate is then bounded from above by:

$$\begin{aligned} & \sup_{f \geq 0: \nu_f(N\mathcal{E}_r(d))=1} \left\{ \sum_{\ell=\ell_{\min}(k)}^k \nu_f(M_\ell)\mathbb{E}_{\bar{\mu}_\ell}[\bar{f}_\ell\mathbf{1}_{W_\ell}] \left[a\mathbb{E}_{\mu_\ell}[f_\ell\phi] - \frac{N}{2}D_\ell(f_\ell) \right] \right\} \\ & \leq a \sup_{f \geq 0: \nu_f(N\mathcal{E}_r(d))=1} \left\{ \sum_{\ell=\ell_{\min}(k)}^k \nu_f(M_\ell)\mathbb{E}_{\bar{\mu}_\ell}[\bar{f}_\ell\mathbf{1}_{W_\ell}] \left[\sup_{\substack{g \geq 0: \mathbb{E}_{\mu_\ell}[g]=1 \\ D_\ell(g) \leq 2a\|\phi\|_\infty/N}} \mathbb{E}_{\mu_\ell}[g\phi] \right] \right\}, \end{aligned} \quad (6.75)$$

The proof of Lemma 6.9 will therefore be concluded if we can prove that, for fixed k and N large, the supremum on g in the right-hand side of (6.75) is bounded by $o_k(1)$ uniformly in $\ell_{\min}(k) \leq \ell \leq k$. Fix $\ell \in \{\ell_{\min}(k), \dots, k\}$. As W_ℓ is compact, the supremum on g in (6.75) is achieved by a density g_ℓ^N for each N . Up to taking a subsequence, by lower semi-continuity of D_ℓ and continuity of the expectation in (6.75) w.r.t weak convergence, we can take the large N limit and restrict ourselves to studying:

$$\sup_{g^\infty: D_\ell(g^\infty)=0} \mathbb{E}_{\mu_\ell}[g^\infty\phi].$$

By definition of D_ℓ , the corresponding dynamics is irreducible on W_ℓ . This is the major difference between the contour dynamics and the 0-temperature stochastic Ising model, which motivated the introduction of the temperature-like parameter β to allow for regrowth. Irreducibility means that any g^∞ satisfying $D_\ell(g^\infty) = 0$ is constant equal to 1, and we are left with the estimate of:

$$\mathbb{E}_{\mu_\ell}[\phi] \quad \text{with} \quad \phi = \mathbf{1}_{p=2} - e^{-\beta}. \quad (6.76)$$

Step 4: equilibrium large deviations and surface tension.

The expectation (6.76) is taken under the equilibrium measure of the zero-range dynamics. Properties of the measure μ_ℓ are analysed in Appendix A.3. In particular, it is proven there that, recalling the definition (6.62) of $\ell_{\min}(k)$:

$$\lim_{k \rightarrow \infty} \sup_{\ell_{\min}(k) \leq \ell \leq k} \mathbb{E}_{\mu_\ell}[\phi] = 0. \quad (6.77)$$

Equation (6.77) concludes the proof of Lemma 6.9 with $G \equiv 1$. □

Remark 6.10. Lemma 6.9 holds for any test function $G \in \mathcal{C}$ and not just $G \equiv 1$: for each $\delta > 0$,

$$\begin{aligned} & \limsup_{\varepsilon \rightarrow 0} \limsup_{N \rightarrow \infty} \frac{1}{N} \log \mathbb{P}_{r,\beta}^N \left(\forall t \in [0, T_0], \gamma_t \in N\mathcal{E}_r(d); \right. \\ & \left. \left| \frac{1}{T_0} \int_0^{T_0} G(t, L_1(t)) (\mathbf{1}_{p=2} - e^{-\beta}) dt \right| \geq \delta \right) = -\infty. \end{aligned}$$

This is proven in the same way as Lemma 6.9, except that curves are further conditioned by fixing the point $x_k(\gamma)$, which is the left extremity of the interval $\{0, \dots, \ell = \|y_k(\gamma) - x_k(\gamma)\|_1\}$ for a curve γ . The expectation in (6.64) becomes, for each $t \leq T_0$ and ν -density f supported in $N\mathcal{E}_r(d)$:

$$\begin{aligned} & \sum_{\ell_{\min}(k) \leq \ell \leq k} \mathbb{E}_{\nu_f} [\mathbf{1}_{M_\ell} \mathbf{1}_{h_k \leq h_{\max}(k)} \phi G(t, L_1/N)] \\ & = \sum_{\ell_{\min}(k) \leq \ell \leq k} \sum_{x \in \Lambda_N} \mathbb{E}_{\nu_f} [\mathbf{1}_{M_\ell} \mathbf{1}_{h_k \leq h_{\max}(k)} \mathbf{1}_{x(\gamma)=x} \phi G(t, x/N)] + o_N(1), \end{aligned}$$

with an error term uniform in f . Indeed, the difference between $G(t, L_1/N)$ and $G(x/N)$ is bounded by $N^{-1}(h_{\max}(k) + k)\|\nabla G\|_\infty = o_N(1)$ thanks to the conditions $\ell_k \leq k$, $h_k \leq h_{\max}(k)$.

The position of $x_k(\gamma)$ is unchanged by the ZRP dynamics, see the discussion following (6.70). As such, the rest of the arguments in the proof of Lemma 6.9 go through unchanged, except that one has to rewrite everything with x fixed, e.g. to consider $M_{\ell,x} = M_\ell \cap \{x_k(\gamma) = x\}$ instead of M_ℓ everywhere, and to correspondingly change f_ℓ into $f_{\ell,x}$. The Dirichlet form D_ℓ in (6.70), however, does not depend on x , as in the proof of Lemma 6.5: the ZRP dynamics acts on the local gradients of curves, not on their absolute position. \blacksquare

The method of proof of Lemma 6.9 can be used to obtain tighter estimates on the slope at the poles. An example is given in the following corollary, used in Appendix B.3 to obtain exponential tightness.

Corollary 6.11 (One and two block estimates for deviations from the average). *For each $\delta, \eta > 0$:*

$$\limsup_{n \rightarrow \infty} \limsup_{N \rightarrow \infty} \frac{1}{N} \log \mathbb{P}_{r,\beta}^N \left(\text{for a.e. } t \in [0, T_0], \Gamma_t \in \mathcal{E}_r(d); \right. \\ \left. \frac{1}{T_0} \int_0^{T_0} \mathbf{1}_{|\xi_{L_1}^{\pm,n} - e^{-\beta}| \geq \delta} dt > \eta \right) = -\infty. \quad (6.78)$$

and:

$$\limsup_{n \rightarrow \infty} \limsup_{\varepsilon \rightarrow 0} \limsup_{N \rightarrow \infty} \frac{1}{N} \log \mathbb{P}_{r,\beta}^N \left(\text{for a.e. } t \in [0, T_0], \Gamma_t \in \mathcal{E}_r(d); \right. \\ \left. \frac{1}{T_0} \int_0^{T_0} \mathbf{1}_{|\xi_{L_1}^{\pm,n} - \xi_{L_1}^{\pm,\varepsilon N}| \geq \delta} dt > \eta \right) = -\infty. \quad (6.79)$$

Remark 6.12. Note that $\mathbf{1}_{|\xi_{L_1}^{\pm,n} - e^{-\beta}| \geq \delta}$ is simply a cylindrical function, which has average $o_n(1)$ under the invariant measure ν . Corollary 6.11 thus says no more than the usual replacement lemmas. \blacksquare

Proof. Equation (6.79) is a two block estimate which uses only the SSEP part of the dynamics. The method of proof has already been explained in Lemma 6.5.

Consider instead (6.78). The apparent difference with Lemma 6.9 is that, e.g. for $\xi_{L_1}^{+,n}$, we need to focus on a frame around the pole which, in addition, has at least n edges to the the right of the pole. The fact that it is possible has actually already been proven.

Indeed, by (6.60), the event $h_k \geq \sqrt{k/2} - 1$ is typical under ν_f for any f with $D_N(f) \leq C/N$, $C > 0$. To ensure that there are at least n edges on either side of the pole with probability going to 1 in the large n limit, it is enough to choose k such that $(k/2)^{1/2} - 1 \geq n$, i.e. any $k \geq 2(n+1)^2$ works. It is convenient to take k independent from n and have k go to infinity before n . The proof of (6.78) is then reduced, as in Lemma 6.9, to an elementary (though more intricate) equilibrium computation under the measure μ_ℓ , defined in (6.73). \square

A Replacement lemma and projection of the dynamics

A.1 Replacement lemma

In this section, we prove the Replacement Lemma 3.8. Let us first introduce some notations. For each $\varepsilon > 0$ and $x \in [-1, 1]^2$, denote by $B(x, \varepsilon N)$ the subset of Λ_N of points at distance less than

εN to x in 1-norm. For $\gamma \in X_r^N$ and $x \in V(\gamma)$, define

$$\phi(\gamma, x) = c_x(\gamma) = \xi_{x+e_x}(1 - \xi_x)/2 + \xi_x(1 - \xi_{x+e_x^-})/2.$$

Recall from (3.3) that $\xi_x^{\varepsilon N}$ is the quantity

$$\xi_x^{\varepsilon N} = \frac{1}{2\varepsilon N + 1} \sum_{y \in V(\gamma) \cap B(x, \varepsilon N)} \xi_y,$$

and define, as in Lemma 3.8, the function $\tilde{\phi}$ by:

$$\tilde{\phi}(\rho) = \rho(1 - \rho), \quad \rho \in [0, 1].$$

Let $G \in C(\mathbb{R}_+ \times [-1, 1]^2)$ be a bounded function. By Chebychev exponential inequality and Lemma 6.3, Lemma 3.8 holds if, uniformly on $t > 0$ and for each $a > 0$:

$$\limsup_{\varepsilon \rightarrow 0} \limsup_{N \rightarrow \infty} \sup_{f \geq 0: \nu_f(N\varepsilon_r)=1} \left\{ \mathbb{E}_{\nu_f} \left[a \left\{ \frac{1}{|\gamma|} \sum_{x \in V(\gamma)} G(t, x/N) \left[\phi(\gamma, x) - \tilde{\phi}(\xi_x^{\varepsilon N}) \right]^2 \right\} \right] - ND_N^S(f) \right\} = 0. \quad (\text{A.1})$$

Recall that D_N^S is the Dirichlet form of the contour dynamics without the pole terms. Following [ELS90] and as $\gamma \in X_r^N$ implies $|\gamma| \geq Nr$, it is sufficient to prove the following two estimates.

Lemma A.1. (*One and two block estimates*)

Fix $d > 0$. Let $\varepsilon > 0, k \in \mathbb{N}^*$, and let $(V_j)_{1 \leq j \leq J}$ denote a partition of $\{-\varepsilon N, \dots, \varepsilon N\}$ in J intervals of length k , except maybe the last one that is of size at most $2k$, such that $\max V_j = \min V_{j+1} - 1$ for $j \leq J - 1$. For $\gamma \in X_r^N$, $x \in V(\gamma)$ and $1 \leq j \leq J$, let $V_j(x)$ be the set of vertices in $B(x, \varepsilon N) \cap V(\gamma)$, whose positions relative to x correspond to elements of V_j . Define also:

$$A(\phi, V_j(x)) := \frac{1}{|V_j(x)|} \sum_{y \in V_j(x)} \phi(\gamma, y), \quad \xi^{V_j(x)} := \frac{1}{|V_j(x)|} \sum_{y \in V_j(x)} \xi_y.$$

Then (*one block estimate*):

$$\limsup_{k \rightarrow \infty} \limsup_{\varepsilon \rightarrow 0} \limsup_{N \rightarrow \infty} \sup_{1 \leq j \leq J} \sup_{f \geq 0: \nu_f(N\varepsilon_r)=1} \left\{ a \int d\nu(\gamma) f(\gamma) \frac{1}{|\gamma|} \sum_{x \in V(\gamma)} \left| A(\phi, V_j(x)) - \tilde{\phi}(\xi^{V_j(x)}) \right|^2 - ND_N^S(f) \right\} = 0, \quad (\text{A.2})$$

and (*two block estimate*):

$$\limsup_{k \rightarrow \infty} \limsup_{\varepsilon \rightarrow 0} \limsup_{N \rightarrow \infty} \sup_{1 \leq b, c \leq J} \sup_{f \geq 0: \nu_f(N\varepsilon_r)=1} \left\{ a \int d\nu(\gamma) f(\gamma) \frac{1}{|\gamma|} \sum_{x \in V(\gamma)} \left| A(\phi, V_b(x)) - A(\phi, V_c(x)) \right|^2 - ND_N^S(f) \right\} = 0. \quad (\text{A.3})$$

Proof. All distances are in 1-norm. In this proof as in the proof of Lemma 6.5, it would be sufficient to look at densities supported in $N\mathcal{E}_r$ and not $N\mathcal{E}_r(d)$. We work with $N\mathcal{E}_r(d)$ to provide a unified picture.

Fix $\phi \in \{\phi_1, \phi_2\}$ and let $R \in \{0, 1\}$ be its range, i.e. $\phi(\tau_x \gamma)$ depends only on $B(x, R) \cap V(\gamma)$ for $\gamma \in X_r^N, x \in V(\gamma)$. The proof of (A.2)-(A.3) consists in showing that the one and two block estimates for the contour dynamics amount to the same estimates for the SSEP, which are well known [ELS90]. We do it for (A.2), (A.3) is similar. The first step is to discard all points in the sum in (A.2) that are close to the poles, so that the pole dynamics can be neglected.

Define thus, for $u > 0$, the set $W^u(\gamma)$, which contains all points of $V(\gamma)$ at distance at least u from each $L_i, i \in \{1, \dots, 4\}$ (compare with $V^u(\gamma)$, defined in Section 3, which contains points at 1-distance at least u from the poles, and not just their left extremities). For $\gamma \in X_r^N$, as $|\gamma| \geq Nr$,

$$\begin{aligned} \frac{1}{|\gamma|} \sum_{x \in V(\gamma)} \left| A(\phi, V_j(x)) - \tilde{\phi}(\xi^{V_j(x)}) \right|^2 &\leq \frac{1}{Nr} \sum_{x \in W^{\varepsilon N + R + 3}(\gamma)} \left| A(\phi, V_j(x)) - \tilde{\phi}(\xi^{V_j(x)}) \right|^2 \\ &+ Cr^{-1} \|\phi\|_{\infty} \varepsilon. \end{aligned} \quad (\text{A.4})$$

The second term in the right-hand side of (A.4) vanishes for ε small, and we now estimate the sum.

Let us split the summand in (A.2) between each quadrant. Inside each quadrant, the arguments of Lemma 6.5 will apply to compare the dynamics to a SSEP.

Denote by M_i the set of all maximal self avoiding paths in the i direction (corresponding to quadrant i), for $i \in \{SE, SW, NW, NE\} = \{1, 2, 3, 4\}$ (S means south, E east, etc.), defined as follows. For $\gamma \in X_r^N$, let γ_i denote the part of γ that comprises all vertices between $L_i + 2e_{L_i}^+$ and the vertex before L_{i+1} , these two vertices included (with $L_{4+1} := L_1$). M_i is then defined as the set of all γ_i for $\gamma \in X_r^N$.

With this construction, if in addition $\gamma \in N\mathcal{E}_r \subset N\mathcal{E}_r(d)$, if $\gamma \setminus \gamma_i$ is fixed, then so are the poles and the single-flip (i.e. SSEP) part of the contour dynamics on γ_i is just the corner-flip dynamics as described in the proof of Lemma 6.5: jump rates are local due to being in $N\mathcal{E}_r$, and no single-flip inside γ_i could shrink a pole of size 2 due to the way the extremities of γ_i are defined.

Define μ_i as the marginal of ν (defined in (2.3)) on M_i :

$$\forall \rho \in M_i, \quad \mu_i(\rho) = \frac{e^{-\beta|\rho|}}{\mathcal{Z}_i}, \quad \mathcal{Z}_i = \sum_{\rho \in M_i} e^{-\beta|\rho|}.$$

Let f be a ν -density supported on $N\mathcal{E}_r(d)$. Define the corresponding μ_i -marginal f_i :

$$\forall \rho \in M_i, \quad f_i(\rho) = \frac{1}{\mu_i(\rho)} \sum_{\gamma \in X_r^N} \mathbf{1}_{\gamma_i = \rho} f(\gamma) \nu(\gamma).$$

In terms of the M_i , the Dirichlet form $D_N^S(f)$ is bounded from below by convexity according to:

$$D_N^S(f) \geq \frac{1}{2} \sum_{i=1}^4 \sum_{\rho \in M_i} \mu_i(\rho) \sum_{x \in V(\rho)} c_x(\rho) [f_i^{1/2}(\rho^{x, x+e_x^-}) - f_i^{1/2}(\rho)]^2 =: \sum_{i=1}^4 D_i^S(f_i), \quad (\text{A.5})$$

where for $i \in \{1, \dots, 4\}$ and a μ_i -density h , the Dirichlet form $D_i^S(h)$ corresponding to the SSEP dynamics in quadrant i is given by:

$$D_i^S(h) = \sum_{\rho \in M_i} \mu_i(\rho) \sum_{x \in V(\rho)} c_x(\rho) [h^{1/2}(\rho^{x, x+e_x^-}) - h^{1/2}(\rho)]^2.$$

Indeed, the jump rates in (A.5) are functions of $\rho \in M_i$ only, $i \in \{1, \dots, 4\}$, since f is supported on $N\mathcal{E}_r(d)$. Let us now see how to use this decomposition of the curves into quadrants to estimate the sum appearing in the right-hand side of (A.4). For short, define Φ_j for $1 \leq j \leq J$ by:

$$\Phi_j(\gamma, x) = \left| A(\phi, V_j(x)) - \tilde{\phi}(\xi^{V_j(x)}) \right|^2, \quad \gamma \in X_r^N, x \in V(\gamma). \quad (\text{A.6})$$

Note that Φ_j only depends on the edge configuration in a neighbourhood of a curve around x , not on the absolute position of x as a point of Λ_N . We thus only need to keep track of the label of x in a well chosen parametrisation of γ . We have:

$$\begin{aligned} (E) &:= \frac{1}{Nr} \sum_{\gamma \in X_r^N \cap N\mathcal{E}_r(d)} \nu(\gamma) f(\gamma) \sum_{x \in W^{\varepsilon N + R + 3}(\gamma)} \Phi_j(\gamma, x) \\ &\leq \frac{1}{Nr} \sum_{i=1}^4 \sum_{\rho \in M_i} \mu_i(\rho) f_i(\rho) \sum_{x \in W^{\varepsilon N + R}(\rho)} \Phi_j(\rho, x), \end{aligned}$$

where $\Phi_j(\rho, \cdot)$ is defined as in (A.6) with $\rho \in M_i$, $1 \leq i \leq 4$ instead of a curve $\gamma \in X_r^N$, which is not ambiguous as it is a local function.

So far, we proved that the one block-estimate (A.2) holds as soon as, for each $j \in \{1, \dots, J\}$:

$$\sup_{f \geq 0: \nu_f(N\mathcal{E}_r) = 1} \left\{ \sum_{i=1}^4 \left[a \sum_{\rho \in M_i} \mu_i(\rho) f_i(\rho) \sum_{x \in W^{\varepsilon N + R}(\rho)} \Phi_j(\rho, x) - ND_i^S(f_i) \right] \right\} \leq 0. \quad (\text{A.7})$$

The estimate for each quadrant i is similar, so we only do it for $i = 1$. Further split paths in M_1 according to their number of vertices. Let $M_1(n)$ be the subset of M_1 of paths with $n + 1$ vertices. All such paths have the same μ_i -measure, thus the marginal of μ_i on $M_1(n)$ is the uniform measure U_n on paths with $n + 1$ vertices or, equivalently, by the correspondence expounded in Section 6.2.2 (see Figure 4.9), of SSEP configurations with n sites. Define $f_{1,n}$ as the corresponding U_n -marginal of f_1 on $M_1(n)$:

$$\forall \rho \in M_1(n), \quad f_{1,n}(\rho) = \mathbb{E}_{\mu_1} [f_1 \mathbf{1}_{M_1(n)}]^{-1} f_1(\rho) \mu_1(\rho) |M_1(n)| \quad \text{provided} \quad \mathbb{E}_{\mu_1} [f_1 M_1(n)] > 0. \quad (\text{A.8})$$

It is a density for U_n , so that by convexity of the Dirichlet form we have:

$$\sum_{n=2\varepsilon N + 2R}^{4N} \mathbb{E}_{\mu_1} [f_1 \mathbf{1}_{M_1(n)}] D_{1,n}(f_{1,n}) \leq D_1(f_1),$$

where $D_{1,n}$ is the Dirichlet form associated with the corner-flip dynamics on $M_1(n)$. The lower bound on n comes from the fact that, for any $\rho \in M_1(n)$ with $n < 2\varepsilon N + 2R$, $W^{\varepsilon N + R}(\rho)$ is empty.

The upper bound comes from the finite length of a quadrant for a curve in $\Lambda_N = [-N, N]^2 \cap \mathbb{Z}^2$. Again by convexity,

$$D_N^S(f) \geq \sum_{n=2\varepsilon N+2R}^{4N} \mathbb{E}_{\mu_1} [f \mathbf{1}_{M_1(n)}] D_{1,n}(f_{1,n}). \quad (\text{A.9})$$

With this decomposition, the term between brackets in (A.7) is bounded from above, for each $i \in \{1, \dots, 4\}$, by:

$$\begin{aligned} & \frac{1}{Nr} \sum_{n=2\varepsilon N+2R}^{4N} \mathbb{E}_{\mu_i} [f_i \mathbf{1}_{M_i(n)}] \frac{1}{|M_i(n)|} \sum_{\rho \in M_i(n)} f_{i,n}(\rho) \sum_{x=\varepsilon N+R+1}^{n-\varepsilon N-R} \Phi_j(\tau_x \rho) \\ &= \frac{1}{Nr} \sum_{n=2\varepsilon N+2R}^{4N} \mathbb{E}_{\mu_i} [f_i \mathbf{1}_{M_i(n)}] \frac{1}{|M_i(n)|} \sum_{\sigma \in \Omega_n} g_{i,n}(\sigma) \sum_{x=\varepsilon N+R+1}^{n-\varepsilon N-R} \Phi_j(\tau_x \sigma). \end{aligned} \quad (\text{A.10})$$

In the last line, Ω_n is the set of SSEP configurations on n sites, and $g_{i,n}$ is defined for $\sigma \in \Omega_n$ by $g_{i,n}(\sigma) = g_{i,n}(\rho(\sigma))$, with $\rho(\sigma)$ the unique path in $M_i(n)$ corresponding to the configuration σ , as pictured in Figure 4.9. In view of (A.7)-(A.9)-(A.10), to prove the one block estimate (A.2), it is sufficient to prove that, uniformly on $j \in \{1, \dots, J\}$:

$$\limsup_{N \rightarrow \infty} \sup_{n \in \{2\varepsilon N+2R, \dots, 4N\}} \sup_{g \geq 0: \mathbb{E}_{U_n}[g]=1} \left\{ \frac{1}{N} \mathbb{E}_{U_n} \left[g \sum_{x=\varepsilon N+R+1}^{n-\varepsilon N-R} \Phi_j(\tau_x \cdot) \right] - N D_n^S(g) \right\} \leq 0. \quad (\text{A.11})$$

The notation D_n^S , already used in Section 6, stands for the Dirichlet form associated with a SSEP on n sites. We are left with a usual one block estimate for a SSEP of size n , proven e.g. in [ELS90]. There, the size n of the SSEP becomes irrelevant due to conditioning on a neighbourhood of size k of x , hence the proof of (A.2). The two block estimate (A.3) is proven similarly. \square

A.2 Projection of the contour dynamics in the good state space

In this section, we prove Lemma 6.3, which states that the contour dynamics can be projected to the effective state space $N\mathcal{E}_r(d)$. We state and prove a more general result.

Let $(X_t)_{t \geq 0}$ be a continuous time Markov chain on a finite state space E , reversible with respect to a measure ν . If $x_0 \in E$, let $\mathbb{P}_{x_0}^X, \mathbb{E}_{x_0}^X$ be the associated probability and expectation. The jump rates of the chain are denoted $c(x, y), (x, y) \in E^2$, with associated Dirichlet form D :

$$\forall f : E \rightarrow \mathbb{R}, \quad D(f) = \frac{1}{2} \sum_{(x,y) \in E^2} \nu(x) c(x, y) [f(y) - f(x)]^2. \quad (\text{A.12})$$

Lemma A.2. *Let $A \subset E$ and $x_0 \in A$. Let also $T_0 > 0$ and $\psi : [0, T_0] \times E \rightarrow \mathbb{R}$ be bounded. Then:*

$$\mathbb{E}_{x_0}^X \left[\mathbf{1}_{\{\forall t \in [0, T_0], X_t \in A\}} \exp \left[\int_0^{T_0} \psi(t, X_t) dt \right] \right] \leq \frac{1}{\nu(x_0)} \exp \left[\int_0^{T_0} dt \sup_{f \geq 0: \nu(f \mathbf{1}_A)=1} \left\{ \nu_f(\psi(t, \cdot)) - D(f^{1/2}) \right\} \right].$$

Proof. Let $(Y_t)_{t \geq 0}$ be the Markov chain X restricted to live inside A for all time. Write $\mathbb{P}_x^Y, \mathbb{E}_x^Y, x \in A$ the associated probability and expectation. On $\{\forall t \in [0, T_0], X_t \in A\}$, the two measures $\mathbb{P}_{x_0}^X$

and $\mathbb{P}_{x_0}^Y$ are equivalent, and the Radon-Nikodym derivative between $\mathbb{P}_{x_0}^Y$ and $\mathbb{P}_{x_0}^X$ up to time T_0 on a trajectory $(X_t)_{t \leq T_0}$ taking values in A reads:

$$\begin{aligned} \frac{d\mathbb{P}_{x_0}^X}{d\mathbb{P}_{x_0}^Y}((X_t)_{t \leq T_0}) &= \exp \left[\int_0^{T_0} \left[\sum_{y \in A} c(X_t, y) - \sum_{y \in E} c(X_t, y) \right] dt - \sum_{t \leq T_0} \log \left(\frac{c(X_{t-}, X_t)}{c(X_{t-}, X_t)} \right) \right] \\ &= \exp \left[- \int_0^{T_0} \sum_{y \notin A} c(X_t, y) dt \right]. \end{aligned}$$

Letting $Q_A(x) = \sum_{y \notin A} c(x, y)$ denote the flux coming out of A from x , we find:

$$\mathbb{E}_{x_0}^X \left[\mathbf{1}_{\{\forall t \in [0, T_0], X_t \in A\}} \exp \left[\int_0^{T_0} \psi(t, X_t) dt \right] \right] = \mathbb{E}_{x_0}^Y \left[\exp \left[\int_0^{T_0} \left\{ \psi(t, Y_t) - Q_A(Y_t) \right\} dt \right] \right]. \quad (\text{A.13})$$

By reversibility of X with respect to ν , the chain Y is still reversible with respect to $\nu(\cdot \cap A)$:

$$\forall x, y \in A, \quad c(x, y)\nu(x) = c(y, x)\nu(y).$$

Let us thus apply Feynman-Kac formula after changing the initial condition to $\nu(\cdot \cap A)$:

$$\mathbb{E}_{x_0}^Y \left[\exp \left[\int_0^{T_0} \left\{ \psi(t, Y_t) - Q_A(Y_t) \right\} dt \right] \right] \leq \frac{1}{\nu(x_0)} \mathbb{E}_{\nu(\cdot \cap A)}^Y \left[\exp \left[\int_0^{T_0} \left\{ \psi(t, Y_t) - Q_A(Y_t) \right\} dt \right] \right].$$

Consequently:

$$\begin{aligned} &\log \mathbb{E}_{x_0}^Y \left[\exp \left[\int_0^{T_0} \left\{ \phi(t, Y_t) - Q_A(Y_t) \right\} dt \right] \right] \\ &\leq -\log \nu(x_0) + \log \int_0^{T_0} \sup_{f \geq 0: \nu(f \mathbf{1}_A) = 1} \left\{ \nu \left(f [\psi(t, \cdot) - Q_A] \right) - D_A(f^{1/2}) \right\}. \end{aligned} \quad (\text{A.14})$$

Above, D_A is the Dirichlet form of the dynamics restricted to A (compare with (A.12)):

$$\forall g : E \rightarrow \mathbb{R}, \quad D_A(g) = \frac{1}{2} \sum_{(x, y) \in A^2} \nu(x)c(x, y) [g(x) - g(y)]^2.$$

This is nearly the statement of Lemma 6.3, except that there the upper-bound involves the original dynamics (in the present case, X) rather than the dynamics restricted to A . To obtain the desired bound, let us write out $D(f^{1/2})$, defined in (A.12), for a ν -density f with $\nu(f \mathbf{1}_A) = 1$:

$$\begin{aligned} D(f^{1/2}) &= \frac{1}{2} \sum_{(x, y) \in A^2} \nu(x)c(x, y) [f^{1/2}(y) - f^{1/2}(x)]^2 \\ &\quad + \frac{1}{2} \sum_{x \in A, y \notin A} \nu(x)c(x, y) f(x) + \frac{1}{2} \sum_{x \notin A, y \in A} \nu(x)c(x, y) f(y). \end{aligned} \quad (\text{A.15})$$

The first line is precisely $D_A(f^{1/2})$. By reversibility, each term on the second line of (A.15) is identical and equal to $\nu(fQ_A/2)$:

$$\nu(fQ_A) = \sum_{x \in A, y \notin A} \nu(x)c(x, y)f(x) = \sum_{x \in A, y \notin A} \nu(y)c(y, x)f(x) = \sum_{x \notin A, y \in A} \nu(x)c(x, y)f(y).$$

As a result, (A.15) becomes:

$$D(f^{1/2}) = D_A(f^{1/2}) + \nu(fQ_A).$$

Inject this equality in the bound (A.14) to find:

$$\begin{aligned} & \log \mathbb{E}_{x_0}^Y \left[\exp \left[\int_0^{T_0} \left\{ \phi(t, Y_t) - Q_A(Y_t) \right\} dt \right] \right] \\ & \leq -\log \nu(x_0) + \log \int_0^{T_0} \sup_{f \geq 0: \nu(f\mathbf{1}_A)=1} \left\{ \nu(f\psi(t, \cdot)) - D(f^{1/2}) \right\}, \end{aligned}$$

which is Lemma A.2 for $\psi \leftarrow N\psi$, $A = N\mathcal{E}_r(d)$ and with a dynamics accelerated by N^2 . \square

A.3 Equilibrium estimates at the pole

In this section, we investigate the equilibrium measure μ_ℓ (see (6.73)) of the zero-range process at the poles. We prove:

Proposition A.3. *The surface tension of the contour model around the pole is given by*

$$\mathfrak{t}_\beta(P) = -\lim_{\ell \rightarrow \infty} \frac{1}{\beta\ell} \log \mathcal{Z}_\ell = 1 + \frac{1}{\beta} \log(1 - e^{-\beta}). \quad (\text{A.16})$$

Moreover, the sequence $(\mu_\ell)_\ell$ satisfies a large deviation principle for the top height of a path (equivalently: the number of particles or of antiparticles) with good, convex rate function given by:

$$\forall u \geq 0, \quad C(u) = 2\beta u - 2u \log(1 + 1/(2u)) - \log(1 + 2u) - \log(1 - e^{-\beta}). \quad (\text{A.17})$$

In particular, recalling that $\ell_{\min}(k) := (1/2)k^{1/2}/\log k$:

$$\lim_{k \rightarrow \infty} \sup_{\ell_{\min}(k) \leq \ell \leq k} \mathbb{E}_{\mu_\ell}[\phi] = 0, \quad \phi = \mathbf{1}_{p=2} - e^{-\beta}. \quad (\text{A.18})$$

Proof. We speak alternately of paths or of particle/antiparticle configurations in the proof depending on what is easier to use, the height of a path corresponding to $\sum_{x \leq L_1} \eta_x = -\sum_{x > L_1} \eta_x$.

Fix $\ell_{\min}(k) \leq \ell \leq k$ throughout. Let us first study the probability to observe a given height under μ_ℓ . There are exactly $\binom{2q+\ell-2}{2q}$ configurations with height $q \in \mathbb{N}$. To see it, notice that this is the number of north-east path of length $2q + \ell - 2$ with $2q$ vertical edges. To each such path ρ , one can associate a unique up-down path of length $2q + \ell$ as follows (see also Figure 13)

- Travelling on the path ρ from its origin, stop at the first point X at height q and cut the path there, in two parts $\rho_{\leq X}$ and $\rho_{> X}$.
- Add two horizontal edges to $\rho_{\leq X}$ immediately after X , call ρ_{X+2} the resulting path.
- Change $\rho_{> X}$ into its symmetrical $\tilde{\rho}_{> X}$ with respect to the horizontal, i.e. change every upwards edge into a downwards one, leaving the horizontal edges unchanged. Stitch the last edge of ρ_{X+2} to the first of $\tilde{\rho}_{> X}$ to obtain an up-down path of height q and length $2q + \ell$.

One easily checks that this mapping is a bijection, whence:

$$\forall q \leq h_{\max}(k) = k(1 + \log k), \quad \mu_\ell \left(\sum_{j \leq L_1} \eta_j = q \right) = \binom{2q + \ell - 2}{2q} e^{-2\beta q - \beta \ell} / \mathcal{Z}_\ell. \quad (\text{A.19})$$

Let us investigate the dependence of this quantity in $q < h_{\max}(k)$:

$$\mu_\ell \left(\sum_{j \leq L_1} \eta_j = q + 1 \right) / \mu_\ell \left(\sum_{j \leq L_1} \eta_j = q \right) = e^{-2\beta} \frac{(2q + \ell)(2q + \ell - 1)}{(2q + 2)(2q + 1)}. \quad (\text{A.20})$$

This quantity increases until some value q_c of q , given by

$$q_c = \frac{1}{2}(e^\beta - 1)^{-1} \ell + o(\ell) =: u_c \ell + o(\ell). \quad (\text{A.21})$$

In particular, due to the logarithm in (A.16), only the maximum value of $\binom{2q + \ell - 2}{2q} e^{-2\beta q - \beta \ell}$ will matter to compute the surface tension $\mathfrak{t}_\beta(P)$. One thus needs only consider heights of order ℓ in the large ℓ limit. For fixed $u > 0$, elementary computations give:

$$\frac{1}{\ell} \log \left[\binom{2\lfloor \ell u \rfloor + \ell - 2}{2\lfloor \ell u \rfloor} e^{-2\beta \lfloor \ell u \rfloor - \beta \ell} \right] = -\beta - 2\beta u + 2u \log(1 + 1/(2u)) + \log(1 + 2u) + o_\ell(1). \quad (\text{A.22})$$

Define the function $D(\cdot)$ on \mathbb{R}_+^* by;

$$\forall u \geq 0, \quad D(u) = \beta + 2\beta u - 2u \log(1 + 1/(2u)) - \log(1 + 2u) \geq 0. \quad (\text{A.23})$$

From (A.22) and with $u_c = \frac{1}{2}(e^\beta - 1)^{-1}$, we obtain for the surface tension $\mathfrak{t}_\beta(P)$:

$$\mathfrak{t}(P) = \lim_{\ell \rightarrow \infty} \frac{1}{\beta \ell} \log \mathcal{Z}_\ell = \frac{D(u_c)}{\beta} = 1 + \frac{1}{\beta} \log(1 - e^{-\beta}). \quad (\text{A.24})$$

We now turn to the large deviation principle for the height of a path. From (A.22) and (A.24), we obtain

$$\frac{1}{\ell} \log \mu_\ell \left(\sum_{j \leq L_1} \eta_j = \lfloor \ell u \rfloor \right) = -(D(u) - D(u_c)) + o_\ell(1), \quad (\text{A.25})$$

Define the rate function $C(\cdot)$ on \mathbb{R}_+^* by

$$\forall u \geq 0, \quad C(u) = D(u) - D(u_c) \geq 0. \quad (\text{A.26})$$

The function C is C^∞ on \mathbb{R}_+^* , and satisfies:

$$C(u_c) = 0 = C'(u_c), \quad C''(u) = \frac{2}{u + 2u^2} > 0 \text{ for each } u > 0,$$

so that C is strictly convex, and a good rate function. The large deviation principle follows from (A.25).

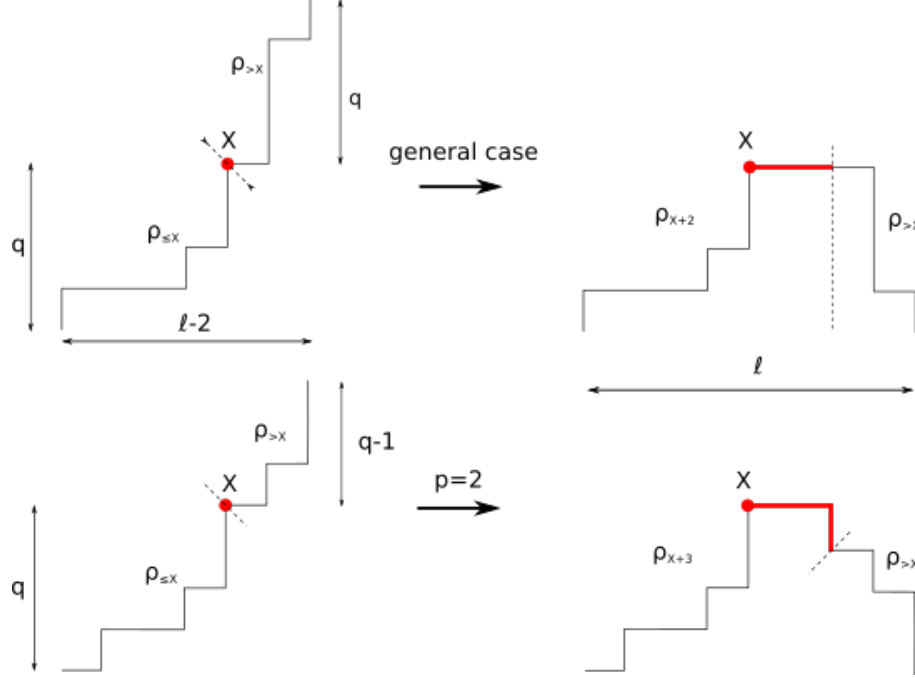

Figure 13 – Bijection argument to count the number of paths with length ℓ and height q (top figure), and with additionally $p = 2$ (bottom figure). Dashed lines delimit portions of the paths, the red dot is the place at which the initial north-east path is split, and the red, thick lines on the right-hand side are the edges added to the initial path to obtain an up-down configuration with height q and length $\ell + 2q$.

It remains to prove (A.18). This follows from the large deviations principle (A.25) and the following observation. Constructing a path with $p = 2$ and height $q \in \mathbb{N}^*$ is done by building a north-east path of length $2q - 1 + \ell - 2$ with $2q - 1$ vertical edges, then cutting it as described previously and taking the symmetric part of the path after the first point X at height q . The only difference is that one now sticks not just two horizontal edges after X , but two horizontal edges followed by a vertical one hanging from below, before stitching back the two parts of the path (see Figure 13). There are thus $\binom{2q+\ell-3}{2q-1}$ configurations with $p = 2$ and height $q \in \mathbb{N}^*$, and:

$$\mu_\ell\left(p = 2, \sum_{j \leq L_1} \eta_j = q\right) = z_\ell^{-1} e^{-\beta\ell - 2\beta q} \binom{2q + \ell - 3}{2q - 1} = \frac{2q}{2q + \ell - 2} \mu_\ell\left(\sum_{j \leq L_1} \eta_j = q\right). \quad (\text{A.27})$$

From (A.27), using $(\ell + 1)\rho^\ell = 2 \sum_{j \leq L_1} \eta_j$, the expectation in (A.18) for each $\ell \in \{\ell_{\min}(k), \dots, k\}$ reads, with $\ell_{\min}(k) = (1/2)k^{1/2}/\log k$:

$$\mathbb{E}_{\mu_\ell}[\phi] = -e^{-\beta} + \sum_{q \geq 1} \mu_\ell\left(p = 2, \sum_{j \leq L_1} \eta_j = q\right) \stackrel{(\text{A.27})}{=} \mathbb{E}_{\mu_\ell} \left[\frac{2 \sum_{j \leq L_1} \eta_j}{2 \sum_{j \leq L_1} \eta_j + \ell - 2} - e^{-\beta} \right]. \quad (\text{A.28})$$

Let $\zeta > 0$. The integrand in (A.28) is bounded and, for all ℓ large enough,

$$\frac{1}{\ell} \log \mu_\ell \left(\frac{1}{\ell} \sum_{j \leq L_1} \eta_j \notin [u_c - \zeta, u_c + \zeta] \right) \leq -C(u_c + \zeta)/2 < 0. \quad (\text{A.29})$$

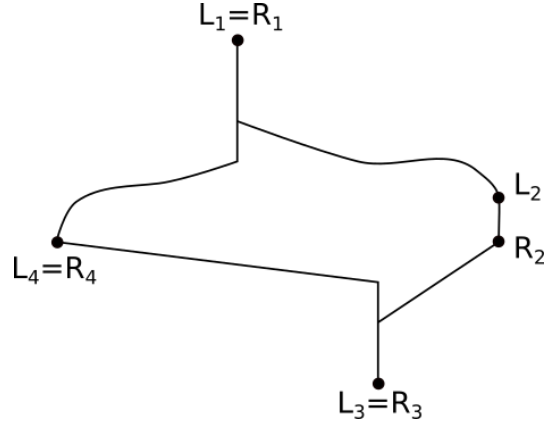

Figure 14 – Example of a droplet in \mathcal{E}_r . Though microscopic curves are Jordan curves, their limits in Hausdorff distance may have self-intersections. Taking curves in \mathcal{E}_r ensures that these self-intersections only occur at the pole, this is condition 5 in Definition B.1 below.

As a result, since $2u_c/(2u_c + 1) = e^{-\beta}$, the expectation in (A.28) is recast as follows:

$$\begin{aligned} \mathbb{E}_{\mu_\ell}[\phi] &= \mathbb{E}_{\mu_\ell} \left[\left(\frac{2^{\ell-1} \sum_{j \leq L_1} \eta_j}{2^{\ell-1} \sum_{j \leq L_1} \eta_j + 1} - e^{-\beta} \right) \mathbf{1}_{u_c - \zeta \leq \ell^{-1} \sum_{j \leq L_1} \eta_j \leq u_c + \zeta} \right] + O(\ell^{-1}) \\ &= O(\zeta) + O(\ell^{-1}). \end{aligned}$$

The $O(\zeta)$ is independent of ℓ , which proves (A.18). □

B Topology results

At the microscopic level, curves are defined in terms of their poles and four monotonous paths, one on each quadrant. The position of the poles in particular plays a big role in the dynamics and appears in the large deviations functional, see Section 4. At the macroscopic level however, the decomposition in poles and quadrants is not very convenient to work with, see Figure 14, as we need to deal with droplets with complicated boundaries. In this section, we define a suitable effective state space and a good topology on trajectories, at the cost of model-specific considerations. Exponential tightness of the laws of the contour dynamics is also shown in Appendix B.3.

B.1 Definition of \mathcal{E}_r and topological properties

In this section, we define the effective state space \mathcal{E}_r , prove that it is closed in Hausdorff topology and establish some topological facts used in the body of the article. Recall that X is the set of non-empty compact and connected subsets of $[-1, 1]^2$. This set is compact for the topology associated with the Hausdorff distance $d_{\mathcal{H}}$.

Definition B.1. For $r > 0$, define the space $\mathcal{E}_r \subset X$ as follows. The first three points mirror the conditions placed on elements of X_r^N .

1. (Four poles). *If R is the rectangle with least area containing Γ , then $R \cap \partial\Gamma$ is composed of at most four segments $[L_k, R_k]$, $k \in \{1, \dots, 4\}$, one on each side of R . These segments are not necessarily disjoint and possibly reduced to a point. Fix $[L_1, R_1]$ to be the segment with highest ordinate and call it the north pole. The others are respectively the east, south and west poles, where by convention $\partial\Gamma$ is travelled on clockwise. Define then the first quadrant as the quarter-space delimited by the vertical axis passing through $L_1(\Gamma)$, and the horizontal axis through $R_2(\Gamma)$. The other quadrants are defined similarly; note that they can intersect (see Figure 4.1).*
2. (Monotonicity condition). *The boundary of Γ between L_k and R_{k+1} can be described as the graph of a 1-Lipschitz function in the reference frame $\mathcal{R}_k = (O, e_{\pi/4-k\pi/2}, e_{\pi/4-(k-1)\pi/2})$ (if $k = 4$, $\mathcal{R}_{k+1} := \mathcal{R}_1$).*
3. (The droplet is not reduced to a point). *One has $y_{\max} - y_{\min} \geq r$, $x_{\max} - x_{\min} \geq r$, where these quantities respectively denote the highest/lowest ordinate/abscissa of points in Γ .*

The last two conditions respectively ensure room in each quadrant by removing droplets that have two different poles that coalesce, and exclude droplets with self-intersections in their bulk (recall Figure 4.4).

4. (Distinguishable poles). *For each $k \in \{1, \dots, 4\}$:*

$$|(L_k - R_{k+1}) \cdot e_1| \geq r, \quad |(L_k - R_{k+1}) \cdot e_2| \geq r. \quad (\text{B.1})$$

5. (Simple boundary away from the poles). *Any two points of the boundary that are not in a pole and belong to opposite quadrants (i.e. quadrants 1 and 3 or 2 and 4) are at 1-distance at least r .*

Remark B.2. • Note that condition 4 is redundant with condition 3. We keep both, however, as they have very different interpretations from the point of view of the dynamics.

- One can convince oneself by geometrical considerations that condition 5 ensures droplets have volume at least $(r\sqrt{2})^2/4 = r^2/2$. In fact, if $\Gamma \in \mathcal{E}_r$ and $x \in \partial\Gamma$ is e.g. in the first quadrant and satisfies $x \cdot e_1 \geq L_1(\Gamma) \cdot e_1 + r$ and $x \cdot e_2 \geq R_2(\Gamma_1) \cdot e_2 + r$ (a neighbourhood around x intersects neither quadrant 2 nor 4), then (see Figure 15):

$$|B_1(x, r) \cap \Gamma| \geq \frac{r^2}{2}, \quad B_1(x, r) = \{y \in \mathbb{R}^2 : \|y - x\|_1 < r\}. \quad (\text{B.2})$$

■

Lemma B.3. *Conditions 1 and 2 on the one hand, and conditions 1 and 2 with any condition from 3 to 5 in Definition B.1 on the other hand define a closed subset of X . As a result, the set \mathcal{E}_r is closed for the Hausdorff topology, hence compact.*

Proof. Let $\Gamma^n \in \mathcal{E}_r, n \in \mathbb{N}$ converge in Hausdorff distance to $\Gamma \in X$. The first three items boil down to the fact that $y_{\max}, x_{\max}, y_{\min}$ and x_{\min} are continuous in Hausdorff distance; as well as the observation that a uniform limit of 1-Lipschitz functions is 1-Lipschitz.

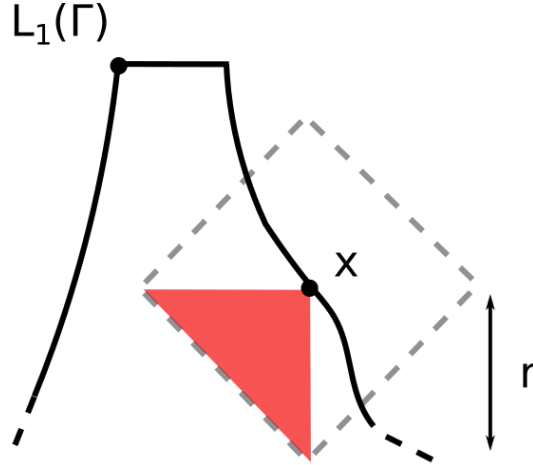

Figure 15 – For a point x of the boundary of a droplet $\Gamma \in \mathcal{E}_r$ that is at vertical and horizontal distance at least r from the pole, at least one fourth of the ball $B_1(x, r)$ is contained in Γ (shaded area).

4. (*Distinguishable poles*). Let us prove the result for the first quadrant, the others are similar. By continuity of y_{\max} , all limit points of $(L_1(\Gamma^n))$ are inside $P_1(\Gamma)$, i.e. to the right of $L_1(\Gamma)$. By continuity of x_{\max} , $(R_2(\Gamma^n) \cdot e_1) = (x_{\max}(\Gamma^n))$ converges to $R_2(\Gamma) \cdot e_1$. The function $\Gamma' \mapsto [R_2(\Gamma') - L_1(\Gamma')] \cdot e_1$ is thus upper semi-continuous, i.e. "quadrants grow in the limit", which is the desired result. The same is true of $\Gamma' \mapsto [L_1(\Gamma') - R_2(\Gamma')] \cdot e_2$.
5. (*Simple boundary away from the poles*). For definiteness, take a point x of $\partial\Gamma$ in the first quadrant and assume $x \notin P_1 \cup P_2$, i.e. $x \cdot e_2 < y_{\max}(\Gamma)$ and $x \cdot e_1 < x_{\max}(\Gamma)$. Take also y in $C_3(\Gamma) \cap \partial\Gamma \setminus (P_3 \cup P_4)$. For n large enough, x, y cannot be in a pole of Γ^n by continuity of $y_{\max}, \dots, x_{\min}$.
By upper semi-continuity of the size of quadrants for the inclusion (see item 4), $d(x, C_1(\Gamma^n) \setminus P^n)$ and $d(y, C_3(\Gamma^n) \setminus P^n)$ vanish for large n , thus:

$$d(x, y) \geq d(C_1(\Gamma^n) \setminus P^n, C_3(\Gamma^n) \setminus P^n) - d(x, C_1(\Gamma^n) \setminus P^n) - d(y, C_3(\Gamma^n) \setminus P^n) \geq r + o_n(1).$$

□

Recall from Definition 2.1 that for $d > 0$, $\mathcal{E}_r(d) \subset \mathcal{E}_r$ is composed of droplets at 1-distance at least d from the domain boundaries $\partial([-1, 1]^2)$. By continuity of $y_{\max}, \dots, x_{\min}$, this set is also compact in Hausdorff topology.

Elements of \mathcal{E}_r have very constrained boundaries. A difference in Hausdorff distance between two sets translates into a difference in volume or in the position of the poles. The following two lemmas give explicit control of the Hausdorff distance that are useful in Section B.2.

Definition B.4. For $k \in \{1, \dots, 4\}$, define $z_k, w_k : \mathcal{E}_r \rightarrow \mathbb{R}$ as the coordinates of the left-most point L_k of pole k of a droplet:

$$z_1 = y_{\max}, \quad z_2 = x_{\max}, \quad z_3 = y_{\min}, \quad z_4 = x_{\min}$$

and the w_k are the other four coordinates. A droplet $\Gamma \in \mathcal{E}_r$ can be described in terms of the position $(z_k, w_k)_{k \in \{1, \dots, 4\}}$ of its four poles, and the largest droplet $\Gamma' \subset \Gamma$ with simple boundary such that $\Gamma = \Gamma'$ up to a set of volume 0. In other words, Γ' is the closure of the interior of Γ . Define:

$$\mathcal{F}_r = \{\Gamma' : \Gamma \in \mathcal{E}_r\}.$$

One can check that \mathcal{F}_r satisfies items 1, 2, 3 and 5 in Definition B.1.

Lemma B.5. *Let $\Gamma_1, \Gamma_2 \in \mathcal{E}_r$. Let $k \in \{1, \dots, 4\}$. Then:*

$$d_{\mathcal{H}}(\Gamma_1, \Gamma_2) \geq |z_k(\Gamma_1) - z_k(\Gamma_2)|.$$

Moreover, if $\alpha > 0$ and $q > 1/\alpha$,

$$\begin{cases} |w_k(\Gamma_1) - w_k(\Gamma_2)| \geq \alpha \\ \forall i \in \{1, 2\}, \quad |z_k(\Gamma_i) - z_k(\Gamma'_i)| \geq 1/q \end{cases} \Rightarrow d_{\mathcal{H}}(\Gamma_1, \Gamma_2) \geq 1/q. \quad (\text{B.3})$$

Proof. Fix $k = 1$ for definiteness. Only (B.3) requires a proof. Assume its left-hand side holds and, without loss of generality, take $k = 1$ and assume that $y_{\max}(\Gamma_1) \geq y_{\max}(\Gamma_2)$. Then both droplets have a line of length at least $1/q$ below their north pole. These lines have abscissas differing at least by $\alpha > 1/q$, which means a fortiori that they are at 1-distance at least $1/q$. Consequently, if $\varepsilon \in (0, 1/q)$, $\text{dist}_1(P_1(\Gamma_1), (\Gamma_2)^{(1/q-\varepsilon)}) > 0$, where $\Gamma_i^{(\varepsilon)}$ is the ε -fattening of Γ_i for $i \in \{1, 2\}$:

$$\Gamma_i^{(\varepsilon)} = \bigcup_{x \in \Gamma_i} B_1(x, \varepsilon), \quad B_1(x, \varepsilon) = \{y \in \mathbb{R}^2 : \|y - x\|_1 < \varepsilon\} \text{ for } x \in \mathbb{R}^2.$$

This implies $d_{\mathcal{H}}(\Gamma_1, \Gamma_2) \geq 1/q - \varepsilon$ and the result. \square

The next lemma gives some sort of a converse statement.

Lemma B.6. *Let $\Gamma_1, \Gamma_2 \in \mathcal{E}_r$ and $\varepsilon \in (0, r)$. Then:*

$$d_{\mathcal{H}}(\Gamma_1, \Gamma_2) \geq \varepsilon \Rightarrow d^{L^1}(\Gamma_1, \Gamma_2) \geq \varepsilon^2/8 \quad \text{or} \\ \max_{1 \leq k, \ell \leq 4} \{\|L_k(\Gamma_1) - L_k(\Gamma_2)\|_1, \|R_\ell(\Gamma_1) - R_\ell(\Gamma_2)\|_1\} \geq \varepsilon/2.$$

Proof. Without loss of generality, assume that $a := d_{\mathcal{H}}(\Gamma_1, \Gamma_2) = \sup_{x \in \Gamma_1} \text{dist}_1(x, \Gamma_2)$, and let $x \in \partial\Gamma_1$ realise that supremum: x is at least as far away from Γ_2 in 1-distance as any other point of Γ_1 , and no point of Γ_2 is at 1-distance strictly less than a from x .

There are two cases to consider: either x is close to a pole and the ball $B_1(x, a) \cap \Gamma_1$ has a small volume, or x is sufficiently far from the poles to ensure that $B_1(x, a) \cap \Gamma_1$ is of order a^2 . The latter will lead to a difference in volume between Γ_1 and Γ_2 , while the former implies that poles cannot be too close. It is convenient to slightly reformulate this dichotomy.

- Suppose Γ_1 has a non-simple boundary, i.e. $\Gamma_1 \neq \Gamma'_1$ with Γ'_1 as in Definition B.4. Suppose further that $x \notin \Gamma'_1$. Then, by definition of \mathcal{E}_r , Γ_1 has at least one pole, say pole $k \in \{1, \dots, 4\}$, that is point-like. By definition of x , $x = L_k(\Gamma_1)$ ($= R_k(\Gamma_1)$). In particular, $L_k(\Gamma_2)$ is a distance at least a from x :

$$\|L_k(\Gamma_1) - L_k(\Gamma_2)\|_1 \geq a.$$

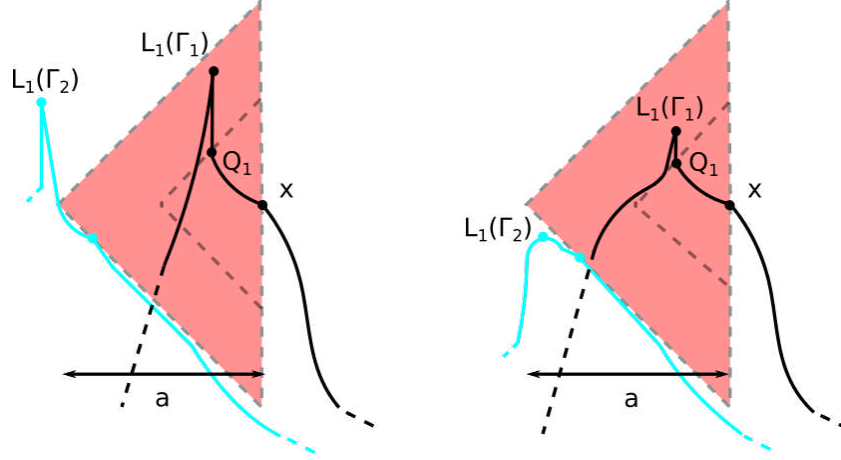

Figure 16 – An example where $[x - L_1(\Gamma_1)] \cdot e_1 \leq a/2 \wedge r$ with $a/2 \leq r$. The shaded area delimited by light dashed lines is the left half of $B_1(x, a)$. The darker dashed lines mark the left half of $B_1(x, a/2)$. $\partial\Gamma_1$ is in solid black lines, $\partial\Gamma_2$ in solid light lines. Left figure: $L_2(\Gamma_1)$ is left of $B_1(x, a)$, hence $[L_1(\Gamma_1) - L_1(\Gamma_2)] \cdot e_1 \geq a/2$. Right figure: $L_2(\Gamma_1)$ is below $B_1(x, a)$, hence $\|L_1(\Gamma_1) - L_1(\Gamma_2)\|_1 \geq \|Q_1 - L_1(\Gamma_2)\|_1 \geq a/2$.

- Assume now that $\Gamma_1 = \Gamma'_1$, or that $\Gamma_1 \neq \Gamma'_1$ and $x \in \Gamma'_1$. Without loss of generality, take x in the first quadrant of Γ_1 . By definition of x and the monotonicity condition on elements of \mathcal{E}_r , any point of Γ_2 at 1-distance a from x must be in quadrant 1 of Γ_2 (including poles 1 and 2).

Suppose first that $[x - L_1(\Gamma_1)] \cdot e_1 > a/2 \wedge r$ and $[x - L_2(\Gamma_1)] \cdot e_2 > a/2 \wedge r$, i.e. the ball $B_1(x, a/2 \wedge r) \cap \partial\Gamma_1$ only contains points to the right of $L_1(\Gamma_1)$ and above $L_2(\Gamma_1)$. Then, by Remark (B.2),

$$|B_1(x, a/2 \wedge r) \cap \Gamma_1| \geq \frac{1}{2}(a/2 \wedge r)^2 \quad \Rightarrow \quad |B_1(x, a) \cap \Gamma_1| \geq \frac{1}{2}(a/2 \wedge r)^2.$$

Suppose instead that $[x - L_1(\Gamma_1)] \cdot e_1 \leq a/2 \wedge r$: x is close to the left extremity of the first quadrant. Let us prove that, necessarily, $L_1(\Gamma_1)$ and $L_1(\Gamma_2)$ are then at 1-distance at least $a/2 \wedge r$.

Define Q_1 as the highest point of $\partial\Gamma'_1$ (defined in Definition B.4) with abscissa $L_1(\Gamma_1) \cdot e_1$ and intersecting the boundary of $B_1(x, a/2)$, see Figure 16. As $\Gamma_2 \cap B_1(x, a) = \emptyset$ by definition of x , $L_1(\Gamma_2)$ must be either to the left of $B_1(x, a)$, or below it. If it is to the left, then the abscissas of $L_1(\Gamma_1)$ and of $L_2(\Gamma_1)$ must differ by at least $a/2 \wedge r$, i.e.: $[L_1(\Gamma_1) - L_2(\Gamma_1)] \cdot e_1 \geq a/2 \wedge r$. If it is below $B_1(x, a)$, then $\|Q_1 - L_1(\Gamma_2)\|_1 \geq a/2 \wedge r$, which by definition of Q_1 implies $\|L_1(\Gamma_1) - L_1(\Gamma_2)\|_1 \geq a/2 \wedge r$. Both cases are illustrated on Figure 16; they both yield:

$$\|L_1(\Gamma_1) - L_1(\Gamma_2)\|_1 \geq a/2 \wedge r.$$

Condition $[x - L_2(\Gamma_1)] \cdot e_2 \leq a/2 \wedge r$ is treated similarly, this time with $R_2(\Gamma_1), R_2(\Gamma_2)$, thus:

$$\max \{ \|L_1(\Gamma_1) - L_1(\Gamma_2)\|_1, \|R_2(\Gamma_1) - R_2(\Gamma_2)\|_1 \} \geq a/2 \wedge r.$$

□

B.2 The set $E([0, T_0], \mathcal{E}_r(d))$

For $T_0 > 0$, the set $E([0, T_0], \mathcal{E}_r(d))$ was defined in Section 2.3 as the completion of $D_{\mathcal{H}}([0, T_0], \mathcal{E}_r(d))$ for the distance d_E (see (B.4)), where $D_{\mathcal{H}}([0, T_0], \mathcal{E}_r(d))$ is the set of $\mathcal{E}_r(d)$ -valued trajectories that are càdlàg in Hausdorff distance $d_{\mathcal{H}}$. The distance d_E was defined as:

$$d_E = d_S^{L^1} + \int_0^{T_0} d_{\mathcal{H}} dt, \quad (\text{B.4})$$

with $d_S^{L^1}$ the Skorokhod distance associated with convergence in the $L^1([-1, 1]^2)$ topology. This topology is metricised by the distance d^{L^1} , defined on the set X of non-empty compact subsets of $[-1, 1]^2$ by:

$$\forall \Gamma, \Gamma' \in X, \quad d^{L^1}(\Gamma, \Gamma') = \int_{[-1, 1]^2} |\mathbf{1}_{\Gamma} - \mathbf{1}_{\Gamma'}| dx. \quad (\text{B.5})$$

For properties of the Skorokhod topology, we refer the reader to [EK09].

In this section, we study $(E([0, T_0], \mathcal{E}_r(d)), d_E)$ for $d \geq 0$. The case $d = 0$ corresponds to $E([0, T_0], \mathcal{E}_r)$. We prove separability, completeness and characterise its relatively compact subsets. The starting point is the following explicit characterisation of $E([0, T_0], \mathcal{E}_r(d))$. Recall from Definition B.4 that $\mathcal{F}_r \subset X$ is the set of droplets with simple boundary, that can be obtained by removing all portions of volume 0 from a droplet in \mathcal{E}_r . Then:

$$E([0, T_0], \mathcal{E}_r(d)) = \left\{ \Gamma \in D_{L^1}([0, T_0], \mathcal{F}_r) : \text{for a.e. } t \in [0, T_0], \Gamma_t \in \mathcal{E}_r(d) \right\}, \quad (\text{B.6})$$

where $\mathcal{E}_r(d) \subset \mathcal{E}_r$ is the set of droplets at 1-distance at least d from the domain boundaries $\partial([-1, 1]^2)$.

B.2.1 Completeness and separability of $E([0, T_0], \mathcal{E}_r(d))$

In this section, we prove that $E([0, T_0], \mathcal{E}_r(d))$ as defined in (B.6) is separable, and that it is indeed the completion, for the distance d_E , of the set $D_{\mathcal{H}}([0, T_0], \mathcal{E}_r(d))$ of $\mathcal{E}_r(d)$ -valued Hausdorff-càdlàg trajectories. Let us first prove that $(E([0, T_0], \mathcal{E}_r(d)), d_E)$ is complete.

Lemma B.7. *The space $(E([0, T_0], \mathcal{E}_r(d)), d_E)$ is complete.*

Proof. Consider a Cauchy sequence $\Gamma_n \in E([0, T_0], \mathcal{E}_r(d))$, $n \in \mathbb{N}$ for d_E . It is a Cauchy sequence for $d_S^{L^1}$ in $D_{L^1}([0, T_0], \mathcal{F}_r)$. The set \mathcal{F}_r is closed, in L^1 topology, in the set of non-empty droplets with measure-theoretic perimeter bounded by 8. This set is compact, assimilating droplets to BV functions with bounded measure-theoretic perimeter, see Theorem 5.5 in [EG15]. There is thus a trajectory Γ^0 in $D_{L^1}([0, T_0], \mathcal{F}_r)$ with $d_S^{L^1}$ distance to Γ_n vanishing with n . More precisely, consider the sequence (Γ'_n) constructed from (Γ_n) as in Definition B.4. As $\Gamma_n(t)$ and $\Gamma'_n(t)$ are equal almost everywhere in \mathbb{R}^2 for each $t \in [0, T_0]$ and each n , (Γ'_n) converges in $D_{L^1}([0, T_0], \mathcal{F}_r)$ to a limit $\Gamma'_\infty = \Gamma^0$.

Γ'_∞ corresponds to the limiting trajectory of the "bulk" of the Γ_n , i.e. without the poles. We still need to figure out what the limiting poles should be, which we do using the $\int_0^{T_0} d_{\mathcal{H}} dt$ part of d_E .

Recall the definitions of z_k, w_k from Definition B.4. For each $k \in \{1, \dots, 4\}$, $(z_k(\Gamma_n))$ is a Cauchy sequence in $L^1([0, T_0], [-1+d, 1-d])$. It thus converges to some limit $z_k^\infty \in L^1([0, T_0], [-1+d, 1-d])$. Moreover, for each n , $z_k(\Gamma_n(t)) \geq z_k(\Gamma'_n(t))$ almost surely and, by convergence in $d_S^{L^1}$ of Γ'_n to Γ'_∞ ,

$$\liminf_{n \rightarrow \infty} z_{1,2}(\Gamma'_n) \geq z_{1,2}(\Gamma'_\infty), \quad \limsup_{n \rightarrow \infty} z_{3,4}(\Gamma'_n) \leq z_{3,4}(\Gamma'_\infty) \quad \text{almost surely.}$$

As a result, $z_{1,2}^\infty(t) \geq z_{1,2}(\Gamma'_\infty(t))$ and $z_{3,4}^\infty(t) \leq z_{3,4}(\Gamma'_\infty(t))$ for almost every $t \in [0, T_0]$, as desired since the z_k are supposed to play the role of the extremal coordinates of the "real" limiting trajectory of the sequence $(\Gamma_n)_n$.

It remains to control the w_k , defined in Definition B.4. Indeed, at present, if on some subset $U \subset [0, T_0]$ of strictly positive measure Γ'_∞ has a flat pole k for some $k \in \{1, \dots, 4\}$, and if $z_k > z_k(\Gamma'_\infty)$ for almost every time in U , then we need to determine where on this flat zone we should add the line $[z_k(\Gamma'_\infty), z_k]$ to construct a limiting trajectory Γ_∞ for d_E .

For $k \in \{1, \dots, 4\}$, define $I_k \subset [0, T_0]$ as the set of times t for which pole k of $\Gamma'_\infty(t)$ is extended, i.e. $|P_k(\Gamma'_\infty(t))| > 0$. If $t \notin I_k$, then there is exactly one point at which the change of monotonicity at pole k in the boundary of $\Gamma'_\infty(t)$ occurs. This means that $w_k(\Gamma_n(t))$ converges to $w_k(\Gamma'_\infty(t))$ for almost every $t \notin I_k$.

To deal with what happens inside I_k , take $k = 1$ for simplicity, so that $z_1 = y_{\max}$. Split I_1 into $J_0 \cup J_>$, where J_0 is the largest subset of I_1 such that $z_1^\infty = y_{\max}(\Gamma'_\infty)$ a.s.. $J_>$ is the largest subset of I_1 on which $z_1^\infty > y_{\max}(\Gamma'_\infty)$ a.s.. For $t \in J_0$, we need not ask where the north pole should be located, since it coincides with the north pole of $\Gamma'_\infty(t)$ almost surely. The set $J_>$ instead requires more work.

Fix $\varepsilon > 0$. For all n, p large enough in terms of ε , the Cauchy condition implies:

$$\int_0^{T_0} \mathbf{1}_{J_>} d_{\mathcal{H}}(\Gamma_n(t), \Gamma_p(t)) dt \leq \varepsilon. \quad (\text{B.7})$$

As $\mathbf{1}_{z_1^\infty \geq y_{\max}(\Gamma'_\infty) + 1/q}$ converges pointwise to $\mathbf{1}_{z_1^\infty > y_{\max}(\Gamma'_\infty)}$ for large q , the integral in (B.7) can be made to bear only on times where z_1^∞ is at least $1/q$ above $z_1(\Gamma'_\infty)$ almost surely. Call $J_>^q \subset J_>$ the largest subset for which this holds. By the monotone convergence theorem, for each $\delta > 0$ and q larger than some $q(\delta)$:

$$\int_0^{T_0} \mathbf{1}_{J_>^q} d_{\mathcal{H}}(\Gamma_n(t), \Gamma_p(t)) dt \leq \varepsilon \quad \text{and} \quad |J_>^q| - |J_>| \leq \delta. \quad (\text{B.8})$$

Fix $\delta > 0$ and such a q . By definition of z_1^∞ , for all n larger than some $n(q)$, $y_{\max}(\Gamma_n(t)) \geq y_{\max}(\Gamma'_\infty(t)) + 1/(2q)$ for almost every $t \in J_>^q$. Impose also that $y_{\max}(\Gamma_n(t)) > y_{\max}(\Gamma'_n(t)) + 1/(2q)$ a.e. in $J_>^q$.

Invoking Lemma B.5 yields that, for each $\alpha > 0$, up to increasing q and $n(q)$, for each $n, p \geq n(q)$,

$$\int_0^{T_0} \mathbf{1}_{J_>^q} \mathbf{1}_{|w_1(\Gamma_n(t)) - w_1(\Gamma_p(t))| \geq \alpha} \leq q \int_0^{T_0} d_{\mathcal{H}}(\Gamma_n(t), \Gamma_p(t)) dt \leq 2q\varepsilon.$$

Summarising, for each $\delta > 0$, choosing α such that $2\alpha T_0 \leq \delta/3$, $q > \alpha^{-1}$ such that $|J_>| - |J_>^q| \leq \delta/3$ and ε to have $4\varepsilon q \leq \delta/3$; one has for all n, p large enough:

$$\int_0^{T_0} \mathbf{1}_{J_>} |w_1(\Gamma_n(t)) - w_1(\Gamma_p(t))| dt \leq \delta.$$

Define \tilde{w}_n to be $w_1(\Gamma_n)$ on $J_>$, 0 elsewhere. Then (\tilde{w}_n) is a Cauchy sequence in $L^1([0, T_0], [-1 + d, 1 - d])$, hence converges to some \tilde{w}_∞ and we can define:

$$\text{for almost every } t \in [0, T_0], \quad w_1^\infty(t) = \begin{cases} \tilde{w}_\infty(t) & \text{if } t \in J_> \\ L_1(\Gamma'_\infty(t)) \cdot e_1 & \text{otherwise.} \end{cases} \quad (\text{B.9})$$

Functions $w_2^\infty, w_3^\infty, w_4^\infty$ are defined similarly for the other poles. Finally, let Γ_∞ be such that $(\Gamma_\infty)' = \Gamma_\infty$ and, for almost every $t \in [0, T_0]$:

$$\begin{aligned} \Gamma_\infty(t) = \Gamma'_\infty(t) \cup & \bigcup_{i \in \{1,3\}} \{w_i(t)e_1 + ue_2 : u \in [z_i(\Gamma'_\infty(t)), z_i(t)]\} \\ & \cup \bigcup_{i \in \{2,4\}} \{ue_1 + w_i(t)e_2 : u \in [z_i(\Gamma'_\infty(t)), z_i(t)]\}. \end{aligned} \quad (\text{B.10})$$

By construction, Γ_∞ belongs to $E([0, T_0], \mathcal{E}_r(d))$, and $\lim_{n \rightarrow \infty} d_E(\Gamma_n, \Gamma_\infty) = 0$ by Lemma B.6, which concludes the proof. \square

Characterisation (B.6) of $E([0, T_0], \mathcal{E}_r(d))$ also yields that $D_{\mathcal{H}}([0, T_0], \mathcal{E}_r(d))$, the set of Hausdorff-càdlàg $\mathcal{E}_r(d)$ -valued droplet trajectories on $[0, T_0]$, is dense in $E([0, T_0], \mathcal{E}_r(d))$ for d_E . Indeed, convergence of the volume is clear and for each $\Gamma \in E([0, T_0], \mathcal{E}_r(d))$, one can find real càdlàg functions, corresponding to the 8 coordinates of the poles, that converge in $L^1([0, T_0], [-1 + d, 1 - d])$ to the $w_k(\Gamma), z_k(\Gamma)$, $k \in \{1, \dots, 4\}$. $E([0, T_0], \mathcal{E}_r(d))$ is thus indeed the completion of $D_{\mathcal{H}}([0, T_0], \mathcal{E}_r(d))$ for d_E . As this set is separable for the Skorokhod topology associated with $d_{\mathcal{H}}$, we obtain:

Lemma B.8. *The space $(E([0, T_0], \mathcal{E}_r(d)), d_E)$ is separable.*

B.2.2 Compact sets in $E([0, T_0], \mathcal{E}_r(d))$ and exponential tightness

In the following subsection, we prove exponential tightness, for each bias $H \in \mathcal{C}$, of the laws $(Q_{r,\beta,H}^N)_N$ restricted to trajectories in $E([0, T_0], \mathcal{E}_r(d))$. To do so, we need a sufficient condition for a subset of $E([0, T_0], \mathcal{E}_r(d))$ to be compact. This is the object of this section.

Proposition B.9 (Compact sets for d_E). *The following equivalence holds:*

(i) $K \subset E([0, T_0], \mathcal{E}_r(d))$ is relatively compact for the topology induced by d_E .

(ii) If $\omega^{L^1}(\Gamma)$ is the Skorokhod modulus of continuity associated with volume convergence for a trajectory $\Gamma \in E([0, T_0], \mathcal{E}_r(d))$ (see [EK09]), then:

$$\limsup_{\eta \rightarrow 0} \sup_{h \leq \eta} \sup_{\Gamma \in K} \left\{ \omega_h^{L^1}(\Gamma) + \int_0^{T_0-h} d_{\mathcal{H}}(\Gamma_t, \Gamma_{t+h}) dt \right\} = 0. \quad (\text{B.11})$$

Proof. The proof uses notations and results from the proof of Lemma B.7. We only give details for (ii) \Rightarrow (i) as we do not need the converse implication, which follows from total boundedness of relatively compact sets and the fact that (B.11) is true for singletons thanks to Lemma B.6.

(ii) \Rightarrow (i). According to the characterisation of relatively compact sets in the Skorokhod topology in [EK09], K is relatively compact in $d_{\mathcal{S}}^{L^1}$. Take $\{\Gamma^n, n \in \mathbb{N}\} \subset K$ and let Γ'_∞ be a limit point

in $d_S^{L^1}$ of a subsequence that we still write $(\Gamma^n)_n$. As in the proof of Lemma B.7, we can take $\Gamma'_\infty \in D_{L^1}([0, T_0], \mathcal{F}_r)$ such that $\partial\Gamma'_t$ is a simple curve at all times $t \in [0, T_0]$. Recall that $\mathcal{F}_r \subset \mathcal{E}_r$ is the set of droplets for which items 1, 2, 3 and 5 in Definition B.1 hold.

Let us now prove that some subsequence of the (Γ^n) has converging z_k^n, w_k^n , writing $z_k^n = z_k(\Gamma^n)$ and similarly for w_k^n . z_k, w_k are defined in Definition B.4 and correspond to the coordinates of the left extremity L_k of pole $k \in \{1, \dots, 4\}$. The proof is very similar to that of the completeness of $E([0, T_0], \mathcal{E}_r(d))$ for d_E in Lemma B.7. There, we had for each $\varepsilon > 0$ and some $N(\varepsilon) \in \mathbb{N}$:

$$\sup_{n \geq N(\varepsilon)} \sup_{p \in \mathbb{N}} \int_0^{T_0} d_{\mathcal{H}}(\Gamma^n(t), \Gamma^{n+p}(t)) dt \leq \varepsilon.$$

Compare with:

$$\sup_{h \leq \eta} \sup_{n \in \mathbb{N}} \int_0^{T_0-h} d_{\mathcal{H}}(\Gamma^n(t), \Gamma^n(t+h)) dt \leq \varepsilon. \quad (\text{B.12})$$

Here as well, Lemma B.5 yields that (B.12) holds with $(z_k^n), (w_k^n)$ replacing $d_{\mathcal{H}}$ on $[0, T_0 - h]$. By the Kolmogorov-Riesz theorem (Theorem 4.26 in [Bre10]), this implies the relative compactness of the sequences $(z_k^n), (w_k^n)$ in $L^1([0, T_0], [-1+d, 1-d])$. A trajectory Γ_∞ to which (Γ^n) converges in d_E up to a subsequence is then built as in Lemma B.7. This concludes the proof of $(ii) \Rightarrow (i)$. \square

We now conclude the proof of tightness, and exponential tightness on trajectories restricted to $E([0, T_0], \mathcal{E}_r(d))$. This step is classical, but requires some care in our case as some estimates hold only for $\mathcal{E}_r(d)$ -valued trajectories and not on the whole state space.

Corollary B.10 (Sufficient condition for the tightness of $(Q_{r,\beta,H}^N)_N$). *Let $T_0 > 0$. Assume that, for each $H \in \mathcal{C}$,*

$$\limsup_{N \rightarrow \infty} \mathbb{P}_{r,\beta,H}^N(E([0, T_0], \mathcal{E}_r(d))^c) = o_N(1), \quad (\text{B.13})$$

so that trajectories are typically almost always in $\mathcal{E}_r(d)$ on $[0, T_0]$. Assume further that, for each $G \in C^2([-1, 1]^2)$ and each $\varepsilon > 0$,

$$\begin{aligned} \limsup_{\eta \rightarrow 0} \limsup_{N \rightarrow \infty} \frac{1}{N} \log \mathbb{P}_{r,\beta}^N \left(E([0, T_0], \mathcal{E}_r(d)), \left\{ \sup_{|s-t| \leq \eta} |\langle \Gamma_t, G \rangle - \langle \Gamma_s, G \rangle| \right. \right. \\ \left. \left. + \sup_{h \leq \eta} \sum_{k=1}^4 \int_0^{T_0-h} \left[\|L_k(\Gamma_t) - L_k(\Gamma_{t+h})\|_1 + \|R_k(\Gamma_t) - R_k(\Gamma_{t+h})\|_1 \right] dt \geq \varepsilon \right\} \right) = -\infty. \end{aligned} \quad (\text{B.14})$$

Then for each $H \in \mathcal{C}$ and $q \in \mathbb{N}^$, there are compact sets $K_q = K_q(H)$ such that:*

$$\sup_N Q_{r,\beta,H}^N((K_q)^c) \leq \frac{2}{q}, \quad \sup_N \frac{1}{N} \log Q_{r,\beta,H}^N(E([0, T_0], \mathcal{E}_r(d)) \cap (K_q)^c) \leq -q.$$

In particular, $\{Q_{r,\beta,H}^N : N \in \mathbb{N}^\}$ is relatively compact as a family of measures on trajectories up to time T_0 , and its weak limit points are supported in $E([0, T_0], \mathcal{E}_r(d))$.*

Proof. As (B.14) also holds under $\mathbb{P}_{r,\beta,H}^N$ for any $H \in \mathcal{C}$, we prove the corollary only for $H \equiv 0$. Consider a sequence $G_\ell \in C^2([-1, 1]^2)$, $\ell \geq 1$, dense for the uniform norm. According to (B.14), for each $q, n \in \mathbb{N}^*$, there is $\eta = \eta(q, \ell, n)$ and $N_0 = N_0(\eta)$ such that:

$$\begin{aligned} & \sup_{N \geq N(\eta)} \frac{1}{N} \log \mathbb{P}_{r,\beta}^N \left(E([0, T_0], \mathcal{E}_r(d)), \left\{ \sup_{|s-t| \leq \eta} |\langle \Gamma_t, G_\ell \rangle - \langle \Gamma_s, G_\ell \rangle| \right. \right. \\ & \left. \left. + \sup_{h \leq \eta} \sum_{k=1}^4 \int_0^{T_0-h} [\|L_k(\Gamma_t) - L_k(\Gamma_{t+h})\|_1 + \|R_k(\Gamma_t) - R_k(\Gamma_{t+h})\|_1] dt \geq \frac{1}{n} \right\} \right) \leq -qn\ell. \end{aligned} \quad (\text{B.15})$$

By (B.13), consider also $N_1 = N_1(q, \ell, n)$ such that:

$$\sup_{N \geq N_1} \mathbb{P}_{r,\beta}^N (E([0, T_0], \mathcal{E}_r(d))^c) \leq \frac{1}{q2^{\ell+n}}.$$

Let $N_2 = \max\{N_0, N_1\}$. For $N \leq N_2$, L_k, R_k , $k \in \{1, \dots, 4\}$ are càdlàg functions in Hausdorff distance on $N^{-1}X_r^N$. As a result, (B.15) holds for $N \leq N_2$ as well up to choosing $\eta' = \eta'(q, \ell, n) \leq \eta$, hence for all N in \mathbb{N}^* . For $G \in C^2([-1, 1]^2)$, let thus $\omega^{L^1}(\langle \Gamma, G \rangle)$ be the Skorokhod modulus of continuity associated with the trajectory $(\langle \Gamma_t, G \rangle)_t$ (see [EK09]); it satisfies:

$$\forall \theta > 0, \quad \omega_\theta^{L^1}(\langle \Gamma, G \rangle) \leq \sup_{|s-t| \leq \theta} |\langle \Gamma_t, G \rangle - \langle \Gamma_s, G \rangle|.$$

Define then $K_q = \bar{U}_q$, with U_q as follows:

$$\begin{aligned} U_q := \bigcap_{\ell, n \in \mathbb{N}^*} \left\{ \omega_{\eta'}^{L^1}(\langle \Gamma, G_\ell \rangle) + \sup_{h \leq \eta'} \sum_{k=1}^4 \int_0^{T_0-h} [\|L_k(\Gamma_t) - L_k(\Gamma_{t+h})\|_1 \right. \\ \left. + \|R_k(\Gamma_t) - R_k(\Gamma_{t+h})\|_1] dt \geq \frac{1}{n} \right\}. \end{aligned}$$

By Proposition B.9 and Lemma B.6, K_q is compact, and it satisfies by construction:

$$\sup_{N \in \mathbb{N}^*} \frac{1}{N} \log Q_{r,\beta}^N (E([0, T_0], \mathcal{E}_r(d)) \cap (K_q)^c) \leq -q.$$

This concludes the proof of exponential tightness inside $E([0, T_0], \mathcal{E}_r(d))$. Moreover, also by construction and since $e^{-Nq\ell n} \leq 2^{-\ell-n}/q$ for each $N \geq 1$,

$$\sup_N Q_{r,\beta}^N ((K_q)^c) \leq 2/q.$$

By Prohorov's theorem (Theorem 2.2. p104 in [EK09]), $(Q_{r,\beta}^N)_N$ is relatively compact, and its weak limit points are concentrated on $E([0, T_0], \mathcal{E}_r(d))$ by (B.13). This concludes the proof. \square

B.3 Proof of the sufficient condition for exponential tightness

In this section, we provide the proof of the sub-exponential estimate in Corollary B.10, i.e. the proof of (B.14). The first step is to control the volume variations of a droplet, in Section B.3.1. Next, we prove that the (time integrated) volume beneath each pole has a fixed value in terms of β , imposed by the reservoir-like behaviour of the poles. This estimate is used in Section B.3.3 to obtain a control on the motion of the poles. Parameters r, β, H are fixed throughout as in Definition 2.1.

B.3.1 Estimate in $L^1([-1, 1]^2)$ topology

In this section, we prove exponential tightness in volume, i.e. in $L^1([-1, 1]^2)$ topology, with the metric d^{L^1} defined in (B.5). Equivalently, d^{L^1} is characterised as follows.

Lemma B.11. *Let $(G_\ell)_{\ell \geq 1}$ be a family of functions of $C^2([-1, 1]^2, \mathbb{R})$, dense for the uniform sup $_{[-1, 1]^2} |\cdot|$. Then d^{L^1} is topologically equivalent to the distance \tilde{d}^{L^1} defined as follows:*

$$\forall \Gamma, \Gamma' \in X, \quad \tilde{d}^{L^1}(\Gamma, \Gamma') = \sum_{\ell \geq 1} \frac{1}{2^\ell} \frac{|\langle \Gamma, G_\ell \rangle - \langle \Gamma', G_\ell \rangle|}{1 + |\langle \Gamma, G_\ell \rangle - \langle \Gamma', G_\ell \rangle|}.$$

In the sequel, \tilde{d}^{L^1} and d^{L^1} are identified.

Lemma B.12. *Let $T_0 > 0$ and $G \in C^2([-1, 1]^2)$. Then, for each $\varepsilon > 0$:*

$$\limsup_{\delta \rightarrow 0} \limsup_{N \rightarrow \infty} \frac{1}{N} \log \mathbb{P}_{r, \beta}^N \left(\text{for a.e. } t \leq T_0, \Gamma_t \in \mathcal{E}_r; \sup_{|t-s| \leq \delta} \left| \int_{\Gamma_t} G - \int_{\Gamma_s} G \right| > \varepsilon \right) = -\infty. \quad (\text{B.16})$$

Proof. Compared to Chapter 10 in [KL99], the only subtleties to prove (B.16) are in the introduction of the condition $\{\text{for a.e. } t \leq T_0, \Gamma_t \in \mathcal{E}_r\}$ to be able to use the computations of Section 3, and in the control of the poles. As this does not present any particular difficulty, the proof is omitted. \square

B.3.2 Precise control of the slope and volume around the poles

In this section, we prove that the volume below the pole is fixed by their reservoir-like behaviour induced by the dynamics. This relies on a microscopic estimate of the slope at the pole, obtained in Section 6.2.4 in Corollary 6.11.

Lemma B.13 (Control of the deviations of the width at distance $\alpha > 0$ below the pole). *For $\alpha > 0$ and $\Gamma \in \mathcal{E}_r$, let $g^+(\alpha) = g^+(\alpha)(\Gamma)$ be the width of the horizontal segment of Γ at height $y_{\max}(\Gamma) - \alpha$ to the right of $L_1(\Gamma)$. Define similarly $g^-(\alpha)$ to the left of $L_1(\Gamma)$. For each $\delta, \eta > 0$:*

$$\limsup_{\alpha \rightarrow 0} \limsup_{N \rightarrow \infty} \frac{1}{N} \log \mathbb{P}_{r, \beta}^N \left(\text{for a.e. } t \in [0, T_0], \Gamma_t \in \mathcal{E}_r(d); \right. \\ \left. \frac{1}{T_0} \int_0^{T_0} \mathbf{1}_{|\alpha^{-1}g^\pm(\alpha) - (e^\beta - 1)| \geq \delta} dt > \eta \right) = -\infty.$$

Proof. Take $\zeta^1, \zeta^2 > 0$ to be determined later, and $\theta > 0$ which will be small. We prove the result for g^+ , g^- is similar. By Corollary 6.11, it is sufficient to prove:

$$\limsup_{\zeta^1, \zeta^2 \rightarrow 0} \limsup_{\alpha \rightarrow 0} \limsup_{N \rightarrow \infty} \frac{1}{N} \log \mathbb{P}_{r, \beta}^N \left(\text{for a.e. } t \in [0, T_0], \Gamma_t \in \mathcal{E}_r(d); \right. \\ \left. \frac{1}{T_0} \int_0^{T_0} \mathbf{1}_{|\alpha^{-1}g^+(\alpha) - (e^\beta - 1)| \geq \delta} \mathbf{1}_{|\xi^+, \zeta^1 N - e^{-\beta}| \leq \theta} \mathbf{1}_{|\xi^+, \zeta^2 N - e^{-\beta}| \leq \theta} dt > \eta/3 \right) = -\infty.$$

Consider the event bearing on $\xi^+, \zeta^1 N$. It enforces:

$$\xi^+, \zeta^1 N \in [e^{-\beta} - \theta, e^{-\beta} + \theta].$$

Choose ζ^1 such that $(e^{-\beta} - \theta)\zeta^1 = \alpha$. Then $\zeta^1 \xi^{+, \zeta^1 N} \geq \alpha$ means that, by definition, $g^+(\alpha)$ must be smaller than $\zeta^1(1 - \xi^{+, \zeta^1 N})$:

$$\xi^{+, \zeta^1 N} \in [e^{-\beta} - \theta, e^{-\beta} + \theta] \text{ and } (e^{-\beta} - \theta)\zeta^1 = \alpha \quad \Rightarrow \quad \alpha^{-1}g^+(\alpha) \leq \frac{1 - e^{-\beta} + \theta}{e^{-\beta} - \theta} = e^\beta - 1 + O(\theta),$$

where $O(\theta)$ is a positive function. Similarly, choose ζ^2 such that $(e^{-\beta} + \theta)\zeta^2 = \alpha$. Then:

$$\xi^{+, \zeta^2 N} \in [e^{-\beta} - \theta, e^{-\beta} + \theta] \text{ and } (e^{-\beta} + \theta)\zeta^2 = \alpha \quad \Rightarrow \quad \alpha^{-1}g^+(\alpha) \geq \frac{1 - e^{-\beta} - \theta}{e^{-\beta} + \theta} = e^\beta - 1 - O(\theta).$$

$O(\theta)$ is again a positive function. Taking θ small enough to contradict $|\alpha^{-1}g^+(\alpha) - (e^\beta - 1)| \geq \delta$ concludes the proof. \square

Lemma B.14 (Control of the deviations of the volume at distance $\alpha > 0$ below the pole). *For $\Gamma \in \mathcal{E}_r$, let $V^\alpha = V^\alpha(\Gamma)$ be defined as:*

$$V^\alpha(\Gamma) = \alpha^{-2} |\{x \in \Gamma : x \cdot e_2 \geq y_{\max}(\Gamma) - \alpha\}|.$$

Then for each $\delta, \eta > 0$:

$$\limsup_{\alpha \rightarrow 0} \limsup_{N \rightarrow \infty} \frac{1}{N} \log \mathbb{P}_{r, \beta}^N \left(\text{for a.e. } t \in [0, T_0], \Gamma_t \in \mathcal{E}_r(d); \frac{1}{T_0} \int_0^{T_0} \mathbf{1}_{|V^{\alpha - (e^\beta - 1)}| > \delta} dt > \eta \right) = -\infty.$$

Proof. Fix $k \in \mathbb{N}^*$ and $\theta > 0$ to be chosen later. By Lemma B.13, it is sufficient to prove:

$$\limsup_{\alpha \rightarrow 0} \limsup_{N \rightarrow \infty} \frac{1}{N} \log \mathbb{P}_{r, \beta}^N \left(\text{for a.e. } t \in [0, T_0], \Gamma_t \in \mathcal{E}_r(d); \right. \tag{B.17}$$

$$\left. \frac{1}{T_0} \int_0^{T_0} \mathbf{1}_{|V^{\alpha - (e^\beta - 1)}| > \delta} \mathbf{1}_{\forall j \in \{1, \dots, k\}, \left| \frac{k}{j\alpha} g^\pm(j\alpha/k) - (e^\beta - 1) \right| \leq \theta} dt > \eta/2 \right) = -\infty.$$

By definition of $g^\pm(\alpha)$ for $\alpha > 0$ (see Lemma B.13), for $\Gamma \in \mathcal{E}_r$ the quantity $V^\alpha(\Gamma)$ satisfies:

$$V^\alpha(\Gamma) = \alpha^{-2} \int_0^\alpha (g^+(u) + g^-(u)) du.$$

As microscopic curves have 1-Lipschitz boundaries, on the event that $(k/j\alpha)g^\pm(j\alpha/k) \in [e^\beta + 1 - \theta, e^\beta - 1 - \theta]$ for each $1 \leq j \leq k$, one obtains the following bound for V^α :

$$\alpha^2 V^\alpha(\Gamma) = |\{x \in \Gamma : y(x) \geq y_{\max} - \alpha\}| \geq 2 \sum_{j=1}^{k-1} \frac{j}{k\alpha} (e^\beta + 1 - \theta) \times \frac{\alpha}{k} = \frac{k-1}{k} (e^\beta - 1 - \theta) \alpha^2.$$

Similarly,

$$\alpha^2 V^\alpha(\Gamma) \leq 2 \sum_{j=1}^k \frac{j}{k\alpha} (e^\beta + 1 - \theta) \times \frac{\alpha}{k} = \frac{k+1}{k} (e^\beta - 1 + \theta) \alpha^2.$$

To conclude the proof, it remains to take k, θ such that the indicator functions appearing in (B.17) bear on incompatible events. This is achieved provided:

$$\frac{k-1}{k} (e^\beta - 1 - \theta) \geq e^\beta - 1 - \delta \quad \text{and} \quad \frac{k+1}{k} (e^\beta - 1 + \theta) \leq e^\beta - 1 + \delta.$$

\square

B.3.3 Tightness in $L^1([0, T_0])$ distance for the motion of the poles

In this section, we prove exponential tightness for the motion of the poles assuming trajectories live in $\mathcal{E}_r(d)$ for almost every time. As argued in Appendix B.2.2, it is sufficient to find a compact set of $L^1([0, T_0], [-1 + d, 1 - d]^2)$ in which the trajectories of the poles concentrate at scale e^{-N} . We proceed coordinates by coordinates of the L_k , $k \in \{1, \dots, 4\}$. This will also work for the R_k since they are microscopically close to the L_k by Lemma 6.1. According to the Kolmogorov-Riesz compactness theorem (Theorem 4.26 in [Bre10]), a set $K \subset L^1([0, T_0], [-1 + d, 1 - d])$ is relatively compact if and only if:

$$\sup_{h \leq \eta} \sup_{f \in K} \int_0^{T_0-h} |f(t+h) - f(t)| dt = o_\eta(1). \quad (\text{B.18})$$

To prove exponential tightness for the poles, we thus only have to prove that (B.18) holds for each of the eight coordinates of the L_k , $k \in \{1, \dots, 4\}$. We prove it for the motion of $y(L_1) = y_{\max}$ in the following lemma. The proof for the other seven coordinates is similar.

Lemma B.15 (Tightness in L^1 distance for y_{\max}). *Let $\varepsilon > 0$. Then:*

$$\limsup_{\eta \rightarrow 0} \limsup_{N \rightarrow \infty} \frac{1}{N} \log \mathbb{P}_{r,\beta}^N \left(\text{for a.e. } t \in [0, T_0], \Gamma_t \in \mathcal{E}_r(d); \sup_{h \leq \eta} \frac{1}{T_0} \int_0^{T_0-h} |y_{\max}(t+h) - y_{\max}(t)| dt > \varepsilon \right) = -\infty. \quad (\text{B.19})$$

Proof. For each $h \in [0, \eta]$ and $t \in [0, T_0 - h]$, write $\Delta_h(t) = |y_{\max}(t+h) - y_{\max}(t)|$ for brevity. Since y_{\max} is bounded by 1, (B.19) is proven as soon as

$$\limsup_{\eta \rightarrow 0} \limsup_{N \rightarrow \infty} \frac{1}{N} \log \mathbb{P}_{r,\beta}^N \left(\text{for a.e. } t \in [0, T_0], \Gamma_t \in \mathcal{E}_r(d); \sup_{h \leq \eta} \frac{1}{T_0} \int_0^{T_0-h} \mathbf{1}_{\Delta_h(t) \geq \varepsilon/2} dt > \varepsilon/4 \right) = -\infty.$$

Fix $\delta > 0$ that will be chosen small enough in the following. Define, for $\alpha > 0$ and $t \in [0, T_0]$, the quantity $\Delta V^\alpha(t)$ as follows (recall Lemma B.14):

$$\Delta V^\alpha(t) = |V^\alpha(\Gamma_t) - (e^\beta - 1)|.$$

Lemma B.14 tells us:

$$\limsup_{\alpha \rightarrow 0} \limsup_{N \rightarrow \infty} \frac{1}{N} \log \mathbb{P}_{r,\beta}^N \left(\text{for a.e. } t \in [0, T_0], \Gamma_t \in \mathcal{E}_r(d); \frac{1}{T_0} \int_0^{T_0} \mathbf{1}_{\Delta V^\alpha(t) > \delta} dt > \varepsilon/12 \right) = -\infty.$$

Notice in addition that:

$$\left\{ \sup_{h \leq \eta} \frac{1}{T_0} \int_0^{T_0-h} \mathbf{1}_{\Delta V^\alpha(t+h) > \delta} dt > \varepsilon/12 \right\} \subset \left\{ \frac{1}{T_0} \int_0^{T_0} \mathbf{1}_{\Delta V^\alpha(t) > \delta} dt > \varepsilon/12 \right\}.$$

As a result, (B.19) holds as soon as:

$$\limsup_{\alpha \rightarrow 0} \limsup_{\eta \rightarrow 0} \limsup_{N \rightarrow \infty} \frac{1}{N} \log \mathbb{P}_{r,\beta}^N \left(\text{for a.e. } t \in [0, T_0], \Gamma_t \in \mathcal{E}_r(d); \sup_{h \leq \eta} \lambda \left[\Delta_h(t) \geq \varepsilon/2, |\Delta V^\alpha(t)| \leq \delta, |\Delta V^\alpha(t+h)| \leq \delta \right] > \varepsilon/12 \right) = -\infty, \quad (\text{B.20})$$

where λ is T_0^{-1} times the Lebesgue measure on $[0, T_0]$. By Lemma B.12 on exponential tightness in $d_S^{L^1}$ topology, (B.20) is proven as soon as the following holds:

$$\limsup_{\alpha \rightarrow 0} \limsup_{\eta \rightarrow 0} \limsup_{N \rightarrow \infty} \frac{1}{N} \log \mathbb{P}_{r, \beta}^N \left(\text{for a.e. } t \in [0, T_0], \Gamma_t \in \mathcal{E}_r(d); \right. \\ \left. \sup_{\substack{(s, t) \in [0, T_0]^2 \\ |s-t| \leq \eta}} d^{L^1}(\Gamma_s, \Gamma_t) < \alpha^2(e^\beta - 1)/2; \right. \\ \left. \sup_{h \leq \eta} \lambda \left[\Delta_h(t) \geq \varepsilon/2, |\Delta V^\alpha(t)| \leq \delta, |\Delta V^\alpha(t+h)| \leq \delta \right] > \varepsilon/12 \right) = -\infty, \quad (\text{B.21})$$

Take $\delta < (e^\beta - 1)/2$ and an arbitrary $\alpha \in (0, \varepsilon/2]$. For any trajectory $(\Gamma_t)_{t \in [0, T_0]}$ in the event inside the probability in (B.21), there must be $t \in [0, T_0]$ and $h < \eta$ such that, simultaneously:

- The north poles of Γ_t, Γ_{t+h} are at vertical distance at least $\varepsilon/2$, so that either $\{x \in \Gamma_t : x \cdot e_2 \geq y_{\max}(\Gamma_t) - \alpha\} \cap \Gamma_{t+h} = \emptyset$ or $\{x \in \Gamma_{t+h} : x \cdot e_2 \geq y_{\max}(\Gamma_{t+h}) - \alpha\} \cap \Gamma_t = \emptyset$.
- Recall that $V^\alpha(t) = \alpha^{-2} |\{x \in \Gamma_t : x \cdot e_2 \geq y_{\max}(\Gamma_t) - \alpha\}|$. $V^\alpha(\Gamma_t)$ and $V^\alpha(\Gamma_{t+h})$ are both at least $e^\beta - 1 - \delta > (e^\beta - 1)/2$ so that, by the first point, the difference in volume between Γ_t and Γ_{t+h} is at least $\alpha^2(e^\beta - 1)/2$;
- yet, $d^{L^1}(\Gamma_t, \Gamma_{t+h}) < \alpha^2(e^\beta - 1)/2$, which is incompatible with point 2. This concludes the proof. □

Remark B.16. The proof for y_{\min}, x_{\min} and x_{\max} is identical to the above. For the w_k , i.e. $L_1 \cdot e_1, L_2 \cdot e_2, L_3 \cdot e_1$ and $L_4 \cdot e_2$, slight modifications are required: in addition to the indicator functions on the volumes $\Delta V^\alpha(t) < \delta, \Delta V^\alpha(t+h) < \delta$, one has to introduce the events $\{g_\alpha^\pm(t+h) < \delta\}, \{g_\alpha^\pm(t) < \delta\}$, where g_α^\pm , the width of the level at distance α beneath the pole, is defined in Lemma B.13.

The idea is that if α is taken small enough as a function of ε and β (in practice, $(e^\beta - 1)^{-1} \varepsilon/2$ times a numerical constant), then the horizontal distance between $L_1(t) \cdot e_1$ and $L_1(t+h) \cdot e_1$ is going to be at least $\min\{g_\alpha^+(t+h) + g_\alpha^-(t), g_\alpha^+(t) + g_\alpha^-(t+h)\}$.

As a result, the set of points above $y_{\max}(\Gamma_t) - \alpha$ in Γ_t and the set of points above $y_{\max}(\Gamma_{t+h}) - \alpha$ in Γ_{t+h} are disjoint. Thanks to the indicator functions on the volumes ΔV^α , this implies a difference in volume, which is again impossible for η small enough. ■

Bibliography

- [Doo57] J. L. Doob. “Conditional brownian motion and the boundary limits of harmonic functions”. In: *Bulletin de la Société Mathématique de France* 85 (1957), pp. 431–458. DOI: 10.24033/bsmf.1494 (cit. on p. 32).
- [Lif62] I. Lifshitz. “Kinetics of Ordering during Second-Order Phase Transitions”. In: *Soviet Physics–JETP [translation of Zhurnal Eksperimentalnoi i Teoreticheskoi Fiziki]* 15 (1962), p. 939 (cit. on pp. 34, 51, 154).
- [Ber74] S. J. Bernau. “Products of Positive Operators”. In: *Mathematical Proceedings of the Cambridge Philosophical Society* 76.2 (1974), pp. 415–416. ISSN: 1469-8064, 0305-0041. DOI: 10.1017/S0305004100049100 (cit. on p. 60).
- [DV75] M. D. Donsker and S. R. S. Varadhan. “Asymptotic Evaluation of Certain Markov Process Expectations for Large Time, I”. In: *Communications on Pure and Applied Mathematics* 28.1 (1975), pp. 1–47. ISSN: 1097-0312. DOI: 10.1002/cpa.3160280102 (cit. on pp. 15, 55).
- [Spo83] H. Spohn. “Long Range Correlations for Stochastic Lattice Gases in a Non-Equilibrium Steady State”. In: *Journal of Physics A: Mathematical and General* 16.18 (1983), p. 4275 (cit. on pp. 8, 13, 17, 23, 50, 54–56, 58–59).
- [Can84] J. R. Cannon. *The One-Dimensional Heat Equation*. Encyclopedia of Mathematics and Its Applications. Cambridge: Cambridge University Press, 1984. ISBN: 978-0-521-30243-2. DOI: 10.1017/CB09781139086967 (cit. on p. 48).
- [DFL86] A. De Masi, P. A. Ferrari, and J. L. Lebowitz. “Reaction-Diffusion Equations for Interacting Particle Systems”. In: *Journal of statistical physics* 44.3-4 (1986), pp. 589–644 (cit. on pp. 25, 155).
- [Com87] F. Comets. “Nucleation for a Long Range Magnetic Model”. In: *Annales de l’IHP Probabilités et Statistiques*. Vol. 23. 2. 1987, pp. 135–178 (cit. on p. 155).
- [FPV88] P. A. Ferrari, E. Presutti, and M. E. Vares. “Non equilibrium fluctuations for a zero range process”. In: *Annales de l’I.H.P. Probabilités et statistiques* 24.2 (1988), pp. 237–268 (cit. on p. 25).
- [GPV88] M. Z. Guo, G. C. Papanicolaou, and S. R. S. Varadhan. “Nonlinear Diffusion Limit for a System with Nearest Neighbor Interactions”. In: *Communications in Mathematical Physics* 118.1 (1988), pp. 31–59. ISSN: 0010-3616, 1432-0916 (cit. on pp. 12, 56).
- [Cia89] P. G. Ciarlet. *Introduction to Numerical Linear Algebra and Optimisation*. Cambridge Texts in Applied Mathematics. Cambridge: Cambridge University Press, 1989. DOI: 10.1017/9781139171984 (cit. on p. 119).

- [DV89] M. D. Donsker and S. R. S. Varadhan. “Large Deviations from a Hydrodynamic Scaling Limit”. In: *Communications on Pure and Applied Mathematics* 42.3 (1989), pp. 243–270. ISSN: 1097-0312. DOI: 10.1002/cpa.3160420303 (cit. on p. 12).
- [KOV89] C. Kipnis, S. Olla, and S. Varadhan. “Hydrodynamics and Large Deviation for Simple Exclusion Processes”. In: *Communications on Pure and Applied Mathematics* 42.2 (1989), pp. 115–137 (cit. on pp. 11–12, 27, 45, 47, 49–51, 56, 156, 173).
- [ELS90] G. Eyink, J. L. Lebowitz, and H. Spohn. “Hydrodynamics of Stationary Non-Equilibrium States for Some Stochastic Lattice Gas Models”. In: *Communications in mathematical physics* 132.1 (1990), pp. 253–283 (cit. on pp. 10, 13, 55, 167, 212, 228–229, 231).
- [Gar+90] P. L. Garrido, J. L. Lebowitz, C. Maes, and H. Spohn. “Long-Range Correlations for Conservative Dynamics”. In: *Physical Review A* 42.4 (1990), pp. 1954–1968. DOI: 10.1103/PhysRevA.42.1954 (cit. on pp. 17, 54).
- [Yau91] H.-T. Yau. “Relative Entropy and Hydrodynamics of Ginzburg-Landau Models”. In: *Letters in Mathematical Physics* 22.1 (1991), pp. 63–80. ISSN: 1573-0530. DOI: 10.1007/BF00400379 (cit. on pp. 23, 25–26, 30, 56, 64, 67).
- [ESS92] L. C. Evans, H. M. Soner, and P. E. Souganidis. “Phase Transitions and Generalized Motion by Mean Curvature”. In: *Communications on Pure and Applied Mathematics* 45.9 (1992), pp. 1097–1123 (cit. on p. 156).
- [BSS93] G. Barles, H. M. Soner, and P. E. Souganidis. “Front Propagation and Phase Field Theory”. In: *SIAM Journal on Control and Optimization* 31.2 (1993), pp. 439–469 (cit. on p. 156).
- [De +93] A. De Masi, E. Orlandi, E. Presutti, and L. Triolo. “Motion by Curvature by Scaling Nonlocal Evolution Equations”. In: *Journal of statistical physics* 73.3-4 (1993), pp. 543–570 (cit. on p. 155).
- [Ilm93] T. Ilmanen. “Convergence of the Allen-Cahn Equation to Brakke’s Motion by Mean Curvature”. In: *J. Differential Geometry* 38.2 (1993), pp. 417–461 (cit. on p. 156).
- [JLV93] G. Jona-Lasinio, C. Landim, and M. E. Vares. “Large Deviations for a Reaction Diffusion Model”. In: *Probability Theory and Related Fields* 97.3 (1993), pp. 339–361. ISSN: 1432-2064. DOI: 10.1007/BF01195070 (cit. on p. 12).
- [Spo93] H. Spohn. “Interface Motion in Models with Stochastic Dynamics”. In: *Journal of Statistical Physics* 71.5-6 (1993), pp. 1081–1132. DOI: 10.1007/bf01049962 (cit. on pp. 20, 34, 45, 47, 51, 154–155, 165–166, 172).
- [De +94] A. De Masi, E. Orlandi, E. Presutti, and L. Triolo. “Glauber Evolution with Kac Potentials. I. Mesoscopic and Macroscopic Limits, Interface Dynamics”. In: *Nonlinearity* 7.3 (1994), p. 633 (cit. on p. 155).
- [KS94] M. A. Katsoulakis and P. E. Souganidis. “Interacting Particle Systems and Generalized Evolution of Fronts”. In: *Archive for rational mechanics and analysis* 127.2 (1994), pp. 133–157 (cit. on p. 155).
- [BKL95] O. Benois, C. Kipnis, and C. Landim. “Large Deviations from the Hydrodynamical Limit of Mean Zero Asymmetric Zero Range Processes”. In: *Stochastic processes and their applications* 55.1 (1995), pp. 65–89 (cit. on p. 12).

- [CSS95] L. Chayes, R. H. Schonmann, and G. Swindle. “Lifshitz’ Law for the Volume of a Two-Dimensional Droplet at Zero Temperature”. In: *Journal of Statistical Physics* 79.5 (1995), pp. 821–831. ISSN: 1572-9613. DOI: 10.1007/BF02181205 (cit. on pp. 34, 51).
- [Qua95] J. Quastel. “Large Deviations from a Hydrodynamic Scaling Limit for a Nongradient System”. In: *The Annals of Probability* 23.2 (1995), pp. 724–742. ISSN: 0091-1798, 2168-894X. DOI: 10.1214/aop/1176988286 (cit. on p. 12).
- [BKM96] A. V. Bukhvalov, V. B. Korotkov, and B. M. Makarovt. “Integral Operators”. In: *Vector Lattices and Integral Operators*. Ed. by S. S. Kutateladze. Mathematics and Its Applications. Dordrecht: Springer Netherlands, 1996, pp. 279–346. ISBN: 978-94-009-0195-7. DOI: 10.1007/978-94-009-0195-7_4 (cit. on p. 65).
- [CS96] L. Chayes and G. Swindle. “Hydrodynamic Limits for One-Dimensional Particle Systems with Moving Boundaries”. In: *The Annals of Probability* 24.2 (1996), pp. 559–598. ISSN: 0091-1798, 2168-894X. DOI: 10.1214/aop/1039639355 (cit. on pp. 48, 155).
- [DS96] P. Diaconis and L. Saloff-Coste. “Logarithmic Sobolev Inequalities for Finite Markov Chains”. In: *The Annals of Applied Probability* 6.3 (1996), pp. 695–750. ISSN: 1050-5164, 2168-8737. DOI: 10.1214/aoap/1034968224 (cit. on p. 122).
- [FS97] T. Funaki and H. Spohn. “Motion by Mean Curvature from the Ginzburg-Landau Interface Model”. In: *Communications in Mathematical Physics* 185.1 (1997), pp. 1–36 (cit. on p. 155).
- [SS98] R. H. Schonmann and S. B. Shlosman. “Wulff Droplets and the Metastable Relaxation of Kinetic Ising Models”. In: *Communications in mathematical physics* 194.2 (1998), pp. 389–462 (cit. on pp. 157, 173).
- [KL99] C. Kipnis and C. Landim. *Scaling Limits of Interacting Particle Systems*. Springer Berlin Heidelberg, 1999. DOI: 10.1007/978-3-662-03752-2 (cit. on pp. 8, 10–11, 14, 20, 26, 28, 50, 56–57, 61, 87, 89, 92, 95, 103, 110, 156, 165, 170, 173–174, 191–192, 196–197, 214, 225, 246).
- [Mar99] F. Martinelli. “Lectures on Glauber Dynamics for Discrete Spin Models”. In: *Lecture Notes in Mathematics*. Springer Berlin Heidelberg, 1999, pp. 93–191. DOI: 10.1007/978-3-540-48115-7_2 (cit. on pp. 33, 157).
- [QRV99] J. Quastel, F. Rezakhanlou, and S. R. S. Varadhan. “Large Deviations for the Symmetric Simple Exclusion Process in Dimensions $D \geq 3$ ”. In: *Probability Theory and Related Fields* 113.1 (1999), pp. 1–84. ISSN: 1432-2064. DOI: 10.1007/s004400050202 (cit. on p. 12).
- [BIV99] T. Bodineau, D. Ioffe, and Y. Velenik. “Rigorous Probabilistic Analysis of Equilibrium Crystal Shapes”. In: *Journal of mathematical physics* (1999-11-15, 1999). DOI: 10.1063/1.533180. arXiv: math/9911106v1 (cit. on p. 33).
- [Doo01] J. L. Doob. *Classical Potential Theory and Its Probabilistic Counterpart*. Classics in Mathematics. Berlin Heidelberg: Springer-Verlag, 2001. ISBN: 978-3-540-41206-9. DOI: 10.1007/978-3-642-56573-1 (cit. on p. 32).

- [Ber+02] L. Bertini, A. De Sole, D. Gabrielli, G. Jona-Lasinio, and C. Landim. “Macroscopic Fluctuation Theory for Stationary Non-Equilibrium States”. In: *Journal of Statistical Physics* 107.3 (2002), pp. 635–675. ISSN: 1572-9613. DOI: 10.1023/A:1014525911391 (cit. on p. 14).
- [DLS02] B. Derrida, J. L. Lebowitz, and E. R. Speer. “Large Deviation of the Density Profile in the Steady State of the Open Symmetric Simple Exclusion Process”. In: *Journal of statistical physics* 107.3-4 (2002), pp. 599–634 (cit. on pp. 13–14, 17, 23, 50, 59, 64).
- [AF03] R. A. Adams and J. J. Fournier. *Sobolev Spaces*. Elsevier, 2003 (cit. on p. 145).
- [Ber+03] L. Bertini, A. De Sole, D. Gabrielli, G. Jona-Lasinio, and C. Landim. “Large Deviations for the Boundary Driven Symmetric Simple Exclusion Process”. In: *Mathematical Physics, Analysis and Geometry* 6.3 (2003), pp. 231–267 (cit. on pp. 11–13, 17).
- [BG04] T. Bodineau and G. Giacomin. “From Dynamic to Static Large Deviations in Boundary Driven Exclusion Particle Systems”. In: *Stochastic Processes and their Applications* 110.1 (2004), pp. 67–81. ISSN: 0304-4149. DOI: 10.1016/j.spa.2003.10.005 (cit. on p. 17).
- [Der+05] B. Derrida, C. Enaud, C. Landim, and S. Olla. “Fluctuations in the Weakly Asymmetric Exclusion Process with Open Boundary Conditions”. In: *Journal of Statistical Physics* 118.5 (2005), pp. 795–811. ISSN: 1572-9613. DOI: 10.1007/s10955-004-1989-x (cit. on pp. 20, 25, 56).
- [Lig05] T. M. Liggett. *Interacting Particle Systems*. Springer Berlin Heidelberg, 2005. DOI: 10.1007/b138374 (cit. on pp. 8, 25, 50).
- [OV05] E. Olivieri and M. E. Vares. *Large Deviations and Metastability*. Vol. 100. Cambridge University Press, 2005 (cit. on p. 157).
- [LMO06] C. Landim, A. Milanés, and S. Olla. “Stationary and Nonequilibrium Fluctuations in Boundary Driven Exclusion Processes”. In: *Markov processes and related fields* 14.2 (2006), pp. 165–184 (cit. on pp. 20, 25, 56–57).
- [Ass07] S. Assing. “A Limit Theorem for Quadratic Fluctuations in Symmetric Simple Exclusion”. In: *Stochastic Processes and their Applications* 117.6 (2007), pp. 766–790. ISSN: 0304-4149. DOI: 10.1016/j.spa.2006.10.005 (cit. on pp. 25, 56–57).
- [Bah07] C. Bahadoran. “On the Convergence of Entropy for Stationary Exclusion Processes with Open Boundaries”. In: *Journal of Statistical Physics* 126.4 (2007), pp. 1069–1082. ISSN: 1572-9613. DOI: 10.1007/s10955-006-9229-1 (cit. on p. 128).
- [Ber+07] L. Bertini, A. De Sole, D. Gabrielli, G. Jona-Lasinio, and C. Landim. “Large Deviations of the Empirical Current in Interacting Particle Systems”. In: *Theory of Probability & Its Applications* 51.1 (2007), pp. 2–27. ISSN: 0040-585X. DOI: 10.1137/S0040585X97982256 (cit. on p. 31).
- [CL07] R. Cerf and S. Louhichi. “The Initial Drift of a 2D Droplet at Zero Temperature”. In: *Probability Theory and Related Fields* 137.3-4 (2007), pp. 379–428 (cit. on p. 155).
- [DLS07] B. Derrida, J. L. Lebowitz, and E. R. Speer. “Entropy of Open Lattice Systems”. In: *Journal of Statistical Physics* 126.4-5 (2007), pp. 1083–1108 (cit. on pp. 17, 29, 55, 66, 125, 127–128).

- [Der07] B. Derrida. “Non-Equilibrium Steady States: Fluctuations and Large Deviations of the Density and of the Current”. In: *Journal of Statistical Mechanics: Theory and Experiment* 2007.07 (2007), P07023 (cit. on pp. 14, 55).
- [Bod+08] T. Bodineau, B. Derrida, V. Lecomte, and F. van Wijland. “Long Range Correlations and Phase Transitions in Non-Equilibrium Diffusive Systems”. In: *Journal of Statistical Physics* 133.6 (2008), pp. 1013–1031. ISSN: 1572-9613. DOI: 10.1007/s10955-008-9647-3 (cit. on pp. 32, 67).
- [CK08] L. Chayes and I. C. Kim. “A Two-Sided Contracting Stefan Problem”. In: *Communications in Partial Differential Equations* 33.12 (2008), pp. 2225–2256 (cit. on pp. 48, 155).
- [BLM09] L. Bertini, C. Landim, and M. Mourragui. “Dynamical Large Deviations for the Boundary Driven Weakly Asymmetric Exclusion Process”. In: *The Annals of Probability* 37.6 (2009), pp. 2357–2403. DOI: 10.1214/09-aop472 (cit. on pp. 12–13, 17, 171).
- [EK09] S. N. Ethier and T. G. Kurtz. *Markov Processes: Characterization and Convergence*. Vol. 282. John Wiley & Sons, 2009 (cit. on pp. 241, 243, 245).
- [Bre10] H. Brezis. *Functional Analysis, Sobolev Spaces and Partial Differential Equations*. Springer Science & Business Media, 2010 (cit. on pp. 244, 248).
- [Cap+11] P. Caputo, F. Martinelli, F. Simenhaus, and F. L. Toninelli. ““Zero” Temperature Stochastic 3D Ising Model and Dimer Covering Fluctuations: A First Step towards Interface Mean Curvature Motion”. In: *Communications on Pure and Applied Mathematics* 64.6 (2011), pp. 778–831. ISSN: 1097-0312. DOI: 10.1002/cpa.20359 (cit. on pp. 34, 46, 168, 198).
- [FLM11] J. Farfan, C. Landim, and M. Mourragui. “Hydrostatics and Dynamical Large Deviations of Boundary Driven Gradient Symmetric Exclusion Processes”. In: *Stochastic Processes and their Applications* 121.4 (2011), pp. 725–758. ISSN: 0304-4149. DOI: 10.1016/j.spa.2010.11.014 (cit. on pp. 12–13, 16, 55).
- [Gri11] P. Grisvard. *Elliptic Problems in Nonsmooth Domains*. Classics in Applied Mathematics. Society for Industrial and Applied Mathematics, 2011. ISBN: 978-1-61197-202-3. DOI: 10.1137/1.9781611972030 (cit. on pp. 63, 96, 145, 148–150).
- [BL12] T. Bodineau and M. Lagouge. “Large Deviations of the Empirical Currents for a Boundary-Driven Reaction Diffusion Model”. In: *The Annals of Applied Probability* 22.6 (2012), pp. 2282–2319 (cit. on pp. 12–13).
- [CKG12] L. Chayes, I. C. Kim, and C. Gui. “The Supercooled Stefan Problem in One Dimension”. In: *Communications on Pure & Applied Analysis* 11.2 (2012) (cit. on pp. 48, 155).
- [KLO12] T. Komorowski, C. Landim, and S. Olla. *Fluctuations in Markov Processes: Time Symmetry and Martingale Approximation*. Vol. 345. Springer Science & Business Media, 2012 (cit. on p. 25).
- [Spo12] H. Spohn. *Large Scale Dynamics of Interacting Particles*. Springer Science & Business Media, 2012 (cit. on p. 8).

- [BFG13] L. Bertini, A. Faggionato, and D. Gabrielli. “Large Deviation Principles for Nongradient Weakly Asymmetric Stochastic Lattice Gases”. In: *The Annals of Applied Probability* 23.1 (2013), pp. 1–65. ISSN: 1050-5164, 2168-8737. DOI: 10.1214/11-AAP805 (cit. on p. 12).
- [DR13] B. Derrida and M. Retaux. “Finite Size Corrections to the Large Deviation Function of the Density in the One Dimensional Symmetric Simple Exclusion Process”. In: *Journal of Statistical Physics* 152.5 (2013), pp. 824–845 (cit. on p. 55).
- [Lac13] H. Lacoin. “Approximate Lifshitz Law for the Zero-Temperature Stochastic Ising Model in Any Dimension”. In: *Communications in Mathematical Physics* 318.2 (2013), pp. 291–305. DOI: 10.1007/s00220-013-1667-4 (cit. on p. 34).
- [Lub+13] E. Lubetzky, F. Martinelli, A. Sly, and F. L. Toninelli. “Quasi-Polynomial Mixing of the 2D Stochastic Ising Model with “plus” Boundary up to Criticality”. In: *Journal of the European Mathematical Society* 15.2 (2013), pp. 339–386. ISSN: 1435-9855. DOI: 10.4171/jems/363 (cit. on p. 34).
- [RV13] M. Rudelson and R. Vershynin. “Hanson-Wright Inequality and Sub-Gaussian Concentration”. In: *Electronic Communications in Probability* 18 (none 2013), pp. 1–9. ISSN: 1083-589X, 1083-589X. DOI: 10.1214/ECP.v18-2865 (cit. on p. 112).
- [Lac14] H. Lacoin. “The Scaling Limit of Polymer Pinning Dynamics and a One Dimensional Stefan Freezing Problem”. In: *Communications in Mathematical Physics* 331.1 (2014), pp. 21–66 (cit. on pp. 48, 155).
- [LST14a] H. Lacoin, F. Simenhaus, and F. L. Toninelli. “The Heat Equation Shrinks Ising Droplets to Points”. In: *Communications on Pure and Applied Mathematics* 68.9 (2014), pp. 1640–1681. DOI: 10.1002/cpa.21533 (cit. on pp. 34–37, 51, 155–158, 165, 168, 172, 214).
- [LST14b] H. Lacoin, F. Simenhaus, and F. L. Toninelli. “Zero-Temperature 2D Stochastic Ising Model and Anisotropic Curve-Shortening Flow”. In: *Journal of the European Mathematical Society* 16.12 (2014), pp. 2557–2615. DOI: 10.4171/jems/493 (cit. on pp. 34–37, 40, 42, 51, 155–158, 165, 168, 172).
- [Ber+15] L. Bertini, A. De Sole, D. Gabrielli, G. Jona-Lasinio, and C. Landim. “Macroscopic Fluctuation Theory”. In: *Reviews of Modern Physics* 87.2 (2015), pp. 593–636. DOI: 10.1103/RevModPhys.87.593 (cit. on pp. 13–14, 17).
- [CT15a] R. Chetrite and H. Touchette. “Nonequilibrium Markov Processes Conditioned on Large Deviations”. In: *Annales Henri Poincaré* 16.9 (2015), pp. 2005–2057. ISSN: 1424-0661. DOI: 10.1007/s00023-014-0375-8 (cit. on p. 32).
- [CT15b] R. Chetrite and H. Touchette. “Variational and Optimal Control Representations of Conditioned and Driven Processes”. In: *Journal of Statistical Mechanics: Theory and Experiment* 2015.12 (2015), P12001. ISSN: 1742-5468. DOI: 10.1088/1742-5468/2015/12/P12001 (cit. on p. 32).
- [EG15] L. C. Evans and R. F. Gariepy. *Measure Theory and Fine Properties of Functions*. Chapman and Hall/CRC, 2015 (cit. on pp. 188, 241).

- [BD16] A. Bovier and F. Den Hollander. *Metastability: A Potential-Theoretic Approach*. Vol. 351. Springer, 2016 (cit. on p. 157).
- [Car+16] G. Carinci, A. De Masi, C. Giardinà, and E. Presutti. *Free Boundary Problems in PDEs and Particle Systems*. Springer, 2016 (cit. on p. 155).
- [Siu16] B. Siudeja. “On Mixed Dirichlet-Neumann Eigenvalues of Triangles”. In: *Proceedings of the American Mathematical Society* 144.6 (2016), pp. 2479–2493. ISSN: 0002-9939, 1088-6826. DOI: 10.1090/proc/12888 (cit. on p. 147).
- [BBP17a] L. Bertini, P. Buttà, and A. Pisante. “Stochastic Allen-Cahn Approximation of the Mean Curvature Flow: Large Deviations Upper Bound”. In: *Archive for Rational Mechanics and Analysis* 224.2 (2017), pp. 659–707 (cit. on p. 156).
- [BBP17b] L. Bertini, P. Buttà, and A. Pisante. “Stochastic Allen–Cahn Equation with Mobility”. In: *Nonlinear Differential Equations and Applications* 24.5 (2017), p. 54 (cit. on p. 156).
- [BBP18] L. Bertini, P. Buttà, and A. Pisante. “On Large Deviations of Interface Motions for Statistical Mechanics Models”. In: *Annales Henri Poincaré*. Springer. 2018, pp. 1–37 (cit. on pp. 155–156).
- [JM18a] M. Jara and O. Menezes. *Non-Equilibrium Fluctuations for a Reaction-Diffusion Model via Relative Entropy*. 2018. arXiv: 1810.03418 (cit. on pp. 25, 51, 57, 67–68).
- [JM18b] M. Jara and O. Menezes. *Non-Equilibrium Fluctuations of Interacting Particle Systems*. 2018. arXiv: 1810.09526 (cit. on pp. 25–26, 31, 51, 56–57, 64, 67–69, 112, 116, 129–130).
- [LT18] B. Laslier and F. L. Toninelli. “Lozenge Tiling Dynamics and Convergence to the Hydrodynamic Equation”. In: *Communications in Mathematical Physics* 358.3 (2018), pp. 1117–1149 (cit. on p. 155).
- [BB19] R. Bauerschmidt and T. Bodineau. “A Very Simple Proof of the LSI for High Temperature Spin Systems”. In: *Journal of Functional Analysis* 276.8 (2019), pp. 2582–2588. ISSN: 0022-1236. DOI: 10.1016/j.jfa.2019.01.007 (cit. on p. 120).
- [FT19] T. Funaki and K. Tsunoda. “Motion by Mean Curvature from Glauber–Kawasaki Dynamics”. In: *Journal of Statistical Physics* 177.2 (2019), pp. 183–208 (cit. on pp. 26, 155).
- [GJ19] P. Gonçalves and M. Jara. “Quadratic Fluctuations of the Symmetric Simple Exclusion”. In: *ALEA* 16 (2019), pp. 605–632 (cit. on pp. 20, 25, 56–57, 64, 67).
- [G+19] F. Götze, H. Sambale, A. Sinulis, et al. “Higher Order Concentration for Functions of Weakly Dependent Random Variables”. In: *Electronic Journal of Probability* 24 (2019) (cit. on pp. 27, 120–122).
- [CS20] J. P. Chen and F. Sau. *Higher Order Hydrodynamics and Equilibrium Fluctuations of Interacting Particle Systems*. 2020. arXiv: 2008.13403 (cit. on pp. 25, 57).
- [GMV20] A. Gaudillièrè, P. Milanesi, and M. E. Vares. “Asymptotic Exponential Law for the Transition Time to Equilibrium of the Metastable Kinetic Ising Model with Vanishing Magnetic Field”. In: *Journal of Statistical Physics* (2020), pp. 1–46 (cit. on p. 157).

- [Gon+20] P. Gonçalves, M. Jara, O. Menezes, and A. Neumann. “Non-Equilibrium and Stationary Fluctuations for the SSEP with Slow Boundary”. In: *Stochastic Processes and their Applications* 130.7 (2020), pp. 4326–4357. ISSN: 0304-4149. DOI: 10.1016/j.spa.2019.12.006 (cit. on pp. 25, 56, 64).
- [Ket+20] P. E. Kettani, T. Funaki, D. Hilhorst, H. Park, and S. Sethuraman. *Mean Curvature Interface Limit from Glauber+Zero-Range Interacting Particles*. 2020. arXiv: 2004.05276 (cit. on pp. 26, 155).
- [SS20] H. Sambale and A. Sinulis. “Logarithmic Sobolev Inequalities for Finite Spin Systems and Applications”. In: *Bernoulli* 26.3 (2020), pp. 1863–1890. DOI: 10.3150/19-BEJ1172 (cit. on pp. 27, 120).
- [ACR21] M. Ayala, G. Carinci, and F. Redig. “Higher Order Fluctuation Fields and Orthogonal Duality Polynomials”. In: *Electronic Journal of Probability* 26 (none 2021), pp. 1–35. ISSN: 1083-6489, 1083-6489. DOI: 10.1214/21-EJP586 (cit. on pp. 25, 57).

Titre : Grandes déviations dans des systèmes de particule en interaction : corrélations hors équilibre et dynamique d'interface

Mots clés : Particules en interaction, Grandes déviation, Modèle d'Ising, Corrélations, Interfaces

Résumé : Cette thèse est consacrée à l'étude d'événements dynamiques rares dans des systèmes de particules en interaction. Deux modèles sont considérés : le processus d'exclusion simple symétrique unidimensionnel interagissant avec des réservoirs, et un modèle de dynamiques d'interfaces se rapprochant de la dynamique de Glauber du modèle d'Ising bidimensionnel à température nulle.

Dans le cadre du modèle d'exclusion simple, les travaux présentés visent à l'étude des corrélations à deux points hors équilibre. Plus précisément, le but est d'estimer la probabilité d'obtenir une valeur atypique des corrélations à deux points moyennées en temps dans la limite hydrodynamique et en temps long. Pour étudier les corrélations à deux points avec le niveau de précision requis, il est nécessaire d'améliorer les techniques existantes. En raffinant la méthode d'entropie relative initialement développée par Yau, un principe de grandes déviations pour les corrélations à deux points est obtenu.

La dynamique d'interface modélise l'évolution d'une goutte de spins – d'Ising immergés dans une mer de spins + sur un réseau carré. Dans le cas de la

dynamique d'Ising à température nulle, la frontière de cette goutte évolue selon un mouvement à courbure moyenne anisotrope, comme a été rigoureusement établi par Lacoïn, Simenhaus et Toninelli il y a quelques années. Dans la thèse, c'est la structure des trajectoires atypiques que l'on cherche à comprendre. Pour ce faire, une dynamique d'interface, appelée dynamique de contour et très similaire à la dynamique d'Ising à température nulle est introduite. La seule dissemblance vient de la présence d'un paramètre supplémentaire, jouant le rôle d'une (faible) température agissant localement sur l'interface. En particulier, les dynamiques d'Ising et de contour coïncident quand ce paramètre est nul. Il est montré que la trajectoire typique d'une interface sous la dynamique de contour évolue également par mouvement par courbure moyenne anisotrope, avec une influence du paramètre de température. Un principe de grandes déviations est alors obtenu pour la dynamique de contour, permettant de relier les trajectoires atypiques à des perturbations d'un mouvement à courbure moyenne anisotrope, toujours avec une influence du paramètre de température.

Title : Large deviations in interacting particle systems: out of equilibrium correlations and interface dynamics

Keywords : Interacting particle systems, Large deviations, Ising model, Correlations, Interfaces

Abstract : The objective of this thesis is the study of rare dynamical events in some interacting particle systems. Two models are considered : the one dimensional symmetric simple exclusion process interacting with reservoirs, and an interface dynamics related to the zero temperature Glauber dynamics for the two dimensional Ising model.

In the case of the simple exclusion process, the work presented in the manuscript concerns the study of the out of equilibrium two-point correlation field. More precisely, the objective of the work is to estimate the probability of observing anomalous time-averaged two-point correlations, in the hydrodynamics scaling and the long time limit simultaneously. Studying two-point correlations at a suitable level of precision requires improving existing techniques. A refinement of the relative entropy method initially due to Yau provides a sufficient toolbox, thanks to which a large deviation principle for time-averaged two-point correlations is obtained.

The interface dynamics aims at modelling the evolution of the interface separating a droplet of – Ising

spins in a sea of + spins in the zero temperature Ising model. In the zero temperature Ising case, the boundary of this droplet has been shown to follow an anisotropic motion by curvature by Lacoïn, Simenhaus and Toninelli a few years ago, rigorously establishing a long standing conjecture. In the manuscript, we aim to investigate the structure of atypical interface trajectories. To do so, another interface dynamics, called the contour dynamics, is introduced. Very similar to the zero temperature Ising dynamics, it differs by the presence of an additional parameter, which plays the role of a (small) temperature acting locally on the interface. In particular, Ising and contour dynamics coincide when this parameter vanishes. We show that the typical interface trajectory in the contour dynamics is still given by an anisotropic motion by curvature, with an influence of the temperature-like parameter. A large deviation principle is also established, characterising atypical trajectories as perturbations of the anisotropic motion by curvature, again with an influence of the temperature-like parameter.